

MARKS PUBLISHED FOR OPPOSITION

The following marks are published in compliance with section 12(a) of the Trademark Act of 1946. Applications for the registration of marks in more than one class have been filed as provided in section 30 of said act as amended by Public Law 772, 87th Congress, approved Oct. 9, 1962, 76 Stat. 769. Opposition under section 13 may be filed within thirty days of the date of this publication. See rules 2.101 to 2.105.

A separate fee of three hundred dollars (\$300.00) for opposing each mark in each class must accompany the opposition.

SECTION 1.— INTERNATIONAL CLASSIFICATION

The short titles associated below with the international class numbers are terms designed merely for quick identification and are not an official part of the international classification. The full names of international classes are given in section 6.1 of the trademark rules of practice.

The designation "U.S. Cl." appearing in this section refers to the U.S. class in effect prior to Sep. 1, 1973 rather than the international class which applies to applications filed on or after that date. For adoption of international classification see notice in the OFFICIAL GAZETTE of Jun. 26, 1973 (911 O.G. TM 210).

Application in more than one class

SN 75-804,209. DIME SAVINGS BANK OF NEW YORK, FSB, THE, NEW YORK, NY. FILED 9-21-1999.

SN 76-267,397. TABB, DAMON, FOREST HILLS, NY. FILED 6-5-2001.

DIMEBANK

CLASS 16—PAPER GOODS AND PRINTED MATTER

FOR PUBLICATIONS IN THE NATURE OF MAGAZINES, JOURNALS, NEWSLETTERS, PERIODICALS, BOOKS FEATURING INFORMATION ABOUT BANKING, INVESTMENTS AND FINANCIAL MATTERS (U.S. CLS. 2, 5, 22, 23, 29, 37, 38 AND 50).

CLASS 36—INSURANCE AND FINANCIAL

FOR BANKING SERVICES; MORTGAGE BANKING; DEBIT CARD SERVICES; ELECTRONIC FUNDS TRANSFER; PROVIDING BANKING SERVICES AND INFORMATION RELATED TO BANKING AND FINANCE MATTERS THROUGH A GLOBAL COMPUTER NETWORK; LOAN FINANCING; FINANCING SERVICES; HOME EQUITY LOANS; INSTALLMENT LOANS; MORTGAGE LENDING; MONEY ORDER SERVICES; SAFETY DEPOSIT BOX SERVICES; TRAVELER'S CHECK ISSUANCE; AUTOMATED 24-HOUR BRANCH BANKING SERVICES; PROVIDING BANKING SERVICES VIA REMOTE LOCATIONS; CREDIT AND FINANCIAL SERVICES, NAMELY, PROVIDING A REVOLVING LINE OF CREDIT TO CONSUMERS; SECURITY BROKERAGE SERVICES (U.S. CLS. 100, 101 AND 102).

KATHLEEN M. VANSTON, EXAMINING ATTORNEY

INTELLISTORM

CLASS 9—ELECTRICAL AND SCIENTIFIC APPARATUS

FOR EDUCATIONAL SOFTWARE FEATURING INSTRUCTION IN THE FIELD OF MATH, SCIENCES, SOCIAL SCIENCES, LANGUAGE, ART, VERBAL, LOGIC AND REASONING SKILLS; COMPUTER GAME SOFTWARE; AND COMPUTER GAMES, NAMELY, GAMES FOR USE WITH TELEVISIONS, COMPUTERS AND CONSOLES (U.S. CLS. 21, 23, 26, 36 AND 38).

CLASS 28—TOYS AND SPORTING GOODS

FOR COMPUTER GAMES, NAMELY, HAND HELD UNITS FOR PLAYING VIDEO GAMES (U.S. CLS. 22, 23, 38 AND 50).

BRIAN PINO, EXAMINING ATTORNEY

SN 76-704,449. 21ST CENTURY GAMING CONCEPTS, INC. LOS ANGELES, CA. FILED 9-13-2010.

MONSTER & BUSTER

THE MARK CONSISTS OF STANDARD CHARACTERS WITHOUT CLAIM TO ANY PARTICULAR FONT, STYLE, SIZE, OR COLOR.

CLASS 9—ELECTRICAL AND SCIENTIFIC APPARATUS

FOR DOWNLOADABLE ELECTRONIC PUBLICATIONS IN THE NATURE OF PAMPHLETS FEATURING BETTING RULES FOR CARD GAMES, NAMELY, POW GAI POKER AND BACCARAT, FOR USE BY OTHERS WHO PROVIDE THE SERVICE OF PLAYING CARD GAMES (U.S. CLS. 21, 23, 26, 36 AND 38).

CLASS 16—PAPER GOODS AND PRINTED MATTER

FOR PRINTED MATERIAL IN THE NATURE OF PAMPHLETS FEATURING BETTING RULES FOR CARD GAMES, NAMELY, POW GAI POKER AND BACCARAT, FOR USE BY OTHERS WHO PROVIDE THE SERVICE OF PLAYING CARD GAMES (U.S. CLS. 2, 5, 22, 23, 29, 37, 38 AND 50).
KIM MONINGHOFF, EXAMINING ATTORNEY

SN 76-705,679. CLADDING INNOVATIONS, LLC, DEER PARK, WA. FILED 12-13-2010.



THE MARK CONSISTS OF STANDARD CHARACTERS WITHOUT CLAIM TO ANY PARTICULAR FONT, STYLE, SIZE, OR COLOR.

CLASS 6—METAL GOODS

FOR BUILDING MATERIALS, NAMELY, METAL EXTERIOR BUILDING CLADDING THAT MINIMIZE THERMAL BRIDGES AND REDUCE THERMAL ENERGY TRANSFER (U.S. CLS. 2, 12, 13, 14, 23, 25 AND 50).

CLASS 19—NON-METALLIC BUILDING MATERIALS

FOR BUILDING MATERIALS, NAMELY, NON-METAL EXTERIOR BUILDING CLADDING THAT MINIMIZE THERMAL BRIDGES AND REDUCES THERMAL ENERGY TRANSFER (U.S. CLS. 1, 12, 33 AND 50).
ALYSSA STEEL, EXAMINING ATTORNEY

SN 76-706,725. THE UNIVERSITY OF HOUSTON SYSTEM, HOUSTON, TX. FILED 3-10-2011.



OWNER OF U.S. REG. NOS. 3,025,462, 3,697,389 AND OTHERS.
THE MARK CONSISTS OF A PHOTOGRAPH OF A COUGAR.

CLASS 16—PAPER GOODS AND PRINTED MATTER

FOR PRINT MATERIALS, NAMELY, MAGAZINES IN THE FIELD OF RESEARCH, EDUCATION AND ATHLETICS; BUMPER STICKERS; PENS; PEN SETS COMPRISED OF PENS AND PENCILS; PENCILS; ERASERS; PENCIL TOPPERS, NAMELY, DECORATIVE PENCIL-TOP ORNAMENTS; LOOSE LEAF BINDERS; BOOK-MARKS; BOOK COVERS; PHOTOGRAPHIC ALBUMS; APPOINTMENT BOOKS; ART PHOTOGRAPHS, NAMELY, PHOTOGRAPHS THAT HAVE BEEN COMPUTER MANIPULATED AND ENHANCED TO CONTAIN GRAPHIC ELEMENTS; ADDRESS BOOKS; PAPER BANNERS; CLIP BOARDS; MAGNETIC BOARDS; NOTE-PADS; NOTE PAD HOLDERS; SCRAPBOOKS; NOTEBOOKS; COMPOSITION BOOKS; PICTURE BOOKS; STATIONERY-TYPE PORTFOLIOS; PAPER GIFT WRAP; CALENDARS; BLANK CARDS; GIFT CARDS; GREETING CARDS; BUSINESS CARDS; WRITING PAPER; NOTEPAPER; POSTCARDS; DECALS; PAPER LABELS; BANK CHECKS; CHECKBOOK COVERS; RUBBER STAMPS; BOOKS IN THE FIELD OF RESEARCH, EDUCATION, AND ATHLETICS; BINDERS; LITHOGRAPHS; PRINTS; PREPAID TELEPHONE CALLING CARDS, NOT MAGNETICALLY ENCODED; CREDIT CARDS WITHOUT MAGNETIC ENCODING; TRANSFERABLE TEMPORARY TATTOOS; STICKERS; POSTERS; PARTY GOODS, NAMELY, PAPER PARTY FAVORS, PAPER NAPKINS, AND PAPER PARTY DECORATIONS; DESK ACCESSORIES, NAMELY, BASKETS, DESK PADS, FILE TRAYS, DESKTOP ORGANIZERS, DESKTOP PLANNERS, DESKTOP REVOLVING ROTARY CARD FILES, AND DESK CALENDARS; PRINTED PAPER LABELS FOR BOTTLED WATER (U.S. CLS. 2, 5, 22, 23, 29, 37, 38 AND 50).
FIRST USE 2-1-2000; IN COMMERCE 2-1-2000.

CLASS 41—EDUCATION AND ENTERTAINMENT

FOR EDUCATIONAL SERVICES, NAMELY, PROVIDING COLLEGE AND GRADUATE LEVEL COURSES OF INSTRUCTION, CONTINUING EDUCATION COURSES AND SEMINARS IN THE FIELDS OF BUSINESS, ACCOUNTING, ENGINEERING, SCIENCE, LEGAL, MEDICAL, HEALTH SCIENCE, LITERATURE, HISTORY, AND MATH; EDUCATIONAL SERVICES, NAMELY, PROVIDING OPPORTUNITIES FOR STUDENTS TO PARTICIPATE IN EDUCATIONAL RESEARCH PROGRAMS; ENTERTAINMENT SERVICES, NAMELY, PROVIDING COLLEGE ATHLETIC AND SPORTING EVENTS IN THE FIELDS OF FOOTBALL, BASKETBALL, SOCCER, HOCKEY, TENNIS, VOLLEYBALL, TRACK AND FIELD, AND BASEBALL; ENTERTAINMENT SERVICES, NAMELY, LIVE PERFORMANCES OF DRAMATIC WORKS AND LIVE MUSICAL PERFORMANCES (U.S. CLS. 100, 101 AND 107).
FIRST USE 2-1-2000; IN COMMERCE 2-1-2000.
JANET LEE, EXAMINING ATTORNEY

SN 76-707,875. GORILLA COFFEE, INC., BROOKLYN, NY. FILED 6-6-2011.

BROOKLYN ROASTED

THE MARK CONSISTS OF STANDARD CHARACTERS WITHOUT CLAIM TO ANY PARTICULAR FONT, STYLE, SIZE, OR COLOR.
NO CLAIM IS MADE TO THE EXCLUSIVE RIGHT TO USE "ROASTED", APART FROM THE MARK AS SHOWN.
SEC. 2(F).

CLASS 16—PAPER GOODS AND PRINTED MATTER

FOR BOXES, CARTONS, STORAGE CONTAINERS AND PACKAGING CONTAINERS MADE OF PAPER OR CARDBOARD; CARDBOARD CONTAINERS; CONTAINERS FOR STORAGE OR TRANSPORT MADE OF PAPER OR CARDBOARD; PACKAGING CONTAINERS OF PAPER; PACKAGING CARDBOARD CONTAINERS; PAPER CLOSURES FOR CONTAINERS; PAPER CLOSURES FOR SEALING CONTAINERS; PAPER CONTAINERS; STORAGE CONTAINERS MADE OF PAPER; PAPER BAGS; PAPER BAGS FOR PACKAGING (U.S. CLS. 2, 5, 22, 23, 29, 37, 38 AND 50).

FIRST USE 2-1-2003; IN COMMERCE 8-1-2003.

CLASS 21—HOUSEWARES AND GLASS

FOR COFFEE CUPS, TEA CUP MUGS, COFFEE MUGS, EARTHENWARE MUGS, GLASS MUGS, MUGS NOT OF PRECIOUS METAL, PORCELAIN MUGS, LUNCH BOXES, LUNCH BOX MADE OF METAL, LUNCH BOX MADE OF PLASTIC (U.S. CLS. 2, 13, 23, 29, 30, 33, 40 AND 50).

FIRST USE 2-1-2003; IN COMMERCE 8-1-2003.

CLASS 25—CLOTHING

FOR TEE SHIRTS, SWEAT SHIRTS, HOODED SWEAT SHIRTS, HATS (U.S. CLS. 22 AND 39).

FIRST USE 2-1-2003; IN COMMERCE 8-1-2003.

CLASS 30—STAPLE FOODS

FOR COFFEE, COFFEE, NAMELY, ROASTED, POWDERED, GRANULATED, OR IN DRINKS, COFFEE BASED BEVERAGES, COFFEE BEANS, COFFEE BEVERAGES WITH MILK, COFFEE EXTRACTS, COFFEE FLAVORED SYRUP USED IN MAKING FOOD BEVERAGES, BEVERAGES MADE WITH A COFFEE BASE, COFFEE ESSENCES, ROASTED COFFEE BEANS, COFFEE AND TEA (U.S. CL. 46).

FIRST USE 2-1-2003; IN COMMERCE 8-1-2003.

CHRISIE B. KING, EXAMINING ATTORNEY

SN 76-708,638. ESSLOR OF AMERICA, INC., DALLAS, TX. FILED 8-8-2011.

TREXA

THE MARK CONSISTS OF STANDARD CHARACTERS WITHOUT CLAIM TO ANY PARTICULAR FONT, STYLE, SIZE, OR COLOR.

CLASS 1—CHEMICALS

FOR CHEMICALS FOR MAKING TRANSPARENT OPTICAL COMPONENTS; CURABLE ARTIFICIAL RESINS FOR MAKING TRANSPARENT OPTICAL COMPONENTS (U.S. CLS. 1, 5, 6, 10, 26 AND 46).

CLASS 2—PAINTS

FOR NATURAL RESIN THAT OCCURS NATURALLY AS A RESIN IN NATURE (U.S. CLS. 6, 11 AND 16).

KATHERINE STOIDES, EXAMINING ATTORNEY

SN 77-140,984. SATURN WIRELESS, LLC, JERSEY CITY, NJ. FILED 3-27-2007.

SATURN WIRELESS

THE MARK CONSISTS OF STANDARD CHARACTERS WITHOUT CLAIM TO ANY PARTICULAR FONT, STYLE, SIZE, OR COLOR.

NO CLAIM IS MADE TO THE EXCLUSIVE RIGHT TO USE "WIRELESS", APART FROM THE MARK AS SHOWN.

CLASS 38—COMMUNICATION

FOR CONSULTING SERVICES IN THE FIELD OF PORTABLE WIRELESS TELECOMMUNICATION DEVICES (U.S. CLS. 100, 101 AND 104).

FIRST USE 11-0-2001; IN COMMERCE 11-0-2001.

CLASS 41—EDUCATION AND ENTERTAINMENT

FOR TRAINING IN THE USE OF PORTABLE WIRELESS TELECOMMUNICATION DEVICES (U.S. CLS. 100, 101 AND 107).

FIRST USE 11-0-2001; IN COMMERCE 11-0-2001.

ESTHER A. BORSUK, EXAMINING ATTORNEY

SN 77-163,064. GBD CORPORATION, NASSAU, BAHAMAS. FILED 4-23-2007.

UNITY

THE MARK CONSISTS OF STANDARD CHARACTERS WITHOUT CLAIM TO ANY PARTICULAR FONT, STYLE, SIZE, OR COLOR.

CLASS 7—MACHINERY

FOR VACUUM CLEANERS; ELECTRIC SWEEPERS; ELECTRIC CARPET CLEANERS AND CARPET EXTRACTORS; STEAM CLEANERS; BARE-FLOOR CLEANING MACHINES; PRESSURE WASHERS; ELECTRIC FOOD BLENDERS AND MIXERS (U.S. CLS. 13, 19, 21, 23, 31, 34 AND 35).

CLASS 9—ELECTRICAL AND SCIENTIFIC APPARATUS

FOR CLOTHES IRONS; CLOTHES PRESSES; GARMENT STEAMERS; BREATHING MASKS NOT FOR MEDICAL USE (U.S. CLS. 21, 23, 26, 36 AND 38).

CLASS 11—ENVIRONMENTAL CONTROL APPARATUS

FOR ROOM AIR CLEANERS; AIR CLEANERS FOR HOUSES; AIR CONDITIONERS; FURNACES; PORTABLE HEATERS; SPACE HEATERS; FURNACE FILTERS; HUMIDIFIERS; FIREPLACES; COOKING APPLIANCES, NAMELY, BARBECUE GRILLS, ELECTRIC TOASTERS, TOASTER OVENS, RANGES, BARBEQUES, ELECTRIC FRYERS, SMOKERS, COOKTOPS; ELECTRIC COFFEE MAKERS, TEA MAKERS, AND KETTLES; REFRIGERATORS AND LIGHT BULBS (U.S. CLS. 13, 21, 23, 31 AND 34).

CLASS 21—HOUSEWARES AND GLASS

FOR NON-ELECTRIC CARPET SWEEPERS, CARPET CLEANERS, AND CARPET EXTRACTORS; BARE-FLOOR CLEANERS IN THE NATURE OF MOPS AND BROOMS; GLASS FOOD PRESERVING JARS; DISPENSERS FOR DISINFECTING SOLUTIONS; NON-ELECTRIC COFFEE MAKERS, TEA MAKERS, AND KETTLES (U.S. CLS. 2, 13, 23, 29, 30, 33, 40 AND 50).

KIMBERLY FRYE, EXAMINING ATTORNEY

SN 77-187,244. MEDICA HEALTH PLANS, MINNETONKA, MN. FILED 5-22-2007.

MEDICA ADVANTAGE SOLUTION

THE MARK CONSISTS OF STANDARD CHARACTERS WITHOUT CLAIM TO ANY PARTICULAR FONT, STYLE, SIZE, OR COLOR.

OWNER OF U.S. REG. NOS. 2,832,587 AND 2,832,588.

CLASS 36—INSURANCE AND FINANCIAL

FOR ADMINISTRATION OF PRE-PAID HEALTH CARE PLANS; UNDERWRITING INSURANCE FOR PRE-PAID HEALTH CARE; MEDICAL INSURANCE UNDERWRITING (U.S. CLS. 100, 101 AND 102).

FIRST USE 9-26-2005; IN COMMERCE 9-26-2005.

CLASS 44—MEDICAL, BEAUTY AND AGRICULTURAL SERVICES

FOR HEALTH CARE IN THE NATURE OF HEALTH MAINTENANCE ORGANIZATIONS (U.S. CLS. 100 AND 101).

FIRST USE 9-26-2005; IN COMMERCE 9-26-2005.
JEAN IM, EXAMINING ATTORNEY

SN 77-245,348. 0779147 B.C. LTD., VANCOUVER, CANADA, FILED 8-2-2007.

SEEK SHELTER

THE MARK CONSISTS OF STANDARD CHARACTERS WITHOUT CLAIM TO ANY PARTICULAR FONT, STYLE, SIZE, OR COLOR.

PRIORITY CLAIMED UNDER SEC. 44(D) ON CANADA APPLICATION NO. 1337737, FILED 3-2-2007, REG. NO. TMA780,855, DATED 10-27-2010, EXPIRES 10-27-2025.

CLASS 8—HAND TOOLS

FOR (BASED ON INTENT TO USE) TABLEWARE, NAMELY, KNIVES, SPOONS, FORKS, PLATES (U.S. CLS. 23, 28 AND 44).

CLASS 21—HOUSEWARES AND GLASS

FOR (BASED ON INTENT TO USE) DRINKING GLASSES AND PLATES (U.S. CLS. 2, 13, 23, 29, 30, 33, 40 AND 50).

CLASS 25—CLOTHING

FOR (BASED ON INTENT TO USE) (BASED ON 44(E) PURSUANT TO CANADIAN FOREIGN REGISTRATION NUMBER TMA780855) CLOTHING, NAMELY, T-SHIRTS, SWEATERS, VESTS, CAPS, JACKETS, HATS AND UNDERWEAR (U.S. CLS. 22 AND 39).

CLASS 29—MEATS AND PROCESSED FOODS

FOR (BASED ON INTENT TO USE) PRE-PACKAGED TAKE-HOME MEALS CONSISTING PRIMARILY OF MEAT, FISH, POULTRY OR VEGETABLES (U.S. CL. 46).

CLASS 30—STAPLE FOODS

FOR (BASED ON INTENT TO USE) FOOD, NAMELY, SAUCES, SALAD DRESSINGS, CURRY SAUCES, AND PASTA SAUCES FOR MEAT (U.S. CL. 46).

CLASS 32—LIGHT BEVERAGES

FOR (BASED ON INTENT TO USE) (BASED ON 44(E) PURSUANT TO CANADIAN FOREIGN REGISTRATION NUMBER TMA780855) BEVERAGES, NAMELY, BEER (U.S. CLS. 45, 46 AND 48).

CLASS 42—SCIENTIFIC AND COMPUTER SERVICES

FOR (BASED ON INTENT TO USE) (BASED ON 44(E) PURSUANT TO CANADIAN FOREIGN REGISTRATION NUMBER TMA780855) RESTAURANT DESIGN SERVICES, NAMELY, DESIGN OF SPECIALTY INTERIOR AND EXTERIOR ENVIRONMENT SETTINGS IN RESTAURANTS (U.S. CLS. 100 AND 101).

SKYE YOUNG, EXAMINING ATTORNEY

SN 77-245,379. 0779147 B.C. LTD., VANCOUVER, CANADA, FILED 8-2-2007.

FOOD WINE SHELTER

THE MARK CONSISTS OF STANDARD CHARACTERS WITHOUT CLAIM TO ANY PARTICULAR FONT, STYLE, SIZE, OR COLOR.

PRIORITY CLAIMED UNDER SEC. 44(D) ON CANADA APPLICATION NO. 1337747, FILED 3-2-2007, REG. NO. TMA780854, DATED 10-27-2010, EXPIRES 10-27-2025.

NO CLAIM IS MADE TO THE EXCLUSIVE RIGHT TO USE "FOOD WINE", APART FROM THE MARK AS SHOWN.

CLASS 8—HAND TOOLS

FOR (BASED ON INTENT TO USE) TABLEWARE, NAMELY, KNIVES, SPOONS, FORKS, PLATES (U.S. CLS. 23, 28 AND 44).

CLASS 21—HOUSEWARES AND GLASS

FOR (BASED ON INTENT TO USE) DRINKING GLASSES AND PLATES (U.S. CLS. 2, 13, 23, 29, 30, 33, 40 AND 50).

CLASS 25—CLOTHING

FOR (BASED ON INTENT TO USE) (BASED ON 44(E) PURSUANT TO CANADIAN FOREIGN REGISTRATION NUMBER TMA780855) CLOTHING, NAMELY, T-SHIRTS, SWEATERS, VESTS, CAPS, JACKETS, HATS AND UNDERWEAR (U.S. CLS. 22 AND 39).

CLASS 29—MEATS AND PROCESSED FOODS

FOR (BASED ON INTENT TO USE) PRE-PACKAGED TAKE-HOME MEALS CONSISTING PRIMARILY OF MEAT, FISH, POULTRY OR VEGETABLES (U.S. CL. 46).

CLASS 30—STAPLE FOODS

FOR (BASED ON INTENT TO USE) FOOD, NAMELY, SAUCES, SALAD DRESSINGS, CURRY SAUCES, AND PASTA SAUCES FOR MEATS (U.S. CL. 46).

CLASS 32—LIGHT BEVERAGES

FOR (BASED ON INTENT TO USE) (BASED ON 44(E) PURSUANT TO CANADIAN FOREIGN REGISTRATION NUMBER TMA780855) BEVERAGES, NAMELY, BEER (U.S. CLS. 45, 46 AND 48).

CLASS 42—SCIENTIFIC AND COMPUTER SERVICES

FOR (BASED ON INTENT TO USE) (BASED ON 44(E) PURSUANT TO CANADIAN FOREIGN REGISTRATION NUMBER TMA780855) RESTAURANT DESIGN SERVICES, NAMELY, DESIGN OF SPECIALTY INTERIOR AND EXTERIOR ENVIRONMENT SETTINGS IN RESTAURANTS (U.S. CLS. 100 AND 101).
SKYE YOUNG, EXAMINING ATTORNEY

SN 77-245,401. 0779147 B.C. LTD., VANCOUVER, CANADA,
FILED 8-2-2007.

SHELTER RESTAURANTS

THE MARK CONSISTS OF STANDARD CHARACTERS WITHOUT CLAIM TO ANY PARTICULAR FONT, STYLE, SIZE, OR COLOR.

OWNER OF CANADA REG. NO. TMA777,011, DATED 9-14-2010, EXPIRES 9-14-2025.

NO CLAIM IS MADE TO THE EXCLUSIVE RIGHT TO USE "RESTAURANTS", APART FROM THE MARK AS SHOWN.

CLASS 8—HAND TOOLS

FOR (BASED ON INTENT TO USE) TABLEWARE, NAMELY, KNIVES, SPOONS, FORKS, PLATES (U.S. CLS. 23, 28 AND 44).

CLASS 21—HOUSEWARES AND GLASS

FOR (BASED ON INTENT TO USE) DRINKING GLASSES AND PLATES (U.S. CLS. 2, 13, 23, 29, 30, 33, 40 AND 50).

CLASS 25—CLOTHING

FOR (BASED ON INTENT TO USE) (BASED ON 44(E) PURSUANT TO CANADIAN FOREIGN REGISTRATION NUMBER TMA777011) CLOTHING, NAMELY, T-SHIRTS, SWEATERS, VESTS, CAPS, JACKETS, HATS AND UNDERWEAR (U.S. CLS. 22 AND 39).

CLASS 29—MEATS AND PROCESSED FOODS

FOR (BASED ON INTENT TO USE) PRE-PACKAGED TAKE-HOME MEALS CONSISTING PRIMARILY OF MEAT, FISH, POULTRY OR VEGETABLES (U.S. CL. 46).

CLASS 30—STAPLE FOODS

FOR (BASED ON INTENT TO USE) FOOD, NAMELY, SAUCES, SALAD DRESSINGS, CURRY SAUCES, AND PASTA SAUCES FOR MEAT (U.S. CL. 46).

CLASS 32—LIGHT BEVERAGES

FOR (BASED ON INTENT TO USE) (BASED ON 44(E) PURSUANT TO CANADIAN FOREIGN REGISTRATION NUMBER TMA777011) BEVERAGES, NAMELY, BEER (U.S. CLS. 45, 46 AND 48).

CLASS 42—SCIENTIFIC AND COMPUTER SERVICES

FOR (BASED ON INTENT TO USE) (BASED ON 44(E) PURSUANT TO CANADIAN FOREIGN REGISTRATION NUMBER TMA777011) RESTAURANT DESIGN SERVICES, NAMELY, DESIGN OF SPECIALTY INTERIOR AND EXTERIOR ENVIRONMENT SETTINGS IN RESTAURANTS (U.S. CLS. 100 AND 101).
SKYE YOUNG, EXAMINING ATTORNEY

SN 77-245,420. 0779147 B.C. LTD., VANCOUVER, CANADA,
FILED 8-2-2007.

SHELTER

THE MARK CONSISTS OF STANDARD CHARACTERS WITHOUT CLAIM TO ANY PARTICULAR FONT, STYLE, SIZE, OR COLOR.

PRIORITY CLAIMED UNDER SEC. 44(D) ON CANADA APPLICATION NO. 1337735, FILED 3-2-2007, REG. NO. TMA780,852, DATED 10-27-2010, EXPIRES 10-27-2025.

CLASS 8—HAND TOOLS

FOR (BASED ON INTENT TO USE) TABLEWARE, NAMELY, KNIVES, SPOONS, FORKS, PLATES (U.S. CLS. 23, 28 AND 44).

CLASS 21—HOUSEWARES AND GLASS

FOR (BASED ON INTENT TO USE) DRINKING GLASSES AND PLATES (U.S. CLS. 2, 13, 23, 29, 30, 33, 40 AND 50).

CLASS 29—MEATS AND PROCESSED FOODS

FOR (BASED ON INTENT TO USE) PRE-PACKAGED TAKE-HOME MEALS CONSISTING PRIMARILY OF MEAT, FISH, POULTRY OR VEGETABLES (U.S. CL. 46).

CLASS 30—STAPLE FOODS

FOR (BASED ON INTENT TO USE) FOOD, NAMELY, SAUCES, SALAD DRESSINGS, CURRY SAUCES, AND PASTA SAUCES FOR MEAT (U.S. CL. 46).

CLASS 32—LIGHT BEVERAGES

FOR (BASED ON INTENT TO USE) (BASED ON 44(E) PURSUANT TO CANADIAN FOREIGN REGISTRATION NUMBER TMA780852) BEVERAGES, NAMELY, BEER (U.S. CLS. 45, 46 AND 48).

SN 77-301,080. EDISEA LIMITED, SURREY KT2 7PW, UNITED KINGDOM, FILED 10-10-2007.

CLASS 42—SCIENTIFIC AND COMPUTER SERVICES

FOR (BASED ON INTENT TO USE) (BASED ON 44(E) PURSUANT TO CANADIAN FOREIGN REGISTRATION NUMBER TMA780852) RESTAURANT DESIGN SERVICES, NAMELY, DESIGN OF SPECIALTY INTERIOR AND EXTERIOR ENVIRONMENT SETTINGS IN RESTAURANTS (U.S. CLS. 100 AND 101).

SKYE YOUNG, EXAMINING ATTORNEY

CAPTAIN'S HIDEOUT

SN 77-271,059. SHUBIZ LIMITED, LONDON, UNITED KINGDOM, FILED 9-4-2007.

SHUBIZ

THE MARK CONSISTS OF STANDARD CHARACTERS WITHOUT CLAIM TO ANY PARTICULAR FONT, STYLE, SIZE, OR COLOR.

OWNER OF ERPN CMNTY TM OFC REG. NO. 001242890, DATED 7-21-2000, EXPIRES 7-9-2019.

CLASS 18—LEATHER GOODS

FOR LEATHER SHOPPING BAGS; LEATHER CASES FOR CALLING CARDS; HAT BOXES OF LEATHER; LEATHER BOXES FOR STORING GREETING CARDS; BACKPACKS FOR CLIMBERS AND CAMPERS; LEATHER LEADS AND LEATHER LEASHES FOR ANIMALS; UNFITTED VANITY CASES; LEATHER AND IMITATION LEATHER; TRAVELING BAGS; TRAVELING TRUNKS; SCHOOL BAGS; SATCHELS; BACKPACKS; RUCKSACKS; HAVERSACKS; BAGS OF LEATHER, FOR PACKING; BANDS OF LEATHER; BEACH BAGS; HANDBAG FRAMES OF LEATHER; SUITCASES; KEY CASES; POCKET WALLETS; POUCHES OF LEATHER; PURSES; VALISES; ARTICLES OF LUGGAGE; HANDBAGS; BRIEFCASES AND WALLETTS (U.S. CLS. 1, 2, 3, 22 AND 41).

CLASS 25—CLOTHING

FOR CLOTH BIBS; SKI BIBS; BEACH CLOTHES, NAMELY, SWIMSUITS, SWIM TRUNKS, COVER-UPS, HATS; CLOTHING OF LEATHER, NAMELY, PANTS, JACKETS, GLOVES, HATS; KNITWEAR, NAMELY, SWEATERS, VESTS, JUMPERS, MITTENS, HATS; APRONS; BATH ROBES; BATHING SUITS; BERETS; BODICES; BRACES FOR CLOTHING; CAMISOLES; CAPS; COATS; CUFFS; DRESSING GOWNS; EAR MUFFS; GLOVES; GOWNS; HATS; HEADBANDS; JACKETS; JERSEYS; JUMPERS; MITTENS; NECKTIES; OVERALLS; PAJAMAS; UNDERWEAR; SCARVES; SHAWLS; SHIRTS; SKIRTS; SOCKS; SUITS; SWEATERS; T-SHIRTS; TROUSERS; UNDERGARMENTS; VESTS; WAISTCOATS; WRISTBANDS; FOOTWEAR; BOOTS, SHOES, SLIPPERS AND SANDALS; HOSIERY; BELTS (U.S. CLS. 22 AND 39).

CHRISTINE COOPER, EXAMINING ATTORNEY

THE MARK CONSISTS OF STANDARD CHARACTERS WITHOUT CLAIM TO ANY PARTICULAR FONT, STYLE, SIZE, OR COLOR.

PRIORITY CLAIMED UNDER SEC. 44(D) ON ERPN CMNTY TM OFC APPLICATION NO. 5825351, FILED 4-11-2007, REG. NO. 5825351, DATED 4-24-2008, EXPIRES 4-11-2017.

CLASS 9—ELECTRICAL AND SCIENTIFIC APPARATUS

FOR SUNGLASSES; ELECTRONIC DOWN LOADABLE PUBLICATIONS IN THE NATURE OF BOOKS, MAGAZINES, E-ZINES, NEWSLETTERS, JOURNALS, GUIDES AND REPORTS IN THE FIELDS OF MARINE ENGINEERING AND DESIGN, MARINE INDUSTRY, MARINE GOODS AND SERVICES, DESIGN LAYOUT, SPORT, SPORTS EVENTS, FITNESS, VEHICLES AND PARTS THEREFORE, LEISURE AND FITNESS ACTIVITIES, AND INTERIOR DESIGN; DOWNLOADABLE ELECTRONIC DATA FILES AND DOWNLOADABLE DATA ALL IN THE FIELD OF BOATS, MARINE GOODS AND SERVICES, MARITIME CREWS, BOATING AND LEISURE EVENTS AND ACTIVITIES; ELECTRONIC GAMES PROGRAMS AND DOWN LOADABLE ELECTRONIC GAMES VIA THE INTERNET AND WIRELESS DEVICES; PRE-RECORDED CDS, CD-ROMS, CDIS, DVDS, AND MACHINE READABLE COMPUTER PROGRAMS FEATURING SPORTS, SPORTING EVENTS, YACHTING AND BOATING PROGRAMS, MAGAZINES AND REPORTS RELATING TO MARINE ENGINEERING AND DESIGN, MARINE GOODS AND SERVICES, DESIGN, MARINE INDUSTRY, DESIGN LAYOUT, SPORT, SPORTS EVENTS, FITNESS, VEHICLES AND PARTS THEREFORE, LEISURE AND FITNESS ACTIVITIES, AND INTERIOR DESIGN (U.S. CLS. 21, 23, 26, 36 AND 38).

CLASS 16—PAPER GOODS AND PRINTED MATTER

FOR PRINTED MATTER AND PUBLICATIONS, NAMELY, BOOKS, MAGAZINES, NEWSLETTERS, JOURNALS, GUIDES AND REPORTS ALL IN THE FIELDS OF MARINE ENGINEERING AND DESIGN, MARINE GOODS AND SERVICES, MARINE ENGINEERING AND DESIGN, MARINE INDUSTRY, DESIGN LAYOUT, SPORT, SPORTS EVENTS, FITNESS, VEHICLES AND PARTS THEREFOR, LEISURE AND FITNESS ACTIVITIES, AND INTERIOR DESIGN; PHOTOGRAPHS; PRINTED INSTRUCTIONAL AND TEACHING MATERIALS IN THE FIELDS OF MARINE ENGINEERING AND DESIGN, MARINE GOODS AND SERVICES, MARINE INDUSTRY, DESIGN LAYOUT, SPORT, SPORTS EVENTS, FITNESS, VEHICLES AND PARTS THEREFOR, LEISURE AND FITNESS ACTIVITIES, AND INTERIOR DESIGN; DRAWINGS (U.S. CLS. 2, 5, 22, 23, 29, 37, 38 AND 50).

CLASS 41—EDUCATION AND ENTERTAINMENT

FOR ENTERTAINMENT SERVICES IN THE NATURE OF ARRANGING TICKET RESERVATIONS FOR SHOWS AND OTHER ENTERTAINMENT EVENTS, PROVIDING MOTIVATIONAL AND EDUCATIONAL SPEAKERS; ORGANIZING AND CONDUCTING SPORTS ACTIVITIES, CONTESTS AND RACES, NAMELY, YACHTING AND BOATING CONTESTS AND RACES, LIVE PERFORMANCES BY SPORTSMEN; ENTERTAINMENT SERVICES IN THE NATURE OF LIVE SHOW PERFORMANCES AND WEB BASED PROGRAMS ALL RELATING TO MARINE ENGINEERING AND DESIGN, MARINE INDUSTRY, DESIGN LAYOUT, SPORT, SPORTS EVENTS, FITNESS, VEHICLES AND PARTS THEREFORE, LEISURE AND FITNESS ACTIVITIES, AND INTERIOR DESIGN; ENTERTAINMENT SERVICES IN THE NATURE OF ORGANIZING AND CONDUCTING EDUCATIONAL AND ENTERTAINMENT EXHIBITIONS, CONFERENCES, SEMINARS AND LECTURES, PROVIDING PODCASTS, PROVIDING WEBCASTS, ALL IN THE FIELDS OF MARINE ENGINEERING AND DESIGN, MARINE INDUSTRY, DESIGN LAYOUT, SPORT, SPORTS EVENTS, FITNESS, VEHICLES AND PARTS THEREFORE, LEISURE AND FITNESS ACTIVITIES, AND INTERIOR DESIGN; CULTURAL ACTIVITIES, NAMELY, ORGANIZING COMMUNITY SPORTING EVENTS AND ENTERTAINMENT IN THE NATURE OF LIVE BOAT SHOWS FOR ENTERTAINMENT PURPOSES AND RACES FOR YACHTS, ARRANGING HOSPITALITY AND MEETING AREAS; EDUCATION, NAMELY, PROVIDING COURSES, SEMINARS, INSTRUCTION AND TRAINING ALL IN THE FIELDS OF MARINE ENGINEERING, DESIGN, MARINE INDUSTRY, DESIGN LAYOUT, SPORT, SPORTS EVENTS, FITNESS, VEHICLES AND PARTS THEREFORE, LEISURE AND FITNESS ACTIVITIES, AND INTERIOR DESIGN; PUBLISHING OF BOOKS, PERIODICALS, MAGAZINES, NEWSLETTERS, GUIDES AND REPORTS; PROVIDING ON-LINE, NONDOWNLOADABLE PUBLICATIONS IN THE NATURE OF BOOKS, PERIODICALS, MAGAZINES, NEWSLETTERS, CATALOGUES, BULLETINS, GUIDES, AND REPORTS ALL IN THE FIELDS OF MARINE ENGINEERING AND DESIGN, MARINE INDUSTRY, DESIGN LAYOUT, SPORT, SPORTS EVENTS, FITNESS, VEHICLES AND PARTS THEREFORE, LEISURE AND FITNESS ACTIVITIES, AND INTERIOR DESIGN; PRODUCTION AND DISTRIBUTION OF WEB AND POD PROGRAMS OVER THE INTERNET AND OTHER ELECTRONIC COMMUNICATIONS NETWORKS RELATING TO MARINE VEHICLES, CONTESTS, EVENTS AND CONFERENCES; PROVIDING ENTERTAINMENT-RELATED INFORMATION IN INTERACTIVE DATABASE SERVICES IN THE FIELDS OF ENTERTAINMENT, EDUCATION AND CONTESTS, ALL IN THE FIELDS OF MARINE VEHICLES AND PARTS THEREFORE ; ORGANIZATION OF SPECIAL EVENTS, CONTESTS AND EDUCATIONAL AND ENTERTAINMENT CONFERENCES ALL IN THE FIELD OF SAILING ; ARRANGING AND CONDUCTING EDUCATIONAL AND ENTERTAINMENT SYMPOSIUMS, SEMINARS, BOAT SHOWS, CONGRESSES, CONFERENCES, EXHIBITIONS, SPECIAL EVENTS AND WORKSHOPS IN THE FIELDS OF MARINE ENGINEERING AND DESIGN, MARINE INDUSTRY, DESIGN LAYOUT, SPORT, SPORTS EVENTS, FITNESS, VEHICLES AND PARTS THEREFORE, LEISURE AND FITNESS ACTIVITIES, AND INTERIOR DESIGN; ENTERTAINMENT SERVICES IN THE NATURE OF ORGANIZING AWARDS CEREMONIES; PROVISION OF INFORMATION IN THE FIELDS OF SPORT, EDUCATIONAL TRAINING, GAMES, AUDIO AND VIDEO ENTERTAINMENT FILES, ENTERTAINMENT-RELATED INFORMATION ABOUT PLEASURE VEHICLES, AND SPORTS AND ENTERTAINMENT CONTESTS AND EVENTS (U.S. CLS. 100, 101 AND 107).

ELISSA GARBER KON, EXAMINING ATTORNEY

SN 77-392,271. SENTRANA INC., WASHINGTON, DC. FILED 2-8-2008.

MARKETMOVER

THE MARK CONSISTS OF STANDARD CHARACTERS WITHOUT CLAIM TO ANY PARTICULAR FONT, STYLE, SIZE, OR COLOR.

CLASS 37—CONSTRUCTION AND REPAIR

FOR COMPUTER HARDWARE AND APPLICATION PLATFORM COMPUTER HARDWARE MAINTENANCE, INSTALLATION, AND REPAIR; TECHNICAL SUPPORT SERVICES, NAMELY, TROUBLESHOOTING IN THE NATURE OF THE REPAIR OF COMPUTER HARDWARE; ALL NOT FOR USE IN THE FIELD OF GRAPHIC COMMUNICATIONS (U.S. CLS. 100, 103 AND 106).

CLASS 42—SCIENTIFIC AND COMPUTER SERVICES

FOR APPLICATION SERVICE PROVIDER (ASP), NAMELY, HOSTING A COMPUTER SOFTWARE APPLICATION USED FOR DATA COLLECTION, ANALYSIS AND MODELING OF PRODUCT/SERVICE DEMANDS FOR OPTIMUM PRICING FOR PRODUCTS/SERVICES AND/OR AN ASSORTMENT OF PRODUCTS/SERVICES AND/OR FOR MEETING PRODUCT/SERVICE DEMANDS; COMPUTER SOFTWARE TECHNICAL SUPPORT RELATED THERETO, NAMELY, TECHNICAL SUPPORT SERVICES IN THE NATURE OF TROUBLESHOOTING OF COMPUTER SOFTWARE PROBLEMS, DEVELOPMENT OF COMPUTER SOFTWARE AND COMPUTER HARDWARE, MAINTENANCE, INSTALLATION, AND REPAIR OF COMPUTER SOFTWARE RELATED THERETO; ALL NOT FOR USE IN THE FIELD OF GRAPHIC COMMUNICATIONS (U.S. CLS. 100 AND 101).

BRENDAN MCCAULEY, EXAMINING ATTORNEY

SN 77-417,561. THISIT LIMITED, NICOSIA, CYPRUS, FILED 3-10-2008.

iDance

THE MARK CONSISTS OF STANDARD CHARACTERS WITHOUT CLAIM TO ANY PARTICULAR FONT, STYLE, SIZE, OR COLOR.

PRIORITY CLAIMED UNDER SEC. 44(D) ON ERPN CMNTY TM OFC APPLICATION NO. 006742043, FILED 3-10-2008, REG. NO. 006742043, DATED 7-13-2010, EXPIRES 3-10-2018.

CLASS 9—ELECTRICAL AND SCIENTIFIC APPARATUS

FOR DOWNLOADABLE AND RECORDED SOFTWARE PROGRAMS FOR ARCADE VIDEO GAME MACHINES, NAMELY, DANCE SIMULATION VIDEO GAMES AND EXERCISE AND FITNESS GAMES; COMPUTER SOFTWARE FOR USE WITH COMPUTER GAMES AND VIDEO GAMES, NAMELY, DANCE SIMULATION GAMES AND EXERCISE AND FITNESS GAMES; COMPUTER GAME PROGRAMS, NAMELY, DANCE SIMULATION PROGRAMS, EXERCISE AND FITNESS PROGRAMS; VIDEO GAME SOFTWARE AND VIDEO GAME PROGRAMS ALL RELATING TO DANCE SIMULATION GAMES AND TO EXERCISE AND FITNESS GAMES; DOWNLOADABLE AND RECORDED DANCE SIMULATION GAME PROGRAMS AS WELL AS EXERCISE AND FITNESS GAME PROGRAMS FOR PERSONAL COMPUTERS; DOWNLOADABLE AND RECORDED DANCE SIMULATION GAME PROGRAMS FOR CONSUMER VIDEO GAMES; EXERCISE AND FITNESS GAME PROGRAMS FOR CONSUMER VIDEO GAMES; DOWNLOADABLE AND RECORDED DANCE SIMULATION GAME PROGRAMS FOR HAND-HELD GAMES, ALSO FOR MOBILE PHONES; EXERCISE AND FITNESS GAME PROGRAMS FOR HAND-HELD GAMES, ALSO FOR MOBILE PHONES; DANCE MATS IN THE NATURE OF VIDEO GAME INTERACTIVE CONTROL FLOOR MATS; INTERACTIVE DANCE SIMULATION PADS SOLD AS A UNIT WITH COMPUTER GAME SOFTWARE FOR DANCE SIMULATION (U.S. CLS. 21, 23, 26, 36 AND 38).

FIRST USE 8-25-2008; IN COMMERCE 8-25-2008.

CLASS 28—TOYS AND SPORTING GOODS

FOR ELECTRONIC SPORTS TRAINING AND EXERCISE SIMULATORS; ELECTRONIC DANCE SIMULATORS; DANCE MATS SOLD AS A UNIT WITH ELECTRONIC DANCE SIMULATORS; DANCE SIMULATION PADS SOLD AS A UNIT WITH ELECTRONIC DANCE SIMULATORS; ARCADE GAME MACHINES, GAME MACHINES AND GAMING MACHINES, NAMELY, DANCE SIMULATION MACHINES FOR FITNESS AND EXERCISE USE AND FOR PLAY; GYMNASIAC APPARATUS (U.S. CLS. 22, 23, 38 AND 50).

FIRST USE 8-25-2008; IN COMMERCE 8-25-2008.
CYNTHIA TRIPI, EXAMINING ATTORNEY

SN 77-474,857. XEROX CORPORATION, NORWALK, CT.
FILED 5-15-2008.

XEROX KNOWLEDGE AS A SERVICE

THE MARK CONSISTS OF STANDARD CHARACTERS WITHOUT CLAIM TO ANY PARTICULAR FONT, STYLE, SIZE, OR COLOR.

OWNER OF U.S. REG. NOS. 1,010,557, 2,478,334 AND OTHERS.

CLASS 35—ADVERTISING AND BUSINESS

FOR DATABASE MANAGEMENT SERVICES; DOCUMENT CREATION SERVICES, NAMELY, COMPILING DATA AND ASSEMBLING RETRIEVED INFORMATION INTO A DOCUMENT FOR OTHERS; PROVIDING BUSINESS INFORMATION FROM A COMPUTER DATABASE OR VIA AN INTRANET OR ON THE INTERNET; COMPUTER SERVICES, NAMELY, PROVIDING ELECTRONIC DATA PROCESSING OF STRUCTURED AND UNSTRUCTURED INFORMATION FOR PURPOSES OF RECOGNITION, CLASSIFICATION, AND RETRIEVAL, AS WELL AS INTELLIGENT CONTENT IDENTIFICATION AND MATCHING (U.S. CLS. 100, 101 AND 102).

CLASS 42—SCIENTIFIC AND COMPUTER SERVICES

FOR COMPUTER SERVICES NAMELY, PROVIDING SEARCH PLATFORMS TO ALLOW USERS TO REQUEST CONTENT FROM AND RECEIVE CONTENT FROM COMPUTER DATABASES (U.S. CLS. 100 AND 101).

DAVID MILLER, EXAMINING ATTORNEY

SN 77-490,384. BLARTER MUSIC PTY LIMITED, WAHROONGA, 2076, NSW, AUSTRALIA, FILED 6-4-2008.

MODELICIOUS

THE MARK CONSISTS OF STANDARD CHARACTERS WITHOUT CLAIM TO ANY PARTICULAR FONT, STYLE, SIZE, OR COLOR.

OWNER OF AUSTRALIA REG. NO. 1175903, DATED 5-16-2007, EXPIRES 5-16-2017.

CLASS 3—COSMETICS AND CLEANING PREPARATIONS

FOR COSMETICS; NON-MEDICATED SKIN PREPARATIONS; HAIR CARE PREPARATIONS; BATH SOAPS, SHOWER GEL, BUBBLE BATH; PERFUMERY; ESSENTIAL OILS; NAIL CARE PREPARATIONS; NON-MEDICATED SUN CARE PREPARATIONS (U.S. CLS. 1, 4, 6, 50, 51 AND 52).

CLASS 9—ELECTRICAL AND SCIENTIFIC APPARATUS

FOR SERIES OF MUSICAL SOUND RECORDINGS; MUSICAL VIDEO RECORDINGS; DOWNLOADABLE GRAPHICS, RING TONES, VIDEOS AND MUSIC VIA THE INTERNET AND WIRELESS DEVICES (U.S. CLS. 21, 23, 26, 36 AND 38).

CLASS 25—CLOTHING

FOR CLOTHING, NAMELY, T-SHIRTS, TOPS, SHIRTS, SWEATSHIRTS, HATS, SCARVES, UNDERWEAR, FOOTWEAR, HEADWEAR, LOUNGEWEAR, SWIMWEAR, SLEEPWEAR (U.S. CLS. 22 AND 39).

CLASS 41—EDUCATION AND ENTERTAINMENT

FOR DISTRIBUTION OF TELEVISION PROGRAMS FOR OTHERS; PRODUCTION OF RADIO AND TELEVISION PROGRAMS; ENTERTAINMENT SERVICES, NAMELY, PROVIDING A TELEVISION PROGRAM IN THE FIELD OF MUSIC AND VARIETY VIA A GLOBAL COMPUTER NETWORK; LIVE PERFORMANCES BY A MUSICAL BAND; PROVIDING A WEB SITE FEATURING INFORMATION ABOUT ENTERTAINMENT, MUSIC CONCERTS, RECORDING ARTISTS AND POPULAR CULTURE, AND SOUND AND VIDEO RECORDINGS (U.S. CLS. 100, 101 AND 107).

MICHELE SWAIN, EXAMINING ATTORNEY

SN 77-538,452. CONTAGIOUS COMMUNICATIONS LIMITED, LONDON, ENGLAND, UNITED KINGDOM, FILED 8-4-2008.



PRIORITY CLAIMED UNDER SEC. 44(D) ON ERPNCMNTY TM OFC APPLICATION NO. 007074248, FILED 7-17-2008, REG. NO. 007074248, DATED 5-15-2009, EXPIRES 7-17-2018.

THE MARK CONSISTS OF A BOX DESIGN CONSISTING OF STRIPES ON AN ANGLE WITH THE WORD "CONTAGIOUS" SITUATED UNDER THE BOX.

CLASS 9—ELECTRICAL AND SCIENTIFIC APPARATUS

FOR DOWNLOADABLE ELECTRONIC PUBLICATIONS AND INTERACTIVE DOWNLOADABLE ELECTRONIC PUBLICATIONS, NAMELY, MAGAZINES, NEWSLETTERS, GUIDES, LEAFLETS, PAMPHLETS, INSTRUCTIONAL AND TEACHING MATERIALS AND REPORTS, AND ELECTRONIC NEWSLETTERS AND PUBLICATIONS DOWNLOADABLE FROM THE INTERNET OR FROM MOBILE HANDSETS, INCLUDING WIDGETS AND MOBILE PHONE APPLICATIONS, NAMELY, MAGAZINES, GUIDES, LEAFLETS, PAMPHLETS, INSTRUCTIONAL AND TEACHING MATERIALS AND REPORTS, ALL RELATING TO BUSINESS INFORMATION, BUSINESS DATA AND BUSINESS FORECASTS, MARKETING AND ADVERTISING, BRANDING, DESIGN, PRODUCT DESIGN, TELEVISION AND PRINT ADVERTISING CAMPAIGNS, SPONSORSHIP, PR, EVENTS, RETAIL INITIATIVES, THE INTERNET, MARKET TRENDS AND MARKET ANALYSIS, ARCHITECTURE, FASHION, MUSIC, TECHNOLOGY, ENVIRONMENTAL ISSUES, INTERACTIVE ONLINE MEDIA, MOBILE MEDIA AND NEW MEDIA, MOBILE MARKETING, BRANDED ENTERTAINMENT, GAMING, POP CULTURE, RECRUITMENT, SOCIAL NETWORKING, SOCIAL MEDIA METRICS, AND THE ORGANISATION AND MANAGEMENT OF SEMINARS, FESTIVALS, EVENTS AND WORKSHOPS; PRE-RECORDED CDS, DVDS, DISCS AND OTHER PRE-RECORDED ELECTRONIC MEDIA, ELECTRONIC BOOKS AND PODCASTS, ALL RELATING TO BUSINESS INFORMATION, BUSINESS DATA AND BUSINESS FORECASTS, MARKETING AND ADVERTISING, BRANDING, DESIGN, PRODUCT DESIGN, TELEVISION AND PRINT ADVERTISING CAMPAIGNS, SPONSORSHIP, PR, EVENTS, RETAIL INITIATIVES, THE INTERNET, MARKET TRENDS AND MARKET ANALYSIS, ARCHITECTURE, FASHION, MUSIC, TECHNOLOGY, ENVIRONMENTAL ISSUES, INTERACTIVE ONLINE MEDIA, MOBILE MEDIA AND NEW MEDIA, MOBILE MARKETING, BRANDED ENTERTAINMENT, GAMING, POP CULTURE, RECRUITMENT, SOCIAL NETWORKING, SOCIAL MEDIA METRICS, AND THE ORGANISATION AND MANAGEMENT OF SEMINARS, FESTIVALS, EVENTS AND WORKSHOPS; DOWNLOADABLE COMPUTER DATABASES FEATURING RESOURCES, INFORMATION, DATA, STATISTICS AND METRICS, COMPANY INFORMATION AND KEY PROFESSIONALS' PROFILES, ALL IN THE FIELDS OF ADVERTISING AND MARKETING; COMPUTER DATABASES RECORDED ON COMPUTER MEDIA FEATURING RESOURCES, INFORMATION, DATA, STATISTICS AND METRICS, COMPANY INFORMATION AND KEY

PROFESSIONALS' PROFILES, ALL IN THE FIELDS OF ADVERTISING AND MARKETING; DOWNLOADABLE ELECTRONIC REPORTS FEATURING BUSINESS INFORMATION, DATA, ANALYSIS, ADVICE AND COMMENT, AND INFORMATION, DATA, ANALYSIS, ADVICE AND COMMENT IN THE FIELDS OF ADVERTISING, MARKETING AND NEW MEDIA; DOWNLOADABLE MARKETING AND ADVERTISING MATERIALS; ALL OF THE AFORESAID GOODS BEING FOR BUSINESS PROFESSIONALS IN THE MARKETING AND ADVERTISING INDUSTRIES (U.S. CLS. 21, 23, 26, 36 AND 38).

CLASS 16—PAPER GOODS AND PRINTED MATTER

FOR GUIDES, REPORTS, MAGAZINES, NEWSLETTERS, BOOKS, LEAFLETS, PAMPHLETS AND INSTRUCTIONAL AND TEACHING MATERIALS RELATING TO BUSINESS INFORMATION, BUSINESS DATA AND BUSINESS FORECASTS, MARKETING AND ADVERTISING, BRANDING, DESIGN, PRODUCT DESIGN, TELEVISION AND PRINT ADVERTISING CAMPAIGNS, SPONSORSHIP, PR, EVENTS, RETAIL INITIATIVES, THE INTERNET, MARKET TRENDS AND MARKET ANALYSIS, ARCHITECTURE, FASHION, MUSIC, TECHNOLOGY, ENVIRONMENTAL ISSUES, INTERACTIVE ONLINE MEDIA, MOBILE MEDIA AND NEW MEDIA, MOBILE MARKETING, BRANDED ENTERTAINMENT, GAMING, POP CULTURE, RECRUITMENT, SOCIAL NETWORKING, SOCIAL MEDIA METRICS, AND THE ORGANISATION AND MANAGEMENT OF SEMINARS, FESTIVALS, EVENTS AND WORKSHOPS; PRINTED REPORTS FEATURING BUSINESS INFORMATION, DATA, ANALYSIS, ADVICE AND COMMENT, AND INFORMATION, DATA, ANALYSIS, ADVICE AND COMMENT IN THE FIELDS OF ADVERTISING, MARKETING AND NEW MEDIA; ALL OF THE AFORESAID GOODS BEING FOR BUSINESS PROFESSIONALS IN THE MARKETING AND ADVERTISING INDUSTRIES (U.S. CLS. 2, 5, 22, 23, 29, 37, 38 AND 50).

CLASS 35—ADVERTISING AND BUSINESS

FOR ADVERTISING, MARKETING AND PROMOTIONAL SERVICES; BUSINESS MANAGEMENT AND CONSULTANCY; BUSINESS RESEARCH; RESEARCH IN THE FIELDS OF MARKETING AND ADVERTISING; PROVISION OF BUSINESS INFORMATION, BUSINESS, ADVERTISING, MARKETING AND PROMOTIONAL DATA, ANALYSIS, ADVICE, AND BUSINESS, ADVERTISING, MARKETING AND PROMOTIONAL COMMENT; PROVISION OF INFORMATION, DATA, ANALYSIS, ADVICE AND COMMENT IN RELATION TO MARKETING, ADVERTISING AND NEW ADVERTISING AND MARKETING MEDIA TECHNIQUES AND TECHNOLOGY; PREPARING AND PROVIDING INFORMATIONAL REPORTS FEATURING BUSINESS INFORMATION, DATA, ANALYSIS, ADVICE AND COMMENT, AND INFORMATION, DATA, ANALYSIS, ADVICE AND COMMENT IN THE FIELDS OF ADVERTISING, MARKETING AND NEW ADVERTISING AND MARKETING MEDIA TECHNIQUES AND TECHNOLOGY; PROVIDING ADVERTISING, MARKETING AND PROMOTIONAL SERVICES, NAMELY, DEVELOPMENT OF ADVERTISING CAMPAIGNS FOR TELEVISION, PRINT, CD-ROM, AND WEB DESIGN; PROMOTING THE GOODS AND SERVICES OF OTHERS, NAMELY, ARRANGING SPONSORSHIP AGREEMENTS AND LICENSES, PUBLIC RELATIONS, ADVERTISING AND PROMOTIONAL EVENTS FOR THE PROMOTION OF OTHERS' GOODS AND SERVICES, RETAIL ADVERTISING AND MARKETING INITIATIVES, USE OF THE INTERNET FOR ADVERTISING AND MARKETING PURPOSES, MARKET TRENDS AND MARKET ANALYSIS, MOBILE MARKETING, PERSONNEL RECRUITMENT, SOCIAL MEDIA METRICS AND THE ORGANISATION AND MANAGEMENT OF BUSINESS, MARKETING AND ADVERTISING SEMINARS, FESTIVALS, EVENTS AND WORKSHOPS AND INTERACTIVE ONLINE MEDIA, MOBILE MEDIA AND NEW MEDIA USED FOR ADVERTISING AND MARKETING PURPOSES; PRODUCTION OF TELEVISION AND RADIO ADVERTISEMENTS; PUBLIC AND MARKET OPINION POLLING; DATA PROCESSING; COMPILATION OF INFORMATION INTO COMPUTER DATABASES; OR-

GANISING, ARRANGING AND HOSTING OF FESTIVALS, WORKSHOPS AND EVENTS FOR ADVERTISING PURPOSES; ORGANISING, ARRANGING AND HOSTING OF FESTIVALS, WORKSHOPS AND EVENTS FOR BUSINESS PURPOSES; PERSONNEL RECRUITMENT SERVICES; BUSINESS SERVICES IN THE NATURE OF ARRANGING MEETINGS AND PITCHES FOR BRAND OWNERS AND ADVERTISING AND MARKETING AGENCIES, GIVING THE PARTICIPANTS THE OPPORTUNITY TO COMPETE AND BID TO BE SELECTED TO PROVIDE THEIR SERVICES; ALL OF THE AFORESAID SERVICES BEING FOR BUSINESS PROFESSIONALS IN THE MARKETING AND ADVERTISING INDUSTRIES; PROVISION OF ONLINE NON-DOWNLOADABLE MARKETING AND ADVERTISING MATERIALS; PROVISION OF NON-DOWNLOADABLE ELECTRONIC REPORTS FEATURING BUSINESS INFORMATION, DATA, ANALYSIS, ADVICE AND COMMENT, AND INFORMATION, DATA, ANALYSIS, ADVICE AND COMMENT IN THE FIELDS OF ADVERTISING, MARKETING AND NEW MEDIA (U.S. CLS. 100, 101 AND 102).

PAMPHLETS, INSTRUCTIONAL AND TEACHING MATERIALS AND REPORTS; PREPARING AND PROVIDING INFORMATIONAL REPORTS RELATING TO MUSIC, BRANDED ENTERTAINMENT, GAMING AND POP CULTURE; EDUCATIONAL AND ENTERTAINMENT INFORMATION, ADVISORY AND CONSULTANCY SERVICES RELATING TO ALL THE AFORESAID SERVICES; ALL OF THE AFORESAID SERVICES BEING FOR BUSINESS PROFESSIONALS IN THE MARKETING AND ADVERTISING INDUSTRIES (U.S. CLS. 100, 101 AND 107).

KELLEY WELLS, EXAMINING ATTORNEY

CLASS 41—EDUCATION AND ENTERTAINMENT

FOR EDUCATION AND TRAINING SERVICES, NAMELY, PROVIDING CLASSES, WORKSHOPS, ONE-ONE TRAINING AND SEMINARS IN THE FIELDS OF BUSINESS INFORMATION, BUSINESS DATA AND BUSINESS FORECASTS, MARKETING AND ADVERTISING, BRANDING, DESIGN, PRODUCT DESIGN, TELEVISION AND PRINT ADVERTISING CAMPAIGNS, SPONSORSHIP, PR, EVENTS, RETAIL INITIATIVES, THE INTERNET, MARKET TRENDS AND MARKET ANALYSIS, ARCHITECTURE, FASHION, MUSIC, TECHNOLOGY, ENVIRONMENTAL ISSUES, INTERACTIVE ONLINE MEDIA, MOBILE MEDIA AND NEW MEDIA, MOBILE MARKETING, BRANDED ENTERTAINMENT, GAMING, POP CULTURE, RECRUITMENT, SOCIAL NETWORKING, SOCIAL MEDIA METRICS, AND THE ORGANISATION AND MANAGEMENT OF SEMINARS, FESTIVALS, EVENTS AND WORKSHOPS; ORGANISING LIVE AND ON-LINE EXHIBITIONS, FESTIVALS, SEMINARS, WORKSHOPS AND CONFERENCES IN THE FIELDS OF EDUCATION AND ENTERTAINMENT FOR NON-BUSINESS AND NON-COMMERCIAL PURPOSES; ORGANISING, ARRANGING AND HOSTING SEMINARS, WORKSHOPS, FESTIVALS AND EVENTS, ALL BEING FOR EDUCATIONAL, TRAINING OR ENTERTAINMENT PURPOSES, AND ALL RELATING TO BUSINESS INFORMATION, BUSINESS DATA AND BUSINESS FORECASTS, MARKETING AND ADVERTISING, BRANDING, DESIGN, PRODUCT DESIGN, TELEVISION AND PRINT ADVERTISING CAMPAIGNS, SPONSORSHIP, PR, EVENTS, RETAIL INITIATIVES, THE INTERNET, MARKET TRENDS AND MARKET ANALYSIS, ARCHITECTURE, FASHION, MUSIC, TECHNOLOGY, ENVIRONMENTAL ISSUES, INTERACTIVE ONLINE MEDIA, MOBILE MEDIA AND NEW MEDIA, MOBILE MARKETING, BRANDED ENTERTAINMENT, GAMING, POP CULTURE, RECRUITMENT, SOCIAL NETWORKING, SOCIAL MEDIA METRICS, AND THE ORGANISATION AND MANAGEMENT OF SEMINARS, FESTIVALS, EVENTS AND WORKSHOPS; HOSTING AWARDS CEREMONIES; NON-DOWNLOADABLE ELECTRONIC NEWSLETTERS AND PUBLICATIONS, INTERACTIVE NON-DOWNLOADABLE ELECTRONIC PUBLICATIONS AND ONLINE PUBLICATIONS, NAMELY, ONLINE NEWSFEEDS, BOOKS, MAGAZINES, GUIDES, LEAFLETS, PAMPHLETS, INSTRUCTIONAL AND TEACHING MATERIALS AND REPORTS, ALL RELATING TO BUSINESS INFORMATION, BUSINESS DATA AND BUSINESS FORECASTS, MARKETING AND ADVERTISING, BRANDING, DESIGN, PRODUCT DESIGN, TELEVISION AND PRINT ADVERTISING CAMPAIGNS, SPONSORSHIP, PR, EVENTS, RETAIL INITIATIVES, THE INTERNET, MARKET TRENDS AND MARKET ANALYSIS, ARCHITECTURE, FASHION, MUSIC, TECHNOLOGY, ENVIRONMENTAL ISSUES, INTERACTIVE ONLINE MEDIA, MOBILE MEDIA AND NEW MEDIA, MOBILE MARKETING, BRANDED ENTERTAINMENT, GAMING, POP CULTURE, RECRUITMENT, SOCIAL NETWORKING, SOCIAL MEDIA METRICS, AND THE ORGANISATION AND MANAGEMENT OF SEMINARS, FESTIVALS, EVENTS AND WORKSHOPS; PUBLICATION FOR OTHERS OF BOOKS, MAGAZINES, NEWSLETTERS, GUIDES, LEAFLETS,

SN 77-545,099. ITC ENTERTAINMENT GROUP LIMITED, LONDON, UNITED KINGDOM, FILED 8-12-2008.

FAB

THE MARK CONSISTS OF STANDARD CHARACTERS WITHOUT CLAIM TO ANY PARTICULAR FONT, STYLE, SIZE, OR COLOR.

CLASS 9—ELECTRICAL AND SCIENTIFIC APPARATUS

FOR CINEMATOGRAPHIC AND PHOTOGRAPHIC FILMS IN THE FIELD OF SCIENCE FICTION AND ADVENTURE; SOUND AND VIDEO RECORDINGS, NAMELY, PHONOGRAPHIC RECORDS, AUDIO AND VIDEO DISCS, AUDIO AND VIDEO TAPES, AUDIO AND VIDEO CASSETTES, CDS AND VIDEO TAPES IN THE FIELD OF SCIENCE FICTION AND ADVENTURE; APPARATUS FOR RECORDING, TRANSMISSION OR REPRODUCTION OF SOUND OR IMAGES, NAMELY, VCRS, CASSETTE RECORDERS, DVD RECORDERS, PERSONAL DIGITAL RECORDERS, AND RECORD PLAYERS, TAPE PLAYERS AND RECORDERS, CASSETTE PLAYERS AND RECORDERS, COMPACT DISC AND DVD PLAYERS AND RECORDERS, AND CD PLAYERS AND RECORDERS; BLANK MAGNETIC DATA CARRIERS, BLANK RECORDING DISCS; SOUND, VIDEO AND DATA AND DATA RECORDING AND REPRODUCING APPARATUS, NAMELY, VCRS, CASSETTE RECORDERS, DVD RECORDERS, PERSONAL DIGITAL RECORDERS AND RECORD, TAPE, CASSETTE, DISC AND CD PLAYERS AND RECORDERS; RECORDS, DISCS, TAPES, CASSETTES, CARTRIDGES, CARDS AND OTHER CARRIERS, ALL BEING BLANK; RECORDS, DISCS, TAPES, CASSETTES, CARTRIDGES, CARDS AND OTHER CARRIERS, ALL BEARING SOUND RECORDINGS, VIDEO RECORDINGS, DATA, IMAGES, GRAPHICS, TEXT, PROGRAMS, OR INFORMATION IN THE FIELD OF SCIENCE FICTION AND ADVENTURE; MEMORY CARRIERS, INTERACTIVE COMPACT DISCS, CD-ROMS AND DVDS IN THE FIELD OF SCIENCE FICTION AND ADVENTURE; PARTS AND FITTINGS FOR ALL THE AFORESAID GOODS (U.S. CLS. 21, 23, 26, 36 AND 38).

CLASS 16—PAPER GOODS AND PRINTED MATTER

FOR BOOKS IN THE FIELD OF SCIENCE FICTION AND ADVENTURE; PRINTED MATTER, NAMELY, PERIODICALS, MAGAZINES, BOOKLETS, NEWSLETTERS, BROCHURES, PAMPHLETS, LEAFLETS IN THE FIELD OF SCIENCE FICTION AND ADVENTURE; MONOGRAPHS IN THE FIELD OF SCIENCE FICTION AND ADVENTURE; PHOTOGRAPHS, CALENDARS, DIARIES; POSTERS; STATIONERY; NOTE PADS; NOTEBOOKS, ADDRESS BOOKS; PERSONAL ORGANIZERS; PHOTOGRAPH ALBUMS; GIFT BOXES MADE OF PAPER OR CARDBOARD; PRINTED INSTRUCTIONAL AND TEACHING MATERIALS IN THE FIELD OF SCIENCE FICTION AND ADVENTURE; ARTISTS' MATERIALS, NAMELY, PAINTING SETS FOR CHILDREN, STENCILS, PAINT BRUSHES, CRAYONS, MARKERS AND PAPER (U.S. CLS. 2, 5, 22, 23, 29, 37, 38 AND 50).

CLASS 41—EDUCATION AND ENTERTAINMENT

FOR ENTERTAINMENT AND ENTERTAINMENT SERVICES IN THE NATURE OF ON-GOING TELEVISION PROGRAMS IN THE FIELD OF SCIENCE FICTION AND ADVENTURE TELEVISION; ENTERTAINMENT SERVICES, NAMELY, TELEVISION PROGRAMS, RADIO, CABLE, SATELLITE AND INTERNET PROGRAMS IN THE FIELD OF SCIENCE FICTION AND ADVENTURE; PRODUCTION AND PRESENTATION OF TELEVISION PROGRAMS, SHOWS, FILMS, VIDEOS, AND DVDS IN THE FIELD OF SCIENCE FICTION AND ADVENTURE; PRODUCTION AND PRESENTATION OF TELEVISION, RADIO, CABLE, SATELLITE AND INTERNET PROGRAMS IN THE FIELD OF SCIENCE FICTION AND ADVENTURE; PRODUCTION, PRESENTATION, DISTRIBUTION, SYNDICATION, AND RENTAL OF TELEVISION, RADIO, CABLE, SATELLITE AND INTERNET PROGRAMS AND OF FILMS, SOUND RECORDINGS, VIDEO RECORDINGS AND DVDS; EDUCATIONAL SERVICES RELATING TO ENTERTAINMENT, NAMELY, CONDUCTING SEMINARS, CONFERENCES, WORKSHOPS, RETREATS, COURSES, AND CAMPS IN THE FIELD OF SCIENCE FICTION AND ADVENTURE; INFORMATION RELATING TO ENTERTAINMENT AND EDUCATION IN THE FIELD OF SCIENCE FICTION AND ADVENTURE PROVIDED ONLINE FROM A COMPUTER DATABASE OR THE INTERNET OR BY COMMUNICATIONS SATELLITE, MICROWAVE OR OTHER ELECTRONIC, DIGITAL OR ANALOGUE MEDIA; PUBLISHING, NAMELY, PUBLICATION OF NEWSPAPERS, MAGAZINES, BROCHURES, GUIDES AND BOOKS; ORGANIZATION, PRODUCTION AND PRESENTATION OF COMPETITIONS, CONTESTS, GAMES, GAME SHOWS, QUIZZES, FUN DAYS, EXHIBITIONS, SHOWS, ROAD SHOWS, STAGED EVENTS, RAVES, THEATRICAL PERFORMANCE, CONCERTS, LIVE PERFORMANCES AND PARTICIPATION EVENTS IN THE FIELD OF EDUCATIONAL, CULTURAL OR ENTERTAINMENT PURPOSES; INFORMATION AND CONSULTING SERVICES RELATING TO ANY OF THE AFORESAID SERVICES (U.S. CLS. 100, 101 AND 107).

APRIL HESIK, EXAMINING ATTORNEY

SN 77-556,988. PARAGON RELOCATION HOLDINGS, BLANCHARDSTOWN DUBLIN, IRELAND, FILED 8-27-2008.

PARAGON RELOCATION

THE MARK CONSISTS OF STANDARD CHARACTERS WITHOUT CLAIM TO ANY PARTICULAR FONT, STYLE, SIZE, OR COLOR.

OWNER OF U.S. REG. NOS. 3,023,175, 3,053,285 AND 3,113,691.

NO CLAIM IS MADE TO THE EXCLUSIVE RIGHT TO USE "RELOCATION", APART FROM THE MARK AS SHOWN.

CLASS 35—ADVERTISING AND BUSINESS

FOR DOMESTIC AND INTERNATIONAL BUSINESS AND EMPLOYEE RELOCATION AND DESTINATION RELOCATION SERVICES RELATED TO RELOCATION OF BUSINESSES AND EMPLOYEES, AND PROVIDING INFORMATION AND REFERRALS RELATING THERETO; CONSULTATION SERVICES IN THE FIELDS OF BUSINESS AND EMPLOYEE RELOCATION, RELOCATION POLICY, AND RELOCATION INFORMATION AT BOTH ORIGIN AND DESTINATION; BUSINESS AND EMPLOYEE RELOCATION SERVICES RELATED TO DESTINATION, NAMELY, PROVIDING PRE-DECISION DESTINATION INFORMATION, PROVIDING EMPLOYMENT INFORMATION AND COUNSELING TO ASSIST IN FAMILY MEMBERS' JOB SEARCHES; EMPLOYEE RELOCATION SERVICES, NAMELY, ARRANGING FOR THE COMMENCEMENT OF UTILITY SERVICES FOR RESIDENTIAL PROPERTIES OF RELOCATED PERSONNEL; ADMINISTRATION OF RELOCATION REIMBURSEMENT, NAMELY, PROCESSING REIMBURSEMENT OF RELOCATION EXPENSES AND RELOCATION BENEFIT PAYMENTS AND PAYMENT TO VENDORS SUPPORTING AND ASSISTING WITH RELOCATION; PROVIDING REAL ESTATE LEADS AND REFERENCES FOR PROSPECTIVE PURCHASERS AND LESSEES; REFERRALS IN THE FIELD OF LANGUAGE AND CULTURAL TRAINING; REFERRALS IN THE FIELD OF IMMIGRATION (U.S. CLS. 100, 101 AND 102).

CLASS 36—INSURANCE AND FINANCIAL

FOR BENEFITS COUNSELING, NAMELY, THE ADMINISTRATION OF EMPLOYEE RELOCATION BENEFITS PROGRAMS (U.S. CLS. 100, 101 AND 102).

JEFFERY COWARD, EXAMINING ATTORNEY

SN 77-571,452. PARAGON RELOCATION HOLDINGS, DUBLIN, IRELAND, FILED 9-16-2008.



OWNER OF U.S. REG. NOS. 3,023,175, 3,053,285 AND 3,113,691.

NO CLAIM IS MADE TO THE EXCLUSIVE RIGHT TO USE "RELOCATION", APART FROM THE MARK AS SHOWN.

THE MARK CONSISTS OF THE WORDING "PARAGON RELOCATION" WITH THE WORD "PARAGON" ABOVE LINE AND THE WORD "RELOCATION" BELOW THE LINE. A DESIGN COMPRISED OF TWO INTERLOCKING DIAMONDS APPEARS TO THE LEFT OF THE WORDING.

CLASS 35—ADVERTISING AND BUSINESS

FOR DOMESTIC AND INTERNATIONAL BUSINESS AND EMPLOYEE RELOCATION AND DESTINATION RELOCATION SERVICES RELATED TO RELOCATION OF BUSINESSES AND EMPLOYEES, AND PROVIDING INFORMATION AND REFERRALS RELATING THERETO; CONSULTATION SERVICES IN THE FIELDS OF BUSINESS AND EMPLOYEE RELOCATION, RELOCATION POLICY, AND RELOCATION INFORMATION AT BOTH ORIGIN AND DESTINATION; BUSINESS AND EMPLOYEE RELOCATION SERVICES RELATED TO DESTINATION, NAMELY, PROVIDING PRE-DECISION DESTINATION INFORMATION, PROVIDING EMPLOYMENT INFORMATION AND COUNSELING TO ASSIST IN FAMILY MEMBERS' JOB SEARCHES; EMPLOYEE RELOCATION SERVICES, NAMELY, ARRANGING FOR THE COMMENCEMENT OF UTILITY SERVICES FOR RESIDENTIAL PROPERTIES OF RELOCATED PERSONNEL; ADMINISTRATION OF RELOCATION REIMBURSEMENT, NAMELY, PROCESSING REIMBURSEMENT OF RELOCATION EXPENSES AND RELOCATION BENEFIT PAYMENTS AND PAYMENT TO VENDORS SUPPORTING AND ASSISTING WITH RELOCATION; PROVIDING REAL ESTATE LEADS AND REFERENCES FOR PROSPECTIVE PURCHASERS AND LESSEES; REFERRALS IN THE FIELD OF LANGUAGE AND CULTURAL TRAINING; REFERRALS IN THE FIELD OF IMMIGRATION (U.S. CLS. 100, 101 AND 102).

CLASS 36—INSURANCE AND FINANCIAL

FOR BENEFITS COUNSELING, NAMELY, THE ADMINISTRATION OF EMPLOYEE RELOCATION BENEFITS PROGRAMS (U.S. CLS. 100, 101 AND 102).
JEFFERY COWARD, EXAMINING ATTORNEY

SN 77-582,920. THOMSON REUTERS CANADA LIMITED, TORONTO, ONTARIO, CANADA, FILED 10-1-2008.



THOMSON REUTERS

THE COLOR(S) ORANGE AND GRAY IS/ARE CLAIMED AS A FEATURE OF THE MARK.

THE MARK CONSISTS OF AN ORANGE CIRCULAR KINESIS DESIGN AND THE GRAY WORDING "THOMSON REUTERS".

CLASS 9—ELECTRICAL AND SCIENTIFIC APPARATUS

FOR PRE-RECORDED COMPACT DISCS CONTAINING REFERENCE INFORMATION IN THE FIELDS OF FINANCE, INVESTMENTS, BANKING REGULATIONS, CORPORATE OWNERSHIP, BUSINESSES, TAXATION AND ACCOUNTING, MEDICINE, PHARMACEUTICALS, LAW, HEALTHCARE AND INSURANCE FOR USE IN RESEARCH, EDUCATION, AND INFORMATION GATHERING, COMPUTER SOFTWARE RECORDED ON CD-ROM THAT PROVIDES ACCESS TO BIBLIOGRAPHIC CITATIONS AND ABSTRACTS OF RESEARCH MATERIAL AND UPDATES OF JOURNAL LITERATURE IN THE FIELD OF SCIENCE; PRERECORDED CD-ROMS PROVIDING RESEARCH AND PRACTICAL ENGAGEMENT GUIDANCE FOR USE BY ACCOUNTING PROFESSIONALS IN PROVIDING CONSULTING SERVICES, NAMELY, BUSINESS VALUATION, LITIGATION SUPPORT AND FRAUD INVESTIGATIONS FOR THEIR CLIENT; COMPUTER PROGRAMS FOR ACCESSING A VARIETY OF DATABASES IN THE FIELDS OF BUSINESS, LAW, SCIENCE AND TECHNOLOGY, HUMANITIES AND SOCIAL SCIENCE; COMPUTER SOFTWARE AND INSTRUCTION MANUALS FOR RESEARCH AND EDUCATIONAL PURPOSES AND INFORMATION GATHERING, ALL SOLD AS A UNIT FOR USE IN THE FIELD OF LEGAL RESEARCH; COMPUTER SOFTWARE FOR RESEARCH AND INFORMATION GATHERING FOR USE IN THE FIELDS OF LAW, COMMUNICATIONS SOFTWARE TO FACILITATE THE TRANSFER OF ELECTRONIC DATA BY PROVIDING ACCESS TO DATABASES WHICH PROVIDE INFORMATION ON BUSINESS, SCIENCE AND TECHNOLOGY, HUMANITIES AND THE SOCIAL SCIENCES, PRE-RECORDED AUDIO AND VIDEO COMPACT DISCS FEATURING FINANCIAL DATA; READ-ONLY MEMORY COMPACT DISCS FEATURING FINANCIAL DATA; COMPUTER OPERATING PROGRAMS; COMPUTER PROGRAMS FOR USE IN TRADING STOCKS AND BONDS; COMPUTER SOFTWARE RELATING TO THE COLLECTION AND DISTRIBUTION OF DATA, FINANCIAL EXCHANGES, SHARE DEALING, STOCK DEALING, FINANCIAL TRANSACTIONS AND NEWS AGENCIES; BLANK MAGNETIC DATA MEDIA; BLANK OPTICAL DATA MEDIA; BLANK MAGNETIC DISCS; MAGNETIC ENCODED CARDS; USER INTERFACES FOR COMPUTERS; TELEPRINTERS; TELEVISION APPARATUS, NAMELY, TELEVISION SCREENS; TELECOMMUNICATION APPARATUS AND INSTRUMENTS, NAMELY, FACSIMILE MACHINES; COMPUTERS; COMPUTER KEYBOARDS; COMPUTER PERIPHERAL DEVICES; PRINTERS FOR USE WITH COMPUTERS; MODEMS; COMPUTER MOUSE; COMPUTER TERMINALS, AND INSTRUCTION MANUALS FOR USE WITH THE AFORESAID GOODS, SOLD AS A UNIT THEREWITH (U.S. CLS. 21, 23, 26, 36 AND 38).

CLASS 16—PAPER GOODS AND PRINTED MATTER

FOR PRINTED PUBLICATIONS, NAMELY, BOOKS, MAGAZINES, JOURNALS, DIRECTORIES, LOOSE LEAF BINDERS, PAMPHLETS AND BROCHURES CONTAINING REFERENCE INFORMATION ON A VARIETY OF TOPICS IN THE FIELDS OF FINANCE, INVESTMENTS, BANKING REGULATIONS, CORPORATE OWNERSHIP, BUSINESSES, TAXATION AND ACCOUNTING, MEDICINE, PHARMACEUTICALS, LAW, HEALTHCARE AND INSURANCE; PRINTED REPORTS FEATURING INFORMATION ABOUT CORPORATIONS, HEALTH FACILITIES AND OTHER ORGANIZATIONS IN THE PUBLIC AND PRIVATE SECTORS; TECHNICAL REFERENCE MANUALS, NEWSLETTERS AND CATALOGS FOR USE IN THE AREAS OF ACCOUNTING, AUDITING, TAXATION AND BUSINESS MANAGEMENT; PAMPHLETS, NON-ADVERTISING BROCHURES CONTAINING CLINICAL MEDICAL AND SCIENTIFIC INFORMATION AND COMPUTER PROGRAM MANUALS; PUBLICA-

TIONS, NAMELY, BOOKS, JOURNALS, FOR CONDUCTING LEGAL RESEARCH; NON-FICTION BOOKS, PERIODICALS AND PUBLICATIONS, NAMELY, BROCHURES, PAMPHLETS AND MAGAZINES IN THE FIELD OF THE PROVISION OF FINANCIAL AND COMMERCIAL INFORMATION AND NEWS, AND CURRENT AFFAIRS; PRINTED INSTRUCTIONAL AND TEACHING MATERIAL RELATING TO ECONOMIC AND FINANCIAL INFORMATION, COMPUTER HARDWARE AND COMPUTER SOFTWARE AND NEWS AND CURRENT AFFAIRS; PHOTOGRAPHIC PRINTS (U.S. CLS. 2, 5, 22, 23, 29, 37, 38 AND 50).

CLASS 35—ADVERTISING AND BUSINESS

FOR HEALTH CARE COST REVIEW AND DATA PROCESSING SERVICES FOR HEALTH CARE AND HEALTH CLAIMS AND INSURANCE INFORMATION AND INFORMATION FOR CONTROLLING MEDICAL COSTS, MEASURING HEALTH CARE MARKETS AND RESEARCH PURPOSES; COMPUTER SERVICES, NAMELY, PROVIDING A DATABASE FEATURING BUSINESS NEWS AND INFORMATION, BUSINESS CORPORATE FILINGS, AND BUSINESS REPORTS FOR LEGAL RESEARCH; PROVIDE CUSTOMIZED STATISTICAL REPORTS CONCERNING DEMOGRAPHIC DATA; ADVERTISING SERVICES, NAMELY, DISSEMINATING THE ADVERTISING MATTER OF OTHERS; BUSINESS APPRAISAL SERVICES; BUSINESS INFORMATION SERVICES; BUSINESS INVESTIGATION SERVICES; COMMERCIAL INFORMATION AGENCIES; ECONOMIC FORECASTING SERVICES; RENTAL OF OFFICE MACHINERY AND EQUIPMENT; BUSINESS RESEARCH SERVICES; PROVIDING STATISTICAL INFORMATION; PROVIDING TAX ESTIMATES; PROVISION OF INFORMATION ON THE TOPICS OF ACCOUNTING AND AUDITING, AND TAX PLANNING; PROVIDING RESEARCH ASSISTANCE ON THE TOPICS OF ACCOUNTING AND AUDITING, AND TAX PLANNING; PROVIDING A DATABASE AND INDICES FEATURING INFORMATION ON SOCIAL SCIENCE, NAMELY, POLITICAL SCIENCE AND ECONOMICS, GOVERNMENT AND POLITICS FOR LEGAL RESEARCH; BUSINESS INFORMATION REPORTING SERVICES THAT PROVIDE CUSTOMIZED STATISTICAL REPORTS CONCERNING HEALTH CARE PROVIDER, PATIENT, CLINICAL AND HEALTH CLAIMS; PROVIDING INFORMATION, ANALYSIS AND REPORTS ON MUNICIPAL MARKETS AND TREASURY CASH, MERGERS AND ACQUISITIONS, OWNERSHIP OF CORPORATIONS, INFORMATION REGARDING CORPORATE AND FINANCIAL EXECUTIVES, POST TRADE OPERATIONS IN THE GLOBAL SECURITIES MARKETS; PROVIDING INFORMATION SERVICES IN THE FIELDS OF ECONOMIC, FINANCIAL, MONETARY AND STOCK EXCHANGE INFORMATION, CURRENCY TRADING INFORMATION (U.S. CLS. 100, 101 AND 102).

CLASS 36—INSURANCE AND FINANCIAL

FOR PROVISION OF INFORMATION ON THE TOPIC OF FINANCIAL ADVISORY SERVICES; PROVIDING RESEARCH ASSISTANCE ON THE TOPIC OF FINANCIAL ADVISORY SERVICES; PROVIDING CUSTOMIZED STATISTICAL REPORTS CONCERNING FINANCIAL DATA; FINANCIAL ANALYSIS; FINANCIAL CONSULTANCY; FISCAL ASSESSMENTS; STOCK EXCHANGE PRICE QUOTATIONS; ELECTRONIC FUNDS TRANSFERS; PROVIDING FINANCIAL INFORMATION ON BONDS; WARRANT BONDS, COMMERCIAL SALES, AND EXCHANGE AND INVESTMENT TRUSTS (U.S. CLS. 100, 101 AND 102).

CLASS 37—CONSTRUCTION AND REPAIR

FOR INSTALLATION, MAINTENANCE AND REPAIR OF COMPUTER HARDWARE, PERIPHERAL DEVICES AND COMPUTER SYSTEMS (U.S. CLS. 100, 103 AND 106).

CLASS 38—COMMUNICATION

FOR TELECOMMUNICATIONS SERVICES, NAMELY, PROVIDING TELECOMMUNICATIONS CONNECTIONS TO A GLOBAL COMPUTER NETWORK; BROADCASTING SERVICES, NAMELY, TELEVISION, RADIO AND CABLE TELEVISION BROADCASTING SERVICES; COMMUNICATION BY COMPUTER TERMINALS, NAMELY, ELECTRONIC TRANSMISSION OF DATA, MESSAGES, AND DOCUMENTS VIA COMPUTER TERMINALS; COMPUTER-AIDED TRANSMISSION OF DATA, MESSAGES, INFORMATION AND IMAGES; ELECTRONIC MAIL SERVICES; ELECTRONIC TRANSMISSION OF MESSAGES; RENTAL OF MESSAGE SENDING APPARATUS; TELEGRAPH SERVICES (U.S. CLS. 100, 101 AND 104).

CLASS 39—TRANSPORTATION AND STORAGE

FOR COMPUTERIZED INFORMATION STORAGE OF FILES AND DOCUMENTS IN THE AREA OF LEGAL RESEARCH (U.S. CLS. 100 AND 105).

CLASS 41—EDUCATION AND ENTERTAINMENT

FOR PROVISION OF CONTINUING PROFESSIONAL EDUCATIONAL (CPE) COURSES TO THE ACCOUNTING FIRM MARKET VIA A GLOBAL COMPUTER NETWORK; PROVIDING CONTINUING LEGAL EDUCATION (CLE) PROGRAMS; PROVIDING A DATABASE FEATURING INFORMATION ON LIBRARY SCIENCE, HUMANITIES, NAMELY, THE ARTS, HISTORICAL EVENTS, AND BIOGRAPHICAL DATA FOR LEGAL RESEARCH; PROVIDING ONLINE PUBLICATIONS IN THE NATURE OF DIRECTORIES AND REFERENCE MATERIAL, NAMELY, JOURNALS FEATURING INFORMATION ON SOCIAL SCIENCE AND THE HUMANITIES, GOVERNMENT AND POLITICS, LIBRARY SCIENCE, MEDICAL AND BIOGRAPHICAL DATA; PROVIDING INDICES FEATURING INFORMATION ON SOCIAL SCIENCE, NAMELY, ANTHROPOLOGY, HUMANITIES, NAMELY, THE ARTS, HISTORICAL EVENTS, LIBRARY SCIENCE, AND BIOGRAPHICAL DATA (U.S. CLS. 100, 101 AND 107).

CLASS 42—SCIENTIFIC AND COMPUTER SERVICES

FOR CUSTOMIZED COMPUTER RESEARCH IN THE FIELD OF SCIENCE; ONLINE DATABASES WHICH PROVIDE SCIENTIFIC AND PATENT INFORMATION; MAINTENANCE OF COMPUTER SOFTWARE; COMPUTERIZED INFORMATION RETRIEVAL SERVICES IN THE NATURE OF SEARCH ENGINES FOR RETRIEVING LEGAL RESEARCH (U.S. CLS. 100 AND 101).

CLASS 44—MEDICAL, BEAUTY AND AGRICULTURAL SERVICES

FOR PROVIDING MEDICAL AND CLINICAL HEALTH CARE INFORMATION VIA THE INTERNET; AND PROVIDING HEALTH CARE INFORMATION; PROVIDING A DATABASE AND INDICES FEATURING INFORMATION ON SOCIAL SCIENCE, NAMELY, PSYCHOLOGY AND MEDICAL DATA (U.S. CLS. 100 AND 101).

CLASS 45—PERSONAL AND LEGAL SERVICES

FOR PROVIDING LINKS TO LEGAL PUBLICATIONS AND INFORMATION WEB SITES OF OTHERS FEATURING LEGAL MATTERS; PROVIDING ONLINE DATABASES FEATURING INFORMATION ON STATE AND FEDERAL LAWS AND STATUTES, CASE LAW, NEW LEGISLATION AND REGULATIONS FOR LEGAL RESEARCH; LICENSING OF COMPUTER SOFTWARE AND CUSTOMIZED DATABASES, TABLES AND DATA SUMMARIES FOR THE PROCESSING OF HEALTH CARE AND HEALTH CLAIMS INFORMATION AND INFORMATION FOR CONTROLLING MEDICAL COSTS, MEASURING HEALTH CARE MARKETS AND HEALTH CARE RESEARCH PURPOSES; TRADEMARK RESEARCH SERVICES, NAMELY, PROVIDING COMPREHENSIVE INFORMATION AS TO THE USE, STATUS, HISTORY AND OWNERSHIP OF TRADEMARKS AND COMPANY NAMES; PROVISION OF INFORMATION ON COMPLIANCE WITH IRS AND STATE TAX LAWS AND REGULATION; PROVIDING RESEARCH ASSISTANCE ON THE TOPIC OF COMPLIANCE WITH IRS AND STATE TAX LAWS AND REGULATIONS (U.S. CLS. 100 AND 101).

MATTHEW PAPPAS, EXAMINING ATTORNEY

CLASS 45—PERSONAL AND LEGAL SERVICES

FOR PROVIDING SOCIAL NETWORKING SERVICES VIA GLOBAL COMMUNICATION NETWORKS; PROVIDING INFORMATION IN THE FIELD OF PERSONAL DEVELOPMENT, NAMELY, SELF-IMPROVEMENT AND SELF-FULFILLMENT; PROVIDING INFORMATION ABOUT ONLINE SOCIAL NETWORKING FOR PERSONS INTERESTED IN EXPANDING THEIR PERSONAL DEVELOPMENT THROUGH CONNECTING WITH CHARITABLE, PHILANTHROPIC, VOLUNTEER, HUMANITARIAN, AND PUBLIC AND COMMUNITY SERVICE ORGANIZATIONS AND OPPORTUNITIES (U.S. CLS. 100 AND 101).

LESLIE RICHARDS, EXAMINING ATTORNEY

SN 77-589,935. FACEBOOK, INC., MENLO PARK, CA. FILED 10-9-2008.

FACEBOOK FOR GOOD

THE MARK CONSISTS OF STANDARD CHARACTERS WITHOUT CLAIM TO ANY PARTICULAR FONT, STYLE, SIZE, OR COLOR.

OWNER OF U.S. REG. NOS. 3,041,791 AND 3,122,052.

CLASS 35—ADVERTISING AND BUSINESS

FOR CHARITABLE SERVICES, NAMELY, PROMOTING PUBLIC AWARENESS ABOUT CHARITABLE, PHILANTHROPIC, VOLUNTEER, PUBLIC AND COMMUNITY SERVICE AND HUMANITARIAN ACTIVITIES (U.S. CLS. 100, 101 AND 102).

CLASS 41—EDUCATION AND ENTERTAINMENT

FOR CONDUCTING CONTEST AND INCENTIVE AWARD PROGRAMS DESIGNED TO RECOGNIZE AND REWARD INDIVIDUALS AND GROUPS WHICH ENGAGE IN SELF-IMPROVEMENT, SELF-FULFILLMENT, CHARITABLE, PHILANTHROPIC, VOLUNTEER, PUBLIC AND COMMUNITY SERVICE, AND HUMANITARIAN ACTIVITIES (U.S. CLS. 100, 101 AND 107).

CLASS 42—SCIENTIFIC AND COMPUTER SERVICES

FOR HOSTING AN ONLINE COMMUNITY WEBSITE FEATURING SHARED COMMUNICATIONS BETWEEN COMMUNITY MEMBERS INTERESTED IN SELF-IMPROVEMENT, SELF-FULFILLMENT, CHARITABLE, PHILANTHROPIC, VOLUNTEER, PUBLIC AND COMMUNITY SERVICE, AND HUMANITARIAN ACTIVITIES ALL VIA GLOBAL COMMUNICATION NETWORKS (U.S. CLS. 100 AND 101).

SN 77-602,404. VEREDUS LABORATORIES PTE LTD, SINGAPORE, SINGAPORE, FILED 10-28-2008.

VEREFLU

THE MARK CONSISTS OF STANDARD CHARACTERS WITHOUT CLAIM TO ANY PARTICULAR FONT, STYLE, SIZE, OR COLOR.

PRIORITY CLAIMED UNDER SEC. 44(D) ON SINGAPORE APPLICATION NO. T0812648B, FILED 9-16-2008, REG. NO. T0812648B, DATED 9-16-2008, EXPIRES 9-16-2018.

CLASS 9—ELECTRICAL AND SCIENTIFIC APPARATUS

FOR LABORATORY AND SCIENTIFIC EQUIPMENT FOR GENETIC SAMPLING AND ANALYSIS, NAMELY, DIAGNOSTIC TESTING EQUIPMENT FEATURING MICROCHIPS AND DIAGNOSTIC TEST KITS COMPRISING MICROCHIPS FOR SCREENING SAMPLES, DETECTING THE PRESENCE OF ANALYTES IN SAMPLES AND IDENTIFYING SAMPLE TYPE; MICROFLUIDIC MICROCHIPS FOR LABORATORY ANALYSIS; LAB-ON-A-CHIP ANALYZERS, NAMELY, MICROCHIPS FOR LABORATORY ANALYSIS; GEL-BASED DETECTION KITS COMPRISING MICROCHIPS FOR LABORATORY ANALYSIS; COMPUTER SOFTWARE FOR USE IN THE ANALYSIS AND DIAGNOSIS OF MEDICAL CONDITIONS; ELECTRONIC PUBLICATIONS, NAMELY, BOOKS, BOOKLETS, GUIDES, PAMPHLETS, USER MANUALS, BROCHURES AND DATA AND TECHNICAL INFORMATIONAL SHEETS ALL IN THE FIELD OF MEDICAL AND LABORATORY EQUIPMENT RECORDED ON COMPUTER MEDIA (U.S. CLS. 21, 23, 26, 36 AND 38).

CLASS 10—MEDICAL APPARATUS

FOR MEDICAL AND VETERINARY APPARATUS AND INSTRUMENTATION, NAMELY, MEDICAL APPARATUS AND INSTRUMENTS FEATURING MICROCHIPS FOR GENETIC SAMPLING AND ANALYSIS; MEDICAL AND VETERINARY APPARATUS AND INSTRUMENTATION, NAMELY, MEDICAL DIAGNOSTIC APPARATUS AND INSTRUMENTS FOR DETECTION OF TISSUE AND CELL-BASED SAMPLES; MEDICAL AND VETERINARY DIAGNOSTIC TEST EQUIPMENT FOR USE WITH CHEMICAL AND BIOCHEMICAL REAGENTS (U.S. CLS. 26, 39 AND 44).

CLASS 16—PAPER GOODS AND PRINTED MATTER

FOR PRINTED MATTER, NAMELY, BOOKS, MAGAZINES, BOOKLETS, GUIDES, PAMPHLETS, BROCHURES, FOLDERS, INFORMATIONAL FLYERS, PROSPECTUS, PLACARDS OF PAPER OR CARDBOARD, POSTERS, STATIONERY, INSTRUCTIONAL AND TEACHING MATERIALS, DATA AND TECHNICAL INFORMATIONAL SHEETS AND USER MANUALS IN THE FIELDS OF BIOINFORMATICS, MEDICAL LABORATORY RESEARCH, GENETIC SAMPLING AND ANALYSIS AND DIAGNOSTIC APPARATUS AND INSTRUMENTS; STICKERS; BALLPOINT PENS; CORRUGATED BOXES; PHOTOGRAPHS; PLASTIC BAGS AND BUBBLE PACKS FOR PACKAGING (U.S. CLS. 2, 5, 22, 23, 29, 37, 38 AND 50).

CLASS 42—SCIENTIFIC AND COMPUTER SERVICES

FOR SCIENTIFIC RESEARCH AND DEVELOPMENT SERVICES IN THE FIELD OF DIAGNOSTIC APPARATUS; SERVICES PROVIDED BY SCIENTISTS, NAMELY, RESEARCH AND DEVELOPMENT FOR NEW PRODUCTS FOR OTHERS IN THE FIELD OF LABORATORY AND MEDICAL PREPARATION, ANALYSES AND RESEARCH PRODUCTS; SCIENTIFIC SERVICES, NAMELY, DEVELOPMENT AND ESTABLISHMENT OF TESTING SPECIFICATIONS AND PROCEDURES FOR RESEARCHING AND ESTABLISHING NEW PRODUCTS IN THE FIELDS OF DIAGNOSTIC CHEMICALS, BIOCHEMICAL SENSORS, BIOINFORMATICS, MEDICAL LABORATORY RESEARCH, GENETIC SAMPLING AND ANALYSIS AND DIAGNOSTIC APPARATUS AND INSTRUMENTS; SCIENTIFIC SERVICES, NAMELY, NEW PRODUCT DEVELOPMENT FOR OTHERS IN THE FIELD OF CHEMICAL REAGENTS AND BIOCHEMICAL ASSAYS; SCIENTIFIC RESEARCH SERVICES IN THE FIELD OF FORENSIC SCIENCE, NAMELY, ANALYSIS OF BIOLOGICAL SUBSTANCES IN FORENSIC SAMPLES FOR THIRD PARTIES IN THE FIELDS OF HEALTH CARE AND VETERINARY MEDICINE; MEDICAL AND CHEMICAL LABORATORIES THAT COLLECT BIOLOGICAL SAMPLES FOR THIRD PARTIES IN THE FIELDS OF FORENSIC MEDICINE, HEALTH CARE AND VETERINARY MEDICINE; CHEMICAL AND BIOCHEMICAL ANALYSIS FOR OTHERS THROUGH THE USE OF MICROCHIPS IN THE FIELD OF HUMAN DISEASE; SCIENTIFIC ANALYSIS, NAMELY, CHEMICAL AND BIOCHEMICAL ANALYSIS THROUGH THE USE OF MICROCHIPS IN THE FIELD OF HUMAN DISEASE; SCIENTIFIC RESEARCH, NAMELY, DEVELOPING AND ESTABLISHING TESTING SPECIFICATIONS AND PROCEDURES BASED ON MICROFLUIDICS FOR RESEARCHING AND ESTABLISHING NEW PRODUCTS IN THE FIELDS OF BIOINFORMATICS, MEDICAL LABORATORY RESEARCH, GENETIC SAMPLING AND ANALYSIS AND VETERINARY MEDICINE AND RESEARCH (U.S. CLS. 100 AND 101).

DAVID YONTEF, EXAMINING ATTORNEY

CLASS 9—ELECTRICAL AND SCIENTIFIC APPARATUS

FOR LABORATORY AND SCIENTIFIC EQUIPMENT FOR GENETIC SAMPLING AND ANALYSIS, NAMELY, DIAGNOSTIC TESTING EQUIPMENT FEATURING MICROCHIPS AND DIAGNOSTIC TEST KITS COMPRISING MICROCHIPS FOR SCREENING SAMPLES, DETECTING THE PRESENCE OF ANALYTES IN SAMPLES AND IDENTIFYING SAMPLE TYPE; MICROFLUIDIC MICROCHIPS FOR LABORATORY ANALYSIS; LAB-ON-A-CHIP ANALYZERS, NAMELY, MICROCHIPS FOR LABORATORY ANALYSIS; GEL-BASED DETECTION KITS COMPRISING MICROCHIPS FOR LABORATORY ANALYSIS; COMPUTER SOFTWARE FOR USE IN THE ANALYSIS AND DIAGNOSIS OF MEDICAL CONDITIONS; ELECTRONIC PUBLICATIONS, NAMELY, BOOKS, BOOKLETS, GUIDES, PAMPHLETS, USER MANUALS, BROCHURES AND DATA AND TECHNICAL INFORMATIONAL SHEETS ALL IN THE FIELD OF MEDICAL AND LABORATORY EQUIPMENT RECORDED ON COMPUTER MEDIA (U.S. CLS. 21, 23, 26, 36 AND 38).

CLASS 10—MEDICAL APPARATUS

FOR MEDICAL AND VETERINARY APPARATUS AND INSTRUMENTATION, NAMELY, MEDICAL APPARATUS AND INSTRUMENTS FEATURING MICROCHIPS FOR GENETIC SAMPLING AND ANALYSIS; MEDICAL AND VETERINARY APPARATUS AND INSTRUMENTATION, NAMELY, MEDICAL DIAGNOSTIC APPARATUS AND INSTRUMENTS FOR DETECTION OF TISSUE AND CELL-BASED SAMPLES; MEDICAL AND VETERINARY DIAGNOSTIC TEST EQUIPMENT FOR USE WITH CHEMICAL AND BIOCHEMICAL REAGENTS (U.S. CLS. 26, 39 AND 44).

CLASS 16—PAPER GOODS AND PRINTED MATTER

FOR PRINTED MATTER, NAMELY, BOOKS, MAGAZINES, BOOKLETS, GUIDES, PAMPHLETS, BROCHURES, FOLDERS, INFORMATIONAL FLYERS, PROSPECTUS, PLACARDS OF PAPER OR CARDBOARD, POSTERS, STATIONERY, INSTRUCTIONAL AND TEACHING MATERIALS, DATA AND TECHNICAL INFORMATIONAL SHEETS AND USER MANUALS IN THE FIELDS OF BIOINFORMATICS, MEDICAL LABORATORY RESEARCH, GENETIC SAMPLING AND ANALYSIS AND DIAGNOSTIC APPARATUS AND INSTRUMENTS; STICKERS; BALLPOINT PENS; CORRUGATED BOXES; PHOTOGRAPHS; PLASTIC BAGS AND BUBBLE PACKS FOR PACKAGING (U.S. CLS. 2, 5, 22, 23, 29, 37, 38 AND 50).

CLASS 42—SCIENTIFIC AND COMPUTER SERVICES

FOR SCIENTIFIC RESEARCH AND DEVELOPMENT SERVICES IN THE FIELD OF DIAGNOSTIC APPARATUS; SERVICES PROVIDED BY SCIENTISTS, NAMELY, RESEARCH AND DEVELOPMENT FOR NEW PRODUCTS FOR OTHERS IN THE FIELD OF LABORATORY AND MEDICAL PREPARATION, ANALYSES AND RESEARCH PRODUCTS; SCIENTIFIC SERVICES, NAMELY, DEVELOPMENT AND ESTABLISHMENT OF TESTING SPECIFICATIONS AND PROCEDURES FOR RESEARCHING AND ESTABLISHING NEW PRODUCTS IN THE FIELDS OF DIAGNOSTIC CHEMICALS, BIOCHEMICAL SENSORS, BIOINFORMATICS, MEDICAL LABORATORY RESEARCH, GENETIC SAMPLING AND ANALYSIS AND DIAGNOSTIC APPARATUS AND INSTRUMENTS; SCIENTIFIC SERVICES, NAMELY, NEW PRODUCT DEVELOPMENT FOR OTHERS IN THE FIELD OF CHEMICAL REAGENTS AND BIOCHEMICAL ASSAYS; SCIENTIFIC RESEARCH SERVICES IN THE FIELD OF FORENSIC SCIENCE, NAMELY, ANALYSIS OF BIOLOGICAL SUBSTANCES IN FORENSIC SAMPLES FOR THIRD PARTIES IN THE FIELDS OF HEALTH CARE AND VETERINARY MEDICINE; MEDICAL AND CHEMICAL LABORATORIES THAT COLLECT BIOLOGICAL SAMPLES FOR THIRD PARTIES IN THE FIELDS OF FORENSIC MEDICINE, HEALTH CARE AND VETERINARY MEDICINE; CHEMICAL AND BIOCHEMICAL ANALYSIS FOR OTHERS

SN 77-602,418. VEREDUS LABORATORIES PTE LTD, SINGAPORE, SINGAPORE, FILED 10-28-2008.

VERETHREAT

THE MARK CONSISTS OF STANDARD CHARACTERS WITHOUT CLAIM TO ANY PARTICULAR FONT, STYLE, SIZE, OR COLOR.

PRIORITY CLAIMED UNDER SEC. 44(D) ON SINGAPORE APPLICATION NO. T0812650D, FILED 9-16-2008, REG. NO. T0812650D, DATED 9-16-2008, EXPIRES 9-16-2018.

THROUGH THE USE OF MICROCHIPS IN THE FIELD OF HUMAN DISEASE; SCIENTIFIC ANALYSIS, NAMELY, CHEMICAL AND BIOCHEMICAL ANALYSIS THROUGH THE USE OF MICROCHIPS IN THE FIELD OF HUMAN DISEASE; SCIENTIFIC RESEARCH, NAMELY, DEVELOPING AND ESTABLISHING TESTING SPECIFICATIONS AND PROCEDURES BASED ON MICROFLUIDICS FOR RESEARCHING AND ESTABLISHING NEW PRODUCTS IN THE FIELDS OF BIOINFORMATICS, MEDICAL LABORATORY RESEARCH, GENETIC SAMPLING AND ANALYSIS AND VETERINARY MEDICINE AND RESEARCH (U.S. CLS. 100 AND 101).

DAVID YONTEF, EXAMINING ATTORNEY

SN 77-622,346. BEST BUY CANADA LTD./MAGASINS BEST BUY LTEE, BURNABY, CANADA, FILED 11-26-2008.

FUTURE SHOP CELLSHOP

THE MARK CONSISTS OF STANDARD CHARACTERS WITHOUT CLAIM TO ANY PARTICULAR FONT, STYLE, SIZE, OR COLOR.

PRIORITY CLAIMED UNDER SEC. 44(D) ON CANADA APPLICATION NO. 1416290, FILED 10-29-2008, REG. NO. TMA810,668, DATED 10-31-2011, EXPIRES 10-31-2026.

OWNER OF U.S. REG. NO. 1,537,745.

NO CLAIM IS MADE TO THE EXCLUSIVE RIGHT TO USE "SHOP CELLSHOP", APART FROM THE MARK AS SHOWN.

CLASS 35—ADVERTISING AND BUSINESS

FOR OPERATION OF RETAIL STORES FEATURING CONSUMER ELECTRONICS AND COMMUNICATIONS DEVICES; COMPUTERIZED ONLINE RETAIL STORE SERVICES ACCESSIBLE VIA A GLOBAL COMPUTER NETWORK, FEATURING CONSUMER ELECTRONICS AND COMMUNICATION DEVICES (U.S. CLS. 100, 101 AND 102).

CLASS 36—INSURANCE AND FINANCIAL

FOR UNDERWRITING OF EQUIPMENT REPLACEMENT, WARRANTY AND INSURANCE PLAN SERVICES IN THE FIELD OF MOBILE TELEPHONES AND MOBILE ACCESSORIES (U.S. CLS. 100, 101 AND 102).

CLASS 37—CONSTRUCTION AND REPAIR

FOR PROVISION OF REPAIR AND MAINTENANCE SERVICES IN THE FIELD OF MOBILE TELEPHONES AND MOBILE ACCESSORIES (U.S. CLS. 100, 103 AND 106).

CLASS 38—COMMUNICATION

FOR ADMINISTRATION OF MOBILE PHONE AIRTIME PLANS AND CONTRACTS; PROVISION OF TECHNICAL ADVICE AND ASSISTANCE ON THE USE OF MOBILE TELEPHONES AND MOBILE ACCESSORIES; PROVISION OF LOANER MOBILE PHONES; PROVISION OF ADVICE AND CONSULTATION SERVICES FOR SELECTION OF MOBILE TELEPHONES, MOBILE TELEPHONE ACCESSORIES, MOBILE NETWORKS AND MOBILE PHONE AIRTIME PLANS AND PROGRAMS PROVISION (U.S. CLS. 100, 101 AND 104).

MICHAEL KEATING, EXAMINING ATTORNEY

SN 77-623,673. IRVING TISSUE CORPORATION, DIEPPE, CANADA, FILED 12-1-2008.



PRIORITY CLAIMED UNDER SEC. 44(D) ON CANADA APPLICATION NO. 1419205, FILED 11-21-2008, REG. NO. TMA811224, DATED 11-7-2011, EXPIRES 11-7-2026.

THE MARK CONSISTS OF A STYLIZED CONICAL-SHAPED TREE FORMED BY ARROWS.

CLASS 16—PAPER GOODS AND PRINTED MATTER

FOR (SECTION 44(E) AND SECTION 1(B)) FACIAL TISSUE, BATHROOM TISSUE, PAPER TOWELS; (SECTION 1(B) ONLY) PAPER NAPKINS, PAPER AND DISPOSABLE DIAPERS (U.S. CLS. 2, 5, 22, 23, 29, 37, 38 AND 50).

CLASS 35—ADVERTISING AND BUSINESS

FOR (SECTION 44(E) AND SECTION 1(B)) ASSOCIATION SERVICES, NAMELY, PROMOTING THE INTERESTS OF THE FOREST, PAPER AND WOOD PRODUCTS INDUSTRY, AND PROMOTING PUBLIC AWARENESS OF ENVIRONMENTAL ISSUES AND INITIATIVES IN THE FOREST, PAPER AND WOOD PRODUCTS INDUSTRY (U.S. CLS. 100, 101 AND 102).

ZHALEH DELANEY, EXAMINING ATTORNEY

SN 77-626,275. THEMIS SOLUTIONS INC., VANCOUVER, BRITISH COLUMBIA, CANADA, FILED 12-4-2008.

CLIO

THE MARK CONSISTS OF STANDARD CHARACTERS WITHOUT CLAIM TO ANY PARTICULAR FONT, STYLE, SIZE, OR COLOR.

PRIORITY CLAIMED UNDER SEC. 44(D) ON CANADA APPLICATION NO. 1398528, FILED 6-6-2008, REG. NO. TMA812223, DATED 11-21-2011, EXPIRES 11-21-2026.

CLASS 9—ELECTRICAL AND SCIENTIFIC APPARATUS

FOR COMPUTER SOFTWARE AND APPLICATION SOFTWARE FOR LAW PRACTICE MANAGEMENT AND ADMINISTRATION; (BASED ON 44(D) PRIORITY APPLICATION PURSUANT TO CANADIAN APPLICATION NUMBER 1398528) COMPUTER SOFTWARE AND APPLICATION SOFTWARE FOR LAW PRACTICE MANAGEMENT (U.S. CLS. 21, 23, 26, 36 AND 38).

FIRST USE 5-1-2009; IN COMMERCE 5-1-2009.

CLASS 42—SCIENTIFIC AND COMPUTER SERVICES

FOR (BASED ON USE IN COMMERCE) SOFTWARE AS A SERVICE (SAAS) SERVICES FEATURING SOFTWARE AND WEB-BASED APPLICATIONS FOR LAW PRACTICE MANAGEMENT AND ADMINISTRATION; BASED ON 44(D) PRIORITY APPLICATION PURSUANT TO CANADIAN APPLICATION NUMBER 1398528) SOFTWARE AS A SERVICE (SAAS) SERVICES FEATURING SOFTWARE AND WEB-BASED APPLICATIONS FOR LAW PRACTICE MANAGEMENT (U.S. CLS. 100 AND 101).

FIRST USE 10-1-2008; IN COMMERCE 10-1-2008.
INGA ERVIN, EXAMINING ATTORNEY

CLASS 29—MEATS AND PROCESSED FOODS

FOR PROCESSED FRUIT IN SYRUP; MILK BASED BEVERAGES CONTAINING SYRUP; MARMALADES, JAMS AND JELLIES CONTAINING FLAVORING SYRUPS; MEAT, FISH, POULTRY AND GAME; MEAT EXTRACT; PRESERVED, DRIED AND COOKED FRUITS AND VEGETABLES; JELLIES, JAMS, FRUIT PUREE; EGGS; MILK AND MILK PRODUCTS, EXCLUDING ICE CREAM, ICE MILK AND FROZEN YOGURT; EDIBLE OILS AND FATS, MARMALADE, JAMS, JELLIES; PRESERVED FRUITS; PROTEIN FOR USE AS A FOOD FILLER; PROTEIN FOR USE AS A FOOD ADDITIVE FOR HUMAN CONSUMPTION; PROTEIN IN LIQUID FORM FOR USE AS A FOOD FILLER FOR HUMAN CONSUMPTION; WHEY (U.S. CL. 46).

SN 77-651,238. BRILLIANT IDEAS GLOBAL, LLC, SAN ANTONIO, TX. FILED 1-16-2009.

SoxMonster

THE MARK CONSISTS OF STANDARD CHARACTERS WITHOUT CLAIM TO ANY PARTICULAR FONT, STYLE, SIZE, OR COLOR.

CLASS 18—LEATHER GOODS

FOR GARMENT BAGS FOR TRAVEL (U.S. CLS. 1, 2, 3, 22 AND 41).

CLASS 22—CORDAGE AND FIBERS

FOR LAUNDRY BAGS; LAUNDRY WASH BAGS; MESH BAGS FOR STORAGE; MESH LINGERIE BAGS FOR WASHING LINGERIE; MULTI-PURPOSE CLOTH BAGS (U.S. CLS. 1, 2, 7, 19, 22, 42 AND 50).

NORA BUCHANAN WILL, EXAMINING ATTORNEY

CLASS 30—STAPLE FOODS

FOR GOLDEN SYRUP; MAPLE SYRUP; MAPLE FLAVORED SYRUPS; CAKES CONTAINING GOLDEN SYRUP; BISCUITS CONTAINING GOLDEN SYRUP; TREACLE TARTS; FLAPJACKS; FRUCTOSE SYRUP FOR USE IN THE MANUFACTURE OF FOODS; MOLASSES SYRUP FOR FOOD; SUGAR; INVERTED SUGAR; PARTIALLY INVERTED SUGAR; LIQUID SUGAR; COFFEE; TEA; COCOA; RICE; TAPIOCA; SAGO; BREAD; PASTRY; ICES; HONEY; TREACLE; SALT; MUSTARD; VINEGAR; SAUCES; SPICES; FROZEN CONFECTIONERY; COCOA; CHOCOLATE; BISCUITS AND CAKES NOT INCLUDING LIQUORICE CANDY (U.S. CL. 46).

CLASS 32—LIGHT BEVERAGES

FOR GOLDEN SYRUP FOR MAKING BEVERAGES; SOFT DRINKS CONTAINING GOLDEN SYRUP BEVERAGES CONTAINING, OR CONSISTING OF, SWEETENING MATERIALS, PREPARATIONS AND SUBSTANCES, NAMELY, SOFT DRINKS AND FRUIT DRINKS; NON-ALCOHOLIC BEVERAGES MADE FROM SYRUPS, NAMELY, SOFT DRINKS AND FRUIT DRINKS; SYRUP FOR MAKING BEVERAGES; SYRUP POWDER FOR MAKING BEVERAGES; NON-ALCOHOLIC BREWED MALT BEVERAGES; MALT BASED PREPARATIONS FOR MAKING BEVERAGES (U.S. CLS. 45, 46 AND 48).

SN 77-694,021. TATE & LYLE PLC, LONDON, UNITED KINGDOM, FILED 3-18-2009.

CORNGERM

THE MARK CONSISTS OF STANDARD CHARACTERS WITHOUT CLAIM TO ANY PARTICULAR FONT, STYLE, SIZE, OR COLOR.

OWNER OF ERPN CMNTY TM OFC REG. NO. 007189251, DATED 8-15-2008, EXPIRES 8-15-2018.

CLASS 42—SCIENTIFIC AND COMPUTER SERVICES

FOR SCIENTIFIC RESEARCH AND DEVELOPMENT; SCIENTIFIC RESEARCH AND DEVELOPMENT RELATING TO FOODSTUFFS AND FOOD PRODUCTS; CONSULTATION SERVICES IN THE FIELD OF FOOD TECHNOLOGY AND FOOD SCIENCE; COMPUTERIZED FOOD ANALYSIS SERVICES; CONTRACT RESEARCH SERVICES IN THE FIELD OF FOOD TECHNOLOGY AND FOOD SCIENCE; NEW PRODUCT DEVELOPMENT AND RESEARCH; QUALITY CONTROL FOR OTHERS RELATING TO THE HYGIENE OF FOOD AND FOODSTUFFS; CONSULTATION AND ADVISORY SERVICES IN THE FIELD OF FOOD TECHNOLOGY AND FOOD SCIENCE; PROVIDING INFORMATION ABOUT FOOD SCIENCE AND FOOD TECHNOLOGY VIA THE INTERNET (U.S. CLS. 100 AND 101).

DAWN FELDMAN, EXAMINING ATTORNEY

SN 77-707,111. ASTELLAS PHARMA INC., TOKYO, JAPAN,
FILED 4-5-2009.

SN 77-724,026. ONEXONE FOUNDATION, MONTREAL,
QUEBEC, CANADA, FILED 4-28-2009.

Astellas Reimbursement Services

THE MARK CONSISTS OF STANDARD CHARACTERS WITHOUT CLAIM TO ANY PARTICULAR FONT, STYLE, SIZE, OR COLOR.

PRIORITY CLAIMED UNDER SEC. 44(D) ON JAPAN APPLICATION NO. 2009-023639, FILED 3-31-2009, REG. NO. 5285869, DATED 12-4-2009, EXPIRES 12-4-2019.

OWNER OF U.S. REG. NOS. 3,195,446 AND 3,449,484.

NO CLAIM IS MADE TO THE EXCLUSIVE RIGHT TO USE "REIMBURSEMENT SERVICES", APART FROM THE MARK AS SHOWN.

CLASS 35—ADVERTISING AND BUSINESS

FOR MANAGEMENT OF TELEPHONE CALL CENTERS FOR OTHERS; OPERATION OF TELEPHONE CALL CENTERS FOR OTHERS; ADMINISTRATION OF PATIENT REIMBURSEMENT PROGRAMS IN ORDER TO ASSIST PATIENTS IN OBTAINING REIMBURSEMENTS FROM INSURERS OF HEALTH CARE COSTS (U.S. CLS. 100, 101 AND 102).

CLASS 36—INSURANCE AND FINANCIAL

FOR INSURANCE AGENCIES EXCLUDING LIFE INSURANCE AGENCIES; PROVIDING INFORMATION ON INSURANCE MATTERS; PROVIDING GRANTS TO PATIENTS AND THEIR FAMILIES FOR IMPROVING THEIR QUALITY OF LIFE; PROVIDING GRANTS TO MEDICAL RESEARCH ORGANIZATIONS AND BUSINESS ASSOCIATIONS IN SUPPORT OF SCIENTIFIC, MEDICAL AND BUSINESS MEETINGS AND WORKSHOPS; PROVIDING GRANTS TO EDUCATIONAL INSTITUTIONS AND RESEARCH ORGANIZATIONS IN SUPPORT OF EDUCATING THE PUBLIC ABOUT MEDICAL ISSUES (U.S. CLS. 100, 101 AND 102).

CLASS 41—EDUCATION AND ENTERTAINMENT

FOR EDUCATIONAL SERVICES, NAMELY, PROVIDING TRAINING AND INSTRUCTION IN THE USE OF SPECIALIZED DRUG ADMINISTRATION TECHNIQUES AND CONDUCTING SEMINARS IN THE MEDICAL FIELD (U.S. CLS. 100, 101 AND 107).

CLASS 42—SCIENTIFIC AND COMPUTER SERVICES

FOR RESEARCH AND CONSULTATION SERVICES IN THE FIELD OF BIOTECHNOLOGY (U.S. CLS. 100 AND 101).

CLASS 44—MEDICAL, BEAUTY AND AGRICULTURAL SERVICES

FOR PROVIDING HEALTH CARE SERVICES, NAMELY, PROVIDING HEALTH CARE INFORMATION TO PATIENTS BY MEANS OF A TOLL-FREE TELEPHONE NUMBER, MEDICAL EVALUATION SERVICES, NAMELY, ASSESSMENT PROGRAM FOR PATIENTS RECEIVING DRUG TREATMENT SERVICES FOR THE PURPOSE OF MONITORING PATIENT'S COMPLIANCE WITH DRUG PROCEDURES AND PROVIDING MEDICAL ADVISORY SERVICES RELATED THERETO (U.S. CLS. 100 AND 101).

ODESSA BIBBINS, EXAMINING ATTORNEY

ONE DAY I'LL CHANGE THE
WORLD...UNTIL THEN, I NEED
YOUR HELP

THE MARK CONSISTS OF STANDARD CHARACTERS WITHOUT CLAIM TO ANY PARTICULAR FONT, STYLE, SIZE, OR COLOR.

OWNER OF CANADA REG. NO. TMA821997, DATED 4-11-2012, EXPIRES 4-11-2027.

CLASS 14—JEWELRY

FOR JEWELRY, NAMELY, RINGS, NECKLACES, EARRINGS, PENDANTS, AND BRACELETS (U.S. CLS. 2, 27, 28 AND 50).

CLASS 25—CLOTHING

FOR CLOTHING, NAMELY, SHIRTS, SWEATERS, JACKETS, PANTS, SHORTS, SWEAT SHIRTS, T-SHIRTS, SHOES, AND HATS (U.S. CLS. 22 AND 39).

CLASS 36—INSURANCE AND FINANCIAL

FOR CHARITABLE FUND RAISING SERVICES (U.S. CLS. 100, 101 AND 102).

JANICE KIM, EXAMINING ATTORNEY

SN 77-726,690. CARBON GOLD LIMITED, LONDON, UNITED KINGDOM, FILED 5-1-2009.

CARBON GOLD

THE MARK CONSISTS OF STANDARD CHARACTERS WITHOUT CLAIM TO ANY PARTICULAR FONT, STYLE, SIZE, OR COLOR.

PRIORITY CLAIMED UNDER SEC. 44(D) ON ERPNCMNTY TM OFC APPLICATION NO. 007361215, FILED 11-3-2008, REG. NO. 007361215, DATED 7-20-2011, EXPIRES 11-3-2018.

NO CLAIM IS MADE TO THE EXCLUSIVE RIGHT TO USE "CARBON", APART FROM THE MARK AS SHOWN.

CLASS 1—CHEMICALS

FOR (BASED ON INTENT TO USE) AGRICULTURAL CHEMICALS EXCEPT FUNGICIDES, HERBICIDES, INSECTICIDES AND PARASITICIDES; MIXTURES OF CHEMICALS AND NATURAL MATERIALS, NAMELY, CHARCOAL, ORGANIC CHARCOAL, MYCORRHIZAL FUNGI, SEAWEED, WORMCAST, ORGANIC COIR FOR USE AS AGRICULTURAL FERTILIZERS; POLYMERS FOR USE IN MANUFACTURING AGRICULTURAL CHEMICALS; CHEMICAL ADDITIVES FOR MANURES; AMMONIACAL PRODUCTS, NAMELY, ORGANIC CHARCOAL OR CHARCOAL IMPREGNATED WITH NITRATE FERTILIZERS FOR USE AS MANURE; ARTIFICIAL MANURES PRODUCED FROM ORGANIC WASTE MATTER; FIBROUS MATERIAL MADE OF COCONUT FIBRE, COIR, PEAT, PEAT SUBSTITUTES OR ORGANIC CHARCOAL FOR USE AS MANURES; LIQUID MANURE SUBSTITUTE; MANURE; MANURE FOR AGRICULTURE; MANURE IN LIQUID FORM; MANURE IN SOLID FORM; MANURES FOR THE SOIL; MANURES FOR USE ON GRASS OR GRASSLAND; MANURES OBTAINED BY THE TREATMENT OF REFUSE WITH EARTHWORMS; NATURAL MANURE; NITROGENOUS LIME FOR AGRICULTURAL PURPOSES; ORGANIC MANURE; RIGID MANURES; SYNTHETIC MANURES; CHARCOAL FOR USE AS A SOIL CONDITIONER (U.S. CLS. 1, 5, 6, 10, 26 AND 46).

CLASS 4—LUBRICANTS AND FUELS

FOR (BASED ON INTENT TO USE) (BASED ON 44E) INDUSTRIAL OILS AND GREASES; BIO-OIL LUBRICANTS; FUELS AND ILLUMINANTS, NAMELY, BIO-OIL; CHARCOAL FOR USE AS FUEL; CHARCOAL BASED PRODUCTS FOR USE AS A FUEL, NAMELY, COCONUT CHARCOAL FOR FUEL OR WOOD CHARCOAL FOR FUEL, INCLUDING BRIQUETTED PRODUCTS; ELECTRICAL ENERGY (U.S. CLS. 1, 6 AND 15).

CLASS 35—ADVERTISING AND BUSINESS

FOR (BASED ON INTENT TO USE) (BASED ON 44E) BUSINESS MANAGEMENT SERVICES; PUBLIC RELATIONS SERVICES; PUBLICITY SERVICES; MARKETING SERVICES; CONSULTANCY, ADVISORY AND INFORMATION SERVICES RELATING TO THE AFORESAID; FORESTRY MANAGEMENT; PROVISION OF INFORMATION, ADVICE AND CONSULTANCY IN RELATION TO ENERGY USAGE MANAGEMENT THROUGH CARBON OFFSETTING; BUSINESS ADVISORY SERVICES RELATING TO ENERGY EFFICIENCY AND RENEWABLE ENERGY; BUSINESS CONSULTING AND ADVISORY SERVICES IN THE FIELDS OF ENERGY EFFICIENCY, WASTE MINIMIZATION, RENEWABLE ENERGY AND RESOURCE CONSERVATION (U.S. CLS. 100, 101 AND 102).

CLASS 36—INSURANCE AND FINANCIAL

FOR (BASED ON INTENT TO USE) FINANCIAL SERVICES, NAMELY, INVESTMENT FUND TRANSFER AND TRANSACTION SERVICES; CARBON CREDIT PROCUREMENT AND CANCELLATION SERVICES, NAMELY, BROKERAGE OF CARBON DIOXIDE AND OTHER GREENHOUSE GAS EMISSION CREDITS, ALLOWANCES OR OFFSETS ON BEHALF OF OFFSET PRODUCERS OR CONSUMERS (U.S. CLS. 100, 101 AND 102).

CLASS 40—MATERIAL TREATMENT

FOR (BASED ON INTENT TO USE) (BASED ON 44E) PRODUCTION OF ENERGY (U.S. CLS. 100, 103 AND 106).

CLASS 41—EDUCATION AND ENTERTAINMENT

FOR (BASED ON INTENT TO USE) (BASED ON 44E) EDUCATION SERVICES, NAMELY, PROVIDING SEMINARS AND WORKSHOPS IN THE FIELD OF ENVIRONMENTAL MATTERS (U.S. CLS. 100, 101 AND 107).

CLASS 42—SCIENTIFIC AND COMPUTER SERVICES

FOR (BASED ON INTENT TO USE) (BASED ON 44E) ENGINEERING SERVICES, NAMELY, CALCULATION OF CARBON EMISSIONS IN ORDER TO REDUCE GREENHOUSE GAS LEVELS IN THE ENVIRONMENT; TECHNICAL ADVISORY SERVICES IN THE FIELD OF EMISSIONS REDUCTION; TECHNOLOGICAL DEVELOPMENT IN THE FIELDS OF ENERGY EFFICIENCY, WASTE MINIMIZATION, RENEWABLE ENERGY AND RESOURCE CONSERVATION; TECHNICAL CONSULTANCY SERVICES IN RELATION TO THE IMPLEMENTATION OF CLIMATE CHANGE AND CARBON MITIGATION PROGRAMS AND TO EMISSION REDUCTION PROJECTS (U.S. CLS. 100 AND 101).

CLASS 44—MEDICAL, BEAUTY AND AGRICULTURAL SERVICES

FOR (BASED ON INTENT TO USE) (BASED ON 44E) HORTICULTURAL SERVICES, NAMELY, PLANTING OF TREES FOR CARBON OFFSETTING PURPOSES; TREE PLANTING; TREE CONSERVATION, NAMELY, COPPING AND SUSTAINABLE HARVESTING (U.S. CLS. 100 AND 101).

BRIAN CALLAGHAN, EXAMINING ATTORNEY

SN 77-754,375. NETMINING LLC, NEW YORK, NY. FILED 6-8-2009.

LIVEMARKETER

THE MARK CONSISTS OF STANDARD CHARACTERS WITHOUT CLAIM TO ANY PARTICULAR FONT, STYLE, SIZE, OR COLOR.

CLASS 35—ADVERTISING AND BUSINESS

FOR ADVERTISING AND MARKETING SERVICES, NAMELY, MONITORING AND TRACKING CONSUMER USAGE OF CLIENT WEBSITES TO ENABLE SUCH CLIENTS TO DEVELOP MARKETING STRATEGIES AND INSIGHTS, MARKETING AND SALES INFORMATION, AND TO UNDERSTAND AND PREDICT CONSUMER PREFERENCES AND BUYING PATTERNS (U.S. CLS. 100, 101 AND 102).

CLASS 42—SCIENTIFIC AND COMPUTER SERVICES

FOR PROVIDING CLIENTS WITH TEMPORARY USE OF NON-DOWNLOADABLE SOFTWARE CONTAINING A PROPRIETARY MARKETING PROFILING ENGINE FOR TRACKING, MONITORING AND GENERATING MARKETING INFORMATION WITH A REAL-TIME VISUALIZATION OF THE CUSTOMERS ON A CLIENT'S WEBSITE FOR ADVERTISING AND MARKETING PURPOSES (U.S. CLS. 100 AND 101).

SUSAN RICHARDS, EXAMINING ATTORNEY

SN 77-760,086. EXACTEARTH LTD., CAMBRIDGE, ONTARIO, CANADA, FILED 6-15-2009.

OWNER OF U.S. REG. NO. 3,506,837.

EXACTEARTH

THE MARK CONSISTS OF STANDARD CHARACTERS WITHOUT CLAIM TO ANY PARTICULAR FONT, STYLE, SIZE, OR COLOR.

PRIORITY CLAIMED UNDER SEC. 44(D) ON CANADA APPLICATION NO. 1441117, FILED 6-10-2009, REG. NO. TMA815,594, DATED 1-16-2012, EXPIRES 1-16-2027.

CLASS 9—ELECTRICAL AND SCIENTIFIC APPARATUS

FOR SOFTWARE FOR MONITORING AND TRACKING MARINE VESSELS VIA SATELLITE; SOFTWARE FOR GATHERING, PROCESSING AND TRANSMITTING MARINE VESSEL POSITION DATA; PRE-RECORDED MAGNETIC DATA CARRIERS CONTAINING MARINE POSITION DATA (U.S. CLS. 21, 23, 26, 36 AND 38).

CLASS 35—ADVERTISING AND BUSINESS

FOR MONITORING AND TRACKING MARINE VESSELS VIA SATELLITE FOR COMMERCIAL PURPOSES; DATA PROCESSING SERVICES, NAMELY, PROCESSING MARINE VESSEL POSITION DATA (U.S. CLS. 100, 101 AND 102).

CLASS 38—COMMUNICATION

FOR SATELLITE TRANSMISSION OF CARRIER SIGNALS CONVEYING MARINE VESSEL POSITION DATA; PROVIDING USERS WITH INTERNET ACCESS, SECURE FTP ACCESS, COMPUTER NETWORK ACCESS, AND TELECOMMUNICATION ACCESS TO CARRIER SIGNALS CONVEYING MARINE VESSEL POSITION DATA; LEASING OF TELECOMMUNICATIONS EQUIPMENT WHICH ENABLES ACCESS TO A NETWORK OF EARTH BASED SATELLITE STATIONS; RENTAL OF ACCESS TIME TO A COMPUTER NETWORK OF EARTH BASED SATELLITE STATIONS (U.S. CLS. 100, 101 AND 104).

CLASS 42—SCIENTIFIC AND COMPUTER SERVICES

FOR COMPUTER SERVICES, NAMELY, ELECTRONICALLY GATHERING, ANALYZING AND FORMATTING POSITION DATA FOR MARINE VESSELS (U.S. CLS. 100 AND 101).

SAIMA MAKHDOOM, EXAMINING ATTORNEY

SN 77-792,368. MILES-BRAMWELL EXECUTIVE SERVICES LIMITED, DERBYSHIRE, UNITED KINGDOM, FILED 7-29-2009.

FREE

THE MARK CONSISTS OF STANDARD CHARACTERS WITHOUT CLAIM TO ANY PARTICULAR FONT, STYLE, SIZE, OR COLOR.

OWNER OF ERPN CMNTY TM OFC REG. NO. 008177081, DATED 12-8-2010, EXPIRES 3-25-2019.

CLASS 16—PAPER GOODS AND PRINTED MATTER

FOR PRINTED MATTER, NAMELY, PRINTED GUIDES, DIARIES, LEAFLETS, PAMPHLETS, BOOKS, BOOKLETS, AND PRINTED TABLES OF INFORMATION ALL RELATING TO SLIMMING, WEIGHT CONTROL, DIET, DIETING, EXERCISE AND HEALTH; PRINTED EXERCISE AND DIETARY SCHEDULES RELATING TO SLIMMING, WEIGHT CONTROL, DIET, DIETING, EXERCISE AND HEALTH; PRINTED CHARTS, PRINTED INFORMATIONAL CARDS ALL IN THE FIELDS OF OR RELATING TO, SLIMMING, WEIGHT CONTROL, DIET, DIETING, EXERCISE AND HEALTH; PRINTED DIRECTORIES OF DIETARY INFORMATION FOR FOOD AND DRINK ITEMS FOR USE IN THE AREAS OF, OR RELATING TO, SLIMMING, WEIGHT CONTROL, DIET, DIETING, EXERCISE AND HEALTH; PAMPHLETS AND CHARTS ALL FOR USE IN THE AREAS OF, OR RELATING TO, SLIMMING, WEIGHT CONTROL, DIET, DIETING, EXERCISE AND HEALTH; RECIPE BOOKS, RECIPE CARDS, RECIPE LEAFLETS, RECIPE BOOKLETS; PUBLICATIONS IN THE NATURE OF BOOKS, MAGAZINES, DIARIES, BROCHURES, LEAFLETS, PAMPHLETS, DIRECTORIES OF DIETARY INFORMATION FOR FOOD AND DRINK ITEMS, GUIDES AND BOOKLETS ALL IN THE AREAS OF, OR RELATING TO, SLIMMING WEIGHT CONTROL, DIET, DIETING, EXERCISE AND HEALTH (U.S. CLS. 2, 5, 22, 23, 29, 37, 38 AND 50).

CLASS 29—MEATS AND PROCESSED FOODS

FOR FOOD PRODUCTS, NAMELY, PREPARED AND PART-PREPARED FOOD PRODUCTS COMPRISED PRIMARILY OF MEAT, FISH, POULTRY, PROCESSED FRUIT AND VEGETABLES; PREPARED MEALS, NAMELY, PRESERVED, CHILLED AND FROZEN MEALS CONSISTING PRIMARILY OF MEAT, FISH, POULTRY, PROCESSED FRUIT AND VEGETABLES; SNACK FOOD PACKAGE COMBINATIONS CONSISTING PRIMARILY OF MEAT, FISH, POULTRY, PROCESSED FRUIT OR VEGETABLES; PREPARED AND PACKAGED FOODS, NAMELY, CHILLED, FROZEN AND PRESERVED MEALS AND FOODS CONSISTING PRIMARILY OF MEAT, FISH, POULTRY, VEGETABLES AND PROCESSED FRUIT; EDIBLE OILS AND FATS; PREPARED AND PACKAGED MEALS, NAMELY, CHILLED AND FROZEN PACKAGED MAIN MEAL MIXES CONSISTING PRIMARILY OF POTATOES; POTATO CRISPS; POTATO CHIPS (U.S. CL. 46).

CLASS 30—STAPLE FOODS

FOR AROMATIC PREPARATIONS OF FOOD, NAMELY, PROCESSED HERBS, SPICES, SPICY SEASONING PASTES AND SAUCES; CARBOHYDRATE PREPARATIONS OF FOOD, NAMELY, POTATO FLOUR, CEREAL FLOUR, CORN FLOUR, RICE FLOUR; FARINACEOUS FOODS, NAMELY, PASTES FOR HUMAN CONSUMPTION, POTATO-BASED PRODUCTS, NAMELY, POTATO FLOUR; FLOUR; CHOCOLATE BASED SNACK BARS, COCOA BASED SNACK BARS, RICE BASED SNACK BARS; PREPARED AND PACKAGED MEALS, NAMELY, CHILLED AND FROZEN MEALS CONSISTING PRIMARILY OF ONE OR MORE OF PASTA, RICE, GRAIN, PROCESSED OATS AND CEREAL; HONEY, TREACLE, YEAST, BAKING POWDER, SALT, MUSTARD, VINEGAR, SAUCES, NAMELY, MEAT SAUCES, NAMELY, BASTING SAUCES, BARBECUE SAUCES, MARINADES, VEGETABLE SAUCES, NAMELY, SAUCES MADE PREDOMINANTLY OF VEGETABLES, SALAD DRESSINGS, SPICES; PRODUCTS CONTAINING MEAT, NAMELY, MEAT PIES, MEAT PASTIES, MEAT PASTRIES, SAUSAGE ROLLS, PORK PIES (U.S. CL. 46).

CLASS 32—LIGHT BEVERAGES

FOR BEERS, MINERAL AND AERATED WATERS AND OTHER NON-ALCOHOLIC DRINKS, NAMELY, NON-ALCOHOLIC BEVERAGES CONTAINING FRUIT JUICE, VEGETABLE JUICE, FRUIT FLAVOURED BEVERAGES, VEGETABLE FLAVOURED BEVERAGES, COLA FLAVOURED BEVERAGES; FRUIT DRINKS AND FRUIT JUICES, SYRUPS AND PREPARATIONS FOR MAKING BEVERAGES, NAMELY, FRUIT DRINKS, VEGETABLE DRINKS; ALL OF THE AFORESAID BEING SOLD TO MEMBERS OF A SLIMMING, DIET, DIETING, EXERCISE AND HEALTH PROGRAM EXCLUSIVELY THROUGH MEMBERSHIP CHANNELS OF TRADE (U.S. CLS. 45, 46 AND 48).

CLASS 41—EDUCATION AND ENTERTAINMENT

FOR TRAINING IN THE NATURE OF PERSONAL, ON-LINE, GROUP AND CLASS BASED TRAINING IN THE FIELDS OF SLIMMING, DIET, DIETING, WEIGHT CONTROL AND HEALTH; EDUCATION AND TRAINING IN THE NATURE OF ARRANGING AND CONDUCTING EDUCATIONAL SEMINARS AND CLASSES RELATING TO SLIMMING, WEIGHT CONTROL, DIET, DIETING, EXERCISE AND HEALTH AND THE DISSEMINATION OF EDUCATIONAL PUBLICATIONS, VIDEOS, DVDS, AND TUTORIALS FOR USE IN CONNECTION THEREWITH; ADVISORY SERVICES AND COUNSELING RELATING TO PHYSICAL EXERCISE (U.S. CLS. 100, 101 AND 107).

CLASS 44—MEDICAL, BEAUTY AND AGRICULTURAL SERVICES

FOR ADVISORY AND COUNSELLING SERVICES RELATING TO AND IN THE FIELDS OF SLIMMING, DIET, DIETING, WEIGHT CONTROL AND HEALTHCARE (U.S. CLS. 100 AND 101).

ASMAT KHAN, EXAMINING ATTORNEY

CLASS 29—MEATS AND PROCESSED FOODS

FOR SOUPS, NAMELY, SOYBEAN BASED, SEITEN, GLUTEN BASED, WHEAT FREE VEGETARIAN, CHICKEN, MEAT, SEAFOOD, FRUIT, DAIRY, NOODLE BASED SOUPS, CONGEE BASED SOUPS, AND VEGETABLE BASED SOUPS; SALADS, NAMELY, VEGETABLE SALADS, FRUIT SALADS, FRUIT AND VEGETABLE SALADS, MEAT SALADS, SEAFOOD SALADS, POMELO SALAD, GRAPEFRUIT SALAD, BEET SALAD, TOFU SALAD, LOTUS ROOT SALAD, CUCUMBER SALAD, MANGO SALAD, PAPAYA SALAD, CHICKEN AND CABBAGE SALAD, GRILLED SHRIMP AND WATERCRESS SALAD; PREPARED ENTREES CONSISTING PRIMARILY OF VEGETABLES, SOUPS, FRUIT SALADS AND VEGETABLE SALADS; PACKAGED COOKED FRUITS AND VEGETABLES; FERMEN- TED VEGETABLES; PICKLED VEGETABLES; PICKLED VEGETABLES IN SOY SAUCE, SOYBEAN PASTE OR VINEGAR; PRESERVED FRUITS AND VEGETABLES; PROCESSED VEGETABLES, NAMELY, COOKED CUCUMBER, DAIKON, MUSHROOMS, BELLFLOWER ROOT, SPINACH, SOYBEAN SPROUTS AND BRACKEN FERN STEMS; VEGETABLE YOGURTS; PACKAGED READY-TO-EAT MEALS CONSISTING PRIMARILY OF SEAFOOD, POULTRY, MEAT, GAME, AND VEGETARIAN PRODUCTS; VEGETARIAN PRODUCTS, NAMELY, PROCESSED SOY BEANS, SEITAN, PROCESSED VEGETABLES, TOFU, AND TEMPEH; PREPARED AND PACKAGED VEGETABLE-BASED ENTREES; PREPARED MEALS CONSISTING PRIMARILY OF MEAT, FISH, POULTRY OR VEGETABLES; PREPARED VEGETABLE-BASED ENTREES; COMBINATION MEALS CONSISTING PRIMARILY OF A MEAT OR VEGETABLE-BASED ENTRÉE AND A SOUP OR SALAD; SEAFOOD, POULTRY, MEAT, AND GAME; DAIRY-BASED BEVERAGES; FRUIT-BASED FOOD BEVERAGE; MILK BASED BEVERAGES CONTAINING FRUIT JUICE; MILK BEVERAGES CONTAINING FRUITS; BAKERY DESSERTS CONSISTING OF FRUIT AND CREAM OR CREAM SUBSTITUTES; NUT PRODUCTS, NAMELY, BLANCHED NUTS, CANDIED NUTS, NUT TOPPING, PREPARED NUTS, ROASTED NUTS, SEASONED NUTS, AND SHELLED NUTS; PREPARED ENTREES CONSISTING PRIMARILY OF VEGETABLES, SOUPS, FRUIT SALADS AND VEGETABLE SALADS; COOKED FRUITS AND VEGETABLES; CUT FRUITS PACKAGED IN PLASTIC CUPS; DEHYDRATED FRUIT SNACKS; DRIED FRUIT AND VEGETABLES; FRUITS IN PRESERVED FORM; FRUIT-BASED FOOD BEVERAGE; FRUIT-BASED SNACK FOOD; MILK BASED BEVERAGES CONTAINING FRUIT JUICE; PICKLED FRUITS (U.S. CL. 46).

FIRST USE 12-15-2008; IN COMMERCE 12-15-2008.

SN 77-805,767. MY LINH A TASTE OF VIETNAM, INC., ALBANY, NY. FILED 8-17-2009.

mỹ linh
a taste of vietnam

NO CLAIM IS MADE TO THE EXCLUSIVE RIGHT TO USE "VIETNAM", APART FROM THE MARK AS SHOWN.

THE MARK CONSISTS OF THE WORDS, "MY LINH", DISPOSED ABOVE THE WORDS, "A TASTE OF VIETNAM", ALL IN LOWERCASE LETTERS, THE LETTERS IN "MY LINH" ARE IN A FONT ABOUT TRIPLE THE SIZE OF THAT OF "A TASTE OF VIETNAM". THE LETTER, "Y", IN "MY" HAS A TILDE ABOVE IT.

THE ENGLISH TRANSLATION OF "MY LINH" IN THE MARK IS "BEAUTIFUL LINH" OR "AMERICAN LINH".

CLASS 30—STAPLE FOODS

FOR DRIED HERBS; EXTRACTS USED AS FLAVORINGS, NAMELY, VANILLA EXTRACT, PANDAN EXTRACT; VIETNAMESE DELI PRODUCTS, NAMELY, SUMMER ROLLS, SPRING ROLLS, AND SANDWICHES; PREPARED FOOD PRODUCTS, NAMELY, VERMICELLI NOODLES AND RICE; BEVERAGES, NAMELY, COFFEE, TEA, HOT OR ICED COFFEE WITH CREAM, MILK, OR CONDENSED MILK, HOT OR ICED TEAS WITH CREAM, MILK, OR CONDENSED MILK; TEA-BASED BEVERAGES WITH FRUIT FLAVORING; DESSERTS, NAMELY, FLAN OR EGG CUSTARDS, CAKE, PASTRY, COOKIES; DESSERT PUDDINGS; FLAVORED, SWEETENED GELATIN DESSERTS; MAIZE-BASED PUDDING DESSERT (MAZAMORRA MORADA); RICE-BASED PUDDING DESSERT; FROZEN YOGURT WITH FRUIT TOPPING; COCONUT EXTRACT (U.S. CL. 46).

FIRST USE 12-15-2008; IN COMMERCE 12-15-2008.

KATHERINE STOIDES, EXAMINING ATTORNEY

SN 77-854,616. WOMBLE CARLYLE SANDRIDGE & RICE, PLLC, WINSTON-SALEM, NC. FILED 10-22-2009.



OWNER OF U.S. REG. NOS. 2,150,427, 2,151,979 AND 2,151,980.

NO CLAIM IS MADE TO THE EXCLUSIVE RIGHT TO USE "ECOLOGY INNOVATIONS, LLC", APART FROM THE MARK AS SHOWN.

THE MARK CONSISTS OF THE WORDS "WOMBLE CARLYLE ECOLOGY INNOVATIONS, LLC" AND A TRIANGULAR DESIGN WITH A SCALLOPED EDGE CONTAINING THE IMAGE OF TWO CATTAILS.

CLASS 35—ADVERTISING AND BUSINESS

FOR ENVIRONMENTAL MITIGATION BANKING SERVICES FOR OTHERS, NAMELY, REVIEW OF LAND, WATER, WETLAND AND OTHER NATURAL RESOURCE SITE SELECTIONS FOR ECOLOGICAL, CONSERVATION AND ENVIRONMENTAL PURPOSES; ANALYSIS OF SITE SELECTION REVIEW TESTING RESULTS THEREFOR, AND VALUATION ASSESSMENT OF SUCH LAND, WATER, WETLANDS, AND OTHER NATURAL RESOURCES TO DETERMINE THE VIABILITY FOR ECOLOGICAL DEVELOPMENT PURPOSES; ENVIRONMENTAL MITIGATION BANKING SERVICE FOR OTHERS, NAMELY, ARRANGING AND NEGOTIATING CONTRACTS WITH LANDOWNERS FOR THE SALE OF CREDITS, NAMELY, CONSERVATION, ECOLOGICAL, AND ENVIRONMENTAL CREDITS, FOR ECOLOGICAL REMEDIATION AND DEVELOPMENT AS COMPENSATION AND MITIGATION FOR RESOURCE LOSSES CAUSED BY AREA DEVELOPMENT FOR NON-ECOLOGICAL USES; ENVIRONMENTAL MITIGATION BANKING SERVICES FOR OTHERS, NAMELY, ARRANGING AND NEGOTIATING CONTRACTS WITH LANDOWNERS FOR THE SALE OF WETLAND AND HABITAT CREDITS, NAMELY, CONSERVATION, ECOLOGICAL, AND ENVIRONMENTAL CREDITS, WITH OTHER RELATED ENVIRONMENTAL BENEFITS (U.S. CLS. 100, 101 AND 102).

CLASS 37—CONSTRUCTION AND REPAIR

FOR NATURAL RESOURCE PRESERVATION SERVICES IN THE NATURE OF PROVIDING ALTERNATE MANDATORY HABITAT SET ASIDE AREAS THROUGH THE RECLAMATION OF LAND, WETLANDS, WATER, AND OTHER NATURAL RESOURCES TO ENHANCE AND PROTECT ENVIRONMENTALLY SENSITIVE HABITATS AS COMPENSATION AND MITIGATION FOR RESOURCE LOSS CAUSED BY AREA DEVELOPMENT FOR NON-ECOLOGICAL USE (U.S. CLS. 100, 103 AND 106).

CLASS 42—SCIENTIFIC AND COMPUTER SERVICES

FOR ENVIRONMENTAL MITIGATION BANKING SERVICES, ENVIRONMENTAL HABITAT DEVELOPMENT AND PRESERVATION SERVICES, NAMELY, MONITORING, TESTING AND ANALYZING ECOLOGICAL SUCCESS IN THE ENVIRONMENTAL FIELD, TO DETERMINE THE VIABILITY OF UNUSED LAND AND OTHER NATURAL RESOURCES FOR ECOLOGICAL DEVELOPMENT PURPOSES (U.S. CLS. 100 AND 101).

CLASS 45—PERSONAL AND LEGAL SERVICES

FOR ADVICE AND CONSULTANCY ON ENVIRONMENTAL REGULATORY MATTERS (U.S. CLS. 100 AND 101).

BILL DAWE, EXAMINING ATTORNEY

SN 77-866,361. EDUCATION RESOURCES, LLC, PHOENIX, AZ. FILED 11-5-2009.



NO CLAIM IS MADE TO THE EXCLUSIVE RIGHT TO USE "ACADEMY", APART FROM THE MARK AS SHOWN.

THE MARK CONSISTS OF THE BLOCK LETTER WORDS "STARSHINE ACADEMY" BELOW A SILHOUETTE OF A CHILD WALKING, CARRYING A BAG AND SPRINKLING STARS.

CLASS 16—PAPER GOODS AND PRINTED MATTER

FOR CALENDARS AND NOTEBOOKS (U.S. CLS. 2, 5, 22, 23, 29, 37, 38 AND 50).

FIRST USE 1-31-2003; IN COMMERCE 1-31-2003.

CLASS 25—CLOTHING

FOR T-SHIRTS, SWEATSHIRTS, CAPS (U.S. CLS. 22 AND 39).

FIRST USE 8-31-2002; IN COMMERCE 8-31-2002.

CLASS 41—EDUCATION AND ENTERTAINMENT

FOR PROVIDING COURSES OF INSTRUCTION FOR STUDENTS AT THE ELEMENTARY, MIDDLE SCHOOL LEVELS AND HIGH SCHOOL LEVELS IN THE FIELDS OF MATHEMATICS, HISTORY, LANGUAGE ARTS AND OTHER SUBJECT MATTERS, WITHIN CHARTER SCHOOLS AT GRADE LEVELS K-12 (U.S. CLS. 100, 101 AND 107).

FIRST USE 8-31-2002; IN COMMERCE 8-31-2002.

WARREN L. OLANDRIA, EXAMINING ATTORNEY

SN 77-878,087. HERO CLUB LIMITED, LONDON, UNITED KINGDOM, FILED 11-20-2009.

HERO

THE MARK CONSISTS OF STANDARD CHARACTERS WITHOUT CLAIM TO ANY PARTICULAR FONT, STYLE, SIZE, OR COLOR.

CLASS 6—METAL GOODS

FOR METAL ORNAMENTS, NAMELY, METAL KEY RINGS; METAL KEY FOBS; METAL NAME BADGES AND BADGE MOUNTINGS (U.S. CLS. 2, 12, 13, 14, 23, 25 AND 50).

CLASS 9—ELECTRICAL AND SCIENTIFIC APPARATUS

FOR APPARATUS FOR RECORDING, TRANSMISSION OR REPRODUCTION OF SOUND OR IMAGES; BLANK MAGNETIC DATA CARRIERS AND RECORDING DISCS; DATA PROCESSORS AND COMPUTERS; FIRE-EXTINGUISHERS; PRE-RECORDED ELECTRONIC MEDIA FEATURING MOTOR SPORTS; COMPUTER HARDWARE AND FIRMWARE; COMPUTER SOFTWARE FOR USE IN CONNECTION WITH THE PROMOTION OF AND PARTICIPATION IN ORGANIZED EVENTS IN THE FIELD OF MOTOR SPORTS; SOFTWARE DOWNLOADABLE FROM THE INTERNET FOR USE IN CONNECTION WITH THE PROMOTION OF AND PARTICIPATION IN ORGANIZED EVENTS IN THE FIELD OF MOTOR SPORTS; DOWNLOADABLE ELECTRONIC PUBLICATIONS IN THE NATURE OF MAGAZINES, NEWSLETTERS AND PERIODICAL IN THE FIELD OF MOTOR SPORTS AND CLASSIC AUTOMOBILES; COMPACT DISCS FEATURING MOTOR SPORTS; DIGITAL MUSIC DOWNLOADABLE FROM THE INTERNET; TELECOMMUNICATIONS APPARATUS, NAMELY, MOBILE PHONES, PDAS AND HAND HELD COMPUTERS; COMPUTER GAMES EQUIPMENT ADAPTED FOR USE WITH AN EXTERNAL DISPLAY SCREEN OR MONITOR; MOUSE MATS; MOBILE PHONE ACCESSORIES, NAMELY, HEADPHONES, EAR JACKS AND MOBILE PHONE COVERS; CONTACT LENSES, SPECTACLES AND SUNGLASSES; CLOTHING FOR PROTECTION AGAINST INJURY, ACCIDENT, IRRADIATION OR FIRE; COMPACT DISC AND DVD CASES (U.S. CLS. 21, 23, 26, 36 AND 38).

CLASS 14—JEWELRY

FOR CLOCKS, WATCHES, WATCH BRACELETS, WATCH CHAINS, JEWELRY; ARTICLES MADE OF PRECIOUS STONES, AND ARTICLES MADE OF PRECIOUS METALS OR COATED THEREWITH, NAMELY, PLATES, CUPS, MEDALS; CUFFLINKS, TIE PINS, TIE FASTENERS; PENDANTS (U.S. CLS. 2, 27, 28 AND 50).

CLASS 16—PAPER GOODS AND PRINTED MATTER

FOR PAPER, CARDBOARD PRINTED MATTER, NAMELY, BOOKS, PERIODICALS, MAGAZINES, NEWSLETTERS, LEAFLETS, MAPS, NEWSPAPERS; BOOK BINDING MATERIAL; PHOTOGRAPHS; STATIONERY; ADHESIVES FOR STATIONERY OR HOUSEHOLD PURPOSES; ARTISTS' MATERIALS, NAMELY, BRUSHES, PASTELS PENCILS, PENS, CANVAS PANELS; PAINT BRUSHES; TYPEWRITERS; PRINTERS' TYPE; PRINTING BLOCKS; DISPOSABLE NAPPIES OF PAPER FOR BABIES; PRINTED PUBLICATIONS, NAMELY, BOOKS, PERIODICALS, MAGAZINES, NEWSLETTERS, LEAFLETS, MAPS, NEWSPAPERS ON THE SUBJECT OF MOTOR SPORTS; PAINT BOXES FOR CHILDREN; CHECK BOOK HOLDERS (U.S. CLS. 2, 5, 22, 23, 29, 37, 38 AND 50).

CLASS 18—LEATHER GOODS

FOR BAGS, NAMELY, BACKPACKS, GARMENT BAGS FOR TRAVEL, TRAVELLING BAGS, CARRY BAGS, TOTE BAGS; POCKET WALLETS, KEY FOBS MADE OF LEATHER OR OF IMITATION LEATHER AND PURSES NOT OF PRECIOUS METALS AND NOT COATED THEREWITH; LUGGAGE; UMBRELLAS (U.S. CLS. 1, 2, 3, 22 AND 41).

CLASS 21—HOUSEWARES AND GLASS

FOR TANKARDS, GOBLETS, SERVING TRAYS; FLASKS AND DISHES, ALL BEING DOMESTIC UTENSILS OR CONTAINERS AND NONE OF PRECIOUS METALS OR COATED THEREWITH; DRINKING GLASSES, DECANTERS, MUGS, BRUSHES, NAMELY, HAIR BRUSHES, CLOTHES BRUSHES, SWEEPING AND HAND BRUSHES; COMBS; CHINA AND GLASS ORNAMENTS (U.S. CLS. 2, 13, 23, 29, 30, 33, 40 AND 50).

CLASS 25—CLOTHING

FOR CLOTHING, NAMELY, ANORAKS, BATHROBES, BEACHWEAR, BELTS, BERMUDA SHORTS, BLAZERS, BLOUSES, BOARD SHORTS, BOXER BRIEFS, BOXER SHORTS, BRIEFS, CARDIGANS, COATS, DRESSES, FLEECE JACKETS, FLEECE PULLOVERS, FLEECE SHORTS, FOUL WEATHER GEAR, GAITERS, GALOSHES, GLOVES, HOSIERY, SOCKS, JACKETS, JEANS, JERKINS, JERSEYS, JOGGING PANTS, JOGGING SUITS, LIGHT REFLECTING COATS AND JACKETS, JUMPERS, JUMPSUITS, KNICKERS, LOUNGEWEAR, PAJAMAS, PANTIES, PANTS, PARKAS, POLO SHIRTS, PULLOVERS, RAINWEAR, SCARVES, SHIRTS, SHORTS, SHORT-SLEEVED OR LONG-SLEEVED T-SHIRTS, SWEAT SHIRTS, SWEAT PANTS, TANK TOPS, TIGHTS, TOP COATS, TROUSERS, UNDERCLOTHES, UNDERPANTS, UNDERSHIRTS, UNDERWEAR, VESTS, WATERPROOF JACKETS AND PANTS, WIND COATS, WIND RESISTANT JACKETS; FOOTWEAR; HEADWEAR (U.S. CLS. 22 AND 39).

CLASS 26—FANCY GOODS

FOR ORNAMENTAL NOVELTY BADGES FOR WEAR, ORNAMENTS FOR PERSONAL WEAR, NAMELY, HAIR AND SHOE ORNAMENTS; BUCKLES AND BUTTONS, ALL IN THE NATURE OF CLOTHING FASTENERS; BROOCHES AND, ALL BEING CLOTHING ACCESSORIES OTHER THAN JEWELRY; NONE MADE OF PRECIOUS METALS OR COATED THEREWITH (U.S. CLS. 37, 39, 40, 42 AND 50).

CLASS 34—SMOKERS' ARTICLES

FOR TOBACCO; SMOKERS' ARTICLES, NAMELY, MATCH BOOKS, CIGARETTE HOLDERS, CIGARETTE BOXES, CIGARETTE-MAKING MACHINES, TOBACCO POUCHES, MATCHES (U.S. CLS. 2, 8, 9 AND 17).

CLASS 37—CONSTRUCTION AND REPAIR

FOR REPAIR AND MAINTENANCE SERVICES, ALL RELATING TO VEHICLES; EMERGENCY ROADSIDE ASSISTANCE SERVICES, NAMELY, RESPONDING TO CALLS FOR ROADSIDE ASSISTANCE, FLAT TIRE CHANGING, EMERGENCY FUEL SUPPLYING, AND BATTERY JUMP STARTING (U.S. CLS. 100, 103 AND 106).

CLASS 41—EDUCATION AND ENTERTAINMENT

FOR ENTERTAINMENT SERVICES, NAMELY, CONDUCTING ENTERTAINMENT EXHIBITIONS IN THE NATURE OF AUTOMOTIVE VEHICLE DISPLAYS AND DEMONSTRATIONS; ARRANGING AND CONDUCTING COMPETITIONS FOR MOTOR SPORTS; SPORTING AND CULTURAL ACTIVITIES, NAMELY, AUTOMOTIVE TOURS, RACES AND RALLIES (U.S. CLS. 100, 101 AND 107).

LINDA MICKLEBURGH, EXAMINING ATTORNEY

SN 77-898,133. TAYLOR PRECISION PRODUCTS, INC., OAK BROOK, IL. FILED 12-21-2009.



OWNER OF U.S. REG. NOS. 2,272,833, 2,362,880 AND 2,914,144.

NO CLAIM IS MADE TO THE EXCLUSIVE RIGHT TO USE "GREEN", APART FROM THE MARK AS SHOWN.

THE MARK CONSISTS OF GREEN LIVING IN LOWER CASE LETTERS. THE "L" IN "LIVING" IS COMPRISED OF A STEM OF A PLANT WITH TWO LEAVES AT THE TOP OF IT. BENEATH THE "GREEN LIVING" PORTION OF THE MARK IS THE PHRASE "BY TAYLOR", WITH THE "BY" PORTION IN LOWER CASE LETTERS AND THE "TAYLOR" PORTION IN CAPITAL LETTERS. INSIDE THE "O" OF "TAYLOR" A TRIANGLE IS LOCATED IN THE UPPER HALF.

CLASS 9—ELECTRICAL AND SCIENTIFIC APPARATUS

FOR BATH SCALES, COMPOST THERMOMETERS, SUN METERS, NAMELY, AN APPARATUS FOR MEASURING THE AMOUNT OF SUNLIGHT THAT FALLS ON A PARTICULAR LOCATION, SOIL PH METERS, GREENHOUSE THERMOMETERS, HYGROMETERS, AND AUTOMATIC WATERING SYSTEMS COMPRISING AUTOMATIC VALVES (U.S. CLS. 21, 23, 26, 36 AND 38).

CLASS 11—ENVIRONMENTAL CONTROL APPARATUS

FOR SOLAR LAMPS; AUTOMATIC IRRIGATION SYSTEMS, COMPRISING VALVES, FILTERS, AND REGULATORS (U.S. CLS. 13, 21, 23, 31 AND 34).

CLASS 12—VEHICLES

FOR FOLDING WHEELBARROWS (U.S. CLS. 19, 21, 23, 31, 35 AND 44).

CLASS 19—NON-METALLIC BUILDING MATERIALS

FOR PRE-FABRICATED NON-METAL GREENHOUSES; RAISED GARDEN BEDS, NAMELY, PRE-FABRICATED NON-METAL STRUCTURES USED TO MAKE RAISED GARDEN BEDS (U.S. CLS. 1, 12, 33 AND 50).

CLASS 20—FURNITURE AND ARTICLES NOT OTHERWISE CLASSIFIED

FOR NON-METAL COMPOST BINS AND NON-METAL RAIN BARRELS (U.S. CLS. 2, 13, 22, 25, 32 AND 50).

CLASS 21—HOUSEWARES AND GLASS

FOR RAISED GARDEN BEDS, NAMELY, RAISED PLASTIC CONTAINERS FOR PLANTING CONTAINED GARDENS (U.S. CLS. 2, 13, 23, 29, 30, 33, 40 AND 50).
KELLY BOULTON, EXAMINING ATTORNEY

SN 77-907,898. ALTAIR ENGINEERING, INC., TROY, MI. FILED 1-8-2010.

INNOVATION INTELLIGENCE QUOTIENT

THE MARK CONSISTS OF STANDARD CHARACTERS WITHOUT CLAIM TO ANY PARTICULAR FONT, STYLE, SIZE, OR COLOR.

OWNER OF U.S. REG. NO. 3,399,656.

CLASS 35—ADVERTISING AND BUSINESS

FOR BUSINESS CONSULTING SERVICES IN THE FIELD OF EVALUATION OF APPLICATION OF TECHNOLOGY TO ALL ASPECTS OF BUSINESS (U.S. CLS. 100, 101 AND 102).

CLASS 42—SCIENTIFIC AND COMPUTER SERVICES

FOR ENGINEERING CONSULTATION SERVICES IN THE FIELD OF ENGINEERING AND INFORMATION TECHNOLOGY; ENGINEERING RESEARCH AND DESIGN FOR OTHERS IN THE FIELDS OF ENGINEERING AND INFORMATION TECHNOLOGY; CONSULTATION IN THE FIELD OF COMPUTER-BASED INFORMATION SYSTEMS FOR BUSINESSES (U.S. CLS. 100 AND 101).
KAELE KUNG, EXAMINING ATTORNEY

SN 77-923,762. ROBINSON, MARK, DBA JUVENATE BRANDS, LAKE WORTH, FL. FILED 1-29-2010.

Juvenate

THE MARK CONSISTS OF STANDARD CHARACTERS WITHOUT CLAIM TO ANY PARTICULAR FONT, STYLE, SIZE, OR COLOR.

CLASS 3—COSMETICS AND CLEANING PREPARATIONS

FOR ANTI-AGING CREAM; ANTI-AGING CREAMS; ANTI-AGING MOISTURIZER; ANTI-AGING TONER; ANTI-WRINKLE CREAMS (U.S. CLS. 1, 4, 6, 50, 51 AND 52).

CLASS 5—PHARMACEUTICALS

FOR DIETARY AND NUTRITIONAL SUPPLEMENTS; DIETARY BEVERAGE SUPPLEMENTS FOR HUMAN CONSUMPTION IN LIQUID AND DRY MIX FORM FOR THERAPEUTIC PURPOSES; DIETARY SUPPLEMENTAL DRINKS IN THE NATURE OF VITAMIN AND MINERAL BEVERAGES; LIQUID NUTRITIONAL SUPPLEMENT; NUTRITIONAL ENERGY BARS FOR USE AS A MEAL SUBSTITUTE; NUTRITIONAL FOOD BARS FOR USE AS A MEAL REPLACEMENT; NUTRITIONAL SHAKES FOR USE AS A MEAL SUBSTITUTE; NUTRITIONAL SUPPLEMENTS; NUTRITIONALLY FORTIFIED BEVERAGES; NUTRITIONALLY FORTIFIED WATER; VITAMIN ENRICHED WATER; VITAMIN FORTIFIED BEVERAGES (U.S. CLS. 6, 18, 44, 46, 51 AND 52).

CLASS 32—LIGHT BEVERAGES

FOR BEAUTY BEVERAGES, NAMELY, FRUIT JUICES AND ENERGY DRINKS CONTAINING NUTRITIONAL SUPPLEMENTS; BOTTLED ARTESIAN WATER; BOTTLED DRINKING WATER; BOTTLED WATER; DRINKING WATER; DRINKING WATER WITH VITAMINS; DRINKING WATERS (U.S. CLS. 45, 46 AND 48).

CLASS 44—MEDICAL, BEAUTY AND AGRICULTURAL SERVICES

FOR COUNSELING SERVICES IN THE FIELDS OF HEALTH, NUTRITION AND LIFESTYLE WELLNESS; DIETARY AND NUTRITIONAL GUIDANCE; PROVIDING A WEB SITE FEATURING EDUCATIONAL INFORMATION REGARDING NUTRITION AND GENETICS; PROVIDING A WEB SITE FEATURING INFORMATION ON HEALTH AND NUTRITION; PROVIDING A WEB SITE THAT FEATURES INFORMATION ON CHILDREN'S NUTRITION; PROVIDING AN ON-LINE COMPUTER DATABASE FEATURING INFORMATION REGARDING HEALTH AND NUTRITION; PROVIDING ASSISTANCE, FITNESS EVALUATION AND CONSULTATION TO INDIVIDUALS TO HELP THEM MAKE HEALTH, WELLNESS AND NUTRITIONAL CHANGES IN THEIR DAILY LIVING TO IMPROVE HEALTH; PROVIDING HEALTHY LIFESTYLE AND NUTRITION SERVICES, NAMELY, PERSONAL ASSESSMENTS, PERSONALIZED ROUTINES, MAINTENANCE SCHEDULES, AND COUNSELING; PROVIDING INFORMATION ABOUT DIETARY SUPPLEMENTS AND NUTRITION (U.S. CLS. 100 AND 101).

VERNA BETH RIRIE, EXAMINING ATTORNEY

CLASS 41—EDUCATION AND ENTERTAINMENT

FOR EDUCATION SERVICES, NAMELY, PROVIDING SEMINARS AND WORKSHOPS IN THE FIELD OF MUSIC; TRAINING SERVICES IN THE FIELD OF MUSIC; TEACHING IN THE FIELD OF MUSIC; MAGAZINE PUBLISHING AND NEWSPAPER PUBLISHING; PUBLICATION OF TEXTS, BOOKS, MAGAZINES AND OTHER PRINTED MATTER (U.S. CLS. 100, 101 AND 107).

SANJEEV VOHRA, EXAMINING ATTORNEY

SN 79-077,712. SARL ELEOUSA, FRANCE, FILED 9-25-2009.



SN 79-012,662. PURE MUSIC SPRL, BELGIUM, FILED 2-21-2005.

Avanticlassic

THE MARK CONSISTS OF STANDARD CHARACTERS WITHOUT CLAIM TO ANY PARTICULAR FONT, STYLE, SIZE, OR COLOR.

PRIORITY DATE OF 9-1-2004 IS CLAIMED.

OWNER OF INTERNATIONAL REGISTRATION 0854935 DATED 2-21-2005, EXPIRES 2-21-2015.

CLASS 9—ELECTRICAL AND SCIENTIFIC APPARATUS

FOR APPARATUS FOR RECORDING, TRANSMITTING AND REPRODUCING SOUND OR IMAGES; BLANK MEDIA FOR RECORDING SOUND, VIDEO, MULTIMEDIA AND COMPUTING FILES FOR INTERACTIVE OR OTHER USE, NAMELY, BLANK TAPES, BLANK CD'S, BLANK CD-ROMS FOR SOUND AND IMAGE RECORDING; PRERECORDED CD'S, VIDEO TAPES, LASER DISKS AND DVD'S FEATURING MUSIC, CONCERTS AND MUSICAL EVENTS; DATA PROCESSING EQUIPMENT, NAMELY, DATA PROCESSORS; COMPUTERS; MUSICAL COMPILATIONS, NAMELY, MUSICAL SOUND RECORDINGS; COMPUTER SOFTWARE USED IN DATABASE MANAGEMENT IN THE FIELD OF MUSIC, THAT MAY BE DOWNLOADED FROM A GLOBAL COMPUTER NETWORK (U.S. CLS. 21, 23, 26, 36 AND 38).

CLASS 35—ADVERTISING AND BUSINESS

FOR ADVERTISING AND PUBLICITY SERVICES; BUSINESS MANAGEMENT SERVICES, BUSINESS MANAGEMENT SERVICES OFFERED VIA THE INTERNET; PUBLIC RELATIONS; ADVERTISING AND PROMOTION SERVICES AND RELATED CONSULTING, BUSINESS MARKETING AND DIRECT MAIL CONSULTING SERVICES RELATING TO MUSICAL PRODUCTION; BUSINESS MANAGEMENT SERVICES FOR PERFORMING ARTISTS (U.S. CLS. 100, 101 AND 102).

PRIORITY DATE OF 5-29-2009 IS CLAIMED.

OWNER OF INTERNATIONAL REGISTRATION 1025996 DATED 9-25-2009, EXPIRES 9-25-2019.

THE COLOR(S) YELLOW, WHITE, BLUE, DARK BLUE AND LIGHT BLUE IS/ARE CLAIMED AS A FEATURE OF THE MARK.

THE MARK CONSISTS OF THE STYLIZED WORDING "THEOTOKOS", WITH "THEO" APPEARING IN DARK BLUE AND "TOKOS" APPEARING IN LIGHT BLUE; BENEATH THE WORDING "THEOTOKOS" APPEARS THE STYLIZED WORDING "LA RENCONTRE TOUT SIMPLEMENT" IN THE COLOR BLUE; TO THE LEFT OF ALL AFOREMENTIONED APPEARS A DESIGN FEATURING TWO ROUGHLY RECTANGULAR UPRIGHT SHAPES WITH EACH HAVING A NOTCH IN THE SIDE FACING THE OTHER RECTANGULAR ELEMENT AND EACH HAVING AN INTERIOR CIRCLE ABOVE THE NOTCHED PORTION; THE LEFT RECTANGULAR DESIGN APPEARS IN THE COLOR DARK BLUE WITH A YELLOW CIRCLE DESIGN AND THE RIGHT RECTANGULAR DESIGN APPEARS IN THE COLOR LIGHT BLUE WITH A WHITE CIRCLE DESIGN.

THE ENGLISH TRANSLATION OF "LA RENCONTRE TOUT SIMPLEMENT" IN THE MARK IS "SO THAT EACH ENCOUNTER MAKES SENSE".

CLASS 35—ADVERTISING AND BUSINESS

FOR BUSINESS MANAGEMENT; BUSINESS ADMINISTRATION; BUSINESS MANAGEMENT AND ORGANIZATION CONSULTANCY; DOCUMENT REPRODUCTION; EMPLOYMENT AGENCIES; COMPUTERIZED FILE MANAGEMENT; ORGANIZATION OF EXHIBITIONS FOR COMMERCIAL OR ADVERTISING PURPOSES; ONLINE ADVERTISING ON A COMPUTER NETWORK; RENTAL OF ADVERTISING TIME ON ANY COMMUNICATION MEDIA; PUBLICATION OF ADVERTISING TEXTS; RENTAL OF ADVERTISING SPACE; DISSEMINATION OF ADVERTISING MATTER; PUBLIC RELATIONS (U.S. CLS. 100, 101 AND 102).

CLASS 38—COMMUNICATION

FOR PROVIDING ACCESS TO A GLOBAL COMPUTER NETWORK; RENTAL OF TELECOMMUNICATION APPARATUS; TELECONFERENCING SERVICES; ELECTRONIC MESSAGING SERVICES, PROVIDING A DEDICATED AND PRIVATE E-MAIL BOX TO USERS; RENTAL OF ACCESS TIME TO GLOBAL COMPUTER NETWORKS (U.S. CLS. 100, 101 AND 104).

CLASS 41—EDUCATION AND ENTERTAINMENT

FOR PUBLICATION OF BOOKS; LENDING LIBRARIES; VIDEOTAPE FILM PRODUCTION; RENTAL OF MOTION PICTURES; RENTAL OF SOUND RECORDINGS; RENTAL OF VIDEO CASSETTE RECORDERS OR OF RADIO AND TELEVISION SETS; VIDEOTAPE EDITING; PHOTOGRAPHY SERVICES; BOOKING OF SEATS FOR SHOWS; PROVIDING ONLINE GAMES ON A COMPUTER NETWORK; GAMBLING SERVICES; ELECTRONIC PUBLISHING OF BOOKS AND PERIODICALS ONLINE (U.S. CLS. 100, 101 AND 107).

CLASS 42—SCIENTIFIC AND COMPUTER SERVICES

FOR DESIGN AND DEVELOPMENT OF COMPUTER HARDWARE AND SOFTWARE; RESEARCH AND DEVELOPMENT OF NEW PRODUCTS FOR THIRD PARTIES; COMPUTER PROGRAMMING; COMPUTER CONSULTING; CONVERSION OF COMPUTER PROGRAMS AND DATA OTHER THAN PHYSICAL CONVERSION; CONVERSION OF DATA OR DOCUMENTS FROM PHYSICAL TO ELECTRONIC MEDIA; GRAPHIC ARTS DESIGNING (U.S. CLS. 100 AND 101).

CLASS 45—PERSONAL AND LEGAL SERVICES

FOR MARRIAGE BUREAUS; HOROSCOPE CASTING (U.S. CLS. 100 AND 101).
DAVID HOFFMAN, EXAMINING ATTORNEY

SN 79-082,157. EWM HIGHTEC WELDING GMBH, 56271 MÜNDERSBACH, FED REP GERMANY, FILED 1-5-2010.

CENTRO TIG

THE MARK CONSISTS OF STANDARD CHARACTERS WITHOUT CLAIM TO ANY PARTICULAR FONT, STYLE, SIZE, OR COLOR.

PRIORITY DATE OF 7-30-2009 IS CLAIMED.
OWNER OF INTERNATIONAL REGISTRATION 1037562 DATED 1-5-2010, EXPIRES 1-5-2020.

NO CLAIM IS MADE TO THE EXCLUSIVE RIGHT TO USE "TIG", APART FROM THE MARK AS SHOWN.

CLASS 7—MACHINERY

FOR MACHINES, NAMELY, SOLDERING AND WELDING AND CUTTING MACHINES; ACCESSORIES FOR SOLDERING AND WELDING MACHINES AND CUTTING MACHINES, NAMELY, FOR CONVEYORS AND ELECTRICALLY OPERATED SUCTION TABLES AND TABLES SPECIALLY ADAPTED TO HOLD POWERED MACHINERY FOR MONITORING AND ADJUSTING WORK-PIECES PRODUCED BY SOLDERING AND WELDING MACHINES AND COOLING MODULES FOR SOLDERING AND WELDING MACHINES; AUTOMATED FILLER WIRE FEED DEVICES, NAMELY, AN ELECTRIC WELDING WIRE FEEDER FOR SOLDERING AND WELDING MACHINES; CUTTING TORCHES; ELECTRIC ARC WELDING TORCHES (U.S. CLS. 13, 19, 21, 23, 31, 34 AND 35).

CLASS 9—ELECTRICAL AND SCIENTIFIC APPARATUS

FOR ELECTRIC SOLDERING AND WELDING APPARATUS, ARC-SOLDERING AND ARC-WELDING APPARATUS AND ACCESSORIES THEREFOR, NAMELY, AN ELECTRIC WELDING POWER SOURCE CONSISTING OF A TRANSFORMER, ELECTRICAL CURRENT REDRESSERS, AND ELECTRONIC CONTROLS FOR CONTROLLING THE ELECTRIC CURRENT USED FOR WELDING AND FOR SELECTING WELDING PARAMETERS, NAMELY, ELECTRIC CURRENT, TENSION, AND WELDING METHOD, ELECTRODES, AND REMOTE CONTROLS; WELDING TORCHES (U.S. CLS. 21, 23, 26, 36 AND 38).

CLASS 40—MATERIAL TREATMENT

FOR SOLDERING AND WELDING (U.S. CLS. 100, 103 AND 106).
RAMONA ORTIGA, EXAMINING ATTORNEY

SN 79-083,584. KABUSHIKI KAISHA DEI RAITSU KURIEI-TIBU (D-LIGHTS CREATIVE CO., LTD.), TOKYO 108-0014, JAPAN, FILED 4-19-2010.

Enevare

OWNER OF INTERNATIONAL REGISTRATION 1041480 DATED 4-19-2010, EXPIRES 4-19-2020.

THE MARK CONSISTS OF A STYLIZED DRAWING OF THE WORD "ENEVARE".

THE WORDING "ENEVARE" HAS NO MEANING IN A FOREIGN LANGUAGE.

CLASS 14—JEWELRY

FOR PRECIOUS METALS; KEYRINGS, NAMELY, TRINKETS AND FOBS OF PRECIOUS METAL; PERSONAL ORNAMENTS OF PRECIOUS METAL; SEMI-WROUGHT PRECIOUS STONES AND THEIR IMITATIONS; SHOE ORNAMENTS OF PRECIOUS METAL; CLOCKS AND WATCHES (U.S. CLS. 2, 27, 28 AND 50).

CLASS 18—LEATHER GOODS

FOR HANDBAG FRAMES; PURSE FRAMES; HORSESHOES; INDUSTRIAL PACKAGING CONTAINERS OF LEATHER; CLOTHING FOR DOMESTIC PETS; ALL-PURPOSE CARRYING BAGS; FOLDING BRIEFCASES; SHOULDER BAGS; GLADSTONE BAGS; JAPANESE KORI WICKER TRUNKS; BRIEFCASES; SUITCASES; CARRY-ON BAGS; TRUNKS; HANDBAGS; BOSTON BAGS; SCHOOLCHILDREN'S BACKPACKS; BACKPACKS; RUCKSACKS; LEATHER POUCHES; CHARM BAGS (OMAMORI-IRE); CREDIT CARD CASES; NAME CARD CASES; LEATHER SHOPPING BAGS; TEXTILE SHOPPING BAGS; WHEELED SHOPPING BAGS; PURSES; KEY CASES; WALLETS; JAPANESE UTILITY POUCHES (SHINGEN-BUKURO); BUSINESS CARD CASES; UNFITTED VANITY CASES; UMBRELLAS AND THEIR PARTS; SADDLERY (U.S. CLS. 1, 2, 3, 22 AND 41).

CLASS 25—CLOTHING

FOR CLOTHING, NAMELY, EVENING DRESSES, SCHOOL UNIFORMS, CHILDREN'S WEAR IN THE NATURE OF HATS FOR CHILDREN, CHILDREN'S CLOTH BIBS, SHIRTS FOR CHILDREN, ONE-PIECE GARMENTS FOR CHILDREN, JUMPERS, OVERALLS, JEANS, CHILDREN'S UNDERWEAR AND CHILDREN'S UNDERPANTS, WORKING CLOTHING IN THE NATURE OF OVERALLS, JEANS AND UNION SUITS, JACKETS, JOGGING PANTS, SWEAT PANTS, SUITS, SKIRTS, SKI JACKETS, SKI PANTS, TROUSERS, SMOCKS, FORMALWEAR IN THE NATURE OF TUXEDOS, DRESSES AND ONE-PIECE GARMENTS FOR CEREMONIAL OCCASIONS, OVERCOATS, TOPCOATS, MANTLES, RAINCOATS, CARDIGANS, SWEATERS, VESTS AND WAISTCOATS, OPEN-NECKED SHIRTS, CUFFS, COLLARS FOR CLOTHING, SPORT SHIRTS, BLOUSES, POLO SHIRTS, SKIRTS FOR SUITS, NIGHT GOWNS, NEGLIGEEES, JAPANESE SLEEPING ROBES (NEMAKI), PAJAMAS, BATH ROBES, CAMISOLES, CORSETS IN THE NATURE OF FOUNDATION CLOTHING, CLOTHING COMBINATIONS, UNDERSHIRTS, CHEMISES, MEN'S AND LADIES' UNDERWEAR AND UNDERPANTS, SLIPS, PANTIES, SHORTS AND BRIEFS, BRASSIERES, PETTICOATS, SWIMWEAR, BATHING SUITS, SWIMMING CAPS, BATHING CAPS, SASH BANDS FOR KIMONOS (OBI), BUSTLE HOLDER BANDS FOR OBI (OBIAGE), BUSTLES FOR OBI-KNOTS (OBIAGE-SHIN), WAIST STRINGS FOR KIMONOS (KOSHIHIMO), UNDERSHIRTS FOR KIMONOS (KOSHIMAKI), UNDERSHIRTS FOR KIMONOS (JUBAN), TIGHTENING-UP STRINGS FOR KIMONOS (DATEJIME), WRAP BELTS FOR KIMONOS (DATEMAKI), FULL-LENGTH KIMONOS (NAGAGI), SHORT OVERCOAT FOR KIMONOS (HAORI), STRING FASTENERS FOR HAORI (HAORI-HIMO), PLEATED SKIRTS FOR FORMAL KIMONOS (HAKAMA), DETACHABLE NECKPIECES FOR KIMONOS (HANERI), APRONS, COLLAR PROTECTORS, SOCKS AND STOCKINGS, PUTTEES AND GAITERS, FUR STOLEES, SHAWLS, SCARVES, SCARFS, JAPANESE STYLE SOCKS (TABI), JAPANESE STYLE SOCKS (TABI COVERS), GLOVES AND MITTENS, NECKTIES, BANDANAS, NECKERCHIEFS, MUFFLERS, EAR MUFFS, HOODS, SEDGE HATS (SUGEGASA), NIGHTCAPS, AND HEADGEAR FOR CLOTHING IN THE NATURE OF CAPS AND HATS; GARTERS; SOCK SUSPENDERS; SUSPENDERS; BRACES; WAISTBANDS; BELTS FOR CLOTHING; SHOES AND BOOTS EXCLUDING SHOE DOWELS, SHOE PEGS, SHOE HANDLES, HOBNAILED AND SHOE PROTECTIVE METAL MEMBERS (U.S. CLS. 22 AND 39).

ROBERT C. CLARK JR., EXAMINING ATTORNEY

CLASS 9—ELECTRICAL AND SCIENTIFIC APPARATUS

FOR SCIENTIFIC, PHOTOGRAPHIC, CINEMATOGRAPHIC, OPTICAL, SIGNALLING, CHECKING AND SUPERVISION APPARATUS AND INSTRUMENTS, NAMELY, ROBOTS FOR PERSONAL, EDUCATIONAL AND HOBBY USE AND STRUCTURAL PARTS THEREFOR; WIRELESS COMMUNICATION DEVICE FEATURING VOICE, DATA AND IMAGE TRANSMISSION AND RECEPTION INCLUDING VOICE, TEXT AND PICTURE MESSAGING, ELECTRONIC ORGANIZER, PERSONAL DIGITAL ASSISTANT, WEBCAM, LIVE CHAT, VOICE RECOGNITION, VOICE SYNTHESIZER, RFID READER AND CHIPS, WIRELESS INTERNET CONNECTION, STREAMED AND NON-STREAMED WEBCAST ACCESS, WEB BROWSER, SPEAKER, MICROPHONE, RADIO, MP3 PLAYER, ADVANCED AUDIO CODING (AAC), RSS (REALLY SIMPLE SYNDICATION) READER, INTERACTIVE GAMES AND EDUCATIONAL ACTIVITIES, USB PORT, ALSO FUNCTIONAL TO PURCHASE MUSIC, GAMES, VIDEO AND SOFTWARE APPLICATIONS FOR DOWNLOADING TO THE DEVICE; MUSIC, ELECTRONIC GAMES AND VIDEOS FEATURING LEISURE VIDEOS, AMATEUR VIDEOS FOR DOWNLOADING TO A WIRELESS COMMUNICATION DEVICE; SOFTWARE APPLICATIONS FOR DOWNLOADING TO A WIRELESS COMMUNICATION DEVICE, FOR DEMONSTRATING AND CONTROLLING THE DEVICE, FOR COMMUNICATING WITH OTHER DEVICES, FOR SENDING AND RECEIVING PHONE CALLS, ELECTRONIC MAIL AND OTHER DIGITAL DATA, FOR SOCIAL NETWORKING AND CHAT, FOR REMINDERS AND ALERTS, FOR RSS FEEDS, FOR SURVEILLANCE, FOR NEWS, WEATHER, TRAFFIC AND STOCK EXCHANGE UPDATES, FOR RADIO, FOR PODCASTS, FOR PLAYING MUSIC, FOR CHILDREN'S STORIES AND SONGS, FOR GAMES AND QUIZZES; REMOTE HAND-HELD DEVICES CONTAINING RFID CHIPS FOR LAUNCHING APPLICATIONS ON A WIRELESS COMMUNICATION DEVICE; COVERING FOR WIRELESS COMMUNICATION DEVICE WHICH INCORPORATES RFID CHIP FOR ACTIVATING APPLICATIONS; ELECTRONIC DOCKING STATION, NAMELY, A MUSIC DOCK; STEREO SPEAKERS; CHARGING STATION FOR CHARGING A WIRELESS COMMUNICATION DEVICE; BATTERIES; BLANK SOUND RECORDING DISKS; PRE-RECORDED SOUND RECORDING DISKS FEATURING MUSIC; BLANK AUDIO DIGITAL DISKS, PRE-RECORDED AUDIO DIGITAL DISKS FEATURING MUSIC; BLANK CD-ROMS FOR SOUND OR VIDEO RECORDING; PRE-RECORDED CD-ROMS FEATURING MUSIC; BLANK DIGITAL VERSATILE DISKS, NAMELY, DVDS; PRE-RECORDED BLANK DIGITAL VERSATILE DISKS, NAMELY, DVDS FEATURING MUSIC; INFORMATION PROCESSING AND COMPUTER EQUIPMENT, NAMELY, CENTRAL PROCESSING UNITS FOR PROCESSING INFORMATION; VIDEO CAMERAS; VIDEO GAME CARTRIDGES; RECORDED VIDEO GAME DISCS; ELECTRONIC GAME SOFTWARE FOR CONSOLES; ELECTRONIC VIDEO GAME CONSOLES FOR USE WITH AN EXTERNAL DISPLAY SCREEN OR A MONITOR; COMPUTER OR VIDEO GAME JOYSTICKS; TELEPHONE RECEIVERS; TELECOMMUNICATION TRANSMITTERS; TRANSMITTERS OF ELECTRONIC SIGNALS; AUDIO-VISUAL RECEIVERS; LOUDSPEAKERS; VIDEO OR COMPUTER GAME CONSOLE APPARATUS ADAPTED FOR USE WITH AN EXTERNAL DISPLAY SCREEN OR MONITOR; RECORDED PROGRAMS, NAMELY, SOFTWARE FOR DEMONSTRATING AND CONTROLLING THE DEVICE, FOR COMMUNICATING WITH OTHER DEVICES, FOR SENDING AND RECEIVING PHONE CALLS, ELECTRONIC MAIL AND OTHER DIGITAL DATA, FOR SOCIAL NETWORKING AND CHAT, FOR REMINDERS AND ALERTS, FOR RSS FEEDS, FOR SURVEILLANCE, FOR NEWS, WEATHER, TRAFFIC AND STOCK EXCHANGE UPDATES, FOR RADIO, FOR PODCASTS, FOR PLAYING MUSIC, FOR CHILDREN'S STORIES AND SONGS, FOR GAMES AND QUIZZES; COMPUTER PROGRAMS, NAMELY, DOWNLOADABLE SOFTWARE FOR DEMONSTRATING AND CONTROLLING THE DEVICE, FOR COMMUNICATING WITH OTHER DEVICES, FOR SENDING AND RECEIVING PHONE CALLS, ELECTRONIC MAIL AND OTHER DIGITAL DATA, FOR SOCIAL NETWORKING AND CHAT, FOR REMINDERS AND ALERTS, FOR RSS FEEDS, FOR SURVEILLANCE, FOR NEWS, WEATHER, TRAFFIC AND STOCK EXCHANGE UPDATES, FOR RADIO, FOR PODCASTS, FOR PLAY-

SN 79-083,892. MINDSCAPE, FRANCE, FILED 4-15-2010.

KAROTZ

THE MARK CONSISTS OF STANDARD CHARACTERS WITHOUT CLAIM TO ANY PARTICULAR FONT, STYLE, SIZE, OR COLOR.

PRIORITY DATE OF 4-8-2010 IS CLAIMED.
OWNER OF INTERNATIONAL REGISTRATION 1042438
DATED 4-15-2010, EXPIRES 4-15-2020.

CLASS 7—MACHINERY

FOR MACHINES, NAMELY, INDUSTRIAL ROBOTS (U.S. CLS. 13, 19, 21, 23, 31, 34 AND 35).

ING MUSIC, FOR CHILDREN'S STORIES AND SONGS, FOR GAMES AND QUIZZES, RECORDED COMPUTER SOFTWARE AND PROGRAM PACKAGES FOR DEMONSTRATING AND CONTROLLING THE DEVICE, FOR COMMUNICATING WITH OTHER DEVICES, FOR SENDING AND RECEIVING PHONE CALLS, ELECTRONIC MAIL AND OTHER DIGITAL DATA, FOR SOCIAL NETWORKING AND CHAT, FOR REMINDERS AND ALERTS, FOR RSS FEEDS, FOR SURVEILLANCE, FOR NEWS, WEATHER, TRAFFIC AND STOCK EXCHANGE UPDATES, FOR RADIO, FOR PODCASTS, FOR PLAYING MUSIC, FOR CHILDREN'S STORIES AND SONGS, FOR GAMES AND QUIZZES; CHILDREN'S EDUCATIONAL SOFTWARE; LEISURE SOFTWARE FOR SYNCHING MUSIC TO A MP3 PLAYER, PLAYING GAMES; COMPUTER GAME PROGRAMS; OPTICAL GOODS, NAMELY, OPTICAL FILTERS, OPTICAL GLASSES; SPECTACLES; SPECTACLES FOR VIDEO OR ELECTRONIC GAMES; SPECTACLE FRAMES; BINOCULARS; DOWNLOADABLE ELECTRONIC PUBLICATIONS, NAMELY, MAGAZINES, BOOKS, FEATURING INFORMATION IN THE FIELD OF WIRELESS COMMUNICATION; BAR CODE READERS; OPTICAL CHARACTER READERS; MICROPHONES; COMPUTER PERIPHERAL DEVICES; RADIOS; WALKIE TALKIES; TELEPHONE APPARATUS; MOBILE TELEPHONES; VIDEO TELEPHONES; TRANSMITTERS OF ELECTRONIC SIGNALS; LIGHT SIGNAL TRANSMITTERS; APPARATUS AND DEVICES FOR RADIOFREQUENCY IDENTIFICATION, NAMELY, RFID TAGS, RFID READERS; RFID READERS; APPARATUS FOR RECORDING, TRANSMISSION OR REPRODUCTION OF SOUND OR IMAGES; ELECTRIC BATTERIES; MP3 PLAYERS; VIDEO TELEPHONES; VIDEO PROJECTORS; TELEPHONE ANSWERING MACHINES; COMPUTER SOFTWARE FOR CONTROLLING CLOCK AND ALARM CLOCK FUNCTIONALITY; RADIOS INCORPORATING CLOCKS; BLANK USB FLASH DRIVES; BLANK INTEGRATED CIRCUIT CARDS; BLANK SMART CARDS; EXTERNAL HARD DISKS, NAMELY, EXTERNAL COMPUTER HARD DRIVES (U.S. CLS. 21, 23, 26, 36 AND 38).

CLASS 28—TOYS AND SPORTING GOODS

FOR GAMES AND TOYS, NAMELY, APPARATUS FOR ELECTRONIC OR VIDEO GAMES OTHER THAN THOSE ADAPTED FOR USE WITH AN EXTERNAL DISPLAY SCREEN OR MONITOR; TOY ROBOTS; ELECTRONIC GAMES, NAMELY, GAMES FOR THE TEACHING OF CHILDREN, QUIZZES (U.S. CLS. 22, 23, 38 AND 50).

CLASS 35—ADVERTISING AND BUSINESS

FOR RETAIL STORE SERVICES PROVIDED VIA COMMUNICATIONS NETWORKS FEATURING ROBOTS, WIRELESS COMMUNICATIONS DEVICES, SOFTWARE APPLICATIONS FOR WIRELESS COMMUNICATIONS DEVICES, ACCESSORIES AND COMPONENTS FOR WIRELESS COMMUNICATION DEVICES, SCIENTIFIC, PHOTOGRAPHIC, CINEMATOGRAPHIC, OPTICAL, SIGNALING, CHECKING, AND SUPERVISION APPARATUS AND INSTRUMENTS, APPARATUS FOR RECORDING, TRANSMISSION OR REPRODUCTION OF SOUND OR IMAGES, DIGITAL RECORDING MEDIA, SOUND RECORDING DISKS, AUDIO DIGITAL DISKS, CD-ROMS, DIGITAL VERSATILE DISKS, NAMELY, DVDS, DATA PROCESSING EQUIPMENT AND COMPUTERS, VIDEO CAMERAS, VIDEO GAME CARTRIDGES, RECORDED VIDEO GAMES, ELECTRONIC GAMES FOR CONSOLES, ELECTRONIC GAME CONSOLES, APPARATUS FOR ENTERTAINMENT DESIGNED TO BE USED WITH A SEPARATE DISPLAY SCREEN OR A MONITOR, JOYSTICKS, TELEPHONE RECEIVERS, TELECOMMUNICATION TRANSMITTING SETS, TRANSMITTERS OF ELECTRONIC SIGNALS, AUDIO AND VIDEO RECEIVERS, LOUDSPEAKERS, APPARATUS FOR GAMES ADAPTED FOR USE WITH AN EXTERNAL DISPLAY SCREEN OR MONITOR, RECORDED PROGRAMS, NAMELY, SOFTWARE, COMPUTER PROGRAMS, NAMELY, DOWNLOADABLE SOFTWARE, RECORDED COMPUTER SOFTWARE AND PROGRAM PACKAGES, EDUCATIONAL SOFTWARE, LEISURE SOFTWARE, COMPUTER GAME PROGRAMS, OPTICAL GOODS, SPECTACLES, SPECTACLES FOR VIDEO OR ELECTRONIC GAMES, SPECTACLE FRAMES, BINOCULARS,

BARCODE READERS, OPTICAL CHARACTER READERS, MICROPHONES, COMPUTER PERIPHERAL DEVICES, RADIOS, WALKIE TALKIES, TELEPHONE APPARATUS, MOBILE TELEPHONES, VIDEO TELEPHONES, TRANSMITTERS OF ELECTRONIC SIGNALS AND OF LIGHT SIGNALS, RADIO-FREQUENCY IDENTIFICATION APPARATUS AND DEVICES, RFID READERS, APPARATUS FOR RECORDING, TRANSMISSION OR REPRODUCTION OF SOUND OR IMAGES IN CONNECTION WITH RFID TECHNOLOGY, ELECTRIC BATTERIES, MP3 PLAYERS, VIDEOPHONES, VIDEO PROJECTORS, TELEPHONE ANSWERING MACHINES, COMPUTER SOFTWARE WITH CLOCK AND ALARM CLOCK FUNCTIONALITY, RADIO ALARMS, USB FLASH DRIVES, INTEGRATED CIRCUIT CARDS AND SMART CARDS, EXTERNAL HARD DISKS, GAMES, TOYS, APPARATUS FOR GAMES OTHER THAN THOSE ADAPTED FOR USE WITH AN EXTERNAL DISPLAY SCREEN OR MONITOR, TOY ROBOTS, ELECTRONIC GAMES, AS WELL AS SERVICES WITH REGARD TO PRODUCT PRESENTATION TO THE PUBLIC OF GOODS RELATED THERETO, ONLINE RETAIL STORE SERVICES FEATURING ROBOTS, SCIENTIFIC, PHOTOGRAPHIC, CINEMATOGRAPHIC, OPTICAL, SIGNALING, CHECKING, AND SUPERVISION APPARATUS AND INSTRUMENTS, APPARATUS FOR RECORDING, TRANSMISSION OR REPRODUCTION OF SOUND OR IMAGES, DIGITAL RECORDING MEDIA, SOUND RECORDING DISKS, AUDIO DIGITAL DISKS, CD-ROMS, DIGITAL VERSATILE DISKS, NAMELY, DVDS, DATA PROCESSING EQUIPMENT AND COMPUTERS, VIDEO CAMERAS, VIDEO GAME CARTRIDGES, RECORDED VIDEO GAMES, ELECTRONIC GAMES FOR CONSOLES, ELECTRONIC GAME CONSOLES, APPARATUS FOR ENTERTAINMENT DESIGNED TO BE USED WITH A SEPARATE DISPLAY SCREEN OR A MONITOR, JOYSTICKS, TELEPHONE RECEIVERS, TELECOMMUNICATION TRANSMITTING SETS, TRANSMITTERS OF ELECTRONIC SIGNALS, AUDIO AND VIDEO RECEIVERS, LOUDSPEAKERS, APPARATUS FOR GAMES ADAPTED FOR USE WITH AN EXTERNAL DISPLAY SCREEN OR MONITOR, RECORDED PROGRAMS, NAMELY, SOFTWARE, COMPUTER PROGRAMS, NAMELY, DOWNLOADABLE SOFTWARE, RECORDED COMPUTER SOFTWARE AND PROGRAM PACKAGES, EDUCATIONAL SOFTWARE, LEISURE SOFTWARE, COMPUTER GAME PROGRAMS, OPTICAL GOODS, SPECTACLES, SPECTACLES FOR VIDEO OR ELECTRONIC GAMES, SPECTACLE FRAMES, BINOCULARS, BARCODE READERS, OPTICAL CHARACTER READERS, MICROPHONES, COMPUTER PERIPHERAL DEVICES, RADIOS, WALKIE TALKIES, TELEPHONE APPARATUS, MOBILE TELEPHONES, VIDEO TELEPHONES, TRANSMITTERS OF ELECTRONIC SIGNALS AND OF LIGHT SIGNALS, RADIO-FREQUENCY IDENTIFICATION APPARATUS AND DEVICES, RFID READERS, APPARATUS FOR RECORDING, TRANSMISSION OR REPRODUCTION OF SOUND OR IMAGES IN CONNECTION WITH RFID TECHNOLOGY, ELECTRIC BATTERIES, MP3 PLAYERS, VIDEOPHONES, VIDEO PROJECTORS, TELEPHONE ANSWERING MACHINES, COMPUTER SOFTWARE WITH CLOCK AND ALARM CLOCK FUNCTIONALITY, RADIO ALARMS, USB FLASH DRIVES, INTEGRATED CIRCUIT CARDS AND SMART CARDS, EXTERNAL HARD DISKS, GAMES, TOYS, APPARATUS FOR GAMES OTHER THAN THOSE ADAPTED FOR USE WITH AN EXTERNAL DISPLAY SCREEN OR MONITOR, TOY ROBOTS, ELECTRONIC GAMES, AS WELL AS SERVICES WITH REGARD TO ONLINE PRODUCT PRESENTATION TO THE PUBLIC OF GOODS RELATED THERETO (U.S. CLS. 100, 101 AND 102).

CLASS 38—COMMUNICATION

FOR TELECOMMUNICATIONS, NAMELY, PROVIDING FORUMS FOR TRANSMISSION OF MESSAGES AMONG WIRELESS COMMUNICATION DEVICE USERS; PROVIDING ON-LINE CHAT ROOMS FOR SOCIAL NETWORKING; PROVIDING ON-LINE CHAT ROOMS FOR TRANSMISSION OF MESSAGES AMONG USERS IN THE FIELD OF WIRELESS COMMUNICATION DEVICES AND TOPICS OF GENERAL INTEREST; PROVIDING A WEBSITE FEATURING A FORUM AND CHAT ROOM IN THE FIELDS OF TECHNOLOGY AND SOFTWARE DEVELOPMENT FOR DEVELOPERS OF APPLICATIONS FOR PARTICULAR WIRELESS COMMUNICATION DEVICE; DELIVERY OF MESSAGES BY

ELECTRONIC TRANSMISSION; PROVISION OF TELECOMMUNICATIONS CONNECTIONS TO ELECTRONIC COMMUNICATIONS NETWORKS, FOR TRANSMISSION OR RECEPTION OF AUDIO, VIDEO OR MULTIMEDIA CONTENT; COMMUNICATION BY TELEPHONE; RADIO BROADCASTING SERVICES; COMMUNICATIONS BY COMPUTER TERMINALS; MAILING AND TRANSMISSION OF DISPATCHES IN THE NATURE OF ELECTRONIC MESSAGES; PROVIDING ACCESS TO DATABASES; ELECTRONIC MAIL; MESSAGE SENDING; COMPUTER-AIDED TRANSMISSION OF MESSAGES; TELEPHONE SERVICES; DIRECT TECHNICAL TRANSMISSION OF IMAGES FROM A WEBCAM; TRANSMISSION OF DATA, SOUND, IMAGES AND TEXT OVER THE INTERNET (U.S. CLS. 100, 101 AND 104).

SN 79-085,880. INOS AUTOMATIONSSOFTWARE GMBH, 70563 STUTTGART, FED REP GERMANY, FILED 5-17-2010.

SENSIBOT

CLASS 41—EDUCATION AND ENTERTAINMENT

FOR ENTERTAINMENT, NAMELY, PROVIDING VIRTUAL ENVIRONMENTS IN WHICH USERS CAN INTERACT FOR RECREATIONAL, LEISURE OR ENTERTAINMENT PURPOSE; PROVIDING WEBCASTS AND PODCASTS FOR ENTERTAINMENT PURPOSE IN THE FIELD OF ENTERTAINMENT, NEW TECHNOLOGY, COMPUTERS, ELECTRONIC GAMES; PROVIDING A WEBSITE FEATURING BLOGS FEATURING NEWS, PHOTOS, VIDEOS, GAMES AND OTHER INFORMATION OF INTEREST TO OWNERS OF PARTICULAR WIRELESS COMMUNICATION DEVICES; ENTERTAINMENT INFORMATION; ONLINE COMPUTER GAME SERVICES PROVIDED VIA A COMPUTER NETWORK; CASINO GAMING; PRODUCTION OF DIGITAL AUDIO-VIDEO DISKS; PRODUCTION OF EDUCATIONAL VIDEO AND COMPUTER GAME SOFTWARE; INFORMATION ON ENTERTAINMENT AND RECREATIONAL ACTIVITIES; PRODUCTION OF COMPUTER GAME PROGRAMS AND INSTRUCTIONS IN CONNECTION WITH COMPUTER GAME SOFTWARE; ORGANIZATION OF CONTESTS AND OF EDUCATIONAL AND RECREATIONAL GAMES; ONLINE COMPUTER GAMING SERVICES (U.S. CLS. 100, 101 AND 107).

CLASS 42—SCIENTIFIC AND COMPUTER SERVICES

FOR SCIENTIFIC AND TECHNOLOGICAL CONSULTATION IN THE FIELD OF WIRELESS COMMUNICATION DEVICE AND RESEARCH AND DESIGN RELATING THERETO, IN THE FIELD OF ROBOTS AND WIRELESS COMMUNICATION; PROVIDING A WEBSITE FEATURING INFORMATION IN THE FIELDS OF TECHNOLOGY AND SOFTWARE DEVELOPMENT FOR DEVELOPERS OF APPLICATIONS FOR PARTICULAR WIRELESS COMMUNICATION DEVICE; INDUSTRIAL ANALYSIS AND RESEARCH IN THE FIELD OF ROBOTS AND WIRELESS COMMUNICATION; DESIGN AND DEVELOPMENT OF COMPUTERS AND SOFTWARE, OF CD-ROMS, AND OF COMPUTER GAMES; DEVELOPMENT OF VIDEO OR ELECTRONIC GAMES; COMPUTER SOFTWARE CONSULTATION; SETTING UP AND DESIGN OF INTERNET SITES; WEB SITE HOSTING; METEOROLOGICAL INFORMATION SERVICES; UPDATING OF SOFTWARE; COMPUTER PROGRAMMING SERVICES; DESIGN OF AND RESEARCH INTO ELECTRONIC IDENTIFICATION SOLUTIONS USING RADIO FREQUENCY IDENTIFICATION; DESIGN AND DEVELOPMENT OF IDENTIFICATION SYSTEMS USING RADIO FREQUENCY IDENTIFICATION; DESIGN OF COMPUTER SYSTEMS AND COMPUTER NETWORKS FOR OTHERS; INSTALLATION OF SOFTWARE AND CD-ROMS (U.S. CLS. 100 AND 101).
TOBY BULLOFF, EXAMINING ATTORNEY

THE MARK CONSISTS OF STANDARD CHARACTERS WITHOUT CLAIM TO ANY PARTICULAR FONT, STYLE, SIZE, OR COLOR.

OWNER OF INTERNATIONAL REGISTRATION 1047117 DATED 5-17-2010, EXPIRES 5-17-2020.

CLASS 7—MACHINERY

FOR PACKAGING MACHINES; SERVICE ROBOTS FOR USE IN THE BEVERAGE INDUSTRY FOR EQUIPPING BEVERAGE CRATES WITH DESIRED BEVERAGE CONTAINERS, IN PARTICULAR BEVERAGE BOTTLES, AND FOR EQUIPPING PALLETS WITH BEVERAGE CRATES; SERVICE ROBOTS FOR USE IN DISTRIBUTION CENTERS, IN PARTICULAR FOR PICKING, GATHERING, SEPARATING AND SORTING LETTERS OR PARCELS IN A LETTER OR PARCEL DISTRIBUTION CENTER OR A POST OFFICE, AND FOR PICKING, GATHERING, SEPARATING AND SORTING MERCHANDISE IN A MERCHANDISE DISTRIBUTION CENTER OR A SHOP; SERVICE ROBOTS FOR USE IN AGRICULTURE FOR SOWING SEEDS, FOR PLANTING SEEDLINGS OR PLANTS, OR FOR HARVESTING OR PICKING FRUIT AND VEGETABLES; ALL MENTIONED SERVICE ROBOTS MOBILE OR STATIONARY; INDUSTRIAL ROBOTS (U.S. CLS. 13, 19, 21, 23, 31, 34 AND 35).

CLASS 9—ELECTRICAL AND SCIENTIFIC APPARATUS

FOR APPARATUS FOR RECORDING, TRANSMISSION OR REPRODUCTION OF SOUND OR IMAGES; SENSORS FOR MONITORING AN INDUSTRIAL ROBOT'S OR A SERVICE ROBOT'S AREA OF MOTION, IN PARTICULAR OPTICAL SENSORS AND TACTILE SENSORS; DATA-PROCESSING EQUIPMENT AND COMPUTERS; SOFTWARE FOR CONTROLLING THE MOVEMENT OF AN INDUSTRIAL ROBOT OR A SERVICE ROBOT BY GENERATING APPROPRIATE CONTROL SIGNALS FOR THE ROBOT, IN PARTICULAR SOFTWARE FOR RECEIVING SENSOR SIGNALS DEPENDING ON WHETHER OBJECTS, HUMAN BEINGS OR ANIMALS HAVE BEEN DETECTED WITHIN THE ROBOT'S AREA OF MOTION, AND FOR GENERATING CONTROL SIGNALS FOR THE ROBOT'S MOTION ACCORDING TO THE SENSOR SIGNALS, IN PARTICULAR FOR SLOWING DOWN OR STOPPING THE ROBOT'S MOTION IN CASE OBJECTS, HUMAN BEINGS OR ANIMALS HAVE BEEN DETECTED WITHIN THE ROBOT'S AREA OF MOTION; IMAGE PROCESSING SOFTWARE (U.S. CLS. 21, 23, 26, 36 AND 38).

CLASS 42—SCIENTIFIC AND COMPUTER SERVICES

FOR DEVELOPMENT, DESIGN AND MAINTENANCE OF SOFTWARE, IN PARTICULAR CONTROL PROGRAMS FOR USE IN THE FIELDS OF MEASURING, CONTROLLING AND REGULATING, IN PARTICULAR IN THE FIELDS OF AUTOMATION TECHNOLOGY AND QUALITY ASSURANCE; DEVELOPMENT, CREATION AND MAINTENANCE OF SOFTWARE FOR THE CONTROL AND/OR REGULATION OF HANDLING APPARATUS, SERVICE ROBOTS, STATIONARY OR MOBILE ROBOTS AND TELEOPERATORS, IN PARTICULAR ROBOTS AND TELEOPERATORS WITH SENSORS FOR TOUCH FUNCTIONS AND VISUAL DISPLAY FUNCTIONS; DEVELOPMENT, DESIGN AND MAINTENANCE OF IMAGE PROCESSING SOFTWARE; DEVELOPMENT, CREATION AND MAINTENANCE OF IMAGE PROCESSING SOFTWARE FOR IMPLEMENTING VISUAL DISPLAY FUNCTIONS ON HANDLING APPARATUS, ROBOTS AND TELEOPERATORS, IN PARTICULAR IMAGE PROCESSING SOFTWARE FOR IMAGE PROCESSING SENSORS ON HANDLING APPARATUS, ROBOTS AND TELEOPERATORS (U.S. CLS. 100 AND 101).

KELLY TRUSILO, EXAMINING ATTORNEY

SN 79-086,574. CROWN CREATIVE CO., LTD., JAPAN, FILED 1-13-2010.



PRIORITY DATE OF 7-14-2009 IS CLAIMED.
OWNER OF INTERNATIONAL REGISTRATION 1048994 DATED 1-13-2010, EXPIRES 1-13-2020.

THE MARK CONSISTS OF THE HEAD OF A BEAR WITH HEARTS IN ITS EARS ABOVE THE STYLIZED WORD "MISTEEZ".

CLASS 9—ELECTRICAL AND SCIENTIFIC APPARATUS

FOR RECORDED MEDIA, NAMELY, EXPOSED CINEMATOGRAPHIC FILMS, VIDEO DISCS, AND VIDEO TAPES ALL FEATURING ANIMATION, SPORTS, MUSIC, AND COMEDY; DOWNLOADABLE FILES FEATURING SOUNDS, MUSIC, IMAGES, VIDEO IMAGES AND TEXT; DOWNLOADABLE FILES FEATURING SOUNDS, MUSIC, IMAGES, VIDEO IMAGES AND TEXT FOR MOBILE TELEPHONES; COMPUTER GAME PROGRAMS; GAME PROGRAMS FOR MOBILE TELEPHONES; GAME PROGRAMS FOR CONSUMER VIDEO GAMES; GAME PROGRAMS FOR HAND-HELD GAMES WITH LIQUID CRYSTAL DISPLAYS; GAME PROGRAMS FOR ARCADE VIDEO GAME MACHINES; DOWNLOADABLE GAME PROGRAMS; MOBILE TELEPHONE ACCESSORIES, NAMELY, HEADSETS, MICROPHONES AND HEADPHONES; MOBILE TELEPHONE STRAPS; AMUSEMENT APPARATUS ADAPTED FOR USE WITH AN EXTERNAL DISPLAY SCREEN OR MONITOR; TELECOMMUNICATIONS DEVICES, APPARATUS AND INSTRUMENTS, NAMELY, INTERCOMS, MOBILE PHONES, TELEPHONE SETS, FACSIMILE MACHINES, BROADCASTING MACHINES, NAMELY, TELEVISION AND RADIO RECEIVERS AND

TRANSMITTERS, DIGITAL CAMERAS, VIDEO CAMERAS, WIRELESS COMMUNICATION DEVICE FEATURING VOICE, DATA AND IMAGE TRANSMISSION INCLUDING VOICE, TEXT AND PICTURE MESSAGING, A VIDEO AND STILL IMAGE CAMERA, ALSO FUNCTIONAL TO PURCHASE MUSIC, GAMES, VIDEO AND SOFTWARE APPLICATIONS OVER THE AIR FOR DOWNLOADING TO THE DEVICE; VIDEO FREQUENCY MACHINES AND APPARATUS, NAMELY, DIGITAL CAMERAS, VIDEO CAMERAS, DVD PLAYERS AND RECORDERS, VIDEO PLAYERS AND RECORDERS; AUDIO FREQUENCY MACHINES AND APPARATUS, NAMELY, JUKEBOXES, SOUND RECORDING INSTRUMENTS AND APPARATUS, AUDIO RECORDERS, DIGITAL AUDIO PLAYERS; PARTS AND ACCESSORIES FOR TELECOMMUNICATIONS DEVICES, APPARATUS AND INSTRUMENTS, NAMELY, CABINETS FOR LOUDSPEAKERS, BLANK VIDEO TAPES, BLANK RECORDABLE DVDS, BLANK RECORD DISKS, BLANK DIGITAL STORAGE MEDIA, BLANK ELECTRONIC MEDIA, HEADPHONES, MICROPHONES, PHONOGRAPHIC RECORD CLEANING KITS COMPRISED PRIMARILY OF REPLACEMENT STYLUS NEEDLES AND ALSO INCLUDING CLEANING SOLUTIONS AND BRUSHES; ELECTRONIC MACHINES, APPARATUS AND THEIR PARTS, NAMELY, ELECTRONIC DESK CALCULATORS, COMPUTER MOUSE AND KEYBOARDS; COMPUTERS; PROGRAMS FOR COMPUTER OPERATING SYSTEMS, COMPUTER SOFTWARE THAT IS DOWNLOADABLE AND ALLOWS THE USER ACCESS TO RING TONES, AUDIO FILES, MUSIC FILES, IMAGES, VIDEO IMAGES AND ELECTRONIC GAMES; EYEGLASSES; SPECTACLES; CONTACT LENSES; PARTS AND ACCESSORIES FOR EYEGLASSES, GOGGLES, AND SPECTACLES, NAMELY, CONTAINERS, TEMPLS, PINCE-NEZ CORDS, CASES, FRAMES, CONTAINERS FOR CONTACT LENSES, EYEGLASSES WIPES, AND SPORTS GOGGLE WIPES; DIVING GOGGLES; SKI GOGGLES; GOGGLES FOR SPORTS; MOTORCYCLE GOGGLES; APPARATUS FOR GAMES ADAPTED FOR USE WITH AN EXTERNAL DISPLAY SCREEN OR MONITOR; ELECTRONIC CIRCUITS AND CD-ROMS RECORDED WITH PROGRAMS FOR HAND-HELD GAMES WITH LIQUID CRYSTAL DISPLAYS; INFLATABLE SWIMMING FLOATS FOR SAFETY PURPOSES; PROTECTIVE HELMETS FOR SPORTS; SWIMMING FLUTTER BOARDS FOR SAFETY PURPOSES; PHONOGRAPH RECORDS FEATURING MUSIC; SOUND RECORDED MAGNETIC CARDS, SHEETS AND TAPES; RECORDED COMPACT DISCS FEATURING SOUNDS, MUSIC, ANIMATION, IMAGES, VIDEO IMAGES, MOVIES, TELEVISION PROGRAMS AND INTERNET TELEVISION PROGRAMS; ELECTRONIC CIRCUITS AND CD-ROMS RECORDED WITH AUTOMATIC PERFORMANCE PROGRAMS FOR ELECTRONIC MUSICAL INSTRUMENTS; EXPOSED CINEMATOGRAPHIC FILMS; EXPOSED SLIDE FILMS; RECORDED VIDEO DISCS AND VIDEO TAPES FEATURING SOUNDS, MUSIC, ANIMATION, IMAGES, VIDEO IMAGES, MOVIES, TELEVISION PROGRAMS AND INTERNET TELEVISION PROGRAMS; DOWNLOADABLE ELECTRONIC PUBLICATIONS, NAMELY, BOOKS, MAGAZINES, NEWSLETTERS, MAPS, PICTURES, DRAWINGS, AND COMICS FEATURING MUSIC, IMAGES, VIDEO IMAGES, SOUNDS, TEXT, ANIMATION AND INFORMATION RELATED TO FICTIONAL CHARACTERS AND SUBJECTS OF GENERAL INTEREST; DOWNLOADABLE DATA FILES RELATED TO FICTIONAL CHARACTERS OF MAGAZINES, DOWNLOADABLE BOOKS RELATED TO FICTIONAL CHARACTERS AND SUBJECTS OF GENERAL INTEREST; DOWNLOADABLE NEWSPAPERS, MAPS, PICTURE FILES AND DRAWING FILES; ELECTRONIC PUBLICATIONS, NAMELY, BOOKS, MAGAZINES, NEWSLETTERS AND COMICS FEATURING MUSIC, IMAGES, VIDEO IMAGES, SOUNDS, ANIMATION, TEXT, AND INFORMATION RELATED TO FICTIONAL CHARACTERS AND SUBJECTS OF GENERAL INTEREST, RECORDED ON ELECTRONIC MEDIA, NAMELY, ENCODED ELECTRONIC CIRCUITS, IC CARDS, MAGNETIC TAPES, MAGNETIC DISCS, OPTICAL DISCS, MAGNETIC OPTICAL DISCS, CD-ROMS AND DVDS RECORDED WITH MUSIC, SOUNDS, IMAGES, VIDEO IMAGES (U.S. CLS. 21, 23, 26, 36 AND 38).

CLASS 14—JEWELRY

FOR PRECIOUS METALS; KEY RINGS OF PRECIOUS METAL, IMITATION PRECIOUS METAL OR SEMI-PRECIOUS METAL; TRINKETS, NAMELY, RINGS OR WATCH FOBS OF PRECIOUS METAL, IMITATION PRECIOUS METAL OR SEMI-PRECIOUS METAL; JEWEL CASES; PRECIOUS METAL TROPHIES; PRECIOUS METAL COMMEMORATIVE SHIELDS; PERSONAL ORNAMENTS BEING JEWELRY OF PRECIOUS METAL, IMITATION PRECIOUS METAL OR SEMI-PRECIOUS METAL; ORNAMENTS BEING JEWELRY; EARRINGS; INSIGNIAS OF PRECIOUS METAL; BADGES OF PRECIOUS METAL; BONNET PINS OF PRECIOUS METAL; TIE CLIPS; TIE PINS; NECKLACES; BRACELETS; PENDANTS; GEM BROOCHES; MEDALS; RINGS BEING TRINKETS; MEDALLIONS; JEWELRY CHAINS; JEWELRY CHARMS; SILVER ORNAMENTS; AMULETS BEING JEWELRY; CLOISONNÉ JEWELRY; HAT ORNAMENTS OF PRECIOUS METAL; ORNAMENTS OF JET; JEWELRY OF YELLOW AMBER; PASTE JEWELRY; JEWELRY PINS; ORNAMENTAL PINS; TRINKETS BEING JEWELRY; CUFF LINKS; UNPROCESSED AND SEMI-PROCESSED PRECIOUS STONES AND THEIR IMITATIONS; SHOE ORNAMENTS OF PRECIOUS METAL; CLOCKS; WATCHES; PARTS OF CLOCKS AND WATCHES; ACCESSORIES OF CLOCKS AND WATCHES, NAMELY, WATCH STRAPS AND BANDS, CLOCK AND WATCH HANDS, CASES FOR CLOCKS AND WATCHES, CHAINS FOR CLOCKS AND WATCHES, FOBS FOR CLOCKS AND WATCHES, AND DIALS FOR CLOCKS AND WATCHES (U.S. CLS. 2, 27, 28 AND 50).

CLASS 16—PAPER GOODS AND PRINTED MATTER

FOR PASTES AND OTHER ADHESIVES FOR STATIONERY OR HOUSEHOLD PURPOSES; DISPOSABLE BABIES' DIAPER-PANTS OF PAPER; INDUSTRIAL PACKAGING CONTAINERS OF PAPER; HYGIENIC PAPER; TOWELS OF PAPER; TABLE NAPKINS OF PAPER; HAND TOWELS OF PAPER; HANDKERCHIEFS OF PAPER; TABLE CLOTHS OF PAPER; PAPER AND CARDBOARD; STATIONERY; STUDY MATERIALS, NAMELY, SCHOOL WORK DESK BASKETS, AND STUDY GUIDES; PAPER STATIONERY; WRITING INSTRUMENTS; PAINTERS' ARTICLES, NAMELY, CRAYONS, PASTELS AND PALLETS FOR PAINTING; PRINTED MATTER, NAMELY, PICTURE POSTCARDS, POSTERS, SHEET MUSIC, CALENDARS, NEWSPAPERS, GEOGRAPHIC MAPS AND DIARIES; PRINTED MATTER, NAMELY, CATALOGS, MAGAZINES, BOOKS, NEWSLETTERS, PAMPHLETS, PRINTED PERIODICALS, HANDBOOKS AND LEAFLETS FEATURING ADVERTISEMENTS, COMICS, NOVELS, PRODUCTS AND INFORMATION RELATED TO FICTIONAL CHARACTERS; PHOTOGRAPHS; PHOTOGRAPH STANDS (U.S. CLS. 2, 5, 22, 23, 29, 37, 38 AND 50).

CLASS 18—LEATHER GOODS

FOR CLOTHING FOR PETS; LEADS FOR PETS; BOOTS AND SHOES FOR PETS; COLLARS FOR PETS; BELLY BANDS FOR PETS; ORNAMENTS FOR PETS, NAMELY, RIBBONS, BOWS AND CHARMS FOR PET COLLARS, CLOTHING FOR PETS, NAMELY, PET HAIR RIBBONS, BOWS, AND CHARMS; BLANKETS FOR PETS (U.S. CLS. 1, 2, 3, 22 AND 41).

CLASS 24—FABRICS

FOR WOVEN FABRICS; KNITTED FABRICS; PERSONAL ARTICLES OF WOVEN TEXTILE NOT FOR WEAR, NAMELY, HAND TOWELS, TEXTILE HAND TOWELS, HANDKERCHIEFS, TEXTILE HANDKERCHIEFS, TOWELS AND TEXTILE TOWELS; BED SHEETS; FUTON QUILTS; QUILTS; LINEN COVERS FOR FUTON BEING FUTON QUILTS AND QUILTS; TICKS, BEING MATTRESS COVERS FOR UNSTUFFED FUTONS; PILLOW-CASES; BED BLANKETS, BLANKET TROWS, BLANKETS FOR OUTDOOR USE, CHILDREN'S BLANKETS, AND PET BLANKETS; TABLE NAPKINS OF TEXTILE; DISH DRYING CLOTHS; SHOWER CURTAINS; TOILET SEAT COVERS OF TEXTILE; TEXTILE CUSHION COVERS; UNFITTED TEXTILE FURNITURE COVERS FOR CHAIRS; WALL HANGINGS OF TEXTILE; CURTAINS; TABLE CLOTHS NOT OF PAPER; LABELS OF CLOTH; TOWELS FOR ANIMALS (U.S. CLS. 42 AND 50).

CLASS 25—CLOTHING

FOR CLOTHING, NAMELY, BABY BODYSUITS, BABY BOTTOMS, BABY BUNTINGS, BABY DOLL PJAMAS, BABY TOPS, BATHING SUITS, BATHING SUITS FOR MEN, BATHING SUITS FOR KIDS, BEACH COVER-UPS, BEACHWEAR, BATHROBES, TEXTILE BELTS, BLOUSONS, BODY LINENS, BOMBER JACKETS, CAMISOLES, CAPRI PANTS, PARKAS, SHORTS, CHILDREN'S AND INFANTS' CLOTH BIBS, NECK TUBES, DRESS SHIRTS, DRESS SUITS, DRESSES, GOLF SHIRTS, GOLF TROUSERS, GYM SUITS, JACKETS, JEANS, JERSEYS, JOGGING OUTFITS, JUMPERS, JUMPSUITS, LEATHER JACKETS, LEG WARMERS, SUITS, NURSE DRESSES, ONE PIECE OUTFITS BEING ONE PIECE GARMENTS FOR INFANTS, CHILDREN AND ADULTS, PANTS, RAINCOATS, RAINWEAR, ROBES, ROMPERS, SHIRTS, SILK SCARVES, SKI SUITS, SNOW SUITS, SPORT JERSEYS, TANK TOPS, TIES, VESTS, AND WIND COATS; COATS; SWEATERS, CARDIGAN SWEATERS AND VESTS; SHIRTS, T-SHIRTS, BLOUSES, POLO SHIRTS AND SWEATSHIRTS; NIGHTWEAR; UNDERWEAR; SWIMWEAR; SWIMMING CAPS; JAPANESE TRADITIONAL CLOTHING, NAMELY, KIMONOS, SASH BANDS FOR KIMONO OBI, BUSTLE HOLDER BANDS FOR OBI (OBIAGE), BUSTLES FOR OBI-KNOTS (OBIAGESHIN), WAIST STRINGS FOR KIMONOS (KOSHIHIMO), UNDERSHIRTS FOR KIMONOS (KOSHIMAKI), UNDERSHIRTS FOR KIMONOS (JUBAN), TIGHTENING-UP STRINGS FOR KIMONOS (DATEJIME), WRAP BELTS FOR KIMONOS (DATEMAKI), FULLLENGTH KIMONOS (NAGAGI), SHORT OVERCOAT FOR KIMONO (HAORI), STRING FASTENERS FOR HAORI (HAORI-HIMO), PLEATED SKIRTS FOR FORMAL KIMONOS (HAKAMA), AND DETACHABLE NECKPIECES FOR KIMONOS (HANERI); SLEEP MASKS; APRONS FOR WEAR; COLLAR PROTECTORS FOR WEAR; SOCKS AND STOCKINGS; PUTTEES AND GAITERS; FUR STOLE; SHAWLS; SCARVES; JAPANESE STYLE SOCKS (TABI); JAPANESE STYLE SOCKS (TABI COVERS); GLOVES AND MITTENS; BABIES' DIAPERS OF TEXTILE; NECKTIES; NECKERCHIEVES; BANDANAS BEING NECKERCHIEFS; WARM-KEEPING SUPPORTS, NAMELY, LEG WARMERS, LEGGINGS, SUPPORT STOCKINGS AND SUPPORT HOSE; MUFFLERS; EAR MUFFS; HOODS; SEDGE HATS (SUGEGASA); NIGHTCAPS; HEADWEAR AND CAPS; THERMAL HEADWEAR; GARTERS; SOCK SUSPENDERS; SUSPENDERS; WAISTBANDS; BELTS FOR CLOTHING; FOOTWEAR OTHER THAN BOOTS FOR SPORTS; SHOES AND BOOTS; SHOE DOWELS, SHOE PEGS, TONGUES OR PULL STRAPS FOR SHOES AND BOOTS, HOBNAILS; PROTECTIVE METAL MEMBERS FOR SHOES AND BOOTS, SLIPPERS; JAPANESE STYLE WOODEN CLOGS (GETA); JAPANESE STYLE SANDALS (ZORI); MASQUERADE COSTUMES; SPECIAL SPORTSWEAR, NAMELY, SHORTS, SHIRTS, PANTS, JACKETS, COATS, VESTS AND BATHING SUITS; SPECIAL SPORTS FOOTWEAR; HORSE-RIDING BOOTS (U.S. CLS. 22 AND 39).

CLASS 28—TOYS AND SPORTING GOODS

FOR AMUSEMENT MACHINES AND APPARATUS FOR USE IN AMUSEMENT PARKS OTHER THAN ARCADE VIDEO GAME MACHINES, NAMELY, AMUSEMENT GAME MACHINES, STAND ALONE VIDEO GAME MACHINES; TOYS FOR DOMESTIC PETS; TOYS, NAMELY, BABY MULTIPLE ACTIVITY TOYS, BATH TOYS, BATTERY OPERATED ACTION TOYS, BENDABLE TOYS, CLOCKWORK TOYS OF PLASTIC, COLLECTABLE TOY FIGURES, DOG TOYS, DRAWING TOYS, EDUCATIONAL TOYS FOR PURPOSES OF THE DEMONSTRATION OF ALTERNATIVE ENERGY SOURCES, ELECTRIC ACTION TOYS, FANTASY CHARACTER TOYS, INFANT TOYS, MUSICAL TOYS, PET TOYS, PLASTIC CHARACTER TOYS, PLUSH TOYS, POP UP TOYS, POSITIONABLE TOY FIGURES, PRINTING TOYS, PULL TOYS, PUSH TOYS, REMOTE CONTROL TOYS, NAMELY, CARS, TRUCKS, AIRPLANES, TRAINS AND BOATS, STUFFED ANIMAL TOYS, AND GIRLS DOLLS WITH CLOTHING; DOLLS; HAND-HELD GAMES WITH LIQUID CRYSTAL DISPLAYS; GAMES, NAMELY, BOARD GAMES; CARD GAMES; DICE; DICE CUPS; CHESS GAMES; CHECKERS BEING CHECKER SETS; DOMINOES; PLAYING CARDS; MAH-JONG; GAME MACHINES AND APPARATUS, NAMELY, STAND ALONE VIDEO GAME MACHINES, AMUSEMENT GAME MACHINES; BILLIARD EQUIPMENT; SPORTS EQUIPMENT, NAMELY, TENNIS RACKETS, BADMINTON RACKETS, TABLE TENNIS RACKETS, GOLF BAGS, GOLF CLUBS, GOLF BALLS, GOLF BALL MARKERS, GOLF GLOVES, GOLF CLUB COVERS, SKIS, SKI CASES, SWIM FINNS, SKATEBOARDS, SNOWBOARDS, SNOWBOARD CASES, SURFBOARDS, AND SURFBOARD CASES; ORNAMENTS FOR CHRISTMAS TREES, EXCEPT ILLUMINATION ARTICLES AND CONFECTIONERY; PARTY FAVORS, NAMELY, BLOW-OUTS, CRACKERS, NOISEMAKERS, SMALL TOYS; DRESS UP DOLLS; STUFFED DOLLS; TOY MUSICAL BOXES (U.S. CLS. 22, 23, 38 AND 50).

LEIGH CAROLINE CASE, EXAMINING ATTORNEY

SN 79-089,153. SNOWLIFE AG, SWITZERLAND, FILED 10-15-2010.



PRIORITY DATE OF 6-28-2010 IS CLAIMED.
OWNER OF INTERNATIONAL REGISTRATION 1056148 DATED 10-15-2010, EXPIRES 10-15-2020.
OWNER OF U.S. REG. NOS. 3,085,627 AND 3,218,286.
THE MARK CONSISTS OF THE WORD "SNOWLIFE" WITH FIVE CIRCLES OVER THE "I" RESEMBLING A SNOWFLAKE.

CLASS 9—ELECTRICAL AND SCIENTIFIC APPARATUS

FOR FACE SCREENS, NAMELY, PROTECTIVE FACE MASKS NOT FOR MEDICAL PURPOSES, PROTECTIVE FACE-SHIELDS FOR PROTECTIVE HELMETS AND FACE-PROTECTION SHIELDS (U.S. CLS. 21, 23, 26, 36 AND 38).

CLASS 25—CLOTHING

FOR CLOTHING AND FOOTWEAR FOR SPORT AND LEISURE USE, NAMELY, BOOTS, GLOVES, SKI GLOVES, STOCKINGS, HEAD COVERINGS IN THE NATURE OF CAPS, HATS, SOCKS, BELTS, GLOVES FOR SKIERS AND SKI JUMPERS (U.S. CLS. 22 AND 39).

CLASS 28—TOYS AND SPORTING GOODS

FOR GOODS FOR GYMNASICS AND SPORTS, NAMELY, SKI POLES, BAGS ESPECIALLY ADAPTED FOR SPORTS EQUIPMENT, MASKS FOR SKIERS AND SKI JUMPERS (U.S. CLS. 22, 23, 38 AND 50).

CARYN GLASSER, EXAMINING ATTORNEY

SN 79-089,957. ANVIS SD FRANCE S.A.S., FRANCE, FILED 6-16-2010.

IMPACTOR

THE MARK CONSISTS OF STANDARD CHARACTERS WITHOUT CLAIM TO ANY PARTICULAR FONT, STYLE, SIZE, OR COLOR.

PRIORITY DATE OF 12-18-2009 IS CLAIMED.

OWNER OF INTERNATIONAL REGISTRATION 1058211 DATED 6-16-2010, EXPIRES 6-16-2020.

CLASS 7—MACHINERY

FOR SUSPENSIONS FOR EXHAUST SYSTEMS, NAMELY, FOR EXHAUST PIPES, SILENCERS AND CATALYSERS FOR LAND VEHICLES; PARTS OF MOTORS AND DRIVE COMPONENTS NOT FOR LAND VEHICLES, NAMELY, ELASTOMER-METAL BEARINGS AND BEARING SYSTEMS COMPRISED PRIMARILY OF RUBBER BUSHINGS, RUBBER MOUNTS, AXLE BUSHINGS, AXLE MOUNTS, STRUT MOUNTS, HYDRO BUSHINGS, HYDRO MOUNTS, CRADLE MOUNTS, CONTROL ARM MOUNTS, SHOCK ABSORBER BUSHINGS AND SHOCK ABSORBER MOUNTS, FOR ARRANGING THE BEARINGS IN MOTORS AND ENGINES AND IN DRIVING GEARS; PARTS OF GAS CATALYTIC CONVERTER UNITS FOR MOTORS AND ENGINES, NAMELY, SUSPENSION SYSTEMS CONSISTING OF SPRINGS AND SHOCK ABSORBERS OTHER THAN FOR LAND VEHICLES, FOR USE WITH SUCTION PIPE AND EXHAUST PIPE BANDS AND COMPONENTS THEREOF (U.S. CLS. 13, 19, 21, 23, 31, 34 AND 35).

CLASS 9—ELECTRICAL AND SCIENTIFIC APPARATUS

FOR TESTING DEVICES CONSISTING OF AN IMPACT HEAD AND ACCELERATOR SENSORS FOR THE CONTROL OF THE FUNCTIONALITY OF ELASTIC ARTICULATIONS IN VEHICLE SUSPENSION SYSTEMS, ENGINE MOUNTING SYSTEMS, AND ALL OTHER VEHICLE DECOUPLING SYSTEMS (U.S. CLS. 21, 23, 26, 36 AND 38).

CLASS 12—VEHICLES

FOR STRUCTURAL COMPONENTS OF AUTOMOBILES, NAMELY, PARTS OF SUSPENSION SYSTEMS IN THE NATURE OF DECOUPLINGS, AND REDUCERS AND VIBRATIONAL RUNNING GEAR PARTS MADE OF ELASTOMERS AND/OR PLASTIC, AND OF THESE MATERIALS COMBINED WITH OTHER MATERIALS, IN PARTICULAR COMBINED WITH METAL; ACTIVE AND PASSIVE STRUCTURAL COMPONENTS OF LAND VEHICLES FOR DAMPING AND REDUCING VIBRATIONS, NAMELY, SUSPENSION SYSTEMS CONSISTING OF SPRINGS AND SHOCK ABSORBERS FOR AUTOMOBILES AND UTILITY VEHICLES (U.S. CLS. 19, 21, 23, 31, 35 AND 44).

TRACY FLETCHER, EXAMINING ATTORNEY

SN 79-090,385. TETRA LAVAL HOLDINGS & FINANCE S.A.,
CH-1009 PULLY, SWITZERLAND, FILED 5-10-2010.

TETRA VICTENSO

THE MARK CONSISTS OF STANDARD CHARACTERS WITHOUT CLAIM TO ANY PARTICULAR FONT, STYLE, SIZE, OR COLOR.

PRIORITY DATE OF 11-13-2009 IS CLAIMED.

OWNER OF INTERNATIONAL REGISTRATION 1059591
DATED 5-10-2010, EXPIRES 5-10-2020.

OWNER OF U.S. REG. NOS. 580,219, 1,013,119 AND
3,841,528.

THE ENGLISH TRANSLATION OF "TETRA" IN THE
MARK IS "FOUR" IN GREEK. THE WORDING "VICTEN-
SO" HAS NO MEANING IN A FOREIGN LANGUAGE.

CLASS 7—MACHINERY

FOR MACHINES AND APPARATUS FOR THE PROCESSING, TREATMENT AND FINISHING OF FOOD AND LIQUID PRODUCTS, NAMELY, MACHINES AND APPARATUS FOR RAW MATERIAL RECEPTION, BULK AND UNIT HANDLING, STORAGE AND DISTRIBUTION WHEN MAKING FOOD AND LIQUID PRODUCTS, MACHINES AND APPARATUS FOR POWDER MIXING AND DISSOLVING FOR MAKING FOOD AND LIQUID PRODUCTS, MACHINES AND APPARATUS FOR USE IN INDUSTRIAL FOOD PROCESSING DESIGNED FOR THE THERMAL TREATMENT OF FOOD PRODUCTS, MACHINES AND APPARATUS FOR ASEPTIC STORAGE OF FOOD AND LIQUID PRODUCTS, ELECTRIC FOOD PROCESSORS, AGITATORS FOR CIRCULATING LIQUID MEDIA, PACKAGING MACHINES FOR FOOD AND LIQUID PRODUCTS; VACUUM PACKING MACHINES; GRINDING MILLS; ELECTRIC FOOD BLENDER; CHEESE CUTTING MACHINES; CHEESE SHREDDER MACHINES; DAIRY EQUIPMENT, NAMELY, MACHINES FOR INDUSTRIAL MANUFACTURING OF DAIRY PRODUCTS; STIRRING MACHINES; EXTRACTING MACHINES FOR EXTRACTION OF FOOD AND LIQUID PRODUCTS; MACHINES, NAMELY, CENTRIFUGES; SEPARATOR MACHINES, NAMELY, CENTRIFUGAL SEPARATORS FOR SEPARATING INGREDIENTS WHEN MAKING FOOD AND BEVERAGES; MACHINES AND APPARATUS FOR BLENDING OR DOSING FOOD AND LIQUID PRODUCTS, NAMELY, BLENDER MACHINES FOR FOOD AND LIQUID PRODUCTS FOR USE IN INDUSTRIAL OR COMMERCIAL APPLICATIONS, DOSING MACHINES FOR ADDING INGREDIENTS IN THE PROCESSING OF FOOD AND BEVERAGES; MIXING MACHINES FOR MIXTURE AND DILUTION OF FOOD AND LIQUID PRODUCTS; MIXING MACHINES FOR RECOMBINATION OF FOOD AND LIQUID PRODUCTS; MACHINES AND APPARATUS FOR THE CONCENTRATION OF FOOD AND LIQUID PRODUCTS, NAMELY, MACHINES FOR THE EXTRACTION OF EXCESS WATER FROM FOODS AND LIQUID PRODUCTS; MIXING MACHINES FOR MIXING FOOD OR LIQUID PRODUCTS; REGULATING MACHINES FOR REGULATION OF FAT CONTENTS IN FOOD AND LIQUID PRODUCTS; MACHINE PARTS, NAMELY, PUMPS AND VALVES DESIGNED FOR THE FOODSTUFF INDUSTRY; HEAT EXCHANGERS BEING PARTS OF MACHINES; FILTERS, NAMELY, MEMBRANE FILTERS, WATER FILTERS, STERILE AIR FILTERS, FILTERS FOR BACTERIA AND SPORE REMOVAL AND FILTERS FOR FILTERING PARTICLES WHEN MAKING FOOD AND LIQUID PRODUCTS, ALL OF THE AFOREMENTIONED FILTERS FOR FOOD AND LIQUID PROCESSING MACHINES; MACHINES AND APPARATUS FOR USE IN THE BREWERY AND BEVERAGE INDUSTRY, NAMELY, YEAST PROPAGATION MACHINES, YEAST MIXING MACHINES; APPARATUS FOR AERATION AND DE-AERATION, NAMELY, AERATORS AND DE-AERATING MACHINES; MACHINES AND APPARATUS FOR BIOTECHNOLOGICAL PRODUCTION OF NEUTRACEUTICALS; FEEDERS, NAMELY, INGREDIENT FEEDERS FOR USE IN FOOD AND BEVERAGE MANUFACTURE; EXTRUSION MOLDING MACHINES; CONVEYORS; FILLING AND PACKAGING MACHINES FOR FOOD AND LIQUID PRODUCTS; WRAPPING MACHINES; HOMOGENIZER MACHINES FOR INDUSTRIAL USE; MACHINE PARTS, NAMELY, MOULDS FOR USE IN THE MANU-

FACTURE OF FOOD CONTAINERS; MACHINES FOR MEMBRANE FILTRATION OF FOOD AND LIQUID PRODUCTS; POWER-OPERATED DECANTERS, NAMELY, MACHINES FOR DECANTING LIQUIDS; ELECTRIC FOOD PREPARATION APPARATUS, NAMELY, MACHINES AND APPARATUS FOR THE RESTITUTION OF AROMAS OF FOOD AND LIQUID PRODUCTS; MACHINES AND APPARATUS FOR WASHING AND CLEANING OF PROCESS SYSTEMS AND MACHINES AS WELL AS FOR TANK AND CONTAINER CLEANING; MACHINE TOOLS, PARTS AND COMPONENTS FOR THE AFORESAID GOODS (U.S. CLS. 13, 19, 21, 23, 31, 34 AND 35).

CLASS 9—ELECTRICAL AND SCIENTIFIC APPARATUS

FOR APPARATUS AND INSTRUMENTS FOR MONITORING, CONTROLLING, OPERATING, DOSING, SUPERVISING, WEIGHING, CHECKING AND MEASURING IN THE PROCESSING, TREATMENT AND FINISHING OF FOOD AND LIQUID PRODUCTS, RACKING, FILLING AND PACKAGING OF FOOD AND LIQUID PRODUCTS, NAMELY, ELECTRONIC CONTROL SYSTEMS FOR FOOD AND LIQUID PROCESSING MACHINES, ELECTRONIC REGULATING AND CONTROL DEVICES FOR THE OPERATION OF FOOD AND LIQUID PROCESSING MACHINES, COMPUTER SOFTWARE AND HARDWARE TO MONITOR AND CONTROL FACTORY MANUFACTURING PROCESSES, NAMELY, FOOD AND LIQUID PROCESSING, DOSIMETERS, WEIGHING APPARATUS AND INSTRUMENTS, INSTRUMENTS FOR MEASURING FOOD AND BEVERAGE QUALITY PARAMETERS; COMPUTER SOFTWARE PROGRAMS FOR MONITORING, CONTROLLING, OPERATING, DOSING, SUPERVISING, WEIGHING, CHECKING AND MEASURING IN THE PROCESSING, TREATMENT AND FINISHING OF FOOD AND LIQUID PRODUCTS, RACKING, AND PACKAGING OF FOOD AND LIQUID PRODUCTS; FLOW-METERS; FLOW INDICATORS; PRESSURE INDICATORS; THERMOMETERS; PARTS AND COMPONENTS FOR THE AFORESAID GOODS (U.S. CLS. 21, 23, 26, 36 AND 38).

CLASS 11—ENVIRONMENTAL CONTROL APPARATUS

FOR APPARATUS AND INSTRUMENTS FOR HEATING, HEAT RECOVERING, COOLING, REFRIGERATION, VENTILATION, BOILING, LIGHTING, COOKING, STEAM GENERATION, CONCENTRATION, DRYING, PASTEURIZATION, DISTILLATION, STERILIZATION, DISINFECTION AND DESALINATION, ALL THE AFOREMENTIONED GOODS FOR USE IN THE FOOD AND LIQUID PROCESSING INDUSTRY, NAMELY, HEATING AND COOLING UNITS, REFRIGERATING MACHINES, VENTILATORS, ELECTRICAL BOILERS, LIGHTING APPARATUS, COOKING OVENS, STEAM GENERATORS, INDUSTRIAL DRYERS, PASTEURIZERS, DISTILLERS, STERILIZERS, DISINFECTANT APPARATUS FOR INDUSTRIAL PURPOSES AND DESALINATION UNITS, ALL THE AFOREMENTIONED GOODS FOR USE IN THE FOOD AND LIQUID PROCESSING INDUSTRY; FILTERS AND MEMBRANE FILTERS FOR FILTERING PARTICLES WHEN PROCESSING FOOD AND BEVERAGES; APPARATUS, NAMELY, THERMOELECTRIC HEATER FOR THE THERMAL TREATMENT OF FOOD AND LIQUID PRODUCTS; HEAT EXCHANGERS; EVAPORATORS; FREEZERS; APPARATUS AND INSTRUMENTS, NAMELY, FREEZERS FOR HARDENING AND FREEZING WHEN MANUFACTURING FOOD AND LIQUID PRODUCTS; APPARATUS AND TANKS FOR STERILE STORAGE OF STERILIZED FOOD AND LIQUID PRODUCTS; PARTS AND COMPONENTS FOR THE AFORESAID GOODS (U.S. CLS. 13, 21, 23, 31 AND 34).

CLASS 42—SCIENTIFIC AND COMPUTER SERVICES

FOR ENGINEERING SERVICES; COMPUTER HARDWARE AND SOFTWARE CONSULTANCY; DEVELOPMENT OF DATA PROCESSING PROGRAMS BY ORDER OF THIRD PARTIES; COMPUTER TECHNICAL SUPPORT AND CONSULTATION SERVICES FOR MANAGING COMPUTER SYSTEMS, DATABASES AND APPLICATIONS; CONSTRUCTION AND DESIGN OF PACKAGING, NAMELY, PACKAGING DESIGN; PROFESSIONAL CONSULTANCY IN PLANNING AND DESIGN OF FACTORY BUILDINGS; TECHNICAL CONSULTANCY REGARDING THE PLANNING AND DESIGN OF FACTORY BUILDINGS; SCIENTIFIC AND TECHNOLOGICAL RESEARCH AND DEVELOPMENT SERVICES, NAMELY, SCIENTIFIC RESEARCH AND DEVELOPMENT, TECHNOLOGICAL PRODUCT RESEARCH AND DEVELOPMENT; ALL AFOREMENTIONED SERVICES RELATED TO INDUSTRIAL FOOD AND LIQUID PROCESSING MACHINES, INDUSTRIAL FOOD AND LIQUID PACKAGE FILLING MACHINES, AND INDUSTRIAL FOOD AND LIQUID DISTRIBUTION MACHINES AND OTHER MACHINES IN THE PROCESSING AND PACKAGING OF FOOD AND LIQUID PRODUCTS (U.S. CLS. 100 AND 101).

DAVID ELTON, EXAMINING ATTORNEY

CLASS 8—HAND TOOLS

FOR HAND-OPERATED AGRICULTURAL IMPLEMENTS, NAMELY, TROWELS, WEEDING FORKS, GARDEN FORKS, SPADES, SHOVELS, HOES, CULTIVATORS, PRUNERS, PRUNING SAWS, RAKES, SHEARS, EDGERS; SMALL APPARATUS FOR SOIL, LAWN AND PLANT CULTIVATION AND CARE, NAMELY, HAND-OPERATED LAWN MOWERS, SCARIFIERS, EDGE CUTTERS, AERATORS AND HAND-OPERATED SPREADERS AND BUCKETS THEREFORE; CUTTING APPARATUS, NAMELY, HAND-HELD SAWS AND SHEARS, BRANCH HOOKS, FRUIT PICKERS, SCARIFIERS, CULTIVATORS, GRUBBERS, GARDEN TILLERS, COMBINATION TILLERS, ROTARY HOES, CULTIVATORS, SCRAPERS, LADLES, PRICKERS AND PLANTERS, FORKS, WEEDERS, SOWING IMPLEMENTS FOR SEEDS, SCOOPS, EXTRACTORS AND DUTCH HOES, RAKES, PLIERS, RIDGERS, WEEDERS, AND EDGERS, DUST PANS, AERATING RIDGERS AND ROLLERS AS WELL AS SWIVEL AERATORS (U.S. CLS. 23, 28 AND 44).

GINA HAYES, EXAMINING ATTORNEY

SN 79-090,993, MTD PRODUCTS INC., UNITED STATES, FILED 7-14-2010.

POWER

PRIORITY DATE OF 1-18-2010 IS CLAIMED.
OWNER OF INTERNATIONAL REGISTRATION 1061072 DATED 7-14-2010, EXPIRES 7-14-2020.
NO CLAIM IS MADE TO THE EXCLUSIVE RIGHT TO USE "POWER", APART FROM THE MARK AS SHOWN.

CLASS 6—METAL GOODS

FOR COMMON METALS AND THEIR ALLOYS; IRONMONGERY, NAMELY, BOLTS, NUTS, SCREWS; GOODS OF METAL, NAMELY, GARDEN HOSES OF METAL, METAL HOLDERS AND COUPLINGS FOR GARDEN HOSES, HAND OPERATED METAL GARDEN HOSE REELS, METAL HANDLES FOR GARDENING TOOLS, METAL BUCKETS, AND RACK SYSTEMS FOR TOOLS CONSISTING PRIMARILY OF FRAMEWORKS OF METAL AND HANGERS OF METAL FOR HOLDING HAND OPERATED AGRICULTURAL AND HORTICULTURAL IMPLEMENTS AND SMALL APPARATUSES FOR SOIL AND LAWN CULTIVATION AS WELL AS APPARATUSES FOR PLANT CULTIVATION AND CARE (U.S. CLS. 2, 12, 13, 14, 23, 25 AND 50).

CLASS 7—MACHINERY

FOR MOTORIZED AGRICULTURAL AND HORTICULTURAL IMPLEMENTS, NAMELY, POWER OPERATED CHIPPERS, SHREDDERS, TRIMMERS, CULTIVATORS, LAWN AND GARDEN EDGERS, SPRAY GUNS; MECHANICAL SOIL AND LAWN CULTIVATION APPARATUS AND APPARATUS FOR PLANT CULTIVATION AND CARE, NAMELY, MOTORIZED SHEARS, TRIMMERS, SCARIFIERS AND AERATORS, MOTOR OPERATED SAWS AND SHREDDERS, SLICERS AND PRESSES, MOTORIZED CLEANING AND MAINTENANCE MACHINES FOR LAWN AND GROUND CLEANING, AND ELECTRIC, BATTERY, AND GASOLINE POWERED WALK-BEHIND AND RIDE-ON MOWERS (U.S. CLS. 13, 19, 21, 23, 31, 34 AND 35).

SN 79-091,655, LG CORP., SEOUL, 150-721, REPUBLIC OF KOREA, FILED 8-24-2010.

LG Live Green

PRIORITY DATE OF 7-30-2010 IS CLAIMED.
OWNER OF INTERNATIONAL REGISTRATION 1062577 DATED 8-24-2010, EXPIRES 8-24-2020.
OWNER OF U.S. REG. NOS. 3,250,589 AND 3,250,591.
NO CLAIM IS MADE TO THE EXCLUSIVE RIGHT TO USE "GREEN", APART FROM THE MARK AS SHOWN.

CLASS 7—MACHINERY

FOR ELECTRIC WASHING MACHINES FOR CLOTHES; AUTOMATIC DISHWASHERS; ELECTRIC VACUUM CLEANERS (U.S. CLS. 13, 19, 21, 23, 31, 34 AND 35).

CLASS 9—ELECTRICAL AND SCIENTIFIC APPARATUS

FOR WIRED TELEPHONE SETS; WIRELESS TELEPHONE SETS; PORTABLE COMMUNICATIONS APPARATUS, NAMELY, MOBILE PHONE HANDSETS, WALKIE-TALKIES, SATELLITE TELEPHONES AND PERSONAL DIGITAL ASSISTANTS; MOBILE PHONES; MPEG AUDIO LAYER-3 PLAYERS; TELEVISION RECEIVERS; REMOTE CONTROLS FOR TELEVISION; ENCODED ELECTRONIC CHIP CARDS FOR IMPROVEMENT OF TELEVISION IMAGE QUALITY; UNIVERSAL SERIAL BUS USB DRIVES; DIGITAL MEDIA BROADCASTING DMB PLAYERS, NAMELY, DIGITAL AUDIO PLAYERS; HEADSETS FOR MOBILE PHONES; PORTABLE CHARGERS FOR ELECTRIC BATTERIES; ELECTRONIC PHOTO ALBUMS, NAMELY, DIGITAL PHOTO FRAMES FOR DISPLAYING DIGITAL PICTURES; DIGITAL PHOTO FRAMES FOR DISPLAYING DIGITAL PICTURES; MONITORS FOR COMPUTERS; LAPTOP COMPUTERS; COMPUTERS; DIGITAL VERSATILE DISC PLAYERS; PORTABLE HARD DISK DRIVES; APPARATUS FOR RECORDING, TRANSMISSION OR REPRODUCTION OF SOUND OR IMAGES FOR USE IN TELECOMMUNICATION; APPARATUS FOR RECORDING, TRANSMISSION OR REPRODUCTION OF SOUND OR IMAGES; COMPUTER APPLICATION SOFTWARE FOR MOBILE PHONE FOR RECEIVING AND TRANSMISSION OF MESSAGE IN THE NATURE OF DATA, TEXT, LANGUAGE, SOUND, IMAGE AND VIDEO; COMPUTER APPLICATION SOFTWARE FOR TELEVISION, NAMELY, SOFTWARE FOR SETTING-UP AND CALIBRATING TELEVISIONS; COMPUTER APPLICATION SOFTWARE FOR PERSONAL COMPUTER MONITORS, NAMELY, SOFTWARE FOR SOFTWARE FOR SETTING-UP AND CALIBRATING PERSONAL COMPUTER MONITORS; DIGITAL VERSATILE DISC PLAYERS FOR HOME THEATERS; AUDIO SPEAKERS FOR HOME THEATERS; AUDIO-VIDEO RECEIVERS FOR HOME THEATERS; PROJECTORS FOR HOME THEATERS; INTEGRATED CIRCUITS; AUDIO RECEIVERS; ON-BOARD UNITS, NAMELY, COMPUTERS INSTALLED ON-BOARD VEHICLES FOR USE IN ELECTRONIC TOLL COLLECTION SYSTEMS AND ELECTRONIC ENCODED TOLL SMART CARDS CONTAINING PROGRAMMING USED TO PAY ELECTRONIC TOLL COLLECTIONS; TRANSPONDERS, NAMELY, ELECTRONIC TERMINALS EQUIPPED IN VEHICLES FOR ELECTRONIC COMMERCIAL TRANSACTIONS; CLOSED-CIRCUIT TELEVISION CAMERAS; NETWORK MONITORING CAMERAS, NAMELY, FOR SURVEILLANCE; DIGITAL SIGNAGE MONITORS; THERMAL PRINTERS; DIGITAL COLOUR PRINTERS; LASER PRINTERS; INK JET PRINTERS; COLOUR PRINTERS; PRINTERS FOR USE WITH COMPUTERS; SOLAR BATTERIES (U.S. CLS. 21, 23, 26, 36 AND 38).

CLASS 10—MEDICAL APPARATUS

FOR MESSAGE APPARATUS; VIBROMASSAGE APPARATUS; ELECTRIC MASSAGE APPARATUS FOR HOUSEHOLD USE; MASSAGE APPARATUS FOR PERSONAL USE; BED VIBRATORS; CHAIRS FOR ELECTRIC MASSAGE; ESTHETIC MASSAGE APPARATUS (U.S. CLS. 26, 39 AND 44).

CLASS 11—ENVIRONMENTAL CONTROL APPARATUS

FOR ELECTRIC REFRIGERATORS; REFRIGERATORS FOR FERMENTED VEGETABLE FOOD, NAMELY, KIMCHI; LIGHTWAVE COOKING OVENS; TEMPERATURE CONTROLLED ELECTRIC WINE CELLARS; ELECTRIC COOKING OVENS; ELECTRIC FREEZERS; ELECTRIC LAUNDRY DRYERS IN THE NATURE OF CLOTHES DRYERS; GAS RANGES; MICROWAVE OVENS; GAS COOKTOP; ELECTRIC RANGES FOR HOUSEHOLD USE; AIR PURIFIERS; AIR CONDITIONERS; HOT AIR SPACE HEATING APPARATUS IN THE NATURE OF ELECTRIC SPACE HEATERS; HUMIDIFIERS; ELECTRIC DEHUMIDIFIER FOR HOUSEHOLD USE; GAS GRILLS; DISH DISINFECTANT APPARATUS FOR HOUSEHOLD PURPOSES; WATER PURIFIERS FOR HOUSEHOLD PURPOSES; ELECTRIC WATER PURIFIERS FOR HOUSEHOLD USE; WATER IONIZERS; WATER IONIZATION APPARATUS FOR HOUSEHOLD PURPOSES; WATER PURIFIERS FOR HOUSEHOLD PURPOSES NON-ELECTRIC; WATER PURIFYING APPARATUS; ELECTRIC FOOTWARMERS; WATER PURIFICATION INSTALLATIONS; PRECISION FILTERS FOR WATER TREATING (U.S. CLS. 13, 21, 23, 31 AND 34).

CLASS 35—ADVERTISING AND BUSINESS

FOR PUBLIC OPINION POLLING; WHOLESALE STORE SERVICES FEATURING COMMUNICATION MACHINES AND APPARATUS; RETAIL STORE SERVICES FEATURING COMMUNICATION MACHINES AND APPARATUS; WHOLESALE STORE SERVICES FEATURING PORTABLE COMMUNICATIONS APPARATUS; RETAIL STORE SERVICES FEATURING PORTABLE COMMUNICATIONS APPARATUS; WHOLESALE STORE SERVICES FEATURING COMPUTERS; RETAIL STORE SERVICES FEATURING COMPUTERS; WHOLESALE STORE SERVICES FEATURING TELECOMMUNICATION MACHINES AND APPARATUS; RETAIL STORE SERVICES FEATURING TELECOMMUNICATION MACHINES AND APPARATUS; WHOLESALE STORE SERVICES FEATURING ELECTRONIC MACHINES AND APPARATUS AND THEIR PARTS; RETAIL STORE SERVICES FEATURING ELECTRONIC MACHINES AND APPARATUS AND THEIR PARTS; WHOLESALE STORE SERVICES FEATURING COMPUTER MONITORS; RETAIL STORE SERVICES FEATURING COMPUTER MONITORS; OPERATION OF BROADBAND TELECOMMUNICATION NETWORKS (U.S. CLS. 100, 101 AND 102).

CLASS 38—COMMUNICATION

FOR COMMUNICATIONS BY FIBER OPTIC NETWORKS; DATA COMMUNICATION, NAMELY, ELECTRONIC TRANSMISSION OF DATA AMONG USERS OF COMPUTERS; WIRELESS BROADBAND COMMUNICATION SERVICES; VAN COMMUNICATIONS, NAMELY, PROVIDING COMMUNICATIONS VIA VALUE-ADDED NETWORK (VAN) TRANSMISSION SERVICES; COMMUNICATION BETWEEN REMOTE TERMINALS, NAMELY, PROVIDING FACILITIES AND EQUIPMENT FOR VIDEO CONFERENCING SERVICES USING ON-SCREEN VIDEO; RENTAL OF TELECOMMUNICATION EQUIPMENT; COMMUNICATION BY COMPUTER TERMINALS; TELECOMMUNICATIONS AGENCIES, NAMELY, TRANSMISSION OF NEWS ITEMS TO NEWS REPORTING ORGANIZATIONS; CELLULAR TELEPHONE COMMUNICATION; CABLE TELEVISION BROADCASTING (U.S. CLS. 100, 101 AND 104).

CURTIS FRENCH, EXAMINING ATTORNEY

SN 79-091,789. RAYNER DESIGN PTY LTD, AUSTRALIA,
FILED 12-3-2010.

SN 79-091,987. AKZO NOBEL COATINGS INTERNATIONAL
B.V., NETHERLANDS, FILED 12-13-2010.

CUTTER MOUSE

THE MARK CONSISTS OF STANDARD CHARACTERS WITHOUT CLAIM TO ANY PARTICULAR FONT, STYLE, SIZE, OR COLOR.

OWNER OF INTERNATIONAL REGISTRATION 1062991
DATED 12-3-2010, EXPIRES 12-3-2020.

NO CLAIM IS MADE TO THE EXCLUSIVE RIGHT TO USE "CUTTER", APART FROM THE MARK AS SHOWN.

CLASS 8—HAND TOOLS

FOR PAPER TRIMMERS, HAND-OPERATED, NOT FOR OFFICE USE; HAND-OPERATED CUTTING TOOLS; SHEARERS INCLUDING SELF-SHARPENING ROTARY SHEARERS (U.S. CLS. 23, 28 AND 44).

CLASS 16—PAPER GOODS AND PRINTED MATTER

FOR HAND OPERATED PAPER TRIMMERS FOR OFFICE OR DOMESTIC USE; PAPER CUTTERS FOR OFFICE USE; PAPER CUTTERS (U.S. CLS. 2, 5, 22, 23, 29, 37, 38 AND 50).

MICHAEL WEBSTER, EXAMINING ATTORNEY

SN 79-091,856. LABORATORIUM DR. G. BICHSEL AG,
SWITZERLAND, FILED 11-10-2010.

EQUI-BISEROL

THE MARK CONSISTS OF STANDARD CHARACTERS WITHOUT CLAIM TO ANY PARTICULAR FONT, STYLE, SIZE, OR COLOR.

PRIORITY DATE OF 6-4-2010 IS CLAIMED.

OWNER OF INTERNATIONAL REGISTRATION 1063189
DATED 11-10-2010, EXPIRES 11-10-2020.

CLASS 5—PHARMACEUTICALS

FOR PHARMACEUTICAL AND VETERINARY PRODUCTS IN PARTICULAR FOR VETERINARY USE FOR GASTRO-INTESTINAL DISORDERS; CHEMICAL PREPARATIONS FOR PHARMACEUTICAL OR MEDICAL PURPOSES FOR USE WITH ABSTINENCE AND ANORECTIC EQUINES WITH GASTROINTESTINAL DISEASES, NAMELY, COLIC, CONSERVATIVE AND SURGICAL, COLITIS, DIARRHEA, STOMACH-REFLUX AND EQUINES WHICH COULD NOT EAT OR COULD NOT EAT ENOUGH, DIETETIC FOODS ADAPTED FOR MEDICAL USE; SANITARY PREPARATIONS FOR MEDICAL USE (U.S. CLS. 6, 18, 44, 46, 51 AND 52).

CLASS 10—MEDICAL APPARATUS

FOR SURGICAL APPARATUS AND INSTRUMENTS FOR MEDICAL, DENTAL OR VETERINARY USE (U.S. CLS. 26, 39 AND 44).

CLASS 44—MEDICAL, BEAUTY AND AGRICULTURAL SERVICES

FOR VETERINARY SERVICES; HYGIENIC AND BEAUTY CARE, ANIMAL GROOMING SERVICES (U.S. CLS. 100 AND 101).

LOURDES AYALA, EXAMINING ATTORNEY

SIKKENS CREATING TOGETHER

THE MARK CONSISTS OF STANDARD CHARACTERS WITHOUT CLAIM TO ANY PARTICULAR FONT, STYLE, SIZE, OR COLOR.

PRIORITY DATE OF 10-28-2010 IS CLAIMED.

OWNER OF INTERNATIONAL REGISTRATION 1063477
DATED 12-13-2010, EXPIRES 12-13-2020.

OWNER OF U.S. REG. NO. 1,017,246.

CLASS 1—CHEMICALS

FOR PUTTIES, NAMELY, GLAZIERS PUTTY AND OIL CEMENT, ALL FOR USE IN THE AUTOMOTIVE INDUSTRY (U.S. CLS. 1, 5, 6, 10, 26 AND 46).

CLASS 2—PAINTS

FOR COATINGS IN THE NATURE OF AUTOMOBILE FINISHING; PAINTS; VARNISHES; LACQUERS; PRIMERS; THINNERS FOR PAINTS; THICKENERS, NAMELY, THICKENERS FOR PAINTS; PRESERVATIVES AGAINST RUST IN THE NATURE OF A COATING; COLORANTS; COLORANT DISPERSIONS FOR USE IN SURFACE COATING COMPOSITIONS; MORDANTS; NATURAL RESINS; METALS IN FOIL AND POWDER FORM FOR PAINTERS AND DECORATORS; ALL FOR USE IN AUTOMOTIVE INDUSTRY (U.S. CLS. 6, 11 AND 16).

CLASS 3—COSMETICS AND CLEANING PREPARATIONS

FOR BLEACHING PREPARATIONS FOR LAUNDRY USE; CLEANING, POLISHING, SCOURING AND ABRASIVE PREPARATIONS, ALL FOR USE IN THE AUTOMOTIVE INDUSTRY (U.S. CLS. 1, 4, 6, 50, 51 AND 52).

CLASS 17—RUBBER GOODS

FOR PACKING, STOPPING, FILLING AND INSULATING MATERIALS, ALL FOR THE AUTOMOTIVE INDUSTRY (U.S. CLS. 1, 5, 12, 13, 35 AND 50).

CLASS 41—EDUCATION AND ENTERTAINMENT

FOR EDUCATION SERVICES, NAMELY, PROVIDING CLASSES, SEMINARS, WORKSHOPS, TRAINING IN THE FIELDS OF AUTOMOTIVE REFINISHING AND APPLICATION OF COATINGS (U.S. CLS. 100, 101 AND 107).

CLASS 42—SCIENTIFIC AND COMPUTER SERVICES

FOR MAINTENANCE, IMPLEMENTATION, DEVELOPMENT AND UPDATING OF SOFTWARE IN RELATION TO THE AUTOMOTIVE INDUSTRY (U.S. CLS. 100 AND 101).

JENNIFER DIXON, EXAMINING ATTORNEY

SN 79-092,551. MERCK KGAA, FED REP GERMANY, FILED 12-24-2010.



PRIORITY DATE OF 10-15-2010 IS CLAIMED.
OWNER OF INTERNATIONAL REGISTRATION 1065068
DATED 12-24-2010, EXPIRES 12-24-2020.

THE COLOR(S) ORANGE AND BRIGHT YELLOW IS/ARE CLAIMED AS A FEATURE OF THE MARK.

THE MARK CONSISTS OF A STYLIZED LETTER "M" WITH THE FIRST LEG OF THE LETTER DIVIDED INTO TWO SECTIONS. THE BOTTOM LEFT CORNER OF THE "M" IS BRIGHT YELLOW AND THE REMAINDER OF THE LETTER "M" IS ORANGE.

CLASS 1—CHEMICALS

FOR CHEMICALS FOR USE IN INDUSTRY AND SCIENCE; CHEMICALS USED IN AGRICULTURE, HORTICULTURE AND FORESTRY EXCEPT FUNGICIDES, HERBICIDES, INSECTICIDES AND PARASITICIDES; UNPROCESSED ARTIFICIAL RESINS, UNPROCESSED PLASTICS; MANURES; FIRE EXTINGUISHING COMPOSITIONS; TEMPERING PREPARATIONS; SOLDERING PREPARATIONS, NAMELY, FLUXES; CHEMICAL SUBSTANCES FOR PRESERVING FOODSTUFFS; TANNING AGENTS FOR USE IN THE MANUFACTURE OF LEATHER; ADHESIVES USED IN INDUSTRY (U.S. CLS. 1, 5, 6, 10, 26 AND 46).

CLASS 5—PHARMACEUTICALS

FOR PHARMACEUTICAL PREPARATIONS, NAMELY, PREPARATIONS FOR THE TREATMENT OF INFERTILITY, OVULATION INDUCTION, INFERTILITY AND OVULATION INDUCTION, AUTOIMMUNE DISEASES, HYPERSENSITIVITIES, IMMUNE DEFICIENCY, ALLOGRAFT REJECTION, CARDIOVASCULAR AND CIRCULATORY DISEASES, AUTO IMMUNE DISEASES, GROWTH AND METABOLIC DISEASES, DISEASES OF THE CENTRAL NERVOUS SYSTEM, DISEASES OF THE METABOLIC AND ENDOCRINE SYSTEMS, RESPIRATORY DISEASES, CANCER, GASTROINTESTINAL DISEASE, SEXUAL DYSFUNCTIONS, VIRAL DISEASES, INFLAMMATORY AND HEMATOLOGICAL DISORDERS AND CALCIUM DISORDERS; ANTIVIRAL PREPARATIONS FOR OPHTHALMIC USE; SANITARY PREPARATIONS FOR MEDICAL PURPOSES; DIETETIC FOOD ADAPTED FOR MEDICAL USE, FOOD FOR BABIES; PLASTERS FOR MEDICAL PURPOSES, GAUZE FOR DRESSINGS; MATERIAL FOR STOPPING TEETH, DENTAL WAX; ALL PURPOSE DISINFECTANTS; PREPARATIONS FOR DESTROYING VERMIN; FUNGICIDES, HERBICIDES (U.S. CLS. 6, 18, 44, 46, 51 AND 52).

CLASS 9—ELECTRICAL AND SCIENTIFIC APPARATUS

FOR SCIENTIFIC, NAUTICAL, SURVEYING, PHOTOGRAPHIC, CINEMATOGRAPHIC, OPTICAL, WEIGHING, MEASURING, SIGNALING, CHECKING, LIFE-SAVING AND TEACHING APPARATUS AND INSTRUMENTS, NAMELY, APPARATUS AND INSTRUMENTS IN THE NATURE OF ELECTRO-OPTICAL LCD DISPLAYS CONTAINING OPTICAL FOILS OR FILMS AS PART OF DISPLAY DEVICES OR INTELLIGENT OPTICAL SURFACES; APPARATUS FOR RECORDING, TRANSMISSION OR REPRODUCTION OF SOUND OR IMAGES; BLANK MAGNETIC DATA CARRIERS AND BLANK OPTICAL RECORDING DISCS; CASH REGISTERS, CALCULATING MACHINES; DATA PROCESSING EQUIPMENT AND COMPUTERS; FIRE-EXTINGUISHERS (U.S. CLS. 21, 23, 26, 36 AND 38).

CLASS 16—PAPER GOODS AND PRINTED MATTER

FOR PAPER, CARDBOARD AND GOODS MADE FROM THESE MATERIALS, NAMELY, CARDBOARD, CARDBOARD BOXES AND CONTAINERS, WRITING PAPER, BOND PAPER, CRAFT PAPER, COPY PAPER, BROCHURES ABOUT CHEMICALS AND PHOTOVOLTAICS, BOOKS IN THE FIELD OF PHOTOVOLTAICS AND CHEMICAL PROCESSES; PRINTED MATTER, NAMELY, NEWSLETTERS, MAGAZINES AND INFORMATION SHEETS IN THE FIELD OF CHEMICALS AND PHOTOVOLTAICS; PRINTED INSTRUCTIONAL AND TEACHING MATERIAL IN THE FIELD OF PHOTOVOLTAICS AND CHEMICAL PROCESSES; PLASTIC MATERIALS FOR PACKAGING, NAMELY, PLASTIC BAGS FOR PACKAGING, PLASTIC BAGS FOR MERCHANDISE PACKAGING, AND PLASTIC BUBBLE PACKS; OFFICE MACHINES, NAMELY, PAPER FOLDING MACHINES FOR OFFICE USE, AND OFFICE PERFORATING MACHINES (U.S. CLS. 2, 5, 22, 23, 29, 37, 38 AND 50).

CLASS 42—SCIENTIFIC AND COMPUTER SERVICES

FOR SCIENTIFIC AND INDUSTRIAL RESEARCH, NAMELY, SCIENTIFIC RESEARCH AND DEVELOPMENT IN THE AREA OF PHARMACY, MEDICINE, BIOLOGY AND CHEMISTRY; COMPUTER PROGRAMMING FOR DATA PROCESSING PURPOSES; SCIENTIFIC CONSULTING SERVICES IN THE FIELDS OF ONCOLOGY, METABOLIC AND CARDIOVASCULAR DISEASES OR DISORDERS, DISEASES AND DISORDERS OF THE CENTRAL NERVOUS SYSTEM, RESPIRATORY DISEASES, GASTROINTESTINAL DISEASES, AUTOIMMUNE DISEASE; DRAWING UP SCIENTIFIC EXPERT REPORTS; DRAWING UP MEDICAL AND PHARMACEUTICAL EXPERT REPORTS; MEDICAL AND SCIENTIFIC RESEARCH, NAMELY, PLANNING, PERFORMING AND EVALUATING SCIENTIFIC STUDIES; MEDICAL AND SCIENTIFIC RESEARCH, NAMELY, PLANNING, PERFORMING AND EVALUATING MEDICAL AND PHARMACEUTICAL STUDIES (U.S. CLS. 100 AND 101).

MICHELE SWAIN, EXAMINING ATTORNEY

SN 79-093,361. NORSLUND A/S, DENMARK, FILED 1-26-2011.

LITTLE MIRACLES

THE MARK CONSISTS OF STANDARD CHARACTERS WITHOUT CLAIM TO ANY PARTICULAR FONT, STYLE, SIZE, OR COLOR.

PRIORITY DATE OF 10-1-2010 IS CLAIMED.
OWNER OF INTERNATIONAL REGISTRATION 1067096
DATED 1-26-2011, EXPIRES 1-26-2021.

CLASS 30—STAPLE FOODS

FOR COFFEE, TEA, COCOA, SUGAR, RICE, TAPIOCA, SAGO, ARTIFICIAL COFFEE; FLOUR, BREAD, PASTRY, ICES; HONEY, TREACLE; YEAST, BAKING POWDER; SALT, MUSTARD; VINEGAR, SAUCES; SPICES; ICE (U.S. CL. 46).

CLASS 32—LIGHT BEVERAGES

FOR BEERS; MINERAL AND AERATED WATERS AND OTHER NON-ALCOHOLIC DRINKS, NAMELY, SOFT DRINKS, DRINKS FLAVORED WITH PLANT AND/OR ROOT EXTRACTS, NAMELY, TEA, GINSENG, POMEGRANATE, ACAI, PEACH AND CHERRY; FRUIT DRINKS AND FRUIT JUICES; SYRUPS FOR MAKING BEVERAGES; OTHER PREPARATIONS FOR MAKING BEVERAGES, NAMELY, CONCENTRATES AND POWDERS FOR MAKING SOFT DRINKS (U.S. CLS. 45, 46 AND 48).

AISHA SALEM, EXAMINING ATTORNEY

SN 79-094,120. AM ALPHA GMBH, FED REP GERMANY, FILED 11-22-2010.

AM alpha

THE MARK CONSISTS OF STANDARD CHARACTERS WITHOUT CLAIM TO ANY PARTICULAR FONT, STYLE, SIZE, OR COLOR.

PRIORITY DATE OF 5-27-2010 IS CLAIMED.

OWNER OF INTERNATIONAL REGISTRATION 1068576 DATED 11-22-2010, EXPIRES 11-22-2020.

NO CLAIM IS MADE TO THE EXCLUSIVE RIGHT TO USE "AM", APART FROM THE MARK AS SHOWN.

CLASS 36—INSURANCE AND FINANCIAL

FOR SECURITIES BROKERAGE; BUILDING PROMOTER SERVICES, NAMELY, FINANCIAL PREPARATION OF BUILDING PROJECTS IN THE NATURE OF BUDGET PLANNING AND PROJECT FINANCING, RENTAL PROPERTY MANAGEMENT, AND APPRAISAL OF REAL ESTATE ALL WITHIN THE FRAMEWORK OF PROPERTY MANAGEMENT SERVICES; TRUSTEE SERVICES, NAMELY, ASSET MANAGEMENT BY TRUSTEES IN CONNECTION WITH MONETARY AFFAIRS; REAL ESTATE RELATED FINANCIAL PLANNING; FINANCIAL AFFAIRS AND MONETARY AFFAIRS, NAMELY, FINANCIAL INFORMATION, MANAGEMENT AND ANALYSIS SERVICES; REAL ESTATE MANAGEMENT AND BROKERAGE; RENTAL OF REAL ESTATE, NAMELY, RENTAL OF RESIDENTIAL HOUSING, RENTAL OF VACATION HOMES, RENTAL OF SHORT-TERM FURNISHED APARTMENTS AND LEASING OF REAL ESTATE; REAL ESTATE AFFAIRS, NAMELY, REAL ESTATE AGENCIES, REAL ESTATE CONSULTATION, AND REAL ESTATE LISTING; REPAIR COSTS EVALUATION; RENTAL OF APARTMENTS; MUTUAL FUNDS, NAMELY, MUTUAL FUND BROKERAGE, MUTUAL FUND DISTRIBUTION, AND MUTUAL FUND INVESTMENT; INSURANCE BROKERAGE; INSURANCE, NAMELY, INSURANCE AGENCIES, INSURANCE CONSULTATION, AND INSURANCE INFORMATION; ACCOMMODATION BUREAUX, NAMELY, HOUSING AGENCIES (U.S. CLS. 100, 101 AND 102).

SN 79-093,896. NURPHY LTD, UNITED KINGDOM, FILED 9-17-2010.

Nurph

THE MARK CONSISTS OF STANDARD CHARACTERS WITHOUT CLAIM TO ANY PARTICULAR FONT, STYLE, SIZE, OR COLOR.

PRIORITY DATE OF 3-29-2010 IS CLAIMED.

OWNER OF INTERNATIONAL REGISTRATION 1068028 DATED 9-17-2010, EXPIRES 9-17-2020.

CLASS 35—ADVERTISING AND BUSINESS

FOR ADVERTISING; BUSINESS MANAGEMENT; COMPILATION OF INFORMATION INTO COMPUTER DATABASES; ADVERTISING SERVICES PROVIDED VIA THE INTERNET; MARKET OPINION POLLING; PUBLIC OPINION POLLING; DATA PROCESSING; PROVISION OF BUSINESS INFORMATION; PROVIDING ON-LINE DIRECTORY INFORMATION SERVICES ALSO FEATURING HYPERLINKS TO OTHER WEB SITES; PROVIDING A COMMERCIAL INFORMATION DIRECTORY OF HYPERLINKS (U.S. CLS. 100, 101 AND 102).

CLASS 38—COMMUNICATION

FOR TELECOMMUNICATIONS SERVICES, NAMELY, TRANSMISSION OF VOICE, DATA, GRAPHICS, SOUND AND VIDEO BY MEANS OF BROADBAND POWER LINES OR WIRELESS NETWORKS; PROVIDING INTERNET CHAT ROOM AND PROVIDING ON-LINE FORUMS FOR TRANSMISSION OF MESSAGES AMONG COMPUTER USERS; PROVIDING E-MAIL SERVICES; PROVIDING ON-LINE COMMUNICATIONS LINKS WHICH TRANSFER THE WEB SITE USER TO OTHER LOCAL AND GLOBAL WEB PAGES (U.S. CLS. 100, 101 AND 104).

KELLEY WELLS, EXAMINING ATTORNEY

CLASS 37—CONSTRUCTION AND REPAIR

FOR PAINTING AND REPAIRING OF SIGNS; CONSTRUCTION, NAMELY, CONSTRUCTION CONSULTATION AND CONSTRUCTION PLANNING; BUILDING CONSTRUCTION INFORMATION; BUILDING REPAIR INFORMATION; CONSTRUCTION OF EXHIBITION STANDS AND SHOPS; BUILDING SERVICES, NAMELY, BUILDING REPAIR AND MAINTENANCE; CONSTRUCTION AND REPAIR OF WAREHOUSES; SUPERVISION OF BUILDING CONSTRUCTION; BUILDING CONSTRUCTION MANAGEMENT; BUILDING CONSTRUCTION; CONSTRUCTION SERVICES, NAMELY, IN THE FIELD OF STRUCTURAL ENGINEERING, IN PARTICULAR THE ERECTION OF SCAFFOLDING; HARBOUR CONSTRUCTION; SHIPBUILDING; PIER BREAKWATER BUILDING AND HOUSING CONSTRUCTION; VEHICLE SERVICING, NAMELY, REPAIR AND MAINTENANCE OF VEHICLES; INSTALLATION AND REPAIR OF LIFTS; INSTALLATION AND REPAIR OF IRRIGATION DEVICES; INSTALLATION AND REPAIR OF OFFICE EQUIPMENT; INSTALLATION AND REPAIR OF STEAM BOILER; INSTALLATION AND REPAIR OF BURGLAR ALARMS; INSTALLATION AND REPAIR OF FIRE ALARMS; INSTALLATION AND REPAIR OF FILM PROJECTION APPARATUS; INSTALLATION AND REPAIR OF HEATING APPARATUS; INSTALLATION AND REPAIR OF AIR-CONDITIONING APPARATUS; INSTALLATION AND REPAIR OF REFRIGERATING APPARATUS; INSTALLATION AND REPAIR OF OVENS; INSTALLATION AND REPAIR OF TELEPHONES; INSTALLATION, REPAIR AND MAINTENANCE OF COMPUTER HARDWARE SYSTEMS; REPAIR AND CLEANING SERVICES FOR HOUSEHOLD PURPOSES, NAMELY, REPAIR OF

HOUSEHOLD APPLIANCES AND CLEANING OF RESIDENTIAL HOUSES; CABINET MAKING, NAMELY, CABINET REPAIR; REPAIR OF INDUSTRIAL LAMINATING MACHINES; REPAIR OF UPHOLSTERY; REPAIR OF PUMPS; REPAIR OF LOCKS; REPAIR OF CLOCKS AND WATCHES; REPAIR, NAMELY, REPAIR OF BUILDINGS; REPAIR OF WAREHOUSES; REPAIR OF FURNISHINGS, NAMELY, FURNITURE; UNDERWATER REPAIR; RENTAL OF CONSTRUCTION EQUIPMENT; MAINTENANCE AND REPAIR OF BURNERS; MAINTENANCE AND REPAIR OF MOTOR VEHICLES; MAINTENANCE AND REPAIR OF SAFES; MAINTENANCE AND REPAIR OF STRONG-ROOMS (U.S. CLS. 100, 103 AND 106).

CLASS 42—SCIENTIFIC AND COMPUTER SERVICES

FOR ARCHITECTURE, NAMELY, ARCHITECTURAL CONSULTATION, ARCHITECTURAL DESIGN, AND ARCHITECTURAL RESEARCH; DRAFTSMAN'S SERVICES IN THE NATURE OF TECHNICAL DRAWING; ENGINEERING; DESIGN OF INTERIOR DECOR; CONDUCTING TECHNICAL PROJECT STUDIES FOR CONSTRUCTION PROJECTS, NAMELY, CONSTRUCTION DRAFTING; INDUSTRIAL ANALYSIS AND RESEARCH IN THE FIELDS OF ASSET MANAGEMENT; TECHNOLOGICAL SERVICES AND RESEARCH AND DESIGN RELATING THERETO, NAMELY, TECHNOLOGICAL CONSULTATION IN THE TECHNOLOGY FIELD OF COMPUTER HARDWARE SYSTEMS; SCIENTIFIC SERVICES AND RESEARCH AND DESIGN RELATING THERETO, NAMELY, SCIENTIFIC RESEARCH AND DEVELOPMENT; TECHNICAL EVALUATION OF CONSTRUCTION PROJECTS, NAMELY, CONDUCTING OF FEASIBILITY STUDIES (U.S. CLS. 100 AND 101).

HAI-LY LAM, EXAMINING ATTORNEY

SN 79-094,511, SHAUN PULFREY, UNITED KINGDOM, FILED 10-20-2010.

MAGIC FLOWERPOT

THE MARK CONSISTS OF STANDARD CHARACTERS WITHOUT CLAIM TO ANY PARTICULAR FONT, STYLE, SIZE, OR COLOR.

PRIORITY DATE OF 4-21-2010 IS CLAIMED.

OWNER OF INTERNATIONAL REGISTRATION 1069527 DATED 10-20-2010, EXPIRES 10-20-2020.

CLASS 3—COSMETICS AND CLEANING PREPARATIONS

FOR NON-MEDICATED TOILET PREPARATIONS, NAMELY, SOAPS, BODY AND SKIN CLEANSERS, SHAMPOOS, SCALP TREATMENTS, DENTIFRICES; PREPARATIONS AND SUBSTANCES FOR CARE OF THE HAIR, SKIN AND TEETH, NAMELY, SHAMPOOS, CONDITIONERS, HAIR GELS, HAIR STYLING FOAMS, HAIR STYLING MOUSSE, NON-MEDICATED HAIR SERUMS, HAIR CONDITIONING OILS, HAIR COLORANTS, NON-MEDICATED HAIR TREATMENTS, HAIR FIXING SPRAY, SKIN CREAMS, SOAPS, BODY AND HAND WASHES, SKIN CLEANSERS, SHOWER CREAM, SHOWER GEL, BATH FOAM, BATH OILS, MOISTURIZING CREAMS, MASSAGE CREAMS, MASSAGE OILS, DEODORANTS FOR PERSONAL USE, MOUTHWASH, TOOTHPASTE; COSMETICS, PERFUMERY, ESSENTIAL OILS (U.S. CLS. 1, 4, 6, 50, 51 AND 52).

CLASS 16—PAPER GOODS AND PRINTED MATTER

FOR CARDBOARD; PRINTED MATTER, NAMELY, PAPER, LEAFLETS IN THE FIELD OF HAIR AND BEAUTY AND OF CHILDREN'S CHARACTER STORIES; PUBLICATIONS, NAMELY, PAMPHLETS, BROCHURES IN THE FIELD OF HAIR AND BEAUTY AND OF CHILDREN'S CHARACTER STORIES; MAGAZINES IN THE FIELD OF HAIR AND BEAUTY AND OF CHILDREN'S CHARACTER STORIES; MAGAZINES IN THE FIELD OF HAIR AND BEAUTY AND OF CHILDREN'S CHARACTER STORIES; MAGAZINES IN THE FIELD OF HAIR AND BEAUTY AND OF CHILDREN'S CHARACTER STORIES, BOOKLETS IN THE FIELD OF HAIR AND BEAUTY AND OF CHILDREN'S CHARACTER STORIES; STATIONERY; POSTERS; PAPER GIFT CARDS, PAPER GIFT WRAP; CALENDARS; PENS; PENCILS (U.S. CLS. 2, 5, 22, 23, 29, 37, 38 AND 50).

CLASS 21—HOUSEWARES AND GLASS

FOR BRUSHES AND COMBS FOR THE HAIR; SPONGES FOR USE IN APPLICATION OF COSMETICS AND OF HAIR CARE PREPARATIONS; TOOTHBRUSHES; COSMETIC UTENSILS, NAMELY, COSMETIC APPLICATORS IN THE NATURE OF APPLICATOR STICKS FOR APPLYING MAKE-UP, COSMETIC BRUSHES, BRUSHES FOR THE APPLICATION OF HAIR CARE PREPARATIONS (U.S. CLS. 2, 13, 23, 29, 30, 33, 40 AND 50).

CLASS 25—CLOTHING

FOR FOOTWEAR; CLOTHING, NAMELY, SHIRTS, T-SHIRTS, PANTS, SHORTS, DRESSES, SKIRTS, JEANS, JUMPERS, COATS, JACKETS, SLEEPWEAR, UNDERWEAR, HATS, SCARVES, GLOVES, SOCKS AND STOCKINGS; KNITWEAR, NAMELY, KNIT SHIRTS, KNIT SHORTS, AND KNIT JACKETS; LEISUREWEAR, NAMELY, TOPS, T-SHIRTS, POLO SHIRTS, SHORTS, SWEATERS, PANTS, SKIRTS, DRESSES, JACKETS AND CAPS (U.S. CLS. 22 AND 39).

CLASS 26—FANCY GOODS

FOR ARTICLES FOR THE HAIR, NAMELY, HAIR BANDS, HAIR BOWS, HAIR CLIPS, HAIR GRIPS, HAIR PINS AND HAIR FASTENERS; HAIR RIBBONS, HAIR ORNAMENTS, HAIR PIECES, HAIR SLIDES; ELASTIC HAIR BANDS; NON-ELECTRIC HAIR CURLERS, NON-ELECTRIC HAIR ROLLERS; HEAD BANDS (U.S. CLS. 37, 39, 40, 42 AND 50).

ELIZABETH KAJUBI, EXAMINING ATTORNEY

SN 79-094,718, GUANGDONG TAYO MOTORCYCLE TECHNOLOGY CO., LTD., CHINA, FILED 9-25-2010.

ZONTES

OWNER OF INTERNATIONAL REGISTRATION 1070089 DATED 9-25-2010, EXPIRES 9-25-2020.

OWNER OF U.S. REG. NO. 3,508,919.

THE WORDING "ZONTES" HAS NO MEANING IN A FOREIGN LANGUAGE.

CLASS 4—LUBRICANTS AND FUELS

FOR LUBRICATING OILS; ADDITIVES, NON-CHEMICAL, TO MOTOR-FUEL; GREASE FOR AUTOMOTIVE, MACHINE AND MOTORCYCLE BELTS; LUBRICATING OILS; INDUSTRIAL OIL, NAMELY, OIL FOR MOISTENING; LUBRICATING GREASE; FUEL; INDUSTRIAL OIL; MINERAL OILS FOR USE IN THE MANUFACTURE OF PAINTS, SOYBEAN OIL AND VEGETABLE OILS FOR USE IN THE MANUFACTURE OF PAINTS (U.S. CLS. 1, 6 AND 15).

CLASS 6—METAL GOODS

FOR METAL LOCKS, METAL LATCHES AND METAL BOLTS; METAL HOUSE NUMBERS AND LETTERS AND METAL NUMBERS AND LETTERS FOR MOTORCYCLES; WORKS OF ART OF COMMON METAL; BRONZE; STATUES OF COMMON METAL; MEMORIAL PLAQUES OF METAL (U.S. CLS. 2, 12, 13, 14, 23, 25 AND 50).

CLASS 7—MACHINERY

FOR SPARK PLUGS; CARBURETOR; FUEL INJECTORS; KICK STARTERS FOR MOTORCYCLES; PISTON RINGS; MUFFLERS FOR MOTORS AND ENGINES; OIL FILTER; AIR FILTERS FOR VEHICLES MOTORS AND ENGINES; ROLLER BEARINGS FOR MACHINES; EXHAUST PIPES AND EXHAUST MANIFOLDS FOR VEHICLES (U.S. CLS. 13, 19, 21, 23, 31, 34 AND 35).

CLASS 9—ELECTRICAL AND SCIENTIFIC APPARATUS

FOR SPEEDOMETER OR TACHOMETER; OIL METER; ELECTRICAL CABLES FOR MOTORS; INDUSTRIAL PROCESS ANNUNCIATOR; BATTERY; CABLES, ELECTRIC; BICYCLE AND MOTORCYCLE HELMETS; DIVING AND MOTORCYCLE GOGGLES; VIDEO DISKS AND VIDEO TAPES RECORDED WITH ANIMATION (U.S. CLS. 21, 23, 26, 36 AND 38).

CLASS 18—LEATHER GOODS

FOR PURSES; SACHEL; WALLETS; MESH SHOPPING BAG, SHOPPING BAGS MADE OF SKINS AND SHOPPING BAGS WITH WHEELS ATTACHED; BRIEF BAG OR CASE; HANDBAGS; TRAVEL BAGS; VALISES; BAGS FOR SPORTS; UMBRELLA (U.S. CLS. 1, 2, 3, 22 AND 41).

CLASS 24—FABRICS

FOR WALL HANGINGS OF TEXTILE; SILK FABRIC FOR PRINTING PATTERNS; BORCADE AND BROCADE FLAGS; PAINTING ON PLUSH SILK; TEXTILE, NAMELY SILK FABRICS WITH SILK PAINTING; TEXTILE, NAMELY SILK FABRICS WITH HAND AND MACHINE EMBROIDERED PICTURES; SILK FABRICS CONTAINING ART WORK ON THE FABRICS; FLAGS AND BANNERS OF TEXTILE; TOWELS (U.S. CLS. 42 AND 50).

CLASS 25—CLOTHING

FOR HAT; T-SHIRTS AND SHORTS; TIE OR ASCOT; GLOVES; STOCKING; SOCKS; SCARFS; BOOTS AND SHOES; MOTORISTS' CLOTHING NAMELY, T-SHIRTS AND SHORTS AND MOTORCYCLE GLOVES AND MOTORCYCLE JACKETS AND MOTORCYCLE RAIN SUITS; GIRDLES; SASHES FOR WEAR (U.S. CLS. 22 AND 39).

CLASS 28—TOYS AND SPORTING GOODS

FOR MODEL TOY VEHICLES AND JIGSAW PUZZLES; ELBOW GUARDS FOR ATHLETIC USE; KNEE GUARDS FOR ATHLETIC USE; PROTECTIVE PADDING FOR MOTORCYCLING; PROTECTIVE PADDINGS FOR PALMS, LEGS, FACE AND BODY; FOOTBALL GIRDLES; PROTECTIVE COVERS FOR RACKETS; EXERCISE MACHINES (U.S. CLS. 22, 23, 38 AND 50).

CLASS 35—ADVERTISING AND BUSINESS

FOR SALES PROMOTION FOR OTHERS; PROCUREMENT SERVICES FOR OTHERS, NAMELY, PURCHASING MOTORCYCLES AND MOTORCYCLE SPARE PARTS FOR OTHERS; IMPORT-EXPORT AGENCIES; PRESENTATION OF GOODS ON COMMUNICATION MEDIA, FOR RETAIL PURPOSES; ORGANIZATION OF TRADE FAIRS FOR COMMERCIAL OR ADVERTISING PURPOSES; COMMERCIAL ADMINISTRATION OF THE LICENSING OF THE GOODS AND SERVICES OF OTHERS; OUTSOURCING SERVICES; ORGANIZING TECHNOLOGY EXHIBITION FOR COMMERCIAL OR ADVERTISING PURPOSES; COMMERCIAL OR INDUSTRIAL MANAGEMENT ASSISTANCE; AUCTIONEERING (U.S. CLS. 100, 101 AND 102).

CLASS 41—EDUCATION AND ENTERTAINMENT

FOR ENTERTAINMENT AND EDUCATION CLUB SERVICES, NAMELY, CLUBS FOR MOTORCYCLE ENTHUSIASTS; HEALTH CLUB SERVICES, NAMELY PROVIDING INSTRUCTION AND EQUIPMENT IN THE FIELD OF PHYSICAL EXERCISE; LIVE PERFORMANCES BY A MUSICAL BAND; ENTERTAINER SERVICES, NAMELY, LIVE, TELEVISED, AND MOVIE APPEARANCES BY A PROFESSIONAL ENTERTAINER; PROVIDING SPORTS FACILITIES; TEACHING, NAMELY TECHNIQUE TRAINING FOR RIDING MOTORCYCLES; ARRANGING AND CONDUCTING OF EDUCATIONAL CONFERENCES; ORGANIZATION OF SHOWS AND PERFORMANCES, NAMELY, ORGANIZING LIVE SHOWS OF MOTORCYCLE RIDING TECHNIQUES; PUBLICATION OF BOOKS (U.S. CLS. 100, 101 AND 107).

CLASS 43—HOTEL AND RESTAURANT SERVICES

FOR PROVIDING TEMPORARY HOUSING ACCOMMODATIONS, NAMELY ACCOMMODATIONS IN HOTELS AND BOARDING HOUSE; CAFETERIAS; HOTELS; BAR; BAR SERVICES; PROVIDING CAMPGROUND FACILITIES; TOURIST HOMES; RENTAL OF TENTS; RENTAL OF ROOMS FOR SOCIAL FUNCTIONS; PROVIDING TEMPORARY LODGING AT HOLIDAY CAMPS (U.S. CLS. 100 AND 101).

DORITT L. CARROLL, EXAMINING ATTORNEY

SN 79-095,408. BILLERUD AB, SWEDEN, FILED 2-25-2011.

FIBREFORM

THE MARK CONSISTS OF STANDARD CHARACTERS WITHOUT CLAIM TO ANY PARTICULAR FONT, STYLE, SIZE, OR COLOR.

OWNER OF INTERNATIONAL REGISTRATION 0992647 DATED 1-21-2009, EXPIRES 1-21-2019.

CLASS 1—CHEMICALS

FOR WOOD PULP, NAMELY, WOOD PULP FOR MANUFACTURING PURPOSES; PAPER PULP; PAPER PULP FOR PRODUCTION OF PACKAGES, TISSUE PRODUCTS, FINE PAPERS, PACKAGING PAPERS AND BOARDS, MAGAZINE PAPERS (U.S. CLS. 1, 5, 6, 10, 26 AND 46).

CLASS 16—PAPER GOODS AND PRINTED MATTER

FOR PAPER, CARDBOARD AND GOODS MADE FROM THESE MATERIALS, NAMELY, NEWSPRINT PAPER, MAGAZINE PAPER, PRINTING PAPER, WRITING PAPER, CRAFT PAPERS, CORRUGATED PAPERS AND BOARDS, LAMINATED PAPERS AND BOARDS, PAPER FOR MAKING BAGS AND SACKS, FLUTED PAPER, CONTAINER BOARD, PAPER COMPRISED OF A COMBINATION OF VIRGIN PAPER FIBRE AND A BARRIER COATING TO HOLD LIQUIDS FOR HOUSEHOLD USE, MEDICAL PACKAGING PAPER AND BOARD, CORE BOARD AND CORES, TISSUE PAPER, FINE PAPER IN THE NATURE OF WRITING AND DRAWING PAPER, COPYING PAPER, OFFSET PAPER, CONTINUOUS STATIONERY PAPER, LABEL PAPER, ENVELOPE PAPERS, PAPER FOR USE IN THE GRAPHIC ARTS INDUSTRY, PAPER AND CARDBOARD BOXES AND BAGS AND/OR IN COMBINATION WITH PLASTIC OR FOILS; ARTICLES OF PAPER OR CARDBOARD FOR PACKAGING OR WRAPPING, NAMELY, WRAPPING PAPER, PACKAGING PAPER, PACKAGING BOARD, PACKAGING CONTAINERS OF PAPER AND CARDBOARD, PAPER BAGS FOR PACKAGING, AND CORRUGATED CARDBOARD COMBINED WITH AN INNER PROTECTIVE PACKAGING OF PLASTIC IN THE FORM OF FOILS AND/OR BUBBLE PACK AND/OR FOAMED SHAPED PIECES FOR PACKAGING; PAPER OR CARDBOARD CONTAINERS, BAGS, BOXES AND SACKS; STATIONERY; PLASTIC MATERIALS FOR PACKAGING, NAMELY, PLASTIC BAGS, BOXES AND CONTAINERS, PLASTIC BUBBLE PACKS, AND PLASTIC FOILS (U.S. CLS. 2, 5, 22, 23, 29, 37, 38 AND 50).

RICHARD WHITE, EXAMINING ATTORNEY

CLASS 16—PAPER GOODS AND PRINTED MATTER

FOR PAPER, CARDBOARD AND GOODS MADE FROM THESE MATERIALS, NAMELY, NEWSPRINT PAPER, MAGAZINE PAPER, PRINTING PAPER, WRITING PAPER, CRAFT PAPERS, CORRUGATED PAPERS AND BOARDS, LAMINATED PAPERS AND BOARDS, PAPER FOR MAKING BAGS AND SACKS, FLUTED PAPER, CONTAINER BOARD, PAPER COMPRISED OF A COMBINATION OF VIRGIN PAPER FIBRE AND A BARRIER COATING TO HOLD LIQUIDS FOR HOUSEHOLD USE, MEDICAL PACKAGING PAPER AND BOARD, CORE BOARD AND CORES, TISSUE PAPER, FINE PAPER IN THE NATURE OF WRITING AND DRAWING PAPER, COPYING PAPER, OFFSET PAPER, CONTINUOUS STATIONERY PAPER, LABEL PAPER, ENVELOPE PAPERS, PAPER FOR USE IN THE GRAPHIC ARTS INDUSTRY, PAPER AND CARDBOARD BOXES AND BAGS AND/OR IN COMBINATION WITH PLASTIC OR FOILS; ARTICLES OF PAPER OR CARDBOARD FOR PACKAGING OR WRAPPING, NAMELY, WRAPPING PAPER, PACKAGING PAPER, PACKAGING BOARD, PACKAGING CONTAINERS OF PAPER AND CARDBOARD, PAPER BAGS FOR PACKAGING, AND CORRUGATED CARDBOARD COMBINED WITH AN INNER PROTECTIVE PACKAGING OF PLASTIC IN THE FORM OF FOILS AND/OR BUBBLE PACK AND/OR FOAMED SHAPED PIECES FOR PACKAGING; PAPER OR CARDBOARD CONTAINERS, BAGS, BOXES AND SACKS; STATIONERY; PLASTIC MATERIALS FOR PACKAGING, NAMELY, PLASTIC BAGS, BOXES AND CONTAINERS, PLASTIC BUBBLE PACKS, AND PLASTIC FOILS (U.S. CLS. 2, 5, 22, 23, 29, 37, 38 AND 50).

RICHARD WHITE, EXAMINING ATTORNEY

SN 79-095,411. BILLERUD AB, SWEDEN, FILED 2-25-2011.



OWNER OF INTERNATIONAL REGISTRATION 1030047 DATED 2-5-2010, EXPIRES 2-5-2020.

THE COLOR(S) GREEN AND WHITE IS/ARE CLAIMED AS A FEATURE OF THE MARK.

THE MARK CONSISTS OF ALTERNATING, STYLIZED, HORIZONTAL, GREEN AND WHITE LINES WITH A WAVE-LINE PATTERN RUNNING VERTICALLY THROUGH THE APPROXIMATE CENTER OF THE LINES FORMING THE SHAPE OF THE LETTER "F".

CLASS 1—CHEMICALS

FOR WOOD PULP, NAMELY, WOOD PULP FOR MANUFACTURING PURPOSES; PAPER PULP; PAPER PULP FOR PRODUCTION OF PACKAGES, TISSUE PRODUCTS, FINE PAPERS, PACKAGING PAPERS AND BOARDS, MAGAZINE PAPERS (U.S. CLS. 1, 5, 6, 10, 26 AND 46).

SN 79-095,681. REINZ DICHTUNGS-GMBH, 89233 NEULM, FED REP GERMANY, FILED 3-25-2011.

REINZOPLAST

THE MARK CONSISTS OF STANDARD CHARACTERS WITHOUT CLAIM TO ANY PARTICULAR FONT, STYLE, SIZE, OR COLOR.

PRIORITY DATE OF 10-13-2010 IS CLAIMED.

OWNER OF INTERNATIONAL REGISTRATION 1072786 DATED 3-25-2011, EXPIRES 3-25-2021.

OWNER OF U.S. REG. NO. 639,374.

CLASS 1—CHEMICALS

FOR CHEMICALS FOR USE IN INDUSTRY, UNPROCESSED ARTIFICIAL RESINS, UNPROCESSED PLASTICS; INDUSTRIAL ADHESIVES (U.S. CLS. 1, 5, 6, 10, 26 AND 46).

CLASS 17—RUBBER GOODS

FOR SEALING MATERIALS, NAMELY, LIQUID SEALING COMPOUNDS IN THE NATURE OF GENERAL PURPOSE SILICON RUBBER SEALANTS FOR USE IN THE AUTOMOTIVE FIELD (U.S. CLS. 1, 5, 12, 13, 35 AND 50).

KEVIN CORWIN, EXAMINING ATTORNEY

SN 79-095,682. REINZ DICHTUNGS-GMBH, 89233 NEU-ULM, FED REP GERMANY, FILED 3-25-2011.

REINZOSIL

THE MARK CONSISTS OF STANDARD CHARACTERS WITHOUT CLAIM TO ANY PARTICULAR FONT, STYLE, SIZE, OR COLOR.

PRIORITY DATE OF 10-13-2010 IS CLAIMED.
OWNER OF INTERNATIONAL REGISTRATION 1072787 DATED 3-25-2011, EXPIRES 3-25-2021.
OWNER OF U.S. REG. NO. 639,374.

CLASS 1—CHEMICALS

FOR CHEMICALS FOR USE IN INDUSTRY, UNPROCESSED ARTIFICIAL RESINS, UNPROCESSED PLASTICS; INDUSTRIAL ADHESIVES (U.S. CLS. 1, 5, 6, 10, 26 AND 46).

CLASS 17—RUBBER GOODS

FOR SEALING MATERIALS, NAMELY, LIQUID SEALING COMPOUNDS IN THE NATURE OF GENERAL PURPOSE SILICON RUBBER SEALANTS FOR USE IN THE AUTOMOTIVE FIELD (U.S. CLS. 1, 5, 12, 13, 35 AND 50).
KEVIN CORWIN, EXAMINING ATTORNEY

SN 79-095,848. FERRERO S.P.A., ITALY, FILED 1-27-2011.

nutella

OWNER OF INTERNATIONAL REGISTRATION 1073241 DATED 1-27-2011, EXPIRES 1-27-2021.

OWNER OF U.S. REG. NOS. 1,296,656, 3,930,669 AND OTHERS.

THE COLOR(S) BLACK, RED-ORANGE IS/ARE CLAIMED AS A FEATURE OF THE MARK.

THE MARK CONSISTS OF STYLIZED WORDING "NUTELLA" WITH THE "N" APPEARING IN BLACK AND THE "UTELLA" APPEARING IN RED-ORANGE.

CLASS 16—PAPER GOODS AND PRINTED MATTER

FOR PRINTED MATTER, NAMELY, NEWSPAPERS, PHOTOGRAPHS, MAGAZINES, BOOKS, PRINTED PERIODICALS, NEWSLETTERS, AND BROCHURES ALL IN THE FIELD OF FOOD; BOOK BINDING MATERIAL; PHOTOGRAPHS; STATIONERY; ADHESIVES FOR STATIONERY OR HOUSEHOLD PURPOSES (U.S. CLS. 2, 5, 22, 23, 29, 37, 38 AND 50).

CLASS 29—MEATS AND PROCESSED FOODS

FOR MEAT, FISH, POULTRY AND GAME; MEAT EXTRACTS; PRESERVED, FROZEN, DRIED AND COOKED FRUITS AND VEGETABLES; JELLIES, JAMS, COMPOTES; EGGS, MILK AND MILK PRODUCTS EXCLUDING ICE CREAM, ICE MILK AND FROZEN YOGURT; EDIBLE OILS AND FATS (U.S. CL. 46).

CLASS 30—STAPLE FOODS

FOR COFFEE, TEA, SUGAR, RICE, TAPIOCA, SAGO, SUBSTITUTE OF COFFEE, FLOUR, BREAD, BISCUITS, CAKES, PASTRY AND CONFECTIONARY, NAMELY, CANDY, CAKES, WAFERS, WAFFLES, MUFFINS; EATABLE ICE-CREAMS; HONEY, TREACLE, YEAST, BAKING POWDER; SALT, MUSTARD, PEPPER, VINEGAR, SAUCES; SPICES; ICE; SPREAD CREAMS, NAMELY, COCOA BASED SPREAD, CHOCOLATE AND CHOCOLATE PRODUCTS, NAMELY, PASTRY FOR CHOCOLATE BEVERAGE, CHOCOLATE PASTRY, CHOCOLATE COVERINGS, CHOCOLATE, PRALINE, CHOCOLATE FOR DECORATIONS OF CHRISTMAS TREE, CHOCOLATE COVERED CANDY CONTAINING ALCOHOLIC BEVERAGE CONTENT; PASTRY, CHEWING GUM, CHEWING GUM WITHOUT SUGAR, CANDIES WITHOUT SUGAR (U.S. CL. 46).

CLASS 32—LIGHT BEVERAGES

FOR BEERS; MINERAL AND AERATED WATERS AND OTHER NON-ALCOHOLIC DRINKS, NAMELY, CARBONATED BEVERAGES; FRUIT DRINKS AND FRUIT JUICES; SYRUPS AND SYRUP SUBSTITUTES FOR MAKING BEVERAGES (U.S. CLS. 45, 46 AND 48).

CLASS 33—WINES AND SPIRITS

FOR ALCOHOLIC BEVERAGES EXCEPT BEERS (U.S. CLS. 47 AND 49).

CLASS 35—ADVERTISING AND BUSINESS

FOR ADVERTISING; BUSINESS MANAGEMENT; BUSINESS ADMINISTRATION; PROVIDING OFFICE FUNCTIONS (U.S. CLS. 100, 101 AND 102).

CLASS 41—EDUCATION AND ENTERTAINMENT

FOR EDUCATION AND ENTERTAINMENT SERVICES PROVIDED VIA THE INTERNET, NAMELY, PROVISION OF AN INTERACTIVE ENTERTAINMENT WEBSITE FEATURING INFORMATION ABOUT FOOD TASTING, PROVISION OF ONLINE NON-DOWNLOADABLE VIDEO GAMES VIA A WEBSITE, ORGANIZING COMMUNITY SPORTING AND CULTURAL EVENTS, CONTESTS AND GAMES (U.S. CLS. 100, 101 AND 107).

CLASS 43—HOTEL AND RESTAURANT SERVICES

FOR SERVICES FOR PROVIDING FOOD AND DRINK (U.S. CLS. 100 AND 101).
JENNIFER WILLISTON, EXAMINING ATTORNEY

SN 79-095,936. WESTERMANN LERNSPIELVERLAG GMBH, FED REP GERMANY, FILED 5-26-2010.

mini LÜK

OWNER OF INTERNATIONAL REGISTRATION 0910988 DATED 3-30-2006, EXPIRES 3-30-2016.

OWNER OF U.S. REG. NOS. 3,476,420, 3,821,289 AND 3,902,796.

THE MARK CONSISTS OF THE WORDING "MINI" IN SCRIPT AND THE WORDING "LÜK" IN OUTLINED BLOCK LETTERS INSIDE OF A RECTANGLE WITH THE TWO DOTS OVER THE "U" FORMED BY SQUARES.

CLASS 16—PAPER GOODS AND PRINTED MATTER

FOR EDUCATIONAL PRINTED MATTER, PARTICULARLY BOOKS FOR INSTRUCTIONAL AND TEACHING PURPOSES, NAMELY, CHILDREN'S ACTIVITY BOOKS AND CHILDREN'S INTERACTIVE EDUCATIONAL BOOKS, AND PRINTED INSTRUCTIONAL AND TEACHING MATERIAL IN THE FIELDS OF CHILDREN'S EDUCATION AND COGNITIVE LEARNING (U.S. CLS. 2, 5, 22, 23, 29, 37, 38 AND 50).

CLASS 28—TOYS AND SPORTING GOODS

FOR EDUCATIONAL GAMES IN TRADITIONAL AS WELL AS ELECTRONIC FORMAT, EXCEPT IN THE FORM OF ADDITIONAL APPARATUS FOR TELEVISION SETS, NAMELY, CARD GAMES, HANDHELD UNITS FOR PLAYING ELECTRONIC GAMES NOT FOR USE WITH AN EXTERNAL DISPLAY SCREEN OR MONITOR, BOARD GAMES, MATCHING GAMES AND BUILDING GAMES (U.S. CLS. 22, 23, 38 AND 50).
APRIL ROACH, EXAMINING ATTORNEY

SN 79-095,999. ZEON LIMITED, UNITED KINGDOM, FILED 12-2-2010.

BIG TRAK

THE MARK CONSISTS OF STANDARD CHARACTERS WITHOUT CLAIM TO ANY PARTICULAR FONT, STYLE, SIZE, OR COLOR.

PRIORITY DATE OF 12-2-2010 IS CLAIMED.
OWNER OF INTERNATIONAL REGISTRATION 1073558 DATED 12-2-2010, EXPIRES 12-2-2020.

OWNER OF U.S. REG. NO. 3,889,409.
NO CLAIM IS MADE TO THE EXCLUSIVE RIGHT TO USE "TRACK", APART FROM THE MARK AS SHOWN.

SN 79-095,937. WESTERMANN LERNSPIELVERLAG GMBH, FED REP GERMANY, FILED 5-26-2010.



OWNER OF INTERNATIONAL REGISTRATION 0910989 DATED 3-30-2006, EXPIRES 3-30-2016.
OWNER OF U.S. REG. NOS. 3,476,420, 3,821,289 AND 3,902,796.

THE MARK CONSISTS OF THE WORDING "LÜK" IN OUTLINED BLOCK LETTERS INSIDE OF A RECTANGLE WITH THE TWO DOTS OVER THE "U" FORMED BY SQUARES.

CLASS 16—PAPER GOODS AND PRINTED MATTER

FOR EDUCATIONAL PRINTED MATTER, PARTICULARLY BOOKS FOR INSTRUCTIONAL AND TEACHING PURPOSES, NAMELY, CHILDREN'S ACTIVITY BOOKS AND CHILDREN'S INTERACTIVE EDUCATIONAL BOOKS, AND PRINTED INSTRUCTIONAL AND TEACHING MATERIAL IN THE FIELDS OF CHILDREN'S EDUCATION AND COGNITIVE LEARNING (U.S. CLS. 2, 5, 22, 23, 29, 37, 38 AND 50).

CLASS 28—TOYS AND SPORTING GOODS

FOR EDUCATIONAL GAMES IN TRADITIONAL AS WELL AS ELECTRONIC FORMAT, EXCEPT IN THE FORM OF ADDITIONAL APPARATUS FOR TELEVISION SETS, NAMELY, CARD GAMES, HANDHELD UNITS FOR PLAYING ELECTRONIC GAMES NOT FOR USE WITH AN EXTERNAL DISPLAY SCREEN OR MONITOR, BOARD GAMES, MATCHING GAMES AND BUILDING GAMES (U.S. CLS. 22, 23, 38 AND 50).
APRIL ROACH, EXAMINING ATTORNEY

CLASS 7—MACHINERY

FOR MACHINES AND MACHINE TOOLS, NAMELY, VACUUM CLEANERS AND THEIR COMPONENTS; MOTORS AND ENGINES, NOT FOR LAND VEHICLES; MACHINE COUPLING AND TRANSMISSION COMPONENTS, EXCEPT FOR LAND VEHICLES; COMPONENT AND REPLACEMENT PARTS AND FITTINGS FOR ALL THE AFORESAID GOODS (U.S. CLS. 13, 19, 21, 23, 31, 34 AND 35).

CLASS 9—ELECTRICAL AND SCIENTIFIC APPARATUS

FOR SCIENTIFIC, NAUTICAL, SURVEYING, PHOTOGRAPHIC, CINEMATOGRAPHIC, OPTICAL, WEIGHING, MEASURING, SIGNALING, CHECKING, LIFE-SAVING AND TEACHING APPARATUS AND INSTRUMENTS, NAMELY, CAMERAS, DIGITAL CAMERAS, WIRELESS COMMUNICATION DEVICES FOR VOICE, DATA, OR IMAGE TRANSMISSION, WIRELESS CONNECTION MODULES, LIGHTS, NAMELY, LIGHT EMITTING DIODES (LEDS) AND LIGHTS FOR USE ON CAMERAS; ELECTRONIC CONTROL PANELS AND KEYPADS, COMPUTER HARDWARE AND PERIPHERAL DEVICES, PANELS AND KEYPADS FOR PROGRAMMING COMMANDS AND COMPUTER SOFTWARE FOR OPERATING ELECTRONIC TOY VEHICLES; APPARATUS FOR RECORDING, TRANSMISSION OR REPRODUCTION OF SOUND OR IMAGES; PRERECORDED MAGNETIC DATA CARRIERS FEATURING COMPUTER SOFTWARE FOR OPERATING ELECTRONIC TOY VEHICLES; AUTOMATIC VENDING MACHINES AND MECHANISMS FOR COIN-OPERATED APPARATUS; CASH REGISTERS, CALCULATING MACHINES, DATA PROCESSING EQUIPMENT AND COMPUTERS; CAMERAS, DIGITAL CAMERAS (U.S. CLS. 21, 23, 26, 36 AND 38).

CLASS 28—TOYS AND SPORTING GOODS

FOR TOYS, GAMES AND PLAYTHINGS, NAMELY, ELECTRONIC TOY VEHICLES AND ACCESSORIES THEREFOR; PROGRAMMABLE ELECTRONIC TOY VEHICLES AND ACCESSORIES THEREFOR; PROGRAMMABLE ELECTRONIC TOY VEHICLES WHICH RESPOND TO COMMANDS ENTERED BY AN ELECTRONIC KEYPAD; ELECTRONIC TOY VEHICLES INCORPORATING CAMERAS; TOY MISSILE LAUNCHERS, BEVERAGE CAN HOLDERS, TOY GUNS, INFRARED LAMPS, WIRELESS CONNECTION MODULES, AND LIGHTS; PARTS AND FITTINGS FOR ALL THE AFORESAID GOODS, NAMELY, WHEELS FOR TOY VEHICLES, TOY MISSILE LAUNCHERS, AND TOY GUNS (U.S. CLS. 22, 23, 38 AND 50).
TASNEEM HUSSAIN, EXAMINING ATTORNEY

SN 79-096,438. GTB GLOBAL TRADE BERLIN GMBH, FED REP GERMANY, FILED 1-18-2011.

SN 79-096,925. ZHANG JIN LAN, 510000 GUANGDONG PROVINCE, CHINA, FILED 4-11-2011.



PRIORITY DATE OF 7-22-2010 IS CLAIMED.
OWNER OF INTERNATIONAL REGISTRATION 1074557
DATED 1-18-2011, EXPIRES 1-18-2021.
THE MARK CONSISTS OF A STYLIZED "WD".

CLASS 9—ELECTRICAL AND SCIENTIFIC APPARATUS

FOR APPARATUS FOR RECORDING, TRANSMISSION OR REPRODUCTION OF SOUND AND IMAGES, AND PARTS AND ACCESSORIES, NAMELY, MEMORY CARDS AND BLANK USB FLASH DRIVES, AND CASINGS, NAMELY, CARRYING CASES AND PROTECTIVE CASES FOR TABLET COMPUTERS, PERSONAL COMPUTERS, LAPTOP COMPUTERS, MEMORY CARDS, USB FLASH DRIVES, CAMERAS, MP3 PLAYERS, AND MOBILE PHONES, AND CASING REPLACEMENT PARTS THEREOF (U.S. CLS. 21, 23, 26, 36 AND 38).

CLASS 16—PAPER GOODS AND PRINTED MATTER

FOR PAPER, CARDBOARD AND GOODS MADE FROM THESE MATERIALS, NAMELY, FLYERS; PHOTOGRAPHS; STATIONERY; SELF-ADHESIVE AND SELF-ADHERENT STICKERS MADE FROM PLASTIC, LABELS, STICKERS; DECAL PICTURES (U.S. CLS. 2, 5, 22, 23, 29, 37, 38 AND 50).

CLASS 25—CLOTHING

FOR CLOTHING, NAMELY, SHORTS, PANTS, SHIRTS, UNDERWEAR, TROUSERS, FOOTWEAR AND HEADGEAR, NAMELY, HATS, CAPS, VISORS (U.S. CLS. 22 AND 39).

CLASS 40—MATERIAL TREATMENT

FOR MATERIAL TREATMENT, IN PARTICULAR THE APPLICATION OF PRECIOUS METALS AND THEIR ALLOYS, PRECIOUS STONES, JEWELRY AND FASHION JEWELRY ON METALS, PLASTICS, WOOD AND ARTICLES THEREOF, AND ON DEVICES FOR RECORDING, TRANSMISSION OR REPRODUCTION OF SOUND AND IMAGES, ON THEIR PARTS, ACCESSORIES, CASINGS AND CASING PARTS AND ON LABELS, STICKERS, DECAL PICTURES, CLOTHING, FOOTWEAR AND HEADGEAR (U.S. CLS. 100, 103 AND 106).

GIANCARLO CASTRO, EXAMINING ATTORNEY

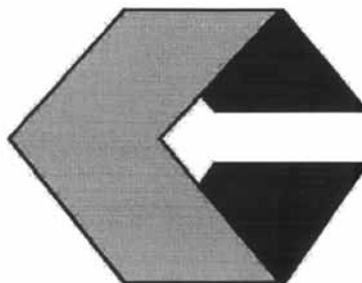

OWNER OF INTERNATIONAL REGISTRATION 1075883
DATED 4-11-2011, EXPIRES 4-11-2021.

THE MARK CONSISTS OF A MISCELLANEOUS FOUR-SIDED SHAPE OPEN ON ONE SIDE.

CLASS 6—METAL GOODS

FOR BUILDING MATERIALS MADE PREDOMINANTLY FROM ALUMINUM, NAMELY, ALUMINUM-PLASTIC BOARDS; BUILDING PANELS OF METAL, NAMELY, DOOR PANELS, CEILING PANELS, AND FLOOR PANELS; BUILDING BOARDS OF METAL, NAMELY, FLOOR BOARDS AND WALL BOARDS; BUILDING MATERIALS OF METAL, NAMELY, SOFFITS, FASCIA, STAIR NOSING, COUNTERTOPS FOR FURTHER INSTALLATION, AND WALL FRAMING; FOILS OF METAL FOR WRAPPING AND PACKAGING SHEETS AND PLATES OF METAL, NAMELY, SHEETS OF COMMON METAL, CLAD STEEL PLATES, METAL MAIL PLATES, AND METAL PLATES IN THE NATURE OF CONSTRUCTION MATERIALS; ALUMINUM ALLOYS OF COMMON METAL; SILVER PLATED TIN ALLOY; ANTI-FRICTION METAL FOR FURTHER MANUFACTURING (U.S. CLS. 2, 12, 13, 14, 23, 25 AND 50).

CLASS 19—NON-METALLIC BUILDING MATERIALS

FOR PLASTIC BOARDS FOR CONSTRUCTION; FOUNDRY MOLDS, NOT OF METAL; LIGHTING SLABS, NAMELY, NON-METAL BUILDING MATERIALS IN THE NATURE OF FIBERGLASS PANELS; NON-METAL COVERINGS FOR BUILDING, NAMELY, CEILING COVERINGS, ROOF COVERINGS; BUILDING CARDBOARD; NON-METAL PARTITIONS IN THE NATURE OF SLIDING DOORS; FACINGS, NOT OF METAL, NAMELY, CERAMIC TILES FOR FACING, FIREPLACE FACINGS, EXTERIOR BOARDS FOR BUILDING; REINFORCING MATERIALS, NOT OF METAL, FOR BUILDING; BUILDING PANELS, NOT OF METAL (U.S. CLS. 1, 12, 33 AND 50).

REBECCA POVARCHUK, EXAMINING ATTORNEY

SN 79-097,400. ASTRON FIAMM SAFETY SARL, FRANCE,
FILED 11-2-2010.

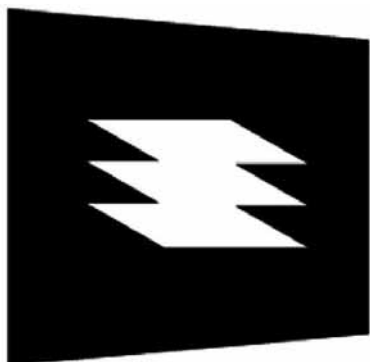

PRIORITY DATE OF 6-28-2010 IS CLAIMED.
OWNER OF INTERNATIONAL REGISTRATION 1077190
DATED 11-2-2010, EXPIRES 11-2-2020.

THE MARK CONSISTS OF A SERIES OF THREE HORIZONTAL DIAMONDS THAT OVERLAP IN THE MIDDLE, ALL OF WHICH ARE ENCLOSED IN A SQUARE.

CLASS 9—ELECTRICAL AND SCIENTIFIC APPARATUS

FOR APPARATUS AND INSTRUMENTS FOR CONDUCTING, SWITCHING, TRANSFORMING, ACCUMULATING, REGULATING OR CONTROLLING ELECTRICITY; APPARATUS FOR RECORDING, TRANSMISSION AND REPRODUCTION OF IMAGES; BLANK MAGNETIC DISKS, REFLECTING DISKS FOR CLOTHING FOR THE PREVENTION OF TRAFFIC ACCIDENTS, LUMINOUS SAFETY BEACONS, LUMINOUS OR MECHANICAL ROAD SIGNS, MARKER BUOYS, SIGNALING BUOYS, CHROMATOGRAPHY APPARATUS FOR LABORATORY USE, PRINTED CIRCUITS, FLASHING SAFETY LIGHTS, COMPUTER KEYBOARDS, SIGNAL BELLS, REVOLUTION COUNTERS, GLASS COVERED WITH AN ELECTRICAL CONDUCTOR, PHOTOGRAPHIC SLIDES, PROJECTION SCREENS, FLUORESCENT SCREENS, VIDEO SCREENS, LUMINOUS SIGNS, ELECTRONIC TAGS FOR GOODS, TRAFFIC LIGHTS, LIGHT CONDUCTING FILAMENTS, HOLOGRAM APPARATUS, OPTICAL LAMPS, SIGNAL LANTERNS, MAGIC LANTERNS, OPTICAL LANTERNS, LASERS NOT FOR MEDICAL PURPOSES, NEON SIGNS, SILICON WAFERS, ELECTRIC LIGHT DIMMERS, LIGHTING REGULATORS USED FOR STAGE DESIGNS; TELEVISION APPARATUS, NAMELY, THERMOICONIC LAMPS AND TUBES, LIGHTING EMITTING DIODES (LED), LASER DIODES AND ZENER DIODES; ELECTRONIC COMPONENTS FOR LIGHTING, NAMELY, LED MODULES COMPRISING ENTIRELY OR PARTIALLY OF LIGHT EMITTING DIODES, ORGANIC LIGHT EMITTING DIODES USING POLYMERS, INTEGRATED LIGHT EMITTING DIODES, ALL THE AFORESAID GOODS BEING DESIGNED FOR LIGHTING INCLUDING LIGHTING OF THE SEMI CONDUCTOR TYPE; DIODES, ORGANIC LIGHT EMITTING DIODES, LIGHT EMITTING DIODES USING POLYMERS, CELL PHONES, DIGITAL PHOTOGRAPHIC CAMERAS, PERSONAL MP3 PLAYERS, UPRIGHT DISPLAY MONITORS FOR USE IN AIRCRAFT, AUTOMOBILES OR VESSELS, ELECTRICAL CIRCUITS FOR LIGHTING CONTROL SYSTEMS AND LIGHTING MANAGEMENT SYSTEMS; BLUEPRINT PRINTER (U.S. CLS. 21, 23, 26, 36 AND 38).

CLASS 10—MEDICAL APPARATUS

FOR SURGICAL APPARATUS AND INSTRUMENTS FOR MEDICAL, DENTAL AND VETERINARY USE, LAMPS FOR MEDICAL PURPOSES, LASERS FOR MEDICAL PURPOSES, ILLUMINATED MIRRORS FOR SURGEONS, ILLUMINATED MIRRORS FOR DENTISTS (U.S. CLS. 26, 39 AND 44).

CLASS 11—ENVIRONMENTAL CONTROL APPARATUS

FOR LIGHTING FIXTURES, TURNING INDICATOR LIGHT BULBS FOR VEHICLES, ELECTRIC LIGHT BULBS, ANTI-GLARE DIFFUSERS FOR VEHICLE LAMPS, ELECTRIC LIGHTS FOR CHRISTMAS TREES, BICYCLE LIGHTS, ELECTRIC DISCHARGE TUBES FOR LIGHTING, LIGHT APPARATUS FOR VEHICLES; LIGHTING APPARATUS AND INSTALLATIONS, NAMELY, LAMPS, LIGHTS FOR VEHICLES, FILAMENTS FOR ELECTRIC LAMPS, LAMP GLOBES, LIGHT COVER PLATES, FLOOR LAMPS, LABORATORY LAMPS, POCKET LAMPS, SAFETY LAMPS, AQUARIUM LIGHTS, ELECTRIC LAMPS, PROJECTOR LAMPS, LAMP PIPES, LAMP GLASSES, FAIRY LIGHTING TUBES FOR FESTIVE DECORATION, LANTERNS FOR LIGHTING, FAIRY LIGHTS FOR FESTIVE DECORATION, LIGHTING INSTALLATIONS FITTED WITH LIGHT SOURCES USING LIGHT EMITTING DIODES, LAMPS AND LIGHTING FIXTURES OF THE ORGANIC LIGHT EMITTING DIODE (OLED) TYPE, LAMPS AND LIGHTING FIXTURES USING DIODES, LAMP AND LIGHTING FIXTURES USING ORGANIC LIGHT EMITTING DIODES, LAMPS AND LIGHTING FIXTURES USING POLYMERIC LIGHT EMITTING DIODES, CHANDELIERS, LUMINOUS HOUSE NUMBERS, VEHICLE HEADLIGHTS, CEILING LIGHTS, WALL LIGHTS, DIVIDING LIGHTS, LAMP REFLECTORS, VEHICLE REFLECTORS, FLASHLIGHTS, LAMP CHIMNEYS, LUMINOUS TUBES FOR LIGHTING, ILLUMINATED LICENSE PLATES, AND PARTS FOR ALL THE AFOREMENTIONED GOODS; VEHICLE LAMPS, LIGHT PANELS FOR VEHICLES, NAMELY, CARS, TRUCKS, VANS, SUVs, BOATS AND BICYCLES; GLASS FOR VEHICLES INCORPORATING LIGHTING FUNCTIONALITIES SUCH AS LIGHTING AND DIRECTION INDICATORS, FOG LIGHTS (U.S. CLS. 13, 21, 23, 31 AND 34).

CLASS 12—VEHICLES

FOR VEHICLES, NAMELY, AUTOMOBILES, BOATS, TRAINS AND AIRCRAFT; APPARATUS FOR LOCOMOTION BY LAND, AIR OR WATER, NAMELY, AUTOMOBILES, BOATS, TRAINS AND AIRCRAFT; DIRECTION SIGNALS FOR VEHICLES (U.S. CLS. 19, 21, 23, 31, 35 AND 44).

CLASS 20—FURNITURE AND ARTICLES NOT OTHERWISE CLASSIFIED

FOR FURNITURE, MIRRORS, PICTURE FRAMES, DISPLAY BOARDS, CUPBOARDS, LIBRARY SHELVES, CORKS FOR BOTTLES, CHESTS OF DRAWERS, PLACARDS OF WOOD OR PLASTICS, PACKAGING CONTAINERS OF PLASTIC, LICENSE PLATES NOT OF METAL, OFFICE FURNITURE, MIRROR TILES, SEATS, SOFAS, TABLE TOPS, SHOWCASES (U.S. CLS. 2, 13, 22, 25, 32 AND 50).

CLASS 42—SCIENTIFIC AND COMPUTER SERVICES

FOR SCIENTIFIC AND TECHNOLOGICAL SERVICES, NAMELY, RESEARCH AND DESIGN IN THE FIELD OF ENGINEERING; RESEARCH AND DEVELOPMENT OF NEW PRODUCTS; DESIGN AND DEVELOPMENT OF COMPUTER HARDWARE AND SOFTWARE; ARCHITECTURAL DESIGN, ARCHITECTURAL CONSULTATION, CONSULTANCY IN THE FIELD OF ENERGY-SAVING; DESIGN OF INTERIOR DÉCOR, INDUSTRIAL DESIGN, MATERIAL TESTING; TECHNICAL PROJECT PLANNING FOR THE TRANSPORTATION INDUSTRY, TECHNICAL RESEARCH IN THE FIELD OF ARCHITECTURE, COMPUTER HARDWARE AND SOFTWARE AND ENGINEERING; GRAPHIC ARTS DESIGNING, PACKAGING DESIGN (U.S. CLS. 100 AND 101).

TINA L. SNAPP, EXAMINING ATTORNEY

SN 79-097,763. FEDERATION NATIONALE DES CENTRES DE LUTTE CONTRE LE CANCER- FNCLCC, FRANCE, FILED 9-29-2010.



PRIORITY DATE OF 9-20-2010 IS CLAIMED.
OWNER OF INTERNATIONAL REGISTRATION 1078260
DATED 9-29-2010, EXPIRES 9-29-2020.
OWNER OF U.S. REG. NO. 4,011,019.

NO CLAIM IS MADE TO THE EXCLUSIVE RIGHT TO USE "R&D", APART FROM THE MARK AS SHOWN.

THE COLOR(S) ORANGE, GRAY AND WHITE IS/ARE CLAIMED AS A FEATURE OF THE MARK.

THE MARK CONSISTS OF TWO OVERLAPPING SQUARES WHEREIN THE LOWER RIGHT CORNER OF EACH SQUARE IS ROUNDED. THE UPPER SQUARE IS SHOWN IN GREY AS IS THE OUTLINE OF THE BOTTOM SQUARE. THE COLOR ORANGE APPEARS IN THE WORDING "UNI" AND IN A SMALL SQUARE WITH ROUNDED BOTTOM RIGHT CORNER LOCATED AT THE BOTTOM RIGHT OF THE GREY SQUARE. THE COLOR WHITE APPEARS IN THE WORDING "CANCER"; THE BACKGROUND OF THE LOWER WHITE SQUARE AND IN A SMALL RIGHT ANGLE LINE ABOVE THE ORANGE SQUARE.

CLASS 41—EDUCATION AND ENTERTAINMENT

FOR ARRANGING AND CONDUCTING MEDICAL COLLOQUIUMS, CONFERENCES AND CONGRESSES ON THE SUBJECT OF ONCOLOGY; PROVIDING RECREATION FACILITIES; PUBLICATION OF BOOKS; LENDING LIBRARIES; ANIMAL TRAINING; VIDEOTAPE FILM PRODUCTION; RENTAL OF MOTION PICTURES; RENTAL OF SOUND RECORDINGS; RENTAL OF VIDEO CASSETTE RECORDERS; RENTAL OF RADIO AND TELEVISION SETS; RENTAL OF SHOW SCENERY; VIDEOTAPE EDITING; PHOTOGRAPHY; ORGANIZATION OF EXHIBITIONS FOR CULTURAL OR EDUCATIONAL PURPOSES; BOOKING OF SEATS FOR SHOWS; PUBLICATION OF ELECTRONIC BOOKS AND JOURNALS ONLINE; ELECTRONIC DESKTOP PUBLISHING (U.S. CLS. 100, 101 AND 107).

CLASS 42—SCIENTIFIC AND COMPUTER SERVICES

FOR SCIENTIFIC, TECHNICAL AND CLINICAL RESEARCH IN THE FIELD OF CANCER; RESEARCH AND DEVELOPMENT OF QUALITY PROGRAMS AND INDICATORS IN CONNECTION WITH HEALTH AND ONCOLOGY; ENGINEERING SERVICES FOR OTHERS FEATURING SCIENTIFIC AND TECHNOLOGICAL INVESTIGATIONS; SCIENTIFIC APPRAISALS AND ESTIMATES PROVIDED BY ENGINEERS; PROVIDING TECHNICAL PROJECT FEASIBILITY STUDIES; PRODUCT RESEARCH AND DEVELOPMENT FOR OTHERS (U.S. CLS. 100 AND 101).

CLASS 44—MEDICAL, BEAUTY AND AGRICULTURAL SERVICES

FOR COSMETIC BODY CARE; HYGIENIC AND BEAUTY CARE SERVICES FOR HUMANS; GENERAL AND ESTHETIC SURGERY; AND PHARMACY SERVICES, NAMELY, DISPENSING OF PHARMACEUTICALS IN THE FIELD OF ONCOLOGY (U.S. CLS. 100 AND 101).

DANNEAN HETZEL, EXAMINING ATTORNEY

SN 79-098,043. EWA IWALLA - ART DESIGN AB, SE-826 40 SÖDERHAMN, SWEDEN, FILED 5-3-2011.

OWNER OF INTERNATIONAL REGISTRATION 1079168
DATED 5-3-2011, EXPIRES 5-3-2021.

THE NAME(S), PORTRAIT(S), AND/OR SIGNATURE(S) SHOWN IN THE MARK IDENTIFIES "EWA IWALLA", WHOSE CONSENT(S) TO REGISTER IS MADE OF RECORD.

CLASS 25—CLOTHING

FOR COLLARS; UNDERWEAR; BODY LINEN; CLOTHING, NAMELY, TROUSERS, SKIRTS, TANK TOPS, TOPS, READY-MADE OUTERWEAR, NAMELY, COATS, PARKAS, VESTS, JACKETS; READY-MADE AND KNIT ACCESSORIES, NAMELY, BELTS, LEG WARMERS, ARM WARMERS, COLLARS, APRONS; SHOES; READY-MADE AND KNIT CHILDRENS CLOTHING, NAMELY, SKIRTS, TANK TOPS, TOPS, BLOUSES, SHIRTS, TROUSERS, DRESSES, JACKETS, COATS, VESTS; FURS, NAMELY, JACKETS, GOWNS; COMBINATIONS; READY MADE CLOTHING, NAMELY, TROUSERS, SKIRTS, TANK TOPS, TOPS; EAR MUFFS; OUTER CLOTHING, NAMELY, JACKETS, GOWNS; KNITWEAR, NAMELY, CARDIGANS, SWEATERS; CORSETS; LAYETTES; WRISTBANDS; APRONS; MUFFS; BEACH CLOTHES, NAMELY, TANK TOPS, WRAP-AROUND SKIRTS; VEILS; HEADBANDS; TEDDIES; CLOTHING OF IMITATIONS OF LEATHER, NAMELY, JACKETS, GOWNS; CLOTHING OF LEATHER, NAMELY, JACKETS, GOWNS; FOOTWEAR; HEADGEAR, NAMELY, HATS, BERETS, CAPS (U.S. CLS. 22 AND 39).

CLASS 35—ADVERTISING AND BUSINESS

FOR RETAIL TRADE FAIR SERVICES, NAMELY, THE BRINGING TOGETHER, FOR THE BENEFIT OF OTHERS, OF A VARIETY OF GOODS IN A TRADE FAIR SETTING, ENABLING CUSTOMERS TO CONVENIENTLY VIEW AND PURCHASE THOSE GOODS, FEATURING TEXTILES AND TEXTILE GOODS, BED AND TABLE COVERS, BAGS AND JEWELRY, CLOTHING, FOOTWEAR AND HEADGEAR; RETAIL SHOWROOM SERVICES, NAMELY, THE BRINGING TOGETHER, FOR THE BENEFIT OF OTHERS, OF A VARIETY OF GOODS IN A SHOWROOM SETTING, ENABLING CUSTOMERS TO CONVENIENTLY VIEW AND PURCHASE THOSE GOODS, FEATURING TEXTILES AND TEXTILE GOODS, BED AND TABLE COVERS, BAGS AND JEWELRY, CLOTHING, FOOTWEAR AND HEADGEAR; RETAIL STORE SERVICES FEATURING TEXTILES AND TEXTILE GOODS, BED AND TABLE COVERS, BAGS AND JEWELRY, CLOTHING, FOOTWEAR AND HEADGEAR; ON LINE RETAIL STORE SERVICES FEATURING TEXTILES AND TEXTILE GOODS, BED AND TABLE COVERS, BAGS AND JEWELRY, CLOTHING, FOOTWEAR AND HEADGEAR (U.S. CLS. 100, 101 AND 102).

LIEF MARTIN, EXAMINING ATTORNEY

SN 79-098,239. PHILPARK ENTERPRISES, S.L., E-08017 BARCELONA, SPAIN, FILED 5-26-2011.

PHILPARK

THE MARK CONSISTS OF STANDARD CHARACTERS WITHOUT CLAIM TO ANY PARTICULAR FONT, STYLE, SIZE, OR COLOR.

OWNER OF INTERNATIONAL REGISTRATION 1079619 DATED 5-26-2011, EXPIRES 5-26-2021.

THE NAME(S), PORTRAIT(S), AND/OR SIGNATURE(S) SHOWN IN THE MARK DOES NOT IDENTIFY A PARTICULAR LIVING INDIVIDUAL.

CLASS 16—PAPER GOODS AND PRINTED MATTER

FOR ADHESIVES (GLUES) FOR STATIONERY OR HOUSEHOLD PURPOSES; RUBBER BANDS (U.S. CLS. 2, 5, 22, 23, 29, 37, 38 AND 50).

CLASS 25—CLOTHING

FOR CLOTHING, NAMELY, TEE SHIRTS, HOODS, HOODED SWEATSHIRTS, HOODED PULLOVERS, JERSEYS, FLEECE BOTTOMS, FLEECE TOPS, FLEECE PULLOVERS, FLEECE SHORTS, PANTS, JACKETS, WIND-JACKETS, WIND SHIRTS, SKI JACKETS, SKI PANTS, POLO SHIRTS, VESTS, SURF WEAR, SHORTS, SHORT TROUSERS, SHIRTS, FLANNEL SHIRTS; HEAD GEAR, NAMELY, HATS, CAPS, BEANIES AND BANDANAS (U.S. CLS. 22 AND 39).

CHARLOTTE CORWIN, EXAMINING ATTORNEY

SN 79-098,321. ALICE ALLISON SA, GRONO, SWITZERLAND, FILED 5-6-2011.

NexPod

THE MARK CONSISTS OF STANDARD CHARACTERS WITHOUT CLAIM TO ANY PARTICULAR FONT, STYLE, SIZE, OR COLOR.

PRIORITY DATE OF 11-8-2010 IS CLAIMED.

OWNER OF INTERNATIONAL REGISTRATION 1079816 DATED 5-6-2011, EXPIRES 5-6-2021.

OWNER OF U.S. REG. NO. 3,946,909.

THE WORD "NEXPOD" HAS NO KNOWN MEANING IN A FOREIGN LANGUAGE.

CLASS 5—PHARMACEUTICALS

FOR DIETETIC FOODS FOR MEDICAL PURPOSES, MEDICAL FOODSTUFFS ADDITIVES FOR MEDICAL PURPOSES, FOOD FOR BABIES (U.S. CLS. 6, 18, 44, 46, 51 AND 52).

CLASS 30—STAPLE FOODS

FOR COFFEE, TEA, COCOA, PLANT DERIVATIVES IN THE FORM OF HERBAL TEAS AND PREPARATIONS MADE WITH PLANT EXTRACTS, NAMELY, HERBAL TEA, VERBENA TEA, FRUIT TEA, GREEN TEA, ROOIBOS TEA, CHAMOMILE TEA, LIME BLOSSOMS TEA, CINNAMON TEA, INFUSION PREPARATIONS FOR MAKING HOT BEVERAGES, NAMELY, CHAMOMILE, VERBENA, ARTIFICIAL COFFEE AND ARTIFICIAL COFFEE EXTRACTS, INSTANT PREPARATIONS FOR MAKING TEA, NAMELY, INSTANT TEA, COFFEE AND COCOA-BASED BEVERAGES, INSTANT BEVERAGES MADE WITH COFFEE, NAMELY, INSTANT COFFEE, SUGAR FOR MAKING BEVERAGES, LIQUID SYRUP BEING FLAVORING SYRUP, FRUIT SYRUP; SUGAR SYRUP, TREACLE, SAUCES, SEASONING MIXES FOR SOUPS, FLAVORINGS FOR SOUPS (U.S. CL. 46).

RUDY R. SINGLETON, EXAMINING ATTORNEY

SN 79-098,594. TECHNICOLOR, FRANCE, FILED 5-20-2011.

MEDIAENCORE

THE MARK CONSISTS OF STANDARD CHARACTERS WITHOUT CLAIM TO ANY PARTICULAR FONT, STYLE, SIZE, OR COLOR.

PRIORITY DATE OF 12-16-2010 IS CLAIMED.

OWNER OF INTERNATIONAL REGISTRATION 1080492 DATED 5-20-2011, EXPIRES 5-20-2021.

CLASS 9—ELECTRICAL AND SCIENTIFIC APPARATUS

FOR PLATFORMS FOR THE DIGITAL DISTRIBUTION OF AUDIO AND VIDEO CONTENT, NAMELY, MULTIMEDIA RESIDENTIAL GATEWAYS, SET-TOP BOXES FOR RECEIVING MULTIMEDIA CONTENT, MULTIMEDIA COMPUTER SERVERS, APPARATUS FOR THE STORAGE OF DIGITAL DATA, NAMELY, COMPUTER HARDWARE AND BLANK DIGITAL STORAGE RECORDING MEDIA (U.S. CLS. 21, 23, 26, 36 AND 38).

CLASS 38—COMMUNICATION

FOR TELECOMMUNICATIONS SERVICES, NAMELY, THE TRANSMISSION OF VIDEO, DATA AND/OR VOICE; TELECOMMUNICATIONS SERVICES, NAMELY, TRANSFER, MIGRATION AND DISTRIBUTION OF VIDEO, DATA AND/OR VOICE BY TELECOMMUNICATION; DISSEMINATION OF DATA VIA ELECTRONIC MEANS AND COMPUTER COMMUNICATION MEANS; DIGITAL TRANSMISSION SERVICES OF FILMS IN REAL-TIME OR NOT; DOWNLOADING OF AUDIO AND VIDEO CONTENT, VIDEO-ON-DEMAND (VOD) SERVICES (U.S. CLS. 100, 101 AND 104).

WARREN L. OLANDRIA, EXAMINING ATTORNEY

SN 79-098,604. WINGSPLAY, FRANCE, FILED 5-12-2011.

Wingsplay

THE MARK CONSISTS OF STANDARD CHARACTERS WITHOUT CLAIM TO ANY PARTICULAR FONT, STYLE, SIZE, OR COLOR.

PRIORITY DATE OF 1-4-2011 IS CLAIMED.

OWNER OF INTERNATIONAL REGISTRATION 1080523 DATED 5-12-2011, EXPIRES 5-12-2021.

CLASS 35—ADVERTISING AND BUSINESS

FOR BUSINESS MANAGEMENT; BUSINESS ADMINISTRATION; OFFICE FUNCTIONS; DIRECT MAIL ADVERTISING; ARRANGING NEWSPAPER SUBSCRIPTIONS FOR OTHERS; BUSINESS MANAGEMENT AND ORGANIZATION CONSULTANCY; BOOK-KEEPING; DOCUMENT REPRODUCTION; EMPLOYMENT AGENCIES; COMPUTERIZED FILE MANAGEMENT; ORGANIZATION OF EXHIBITIONS FOR COMMERCIAL OR ADVERTISING PURPOSES; ONLINE ADVERTISING ON A COMPUTER NETWORK; PUBLICATION OF PUBLICITY TEXTS; RENTAL OF ADVERTISING SPACE; DISSEMINATION OF ADVERTISING MATTER; PUBLIC RELATIONS (U.S. CLS. 100, 101 AND 102).

CLASS 41—EDUCATION AND ENTERTAINMENT

FOR PROVIDING RECREATION FACILITIES; PUBLICATION OF BOOKS; LENDING LIBRARIES; ANIMAL TRAINING; VIDEOTAPE FILM PRODUCTION; RENTAL OF MOTION PICTURES; RENTAL OF SOUND RECORDINGS; RENTAL OF VIDEO CASSETTE RECORDERS OR OF RADIO AND TELEVISION SETS; RENTAL OF SHOW SCENERY; VIDEOTAPE EDITING; PHOTOGRAPHY; ARRANGING AND CONDUCTING OF COLLOQUIUMS, CONFERENCES OR CONGRESSES; ORGANIZATION OF EXHIBITIONS FOR CULTURAL OR EDUCATIONAL PURPOSES; BOOKING OF SEATS FOR SHOWS; PUBLICATION OF ELECTRONIC BOOKS AND JOURNALS ON-LINE; ELECTRONIC DESKTOP PUBLISHING (U.S. CLS. 100, 101 AND 107).

JANICE KIM, EXAMINING ATTORNEY

CLASS 42—SCIENTIFIC AND COMPUTER SERVICES

FOR DESIGN AND DEVELOPMENT OF SOFTWARE; WRITING AND UPDATING OF COMPUTER SOFTWARE; INSTALLATION AND SET-UP OF SOFTWARE; INTEGRATION AND CUSTOMISATION OF SOFTWARE; RENTAL OF SOFTWARE; REPAIR AND MAINTENANCE OF SOFTWARE; PROVIDING SOFTWARE FOR DATA ANALYSIS, DATA CONVERSION, DATA MANAGEMENT, DATA NAVIGATION, DATA PRESENTATION, ELECTRONIC COMMERCE AND RECOMMENDATION FOR DOWNLOAD OR USE VIA THE INTERNET OR OTHER DATA NETWORKS; CONSULTANCY RELATING TO SOFTWARE; TECHNICAL CONSULTANCY RELATING TO SOFTWARE; COMPUTER SOFTWARE TECHNICAL SUPPORT SERVICES (U.S. CLS. 100 AND 101).

JOHN DALIER, EXAMINING ATTORNEY

SN 79-099,402. NUPO A/S, GREVE, DENMARK, FILED 5-24-2011.

SN 79-098,888. OMIKRON DATA QUALITY GMBH, FED REP GERMANY, FILED 3-23-2011.

FACT-Finder

THE MARK CONSISTS OF STANDARD CHARACTERS WITHOUT CLAIM TO ANY PARTICULAR FONT, STYLE, SIZE, OR COLOR.

PRIORITY DATE OF 9-27-2010 IS CLAIMED.

OWNER OF INTERNATIONAL REGISTRATION 1081353 DATED 3-23-2011, EXPIRES 3-23-2021.

CLASS 9—ELECTRICAL AND SCIENTIFIC APPARATUS

FOR SOFTWARE FOR DATA ANALYSIS, DATA CONVERSION, DATA MANAGEMENT, DATA NAVIGATION, DATA PRESENTATION, ELECTRONIC COMMERCE AND RECOMMENDATION; ELECTRONIC PUBLICATIONS, NAMELY, OPERATING AND USER INSTRUCTIONS FOR SOFTWARE STORED IN DIGITAL FORM (U.S. CLS. 21, 23, 26, 36 AND 38).

CLASS 16—PAPER GOODS AND PRINTED MATTER

FOR MANUALS IN THE FIELD OF SOFTWARE CONTAINING OPERATING AND USER INSTRUCTIONS FOR SOFTWARE (U.S. CLS. 2, 5, 22, 23, 29, 37, 38 AND 50).

PRIORITY DATE OF 12-7-2010 IS CLAIMED.

OWNER OF INTERNATIONAL REGISTRATION 1082641 DATED 5-24-2011, EXPIRES 5-24-2021.

THE WORDING "NUPO" HAS NO MEANING IN A FOREIGN LANGUAGE.

CLASS 5—PHARMACEUTICALS

FOR FOOD SUPPLEMENTS; DIETETIC FOODS ADAPTED FOR MEDICAL USE (U.S. CLS. 6, 18, 44, 46, 51 AND 52).

CLASS 29—MEATS AND PROCESSED FOODS

FOR DAIRY PRODUCTS, EXCLUDING ICE CREAM, ICE MILK AND FROZEN YOGURT; DAIRY BASED POWDERS FOR MAKING LOW CALORIE DAIRY BASED FOOD, BEVERAGES AND SHAKES; MEAT, FISH, POULTRY; MEAT, FISH AND POULTRY BASED POWDERS FOR MAKING LOW CALORIE MEAT, FISH AND POULTRY BASED FOOD, BEVERAGES AND SHAKES; CONSERVED, DRIED AND COOKED FRUITS AND VEGETABLES; FRUIT AND VEGETABLE BASED POWDERS FOR MAKING LOW CALORIE FRUIT AND VEGETABLE BASED FOOD, BEVERAGES, AND SHAKES; SNACK BARS CONSISTING PRIMARILY OF PROCESSED NUTS, FRUITS AND VEGETABLES; AND MEAL REPLACEMENT BARS, MAINLY CONSISTING OF PROCESSED FRUITS, VEGETABLE AND NUTS (U.S. CL. 46).

JASON TURNER, EXAMINING ATTORNEY

SN 79-099,577. FLEXLINK AB, GÖTEBORG, SWEDEN,
FILED 5-12-2011.

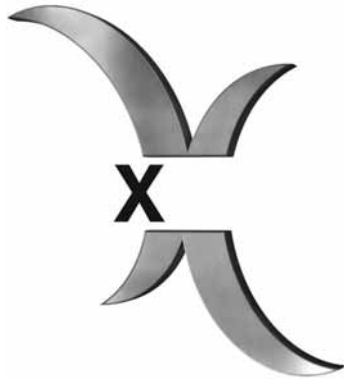

PRIORITY DATE OF 11-15-2010 IS CLAIMED.
OWNER OF INTERNATIONAL REGISTRATION 1083106
DATED 5-12-2011, EXPIRES 5-12-2021.
OWNER OF U.S. REG. NO. 4,036,888.

THE MARK CONSISTS OF A LARGE "X" WITH CURVED
ARMS SEPARATED IN THE MIDDLE INTO AN UPPER
PORTION AND A LOWER PORTION, A SMALLER "X"
APPEARS TO THE LEFT OF THE AREA SEPARATING THE
TWO PORTIONS OF THE LARGE "X".

CLASS 7—MACHINERY

FOR CONVEYORS; PACKAGING MACHINES; AUTO-
MATIC HANDLING MACHINES FOR PICKING, MOV-
ING AND PLACING GOODS TO AND FROM OTHER
MACHINES; MANIPULATORS FOR AUTOMATIC
HANDLING MACHINES; PALLET HANDLING MA-
CHINES; DRIVING DEVICES FOR LIFTS, CONVEYORS,
ELEVATORS AND AUTOMATIC HANDLING MA-
CHINES; GEAR BOXES OTHER THAN FOR LAND
VEHICLES; ELEVATORS; MOTORS AND ENGINES
FOR OTHER THAN LAND VEHICLES; ELECTRIC MA-
CHINES FOR CLEANING LIFTS, CONVEYORS, ELEV-
ATORS AND AUTOMATIC HANDLING MACHINES;
MACHINES FOR WASHING METAL, GLASS, PLASTIC
PARTS AND PACKAGES; LINE CONTROL, CONFIG-
URATION AND ADJUSTMENT MACHINES FOR CON-
TROLLING, CONFIGURING AND ADJUSTING THE
AFORESAID CONVEYORS, MACHINES, MOTORS AND
ENGINES; PLASTIC CHAINS AND BELTS FOR CON-
VEYORS AND CONVEYOR SYSTEMS; CONVEYOR
BELTS; STRUCTURAL PARTS AND COMPONENTS
FOR THE AFORESAID CONVEYORS, MACHINES, MO-
TORS AND ENGINES (U.S. CLS. 13, 19, 21, 23, 31, 34 AND
35).

CLASS 9—ELECTRICAL AND SCIENTIFIC APPARATUS

FOR APPARATUS AND INSTRUMENTS FOR RE-
CORDING, TRANSMISSION OR REPRODUCTION OF
SOUND OR IMAGES; BLANK MAGNETIC DATA CAR-
RIERS; DATA PROCESSING EQUIPMENT AND COM-
PUTERS; SURVEYING AND WEIGHING APPARATUS
AND INSTRUMENTS; MEASURING APPARATUS AND
INSTRUMENTS, NAMELY, SCALES FOR MEASURING
WEIGHT; CHECKING APPARATUS AND INSTRU-
MENTS, NAMELY, DETECTORS FOR DETECTING
PROBLEMS AND STATUS OF PRODUCT FLOWS IN
CONVEYOR SYSTEMS, CAMERAS FOR SUPERVISION
OF PRODUCT FLOWS IN CONVEYOR SYSTEMS, AND
SENSORS FOR SENSING WEIGHT, MOVEMENTS, STA-
TUS, AND PROBLEMS IN CONVEYOR SYSTEM PRO-
DUCT FLOWS; SUPERVISION APPARATUS AND
INSTRUMENTS, NAMELY, VIDEO RECORDERS, CAM-
ERAS AND COMPUTERS, USED FOR PICKING AND
PLACING OF PRODUCTS IN PRODUCTION FLOW AND
CONVEYOR SYSTEMS, FOR IDENTIFYING PRODUCTS
IN PRODUCTION FLOW AND CONVEYOR SYSTEMS,
AND FOR CHECKING PRODUCTION PROCESS
EVENTS; SIGNALING APPARATUS AND INSTRU-
MENTS, NAMELY, INDICATORS FOR INDICATING
WEIGHT, MOVEMENTS, STATUS, AND PROBLEMS IN
CONVEYOR SYSTEM PRODUCT FLOWS; RECORDED
COMPUTER PROGRAMS FOR USE IN DATABASE
MANAGEMENT, PRODUCTION CONTROL, PRODUCT
DATA MANAGEMENT, AND MANUFACTURING EX-
ECUTION; BLANK CD-ROMS; COMPUTER CONTROL
AND OPERATING SYSTEMS; ELECTRIC CABLES (U.S.
CLS. 21, 23, 26, 36 AND 38).

CLASS 42—SCIENTIFIC AND COMPUTER SERVICES

FOR COMPUTER PROGRAMMING FOR OTHERS;
MAINTAINING, UPDATING AND DESIGNING COM-
PUTER PROGRAMS FOR OTHERS; ANALYZING COM-
PUTER SYSTEMS; CONSULTANCY IN THE FIELD OF
COMPUTER HARDWARE; RENTAL OF COMPUTERS
AND COMPUTER SOFTWARE; INDUSTRIAL DESIGN;
SCIENTIFIC RESEARCH AND DEVELOPMENT FOR
OTHERS AND INDUSTRIAL RESEARCH FOR OTHERS
IN THE FIELD OF PRODUCTION SYSTEMS; ENGI-
NEERING; QUALITY CONTROL FOR OTHERS; MATE-
RIAL TESTING; TECHNICAL PROJECT STUDIES,
NAMELY, CONDUCTING OF FEASIBILITY STUDIES,
RESEARCH AND DEVELOPMENT OF NEW PRODUCTS
FOR OTHERS AND MECHANICAL RESEARCH FOR
PRODUCTION SYSTEMS, SOFTWARE AND EQUIP-
MENT; CONSTRUCTION DRAFTING (U.S. CLS. 100
AND 101).

MICHAEL TANNER, EXAMINING ATTORNEY

SN 79-099,640. BACHET SARL, FRANCE, FILED 5-27-2011.

OWNER OF INTERNATIONAL REGISTRATION 1083297
DATED 5-27-2011, EXPIRES 5-27-2021.

THE MARK CONSISTS OF THE STYLIZED TERM
"BACHET".

THE WORDING "BACHET" HAS NO MEANING IN A
FOREIGN LANGUAGE.

CLASS 8—HAND TOOLS

FOR CUTLERY, NAMELY, KNIVES, FORKS AND
SPOONS (U.S. CLS. 23, 28 AND 44).

CLASS 14—JEWELRY

FOR JEWELRY; JEWELRY PRODUCTS, NAMELY, RINGS, EARRINGS, BRACELETS, NECKLACES, PENDANTS, HOOPS, NAMELY, HOOP EARRINGS, HOOP EARRINGS OF PRECIOUS METAL, MEDALS, MEDALLIONS, PEARLS, GEMSTONE JEWELRY, DIAMONDS, BLACK DIAMONDS, WHITE DIAMONDS, BROACHES, HAT ORNAMENTS OF PRECIOUS METAL, PINS FOR USE WITH HATS, TIE PINS, WATCH CHAINS, PRECIOUS STONES; TIMEPIECES AND CHRONOMETRIC INSTRUMENTS; PRECIOUS METALS AND THEIR ALLOYS; WORKS OF ART OF PRECIOUS METAL; JEWELRY CASES; BOXES OF PRECIOUS METAL; WATCH CASES, BANDS, CHAINS, SPRINGS OR GLASSES; KEY RINGS, TRINKETS OR FOBS, ALL OF PRECIOUS METAL; STATUES AND FIGURINES OF PRECIOUS METAL; CASES OR PRESENTATION CASES FOR TIMEPIECES (U.S. CLS. 2, 27, 28 AND 50).

CLASS 16—PAPER GOODS AND PRINTED MATTER

FOR PHOTOGRAPHS; OFFICE REQUISITES EXCEPT FURNITURE, NAMELY, BOOK ENDS, LETTER OPENERS, WRITING PADS, SEAL INK PAD, SEALS, CACHETS, BALL POINT PENS, MECHANICAL PENCILS; BOXES OF CARDBOARD OR PAPER; POSTERS; ALBUMS FOR STAMPS AND PHOTOGRAPHS; PAMPHLETS IN THE FIELD OF JEWELRY; LITHOGRAPHIC OR ENGRAVED WORKS OF ART ON PAPER (U.S. CLS. 2, 5, 22, 23, 29, 37, 38 AND 50).

CLASS 18—LEATHER GOODS

FOR LEATHER AND IMITATIONS OF LEATHER, NAMELY, BAGS, ALL-PURPOSE CARRYING BAGS, BABY CARRYING BAGS, CARRY-ALL BAGS, BEACH BAGS, HIKING BAGS, TRAVELING BAGS, SCHOOL BAGS, SLING BAGS FOR CARRYING INFANTS, SUIT BAGS, BRIEFCASES; TRUNKS AND SUITCASES; UMBRELLAS, PARASOLS AND WALKING STICKS; WHIPS, HARNESSSES AND SADDLERY; WALLETS; PURSES; HANDBAGS, BACKPACKS, WHEELED BAGS; UNFITTED VANITY CASES; BAGS OR SMALL BAGS, ENVELOPES, POUCHES ALL MADE OF LEATHER FOR MERCHANDISE PACKAGING (U.S. CLS. 1, 2, 3, 22 AND 41).

MARLENE BELL, EXAMINING ATTORNEY

SN 79-099,652. RINGSPANN GMBH, FED REP GERMANY, FILED 9-7-2010.

RINGSPANN

OWNER OF INTERNATIONAL REGISTRATION 0420547 DATED 1-21-1976, EXPIRES 1-21-2016.
OWNER OF U.S. REG. NO. 996,948.

CLASS 6—METAL GOODS

FOR CONSTRUCTION ELEMENTS, IN THE NATURE OF CLAMPING, FASTENING AND SECURING ELEMENTS IN THE NATURE OF SPRING ELEMENTS AND CONNECTING ELEMENTS MADE OF METAL IN THE FORM OF STAR-SHAPED CLAMPING, FASTENING AND SECURING DISCS, NAMELY, SHALLOW-TAPERED DISCS ALTERNATELY SLOTTED FROM INSIDE AND OUTSIDE AROUND THEIR CIRCUMFERENCE AND MACHINE PARTS, NAMELY, DISC ASSEMBLIES INCORPORATING SUCH STAR-SHAPED DISCS (U.S. CLS. 2, 12, 13, 14, 23, 25 AND 50).

CLASS 7—MACHINERY

FOR CONTROL, SAFETY, CONNECTING AND FREE COUPLINGS FOR MACHINES AND THEIR STRUCTURAL PARTS, NOT INTENDED FOR USE WITH LAND VEHICLES; TRANSMISSION GEARS FOR MACHINES, SPEED-CHANGING GEARS FOR MACHINES AND STRUCTURAL PARTS THEREOF (U.S. CLS. 13, 19, 21, 23, 31, 34 AND 35).

CLASS 8—HAND TOOLS

FOR FASTENING HAND TOOLS, NAMELY, CLAMPS IN THE NATURE OF CLAMPING CLUTCHES (U.S. CLS. 23, 28 AND 44).

CLASS 12—VEHICLES

FOR GEAR WHEELS AND STRUCTURAL PARTS THEREFOR; TRANSMISSION GEARS FOR VEHICLES, SPEED-CHANGING GEARS FOR VEHICLES AND STRUCTURAL PARTS THEREOF (U.S. CLS. 19, 21, 23, 31, 35 AND 44).

MARC LEIPZIG, EXAMINING ATTORNEY

SN 79-099,816. MXP4, F-75010 PARIS, FRANCE, FILED 6-14-2011.

BOPLER

THE MARK CONSISTS OF STANDARD CHARACTERS WITHOUT CLAIM TO ANY PARTICULAR FONT, STYLE, SIZE, OR COLOR.

PRIORITY DATE OF 3-2-2011 IS CLAIMED.

OWNER OF INTERNATIONAL REGISTRATION 1083640 DATED 6-14-2011, EXPIRES 6-14-2021.

THE WORDING "BOPLER" HAS NO MEANING IN A FOREIGN LANGUAGE.

CLASS 9—ELECTRICAL AND SCIENTIFIC APPARATUS

FOR COMPUTER GAME PROGRAMS; COMPUTER MUSIC GAME PROGRAMS; COMPUTER SOFTWARE, RECORDED, FOR READING MUSIC, CREATING MUSIC, COMBINING THE LISTENING AND CREATION OF MUSIC WITH PLAYING A GAME; APPARATUS FOR RECORDING, TRANSMITTING, REPRODUCING OR PROCESSING SOUND OR IMAGES; AMUSEMENT APPARATUS FOR MUSIC ENTERTAINMENT ADAPTED FOR USE WITH AN EXTERNAL DISPLAY SCREEN OR MONITOR (U.S. CLS. 21, 23, 26, 36 AND 38).

CLASS 28—TOYS AND SPORTING GOODS

FOR GAMES OTHER THAN THOSE ADAPTED FOR USE WITH AN EXTERNAL DISPLAY SCREEN OR MONITOR, NAMELY, ARCADE GAMES, LCD GAMES MACHINES, TABLETOP UNITS FOR PLAYING ELECTRONIC GAMES OTHER THAN IN CONJUNCTION WITH A TELEVISION OR COMPUTER; GAMES IN CONNECTION WITH MUSIC OTHER THAN THOSE ADAPTED FOR USE WITH AN EXTERNAL DISPLAY SCREEN OR MONITOR, NAMELY, ARCADE GAMES, LCD GAMES MACHINES, TABLETOP UNITS FOR PLAYING ELECTRONIC GAMES OTHER THAN IN CONJUNCTION WITH A TELEVISION OR COMPUTER; APPARATUS FOR ELECTRONIC GAMES OTHER THAN THOSE ADAPTED FOR USE WITH AN EXTERNAL DISPLAY SCREEN OR MONITOR (U.S. CLS. 22, 23, 38 AND 50).

CLASS 41—EDUCATION AND ENTERTAINMENT

FOR ENTERTAINMENT SERVICES, NAMELY, PROVIDING AN ONLINE COMPUTER GAME OVER A GLOBAL COMPUTER NETWORK; ENTERTAINMENT IN CONNECTION WITH MUSIC, NAMELY, AN ONLINE ACTIVITY WHERE YOU PLAY WITH A GAME AND CREATE AND LISTEN TO MUSIC SIMULTANEOUSLY, PROVIDING INFORMATION IN THE FIELD OF MUSIC, ALL ON-LINE VIA A GLOBAL COMPUTER NETWORK; ORGANIZING COMPETITIONS IN CONNECTION WITH MUSIC, NAMELY, ORGANIZING COMPETITIONS IN THE FIELD OF WRITING AND PLAYING MUSIC FOR ENTERTAINMENT PURPOSES (U.S. CLS. 100, 101 AND 107).

ROBIN MITTLER, EXAMINING ATTORNEY

SN 79-099,854. FÉDÉRATION INTERNATIONALE DE BOBSLEIGH ET DE TOBOGGANING (FIBT) (CIVIL ASSOCIATION), CH-1000 LAUSANNE, SWITZERLAND, FILED 2-17-2011.



PRIORITY DATE OF 10-22-2010 IS CLAIMED.
OWNER OF INTERNATIONAL REGISTRATION 1083743 DATED 2-17-2011, EXPIRES 2-17-2021.

NO CLAIM IS MADE TO THE EXCLUSIVE RIGHT TO USE "FÉDÉRATION INTERNATIONALE DE BOBSLEIGH ET DE TOBOGGANING", APART FROM THE MARK AS SHOWN.

THE COLOR(S) BLUEGREEN (PANTONE 3145), GOLD (PANTONE 871) AND WHITE IS/ARE CLAIMED AS A FEATURE OF THE MARK.

THE MARK CONSISTS OF A DESIGN OF A SLED IN GOLD AND WHITE FOR WHICH THE LETTERS "FIBT" APPEAR IN GOLD ATOP THE DESIGN, ALL WITHIN A CIRCLE. THE DESIGN EXTENDS ACROSS AN OUTER CIRCLE WITH A BLUEGREEN BACKGROUND AND GOLD OUTLINING FOR WHICH THE WORDING "FÉDÉRATION INTERNATIONALE DE BOBSLEIGH ET DE TOBOGGANING" APPEARS WITHIN THE CIRCLE IN WHITE.

THE ENGLISH TRANSLATION OF "FÉDÉRATION INTERNATIONALE DE" AND "ET DE" IN THE MARK IS "INTERNATIONAL FEDERATION OF" AND "AND OF".

CLASS 28—TOYS AND SPORTING GOODS

FOR ACTION GAMES, NAMELY, FOR SLEDGING, NAMELY, SNOW SLEDS, BOB SLEDS AND SKELETON SLEDS, ALL FOR RECREATIONAL USE; PLAYTHINGS, NAMELY, PLUSH TOYS, STUFFED TOY ANIMALS, PLAY FIGURES, TOY BOBSLEDS, BOARD GAMES RELATING TO SLEDGING, ACTION SKILL GAMES, ADULTS' AND CHILDREN'S PARTY GAMES, GAMES CONSISTING OF A QUIZ CONCERNING BOBSLEIGH AND TOBOGGANING AND ELECTRONIC VIDEO ARCADE GAME MACHINES, BALLOONS, JIGSAW PUZZLES, SNOW TOYS NAMELY, SNOW SLEDS AND SNOW TUBES, MINIATURE TOY HELMETS AND SLEDS; GYMNAS TIC APPARATUS; SNOW SLEDS, BOB SLEDS, SKELETON SLEDS FOR RECREATIONAL USE (U.S. CLS. 22, 23, 38 AND 50).

CLASS 35—ADVERTISING AND BUSINESS

FOR ADVERTISING AND PROMOTION SERVICES; CANVASSING FOR ADVERTISEMENTS, NAMELY, PUBLICITY AND SALES PROMOTION SERVICES; PRODUCT MERCHANDISING; BUSINESS MANAGEMENT; PROVIDING OFFICE FUNCTIONS (U.S. CLS. 100, 101 AND 102).

CLASS 41—EDUCATION AND ENTERTAINMENT

FOR EDUCATIONAL SERVICES, NAMELY, CLASSES, SEMINARS AND WORKSHOPS IN THE FIELD OF SLEDGING TRAINING; PROVIDING OF SLEDGING TRAINING; ENTERTAINMENT, NAMELY, ORGANIZATION OF SLEDGING EVENTS; ORGANIZING SPORTING AND CULTURAL EVENTS, NAMELY, COMMUNITY SPORTING AND CULTURAL EVENTS; ONLINE ELECTRONIC PUBLISHING OF BOOKS, MAGAZINES, PERIODICALS AND NEWSLETTERS; PUBLISHING OF BOOKS, NEWSPAPERS, MAGAZINES, PERIODICALS, AND NEWSLETTERS ON THE SUBJECT OF SPORTS; PRODUCTION OF TELEVISION PROGRAMS (U.S. CLS. 100, 101 AND 107).

BERNICE MIDDLETON, EXAMINING ATTORNEY

SN 79-099,923. PAGAMEE SA, SWITZERLAND, FILED 6-20-2011.

PAGAMEE

THE MARK CONSISTS OF STANDARD CHARACTERS WITHOUT CLAIM TO ANY PARTICULAR FONT, STYLE, SIZE, OR COLOR.

PRIORITY DATE OF 12-22-2010 IS CLAIMED.

OWNER OF INTERNATIONAL REGISTRATION 1083946 DATED 6-20-2011, EXPIRES 6-20-2021.

CLASS 35—ADVERTISING AND BUSINESS

FOR ADVERTISING SERVICES; BUSINESS ADMINISTRATION AND MANAGEMENT; PROVIDING OFFICE FUNCTIONS; INFORMATION AND DATA COMPILING AND ANALYZING RELATING TO BUSINESS MANAGEMENT; BUSINESS ADMINISTRATION FOR PROCESSING COMMERCIAL SALES VIA THE INTERNET OR VIA WIRELESS ELECTRONIC COMMUNICATION DEVICES; E-COMMERCE SERVICES, NAMELY, ADVERTISING FOR OTHERS IN THE FORM OF DATA, TEXTS, IMAGES, SOUNDS BY MEANS OF THE INTERNET, FOR THE SALE OF GOODS AND SERVICES OF ALL TYPES; PROVIDING ADVERTISING SPACE ON A WEBSITE FOR THIRD PARTIES (U.S. CLS. 100, 101 AND 102).

CLASS 36—INSURANCE AND FINANCIAL

FOR FINANCIAL AFFAIRS AND MONETARY AFFAIRS, NAMELY, FINANCIAL INFORMATION, MANAGEMENT AND ANALYSIS SERVICES; FINANCIAL RISK MANAGEMENT; BANKING; CREDIT CARD SERVICES; FINANCIAL TRANSACTION SERVICES, NAMELY, PROVIDING SECURE COMMERCIAL TRANSACTIONS AND PAYMENT OPTIONS; ELECTRONIC PAYMENT, NAMELY, ELECTRONIC PROCESSING AND TRANSMISSION OF BILL PAYMENT DATA; MERCHANT SERVICES, NAMELY, PAYMENT TRANSACTION PROCESSING SERVICES; PROVIDING ELECTRONIC PROCESSING OF CREDIT CARD TRANSACTIONS AND ELECTRONIC PAYMENTS VIA A GLOBAL COMPUTER NETWORK; ELECTRONIC FUNDS TRANSFER; FINANCIAL SERVICES, NAMELY, PROVIDING FOR THE EXCHANGE OF FOREIGN CURRENCY, COMMODITIES, FINANCIAL DERIVATIVES, INTEREST RATE PRODUCTS, AND EQUITIES VIA THE INTERNET AND INTRANET SYSTEMS; INFORMATION ON FINANCIAL AND MONETARY MATTERS; INSURANCE AND FINANCIAL INFORMATION AND CONSULTANCY SERVICES; UNDERWRITING AND ADMINISTRATION OF COMMERCIAL COLLATERAL LIABILITY INSURANCE; FINANCIAL EVALUATION FOR INSURANCE PURPOSES (U.S. CLS. 100, 101 AND 102).

LINDA MICKLEBURGH, EXAMINING ATTORNEY

SN 79-100,107. C & T MATRIX LIMITED, NORTHAMPTON-SHIRE NN8 4 NL, UNITED KINGDOM, FILED 6-6-2011.



THE MARK CONSISTS OF STANDARD CHARACTERS WITHOUT CLAIM TO ANY PARTICULAR FONT, STYLE, SIZE, OR COLOR.

OWNER OF INTERNATIONAL REGISTRATION 1084398 DATED 6-6-2011, EXPIRES 6-6-2021.

CLASS 7—MACHINERY

FOR PARTS AND FITTINGS, NAMELY, CREASING MATRIX, FOR PRECISION CREASING MACHINES AND DIE-CUTTING MACHINES (U.S. CLS. 13, 19, 21, 23, 31, 34 AND 35).

CLASS 42—SCIENTIFIC AND COMPUTER SERVICES

FOR DESIGN AND DEVELOPMENT OF MANUFACTURING PROCESSES AND EQUIPMENT, NAMELY, CREASING MATRIXES, FOR USE IN PRECISION CREASING SYSTEMS, NAMELY, CREASING MACHINES AND DIE-CUTTING MACHINES; PRODUCT RESEARCH AND DEVELOPMENT RELATING THERE TO (U.S. CLS. 100 AND 101).

MAYUR VAGHANI, EXAMINING ATTORNEY

SN 79-099,946. C & T MATRIX LIMITED, NORTHAMPTON-SHIRE, UNITED KINGDOM, FILED 6-6-2011.



THE MARK CONSISTS OF STANDARD CHARACTERS WITHOUT CLAIM TO ANY PARTICULAR FONT, STYLE, SIZE, OR COLOR.

OWNER OF INTERNATIONAL REGISTRATION 1083994 DATED 6-6-2011, EXPIRES 6-6-2021.

CLASS 7—MACHINERY

FOR PARTS AND FITTINGS, NAMELY, CREASING MATRIX, FOR PRECISION CREASING MACHINES AND DIE-CUTTING MACHINES (U.S. CLS. 13, 19, 21, 23, 31, 34 AND 35).

CLASS 42—SCIENTIFIC AND COMPUTER SERVICES

FOR DESIGN AND DEVELOPMENT OF MANUFACTURING PROCESSES AND EQUIPMENT, NAMELY CREASING MATRIXES, FOR USE IN PRECISION CREASING SYSTEMS, NAMELY, CREASING MACHINES AND DIE-CUTTING MACHINES; PRODUCT RESEARCH AND DEVELOPMENT RELATING THERE TO (U.S. CLS. 100 AND 101).

MAYUR VAGHANI, EXAMINING ATTORNEY

SN 79-100,371. VIDEO SYSTEMS S.R.L., ITALY, FILED 4-8-2011.



VIDEOSYSTEMS

PRIORITY DATE OF 12-31-2010 IS CLAIMED.
OWNER OF INTERNATIONAL REGISTRATION 1084989 DATED 4-8-2011, EXPIRES 4-8-2021.

NO CLAIM IS MADE TO THE EXCLUSIVE RIGHT TO USE "VIDEO SYSTEMS", APART FROM THE MARK AS SHOWN.

THE MARK CONSISTS OF THE WORDING "VIDEOSYSTEMS" AND A STYLIZED DESIGN COMPRISING TWO IRREGULAR ELLIPSES.

CLASS 9—ELECTRICAL AND SCIENTIFIC APPARATUS

FOR SCIENTIFIC, PHOTOGRAPHIC, CINEMATOGRAPHIC, OPTICAL, WEIGHING, MEASURING, SIGNALING, CHECKING, SURVEILLANCE APPARATUS AND INSTRUMENTS, NAMELY, COMPUTER HARDWARE FOR IP (INTERNET PROTOCOL) VIDEO SURVEILLANCE, CLOSED CIRCUIT TV SYSTEMS FOR SECURITY AND SURVEILLANCE, ELECTRIC AND ELECTRONIC VIDEO SURVEILLANCE INSTALLATIONS, CAMERA HARDWARE SYSTEMS FOR IP (INTERNET PROTOCOL) VIDEO SURVEILLANCE, OPTICAL SENSORS, PHOTOELECTRIC SENSORS, SENSORS AND SIGNALING DEVICES FOR MONITORING OF MANUFACTURING MACHINES, SENSORS AND SIGNALING DEVICES FOR CONTROLLING MANUFACTURING MACHINES DURING MANUFACTURING INDUSTRIAL PROCESSES, SENSORS AND SIGNALING DEVICES FOR MONITORING OF MANUFACTURING MACHINES DURING MANUFACTURING INDUSTRIAL PROCESSES, SENSORS AND SIGNALING DEVICES FOR PREVENTING MALFUNCTIONING OF MANUFACTURING MACHINES DURING MANUFACTURING INDUSTRIAL PROCESSES, SENSORS AND SIGNALING DEVICES FOR OPERATING MANUFACTURING MACHINES DURING MANUFACTURING INDUSTRIAL PROCESSES, SENSORS AND SIGNALING DEVICES FOR ACTUATING MANUFACTURING MACHINES DURING MANUFACTURING INDUSTRIAL PROCESSES; APPARATUS FOR RECORDING, TRANSMISSION OR REPRODUCTION OF SOUND OR IMAGES; BLANK MAGNETIC DATA CARRIERS; DATA PROCESSING EQUIPMENT AND COMPUTERS; ALARM DEVICES, APPARATUS AND INSTRUMENTS, NAMELY, ACOUSTIC SOUND ALARMS, ALARM CENTRAL UNITS, ALARM MONITORING SYSTEMS; THEFT PREVENTION INSTALLATIONS OTHER THAN FOR VEHICLES AND THEFT PREVENTION ELECTRIC INSTALLATIONS, NAMELY, ANTI-INTRUSION ALARMS, BURGLAR ALARMS, DOOR ALARMS, SECURITY ALARM CONTROLLERS, BUILDING SECURITY SYSTEMS COMPRISING SOFTWARE AND HARDWARE FOR PROVIDING PICTURE, VIDEO, ALARM STATUS, BUILDING PLANS, AND OTHER INFORMATION TO A REMOTE STATION; ELECTRIC SENSORS, NAMELY, MOVEMENT SENSORS; SCANNERS; CAMERAS, NAMELY, INFRARED CAMERAS, SECURITY CAMERAS, CAMERAS FOR CHECKING AND INSPECTING PREMISES, INDIVIDUALS, OBJECTS OR MANUFACTURING INDUSTRIAL PROCESSES; VIEWERS, NAMELY, VIEWING TERMINALS; COMPUTER SOFTWARE, NAMELY, NETWORK VIDEO RECORDING SOFTWARE FOR IP (INTERNET PROTOCOL) VIDEO SURVEILLANCE, DIGITAL VIDEO RECORDING SOFTWARE FOR IP VIDEO SURVEILLANCE; COMPUTER SOFTWARE TO RECOGNIZE AND ANALYZE THINGS, PERSONS AND PARTS THEREOF; COMPUTER SOFTWARE FOR INTERPRETING FINGERPRINTS OR PALM PRINTS; SELF-LEARNING COMPUTER SOFTWARE FOR CHECKING PURPOSES, RECOGNIZING PURPOSES, SECURITY PURPOSES OR ALARM PURPOSES; COMPUTER SOFTWARE FOR QUALITY CONTROLS USED IN CONNECTION WITH MANUFACTURING MACHINES FOR SUPERVISION AND VERIFICATION OF THE QUALITY OF RAW MATERIALS, COMMODITIES, MANUFACTURED, SEMI-MANUFACTURED AND TRANSFORMED GOODS DURING MANUFACTURING INDUSTRIAL PROCESSES (U.S. CLS. 21, 23, 26, 36 AND 38).

CLASS 37—CONSTRUCTION AND REPAIR

FOR INSTALLATION AND REPAIR OF ALARMS; INSTALLATION AND REPAIR OF SECURITY SYSTEMS; INSTALLATION AND REPAIR OF INSPECTION SYSTEMS (U.S. CLS. 100, 103 AND 106).

CLASS 42—SCIENTIFIC AND COMPUTER SERVICES

FOR DESIGN AND DEVELOPMENT OF COMPUTER HARDWARE AND SOFTWARE; UPDATING AND MAINTENANCE OF SOFTWARE AND PROGRAMS; QUALITY CONTROL FOR OTHERS; DESIGN AND DEVELOPMENT OF ALARMS; DESIGN AND DEVELOPMENT OF SECURITY SYSTEMS; DESIGN AND DEVELOPMENT OF INSPECTION SYSTEMS (U.S. CLS. 100 AND 101).

PAUL MORENO, EXAMINING ATTORNEY

SN 79-100,467, SCHIESSER AG, FED REP GERMANY, FILED 3-14-2011.

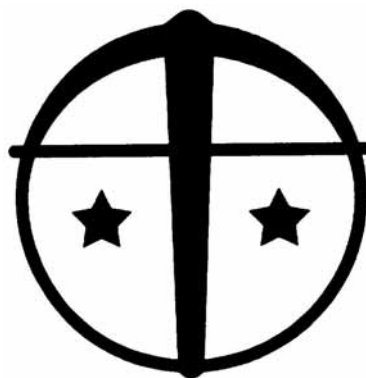

PRIORITY DATE OF 12-20-2010 IS CLAIMED.
OWNER OF INTERNATIONAL REGISTRATION 1085250 DATED 3-14-2011, EXPIRES 3-14-2021.

THE MARK CONSISTS OF THE DESIGN OF A CROSSBOW WITH TWO STARS, ONE ON EACH SIDE OF THE CROSSBOW.

CLASS 18—LEATHER GOODS

FOR LEATHER AND IMITATION LEATHER BAGS; LEATHER BAGS; SMALL LEATHER GOODS, NAMELY, WALLETS; TRAVEL CASES; SUITCASES; ALL PURPOSE CARRYING BAGS; SPORT BAGS; BEACH BAGS; COSMETIC BAGS SOLD EMPTY; HANDBAGS; PURSES; TRAVEL BAGS (U.S. CLS. 1, 2, 3, 22 AND 41).

CLASS 25—CLOTHING

FOR CLOTHING, NAMELY, HATS, GLOVES, MITTENS AND SCARVES FOR WOMEN, MEN AND CHILDREN; OUTER CLOTHING FOR WOMEN, MEN AND CHILDREN, NAMELY, SWEATERS, HATS AND SCARVES ALL MADE OF WOOL; READY TO WEAR CLOTHING, NAMELY, DRESSES; CARDIGANS; SLACKS; SHORTS; SUITS, SHIRTS, TROUSERS, BERMUDA SHORTS; FROCKS, BLOUSES, JUMPERS, SKIRTS; JACKETS, STUFF JACKETS, WAISTCOATS, COATS, OVERALLS, PARKAS, RAINCOATS, WIND JACKETS; HOSIERY, PULLOVERS, SWEATERS, BANDANAS, JERSEYS, T-SHIRTS, SWEATSHIRTS; TERRY CLOTHING, NAMELY, MOISTURE OR LIQUID ABSORB ANT AND PERSPIRATION ABSORB ANT UNDERWEAR; WOMEN'S, MEN'S AND CHILDREN'S UNDERWEAR; UNDERWEAR; BRAS; WOMEN'S UNDERPANTS; BREECHES; WOMEN'S VESTS; BUSTIERS; CORSELETS; BODICES; TEDDIES; BODYSUITS; LINGERIE; LINGERIE IN THE NATURE OF COMBINATIONS OF VESTS AND SLIPS; SLIPS, PETTICOATS, NEGLIGEEES; MEN'S UNDERPANTS, BOXER SHORTS, MEN'S VESTS; CHILDREN'S UNDERPANTS, CHILDREN'S VESTS; WOMEN'S, MEN'S AND CHILDREN'S SPORTS UNDERWEAR; SPORTS BRAS; SOCKS; STOCKINGS; MID-CALF LENGTH SOCKS; TIGHTS; SOCK SUSPENDERS; OUTER CLOTHING FOR SPORTS, NAMELY, GLOVES, MITTENS, SCARVES; SKI SHELLS, NAMELY, SKI VESTS, SKI HOODED JACKETS, HIKING JACKETS, HIKING HOODED JACKETS, HOODED SWEATSHIRTS, RUNNING JACKETS, WIND VESTS, HIKING PANTS, PARKAS, INSULATED VESTS, HATS FOR OUTDOOR PURSUITS AND SPORTS; CLOTHING FOR GYMNASTICS, NAMELY, GYM SHORTS, GYM SUITS, LEOTARDS, TIGHTS; JOGGING SUITS, LEGGINGS; CYCLISTS' CLOTHING, NAMELY, CYCLISTS' JERSEYS; KNITWEAR, NAMELY, KNITTED UNDERWEAR; SINGLET; BATH WEAR, NAMELY, ROBES; BATHING SUITS; BATHING TRUNKS; SWIMWEAR FOR WOMEN, MEN AND CHILDREN; SWIM SUITS; SWIM TRUNKS; BATHROBES; BEACH CLOTHES, NAMELY, BEACH COVERUPS; BEACHWEAR; NIGHTWEAR FOR WOMEN, MEN AND CHILDREN; PYJAMAS; NIGHTGOWNS; DRESSING GOWNS; LAYETTES; BABY CLOTHES, NAMELY, INFANTWEAR; BABY PYJAMAS; BABY UNDERWEAR; BABIES' NAPKIN-PANTS, NAMELY, INFANT DIAPER COVERS OF TEXTILE; BABIES' DIAPERS OF TEXTILE; TEXTILE GLOVES; WRIST BANDS; SWEATBANDS; HEADBANDS; BELTS; LEATHER BELTS; SUSPENDERS, NECKTIES, SCARVES, SHAWLS; EAR PROTECTORS, NAMELY, EAR MUFFS; APRONS; SHOES, BATH SANDALS, BATH SLIPPERS, SANDALS, SPORT SHOES, ESPARTO SHOES, BEACH SHOES; HEADWEAR; BATHING CAPS, SHOWER CAPS, HATS, HOODS, CAPS (U.S. CLS. 22 AND 39).

SUSAN RICHARDS, EXAMINING ATTORNEY

CLASS 9—ELECTRICAL AND SCIENTIFIC APPARATUS

FOR COMPUTER PROGRAMS FOR THE SECURITY OF COMPUTER SYSTEMS, ANTI-VIRUS COMPUTER PROGRAMS, ANTI-SPYWARE COMPUTER PROGRAMS; PARTS AND FITTINGS FOR COMPUTER PROGRAMS, NAMELY, COMPUTER SUBPROGRAMS FOR THE SECURITY OF COMPUTER SYSTEMS, COMPUTER PROGRAM MODULES FOR THE SECURITY OF COMPUTER SYSTEMS, COMPUTER PROGRAMS FOR GENERATING COMPUTER PROGRAMS, SUPPORT SOFTWARE FOR THE SECURITY OF COMPUTER SYSTEMS, AND INTERFACES FOR COMPUTERS; PRE-RECORDED MAGNETIC AND OPTICAL DATA CARRIERS FEATURING DATA ABOUT COMPUTER VIRUSES, SPYWARE, AND OTHER DATA ABOUT THE SECURITY OF COMPUTER SYSTEMS (U.S. CLS. 21, 23, 26, 36 AND 38).

CLASS 41—EDUCATION AND ENTERTAINMENT

FOR EDUCATION SERVICES, NAMELY, PROVIDING CLASSES, SEMINARS, AND WORKSHOPS IN THE FIELD OF COMPUTER SYSTEM SECURITY; TRAINING SERVICES IN THE FIELD OF COMPUTER SYSTEM SECURITY; WRITING OF TEXTS AND PUBLISHING OF BOOKS, REVIEWS, MAGAZINES, AND ELECTRONIC PUBLICATIONS USING MEDIA OF ALL KINDS (U.S. CLS. 100, 101 AND 107).

CLASS 42—SCIENTIFIC AND COMPUTER SERVICES

FOR COMPUTER PROGRAMMING; COMPUTER SOFTWARE CONSULTANCY WITH REGARD TO THE USE AND APPLICATION OF SOFTWARE, INSTALLATION AND MAINTENANCE OF SOFTWARE; SERVICES OF A SOFTWARE COMPANY, NAMELY, THE DESIGN OF COMPUTER SOFTWARE, DEVELOPMENT OF COMPUTER SOFTWARE, COMPUTER PROGRAMMING, UPDATING OF COMPUTER SOFTWARE, MAINTENANCE AND INSTALLATION OF SOFTWARE; COMPUTER SYSTEMS ANALYSIS; COMPUTER SOFTWARE APPLICATION CONSULTANCY WITH REGARD TO SOFTWARE; COMPUTER CONSULTANCY; TECHNOLOGICAL SERVICES TO SUPPORT AND IMPLEMENT THE LOCALISATION OF DATA STRUCTURES AND THE AMENDMENT THEREOF, NAMELY, SOFTWARE APPLICATIONS CONSULTANCY AND TECHNICAL SUPPORT IN THE NATURE OF TROUBLESHOOTING COMPUTER SOFTWARE PROBLEMS; INTERNET SERVICES, NAMELY, CREATING AND MAINTENANCE OF COMPUTER PROGRAMS FOR USE ON THE INTERNET AND/OR FOR THE USE OF THE INTERNET, AND COMPUTER SOFTWARE CONSULTANCY WITH REGARD TO THE APPLICATION AND FURTHER DEVELOPMENT OF SUCH PROGRAMS (U.S. CLS. 100 AND 101).

SN 79-100,621. TJARK AUERBACH, FED REP GERMANY, FILED 6-6-2011.

EXTREME RELIABILITY

THE MARK CONSISTS OF STANDARD CHARACTERS WITHOUT CLAIM TO ANY PARTICULAR FONT, STYLE, SIZE, OR COLOR.

PRIORITY DATE OF 12-14-2010 IS CLAIMED.

OWNER OF INTERNATIONAL REGISTRATION 1085620 DATED 6-6-2011, EXPIRES 6-6-2021.

CLASS 45—PERSONAL AND LEGAL SERVICES

FOR SECURITY SERVICES FOR THE PROTECTION OF PROPERTY AND INDIVIDUALS, NAMELY, PERSONAL SECURITY CONSULTATION FOR THE PROTECTION OF INDIVIDUALS AND PERSONAL SECURITY CONSULTATION FOR THE MONITORING OF COMPUTER SYSTEMS FOR SECURITY PURPOSES (U.S. CLS. 100 AND 101).

COLLEEN DOMBROW, EXAMINING ATTORNEY

SN 79-100,697. HUBER SE, FED REP GERMANY, FILED 5-24-2011.

TrashMax

THE MARK CONSISTS OF STANDARD CHARACTERS WITHOUT CLAIM TO ANY PARTICULAR FONT, STYLE, SIZE, OR COLOR.

PRIORITY DATE OF 11-29-2010 IS CLAIMED.

OWNER OF INTERNATIONAL REGISTRATION 1085780 DATED 5-24-2011, EXPIRES 5-24-2021.

CLASS 7—MACHINERY

FOR CONVEYORS AND FEEDERS AS PARTS OF MACHINES, NAMELY, MECHANICAL MACHINES FOR REMOVAL OF SOLIDS FROM LIQUIDS; MECHANICAL MUD COLLECTORS AS PARTS OF MACHINES THAT SEPARATE SOLIDS FROM LIQUIDS; MECHANICAL SEPARATORS FOR SEPARATING SOLIDS FROM LIQUIDS; SIFTING INSTALLATIONS COMPRISING BARS OR PERFORATED PLATES TO REMOVE SOLIDS FROM WATER; RAKING INSTALLATIONS FOR REMOVAL OF SOLIDS FROM LIQUIDS, ESSENTIALLY CONSISTING OF MECHANICAL RAKES INSTALLED IN CHANNELS OF CONCRETE OR IN STEEL CONTAINERS; MACHINES FOR SEPARATION OF SOLIDS FROM SLUDGE; MECHANICAL CLIMBING RAKES FOR REMOVAL OF WASTE SOLIDS FROM WASTE LIQUIDS (U.S. CLS. 13, 19, 21, 23, 31, 34 AND 35).

CLASS 11—ENVIRONMENTAL CONTROL APPARATUS

FOR WATER PURIFICATION APPARATUS, MACHINES AND INSTALLATIONS; PURIFICATION INSTALLATIONS FOR SEWAGE (U.S. CLS. 13, 21, 23, 31 AND 34).

EDWARD FENNESSY, EXAMINING ATTORNEY

SN 79-100,762. JESÚS CANDEL FÁBREGAS, E-18220 ALBOLOTE (GRANADA), SPAIN, FILED 3-11-2011.



OWNER OF INTERNATIONAL REGISTRATION 1085998 DATED 3-11-2011, EXPIRES 3-11-2021.

THE MARK CONSISTS OF A TENNIS BALL WITH TWO SWIRLS AROUND IT, AND BELOW, THE STYLIZED WORDING "SPIRIBOL" WITH A LINE ACROSS THIS WORDING.

THE WORDING "SPIRIBOL" HAS NO MEANING IN A FOREIGN LANGUAGE.

CLASS 25—CLOTHING

FOR COATS, BATH ROBES, FOOTWEAR, SHORT-SLEEVED SHIRTS, SHIRTS, HEADWEAR, BATHING SUITS, TIES, SCARVES, JACKETS, SKIRTS, RAINCOATS, JERSEYS, TROUSERS, PULLOVERS, SANDALS, GYM SHOES, BEACH SHOES, DRESSES (U.S. CLS. 22 AND 39).

CLASS 28—TOYS AND SPORTING GOODS

FOR SPORTS GAME APPARATUS, NAMELY, A TENNIS BALL TETHERED TO A POLE, AND A PADDLE, FOR PLAYING INDOOR AND OUTDOOR GAMES (U.S. CLS. 22, 23, 38 AND 50).

CLASS 35—ADVERTISING AND BUSINESS

FOR BUSINESS ADVISORY SERVICES, CONSULTANCY AND INFORMATION RELATING TO RETAIL STORE AND ON-LINE RETAIL STORE SERVICES FEATURING COATS, BATH ROBES, FOOTWEAR, SHORT-SLEEVED SHIRTS, SHIRTS, HEADGEAR, BATHING SUITS, TIES, SCARVES, JACKETS, SKIRTS, RAINCOATS, JERSEYS, TROUSERS, PULLOVERS, SANDALS, GYM SHOES, BEACH SHOES, DRESSES, SPORTS GAME APPARATUS, NAMELY, A TENNIS BALL TETHERED TO A POLE, AND A PADDLE, FOR PLAYING INDOOR AND OUTDOOR GAMES (U.S. CLS. 100, 101 AND 102).

RONALD DELGIZZI, EXAMINING ATTORNEY

SN 79-100,856. MAYR-MELNHOF KARTON AKTIENGESELLSCHAFT, AUSTRIA, FILED 5-20-2011.

Foodboard

THE MARK CONSISTS OF STANDARD CHARACTERS WITHOUT CLAIM TO ANY PARTICULAR FONT, STYLE, SIZE, OR COLOR.

OWNER OF INTERNATIONAL REGISTRATION 1052115 DATED 8-30-2010, EXPIRES 8-30-2020.

CLASS 1—CHEMICALS

FOR CHEMICAL PREPARATIONS FOR USE IN INDUSTRY (U.S. CLS. 1, 5, 6, 10, 26 AND 46).

CLASS 16—PAPER GOODS AND PRINTED MATTER

FOR PAPER, CARDBOARD AND GOODS MADE FROM THESE MATERIALS, NAMELY, PAPER AND CARDBOARD PACKAGING AND WRAPPING MATERIALS FOR FOOD, HOUSEHOLD ARTICLES, ELECTRICAL ITEMS, DETERGENTS, GLASSWARE, BEVERAGES; CARDBOARD ARTICLES, NAMELY, POSTCARDS AND GREETING CARDS, BOTTLE WRAPPERS OF CARDBOARD OR PAPER, SHEETS OF RECLAIMED CELLULOSE FOR WRAPPING, BOXES OF CARDBOARD OR PAPER, BAGS, ENVELOPES AND POUCHES OF PAPER OR CARDBOARD FOR PACKAGING, SHEETS OF PAPER OR CARDBOARD FOR WRAPPING OR PACKAGING, PAPER OR CARDBOARD MATERIALS FOR PACKAGING, DISPLAYS OF CARDBOARD OR PAPER; PRINTED MATTER, NAMELY, MAGAZINES AND BOOKLETS FOR THE CARDBOARD AND PACKAGING INDUSTRIES (U.S. CLS. 2, 5, 22, 23, 29, 37, 38 AND 50).

CLASS 42—SCIENTIFIC AND COMPUTER SERVICES

FOR PACKAGING DESIGN SERVICES; TECHNICAL DEVELOPMENT, DESIGN AND PLANNING IN THE FIELD OF PACKAGING TECHNOLOGY; TECHNICAL DEVELOPMENT, DESIGN AND PLANNING IN THE FIELD OF MANUFACTURING TECHNOLOGY (U.S. CLS. 100 AND 101).

ANNE MADDEN, EXAMINING ATTORNEY

SN 79-100,985. ROGER ANDRÉ EILERTSEN, NORWAY,
FILED 6-6-2011.

SUPERDAY

THE MARK CONSISTS OF STANDARD CHARACTERS WITHOUT CLAIM TO ANY PARTICULAR FONT, STYLE, SIZE, OR COLOR.

OWNER OF INTERNATIONAL REGISTRATION 1086597 DATED 6-6-2011, EXPIRES 6-6-2021.

CLASS 35—ADVERTISING AND BUSINESS

FOR ADVERTISING SERVICES; BUSINESS ADMINISTRATION AND MANAGEMENT; PROVIDING OFFICE FUNCTIONS (U.S. CLS. 100, 101 AND 102).

CLASS 39—TRANSPORTATION AND STORAGE

FOR TRANSPORT OF GOODS AND PEOPLE; PACKAGING ARTICLES FOR TRANSPORTATION; PROVIDING STORAGE FACILITIES FOR ARTICLES UNDER TRANSPORTATION; ARRANGING AND COORDINATING TRAVEL ARRANGEMENTS FOR INDIVIDUALS AND GROUPS, NAMELY, BOOKING OF TRAVEL TICKETS, ARRANGING FOR TRAVEL VISAS, PASSPORTS, TRAVEL VOUCHERS AND OTHER TRAVEL DOCUMENTS FOR PERSONS TRAVELING ABROAD AND ORGANIZATION OF EXCURSIONS, SIGHTSEEING TOURS, PACKAGE TOURS AND CUSTOM-ADAPTED TRAVEL; TRAVEL AGENCY SERVICES, NAMELY, PROVIDING CUSTOMIZED TRAVEL ITINERARIES (U.S. CLS. 100 AND 105).

CLASS 41—EDUCATION AND ENTERTAINMENT

FOR EDUCATIONAL SERVICES, NAMELY, PROVIDING CLASSES, SEMINARS OR LECTURES IN THE FIELDS OF TRAVEL, ROLE-PLAY GAMING EVENTS AND PRODUCTION OF MOVIES, TV PROGRAMS AND THEATRICAL WORKS, AND ARRANGING AND PRESENTING OF POP, ROCK AND CLASSICAL MUSIC CONCERTS AND TALENT MANAGEMENT; ENTERTAINMENT, NAMELY, ARRANGING AND PRESENTING OF POP, ROCK AND CLASSICAL MUSIC CONCERTS, CABARET AND VARIETY SHOWS, LITERARY READINGS, ACTING PERFORMANCES AND ORAL PRESENTATIONS BY WRITERS, ACTORS, ARTISTS AND SPEAKERS, THEATER PRODUCTIONS, ROLE-PLAY GAMING EVENTS, PUBLIC AND PRIVATE LIVE PERFORMANCES WITH ARTISTS, ACTORS, BANDS, MUSICIANS, COMEDIANS, MAGICIANS, DISC JOCKEYS AND THEATRICAL GROUPS, AND PERSONAL APPEARANCES BY MODELS, CELEBRITIES, MEDIA PERSONALITIES AND SPORTS PERSONALITIES; ORGANIZING COMMUNITY SPORTING AND CULTURAL EVENTS (U.S. CLS. 100, 101 AND 107).

EDWARD FENNESSY, EXAMINING ATTORNEY

SN 79-101,285. KOUBACHI AG, CH-8092 ZÜRICH, SWITZERLAND, FILED 5-23-2011.

Koubachi

PRIORITY DATE OF 2-7-2011 IS CLAIMED.
OWNER OF INTERNATIONAL REGISTRATION 1087342 DATED 5-23-2011, EXPIRES 5-23-2021.

THE WORDING "KOUBACHI" HAS NO MEANING IN A FOREIGN LANGUAGE.

CLASS 9—ELECTRICAL AND SCIENTIFIC APPARATUS

FOR SURVEYING, PHOTOGRAPHIC, CINEMATOGRAPHIC, OPTICAL, MEASURING, SIGNALING, CHECKING, LIFE-SAVING AND TEACHING APPARATUS AND INSTRUMENTS, NAMELY, SURVEYING INSTRUMENTS, CAMERAS, CINEMATOGRAPHIC PROJECTORS, BLANK OPTICAL DISKS, ANGLE FINDERS, LIFE SAVING RAFTS, MEDICAL TEACHING MANNEQUINS; APPARATUS AND INSTRUMENTS FOR CONDUCTING, SWITCHING, TRANSFORMING, ACCUMULATING, REGULATING AND CONTROLLING ELECTRICITY, NAMELY, ELECTRIC CONDUCTORS, ELECTRIC SWITCHES, ELECTRIC TRANSFORMERS, ACCUMULATORS, VOLTAGE REGULATORS, ELECTRICAL CONTROLLERS; APPARATUS FOR RECORDING, TRANSMITTING AND REPRODUCING SOUND OR IMAGES; MAGNETIC RECORDING MEDIA, NAMELY, BLANK MAGNETIC DISCS, BLANK MAGNETIC TAPES FOR TAPE RECORDERS; CALCULATORS, COMPUTER AND DATA PROCESSORS, AEROMETERS; BURGLAR, FIRE, PERSONAL SECURITY ALARMS; ANALYSIS APPARATUS, NOT FOR MEDICAL USE, NAMELY, AIR ANALYSIS APPARATUS, ANALYSIS INSTRUMENTS FOR PHOTOGRAMMETRIC PURPOSES; APPARATUS FOR WIRELESS CONNECTION OF PORTABLE ELECTRONIC APPARATUS, NAMELY, MODEMS; APPARATUS AND INSTRUMENTS FOR CONDUCTING, SWITCHING, TRANSFORMING, ACCUMULATING, REGULATING OR CONTROLLING ELECTRIC CURRENT, NAMELY, ELECTRIC CONDUCTORS, ELECTRIC SWITCHES, ELECTRIC TRANSFORMERS, ACCUMULATORS, VOLTAGE REGULATORS, ELECTRICAL CONTROLLERS; APPARATUS AND INSTALLATIONS INCLUDING COMPONENTS FOR RECORDING, STORING, TRANSMITTING, BROADCASTING, RECEIVING AND REPRODUCING SOUND, IMAGES, DATA AND SIGNALS, NAMELY, APPARATUS FOR BROADCASTING, RECORDING, TRANSMISSION AND REPRODUCTION OF SOUND AND IMAGE; COMPUTER APPLICATION PROGRAMS FOR MOBILE PHONES, PORTABLE MEDIA PLAYERS, HANDHELD COMPUTERS, NAMELY, SOFTWARE FOR CREATING SEARCHABLE DATABASES OF INFORMATION AND DATA, FOR USE IN RELATION TO DIGITAL ANIMATION AND SPECIAL EFFECTS OF IMAGES, FOR WIRELESS CONTENT DELIVERY, FOR COMMUNICATING WITH USERS OF HAND-HELD COMPUTERS, FOR THE COLLECTION, EDITING, ORGANIZING, MODIFYING, BOOK MARKING, TRANSMISSION, STORAGE AND SHARING OF DATA AND INFORMATION, FOR ACCESSING INFORMATION DIRECTORIES THAT MAY BE DOWNLOADED FROM THE GLOBAL COMPUTER NETWORK FOR USE IN DATABASE MANAGEMENT, USE IN ELECTRONIC STORAGE OF DATA; INTEGRATED CIRCUITS; COMPUTER HARDWARE AND SOFTWARE FOR USE IN NETWORK MANAGEMENT; COMPUTER OPERATING SYSTEM PROGRAMS; COMPUTER HARDWARE; COMPUTER PERIPHERAL DEVICES, NAMELY, PRINTERS, MICE, KEYBOARDS; COMPUTER SOFTWARE FOR CREATING SEARCHABLE DATABASES OF INFORMATION AND DATA, FOR USE IN RELATION TO DIGITAL ANIMATION AND SPECIAL EFFECTS OF IMAGES, FOR WIRELESS CONTENT DELIVERY, FOR COMMUNICATING WITH USERS OF HAND-HELD COMPUTERS, FOR THE COLLECTION, EDITING, ORGANIZING, MODIFYING, BOOK MARKING, TRANSMISSION, STORAGE AND SHARING OF DATA AND INFORMATION, FOR ACCESSING INFORMATION DIRECTORIES THAT MAY BE DOWNLOADED FROM THE GLOBAL COMPUTER NETWORK; DATA BANKS, NAMELY, COMPUTER HARDWARE AND SOFTWARE FOR THE ORGANIZATION, STORAGE AND ACCESS OF DATA; DATA MEMORIES, NAMELY, COMPUTER HARDWARE AND SOFTWARE FOR COLLECTING AND MAINTAINING DATA; CARBON DIOXIDE, FIRE AND SMOKE DETECTORS; DIAGNOSTIC APPARATUS FOR TESTING FOOD, THE DETECTION OF PATHOGENS FOR LABORATORY OR RESEARCH USE, NOT FOR MEDICAL USE; PRESSURE MEASURING APPARATUS, NAMELY, PRESSURE GAUGES, PRESSURE INDICATORS; ELECTRONIC MONITORING INSTALLATIONS, NAMELY, ALARM MONITORING SYSTEMS, BABY MONITORS; REMOTE CONTROLS FOR RADIOS, TELEVISIONS, STEREOS; COMPUTER FIRMWARE FOR USE IN DATABASE MANAGEMENT, USE AS A SPREADSHEET, WORD PROCESSING; RADIO

RECEIVERS; PRINTED CIRCUITS; SEMICONDUCTORS; ELECTRONIC CONTROLLERS FOR APPARATUS FOR BROADCASTING, RECORDING, TRANSMISSION AND REPRODUCTION OF SOUND AND IMAGE, FOR CARBON DIOXIDE, FIRE AND SMOKE DETECTORS, FOR DIAGNOSTIC APPARATUS FOR TESTING FOOD, THE DETECTION OF PATHOGENS FOR LABORATORY OR RESEARCH USE NOT FOR MEDICAL USE, FOR PRESSURE MEASURING APPARATUS, NAMELY, PRESSURE GAUGES, PRESSURE INDICATORS, FOR ALARM MONITORING SYSTEMS, FOR BABY MONITORS, FOR REMOTE CONTROLS FOR RADIOS TELEVISIONS AND STEREOS, FOR DISTANCE MEASURING APPARATUS, GRAVITY MEASURING INSTRUMENTS, FOR INSTRUMENTS FOR MEASURING LENGTH, FOR METEOROLOGICAL INSTRUMENTS; DOWNLOADABLE RING TONES, MUSIC, ELECTRONIC GAMES VIA THE INTERNET AND WIRELESS DEVICES; HYGROMETERS; APPARATUS FOR RECORDING, TRANSMISSION, PROCESSING AND REPRODUCTION OF SOUND, IMAGES OR DATA; MEASURING APPARATUS AND MEASURING INSTRUMENTS, NAMELY, DISTANCE MEASURING APPARATUS, GRAVITY MEASURING INSTRUMENTS, INSTRUMENTS FOR MEASURING LENGTH; METEOROLOGICAL INSTRUMENTS; SMOKE DETECTORS; ELECTRONIC SIGNAL TRANSMITTERS; TEMPERATURE GAUGES; THERMOSTATS; SURVEILLANCE APPARATUS AND INSTRUMENTS, NAMELY, ELECTRIC AND ELECTRONIC VIDEO SURVEILLANCE INSTALLATIONS; SCIENTIFIC, NAVIGATION, SURVEYING, OPTICAL, WEIGHING, MEASURING, SIGNALING, CHECKING AND TEACHING APPARATUS AND INSTRUMENTS, NAMELY, GPS NAVIGATION DEVICE; METERS (U.S. CLS. 21, 23, 26, 36 AND 38).

CLASS 28—TOYS AND SPORTING GOODS

FOR GAMES, NAMELY, ACTION SKILL GAMES, CHESS GAMES, PARLOR GAMES; TOYS, NAMELY, BATH TOYS, BENDABLE TOYS, DRAWING TOYS, INFLATABLE TOYS; AUTOMATIC GAMES WITH VIDEO, NAMELY, STAND ALONE VIDEO GAME MACHINES; GAME CONSOLES, TELEPHONES AND OTHER ELECTRONIC APPARATUS FOR PLAY AT HOME, NAMELY, ARCADE GAMES, TOY TELEPHONES, STAND ALONE VIDEO GAME MACHINES; ELECTRONIC GAMES, NAMELY, ELECTRONIC DART GAMES, ARCADE-TYPE ELECTRONIC VIDEO GAMES; GAMES OF INTELLIGENCE, NAMELY, CHESS GAMES, PUZZLES; AUTOMATIC ELECTRONIC EDUCATIONAL GAMES MACHINES FOR CHILDREN; MUSICAL TOYS; REMOTE-CONTROLLED BATTERY-OPERATED TOY VEHICLES; BOARD GAMES; CARD GAMES; PLAYING CARDS; PARTS AND ADD-ON PARTS FOR ALL THE ABOVE GOODS, NAMELY, PROTECTIVE CARRYING CASES SPECIALLY ADAPTED FOR HANDHELD VIDEO GAMES; SPORTS AND GAME ACCESSORIES, NAMELY, TENNIS RACKETS, FOOT BALLS, HOCKEY STICKS (U.S. CLS. 22, 23, 38 AND 50).

CLASS 38—COMMUNICATION

FOR TELECOMMUNICATIONS, NAMELY, CALL HUNTING, TRANSMISSION OF WEB CASTS, WIRELESS TELEPHONE SERVICES; ELECTRONIC DATA TRANSMISSION VIA GLOBAL COMPUTER NETWORKS; ELECTRONIC AND DIGITAL TRANSMISSION OF DATA, DOCUMENTS, SOUNDS AND IMAGES; CONSULTING IN THE FIELD OF TELECOMMUNICATIONS TECHNOLOGY; INFORMATION ABOUT TELECOMMUNICATION; PROVIDING ACCESS TO DATA BANKS, NAMELY, DATABASES; RENTAL OF ACCESS TIME TO COMPUTER DATABASES, COMPUTER NETWORKS AND INTERACTIVE COMPUTER CONNECTION NETWORKS; PROVIDING OF DISCUSSION FORUMS, NAMELY, CHAT ROOMS ON THE INTERNET; PROVIDING REMOTE INTERNET ACCESS; PROVIDING USER

ACCESS TO A GLOBAL COMPUTER NETWORK; TRANSFER OF DATA BY TELECOMMUNICATIONS; ELECTRONIC MESSAGE TRANSMISSION; E-MAIL SERVICES; PROVIDING TELECOMMUNICATIONS CONNECTIONS TO A GLOBAL COMPUTER NETWORK; ELECTRONIC TRANSMISSION OF DATA FROM A DATA BANK; PROVIDING ACCESS TO INTERNET PLATFORMS FOR PROVIDING OFFERS FOR GOODS AND SERVICES IN ELECTRONICALLY ACCESSIBLE DATABASES, WITH INTERACTIVE ACCESS AND THE POSSIBILITY OF DIRECT ORDERING (U.S. CLS. 100, 101 AND 104).

CLASS 42—SCIENTIFIC AND COMPUTER SERVICES

FOR SCIENTIFIC AND TECHNOLOGICAL SERVICES, NAMELY, RESEARCH AND DESIGN IN THE FIELD OF CREATING SEARCHABLE DATABASES OF INFORMATION AND DATA, OF USING SOFTWARE IN RELATION TO DIGITAL ANIMATION AND SPECIAL EFFECTS OF IMAGES, OF WIRELESS CONTENT DELIVERY, OF COMMUNICATING WITH USERS OF HAND-HELD COMPUTERS, OF THE COLLECTION, EDITING, ORGANIZING, MODIFYING, BOOK MARKING, TRANSMISSION, STORAGE AND SHARING OF DATA AND INFORMATION, OF ACCESSING INFORMATION DIRECTORIES THAT MAY BE DOWNLOADED FROM THE GLOBAL COMPUTER NETWORK; INDUSTRIAL ANALYSIS AND RESEARCH IN THE FIELD OF COMPUTER NETWORKING HARDWARE, OF COMPUTER DATACENTER ARCHITECTURE, OF ELECTRONIC DATA TRANSMISSION VIA GLOBAL COMPUTER NETWORKS, OF ELECTRONIC AND DIGITAL, TRANSMISSION OF DATA, DOCUMENTS, SOUNDS AND IMAGES, OF CREATING SEARCHABLE DATABASES OF INFORMATION AND DATA, OF USING SOFTWARE IN RELATION TO DIGITAL ANIMATION AND SPECIAL EFFECTS OF IMAGES, OF WIRELESS CONTENT DELIVERY, OF COMMUNICATING WITH USERS OF HAND-HELD COMPUTERS, OF THE COLLECTION, EDITING, ORGANIZING, MODIFYING, BOOK MARKING, TRANSMISSION, STORAGE AND SHARING OF DATA AND INFORMATION, OF ACCESSING INFORMATION DIRECTORIES THAT MAY BE DOWNLOADED FROM THE GLOBAL COMPUTER NETWORK; COMPUTER HARDWARE AND SOFTWARE DESIGN AND DEVELOPMENT; COMPUTER SOFTWARE UPDATING FOR OTHERS; INTERNET SITE HOSTING FOR OTHERS; TECHNOLOGICAL CONSULTING SERVICES IN THE FIELD OF ALTERNATIVE ENERGY GENERATION; COMPUTER SOFTWARE DEVELOPMENT AND DESIGN; DEVELOPMENT AND DESIGN OF DATABASES AND WEB SITES; DEVELOPMENT OF COMPUTER SOFTWARE; INSTALLATION, INTEGRATION AND MAINTENANCE OF COMPUTER PROGRAMS; BUILDING OF DATA BANKS, NAMELY, DATABASE DESIGN AND DEVELOPMENT; ONLINE TECHNICAL SUPPORT, NAMELY, MONITORING OF NETWORK SYSTEMS; RENTAL OF COMPUTER SOFTWARE; ENCODING OF MAGNETIC CARDS; DATA ENCRYPTION AND DECODING SERVICES; COMPUTER SOFTWARE MAINTENANCE (U.S. CLS. 100 AND 101).

DEIRDRE ROBERTSON, EXAMINING ATTORNEY

SN 79-101,454, LIDL STIFTUNG & CO. KG, FED REP GERMANY, FILED 7-20-2011.

CRIVIT

THE MARK CONSISTS OF STANDARD CHARACTERS WITHOUT CLAIM TO ANY PARTICULAR FONT, STYLE, SIZE, OR COLOR.

OWNER OF INTERNATIONAL REGISTRATION 1039044 DATED 12-9-2009, EXPIRES 12-9-2019.

THE WORDING "CRIVIT" HAS NO MEANING IN A FOREIGN LANGUAGE.

CLASS 7—MACHINERY

FOR NET HAULING MACHINES FOR USE IN FISHING (U.S. CLS. 13, 19, 21, 23, 31, 34 AND 35).

CLASS 8—HAND TOOLS

FOR CUTLERY, NAMELY, SCALING KNIVES AND KNIVES FOR FILLETING FISH FOR FISHERS; HARPOONS FOR COMMERCIAL FISHING (U.S. CLS. 23, 28 AND 44).

CLASS 9—ELECTRICAL AND SCIENTIFIC APPARATUS

FOR PROTECTIVE CLOTHING FOR MOTORCYCLISTS FOR PROTECTION AGAINST ACCIDENT OR INJURY, MOTORCYCLE HELMETS, PROTECTIVE GLOVES FOR MOTORCYCLISTS FOR PROTECTION AGAINST ACCIDENTS; SUNGLASSES; NAUTICAL APPARATUS AND INSTRUMENTS, NAMELY, UNDERWATER HOUSINGS FOR CAMERAS, UNDERWATER ENCLOSURES FOR CAMERAS, MARINE RADIO COMMUNICATION MACHINES, SIGNALING LIGHTS AND BUOYS; EQUIPMENT FOR DIVERS, NAMELY, DIVING SUITS, DIVERS MASKS, SWIMMING LIFE JACKETS AND LIFE-SAVING JACKETS, INFLATABLE OR NOT INFLATABLE; SNORKELS, WEIGHTS IN THE NATURE OF WEIGHT BELTS, UNDERWATER BREATHING APPARATUS, AIR TANKS, REGULATORS FOR USE IN SCUBA DIVING, MARINE DEPTH FINDERS, PRESSURE GAUGES, DIRECTIONAL COMPASSES AND THERMOMETERS, EAR MOLDS IN THE NATURE OF EAR PLUGS FOR SWIMMING AND DIVING, NOSE CLIPS FOR DIVERS AND SWIMMERS; CLOTHING, GLOVES, FOOTWEAR AND HEADGEAR FOR DIVING, NAMELY, DIVING SUITS, DIVING GLOVES, SCUBA FLIPPERS, DIVERS MASKS; UNDERWATER CAMERAS; PHOTOGRAPHIC, CINEMATOGRAPHIC, OPTICAL, WEIGHING, MEASURING, SIGNALING, CHECKING AND SUPERVISION, EMERGENCY LIFE-SAVING AND TEACHING APPARATUS AND INSTRUMENTS, NAMELY, SCALES, DIRECTIONAL COMPASSES AND PROTECTION AND SAFETY APPARATUS, NAMELY, INFLATABLE FLOATATION DEVICES; SPECTACLES, SUNGLASSES, SKI GOGGLES, PROTECTIVE SCUBA AND SWIMMING GOGGLES, GOGGLES, ANTI-GLARE GOGGLES; SPECTACLE FRAMES, SPECTACLE LENSES; SPECTACLE CASES, HELMETS FOR BICYCLES; TACHOMETERS; GROUND DEPTH GAUGES, NAMELY, MARINE DEPTH FINDERS (U.S. CLS. 21, 23, 26, 36 AND 38).

CLASS 11—ENVIRONMENTAL CONTROL APPARATUS

FOR POCKET LAMPS, LAMPS; LUMINARIES, NAMELY, LUMINOUS DIODES FOR USE AS FISHING ACCESSORIES, LUMINESCENT STICKS (U.S. CLS. 13, 21, 23, 31 AND 34).

CLASS 12—VEHICLES

FOR ACCESSORIES AND PARTS FOR VEHICLES OF ALL KINDS, NAMELY, BICYCLE WHEEL RIMS, HANDLEBARS, BICYCLE FRAMES, HANDLE BAR ENDS BEING BICYCLE PARTS, AUTOMOBILE DOOR HANDLES, VEHICLE WINDOWS, BICYCLE SEATS, VEHICLE SEATS, DOOR PANELS FOR LAND VEHICLES, LICENSE PLATE FRAMES, FITTED CANVAS COVERS FOR BOATS AND AUTOMOBILES AND CAR TRAILERS; PROPELLER BLADE PROTECTORS FOR BOATS; TRAILER HITCH COVERS, BUMPER FOR AUTOMOBILES AND BOATS; AUTOMOBILE AND BOAT SEAT CUSHIONS, PROTECTIVE POLYMER STRIPS TO BE AFFIXED TO THE HULLS OF BOATS AS STRUCTURAL PARTS OF BOATS IN THE NATURE OF BOAT FENDERS, OARS, SADDLE COVERS FOR BICYCLES, BICYCLE SADDLES, BICYCLE BELLS, SAFETY PADS FOR BICYCLES AND WATER BOTTLE HOLDERS FOR BICYCLES, LUGGAGE CARRIERS FOR VEHICLES, LUGGAGE NETS THAT ATTACH TO VEHICLES, BEING

STRUCTURAL PARTS OF LAND VEHICLES; WHEELS FOR VEHICLES, WHEEL COVERS, AUTOMOBILE WINDSHIELD SUN SHADES, NAMELY, AUTOMOBILE WINDSHIELD SHADE SCREENS, WHEEL RIMS AND SEAT COVERS FOR VEHICLES; GOLF EQUIPMENT, NAMELY, MOTORIZED GOLF CARTS; BICYCLES AND BICYCLE ACCESSORIES, NAMELY, PANNIER BAGS FOR BICYCLES; BASKETS ADAPTED FOR BICYCLES; BICYCLE PUMPS; DIRECTIONAL SIGNALS FOR BICYCLES; BOATS AND BOAT ACCESSORIES, NAMELY, WAKEBOARD TOWERS FOR BOATS (U.S. CLS. 19, 21, 23, 31, 35 AND 44).

CLASS 13—FIREARMS

FOR RIFLES (U.S. CLS. 2 AND 9).

CLASS 14—JEWELRY

FOR WATCHES (U.S. CLS. 2, 27, 28 AND 50).

CLASS 18—LEATHER GOODS

FOR SPORTS BAGS, NAMELY, TENNIS BAGS; BADMINTON BAGS AND SQUASH BAGS; SPORTS BAGS AND ALL PURPOSE SPORTS BAGS, SMALL BAGS FOR MEN; CARRY-ALL BAGS AND SHOULDER-STRAP BAGS; OVER-THE-SHOULDER BICYCLE CARRIER BAGS; SMALL PACKING BAGS OF LEATHER; BACKPACKS, PACKAGING BAGS OF LEATHER; DAY PACKS; NECK STRAPS FOR DOGS; WALKING STICKS, MOUNTAINEERING STICKS, HIKING STICKS, SADDLERY, BACKPACKS, DUFFEL BAGS AND TRANSPORT BAGS IN THE NATURE OF LUGGAGE, GARMENT BAGS FOR TRAVEL, TOTE BAGS, SHOULDER BAGS AND BACKPACKS; PACKAGING BAGS OF LEATHER, SATCHELS, UMBRELLAS (U.S. CLS. 1, 2, 3, 22 AND 41).

CLASS 20—FURNITURE AND ARTICLES NOT OTHERWISE CLASSIFIED

FOR CHAIRS AND BEDS; BASKETS FOR TRANSPORTING GOODS FOR COMMERCIAL PURPOSES; CUSHIONS FOR FISHING (U.S. CLS. 2, 13, 22, 25, 32 AND 50).

CLASS 21—HOUSEWARES AND GLASS

FOR DRINKING FLASKS AND DRINKING VESSELS (U.S. CLS. 2, 13, 23, 29, 30, 33, 40 AND 50).

CLASS 22—CORDAGE AND FIBERS

FOR TENTS, TARPAULINS; NETS, NAMELY, INSECT PROTECTION NETS; FISHING NETS, RAISING AND LOWERING NETS AND REINFORCEMENTS FOR RAISING AND LOWERING NETS FOR FISHING (U.S. CLS. 1, 2, 7, 19, 22, 42 AND 50).

CLASS 24—FABRICS

FOR FABRICS AND TEXTILE GOODS, NAMELY, TEXTILE FABRICS FOR MANUFACTURING OF CLOTHING; BED SHEETS, BED AND TABLE LINEN; BED COVERS AND BED BLANKETS; COTTON FABRIC; WOOLEN FABRIC; HANDKERCHIEFS OF TEXTILE; WALL HANGINGS OF TEXTILE; COTTON GOODS, NAMELY, COTTON FABRIC, COTTON CLOTH, COTTON-SILK MIXED FABRICS AND COTTON-WOOL MIXED FABRICS; WOOLEN CLOTH; TEXTILE USED AS LININGS FOR CLOTHING; NON-WOVEN FABRICS; BATH LINEN, HAND TOWELS OF TEXTILE (U.S. CLS. 42 AND 50).

CLASS 25—CLOTHING

FOR CLOTHING, NAMELY, SHIRTS, PANTS, JOGGING SUITS, YOGA PANTS, EXERCISE SHORTS, SHORTS, SOCKS, BLOUSES, DRESSES AND UNDERWEAR; FOOTWEAR, GLOVES, HEADWEAR, ALL THE AFORESAID GOODS EXCLUSIVELY FOR THE SPORTS SECTOR; MOTORCYCLE BOOTS, RAINWEAR, NAMELY, RAINWEAR FOR MOTORCYCLISTS, MOTORCYCLE CLOTHING, NAMELY, JACKETS, GLOVES AND RAIN SUITS; CLOTHING, NAMELY, SHIRTS, VESTS, WADERS, SLACKS, JACKETS, FOOTWEAR AND HEADWEAR FOR FISHING; FISHING GLOVES; SPECIAL HIP GUARDS FOR ANGLERS (U.S. CLS. 22 AND 39).

CLASS 27—FLOOR COVERINGS

FOR MATS, NAMELY, GYMNASICS MATS, SPORTS MATS IN THE NATURE OF GYMNASIAC MATS, WRESTLING MATS, TRAVEL MATS IN THE NATURE OF PERSONAL SITTING OR RESTING MATS, TREKKING AND CAMPING MATS IN THE NATURE OF PERSONAL SITTING MATS, AND INSULATING MATS IN THE NATURE OF PERSONAL SITTING MATS CONTAINING INSULATING MATERIAL (U.S. CLS. 19, 20, 37, 42 AND 50).

CLASS 28—TOYS AND SPORTING GOODS

FOR GYMNASIAC AND SPORTING ARTICLES, NAMELY, PARALLEL BARS, POMMEL HORSES, GYMNASIAC APPARATUS, GYMNASIAC HORIZONTAL BARS; GYMNASIAC TRAINING STOOLS; GYMNASIAC VAULTING HORSES; GOLF EQUIPMENT, NAMELY, GOLF BALLS, GOLF CLUBS AND GOLF CLUB COVERS, BALL MARKERS, GOLF GREEN FORKS, NAMELY, DIVOT REPAIR TOOLS, CHIPPING NETS, NAMELY, GOLF PRACTICE NETS, SCORE COUNTERS, GOLF BAGS; TENNIS EQUIPMENT, NAMELY, TENNIS BALLS, TENNIS RACKETS AND TENNIS RACKET COVERS, TENNIS NETS AND POLES FOR TENNIS NETS; TABLE TENNIS EQUIPMENT, NAMELY, TABLE TENNIS BALLS, TABLE TENNIS BATS AND COVERS FOR TABLE TENNIS BATS, TABLE TENNIS NETS AND POLES FOR TABLE TENNIS NETS; BADMINTON EQUIPMENT, NAMELY, SHUTTLECOCKS FOR BADMINTON AND BADMINTON RACKETS AND COVERS FOR BADMINTON RACKETS, BADMINTON NETS AND POLES FOR BADMINTON NETS; SQUASH EQUIPMENT, NAMELY, SQUASH BALLS, SQUASH RACKETS AND COVERS FOR SQUASH RACKETS; FISHING LINES, FISHING TACKLE, FISHING RODS AND THEIR PARTS, NAMELY, FISHING REELS, RINGS, GUIDES, GUT FOR FISHING, FISH HOOKS, FISHING SINKERS, FISHING FLOATS, SWIVELS AND TONGS FOR FISHING, SPOONS FOR FISHING; FISHING LURES, NAMELY, SPOONS, SWEEP GENERATORS AND SPOONS, ARTIFICIAL FISHING FLIES, BOXES FOR FISHING LURES, HOLDERS FOR FISHING RODS, SPINDLES FOR FISHING RODS, PLUMB LINES FOR FISHING POLES, CREELS FOR FISHING; FISHING TACKLE, NAMELY, BITE DETECTORS, HAND-HELD LANDING NETS FOR FISHING; ARTIFICIAL FISHING BAITS, NAMELY, DUMMIES FOR FISHING, GUIDES FOR FISHING LINES, ARTIFICIAL FISHING BAITS, CREELS, GLOVES SPECIALLY DESIGNED FOR FISHING, HOOKS FOR FISHING; SPEARFISHING HARPOON GUNS AS SPORTS ARTICLES; STRETCHING REELS FOR FISHING, STRIPPER BASKETS FOR FLY FISHING; ARTIFICIAL LURES AND FISHING BAIT, EXCLUDING LIVE BAIT; DISHES FOR MIXING BAIT; FISHING POLES; UTENSILS FOR REMOVING HOOKS, BAITING NEEDLES, NEEDLES FOR WORMS; FISHING TACKLE, NAMELY, DEPTH SIGHTS, STOP BEADS, PLACEMENT RINGS, SPLIT RINGS, SINKERS FOR FISHING YARNS; SHIELDS FOR FISHING RODS; FISHING ARTICLES, NAMELY, FISHING BUOYS, FISHING LURES, CLAMPS FOR SECURING FISHING EQUIPMENT ON BODY, FISHING LURE RETRIEVERS, FISHING POLE HOLDERS WORN ON THE BODY, FISHING LINES, SPLIT RINGS FOR FISHING, SLIDING VALVES FOR FISHING, UNHOOKING APPARATUS FOR FISHING, FIXING BANDS AND BINDINGS FOR FISHING, GUIDES FOR FISHING, REEL MOUNTS FOR FISHING, FISHING YARNS, RINGS WITH SLOTS, SLIDERS, APPARATUS FOR NOTCHING, FASTENING STRIPS AND BANDS, GUIDES, CATCHERS FOR FISHING

REELS; BEACH BALLS; FISHING LURES, NAMELY, TORPEDO SPOONS AND SPOONS OF METAL; FISHING TACKLE BOXES, NAMELY, CONTAINERS FOR FISHING TACKLE AND BAGS FOR FISHING AND FISHING ACCESSORIES; SWIM FINNS; GAMES AND TOYS, NAMELY, CARD GAMES, BOARD GAMES, DICE GAMES, PARLOR GAMES, PARTY GAMES, MAH JONG GAMES, DART GAMES, ACTION SKILL GAMES, BACKGAMMON GAMES; PLAYTHINGS, NAMELY, BALLOONS, BILLIARD TABLES, PUPPET THEATRES, PUPPETS; PLAY BALLS, PLAY BALLOONS, PLAY MONEY, CHILDREN'S PLAY COSMETICS, PLAY TENTS, PLAY TUNNELS, PLAY WANDS, PLAY HOUSES, PLAY FIGURES, PLAY SWIMMING POOLS, STUFFED TOY BEARS, STUFFED TOY ANIMALS AND PLAY MOTOR CARS, KALEIDOSCOPIES; AUTOMATIC AMUSEMENT GAME MACHINES; TOY SCALE MODEL VEHICLES; BAGS SPECIALLY ADAPTED FOR SPORTING EQUIPMENT; SKIS AND ACCESSORIES FOR SKIING, NAMELY, SKI FITTINGS, SKI POLES, SKI WAX, SKI CASES (U.S. CLS. 22, 23, 38 AND 50).

GINA FINK, EXAMINING ATTORNEY

SN 79-101,585. FORTUM OYJ, FINLAND, FILED 6-1-2011.

NURES

THE MARK CONSISTS OF STANDARD CHARACTERS WITHOUT CLAIM TO ANY PARTICULAR FONT, STYLE, SIZE, OR COLOR.

PRIORITY DATE OF 12-1-2010 IS CLAIMED.
OWNER OF INTERNATIONAL REGISTRATION 1088098
DATED 6-1-2011, EXPIRES 6-1-2021.

CLASS 7—MACHINERY

FOR MACHINES FOR USE IN THE PROCESSING OF WATER, NAMELY, WATER TREATMENT EQUIPMENT, NAMELY, WATER PUMPS, WASTE WATER DISPOSAL PUMPS, AND DIFFUSERS USED IN MACHINES FOR WASTE WATER AND CLEAN WATER TREATMENT; WASTE DISPOSAL APPARATUS AND MACHINES, NAMELY, WASTE COMPACTING MACHINES, WASTE COMPACTORS, WASTE CRUSHING MACHINES, WASTE MATERIAL CONVEYING MACHINES, WASTE SEPARATING MACHINES, AND MACHINE TOOLS FOR REMOVING WASTE MATERIAL; SEWAGE TREATMENT MACHINES AND APPARATUS, NAMELY, SEWAGE PUMPS; MACHINES FOR HANDLING RADIOACTIVE MATERIALS, NAMELY, SEPARATING MACHINES, INDUSTRIAL ROBOTS, AND MACHINE TOOLS FOR REMOVING RADIOACTIVE WASTE MATERIAL; MACHINES FOR HANDLING NUCLEAR WASTE, NAMELY, SEPARATING MACHINES, INDUSTRIAL ROBOTS, AND MACHINE TOOLS FOR REMOVING NUCLEAR WASTE MATERIAL (U.S. CLS. 13, 19, 21, 23, 31, 34 AND 35).

CLASS 11—ENVIRONMENTAL CONTROL APPARATUS

FOR WATER TREATMENT PLANTS, NAMELY, WATER PURIFICATION UNITS, WATER PURIFICATION INSTALLATIONS, WATER FILTRATION UNITS, CHEMICAL STERILIZATION UNITS, AND WATER PURIFICATION AND FILTRATION APPARATUS; SEWAGE TREATMENT PLANTS; INDUSTRIAL WASTE WATER PURIFICATION INSTALLATIONS; WASTE WATER TREATMENT INSTALLATIONS; SEWAGE TREATMENT PURIFICATION INSTALLATIONS; PURIFICATION INSTALLATIONS FOR WASTE MATERIAL, NAMELY, PURIFICATION INSTALLATIONS FOR SEWAGE, WASTE WATER AND NUCLEAR WASTE (U.S. CLS. 13, 21, 23, 31 AND 34).

CLASS 40—MATERIAL TREATMENT

FOR TREATMENT OF WATER, WASTE WATER AND SEWAGE; TREATMENT OF HAZARDOUS WASTE; DECONTAMINATION OF NUCLEAR WASTE; RENTAL OF WATER TREATMENT EQUIPMENT (U.S. CLS. 100, 103 AND 106).

CARYN GLASSER, EXAMINING ATTORNEY

CLASS 25—CLOTHING

FOR CLOTHING, NAMELY, SHIRTS, SHORTS, SWEATERS, JACKETS, FOOTWEAR, HEADWEAR; BEACH WEAR AND BATHING WEAR, NAMELY, BATHING SUITS, SWIM TRUNKS, BIKINIS (CLOTHING) (U.S. CLS. 22 AND 39).

GENE MACIOL, EXAMINING ATTORNEY

SN 79-101,608. SUAVESOLES B.V., NETHERLANDS, FILED 6-15-2011.

SUAVESOLES

THE MARK CONSISTS OF STANDARD CHARACTERS WITHOUT CLAIM TO ANY PARTICULAR FONT, STYLE, SIZE, OR COLOR.

PRIORITY DATE OF 4-28-2011 IS CLAIMED.

OWNER OF INTERNATIONAL REGISTRATION 1088141 DATED 6-15-2011, EXPIRES 6-15-2021.

CLASS 9—ELECTRICAL AND SCIENTIFIC APPARATUS

FOR EYEWEAR, NAMELY, SUNGLASSES, EYEGLASSES AND OPHTHALMIC FRAMES AND CASES THEREFORE (U.S. CLS. 21, 23, 26, 36 AND 38).

CLASS 14—JEWELRY

FOR WATCHES (U.S. CLS. 2, 27, 28 AND 50).

CLASS 25—CLOTHING

FOR CLOTHING, NAMELY, SHIRTS, SHORTS, SWEATERS, JACKETS, FOOTWEAR, HEADWEAR; BEACH WEAR AND BATHING WEAR, NAMELY, BATHING SUITS, SWIM TRUNKS, BIKINIS (CLOTHING) (U.S. CLS. 22 AND 39).

GENE MACIOL, EXAMINING ATTORNEY

SN 79-101,609. SUAVESOLES B.V., NETHERLANDS, FILED 6-15-2011.



PRIORITY DATE OF 5-3-2011 IS CLAIMED.
OWNER OF INTERNATIONAL REGISTRATION 1088142 DATED 6-15-2011, EXPIRES 6-15-2021.

THE MARK CONSISTS OF THE STYLIZED TERM "SUAVESOLES" OVER A CURVED S-SHAPED WAVE DESIGN LYING ON ITS SIDE.

CLASS 9—ELECTRICAL AND SCIENTIFIC APPARATUS

FOR EYEWEAR, NAMELY, SUNGLASSES, EYEGLASSES AND OPHTHALMIC FRAMES AND CASES THEREFORE (U.S. CLS. 21, 23, 26, 36 AND 38).

CLASS 14—JEWELRY

FOR WATCHES (U.S. CLS. 2, 27, 28 AND 50).

SN 79-101,698. BINDER GMBH, FED REP GERMANY, FILED 6-22-2011.

VIP.COMPOSITE

THE MARK CONSISTS OF STANDARD CHARACTERS WITHOUT CLAIM TO ANY PARTICULAR FONT, STYLE, SIZE, OR COLOR.

PRIORITY DATE OF 12-29-2010 IS CLAIMED.

OWNER OF INTERNATIONAL REGISTRATION 1088380 DATED 6-22-2011, EXPIRES 6-22-2021.

CLASS 9—ELECTRICAL AND SCIENTIFIC APPARATUS

FOR LABORATORY APPARATUS, NAMELY, HEATED, CLIMATIC, AND LABORATORY CABINETS IN THE NATURE OF HEATED LABORATORY CABINETS, BREEDING CHAMBERS, COOLING INCUBATORS, TEMPERATURE SHOCK CHAMBERS, INCUBATORS, VACUUM CABINETS, ENVIRONMENTAL SIMULATION CABINETS, INSULATORS, GROWING CABINETS, AGEING CABINETS, GASSING INCUBATORS, CLEAN ROOM WORKBENCHES, BIOTECHNOLOGICAL LABORATORY CABINETS (U.S. CLS. 21, 23, 26, 36 AND 38).

CLASS 11—ENVIRONMENTAL CONTROL APPARATUS

FOR HEATED, CLIMATIC AND LABORATORY CABINETS, NAMELY, FREEZING APPARATUS, COLD/HEAT CHAMBERS, LACQUER DRYING CABINETS, HEATED DRYING CABINETS, STERILISERS (U.S. CLS. 13, 21, 23, 31 AND 34).

ALYSSA STEEL, EXAMINING ATTORNEY

SN 79-101,712. GOLF TECH GOLFARTIKELVERTRIEBSGMBH, A-1230 WIEN, AUSTRIA, FILED 4-11-2011.



PRIORITY DATE OF 10-13-2010 IS CLAIMED.
OWNER OF INTERNATIONAL REGISTRATION 1088417 DATED 4-11-2011, EXPIRES 4-11-2021.

NO CLAIM IS MADE TO THE EXCLUSIVE RIGHT TO USE "E" AND "DRIVE", APART FROM THE MARK AS SHOWN.

THE COLOR(S) BLUE, BLACK, WHITE, AND SILVER IS/ARE CLAIMED AS A FEATURE OF THE MARK.

THE MARK CONSISTS OF THE FOLLOWING: THE STYLIZED WORDING "MPF DRIVE" IN BLACK; A CIRCULAR DESIGN IN WHICH THE STYLIZED LETTER "E" IS SET UNDER A GEAR DESIGN IN SILVER AND GRAY WITH A BLUE BACKGROUND.

CLASS 7—MACHINERY

FOR GENERATORS OF ELECTRICITY (U.S. CLS. 13, 19, 21, 23, 31, 34 AND 35).

CLASS 9—ELECTRICAL AND SCIENTIFIC APPARATUS

FOR BATTERIES; ACCUMULATORS; ELECTRONIC CONTROLS FOR MOTORS, NAMELY, FOR BICYCLES, ELECTRIC VEHICLES, ELECTRIC MOTORCYCLES AND ELECTRIC MOPEDS (U.S. CLS. 21, 23, 26, 36 AND 38).

CLASS 12—VEHICLES

FOR BICYCLES; MOTORIZED BICYCLES, NAMELY, BICYCLES WITH ELECTRIC DRIVE AND BICYCLES OPERATED IN ANY OTHER WAY; MOPEDS, NAMELY, MOPEDS WITH ELECTRIC DRIVE AND MOPEDS OPERATED IN ANY OTHER FORM; ELECTRIC VEHICLES, NAMELY, ELECTRIC BICYCLES, MOPEDS, CARS AND GOLFCARTS; ELECTRIC MOTORCYCLES AND ELECTRIC MOPEDS; ELECTRIC MOTORS FOR LAND VEHICLES; ELECTRIC DRIVES FOR VEHICLES, NAMELY, BICYCLES AND MOPEDS (U.S. CLS. 19, 21, 23, 31, 35 AND 44).

TIMOTHY FINNEGAN, EXAMINING ATTORNEY

CLASS 39—TRANSPORTATION AND STORAGE

FOR TRANSPORT OF TRAVELLERS; TAXI TRANSPORT; BUS TRANSPORT; CAR PARKING; CAR RENTAL; CHAUFFEUR SERVICES; BOOKING OF SEATS FOR TRAVEL THROUGH TOURIST OFFICES; ESCORTING OF TRAVELLERS; ORGANIZATION OF SIGHTSEEING TOURS; TRAVEL BOOKING AGENCIES; BOAT RENTAL; AIR TRANSPORT; STORAGE OF GOODS; RENTAL OF DEEP WATER DIVING SUITS; DISTRIBUTION OF ENERGY; OPERATION OF CANAL LOCKS; COURIER SERVICES INCLUDING MESSAGES AND MERCHANDISE; TRANSPORT BY PIPELINE (U.S. CLS. 100 AND 105).

CLASS 43—HOTEL AND RESTAURANT SERVICES

FOR ACCOMMODATION SERVICES IN THE NATURE OF HOTELS, BOARDING HOUSES; CATERING; CAFES; CAFETERIAS; HOTELS; MAKING HOTEL RESERVATIONS FOR OTHERS; SNACK BARS; MOTELS; RENTAL OF BUSINESS MEETING ROOMS; DAY-CARE NURSERIES; BAR; TEAHOUSE (U.S. CLS. 100 AND 101).

TRACY WHITTAKER-BROWN, EXAMINING ATTORNEY

SN 79-101,753. JIN JIANG INTERNATIONAL HOLDINGS CO., LTD., CHINA, FILED 4-15-2011.



PRIORITY DATE OF 12-22-2010 IS CLAIMED.
OWNER OF INTERNATIONAL REGISTRATION 1088551 DATED 4-15-2011, EXPIRES 4-15-2021.
OWNER OF U.S. REG. NOS. 2,956,395, 3,302,785 AND OTHERS.
THE MARK CONSISTS OF A STYLIZED LETTER "J" SURROUNDED BY AN ELLIPSE.

CLASS 35—ADVERTISING AND BUSINESS

FOR ADVERTISING, NAMELY, ADVERTISING AGENCIES; ORGANIZATION OF EXHIBITIONS FOR COMMERCIAL OR ADVERTISING PURPOSES; BUSINESS MANAGEMENT OF HOTELS; HOTEL MANAGEMENT FOR OTHERS; IMPORT-EXPORT AGENCIES; PERSONNEL MANAGEMENT CONSULTANCY; RELOCATION SERVICES FOR BUSINESSES; OFFICE MACHINES AND EQUIPMENT RENTAL; BUSINESS AUDITING; ADVISORY SERVICES FOR BUSINESS MANAGEMENT (U.S. CLS. 100, 101 AND 102).

SN 79-101,754. JIN JIANG INTERNATIONAL HOLDINGS CO., LTD., CHINA, FILED 4-15-2011.



HOTEL · J
锦江·J

PRIORITY DATE OF 12-22-2010 IS CLAIMED.
OWNER OF INTERNATIONAL REGISTRATION 1088552 DATED 4-15-2011, EXPIRES 4-15-2021.
OWNER OF U.S. REG. NOS. 2,956,395, 3,302,785 AND OTHERS.
NO CLAIM IS MADE TO THE EXCLUSIVE RIGHT TO USE "HOTEL.", APART FROM THE MARK AS SHOWN.
FROM TOP DOWN, THE MARK CONSISTS OF A STYLIZED LETTER "J" SURROUNDED BY AN ELLIPSE, LETTERS "HOTEL J" WITH A DOT IN THE MIDDLE, A LINE, TWO CHINESE CHARACTERS WITH TRANSLITERATION OF "JIN JIANG", A DOT AND LETTER "J".
THE NON-LATIN CHARACTERS IN THE MARK TRANSLITERATE TO "JIN JIANG" AND THIS MEANS "BRIGHT AND BEAUTIFUL RIVER" IN ENGLISH.

CLASS 35—ADVERTISING AND BUSINESS

FOR ADVERTISING, NAMELY, ADVERTISING AGENCIES; ORGANIZATION OF EXHIBITIONS FOR COMMERCIAL OR ADVERTISING PURPOSES; BUSINESS MANAGEMENT OF HOTELS; HOTEL MANAGEMENT FOR OTHERS; IMPORT-EXPORT AGENCIES; PERSONNEL MANAGEMENT CONSULTANCY; RELOCATION SERVICES FOR BUSINESSES; OFFICE MACHINES AND EQUIPMENT RENTAL; BUSINESS AUDITING; ADVISORY SERVICES FOR BUSINESS MANAGEMENT (U.S. CLS. 100, 101 AND 102).

CLASS 39—TRANSPORTATION AND STORAGE

FOR TRANSPORT OF TRAVELLERS; TAXI TRANSPORT; BUS TRANSPORT; CAR PARKING; CAR RENTAL; CHAUFFEUR SERVICES; BOOKING OF SEATS FOR TRAVEL THROUGH TOURIST OFFICES; ESCORTING OF TRAVELLERS; ORGANIZATION OF SIGHTSEEING TOURS; TRAVEL BOOKING AGENCIES; BOAT RENTAL; AIR TRANSPORT; STORAGE OF GOODS; RENTAL OF DEEP WATER DIVING SUITS; DISTRIBUTION OF ENERGY; OPERATION OF CANAL LOCKS; COURIER SERVICES INCLUDING MESSAGES AND MERCHANDISE; TRANSPORT BY PIPELINE (U.S. CLS. 100 AND 105).

CLASS 43—HOTEL AND RESTAURANT SERVICES

FOR ACCOMMODATION SERVICES IN THE NATURE OF HOTELS, BOARDING HOUSES; CATERING; CAFES; CAFETERIAS; HOTELS; MAKING HOTEL RESERVATIONS FOR OTHERS; SNACK BARS; MOTELS; RENTAL OF BUSINESS MEETING ROOMS; DAY-CARE NURSERIES; BAR; TEAHOUSE (U.S. CLS. 100 AND 101).

TRACY WHITTAKER-BROWN, EXAMINING ATTORNEY

CLASS 39—TRANSPORTATION AND STORAGE

FOR TRANSPORT OF TRAVELLERS; TAXI TRANSPORT; BUS TRANSPORT; CAR PARKING; CAR RENTAL; CHAUFFEUR SERVICES; BOOKING OF SEATS FOR TRAVEL THROUGH TOURIST OFFICES; ESCORTING OF TRAVELLERS; ORGANIZATION OF SIGHTSEEING TOURS; TRAVEL BOOKING AGENCIES; BOAT RENTAL; AIR TRANSPORT; STORAGE OF GOODS; RENTAL OF DEEP WATER DIVING SUITS; DISTRIBUTION OF ENERGY; OPERATION OF CANAL LOCKS; COURIER SERVICES INCLUDING MESSAGES AND MERCHANDISE; TRANSPORT BY PIPELINE (U.S. CLS. 100 AND 105).

CLASS 43—HOTEL AND RESTAURANT SERVICES

FOR ACCOMMODATION SERVICES IN THE NATURE OF HOTELS, BOARDING HOUSES; CATERING; CAFES; CAFETERIAS; HOTELS; MAKING HOTEL RESERVATIONS FOR OTHERS; SNACK BARS; MOTELS; RENTAL OF BUSINESS MEETING ROOMS; DAY-CARE NURSERIES; BAR; TEAHOUSE (U.S. CLS. 100 AND 101).

TRACY WHITTAKER-BROWN, EXAMINING ATTORNEY

SN 79-101,755, JIN JIANG INTERNATIONAL HOLDINGS CO., LTD., CHINA, FILED 4-15-2011.



PRIORITY DATE OF 12-22-2010 IS CLAIMED.
OWNER OF INTERNATIONAL REGISTRATION 1088553 DATED 4-15-2011, EXPIRES 4-15-2021.

OWNER OF U.S. REG. NOS. 2,956,395, 3,302,785 AND OTHERS.

NO CLAIM IS MADE TO THE EXCLUSIVE RIGHT TO USE "HOTEL", APART FROM THE MARK AS SHOWN.

FROM TOP DOWN, THE MARK CONSISTS OF A STYLIZED LETTER "J" SURROUNDED BY AN ELLIPSE, LETTERS "J HOTEL" WITH A DOT IN THE MIDDLE, A LINE, THE LETTER "J", A DOT AND TWO CHINESE CHARACTERS WITH TRANSLITERATION OF "JIN JIANG".

THE NON-LATIN CHARACTERS IN THE MARK TRANSLITERATE TO "JIN JIANG" AND THIS MEANS "BRIGHT AND BEAUTIFUL RIVER" IN ENGLISH.

CLASS 35—ADVERTISING AND BUSINESS

FOR ADVERTISING, NAMELY, ADVERTISING AGENCIES; ORGANIZATION OF EXHIBITIONS FOR COMMERCIAL OR ADVERTISING PURPOSES; BUSINESS MANAGEMENT OF HOTELS; HOTEL MANAGEMENT FOR OTHERS; IMPORT-EXPORT AGENCIES; PERSONNEL MANAGEMENT CONSULTANCY; RELOCATION SERVICES FOR BUSINESSES; OFFICE MACHINES AND EQUIPMENT RENTAL; BUSINESS AUDITING; ADVISORY SERVICES FOR BUSINESS MANAGEMENT (U.S. CLS. 100, 101 AND 102).

SN 79-101,756, CLINIQUE LA PRAIRIE FRANCHISING SA, SWITZERLAND, FILED 6-17-2011.



PRIORITY DATE OF 12-17-2010 IS CLAIMED.
OWNER OF INTERNATIONAL REGISTRATION 1088560 DATED 6-17-2011, EXPIRES 6-17-2021.

OWNER OF U.S. REG. NOS. 1,379,697, 1,779,993 AND 3,212,028.

NO CLAIM IS MADE TO THE EXCLUSIVE RIGHT TO USE "CLINIQUE", APART FROM THE MARK AS SHOWN. THE ENGLISH TRANSLATION OF "CLINIQUE LA PRAIRIE" IN THE MARK IS "THE MEADOW CLINIC".

CLASS 5—PHARMACEUTICALS

FOR VITAMIN PREPARATIONS; NUTRITIONAL SUPPLEMENTS FOR MEDICAL PURPOSES; NUTRITIONAL ADDITIVES FOR MEDICAL PURPOSES FOR USE IN FOODS AND DIETARY SUPPLEMENTS FOR HUMAN CONSUMPTION; DIETETIC BEVERAGES ADAPTED FOR MEDICAL PURPOSES; FOODSTUFFS AND SUBSTANCES FOR MEDICAL PURPOSES, NAMELY, HERBAL SUPPLEMENTS, VITAMIN SUPPLEMENTS, ANTI-OXIDANTS SUPPLEMENTS, SUPPLEMENTS OF GOLD, COPPER, SILVER, IRON, AND MAGNESIUM FOR NUTRITIONAL PURPOSES, MINERAL SUPPLEMENTS, POLYPHENOLS SUPPLEMENTS, PHYTOSTERONES SUPPLEMENTS, MICRONUTRIENT PREPARATIONS, PROTEIN-ENRICHED PREPARATIONS; HERBAL TEAS FOR MEDICAL PURPOSES; MEDICAL PREPARATIONS FOR SLIMMING PURPOSES; FOOD FOR DIABETICS, NAMELY, DIABETIC BREAD; CHEWING GUM FOR MEDICAL PURPOSES (U.S. CLS. 6, 18, 44, 46, 51 AND 52).

CLASS 29—MEATS AND PROCESSED FOODS

FOR DIETETIC FOOD OR FOOD SUPPLEMENTS, FOR USES OTHER THAN MEDICAL, MADE WITH PROTEINS INCLUDING ALBUMEN, CASEINE AND OTHERS, LIPIDS OR FATTY ACIDS AND ENRICHED WITH VITAMINS, MINERALS, TRACE ELEMENTS, EITHER SEPARATELY OR IN COMBINATION, INCLUDED IN THIS CLASS, NAMELY, PROTEIN ENRICHED PREPARATIONS FOR FOOD, LIVER FOR FOOD, PROCESSED OILS AND FATS FOR FOOD, LARD FOR FOOD; ALBUMEN FOR USE IN FOOD; POLLEN PREPARED AS FOODSTUFF; MEAT, FISH, POULTRY AND GAME; MEAT EXTRACTS; PRESERVED, DRIED AND COOKED FRUITS AND VEGETABLES; JELLIES; JAMS; COMPOTES; EGGS, MILK AND DAIRY PRODUCTS, EXCLUDING ICE CREAM, ICE MILK, AND FROZEN YOGURT; EDIBLE OILS AND FATS; WEED EXTRACTS FOR FOOD FOR HUMAN CONSUMPTION; FAT-CONTAINING MIXTURES FOR BREAD SLICES, NAMELY, MARGARINE AND BUTTER; YOGURT; KEFIR; SOUPS; PREPARED NUTS; STEWED, PRESERVED, AND FROZEN FRUIT; PROTEIN FOR HUMAN CONSUMPTION, NAMELY, PROTEIN POWDERS FOR USE AS A FOOD ADDITIVE, FORMED PROTEIN FOR USE AS A MEAT SUBSTITUTE, MEAT OR LIVER EXTRACTS AS A FOOD ADDITIVE (U.S. CL. 46).

CLASS 30—STAPLE FOODS

FOR DIETETIC FOOD OR FOOD SUPPLEMENTS, FOR USES OTHER THAN MEDICAL, MADE WITH CARBOHYDRATES OR DIETARY FIBERS AND ENRICHED WITH VITAMINS, MINERALS OR TRACE ELEMENTS, EITHER SEPARATELY OR IN COMBINATION, INCLUDED IN THIS CLASS, NAMELY, FOOD SEASONINGS, FLAVORINGS FOR FOOD, MICRONUTRIENT PREPARATIONS; COFFEE AND ARTIFICIAL COFFEE; TEA; COCOA; SUGAR; RICE; TAPIOCA; SAGO; FLOUR AND CEREAL PREPARATIONS, NAMELY, CEREAL-BASED SNACK FOODS, CEREAL BARS, FLOUR-BASED CHIPS; BREAD; PASTRIES; SUGAR-BASED CONFECTIONERY IN THE NATURE OF CANDY; EDIBLE ICE; HONEY, TABLE SYRUP; YEAST, BICARBONATE OF SODA FOR BAKING PURPOSES; SALT; MUSTARD; VINEGAR, SAUCES IN THE NATURE OF CONDIMENTS; SPICES; CORN FLAKES; ESSENCES FOR FOODSTUFFS, EXCEPT ETHERIC ESSENCES AND ESSENTIAL OILS; CAKE PASTE; TEA-BASED BEVERAGES; YEAST IN PILL FORM, NOT FOR MEDICAL USE; CHEWING GUM, NOT FOR MEDICAL PURPOSES; MALT EXTRACT FOR FOOD; FLOUR-MILLING PRODUCTS FOR FOOD, NAMELY, WHEAT FLOUR, CORN FLOUR; MUESLI; NATURAL SWEETENERS; INFUSIONS, NOT MEDICINAL; GLUCOSE FOR FOOD; RUSKS (U.S. CL. 46).

CLASS 32—LIGHT BEVERAGES

FOR MINERAL AND CARBONATED WATERS; NON-ALCOHOLIC BEVERAGES, NAMELY, ENERGY DRINKS WITH PLANT EXTRACTS, HERBAL DRINKS WITH PLANT EXTRACTS, ENERGY DRINKS, SOFT DRINKS; FRUIT DRINKS AND FRUIT JUICES; SYRUPS AND OTHER PREPARATIONS FOR MAKING BEVERAGES (U.S. CLS. 45, 46 AND 48).

CLASS 43—HOTEL AND RESTAURANT SERVICES

FOR SERVICES FOR PROVIDING FOOD AND DRINK; CAFETERIAS; BAR SERVICES; INFORMATION AND ADVICE CONCERNING ALL THE FOREMENTIONED SERVICES, NAMELY, INFORMATIONAL SERVICES IN THE FIELD OF FOOD, DRINKS, BARS, AND RESTAURANTS; ALL THE FOREMENTIONED SERVICES BEING PROVIDED IN CONNECTION WITH HEALTH CLINICS AND/OR MEDICAL CLINICS (U.S. CLS. 100 AND 101).

CLASS 44—MEDICAL, BEAUTY AND AGRICULTURAL SERVICES

FOR MEDICAL SERVICES; SURGERY; DENTISTRY; HOSPITALS; MEDICAL CLINICS; MEDICAL ASSISTANCE SERVICES; MASSAGES, THIS SERVICE BEING PROVIDED EXCLUSIVELY IN CONNECTION WITH HEALTH CLINICS; PHYSIOTHERAPY; PROVIDING TURKISH BATH FACILITIES, THIS SERVICE BEING PROVIDED EXCLUSIVELY IN CONNECTION WITH HEALTH CLINICS; HEALTH CARE, ESPECIALLY DRAINING AND LYMPHATIC DRAINAGE PROVIDED EXCLUSIVELY IN CONNECTION WITH HEALTH CLINICS; HYDROTHERAPY, THIS SERVICE BEING PROVIDED EXCLUSIVELY IN CONNECTION WITH HEALTH CLINICS; BALNEOTHERAPY, THIS SERVICE BEING PROVIDED EXCLUSIVELY IN CONNECTION WITH HEALTH CLINICS; THALASSOTHERAPY, THIS SERVICE BEING PROVIDED EXCLUSIVELY IN CONNECTION WITH HEALTH CLINICS; AROMATHERAPY AND CHIROPRACTICS PROVIDED EXCLUSIVELY IN CONNECTION WITH HEALTH CLINICS; NUTRITIONAL GUIDANCE PROVIDED EXCLUSIVELY IN CONNECTION WITH HEALTH CLINICS; SERVICES OF A PSYCHOLOGIST, NAMELY, PSYCHOLOGICAL COUNSELING; TELEMEDICINE SERVICES; MEDICAL ADVICE AND INFORMATION REGARDING ALL THE FOREMENTIONED SERVICES BEING PROVIDED IN CONNECTION WITH HEALTH CLINICS AND/OR MEDICAL CLINICS (U.S. CLS. 100 AND 101).

ALAIN LAPTER, EXAMINING ATTORNEY

SN 79-101,757. CONERGY AG, 20537 HAMBURG, FED REP GERMANY, FILED 6-17-2011.

CONERGY COMPLETE

THE MARK CONSISTS OF STANDARD CHARACTERS WITHOUT CLAIM TO ANY PARTICULAR FONT, STYLE, SIZE, OR COLOR.

OWNER OF INTERNATIONAL REGISTRATION 1088562 DATED 6-17-2011, EXPIRES 6-17-2021.

OWNER OF U.S. REG. NOS. 3,177,242, 3,194,562 AND 3,864,418.

CLASS 6—METAL GOODS

FOR PORTABLE METAL BUILDINGS; GOODS OF COMMON METAL, NAMELY, METAL MOUNTING SYSTEMS COMPRISED OF METAL SHELVES, METAL SHELF BRACKETS, METAL SHELF SUPPORT BARS, METAL BOLTS, RIVETS, SCREWS AND METAL THREADED FASTENERS; METAL FRAME WORK; METAL FASTENING SYSTEMS, NAMELY, METAL BOLTS, RIVETS SCREWS AND METAL THREADED FASTENERS (U.S. CLS. 2, 12, 13, 14, 23, 25 AND 50).

CLASS 9—ELECTRICAL AND SCIENTIFIC APPARATUS

FOR PHOTOVOLTAIC CELLS ALSO INCLUDING A SOLAR THERMAL COLLECTOR SOLD AS A UNIT; ELECTRONIC COMPONENTS BEING PARTS FOR SOLAR INSTALLATIONS, NAMELY, ELECTRONIC SENSORS FOR MEASURING SOLAR RADIATION, SOLAR CELLS, SOLAR COLLECTORS, SOLAR HEAT COLLECTION PANELS; APPARATUS FOR CONVERTING ELECTRONIC RADIATION TO ELECTRICAL ENERGY, NAMELY, PHOTOVOLTAIC SOLAR MODULES; APPARATUS FOR CONVERTING ELECTRONIC RADIATION TO ELECTRICAL ENERGY, NAMELY, PHOTOVOLTAIC SOLAR-THERMAL HYBRID MODULES; ELECTRIC CABLES SOLAR CELLS AND PHOTOVOLTAIC SOLAR MODULES (U.S. CLS. 21, 23, 26, 36 AND 38).

CLASS 37—CONSTRUCTION AND REPAIR

FOR INSTALLATION SERVICES, NAMELY, INSTALLATION OF SOLAR THERMAL ENERGY POWER PLANTS, SOLAR THERMAL ENERGY STORAGE PLANTS, WIND ENERGY POWER PLANTS, PHOTO-VOLTAIC ENERGY POWER PLANTS; REPAIR, CONSTRUCTION AND MAINTENANCE OF RENEWABLE ENERGY INSTALLATIONS (U.S. CLS. 100, 103 AND 106).

CLASS 38—COMMUNICATION

FOR INTERNET SERVICES, NAMELY, PROVIDING ACCESS TO INFORMATION IN TERMS OF DATA, ANALYSIS AND STATISTICS TO MONITOR AND CONTROL CONCERNING INSTALLATIONS FOR GENERATING RENEWABLE ENERGY (U.S. CLS. 100, 101 AND 104).

CLASS 40—MATERIAL TREATMENT

FOR PRODUCTION OF ENERGY (U.S. CLS. 100, 103 AND 106).

CLASS 42—SCIENTIFIC AND COMPUTER SERVICES

FOR SCIENTIFIC RESEARCH; INDUSTRIAL RESEARCH SERVICES IN THE FIELD OF RENEWABLE ENERGY PRODUCTION; TECHNICAL RESEARCH IN THE FIELD OF RENEWABLE ENERGIES; DEVELOPMENT OF PRODUCTS FOR RENEWABLE ENERGY PRODUCTION (U.S. CLS. 100 AND 101).

DANNEAN HETZEL, EXAMINING ATTORNEY

CLASS 9—ELECTRICAL AND SCIENTIFIC APPARATUS

FOR CENTRAL PROCESSING UNITS, NAMELY, COMPUTERS, COMPUTER HARDWARE, NAMELY, MICROPROCESSORS; ELECTRONIC COMPONENTS IN THE NATURE OF DISK DRIVES, NAMELY, COMPUTER DISK DRIVES, DIGITAL DISK DRIVES, OPTICAL DISK DRIVES; DATA CONVERTERS, NAMELY, ENCODERS AND TELEVISION DECODERS; ELECTRONIC DEVICES FOR CONNECTING A COMPUTER AND A COMMUNICATION NETWORK, NAMELY, MODEMS; PROGRAMS FOR COMPUTERS FOR READING OF CHIPS AND THE MODIFICATION FOR SAFETY OF DATA IN THE FIELD OF PAYMENTS, FINANCE, TELEPHONY, TRANSPORT, ACCESS CONTROL, ELECTRONIC IDENTIFICATION, RETAIL AND GIFT CARD, ALL TO FACILITATE COMMUNICATION BETWEEN HAND-HELD ELECTRONIC DEVICES; ENCRYPTION AND DECRYPTION PROGRAMS FOR COMPUTER DATA; COMPUTER SOFTWARE FOR THE MANAGEMENT OF DATABASE; COMMUNICATION INTERFACE CARDS FOR DATA PROCESSING EQUIPMENT IN THE FORM OF PRINTED CIRCUITS; INTERFACES FOR COMPUTERS BEING COMMUNICATION INTERFACE MODULES FOR THE EXCHANGE OF DATA; ELECTRONIC DATA CONVERTERS FOR DATA RECORDED ON COMPUTER MEDIA; CHIPS, NAMELY, INTEGRATED CIRCUITS; ELECTRONIC COMPUTER CHIPS, NAMELY, CONTACTLESS INTERFACE CHIPS, SEMICONDUCTOR CHIPS, AND SILICON CHIPS; MICRO-CIRCUITS FOR CODING AND DECODING DATA; PRINTED CIRCUITS; SEMICONDUCTORS; CENTRAL PROCESSING UNITS; MICROPROCESSORS; MICRO-CONTROLLERS; ELECTRONIC TAGS, NAMELY, TAGS FOR CONTROLLING ACCESS, MANAGEMENT OF STOCK, TRACEABILITY OF GOODS, AND PROTECTION AGAINST THEFT; CHIP CARDS, NAMELY, BLANK ELECTRONIC CHIP CARDS; ENCODED ELECTRONIC CHIP CARDS CONTAINING PROGRAMMING FOR READING, WRITING, CONTROLLING, EXCHANGING AND MODIFICATION OF DATA FOR USE IN THE FIELD OF PAYMENT, FINANCE, ACCESS, CONTROL, TRANSPORT, TICKETING, ELECTRONIC IDENTIFICATION, RETAIL AND GIFT CARD AND MOBILE COMMUNICATION FIELDS FOR USE WITH SMART CARDS, KEY FOBS, MOBILE PHONES, HANDHELD CONSUMER ELECTRONIC DEVICES, POINT OF SALE DISPLAYS AND PC PERIPHERALS; MEMORY CARDS FOR ELECTRONIC AUDIO AND VIDEO DEVICES, MOBILE PHONES, COMPUTERS, PLAYERS, AND MOVIE AND STILL CAMERAS; ELECTRIC AND ELECTRONIC LOCKS (U.S. CLS. 21, 23, 26, 36 AND 38).

SN 79-101,802. INSIDE SECURE, FRANCE, FILED 3-16-2011.

CLASS 35—ADVERTISING AND BUSINESS

FOR RETAIL STORE SERVICES, WHOLESALE STORES, AND MAIL ORDER SERVICES FEATURING COMPUTER HARDWARE, COMPUTER PROGRAMS, SOFTWARE, COMMUNICATION INTERFACES, COMMUNICATION INTERFACE MODULES, COMMUNICATION INTERFACE CARDS, INTEGRATED CIRCUITS, MICRO-CIRCUITS, PRINTED CIRCUITS, SEMI-CONDUCTORS, PROCESSORS, MICROPROCESSORS, MICRO-CONTROLLERS, ELECTRONIC TAGS, ESPECIALLY RADIOFREQUENCY TAGS USED FOR ACCESS CONTROL, STOCK MANAGEMENT, TRACEABILITY OF GOODS, COMBATING THEFT, ELECTRONIC CHIPS, ELECTRONIC CHIP CARDS, ESPECIALLY BLANK CARDS, CODED CHIP CARDS CONTAINING ESPECIALLY PROGRAMS USED IN THE SPHERES OF MONEY, TRANSPORT, COMMUNICATIONS, TELEPHONY, IDENTIFICATION, SECURITY ON COMPUTERS, AND MEMORY CARDS, ESPECIALLY FOR ELECTRONIC AUDIO AND VIDEO DEVICES, MOBILE PHONES, COMPUTERS, PLAYERS, MOVIE AND STILL CAMERAS, ELECTRIC AND ELECTRONIC LOCKS, TELEPHONE SETS (U.S. CLS. 100, 101 AND 102).

PRIORITY DATE OF 10-27-2010 IS CLAIMED.
OWNER OF INTERNATIONAL REGISTRATION 1088648
DATED 3-16-2011, EXPIRES 3-16-2021.

THE COLOR(S) ORANGE IS/ARE CLAIMED AS A FEATURE OF THE MARK.

THE MARK CONSISTS OF THE WORDING "DRIVING TRUST" IN STYLIZED FONT ALL IN THE COLOR ORANGE.

CLASS 38—COMMUNICATION

FOR COMMUNICATION SERVICES USING COMPUTER, TELECOMMUNICATION AND DATA TRANSMISSION NETWORKS, NAMELY, COMMUNICATIONS BY COMPUTER TERMINALS; SERVICES FOR SUPPLYING TELECOMMUNICATION NETWORKS, NAMELY, PROVIDING THIRD PARTY USERS WITH ACCESS TO TELECOMMUNICATION INFRASTRUCTURE; DATA TRACEABILITY SERVICES, NAMELY, CO-LOCATION SERVICES FOR VOICE, VIDEO AND DATA COMMUNICATIONS APPLICATIONS; PROVIDING INFORMATION REGARDING ELECTRONIC DATA TRANSMISSION AND TELECOMMUNICATION; CONSULTING SERVICES IN THE FIELD OF ELECTRONIC DATA TRANSMISSION AND TELECOMMUNICATION; RENTAL OF TELECOMMUNICATIONS EQUIPMENT IN THE NATURE OF MESSAGE AND DATA TRANSMISSION APPARATUS (U.S. CLS. 100, 101 AND 104).

CLASS 42—SCIENTIFIC AND COMPUTER SERVICES

FOR ENGINEERING SERVICES, DESIGN AND DEVELOPMENT OF COMPUTER EQUIPMENT, COMPUTER PROGRAMS, INTEGRATED CIRCUITS, MICROCONTROLLERS, COMPUTER CHIPS, DESIGN OF PROGRAMS FOR COMPUTERS AND MICROPROCESSORS, MICROPROCESSOR-BASED PROGRAMMING, COMPUTER PROGRAMMING SERVICES, DESIGN, DEVELOPMENT AND TECHNICAL STUDY OF COMPUTER SYSTEMS, DESIGN, DEVELOPMENT AND TECHNICAL STUDY OF DATA EXCHANGE SYSTEMS IN THE FIELD OF TACTILE TECHNOLOGY, TECHNICAL SUPPORT IN THE FIELD OF DATA COMMUNICATION, REMOTE MONITORING SERVICES FOR COMPUTER SYSTEMS, DESIGN, DEVELOPMENT, CUSTOMIZATION AND UPDATING OF SOFTWARE AND COMPUTER PROGRAMS, DESIGN, DEVELOPMENT, CUSTOMIZATION AND TECHNICAL STUDY OF SMART CARDS AND ELECTRONIC CARDS, INTEGRATED CIRCUIT CARDS (SMART CARDS), MICRO-CIRCUIT CARDS, MAGNETIC CARDS, MEMORY CARDS, CONTACTLESS CARDS, RESEARCH AND DEVELOPMENT OF NEW PRODUCTS FOR OTHERS, INFORMATION, ADVISORY AND CONSULTANCY SERVICES IN THE FIELD OF COMPUTING, DEVELOPMENT OF CONTACT-FREE SOLUTIONS IN THE FIELD OF COMMUNICATIONS AND TELECOMMUNICATIONS (U.S. CLS. 100 AND 101).

WILLIAM ROSSMAN, EXAMINING ATTORNEY

SN 79-101,809. KTM-SPORTMOTORCYCLE AG, A-5230 MATTIGHOFEN, AUSTRIA, FILED 3-28-2011.

DUKE

THE MARK CONSISTS OF STANDARD CHARACTERS WITHOUT CLAIM TO ANY PARTICULAR FONT, STYLE, SIZE, OR COLOR.

PRIORITY DATE OF 12-23-2010 IS CLAIMED. OWNER OF INTERNATIONAL REGISTRATION 1088678 DATED 3-28-2011, EXPIRES 3-28-2021.

CLASS 12—VEHICLES

FOR BICYCLES, MOTORCYCLES, LIGHT MOTORCYCLES, SCOOTERS, MOPEDS, AS WELL AS THEIR PARTS AND ACCESSORIES, NAMELY, MOTORS FOR LAND VEHICLES, SADDLES FOR BICYCLES AND MOTORCYCLES, WHEELS, RIMS, BRAKE LININGS, BRAKE DISCS, FAIRINGS, LUGGAGE CARRIERS FOR MOTORCYCLES, CASES FOR LUGGAGE ADAPTED FOR USE WITH MOTORCYCLES, TRANSPORT CASES ADAPTED FOR USE WITH MOTORCYCLES, SADDLEBAGS ADAPTED FOR USE WITH BICYCLES AND MOTORCYCLES, TANK BAGS ADAPTED FOR USE WITH MOTORCYCLES, STANDS, MUDGUARDS, SPOILERS, AFTER BODY, REAR-VIEW MIRRORS, LICENSE PLATE HOLDERS, FUEL TANK CAPS, FUEL TANKS, CHAINS, MOTORCYCLE SEATS, IGNITION COVERS, VEHICLES AND THEIR PARTS (U.S. CLS. 19, 21, 23, 31, 35 AND 44).

CLASS 37—CONSTRUCTION AND REPAIR

FOR MAINTENANCE AND REPAIR OF MOTOR VEHICLES; REPAIR OF MOTOR VEHICLES AND ENGINES AS WELL AS PARTS OF THESE PRODUCTS (U.S. CLS. 100, 103 AND 106).

CLASS 41—EDUCATION AND ENTERTAINMENT

FOR ENTERTAINMENT, IN THE NATURE OF MOTORCYCLING EVENTS AND ORGANIZING MOTORCYCLE RACING ADVENTURE COMPETITIONS WHICH LAST SEVERAL DAYS; SPORTING AND ENTERTAINMENT COMPETITIONS WITH RESPECT TO AUTOMOBILES AND MOTORCYCLES; AUTOMOBILE AND MOTORCYCLE RACES; ORGANIZING AUTOMOBILE AND MOTORCYCLE SHOWS WITH STUNT RIDERS AND FREESTYLE RIDERS; ORGANIZING FASHION SHOWS; ORGANIZING PARTIES AND ORGANIZING COMMUNITY SPORTING AND CULTURAL EVENTS (U.S. CLS. 100, 101 AND 107).

WILLIAM ROSSMAN, EXAMINING ATTORNEY

SN 79-101,979. BLUE SKY SRL, ITALY, FILED 8-3-2011.

i'm
WATCH

PRIORITY DATE OF 5-3-2011 IS CLAIMED. OWNER OF INTERNATIONAL REGISTRATION 1089185 DATED 8-3-2011, EXPIRES 8-3-2021.

NO CLAIM IS MADE TO THE EXCLUSIVE RIGHT TO USE "WATCH", APART FROM THE MARK AS SHOWN. THE MARK CONSISTS OF THE STYLIZED WORD "I'M" ABOVE THE STYLIZED WORD "WATCH".

CLASS 9—ELECTRICAL AND SCIENTIFIC APPARATUS

FOR RADIO RECEIVERS AND TRANSMITTERS; CELLULAR PHONES; CELL PHONES IN THE FORM OF A WRISTWATCH (U.S. CLS. 21, 23, 26, 36 AND 38).

CLASS 14—JEWELRY

FOR WATCHES (U.S. CLS. 2, 27, 28 AND 50).

GINA FINK, EXAMINING ATTORNEY

CLASS 38—COMMUNICATION

FOR TELECOMMUNICATIONS, NAMELY, PROVIDING TELECOMMUNICATIONS CONNECTIONS TO THE INTERNET OR DATABASES, TRANSMISSION OF VOICE, AUDIO, VISUAL IMAGES AND DATA BY TELECOMMUNICATIONS NETWORKS, WIRELESS COMMUNICATION NETWORKS, THE INTERNET, INFORMATION SERVICES NETWORKS AND DATA NETWORKS (U.S. CLS. 100, 101 AND 104).

WILLIAM VERHOSEK, EXAMINING ATTORNEY

SN 79-102,187. DAKO-WERK DOWIDAT KG, FED REP GERMANY, FILED 1-24-2011.

SN 79-102,164. NABELL CORPORATION, IGA-SHI; MIE 518-0873, JAPAN, FILED 3-2-2011.

Bella-Flex

PRIORITY DATE OF 2-14-2011 IS CLAIMED.
OWNER OF INTERNATIONAL REGISTRATION 1089749 DATED 3-2-2011, EXPIRES 3-2-2021.
THE WORD(S) "BELLA-FLEX" HAS NO MEANING IN A FOREIGN LANGUAGE.

**CLASS 7—MACHINERY**

FOR METALWORKING MACHINES TOOLS AND REPLACEMENT PARTS THEREFORE; ACCESSORIES OF METALWORKING MACHINE TOOLS, NAMELY, BELLOWS AND TELESCOPIC COVERS; SEMICONDUCTOR MANUFACTURING MACHINES AND REPLACEMENT PARTS THEREFORE; AND ACCESSORIES OF SEMICONDUCTOR MANUFACTURING MACHINES AND SYSTEMS, NAMELY, BELLOWS AND TELESCOPIC COVERS (U.S. CLS. 13, 19, 21, 23, 31, 34 AND 35).

OWNER OF INTERNATIONAL REGISTRATION 0566814 DATED 1-22-1991, EXPIRES 1-22-2021.

OWNER OF U.S. REG. NO. 3,972,744.

THE MARK CONSISTS OF THE WORDING "SCHENKOPF" ABOVE A DESIGN OF AN OX'S HEAD WITHIN A CIRCLE WITH THE LETTERING "CB" ABOVE THE OX AND "F" TO THE RIGHT AND LEFT OF THE OX'S HEAD.

THE ENGLISH TRANSLATION OF "SCHENKOPF" IN THE MARK IS "OX'S HEAD".

CLASS 9—ELECTRICAL AND SCIENTIFIC APPARATUS

FOR BELLOWS FOR CAMERAS; BELLOWS FOR PROJECTORS; BELLOWS FOR OPTICAL APPARATUS AND INSTRUMENTS, NAMELY, LIGHT SHIELDING APPARATUS, OPTICAL ANALYZERS, VISUAL INSPECTORS AND MONITOR HOODS; PARTS AND ACCESSORIES OF PRECISION MEASURING MACHINES AND INSTRUMENTS, NAMELY, BELLOWS AND TELESCOPIC COVERS; PARTS AND ACCESSORIES OF IMAGE MEASURING EQUIPMENT, NAMELY, BELLOWS AND TELESCOPIC COVERS; PARTS AND ACCESSORIES OF SHAPE MEASURING EQUIPMENT, NAMELY, BELLOWS AND TELESCOPIC COVERS; PARTS AND ACCESSORIES OF PRECISION TESTING MACHINES AND INSTRUMENTS, NAMELY, BELLOWS AND TELESCOPIC COVERS (U.S. CLS. 21, 23, 26, 36 AND 38).

CLASS 8—HAND TOOLS

FOR AXES, HATCHETS, SICKLES; HAND TOOLS, PARTICULARLY TOOLS FOR LOGGING PURPOSES AND BUTCHERY, NAMELY, AXES, HATCHETS, SICKLES, SAWS, PRUNING SAWS, METAL CUTTING SAWS, PIT SAWS, SAWS FOR CUTTING BRANCHES, SAWS (HAND-OPERATED), SPLITTING WEDGES, BUTCHER KNIVES; GOODS FOR KNIFEMAKERS, NAMELY, HAND TOOLS, NAMELY, KNIVES, KNIFE SHARPENERS, FIXED BLADE KNIVES, FOLDING KNIVES, PUTTY KNIVES, FARRIER'S KNIVES, HAND OPERATED KNIFE TO AID IN SKINNING AN ANIMAL, HUNTING KNIVES, JACK KNIVES, KNIFE BAGS, KNIFE SHEATHS, KNIFE SHEATHS OF LEATHER, RAZOR KNIVES, PRUNING KNIVES, POCKET KNIVES, PALETTE KNIVES, PARING KNIVES; GRIPS SPECIALLY DESIGNED FOR THE AFOREMENTIONED GOODS, OF WOOD OR PLASTIC (U.S. CLS. 23, 28 AND 44).

CLASS 10—MEDICAL APPARATUS

FOR BELLOWS, NAMELY, MEDICAL PRODUCTS, NAMELY, THERAPEUTIC MATTRESSES, BEDS, SEATS AND CUSHIONS AS PART OF BEDS FOR MAGNETIC RESONANCE CT APPARATUS; BELLOWS, NAMELY, MEDICAL PRODUCTS, NAMELY, THERAPEUTIC MATTRESSES, BEDS, SEATS AND CUSHIONS AS PARTS OF BEDS FOR X-RAY CT SCANNERS; BELLOWS, NAMELY, MEDICAL PRODUCTS, NAMELY, THERAPEUTIC MATTRESSES, BEDS, SEATS AND CUSHIONS FOR X-RAY DIAGNOSTIC APPARATUS FOR MEDICAL PURPOSES; BELLOWS, NAMELY, MEDICAL PRODUCTS, NAMELY, MATTRESSES, BEDS, SEATS, AND CUSHIONS FOR BEDS, SPECIALLY FOR MEDICAL PURPOSES; BELLOWS, NAMELY, MEDICAL PRODUCTS, NAMELY, THERAPEUTIC MATTRESSES, BEDS, SEATS AND CUSHIONS FOR DENTISTS' CHAIRS (U.S. CLS. 26, 39 AND 44).

CLASS 20—FURNITURE AND ARTICLES NOT OTHERWISE CLASSIFIED

FOR HANDLES OF WOOD OR PLASTIC FOR AXES, HATCHETS, SICKLES, SAWS, PRUNING SAWS, METAL CUTTING SAWS, PIT SAWS, SAWS FOR CUTTING BRANCHES, SAWS (HAND-OPERATED), BUTCHER KNIVES, KNIVES, KNIFE SHARPENERS, FIXED BLADE KNIVES, FOLDING KNIVES, PUTTY KNIVES, FARRIER'S KNIVES, HAND OPERATED KNIVES TO AID IN SKINNING AN ANIMAL, HUNTING KNIVES, JACK KNIVES, RAZOR KNIVES, PRUNING KNIVES, POCKET KNIVES, PALETTE KNIVES, PARING KNIVES AND GRIPS DESIGNED FOR THE AFOREMENTIONED GOODS (U.S. CLS. 2, 13, 22, 25, 32 AND 50).

GINA FINK, EXAMINING ATTORNEY

SN 79-102,337. NEUMAYER TEKFOR HOLDING GMBH, FED REP GERMANY, FILED 11-17-2010.

ESpeed

THE MARK CONSISTS OF STANDARD CHARACTERS WITHOUT CLAIM TO ANY PARTICULAR FONT, STYLE, SIZE, OR COLOR.

PRIORITY DATE OF 5-21-2010 IS CLAIMED.
OWNER OF INTERNATIONAL REGISTRATION 1090127 DATED 11-17-2010, EXPIRES 11-17-2020.

CLASS 6—METAL GOODS

FOR METALLIC FASTENERS, IN PARTICULAR NUTS, LOCKING NUTS, SAFETY NUTS, SPECIAL NUTS, IN PARTICULAR FOR THE DRIVE TRAIN AS WELL AS FOR ENGINE AND CHASSIS APPLICATIONS, WHEEL NUTS, AXLE CONTROL NUTS, WHEEL CENTRAL LOCKING ELEMENTS IN THE NATURE OF NUTS, QUICK CLAMPING PARTS IN THE NATURE OF NUTS (U.S. CLS. 2, 12, 13, 14, 23, 25 AND 50).

CLASS 7—MACHINERY

FOR MACHINE PARTS, NAMELY, CAM SHAFTS, CAM SHAFT PARTS IN THE NATURE OF CAM COVERS FOR VEHICLES AND CAM SHAFT MODULES MADE THEREFROM IN THE NATURE OF CAM COVERS FOR VEHICLES, VARIABLE CAMSHAFT ADJUSTMENT PARTS IN THE NATURE OF CAM COVERS FOR VEHICLES, CONNECTING RODS, IN PARTICULAR FROM STEEL OR CERAMICS, ONE-PIECE AND COMPOSITE CONNECTING RODS, CRANK SHAFTS FOR USE IN CONNECTION WITH MOTOR VEHICLES, COMPOSITE AND ASSEMBLED CRANKSHAFTS FOR USE IN CONNECTION WITH MOTOR VEHICLES, PISTONS FOR USE IN CONNECTION WITH MOTOR VEHICLES, COMPRESSORS, NAMELY, ELECTRONIC COMPRESSORS, AND COMPONENTS FOR VARIABLE COMPRESSION, NAMELY, CAM SHAFTS, ENGINES NOT FOR MOTOR VEHICLES, AND ENGINE PARTS, NAMELY, CAM SHAFTS, PUMPS, NAMELY, PUMPS AS PARTS OF MACHINES, AND HYBRID DRIVES, NAMELY, VARIABLE SPEED DRIVES FOR MACHINES, JOINTS AND SHOCK ABSORBERS, NAMELY, SHOCK ABSORBERS FOR MACHINES; TRANSMISSIONS FOR MACHINES, AIR-CONDITIONING COMPRESSORS (U.S. CLS. 13, 19, 21, 23, 31, 34 AND 35).

CLASS 12—VEHICLES

FOR AUTOMOTIVE PARTS, IN PARTICULAR PUMPS, NAMELY, AIR PUMPS, HYBRID DRIVES, NAMELY, ENGINES FOR LAND VEHICLES, ENGINE PARTS, NAMELY, ENGINE PARTS FOR LAND VEHICLES, AND UNITS FOR THE DRIVE TRAIN MADE THEREFROM, NAMELY, WHEEL HUBS, WHEEL BEARINGS, WHEEL BEARING UNITS, NAMELY, WHEEL BEARINGS, AND PARTS THEREOF, NAMELY, DRIVE SHAFTS AND GEAR WHEELS AND UNITS ASSEMBLED THEREOF, NAMELY, GEAR WHEEL UNITS, SPEED-INCREASING GEARS, NAMELY, GEAR WHEELS, SPEED-REDUCING GEARS, NAMELY, GEAR WHEELS, SHIFTING CLAWS, NAMELY, GEAR SHIFTS, DIFFERENTIAL GEARS, NAMELY, GEAR WHEELS, LIGHTWEIGHT GEARS, NAMELY, GEAR WHEELS, LOW-COST GEARS, NAMELY, GEAR WHEELS; CONNECTING RODS FOR LAND VEHICLES, EXCEPT FOR ENGINE PARTS, IN PARTICULAR FROM STEEL AND CERAMICS, IN PARTICULAR ONE-PIECE AND COMPOSITE CONNECTING RODS; ENGINES FOR AUTOMOBILES, IN PARTICULAR LIGHTWEIGHT INTERNAL COMBUSTION ENGINES; UNITS FOR DRIVE TRAIN OF AUTOMOBILES, NAMELY, WHEEL HUBS, WHEEL BEARINGS, WHEEL BEARING UNITS, NAMELY, WHEEL BEARINGS, CONSTANT VELOCITY AND LENGTH ADJUSTMENT UNITS, NAMELY, WHEEL BEARINGS; LONGITUDINAL SHAFTS, NAMELY, DRIVE SHAFTS; SIDE SHAFTS, NAMELY,

DRIVE SHAFTS; TORSION SHAFTS, NAMELY, DRIVE SHAFTS, ALL FOR AUTOMOBILES AND PARTS THEREOF, INCLUDED IN THIS CLASS, IN PARTICULAR DRIVE SHAFTS, HUBS, NAMELY, WHEEL HUBS, CONNECTIONS FOR LONGITUDINAL SHAFTS, NAMELY, DRIVE SHAFTS FOR LAND VEHICLES, SIDE SHAFTS, NAMELY, DRIVE SHAFTS FOR LAND VEHICLES, AND TORSION SHAFTS, NAMELY, DRIVE SHAFTS FOR LAND VEHICLES; AUTOMOBILE TRANSMISSIONS AND PARTS THEREOF, IN PARTICULAR SHAFTS, NAMELY, DRIVE SHAFTS FOR LAND VEHICLES AND GEAR WHEELS AND UNITS ASSEMBLED THEREOF, NAMELY, GEAR WHEELS, SPEED-INCREASING GEARS, NAMELY, GEAR WHEELS, AND SPEED-REDUCING GEARS, NAMELY, GEAR WHEELS, SYNCHROMESH TRANSMISSIONS, SHIFTING CLAWS, NAMELY, GEAR WHEELS, TRANSMISSIONS FOR ELECTRIC DRIVES (U.S. CLS. 19, 21, 23, 31, 35 AND 44).
JAMES STEIN, EXAMINING ATTORNEY

SN 79-102,339. B.I.G. BIOENGINEERED GERMANY GMBH, 21423 WINSSEN/LUHE, FED REP GERMANY, FILED 2-17-2011.

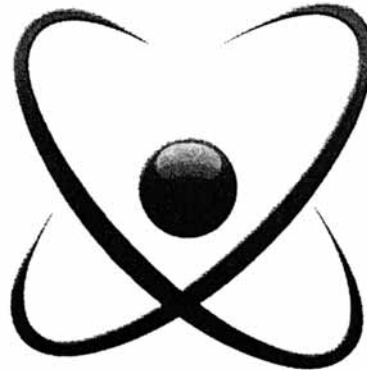

PRIORITY DATE OF 9-11-2010 IS CLAIMED.
OWNER OF INTERNATIONAL REGISTRATION 1090130 DATED 2-17-2011, EXPIRES 2-17-2021.

THE MARK CONSISTS OF A DESIGN OF A STYLIZED ATOM FORMED BY TWO INCOMPLETE CIRCLES SURROUNDING A SHADED CIRCLE.

CLASS 9—ELECTRICAL AND SCIENTIFIC APPARATUS

FOR SKI GOGGLES, SKI HELMETS, MOTORCYCLE HELMETS (U.S. CLS. 21, 23, 26, 36 AND 38).

CLASS 12—VEHICLES

FOR ELECTRIC GOLF TROLLEYS, ELECTRIC GOLF CADDIES (U.S. CLS. 19, 21, 23, 31, 35 AND 44).

CLASS 16—PAPER GOODS AND PRINTED MATTER

FOR SCORE-CARD BOOKS (U.S. CLS. 2, 5, 22, 23, 29, 37, 38 AND 50).

CLASS 18—LEATHER GOODS

FOR UMBRELLAS, SPORTS BAGS (U.S. CLS. 1, 2, 3, 22 AND 41).

CLASS 21—HOUSEWARES AND GLASS

FOR CLOTHES DRYING HANGERS, CLOTHES RACKS FOR DRYING; CLOTHES BRUSHES; CLOTHES PINS (U.S. CLS. 2, 13, 23, 29, 30, 33, 40 AND 50).

CLASS 25—CLOTHING

FOR GOLF CLOTHING, NAMELY, HATS, SHIRTS, PANTS, SHOES AND SOCKS; TENNIS WEAR; TENNIS SHOES; CAPS, SUN CAPS, RAIN CAPS, SPORT CLOTHING FOR GOLF, NAMELY, RAINWEAR, WIND-RESISTANT JACKETS, GOLF SHIRTS, WIND-RESISTANT VESTS, POLO SHIRTS, WIND-RESISTANT PULLOVERS AND SLIPOVERS, RAIN HATS AND SUN CAPS; RAINCOATS; CYCLING SHOES; SHORTS AND JERSEYS AND MOTORCYCLE GLOVES (U.S. CLS. 22 AND 39).

CLASS 28—TOYS AND SPORTING GOODS

FOR GOLF CADDIES IN THE NATURE OF WHEELED CARTS; NON-MOTORIZED GOLF TROLLEYS; GOLF CLUBS, NAMELY, PUTTERS, WEDGES AND CHIPPERS; GOLF BALLS AND GOLF BAGS; BALL ANGLERS IN THE NATURE OF GOLF CLUB SWING PATH TRAINING AIDS; GOLF DIVOT REPAIR TOOLS IN THE NATURE OF PITCH FORKS; WOODEN AND PLASTIC GOLF TEES; GOLF CLUBS; GOLF HANDLES IN THE NATURE OF GOLF CLUB GRIPS; GOLF SHAFTS; GOLF BALL COLLECTION TUBES ADAPTED SPECIFICALLY FOR COLLECTING GOLF BALLS; GOLF PRACTICE NETS; GOLF CLUB TRAVEL COVERS; TENNIS EQUIPMENT, NAMELY, TENNIS RACQUETS, TENNIS BALLS, TENNIS BAGS, TENNIS VIBRATOR DAMPENERS, TENNIS STRINGS, GRIPS, TAPES FOR GRIPS, TENNIS BALL MACHINES; EXERCISE EQUIPMENT, NAMELY, BAR BELLS AND DOOR-MOUNTED GYMNASIAC HORIZONTAL BARS; GOLF GLOVES; GOLF PUTTING MATS; GOLF TEEING MATS; ARTIFICIAL GOLF PUTTING MATS (U.S. CLS. 22, 23, 38 AND 50).

EDWARD NELSON, EXAMINING ATTORNEY

CLASS 7—MACHINERY

FOR MACHINE PARTS, NAMELY, CORE NOZZLES OF FURNACES FOR FIBER-OPTIC LINE DRAWING MACHINES; MACHINE PARTS, NAMELY, HOT PLATE FOR WELDING MACHINES USED FOR COMPOUNDING ROOFING MATERIALS OF SYNTHETIC RESIN; MACHINE PARTS, NAMELY, CRUCIBLES FOR ORGANIC ELECTRO-LUMINESCENCE MANUFACTURING MACHINES; MACHINE PARTS, NAMELY, HEATERS FOR CRUCIBLES FOR ORGANIC ELECTRO-LUMINESCENCE MANUFACTURING MACHINES; MACHINE PARTS, NAMELY, CRUCIBLES FOR SOLAR-BATTERY MANUFACTURING MACHINES; MACHINE PARTS, NAMELY, HEATERS FOR CRUCIBLES FOR SOLAR-BATTERY MANUFACTURING MACHINES; MACHINE PARTS, NAMELY, HEATERS AND SUSCEPTORS FOR EPITAXIAL GROWTH SYSTEM FOR SEMICONDUCTOR MANUFACTURING MACHINES; MACHINE PARTS, NAMELY, REPLACEMENT PARTS FOR FURNACES USED IN CONNECTION WITH MACHINES FOR GROWING SINGLE CRYSTALS USING THE PULLING METHOD FOR THE MANUFACTURE OF SEMICONDUCTORS; MACHINE PARTS, NAMELY, FITTINGS FOR FURNACES USED IN CONNECTION WITH MACHINES FOR GROWING SINGLE CRYSTALS USING THE PULLING METHOD FOR THE MANUFACTURE OF SEMICONDUCTORS, NAMELY, ELECTRIC HEATERS AND SUSCEPTORS; MACHINE PARTS, NAMELY, SEALING JIGS FOR SEMI-CONDUCTOR MANUFACTURING MACHINES; PARTS FOR COMPOUND SEMICONDUCTOR MANUFACTURING MACHINES AND FITTINGS FOR COMPOUND SEMICONDUCTOR MANUFACTURING MACHINES, NAMELY, CRUCIBLES, HEATERS AND SUSCEPTORS (U.S. CLS. 13, 19, 21, 23, 31, 34 AND 35).

CLASS 11—ENVIRONMENTAL CONTROL APPARATUS

FOR CRUCIBLES, NAMELY, CONTAINERS FOR MELTING MATERIAL AT HIGH TEMPERATURES FOR INDUSTRIAL USE; CRUCIBLES, NAMELY, CONTAINERS FOR RETAINING MELTING MATERIAL FOR INDUSTRIAL USE; CRUCIBLES, NAMELY, CONTAINERS FOR MELTING MATERIAL AS PARTS OF INDUSTRIAL FURNACES; INDUSTRIAL HEATERS FOR CRUCIBLES; REPLACEMENT PARTS FOR FURNACES FOR ANNEALING TREATMENT MACHINES AND FITTINGS FOR FURNACES FOR ANNEALING TREATMENT MACHINES, NAMELY, ELECTRIC HEATERS AND SUSCEPTORS; ELECTRIC HEATERS BEING PARTS OF INDUSTRIAL FURNACES (U.S. CLS. 13, 21, 23, 31 AND 34).

JEFFERY COWARD, EXAMINING ATTORNEY

SN 79-102,340. TOYO TANSO CO., LTD., OSAKA 555-0011, JAPAN, FILED 3-31-2011.

SN 79-102,404. SUSTAINABLE REFERENCE, S.L., SPAIN, FILED 3-9-2011.

PERMA KOTE



OWNER OF INTERNATIONAL REGISTRATION 1090320 DATED 3-9-2011, EXPIRES 3-9-2021.

NO CLAIM IS MADE TO THE EXCLUSIVE RIGHT TO USE "SUSTAINABLE REFERENCE", APART FROM THE MARK AS SHOWN.

THE COLOR(S) ORANGE, GREEN AND BLACK IS/ARE CLAIMED AS A FEATURE OF THE MARK.

THE MARK CONSISTS OF THE TERM "SUSTAINABLE REFERENCE", WHERE THE WORD "SUSTAINABLE" IS IN GREEN LETTERS AND "REFERENCE" IS IN ORANGE LETTERS. TO THE LEFT OF THE TERM IS A CIRCULAR DESIGN HAVING A HEART-SHAPED DESIGN WITHIN THE CIRCLE. THE LEFT HALF OF THE DESIGN IS GREEN WITH BLACK SHADOWING AND THE RIGHT HALF OF THE DESIGN IS ORANGE WITH BLACK SHADOWING.

THE MARK CONSISTS OF STANDARD CHARACTERS WITHOUT CLAIM TO ANY PARTICULAR FONT, STYLE, SIZE, OR COLOR.

OWNER OF INTERNATIONAL REGISTRATION 1090132 DATED 3-31-2011, EXPIRES 3-31-2021.

CLASS 35—ADVERTISING AND BUSINESS

FOR ADVERTISING AND MARKETING; BUSINESS MANAGEMENT AND ADMINISTRATION; PROVIDING OFFICE FUNCTIONS; BUSINESS MANAGEMENT AND ORGANIZATION CONSULTING SERVICES; BUSINESS MANAGEMENT ASSISTANCE SERVICES; BUSINESS MANAGEMENT CONSULTANCY; PROFESSIONAL BUSINESS CONSULTANCY; MARKET RESEARCH STUDIES; MARKET ANALYSIS SERVICES; MARKETING RESEARCH; SERVICES OF ORGANIZING AND CONDUCTING TRADE FAIRS, ARRANGING AND CONDUCTING EXHIBITIONS AND TRADE SHOW EVENTS FOR COMMERCIAL AND ADVERTISING PURPOSES; PUBLISHING OF ADVERTISING TEXTS; WHOLESALE, CATALOG, ONLINE AND RETAIL STORE SERVICES FEATURING BATHROOM FITTINGS, FAUCETS, LIGHTING APPARATUS, CONSTRUCTION MATERIALS, MACHINES AND MACHINE TOOLS, TOOLS AND IMPLEMENTS FOR CONSTRUCTION, PERSONAL PROTECTION EQUIPMENT, PUBLICATIONS, DVDS, AUDIO AND VIDEO RECORDINGS, RECORDING MEDIA FOR AUDIO, VIDEO AND DOCUMENTS, RECORDING MEDIA FOR COMPUTER PROGRAMS AND COMPUTER APPLICATIONS, HEATING APPARATUS, ELECTRIC RADIATORS, RADIATORS, AIR CONDITIONING APPARATUS, AIR QUALITY CONTROL APPARATUS, REFRIGERATING APPARATUS, HOUSEHOLD ELECTRICALS, TELECOMMUNICATIONS APPARATUS, SOUND AND IMAGE APPARATUS, VEHICLES, BICYCLES, SOFTWARE AND HARDWARE, ELECTRIC MOTORS, PHOTOVOLTAIC PANELS, SOLAR ELECTRICITY GENERATORS, WIND TURBINES, AS WELL AS PARTS, SPARE PARTS AND COMPONENTS OF THE AFORESAID GOODS (U.S. CLS. 100, 101 AND 102).

CLASS 38—COMMUNICATION

FOR TELECOMMUNICATIONS CONSULTING AND GATEWAY SERVICES; PROVISION OF ACCESS TO A GLOBAL COMPUTER NETWORK; NEWS AGENCY SERVICES FOR ELECTRONIC TRANSMISSION; ELECTRONIC BULLETIN BOARD SERVICES; PROVIDING TELECOMMUNICATIONS CONNECTIONS TO A GLOBAL COMPUTER NETWORK; TELEVISION AND RADIO PROGRAM BROADCASTING; COMPUTER-ASSISTED MESSAGE AND IMAGE TRANSMISSION; RENTAL OF TELECOMMUNICATIONS APPARATUS; TRANSMISSION OF NEWS IN CONNECTION WITH THE ENVIRONMENT, SUSTAINABLE CONSTRUCTION AND THE DISSEMINATION OF SUSTAINABLE PRODUCTS, STRATEGIES AND TECHNOLOGIES APPLICABLE TO ANY SECTOR OF INDUSTRY; TELEVISION AND RADIO PROGRAM BROADCASTING IN CONNECTION WITH THE ENVIRONMENT, SUSTAINABLE CONSTRUCTION AND THE DISSEMINATION OF SUSTAINABLE PRODUCTS, STRATEGIES AND TECHNOLOGIES APPLICABLE TO ANY SECTOR OF INDUSTRY (U.S. CLS. 100, 101 AND 104).

CLASS 41—EDUCATION AND ENTERTAINMENT

FOR EDUCATION SERVICES, NAMELY, PROVIDING OF TRAINING IN THE FORM OF CLASSES IN THE FIELD OF SUSTAINABLE ENERGY SOLUTIONS; ENTERTAINMENT, NAMELY, ORGANIZING COMMUNITY SPORTING AND CULTURAL ACTIVITIES; EDUCATIONAL SERVICES, NAMELY, ARRANGING AND CONDUCTING OF SEMINARS, COLLOQUIUMS, SYMPOSIUMS, CONVENTIONS AND CONFERENCES IN THE FIELD OF SUBJECT OF THE ENVIRONMENT, SUSTAINABLE CONSTRUCTION AND DISSEMINATING SUSTAINABLE PRODUCTS, STRATEGIES AND TECHNOLOGIES APPLICABLE TO ANY SECTOR OF INDUSTRY; PROVIDING ENVIRONMENTAL TRAINING IN THE FORM OF CLASSES IN SUSTAINABLE CONSTRUCTION, DESIGN AND DEVELOPMENT OF

SUSTAINABLE PRODUCTS, STRATEGIES AND TECHNOLOGIES APPLICABLE TO ANY SECTOR OF INDUSTRY; PROVIDING TRAINING AND EDUCATION CENTERS FEATURING CLASSES IN THE FIELD OF SUSTAINABLE ENERGY SOLUTIONS; VOCATIONAL TRAINING SERVICES IN THE FIELD OF SUSTAINABLE ENERGY SOLUTIONS; PROVIDING SPORTS FACILITIES; PUBLICATION OF TEXTS; PUBLISHING OF ELECTRONIC PUBLICATIONS, PERIODICALS AND MAGAZINES ONLINE; EDITING AND PRODUCTION OF FILMS; EDITING OF RADIO AND TELEVISION PROGRAMS (U.S. CLS. 100, 101 AND 107).

CLASS 42—SCIENTIFIC AND COMPUTER SERVICES

FOR SCIENTIFIC AND TECHNOLOGICAL SERVICES, NAMELY, RESEARCH AND DESIGN SERVICES IN THE FIELD OF SUSTAINABLE ENERGY SOLUTIONS; INDUSTRIAL ANALYSIS AND RESEARCH SERVICES IN THE FIELD OF SUSTAINABLE ENERGY SOLUTIONS; DESIGN AND DEVELOPMENT OF COMPUTER HARDWARE AND SOFTWARE; SURVEYING; ARCHITECTURAL SERVICES; TECHNICAL CONSULTATION IN RELATION TO ARCHITECTURE AND ENGINEERING; TECHNICAL CONSULTATION IN THE FIELD OF ENVIRONMENTAL ENGINEERING; SUSTAINABLE TECHNICAL CONSTRUCTION DRAFTING; DESIGN AND DEVELOPMENT OF COMPUTER PROGRAMS; DESIGN OF WEB SITES; DESIGN AND DEVELOPMENT OF COMPUTER PROGRAMS FOR MANAGING AND PROMOTING THE ENVIRONMENT, SUSTAINABLE CONSTRUCTION AND THE DESIGN AND DEVELOPMENT OF SUSTAINABLE PRODUCTS, STRATEGIES AND TECHNOLOGIES APPLICABLE TO ANY SECTOR OF INDUSTRY (U.S. CLS. 100 AND 101).

SUSAN LESLIE DUBOIS, EXAMINING ATTORNEY

SN 79-102,419. ALFRED FREH, A-8380 JENNERSDORF, AUSTRIA, FILED 6-9-2011.

contain dry

PRIORITY DATE OF 12-17-2010 IS CLAIMED.

OWNER OF INTERNATIONAL REGISTRATION 1090352 DATED 6-9-2011, EXPIRES 6-9-2021.

NO CLAIM IS MADE TO THE EXCLUSIVE RIGHT TO USE "DRY", APART FROM THE MARK AS SHOWN.

CLASS 11—ENVIRONMENTAL CONTROL APPARATUS

FOR PLANTS, FACILITIES, APPARATUS AND DEVICES FOR DRYING AND DEHUMIDIFYING GOODS AND OBJECTS, NAMELY, INDUSTRIAL DRYERS FOR HEATING AND DEHUMIDIFYING; PLANTS, FACILITIES, APPARATUS AND DEVICES FOR DRYING FOOD, TEXTILES, PAPER, CARDBOARD, WOOD, WOOD-BASED MATERIALS, CHEMICALS, MINERALS, BUILDING MATERIALS AND BUILDINGS, NAMELY, PORTABLE ELECTRIC WARM AIR DRYERS; MOBILE SYSTEMS, FACILITIES, APPARATUS AND DEVICES FOR DRYING FOOD, TEXTILES, PAPER, CARDBOARD, WOOD, WOOD-BASED MATERIALS, CHEMICALS, MINERALS, BUILDING MATERIALS AND BUILDINGS, NAMELY, LYOPHILIZERS FOR USE IN FREEZE DRYING EQUIPMENT; PLANTS, FACILITIES, APPARATUS AND DEVICES FOR DEHUMIDIFYING FOOD, TEXTILES, PAPER, CARDBOARD, WOOD, WOOD-BASED MATERIALS, CHEMICALS, MINERALS, BUILDING MATERIALS AND BUILDINGS, NAMELY, INDUSTRIAL DRYERS FOR HEATING AND DEHUMIDIFYING (U.S. CLS. 13, 21, 23, 31 AND 34).

CLASS 37—CONSTRUCTION AND REPAIR

FOR DRYING AND DEHUMIDIFYING BUILDINGS, NAMELY, DRYING OF PARTICULATE AND MOISTURE CONTAMINANTS FOR BUILDING AND CONTENTS THEREIN FOR ENVIRONMENTAL CONTAINMENT PURPOSES (U.S. CLS. 100, 103 AND 106).

CLASS 40—MATERIAL TREATMENT

FOR DRYING FOOD, TEXTILES, PAPER, CARDBOARD, WOOD, WOOD-BASED MATERIALS, CHEMICALS, MINERALS, AND BUILDING MATERIALS, WASTE PROCESSING; DEHUMIDIFICATION OF FOOD, TEXTILES, PAPER, CARDBOARD, WOOD, WOOD-BASED MATERIALS, CHEMICALS, MINERALS, AND BUILDING MATERIALS (U.S. CLS. 100, 103 AND 106).
ESTHER BELENKER, EXAMINING ATTORNEY

CLASS 41—EDUCATION AND ENTERTAINMENT

FOR PROVIDING COMPUTER AND VIDEO GAMES ONLINE (U.S. CLS. 100, 101 AND 107).

CLASS 42—SCIENTIFIC AND COMPUTER SERVICES

FOR DEVELOPMENT, CREATION, DESIGN, UPDATING AND CUSTOMIZING OF COMPUTER PROGRAMS FOR DATA PROCESSING AND FOR MANAGEMENT OF DATA FILES IN THE FIELDS OF COMPUTER AND VIDEO GAMES AND OF MULTIMEDIA COMPUTER PROGRAMMES AND OF HOMEPAGES AND WEBSITES (U.S. CLS. 100 AND 101).

LYDIA BELZER, EXAMINING ATTORNEY

SN 79-102,475. ACONY GMBH & CO.KG, VILLINGEN-SCHWENNINGEN, FED REP GERMANY, FILED 6-8-2011.



PRIORITY DATE OF 5-18-2011 IS CLAIMED.
OWNER OF INTERNATIONAL REGISTRATION 1090566 DATED 6-8-2011, EXPIRES 6-8-2021.

THE MARK CONSISTS OF THE STYLIZED WORDING "HEDONE" WITH A 5-POINTED STAR FORMING THE MIDDLE OF THE LETTER "O", SUPERIMPOSED OVER A SERIES OF STYLIZED GUNS AND RIFLES IN VERTICAL POSITIONS.

THE ENGLISH TRANSLATION OF "HEDONE" IS "PLEASURE".

CLASS 9—ELECTRICAL AND SCIENTIFIC APPARATUS

FOR RECORDED COMPUTER PROGRAMMES FEATURING COMPUTER AND VIDEO GAMES; DOWNLOADABLE COMPUTER PROGRAMMES FEATURING COMPUTER AND VIDEO GAMES; DOWNLOADABLE ELECTRONIC PUBLICATIONS, NAMELY, NEWSLETTERS AND MANUALS IN THE FIELD OF COMPUTER AND VIDEO GAMES (U.S. CLS. 21, 23, 26, 36 AND 38).

CLASS 16—PAPER GOODS AND PRINTED MATTER

FOR PRINTED MATTER, PARTICULARLY IN THE FIELDS OF COMPUTER TECHNOLOGY AND COMPUTER PROGRAMMES, NAMELY, OPERATING INSTRUCTIONS AND INSTRUCTIONS FOR USE OF COMPUTER SOFTWARE, PROGRAMME DOCUMENTATION AND ACCOMPANYING MATERIAL IN PRINTED FORM FOR COMPUTER PROGRAMMES; BROCHURES, NAMELY, IN THE FIELD OF COMPUTER AND VIDEO GAMES; BOOKS, NAMELY, IN THE FIELD OF COMPUTER AND VIDEO GAMES; COMIC BOOKS, HANDBOOKS AND PROSPECTUSES, NAMELY, IN THE FIELD OF COMPUTER AND VIDEO GAMES; PRINTED PUBLICATIONS, NAMELY, NEWSLETTERS IN THE FIELD OF COMPUTER AND VIDEO GAMES; MAGAZINES, NAMELY, IN THE FIELD OF COMPUTER AND VIDEO GAMES; POSTERS (U.S. CLS. 2, 5, 22, 23, 29, 37, 38 AND 50).

CLASS 28—TOYS AND SPORTING GOODS

FOR TOYS RELATED TO COMPUTER AND VIDEO GAMES, NAMELY, ACTION TOY FIGURES AND ACCESSORIES THEREFOR (U.S. CLS. 22, 23, 38 AND 50).

SN 79-102,500. HITURN AS, NORWAY, FILED 7-25-2011.

#LOBSTER

PRIORITY DATE OF 1-25-2011 IS CLAIMED.
OWNER OF INTERNATIONAL REGISTRATION 1090630 DATED 7-25-2011, EXPIRES 7-25-2021.

THE MARK CONSISTS OF THE STYLIZED WORD "LOBSTER" TO THE RIGHT OF A CROSS HATCH GRID DESIGN.

CLASS 18—LEATHER GOODS

FOR SUITCASES AND TRAVEL BAGS (U.S. CLS. 1, 2, 3, 22 AND 41).

CLASS 28—TOYS AND SPORTING GOODS

FOR SPORTING ARTICLES, NAMELY, SKIS, SNOWBOARDS, SNOW SLEDS FOR RECREATIONAL USE, SKATEBOARDS FOR RECREATIONAL USE, SKI BINDINGS AND PARTS THEREFOR, SNOWBOARD BINDINGS AND PARTS THEREFOR (U.S. CLS. 22, 23, 38 AND 50).

PATRICIA EVANKO, EXAMINING ATTORNEY

SN 79-102,590. ELENA GHISELLINI, ITALY, FILED 2-1-2011.

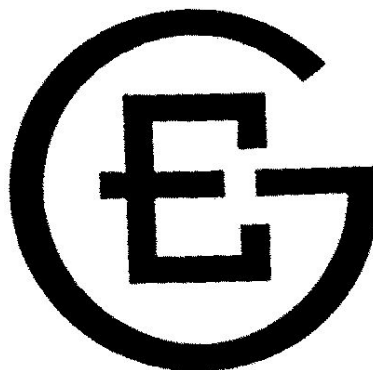

PRIORITY DATE OF 8-3-2010 IS CLAIMED.
OWNER OF INTERNATIONAL REGISTRATION 1090790 DATED 2-1-2011, EXPIRES 2-1-2021.

CLASS 18—LEATHER GOODS

FOR GOODS OF LEATHER AND OF IMITATION OF LEATHER, NAMELY, TRUNKS, TRAVELING CASES, SUITCASES, LUGGAGE, BAGS, NAMELY, BOOK BAGS, CLUTCH BAGS, DUFFEL BAGS, DIAPER BAGS, SHOPPING BAGS, UMBRELLAS (U.S. CLS. 1, 2, 3, 22 AND 41).

CLASS 21—HOUSEWARES AND GLASS

FOR GOODS OF PRECIOUS METAL OR PLATED THEREWITH, NAMELY, COFFEE POTS OF PRECIOUS METAL (U.S. CLS. 2, 13, 23, 29, 30, 33, 40 AND 50).

CLASS 25—CLOTHING

FOR CLOTHES, NAMELY, JACKETS, SHIRTS, BLOUSES, PANTS, KNITWEAR, NAMELY, KNIT SOCKS, KNIT SWEATERS, KNIT SHIRTS, SKIRTS, T-SHIRTS, UNDERWEAR, LINGERIE, SCARVES, FOU-LARDS, SOCKS, STOCKINGS, GLOVES, HATS, COATS, DRESSES, EVENING DRESSES, SUITS; SHOES, HATS (U.S. CLS. 22 AND 39).

DORITT L. CARROLL, EXAMINING ATTORNEY

CLASS 38—COMMUNICATION

FOR TELECOMMUNICATIONS, NAMELY, TRANS-FER OF DATA, NAMELY, ROAD AND DRIVING RELATED INFORMATION, INFORMATION ON SPECIAL OFFERS, PROMOTION AND USER RECOMMEN-DATIONS BY TELECOMMUNICATIONS; COMMUNICATION BY MOBILE PHONES, PDAS, HANDHELD COMPUTERS, TABLETS AND SMART PHONES, AND RADIO, NAMELY, FOR DISPLAYING ROAD AND DRIVING RELATED INFORMATION, IN-FORMATION ON SPECIAL OFFERS, PROMOTION AND USER RECOMMENDATIONS; TELECOM SERVICES, NAMELY, ELECTRONIC BULLETIN BOARD SERVICES DISPLAYING ROAD AND DRIVING RELATED IN-FORMATION, INFORMATION ON SPECIAL OFFERS, PROMOTION AND USER RECOMMENDATIONS; TELECOMMUNICATION SERVICES WHICH ENABLES A USER TO SEND AND/OR TO RECEIVE MESSAGES VIA A CORDLESS DATA NETWORK; DATA COMMU-NICATION SERVICES VIA INTERNET FOR UPLOAD-ING, ANNOUNCING, SHOWING, DISPLAYING, LABELING, BLOGGING, SHARING OR OTHERWISE PROVIDING OF ELECTRONIC MEDIA OR INFORMAT-ION, NAMELY, TRANSMISSION OF VOICE, DATA, GRAPHICS, IMAGES, AUDIO AND VIDEO BY MEANS OF THE INTERNET; PROVISION OF ONLINE CHAT ROOMS AND ELECTRONIC BULLETIN BOARDS FOR TRANSMISSION OF MESSAGES, IMAGES, SOUND, GEOGRAPHICAL INFORMATION AND OTHER DATA BETWEEN MOBILE DEVICES USERS ON THE SUBJECT OF LOCATION BASED INFORMATION; PROVIDING ON-LINE FORUMS FOR TRANSMISSION OF MES-SAGES AMONG MOBILE DEVICES USERS CONCERN-ING ROAD AND DRIVING RELATED INFORMATION, TRAFFIC ALERTS, INFORMATION ON SPECIAL OF-FERS, PROMOTION AND USER RECOMMENDATIONS (U.S. CLS. 100, 101 AND 104).

SN 79-102,723. TELMAP LTD., ISRAEL, FILED 4-28-2011.

CLASS 42—SCIENTIFIC AND COMPUTER SERVICES

FOR HOSTING AN ONLINE COMMUNITY WEBSITE FEATURING SHARED COMMUNICATIONS BETWEEN COMMUNITY MEMBERS INTERESTED IN ROAD AND DRIVING RELATED INFORMATION, INFORMATION ON SPECIAL OFFERS, PROMOTION AND USER RE-COMMENDATIONS (U.S. CLS. 100 AND 101).

ADA HAN, EXAMINING ATTORNEY

SN 79-102,760. ROTAPHARM ILAÇLARI LIMITED SIRKETI, BAGCILAR ISTANBUL, TURKEY, FILED 5-5-2011.

PRIORITY DATE OF 4-26-2011 IS CLAIMED.
OWNER OF INTERNATIONAL REGISTRATION 1091167 DATED 4-28-2011, EXPIRES 4-28-2021.

THE COLOR(S) TURQUOISE, BLUE, AND GREEN IS/ARE CLAIMED AS A FEATURE OF THE MARK.

THE MARK CONSISTS OF THE STYLIZED WORD "STREETIPS" WHERE "STREE" IS IN THE COLOR TUR-QUOISE, AND "TIPS" IS IN THE COLOR BLUE; A SMILEY FACE INSIDE A CAPTION BUBBLE APPEARS TO THE RIGHT IN THE COLOR GREEN.

CLASS 9—ELECTRICAL AND SCIENTIFIC APPARATUS

FOR COMPUTER SOFTWARE FOR USE IN GENERA-TION, TRANSMISSION, AND DISPLAY OF MAPS IN GRAPHIC FORM ON CELLULAR TELEPHONES, HANDHELD COMPUTERS (PDAS), NET BOOKS, NET TABLETS, AND IN-CAR PDAS ENABLING COLLEC-TION, COMPILATION, PROCESSING, TRANSMISSION, DISSEMINATION AND SHARING OF LOCATION BASED DATA, NAMELY, ROAD AND DRIVING RE-LATED INFORMATION, INFORMATION ON SPECIAL OFFERS, PROMOTION AND USER RECOMMENDA-TIONS (U.S. CLS. 21, 23, 26, 36 AND 38).



OWNER OF INTERNATIONAL REGISTRATION 1091273 DATED 5-5-2011, EXPIRES 5-5-2021.

THE COLOR(S) BLUE AND WHITE IS/ARE CLAIMED AS A FEATURE OF THE MARK.

THE MARK CONSISTS OF THE STYLIZED LETTER "R" IN THE COLOR BLUE INSIDE A WHITE CIRCLE, INSIDE A BLUE AND WHITE TRIANGLE.

CLASS 5—PHARMACEUTICALS

FOR MEDICINES FOR HUMAN PURPOSES, NAMELY, ANTIBIOTICS, AND FOR COUNTERACTING FUNGAL GROWTH, NAMELY, FUNGICIDES, ANTI-NEMIC PREPARATIONS, ANTHELMINTIC PREPARATIONS, ANTIHISTAMINES, DIURETIC MEDICINES, NERVOUS SYSTEM MEDICINES, ANTIPILEPTIC MEDICINES, PAIN KILLERS, RESPIRATORY SYSTEM MEDICINES, MULTIVITAMINS, POLIVITAMINS, AND CARDIOVASCULAR MEDICINES; MEDICINES FOR VETERINARY PURPOSES, NAMELY, ANTIBIOTICS, AND FOR COUNTERACTING FUNGAL GROWTH, NAMELY, FUNGICIDES, ANTI-NEMIC PREPARATIONS, ANTHELMINTIC PREPARATIONS, ANTIHISTAMINES, DIURETIC MEDICINES, NERVOUS SYSTEM MEDICINES, ANTIPILEPTIC MEDICINES, PAIN KILLERS, RESPIRATORY SYSTEM MEDICINES, MULTIVITAMINS, POLIVITAMINS, AND CARDIOVASCULAR MEDICINES; DIETETIC SUGAR ADAPTED FOR MEDICAL USE; DIETETIC FOODS ADAPTED FOR MEDICAL PURPOSES; BABY FOODS, MEDICINAL HERBS, HERBAL TEAS ADAPTED FOR MEDICAL PURPOSES; MEDICINES FOR DENTAL PURPOSES, NAMELY, ANTI-CAVITY DENTAL COATING PREPARATIONS CONTAINING FLUORIDE, HYGIENIC PRODUCTS FOR MEDICAL PURPOSES, NAMELY, SANITARY PADS, WADDINGS FOR MEDICAL PURPOSES, PLASTERS FOR MEDICAL PURPOSES, DRESSINGS FOR MEDICAL PURPOSES, NAMELY, MEDICAL DRESSINGS; PREPARATIONS FOR DESTROYING NOXIOUS PLANTS, NAMELY, WEED KILLERS FOR AGRICULTURAL USE; PREPARATIONS FOR DESTROYING NOXIOUS ANIMALS, NAMELY, RAT POISON AND ANIMAL REPELLANTS, FUNGICIDES, DEODORANTS OTHER THAN FOR PERSONAL USE, NAMELY, AIR DEODORANTS; DISINFECTANTS FOR HYGIENE PURPOSES, ANTISEPTICS, DETERGENTS FOR MEDICAL PURPOSES, NAMELY, CHEMICAL PREPARATIONS FOR SANITARY PURPOSES (U.S. CLS. 6, 18, 44, 46, 51 AND 52).

CLASS 10—MEDICAL APPARATUS

FOR SURGICAL, MEDICAL, DENTAL AND VETERINARY APPARATUS AND INSTRUMENTS, NAMELY, SURGICAL INSTRUMENTS AND APPARATUS; SURGICAL AND MEDICAL APPARATUS AND INSTRUMENTS FOR USE IN GENERAL SURGERY; DENTAL INSTRUMENTS, NAMELY, PICKS, BURRS, MIRRORS; SURGICAL APPARATUS AND INSTRUMENTS FOR DENTAL OR VETERINARY USE; ARTIFICIAL LIMBS, EYES AND TEETH AND ARM, FEET, HAND, LEG PROSTHESIS; ORTHOPEDIC ARTICLES, NAMELY, ORTHOPEDIC BRACES, ORTHOPEDIC FOOTWEAR, ORTHOPEDIC JOINT IMPLANTS, ORTHOPEDIC SUPPORT BANDAGES; SUTURE MATERIALS; ADULT SEXUAL AIDS, NAMELY, VIBRATORS AND MASSAGERS; FEEDING BOTTLES, BABY BOTTLES, TEETHERS FOR BABIES (U.S. CLS. 26, 39 AND 44).

CLASS 35—ADVERTISING AND BUSINESS

FOR ADVERTISING AND MARKETING SERVICES; PUBLIC RELATIONS; AND ORGANIZATION OF EXHIBITIONS AND TRADE FAIR FOR BUSINESS AND PROMOTION PURPOSES, OFFICE ADMINISTRATION SERVICES, BUSINESS MANAGEMENT AND ADMINISTRATION, CONSULTANCY FOR BUSINESS MANAGEMENT AND ADMINISTRATION IN THE FIELD OF ACCOUNTANCY SERVICES, IMPORT EXPORT AGENCY SERVICES (U.S. CLS. 100, 101 AND 102).

CLASS 36—INSURANCE AND FINANCIAL

FOR INSURANCE BROKERAGE, INSURANCE CONSULTANCY, INSURANCE SERVICES, NAMELY, UNDERWRITING LIFE, HEALTH, ACCIDENT, AND FIRE INSURANCE, INSURANCE AGENCIES IN THE FIELD OF HOME, ACCIDENT, AND LIFE; FINANCIAL AND MONETARY SERVICES, NAMELY, FINANCIAL ANALYSIS AND CONSULTATION, FINANCIAL EXCHANGE, FINANCIAL GUARANTEE AND SURETY, FINANCIAL AFFAIRS AND MONETARY AFFAIRS, NAMELY, FINANCIAL INFORMATION, MANAGEMENT AND ANALYSIS SERVICES; REAL ESTATE BROKERAGE, CUSTOMS BROKERAGE (U.S. CLS. 100, 101 AND 102).

CLASS 39—TRANSPORTATION AND STORAGE

FOR TRANSPORT BY FERRY, BOAT, RAIL, AND AIR; RENTAL OF TRANSPORTATION VIA LAND, AIR, AND SEA, NAMELY, CAR RENTAL, BOAT RENTAL, AIRPLANE RENTAL, AND TRANSPORTATION RESERVATION SERVICES, ARRANGING OF TOURS; COURIER SERVICES; CAR PARKING AND GARAGE RENTAL SERVICES; BOAT SHELTERING SERVICES; TRANSPORT BY PIPELINE; ELECTRICITY DISTRIBUTION SERVICES; WATER SUPPLY SERVICES; VEHICLE AND GOOD RESCUE SERVICES; WAREHOUSING SERVICES, NAMELY, STORAGE, PACKING, AND CRATING OF MERCHANDISE OF OTHERS; TRANSPORT OF GARBAGE AND WASTE, NAMELY, GARBAGE AND WASTE COLLECTION AND HAZARDOUS WASTE TRANSPORTATION SERVICES (U.S. CLS. 100 AND 105).

CLASS 44—MEDICAL, BEAUTY AND AGRICULTURAL SERVICES

FOR MEDICAL SERVICES; HYGIENIC AND BEAUTY CARE FOR HUMAN BEINGS; VETERINARY SERVICES (U.S. CLS. 100 AND 101).

ADA HAN, EXAMINING ATTORNEY

SN 79-102,779. GRUNDFOS HOLDING A/S, DENMARK, FILED 6-17-2011.

ZERO PLANT

THE MARK CONSISTS OF STANDARD CHARACTERS WITHOUT CLAIM TO ANY PARTICULAR FONT, STYLE, SIZE, OR COLOR.

PRIORITY DATE OF 3-1-2011 IS CLAIMED.

OWNER OF INTERNATIONAL REGISTRATION 1091336 DATED 6-17-2011, EXPIRES 6-17-2021.

NO CLAIM IS MADE TO THE EXCLUSIVE RIGHT TO USE "PLANT", APART FROM THE MARK AS SHOWN.

CLASS 7—MACHINERY

FOR WATER PUMPS FOR WATER FILTERING UNITS; PUMPS FOR MACHINES; SEWAGE PUMPS; WATER AERATION SYSTEMS COMPRISING WATER PUMPS AND AIR COMPRESSORS (U.S. CLS. 13, 19, 21, 23, 31, 34 AND 35).

CLASS 11—ENVIRONMENTAL CONTROL APPARATUS

FOR WATER PURIFICATION INSTALLATIONS; WASTE WATER PURIFICATION APPARATUS, INSTALLATIONS AND TANKS; WATER PURIFICATION, SEDIMENTATION AND FILTRATION APPARATUS FOR CLARIFICATION, THICKENING AND FILTRATION OF WATER, WASTE WATER AND INDUSTRIAL WATER (U.S. CLS. 13, 21, 23, 31 AND 34).

CLASS 37—CONSTRUCTION AND REPAIR

FOR CONSULTING SERVICES IN THE FIELD OF PHYSICAL MAINTENANCE OF SEWAGE AND POLLUTED WATER INSTALLATIONS INCORPORATING PUMPS, MIXERS AND FLOWMAKERS; CONSULTING SERVICES IN THE CHOICE OF WATER PUMPS FOR CONSTRUCTING, MAINTAINING, AND REPAIRING SEWAGE AND WATER FILTRATION PLANTS (U.S. CLS. 100, 103 AND 106).

MICHAEL WIENER, EXAMINING ATTORNEY

CLASS 14—JEWELRY

FOR PRECIOUS METALS AND THEIR ALLOYS AND GOODS IN PRECIOUS METALS OR COATED THEREWITH NOT INCLUDED IN OTHER CLASSES, NAMELY, NOVELTY ITEMS, NAMELY, RUBBER OR SILICON WRISTBANDS IN THE NATURE OF A BRACELET, DECORATIVE CHAINS OF PRECIOUS METALS FOR TROUSERS, JEANS, SWEATERS, SKIRTS AND SHIRTS, KEY FOBS OF PRECIOUS METAL, PURSES AND WALLETS MADE OF PRECIOUS METALS; JEWELRY, PRECIOUS STONES; HOROLOGICAL AND CHRONOMETRIC INSTRUMENTS AND PARTS THEREOF; ACCESSORIES FOR ALL THE AFORESAID GOODS INCLUDED IN THIS CLASS, NAMELY, WATCH BANDS AND STRAPS; JEWELRY FOR ATTACHMENT TO CLOTHING; JEWELRY, NAMELY, CHAINS, BRACELETS, WRISTBANDS, AND EARRINGS; JEWELRY, NAMELY, BODY JEWELRY, BRACELETS, BROACHES, BRONZE JEWELRY, BROOCHES, CAMEOS, CHARMS, CHARMS FOR COLLAR JEWELRY AND BRACELET, HAIR JEWELRY IN THE NATURE OF JEWELRY FOR USE IN THE HAIR, IMITATION JEWELRY, JEWELRY AND WATCHES, JEWELRY CASES, KEY CHAINS AS JEWELRY, LAPEL PINS, AND RINGS (U.S. CLS. 2, 27, 28 AND 50).

SN 79-102,789, TALLY WEIJL HOLDING AG, SWITZERLAND, FILED 8-2-2011.

TALLY WEIJL

THE MARK CONSISTS OF STANDARD CHARACTERS WITHOUT CLAIM TO ANY PARTICULAR FONT, STYLE, SIZE, OR COLOR.

PRIORITY DATE OF 2-25-2011 IS CLAIMED.

OWNER OF INTERNATIONAL REGISTRATION 1091373 DATED 8-2-2011, EXPIRES 8-2-2021.

OWNER OF U.S. REG. NOS. 3,756,128, 3,856,809 AND OTHERS.

THE NAME(S) AND/OR SIGNATURE(S) SHOWN IN THE MARK IDENTIFIES "RAVITAL ELFASSI-WEIJL", WHOSE CONSENT(S) TO REGISTER IS MADE OF RECORD.

CLASS 3—COSMETICS AND CLEANING PREPARATIONS

FOR SOAPS; PERFUMERY, ESSENTIAL OILS, HAIR LOTIONS; DENTIFRICES; CREAMS, LOTIONS, EXFOLIATION PRODUCTS, NAMELY, HAIR CREAMS, SKIN CREAMS, COLD CREAMS, CLEANSING CREAMS, BODY CREAMS, SHAVING CREAMS, BABY LOTIONS, SKIN LOTIONS, BODY LOTIONS, EXFOLIANT CREAMS, EXFOLIANT LOTIONS; MAKE-UP, NAIL POLISH, SHAMPOOS, BATH AND SHOWER GELS, HAIR CARE PREPARATIONS; COSMETICS; COSMETICS, NAMELY, COSMETIC PREPARATIONS FOR EYE LASHES; COSMETIC PREPARATIONS FOR NAIL DRYING; COSMETICS AND MAKE-UP; EYEBROW COSMETICS (U.S. CLS. 1, 4, 6, 50, 51 AND 52).

CLASS 9—ELECTRICAL AND SCIENTIFIC APPARATUS

FOR COMPUTER EQUIPMENT, NAMELY, COMPUTER HARDWARE AND COMPUTER PERIPHERALS; COMPUTER SOFTWARE FOR FASHION DESIGN, NAMELY, THE CREATION AND DESIGN OF CLOTHING AND CLOTHING ENSEMBLES; SPECTACLES, SUNGLASSES; SPECTACLE CASES (U.S. CLS. 21, 23, 26, 36 AND 38).

CLASS 18—LEATHER GOODS

FOR LEATHER AND IMITATION LEATHER AND GOODS MADE OF THESE MATERIALS AND NOT INCLUDED IN OTHER CLASSES, NAMELY LEATHER HANDBAGS, SEWING BAGS SOLD EMPTY, VANITY CASES SOLD EMPTY; ANIMAL SKINS; TRUNKS AND SUITCASES; UMBRELLAS, PARASOLS AND WALKING STICKS; SADDLERY; HANDBAGS, ALL-PURPOSE CARRYING, ATHLETIC, SPORTS AND DUFFLE BAGS, BEACH BAGS, CARRY-ON BAGS, TRAVELLING BAGS, PURSES, LEATHER KEY CASES, CHANGE PURSES AND WALLETS IN LEATHER AND IMITATION LEATHER (U.S. CLS. 1, 2, 3, 22 AND 41).

CLASS 25—CLOTHING

FOR CLOTHING, NAMELY, SHIRTS, T-SHIRTS, SWEATSHIRTS, TANK TOPS, SWEATERS, BLOUSES, JERSEYS, TURTLE-NECKS, CARDIGANS, SHORTS, SWEATPANTS, BLAZERS, PANTS, JEANS, SKIRTS, SUITS, VESTS, JACKETS, COATS, PARKAS, PONCHOS, SWIMWEAR, BIKINIS, SWIM TRUNKS, OVERCOATS, ROBES, UNDERWEAR, LINGERIE, STOCKINGS, PANTY HOSE, SCARVES, GLOVES, SOCKS, WRISTBANDS; FOOTWEAR; HEADGEAR, NAMELY, HATS, CAPS, SUN VISORS, BERETS, HOODS, TURBANS, TOP HATS; BELTS, BRACES (U.S. CLS. 22 AND 39).

CLASS 35—ADVERTISING AND BUSINESS

FOR ADVERTISING; BUSINESS MANAGEMENT; BUSINESS ADMINISTRATION AND MANAGEMENT; PROVIDING OFFICE FUNCTIONS; ADVERTISING TEXT PUBLICATION SERVICES, DISTRIBUTION OF ADVERTISING MATERIAL, RADIO AND TELEVISION ADVERTISING, FILM ADVERTISING, ON-LINE ADVERTISING ON A COMPUTER NETWORK; WINDOW DRESSING AND DISPLAY ARRANGEMENT SERVICES; BRINGING TOGETHER OF A VARIETY OF GOODS, EXCLUDING THE TRANSPORT THEREOF, FOR THIRD PARTIES, NOTABLY CLOTHING, FOOTWEAR, HEADGEAR, FASHION ACCESSORIES, AND FASHION ACCESSORIES IN THE NATURE OF COSMETICS, ENABLING CUSTOMERS TO CONVENIENTLY VIEW AND PURCHASE THOSE GOODS IN THE FIELD OF CLOTHING, FOOTWEAR, HEADGEAR, FASHION ACCESSORIES AND FASHION ACCESSORIES IN THE NATURE OF COSMETICS; MARKETING SERVICES, NAMELY, PROMOTING OR ADVERTISING THE GOODS AND SERVICES OF OTHERS; MARKET RESEARCH AND ANALYSIS; BUSINESS ORGANIZATION AND MANAGEMENT CONSULTANT; BUSINESS ORGANIZATION CONSULTANT; PROFESSIONAL CONSULTANT IN BUSINESS MANAGEMENT; FRANCHISE SERVICES, NAMELY, OFFERING BUSINESS MANAGEMENT ASSISTANCE IN THE ESTABLISHMENT AND OPERATION OF FASHION CLOTHING STORES, NAMELY, APPRAISAL SERVICES RELATING TO BUSINESS AND ORGANIZATION; COMMERCIAL ADMIN-

ISTRATION OF THE LICENSING OF GOODS AND SERVICES OF OTHERS; CORPORATE IMAGE CONSULTING SERVICES RELATING TO BUSINESS MANAGEMENT AND ADMINISTRATION IN CONNECTION WITH THE IMAGE OF FRANCHISE HOLDERS AND HOLDERS OF MARKET LICENSES, MANAGING COMPANIES THAT SELL FASHION CLOTHING AND COMPANIES IN THAT FIELD; MAIL ORDER CATALOG SERVICES FEATURING CLOTHING, FOOTWEAR, HEADGEAR, FASHION ACCESSORIES AND FASHION ACCESSORIES IN THE NATURE OF COSMETICS (U.S. CLS. 100, 101 AND 102).

CLASS 39—TRANSPORTATION AND STORAGE

FOR TRANSPORTATION AND DELIVERY SERVICES, NAMELY, SAME DAY SHIPMENT SERVICES; DELIVERY OF GOODS SOLD VIA CATALOGUE; PACKAGING AND STORAGE OF GOODS, NAMELY, CLOTHING, FOOTWEAR, HEADGEAR AND FASHION ACCESSORIES AND COSMETICS; ARRANGING OF TOURS (U.S. CLS. 100 AND 105).

ANNE E. GUSTASON, EXAMINING ATTORNEY

SN 79-102,816. ASTELLAS PHARMA INC., JAPAN, FILED 7-22-2011.

Leading Light for Life

OWNER OF INTERNATIONAL REGISTRATION 1091455 DATED 7-22-2011, EXPIRES 7-22-2021.
OWNER OF U.S. REG. NO. 3,251,934.

CLASS 5—PHARMACEUTICALS

FOR PHARMACEUTICAL PREPARATIONS FOR THE TREATMENT OF THE CENTRAL NERVOUS SYSTEM DISEASES, NAMELY, PSYCHIATRIC DISEASES, CENTRAL NERVOUS SYSTEM INFECTIONS, BRAIN DISEASES, CENTRAL NERVOUS SYSTEM MOVEMENT DISORDERS, OCULAR MOTILITY DISORDERS, SPINAL CORD DISEASES, CENTRAL NERVOUS SYSTEM NEUROPATHIC PAIN; PHARMACEUTICAL PREPARATIONS FOR THE TREATMENT OF THE PERIPHERAL NERVOUS SYSTEM DISEASES, NAMELY, POLY NEUROPATHY, FACIAL PARALYSIS, ENTRAPMENT NEUROPATHY, PERIPHERAL NERVOUS SYSTEM NEUROPATHIC PAIN; PHARMACEUTICAL PREPARATIONS FOR THE TREATMENT OF THE SENSORY ORGANS, NAMELY, HEARING LOSS, ACUTE PAIN; PHARMACEUTICAL PREPARATIONS FOR THE TREATMENT OF CARDIOVASCULAR DISEASES; PHARMACEUTICAL PREPARATIONS FOR THE TREATMENT OF THE RESPIRATORY SYSTEM; PHARMACEUTICAL PREPARATIONS FOR USE IN GASTROENTERITIS; PHARMACEUTICAL PREPARATIONS OF HORMONES FOR USE IN THE TREATMENT OF INFERTILITY; PHARMACEUTICAL PREPARATIONS FOR THE TREATMENT OF GENITOURINARY DISEASES, NAMELY, INFERTILITY, SEXUALLY TRANSMITTED DISEASES, INFLAMMATORY PELVIC DISEASES; PHARMACEUTICAL PREPARATIONS FOR THE TREATMENT OF UROLOGICAL DISEASES, NAMELY, BENIGN PROSTATIC HYPERPLASIA, OVER ACTIVE BLADDER; PHARMACEUTICAL PREPARATIONS FOR USE IN DERMATOLOGY, NAMELY, DERMATITIS, SKIN PIGMENTATION DISEASES, ACNE MEDICATION; PHARMACEUTICAL PREPARATIONS FOR THE TREATMENT OF HEMATOLOGICAL DISEASES, NAMELY ANEMIA; PHARMACEUTICAL PREPARATIONS FOR THE TREATMENT OF IMMUNOLOGICAL DISEASES, NAMELY, REJECTION IN TRANSPLANTATION, AUTOIMMUNE DISEASES, IMMUNOLOGIC DEFICIENCY SYNDROMES, ALLERGY MEDICATION; VITAMINS; PHARMACEUTICAL PREPARATIONS FOR THE TREATMENT OF METABOLIC DISORDERS; PHARMACEUTICAL PREPARATIONS FOR THE TREATMENT OF CANCER, NAMELY, TUMOR SUPPRESSING AGENTS; ANTIBIOTICS, ANTIFUNGALS, ANTI-VIRAL DRUGS; VACCINES FOR THE TREATMENT OF INFECTIOUS DISEASES; DIAGNOSTIC PRE-

PARATIONS FOR USE IN TESTING URINE, FECAL OCCULT BLOOD AND OTHER BLOOD DISEASES, NAMELY, ANEMIA, LEUKEMIA, HEMOPHILIA; PHARMACEUTICALS FOR HUMAN USE, NAMELY, ANTHELMINTICS; SANITARY PREPARATIONS, NAMELY, GERMICIDES (U.S. CLS. 6, 18, 44, 46, 51 AND 52).

CLASS 42—SCIENTIFIC AND COMPUTER SERVICES

FOR TESTING, INSPECTION OR RESEARCH OF PHARMACEUTICALS; PROVIDING MEDICAL RESEARCH INFORMATION IN THE FIELD OF PHARMACEUTICALS (U.S. CLS. 100 AND 101).

APRIL HESIK, EXAMINING ATTORNEY

SN 79-102,877. THYSSENKRUPP STEEL EUROPE AG, FED REP GERMANY, FILED 8-4-2011.

InCarbon

THE MARK CONSISTS OF STANDARD CHARACTERS WITHOUT CLAIM TO ANY PARTICULAR FONT, STYLE, SIZE, OR COLOR.

PRIORITY DATE OF 3-2-2011 IS CLAIMED.

OWNER OF INTERNATIONAL REGISTRATION 1091531 DATED 8-4-2011, EXPIRES 8-4-2021.

CLASS 6—METAL GOODS

FOR COMMON METALS AND THEIR ALLOYS; STEEL; STAINLESS STEELS AND OTHER RUST-PROOF, ACID-RESISTANT STEELS; SEMI-FINISHED GOODS MADE FROM THE AFORESAID METALS, ALLOYS AND STEEL, IN PARTICULAR STRUCTURAL ELEMENTS FOR MOTOR VEHICLES (U.S. CLS. 2, 12, 13, 14, 23, 25 AND 50).

CLASS 12—VEHICLES

FOR VEHICLES, APPARATUS FOR LOCOMOTION BY LAND, AIR OR WATER, NAMELY, LAND VEHICLES; PARTS OF VEHICLES AND APPARATUS FOR LOCOMOTION BY LAND, AIR OR WATER, NAMELY, EXTERNAL COMPONENT STRUCTURAL PARTS FOR THE BODIES OF LAND VEHICLES; VEHICLE BODIES OF METAL; DRIVING MOTORS FOR LAND VEHICLES; ELECTRIC DRIVES FOR LAND VEHICLES; PARTS FOR DRIVES FOR LAND VEHICLES, NAMELY, COMPONENT PARTS OF DRIVE SHAFTS FOR LAND VEHICLES (U.S. CLS. 19, 21, 23, 31, 35 AND 44).

CLASS 42—SCIENTIFIC AND COMPUTER SERVICES

FOR ENGINEERING SERVICES, IN PARTICULAR CONSTRUCTION DRAFTING AND ARCHITECTURAL CONSULTANCY; COMMUNICATION VIA FIBRE OPTIC NETWORKS; TECHNICAL PROJECT PLANNING IN THE FIELD OF VEHICLES (U.S. CLS. 100 AND 101).

KEVON CHISOLM, EXAMINING ATTORNEY

SN 79-102,907. SAINT-GOBAIN ADFORS, FRANCE, FILED 5-13-2011.

SN 79-102,989. NOVAK DOKOVIC, SERBIA, FILED 4-19-2011.

ADFORS 

PRIORITY DATE OF 12-13-2010 IS CLAIMED.
OWNER OF INTERNATIONAL REGISTRATION 1091621
DATED 5-13-2011, EXPIRES 5-13-2021.

CLASS 6—METAL GOODS

FOR METAL CONSTRUCTION MATERIALS, NAMELY, METAL WALL PANELS AND METAL CEILING PANELS AND METAL FASTENERS IN THE NATURE OF BOLTS, NAILS, RIVETS, SCREWS FOR CONSTRUCTION PURPOSES; METAL SIDINGS FOR INSULATING PANELS FOR CONSTRUCTION PURPOSES (U.S. CLS. 2, 12, 13, 14, 23, 25 AND 50).

CLASS 17—RUBBER GOODS

FOR FIBERGLASS INSULATION FOR BUILDINGS; FIBERGLASS YARN FOR INSULATION PURPOSES; FIBERGLASS FABRIC FOR INSULATION PURPOSES; INSULATION MATERIALS, NAMELY, GLASS WOOL PANELS REINFORCED WITH FIBERGLASS MATS FOR USE IN CONSTRUCTION; INSULATING PANELS COATED IN FIBERGLASS MATS; INSULATING MATERIALS COATED WITH FIBERGLASS SURFACING MATS FOR BUILDINGS (U.S. CLS. 1, 5, 12, 13, 35 AND 50).

CLASS 19—NON-METALLIC BUILDING MATERIALS

FOR NON-METAL CONSTRUCTION MATERIALS, NAMELY, GLASS IN THE FORM OF MATS FOR CONSTRUCTION AND ROOFING PURPOSES; CONSTRUCTION MATERIALS, NAMELY, NON-METAL PANELS, BOARDS AND ROLLS TREATED WITH FIRE-RESISTANT COATINGS FOR USE IN THE CONSTRUCTION OF WALLS, PARTITIONS, CEILINGS, FALSE CEILINGS, SUSPENDED CEILINGS, FLOORING, ROOFING, FALSE ROOFS, AND FACING; NON-METAL MODULAR FLOORING UNITS WITH WATERPROOF MEMBRANE FOR USE AS FLOOR UNDERLAYMENT (U.S. CLS. 1, 12, 33 AND 50).

CLASS 24—FABRICS

FOR FABRICS AND FIBERGLASS REINFORCEMENT FABRIC FOR USE IN REINFORCING PLASTIC, RUBBER, METALS, BITUMEN, PLASTER, PAPER AND TEXTILES; WALL HANGINGS AND WALL COVERINGS OF TEXTILE (U.S. CLS. 42 AND 50).

CLASS 27—FLOOR COVERINGS

FOR NON-TEXTILE WALL COVERINGS, WALL HANGINGS AND WALLPAPER, AND WALL COVERINGS OF PLASTIC MATERIALS (U.S. CLS. 19, 20, 37, 42 AND 50).

KAREN SEVERSON, EXAMINING ATTORNEY

PRIORITY DATE OF 12-23-2010 IS CLAIMED.
OWNER OF INTERNATIONAL REGISTRATION 1091864
DATED 4-19-2011, EXPIRES 4-19-2021.

THE NAME(S), PORTRAIT(S), AND/OR SIGNATURE(S) SHOWN IN THE MARK IDENTIFIES NOVAK DOKOVIC, WHOSE CONSENT(S) TO REGISTER IS MADE OF RECORD.

THE MARK CONSISTS OF THE TERM "NOVAK" APPEARING IN STYLIZED FONT WITH THE STYLIZED "O" IN NOVAK DEPICTING A TENNIS BALL.

CLASS 3—COSMETICS AND CLEANING PREPARATIONS

FOR PERFUMES, TOILET WATER; SHAVING LOTIONS AND CREAMS; PERSONAL CARE AND HYGIENE PRODUCTS, NAMELY, SOAPS, COSMETICS, SHAMPOOS AND LOTIONS FOR HAIR AND BODY CARE, PACKED INDIVIDUALLY OR IN PACKETS (U.S. CLS. 1, 4, 6, 50, 51 AND 52).

CLASS 16—PAPER GOODS AND PRINTED MATTER

FOR GOODS MADE OF PAPER AND CARDBOARD, NAMELY, CARDBOARD, CARDBOARD BOXES, PAPER, PACKAGING CONTAINERS OF PAPER; PRINTED MATTER, NAMELY, POSTERS, PHOTOGRAPHS, GIFT CARDS; BOOKS IN THE FIELD OF TENNIS; PHOTOGRAPHS; POSTERS; STATIONERY; PRINTED INSTRUCTIONAL AND TEACHING MATERIALS IN THE FIELD OF TENNIS; PLASTIC MATERIALS FOR PACKAGING, NAMELY, BAGS, BUBBLE PACKS; PRINTING ACCESSORIES, NAMELY, PAPER, TYPE, PRINTING CLICHES; PRINTING BLOCKS; ADDRESS, ADHESIVE, AND BAR CODE LABELS AND STICKERS FOR GOODS; PACKAGING, NAMELY, PAPER FOR WRAPPING GOODS; PRINTED USER MANUALS IN THE FIELD OF TENNIS; PRINTED CATALOGS IN THE FIELD OF TENNIS (U.S. CLS. 2, 5, 22, 23, 29, 37, 38 AND 50).

CLASS 18—LEATHER GOODS

FOR LEATHER AND IMITATION LEATHER; LEATHER AND IMITATION LEATHER GOODS, NAMELY, KEY CASES, SUITCASES, BAGS AND BACKPACKS, HIKING BAGS; UMBRELLAS, PARASOLS, PARTS AND ACCESSORIES FOR THE AFORESAID GOODS, NAMELY, FRAMES FOR UMBRELLAS AND PARASOLS (U.S. CLS. 1, 2, 3, 22 AND 41).

CLASS 25—CLOTHING

FOR CLOTHING, NAMELY, SHIRTS, SHORTS, PANTS, TOPS; FOOTWEAR; CAPS, HATS AND HEADWEAR; CLOTHING AND FOOTWEAR FOR SPORTS, NAMELY, SHIRTS, SHORTS, PANTS, TOPS AND FOOTWEAR; CLOTHING, FOOTWEAR AND HEADWEAR FOR ADVERTISING PURPOSES, NAMELY, SHIRTS, SHORTS, PANTS, TOPS, FOOTWEAR AND HEADWEAR; SPORTS COATS, MORNING COATS; SHORTS, TEE-SHIRTS, SWEATERS, VISORS; CLOTHING, FOOTWEAR, AND HEADWEAR ACCESSORIES, NAMELY, BELTS, AND SCARVES (U.S. CLS. 22 AND 39).

CLASS 28—TOYS AND SPORTING GOODS

FOR GAMES AND TOYS, NAMELY, CARD GAMES, PARLOR GAMES, ELECTRONIC ACTION TOYS, INFANT TOYS; GYMNAS TIC AND SPORTING ARTICLES NOT INCLUDED IN OTHER CLASSES, NAMELY, PERSONAL GYMNAS TIC EXERCISE MATS, TENNIS RACKETS, TENNIS BALLS; DECORATIONS FOR CHRISTMAS TREES EXCEPT ILLUMINATED DECORATIONS (U.S. CLS. 22, 23, 38 AND 50).

CLASS 30—STAPLE FOODS

FOR COFFEE, TEA, COCOA, SUGAR, RICE, TAPIOCA, SAGO, ARTIFICIAL COFFEE; FLOUR AND PREPARATIONS MADE FROM CEREALS, NAMELY, CEREAL BASED SNACK FOODS; BREAD, PASTRY AND CONFECTIONERY MADE OF SUGAR, EDIBLE ICES; HONEY, TREA CLE; YEAST, BAKING-POWDER; SALT, MUSTARD; VINEGAR, SAUCES; SPICES; ICE FOR REFRESHMENT (U.S. CL. 46).

CLASS 35—ADVERTISING AND BUSINESS

FOR ADVERTISING; BUSINESS MANAGEMENT; BUSINESS ADMINISTRATION; OFFICE FUNCTIONS; RETAIL, WHOLESALE, ONLINE RETAIL AND ONLINE WHOLESALE STORE SERVICES FEATURING GAMES, TOYS, CLOTHING, FOOD, LEATHER BAGS, COSMETICS, PRINTED MATERIALS (U.S. CLS. 100, 101 AND 102).

CLASS 41—EDUCATION AND ENTERTAINMENT

FOR TEACHING IN THE FIELD OF TENNIS; TRAINING IN THE FIELD OF TENNIS; ENTERTAINMENT, NAMELY, PERSONAL APPEARANCES BY A SPORTS CELEBRITY; ENTERTAINMENT IN THE NATURE OF TENNIS TOURNAMENTS (U.S. CLS. 100, 101 AND 107).

CLASS 43—HOTEL AND RESTAURANT SERVICES

FOR HOTEL AND RESTAURANT SERVICES, PROVIDING FOOD AND DRINK; TEMPORARY ACCOMMODATION, CAFÉ SERVICES, CATERING SERVICES, PROVISION OF BEVERAGES AND FOOD NEAR SPORTS FIELDS AND VENUES WHERE SPORTING AND CULTURAL EVENTS ARE TAKING PLACE (U.S. CLS. 100 AND 101).

ASMAT KHAN, EXAMINING ATTORNEY

SN 79-103,125. KARL STORZ GMBH & CO. KG, FED REP GERMANY, FILED 8-5-2011.



PRIORITY DATE OF 2-28-2011 IS CLAIMED.
OWNER OF INTERNATIONAL REGISTRATION 1092270 DATED 8-5-2011, EXPIRES 8-5-2021.
OWNER OF U.S. REG. NOS. 2,539,069, 3,388,360 AND OTHERS.

NO CLAIM IS MADE TO THE EXCLUSIVE RIGHT TO USE "PROFESSIONAL IMAGE ENHANCEMENT SYSTEM", APART FROM THE MARK AS SHOWN.

THE NAME(S), PORTRAIT(S), AND/OR SIGNATURE(S) SHOWN IN THE MARK DOES NOT IDENTIFY A PARTICULAR LIVING INDIVIDUAL.

CLASS 9—ELECTRICAL AND SCIENTIFIC APPARATUS

FOR PHOTOGRAPHY MATERIALS, NAMELY, EXPOSED PHOTOGRAPHIC FILM; OPTICAL, MEASURING, SIGNAL, CONTROL AND SCIENTIFIC INSTRUCTIONAL APPARATUS AND INSTRUMENTS IN THE NATURE OF NON-MEDICAL ENDOSCOPES AND CAMERAS; DEVICES FOR THE RECORDING, TRANSMISSION AND RENDITION OF DATA AND PICTURES; DATA PROCESSORS AND COMPUTERS, ALL EXCLUDING USE IN THE OPHTHALMIC FIELD (U.S. CLS. 21, 23, 26, 36 AND 38).

CLASS 10—MEDICAL APPARATUS

FOR SURGICAL, MEDICAL, AND VETERINARY INSTRUMENTS AND APPARATUS, NAMELY, SURGICAL AND MEDICAL APPARATUS AND INSTRUMENTS FOR USE IN GENERAL AND ENDOSCOPIC SURGERY, ALL EXCLUDING USE IN THE OPHTHALMIC FIELD (U.S. CLS. 26, 39 AND 44).

CLASS 16—PAPER GOODS AND PRINTED MATTER

FOR PRINTED MATERIALS, NAMELY, BOOKS, PAMPHLETS, AND INFORMATION SHEETS IN THE FIELD OF MEDICAL TECHNOLOGY; BOOKBINDING MATERIALS; USER AND INSTRUCTION MANUALS FOR MEDICAL TECHNOLOGY AND ENDOSCOPES; BROCHURES; CATALOGS, ALL EXCLUDING USE IN THE OPHTHALMIC FIELD (U.S. CLS. 2, 5, 22, 23, 29, 37, 38 AND 50).

JOHN DWYER, EXAMINING ATTORNEY

SN 79-103,156. "ASHFORD" FEINCHEMIKALIEN HANDELS GMBH, MÖNCHENGLADBACH, FED REP GERMANY, FILED 6-10-2011.

LEGEND TREASURE

THE MARK CONSISTS OF STANDARD CHARACTERS WITHOUT CLAIM TO ANY PARTICULAR FONT, STYLE, SIZE, OR COLOR.

OWNER OF INTERNATIONAL REGISTRATION 1092364 DATED 6-10-2011, EXPIRES 6-10-2021.

CLASS 29—MEATS AND PROCESSED FOODS

FOR MEAT; FISH, NOT LIVE; POULTRY, NOT LIVE; GAME, NOT LIVE; MEAT EXTRACTS; PRESERVED, DRIED AND COOKED FRUITS AND VEGETABLES; MEAT JELLIES; FISH JELLIES; FRUIT JELLIES; VEGETABLE JELLIES; SHELLFISH, NOT LIVE; JAMS; EGGS; MILK; MILK PRODUCTS, EXCLUDING ICE CREAM, ICED MILK AND FROZEN YOGURT; BUTTER, CHEESE, CREAM BEING A DAIRY PRODUCT; YOGHURT, POWDERED MILK; MILK BEVERAGES, MILK PREDOMINATING; DESSERTS FROM YOGHURT, CURD AND CREAM EXCLUDING ICE CREAM, ICED MILK AND FROZEN YOGURT; EDIBLE OILS; EDIBLE FATS, NAMELY, FATTY SUBSTANCES FOR THE MANUFACTURE OF EDIBLE FATS; MEAT, TINNED; FISH, TINNED; VEGETABLES, TINNED; FRUIT, TINNED; FRUIT PRESERVED IN ALCOHOL; FRUIT PULP; CHARCUTERIE (U.S. CL. 46).

CLASS 30—STAPLE FOODS

FOR COFFEE, TEA, COCOA, SUGAR, RICE, TAPIOCA, SAGO, ARTIFICIAL COFFEE; FLOUR AND PREPARATIONS MADE FROM CEREALS, NAMELY, BREAKFAST CEREALS, CEREAL-BASED SNACK FOOD; BREAD, PASTRY AND CONFECTIONERY, NAMELY, CONFECTIONERY MADE FROM CHOCOLATE, CONFECTIONERY MADE FROM SUGAR; ICES; HONEY, TREACLE; YEAST, BAKING-POWDER; SALT, MUSTARD; VINEGAR, SAUCES BEING CONDIMENT; SPICES; FLAVOURINGS, OTHER THAN ESSENTIAL OILS; SWEATMEATS BEING CANDY; HERBAL INFUSIONS, NOT MEDICINAL; MAYONNAISE; MUESLI; SUSHI; DRESSINGS FOR SALAD (U.S. CL. 46).

CLASS 31—NATURAL AGRICULTURAL PRODUCTS

FOR AGRICULTURAL, HORTICULTURAL AND FORESTRY PRODUCTS AND GRAINS NOT INCLUDED IN OTHER CLASSES, NAMELY, AGRICULTURAL GRAINS FOR PLANTING, AGRICULTURAL SEEDS, HERB SEEDS FOR PLANTING, SEEDS FOR HORTICULTURAL PURPOSES, VEGETABLE SEEDS FOR PLANTING, HORTICULTURAL BULBS, UNPROCESSED GRAIN; LIVE ANIMALS; FRESH FRUITS AND VEGETABLES; NATURAL PLANTS AND FLOWERS; FOODSTUFFS FOR ANIMALS; MALT FOR BREWING AND DISTILLING; PLANTS, DRIED FOR DECORATIONS; FRESH NUTS; LIFTER PEAT, NAMELY, PEAT MOSS; BERRIES BEING FRESH FRUITS; FLOWER BULBS; FISH, LIVE; HOPS; ANIMAL FORAGE, NAMELY, FOOD FOR ANIMALS; WREATHS OF NATURAL FLOWERS; NATURAL TURF; FODDER (U.S. CLS. 1 AND 46).

CLASS 32—LIGHT BEVERAGES

FOR BEERS; MINERAL AND AERATED WATERS AND OTHER NON-ALCOHOLIC DRINKS, NAMELY, NON-ALCOHOLIC APERITIFS, NON-ALCOHOLIC BEER, NON-ALCOHOLIC BEVERAGES, NAMELY, CARBONATED BEVERAGES, NON-ALCOHOLIC BEVERAGES CONTAINING FRUIT JUICES, NON-ALCOHOLIC BEVERAGES WITH TEA FLAVOUR, NON-ALCOHOLIC CIDER, NON-ALCOHOLIC COCKTAIL MIXES, NON-ALCOHOLIC COCKTAILS, NAMELY, MOCKTAILS, NON-ALCOHOLIC DRINKS, NAMELY, ENERGY SHOTS, NON-ALCOHOLIC FRUIT EXTRACTS USED IN THE PREPARATION OF BEVERAGES, NON-ALCOHOLIC FRUIT JUICE BEVERAGES, NON-ALCOHOLIC MALT BEVERAGE, NON-ALCOHOLIZED WINES, NON-CARBONATED, NON-ALCOHOLIC FROZEN FLAVORED BEVERAGES FRUIT DRINKS AND FRUIT JUICES; SYRUPS AND OTHER PREPARATIONS FOR MAKING BEVERAGES, NAMELY, NON-ALCOHOLIC FRUIT-FLAVORED BEVERAGES AND SOFT DRINKS; HOPS AND EXTRACTS OF FOR MAKING BEER (U.S. CLS. 45, 46 AND 48).

CLASS 33—WINES AND SPIRITS

FOR ALCOHOLIC BEVERAGES EXCEPT BEERS (U.S. CLS. 47 AND 49).

CLASS 43—HOTEL AND RESTAURANT SERVICES

FOR RESTAURANTS; FOOD AND DRINK CATERING; PLANNING OF PARTIES CATERING; RENTAL OF TEMPORARY ACCOMMODATION; RENTAL OF TRANSPORTABLE BUILDINGS; RENTAL OF MEETING ROOMS; RENTAL OF TENTS; CANTEEN SERVICES; SELF-SERVICE RESTAURANTS; TEMPORARY ACCOMMODATION RESERVATIONS; ACCOMMODATION BUREAUX, NAMELY, HOTEL SERVICES AND BOARDING HOUSES (U.S. CLS. 100 AND 101).

APRIL HESIK, EXAMINING ATTORNEY

SN 79-103,268. MUSIARA LIMITED, 00100 NAIROBI, KENYA, FILED 5-10-2011.

GOVERNORS' CAMP

THE MARK CONSISTS OF STANDARD CHARACTERS WITHOUT CLAIM TO ANY PARTICULAR FONT, STYLE, SIZE, OR COLOR.

OWNER OF INTERNATIONAL REGISTRATION 1092615 DATED 5-10-2011, EXPIRES 5-10-2021.

NO CLAIM IS MADE TO THE EXCLUSIVE RIGHT TO USE "CAMP", APART FROM THE MARK AS SHOWN.

CLASS 39—TRANSPORTATION AND STORAGE

FOR COORDINATING TRAVEL ARRANGEMENTS FOR INDIVIDUALS AND FOR GROUPS; TRAVEL AND TOUR RESERVATION SERVICE; ARRANGING TOURS AND PROVIDING TRAVEL INFORMATION ABOUT JOURNEYS, SAFARI AND TOURIST CAMPS, HOTELS AND LODGES (U.S. CLS. 100 AND 105).

CLASS 43—HOTEL AND RESTAURANT SERVICES

FOR MAKING RESERVATIONS AND BOOKINGS FOR OTHERS FOR ACCOMMODATIONS AND MEALS AT CAMPS, HOTELS AND LODGES IN TOURIST DESTINATIONS (U.S. CLS. 100 AND 101).

ESTHER BELENKER, EXAMINING ATTORNEY

SN 79-103,275. HAFENBAHN GMBH & CO. KG, 48431 RHEINE, FED REP GERMANY, FILED 8-1-2011.

VarioTwin

THE MARK CONSISTS OF STANDARD CHARACTERS WITHOUT CLAIM TO ANY PARTICULAR FONT, STYLE, SIZE, OR COLOR.

PRIORITY DATE OF 2-7-2011 IS CLAIMED.

OWNER OF INTERNATIONAL REGISTRATION 1092633 DATED 8-1-2011, EXPIRES 8-1-2021.

THE WORDING "VARIOTWIN" HAS NO MEANING IN A FOREIGN LANGUAGE.

CLASS 17—RUBBER GOODS

FOR PLASTICS IN EXTRUDED FORM FOR USE IN MANUFACTURE, NOT INCLUDED IN OTHER CLASSES; PLASTIC, SEMI-PROCESSED, IN THE FORM OF FILMS, PANELS OR RODS (U.S. CLS. 1, 5, 12, 13, 35 AND 50).

CLASS 19—NON-METALLIC BUILDING MATERIALS

FOR NON-METALLIC BUILDING MATERIALS, IN PARTICULAR PRESS FASTENERS, PRESS STUDS AND NON-METALLIC STRUCTURES FOR ERECTING SOLAR PANEL MOUNTS; NON-METALLIC BUILDING MATERIALS FOR SOLAR PANEL MOUNTS, NAMELY, PRESS FASTENERS, PRESS STUDS AND NON-METALLIC STRUCTURES FOR MOUNTING SOLAR PANEL MOUNTS; PLATES OF PLASTIC, IN PARTICULAR REINFORCEMENTS FOR ERECTING SOLAR PANEL MOUNTS (U.S. CLS. 1, 12, 33 AND 50).

CLASS 20—FURNITURE AND ARTICLES NOT OTHERWISE CLASSIFIED

FOR GOODS OF PLASTIC, NOT INCLUDED IN OTHER CLASSES, NAMELY, PLASTIC HOLDERS FOR SOLAR PANELS AND PLASTIC MOLDED SUPPORT FOR SETTING OUTDOORS OF SOLAR PANELS; FASTENING MATERIALS OF PLASTIC, IN PARTICULAR FOR SOLAR PANEL MOUNTS, NAMELY, BOLTS, NAILS, RIVETS, SCREWS, BRACES, MECHANICAL FASTENING ELEMENTS, BRADS, CLAMPS, NUTS, CRAMPS, HOOK AND LOOP FASTENERS; SOLAR PANEL MOUNTS OF PLASTIC (U.S. CLS. 2, 13, 22, 25, 32 AND 50).

JESSICA A. POWERS, EXAMINING ATTORNEY

SN 79-103,311. BAYERISCHE MOTOREN WERKE AKTIENGESELLSCHAFT, FED REP GERMANY, FILED 7-9-2011.

BMW Motorrad Premium Selection

THE MARK CONSISTS OF STANDARD CHARACTERS WITHOUT CLAIM TO ANY PARTICULAR FONT, STYLE, SIZE, OR COLOR.

PRIORITY DATE OF 3-10-2011 IS CLAIMED.

OWNER OF INTERNATIONAL REGISTRATION 1092725 DATED 7-9-2011, EXPIRES 7-9-2021.

OWNER OF U.S. REG. NOS. 3,226,368, 3,627,334 AND 3,722,615.

NO CLAIM IS MADE TO THE EXCLUSIVE RIGHT TO USE "MOTORRAD PREMIUM SELECTION", APART FROM THE MARK AS SHOWN.

THE ENGLISH TRANSLATION OF "MOTORRAD" IN THE MARK IS "MOTORCYCLE".

CLASS 12—VEHICLES

FOR MOTORCYCLES (U.S. CLS. 19, 21, 23, 31, 35 AND 44).

CLASS 36—INSURANCE AND FINANCIAL

FOR INSURANCE SERVICES, NAMELY, UNDERWRITING EXTENDED WARRANTY CONTRACTS IN THE FIELD OF MOTORCYCLES; FINANCING OF MOTORCYCLE PURCHASES (U.S. CLS. 100, 101 AND 102).

CLASS 37—CONSTRUCTION AND REPAIR

FOR MAINTENANCE, CLEANING AND REPAIR OF MOTORCYCLES (U.S. CLS. 100, 103 AND 106).

BRIAN CALLAGHAN, EXAMINING ATTORNEY

SN 79-103,347. PRAGA-EXPORT S.R.O., CZ-103 00 PRAHA 10 - BENICE, CZECH REPUBLIC, FILED 2-28-2011.



PRIORITY DATE OF 1-3-2011 IS CLAIMED.

OWNER OF INTERNATIONAL REGISTRATION 1092854 DATED 2-28-2011, EXPIRES 2-28-2021.

NO CLAIM IS MADE TO THE EXCLUSIVE RIGHT TO USE "PRAGA", APART FROM THE MARK AS SHOWN.

THE MARK CONSISTS OF A CROWN WITH THE WORDING "PRAGA" APPEARING ACROSS THE FRONT.

THE ENGLISH TRANSLATION OF "PRAGA" IN THE MARK IS "PRAGUE".

CLASS 12—VEHICLES

FOR CARS, TIRE CHAINS, LAND VEHICLE PARTS IN THE NATURE OF CAR BODIES; SUN SHIELDS FOR CARS, VEHICLE SAFETY SEAT BELTS, CHILD SAFETY SEATS FOR USE IN VEHICLES, MUDGUARDS, BRAKE LININGS FOR LAND VEHICLES; BRAKE BLOCKS FOR LAND VEHICLES; AUTOMOTIVE WINDSCREENS; AXLE BEARINGS FOR LAND VEHICLES; LAND VEHICLE PARTS, NAMELY, AXLES; BOATS; LAND VEHICLE PARTS IN THE NATURE OF DOORS FOR MEANS OF TRANSPORT; ELECTRIC-POWERED VEHICLES, NAMELY, CARS AND GO-KARTS; DRIVING MECHANISMS FOR LAND VEHICLES, NAMELY, ACTUATORS; DRIVING SHAFTS FOR LAND VEHICLES; TRANSMISSION SHAFTS FOR LAND VEHICLES; HYDRAULIC CIRCUITS FOR VEHICLES; GUARD HOODS, NAMELY, HOOD SHIELDS AS STRUCTURAL PARTS OF VEHICLES; HORNS FOR VEHICLES; CRANKCASES FOR LAND VEHICLE BEING OTHER THAN ENGINE BASES; WHEELS OF MEANS OF TRANSPORT BEING LAND VEHICLE AND GO KART PARTS; WHEEL HUB CAPS; STEERING WHEEL COVERS; BRAKE PLATES FOR VEHICLES; MOTORCYCLES; ENGINES FOR MOTORCYCLES; FUEL PUMPS FOR MOTORCYCLES; OIL PUMPS FOR MOTORCYCLES; ENGINES FOR LAND VEHICLES AND TRUCKS; BUMPERS FOR LAND VEHICLES; WINDOWS FOR LAND VEHICLES; HEAD RESTS FOR AUTOMOBILE SEATS; GEAR TEETH FOR LAND VEHICLES AND GO KARTS; TRANSMISSIONS AND GEARS OF LAND VEHICLES; SUSPENSION SPRINGS FOR MOTOR CARS; TIRES; VEHICLE CHASSIS; AIRBAGS FOR LAND VEHICLES AND GO KARTS; ALARM SECURITY DEVICES FOR VEHICLES; CLUTCHES AND TRANSMISSIONS FOR LAND VEHICLES; SPRINGS, NAMELY, SHOCK ABSORBERS FOR LAND VEHICLES; VEHICLE GEARBOXES; RIMS FOR WHEELS OF VEHICLES; SEATS FOR VEHICLES; WINDSCREEN WIPERS; PETROL TANK CAPS FOR AUTOMOBILES; CAR ENGINE COVERS, NAMELY, ENGINE BONNETS; MILITARY TRANSPORT VEHICLES; REAR VIEW MIRRORS; GO-KARTS; GO-KART ACCESSORIES AND SUBASSEMBLIES (U.S. CLS. 19, 21, 23, 31, 35 AND 44).

CLASS 25—CLOTHING

FOR OVERALLS, SHOES, GLOVES, CAPS, TEXTILE HOODS, T-SHIRTS (U.S. CLS. 22 AND 39).

JANICE KIM, EXAMINING ATTORNEY

SN 79-103,402. ATLISSIAN PTY LTD (ACN 102 443 916), AUSTRALIA, FILED 8-16-2011.

BITBUCKET

THE MARK CONSISTS OF STANDARD CHARACTERS WITHOUT CLAIM TO ANY PARTICULAR FONT, STYLE, SIZE, OR COLOR.

PRIORITY DATE OF 5-31-2011 IS CLAIMED.

OWNER OF INTERNATIONAL REGISTRATION 1092975 DATED 8-16-2011, EXPIRES 8-16-2021.

OWNER OF U.S. REG. NO. 3,208,354.

THE WORDING "BITBUCKET" HAS NO MEANING IN A FOREIGN LANGUAGE.

CLASS 9—ELECTRICAL AND SCIENTIFIC APPARATUS

FOR DOWNLOADABLE COMPUTER SOFTWARE FOR MANAGING BACKLOG, PLANNING SPRINTS AND TRACKING TEAMS IN THE FIELDS OF PROJECT MANAGEMENT AND DEVELOPMENT; COMPUTER SOFTWARE FOR MANAGING BACKLOG, PLANNING SPRINTS AND TRACKING TEAMS IN THE FIELDS OF PROJECT MANAGEMENT AND DEVELOPMENT RECORDED ON COMPUTER MEDIA; COMPUTER PROGRAMS AND RECORDED SOFTWARE FOR MANAGING BACKLOG, PLANNING SPRINTS AND TRACKING TEAMS IN THE FIELDS OF PROJECT MANAGEMENT AND DEVELOPMENT; DOWNLOADABLE ELECTRONIC PUBLICATIONS, NAMELY, NEWSLETTERS, BROCHURES, TECHNICAL DATA SHEETS, PAMPHLETS AND REPORTS IN THE FIELDS OF PROJECT MANAGEMENT AND DEVELOPMENT; ELECTRONIC PUBLICATIONS, NAMELY, NEWSLETTERS, BROCHURES, TECHNICAL DATA SHEETS, PAMPHLETS AND REPORTS IN THE FIELDS OF PROJECT MANAGEMENT AND DEVELOPMENT RECORDED ON COMPUTER MEDIA; DOWNLOADABLE ELECTRONIC NEWSLETTERS IN THE FIELDS OF PROJECT MANAGEMENT AND DEVELOPMENT; DOWNLOADABLE EDUCATIONAL SOFTWARE FEATURING INSTRUCTION IN PROJECT MANAGEMENT AND DEVELOPMENT (U.S. CLS. 21, 23, 26, 36 AND 38).

CLASS 38—COMMUNICATION

FOR PROVISION OF ACCESS TO COMPUTER DATABASES; PROVIDING AN ON-LINE COMPUTER DATABASE IN THE FIELD OF TELECOMMUNICATIONS (U.S. CLS. 100, 101 AND 104).

CLASS 42—SCIENTIFIC AND COMPUTER SERVICES

FOR COMPUTER SERVICES, NAMELY, HOSTING AND MAINTAINING AN ON-LINE WEB SITE TO ENABLE OTHERS TO MANAGE USER STORIES, REQUIREMENTS AND DEVELOPMENT TASKS; CONSULTING SERVICES IN THE FIELD OF DESIGN AND DEVELOPMENT OF COMPUTER SOFTWARE; SERVICES OF AN APPLICATION SERVICE PROVIDER, NAMELY, HOSTING COMPUTER SOFTWARE APPLICATIONS OF OTHERS; COMPUTER SOFTWARE DESIGN; INSTALLATION, MODIFICATION AND MAINTENANCE OF COMPUTER SOFTWARE; COMPUTER SYSTEM DESIGN AND ANALYSIS; DATA HOSTING SERVICES, NAMELY, APPLICATION SERVICE PROVIDER IN THE FIELD OF KNOWLEDGE MANAGEMENT TO HOST COMPUTER APPLICATION SOFTWARE FOR CREATING SEARCHABLE DATABASES OF INFORMATION AND DATA AND INTERACTIVE HOSTING SERVICES WHICH ALLOW THE USER TO PUBLISH AND SHARE THEIR OWN CONTENT AND IMAGES ONLINE; DATA CONVERSION OF COMPUTER PROGRAMS AND DATA, NOT PHYSICAL CONVERSION; CONSULTANCY SERVICES IN THE FIELD OF COMPUTERS AND SOFTWARE; PROVIDING INFORMATION AND CONSULTANCY SERVICES IN THE FIELDS OF DESIGN AND DEVELOPMENT OF COMPUTER SOFTWARE, COMPUTER SOFTWARE SYSTEM DESIGN AND ANALYSIS AND DATA HOSTING SERVICES, INCLUDING BY ELECTRONIC MEANS VIA A GLOBAL COMPUTER NETWORK (U.S. CLS. 100 AND 101).

LEIGH CAROLINE CASE, EXAMINING ATTORNEY

SN 79-103,463. PROMOTIE VOOR SPECIALE EVENEMENTEN-BELGIUM IN'T KORT P.S.E.-BELGIUM, NAAMLOZE VENNOOTSCHAP, BELGIUM, FILED 2-2-2011.

NIGHT OF THE PROMS

OWNER OF INTERNATIONAL REGISTRATION 0567017 DATED 2-1-1991, EXPIRES 2-1-2021.

CLASS 35—ADVERTISING AND BUSINESS

FOR ADVERTISING AND MARKETING; PROMOTIONAL SPONSORSHIP OF LIVE MUSIC EVENTS AND EVENTS BY PERFORMING ARTISTS (U.S. CLS. 100, 101 AND 102).

CLASS 41—EDUCATION AND ENTERTAINMENT

FOR ENTERTAINMENT SERVICES, NAMELY, ORGANIZING LIVE MUSICAL PERFORMANCES; PRODUCTION OF RADIO AND TELEVISION PROGRAMS; PRODUCTION OF MUSICAL VIDEOS AND MUSICAL SOUND RECORDINGS, AND RECORDING STUDIO SERVICES (U.S. CLS. 100, 101 AND 107).

CHRISIE B. KING, EXAMINING ATTORNEY

SN 79-103,535. KABUSHIKI KAISHA SEGA D/B/A SEGA CORPORATION, JAPAN, FILED 8-25-2011.



PRIORITY DATE OF 8-16-2011 IS CLAIMED. OWNER OF INTERNATIONAL REGISTRATION 1093213 DATED 8-25-2011, EXPIRES 8-25-2021.

THE MARK CONSISTS OF THE STYLIZED WORDING "RHYTHM THIEF" ABOVE THE WORDING "& THE EMPEROR'S TREASURE" APPEARING ON A STYLIZED BANNER TYPE CARRIER.

CLASS 9—ELECTRICAL AND SCIENTIFIC APPARATUS

FOR COMPUTER GAME PROGRAMS; VIDEO GAME SOFTWARE; VIDEO GAME PROGRAMS; VIDEO GAME DISCS AND CARTRIDGES; GAME PROGRAMS FOR ARCADE GAME MACHINES (U.S. CLS. 21, 23, 26, 36 AND 38).

CLASS 41—EDUCATION AND ENTERTAINMENT

FOR PROVIDING AMUSEMENT FACILITIES; PROVIDING AMUSEMENT ARCADE SERVICES; ENTERTAINMENT SERVICES, NAMELY, PROVIDING ON-LINE VIDEO AND COMPUTER GAMES OVER A GLOBAL COMPUTER NETWORK; PROVIDING INFORMATION ON ON-LINE VIDEO AND COMPUTER GAMES (U.S. CLS. 100, 101 AND 107).

ELI HELLMAN, EXAMINING ATTORNEY

SN 79-103,685. GATEWING NV, B-9000 GENT, BELGIUM, FILED 8-30-2011.

GATEWING

THE MARK CONSISTS OF STANDARD CHARACTERS WITHOUT CLAIM TO ANY PARTICULAR FONT, STYLE, SIZE, OR COLOR.

PRIORITY DATE OF 3-24-2011 IS CLAIMED. OWNER OF INTERNATIONAL REGISTRATION 1093625 DATED 8-30-2011, EXPIRES 8-30-2021.

CLASS 9—ELECTRICAL AND SCIENTIFIC APPARATUS

FOR SCIENTIFIC, NAUTICAL, SURVEYING, PHOTOGRAPHIC, CINEMATOGRAPHIC, OPTICAL, WEIGHING, MEASURING, SIGNALING, CHECKING, SUPERVISION, LIFE-SAVING AND TEACHING APPARATUS AND INSTRUMENTS, NAMELY, TERRAIN MAPPING SOFTWARE; APPARATUS FOR RECORDING, TRANSMISSION OR REPRODUCTION OF SOUND OR IMAGES; AUTOMATIC STEERING APPARATUS, NAMELY, HARDWARE AND SOFTWARE FOR AUTOMATED STEERING OF AIRCRAFT NOT BEING AIRCRAFT PARTS; CAMERAS; DATA PROCESSING EQUIPMENT AND COMPUTERS; SOFTWARE FOR PROGRAMMING, OPERATING AND MONITORING LAND SURVEYING AIRCRAFT, IMAGE ACQUISITION FROM LAND SURVEYING AIRCRAFT, OPERATING LAND SURVEYING COMPUTER HARDWARE, AND PROCESSING AND ANALYZING IMAGES AND DATA GENERATED BY LAND SURVEYING APPARATUS; COMPUTER HARDWARE FOR LAND SURVEYING APPARATUS (U.S. CLS. 21, 23, 26, 36 AND 38).

CLASS 12—VEHICLES

FOR VEHICLES, NAMELY, AIRCRAFT; REMOTE CONTROL AEROPLANES, OTHER THAN TOYS; AERONAUTICAL APPARATUS, MACHINES AND APPLIANCES, NAMELY, STRUCTURAL PARTS FOR AIRPLANES; LAUNCHES FOR AEROPLANES, OTHER THAN TOYS (U.S. CLS. 19, 21, 23, 31, 35 AND 44).
BRENDAN MCCAULEY, EXAMINING ATTORNEY

CLASS 9—ELECTRICAL AND SCIENTIFIC APPARATUS

FOR VIDEO GAME MACHINES FOR USE WITH TELEVISION AND WITH AN EXTERNAL DISPLAY SCREEN OR MONITOR; AMUSEMENT APPARATUS AND GAMES ADAPTED FOR USE WITH TELEVISION RECEIVERS AND WITH AN EXTERNAL DISPLAY SCREEN OR MONITOR; COMPUTER GAME EQUIPMENT IN THE NATURE OF STEERING WHEELS FOR PCS WITH DOUBLE GEAR-SHIFTING SYSTEMS; VIDEO GAMES FOR USE WITH AUTOMATIC OR TOKEN-OPERATED MACHINES; CONTROLLERS, JOYSTICKS, CONSOLES, MEMORY CARDS, VOLUME CONTROLLERS AND MICE FOR CONSUMER VIDEO GAME MACHINES ADAPTED FOR USE WITH TELEVISION RECEIVERS AND WITH AN EXTERNAL DISPLAY SCREEN OR MONITOR; MEDIA-RECORDED PROGRAMS FOR HAND-HELD ELECTRONIC GAMES; VIDEO GAME CASSETTES, CARTRIDGES AND DISCS; COMPUTER GAME EQUIPMENT CONTAINING MEMORY DISCS; COMPUTER GAME PROGRAMS; RECORDED PROGRAMS FOR ELECTRONIC GAMES; RECORDED COMPUTER SOFTWARE FOR VIDEO GAMES TO BE USED IN CONNECTION WITH AUTOMATIC AND COIN OPERATED MACHINES; EARPHONES FOR USE WITH FOR HAND-HELD GAMES WITH LIQUID CRYSTAL DISPLAYS; VIDEO GAME INTERACTIVE REMOTE CONTROL UNITS (U.S. CLS. 21, 23, 26, 36 AND 38).

CLASS 12—VEHICLES

FOR CARS; LAND VEHICLES AND STRUCTURAL PARTS THEREOF (U.S. CLS. 19, 21, 23, 31, 35 AND 44).

CLASS 28—TOYS AND SPORTING GOODS

FOR MODEL CARS, TOY MODEL CARS, RIDE-ON TOY CARS, SCALE MODEL RACING VEHICLES; RACING CAR MODEL SILHOUETTES; FULL-SIZE CAR REPLICAS FOR SPORTING EXHIBITIONS AND ENTERTAINMENT PURPOSES, BEING TOYS; HAND HELD VIDEO GAMES FEATURING CARS; POCKET OR HAND-HELD VIDEO GAMES; APPARATUS FOR GAMES OTHER THAN THOSE ADAPTED FOR USE WITH AN EXTERNAL DISPLAY SCREEN OR MONITOR; ELECTRONIC GAMES AND AMUSEMENT MACHINES OTHER THAN THOSE ADAPTED FOR USE WITH TELEVISION SETS AND WITH AN EXTERNAL DISPLAY SCREEN OR MONITOR; STAND-ALONE MACHINES FOR VIDEO GAMES; STAND-ALONE POCKET-SIZED ELECTRONIC GAMES; PORTABLE ELECTRONIC GAMES AND TOYS OTHER THAN THOSE ADAPTED FOR USE WITH AN EXTERNAL DISPLAY SCREEN OR MONITOR; HAND-HELD UNITS FOR PLAYING VIDEO GAMES OTHER THAN THOSE ADAPTED FOR USE WITH TELEVISION SETS AND WITH AN EXTERNAL DISPLAY SCREEN OR MONITOR; STAND ALONE VIDEO GAME MACHINES; ARCADE-TYPE ELECTRONIC VIDEO GAMES NOT FOR USE WITH TELEVISION RECEIVERS; COIN OR TOKEN-OPERATED VIDEO GAME MACHINES USED IN STORES AND NOT FOR USE WITH TELEVISION SETS AND WITH AN EXTERNAL DISPLAY SCREEN OR MONITOR; SLOT MACHINES (U.S. CLS. 22, 23, 38 AND 50).

DORITT L. CARROLL, EXAMINING ATTORNEY

SN 79-103,763. FERRARI S.P.A., ITALY, FILED 2-24-2011.



PRIORITY DATE OF 9-24-2010 IS CLAIMED.
OWNER OF INTERNATIONAL REGISTRATION 1093825 DATED 2-24-2011, EXPIRES 2-24-2021.

THE MARK CONSISTS OF A SIGN DEPICTING THE WORDING "SA APERTA" IN FANCY CHARACTERS DOUBLY PROFILED AND PLACED ON TWO LINES, THE LETTERS "S" AND "A" BEING OF A LARGER SIZE AND CONTAINING THEREIN THE CORRESPONDING LETTERS MARKED AGAIN, THE EXPRESSION "APERTA" BEING PLACED BELOW IN AN OFFSET POSITION TOWARDS THE RIGHT, WITH THE FIRST LETTER A POSITIONED UNDER THE OBLIQUE RIGHT-HAND STROKE OF THE LETTER "A" OF THE EXPRESSION "SA".

THE ENGLISH TRANSLATION OF THE FOREIGN WORD(S) IN THE MARK IS: "OPEN".

SN 79-103,859. THEATRE DES FOLIES BERGERE, FRANCE, FILED 9-15-2011.

FOLIES BERGERE

THE MARK CONSISTS OF STANDARD CHARACTERS WITHOUT CLAIM TO ANY PARTICULAR FONT, STYLE, SIZE, OR COLOR.

PRIORITY DATE OF 8-3-2011 IS CLAIMED.
OWNER OF INTERNATIONAL REGISTRATION 1094044 DATED 9-15-2011, EXPIRES 9-15-2021.

THE ENGLISH TRANSLATION OF THE WORDING "FOLIES" IS "FOLLIES." THE WORDING "BERGERE" HAS NO MEANING IN A FOREIGN LANGUAGE.

CLASS 3—COSMETICS AND CLEANING PREPARATIONS

FOR SOAPS FOR PERSONAL USE; PERFUMERY; ESSENTIAL OILS; COSMETICS; HAIR LOTIONS; DENTIFRICES; SUN BLOCK PREPARATIONS; COSMETIC PREPARATIONS FOR BATH AND SHOWER; COTTON STICKS FOR COSMETIC PURPOSES; BEAUTY MASKS; NON-MEDICATED MOUTH WASHES; SUNSCREEN PREPARATIONS; DEPILATORY WAX; EAU DE COLOGNE; COSMETIC KITS IN THE NATURE OF MAKE-UP KITS COMPRISED OF MASCARA, EYE LINER, EYE SHADOW, EYEBROW PENCIL, LIPSTICKS, NAIL POLISH, BLUSH, FOUNDATION CREAMS AND POWDER; COSMETIC CREAMS; MAKE-UP PREPARATIONS; MAKE-UP REMOVING PREPARATIONS; DEPILATORY PREPARATIONS; NAIL CARE PREPARATIONS; COSMETIC PREPARATIONS FOR SKIN CARE; LIPSTICKS; CAKES OF TOILET SOAP; NON-MEDICATED BATH SALTS; SHAMPOOS (U.S. CLS. 1, 4, 6, 50, 51 AND 52).

CLASS 25—CLOTHING

FOR CLOTHING, NAMELY, TEDDIES, SWEATERS, SHIRTS, CHEMISETTES, WAISTCOATS, SKIRTS, FROCKS, TROUSERS, PULLOVERS, TEE-SHIRTS, JACKETS, COATS, PARKAS, GABARDINES IN THE NATURE OF SUITS AND JACKETS, LEATHER JACKETS AND LEATHER PANTS, WATERPROOF CLOTHING IN THE NATURE OF WATERPROOF JACKETS AND PANTS, PAJAMAS, UNDERGARMENTS, UNDERWEAR, WOMEN'S UNDERGARMENTS, TIGHTS, STOCKINGS, GARTER BELTS, WAIST CINCHERS, CORSETS, BATHING SUITS AND TRUNKS, BATH ROBES, HEADBANDS, BELTS, BRACES, SCARVES, SASHES, COLLAR PROTECTORS, FUR STOLEES, GLOVES, SOCKS; BOOTS, HALF-BOOTS, SLIPPERS, FOOTWEAR EXCLUDING ORTHOPEDIC FOOTWEAR, BATH SANDALS AND SHOES; HATS, BERETS, CAPS, CAP PEAKS (U.S. CLS. 22 AND 39).

NAPOLEON SHARMA, EXAMINING ATTORNEY

CLASS 18—LEATHER GOODS

FOR LEATHER AND IMITATIONS OF LEATHER, AND GOODS MADE OF LEATHER AND IMITATIONS OF LEATHER, NAMELY, LUGGAGE, UMBRELLAS, SPORTS BAGS, DUFFEL BAGS, GARMENT BAGS, BACKPACKS, BRIEFCASES, FANNY PACKS, HANDBAGS, LUGGAGE TAGS, TOTE BAGS, PURSES, WALLETS, CREDIT CARD CASES, GYM BAGS, SCHOOL BAGS, MESSENGER BAGS AND TOILETRY BAGS SOLD EMPTY; ANIMAL SKINS, HIDES; TRUNKS AND TRAVELLING BAGS; UMBRELLAS, PARASOLS AND WALKING STICKS; WHIPS, HARNESS AND SADDLERY (U.S. CLS. 1, 2, 3, 22 AND 41).

CLASS 28—TOYS AND SPORTING GOODS

FOR GAMES AND PLAYTHINGS, NAMELY, PLUSH TOYS, BALLOONS, RIDE-ON TOYS, TOY VEHICLES, DOLLS, CARD GAMES, JIGSAWS, MANIPULATIVE PUZZLES, SWIMMING FLOATS FOR RECREATIONAL USE, BOARD GAMES, FLYING TOY DISCS, KITES, ROLLER SKATES, TOY SCOOTERS, SKATEBOARDS, TOY SPINNING TOPS, TOY MASKS AND TOY SNOW GLOBES; GYMNASTIC APPARATUS; SPORTING ARTICLES, NAMELY, BASEBALL BATS, BASEBALL GLOVES, BASEBALLS, BASKETBALLS, BOWLING BALLS, FOOTBALLS, GOLF BALLS, HANDBALLS, PLAYGROUND BALLS, BILLIARD BALLS, SOCCER BALLS, TENNIS BALLS, VOLLEY BALLS, BEACH BALLS, RACQUET BALLS, LACROSSE BALLS, PADDLE BALLS, RUBBER BALLS, CRICKET BATS, CRICKET BALLS, FIELD HOCKEY STICKS, FIELD HOCKEY BALLS, NET BALLS, RUGBY BALLS, SPORTS BALLS, SQUASH BALLS, TETHER BALLS, BOCCI BALLS, TABLE TENNIS BALLS, GOLF BALLS, GOLF CLUBS AND BOXING GLOVES; DECORATIONS FOR CHRISTMAS TREES (U.S. CLS. 22, 23, 38 AND 50).

AISHA CLARKE, EXAMINING ATTORNEY

SN 79-104,124. MAGMATIC LIMITED, UNITED KINGDOM, FILED 8-22-2011.



PRIORITY DATE OF 8-5-2011 IS CLAIMED. OWNER OF INTERNATIONAL REGISTRATION 1094706 DATED 8-22-2011, EXPIRES 8-22-2021. OWNER OF U.S. REG. NOS. 3,298,357, 3,910,404 AND 4,069,104. THE MARK CONSISTS OF THE STYLIZED WORD "TRUNKI" IN LOWERCASE LETTERS WITH A STYLIZED CIRCUMFLEX OVER THE LETTER "U".

SN 79-104,261. BRITZ INNOVATION PTY LTD, RICHLANDS QLD 4077, AUSTRALIA, FILED 9-29-2011.



PRIORITY DATE OF 3-29-2011 IS CLAIMED. OWNER OF INTERNATIONAL REGISTRATION 1095052 DATED 9-29-2011, EXPIRES 9-29-2021. THE MARK CONSISTS OF A STYLIZED HAND, PALM FACING WITH THE THUMB AND FIFTH FINGER EXTENDED.

CLASS 25—CLOTHING

FOR CLOTHING, NAMELY, SHIRTS, POLO SHIRTS, SWEAT SHIRTS, BLOUSES, TROUSERS, PANTS, GYM PANTS, SHORTS, DRESSES, JACKETS, VESTS, SWEATERS, JUMPERS, COATS, TRACK SUITS, SCARVES, SHAWLS, GLOVES, UNIFORMS, WIND RESISTANT JACKETS, WIND RESISTANT COATS, RAINCOATS, RAIN WEAR, SOCKS, HOSIERY; FOOTWEAR; HEADWEAR (U.S. CLS. 22 AND 39).

CLASS 28—TOYS AND SPORTING GOODS

FOR TOYS, GAMES, PLAYTHINGS, NAMELY, ACTION FIGURES, BOARD GAMES, DOLLS, PLUSH TOYS, WATER TOYS, TOY ROCKETS, WATER PISTOLS, KITES, PORTABLE WATER SLIDES, INFLATABLE FLOATATION DEVICES FOR RECREATIONAL USE; BALLS FOR SPORT; FOOTBALLS; BEACH BALLS; CRICKET SETS COMPRISED OF BALLS AND BATS; FLYING DISCS; BODY BOARDS; SWIMMING KICK BOARDS; SURF BOARDS; SURF SKIS; SKIM BOARDS; SURF MATS; GYMNASIAC AND SPORTING GOODS, NAMELY, VOLLEYBALL GAME PLAYING EQUIPMENT, BASKETBALL HOOPS, BASKETBALL NETS, SPORTS TRAINING DEVICES TO IMPROVE STRENGTH, TONING, CONDITIONING AND BALANCE (U.S. CLS. 22, 23, 38 AND 50).

DAVID TOOLEY, EXAMINING ATTORNEY

CLASS 25—CLOTHING

FOR CLOTHING, NAMELY, TROUSERS, JACKETS, OVERCOATS, COATS, SKIRTS, SUITS, JERSEYS, WAISTCOATS, SHIRTS, T-SHIRTS, SWEATSHIRTS, DRESSES, BERMUDA SHORTS, SHORTS, PAJAMAS, PULLOVERS, JEANS, TRACKSUITS, RAINWEAR, BEACHWEAR, BATHING SUITS, SWIMMING SUITS; CLOTHING FOR SPORTS FOR EXCLUSIVE USE FOR SPORTS, NAMELY, SPORTS OVER UNIFORMS, CLOTHING FOR BABIES, NAMELY, SHIRTS, PANTS, COATS, DRESSES; UNDERCLOTHING, NAMELY, BOXER SHORTS, BRASSIERES, BRIEFS, PANTS, SOCKS; FOOTWEAR, NAMELY, SHOES EXCLUDING ORTHOPEDIC SHOES, SANDALS, WATERPROOF BOOTS, WALKING BOOTS, BOOTEES, SPORTING SHOES, SLIPPERS; SHOE PARTS, NAMELY, HEELPIECES, INSOLES FOR FOOTWEAR, FOOTWEAR UPPERS; HEADGEAR, NAMELY, CAPS, SKULL CAPS, SPORTS CAPS, HATS, BERETS; GLOVES FOR CLOTHING, STOCKINGS, BELTS FOR CLOTHING, CAMISOLES, SARONGS, SCARVES, NECK SCARVES, SHAWLS, COLLARS, NECKTIES, TIES, SUSPENDER BELTS (U.S. CLS. 22 AND 39).

CLASS 35—ADVERTISING AND BUSINESS

FOR ADVERTISING AGENCIES SERVICES, MARKETING AND PUBLICITY BUREAUS SERVICES INCLUDING COMMERCIAL OR ADVERTISEMENT EXHIBITION AND TRADE FAIR ORGANIZATION SERVICES; PROVIDING OFFICE FUNCTIONS; BUSINESS MANAGEMENT; BUSINESS ADMINISTRATION; IMPORT AND EXPORT AGENCIES; BUSINESS INVESTIGATIONS, EVALUATIONS, EXPERT APPRAISALS, INFORMATION AND RESEARCH OF INDUSTRIAL AND COMMERCIAL GOODS; AUCTIONEERING; THE BRINGING TOGETHER, FOR THE BENEFIT OF OTHERS, OF WOVEN TEXTILE FABRICS FOR USE IN THE MANUFACTURE OF CLOTHING, NON-WOVEN TEXTILE FABRICS FOR USE IN THE MANUFACTURE OF CLOTHING, CLOTHING, FOOTWEAR, HEADGEAR, EXCLUDING THE TRANSPORT THEREOF, ENABLING CUSTOMERS TO CONVENIENTLY VIEW AND PURCHASE THOSE GOODS; RETAIL STORE SERVICES WHOLESALE STORE OUTLET SERVICES, MAIL ORDER CATALOGUE SERVICES, WEB SITES, NAMELY ON-LINE RETAIL STORE SERVICES OR TELEVISION SHOPPING PROGRAMMES, FEATURING WOVEN TEXTILE FABRICS, NON-WOVEN TEXTILE FABRICS (U.S. CLS. 100, 101 AND 102).

SN 79-104,411. SANKO TEKSTIL ISLETMELERI; SANAYI VE TICARET ANONIM SIRKETI, TURKEY, FILED 8-19-2011.

İSKO TURBOTECH

THE MARK CONSISTS OF STANDARD CHARACTERS WITHOUT CLAIM TO ANY PARTICULAR FONT, STYLE, SIZE, OR COLOR.

PRIORITY DATE OF 8-8-2011 IS CLAIMED.

OWNER OF INTERNATIONAL REGISTRATION 1095429 DATED 8-19-2011, EXPIRES 8-19-2021.

OWNER OF U.S. REG. NO. 3,885,599.

THE WORDING "İSKO" HAS NO MEANING IN A FOREIGN LANGUAGE.

CLASS 24—FABRICS

FOR WOVEN TEXTILE FABRICS FOR USE IN THE MANUFACTURE OF CLOTHING, TOWELS, TABLE LINEN, BED LINEN, HOUSEHOLD LINEN; NON-WOVEN TEXTILE FABRICS FOR USE IN THE MANUFACTURE OF CLOTHING, TOWELS, TABLE LINEN, BED LINEN, HOUSEHOLD LINEN; FIBERGLASS FABRICS FOR TEXTILE USE; FABRIC IMPERVIOUS TO GASES FOR AERONAUTICAL BALLOONS; WATERPROOF FABRICS, NAMELY, WATERPROOF FABRIC FOR MANUFACTURING CLOTHING, FURNITURE, LUGGAGE AND AUTOMOBILE UPHOLSTERY; GUMMED WATERPROOF CLOTH; FABRIC OF IMITATION ANIMAL SKINS; TEXTILE LININGS, NAMELY, LINEN LINING FABRIC FOR SHOES, UNFINISHED TEXTILE FOR THE MANUFACTURE OF LININGS FOR GARMENTS, TEXTILE USED AS LINING FOR CLOTHING; BUCKRAM; QUILTS OF TEXTILE, BLANKETS, NAMELY, BED BLANKETS; WASHING MITTS, BATH LINEN, HAND TOWELS, FACE TOWELS OF TEXTILE, BATHING TOWELS; TAPESTRIES OF TEXTILE, HANDKERCHIEFS OF TEXTILE, BANNERS OF TEXTILE, NAMELY, CLOTH BANNERS; FLAGS NOT OF PAPER, NAMELY, CLOTH FLAGS, FABRIC FLAGS; TRAVELING RUGS, NAMELY, LAP RUGS; CURTAINS OF TEXTILE, SHOWER CURTAINS OF TEXTILE, SHOWER CURTAINS OF PLASTICS; OILCLOTH FOR USE AS TABLE CLOTHS; BED COVERS, NAMELY, BED BLANKETS, BED SHEETS, BEDSPREADS, BED LINEN, DIAPERED LINEN, NAMELY, LINEN FABRIC, LINEN CLOTH, LINEN FOR HOUSEHOLD PURPOSES, TABLE AND BED LINEN, PILLOWCASES, QUILT COVERS; FURNITURE COVERINGS OF TEXTILE, NAMELY, UNFITTED FABRIC FURNITURE COVERS; UPHOLSTERY FABRICS; TABLE NAPKINS OF TEXTILE; BED COVERS OF PAPER (U.S. CLS. 42 AND 50).

CLASS 40—MATERIAL TREATMENT

FOR METAL TREATMENT SERVICES, NAMELY, GALVANIZING, METAL PLATING, METAL CASTING, BOILERMAKING, METAL TEMPERING, PROVIDING MATERIAL TREATMENT INFORMATION; METAL TREATMENT SERVICES, NAMELY, METAL PLATING, PROVIDING MATERIAL TREATMENT INFORMATION; PROCESSING OF CINEMATOGRAPHIC FILMS, PHOTOGRAPHIC PROCESSING, PHOTOGRAPHIC FILM DEVELOPING, PHOTOGRAPHIC PRINTING, PHOTOGRAVURE, PHOTOCOMPOSING SERVICES; PROCESSING OF RAW MATERIALS FOR USE IN THE MANUFACTURE OF FOOD, MILLWORKING, FLOUR MILLING, FOOD CANNING; SLAUGHTERING OF ANIMALS; FUR AND LEATHER TREATMENT, NAMELY, FUR DYEING, LEATHER STAINING, TANNING OF LEATHER, MOTHPROOFING, FUR CONDITIONING, LEATHER CONDITIONING, FUR GLOSSING, LEATHER GLOSSING; SADDLERY WORKING; TREATMENT OF FABRIC, NAMELY, YARN WARPING ON LOOMS, MOTHPROOFING OF FABRIC, EDGING OF FABRIC, CUTTING OF FABRIC, BLEACHING OF FABRIC, DYEING OF FABRIC, PERMANENT PRESS TREATMENT OF FABRIC, FIREPROOFING OF FABRIC, WATERPROOFING OF FABRIC, PRE-SHRINKING OF FABRIC, CREASE RESISTANT TREATMENT OF FABRIC, WOOL TREATMENT AND FINISHING; TAILORING OR DRESSMAKING, SEWING SERVICES, CUTTING OF CLOTH, CLOTHING ALTERATION, EMBROIDERY SERVICES; WOODWORKING, TIMBER FELLING AND PROCESSING, TIMBER LOGGING, SAWMILL PLANNING, ENGRAVING; FRAMING OF WORKS OF ART; ENVIRONMENTAL REMEDIATION SERVICES, NAMELY, WASTE AND WATER TREATMENT SERVICES, AIR DEODORIZING, RECYCLING OF WASTE MATERIALS, SORTING OF WASTE AND

RECYCLABLE MATERIAL, FUEL TREATMENT SERVICES, FUEL REFINING, WATER TREATMENT AND PURIFICATION; MATERIAL TREATMENT OF GLASS, OPTICAL GLASS GRINDING, GLASS BLOWING, GLASS TINTING, GLASS PLATING, GRINDING AND POLISHING GLASS FOR EYEGLASSES; CUSTOM ASSEMBLING OF PRODUCTS FOR OTHERS; DENTAL TECHNICIAN SERVICES; POTTERY FIRING; PRODUCTION OF ENERGY, RENTAL OF ELECTRIC POWER GENERATORS; PAPER TREATMENT, PAPER FINISHING; PRINTING OF BOOKS, OFFSET PRINTING, LITHOGRAPHIC PRINTING, SILK SCREEN PRINTING, PRINTING OF PATTERNS ON TEXTILES, BOOKBINDING; MATERIAL TREATMENT OF PLASTICS, NAMELY, LAMINATING OF PLASTIC SHEETS, MOULDING OF PLASTICS (U.S. CLS. 100, 103 AND 106).

CARYN GLASSER, EXAMINING ATTORNEY

SN 79-104,538. LOUIS VUITTON MALLETIER, PARIS, FRANCE, FILED 9-19-2011.



PRIORITY DATE OF 3-28-2011 IS CLAIMED.
OWNER OF INTERNATIONAL REGISTRATION 1095708 DATED 9-19-2011, EXPIRES 9-19-2021.
OWNER OF U.S. REG. NOS. 1,875,198, 2,361,695 AND OTHERS.
THE MARK CONSISTS OF FLOWER-LIKE DESIGNS SURROUNDING THE LETTERS "LV".

CLASS 3—COSMETICS AND CLEANING PREPARATIONS

FOR SOAPS FOR PERSONAL USE; PERFUMERY; ESSENTIAL OILS; COSMETICS; CREAMS FOR THE HAIR, FACE, AND BODY; LOTIONS FOR THE HAIR, FACE, AND BODY; SHOWER AND BATH GELS; SHOWER AND BATH PREPARATIONS; SHAMPOOS; MAKE-UP PREPARATIONS, NAMELY, FOUNDATIONS, LIPSTICKS, EYE SHADOWS, MASCARA, MAKE-UP POWDER, AND NAIL POLISH (U.S. CLS. 1, 4, 6, 50, 51 AND 52).

CLASS 9—ELECTRICAL AND SCIENTIFIC APPARATUS

FOR SUNGLASSES; SPECTACLES; OPTICAL LENSES; SPECTACLE CASES; TELEPHONES; MOBILE TELEPHONES; SMART PHONES; PC TABLETS; PERSONAL DIGITAL ASSISTANTS; MP3 PLAYERS; ACCESSORIES FOR TELEPHONES, MOBILE TELEPHONES, SMART PHONES, PC TABLETS, PERSONAL DIGITAL ASSISTANTS, AND MP3 PLAYERS, NAMELY, HANDS-FREE KITS FOR TELEPHONES, BATTERIES, COVERS, HOUSINGS, FAÇADES, CHARGERS, HAND STRAPS, AND NECK STRAPS (U.S. CLS. 21, 23, 26, 36 AND 38).

CLASS 14—JEWELRY

FOR JEWELRY; KEY RINGS OF PRECIOUS METAL; TIE PINS; MEDALLIONS; JEWELRY BOXES; WATCHES; WATCH BANDS; ALARM CLOCKS; CASES FOR TIMEPIECES (U.S. CLS. 2, 27, 28 AND 50).

CLASS 16—PAPER GOODS AND PRINTED MATTER

FOR PRINTED MATTER, NAMELY, PAMPHLETS, CATALOGS, AND BOOKS IN THE FIELD OF TRAVEL, LUGGAGE, LUXURY GOODS, FASHION, CLOTHING, SPORTS, THE ARTS; PUBLICATIONS, NAMELY, BROCHURES AND BOOKLETS IN THE FIELD OF TRAVEL, LUGGAGE, LUXURY GOODS, FASHION, CLOTHING, SPORTS, THE ART; STATIONERY; STATIONERY ARTICLES, NAMELY, NOTE PADS, WRITING BOOKS, DRAWING BOOKS, CALENDARS, AGENDAS, NOTEBOOKS, ENVELOPES, LETTER PAPER, AND INDEX CARDS; COVERS FOR DIARIES, INDEXES, AND PADS; OFFICE REQUISITES, NAMELY, LETTER TRAYS, PAPER CUTTERS, PENCILS, INKSTANDS, INKWELLS, PAPERWEIGHTS, PENCIL HOLDERS, PEN HOLDERS, WRITING PADS, PENS, BALLS, AND NIBS FOR PENS; POSTCARDS; PAPER LABELS; NEWSPAPERS; PRINTED DOCUMENTS, NAMELY, PRINTED CERTIFICATES (U.S. CLS. 2, 5, 22, 23, 29, 37, 38 AND 50).

CLASS 18—LEATHER GOODS

FOR BOXES OF LEATHER OR IMITATION LEATHER FOR PACKAGING AND CARRYING GOODS; TRAVELING BAGS; LEATHER TRAVELING SETS OF LUGGAGE; TRUNKS; SUITCASES; GARMENT BAGS FOR TRAVEL; VANITY CASES SOLD EMPTY; TOILETRY BAGS SOLD EMPTY; BACKPACKS; HANDBAGS; ATTACHÉ CASES; LEATHER DOCUMENT CASES; WALLETS; PURSES; LEATHER KEY CASES; UMBRELLAS (U.S. CLS. 1, 2, 3, 22 AND 41).

CLASS 24—FABRICS

FOR TEXTILES AND TEXTILE GOODS, NAMELY, BATH LINEN, BED LINEN, TABLE LINEN, TOWELS, BED COVERS, TEXTILE TABLE CLOTHS (U.S. CLS. 42 AND 50).

CLASS 25—CLOTHING

FOR CLOTHING, NAMELY, UNDERWEAR, SHIRTS, TEE-SHIRTS, PULLOVERS, SKIRTS, DRESSES, TROUSERS, COATS, JACKETS, BELTS FOR CLOTHING, SCARVES, SASHES FOR WEAR, GLOVES, NECKTIES, SOCKS, BATHING SUITS; FOOTWEAR; HEADWEAR (U.S. CLS. 22 AND 39).

CLASS 34—SMOKERS' ARTICLES

FOR CIGAR AND CIGARETTE CASES OF LEATHER AND IMITATION LEATHER (U.S. CLS. 2, 8, 9 AND 17).
HOWARD SMIGA, EXAMINING ATTORNEY

SN 79-104,556. IAME S.P.A., I-24040 ZINGONIA (BG), ITALY, FILED 9-6-2011.



OWNER OF INTERNATIONAL REGISTRATION 1095753 DATED 9-6-2011, EXPIRES 9-6-2021.
OWNER OF U.S. REG. NOS. 3,199,109 AND 3,551,513.

THE MARK CONSISTS OF THE STYLIZED WORDING "X30 BY IAME" WITH THE WORDS "IAME" IN A SHADED RECTANGLE.

CLASS 12—VEHICLES

FOR ENGINES FOR GO-KARTS; INTERNAL COMBUSTION PISTON ENGINES FOR GO-KARTS; INTERNAL COMBUSTION ENGINES FOR GO-KARTS (U.S. CLS. 19, 21, 23, 31, 35 AND 44).

CLASS 25—CLOTHING

FOR CLOTHING, NAMELY, SHIRTS, SHORTS, SWEATERS, JACKETS, JERSEYS, SKIRTS, BLOUSES, TIES; FOOTWEAR; HEADGEAR, NAMELY, CAPS AND HATS (U.S. CLS. 22 AND 39).

CLASS 41—EDUCATION AND ENTERTAINMENT

FOR EDUCATIONAL SERVICES, NAMELY, CONDUCTING CLASSES, SEMINARS OR WORKSHOPS IN THE FIELD OF ENGINEERING FOR LAND VEHICLES; TRAINING IN THE FIELD OF ENGINEERING FOR LAND VEHICLES; ORGANIZING COMMUNITY SPORTING AND CULTURAL EVENTS; ORGANIZATION OF SPORTING EVENTS IN THE FIELD OF GO-KART RACING (U.S. CLS. 100, 101 AND 107).

EVELYN BRADLEY, EXAMINING ATTORNEY

SN 79-104,568. WALTER RINGL, AUSTRIA, FILED 9-20-2011.



PRIORITY DATE OF 4-7-2011 IS CLAIMED.
OWNER OF INTERNATIONAL REGISTRATION 1095798 DATED 9-20-2011, EXPIRES 9-20-2021.

THE MARK CONSISTS OF THE STYLIZED LETTERS OR WITH THE R TRANSPOSED OVER THE TOP RIGHT PORTION OF THE LETTER O.

CLASS 14—JEWELRY

FOR BRACELETS; DIAMONDS; THREADS OF PRECIOUS METAL; ALLOYS OF PRECIOUS METAL; PRECIOUS METALS, UNWROUGHT OR SEMI-WROUGHT; PRECIOUS STONES; GOLD, UNWROUGHT OR BEATEN; GOLD THREAD JEWELRY; SEMI-PRECIOUS STONES; NECKLACES; JEWELLERY; JEWELRY CHAINS; WORKS OF ART OF PRECIOUS METAL; CUFF LINKS; MEDALLIONS; EARRINGS; PEARLS; PLATINUM; RINGS; KEY RINGS OF PRECIOUS METAL; ORNAMENTS OF PRECIOUS METAL IN THE NATURE OF JEWELRY; PERSONAL ORNAMENTS OF PRECIOUS METAL; SILVER, UNWROUGHT OR BEATEN; SILVER ORNAMENTS (U.S. CLS. 2, 27, 28 AND 50).

CLASS 20—FURNITURE AND ARTICLES NOT OTHERWISE CLASSIFIED

FOR FURNITURE; DECORATIVE MOBILES (U.S. CLS. 2, 13, 22, 25, 32 AND 50).

CLASS 21—HOUSEWARES AND GLASS

FOR VASES (U.S. CLS. 2, 13, 23, 29, 30, 33, 40 AND 50).

CLASS 28—TOYS AND SPORTING GOODS

FOR DIVOT REPAIR TOOLS (U.S. CLS. 22, 23, 38 AND 50).
KATHERINE CONNOLLY, EXAMINING ATTORNEY

SN 79-104,915. QUERCUS PUBLISHING PLC, LONDON WC1A 2NS, UNITED KINGDOM, FILED 9-21-2011.

QUERCUS

THE MARK CONSISTS OF STANDARD CHARACTERS WITHOUT CLAIM TO ANY PARTICULAR FONT, STYLE, SIZE, OR COLOR.

PRIORITY DATE OF 4-15-2011 IS CLAIMED.
OWNER OF INTERNATIONAL REGISTRATION 1096448 DATED 9-21-2011, EXPIRES 9-21-2021.
OWNER OF U.S. REG. NOS. 3,720,580, 3,738,601 AND OTHERS.

CLASS 9—ELECTRICAL AND SCIENTIFIC APPARATUS

FOR DOWNLOADABLE ELECTRONIC PUBLICATIONS AND ELECTRONIC PUBLICATIONS RECORDED ON COMPUTER MEDIA, IN THE NATURE OF GENERAL FEATURE MAGAZINES AND FICTION AND NON-FICTION BOOKS ON A VARIETY OF TOPICS; DOWNLOADABLE ELECTRONIC PUBLICATIONS AND ELECTRONIC PUBLICATIONS ON RECORDED COMPUTER MEDIA IN THE NATURE OF NEWSLETTERS, MANUALS, HANDBOOKS, PERIODICALS, JOURNALS, BOOKLETS AND PAMPHLETS IN THE FIELDS OF FICTION, HISTORY, HISTORICAL FIGURES, MILITARIA AND MILITARY HISTORY, BIOGRAPHY, MEDICINE, PALEONTOLOGY, ZOOLOGY, PHILOSOPHY, THE ARTS, THE HUMANITIES, POPULAR CULTURE, CRAFTS, RELIGION, SPORTS, MATH, COSMOLOGY, CARTOGRAPHY, ARCHITECTURE, INVENTIONS, MACHINES, TECHNOLOGY, AVIATION, TRANSPORT, TRAVEL AND PRACTICAL GUIDES AND HOW TO GUIDES; AUDIO BOOKS IN DVD AND CD AND CASSETTE AND WEB CAST AND POD CAST FORM FEATURING FICTION BOOKS AND NON-FICTION BOOKS IN THE FIELDS OF HISTORY, HISTORICAL FIGURES, MILITARIA AND MILITARY HISTORY, BIOGRAPHY, MEDICINE, PALEONTOLOGY, ZOOLOGY, PHILOSOPHY, THE ARTS, THE HUMANITIES, POPULAR CULTURE, CRAFTS, RELIGION, SPORTS, MATH, COSMOLOGY, CARTOGRAPHY, ARCHITECTURE, INVENTIONS, MACHINES, TECHNOLOGY, AVIATION, TRANSPORT, TRAVEL AND PRACTICAL GUIDES AND HOW TO GUIDES; AUDIO RECORDINGS AND ELECTRONIC BOOKS IN THE FIELDS OF FICTION, HISTORY, HISTORICAL FIGURES, MILITARIA AND MILITARY HISTORY, BIOGRAPHY, MEDICINE, PALEONTOLOGY, ZOOLOGY, PHILOSOPHY, THE ARTS, THE HUMANITIES, POPULAR CULTURE, CRAFTS, RELIGION, SPORTS, MATH, COSMOLOGY, CARTOGRAPHY, ARCHITECTURE, INVENTIONS, MACHINES, TECHNOLOGY, AVIATION, TRANSPORT, TRAVEL AND PRACTICAL GUIDES AND HOW TO GUIDES; DIGITAL BOOKS, DIGITAL PERIODICALS, E-BOOKS, ELECTRONIC CONTENT FOR USE WITH E-BOOK READERS IN THE FIELDS OF FICTION, HISTORY, HISTORICAL FIGURES, MILITARIA AND MILITARY HISTORY, BIOGRAPHY, MEDICINE, PALEONTOLOGY, ZOOLOGY,

PHILOSOPHY, THE ARTS, THE HUMANITIES, POPULAR CULTURE, CRAFTS, RELIGION, SPORTS, MATH, COSMOLOGY, CARTOGRAPHY, ARCHITECTURE, INVENTIONS, MACHINES, TECHNOLOGY, AVIATION, TRANSPORT, TRAVEL AND PRACTICAL GUIDES AND HOW TO GUIDES (U.S. CLS. 21, 23, 26, 36 AND 38).

CLASS 16—PAPER GOODS AND PRINTED MATTER

FOR PAPER, CARDBOARD AND GOODS MADE FROM THESE MATERIALS, NAMELY, PRINTED ADVERTISING BOARDS, ADVERTISING SIGNS, BOTTLE WRAPPERS, BOXES, CARDBOARD BACKING FOR BINDING BOOKS, CARDBOARD CARTONS, PAPER CONTAINERS, HANG TAGS, MAILING TUBES, CARDBOARD PACKAGING, PICTURE MOUNTS, PLACARDS AND TRADING CARD DISCS; PRINTED MATTER, NAMELY, BOOKS, MAGAZINES, NEWSLETTERS, MANUALS, HANDBOOKS, PERIODICALS, BOOKLETS, PAMPHLETS IN THE FIELDS OF FICTION, HISTORY, HISTORICAL FIGURES, MILITARIA AND MILITARY HISTORY, BIOGRAPHY, MEDICINE, PALEONTOLOGY, ZOOLOGY, PHILOSOPHY, THE ARTS, THE HUMANITIES, POPULAR CULTURE, CRAFTS, RELIGION, SPORTS, MATH, COSMOLOGY, CARTOGRAPHY, ARCHITECTURE, INVENTIONS, MACHINES, TECHNOLOGY, AVIATION, TRANSPORT, TRAVEL AND PRACTICAL GUIDES AND HOW TO GUIDES; PRINTED MATTER, NAMELY, PRINTED PAPER LABELS, PRINTED POSTCARDS, PRINTED FORMS, PRINTED ART REPRODUCTIONS, PRINTED CALENDARS, PRINTED AWARDS, PRINTED CERTIFICATES, PRINTED GRAPHS, PRINTED EMBLEMS, PRINTED GREETING CARDS, PRINTED HOLOGRAMS, PRINTED HOROSCOPES, PRINTED INVITATIONS, PRINTED LECTURES, PRINTED SEMINAR NOTES, PRINTED PAPER SIGNS, PRINTED PLANS, PRINTED TICKETS, PRINTED TIMETABLES; EDUCATIONAL PRINTED PUBLICATIONS, NAMELY, QUICK REFERENCE POCKET GUIDES, TRAINING MANUALS, EDUCATIONAL LEARNING CARDS, FLASH CARDS, ACTIVITY CARDS, WORKBOOKS, TEXTBOOKS, ACTIVITY BOOKS, STORY BOOKS, PUZZLE BOOKS, PRINTED PUZZLES, TEACHER GUIDES, POSTERS AND EDUCATIONAL BOOKLETS, ALL IN THE FIELDS OF CHILDHOOD DEVELOPMENT AND TRAINING METHODS FOR EARLY CHILDHOOD AND ADULT PROFESSIONAL EDUCATION; MAPS; PRINTED CHARTS; BOOK BINDING MATERIAL; PHOTOGRAPHS; STATIONERY; PRINTED INSTRUCTIONAL AND TEACHING MATERIALS IN THE FIELDS OF FICTION, HISTORY, HISTORICAL FIGURES, MILITARIA AND MILITARY HISTORY, BIOGRAPHY, MEDICINE, PALEONTOLOGY, ZOOLOGY, PHILOSOPHY, THE ARTS, THE HUMANITIES, POPULAR CULTURE, CRAFTS, RELIGION, SPORTS, MATH, COSMOLOGY, CARTOGRAPHY, ARCHITECTURE, INVENTIONS, MACHINES, TECHNOLOGY, AVIATION, TRANSPORT, TRAVEL AND PRACTICAL GUIDES AND HOW TO GUIDES; PRINTERS' TYPE; PRINTING BLOCKS (U.S. CLS. 2, 5, 22, 23, 29, 37, 38 AND 50).

CLASS 41—EDUCATION AND ENTERTAINMENT

FOR EDUCATION SERVICES, NAMELY, PROVIDING MENTORING, TUTORING, CLASSES, SEMINARS AND WORKSHOPS IN THE FIELDS OF READING, WRITING AND DISCUSSING FICTION, HISTORY, RESEARCHING REFERENCE MATERIALS, SPORTS, MUSIC, READING, WRITING AND DISCUSSING NON-FICTION, CURRENT AFFAIRS, ART, MEDICINE, LAW, FINANCE, EDUCATIONAL TRAINING AND TEACHING, MUSIC, FILM, VIDEO PRODUCTION, LITERARY CREATIVE WORKS, PHOTOGRAPHY, RADIO AND TELEVISION ENTERTAINMENT INSTRUCTION, TECHNOLOGY AND TRAVEL; ENTERTAINMENT, NAMELY, PROVIDING ONLINE REVIEWS OF FICTION AND NON-FICTION BOOKS AND MUSICAL AUDIO RECORDINGS, AND PROVIDING ENTERTAINMENT INFORMATION, COMMENTARY IN THE FIELDS OF ENTERTAINMENT AND ARTICLES ABOUT FICTION AND NON-FICTION BOOKS AND MUSICAL AUDIO RECORDINGS; EDUCATIONAL AND ENTERTAINMENT SERVICES, NAMELY, PROVIDING MOTIVATIONAL AND EDUCATIONAL SPEAKERS; EDUCATION AND ENTERTAINMENT IN

THE NATURE OF A CONTINUING PROGRAM ABOUT READING, WRITING AND DISCUSSING FICTION, HISTORY, RESEARCHING REFERENCE MATERIALS, SPORTS, MUSIC, READING, WRITING AND DISCUSSING NON-FICTION, FICTION, CURRENT AFFAIRS, ART, MEDICINE, LAW, FINANCE, EDUCATIONAL TRAINING AND TEACHING, MUSIC, FILM, VIDEO PRODUCTION, LITERARY CREATIVE WORKS, PHOTOGRAPHY, RADIO AND TELEVISION ENTERTAINMENT INSTRUCTION, TECHNOLOGY AND TRAVEL ACCESSIBLE BY RADIO, TELEVISION, SATELLITE, AUDIO, VIDEO AND COMPUTER NETWORKS; PROVIDING A WEBSITE FEATURING ONLINE NON-DOWNLOADABLE ELECTRONIC PUBLICATIONS IN THE NATURE OF FICTION AND NON-FICTION BOOKS, MAGAZINES, NEWSLETTERS, MANUALS, HANDBOOKS, PERIODICALS, JOURNALS, BOOKLETS, PUBLICATION OF BOOKS, REVIEWS AND MAGAZINES, PUBLICATION OF ELECTRONIC BOOKS AND JOURNALS ONLINE, PUBLICATION OF TEXT BOOKS; MULTIMEDIA PUBLISHING OF BOOKS AND MAGAZINES IN THE FIELDS OF FICTION, HISTORY, HISTORICAL FIGURES, MILITARIA AND MILITARY HISTORY, BIOGRAPHY, MEDICINE, PALEONTOLOGY, ZOOLOGY, PHILOSOPHY, THE ARTS, THE HUMANITIES, POPULAR CULTURE, CRAFTS, RELIGION, SPORTS, MATH, COSMOLOGY, CARTOGRAPHY, ARCHITECTURE, INVENTIONS, MACHINES, TECHNOLOGY, AVIATION, TRANSPORT, TRAVEL AND PRACTICAL GUIDES AND HOW TO GUIDES; DIGITAL VIDEO, AUDIO, AND MULTIMEDIA PUBLISHING; ELECTRONIC PUBLISHING SERVICES, NAMELY, PUBLICATION OF TEXT AND GRAPHIC WORKS OF OTHERS ON CD, DVD AND ONLINE FEATURING FICTION OR EDUCATIONAL INSTRUCTION FOR CHILDHOOD, EARLY CHILDHOOD AND ADULT PROFESSIONAL INSTRUCTION; MAGAZINE PUBLISHING; PROVIDING ONLINE NON-DOWNLOADABLE ELECTRONIC PUBLICATIONS IN THE NATURE OF MAGAZINES, NEWSLETTERS, MANUALS, HANDBOOKS, PERIODICALS, JOURNALS, BOOKLETS AND PAMPHLETS IN THE FIELDS OF LITERATURE; PUBLICATION OF BOOKS, PUBLICATION OF ELECTRONIC BOOKS AND JOURNALS ONLINE, PUBLICATION OF TEXT BOOKS; MULTIMEDIA PUBLISHING OF BOOKS AND MAGAZINES; PRODUCTION OF TELEVISION PROGRAMS (U.S. CLS. 100, 101 AND 107).

FRED CARL, EXAMINING ATTORNEY

SN 79-105,011. BRUEL S.P.A., I-36061 BASSANO DEL GRAPPA (VI), ITALY, FILED 8-23-2011.



PRIORITY DATE OF 6-28-2011 IS CLAIMED.
OWNER OF INTERNATIONAL REGISTRATION 1096720 DATED 8-23-2011, EXPIRES 8-23-2021.

NO CLAIM IS MADE TO THE EXCLUSIVE RIGHT TO USE ".COM", APART FROM THE MARK AS SHOWN.

THE WORDING "BRUNO PREMI" IN THE MARK IS A NAME WHICH IDENTIFIES A LIVING INDIVIDUAL WHOSE CONSENT IS OF RECORD.

THE MARK CONSISTS OF THE STYLIZED WORDING "BRUNO PREMI.COM" IN WHICH THE ".COM" IS ORIENTED VERTICALLY NEXT TO THE STACKED WORDING "BRUNO" AND "PREMI"; TO THE LEFT OF THE WORDING IS A STYLIZED DRAWING OF A FOUR-LEAVED CLOVER.

CLASS 14—JEWELRY

FOR PRECIOUS METALS AND THEIR ALLOYS AND GOODS IN PRECIOUS METALS OR COATED THEREWITH, NAMELY, WORKS OF ART; JEWELRY, PRECIOUS STONES; HOROLOGICAL AND CHRONOMETRIC INSTRUMENTS (U.S. CLS. 2, 27, 28 AND 50).

CLASS 18—LEATHER GOODS

FOR LEATHER AND IMITATIONS OF LEATHER, AND GOODS MADE OF THESE MATERIALS, NAMELY, BAGS, SUITCASES AND WALLETS; ANIMAL SKINS, HIDES; TRUNKS AND TRAVELING BAGS; UMBRELLAS, PARASOLS AND WALKING STICKS; WHIPS, HARNESS, AND SADDLERY (U.S. CLS. 1, 2, 3, 22 AND 41).

CLASS 25—CLOTHING

FOR CLOTHING ARTICLES FOR MEN, WOMEN AND CHILDREN, NAMELY, PANTS, SWEATSHIRTS, SWEATERS, T-SHIRTS, BLOUSES, SHIRTS, PULLOVERS, SKIRTS, TROUSERS, JACKETS, COATS AND OVERCOATS, GLOVES, SHAWLS, SOCKS, STOCKINGS, UNDERWEAR, BATHING COSTUMES, DRESSES AND SUITS; FOOTWEAR AND HEADGEAR, NAMELY, HATS, CAPS, BERETS, SCARVES AND SOCKS (U.S. CLS. 22 AND 39).

CLASS 35—ADVERTISING AND BUSINESS

FOR THE BRINGING TOGETHER, FOR THE BENEFIT OF OTHERS, OF A VARIETY OF GOODS EXCLUDING THE TRANSPORT THEREOF ENABLING CUSTOMERS TO CONVENIENTLY VIEW AND PURCHASE THOSE GOODS IN THE FIELD OF JEWELRY, BAGS, AND CLOTHING WITH SUCH SERVICES PROVIDED BY RETAIL STORES, WHOLESALE OUTLETS, THROUGH MAIL ORDER CATALOGUES OR BY MEANS OF ELECTRONIC MEDIA, FOR EXAMPLE, THROUGH WEB SITES OR TELEVISION SHOPPING PROGRAMS (U.S. CLS. 100, 101 AND 102).

TASNEEM HUSSAIN, EXAMINING ATTORNEY

SN 79-105,120. KOPPERT B.V., BE BERKEL EN RODENRIJS, NETHERLANDS, FILED 9-13-2011.

NATUPOL

THE MARK CONSISTS OF STANDARD CHARACTERS WITHOUT CLAIM TO ANY PARTICULAR FONT, STYLE, SIZE, OR COLOR.

PRIORITY DATE OF 4-5-2011 IS CLAIMED.

OWNER OF INTERNATIONAL REGISTRATION 1096932 DATED 9-13-2011, EXPIRES 9-13-2021.

CLASS 20—FURNITURE AND ARTICLES NOT OTHERWISE CLASSIFIED

FOR BEEHIVES, NEST BOXES FOR BUMBLEBEES (U.S. CLS. 2, 13, 22, 25, 32 AND 50).

CLASS 31—NATURAL AGRICULTURAL PRODUCTS

FOR LIVE ANIMALS, PARTICULARLY BUMBLEBEES (U.S. CLS. 1 AND 46).

SHAILA SETTLES, EXAMINING ATTORNEY

SN 79-105,450. ASLAN TICARET DAYANIKLI; TÜKETİM MALLARI; LIMITED SİRKETİ, TURKEY, FILED 7-19-2011.

W.BESTECKHAUS

SCHAFFER

OWNER OF INTERNATIONAL REGISTRATION 1067696 DATED 6-11-2010, EXPIRES 6-11-2020.

THE NAME(S), PORTRAIT(S), AND/OR SIGNATURE(S) SHOWN IN THE MARK DOES NOT IDENTIFY A PARTICULAR LIVING INDIVIDUAL.

THE MARK CONSISTS OF "W. BESTECKHAUS" STACKED ABOVE THE TERMS "SCHAFFER".

CLASS 8—HAND TOOLS

FOR GOODS, NAMELY, FORKS, SPOONS AND KNIVES; FORKS, SPOONS, AND KNIVES MADE OF PRECIOUS METALS; KNIVES, FORKS, SPOONS; NON-ELECTRIC CHEESE AND EGG SLICING TOOLS, NAMELY, NON-ELECTRIC CHEESE AND EGG SLICERS; PIZZA CUTTERS, PEELING TOOLS FOR VEGETABLES AND FRUITS, NAMELY, NON-ELECTRIC FRUIT AND VEGETABLE PEELERS; CUTTING WEAPONS AND SIDE ARMS, NOT INCLUDING FIREARMS, NAMELY, HUNTING KNIVES, SWORDS, SHORT SWORDS, DAGGERS, SHORT CURVED DAGGERS, HARPOONS FOR COMMERCIAL FISHING; SHAVING BLADES, RAZOR BLADES, RAZORS, ELECTRIC DEPI-LATORY APPLIANCES, SCISSORS, NAIL CLIPPERS (U.S. CLS. 23, 28 AND 44).

CLASS 11—ENVIRONMENTAL CONTROL APPARATUS

FOR LIGHTING APPARATUS, NAMELY, LIGHTING INSTALLATIONS; LAMPS, ELECTRIC BULBS, LAMP BULBS, LIGHT BULBS, FLASHLIGHTS, CHANDELIERS, LAMP GLASSES, LIGHTING AND SIGNALING LAMPS, AUTOMOTIVE HEADLAMPS, OUTDOOR PORTABLE LIGHTING PRODUCTS, NAMELY, HEAD LAMPS; STOPPING LAMPS FOR VEHICLES, APPARATUS FOR HEATING AND STEAM PRODUCTION INSTALLATIONS, NAMELY, STEAM HEATING APPARATUS, HEATING INSTALLATIONS AND APPARATUS FOR THE EXCHANGE OF SUBSTANCES AND HEAT FOR USE IN THE PRODUCTION OF STEAM, FOR USE IN COOKING AND FOR USE IN REFRIGERATION; BOILERS FOR STOVES, CENTRAL HEATING INSTALLATIONS AND NATURAL GAS INSTALLATIONS, NAMELY, GAS RANGERS, GAS BURNERS, GAS COOK-TOPS, AS PART OF HEATING INSTALLATIONS; STEAM BOILERS, HEAT EXCHANGERS, GAS BURNERS; APARTMENT HEATING APPARATUS, NAMELY, ELECTRIC SPACE HEATERS; WATER HEATERS USED ALSO AS APARTMENT HEATING INSTALLATIONS, WATER HEATERS, RADIATORS, HEAT PUMPS, ELECTRICAL WATER BOILERS, SUN ENERGY COLLECTORS AND DEVICES, NAMELY, SOLAR ENERGY RECEIVERS; GAS FUEL STOVES AND ELECTRIC STOVES, COOK STOVES, NAMELY, ELECTRIC STOVES, GAS STOVES, AND CERAMIC STOVES; CLIMATIZATION AND AIR-CONDITIONING DEVICES, NAMELY, AIR CONDITIONERS, ELECTRIC FANS AND HOT AIR BLOWERS, AIR CONDITIONERS AND AIR CONDITIONERS FOR VEHICLES; AIR DISINFECTING AND CLEANING INSTRUMENTS AND APPARATUS FOR PLACES AND PARTS AND ACCESSORIES THEREOF, NAMELY, DISINFECTING ULTRAVIOLET LAMPS HOUSED IN A CONTAINER OR COVER FOR DISINFECTING OBJECTS PLACED THEREIN; COOLING APPARATUS, NAMELY, REFRIGERATORS, DEEP-FREEZERS, ICE BOXES, ICE MACHINES AND APPARATUS; ELECTRIC AND GAS APPARATUS, MACHINES AND DEVICES USED FOR COOKING AND BOILING, NAMELY, GAS AND ELECTRIC BOILERS, GAS AND ELECTRIC BROILERS, GAS AND ELECTRIC ROAST-

ERS, GAS AND ELECTRIC BRAISING PANS; SANDWICH GRILLING MACHINES, NAMELY, ELECTRIC GRILLS AND GAS GRILLS; TOASTERS, DEEP FRYERS, BARBECUE GRILLS, COOKING OVENS, STOVES, NAMELY, GAS STOVES AND WOOD BURNING STOVES; POPCORN MACHINES, NAMELY, ELECTRIC POPCORN POPPERS; ELECTRIC AUTOCLAVES, ELECTRIC COFFEE MACHINE AND ELECTRIC TEA MACHINES, WATER BOILERS, NAMELY, ELECTRIC KETTLES; SHOWER TUBS, BIDETS, BATH TUBS, SHOWER CUBICLES, URINALS, TOILET SEATS, TOILET BOWLS, SINKS, TAPS FOR WATER AND GAS INSTALLATIONS, THERMOSTATIC VALVES AS PARTS OF HEATING INSTALLATION, COCKS FOR AUTOMATIC WATERING INSTALLATIONS, SHOWER HANDLES AND HOSES, FLEXIBLE PIPES AS PARTS OF SANITARY INSTALLATION; WATERING MACHINES FOR AGRICULTURAL PURPOSES; WATER SOFTENING APPARATUS, WATER PURIFYING APPARATUS, WATER PURIFYING INSTALLATIONS, SEWAGE PURIFYING INSTALLATIONS; HAND HELD ELECTRIC HAIR DRYERS, ELECTRIC HAND DRYING APPARATUS FOR WASHROOMS, TOUCHLESS HAND DRYING APPARATUS; ELECTRICAL COVERLETS AND ELECTRICAL QUILTS NOT FOR MEDICAL PURPOSES, HEATING PILLOWS, ELECTRICAL OR NON-ELECTRICAL FOOT HEATERS, HOT WATER BOTTLES; LIGHTERS USED IN KITCHEN, NAMELY, FOR LIGHTING FIREPLACES, GRILLS AND CANDLES; LIGHTERS AS PARTS OF HEATING AND COOKING APPARATUS; INDUSTRIAL COOKING OVENS; INDUSTRIAL DRYING APPARATUS FOR USE IN HEATING, VENTILATION SYSTEMS, AIR CONDITIONING SYSTEMS AND REFRIGERATION SYSTEMS; INDUSTRIAL TYPE COOLING INSTALLATIONS, NAMELY, AIR COOLING APPARATUS, AIR-CONDITIONING, AIR COOLING AND VENTILATION APPARATUS AND INSTRUMENTS AND WATER COOLING TOWERS; INCANDESCENT GAS BURNERS, ACETYLENE GAS BURNERS AND GENERATORS, NAMELY, ACETYLENE GENERATORS, FOG GENERATORS, HEAT GENERATORS AND STEAM GENERATORS; PASTEURISERS FOR THE FOOD, BEVERAGE AND PHARMACEUTICAL INDUSTRY AND STERILIZERS; LAUNDRY DRYERS; CUPOLA FURNACES; FILTERS FOR APPARATUS USED AT HOME, NAMELY, AIR FILTERS FOR DOMESTIC USE, WATER FILTERS AND AIR CONDITIONING FILTERS; FILTERS AS PARTS OF INDUSTRIAL EQUIPMENT, NAMELY, AIR FILTERS FOR INDUSTRIAL INSTALLATIONS; BARBECUE CHARCOAL GRILLS, BARBECUE GRILLS (U.S. CLS. 13, 21, 23, 31 AND 34).

CLASS 21—HOUSEWARES AND GLASS

FOR SMALL NON-ELECTRICAL HAND-OPERATED DEVICES FOR HOUSEHOLD AND KITCHEN USE, NAMELY, NON-ELECTRIC FOOD MIXERS, NON-ELECTRIC FOOD BLENDERS, HAND-OPERATED COFFEE AND SPICE MILLS, FRUIT AND VEGETABLE PRESSES, GRINDERS, NAMELY, NON-ELECTRIC COFFEE, MEAT AND FOOD GRINDERS; PLATES; CLEANING BRUSHES FOR HOUSEHOLD PURPOSES, POT CLEANING BRUSHES, MATERIALS USED FOR BRUSH MAKING, SPONGES FOR HOUSEHOLD PURPOSES, STEEL WOOL, CLEANING WOOL, NAMELY, METAL WOOL FOR CLEANING, CLEANING AND WIPING CLOTHS MADE OF TEXTILE, DISH-WASHING GLOVES; CARPET BEATERS AND CARPET SWEEPERS, CARPET BROOMS, MOPS; PADS FOR CLEANING PURPOSES; TOOTHBRUSHES, ELECTRICAL TOOTHBRUSHES, DENTAL FLOSS, SHAVING BRUSHES, HAIR BRUSHES, COMBS; TABLE PLATES MADE OF GLASS, PORCELAIN, CERAMIC, COMMON METALS, PLASTIC, SYNTHETIC SUBSTANCES AND OTHER MATERIALS; BUCKETS, GARBAGE BINS, POTS, PLATES, PAPER PLATES AND DRINKING GLASSES, SERVING TRAYS, TRAYS FOR DOMESTIC PURPOSES; COFFEE POTS, COLANDERS, SERVING LADLES, SPATULAS, WASH BOWLS, BOWLS, EGG CUPS, CAKE MOULDS, DECANTERS, FOOD STORING CONTAINERS, NAMELY, HOUSEHOLD CONTAINERS FOR FOOD, COASTERS NOT OF PAPER AND NOT BEING TABLE LINEN FOR GLASSES AND POTS; FLOWER POTS, SOAP DISHES, SOAP DISPENSERS, PAPER TOWEL DISPENSERS, TOILET PAPER HOLDERS, BABY BATHTUBS, ICE TRAYS AND ICE BUCKETS; HEAT INSULATED CONTAINERS FOR FOOD OR BEVERAGE FOR DOMESTIC USE, PLASTIC WATER BOTTLES SOLD EMPTY, READY PICNIC BAS-

KETS FILLED WITH PLATES, CUPS GIVEN DURING SPORTS COMPETITIONS, BREAD CONTAINERS, NAMELY, BREAD BOXES, BREAD BASKETS, BREAD-CUTTING BOARDS AND BREAD-CUTTING BOARDS MADE OF SYNTHETIC SUBSTANCES; NON-ELECTRIC COOKING AND HEATING MATERIALS, NAMELY, NON-ELECTRIC PRESSURE COOKERS, NON-ELECTRIC HEATERS FOR FEEDING BOTTLES, GRILLS, METAL COOKING SKEWERS; IRONING BOARDS, IRONING BOARD COVERS, CLOTHES DRYING RACKS, CAGES FOR PETS, FEED AND WATER TROUGHS, BIRD BATHS, RINGS FOR BIRDS, NAMELY, RINGS FOR IDENTIFYING BIRDS; DECORATIVE ARTICLES, NAMELY, STATUES, FIGURINES AND WORKS OF ART MADE OF GLASS, PORCELAIN, CERAMIC AND CLAY; JARS, NAMELY, GLASS JAR AND COOKIE JARS; DEMIJOHNS, NAMELY, BEVERAGeware; PORCELAIN DOOR STOPS AND PORCELAIN HANDLES; MOUSETRAPS, INSECT TRAPS, FLY CATCHERS, PERFUME BURNERS (BURNERS GIVING OFF SCENTS WHEN LIT), PERFUMING PANS, PERFUME SPRAYS AND PERFUME VAPORIZERS SOLD EMPTY; POWDER PUFFS, BOXES FOR TOILET ARTICLES, NAMELY, SOAP BOXES; HEADS FOR WATER SPRINKLERS, WATERING SPRINKLERS FOR LAWN, FLOWERS AND PLANTS, GARDEN WATERING SPRINKLERS, BOTTLE OPENERS, SHOE HORNS; TOOTHPICKS, PLANT AND ANIMAL RAISING AREAS USED IN THE HOUSEHOLD, NAMELY, TERRARIUMS FOR PLANT AND ANIMALS (U.S. CLS. 2, 13, 23, 29, 30, 33, 40 AND 50).

JANICE KIM, EXAMINING ATTORNEY

SN 79-105,576. GOTEK GORSCHLUETER GMBH, FED REP GERMANY, FILED 7-22-2011.

GOTEK

THE MARK CONSISTS OF STANDARD CHARACTERS WITHOUT CLAIM TO ANY PARTICULAR FONT, STYLE, SIZE, OR COLOR.

PRIORITY DATE OF 6-29-2011 IS CLAIMED.
OWNER OF INTERNATIONAL REGISTRATION 1097790 DATED 7-22-2011, EXPIRES 7-22-2021.

CLASS 1—CHEMICALS

FOR CHEMICAL PRODUCTS, NAMELY, ADHESIVE POWER ENHANCERS FOR INDUSTRIAL PURPOSES FOR THE CONNECTION BETWEEN RUBBER, METAL AND PLASTIC (U.S. CLS. 1, 5, 6, 10, 26 AND 46).

CLASS 6—METAL GOODS

FOR METAL GOODS FOR THE AUTOMOTIVE SUPPLY INDUSTRY NOT BEING MACHINE PARTS IN THE FORM OF SLEEVES, BUSHINGS, OUTER AND INNER SHELLS OF METAL, IN PARTICULAR FOR VIBRATION AND DAMPING BEARINGS (U.S. CLS. 2, 12, 13, 14, 23, 25 AND 50).

CLASS 40—MATERIAL TREATMENT

FOR MATERIAL TREATMENT, NAMELY, PREPARATION FOR THE APPLICATION OF ADHESIVE POWER ENHANCERS TO METAL PARTS, PLASTIC AND RUBBER; PHYSICAL TREATMENT OF METAL, NAMELY, DEGREASING, IRRADIATION AND COATING OF VULCANIZATION SUPPORTS; ZINC PLATING, NICKEL PLATING AND PHOSPHATING OF METAL PARTS (U.S. CLS. 100, 103 AND 106).

KRISTIN DAHLING, EXAMINING ATTORNEY

SN 79-105,593. MADD GEAR PTY LTD, AUSTRALIA, FILED 10-19-2011.



PRIORITY DATE OF 9-30-2011 IS CLAIMED.
OWNER OF INTERNATIONAL REGISTRATION 1097844 DATED 10-19-2011, EXPIRES 10-19-2021.
NO CLAIM IS MADE TO THE EXCLUSIVE RIGHT TO USE "TAPE", APART FROM THE MARK AS SHOWN.
THE MARK CONSISTS OF THE WORDING "SHOCK TAPE" IN A STYLIZED FONT MADE TO LOOK LIKE THE WORDS ARE WRITTEN IN ADHESIVE TAPE.

CLASS 12—VEHICLES

FOR NON-MOTORISED VEHICLES, NAMELY, BICYCLES, TRICYCLES, SCOOTERS, CARTS, TWO-WHEELED CYCLE WITH HANDBRAKES WHICH IS PUSHED NOT PEDALLED, SCOOTERS, AND STRUCTURAL PARTS AND ACCESSORIES THEREOF, NAMELY, WHEELS, TYRES, BRAKES, SCOOTER DECKS, HANDLEBARS, GRIPS, GRIP TAPE, PEDALS, SPOKES, RIMS, SEATS, FORKS, BARS, CLAMPS, BEARINGS, HEADSETS WHICH PROVIDE A ROTATABLE INTERFACE BETWEEN THE BICYCLE, TRICYCLE, CYCLE OR SCOOTER FORK AND THE BICYCLE, TRICYCLE, CYCLE OR SCOOTER FRAME, PEGS, PEDALS AND CRANKS ALL FOR BICYCLES AND SCOOTERS (U.S. CLS. 19, 21, 23, 31, 35 AND 44).

CLASS 28—TOYS AND SPORTING GOODS

FOR GAMES AND PLAYTHINGS, NAMELY, BALLS, TOY SCOOTERS, TOY BICYCLES OTHER THAN FOR TRANSPORT, TOY TRICYCLES OTHER THAN FOR TRANSPORT, TOY CARTS, AND STRUCTURAL PARTS AND ACCESSORIES THEREOF, NAMELY, WHEELS, TYRES, BRAKES, SCOOTER DECKS, HANDLEBARS, GRIPS, GRIP TAPE, PEDALS, SPOKES, RIMS, SEATS, FORKS, BARS, CLAMPS, BEARINGS, HEADSETS, PEGS, PEDALS AND CRANKS ALL FOR TOY BICYCLES AND TOY SCOOTERS; GYMNASTICS AND SPORTING ARTICLES, NAMELY, SKATEBOARDS, SNOWBOARDS, ICE SKATES, IN-LINE SKATES, ROLLER SKATES, AND STRUCTURAL PARTS AND ACCESSORIES THEREOF, NAMELY, WHEELS, BOARD WAX, BRAKES (U.S. CLS. 22, 23, 38 AND 50).

LINDA LAVACHE, EXAMINING ATTORNEY

SN 79-105,923. HOFFMEISTER LEUCHTEN GMBH, FED REP GERMANY, FILED 6-22-2011.

HOFFMEISTER

THE MARK CONSISTS OF STANDARD CHARACTERS WITHOUT CLAIM TO ANY PARTICULAR FONT, STYLE, SIZE, OR COLOR.

OWNER OF INTERNATIONAL REGISTRATION 1098514 DATED 6-22-2011, EXPIRES 6-22-2021.

THE WORDING "HOFFMEISTER" HAS NO MEANING IN A FOREIGN LANGUAGE.

SEC. 2(F).

CLASS 9—ELECTRICAL AND SCIENTIFIC APPARATUS

FOR ELECTRIC LIGHT ACCESSORIES, NAMELY, ELECTRIC LIGHT SWITCHES; INSTALLATION MATERIAL FOR ELECTRIC LINES, NAMELY, ELECTRIC CONDUCTOR RAILS, PLUG CONNECTORS, ADAPTORS, AND CONNECTING ELECTRICAL FEEDER CABLES FOR SPOTLIGHTS (U.S. CLS. 21, 23, 26, 36 AND 38).

CLASS 11—ENVIRONMENTAL CONTROL APPARATUS

FOR INTERIOR, EXTERIOR AND STREET ELECTRIC LIGHTING FIXTURES; ELECTRIC SPOT LIGHTS AND ACCESSORIES, NAMELY, INCANDESCENT LAMPS AND THEIR FITTINGS, LAMP GLASSES, SUSPENSION PENDULUMS FOR SUSPENSION LAMPS (U.S. CLS. 13, 21, 23, 31 AND 34).

CLASS 20—FURNITURE AND ARTICLES NOT OTHERWISE CLASSIFIED

FOR ELECTRIC LIGHT ACCESSORIES, NAMELY, NON-METAL CLIPS FOR LIGHTING PURPOSES (U.S. CLS. 2, 13, 22, 25, 32 AND 50).

EMILY CHUO, EXAMINING ATTORNEY

SN 79-105,999. SINBAR, FRANCE, FILED 4-18-2011.

PRIORITY DATE OF 10-25-2010 IS CLAIMED.
OWNER OF INTERNATIONAL REGISTRATION 1098763 DATED 4-18-2011, EXPIRES 4-18-2021.

THE MARK CONSISTS OF THE WORDING "SOLEXITY" IN STYLIZED FORM.

CLASS 9—ELECTRICAL AND SCIENTIFIC APPARATUS

FOR ELECTRIC BATTERIES FOR LAND VEHICLES; PROTECTIVE HELMETS; CYCLING HELMETS; MOTORCYCLE HELMETS; APPARATUS FOR GAMES ADAPTED FOR USE WITH AN EXTERNAL DISPLAY SCREEN OR MONITOR, NAMELY, COMPUTER GAME CONSOLES, ELECTRONIC INTERACTIVE BOARD GAMES; HAND-HELD UNITS FOR PLAYING ELECTRONIC; COMPUTER GAME PROGRAMS; OPTICAL GOODS, NAMELY, BLANK OPTICAL DISKS, OPTICAL CABLES, OPTICAL GLASSES, OPTICAL READERS; SUNGLASSES (U.S. CLS. 21, 23, 26, 36 AND 38).

CLASS 12—VEHICLES

FOR VEHICLES WITH TWO OR THREE-WHEELS, NAMELY, BICYCLES, MOPEDS, MOTORCYCLES; ELECTRIC VEHICLES WITH TWO OR THREE-WHEELS, NAMELY, BICYCLES, MOPEDS, MOTORCYCLES; ELECTRICALLY ASSISTED VEHICLES WITH TWO OR THREE-WHEELS, NAMELY, BICYCLES, MOPEDS, MOTORCYCLES; CYCLES WITH TWO OR THREE-WHEELS, NAMELY, BICYCLES, MOPEDS, MOTORCYCLES; ELECTRIC CYCLES WITH TWO OR THREE-WHEELS, NAMELY, BICYCLES, MOPEDS, MOTORCYCLES; ELECTRICALLY ASSISTED CYCLES WITH TWO OR THREE-WHEELS, NAMELY, BICYCLES, MOPEDS, MOTORCYCLES; ELECTRIC MOTORS FOR LAND VEHICLES; STRUCTURAL AND REPLACEMENT PARTS FOR MOTOR CYCLES AND BICYCLES OTHER THAN LIGHTS AND DYNAMOS, NAMELY, BICYCLE STANDS, TIRES, PUMPS, SADDLES, SPOKES, TUBULAR TIRES, REARVIEW MIRRORS, BELLS, CHAINS, PEDALS, WHEEL RIMS, CYCLE BRAKES, MUDGUARDS; KITS FOR REPAIRING INNER TUBES, NAMELY, TIRE PATCHES, TIRE LEVERS, RUBBER CEMENT FOR REPAIRING PNEUMATIC TIRES, SAND-PAPER (U.S. CLS. 19, 21, 23, 31, 35 AND 44).

CLASS 37—CONSTRUCTION AND REPAIR

FOR REPAIR, UPKEEP AND MAINTENANCE OF VEHICLES, ELECTRIC VEHICLES, ELECTRICALLY ASSISTED VEHICLES, CYCLES, ELECTRIC CYCLES, ELECTRICALLY ASSISTED CYCLES, ELECTRIC BATTERIES, ELECTRIC MOTORS (U.S. CLS. 100, 103 AND 106).

JANET LEE, EXAMINING ATTORNEY

SN 79-106.262. DAIICHI FINE CHEMICAL CO., LTD.,
TOYAMA 933-8511, JAPAN, FILED 10-26-2011.

Panadoxine

OWNER OF INTERNATIONAL REGISTRATION 1099571
DATED 10-26-2011, EXPIRES 10-26-2021.

CLASS 1—CHEMICALS

FOR CHEMICALS, NAMELY, CHEMICAL ADDITIVES FOR USE IN THE MANUFACTURE OF SKIN CARE AND HAIR PRODUCTS; CHEMICALS, NAMELY, PYRIDOXINE PHOSPHATE; CHEMICAL REAGENTS OTHER THAN FOR MEDICAL OR VETERINARY PURPOSES (U.S. CLS. 1, 5, 6, 10, 26 AND 46).

CLASS 3—COSMETICS AND CLEANING PREPARATIONS

FOR SOAPS AND DETERGENTS; PERFUMERY, FRAGRANCES AND INCENSES, ALL OTHER THAN PERFUMES USED AS COSMETICS OR TOILETRIES; COSMETICS AND NON-MEDICATED TOILETRIES; DENTIFRICES (U.S. CLS. 1, 4, 6, 50, 51 AND 52).

CLASS 5—PHARMACEUTICALS

FOR PHARMACEUTICAL, VETERINARY AND SANITARY PREPARATIONS, NAMELY, ANTIBIOTICS, PHARMACEUTICAL PREPARATIONS FOR THE TREATMENT OF INFECTIOUS DISEASES, ALLERGY MEDICATIONS, VETERINARY VACCINES, FLEA POWDERS, HAND-SANITIZING PREPARATIONS, DISINFECTANTS FOR MEDICAL INSTRUMENTS; REAGENTS FOR MEDICAL PURPOSES (U.S. CLS. 6, 18, 44, 46, 51 AND 52).

APRIL ROACH, EXAMINING ATTORNEY

SN 79-106.292. BYK KOMETRA GMBH, FED REP GERMANY, FILED 10-18-2011.

SCONA

OWNER OF INTERNATIONAL REGISTRATION 0328592
DATED 11-29-1966, EXPIRES 11-29-2016.

THE WORDING "SCONA" HAS NO MEANING IN A FOREIGN LANGUAGE.

CLASS 1—CHEMICALS

FOR PLASTIC MATERIAL IN THE FORM OF DISPERSIONS, EMULSIONS, SUSPENSIONS, SOLUTIONS, PASTES, GRANULES, PEARLS, POWDERS, INTERMEDIATE CHEMICALS, AUXILIARY PRODUCTS AND ADDITIVES FOR THE PURPOSE OF MANUFACTURE, MACHINING AND IMPROVEMENT OF PLASTIC MATERIALS, NAMELY, EMOLLIENTS, PLASTIFIERS, STABILIZERS AND THICKENERS; ANTI-FREEZE; AUXILIARY PRODUCTS FOR THE PAPER INDUSTRY, NAMELY, COATING AND IMPREGNATING PRODUCTS IN THE NATURE OF CHEMICAL AGENTS FOR IMPREGNATING OR COATING OF PAPER, COMPATIBILIZERS, COUPLING AGENTS; CHEMICALS IN THE NATURE OF AUXILIARY AGENTS FOR WORKING RUBBER, NAMELY, SYNTHETIC ADHESIVE RESINS FOR RUBBER MIXTURES, SPECIAL ADHESIVES FOR GUM, SUBSTANCES FOR SOFTENING, THICKENING AGENTS FOR LATEX RUBBER (U.S. CLS. 1, 5, 6, 10, 26 AND 46).

CLASS 4—LUBRICANTS AND FUELS

FOR AUXILIARY PRODUCTS AND ADDITIVES FOR THE PURPOSE OF MANUFACTURE, MACHINING AND IMPROVEMENT OF PLASTIC MATERIALS, NAMELY, LUBRICANTS AND SIZING AGENTS IN THE FORM OF LUBRICANTS, OILS AND GREASE FOR USE IN THE TEXTILE INDUSTRY (U.S. CLS. 1, 6 AND 15).

CLASS 17—RUBBER GOODS

FOR PLASTIC MATERIALS IN THE FORM OF SHEETS, FILMS, COMPOUND FOAMS, BARS, BLOCKS, SHAPED SECTIONS, TUBES AND PIPES; JOINT PACKINGS IN THE NATURE OF PLASTIC SEALS, SYNTHETIC FOILS AND PLASTIC FILM FOR USE IN THE MANUFACTURE OF CABLES, PAPER AND WOOD PLASTIC COMPOSITES, AUTOMOTIVE PARTS, ELECTRIC APPLIANCES AND WHITE GOODS AND FILLERS IN THE NATURE OF PLASTIC POWDERS AND PLASTIC GRANULES FOR USE IN MANUFACTURING; THERMAL INSULATION AND INSULATION PRODUCTS BASED ON PLASTIC MATERIALS AND SYNTHETIC RUBBER, NAMELY, INSULATING PAINTS, INSULATING PLASTER, INSULATING SPLICE COVER FOR ELECTRICAL CABLES, INSULATING OILS AND INSULATING WIRE ENAMELS; GUM IN THE NATURE OF NATURAL RUBBER IN SHEETS, FILMS, COMPOUND FOAMS, BARS, BLOCKS, SHAPED SECTIONS, TUBES AND PIPES AND GUM PRODUCTS IN THE NATURE OF NATURAL RUBBER FOR USE IN INDUSTRY, NAMELY, THE MANUFACTURE OF CABLES, PAPER AND WOOD PLASTIC COMPOSITES, AUTOMOTIVE PARTS, ELECTRIC APPLIANCES AND WHITE GOODS; RUBBER LATEX FOR USE IN THE MANUFACTURE OF CABLES, PAPER AND WOOD PLASTIC COMPOSITES, AUTOMOTIVE PARTS, ELECTRIC APPLIANCES AND WHITE GOODS (U.S. CLS. 1, 5, 12, 13, 35 AND 50).

KRISTINA MORRIS, EXAMINING ATTORNEY

SN 79-106,454. FUN FACTORY GMBH, FED REP GERMANY, FILED 11-7-2011.

Press FUN to play

THE MARK CONSISTS OF STANDARD CHARACTERS WITHOUT CLAIM TO ANY PARTICULAR FONT, STYLE, SIZE, OR COLOR.

PRIORITY DATE OF 9-27-2011 IS CLAIMED.

OWNER OF INTERNATIONAL REGISTRATION 1099835 DATED 11-7-2011, EXPIRES 11-7-2021.

CLASS 5—PHARMACEUTICALS

FOR PERSONAL LUBRICANTS BEING SEXUAL AIDS (U.S. CLS. 6, 18, 44, 46, 51 AND 52).

CLASS 10—MEDICAL APPARATUS

FOR MASSAGE APPARATUS, IN PARTICULAR MASSAGE RODS WITH AND WITHOUT MOTORS AND MASSAGE BALLS; SEXUAL AIDS OF SILICON AND OTHER PLASTICS, NAMELY, VIBRATORS AND DILDOS; ERECTION AND ORGASM-ENHANCING ARTICLES, NAMELY, LOVE BALLS, PENIS RINGS (U.S. CLS. 26, 39 AND 44).

CLASS 18—LEATHER GOODS

FOR LEATHERWARE, NAMELY, LEATHER STRAPS, WHIPS, LEASHES AND HARNESSES (U.S. CLS. 1, 2, 3, 22 AND 41).

CLASS 25—CLOTHING

FOR CLOTHING, IN PARTICULAR UNDERWEAR AND SEXY UNDERWEAR OF LEATHER, RUBBER AND LATEX (U.S. CLS. 22 AND 39).

DAVID HOFFMAN, EXAMINING ATTORNEY

SN 79-106,651. SIKA AG, SWITZERLAND, FILED 9-16-2011.

SIKA COMFORTFLOOR

THE MARK CONSISTS OF STANDARD CHARACTERS WITHOUT CLAIM TO ANY PARTICULAR FONT, STYLE, SIZE, OR COLOR.

PRIORITY DATE OF 4-6-2011 IS CLAIMED.

OWNER OF INTERNATIONAL REGISTRATION 1100400 DATED 9-16-2011, EXPIRES 9-16-2021.

OWNER OF U.S. REG. NOS. 2,294,043, 3,983,468 AND OTHERS.

CLASS 1—CHEMICALS

FOR CHEMICALS FOR USE IN INDUSTRY, IN THE NATURE OF PLASTIC MATERIALS MADE OF POLYURETHANE FOR FLOORS AND WALLS (U.S. CLS. 1, 5, 6, 10, 26 AND 46).

CLASS 17—RUBBER GOODS

FOR ELASTIC AND DECORATIVE POLYURETHANE COATINGS FOR FLOORS AND WALLS FOR INSULATING AND BLOCKING (U.S. CLS. 1, 5, 12, 13, 35 AND 50).

CLASS 19—NON-METALLIC BUILDING MATERIALS

FOR BUILDING MATERIALS, NOT OF METAL, NAMELY, LIQUID-APPLIED PLASTIC MEMBRANES FOR COVERING FLOORS AND WALLS; NON-METAL FLOORS (U.S. CLS. 1, 12, 33 AND 50).

CLASS 27—FLOOR COVERINGS

FOR FLOOR COVERINGS; LIQUID-APPLIED PLASTIC FLOOR COVERINGS (U.S. CLS. 19, 20, 37, 42 AND 50).

LAURA KOVALSKY, EXAMINING ATTORNEY

SN 79-106,719. APOSTOLOS ATHANASOPOULOS, GR-152 35 ATHENS, GREECE, FILED 10-6-2011.



PRIORITY DATE OF 8-1-2011 IS CLAIMED.

OWNER OF INTERNATIONAL REGISTRATION 1100565 DATED 10-6-2011, EXPIRES 10-6-2021.

NO CLAIM IS MADE TO THE EXCLUSIVE RIGHT TO USE "GREECE", APART FROM THE MARK AS SHOWN.

THE COLOR(S) RED IS/ARE CLAIMED AS A FEATURE OF THE MARK.

THE MARK CONSISTS OF THE WORD "EPOCH" WITH A LEAF FORMING PART OF THE LETTER "O", ABOVE THE SMALLER WORDING "PURE GREECE" AND "WWW.ELGEO.COM.GR"; ALL ABOVE A DESIGN OF LEAVES. ALL OF THE ELEMENTS IN THE MARK ARE IN THE COLOR RED. THE COLOR WHITE IS BACKGROUND AND IS NOT PART OF THE MARK.

CLASS 29—MEATS AND PROCESSED FOODS

FOR MEAT, FISH, POULTRY AND GAME; MEAT EXTRACTS; PRESERVED, FROZEN, DRIED AND COOKED FRUITS AND VEGETABLES; JELLIES, JAMS, COMPOTES; EGGS, MILK, AND MILK PRODUCTS EXCLUDING ICE CREAM, ICE MILK AND FROZEN YOGURT; EDIBLE OILS AND FATS (U.S. CL. 46).

CLASS 31—NATURAL AGRICULTURAL PRODUCTS

FOR AGRICULTURAL, HORTICULTURAL AND FORESTRY PRODUCTS AND GRAINS NOT INCLUDED IN OTHER CLASSES, NAMELY, UNPROCESSED GRAIN, AGRICULTURAL SEEDS, LIVING PLANTS; LIVE ANIMALS; FRESH FRUITS AND VEGETABLES; PLANT SEEDS; NATURAL PLANTS AND FLOWERS; FOODSTUFFS FOR ANIMALS (U.S. CLS. 1 AND 46).

CLASS 32—LIGHT BEVERAGES

FOR MINERAL AND AERATED WATERS; FRUIT DRINKS AND FRUIT JUICES; SYRUPS FOR MAKING FRUIT BEVERAGES; PREPARATIONS FOR MAKING BEVERAGES, NAMELY, FRUIT DRINKS, SPORTS DRINKS (U.S. CLS. 45, 46 AND 48).

JAMES GRIFFIN, EXAMINING ATTORNEY

SN 79-106,745. X-TECHNOLOGY SWISS GMBH, SWITZERLAND, FILED 10-31-2011.

Physio

THE MARK CONSISTS OF STANDARD CHARACTERS WITHOUT CLAIM TO ANY PARTICULAR FONT, STYLE, SIZE, OR COLOR.

OWNER OF INTERNATIONAL REGISTRATION 1100624 DATED 10-31-2011, EXPIRES 10-31-2021.

CLASS 18—LEATHER GOODS

FOR LEATHER AND IMITATION LEATHER AND GOODS MADE OF THESE MATERIALS, NAMELY, PURSES, WALLETS, BRIEFCASES; ANIMAL SKINS; TRUNKS AND TRAVELING BAGS; UMBRELLAS, PARASOLS AND WALKING STICKS, IN PARTICULAR, WALKING-STICK SEATS, HIKING POLES, MOUNTAINEERING STICKS, NORDIC WALKING STICKS; WHIPS, HARNESSES AND SADDLERY; BAGS, NAMELY, SCHOOL BAGS AND MOUNTAINEERING BAGS, BABY CARRIERS WORN ON THE BACK OR CHEST, HANDBAGS, SHOPPING BAGS, NAMELY, TEXTILE SHOPPING BAGS; ALL-PURPOSE SPORTS BAGS (U.S. CLS. 1, 2, 3, 22 AND 41).

CLASS 25—CLOTHING

FOR CLOTHING AND SPORTSWEAR, NAMELY, BANDANAS, SHIRTS, SLIPS, SOCKS, UNDERGARMENTS, SPORTS JERSEYS, TIGHTS, PAJAMAS, UNDERWEAR, OUTDOOR CLOTHING AND APPAREL FOR HIKING, NAMELY, PANTS AND JACKETS; BODY SUITS, BODY STOCKINGS, LEOTARDS, SHORTS, TOPS, SWEAT SHIRTS, SWEAT PANTS, UNITARDS, LEGGINGS, GYM SUITS, STOCKINGS, KNITWEAR, NAMELY, KNITTED DRESSES, KNITTED SHIRTS, KNITTED TROUSERS, KNITTED SKIRTS AND KNITTED SEAT SUITS, FOOTWEAR; HEADGEAR, NAMELY, CAPS AND HOODS (U.S. CLS. 22 AND 39).
SAIMA MAKHDOOM, EXAMINING ATTORNEY

SN 79-106,926. SIKA AG, SWITZERLAND, FILED 10-24-2011.

SIKAHYFLEX

THE MARK CONSISTS OF STANDARD CHARACTERS WITHOUT CLAIM TO ANY PARTICULAR FONT, STYLE, SIZE, OR COLOR.

PRIORITY DATE OF 6-22-2011 IS CLAIMED.
OWNER OF INTERNATIONAL REGISTRATION 1100978 DATED 10-24-2011, EXPIRES 10-24-2021.

OWNER OF U.S. REG. NOS. 2,294,043, 3,983,468 AND OTHERS.

CLASS 1—CHEMICALS

FOR INDUSTRIAL CHEMICALS, NAMELY, FOR CONSTRUCTING BUILDINGS; CHEMICAL THICKENERS MADE WITH POLYURETHANE, SILICONE OR POLYMERS FOR USE IN THE MANUFACTURE OF WEATHERSTRIPPING MATERIALS; ADHESIVES FOR INDUSTRIAL PURPOSES (U.S. CLS. 1, 5, 6, 10, 26 AND 46).

CLASS 17—RUBBER GOODS

FOR WEATHERSTRIPPING AND INSULATION FOR USE IN THE CONSTRUCTION INDUSTRY; WEATHERSTRIPPING MATERIALS MADE WITH POLYURETHANE, SILICONE OR POLYMERS, IN THE NATURE OF CAULK, FOR BUILDING FAÇADES, ROOFING AND WINDOWS; PACKING MATERIAL FOR FORMING SEALS; ADHESIVE SEALING STRIPS (U.S. CLS. 1, 5, 12, 13, 35 AND 50).

LAURA KOVALSKY, EXAMINING ATTORNEY

SN 79-107,727. GLOGSTER, A.S., CZECH REPUBLIC, FILED 5-3-2011.

Glog

THE MARK CONSISTS OF STANDARD CHARACTERS WITHOUT CLAIM TO ANY PARTICULAR FONT, STYLE, SIZE, OR COLOR.

PRIORITY DATE OF 4-26-2011 IS CLAIMED.
OWNER OF INTERNATIONAL REGISTRATION 1103072 DATED 5-3-2011, EXPIRES 5-3-2021.

OWNER OF U.S. REG. NO. 3,845,339.

CLASS 9—ELECTRICAL AND SCIENTIFIC APPARATUS

FOR SOFTWARE TO ENABLE UPLOADING, POSTING, SHOWING, DISPLAYING, TAGGING, BLOGGING, SHARING OR OTHERWISE PROVIDING ELECTRONIC MEDIA OR INFORMATION OVER THE INTERNET OR OTHER COMMUNICATIONS NETWORKS (U.S. CLS. 21, 23, 26, 36 AND 38).

CLASS 35—ADVERTISING AND BUSINESS

FOR ADVERTISING AND PUBLICITY, PROMOTION AND MARKETING SERVICES FOR OTHERS IN THE FORM OF PROVIDING INFORMATION AND MULTIMEDIA CONTENT, NAMELY, PRERECORDED DVDS, CDS, PHOTOS, VIDEOS AND AUDIO CONTENT AND USER GENERATED MULTIMEDIA CONTENT OVER THE INTERNET AND OTHER COMMUNICATIONS NETWORKS (U.S. CLS. 100, 101 AND 102).

CLASS 38—COMMUNICATION

FOR BROADCASTING AND WEBCASTING SERVICES, NAMELY, UPLOADING, POSTING, SHOWING, DISPLAYING, TAGGING, BLOGGING, SHARING, AND OTHERWISE PROVIDING ACCESS TO AND TRANSMISSION OF ELECTRONIC MEDIA, MULTIMEDIA CONTENT AND INFORMATION OVER THE INTERNET AND OTHER COMMUNICATIONS NETWORKS; PROVIDING ACCESS TO AN ONLINE COMPUTER DATA BASE FEATURING VIDEO AND AUDIO CONTENT AND USER GENERATED MULTIMEDIA CONTENT; PROVIDING ONLINE FORUMS AND ONLINE CHAT ROOMS FOR TRANSMISSION OF MESSAGES AMONG USERS CONCERNING COLLEGIATE LIFE, GENERAL INTEREST, VIRTUAL COMMUNITY, PHOTO AND VIDEO SHARING; PROVIDING ACCESS TO A GLOBAL COMPUTER NETWORK, NAMELY, ACCESS TO BLOGS, BROADCASTING OF AUDIO AND VIDEO PROGRAMMES OVER A GLOBAL COMPUTER NETWORK (U.S. CLS. 100, 101 AND 104).

CLASS 41—EDUCATION AND ENTERTAINMENT

FOR EDUCATIONAL AND ENTERTAINMENT SERVICES PROVIDED VIA THE INTERNET AND OTHER COMPUTER AND COMMUNICATIONS NETWORKS, NAMELY, PROVIDING AN INTERNET WEBSITE FEATURING, USER-GENERATED PHOTOGRAPHIC, AUDIO, VIDEO AND PROSE PRESENTATIONS FEATURING INFORMATION ON ART, MUSIC, POP CULTURE, EDUCATION, ENTERTAINMENT, SPORTS, AND PERSONAL RELATIONSHIP ADVICE FOR ENTERTAINMENT PURPOSE ONLY; ON-LINE COMPUTER GAMES, MULTIMEDIA PUBLISHING OF ELECTRONIC PUBLICATIONS, NAMELY, ONLINE ELECTRONIC PUBLISHING OF TEXT AND GRAPHIC WORKS OF OTHERS FEATURING USER-GENERATED PHOTOGRAPHIC, AUDIO, VIDEO AND PROSE PRESENTATIONS FEATURING INFORMATION ON ART, MUSIC, POP CULTURE, EDUCATION, ENTERTAINMENT, SPORTS, AND PERSONAL RELATIONSHIP ADVICE FOR ENTERTAINMENT PURPOSE ONLY; ON-LINE JOURNALS, NAMELY, BLOGS FEATURING USER-GENERATED PHOTOGRAPHIC, AUDIO, VIDEO AND PROSE PRESENTATIONS FEATURING INFORMATION ON ART, MUSIC, POP CULTURE, EDUCATION, ENTERTAINMENT, SPORTS, AND PERSONAL RELATIONSHIP ADVICE FOR ENTERTAINMENT PURPOSE ONLY (U.S. CLS. 100, 101 AND 107).

CLASS 42—SCIENTIFIC AND COMPUTER SERVICES

FOR COMPUTER AND INTERNET-RELATED EXPERT TECHNICAL SERVICES, NAMELY, INTERACTIVE HOSTING SERVICES WHICH ALLOW THE USER TO PUBLISH AND SHARE THEIR OWN CONTENT AND IMAGES ON-LINE, APPLICATION SERVICE PROVIDER (ASP), NAMELY, HOSTING COMPUTER SOFTWARE APPLICATIONS OF OTHERS THAT PROVIDE ACCESS TO NON-DOWNLOADABLE SOFTWARE TO ENABLE SHARING OF MULTIMEDIA CONTENT AND COMMENTS AMONG USERS AND PROVIDE UPLOADING, DOWNLOADING, CAPTURING, SHOWING, EDITING, PLAYING, STREAMING, VIEWING, TAGGING, BLOGGING, SHARING, MANIPULATING, DISTRIBUTING, PUBLISHING AND REPRODUCING ELECTRONIC MEDIA, INFORMATION AND MULTIMEDIA CONTENT VIA THE INTERNET AND OTHER COMPUTER AND COMMUNICATIONS NETWORK, NAMELY, VIDEOS, PICTURES, TEXT, GAMES, USER-GENERATED CONTENT IN THE FORM OF SHARING OF MULTIMEDIA CONTENT VIA THE INTERNET AND OTHER COMPUTER AND COMMUNICATIONS NETWORKS, HOSTING OF DIGITAL CONTENT ON THE INTERNET, NAMELY, MULTIMEDIA DIGITAL CONTENT FOR OTHERS (U.S. CLS. 100 AND 101).

DAVID HOFFMAN, EXAMINING ATTORNEY

SN 79-107,734. SOKEN CHEMICAL & ENGINEERING CO., LTD., JAPAN, FILED 10-6-2011.



PRIORITY DATE OF 4-20-2011 IS CLAIMED.
OWNER OF INTERNATIONAL REGISTRATION 1103091 DATED 10-6-2011, EXPIRES 10-6-2021.

NO CLAIM IS MADE TO THE EXCLUSIVE RIGHT TO USE THE JAPANESE CHARACTERS THAT TRANSLATE TO "STAMP", APART FROM THE MARK AS SHOWN.

THE MARK CONSISTS OF A DESIGN OF AN INDUSTRIAL STAMP ABOVE AND TO THE LEFT OF JAPANESE CHARACTERS WHICH ARE ABOVE THE WORDING "STAMP KING".

THE ENGLISH TRANSLATION OF THE WORDS IN THE MARK IS: "STAMP KING".

THE NON-LATIN CHARACTERS IN THE MARK TRANSLITERATE TO "KOKUO".

CLASS 7—MACHINERY

FOR INDUSTRIAL PRINTING MACHINES; BOOK-BINDING MACHINES; MACHINE PARTS, NAMELY, MOULDS FOR NANOIMPRINTING OR NANOIMPRINT LITHOGRAPHY; PARTS OF MACHINES BEING MOULDS USED FOR MANUFACTURING PLASTICS; PARTS OF MACHINES BEING MOULDS USED FOR MANUFACTURING RUBBERS; STAMPING MACHINES; AUTOMATIC STAMPING MACHINES (U.S. CLS. 13, 19, 21, 23, 31, 34 AND 35).

CLASS 40—MATERIAL TREATMENT

FOR METAL WORKING, NAMELY, METAL TREATING AND METAL STAMPING; PROCESSING OF RUBBER; PAPER TREATING; CERAMIC PROCESSING; PROCESSING OF PLASTICS; LETTERPRESS PRINTING; PRINTING (U.S. CLS. 100, 103 AND 106).

JAMES GRIFFIN, EXAMINING ATTORNEY

SN 79-107,757. BODMER INNOCOACH AG, SWITZERLAND, FILED 12-7-2011.

InnoCoach

THE MARK CONSISTS OF STANDARD CHARACTERS WITHOUT CLAIM TO ANY PARTICULAR FONT, STYLE, SIZE, OR COLOR.

OWNER OF INTERNATIONAL REGISTRATION 1103149 DATED 12-7-2011, EXPIRES 12-7-2021.

CLASS 35—ADVERTISING AND BUSINESS

FOR BUSINESS CONSULTANCY; BUSINESS CONSULTING SERVICES RENDERED TO EMPLOYEES RELATING TO BUSINESS OPERATIONS; BUSINESS ORGANIZATION AND CORPORATE GOVERNANCE CONSULTANCY; BUSINESS MANAGEMENT CONSULTANCY; OPERATIONAL BUSINESS CONSULTANCY; ORGANIZATION CONSULTANCY IN BUSINESS MATTERS (U.S. CLS. 100, 101 AND 102).

CLASS 41—EDUCATION AND ENTERTAINMENT

FOR EDUCATION, TRAINING CONSULTANCY AND COACHING IN THE FIELDS OF MANAGEMENT, ENGINEERING, FINANCE AND TECHNOLOGY; ORGANIZATION AND CONDUCTING OF CONFERENCES, CONGRESSES, SYMPOSIUMS IN THE FIELDS OF ENGINEERING, FINANCE AND TECHNOLOGY; ARRANGING AND CONDUCTING OF SEMINARS AND WORKSHOPS IN THE FIELDS OF MANAGEMENT, ENGINEERING, FINANCE AND TECHNOLOGY; ARRANGING AND CONDUCTING OF COLLOQUIUMS IN THE FIELDS OF MANAGEMENT, ENGINEERING, FINANCE AND TECHNOLOGY; PUBLICATION OF BOOKS (U.S. CLS. 100, 101 AND 107).

CLASS 42—SCIENTIFIC AND COMPUTER SERVICES

FOR INDUSTRIAL RESEARCH IN THE FIELD OF ENGINEERING; SCIENTIFIC RESEARCH; SERVICE OF AN ENGINEER; RESEARCH IN THE FIELD OF ENGINEERING (U.S. CLS. 100 AND 101).

MICHAEL KEATING, EXAMINING ATTORNEY

SN 79-108,075. SANDVIK INTELLECTUAL PROPERTY AB,
SANDVIKEN, SWEDEN, FILED 12-7-2011.

INVOMILLING

THE MARK CONSISTS OF STANDARD CHARACTERS WITHOUT CLAIM TO ANY PARTICULAR FONT, STYLE, SIZE, OR COLOR.

OWNER OF INTERNATIONAL REGISTRATION 1104035 DATED 12-7-2011, EXPIRES 12-7-2021.

CLASS 7—MACHINERY

FOR MILLING MACHINES; MACHINES FOR GEAR MILLING; MACHINE TOOLS FOR GEAR MILLING (U.S. CLS. 13, 19, 21, 23, 31, 34 AND 35).

CLASS 9—ELECTRICAL AND SCIENTIFIC APPARATUS

FOR COMPUTER PROGRAMS AND SOFTWARE FOR CONTROLLING AND STEERING MILLING MACHINES (U.S. CLS. 21, 23, 26, 36 AND 38).

ESTHER BELENKER, EXAMINING ATTORNEY

SN 79-108,172. HILDEBRAND TECHNOLOGY AG, SWITZERLAND, FILED 9-9-2011.



PRIORITY DATE OF 3-12-2011 IS CLAIMED.
OWNER OF INTERNATIONAL REGISTRATION 1104318 DATED 9-9-2011, EXPIRES 9-9-2021.

NO CLAIM IS MADE TO THE EXCLUSIVE RIGHT TO USE "DC", APART FROM THE MARK AS SHOWN.

THE COLOR(S) ORANGE AND BLUE IS/ARE CLAIMED AS A FEATURE OF THE MARK.

THE MARK CONSISTS OF THE WORDING "TRUE" IN ORANGE AND "DC" IN BLUE, AND "DC" IS UNDERLINED IN ORANGE.

CLASS 9—ELECTRICAL AND SCIENTIFIC APPARATUS

FOR SOFTWARE FOR OPERATING ELECTROSTATIC NEUTRALISING AND IONISING SYSTEMS, STATIC ELIMINATION SYSTEMS AND AIR IONISING SYSTEMS AND AIR DEIONISING SYSTEMS FOR USE IN COMMERCIAL AND INDUSTRIAL APPLICATIONS FOR CONTROLLING ELECTROSTATIC CHARGE GENERATED BY MACHINES, IN WHICH AT LEAST ONE MOBILE PART IS MOVED WITH RESPECT TO AT LEAST ONE STATIONARY PART, SUCH AS A WEB MACHINING MACHINE, IN WHICH A WEB MATERIAL IS MOVED WITH RESPECT TO ROLLERS AND/OR BARS; ELECTROSTATICALLY NEUTRALISING ELECTRODE CARRIERS AND ACCESSORIES THEREFOR, SUCH AS CHARGING APPARATUS, POWER SUPPLY UNITS, CONTROL DEVICES (U.S. CLS. 21, 23, 26, 36 AND 38).

CLASS 11—ENVIRONMENTAL CONTROL APPARATUS

FOR ELECTRICAL DISCHARGING APPARATUS FOR ELECTROSTATIC NEUTRALISING AND IONISING SYSTEMS, STATIC ELIMINATION SYSTEMS, AIR IONISING SYSTEMS AND AIR DEIONISING SYSTEMS FOR USE IN COMMERCIAL AND INDUSTRIAL APPLICATIONS FOR CONTROLLING ELECTROSTATIC CHARGE GENERATED BY MACHINES, IN PARTICULAR FOR CONTROLLING ELECTROSTATIC CHARGE GENERATED IN MACHINES, IN WHICH AT LEAST ONE MOBILE PART IS MOVED WITH RESPECT TO AT LEAST ONE STATIONARY PART, SUCH AS A WEB MACHINING MACHINE, IN WHICH A WEB MATERIAL IS MOVED WITH RESPECT TO ROLLERS AND/OR BARS (U.S. CLS. 13, 21, 23, 31 AND 34).

CLASS 16—PAPER GOODS AND PRINTED MATTER

FOR USER MANUALS FOR ELECTROSTATIC NEUTRALISING AND IONISING SYSTEMS, STATIC ELIMINATION SYSTEMS, AIR IONISING SYSTEMS AND AIR DEIONISING SYSTEMS FOR USE IN COMMERCIAL AND INDUSTRIAL APPLICATIONS FOR CONTROLLING ELECTROSTATIC CHARGE GENERATED BY MACHINES, IN WHICH AT LEAST ONE MOBILE PART IS MOVED WITH RESPECT TO AT LEAST ONE STATIONARY PART, SUCH AS A WEB MACHINING MACHINE, IN WHICH A WEB MATERIAL IS MOVED WITH RESPECT TO ROLLERS AND/OR BARS; USER MANUALS FOR ELECTROSTATICALLY NEUTRALISING ELECTRODE CARRIERS AND ACCESSORIES THEREFOR, SUCH AS CHARGING APPARATUS, POWER SUPPLY UNITS, CONTROL DEVICES (U.S. CLS. 2, 5, 22, 23, 29, 37, 38 AND 50).

PAUL MORENO, EXAMINING ATTORNEY

SN 79-108,452. NOVATEC SOLAR GMBH, FED REP GERMANY, FILED 11-30-2011.



PRIORITY DATE OF 5-30-2011 IS CLAIMED.
OWNER OF INTERNATIONAL REGISTRATION 1105009 DATED 11-30-2011, EXPIRES 11-30-2021.

NO CLAIM IS MADE TO THE EXCLUSIVE RIGHT TO USE "SOLAR", APART FROM THE MARK AS SHOWN.

THE COLOR(S) GREY, WHITE, ORANGE AND YELLOW IS/ARE CLAIMED AS A FEATURE OF THE MARK.

THE MARK CONSISTS OF THE STYLIZED WORDING "NOVATEC SOLAR" WITH THE LETTERS "NOVATEC" IN GREY AND THE LETTERS "SOLAR" IN ORANGE, AND AN ORANGE CIRCLE CUT IN THE MIDDLE BY A WAVY LINE WITH YELLOW HIGHLIGHTS IN THE UPPER PART OF THE CIRCLE, ALL ON A WHITE RECTANGULAR BACKGROUND.

CLASS 6—METAL GOODS

FOR PREFABRICATED METAL BUILDINGS AS PARTS OF SOLAR THERMAL POWER STATIONS, NAMELY, CARRIER STRUCTURES; ALL AFOREMENTIONED GOODS NOT IN THE FIELD OF PHOTOVOLTAICS (U.S. CLS. 2, 12, 13, 14, 23, 25 AND 50).

CLASS 9—ELECTRICAL AND SCIENTIFIC APPARATUS

FOR SOLAR COLLECTORS FOR ELECTRICITY GENERATION; PARTS OF SOLAR THERMAL POWER STATIONS, NAMELY, OPTICAL MIRRORS, NAMELY, HELIOSTATS, AS WELL AS ELECTRIC ACTUATORS AND SENSORS FOR CONTROLLING A SUN TRACKING SYSTEM AS WELL AS ELECTRONIC CONTROLLING DEVICES FOR THE SUN TRACKING SYSTEM ALL AFOREMENTIONED GOODS NOT IN THE FIELD OF PHOTOVOLTAICS (U.S. CLS. 21, 23, 26, 36 AND 38).

CLASS 11—ENVIRONMENTAL CONTROL APPARATUS

FOR SOLAR ENERGY RECEIVERS AS PARTS OF SOLAR THERMAL POWER STATIONS; ALL AFOREMENTIONED GOODS NOT IN THE FIELD OF PHOTOVOLTAICS (U.S. CLS. 13, 21, 23, 31 AND 34).
NICHOLAS COLEMAN, EXAMINING ATTORNEY

SN 79-108,873. NOVATEC SOLAR GMBH, FED REP GERMANY, FILED 11-30-2011.



PRIORITY DATE OF 7-1-2011 IS CLAIMED.
OWNER OF INTERNATIONAL REGISTRATION 1105995 DATED 11-30-2011, EXPIRES 11-30-2021.

THE COLOR(S) ORANGE, YELLOW AND GREY IS/ARE CLAIMED AS A FEATURE OF THE MARK.

THE MARK CONSISTS OF THE STYLIZED WORDING "NOVA-1" WITH THE LETTERS "NOVA-" IN GREY AND THE NUMBER "1" IN ORANGE, AND AN ORANGE CIRCLE CUT IN THE MIDDLE BY A WAVY LINE WITH YELLOW HIGHLIGHTS IN THE UPPER PART OF THE CIRCLE.

CLASS 6—METAL GOODS

FOR PREFABRICATED METAL BUILDINGS AS PARTS OF SOLAR THERMAL POWER STATIONS, NAMELY, CARRIER STRUCTURES; ALL AFOREMENTIONED GOODS NOT IN THE FIELD OF PHOTOVOLTAICS (U.S. CLS. 2, 12, 13, 14, 23, 25 AND 50).

CLASS 9—ELECTRICAL AND SCIENTIFIC APPARATUS

FOR PARTS OF SOLAR THERMAL POWER STATIONS, NAMELY, ELECTRIC ACTUATORS AND SENSORS FOR CONTROLLING A SUN TRACKING SYSTEM AS WELL AS ELECTRONIC CONTROLLING DEVICES FOR THE SUN TRACKING SYSTEM; PRIMARY OPTICAL MIRRORS, NAMELY, HELIOSTATS NOT OF METAL, AS PARTS OF SOLAR THERMAL POWER STATIONS; ALL AFOREMENTIONED GOODS NOT IN THE FIELD OF PHOTOVOLTAICS (U.S. CLS. 21, 23, 26, 36 AND 38).

CLASS 11—ENVIRONMENTAL CONTROL APPARATUS

FOR SOLAR COLLECTORS FOR HEAT GENERATION; SOLAR ENERGY RECEIVERS AS PARTS OF SOLAR THERMAL POWER STATIONS; ALL AFOREMENTIONED GOODS NOT IN THE FIELD OF PHOTOVOLTAICS (U.S. CLS. 13, 21, 23, 31 AND 34).
NICHOLAS COLEMAN, EXAMINING ATTORNEY

SN 79-108,961. NOVATEC SOLAR GMBH, FED REP GERMANY, FILED 11-30-2011.

SUPERNOVA

THE MARK CONSISTS OF STANDARD CHARACTERS WITHOUT CLAIM TO ANY PARTICULAR FONT, STYLE, SIZE, OR COLOR.

PRIORITY DATE OF 5-30-2011 IS CLAIMED.
OWNER OF INTERNATIONAL REGISTRATION 1106291 DATED 11-30-2011, EXPIRES 11-30-2021.

CLASS 6—METAL GOODS

FOR PREFABRICATED METAL BUILDINGS AS PARTS OF SOLAR THERMAL POWER STATIONS, NAMELY, CARRIER STRUCTURES; ALL AFOREMENTIONED GOODS NOT IN THE FIELD OF PHOTOVOLTAICS (U.S. CLS. 2, 12, 13, 14, 23, 25 AND 50).

CLASS 9—ELECTRICAL AND SCIENTIFIC APPARATUS

FOR SOLAR COLLECTORS FOR ELECTRICITY GENERATION; PARTS OF SOLAR THERMAL POWER STATIONS, NAMELY, OPTICAL MIRRORS, NAMELY, HELIOSTATS, AS WELL AS ELECTRIC ACTUATORS AND SENSORS FOR CONTROLLING A SUN TRACKING SYSTEM AS WELL AS ELECTRONIC CONTROLLING DEVICES FOR THE SUN TRACKING SYSTEM; ALL AFOREMENTIONED GOODS NOT IN THE FIELD OF PHOTOVOLTAICS (U.S. CLS. 21, 23, 26, 36 AND 38).

CLASS 11—ENVIRONMENTAL CONTROL APPARATUS

FOR SOLAR ENERGY RECEIVERS AS PARTS OF SOLAR THERMAL POWER STATIONS; ALL AFOREMENTIONED GOODS NOT IN THE FIELD OF PHOTOVOLTAICS (U.S. CLS. 13, 21, 23, 31 AND 34).

NICHOLAS COLEMAN, EXAMINING ATTORNEY

SN 79-109,306. OSRAM AG, AKA OSRAM AKTIENGESELLSCHAFT, MÜNCHEN, FED REP GERMANY, FILED 10-24-2011.

HPMSL

THE MARK CONSISTS OF STANDARD CHARACTERS WITHOUT CLAIM TO ANY PARTICULAR FONT, STYLE, SIZE, OR COLOR.

PRIORITY DATE OF 6-10-2011 IS CLAIMED.
OWNER OF INTERNATIONAL REGISTRATION 1107249 DATED 10-24-2011, EXPIRES 10-24-2021.

CLASS 9—ELECTRICAL AND SCIENTIFIC APPARATUS

FOR APPARATUS AND INSTRUMENTS FOR CONDUCTING, SWITCHING, TRANSFORMING, ACCUMULATING, REGULATING OR CONTROLLING ELECTRICITY; LASERS, NOT FOR MEDICAL PURPOSES; LIGHT CONTROL SYSTEMS; LIGHT-EMITTING DIODES, INCLUDING ORGANIC LIGHT-EMITTING DIODES, LASER DIODES, ESPECIALLY POWER LASER DIODES, SEMICONDUCTOR POWER LASER DIODES FOR MATERIAL PROCESSING, SEMI-CONDUCTOR COMPONENTS, FIBRE OPTICAL LIGHT CONDUCTORS INCLUSIVE LED OPERATED FIBRE OPTICAL LIGHT CONDUCTORS, OPTOCOUPERS, OPTICAL SENSORS, LIGHT BARRIERS, LIGHT-EMITTING DIODE MODULES (MODULES WITH LIGHT FUNCTIONS, CONSTRUCTED FROM LIGHT-EMITTING DIODES, INCLUDING ORGANIC LIGHT-EMITTING DIODES WITH LIGHT FUNCTIONS), ESPECIALLY FOR LIGHTING), ESPECIALLY FOR AND SIGNALLING APPLICATIONS, DISPLAYS, INCLUDING ORGANIC LIGHT-EMITTING DIODE TECHNOLOGY DISPLAYS; PARTS FOR ALL THE AFORESAID GOODS, INCLUDED IN THIS CLASS (U.S. CLS. 21, 23, 26, 36 AND 38).

CLASS 11—ENVIRONMENTAL CONTROL APPARATUS

FOR APPARATUS FOR LIGHTING, ESPECIALLY ELECTRIC LAMPS AND LUMINAIRES; LIGHTING APPARATUS AND SYSTEMS CONSISTING OF LIGHTING APPARATUS, ESPECIALLY LIGHTING APPARATUS AND SYSTEMS BASED ON LIGHT EMITTING DIODES (LEDS), INCLUDING ORGANIC LIGHT-EMITTING DIODES, LED LAMPS AND LED LUMINAIRES AND THEIR PARTS, LIGHTING LAMPS AND LIGHTING APPARATUS AND FACILITIES CONSISTING OF LIGHTING LAMPS AND LIGHTING APPARATUS AS WELL AS THEIR PARTS (INCLUDED IN THIS CLASS) ON BASIS OF LIGHT EMITTING DIODES (LED); LED-MODULES, NAMELY, MODULES CONSTRUCTED OF LED'S (INCLUSIVE ORGANIC LED'S) WITH LIGHT FUNCTIONS AND FOR LIGHTING APPLICATIONS (U.S. CLS. 13, 21, 23, 31 AND 34).

KEVIN CORWIN, EXAMINING ATTORNEY

SN 79-109,440. HEINRICH KINIGADNER, AUSTRIA, FILED 11-24-2011.

FULLGAS

THE MARK CONSISTS OF STANDARD CHARACTERS WITHOUT CLAIM TO ANY PARTICULAR FONT, STYLE, SIZE, OR COLOR.

PRIORITY DATE OF 8-9-2011 IS CLAIMED.
OWNER OF INTERNATIONAL REGISTRATION 1107544 DATED 11-24-2011, EXPIRES 11-24-2021.

CLASS 25—CLOTHING

FOR CLOTHING, IN PARTICULAR BANDANAS, BELTS, GLOVES, SHIRTS, TROUSERS, JACKETS, LEATHER COATS, PARKAS, PULLOVERS, PYJAMAS, WATERPROOF CLOTHING IN THE NATURE OF WATERPROOF JACKETS AND PANTS, SCARVES, SHOES, BOOTS, SWEATERS, SINGLET, T-SHIRTS, HEADGEAR, IN PARTICULAR CAPS, HOODS, BONNETS (U.S. CLS. 22 AND 39).

CLASS 39—TRANSPORTATION AND STORAGE

FOR TRAVEL ARRANGEMENT (U.S. CLS. 100 AND 105).

CLASS 41—EDUCATION AND ENTERTAINMENT

FOR EVENTS, IN PARTICULAR ORGANIZING AND CONDUCTING OF COMMUNITY CULTURAL AND SPORTING EVENTS, CONDUCTING OF LIVE EVENTS IN THE NATURE OF MOTOR SPORTS EVENTS (U.S. CLS. 100, 101 AND 107).

KRISTINA MORRIS, EXAMINING ATTORNEY

SN 79-109,773. KONG S.P.A., MONTE MARENZO (LECCO), ITALY, FILED 5-31-2011.



PRIORITY DATE OF 5-12-2011 IS CLAIMED.
OWNER OF INTERNATIONAL REGISTRATION 1108362 DATED 5-31-2011, EXPIRES 5-31-2021.

OWNER OF U.S. REG. NO. 1,301,195.
THE MARK CONSISTS OF A STYLIZED LETTER "K" INSIDE OF AN OVAL THAT RESEMBLES A CARABINER.

CLASS 6—METAL GOODS

FOR METAL HARDWARE, NAMELY, CARABINERS BEING CONNECTORS; ICE AND CLIMBING PITONS OF METAL FOR MOUNTAINEERING; PULLEYS OF METAL OTHER THAN FOR MACHINES; ROPE CLAMP OF METAL; METAL DEVICES FOR ROPE, NAMELY, METAL HARDWARE BELAYS, HANDLES, AND HOOKS (U.S. CLS. 2, 12, 13, 14, 23, 25 AND 50).

CLASS 9—ELECTRICAL AND SCIENTIFIC APPARATUS

FOR HELMETS FOR CLIMBER; RESCUE STRETCHERS; RESCUE TRIPODS; RESCUE POLES; RESCUE DEVICES, NAMELY, RESCUE FLARES, LIFE PRESERVERS; FALL PROTECTION HARNESS FOR USE IN EVACUATION (U.S. CLS. 21, 23, 26, 36 AND 38).

CLASS 18—LEATHER GOODS

FOR BAGS, ALL PURPOSE CARRYING BAGS, DUFFEL BAGS, TRAVEL BAGS; KNAPSACKS; WORK BAGS, NAMELY, BRIEFCASES AND ATTACHE CASES; HAND BAGS (U.S. CLS. 1, 2, 3, 22 AND 41).

CLASS 22—CORDAGE AND FIBERS

FOR ROPES AND CORDS (U.S. CLS. 1, 2, 7, 19, 22, 42 AND 50).

CLASS 25—CLOTHING

FOR CLOTHING, NAMELY, BERETS, HATS, BELTS, SKIRTS, JACKETS, SWEATERS, JERSEY, BLOUSES, BALL-GOWNS, DRESSING-GOWNS, UNDER-SKIRTS, BATHING-SUITS, UNDERWEAR, BLOUSES, BODY SUITS, BODY SHAPERS, SOCKS, TIGHTS, TIES, GLOVES, MANTLES, CAPES, WAISTCOATS, TROUSERS, PARKAS, PYJAMAS, PULLOVERS, SCARVES, SHAWLS, OVERCOATS, OVERALLS; FOOTWEAR, NAMELY SHOES, BOOTS, AND SLIPPERS (U.S. CLS. 22 AND 39).

CLASS 28—TOYS AND SPORTING GOODS

FOR HARNESS FOR CLIMBERS; HARNESS FOR SAILBOARD; HARNESS FOR SPORTS, NAMELY, HARNESS FOR WATERSKI TOWING (U.S. CLS. 22, 23, 38 AND 50).

APRIL ROACH, EXAMINING ATTORNEY

SN 79-109,795. FIRMENICH SA, SWITZERLAND, FILED 1-18-2012.

SPLENDIONE

THE MARK CONSISTS OF STANDARD CHARACTERS WITHOUT CLAIM TO ANY PARTICULAR FONT, STYLE, SIZE, OR COLOR.

PRIORITY DATE OF 7-27-2011 IS CLAIMED.

OWNER OF INTERNATIONAL REGISTRATION 1108424 DATED 1-18-2012, EXPIRES 1-18-2022.

CLASS 1—CHEMICALS

FOR CHEMICALS FOR USE IN THE MANUFACTURE OF PERFUMES, NAMELY, KETONES FOR USE IN THE MANUFACTURE OF PERFUMES AND ESTERS FOR USE IN THE MANUFACTURE OF PERFUMES; CHEMICAL ADDITIVES FOR USE IN THE FLAVORING INDUSTRY, NAMELY, CHEMICAL ADDITIVES FOR USE IN THE MANUFACTURE OF FOODS, BEVERAGES, PHARMACEUTICAL PREPARATIONS AND MOUTH CARE PRODUCTS (U.S. CLS. 1, 5, 6, 10, 26 AND 46).

CLASS 3—COSMETICS AND CLEANING PREPARATIONS

FOR NATURAL AND ARTIFICIAL PERFUMES; ESSENTIAL OILS FOR USE IN THE MANUFACTURE OF CONSUMER PRODUCTS, NAMELY, PERFUMES, COSMETICS, SOAPS, DETERGENTS AND FOODSTUFFS, BEVERAGES, PHARMACEUTICAL PRODUCTS AND MOUTH CARE PRODUCTS (U.S. CLS. 1, 4, 6, 50, 51 AND 52).

CLASS 30—STAPLE FOODS

FOR FLAVORS AND FLAVORING COMPOSITIONS, OTHER THAN ESSENTIAL OILS, INTENDED TO IMPART TASTE TO FOODSTUFFS, TO BEVERAGES, TO PHARMACEUTICAL PREPARATIONS AND TO MOUTH CARE PRODUCTS, NAMELY FLAVOR ENHANCERS USED IN FOODS, BEVERAGES, PHARMACEUTICAL PREPARATIONS AND MOUTH CARE PRODUCTS, FLAVORING ADDITIVES FOR NON-NUTRITIONAL PURPOSES, FLAVORINGS FOR FOODS, BEVERAGES, PHARMACEUTICAL PREPARATIONS AND MOUTH CARE PRODUCTS, OTHER THAN ESSENTIAL OILS, EXTRACTS USED AS FLAVORING OTHER THAN ESSENTIAL OILS, FOOD ADDITIVES FOR NON-NUTRITIONAL PURPOSES FOR USE AS A FLAVORING (U.S. CL. 46).

SANI KHOURI, EXAMINING ATTORNEY

SN 79-110,506. FIRMENICH SA, SWITZERLAND, FILED 1-18-2012.

VELOUTONE

THE MARK CONSISTS OF STANDARD CHARACTERS WITHOUT CLAIM TO ANY PARTICULAR FONT, STYLE, SIZE, OR COLOR.

PRIORITY DATE OF 7-27-2011 IS CLAIMED.

OWNER OF INTERNATIONAL REGISTRATION 1110318 DATED 1-18-2012, EXPIRES 1-18-2022.

CLASS 1—CHEMICALS

FOR CHEMICALS FOR USE IN THE MANUFACTURE OF PERFUMES NAMELY KETONES FOR USE IN THE MANUFACTURE OF PERFUMES (U.S. CLS. 1, 5, 6, 10, 26 AND 46).

CLASS 3—COSMETICS AND CLEANING PREPARATIONS

FOR NATURAL AND ARTIFICIAL PERFUMES, ESSENTIAL OILS FOR USE IN THE MANUFACTURE OF CONSUMER PRODUCTS, NAMELY, PERFUMES, COSMETICS, SOAPS, DETERGENTS (U.S. CLS. 1, 4, 6, 50, 51 AND 52).

SANI KHOURI, EXAMINING ATTORNEY

SN 85-022,532. NEPTUNE MANAGEMENT CORP., DBA NEPTUNE SOCIETY, PLANTATION, FL. FILED 4-25-2010.



REGISTRATION LIMITED TO THE AREA COMPRISING THE ENTIRE UNITED STATES OF AMERICA, ITS TERRITORIES AND POSSESSIONS INCLUDING THE STATE OF CALIFORNIA, EXCEPT FOR THE FOLLOWING COUNTIES WITHIN THE STATE OF CALIFORNIA: IMPERIAL, RIVERSIDE, SAN BERNADINO, SAN DIEGO, ALAMEDA, ALPINE, AMADOR, BUTTE, CALAVERAS, COLUSA, CONTRA COSTA, DEL NORTE, EL DORADO, GLENN, HUMBOLDT, LAKE, LASSEN, MARIN, MENDOCINO, MODOC, NAPA, NEVADEA, PLACER, PLUMAS, SACRAMENTO, SAN FRANCISCO, SAN JOAQUIN, SAN MATEO, SHASTA, SIERRA, SISKIYOU, SOLANO, SONOMA, SUTTER, TEHAMA, TRINITY, YOLO, YUBA, FRESNO, INYO, KERN, KINGS, MADERA, MARIPOSA, MERCED, MONO, MONTEREY, ORANGE, SAN BENITO, SANTA CLARA, SANTA CRUZ, STANISLAUS, TULARE, AND TOULOMNE PURSUANT TO THE DECREE OF PATENT AND TRADEMARK OFFICE TRADEMARK TRIAL AND APPEAL BOARD, CONCURRENT USE NO. 871, DATED JANUARY 17, 1996, CONCURRENT REGISTRATION WITH U.S. REGISTRATION NO. 1984893.

OWNER OF U.S. REG. NOS. 1,984,894, 3,317,990 AND 8,502,253.

NO CLAIM IS MADE TO THE EXCLUSIVE RIGHT TO USE "SOCIETY", APART FROM THE MARK AS SHOWN.

THE COLOR(S) PURPLE AND BLACK IS/ARE CLAIMED AS A FEATURE OF THE MARK.

THE MARK CONSISTS OF "NEPTUNE SOCIETY" IN BLACK, UNDERLINED BY A PURPLE HORIZONTAL LINE. A DESIGN ELEMENT OF A PURPLE DOVE IS PERCHED ON THE LETTER "S".

CLASS 40—MATERIAL TREATMENT

FOR CREMATION SERVICES (U.S. CLS. 100, 103 AND 106).

FIRST USE 5-23-2010; IN COMMERCE 1-11-2011.

CLASS 45—PERSONAL AND LEGAL SERVICES

FOR FUNERAL SERVICES ACCOMPANYING CREMATION (U.S. CLS. 100 AND 101).

FIRST USE 5-1-2010; IN COMMERCE 1-11-2011.

WENDY JUN, EXAMINING ATTORNEY

SN 85-025,381. MAUI COMPOSITES INC., HAIKU, HI. FILED 4-28-2010.



THE MARK CONSISTS OF THE STYLIZED WORD "MFC" DISPLAYED USING A SANS-SERIF FONT TYPE.

CLASS 9—ELECTRICAL AND SCIENTIFIC APPARATUS

FOR COMPUTER BAGS; BACKPACKS ESPECIALLY ADAPTED FOR HOLDING LAPTOPS AND NOTEBOOK COMPUTERS; BAGS AND CASES ESPECIALLY ADAPTED FOR HOLDING LAPTOPS AND NOTEBOOK COMPUTERS; SUNGLASSES (U.S. CLS. 21, 23, 26, 36 AND 38).

FIRST USE 12-31-2002; IN COMMERCE 12-31-2002.

CLASS 18—LEATHER GOODS

FOR BACKPACKS, RUCKSACKS, MESSENGER BAGS AND GENERAL PURPOSE SPORT TROLLEY BAGS ESPECIALLY FOR USE IN THE FIELD OF WINDSURFING; GENERAL PURPOSE WHEELED BAGS (U.S. CLS. 1, 2, 3, 22 AND 41).

FIRST USE 12-31-2002; IN COMMERCE 12-31-2002.

CLASS 28—TOYS AND SPORTING GOODS

FOR SURF FINS; FINS FOR SURFBOARDS OR BODY BOARDS; BAGS SPECIALLY DESIGNED AND ADAPTED FOR SURFING EQUIPMENT SUCH AS SURFBOARDS, BODY BOARDS, SAILS AND MAST FOR SURFBOARDS; SAIL BOARD FOOT STRAPS; SURFBOARD AND BODY BOARD ACCESSORIES, NAMELY, HARNESS STRAPS AND HARNESS LINES, SEAT HARNESSES, WAIST HARNESSES AND SAIL BOARD FOOT STRAPS ALL FOR USE ESPECIALLY WITH SURFBOARDS OR BODY BOARDS (U.S. CLS. 22, 23, 38 AND 50).

FIRST USE 12-31-1986; IN COMMERCE 12-31-1986.
LESLEY LAMOTHE, EXAMINING ATTORNEY

SN 85-032,472. VALLOPILLIL, SINDHYA, NEW YORK, NY. FILED 5-7-2010.



THE MARK CONSISTS OF STANDARD CHARACTERS WITHOUT CLAIM TO ANY PARTICULAR FONT, STYLE, SIZE, OR COLOR.

CLASS 3—COSMETICS AND CLEANING PREPARATIONS

FOR MEN'S LIFESTYLE PRODUCTS, NAMELY, NON-MEDICATED SKIN CARE PREPARATIONS, SHOWER GELS, HAIR CARE PREPARATIONS, SOAPS FOR BODY CARE, PERFUMES AND COLOGNES, BODY WASH, NON-MEDICATED HAND WASH, AND ESSENTIAL OILS; SHAVING PRODUCTS, NAMELY, SHAVING BALMS, CREAMS, GELS, LOTION, AND PREPARATIONS FOR MEN (U.S. CLS. 1, 4, 6, 50, 51 AND 52).

CLASS 4—LUBRICANTS AND FUELS

FOR CANDLES (U.S. CLS. 1, 6 AND 15).
JORDAN BAKER, EXAMINING ATTORNEY

SN 85-034,599. PRZ, LLC, VIENNA, VA. FILED 5-10-2010.



THE MARK CONSISTS OF STANDARD CHARACTERS WITHOUT CLAIM TO ANY PARTICULAR FONT, STYLE, SIZE, OR COLOR.

THE NAME(S), PORTRAIT(S), AND/OR SIGNATURE(S) SHOWN IN THE MARK IDENTIFIES PIROOZ SARSHAR, WHOSE CONSENT(S) TO REGISTER IS MADE OF RECORD.

CLASS 41—EDUCATION AND ENTERTAINMENT

FOR PROVIDING AN INTERNET WEBSITE PROVIDING INFORMATION THAT EDUCATES MEN ABOUT MEN'S ISSUES, NAMELY, EXERCISE, FITNESS, ENTERTAINMENT, LEISURE AND RECREATION ACTIVITIES, SPORT, ARTS, POP CULTURE, MUSIC (U.S. CLS. 100, 101 AND 107).

CLASS 43—HOTEL AND RESTAURANT SERVICES

FOR PROVIDING AN INTERNET WEBSITE PROVIDING INFORMATION THAT EDUCATES MEN ABOUT MEN'S ISSUES, NAMELY, FOOD, NAMELY, COOKING AND RECIPES AND DRINKS (U.S. CLS. 100 AND 101).

CLASS 44—MEDICAL, BEAUTY AND AGRICULTURAL SERVICES

FOR PROVIDING AN INTERNET WEBSITE PROVIDING INFORMATION THAT EDUCATES MEN ABOUT MEN'S ISSUES, NAMELY, PERSONAL HYGIENE, GROOMING AND COSMETICS, FOOD NUTRITION, HEALTH ISSUES RELATING TO SEX (U.S. CLS. 100 AND 101).

CLASS 45—PERSONAL AND LEGAL SERVICES

FOR PROVIDING AN INTERNET WEBSITE PROVIDING INFORMATION THAT EDUCATES MEN ABOUT MEN'S ISSUES, NAMELY, PERSONAL RELATIONSHIPS AND SEXUALITY, FASHION AND HUMAN CULTURES (U.S. CLS. 100 AND 101).

JENNY PARK, EXAMINING ATTORNEY

SN 85-048,529. CONCHY JOE'S RESTAURANTS, INC., AKA CONCHY JOE'S SEAFOOD RESTAURANT, JENSEN BEACH, FL. FILED 5-26-2010.

CONCHY JOE'S

THE MARK CONSISTS OF STANDARD CHARACTERS WITHOUT CLAIM TO ANY PARTICULAR FONT, STYLE, SIZE, OR COLOR.
"CONCHY JOE" DOES NOT IDENTIFY A LIVING INDIVIDUAL.

CLASS 35—ADVERTISING AND BUSINESS

FOR ON-LINE RETAIL GIFT SHOPS (U.S. CLS. 100, 101 AND 102).

CLASS 43—HOTEL AND RESTAURANT SERVICES

FOR RESTAURANT (U.S. CLS. 100 AND 101).
FIRST USE 10-27-1982; IN COMMERCE 10-27-1982.
JASON BLAIR, EXAMINING ATTORNEY

SN 85-049,341. LG ELECTRONICS INC., SEOUL, REPUBLIC OF KOREA, FILED 5-27-2010.

Pixel soldier

THE MARK CONSISTS OF STANDARD CHARACTERS WITHOUT CLAIM TO ANY PARTICULAR FONT, STYLE, SIZE, OR COLOR.

PRIORITY CLAIMED UNDER SEC. 44(D) ON REPUBLIC OF KOREA APPLICATION NO. 45-2010-0000, FILED 3-8-2010, REG. NO. 0037466, DATED 12-13-2011, EXPIRES 12-13-2021.

NO CLAIM IS MADE TO THE EXCLUSIVE RIGHT TO USE "PIXEL", APART FROM THE MARK AS SHOWN.

CLASS 9—ELECTRICAL AND SCIENTIFIC APPARATUS

FOR TELEVISION RECEIVERS; COMPUTER MONITORS (U.S. CLS. 21, 23, 26, 36 AND 38).

CLASS 35—ADVERTISING AND BUSINESS

FOR ADVERTISEMENT PLANNING; ADVERTISING AGENCIES; DEMONSTRATION OF GOODS; PUBLIC OPINION POLLING; PROVISION OF COMMERCIAL INFORMATION VIA THE INTERNET; SALES PROMOTION VIA COMPUTER NETWORK; PROVISION OF CONSUMER INFORMATION IN THE FIELD OF ELECTRONIC MACHINES AND APPARATUS, NAMELY, TELEVISIONS AND COMPUTER MONITORS VIA COMPUTER NETWORK; PROVISION OF INFORMATION IN THE FIELD OF BUSINESS VIA GLOBAL COMPUTER NETWORK; PROVISION OF A WEB SITE FEATURING CONSUMER INFORMATION ON SHOPPING AND GIFT BUYING BASED ON INFORMATION PROVIDED BY CUSTOMERS; ADVERTISING VIA ELECTRONIC MEDIA AND SPECIFICALLY THE INTERNET; ON-LINE ADVERTISING ON COMPUTER COMMUNICATION NETWORKS; WHOLESALE DISTRIBUTORSHIPS FEATURING COMMUNICATION MACHINES AND APPARATUS; RETAIL SERVICES FOR COMMUNICATION MACHINES AND APPARATUS, NAMELY, RETAIL STORE SERVICES FEATURING COMMUNICATION MACHINES AND APPARATUS; WHOLESALE DISTRIBUTORSHIPS FEATURING PORTABLE COMMUNICATIONS APPARATUS; RETAIL SERVICES FOR PORTABLE COMMUNICATIONS APPARATUS, NAMELY, RETAIL STORE SERVICES FEATURING PORTABLE COMMUNICATIONS APPARATUS; WHOLESALE DISTRIBUTORSHIPS FEATURING COMPUTERS; RETAIL SERVICES FOR COMPUTERS, NAMELY, RETAIL STORE SERVICES FEATURING COMPUTERS; WHOLESALE DISTRIBUTORSHIPS FEATURING TELECOMMUNICATION MACHINES AND APPARATUS; RETAIL SERVICES FOR TELECOMMUNICATION MACHINES AND APPARATUS, NAMELY, RETAIL STORE SERVICES FEATURING TELECOMMUNICATIONS MACHINES AND APPARATUS; WHOLESALE DISTRIBUTORSHIPS FEATURING ELECTRONIC MACHINES AND APPARATUS AND THEIR PARTS; RETAIL SERVICES FOR ELECTRONIC MACHINES AND APPARATUS AND THEIR PARTS, NAMELY, RETAIL STORE SERVICES FEATURING ELECTRONIC MACHINES AND APPARATUS AND THEIR PARTS; WHOLESALE DISTRIBUTORSHIPS FEATURING COMPUTER MONITORS; RETAIL SERVICES FOR COMPUTER MONITORS, NAMELY, RETAIL STORE SERVICES FEATURING COMPUTER MONITORS; MARKETING SERVICES FOR COMPUTER MONITORS VIA THE INTERNET, NAMELY, BUSINESS MARKETING SERVICES FOR COMPUTER MONITORS VIA THE INTERNET; BUSINESS MARKETING SERVICES; PRESENTATION OF GOODS ON COMMUNICATION MEDIA FOR RETAIL PURPOSES (U.S. CLS. 100, 101 AND 102).

DOUGLAS LEE, EXAMINING ATTORNEY

SN 85-050,506. CONCHY JOE'S RESTAURANTS, INC., AKA CONCHY JOE'S SEAFOOD RESTAURANT, JENSEN BEACH, FL. FILED 5-28-2010.

CONCHY JOE'S SEAFOOD

THE MARK CONSISTS OF STANDARD CHARACTERS WITHOUT CLAIM TO ANY PARTICULAR FONT, STYLE, SIZE, OR COLOR.

NO CLAIM IS MADE TO THE EXCLUSIVE RIGHT TO USE "SEAFOOD", APART FROM THE MARK AS SHOWN.

"CONCHY JOE" DOES NOT IDENTIFY A LIVING INDIVIDUAL.

CLASS 35—ADVERTISING AND BUSINESS

FOR ON-LINE RETAIL GIFT SHOPS (U.S. CLS. 100, 101 AND 102).

CLASS 43—HOTEL AND RESTAURANT SERVICES

FOR RESTAURANT (U.S. CLS. 100 AND 101).
FIRST USE 10-27-1982; IN COMMERCE 10-27-1982.
JASON BLAIR, EXAMINING ATTORNEY

SN 85-085,673. PREMIUM LATIN MUSIC, INC., POMONA, NY. FILED 7-15-2010.

RITA INDIANA Y LOS MISTERIOS

SN 85-074,972. J.J. MACKAY CANADA LIMITED, NEW GLASGOW, NOVA SCOT, CANADA, FILED 6-30-2010.

THE MARK CONSISTS OF STANDARD CHARACTERS WITHOUT CLAIM TO ANY PARTICULAR FONT, STYLE, SIZE, OR COLOR.

THE NAME(S), PORTRAIT(S), AND/OR SIGNATURE(S) SHOWN IN THE MARK IDENTIFIES "RITA INDIANA HERNANDEZ", WHOSE CONSENT(S) TO REGISTER IS MADE OF RECORD.

THE ENGLISH TRANSLATION OF "LOS MISTERIOS" IN THE MARK IS "THE MYSTERIES".

SENTINEL

THE MARK CONSISTS OF STANDARD CHARACTERS WITHOUT CLAIM TO ANY PARTICULAR FONT, STYLE, SIZE, OR COLOR.

PRIORITY CLAIMED UNDER SEC. 44(D) ON CANADA APPLICATION NO. 1484253, FILED 6-8-2010, REG. NO. TMA821592, DATED 4-4-2012, EXPIRES 4-4-2027.

CLASS 9—ELECTRICAL AND SCIENTIFIC APPARATUS

FOR COMPACT DISCS FEATURING MUSIC; DIGITAL MEDIA, NAMELY, PRE-RECORDED VIDEO CASSETTES, DIGITAL VIDEO DISCS, DIGITAL VERSATILE DISCS, DOWNLOADABLE AUDIO AND VIDEO RECORDINGS, DVDS, AND HIGH DEFINITION DIGITAL DISCS FEATURING MUSIC; DOWNLOADABLE MP3 FILES, MP3 RECORDINGS, ON-LINE DISCUSSION BOARDS, WEBCASTS, WEBINARS AND PODCASTS FEATURING MUSIC, AUDIO BOOKS IN THE FIELD OF MUSIC AND NEWS BROADCASTS IN THE FIELD OF MUSIC (U.S. CLS. 21, 23, 26, 36 AND 38).

CLASS 9—ELECTRICAL AND SCIENTIFIC APPARATUS

FOR SOFTWARE, NAMELY, DOWNLOADABLE SOFTWARE FOR USE WITH SINGLE SPACE PARKING METERS AND MULTIPLE PARKING SPACE PAY STATIONS FOR THEIR REMOTE MANAGEMENT, CONFIGURATION, PROVISION, ALERT NOTIFICATION, REPORTING, RECONCILIATION, AUDITING, ACCOUNTING AND ENFORCEMENT OF PARKING; DOWNLOADABLE SOFTWARE FOR REMOTE PURCHASE TRANSACTIONS FOR SINGLE SPACE PARKING METERS AND MULTIPLE PARKING SPACE PAY STATIONS SENT BY SMS MESSAGE FORMAT; DOWNLOADABLE SOFTWARE FOR REMOTE COMMAND DELIVERY TO SINGLE SPACE PARKING METERS AND MULTIPLE PARKING SPACE PAY STATIONS SENT BY SMS MESSAGE FORMAT (U.S. CLS. 21, 23, 26, 36 AND 38).

CLASS 41—EDUCATION AND ENTERTAINMENT

FOR ENTERTAINMENT IN THE NATURE OF VISUAL AND AUDIO PERFORMANCES, NAMELY, MUSICAL BAND, ROCK GROUP, GYMNASTIC, DANCE, AND BALLET PERFORMANCES; ENTERTAINMENT SERVICES IN THE NATURE OF LIVE MUSICAL PERFORMANCES; ENTERTAINMENT, NAMELY, LIVE MUSIC CONCERTS; ENTERTAINMENT, NAMELY, LIVE PERFORMANCES BY A MUSICAL BAND (U.S. CLS. 100, 101 AND 107).

JUSTINE D. PARKER, EXAMINING ATTORNEY

CLASS 42—SCIENTIFIC AND COMPUTER SERVICES

FOR APPLICATION SERVICE PROVIDER (ASP) SERVICES FEATURING WEB-BASED SOFTWARE FOR USE WITH SINGLE SPACE PARKING METERS AND MULTIPLE PARKING SPACE PAY STATIONS ALLOWING FOR THEIR REMOTE MANAGEMENT, CONFIGURATION, PROVISION, ALERT NOTIFICATION, REPORTING, RECONCILIATION, AUDITING, ACCOUNTING AND ENFORCEMENT OF PARKING; WEB-BASED SOFTWARE FOR USE WITH SINGLE SPACE PARKING METERS AND MULTIPLE PARKING SPACE PAY STATIONS FOR THEIR REMOTE MANAGEMENT, CONFIGURATION, PROVISION, ALERT NOTIFICATION, REPORTING, RECONCILIATION, AUDITING, ACCOUNTING AND ENFORCEMENT OF PARKING; WEB-BASED SOFTWARE FOR REMOTE PURCHASE TRANSACTIONS FOR SINGLE SPACE PARKING METERS AND MULTIPLE PARKING SPACE PAY STATIONS SENT BY SMS MESSAGE FORMAT; WEB-BASED SOFTWARE FOR REMOTE COMMAND DELIVERY TO SINGLE SPACE PARKING METERS AND MULTIPLE PARKING SPACE PAY STATIONS SENT BY SMS MESSAGE FORMAT (U.S. CLS. 100 AND 101).

MARILYN IZZI, EXAMINING ATTORNEY

SN 85-090,926. PETROLEUM DEVELOPMENT CORPORATION, DBA PCD ENERGY, DENVER, CO. FILED 7-22-2010.

PDC Energy

THE MARK CONSISTS OF STANDARD CHARACTERS WITHOUT CLAIM TO ANY PARTICULAR FONT, STYLE, SIZE, OR COLOR.

NO CLAIM IS MADE TO THE EXCLUSIVE RIGHT TO USE "ENERGY", APART FROM THE MARK AS SHOWN.

CLASS 37—CONSTRUCTION AND REPAIR

FOR EXTRACTION OF OIL; OIL AND GAS DRILLING; OIL PUMPING AND EXTRACTION (U.S. CLS. 100, 103 AND 106).

FIRST USE 7-15-2010; IN COMMERCE 7-15-2010.

CLASS 40—MATERIAL TREATMENT

FOR GAS PRODUCTION SERVICES; OIL PRODUCTION SERVICES (U.S. CLS. 100, 103 AND 106).
FIRST USE 7-15-2010; IN COMMERCE 7-15-2010.

SN 85-111,506. EUROP ASSISTANCE HOLDING, PARIS, FRANCE, FILED 8-19-2010.

CLASS 42—SCIENTIFIC AND COMPUTER SERVICES

FOR EXPLORATION AND SEARCHING OF OIL AND GAS; GAS EXPLORATION (U.S. CLS. 100 AND 101).
FIRST USE 7-15-2010; IN COMMERCE 7-15-2010.
WON TEAK OH, EXAMINING ATTORNEY

DOCTICARE

SN 85-090,969. PETROLEUM DEVELOPMENT CORPORATION, DBA PDC ENERGY, DENVER, CO. FILED 7-22-2010.

THE MARK CONSISTS OF STANDARD CHARACTERS WITHOUT CLAIM TO ANY PARTICULAR FONT, STYLE, SIZE, OR COLOR.

PRIORITY CLAIMED UNDER SEC. 44(D) ON ERPNCMNTY TM OFC APPLICATION NO. 008954679, FILED 3-15-2010, REG. NO. 008954679, DATED 1-12-2012, EXPIRES 3-15-2020.



NO CLAIM IS MADE TO THE EXCLUSIVE RIGHT TO USE 'ENERGY', APART FROM THE MARK AS SHOWN.

THE COLOR(S) BLACK AND RUST IS/ARE CLAIMED AS A FEATURE OF THE MARK.

THE MARK CONSISTS OF THE MARK CONSISTS OF A ROUND FLAME DESIGN AND THE LETTERS "PDC" TO THE RIGHT OF THE FLAME DESIGN, AND THE WORDING "ENERGY" BENEATH THE LETTERS "PDC". THE COLOR BLACK APPEARS IN THE FLAME DESIGN AND THE LETTERS "PDC". THE COLOR RUST APPEARS IN A ROUND DESIGN FRAMING THE BLACK FLAME DESIGN AND IN THE WORDING "ENERGY".

CLASS 35—ADVERTISING AND BUSINESS

FOR ADVERTISING; BUSINESS MANAGEMENT, NAMELY, ASSISTANCE REGARDING THE OPERATION OR MANAGEMENT OF INDUSTRIAL AND COMMERCIAL COMPANIES, AND IN MANAGING THE BUSINESS AND COMMERCIAL ACTIVITIES OF AN INDUSTRIAL AND COMMERCIAL COMPANY; BUSINESS CONSULTATION; PROVIDING BUSINESS DATA ANALYSIS AND BUSINESS INFORMATION SERVICES TO THE FINANCE, INSURANCE, TRAVEL AND HEALTH INDUSTRIES; DISSEMINATION OF ADVERTISING MATERIAL IN THE NATURE OF LEAFLETS, PROSPECTUSES AND SAMPLES; CONDUCTING PUBLIC OPINION POLLS; PROVIDING STATISTICAL INFORMATION; ORGANIZATION OF EXHIBITIONS FOR COMMERCIAL OR ADVERTISING PURPOSES IN THE NATURE OF PRESENTATIONS OCCURRING DURING TRADE FAIRS; ASSISTANCE, ADVICE AND INFORMATION ON BUSINESS ADMINISTRATION CONCERNING MANAGEMENT OF TRAVEL AND LIVING CONDITIONS ABROAD (U.S. CLS. 100, 101 AND 102).

CLASS 36—INSURANCE AND FINANCIAL

FOR ASSISTANCE, ADVICE AND INFORMATION ON PROCESSING AND ADMINISTERING EMPLOYEE BENEFITS PLANS CONCERNING HEALTH INSURANCE (U.S. CLS. 100, 101 AND 102).

CLASS 38—COMMUNICATION

FOR TELECOMMUNICATION SERVICES, NAMELY, COMMUNICATIONS SERVICES BY TELEPHONE, BY MOBILE TELEPHONE, OPTICAL FIBER AND CABLE NETWORKS, AND BY ALL REMOTE DATA PROCESSING MEANS, NAMELY, VIA REMOTE INTERNET ACCESS, ELECTRONIC COMMUNICATION NETWORKS, ELECTRONIC MAIL, GLOBAL COMPUTER NETWORKS, WIRELESS BROADBAND COMMUNICATION; COMMUNICATIONS BY COMPUTER TERMINALS AND BY OPTICAL FIBER NETWORKS; PROVIDING TELECOMMUNICATION SERVICES IN THE FIELD OF RADIO AND TELEPHONE TELECOMMUNICATION, MOBILE RADIOTELEPHONY SERVICES; PROVIDING ACCESS TO A GLOBAL COMPUTER NETWORK, NAMELY, TELECOMMUNICATION SERVICES, NAMELY, ELECTRONIC TRANSMISSION OF SOUND, IMAGES AND DATA; PROVIDING TELECOMMUNICATIONS CONNECTIONS TO A GLOBAL COMPUTER NETWORK; RENTAL OF TELECOMMUNICATION APPARATUS AND INSTALLATIONS; TELECOMMUNICATION SERVICES, NAMELY, ELECTRONIC MESSAGING, RENTAL OF ACCESS TIME TO GLOBAL COMPUTER NETWORKS (U.S. CLS. 100, 101 AND 104).

CLASS 37—CONSTRUCTION AND REPAIR

FOR EXTRACTION OF OIL; OIL AND GAS DRILLING; OIL PUMPING AND EXTRACTION (U.S. CLS. 100, 103 AND 106).

FIRST USE 7-15-2010; IN COMMERCE 7-15-2010.

CLASS 40—MATERIAL TREATMENT

FOR GAS PRODUCTION SERVICES; OIL PRODUCTION SERVICES (U.S. CLS. 100, 103 AND 106).
FIRST USE 7-15-2010; IN COMMERCE 7-15-2010.

CLASS 42—SCIENTIFIC AND COMPUTER SERVICES

FOR EXPLORATION AND SEARCHING OF OIL AND GAS; GAS EXPLORATION (U.S. CLS. 100 AND 101).
FIRST USE 7-15-2010; IN COMMERCE 7-15-2010.
WON TEAK OH, EXAMINING ATTORNEY

CLASS 41—EDUCATION AND ENTERTAINMENT

FOR PROVIDING ON-LINE PUBLICATION OF ELECTRONIC BOOKS, JOURNALS AND MAGAZINES THROUGH THE INTERNET; LEISURE SERVICES, NAMELY, AMUSEMENT AND THEME PARK SERVICES; ENTERTAINMENT IN THE NATURE OF AMUSEMENT PARKS, THEME PARKS AND LIVE PERFORMANCES, NAMELY, THEATRICAL PERFORMANCES; ARRANGING AND CONDUCTING OF EDUCATIONAL COLLOQUIUMS, CONFERENCES AND CONGRESSES IN THE MEDICAL FIELD (U.S. CLS. 100, 101 AND 107).

CLASS 44—MEDICAL, BEAUTY AND AGRICULTURAL SERVICES

FOR HEALTH CARE, MEDICAL AND BEAUTY CARE; PLASTIC SURGERY; PHARMACEUTICAL ADVICE, NAMELY, ADVICE REGARDING THE CHOICE OF DRUGS AND MEDICINES, CONVALESCENCE OR REST HOMES; MEDICALISED HOUSES, NAMELY, HEALTH CARE, MEDICAL AND BEAUTY CARE SERVICES RENDERED IN HOSPITALS, OSPICES, CONVALESCENCE OR REST HOMES; NURSING SERVICES; PROVIDING IN-HOME MEDICAL ASSISTANCE SERVICES TO TRAVELERS IN FRANCE AND ABROAD; MEDICAL SERVICES, NAMELY, PSYCHOLOGICAL COUNSELING; PROVIDING PERSONAL MEDICAL ASSISTANCE SERVICES FOR OTHERS IN THE NATURE OF COORDINATION OF CONTACT WITH MEDICAL AND HOSPITAL FACILITIES AND HEALTH CENTERS TO OBTAIN HEALTH CARE AND MEDICAL SERVICES VIA TELECOMMUNICATION AND GLOBAL COMPUTER NETWORKS THROUGH THE USE OF WEARABLE MEDICAL DEVICES WITH AUTOMATED ALERT AND MONITORING CAPACITY, VIA THE INTERNET AND GLOBAL COMPUTER NETWORKS THROUGH THE USE OF ARCHIVED MEDICAL IMAGES AND A DATA STORAGE AND RETRIEVAL SYSTEM; EMERGENCY MEDICAL ASSISTANCE; CONSULTING AND ADVICE IN CONNECTION WITH THE AFORESAID SERVICES, NAMELY, IN CONNECTION WITH HEALTHCARE, MEDICAL AND BEAUTY CARE, PLASTIC SURGERY, PHARMACEUTICAL ADVICE, CONVALESCENCE OR REST HOMES, MEDICALISED HOUSES, NAMELY, HEALTH CARE, MEDICAL AND BEAUTY CARE SERVICES, RENDERED IN HOSPITALS, HOSPICES, CONVALESCENCE OR REST HOMES; NURSING SERVICES, PROVIDING IN-HOME MEDICAL ASSISTANCE SERVICES TO TRAVELERS IN FRANCE AND ABROAD (U.S. CLS. 100 AND 101).

CLASS 45—PERSONAL AND LEGAL SERVICES

FOR PROVIDING NON-MEDICAL ASSISTANT SERVICES FOR OTHERS IN THE NATURE OF PLANNING, ORGANIZING AND COORDINATING MEDICAL APPOINTMENTS FOR OTHERS RENDERED THROUGH TELEPHONE, COMPUTER NETWORKS, AND THE INTERNET; CONSULTING AND ADVICE IN CONNECTION WITH NON-MEDICAL ASSISTANT SERVICES FOR OTHERS IN THE NATURE OF PLANNING, ORGANIZING AND COORDINATING MEDICAL APPOINTMENTS FOR OTHERS RENDERED THROUGH TELEPHONE, COMPUTER NETWORKS, AND THE INTERNET (U.S. CLS. 100 AND 101).

SANDRA BUJA, EXAMINING ATTORNEY

SN 85-120,090. PEERLESS INDUSTRIAL SYSTEMS PTY LTD, HIGHTT, AUSTRALIA, FILED 8-31-2010.

KIS

THE MARK CONSISTS OF STANDARD CHARACTERS WITHOUT CLAIM TO ANY PARTICULAR FONT, STYLE, SIZE, OR COLOR.

OWNER OF AUSTRALIA REG. NO. 1279659, DATED 12-24-2008, EXPIRES 12-24-2018.

CLASS 2—PAINTS

FOR (BASED ON INTENT TO USE) (BASED ON 44 (E)) ANTI-CORROSIVE COATINGS; (BASED ON INTENT TO USE) COATINGS IN THE NATURE OF INDUSTRIAL SEALANTS FOR WATERPROOFING; POLYMER-BASED COATINGS AND ELASTOMERIC-BASED COATINGS FOR USE ON ROOFS, WALLS, AND BUILDING FOUNDATIONS (U.S. CLS. 6, 11 AND 16).

CLASS 17—RUBBER GOODS

FOR (BASED ON 44(E)) (BASED ON INTENT TO USE) ELASTOMERIC COMPOUNDS, COMPOSITIONS AND COMPOSITES, NAMELY, ADHESIVE SEALANT AND CAULKING COMPOUND; CAULKING COMPOUNDS; SEALANT COMPOUNDS FOR JOINTS; CHEMICAL RESISTANT SEALANTS, TREATMENTS AND COMPOSITES, NAMELY, ADHESIVE SEALANT AND CAULKING COMPOUND; ADHESIVE SEALANTS FOR USE IN ROOFING; GROUT SEALANT; INTERIOR LININGS MADE OF NON-METAL FABRIC AND SEALANT FOR THE REPAIR OF ELECTRICAL, TELECOMMUNICATION AND NATURAL GAS UTILITY CONDUITS AND PIPES; PIPE JOINT SEALANT; POLYMER SEALANT FOR USE IN CONNECTION WITH THE INSTALLATION OF FLOORING; RESIN-BASED SEALANTS FOR USE ON ROOFS, WALLS AND PAVEMENTS; SEALANT COMPOUNDS FOR JOINTS; SEALANTS FOR BUILDINGS; SEALANTS FOR PAVEMENT JOINTS; WATERPROOF SEALANTS; WEATHERSTRIPPING SEALANTS IN THE NATURE OF CAULK; CHEMICAL-RESISTANT POLYMERS, SEMI-PROCESSED OR SEMI FINISHED REPAIR POLYMERIC AND EPOXY RESIN COMPOUNDS AND COMPOSITES, NAMELY, POLYMER SEALANT FOR USE IN CONNECTION WITH THE INSTALLATION OF FLOORING; POLYMER-BASED PATCHING AND SEALING COMPOUNDS FOR MASONRY AND WOOD; RAPID CURE, HIGH STRENGTH, POLYMER-BASED CONCRETE PATCHING COMPOUND; SEMI PROCESSED OR SEMI FINISHED ACRYLIC, ARTIFICIAL AND SYNTHETIC RESINS; ALL OF THE FOREGOING USED IN INDUSTRIAL OR BUILDING CONSTRUCTION APPLICATION (U.S. CLS. 1, 5, 12, 13, 35 AND 50).

DAVID C. REIHNER, EXAMINING ATTORNEY

SN 85-122,540. UNITED SAFETY, LTD., AIRDRIE, ALBERTA, CANADA, FILED 9-3-2010.

PROTECTUS

THE MARK CONSISTS OF STANDARD CHARACTERS WITHOUT CLAIM TO ANY PARTICULAR FONT, STYLE, SIZE, OR COLOR.

PRIORITY CLAIMED UNDER SEC. 44(D) ON CANADA APPLICATION NO. 1490674, FILED 7-30-2010, REG. NO. TMA800008, DATED 6-15-2011, EXPIRES 6-15-2026.

SN 85-126,045. THE YALE CLUB OF NEW YORK CITY, NEW YORK, NY. FILED 9-9-2010.

CLASS 38—COMMUNICATION

FOR RENTAL OF EQUIPMENT, NAMELY, TELECOMMUNICATIONS EQUIPMENT FOR USE IN LIVE TRANSMISSION OF DATA VIA THE INTERNET IN THE AREAS OF WORKPLACE AND PUBLIC SAFETY NEEDS FOR THE OIL AND GAS, PETROCHEMICAL, REFINING, MINING AND POWER GENERATION INDUSTRIES (U.S. CLS. 100, 101 AND 104).

CLASS 42—SCIENTIFIC AND COMPUTER SERVICES

FOR RENTAL OF ELECTRONIC EQUIPMENT, NAMELY, A PORTABLE, BATTERY-POWERED, SENSING DEVICE FOR USE IN MONITORING AND RECORDING DATA REGARDING GAS CONCENTRATIONS AND CLIMATE CONDITIONS IN THE OIL AND GAS, PETROCHEMICAL, REFINING, MINING AND POWER GENERATION INDUSTRIES IN THE AREAS OF WORKPLACE AND PUBLIC SAFETY NEEDS (U.S. CLS. 100 AND 101).

RAMONA ORTIGA, EXAMINING ATTORNEY

SN 85-124,818. CEG WORLDWIDE, LLC, SAN MARTIN, CA. FILED 9-8-2010.

ELITE ADVISOR FORUM

THE MARK CONSISTS OF STANDARD CHARACTERS WITHOUT CLAIM TO ANY PARTICULAR FONT, STYLE, SIZE, OR COLOR.

NO CLAIM IS MADE TO THE EXCLUSIVE RIGHT TO USE "ADVISOR FORUM", APART FROM THE MARK AS SHOWN.

CLASS 9—ELECTRICAL AND SCIENTIFIC APPARATUS

FOR DOWNLOADABLE ELECTRONIC PUBLICATIONS IN THE NATURE OF ARTICLES, WHITE PAPERS, AND E-BOOKS IN THE FIELD OF FINANCIAL ADVISING; DOWNLOADABLE VIDEOS AND MP3 RECORDINGS IN THE FIELD OF FINANCIAL ADVISING (U.S. CLS. 21, 23, 26, 36 AND 38).

CLASS 35—ADVERTISING AND BUSINESS

FOR PROVIDING ONLINE INFORMATION IN THE NATURE OF PROFILES OF SUCCESSFUL FINANCIAL CONSULTANTS FOR BUSINESS PURPOSES (U.S. CLS. 100, 101 AND 102).

CLASS 41—EDUCATION AND ENTERTAINMENT

FOR NON-DOWNLOADABLE ELECTRONIC PUBLICATIONS IN THE NATURE OF ARTICLES, WHITE PAPERS, AND E-BOOKS IN THE FIELD OF FINANCIAL ADVISING; NON-DOWNLOADABLE VIDEOS AND MP3 RECORDINGS IN THE FIELD OF FINANCIAL ADVISING (U.S. CLS. 100, 101 AND 107).

LEIGH CAROLINE CASE, EXAMINING ATTORNEY

50 VANDERBILT

THE MARK CONSISTS OF STANDARD CHARACTERS WITHOUT CLAIM TO ANY PARTICULAR FONT, STYLE, SIZE, OR COLOR.

SEC. 2(F).

CLASS 9—ELECTRICAL AND SCIENTIFIC APPARATUS

FOR DOWNLOADABLE ELECTRONIC NEWSLETTERS DELIVERED BY E-MAIL FEATURING INFORMATION OF INTEREST TO CLUB MEMBERS, PROSPECTIVE MEMBERS AND GUESTS REGARDING EDUCATIONAL, SOCIAL AND SPORTING EVENTS, LODGING AND DINING FACILITIES AND OTHER CLUB SERVICES (U.S. CLS. 21, 23, 26, 36 AND 38).

FIRST USE 11-0-2008; IN COMMERCE 11-0-2008.

CLASS 16—PAPER GOODS AND PRINTED MATTER

FOR PRINTED MATERIALS, NAMELY, NEWSLETTERS, BROCHURES AND CALENDARS FEATURING INFORMATION OF INTEREST TO CLUB MEMBERS, PROSPECTIVE MEMBERS AND GUESTS REGARDING EDUCATIONAL, SOCIAL AND SPORTING EVENTS, LODGING AND DINING FACILITIES AND OTHER CLUB SERVICES (U.S. CLS. 2, 5, 22, 23, 29, 37, 38 AND 50).

FIRST USE 11-0-2008; IN COMMERCE 11-0-2008.

RONALD AIKENS, EXAMINING ATTORNEY

SN 85-127,948. STEELBRIDGE VENTURES CONSULTING, LLC, PITTSBURGH, PA. FILED 9-13-2010.

STEELBRIDGE VENTURES CONSULTING

THE MARK CONSISTS OF STANDARD CHARACTERS WITHOUT CLAIM TO ANY PARTICULAR FONT, STYLE, SIZE, OR COLOR.

NO CLAIM IS MADE TO THE EXCLUSIVE RIGHT TO USE "VENTURES CONSULTING", APART FROM THE MARK AS SHOWN.

CLASS 35—ADVERTISING AND BUSINESS

FOR BUSINESS STRATEGY DEVELOPMENT SERVICES; BUSINESS CONSULTING, NAMELY, DESIGN AND IMPLEMENTATION OF BUSINESS OPERATIONAL PROCEDURES FOR OTHERS; PROJECT MANAGEMENT FOR OTHERS FOR BUSINESS PURPOSES IN THE FIELD OF INVESTMENT MANAGEMENT FINANCE AND OPERATIONS (U.S. CLS. 100, 101 AND 102).

FIRST USE 10-31-2008; IN COMMERCE 10-31-2008.

CLASS 42—SCIENTIFIC AND COMPUTER SERVICES

FOR INFORMATION TECHNOLOGY CONSULTING IN THE FIELD OF INVESTMENT MANAGEMENT FINANCE AND OPERATIONS (U.S. CLS. 100 AND 101).
FIRST USE 10-31-2008; IN COMMERCE 10-31-2008.
PATRICIA EVANKO, EXAMINING ATTORNEY

SN 85-132,340, HUTCHISON WHAMPOA ENTERPRISES LIMITED, ROAD TOWN, TORTOLA, BR.VIRGIN ISLANDS, FILED 9-17-2010.

HutchConnect

OWNER OF U.S. REG. NO. 3,122,266.
THE MARK CONSISTS OF THE TERM "HUTCHCONNECT" WITH "CONNECT" IN ITALIC CHARACTERS.

CLASS 9—ELECTRICAL AND SCIENTIFIC APPARATUS

FOR ELECTRIC CAPACITORS; ELECTRONIC APPARATUS AND INSTRUMENTS FOR CONTROLLING, ADJUSTING AND TESTING OF DRIVES AND MOTORS; PHOTOGRAPHIC PROJECTORS; CINEMATOGRAPHIC CAMERAS; OPTICAL INSPECTION APPARATUS; SIGNALING BUOYS; APPARATUS FOR CHECKING FLIGHT PARAMETERS; TEACHING APPARATUS AND INSTRUMENTS, NAMELY, MEDICAL TEACHING MANNEQUINS; TELEVISION SETS; TELECOMMUNICATIONS CABLES, EXCHANGERS AND SWITCHES; ELECTRONIC DEVICES IN THE NATURE OF WIRELESS TRANSMITTER AND RECEIVERS FOR RECEIVING TELEVISION AND GLOBAL COMMUNICATION NETWORK TRANSMISSIONS AND TRANSMITTING THEM TO A TELEVISION OR OTHER DISPLAY DEVICE AND COMPUTER OPERATING SOFTWARE FOR USE THEREWITH; OPTICAL DISC PLAYERS AND COMPUTER OPERATING SOFTWARE FOR USE THEREWITH; BLANK MAGNETIC DATA CARRIERS, BLANK SMART CARDS; BLANK RECORDABLE OPTICAL DISCS; APPARATUS FOR RECORDING, TRANSMISSION OR REPRODUCTION OF SOUND, IMAGES, DATA; CALCULATING MACHINES; TELECOMMUNICATIONS TRANSMITTERS; FACSIMILE APPARATUS; TELEPHONE APPARATUS, TELEGRAPHS; AND DATA ACQUISITION INSTALLATION APPARATUS AND INSTRUMENTS, NAMELY, DATA ACCESS PORT FOR USE WITH ELECTRICAL CONTROL PANELS FOR CONNECTING MULTIPLE DATA AND ELECTRICAL DEVICES; COMPUTER PROGRAMS DOWNLOADABLE FROM THE INTERNET CONSISTING OF OPERATING SOFTWARE AND SEARCH ENGINE SOFTWARE FOR RUNNING A COMPUTER TO ACHIEVE CERTAIN TASKS IN THE NATURE OF COPYING, ANALYZING, STORING AND COMPILING DATA; COMPUTER SOFTWARE FOR USE IN DATABASE MANAGEMENT, USE AS A SPREADSHEET, WORD PROCESSING; COMPUTER SOFTWARE AND TELECOMMUNICATION SWITCHES AND MODEMS TO ENABLE CONNECTION TO DATABASES AND THE INTERNET; OPERATING SYSTEM PROGRAMS; COMPUTER SOFTWARE AND NETWORKING HARDWARE FOR THE FACILITATION OF INTERACTIVE MULTIMEDIA COMMUNICATIONS;

COMPUTER SOFTWARE FOR USE IN CREATING, EDITING AND DELIVERING TEXTUAL AND GRAPHIC INFORMATION VIA COMPUTER COMMUNICATION NETWORKS; COMPUTER PROGRAMS FOR DIGITAL PUBLISHING, PRINTING, IMAGING, AND ELECTRONIC DOCUMENT STORAGE, MANIPULATION, TRANSFER AND RETRIEVAL; COMPUTERS, HANDHELD COMPUTERS; COMPUTER PROGRAMS FOR MANAGING COMMUNICATIONS AND DATA EXCHANGE BETWEEN HANDHELD COMPUTERS AND DESKTOP COMPUTERS; COMPUTER HARDWARE AND COMPUTER OUTPUT DEVICES IN THE NATURE OF MONITORS, PRINTERS, IMAGE SETTERS IN THE NATURE OF IMAGE FUSER UNITS FOR COMPUTER PRINTERS COMPRISING ELECTRO-MECHANICAL ROLLERS FOR THE PURPOSE OF TRANSFERRING TONER ONTO PAPER, PHOTOCOPIERS, CD-ROM WRITERS, ELECTRONIC AND ELECTRIC SCREEN DISPLAYS, LIQUID CRYSTAL DISPLAY SCREENS; DIGITAL WIRELESS TELECOMMUNICATIONS COMPUTER HARDWARE AND OPERATING SOFTWARE FOR USE THEREWITH; DOWNLOADABLE ELECTRONIC PUBLICATIONS IN THE NATURE OF BOOKS, MAGAZINES, MANUALS IN THE FIELD OF GENERAL BUSINESS INFORMATION; DOWNLOADABLE COMPUTER SOFTWARE FOR USE AS A SPREADSHEET, WORD PROCESSING; DOWNLOADABLE ELECTRONIC PUBLICATIONS IN THE NATURE OF STREET MAPS; DOWNLOADABLE ELECTRONIC PUBLICATIONS IN THE NATURE OF BOOKS, MAGAZINES, MANUALS FEATURING CORPORATE BUSINESS INFORMATION; DOWNLOADABLE COMPUTER SOFTWARE FOR USE AS A SPREADSHEET, WORD PROCESSING, SUPPLIED ON-LINE FROM DATABASES OR FROM FACILITIES PROVIDED ON THE INTERNET AND WEB SITES; DOWNLOADABLE PUBLICATIONS IN ELECTRONIC FORM IN THE NATURE OF BOOKS, MAGAZINES, MANUALS IN THE FIELD OF GENERAL BUSINESS INFORMATION SUPPLIED ON-LINE FROM DATABASES OR FROM FACILITIES PROVIDED ON THE INTERNET AND WEB SITES; ELECTRONIC AND COMPUTER GAME SOFTWARE, GAMES PROGRAMS, AND GAME CARTRIDGES; ENTERTAINMENT CONSOLES, NAMELY, VIDEO GAME CONSOLES FOR USE WITH AN EXTERNAL DISPLAY SCREEN OR MONITOR; ENTERTAINMENT CONSOLES IN THE NATURE OF COMPUTER GAME CONSOLES FOR USE WITH AN EXTERNAL DISPLAY SCREEN OR MONITOR COMPRISING COMPUTER HARDWARE AND SOFTWARE FOR PROVIDING AUDIO, VIDEO, AND MULTIMEDIA OUTPUT; AND REPLACEMENT PARTS FOR ALL THE AFORESAID GOODS IN THE NATURE OF VIDEO AND COMPUTER MONITORS, COMPUTER CIRCUIT BOARDS AND VIDEO ADAPTORS (U.S. CLS. 21, 23, 26, 36 AND 38).

CLASS 35—ADVERTISING AND BUSINESS

FOR COMMERCIAL OR INDUSTRIAL MANAGEMENT ASSISTANCE; COMMERCIAL OR INDUSTRIAL BUSINESS INFORMATION AGENCIES; BUSINESS MANAGEMENT OF PORTS; ADVERTISING AND PROMOTION AND INFORMATION SERVICES RELATING THERETO; RENTAL OF ADVERTISING SPACE; PRODUCTION OF TELEVISION ADVERTISING COMMERCIALS; COMPILATION OF ADVERTISEMENTS FOR USE AS WEB PAGES ON THE INTERNET; PREPARATION AND PRESENTATION OF AUDIO VISUAL DISPLAYS FOR GENERAL BUSINESS INFORMATION, FASHION ADVERTISING; DISSEMINATION OF ADVERTISING MATTER; BUSINESS INFORMATION SERVICES; PROVISION OF COMPUTERIZED BUSINESS INFORMATION DATA; MARKETING STUDIES; BUSINESS PLANNING, BUSINESS APPRAISAL; BUSINESS MANAGEMENT; BUSINESS ADMINISTRATION; OFFICE ADMINISTRATION FOR OTHERS; BUSINESS MARKETING AND BUSINESS RESEARCH; COMPILATION OF BUSINESS STATISTICS AND COMMERCIAL INFORMATION; AUCTIONEERING; THE BRINGING TOGETHER, FOR THE BENEFIT OF OTHERS OF A VARIETY OF GOODS IN A DEPARTMENT STORE, OR A SUPERMARKET, OR RETAIL ELECTRICAL STORE OR PHARMACY, OR FROM A WEBSITE, ENABLING CUSTOMERS TO CONVENIENTLY VIEW AND PURCHASE THOSE GOODS IN THE FIELD OF ELECTRICAL EQUIPMENT, PHARMACY GOODS, TELECOMMUNICATIONS APPARATUS AND INSTRUMENTS AND MOBILE PHONE ACCESSORIES; RETAIL STORE SERVICES IN THE FIELD OF TELECOMMUNICATIONS EQUIP-

MENT; ADVICE AND ASSISTANCE IN THE SELECTION OF GOODS AND SERVICES ON BEHALF OF OTHERS, NAMELY, INFOMEDIARY SERVICES, NAMELY, FACILITATING TRANSACTIONS BETWEEN BUYERS AND SELLERS THROUGH PROVIDING BUYERS WITH INFORMATION ABOUT SELLERS, GOODS, AND/OR SERVICES; COMMERCIAL INFORMATION AGENCY SERVICES RELATING TO BRINGING CUSTOMERS AND/OR BUYERS AND SELLERS TOGETHER; ORGANIZATION OF PROMOTIONS USING AUDIO VISUAL MEDIA; PROVISION OF INFORMATION, CONSULTANCY SERVICES AND ADVICE RELATING TO THE FOREGOING (U.S. CLS. 100, 101 AND 102).

CLASS 36—INSURANCE AND FINANCIAL

FOR ARRANGING MONETARY TRANSFERS, FOREIGN MONETARY EXCHANGE ADVISORY SERVICES, MONETARY EXCHANGE, MONETARY TRANSACTION SERVICES IN THE NATURE OF ELECTRONIC CASH TRANSACTIONS, MONETARY TRANSFER; FINANCIAL SERVICES IN THE NATURE OF AN INVESTMENT SECURITY; FINANCIAL MANAGEMENT AND ADVISORY SERVICES RELATING TO INVESTMENT; FINANCIAL PLANNING; FINANCIAL APPRAISAL OF REAL ESTATE; BANKING EVALUATION IN THE NATURE OF FINANCIAL EVALUATIONS OF BANKS; FINANCIAL INVESTMENT BROKERAGE SERVICES; SECURITIES BROKERAGE AND ELECTRONIC DISCOUNT SECURITIES BROKERAGE SERVICES AND ON-LINE DISCOUNT SECURITIES BROKERAGE SERVICES; STOCKS AND BONDS BROKERAGE; INVESTMENT ADVICE; COMMERCIAL LENDING SERVICES AND MONEY LENDING AGAINST SECURITY; ON-LINE TRADING OF TREASURY FINANCIAL INSTRUMENTS AND DERIVATIVE FINANCIAL PRODUCTS; INVESTMENT BANKING, TREASURY SECURITIES EXCHANGE AND FOREIGN EXCHANGE SERVICES, AND PROVIDING FINANCIAL EXCHANGE RATE INFORMATION TO INSTITUTIONAL INVESTMENT CLIENTS; FINANCIAL TRUST PLANNING, CREDIT UNIONS, SAVINGS ACCOUNT, SAFETY DEPOSIT BOX, LOAN FINANCING, SECURITY SERVICES IN THE NATURE OF GUARANTEEING LOANS; ACTUARIAL SERVICES; LIFE INSURANCE UNDERWRITING; GUARANTY ASSURANCE UNDERWRITING; ESTABLISHING MUTUAL FUNDS FOR OTHERS; FINANCIAL MANAGEMENT OF LIFE INSURANCES, GUARANTEE INSURANCE AND MUTUAL FUNDS; ADMINISTRATION OF EMPLOYEE PENSION PLANS; INSURANCE UNDERWRITING SERVICES FOR ALL TYPES OF INSURANCE; TRAVEL INSURANCE UNDERWRITING; BANKERS' CLEARING SERVICES, NAMELY, CLEARING AND RECONCILING FINANCIAL BANK TRANSACTIONS VIA A GLOBAL COMPUTER NETWORK; FINANCIAL CLEARING-HOUSE SERVICES; ISSUING OF TRAVELERS' CHEQUES; CURRENCY EXCHANGE SERVICES; ESCROW SERVICES FOR THE TRAVEL INDUSTRY; STOCKBROKING AGENCY SERVICES; EXECUTORS' TRUSTEE SERVICES; PROVISION OF FINANCIAL GUARANTEES; ISSUING LETTERS OF CREDIT AND CERTIFICATES OF DEPOSIT; REAL ESTATE INVESTMENT TRUST SERVICES; SURETY SERVICES; SHARE UNDERWRITING IN THE NATURE OF FINANCIAL INVESTMENT SERVICES, NAMELY, ADMINISTERING THE UNDERWRITING OF SECURITIES; INSURANCE BROKERAGE SERVICES; INSURANCE CONSULTANCY; INSURANCE INFORMATION; INSURANCE UNDERWRITING IN THE FIELD OF ACCIDENT INSURANCE UNDERWRITING, FIRE INSURANCE UNDERWRITING, HEALTH INSURANCE UNDERWRITING, LIFE INSURANCE UNDERWRITING, MARINE INSURANCE UNDERWRITING; INSURANCE BROKERAGE, ACCIDENT INSURANCE BROKERAGE, FIRE INSURANCE BROKERAGE, HEALTH INSURANCE BROKERAGE, LIFE INSURANCE BROKERAGE, MARINE INSURANCE BROKERAGE; CREDIT BUREAU; ISSUE OF TOKENS OF VALUE; TRAVEL VOUCHER SERVICES, NAMELY, PROVIDING VOUCHERS FOR PAYMENT OF TRANSPORTATION EXPENSES; SAFETY DEPOSIT BOX SERVICES FOR DEPOSIT OF VALUABLES; SAFE DEPOSIT BOX SERVICES; ELECTRONIC FUNDS TRANSFER BY TELECOMMUNICATIONS; ELECTRONIC FUNDS TRANSFER; ELECTRONIC PAYMENT SERVICES, NAMELY, ELECTRONIC PROCESSING AND TRANSMISSION OF BILL PAYMENT DATA; FIDUCIARY SERVICES, NAMELY, FIDUCIARY REPRESENTATIVE

SERVICES; STOCK EXCHANGE QUOTATIONS; FISCAL ASSESSMENTS; FINANCIAL MANAGEMENT; INSTALLMENT LOANS FINANCING; LEASE-PURCHASE FINANCING, HIRE-PURCHASE FINANCING, MORTGAGE BANKING; RETIREMENT PAYMENT SERVICES, NAMELY, INDIVIDUAL RETIREMENT ACCOUNT SERVICES; REAL ESTATE FINANCING SERVICES; CHARITABLE FUND RAISING; FINANCIAL SPONSORSHIP OF ATHLETIC COMPETITIONS; PROVISION OF INFORMATION, CONSULTANCY SERVICES AND ADVISORY SERVICES RELATING TO ALL THE AFORESAID SERVICES; AND ALL THE ABOVE ALSO PROVIDED ON-LINE FROM A COMPUTER DATABASE OR THE INTERNET (U.S. CLS. 100, 101 AND 102).

CLASS 37—CONSTRUCTION AND REPAIR

FOR CONSTRUCTION, REPAIR AND INSTALLATION SERVICES FOR COMPUTERS, COMPUTER NETWORK HARDWARE, TELECOMMUNICATIONS APPARATUS, EQUIPMENT, AND NETWORK HARDWARE; INSTALLATION AND REPAIR SERVICES OF INFORMATION TECHNOLOGY HARDWARE; MAINTENANCE, REPAIR, INSTALLATION SERVICES FOR COMPUTERS, COMPUTER PERIPHERAL DEVICES, TELECOMMUNICATION APPARATUS, AND PARTS AND ACCESSORIES THEREFOR; ON-SITE COMPUTER SET-UP AND INSTALLATION SERVICES AND MAINTENANCE OF COMPUTERS, COMPUTER SYSTEM HARDWARE AND TELECOMMUNICATION APPARATUS; PROVISION OF INFORMATION RELATING TO REPAIR OR INSTALLATION OF COMPUTER HARDWARE PROVIDED ON-LINE FROM A COMPUTER DATABASE OR THE INTERNET; PROVISION OF INFORMATION, CONSULTANCY SERVICES AND ADVICE RELATING TO THE FOREGOING; TECHNICAL SUPPORT SERVICES, NAMELY, TROUBLESHOOTING IN THE NATURE OF THE REPAIR OF COMPUTER HARDWARE (U.S. CLS. 100, 103 AND 106).

CLASS 38—COMMUNICATION

FOR ELECTRONIC DATA TRANSMISSION AND TELECOMMUNICATION TRANSMISSION OF WEBCASTS; TRANSMISSION OF DATA, DOCUMENTS, MESSAGES, IMAGES, SOUNDS, VOICES, TEXT, AUDIO, VIDEO AND ELECTRONIC COMMUNICATIONS AND DATA AND INFORMATION BY ELECTRONIC, COMPUTER, CABLE, RADIO, RADIOPAGING, TELEPRINTER, TELETYPE, ELECTRONIC MAIL, FACSIMILE MACHINE, TELEVISION, MICROWAVE, LASER BEAM, COMMUNICATIONS SATELLITE, MICROWAVE LINK, TERRESTRIAL CABLE, WIRELESS OR WIRE MULTIPLEXING SYSTEM OR THE INTERNET OR OTHER TELECOMMUNICATIONS MEANS; RADIO AND TELEVISION BROADCASTING SERVICES; PROVISION OF MULTIMEDIA TELECOMMUNICATION TRANSMISSION INFORMATION AND INTERACTIVE MULTIMEDIA SERVICES, NAMELY, TRANSMISSION OF SOUND AND VISION VIA SATELLITE OR INTERACTIVE MULTIMEDIA NETWORKS; TELECOMMUNICATIONS GATEWAY SERVICES, NAMELY, PROVISION OF TELECOMMUNICATION LINK FOR OPERATION OF SEARCH ENGINES; CONSULTANCY SERVICES RELATING TO DATA COMMUNICATIONS IN THE NATURE OF TECHNICAL CONSULTING IN THE FIELD OF AUDIO, TEXT AND VISUAL DATA TRANSMISSION AND COMMUNICATION; TELECOMMUNICATION SERVICES IN THE NATURE OF TRANSMISSION AND RECEPTION OF DATABASE INFORMATION FOR BUSINESS OR DOMESTIC PURPOSES FROM A COMPUTER-STORED DATA BANK VIA TELECOMMUNICATIONS NETWORKS; ELECTRONIC MAIL SERVICES; TELECOMMUNICATION SERVICES RELATING TO THE INTERNET, NAMELY, PROVIDING TELECOMMUNICATION CONNECTIONS TO THE INTERNET; TELECOMMUNICATION OF INFORMATION AND WEB PAGES, COMPUTER PROGRAMS AND ANY OTHER DATA VIA TELECOMMUNICATIONS NETWORKS; PROVIDING TELECOMMUNICATIONS CONNECTIONS TO THE INTERNET OR DATABASES; TELETXT SERVICES; TELECOMMUNICATION ACCESS SERVICES; PROVISION OF TELECOMMUNICATION ON-LINE ACCESS AND LINKS TO THE INTERNET AND INTRANET; PROVISION OF TELECOMMUNICATION ACCESS TO THE INTERNET; PROVIDING AN INTERNET WEBSITE PORTAL IN THE FIELD OF TELECOMMUNICATIONS

TRANSMISSION NETWORKS; INTERNET SERVICES PROVIDERS (ISPS); PROVIDING ACCESS TO DIGITAL MUSIC MP3 WEB SITES ON THE INTERNET; PROVIDING ACCESS TO DIGITAL MUSIC WEB SITES ON THE INTERNET; PROVIDING AN ONLINE INTERACTIVE ELECTRONIC BULLETIN BOARD; RENTAL AND LEASING OF SET-TOP BOXES FOR USE WITH TELEVISIONS; PROVISION OF INFORMATION, CONSULTANCY SERVICES AND ADVICE RELATING TO THE FOREGOING SERVICES; PROVISION OF COMPUTER ACCESS TO SITES ON ELECTRONIC INFORMATION NETWORKS; PROVISION OF COMPUTER ACCESS TO VARIOUS DATABASES; PROVIDING USER ACCESS TO THE INTERNET; MOBILE MEDIA SERVICES IN THE NATURE OF ELECTRONIC TRANSMISSION OF ENTERTAINMENT MEDIA CONTENT INCLUDING JOKES VIA TEXT MESSAGE AND SMS; PROVIDING ON-LINE CHAT ROOMS FOR TRANSMISSION OF MESSAGES AMONG COMPUTER USERS CONCERNING MATTERS OF GENERAL INTEREST; PROVIDING TECHNICAL SUPPORT SERVICES REGARDING THE USAGE OF COMMUNICATIONS EQUIPMENT; ALL THE AFORESAID SERVICES ALSO PROVIDED ON-LINE FROM A COMPUTER DATA BASE OR FROM THE INTERNET (U.S. CLS. 100, 101 AND 104).

CLASS 39—TRANSPORTATION AND STORAGE

FOR STORAGE OF COMPUTERIZED BUSINESS INFORMATION DIGITAL DATA; WAREHOUSING SERVICES; TRAVEL ARRANGEMENT SERVICES; TOURIST OFFICE SERVICES EXCEPT FOR HOTEL RESERVATIONS; TOURIST AGENCY SERVICES, NAMELY, ARRANGING EXCURSIONS FOR TOURISTS; TRANSPORTATION LOGISTICS SERVICES, NAMELY, ARRANGING THE TRANSPORTATION OF GOODS FOR OTHERS; ARRANGING AND PROVIDING TRANSPORT BY LAND, SEA AND AIR; ARRANGING, ORGANIZING AND PROVIDING TOURS AND CRUISES; TRAVEL AGENCY SERVICES, NAMELY, MAKING RESERVATIONS AND BOOKINGS FOR TRANSPORTATION; TRAVEL TICKET RESERVATION SERVICES; RENTAL OF APPARATUS FOR TRANSPORTATION BY LAND, SEA AND AIR IN THE NATURE OF CARS, BOATS AND AIRCRAFT; CARGO HANDLING; PROVISION OF CAR PARKING FACILITIES; CARTING TRANSPORTATION SERVICES, NAMELY, PROVIDING SHUTTLE SERVICES BY GOLF CART; AND CHAUFFEUR SERVICES; STORAGE OF GOODS FOR TRANSPORTATION; CRATING OF GOODS; DELIVERY OF GOODS SERVICES; ESCORTING OF TRAVELERS; GUARDED TRANSPORT OF VALUABLES; TRAVEL GUIDE SERVICES; TRIP ROUTE PLANNING; PORTER SERVICES; CONDUCTING SIGHTSEEING TOURS FOR OTHERS; TOUR OPERATING AND ORGANIZING; TRANSPORT BROKERAGE; TRAVEL COURIER SERVICES; CHARTERING OF TRANSPORT IN THE NATURE OF PLANES, YACHTS, BOATS, BUSES; CHARTERING OF SHIPS; CRUISE SHIP SERVICES; FERRY TRANSPORT SERVICES; SEA FREIGHT SHIP SERVICES; MARINE TRANSPORT SERVICES; PILOTING OF SHIPS; PLEASURE BOAT TRANSPORT SERVICES; RIVER TRANSPORT BY BOAT; RESERVATION SERVICES FOR TRAVEL; FREIGHT AND CARGO SHIP TRANSPORTATION SERVICES; FREIGHT FORWARDING, FREIGHT BROKERAGE SERVICES; SHIPPING AGENCY, NAMELY, MAKING RESERVATIONS AND BOOKINGS FOR TRANSPORTATION OF GOODS BY SHIP; TRANSPORTATION OF GOODS, SHIPPING OF GOODS, PACKAGING AND STORAGE OF GOODS; PROVISION OF INFORMATION, CONSULTANCY SERVICES AND ADVISORY SERVICES RELATING TO ALL THE AFORESAID SERVICES; AND ALL THE AFORESAID SERVICES ALSO PROVIDED ON-LINE FROM A COMPUTER DATA BASE OR FROM THE INTERNET (U.S. CLS. 100 AND 105).

CLASS 41—EDUCATION AND ENTERTAINMENT

FOR ARRANGING AND CONDUCTING OF EDUCATIONAL CONFERENCES, ART EXHIBITIONS, ATHLETIC COMPETITIONS AND ENTERTAINMENT QUIZ COMPETITIONS IN THE FIELD OF SPELLING; ORGANIZATION OF EXHIBITIONS FOR CULTURAL OR EDUCATIONAL PURPOSES; ORGANIZATION OF SPORTS COMPETITIONS; ARRANGING PROFESSIONAL WORKSHOPS; ARRANGING AND CONDUCTING OF EDUCATIONAL SEMINARS IN SELF-AWARENESS, ART APPRECIATION; PROVISION OF TRAINING RELATING TO OPERATION AND REPAIR OF TELECOMMUNICATIONS EQUIPMENT AND COOKING; PUBLICATION OF BOOKS AND TEXTS; ENTERTAINMENT SERVICES, NAMELY, PROVIDING ONLINE REVIEWS OF MUSIC, MUSIC VIDEOS APPEARING ON TELEVISION, AND MOVIES; TELEVISION ENTERTAINMENT, NAMELY, PRODUCTION OF TELEVISION PROGRAMS; PLANNING ARRANGEMENT OF SHOWING MOVIES, SHOWS, PLAYS OR MUSICAL PERFORMANCES ON-LINE FROM A COMPUTER DATABASE OR THE INTERNET OR VIA TERRESTRIAL MEANS, CABLE, SATELLITE CHANNELS, WIRELESS OR FIBER OPTIC WIRE SYSTEMS AND OTHER MEANS OF COMMUNICATION; PRODUCTION AND DISTRIBUTION OF LIVE OR RECORDED RADIO PROGRAMS, TELEVISION SHOWS, MOVIES, AND VIDEOS IN THE FIELD OF SPORTS AND LEISURE ACTIVITIES FOR BROADCASTING ON TERRESTRIAL MEANS, CABLE, SATELLITE CHANNELS, THE INTERNET, WIRELESS OR FIBER OPTIC WIRE SYSTEMS AND OTHER MEANS OF COMMUNICATION; PROVISION OF INFORMATION RELATING TO TELEVISION AND RADIO PROGRAMS, ENTERTAINMENT, MUSIC, SPORT AND RECREATION; PROVISION OF INFORMATION ABOUT ENTERTAINMENT AND EDUCATION PROVIDED ON-LINE FROM A COMPUTER DATABASE OR THE INTERNET OR VIA TERRESTRIAL MEANS, CABLE, SATELLITE CHANNELS, WIRELESS OR FIBER OPTIC WIRE SYSTEMS AND OTHER MEANS OF COMMUNICATION; ELECTRONIC GAMES SERVICES PROVIDED BY MEANS OF THE INTERNET; PROVIDING ONLINE ELECTRONIC GAMES VIA TERRESTRIAL COMMUNICATIONS NETWORKS, CABLE, SATELLITE CHANNELS, WIRELESS OR FIBER OPTIC WIRE SYSTEMS AND OTHER MEANS OF COMMUNICATION; PROVIDING ON-LINE NON-DOWNLOADABLE ELECTRONIC PUBLICATIONS IN THE NATURE OF ARTICLES, BROCHURES IN THE FIELD OF GENERAL BUSINESS INTEREST; PROVIDING ON-LINE NON-DOWNLOADABLE ELECTRONIC DICTIONARIES AND THESAURUS; ON-LINE PUBLICATION OF ELECTRONIC BOOKS AND JOURNALS; BOOKING AND RESERVATION OF TICKETS FOR EDUCATION AND ENTERTAINMENT EVENTS; GAMING SERVICES IN THE NATURE OF CASINO GAMING; BETTING, LOTTERY AND GAMBLING SERVICES; EDUCATION INFORMATION; PROVIDING ADVICE REGARDING EDUCATION OPTIONS IN THE NATURE OF CAREER COUNSELING; ENTERTAINMENT INFORMATION; ADVISORY SERVICES IN THE FIELD OF SPECIAL EVENT PLANNING FOR SOCIAL ENTERTAINMENT PURPOSES; RENTAL AND LEASING OF TELEVISIONS AND TELEVISION DISPLAY APPARATUS; PROVISION OF NEWS ON-LINE IN THE NATURE OF CURRENT EVENT REPORTING; PROVISION OF INFORMATION, CONSULTANCY SERVICES AND ADVICE RELATING TO THE AFORESAID SERVICES; AND ALL THE AFORESAID SERVICES ALSO PROVIDED ON-LINE FROM A COMPUTER DATA BASE OR FROM THE INTERNET (U.S. CLS. 100, 101 AND 107).

CLASS 42—SCIENTIFIC AND COMPUTER SERVICES

FOR DESIGN OF HOME PAGES AND WEB SITES; DRAWING UP OF PLANS AND ENGINEERING DRAWINGS FOR VIEWING ON INTERNET WEB PAGES; AND COMMISSIONED TECHNICAL WRITING FOR OTHERS CONCERNING THE COMPILATION OF WEB PAGES ON THE INTERNET; CREATING AND MAINTAINING WEB SITES; HOSTING WEB SITES OF OTHERS; INSTALLATION AND MAINTENANCE OF COMPUTER SOFTWARE; RENTAL AND LEASING OF COMPUTERS, COMPUTER PROGRAMS, COMPUTER TERMINALS, COMPUTER MONITORS, COMPUTER KEYBOARDS, LAPTOP COMPUTERS, MODEMS, COMPUTER PERIPHERALS, AND REPLACEMENT PARTS THEREFOR; COMPUTER PROGRAMMING SERVICES; ON-LINE BATCH COMPUTER SERVICES, NAMELY, CONFIGURATION OF MULTIPLE FILES INTO A SINGLE GROUP PROVIDED ONLINE FROM THE INTERNET; CONSULTANCY SERVICES RELATING TO COMPUTER SOFTWARE; TECHNICAL SUPPORT SERVICES, NAMELY, TROUBLESHOOTING IN THE NATURE OF DIAGNOSING COMPUTER HARDWARE PROBLEMS; PROVISION OF INFORMATION AND ADVICE RELATING TO THE AFORESAID SERVICES, AND ALL THE AFORESAID SERVICES ALSO PROVIDED ON-LINE FROM A COMPUTER DATA BASE OR FROM THE INTERNET (U.S. CLS. 100 AND 101).

NELSON SNYDER, EXAMINING ATTORNEY

SN 85-133,488. NO KILL NATION, INC., LIGHTHOUSE POINT, FL. FILED 9-20-2010.



THE MARK CONSISTS OF THE STYLIZED LETTERS "NKN". TO THE LEFT OF THE LEFT "N" IS THE SILHOUETTE OF A CAT; TO THE RIGHT OF THE RIGHT "N" IS THE SILHOUETTE OF A DOG. UNDER THESE IS THE STYLIZED WORDING "NO KILL NATION" AGAINST A FILLED RECTANGLE.

CLASS 36—INSURANCE AND FINANCIAL

FOR CHARITABLE SERVICES, NAMELY, RAISING MONEY FOR ANIMAL WELFARE ORGANIZATIONS THROUGH PROMOTIONS AND/OR INCENTIVES (U.S. CLS. 100, 101 AND 102).

FIRST USE 6-1-2010; IN COMMERCE 8-28-2010.

CLASS 39—TRANSPORTATION AND STORAGE

FOR PROVIDING A WEBSITE FEATURING INFORMATION ON ANIMAL RESCUE SERVICES (U.S. CLS. 100 AND 105).

FIRST USE 6-1-2010; IN COMMERCE 8-28-2010.
DAWN HAN, EXAMINING ATTORNEY

SN 85-142,381. VI INTERNATIONAL LIMITED, HOVE, SUSSEX, UNITED KINGDOM, FILED 9-30-2010.

Viinternational

PRIORITY CLAIMED UNDER SEC. 44(D) ON ERP N CMNTY TM OFC APPLICATION NO. 009192956, FILED 6-22-2010, REG. NO. 009192956, DATED 11-25-2011, EXPIRES 11-25-2021.

OWNER OF U.S. REG. NO. 3,585,265.

NO CLAIM IS MADE TO THE EXCLUSIVE RIGHT TO USE "INTERNATIONAL", APART FROM THE MARK AS SHOWN.

THE MARK CONSISTS OF THE BLACK WORDING "VI INTERNATIONAL" WITH THE LETTERS "V","I" IN WIDER, BOLD-FACED TYPE, AND A RED SQUARE-SHAPED BLOCK ON TOP OF THE LETTER "I" THAT FOLLOWS THE LETTER "V".

CLASS 9—ELECTRICAL AND SCIENTIFIC APPARATUS

FOR APPARATUS FOR RECORDING, TRANSMISSION, OR REPRODUCTION OF SOUND OR IMAGES, AND PARTS AND FITTINGS THEREFORE FOR USE IN THE COACHING AND TRAINING EMPLOYEES TO IMPROVE THEIR LEADERSHIP SKILLS, TEAM BUILDING SKILLS, PRESENTATION SKILLS, AND COMMUNICATION TECHNIQUES; COMPUTER SOFTWARE IN THE FIELD OF COACHING AND TRAINING EMPLOYEES TO IMPROVE THEIR LEADERSHIP SKILLS, TEAM BUILDING SKILLS, PRESENTATION SKILLS, AND COMMUNICATION TECHNIQUES; PRE-RECORDED CDS, DVDS, VIDEOTAPES AND AUDIO TAPES FEATURING INFORMATION ON COACHING AND TRAINING EMPLOYEES TO IMPROVE THEIR LEADERSHIP SKILLS, TEAM BUILDING SKILLS, PRESENTATION SKILLS, AND COMMUNICATION TECHNIQUES; INTERACTIVE COMPUTER SOFTWARE IN THE FIELD OF COACHING AND TRAINING EMPLOYEES TO IMPROVE THEIR LEADERSHIP SKILLS, TEAM BUILDING SKILLS, PRESENTATION SKILLS, AND COMMUNICATION TECHNIQUES; DOWNLOADABLE ELECTRONIC PUBLICATIONS IN THE NATURE OF NEWSLETTERS, BROCHURES, PAMPHLETS AND LEAFLETS FEATURING INFORMATION ON COACHING AND TRAINING EMPLOYEES TO IMPROVE THEIR LEADERSHIP SKILLS, TEAM BUILDING SKILLS, PRESENTATION SKILLS, AND COMMUNICATION TECHNIQUES; DOWNLOADABLE DIGITAL AUDIO SOUND, MUSIC, IMAGES AND MULTIMEDIA CONTENT PROVIDED FROM THE INTERNET, INCLUDING FIXED AND MOBILE INTERNET FEATURING INFORMATION ON COACHING AND TRAINING EMPLOYEES TO IMPROVE THEIR LEADERSHIP SKILLS, TEAM BUILDING SKILLS, PRESENTATION SKILLS, AND COMMUNICATION TECHNIQUES; APPARATUS, INSTRUMENTS AND MEDIA FOR RECORDING, REPRODUCING, CARRYING, STORING, PROCESSING, MANIPULATING, TRANSMITTING, BROADCASTING, RETRIEVING AND REPRODUCING MUSIC, SOUNDS, IMAGES, TEXT, SIGNALS, SOFTWARE, INFORMATION, DATA AND CODE, NAMELY, CCTV EQUIPMENT FOR PRESENTATION SKILLS, AND PARTS AND FITTINGS THEREFORE, ALL OF THE FOREGOING PRODUCTS NOT INTENDED FOR USE ON MUSIC BASED MEDIA, INSPECTION SOFTWARE, AND FAULT DETECTION SOFTWARE (U.S. CLS. 21, 23, 26, 36 AND 38).

CLASS 16—PAPER GOODS AND PRINTED MATTER

FOR PRINTED MATERIALS AND IMPLEMENTS FOR USE IN COACHING PRESENTATION SKILLS, NAMELY, COPY AND WRITING PAPER, CARDBOARD, DRAWING PAPER, CRAYONS, ERASERS, PENCIL SHARPENERS, WRITING AND DRAWING IMPLEMENTS, NAMELY, MARKERS, PENS, PENCILS; PRINTED MATTER IN THE NATURE OF FORMS, PRINTED PUBLICATIONS, NAMELY, BOOKS AND LEAFLETS RELATING TO PSYCHOMETRIC ASSESSMENT FEEDBACK; SERIES OF NONFICTION BOOKS, MANUALS, PRINTED PERIODICALS, MAGAZINES, PRINTED CERTIFICATES, CARDS, GUIDES, HANDBOOKS, LEAFLETS, BROCHURES, PAPER FLIP CHART PAGES, NOTEBOOKS, DIARIES, CALENDARS, STATIONERY, INSTRUCTIONAL AND TEACHING MATERIALS, STICKERS, CHARTS, POSTERS, DIAGRAMS FOR USE IN LEARNING, PRINTED SIGNS OF PAPER OR CARDBOARD, DECALCOMANIAS AND PHOTOGRAPH ALBUMS, ALL IN THE FIELD OF/OR FOR USE IN COACHING AND TEACHING PRESENTATION SKILLS (U.S. CLS. 2, 5, 22, 23, 29, 37, 38 AND 50).

CLASS 35—ADVERTISING AND BUSINESS

FOR BUSINESS CONSULTANCY SERVICES, AND INFORMATION, ADVISORY AND CONSULTATION SERVICES RELATING THERETO; BUSINESS ORGANIZATION CONSULTANCY, AND INFORMATION, ADVISORY AND CONSULTATION SERVICES RELATING THERETO; BUSINESS MANAGEMENT SERVICES, AND INFORMATION, ADVISORY AND CONSULTATION SERVICES RELATING THERETO; BUSINESS LEADERSHIP DEVELOPMENT SERVICES, AND INFORMATION, ADVISORY AND CONSULTATION SERVICES RELATING THERETO; BUSINESS PLANNING, AND INFORMATION, ADVISORY AND CONSULTATION SERVICES RELATING THERETO; BUSINESS AND MANAGEMENT APPRAISAL SERVICES, NAMELY, BUSINESS CONSULTATION IN THE FIELD OF MANAGEMENT EVALUATION, AND INFORMATION, ADVISORY AND CONSULTATION SERVICES RELATING THERETO; BUSINESS ADMINISTRATION CONSULTATION SERVICES, AND INFORMATION, ADVISORY AND CONSULTATION SERVICES RELATING THERETO; BUSINESS DEVELOPMENT, NAMELY, PROVIDING START UP SUPPORT FOR BUSINESSES OF OTHERS; BUSINESS ADVISORY SERVICES RELATING TO COMPANY PERFORMANCE, AND INFORMATION, ADVISORY AND CONSULTATION SERVICES RELATING THERETO; BUSINESS COMMUNICATIONS STRATEGY DEVELOPMENT CONSULTATION AND MONITORING, AND INFORMATION, ADVISORY AND CONSULTATION SERVICES RELATING THERETO; HUMAN RESOURCES MANAGEMENT, AND INFORMATION, ADVISORY AND CONSULTATION SERVICES RELATING THERETO; BUSINESS MANAGEMENT OF CLIENT ACCOUNTS, AND INFORMATION, ADVISORY AND CONSULTATION SERVICES RELATING THERETO; BUSINESS MANAGEMENT CONSULTANCY IN THE FIELD OF PROJECT MANAGEMENT AND PERFORMANCE MANAGEMENT, AND INFORMATION, ADVISORY AND CONSULTATION SERVICES RELATING THERETO; BUSINESS MARKETING CONSULTATION SERVICES, AND INFORMATION, ADVISORY AND CONSULTATION SERVICES RELATING THERETO; BUSINESS RESEARCH AND BUSINESS ORGANIZATION CONSULTANCY SERVICES, AND INFORMATION, ADVISORY AND CONSULTATION SERVICES RELATING THERETO; BUSINESS ORGANIZATION EFFICIENCY CONSULTATION SERVICES, AND INFORMATION, ADVISORY AND CONSULTATION SERVICES RELATING THERETO; BUSINESS ORGANIZATION EFFECTIVENESS STUDIES, AND INFORMATION, ADVISORY AND CONSULTATION SERVICES RELATING THERETO; BUSINESS EFFICIENCY CONSULTATION SERVICES, AND INFORMATION, ADVISORY AND CONSULTATION SERVICES RELATING THERETO; BUSINESS MANAGEMENT CONSULTATION IN THE FIELD OF TEAM ASSESSMENT, MODIFICATION AND DEVELOPMENT, AND INFORMATION, ADVISORY AND CONSULTATION SERVICES RELATING THERETO; PERSONNEL RECRUITMENT SERVICES, AND INFORMATION, ADVISORY AND CONSULTATION SERVICES RELATING THERETO; MARKETING CONSULTING SERVICES, AND INFORMATION, ADVISORY

AND CONSULTATION SERVICES RELATING THERETO; MARKET RESEARCH, AND INFORMATION, ADVISORY AND CONSULTATION SERVICES RELATING THERETO; MARKET RESEARCH STUDIES, AND INFORMATION, ADVISORY AND CONSULTATION SERVICES RELATING THERETO; PUBLIC RELATIONS, AND INFORMATION, ADVISORY AND CONSULTATION SERVICES RELATING THERETO; ARRANGING AND CONDUCTING EXHIBITIONS FOR BUSINESS PURPOSES AND BUSINESS CONFERENCES, AND INFORMATION, ADVISORY AND CONSULTATION SERVICES RELATING THERETO; INFORMATION AND DATA COMPILING AND ANALYZING RELATING TO BUSINESS MANAGEMENT, AND INFORMATION, ADVISORY AND CONSULTATION SERVICES RELATING THERETO; BUSINESS RESEARCH SERVICES, NAMELY, PROVIDING ANALYSIS OF RETAIL DATA ON SPECIFIC BUSINESS LOCATIONS, AND INFORMATION, ADVISORY AND CONSULTATION SERVICES RELATING THERETO; PROVIDING STATISTICAL INFORMATION; INFORMATION AND DATA COMPILING AND ANALYZING RELATING TO BUSINESS MANAGEMENT, AND INFORMATION, ADVISORY AND CONSULTATION SERVICES RELATING THERETO; CORPORATE IMAGE CONSULTATION STUDIES, AND INFORMATION, ADVISORY AND CONSULTATION SERVICES RELATING THERETO; BUSINESS ADVISORY SERVICES RELATING TO CORPORATE IDENTITY, AND INFORMATION, ADVISORY AND CONSULTATION SERVICES RELATING THERETO; BUSINESS MARKETING IN THE NATURE OF PREPARATION OF CORPORATE LITERATURE, AND INFORMATION, ADVISORY AND CONSULTATION SERVICES RELATING THERETO; PERSONNEL PLACEMENT AND EMPLOYMENT AGENCY SERVICES, AND INFORMATION, ADVISORY AND CONSULTATION SERVICES RELATING THERETO (U.S. CLS. 100, 101 AND 102).

CLASS 39—TRANSPORTATION AND STORAGE

FOR COMPUTERIZED BUSINESS INFORMATION STORAGE SERVICES AND INFORMATION, ADVISORY AND CONSULTANCY SERVICES RELATING THERETO, INCLUDING THAT PROVIDED ON-LINE FROM A COMPUTER DATABASE (U.S. CLS. 100 AND 105).

CLASS 41—EDUCATION AND ENTERTAINMENT

FOR EDUCATIONAL SERVICES, NAMELY, CONDUCTING CLASSES, SEMINARS, AND WORKSHOPS, AND INFORMATION, ADVISORY AND CONSULTANCY SERVICES RELATING THERETO, NOT USED IN CONJUNCTION WITH MUSICAL ENTERTAINMENT IN THE NATURE OF HIP-HOP MUSIC, ALL IN THE FIELD OF EXECUTIVE COURSES FOR "ONE ON ONE" COACHING IN LEADERSHIP SKILLS, TEAM FACILITATION, COACHING IN VISUAL IMPACT AND PRESENTATIONAL SKILLS, COMMUNICATION TECHNIQUES, VOICE TRAINING, BREATHING EXERCISES, INTONATION EXERCISES, INSPIRATIONAL TRAINING, HOW TO STAND, WALK, AND TO GENERALLY PRESENT YOURSELF IN THE BUSINESS WORLD IN THE BEST LIGHT; TRAINING SERVICES, TRAINING SERVICES PROVIDED ON LINE, TEACHING SERVICES, EDUCATIONAL TUTORING SERVICES, COACHING SERVICES AND MENTOR SERVICES, AND INFORMATION, ADVISORY AND CONSULTANCY SERVICES RELATING THERETO, NOT USED IN CONJUNCTION WITH MUSICAL ENTERTAINMENT IN THE NATURE OF HIP-HOP MUSIC, ALL IN THE FIELD OF EXECUTIVE COURSES FOR "ONE ON ONE" COACHING IN LEADERSHIP SKILLS, TEAM FACILITATION, COACHING IN VISUAL IMPACT AND PRESENTATIONAL SKILLS, COMMUNICATION TECHNIQUES, VOICE TRAINING, BREATHING EXERCISES, INTONATION EXERCISES, INSPIRATIONAL TRAINING, HOW TO STAND, WALK, AND TO GENERALLY PRESENT YOURSELF IN THE BUSINESS WORLD IN THE BEST LIGHT; LIFE COACHING SERVICES, NAMELY, PROVIDING ADVICE, GUIDANCE AND TRAINING ON PERSONAL APPEARANCE, AND INFORMATION, ADVISORY AND CONSULTANCY SERVICES RELATING THERETO, NOT USED IN CONJUNCTION WITH MUSICAL ENTERTAINMENT IN THE NATURE OF HIP-HOP

MUSIC; EDUCATIONAL EXAMINATION SERVICES, AND INFORMATION, ADVISORY AND CONSULTANCY SERVICES RELATING THERETO, NOT USED IN CONJUNCTION WITH MUSICAL ENTERTAINMENT IN THE NATURE OF HIP-HOP MUSIC; EDUCATIONAL ASSESSMENT SERVICES, AND INFORMATION, ADVISORY AND CONSULTANCY SERVICES RELATING THERETO, NOT USED IN CONJUNCTION WITH MUSICAL ENTERTAINMENT IN THE NATURE OF HIP-HOP MUSIC; EDUCATIONAL ASSESSMENT, NAMELY, SKILL ASSESSMENT SERVICES, AND INFORMATION, ADVISORY AND CONSULTANCY SERVICES RELATING THERETO, NOT USED IN CONJUNCTION WITH MUSICAL ENTERTAINMENT IN THE NATURE OF HIP-HOP MUSIC; BUSINESS MANAGEMENT DEVELOPMENT TRAINING, AND INFORMATION, ADVISORY AND CONSULTANCY SERVICES RELATING THERETO, NOT USED IN CONJUNCTION WITH MUSICAL ENTERTAINMENT IN THE NATURE OF HIP-HOP MUSIC; LEADERSHIP TRAINING, AND INFORMATION, ADVISORY AND CONSULTANCY SERVICES RELATING THERETO, NOT USED IN CONJUNCTION WITH MUSICAL ENTERTAINMENT IN THE NATURE OF HIP-HOP MUSIC; FILM PRODUCTION, AND INFORMATION, ADVISORY AND CONSULTANCY SERVICES RELATING THERETO, NOT USED IN CONJUNCTION WITH MUSICAL ENTERTAINMENT IN THE NATURE OF HIP-HOP MUSIC, ALL FOR USE IN EXECUTIVE COURSES FOR "ONE ON ONE" COACHING IN LEADERSHIP SKILLS, TEAM FACILITATION, COACHING IN VISUAL IMPACT AND PRESENTATIONAL SKILLS, COMMUNICATION TECHNIQUES, VOICE TRAINING, BREATHING EXERCISES, INTONATION EXERCISES, INSPIRATIONAL TRAINING, HOW TO STAND, WALK, AND TO GENERALLY PRESENT YOURSELF IN THE BUSINESS WORLD IN THE BEST LIGHT; ORGANIZATION AND PROVISION OF TRAINING COURSES, WORKSHOPS, SEMINARS, SYMPOSIUMS AND FORUMS, AND INFORMATION, ADVISORY AND CONSULTANCY SERVICES RELATING THERETO, NOT USED IN CONJUNCTION WITH MUSICAL ENTERTAINMENT IN THE NATURE OF HIP-HOP MUSIC, ALL IN THE FIELDS OF EXECUTIVE COURSES FOR "ONE ON ONE" COACHING IN LEADERSHIP SKILLS, TEAM FACILITATION, COACHING IN VISUAL IMPACT AND PRESENTATIONAL SKILLS, COMMUNICATION TECHNIQUES, VOICE TRAINING, BREATHING EXERCISES, INTONATION EXERCISES, INSPIRATIONAL TRAINING, HOW TO STAND, WALK, AND TO GENERALLY PRESENT YOURSELF IN THE BUSINESS WORLD IN THE BEST LIGHT; PROVISION OF EDUCATIONAL/RECREATIONAL CONFERENCES AND EXHIBITIONS, AND INFORMATION, ADVISORY AND CONSULTANCY SERVICES RELATING THERETO, NOT USED IN CONJUNCTION WITH MUSICAL ENTERTAINMENT IN THE NATURE OF HIP-HOP MUSIC; PUBLISHING OF BOOKS AND MAGAZINES, AND INFORMATION, ADVISORY AND CONSULTANCY SERVICES RELATING THERETO, NOT USED IN CONJUNCTION WITH MUSICAL ENTERTAINMENT IN THE NATURE OF HIP-HOP MUSIC; PUBLISHING TRAINING COURSE MATERIAL, FOLDERS, BROCHURES, GUIDES CONTAINING PRINTED DOCUMENTATION, INFORMATION, AND INFORMATION, ADVISORY AND CONSULTANCY SERVICES RELATING THERETO, NOT USED IN CONJUNCTION WITH MUSICAL ENTERTAINMENT IN THE NATURE OF HIP-HOP MUSIC; ONLINE PUBLISHING OF MATERIALS, AND INFORMATION, ADVISORY AND CONSULTANCY SERVICES RELATING THERETO, NOT USED IN CONJUNCTION WITH MUSICAL ENTERTAINMENT IN THE NATURE OF HIP-HOP MUSIC, ALL FOR USE IN CONNECTION WITH EXECUTIVE COURSES FOR "ONE ON ONE" COACHING IN LEADERSHIP SKILLS, TEAM FACILITATION, COACHING IN VISUAL IMPACT AND PRESENTATIONAL SKILLS, COMMUNICATION TECHNIQUES, VOICE TRAINING, BREATHING EXERCISES, INTONATION EXERCISES, INSPIRATIONAL TRAINING, HOW TO STAND, WALK,

AND TO GENERALLY PRESENT YOURSELF IN THE BUSINESS WORLD IN THE BEST LIGHT; PHOTOGRAPHY SERVICES, AND INFORMATION, ADVISORY AND CONSULTANCY SERVICES RELATING THERETO, NOT USED IN CONJUNCTION WITH MUSICAL ENTERTAINMENT IN THE NATURE OF HIP-HOP MUSIC; VIDEOTAPE FILM PRODUCTION, AND INFORMATION, ADVISORY AND CONSULTANCY SERVICES RELATING THERETO, NOT USED IN CONJUNCTION WITH MUSICAL ENTERTAINMENT IN THE NATURE OF HIP-HOP MUSIC, ALL FOR USE IN EXECUTIVE COURSES FOR "ONE ON ONE" COACHING IN LEADERSHIP SKILLS, TEAM FACILITATION, COACHING IN VISUAL IMPACT AND PRESENTATIONAL SKILLS, COMMUNICATION TECHNIQUES, VOICE TRAINING, BREATHING EXERCISES, INTONATION EXERCISES, INSPIRATIONAL TRAINING, HOW TO STAND, WALK, AND TO GENERALLY PRESENT YOURSELF IN THE BUSINESS WORLD IN THE BEST LIGHT; PERSONAL IMAGE DEVELOPMENT TRAINING (U.S. CLS. 100, 101 AND 107).

CLASS 45—PERSONAL AND LEGAL SERVICES

FOR ADVICE ON PERSONAL APPEARANCE, NAMELY, REGARDING FASHION AND WARDROBE (U.S. CLS. 100 AND 101).

REBECCA EISINGER, EXAMINING ATTORNEY

SN 85-152,051. RED GRANITE PICTURES LTD., LOS ANGELES, CA. FILED 10-13-2010.

RED GRANITE

THE MARK CONSISTS OF STANDARD CHARACTERS WITHOUT CLAIM TO ANY PARTICULAR FONT, STYLE, SIZE, OR COLOR.

CLASS 9—ELECTRICAL AND SCIENTIFIC APPARATUS

FOR AUDIOVISUAL RECORDINGS OF MOTION PICTURES AND TELEVISION PROGRAMS; MUSICAL SOUND RECORDINGS (U.S. CLS. 21, 23, 26, 36 AND 38).

CLASS 36—INSURANCE AND FINANCIAL

FOR FINANCING OF MOTION PICTURES AND TELEVISION PROGRAM PRODUCTIONS (U.S. CLS. 100, 101 AND 102).

CLASS 41—EDUCATION AND ENTERTAINMENT

FOR PRODUCTION AND DISTRIBUTION OF MOTION PICTURES; PRODUCTION AND DISTRIBUTION OF TELEVISION PROGRAMS (U.S. CLS. 100, 101 AND 107).

NAAKWAMA ANKRAH, EXAMINING ATTORNEY

SN 85-152,857. CINTECH SERVICES, LLC, ROCKWALL, TX.
FILED 10-14-2010.

SN 85-156,745. UNITY CORPORATION, INC., EAGLE, ID.
FILED 10-20-2010.

CinTech

THE MARK CONSISTS OF STANDARD CHARACTERS WITHOUT CLAIM TO ANY PARTICULAR FONT, STYLE, SIZE, OR COLOR.

CLASS 35—ADVERTISING AND BUSINESS

FOR PROJECT MANAGEMENT SERVICES FOR OTHERS FOR BUSINESS PURPOSES IN THE FIELD OF COORDINATION FOR DIGITAL PROJECTOR INSTALLATIONS (U.S. CLS. 100, 101 AND 102).
FIRST USE 9-24-2010; IN COMMERCE 9-24-2010.

CLASS 37—CONSTRUCTION AND REPAIR

FOR INSTALLATION OF DIGITAL PROJECTORS IN COMMERCIAL MOVIE THEATERS (U.S. CLS. 100, 103 AND 106).
FIRST USE 9-24-2010; IN COMMERCE 9-24-2010.
WANDA KAY PRICE, EXAMINING ATTORNEY

SN 85-153,447. POLYTAK PROTECTION SYSTEMS, INC., TUSTIN, CA. FILED 10-15-2010.

MAXCLEAN

THE MARK CONSISTS OF STANDARD CHARACTERS WITHOUT CLAIM TO ANY PARTICULAR FONT, STYLE, SIZE, OR COLOR.

CLASS 9—ELECTRICAL AND SCIENTIFIC APPARATUS

FOR CLEAN ROOM ACCESSORIES, NAMELY, PROTECTIVE WORK GLOVES (U.S. CLS. 21, 23, 26, 36 AND 38).

CLASS 21—HOUSEWARES AND GLASS

FOR CLEAN ROOM ACCESSORIES, NAMELY, DISPOSABLE WIPES NOT IMPREGNATED WITH CHEMICALS OR COMPOUNDS (U.S. CLS. 2, 13, 23, 29, 30, 33, 40 AND 50).

CLASS 27—FLOOR COVERINGS

FOR CLEAN ROOM ACCESSORIES, NAMELY, ENTRANCE MATS FOR CLEANING SHOE SOLES, FLOOR MATS FOR CLEANING SHOE SOLES, DISPOSABLE ABSORBENT FLOOR PADS (U.S. CLS. 19, 20, 37, 42 AND 50).
ARETHA SOMERVILLE, EXAMINING ATTORNEY

UNITY MEDIA GROUP

THE MARK CONSISTS OF STANDARD CHARACTERS WITHOUT CLAIM TO ANY PARTICULAR FONT, STYLE, SIZE, OR COLOR.

NO CLAIM IS MADE TO THE EXCLUSIVE RIGHT TO USE "MEDIA GROUP", APART FROM THE MARK AS SHOWN.

CLASS 38—COMMUNICATION

FOR AUDIO AND VIDEO BROADCASTING SERVICES OVER THE INTERNET OR OTHER COMMUNICATIONS NETWORKS, NAMELY, ELECTRONICALLY TRANSMITTING INFORMATION, AUDIO CLIPS, AND VIDEO CLIPS; PROVIDING ACCESS TO INFORMATION, AUDIO CLIPS, AND VIDEO CLIPS VIA WEBSITES AND BLOGS OVER THE INTERNET; PROVIDING ONLINE CHAT ROOMS AND ELECTRONIC BULLETIN BOARDS FOR TRANSMISSION OF MESSAGES AMONG USERS IN THE FIELD OF GENERAL INTEREST, EDUCATION, HEALTHCARE AND BUSINESS (U.S. CLS. 100, 101 AND 104).
FIRST USE 2-6-2007; IN COMMERCE 2-6-2007.

CLASS 41—EDUCATION AND ENTERTAINMENT

FOR EDUCATION AND ENTERTAINMENT SERVICES, NAMELY, PROVIDING A WEBSITE FEATURING NON-DOWNLOADABLE AUDIO CLIPS, NON-DOWNLOADABLE VIDEO CLIPS, OTHER NON-DOWNLOADABLE MULTI-MEDIA MATERIALS, AND INFORMATION ALL IN THE FIELD OF EDUCATION; AND ONLINE JOURNALS, NAMELY, BLOGS FEATURING INFORMATION IN THE FIELDS OF GENERAL INTEREST, EDUCATION, HEALTHCARE AND BUSINESS (U.S. CLS. 100, 101 AND 107).
FIRST USE 2-6-2007; IN COMMERCE 2-6-2007.

CLASS 44—MEDICAL, BEAUTY AND AGRICULTURAL SERVICES

FOR PROVIDING HEALTHCARE INFORMATION, NAMELY, PROVIDING A WEBSITE FEATURING NON-DOWNLOADABLE AUDIO CLIPS, NON-DOWNLOADABLE VIDEO CLIPS, OTHER NON-DOWNLOADABLE MULTI-MEDIA MATERIALS, AND INFORMATION ALL IN THE FIELD OF HEALTHCARE (U.S. CLS. 100 AND 101).
FIRST USE 2-6-2007; IN COMMERCE 2-6-2007.
TINA MAI, EXAMINING ATTORNEY

SN 85-164,610. THE LUTHERAN UNIVERSITY ASSOCIATION, INC., VALPARAISO, IL. FILED 10-29-2010.



OWNER OF U.S. REG. NOS. 1,680,309 AND 1,682,897.
NO CLAIM IS MADE TO THE EXCLUSIVE RIGHT TO USE "UNIVERSITY" AND "1859", APART FROM THE MARK AS SHOWN.

THE MARK CONSISTS OF CIRCULAR SEAL CONTAINING THE WORDS "VALPARAISO UNIVERSITY 1859" AROUND A LETTER "V" AND A TORCH WITH THE WORDS "IN LUCE TUA VIDEMUS LUCEM" IN A BANNER.

THE ENGLISH TRANSLATION OF "IN LUCE TUA VIDEMUS LUCEM" IN THE MARK IS "IN THY LIGHT WE SEE LIGHT".

SEC. 2(F) AS TO "VALPARAISO UNIVERSITY".

CLASS 16—PAPER GOODS AND PRINTED MATTER

FOR NEWSPAPERS, BOOKS, BROCHURES AND PAMPHLETS CONCERNING UNIVERSITY ADMISSIONS, ALUMNI ACTIVITIES AND GENERAL UNIVERSITY INFORMATION; STATIONERY; PRINTED INVITATIONS; POSTERS; NOTEBOOKS; NOTEPADS (U.S. CLS. 2, 5, 22, 23, 29, 37, 38 AND 50).

FIRST USE 1-0-1996; IN COMMERCE 1-0-1996.

CLASS 18—LEATHER GOODS

FOR TOTE BAGS; BACKPACKS; BRIEFCASE-TYPE LEATHER PORTFOLIOS; LEATHER KEY CHAINS; WALLETS; PURSES; UMBRELLAS (U.S. CLS. 1, 2, 3, 22 AND 41).

FIRST USE 1-0-1996; IN COMMERCE 1-0-1996.

CLASS 20—FURNITURE AND ARTICLES NOT OTHERWISE CLASSIFIED

FOR PICTURE FRAMES (U.S. CLS. 2, 13, 22, 25, 32 AND 50).

FIRST USE 1-0-1996; IN COMMERCE 1-0-1996.

CLASS 21—HOUSEWARES AND GLASS

FOR MUGS; CUPS; DRINKING GLASSWARE (U.S. CLS. 2, 13, 23, 29, 30, 33, 40 AND 50).

FIRST USE 1-0-1996; IN COMMERCE 1-0-1996.

CLASS 25—CLOTHING

FOR CLOTHING AND ACCESSORIES, NAMELY, T-SHIRTS, HATS, SWEATSHIRTS, SHIRTS, SWEAT PANTS, SHORTS, TIES, FOOTWEAR AND BELTS (U.S. CLS. 22 AND 39).

FIRST USE 1-0-1996; IN COMMERCE 1-0-1996.

CLASS 35—ADVERTISING AND BUSINESS

FOR ASSOCIATION SERVICES, NAMELY, PROMOTING THE INTERESTS OF UNIVERSITY ALUMNI (U.S. CLS. 100, 101 AND 102).

FIRST USE 1-0-1996; IN COMMERCE 1-0-1996.

CLASS 41—EDUCATION AND ENTERTAINMENT

FOR EDUCATIONAL SERVICES, NAMELY, PROVIDING INSTRUCTION AT THE UNIVERSITY LEVEL; EDUCATIONAL RESEARCH; ARRANGING AND CONDUCTING EDUCATIONAL CONFERENCES; ENTERTAINMENT SERVICES IN THE NATURE OF CONDUCTING COLLEGIATE SPORTING EVENTS; PROVIDING FACILITIES FOR RECREATIONAL ACTIVITIES, NAMELY, ATHLETIC TRAINING, BASEBALL, BASKETBALL, BOWLING, CROSS COUNTRY, FOOTBALL, GOLF, RECREATIONAL SPORTS, SOCCER, SOFTBALL, STRENGTH AND CONDITIONING, SWIMMING AND DIVING, TENNIS, TRACK AND FIELD, AND VOLLEYBALL; ARRANGING AND CONDUCTING ARTISTIC PERFORMANCES AND CULTURAL EVENTS; PROVIDING ONLINE INFORMATION CONCERNING UNIVERSITY ADMISSIONS, ALUMNI ACTIVITIES AND GENERAL UNIVERSITY INFORMATION; BOOK AND JOURNAL PUBLISHING (U.S. CLS. 100, 101 AND 107).

FIRST USE 1-0-1996; IN COMMERCE 1-0-1996.

WON TEAK OH, EXAMINING ATTORNEY

SN 85-167,619. OMEGA INSIGHTS GMBH, KUSNACHT, SWITZERLAND, FILED 11-2-2010.

OMEGA INSIGHTS

THE MARK CONSISTS OF STANDARD CHARACTERS WITHOUT CLAIM TO ANY PARTICULAR FONT, STYLE, SIZE, OR COLOR.

PRIORITY CLAIMED UNDER SEC. 44(D) ON SWITZERLAND APPLICATION NO. 54407/2010, FILED 5-4-2010.

CLASS 35—ADVERTISING AND BUSINESS

FOR ADVERTISING AND MARKETING CONSULTANCY; ADVICE IN THE FIELD OF BUSINESS MANAGEMENT AND MARKETING; CONSULTING SERVICES RELATED TO BUSINESS STRATEGY, BRANDING, MANAGING INTELLECTUAL PROPERTY, CORPORATE IMAGE, AND CORPORATE IDENTITY; MARKET RESEARCH SERVICES; COLLECTION OF MARKET RESEARCH INFORMATION; ANALYSIS OF MARKET RESEARCH DATA AND STATISTICS; BRAND CONCEPT AND BRAND DEVELOPMENT SERVICES FOR CORPORATE AND INDIVIDUAL CLIENTS; CREATING CORPORATE AND BRAND IDENTITY FOR OTHERS; BRAND EVALUATION SERVICES; SERVICES RELATING TO THE ANALYSIS, EVALUATION, CREATION AND BRAND ESTABLISHMENT OF TRADEMARKS, TRADE NAMES AND DOMAIN NAMES; MARKETING ANALYSIS AND RESEARCH SERVICES IN THE FIELD OF TRADEMARKS; CREATING AND UPDATING ADVERTISING MATERIALS; CREATING AND UPDATING MARKETING MATERIALS; DESIGN OF ADVERTISING MATERIALS FOR OTHERS; DESIGN OF MARKETING MATERIALS FOR OTHERS (U.S. CLS. 100, 101 AND 102).

CLASS 41—EDUCATION AND ENTERTAINMENT

FOR EDUCATIONAL SERVICES, NAMELY, DEVELOPING AND CONDUCTING TRAINING SEMINARS AND COURSES OF INSTRUCTION ALL IN THE FIELDS OF BRANDING, TRADEMARKS, AND MARKETING COMMUNICATIONS; DEVELOPMENT AND DISSEMINATION OF EDUCATIONAL MATERIALS FOR OTHERS ALL IN THE FIELDS OF BRANDING, TRADEMARKS, AND MARKETING COMMUNICATIONS; PROVIDING ON-LINE PUBLICATIONS IN THE NATURE OF NEWSLETTERS, ARTICLES, ESSAYS, CASE STUDIES, AND BLOGS ALL IN THE FIELDS OF BRANDING, TRADEMARKS, AND MARKETING COMMUNICATIONS; TRANSLATION SERVICES; LANGUAGE INTERPRETATION (U.S. CLS. 100, 101 AND 107).

CLASS 42—SCIENTIFIC AND COMPUTER SERVICES

FOR GRAPHIC ARTS DESIGN SERVICES IN CONNECTION WITH BRANDING, TRADEMARKS, MARKETING, AND CORPORATE COMMUNICATIONS; TECHNICAL RESEARCH SERVICES IN THE FIELD OF LINGUISTICS, NAMELY, EVALUATING THE MEANING OF TRADEMARKS AND BRAND NAMES IN INTERNATIONAL MARKETS; SCIENTIFIC AND TECHNOLOGICAL SERVICES, NAMELY, RESEARCH AND DEVELOPMENT AND CONSULTATION RELATED THERETO ALL IN THE FIELD OF MARKET RESEARCH METHODS, BRAND CREATION, BRAND NAME TESTING, BRAND VALUE ASSESSMENT, MARKET ANALYSIS, TRADEMARK STRATEGIES, AND CORPORATE IDENTITY (U.S. CLS. 100 AND 101).

CLASS 45—PERSONAL AND LEGAL SERVICES

FOR LEGAL SERVICES, NAMELY, INTELLECTUAL PROPERTY CONSULTING SERVICES IN THE FIELDS OF MARKETING, BRANDING, TRADEMARKS, AND CORPORATE COMMUNICATIONS (U.S. CLS. 100 AND 101).

BERYL GARDNER, EXAMINING ATTORNEY

SN 85-172,516. 17 DAY DIET, INC., BEVERLY HILLS, CA. FILED 11-9-2010.

The 17 Day Diet

THE MARK CONSISTS OF STANDARD CHARACTERS WITHOUT CLAIM TO ANY PARTICULAR FONT, STYLE, SIZE, OR COLOR.

NO CLAIM IS MADE TO THE EXCLUSIVE RIGHT TO USE "DIET", APART FROM THE MARK AS SHOWN. SEC. 2(F).

CLASS 9—ELECTRICAL AND SCIENTIFIC APPARATUS

FOR PRE-RECORDED DVDS AND AUDIO TAPES FEATURING INFORMATION RELATING TO HEALTH, HEALTHCARE, NUTRITION, DIET, WEIGHT LOSS, EXERCISE, FITNESS, MENU PLANNING, AND A HEALTHY LIFESTYLE (U.S. CLS. 21, 23, 26, 36 AND 38). FIRST USE 11-29-2010; IN COMMERCE 11-29-2010.

CLASS 16—PAPER GOODS AND PRINTED MATTER

FOR PRINTED PUBLICATIONS AND PRINTED MATTER, NAMELY, MAGAZINES, JOURNALS, BOOKS, MANUALS, DIARIES, CALENDARS, CHARTS, AND PRINTED RECIPES SOLD AS A COMPONENT OF MEAL PLANS, IN THE FIELDS OF HEALTH, HEALTHCARE, NUTRITION, DIET, WEIGHT LOSS, EXERCISE, FITNESS, MENU PLANNING, AND A HEALTHY LIFESTYLE; PRINTED INSTRUCTIONAL AND TEACHING MATERIALS IN THE FIELDS OF HEALTH, HEALTHCARE, NUTRITION, DIET, WEIGHT LOSS, EXERCISE, FITNESS, MENU PLANNING, AND A HEALTHY LIFESTYLE (U.S. CLS. 2, 5, 22, 23, 29, 37, 38 AND 50).

FIRST USE 11-29-2010; IN COMMERCE 11-29-2010.

CLASS 41—EDUCATION AND ENTERTAINMENT

FOR ENTERTAINMENT SERVICES, NAMELY, ORGANIZING AND MANAGING COMPETITIONS RELATING TO A HEALTHY LIFESTYLE THAT INVOLVE NUTRITION, DIET, WEIGHT LOSS, EXERCISE, FITNESS, AND MENU PLANNING (U.S. CLS. 100, 101 AND 107).

FIRST USE 11-29-2010; IN COMMERCE 11-29-2010.

CLASS 44—MEDICAL, BEAUTY AND AGRICULTURAL SERVICES

FOR PROVIDING A WEBSITE WITH INFORMATION ABOUT DIET, WEIGHT REDUCTION, WELLNESS, NUTRITION AND MENU PLANNING; HEALTHCARE SERVICES, NAMELY, TREATMENT OF PATIENTS WITH WEIGHT RELATED MEDICAL ISSUES (U.S. CLS. 100 AND 101).

FIRST USE 11-29-2010; IN COMMERCE 11-29-2010.

LESLEY LAMOTHE, EXAMINING ATTORNEY

SN 85-173,396. AARP, WASHINGTON, DC. FILED 11-10-2010.

DRIVE TO END HUNGER

THE MARK CONSISTS OF THE WORDS "DRIVE TO END HUNGER" WITH THE LETTER "D" IN THE WORD "DRIVE" DEPICTING A STYLIZED IMAGE OF A FORK.

CLASS 6—METAL GOODS

FOR METAL KEY CHAINS, METAL LICENSE PLATES, AND WALL PLAQUES MADE OF COMMON METAL; THREE-DIMENSIONAL DECORATIVE WINDOW ORNAMENTS MADE OF NON-PRECIOUS METAL (U.S. CLS. 2, 12, 13, 14, 23, 25 AND 50).

CLASS 8—HAND TOOLS

FOR POCKET KNIVES (U.S. CLS. 23, 28 AND 44).

CLASS 9—ELECTRICAL AND SCIENTIFIC APPARATUS

FOR COMPUTER SOFTWARE FOR SAVING SCREENS, TELEPHONES, DECORATIVE MAGNETS, COMPUTER BAGS, COMPUTER GAME CARTRIDGES, MAGNETICALLY ENCODED CREDIT CARDS (U.S. CLS. 21, 23, 26, 36 AND 38).

CLASS 12—VEHICLES

FOR LICENSE PLATE FRAMES; AUTOMOBILE STRUCTURAL PARTS, NAMELY, REPLICA HOODS OF PLASTIC (U.S. CLS. 19, 21, 23, 31, 35 AND 44).

CLASS 14—JEWELRY

FOR CLOCKS; THREE-DIMENSIONAL DECORATIVE WINDOW ORNAMENTS MADE OF PRECIOUS METAL (U.S. CLS. 2, 27, 28 AND 50).

CLASS 16—PAPER GOODS AND PRINTED MATTER

FOR BOOKS FEATURING INFORMATION AND THEMES RELATED TO RACING AND/OR TO HUNGER ISSUES, BUMPER STICKERS, CALENDARS, COMMEMORATIVE SHEETS OF TRADING CARDS, DECALS, LIMITED EDITION PICTORIAL PRINTS, LITHOGRAPHIC PRINTS, DECALS FOR MODEL CARS, PAPER NAPKINS, PENCILS, PENS, FRAMED PHOTOGRAPHS, DAILY PLANNERS, POST CARDS, POSTERS, STATIC DECALS, STICKERS, TRADING CARDS, WINDOW DECALS, PRINTED COLLECTOR CARDS MADE PRIMARILY OF PAPER BUT ALSO INCLUDING METAL, PRINTED MATTER, NAMELY, MAGNETIC VINYL EMBLEMS; TRADING CARDS MADE PRIMARILY OF NON-PRECIOUS METAL (U.S. CLS. 2, 5, 22, 23, 29, 37, 38 AND 50).

CLASS 18—LEATHER GOODS

FOR UMBRELLAS AND LEATHER KEY CHAINS (U.S. CLS. 1, 2, 3, 22 AND 41).

CLASS 20—FURNITURE AND ARTICLES NOT OTHERWISE CLASSIFIED

FOR PHOTO PLAQUES MADE PRIMARILY OF PLASTIC OR WOOD, PICTURE FRAMES, WOODEN PLAQUES, CUSHIONS, THREE-DIMENSIONAL PLASTIC OR WOOD DECORATIVE WINDOW ORNAMENTS, PET CUSHIONS (U.S. CLS. 2, 13, 22, 25, 32 AND 50).

CLASS 21—HOUSEWARES AND GLASS

FOR PLASTIC COASTERS; PORTABLE BEVERAGE COOLERS; THERMAL INSULATED COOLER BAGS FOR BEVERAGES; INSULATED PORTABLE SPORTS COOLERS FOR BEVERAGES; THERMAL INSULATED CONTAINERS FOR CAN BEVERAGES; COFFEE CUPS; PLASTIC SPORTS BOTTLES SOLD EMPTY (U.S. CLS. 2, 13, 23, 29, 30, 33, 40 AND 50).

CLASS 24—FABRICS

FOR AFGHANS, CLOTH FLAGS, CLOTH PENNANTS, TOWELS (U.S. CLS. 42 AND 50).

CLASS 25—CLOTHING

FOR CLOTHING, NAMELY, LEATHER JACKETS, CREW NECK SHIRTS, GOLF SHIRTS, HATS, CAPS, INFANT SHIRTS, JACKETS, JERSEYS, POLO SHIRTS, PULLOVER SHIRTS, SWEATSHIRTS, T-SHIRTS, TANK TOPS, TOBOGGAN-TYPE KNIT CAPS, VISORS (U.S. CLS. 22 AND 39).

CLASS 28—TOYS AND SPORTING GOODS

FOR TOY REPLICA CAR OF PLASTIC, TOY REPLICA HOODS OF PLASTIC, TOY REPLICA TRUNK LIDS OF PLASTIC, CHRISTMAS TREE ORNAMENTS, TOY TRACTOR-TRAILERS OF METAL AND PLASTIC, TOY CARS OF PLASTIC AND METAL, TOY MOTORCYCLES MADE OF PLASTIC AND METAL, PLAYING CARDS AND CARD GAMES, TOY VEHICLE HAULERS, TOY MODEL CARS AND RELATED ACCESSORIES SOLD AS A UNIT, TOY TRUCKS, DIECAST TOY CARS, AND DIECAST TOY VEHICLE HAULERS (U.S. CLS. 22, 23, 38 AND 50).

CLASS 35—ADVERTISING AND BUSINESS

FOR ADVERTISING SERVICES, NAMELY, PROVIDING ADVERTISING SPACE ON AUTOMOBILES PARTICIPATING IN STOCK CAR EVENTS; CHARITABLE SERVICES, NAMELY, PROMOTING PUBLIC AWARENESS ABOUT HUNGER, ORGANIZING AND CONDUCTING COMMUNITY SERVICE PROJECTS TO ADDRESS HUNGER, ORGANIZING AND CONDUCTING HUMANITARIAN EFFORTS IN THE NATURE OF COORDINATION OF THE PROCUREMENT AND DISTRIBUTION OF FOOD DONATIONS FROM INDIVIDUALS AND RETAILERS TO ORGANIZATIONS PROVIDING FREE FOOD TO NEEDY PEOPLE AND PROVIDING A WEBSITE FEATURING INFORMATION RELATED TO THE FOREGOING (U.S. CLS. 100, 101 AND 102).

CLASS 41—EDUCATION AND ENTERTAINMENT

FOR ENTERTAINMENT SERVICES IN THE NATURE OF PARTICIPATING IN PROFESSIONAL AUTO RACES; CHARITABLE SERVICES, NAMELY, ORGANIZING AND CONDUCTING PROGRAMS TO ADDRESS HUNGER IN THE NATURE OF SOCIAL ENTERTAINMENT EVENTS THE PROCEEDS OF WHICH ARE DONATED TO ORGANIZATIONS PROVIDING FOOD TO NEEDY PEOPLE AND PROVIDING A WEBSITE FEATURING INFORMATION RELATED THERETO (U.S. CLS. 100, 101 AND 107).

ANDREW LEASER, EXAMINING ATTORNEY

SN 85-173,525. LAWRENCE, SHANNON SLAM, VOORHEES, NJ. FILED 11-10-2010.

FULL COURT PRESS

THE MARK CONSISTS OF STANDARD CHARACTERS WITHOUT CLAIM TO ANY PARTICULAR FONT, STYLE, SIZE, OR COLOR.

NO CLAIM IS MADE TO THE EXCLUSIVE RIGHT TO USE "PRESS", APART FROM THE MARK AS SHOWN.

CLASS 9—ELECTRICAL AND SCIENTIFIC APPARATUS

FOR PRE-RECORDED AUDIO TAPES, DISCS AND CASSETTES, VIDEO TAPES, DISCS AND CASSETTES, DIGITAL AUDIO AND AUDIO VIDEO TAPES AND DISCS, CDS, DVDS, LASER DISCS, AND PHONOGRAPH RECORDS FEATURING MUSIC, SOUNDS AND ENTERTAINMENT; MUSICAL SOUND AND VIDEO RECORDINGS; DOWNLOADABLE RING TONES, MUSIC, SOUNDS, MP3 FILES, GRAPHICS, GAMES, IMAGES AND VIDEOS FOR WIRELESS COMMUNICATION DEVICES; DOWNLOADABLE MUSIC, SOUNDS, MP3 FILES, GRAPHICS, COMPUTER GAMES, IMAGES AND VIDEOS (U.S. CLS. 21, 23, 26, 36 AND 38).

CLASS 25—CLOTHING

FOR CLOTHING, NAMELY, JACKETS, PANTS, COATS, SWEATERS, T-SHIRTS; HEADWEAR (U.S. CLS. 22 AND 39).

SN 85-177,765. SC PRODAL '94 SRL, JUDETUL, ROMANIA, FILED 11-16-2010.

**CLASS 35—ADVERTISING AND BUSINESS**

FOR WHOLESALE DISTRIBUTORSHIP SERVICES FEATURING PRE-RECORDED AUDIO TAPES, DISCS AND CASSETTES, VIDEO TAPES, DISCS AND CASSETTES, DIGITAL AUDIO AND AUDIO VIDEO TAPES AND DISCS, CDS, DVDS, LASER DISCS, AND PHONOGRAPH RECORDS FEATURING MUSIC, SOUNDS AND ENTERTAINMENT, MUSICAL SOUND AND VIDEO RECORDINGS, DOWNLOADABLE RING TONES, MUSIC, SOUNDS, MP3 FILES, GRAPHICS, GAMES, IMAGES AND VIDEOS FOR WIRELESS COMMUNICATION DEVICES, DOWNLOADABLE MUSIC, SOUNDS, MP3 FILES, GRAPHICS, COMPUTER GAMES, IMAGES AND VIDEOS; DISTRIBUTION OF MUSICAL AND NON-MUSICAL SOUND PERFORMANCES AND VIDEO PERFORMANCES; ADVERTISING AND PROMOTION SERVICES AND RELATED CONSULTING SERVICES; ADVERTISING AND PUBLICITY SERVICES; ASSOCIATION SERVICES, NAMELY, PROMOTING THE INTERESTS OF MUSICIANS, SINGERS, SONGWRITERS, MUSICAL PERFORMERS AND ARTISTS; COMPUTERIZED ONLINE ORDERING FEATURING GENERAL MERCHANDISE AND GENERAL CONSUMER GOODS; COMPUTERIZED ONLINE ORDERING SERVICES IN THE FIELD OF MUSIC AND ENTERTAINMENT; COMPUTERIZED ONLINE RETAIL STORE SERVICES IN THE FIELD OF MUSIC AND ENTERTAINMENT; MAIL ORDER CATALOG SERVICES FEATURING CD'S, CASSETTES, DVD'S AND GENERAL MERCHANDISE; ONLINE RETAIL STORE SERVICES FEATURING DOWNLOADABLE PRE-RECORDED MUSIC AND AUDIO-VISUAL CONTENT, NAMELY, PRE-RECORDED AUDIO-VISUAL RECORDINGS, MUSICAL SOUND AND VIDEO RECORDINGS, AND GENERAL MERCHANDISE, NAMELY, GRAPHICS, COMPUTER GAMES, IMAGES AND VIDEOS; PREPARATION OF PROMOTIONAL MATERIALS AND PROGRAMS USING AUDIO-VISUAL MEDIA; PREPARING AUDIO-VISUAL DISPLAYS IN THE FIELD OF MUSIC; PREPARATION OF AUDIO VISUAL PRODUCTIONS FOR USE IN ADVERTISING; ARRANGING AND CONDUCTING FAIRS AND EXHIBITIONS FOR BUSINESS AND ADVERTISING PURPOSES; PROMOTING THE CONCERTS OF OTHERS; PROMOTING THE GOODS AND SERVICES OF OTHERS BY ARRANGING FOR SPONSORS TO AFFILIATE THEIR GOODS AND SERVICES WITH CONCERTS, MUSICAL AND SPORTS EVENTS; PROMOTING THE GOODS OF OTHERS BY PREPARING AND PLACING ADVERTISEMENTS IN AN ELECTRONIC MAGAZINE ACCESSED THROUGH A GLOBAL COMPUTER NETWORK; PROVIDING INFORMATION ABOUT THE GOODS AND SERVICES OF OTHERS VIA A GLOBAL COMPUTER NETWORK; RETAIL STORE SERVICES AVAILABLE THROUGH COMPUTER COMMUNICATIONS FEATURING CD'S, CASSETTES, DVD'S, VIDEO-CASSETTES AND LICENSED MERCHANDISE; MANAGEMENT SERVICES FOR PROFESSIONAL ARTISTS; TALENT AGENCY SERVICES; ADVERTISING, INCLUDING PROMOTION OF PRODUCTS AND SERVICES OF THIRD PARTIES THROUGH SPONSORING ARRANGEMENTS AND LICENSE AGREEMENTS RELATING TO MUSIC EVENTS; PROMOTING MUSIC COMPETITIONS AND EVENTS FOR OTHERS, PROMOTING GOODS AND SERVICES OF OTHERS BY ARRANGING FOR SPONSORS TO AFFILIATE THEIR GOODS AND SERVICES WITH MUSIC COMPETITIONS; PROMOTING THE INTERESTS OF PEOPLE INVOLVED AND CONCERNED WITH MUSIC; PROVIDING ONLINE REGISTRATION SERVICES FOR MUSIC COMPETITIONS; COMMERCIAL ADMINISTRATION OF LICENSING OF MUSICAL AND NON-MUSICAL SOUND RECORDINGS (U.S. CLS. 100, 101 AND 102).

JILL C. ALT, EXAMINING ATTORNEY

PRIORITY CLAIMED UNDER SEC. 44(D) ON ROMANIA APPLICATION NO. M/7925, FILED 11-3-2010, REG. NO. 114053, DATED 11-3-2010, EXPIRES 11-3-2020.

NO CLAIM IS MADE TO THE EXCLUSIVE RIGHT TO USE "PREMIUM VODKA" AND "ORIGINAL", APART FROM THE MARK AS SHOWN.

THE COLOR(S) RED, BLACK, WHITE, GOLD AND GRAY IS/ARE CLAIMED AS A FEATURE OF THE MARK.

THE MARK CONSISTS OF THE WORD "STALINSKAYA" IN WHITE AGAINST A RED BACKGROUND BORDERED IN GOLD; BELOW THE WORD "STALINSKAYA" IS THE WORDING "PREMIUM VODKA" IN GOLD ABOVE THE WORD "ORIGINAL" IN BLACK; THE WORD "ORIGINAL" APPEARS OVER A DESIGN CONSISTING OF A TWO HEADED DRAGON AND THE LETTER "P" IN GRAY; ABOVE THE WORD "STALINSKAYA" APPEARS A DESIGN CONSISTING OF A CROWN AND A PAIR OF WINGS WITH TWO BIRD HEADS FACING A LETTER "P" IN GOLD; ALL THE PRECEDING IS ENCLOSED IN A RED CREST BORDERED IN GOLD WITH A WHITE INTERIOR.

THE ENGLISH TRANSLATION OF "STALINSKAYA" IN THE MARK IS "STRONG AS STEEL".

CLASS 33—WINES AND SPIRITS

FOR ALCOHOLIC BEVERAGES EXCEPT BEERS (U.S. CLS. 47 AND 49).

CLASS 35—ADVERTISING AND BUSINESS

FOR ADVERTISING; BUSINESS MANAGEMENT; BUSINESS ADMINISTRATION; OFFICE FUNCTIONS (U.S. CLS. 100, 101 AND 102).

CLASS 39—TRANSPORTATION AND STORAGE

FOR TRANSPORT OF PERSONS AND GOODS; PACKAGING OF GOODS FOR TRANSPORT; STORAGE OF GOODS (U.S. CLS. 100 AND 105).

DAVID ELTON, EXAMINING ATTORNEY

SN 85-181,870. STICKY FINGERS BAKERY, INC, WASHINGTON, DC. FILED S.R. 11-20-2010; AM. P.R. 4-6-2012.

STICKY FINGERS SWEETS & EATS

THE MARK CONSISTS OF STANDARD CHARACTERS WITHOUT CLAIM TO ANY PARTICULAR FONT, STYLE, SIZE, OR COLOR.

NO CLAIM IS MADE TO THE EXCLUSIVE RIGHT TO USE "SWEETS & EATS", APART FROM THE MARK AS SHOWN.

CLASS 30—STAPLE FOODS

FOR VEGAN BAKERY PRODUCTS (U.S. CL. 46).
FIRST USE 9-1-2010; IN COMMERCE 9-1-2010.

CLASS 35—ADVERTISING AND BUSINESS

FOR RETAIL VEGAN BAKERY SHOP OFFERING CAKES, CUPCAKES, MUFFINS, COOKIES, SPECIALTY CAKES AND OTHER BAKED GOODS AS WELL AS SANDWICHES, COFFEE DRINKS, SALADS AND SOUPS (U.S. CLS. 100, 101 AND 102).

FIRST USE 9-1-2010; IN COMMERCE 9-1-2010.
H. M. FISHER, EXAMINING ATTORNEY

SN 85-186,326. BLUEFISH PHARMACEUTICALS AB (PUBL),
111 23 STOCKHOLM, SWEDEN, FILED 11-29-2010.

BLUEFISH

THE MARK CONSISTS OF STANDARD CHARACTERS WITHOUT CLAIM TO ANY PARTICULAR FONT, STYLE, SIZE, OR COLOR.

CLASS 5—PHARMACEUTICALS

FOR A FULL LINE OF PHARMACEUTICAL PREPARATIONS FOR HUMANS FOR THE TREATMENT OF A WIDE RANGE OF DISEASES AND AILMENTS (U.S. CLS. 6, 18, 44, 46, 51 AND 52).

CLASS 10—MEDICAL APPARATUS

FOR A FULL LINE OF MEDICAL APPARATUS AND INSTRUMENTS; A FULL LINE OF ORTHOPEDIC ARTICLES (U.S. CLS. 26, 39 AND 44).

CLASS 35—ADVERTISING AND BUSINESS

FOR WHOLESALE DISTRIBUTORSHIP SERVICES IN THE FIELD OF PHARMACEUTICALS (U.S. CLS. 100, 101 AND 102).
JORDAN BAKER, EXAMINING ATTORNEY

SN 85-187,374. FYI SENIOR LIVING SOLUTIONS, INC., RYE,
NY. FILED 11-30-2010.

FYI SENIOR LIVING SOLUTIONS

THE MARK CONSISTS OF STANDARD CHARACTERS WITHOUT CLAIM TO ANY PARTICULAR FONT, STYLE, SIZE, OR COLOR.

NO CLAIM IS MADE TO THE EXCLUSIVE RIGHT TO USE "SENIOR LIVING SOLUTIONS", APART FROM THE MARK AS SHOWN.

CLASS 43—HOTEL AND RESTAURANT SERVICES

FOR ELDER CARE PLANNING AND CONSULTING SERVICES, NAMELY, PROVIDING CONSULTATION IN REGARD TO NON-MEDICAL ASSISTED LIVING SERVICES FOR PERSONAL PURPOSES, NAMELY, ASSISTING WITH FINDING ALTERNATIVE LIVING ARRANGEMENTS IF NEEDED (U.S. CLS. 100 AND 101).

CLASS 45—PERSONAL AND LEGAL SERVICES

FOR ELDER CARE PLANNING AND CONSULTING SERVICES, NAMELY, PROVIDING CONSULTATION IN REGARD TO NON-MEDICAL ASSISTED LIVING SERVICES FOR PERSONAL PURPOSES, NAMELY, ARRANGING FOR SERVICES OF LEGAL ADVISORS AND ASSISTING IN OBTAINING RECOMMENDED DOCUMENTS SUCH AS ADVANCE DIRECTIVES, DURABLE POWERS OF ATTORNEY, WILLS, AND HEALTHCARE PROXY DOCUMENTATION (U.S. CLS. 100 AND 101).
KELLEY WELLS, EXAMINING ATTORNEY

SN 85-187,532. OUTPATIENT OPHTHALMIC SURGERY SOCIETY, ARVADA, CO. FILED 11-30-2010.

Belong Today Shape Tomorrow

THE MARK CONSISTS OF STANDARD CHARACTERS WITHOUT CLAIM TO ANY PARTICULAR FONT, STYLE, SIZE, OR COLOR.

CLASS 35—ADVERTISING AND BUSINESS

FOR ASSOCIATION SERVICES, NAMELY, PROMOTING THE INTERESTS OF OPHTHALMIC SURGEONS AND OPHTHALMOLOGISTS (U.S. CLS. 100, 101 AND 102).

CLASS 44—MEDICAL, BEAUTY AND AGRICULTURAL SERVICES

FOR PROVIDING EDUCATIONAL INFORMATION IN THE FIELD OF OPHTHALMOLOGY, OPHTHALMIC SURGERY AND AMBULATORY SURGERY CENTERS (U.S. CLS. 100 AND 101).
LAKEISHA LEWIS, EXAMINING ATTORNEY

SN 85-188,069. UNIVERSITY OF BALTIMORE, BALTIMORE,
MD. FILED 12-1-2010.



NO CLAIM IS MADE TO THE EXCLUSIVE RIGHT TO USE "UNIVERSITY", APART FROM THE MARK AS SHOWN.

THE MARK CONSISTS OF THE WORDS "UNIVERSITY OF BALTIMORE" WHICH APPEAR IN LOWERCASE AND IN METABOOK ROMAN FONT. THE WORDS "UNIVERSITY OF" ARE ABOVE AND TO THE RIGHT OF THE WORD "BALTIMORE". THE DOTTED PART OF THE "I" IN "BALTIMORE" APPEARS BEFORE THE WORD "UNIVERSITY".

SEC. 2(F).

CLASS 6—METAL GOODS

FOR KEY CHAIN FOBS OF COMMON METAL BEARING THE UNIVERSITY LOGO (U.S. CLS. 2, 12, 13, 14, 23, 25 AND 50).

FIRST USE 1-1-2006; IN COMMERCE 3-1-2006.

CLASS 9—ELECTRICAL AND SCIENTIFIC APPARATUS

FOR DOWNLOADABLE ELECTRONIC PUBLICATIONS IN THE NATURE OF CATALOGS, BROCHURES, NEWSLETTERS, MAGAZINES, NEWS ARTICLES AND RELEASES, AND PAPERS FEATURING SPEECHES AND STATEMENTS MADE BY UNIVERSITY EMPLOYEES, UNIVERSITY POLICIES, PROCEDURES AND PROGRAMS, AND ACADEMIC AND RESEARCH OFFERINGS AND ACTIVITIES ARISING OUT OF THE UNIVERSITY'S DIFFERENT ACADEMIC DEPARTMENTS (U.S. CLS. 21, 23, 26, 36 AND 38).

FIRST USE 1-1-2006; IN COMMERCE 1-1-2006.

CLASS 16—PAPER GOODS AND PRINTED MATTER

FOR SCHOLARLY PAPERS AND PUBLICATIONS IN THE NATURE OF CATALOGS, BROCHURES, NEWSLETTERS, MAGAZINES, NEWS ARTICLES AND RELEASES, AND PAPERS RELATED TO ACADEMIC AND RESEARCH OFFERINGS AND ACTIVITIES IN ACADEMIC FIELDS OF ARTS AND HUMANITIES, BEHAVIORAL AND SOCIAL SCIENCES, BUSINESS, COMPUTER, MATHEMATICAL AND PHYSICAL SCIENCES, EDUCATION, ENGINEERING, HEALTH AND HUMAN PERFORMANCE, COMMUNICATION, COMMUNITY STUDIES AND CIVIC ENGAGEMENT, LIBRARY AND INFORMATION SERVICES, LIFE SCIENCES, ENVIRONMENTAL STUDIES, COMPUTER SIMULATIONS, THE DIGITAL ENTERTAINMENT FIELD, AND PUBLIC AFFAIRS; UNIVERSITY STATIONERY, MAGAZINES, CATALOGS AND PAMPHLETS DESCRIBING THE UNIVERSITY'S EDUCATIONAL AND RESEARCH SERVICES; UNIVERSITY POSTCARDS, DECALS, ADDRESS LABELS, ANNOUNCEMENT AND NOTE CARDS; GRAPHIC ART REPRODUCTIONS; PRINTED AWARDS; PAPER NAME BADGES; PLASTIC AND PAPER MERCHANDISE BAGS; PAPER BANNERS; DESK ACCESSORIES, NAMELY, DESK BLOTTERS, PENCIL HOLDERS, PAPER WEIGHT AND PAPER CLIP HOLDERS AND STATIONERY NOTE PAD HOLDERS; LOOSE LEAF BINDER SETS; BOOK COVERS; BULLETINS CONCERNING UNIVERSITY EVENTS AND POLICIES; BUMPER STICKERS; CHRISTMAS CARDS; PRINTED INSTRUCTIONAL, EDUCATIONAL AND TEACHING MATERIALS, NAMELY, COURSE MATERIALS IN THE FIELDS OF ARTS AND HUMANITIES, BEHAVIORAL AND SOCIAL SCIENCES, BUSINESS, COMPUTER, MATHEMATICAL AND PHYSICAL SCIENCES, EDUCATION, ENGINEERING, HEALTH AND HUMAN PERFORMANCE, COMMUNICATION, COMMUNITY STUDIES AND CIVIC ENGAGEMENT, LIBRARY AND INFORMATION SERVICES, LIFE SCIENCES, ENVIRONMENTAL STUDIES, COMPUTER SIMULATIONS, THE DIGITAL ENTERTAINMENT FIELD AND PUBLIC AFFAIRS; TELEPHONE DIRECTORIES (U.S. CLS. 2, 5, 22, 23, 29, 37, 38 AND 50).

FIRST USE 1-1-2006; IN COMMERCE 3-1-2006.

CLASS 25—CLOTHING

FOR T-SHIRTS, SWEAT SHIRTS, SWEAT PANTS, GYM SHORTS, ATHLETIC JACKETS AND UNIFORMS, WIND RESISTANT JACKETS, BASEBALL CAPS, SWEAT BANDS, INFANT WEAR, NECKTIES (U.S. CLS. 22 AND 39).

FIRST USE 1-1-2006; IN COMMERCE 3-1-2006.

CLASS 41—EDUCATION AND ENTERTAINMENT

FOR EDUCATIONAL SERVICES, NAMELY, DEVELOPING, ARRANGING FOR AND PROVIDING COURSES OF INSTRUCTION AT THE UNDERGRADUATE, GRADUATE AND POSTGRADUATE UNIVERSITY LEVELS; CONTINUING AND COMMUNITY EDUCATION SERVICES, NAMELY, PROVIDING LIVE AND ON-LINE CONTINUING EDUCATION SEMINARS IN THE LEGAL, BUSINESS, ARTS, SCIENCES AND PUBLIC AFFAIRS FIELDS; DEVELOPING AND ARRANGING FOR AND PROVIDING SEMINARS, CONFERENCES AND WORKSHOPS IN THE FIELDS OF ARTS AND HUMANITIES, BEHAVIORAL AND SOCIAL SCIENCES, BUSINESS, COMPUTER, MATHEMATICAL AND PHYSICAL SCIENCES, EDUCATION, ENGINEERING, HEALTH AND HUMAN PERFORMANCE, COMMUNICATION, COMMUNITY STUDIES AND CIVIC ENGAGEMENT, LIBRARY AND INFORMATION SERVICES, LIFE SCIENCES, ENVIRONMENTAL STUDIES, COMPUTER SIMULATIONS, THE DIGITAL ENTERTAINMENT FIELD, AND PUBLIC AFFAIRS; PROVIDING COURSES OF INSTRUCTION IN AND DISTRIBUTING COURSE, SEMINAR, CONFERENCE AND WORKSHOP MATERIALS IN CONNECTION WITH THE FIELDS OF ARTS AND HUMANITIES, BEHAVIORAL AND SOCIAL SCIENCES, BUSINESS, COMPUTER, COMMUNITY STUDIES AND CIVIC ENGAGEMENT, MATHEMATICAL AND PHYSICAL SCIENCES, EDUCATION, ENGINEERING, ENGLISH, FORENSIC STUDIES, ENVIRONMENTAL SUSTAINABILITY AND HUMAN ECOLOGY, HEALTH AND HUMAN PERFORMANCE, INTERNATIONAL STUDIES, LIBRARY AND INFORMATION SERVICES, LIFE SCIENCES, PUBLIC AFFAIRS, COMPUTER SIMULATIONS, AND THE DIGITAL ENTERTAINMENT FIELD; DEVELOPMENT AND DISSEMINATION OF EDUCATIONAL MANUALS FOR OTHERS IN THE FIELDS OF ARTS AND HUMANITIES, BEHAVIORAL AND SOCIAL SCIENCES, BUSINESS, COMPUTER, COMMUNITY STUDIES AND CIVIC ENGAGEMENT, MATHEMATICAL AND PHYSICAL SCIENCES, EDUCATION, ENGINEERING, ENGLISH, FORENSIC STUDIES, ENVIRONMENTAL SUSTAINABILITY AND HUMAN ECOLOGY, HEALTH AND HUMAN PERFORMANCE, INTERNATIONAL STUDIES, LIBRARY AND INFORMATION SERVICES, LIFE SCIENCES, PUBLIC AFFAIRS, COMPUTER SIMULATIONS AND THE DIGITAL ENTERTAINMENT FIELD; CONDUCTING EDUCATIONAL DEMONSTRATIONS, RESEARCH AND TESTING; EDUCATIONAL SERVICES, NAMELY, PROVIDING INCENTIVES TO PEOPLE THROUGH ISSUING AWARDS AND/OR DEGREES TO PERSONS WHO DEMONSTRATE EXCELLENCE IN ACADEMIC AND RESEARCH ENDEAVORS; ORGANIZING AND OFFERING EDUCATIONAL, CULTURAL, SPORTING EVENTS AND ENTERTAINMENT PROGRAMS, PERFORMANCES AND EXHIBITIONS IN THE NATURE OF ART EXHIBITS, THEATRICAL PERFORMANCES, MUSICAL PERFORMANCES IN THE FORM OF OPERAS, MUSICALS, ORCHESTRAL, BAND, JAZZ AND STRING ENSEMBLES; LECTURES ON ISSUES AND TOPICS RELATED TO THE FIELDS OF ARTS AND HUMANITIES, BEHAVIORAL AND SOCIAL SCIENCES, BUSINESS, COMPUTER, COMMUNITY STUDIES AND CIVIC ENGAGEMENT, MATHEMATICAL AND PHYSICAL SCIENCES, EDUCATION, ENGINEERING, ENGLISH, FORENSIC STUDIES, ENVIRONMENTAL SUSTAINABILITY AND HUMAN ECOLOGY, HEALTH AND HUMAN PERFORMANCE, INTERNATIONAL STUDIES, LIBRARY AND INFORMATION SERVICES, LIFE SCIENCES, PUBLIC AFFAIRS, COMPUTER SIMULATIONS AND THE DIGITAL ENTERTAINMENT FIELD; PUBLISHING AND DISTRIBUTING SCHOLARLY PUBLICATIONS, NAMELY, THESES, DISSERTATIONS, AND SCHOLARLY PAPERS, IN THE FIELDS OF ARTS AND HUMANITIES, BEHAVIORAL AND SOCIAL SCIENCES, BUSINESS, COMPUTER, COMMUNITY STUDIES AND CIVIC ENGAGEMENT, MATHEMATICAL AND PHYSICAL SCIENCES, EDUCATION, ENGINEERING, ENGLISH, FORENSIC STUDIES, ENVIRONMENTAL SUSTAINABILITY AND HUMAN ECOLOGY, HEALTH AND HUMAN PERFORMANCE, INTERNATIONAL STUDIES, LIBRARY AND INFORMATION SERVICES, LIFE SCIENCES, PUBLIC AFFAIRS, COMPUTER SIMULATIONS AND THE DIGITAL ENTERTAINMENT FIELD (U.S. CLS. 100, 101 AND 107).

FIRST USE 1-1-2006; IN COMMERCE 3-1-2006.

JASON TURNER, EXAMINING ATTORNEY

SN 85-188,770. VIACOM 18 MEDIA PRIVATE LIMITED,
MUMBAI, INDIA, FILED 12-1-2010.

AAPKA COLORS

THE MARK CONSISTS OF STANDARD CHARACTERS WITHOUT CLAIM TO ANY PARTICULAR FONT, STYLE, SIZE, OR COLOR.

THE ENGLISH TRANSLATION OF "AAPKA COLORS" IN THE MARK IS "RESPECTFULLY YOUR COLORS".

CLASS 38—COMMUNICATION

FOR TELEVISION BROADCASTING SERVICES; RADIO BROADCASTING AND TRANSMISSION SERVICES; TELECOMMUNICATIONS SERVICES, NAMELY, TRANSMISSION OF RING TONES, VOICE, MUSIC MP3S, GRAPHICS, VIDEO IMAGES, INFORMATION, AND NEWS BY MEANS OF WIRELESS NETWORKS; ELECTRONIC, ELECTRIC AND DIGITAL TRANSMISSION OF VOICE AND TEXT MESSAGE TRANSMISSION SERVICES (U.S. CLS. 100, 101 AND 104).

CLASS 41—EDUCATION AND ENTERTAINMENT

FOR ENTERTAINMENT SERVICES, NAMELY, PRODUCTION OF RADIO PROGRAMS, TELEVISION PROGRAMS, TELEVISION SHOWS, AND TELEVISION NEWS; PRODUCTION OF TELEVISION FEATURES, NAMELY, PROGRAMS, SHOWS, MOVIES, AND DOCUMENTARIES FEATURING NEWS, COMEDY, COMMENTARY, DRAMA OR VARIETY (U.S. CLS. 100, 101 AND 107).

CLASS 42—SCIENTIFIC AND COMPUTER SERVICES

FOR COMPUTER SERVICES, NAMELY, UPLOADING OF RING TONES, VOICE, MUSIC MP3S, GRAPHICS, VIDEO IMAGES, INFORMATION, AND NEWS TO THE INTERNET FOR OTHERS (U.S. CLS. 100 AND 101).

B. PARADEWELAI, EXAMINING ATTORNEY

SN 85-189,420. MARIA SNYDER INC., NEW YORK, NY.
FILED 12-2-2010.

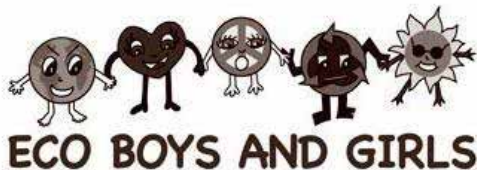

NO CLAIM IS MADE TO THE EXCLUSIVE RIGHT TO USE "ECO", APART FROM THE MARK AS SHOWN.

THE MARK CONSISTS OF A GROUP OF CIRCULAR CHARACTERS, NAMELY, FROM LEFT TO RIGHT, A GLOBE WITH FACE, HANDS, AND FEET WITH THE CONTINENTS OF NORTH AMERICA, SOUTH AMERICA, AFRICA AND EUROPE VISIBLE, A HEART WITH FACE, HANDS, AND FEET, A PEACE SYMBOL WITH FACE, HANDS, AND FEET, A RECYCLE SYMBOL WITH FACE, HANDS, AND FEET, AND A SUN WEARING SUNGLASSES WITH FACE, HANDS, AND FEET, WITH THE WORDS "ECO BOYS AND GIRLS" BENEATH THE CHARACTERS.

CLASS 9—ELECTRICAL AND SCIENTIFIC APPARATUS

FOR COMPUTER GAME PROGRAMS; COMPUTER GAME SOFTWARE; DOWNLOADABLE COMPUTER GAME PROGRAMS (U.S. CLS. 21, 23, 26, 36 AND 38).

CLASS 28—TOYS AND SPORTING GOODS

FOR CHILDREN'S MULTIPLE ACTIVITY TOYS; INFANT TOYS; PLUSH TOYS; POSITIONABLE THREE DIMENSIONAL TOYS FOR USE IN GAMES; POSITIONABLE TWO DIMENSIONAL TOYS FOR USE IN GAMES; PUZZLE GAMES; STUFFED TOYS (U.S. CLS. 22, 23, 38 AND 50).

CLASS 41—EDUCATION AND ENTERTAINMENT

FOR ELECTRONIC GAMES SERVICES PROVIDED BY MEANS OF THE INTERNET; ENTERTAINMENT SERVICES, NAMELY, PROVIDING AN ON-LINE COMPUTER GAME (U.S. CLS. 100, 101 AND 107).

JASON BLAIR, EXAMINING ATTORNEY

SN 85-190,099. TEK GEAR, INC., WINNIPEG, MANITOBA,
CANADA, FILED 12-3-2010.



NO CLAIM IS MADE TO THE EXCLUSIVE RIGHT TO USE "TECH GEAR", APART FROM THE MARK AS SHOWN.

THE COLOR(S) BROWN AND ORANGE IS/ARE CLAIMED AS A FEATURE OF THE MARK.

THE MARK CONSISTS OF THE WORDING "TEKGear" WITH THE "TEK" DISPLAYED IN ORANGE AND "GEAR" DISPLAYED IN BROWN WITH A BROWN ARC AROUND "TEK".

CLASS 9—ELECTRICAL AND SCIENTIFIC APPARATUS

FOR VIRTUAL REALITY PERIPHERALS, NAMELY, HEAD MOUNTED VIDEO DISPLAYS AND POSITIONAL AND ORIENTATION TRACKERS BEING COMPUTER PERIPHERALS USED TO TRACK POSITION AND ORIENTATION OF VIRTUAL REALITY GAMING PARTICIPANT; PORTABLE AND WEARABLE COMPUTING PERIPHERALS, NAMELY, WEARABLE COMPUTERS, KEYBOARDS, MICE, TELECOMMUNICATIONS AND DATA NETWORKING HARDWARE IN THE NATURE OF DEVICES FOR TRANSPORTING AND AGGREGATING VOICE, DATA, AND VIDEO COMMUNICATIONS ACROSS MULTIPLE NETWORK INFRASTRUCTURES AND COMMUNICATIONS PROTOCOLS AND BLANK USB FLASH DRIVES; ELECTRONICS, NAMELY, SPECIALIZED ELECTRONICS FOR LCD AND OLED MICRODISPLAYS, NAMELY, DRIVERS (U.S. CLS. 21, 23, 26, 36 AND 38).

FIRST USE 4-1-2001; IN COMMERCE 4-1-2001.

CLASS 35—ADVERTISING AND BUSINESS

FOR ONLINE RETAIL STORE SERVICES FEATURING VIRTUAL REALITY PERIPHERALS, NAMELY, HEAD MOUNTED DISPLAYS AND POSITIONAL AND ORIENTATION TRACKERS; ONLINE RETAIL STORE SERVICES FEATURING PORTABLE AND WEARABLE COMPUTING PERIPHERALS, NAMELY, WEARABLE COMPUTERS, KEYBOARDS, MICE, TELECOMMUNICATIONS AND DATA NETWORKING HARDWARE IN THE NATURE OF DEVICES FOR TRANSPORTING AND AGGREGATING VOICE, DATA, AND VIDEO COMMUNICATIONS ACROSS MULTIPLE NETWORK INFRASTRUCTURES AND COMMUNICATIONS PROTOCOLS AND BLANK USB FLASH DRIVES; ONLINE RETAIL STORE SERVICES FEATURING DRIVERS FOR LCD AND OLED MICRO DISPLAYS (U.S. CLS. 100, 101 AND 102).

FIRST USE 4-1-2001; IN COMMERCE 4-1-2001.

CLASS 42—SCIENTIFIC AND COMPUTER SERVICES

FOR ENGINEERING SERVICES (U.S. CLS. 100 AND 101).

FIRST USE 4-1-2001; IN COMMERCE 4-1-2001.
MELISSA VALLILLO, EXAMINING ATTORNEY

SN 85-190,556. INTERTEX, INC., GLENDALE, CA. FILED 12-3-2010.

SUMMIT AIR

THE MARK CONSISTS OF STANDARD CHARACTERS WITHOUT CLAIM TO ANY PARTICULAR FONT, STYLE, SIZE, OR COLOR.

NO CLAIM IS MADE TO THE EXCLUSIVE RIGHT TO USE "AIR", APART FROM THE MARK AS SHOWN.

CLASS 7—MACHINERY

FOR COMPRESSED AIR PUMPS; AIR MOVER AND DRYER SYSTEMS COMPRISED OF AIR COMPRESSORS, COMPRESSED AIR MACHINES FOR THE INFLATABLE INDUSTRY, PET AND ANIMAL INDUSTRY AND RESTORATION INDUSTRY; NONE OF THE AFOREMENTIONED GOODS IS BEING USED FOR DRYING CLOTHES OR LAUNDRY (U.S. CLS. 13, 19, 21, 23, 31, 34 AND 35).

CLASS 11—ENVIRONMENTAL CONTROL APPARATUS

FOR RESTORATIVE DRYING EQUIPMENT AND PARTS THEREOF, NAMELY, BLOWERS; INDUSTRIAL DRYERS FOR HEATING AND MOVING AIR; PORTABLE ELECTRIC WARM AIR DRYER; DRYING APPARATUS FOR USE IN HEATING, VENTILATION SYSTEMS, AIR CONDITIONING SYSTEMS AND REFRIGERATION SYSTEMS; ELECTRIC FANS FOR COMMERCIAL AND INDUSTRIAL USE; AIR VENTILATION UNITS FOR PERSONAL, COMMERCIAL AND INDUSTRIAL USE; DRYERS FOR ANIMAL DRYING AND GROOMING; AIR MOVERS IN THE NATURE OF ELECTRIC FANS, AIR BLOWERS; AIR MOVER AND DRYER SYSTEMS COMPRISED OF AIR BLOWERS, ELECTRIC FANS FOR THE INFLATABLE INDUSTRY, PET AND ANIMAL INDUSTRY AND RESTORATION INDUSTRY; NONE OF THE AFOREMENTIONED GOODS BEING USED FOR DRYING CLOTHES OR LAUNDRY (U.S. CLS. 13, 21, 23, 31 AND 34).

TOBY BULLOFF, EXAMINING ATTORNEY

SN 85-190,570. TRUSTEES OF THE TWIGZ TRUST, A TRUST OF AUSTRALIA, THE TRUSTEE COMPRISING TWIGZ PTY LIMITED, A COMPANY OF AUSTRALIA, THE, SYDNEY, AUSTRALIA, FILED 12-3-2010.



PRIORITY CLAIMED UNDER SEC. 44(D) ON ERPN CMNTY TM OFC APPLICATION NO. 009154345, FILED 6-4-2010.

OWNER OF AUSTRALIA REG. NO. 1253735, DATED 3-10-2009, EXPIRES 7-28-2018.

THE MARK CONSISTS OF THE WORD "TWIGZ" IN LOWER CASE PRINT FONT, THE WORDS "PLANTS", "GROW" AND "KIDS" IN LOWER CASE PRINT FONT BELOW THE WORD "TWIGZ" AND THREE CIRCLES ABOVE THE WORD "TWIGZ". INSIDE THE LEFT CIRCLE IS A LEAF, INSIDE THE MIDDLE CIRCLE IS A SUN AND INSIDE THE RIGHT CIRCLE IS A HAND PRINT.

CLASS 8—HAND TOOLS

FOR (BASED ON 44(D) PURSUANT TO AUSTRALIAN PRIORITY APPLICATION NUMBER 1253735) CUTLERY; HAMMERS, PLIERS, HAND TOOLS, NAMELY, CLAMPS, CHISELS, SCISSORS (U.S. CLS. 23, 28 AND 44).

CLASS 21—HOUSEWARES AND GLASS

FOR (BASED ON 44(D) PRIORITY APPLICATION PURSUANT TO EUROPEAN COMMUNITY FOREIGN APPLICATION NUMBER 009154345) COMBS; CLEANING AND SCRUBBING SPONGES; FLOOR BRUSHES; BROOMS; DUST PANS AND BRUSHES; INSECT TRAPS; INSECT AND BUG COLLECTING CAGES; FLY TRAPS; WATERING CANS; BUCKETS; PICNIC BASKETS SOLD EMPTY; FITTED PICNIC BASKETS; LUNCH BOXES; PLATES; DRINKING VESSELS; POTS, PANS; CHOPPING BOARDS FOR KITCHEN USE; POTS FOR PLANTS; FLOWER POTS; REFUSE BINS (U.S. CLS. 2, 13, 23, 29, 30, 33, 40 AND 50).

CLASS 25—CLOTHING

FOR (BASED ON 44(D) PURSUANT TO AUSTRALIAN PRIORITY APPLICATION NUMBER 1253735) CLOTHING, NAMELY, T-SHIRTS, POLO SHIRTS, SHORTS, SWEATSHIRTS, SOCKS; FOOTWEAR; BOOTS; HEADGEAR, NAMELY, HATS AND CAPS; BELTS; APRONS (U.S. CLS. 22 AND 39).

CLASS 28—TOYS AND SPORTING GOODS

FOR (BASED ON 44(D) PURSUANT TO AUSTRALIAN PRIORITY APPLICATION NUMBER 1253735) PLAYING CARDS, BOARD GAMES; SWINGS; TOY INSECT CATCHERS, TOY BUCKETS, TOY WHEELBARROWS, TOY GARDENING TOOLS; TOY GARDENING SETS COMPRISED PRIMARILY OF A TOY BUCKET, A SET OF TOY HAND TOOLS AND A PAIR OF GLOVES; TOY TENTS AND TOY GREENHOUSES FOR CHILDREN; TOY FURNITURE, NAMELY, TOY TABLES AND CHILDREN'S MULTIPLE ACTIVITY TABLES; PLAYGROUND EQUIPMENT, NAMELY, SANDBOXES; TOY BUTTERFLY NETS; CHILDREN'S TOY BICYCLES, OTHER THAN FOR TRANSPORT (U.S. CLS. 22, 23, 38 AND 50).
HOWARD B. LEVINE, EXAMINING ATTORNEY

SN 85-191,429. SÜD-CHEMIE AG, MUNICH, FED REP GERMANY, FILED 12-6-2010.

BENTONIL

THE MARK CONSISTS OF STANDARD CHARACTERS WITHOUT CLAIM TO ANY PARTICULAR FONT, STYLE, SIZE, OR COLOR.

CLASS 1—CHEMICALS

FOR CHEMICALS FOR USE IN INDUSTRY; CHEMICAL SORBING COMPOSITIONS ON THE BASIS OF INORGANIC SORPTION AGENT; BENTONITES; CHEMICALLY MODIFIED CLAY COMPOSITION FOR USE IN CIVIL ENGINEERING, CONSTRUCTION, AND MINING; CHEMICALS FOR USE IN INDUSTRY AS DEFLOCCULANTS; CLAY POWDERS, EITHER ON DRY FORM OR SLURRY, EITHER IN READY-TO-USE MIXTURES OR PREPARED IN SITU FOR USE AS DRILLING FLUIDS, CONSTRUCTION FLUIDS, SEALANTS AND SOIL CONDITIONING FLUIDS; BINDING MATERIAL, NAMELY, INORGANIC SORBENT BASED CHEMICAL ADMIXTURES FOR USE AS DRILLING FLUIDS, CONSTRUCTION FLUIDS, SEALANTS, AND SOIL CONDITIONING FLUIDS (U.S. CLS. 1, 5, 6, 10, 26 AND 46).

CLASS 19—NON-METALLIC BUILDING MATERIALS

FOR CLAY SLURRIES AND SUSPENSIONS USED FOR CIVIL ENGINEERING WORKS, NAMELY, DIAPHRAGM WALLS, BORED PILES, CUT-OFF-WALLS, DIRECTIONAL DRILLING, TUNNELING, PIPE JACKING, VERTICAL DRILLING FOR OIL AND GAS, WATER, MINERAL AND GEOTECHNICAL INVESTIGATION, SHAFT SINKING, AND SOIL SEALING (U.S. CLS. 1, 12, 33 AND 50).
LAKEISHA LEWIS, EXAMINING ATTORNEY

SN 85-192,300. SEITENBACHER GMBH & CO., NATURKOST, BUCHEN, FED REP GERMANY, FILED 12-7-2010.

Green-Felder

THE MARK CONSISTS OF STANDARD CHARACTERS WITHOUT CLAIM TO ANY PARTICULAR FONT, STYLE, SIZE, OR COLOR.

CLASS 3—COSMETICS AND CLEANING PREPARATIONS

FOR BLEACHING PREPARATIONS AND OTHER SUBSTANCES FOR LAUNDRY USE, NAMELY, LAUNDRY DETERGENTS, LAUNDRY BLEACH, LAUNDRY SOAP, LAUNDRY STARCH; SOAPS, NAMELY, BATH SOAPS, COSMETIC SOAPS, BAR SOAPS, LIQUID SOAPS, MEDICATED SOAPS, SOAPS FOR HOUSEHOLD USE, SOAPS FOR PERSONAL USE; PERFUMERY, ESSENTIAL OILS, COSMETICS, HAIR LOTIONS; DENTIFICES (U.S. CLS. 1, 4, 6, 50, 51 AND 52).

CLASS 5—PHARMACEUTICALS

FOR PHARMACEUTICAL PREPARATIONS FOR USE IN DERMATOLOGY; SANITARY PREPARATIONS FOR MEDICAL PURPOSES; DIETETIC SUBSTANCES, NAMELY, MEAL REPLACEMENT BARS, MEAL REPLACEMENT DRINKS, MEAL REPLACEMENT POWDERS, NUTRITIONAL AND DIETARY SUPPLEMENTS, PROTEIN SUPPLEMENTS, MINERAL SUPPLEMENTS, VITAMIN SUPPLEMENTS, DIETETIC FOODS, AND DIETETIC BEVERAGES ADAPTED FOR MEDICAL USE; FOOD FOR BABIES; PLASTERS FOR MEDICAL PURPOSES, MATERIALS FOR DRESSING, NAMELY, BANDAGES, GAUZE; MATERIAL FOR STOPPING TEETH, DENTAL WAX; ALL PURPOSE DISINFECTANTS, DISINFECTANTS FOR HYGIENIC PURPOSES, DISINFECTANTS FOR SANITARY PURPOSES; NUTRITIONAL SUPPLEMENTS NOT FOR MEDICAL PURPOSES, BASED ON PROTEINS, FATS, ROUGHAGE OR CARBOHYDRATE (U.S. CLS. 6, 18, 44, 46, 51 AND 52).

CLASS 29—MEATS AND PROCESSED FOODS

FOR MEAT, FISH THAT IS NOT LIVE, POULTRY AND GAME; MEAT EXTRACTS; PRESERVED, DRIED AND COOKED FRUITS AND VEGETABLES; SOUPS AND PREPARATIONS FOR MAKING SOUPS; JELLIES, JAMS, FRUIT PUREES, EGGS, MILK AND MILK PRODUCTS EXCLUDING ICE CREAM, ICE MILK AND FROZEN YOGURT; EDIBLE OILS AND FATS (U.S. CL. 46).

CLASS 30—STAPLE FOODS

FOR COFFEE, TEA, COCOA, SUGAR, RICE, TAPIOCA, SAGO, ARTIFICIAL COFFEE; FLOUR AND PREPARATIONS MADE FROM CEREALS, NAMELY, BREAKFAST CEREALS AND CEREAL BASED SNACK FOODS, BREAD, BAKERY GOODS AND PASTRY, EDIBLE ICES; HONEY, TREACLE, YEAST, BAKING POWDER, SALT, MUSTARD, VINEGAR, SAUCES, SEASONING MIXES FOR SAUCES, SPICES, FLOUR SOURDOUGH FOR MAKING BREAD, CANDIES, IN PARTICULAR GUMMY CANDIES, MUESLI, GRAIN-BASED FOOD BARS ALSO CONTAINING FRUITS AND CHOCOLATE, SPREAD CONTAINING CHOCOLATE, NUTS AND NOUGAT; CHOCOLATE, COCOA-BASED BEVERAGES (U.S. CL. 46).

CLASS 32—LIGHT BEVERAGES

FOR BEER; MINERAL AND AERATED WATERS AND NON-ALCOHOLIC BEVERAGES, NAMELY, CARBONATED BEVERAGES; FRUIT DRINKS AND FRUIT JUICES; SYRUPS FOR MAKING BEVERAGES, PREPARATIONS FOR MAKING BEVERAGES, NAMELY, FRUIT DRINKS, VEGETABLES JUICE, ISOTONIC DRINKS AND SPORT DRINKS (U.S. CLS. 45, 46 AND 48).

ALICE BENMAMAN, EXAMINING ATTORNEY

SN 85-192,720. MOGGYFOGGY LLC, ORANGE, CA. FILED 12-7-2010.

MOGGY FOGGY

THE MARK CONSISTS OF STANDARD CHARACTERS WITHOUT CLAIM TO ANY PARTICULAR FONT, STYLE, SIZE, OR COLOR.

CLASS 16—PAPER GOODS AND PRINTED MATTER

FOR PAPER AND CARDBOARD GOODS, NAMELY, BOOKS, MAGAZINES, JOURNALS, NEWSLETTERS, LEAFLETS, BOOKLETS, PAMPHLETS, BROCHURES, POSTERS, CALENDARS, STICKERS, DECALS, BUMPER STICKERS, GIFT AND GREETING CARDS, MOTIVATIONAL CARDS, OCCASION CARDS, POSTCARDS, PICTURE BOOKS, IN THE FIELD OF ANIMALS, PETS AND PET OWNERS; STATIONERY; ARTISTS' MATERIALS, NAMELY, PAINTINGS AND PAINTING REPRODUCTIONS (U.S. CLS. 2, 5, 22, 23, 29, 37, 38 AND 50).

CLASS 25—CLOTHING

FOR CLOTHING, NAMELY, ENTIRE LINE OF CLOTHING ITEMS FOR HUMANS; FOOTWEAR AND HEADWEAR (U.S. CLS. 22 AND 39).

CLASS 28—TOYS AND SPORTING GOODS

FOR GAMES, TOYS AND PLAYTHINGS FOR PET OWNERS, NAMELY, PLUSH TOYS SHAPED LIKE DOGS, PLUSH TOYS SHAPED LIKE CATS AND PLUSH ANIMAL TOYS; GAMES, TOYS AND PLAYTHINGS FOR PETS, NAMELY, DOG TOYS, CAT TOYS AND PET TOYS (U.S. CLS. 22, 23, 38 AND 50).

CLASS 31—NATURAL AGRICULTURAL PRODUCTS

FOR FOODSTUFFS FOR ANIMALS (U.S. CLS. 1 AND 46).

CLASS 41—EDUCATION AND ENTERTAINMENT

FOR TRAINING, NAMELY, PROVIDING INSTRUCTION ON TOPICS RELATING TO ANIMALS AND PETS AND ON TOPICS OF INTEREST TO PET OWNERS; PROVIDING AN ONLINE INTERACTIVE WEBSITE PROVIDING INFORMATION IN THE FIELDS OF ANIMALS AND PETS IN THE FIELD OF ANIMAL TRAINING AND ANIMAL EXHIBITIONS FOR EDUCATIONAL OR ENTERTAINMENT PURPOSES (U.S. CLS. 100, 101 AND 107).

KELLY BOULTON, EXAMINING ATTORNEY

SN 85-195,490. ZENIMAX MEDIA INC., ROCKVILLE, MD. FILED 12-10-2010.

Bethesda

OWNER OF U.S. REG. NOS. 2,689,683, 3,601,945 AND OTHERS.

NO CLAIM IS MADE TO THE EXCLUSIVE RIGHT TO USE "BETHESDA", APART FROM THE MARK AS SHOWN. THE MARK CONSISTS OF THE WORD "BETHESDA" WITH A BOX TO THE UPPER LEFT.

CLASS 9—ELECTRICAL AND SCIENTIFIC APPARATUS

FOR COMPUTER GAME SOFTWARE FOR USE WITH COMPUTERS AND VIDEO GAME CONSOLES; DOWNLOADABLE COMPUTER GAME SOFTWARE OFFERED VIA THE INTERNET AND WIRELESS DEVICES; COMPUTER GAME SOFTWARE FOR USE WITH ON-LINE INTERACTIVE GAMES (U.S. CLS. 21, 23, 26, 36 AND 38). FIRST USE 5-10-2011; IN COMMERCE 5-10-2011.

CLASS 41—EDUCATION AND ENTERTAINMENT

FOR ENTERTAINMENT SERVICES, NAMELY, PROVIDING INFORMATION RELATING TO ELECTRONIC COMPUTER GAMES VIA THE INTERNET; MULTIMEDIA ENTERTAINMENT SOFTWARE PUBLISHING SERVICES; MULTIMEDIA PUBLISHING OF INTERACTIVE COMPUTER AND VIDEO GAME SOFTWARE (U.S. CLS. 100, 101 AND 107).

FIRST USE 5-10-2011; IN COMMERCE 5-10-2011.

JASON TURNER, EXAMINING ATTORNEY

SN 85-197,351. PLUS MARKETS PLC, LONDON E1 8AA, UNITED KINGDOM, FILED 12-14-2010.

PLUS-SX

THE MARK CONSISTS OF STANDARD CHARACTERS WITHOUT CLAIM TO ANY PARTICULAR FONT, STYLE, SIZE, OR COLOR.

PRIORITY CLAIMED UNDER SEC. 44(D) ON ERPNTY TM OFC APPLICATION NO. 9521675, FILED 11-15-2010, REG. NO. 9521675, DATED 5-2-2011, EXPIRES 5-2-2021.

CLASS 16—PAPER GOODS AND PRINTED MATTER

FOR PRINTED PUBLICATIONS, NAMELY, LEAFLETS, PAMPHLETS, BROCHURES, NEWSPAPERS, NEWSLETTERS, MAGAZINES, BOOKS, AND JOURNALS ALL IN THE FIELD OF BUSINESS SERVICES, FINANCIAL SERVICES AND STOCK EXCHANGES; PRINTED INSTRUCTIONAL AND TEACHING MATERIALS, ALL IN THE FIELD OF BUSINESS SERVICES, FINANCIAL SERVICES AND STOCK EXCHANGES (U.S. CLS. 2, 5, 22, 23, 29, 37, 38 AND 50).

CLASS 35—ADVERTISING AND BUSINESS

FOR BUSINESS ADVICE, CONSULTANCY, RESEARCH AND INFORMATION SERVICES; PROVISION OF ON-LINE BUSINESS INFORMATION (U.S. CLS. 100, 101 AND 102).

CLASS 36—INSURANCE AND FINANCIAL

FOR FINANCIAL ADVICE, CONSULTANCY, RESEARCH AND INFORMATION SERVICES; STOCKS AND BOND BROKERAGE, STOCK EXCHANGE QUOTATIONS; INFORMATION, ADVICE AND CONSULTANCY ON SHARES, STOCKS, BONDS, SECURITIES AND FUTURES (U.S. CLS. 100, 101 AND 102).

MICHAEL ENGEL, EXAMINING ATTORNEY

CLASS 35—ADVERTISING AND BUSINESS

FOR ASSOCIATION SERVICES, NAMELY, PROMOTING WATER QUALITY AND THE INTERESTS OF THE PRIVATELY-OWNED WATER AND WASTEWATER SERVICE INDUSTRY; LOBBYING SERVICES, NAMELY, PROMOTING THE INTERESTS OF THE PRIVATELY-OWNED WATER AND WASTEWATER SERVICE INDUSTRY IN THE AREAS OF FEDERAL, STATE AND LOCAL POLITICS, POLICY-MAKING AND LEGISLATION, AND REGULATION; CONDUCTING BUSINESS RESEARCH AND SURVEYS TO ASSIST THE EFFORTS OF THE PRIVATE WATER AND WASTEWATER INDUSTRY; PROVIDING INFORMATION TO THE PUBLIC AND MEDIA REGARDING THE IMPORTANCE OF WATER INFRASTRUCTURE TO THE ECONOMIC VITALITY OF COMMUNITIES (U.S. CLS. 100, 101 AND 102).

SN 85-199,028. VIVINT, INC., PROVO, UT. FILED 12-15-2010.

CLASS 41—EDUCATION AND ENTERTAINMENT

FOR PROVIDING INFORMATION IN THE FIELDS OF SUSTAINABLE WATER AND WASTEWATER TREATMENT, NAMELY, PUBLICATION OF ARTICLES AND CASE STUDIES IN THE FIELDS OF SUSTAINABLE WATER AND WASTEWATER TREATMENT (U.S. CLS. 100, 101 AND 107).

SIMPLY SMARTER

THE MARK CONSISTS OF STANDARD CHARACTERS WITHOUT CLAIM TO ANY PARTICULAR FONT, STYLE, SIZE, OR COLOR.

CLASS 42—SCIENTIFIC AND COMPUTER SERVICES

FOR MONITORING OF BUILDING CONTROL AND AUTOMATION SYSTEMS, NAMELY, MONITORING HVAC SYSTEMS AND MONITORING OF ENERGY MANAGEMENT SYSTEMS (U.S. CLS. 100 AND 101).

CLASS 42—SCIENTIFIC AND COMPUTER SERVICES

FOR SURVEY DESIGN AND RESEARCH, NAMELY, DEVELOPING SURVEYS IN THE FIELD OF WATER AND WASTEWATER TREATMENT AS IT ASSISTS THE EFFORTS OF THE PRIVATE WATER AND WASTEWATER SERVICE INDUSTRY; PROVIDING INFORMATION TO THE PUBLIC AND MEDIA REGARDING THE IMPORTANCE OF THE ENGINEERING AND DESIGN OF WATER INFRASTRUCTURE TO PUBLIC AND ENVIRONMENTAL HEALTH (U.S. CLS. 100 AND 101).

LINDA ORNDORFF, EXAMINING ATTORNEY

CLASS 45—PERSONAL AND LEGAL SERVICES

FOR MONITORING SECURITY SYSTEMS; MONITORING BURGLAR, TROUBLE, FIRE AND SECURITY ALARM SYSTEMS; MONITORING OF DOOR LOCKING SYSTEMS FOR SECURITY PURPOSES, NAMELY, PROVIDING INTRUSION AND TROUBLE ALERTS THROUGH WIRELESS COMMUNICATION; LIVE MONITORING FOR SECURITY PURPOSES, NAMELY, PROVIDING CCTV AND VIDEO MONITORING OF FACILITIES, VIEWABLE THROUGH A COMMUNICATIONS NETWORK (U.S. CLS. 100 AND 101).

ANN E. SAPPENFIELD, EXAMINING ATTORNEY

SN 85-199,799. NATIONAL ASSOCIATION OF WATER COMPANIES, WASHINGTON, DC. FILED 12-16-2010.

NATIONAL ASSOCIATION OF WATER COMPANIES

THE MARK CONSISTS OF STANDARD CHARACTERS WITHOUT CLAIM TO ANY PARTICULAR FONT, STYLE, SIZE, OR COLOR.

NO CLAIM IS MADE TO THE EXCLUSIVE RIGHT TO USE "ASSOCIATION", APART FROM THE MARK AS SHOWN.

SEC. 2(F).

SN 85-199,797. NATIONAL ASSOCIATION OF WATER COMPANIES, WASHINGTON, DC. FILED 12-16-2010.

CLASS 35—ADVERTISING AND BUSINESS

FOR ASSOCIATION SERVICES, NAMELY, PROMOTING WATER QUALITY AND THE INTERESTS OF THE PRIVATELY-OWNED WATER AND WASTEWATER SERVICE INDUSTRY; LOBBYING SERVICES, NAMELY, PROMOTING THE INTERESTS OF THE PRIVATELY-OWNED WATER AND WASTEWATER SERVICE INDUSTRY IN THE AREAS OF FEDERAL, STATE AND LOCAL POLITICS, POLICY-MAKING AND LEGISLATION, AND REGULATION; CONDUCTING BUSINESS RESEARCH AND SURVEYS TO ASSIST THE EFFORTS OF THE PRIVATE WATER AND WASTEWATER INDUSTRY; PROVIDING INFORMATION TO THE PUBLIC AND MEDIA REGARDING THE IMPORTANCE OF WATER INFRASTRUCTURE TO THE ECONOMIC VITALITY OF COMMUNITIES (U.S. CLS. 100, 101 AND 102).

FIRST USE 12-31-1971; IN COMMERCE 12-31-1971.

MOVING WATER FORWARD

THE MARK CONSISTS OF STANDARD CHARACTERS WITHOUT CLAIM TO ANY PARTICULAR FONT, STYLE, SIZE, OR COLOR.

NO CLAIM IS MADE TO THE EXCLUSIVE RIGHT TO USE "WATER", APART FROM THE MARK AS SHOWN.

CLASS 41—EDUCATION AND ENTERTAINMENT

SN 85-202,432. MAPLO L.L.C., DOVER, DE. FILED 12-21-2010.

FOR PROVIDING INFORMATION IN THE FIELDS OF SUSTAINABLE WATER AND WASTEWATER TREATMENT, NAMELY, PUBLICATION OF ARTICLES AND CASE STUDIES IN THE FIELDS OF SUSTAINABLE WATER AND WASTEWATER TREATMENT (U.S. CLS. 100, 101 AND 107).

FIRST USE 12-31-1971; IN COMMERCE 12-31-1971.

CLASS 42—SCIENTIFIC AND COMPUTER SERVICES

FOR SURVEY DESIGN AND RESEARCH, NAMELY, DEVELOPING SURVEYS IN THE FIELD OF WATER AND WASTEWATER TREATMENT AS IT ASSISTS THE EFFORTS OF THE PRIVATE WATER AND WASTEWATER SERVICE INDUSTRY; PROVIDING INFORMATION TO THE PUBLIC AND MEDIA REGARDING THE IMPORTANCE OF THE ENGINEERING AND DESIGN OF WATER INFRASTRUCTURE TO PUBLIC AND ENVIRONMENTAL HEALTH (U.S. CLS. 100 AND 101).

FIRST USE 12-31-1971; IN COMMERCE 12-31-1971.

LINDA ORNDORFF, EXAMINING ATTORNEY



THE MARK CONSISTS OF THE DESIGN OF THE LETTER "M" ABOVE THE WORD "MARPRESSEL".

CLASS 18—LEATHER GOODS

FOR WALLETS; POCKETBOOKS; PURSES; COSMETIC CASES SOLD EMPTY; BRIEFCASES; LEATHER SUITCASES; HANDBAGS; SUITCASES; REUSABLE SHOPPING BAGS; LUGGAGE; KEY CHAIN PURSES; UMBRELLAS (U.S. CLS. 1, 2, 3, 22 AND 41).

CLASS 24—FABRICS

FOR QUILTS; QUILT COVERS; BED SHEETS; COVERLETS; PILLOWCASES; WOOLLEN BLANKETS; HANDKERCHIEFS; CURTAINS; SHOWER CURTAINS; DOOR CURTAINS; TABLE PADS; UNFITTED FABRIC FURNITURE COVERS; TOWELS; BATH TOWELS; TABLECLOTHS, NOT OF PAPER; TEXTILE NAPKINS (U.S. CLS. 42 AND 50).

CLASS 25—CLOTHING

FOR CLOTHING FOR SPORTS USE, NAMELY, PADDED SHORTS, PADDED PANTS, PADDED SHIRTS AND ATHLETIC UNIFORMS; WOMEN'S DRESSES; WAISTCOATS; SWEATERS; SHIRTS; T-SHIRTS; JEANS; COATS; JACKETS; DRESSES; SKIRTS; MATERNITY DRESSES; SOCKS; GLOVES; HATS; WAISTBANDS; SHOES; SCARFS; UNDERWEAR (U.S. CLS. 22 AND 39).

SKYE YOUNG, EXAMINING ATTORNEY

SN 85-200,370. PHARMACHEM LABORATORIES, INC., KEARNY, NJ. FILED 12-17-2010.



THE MARK CONSISTS OF STANDARD CHARACTERS WITHOUT CLAIM TO ANY PARTICULAR FONT, STYLE, SIZE, OR COLOR.

CLASS 1—CHEMICALS

FOR NATURAL DAIRY-BASED INGREDIENTS, NAMELY, MILK PROTEIN HYDROLYSATES FOR USE IN THE MANUFACTURE OF DIETARY SUPPLEMENTS FOR PROMOTING SLEEP AND RELAXATION (U.S. CLS. 1, 5, 6, 10, 26 AND 46).

CLASS 5—PHARMACEUTICALS

FOR DIETARY SUPPLEMENTS FOR PROMOTING SLEEP AND RELAXATION; DIETARY SUPPLEMENT BEVERAGES AND POWDERED BEVERAGE MIXERS IN THE NATURE OF DIETARY SUPPLEMENTS, ALL FOR PROMOTING SLEEP AND RELAXATION (U.S. CLS. 6, 18, 44, 46, 51 AND 52).

MAUREEN DALL, EXAMINING ATTORNEY

SN 85-202,460. EDUCATIONAL TESTING SERVICE, PRINCETON, NJ. FILED 12-22-2010.



THE MARK CONSISTS OF STANDARD CHARACTERS WITHOUT CLAIM TO ANY PARTICULAR FONT, STYLE, SIZE, OR COLOR.

NO CLAIM IS MADE TO THE EXCLUSIVE RIGHT TO USE "LANGUAGE", APART FROM THE MARK AS SHOWN.

CLASS 9—ELECTRICAL AND SCIENTIFIC APPARATUS

FOR ELECTRONIC PUBLICATIONS DOWNLOADABLE FROM THE INTERNET FOR USE BY TEACHERS FOR PROFESSIONAL DEVELOPMENT, NAMELY, MANUALS, BOOKS, WORKBOOKS, AND TEXTS IN THE FIELD OF LANGUAGE INSTRUCTION, FOR CLASSROOM LESSON PLANNING, AND FOR DEVELOPING INSTRUCTIONAL, EDUCATIONAL, AND TEACHING MATERIALS FOR OTHERS IN THE FIELD OF LANGUAGE INSTRUCTION (U.S. CLS. 21, 23, 26, 36 AND 38).

CLASS 41—EDUCATION AND ENTERTAINMENT

FOR EDUCATIONAL SERVICES, NAMELY, AN ONLINE INTERACTIVE WEBSITE FOR USE BY TEACHERS FOR PROFESSIONAL EDUCATIONAL DEVELOPMENT, FOR CLASSROOM LESSON PLANNING, AND FOR DEVELOPING INSTRUCTIONAL, EDUCATIONAL, AND TEACHING MATERIALS FOR OTHERS IN THE FIELD OF LANGUAGE INSTRUCTION (U.S. CLS. 100, 101 AND 107).

CHRISTOPHER BUONGIORNO, EXAMINING ATTORNEY

SN 85-202,958. PUROLATOR INC., MISSISSAUGA, ONTARIO, CANADA, FILED 12-21-2010.

PUROLATOR WE DELIVER CANADA

THE MARK CONSISTS OF STANDARD CHARACTERS WITHOUT CLAIM TO ANY PARTICULAR FONT, STYLE, SIZE, OR COLOR.

OWNER OF U.S. REG. NOS. 3,381,721 AND 3,604,273.

NO CLAIM IS MADE TO THE EXCLUSIVE RIGHT TO USE "DELIVER CANADA", APART FROM THE MARK AS SHOWN.

CLASS 9—ELECTRICAL AND SCIENTIFIC APPARATUS

FOR (BASED ON INTENT TO USE) COMPUTER SOFTWARE AND HARDWARE FOR SHIPPING, TRACKING, ESTIMATING THE COST OF SHIPPING, LABELING FREIGHT GOODS, AND REPORTING ON SHIPMENTS OF GOODS AND FREIGHT WITHIN, TO AND FROM BOTH CANADA AND THE UNITED STATES (U.S. CLS. 21, 23, 26, 36 AND 38).

CLASS 35—ADVERTISING AND BUSINESS

FOR (BASED ON USE IN COMMERCE) ORDER FULFILLMENT SERVICES; BUSINESS SERVICES, NAMELY, SHIPMENT PROCESSING SERVICES OVER COMPUTER AND WIRELESS NETWORKS, INTRANETS AND INTERNETS; ONLINE SERVICES IN THE FIELD OF PARCEL FREIGHT TRANSPORTATION AND DELIVERY, NAMELY, COMPUTERIZED TRACKING OF PACKAGES IN TRANSIT OVER COMPUTER AND WIRELESS NETWORKS, INTRANETS AND INTERNETS; BUSINESS SERVICES, NAMELY, FREIGHT INFORMATION MANAGEMENT SERVICES, NAMELY, PREPARING INVOICES OVER COMPUTER AND WIRELESS NETWORKS, INTRANETS AND INTERNETS; PROVIDING ONLINE SERVICES IN THE FIELD OF PARCEL AND FREIGHT TRANSPORTATION AND DELIVERY, NAMELY, TAX ASSESSMENT IN THE FORM OF ESTIMATING TAXES OVER COMPUTER AND WIRELESS NETWORKS, INTRANET AND INTERNETS (U.S. CLS. 100, 101 AND 102).

FIRST USE 8-0-2010; IN COMMERCE 8-0-2010.

CLASS 36—INSURANCE AND FINANCIAL

FOR (BASED ON USE IN COMMERCE) CUSTOMS BROKERAGE; PROVIDING ON-LINE SERVICES IN THE FIELD OF COURIER AND FREIGHT TRANSPORTATION AND DELIVERY, NAMELY, ELECTRONIC FUNDS TRANSFER; PROVIDING ONLINE SERVICES IN THE FIELD OF PARCEL FREIGHT TRANSPORTATION AND DELIVERY, NAMELY, DUTY DRAWBACK SERVICES (U.S. CLS. 100, 101 AND 102).

FIRST USE 8-0-2010; IN COMMERCE 8-0-2010.

CLASS 39—TRANSPORTATION AND STORAGE

FOR (BASED ON USE IN COMMERCE) FREIGHT AND PARCEL TRANSPORTATION AND DELIVERY SERVICES; DELIVERY SERVICES, NAMELY, DELIVERY OF GOODS AND FREIGHT BY MOTOR VEHICLES, AUTOMOBILES, TRUCKS, RAILWAYS, SHIPS, AND PLANES; PARCEL DELIVERY SERVICES; FREIGHT DECONSOLIDATION, NAMELY, UNBUNDLING BULK SHIPMENTS AND TRANSPORTING UNBUNDLED SHIPMENTS TO DESIGNEE AND FREIGHT FORWARDING SERVICES; FREIGHT AND PARCEL WAREHOUSING AND STORAGE SERVICES; ONLINE ORDERING OF SERVICES IN THE FIELD OF PARCEL AND FREIGHT TRANSPORTATION AND DELIVERY, NAMELY, SHIPPING (U.S. CLS. 100 AND 105).

FIRST USE 8-0-2010; IN COMMERCE 8-0-2010.

CLASS 42—SCIENTIFIC AND COMPUTER SERVICES

FOR (BASED ON INTENT TO USE) PROVIDING A WEBSITE FEATURING NON-DOWNLOADABLE SOFTWARE FOR SHIPPING, TRACKING, ESTIMATING THE COST OF SHIPPING, LABELING FREIGHT GOODS, AND REPORTING ON SHIPMENTS OF GOODS AND FREIGHT WITHIN, TO AND FROM BOTH CANADA AND THE UNITED STATES; PROVIDING TEMPORARY USE OF NON-DOWNLOADABLE COMPUTER SOFTWARE FOR PREPARING INVOICES OVER COMPUTER NETWORKS AND THE INTERNET; PROVIDING A SECURE ELECTRONIC ONLINE SYSTEM FEATURING TECHNOLOGY WHICH ALLOWS VENDORS TO SUBMIT ELECTRONIC INVOICES TO SALES REPRESENTATIVE AGENCIES FOR IMPORTING AND PROCESSING OF ELECTRONIC INVOICES TO SAVE TIME AND IMPROVE ACCURACY IN THE FIELD OF PARCEL FREIGHT TRANSPORTATION AND DELIVERY (U.S. CLS. 100 AND 101).

NAKIA HENRY, EXAMINING ATTORNEY

SN 85-202,983. PUROLATOR INC., MISSISSAUGA, ONTARIO, CANADA, FILED 12-21-2010.

We deliver Canada

OWNER OF U.S. REG. NOS. 3,381,721 AND 3,604,273.

NO CLAIM IS MADE TO THE EXCLUSIVE RIGHT TO USE "DELIVER CANADA", APART FROM THE MARK AS SHOWN.

THE MARK CONSISTS OF THE WORD "PUROLATOR" WITH A STYLIZED LETTER "P" ABOVE THE STYLIZED WORDING "WE DELIVER CANADA".

CLASS 9—ELECTRICAL AND SCIENTIFIC APPARATUS

FOR (BASED ON INTENT TO USE) COMPUTER SOFTWARE AND HARDWARE FOR SHIPPING, TRACKING, ESTIMATING THE COST OF SHIPPING, LABELING FREIGHT GOODS, AND REPORTING ON SHIPMENTS OF GOODS AND FREIGHT WITHIN, TO AND FROM BOTH CANADA AND THE UNITED STATES (U.S. CLS. 21, 23, 26, 36 AND 38).

CLASS 35—ADVERTISING AND BUSINESS

FOR (BASED ON USE IN COMMERCE) ORDER FULFILLMENT SERVICES; BUSINESS SERVICES, NAMELY, SHIPMENT PROCESSING SERVICES OVER COMPUTER AND WIRELESS NETWORKS, INTRANETS AND INTERNETS; ONLINE SERVICES IN THE FIELD OF PARCEL FREIGHT TRANSPORTATION AND DELIVERY, NAMELY, COMPUTERIZED TRACKING OF PACKAGES IN TRANSIT OVER COMPUTER AND WIRELESS NETWORKS, INTRANETS AND INTERNETS; BUSINESS SERVICES, NAMELY, FREIGHT INFORMATION MANAGEMENT SERVICES, NAMELY, PREPARING INVOICES OVER COMPUTER AND WIRELESS NETWORKS, INTRANETS AND INTERNETS; PROVIDING ONLINE SERVICES IN THE FIELD OF PARCEL AND FREIGHT TRANSPORTATION AND DELIVERY, NAMELY, TAX ASSESSMENT IN THE FORM OF ESTIMATING TAXES OVER COMPUTER AND WIRELESS NETWORKS, INTRANET AND INTERNETS (U.S. CLS. 100, 101 AND 102).

FIRST USE 8-0-2010; IN COMMERCE 8-0-2010.

CLASS 36—INSURANCE AND FINANCIAL

FOR (BASED ON USE IN COMMERCE) CUSTOMS BROKERAGE; PROVIDING ON-LINE SERVICES IN THE FIELD OF COURIER AND FREIGHT TRANSPORTATION AND DELIVERY, NAMELY, ELECTRONIC FUNDS TRANSFER; PROVIDING ONLINE SERVICES IN THE FIELD OF PARCEL FREIGHT TRANSPORTATION AND DELIVERY, NAMELY, DUTY DRAWBACK SERVICES (U.S. CLS. 100, 101 AND 102).

FIRST USE 8-0-2010; IN COMMERCE 8-0-2010.

CLASS 39—TRANSPORTATION AND STORAGE

FOR (BASED ON USE IN COMMERCE) FREIGHT AND PARCEL TRANSPORTATION AND DELIVERY SERVICES; DELIVERY SERVICES, NAMELY, DELIVERY OF GOODS AND FREIGHT BY MOTOR VEHICLES, AUTOMOBILES, TRUCKS, RAILWAYS, SHIPS, AND PLANES; PARCEL DELIVERY SERVICES; FREIGHT DECONSOLIDATION, NAMELY, UNBUNDLING BULK SHIPMENTS AND TRANSPORTING UNBUNDLED SHIPMENTS TO DESIGNEE AND FREIGHT FORWARDING SERVICES; FREIGHT AND PARCEL WAREHOUSING AND STORAGE SERVICES; ONLINE ORDERING OF SERVICES IN THE FIELD OF PARCEL AND FREIGHT TRANSPORTATION AND DELIVERY, NAMELY, SHIPPING (U.S. CLS. 100 AND 105).

FIRST USE 8-0-2010; IN COMMERCE 8-0-2010.

CLASS 42—SCIENTIFIC AND COMPUTER SERVICES

FOR (BASED ON INTENT TO USE) PROVIDING A WEBSITE FEATURING NON-DOWNLOADABLE SOFTWARE FOR SHIPPING, TRACKING, ESTIMATING THE COST OF SHIPPING, LABELING FREIGHT GOODS, AND REPORTING ON SHIPMENTS OF GOODS AND FREIGHT WITHIN, TO AND FROM BOTH CANADA AND THE UNITED STATES; PROVIDING TEMPORARY USE OF NON-DOWNLOADABLE COMPUTER SOFTWARE FOR PREPARING INVOICES OVER COMPUTER NETWORKS AND THE INTERNET; PROVIDING A SECURE ELECTRONIC ONLINE SYSTEM FEATURING TECHNOLOGY WHICH ALLOWS VENDORS TO SUBMIT ELECTRONIC INVOICES TO SALES REPRESENTATIVE AGENCIES FOR IMPORTING AND PROCESSING OF ELECTRONIC INVOICES TO SAVE TIME AND IMPROVE ACCURACY IN THE FIELD OF PARCEL FREIGHT TRANSPORTATION AND DELIVERY (U.S. CLS. 100 AND 101).

NAKIA HENRY, EXAMINING ATTORNEY

SN 85-202,984. GILBANE BUILDING COMPANY, PROVIDENCE, RI. FILED 12-21-2010.

GILBANE CONSULTING

THE MARK CONSISTS OF STANDARD CHARACTERS WITHOUT CLAIM TO ANY PARTICULAR FONT, STYLE, SIZE, OR COLOR.

NO CLAIM IS MADE TO THE EXCLUSIVE RIGHT TO USE "CONSULTING", APART FROM THE MARK AS SHOWN.

SEC. 2(F) AS TO "GILBANE".

CLASS 35—ADVERTISING AND BUSINESS

FOR MOVING AND RELOCATION SERVICES, NAMELY, PLANNING, PROJECT OVERSIGHT AND IMPLEMENTING MOVES OF OFFICES FOR OTHERS; PROCUREMENT AND INVENTORY MANAGEMENT, NAMELY, ASSESSING, PLANNING, PURCHASING AND COORDINATION OF OFFICE FURNITURE AND EQUIPMENT FOR OTHERS; CONSULTING SERVICES IN THE FIELD OF CONSTRUCTION PROJECT COST MANAGEMENT; BUSINESS CONSULTING SERVICES IN THE FIELD OF PLANNING, OPERATION AND UTILIZATION OF FACILITIES (U.S. CLS. 100, 101 AND 102).

CLASS 37—CONSTRUCTION AND REPAIR

FOR CONSULTING SERVICES IN THE FIELD OF BUILDING REPAIR, RESTORATION, MAINTENANCE AND CONSTRUCTION; CONSULTING SERVICES IN THE FIELDS OF CONSTRUCTION PROJECT MANAGEMENT AND CONSTRUCTION DOCUMENT MANAGEMENT; CONSULTING SERVICES IN THE FIELD OF CONSTRUCTION OF ENERGY EFFICIENT AND SUSTAINABLE FACILITIES; CONSULTING SERVICES IN THE FIELD OF REGULATED ENVIRONMENTAL WORK FOR CONSTRUCTION PROJECTS; CONSULTING SERVICES IN THE FIELD OF BUILDING CONSTRUCTION RELATING TO ASSESSMENT AND QUANTIFICATION OF IMPACT TO PROPERTY AND PROPERTY LOSS; CONSULTING SERVICES, NAMELY, CONSTRUCTION CONSULTATION TO BUILDING OWNERS IN COMPLETION OF CREDITS FOR A CERTIFYING ENTITY'S SUSTAINABLE BUILDING CERTIFICATION PROGRAM (U.S. CLS. 100, 103 AND 106).

CLASS 41—EDUCATION AND ENTERTAINMENT

FOR DEVELOPING TRAINING PROGRAMS FOR OTHERS IN THE FIELD OF ENVIRONMENTAL AND INDUSTRIAL HYGIENE COMPLIANCE AND SAFETY (U.S. CLS. 100, 101 AND 107).

CLASS 42—SCIENTIFIC AND COMPUTER SERVICES

FOR CONSULTING IN THE FIELD OF INFORMATION TECHNOLOGY SYSTEMS PLANNING AND COORDINATION; PROVIDING PLANNING AND ENGINEERING SERVICES IN THE FIELD OF INFORMATION AND COMMUNICATIONS NETWORKS; CONSULTATION SERVICES IN THE FIELDS OF IMPLEMENTATION AND USE OF COMPUTER SOFTWARE FOR CONSTRUCTION PROJECT MODELING AND VISUALIZATION, CONSTRUCTION PROJECT MANAGEMENT, FACILITY OPERATIONS, AND CONSTRUCTION PROJECT COST MANAGEMENT (U.S. CLS. 100 AND 101).

CLASS 45—PERSONAL AND LEGAL SERVICES

FOR PERMITTING, NAMELY, OBTAINING ENVIRONMENTAL, DESIGN, ZONING AND OTHER GOVERNMENTAL PERMITS FOR DEVELOPMENT PROJECTS; REGULATORY CONSULTING SERVICES IN THE FIELD OF ENVIRONMENTAL AND INDUSTRIAL HYGIENE COMPLIANCE AND SAFETY (U.S. CLS. 100 AND 101).

TINA L. SNAPP, EXAMINING ATTORNEY

SN 85-205,762. GILBANE BUILDING COMPANY, PROVIDENCE, RI. FILED 12-27-2010.



NO CLAIM IS MADE TO THE EXCLUSIVE RIGHT TO USE "CONSULTING", APART FROM THE MARK AS SHOWN.

THE MARK CONSISTS OF THE WORDS "GILBANE CONSULTING", WHEREIN THE "G" IN "GILBANE" IS IN DARK LETTERING FOLLOWED BY A RECTANGULAR DARK BACKGROUND CARRIER CONTAINING THE LETTERS "ILBANE" IN CONTRAST TO THE BACKGROUND, WITH THE WORD "CONSULTING" IN ALL CAPITAL LETTERS DISPOSED BELOW THE "ILBANE" PORTION OF "GILBANE".

SEC. 2(F) AS TO "GILBANE".

CLASS 35—ADVERTISING AND BUSINESS

FOR MOVING AND RELOCATION SERVICES, NAMELY, PLANNING, PROJECT OVERSIGHT AND IMPLEMENTING MOVES OF OFFICES FOR OTHERS; PROCUREMENT AND INVENTORY MANAGEMENT, NAMELY, ASSESSING, PLANNING, PURCHASING AND COORDINATION OF OFFICE FURNITURE AND EQUIPMENT FOR OTHERS; CONSULTING SERVICES IN THE FIELD OF CONSTRUCTION PROJECT COST MANAGEMENT; BUSINESS CONSULTING SERVICES IN THE FIELD OF PLANNING, OPERATION AND UTILIZATION OF FACILITIES (U.S. CLS. 100, 101 AND 102).

CLASS 37—CONSTRUCTION AND REPAIR

FOR CONSULTING SERVICES IN THE FIELD OF BUILDING REPAIR, RESTORATION, MAINTENANCE AND CONSTRUCTION; CONSULTING SERVICES IN THE FIELDS OF CONSTRUCTION PROJECT MANAGEMENT AND CONSTRUCTION DOCUMENT MANAGEMENT; CONSULTING SERVICES IN THE FIELD OF CONSTRUCTION OF ENERGY EFFICIENT AND SUSTAINABLE FACILITIES; CONSULTING SERVICES IN THE FIELD OF REGULATED ENVIRONMENTAL WORK FOR CONSTRUCTION PROJECTS; CONSULTING SERVICES IN THE FIELD OF BUILDING CONSTRUCTION RELATING TO ASSESSMENT AND QUANTIFICATION OF IMPACT TO PROPERTY AND PROPERTY LOSS; CONSULTING SERVICES, NAMELY, CONSTRUCTION CONSULTATION TO BUILDING OWNERS IN COMPLETION OF CREDITS FOR A CERTIFYING ENTITY'S SUSTAINABLE BUILDING CERTIFICATION PROGRAM (U.S. CLS. 100, 103 AND 106).

CLASS 41—EDUCATION AND ENTERTAINMENT

FOR DEVELOPING TRAINING PROGRAMS FOR OTHERS IN THE FIELD OF ENVIRONMENTAL AND INDUSTRIAL HYGIENE COMPLIANCE AND SAFETY (U.S. CLS. 100, 101 AND 107).

CLASS 42—SCIENTIFIC AND COMPUTER SERVICES

FOR CONSULTING IN THE FIELD OF INFORMATION TECHNOLOGY SYSTEMS PLANNING AND COORDINATION; PROVIDING PLANNING AND ENGINEERING SERVICES IN THE FIELD OF INFORMATION AND COMMUNICATIONS NETWORKS; CONSULTATION SERVICES IN THE FIELDS OF IMPLEMENTATION AND USE OF COMPUTER SOFTWARE FOR CONSTRUCTION PROJECT MODELING AND VISUALIZATION, CONSTRUCTION PROJECT MANAGEMENT, FACILITY OPERATIONS, AND CONSTRUCTION PROJECT COST MANAGEMENT (U.S. CLS. 100 AND 101).

CLASS 45—PERSONAL AND LEGAL SERVICES

FOR PERMITTING, NAMELY, OBTAINING ENVIRONMENTAL, DESIGN, ZONING AND OTHER GOVERNMENTAL PERMITS FOR DEVELOPMENT PROJECTS; REGULATORY CONSULTING SERVICES IN THE FIELD OF ENVIRONMENTAL AND INDUSTRIAL HYGIENE COMPLIANCE AND SAFETY (U.S. CLS. 100 AND 101).

TINA L. SNAPP, EXAMINING ATTORNEY

SN 85-206,210. ADVANCED ONLINE SOLUTIONS, INC., TULSA, OK. FILED 12-27-2010.

The logo for hostek features the word "hostek" in a lowercase, black, sans-serif font.

THE MARK CONSISTS OF STANDARD CHARACTERS WITHOUT CLAIM TO ANY PARTICULAR FONT, STYLE, SIZE, OR COLOR.

CLASS 42—SCIENTIFIC AND COMPUTER SERVICES

FOR HOSTING OF WEB SITES (U.S. CLS. 100 AND 101).

FIRST USE 1-20-1998; IN COMMERCE 2-28-1998.

CLASS 45—PERSONAL AND LEGAL SERVICES

FOR DOMAIN NAME REGISTRATION SERVICES (U.S. CLS. 100 AND 101).
FIRST USE 1-20-1998; IN COMMERCE 2-28-1998.
NICHOLAS COLEMAN, EXAMINING ATTORNEY

NO CLAIM IS MADE TO THE EXCLUSIVE RIGHT TO USE "INTENT MARKETPLACE", APART FROM THE MARK AS SHOWN.

SN 85-207,805. STICKY FINGERS OF LI INC., DBA 18 BAY, BAYVILLE, NY. FILED 12-30-2010.



THE COLOR(S) GREEN, PINK AND BLACK IS/ARE CLAIMED AS A FEATURE OF THE MARK.

THE MARK CONSISTS OF GREEN AND BLACK VINES, A WATERMELON SLICE WITH A GREEN EXTERIOR, PINK INTERIOR WITH BLACK SEEDS AND THE BLACK WORDING "18 BAY".

CLASS 29—MEATS AND PROCESSED FOODS

FOR (BASED ON INTENT TO USE) MEAT, FISH, POULTRY AND GAME; DRIED FRUITS AND VEGETABLES; JARRED FRUITS AND VEGETABLES; INFUSED OILS FOR COOKING; PREPARED FOODS, NAMELY, CURDS (U.S. CL. 46).

CLASS 30—STAPLE FOODS

FOR (BASED ON INTENT TO USE) PACKAGED ENTREES CONSISTING PRIMARILY OF PASTA; PASTA SAUCE; PREPARED FOODS, NAMELY, CUPCAKES, CAKE, PIES, COOKIES, GRANOLA-BASED SNACK BARS, CONFECTIONS, NAMELY, BAKERY DESSERTS; BREADS; FOOD FLAVORINGS, NAMELY, INFUSED OILS, NOT BEING ESSENTIAL OILS (U.S. CL. 46).

CLASS 43—HOTEL AND RESTAURANT SERVICES

FOR (BASED ON USE IN COMMERCE) RESTAURANT AND RESTAURANT CARRYOUT SERVICES (U.S. CLS. 100 AND 101).

FIRST USE 7-1-2005; IN COMMERCE 7-1-2005.
LAURA HAMMEL, EXAMINING ATTORNEY

SN 85-208,646. ADCHEMY, INC., FOSTER CITY, CA. FILED 12-31-2010.

ADCHEMY INTENT MARKETPLACE

THE MARK CONSISTS OF STANDARD CHARACTERS WITHOUT CLAIM TO ANY PARTICULAR FONT, STYLE, SIZE, OR COLOR.

OWNER OF U.S. REG. NOS. 3,196,615 AND 3,930,745.

CLASS 35—ADVERTISING AND BUSINESS

FOR ADVERTISING AND MARKETING SERVICES; ONLINE ADVERTISING SERVICES FOR OTHERS; ADVERTISING CONSULTATION; ADVERTISING AND MARKETING; ADVERTISEMENT, PROMOTION AND MARKETING SERVICES FOR PROVIDING ELECTRONIC MEDIA OR INFORMATION OVER THE INTERNET OR OTHER COMMUNICATIONS NETWORK; BUSINESS MARKETING MONITORING AND OPTIMIZATION SERVICES, NAMELY, TRACKING WEB PAGES OF CUSTOMERS TO PROVIDE DETAILS ABOUT THEIR SITE USERS, USER CLICK TRAFFIC OR VISITS TO THE WEB SITE; ANALYSIS OF ADVERTISING RESPONSES, NAMELY, SERVICES TO DETERMINE THE AUDIENCE AFFECTED BY CUSTOMER ADVERTISEMENTS, OFFERS THROUGH PRODUCT ADVERTISING, AND WEB CONTENT, NAMELY, INTERNET ADVERTISEMENTS AND MARKETING; SERVICES TO HELP ADVERTISERS AND MARKETERS CAPTURE, AND ANALYZE THE INTENT OF INTERNET USERS AS WELL AS DATA ABOUT INTERNET USERS FROM VARIOUS SOURCES, FOR ADVERTISING AND MARKETING PURPOSES, NAMELY, BUSINESS MARKETING MONITORING AND OPTIMIZATION SERVICES, NAMELY, SERVICES FOR OTHERS TO UNDERSTAND CONSUMERS' INTENT EXPRESSED THROUGH QUERIES AND OTHER ONLINE ACTIVITIES IN ORDER TO IMPROVE MARKETING EFFECTIVENESS, STRATEGY AND INSIGHT, PARTICULARLY SPECIALIZING IN THE USE OF MAPPING AND ANALYTICAL TOOLS FOR UNDERSTANDING AND PREDICTING CONSUMERS' DESIRES, NEEDS AND INTENDED ONLINE PURCHASES AND OTHER ONLINE ACTIVITIES (U.S. CLS. 100, 101 AND 102).

CLASS 42—SCIENTIFIC AND COMPUTER SERVICES

FOR APPLICATION SERVICE PROVIDER FEATURING SOFTWARE FOR PROVIDING, HOSTING, MANAGING, DEVELOPING, RESEARCHING, ANALYZING, REPORTING, CAPTURING, STORING AND MAINTAINING APPLICATIONS, SOFTWARE, WEBSITES, AND DATABASES OF OTHERS IN THE FIELDS OF ADVERTISING AND MARKETING; APPLICATION SERVICE PROVIDER FEATURING SOFTWARE FOR ORGANIZING, TAGGING, COLLECTING, TRACKING, ANALYZING, ORGANIZING, INTEGRATING, CONTROLLING AND MANAGING A WIDE VARIETY OF DATA AND INFORMATION FROM VARIOUS SOURCES THROUGH A SINGLE INTERFACE IN THE FIELDS OF ADVERTISING AND MARKETING; APPLICATION SERVICE PROVIDER FEATURING SOFTWARE FOR ALLOWING OTHERS TO CAPTURE, ANALYZE, OPTIMIZE, AND MONETIZE SEARCH QUERY, DEMOGRAPHIC, LIFESTYLE, CONSUMER PURCHASING DECISIONS, AND OTHER DATA AND INFORMATION FROM ONLINE WEBSITE TRAFFIC AND THIRD-PARTY SOURCES IN THE FIELDS OF ADVERTISING AND MARKETING; RESEARCH AND DEVELOPMENT OF TECHNOLOGY IN THE FIELD OF DIGITAL ADVERTISING MARKETS; APPLICATION SERVICE PROVIDER FEATURING SOFTWARE IN THE FIELD OF WEB ANALYTICS THAT COLLECTS, MANAGES, INTEGRATES, ANALYZES, MONITORS, OPTIMIZES AND TRACKS THE PERFORMANCE OF WEBSITES AND INTERNET ADVERTISEMENTS THROUGH WEB USER BEHAVIOR (U.S. CLS. 100 AND 101).

LINDSEY RUBIN, EXAMINING ATTORNEY

SN 85-209,583. HAVEN'S KITCHEN LLC, NEW YORK, NY.
FILED 1-3-2011.

HAVEN'S KITCHEN

THE MARK CONSISTS OF STANDARD CHARACTERS WITHOUT CLAIM TO ANY PARTICULAR FONT, STYLE, SIZE, OR COLOR.

NO CLAIM IS MADE TO THE EXCLUSIVE RIGHT TO USE "KITCHEN", APART FROM THE MARK AS SHOWN.

CLASS 35—ADVERTISING AND BUSINESS

FOR RETAIL STORE SERVICES FEATURING LINENS FOR KITCHEN AND TABLE, COOKBOOKS, CUTLERY, HOUSEWARES, BARWARE, GIFTWARE, BAKEWARE, KITCHENWARE, DINNERWARE, TABLEWARE, COOKWARE, GLASSWARE, FLATWARE, KITCHEN GADGETS, APPLIANCES AND UTENSILS, ORGANIC, GOURMET, LOCAL, SPECIALTY, NATURAL, ARTISAN AND HEALTHY FOODS AND GROCERIES BUT EXCLUDING WINE (U.S. CLS. 100, 101 AND 102).

CLASS 41—EDUCATION AND ENTERTAINMENT

FOR EDUCATIONAL AND ENTERTAINMENT SERVICES, NAMELY, CULINARY SCHOOL SERVICES, PROVIDING CLASSES, SEMINARS AND WORKSHOPS IN THE FIELDS OF FOOD, COOKING, ENTERTAINMENT AND LIFESTYLE BUT EXCLUDING WINE; ENTERTAINMENT SERVICES, NAMELY, ARRANGING, ORGANIZING, CONDUCTING, AND HOSTING SOCIAL ENTERTAINMENT AND CULTURAL EVENTS (U.S. CLS. 100, 101 AND 107).

CLASS 43—HOTEL AND RESTAURANT SERVICES

FOR PROVIDING A WEBSITE FEATURING INFORMATION IN THE FIELD OF CULINARY ARTS, RECIPES, FOOD, INGREDIENTS AND COOKING BUT EXCLUDING WINE; PRIVATE DINING CLUB SERVICES, NAMELY, THE SERVING OF FOOD AND DRINK IN A PRIVATE DINING CLUB SETTING (U.S. CLS. 100 AND 101).

SHAUNIA CARLYLE, EXAMINING ATTORNEY

SN 85-211,331. MIGUEL MEDELLIN GARCIA, QUERÉTARO, QUERÉTARO, MEXICO, FILED 1-5-2011.

MERCENARIO

THE MARK CONSISTS OF STANDARD CHARACTERS WITHOUT CLAIM TO ANY PARTICULAR FONT, STYLE, SIZE, OR COLOR.

THE ENGLISH TRANSLATION OF "MERCENARIO" IN THE MARK IS "MERCENARY".

CLASS 9—ELECTRICAL AND SCIENTIFIC APPARATUS

FOR PRE-RECORDED CDS, VIDEO TAPES, LASER DISKS AND DVDS FEATURING MUSIC (U.S. CLS. 21, 23, 26, 36 AND 38).

FIRST USE 1-1-1992; IN COMMERCE 1-1-1992.

CLASS 41—EDUCATION AND ENTERTAINMENT

FOR ENTERTAINMENT IN THE NATURE OF LIVE PERFORMANCES BY A VOCAL AND INSTRUMENTAL MUSICAL GROUP (U.S. CLS. 100, 101 AND 107).

FIRST USE 1-1-1992; IN COMMERCE 1-1-1992.

KATHERINE STOIDES, EXAMINING ATTORNEY

SN 85-211,445. ISABELLA AND MAX, LLC, DBA HOUSE OF FIFTY, WILSONVILLE, OR. FILED 1-5-2011.

House Of Fifty

THE MARK CONSISTS OF STANDARD CHARACTERS WITHOUT CLAIM TO ANY PARTICULAR FONT, STYLE, SIZE, OR COLOR.

CLASS 16—PAPER GOODS AND PRINTED MATTER

FOR PRINTED GENERAL FEATURES MAGAZINE IN THE FIELD OF LIFESTYLE FEATURING INTERIORS, FASHION, FOOD, FITNESS, ENTERTAINING, BEAUTY AND PRODUCT REVIEWS (U.S. CLS. 2, 5, 22, 23, 29, 37, 38 AND 50).

FIRST USE 1-1-2011; IN COMMERCE 1-3-2011.

CLASS 41—EDUCATION AND ENTERTAINMENT

FOR PROVIDING AN ON-LINE GENERAL FEATURES MAGAZINE IN THE FIELD OF LIFESTYLE FEATURING INTERIORS, FASHION, FOOD, FITNESS, ENTERTAINING, BEAUTY, AND PRODUCT REVIEWS (U.S. CLS. 100, 101 AND 107).

FIRST USE 1-1-2011; IN COMMERCE 1-3-2011.

KATHLEEN M. VANSTON, EXAMINING ATTORNEY

SN 85-213,610. FOR-SIDE.COM CO., LTD., TOKYO, JAPAN, FILED 1-9-2011.



OWNER OF JAPAN REG. NO. 4707089, DATED 9-5-2003, EXPIRES 9-5-2013.

THE COLOR(S) BLACK, WHITE AND RED IS/ARE CLAIMED AS A FEATURE OF THE MARK.

THE MARK CONSISTS OF THE LETTERING "FOR-SIDE.COM" IN WHITE AND RED AGAINST A BACKGROUND OF A BLACK DIAMOND SHAPE.

CLASS 9—ELECTRICAL AND SCIENTIFIC APPARATUS

FOR DOWNLOADABLE ELECTRONIC PUBLICATIONS, NAMELY AUDIO BOOKS, BOOKS, MAGAZINES, JOURNALS, NEWSPAPERS, MULTIMEDIA PRESENTATIONS, FOREIGN BOOK, COMICS, PHOTO BOOK, PRACTICAL BOOK, SERIES OF BOOKS FOR LITERATURE AND REFERENCE BOOKS FEATURING FICTIONAL STORIES, NON-FICTIONAL STORIES, INFORMATION IN THE FIELD OF ENTERTAINMENT, NEWS, HISTORY, SPORTS, GAMES, REGION, SCIENCE, PHILOSOPHY, PHOTOS, POLITICS, NATURE, LAW, MATHEMATICS, ARCHITECTURE, EDUCATION, CURRENT EVENTS, BIBLE, ART, DRAMA, PET ANIMALS, PSYCHOLOGY, LANGUAGE, CRIMINOLOGY, HOUSE AND HOME, COMEDY, MEDICAL CARE, MUSIC, PERFORMING ART, PERSONAL DEVELOPMENT, TECHNOLOGICAL INFORMATION, TRAFFIC INFORMATION, MOVIE-RELATED AREAS, FREE-ONLINE LIBRARY, TRAVEL, SOCIAL SCIENCE, DESIGN, LOVE, POEM, GENERAL KNOWLEDGE, COMPUTER, SPORTS AND RECREATION, ANTIQUE AND COLLECTION, BIOGRAPHY AND AUTOBIOGRAPHY, BODY AND SPIRIT, BUSINESS AND ECONOMY, GARDENING, FAMILY AND MALE-FEMALE RELATIONSHIP, CARTOON AND GRAPHIC NOVEL, STUDYING FOREIGN LANGUAGE, PIN-UP MOTION PICTURE AND PIN-UP PHOTO BOOK, HEALTH AND FITNESS AND OTHER TOPICS OF GENERAL INTEREST; COMPUTERS INCLUDING COMPUTERS FOR READING ELECTRONIC PUBLICATIONS; COMPUTER PROGRAMS FOR WORD PROCESSING; COMPUTER PROGRAMS FOR READING ELECTRONIC PUBLICATIONS; ELECTRONIC MACHINES, APPARATUS AND THEIR STRUCTURAL AND REPLACEMENT PARTS, NAMELY, DIGITAL BOOK READERS, PERSONAL COMPUTERS AND TABLET COMPUTERS; TELECOMMUNICATION DEVICES AND APPARATUS, NAMELY TELECOMMUNICATION CABLES, MOBILE PHONES; ELECTRONIC CIRCUITS AND DISCS RECORDED WITH COMPUTER GAME PROGRAMS; DOWNLOADABLE MUSIC FILES AND SOUND FILES; DOWNLOADABLE IMAGE FILES CONTAINING IMAGES OF PEOPLE, ANIMALS, LANDSCAPES, INANIMATE OBJECTS, MASCOTS, CARTOON AND COMICS CHARACTERS; RECORDED VIDEO DISCS AND VIDEO TAPES FEATURING MUSIC, SHOWS, SOUND, MOTION, PICTURES OF LIVE ACTORS, INANIMATE OBJECTS, MASCOTS, CARTOON AND COMICS CHARACTERS (U.S. CLS. 21, 23, 26, 36 AND 38).

CLASS 35—ADVERTISING AND BUSINESS

FOR RETAIL STORE SERVICES FEATURING ELECTRONIC PUBLICATIONS; WHOLESALE STORE SERVICES FEATURING ELECTRONIC PUBLICATIONS; ADVERTISING AND PUBLICITY SERVICES INCLUDING ON-LINE ADVERTISING ON A COMPUTER NETWORK (U.S. CLS. 100, 101 AND 102).

CLASS 41—EDUCATION AND ENTERTAINMENT

FOR PROVIDING NON-DOWNLOADABLE ELECTRONIC PUBLICATIONS IN THE NATURE OF AUDIO BOOKS, BOOKS, MAGAZINES, JOURNALS, NEWSPAPERS, MULTIMEDIA PRESENTATIONS, FOREIGN BOOKS, COMICS, PHOTO BOOKS, PRACTICAL BOOKS, SERIES OF BOOKS FOR LITERATURE AND REFERENCE BOOKS FEATURING FICTIONAL STORIES, NON-FICTIONAL STORES, INFORMATION IN THE FIELD OF ENTERTAINMENT, NEWS, HISTORY, SPORTS, GAMES, REGION, SCIENCE, PHILOSOPHY, PHOTOS, POLITICS, NATURE, LAW, MATHEMATICS, ARCHITECTURE, EDUCATION, CURRENT EVENTS, BIBLE, ART, DRAMA, PET ANIMALS, PSYCHOLOGY, LANGUAGE, CRIMINOLOGY, HOUSE AND HOME, COMEDY, MEDICAL CARE, MUSIC, PERFORMING ART, PERSONAL DEVELOPMENT, TECHNOLOGICAL INFORMATION, TRAFFIC INFORMATION, MOVIE-RELATED AREAS, FREE-ONLINE LIBRARY, TRAVEL, SOCIAL SCIENCE, DESIGN, LOVE, POEM, GENERAL KNOWLEDGE, COMPUTER, SPORTS AND RECREATION, ANTIQUE AND COLLECTION, BIOGRAPHY AND AUTOBIOGRAPHY, BODY AND SPIRIT, BUSINESS AND ECONOMY, GARDENING, FAMILY AND

MALE-FEMALE RELATIONSHIP, CARTOON AND GRAPHIC NOVEL, STUDYING FOREIGN LANGUAGE, PIN-UP MOTION PICTURE AND PIN-UP PHOTO BOOK, HEALTH AND FITNESS AND OTHER TOPICS OF GENERAL INTEREST; LIBRARY SERVICES; PROVIDING NON-DOWNLOADABLE PRE-RECORDED ELECTRONIC MUSIC, IMAGE AND SOUNDS PRESENTED TO MOBILE COMMUNICATIONS DEVICES VIA A GLOBAL COMPUTER NETWORK; EDITING AND PUBLICATION OF BOOKS AND PUBLISHING OF ELECTRONIC PUBLICATIONS; RENTAL OF BOOKS, PAINTINGS AND CALLIGRAPHIC WORDS INCLUDING ELECTRONIC PUBLICATIONS; INFORMATION FOR RENTAL OF BOOKS, PAINTINGS AND CALLIGRAPHIC WORDS INCLUDING ELECTRONIC PUBLICATIONS; RENTAL OF RECORDED MEDIA CONTAINING IMAGES AND CHARACTER INFORMATION FROM BOOKS; RENTAL OF DOWNLOADABLE PUBLICATIONS; RENTAL OF SOUND RECORDINGS (U.S. CLS. 100, 101 AND 107).

TOBY BULLOFF, EXAMINING ATTORNEY

SN 85-214,415. N.V. PERRICONE LLC, MERIDEN, CT. FILED 1-10-2011.

THE SCIENCE OF BEAUTY

THE MARK CONSISTS OF STANDARD CHARACTERS WITHOUT CLAIM TO ANY PARTICULAR FONT, STYLE, SIZE, OR COLOR.

OWNER OF U.S. REG. NOS. 3,493,605, 3,664,950 AND OTHERS.

CLASS 3—COSMETICS AND CLEANING PREPARATIONS

FOR BEAUTY SERUMS; COSMETIC CREAMS FOR SKIN CARE; COSMETIC PREPARATIONS FOR SKIN RENEWAL; SKIN CLEANSERS; SKIN CONDITIONERS; SKIN CREAM; SKIN LOTION; SKIN MOISTURIZER; SKIN TONERS (U.S. CLS. 1, 4, 6, 50, 51 AND 52).

CLASS 5—PHARMACEUTICALS

FOR NUTRITIONAL SUPPLEMENTS; POWDERED NUTRITIONAL SUPPLEMENT DRINK MIX; VITAMIN SUPPLEMENTS (U.S. CLS. 6, 18, 44, 46, 51 AND 52).

GIANCARLO CASTRO, EXAMINING ATTORNEY

SN 85-216,202. PERFECT FIT MEALS, LLC, DBA PERFECT FIT MEALS, HOUSTON, TX. FILED 1-12-2011.

GreenBox

THE MARK CONSISTS OF STANDARD CHARACTERS WITHOUT CLAIM TO ANY PARTICULAR FONT, STYLE, SIZE, OR COLOR.

CLASS 35—ADVERTISING AND BUSINESS

FOR FOOD KIOSK SERVICES; MOBILE FOOD KIOSK SERVICES; MOBILE STREET VENDOR SERVICES FEATURING FOOD AND DRINK; MOBILE VENDING IN THE FIELD OF FOOD AND DRINK; STREET VENDOR SERVICES FEATURING FOOD AND DRINK (U.S. CLS. 100, 101 AND 102).

CLASS 43—HOTEL AND RESTAURANT SERVICES

FOR FOOD PREPARATION SERVICES; FOOD PREPARATION SERVICES FEATURING FRESH, PROPERLY PROPORTIONED, HEALTHY MEALS DESIGNED TO FUEL METABOLISM AND BURN FAT AND MADE TO ORDER FOR DELIVERY OR PICK UP; PREPARATION OF FOOD AND BEVERAGES; PROVIDING OF FOOD AND DRINK; PROVIDING OF FOOD AND DRINK VIA A MOBILE TRUCK (U.S. CLS. 100 AND 101).
DAVID TAYLOR, EXAMINING ATTORNEY

SN 85-216,877. FLORISTS' TRANSWORLD DELIVERY, INC., DOWNERS GROVE, IL. FILED 1-13-2011.

**FLOWERS SAY IT BETTER.
FTD SAYS IT BEST.**

THE MARK CONSISTS OF STANDARD CHARACTERS WITHOUT CLAIM TO ANY PARTICULAR FONT, STYLE, SIZE, OR COLOR.
OWNER OF U.S. REG. NOS. 821,318, 4,020,245 AND OTHERS.

CLASS 31—NATURAL AGRICULTURAL PRODUCTS

FOR FLOWERS AND LIVE FLORAL ARRANGEMENTS (U.S. CLS. 1 AND 46).

CLASS 35—ADVERTISING AND BUSINESS

FOR RETAIL SERVICES, NAMELY, ONLINE STORE, RETAIL STORE AND SHOP-BY-TELEPHONE SERVICES FEATURING FLOWERS AND GIFTS; PROMOTING THE RETAIL FLORAL AND GIFT SERVICES OF OTHERS THROUGH ADVERTISING IN ELECTRONIC, BROADCAST AND PRINT MEDIA AND THE PROVIDING OF COUPONS AND DISCOUNTS (U.S. CLS. 100, 101 AND 102).

BRENDAN REGAN, EXAMINING ATTORNEY

SN 85-218,328. FICKEWIRTH, JOHN M., OJAI, CA. FILED 1-14-2011.

LABOR RESEARCH PARTNERS

THE MARK CONSISTS OF STANDARD CHARACTERS WITHOUT CLAIM TO ANY PARTICULAR FONT, STYLE, SIZE, OR COLOR.

OWNER OF U.S. REG. NO. 3,150,265.

NO CLAIM IS MADE TO THE EXCLUSIVE RIGHT TO USE "LABOR RESEARCH", APART FROM THE MARK AS SHOWN.

SEC. 2(F).

CLASS 35—ADVERTISING AND BUSINESS

FOR BUSINESS CONSULTING AND RESEARCH FOR LABOR UNIONS IN THE FIELD OF LABOR-MANAGEMENT RELATIONS, NAMELY, HUMAN RESOURCES CONSULTING, AND RESEARCH CASE STUDIES ABOUT WAGE TRENDS (U.S. CLS. 100, 101 AND 102).
FIRST USE 12-1-2005; IN COMMERCE 12-1-2005.

CLASS 36—INSURANCE AND FINANCIAL

FOR CONSULTING AND RESEARCH FOR LABOR UNIONS IN THE FIELD OF FINANCIAL AND INSURANCE EMPLOYEE BENEFITS (U.S. CLS. 100, 101 AND 102).

FIRST USE 12-1-2005; IN COMMERCE 12-1-2005.

CLASS 45—PERSONAL AND LEGAL SERVICES

FOR CONSULTING AND RESEARCH FOR LABOR UNIONS IN THE FIELD OF LEGISLATIVE ANALYSIS, NAMELY, LEGAL ANALYSIS OF LEGISLATION (U.S. CLS. 100 AND 101).

FIRST USE 12-1-2005; IN COMMERCE 12-1-2005.

APRIL ROACH, EXAMINING ATTORNEY

SN 85-219,756. VALKEE OY, OULU, FINLAND, FILED 1-18-2011.

VALKEE

THE MARK CONSISTS OF STANDARD CHARACTERS WITHOUT CLAIM TO ANY PARTICULAR FONT, STYLE, SIZE, OR COLOR.

THE WORDING "VALKEE" HAS NO MEANING IN A FOREIGN LANGUAGE.

CLASS 9—ELECTRICAL AND SCIENTIFIC APPARATUS

FOR SCIENTIFIC APPARATUS, NAMELY, COMPUTER OPERATING SYSTEMS; COMPUTER APPLICATION SOFTWARE FOR MEDICAL DEVICES FOR RECEIVING, PROCESSING, ANALYZING, TRANSMITTING, AND DISPLAYING DATA; COMPUTER PROGRAMS FOR USE IN THE OPERATION OF BRIGHT LIGHT THERAPY DEVICES (U.S. CLS. 21, 23, 26, 36 AND 38).

CLASS 10—MEDICAL APPARATUS

FOR SURGICAL AND MEDICAL APPARATUS AND INSTRUMENTS, NAMELY, HEADSETS FOR TRANSMITTING BRIGHT LIGHT THROUGH THE EAR CANALS TO THE BRAIN FOR THERAPEUTIC PURPOSE (U.S. CLS. 26, 39 AND 44).

CLASS 11—ENVIRONMENTAL CONTROL APPARATUS

FOR APPARATUS FOR LIGHTING, NAMELY, HEADMOUNTED LIGHTS AND HEADSETS TRANSMITTING BRIGHT LIGHT (U.S. CLS. 13, 21, 23, 31 AND 34).

CLASS 44—MEDICAL, BEAUTY AND AGRICULTURAL SERVICES

FOR MEDICAL SERVICES, NAMELY, BRIGHT LIGHT THERAPY (U.S. CLS. 100 AND 101).
KIMBERLY PERRY, EXAMINING ATTORNEY

SN 85-233,524. MCARTHUR/GLEN EUROPE HOLDINGS LIMITED LLC, WILMINGTON, DE. FILED 2-3-2011.

SN 85-228,077. AMERICAN ACADEMY OF PEDIATRICS, ELK GROVE VILLAGE, IL. FILED 1-27-2011.

NRP



THE MARK CONSISTS OF STANDARD CHARACTERS WITHOUT CLAIM TO ANY PARTICULAR FONT, STYLE, SIZE, OR COLOR.

CLASS 41—EDUCATION AND ENTERTAINMENT

FOR EDUCATIONAL SERVICES, NAMELY, PROVIDING COURSES AND WEBINARS IN THE FIELD OF NEONATAL RESUSCITATION (U.S. CLS. 100, 101 AND 107).
FIRST USE 12-31-1987; IN COMMERCE 12-31-1987.

CLASS 44—MEDICAL, BEAUTY AND AGRICULTURAL SERVICES

FOR PROVIDING MEDICAL INFORMATION IN THE FIELD OF NEONATAL RESUSCITATION (U.S. CLS. 100 AND 101).
FIRST USE 12-31-1987; IN COMMERCE 12-31-1987.
MARK SPARACINO, EXAMINING ATTORNEY

OWNER OF ERPN CMNTY TM OFC REG. NO. 006738033, DATED 1-5-2009, EXPIRES 3-7-2018.
OWNER OF U.S. REG. NOS. 3,398,386, 3,930,741 AND OTHERS.

THE MARK CONSISTS OF A TILTED SQUARE WITH A RECTANGLE SHAPE AT THE BOTTOM OF THE SQUARE.

CLASS 35—ADVERTISING AND BUSINESS

FOR ADVERTISING SERVICES; BUSINESS MANAGEMENT AND BUSINESS ADMINISTRATION; PROVIDING OFFICE FUNCTIONS; BUSINESS MANAGEMENT AND ADMINISTRATION OF RETAIL OUTLETS; BUSINESS MANAGEMENT AND ADMINISTRATION OF RETAIL OUTLETS AND UNITS WITHIN AIRPORTS; BUSINESS MANAGEMENT OF SHOP UNITS, SHOPPING CENTRES AND SHOPPING MALLS; THE BRINGING TOGETHER FOR THE BENEFIT OF OTHERS, OF A VARIETY OF GOODS FROM RETAIL OUTLETS AND, ENTERTAINMENT, RESTAURANT AND OTHER CONSUMER SERVICES, ENABLING CUSTOMERS TO CONVENIENTLY VIEW AND PURCHASE THOSE GOODS AND SELECT SERVICE PROVIDERS IN A SHOPPING CENTRE OR MALL, WITHIN AIRPORTS, IN DEPARTMENT STORES OR ON INTERNET WEBSITES; PROVISION OF INFORMATION IN THE FIELD OF RETAIL OUTLETS AND RETAIL OPPORTUNITIES; BUSINESS MANAGEMENT ASSISTANCE AND BUSINESS MANAGEMENT CONSULTANCY SERVICES FOR RETAIL OUTLETS AND FOR COMMERCIAL ENTERPRISES, CENTRES AND COMPLEXES; BUSINESS AND COMMERCIAL ASSISTANCE IN THE EXPLOITATION OR THE MANAGEMENT OF RETAIL UNITS AND OF SHOPPING CENTRES AND COMPLEXES; BUSINESS CONSULTING SERVICES IN THE FIELD OF RETAIL SALE AND DISTRIBUTION OF PRODUCTS; BUSINESS CONSULTING SERVICES RELATING TO THE ORGANIZATIONAL OPTIMIZATION AND THE MANAGEMENT OF SHOPPING CENTRES AND RETAIL OUTLETS; ADVERTISING AND PROMOTIONAL SERVICES; BUSINESS RESEARCH; ADVERTISING AND PROMOTION OF COMMERCIAL BUILDINGS, NAMELY, SHOPPING CENTRES AND RETAIL OUTLETS; CONDUCTING INCENTIVE AWARD PROGRAMS TO PROMOTE THE FREQUENT SHOPPING AT SHOPPING CENTERS AND RETAIL OUTLETS; REAL ESTATE SALES MANAGEMENT (U.S. CLS. 100, 101 AND 102).

SN 85-230,091. MARQUÉ 5, INDIAN HEAD, MD. FILED 1-31-2011.

Marqué 5

THE MARK CONSISTS OF STANDARD CHARACTERS WITHOUT CLAIM TO ANY PARTICULAR FONT, STYLE, SIZE, OR COLOR.

CLASS 25—CLOTHING

FOR HATS; HOODED SWEAT SHIRTS; SWEAT SHIRTS; T-SHIRTS (U.S. CLS. 22 AND 39).

CLASS 41—EDUCATION AND ENTERTAINMENT

FOR MUSIC PRODUCTION SERVICES (U.S. CLS. 100, 101 AND 107).
DEZMONA MIZELLE, EXAMINING ATTORNEY

CLASS 36—INSURANCE AND FINANCIAL

FOR FINANCIAL AFFAIRS, NAMELY, MANAGEMENT AND ANALYSIS SERVICES; MONETARY AFFAIRS, NAMELY, MONETARY INFORMATION, MANAGEMENT AND ANALYSIS SERVICES; REAL ESTATE AFFAIRS, NAMELY, LEASING OF REAL ESTATE; PROPERTY MANAGEMENT SERVICES, NAMELY, RENTAL PROPERTY MANAGEMENT, COMMERCIAL PROPERTY MANAGEMENT SERVICES; RENTAL PROPERTY PORTFOLIO MANAGEMENT; RENTAL OF REAL PROPERTY; ARRANGING LEASES FOR THE RENTAL OF REAL PROPERTY; LEASING OF RETAIL SPACE; LEASING OF RETAIL SPACE WITHIN SHOPPING CENTRES AND COMPLEXES AND WITHIN AIRPORTS; INVESTING FOR OTHERS IN REAL PROPERTY; REAL ESTATE BROKERAGE, MANAGEMENT AND APPRAISAL SERVICES; MANAGEMENT OF COMMERCIAL REAL PROPERTY AND REAL ESTATE; RENT COLLECTION SERVICES; ISSUE OF TOKENS OF VALUE, NAMELY, STORED VALUE GIFT VOUCHERS; ADVICE AND INFORMATION RELATING TO REAL PROPERTY; PROVISION, NAMELY, LEASING OF RETAIL SPACE; PROVISION, NAMELY, LEASING OF SPACE FOR RESTAURANT, CAFE, CINEMA, CRECHE, NURSERY, HEALTH CLUB, BEAUTY SALON AND BANKING SERVICES; INFORMATION, ADVISORY AND CONSULTANCY SERVICES RELATING TO THE AFORESAID (U.S. CLS. 100, 101 AND 102).

CLASS 39—TRANSPORTATION AND STORAGE

FOR TRANSPORT BY TRUCK, TRAIN AND AIR; PROVISION OF CAR PARKING FACILITIES; CAR PARKING; CAR VALET PARKING SERVICES; TRANSPORT OF GOODS; PACKING ARTICLES FOR TRANSPORTATION INCLUDING WITHIN COMMERCIAL CENTRES; STORAGE OF GOODS INCLUDING WITHIN COMMERCIAL CENTRES; FREIGHT DEPOT SERVICES, NAMELY, FREIGHT WAREHOUSING, LOADING AND FORWARDING INCLUDING WITHIN COMMERCIAL CENTRES; INFORMATION, CONSULTANCY AND ADVISORY SERVICES RELATING TO THE AFORESAID (U.S. CLS. 100 AND 105).

CLASS 42—SCIENTIFIC AND COMPUTER SERVICES

FOR INTERIOR DESIGN OF RETAIL OUTLETS, RETAIL SPACE, RETAIL UNITS AND SHOPPING CENTRES; ARCHITECTURAL CONSULTANCY SERVICES; ARCHITECTURAL DESIGN; DESIGN OF COMMERCIAL BUILDINGS FOR CONSTRUCTION; CONSULTATION SERVICES IN THE FIELD OF ARCHITECTURAL DESIGN AND DESIGN OF BUILDINGS FOR CONSTRUCTION (U.S. CLS. 100 AND 101).

KATHERINE CHANG, EXAMINING ATTORNEY

SN 85-233,536. MCARTHUR/GLEN EUROPE HOLDINGS LIMITED LLC, WILMINGTON, DE. FILED 2-3-2011.



OWNER OF ERPN CMNTY TM OFC REG. NO. 008158404, DATED 11-10-2009, EXPIRES 3-16-2019.

OWNER OF U.S. REG. NOS. 3,398,386, 3,930,741 AND OTHERS.

THE COLOR(S) BLUE AND RED IS/ARE CLAIMED AS A FEATURE OF THE MARK.

THE MARK CONSISTS OF A TILTED BLUE SQUARE WITH A RED RECTANGLE SHAPE AT THE BOTTOM OF THE SQUARE.

CLASS 35—ADVERTISING AND BUSINESS

FOR ADVERTISING SERVICES; BUSINESS MANAGEMENT AND BUSINESS ADMINISTRATION; PROVIDING OFFICE FUNCTIONS; BUSINESS MANAGEMENT AND ADMINISTRATION OF RETAIL OUTLETS; BUSINESS MANAGEMENT AND ADMINISTRATION OF RETAIL OUTLETS AND UNITS WITHIN AIRPORTS; BUSINESS MANAGEMENT OF SHOP UNITS, SHOPPING CENTRES AND SHOPPING MALLS; THE BRINGING TOGETHER FOR THE BENEFIT OF OTHERS, OF A VARIETY OF RETAIL OUTLETS, ENTERTAINMENT, RESTAURANT AND OTHER SERVICES, ENABLING CUSTOMERS TO CONVENIENTLY VIEW AND PURCHASE PERFUMERY, COSMETICS, PAINTS, TOOLS, APPARATUS FOR RECORDING, TRANSMISSION OR REPRODUCTION OF SOUND OR IMAGES, SPECTACLES, SUNGLASSES, PHOTOGRAPHIC CAMERAS AND EQUIPMENT, COMPUTERS, COMPUTER EQUIPMENT, TELEPHONES AND TELEPHONES APPARATUS, MOBILE PHONES, ELECTRONIC GAMES, HOUSEHOLD ELECTRICAL GOODS, SPORTING GOODS, PRECIOUS METALS, STONES AND JEWELLERY, WATCHES AND CLOCKS, CUFF LINKS, TIE CLIPS AND PINS, ORNAMENTS, KITCHEN UTENSILS, PENS, PENCILS, PAPER AND GOODS MADE FROM PAPER, PRINTED MATTER, PHOTOGRAPHS, STATIONERY, PICTURES, GOODS MADE OF LEATHER OR IMITATION LEATHER, LUGGAGE, UMBRELLAS, WALKING STICKS, BACKPACKS, FURNITURE, MIRRORS, FURNISHINGS, MATTRESSES AND BEDDING, CURTAINS, IRONMONGERY, GLASSWARE, PORCELAIN, EARTHENWARE, TEXTILES AND TEXTILE GOODS, BED AND TABLE COVERS, CLOTHING, FOOTWEAR, HEADGEAR, HABERDASHERY, CARPETS, RUGS, MATS, WALL HANGINGS, GAMES, PLAYTHINGS, GYMNASTIC ARTICLES, FOOD, BEVERAGES, CONFECTIONERY, FLOWERS AND PLANTS FROM SELECT SERVICE PROVIDERS IN A SHOPPING CENTRE OR MALL, WITHIN AIRPORTS, IN DEPARTMENT STORES OR ON INTERNET WEBSITES; PROVISION OF INFORMATION IN THE FIELD OF RETAIL OUTLETS AND RETAIL OPPORTUNITIES; BUSINESS MANAGEMENT ASSISTANCE AND BUSINESS MANAGEMENT CONSULTANCY SERVICES FOR RETAIL OUTLETS AND FOR COMMERCIAL ENTERPRISES, CENTRES AND COMPLEXES; BUSINESS AND COMMERCIAL ASSISTANCE IN THE EXPLOITATION OR THE MANAGEMENT OF RETAIL UNITS AND OF SHOPPING CENTRES AND COMPLEXES; BUSINESS CONSULTING SERVICES IN THE FIELD OF RETAIL SALE AND DISTRIBUTION OF PRODUCTS; BUSINESS CONSULTING SERVICES RELATING TO THE ORGANIZATIONAL OPTIMIZATION AND THE MANAGEMENT OF SHOPPING CENTRES AND RETAIL OUTLETS; ADVERTISING AND PROMOTIONAL SER-

VICES; BUSINESS RESEARCH; ADVERTISING AND PROMOTION OF COMMERCIAL BUILDINGS, NAMELY, SHOPPING CENTRES AND RETAIL OUTLETS; CONDUCTING INCENTIVE AWARD PROGRAMS TO PROMOTE THE FREQUENT SHOPPING AT SHOPPING CENTERS AND RETAIL OUTLETS; REAL ESTATE SALES MANAGEMENT (U.S. CLS. 100, 101 AND 102).

SN 85-233,588. MCARTHUR/GLEN EUROPE HOLDINGS LIMITED LLC, WILMINGTON, DE. FILED 2-3-2011.



CLASS 36—INSURANCE AND FINANCIAL

FOR FINANCIAL AFFAIRS, NAMELY, MANAGEMENT AND ANALYSIS SERVICES; MONETARY AFFAIRS, NAMELY, MONETARY INFORMATION, MANAGEMENT AND ANALYSIS SERVICES; REAL ESTATE AFFAIRS, NAMELY, LEASING OF REAL ESTATE; PROPERTY MANAGEMENT SERVICES, NAMELY, RENTAL PROPERTY MANAGEMENT, COMMERCIAL PROPERTY MANAGEMENT SERVICES; RENTAL PROPERTY PORTFOLIO MANAGEMENT; RENTAL OF REAL PROPERTY; ARRANGING LEASES FOR THE RENTAL OF REAL PROPERTY; LEASING OF RETAIL SPACE; LEASING OF RETAIL SPACE WITHIN SHOPPING CENTRES AND COMPLEXES AND WITHIN AIRPORTS; INVESTING FOR OTHERS IN REAL PROPERTY; REAL ESTATE BROKERAGE, MANAGEMENT AND APPRAISAL SERVICES; MANAGEMENT OF COMMERCIAL REAL PROPERTY AND REAL ESTATE; RENT COLLECTION SERVICES; ISSUE OF TOKENS OF VALUE, NAMELY, STORED VALUE GIFT VOUCHERS; ADVICE AND INFORMATION RELATING TO REAL PROPERTY; PROVISION, NAMELY, LEASING OF RETAIL SPACE; PROVISION, NAMELY, LEASING OF SPACE FOR RESTAURANT, CAFE, CINEMA, CRECHE, NURSERY, HEALTH CLUB, BEAUTY SALON AND BANKING SERVICES; INFORMATION, ADVISORY AND CONSULTANCY SERVICES RELATING TO THE AFORESAID (U.S. CLS. 100, 101 AND 102).

CLASS 39—TRANSPORTATION AND STORAGE

FOR TRANSPORT BY TRUCK, TRAIN AND AIR; PROVISION OF CAR PARKING FACILITIES; CAR PARKING; CAR VALET PARKING SERVICES; TRANSPORT OF GOODS; PACKING ARTICLES FOR TRANSPORTATION INCLUDING WITHIN COMMERCIAL CENTRES; STORAGE OF GOODS INCLUDING WITHIN COMMERCIAL CENTRES; FREIGHT DEPOT SERVICES, NAMELY, FREIGHT WAREHOUSING, LOADING AND FORWARDING INCLUDING WITHIN COMMERCIAL CENTRES; INFORMATION, CONSULTANCY AND ADVISORY SERVICES RELATING TO THE AFORESAID (U.S. CLS. 100 AND 105).

CLASS 42—SCIENTIFIC AND COMPUTER SERVICES

FOR INTERIOR DESIGN OF RETAIL OUTLETS, RETAIL SPACE, RETAIL UNITS AND SHOPPING CENTRES; ARCHITECTURAL CONSULTANCY SERVICES; ARCHITECTURAL DESIGN; DESIGN OF COMMERCIAL BUILDINGS FOR CONSTRUCTION; CONSULTANCY SERVICES IN THE FIELD OF ARCHITECTURAL DESIGN AND DESIGN OF BUILDINGS FOR CONSTRUCTION (U.S. CLS. 100 AND 101).

KATHERINE CHANG, EXAMINING ATTORNEY

OWNER OF ERPN CMNTY TM OFC REG. NO. 008158453, DATED 12-11-2009, EXPIRES 3-16-2019.

OWNER OF U.S. REG. NOS. 3,398,385, 3,934,008 AND OTHERS.

NO CLAIM IS MADE TO THE EXCLUSIVE RIGHT TO USE "DESIGNER OUTLET", APART FROM THE MARK AS SHOWN.

THE MARK CONSISTS OF THE WORDING "MCARTHUR GLEN" AT THE TOP OF A TILTED SQUARE WITH THE WORDING "DESIGNER OUTLET" IN A RECTANGLE SHAPE AT THE BOTTOM OF THE SQUARE.

CLASS 36—INSURANCE AND FINANCIAL

FOR FINANCIAL AFFAIRS, NAMELY, MANAGEMENT AND ANALYSIS SERVICES; MONETARY AFFAIRS, NAMELY, MONETARY INFORMATION, MANAGEMENT AND ANALYSIS SERVICES; REAL ESTATE AFFAIRS, NAMELY, LEASING OF REAL ESTATE; PROPERTY MANAGEMENT SERVICES, NAMELY, RENTAL PROPERTY MANAGEMENT; RENTAL PROPERTY PORTFOLIO MANAGEMENT; RENTAL OF REAL PROPERTY; ARRANGING LEASES FOR THE RENTAL OF PROPERTY; LEASING OF RETAIL SPACE; LEASING OF RETAIL SPACE WITHIN SHOPPING CENTRES AND COMPLEXES AND WITHIN AIRPORTS; INVESTING FOR OTHERS IN REAL PROPERTY; REAL ESTATE BROKERAGE, MANAGEMENT AND APPRAISAL SERVICES; MANAGEMENT OF COMMERCIAL REAL PROPERTY AND REAL ESTATE; RENT COLLECTION SERVICES; ISSUE OF TOKENS OF VALUE, NAMELY, STORED VALUE GIFT VOUCHERS; ADVICE AND INFORMATION RELATING TO REAL PROPERTY; PROVISION, NAMELY, LEASING OF RETAIL SPACE; PROVISION, NAMELY, LEASING OF SPACE FOR THE PROVISION OF SERVICES INCLUDING RESTAURANT, CAFE, CINEMA, CRECHE, NURSERY, HEALTH CLUB, BEAUTY SALON AND BANKING SERVICES; INFORMATION, ADVISORY AND CONSULTANCY SERVICES RELATING TO THE AFORESAID (U.S. CLS. 100, 101 AND 102).

CLASS 39—TRANSPORTATION AND STORAGE

FOR TRANSPORT BY TRUCK, TRAIN AND AIR; PACKAGING GOODS FOR TRANSPORTATION AND STORAGE OF GOODS; TRANSPORT OF GOODS INCLUDING WITHIN COMMERCIAL CENTRES; PACKING ARTICLES FOR TRANSPORTATION INCLUDING WITHIN COMMERCIAL CENTRES; STORAGE OF GOODS INCLUDING WITHIN COMMERCIAL CENTRES; FREIGHT DEPOT SERVICES, NAMELY, FREIGHT WAREHOUSING, LOADING AND FORWARDING INCLUDING WITHIN COMMERCIAL CENTRES; CONSULTING SERVICES AND CO-ORDINATION AS REGARDS DISTRIBUTION IN A CONTROLLED AND EFFECTIVE MANNER OF SURPLUS STOCKS OF QUALITY AND DELUXE BRANDS, NAMELY, DELIVERY OF LUXURY GOODS AND RELATED CONSULTING SERVICES; PROVISION OF CAR PARKING FACILITIES (U.S. CLS. 100 AND 105).

KATHERINE CHANG, EXAMINING ATTORNEY

SN 85-233,838. LUX DELUX, INC., SAN FRANCISCO, CA.
FILED 2-3-2011.

LUX DELUX

THE MARK CONSISTS OF STANDARD CHARACTERS WITHOUT CLAIM TO ANY PARTICULAR FONT, STYLE, SIZE, OR COLOR.

NO CLAIM IS MADE TO THE EXCLUSIVE RIGHT TO USE "DELUXE", APART FROM THE MARK AS SHOWN.

CLASS 35—ADVERTISING AND BUSINESS

FOR PROMOTING THE GOODS AND SERVICES OF OTHERS BY PROVIDING A SECURE, MEMBERS-ONLY WEBSITE FEATURING SPECIAL OFFERS, LIMITED ACCESS OPPORTUNITIES AND DISCOUNTS FOR THE GOODS AND SERVICES OF OTHERS (U.S. CLS. 100, 101 AND 102).

CLASS 42—SCIENTIFIC AND COMPUTER SERVICES

FOR PROVIDING A SECURED-ACCESS, MEMBERS ONLY WEB SITE FEATURING TECHNOLOGY THAT PROVIDES MEMBERS WITH THE ABILITY TO SEARCH FOR, VIEW, EVALUATE, AND PURCHASE OR RESERVE UNIQUE AND HIGHLY VALUED OR SOUGHT-AFTER EXPERIENCES, NAMELY, TICKETS, ACCESS PASSES OR GRANTS OF ENTRY TO THEATRICAL SHOWS, CONCERTS, FIGHTS, SPORTING EVENTS, TRAVEL AND LODGING DEALS, AND LIMITED ACCESS OPPORTUNITIES AT RESTAURANTS, NIGHT-CLUBS, HOTELS, RESORTS, SPAS, AND AMONG CELEBRITIES, UNIQUE PEOPLE, UNIQUE PLACES OR UNIQUE EVENTS; PROVIDING A WEB SITE THAT FEATURES TECHNOLOGY THAT ENABLES THE SECURE EXCHANGE OF INFORMATION BY USERS (U.S. CLS. 100 AND 101).

CLASS 45—PERSONAL AND LEGAL SERVICES

FOR ONLINE SOCIAL NETWORKING SERVICES (U.S. CLS. 100 AND 101).
EDWARD FENNESSY, EXAMINING ATTORNEY

SN 85-237,122. ASCENTIAL SERVICE CORPORATION, RACINE, WI. FILED 2-8-2011.

ASCENTIAL

THE MARK CONSISTS OF STANDARD CHARACTERS WITHOUT CLAIM TO ANY PARTICULAR FONT, STYLE, SIZE, OR COLOR.

CLASS 37—CONSTRUCTION AND REPAIR

FOR EMERGENCY REPAIR AND PLANNED MAINTENANCE OF PLUMBING FIXTURES, ELECTRICAL SYSTEMS, EMERGENCY GENERATORS, HEATING SYSTEMS, VENTILATION SYSTEMS, AIR CONDITIONING SYSTEMS, BOILERS, ENERGY MANAGEMENT SYSTEMS, REFRIGERATION SYSTEMS, APPLIANCES, FIRE SPRINKLER SYSTEMS, GLASS, DOORS AND LOCKS; CARPENTRY; GENERAL BUILDING REPAIRS AND MAINTENANCE; PARKING LOT REPAIR AND MAINTENANCE; INSTALLING FLOORING; PAINTING; PEST CONTROL; JANITORIAL SERVICES; INSTALLATION AND MAINTENANCE OF DIGITAL SIGNAGE AND AUDIO VISUAL PRODUCTS SOLD THEREWITH; ROOFING REPAIR; SNOW REMOVAL; TECHNICAL ADVICE RELATING TO ALL OF THE ABOVE, NAMELY, ASSESSMENT AND RECOMMENDATIONS FOR REPAIRS AND REPLACEMENTS; ALL PERFORMED BY EMPLOYEES AND THROUGH THE MANAGEMENT OF CONTRACTED SERVICE PROVIDERS (U.S. CLS. 100, 103 AND 106).

CLASS 42—SCIENTIFIC AND COMPUTER SERVICES

FOR FACILITIES MANAGEMENT SERVICES, AND DESIGNING PROGRAMS FOR FACILITIES MANAGEMENT AND REPAIR (U.S. CLS. 100 AND 101).

CLASS 44—MEDICAL, BEAUTY AND AGRICULTURAL SERVICES

FOR LANDSCAPE MAINTENANCE, GARDENING, GRASS CUTTING, AND WEEDING SERVICES (U.S. CLS. 100 AND 101).

GINA HAYES, EXAMINING ATTORNEY

SN 85-241,231. HERCULES PRODUCTS, INC., AVENTURA, FL. FILED 2-14-2011.

HERCULES CAR

THE MARK CONSISTS OF STANDARD CHARACTERS WITHOUT CLAIM TO ANY PARTICULAR FONT, STYLE, SIZE, OR COLOR.

NO CLAIM IS MADE TO THE EXCLUSIVE RIGHT TO USE "CAR", APART FROM THE MARK AS SHOWN.

CLASS 12—VEHICLES

FOR AUTOMOTIVE WINDSHIELD SHADE SCREENS; FITTED AUTOMOTIVE SEAT COVERS; WINDSHIELD WIPER BLADES FOR VEHICLES (U.S. CLS. 19, 21, 23, 31, 35 AND 44).

FIRST USE 5-2-2001; IN COMMERCE 5-2-2001.

CLASS 27—FLOOR COVERINGS

FOR FLOOR MATS FOR AUTOMOBILES (U.S. CLS. 19, 20, 37, 42 AND 50).

FIRST USE 5-2-2001; IN COMMERCE 5-2-2001.
IRA J. GOODSaid, EXAMINING ATTORNEY

SN 85-241,240. IVOCLAR VIVADENT, INC., AMHERST, NY.
FILED 2-14-2011.

SR PHONARES STYLE NHC

THE MARK CONSISTS OF STANDARD CHARACTERS WITHOUT CLAIM TO ANY PARTICULAR FONT, STYLE, SIZE, OR COLOR.

OWNER OF U.S. REG. NO. 3,782,800.
NO CLAIM IS MADE TO THE EXCLUSIVE RIGHT TO USE "SR" AND "NHC", APART FROM THE MARK AS SHOWN.

CLASS 5—PHARMACEUTICALS

FOR MATERIALS FOR USE IN DENTISTRY, NAMELY, MATERIALS FOR THE MANUFACTURE OF ARTIFICIAL TEETH (U.S. CLS. 6, 18, 44, 46, 51 AND 52).

CLASS 10—MEDICAL APPARATUS

FOR DENTAL PROSTHESIS; ARTIFICIAL TEETH, APPARATUS AND INSTRUMENTS FOR DENTAL TECHNOLOGY, NAMELY, ARTICULATORS, TOOTH CARDS, SHADE GUIDES (U.S. CLS. 26, 39 AND 44).
DEZMONA MIZELLE, EXAMINING ATTORNEY

SN 85-242,714. ABAKUS SOLAR AG, GELSENKIRCHEN, FED REP GERMANY, FILED 2-15-2011.

ABAKUS SOLAR

THE MARK CONSISTS OF STANDARD CHARACTERS WITHOUT CLAIM TO ANY PARTICULAR FONT, STYLE, SIZE, OR COLOR.

OWNER OF ERPN CMNTY TM OFC REG. NO. 007212831, DATED 4-15-2009, EXPIRES 9-4-2018.
NO CLAIM IS MADE TO THE EXCLUSIVE RIGHT TO USE "SOLAR", APART FROM THE MARK AS SHOWN.

CLASS 9—ELECTRICAL AND SCIENTIFIC APPARATUS

FOR SYSTEMS FOR THE CAPTURE AND CONVERSION OF SOLAR ENERGY INTO ELECTRIC POWER, COMPRISED OF PHOTOVOLTAIC CLADDING PANELS, AND APPARATUS, MODULES AND COMPONENTS INTERCONNECTION DEVICES, NAMELY, PHOTOVOLTAIC CELLS, PHOTOVOLTAIC MODULES, PHOTOVOLTAIC INVERTERS, PHOTOVOLTAIC ROOFING MEMBERS, INTER PANELS JUNCTION BOX (U.S. CLS. 21, 23, 26, 36 AND 38).

CLASS 19—NON-METALLIC BUILDING MATERIALS

FOR NON-METALLIC RIGID PIPES FOR BUILDINGS; ASPHALT, PITCH AND BITUMEN; NON-METALLIC TRANSPORTABLE BUILDINGS; MONUMENTS, NOT OF METAL (U.S. CLS. 1, 12, 33 AND 50).

CLASS 37—CONSTRUCTION AND REPAIR

FOR BUILDING CONSTRUCTION; REPAIR AND MAINTENANCE OF PHOTOVOLTAIC INSTALLATIONS (U.S. CLS. 100, 103 AND 106).

CLASS 42—SCIENTIFIC AND COMPUTER SERVICES

FOR SCIENTIFIC AND TECHNOLOGICAL SERVICES, NAMELY, SCIENTIFIC RESEARCH AND ANALYSIS IN THE FIELD OF REGENERATIVE ENERGIES, NAMELY, PHOTOVOLTAICS; DESIGN AND DEVELOPMENT OF COMPUTER HARDWARE AND SOFTWARE IN THE FIELD OF REGENERATIVE ENERGIES, NAMELY, PHOTOVOLTAICS (U.S. CLS. 100 AND 101).
GIANCARLO CASTRO, EXAMINING ATTORNEY

SN 85-248,284. 2ZC, LLC, LOS ANGELES, CA. FILED 2-22-2011.



THE MARK CONSISTS OF STANDARD CHARACTERS WITHOUT CLAIM TO ANY PARTICULAR FONT, STYLE, SIZE, OR COLOR.

CLASS 41—EDUCATION AND ENTERTAINMENT

FOR EDUCATIONAL AND ENTERTAINMENT SERVICES, NAMELY, PROVIDING A WEB SITE FEATURING NON-DOWNLOADABLE PHOTOGRAPHS, VIDEOS, AND ONLINE BLOGS CHRONICLING THE EXPERIENCES OF VOLUNTEERS AND MENTORS PARTICIPATING IN RECREATIONAL ACTIVITIES, LITERACY TRAINING, ART EVENTS, AND OTHER CULTURAL EXPERIENCES TO CHANGE THE LIVES OF OTHERS (U.S. CLS. 100, 101 AND 107).
FIRST USE 6-1-2010; IN COMMERCE 6-1-2010.

CLASS 42—SCIENTIFIC AND COMPUTER SERVICES

FOR PROVIDING A WEB SITE THAT GIVES COMPUTER USERS THE ABILITY TO UPLOAD, EXCHANGE AND SHARE PHOTOS, VIDEOS AND VIDEO LOGS FEATURING EDUCATIONAL AND CULTURAL ACTIVITIES CHRONICLING THE EXPERIENCES OF VOLUNTEERS AND MENTORS PARTICIPATING IN RECREATIONAL ACTIVITIES, LITERACY TRAINING, ART EVENTS, AND OTHER CULTURAL EXPERIENCES TO CHANGE THE LIVES OF OTHERS (U.S. CLS. 100 AND 101).
FIRST USE 6-1-2010; IN COMMERCE 6-1-2010.
MARK T. MULLEN, EXAMINING ATTORNEY

SN 85-248,500. GENOMIC HEALTH, INC., REDWOOD CITY, CA. FILED 2-22-2011.

NGDX

THE MARK CONSISTS OF STANDARD CHARACTERS WITHOUT CLAIM TO ANY PARTICULAR FONT, STYLE, SIZE, OR COLOR.

CLASS 42—SCIENTIFIC AND COMPUTER SERVICES

FOR PROVIDING LABORATORY RESEARCH SERVICES IN THE FIELD OF GENE EXPRESSION, NAMELY, CANCER BIOLOGY; PROVIDING MEDICAL TESTING SERVICES AND INFORMATION IN THE FIELD OF CANCER RESEARCH AND DISEASE CLASSIFICATION (U.S. CLS. 100 AND 101).

CLASS 44—MEDICAL, BEAUTY AND AGRICULTURAL SERVICES

FOR PROVIDING MEDICAL TESTING SERVICES AND INFORMATION FOR DIAGNOSTIC OR TREATMENT PURPOSES IN THE FIELD OF CANCER RESEARCH AND DISEASE CLASSIFICATION (U.S. CLS. 100 AND 101).

ZACHARY BELLO, EXAMINING ATTORNEY

SN 85-248,517. BODY & MIND BEVERAGES B.V., GRONINGEN, NETHERLANDS, FILED 2-22-2011.

CHILLCAT

THE MARK CONSISTS OF STANDARD CHARACTERS WITHOUT CLAIM TO ANY PARTICULAR FONT, STYLE, SIZE, OR COLOR.

PRIORITY CLAIMED UNDER SEC. 44(D) ON ERPNCMNTY TM OFC APPLICATION NO. 9330788, FILED 8-24-2010, REG. NO. 009330788, DATED 2-17-2012, EXPIRES 8-24-2020.

CLASS 30—STAPLE FOODS

FOR TEA, COCOA, EDIBLE ICES; SPICES; HERBAL FOOD BARS, NAMELY, GRAIN-BASED FOOD BARS FEATURING HERBS; COFFEE, TEA, HERBAL FOOD DRINKS, TEA-BASED DRINKS, HERB-BASED SNACK BARS; HERBAL SUBSTITUTES, NAMELY, HERBAL TEAS; HERBAL PREPARATIONS AND SUBSTANCES, NAMELY, HERBAL TEAS, DRIED HERBS; HERB-BASED FOOD BARS, PROCESSED GRAINS PREPARED WITH HERBS; HERBAL TEA-BASED BEVERAGES FOR NON-MEDICINAL PURPOSES (U.S. CL. 46).

CLASS 32—LIGHT BEVERAGES

FOR NON-ALCOHOLIC BEVERAGES, NAMELY, SOFT DRINKS; MINERAL AND AERATED WATERS; FRUIT DRINKS AND FRUIT JUICES; SYRUPS AND OTHER PREPARATIONS FOR MAKING SOFT DRINKS; LOW-CALORIE BEVERAGES, NAMELY, LOW-CALORIE SOFT DRINKS; HERBAL BEVERAGES, NAMELY, HERBAL SODA POPS; DRINKS, NAMELY, PURIFIED DRINKING WATER AND PURIFIED DRINKING WATER FLAVORED WITH NON-MEDICINAL HERBAL TEAS AND OTHER NON-MEDICINAL NATURAL INGREDIENTS/ADDITIVES; NON-ALCOHOLIC BEVERAGES, NAMELY, AERATED AND STILL DRINKS IN THE NATURE OF SOFT DRINKS (U.S. CLS. 45, 46 AND 48).

DEBRA LEE, EXAMINING ATTORNEY

SN 85-252,017. BOWTIE, INC., IRVINE, CA. FILED 2-25-2011.

BIRD CHANNEL

THE MARK CONSISTS OF STANDARD CHARACTERS WITHOUT CLAIM TO ANY PARTICULAR FONT, STYLE, SIZE, OR COLOR.
SEC. 2(F).

CLASS 35—ADVERTISING AND BUSINESS

FOR PROVIDING ONLINE BUSINESS DIRECTORIES FEATURING ANIMAL BREEDERS; PROMOTING THE GOODS AND SERVICES OF OTHERS THROUGH ONLINE ADVERTISEMENTS; PROVIDING ONLINE CLASSIFIED ADVERTISING SPACE; INFORMATION DISTRIBUTION SERVICES, NAMELY, PROVIDING CONSUMER PRODUCT INFORMATION VIA THE INTERNET, FEATURING ANIMAL-RELATED PRODUCTS AND SERVICES; PROVIDING A SEARCHABLE WEBSITE DATABASE FEATURING THE ANIMAL-RELATED CONSUMER PRODUCTS AND SERVICES OF OTHER VENDORS (U.S. CLS. 100, 101 AND 102).

FIRST USE 10-0-2006; IN COMMERCE 10-0-2006.

CLASS 38—COMMUNICATION

FOR PROVIDING ON-LINE FORUMS FOR TRANSMISSION OF MESSAGES AMONG COMPUTER USERS CONCERNING ANIMALS AND TOPICS OF GENERAL INTEREST; PROVIDING ON-LINE ELECTRONIC BULLETIN BOARDS FOR TRANSMISSION OF MESSAGES AMONG COMPUTER USERS CONCERNING ANIMALS AND TOPICS OF GENERAL INTEREST; TRANSMISSION OF SOUND, VIDEO AND INFORMATION (U.S. CLS. 100, 101 AND 104).

FIRST USE 10-0-2006; IN COMMERCE 10-0-2006.

CLASS 44—MEDICAL, BEAUTY AND AGRICULTURAL SERVICES

FOR PROVIDING INFORMATION IN THE FIELDS OF ANIMALS AND PET BREEDING, SELECTION OF THE ANIMALS AND PETS, GROOMING, HEALTH AND NUTRITION (U.S. CLS. 100 AND 101).

FIRST USE 10-0-2005; IN COMMERCE 10-0-2005.
NICHOLAS ALTREE, EXAMINING ATTORNEY

SN 85-252,048. BOWTIE, INC., IRVINE, CA. FILED 2-25-2011.

FISH CHANNEL

THE MARK CONSISTS OF STANDARD CHARACTERS WITHOUT CLAIM TO ANY PARTICULAR FONT, STYLE, SIZE, OR COLOR.
SEC. 2(F).

CLASS 35—ADVERTISING AND BUSINESS

FOR PROVIDING ONLINE BUSINESS DIRECTORIES FEATURING ANIMAL BREEDERS; PROMOTING THE GOODS AND SERVICES OF OTHERS THROUGH ONLINE ADVERTISEMENTS; PROVIDING ONLINE CLASSIFIED ADVERTISING SPACE; INFORMATION DISTRIBUTION SERVICES, NAMELY, PROVIDING CONSUMER PRODUCT INFORMATION VIA THE INTERNET, FEATURING ANIMAL-RELATED PRODUCTS AND SERVICES; PROVIDING A SEARCHABLE WEBSITE DATABASE FEATURING THE ANIMAL-RELATED CONSUMER PRODUCTS AND SERVICES OF OTHER VENDORS (U.S. CLS. 100, 101 AND 102).
FIRST USE 4-0-2007; IN COMMERCE 4-0-2007.

CLASS 38—COMMUNICATION

FOR PROVIDING ON-LINE FORUMS FOR TRANSMISSION OF MESSAGES AMONG COMPUTER USERS CONCERNING ANIMALS AND TOPICS OF GENERAL INTEREST; PROVIDING ON-LINE ELECTRONIC BULLETIN BOARDS FOR TRANSMISSION OF MESSAGES AMONG COMPUTER USERS CONCERNING ANIMALS AND TOPICS OF GENERAL INTEREST; TRANSMISSION OF SOUND, VIDEO AND INFORMATION (U.S. CLS. 100, 101 AND 104).
FIRST USE 4-0-2007; IN COMMERCE 4-0-2007.

CLASS 44—MEDICAL, BEAUTY AND AGRICULTURAL SERVICES

FOR PROVIDING INFORMATION IN THE FIELDS OF ANIMALS AND PET BREEDING, SELECTION OF THE ANIMALS AND PETS, GROOMING, HEALTH AND NUTRITION (U.S. CLS. 100 AND 101).
FIRST USE 1-0-2007; IN COMMERCE 1-0-2007.
NICHOLAS ALTREE, EXAMINING ATTORNEY

SN 85-253,910. LEVEL 3 COMMUNICATIONS, LLC, BROOMFIELD, CO. FILED 2-28-2011.

TO BE THE TRUSTED CONNECTION TO THE NETWORKED WORLD.

THE MARK CONSISTS OF STANDARD CHARACTERS WITHOUT CLAIM TO ANY PARTICULAR FONT, STYLE, SIZE, OR COLOR.

CLASS 38—COMMUNICATION

FOR TELECOMMUNICATIONS GATEWAY SERVICES; TELECOMMUNICATIONS SERVICES, NAMELY, LOCAL AND LONG DISTANCE TELEPHONE SERVICES, FACSIMILE, AND DATA TRANSMISSION SERVICES VIA A FIBER OPTIC NETWORK; PROVIDING MULTIPLE USER ACCESS TO A GLOBAL COMPUTER INFORMATION NETWORK; INTERNET AND CONTENT DELIVERY SERVICES, NAMELY, ELECTRONIC DELIVERY OF VIDEO, IMAGES, PHOTOGRAPHS, AUDIO, SOFTWARE AND OTHER MEDIA IN THE NATURE OF DOCUMENTS AND MUSIC, OVER A TELECOMMUNICATIONS NETWORK; ELECTRONIC TRANSMISSION, DELIVERY AND STREAMING OF DIGITAL MEDIA CONTENT FOR OR ON BEHALF OF OTHERS VIA THE INTERNET, INTRANETS, WIDE AREA NETWORKS, METROPOLITAN AREA NETWORKS, LOCAL AREA NETWORKS AND/OR LOCAL COMPUTER NETWORKS; PROVIDING THIRD PARTY USERS WITH ACCESS TO TELECOMMUNICATION INFRASTRUCTURE (U.S. CLS. 100, 101 AND 104).

CLASS 39—TRANSPORTATION AND STORAGE

FOR ELECTRONIC STORAGE OF MEDIA CONTENT (U.S. CLS. 100 AND 105).
ELLEN PERKINS, EXAMINING ATTORNEY

SN 85-261,048. AIRITY, INC., DALLAS, TX. FILED 3-8-2011.

AIRITY

THE MARK CONSISTS OF STANDARD CHARACTERS WITHOUT CLAIM TO ANY PARTICULAR FONT, STYLE, SIZE, OR COLOR.

CLASS 35—ADVERTISING AND BUSINESS

FOR PROVIDING ADVERTISING SERVICES AND BUSINESS DATABASE COMPILATIONS FEATURING INFORMATION PERTAINING TO ELECTRONIC WHITE SPACE TELECOMMUNICATIONS CHANNELS, CONNECTIONS AND NETWORKS (U.S. CLS. 100, 101 AND 102).

CLASS 38—COMMUNICATION

FOR PROVIDING ACCESS TO TELECOMMUNICATION NETWORKS FOR ALLOCATION OF WHITE SPACE CHANNEL CONNECTIVITY TO USERS, DEVICES AND SERVICE PROVIDERS (U.S. CLS. 100, 101 AND 104).

CLASS 42—SCIENTIFIC AND COMPUTER SERVICES

FOR TECHNICAL SUPPORT SERVICES FOR ADMINISTRATION OF DATABASE APPLICATIONS FOR ELECTRONIC WHITE SPACE TELECOMMUNICATIONS CONNECTIONS AND CHANNEL INFORMATION (U.S. CLS. 100 AND 101).
LESLIE RICHARDS, EXAMINING ATTORNEY

SN 85-262,545. JORDAN MCGRAW, BEVERLY HILLS, CA.
FILED 3-9-2011.

SN 85-263,611. OUR CHILDREN LA, PACIFIC PALISADES,
CA. FILED 3-10-2011.

OUR CHILDREN LA

STARS IN STEREO

THE MARK CONSISTS OF STANDARD CHARACTERS WITHOUT CLAIM TO ANY PARTICULAR FONT, STYLE, SIZE, OR COLOR.

CLASS 9—ELECTRICAL AND SCIENTIFIC APPARATUS

FOR MUSICAL SOUND RECORDINGS; MUSICAL VIDEO AND AUDIO RECORDINGS; PRERECORDED AUDIO AND VISUAL TAPES, PRERECORDED PHONOGRAPH RECORDS AND PRERECORDED COMPACT DISCS AND DVDS ALL FEATURING MUSIC (U.S. CLS. 21, 23, 26, 36 AND 38).

CLASS 16—PAPER GOODS AND PRINTED MATTER

FOR PRINTED MATTER FOR PUBLICITY AND PROMOTIONAL MATERIALS, NAMELY, POSTERS; STICKERS; POSTCARDS; MOUNTED AND UNMOUNTED PHOTOGRAPHS AND PHOTOGRAPHIC PRINTS; NEWSLETTERS IN THE FIELDS OF MUSIC AND ENTERTAINMENT; CALENDARS, DECALS; PRINTED CONCERT TICKETS; PRINTED BACKSTAGE PASSES; SOUVENIR PROGRAMS FOR MUSIC AND ENTERTAINMENT CONCERNING MUSIC EVENTS; BOOKS AND MAGAZINES ALL IN THE FIELD OF MUSIC AND ENTERTAINMENT (U.S. CLS. 2, 5, 22, 23, 29, 37, 38 AND 50).

CLASS 25—CLOTHING

FOR CLOTHING, NAMELY, SHIRTS, T-SHIRTS, HATS, CAPS, AND SWEATSHIRTS (U.S. CLS. 22 AND 39).

CLASS 41—EDUCATION AND ENTERTAINMENT

FOR ENTERTAINMENT SERVICES, NAMELY, LIVE PERFORMANCES AND APPEARANCES BY A VOCAL AND INSTRUMENTAL GROUP, AND LIVE PERFORMANCE AND APPEARANCES FEATURING PRERECORDED MUSIC BY A VOCAL AND INSTRUMENTAL GROUP; FAN CLUB SERVICES; PROVIDING A WEBSITE FEATURING ENTERTAINMENT INFORMATION, NAMELY, REVIEWS, ARTICLES, INTERVIEWS, MUSIC VIDEOS, MUSIC CHARTS, PERSONAL BIOGRAPHIES, DIARIES, INFORMATION ON MUSIC INSTRUMENTS, TOUR DATES, GAMES, TRIVIA, ACCESS TO MEMORABILIA, PHOTOGRAPHS, VIDEO CLIPS, AND AUDIO CLIPS, ALL AVAILABLE VIA A GLOBAL COMPUTER NETWORK (U.S. CLS. 100, 101 AND 107).

ELIZABETH KAJUBI, EXAMINING ATTORNEY

THE MARK CONSISTS OF STANDARD CHARACTERS WITHOUT CLAIM TO ANY PARTICULAR FONT, STYLE, SIZE, OR COLOR.

NO CLAIM IS MADE TO THE EXCLUSIVE RIGHT TO USE "LA", APART FROM THE MARK AS SHOWN.

CLASS 35—ADVERTISING AND BUSINESS

FOR INFORMATION SERVICES, NAMELY, PROVIDING A WEB SITE FEATURING INFORMATION FOR PROMOTING THE INTERESTS OF CHILDREN; INFORMATION SERVICES FOR LOBBYING, NAMELY, PROVIDING INFORMATION PROMOTING THE INTEREST OF CHILDREN IN THEIR FAMILY LIFE, EDUCATION, HEALTH, AND WELFARE IN THE FIELDS OF LEGISLATION AND REGULATION; PROVIDING INFORMATION IN THE FIELD OF PUBLIC ADVOCACY IN THE NATURE OF LEGISLATIVE AND GOVERNMENTAL ADVOCACY TO PROMOTE AWARENESS OF CHILDREN'S FAMILY, EDUCATION, HEALTH, AND WELFARE ISSUES; PROVIDING INFORMATION REGARDING DEMOGRAPHIC STUDIES AND CENSUS DATA PERTAINING TO CHILDREN FOR PROMOTING THE INTERESTS OF CHILDREN; PROVIDING ONLINE DIRECTORY INFORMATION SERVICES ALSO FEATURING HYPERLINKS TO OTHER WEBSITES FOR SERVICES PROVIDERS RELATED TO CHILDREN'S INTERESTS; PROVIDING PUBLIC POLICY INFORMATION IN THE NATURE OF PUBLIC POLICY RESEARCH, POLICY INFORMATION, AND POLICY PRACTICES THAT AFFECT CHILDREN; PROVIDING PUBLIC POLICY INFORMATION REGARDING SOCIO-ECONOMIC ISSUES OF CHILDREN; PROVIDING INFORMATION ABOUT PROMOTING PUBLIC AWARENESS OF CHARITABLE FOUNDATIONS PERTAINING TO CHILDREN (U.S. CLS. 100, 101 AND 102).

CLASS 36—INSURANCE AND FINANCIAL

FOR CHARITABLE FUNDRAISING SERVICES; PROVIDING INFORMATION ABOUT CHARITABLE FOUNDATIONS PROVIDING GRANTS FOR CHILDREN'S INTERESTS (U.S. CLS. 100, 101 AND 102).

MAYUR VAGHANI, EXAMINING ATTORNEY

SN 85-269,596. FLOATING UNIVERSITY, LLC, NEW YORK, NY. FILED 3-17-2011.

THE FLOATING UNIVERSITY

THE MARK CONSISTS OF STANDARD CHARACTERS WITHOUT CLAIM TO ANY PARTICULAR FONT, STYLE, SIZE, OR COLOR.

NO CLAIM IS MADE TO THE EXCLUSIVE RIGHT TO USE "UNIVERSITY", APART FROM THE MARK AS SHOWN.

CLASS 38—COMMUNICATION

FOR AUDIO AND VIDEO BROADCASTING SERVICES OVER THE INTERNET OR OTHER COMMUNICATIONS NETWORK, NAMELY, SHOWING, DISPLAYING AND ELECTRONICALLY TRANSMITTING INFORMATION, AUDIO, AND VIDEO CLIPS; STREAMING OF VIDEO MATERIAL ON THE INTERNET; PROVIDING ON-LINE CHAT ROOMS AND ELECTRONIC BULLETIN BOARDS FOR TRANSMISSION OF MESSAGES AMONG USERS IN THE FIELD OF GENERAL INTEREST; VIDEO BROADCASTING SERVICES OVER THE INTERNET FEATURING THE UPLOADED AND TAGGED VIDEOS OF OTHERS; CABLE RADIO BROADCASTING; CELLULAR TELEPHONE COMMUNICATION; RADIO BROADCASTING; TELEVISION BROADCASTING (U.S. CLS. 100, 101 AND 104).

CLASS 41—EDUCATION AND ENTERTAINMENT

FOR EDUCATION SERVICES, NAMELY, PROVIDING EDUCATIONAL INFORMATION IN THE ACADEMIC FIELDS OF POLITICS, SCIENCE, LINGUISTICS, PHILOSOPHY, COSMOLOGY, DEMOGRAPHY, EPISTEMOLOGY, STATISTICS, MEDICAL RESEARCH, MEDICINE, CURRENT EVENTS, ART, HISTORY, CELEBRITIES, BUSINESS, CULTURAL SUBJECT MATTER IN THE NATURE OF CULTURAL EVENTS, AND GENERAL INTEREST IN THE NATURE OF GOVERNMENT AND POLITICS AND DIPLOMACY, ALL FOR THE PURPOSE OF ACADEMIC STUDY; BLOGS FEATURING POLITICS, SCIENCE, LINGUISTICS, PHILOSOPHY, COSMOLOGY, DEMOGRAPHY, EPISTEMOLOGY, STATISTICS, MEDICAL RESEARCH, MEDICINE, CURRENT EVENTS, ART, HISTORY, CELEBRITIES, BUSINESS, CULTURAL SUBJECT MATTER IN THE NATURE OF CULTURAL EVENTS, AND GENERAL INTEREST IN THE NATURE OF GOVERNMENT AND POLITICS AND DIPLOMACY; PROVIDING AN INTERNET NEWS PORTAL FEATURING LINKS TO ARTICLES IN THE FIELD OF CURRENT EVENTS; EDUCATIONAL SERVICES, NAMELY, PROVIDING CLASSES, SEMINARS, WORKSHOPS, PRESENTATIONS IN THE FIELDS OF POLITICS, SCIENCE, LINGUISTICS, PHILOSOPHY, COSMOLOGY, DEMOGRAPHY, EPISTEMOLOGY, STATISTICS, MEDICAL RESEARCH, MEDICINE, CURRENT EVENTS, ART, HISTORY, CELEBRITIES, BUSINESS, CULTURAL SUBJECT MATTER IN THE NATURE OF CULTURAL EVENTS, AND GENERAL INTEREST IN THE NATURE OF GOVERNMENT AND POLITICS AND DIPLOMACY; EDUCATIONAL SERVICES, NAMELY, PROVIDING COURSES OF INSTRUCTION AT THE POST-SECONDARY LEVEL (U.S. CLS. 100, 101 AND 107).
TRACY WHITTAKER-BROWN, EXAMINING ATTORNEY

SN 85-269,834. WORLDPLAY (BARBADOS) INC., CALGARY, ALBERTA, CANADA, FILED 3-17-2011.

WORLDPLAY COMMUNICATIONS

THE MARK CONSISTS OF STANDARD CHARACTERS WITHOUT CLAIM TO ANY PARTICULAR FONT, STYLE, SIZE, OR COLOR.

PRIORITY CLAIMED UNDER SEC. 44(D) ON CANADA APPLICATION NO. 1515827, FILED 2-17-2011, REG. NO. TMA820,965, DATED 3-28-2012, EXPIRES 3-28-2027.

NO CLAIM IS MADE TO THE EXCLUSIVE RIGHT TO USE "COMMUNICATIONS", APART FROM THE MARK AS SHOWN.

CLASS 38—COMMUNICATION

FOR TELECOMMUNICATION SERVICES, NAMELY, DISTRIBUTION, TRANSMISSION AND BROADCASTING OF STANDARD AND HIGH-DEFINITION VIDEO PROGRAMMING; INTERACTIVE ELECTRONIC COMMUNICATION SERVICES, NAMELY, ELECTRONIC TRANSMISSION OF INFORMATION AND ENTERTAINMENT CONTENTS FEATURING MOVIES, SPORTS, TELEVISION PROGRAMS AND GAMES BY MEANS OF TELEVISION, SATELLITE, COMPUTER, TELEPHONE, AUDIO AND THE INTERNET TO ALLOW SOCIAL NETWORKING COMMUNICATION BETWEEN TWO PARTIES (U.S. CLS. 100, 101 AND 104).

CLASS 45—PERSONAL AND LEGAL SERVICES

FOR LICENSING TECHNOLOGY RELATING TO COMPRESSION, DISTRIBUTION, TRANSMISSION AND BROADCASTING OF AUDIO AND VIDEO PROGRAMMING (U.S. CLS. 100 AND 101).

JENNY PARK, EXAMINING ATTORNEY

SN 85-269,951. PIZZA HUT, INC., PLANO, TX. FILED 3-17-2011.



THE MARK CONSISTS OF A BROKEN SQUARE LINE ENDING WITH A PINE TREE AND CONTAINING THE STACKED TEXT "THE ECO BOX".

CLASS 29—MEATS AND PROCESSED FOODS

FOR COOKED AND PREPARED CHICKEN (U.S. CL. 46).

CLASS 30—STAPLE FOODS

FOR PIZZA; PREPARED PASTA ENTREES (U.S. CL. 46).

CLASS 39—TRANSPORTATION AND STORAGE

FOR PIZZA, COOKED PASTA AND COOKED CHICKEN DELIVERY SERVICES (U.S. CLS. 100 AND 105).

CLASS 43—HOTEL AND RESTAURANT SERVICES

FOR RESTAURANT SERVICES (U.S. CLS. 100 AND 101).

MICHAEL KEATING, EXAMINING ATTORNEY

SN 85-270,220. BRAND KNEW LLC, HAVERTOWN, PA. FILED 3-17-2011.



THE COLOR(S) AQUA BLUE, DARK BLUE AND WHITE IS/ARE CLAIMED AS A FEATURE OF THE MARK.

THE MARK CONSISTS OF THE WORDING BRAND KNEW IN WHITE LOWER CASE LETTERS IN AN OVAL SPEECH CLOUD OVERLAPPING A ROUNDED RECTANGULAR SPEECH CLOUD; SPEECH CLOUDS ARE DARK BLUE EXCEPT THE COLOR IS AQUA BLUE WHERE THE OVAL SPEECH CLOUD OVERLAPS THE ROUNDED RECTANGULAR SPEECH CLOUD.

CLASS 35—ADVERTISING AND BUSINESS

FOR MARKETING AND BRANDING SERVICES, NAMELY, PROVIDING SOCIAL STRUCTURE DEVELOPMENT FOR SOCIAL NETWORKING PROGRAMS, AUCTION PROGRAMS AND E-COMMERCE SOLUTIONS; CONSULTING, DEVELOPMENT, MANAGEMENT AND MARKETING OF BRANDS FOR BUSINESSES; DESIGN OF ADVERTISING BROCHURES, LOOK-BOOKS AND PRESS PACKETS FOR OTHERS (U.S. CLS. 100, 101 AND 102).

FIRST USE 11-20-2009; IN COMMERCE 11-20-2009.

CLASS 42—SCIENTIFIC AND COMPUTER SERVICES

FOR CREATION, DESIGN, DEVELOPMENT AND MAINTENANCE OF WEB SITES FOR THIRD PARTIES; CREATION OF BLOGS FOR OTHERS; SOFTWARE DESIGN AND DEVELOPMENT, NAMELY, MOBILE APPLICATION DEVELOPMENT, TABLET APPLICATION DEVELOPMENT; GRAPHIC ART DESIGN SERVICES, NAMELY, LOGO CONCEPT DESIGN; WEB PAGE DESIGN, NAMELY, SOCIAL NETWORK PAGE DESIGN AND SPLASH PAGE DESIGN (U.S. CLS. 100 AND 101).

FIRST USE 11-20-2009; IN COMMERCE 11-20-2009.

WILLIAM BRECKENFELD, EXAMINING ATTORNEY

SN 85-273,797. OPPTALK INC., PANAMA, PANAMA, FILED 3-22-2011.



PRIORITY CLAIMED UNDER SEC. 44(D) ON ERPNTY TM OFC APPLICATION NO. 9689852, FILED 1-27-2011, REG. NO. 9689852, DATED 12-2-2011, EXPIRES 1-27-2021.

THE COLOR(S) GREEN AND MAGENTA IS/ARE CLAIMED AS A FEATURE OF THE MARK.

THE MARK CONSISTS OF THE WORD "OPPTALK" IN GREEN FOLLOWED BY A MAGENTA RING AROUND A GREEN CIRCLE.

CLASS 9—ELECTRICAL AND SCIENTIFIC APPARATUS

FOR PORTABLE AND HANDHELD ELECTRONIC DEVICES FOR RECORDING, ORGANIZING, TRANSMITTING, MANIPULATING, AND REVIEWING TEXT, DATA, IMAGE, AND AUDIO FILES; APPARATUS FOR RECORDING, TRANSMISSION, PROCESSING AND REPRODUCTION OF SOUND, IMAGES OR DATA; BLANK ELECTRONIC STORAGE MEDIA; BLANK MAGNETIC DATA CARRIERS; BLANK DIGITAL STORAGE MEDIA; VIDEO AND COMPACT DISC PLAYERS; VIDEO AND COMPACT DISCS FEATURING AUDIO AND VIDEO FILES FEATURING MUSICAL AND VIDEO RECORDINGS IN FIELD OF ENTERTAINMENT AND EDUCATION; COMPUTER GAME SOFTWARE; COMPUTER MEMORY HARDWARE; SEMICONDUCTOR MEMORY UNITS; FLASH MEMORY CARD; MEMORIES FOR USE WITH COMPUTERS; MEMORY BOARDS; MEMORY EXPANSION MODULES; RAM (RANDOM ACCESS MEMORY) CARD; COMPUTER OPERATING PROGRAMS, RECORDED; COMPUTER PERIPHERAL DEVICES; COMPUTER SOFTWARE FOR DATABASE MANAGEMENT, UPLOADING AND DOWNLOADING OF AUDIO AND VIDEO FILES AND CONTENT SHARING; DOWNLOADABLE SOFTWARE FOR UPDATING INFORMATION STORED ON UNIT UPDATING FILES FOR OPERATING SOFTWARE, AUDIO AND VIDEO FILES AND CONTENT SHARING; DATA PROCESSORS; DEVICES USED TO OPTICALLY, DIGITALLY, AND ELECTRONICALLY DETECT PRE-PRINTED COLORS ON ANY TYPE OF MATERIAL, INCLUDING PAPER, GLASS, PLASTIC; ELECTRONIC TRANSLATORS; GAMES ADAPTED FOR USE WITH TELEVISION RECEIVERS; LABELS CARRYING MAGNETICALLY, OPTICALLY, OR ELECTRONICALLY RECORDED OR ENCODED INFORMATION; OPTICAL CHARACTER READERS; SCANNERS; SOUND RECORDING APPARATUS; SOUND REPRODUCTION APPARATUS; SOUND TRANSMITTING APPARATUS; VIDEO GAME CARTRIDGES; VIDEO RECORDERS (U.S. CLS. 21, 23, 26, 36 AND 38).

CLASS 16—PAPER GOODS AND PRINTED MATTER

FOR ATLASES; COMIC BOOKS; GEOGRAPHICAL MAPS; PICTURES; PORTRAITS; SONG BOOKS (U.S. CLS. 2, 5, 22, 23, 29, 37, 38 AND 50).

CLASS 28—TOYS AND SPORTING GOODS

FOR BOARD GAMES; DOLLS; ELECTRONIC EDUCATIONAL GAME MACHINES FOR CHILDREN; HANDHELD UNITS FOR PLAYING ELECTRONIC GAMES OTHER THAN THOSE ADAPTED FOR USE WITH AN EXTERNAL DISPLAY SCREEN OR MONITOR; ELECTRONIC EDUCATIONAL GAME UNITS FOR CHILDREN IN THE NATURE OF ELECTRONIC GAMES FOR TEACHING OF CHILDREN, ELECTRONIC EDUCATIONAL TOYS TO TEACH READING, MATHEMATICS, SCIENCE AND PRINTED INSTRUCTIONAL CARDS SOLD AS A UNIT THEREWITH; PLAYING CARDS; PLUSH TOYS; PUPPETS; PUZZLES (U.S. CLS. 22, 23, 38 AND 50).

CLASS 35—ADVERTISING AND BUSINESS

FOR ADVERTISING SERVICES; COMPILING OF INFORMATION INTO COMPUTER DATABASES; SYSTEMATIZATION OF DATA IN COMPUTER DATABASES; COMPILATION AND SYSTEMATIZATION OF INFORMATION INTO COMPUTER DATABASES; ON-LINE ADVERTISING ON A COMPUTER NETWORK; ORGANIZATION OF FAIRS FOR COMMERCIAL OR ADVERTISING PURPOSES; PRESENTATION OF GOODS ON COMMUNICATION MEDIA FOR RETAIL PURPOSES (U.S. CLS. 100, 101 AND 102).

CLASS 41—EDUCATION AND ENTERTAINMENT

FOR ENTERTAINMENT INFORMATION; ENTERTAINMENT SERVICES, NAMELY, PROVIDING ONLINE COMPUTER GAMES; PUBLICATION OF BOOKS; PUBLISHING OF ELECTRONIC PUBLICATIONS; PUBLICATION OF TEXTS, BOOKS, JOURNALS; RELIGIOUS INSTRUCTION SERVICES; RENTAL OF SOUND RECORDINGS; WRITING OF TEXTS OTHER THAN PUBLICITY TEXTS; TRANSLATION SERVICES; VIDEO TAPE EDITING (U.S. CLS. 100, 101 AND 107).

MELISSA VALLILLO, EXAMINING ATTORNEY

SN 85-273,817. OPPTALK INC., PANAMA, PANAMA, FILED 3-22-2011.

OPPTALK

THE MARK CONSISTS OF STANDARD CHARACTERS WITHOUT CLAIM TO ANY PARTICULAR FONT, STYLE, SIZE, OR COLOR.

PRIORITY CLAIMED UNDER SEC. 44(D) ON ERPNCMNTY TM OFC APPLICATION NO. 9689589, FILED 1-27-2011, REG. NO. 9689589, DATED 12-10-2011, EXPIRES 1-27-2021.

CLASS 9—ELECTRICAL AND SCIENTIFIC APPARATUS

FOR PORTABLE AND HANDHELD ELECTRONIC DEVICES FOR RECORDING, ORGANIZING, TRANSMITTING, MANIPULATING, AND REVIEWING TEXT, DATA, IMAGE, AND AUDIO FILES; APPARATUS FOR RECORDING, TRANSMISSION, PROCESSING AND REPRODUCTION OF SOUND, IMAGES OR DATA; BLANK ELECTRONIC STORAGE MEDIA; BLANK MAGNETIC DATA CARRIERS; BLANK DIGITAL STORAGE MEDIA; VIDEO AND COMPACT DISC PLAYERS; VIDEO AND COMPACT DISCS FEATURING AUDIO AND VIDEO FILES FEATURING MUSICAL AND VIDEO RECORDINGS IN THE FIELD OF ENTERTAINMENT AND EDUCATION; COMPUTER GAME SOFTWARE; COMPUTER MEMORY HARDWARE; SEMICONDUCTOR MEMORY UNITS; FLASH MEMORY CARD; MEMORIES FOR USE WITH COMPUTERS; MEMORY BOARDS; MEMORY EXPANSION MODULES; RAM (RANDOM ACCESS MEMORY) CARD; COMPUTER OPERATING PROGRAMS, RECORDED; COMPUTER PERIPHERAL DEVICES; COMPUTER SOFTWARE FOR DATABASE MANAGEMENT, UPLOADING AND DOWNLOADING OF AUDIO AND VIDEO FILES AND CONTENT SHARING; DOWNLOADABLE SOFTWARE FOR UPDATING INFORMATION STORED ON UNIT UPDATING FILES FOR OPERATING SOFTWARE, AUDIO AND VIDEO FILES AND CONTENT SHARING; DATA PROCESSORS; DEVICES USED TO OPTICALLY, DIGITALLY, AND ELECTRONICALLY DETECT PRE-PRINTED COLORS ON ANY TYPE OF MATERIAL, INCLUDING PAPER, GLASS, PLASTIC; ELECTRONIC TRANSLATORS; GAMES ADAPTED FOR USE WITH TELEVISION RECEIVERS; LABELS CARRYING MAGNETICALLY, OPTICALLY, OR ELECTRONICALLY RECORDED OR ENCODED INFORMATION; OPTICAL CHARACTER READERS; SCANNERS; SOUND RECORDING APPARATUS; SOUND REPRODUCTION APPARATUS; SOUND TRANSMITTING APPARATUS; VIDEO GAME CARTRIDGES; VIDEO RECORDERS (U.S. CLS. 21, 23, 26, 36 AND 38).

CLASS 16—PAPER GOODS AND PRINTED MATTER

FOR ATLASES; COMIC BOOKS; GEOGRAPHICAL MAPS; PICTURES; PORTRAITS; SONG BOOKS (U.S. CLS. 2, 5, 22, 23, 29, 37, 38 AND 50).

CLASS 28—TOYS AND SPORTING GOODS

FOR BOARD GAMES; DOLLS; ELECTRONIC EDUCATIONAL GAME MACHINES FOR CHILDREN; HANDHELD UNITS FOR PLAYING ELECTRONIC GAMES OTHER THAN THOSE ADAPTED FOR USE WITH AN EXTERNAL DISPLAY SCREEN OR MONITOR; ELECTRONIC EDUCATIONAL GAME UNITS FOR CHILDREN IN THE NATURE OF ELECTRONIC GAMES FOR TEACHING OF CHILDREN, ELECTRONIC EDUCATIONAL TOYS TO TEACH READING, MATHEMATICS, SCIENCE AND PRINTED INSTRUCTIONAL CARDS SOLD AS A UNIT THEREWITH; PLAYING CARDS; PLUSH TOYS; PUPPETS; PUZZLES (U.S. CLS. 22, 23, 38 AND 50).

CLASS 35—ADVERTISING AND BUSINESS

FOR ADVERTISING SERVICES; COMPILING OF INFORMATION INTO COMPUTER DATABASES; SYSTEMATIZATION OF DATA IN COMPUTER DATABASES; COMPILATION AND SYSTEMATIZATION OF INFORMATION INTO COMPUTER DATABASES; ON-LINE ADVERTISING ON A COMPUTER NETWORK; ORGANIZATION OF FAIRS FOR COMMERCIAL OR ADVERTISING PURPOSES; PRESENTATION OF GOODS ON COMMUNICATION MEDIA FOR RETAIL PURPOSES (U.S. CLS. 100, 101 AND 102).

CLASS 41—EDUCATION AND ENTERTAINMENT

FOR ENTERTAINMENT INFORMATION; ENTERTAINMENT SERVICES, NAMELY, PROVIDING ONLINE COMPUTER GAMES; PUBLICATION OF BOOKS; RELIGIOUS INSTRUCTION SERVICES; RENTAL OF SOUND RECORDINGS; VIDEO TAPE EDITING; PUBLICATION OF ONLINE, ELECTRONIC BOOKS; PUBLICATION OF ONLINE, ELECTRONIC TEXTS, BOOKS, JOURNALS; PUBLISHING OF ONLINE, ELECTRONIC PUBLICATIONS (U.S. CLS. 100, 101 AND 107).

MELISSA VALLILLO, EXAMINING ATTORNEY

SN 85-274,486. COUNTRY QUEEN FOODS LP, ONTARIO, CANADA, FILED 3-23-2011.



PRIORITY CLAIMED UNDER SEC. 44(D) ON CANADA APPLICATION NO. 1519425, FILED 3-16-2011, REG. NO. TMA819805, DATED 3-14-2012, EXPIRES 3-14-2027.

NO CLAIM IS MADE TO THE EXCLUSIVE RIGHT TO USE "ORIGINAL RECIPE" AND "SINCE 1978", APART FROM THE MARK AS SHOWN.

THE MARK CONSISTS OF THE WORDS "COUNTRY QUEEN" WITHIN A RECTANGLE, THE WORDS "ORIGINAL RECIPE" IN A SEMICIRCLE ABOVE THE RECTANGLE, AND THE WORDS "SINCE 1978" IN A SEMICIRCLE BENEATH THE RECTANGLE.

CLASS 29—MEATS AND PROCESSED FOODS

FOR EGGS, FROZEN FRIED EGGS AND FROZEN EGG OMELETS; FRESH CARTONED EGGS, HARD COOKED EGGS, CHOPPED FROZEN EGGS, WHOLE FROZEN EGGS, SCRAMBLED MIX EGGS, FROZEN EGG WHITES AND YOLKS; AND SALADS, EXCEPT MACARONI, PASTA, AND RICE SALADS (U.S. CL. 46).

CLASS 30—STAPLE FOODS

FOR MACARONI SALADS; PASTA SALADS; RICE SALADS (U.S. CL. 46).
WILLIAM ROSSMAN, EXAMINING ATTORNEY

SN 85-275,281. R.O.B.A. INTERACTIVE, LLC, MIAMI, FL.
FILED 3-24-2011.

ROBA

THE MARK CONSISTS OF STANDARD CHARACTERS WITHOUT CLAIM TO ANY PARTICULAR FONT, STYLE, SIZE, OR COLOR.

CLASS 9—ELECTRICAL AND SCIENTIFIC APPARATUS

FOR COMPUTER APPLICATION SOFTWARE FOR MOBILE PHONES, COMPUTERS, HANDHELD ELECTRONIC DEVICES, DEVICES THAT DISTRIBUTE AND DISPLAY TEXT, VIDEO AND AUDIO, SMARTPHONES, TABLETS, COMPUTERS AND DIGITAL CONTENT DISTRIBUTION SYSTEMS, NAMELY, SOFTWARE FOR MUSIC, MUSIC HISTORY, INTERVIEWS, MUSIC NEWS, CONCERT FOOTAGE, ARCHIVAL FOOTAGE, EDUCATIONAL ELEMENTS, NAMELY, TESTS, QUIZZES AND EDUCATIONAL GAMES, AND MUSIC-CREATION.; DIGITAL MEDIA, NAMELY, HARD DRIVES, FLASH DRIVES, DIGITAL CHIPS, DOWNLOADABLE SOFTWARE, STREAMING SOFTWARE, CLOUD-BASED SOFTWARE PRE-RECORDED DVDS, DOWNLOADABLE AUDIO AND VIDEO RECORDINGS, AND CDS PROMOTING AND FEATURING MUSIC, MUSIC HISTORY, INTERVIEWS, MUSIC NEWS, CONCERT FOOTAGE, ARCHIVAL FOOTAGE, EDUCATIONAL ELEMENTS, NAMELY, TESTS, QUIZZES AND EDUCATIONAL GAMES, AND MUSIC-CREATION.; PRE-RECORDED CDS, VIDEO TAPES, LASER DISKS AND DVDS FEATURING MUSIC, MUSIC HISTORY, INTERVIEWS, MUSIC NEWS, CONCERT FOOTAGE, ARCHIVAL FOOTAGE, EDUCATIONAL ELEMENTS, NAMELY, TESTS, QUIZZES AND EDUCATIONAL GAMES, AND MUSIC-CREATION (U.S. CLS. 21, 23, 26, 36 AND 38).

CLASS 35—ADVERTISING AND BUSINESS

FOR ADVERTISING AND MARKETING CONSULTANCY; ADVERTISING AND MARKETING SERVICES, NAMELY, PROMOTING THE GOODS AND SERVICES OF OTHERS; ADVERTISING, MARKETING AND PROMOTION SERVICES; CONSULTATION SERVICES, NAMELY, CREATIVE AND STRATEGIC CONSULTATION REGARDING DEVELOPMENT AND PRODUCTION OF MARKETING CAMPAIGNS FOR OTHERS; CONSULTING SERVICES IN THE FIELD OF INTERNET MARKETING; ENTERTAINMENT MARKETING SERVICES, NAMELY, MARKETING, PROMOTION AND ADVERTISING FOR INDEPENDENT RECORDING ARTISTS; ENTERTAINMENT MARKETING SERVICES, NAMELY, MARKETING, PROMOTION AND ADVERTISING FOR RECORDING AND PERFORMING ARTISTS (U.S. CLS. 100, 101 AND 102).

FIRST USE 9-21-2010; IN COMMERCE 10-31-2010.

CLASS 42—SCIENTIFIC AND COMPUTER SERVICES

FOR PROVIDING A WEBSITE ALLOWING USERS TO DOWNLOAD MUSIC AND MUSIC VIDEOS; PROVIDING A WEBSITE FEATURING NON-DOWNLOADABLE SOFTWARE FOR VIEWING MUSIC, MUSIC HISTORY, INTERVIEWS, MUSIC NEWS, CONCERT FOOTAGE, ARCHIVAL FOOTAGE, EDUCATIONAL ELEMENTS, NAMELY, TESTS, QUIZZES AND EDUCATIONAL GAMES, AND MUSIC-CREATION.; PROVIDING A WEBSITE FEATURING TECHNOLOGY THAT ENABLES USERS TO VIEW, RATE, REVIEW AND DISCUSS MUSIC, MUSIC HISTORY, INTERVIEWS, MUSIC NEWS, CONCERT FOOTAGE, ARCHIVAL FOOTAGE, EDUCATIONAL ELEMENTS, NAMELY, TESTS, QUIZZES AND EDUCATIONAL GAMES, AND MUSIC-CREATION (U.S. CLS. 100 AND 101).

FIRST USE 9-21-2010; IN COMMERCE 10-31-2010.
TIMOTHY FINNEGAN, EXAMINING ATTORNEY

SN 85-277,661. ORNISH, DEAN, SAUSALITO, CA. FILED 3-25-2011.

DR. ORNISH'S PROGRAM FOR REVERSING HEART DISEASE

THE MARK CONSISTS OF STANDARD CHARACTERS WITHOUT CLAIM TO ANY PARTICULAR FONT, STYLE, SIZE, OR COLOR.

NO CLAIM IS MADE TO THE EXCLUSIVE RIGHT TO USE "PROGRAM FOR REVERSING HEART DISEASE", APART FROM THE MARK AS SHOWN.

THE NAME(S), PORTRAIT(S), AND/OR SIGNATURE(S) SHOWN IN THE MARK IDENTIFIES "DR. ORNISH", WHOSE CONSENT(S) TO REGISTER IS MADE OF RECORD.

CLASS 5—PHARMACEUTICALS

FOR DIETARY SUPPLEMENTS, NUTRITIONAL SUPPLEMENTS; HERBAL SUPPLEMENTS; VITAMIN SUPPLEMENTS; MINERAL SUPPLEMENTS; DIETARY SUPPLEMENT DRINKS; NUTRITIONAL SUPPLEMENTS IN LIQUID, POWDER AND BAR FORM, DESIGNED TO HELP FULFILL DIETARY REQUIREMENTS, MEAL REPLACEMENT BARS; MEAL REPLACEMENT DRINKS; MEAL REPLACEMENT POWDERS; MEAL REPLACEMENT SHAKES; MEAL REPLACEMENT SNACKS, DIETARY FOOD SUPPLEMENTS USED FOR WEIGHT STABILIZATION, REDUCTION, AND MAINTENANCE; DIETARY AND NUTRITIONALLY FORTIFIED FOOD AND BEVERAGE PRODUCTS ADAPTED FOR MEDICINAL PURPOSES (U.S. CLS. 6, 18, 44, 46, 51 AND 52).

CLASS 9—ELECTRICAL AND SCIENTIFIC APPARATUS

FOR DOWNLOADABLE AUDIO FILES, VIDEO FILES, MULTIMEDIA FILES, WEBCASTS, AND PODCASTS FEATURING INFORMATION ON HEALTH, WELLNESS, LONGEVITY, WEIGHT LOSS, AND PREVENTION AND TREATMENT OF HEART DISEASE AND OTHER DISEASES THROUGH MANAGEMENT OF DIET, EXERCISE, AND LIFESTYLE; PRERECORDED MAGNETIC DATA MEDIA, NAMELY, CDS, DVDS, AND MAGNETIC DATA TAPES FEATURING INFORMATION ON HEALTH, WELLNESS, LONGEVITY, WEIGHT LOSS, AND PREVENTION AND TREATMENT OF HEART DISEASE AND OTHER DISEASES THROUGH MANAGEMENT OF DIET, EXERCISE, AND LIFESTYLE (U.S. CLS. 21, 23, 26, 36 AND 38).

CLASS 16—PAPER GOODS AND PRINTED MATTER

FOR A SERIES OF NON-FICTION BOOKS ABOUT DIET, HEALTH AND WELLNESS; A MAGAZINE COLUMN FEATURING INFORMATION ON HEALTH, WELLNESS, LONGEVITY, WEIGHT LOSS, AND PREVENTION AND TREATMENT OF HEART DISEASE AND OTHER DISEASES THROUGH MANAGEMENT OF DIET, EXERCISE, AND LIFESTYLE (U.S. CLS. 2, 5, 22, 23, 29, 37, 38 AND 50).

CLASS 29—MEATS AND PROCESSED FOODS

FOR MEATS, FISH, POULTRY, GAME, PRESERVED, DRIED AND COOKED FRUITS AND VEGETABLES; JELLIES, JAMS, EGGS, MILK AND OTHER DAIRY PRODUCTS EXCLUDING ICE CREAM, ICE MILK, AND FROZEN YOGURT, EDIBLE OILS AND FATS, MEAT, FISH, FRUIT AND VEGETABLE PRESERVES, PICKLES (U.S. CL. 46).

CLASS 30—STAPLE FOODS

FOR COFFEE, TEA, COCOA, COFFEE SUBSTITUTES, PREPARATIONS MADE FROM PROCESSED CEREALS, NAMELY, CEREAL BARS, CEREAL-BASED SNACK FOODS, BREAKFAST CEREALS, READY-TO-EAT CEREALS, BREAD, BISCUITS, CAKES, PASTRY AND CONFECTIONERY MADE OF SUGAR, EDIBLE ICES, MUSTARD, PEPPER, VINEGAR, SAUCES, SPICES; ICE CREAM, ICE MILK, AND FROZEN YOGURT (U.S. CL. 46).

CLASS 31—NATURAL AGRICULTURAL PRODUCTS

FOR OTHER AGRICULTURAL PRODUCTS, NAMELY, RAW NUTS, UNPROCESSED NUTS, UNPROCESSED EDIBLE SEEDS, FRESH FRUITS AND VEGETABLES (U.S. CLS. 1 AND 46).

CLASS 32—LIGHT BEVERAGES

FOR AERATED WATERS AND OTHER NONALCOHOLIC DRINKS, NAMELY, DRINKING WATER, BOTTLED WATER, COCONUT WATER, MINERAL WATER, FRUIT BEVERAGES, ISOTONIC BEVERAGES, VEGETABLE JUICE, AND BEVERAGES WITH TEA FLAVOR (U.S. CLS. 45, 46 AND 48).

CLASS 38—COMMUNICATION

FOR PROVIDING ONLINE FORUMS, MESSAGE BOARDS AND CHAT ROOMS VIA AN INTERACTIVE WEBSITE IN THE FIELDS OF WELLNESS, WEIGHT LOSS AND PREVENTION OF HEART DISEASE AND OTHER DISEASES (U.S. CLS. 100, 101 AND 104).

CLASS 41—EDUCATION AND ENTERTAINMENT

FOR PROVIDING ONLINE PUBLICATIONS, NAMELY, A MAGAZINE COLUMN FEATURING INFORMATION ON HEALTH, WELLNESS, LONGEVITY, WEIGHT LOSS, AND PREVENTION AND TREATMENT OF HEART DISEASE AND OTHER DISEASES THROUGH MANAGEMENT OF DIET, EXERCISE, AND LIFESTYLE; PROVIDING AN ONLINE JOURNAL IN THE NATURE OF A BLOG AND VIDEO BLOG VIA AN INTERACTIVE WEBSITE IN THE FIELDS OF WELLNESS, WEIGHT LOSS AND PREVENTION OF HEART DISEASE AND OTHER DISEASES (U.S. CLS. 100, 101 AND 107).

CLASS 42—SCIENTIFIC AND COMPUTER SERVICES

FOR PROVIDING AN INTERACTIVE WEBSITE, NAMELY, CREATING AN ON-LINE VIRTUAL COMMUNITY FOR REGISTERED USERS TO PARTICIPATE IN DISCUSSIONS, GET FEEDBACK FROM THEIR PEERS, FORM VIRTUAL COMMUNITIES, AND ENGAGE IN SOCIAL NETWORKING IN THE FIELDS OF WELLNESS, WEIGHT LOSS AND PREVENTION OF HEART DISEASE AND OTHER DISEASES (U.S. CLS. 100 AND 101).

CLASS 44—MEDICAL, BEAUTY AND AGRICULTURAL SERVICES

FOR HEALTH CARE SERVICES, NAMELY, PROGRAMS FOR WELLNESS, LONGEVITY, WEIGHT LOSS, AND PREVENTION AND TREATMENT OF HEART DISEASE AND OTHER DISEASES THROUGH MANAGEMENT OF DIET, EXERCISE, AND LIFESTYLE AND MATERIALS DISTRIBUTED THEREWITH; PROVIDING HEALTH INFORMATION ON HEALTH, WELLNESS, LONGEVITY, WEIGHT LOSS, AND PREVENTION AND TREATMENT OF DISEASES THROUGH MANAGEMENT OF DIET, EXERCISE, AND LIFESTYLE THROUGH ELECTRONIC, BROADCAST AND PRINT MEDIA; PROVIDING AN INTERACTIVE WEBSITE FEATURING HEALTH-RELATED INFORMATION IN THE FIELDS OF WELLNESS, WEIGHT LOSS AND PREVENTION OF HEART DISEASE AND OTHER DISEASES (U.S. CLS. 100 AND 101).

CLASS 45—PERSONAL AND LEGAL SERVICES

FOR PROVIDING AN INTERACTIVE SOCIAL NETWORKING WEBSITE IN THE FIELDS OF WELLNESS, WEIGHT LOSS AND PREVENTION OF HEART DISEASE AND OTHER DISEASES (U.S. CLS. 100 AND 101).
JENNIFER VASQUEZ, EXAMINING ATTORNEY

SN 85-279,871. WORLDPLAY (BARBADOS) INC., BRIDGETOWN, BARBADOS, FILED 3-29-2011.

WORLDPLAY.COM

THE MARK CONSISTS OF STANDARD CHARACTERS WITHOUT CLAIM TO ANY PARTICULAR FONT, STYLE, SIZE, OR COLOR.

PRIORITY CLAIMED UNDER SEC. 44(D) ON CANADA APPLICATION NO. 1498631, FILED 10-5-2010, REG. NO. TMA820,894, DATED 3-28-2012, EXPIRES 3-28-2022.

CLASS 9—ELECTRICAL AND SCIENTIFIC APPARATUS

FOR SET TOP BOXES (U.S. CLS. 21, 23, 26, 36 AND 38).

CLASS 38—COMMUNICATION

FOR TELECOMMUNICATION SERVICES, NAMELY, DISTRIBUTION, TRANSMISSION AND BROADCASTING OF STANDARD AND HIGH-DEFINITION VIDEO PROGRAMMING; INTERACTIVE ELECTRONIC COMMUNICATION SERVICES, NAMELY, ELECTRONIC TRANSMISSION OF INFORMATION AND ENTERTAINMENT CONTENTS FEATURING MOVIES, SPORTS, TELEVISION PROGRAMS AND GAMES BY MEANS OF TELEVISION, SATELLITE, COMPUTER, TELEPHONE, AUDIO AND THE INTERNET TO ALLOW SOCIAL NETWORKING COMMUNICATION BETWEEN TWO PARTIES (U.S. CLS. 100, 101 AND 104).

CLASS 45—PERSONAL AND LEGAL SERVICES

FOR LICENSING TECHNOLOGY RELATING TO DISTRIBUTION, TRANSMISSION AND BROADCASTING OF AUDIO AND VIDEO PROGRAMMING (U.S. CLS. 100 AND 101).

JENNY PARK, EXAMINING ATTORNEY

SN 85-280,294. CAREN FORBES & COMPANY, LLC, NEW CANAAN, CT. FILED 3-29-2011.



THE MARK CONSISTS OF TWO CURVED LINES REPRESENTING A STYLIZED REPRESENTATION OF THE LETTERS CF.

CLASS 18—LEATHER GOODS

FOR ALL-PURPOSE CARRYING BAGS; BACKPACKS; GYM BAGS; SPORTS BAGS; HANDBAGS; PURSES; CLUTCH BAGS; DUFFEL BAGS; SHOULDER BAGS; DIAPER BAGS; TOTE BAGS; SLING BAGS; MESSENGER BAGS; SACHELS; WALLET (U.S. CLS. 1, 2, 3, 22 AND 41).

FIRST USE 11-0-2009; IN COMMERCE 4-0-2010.

CLASS 25—CLOTHING

FOR CLOTHING, NAMELY, TOPS, T-SHIRTS, BOTTOMS, SHORTS, PANTS, HEADWEAR, FOOTWEAR, SHOES, SLEEPWEAR, UNDERWEAR, SWEATSHIRTS, SWEAT PANTS, SWEATERS, JACKETS, OUTERWEAR, NAMELY, PARKAS, COATS, WATER RESISTANT JACKETS AND COATS, CAPES, PONCHOS, WRAPS; GLOVES, BEACH WEAR, PULLOVERS, CAPS, HATS, BELTS, SOCKS, TIGHTS, SCARVES, TUNICS, SKIRTS, DRESSES (U.S. CLS. 22 AND 39).

FIRST USE 11-0-2009; IN COMMERCE 4-0-2010.
KAREN SEVERSON, EXAMINING ATTORNEY

SN 85-284,188. BOARD OF REGENTS, THE UNIVERSITY OF TEXAS SYSTEM, AUSTIN, TX. FILED 4-1-2011.

LHN

THE MARK CONSISTS OF STANDARD CHARACTERS WITHOUT CLAIM TO ANY PARTICULAR FONT, STYLE, SIZE, OR COLOR.

CLASS 9—ELECTRICAL AND SCIENTIFIC APPARATUS

FOR PRE-RECORDED AUDIO AND VIDEO RECORDINGS, DOWNLOADABLE COMPUTER GRAPHICS, DOWNLOADABLE TELEVISION PROGRAMS, AND DOWNLOADABLE AUDIO AND VIDEO RECORDINGS ALL FEATURING CONTENT IN THE FIELDS OF COLLEGIATE ATHLETICS, FINE ARTS AND ENTERTAINMENT PERFORMANCES, COLLEGIATE LIFE, SEMINARS AND LECTURES OF AN EDUCATIONAL NATURE AT THE UNDERGRADUATE, GRADUATE AND POST-GRADUATE LEVEL, AND OTHER COLLEGIATE EVENTS; DOWNLOADABLE COMPUTER WALLPAPER; COMPUTER APPLICATION SOFTWARE FOR MOBILE PHONES AND MOBILE DEVICES TO ENABLE USERS TO ACCESS LIVE AND PRE-RECORDED TELEVISION PROGRAMS AND AUDIO AND VIDEO RECORDINGS IN THE FIELDS OF COLLEGIATE ATHLETICS, FINE ART AND ENTERTAINMENT PERFORMANCES, COLLEGIATE LIFE, SEMINARS AND LECTURES OF AN EDUCATIONAL NATURE, AND OTHER COLLEGIATE EVENTS AND TO ACCESS PREVIEWS, REPLAYS, SPORTS-RELATED INFORMATION, CURRENT EVENT NEWS-RELATED INFORMATION, ENTERTAINMENT-RELATED INFORMATION, EDUCATION INFORMATION, AND INFORMATION IN THE FIELD OF TELEVISION AND AUDIO AND VIDEO ENTERTAINMENT, NAMELY, INFORMATION ON TELEVISION SCHEDULING, TELEVISION PREVIEWS AND TELEVISION REPLAYS, ALL ON THEIR MOBILE PHONES AND MOBILE DEVICES (U.S. CLS. 21, 23, 26, 36 AND 38).

CLASS 38—COMMUNICATION

FOR TRANSMISSION OF SOUND, VIDEO AND INFORMATION VIA WEBCAM FEEDS ON THE SUBJECT OF SPORTS, NEWS, EDUCATION AND ENTERTAINMENT, ALL TRANSMITTED VIA A GLOBAL COMPUTER NETWORK, AND THROUGH WIRELESS AND MOBILE DEVICES, AND THROUGH THE MEDIUM OF INTERACTIVE TELEVISION (U.S. CLS. 100, 101 AND 104).

CLASS 41—EDUCATION AND ENTERTAINMENT

FOR ENTERTAINMENT SERVICES, NAMELY, PRODUCTION AND DISTRIBUTION OF TELEVISION PROGRAMS; ENTERTAINMENT AND EDUCATION IN THE NATURE OF SCHEDULING OF PROGRAMS IN THE FIELDS OF COLLEGIATE ATHLETICS, FINE ART AND ENTERTAINMENT PERFORMANCES, COLLEGIATE LIFE, SEMINARS AND LECTURES OF AN EDUCATIONAL NATURE, AND OTHER COLLEGIATE EVENTS, ALL TRANSMITTED VIA A GLOBAL COMPUTER NETWORK, VIA WIRELESS AND MOBILE DEVICES, AND THROUGH THE MEDIUMS OF TELEVISION, INTERACTIVE TELEVISION, AND RADIO; ENTERTAINMENT AND EDUCATION IN THE NATURE OF PROGRAMS IN THE FIELDS OF COLLEGIATE ATHLETICS, FINE ART AND ENTERTAINMENT PERFORMANCES, COLLEGIATE LIFE, SEMINARS AND LECTURES OF AN EDUCATIONAL NATURE, AND OTHER COLLEGIATE EVENTS, ALL TRANSMITTED VIA A GLOBAL COMPUTER NETWORK, VIA WIRELESS AND MOBILE DEVICES, AND THROUGH THE MEDIUMS OF TELEVISION, INTER-

ACTIVE TELEVISION, AND RADIO; PRODUCTION AND DISTRIBUTION OF PROGRAMS FEATURING COLLEGIATE ATHLETICS, FINE ART AND ENTERTAINMENT PERFORMANCES, COLLEGIATE LIFE, SEMINARS AND LECTURES OF AN EDUCATIONAL NATURE, AND OTHER COLLEGIATE EVENTS, ALL PROGRAMS ABLE TO BE TRANSMITTED TO THE FINAL CONSUMER AFTER DISTRIBUTION VIA A GLOBAL COMPUTER NETWORK, VIA WIRELESS AND MOBILE DEVICES, AND THROUGH THE MEDIUMS OF TELEVISION, INTERACTIVE TELEVISION, AND RADIO; ENTERTAINMENT SERVICES, NAMELY, PROVIDING SPORTS-RELATED INFORMATION, PROVIDING CURRENT EVENT NEWS-RELATED INFORMATION, PROVIDING ENTERTAINMENT-RELATED INFORMATION, PROVIDING INFORMATION ABOUT EDUCATION, PROVIDING ENTERTAINMENT INFORMATION IN THE FIELD OF TELEVISION AND AUDIO AND VIDEO ENTERTAINMENT, NAMELY, INFORMATION ON TELEVISION SCHEDULING, TELEVISION PREVIEWS AND TELEVISION REPLAYS, ALL TRANSMITTED VIA A GLOBAL COMPUTER NETWORK, VIA WIRELESS AND MOBILE DEVICES, AND THROUGH THE MEDIUMS OF TELEVISION, INTERACTIVE TELEVISION, AND RADIO; PROVIDING SPORTS AND ENTERTAINMENT-RELATED COMPETITIONS AND CONTESTS, AND ENTERTAINMENT PRIZE GIVEAWAYS AND SWEEPSTAKE SERVICES, ALL TRANSMITTED VIA A GLOBAL COMPUTER NETWORK, VIA WIRELESS AND MOBILE DEVICES, AND THROUGH THE MEDIUMS OF TELEVISION, AND INTERACTIVE TELEVISION AND RADIO; PROVIDING ONLINE VIDEO GAMES VIA A GLOBAL COMPUTER NETWORK, VIA WIRELESS AND MOBILE DEVICES, AND THROUGH THE MEDIUM OF INTERACTIVE TELEVISION; PROVISION OF NON-DOWNLOADABLE SPORTS PROGRAMS IN THE NATURE OF SPORTS REPLAYS VIA VIDEO-ON-DEMAND SERVICE (U.S. CLS. 100, 101 AND 107).

DAVID C. REIHNER, EXAMINING ATTORNEY

CLASS 9—ELECTRICAL AND SCIENTIFIC APPARATUS

FOR PRE-RECORDED AUDIO AND VIDEO RECORDINGS, DOWNLOADABLE COMPUTER GRAPHICS, DOWNLOADABLE TELEVISION PROGRAMS, AND DOWNLOADABLE AUDIO AND VIDEO RECORDINGS ALL FEATURING CONTENT IN THE FIELDS OF COLLEGIATE ATHLETICS, FINE ARTS AND ENTERTAINMENT PERFORMANCES, COLLEGIATE LIFE, SEMINARS AND LECTURES OF AN EDUCATIONAL NATURE AT THE UNDERGRADUATE, GRADUATE AND POST-GRADUATE LEVEL, AND OTHER COLLEGIATE EVENTS; DOWNLOADABLE COMPUTER WALLPAPER; COMPUTER APPLICATION SOFTWARE FOR MOBILE PHONES AND MOBILE DEVICES TO ENABLE USERS TO ACCESS LIVE AND PRE-RECORDED TELEVISION PROGRAMS AND AUDIO AND VIDEO RECORDINGS IN THE FIELDS OF COLLEGIATE ATHLETICS, FINE ART AND ENTERTAINMENT PERFORMANCES, COLLEGIATE LIFE, SEMINARS AND LECTURES OF AN EDUCATIONAL NATURE, AND OTHER COLLEGIATE EVENTS AND TO ACCESS PREVIEWS, REPLAYS, SPORTS-RELATED INFORMATION, CURRENT EVENT NEWS-RELATED INFORMATION, ENTERTAINMENT-RELATED INFORMATION, EDUCATION INFORMATION, AND INFORMATION IN THE FIELD OF TELEVISION AND AUDIO AND VIDEO ENTERTAINMENT, NAMELY, INFORMATION ON TELEVISION SCHEDULING, TELEVISION PREVIEWS AND TELEVISION REPLAYS, ALL ON THEIR MOBILE PHONES AND MOBILE DEVICES (U.S. CLS. 21, 23, 26, 36 AND 38).

CLASS 38—COMMUNICATION

FOR TRANSMISSION OF SOUND, VIDEO AND INFORMATION VIA WEBCAM FEEDS ON THE SUBJECT OF SPORTS, NEWS, EDUCATION AND ENTERTAINMENT, ALL TRANSMITTED VIA A GLOBAL COMPUTER NETWORK, AND THROUGH WIRELESS AND MOBILE DEVICES, AND THROUGH THE MEDIUM OF INTERACTIVE TELEVISION (U.S. CLS. 100, 101 AND 104).

CLASS 41—EDUCATION AND ENTERTAINMENT

FOR ENTERTAINMENT SERVICES, NAMELY, PRODUCTION AND DISTRIBUTION OF TELEVISION PROGRAMS; ENTERTAINMENT AND EDUCATION IN THE NATURE OF SCHEDULING OF PROGRAMS IN THE FIELDS OF COLLEGIATE ATHLETICS, FINE ART AND ENTERTAINMENT PERFORMANCES, COLLEGIATE LIFE, SEMINARS AND LECTURES OF AN EDUCATIONAL NATURE, AND OTHER COLLEGIATE EVENTS, ALL TRANSMITTED VIA A GLOBAL COMPUTER NETWORK, VIA WIRELESS AND MOBILE DEVICES, AND THROUGH THE MEDIUMS OF TELEVISION, INTERACTIVE TELEVISION, AND RADIO; ENTERTAINMENT AND EDUCATION IN THE NATURE OF PROGRAMS IN THE FIELDS OF COLLEGIATE ATHLETICS, FINE ART AND ENTERTAINMENT PERFORMANCES, COLLEGIATE LIFE, SEMINARS AND LECTURES OF AN EDUCATIONAL NATURE, AND OTHER COLLEGIATE EVENTS, ALL TRANSMITTED VIA A GLOBAL COMPUTER NETWORK, VIA WIRELESS AND MOBILE DEVICES, AND THROUGH THE MEDIUMS OF TELEVISION, INTERACTIVE TELEVISION, AND RADIO; PRODUCTION AND DISTRIBUTION OF PROGRAMS FEATURING COLLEGIATE ATHLETICS, FINE ART AND ENTERTAINMENT PERFORMANCES, COLLEGIATE LIFE, SEMINARS AND LECTURES OF AN EDUCATIONAL NATURE, AND OTHER COLLEGIATE EVENTS, ALL PROGRAMS ABLE TO BE TRANSMITTED TO THE FINAL CONSUMER AFTER DISTRIBUTION VIA A GLOBAL COMPUTER NETWORK, VIA WIRELESS AND MOBILE DEVICES, AND THROUGH THE MEDIUMS OF TELEVISION, INTERACTIVE TELEVISION, AND RADIO; ENTERTAINMENT SERVICES, NAMELY, PROVIDING SPORTS-RELATED INFORMATION, PROVIDING CURRENT EVENT NEWS-RELATED INFORMATION, PROVIDING ENTERTAINMENT-RELATED INFORMATION, PROVIDING INFORMATION ABOUT EDUCATION, PROVIDING ENTERTAINMENT INFORMATION IN THE FIELD OF TELEVISION AND AUDIO

SN 85-284,198. BOARD OF REGENTS, THE UNIVERSITY OF TEXAS SYSTEM, AUSTIN, TX. FILED 4-1-2011.



THE MARK CONSISTS OF THE CAPITAL LETTERS "L", "H", AND "N", WITH A SILHOUETTE OF A LONGHORN HEAD SUPERIMPOSED OVER THE "H" AND THE "N".

AND VIDEO ENTERTAINMENT, NAMELY, INFORMATION ON TELEVISION SCHEDULING, TELEVISION PREVIEWS AND TELEVISION REPLAYS, ALL TRANSMITTED VIA A GLOBAL COMPUTER NETWORK, VIA WIRELESS AND MOBILE DEVICES, AND THROUGH THE MEDIUMS OF TELEVISION, INTERACTIVE TELEVISION, AND RADIO; PROVIDING SPORTS AND ENTERTAINMENT-RELATED COMPETITIONS AND CONTESTS, AND ENTERTAINMENT PRIZE GIVEAWAYS AND SWEEPSTAKE SERVICES, ALL TRANSMITTED VIA A GLOBAL COMPUTER NETWORK, VIA WIRELESS AND MOBILE DEVICES, AND THROUGH THE MEDIUMS OF TELEVISION, AND INTERACTIVE TELEVISION AND RADIO; PROVIDING ONLINE VIDEO GAMES VIA A GLOBAL COMPUTER NETWORK, VIA WIRELESS AND MOBILE DEVICES, AND THROUGH THE MEDIUM OF INTERACTIVE TELEVISION; PROVISION OF NON-DOWNLOADABLE SPORTS PROGRAMS IN THE NATURE OF SPORTS REPLAYS VIA VIDEO-ON-DEMAND SERVICE (U.S. CLS. 100, 101 AND 107).

DAVID C. REIHNER, EXAMINING ATTORNEY

SN 85-284,211. BOARD OF REGENTS, THE UNIVERSITY OF TEXAS SYSTEM, AUSTIN, TX. FILED 4-1-2011.



NO CLAIM IS MADE TO THE EXCLUSIVE RIGHT TO USE "NETWORK", APART FROM THE MARK AS SHOWN.

THE MARK CONSISTS OF A SILHOUETTE OF A LONGHORN HEAD APPEARING AGAINST A BACKGROUND OF A RECTANGLE VERTICALLY DIVIDED EQUALLY INTO TWO SMALLER RECTANGLES, WITH THE WORDS "LONGHORN NETWORK" APPEARING TO THE RIGHT, WITH "LONGHORN" APPEARING ABOVE "NETWORK".

CLASS 9—ELECTRICAL AND SCIENTIFIC APPARATUS

FOR PRE-RECORDED AUDIO AND VIDEO RECORDINGS, DOWNLOADABLE COMPUTER GRAPHICS, DOWNLOADABLE TELEVISION PROGRAMS, AND DOWNLOADABLE AUDIO AND VIDEO RECORDINGS ALL FEATURING CONTENT IN THE FIELDS OF COLLEGIATE ATHLETICS, FINE ARTS AND ENTERTAINMENT PERFORMANCES, COLLEGIATE LIFE, SEMINARS AND LECTURES OF AN EDUCATIONAL NATURE AT THE UNDERGRADUATE, GRADUATE AND POST-GRADUATE LEVEL, AND OTHER COLLEGIATE EVENTS; DOWNLOADABLE COMPUTER WALLPAPER; COMPUTER APPLICATION SOFTWARE FOR MOBILE PHONES AND MOBILE DEVICES TO ENABLE USERS TO ACCESS LIVE AND PRE-RECORDED TELEVISION PROGRAMS AND AUDIO AND VIDEO RECORDINGS IN THE FIELDS OF COLLEGIATE ATHLETICS, FINE ART AND ENTERTAINMENT PERFORMANCES, COLLEGIATE LIFE, SEMINARS AND LECTURES OF AN EDUCATIONAL NATURE, AND OTHER COLLEGIATE EVENTS AND TO ACCESS PREVIEWS, REPLAYS, SPORTS-RELATED INFORMATION, CURRENT EVENT NEWS-RELATED INFORMATION, ENTERTAINMENT-RELATED INFORMATION, EDUCATION INFORMATION, AND INFORMATION IN THE FIELD OF TELEVISION AND AUDIO AND VIDEO ENTERTAINMENT, NAMELY, INFORMATION ON TELEVISION SCHEDULING, TELEVISION PREVIEWS AND TELEVISION REPLAYS, ALL ON THEIR MOBILE PHONES AND MOBILE DEVICES (U.S. CLS. 21, 23, 26, 36 AND 38).

CLASS 38—COMMUNICATION

FOR TRANSMISSION OF SOUND, VIDEO AND INFORMATION VIA WEBCAM FEEDS ON THE SUBJECT OF SPORTS, NEWS, EDUCATION AND ENTERTAINMENT, ALL TRANSMITTED VIA A GLOBAL COMPUTER NETWORK, AND THROUGH WIRELESS AND MOBILE DEVICES, AND THROUGH THE MEDIUM OF INTERACTIVE TELEVISION (U.S. CLS. 100, 101 AND 104).

CLASS 41—EDUCATION AND ENTERTAINMENT

FOR ENTERTAINMENT SERVICES, NAMELY, PRODUCTION AND DISTRIBUTION OF TELEVISION PROGRAMS; ENTERTAINMENT AND EDUCATION IN THE NATURE OF SCHEDULING OF PROGRAMS IN THE FIELDS OF COLLEGIATE ATHLETICS, FINE ART AND ENTERTAINMENT PERFORMANCES, COLLEGIATE LIFE, SEMINARS AND LECTURES OF AN EDUCATIONAL NATURE, AND OTHER COLLEGIATE EVENTS, ALL TRANSMITTED VIA A GLOBAL COMPUTER NETWORK, VIA WIRELESS AND MOBILE DEVICES, AND THROUGH THE MEDIUMS OF TELEVISION, INTERACTIVE TELEVISION, AND RADIO; ENTERTAINMENT AND EDUCATION IN THE NATURE OF PROGRAMS IN THE FIELDS OF COLLEGIATE ATHLETICS, FINE ART AND ENTERTAINMENT PERFORMANCES, COLLEGIATE LIFE, SEMINARS AND LECTURES OF AN EDUCATIONAL NATURE, AND OTHER COLLEGIATE EVENTS, ALL TRANSMITTED VIA A GLOBAL COMPUTER NETWORK, VIA WIRELESS AND MOBILE DEVICES, AND THROUGH THE MEDIUMS OF TELEVISION, INTERACTIVE TELEVISION, AND RADIO; PRODUCTION AND DISTRIBUTION OF PROGRAMS FEATURING COLLEGIATE ATHLETICS, FINE ART AND ENTERTAINMENT PERFORMANCES, COLLEGIATE LIFE, SEMINARS AND LECTURES OF AN EDUCATIONAL NATURE, AND OTHER COLLEGIATE EVENTS, ALL PROGRAMS ABLE TO BE TRANSMITTED TO THE FINAL CONSUMER AFTER DISTRIBUTION VIA A GLOBAL COMPUTER NETWORK, VIA WIRELESS AND MOBILE DEVICES, AND THROUGH THE MEDIUMS OF TELEVISION, INTERACTIVE TELEVISION, AND RADIO; ENTERTAINMENT SERVICES, NAMELY, PROVIDING SPORTS-RELATED INFORMATION, PROVIDING CURRENT EVENT NEWS-RELATED INFORMATION, PROVIDING ENTERTAINMENT-RELATED INFORMATION, PROVIDING INFORMATION ABOUT EDUCATION, PROVIDING ENTERTAINMENT INFORMATION IN THE FIELD OF TELEVISION AND AUDIO AND VIDEO ENTERTAINMENT, NAMELY, INFORMATION ON TELEVISION SCHEDULING, TELEVISION PREVIEWS AND TELEVISION REPLAYS, ALL TRANSMITTED VIA A GLOBAL COMPUTER NETWORK, VIA WIRELESS AND MOBILE DEVICES, AND THROUGH THE MEDIUMS OF TELEVISION, INTERACTIVE TELEVISION, AND RADIO; PROVIDING SPORTS AND ENTERTAINMENT-RELATED COMPETITIONS AND CONTESTS, AND ENTERTAINMENT PRIZE GIVEAWAYS AND SWEEPSTAKE SERVICES, ALL TRANSMITTED VIA A GLOBAL COMPUTER NETWORK, VIA WIRELESS AND MOBILE DEVICES, AND THROUGH THE MEDIUMS OF TELEVISION, AND INTERACTIVE TELEVISION AND RADIO; PROVIDING ONLINE VIDEO GAMES VIA A GLOBAL COMPUTER NETWORK, VIA WIRELESS AND MOBILE DEVICES, AND THROUGH THE MEDIUM OF INTERACTIVE TELEVISION; PROVISION OF NON-DOWNLOADABLE SPORTS PROGRAMS IN THE NATURE OF SPORTS REPLAYS VIA VIDEO-ON-DEMAND SERVICE (U.S. CLS. 100, 101 AND 107).

DAVID C. REIHNER, EXAMINING ATTORNEY

SN 85-285,662. HEBELER CORPORATION, TONAWANDA, NY. FILED 4-4-2011.

HIGH ENERGY LNG

THE MARK CONSISTS OF STANDARD CHARACTERS WITHOUT CLAIM TO ANY PARTICULAR FONT, STYLE, SIZE, OR COLOR.

NO CLAIM IS MADE TO THE EXCLUSIVE RIGHT TO USE "LNG", APART FROM THE MARK AS SHOWN.

CLASS 6—METAL GOODS

FOR LIQUEFIED NATURAL GAS STORAGE AND DISPENSING EQUIPMENT AND COMPONENTS, NAMELY, METAL STORAGE TANKS, LIQUEFACTION TANKS OF METAL (U.S. CLS. 2, 12, 13, 14, 23, 25 AND 50).

CLASS 7—MACHINERY

FOR LIQUEFIED NATURAL GAS STORAGE AND DISPENSING EQUIPMENT AND COMPONENTS, NAMELY, NATURAL GAS DIVERTERS CONSISTING OF A PUMP, STORAGE AND REFILLING TANK, PRE-HEATER, VAPORIZER, RECUPERATOR, CONDENSER AND VALVES (U.S. CLS. 13, 19, 21, 23, 31, 34 AND 35).

CLASS 9—ELECTRICAL AND SCIENTIFIC APPARATUS

FOR LIQUEFIED NATURAL GAS STORAGE AND DISPENSING EQUIPMENT AND COMPONENTS, NAMELY, METERED LIQUEFIED NATURAL GAS PUMPS (U.S. CLS. 21, 23, 26, 36 AND 38).

ROSELLE HERRERA, EXAMINING ATTORNEY

SN 85-285,753. WILDERNESS ATHLETE, SCOTTSDALE, AZ. FILED 4-4-2011.

Wilderness Athlete

THE MARK CONSISTS OF STANDARD CHARACTERS WITHOUT CLAIM TO ANY PARTICULAR FONT, STYLE, SIZE, OR COLOR.

OWNER OF U.S. REG. NO. 3,446,531.

NO CLAIM IS MADE TO THE EXCLUSIVE RIGHT TO USE "ATHLETE" IN INTERNATIONAL CLASSES 016, 025, 035 AND 041, APART FROM THE MARK AS SHOWN.

CLASS 5—PHARMACEUTICALS

FOR FEED SUPPLEMENTS FOR ANIMALS (U.S. CLS. 6, 18, 44, 46, 51 AND 52).

CLASS 16—PAPER GOODS AND PRINTED MATTER

FOR MAGAZINES FEATURING INFORMATION ON THE OUTDOORS, NAMELY HUNTING, FISHING, CAMPING AND FITNESS (U.S. CLS. 2, 5, 22, 23, 29, 37, 38 AND 50).

CLASS 25—CLOTHING

FOR ATHLETIC APPAREL, NAMELY, SHIRTS, PANTS, JACKETS, FOOTWEAR, HATS AND CAPS, ATHLETIC UNIFORMS (U.S. CLS. 22 AND 39).
FIRST USE 1-1-2010; IN COMMERCE 1-1-2010.

CLASS 35—ADVERTISING AND BUSINESS

FOR RETAIL STORE AND ON-LINE RETAIL STORE SERVICES FEATURING OUTDOOR SUPPLIES FOR HUNTING, FISHING, CAMPING, AND CLOTHING, NAMELY, HEADWEAR, FOOTWEAR, SHIRTS AND PANTS (U.S. CLS. 100, 101 AND 102).

FIRST USE 1-1-2010; IN COMMERCE 1-1-2010.

CLASS 41—EDUCATION AND ENTERTAINMENT

FOR EDUCATION SERVICES, NAMELY, PROVIDING CLASSES, SEMINARS IN THE FIELDS OF OUTDOOR FITNESS FOR HUNTING, FISHING, AND CAMPING (U.S. CLS. 100, 101 AND 107).

MAYUR VAGHANI, EXAMINING ATTORNEY

SN 85-288,073. MOUSER ELECTRONICS, INC., MANSFIELD, TX. FILED 4-6-2011.

WHAT'S NEXT

THE MARK CONSISTS OF STANDARD CHARACTERS WITHOUT CLAIM TO ANY PARTICULAR FONT, STYLE, SIZE, OR COLOR.

CLASS 9—ELECTRICAL AND SCIENTIFIC APPARATUS

FOR ELECTRONIC COMPONENTS, NAMELY, ANTENNAS, BATTERIES, BATTERY CLIPS, BATTERY HOLDERS, BATTERY SNAPS, ELECTRIC BUZZERS, ELECTRICAL CABLES, CAPACITORS, ELECTRICAL CIRCUIT BOARDS, ELECTRICAL CLIPS ADAPTED FOR USE IN HOLDING ELECTRICAL CABLES AND WIRES AND FOR SECURING ELECTRONIC COMPONENTS IN PLACE, COILS, RADIO FREQUENCY AND AUDIO FREQUENCY CHOKES, ELECTRICAL CONNECTORS AND SOCKETS, EARPHONES, FUSES, FUSE BLOCKS, FUSE CLIPS, FUSE HOLDERS, ELECTRICAL HEAT SINKS, ELECTRICAL INSTRUMENT ENCLOSURE CASES, ELECTRICAL VARIABLE DIAL KNOBS, ELECTRICAL METERS, MICROPHONES, POTENTIOMETERS, ELECTRICAL RELAYS, RESISTORS, SEMICONDUCTORS, ELECTRONIC SIRENS, AUDIO SPEAKERS, ELECTRICAL SWITCHES, TERMINAL BOARDS, TRANSFORMERS, AND ELECTRICAL WIRES (U.S. CLS. 21, 23, 26, 36 AND 38).

CLASS 35—ADVERTISING AND BUSINESS

FOR CATALOG ORDERING SERVICE FEATURING SEMICONDUCTOR ELECTRONIC COMPONENTS; ELECTRONIC CATALOG SERVICES FEATURING SEMICONDUCTOR ELECTRONIC COMPONENTS; ELECTRONIC COMMERCE SERVICES, NAMELY, PROVIDING INFORMATION ABOUT PRODUCTS VIA TELECOMMUNICATION NETWORKS FOR ADVERTISING AND SALES PURPOSES; MAIL ORDER CATALOG SERVICES FEATURING SEMICONDUCTOR ELECTRONIC COMPONENTS (U.S. CLS. 100, 101 AND 102).

JEFFREY LOOK, EXAMINING ATTORNEY

SN 85-289,018. HICKENBOTTOM, MICHAEL, CARLSBAD, CA. FILED 4-7-2011.

THE SHOWSTOPPER

THE MARK CONSISTS OF STANDARD CHARACTERS WITHOUT CLAIM TO ANY PARTICULAR FONT, STYLE, SIZE, OR COLOR.

"THE SHOWSTOPPER" IDENTIFIES THE PSEUDONYM/STAGE NAME/NICKNAME OF MICHAEL HICKENBOTTOM, A LIVING INDIVIDUAL WHOSE CONSENT IS OF RECORD.

CLASS 9—ELECTRICAL AND SCIENTIFIC APPARATUS

FOR DIGITAL VIDEO DISCS AND DIGITAL VERSATILE DISCS ALL FEATURING SPORTS (U.S. CLS. 21, 23, 26, 36 AND 38).

CLASS 25—CLOTHING

FOR WEARING APPAREL, NAMELY, WARM-UP SUITS, SWEATSHIRTS, TEE-SHIRTS; MUSCLE SHIRTS; SPORTS SHIRTS; TANK TOPS; BATHING SUITS; BEACH WEAR; JOGGING SUITS; SHORTS; SHIRTS; GLOVES; UNDERWEAR; JERSEYS; HEADWEAR; FOOTWEAR, BELTS, SOCKS, HATS; CAPS; HUNTING APPAREL, NAMELY, HUNTING JACKETS, HUNTING PANTS, HUNTING SHIRTS, AND HUNTING VESTS; WORKOUT AND SPORTS APPAREL, NAMELY, SHORTS AND SHIRTS (U.S. CLS. 22 AND 39).

CLASS 28—TOYS AND SPORTING GOODS

FOR WRESTLING GLOVES; BOXING GLOVES, SPORTS FACE MASKS FOR FOOTBALL (U.S. CLS. 22, 23, 38 AND 50).

COLLEEN DOMBROW, EXAMINING ATTORNEY

SN 85-292,449. GRANT THORNTON LLP, CHICAGO, IL. FILED 4-12-2011.

EXPEDITIONGRC

THE MARK CONSISTS OF STANDARD CHARACTERS WITHOUT CLAIM TO ANY PARTICULAR FONT, STYLE, SIZE, OR COLOR.

CLASS 9—ELECTRICAL AND SCIENTIFIC APPARATUS

FOR COMPUTER SOFTWARE FOR ASSIGNING, TRACKING, AND VIEWING WORK STEPS, GENERATING REPORTS, DEVELOPING AUDIT PLANS, MAINTAINING AN ONLINE LIBRARY OF CONTROLS, PROCESSES, AND WORK STEPS, BUDGETING AND EXPENSE TRACKING, CREATION, MONITORING AND REPORTING OF ACTION ITEMS, AND DATABASE MANAGEMENT, ALL OF THE AFORESAID IN PROVIDING BUSINESS AUDITING, ACCOUNTING AND COMPLIANCE SERVICES AND MANAGING SYSTEMS OF INTERNAL CONTROLS FOR FINANCIAL REPORTING (U.S. CLS. 21, 23, 26, 36 AND 38).

CLASS 42—SCIENTIFIC AND COMPUTER SERVICES

FOR SOFTWARE AS A SERVICE, NAMELY, NON-DOWNLOADABLE SOFTWARE FOR ASSIGNING, TRACKING, AND VIEWING WORK STEPS, GENERATING REPORTS, DEVELOPING AUDIT PLANS, MAINTAINING AN ONLINE LIBRARY OF CONTROLS, PROCESSES, AND WORK STEPS, BUDGETING AND EXPENSE TRACKING, CREATION, MONITORING AND REPORTING OF ACTION ITEMS, AND DATABASE MANAGEMENT, ALL OF THE AFORESAID IN PROVIDING BUSINESS AUDITING, ACCOUNTING AND COMPLIANCE SERVICES AND MANAGING SYSTEMS OF INTERNAL CONTROLS FOR FINANCIAL REPORTING (U.S. CLS. 100 AND 101).

NELSON SNYDER, EXAMINING ATTORNEY

SN 85-293,275. ACADEMIXDIRECT, INC., MOUNTAIN VIEW, CA. FILED 4-12-2011.

ACADEMIXDIRECT

THE MARK CONSISTS OF STANDARD CHARACTERS WITHOUT CLAIM TO ANY PARTICULAR FONT, STYLE, SIZE, OR COLOR.

CLASS 35—ADVERTISING AND BUSINESS

FOR ADVERTISING, MARKETING, AND PROMOTIONAL SERVICES; PROVIDING DEMAND CREATION AND LEAD GENERATION ACTIVITIES AND SERVICES; ACTING AS A REFERRAL SOURCE AND LEAD GENERATOR FOR LOCATING, EVALUATING, AND ENROLLING STUDENTS IN EDUCATIONAL PROGRAMS, COURSES, CLASSES, SEMINARS, WORKSHOPS, AND DEGREE PROGRAMS FOR EDUCATIONAL INSTITUTIONS, TEST PREPARATION PROGRAMS, TRAINING PROGRAMS, TUTORING SERVICES, STUDY AIDE PROVIDERS, DAY CARE PROVIDERS, AND CHILD CARE PROVIDERS; PROVIDING LEAD GENERATION AND REFERRALS IN THE FIELD OF EDUCATIONAL GOODS AND SERVICES TO SCHOOL SUPPLY COMPANIES, PROVIDERS OF TEACHING RESOURCES, AND SOFTWARE COMPANIES; COMPUTER SERVICES, NAMELY, PROVIDING A WEBSITE FEATURING REFERRALS FOR STUDENTS, PROSPECTIVE STUDENTS AND OTHERS TO LOCATE AND ENROLL IN EDUCATION PROGRAMS, COURSES, CLASSES, SEMINARS, WORKSHOPS, AND DEGREE PROGRAMS, AND TO LOCATE AND EVALUATE THE SAME IN ORDER TO IDENTIFY THE PROGRAMS, COURSES, CLASSES, SEMINARS, WORKSHOPS OR DEGREE PROGRAMS THAT BEST MEET THE INDIVIDUAL'S EDUCATIONAL NEEDS AND GOALS (U.S. CLS. 100, 101 AND 102).

CLASS 41—EDUCATION AND ENTERTAINMENT

FOR EDUCATION SERVICES, NAMELY, PROVIDING A WEBSITE FEATURING INFORMATION FOR STUDENTS, PROSPECTIVE STUDENTS AND OTHERS TO LOCATE AND ENROLL IN EDUCATION PROGRAMS, COURSES, CLASSES, SEMINARS, WORKSHOPS, AND DEGREE PROGRAMS; EDUCATIONAL SERVICES, NAMELY, EVALUATING AND PROVIDING ALTERNATIVES AND RECOMMENDATIONS REGARDING EDUCATIONAL PROGRAMS, COURSES, CLASSES, SEMINARS, WORKSHOPS, AND DEGREE PROGRAMS THAT BEST MEET AN INDIVIDUAL'S EDUCATIONAL NEEDS AND GOALS; PROVIDING A WEBSITE THAT FEATURES INFORMATION AND NEWS IN THE FIELD OF EDUCATION; COMPUTER SERVICES, NAMELY, PROVIDING A WEBSITE FEATURING EDUCATIONAL INFORMATION FOR STUDENTS, PROSPECTIVE STUDENTS AND OTHERS TO LOCATE AND ENROLL IN EDUCATION PROGRAMS, COURSES, CLASSES, SEMINARS, WORKSHOPS, AND DEGREE PROGRAMS, AND TO LOCATE AND EVALUATE THE SAME IN ORDER TO IDENTIFY THE PROGRAMS, COURSES, CLASSES, SEMINARS, WORKSHOPS OR DEGREE PROGRAMS THAT BEST MEET THE INDIVIDUAL'S EDUCATIONAL NEEDS AND GOALS (U.S. CLS. 100, 101 AND 107).

CLASS 42—SCIENTIFIC AND COMPUTER SERVICES

FOR COMPUTER SERVICES, NAMELY, PROVIDING A WEBSITE FEATURING ONLINE NON-DOWNLOADABLE SOFTWARE THAT GENERATES LEADS AND REFERRALS FOR EDUCATIONAL INSTITUTIONS, TEST PREPARATION PROGRAMS, TRAINING PROGRAMS, TUTORING SERVICES, STUDY AIDE PROVIDERS, DAY CARE PROVIDERS, CHILD CARE PROVIDERS, SCHOOL SUPPLY COMPANIES, PROVIDERS OF TEACHING RESOURCES, AND SOFTWARE COMPANIES; COMPUTER SERVICES, NAMELY, PROVIDING A WEBSITE FEATURING ONLINE NON-DOWNLOADABLE SOFTWARE THAT GENERATES LEADS AND REFERRALS FOR EDUCATIONAL INSTITUTIONS, TEST PREPARATION PROGRAMS, TRAINING PROGRAMS, TUTORING SERVICES, STUDY AIDE PROVIDERS, DAY CARE PROVIDERS, CHILD CARE PROVIDERS, SCHOOL SUPPLY COMPANIES, PROVIDERS OF TEACHING RESOURCES, AND SOFTWARE COMPANIES; DESIGN AND DEVELOPMENT OF COMPUTER HARDWARE AND SOFTWARE; PROVIDING ONLINE NON-DOWNLOADABLE SOFTWARE FOR MAKING RESOURCES AVAILABLE TO STUDENTS, PROSPECTIVE STUDENTS AND OTHERS TO LOCATE AND ENROLL IN EDUCATION PROGRAMS, COURSES, CLASSES, SEMINARS, WORKSHOPS, AND DEGREE PROGRAMS, AND TO EVALUATE THE SAME IN ORDER TO IDENTIFY THE PROGRAMS, COURSES, CLASSES, SEMINARS, WORKSHOPS OR DEGREE PROGRAMS THAT BEST MEET THE INDIVIDUAL'S EDUCATIONAL NEEDS AND GOALS; PROVIDING ONLINE NON-DOWNLOADABLE SOFTWARE FOR GENERATING LEADS AND REFERRALS FOR EDUCATIONAL INSTITUTIONS, TEST PREPARATION PROGRAMS, TRAINING PROGRAMS, TUTORING SERVICES, STUDY AIDE PROVIDERS, DAY CARE PROVIDERS, CHILD CARE PROVIDERS, SCHOOL SUPPLY COMPANIES, PROVIDERS OF TEACHING RESOURCES, AND SOFTWARE COMPANIES; PLATFORM AS A SERVICE FEATURING COMPUTER SOFTWARE TO MATCH PROSPECTIVE STUDENTS WITH EDUCATIONAL INSTITUTIONS; COMPUTER SERVICES, NAMELY, CREATING AN ONLINE COMMUNITY FOR REGISTERED USERS TO PARTICIPATE IN DISCUSSIONS, GET FEEDBACK FROM PEERS, FORM VIRTUAL COMMUNITIES, AND ENGAGE IN SOCIAL NETWORKING (U.S. CLS. 100 AND 101).

KRISTINA MORRIS, EXAMINING ATTORNEY

SN 85-295,004. ISEEU GLOBAL LIMITED, CLEVEDON, UNITED KINGDOM, FILED 4-14-2011.

ISEEU GLOBAL MEETING CENTRE

THE MARK CONSISTS OF STANDARD CHARACTERS WITHOUT CLAIM TO ANY PARTICULAR FONT, STYLE, SIZE, OR COLOR.

OWNER OF UNITED KINGDOM REG. NO. 2562709, DATED 2-11-2011, EXPIRES 10-29-2020.

OWNER OF U.S. REG. NOS. 3,713,884 AND 3,717,394.

NO CLAIM IS MADE TO THE EXCLUSIVE RIGHT TO USE "GLOBAL MEETING CENTRE", APART FROM THE MARK AS SHOWN.

CLASS 35—ADVERTISING AND BUSINESS

FOR ARRANGING AND CONDUCTING OF BUSINESS CONFERENCES, BUSINESS MEETINGS, BUSINESS EXHIBITIONS AND BUSINESS FAIRS; PROVIDING BUSINESS INFORMATION RELATING TO ALL THE AFORESAID (U.S. CLS. 100, 101 AND 102).

CLASS 38—COMMUNICATION

FOR VIDEO CONFERENCING SERVICES; TELEPHONE AND VIDEO CONFERENCING SERVICES; TELECONFERENCING SERVICES; COMMUNICATION SERVICES, NAMELY, TRANSMISSION OF DATA AND INFORMATION FOR VIDEO CONFERENCING SERVICES; SATELLITE VIDEO CONFERENCING SERVICES; PROVIDING FACILITIES FOR TELECONFERENCING; DATA COMMUNICATION SERVICES ACCESSIBLE BY ACCESS CODE, NAMELY, ELECTRONIC TRANSMISSION OF DATA VIA COMPUTER NETWORKS; DATA COMMUNICATION SERVICES ACCESSIBLE BY PASSWORD, NAMELY, ELECTRONIC TRANSMISSION OF DATA VIA COMPUTER NETWORKS; PROVIDING ACCESS TO COMPUTER DATABASES; PROVIDING ACCESS TO COMMUNICATION NETWORKS BY COMPUTER TERMINAL; PROVIDING ACCESS TO ELECTRONIC MESSAGING SYSTEMS; PROVIDING ACCESS TO THE INTERNET, DATABASES AND WEB PAGES; ELECTRONIC TRANSMISSION OF SOUND, IMAGES AND DATA; PROVIDING TELECOMMUNICATIONS CONNECTIONS TO THE INTERNET; ELECTRONIC TRANSMISSION OF SOUND, IMAGES AND DATA; PROVIDING TELECOMMUNICATION CONNECTIVITY SERVICE FOR THE TRANSFER OF IMAGES, MESSAGES, AUDIO, VISUAL, AUDIOVISUAL AND MULTIMEDIA WORKS; PROVIDING TELECOMMUNICATIONS INFORMATION AND CONSULTATION RELATING TO ALL THE AFORESAID (U.S. CLS. 100, 101 AND 104).

CLASS 41—EDUCATION AND ENTERTAINMENT

FOR EDUCATIONAL SERVICES, NAMELY, ARRANGING AND CONDUCTING EDUCATIONAL LECTURES IN THE FIELD OF BUSINESS (U.S. CLS. 100, 101 AND 107).

CLASS 42—SCIENTIFIC AND COMPUTER SERVICES

FOR RENTAL OF COMPUTER SOFTWARE AND PROVIDING COMPUTER SOFTWARE CONSULTATION (U.S. CLS. 100 AND 101).

MICHELE SWAIN, EXAMINING ATTORNEY

SN 85-297,400. KABUSHIKI KAISHA TOSHIBA, TA TOSHIBA CORPORATION, TOKYO, JAPAN, FILED 4-18-2011.

AZF Stereo Imaging

THE MARK CONSISTS OF STANDARD CHARACTERS WITHOUT CLAIM TO ANY PARTICULAR FONT, STYLE, SIZE, OR COLOR.

PRIORITY CLAIMED UNDER SEC. 44(D) ON JAPAN APPLICATION NO. 2010-092478, FILED 11-29-2010, REG. NO. 5408220, DATED 4-22-2011, EXPIRES 4-22-2021.

NO CLAIM IS MADE TO THE EXCLUSIVE RIGHT TO USE "STEREO IMAGING", APART FROM THE MARK AS SHOWN.

CLASS 9—ELECTRICAL AND SCIENTIFIC APPARATUS

FOR COMPUTER SOFTWARE FOR TRANSFORMING 2D IMAGES INTO 3D IMAGES; MOBILE PHONES, VIDEO-GAME MACHINES FOR USE WITH EXTERNAL DISPLAY SCREEN OR MONITOR, DIGITAL CAMERAS, DIGITAL VIDEO CAMERAS, DIGITAL PHOTO FRAMES, TV SETS AND PERSONAL COMPUTERS WITH BUILT-IN AFORESAID SOFTWARE (U.S. CLS. 21, 23, 26, 36 AND 38).

CLASS 28—TOYS AND SPORTING GOODS

FOR LCD GAME MACHINES WITH BUILT-IN COMPUTER SOFTWARE FOR TRANSFORMING 2D IMAGES INTO 3D IMAGES (U.S. CLS. 22, 23, 38 AND 50).

BRENDAN REGAN, EXAMINING ATTORNEY

SN 85-298,812. CBM CREATIVE BRANDS MARKEN GMBH, ZURICK, SWITZERLAND, FILED 4-19-2011.



THE MARK CONSISTS OF THE WORK "BLACK" IN FRONT OF A BIRD THAT IS A FALCON WHICH IS BEFORE THE WORD "FALCON".

CLASS 25—CLOTHING

FOR CLOTHING, NAMELY, APRONS, ASCOTS, BANDANAS, BATHROBES, BATHING SUITS, BELTS FOR CLOTHING, BLOUSES, BOAS, CAMISOLES, CARDIGANS, COATS, CORSETS, CUFFS, DRESSES, DRESSING GOWNS, FROCKS, FUR STOLEES, GARTERS, GIRDLES, GLOVES, HEADBANDS, HOSIERY, JACKETS, JERSEYS, JUMPERS, LEGGINGS, MITTENS, MUFFS, NECKERCHIEFS, NECKTIES, OVERALLS, PAJAMAS, PANTS, PARKAS, PETTICOATS, SCARVES, SHAWLS, SHIRTS, SHORTS, SKIRTS, SOCKS, STOCKINGS, SUITS, SWEATERS, SWIMSUITS, TEDDIES, T-SHIRTS, TIGHTS, UNDERWEAR, VEILS, AND VESTS; FOOTWEAR, HEADGEAR, NAMELY, CAPS AND HATS (U.S. CLS. 22 AND 39).

CLASS 35—ADVERTISING AND BUSINESS

FOR ADVERTISING; BUSINESS MANAGEMENT; BUSINESS ADMINISTRATION; PROVIDING OFFICE FUNCTIONS; RETAIL STORE SERVICES, ALSO ACCESSIBLE ON-LINE AND BY TELEPHONE, IN THE FIELDS OF CLOTHING, FOOTWEAR, HEADGEAR, BLEACHING PREPARATIONS AND OTHER SUBSTANCES FOR LAUNDRY USE, CLEANING, POLISHING, SCOURING AND ABRASIVE PREPARATIONS, SOAPS, PERFUMERY, ESSENTIAL OILS, COSMETICS, HAIR LOTIONS, DENTIFRICES, SUN GLASSES, PRECIOUS METALS AND THEIR ALLOYS AND GOODS IN PRECIOUS METALS OR COATED THEREWITH, JEWELLERY, PRECIOUS STONES, HOROLOGICAL AND CHRONOMETRIC INSTRUMENTS, LEATHER AND IMITATIONS OF LEATHER, AND GOODS MADE OF THESE MATERIALS, ANIMAL SKINS, HIDES, TRUNKS AND TRAVELLING BAGS, SUITCASES, BAGS, HANDBAGS, BILLFOLDS, PURSES, KEY CASES, BACKPACKS, POUCHES, UMBRELLAS, PARASOLS AND WALKING STICKS, WHIPS, HARNESS AND SADDLERY; ORGANISATION AND REALISATION OF PROMOTIONAL EVENTS AND CUSTOMER LOYALTY SCHEMES, NAMELY, ARRANGING AND CONDUCTING MARKETING PROMOTIONAL EVENTS FOR OTHERS, PROMOTING THE GOODS AND SERVICES OF OTHERS BY MEANS OF THE ISSUANCE OF LOYALTY REWARDS CARDS, CUSTOMER LOYALTY SERVICES FOR COMMERCIAL, PROMOTIONAL AND/OR ADVERTISING PURPOSES (U.S. CLS. 100, 101 AND 102).

CLASS 41—EDUCATION AND ENTERTAINMENT

FOR EDUCATION, NAMELY, PROVIDING CLASSES, SEMINARS, AND WORKSHOPS IN THE FIELDS OF FASHION, BUSINESS, ENTERTAINMENT, AND SPORTS; PROVIDING OF TRAINING IN THE FIELDS OF FASHION, BUSINESS MANAGEMENT, BUSINESS OPERATIONS, HUMAN RESOURCES, SALES AND MARKETING, SPORTS AND ENTERTAINMENT; ENTERTAINMENT, NAMELY, COMPETITIONS IN THE FIELDS OF FASHION SHOWS AND SPORTING EVENTS; SPORTING AND CULTURAL ACTIVITIES, NAMELY, ORGANIZING SPORTING AND CULTURAL ACTIVITIES AND EVENTS (U.S. CLS. 100, 101 AND 107).

CURTIS FRENCH, EXAMINING ATTORNEY

SN 85-299,273. ACADEMIXDIRECT, INC., MOUNTAIN VIEW, CA. FILED 4-19-2011.

academix
direct

NO CLAIM IS MADE TO THE EXCLUSIVE RIGHT TO USE "ACADEMIX", APART FROM THE MARK AS SHOWN.

THE MARK CONSISTS OF A LOWER-CASE WORD "ACADEMIX" ABOVE THE LOWER-CASE WORD "DIRECT" WHERE THE "X" IN "ACADEMIX" IS A STYLIZED IMAGE OF A PERSON, INCLUDING A DOT OVER THE X REPRESENTING THE PERSON'S HEAD.

CLASS 35—ADVERTISING AND BUSINESS

FOR ADVERTISING, MARKETING, AND PROMOTIONAL SERVICES; PROVIDING DEMAND CREATION AND LEAD GENERATION ACTIVITIES AND SERVICES; ACTING AS A REFERRAL SOURCE AND LEAD GENERATOR FOR LOCATING, EVALUATING, AND ENROLLING STUDENTS IN EDUCATIONAL PROGRAMS, COURSES, CLASSES, SEMINARS, WORKSHOPS, AND DEGREE PROGRAMS FOR EDUCATIONAL INSTITUTIONS, TEST PREPARATION PROGRAMS, TRAINING PROGRAMS, TUTORING SERVICES, STUDY AIDE PROVIDERS, DAY CARE PROVIDERS, AND CHILD CARE PROVIDERS; PROVIDING LEAD GENERATION AND REFERRALS IN THE FIELD OF EDUCATIONAL GOODS AND SERVICES TO SCHOOL SUPPLY COMPANIES, PROVIDERS OF TEACHING RESOURCES, AND SOFTWARE COMPANIES; COMPUTER SERVICES, NAMELY, PROVIDING A WEBSITE FEATURING REFERRALS FOR STUDENTS, PROSPECTIVE STUDENTS AND OTHERS TO LOCATE AND ENROLL IN EDUCATION PROGRAMS, COURSES, CLASSES, SEMINARS, WORKSHOPS, AND DEGREE PROGRAMS, AND TO LOCATE AND EVALUATE THE SAME IN ORDER TO IDENTIFY THE PROGRAMS, COURSES, CLASSES, SEMINARS, WORKSHOPS OR DEGREE PROGRAMS THAT BEST MEET THE INDIVIDUAL'S EDUCATIONAL NEEDS AND GOALS (U.S. CLS. 100, 101 AND 102).

CLASS 41—EDUCATION AND ENTERTAINMENT

FOR EDUCATION SERVICES, NAMELY, PROVIDING A WEBSITE FEATURING INFORMATION FOR STUDENTS, PROSPECTIVE STUDENTS AND OTHERS TO LOCATE AND ENROLL IN EDUCATION PROGRAMS, COURSES, CLASSES, SEMINARS, WORKSHOPS, AND DEGREE PROGRAMS; EDUCATIONAL SERVICES, NAMELY, EVALUATING AND PROVIDING ALTERNATIVES AND RECOMMENDATIONS REGARDING EDUCATIONAL PROGRAMS, COURSES, CLASSES, SEMINARS, WORKSHOPS, AND DEGREE PROGRAMS THAT BEST MEET AN INDIVIDUAL'S EDUCATIONAL NEEDS AND GOALS; PROVIDING A WEBSITE THAT FEATURES INFORMATION AND NEWS IN THE FIELD OF EDUCATION; COMPUTER SERVICES, NAMELY, PROVIDING A WEBSITE FEATURING EDUCATIONAL INFORMATION FOR STUDENTS, PROSPECTIVE STUDENTS AND OTHERS TO LOCATE AND ENROLL IN EDUCATION PROGRAMS, COURSES, CLASSES, SEMINARS, WORKSHOPS, AND DEGREE PROGRAMS, AND TO LOCATE AND EVALUATE THE SAME IN ORDER TO IDENTIFY THE PROGRAMS, COURSES, CLASSES, SEMINARS, WORKSHOPS OR DEGREE PROGRAMS THAT BEST MEET THE INDIVIDUAL'S EDUCATIONAL NEEDS AND GOALS (U.S. CLS. 100, 101 AND 107).

CLASS 42—SCIENTIFIC AND COMPUTER SERVICES

FOR COMPUTER SERVICES, NAMELY, PROVIDING A WEBSITE FEATURING ONLINE NON-DOWNLOADABLE SOFTWARE THAT GENERATES LEADS AND REFERRALS FOR EDUCATIONAL INSTITUTIONS, TEST PREPARATION PROGRAMS, TRAINING PROGRAMS, TUTORING SERVICES, STUDY AIDE PROVIDERS, DAY CARE PROVIDERS, CHILD CARE PROVIDERS, SCHOOL SUPPLY COMPANIES, PROVIDERS OF TEACHING RESOURCES, AND SOFTWARE COMPANIES; COMPUTER SERVICES, NAMELY, PROVIDING A WEBSITE FEATURING ONLINE NON-DOWNLOADABLE SOFTWARE THAT GENERATES LEADS AND REFERRALS FOR EDUCATIONAL INSTITUTIONS, TEST PREPARATION PROGRAMS, TRAINING PROGRAMS, TUTORING SERVICES, STUDY AIDE PROVIDERS, DAY CARE PROVIDERS, CHILD CARE PROVIDERS, SCHOOL SUPPLY COMPANIES, PROVIDERS OF TEACHING RESOURCES, AND SOFTWARE COMPANIES; DESIGN AND DEVELOPMENT OF COMPUTER HARDWARE AND SOFTWARE; PROVIDING ONLINE NON-DOWNLOADABLE SOFTWARE FOR MAKING RESOURCES AVAILABLE TO STUDENTS, PROSPECTIVE STUDENTS AND OTHERS TO LOCATE AND ENROLL IN EDUCATION PROGRAMS, COURSES, CLASSES, SEMINARS, WORKSHOPS, AND DEGREE PROGRAMS, AND TO EVALUATE THE SAME IN

ORDER TO IDENTIFY THE PROGRAMS, COURSES, CLASSES, SEMINARS, WORKSHOPS OR DEGREE PROGRAMS THAT BEST MEET THE INDIVIDUAL'S EDUCATIONAL NEEDS AND GOALS; PROVIDING ONLINE NON-DOWNLOADABLE SOFTWARE FOR GENERATING LEADS AND REFERRALS FOR EDUCATIONAL INSTITUTIONS, TEST PREPARATION PROGRAMS, TRAINING PROGRAMS, TUTORING SERVICES, STUDY AIDE PROVIDERS, DAY CARE PROVIDERS, CHILD CARE PROVIDERS, SCHOOL SUPPLY COMPANIES, PROVIDERS OF TEACHING RESOURCES, AND SOFTWARE COMPANIES; PLATFORM AS A SERVICE FEATURING COMPUTER SOFTWARE TO MATCH PROSPECTIVE STUDENTS WITH EDUCATIONAL INSTITUTIONS; COMPUTER SERVICES, NAMELY, CREATING AN ONLINE COMMUNITY FOR REGISTERED USERS TO PARTICIPATE IN DISCUSSIONS, GET FEEDBACK FROM PEERS, FORM VIRTUAL COMMUNITIES, AND ENGAGE IN SOCIAL NETWORKING (U.S. CLS. 100 AND 101).

KRISTINA MORRIS, EXAMINING ATTORNEY

SN 85-299,634, CAHILL SOFTWARE LIMITED, DUBLIN 14, IRELAND, FILED 4-20-2011.



OWNER OF ERPN CMNTY TM OFC REG. NO. 009864521, DATED 9-28-2011, EXPIRES 4-4-2021.

OWNER OF U.S. REG. NO. 3,344,489.

THE COLOR(S) NAVY BLUE, ORANGE AND WHITE IS/ARE CLAIMED AS A FEATURE OF THE MARK.

THE MARK CONSISTS OF THE WORD "AZYRA" IN A STYLISED FORM IN THE COLOR OF NAVY BLUE NEXT TO AN ORANGE BALL WITH A WHITE CHECK MARK INSIDE THE BALL.

CLASS 9—ELECTRICAL AND SCIENTIFIC APPARATUS

FOR COMPUTER SOFTWARE PROGRAMS FOR RECORD KEEPING, DATABASE MANAGEMENT, STATISTICAL ANALYSIS, REPORTING AND INTERACTIVE DATA ENTRY FOR SCHEDULING, COORDINATION AND ORGANIZATION OF BUSINESS AND ADMINISTRATION ACTIVITIES AND SERVICES IN THE FIELDS OF BUSINESS, PUBLIC SERVICE ADMINISTRATION AND ACCOUNTING (U.S. CLS. 21, 23, 26, 36 AND 38).

CLASS 42—SCIENTIFIC AND COMPUTER SERVICES

FOR HOSTING OF COMPUTER SOFTWARE APPLICATIONS OF OTHERS FOR REMOTE USERS WHO ACCESS THE APPLICATIONS VIA COMMUNICATIONS OF ANY FORM INCLUDING DIAL-UP LINES, LEASED LINES, THE INTERNET, VIRTUAL PRIVATE NETWORKS, SATELLITE LINKS, OR SIMILAR FORMS OF COMMUNICATION (U.S. CLS. 100 AND 101).

DEBRA LEE, EXAMINING ATTORNEY

SN 85-299,827. UPTAKE MEDICAL CORPORATION, SEATTLE, WA. FILED 4-20-2011.

SN 85-307,287. WAPIYAPI, DENVER, CO. FILED 4-28-2011.

**INTERVAPOR PERSONALIZED
PROCEDURE PROGRAM**

THE MARK CONSISTS OF STANDARD CHARACTERS WITHOUT CLAIM TO ANY PARTICULAR FONT, STYLE, SIZE, OR COLOR.

NO CLAIM IS MADE TO THE EXCLUSIVE RIGHT TO USE "PERSONALIZED PROCEDURE PROGRAM", APART FROM THE MARK AS SHOWN.

CLASS 10—MEDICAL APPARATUS

FOR MEDICAL APPARATUS, NAMELY, CATHETERS, AND VAPOR-GENERATING DEVICES GENERATING THERMAL VAPOR FOR USE IN MEDICAL TREATMENT IN THE FIELD OF EMPHYSEMA AND CHRONIC OBSTRUCTIVE PULMONARY DISEASE (U.S. CLS. 26, 39 AND 44).

CLASS 44—MEDICAL, BEAUTY AND AGRICULTURAL SERVICES

FOR PROVIDING MEDICAL INFORMATION AND TREATMENT PLANS IN THE FIELD OF EMPHYSEMA AND CHRONIC OBSTRUCTIVE PULMONARY DISEASE (U.S. CLS. 100 AND 101).

ROBIN MITTLER, EXAMINING ATTORNEY

SN 85-304,158. WILDERNESS ATHLETE, SCOTTSDALE, AZ. FILED 4-25-2011.

Wilderness Athlete

THE MARK CONSISTS OF STANDARD CHARACTERS WITHOUT CLAIM TO ANY PARTICULAR FONT, STYLE, SIZE, OR COLOR.

OWNER OF U.S. REG. NO. 3,446,531.

NO CLAIM IS MADE TO THE EXCLUSIVE RIGHT TO USE "ATHLETE", APART FROM THE MARK AS SHOWN.

CLASS 18—LEATHER GOODS

FOR BACK PACKS (U.S. CLS. 1, 2, 3, 22 AND 41).

CLASS 28—TOYS AND SPORTING GOODS

FOR SNOW SHOES (U.S. CLS. 22, 23, 38 AND 50).
MAYUR VAGHANI, EXAMINING ATTORNEY

Wapiyapi

THE MARK CONSISTS OF STANDARD CHARACTERS WITHOUT CLAIM TO ANY PARTICULAR FONT, STYLE, SIZE, OR COLOR.

CLASS 36—INSURANCE AND FINANCIAL

FOR CHARITABLE FUNDRAISING TO SUPPORT CHILDREN WITH CANCER AND THEIR FAMILIES (U.S. CLS. 100, 101 AND 102).

FIRST USE 5-6-1998; IN COMMERCE 5-6-1998.

CLASS 45—PERSONAL AND LEGAL SERVICES

FOR SUPPORT SERVICES FOR CHILDREN WITH CANCER AND THEIR FAMILIES, NAMELY, PROVIDING PERSONAL SUPPORT SERVICES FOR PATIENTS AND FAMILIES OF PATIENTS WITH CANCER, NAMELY, EMOTIONAL SUPPORT (U.S. CLS. 100 AND 101).

FIRST USE 5-6-1998; IN COMMERCE 5-6-1998.

BENJAMIN OKEKE, EXAMINING ATTORNEY

SN 85-307,615. A&E TELEVISION NETWORKS, LLC, NEW YORK, NY. FILED 4-28-2011.

LIFE IS ENTERTAINING

THE MARK CONSISTS OF STANDARD CHARACTERS WITHOUT CLAIM TO ANY PARTICULAR FONT, STYLE, SIZE, OR COLOR.

CLASS 9—ELECTRICAL AND SCIENTIFIC APPARATUS

FOR DIGITAL MEDIA IN THE FORM OF DVDS, DOWNLOADABLE WEBCASTS, AUDIO AND VIDEO FILES, AND DOWNLOADS TO MOBILE DEVICES, ALL FEATURING TELEVISION PROGRAMS AND MOTION PICTURES OF GENERAL INTEREST; DOWNLOADABLE ELECTRONIC PUBLICATIONS IN THE NATURE OF NEWSLETTERS IN THE FIELD OF TELEVISION PROGRAMS, TELEVISION BROADCASTING, AND MOTION PICTURES; MUSICAL SOUND RECORDINGS (U.S. CLS. 21, 23, 26, 36 AND 38).

CLASS 35—ADVERTISING AND BUSINESS

FOR MARKETING AND PROMOTION OF TELEVISION PROGRAMMING AND MOTION PICTURES OF OTHERS; WHOLESALE DISTRIBUTORSHIP SERVICES FOR OTHERS IN THE FIELD OF ENTERTAINMENT FEATURING TELEVISION PROGRAMS AND MOTION PICTURES; ONLINE RETAIL STORE SERVICES AND MAIL ORDER SERVICES FEATURING HOUSEHOLD ITEMS, DVDS, COMPACT DISCS, AUDIO DISCS, BOOKS, MAGAZINES, HEADPHONES, DOCKING STATIONS FOR HANDHELD ELECTRONICS, UNIVERSAL REMOTES, VIDEOGAMES, FLASHLIGHTS, BAGS, BACKPACKS, GHOST HUNTING KITS, BANDANAS, GLOVES, HATS, CLOTHING, ELECTRONICS, TELESCOPES, MUGS, GLASSES, SHOT GLASSES, EXERCISE EQUIPMENT, WATER BOTTLES, MODELS FOR VEHICLES, MODELS FOR SHIPS, MODELS FOR AIRCRAFT, SPORTS ITEMS, PRINTS, GLOBES, MAPS, STAMPS, COINS, MOUSEPADS, WATCHES, JEWELRY, WRISTBANDS, BOBBLEHEADS, TOYS, GAMES, PUZZLES; PROVIDING SERVICES OF SELECTION OF MUSIC FOR USE IN TELEVISION ADVERTISEMENTS (U.S. CLS. 100, 101 AND 102).

CLASS 38—COMMUNICATION

FOR BROADCASTING SERVICES, NAMELY, TELEVISION BROADCASTING, VIDEO BROADCASTING, INTERNET BROADCASTING, AUDIO BROADCASTING AND SUBSCRIPTION TELEVISION BROADCASTING; SATELLITE TRANSMISSION SERVICES; ELECTRONIC TRANSMISSION OF DATA VIA SATELLITE LINK; ELECTRONIC TRANSMISSION OF DATA AND DOCUMENTS VIA COMPUTER NETWORKS; VIDEO-ON-DEMAND TRANSMISSION SERVICES; WIRELESS COMMUNICATION SERVICES, NAMELY, TRANSMISSION OF TELEVISION PROGRAMS AND MOTION PICTURES TO MOBILE DEVICES; PROVIDING ONLINE CHAT ROOMS AND ELECTRONIC BULLETIN BOARDS FOR THE ELECTRONIC TRANSMISSION OF MESSAGES AMONG USERS IN THE FIELDS OF BROADCAST ENTERTAINMENT AND GENERAL INTEREST; PROVIDING MULTIPLE USER ACCESS TO A GLOBAL COMPUTER INFORMATION NETWORK (U.S. CLS. 100, 101 AND 104).

CLASS 41—EDUCATION AND ENTERTAINMENT

FOR PRODUCTION AND DISTRIBUTION OF TELEVISION PROGRAMS AND MOTION PICTURES; AUDIO RECORDING PRODUCTION SERVICES; PRODUCTION OF TELEVISION PROGRAMS, MOTION PICTURES AND AUDIO RECORDINGS FOR USE IN INTERNET BROADCASTS, WEBCASTS OR FOR TRANSMISSION TO WIRELESS MOBILE DEVICES; SCHEDULING OF TELEVISION PROGRAMMING FOR OTHERS; PROVIDING A WEBSITE FEATURING ENTERTAINMENT PROGRAMMING CONCERNING MATTERS OF GENERAL INTEREST PROVIDED VIA INTERNET BROADCASTS OR VIA WIRELESS MOBILE DEVICES BY THE BROADCASTING INDUSTRY; PROVIDING A WEBSITE IN THE FIELD OF ARTS AND ENTERTAINMENT FEATURING CURRENT-EVENTS NEWS AND STORIES DEALING WITH THE ACHIEVEMENTS OF NOTABLE PEOPLE; EDUCATIONAL AND ENTERTAINMENT SERVICES, NAMELY, PROVIDING EDUCATIONAL PROGRAMS VIA TRANSMISSION BY RADIO, TELEVISION, SATELLITE, OR WIRELESS AND COMPUTER NETWORKS IN THE AREAS OF HISTORY, MILITARY HISTORY, BIOGRAPHIES, CRIME AND INVESTIGATIONS OF CRIMES, THE ARTS, THE PERFORMING ARTS, FILM, LITERATURE, AND TRAVEL; EDUCATIONAL AND ENTERTAINMENT SERVICES, NAMELY, PRODUCTION OF MOTION PICTURE FILMS AND TELEVISION SERIES RELATING TO A WIDE RANGE OF EDUCATION AND ENTERTAINMENT SUBJECTS; EDUCATIONAL AND ENTERTAINMENT SERVICES, NAMELY, CLASSES AND INFORMATION IN THE FIELDS OF HISTORY, HISTORICAL SETTINGS, HISTORICAL DRAMAS, HISTORICAL DOCUMENTARIES, HISTORIC INDIVIDUALS, HISTORICAL SUBJECTS, NEWS, MUSIC, RENDERED THROUGH A GLOBAL COMPUTER NETWORK, FEATURING MULTIMEDIA PRESENTATIONS INCORPORATING TEXT, SOUND, MUSIC, AND STILL AND MOVING IMAGES; PROVID-

ING INFORMATION RELATING TO ONLINE COMPUTER GAMES RENDERED THROUGH A GLOBAL COMPUTER NETWORK; PROVIDING ONLINE COMPUTER GAMES, PROVIDING ON-LINE DATABASES AND LINKS TO WEB SITES OF OTHER CONTENT PROVIDERS FEATURING EDUCATIONAL TOPICS RELATING TO HISTORY, HISTORICAL SETTINGS, HISTORICAL DRAMAS, HISTORICAL DOCUMENTARIES, HISTORICAL SUBJECTS AND INDIVIDUALS, AND HISTORICAL EVENTS VIA A GLOBAL COMPUTER NETWORK; PROVIDING EDUCATIONAL INFORMATION REGARDING HISTORY, HISTORICAL SETTINGS, HISTORICAL DRAMAS, HISTORICAL DOCUMENTARIES, HISTORICAL SUBJECTS AND INDIVIDUALS, AND HISTORICAL EVENTS BY MEANS OF A GLOBAL COMPUTER NETWORK; EDUCATIONAL SERVICES, NAMELY, PROVIDING INFORMATION AND LESSONS IN THE FIELDS OF HISTORY, HISTORICAL SETTINGS, HISTORICAL DRAMAS, HISTORICAL DOCUMENTARIES, HISTORIC INDIVIDUALS, HISTORICAL SUBJECTS, NEWS, AND MUSIC, INCORPORATING EDUCATIONAL DIGITAL MEDIA TO SCHOOLS AND COMMUNITY ORGANIZATIONS; MUSIC PUBLISHING SERVICES; PROVIDING INFORMATION ABOUT PERFORMANCES OF MUSICAL ARTISTS BY MEANS OF A GLOBAL COMPUTER INFORMATION NETWORK; MUSIC PRODUCTION FOR USE IN THE PRODUCTION OF TELEVISION SHOWS, MOTION PICTURES, AND MUSIC VIDEOS; MUSIC PRODUCTION FOR IN-HOUSE PRODUCTIONS OF OTHERS USED FOR ENTERTAINMENT IN THE NATURE OF TELEVISION SHOWS, MOTION PICTURES, MUSIC VIDEOS, WEBCASTS, PODCASTS, DISCUSSION BOARDS, AND MOBILE NETWORKS (U.S. CLS. 100, 101 AND 107).

CLASS 45—PERSONAL AND LEGAL SERVICES

FOR LICENSING OF TELEVISION PROGRAMS, MOTION PICTURES AND AUDIO MUSICAL PERFORMANCES FOR USE BY TELEVISION BROADCASTERS, WEBCASTERS, OPERATORS, AND THE HOME VIDEO AND EDUCATIONAL VIDEO MARKETS; LICENSING OF ENTERTAINMENT MERCHANDISING IN THE NATURE OF TELEVISION PROGRAMS, TELEVISION BROADCASTING, AND MOTION PICTURES (U.S. CLS. 100 AND 101).

BRENDAN REGAN, EXAMINING ATTORNEY

SN 85-308,218. A&E TELEVISION NETWORKS, LLC, NEW YORK, NY. FILED 4-29-2011.

The logo for A&E Networks, featuring the letters 'A' and 'E' in a stylized, bold font with a plus sign between them, followed by the word 'NETWORKS' in a similar bold font.

OWNER OF U.S. REG. NOS. 1,845,909 AND 3,662,347.

NO CLAIM IS MADE TO THE EXCLUSIVE RIGHT TO USE "NETWORKS", APART FROM THE MARK AS SHOWN.

THE MARK CONSISTS OF THE LETTERS "A" AND "E" AND THE WORD "NETWORKS", ALL IN STYLIZED FONT, WITH A MODERN VERSION OF THE PLUS SIGN BETWEEN THE LETTERS "A" AND "E".

CLASS 9—ELECTRICAL AND SCIENTIFIC APPARATUS

FOR DIGITAL MEDIA IN THE FORM OF DVDS, DOWNLOADABLE WEBCASTS, AUDIO AND VIDEO FILES, AND DOWNLOADS TO MOBILE DEVICES, ALL FEATURING TELEVISION PROGRAMS AND MOTION PICTURES OF GENERAL INTEREST; DOWNLOADABLE ELECTRONIC PUBLICATIONS IN THE NATURE OF NEWSLETTERS IN THE FIELD OF TELEVISION PROGRAMS, TELEVISION BROADCASTING, AND MOTION PICTURES; MUSICAL SOUND RECORDINGS (U.S. CLS. 21, 23, 26, 36 AND 38).

CLASS 35—ADVERTISING AND BUSINESS

FOR MARKETING AND PROMOTION OF TELEVISION PROGRAMMING AND MOTION PICTURES OF OTHERS; WHOLESALE DISTRIBUTORSHIP SERVICES FOR OTHERS IN THE FIELD OF ENTERTAINMENT FEATURING TELEVISION PROGRAMS AND MOTION PICTURES; ONLINE RETAIL STORE SERVICES AND MAIL ORDER SERVICES FEATURING HOUSEHOLD ITEMS, DVDS, COMPACT DISCS, AUDIO DISCS, BOOKS, MAGAZINES, HEADPHONES, DOCKING STATIONS FOR HANDHELD ELECTRONICS, UNIVERSAL REMOTES, VIDEO GAMES, FLASHLIGHTS, BAGS, BACKPACKS, GHOST HUNTING KITS, BANDANAS, GLOVES, HATS, CLOTHING, ELECTRONICS, TELESCOPES, MUGS, GLASSES, SHOT GLASSES, EXERCISE EQUIPMENT, WATER BOTTLES, MODELS FOR VEHICLES, MODELS FOR SHIPS, MODELS FOR AIRCRAFT, SPORTS ITEMS, PRINTS, GLOBES, MAPS, STAMPS, COINS, MOUSEPADS, WATCHES, JEWELRY, WRISTBANDS, BOBBLEHEADS, TOYS, GAMES, PUZZLES; PROVIDING SERVICES OF SELECTION OF MUSIC FOR USE IN TELEVISION ADVERTISEMENTS (U.S. CLS. 100, 101 AND 102).

CLASS 38—COMMUNICATION

FOR BROADCASTING SERVICES, NAMELY, TELEVISION BROADCASTING, VIDEO BROADCASTING, INTERNET BROADCASTING, AUDIO BROADCASTING AND SUBSCRIPTION TELEVISION BROADCASTING; SATELLITE TRANSMISSION SERVICES; ELECTRONIC TRANSMISSION OF DATA VIA SATELLITE LINK; ELECTRONIC TRANSMISSION OF DATA AND DOCUMENTS VIA COMPUTER NETWORKS; VIDEO-ON-DEMAND TRANSMISSION SERVICES; WIRELESS COMMUNICATION SERVICES, NAMELY, TRANSMISSION OF TELEVISION PROGRAMS AND MOTION PICTURES TO MOBILE DEVICES; PROVIDING ONLINE CHAT ROOMS AND ELECTRONIC BULLETIN BOARDS FOR THE ELECTRONIC TRANSMISSION OF MESSAGES AMONG USERS IN THE FIELDS OF BROADCAST ENTERTAINMENT AND GENERAL INTEREST; PROVIDING MULTIPLE USER ACCESS TO A GLOBAL COMPUTER INFORMATION NETWORK (U.S. CLS. 100, 101 AND 104).

CLASS 41—EDUCATION AND ENTERTAINMENT

FOR PRODUCTION AND DISTRIBUTION OF TELEVISION PROGRAMS AND MOTION PICTURES; AUDIO RECORDING PRODUCTION SERVICES; PRODUCTION OF TELEVISION PROGRAMS, MOTION PICTURES AND AUDIO RECORDINGS FOR USE IN INTERNET BROADCASTS, WEBCASTS OR FOR TRANSMISSION TO WIRELESS MOBILE DEVICES; SCHEDULING OF TELEVISION PROGRAMMING FOR OTHERS; PROVIDING A WEBSITE FEATURING ENTERTAINMENT PROGRAMMING CONCERNING MATTERS OF GENERAL INTEREST PROVIDED VIA INTERNET BROADCASTS OR VIA WIRELESS MOBILE DEVICES BY THE BROADCASTING INDUSTRY; PROVIDING A WEBSITE IN THE FIELD OF ARTS AND ENTERTAINMENT FEATURING CURRENT-EVENTS NEWS AND STORIES DEALING WITH THE ACHIEVEMENTS OF NOTABLE PEOPLE; EDUCATIONAL AND ENTERTAINMENT SERVICES, NAMELY, PROVIDING EDUCATIONAL PROGRAMS VIA TRANSMISSION BY RADIO, TELEVISION, SATELLITE, OR WIRELESS AND COMPUTER NETWORKS IN THE AREAS OF HISTORY, MILITARY HISTORY, BIOGRAPHIES, CRIME AND INVESTIGATIONS OF CRIMES, THE ARTS, THE PERFORMING ARTS, FILM, LITERATURE, AND TRAVEL; EDUCATIONAL AND ENTERTAINMENT SERVICES, NAMELY, PRODUCTION OF MOTION PICTURE FILMS AND TELEVISION SERIES RELATING TO A WIDE RANGE OF EDUCATION AND ENTERTAINMENT SUBJECTS; EDUCATIONAL AND ENTERTAINMENT SERVICES, NAMELY, CLASSES AND INFORMATION IN THE FIELDS OF HISTORY, HISTORICAL SETTINGS, HISTORICAL DRAMAS, HISTORICAL DOCUMENTARIES, HISTORIC INDIVIDUALS, HISTORICAL SUBJECTS, NEWS, MUSIC, RENDERED THROUGH A GLOBAL COMPUTER NETWORK, FEATURING MULTIMEDIA PRESENTATIONS INCORPORATING TEXT, SOUND, MUSIC, AND STILL AND MOVING IMAGES; PROVID-

ING INFORMATION RELATING TO ONLINE COMPUTER GAMES RENDERED THROUGH A GLOBAL COMPUTER NETWORK; PROVIDING ONLINE COMPUTER GAMES, PROVIDING ON-LINE DATABASES AND LINKS TO WEB SITES OF OTHER CONTENT PROVIDERS FEATURING EDUCATIONAL TOPICS RELATING TO HISTORY, HISTORICAL SETTINGS, HISTORICAL DRAMAS, HISTORICAL DOCUMENTARIES, HISTORICAL SUBJECTS AND INDIVIDUALS, AND HISTORICAL EVENTS VIA A GLOBAL COMPUTER NETWORK; PROVIDING EDUCATIONAL INFORMATION REGARDING HISTORY, HISTORICAL SETTINGS, HISTORICAL DRAMAS, HISTORICAL DOCUMENTARIES, HISTORICAL SUBJECTS AND INDIVIDUALS, AND HISTORICAL EVENTS BY MEANS OF A GLOBAL COMPUTER NETWORK; EDUCATIONAL SERVICES, NAMELY, PROVIDING INFORMATION AND LESSONS IN THE FIELDS OF HISTORY, HISTORICAL SETTINGS, HISTORICAL DRAMAS, HISTORICAL DOCUMENTARIES, HISTORIC INDIVIDUALS, HISTORICAL SUBJECTS, NEWS, AND MUSIC, INCORPORATING EDUCATIONAL DIGITAL MEDIA TO SCHOOLS AND COMMUNITY ORGANIZATIONS; MUSIC PUBLISHING SERVICES; PROVIDING INFORMATION ABOUT PERFORMANCES OF MUSICAL ARTISTS BY MEANS OF A GLOBAL COMPUTER INFORMATION NETWORK; MUSIC PRODUCTION FOR USE IN THE PRODUCTION OF TELEVISION SHOWS, MOTION PICTURES, AND MUSIC VIDEOS; MUSIC PRODUCTION FOR IN-HOUSE PRODUCTIONS OF OTHERS USED FOR ENTERTAINMENT IN THE NATURE OF TELEVISION SHOWS, MOTION PICTURES, MUSIC VIDEOS, WEBCASTS, PODCASTS, DISCUSSION BOARDS, AND MOBILE NETWORKS (U.S. CLS. 100, 101 AND 107).

CLASS 45—PERSONAL AND LEGAL SERVICES

FOR LICENSING OF TELEVISION PROGRAMS, MOTION PICTURES AND AUDIO MUSICAL PERFORMANCES FOR USE BY TELEVISION BROADCASTERS, WEBCASTERS, OPERATORS, AND THE HOME VIDEO AND EDUCATIONAL VIDEO MARKETS; LICENSING OF ENTERTAINMENT MERCHANDISING IN THE NATURE OF TELEVISION PROGRAMS, TELEVISION BROADCASTING, AND MOTION PICTURES (U.S. CLS. 100 AND 101).

BRENDAN REGAN, EXAMINING ATTORNEY

SN 85-309,953. DEMIAN NEUFELD, NEW YORK, NY. AND PLASKACZ, TODD, CHELSEA, QUEBEC, CANADA, FILED 5-2-2011.

RYDERS ALLEY

THE MARK CONSISTS OF STANDARD CHARACTERS WITHOUT CLAIM TO ANY PARTICULAR FONT, STYLE, SIZE, OR COLOR.

NO CLAIM IS MADE TO THE EXCLUSIVE RIGHT TO USE "RIDERS", APART FROM THE MARK AS SHOWN.

CLASS 37—CONSTRUCTION AND REPAIR

FOR REPAIR, SERVICING AND MAINTENANCE OF MOTORCYCLES; MAINTENANCE AND REPAIR SERVICES FOR MOTORCYCLES, NAMELY, INSTALLATION OF PARTS FOR MOTORCYCLES, VEHICLE LUBRICATION AND OIL CHANGE SERVICES FOR MOTORCYCLES (U.S. CLS. 100, 103 AND 106).

FIRST USE 1-1-2009; IN COMMERCE 1-1-2009.

CLASS 39—TRANSPORTATION AND STORAGE

FOR STORAGE OF MOTORCYCLES FOR OTHERS (U.S. CLS. 100 AND 105).
FIRST USE 1-1-2009; IN COMMERCE 1-1-2009.
EDWARD FENNESSY, EXAMINING ATTORNEY

SN 85-311,589. QATAR FOUNDATION FOR EDUCATION, SCIENCES & COMMUNITY DEVELOPMENT, DOHA, QATAR, FILED 5-3-2011.



NO CLAIM IS MADE TO THE EXCLUSIVE RIGHT TO USE "BIOBANKQATAR FOR MEDICAL RESEARCH", APART FROM THE MARK AS SHOWN.

THE MARK CONSISTS OF THE WORDING "BIOBANK-QATAR FOR MEDICAL RESEARCH" IN STYLIZED FONT. TO THE LEFT OF THE WORDING IS A DESIGN IN THE SHAPE OF A HELIX THAT IS FORMED INTO THE LETTER "B".

CLASS 9—ELECTRICAL AND SCIENTIFIC APPARATUS

FOR ELECTRONIC DATABASE CONTAINING CLINICAL, SOCIAL AND SCIENTIFIC DATA ASSOCIATED WITH HUMAN BIOLOGICAL SAMPLES RECORDED ON COMPUTER MEDIA; ELECTRONIC DATABASE CONTAINING STATISTICAL DATA RELATING TO MEDICAL RESEARCH RECORDED ON COMPUTER MEDIA (U.S. CLS. 21, 23, 26, 36 AND 38).

CLASS 42—SCIENTIFIC AND COMPUTER SERVICES

FOR COMPILING AND INDEXING DATA FOR RESEARCH PURPOSES IN THE FIELD OF MEDICAL SCIENCE, NAMELY, INDEXING AND COMPILATION OF HUMAN BIOLOGICAL SAMPLES INTO CATALOGUES; COMPILATION OF CLINICAL, SOCIAL AND SCIENTIFIC DATA ASSOCIATED WITH HUMAN BIOLOGICAL SAMPLES INTO REPORTS, DATABASES AND CATALOGUES; COMPILATION OF STATISTICAL DATA RELATING TO MEDICAL RESEARCH; INDEXING AND COMPILATION OF BIOLOGICAL SAMPLES INTO CATALOGUES; AND COMPILATION OF DATA INTO DATABASES FOR MEDICAL RESEARCH PURPOSES (U.S. CLS. 100 AND 101).

LAKEISHA LEWIS, EXAMINING ATTORNEY

SN 85-312,164. TOPP CONSTRUCTION SERVICES, INC., ASTON, PA. FILED 5-4-2011.

**TEMPORARY EQUIPMENT,
LIFETIME CUSTOMERS.**

THE MARK CONSISTS OF STANDARD CHARACTERS WITHOUT CLAIM TO ANY PARTICULAR FONT, STYLE, SIZE, OR COLOR.

CLASS 7—MACHINERY

FOR CONSTRUCTION EQUIPMENT, NAMELY, AC GENERATORS, DC GENERATORS, ELECTRIC POWER GENERATORS (U.S. CLS. 13, 19, 21, 23, 31, 34 AND 35).
FIRST USE 4-0-2007; IN COMMERCE 4-0-2007.

CLASS 11—ENVIRONMENTAL CONTROL APPARATUS

FOR CONSTRUCTION EQUIPMENT, NAMELY, AIR CONDITIONERS, PORTABLE AIR CONDITIONING UNITS, DEHUMIDIFIERS, ELECTRIC FANS, FANS FOR INDUSTRIAL AND COMMERCIAL USE, AIR CIRCULATORS, PORTABLE ELECTRIC HEATERS, COMMERCIAL AND INDUSTRIAL HEATERS (U.S. CLS. 13, 21, 23, 31 AND 34).
FIRST USE 4-0-2007; IN COMMERCE 4-0-2007.

CLASS 40—MATERIAL TREATMENT

FOR RENTAL OF EQUIPMENT, NAMELY, AIR CONDITIONING UNITS, DEHUMIDIFIERS, COMMERCIAL AND INDUSTRIAL HEATERS IN THE NATURE OF INDIRECT FIRED HEATERS AND PORTABLE ELECTRIC HEATERS, PORTABLE AIR CONDITIONERS, AIR CIRCULATORS, AND GENERATORS (U.S. CLS. 100, 103 AND 106).

FIRST USE 4-0-2007; IN COMMERCE 4-0-2007.

JACLYN KIDWELL WALKER, EXAMINING ATTORNEY

SN 85-312,356. DEFENSE INFORMATION SYSTEMS AGENCY, FORT MEADE, MD. FILED 5-4-2011.

DCS

THE MARK CONSISTS OF STANDARD CHARACTERS WITHOUT CLAIM TO ANY PARTICULAR FONT, STYLE, SIZE, OR COLOR.

CLASS 38—COMMUNICATION

FOR TELECOMMUNICATIONS SERVICES, NAMELY, PROVIDING THE U.S. DEPARTMENT OF DEFENSE, MILITARY SERVICES, COMBATANT COMMANDS, AND FEDERAL, STATE, LOCAL AND COALITION PARTNERS ACCESS TO THE INTERNET FEATURING STREAMING OF AUDIO MATERIAL AND VIDEO MATERIAL, ELECTRONIC MESSAGING, AND INTERNET VIRTUAL CHAT ROOMS TRANSMITTED OVER INTERNET PROTOCOL BASED NETWORKS; PROVIDING THE U.S. DEPARTMENT OF DEFENSE, MILITARY SERVICES, COMBATANT COMMANDS, AND FEDERAL, STATE, LOCAL AND COALITION PARTNERS AN INTEGRATED SERVICE, NAMELY, TRANSFER OF DATA BY TELECOMMUNICATIONS FEATURING EXTENSIBLE MESSAGING AND PRESENCE PROTOCOL (XMPP) BASED CHAT SERVICES, REAL-TIME TRANSPORT PROTOCOL (RTP) BASED VIDEO SERVICES, AND VOICE OVER INTERNET PROTOCOL (VOIP) SERVICES TO CONDUCT MEETINGS, CONFERENCES, DEMONSTRATIONS, VIRTUAL TOURS, PRESENTATIONS, TRAINING, AND INTERACTIVE DISCUSSIONS (U.S. CLS. 100, 101 AND 104).

FIRST USE 5-1-2009; IN COMMERCE 5-1-2009.

CLASS 42—SCIENTIFIC AND COMPUTER SERVICES

FOR PROVIDING THE U.S. DEPARTMENT OF DEFENSE, MILITARY SERVICES, COMBATANT COMMANDS, AND FEDERAL, STATE, LOCAL AND COALITION PARTNERS NON-DOWNLOADABLE SOFTWARE FOR APPLICATION SHARING, SCREEN SHARING, FILE TRANSFERRING, VOTING AND POLLING, RECORDING AND PLAYBACK OF MULTIMEDIA RECORDINGS, AND PRESENCE AND AWARENESS IN THE NATURE OF USER ACTIVITY (U.S. CLS. 100 AND 101).

FIRST USE 5-1-2009; IN COMMERCE 5-1-2009.
RAMONA ORTIGA, EXAMINING ATTORNEY

SN 85-313,600. ARTIS GMBH, BISPINGEN-BEHRINGEN, FED REP GERMANY, FILED 5-5-2011.



OWNER OF U.S. REG. NO. 2,383,787.
THE COLOR(S) BLACK, YELLOW/ORANGE, AND GREY IS/ARE CLAIMED AS A FEATURE OF THE MARK.

THE MARK CONSISTS OF THE WORD "ARTIS" IN BLACK, A STYLIZED LINE AND TRIANGLE ELEMENT IN YELLOW/ORANGE, AND THE WORD "MARPOSS" IN GRAY.

CLASS 9—ELECTRICAL AND SCIENTIFIC APPARATUS

FOR MONITORING AND CONTROLLING APPARATUS AND DEVICES, NAMELY, ELECTRONIC PROCESS MONITORS AND ELECTRONIC CONTROLLERS FOR MONITORING AND CONTROLLING PROCESSES OF MACHINE TOOLS; COMPUTER PROGRAMS FOR PROCESS VISUALIZATION IN THE FIELD OF MACHINE TOOLS (U.S. CLS. 21, 23, 26, 36 AND 38).

CLASS 37—CONSTRUCTION AND REPAIR

FOR INSTALLATION OF APPARATUS AND DEVICES FOR MONITORING AND CONTROLLING PROCESSES OF MACHINE TOOLS, NAMELY, ELECTRONIC PROCESS MONITORS AND ELECTRONIC CONTROLLERS FOR MONITORING AND CONTROLLING PROCESSES OF MACHINE TOOLS; MAINTENANCE, ADJUSTMENT AND REPAIR OF CUTTING MACHINE TOOLS, NAMELY, OPTIMIZATION OF CUTTING PROCESSES BY THE USE OF ADAPTIVE CONTROL AND PROCESS ANALYSIS (U.S. CLS. 100, 103 AND 106).

CLASS 42—SCIENTIFIC AND COMPUTER SERVICES

FOR PROGRAMMING SERVICES, NAMELY, DESIGNING COMPUTER PROGRAMS FOR THE VISUALIZATION AND DIAGNOSIS OF TECHNICAL PROCESSES, NAMELY, MONITORING AND CONTROLLING PROCESSES OF MACHINE TOOLS FOR OTHERS (U.S. CLS. 100 AND 101).

LINDA MICKLEBURGH, EXAMINING ATTORNEY

SN 85-313,748. GENERAL CANNABIS, INC., NEWPORT BEACH, CA. FILED 5-5-2011.

WEEDMAPS

THE MARK CONSISTS OF STANDARD CHARACTERS WITHOUT CLAIM TO ANY PARTICULAR FONT, STYLE, SIZE, OR COLOR.

CLASS 35—ADVERTISING AND BUSINESS

FOR PROMOTING THE GOODS AND SERVICES OF OTHERS BY PROVIDING A WEBSITE FEATURING COUPONS, REBATES, PRICE-COMPARISON INFORMATION, PRODUCT REVIEWS, LINKS TO THE WEBSITES OF OTHERS, AND DISCOUNT INFORMATION; ON-LINE CATALOGING OF THE GOODS OF OTHERS; ELECTRONIC CATALOG SERVICES FEATURING HERBAL PRODUCTS; ONLINE SERVICES, NAMELY, INVENTORY MONITORING AND MANAGEMENT FOR HERBAL PRODUCTS (U.S. CLS. 100, 101 AND 102).

CLASS 38—COMMUNICATION

FOR PROVIDING ON-LINE FORUMS FOR TRANSMISSION OF MESSAGES AMONG COMPUTER USERS CONCERNING HERBAL PRODUCTS (U.S. CLS. 100, 101 AND 104).

LINDSEY RUBIN, EXAMINING ATTORNEY

SN 85-314,884. DREANIE, LLC, MANDEVILLE, LA. FILED 5-6-2011.

DREANIE

THE MARK CONSISTS OF STANDARD CHARACTERS WITHOUT CLAIM TO ANY PARTICULAR FONT, STYLE, SIZE, OR COLOR.

CLASS 35—ADVERTISING AND BUSINESS

FOR PROVIDING A WEBSITE FOR PROPERTY OWNERS TO ADVERTISE AND MARKET VACATION PROPERTIES (U.S. CLS. 100, 101 AND 102).

CLASS 39—TRANSPORTATION AND STORAGE

FOR PROVIDING A WEBSITE FEATURING INFORMATION ON TRAVEL AND VACATIONS; TRAVEL GUIDE AND TRAVEL INFORMATION SERVICES; PROVIDING AN ON-LINE COMPUTER DATABASE IN THE FIELD OF TRAVEL INFORMATION SERVICES; PROVIDING LINKS TO WEBSITES OF OTHERS FEATURING TRAVEL (U.S. CLS. 100 AND 105).

CLASS 43—HOTEL AND RESTAURANT SERVICES

FOR PROVIDING A WEBSITE FOR USERS TO MAKE RESERVATIONS FOR VACATION PROPERTIES (U.S. CLS. 100 AND 101).

WANDA KAY PRICE, EXAMINING ATTORNEY

SN 85-314,949. ONE SKY MEDIA BV, 1070 AV AMSTERDAM, NETHERLANDS, FILED 5-6-2011.

SKYLINES

THE MARK CONSISTS OF STANDARD CHARACTERS WITHOUT CLAIM TO ANY PARTICULAR FONT, STYLE, SIZE, OR COLOR.

CLASS 9—ELECTRICAL AND SCIENTIFIC APPARATUS

FOR COMPUTER HARDWARE; COMPUTER SOFTWARE FOR CREATING INDEXES OF PHOTOGRAPHS AND VIDEO; COMPUTER SOFTWARE FOR SEARCHING, COMPILING, INDEXING AND ORGANIZING PHOTOGRAPHS AND VIDEO ON COMPUTER NETWORKS; COMPUTER SOFTWARE FOR CREATING INDEXES OF INFORMATION, INDEXES OF WEB SITES AND INDEXES OF OTHER INFORMATION RESOURCES; MOUSE PADS; HAND HELD COMPUTERS, NAMELY, HAND-HELD TOUCH SCREEN COMPUTING DEVICE FOR WIRELESS NETWORKING (U.S. CLS. 21, 23, 26, 36 AND 38).

CLASS 35—ADVERTISING AND BUSINESS

FOR ADVERTISING SERVICES; BUSINESS ADMINISTRATION AND MANAGEMENT; COMMERCIAL INFORMATION AND ADVICE FOR CONSUMERS; PROVIDING AN ONLINE SEARCHABLE DATABASE FEATURING DATA REGARDING THE PURCHASE AND SALE OF A WIDE VARIETY OF GOODS AND SERVICES OF OTHERS; ON-LINE ADVERTISING SERVICES ON A COMPUTER NETWORK; COMPILATION AND SYSTEMIZATION OF INFORMATION INTO COMPUTER DATABASES; ADVERTISING AND MARKETING SERVICES; ADVERTISING AND PROMOTION SERVICES (U.S. CLS. 100, 101 AND 102).

CLASS 38—COMMUNICATION

FOR TELECOMMUNICATION SERVICES, NAMELY, PERSONAL COMMUNICATION SERVICES; DATA TRANSMISSION AND RECEPTION SERVICES VIA TELECOMMUNICATION MEANS; ELECTRONIC EXCHANGE OF DATA STORED IN DATABASES ACCESSIBLE VIA TELECOMMUNICATION NETWORKS, NAMELY, ELECTRONIC EXCHANGE OF VOICE, DATA, AND GRAPHICS ACCESSIBLE VIA COMPUTER AND TELECOMMUNICATION NETWORKS; LOCAL AND LONG DISTANCE TRANSMISSION OF VOICE, DATA, GRAPHICS VIA COMPUTER AND TELECOMMUNICATIONS NETWORKS; INSTANT MESSAGING SERVICES; VOICE OVER IP SERVICES; TELECONFERENCING AND VIDEO CONFERENCING SERVICES, NAMELY, VIDEO AND AUDIO CONFERENCING SERVICES CONDUCTED VIA THE WEB, TELEPHONE, AND MOBILE DEVICES; COMMUNICATIONS BY COMPUTER TERMINALS; LOCAL AND LONG DISTANCE TELEPHONE SERVICES; MOBILE TELEPHONE COMMUNICATION SERVICES; WIRELESS BROADBAND COMMUNICATION SERVICES; CONSULTING FOR THE AFOREMENTIONED TELECOMMUNICATION SERVICES; PROVIDING MULTIPLE-USER ACCESS TO A GLOBAL COMPUTER INFORMATION NETWORK, NAMELY, PROVIDING MULTIPLE USER ACCESS TO PROPRIETARY COLLECTIONS OF INFORMATION, PHOTOGRAPHS, AND VIDEO BY MEANS OF GLOBAL COMPUTER INFORMATION NETWORKS (U.S. CLS. 100, 101 AND 104).

CLASS 42—SCIENTIFIC AND COMPUTER SERVICES

FOR COMPUTER SERVICES, NAMELY, PROVIDING NON-DOWNLOADABLE SOFTWARE INTERFACES AVAILABLE OVER A NETWORK IN ORDER TO CREATE PERSONALIZED ON-LINE INFORMATION SERVICES; DATA MINING, NAMELY, EXTRACTION AND RETRIEVAL OF INFORMATION AND DATA MINING BY MEANS OF GLOBAL COMPUTER NETWORKS; CREATING INDEXES OF INFORMATION, PHOTOGRAPHS, AND VIDEO, INDEXES OF WEB SITES AND INDEXES OF OTHER INFORMATION SOURCES IN CONNECTION WITH GLOBAL COMPUTER NETWORK; PROVIDING A WEBSITE FEATURING A MEDIA AGGREGATOR AND SEARCH ENGINE FOR INTERNET CONTENT, NAMELY, PROVIDING INFORMATION FROM SEARCHABLE INDEXES AND DATABASES OF INFORMATION, INCLUDING TEXT, ELECTRONIC DOCUMENTS, DATABASES, GRAPHIC AND AUDIO VISUAL INFORMATION, BY MEANS OF GLOBAL COMPUTER INFORMATION NETWORKS; COMPUTER SERVICES, NAMELY, PROVIDING SEARCH ENGINES FOR OBTAINING DATA ON A GLOBAL COMPUTER NETWORK; COMPUTER SERVICES, NAMELY, PROVIDING A WEB-BASED SYSTEMS AND ONLINE PORTAL FOR CUSTOMERS TO REMOTELY MANAGE, SEARCH, ADMINISTER, MODIFY AND CONTROL THEIR END USER COMPUTER DEVICES, DATA AND SOFTWARE APPLICATIONS (U.S. CLS. 100 AND 101).
BENJAMIN OKEKE, EXAMINING ATTORNEY

SN 85-315,601. DR. INTERNS, INC., ROBBINSVILLE, NJ. FILED S.R. 5-9-2011; AM. P.R. 4-12-2012.



NO CLAIM IS MADE TO THE EXCLUSIVE RIGHT TO USE "DR. INTERNS", APART FROM THE MARK AS SHOWN.

THE MARK CONSISTS OF STYLIZED LETTERS "DR. INTERNS" WITH A STETHOSCOPE WRAPPING AROUND THE LETTERS AND THE STETHOSCOPE'S CHESTPIECE FORMING A DOT OF THE WORD "DR".

CLASS 41—EDUCATION AND ENTERTAINMENT

FOR CHARITABLE SERVICES, NAMELY, PROVIDING TRAINING IN THE FIELD OF MEDICAL CARE, HEALTH CARE, AND PATIENT AND COMMUNITY RELATIONS (U.S. CLS. 100, 101 AND 107).

FIRST USE 12-5-2010; IN COMMERCE 12-5-2010.

CLASS 44—MEDICAL, BEAUTY AND AGRICULTURAL SERVICES

FOR CHARITABLE SERVICES, NAMELY, PROVIDING MEDICAL ATTENTION TO THOSE IN DEVELOPING COUNTRIES; CHARITABLE SERVICES, NAMELY, PROVIDING MEDICAL EQUIPMENT AND SERVICES TO UNDERSERVED COMMUNITIES; CHARITABLE SERVICES, NAMELY, PROVIDING MEDICAL SERVICES TO UNDERDEVELOPED COUNTRIES (U.S. CLS. 100 AND 101).

FIRST USE 12-5-2010; IN COMMERCE 12-5-2010.
JOHN WILKE, EXAMINING ATTORNEY

SN 85-316,690. RADICAL SPORTSCARS LIMITED, SPALDING, LINCOLNSHIRE, UNITED KINGDOM, FILED 5-10-2011.



PRIORITY CLAIMED UNDER SEC. 44(D) ON UNITED KINGDOM APPLICATION NO. 2564638, FILED 11-12-2010, REG. NO. 2564638, DATED 2-25-2011, EXPIRES 11-12-2020.

THE MARK CONSISTS OF A RECTANGLE WITH THE LOWER TWO-THIRDS SECTION TERMINATING IN A CONVEX CURVE AT ITS UPPER EDGE AND THE UPPER ONE-THIRD SECTION HAVING ITS LOWER EDGE TERMINATING AT THE CONVEX CURVE. A STYLIZED LETTER "R" OVERLAPPING THE UPPER AND LOWER SECTIONS OF THE RECTANGLE AND HAVING AN OUTLINE ALONG THE LEFT EDGES THEREOF, A STYLIZED WORD "RADICAL" BELOW THE LETTER "R", THE STYLIZED WORD "RADICAL" HAVING AN OUTLINE ALONG THE LEFT EDGES THEREOF, AND AN UNDERLINE WITH AN OUTLINE AT THE LOWER PORTION THEREOF, BENEATH THE WORD "RADICAL".

CLASS 7—MACHINERY

FOR HYDRAULIC LIFTING APPARATUS FOR VEHICLES; EXHAUSTS FOR VEHICLES, NAMELY, ENGINE EXHAUST SYSTEMS COMPRISED OF PIPES, COLLECTOR AND MUFFLER; VEHICLE PUMPS, NAMELY, FUEL PUMPS, OIL PUMPS AND WATER PUMPS FOR LAND VEHICLES; STRUCTURAL PARTS AND FITTINGS FOR ALL THE AFORESAID GOODS AND FOR INTERNAL COMBUSTION ENGINES; MOTOR STARTERS, MOTOR MUFFLERS, BELTS FOR ENGINES, FANS FOR ENGINES, CYLINDERS FOR MOTORS AND ENGINES AND IGNITION DEVICES FOR LAND VEHICLE MOTORS (U.S. CLS. 13, 19, 21, 23, 31, 34 AND 35).

CLASS 12—VEHICLES

FOR MOTOR VEHICLES, NAMELY, AUTOMOBILES AND CARS; RACING AND PERFORMANCE CARS; PARTS FOR CARS, NAMELY, VEHICLE CHASSIS, SUSPENSION SHOCK ABSORBERS FOR VEHICLES, TRANSMISSION SHAFTS FOR LAND VEHICLES, TORQUE CONVERTERS FOR LAND VEHICLES, REAR VIEW MIRRORS; CAR BODY PARTS IN THE NATURE OF BODYWORKS FOR MOTOR VEHICLES; CAR BODY MODIFICATION PARTS FOR SALE IN KIT FORM IN THE NATURE OF AUTOMOTIVE BODY KITS COMPRISING STRUCTURAL PARTS OF AUTOMOBILES; ENGINES FOR CARS; BRAKES FOR MOTOR CARS; HORNS FOR VEHICLES; GEARING FOR LAND VEHICLES; COUPLINGS FOR LAND VEHICLES, NAMELY, GEAR DRIVE UNIT COUPLINGS; VEHICLE SEATS; VEHICLE PARTS, NAMELY, STEERING WHEELS; VEHICLE WHEELS; TIRES; RIMS FOR VEHICLE WHEELS; TIRE VALVES FOR VEHICLE TIRES; VEHICLE BUMPERS BEING AUTOMOTIVE BUMPERS; VEHICLE WINDSCREENS; SAFETY BELTS FOR VEHICLES; VEHICLE ACCESSORIES, NAMELY, VEHICLE CUSTOM GRILLS; LUGGAGE RACKS FOR MOTOR CARS; LAND VEHICLE PARTS, NAMELY, MUD GUARDS; ANTI-SKID CHAINS FOR VEHICLES (U.S. CLS. 19, 21, 23, 31, 35 AND 44).

CLASS 37—CONSTRUCTION AND REPAIR

FOR CONSTRUCTION, REPAIR AND MAINTENANCE OF VEHICLES; CONSTRUCTION, REPAIR AND MAINTENANCE OF RACING CARS; VEHICLE REPAIR SERVICES; VEHICLE BREAKDOWN SERVICE; FITTING AND REPAIRING VEHICLE PARTS AND ACCESSORIES; CLEANING, LUBRICATING, MAINTAINING, POLISHING AND REPAIRING VEHICLES; FITTING AND REPAIRING VEHICLE ACCESSORIES AND SPARE PARTS (U.S. CLS. 100, 103 AND 106).

CLASS 42—SCIENTIFIC AND COMPUTER SERVICES

FOR ENGINEERING SERVICES AND DESIGN SERVICES ALL RELATING TO AUTOMOBILES; AUTOMOBILE DESIGN SERVICES; MOTOR VEHICLE PARTS DESIGN SERVICES; RESEARCH, DEVELOPMENT AND CONSULTATION SERVICES RELATING TO MOTOR LAND VEHICLES AND ENGINES; SMOG TESTING OF MOTOR VEHICLES; INSPECTION OF VEHICLES FOR ROADWORTHINESS, NAMELY, DEVELOPMENT AND TESTING OCCUPANT PROTECTION SYSTEMS FOR MOTOR VEHICLES; AUTOMOTIVE TRANSMISSION DIAGNOSTIC SERVICES FOR VEHICLES (U.S. CLS. 100 AND 101).

NAPOLEON SHARMA, EXAMINING ATTORNEY

SN 85-317,113. FANCL CORPORATION, KANAGAWA-KEN, JAPAN, FILED 5-10-2011.

Cosmetology

THE MARK CONSISTS OF STANDARD CHARACTERS WITHOUT CLAIM TO ANY PARTICULAR FONT, STYLE, SIZE, OR COLOR.

CLASS 30—STAPLE FOODS

FOR RICE; GERMINATED RICE; RICE GRUEL; COOKED OR OTHERWISE PROCESSED RICE; RICE FLOUR; ROASTED AND GROUND RICE, CRACKERS CONSISTING PRIMARILY OF RICE; RICE-BASED SNACK FOODS; FOOD PREPARED GRAINS, NAMELY BREAKFAST CEREALS; FERMENTED SOYBEAN PASTE; GREEN TEA; TEA; PROCESSED TEA IN THE FORM OF POWDERS; PROCESSED DRIED TEA IN THE FORM OF CAPSULES; PROPOLIS FOR FOOD PURPOSES; COFFEE; RICE-BASED COFFEE SUBSTITUTES; CONFECTIONERY, NAMELY, CANDY, CAKES, AND ICE CREAM; CHEWING GUM, NOT FOR MEDICAL PURPOSES; COOKIES; PUDDINGS; BREAD AND BUNS; FROZEN YOGURT; CEREAL PREPARATIONS, NAMELY, PROCESSED BASED SNACK FOODS; NOODLES; SEASONINGS AND CONDIMENTS, NAMELY, WORCESTERSHIRE SAUCE, SOY SAUCE, SALAD DRESSINGS; SUGAR; COOKING SALT; VINEGAR; READY-TO-EAT PREPARED ENTREES CONSISTING PRIMARILY OF SEASONED STEAMED RICE WITH VEGETABLES AND MEAT; READY-TO-EAT PREPARED ENTREES CONSISTING PRIMARILY OF SEASONED STEAMED RICE WITH VEGETABLES; READY-TO-EAT PREPARED ENTREES CONSISTING PRIMARILY OF SEASONED STEAMED RICE WITH CRAB; ALMOND PASTE; PROCESSED HERBS; MOLASSES FOR FOOD; ROYAL JELLY FOR HUMAN CONSUMPTION, NOT FOR MEDICAL PURPOSES (U.S. CL. 46).

CLASS 32—LIGHT BEVERAGES

FOR NON-ALCOHOLIC BEVERAGES, NAMELY, NON-ALCOHOLIC FRUIT-FLAVORED BEVERAGES, NON-ALCOHOLIC FRUIT JUICE BEVERAGES, NON-ALCOHOLIC VEGETABLE BEVERAGES, NON-ALCOHOLIC FRUIT-FLAVORED BEVERAGES CONTAINING COLLAGEN, NON-ALCOHOLIC BEVERAGES CONTAINING VINEGAR; POWDERS FOR THE PREPARATION OF NON-ALCOHOLIC VEGETABLE BEVERAGES; MINERAL AND AERATED WATERS; BEVERAGES ENRICHED WITH ADDED VITAMINS OR MINERALS; BEVERAGES FOR USE AS AIDS TO DIETING; NON-ALCOHOLIC LOW CALORIE CONTENT BEVERAGES; NON-MEDICATED BEVERAGES FOR USE AS PART OF A CALORIE CONTROLLED DIET; SOFT DRINKS (U.S. CLS. 45, 46 AND 48).

MARK T. MULLEN, EXAMINING ATTORNEY

SN 85-317,114. NATIONAL FOOTBALL MUSEUM INC., DBA THE PROFESSIONAL FOOTBALL HALL OF FAME, THE PRO FOOTBALL HALL OF FAME, AND PROFESSIONAL FOOTBALL'S HALL OF FAME, CANTON, OH. FILED 5-10-2011.



OWNER OF U.S. REG. NOS. 1,009,603, 1,025,909 AND 1,025,910.

NO CLAIM IS MADE TO THE EXCLUSIVE RIGHT TO USE "PRO FOOTBALL" AND "CANTON, OHIO", APART FROM THE MARK AS SHOWN.

THE MARK CONSISTS OF A STYLIZED REPRESENTATION OF A BUILDING INSIDE A POLYGON. THE WORDS "PRO FOOTBALL," "HALL OF FAME" AND "CANTON OHIO" ARE BENEATH THE STYLIZED BUILDING DESIGN IN 3 SEPARATE BANNERS READING TOP TO BOTTOM.

SEC. 2(F) AS TO "HALL OF FAME".

CLASS 9—ELECTRICAL AND SCIENTIFIC APPARATUS

FOR VIDEO GAMES AND VIDEO MEDIA, NAMELY, INTERACTIVE VIDEO GAME PROGRAMS, AND COMPUTER PROGRAMS FOR VIDEO GAMES; DIGITAL MEDIA, NAMELY, PRE-RECORDED DVDS, DOWNLOADABLE AUDIO AND VIDEO RECORDINGS, AND CDS FEATURING AND PROMOTING THE PRO FOOTBALL HALL OF FAME ENSHRINEMENT CEREMONY; FULL-SIZED FOOTBALL HELMETS; AND MAGNETS (U.S. CLS. 21, 23, 26, 36 AND 38).

FIRST USE 9-1-1996; IN COMMERCE 9-1-1996.

CLASS 14—JEWELRY

FOR JEWELRY AND COLLECTIBLE COINS (U.S. CLS. 2, 27, 28 AND 50).

FIRST USE 9-1-1996; IN COMMERCE 9-1-1996.

CLASS 16—PAPER GOODS AND PRINTED MATTER

FOR BOOKS AND MAGAZINES IN THE FIELD OF PROFESSIONAL FOOTBALL; CARDS, NAMELY, SPORTS TRADING CARDS; POSTERS AND STICKERS; PENS AND PENCILS (U.S. CLS. 2, 5, 22, 23, 29, 37, 38 AND 50).

FIRST USE 9-1-1996; IN COMMERCE 9-1-1996.

CLASS 21—HOUSEWARES AND GLASS

FOR BEVERAGE GLASSWARE (U.S. CLS. 2, 13, 23, 29, 30, 33, 40 AND 50).

FIRST USE 9-1-1996; IN COMMERCE 9-1-1996.

CLASS 25—CLOTHING

FOR CLOTHING, NAMELY, SHORTS, SOCKS, TIES, CAPS, AND SHIRTS, NAMELY, T-SHIRTS, POLO SHIRTS, DRESS SHIRTS, SWEATSHIRTS AND JERSEYS (U.S. CLS. 22 AND 39).

FIRST USE 9-1-1996; IN COMMERCE 9-1-1996.

CLASS 26—FANCY GOODS

FOR ORNAMENTAL NOVELTY PINS (U.S. CLS. 37, 39, 40, 42 AND 50).

FIRST USE 9-1-1996; IN COMMERCE 9-1-1996.

CLASS 28—TOYS AND SPORTING GOODS

FOR COLLECTIBLE TOYS, NAMELY, FULL-SIZED REPLICA FOOTBALL HELMETS AND MINI COLLECTOR FOOTBALL HELMETS, COLLECTIBLE TOY FIGURES, COLLECTIBLE TOY CARS, COLLECTIBLE PLUSH TOYS, COLLECTIBLE TOY BALLS, COLLECTIBLE TOY FOOTBALLS, AND COLLECTIBLE TOY SNOW GLOBES (U.S. CLS. 22, 23, 38 AND 50).

FIRST USE 9-1-1996; IN COMMERCE 9-1-1996.

CLASS 41—EDUCATION AND ENTERTAINMENT

FOR EDUCATIONAL AND ENTERTAINMENT SERVICES IN THE FORM OF A MEMORIAL EXHIBITION AND MUSEUM AND PERIODIC SPECIAL FEATURES RELATING TO PROFESSIONAL FOOTBALL AND ITS HISTORY; ENTERTAINMENT IN THE NATURE OF PROFESSIONAL FOOTBALL GAMES; ENTERTAINMENT IN THE NATURE OF FOOTBALL EXHIBITIONS AND FOOTBALL ENSHRINEMENT CEREMONIES; ENTERTAINMENT SERVICES, NAMELY, THE PROVISION OF CONTINUING TELEVISION SHOWS FEATURING SPORTS (U.S. CLS. 100, 101 AND 107).

FIRST USE 9-1-1996; IN COMMERCE 9-1-1996.

MARK T. MULLEN, EXAMINING ATTORNEY

SN 85-318,080. CASPER DESIGN GROUP, INC., AKA LENS CULTURE, BERKELEY, CA. FILED 5-11-2011.

Lens Culture

THE MARK CONSISTS OF STANDARD CHARACTERS WITHOUT CLAIM TO ANY PARTICULAR FONT, STYLE, SIZE, OR COLOR.

CLASS 35—ADVERTISING AND BUSINESS

FOR ARRANGING AND CONDUCTING BUSINESS CONFERENCES; ON-LINE ART GALLERIES (U.S. CLS. 100, 101 AND 102).

FIRST USE 4-1-2004; IN COMMERCE 4-1-2004.

CLASS 41—EDUCATION AND ENTERTAINMENT

FOR ARRANGING AND CONDUCTING EDUCATIONAL CONFERENCES; ARRANGING OF CONTESTS; ON-LINE JOURNALS, NAMELY, BLOGS FEATURING INFORMATION AND LINKS ABOUT PHOTOGRAPHY AND MULTIMEDIA COMMUNICATIONS, ARTS EVENTS AND EXHIBITIONS.; ORGANIZATION OF EXHIBITIONS FOR CULTURAL OR EDUCATIONAL PURPOSES; ORGANIZING CULTURAL AND ARTS EVENTS (U.S. CLS. 100, 101 AND 107).

FIRST USE 4-1-2004; IN COMMERCE 4-1-2004.
MARTHA FROMM, EXAMINING ATTORNEY

CLASS 35—ADVERTISING AND BUSINESS

FOR MARKETING AND PROMOTION OF TELEVISION PROGRAMMING AND MOTION PICTURES OF OTHERS; WHOLESALE DISTRIBUTORSHIP SERVICES FOR OTHERS IN THE FIELD OF ENTERTAINMENT FEATURING TELEVISION PROGRAMS AND MOTION PICTURES; ONLINE RETAIL STORE SERVICES AND MAIL ORDER SERVICES FEATURING HOUSEHOLD ITEMS, DVDS, COMPACT DISCS, AUDIO DISCS, BOOKS, MAGAZINES, HEADPHONES, DOCKING STATIONS FOR HANDHELD ELECTRONICS, UNIVERSAL REMOTES, VIDEOGAMES, FLASHLIGHTS, BAGS, BACKPACKS, GHOST HUNTING KITS, BANDANAS, GLOVES, HATS, CLOTHING, ELECTRONICS, TELESCOPES, MUGS, GLASSES, SHOT GLASSES, EXERCISE EQUIPMENT, WATER BOTTLES, MODELS FOR VEHICLES, MODELS FOR SHIPS, MODELS FOR AIRCRAFT, SPORTS ITEMS, PRINTS, GLOBES, MAPS, STAMPS, COINS, MOUSEPADS, WATCHES, JEWELRY, WRISTBANDS, BOBBLEHEADS, TOYS, GAMES, PUZZLES; PROVIDING SERVICES OF SELECTION OF MUSIC FOR USE IN TELEVISION ADVERTISEMENTS (U.S. CLS. 100, 101 AND 102).

CLASS 38—COMMUNICATION

FOR BROADCASTING SERVICES, NAMELY, TELEVISION BROADCASTING, VIDEO BROADCASTING, INTERNET BROADCASTING, AUDIO BROADCASTING AND SUBSCRIPTION TELEVISION BROADCASTING; SATELLITE TRANSMISSION SERVICES; ELECTRONIC TRANSMISSION OF DATA VIA SATELLITE LINK; ELECTRONIC TRANSMISSION OF DATA AND DOCUMENTS VIA COMPUTER NETWORKS; VIDEO-ON-DEMAND TRANSMISSION SERVICES; WIRELESS COMMUNICATION SERVICES, NAMELY, TRANSMISSION OF TELEVISION PROGRAMS AND MOTION PICTURES TO MOBILE DEVICES; PROVIDING ONLINE CHAT ROOMS AND ELECTRONIC BULLETIN BOARDS FOR THE ELECTRONIC TRANSMISSION OF MESSAGES AMONG USERS IN THE FIELDS OF BROADCAST ENTERTAINMENT AND GENERAL INTEREST; PROVIDING MULTIPLE USER ACCESS TO A GLOBAL COMPUTER INFORMATION NETWORK (U.S. CLS. 100, 101 AND 104).

CLASS 41—EDUCATION AND ENTERTAINMENT

FOR PRODUCTION AND DISTRIBUTION OF TELEVISION PROGRAMS AND MOTION PICTURES; AUDIO RECORDING PRODUCTION SERVICES; PRODUCTION OF TELEVISION PROGRAMS, MOTION PICTURES AND AUDIO RECORDINGS FOR USE IN INTERNET BROADCASTS, WEBCASTS OR FOR TRANSMISSION TO WIRELESS MOBILE DEVICES; SCHEDULING OF TELEVISION PROGRAMMING FOR OTHERS; PROVIDING A WEBSITE FEATURING ENTERTAINMENT PROGRAMMING CONCERNING MATTERS OF GENERAL INTEREST PROVIDED VIA INTERNET BROADCASTS OR VIA WIRELESS MOBILE DEVICES BY THE BROADCASTING INDUSTRY; PROVIDING A WEBSITE IN THE FIELD OF ARTS AND ENTERTAINMENT FEATURING CURRENT-EVENTS NEWS AND STORIES DEALING WITH THE ACHIEVEMENTS OF NOTABLE PEOPLE; EDUCATIONAL AND ENTERTAINMENT SERVICES, NAMELY, PROVIDING EDUCATIONAL PROGRAMS VIA TRANSMISSION BY RADIO, TELEVISION, SATELLITE, OR WIRELESS AND COMPUTER NETWORKS IN THE AREAS OF HISTORY, MILITARY HISTORY, BIOGRAPHIES, CRIME AND INVESTIGATIONS OF CRIMES, THE ARTS, THE PERFORMING ARTS, FILM, LITERATURE, AND TRAVEL; EDUCATIONAL AND ENTERTAINMENT SERVICES, NAMELY, PRODUCTION OF MOTION PICTURE FILMS AND TELEVISION SERIES RELATING TO A WIDE RANGE OF EDUCATION AND ENTERTAINMENT SUBJECTS; EDUCATIONAL AND ENTERTAINMENT SERVICES, NAMELY, CLASSES AND INFORMATION IN THE FIELDS OF HISTORY, HISTORICAL SETTINGS, HISTORICAL DRAMAS, HISTORICAL DOCUMENTARIES, HISTORIC INDIVIDUALS, HISTORICAL SUBJECTS, NEWS, MUSIC, RENDERED THROUGH A GLOBAL COMPUTER NETWORK, FEATURING MULTIMEDIA PRESENTATIONS INCORPORATING TEXT, SOUND, MUSIC, AND STILL AND MOVING IMAGES; PROVID-

SN 85-318,368. A&E TELEVISION NETWORKS, LLC, NEW YORK, NY. FILED 5-11-2011.



OWNER OF U.S. REG. NOS. 1,845,909 AND 3,662,347.
NO CLAIM IS MADE TO THE EXCLUSIVE RIGHT TO USE "NETWORKS", APART FROM THE MARK AS SHOWN.

THE COLOR(S) PINK, ORANGE, CYAN, BLUE, WHITE AND GRAY IS/ARE CLAIMED AS A FEATURE OF THE MARK.

THE MARK CONSISTS OF THE LETTERS "A" AND "E" IN BLUE STYLIZED FONT WITH A MODERN VERSION OF THE PLUS SIGN BETWEEN THE LETTERS "A" AND "E" AND THE WORD "NETWORKS" IN BLUE STYLIZED FONT BENEATH IT, ALL ON A WHITE-AND-GRAY CHECKERED BACKGROUND. THE PLUS SIGN HAS A PINK WESTERN LEG, ORANGE SOUTHERN LEG, CYAN EASTERN LEG, AND BLUE NORTHERN LEG.

CLASS 9—ELECTRICAL AND SCIENTIFIC APPARATUS

FOR DIGITAL MEDIA IN THE FORM OF DVDS, DOWNLOADABLE WEBCASTS, AUDIO AND VIDEO FILES, AND DOWNLOADS TO MOBILE DEVICES, ALL FEATURING TELEVISION PROGRAMS AND MOTION PICTURES OF GENERAL INTEREST; DOWNLOADABLE ELECTRONIC PUBLICATIONS IN THE NATURE OF NEWSLETTERS IN THE FIELD OF TELEVISION PROGRAMS, TELEVISION BROADCASTING, AND MOTION PICTURES; MUSICAL SOUND RECORDINGS (U.S. CLS. 21, 23, 26, 36 AND 38).

ING INFORMATION RELATING TO ONLINE COMPUTER GAMES RENDERED THROUGH A GLOBAL COMPUTER NETWORK; PROVIDING ONLINE COMPUTER GAMES. PROVIDING ON-LINE DATABASES AND LINKS TO WEB SITES OF OTHER CONTENT PROVIDERS FEATURING EDUCATIONAL TOPICS RELATING TO HISTORY, HISTORICAL SETTINGS, HISTORICAL DRAMAS, HISTORICAL DOCUMENTARIES, HISTORICAL SUBJECTS AND INDIVIDUALS, AND HISTORICAL EVENTS VIA A GLOBAL COMPUTER NETWORK; PROVIDING EDUCATIONAL INFORMATION REGARDING HISTORY, HISTORICAL SETTINGS, HISTORICAL DRAMAS, HISTORICAL DOCUMENTARIES, HISTORICAL SUBJECTS AND INDIVIDUALS, AND HISTORICAL EVENTS BY MEANS OF A GLOBAL COMPUTER NETWORK; EDUCATIONAL SERVICES, NAMELY, PROVIDING INFORMATION AND LESSONS IN THE FIELDS OF HISTORY, HISTORICAL SETTINGS, HISTORICAL DRAMAS, HISTORICAL DOCUMENTARIES, HISTORICAL SUBJECTS AND INDIVIDUALS, AND HISTORICAL EVENTS; NEWS, AND MUSIC, INCORPORATING EDUCATIONAL DIGITAL MEDIA TO SCHOOLS AND COMMUNITY ORGANIZATIONS; MUSIC PUBLISHING SERVICES; PROVIDING INFORMATION ABOUT PERFORMANCES OF MUSICAL ARTISTS BY MEANS OF A GLOBAL COMPUTER INFORMATION NETWORK; MUSIC PRODUCTION FOR USE IN THE PRODUCTION OF TELEVISION SHOWS, MOTION PICTURES, AND MUSIC VIDEOS; MUSIC PRODUCTION FOR IN-HOUSE PRODUCTIONS OF OTHERS USED FOR ENTERTAINMENT IN THE NATURE OF TELEVISION SHOWS, MOTION PICTURES, MUSIC VIDEOS, WEBCASTS, PODCASTS, DISCUSSION BOARDS, AND MOBILE NETWORKS (U.S. CLS. 100, 101 AND 107).

CLASS 45—PERSONAL AND LEGAL SERVICES

FOR LICENSING OF TELEVISION PROGRAMS, MOTION PICTURES AND AUDIO MUSICAL PERFORMANCES FOR USE BY TELEVISION BROADCASTERS, WEBCASTERS, OPERATORS, AND THE HOME VIDEO AND EDUCATIONAL VIDEO MARKETS; LICENSING OF ENTERTAINMENT MERCHANDISING IN THE NATURE OF TELEVISION PROGRAMS, TELEVISION BROADCASTING, AND MOTION PICTURES (U.S. CLS. 100 AND 101).

BRENDAN REGAN, EXAMINING ATTORNEY

SN 85-319,823. RICHARD REID PRODUCTIONS, INC., WOODLAND HILLS, CA. FILED 5-12-2011.

DIASPORA

THE MARK CONSISTS OF STANDARD CHARACTERS WITHOUT CLAIM TO ANY PARTICULAR FONT, STYLE, SIZE, OR COLOR.

CLASS 21—HOUSEWARES AND GLASS

FOR MUGS (U.S. CLS. 2, 13, 23, 29, 30, 33, 40 AND 50).

CLASS 24—FABRICS

FOR TOWELS (U.S. CLS. 42 AND 50).
BRENDAN MCCAULEY, EXAMINING ATTORNEY

SN 85-321,565. THE TRUSTEES FOR THE TIME BEING OF THE SOCIETY OF JESUS - IRISH PROVINCE, AN IRISH TRUST, THE TRUSTEES COMPRISING FR. CHARLES DAVY, A REPUBLIC OF IRELAND CITIZEN; FR. GERARD O'HANLON, A REPUBLIC OF IRELAND CITIZEN; AND FR. WILLIAM TONER, A REPUBLIC OF IRELAND CITIZEN, DUBLIN 6, IRELAND, FILED 5-16-2011.

SACRED SPACE

THE MARK CONSISTS OF STANDARD CHARACTERS WITHOUT CLAIM TO ANY PARTICULAR FONT, STYLE, SIZE, OR COLOR.

PRIORITY CLAIMED UNDER SEC. 44(D) ON IRELAND APPLICATION NO. 2010/01985, FILED 11-16-2010, REG. NO. 244668, DATED 11-16-2010, EXPIRES 11-16-2020.

CLASS 9—ELECTRICAL AND SCIENTIFIC APPARATUS

FOR MOBILE PHONES; PRE-RECORDED DVD'S FEATURING RELIGION, SPIRITUALITY AND PRAYER; ELECTRONIC PUBLICATIONS, NAMELY, MAGAZINES AND NEWSLETTERS FEATURING RELIGION, SPIRITUALITY AND PRAYER, RECORDED ON COMPUTER MEDIA (U.S. CLS. 21, 23, 26, 36 AND 38).

CLASS 16—PAPER GOODS AND PRINTED MATTER

FOR PRAYER BOOKS; PRINTED MATTER, NAMELY, BOOKS, NEWSLETTERS, PERIODICALS AND MAGAZINES IN THE FIELD OF RELIGION, PRAYER AND SPIRITUALITY; PHOTOGRAPHS; STATIONERY; PRINTED INSTRUCTIONAL AND TEACHING MATERIALS IN THE FIELD OF RELIGION, PRAYER AND SPIRITUALITY (U.S. CLS. 2, 5, 22, 23, 29, 37, 38 AND 50).

CLASS 41—EDUCATION AND ENTERTAINMENT

FOR EDUCATIONAL SERVICES, NAMELY, PROVIDING COURSES OF INSTRUCTION IN THE FIELD OF RELIGION AND SPIRITUALITY; HOLDING AND CONDUCTING SPIRITUAL AND RELIGIOUS EDUCATIONAL CONVENTIONS, CONFERENCES, CLASSES AND SYMPOSIUMS (U.S. CLS. 100, 101 AND 107).

CLASS 45—PERSONAL AND LEGAL SERVICES

FOR CONDUCTING RELIGIOUS PRAYER SERVICES, NAMELY, CONDUCTING PRAYER MEETINGS AND SPIRITUAL AND RELIGIOUS CONVENTIONS; CONDUCTING OF PRAYER ON-LINE SERVICES; RELIGIOUS AND SPIRITUAL SERVICES, NAMELY, PRAYER MEETINGS; ADVISORY SERVICES IN THE FIELD OF PRAYER MEETINGS; ONLINE SOCIAL NETWORKING SERVICES IN THE FIELD OF PRAYER (U.S. CLS. 100 AND 101).

KAPIL BHANOT, EXAMINING ATTORNEY

SN 85-322,141. XYNERGY, INC., SANTA FE, NM. FILED 5-16-2011.



THE MARK CONSISTS OF THE WORDING "XYNERGY" AND A DESIGN OF A LETTER "X" WITH ITS SHADOW.

CLASS 35—ADVERTISING AND BUSINESS

FOR DEVELOPMENT OF MARKETING STRATEGIES, CONCEPTS AND TACTICS, NAMELY, AUDIENCE DEVELOPMENT, BRAND AWARENESS, CUSTOMER RELATIONS, ONLINE COMMUNITY BUILDING AND DIGITAL WORD OF MOUTH COMMUNICATIONS (U.S. CLS. 100, 101 AND 102).

FIRST USE 12-2-1994; IN COMMERCE 0-0-1995.

CLASS 42—SCIENTIFIC AND COMPUTER SERVICES

FOR CREATION, DESIGN, DEVELOPMENT AND MAINTENANCE OF WEB SITES FOR THIRD PARTIES (U.S. CLS. 100 AND 101).

FIRST USE 12-2-1994; IN COMMERCE 0-0-1995.
SEAN CROWLEY, EXAMINING ATTORNEY

SN 85-323,695. ATLANCO, INC., MARIETTA, GA. FILED 5-18-2011.

ATLANCO

THE MARK CONSISTS OF STANDARD CHARACTERS WITHOUT CLAIM TO ANY PARTICULAR FONT, STYLE, SIZE, OR COLOR.

OWNER OF U.S. REG. NOS. 1,463,146 AND 3,444,809.

CLASS 18—LEATHER GOODS

FOR DUFFEL BAGS MADE FROM TEXTILE AND POUCHES MADE FROM TEXTILE (U.S. CLS. 1, 2, 3, 22 AND 41).

FIRST USE 12-2-1985; IN COMMERCE 12-2-1985.

CLASS 22—CORDAGE AND FIBERS

FOR CORD (U.S. CLS. 1, 2, 7, 19, 22, 42 AND 50).

FIRST USE 12-2-1985; IN COMMERCE 12-2-1985.

CLASS 25—CLOTHING

FOR CLOTHING, NAMELY, HEADWEAR, SHIRTS, PANTS, BELTS, SOCKS, GLOVES; OUTERWEAR, NAMELY, COATS AND JACKETS (U.S. CLS. 22 AND 39).

FIRST USE 12-2-1985; IN COMMERCE 12-2-1985.
CARYN GLASSER, EXAMINING ATTORNEY

SN 85-323,768. WEBSTER, CHRIS P., REDONDO BEACH, CA. FILED 5-18-2011.



THE MARK CONSISTS OF THE CAPITAL LETTER "M" WITH A DRAWING OF A SCORPION IN THE "V" PART OF THE MIDDLE OF THE "M" WITH OUTSTRETCHED CLAWS AND THE TAIL ABOVE THE WORD "MOTIV" IN CAPITAL LETTERS.

CLASS 12—VEHICLES

FOR VEHICLE WHEEL RIMS; VEHICLE WHEEL COVERS; FITTED LINERS FOR THE CARGO AREA OF VEHICLES; AUTOMOBILE SUNROOFS; AUTOMOBILE WINDSHIELD SUNSHADES; SKI, BICYCLE, AND LUGGAGE RACKS FOR VEHICLES; GOLF CART WHEEL RIMS; HUB CAPS; FITTED AND SEMI-FITTED COVERS FOR VEHICLES; VEHICLE SEAT COVERS; VEHICLE SEATS; AND TIRES (U.S. CLS. 19, 21, 23, 31, 35 AND 44).

FIRST USE 10-22-2000; IN COMMERCE 1-1-2001.

CLASS 25—CLOTHING

FOR CLOTHING, NAMELY, SHIRTS, SHORTS, BATHING SUITS, BEACH WEAR, BIKINIS, SUN-SUITS, SNOWBOARD BOOTS, SNOWBOARD GLOVES, APRONS, ATHLETIC FOOTWEAR, GYM SHORTS, GYM SUITS, JEANS, T-SHIRTS, PANTS, LEATHER JACKETS, SKIRTS, SOCKS, AND UNDERWEAR (U.S. CLS. 22 AND 39).

FIRST USE 1-1-2001; IN COMMERCE 1-1-2001.

MARGARET POWER, EXAMINING ATTORNEY

SN 85-323,985. J'A GROUP HOLDINGS, LLC, BRENTWOOD, TN. FILED 5-18-2011.

BOBBY PANDA

THE MARK CONSISTS OF STANDARD CHARACTERS WITHOUT CLAIM TO ANY PARTICULAR FONT, STYLE, SIZE, OR COLOR.

THE NAME "BOBBY PANDA" DOES NOT IDENTIFY A LIVING INDIVIDUAL.

CLASS 28—TOYS AND SPORTING GOODS

FOR STUFFED TOY ANIMALS (U.S. CLS. 22, 23, 38 AND 50).

CLASS 36—INSURANCE AND FINANCIAL

FOR FINANCIAL AND MONETARY AFFAIRS, NAMELY, ELECTRONIC FINANCIAL TRANSACTION PROCESSING SERVICES; ELECTRONIC TRANSFER OF MONEY; ELECTRONIC FINANCIAL TRANSACTION PROCESSING SERVICES VIA ELECTRONIC COMMUNICATIONS NETWORKS (U.S. CLS. 100, 101 AND 102).

ASMAT KHAN, EXAMINING ATTORNEY

SN 85-324,596. A&E TELEVISION NETWORKS, LLC, NEW YORK, NY. FILED 5-19-2011.



THE COLOR(S) PINK, ORANGE, CYAN, BLUE, WHITE AND GRAY IS/ARE CLAIMED AS A FEATURE OF THE MARK.

THE MARK CONSISTS OF A DECONSTRUCTED PLUS SIGN HAVING PINK WESTERN LEG, ORANGE SOUTHERN LEG, CYAN EASTERN LEG, AND BLUE NORTHERN LEG, ALL ON A WHITE-AND-GRAY CHECKERED BACKGROUND.

CLASS 9—ELECTRICAL AND SCIENTIFIC APPARATUS

FOR DIGITAL MEDIA IN THE FORM OF DVDS, DOWNLOADABLE WEBCASTS, AUDIO AND VIDEO FILES, AND DOWNLOADS TO MOBILE DEVICES, ALL FEATURING TELEVISION PROGRAMS AND MOTION PICTURES OF GENERAL INTEREST; DOWNLOADABLE ELECTRONIC PUBLICATIONS IN THE NATURE OF NEWSLETTERS IN THE FIELD OF TELEVISION PROGRAMS, TELEVISION BROADCASTING, AND MOTION PICTURES; MUSICAL SOUND RECORDINGS (U.S. CLS. 21, 23, 26, 36 AND 38).

CLASS 35—ADVERTISING AND BUSINESS

FOR MARKETING AND PROMOTION OF TELEVISION PROGRAMMING AND MOTION PICTURES OF OTHERS; WHOLESALE DISTRIBUTORSHIP SERVICES FOR OTHERS IN THE FIELD OF ENTERTAINMENT FEATURING TELEVISION PROGRAMS AND MOTION PICTURES; ONLINE RETAIL STORE SERVICES AND MAIL ORDER SERVICES FEATURING HOUSEHOLD ITEMS, DVDS, COMPACT DISCS, AUDIO DISCS, BOOKS, MAGAZINES, HEADPHONES, DOCKING STATIONS FOR HANDHELD ELECTRONICS, UNIVERSAL REMOTES, VIDEOGAMES, FLASHLIGHTS, BAGS, BACKPACKS, GHOST HUNTING KITS, BANDANAS, GLOVES, HATS, CLOTHING, ELECTRONICS, TELESCOPES, MUGS, GLASSES, SHOT GLASSES, EXERCISE EQUIPMENT, WATER BOTTLES, MODELS FOR VEHICLES, MODELS FOR SHIPS, MODELS FOR AIRCRAFT, SPORTS ITEMS, PRINTS, GLOBES, MAPS, STAMPS, COINS, MOUSEPADS, WATCHES, JEWELRY, WRISTBANDS, BOBBLEHEADS, TOYS, GAMES, PUZZLES; PROVIDING SERVICES OF SELECTION OF MUSIC FOR USE IN TELEVISION ADVERTISEMENTS (U.S. CLS. 100, 101 AND 102).

CLASS 38—COMMUNICATION

FOR BROADCASTING SERVICES, NAMELY, TELEVISION BROADCASTING, VIDEO BROADCASTING, INTERNET BROADCASTING, AUDIO BROADCASTING AND SUBSCRIPTION TELEVISION BROADCASTING; SATELLITE TRANSMISSION SERVICES; ELECTRONIC TRANSMISSION OF DATA VIA SATELLITE LINK; ELECTRONIC TRANSMISSION OF DATA AND DOCUMENTS VIA COMPUTER NETWORKS; VIDEO-ON-DEMAND TRANSMISSION SERVICES; WIRELESS COMMUNICATION SERVICES, NAMELY, TRANSMISSION OF TELEVISION PROGRAMS AND MOTION PICTURES TO MOBILE DEVICES; PROVIDING ONLINE CHAT ROOMS AND ELECTRONIC BULLETIN BOARDS FOR THE ELECTRONIC TRANSMISSION OF MESSAGES AMONG USERS IN THE FIELDS OF BROADCAST ENTERTAINMENT AND GENERAL INTEREST; PROVIDING MULTIPLE USER ACCESS TO A GLOBAL COMPUTER INFORMATION NETWORK (U.S. CLS. 100, 101 AND 104).

CLASS 41—EDUCATION AND ENTERTAINMENT

FOR PRODUCTION AND DISTRIBUTION OF TELEVISION PROGRAMS AND MOTION PICTURES; AUDIO RECORDING PRODUCTION SERVICES; PRODUCTION OF TELEVISION PROGRAMS, MOTION PICTURES AND AUDIO RECORDINGS FOR USE IN INTERNET BROADCASTS, WEBCASTS OR FOR TRANSMISSION TO WIRELESS MOBILE DEVICES; SCHEDULING OF TELEVISION PROGRAMMING FOR OTHERS; PROVIDING A WEBSITE FEATURING ENTERTAINMENT PROGRAMMING CONCERNING MATTERS OF GENERAL INTEREST PROVIDED VIA INTERNET BROADCASTS OR VIA WIRELESS MOBILE DEVICES BY THE BROADCASTING INDUSTRY; PROVIDING A WEBSITE IN THE FIELD OF ARTS AND ENTERTAINMENT FEATURING CURRENT-EVENTS NEWS AND STORIES DEALING WITH THE ACHIEVEMENTS OF NOTABLE PEOPLE; EDUCATIONAL AND ENTERTAINMENT SERVICES, NAMELY, PROVIDING EDUCATIONAL PROGRAMS VIA TRANSMISSION BY RADIO, TELEVISION, SATELLITE, OR WIRELESS AND COMPUTER NETWORKS IN THE AREAS OF HISTORY, MILITARY HISTORY, BIOGRAPHIES, CRIME AND INVESTIGATIONS OF CRIMES, THE ARTS, THE PERFORMING ARTS, FILM, LITERATURE, AND TRAVEL; EDUCATIONAL AND ENTERTAINMENT SERVICES, NAMELY, PRODUCTION OF MOTION PICTURE FILMS AND TELEVISION SERIES RELATING TO A WIDE RANGE OF EDUCATION AND ENTERTAINMENT SUBJECTS; EDUCATIONAL AND ENTERTAINMENT SERVICES, NAMELY, CLASSES AND INFORMATION IN THE FIELDS OF HISTORY, HISTORICAL SETTINGS, HISTORICAL DRAMAS, HISTORICAL DOCUMENTARIES, HISTORIC INDIVIDUALS, HISTORICAL SUBJECTS, NEWS, MUSIC, RENDERED THROUGH A GLOBAL COMPUTER NETWORK, FEATURING MULTIMEDIA PRESENTATIONS INCORPORATING TEXT, SOUND, MUSIC, AND STILL AND MOVING IMAGES; PROVIDING INFORMATION RELATING TO ONLINE COMPUTER GAMES RENDERED THROUGH A GLOBAL COMPUTER NETWORK; PROVIDING ONLINE COMPUTER GAMES, PROVIDING ON-LINE DATABASES AND LINKS TO WEB SITES OF OTHER CONTENT PROVIDERS FEATURING EDUCATIONAL TOPICS RELATING TO HISTORY, HISTORICAL SETTINGS, HISTORICAL DRAMAS, HISTORICAL DOCUMENTARIES, HISTORICAL SUBJECTS AND INDIVIDUALS, AND HISTORICAL EVENTS VIA A GLOBAL COMPUTER NETWORK; PROVIDING EDUCATIONAL INFORMATION REGARDING HISTORY, HISTORICAL SETTINGS, HISTORICAL DRAMAS, HISTORICAL DOCUMENTARIES, HISTORICAL SUBJECTS AND INDIVIDUALS, AND HISTORICAL EVENTS BY MEANS OF A GLOBAL COMPUTER NETWORK; EDUCATIONAL SERVICES, NAMELY, PROVIDING INFORMATION AND LESSONS IN THE FIELDS OF HISTORY, HISTORICAL SETTINGS, HISTORICAL DRAMAS, HISTORICAL DOCUMENTARIES, HISTORIC INDIVIDUALS, HISTORICAL SUBJECTS, NEWS, AND MUSIC, INCORPORATING EDUCATIONAL DIGITAL MEDIA TO SCHOOLS AND COMMUNITY ORGANIZATIONS; MUSIC PUBLISHING SERVICES; PROVIDING INFORMATION ABOUT PERFORMANCES OF MUSICAL ARTISTS BY MEANS OF A GLOBAL COMPUTER INFORMATION NETWORK; MU-

SIC PRODUCTION FOR USE IN THE PRODUCTION OF TELEVISION SHOWS, MOTION PICTURES, AND MUSIC VIDEOS; MUSIC PRODUCTION FOR IN-HOUSE PRODUCTIONS OF OTHERS USED FOR ENTERTAINMENT IN THE NATURE OF TELEVISION SHOWS, MOTION PICTURES, MUSIC VIDEOS, WEBCASTS, PODCASTS, DISCUSSION BOARDS, AND MOBILE NETWORKS (U.S. CLS. 100, 101 AND 107).

CLASS 45—PERSONAL AND LEGAL SERVICES

FOR LICENSING OF TELEVISION PROGRAMS, MOTION PICTURES AND AUDIO MUSICAL PERFORMANCES FOR USE BY TELEVISION BROADCASTERS, WEBCASTERS, OPERATORS, AND THE HOME VIDEO AND EDUCATIONAL VIDEO MARKETS; LICENSING OF ENTERTAINMENT MERCHANDISING IN THE NATURE OF TELEVISION PROGRAMS, TELEVISION BROADCASTING, AND MOTION PICTURES (U.S. CLS. 100 AND 101).

BRENDAN REGAN, EXAMINING ATTORNEY

SN 85-326,373. KORBAN MUSIC GROUP, LLC, GROESBECK, TX. FILED 5-20-2011.

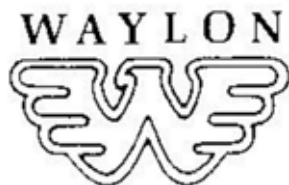

THE MARK CONSISTS OF THE LITERAL ELEMENTS "WAYLON" WHEREIN THE IMAGE CONSISTS OF A LETTER "W" IN THE FORM OF WINGED BIRD BELOW IT AS SHOWN IN THE MARK.

CLASS 35—ADVERTISING AND BUSINESS

FOR RECORD LABEL SERVICES, NAMELY, PERFORMING ARTIST MANAGEMENT, MUSIC BUSINESS MANAGEMENT, MUSIC BUSINESS MARKETING; MUSIC DISTRIBUTION SERVICES, NAMELY, DISTRIBUTORSHIP IN THE FIELD OF RECORDS; RECORD LABEL DEVELOPMENT, NAMELY, BUSINESS MANAGEMENT; PROMOTING THE CONCERTS OF OTHERS; PRODUCTION OF ADVERTISING MATTER AND COMMERCIALS; ADVERTISING ON THE INTERNET FOR OTHERS (U.S. CLS. 100, 101 AND 102).

CLASS 41—EDUCATION AND ENTERTAINMENT

FOR ENTERTAINMENT AND RECORD LABEL SERVICES, NAMELY, MUSIC SONGWRITING, RECORDING, PRODUCTION AND PUBLISHING, MUSIC VIDEO CREATION AND PRODUCTION, ARTIST DEVELOPMENT IN THE NATURE OF MUSICAL TRAINING, MUSIC DISTRIBUTION, NAMELY, PROVIDING NON-DOWNLOADABLE PRERECORDED MUSIC; ARRANGING AND CONDUCTING OF CONCERTS; ORGANIZING EVENTS FEATURING LIVE MUSICAL PERFORMANCES (U.S. CLS. 100, 101 AND 107).

HEATHER BIDDULPH, EXAMINING ATTORNEY

SN 85-327,134. GLOCK, INC., SMYRNA, GA. FILED 5-23-2011.



NO CLAIM IS MADE TO THE EXCLUSIVE RIGHT TO USE "SPORT SHOOTING FOUNDATION", APART FROM THE MARK AS SHOWN.

THE MARK CONSISTS OF THE STYLIZED WORD "GSSF" WHERE A PISTOL SILHOUETTE RUNS THROUGH THE "GSSF" WORDING. THE WORD "GLOCK SPORT SHOOTING FOUNDATION" APPEARS UNDERNEATH THE STYLIZED WORD "GSSF".

CLASS 16—PAPER GOODS AND PRINTED MATTER

FOR PRINTED EDUCATIONAL MATERIALS IN THE FIELD OF GLOCK BRAND FIREARMS (U.S. CLS. 2, 5, 22, 23, 29, 37, 38 AND 50).

FIRST USE 2-1-2011; IN COMMERCE 2-1-2011.

CLASS 25—CLOTHING

FOR TOPS; WEARABLE GARMENTS AND CLOTHING, NAMELY, SHIRTS (U.S. CLS. 22 AND 39).

FIRST USE 2-1-2011; IN COMMERCE 2-1-2011.

CLASS 28—TOYS AND SPORTING GOODS

FOR FIREARM TARGETS (U.S. CLS. 22, 23, 38 AND 50).

FIRST USE 2-1-2011; IN COMMERCE 2-1-2011.

CLASS 41—EDUCATION AND ENTERTAINMENT

FOR EDUCATION SERVICES, NAMELY, PROVIDING INSTRUCTIONAL WORKSHOPS FOR THE SAFE HANDLING OF GLOCK PISTOLS, SPORT SHOOTING TECHNIQUES, FIREARMS SAFETY AND AWARENESS AND PISTOL OWNERSHIP ISSUES IN THE FIELD OF SPORT SHOOTING COMPETITIONS (U.S. CLS. 100, 101 AND 107).

FIRST USE 2-1-2011; IN COMMERCE 2-1-2011.

JANICE KIM, EXAMINING ATTORNEY

SN 85-327,387. HUNTAIR, INC., TUALATIN, OR. FILED 5-23-2011.

FANWALL

THE MARK CONSISTS OF STANDARD CHARACTERS WITHOUT CLAIM TO ANY PARTICULAR FONT, STYLE, SIZE, OR COLOR.

OWNER OF U.S. REG. NOS. 3,236,486, 3,321,029 AND 3,519,115.

CLASS 7—MACHINERY

FOR MOTORS FOR FAN AND BLOWER ASSEMBLIES FOR HEATING, VENTILATING AND AIR CONDITIONING PRODUCTS; FAN BLADES FOR FAN AND BLOWER ASSEMBLIES IN HEATING, VENTILATING AND AIR CONDITIONING PRODUCTS; VARIABLE FREQUENCY DRIVES FOR MOTORS, OTHER THAN FOR LAND VEHICLES, SPECIFICALLY FOR FAN AND BLOWER ASSEMBLIES FOR HEATING, VENTILATING, AND AIR CONDITIONING PRODUCTS; ACTIVE AND PASSIVE SOUND ATTENUATION DEVICES, NAMELY, SILENCERS FOR MOTORS AND ENGINES OF HEATING, VENTILATING AND AIR CONDITIONING PRODUCTS (U.S. CLS. 13, 19, 21, 23, 31, 34 AND 35).

FIRST USE 8-24-2007; IN COMMERCE 8-24-2007.

SN 85-328,471. SUNSHINE SILVER MINES CORPORATION, DENVER, CO. FILED 5-24-2011.

**CLASS 9—ELECTRICAL AND SCIENTIFIC APPARATUS**

FOR MICROPHONES FOR FAN AND BLOWER ASSEMBLIES FOR HEATING, VENTILATING, AND AIR CONDITIONING PRODUCTS; AUDIO SPEAKERS FOR FAN AND BLOWER ASSEMBLIES FOR HEATING, VENTILATING, AND AIR CONDITIONING PRODUCTS; COMPONENT PARTS FOR HEATING, VENTILATING, AND AIR CONDITIONING PRODUCTS, NAMELY, CONTROL SYSTEMS CONSISTING PRIMARILY OF ELECTRIC CONTROL DEVICES FOR FAN AND BLOWER ASSEMBLIES (U.S. CLS. 21, 23, 26, 36 AND 38).

FIRST USE 8-24-2007; IN COMMERCE 8-24-2007.

THE MARK CONSISTS OF A TRIANGLE MADE UP OF PRISMS OF LIGHT WITH A BURST OF LIGHT RADIATING FROM THE BOTTOM CENTER OF THE TRIANGLE OUTWARDS.

CLASS 37—CONSTRUCTION AND REPAIR

FOR MINING EXTRACTION (U.S. CLS. 100, 103 AND 106).

CLASS 42—SCIENTIFIC AND COMPUTER SERVICES

FOR MINING EXPLORATION AND MINERAL EXPLORATION SERVICES (U.S. CLS. 100 AND 101).
HOWARD B. LEVINE, EXAMINING ATTORNEY

CLASS 11—ENVIRONMENTAL CONTROL APPARATUS

FOR HEATING, COOLING, REFRIGERATING, VENTILATION, AND ENERGY RECOVERY EQUIPMENT, NAMELY, AIR HANDLERS AND PACKAGES AND CUSTOM-ENGINEERED AIR CONDITIONERS, CHILLERS, NAMELY, PROCESS CHILLERS THAT PROVIDE TEMPERATURE-CONTROLLED FLUID TO HEATING AND COOLING DEVICE, GAS, ELECTRIC, HYDRONIC AND SOLAR HEATING INSTALLATIONS; VENTILATION FANS FOR RESIDENTIAL, COMMERCIAL AND INDUSTRIAL USE; HUMIDIFIERS AND DEHUMIDIFIERS FOR COMMERCIAL AND INDUSTRIAL USE, AND STEAM GENERATORS; HEATING, VENTILATING, AND AIR CONDITIONING PRODUCTS, NAMELY, VENTILATING LOUVERS; SOUND SILENCERS SOLD AS AN INTEGRAL COMPONENT OF FAN AND AIR BLOWER ASSEMBLIES AND HEATING, COOLING, REFRIGERATING, VENTILATING, AIR QUALITY AND ENERGY RECOVERY EQUIPMENT; INLET CONES FOR THE FLOW OF AIR FOR USE IN FAN AND AIR BLOWER ASSEMBLIES; DAMPERS, NAMELY, CONTROL DEVICES USED IN AIR DUCTS TO REGULATE THE FLOW OF AIR; FUME HOODS; LABORATORY EXHAUST SYSTEMS, NAMELY, VENTILATION EXHAUST FANS, AND AIR BLOWERS; AND SMOKE AND GAS EVACUATION SYSTEMS CONSISTING PRIMARILY OF VENTING, VENTILATION EXHAUST FANS, AND AIR BLOWERS (U.S. CLS. 13, 21, 23, 31 AND 34).

FIRST USE 8-24-2007; IN COMMERCE 8-24-2007.
MICHAEL SOUDERS, EXAMINING ATTORNEY

SN 85-328,622. KYORAKU INDUSTRIAL CO., LTD., NAGOYA-SHI, AICHI PREF, JAPAN, FILED 5-24-2011.

MULTIMATE

THE MARK CONSISTS OF STANDARD CHARACTERS WITHOUT CLAIM TO ANY PARTICULAR FONT, STYLE, SIZE, OR COLOR.

PRIORITY CLAIMED UNDER SEC. 44(D) ON JAPAN APPLICATION NO. 2011-025382, FILED 4-11-2011, REG. NO. 5451915, DATED 11-18-2011, EXPIRES 11-18-2021.

CLASS 9—ELECTRICAL AND SCIENTIFIC APPARATUS

FOR VIDEO GAME MACHINES AND AMUSEMENT APPARATUS AND PARTS THEREFOR FOR USE WITH AN EXTERNAL DISPLAY SCREEN OR MONITOR; ELECTRONIC MACHINES AND APPARATUS AND THEIR PARTS, NAMELY, HARD DISK DRIVES, INTEGRATED CIRCUITS MODULE; CONSUMER GAMES AND PARTS THEREFOR FOR USE WITH AN EXTERNAL DISPLAY SCREEN OR MONITOR, NAMELY, HANDHELD UNITS FOR PLAYING ELECTRONIC GAMES FOR USE WITH EXTERNAL DISPLAY SCREENS OR MONITORS; ELECTRONIC CIRCUITS AND CD-ROMS RECORDED WITH PROGRAMS FOR HAND-HELD GAMES WITH LIQUID CRYSTAL DISPLAYS; PHONOGRAPH RECORDS FEATURING MUSIC; METRONOMES; ELECTRONIC CIRCUITS AND CD-ROMS RECORDED WITH AUTOMATIC PERFORMANCE PROGRAMS FOR ELECTRONIC MUSICAL INSTRUMENTS; DOWNLOADABLE COMPUTER GAME PROGRAMS; DOWNLOADABLE MUSIC FILES; EXPOSED CINEMATOGRAPHIC FILMS; EXPOSED SLIDE FILMS; SLIDE FILM MOUNTS; DOWNLOADABLE IMAGE FILES CONTAINING PHOTOGRAPHS; RECORDED VIDEO DISCS AND VIDEO TAPES FEATURING MANUALS RELATED TO GAME MACHINES; DOWNLOADABLE ELECTRONIC PUBLICATIONS AND ELECTRONIC PUBLICATIONS RECORDED ON COMPUTER MEDIA IN THE NATURE OF BOOKS, MAGAZINES, JOURNALS, AND MANUALS RELATED TO GAME MACHINES; VIDEO GAME MACHINES AND AMUSEMENT APPARATUS AND PARTS THEREFOR FOR USE WITH AN EXTERNAL DISPLAY SCREEN OR MONITOR HAVING A COMMUNICATING FUNCTION; CONSUMER GAMES AND PARTS THEREFOR FOR USE WITH AN EXTERNAL DISPLAY SCREEN OR MONITOR HAVING A COMMUNICATING FUNCTION; ELECTRONIC CIRCUITS AND CD-ROMS RECORDED WITH PROGRAMS FOR HAND-HELD GAMES WITH LIQUID CRYSTAL DISPLAYS HAVING A COMMUNICATING FUNCTION; CASINO MACHINES HAVING A COMMUNICATING FUNCTION; SLOT MACHINES HAVING A COMMUNICATING FUNCTION (U.S. CLS. 21, 23, 26, 36 AND 38).

CLASS 28—TOYS AND SPORTING GOODS

FOR TOYS, NAMELY, TOY CARS, STUFFED ANIMALS; DOLLS; GO GAMES; UTAGARUTA (JAPANESE PLAYING CARDS); SHOGI GAMES (JAPANESE CHESS); DICE; SUGOROKU (JAPANESE DICE GAMES); DICE CUPS; DIAMOND GAMES, NAMELY, CHINESE CHECKERS; CHESS GAMES; CHECKERS AND CHECKER SETS; CONJURING APPARATUS, NAMELY, MAGIC TRICKS; DOMINOES; PLAYING CARDS; HANAFUDA (JAPANESE PLAYING CARDS); MAH-JONG; GAME MACHINES AND APPARATUS, NAMELY, ARCADE GAME MACHINES; BILLIARD EQUIPMENT; GAME MACHINES AND APPARATUS HAVING A COMMUNICATING FUNCTION, NAMELY, ARCADE GAME MACHINES; PACHINKO MACHINES (JAPANESE VERTICAL PINBALL MACHINES HAVING A COMMUNICATING FUNCTION); ARCADE GAMES (U.S. CLS. 22, 23, 38 AND 50).

ESTHER BELENKER, EXAMINING ATTORNEY

SN 85-328,677. KYORAKU INDUSTRIAL CO., LTD., NAGOYA-SHI, AICHI PREF, JAPAN, FILED 5-24-2011.

MULTIMATE LIVESYSTEM

THE MARK CONSISTS OF STANDARD CHARACTERS WITHOUT CLAIM TO ANY PARTICULAR FONT, STYLE, SIZE, OR COLOR.

PRIORITY CLAIMED UNDER SEC. 44(D) ON JAPAN APPLICATION NO. 2011-025383, FILED 4-11-2011, REG. NO. 5451916, DATED 11-18-2011, EXPIRES 11-18-2021.

NO CLAIM IS MADE TO THE EXCLUSIVE RIGHT TO USE "LIVESYSTEM", APART FROM THE MARK AS SHOWN.

CLASS 9—ELECTRICAL AND SCIENTIFIC APPARATUS

FOR VIDEO GAME MACHINES AND AMUSEMENT APPARATUS AND PARTS THEREFOR FOR USE WITH AN EXTERNAL DISPLAY SCREEN OR MONITOR HAVING A COMMUNICATING FUNCTION; CONSUMER GAMES AND PARTS THEREFOR FOR USE WITH AN EXTERNAL DISPLAY SCREEN OR MONITOR HAVING A COMMUNICATING FUNCTION, NAMELY, HANDHELD UNITS FOR PLAYING ELECTRONIC GAMES FOR USE WITH EXTERNAL DISPLAY SCREENS OR MONITORS; ELECTRONIC CIRCUITS AND CD-ROMS RECORDED WITH PROGRAMS FOR HAND-HELD GAMES WITH LIQUID CRYSTAL DISPLAYS HAVING A COMMUNICATING FUNCTION; CASINO MACHINES HAVING A COMMUNICATING FUNCTION; SLOT MACHINES HAVING A COMMUNICATING FUNCTION (U.S. CLS. 21, 23, 26, 36 AND 38).

CLASS 28—TOYS AND SPORTING GOODS

FOR GAME MACHINES AND APPARATUS HAVING A COMMUNICATING FUNCTION, NAMELY, ARCADE GAME MACHINES; PACHINKO MACHINES (JAPANESE VERTICAL PINBALL MACHINES HAVING A COMMUNICATING FUNCTION) (U.S. CLS. 22, 23, 38 AND 50).

ESTHER BELENKER, EXAMINING ATTORNEY

SN 85-328,796. SILLAGE, LLC, CORONA DEL MAR, CA, FILED 5-24-2011.

HOS

THE MARK CONSISTS OF STANDARD CHARACTERS WITHOUT CLAIM TO ANY PARTICULAR FONT, STYLE, SIZE, OR COLOR.

CLASS 3—COSMETICS AND CLEANING PREPARATIONS

FOR PERFUMES AND COLOGNES (U.S. CLS. 1, 4, 6, 50, 51 AND 52).

CLASS 18—LEATHER GOODS

FOR TRAVELING LUGGAGE, TRUNKS, PURSES, RUCKSACKS, BRIEF CASES, ATTACHÉ CASES, WALLETS, KEY CASES, BUSINESS CARD CASES, COSMETIC CASES SOLD EMPTY (U.S. CLS. 1, 2, 3, 22 AND 41).

SANJEEV VOHRA, EXAMINING ATTORNEY

SN 85-329,236. FREEMAN, ANDREW CHARLES, NORTH-AMPTON, UNITED KINGDOM, FILED 5-24-2011.



OWNER OF ERPN CMNTY TM OFC REG. NO. 002553261, DATED 7-28-2003, RENEWED AS REG. NO. 002553261, DATED 5-2-2012, EXPIRES 1-23-2022.

NO CLAIM IS MADE TO THE EXCLUSIVE RIGHT TO USE "GREEN", APART FROM THE MARK AS SHOWN.

THE MARK CONSISTS OF THE WORDS "GREEN STUFF". THE WORD "GREEN" IS SHADED. THE WORD "STUFF" IS WRITTEN UNDER THE WORD "GREEN" IN A LARGER, DECORATIVE FONT.

CLASS 12—VEHICLES

FOR BRAKE PADS FOR VEHICLES AND BRAKE SHOES MADE USING ENVIRONMENTALLY FRIENDLY MATERIALS (U.S. CLS. 19, 21, 23, 31, 35 AND 44).

CLASS 17—RUBBER GOODS

FOR PARTLY-PROCESSED FRICTION LININGS MADE USING ENVIRONMENTALLY-FRIENDLY MATERIALS; PARTLY-PROCESSED AND ENVIRONMENTALLY-FRIENDLY FRICTION MATERIALS FOR CLUTCH FACINGS AND BRAKE LININGS (U.S. CLS. 1, 5, 12, 13, 35 AND 50).

INGA ERVIN, EXAMINING ATTORNEY

SN 85-329,550. SAUTER FEINMECHANIK GMBH, METZINGEN, FED REP GERMANY, FILED 5-25-2011.



OWNER OF ERPN CMNTY TM OFC REG. NO. 001486414, DATED 11-25-2004, EXPIRES 2-2-2020.

OWNER OF U.S. REG. NO. 900,711.

THE MARK CONSISTS OF THE WORD "SAUTER", WITH A CURVED LINE ABOVE THE WORD AND A CURVED LINE BELOW THE WORD FORMING AN INCOMPLETE CIRCLE, ALL IN A BLACK SQUARE BOX.

CLASS 7—MACHINERY

FOR MACHINE TOOLS FOR FORMING, SHAPING OR MACHINING METAL AND PLASTIC OR OTHER RIGID MATERIALS BY CUTTING, BORING, GRINDING, SHARPENING OR FINISHING; MILLING MACHINES; DRILLING MACHINES; COPYING MACHINES, NAMELY, MACHINE TOOLS FOR MACHINING METAL, WHICH COPIES THE FORM OF A SAMPLE ITEM TO A WORKPIECE; TURNING MACHINES IN THE NATURE OF POWER OPERATED METALWORKING MACHINE TOOLS, NAMELY, TURNING TOOLS; MACHINE ELEMENTS NOT FOR LAND VEHICLES, NAMELY, TURNTABLES AND THEIR ROTATING DEVICES; MACHINE PARTS, NAMELY, MOTOR-DRIVEN SPINDLES WITH AND WITHOUT SWIVELING UNITS; TOOL TURRETS, TOOL DISC TURRETS AND TOOL HEAD TYPE TURRETS, ALL BEING ATTACHMENTS FOR MACHINE TOOLS; PARTS FOR THE AFORESAID MACHINES AND TURRETS, IN PARTICULAR ELECTRIC, HYDRAULIC AND ELECTROMECHANICAL DRIVES, NAMELY, POSITIONING DEVICES FOR MACHINES AND MACHINE PARTS, GEARS FOR MACHINES AND MACHINE PARTS, COUPLINGS FOR MACHINES AND MACHINE PARTS, FLUID VALVES FOR MACHINES AND MACHINE PARTS, AND POWER-OPERATED HYDRAULIC, PNEUMATIC AND LUBRICANT-DISPENSING UNITS FOR MACHINES AND MACHINE PARTS; MACHINES, NAMELY, ROTARY INDEXING TABLES FOR POSITIONING AND ROTATING WORK PIECES; MACHINES, NAMELY, B-AXIS ROTARY INDEXING TABLES FOR POSITIONING AND ROTATING WORK PIECES; ACCESSORIES FOR MACHINE TOOLS, NAMELY, SPINDLEHEADS; TOOL STORES, NAMELY, TOOL MAGAZINES; MACHINE TOOL AND WORK PIECE HOLDERS; MACHINE TOOLS AND MACHINE TOOL COMPONENTS, NAMELY, QUICK-CHANGE TOOL HOLDERS; MACHINE TOOL AND WORK PIECE POSITIONING HOLDERS; INTERCHANGEABLE CHUCKS FOR POWER DRILLS (U.S. CLS. 13, 19, 21, 23, 31, 34 AND 35).

CLASS 9—ELECTRICAL AND SCIENTIFIC APPARATUS

FOR ELECTRICAL CONTROLLERS, IN PARTICULAR NUMERICAL CONTROL AND COMPUTER NUMERICAL CONTROL ELECTRICAL CONTROLLERS FOR USE WITH MACHINE TOOLS OF ALL TYPES, TOOL TURRETS, TOOL DISC TURRETS, COMPUTERS AND DATA PROCESSING DEVICES CONNECTED THERETO; COMPUTERS; COMPUTER SOFTWARE FOR USE IN OPERATING MACHINE TOOLS; MEASURING DEVICES, NAMELY, REVOLUTION COUNTERS, TORQUEMETERS, LENGTH MEASURING DEVICES, VIBRATION MEASURING DEVICES, SPEED CONTROL DEVICES, LASER MEASUREMENT APPARATUS; SIGNALING DEVICES, NAMELY, POSITION AND TORQUE SENSORS, INDUCTIVE, CAPACITIVE AND OPTICAL TRANSDUCERS, ANNUNCIATORS AND INDICATOR LIGHTS; SUPERVISION DEVICES, NAMELY, SURVEILLANCE APPARATUS FOR CONTROLLING AND MONITORING THE ACTUAL WORKING SITUATION OF ALL KIND OF WORKING MACHINES AND THEIR PARTS, LIKE TOOL TURRETS (U.S. CLS. 21, 23, 26, 36 AND 38).

KRISTIN CARLSON, EXAMINING ATTORNEY

SN 85-329,701. MAYR-MELNHOF KARTON AKTIENGESELLSCHAFT, WIEN, AUSTRIA, FILED 5-25-2011.



PRIORITY CLAIMED UNDER SEC. 44(D) ON ERPN CMNTY TM OFC APPLICATION NO. 009970088, FILED 5-16-2011, REG. NO. 009970088, DATED 10-19-2011, EXPIRES 5-16-2021.

THE MARK CONSISTS OF THE TEXT "FOODBOARD" WITH A STYLIZED BOX TO THE LEFT THEREOF WITH PANELS WITH MARKINGS THEREON.

CLASS 1—CHEMICALS

FOR CHEMICAL PREPARATIONS FOR USE IN INDUSTRY (U.S. CLS. 1, 5, 6, 10, 26 AND 46).

CLASS 16—PAPER GOODS AND PRINTED MATTER

FOR PAPER, CARDBOARD AND GOODS MADE FROM THESE MATERIALS, NAMELY, PAPER AND CARDBOARD PACKAGING AND WRAPPING MATERIALS FOR FOOD, HOUSEHOLD ARTICLES, ELECTRICAL ITEMS, DETERGENTS, GLASSWARE, BEVERAGES; CARDBOARD ARTICLES, NAMELY, POSTCARDS AND GREETING CARDS, BOTTLE WRAPPERS OF CARDBOARD OR PAPER, SHEETS OF RECLAIMED CELLULOSE FOR WRAPPING, BOXES OF CARDBOARD OR PAPER, BAGS, ENVELOPES AND POUCHES OF PAPER OR CARDBOARD FOR PACKAGING, SHEETS OF PAPER OR CARDBOARD FOR WRAPPING OR PACKAGING, PAPER OR CARDBOARD MATERIALS FOR PACKAGING, DISPLAYS OF CARDBOARD OR PAPER; PRINTED MATTER, NAMELY, MAGAZINES AND BOOKLETS FOR THE CARDBOARD AND PACKAGING INDUSTRIES (U.S. CLS. 2, 5, 22, 23, 29, 37, 38 AND 50).

CLASS 42—SCIENTIFIC AND COMPUTER SERVICES

FOR PACKAGING DESIGN SERVICES; TECHNICAL DEVELOPMENT, DESIGN AND PLANNING IN THE FIELD OF PACKAGING TECHNOLOGY; TECHNICAL DEVELOPMENT, DESIGN AND PLANNING IN THE FIELD OF MANUFACTURING TECHNOLOGY (U.S. CLS. 100 AND 101).

ANNE MADDEN, EXAMINING ATTORNEY

SN 85-330,330. DONALD BUM SIK KANG, DBA ROYAL HAWAIIAN CREATIONS, HONOLULU, HI. FILED 5-25-2011.

MAMO

THE MARK CONSISTS OF STANDARD CHARACTERS WITHOUT CLAIM TO ANY PARTICULAR FONT, STYLE, SIZE, OR COLOR.

OWNER OF U.S. REG. NO. 1,648,204.
THE NAME(S), PORTRAIT(S), AND/OR SIGNATURE(S) SHOWN IN THE MARK IDENTIFIES LEI MAMO HOWELL, WHOSE CONSENT(S) TO REGISTER IS MADE OF RECORD.

CLASS 18—LEATHER GOODS

FOR LUGGAGE, NAMELY, TOTE BAGS (U.S. CLS. 1, 2, 3, 22 AND 41).

CLASS 21—HOUSEWARES AND GLASS

FOR DINNERWARE, NAMELY, PLATES, CUPS AND MUGS (U.S. CLS. 2, 13, 23, 29, 30, 33, 40 AND 50).

CLASS 24—FABRICS

FOR BABY BLANKETS; KITCHEN TEXTILES, NAMELY, KITCHEN APRON, CLOTH POT HOLDERS, CLOTH LUNCH BAGS, OVEN MITTS; KITCHEN TOWELS (U.S. CLS. 42 AND 50).

CLASS 25—CLOTHING

FOR DRESSES, APRONS, BLOUSES, CAFTANS, ROMPERS, TOPS, AND UNIFORMS (U.S. CLS. 22 AND 39).
ANNE E. GUSTASON, EXAMINING ATTORNEY

SN 85-330,369. DONALD BUM SIK KANG, DBA ROYAL HAWAIIAN CREATIONS, HONOLULU, HI. FILED 5-25-2011.



OWNER OF U.S. REG. NO. 1,648,204.
THE NAME(S), PORTRAIT(S), AND/OR SIGNATURE(S) SHOWN IN THE MARK IDENTIFIES LEI MAMO HOWELL, WHOSE CONSENT(S) TO REGISTER IS MADE OF RECORD.

THE MARK CONSISTS OF STYLIZED TYPE OF WORD "MAMO".

CLASS 18—LEATHER GOODS

FOR LUGGAGE, NAMELY, TOTE BAGS (U.S. CLS. 1, 2, 3, 22 AND 41).

CLASS 21—HOUSEWARES AND GLASS

FOR DINNERWARE, NAMELY, PLATES, CUPS AND MUGS (U.S. CLS. 2, 13, 23, 29, 30, 33, 40 AND 50).

CLASS 24—FABRICS

FOR BABY BLANKETS; KITCHEN TEXTILES, NAMELY, KITCHEN APRON, CLOTH POT HOLDERS, CLOTH LUNCH BAGS, OVEN MITTS; KITCHEN TOWELS (U.S. CLS. 42 AND 50).
ANNE E. GUSTASON, EXAMINING ATTORNEY

SN 85-331,135. KNAACK LLC, CRYSTAL LAKE, IL. FILED 5-26-2011.

RAPID MOUNT

THE MARK CONSISTS OF STANDARD CHARACTERS WITHOUT CLAIM TO ANY PARTICULAR FONT, STYLE, SIZE, OR COLOR.

NO CLAIM IS MADE TO THE EXCLUSIVE RIGHT TO USE "MOUNT", APART FROM THE MARK AS SHOWN.

CLASS 12—VEHICLES

FOR PREPACKAGED VAN AND MINIVAN INTERIOR MODULES FOR STORAGE AND SHELVING, NAMELY, VAN SHELVES, CABINETS AND SHELF ACCESSORIES, NAMELY, SECURE STORAGE MODULES, SECURE STORAGE CABINETS, SECURE DRAWER MODULES, SECURE DRAWER CABINETS, BIN STORAGE RACKS, CARGO STORAGE BINS, TOOL AND MATERIAL ORGANIZERS, AND COLLAPSIBLE WHEELED DOLLIES, WORK TOPS, BIN BOXES AND BIN DIVIDERS, SHELF WORK COVERS, HARD HAT RACKS, FIRE EXTINGUISHER RACKS, RETAINER LIPS, STACKING BRACKETS, SHELF MATS, DOORS AND BACK PANELS, ALL FOR THE INTERIOR OF LAND VEHICLES AND SPECIFICALLY ADAPTED FOR USE IN LAND VEHICLES; FREON TANK RACKS AND TANK RINGS, WIRE SPOOL RACKS, FILE BOXES, WINDOW SCREENS, VEHICLE BULKHEAD PANELS AND BULKHEAD CUSTOM ACCESSORIES, NAMELY, BINDER FILES, SPARE TIRE CHOCKS, LITERATURE HOLDERS, HARD HAT RACKS, FIRE EXTINGUISHER HOLDERS, EXTENSION CORD BRACKETS, SPARE TIRE BRACKETS, FIRST AID KIT TRAYS, WINDOW COVERS AND SAFETY REFLECTORS ALL FOR THE INTERIOR OF LAND VEHICLES AND SPECIFICALLY ADAPTED FOR USE IN LAND VEHICLES; BULKHEAD PANELS, SHELVING AND LADDER RACKS, AND STABILIZERS THEREFOR; MATERIAL RACKS SPECIFICALLY ADAPTED FOR USE ON LAND VEHICLES; LADDER GUIDES SPECIFICALLY ADAPTED FOR USE ON LAND VEHICLES; SLIDING PLATFORMS AND RAILS, NAMELY, TRUCK BED EXTENDERS (U.S. CLS. 19, 21, 23, 31, 35 AND 44).

CLASS 27—FLOOR COVERINGS

FOR FLOOR MATS FOR VANS AND MINIVANS (U.S. CLS. 19, 20, 37, 42 AND 50).

KAREN K. BUSH, EXAMINING ATTORNEY

SN 85-331,183. RACECO, LLC, SALT LAKE CITY, UT. FILED 5-26-2011.

RACECO

THE MARK CONSISTS OF STANDARD CHARACTERS WITHOUT CLAIM TO ANY PARTICULAR FONT, STYLE, SIZE, OR COLOR.

CLASS 12—VEHICLES

FOR RACING AND PERFORMANCE AFTER-MARKET AUTOMOBILE PARTS, NAMELY, AUTOMOBILE ENGINES, STRUCTURAL PARTS OF AUTOMOBILES (U.S. CLS. 19, 21, 23, 31, 35 AND 44).

CLASS 35—ADVERTISING AND BUSINESS

FOR RETAIL STORE SERVICES FEATURING AUTOMOBILES AND TOOLS (U.S. CLS. 100, 101 AND 102).

CLASS 37—CONSTRUCTION AND REPAIR

FOR REPAIR AND MAINTENANCE OF AUTOMOBILES AND TOOLS (U.S. CLS. 100, 103 AND 106).

CLASS 40—MATERIAL TREATMENT

FOR MACHINE SHOP SERVICES, NAMELY, MACHINING PARTS FOR OTHERS (U.S. CLS. 100, 103 AND 106).

CLASS 42—SCIENTIFIC AND COMPUTER SERVICES

FOR AUTOMOBILE DESIGN; TOOL DESIGN (U.S. CLS. 100 AND 101).

JEFF DEFORD, EXAMINING ATTORNEY

SN 85-331,704. THE REGENTS OF THE UNIVERSITY OF COLORADO, DENVER, CO. FILED 5-26-2011.



THE COLOR(S) GREY AND YELLOW IS/ARE CLAIMED AS A FEATURE OF THE MARK.

THE MARK CONSISTS OF THE DESIGN OF THE LETTER "I" IN A FULL CIRCLE THAT IS DISPLAYED IN GREY AND YELLOW. THE COLOR WHITE REPRESENTS THE BACKGROUND AND IS NOT PART OF THE MARK.

CLASS 42—SCIENTIFIC AND COMPUTER SERVICES

FOR MEDICAL AND SCIENTIFIC RESEARCH IN THE FIELDS OF BIOTECHNOLOGY, PHARMACEUTICAL DEVELOPMENT AND CLINICAL MEDICINE; RESEARCH AND DEVELOPMENT OF TECHNOLOGY IN THE FIELDS OF BIOTECHNOLOGY, PHARMACEUTICAL DEVELOPMENT AND CLINICAL MEDICINE; DIAGNOSTIC SERVICES IN THE FIELDS OF LIQUID CHROMATOGRAPHY MASS SPECTROMETRY, HIGH-PERFORMANCE LIQUID CHROMATOGRAPHY, GAS CHROMATOGRAPHY- MASS SPECTROMETRY, NUCLEAR MAGNETIC RESONANCE SPECTROSCOPY, IMMUNO-ASSAYS AND PROTEIN ARRAY AND CHIP TECHNOLOGIES (U.S. CLS. 100 AND 101).

FIRST USE 6-1-2010; IN COMMERCE 6-1-2010.

CLASS 44—MEDICAL, BEAUTY AND AGRICULTURAL SERVICES

FOR MEDICAL TESTING FOR DIAGNOSTIC OR TREATMENT PURPOSES; CONSULTING SERVICES IN THE FIELDS OF DIAGNOSTIC MEDICAL TESTING AND NUTRITION (U.S. CLS. 100 AND 101).

FIRST USE 6-1-2010; IN COMMERCE 6-1-2010.

ALEX KEAM, EXAMINING ATTORNEY

SN 85-331,909. RED ROBOT LABS, INC., PALO ALTO, CA. FILED 5-26-2011.

SN 85-332,650. OLSON, ERIC, ATHENS, AL. FILED 5-27-2011.

LIFE IS CRIME

THE MARK CONSISTS OF STANDARD CHARACTERS WITHOUT CLAIM TO ANY PARTICULAR FONT, STYLE, SIZE, OR COLOR.

CLASS 9—ELECTRICAL AND SCIENTIFIC APPARATUS

FOR COMPUTER GAME SOFTWARE (U.S. CLS. 21, 23, 26, 36 AND 38).
FIRST USE 8-0-2011; IN COMMERCE 8-0-2011.

CLASS 41—EDUCATION AND ENTERTAINMENT

FOR ENTERTAINMENT SERVICES, NAMELY, PROVIDING TEMPORARY USE OF NON-DOWNLOADABLE COMPUTER GAMES (U.S. CLS. 100, 101 AND 107).
FIRST USE 8-0-2011; IN COMMERCE 8-0-2011.
ASMAT KHAN, EXAMINING ATTORNEY

SN 85-332,169. KIDSTAR LLC, AKA KIDSTAR PRINTING AND PRODUCTS, DENVER, CO. FILED 5-27-2011.



THE COLOR(S) BLACK, BLUE, YELLOW IS/ARE CLAIMED AS A FEATURE OF THE MARK.

THE MARK CONSISTS OF COMPANY NAME "KIDSTAR" IN BLUE LETTERS WITH A YELLOW STAR OUTLINED IN BLACK PARTIALLY UNDER THE LETTER "R" IN THE NAME "KIDSTAR".

CLASS 16—PAPER GOODS AND PRINTED MATTER

FOR CRAYONS (U.S. CLS. 2, 5, 22, 23, 29, 37, 38 AND 50).
FIRST USE 1-1-2001; IN COMMERCE 1-1-2001.

CLASS 21—HOUSEWARES AND GLASS

FOR DRINKING CUPS FOR CHILDREN AND PARTS AND FITTINGS THEREFOR, NAMELY, DRINKING CUPS FOR CHILDREN SOLD AS A UNIT WITH NON-INSULATED LIDS (U.S. CLS. 2, 13, 23, 29, 30, 33, 40 AND 50).
FIRST USE 1-1-2001; IN COMMERCE 1-1-2001.
LYDIA BELZER, EXAMINING ATTORNEY

OilBuck

THE MARK CONSISTS OF STANDARD CHARACTERS WITHOUT CLAIM TO ANY PARTICULAR FONT, STYLE, SIZE, OR COLOR.

CLASS 9—ELECTRICAL AND SCIENTIFIC APPARATUS

FOR CONSUMER COUPONS DOWNLOADED FROM A GLOBAL COMPUTER NETWORK (U.S. CLS. 21, 23, 26, 36 AND 38).
FIRST USE 4-2-2011; IN COMMERCE 5-20-2011.

CLASS 16—PAPER GOODS AND PRINTED MATTER

FOR COUPONS (U.S. CLS. 2, 5, 22, 23, 29, 37, 38 AND 50).
FIRST USE 4-2-2011; IN COMMERCE 5-20-2011.

CLASS 35—ADVERTISING AND BUSINESS

FOR PROMOTING AND MARKETING THE GOODS AND SERVICES OF OTHERS BY DISTRIBUTING ADVERTISING MATERIAL, COUPONS AND DISCOUNT OFFERS VIA TEXT MESSAGES; PROMOTING THE GOODS AND SERVICES OF OTHERS BY PROVIDING A COMMUNITY-DRIVEN WEB SITE FEATURING USER-SUBMITTED CONTENT IN THE NATURE OF COUPONS, REBATES, PRICE-COMPARISON INFORMATION, PRODUCT REVIEWS, LINKS TO THE RETAIL WEB SITES OF OTHERS, AND DISCOUNT INFORMATION; PROMOTING THE GOODS AND SERVICES OF OTHERS BY PROVIDING HYPERLINKS TO THE WEBSITES OF OTHERS; PROMOTING THE GOODS OF OTHERS, NAMELY, PROVIDING INFORMATION REGARDING DISCOUNTS, COUPONS, REBATES, VOUCHERS AND SPECIAL OFFERS FOR THE GOODS OF OTHERS; PROMOTIONAL SERVICES, NAMELY, DISTRIBUTION OF ADVERTISING FLYERS, COUPONS, CATALOGS AND PROMOTIONAL ITEMS OF OTHERS (U.S. CLS. 100, 101 AND 102).

FIRST USE 4-2-2011; IN COMMERCE 5-20-2011.
HOWARD B. LEVINE, EXAMINING ATTORNEY

SN 85-332,780. Q BONDING + BRANDING + STRATEGY GLOBAL LLC, CHERRY HILLS VILLAGE, CO. FILED 5-27-2011.

GLOBAL BOUTIQUE

THE MARK CONSISTS OF STANDARD CHARACTERS WITHOUT CLAIM TO ANY PARTICULAR FONT, STYLE, SIZE, OR COLOR.

NO CLAIM IS MADE TO THE EXCLUSIVE RIGHT TO USE "BOUTIQUE", APART FROM THE MARK AS SHOWN.

CLASS 11—ENVIRONMENTAL CONTROL APPARATUS

FOR LIGHTING FIXTURES; ORNAMENTAL FOUNTAINS (U.S. CLS. 13, 21, 23, 31 AND 34).

CLASS 20—FURNITURE AND ARTICLES NOT OTHERWISE CLASSIFIED

FOR BENCHES; END TABLES; FURNITURE; OTTOMANS; OUTDOOR FURNITURE; PILLOWS (U.S. CLS. 2, 13, 22, 25, 32 AND 50).

CLASS 21—HOUSEWARES AND GLASS

FOR BAKEWARE; COOKWARE MADE AT LEAST IN PART OF NONSTICK, STAINLESS, CAST, COPPER, ALUMINUM, OR ANODIZED MATERIALS, NAMELY, STOCKPOTS, FRYING PANS, STEAMERS, FONDUE PANS, CREPE PANS, SAUTE PANS, BROILER PANS, MIXING BOWLS, AND CHICKEN FRYERS, NAMELY, NON-ELECTRIC DEEP FRYERS; DINNERWARE; HOUSEHOLD UTENSILS, NAMELY, GRATERS, KITCHEN TONGS, SIEVES, SKIMMERS, SPATULAS, ROLLING PINS, TURNERS, STRAINERS, WHISKS; NON-ELECTRIC FOOD BLENDERS; SERVING DISHES (U.S. CLS. 2, 13, 23, 29, 30, 33, 40 AND 50).

CLASS 24—FABRICS

FOR BED BLANKETS; BED SHEETS; BLANKET THROWS; COMFORTERS; DUVET COVERS; DUVETS; KITCHEN LINENS; PILLOW CASES; THROWS; TOWELS (U.S. CLS. 42 AND 50).

CLASS 25—CLOTHING

FOR BATH SLIPPERS; BATHROBES; FOOTWEAR; SOCKS; TIGHTS (U.S. CLS. 22 AND 39).

CLASS 27—FLOOR COVERINGS

FOR BATH MATS; CARPETS AND RUGS (U.S. CLS. 19, 20, 37, 42 AND 50).
JAY FLOWERS, EXAMINING ATTORNEY

SN 85-332,821. PARTY BOOK S.L., MADRID, SPAIN, FILED 5-27-2011.



The logo for "SmartyGift" features the word "Smarty" in a light blue, rounded font and "Gift" in a dark blue, rounded font. The letters are bold and have a slight shadow effect.

PRIORITY CLAIMED UNDER SEC. 44(D) ON SPAIN APPLICATION NO. 2.957.991, FILED 11-30-2010, REG. NO. 2957991, DATED 5-9-2011, EXPIRES 5-9-2021.

THE COLOR(S) LIGHT BLUE AND DARK BLUE IS/ARE CLAIMED AS A FEATURE OF THE MARK.

THE MARK CONSISTS OF THE STYLIZED WORDING "SMARTYGIFT" WHEREIN THE TERM "SMARTY" APPEARS IN LIGHT BLUE AND THE TERM "GIFT" APPEARS IN DARK BLUE.

CLASS 35—ADVERTISING AND BUSINESS

FOR ADVERTISING SERVICES; BUSINESS MANAGEMENT; ADMINISTRATION, NAMELY, SALES PROMOTION SERVICES FOR OTHERS; PROCUREMENT SERVICES, NAMELY, PURCHASING TOYS OR ACTIVITIES FOR CHILDREN FOR OTHERS; RENTAL OF ADVERTISING SPACE; RENTAL OF ADVERTISING TIME ON COMMUNICATION MEDIA; DISSEMINATION OF ADVERTISING MATTER; ON-LINE ADVERTISING ON A COMPUTER NETWORK; COMMERCIAL INFORMATION AND ADVICE FOR CONSUMERS IN THE FIELD OF CHILDREN, TOYS OR ACTIVITIES POINTED TO CHILDREN; COMPILATION AND SYSTEMIZATION OF INFORMATION INTO COMPUTER DATABASES; MARKETING RESEARCH SERVICES; COMMERCIAL INFORMATION AND DIRECTORY AGENCY (U.S. CLS. 100, 101 AND 102).

CLASS 36—INSURANCE AND FINANCIAL

FOR MONETARY AND FINANCIAL AFFAIRS, NAMELY, CHARITABLE FUNDRAISING, TRUSTEESHIP REPRESENTATIVES, BANKING, ELECTRONIC FUNDS TRANSFER (U.S. CLS. 100, 101 AND 102).

CLASS 38—COMMUNICATION

FOR TELECOMMUNICATION SERVICES, NAMELY, PROVIDING INTERNET CHATROOMS, COMPUTER AIDED TRANSMISSION OF MESSAGES AND IMAGES, ELECTRONIC BULLETIN BOARD SERVICES (U.S. CLS. 100, 101 AND 104).

CLASS 41—EDUCATION AND ENTERTAINMENT

FOR EDUCATIONAL SERVICES, NAMELY, PROVIDING CLASSES, SEMINARS AND WORKSHOPS IN THE FIELD OF NATURE, MANUAL WORKS, SPECIALLY ORIENTED TO KIDS; TRAINING IN THE FIELD OF NATURE, MANUAL WORKS, SPECIALLY ORIENTED TO KIDS; ENTERTAINMENT, NAMELY, ORGANIZING BIRTHDAY PARTIES FOR KIDS; PROVIDING INFORMATION, NEWS AND COMMENTARY IN THE FIELD OF RECREATION AND LEISURE ACTIVITIES; ENTERTAINMENT INFORMATION; PARTY PLANNING (U.S. CLS. 100, 101 AND 107).

JAY FLOWERS, EXAMINING ATTORNEY

SN 85-332,841. EVENTSTYLE, INC., NEW YORK, NY, FILED 5-27-2011.

TABLE CHAMELEON

THE MARK CONSISTS OF STANDARD CHARACTERS WITHOUT CLAIM TO ANY PARTICULAR FONT, STYLE, SIZE, OR COLOR.

NO CLAIM IS MADE TO THE EXCLUSIVE RIGHT TO USE "TABLE", APART FROM THE MARK AS SHOWN.

CLASS 8—HAND TOOLS

FOR FLATWARE, NAMELY, KNIVES, FORKS, SPOONS, SALAD FORKS, SUGAR SHELL SPOONS, COLD MEAT FORKS, STEAK KNIVES (U.S. CLS. 23, 28 AND 44).

CLASS 21—HOUSEWARES AND GLASS

FOR HOUSEWARES, NAMELY, CANDLE HOLDERS, CANDY DISHES, COASTERS NOT MADE OF PAPER AND OTHER THAN TABLE LINEN, GLASS JARS, NAPKIN RINGS, PET BOWLS, SWEETENER PACKET HOLDERS, TOOTHPICK HOLDERS, VASES; DINNERWARE; DISHWARE, NAMELY, BOWLS, DESSERT PLATES, DINNER PLATES, DISHES, ICE CREAM CUPS, SALAD PLATES, TEA CUP PLATES; SERVEWARE, NAMELY, CAKE SERVERS, CHEESE BOARDS, PUNCH BOWLS, SERVING FORKS, SERVING PLATES, SERVING PLATTERS, SERVING SPOONS, SERVING TRAYS; DRINKWARE, NAMELY, BEVERAGE JARS, CARAFES, COFFEE CUPS, DRINKING TUMBLERS, MUGS, TEA CUPS, TRAVEL MUGS, REUSABLE WATER BOTTLES SOLD EMPTY, CHAMPAGNE FLUTES, WINE GLASSES; STEMWARE; BARWARE, NAMELY, PORTABLE BEVERAGE DISPENSERS, COCKTAIL SHAKERS, ICE BUCKETS, PITCHERS, SHOT GLASSES, SWIZZLE STICKS; KITCHENWARE, NAMELY, BUTTER DISHES, KITCHEN CANISTERS, COOKIE JARS, SALT AND PEPPER SHAKERS, TEA POTS; DECORATIVE HOUSEWARES AND KITCHENWARE MADE OF ACRYLIC, NAMELY, BOWLS, BREAD PANS, CAKE PANS, CANDY DISHES, CASSEROLE DISHES, JARS, PANS WITH MATCHING LIDS, RAMEKINS, TART PANS; SERVINGWARE MADE OF ACRYLIC FOR SERVING FOOD AND DRINKS, NAMELY, BEVERAGEWARE, CARAFES, DISHES, DRINKING TUMBLERS, PASTA SERVING FORKS, PITCHERS, SERVING FORKS, SERVING SPOONS, SERVING TONGS, SERVING TRAYS (U.S. CLS. 2, 13, 23, 29, 30, 33, 40 AND 50).

FRED CARL, EXAMINING ATTORNEY

CLASS 35—ADVERTISING AND BUSINESS

FOR RETAIL STORE SERVICES FEATURING DOWNLOADABLE PRE-RECORDED DIGITAL CONTENT, NAMELY, VIDEO FILES, AUDIO FILES, IMAGES, TEXT FILES AND E-BOOKS PROVIDED VIA THE INTERNET, MOBILE DEVICES, WIRELESS INTERNET NETWORKS OR SYSTEMS AND OTHER COMPUTER AND ELECTRONIC COMMUNICATION NETWORKS THROUGH SUBSCRIPTIONS, SUBSCRIBE-TO-VIEW AND ONE-TIME PURCHASES; ADVERTISING AND MARKETING SERVICES PROVIDED VIA THE INTERNET, MOBILE DEVICES, WIRELESS INTERNET NETWORKS OR SYSTEMS AND OTHER COMPUTER AND ELECTRONIC COMMUNICATION NETWORKS (U.S. CLS. 100, 101 AND 102).

CLASS 38—COMMUNICATION

FOR ELECTRONIC TRANSFER OF DATA VIA THE INTERNET, MOBILE DEVICES, WIRELESS INTERNET NETWORKS OR SYSTEMS AND OTHER COMPUTER AND ELECTRONIC COMMUNICATION NETWORKS IN THE NATURE OF STREAMED AND DOWNLOADABLE DIGITAL FILES AND DATA; WEBCASTING SERVICES; PROVIDING ON-LINE FORUMS FOR TRANSFER OF MESSAGES AMONG COMPUTER USERS IN THE FIELDS OF ENTERTAINMENT AND MEDIA PUBLISHING; STREAMING OF AUDIO AND VIDEO MATERIAL ON THE INTERNET (U.S. CLS. 100, 101 AND 104).

CLASS 41—EDUCATION AND ENTERTAINMENT

FOR DIGITAL MULTIMEDIA PUBLISHING PROVIDED VIA THE INTERNET, MOBILE DEVICES, WIRELESS INTERNET NETWORKS OR SYSTEMS AND OTHER COMPUTER AND ELECTRONIC COMMUNICATION NETWORKS; PROVIDING A WEBSITE FEATURING NON-DOWNLOADABLE DIGITAL CONTENT, NAMELY, AUDIO AND VIDEO PRESENTATIONS IN THE FIELDS OF ENTERTAINMENT, MUSIC, SPORTS, FILMS, ART, CULTURAL ACTIVITIES AND EDUCATION VIA THE INTERNET, MOBILE DEVICES, WIRELESS INTERNET NETWORKS OR SYSTEMS AND OTHER COMPUTER AND ELECTRONIC COMMUNICATION NETWORKS; PROVIDING AN ON-LINE WEBSITE FEATURING ENTERTAINMENT INFORMATION ON ARTISTS, PERFORMERS, CELEBRITIES, ATHLETES, AUTHORS, MUSIC, SONGS AND BOOKS VIA A COMPUTER AND ELECTRONIC COMMUNICATION NETWORKS; RENTAL OF PRE-RECORDED DIGITAL CONTENT THAT MAY BE DOWNLOADED OR STREAMED, NAMELY, VIDEO FILES, AUDIO FILES, IMAGES, TEXT FILES AND E-BOOKS PROVIDED VIA THE INTERNET, MOBILE DEVICES, WIRELESS INTERNET NETWORKS OR SYSTEMS AND OTHER COMPUTER AND ELECTRONIC COMMUNICATION NETWORKS (U.S. CLS. 100, 101 AND 107).

SN 85-332,907. CHNL, INC., SANTA MONICA, CA. FILED 5-27-2011.

CHNL

THE MARK CONSISTS OF STANDARD CHARACTERS WITHOUT CLAIM TO ANY PARTICULAR FONT, STYLE, SIZE, OR COLOR.

CLASS 9—ELECTRICAL AND SCIENTIFIC APPARATUS

FOR COMPUTER SOFTWARE AND SOFTWARE APPLICATIONS FOR USE IN DOWNLOADING, VIEWING, TRANSFERRING, DISTRIBUTING, SHARING, RECEIVING AND STREAMING OF DATA, AUDIO, VIDEO AND OTHER DIGITAL FILES, CONTENT AND INFORMATION; COMPUTER SOFTWARE AND SOFTWARE APPLICATIONS FOR USE IN DOWNLOADING, VIEWING, TRANSFERRING, DISTRIBUTING, SHARING, RECEIVING AND STREAMING OF DATA, AUDIO, VIDEO AND OTHER DIGITAL FILES, CONTENT AND INFORMATION VIA THE INTERNET, MOBILE DEVICES, WIRELESS INTERNET NETWORKS OR SYSTEMS AND OTHER COMPUTER AND ELECTRONIC COMMUNICATION NETWORKS; PROVIDING DOWNLOADABLE DIGITAL CONTENT, NAMELY, VIDEO FILES, AUDIO FILES, IMAGES, TEXT FILES AND E-BOOKS IN THE FIELDS OF ENTERTAINMENT, BUSINESS, MUSIC, SPORTS, FILMS, ART, CULTURAL ACTIVITIES AND EDUCATION VIA THE INTERNET, MOBILE DEVICES, WIRELESS INTERNET NETWORKS OR SYSTEMS AND OTHER COMPUTER AND ELECTRONIC COMMUNICATION NETWORKS (U.S. CLS. 21, 23, 26, 36 AND 38).

CLASS 42—SCIENTIFIC AND COMPUTER SERVICES

FOR PROVIDING A WEBSITE FEATURING TECHNOLOGY THAT ENABLES USERS TO UPLOAD AND SHARE USER-GENERATED VIDEOS ON A WIDE VARIETY OF TOPICS AND SUBJECTS; PROVIDING WEB AND CLOUD BASED FILE SHARING, MANAGEMENT AND TRANSFER SERVICES, NAMELY, PROVIDING A WEBSITE FEATURING TECHNOLOGY ENABLING USERS TO UPLOAD AND DOWNLOAD ELECTRONIC FILES; AUDIO, VIDEO AND DIGITAL CONTENT DOWNLOAD SERVICES, NAMELY, PROVIDING A WEBSITE FEATURING TECHNOLOGY ENABLING USERS TO DOWNLOAD ELECTRONIC FILES PROVIDED OVER THE INTERNET, MOBILE DEVICES, WIRELESS INTERNET NETWORKS OR SYSTEMS AND OTHER COMPUTER AND ELECTRONIC COMMUNICATION NETWORKS; SOFTWARE AS A SERVICE (SAAS) FEATURING SOFTWARE FOR USE IN CONNECTION WITH AUDIO, VIDEO AND DIGITAL CONTENT SUBSCRIPTION SERVICE AND ONE-TIME PURCHASES OF AUDIO, VIDEO AND DIGITAL CONTENT, NAMELY, ALLOWING USERS TO PAY FOR AND CREATE SELLER CONTENT; PROVIDING A WEBSITE FEATURING ONLINE NON-DOWNLOADABLE SOFTWARE TO EN-

ABLE USERS TO ACCESS, ARRANGE, PLAY, SHARE AND VIEW AUDIOVISUAL MATERIALS AND DIGITAL CONTENT VIA THE INTERNET, MOBILE DEVICES, WIRELESS INTERNET NETWORKS OR SYSTEMS AND OTHER COMPUTER AND ELECTRONIC COMMUNICATION NETWORKS; PROVIDING TEMPORARY USE OF ONLINE NON-DOWNLOADABLE SOFTWARE TO ENABLE USERS TO PROGRAM AUDIO, VIDEO AND DIGITAL CONTENT; PROVIDING A WEBSITE FEATURING ONLINE NON-DOWNLOADABLE SOFTWARE FOR ENABLING USERS TO PROGRAM AUDIO, VIDEO AND DIGITAL CONTENT THROUGH THE USE OF THE INTERNET, MOBILE DEVICES, WIRELESS INTERNET NETWORKS OR SYSTEMS AND OTHER COMPUTER AND ELECTRONIC COMMUNICATION NETWORKS (U.S. CLS. 100 AND 101).

COURTNEY ALVAREZ, EXAMINING ATTORNEY

CLASS 41—EDUCATION AND ENTERTAINMENT

FOR ENTERTAINMENT SERVICES, NAMELY, LIVE MUSICAL PERFORMANCES; ENTERTAINMENT SERVICES, NAMELY, PROVIDING NON-DOWNLOADABLE PRERECORDED MUSIC AND VIDEO PROGRAMS ONLINE VIA A GLOBAL COMPUTER NETWORK; PROVIDING ONLINE INFORMATION IN THE FIELD OF MUSIC AND MUSICAL ARTISTS VIA THE INTERNET; FAN CLUBS; PROVIDING A WEBSITE FEATURING NON-DOWNLOADABLE MUSICAL SOUND RECORDINGS, MUSICAL VIDEOS, PHOTOGRAPHS AND OTHER MULTIMEDIA MATERIALS FEATURING MUSICAL ENTERTAINMENT AND MUSICAL ARTISTS; PROVIDING NON-DOWNLOADABLE NEWSLETTERS AND ALERTS IN THE FIELD OF MUSIC AND MUSICAL ARTISTS VIA EMAIL; ONLINE JOURNALS, NAMELY, BLOGS IN THE FIELD OF MUSIC AND MUSICAL ARTISTS; ENTERTAINMENT TEXT SERVICES IN THE NATURE OF PROVIDING PRERECORDED MESSAGES CONTAINING INFORMATION ABOUT MUSIC, MUSICAL ARTISTS AND MUSICAL TOURS BY DIGITAL TEXT MESSAGING TO WIRELESS DEVICES (U.S. CLS. 100, 101 AND 107).

FIRST USE 2-1-2011; IN COMMERCE 2-1-2011.

KHANH LE, EXAMINING ATTORNEY

SN 85-332,927. HUNTER EASTON HAYES, NASHVILLE, TN. FILED 5-27-2011.

SN 85-333,442. FUZZYTAILS BY LISA MCCUE, LLC, AKA FUZZYTAILS, ANNAPOLIS, MD. FILED 5-30-2011.



THE MARK CONSISTS OF THE STYLIZED LETTERS "HH" IN A BROKEN CIRCLE.

CLASS 9—ELECTRICAL AND SCIENTIFIC APPARATUS

FOR MUSICAL SOUND RECORDINGS; MUSICAL VIDEO RECORDINGS; DOWNLOADABLE MUSICAL SOUND RECORDINGS (U.S. CLS. 21, 23, 26, 36 AND 38).
FIRST USE 4-12-2011; IN COMMERCE 4-12-2011.

CLASS 38—COMMUNICATION

FOR STREAMING OF AUDIO MATERIAL ON THE INTERNET; STREAMING OF VIDEO MATERIAL ON THE INTERNET (U.S. CLS. 100, 101 AND 104).
FIRST USE 2-1-2011; IN COMMERCE 2-1-2011.

Fuzzytails by Lisa McCue

THE MARK CONSISTS OF STANDARD CHARACTERS WITHOUT CLAIM TO ANY PARTICULAR FONT, STYLE, SIZE, OR COLOR.

THE NAME(S), PORTRAIT(S), AND/OR SIGNATURE(S) SHOWN IN THE MARK IDENTIFIES "LISA MCCUE", WHOSE CONSENT(S) TO REGISTER IS MADE OF RECORD.

CLASS 9—ELECTRICAL AND SCIENTIFIC APPARATUS

FOR DOWNLOADABLE ELECTRONIC GAME PROGRAMS (U.S. CLS. 21, 23, 26, 36 AND 38).

CLASS 28—TOYS AND SPORTING GOODS

FOR TOYS, NAMELY, PLUSH AND BENDABLE PLUSH TOYS; BENDABLE TOYS CONTAINING RUBBER AND (U.S. CLS. 22, 23, 38 AND 50).

FIRST USE 2-16-1986; IN COMMERCE 2-13-2011.

CLASS 41—EDUCATION AND ENTERTAINMENT

FOR PROVIDING ON-LINE PUBLICATIONS IN THE NATURE OF AN E-BOOK IN THE FIELD OF CHILDREN'S EDUCATIONAL AND FICTIONAL ADVENTURE STORIES; ON-LINE JOURNALS, NAMELY, BLOGS FEATURING VOCABULARY BUILDING, ARTS AND CRAFTS, COOKING RECIPES, BASIC SCIENCE AND SCIENCE EXPERIMENTS, FACTS AND TRIVIA, GAMES AND PUZZLES (U.S. CLS. 100, 101 AND 107).

DAWN HAN, EXAMINING ATTORNEY

SN 85-333,574. LIEBERT CORPORATION, COLUMBUS, OH.
FILED 5-31-2011.

LIEBERT VIRTUAL NTEGRITY

THE MARK CONSISTS OF STANDARD CHARACTERS WITHOUT CLAIM TO ANY PARTICULAR FONT, STYLE, SIZE, OR COLOR.

OWNER OF U.S. REG. NOS. 1,185,650, 2,282,525 AND 3,999,203.

CLASS 35—ADVERTISING AND BUSINESS

FOR BUSINESS SERVICES, NAMELY, FACILITIES MANAGEMENT OF TECHNICAL OPERATIONS FOR DATA CENTER EQUIPMENT, INFORMATION MANAGEMENT SYSTEMS, CRITICAL SYSTEMS, NETWORK IT EQUIPMENT, ELECTRICAL POWER SYSTEMS, FIRE SUPPRESSION EQUIPMENT, AIR CONDITIONING UNITS, AND PERSONNEL ACCESS CONTROL DEVICES (U.S. CLS. 100, 101 AND 102).

CLASS 37—CONSTRUCTION AND REPAIR

FOR MAINTENANCE AND REPAIR OF ELECTRICAL POWER UNITS FEATURING POWER CONDITIONING AND DISTRIBUTION EQUIPMENT, UNINTERRUPTIBLE POWER SUPPLIES AND BATTERIES; MAINTENANCE AND REPAIR OF DATA CENTER EQUIPMENT, COMPUTER HARDWARE IN THE NATURE OF INFORMATION MANAGEMENT SYSTEMS, CRITICAL SYSTEM HARDWARE, NETWORK IT EQUIPMENT, ELECTRICAL POWER SYSTEMS, FIRE SUPPRESSION EQUIPMENT, AIR CONDITIONING UNITS AND PERSONNEL ACCESS CONTROL DEVICES (U.S. CLS. 100, 103 AND 106).

CLASS 42—SCIENTIFIC AND COMPUTER SERVICES

FOR MAINTENANCE AND REPAIR OF COMPUTER SOFTWARE IN THE NATURE OF INFORMATION MANAGEMENT SYSTEMS; MAINTENANCE AND REPAIR OF CRITICAL SYSTEMS SOFTWARE FOR GENERATORS, BATTERY SYSTEMS AND UNINTERRUPTIBLE POWER SUPPLIES (U.S. CLS. 100 AND 101).

GRETCHEN ULRICH, EXAMINING ATTORNEY

SN 85-334,993. BREITBARTH, WAYNE C., MEQUON, WI.
FILED 6-1-2011.

Power Formula

THE MARK CONSISTS OF STANDARD CHARACTERS WITHOUT CLAIM TO ANY PARTICULAR FONT, STYLE, SIZE, OR COLOR.

CLASS 9—ELECTRICAL AND SCIENTIFIC APPARATUS

FOR (BASED ON USE IN COMMERCE) DIGITAL MEDIA, NAMELY, PRE-RECORDED DVDS, DOWNLOADABLE AUDIO AND VIDEO RECORDINGS, AND CDS FEATURING AND PROMOTING THE FIELD OF INTERNET-BASED SOCIAL MEDIA AND SOCIAL NETWORKING TECHNOLOGY (U.S. CLS. 21, 23, 26, 36 AND 38).

FIRST USE 1-14-2010; IN COMMERCE 10-10-2010.

CLASS 16—PAPER GOODS AND PRINTED MATTER

FOR (BASED ON INTENT TO USE) A SERIES OF BOOKS, WRITTEN ARTICLES, HANDOUTS AND WORKSHEETS IN THE FIELD OF INTERNET-BASED SOCIAL MEDIA AND SOCIAL NETWORKING TECHNOLOGY (U.S. CLS. 2, 5, 22, 23, 29, 37, 38 AND 50).

CLASS 41—EDUCATION AND ENTERTAINMENT

FOR (BASED ON USE IN COMMERCE) PROVIDING EDUCATION SERVICES, NAMELY, CLASSES AND SEMINARS IN THE FIELD OF INTERNET-BASED SOCIAL MEDIA AND SOCIAL NETWORKING TECHNOLOGY (U.S. CLS. 100, 101 AND 107).

FIRST USE 1-14-2010; IN COMMERCE 10-10-2010.

CLASS 45—PERSONAL AND LEGAL SERVICES

FOR (BASED ON USE IN COMMERCE) PROVIDING INFORMATION AND CONSULTATION IN THE FIELD OF INTERNET-BASED SOCIAL MEDIA AND SOCIAL NETWORKING TECHNOLOGY (U.S. CLS. 100 AND 101).

FIRST USE 1-14-2010; IN COMMERCE 10-10-2010.

ANNE MADDEN, EXAMINING ATTORNEY

SN 85-335,952. CAVIAR PETROSSIAN, PARIS, FRANCE,
FILED 6-2-2011.

SHASSETRA

THE MARK CONSISTS OF STANDARD CHARACTERS WITHOUT CLAIM TO ANY PARTICULAR FONT, STYLE, SIZE, OR COLOR.

OWNER OF FRANCE REG. NO. 093630781, DATED 2-18-2009, EXPIRES 2-18-2019.

THE WORDING "SHASSETRA" HAS NO MEANING IN A FOREIGN LANGUAGE.

CLASS 29—MEATS AND PROCESSED FOODS

FOR CAVIAR, SMOKED FISH, FOIE GRAS, POULTRY, GAME, PREPARED MEALS CONSISTING PRIMARILY OF FISH, MEAT AND VEGETABLES; PRESERVED, DRIED AND COOKED FRUITS AND VEGETABLES; JELLIES, JAMS, MILK PRODUCTS EXCLUDING ICE CREAM, ICE MILK AND FROZEN YOGURT; EDIBLE OILS; PREPARED MEALS CONSISTING PRIMARILY OF FOIE GRAS, SMOKED SALMON, CAVIAR (U.S. CL. 46).

CLASS 30—STAPLE FOODS

FOR COFFEE, TEA, COCOA, SUGAR, RICE, FLOUR; PREPARATIONS MADE FROM CEREALS, NAMELY, BISCUITS, COOKIES, CAKES, CRACKERS, PANCAKES AND BLINIS, BREAD, PASTRY AND CONFECTIONERIES, NAMELY, CHOCOLATES, NOUGATS, TOFFEES, CHOCOLATE TRUFFLES, FUDGES, FRUIT JELLIES; EDIBLE ICES, HONEY, YEAST, SALT, MUSTARD, VINEGAR, SAUCES, SPICES; PACKAGED MEAL MIXES CONSISTING PRIMARILY OF PASTA OR RICE; DRESSINGS FOR SALAD (U.S. CL. 46).

CLASS 31—NATURAL AGRICULTURAL PRODUCTS

FOR STURGEON EGGS INTENDED FOR BREEDING (U.S. CLS. 1 AND 46).
PAUL MORENO, EXAMINING ATTORNEY

SN 85-336,169. ECOTRICITY GROUP LIMITED, GLOUCESTERSHIRE, UNITED KINGDOM, FILED 6-2-2011.

ION HORSE

THE MARK CONSISTS OF STANDARD CHARACTERS WITHOUT CLAIM TO ANY PARTICULAR FONT, STYLE, SIZE, OR COLOR.

PRIORITY CLAIMED UNDER SEC. 44(D) ON ERP N CMNTY TM OFC APPLICATION NO. 10013704, FILED 6-1-2011, REG. NO. 10013704, DATED 11-16-2011, EXPIRES 6-1-2021.

CLASS 9—ELECTRICAL AND SCIENTIFIC APPARATUS

FOR EYEGLASSES; SUNGLASSES; SAFETY GOGGLES; MOTORCYCLE GOGGLES; PROTECTIVE CLOTHING, NAMELY, ARTICLES OF PROTECTIVE CLOTHING FOR WEAR BY MOTORCYCLISTS FOR PROTECTION AGAINST ACCIDENT OR INJURY; PROTECTIVE HELMETS; MOTORCYCLE ELECTRICAL PARTS AND GAUGES, NAMELY, RADIOS, SPEEDOMETERS, TACHOMETERS, BATTERIES, ELECTRICAL WIRING, CRUISE CONTROLS FOR MOTORCYCLES, ELECTRIC SWITCHES, ELECTRICAL SWITCHES, BREAKER POINTS, NAMELY, CONTACT BREAKER; TERMINALS IN THE NATURE OF PARTS OF MOTORCYCLE BATTERIES, STARTERS IN THE NATURE OF MOTORCYCLE ELECTRICAL PARTS, CIRCUIT BREAKERS, THERMOSTATS, BATTERY CHARGERS, ARMATURES AND VOLTAGE REGULATORS (U.S. CLS. 21, 23, 26, 36 AND 38).

CLASS 12—VEHICLES

FOR ELECTRIC VEHICLES, NAMELY, ELECTRIC MOTORCYCLES; MOTORCYCLES, MOTORCYCLE ENGINES AND PARTS, FITTINGS AND ACCESSORIES FOR MOTORCYCLES, NAMELY, AIR PRESSURE PUMPS, MOTORCYCLE INDICATORS IN THE NATURE OF TURN SIGNALS, TAX DISC HOLDERS, HANDLEBAR ENDS, RANK PROTECTORS, HANDLEBAR GRIPS, VALVE CAPS, PILLION GRIPPERS, NUMBERPLATE HANGER BRACKETS, FORK PROTECTORS, STAND SUPPORTS; TURN SIGNALS FOR VEHICLES (U.S. CLS. 19, 21, 23, 31, 35 AND 44).

CLASS 39—TRANSPORTATION AND STORAGE

FOR TRANSMISSION AND DISTRIBUTION OF ELECTRICITY; TRANSMISSION AND DISTRIBUTION OF ELECTRICITY FOR VEHICLES; STORAGE, TRANSPORTATION AND DELIVERY OF ELECTRICITY (U.S. CLS. 100 AND 105).

YAT SYE, LEE, EXAMINING ATTORNEY

SN 85-336,666. LANG-WILLAR, STEPHANE, MIAMI BEACH, FL. FILED 6-2-2011.

STÉPHANE'S

THE MARK CONSISTS OF STANDARD CHARACTERS WITHOUT CLAIM TO ANY PARTICULAR FONT, STYLE, SIZE, OR COLOR.

CLASS 35—ADVERTISING AND BUSINESS

FOR RETAIL STORE SERVICES FEATURING BEER, WINE AND SPIRITS (U.S. CLS. 100, 101 AND 102).

CLASS 43—HOTEL AND RESTAURANT SERVICES

FOR RESTAURANT SERVICES; CARRY-OUT SERVICES; BAR SERVICES (U.S. CLS. 100 AND 101).
TAMARA FRAZIER, EXAMINING ATTORNEY

SN 85-336,964. BURN20, LLC, DBA BURN20, HALLANDALE BEACH, FL. FILED 6-2-2011.

BURN 20

THE MARK CONSISTS OF STANDARD CHARACTERS WITHOUT CLAIM TO ANY PARTICULAR FONT, STYLE, SIZE, OR COLOR.

CLASS 41—EDUCATION AND ENTERTAINMENT

FOR PROVIDING EDUCATIONAL INFORMATION REGARDING PHYSICAL FITNESS AND EXERCISE TO ACHIEVE WEIGHT LOSS; AND ENTERTAINMENT, NAMELY, A CONTINUING NEWS SHOW IN THE FIELDS OF WEIGHT LOSS AND PHYSICAL FITNESS BROADCAST OVER THE INTERNET (U.S. CLS. 100, 101 AND 107).

FIRST USE 5-13-2011; IN COMMERCE 5-13-2011.

CLASS 44—MEDICAL, BEAUTY AND AGRICULTURAL SERVICES

FOR PROVIDING EDUCATIONAL INFORMATION REGARDING DIET AND DIET PLANNING FOR WEIGHT LOSS BROADCAST OVER THE INTERNET (U.S. CLS. 100 AND 101).

FIRST USE 5-13-2011; IN COMMERCE 5-13-2011.
TRACY CROSS, EXAMINING ATTORNEY

SN 85-337,331. BRAND SENSE PARTNERS, LLC, CULVER CITY, CA. FILED 6-3-2011.

SN 85-337,561. RESHMI'S GROUP, INC., KENT, WA. FILED 6-3-2011.

MYPLATE

THE MARK CONSISTS OF STANDARD CHARACTERS WITHOUT CLAIM TO ANY PARTICULAR FONT, STYLE, SIZE, OR COLOR.

CLASS 5—PHARMACEUTICALS

FOR NUTRITIONAL AND DIETARY SUPPLEMENTS (U.S. CLS. 6, 18, 44, 46, 51 AND 52).

CLASS 16—PAPER GOODS AND PRINTED MATTER

FOR PRINTED PUBLICATIONS, NAMELY, MAGAZINES, NEWSLETTERS, BOOKLETS, BROCHURES, AND PAMPHLETS RELATED TO FOOD, NUTRITION, AND DIET (U.S. CLS. 2, 5, 22, 23, 29, 37, 38 AND 50).

CLASS 21—HOUSEWARES AND GLASS

FOR DINNERWARE; DRINKING CUPS FOR BABIES AND CHILDREN (U.S. CLS. 2, 13, 23, 29, 30, 33, 40 AND 50).

CLASS 29—MEATS AND PROCESSED FOODS

FOR FROZEN MEAT, FISH, POULTRY, FRUITS AND VEGETABLES; FRESH MEAT, FISH AND POULTRY (U.S. CL. 46).

CLASS 31—NATURAL AGRICULTURAL PRODUCTS

FOR FRESH FRUITS, FRESH VEGETABLES, AND UNPROCESSED GRAINS (U.S. CLS. 1 AND 46).

CLASS 41—EDUCATION AND ENTERTAINMENT

FOR ONLINE PUBLICATIONS IN THE NATURE OF BLOGS AND MAGAZINES IN THE FIELDS OF FOOD, NUTRITION, AND DIET (U.S. CLS. 100, 101 AND 107).

CLASS 44—MEDICAL, BEAUTY AND AGRICULTURAL SERVICES

FOR ONLINE SERVICES IN THE NATURE OF NUTRITIONAL COUNSELING, DIETARY AND NUTRITIONAL GUIDANCE IN THE FIELDS OF FOOD PREPARATION, NUTRITION, AND DIET (U.S. CLS. 100 AND 101).

WILLIAM BRECKENFELD, EXAMINING ATTORNEY

Siva's

THE MARK CONSISTS OF STANDARD CHARACTERS WITHOUT CLAIM TO ANY PARTICULAR FONT, STYLE, SIZE, OR COLOR.

CLASS 29—MEATS AND PROCESSED FOODS

FOR BEAN FLOUR; CANDIED FRUIT SNACKS; DRIED FRUIT-BASED SNACKS; DRIED LENTILS; FRUIT AND SOY BASED SNACK FOOD; GHEE; GRAM FLOUR; NUT AND SEED-BASED SNACK BARS; NUT-BASED SNACK FOODS; POTATO-BASED SNACK FOODS; SNACK MIX CONSISTING OF DEHYDRATED FRUIT AND PROCESSED NUTS; SNACK MIX CONSISTING PRIMARILY OF PROCESSED FRUITS, PROCESSED NUTS AND/OR RAISINS; SNACK MIX CONSISTING PRIMARILY OF PROCESSED NUTS AND SALTED SQUASH SEEDS AND ALSO INCLUDING TOASTED CORN; SOY-BASED SNACK FOODS; VEGETABLE-BASED SNACK FOODS (U.S. CL. 46).

FIRST USE 9-1-2010; IN COMMERCE 3-1-2011.

CLASS 30—STAPLE FOODS

FOR CINNAMON POWDER; CLOVE POWDER; CORN FLOUR; CURRY POWDER; EDIBLE SPICES; FLOUR; GINGER; HOT PEPPER POWDER; MASALA POWDER AND SPICES; MULTIGRAIN-BASED SNACK FOODS; MUSTARD POWDER; PEPPER; PEPPER POWDER; PUFFED CORN SNACKS; PUFFED RICE; RICE FLOUR; RICE-BASED SNACK FOODS; SPICES; WHEAT FLOUR; WHEAT-BASED SNACK FOODS (U.S. CL. 46).

FIRST USE 9-1-2010; IN COMMERCE 3-1-2011.

ROBIN CHOSID, EXAMINING ATTORNEY

SN 85-337,614. FMG HOLDINGS, LLC, GRAND RAPIDS, MI. FILED 6-3-2011.



OWNER OF U.S. REG. NOS. 2,853,982 AND 2,962,214. NO CLAIM IS MADE TO THE EXCLUSIVE RIGHT TO USE "POWERSPORTS", APART FROM THE MARK AS SHOWN.

THE COLOR(S) BLUE AND GRAY IS/ARE CLAIMED AS A FEATURE OF THE MARK.

THE MARK CONSISTS OF A DEPICTION OF A FOX HEAD IN BLUE, THE WORD "FOX" IN BLUE AND THE WORD "POWERSPORTS" IN GREY WITH LIGHTER GREY SHADOWING.

CLASS 35—ADVERTISING AND BUSINESS

FOR DEALERSHIPS IN THE FIELD OF MOTORCYCLES, SCOOTERS, ATVS, SNOWMOBILES, PERSONAL WATERCRAFT, BOATS, PERSONAL JET BOATS, LAWN MOWERS AND SNOW BLOWERS (U.S. CLS. 100, 101 AND 102).

FIRST USE 2-4-2011. THE MARK WAS FIRST USED ANYWHERE IN A DIFFERENT FORM OTHER THAN THAT SOUGHT TO BE REGISTERED AT LEAST AS EARLY AS 10/18/1999.; IN COMMERCE 2-4-2011. THE MARK WAS FIRST USED IN COMMERCE IN A DIFFERENT FORM OTHER THAN THAT SOUGHT TO BE REGISTERED AT LEAST AS EARLY AS 10/18/1999. .

CLASS 37—CONSTRUCTION AND REPAIR

FOR MAINTENANCE AND/OR REPAIR OF MOTORCYCLES, SCOOTERS, ATVS, SNOWMOBILES, PERSONAL WATERCRAFT, BOATS, PERSONAL JET BOATS, LAWN MOWERS AND SNOW BLOWERS (U.S. CLS. 100, 103 AND 106).

FIRST USE 2-4-2011, THE MARK WAS FIRST USED ANYWHERE IN A DIFFERENT FORM OTHER THAN THAT SOUGHT TO BE REGISTERED AT LEAST AS EARLY AS 10/18/1999.; IN COMMERCE 2-4-2011, THE MARK WAS FIRST USED IN COMMERCE IN A DIFFERENT FORM OTHER THAN THAT SOUGHT TO BE REGISTERED AT LEAST AS EARLY AS 10/18/1999..

DOUGLAS LEE, EXAMINING ATTORNEY

SN 85-339,755. JEFF LEATHAM, INC., NEW YORK, NY. FILED 6-7-2011.

VELVET DAHLIA

THE MARK CONSISTS OF STANDARD CHARACTERS WITHOUT CLAIM TO ANY PARTICULAR FONT, STYLE, SIZE, OR COLOR.

CLASS 3—COSMETICS AND CLEANING PREPARATIONS

FOR FRAGRANCES FOR PERSONAL USE; PERFUMES AND COLOGNES; ROOM FRAGRANCES; SCENTED ROOM SPRAYS (U.S. CLS. 1, 4, 6, 50, 51 AND 52).

CLASS 4—LUBRICANTS AND FUELS

FOR CANDLES (U.S. CLS. 1, 6 AND 15).
ESTHER BELENKER, EXAMINING ATTORNEY

SN 85-338,674. LIPTON, ALLYSON, NEW YORK, NY. FILED 6-6-2011.



SN 85-339,837. AQUION, INC., ELK GROVE VILLAGE, IL. FILED 6-7-2011.

WE TAKE THE WORRY OUT OF WATER

THE COLOR(S) ORANGE, DARK ORANGE, GREEN, LIME GREEN, BROWN, AND DARK BROWN IS/ARE CLAIMED AS A FEATURE OF THE MARK.

THE COLOR ORANGE APPEARS IN THE DESIGN OF A PEACH. THE COLOR DARK ORANGE APPEARS IN THE SKYLINE WHICH APPEARS IN THE PEACH. THE COLOR GREEN APPEARS IN THE LEAF ON THE PEACH. THE COLOR BROWN APPEARS ON THE STEM ON THE PEACH. THE COLOR DARK BROWN APPEARS IN THE WORDS "HERB" AND "PEACH." THE COLOR LIME GREEN ALSO APPEARS IN THE STYLIZED DASHES IN THE SHAPE OF LEAVES ON EITHER SIDE OF THE LETTER "N" WHICH REPRESENTS THE WORD "AND." THE COLOR GREEN ALSO APPEARS IN THE LETTER "N."

CLASS 30—STAPLE FOODS

FOR SANDWICHES; POPCORN; ICE CREAM; ICED TEA; CRÈME BRULÉE; BAKERY GOODS, NAMELY, BROWNIES, SCONES, BREAD AND PASTRIES (U.S. CL. 46).

CLASS 41—EDUCATION AND ENTERTAINMENT

FOR CONSULTATION IN THE FIELD OF SPECIAL EVENT PLANNING FOR SOCIAL ENTERTAINMENT PURPOSES (U.S. CLS. 100, 101 AND 107).
EVELYN BRADLEY, EXAMINING ATTORNEY

THE MARK CONSISTS OF STANDARD CHARACTERS WITHOUT CLAIM TO ANY PARTICULAR FONT, STYLE, SIZE, OR COLOR.

CLASS 37—CONSTRUCTION AND REPAIR

FOR TECHNICAL SUPPORT SERVICES, NAMELY, TECHNICAL ADVICE RELATED TO THE INSTALLATION AND MAINTENANCE OF WATER TREATMENT AND CONDITIONING EQUIPMENT (U.S. CLS. 100, 103 AND 106).

FIRST USE 5-23-2011; IN COMMERCE 5-23-2011.

CLASS 41—EDUCATION AND ENTERTAINMENT

FOR EDUCATIONAL SERVICES, NAMELY, PROVIDING LIVE AND ON-LINE CLASSES AND SEMINARS ON THE INSTALLATION AND MAINTENANCE OF WATER TREATMENT AND CONDITIONING EQUIPMENT (U.S. CLS. 100, 101 AND 107).

FIRST USE 3-22-2011; IN COMMERCE 3-22-2011.
B. PARADEWELAI, EXAMINING ATTORNEY

SN 85-339,851. TRAYPORT LIMITED, LONDON, UNITED KINGDOM, FILED 6-7-2011.

TRAYPORT

THE MARK CONSISTS OF STANDARD CHARACTERS WITHOUT CLAIM TO ANY PARTICULAR FONT, STYLE, SIZE, OR COLOR.

OWNER OF ERPN CMNTY TM OFC REG. NO. 001873587, DATED 3-12-2002, EXPIRES 9-26-2020.

CLASS 9—ELECTRICAL AND SCIENTIFIC APPARATUS

FOR COMPUTERS, COMPUTER HARDWARE, COMPUTER SOFTWARE FOR PROVIDING, HOSTING, SUPPORTING, FACILITATING BROKERAGE, TRADING, STOCK EXCHANGE ACTIVITIES IN FINANCIAL AND COMMODITY MARKETS, DISPLAYING TRADE DATA, INSTANT MESSAGING AND FOR EDUCATIONAL AND NON EDUCATIONAL GAMING; COMPUTER SOFTWARE IN THE NATURE OF DOWNLOADABLE SOFTWARE RELATING TO FINANCIAL AND COMMODITY MARKETS, EDUCATIONAL AND NON EDUCATIONAL GAMING, INFORMATION REGARDING FINANCIAL AND COMMODITY ASSETS AND MARKETS, ANALYSIS OF FINANCIAL AND COMMODITY MARKETS AND ASSETS, LEGAL AFFAIRS REGULATION AND RISK MANAGEMENT RELATING TO COMMODITY AND FINANCIAL MARKETS, PERFORMANCE GUIDANCE AND UPDATES RELATING TO BUSINESS ACTIVITIES AND PRODUCTS IN FINANCIAL AND COMMODITY MARKETS; PARTS AND FITTINGS FOR COMPUTER HARDWARE; COMPUTER PERIPHERALS; INTEGRATED CIRCUITS; DOWNLOADABLE ELECTRONIC PUBLICATIONS, NAMELY, PERIODICALS, MAGAZINES, NEWSLETTERS AND BULLETINS FEATURING SUBJECT MATTER RELATED TO FINANCIAL AND COMMODITY ASSETS AND MARKETS, ANALYSIS OF FINANCIAL AND COMMODITY MARKETS AND ASSETS, LEGAL AFFAIRS, REGULATION AND RISK MANAGEMENT RELATING TO COMMODITY AND FINANCIAL MARKETS, PERFORMANCE, GUIDANCE AND UPDATES RELATING TO BUSINESS ACTIVITIES AND PRODUCTS IN FINANCIAL AND COMMODITIES MARKETS; COMPUTER HARDWARE AND COMPUTER SOFTWARE FOR DATABASE MANAGEMENT; COMPUTER PROGRAMS FOR PROVIDING, HOSTING, SUPPORTING, FACILITATING BROKERAGE, TRADING, STOCK EXCHANGE ACTIVITIES IN FINANCIAL AND COMMODITY MARKETS, DISPLAYING TRADE DATA, INSTANT MESSAGING AND FOR EDUCATIONAL AND NON-EDUCATIONAL GAMING; DOWNLOADABLE COMPUTER SOFTWARE FOR PROVIDING, HOSTING, SUPPORTING AND FACILITATING TRADING ACTIVITY IN FINANCIAL AND COMMODITY MARKETS, DISPLAYING TRADE DATA, INSTANT MESSAGING AND FOR EDUCATIONAL AND NON-EDUCATIONAL GAMING; DOWNLOADABLE ELECTRONIC PUBLICATIONS OF DATA OR INFORMATION RELATED TO BROKERAGE, TRADING, STOCK EXCHANGE ACTIVITIES, INCLUDING MAGAZINES, NEWSLETTERS AND BULLETINS FEATURING SUBJECT MATTER RELATED TO FINANCIAL AND COMMODITY ASSETS AND MARKETS, ANALYSIS OF FINANCIAL AND COMMODITY MARKETS AND ASSETS, LEGAL AFFAIRS, REGULATION AND RISK MANAGEMENT RELATING TO COMMODITY AND FINANCIAL MARKETS, PERFORMANCE, GUIDANCE AND UPDATES RELATING TO BUSINESS ACTIVITIES AND PRODUCTS IN FINANCIAL AND COMMODITIES MARKETS; INTERACTIVE COMPUTER SOFTWARE FOR PROVIDING, HOSTING, SUPPORTING AND FACILITATING BROKERAGE, TRADING, STOCK EXCHANGE ACTIVITIES IN FINANCIAL AND COMMODITY MARKETS, DISPLAYING TRADE DATA, INSTANT MESSAGING AND FOR EDUCATIONAL AND NON-EDUCATIONAL GAMING; COMPUTER SEARCH ENGINE SOFTWARE (U.S. CLS. 21, 23, 26, 36 AND 38).

CLASS 16—PAPER GOODS AND PRINTED MATTER

FOR PRINTED MATTER AND PRINTED PUBLICATIONS, NAMELY, PERIODICALS, MAGAZINES, NEWSLETTERS AND BULLETINS FEATURING SUBJECT MATTER RELATED TO FINANCIAL AND COMMODITY ASSETS AND MARKETS, ANALYSIS OF FINANCIAL AND COMMODITY MARKETS AND ASSETS, LEGAL AFFAIRS, REGULATION AND RISK MANAGEMENT RELATING TO COMMODITY AND FINANCIAL MARKETS, PERFORMANCE, GUIDANCE AND UPDATES RELATING TO BUSINESS ACTIVITIES AND PRODUCTS IN FINANCIAL AND COMMODITIES MARKETS; A SERIES OF NON-FICTION BOOKS IN THE FIELD OF FINANCIAL AND COMMODITY ASSETS AND MARKETS; NEWSLETTERS, MAGAZINES, PAMPHLETS, AND BROCHURES FEATURING SUBJECT MATTER RELATED TO FINANCIAL AND COMMODITY ASSETS AND MARKETS, ANALYSIS OF FINANCIAL AND COMMODITY MARKETS AND ASSETS, LEGAL AFFAIRS, REGULATION AND RISK MANAGEMENT RELATING TO COMMODITY AND FINANCIAL MARKETS, PERFORMANCE, GUIDANCE AND UPDATES RELATING TO BUSINESS ACTIVITIES AND PRODUCTS IN FINANCIAL AND COMMODITIES MARKETS; CATALOGUES FEATURING SUBJECT MATTER RELATED TO FINANCIAL AND COMMODITY ASSETS AND MARKETS, ANALYSIS OF FINANCIAL AND COMMODITY MARKETS AND ASSETS, LEGAL AFFAIRS, REGULATION AND RISK MANAGEMENT RELATING TO COMMODITY AND FINANCIAL MARKETS, PERFORMANCE, GUIDANCE AND UPDATES RELATING TO BUSINESS ACTIVITIES AND PRODUCTS IN FINANCIAL AND COMMODITIES MARKETS; NOTEBOOKS, WRITING PADS, MANUALS FEATURING SUBJECT MATTER RELATED TO FINANCIAL AND COMMODITY ASSETS AND MARKETS, ANALYSIS OF FINANCIAL AND COMMODITY MARKETS AND ASSETS, LEGAL AFFAIRS, REGULATION AND RISK MANAGEMENT RELATING TO COMMODITY AND FINANCIAL MARKETS, PERFORMANCE, GUIDANCE AND UPDATES RELATING TO BUSINESS ACTIVITIES AND PRODUCTS IN FINANCIAL AND COMMODITIES MARKETS; DIARIES; CALENDARS; ADVERTISING MATERIAL IN THE NATURE OF BROCHURES FEATURING SUBJECT MATTER RELATED TO FINANCIAL AND COMMODITY ASSETS AND MARKETS, ANALYSIS OF FINANCIAL AND COMMODITY MARKETS AND ASSETS, LEGAL AFFAIRS, REGULATION AND RISK MANAGEMENT RELATING TO COMMODITY AND FINANCIAL MARKETS, PERFORMANCE, GUIDANCE AND UPDATES RELATING TO BUSINESS ACTIVITIES AND PRODUCTS IN FINANCIAL AND COMMODITIES MARKETS; INSTRUCTIONAL AND TEACHING MATERIAL, NAMELY, BOOKS, WORKBOOKS AND TEXTBOOKS FEATURING SUBJECT MATTER RELATED TO FINANCIAL AND COMMODITY ASSETS AND MARKETS, ANALYSIS OF FINANCIAL AND COMMODITY MARKETS AND ASSETS, LEGAL AFFAIRS, REGULATION AND RISK MANAGEMENT RELATING TO COMMODITY AND FINANCIAL MARKETS, PERFORMANCE, GUIDANCE AND UPDATES RELATING TO BUSINESS ACTIVITIES AND PRODUCTS IN FINANCIAL AND COMMODITIES MARKETS (U.S. CLS. 2, 5, 22, 23, 29, 37, 38 AND 50).

CLASS 35—ADVERTISING AND BUSINESS

FOR ADVERTISING, BUSINESS MANAGEMENT, BUSINESS ADMINISTRATION AND OFFICE FUNCTIONS; COMPUTERIZED ON-LINE BUSINESS MANAGEMENT, COMPUTERIZED ONLINE ORDERING SERVICES FEATURING BOOKS, CATALOGUES, MANUALS, PERIODICALS, MAGAZINES, NEWSLETTERS AND BULLETINS RELATING TO FINANCIAL AND COMMODITY ASSETS AND MARKETS, ANALYSIS OF FINANCIAL AND COMMODITY MARKETS AND ASSETS, LEGAL AFFAIRS, REGULATION AND RISK MANAGEMENT RELATING TO COMMODITY AND FINANCIAL MARKETS, PERFORMANCE, GUIDANCE AND UPDATES RELATING TO BUSINESS ACTIVITIES AND PRODUCTS IN FINANCIAL AND COMMODITIES MARKETS, AVAILABLE IN BOTH DOWNLOADABLE ELECTRONIC FORMAT AND PRINTED FORMAT, COMPUTER SOFTWARE FOR PROVIDING, HOSTING, SUPPORTING, FACILITATING BROKERAGE, TRADING, STOCK EXCHANGE ACTIVITIES IN FINANCIAL

AND COMMODITY MARKETS, DISPLAYING TRADE DATA, INSTANT MESSAGING AND FOR EDUCATIONAL AND NON EDUCATIONAL GAMING, COMPUTER SOFTWARE IN THE NATURE OF DOWNLOADABLE SOFTWARE RELATING TO FINANCIAL AND COMMODITY MARKETS, EDUCATIONAL AND NON EDUCATIONAL GAMING, INFORMATION REGARDING FINANCIAL AND COMMODITY ASSETS AND MARKETS, ANALYSIS OF FINANCIAL AND COMMODITY MARKETS AND ASSETS, LEGAL AFFAIRS REGULATION AND RISK MANAGEMENT RELATING TO COMMODITY AND FINANCIAL MARKETS, PERFORMANCE GUIDANCE AND UPDATES RELATING TO BUSINESS ACTIVITIES AND PRODUCTS IN FINANCIAL AND COMMODITY MARKETS; ADVERTISING, MARKETING, PROMOTIONAL AND CROSS PROMOTIONAL SERVICES, DATABASE MANAGEMENT SERVICES; PROVIDING BUSINESS INFORMATION SERVICES VIA THE INTERNET; CONDUCTING MARKETING SURVEYS; ANALYSIS OF ADVERTISING RESPONSE AND MARKET RESEARCH; COMPILATION OF ADVERTISEMENTS FOR USE AS WEB-PAGES; ADVISORY AND CONSULTANCY RELATED TO ALL OF THE ABOVE MENTIONED SERVICES (U.S. CLS. 100, 101 AND 102).

CLASS 36—INSURANCE AND FINANCIAL

FOR FINANCIAL AND INSURANCE SERVICES; REAL ESTATE AGENCY, VALUATION, MANAGEMENT AND BROKERAGE; LOANS, MORTGAGING, GUARANTEES; FINANCIAL MANAGEMENT, SHARES AND SECURITY BROKERAGE, FINANCIAL INVESTMENTS, INVESTMENT TRUSTS, CONSULTANCY AND BROKERAGE SERVICES; SERVICES FOR THE PROVISION OF TRAVELLERS' CHEQUES; FINANCIAL SERVICES PROVIDED BY BANKS TO BANKS, TRADERS AND EXCHANGES, NAMELY, COMMODITY ASSET AND MARKET MANAGEMENT; TRUSTEESHIP SERVICES; FINANCIAL PLANNING; CONDUCTING VALUATIONS; INVESTMENT TRUSTEESHIP AND ADVISORY SERVICES; MONEY TRANSMISSION SERVICES; FINANCIAL SERVICES, NAMELY, PROVIDING INFORMATION AND ANALYSIS REGARDING FINANCIAL MARKETS; ALL THE AFORESAID SERVICES PROVIDED FROM A GLOBAL COMPUTER NETWORK ON THE INTERNET; INFORMATION, CONSULTANCY AND ADVISORY SERVICES RELATING TO THE AFORESAID SERVICES (U.S. CLS. 100, 101 AND 102).

CLASS 38—COMMUNICATION

FOR TELECOMMUNICATION SERVICES, NAMELY, PROVIDING ACCESS TO THE INTERNET AND PROVIDING ACCESS TO WIRELESS AND BROADBAND COMMUNICATION SERVICES, PROVIDING REMOTE ACCESS TO WORKSTATIONS AND DATABASES, AND REMOTE DATA STORAGE SYSTEMS; ELECTRONIC MAIL SERVICES; MESSAGE SENDING AND RECEIVING SERVICES; INTERNET BROADCASTING SERVICES; TRANSMISSION AND DISTRIBUTION OF DATA OR AUDIO VISUAL IMAGES VIA A GLOBAL COMPUTER NETWORK OR THE INTERNET; PROVIDING ON-LINE COMMUNICATION LINKS WHICH TRANSFER THE WEB SITE USER TO OTHER LOCAL AND GLOBAL WEB PAGES; PROVIDING ADVICE AND CONSULTATION TO THE ABOVE LISTED SERVICES (U.S. CLS. 100, 101 AND 104).

CLASS 42—SCIENTIFIC AND COMPUTER SERVICES

FOR COMPUTER PROGRAMMING; GRAPHIC DESIGN FOR THE COMPILATION OF WEB PAGES ON THE INTERNET; CREATING AND MAINTAINING WEB SITES FOR OTHERS; COMPUTER DATABASE AND COMPUTER APPLICATION MANAGEMENT; PROVIDING DATA AGGREGATION SERVICES; HOSTING THE WEB SITES OF OTHERS; LEASING ACCESS TIME TO A COMPUTER DATABASE; COMPUTER ADVICE AND COMPUTER CONSULTATION SERVICES OFFERED VIA THE INTERNET (U.S. CLS. 100 AND 101).
DAWN FELDMAN, EXAMINING ATTORNEY

SN 85-340,601. BRIAN FREELAND, MORENO VALLEY, CA. FILED 6-8-2011.

SASZGEAR

THE MARK CONSISTS OF STANDARD CHARACTERS WITHOUT CLAIM TO ANY PARTICULAR FONT, STYLE, SIZE, OR COLOR.

CLASS 14—JEWELRY

FOR JEWELRY, NAMELY, RINGS, BRACELETS, NECKLACES, EARRINGS, WATCHES, COLLAR BARS, TIE BARS, BELLY RINGS, TONGUE RINGS, BODY-PIERCING RINGS, BODY-PIERCING STUDS (U.S. CLS. 2, 27, 28 AND 50).

CLASS 25—CLOTHING

FOR MEN'S, WOMEN'S AND CHILDREN'S SPORTSWEAR AND CASUAL WEAR, NAMELY, SHIRTS, SHORTS, PANTS, SKIRTS, DRESSES, JEANS, BELTS, JACKETS, TANK TOPS, TURTLENECKS, CHEERLEADER SHORTS, CHEERLEADER SKIRTS, CHEERLEADER SHIRTS, JERSEYS, TEE-SHIRTS, SWEATSHIRTS, SWEATPANTS, WEIGHT LIFTER SHIRTS, ATHLETIC UNIFORMS, AND HEADGEAR, NAMELY, CAPS, HATS, BEANIES; CLOTHING, NAMELY, MEN'S UNDERWEAR, SOCKS, PAJAMAS, AND LADIES UNDERWEAR, BRAS, PAJAMAS, GOWNS, LINGERIE, CAMISOLES, HALTER TOPS, TANK TOPS, CAPRIS, PANTS, SHORTS, AND TIGHTS, SHOES, NAMELY, BOOTS, ATHLETIC SHOES, SANDALS AND WOMEN'S PUMPS (U.S. CLS. 22 AND 39).

SHAILA SETTLES, EXAMINING ATTORNEY

SN 85-340,676. CENTRAL STATE UNIVERSITY, WILBERFORCE, OH. FILED 6-8-2011.



OWNER OF U.S. REG. NOS. 1,832,266, 1,839,941 AND 1,879,036.

NO CLAIM IS MADE TO THE EXCLUSIVE RIGHT TO USE "1887" IN INTERNATIONAL CLASS 018 AND "STATE UNIVERSITY 1887" IN INTERNATIONAL CLASS 041, APART FROM THE MARK AS SHOWN.

THE MARK CONSISTS OF AN ABSTRACT DEPICTION OF A BELL TOWER, HAVING THREE VERTICAL COLUMNS ON AN ARC, A TRIANGULAR ROOF, AND THREE HORIZONTAL LINES IN BETWEEN THE COLUMNS AND ROOF, WITH THE WORDS "CENTRAL STATE UNIVERSITY" AND DATE "1887" BELOW THE ARC.

CLASS 18—LEATHER GOODS

FOR ALL PURPOSE BAGS, NAMELY, BACKPACKS (U.S. CLS. 1, 2, 3, 22 AND 41).
FIRST USE 10-1-2009; IN COMMERCE 10-1-2009.

CLASS 41—EDUCATION AND ENTERTAINMENT

FOR EDUCATIONAL SERVICES, NAMELY, ARRANGING AND CONDUCTING COLLEGE AND GRADUATE LEVEL COURSES OF INSTRUCTION; ENTERTAINMENT SERVICES, NAMELY, ORGANIZING AND CONDUCTING COLLEGIATE ATHLETIC COMPETITIONS, LIVE MUSICAL PERFORMANCES AND PERFORMANCES OF DRAMATIC WORKS; AND EDUCATIONAL SERVICES, NAMELY, CONDUCTING LECTURES AND SYMPOSIA IN THE FIELD OF HUMANITIES, ARTS, SOCIAL SCIENCES, BUSINESS, SCIENCE, ENGINEERING, AND EDUCATION (U.S. CLS. 100, 101 AND 107).

FIRST USE 10-1-2009; IN COMMERCE 10-1-2009.
NELSON SNYDER, EXAMINING ATTORNEY

MARLENE BELL, EXAMINING ATTORNEY

SN 85-341,073. SC SAM MILLS SRL, BOTIZ, SATU-MARE, ROMANIA, FILED 6-8-2011.



OWNER OF ROMANIA REG. NO. 62691, DATED 5-17-2004, EXPIRES 5-17-2014.

THE NAME(S), PORTRAIT(S), AND/OR SIGNATURE(S) SHOWN IN THE MARK DOES NOT IDENTIFY A PARTICULAR LIVING INDIVIDUAL.

THE MARK CONSISTS OF THE STYLIZED WORDING "SAMMILLS" WRITTEN ACROSS A BANNER WITH BORDER LINES, AND TWO WHEAT STEMS.

SN 85-341,007. WESTERN STATES FIRE PROTECTION COMPANY, CENTENNIAL, CO. FILED 6-8-2011.

WESTERN MONITORING

THE MARK CONSISTS OF STANDARD CHARACTERS WITHOUT CLAIM TO ANY PARTICULAR FONT, STYLE, SIZE, OR COLOR.

OWNER OF U.S. REG. NO. 3,239,378.

NO CLAIM IS MADE TO THE EXCLUSIVE RIGHT TO USE "MONITORING", APART FROM THE MARK AS SHOWN.

CLASS 9—ELECTRICAL AND SCIENTIFIC APPARATUS

FOR ELECTRONIC PRODUCTS, NAMELY, DIGITAL ALARM COMMUNICATOR TRANSMITTERS, UNIVERSAL DIGITAL ALARM COMMUNICATOR TRANSMITTERS, INTERNET PROTOCOL DIGITAL ALARM COMMUNICATOR TRANSMITTERS, SUBSCRIBER TERMINAL UNITS, RADIO ALARM TRANSMITTER TRANSCIEVERS, CELLULAR ALARM TRANSMITTERS, CONTROL/COMMUNICATORS, INTERNAL/BUILT-IN DIGITAL DIALERS, EXTERNAL/SLAVE DIGITAL DIALERS, PERSONAL EMERGENCY RESPONSE SYSTEMS, POLLING COMPUTER/TRANSPONDERS, AND CRITICAL CONDITION COMMUNICATORS, ALL FOR THE TRANSMISSION OF SIGNALS FROM THE PROTECTED PREMISE TO THE MONITORING CENTRAL STATION; FIRE ALARM AND EMERGENCY EVACUATION DEVICES, NAMELY, FIRE ALARM CONTROL PANELS (U.S. CLS. 21, 23, 26, 36 AND 38).

CLASS 45—PERSONAL AND LEGAL SERVICES

FOR EMERGENCY RESPONSE ALARM MONITORING SERVICES, NAMELY, MONITORING OF ALERT DEVICES BY A REMOTE MONITORING CENTER FOR THE DISPATCH OF EMERGENCY PUBLIC HEALTH AND SECURITY SERVICES AND NOTIFICATION TO THIRD PARTIES, THAT INCLUDE THE MONITORING OF FIRE ALARMS, BURGLAR ALARMS, ELEVATORS, TEMPERATURE, WATER LEAKS, GAS LEAKS, EMERGENCY PANIC/HOLD-UP TELEPHONE CALLS, MEDICAL DURESS SIGNALS, CARBON MONOXIDE, EMERGENCY MEDICAL CONDITIONS WITH POLICE, FIRE, AND VIDEO VERIFICATIONS (U.S. CLS. 100 AND 101).

CLASS 29—MEATS AND PROCESSED FOODS

FOR (BASED ON INTENT TO USE) EDIBLE OILS AND FATS; EGGS; JELLIES, JAMS; MEAT EXTRACTS; MEAT, FISH, POULTRY AND GAME; MILK; MILK PRODUCTS EXCLUDING ICE CREAM, ICE MILK AND FROZEN YOGURT; PRESERVED, DRIED AND COOKED FRUIT AND VEGETABLES (U.S. CL. 46).

CLASS 30—STAPLE FOODS

FOR (BASED ON 44(E)) ARTIFICIAL COFFEE; COCOA; COFFEE AND TEA; EDIBLE ICES; FLOUR; HONEY; ICE; MUSTARD; PREPARATIONS MADE FROM CEREALS, NAMELY, BREAD; CORN FLOUR, WHEAT FLOUR, SEMOLINA; RICE; SAGO; SALT; SAUCES; SPICES; SUGAR; TAPIOCA; TREACLE; VINEGAR; YEAST, BAKING POWDER (U.S. CL. 46).

CLASS 39—TRANSPORTATION AND STORAGE

FOR (BASED ON INTENT TO USE) PACKAGING ARTICLES FOR TRANSPORTATION; STORAGE OF GOODS; TRANSPORT BY FERRY, BOAT, RAIL, AIR (U.S. CLS. 100 AND 105).

MICHAEL TANNER, EXAMINING ATTORNEY

SN 85-341,477. THINK SIMPLE S.P.A., PORDENONE, ITALY, FILED 6-8-2011.



OWNER OF ITALY REG. NO. 1408324, DATED 1-20-2011, EXPIRES 11-11-2019.

THE MARK CONSISTS OF THE WORD "VITRUM" IN STYLIZED LETTERING WITH A SEMICIRCLE SURROUNDING THE "U" AND "M" OF THE WORD AND ANOTHER SHORTER CURVED LINE INSIDE THE SEMI-CIRCLE ABOVE THE "U" AND "M".

CLASS 9—ELECTRICAL AND SCIENTIFIC APPARATUS

FOR PLATES FOR ELECTRICAL CONTROLS, NAMELY, CABLE AND WIRING PLATES IN THE NATURE OF PROTECTIVE SHEATHS FOR ELECTRICAL CABLE AND WIRING; ELECTRIC CONTROL PANELS (U.S. CLS. 21, 23, 26, 36 AND 38).

CLASS 11—ENVIRONMENTAL CONTROL APPARATUS

FOR LIGHTING INSTALLATIONS (U.S. CLS. 13, 21, 23, 31 AND 34).
KELLY TRUSILO, EXAMINING ATTORNEY

CLASS 41—EDUCATION AND ENTERTAINMENT

FOR DISTRIBUTION OF MOTION PICTURE FILMS; ENTERTAINMENT IN THE NATURE OF ON-GOING TELEVISION PROGRAMS IN THE FIELD OF COMEDY, DRAMA, ACTION, ADVENTURE AND/OR CARTOONS; ENTERTAINMENT SERVICES, NAMELY, AN ON-GOING SERIES FEATURING COMEDY, DRAMA, ACTION, ADVENTURE AND/OR CARTOONS PROVIDED THROUGH CABLE TELEVISION, SATELLITE CABLE, WEBCAST, AND VIDEO ON DEMAND; ENTERTAINMENT SERVICES, NAMELY, PROVIDING A WEB SITE FEATURING NON-DOWNLOADABLE MUSICAL PERFORMANCES, MUSICAL VIDEOS, RELATED FILM CLIPS, PHOTOGRAPHS, AND OTHER MULTIMEDIA MATERIALS FEATURING ENTERTAINMENT IN THE NATURE NON-DOWNLOADABLE COMEDY, DRAMA, ACTION, ADVENTURE AND/OR CARTOONS VIDEOS; ENTERTAINMENT SERVICES, NAMELY, PROVIDING AN ON-LINE COMPUTER GAME; ENTERTAINMENT SERVICES, NAMELY, PROVIDING ON-GOING TELEVISION PROGRAMS IN THE FIELD OF COMEDY, DRAMA, ACTION, ADVENTURE AND/OR CARTOONS VIA A GLOBAL COMPUTER NETWORK; ENTERTAINMENT SERVICES, NAMELY, PROVIDING ON-GOING WEBSODES FEATURING COMEDY, DRAMA, ACTION, ADVENTURE AND/OR CARTOONS VIA A GLOBAL COMPUTER NETWORK; FILM AND VIDEO PRODUCTION; MEDIA PRODUCTION SERVICES, NAMELY, VIDEO AND FILM PRODUCTION; MOTION PICTURE FILM PRODUCTION; MULTIMEDIA ENTERTAINMENT SERVICES IN THE NATURE OF RECORDING, PRODUCTION AND POST-PRODUCTION SERVICES IN THE FIELDS OF MUSIC, VIDEO, AND FILMS; PRODUCTION OF DVDS FEATURING COMEDY, DRAMA, ACTION, ADVENTURE AND/OR CARTOONS; PRODUCTION OF DVDS, VIDEOTAPES AND TELEVISION PROGRAMS FEATURING COMEDY, DRAMA, ACTION, ADVENTURE AND/OR CARTOONS; PROVISION OF NON-DOWNLOADABLE FILMS AND MOVIES VIA A VIDEO-ON-DEMAND SERVICE; PROVISION OF NON-DOWNLOADABLE FILMS AND TELEVISION PROGRAMMES VIA A VIDEO-ON-DEMAND SERVICE (U.S. CLS. 100, 101 AND 107).

BRENDAN MCCAULEY, EXAMINING ATTORNEY

SN 85-341,527, DUMBBELLS, LLC, BEVERLY HILLS, CA, FILED 6-8-2011.

DUMBBELLS

SN 85-341,736, CIRRUSPATH, LLC, LAGUNA HILLS, CA, FILED 6-9-2011.

THE MARK CONSISTS OF STANDARD CHARACTERS WITHOUT CLAIM TO ANY PARTICULAR FONT, STYLE, SIZE, OR COLOR.

CLASS 9—ELECTRICAL AND SCIENTIFIC APPARATUS

FOR COMPUTER GAME PROGRAMS, CARTRIDGES, AND CASSETTES; COMPUTER GAME SOFTWARE; COMPUTER GAME SOFTWARE DOWNLOADABLE FROM A GLOBAL COMPUTER NETWORK; DIGITAL MATERIALS, NAMELY, DVDS AND DOWNLOADABLE VIDEO FILES PROVIDED VIA A VIDEO-ON-DEMAND SERVICE FEATURING COMEDY, DRAMA, ACTION, ADVENTURE AND/OR CARTOONS; DOWNLOADABLE FILMS AND MOVIES FEATURING COMEDY, DRAMA, ACTION, ADVENTURE AND/OR CARTOONS PROVIDED VIA A VIDEO-ON-DEMAND SERVICE; DOWNLOADABLE FILMS AND TELEVISION PROGRAMS FEATURING COMEDY, DRAMA, ACTION, ADVENTURE AND/OR CARTOONS PROVIDED VIA A VIDEO-ON-DEMAND SERVICE; DVDS FEATURING COMEDY, DRAMA, ACTION, ADVENTURE AND/OR CARTOONS; MOTION PICTURE FILMS ABOUT COMEDY, DRAMA, ACTION, ADVENTURE AND/OR CARTOONS (U.S. CLS. 21, 23, 26, 36 AND 38).



THE COLOR(S) BLUE AND WHITE IS/ARE CLAIMED AS A FEATURE OF THE MARK.

THE MARK CONSISTS OF TWO WORDS, "CIRRUS" AND "INSIGHT" IN ALL LOWERCASE BLUE LETTERS, WITH A WHITE CIRCULAR MARK CONSISTING OF ONE SEMI-CIRCULAR SWIRL ON TOP AND ONE SEMI-CIRCULAR SWIRL UNDERNEATH ON A BLUE SQUARE BACKGROUND TO THE LEFT OF THE TWO WORDS.

CLASS 9—ELECTRICAL AND SCIENTIFIC APPARATUS

FOR COMPUTER SOFTWARE FOR USE IN CUSTOMER RELATIONSHIP MANAGEMENT (CRM); COMPUTER SOFTWARE THAT PROVIDES REAL-TIME, INTEGRATED BUSINESS MANAGEMENT INTELLIGENCE BY COMBINING INFORMATION FROM VARIOUS DATABASES AND PRESENTING IT IN AN EASY-TO-UNDERSTAND USER INTERFACE; NONE OF THE FOREGOING BEING IN RELATION TO CREDIT CARDS, DEBIT CARDS, PAYMENT CARDS, AUTOMATIC TELLER MACHINES (ATMS), POINT OF SALE PAYMENT TERMINALS, FINANCIAL, BANKING AND CREDIT SERVICES, ATM SERVICES, ELECTRONIC FUNDS AND CURRENCY TRANSFER SERVICES, PAYMENT SERVICES AND RELATED PRODUCTS AND SERVICES (U.S. CLS. 21, 23, 26, 36 AND 38).

FIRST USE 5-1-2011; IN COMMERCE 5-1-2011.

CLASS 35—ADVERTISING AND BUSINESS

FOR CUSTOMER RELATIONSHIP MANAGEMENT; PROVIDING A WEBSITE AT WHICH CUSTOMERS CAN MANAGE ACCOUNT INFORMATION RELATED TO TELECOMMUNICATIONS PRODUCTS AND SERVICES; NONE OF THE FOREGOING BEING IN RELATION TO CREDIT CARDS, DEBIT CARDS, PAYMENT CARDS, AUTOMATIC TELLER MACHINES (ATMS), POINT OF SALE PAYMENT TERMINALS, FINANCIAL, BANKING AND CREDIT SERVICES, ATM SERVICES, ELECTRONIC FUNDS AND CURRENCY TRANSFER SERVICES, PAYMENT SERVICES AND RELATED PRODUCTS AND SERVICES (U.S. CLS. 100, 101 AND 102).

FIRST USE 5-1-2011; IN COMMERCE 5-1-2011.

VIVIAN MICZNIK FIRST, EXAMINING ATTORNEY

SN 85-342,255. ILLUMINATING CONCEPTS, LTD., FARMINGTON HILLS, MI. FILED 6-9-2011.

EYESTREETS

THE MARK CONSISTS OF STANDARD CHARACTERS WITHOUT CLAIM TO ANY PARTICULAR FONT, STYLE, SIZE, OR COLOR.

CLASS 9—ELECTRICAL AND SCIENTIFIC APPARATUS

FOR COMPUTER HARDWARE AND SOFTWARE FOR USE IN DATABASE AND INFORMATION MANAGEMENT, REPORT GENERATION, BUSINESS FORECASTING AND MODELING, NETWORKING AND COMMUNICATIONS; COMPUTER SOFTWARE, NAMELY, MULTIMEDIA APPLICATIONS FOR INTEGRATION OF TEXT, AUDIO, VIDEO, GRAPHICS, STILL IMAGES AND MOVING PICTURES IN THE FIELDS OF LIGHTING, SECURITY AND PEDESTRIAN AND TRAFFIC MANAGEMENT (U.S. CLS. 21, 23, 26, 36 AND 38).

CLASS 42—SCIENTIFIC AND COMPUTER SERVICES

FOR PROVIDING NON-DOWNLOADABLE SOFTWARE AND HARDWARE FOR USE IN DATABASE AND INFORMATION MANAGEMENT, REPORT GENERATION, BUSINESS FORECASTING AND MODELING, NETWORKING AND COMMUNICATIONS; PROVIDING NON-DOWNLOADABLE SOFTWARE, NAMELY, MULTIMEDIA APPLICATIONS FOR INTEGRATION OF TEXT, AUDIO, VIDEO, GRAPHICS, STILL IMAGES AND MOVING PICTURES IN THE FIELDS OF LIGHTING, SECURITY AND PEDESTRIAN AND TRAFFIC MANAGEMENT (U.S. CLS. 100 AND 101).

GRETTA YAO, EXAMINING ATTORNEY

SN 85-342,267. ILLUMINATING CONCEPTS, LTD., FARMINGTON HILLS, MI. FILED 6-9-2011.

INTELLIBOLLARD

THE MARK CONSISTS OF STANDARD CHARACTERS WITHOUT CLAIM TO ANY PARTICULAR FONT, STYLE, SIZE, OR COLOR.

CLASS 9—ELECTRICAL AND SCIENTIFIC APPARATUS

FOR COMPUTER HARDWARE; ENVIRONMENTAL SENSORS, NAMELY, TEMPERATURE AND AIR QUALITY SENSORS; COMPUTER HARDWARE, NAMELY, SPEAKERS, CONTROLLERS, AND LIGHTING ELEMENTS FOR GATHERING, RECEIVING, AND DELIVERING INFORMATION, NAMELY, LIGHTING CONTROL AND AUDIO, UTILIZING SENSOR, LIGHT, AUDIO VIA A WIRED OR WIRELESS COMPUTER NETWORK AND THE INTERNET FOR USE BY BUSINESSES AND GOVERNMENTAL AGENCIES; COMPUTER SOFTWARE FOR GATHERING, RECEIVING, AND DELIVERING INFORMATION, NAMELY, LIGHTING CONTROL, AUDIO AND VIDEO, UTILIZING SENSOR, LIGHT, AUDIO AND VISUAL DEVICES VIA A WIRED OR WIRELESS COMPUTER NETWORK AND THE INTERNET FOR USE BY BUSINESSES AND GOVERNMENTAL AGENCIES (U.S. CLS. 21, 23, 26, 36 AND 38).

CLASS 42—SCIENTIFIC AND COMPUTER SERVICES

FOR PROVIDING NON-DOWNLOADABLE SOFTWARE FOR GATHERING, RECEIVING, AND DELIVERING INFORMATION, NAMELY, INFORMATION FROM ENVIRONMENTAL SENSORS, NAMELY, TEMPERATURE AND AIR QUALITY SENSORS, AND MULTIMEDIA CONTENT, NAMELY, LIGHTING CONTROL, AUDIO AND VIDEO UTILIZING SENSOR, LIGHT, AUDIO AND VISUAL DEVICES VIA A WIRED OR WIRELESS COMPUTER NETWORK AND THE INTERNET FOR USE BY BUSINESSES AND GOVERNMENTAL AGENCIES (U.S. CLS. 100 AND 101).

GRETTA YAO, EXAMINING ATTORNEY

SN 85-342,768. REMINGTON ARMS COMPANY, LLC, MADISON, NC. FILED 6-9-2011.

BASIC ISSUE OPTICS

THE MARK CONSISTS OF STANDARD CHARACTERS WITHOUT CLAIM TO ANY PARTICULAR FONT, STYLE, SIZE, OR COLOR.

NO CLAIM IS MADE TO THE EXCLUSIVE RIGHT TO USE "OPTICS", APART FROM THE MARK AS SHOWN.

CLASS 9—ELECTRICAL AND SCIENTIFIC APPARATUS

FOR GUN SCOPES (U.S. CLS. 21, 23, 26, 36 AND 38).
FIRST USE 1-1-2012; IN COMMERCE 1-1-2012.

CLASS 13—FIREARMS

FOR FIREARM ATTACHMENTS, NAMELY, MOUNTS FOR ATTACHING ACCESSORIES TO A FIREARM (U.S. CLS. 2 AND 9).
FIRST USE 1-1-2012; IN COMMERCE 1-1-2012.
EMILY CARLSEN, EXAMINING ATTORNEY

CLASS 42—SCIENTIFIC AND COMPUTER SERVICES

FOR SCIENTIFIC AND TECHNOLOGICAL SERVICES AND RESEARCH SERVICES RELATING THERETO IN THE FIELD OF PRODUCTION OF BIOGAS; INDUSTRIAL RESEARCH IN THE FIELD OF PRODUCTION OF BIOGAS; MECHANICAL ENGINEERING SERVICES; TECHNICAL ADVICE AND CONSULTATION IN THE FIELD OF ENGINEERING; CONSULTATION IN THE FIELD OF ENGINEERING (U.S. CLS. 100 AND 101).
BARBARA A. GOLD, EXAMINING ATTORNEY

SN 85-343,403. LITTLE TREES CREATIVE PLAY LLC, MANDEVILLE, LA. FILED 6-10-2011.

SN 85-343,269. SWEDISH BIOGAS INTERNATIONAL AB, LINKÖPING, SWEDEN, FILED 6-10-2011.

SBI

THE MARK CONSISTS OF STANDARD CHARACTERS WITHOUT CLAIM TO ANY PARTICULAR FONT, STYLE, SIZE, OR COLOR.

PRIORITY CLAIMED UNDER SEC. 44(D) ON ERPN CMNTY TM OFC APPLICATION NO. 009965195, FILED 5-13-2011, REG. NO. 009965195, DATED 10-26-2011, EXPIRES 5-13-2021.

CLASS 7—MACHINERY

FOR PUMPS AND AGITATORS, NAMELY, MIXING APPLIANCES FOR MIXING OF SUBSTRATES FOR BIOGAS INSTALLATIONS; MACHINES AND INSTALLATIONS FOR REPROCESSING OF WASTE USING HEAT AND CHEMICAL BREAKDOWN PROCESSES; MACHINES AND INSTALLATIONS FOR RECYCLING WASTE, NAMELY, WASTE COMPACTING MACHINES; WASTE CRUSHING MACHINES; WASTE MATERIAL CONVEYING MACHINES (U.S. CLS. 13, 19, 21, 23, 31, 34 AND 35).

CLASS 11—ENVIRONMENTAL CONTROL APPARATUS

FOR INSTALLATIONS FOR PRODUCING BIOGAS; INSTALLATIONS CARRYING OUT BIOGAS PROCESSES, NAMELY, POWER PLANTS (U.S. CLS. 13, 21, 23, 31 AND 34).

CLASS 37—CONSTRUCTION AND REPAIR

FOR BUILDING, CONSTRUCTION, REPAIR AND INSTALLATION SERVICES; ADVISORY SERVICES RELATING TO BUILDING CONSTRUCTION; BUILDING CONSTRUCTION AND REPAIR SERVICES; INSTALLATION AND REPAIR OF MACHINES (U.S. CLS. 100, 103 AND 106).

CLASS 40—MATERIAL TREATMENT

FOR RECYCLING OF WASTE AND TRASH; WASTE PROCESSING SERVICES; PRODUCTION OF ENERGY; OPERATIONS OF BIOGAS INSTALLATIONS (U.S. CLS. 100, 103 AND 106).

Tales with a Twist

THE MARK CONSISTS OF STANDARD CHARACTERS WITHOUT CLAIM TO ANY PARTICULAR FONT, STYLE, SIZE, OR COLOR.

CLASS 16—PAPER GOODS AND PRINTED MATTER

FOR SERIES OF FICTION BOOKLETS FEATURING SHORT STORIES WITH INSTRUCTIONS FOR ACCOMPANYING CREATIVE MOVEMENT, EXERCISE, AND YOGA (U.S. CLS. 2, 5, 22, 23, 29, 37, 38 AND 50).

CLASS 41—EDUCATION AND ENTERTAINMENT

FOR INTERACTIVE STORYTELLING SERVICES FEATURING SHORT STORIES WITH ACCOMPANYING CREATIVE MOVEMENT, EXERCISE AND YOGA (U.S. CLS. 100, 101 AND 107).

ROBIN CHOSID, EXAMINING ATTORNEY

SN 85-343,652. BELSTEN & ASSOCIATES, LLC, DBA INSTITUTE FOR SOCIAL & EMOTIONAL INTELLIGENCE, CONIFER, CO. FILED 6-10-2011.

SEIP

THE MARK CONSISTS OF STANDARD CHARACTERS WITHOUT CLAIM TO ANY PARTICULAR FONT, STYLE, SIZE, OR COLOR.

CLASS 35—ADVERTISING AND BUSINESS

FOR BUSINESS SERVICES, NAMELY, DESIGN, DEVELOPMENT AND ANALYSIS OF EMOTIONAL INTELLIGENCE TESTS FOR TESTING PROFESSIONAL COMPETENCY AND FOR ASSESSING PERSONAL AND PROFESSIONAL AWARENESS, MANAGEMENT, PRODUCTIVITY, AND RELATIONSHIPS; HUMAN RESOURCES SERVICES, NAMELY, OFFERING OF EMOTIONAL INTELLIGENCE ASSESSMENTS FOR THE PURPOSE OF PERSONAL AND PROFESSIONAL DEVELOPMENT, ADVANCEMENT AND SKILL ENHANCEMENT (U.S. CLS. 100, 101 AND 102).

FIRST USE 8-6-2010; IN COMMERCE 8-6-2010.

CLASS 42—SCIENTIFIC AND COMPUTER SERVICES

FOR PROVIDING TEMPORARY USE OF ON-LINE NON-DOWNLOADABLE SOFTWARE FOR USE IN ASSESSING, EVALUATING AND REPORTING THE EMOTIONAL INTELLIGENCE OF INDIVIDUALS AND ORGANIZATIONS (U.S. CLS. 100 AND 101).

FIRST USE 8-6-2010; IN COMMERCE 8-6-2010.

CLASS 45—PERSONAL AND LEGAL SERVICES

FOR EMOTIONAL INTELLIGENCE ASSESSMENT SERVICES, NAMELY, PROVIDING LIVE AND ONLINE EMOTIONAL INTELLIGENCE ASSESSMENTS BY MEANS OF EMOTIONAL INTELLIGENCE TESTS, SELF-SCORING INSTRUMENTS, RESULT PROFILES, INTERVIEWS, AND STRATEGY SESSIONS; PROVIDING A RESOURCE WEBSITE FEATURING EMOTIONAL INTELLIGENCE INFORMATION IN THE FIELD OF SELF-DEVELOPMENT (U.S. CLS. 100 AND 101).

FIRST USE 8-6-2010; IN COMMERCE 8-6-2010.

NAKIA HENRY, EXAMINING ATTORNEY

CLASS 35—ADVERTISING AND BUSINESS

FOR ON-LINE RETAIL STORE SERVICES FEATURING: RAMPS, CARRIERS, LIFTS, STANDS, COVERS, TIEDOWNS, AND WHEEL CHOCKS FOR MOTORCYCLES; RAMPS, CARRIERS, COVERS, LIFTS, HITCHES, IMPLEMENTS AND LUGGAGE FOR ALL-TERRAIN VEHICLES AND UTILITY TERRAIN VEHICLES; RAMPS, CARRIERS, TIEDOWNS, LIFTS, ACCESSORIES, AND CARRIERS FOR WHEELCHAIRS; RAMPS, STROLLERS, CARRIERS, AND BARRIERS, CAGES, AND TRAVEL PRODUCTS FOR PETS; RACKS AND CARRIERS FOR BICYCLES; CAR TOP STORAGE RACKS, BARS, BAGS, AND BOXES, HITCH MOUNTED CARGO CARRIERS AND HITCH MOUNTED CARGO ACCESSORIES; TRANSPORT AND STORAGE COVERS FOR POWER SPORT, AUTOMOTIVE, MOBILITY, AND LAWN VEHICLES; HEAVY DUTY RAMPS SYSTEMS FOR LOADING CARS AND FOR LOADING ONTO STEP DECK TRAILERS, CONSTRUCTION EQUIPMENT LOADING RAMPS, WHEEL RISERS AND CAR SERVICE RAMPS; HUNTING ACCESSORIES; INDUSTRIAL USE WHEEL CHOCKS, INDUSTRIAL SAFETY BARRIER; TRAILER HITCHES, TRAILER HITCH RECEIVERS, TRAILER HITCH ADAPTERS; RAMPS AND RAILS FOR SKATEBOARD, INLINE SKATING, RC (RADIO CONTROLLED) CARS AND BMX BICYCLES; PICKUP TRUCK BED BOXES, BINS, AND RACKS; GUN RACKS AND GUN CASES; TIEDOWN STRAPS AND TIEDOWN DEVICES, COVERS, CARTS, AND TRAILERS FOR BOATS, PERSONAL WATERCRAFT, AND OUTBOARD MOTORS; WALK RAMPS, DOCK RAMPS, CURB RAMPS, AND CABLE PROTECTORS FOR COMMERCIAL AND UTILITY APPLICATIONS; TRAILERS FOR MOTORCYCLES, CARGO, ATVS, SNOWMOBILES, PERSONAL WATERCRAFT, CANOES, WHEELCHAIRS, SCOOTERS AND FOR UTILITY PURPOSES, AND RAMPS, COVERS, RACKS, AND LIFTS FOR SNOWMOBILES (U.S. CLS. 100, 101 AND 102).

FIRST USE 4-19-2000; IN COMMERCE 12-4-2000.

CLASS 42—SCIENTIFIC AND COMPUTER SERVICES

FOR CUSTOM DESIGN AND DEVELOPMENT OF GOODS MADE OF METAL (U.S. CLS. 100 AND 101).

FIRST USE 4-19-2000; IN COMMERCE 12-4-2000.

JAMES MACFARLANE, EXAMINING ATTORNEY

SN 85-343,656. DISCOUNT RAMPS.COM, LLC, WEST BEND, WI. FILED 6-10-2011.

SN 85-343,699. BIE MEDIA, INC., DBA THE DRAKE, FORT COLLINS, CO. FILED 6-10-2011.

THE DRAKE

DISCOUNT RAMPS

THE MARK CONSISTS OF STANDARD CHARACTERS WITHOUT CLAIM TO ANY PARTICULAR FONT, STYLE, SIZE, OR COLOR.

CLASS 9—ELECTRICAL AND SCIENTIFIC APPARATUS

FOR ELECTRONIC PUBLICATIONS, NAMELY, MAGAZINES FEATURING INFORMATION, NEWS, ARTICLES, STORIES, EDITORIALS, MESSAGE BOARDS IN THE FIELD OF FISHING RECORDED ON COMPUTER MEDIA (U.S. CLS. 21, 23, 26, 36 AND 38).

FIRST USE 6-30-1998; IN COMMERCE 6-30-1998.

CLASS 16—PAPER GOODS AND PRINTED MATTER

FOR MAGAZINES IN THE FIELD OF FISHING (U.S. CLS. 2, 5, 22, 23, 29, 37, 38 AND 50).

FIRST USE 6-30-1998; IN COMMERCE 6-30-1998.

THE MARK CONSISTS OF STANDARD CHARACTERS WITHOUT CLAIM TO ANY PARTICULAR FONT, STYLE, SIZE, OR COLOR.

NO CLAIM IS MADE TO THE EXCLUSIVE RIGHT TO USE "RAMPS", APART FROM THE MARK AS SHOWN.

SEC. 2(F).

CHARLES L. JENKINS, EXAMINING ATTORNEY

SN 85-344,604. COLLEAGUE CONSULTING, LLC, GREEN-BELT, MD. FILED 6-13-2011.

SN 85-344,385. BAY ARMOUR LLC, DBA BAY ARMOUR, BEDFORD, MA. FILED 6-13-2011.

TRUSTWORTHY CUSTOMER SERVICE

Bay Armour

THE MARK CONSISTS OF STANDARD CHARACTERS WITHOUT CLAIM TO ANY PARTICULAR FONT, STYLE, SIZE, OR COLOR.

NO CLAIM IS MADE TO THE EXCLUSIVE RIGHT TO USE "CUSTOMER SERVICE", APART FROM THE MARK AS SHOWN.

THE MARK CONSISTS OF STANDARD CHARACTERS WITHOUT CLAIM TO ANY PARTICULAR FONT, STYLE, SIZE, OR COLOR.

CLASS 3—COSMETICS AND CLEANING PREPARATIONS

FOR ANTI-BACTERIAL SOAP; LEATHER CLEANING PREPARATIONS (U.S. CLS. 1, 4, 6, 50, 51 AND 52).

CLASS 16—PAPER GOODS AND PRINTED MATTER

FOR PRINTED EDUCATIONAL MATERIALS IN THE FIELD OF BUSINESS COACHING, MENTORING, AND TRAINING IN CAREER COUNSELING (U.S. CLS. 2, 5, 22, 23, 29, 37, 38 AND 50).

CLASS 5—PHARMACEUTICALS

FOR FUNGAL MEDICATIONS (U.S. CLS. 6, 18, 44, 46, 51 AND 52).
SHAILA SETTLES, EXAMINING ATTORNEY

CLASS 41—EDUCATION AND ENTERTAINMENT

FOR EDUCATION SERVICES, NAMELY, PROVIDING CLASSES IN THE FIELDS OF BUSINESS COACHING, MENTORING, AND TRAINING IN CAREER COUNSELING (U.S. CLS. 100, 101 AND 107).
JENNIFER VASQUEZ, EXAMINING ATTORNEY

SN 85-344,563. VINCENT M. PUPILLO, HARLEYSVILLE, PA. FILED 6-13-2011.

SN 85-344,609. COLLEAGUE CONSULTING, LLC, GREEN-BELT, MD. FILED 6-13-2011.

Key Gear

TRUST WORTHY CUSTOMER SERVICE

THE MARK CONSISTS OF STANDARD CHARACTERS WITHOUT CLAIM TO ANY PARTICULAR FONT, STYLE, SIZE, OR COLOR.

NO CLAIM IS MADE TO THE EXCLUSIVE RIGHT TO USE "GEAR", APART FROM THE MARK AS SHOWN.

THE MARK CONSISTS OF STANDARD CHARACTERS WITHOUT CLAIM TO ANY PARTICULAR FONT, STYLE, SIZE, OR COLOR.

NO CLAIM IS MADE TO THE EXCLUSIVE RIGHT TO USE "CUSTOMER SERVICE", APART FROM THE MARK AS SHOWN.

CLASS 35—ADVERTISING AND BUSINESS

FOR RETAIL STORE AND ON-LINE RETAIL STORE SERVICES FEATURING VINTAGE MUSICAL KEYBOARDS AND MUSICAL EQUIPMENT (U.S. CLS. 100, 101 AND 102).

CLASS 16—PAPER GOODS AND PRINTED MATTER

FOR PRINTED EDUCATIONAL MATERIALS IN THE FIELD OF BUSINESS COACHING, MENTORING, AND TRAINING IN CAREER COUNSELING (U.S. CLS. 2, 5, 22, 23, 29, 37, 38 AND 50).

CLASS 37—CONSTRUCTION AND REPAIR

FOR REPAIRING AND RESTORING VINTAGE MUSICAL KEYBOARDS AND MUSICAL EQUIPMENT (U.S. CLS. 100, 103 AND 106).

CLASS 41—EDUCATION AND ENTERTAINMENT

FOR EDUCATION SERVICES, NAMELY, PROVIDING CLASSES IN THE FIELD OF BUSINESS COACHING, MENTORING, AND TRAINING IN CAREER COUNSELING (U.S. CLS. 100, 101 AND 107).
JENNIFER VASQUEZ, EXAMINING ATTORNEY

CLASS 41—EDUCATION AND ENTERTAINMENT

FOR RENTAL OF VINTAGE MUSICAL KEYBOARDS AND MUSICAL EQUIPMENT TO THE TRADE AND TO THE PUBLIC (U.S. CLS. 100, 101 AND 107).
STEVEN PEREZ, EXAMINING ATTORNEY

SN 85-344,646. GREENFLY MEDIA NETWORK, LLC, NEW-PORT BEACH, CA. FILED 6-13-2011.

SN 85-345,146. JON BENSON FITNESS LLC, MCKINNEY, TX. FILED 6-13-2011.

JOCKTALK

THE MARK CONSISTS OF STANDARD CHARACTERS WITHOUT CLAIM TO ANY PARTICULAR FONT, STYLE, SIZE, OR COLOR.

CLASS 38—COMMUNICATION

FOR TELECOMMUNICATION SERVICES, NAMELY, PROVIDING ONLINE AND TELECOMMUNICATION FACILITIES FOR REAL-TIME INTERACTION BETWEEN AND AMONG USERS OF COMPUTERS, MOBILE AND HANDHELD COMPUTERS, AND WIRED AND WIRELESS COMMUNICATION DEVICES, ENABLING REGISTERED FANS TO RECEIVE UPDATES FROM THEIR FAVORITE ATHLETES ON THE INTERNET AND ON MOBILE APPLICATIONS, ENABLING REGISTERED USERS TO SEND AND RECEIVE MESSAGES VIA EMAIL AND INSTANT MESSAGING; PROVIDING ON-LINE CHAT ROOMS AND ELECTRONIC BULLETIN BOARDS FOR TRANSMISSION OF MESSAGES AMONG REGISTERED USERS (U.S. CLS. 100, 101 AND 104).

CLASS 41—EDUCATION AND ENTERTAINMENT

FOR PROVIDING A WEBSITE FOR ENTERTAINMENT PURPOSES WHERE USERS CAN VIEW AND POST PHOTOS AND VIDEOS FEATURING AMATEUR AND PROFESSIONAL ATHLETES, AND SPORTS PERSONALITIES; PROVIDING A WEBSITE FEATURING BLOGS AND NON-DOWNLOADABLE JOURNALS IN THE FIELD OF SPORTS; ON-LINE JOURNALS, NAMELY, BLOGS FEATURING SPORTS (U.S. CLS. 100, 101 AND 107).

CLASS 42—SCIENTIFIC AND COMPUTER SERVICES

FOR PROVIDING A WEBSITE FEATURING TECHNOLOGY THAT ENABLES USERS TO UPLOAD AND SHARE USER-GENERATED SPORTS VIDEOS, PHOTOS, NEWS AND INFORMATION; PROVIDING A WEBSITE FEATURING TECHNOLOGY THAT ENABLES USERS TO CREATE, SHARE, ACCESS SPORTS-RELATED CONTENTS, NAMELY, VIDEOS, PHOTOS, BLOGS, ACTIVITIES AND EVENTS; COMPUTER SERVICES, NAMELY, CREATING AN ON-LINE COMMUNITY FOR REGISTERED USERS TO PARTICIPATE IN DISCUSSIONS AND ENGAGE IN SOCIAL NETWORKING IN THE FIELD OF SPORTS (U.S. CLS. 100 AND 101).

CLASS 45—PERSONAL AND LEGAL SERVICES

FOR ONLINE SOCIAL NETWORKING SERVICES PROVIDED THROUGH A SPORTS COMMUNITY WEBSITE; PROVIDING A SOCIAL NETWORKING WEBSITE FOR ENTERTAINMENT PURPOSES (U.S. CLS. 100 AND 101).

CYNTHIA TRIPI, EXAMINING ATTORNEY

peopletipping

THE MARK CONSISTS OF STANDARD CHARACTERS WITHOUT CLAIM TO ANY PARTICULAR FONT, STYLE, SIZE, OR COLOR.

CLASS 9—ELECTRICAL AND SCIENTIFIC APPARATUS

FOR AUDIO RECORDINGS IN THE FIELD OF MARKETING, MEDIA, PERSUASION AND COMMUNICATIONS; ELECTRONIC PUBLICATIONS, NAMELY, BOOKS IN THE FIELD OF MARKETING, MEDIA, PERSUASION AND COMMUNICATIONS RECORDED ON COMPUTER MEDIA; DOWNLOADABLE ELECTRONIC PUBLICATIONS, NAMELY, BOOKS IN THE FIELD OF MARKETING, MEDIA, PERSUASION AND COMMUNICATIONS (U.S. CLS. 21, 23, 26, 36 AND 38).

CLASS 41—EDUCATION AND ENTERTAINMENT

FOR EDUCATION SERVICES, NAMELY, PROVIDING CLASSES AND SEMINARS IN THE FIELD OF MARKETING, MEDIA, PERSUASION AND COMMUNICATIONS, AND DISTRIBUTION OF COURSE MATERIALS IN CONNECTION THEREWITH, AND EDUCATION CONSULTING SERVICES RELATED THERETO (U.S. CLS. 100, 101 AND 107).

KARANENDRA S. CHHINA, EXAMINING ATTORNEY

SN 85-345,270. CORIZON, INC., BRENTWOOD, TN. FILED 6-14-2011.



THE MARK CONSISTS OF THE WORD "CORIZON" WITH THE FIRST LETTER "O" INCORPORATING THE FANCIFUL DESIGN OF A HIGHWAY AND SUNSET.

CLASS 35—ADVERTISING AND BUSINESS

FOR BUSINESS ADMINISTRATION SERVICES, NAMELY, PROCESSING CLAIMS FOR HEALTH CARE SERVICES (U.S. CLS. 100, 101 AND 102).

CLASS 42—SCIENTIFIC AND COMPUTER SERVICES

FOR PROVIDING A WEBSITE FEATURING TEMPORARY USE OF NON-DOWNLOADABLE SOFTWARE FOR INPUTTING, MAINTAINING, REVIEWING, AND UTILIZING MEDICAL INFORMATION ABOUT PRISONERS, FOR USE BY HEALTHCARE PROVIDERS AT CORRECTIONAL FACILITIES (U.S. CLS. 100 AND 101).

SN 85-345,975. CORIZON, INC., BRENTWOOD, TN. FILED 6-14-2011.



THE COLOR(S) BLUE AND GOLD IS/ARE CLAIMED AS A FEATURE OF THE MARK.

THE MARK CONSISTS OF THE WORD "CORIZON" IN BLUE WITH THE FIRST LETTER "O" INCORPORATING THE FANCIFUL DESIGN OF A HIGHWAY IN BLUE AND SUNSET IN GOLD.

CLASS 44—MEDICAL, BEAUTY AND AGRICULTURAL SERVICES

FOR HEALTH CARE SERVICES RENDERED FOR INDIVIDUALS IN THE CUSTODY OF CORRECTIONAL FACILITIES, NAMELY, PROVIDING MANAGED HEALTH CARE SERVICES, HEALTH SCREENING AND DIAGNOSTIC CARE, EMERGENCY MEDICAL CARE, MENTAL HEALTH, PSYCHIATRIC AND PSYCHOLOGICAL SERVICES, SUBSTANCE ABUSE TREATMENT, DENTAL, VISION AND HEARING CARE, AND PROVIDING DOCTORS, NURSES AND OTHER HEALTH CARE PROFESSIONALS FOR THE TREATMENT OF PATIENTS; TELEMEDICINE SERVICES (U.S. CLS. 100 AND 101).
LESLIE RICHARDS, EXAMINING ATTORNEY

CLASS 35—ADVERTISING AND BUSINESS

FOR BUSINESS ADMINISTRATION SERVICES, NAMELY, PROCESSING CLAIMS FOR HEALTH CARE SERVICES (U.S. CLS. 100, 101 AND 102).

SN 85-345,812. TELETRIPS INC., TORONTO, CANADA, FILED 6-14-2011.

CLASS 42—SCIENTIFIC AND COMPUTER SERVICES

FOR PROVIDING A WEBSITE FEATURING TEMPORARY USE OF NON-DOWNLOADABLE SOFTWARE FOR INPUTTING, MAINTAINING, REVIEWING, AND UTILIZING MEDICAL INFORMATION ABOUT PRISONERS, FOR USE BY HEALTHCARE PROVIDERS AT CORRECTIONAL FACILITIES (U.S. CLS. 100 AND 101).

BETTER WORKPLACE INC.

CLASS 44—MEDICAL, BEAUTY AND AGRICULTURAL SERVICES

FOR HEALTH CARE SERVICES RENDERED FOR INDIVIDUALS IN THE CUSTODY OF CORRECTIONAL FACILITIES, NAMELY, PROVIDING MANAGED HEALTH CARE SERVICES, HEALTH SCREENING AND DIAGNOSTIC CARE, EMERGENCY MEDICAL CARE, MENTAL HEALTH, PSYCHIATRIC AND PSYCHOLOGICAL SERVICES, SUBSTANCE ABUSE TREATMENT, DENTAL, VISION AND HEARING CARE, AND PROVIDING DOCTORS, NURSES AND OTHER HEALTH CARE PROFESSIONALS FOR THE TREATMENT OF PATIENTS; TELEMEDICINE SERVICES (U.S. CLS. 100 AND 101).
LESLIE RICHARDS, EXAMINING ATTORNEY

THE MARK CONSISTS OF STANDARD CHARACTERS WITHOUT CLAIM TO ANY PARTICULAR FONT, STYLE, SIZE, OR COLOR.

NO CLAIM IS MADE TO THE EXCLUSIVE RIGHT TO USE "WORKPLACE, INC.", APART FROM THE MARK AS SHOWN.

CLASS 35—ADVERTISING AND BUSINESS

FOR BUSINESS CONSULTATION SERVICES IN THE NATURE OF IDENTIFYING, IMPLEMENTING AND MONITORING TELEWORKING AND TELECOMMUTING EMPLOYEE PROGRAMS FOR EMPLOYERS (U.S. CLS. 100, 101 AND 102).

SN 85-346,215. SUN DENTAL LABORATORIES, LLC, CLEARWATER, FL. FILED 6-14-2011.

CLASS 42—SCIENTIFIC AND COMPUTER SERVICES

FOR SOFTWARE CONSULTATION SERVICES IN THE FIELD OF BUSINESS, NAMELY, SELECTING, IMPLEMENTING AND MONITORING THE PERFORMANCE OF TELEWORKING AND TELECOMMUTING SOFTWARE PROGRAMS FOR EMPLOYERS; SOFTWARE AS A SERVICE (SAAS) SERVICES FEATURING SOFTWARE FOR USE BY EMPLOYERS TO IDENTIFY, IMPLEMENT, AND MONITOR TELEWORKING AND TELECOMMUTING PROGRAMS IN THE WORKPLACE (U.S. CLS. 100 AND 101).
DEBRA LEE, EXAMINING ATTORNEY

SUNSPARKLE

THE MARK CONSISTS OF STANDARD CHARACTERS WITHOUT CLAIM TO ANY PARTICULAR FONT, STYLE, SIZE, OR COLOR.

CLASS 3—COSMETICS AND CLEANING PREPARATIONS

FOR DENTAL CARE PRODUCTS, NAMELY, TOOTH-PASTE, DENTIFRICES, DENTAL BLEACHING GEL, MOUTHWASH, TOOTH WHITENING CREAMS, GELS AND PASTE, WHITENING STRIPS IMPREGNATED WITH TEETH WHITENING PREPARATIONS, DENTIFRICES IN THE FORM OF TOOTH WHITENING GUM AND CHEWING GUM, DENTURE CLEANERS, PREPARATIONS FOR CLEANING DENTURES (U.S. CLS. 1, 4, 6, 50, 51 AND 52).

CLASS 7—MACHINERY

FOR ELECTRICAL ULTRASONIC CLEANING UNITS FOR DENTURES (U.S. CLS. 13, 19, 21, 23, 31, 34 AND 35). FIRST USE 2-19-2011; IN COMMERCE 2-19-2011.

CLASS 10—MEDICAL APPARATUS

FOR DENTAL APPARATUS AND INSTRUMENTS, NAMELY, DENTAL CROWNS AND DENTAL CAPS, TOOTH IMPLANTS, ARTIFICIAL TEETH, FLEXIBLE PARTIAL DENTURES, CAST PARTIAL DENTAL FRAMEWORKS, ORTHODONTIC APPLIANCES, ABUTMENTS FOR USE WITH DENTAL IMPLANTS; DENTAL PROSTHESES, DENTURES, DENTAL BRIDGES, PROSTHETIC TEETH; PARTS AND FITTINGS FOR ABUTMENTS FOR USE WITH DENTAL IMPLANTS, DENTAL CROWNS AND CAPS, TOOTH IMPLANTS, ARTIFICIAL TEETH, FLEXIBLE PARTIALS, CAST PARTIAL DENTAL FRAMEWORKS, ORTHODONTIC APPLIANCES, DENTAL PROSTHESES, DENTURES, DENTAL BRIDGES, AND PROSTHETIC TEETH (U.S. CLS. 26, 39 AND 44).

CLASS 21—HOUSEWARES AND GLASS

FOR DENTAL CARE PRODUCTS, NAMELY, TOOTHBRUSHES, TOOTHBRUSH HOLDERS, AND DENTAL FLOSS (U.S. CLS. 2, 13, 23, 29, 30, 33, 40 AND 50). BRIAN PINO, EXAMINING ATTORNEY

SN 85-346,522. RECKITT BENCKISER LLC, PARSIPPANY, NJ. FILED 6-15-2011.

TOUCH OF FOAM

THE MARK CONSISTS OF STANDARD CHARACTERS WITHOUT CLAIM TO ANY PARTICULAR FONT, STYLE, SIZE, OR COLOR.

NO CLAIM IS MADE TO THE EXCLUSIVE RIGHT TO USE "FOAM", APART FROM THE MARK AS SHOWN.

CLASS 3—COSMETICS AND CLEANING PREPARATIONS

FOR ANTIBACTERIAL SOAPS; SOAPS FOR PERSONAL USE; HAND CLEANING PREPARATIONS; HAND CLEANING PREPARATIONS IN THE NATURE OF NON-MEDICATED HANDWASHES; LIQUID SOAPS FOR HANDS, FACE AND BODY; NON-MEDICATED SKIN CARE PREPARATIONS, NAMELY, BARRIER CREAMS, LOTIONS AND GELS (U.S. CLS. 1, 4, 6, 50, 51 AND 52).

CLASS 5—PHARMACEUTICALS

FOR SKIN SANITIZING PREPARATIONS; MEDICATED ANTIBACTERIAL SKIN CLEANSERS; ANTIBACTERIAL HANDWASH; ANTIBACTERIAL HAND LOTIONS, CREAMS AND GELS; ANTIBACTERIAL SKIN PROTECTION LOTIONS, CREAMS AND GELS (U.S. CLS. 6, 18, 44, 46, 51 AND 52). NELSON SNYDER, EXAMINING ATTORNEY

SN 85-346,596. XTUIT PHARMACEUTICALS, INC., WALTHAM, MA. FILED 6-15-2011.

XTuit

THE MARK CONSISTS OF STANDARD CHARACTERS WITHOUT CLAIM TO ANY PARTICULAR FONT, STYLE, SIZE, OR COLOR.

CLASS 5—PHARMACEUTICALS

FOR PHARMACEUTICAL PREPARATIONS FOR USE IN THE DIAGNOSIS AND TREATMENT OF ONCOLOGICAL DISEASES OR DISORDERS, TUMOR DISEASES OR DISORDERS, INFLAMMATION AND INFLAMMATORY DISEASES OR DISORDERS, AND OTHER DISEASES OR DISORDERS, NAMELY, FIBROTIC DISEASE, KIDNEY DISEASE, HEART DISEASE, MARFAN'S SYNDROME AND TUBERCULOSIS (U.S. CLS. 6, 18, 44, 46, 51 AND 52).

CLASS 42—SCIENTIFIC AND COMPUTER SERVICES

FOR PHARMACEUTICAL RESEARCH SERVICES; PHARMACEUTICAL RESEARCH AND DEVELOPMENT; MEDICAL RESEARCH; BIOMEDICAL RESEARCH SERVICES; MEDICAL AND SCIENTIFIC RESEARCH, NAMELY, CONDUCTING CLINICAL TRIALS (U.S. CLS. 100 AND 101). ALEX KEAM, EXAMINING ATTORNEY

SN 85-346,821. MSM MUSIC GROUP, INC., ENCINO, CA. FILED 6-15-2011.

Boyz II Men

OWNER OF U.S. REG. NOS. 1,748,978, 1,797,591 AND 1,865,302.

THE MARK CONSISTS OF THE WORDING "BOYZ II MEN" IN STYLIZED FONT.

CLASS 9—ELECTRICAL AND SCIENTIFIC APPARATUS

FOR MUSICAL SOUND RECORDINGS; CDS AND DVDS FEATURING MUSIC AND MUSICAL PERFORMANCES; DOWNLOADABLE MUSICAL SOUND RECORDINGS; AUDIO AND VIDEO RECORDINGS FEATURING MUSIC AND MUSICAL PERFORMANCES, COMPUTER SCREEN SAVER SOFTWARE IN THE FIELD OF MUSIC; COMPUTER SOFTWARE FOR PROCESSING AND PLAYING DIGITAL MUSIC FILES; COMPUTER SOFTWARE FEATURING PRERECORDED MUSIC (U.S. CLS. 21, 23, 26, 36 AND 38).

CLASS 16—PAPER GOODS AND PRINTED MATTER

FOR POSTERS, POSTER BOOKS, STICKERS, DECALS, TOUR BOOKS, BOOKS IN THE FIELD OF MUSIC AND MUSICAL PERFORMERS, SHEET MUSIC, MUSIC BOOKS, CALENDARS, POSTCARDS, AND NOTE CARDS (U.S. CLS. 2, 5, 22, 23, 29, 37, 38 AND 50).

CLASS 25—CLOTHING

FOR CLOTHING, NAMELY, TOPS, BOTTOMS, T-SHIRTS, SHIRTS, PANTS, HEADWEAR, FOOTWEAR, TANK TOPS, SWEATSHIRTS, UNDERWEAR AND JACKETS (U.S. CLS. 22 AND 39).

CLASS 41—EDUCATION AND ENTERTAINMENT

FOR ENTERTAINMENT SERVICES IN THE NATURE OF LIVE MUSICAL PERFORMANCES; ENTERTAINMENT SERVICES, NAMELY, PROVIDING A WEB SITE FEATURING NONDOWNLOADABLE PRE-RECORDED MUSIC AND MUSICAL PERFORMANCES, MUSICAL VIDEOS, PHOTOGRAPHS AND OTHER MULTIMEDIA MATERIALS IN THE FIELD OF MUSIC (U.S. CLS. 100, 101 AND 107).

ASMAT KHAN, EXAMINING ATTORNEY

CLASS 6—METAL GOODS

FOR METALS AND METAL ALLOYS; ALUMINUM AND ALUMINUM ALLOYS; PORTABLE, CONNECTABLE PANELS AND TRACKS OF METAL FOR USE IN CONSTRUCTING RELOCATABLE ROADWAYS AND GROUND COVERINGS; SURFACING MATERIALS FOR USE IN SUPPORTING VEHICLES ON ROADWAYS IN THE NATURE OF PORTABLE METAL PANELS; PORTABLE METAL BUILDINGS; GROUND MOBILITY SYSTEMS COMPRISING METAL AND ALUMINUM ROADWAY PANELS, RAPID LAUNCH AND RECOVERY SPOOLS, SPOOLRACK, AND DISPENSER; MODULAR RELOCATABLE CARRIAGE WAYS IN THE NATURE OF METAL DECKING, PANELS AND TRACKS FOR SUPPORTING VEHICLES; MODULAR AIRFIELD SYSTEMS COMPRISING RELOCATABLE METAL LANDING PADS AND RUNWAY DECKING AND STRUCTURAL AND REPLACEMENT PARTS THEREFOR; METAL GROUND REINFORCEMENT DEVICES, NAMELY, GROUND ANCHORS, SUPPORT POSTS, AND SUPPORT FRAMES; METAL DECKING; METAL TILES; METAL SUPPORT FRAMES FOR RELOCATABLE PANELS; METAL PANELS; MODULAR METAL PADS, PLATES AND PANELS FOR USE IN CONSTRUCTING RELOCATABLE ROADWAYS AND AIRFIELDS; METAL FLOORING AND TEMPORARY AND REMOVABLE METAL FLOORING; MODULAR ALUMINUM PADS, PANELS AND PLATES FOR USE IN CONSTRUCTING RELOCATABLE ROADWAYS AND AIRFIELDS AND STRUCTURAL AND REPLACEMENT PARTS THEREFOR; ALL OF THE ABOVE MADE SUBSTANTIALLY OF METAL, ALUMINUM AND METAL COMPOSITES (U.S. CLS. 2, 12, 13, 14, 23, 25 AND 50).

CLASS 12—VEHICLES

FOR MOTOR VEHICLES, NAMELY, MILITARY VEHICLES IN THE NATURE OF ARMORED CARS, TRUCKS, TRACTORS, AND TRANSPORTERS, TRAILERS FOR USE WITH GROUND MOBILITY SYSTEMS; LAND VEHICLES; MOTOR VEHICLES FOR TRANSPORTING AND LAYING EQUIPMENT USED IN GROUND MOBILITY SYSTEMS; VEHICLES FOR MUNICIPAL USES, NAMELY, WASTE COLLECTION, ROAD-CLEANING AND SWEEPING VEHICLES, ROAD-LAYING VEHICLES, TRACK-LAYING VEHICLES; AND STRUCTURAL AND REPLACEMENT PARTS FOR ALL THE AFORESAID GOODS (U.S. CLS. 19, 21, 23, 31, 35 AND 44).

CLASS 19—NON-METALLIC BUILDING MATERIALS

FOR NON-METAL PORTABLE, CONNECTABLE PANELS AND TRACKS OF METAL FOR USE IN CONSTRUCTING RELOCATABLE ROADWAYS AND GROUND COVERINGS; SURFACING MATERIALS FOR USE IN SUPPORTING VEHICLES ON ROADWAYS IN THE NATURE OF PORTABLE NON-METAL PANELS; PORTABLE NON-METAL BUILDINGS; GROUND MOBILITY SYSTEMS COMPRISING NON-METAL ROADWAY PANELS, RAPID LAUNCH AND RECOVERY SPOOLS, SPOOLRACK, AND DISPENSER; MODULAR RELOCATABLE CARRIAGE WAYS IN THE NATURE OF NON-METAL DECKING, PANELS AND TRACKS FOR SUPPORTING VEHICLES; MODULAR AIRFIELD SYSTEMS COMPRISING NON-METAL LANDING PADS AND RUNWAY DECKING AND STRUCTURAL AND REPLACEMENT PARTS THEREFOR; NON-METAL GROUND REINFORCEMENT DEVICES, NAMELY, GROUND ANCHORS, SUPPORT POSTS, AND SUPPORT FRAMES; NON-METAL DECKING; NON-METAL TILES; NON-METAL SUPPORT FRAMES FOR RELOCATABLE PANELS; NON-METAL PANELS; MODULAR NON-METAL PADS, PLATES AND PANELS FOR USE IN CONSTRUCTING RELOCATABLE ROADWAYS AND AIRFIELDS; NON-METAL FLOORING AND TEMPORARY AND REMOVABLE NON-METAL FLOORING; MODULAR NON-METAL PADS, PANELS AND PLATES FOR USE IN CONSTRUCTING RELOCATABLE ROADWAYS AND AIRFIELDS AND STRUCTURAL AND REPLACEMENT PARTS THEREFOR; ALL OF THE ABOVE MADE SUBSTANTIALLY OF PLASTIC, WOOD AND NON-METAL COMPOSITES (U.S. CLS. 1, 12, 33 AND 50).

SN 85-347,221. FAUN ZOELLER (UK) LIMITED, ANGLESEY, NORTH WALES, UNITED KINGDOM, FILED 6-15-2011.



NO CLAIM IS MADE TO THE EXCLUSIVE RIGHT TO USE "USA", APART FROM THE MARK AS SHOWN.

THE MARK CONSISTS OF THE WORDING "FAUN TRACKWAY USA" AND A CIRCLE WITH A CURVED INTERSECTING LINE.

CLASS 37—CONSTRUCTION AND REPAIR

FOR CONSTRUCTION, INSTALLATION, DISMANTLING, REPAIR, MODIFICATION, REFURBISHMENT AND MAINTENANCE OF PORTABLE AND TEMPORARY ROADWAYS, TRACKS AND GROUND COVERING; CONSTRUCTION PLANNING; PROVIDING INFORMATION, ADVISORY AND CONSULTANCY SERVICES IN THE FIELD OF CONSTRUCTION, REPAIR AND MAINTENANCE; CONSTRUCTION PROJECT MANAGEMENT; CONSTRUCTION MANAGEMENT; AND PROVIDING INFORMATION, ADVISORY CONSULTANCY AND TECHNICAL ADVICE IN RELATION TO ALL OF THE AFORESAID CONSTRUCTION AND MAINTENANCE SERVICES (U.S. CLS. 100, 103 AND 106).

CLASS 42—SCIENTIFIC AND COMPUTER SERVICES

FOR ENGINEERING, NAMELY, MECHANICAL ENGINEERING, CIVIL ENGINEERING, CONSTRUCTION ENGINEERING SERVICES; SCIENTIFIC AND TECHNOLOGICAL SERVICES, NAMELY, RESEARCH, DEVELOPMENT AND DESIGN OF ENGINEERING PRODUCTS; TESTING, ANALYSIS AND EVALUATION SERVICES OF THE STRUCTURAL PROPERTIES OF NON-METAL AND METAL MATERIALS; COMPUTER PROJECT MANAGEMENT; QUALITY CONTROL FOR OTHERS; DESIGN AND MAINTENANCE OF SOFTWARE; CALIBRATION SERVICES; MATERIALS TESTING AND EVALUATION SERVICES; AND PROVIDING INFORMATION, ADVISORY, CONSULTANCY AND TECHNICAL ADVICE IN RELATION TO ALL THE AFORESAID ENGINEERING AND SCIENTIFIC SERVICES, WITH ALL OF THE AFORESAID ENGINEERING AND SCIENTIFIC SERVICES EXCLUDING SERVICES RELATED TO PRODUCT DEVELOPMENT, TESTING AND INDUSTRIAL EFFICIENCY IN THE FIELD OF ASSET TRACKING AND LOGISTICS (U.S. CLS. 100 AND 101).

KAREN BRACEY, EXAMINING ATTORNEY

CLASS 6—METAL GOODS

FOR METALS AND METAL ALLOYS; ALUMINUM AND ALUMINUM ALLOYS; PORTABLE, CONNECTABLE PANELS AND TRACKS OF METAL FOR USE IN CONSTRUCTING RELOCATABLE ROADWAYS AND GROUND COVERINGS; SURFACING MATERIALS FOR USE IN SUPPORTING VEHICLES ON ROADWAYS IN THE NATURE OF PORTABLE METAL PANELS; PORTABLE METAL BUILDINGS; GROUND MOBILITY SYSTEMS COMPRISING METAL AND ALUMINUM ROADWAY PANELS, RAPID LAUNCH AND RECOVERY SPOOLS, SPOOLRACK, AND DISPENSER; MODULAR RELOCATABLE CARRIAGE WAYS IN THE NATURE OF METAL DECKING, PANELS AND TRACKS FOR SUPPORTING VEHICLES; MODULAR AIRFIELD SYSTEMS COMPRISING RELOCATABLE METAL LANDING PADS AND RUNWAY DECKING AND STRUCTURAL AND REPLACEMENT PARTS THEREFOR; METAL GROUND REINFORCEMENT DEVICES NAMELY, GROUND ANCHORS, SUPPORT POSTS, AND SUPPORT FRAMES; METAL DECKING; METAL TILES; METAL SUPPORT FRAMES FOR RELOCATABLE PANELS; METAL PANELS; MODULAR METAL PADS, PLATES AND PANELS FOR USE IN CONSTRUCTING RELOCATABLE ROADWAYS AND AIRFIELDS; METAL FLOORING AND TEMPORARY AND REMOVABLE METAL FLOORING; MODULAR ALUMINUM PADS, PANELS AND PLATES FOR USE IN CONSTRUCTING RELOCATABLE ROADWAYS AND AIRFIELDS AND STRUCTURAL AND REPLACEMENT PARTS THEREFOR; ALL OF THE ABOVE MADE SUBSTANTIALLY OF METAL, ALUMINUM AND METAL COMPOSITES (U.S. CLS. 2, 12, 13, 14, 23, 25 AND 50).

CLASS 12—VEHICLES

FOR MOTOR VEHICLES, NAMELY, MILITARY VEHICLES IN THE NATURE OF ARMORED CARS, TRUCKS, TRACTORS, AND TRANSPORTERS, TRAILERS FOR USE WITH GROUND MOBILITY SYSTEMS; LAND VEHICLES; MOTOR VEHICLES FOR TRANSPORTING AND LAYING EQUIPMENT USED IN GROUND MOBILITY SYSTEMS; VEHICLES FOR MUNICIPAL USES, NAMELY, WASTE COLLECTION, ROAD-CLEANING AND SWEEPING VEHICLES, ROAD-LAYING VEHICLES, TRACK-LAYING VEHICLES; AND STRUCTURAL AND REPLACEMENT PARTS FOR ALL THE AFORESAID GOODS (U.S. CLS. 19, 21, 23, 31, 35 AND 44).

CLASS 19—NON-METALLIC BUILDING MATERIALS

FOR NON-METAL PORTABLE, CONNECTABLE PANELS AND TRACKS OF METAL FOR USE IN CONSTRUCTING RELOCATABLE ROADWAYS AND GROUND COVERINGS; SURFACING MATERIALS FOR USE IN SUPPORTING VEHICLES ON ROADWAYS IN THE NATURE OF PORTABLE NON-METAL PANELS; PORTABLE NON-METAL BUILDINGS; GROUND MOBILITY SYSTEMS COMPRISING NON-METAL ROADWAY PANELS, RAPID LAUNCH AND RECOVERY SPOOLS, SPOOLRACK, AND DISPENSER; MODULAR RELOCATABLE CARRIAGE WAYS IN THE NATURE OF NON-METAL DECKING, PANELS AND TRACKS FOR SUPPORTING VEHICLES; MODULAR AIRFIELD SYSTEMS COMPRISING NON-METAL LANDING PADS AND RUNWAY DECKING AND STRUCTURAL AND REPLACEMENT PARTS THEREFOR; NON-METAL GROUND REINFORCEMENT DEVICES, NAMELY, GROUND ANCHORS, SUPPORT POSTS, AND SUPPORT FRAMES; NON-METAL DECKING; NON-METAL TILES; NON-METAL SUPPORT FRAMES FOR RELOCATABLE PANELS; NON-METAL PANELS; MODULAR NON-METAL PADS, PLATES AND PANELS FOR USE IN CONSTRUCTING RELOCATABLE ROADWAYS AND AIRFIELDS; NON-METAL FLOORING AND TEMPORARY AND REMOVABLE NON-METAL FLOORING; MODULAR NON-METAL PADS, PANELS AND PLATES FOR USE IN CONSTRUCTING RELOCATABLE ROADWAYS AND AIRFIELDS AND STRUCTURAL AND REPLACEMENT PARTS THEREFOR; ALL OF THE ABOVE MADE SUBSTANTIALLY OF PLASTIC, WOOD AND NON-METAL COMPOSITES (U.S. CLS. 1, 12, 33 AND 50).

SN 85-347,227. FAUN ZOELLER (UK) LIMITED, ANGLESEY, NORTH WALES, UNITED KINGDOM, FILED 6-15-2011.

TRACKWAY

THE MARK CONSISTS OF STANDARD CHARACTERS WITHOUT CLAIM TO ANY PARTICULAR FONT, STYLE, SIZE, OR COLOR.

CLASS 37—CONSTRUCTION AND REPAIR

FOR CONSTRUCTION, INSTALLATION, DISMANTLING, REPAIR, MODIFICATION, REFURBISHMENT AND MAINTENANCE OF PORTABLE AND TEMPORARY ROADWAYS, TRACKS AND GROUND COVERING; CONSTRUCTION PLANNING; PROVIDING INFORMATION, ADVISORY AND CONSULTANCY SERVICES IN THE FIELD OF CONSTRUCTION, REPAIR AND MAINTENANCE; CONSTRUCTION PROJECT MANAGEMENT; CONSTRUCTION MANAGEMENT; AND PROVIDING INFORMATION, ADVISORY CONSULTANCY AND TECHNICAL ADVICE IN RELATION TO ALL OF THE AFORESAID CONSTRUCTION AND MAINTENANCE SERVICES (U.S. CLS. 100, 103 AND 106).

CLASS 42—SCIENTIFIC AND COMPUTER SERVICES

FOR ENGINEERING, NAMELY, MECHANICAL ENGINEERING, CIVIL ENGINEERING, CONSTRUCTION ENGINEERING SERVICES; SCIENTIFIC AND TECHNOLOGICAL SERVICES, NAMELY, RESEARCH, DEVELOPMENT AND DESIGN OF ENGINEERING PRODUCTS; TESTING, ANALYSIS AND EVALUATION SERVICES OF THE STRUCTURAL PROPERTIES OF NON-METAL AND METAL MATERIALS; COMPUTER PROJECT MANAGEMENT; QUALITY CONTROL FOR OTHERS; DESIGN AND MAINTENANCE OF SOFTWARE; CALIBRATION SERVICES; MATERIALS TESTING AND EVALUATION SERVICES; AND PROVIDING INFORMATION, ADVISORY, CONSULTANCY AND TECHNICAL ADVICE IN RELATION TO ALL THE AFORESAID ENGINEERING AND SCIENTIFIC SERVICES, WITH ALL OF THE AFORESAID ENGINEERING AND SCIENTIFIC SERVICES EXCLUDING SERVICES RELATED TO PRODUCT DEVELOPMENT, TESTING AND INDUSTRIAL EFFICIENCY IN THE FIELD OF ASSET TRACKING AND LOGISTICS (U.S. CLS. 100 AND 101).

KAREN BRACEY, EXAMINING ATTORNEY

CLASS 6—METAL GOODS

FOR METALS AND METAL ALLOYS; ALUMINUM AND ALUMINUM ALLOYS; PORTABLE, CONNECTABLE PANELS AND TRACKS OF METAL FOR USE IN CONSTRUCTING RELOCATABLE ROADWAYS AND GROUND COVERINGS; SURFACING MATERIALS FOR USE IN SUPPORTING VEHICLES ON ROADWAYS IN THE NATURE OF PORTABLE METAL PANELS; PORTABLE METAL BUILDINGS; GROUND MOBILITY SYSTEMS COMPRISING METAL AND ALUMINUM ROADWAY PANELS, RAPID LAUNCH AND RECOVERY SPOOLS, SPOOLRACK, AND DISPENSER; MODULAR RELOCATABLE CARRIAGE WAYS IN THE NATURE OF METAL DECKING, PANELS AND TRACKS FOR SUPPORTING VEHICLES; MODULAR AIRFIELD SYSTEMS COMPRISING RELOCATABLE METAL LANDING PADS AND RUNWAY DECKING AND STRUCTURAL AND REPLACEMENT PARTS THEREFOR; METAL GROUND REINFORCEMENT DEVICES NAMELY, GROUND ANCHORS, SUPPORT POSTS, AND SUPPORT FRAMES; METAL DECKING; METAL TILES; METAL SUPPORT FRAMES FOR RELOCATABLE PANELS; METAL PANELS; MODULAR METAL PADS, PLATES AND PANELS FOR USE IN CONSTRUCTING RELOCATABLE ROADWAYS AND AIRFIELDS; METAL FLOORING AND TEMPORARY AND REMOVABLE METAL FLOORING; MODULAR ALUMINUM PADS, PANELS AND PLATES FOR USE IN CONSTRUCTING RELOCATABLE ROADWAYS AND AIRFIELDS AND STRUCTURAL AND REPLACEMENT PARTS THEREFOR; ALL OF THE ABOVE MADE SUBSTANTIALLY OF METAL, ALUMINUM AND METAL COMPOSITES (U.S. CLS. 2, 12, 13, 14, 23, 25 AND 50).

CLASS 12—VEHICLES

FOR MOTOR VEHICLES, NAMELY, MILITARY VEHICLES IN THE NATURE OF ARMORED CARS, TRUCKS, TRACTORS, AND TRANSPORTERS, TRAILERS FOR USE WITH GROUND MOBILITY SYSTEMS; LAND VEHICLES; MOTOR VEHICLES FOR TRANSPORTING AND LAYING EQUIPMENT USED IN GROUND MOBILITY SYSTEMS; VEHICLES FOR MUNICIPAL USES, NAMELY, WASTE COLLECTION, ROAD-CLEANING AND SWEEPING VEHICLES, ROAD-LAYING VEHICLES, TRACK-LAYING VEHICLES; AND STRUCTURAL AND REPLACEMENT PARTS FOR ALL THE AFORESAID GOODS (U.S. CLS. 19, 21, 23, 31, 35 AND 44).

CLASS 19—NON-METALLIC BUILDING MATERIALS

FOR NON-METAL PORTABLE, CONNECTABLE PANELS AND TRACKS OF METAL FOR USE IN CONSTRUCTING RELOCATABLE ROADWAYS AND GROUND COVERINGS; SURFACING MATERIALS FOR USE IN SUPPORTING VEHICLES ON ROADWAYS IN THE NATURE OF PORTABLE NON-METAL PANELS; PORTABLE NON-METAL BUILDINGS; GROUND MOBILITY SYSTEMS COMPRISING NON-METAL ROADWAY PANELS, RAPID LAUNCH AND RECOVERY SPOOLS, SPOOLRACK, AND DISPENSER; MODULAR RELOCATABLE CARRIAGE WAYS IN THE NATURE OF NON-METAL DECKING, PANELS AND TRACKS FOR SUPPORTING VEHICLES; MODULAR AIRFIELD SYSTEMS COMPRISING NON-METAL LANDING PADS AND RUNWAY DECKING AND STRUCTURAL AND REPLACEMENT PARTS THEREFOR; NON-METAL GROUND REINFORCEMENT DEVICES, NAMELY, GROUND ANCHORS, SUPPORT POSTS, AND SUPPORT FRAMES; NON-METAL DECKING; NON-METAL TILES; NON-METAL SUPPORT FRAMES FOR RELOCATABLE PANELS; NON-METAL PANELS; MODULAR NON-METAL PADS, PLATES AND PANELS FOR USE IN CONSTRUCTING RELOCATABLE ROADWAYS AND AIRFIELDS; NON-METAL FLOORING AND TEMPORARY AND REMOVABLE NON-METAL FLOORING; MODULAR NON-METAL PADS, PANELS AND PLATES FOR USE IN CONSTRUCTING RELOCATABLE ROADWAYS AND AIRFIELDS AND STRUCTURAL AND REPLACEMENT PARTS THEREFOR; ALL OF THE ABOVE MADE SUBSTANTIALLY OF PLASTIC, WOOD AND NON-METAL COMPOSITES (U.S. CLS. 1, 12, 33 AND 50).

SN 85-347,230. FAUN ZOELLER (UK) LIMITED, ANGLESEY, NORTH WALES, UNITED KINGDOM, FILED 6-15-2011.

TRACKWAY USA

THE MARK CONSISTS OF STANDARD CHARACTERS WITHOUT CLAIM TO ANY PARTICULAR FONT, STYLE, SIZE, OR COLOR.

NO CLAIM IS MADE TO THE EXCLUSIVE RIGHT TO USE "USA", APART FROM THE MARK AS SHOWN.

CLASS 37—CONSTRUCTION AND REPAIR

FOR CONSTRUCTION, INSTALLATION, DISMANTLING, REPAIR, MODIFICATION, REFURBISHMENT AND MAINTENANCE OF PORTABLE AND TEMPORARY ROADWAYS, TRACKS AND GROUND COVERING; CONSTRUCTION PLANNING; PROVIDING INFORMATION, ADVISORY AND CONSULTANCY SERVICES IN THE FIELD OF CONSTRUCTION, REPAIR AND MAINTENANCE; CONSTRUCTION PROJECT MANAGEMENT; CONSTRUCTION MANAGEMENT; AND PROVIDING INFORMATION, ADVISORY CONSULTANCY AND TECHNICAL ADVICE IN RELATION TO ALL OF THE AFORESAID CONSTRUCTION AND MAINTENANCE SERVICES (U.S. CLS. 100, 103 AND 106).

CLASS 42—SCIENTIFIC AND COMPUTER SERVICES

FOR ENGINEERING, NAMELY, MECHANICAL ENGINEERING, CIVIL ENGINEERING, CONSTRUCTION ENGINEERING SERVICES; SCIENTIFIC AND TECHNOLOGICAL SERVICES, NAMELY, RESEARCH, DEVELOPMENT AND DESIGN OF ENGINEERING PRODUCTS; TESTING, ANALYSIS AND EVALUATION SERVICES OF THE STRUCTURAL PROPERTIES OF NON-METAL AND METAL MATERIALS; COMPUTER PROJECT MANAGEMENT; QUALITY CONTROL FOR OTHERS; DESIGN AND MAINTENANCE OF SOFTWARE; CALIBRATION SERVICES; MATERIALS TESTING AND EVALUATION SERVICES; AND PROVIDING INFORMATION, ADVISORY, CONSULTANCY AND TECHNICAL ADVICE IN RELATION TO ALL THE AFORESAID ENGINEERING AND SCIENTIFIC SERVICES, WITH ALL OF THE AFORESAID ENGINEERING AND SCIENTIFIC SERVICES EXCLUDING SERVICES RELATED TO PRODUCT DEVELOPMENT, TESTING AND INDUSTRIAL EFFICIENCY IN THE FIELD OF ASSET TRACKING AND LOGISTICS (U.S. CLS. 100 AND 101).

KAREN BRACEY, EXAMINING ATTORNEY

CLASS 6—METAL GOODS

FOR METALS AND METAL ALLOYS; ALUMINUM AND ALUMINUM ALLOYS; PORTABLE, CONNECTABLE PANELS AND TRACKS OF METAL FOR USE IN CONSTRUCTING RELOCATABLE ROADWAYS AND GROUND COVERINGS; SURFACING MATERIALS FOR USE IN SUPPORTING VEHICLES ON ROADWAYS IN THE NATURE OF PORTABLE METAL PANELS; PORTABLE METAL BUILDINGS; GROUND MOBILITY SYSTEMS COMPRISING METAL AND ALUMINUM ROADWAY PANELS, RAPID LAUNCH AND RECOVERY SPOOLS, SPOOLRACK, AND DISPENSER; MODULAR RELOCATABLE CARRIAGE WAYS IN THE NATURE OF METAL DECKING, PANELS AND TRACKS FOR SUPPORTING VEHICLES; MODULAR AIRFIELD SYSTEMS COMPRISING RELOCATABLE METAL LANDING PADS AND RUNWAY DECKING AND STRUCTURAL AND REPLACEMENT PARTS THEREFOR; METAL GROUND REINFORCEMENT DEVICES, NAMELY, GROUND ANCHORS, SUPPORT POSTS, AND SUPPORT FRAMES; METAL DECKING; METAL TILES; METAL SUPPORT FRAMES FOR RELOCATABLE PANELS; METAL PANELS; MODULAR METAL PADS, PLATES AND PANELS FOR USE IN CONSTRUCTING RELOCATABLE ROADWAYS AND AIRFIELDS; METAL FLOORING AND TEMPORARY AND REMOVABLE METAL FLOORING; MODULAR ALUMINUM PADS, PANELS AND PLATES FOR USE IN CONSTRUCTING RELOCATABLE ROADWAYS AND AIRFIELDS AND STRUCTURAL AND REPLACEMENT PARTS THEREFOR; ALL OF THE ABOVE MADE SUBSTANTIALLY OF METAL, ALUMINUM AND METAL COMPOSITES (U.S. CLS. 2, 12, 13, 14, 23, 25 AND 50).

CLASS 12—VEHICLES

FOR MOTOR VEHICLES, NAMELY, MILITARY VEHICLES IN THE NATURE OF ARMORED CARS, TRUCKS, TRACTORS, AND TRANSPORTERS, TRAILERS FOR USE WITH GROUND MOBILITY SYSTEMS; LAND VEHICLES; MOTOR VEHICLES FOR TRANSPORTING AND LAYING EQUIPMENT USED IN GROUND MOBILITY SYSTEMS; VEHICLES FOR MUNICIPAL USES, NAMELY, WASTE COLLECTION, ROAD-CLEANING AND SWEEPING VEHICLES, ROAD-LAYING VEHICLES, TRACK-LAYING VEHICLES; AND STRUCTURAL AND REPLACEMENT PARTS FOR ALL THE AFORESAID GOODS (U.S. CLS. 19, 21, 23, 31, 35 AND 44).

CLASS 19—NON-METALLIC BUILDING MATERIALS

FOR NON-METAL PORTABLE, CONNECTABLE PANELS AND TRACKS OF METAL FOR USE IN CONSTRUCTING RELOCATABLE ROADWAYS AND GROUND COVERINGS; SURFACING MATERIALS FOR USE IN SUPPORTING VEHICLES ON ROADWAYS IN THE NATURE OF PORTABLE NON-METAL PANELS; PORTABLE NON-METAL BUILDINGS; GROUND MOBILITY SYSTEMS COMPRISING NON-METAL ROADWAY PANELS, RAPID LAUNCH AND RECOVERY SPOOLS, SPOOLRACK, AND DISPENSER; MODULAR RELOCATABLE CARRIAGE WAYS IN THE NATURE OF NON-METAL DECKING, PANELS AND TRACKS FOR SUPPORTING VEHICLES; MODULAR AIRFIELD SYSTEMS COMPRISING NON-METAL LANDING PADS AND RUNWAY DECKING AND STRUCTURAL AND REPLACEMENT PARTS THEREFOR; NON-METAL GROUND REINFORCEMENT DEVICES, NAMELY, GROUND ANCHORS, SUPPORT POSTS, AND SUPPORT FRAMES; NON-METAL DECKING; NON-METAL TILES; NON-METAL SUPPORT FRAMES FOR RELOCATABLE PANELS; NON-METAL PANELS; MODULAR NON-METAL PADS, PLATES AND PANELS FOR USE IN CONSTRUCTING RELOCATABLE ROADWAYS AND AIRFIELDS; NON-METAL FLOORING AND TEMPORARY AND REMOVABLE NON-METAL FLOORING; MODULAR NON-METAL PADS, PANELS AND PLATES FOR USE IN CONSTRUCTING RELOCATABLE ROADWAYS AND AIRFIELDS AND STRUCTURAL AND REPLACEMENT PARTS THEREFOR; ALL OF THE ABOVE MADE SUBSTANTIALLY OF PLASTIC, WOOD AND NON-METAL COMPOSITES (U.S. CLS. 1, 12, 33 AND 50).

SN 85-347,232. FAUN ZOELLER (UK) LIMITED, ANGLESEY, NORTH WALES, UNITED KINGDOM, FILED 6-15-2011.

FAUN TRACKWAY USA

THE MARK CONSISTS OF STANDARD CHARACTERS WITHOUT CLAIM TO ANY PARTICULAR FONT, STYLE, SIZE, OR COLOR.

NO CLAIM IS MADE TO THE EXCLUSIVE RIGHT TO USE "USA", APART FROM THE MARK AS SHOWN.

CLASS 37—CONSTRUCTION AND REPAIR

FOR CONSTRUCTION, INSTALLATION, DISMANTLING, REPAIR, MODIFICATION, REFURBISHMENT AND MAINTENANCE OF PORTABLE AND TEMPORARY ROADWAYS, TRACKS AND GROUND COVERING; CONSTRUCTION PLANNING; PROVIDING INFORMATION, ADVISORY AND CONSULTANCY SERVICES IN THE FIELD OF CONSTRUCTION, REPAIR AND MAINTENANCE; CONSTRUCTION PROJECT MANAGEMENT; CONSTRUCTION MANAGEMENT; AND PROVIDING INFORMATION, ADVISORY CONSULTANCY AND TECHNICAL ADVICE IN RELATION TO ALL OF THE AFORESAID CONSTRUCTION AND MAINTENANCE SERVICES (U.S. CLS. 100, 103 AND 106).

CLASS 42—SCIENTIFIC AND COMPUTER SERVICES

FOR ENGINEERING, NAMELY, MECHANICAL ENGINEERING, CIVIL ENGINEERING, CONSTRUCTION ENGINEERING SERVICES; SCIENTIFIC AND TECHNOLOGICAL SERVICES, NAMELY, RESEARCH, DEVELOPMENT AND DESIGN OF ENGINEERING PRODUCTS; TESTING, ANALYSIS AND EVALUATION SERVICES OF THE STRUCTURAL PROPERTIES OF NON-METAL AND METAL MATERIALS; COMPUTER PROJECT MANAGEMENT; QUALITY CONTROL FOR OTHERS; DESIGN AND MAINTENANCE OF SOFTWARE; CALIBRATION SERVICES; MATERIALS TESTING AND EVALUATION SERVICES; AND PROVIDING INFORMATION, ADVISORY, CONSULTANCY AND TECHNICAL ADVICE IN RELATION TO ALL THE AFORESAID ENGINEERING AND SCIENTIFIC SERVICES, WITH ALL OF THE AFORESAID ENGINEERING AND SCIENTIFIC SERVICES EXCLUDING SERVICES RELATED TO PRODUCT DEVELOPMENT, TESTING AND INDUSTRIAL EFFICIENCY IN THE FIELD OF ASSET TRACKING AND LOGISTICS (U.S. CLS. 100 AND 101).

KAREN BRACEY, EXAMINING ATTORNEY

SN 85-347,277. SOCIALVOLT, INC., LENEXA, KS. FILED 6-15-2011.

SOCIALVOLT

THE MARK CONSISTS OF STANDARD CHARACTERS WITHOUT CLAIM TO ANY PARTICULAR FONT, STYLE, SIZE, OR COLOR.

CLASS 9—ELECTRICAL AND SCIENTIFIC APPARATUS

FOR DOWNLOADABLE ONLINE SOCIAL MEDIA MANAGEMENT SOFTWARE FOR DATA MANAGEMENT IN THE FIELDS OF TARGET MARKET IDENTIFICATION, BRAND MONITORING, CAMPAIGN DEVELOPMENT, SOCIAL MEDIA CONTENT INFORMATION MANAGEMENT, CUSTOMER RELATIONSHIP MANAGEMENT, ANALYSIS SERVICES, COMPLIANCE SERVICES, BACK UP AND ARCHIVE SERVICES (U.S. CLS. 21, 23, 26, 36 AND 38).

CLASS 42—SCIENTIFIC AND COMPUTER SERVICES

FOR PROVIDING NON-DOWNLOADABLE ONLINE SOCIAL MEDIA MANAGEMENT SOFTWARE FOR DATA MANAGEMENT IN THE FIELDS OF TARGET MARKET IDENTIFICATION, BRAND MONITORING, CAMPAIGN DEVELOPMENT, SOCIAL MEDIA CONTENT INFORMATION MANAGEMENT, CUSTOMER RELATIONSHIP MANAGEMENT, ANALYSIS SERVICES, COMPLIANCE SERVICES, BACK UP AND ARCHIVE SERVICES (U.S. CLS. 100 AND 101).

TINA BROWN, EXAMINING ATTORNEY

SN 85-347,436. SUNBLOCK CHALLENGE, JUPITER, FL. FILED 6-15-2011.

SUNBLOCK CHALLENGE

THE MARK CONSISTS OF STANDARD CHARACTERS WITHOUT CLAIM TO ANY PARTICULAR FONT, STYLE, SIZE, OR COLOR.

NO CLAIM IS MADE TO THE EXCLUSIVE RIGHT TO USE "SUNBLOCK" AS TO CLASS 25 ONLY, APART FROM THE MARK AS SHOWN.

CLASS 25—CLOTHING

FOR CLOTHING, NAMELY, T-SHIRTS, SHIRTS, SHORTS, BATHING SUITS, DRESSES, SKIRTS, BEACH COVER-UPS, CAPS, HATS, VISORS, WETSUITS, SWEAT PANTS, SWEATSUITS, SOCKS, SCARVES, BANDANAS AND SUN PROTECTION FACTOR (SPF) COVERINGS, NAMELY, CAPS, SARIS, SUN SLEEVES, HATS, SCARVES, LONG SLEEVE SHIRTS AND JACKETS; FOOTWEAR, NAMELY, BEACH SHOES, SANDALS (U.S. CLS. 22 AND 39).

CLASS 36—INSURANCE AND FINANCIAL

FOR FINANCIAL SPONSORSHIP OF NON-PROFIT OUTDOOR RECREATIONAL EVENTS IN THE NATURE OF SPORT FISHING, SOCCER, GOLF, TENNIS, LACROSSE, SOFTBALL, BASKETBALL, VOLLEYBALL, CYCLING AND BEACH SPORTS, TO PROMOTE SKIN CANCER AWARENESS, SKIN CANCER PROTECTION AND USING SKIN CARE APPLICATIONS THAT REDUCE OR BLOCK PENETRATION OF ULTRA VIOLET RADIATION (U.S. CLS. 100, 101 AND 102).

LEIGH CAROLINE CASE, EXAMINING ATTORNEY

SN 85-347,439. BREAST CANCER EMERGENCY FUND, SAN FRANCISCO, CA. FILED 6-15-2011.

BEATS FOR BOOBS

THE MARK CONSISTS OF STANDARD CHARACTERS WITHOUT CLAIM TO ANY PARTICULAR FONT, STYLE, SIZE, OR COLOR.

CLASS 25—CLOTHING

FOR (BASED ON USE IN COMMERCE) CLOTHING, NAMELY, T-SHIRTS; (BASED ON INTENT TO USE) CLOTHING, NAMELY, SWEATSHIRTS, HOODED SWEATSHIRTS, TOPS, LINGERIE, PAJAMAS, BEACHWEAR, SWEATPANTS, HEADWEAR, AND ACCESSORIES, NAMELY, SCARVES AND SOCKS (U.S. CLS. 22 AND 39).

FIRST USE 10-0-2003; IN COMMERCE 10-0-2008.

CLASS 35—ADVERTISING AND BUSINESS

FOR CHARITABLE FUNDRAISING SERVICES, NAMELY, PROMOTING PUBLIC AWARENESS OF BREAST CANCER THROUGH PROMOTING EDUCATIONAL AND OTHER ACTIVITIES RELATING TO CANCER TREATMENT AND PREVENTION (U.S. CLS. 100, 101 AND 102).

FIRST USE 10-0-2003; IN COMMERCE 10-0-2003.

CLASS 36—INSURANCE AND FINANCIAL

FOR CHARITABLE FUNDRAISING SERVICES BY MEANS OF ENTERTAINMENT EVENTS IN THE NATURE OF FESTIVALS AND EXPOSITIONS FEATURING LIVE MUSICAL PERFORMANCES, FASHION SHOW, PERFORMANCE ART, VISUAL ART, SILENT AUCTION, LIVE AERIAL ACROBATIC PERFORMANCES ON FABRIC, HOOP, AND TRAPEZE (U.S. CLS. 100, 101 AND 102).

FIRST USE 10-0-2003; IN COMMERCE 10-0-2003.
ALICE BENMAMAN, EXAMINING ATTORNEY

SN 85-347,916. CRAWFORD & COMPANY, ATLANTA, GA.
FILED 6-16-2011.

BROADSPIRE@HOME

THE MARK CONSISTS OF STANDARD CHARACTERS WITHOUT CLAIM TO ANY PARTICULAR FONT, STYLE, SIZE, OR COLOR.

OWNER OF U.S. REG. NOS. 3,245,843, 3,245,844 AND 4,017,008.

CLASS 44—MEDICAL, BEAUTY AND AGRICULTURAL SERVICES

FOR HOME HEALTH CARE SERVICES (U.S. CLS. 100 AND 101).

FIRST USE 4-25-2011; IN COMMERCE 4-25-2011.

CLASS 45—PERSONAL AND LEGAL SERVICES

FOR MEDICATION MANAGEMENT, NAMELY, COORDINATING THE PROCUREMENT AND ADMINISTRATION OF MEDICATION; IN-HOME SUPPORT SERVICES TO INJURED WORKERS, NAMELY, CASE MANAGEMENT SERVICES IN THE NATURE OF THE COORDINATION OF NECESSARY SERVICES AND PERSONAL CARE FOR INJURED WORKERS (U.S. CLS. 100 AND 101).

FIRST USE 4-25-2011; IN COMMERCE 4-25-2011.
ROBIN MITTLER, EXAMINING ATTORNEY

SN 85-347,962. ANDREWS MCMEEL PUBLISHING, LLC,
KANSAS CITY, MO. FILED 6-16-2011.

Pocket Posh Plus

THE MARK CONSISTS OF STANDARD CHARACTERS WITHOUT CLAIM TO ANY PARTICULAR FONT, STYLE, SIZE, OR COLOR.

OWNER OF U.S. REG. NOS. 3,602,081 AND 4,119,730.
NO CLAIM IS MADE TO THE EXCLUSIVE RIGHT TO USE "POCKET", APART FROM THE MARK AS SHOWN.

CLASS 9—ELECTRICAL AND SCIENTIFIC APPARATUS

FOR DOWNLOADABLE ELECTRONIC PUBLICATIONS AND CONTENT IN THE NATURE OF BOOKS, E-BOOKS, ELECTRONIC BOOKS AND ELECTRONIC TEXT, DATA AND IMAGES IN THE FIELDS OF PUZZLE BOOKS, GAME BOOKS AND NON-FICTION HUMOR, GIFT AND COOKBOOKS (U.S. CLS. 21, 23, 26, 36 AND 38).

CLASS 16—PAPER GOODS AND PRINTED MATTER

FOR PUZZLE BOOKS, BLANK JOURNALS AND NOTEBOOKS, GREETING CARDS, CALENDARS (U.S. CLS. 2, 5, 22, 23, 29, 37, 38 AND 50).

CLASS 41—EDUCATION AND ENTERTAINMENT

FOR PUBLISHING OF BOOKS, JOURNALS, E-BOOKS AND ELECTRONIC PUBLICATIONS AND TEXT, DATA AND IMAGES; PROVIDING ONLINE NON-DOWNLOADABLE ELECTRONIC PUBLICATIONS AND CONTENT IN THE NATURE OF E-BOOKS, ELECTRONIC BOOKS AND ELECTRONIC TEXT, DATA AND IMAGES IN THE FIELDS OF PUZZLE BOOKS, GAME BOOKS AND NON-FICTION HUMOR, GIFT AND COOKBOOKS (U.S. CLS. 100, 101 AND 107).

CLASS 42—SCIENTIFIC AND COMPUTER SERVICES

FOR PROVIDING TEMPORARY USE OF ON-LINE NON-DOWNLOADABLE SOFTWARE TO ENABLE USERS TO ACCESS E-BOOKS, ELECTRONIC BOOKS AND ELECTRONIC TEXT, DATA AND IMAGES IN THE FIELDS OF PUZZLE BOOKS, GAME BOOKS AND NON-FICTION HUMOR, GIFT AND COOKBOOKS (U.S. CLS. 100 AND 101).

LINDA M. KING, EXAMINING ATTORNEY

SN 85-348,092. TAULIA INC., SAN FRANCISCO, CA. FILED
6-16-2011.

DISCOUNTS AS A SERVICE

THE MARK CONSISTS OF STANDARD CHARACTERS WITHOUT CLAIM TO ANY PARTICULAR FONT, STYLE, SIZE, OR COLOR.

NO CLAIM IS MADE TO THE EXCLUSIVE RIGHT TO USE "DISCOUNTS", APART FROM THE MARK AS SHOWN.

CLASS 9—ELECTRICAL AND SCIENTIFIC APPARATUS

FOR COMPUTER SOFTWARE TO AUTOMATE THE PROCESS OF OBTAINING DISCOUNTS ON ACCOUNTS PAYABLE (U.S. CLS. 21, 23, 26, 36 AND 38).

CLASS 36—INSURANCE AND FINANCIAL

FOR ACCOUNTS PAYABLE DISCOUNT MANAGEMENT SERVICES, NAMELY, CONSULTING, PROCESSING AND ADMINISTRATION OF A SYSTEM ENABLING PURCHASERS TO OBTAIN DISCOUNTS ON ACCOUNTS PAYABLE; PROCUREMENT DISCOUNT OPPORTUNITY SERVICES, NAMELY, CONSULTING REGARDING IMPLEMENTATION OF DYNAMIC DISCOUNTING TERMS; ACCOUNTS PAYABLE FINANCING SERVICES FOR THIRD PARTIES; FACTORING AGENCY SERVICES (U.S. CLS. 100, 101 AND 102).

CLASS 42—SCIENTIFIC AND COMPUTER SERVICES

FOR PROVIDING TEMPORARY USE OF NON-DOWNLOADABLE COMPUTER SOFTWARE ENABLING PURCHASERS TO OBTAIN DISCOUNTS ON ACCOUNTS PAYABLE OVER COMPUTER NETWORKS, INTRANETS AND THE INTERNET (U.S. CLS. 100 AND 101).

MICHAEL ENGEL, EXAMINING ATTORNEY

SN 85-348,170. THE PROCTER & GAMBLE COMPANY, CINCINNATI, OH. FILED 6-16-2011.



OWNER OF U.S. REG. NOS. 2,296,103, 3,277,985 AND OTHERS.

NO CLAIM IS MADE TO THE EXCLUSIVE RIGHT TO USE "PROFESSIONAL", APART FROM THE MARK AS SHOWN.

THE COLOR(S) WHITE, GREEN, YELLOW AND BLUE IS/ARE CLAIMED AS A FEATURE OF THE MARK.

THE MARK CONSISTS OF THE WORDING "SWIFFER PROFESSIONAL" WITH BLUE OUTLINE AND WHITE INTERIOR AND YELLOW DOT MARKS WITH BLUE OUTLINE OVER THE LETTERS "I" IN THE WORDS. A GREEN, YELLOW AND BLUE SWOOSH DESIGN APPEARS BEHIND THE WORDING.

CLASS 21—HOUSEWARES AND GLASS

FOR FLOOR CLEANING AND POLISHING SYSTEM FOR APPLYING CLEANING CHEMICALS AND FINISHING POLISH TO FLOORS COMPOSED PRIMARILY OF MOP LIKE HANDLE FOR HOLDING DISPOSABLE PADS, DISPOSABLE PADS, AND CONTAINER FOR DISPENSING, HOLDING AND CARRYING FLOOR FINISHING PREPARATIONS, SOLD AS A UNIT (U.S. CLS. 2, 13, 23, 29, 30, 33, 40 AND 50).

CLASS 27—FLOOR COVERINGS

FOR DISPOSABLE ABSORBENT PADS, MADE OF PAPER, FOR USE IN APPLYING FLOOR FINISHING PREPARATIONS (U.S. CLS. 19, 20, 37, 42 AND 50).

DANIEL CAPSHAW, EXAMINING ATTORNEY

SN 85-348,362. AUTISM SPEAKS, INC., NEW YORK, NY. FILED 6-16-2011.



OWNER OF U.S. REG. NOS. 3,326,715, 3,389,757 AND OTHERS.

NO CLAIM IS MADE TO THE EXCLUSIVE RIGHT TO USE "AUTISM", APART FROM THE MARK AS SHOWN.

THE MARK CONSISTS OF A SQUARE WITH A SOLID BACKGROUND WITH A LINED DRAWING OF A LIGHT BULB WITH 6 WHITE LINES AROUND IT AND A WHITE PUZZLE PIECE INSIDE THE BULB. BELOW THIS SQUARE ARE THE WORDS "AUTISM SPEAKS" IN SOLID LETTERING ABOVE THE WORD "LIGHT", THE LETTERS OF WHICH ARE OUTLINED AND ARE ABOVE THE WORDS "IT UP" WHICH ARE SUPERIMPOSED OVER A SOLID RECTANGULAR SHAPED BACKGROUND ABOVE THE WORD "BLUE" WHICH IS IN SOLID LETTERING ALL OF WHICH IS CONTAINED WITHIN A GREATER RECTANGULAR BORDER.

CLASS 35—ADVERTISING AND BUSINESS

FOR CHARITABLE SERVICES, NAMELY, PROMOTING THE PUBLIC INTEREST AND AWARENESS IN AUTISM RESEARCH AND EDUCATION (U.S. CLS. 100, 101 AND 102).

CLASS 36—INSURANCE AND FINANCIAL

FOR CHARITABLE FUND RAISING SERVICES FOR AUTISM (U.S. CLS. 100, 101 AND 102).

EMILY CARLSEN, EXAMINING ATTORNEY

SN 85-348,517. GEAR VENTURE, INC., HACIENDA HEIGHTS, CA. FILED 6-16-2011.

RAINBOW PAWS

THE MARK CONSISTS OF STANDARD CHARACTERS WITHOUT CLAIM TO ANY PARTICULAR FONT, STYLE, SIZE, OR COLOR.

CLASS 18—LEATHER GOODS

FOR PET COLLARS AND LEASHES; PET TAGS SPECIALLY ADAPTED FOR ATTACHING TO PET LEASHES OR COLLARS; PET CLOTHING; PET TRAVEL BAGS (U.S. CLS. 1, 2, 3, 22 AND 41).

CLASS 20—FURNITURE AND ARTICLES NOT OTHERWISE CLASSIFIED

FOR BEDS FOR HOUSEHOLD PETS (U.S. CLS. 2, 13, 22, 25, 32 AND 50).

CLASS 28—TOYS AND SPORTING GOODS

FOR PET TOYS (U.S. CLS. 22, 23, 38 AND 50).
STEVEN PEREZ, EXAMINING ATTORNEY

SN 85-348,970. MARIAN LIMITED, LLC, MOORESTOWN, NJ. FILED 6-17-2011.

GOTZZ

THE MARK CONSISTS OF STANDARD CHARACTERS WITHOUT CLAIM TO ANY PARTICULAR FONT, STYLE, SIZE, OR COLOR.

CLASS 9—ELECTRICAL AND SCIENTIFIC APPARATUS

FOR SMALL DECORATIVE CHARMS OF RUBBER, PLASTIC, NON-PRECIOUS STONES OR NON-PRECIOUS METAL CONFIGURED FOR ATTACHMENT TO SWIM GOGGLES AND SOLD AS NOVELTY ITEMS (U.S. CLS. 21, 23, 26, 36 AND 38).

CLASS 35—ADVERTISING AND BUSINESS

FOR ONLINE RETAIL STORE SERVICES FEATURING SMALL DECORATIVE CHARMS OF RUBBER, PLASTIC, NON-PRECIOUS STONES OR NON-PRECIOUS METAL, NAMELY, DECORATIVE TRINKETS CONFIGURED FOR ATTACHMENT TO SWIM GOGGLES AND SOLD AS NOVELTY ITEMS (U.S. CLS. 100, 101 AND 102).
SARA BENJAMIN, EXAMINING ATTORNEY

SN 85-349,259. SEARS BRANDS, LLC, HOFFMAN ESTATES, IL. FILED 6-17-2011.

ASSURELINK

THE MARK CONSISTS OF STANDARD CHARACTERS WITHOUT CLAIM TO ANY PARTICULAR FONT, STYLE, SIZE, OR COLOR.

CLASS 9—ELECTRICAL AND SCIENTIFIC APPARATUS

FOR REMOTE GARAGE DOOR MONITORING SYSTEM FOR OPERATING AND MONITORING THE STATUS OF A GARAGE DOOR, COMPRISING SENSORS AND A COMPUTER HARDWARE AND SOFTWARE GATEWAY CAPABLE OF CONNECTING THE SYSTEM TO THE INTERNET, ALL INTEGRATED WITHIN AN AUTOMATED GARAGE DOOR ASSEMBLY; ONLINE, DOWNLOADABLE SOFTWARE AND DOWNLOADABLE SOFTWARE IN THE NATURE OF A MOBILE APPLICATION FOR COMMUNICATING WITH GARAGE DOOR SENSORS (U.S. CLS. 21, 23, 26, 36 AND 38).

CLASS 42—SCIENTIFIC AND COMPUTER SERVICES

FOR ONLINE, NON-DOWNLOADABLE SOFTWARE FOR COMMUNICATING WITH GARAGE DOOR SENSORS (U.S. CLS. 100 AND 101).
KHANH LE, EXAMINING ATTORNEY

SN 85-349,274. SUMMUS SOFTWARE, INC., PALO ALTO, CA. FILED 6-17-2011.

SUMMUS SOFTWARE

THE MARK CONSISTS OF STANDARD CHARACTERS WITHOUT CLAIM TO ANY PARTICULAR FONT, STYLE, SIZE, OR COLOR.

NO CLAIM IS MADE TO THE EXCLUSIVE RIGHT TO USE "SOFTWARE", APART FROM THE MARK AS SHOWN.

CLASS 9—ELECTRICAL AND SCIENTIFIC APPARATUS

FOR COMPUTER SOFTWARE FOR MANAGEMENT OF INFORMATION TECHNOLOGY INFRASTRUCTURE, NAMELY, FOR USE IN TRACKING COMPUTER ASSETS, FOR TRACKING AND MANAGEMENT OF COMPUTER HARDWARE AND SOFTWARE CONFIGURATIONS, FOR MONITORING AND REPORTING COMPUTER NETWORK AND SYSTEMS AVAILABILITY, SERVICE LEVELS, FUNCTIONALITY PROBLEMS AND FOR MONITORING AND REPORTING COMPUTER SERVER AND DESKTOP AVAILABILITY AND FUNCTIONALITY (U.S. CLS. 21, 23, 26, 36 AND 38).

CLASS 42—SCIENTIFIC AND COMPUTER SERVICES

FOR TECHNICAL SUPPORT SERVICES, NAMELY, REMOTE AND ON-SITE INFRASTRUCTURE MANAGEMENT SERVICES FOR MONITORING, ADMINISTRATION AND MANAGEMENT OF PUBLIC AND PRIVATE CLOUD COMPUTING IT AND APPLICATION SYSTEMS; COMPUTER SERVICES, NAMELY, REMOTE AND ON-SITE MANAGEMENT OF THE INFORMATION TECHNOLOGY (IT) SYSTEMS OF OTHERS; PROVIDING ACCESS TO NON-DOWNLOADABLE SOFTWARE FOR MANAGEMENT OF INFORMATION TECHNOLOGY INFRASTRUCTURE, NAMELY, FOR USE IN TRACKING COMPUTER ASSETS, FOR TRACKING AND MANAGEMENT OF COMPUTER HARDWARE AND SOFTWARE CONFIGURATIONS, FOR MONITORING AND REPORTING COMPUTER NETWORK AND SYSTEMS AVAILABILITY, SERVICE LEVELS, FUNCTIONALITY PROBLEMS AND FOR MONITORING AND REPORTING COMPUTER SERVER AND DESKTOP AVAILABILITY AND FUNCTIONALITY (U.S. CLS. 100 AND 101).
KELLEY WELLS, EXAMINING ATTORNEY

SN 85-349,564. DIRECT2CONSUMER, WEST HOLLYWOOD, CA. FILED 6-17-2011.



THE MARK CONSISTS OF FOUR SOLID BLACK SQUARES WITH ROUNDED EDGES STACKED TWO BY TWO. THE TOP LEFT SQUARE HAS A FACE OF A DOG WITH ONE EAR SHOWING IN WHITE AND A NOSE AND EYES IN BLACK WITH WHITE HIGHLIGHT. THE TOP RIGHT SQUARE HAS A WHITE DOG BONE AND A WHITE FISH SKELETON WITH MOUTH OPENING AND SHOWING A BLACK DOT FOR THE EYE SOCKET. THE BOTTOM LEFT SQUARE HAS A WHITE DOG PAW PRINT. THE BOTTOM RIGHT SQUARE HAS A WHITE FACE OF A CAT WITH ONE EAR SHOWING IN WHITE AND EYES, NOSE, SMILING MOUTH, CHIN AND DOTS AS WHISKERS IN BLACK.

CLASS 5—PHARMACEUTICALS

FOR -PET VITAMINS, PET FOOD SUPPLEMENTS, DIETARY SUPPLEMENTS, NAMELY, PET DIGESTIVE ENZYMES, DIETARY PET SUPPLEMENTS IN THE FORM OF PET TREATS, DIETARY SUPPLEMENTS CONTAINING PET PROBIOTICS.— (U.S. CLS. 6, 18, 44, 46, 51 AND 52).

CLASS 35—ADVERTISING AND BUSINESS

FOR -ON LINE RETAIL STORE SERVICES FEATURING PET VITAMINS, SUPPLEMENTS AND TREATS.— (U.S. CLS. 100, 101 AND 102).

FLORENTINA BLANDU, EXAMINING ATTORNEY

SN 85-349,575. NATIONAL ASSOCIATION OF DRUG COURT PROFESSIONALS, ALEXANDRIA, VA. FILED 6-17-2011.

NATIONAL ASSOCIATION OF
DRUG COURT PROFESSIONALS

THE MARK CONSISTS OF STANDARD CHARACTERS WITHOUT CLAIM TO ANY PARTICULAR FONT, STYLE, SIZE, OR COLOR.

NO CLAIM IS MADE TO THE EXCLUSIVE RIGHT TO USE "ASSOCIATION" AND "PROFESSIONALS", APART FROM THE MARK AS SHOWN.

SEC. 2(F).

CLASS 35—ADVERTISING AND BUSINESS

FOR ASSOCIATION SERVICES, NAMELY, PROMOTING THE INTERESTS OF LEGAL PROFESSIONALS, CLINICAL PROFESSIONALS, AND OTHER DRUG COURT, DWI COURT AND MENTAL HEALTH COURT PROFESSIONALS AND THE DRUG COURT FIELD IN GENERAL; PROMOTING PUBLIC AWARENESS OF DRUG COURTS (U.S. CLS. 100, 101 AND 102).

FIRST USE 0-0-1994; IN COMMERCE 0-0-1994.

CLASS 41—EDUCATION AND ENTERTAINMENT

FOR EDUCATIONAL SERVICES, NAMELY, ARRANGING AND CONDUCTING EDUCATIONAL CONFERENCES, SEMINARS, WEBINARS, CLASSES, WORKSHOPS AND SYMPOSIA ON THE SUBJECTS OF DRUG COURTS, COURT-BASED TREATMENT PROGRAMS, SUBSTANCE ABUSE AND CRIME (U.S. CLS. 100, 101 AND 107).

FIRST USE 0-0-1994; IN COMMERCE 0-0-1994.

FLORENTINA BLANDU, EXAMINING ATTORNEY

SN 85-349,741. CLAY, BRETT, BELLEVUE, WA. FILED 6-17-2011.

CLAY CHANGE TYPE INDICATOR

THE MARK CONSISTS OF STANDARD CHARACTERS WITHOUT CLAIM TO ANY PARTICULAR FONT, STYLE, SIZE, OR COLOR.

NO CLAIM IS MADE TO THE EXCLUSIVE RIGHT TO USE "TYPE INDICATOR", APART FROM THE MARK AS SHOWN.

CLASS 16—PAPER GOODS AND PRINTED MATTER

FOR PRINTED MATERIALS, NAMELY, A SERIES OF BOOKS, STUDY GUIDES, WORKBOOKS, PSYCHOLOGICAL TEST BOOKLETS AND ANSWER SHEETS IN THE FIELD OF PERSONALITY TESTING (U.S. CLS. 2, 5, 22, 23, 29, 37, 38 AND 50).

FIRST USE 6-5-2011; IN COMMERCE 6-5-2011.

CLASS 41—EDUCATION AND ENTERTAINMENT

FOR EDUCATIONAL SERVICES, NAMELY, CONDUCTING WORKSHOPS AND SEMINARS IN PERSON OR OVER THE INTERNET IN THE FIELDS OF PSYCHOLOGICAL TESTING AND SCORING, MANAGEMENT, SALES, INTERPERSONAL SKILLS, AND PERSONAL AND PROFESSIONAL DEVELOPMENT (U.S. CLS. 100, 101 AND 107).

FIRST USE 6-5-2011; IN COMMERCE 6-5-2011.

CLASS 44—MEDICAL, BEAUTY AND AGRICULTURAL SERVICES

FOR INFORMATION IN THE FIELD OF PSYCHOLOGICAL TESTS, NAMELY, PROVIDING INFORMATION OVER THE INTERNET FOR USERS TO ADMINISTER AND SCORE PSYCHOLOGICAL TESTS; PROVIDING INFORMATION REGARDING PSYCHOLOGICAL TESTING AND SCORING ON A GLOBAL COMPUTER NETWORK FOR USE IN BEHAVIOR EVALUATION, COUNSELING, PERSONAL DEVELOPMENT, BUSINESS MANAGEMENT AND EMPLOYEE TRAINING; PERSONALITY TESTING FOR PSYCHOLOGICAL PURPOSES (U.S. CLS. 100 AND 101).

FIRST USE 6-15-2011; IN COMMERCE 6-15-2011.

KELLEY WELLS, EXAMINING ATTORNEY

SN 85-350,416. DIVERSIFIED GRAPHIC MACHINERY, RED BANK, NJ. FILED 6-20-2011.

SN 85-350,138. THOMSON REUTERS CANADA LIMITED, TORONTO, CANADA, FILED 6-20-2011.

THOMSON REUTERS PROVIEW

THE MARK CONSISTS OF STANDARD CHARACTERS WITHOUT CLAIM TO ANY PARTICULAR FONT, STYLE, SIZE, OR COLOR.

OWNER OF U.S. REG. NOS. 2,936,035, 3,419,951 AND OTHERS.

CLASS 9—ELECTRICAL AND SCIENTIFIC APPARATUS

FOR COMPUTER APPLICATION SOFTWARE FOR USE ON COMPUTERS, TABLETS AND SMART DEVICES IN THE NATURE OF SMART PHONES, PORTABLE MEDIA PLAYERS, HANDHELD COMPUTING DEVICES, TABLET PCS, LAPTOPS AND DESKTOPS, TO DOWNLOAD DIGITIZED CONTENT AND ALLOWS THE USER TO VIEW, ANNOTATE, SEARCH AND LINK TO PROPRIETARY FINANCIAL CONTENT AND PROPRIETARY SCIENTIFIC MATERIAL; DOWNLOADABLE ELECTRONIC PUBLICATIONS IN THE NATURE OF BOOKS IN THE FIELD OF LAW, TAX AND ACCOUNTING AND SCIENTIFIC RESEARCH (U.S. CLS. 21, 23, 26, 36 AND 38).

CLASS 41—EDUCATION AND ENTERTAINMENT

FOR NON-DOWNLOADABLE ELECTRONIC PUBLICATIONS IN THE NATURE OF BOOKS IN THE FIELD OF LAW, TAX AND ACCOUNTING AND SCIENTIFIC RESEARCH (U.S. CLS. 100, 101 AND 107).

CLASS 42—SCIENTIFIC AND COMPUTER SERVICES

FOR PROVIDING ONLINE, NON-DOWNLOADABLE, INTERNET-BASED SOFTWARE APPLICATION FOR USE WITH TABLETS AND SMART DEVICES IN THE NATURE SMART PHONES, PORTABLE MEDIA PLAYERS, HANDHELD COMPUTING DEVICES, TABLET PCS, LAPTOPS AND DESKTOPS, THAT ALLOWS THE USER TO VIEW, ANNOTATE, SEARCH AND LINK TO PROPRIETARY FINANCIAL CONTENT; PROVIDING ONLINE, NON-DOWNLOADABLE, INTERNET-BASED SOFTWARE APPLICATION FOR USE WITH TABLETS AND SMART DEVICES IN THE NATURE SMART PHONES, PORTABLE MEDIA PLAYERS, HANDHELD COMPUTING DEVICES, TABLET PCS, LAPTOPS AND DESKTOPS, THAT ALLOWS THE USER TO VIEW, ANNOTATE, SEARCH AND LINK TO PROPRIETARY FINANCIAL CONTENT; PROVIDING ONLINE, NON-DOWNLOADABLE, INTERNET-BASED SOFTWARE APPLICATION FOR USE WITH TABLETS AND SMART DEVICES IN THE NATURE SMART PHONES, PORTABLE MEDIA PLAYERS, HANDHELD COMPUTING DEVICES, TABLET PCS, LAPTOPS AND DESKTOPS, THAT ALLOWS THE USER TO VIEW, ANNOTATE, SEARCH AND LINK TO PROPRIETARY TAX AND ACCOUNTING REFERENCE MATERIAL (U.S. CLS. 100 AND 101).

EMILY CARLSEN, EXAMINING ATTORNEY

FOILDEX

THE MARK CONSISTS OF STANDARD CHARACTERS WITHOUT CLAIM TO ANY PARTICULAR FONT, STYLE, SIZE, OR COLOR.

CLASS 7—MACHINERY

FOR MACHINES FOR THE PACKAGING, PRINTING, PRINT FINISHING AND GRAPHIC ARTS INDUSTRIES, PARTICULARLY MACHINES FOR THE MANUFACTURE OF FOIL PACKAGING AND THE STRUCTURAL PARTS OF THE AFOREMENTIONED GOODS (U.S. CLS. 13, 19, 21, 23, 31, 34 AND 35).

CLASS 37—CONSTRUCTION AND REPAIR

FOR INSTALLATION, REPAIR, MODIFICATION, RECONSTRUCTION AND MAINTENANCE SERVICES FOR MACHINES FOR FOIL APPLICATION AS WELL AS FOR THE STRUCTURAL COMPONENTS AND SPARE PARTS FOR SUCH MACHINES; TECHNICAL SUPPORT SERVICES, NAMELY, PROVIDING TECHNICAL EXPERTISE, ANALYSIS AND ASSISTANCE AND TROUBLESHOOTING FOR PACKAGING AND PRINTING MACHINES, NAMELY, TECHNICAL ADVICE RELATED TO THE REPAIR OF PACKAGING AND PRINTING MACHINES; TECHNICAL SUPPORT SERVICES, NAMELY, PROVIDING TECHNICAL EXPERTISE, ANALYSIS AND ASSISTANCE AND TROUBLESHOOTING FOR PACKAGING AND PRINTING MACHINES, NAMELY, TECHNICAL ADVICE RELATED TO THE INSTALLATION OF PACKAGING AND PRINTING MACHINES (U.S. CLS. 100, 103 AND 106).

CLASS 40—MATERIAL TREATMENT

FOR TECHNICAL SUPPORT SERVICES, NAMELY, PROVIDING TECHNICAL EXPERTISE, ANALYSIS AND ASSISTANCE AND TROUBLESHOOTING FOR PACKAGING AND PRINTING MACHINES, NAMELY, PROVIDING TECHNICAL ADVICE RELATED TO THE MANUFACTURE OF PACKAGING AND PRINTING MACHINES (U.S. CLS. 100, 103 AND 106).

CLASS 41—EDUCATION AND ENTERTAINMENT

FOR TECHNICAL TRAINING, NAMELY, THEORETICAL AND PRACTICAL TRAINING COURSES IN THE USE OF PACKAGING AND PRINTING MACHINES (U.S. CLS. 100, 101 AND 107).

CLASS 42—SCIENTIFIC AND COMPUTER SERVICES

FOR TECHNICAL SUPPORT SERVICES, NAMELY, PROVIDING TECHNICAL EXPERTISE, ANALYSIS AND ASSISTANCE AND TROUBLESHOOTING FOR PACKAGING AND PRINTING MACHINES, NAMELY, TROUBLESHOOTING IN THE NATURE OF DIAGNOSING PROBLEMS WITH PACKAGING AND PRINTING MACHINES (U.S. CLS. 100 AND 101).

LINDSEY RUBIN, EXAMINING ATTORNEY

SN 85-351,071. ING CONSULTING, INC., RENO, NV. FILED 6-20-2011.

SEXUAL FUTURIST

THE MARK CONSISTS OF STANDARD CHARACTERS WITHOUT CLAIM TO ANY PARTICULAR FONT, STYLE, SIZE, OR COLOR.

NO CLAIM IS MADE TO THE EXCLUSIVE RIGHT TO USE "SEXUAL", APART FROM THE MARK AS SHOWN.

CLASS 16—PAPER GOODS AND PRINTED MATTER

FOR (BASED ON INTENT TO USE) PRINTED MATERIALS, NAMELY, BOOKS AND BROCHURES IN THE FIELD OF HEALTHY SEXUALITY, SEXUAL RIGHTS, SEX EDUCATION, AND HEALTHY PERSONAL RELATIONSHIPS (U.S. CLS. 2, 5, 22, 23, 29, 37, 38 AND 50).

CLASS 35—ADVERTISING AND BUSINESS

FOR (BASED ON USE IN COMMERCE) PUBLIC ADVOCACY TO PROMOTE AWARENESS OF HEALTHY SEXUALITY, SEXUAL RIGHTS, SEX EDUCATION, AND HEALTHY PERSONAL RELATIONSHIPS (U.S. CLS. 100, 101 AND 102).

FIRST USE 12-19-2009; IN COMMERCE 12-19-2009.

CLASS 41—EDUCATION AND ENTERTAINMENT

FOR (BASED ON USE IN COMMERCE) PROVIDING A WEB SITE FEATURING ON-LINE PUBLICATIONS IN THE NATURE OF ARTICLES IN THE FIELD OF HEALTHY SEXUALITY, SEXUAL RIGHTS, SEX EDUCATION, AND HEALTHY PERSONAL RELATIONSHIPS (U.S. CLS. 100, 101 AND 107).

FIRST USE 12-19-2009; IN COMMERCE 12-19-2009.

CLASS 45—PERSONAL AND LEGAL SERVICES

FOR (BASED ON USE IN COMMERCE) PROVIDING A WEBSITE FEATURING INFORMATION IN THE FIELD OF HEALTHY SEXUALITY, SEXUAL RIGHTS, SEX EDUCATION, AND HEALTHY PERSONAL RELATIONSHIPS (U.S. CLS. 100 AND 101).

FIRST USE 12-19-2009; IN COMMERCE 12-19-2009.
SHAILA SETTLES, EXAMINING ATTORNEY

SN 85-351,378. SEARS BRANDS, LLC, HOFFMAN ESTATES, IL. FILED 6-21-2011.

SCREW*D

THE MARK CONSISTS OF STANDARD CHARACTERS WITHOUT CLAIM TO ANY PARTICULAR FONT, STYLE, SIZE, OR COLOR.

CLASS 41—EDUCATION AND ENTERTAINMENT

FOR ENTERTAINMENT SERVICES, NAMELY, CONDUCTING A CONTEST IN WHICH PARTICIPANTS SUBMIT VIDEOS TO COMPETE FOR SELECTION AS A CONTESTANT ON A REALITY-BASED WEBISODE SERIES; ENTERTAINMENT SERVICES, NAMELY, PROVIDING A WEBSITE FEATURING NON-DOWNLOADABLE VIDEOS FEATURING CONTESTANTS COMPETING IN A REALITY-BASED CONTEST (U.S. CLS. 100, 101 AND 107).

FIRST USE 6-20-2011; IN COMMERCE 6-20-2011.

CLASS 42—SCIENTIFIC AND COMPUTER SERVICES

FOR PROVIDING A WEBSITE FEATURING NON-DOWNLOADABLE SOFTWARE THAT ENABLES USERS TO VOTE FOR VIDEOS SUBMITTED BY CONTEST PARTICIPANTS (U.S. CLS. 100 AND 101).

FIRST USE 6-20-2011; IN COMMERCE 6-20-2011.
KHANH LE, EXAMINING ATTORNEY

SN 85-351,581. DRI-EAZ PRODUCTS, INC., BURLINGTON, WA. FILED 6-21-2011.

DRIFORCE

THE MARK CONSISTS OF STANDARD CHARACTERS WITHOUT CLAIM TO ANY PARTICULAR FONT, STYLE, SIZE, OR COLOR.

CLASS 11—ENVIRONMENTAL CONTROL APPARATUS

FOR FANS, NAMELY, VENTILATING FANS AND PORTABLE ELECTRIC FANS FOR COMMERCIAL, RESIDENTIAL AND INDUSTRIAL USE; DAMAGE RESTORATION EQUIPMENT FOR RESIDENTIAL, COMMERCIAL AND/OR INDUSTRIAL USES, NAMELY, FANS FOR DRYING PERSONAL AND REAL PROPERTY SUBJECTED TO WATER AND/OR FLOOD DAMAGE AND REPLACEMENT PARTS THEREFOR (U.S. CLS. 13, 21, 23, 31 AND 34).

FIRST USE 12-0-1998; IN COMMERCE 12-0-1998.

CLASS 19—NON-METALLIC BUILDING MATERIALS

FOR NON-METAL AIR GUIDES AND DUCTS, NAMELY, DETACHABLE AIR GUIDES AND DUCTS FOR USE WITH FANS; DAMAGE RESTORATION EQUIPMENT FOR RESIDENTIAL, COMMERCIAL AND/OR INDUSTRIAL USES, NAMELY, NON-METAL AIR GUIDES AND DUCTS FOR DRYING PERSONAL AND REAL PROPERTY SUBJECTED TO WATER AND/OR FLOOD DAMAGE AND REPLACEMENTS PARTS THEREFOR (U.S. CLS. 1, 12, 33 AND 50).

FIRST USE 12-0-1998; IN COMMERCE 12-0-1998.
ROSELLE HERRERA, EXAMINING ATTORNEY

SN 85-351,939. CONTACTLESS DATA, INC., TUSCON, AZ.
FILED 6-21-2011.

SN 85-352,740. FARPRO SECURITY SOLUTIONS INC.,
LACHINE, QUÉBEC, CANADA, FILED 6-22-2011.

XALIS

THE MARK CONSISTS OF STANDARD CHARACTERS WITHOUT CLAIM TO ANY PARTICULAR FONT, STYLE, SIZE, OR COLOR.

CLASS 9—ELECTRICAL AND SCIENTIFIC APPARATUS

FOR SOFTWARE, NAMELY, ELECTRONIC WALLET SOFTWARE FOR USE WITH A MOBILE ELECTRONIC DEVICE, FOR PROCESSING ELECTRONIC FINANCIAL TRANSACTIONS, NAMELY, MANAGING, PROCESSING AND DELIVERING ELECTRONIC COUPONS AND ELECTRONIC CURRENCY USING WIRELESS COMMUNICATIONS (U.S. CLS. 21, 23, 26, 36 AND 38).

CLASS 42—SCIENTIFIC AND COMPUTER SERVICES

FOR PROVIDING AN ELECTRONIC MOBILE COMMERCE NETWORK FOR PROCESSING ELECTRONIC FINANCIAL TRANSACTIONS, NAMELY, PROVIDING TEMPORARY USE OF ONLINE NON-DOWNLOADABLE SOFTWARE FOR USE IN PROCESSING ELECTRONIC FINANCIAL TRANSACTIONS (U.S. CLS. 100 AND 101).
JOHN DWYER, EXAMINING ATTORNEY

SN 85-352,728. HAUGHT, KAREN, HOUSTON, TX. FILED 6-22-2011.

GOD EMPOWERED

THE MARK CONSISTS OF STANDARD CHARACTERS WITHOUT CLAIM TO ANY PARTICULAR FONT, STYLE, SIZE, OR COLOR.

CLASS 9—ELECTRICAL AND SCIENTIFIC APPARATUS

FOR PRE-RECORDED CDS FEATURING LECTURES ON PRACTICAL APPLICATION OF BIBLICAL PRINCIPLES (U.S. CLS. 21, 23, 26, 36 AND 38).
FIRST USE 1-1-2011; IN COMMERCE 1-1-2011.

CLASS 41—EDUCATION AND ENTERTAINMENT

FOR CONDUCTING WORKSHOPS AND SEMINARS IN THE FIELD OF PRACTICAL APPLICATION OF BIBLICAL PRINCIPLES (U.S. CLS. 100, 101 AND 107).
FIRST USE 10-22-2007; IN COMMERCE 10-22-2007.
GISELLE AGOSTO, EXAMINING ATTORNEY

CX5

THE MARK CONSISTS OF STANDARD CHARACTERS WITHOUT CLAIM TO ANY PARTICULAR FONT, STYLE, SIZE, OR COLOR.

PRIORITY CLAIMED UNDER SEC. 44(D) ON CANADA APPLICATION NO. 1516433, FILED 2-23-2011, REG. NO. TMA820400, DATED 3-21-2011, EXPIRES 3-21-2027.

CLASS 6—METAL GOODS

FOR (BASED ON USE IN COMMERCE) (BASED ON 44(E)) SPECIALIZED METAL LOCKSMITH TOOLS, NAMELY, KEY TEMPLATES, AND METAL SHIMS; METAL KEYS; METAL KEY FOBS; METAL DOOR AND LOCK HARDWARE, NAMELY, LOCKS, DOOR AND LEVER HANDLES, DOOR KNOBS, DEAD BOLTS AND DEAD LATCHES, SPRING BOLTS AND SPRING LATCHES; METAL LOCK CYLINDERS; METAL DOOR HANDLES AND HANDLE SETS; METAL PANIC BARS, PUSH BARS AND TRIMS FOR DOORS; METAL DOOR PUSH PLATES; METAL DOOR HINGES; METAL DOOR STOPS (U.S. CLS. 2, 12, 13, 14, 23, 25 AND 50).
FIRST USE 5-1-2008; IN COMMERCE 5-1-2008.

CLASS 20—FURNITURE AND ARTICLES NOT OTHERWISE CLASSIFIED

FOR (BASED ON 44(E)) SPECIALIZED NON-METAL LOCKSMITH TOOLS, NAMELY, KEY TEMPLATES, AND; NON-METAL KEYS; NON-METAL KEY FOBS; NON-METAL DOOR AND LOCK HARDWARE, NAMELY, DOOR LEVER HANDLES, DOOR KNOBS, DEAD BOLTS AND DEAD LATCHES, SPRING BOLTS AND SPRING LATCHES; NON-METAL LOCK CYLINDERS; NON-METAL DOOR HANDLES AND HANDLE SETS; NON-METAL PANIC BARS, PUSH BARS AND TRIMS FOR DOORS; NON-METAL DOOR PUSH PLATES; PLASTIC DOOR STOPS (U.S. CLS. 2, 13, 22, 25, 32 AND 50).
TEJBIR SINGH, EXAMINING ATTORNEY

SN 85-353,062. RONKONKOMA OPERATIONS LLC, DBA SCALAMANDRE, HAUPPAUGE, NY. FILED 6-22-2011.

SCALAMANDRÉ

THE MARK CONSISTS OF STANDARD CHARACTERS WITHOUT CLAIM TO ANY PARTICULAR FONT, STYLE, SIZE, OR COLOR.

OWNER OF U.S. REG. NOS. 1,611,755 AND 2,121,901.
SEC. 2(F).

CLASS 20—FURNITURE AND ARTICLES NOT OTHERWISE CLASSIFIED

FOR FURNITURE (U.S. CLS. 2, 13, 22, 25, 32 AND 50).
FIRST USE 6-0-1999; IN COMMERCE 6-0-1999.

CLASS 24—FABRICS

FOR FABRICS FOR THE MANUFACTURE OF CURTAINS, UPHOLSTERY FABRICS, FABRICS FOR USE IN THE MANUFACTURE OF WALL COVERINGS AND TRIMMINGS (U.S. CLS. 42 AND 50).

FIRST USE 4-0-1946; IN COMMERCE 12-0-1946.

CLASS 27—FLOOR COVERINGS

FOR PAPER WALL COVERINGS (U.S. CLS. 19, 20, 37, 42 AND 50).

FIRST USE 4-0-1946; IN COMMERCE 12-0-1946.

LOURDES AYALA, EXAMINING ATTORNEY

CLASS 41—EDUCATION AND ENTERTAINMENT

FOR ENTERTAINMENT SERVICES, NAMELY, A TELEVISION SERIES IN THE FIELD OF HUNTING PROVIDED THROUGH SATELLITE TELEVISION, TELEVISION BROADCAST, CABLE TELEVISION; PROVIDING INFORMATION IN THE FIELD OF HUNTING AND FISHING VIA THE INTERNET; PROVIDING RECOGNITION AND INCENTIVES BY THE WAY OF AWARDS TO DEMONSTRATE EXCELLENCE IN THE FIELD OF HUNTING, PROVISION OF INFORMATION RELATED TO THE SAME PROVIDED ON-LINE VIA THE INTERNET, AND BANQUETS AND AWARD CEREMONIES RELATED TO THE SAME (U.S. CLS. 100, 101 AND 107).

WILLIAM VERHOSEK, EXAMINING ATTORNEY

SN 85-353,121. TOM MIRANDA OUTDOORS, INC., ENGLEWOOD, FL. FILED 6-22-2011.

SN 85-353,198. TOM MIRANDA OUTDOORS, INC., ENGLEWOOD, FL. FILED 6-22-2011.

WHITETAJLSLAM**LEGENDARYOUTDOORSMAN**

THE MARK CONSISTS OF STANDARD CHARACTERS WITHOUT CLAIM TO ANY PARTICULAR FONT, STYLE, SIZE, OR COLOR.

THE MARK CONSISTS OF STANDARD CHARACTERS WITHOUT CLAIM TO ANY PARTICULAR FONT, STYLE, SIZE, OR COLOR.

CLASS 9—ELECTRICAL AND SCIENTIFIC APPARATUS

FOR DVDS, VIDEOTAPES, AUDIOTAPES, DOWNLOADABLE VIDEO AND AUDIO FILES ALL IN THE FIELD OF HUNTING; ARCHERY EQUIPMENT, NAMELY, TELESCOPIC BOW SIGHTS; HUNTING BINOCULARS (U.S. CLS. 21, 23, 26, 36 AND 38).

CLASS 9—ELECTRICAL AND SCIENTIFIC APPARATUS

FOR DVDS, VIDEOTAPES, AUDIOTAPES, DOWNLOADABLE VIDEO AND AUDIO FILES ALL IN THE FIELD OF HUNTING; ARCHERY EQUIPMENT, NAMELY, TELESCOPIC BOW SIGHTS; HUNTING BINOCULARS (U.S. CLS. 21, 23, 26, 36 AND 38).

CLASS 25—CLOTHING

FOR CLOTHING, NAMELY, SHIRTS, JACKETS, SWEAT SHIRTS, PANTS, SHORTS, VESTS, BIB OVERALLS, HATS, SOCKS, GLOVES, AND FOOTWEAR; HUNTING CLOTHING, NAMELY, SHIRTS, JACKETS, SWEAT SHIRTS, PANTS, SHORTS, VESTS, BIB OVERALLS, HATS, SOCKS, GLOVES, AND FOOTWEAR (U.S. CLS. 22 AND 39).

CLASS 25—CLOTHING

FOR CLOTHING, NAMELY, SHIRTS, JACKETS, SWEAT SHIRTS, PANTS, SHORTS, VESTS, BIB OVERALLS, HATS, SOCKS, GLOVES, AND FOOTWEAR; HUNTING CLOTHING, NAMELY, SHIRTS, JACKETS, SWEAT SHIRTS, PANTS, SHORTS, VESTS, BIB OVERALLS, HATS, SOCKS, GLOVES, AND FOOTWEAR (U.S. CLS. 22 AND 39).

CLASS 28—TOYS AND SPORTING GOODS

FOR HUNTING AND ARCHERY EQUIPMENT, NAMELY, QUIVERS AND BOWS; FIREARMS ACCESSORIES, NAMELY, TARGETS AND FIREARMS TARGET LAUNCHERS; ARCHERY AND HUNTING BOWS; ARCHERY AND HUNTING ARM GUARDS; ARCHERY AND HUNTING ARROW FLETCHING DEVICES; ARCHERY AND HUNTING ARROW POINTS; ARCHERY AND HUNTING ARROWS; ARCHERY AND HUNTING BOW CASES; ARCHERY AND HUNTING BOW STRINGS; ARCHERY AND HUNTING NON-TELESCOPIC BOW SIGHTS AND OPEN BOW SIGHTS; ARCHERY AND HUNTING TARGETS; CAMOUFLAGE NETTING USED IN HUNTING; HUNTING BLINDS; HUNTING DECOY BAGS; HUNTING STANDS; HUNTING GAME CALLS; TREE STANDS FOR HUNTING; ANIMAL AND BIRD HUNTING DECOYS; ARCHERY BROADHEADS (U.S. CLS. 22, 23, 38 AND 50).

CLASS 28—TOYS AND SPORTING GOODS

FOR HUNTING AND ARCHERY EQUIPMENT, NAMELY, QUIVERS AND BOWS; FIREARMS ACCESSORIES, NAMELY, TARGETS AND FIREARMS TARGET LAUNCHERS; ARCHERY AND HUNTING BOWS; ARCHERY AND HUNTING ARM GUARDS; ARCHERY AND HUNTING ARROW FLETCHING DEVICES; ARCHERY AND HUNTING ARROW POINTS; ARCHERY AND HUNTING ARROWS; ARCHERY AND HUNTING BOW CASES; ARCHERY AND HUNTING BOW STRINGS; ARCHERY AND HUNTING NON-TELESCOPIC BOW SIGHTS AND OPEN BOW SIGHTS; ARCHERY AND HUNTING TARGETS; CAMOUFLAGE NETTING USED IN HUNTING; HUNTING BLINDS; HUNTING DECOY BAGS; HUNTING STANDS; HUNTING GAME CALLS; TREE STANDS FOR HUNTING; ANIMAL AND BIRD HUNTING DECOYS; ARCHERY BROADHEADS (U.S. CLS. 22, 23, 38 AND 50).

CLASS 41—EDUCATION AND ENTERTAINMENT

FOR ENTERTAINMENT SERVICES, NAMELY, A TELEVISION SERIES IN THE FIELD OF HUNTING PROVIDED THROUGH SATELLITE TELEVISION, TELEVISION BROADCAST, CABLE TELEVISION; PROVIDING INFORMATION IN THE FIELD OF HUNTING AND FISHING VIA THE INTERNET (U.S. CLS. 100, 101 AND 107).

WILLIAM VERHOSEK, EXAMINING ATTORNEY

SN 85-353,361. ROLAND-SCHUHE GMBH & CO. HANDELS KG, ESSEN, FED REP GERMANY, FILED 6-22-2011.

SN 85-353,213. TOM MIRANDA OUTDOORS, INC., ENGLEWOOD, FL. FILED 6-22-2011.

LEGENDARYOUTDOORSMEN

THE MARK CONSISTS OF STANDARD CHARACTERS WITHOUT CLAIM TO ANY PARTICULAR FONT, STYLE, SIZE, OR COLOR.

CLASS 9—ELECTRICAL AND SCIENTIFIC APPARATUS

FOR DVDS, VIDEOTAPES, AUDIOTAPES, DOWNLOADABLE VIDEO AND AUDIO FILES ALL IN THE FIELD OF HUNTING; ARCHERY EQUIPMENT, NAMELY, TELESCOPIC BOW SIGHTS; HUNTING BINOCULARS (U.S. CLS. 21, 23, 26, 36 AND 38).

CLASS 25—CLOTHING

FOR CLOTHING, NAMELY, SHIRTS, JACKETS, SWEAT SHIRTS, PANTS, SHORTS, VESTS, BIB OVERALLS, HATS, SOCKS, GLOVES, AND FOOTWEAR; HUNTING CLOTHING, NAMELY, SHIRTS, JACKETS, SWEAT SHIRTS, PANTS, SHORTS, VESTS, BIB OVERALLS, HATS, SOCKS, GLOVES, AND FOOTWEAR (U.S. CLS. 22 AND 39).

CLASS 28—TOYS AND SPORTING GOODS

FOR HUNTING AND ARCHERY EQUIPMENT, NAMELY, QUIVERS AND BOWS; FIREARMS ACCESSORIES, NAMELY, TARGETS AND FIREARMS TARGET LAUNCHERS; ARCHERY AND HUNTING BOWS; ARCHERY AND HUNTING ARM GUARDS; ARCHERY AND HUNTING ARROW FLETCHING DEVICES; ARCHERY AND HUNTING ARROW POINTS; ARCHERY AND HUNTING ARROWS; ARCHERY AND HUNTING BOW CASES; ARCHERY AND HUNTING BOW STRINGS; ARCHERY AND HUNTING NON-TELESCOPIC BOW SIGHTS AND OPEN BOW SIGHTS; ARCHERY AND HUNTING TARGETS; CAMOUFLAGE NETTING USED IN HUNTING; HUNTING BLINDS; HUNTING DECOY BAGS; HUNTING STANDS; HUNTING GAME CALLS; TREE STANDS FOR HUNTING; ANIMAL AND BIRD HUNTING DECOYS; ARCHERY BROADHEADS (U.S. CLS. 22, 23, 38 AND 50).

CLASS 41—EDUCATION AND ENTERTAINMENT

FOR ENTERTAINMENT SERVICES, NAMELY, A TELEVISION SERIES IN THE FIELD OF HUNTING PROVIDED THROUGH SATELLITE TELEVISION, TELEVISION BROADCAST, CABLE TELEVISION; PROVIDING INFORMATION IN THE FIELD OF HUNTING AND FISHING VIA THE INTERNET (U.S. CLS. 100, 101 AND 107).

WILLIAM VERHOSEK, EXAMINING ATTORNEY

Limelight

THE MARK CONSISTS OF STANDARD CHARACTERS WITHOUT CLAIM TO ANY PARTICULAR FONT, STYLE, SIZE, OR COLOR.

OWNER OF U.S. REG. NO. 3,714,377.

CLASS 18—LEATHER GOODS

FOR LEATHER AND IMITATION LEATHER BAGS; LEATHER BAGS, SUITCASES AND WALLETS; LEATHER HANDBAGS; LEATHER KEY CASES; LEATHER PURSES (U.S. CLS. 1, 2, 3, 22 AND 41).

FIRST USE 1-2-2009; IN COMMERCE 1-2-2009.

CLASS 25—CLOTHING

FOR FOOTWEAR; HEADGEAR, NAMELY, HATS, CAPS AND VISORS; LEATHER BELTS (U.S. CLS. 22 AND 39).

FIRST USE 1-2-2009; IN COMMERCE 1-2-2009.

REBECCA GILBERT, EXAMINING ATTORNEY

SN 85-353,606. BEACHMINT, INC., LOS ANGELES, CA. FILED 6-22-2011.

THREADMINT

THE MARK CONSISTS OF STANDARD CHARACTERS WITHOUT CLAIM TO ANY PARTICULAR FONT, STYLE, SIZE, OR COLOR.

CLASS 35—ADVERTISING AND BUSINESS

FOR PROVIDING AND OPERATING AN ONLINE MARKETPLACE FEATURING CLOTHING, HEADWEAR, FOOTWEAR AND FASHION ACCESSORIES; ADVERTISING SERVICES FOR THIRD PARTIES IN CONNECTION WITH THE COMMERCIALIZATION AND SALE OF CLOTHING, HEADWEAR, FOOTWEAR AND FASHION ACCESSORIES; PROVIDING ONLINE BUSINESS INFORMATION IN THE FIELD OF CLOTHING, HEADWEAR, FOOTWEAR AND FASHION ACCESSORIES AND THE DESIGN, DEVELOPMENT, CREATION, AND MARKETING OF SAME; MARKETING AND CONSULTING SERVICES IN THE FIELD OF PROMOTING AND TRACKING THE GOODS, SERVICES, AND BRANDS OF OTHERS IN THE FIELD OF CLOTHING, HEADWEAR, FOOTWEAR AND FASHION ACCESSORIES THROUGH ALL PUBLIC COMMUNICATION MEANS, PARTICULARLY SPECIALIZING IN THE USE OF MOBILE, SOCIAL, AND PRINT MEDIA TO DRIVE CONSUMER INTEREST, ENGAGEMENT, AND ACTION; ONLINE SERVICE FOR CONNECTING SOCIAL NETWORK USERS WITH RETAILERS FOR THE PURPOSE OF FACILITATING PURCHASES OF CLOTHING, HEADWEAR, FOOTWEAR AND FASHION ACCESSORIES; PROVIDING A WEBSITE WHERE USERS CAN POST RATINGS, REVIEWS, AND RECOMMENDATIONS REGARDING CLOTHING, HEADWEAR, FOOTWEAR AND FASHION ACCESSORIES FOR COMMERCIAL PURPOSES AND CAN COMMUNICATE WITH OTHER REGISTERED USERS, USERS OF SOCIAL MEDIA WEBSITES, CELEBRITIES AND OTHER WELL-KNOWN OR INFLUENTIAL INDIVIDUALS IN ORDER TO OBTAIN RATINGS, REVIEWS, SUGGESTIONS, AND RECOMMENDATIONS REGARDING CLOTHING, HEADWEAR, FOOTWEAR AND FASHION ACCESSORIES THAT MAY BE OF INTEREST, BENEFIT OR VALUE TO THEM, AND REGARDING SERVICES RELATED TO SUCH PRODUCTS; PROVIDING ADVERTISING SERVICES TO DISTRIBUTE ADVERTISEMENTS FEATURING CLOTHING, HEADWEAR, FOOTWEAR AND FASHION ACCESSORIES FOR DISPLAY ON THE INTERNET, NAMELY, IN WEBSITES, SOCIAL CONVERSATIONS OVER THE INTERNET, E-MAILS, MICROBLOGS, BLOGS, ELECTRONIC MESSAGES, INSTANT MESSAGES, TEXT MESSAGES, MULTIMEDIA MESSAGES, SOCIAL NETWORKS, STATUS UPDATES, FORUMS, ELECTRONIC BULLETIN BOARDS (U.S. CLS. 100, 101 AND 102).

CLASS 38—COMMUNICATION

FOR PROVIDING ONLINE CHAT ROOMS AND ELECTRONIC BULLETIN BOARDS FOR TRANSMISSION OF MESSAGES AMONG USERS CONCERNING CLOTHING, HEADWEAR, FOOTWEAR AND FASHION ACCESSORIES (U.S. CLS. 100, 101 AND 104).

CLASS 42—SCIENTIFIC AND COMPUTER SERVICES

FOR COMPUTER SERVICES, NAMELY, CREATING AN ONLINE COMMUNITY FOR REGISTERED USERS TO PARTICIPATE IN DISCUSSIONS, GET FEEDBACK FROM THEIR PEERS, FORM VIRTUAL COMMUNITIES, AND ENGAGE IN SOCIAL NETWORKING FEATURING SOCIAL MEDIA AND TOPICS CONCERNING CLOTHING, HEADWEAR, FOOTWEAR AND FASHION ACCESSORIES (U.S. CLS. 100 AND 101).

JULIE GUTTADAURO, EXAMINING ATTORNEY

SN 85-353,639. FREEWORLD COATINGS GLOBAL (PROPRIETARY) LIMITED, PAULSHOF, GAUTENG, SOUTH AFRICA, FILED 6-22-2011.



OWNER OF U.S. REG. NO. 1,929,331.

THE MARK CONSISTS OF THE WORD "BIOWASH" WITH A SPLIT LEAF DESIGN AS THE LETTER "O" AND AN ARROW ABOVE THE WORD "BIOWASH" AND AN ARROW BELOW THE WORD "BIOWASH".

CLASS 2—PAINTS

FOR OIL AND COATINGS FOR RESTORING, STABILIZING AND PRESERVING WOOD (U.S. CLS. 6, 11 AND 16).

FIRST USE 3-7-2011; IN COMMERCE 3-7-2011.

CLASS 3—COSMETICS AND CLEANING PREPARATIONS

FOR CLEANING PREPARATIONS FOR WOOD (U.S. CLS. 1, 4, 6, 50, 51 AND 52).

FIRST USE 3-7-2011; IN COMMERCE 3-7-2011.

RUSS HERMAN, EXAMINING ATTORNEY

SN 85-354,196. CATERPILLAR INC., PEORIA, IL. FILED 6-23-2011.

CATERPILLAR

THE MARK CONSISTS OF STANDARD CHARACTERS WITHOUT CLAIM TO ANY PARTICULAR FONT, STYLE, SIZE, OR COLOR.

OWNER OF U.S. REG. NOS. 85,748, 277,417 AND OTHERS.

CLASS 7—MACHINERY

FOR ENGINES, OTHER THAN FOR LAND VEHICLES; ENGINES NOT FOR LAND VEHICLES, COMPRESSORS FOR MACHINES, ELECTRICITY GENERATORS, AND PUMPS FOR MACHINES, FOR USE IN AGRICULTURE, COMPACTION, CONSTRUCTION, DEMOLITION, EARTH CONDITIONING, EARTH CONTOURING, EARTH MOVING, FORESTRY, LANDSCAPING, LAWN CARE, LIFTING, MARINE PROPULSION, MATERIAL HANDLING, MINING, OIL AND GAS PRODUCTION, PAVING, PIPELAYING, POWER GENERATION, AND ROAD BUILDING AND REPAIR; MACHINES AND MACHINE TOOLS FOR USE IN AGRICULTURE, COMPACTION, CONSTRUCTION, DEMOLITION, EARTH CONDITIONING, EARTH CONTOURING, EARTH MOVING, FORESTRY, LANDSCAPING, LAWN CARE, LIFTING, MARINE PROPULSION, MATERIAL HANDLING, MINING, OIL AND GAS PRODUCTION, PAVING, PIPELAYING, POWER GENERATION, AND ROAD BUILDING AND REPAIR (U.S. CLS. 13, 19, 21, 23, 31, 34 AND 35).

FIRST USE 0-0-1910; IN COMMERCE 0-0-1910.

CLASS 12—VEHICLES

FOR LAND VEHICLES FOR USE IN AGRICULTURE, COMPACTION, CONSTRUCTION, DEMOLITION, EARTH CONDITIONING, EARTH CONTOURING, EARTH MOVING, FORESTRY, LANDSCAPING, LAWN CARE, LIFTING, MARINE PROPULSION, MATERIAL HANDLING, MINING, OIL AND GAS PRODUCTION, PAVING, PIPELAYING, POWER GENERATION, AND ROAD BUILDING AND REPAIR; LOCOMOTIVES; ENGINES FOR LAND VEHICLES (U.S. CLS. 19, 21, 23, 31, 35 AND 44).

FIRST USE 0-0-1910; IN COMMERCE 0-0-1910.

RONALD MCMORROW, EXAMINING ATTORNEY

SN 85-354,692. BRIGGS, ELLEN D., BOCA RATON, FL. FILED 6-23-2011.



OWNER OF U.S. REG. NOS. 2,961,031 AND 3,091,667.

THE MARK CONSISTS OF THE WORDING "KID KRITICS APPROVED" WITHIN AN OVAL DESIGN, WHEREIN THE WORDING IS LOCATED WITHIN A STYLIZED "MOUTH" DESIGN IN THE FORM OF TWO GEOMETRIC DESIGNS WITH A CIRCLE REPRESENTING AN "EYE" FOUND WITHIN THE OVAL DESIGN.

SEC. 2(F) AS TO "KID KRITICS APPROVED".

SN 85-354,617. BIEDERMANN TECHNOLOGIES GMBH & CO. KG, DONAUESCHINGEN, FED REP GERMANY, FILED 6-23-2011.

EASY INNIE

THE MARK CONSISTS OF STANDARD CHARACTERS WITHOUT CLAIM TO ANY PARTICULAR FONT, STYLE, SIZE, OR COLOR.

PRIORITY CLAIMED UNDER SEC. 44(D) ON ERP CMNTY TM OFC APPLICATION NO. 9631938, FILED 12-29-2010, REG. NO. 009631938, DATED 7-18-2011, EXPIRES 12-29-2020.

CLASS 10—MEDICAL APPARATUS

FOR MEDICAL INSTRUMENTS AND APPARATUS, NAMELY, IMPLANTS CONSISTING OF ARTIFICIAL MATERIALS AND INSTRUMENTS FOR ATTACHING IMPLANTS AND TESTING IMPLANTS; ORTHOPEDIC ARTICLES, NAMELY, ORTHOPEDIC APPARATUS AND INSTRUMENTS FOR DIAGNOSTIC AND THERAPEUTIC USE (U.S. CLS. 26, 39 AND 44).

CLASS 42—SCIENTIFIC AND COMPUTER SERVICES

FOR DEVELOPMENT OF SURGICAL AND ORTHOPAEDIC ARTICLES, INCLUDING IMPLANTS (U.S. CLS. 100 AND 101).

CLASS 44—MEDICAL, BEAUTY AND AGRICULTURAL SERVICES

FOR MEDICAL SERVICES; MEDICAL SERVICES PERFORMED BY AN ORTHOPAEDIC TECHNICIAN (U.S. CLS. 100 AND 101).

ERIN FALK, EXAMINING ATTORNEY

CLASS 42—SCIENTIFIC AND COMPUTER SERVICES

FOR TESTING AND EVALUATION OF FOOD, BEVERAGE AND SUPPLEMENT PRODUCTS IN THE NATURE OF NUTRITIONAL AND DIETARY SUPPLEMENTS FOR OTHERS; RECIPE DEVELOPMENT IN THE NATURE OF TESTING OF RECIPES (U.S. CLS. 100 AND 101).

FIRST USE 0-0-2003; IN COMMERCE 0-0-2003.

CLASS 44—MEDICAL, BEAUTY AND AGRICULTURAL SERVICES

FOR PROVIDING WEBSITES THAT FEATURES INFORMATION ON CHILDREN AND ADOLESCENTS NUTRITION AND FOOD; CONSULTING SERVICES IN THE FIELD OF CHILDREN AND ADOLESCENT NUTRITION AND FOOD; PROVIDING INFORMATION ABOUT DIETARY SUPPLEMENTS AND NUTRITION (U.S. CLS. 100 AND 101).

FIRST USE 0-0-2003; IN COMMERCE 0-0-2003.

SALLY SHIH, EXAMINING ATTORNEY

SN 85-355,178. METAXAS, NIKOLAS, BOSTON, MA. FILED 6-24-2011.

NIKOLAS METAXAS

THE MARK CONSISTS OF STANDARD CHARACTERS WITHOUT CLAIM TO ANY PARTICULAR FONT, STYLE, SIZE, OR COLOR.

THE NAME(S), PORTRAIT(S), AND/OR SIGNATURE(S) SHOWN IN THE MARK IDENTIFIES "NIKOLAS METAXAS", WHOSE CONSENT(S) TO REGISTER IS MADE OF RECORD.

CLASS 9—ELECTRICAL AND SCIENTIFIC APPARATUS

FOR AUDIO AND VIDEO RECORDINGS FEATURING MUSIC AND ARTISTIC PERFORMANCES (U.S. CLS. 21, 23, 26, 36 AND 38).

FIRST USE 9-5-2009; IN COMMERCE 9-5-2009.

CLASS 41—EDUCATION AND ENTERTAINMENT

FOR ENTERTAINMENT SERVICES IN THE NATURE OF LIVE MUSICAL PERFORMANCES (U.S. CLS. 100, 101 AND 107).

FIRST USE 9-5-2009; IN COMMERCE 9-5-2009.
DAVID I, EXAMINING ATTORNEY

SN 85-355,853. ARISE VIRTUAL SOLUTIONS INC., MIRAMAR, FL. FILED 6-24-2011.

VIRTUALIZE THE ENTERPRISE

THE MARK CONSISTS OF STANDARD CHARACTERS WITHOUT CLAIM TO ANY PARTICULAR FONT, STYLE, SIZE, OR COLOR.

CLASS 35—ADVERTISING AND BUSINESS

FOR OUTSOURCING SERVICES, NAMELY, CONNECTING BUSINESSES WITH REMOTE CUSTOMER SERVICES REPRESENTATIVES CERTIFIED TO WORK IN THE FIELDS OF TELEPHONE AND ELECTRONIC CONTACT CENTER SERVICES, CUSTOMER SERVICE, CUSTOMER SATISFACTION, SALES, TECHNICAL SUPPORT, AND DATA PROCESSING AND MANAGEMENT (U.S. CLS. 100, 101 AND 102).

FIRST USE 5-19-2009; IN COMMERCE 5-19-2009.

CLASS 41—EDUCATION AND ENTERTAINMENT

FOR EDUCATIONAL SERVICES, NAMELY, PROVIDING INSTRUCTIONS VIA WEB BASED COURSES FOR CERTIFICATION AND CONTINUING EDUCATION OF CUSTOMER SERVICE REPRESENTATIVES IN THE FIELDS OF TELEPHONE AND ELECTRONIC CONTACT CENTER SERVICES, CUSTOMER SERVICE, CUSTOMER SATISFACTION, SALES, TECHNICAL SUPPORT, AND DATA PROCESSING AND MANAGEMENT (U.S. CLS. 100, 101 AND 107).

FIRST USE 5-19-2009; IN COMMERCE 5-19-2009.
MATTHEW KLINE, EXAMINING ATTORNEY

SN 85-356,589. DEEBLER INC., CALGARY, ALBERTA, CANADA, FILED 6-27-2011.

DEEBLER

THE MARK CONSISTS OF STANDARD CHARACTERS WITHOUT CLAIM TO ANY PARTICULAR FONT, STYLE, SIZE, OR COLOR.

PRIORITY CLAIMED UNDER SEC. 44(D) ON CANADA APPLICATION NO. 1514003, FILED 2-4-2011.

OWNER OF CANADA REG. NO. TMA820,136, DATED 3-19-2012, EXPIRES 3-19-2027.

THE WORDING "DEEBLER" HAS NO MEANING IN A FOREIGN LANGUAGE.

CLASS 9—ELECTRICAL AND SCIENTIFIC APPARATUS

FOR COMPUTER SOFTWARE FOR USE IN FINDING PRODUCTS IN THE CLOSEST PROXIMITY TO THE USER AND COMPARING PRICES FOR SUCH PRODUCTS; COMPUTER SOFTWARE FOR USE IN FINDING THE LOWEST PRICES FOR SPECIFIC PRODUCTS AND ALERTING THE USER OF SAME; COMPUTER SOFTWARE FOR USE IN NAVIGATING SHOPPING WEBSITES, OBTAINING INFORMATION ABOUT RETAILERS AND THE GOODS AND SERVICES OF OTHERS, PROMOTING THE SALE OF GOODS AND SERVICES OF OTHERS AND IDENTIFYING THE LOCATION OF AND DIRECTION TO SUCH RETAILERS; COMPUTER SOFTWARE FOR USE IN MANAGING CONSUMER PURCHASE INFORMATION; COMPUTER SOFTWARE FOR USE IN GENERATING CUSTOMIZED WEB PAGES; COMPUTER SOFTWARE FOR USE IN STORING DATA RELATING TO CONSUMER PURCHASING PATTERNS AND PERSONAL, SOCIAL AND RECREATIONAL INTERESTS OF OTHERS; COMPUTER SOFTWARE FOR USE IN ADVERTISING, PROMOTING, AND MARKETING THE GOODS AND SERVICES OF OTHERS (U.S. CLS. 21, 23, 26, 36 AND 38).

CLASS 35—ADVERTISING AND BUSINESS

FOR PROVIDING INFORMATION ABOUT THE GOODS AND SERVICES OF OTHERS VIA A GLOBAL COMPUTER NETWORK; PROMOTING THE SALE OF GOODS AND SERVICES, NAMELY, ADVERTISING THE WARES AND SERVICES OF OTHERS OVER THE INTERNET; PROVIDING CONSUMER INFORMATION ABOUT RETAILERS VIA A GLOBAL COMPUTER NETWORK; PROVISION OF INFORMATION AND ADVICE TO CONSUMERS REGARDING THE SELECTION OF PRODUCTS AND ITEMS TO BE PURCHASED OVER A GLOBAL COMPUTER NETWORK; ONLINE RETAIL STORE SERVICES FEATURING COMPUTER SOFTWARE (U.S. CLS. 100, 101 AND 102).

CLASS 39—TRANSPORTATION AND STORAGE

FOR ELECTRONIC STORAGE OF DATA RELATING TO CONSUMER PURCHASING PATTERNS AND PERSONAL, SOCIAL AND RECREATIONAL INTERESTS FOR USE BY OTHERS IN CONNECTION WITH ADVERTISING, PROMOTING, AND MARKETING THE GOODS AND SERVICES OF OTHERS OVER A GLOBAL COMPUTER NETWORK (U.S. CLS. 100 AND 105).

CLASS 42—SCIENTIFIC AND COMPUTER SERVICES

FOR PROVIDING ONLINE USE OF NON-DOWNLOADABLE SOFTWARE FOR USE IN PROVIDING INFORMATION ABOUT THE GOODS AND SERVICES AND LOCATION OF OTHERS; PROVIDING ONLINE USE OF NON-DOWNLOADABLE SOFTWARE FOR USE IN PROMOTING THE SALE OF GOODS AND SERVICES OF OTHERS; PROVIDING ONLINE USE OF NON-DOWNLOADABLE SOFTWARE FOR USE IN PROVIDING INFORMATION ABOUT RETAILERS AND THE LOCATION OF SUCH RETAILERS; PROVIDING ONLINE USE OF NON-DOWNLOADABLE SOFTWARE FOR USE IN MANAGING CONSUMER PURCHASING INFORMATION; PROVIDING A SEARCH ENGINE FOR GENERATING CUSTOMIZED WEB PAGES IN RESPONSE TO THE USER REQUESTED INFORMATION ABOUT THE GOODS AND SERVICES OF OTHERS; PROVIDING ONLINE USE OF NON-DOWNLOADABLE SOFTWARE FOR USE IN PROVIDING INFORMATION ABOUT THE GOODS AND SERVICES OF OTHERS; PROVIDING ONLINE USE OF NON-DOWNLOADABLE SOFTWARE FOR USE IN PROMOTING THE SALE OF GOODS AND SERVICES OF OTHERS; PROVIDING ONLINE USE OF NON-DOWNLOADABLE SOFTWARE FOR USE IN PROVIDING INFORMATION ABOUT RETAILERS; PROVIDING ONLINE USE OF NON-DOWNLOADABLE SOFTWARE FOR USE IN MANAGING CONSUMER PURCHASING INFORMATION (U.S. CLS. 100 AND 101).

KAPIL BHANOT, EXAMINING ATTORNEY

SN 85-356,728. JOHN WALTER MCEUEN, NEW YORK, NY.
FILED 6-27-2011.

Nitty Gritty Dirt Band

THE MARK CONSISTS OF STANDARD CHARACTERS WITHOUT CLAIM TO ANY PARTICULAR FONT, STYLE, SIZE, OR COLOR.

NO CLAIM IS MADE TO THE EXCLUSIVE RIGHT TO USE "BAND" FOR INTERNATIONAL CLASS 41, APART FROM THE MARK AS SHOWN.

CLASS 41—EDUCATION AND ENTERTAINMENT

FOR ENTERTAINMENT, NAMELY, LIVE PERFORMANCES BY A MUSICAL BAND; PROVISION OF INFORMATION RELATING TO LIVE PERFORMANCES, ROAD SHOWS, LIVE STAGE EVENTS, THEATRICAL PERFORMANCES, LIVE MUSIC CONCERTS AND AUDIENCE PARTICIPATION IN SUCH EVENTS (U.S. CLS. 100, 101 AND 107).

CLASS 43—HOTEL AND RESTAURANT SERVICES

FOR RESTAURANT AND BAR SERVICES (U.S. CLS. 100 AND 101).
KAREN BRACEY, EXAMINING ATTORNEY

SN 85-357,917. MATEUS STOCK AKTIEBOLAG, STOCKHOLM, SWEDEN, FILED 6-28-2011.



PRIORITY CLAIMED UNDER SEC. 44(D) ON ERP CMNTY TM OFC APPLICATION NO. 9872953, FILED 4-6-2011, REG. NO. 9872953, DATED 8-18-2011, EXPIRES 4-6-2021.

THE MARK CONSISTS OF THE DESIGN OF A LION WITH THE WORDS "MATEUS MEETS MARCUS MEETS" FORMING A CIRCLE AROUND IT.

CLASS 21—HOUSEWARES AND GLASS

FOR CONTAINERS FOR HOUSEHOLD OR KITCHEN USE; HOUSEHOLD CONTAINERS FOR FOODS; DECORATIVE CENTERPIECES OF CERAMIC; CERAMIC DISHES; FIGURINES OF CERAMIC; STATUETTES OF CERAMIC; CERAMIC BOWLS; CERAMIC POTS; CERAMIC JUGS; CERAMIC CUPS; CERAMIC MUGS; UNWORKED OR SEMI-WORKED GLASS; BEVERAGE GLASSWARE; DRINKING GLASSES; GLASS BEVERAGEWARE; GLASS BOWLS; GLASS DISHES; GLASS MUGS; GLASS PANS; WINE GLASSES; EARTHENWARE MUGS; EARTHENWARE BASINS; PORCELAIN MUGS (U.S. CLS. 2, 13, 23, 29, 30, 33, 40 AND 50).

CLASS 41—EDUCATION AND ENTERTAINMENT

FOR PUBLICATION OF BOOKS (U.S. CLS. 100, 101 AND 107).
AHSEN KHAN, EXAMINING ATTORNEY

SN 85-358,038. MONTEFIORE MEDICAL CENTER, BRONX, NY. FILED 6-28-2011.

LI

THE MARK CONSISTS OF STANDARD CHARACTERS WITHOUT CLAIM TO ANY PARTICULAR FONT, STYLE, SIZE, OR COLOR.

CLASS 35—ADVERTISING AND BUSINESS

FOR PROVIDING BUSINESS INTELLIGENCE SERVICES; PROVIDING BUSINESS INTELLIGENCE SERVICES REGARDING PHENOMENA WHOSE OCCURRENCE REQUIRES ANALYSIS ACROSS TIME (U.S. CLS. 100, 101 AND 102).

CLASS 42—SCIENTIFIC AND COMPUTER SERVICES

FOR SCIENTIFIC AND MEDICAL RESEARCH SERVICES, NAMELY, PROVIDING CLINICAL INTELLIGENCE AND CLINICAL INTELLIGENCE FOR PHENOMENA WHOSE OCCURRENCE REQUIRES ANALYSIS ACROSS TIME, FOR THE PURPOSE OF EVALUATING SCIENTIFIC AND MEDICAL RESEARCH AND CLINICAL STUDIES (U.S. CLS. 100 AND 101).

CLASS 44—MEDICAL, BEAUTY AND AGRICULTURAL SERVICES

FOR MEDICAL INFORMATION SERVICES, NAMELY, PROVIDING CLINICAL INTELLIGENCE AND CLINICAL INTELLIGENCE FOR PHENOMENA WHOSE OCCURRENCE REQUIRES ANALYSIS ACROSS TIME, FOR THE PURPOSE OF EVALUATING AND PREDICTING MEDICAL OUTCOMES AND FOR USE IN PROVIDING MEDICAL TREATMENT INFORMATION TO PATIENTS (U.S. CLS. 100 AND 101).

KIMBERLY FRYE, EXAMINING ATTORNEY

SN 85-358,170. TUCKER, CHARLES, HUNTINGDON VALLEY, PA. AND TUCKER, ROSALIND, HUNTINGDON VALLEY, PA. FILED 6-28-2011.

Oldernotdead.com

THE MARK CONSISTS OF STANDARD CHARACTERS WITHOUT CLAIM TO ANY PARTICULAR FONT, STYLE, SIZE, OR COLOR.

CLASS 41—EDUCATION AND ENTERTAINMENT

FOR PROVIDING ON-LINE INFORMATION, NEWS AND COMMENTARY TARGETED TO CONSUMERS AGED FIFTY AND OVER IN THE FIELD OF EDUCATION, ENTERTAINMENT, EXERCISE, FITNESS, SPORTS, RECREATION AND LEISURE ACTIVITIES, BOOK REVIEWS, FINE ARTS, PERFORMING ARTS, AND COMEDY SHOWS (U.S. CLS. 100, 101 AND 107).

CLASS 44—MEDICAL, BEAUTY AND AGRICULTURAL SERVICES

FOR PROVIDING ON-LINE INFORMATION, NEWS AND COMMENTARY TARGETED TO CONSUMERS AGED FIFTY AND OVER IN THE FIELD OF HEALTH-CARE, NUTRITION, HEALTH, AND WELLNESS (U.S. CLS. 100 AND 101).

JIM RINGLE, EXAMINING ATTORNEY

SN 85-358,320. TIMOTHY MUNFUS, JR., PEARLAND, TX. FILED 6-28-2011.

SPIA

THE MARK CONSISTS OF STANDARD CHARACTERS WITHOUT CLAIM TO ANY PARTICULAR FONT, STYLE, SIZE, OR COLOR.

CLASS 16—PAPER GOODS AND PRINTED MATTER

FOR MAGAZINES FEATURING LIFESTYLE, FASHION AND BEAUTY; PHOTOGRAPHS (U.S. CLS. 2, 5, 22, 23, 29, 37, 38 AND 50).

FIRST USE 8-19-2010; IN COMMERCE 12-28-2010.

CLASS 25—CLOTHING

FOR SHIRTS (U.S. CLS. 22 AND 39).
FIRST USE 1-7-2011; IN COMMERCE 1-7-2011.

CLASS 41—EDUCATION AND ENTERTAINMENT

FOR PHOTOGRAPHY SERVICES (U.S. CLS. 100, 101 AND 107).

FIRST USE 1-22-2011; IN COMMERCE 1-22-2011.
WON TEAK OH, EXAMINING ATTORNEY

SN 85-358,420. UNIVERSITY OF MEDICINE AND DENTISTRY OF NEW JERSEY, SOMERSET, NJ. FILED 6-28-2011.

RESPIRA USA

THE MARK CONSISTS OF STANDARD CHARACTERS WITHOUT CLAIM TO ANY PARTICULAR FONT, STYLE, SIZE, OR COLOR.

NO CLAIM IS MADE TO THE EXCLUSIVE RIGHT TO USE "USA", APART FROM THE MARK AS SHOWN.

THE ENGLISH TRANSLATION OF "RESPIRA" IN THE MARK IS "TO BREATHE".

CLASS 41—EDUCATION AND ENTERTAINMENT

FOR COMMUNITY OUTREACH HEALTH-RELATED SERVICES, NAMELY, PROVIDING BILINGUAL EDUCATIONAL SERVICES, IN SPANISH AND ENGLISH, IN THE NATURE OF WORKSHOPS, SEMINARS AND CLASSES IN THE FIELD OF ASTHMA TO FAMILIES AND CARETAKERS OF ASTHMATIC CHILDREN (U.S. CLS. 100, 101 AND 107).

CLASS 44—MEDICAL, BEAUTY AND AGRICULTURAL SERVICES

FOR COMMUNITY OUTREACH HEALTH-RELATED SERVICES, NAMELY, PROVIDING BILINGUAL INFORMATIONAL SERVICES, IN SPANISH AND ENGLISH, IN THE NATURE OF MEDICAL INFORMATION IN THE FIELD OF ASTHMA TO FAMILIES AND CARETAKERS OF ASTHMATIC CHILDREN (U.S. CLS. 100 AND 101).

WON TEAK OH, EXAMINING ATTORNEY

SN 85-359,023. ETERNAL EAST (HK) LIMITED, HONG KONG, HONG KONG, FILED 6-29-2011.

BONAVITA

THE MARK CONSISTS OF STANDARD CHARACTERS WITHOUT CLAIM TO ANY PARTICULAR FONT, STYLE, SIZE, OR COLOR.

THE WORDING "BONAVITA" HAS NO MEANING IN A FOREIGN LANGUAGE.

CLASS 7—MACHINERY

FOR ELECTRIC MIXERS FOR HOUSEHOLD PURPOSES; KITCHEN MACHINES, NAMELY, ELECTRIC STANDING MIXERS (U.S. CLS. 13, 19, 21, 23, 31, 34 AND 35).

CLASS 11—ENVIRONMENTAL CONTROL APPARATUS

FOR ELECTRIC COFFEE BREWERS; ELECTRIC COFFEE MACHINES; ELECTRIC COFFEE MAKERS; ELECTRIC COFFEE PERCOLATORS; ELECTRIC COFFEE POTS; ELECTRIC KETTLES; ELECTRIC TOASTER OVENS; ELECTRIC TOASTERS (U.S. CLS. 13, 21, 23, 31 AND 34).

CLASS 21—HOUSEWARES AND GLASS

FOR NON-ELECTRIC KETTLES (U.S. CLS. 2, 13, 23, 29, 30, 33, 40 AND 50).

BRENDAN REGAN, EXAMINING ATTORNEY

SN 85-359,104. MEATBALLOBSESSION LLC, SOUTH ORANGE, NJ. FILED 6-29-2011.

MEATBALL OBSESSION

THE MARK CONSISTS OF STANDARD CHARACTERS WITHOUT CLAIM TO ANY PARTICULAR FONT, STYLE, SIZE, OR COLOR.

NO CLAIM IS MADE TO THE EXCLUSIVE RIGHT TO USE "MEATBALL", APART FROM THE MARK AS SHOWN.

CLASS 35—ADVERTISING AND BUSINESS

FOR CONCESSION STANDS FEATURING MEATBALLS (U.S. CLS. 100, 101 AND 102).

CLASS 43—HOTEL AND RESTAURANT SERVICES

FOR RESTAURANT SERVICES (U.S. CLS. 100 AND 101).

JAMES LOVELACE, EXAMINING ATTORNEY

SN 85-359,112. ADVERTISING SPECIALTY INSTITUTE, INC., TREVOSE, PA. FILED 6-29-2011.

ASI

THE MARK CONSISTS OF STANDARD CHARACTERS WITHOUT CLAIM TO ANY PARTICULAR FONT, STYLE, SIZE, OR COLOR.

CLASS 35—ADVERTISING AND BUSINESS

FOR MARKETING SERVICES, NAMELY, PROVIDING ON-LINE NON-DOWNLOADABLE SOFTWARE THAT PERMITS DISTRIBUTORS TO LOCATE PRODUCTS AND SUPPLIERS, PROGRAM PROVIDING SUPPLIER DATA OVER A WIRELESS DEVICE, CREATING AND MAINTAINING INTERNET SITES FOR SUPPLIERS AND DISTRIBUTORS; PUBLISHING OF MAGAZINES AND CATALOGS FOR THE ADVERTISING SPECIALTY/PROMOTIONAL PRODUCTS INDUSTRY; PROMOTING, ADVERTISING AND MARKETING THE ON-LINE ELECTRONIC PUBLICATIONS OF OTHERS; MEMBERSHIP CLUB SERVICES, NAMELY, PROVIDING TRAINING TO MEMBERS IN THE FIELD OF ADVERTISING/PROMOTIONAL PRODUCTS INDUSTRY; ADVERTISING, PROMOTION AND MARKETING SERVICES BASED ON CONSUMER CREDIT REPORTS AND SCORES OF OTHERS (U.S. CLS. 100, 101 AND 102).

FIRST USE 11-0-1995; IN COMMERCE 11-0-1995.

CLASS 36—INSURANCE AND FINANCIAL

FOR ON-LINE FINANCIAL CREDIT SCORING SERVICES THAT REPORT ON THE PAYING HABITS OF DISTRIBUTORS (U.S. CLS. 100, 101 AND 102).

FIRST USE 11-0-1995; IN COMMERCE 11-0-1995.

CLASS 41—EDUCATION AND ENTERTAINMENT

FOR PUBLISHING OF MAGAZINES AND CATALOGS FOR THE ADVERTISING SPECIALTY/PROMOTIONAL PRODUCTS INDUSTRY; NON-DOWNLOADABLE ELECTRONIC PUBLICATIONS IN THE NATURE OF PROMOTIONAL PRODUCTS DISTRIBUTORSHIP IN THE FIELD OF ADVERTISING SPECIALTY/PROMOTIONAL PRODUCTS; MEMBERSHIP CLUB SERVICES, NAMELY, PROVIDING TRAINING TO MEMBERS IN THE FIELD OF BUSINESS AND PROFESSIONAL DEVELOPMENT; CONDUCTING, ARRANGING, AND ORGANIZING TRADE SHOWS FOR COMMERCIAL AND ADVERTISING PURPOSES; EDUCATIONAL SERVICES, NAMELY, PROVIDING ON-LINE CLASSES, SEMINARS, WORKSHOPS IN THE FIELD OF ADVERTISING SPECIALTY/PROMOTIONAL PRODUCTS (U.S. CLS. 100, 101 AND 107).

FIRST USE 10-0-1997; IN COMMERCE 10-0-1997.

CLASS 42—SCIENTIFIC AND COMPUTER SERVICES

FOR PROVIDING A WEBSITE FEATURING NON-DOWNLOADABLE SOFTWARE THAT PERMITS DISTRIBUTORS TO LOCATE PRODUCTS AND SUPPLIERS, PROGRAM PROVIDING SUPPLIER DATA OVER A WIRELESS DEVICE, CREATING AND MAINTAINING INTERNET SITES FOR SUPPLIERS AND DISTRIBUTORS; PROVIDING TEMPORARY USE OF ON-LINE NON-DOWNLOADABLE SOFTWARE DEVELOPMENT TOOLS FOR ADVERTISING SPECIALTY/PROMOTIONAL PRODUCTS INDUSTRY FOR USE IN THE FIELD OF ADVERTISING SPECIALTY/PROMOTIONAL PRODUCTS (U.S. CLS. 100 AND 101).

FIRST USE 11-0-1995; IN COMMERCE 11-0-1995.

MIDGE BUTLER, EXAMINING ATTORNEY

SN 85-359,529. MONTEFIORE MEDICAL CENTER, BRONX, NY. FILED 6-29-2011.

TI

THE MARK CONSISTS OF STANDARD CHARACTERS WITHOUT CLAIM TO ANY PARTICULAR FONT, STYLE, SIZE, OR COLOR.

CLASS 35—ADVERTISING AND BUSINESS

FOR PROVIDING BUSINESS INTELLIGENCE SERVICES; PROVIDING BUSINESS INTELLIGENCE SERVICES REGARDING PHENOMENA WHOSE OCCURRENCE REQUIRES ANALYSIS ACROSS TIME (U.S. CLS. 100, 101 AND 102).

CLASS 42—SCIENTIFIC AND COMPUTER SERVICES

FOR SCIENTIFIC AND MEDICAL RESEARCH SERVICES, NAMELY, PROVIDING CLINICAL INTELLIGENCE AND CLINICAL INTELLIGENCE FOR PHENOMENA WHOSE OCCURRENCE REQUIRES ANALYSIS ACROSS TIME, FOR THE PURPOSE OF EVALUATING SCIENTIFIC AND MEDICAL RESEARCH AND CLINICAL STUDIES (U.S. CLS. 100 AND 101).

CLASS 44—MEDICAL, BEAUTY AND AGRICULTURAL SERVICES

FOR MEDICAL INFORMATION SERVICES, NAMELY, PROVIDING CLINICAL INTELLIGENCE AND CLINICAL INTELLIGENCE FOR PHENOMENA WHOSE OCCURRENCE REQUIRES ANALYSIS ACROSS TIME, FOR THE PURPOSE OF EVALUATING AND PREDICTING MEDICAL OUTCOMES AND FOR USE IN PROVIDING MEDICAL TREATMENT INFORMATION TO PATIENTS (U.S. CLS. 100 AND 101).

KIMBERLY FRYE, EXAMINING ATTORNEY

SN 85-359,845. SHENANDOAH NORTHERN COMPANY, KNOXVILLE, TN. FILED 6-29-2011.



OWNER OF U.S. REG. NO. 3,005,810.

THE MARK CONSISTS OF THE LETTERS "SN" AND THREE HORIZONTAL LINES WITHIN CONCENTRIC CIRCLES.

SN 85-359,543. MONTEFIORE MEDICAL CENTER, BRONX, NY. FILED 6-29-2011.

CLASS 35—ADVERTISING AND BUSINESS

FOR ACQUISITION AND MERGER CONSULTATION FOR SHORT LINE AND REGIONAL RAILROAD BUSINESS; BUSINESS CONSULTATION FOR SHORT LINE AND REGIONAL RAILROAD BUSINESS (U.S. CLS. 100, 101 AND 102).

CLASS 36—INSURANCE AND FINANCIAL

FOR FINANCIAL ANALYSIS AND CONSULTATION FOR SHORT LINE AND REGIONAL RAILROAD BUSINESS (U.S. CLS. 100, 101 AND 102).

JAY FLOWERS, EXAMINING ATTORNEY

TA

SN 85-361,012. MASSIF MOUNTAIN GEAR COMPANY, LLC, ASHLAND, OR. FILED 6-30-2011.

THE MARK CONSISTS OF STANDARD CHARACTERS WITHOUT CLAIM TO ANY PARTICULAR FONT, STYLE, SIZE, OR COLOR.

CLASS 35—ADVERTISING AND BUSINESS

FOR BUSINESS DATA ANALYTICS SERVICES, NAMELY, PROVIDING PREDICTIVE AND DESCRIPTIVE MODELING USED IN THE ANALYSIS AND TRACKING OF BUSINESS-RELATED OUTCOMES THAT ARE RELEVANT TO SPECIFIC, USER-DEFINED FIELDS (U.S. CLS. 100, 101 AND 102).

CLASS 42—SCIENTIFIC AND COMPUTER SERVICES

FOR SCIENTIFIC AND CLINICAL ANALYTICS AND RESEARCH SERVICES, NAMELY, PROVIDING PREDICTIVE AND DESCRIPTIVE MODELING USED IN THE ANALYSIS AND TRACKING OF PATIENT OUTCOMES, FOR SCIENTIFIC AND MEDICAL RESEARCH PURPOSES (U.S. CLS. 100 AND 101).

CLASS 44—MEDICAL, BEAUTY AND AGRICULTURAL SERVICES

FOR MEDICAL ANALYTICS SERVICES, NAMELY, PROVIDING PREDICTIVE AND DESCRIPTIVE MODELING USED IN THE ANALYSIS AND TRACKING OF PATIENT OUTCOMES, FOR MEDICAL TREATMENT PURPOSES (U.S. CLS. 100 AND 101).

KIMBERLY FRYE, EXAMINING ATTORNEY

MASSIF

THE MARK CONSISTS OF STANDARD CHARACTERS WITHOUT CLAIM TO ANY PARTICULAR FONT, STYLE, SIZE, OR COLOR.

OWNER OF U.S. REG. NOS. 3,381,129, 3,977,854 AND OTHERS.

CLASS 14—JEWELRY

FOR WRIST WATCHES (U.S. CLS. 2, 27, 28 AND 50).

CLASS 18—LEATHER GOODS

FOR ATTACHÉ CASES, ALL-PURPOSE CARRYING BAGS, BACKPACKS, BAGS, NAMELY, HANDBAGS, MESSENGER BAGS, PURSES, MEN'S PURSES, AND SMALL BAGS FOR MEN, BILLFOLDS, BRIEF CASES, BRIEFCASE-TYPE PORTFOLIOS, CARRYALLS, LUGGAGE, MEN'S CLUTCH BAGS, TRAVEL GARMENT BAGS, WALLETS, SUITCASES, TRAVELING CASES/BAGS, TOTE BAGS, SHOULDER BAGS, VANITY CASES SOLD EMPTY, SLING BAGS, SUIT CARRIERS, BUSINESS CARD CASES, CALLING CARD CASES (U.S. CLS. 1, 2, 3, 22 AND 41).

B. PARADEWELAI, EXAMINING ATTORNEY

SN 85-361,195. NEXSYS ELECTRONICS, INC., SAN FRANCISCO, CA. FILED 6-30-2011.

SN 85-362,365. DELTA DENTAL PLAN OF NEW HAMPSHIRE, INC., CONCORD, NH. FILED 7-2-2011.

RADREGISTRY

THE MARK CONSISTS OF STANDARD CHARACTERS WITHOUT CLAIM TO ANY PARTICULAR FONT, STYLE, SIZE, OR COLOR.

CLASS 9—ELECTRICAL AND SCIENTIFIC APPARATUS

FOR COMPUTER SOFTWARE FOR ACQUISITION, DISPLAY, STORAGE AND ROUTING OF INFORMATION IN THE FIELD OF MEDICINE AND HEALTHCARE; COMPUTER SOFTWARE FOR IMPLEMENTING WORKFLOW PROCEDURES AND MANAGING WORKFLOW IN THE FIELD OF MEDICINE AND HEALTHCARE (U.S. CLS. 21, 23, 26, 36 AND 38).

CLASS 42—SCIENTIFIC AND COMPUTER SERVICES

FOR SOFTWARE AS A SERVICE (SAAS) SERVICES FEATURING SOFTWARE FOR ACQUISITION, DISPLAY, STORAGE AND ROUTING OF INFORMATION IN THE FIELD OF MEDICINE AND HEALTHCARE; SOFTWARE AS A SERVICE (SAAS) SERVICES FEATURING SOFTWARE FOR IMPLEMENTING WORKFLOW PROCEDURES AND MANAGING WORKFLOW IN THE FIELD OF MEDICINE AND HEALTHCARE; COMPUTER CONSULTING SERVICES (U.S. CLS. 100 AND 101). AMY ALFIERI, EXAMINING ATTORNEY

SN 85-361,985. HADJIGEORGIS, JACOB, ASTORIA, NY. FILED 7-1-2011.

JACOB'S PICKLES

NO CLAIM IS MADE TO THE EXCLUSIVE RIGHT TO USE "PICKLES", APART FROM THE MARK AS SHOWN. THE MARK CONSISTS OF A RECTANGLE WITH THE STYLIZED TEXT "JACOB'S PICKLES".

CLASS 30—STAPLE FOODS

FOR SALT FOR PRESERVING FOOD (U.S. CL. 46).

CLASS 43—HOTEL AND RESTAURANT SERVICES

FOR RESTAURANT AND BAR SERVICES (U.S. CLS. 100 AND 101). DANNEAN HETZEL, EXAMINING ATTORNEY

EUVORIA

THE MARK CONSISTS OF STANDARD CHARACTERS WITHOUT CLAIM TO ANY PARTICULAR FONT, STYLE, SIZE, OR COLOR.

CLASS 35—ADVERTISING AND BUSINESS

FOR DENTAL PRACTICE MANAGEMENT FOR OTHERS, NAMELY, MANAGING A PANEL OF DENTISTS ACCREDITED TO PROVIDE ACCOUNTABLE, RISK-APPROPRIATE ORAL HEALTH CARE TO ENROLLED BENEFICIARIES (U.S. CLS. 100, 101 AND 102).

CLASS 36—INSURANCE AND FINANCIAL

FOR DENTAL HEALTH INSURANCE ADMINISTRATION, NAMELY, PROVIDING PATIENT-CENTERED DENTAL BENEFIT PLANS (U.S. CLS. 100, 101 AND 102). MATTHEW KLINE, EXAMINING ATTORNEY

SN 85-363,348. LANDINI BROTHERS, INC., ALEXANDRIA, VA. FILED 7-5-2011.

CXIIIREX

THE MARK CONSISTS OF STANDARD CHARACTERS WITHOUT CLAIM TO ANY PARTICULAR FONT, STYLE, SIZE, OR COLOR.

CLASS 41—EDUCATION AND ENTERTAINMENT

FOR CIGAR LOUNGE SERVICES FEATURING USE OF WALK-IN HUMIDORS, PERSONAL HUMIDORS, AND PROVIDING CIGAR-SMOKING ROOMS FEATURING USE OF SMOKERS' ARTICLES; ENTERTAINMENT IN THE NATURE OF VISUAL AND AUDIO PERFORMANCES AND MUSICAL SHOWS (U.S. CLS. 100, 101 AND 107).

FIRST USE 11-3-2009; IN COMMERCE 11-3-2009.

CLASS 43—HOTEL AND RESTAURANT SERVICES

FOR RETAIL FOOD SERVICES, NAMELY, SERVING FOOD AND DRINKS; RESTAURANT SERVICES, NAMELY, COCKTAIL LOUNGE, MARTINI BAR, WINE BAR, RESTAURANTS, RESTAURANT FOOD SERVICES; BANQUET SERVICES, NAMELY, PROVIDING BANQUET FACILITIES FOR SPECIAL OCCASIONS AND CATERING OF BANQUETS; BAR SERVICES FEATURING BEVERAGES, NAMELY, NON-ALCOHOLIC BEVERAGES, COFFEE, TEA, CARBONATED BEVERAGES, WATER, ALCOHOLIC BEVERAGES, WINE, BEER, AND SPIRITS; BAR SERVICES; COCKTAIL LOUNGE SERVICES; SOCIAL FUNCTION FACILITIES SERVICES, NAMELY, PROVIDING SOCIAL FUNCTION FACILITIES FOR SPECIAL OCCASIONS (U.S. CLS. 100 AND 101).

FIRST USE 11-3-2009; IN COMMERCE 11-3-2009. ANTHONY RINKER, EXAMINING ATTORNEY

SN 85-363,576. BJ'S RESTAURANTS, INC., HUNTINGTON BEACH, CA. FILED 7-5-2011.



OWNER OF U.S. REG. NOS. 1,199,125, 3,316,736 AND OTHERS.

THE MARK CONSISTS OF THE LETTERS "BJ'S" ON A TRIANGLE.

CLASS 29—MEATS AND PROCESSED FOODS

FOR PREPARED APPETIZER COMBINATION PLATE CONSISTING PRIMARILY OF SPINACH AND ARTI-CHOKE DIP AND MOZZARELLA STICKS, AND ALSO INCLUDING EGG ROLLS AND SPRING ROLLS; APPETIZERS, NAMELY, AHI POKE; APPETIZERS, NAMELY, MEATBALLS; APPETIZERS, NAMELY, FRIED VEGETABLES; APPETIZERS, NAMELY, BONELESS CHICKEN WINGS; APPETIZERS, NAMELY, SPINACH AND ARTI-CHOKE DIP; APPETIZERS, NAMELY, STUFFED MUSHROOMS; APPLESAUCE; BEEF; CALAMARI; CAESAR SALAD; CHEESE; CHICKEN; CHICKEN WINGS; CORN DOGS; DAIRY-BASED DIPS; DIPS; DIP MIXES; FISH; FRENCH FRIED POTATOES; FRESH, FROZEN, PREPARED, OR PACKAGED APPETIZERS CONSISTING PRIMARILY OF MEAT, CHICKEN OR SEAFOOD; FROZEN, PREPARED, OR PACKAGED APPETIZERS CONSISTING PRIMARILY OF VEGETABLES; FROZEN, PREPARED, OR PACKAGED APPETIZERS CONSISTING PRIMARILY OF VEGETABLES, MEAT AND/OR CHEESE; FROZEN, PREPARED, OR PACKAGED BAKED POTATOES; FRESH, FROZEN, PREPARED, OR PACKAGED CHEESE SANDWICH SNACKS; FRESH, FROZEN, PREPARED, OR PACKAGED ENTREES CONSISTING PRIMARILY OF MEAT, FISH, POULTRY OR VEGETABLES; FROZEN, PREPARED, OR PACKAGED ENTREES CONSISTING PRIMARILY OF VEGETABLES, SOUPS, FRUIT SALADS AND VEGETABLE SALADS; FROZEN, PREPARED, OR PACKAGED SIDE DISHES CONSISTING OF VEGETABLES OR FRUIT; FROZEN, PREPARED, OR PACKAGED VEGETABLES; FRIED POTATOES; GARDEN SALADS; GUACAMOLE; HOT DOGS; LETTUCE WRAPS WITH CHICKEN AND/OR SHRIMP; MEAT; MIXES FOR MAKING SOUP; MOZZARELLA STICKS; PORK; POTATO CHIPS; POTATO SKINS; POULTRY; PRE-CUT VEGETABLE SALAD; SALADS EXCEPT MACARONI, RICE, AND PASTA SALAD; SEAFOOD; SHRIMP; SNACK DIPS; AND SOUPS (U.S. CL. 46).

CLASS 30—STAPLE FOODS

FOR BAKERY GOODS; BURGERS CONTAINED IN BREAD ROLLS; CAKES; CARAMEL TOPPING FOR ICE CREAM; CHICKEN BURGER SANDWICHES; CHICKEN WING SAUCE; CHOCOLATE TOPPING; COFFEE AND COFFEE BASED BEVERAGES; COOKIES; COOKIE DOUGH; CORN CHIPS; DESSERT MADE PRIMARILY OF A COOKIE AND ICE CREAM; DIPPING SAUCES; DOUGH; DUMPLINGS; EGG ROLLS; FLOUR-BASED CHIPS; FRESH, FROZEN, PREPARED, OR PACKAGED APPETIZERS CONSISTING PRIMARILY OF PASTA, DUMPLINGS OR TORTILLAS CONTAINING CHEESE, VEGETABLES, MEAT AND/OR OTHER FILLINGS; FRESH, FROZEN, PREPARED, OR PACKAGED DOUGH FOR USE AS PIZZA, BREAD OR OTHER BREAD-TYPE PRODUCTS; FRESH, FROZEN, PREPARED, OR PACK-

AGED FOODS, NAMELY, GRAIN AND BREAD BASED APPETIZERS, HORS D'OEUVRES, AND CANAPÉS; FRESH, FROZEN, PREPARED, OR PACKAGED PIZZA; FRESH, FROZEN, PREPARED, OR PACKAGED MEALS CONSISTING PRIMARILY OF PASTA OR NOODLES; FRESH, FROZEN, PREPARED, OR PACKAGED PREPARED MEALS CONSISTING PRIMARILY OF PASTA OR RICE; FRESH, FROZEN, PREPARED, OR PACKAGED SIDE DISHES CONSISTING OF PASTA, RICE OR GRAINS; FROZEN CONFECTIONS; GRAIN-BASED CHIPS; HAMBURGER SANDWICHES; HOT DOG SANDWICHES; ICE CREAM; ICE CREAM DESSERTS; ICE CREAM DRINKS; ICE CREAM SUNDAES; ICE CREAM SUNDAES WITH TOPPING SOLD THEREWITH; JAMBALAYA, NAMELY, A SPICY CREOLE RICE DISH WITH A MIXTURE OF FISH AND MEAT SUCH AS SHRIMP, CHICKEN, HAM AND SPICY SAUSAGE; KITS COMPRISED OF INGREDIENTS FOR PREPARING PIZZA; MACARONI AND CHEESE; MARSHMALLOW TOPPING; NACHOS; NON-DAIRY FROZEN CONFECTIONS; PASTA; PASTA SAUCE; PASTRIES; PIES; PIZZA; PIZZA CRUST; PIZZA CRUST MIXES; PIZZA DOUGH; PIZZA SAUCE; PREPARED, FROZEN, NON-FROZEN OR REFRIGERATED, AND PACKAGED BAKERY DESSERTS; PREPARED OR FROZEN ICE CREAM DESSERTS; PREPARED PASTA; RICE; SALAD DRESSINGS; SALSA; SANDWICHES; SAUCES; SPRING ROLLS; TACOS; TOPPING SYRUP; TURKEY BURGER SANDWICHES; VEGGIE BURGER SANDWICHES; APPETIZERS, NAMELY, MINI BURGER SANDWICHES; APPETIZERS, NAMELY, FRESH AND FROZEN FLATBREAD PIZZA; APPETIZERS, NAMELY, POT STICKERS; MACARONI SALAD; RICE SALADS; PASTA SALAD; ICED TEA; APPETIZERS, NAMELY, WON TONS; APPETIZERS, NAMELY, BRUSCHETTA-TOPPED BREAD (U.S. CL. 46).

CLASS 32—LIGHT BEVERAGES

FOR BOTTLED WATER; FRUIT FLAVORED SOFT DRINKS; FRUIT JUICES; LEMONADE; NON-ALCOHOLIC BEER; PREPARATIONS FOR MAKING BEVERAGES, NAMELY, POWDERS AND CONCENTRATES, ALL FOR MAKING FRUIT DRINKS, SOFT DRINKS AND MALT BEVERAGES; ROOT BEER; SOFT DRINKS; SYRUPS FOR MAKING BEVERAGES; SPARKLING WATER; AND STILL WATER (U.S. CLS. 45, 46 AND 48).
WON TEAK OH, EXAMINING ATTORNEY

SN 85-363,680. HAWKWILD, LLC, CANOGA PARK, CA. FILED 7-5-2011.

Laughter Heals

THE MARK CONSISTS OF STANDARD CHARACTERS WITHOUT CLAIM TO ANY PARTICULAR FONT, STYLE, SIZE, OR COLOR.

OWNER OF U.S. REG. NO. 3,380,394.

CLASS 16—PAPER GOODS AND PRINTED MATTER

FOR STICKERS, POSTERS, CALENDARS, DIARIES, SCRAPBOOKS, SKETCH BOOKS, NOTEBOOKS, BINDERS, BOOK COVERS, PHOTOGRAPH ALBUMS, HEAT APPLIED APPLIQUES IN THE FORM OF DECALS MADE OF PAPER, PENCILS, PENS, PENCIL CASES, POSTCARDS, GREETING CARDS, NOTE CARDS, ANNOUNCEMENT CARDS, STATIONERY, DECALS AND STICKERS, TEMPORARY TATTOOS, PAPER GIFT WRAP AND PAPER RIBBONS, BOOKS AND BOOKLETS IN THE FIELD OF BREAST CANCER AWARENESS (U.S. CLS. 2, 5, 22, 23, 29, 37, 38 AND 50).

CLASS 36—INSURANCE AND FINANCIAL

FOR CHARITABLE FUNDRAISING (U.S. CLS. 100, 101 AND 102).

FIRST USE 0-0-2004; IN COMMERCE 0-0-2004.
STEVEN JACKSON, EXAMINING ATTORNEY

SN 85-364,047. PACIFIC TRADE INTERNATIONAL, INC.,
ROCKVILLE, MD. FILED 7-6-2011.

CHESAPEAKE BAY WELLNESS

THE MARK CONSISTS OF STANDARD CHARACTERS WITHOUT CLAIM TO ANY PARTICULAR FONT, STYLE, SIZE, OR COLOR.

NO CLAIM IS MADE TO THE EXCLUSIVE RIGHT TO USE "CHESAPEAKE BAY", APART FROM THE MARK AS SHOWN.

CLASS 3—COSMETICS AND CLEANING PREPARATIONS

FOR BODY AND BEAUTY CARE COSMETICS; SHOWER AND BATH GELS; BODY SPRAYS; BEAUTY AND BATH LOTIONS; BEAUTY CREAMS; AROMATIC BODY CARE PRODUCTS, NAMELY, BODY LOTION, SHAMPOO, CONDITIONER, NON-MEDICATED LIP BALM, SOAP, BODY POLISH, BODY AND FOOT SCRUB AND NON-MEDICATED FOOT CREAM; MOUTHWASHES; MASSAGE OILS AND SCENTED OILS; AROMATIC POTPOURRIS; ROOM FRAGRANCES; BODY SPRAY AND PERFUME; HAND LOTION; AND SCENTED ROOM SPRAYS (U.S. CLS. 1, 4, 6, 50, 51 AND 52).

CLASS 5—PHARMACEUTICALS

FOR MEDICATED HAND WASH, HAND SANITIZING PREPARATIONS (U.S. CLS. 6, 18, 44, 46, 51 AND 52).
TARAH HARDY, EXAMINING ATTORNEY

SN 85-364,101. S.S. MARMARA ZEYTIN TARIM SATIS KOOPERATIFLERI BIRLIGI, NILÜFER, BURSA, TURKEY, FILED 7-6-2011.



THE COLOR(S) GREEN, YELLOW AND BLACK IS/ARE CLAIMED AS A FEATURE OF THE MARK.

THE MARK CONSISTS OF THE LETTERS "MB" IN BLACK, STYLIZED, LOWER-CASE LETTERING CONTAINED WITHIN AN ABSTRACT DRAWING OF TWO OLIVES INTERSECTING, CREATING A CRESCENT-

SHAPED FIELD OF GREEN IN THE LEFT PORTION OF THE MARK, AN EGG-SHAPED FIELD OF YELLOW IN THE CENTRAL PORTION OF THE MARK AND A CRESCENT-SHAPED FIELD OF BLACK IN THE RIGHT PORTION OF THE MARK. THE LEFT OLIVE HAS A GREEN LEAF AND BLACK STEM. THE RIGHT OLIVE HAS A BLACK LEAF AND BLACK STEM. THE COLOR WHITE IS INTENDED TO INDICATE BACKGROUND, OUTLINING, SHADING OR TRANSPARENT AREAS AND IS NOT PART OF THE MARK.

CLASS 29—MEATS AND PROCESSED FOODS

FOR PRESERVED, DRIED AND COOKED OLIVES, OLIVE OIL, OLIVE PASTES, CANNED PROCESSED OLIVES (U.S. CL. 46).

CLASS 35—ADVERTISING AND BUSINESS

FOR WHOLESALE AND RETAIL STORE SERVICES FEATURING PRESERVED, DRIED AND COOKED OLIVES, OLIVE OIL, OLIVE PASTES, CANNED PROCESSED OLIVES (U.S. CLS. 100, 101 AND 102).
COLLEEN DOMBROW, EXAMINING ATTORNEY

SN 85-365,088. INTERNATIONAL COLORED GEMSTONE ASSOCIATION, NEW YORK, NY. FILED 7-7-2011.

InColor

THE MARK CONSISTS OF THE WORD "IN" APPEARING IMMEDIATELY ADJOINED TO THE LEFT OF THE WORD "COLOR" WITH THE LETTERS "I" AND "C" CAPITALIZED.

CLASS 16—PAPER GOODS AND PRINTED MATTER

FOR MAGAZINE FEATURING INFORMATION RELATING TO THE GEMSTONE INDUSTRY, MINING, GEMOLOGY, JEWELRY, FASHION TRENDS, AND EDUCATION IN THE FIELDS OF JEWELRY AND FASHION (U.S. CLS. 2, 5, 22, 23, 29, 37, 38 AND 50).
FIRST USE 7-31-2005; IN COMMERCE 7-31-2005.

CLASS 41—EDUCATION AND ENTERTAINMENT

FOR PROVIDING ON-LINE MAGAZINES FEATURING INFORMATION RELATING TO THE GEMSTONE INDUSTRY, MINING, GEMOLOGY, JEWELRY, FASHION TRENDS, AND EDUCATION IN THE FIELDS OF JEWELRY AND FASHION (U.S. CLS. 100, 101 AND 107).
FIRST USE 7-31-2005; IN COMMERCE 7-31-2005.
ALAIN LAPTER, EXAMINING ATTORNEY

SN 85-365,237. JOYETECH (CHANGZHOU) ELECTRONICS CO., LTD., CHANGZHOU, JIANGSU, CHINA, FILED 7-7-2011.

Joyetech

THE MARK CONSISTS OF A STYLIZED VERSION OF THE TERM "JOYETECH".

CLASS 1—CHEMICALS

FOR LIQUID NICOTINE SOLUTIONS, NAMELY, LIQUID NICOTINE FOR USE IN ELECTRONIC CIGARETTES (U.S. CLS. 1, 5, 6, 10, 26 AND 46).

CLASS 34—SMOKERS' ARTICLES

FOR ELECTRONIC CIGARETTES, ELECTRONIC NICOTINE INHALATION DEVICES, NAMELY, ELECTRONIC CIGARETTES, ELECTRONIC CIGARETTE CARTRIDGES, ELECTRONIC CIGARETTE ATOMIZERS, ELECTRONIC CIGARETTE CARTOMIZERS (U.S. CLS. 2, 8, 9 AND 17).

CLASS 35—ADVERTISING AND BUSINESS

FOR DISTRIBUTORSHIP SERVICES IN THE FIELD OF TOBACCO PRODUCTS (U.S. CLS. 100, 101 AND 102).
EMILY CARLSEN, EXAMINING ATTORNEY

SN 85-365,477. AMI ENTERTAINMENT NETWORK, INC., BRISTOL, PA. FILED 7-7-2011.



THE MARK CONSISTS OF A STYLIZED HAND WITH THREE FINGERS BENT AND THE INDEX FINGER AND THUMB EXTENDING UPWARD.

CLASS 9—ELECTRICAL AND SCIENTIFIC APPARATUS

FOR COMPUTER AND ELECTRONIC GAME PROGRAMS; COMPUTER AND ELECTRONIC GAME SOFTWARE; DOWNLOADABLE ELECTRONIC GAMES VIA THE INTERNET AND WIRELESS DEVICES; COMPUTERIZED VIDEO TABLE GAMES FOR GAMING PURPOSES; VIDEO OUTPUT GAME MACHINES FOR USE WITH EXTERNAL DISPLAY SCREEN OR MONITOR; TABLE TOP UPRIGHT VIDEO OUTPUT GAMING MACHINES (U.S. CLS. 21, 23, 26, 36 AND 38).
FIRST USE 12-13-2008; IN COMMERCE 12-13-2008.

CLASS 28—TOYS AND SPORTING GOODS

FOR STAND ALONE VIDEO GAME MACHINES; STAND ALONE VIDEO OUTPUT MACHINES; COIN OPERATED VIDEO GAMES (U.S. CLS. 22, 23, 38 AND 50).

FIRST USE 9-30-2010; IN COMMERCE 9-30-2010.
EMILY CARLSEN, EXAMINING ATTORNEY

SN 85-365,637. PIERRE FABRE S.A., PARIS, FRANCE, FILED 7-7-2011.

NALERGIA

THE MARK CONSISTS OF STANDARD CHARACTERS WITHOUT CLAIM TO ANY PARTICULAR FONT, STYLE, SIZE, OR COLOR.

OWNER OF FRANCE REG. NO. 95604011, DATED 12-19-1995, EXPIRES 12-19-2015.

THE WORDING "NALERGIA" HAS NO MEANING IN A FOREIGN LANGUAGE.

CLASS 3—COSMETICS AND CLEANING PREPARATIONS

FOR COSMETICS AND CLEANING PREPARATIONS, NAMELY, TOILET SOAPS; PERFUMES; ESSENTIAL OILS FOR PERSONAL USE; NON-MEDICATED SKIN CARE PREPARATIONS IN THE NATURE OF CREAMS, OILS, GELS, LOTIONS, MILKS AND EMULSIONS; MAKE-UP; NON-MEDICATED HAIR CARE PREPARATIONS, NAMELY, CREAMS, GELS, LOTIONS, AND SHAMPOOS; DENTIFRICES (U.S. CLS. 1, 4, 6, 50, 51 AND 52).

CLASS 5—PHARMACEUTICALS

FOR PHARMACEUTICALS PREPARATIONS FOR THE TREATMENT OF ALLERGY, CANCER, ASTHMA, CARDIOVASCULAR, NEUROLOGIC, PSYCHIATRIC, RESPIRATORY, UROLOGIC, AND DERMATOLOGICAL DISORDERS AND DISEASES; MEDICATED SKIN CARE PREPARATIONS FOR HYGIENE AND CARE OF THE SKIN; DIETARY FOOD SUPPLEMENTS; FOOD FOR BABIES (U.S. CLS. 6, 18, 44, 46, 51 AND 52).

ELI HELLMAN, EXAMINING ATTORNEY

SN 85-365,698. PIERRE FABRE S.A., PARIS, FRANCE, FILED 7-7-2011.

STANCIEL

THE MARK CONSISTS OF STANDARD CHARACTERS WITHOUT CLAIM TO ANY PARTICULAR FONT, STYLE, SIZE, OR COLOR.

OWNER OF FRANCE REG. NO. 1,541,143, DATED 6-22-1989, EXPIRES 6-22-2019.

THE WORDING "STANCIEL" HAS NO MEANING IN A FOREIGN LANGUAGE.

CLASS 3—COSMETICS AND CLEANING PREPARATIONS

FOR COSMETICS AND CLEANING PREPARATIONS, NAMELY, TOILET SOAPS; PERFUMES; ESSENTIAL OILS FOR PERSONAL USE; NON-MEDICATED SKIN CARE PREPARATIONS IN THE NATURE OF CREAMS, OILS, GELS, LOTIONS, MILKS AND EMULSIONS; HAIR CARE PRODUCTS, NAMELY, SHAMPOOS AND CONDITIONERS; DENTIFRICES (U.S. CLS. 1, 4, 6, 50, 51 AND 52).

CLASS 5—PHARMACEUTICALS

FOR PHARMACEUTICALS PREPARATIONS FOR USE IN THE TREATMENT OF CARDIO-ANGIOLOGICAL, NEUROLOGICAL, PSYCHIATRIC, ONCOLOGICAL, AND DERMATOLOGICAL DISEASES AND DISORDERS (U.S. CLS. 6, 18, 44, 46, 51 AND 52).

ELI HELLMAN, EXAMINING ATTORNEY

SN 85-367,876. HEALTHWAYS, INC., FRANKLIN, TN. FILED 7-11-2011.

HEALTHWAYS INCENTIVEPULSE

THE MARK CONSISTS OF STANDARD CHARACTERS WITHOUT CLAIM TO ANY PARTICULAR FONT, STYLE, SIZE, OR COLOR.

OWNER OF U.S. REG. NOS. 3,226,699, 3,294,917 AND OTHERS.

CLASS 42—SCIENTIFIC AND COMPUTER SERVICES

FOR MEDICAL AND SCIENTIFIC RESEARCH IN THE FIELD OF HEALTH AND WELLNESS (U.S. CLS. 100 AND 101).

CLASS 44—MEDICAL, BEAUTY AND AGRICULTURAL SERVICES

FOR PROVIDING INFORMATION IN THE FIELD OF HEALTH AND WELLNESS (U.S. CLS. 100 AND 101).

DAVID YONTEF, EXAMINING ATTORNEY

SN 85-366,914. F3 BRANDS LLC, MIAMI, OK. FILED 7-8-2011.



OWNER OF U.S. REG. NOS. 1,701,818 AND 2,134,179. THE MARK CONSISTS OF AN IMAGE OF A RHINOCEROS.

CLASS 16—PAPER GOODS AND PRINTED MATTER

FOR OIL CHANGING KITS PRIMARILY CONSISTING OF STICKERS FOR RECORDING AND REMINDING OF OIL CHANGES AND PAPER TOWELS AND ALSO CONTAINING DISPOSABLE LATEX, NITRILE AND PLASTIC GLOVES FOR GENERAL USE (U.S. CLS. 2, 5, 22, 23, 29, 37, 38 AND 50).

CLASS 20—FURNITURE AND ARTICLES NOT OTHERWISE CLASSIFIED

FOR AUTOMOTIVE NON-METAL OIL CHANGE PANS FOR HOUSEHOLD USE; NON-METAL PORTABLE VEHICLE SERVICE RAMPS; NON-METAL WHEEL CHOCKS, NAMELY, PLASTIC WHEEL CHOCKS (U.S. CLS. 2, 13, 22, 25, 32 AND 50).

CLASS 21—HOUSEWARES AND GLASS

FOR NON-METAL HOUSEHOLD CONTAINERS FOR COLLECTING DRAINED MOTOR OIL; NON-METAL HOUSEHOLD CANS FOR COLLECTING MOTOR OIL FOR RECYCLING; FUNNELS AND AUTOMOBILE OIL FUNNELS; POUR SPOUTS FOR OIL CONTAINERS FOR HOUSEHOLD OR DOMESTIC USE (U.S. CLS. 2, 13, 23, 29, 30, 33, 40 AND 50).

DAVID YONTEF, EXAMINING ATTORNEY

SN 85-367,877. YARDESELLR, INC., SAN FRANCISCO, CA. FILED 7-11-2011.

YARDESELLR

THE MARK CONSISTS OF STANDARD CHARACTERS WITHOUT CLAIM TO ANY PARTICULAR FONT, STYLE, SIZE, OR COLOR.

CLASS 35—ADVERTISING AND BUSINESS

FOR OPERATING ONLINE MARKETPLACES FOR SELLERS AND BUYERS OF GOODS AND SERVICES; PROVIDING EVALUATIVE FEEDBACK AND RATINGS OF SELLERS' GOODS AND SERVICES, THE VALUE AND PRICES OF SELLERS' GOODS, BUYERS' AND SELLERS' PERFORMANCE, DELIVERY, AND OVERALL EXPERIENCE IN CONNECTION THEREWITH; PROVIDING A SEARCHABLE ONLINE ADVERTISING GUIDE FEATURING THE GOODS AND SERVICES OF ONLINE VENDORS; PROVIDING A SEARCHABLE ONLINE PRODUCT AND SERVICE EVALUATION DATABASE FOR BUYERS AND SELLERS; ADVERTISING AND ADVERTISEMENT SERVICES; CUSTOMER LOYALTY SERVICES AND CUSTOMER CLUB SERVICES FOR COMMERCIAL, PROMOTIONAL AND ADVERTISING PURPOSES; PROMOTING THE GOODS AND SERVICES OF OTHERS; PROVIDING A SEARCHABLE ONLINE ADVERTISING GUIDE FEATURING THE GOODS AND SERVICES OF ONLINE VENDORS; ARRANGING AND CONDUCTING TRADE SHOWS AND EXHIBITIONS IN THE FIELD OF ONLINE TRADING SERVICES; ELECTRONIC COMMERCE SERVICES, NAMELY, FACILITATING COMMERCIAL TRANSACTIONS BETWEEN MEMBERS OF SOCIAL NETWORKS; PROVIDING CONTESTS TO PROMOTE THE SALE OF PRODUCTS AND SERVICES OF OTHERS VIA THE INTERNET (U.S. CLS. 100, 101 AND 102).

CLASS 36—INSURANCE AND FINANCIAL

FOR ELECTRONIC COMMERCE PAYMENT SERVICES, NAMELY, PROCESSING PAYMENTS FOR THE PURCHASE OF GOODS AND SERVICES VIA AN ELECTRONIC COMMUNICATIONS NETWORK (U.S. CLS. 100, 101 AND 102).

CLASS 38—COMMUNICATION

FOR TELECOMMUNICATIONS SERVICES, NAMELY, THE ELECTRONIC TRANSMISSION OF DATA AND INFORMATION; PAGING SERVICES; PROVIDING AN ONLINE, INTERACTIVE BULLETIN BOARD FOR THE TRANSMISSION OF MESSAGES AMONG COMPUTER USERS CONCERNING HOBBIES, COLLECTIBLES, TRADING, AND THE SALE OF GOODS AND SERVICES VIA A GLOBAL COMMUNICATIONS NETWORK (U.S. CLS. 100, 101 AND 104).

CLASS 41—EDUCATION AND ENTERTAINMENT

FOR ENTERTAINMENT SERVICES, NAMELY, PROVIDING SWEEPSTAKES, GAMES OF CHANCE AND CONDUCTING CONTESTS FOR ENTERTAINMENT PURPOSES VIA THE INTERNET (U.S. CLS. 100, 101 AND 107).

KATHY DE JONGE, EXAMINING ATTORNEY

SN 85-367,879. AMERICAN BOARD OF VETERINARY PRACTITIONERS, INC., NASHVILLE, TN. FILED 7-11-2011.



NO CLAIM IS MADE TO THE EXCLUSIVE RIGHT TO USE "AMERICAN BOARD OF VETERINARY PRACTITIONERS" AND "FOUNDED 1978" AND THE DESCRIPTIVE DESIGN OF THE CADUCEUS, APART FROM THE MARK AS SHOWN.

THE MARK CONSISTS OF "AMERICAN BOARD OF VETERINARY PRACTITIONERS" RUNS ALONG THE OUTSIDE OF THE CIRCLE IN ALL CAPITAL LETTERS WITH A LINE RUNNING ABOVE AND BELOW THE WORDS. A DOT IS ALSO LOCATED IN BETWEEN EACH WORD IN THE PHRASE "AMERICAN BOARD OF VETERINARY PRACTITIONERS". A CADUCEUS IS AT THE TOP OF THE INSIDE OF THE CIRCLE. IN THE MIDDLE OF THE INSIDE OF THE CIRCLE IS "ABVP" WRITTEN IN ALL CAPITAL LETTERS WITH LINES OUTLINING THE RIGHT SIDE AND INSIDE OF THE LETTERS. "ABVP" IS BOXED IN BY A SINGLE LINE. BELOW "ABVP" IS THE WORD "FOUNDED" IN ALL CAPITAL LETTERS. BELOW "FOUNDED" IS "1978" WITH A DOT BEFORE THE "1" AND AFTER THE "8".

CLASS 16—PAPER GOODS AND PRINTED MATTER

FOR PRINTED MATTER, NAMELY, PAPER SIGNS, BOOKS, MANUALS, CURRICULUM, NEWSLETTERS, INFORMATIONAL CARDS AND BROCHURES IN THE FIELD OF VETERINARY MEDICINE (U.S. CLS. 2, 5, 22, 23, 29, 37, 38 AND 50).

FIRST USE 5-1-1978; IN COMMERCE 5-1-1978.

CLASS 42—SCIENTIFIC AND COMPUTER SERVICES

FOR TESTING, ANALYSIS, AND EVALUATION OF THE KNOWLEDGE, SKILLS AND ABILITIES OF OTHERS FOR THE PURPOSE OF CERTIFICATION AND RE-CERTIFICATION IN THE FIELD OF VETERINARY MEDICINE (U.S. CLS. 100 AND 101).

FIRST USE 5-1-1978; IN COMMERCE 5-1-1978.
MARIA-VICTORIA SUAREZ, EXAMINING ATTORNEY

SN 85-368,186. AMERICAN COLLEGE OF RADIOLOGY, RESTON, VA. FILED 7-11-2011.



OWNER OF U.S. REG. NOS. 3,049,102, 4,130,923 AND OTHERS.

NO CLAIM IS MADE TO THE EXCLUSIVE RIGHT TO USE "RADIOLOGY", APART FROM THE MARK AS SHOWN.

THE MARK CONSISTS OF THE WORDING "ACR AMERICAN COLLEGE OF RADIOLOGY PRACTICE LEADERS", WITH A DESIGN CONSISTING OF INTERTWINED BANDS POSITIONED HORIZONTALLY AND THROUGH WHICH A STRAIGHT HORIZONTAL LINE PASSES.

SEC. 2(F) AS TO "AMERICAN COLLEGE OF RADIOLOGY".

CLASS 38—COMMUNICATION

FOR PROVIDING AN ONLINE FORUM TO FACILITATE DISCUSSIONS AMONG PROFESSIONALS IN THE FIELD OF RADIOLOGY (U.S. CLS. 100, 101 AND 104).

FIRST USE 11-0-2009; IN COMMERCE 11-0-2009.

CLASS 42—SCIENTIFIC AND COMPUTER SERVICES

FOR PROVIDING AN INTERNET WEBSITE FEATURING TECHNOLOGY THAT ENABLES PROFESSIONALS IN THE FIELD OF RADIOLOGY TO SHARE, BOOKMARK, INDEX, STORE, AND COLLECT CONTENT, ARTICLES, IMAGES, AND OTHER INFORMATION RESOURCES IN ELECTRONIC FORM IN THE FIELD OF RADIOLOGY (U.S. CLS. 100 AND 101).

FIRST USE 11-0-2009; IN COMMERCE 11-0-2009.
HEATHER THOMPSON, EXAMINING ATTORNEY

SN 85-368,336. TMW MARKETING COMPANY, INC., FREMONT, CA. FILED 7-11-2011.

MEN'S WEARHOUSE EXPRESS

THE MARK CONSISTS OF STANDARD CHARACTERS WITHOUT CLAIM TO ANY PARTICULAR FONT, STYLE, SIZE, OR COLOR.

OWNER OF U.S. REG. NOS. 1,521,918, 3,194,243 AND OTHERS.

NO CLAIM IS MADE TO THE EXCLUSIVE RIGHT TO USE "MEN'S" AND "EXPRESS", APART FROM THE MARK AS SHOWN.

CLASS 35—ADVERTISING AND BUSINESS

FOR RETAIL STORE SERVICES FEATURING MEN'S CLOTHING (U.S. CLS. 100, 101 AND 102).

CLASS 45—PERSONAL AND LEGAL SERVICES

FOR RENTAL OF CLOTHING; RENTAL OF FORMAL WEAR (U.S. CLS. 100 AND 101).
BRENDAN MCCAULEY, EXAMINING ATTORNEY

SN 85-368,571. BOOTSTAYLOR, BRAD, ATLANTA, GA. FILED 7-12-2011.

BRING BIRTH BACK!

THE MARK CONSISTS OF STANDARD CHARACTERS WITHOUT CLAIM TO ANY PARTICULAR FONT, STYLE, SIZE, OR COLOR.

CLASS 41—EDUCATION AND ENTERTAINMENT

FOR PROVIDING ON-LINE PUBLICATIONS IN THE NATURE OF E-BOOKS, ELECTRONIC ARTICLES AND PAMPHLETS IN THE FIELD OF BIRTH; EDUCATIONAL SERVICES, NAMELY, CONDUCTING SEMINARS IN THE FIELD OF BIRTH AND DISTRIBUTING COURSE MATERIAL IN CONNECTION THEREWITH IN THE NATURE OF BOOKS, PAMPHLETS AND ARTICLES (U.S. CLS. 100, 101 AND 107).

CLASS 44—MEDICAL, BEAUTY AND AGRICULTURAL SERVICES

FOR MIDWIFE SERVICES; OBSTETRIC SERVICES (U.S. CLS. 100 AND 101).
WILLIAM BRECKENFELD, EXAMINING ATTORNEY

SN 85-368,717. HIGH LINER FOODS (USA) INCORPORATED, PORTSMOUTH, NH. FILED 7-12-2011.

WE SEA WHAT'S NEXT

THE MARK CONSISTS OF STANDARD CHARACTERS WITHOUT CLAIM TO ANY PARTICULAR FONT, STYLE, SIZE, OR COLOR.

CLASS 35—ADVERTISING AND BUSINESS

FOR BUSINESS CONSULTING SERVICES RENDERED TO INSTITUTIONAL FOOD SERVICE ORGANIZATIONS IN THE FIELDS OF FROZEN SEAFOOD PRODUCT DEVELOPMENT AND PURCHASING (U.S. CLS. 100, 101 AND 102).

CLASS 42—SCIENTIFIC AND COMPUTER SERVICES

FOR RESEARCH AND DEVELOPMENT SERVICES IN THE FIELD OF SEAFOOD (U.S. CLS. 100 AND 101).

CLASS 43—HOTEL AND RESTAURANT SERVICES

FOR CONSULTING SERVICES RENDERED TO INSTITUTIONAL FOOD SERVICE ORGANIZATIONS IN THE FIELD OF MENU PLANNING (U.S. CLS. 100 AND 101).

JUSTINE D. PARKER, EXAMINING ATTORNEY

SN 85-368,928. DOMINION DERBY GIRLS, VIRGINIA BEACH, VA. FILED 7-12-2011.



NO CLAIM IS MADE TO THE EXCLUSIVE RIGHT TO USE "DERBY GIRLS", APART FROM THE MARK AS SHOWN.

THE MARK CONSISTS OF A CIRCULAR REPRESENTATION OF A ROLLER SKATE WHEEL WITH THREE CONCENTRIC BLACK RINGS, OUTLINED IN WHITE, WITH WHITE TRIANGULAR CUTOUPS INSIDE THE SECOND BLACK RING. THERE IS A PARTIAL STYLIZED FEMALE FACE IN WHITE WITH BLACK FEATURES WITH A WHITE FIST IN THE CENTER OF THE WHEEL. ON THE KNUCKLES OF THE FIST, THE LETTERS "D", "D", "G" AND A STAR CONTAINING THE NUMBER "7" APPEAR IN BLACK WITH BLACK AND WHITE SHADING. A WHITE BANNER ACROSS THE BOTTOM PORTION STATES "DOMINION DERBY GIRLS" IN BLACK AND THE BANNER IS OUTLINED IN BLACK.

CLASS 25—CLOTHING

FOR WEARABLE GARMENTS AND CLOTHING, NAMELY, SHIRTS (U.S. CLS. 22 AND 39).
FIRST USE 6-1-2005; IN COMMERCE 1-1-2006.

CLASS 41—EDUCATION AND ENTERTAINMENT

FOR ENTERTAINMENT IN THE NATURE OF ROLLER SKATING COMPETITIONS (U.S. CLS. 100, 101 AND 107).

FIRST USE 6-1-2005; IN COMMERCE 1-1-2006.
HENRY S. ZAK, EXAMINING ATTORNEY

SN 85-369,491. LAKUDA APS, 7140 STOUBY, DENMARK, FILED 7-12-2011.

SN 85-370,812. ERLY, INC., MENLO PARK, CA. FILED 7-13-2011.

JAPCELL

THE MARK CONSISTS OF STANDARD CHARACTERS WITHOUT CLAIM TO ANY PARTICULAR FONT, STYLE, SIZE, OR COLOR.

OWNER OF ERP N CMNTY TM OFC REG. NO. 009367376, DATED 4-19-2011, EXPIRES 4-19-2021.

CLASS 9—ELECTRICAL AND SCIENTIFIC APPARATUS

FOR BATTERIES; DISPOSABLE BATTERIES, PRIMARY BATTERIES, ALKALINE BATTERIES, LITHIUM BATTERIES, ZINC BATTERIES, ZINC-AIR BATTERIES, RECHARGEABLE BATTERIES, NI-MH BATTERIES, NI-CD BATTERIES, LEAD BATTERIES, LEAD ACCUMULATORS, GEL BATTERIES, AGM BATTERIES, DIGITAL CAMERA BATTERIES, VIDEO RECORDER BATTERIES, CELL PHONE BATTERIES, TOOL BATTERIES, LAPTOP BATTERIES, NOTEBOOK BATTERIES, NETBOOK BATTERIES, BATTERIES FOR ROBOTIC VACUUM CLEANERS, VACUUM CLEANER BATTERIES, NAVIGATION BATTERIES, MOBILE BATTERIES, INDUSTRIAL BATTERIES, INDUSTRIAL CELLS, NAMELY, BATTERIES FOR INDUSTRIAL USE; PDA BATTERIES, SMARTPHONE BATTERIES, RC BATTERIES, NAMELY, BATTERIES FOR RADIO CONTROL DEVICES; RC CELLS, NAMELY, BATTERY CELLS FOR RADIO CONTROL DEVICES; RC PACKS, NAMELY, BATTERY PACKS FOR RADIO CONTROL DEVICES; BACK-UP BATTERIES, GASTIGHT BATTERIES, SOLAR CELL BATTERIES, CAR BATTERIES, BATTERIES FOR ALARMS, HEARING AID BATTERIES, BUTTON CELLS, NAMELY, BATTERIES; BATTERY PACKS, BATTERY CHARGERS, BATTERY CHARGERS WITH CONTROL AND ANALYSIS COMPONENTS, POWER SUPPLIES; POWER SUPPLIES FOR NOTEBOOKS, CELL-PHONES, PDA, LCD SCREENS, MOBILE POWER SUPPLIES; BATTERY ELIMINATORS IN THE NATURE OF POWER SUPPLIES, MOBILE CHARGERS, PDA CHARGERS, CELL PHONE CHARGERS, INVERTERS, TRANSFORMERS, STEP-UP TRANSFORMERS, STEP-DOWN TRANSFORMERS, VOLTAGE TRANSFORMERS, VOLTAGE STABILIZERS, SOLAR CELLS, SOLAR CELL CHARGERS, SOLAR CELL MODULES, SOLAR CELL INVERTERS (U.S. CLS. 21, 23, 26, 36 AND 38).

CLASS 35—ADVERTISING AND BUSINESS

FOR RETAIL STORE SERVICES FEATURING BATTERIES (U.S. CLS. 100, 101 AND 102).

CLASS 39—TRANSPORTATION AND STORAGE

FOR WAREHOUSING SERVICES, NAMELY, DISTRIBUTION OF ELECTRONIC AND ELECTRICAL GOODS, PARTICULARLY BATTERIES (U.S. CLS. 100 AND 105). BRIDGETT SMITH, EXAMINING ATTORNEY

ERLY

THE MARK CONSISTS OF STANDARD CHARACTERS WITHOUT CLAIM TO ANY PARTICULAR FONT, STYLE, SIZE, OR COLOR.

CLASS 42—SCIENTIFIC AND COMPUTER SERVICES

FOR PROVIDING A SOCIAL CALENDARING SERVICE, NAMELY, PROVIDING A WEB SITE FEATURING TECHNOLOGY ENABLING USERS TO SHARE CALENDARS TO HELP USERS KEEP TRACK OF THEIR LIFE ACTIVITIES AND SHARE THEIR ACTIVITY PLANS AND INTERESTS WITH OTHERS (U.S. CLS. 100 AND 101).

CLASS 45—PERSONAL AND LEGAL SERVICES

FOR ONLINE SOCIAL NETWORKING SERVICES (U.S. CLS. 100 AND 101). JOHN DWYER, EXAMINING ATTORNEY

SN 85-371,143. AVRIO TECHNOLOGY GROUP, LLC, MIDDLETON, WI. FILED 7-14-2011.



NO CLAIM IS MADE TO THE EXCLUSIVE RIGHT TO USE "TECHNOLOGY GROUP LLC", APART FROM THE MARK AS SHOWN.

THE COLOR(S) RED AND GRAY IS/ARE CLAIMED AS A FEATURE OF THE MARK.

THE MARK CONSISTS OF THE WORDS "AVRIO TECHNOLOGY GROUP" WITH THE WORD "AVRIO" IN LARGE RED LETTERS, AND THE WORDS "TECHNOLOGY GROUP LLC" IN SMALLER GRAY LETTERS BELOW THE WORD "AVRIO", AND A BROKEN GRAY SHADED CURVED LINE BEHIND THE WORD "AVRIO".

THE ENGLISH TRANSLATION OF "AVRIO" IN THE MARK IS "TOMORROW".

CLASS 9—ELECTRICAL AND SCIENTIFIC APPARATUS

FOR ELECTRONIC COMPONENTS, NAMELY, CAVITY FILTERS, NAMELY, RADIO FREQUENCY SELECTIVE FILTERS WHICH EMPLOY A HOLLOW RESONANT CAVITY TO RESONATE OUT UNWANTED RADIO FREQUENCIES, QUARTZ CRYSTALS, QUARTZ CRYSTAL FILTERS, QUARTZ CRYSTAL OSCILLATORS, LC FILTERS, NAMELY, RADIO FREQUENCY SELECTIVE FILTERS EMPLOYING PASSIVE INDUCTIVE AND CAPACITIVE ELEMENTS ARRANGED IN SUCH A MANNER AS TO ALLOW FOR THE TRANSMISSION OR RECEPTION OF SPECIFIC RADIO FREQUENCIES, VOLTAGE CONTROLLED OSCILLATORS, RADIO FREQUENCY ASSEMBLIES, NAMELY, GENERATORS FOR SUPPLYING RADIO-FREQUENCY ENERGY, AND OVEN CONTROLLED CRYSTAL OSCILLATORS (U.S. CLS. 21, 23, 26, 36 AND 38).

CLASS 35—ADVERTISING AND BUSINESS

FOR MAIL ORDER AND WEB BASED CATALOG SERVICES FEATURING ELECTRONIC COMPONENTS, NAMELY, CAVITY FILTERS, NAMELY, RADIO FREQUENCY SELECTIVE FILTERS WHICH EMPLOY A HOLLOW RESONANT CAVITY TO RESONATE OUT UNWANTED RADIO FREQUENCIES, QUARTZ CRYSTALS, QUARTZ CRYSTAL FILTERS, QUARTZ CRYSTAL OSCILLATORS, LC FILTERS, NAMELY, RADIO FREQUENCY SELECTIVE FILTERS EMPLOYING PASSIVE INDUCTIVE AND CAPACITIVE ELEMENTS ARRANGED IN SUCH A MANNER AS TO ALLOW FOR THE TRANSMISSION OR RECEPTION OF SPECIFIC RADIO FREQUENCIES, VOLTAGE CONTROLLED OSCILLATORS, GENERATORS FOR SUPPLYING RADIO-FREQUENCY ENERGY, AND OVEN CONTROLLED CRYSTAL OSCILLATORS (U.S. CLS. 100, 101 AND 102).

CLASS 40—MATERIAL TREATMENT

FOR MANUFACTURING SERVICES TO THE ORDER AND SPECIFICATION OF OTHERS IN THE FIELD OF ELECTRONIC COMPONENTS, NAMELY, CAVITY FILTERS, NAMELY, RADIO FREQUENCY SELECTIVE FILTERS WHICH EMPLOY A HOLLOW RESONANT CAVITY TO RESONATE OUT UNWANTED RADIO FREQUENCIES, QUARTZ CRYSTALS, QUARTZ CRYSTAL FILTERS, QUARTZ CRYSTAL OSCILLATORS, LC FILTERS, NAMELY, RADIO FREQUENCY SELECTIVE FILTERS EMPLOYING PASSIVE INDUCTIVE AND CAPACITIVE ELEMENTS ARRANGED IN SUCH A MANNER AS TO ALLOW FOR THE TRANSMISSION OR RECEPTION OF SPECIFIC RADIO FREQUENCIES, VOLTAGE CONTROLLED OSCILLATORS, GENERATORS FOR SUPPLYING RADIO-FREQUENCY ENERGY, AND OVEN CONTROLLED CRYSTAL OSCILLATORS (U.S. CLS. 100, 103 AND 106).

CLASS 42—SCIENTIFIC AND COMPUTER SERVICES

FOR DESIGN AND TESTING TO THE ORDER AND SPECIFICATION OF OTHERS OF ELECTRONIC COMPONENTS, NAMELY, CAVITY FILTERS, NAMELY, RADIO FREQUENCY SELECTIVE FILTERS WHICH EMPLOY A HOLLOW RESONANT CAVITY TO RESONATE OUT UNWANTED RADIO FREQUENCIES, QUARTZ CRYSTALS, QUARTZ CRYSTAL FILTERS, QUARTZ CRYSTAL OSCILLATORS, LC FILTERS, NAMELY, RADIO FREQUENCY SELECTIVE FILTERS EMPLOYING PASSIVE INDUCTIVE AND CAPACITIVE ELEMENTS ARRANGED IN SUCH A MANNER AS TO ALLOW FOR THE TRANSMISSION OR RECEPTION OF SPECIFIC RADIO FREQUENCIES, VOLTAGE CONTROLLED OSCILLATORS, GENERATORS FOR SUPPLYING RADIO-FREQUENCY ENERGY, AND OVEN CONTROLLED CRYSTAL OSCILLATORS; SYSTEMS ENGINEERING, NAMELY, ENGINEERING IN THE FIELD OF EMBEDDED COMMUNICATIONS SOFTWARE FOR RADIO FREQUENCY COMPONENTS, SUBSYSTEMS AND OTHER ELECTRONIC COMMUNICATIONS DEVICES (U.S. CLS. 100 AND 101).

BILL DAWE, EXAMINING ATTORNEY

SN 85-374,095. BZ MEDIA LLC, HUNTINGTON, NY. FILED 7-18-2011.

SD TIMES

THE MARK CONSISTS OF STANDARD CHARACTERS WITHOUT CLAIM TO ANY PARTICULAR FONT, STYLE, SIZE, OR COLOR.

OWNER OF U.S. REG. NO. 2,462,715.

NO CLAIM IS MADE TO THE EXCLUSIVE RIGHT TO USE "SD", APART FROM THE MARK AS SHOWN.

CLASS 16—PAPER GOODS AND PRINTED MATTER

FOR MAGAZINES FEATURING SOFTWARE DEVELOPMENT (U.S. CLS. 2, 5, 22, 23, 29, 37, 38 AND 50).
FIRST USE 2-23-2000; IN COMMERCE 2-23-2000.

CLASS 42—SCIENTIFIC AND COMPUTER SERVICES

FOR PROVIDING A WEBSITE FEATURING INFORMATION IN THE FIELD OF SOFTWARE DEVELOPMENT (U.S. CLS. 100 AND 101).

FIRST USE 2-23-2000; IN COMMERCE 2-23-2000.

JORDAN BAKER, EXAMINING ATTORNEY

SN 85-374,358. COACH SERVICES, INC., NEW YORK, NY.
FILED 7-18-2011.

COACH NEW YORK

THE MARK CONSISTS OF STANDARD CHARACTERS WITHOUT CLAIM TO ANY PARTICULAR FONT, STYLE, SIZE, OR COLOR.

OWNER OF U.S. REG. NOS. 2,451,168, 3,157,972 AND 3,554,448.

NO CLAIM IS MADE TO THE EXCLUSIVE RIGHT TO USE "NEW YORK", APART FROM THE MARK AS SHOWN.

CLASS 9—ELECTRICAL AND SCIENTIFIC APPARATUS

FOR CASES FOR EYEGLASSES AND SUNGLASSES; SUNGLASSES AND SPECTACLES (U.S. CLS. 21, 23, 26, 36 AND 38).

CLASS 14—JEWELRY

FOR BRACELETS; EARRINGS; JEWELRY; KEY CHAINS AS JEWELLERY; KEY RINGS OF PRECIOUS METAL; NECKLACES; WATCHES (U.S. CLS. 2, 27, 28 AND 50).

CLASS 16—PAPER GOODS AND PRINTED MATTER

FOR CALENDARS AND DIARIES (U.S. CLS. 2, 5, 22, 23, 29, 37, 38 AND 50).

CLASS 24—FABRICS

FOR BATH TOWELS; BEACH TOWELS (U.S. CLS. 42 AND 50).

CLASS 25—CLOTHING

FOR SWIM SUITS; SWIM TRUNKS (U.S. CLS. 22 AND 39).

CHRIS WELLS, EXAMINING ATTORNEY

SN 85-374,859. ASTON MARTIN LAGONDA LIMITED, WARWICK, UNITED KINGDOM, FILED 7-19-2011.

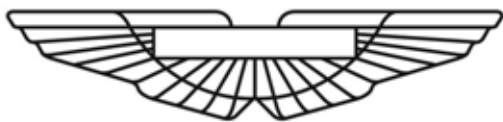

OWNER OF ERPN CMNTY TM OFC REG. NO. 008367831, DATED 2-17-2010, EXPIRES 6-16-2019.

OWNER OF U.S. REG. NOS. 1,333,643, 1,903,400 AND OTHERS.

THE MARK CONSISTS OF A WING DESIGN FEATURING A SOLID RECTANGULAR SHAPED ELEMENT IN THE MIDDLE OF THE DESIGN.

CLASS 9—ELECTRICAL AND SCIENTIFIC APPARATUS

FOR BURGLAR ALARMS; ANTENNAS; BATTERIES, BATTERIES FOR VEHICLES; BATTERY CHARGERS; SAFETY EQUIPMENT, NAMELY, BEACON LIGHTS; MARKER, NAVIGATIONAL AND SIGNALING BUOYS; COAXIAL, COMPUTER, ELECTRICAL AND FIBRE OPTIC CABLES; COMPUTER AND SILICON CHIPS; ELECTRIC CIGARETTE LIGHTERS FOR AUTOMOBILES; CIRCUIT BOARDS; ELECTRICAL AND PRINTED CIRCUIT BOARDS; ELECTRICAL CIRCUIT BOARDS AND INTEGRATED CIRCUITS; MAGNETIC CODED CARDS FOR FINANCIAL SERVICES, NAMELY, DEBIT CARDS AND CARD READERS; ELECTRICAL CONTROLLERS; CONVERTERS; ELECTRIC CONVERTERS; CRUISE CONTROLS FOR MOTOR VEHICLES; SMOKE DETECTORS; ELECTRIC LIGHT DIMMERS; BLANK OPTICAL DISCS; ELECTRIC LUMINESCENT DISPLAY PANELS; LIGHT EMITTING DIODE DISPLAYS; FIBRE OPTIC LIGHT AND IMAGE CONDUITS; FIBRE OPTICS; TELEPHONE APPARATUS, NAMELY, INTERCOMS; LASERS FOR INDUSTRIAL USE; ELECTRONIC MOTION SENSITIVE SWITCHES; SATELLITE PROCESSORS; RADAR AND RADAR DETECTORS; RADIOS; RADIOS FOR VEHICLES; RADIO RECEIVERS; SEMICONDUCTORS AND SEMICONDUCTOR DEVICES; SIGNAL PROCESSORS; SILICON WAFERS; SIRENS FOR VEHICLES; SOLENOID VALVES; ELECTRIC SWITCHES; ELECTRONIC MOTION SENSITIVE SWITCHES AND ELECTRONIC TOUCH SENSITIVE SWITCHES; TACHOMETERS; TELEVISION ANTENNAS; TRANSCEIVERS; ELECTRICAL TRANSFORMERS; RADIO TRANSMITTERS; VOLTAGE SURGE PROTECTORS AND SUPPRESSORS; WARNING TRIANGLES TO INDICATE VEHICLE BREAKDOWN; VIDEO TAPE RECORDERS; VIDEO CAMERAS; COMPACT DISC PLAYERS; MOVIE PROJECTORS; AUDIO CASSETTE DECKS FOR AUTOMOBILES; VIDEO MONITORS; BLANK MAGNETIC DATA CARRIERS; PRE-RECORDED MEDIA, NAMELY, CASSETTES, AUDIO TAPES, COMPACT DISCS AND VIDEOCASSETTES, FEATURING AUTOMOTIVE TOPICS, MUSIC, AND RELATED MATTERS OF INTEREST TO AUTOMOBILE OWNERS, NAMELY, AUTOMOBILE SERVICING, MAINTENANCE, REPAIR, TOWING, TRANSPORTATION, LEASING, RENTING AND TRAVELLING; DATA PROCESSING EQUIPMENT, NAMELY, DATA PROCESSORS, COMPUTERS AND COMPUTER MONITORS; SOFTWARE STORED ON DATA CARRIERS FOR USE IN CONNECTION WITH AUTOMOTIVE AND RELATED FUNCTIONS, NAMELY, AUTOMOTIVE NAVIGATION; SUNGLASSES; SPECTACLES; SPECTACLE FRAMES; SPECTACLE CASES; COMPASSES; FIRE EXTINGUISHING APPARATUS, NAMELY, FIRE EXTINGUISHERS; COMPUTER AIDED AUTOMOBILE DRIVING APPARATUS, NAMELY, A GPS NAVIGATION DEVICE; SIMULATORS FOR TRAINING PERSONS IN THE DRIVING OF VEHICLES; STILL PHOTOGRAPHIC CAMERAS; VIDEO DISCS WITH RECORDED ANIMATED CARTOONS; MOTION PICTURE FILMS ABOUT AUTOMOTIVE TOPICS AND RELATED MATTERS OF INTEREST TO AUTOMOBILE OWNERS, NAMELY, AUTOMOTIVE SERVICING, MAINTENANCE, REPAIR, TOWING, TRANSPORTATION, LEASING, RENTING AND TRAVELLING; PRE-RECORDED MEDIA INCLUDING VIDEO CASSETTES, VIDEO TAPES, COMPACT DISCS, DVDS, AUDIO CASSETTE TAPES, VIDEO GAME CAR-

TRIDGES AND COMPUTER DISCS FEATURING AUTOMOTIVE TOPICS AND RELATED MATTERS OF INTEREST TO AUTOMOBILE OWNERS, NAMELY, AUTOMOTIVE SERVICING, MAINTENANCE, REPAIR, TOWING, TRANSPORTATION, LEASING, RENTING AND TRAVELLING; COMPUTER SOFTWARE CONCERNED WITH CHILDREN'S EDUCATION AND ENTERTAINMENT, NAMELY, COMPUTER GAMES; TELEPHONE APPARATUS AND REPLACEMENT PARTS THEREOF; COMPUTER PERIPHERAL APPARATUS; COMPUTER SOFTWARE FOR USE IN CONTROLLING MOTORS; AUTOMOTIVE NAVIGATION, NAMELY, ROUTE PLANNING OR ROUTE MILEAGE OR CONTAINING CARTOGRAPHIC ROUTING INFORMATION; REFLECTIVE WARNING TRIANGLES; FUSES FOR VEHICLES, MAGNIFYING GLASSES; BATTERY CHARGERS AND CABLE JUMP LEAD SETS; PRESSURE GAUGES FOR VEHICLE TIRES; CIRCUIT TESTERS FOR BATTERIES; TEACHING APPARATUS AND INSTRUMENTS FOR AUTOMOBILE REPAIR; ELECTRICAL APPARATUS AND INSTRUMENTS, ALL FOR USE IN TESTING FUNCTIONS OF MOTOR VEHICLES AND/OR NAVIGATIONAL APPARATUS AND INSTRUMENTS; COMPUTER SIMULATION APPARATUS OR KITS COMPRISED OF NETWORKS OF SIMULATION SENSORS FOR REPRODUCING THE OPERATING FUNCTIONS OF ELECTRICAL, ELECTROMECHANICAL, AND/OR ELECTRONIC COMPONENTS OF AUTOMOBILES; DRIVING EYE GLASSES; DATA-PROCESSING COMPUTERS IN MOTOR VEHICLES; ON-BOARD COMPUTER HARDWARE, SOFTWARE AND DISPLAY MONITORS FOR AUTOMOTIVE APPLICATION WITH FUNCTIONS RELATED TO READING DRIVER-RELEVANT DATA, NAMELY, TRAFFIC AND WEATHER CONDITIONS, TRAVEL DESTINATION INFORMATION, AND PARKING INFORMATION, AS WELL AS SAFETY AND CONVENIENCE SERVICES, NAMELY, ROUTE PLANNING ASSISTANCE, EMERGENCY ROADSIDE ASSISTANCE, EMERGENCY CALL FUNCTIONS, STOLEN VEHICLE RECOVERY, REMOTE DOOR UNLOCK, OPERATOR-ASSISTED CALLS, AND CONCIERGE SERVICES, NAMELY, FUNCTIONS FOR OPERATING AND CONTROLLING ENTERTAINMENT SYSTEMS, COMMUNICATION SYSTEMS, INTERNET ACCESS AND NAVIGATION SYSTEMS (U.S. CLS. 21, 23, 26, 36 AND 38).

CLASS 12—VEHICLES

FOR MOTOR LAND VEHICLES AND PARTS AND FITTINGS THEREFOR, NAMELY, VEHICLE AXLE ASSEMBLIES COMPRISED OF AXELS AND CARDAN SHAFTS, VEHICLE BODIES, BRAKE CALIPERS, BRAKING SYSTEM FOR VEHICLES AND PARTS THEREOF, VEHICLE TOW BARS, AUTOMOTIVE BUMPERS, CLUTCHES, DIFFERENTIAL GEARS, DRIVE GEARS, DRIVE SHAFTS, ENGINES, MOTORS, GEAR CHANGE SELECTORS, TRANSMISSIONS, TRANSMISSION SHAFTS, HYDRAULIC CIRCUITS, TRAILER COUPLINGS; WHEEL BEARINGS, MOTOR VEHICLE CHASSIS; MANUAL AND POWER STEERING APPARATUS, NAMELY, STEERING BREAKS AND STEERING UNITS; PERSONAL SAFETY RESTRAINTS FOR VEHICLE SEATS, SEAT COVERS, SLIDING ROOF PANELS, VEHICLE STEERING COLUMNS, VEHICLE WHEELS HUBS, VEHICLE WHEELS, REPLACEMENT PARTS FOR ALL THE AFOREMENTIONED GOODS, WHEEL COVERS, BUG DEFLECTORS, TURN SIGNALS FOR VEHICLES, DOOR PANELS, AND DOOR PANEL HATCHES, UPHOLSTERY, HANDLES FOR DOOR, HORNS REARVIEW MIRRORS, MUD-FLAPS, ROOF-RACKS, SKI-RACKS, SHOCK ABSORBERS FOR AUTOMOBILES, SUSPENSION SPRINGS FOR MOTOR CARS, SUSPENSION STABILIZER BARS, STEERING WHEELS, STEERING LINKAGES, NAMELY, BALL JOINTS WITH CONTROL ARMS, BUSHING KITS, INNER TIE ROD ENDS, OUTER TIE ROD ENDS, SLEEVES, IDLER ARMS, CENTER LINKS, STABILIZER KITS, INNER SOCKETS AND PITMAN ARMS, SUSPENSIONS SYSTEM, SUSPENSION LOWERING KITS COMPRISED OF LEAF SPRINGS AND COIL SPRINGS, MOTOR LAND VEHICLES AND PARTS AND FITTINGS THEREFOR, NAMELY, TORSION BARS, WINDOWS, WINDOW WINDING MECHANISMS, WINDSCREEN WIPERS, AFTERMARKET AUTOMOBILE ACCESSORIES, NAMELY, ARM RESTS FOR VEHICLE SEATS, BALANCE WEIGHTS FOR WHEELS, BRAKE PADS AND DRUM BRAKE LININGS FOR VEHICLES; TRUCK

PARTS, NAMELY, A PREMIUM-OUTFITTED TRUCK CAB; MOTOR LAND VEHICLES AND PARTS AND FITTINGS THEREFOR, NAMELY, CAPS FOR VEHICLE FUEL TANKS; MECHANICAL STABILITY SYSTEM FOR ALLOWING IMPROVED CONTROL OF POWERED INDUSTRIAL LIFT TRUCKS, SOLD AS AN INTEGRAL COMPONENT OF POWERED INDUSTRIAL LIFT TRUCKS; AUTOMOTIVE ENGINE MOUNTINGS AND FUEL TANKS; FITTED PROTECTIVE COVERS FOR VEHICLES; FLUID RESERVOIRS, NAMELY, BRAKE CYLINDERS; AUTOMOTIVE AFTERMARKET PARTS, NAMELY, TRUCK BED STORAGE BOX; SPARE TIRE CARRIERS FOR VEHICLES, CAB TILT MECHANISMS, HYDRAULIC CIRCUITS; AUTOMOTIVE INTERIOR TRIM PANEL; LAND MOTOR VEHICLE PARTS, NAMELY, SPOILERS, SIDE SKIRTS, NAMELY, AUTOMOTIVE BODY KITS COMPRISING EXTERNAL STRUCTURAL PARTS OF AUTOMOBILES; ANTI-THEFT DEVICES FOR VEHICLES; VEHICLE WINDOW BLINDS; LUGGAGE RESTRAINTS FOR VEHICLES; LUGGAGE NETS FOR VEHICLES; SNOW CHAINS FOR LAND VEHICLES; PET SCREENS FOR USE IN VEHICLES; STONE SCREENS FOR VEHICLE HEADLIGHTS; SAFETY SEATS FOR CHILDREN FOR VEHICLES; SAFETY CUSHION PADDING FOR VEHICLE ROOF RACKS; SUN SHADES FOR CAR WINDOWS; MOBILE TELEPHONE MOUNTING EQUIPMENT; BICYCLES; BOATS; SNOW MOBILES; PERSONAL JET BOATS; HELICOPTERS; AIRCRAFT (U.S. CLS. 19, 21, 23, 31, 35 AND 44).

CLASS 14—JEWELRY

FOR PRECIOUS METALS AND THEIR ALLOYS; GOODS IN PRECIOUS METALS OR COATED THEREWITH, NAMELY, BADGES OF PRECIOUS METAL, NON-MONETARY COINS OF PRECIOUS METAL, TIE PINS AND JEWELRY PINS OF PRECIOUS METAL; JEWELRY; PRECIOUS STONES; HOROLOGICAL AND CHRONOMETRIC INSTRUMENTS, NAMELY, WATCHES, CLOCKS, CHRONOGRAPHS FOR USE AS WATCHES; WATCH ACCESSORIES, NAMELY, CASES FOR WATCHES, WATCH STRAPS OF METAL, LEATHER OR PLASTIC, WATCH CHAINS; CUFFLINKS (U.S. CLS. 2, 27, 28 AND 50).

CLASS 16—PAPER GOODS AND PRINTED MATTER

FOR PRINTED PUBLICATIONS AND PRINTED MATTER, NAMELY, MAGAZINES, ALL RELATING TO MOTOR SPORT, CAR RACING, AUTOMOTIVE HISTORY, DRIVING INSTRUCTION, ROAD SAFETY AND MOTOR VEHICLE MAINTENANCE; BOOKS, GUIDES AND HANDBOOKS ALL RELATING TO MOTOR SPORT, CAR RACING, AUTOMOTIVE HISTORY, DRIVING INSTRUCTION, ROAD SAFETY AND MOTOR VEHICLE MAINTENANCE; NEWSPAPERS, MAGAZINES AND BROCHURES RELATING TO MOTOR SPORTS, CAR RACING, AUTOMOTIVE TRAVEL AND RELATED MATTERS OF INTEREST TO AUTOMOBILE OWNERS; MAPS; STATIONERY; PRINTED TEACHING MATERIALS IN THE AUTOMOTIVE FIELD; ATLASES; BOOKMARKERS; CALENDARS; BLANK CARDS, GREETING CARDS; PAPER GIFT CARD VOUCHERS; LEAFLETS ABOUT AUTOMOBILES; STICKERS; PRINTED PAPER SIGNS; GLUE FOR STATIONERY OR HOUSEHOLD USE; INDIA INK; DOCUMENT FILES AND BOXES OF CARDBOARD FOR STATIONERY AND PAPERS; FOLDERS FOR STATIONERY AND PAPERS; EVENT ALBUMS; BINDERS; WRITING PADS AND PAPER; SKETCH BOOKS, PADS, PENS AND PEN INK CARTRIDGE SETS; NOTE BOOKS AND PADS; MAGAZINES AND NEWSLETTERS IN THE FIELD OF MOTOR VEHICLE MAINTENANCE; MODELING CLAY; PENS, PAINT BOXES, PAINTBRUSHES, PASTELS, CRAYONS, PENCILS; CASES, HOLDERS AND STANDS FOR PENS, PENCILS, PASTELS AND CRAYONS; PENCIL SHARPENERS; RUBBER ERASERS; UNGRADUATED RULERS; PRINTED ART PICTURES AND POSTERS; POSTCARDS; SCRAP BOOKS; STENCILS; STICKERS AND TRANSFERS; TABLECLOTHS, MATS, NAPKINS OF PAPER; WRAPPING PAPER; CALENDARS; POSTERS; PHOTOGRAPHS; PAPER WEIGHTS; SIGN-BOARDS OF PAPER OR CARDBOARD (U.S. CLS. 2, 5, 22, 23, 29, 37, 38 AND 50).

CLASS 18—LEATHER GOODS

FOR LEATHER AND IMITATIONS OF LEATHER, NAMELY, LEATHER SHOULDER BELTS, DOG COLLARS, KEY CASES, LEATHER LEADS, POCKET WALLETS, LEATHER POUCHES FOR PACKAGING, PURSES, TRAVELLING SETS COMPRISED OF LUGGAGE AND LUGGAGE STRAPS; LEATHER AND IMITATION LEATHER WALLETS; TRUNKS AND TRAVELLING BAGS; ATTACHE CASES, BACKPACKS, SPORTS BAGS, ENVELOPES FOR PACKAGING OF LEATHER, LEATHER POUCHES, GARMENT BAGS FOR TRAVEL MADE OF LEATHER, BOXES OF LEATHER OR LEATHERBOARD, BRIEFCASES, BUSINESS CARD CASES, NAME CARD CASES, HANDBAGS, RUCKSACKS, SUITCASES, AND UMBRELLAS (U.S. CLS. 1, 2, 3, 22 AND 41).

CLASS 25—CLOTHING

FOR CLOTHING, FOOTWEAR, AND HEADWEAR, NAMELY, WARM-UP SUITS, BLOUSES, SLACKS, CAPS, HOSE, HOSIERY, SCARVES, TIES, GLOVES, SWEATERS, JACKETS, PARKAS, CLOTH BIBS, COVERALLS, PANTS, SHOES, GOLF SHOES, BOOTS, SHIRTS, VESTS, COATS, AND SPECIAL-PURPOSE CLOTHING IN THE NATURE OF RAINWEAR; SPORTS CLOTHING FOR SNOWBOARDING, NAMELY, SKI JACKETS AND SKI PANTS; EAR MUFFS; GOLF HATS; VISORS; WET SUITS FOR SURFACE WATER SPORTS; WET SUITS FOR USE WHILE WATER SKIING, WINDSURFING OR WAKE BOARDING; SWIMSUITS; WETSUITS; SILK SQUARES, NAMELY, KERCHIEFS; SAUNA SUITS, NAMELY, SWEAT SUITS WORN DURING EXERCISE TO RAISE ONE'S BODY TEMPERATURE (U.S. CLS. 22 AND 39).

CLASS 28—TOYS AND SPORTING GOODS

FOR GAMES, TOYS, AND PLAYTHINGS, NAMELY, BOARD GAMES, MECHANICAL TOYS AND BEAN BAGS; GYMNASIUM APPARATUS AND SPORTING ARTICLES NOT INCLUDED IN OTHER CLASSES, NAMELY, ROWING MACHINES; DECORATIONS FOR CHRISTMAS TREES; TOY MODEL VEHICLES; JIGSAW PUZZLES (U.S. CLS. 22, 23, 38 AND 50).

CLASS 35—ADVERTISING AND BUSINESS

FOR ADVERTISING, MARKETING, AND PUBLICITY SERVICES; BUSINESS MANAGEMENT; BUSINESS ADMINISTRATIONS; PROVIDING OFFICE FUNCTIONS; RETAIL STORE SERVICES FEATURING LAND, WATER AND AIR VEHICLES, APPARATUS FOR LOCOMOTION BY LAND, AIR OR WATER, ENGINES, BOATS, YACHTS, BEAUTY PRODUCTS, TOILETRIES, SEWING MACHINES FOR HOUSEHOLD USE, HAND TOOLS, OPTICAL GOODS, NAMELY, CAMERAS; DOMESTIC ELECTRONICS, NAMELY, CLOCKS; RETAIL STORE SERVICES FEATURING JEWELRY, WATCHES, STATIONERY, PUBLICATIONS, LEATHER GOODS, LUGGAGE, FURNITURE, HOUSEHOLD CONTAINERS AND UTENSILS, FURNISHINGS, TEXTILES, CLOTHING, FOOTWEAR, HEADWEAR, HABERDASHERY, TOYS AND GAMES, SPORTS EQUIPMENT, FOODSTUFFS, DRINKS, TOBACCO PRODUCTS, SPORTING GOODS, KITCHEN UTENSILS AND EQUIPMENT, HOUSEHOLD LINENS, ARTIFICIAL PLANTS AND TREES, GLASSWARE, PORCELAIN AND EARTHENWARE, HOUSEHOLD PAPER PRODUCTS, LAUNDRY PREPARATIONS, SOAPS AND CLEANING PRODUCTS, COSMETICS, PERSONAL CARE PRODUCTS, PHARMACEUTICAL PREPARATIONS, VITAMINS, NUTRITIONAL SUPPLEMENTS, GARDENING PRODUCTS AND EQUIPMENT, PET FOOD AND PET CARE PRODUCTS, POWER AND HAND TOOLS, AUTOMOTIVE GOODS AND GASOLINE, HOUSEHOLD AND OUTDOOR FURNITURE, OFFICE FURNITURE AND EQUIPMENT, COMPUTERS AND COMPUTER PERIPHERALS, COMPUTER SOFTWARE AND HARDWARE, SMALL AND MAJOR APPLIANCES, COMPACT DISCS AND DVDS, CONSUMER ELECTRONICS, BATTERIES, HOLIDAY ORNAMENTS AND DECORATIONS, AND PARTS AND FITTINGS FOR THE AFORESAID GOODS; THE BRINGING TOGETHER, FOR THE BENEFIT OF OTHERS, OF A VARIETY OF SERVICES RELATING TO BUSINESS, FINANCE, REAL ESTATE, INSURANCE, TELECOMMUNICATIONS, TRAVEL, TICKETING AND

RESERVATION, ENABLING CUSTOMERS TO CONVENIENTLY PURCHASE THOSE SERVICES FROM AN INTERNET WEB SITE PARTICULARLY SPECIALIZING IN THE MARKETING OF THE SALE OF GOODS AND SERVICES OF OTHERS; BUSINESS CONSULTATION IN THE FIELD OF SALES OF AUTOMOBILES, BOATS, YACHTS AND AIRCRAFT; PROVIDING INFORMATION IN THE FIELD OF SALES OF AUTOMOBILES, BOATS, YACHTS AND AIRCRAFTS; MANAGEMENT OF PERFORMING ARTISTS; RATING THE CONDITION OF PRE-OWNED CARS FOR BUYERS PRIOR TO PURCHASE TO VERIFY THAT PRE-OWNED CARS HAVE BEEN RECONDITIONED AND ARE IN GOOD WORKING ORDER; DEALERSHIPS FOR NEW OR PRE-OWNED MOTOR VEHICLES (U.S. CLS. 100, 101 AND 102).

CLASS 37—CONSTRUCTION AND REPAIR

FOR REPAIR, RESTORATION, MAINTENANCE, RECONDITIONING, CLEANING, PAINTING AND POLISHING SERVICES FOR MOTOR VEHICLES; VEHICLE REPAIR; MECHANICAL TUNING OF AUTOMOBILES (U.S. CLS. 100, 103 AND 106).

ANTHONY RINKER, EXAMINING ATTORNEY

SN 85-375,580. CARROLL HALL SHELBY TRUST, LOS ANGELES, CA. FILED 7-19-2011.

SHELBY

THE MARK CONSISTS OF STANDARD CHARACTERS WITHOUT CLAIM TO ANY PARTICULAR FONT, STYLE, SIZE, OR COLOR.

OWNER OF U.S. REG. NOS. 1,538,090, 3,518,393 AND OTHERS.

THE NAME "SHELBY" IDENTIFIES A LIVING INDIVIDUAL WHOSE CONSENT IS OF RECORD.

CLASS 7—MACHINERY

FOR AIR FILTERS FOR AUTOMOBILE ENGINES; AUTOMOBILE ENGINE VALVE COVERS; AUTOMOBILE OIL PANS; AUTOMOTIVE PARTS, NAMELY, TURBOCHARGER SYSTEMS; COOLING RADIATORS FOR MOTORS AND ENGINES; ENGINE PARTS, NAMELY, OIL DIPSTICKS; FUEL INJECTOR PARTS FOR LAND AND WATER VEHICLE ENGINES; HEADERS AS PART OF VEHICLE EXHAUST SYSTEM; HEAT EXCHANGERS BEING PARTS OF MACHINES; INTERNAL COMBUSTION ENGINE PARTS, NAMELY, HEADS; INTERNAL COMBUSTION ENGINES LAND VEHICLE PARTS, NAMELY, COILS; INTERNAL COMBUSTION ENGINES LAND VEHICLE PARTS, NAMELY, DISTRIBUTOR CAPS; RADIATORS FOR MOTORS AND ENGINES; RADIATORS FOR MOTORS AND ENGINES; RADIATORS FOR VEHICLES; SHAFT COUPLINGS AS PARTS OF MACHINES; VEHICLE ENGINE PARTS, NAMELY, CHARGE AIR COOLERS AND THEIR COMPONENT PARTS; VEHICLE ENGINE PARTS, NAMELY, OIL COOLERS; VEHICLE ENGINE PARTS, NAMELY, OIL TANK PLUGS AND CAPS; VEHICLE PARTS, NAMELY, CAM COVERS; VEHICLE PARTS, NAMELY, CARBURETORS; VEHICLE PARTS, NAMELY, ENGINE CASES; VEHICLE PARTS, NAMELY, INTAKE MANIFOLDS (U.S. CLS. 13, 19, 21, 23, 31, 34 AND 35).

FIRST USE 1-1-1962; IN COMMERCE 1-1-1962.

CLASS 14—JEWELRY

FOR BRACELETS; BROACHES; DIAMOND JEWELRY; EARRINGS; INEXPENSIVE NON-JEWELRY WATCHES; JEWELRY; JEWELRY STICKPINS; JEWELRY WATCHES; KEY CHAINS AS JEWELLERY; KEY CHAINS OF PRECIOUS METAL; KEY HOLDERS OF PRECIOUS METALS; KEY RINGS OF PRECIOUS METAL; KEY RINGS OF PRECIOUS METALS; LAPEL PINS; RINGS; TIE CLIPS; TIE CLIPS OF PRECIOUS METAL; WATCHES AND JEWELRY; WATCHES, CLOCKS, JEWELRY AND IMITATION JEWELRY; WOMEN'S JEWELRY (U.S. CLS. 2, 27, 28 AND 50).

FIRST USE 1-1-1962; IN COMMERCE 1-1-1998.

CLASS 16—PAPER GOODS AND PRINTED MATTER

FOR ART PRINTS; ART PRINTS COMPRISED OF DIGITAL ILLUSTRATIONS ORIGINATING FROM PHOTOGRAPHS; ART PRINTS ON CANVAS; BALL POINT PENS; BALLPOINT PENS; BANNERS OF PAPER; BLANK OR PARTIALLY PRINTED POSTCARDS; BOOKLETS IN THE FIELD OF SHELBY AUTOMOBILES; BOOKS IN THE FIELD OF SHELBY AUTOMOBILES; BROCHURES ABOUT SHELBY AUTOMOBILES; CARTOON PRINTS; COFFEE TABLE BOOKS FEATURING SHELBY AUTOMOBILES; COLOR PRINTS; COLOURED PENS; COMMEMORATIVE BOOKS FEATURING SHELBY AUTOMOBILES; DIRECTORIES OF SHELBY AUTOMOBILES; FRAMED ART PRINTS; GRAPHIC FINE ART PRINTS; GRAPHIC PRINTS AND REPRESENTATIONS; INK PENS; MAGAZINES IN THE FIELD OF SHELBY AUTOMOBILES; MOUNTED POSTERS; PAPER BANNERS; PEN AND PENCIL CASES; PEN AND PENCIL CASES AND BOXES; PEN AND PENCIL HOLDERS; PEN CASES; PHOTOGRAPHIC PRINTS; PICTORIAL PRINTS; POSTERS; POSTERS MADE OF PAPER; PRINTED CALENDARS; PRINTED CERTIFICATES; PRINTED EMBLEMS; PRINTED MATERIALS, NAMELY, WRITTEN ARTICLES IN THE FIELD OF SHELBY AUTOMOBILES; PRINTED PAPER LABELS; PRINTED PAPER SIGNS; SILK SCREEN PRINTS; UNMOUNTED POSTERS (U.S. CLS. 2, 5, 22, 23, 29, 37, 38 AND 50).

FIRST USE 1-1-1962; IN COMMERCE 1-1-1962.

CLASS 18—LEATHER GOODS

FOR ALL PURPOSE SPORT BAGS; ALL-PURPOSE ATHLETIC BAGS; ALL-PURPOSE CARRYING BAGS; ALL-PURPOSE REUSABLE CARRYING BAGS; ATHLETIC BAGS; BACKPACKS, BOOK BAGS, SPORTS BAGS, BUM BAGS, WALLETS AND HANDBAGS; CANVAS SHOPPING BAGS; CASES FOR KEYS; DUFFLE BAGS; GARMENT BAGS FOR TRAVEL; KEY BAGS; KEY CASES; KEY CASES; KEY CASES OF LEATHER OR IMITATION LEATHER; KEY WALLETS; KEY-CASES; KEY-CASES OF LEATHER AND SKINS; LEATHER BAGS AND WALLETS; LEATHER BAGS, SUITCASES AND WALLETS; LEATHER CASES FOR KEYS; MEN'S CLUTCH BAGS; POUCHES FOR HOLDING KEYS; TOTE BAGS; WINE BAGS WITH HANDLES FOR CARRYING OR HOLDING WINE (U.S. CLS. 1, 2, 3, 22 AND 41).

FIRST USE 1-1-1962; IN COMMERCE 1-1-2006.

CLASS 21—HOUSEWARES AND GLASS

FOR BEER MUGS; BEVERAGE GLASSWARE; COFFEE CUPS, TEA CUPS AND MUGS; COFFEE MUGS; DECORATIVE PLATES; DESSERT PLATES; DISHES AND PLATES; DISPOSABLE TABLE PLATES; DRINKING GLASSES; GLASS MUGS; MUGS; MUGS, NOT OF PRECIOUS METAL; PLASTIC CUPS; PLASTIC PLATES; PLATE GLASS FOR CARS; PLATES; PORCELAIN MUGS; PORTABLE COOLERS, NAMELY, PORTABLE BEVERAGE OR ICE COOLERS MOUNTED ON TELESCOPING WHEELED CADDIES; PORTABLE ICE CHESTS FOR FOOD AND BEVERAGES; REUSABLE PLASTIC WATER BOTTLES SOLD EMPTY; SALT AND PEPPER MILLS; SALT AND PEPPER SHAKERS; SALT SHAKERS; SOUVENIR PLATES (U.S. CLS. 2, 13, 23, 29, 30, 33, 40 AND 50).

FIRST USE 1-1-1962; IN COMMERCE 1-1-2006.

CLASS 25—CLOTHING

FOR BELTS; BUTTON DOWN SHIRTS; COLLARED SHIRTS; DRESS PANTS; DRESS SHIRTS; GLOVES AS CLOTHING; GOLF SHIRTS; JACKETS; JEANS; JERSEYS; LEATHER BELTS; LONG-SLEEVED SHIRTS; PANTS; POLO SHIRTS; SHIRTS; SHORT-SLEEVED SHIRTS; SOCKS; T-SHIRTS; T-SHIRTS FOR CHILDREN; WOMEN, MEN; TEE SHIRTS; TIES; WOMEN'S CLOTHING, NAMELY, SHIRTS, DRESSES, SKIRTS, BLOUSES (U.S. CLS. 22 AND 39).

FIRST USE 1-1-1962; IN COMMERCE 1-1-1962.

CLASS 27—FLOOR COVERINGS

FOR FLOOR MATS FOR AUTOMOBILES; FLOOR MATS FOR VEHICLES (U.S. CLS. 19, 20, 37, 42 AND 50).

FIRST USE 1-1-1962; IN COMMERCE 1-1-1962.

CLASS 28—TOYS AND SPORTING GOODS

FOR MODEL CARS; MODEL TOY VEHICLES; PLAY MOTOR CARS; RADIO CONTROLLED MODEL VEHICLES; REMOTE CONTROL TOYS, NAMELY, RACE CARS AND OTHER VEHICLES; SCALE MODEL VEHICLES; SCALE-MODEL VEHICLES; TOY CARS; TOY MODEL CARS; TOY MODEL KIT CARS; TOY MODEL VEHICLES AND RELATED ACCESSORIES SOLD AS UNITS (U.S. CLS. 22, 23, 38 AND 50).

FIRST USE 1-1-1962; IN COMMERCE 1-1-1988.

CLASS 33—WINES AND SPIRITS

FOR BRANDY SPIRITS; DISTILLED SPIRITS; RED WINE; SPARKLING WINES; TABLE WINES; WHITE WINE; WINE; WINES; WINES AND LIQUEURS (U.S. CLS. 47 AND 49).

FIRST USE 1-1-2006; IN COMMERCE 1-1-2006.

CLASS 35—ADVERTISING AND BUSINESS

FOR ON-LINE RETAIL GIFT SHOPS; ON-LINE RETAIL STORE SERVICES FEATURING A WIDE VARIETY OF CONSUMER GOODS OF OTHERS; ON-LINE RETAIL STORE SERVICES FEATURING SHELBY AUTHORIZED PRODUCTS AND MERCHANDISE, NAMELY, AUTO PARTS, CLOTHING, TOYS, JEWELRY, FOOD PRODUCTS, VEHICLES, BOOKS, MAGAZINES, PHOTOS, DECALS, PLAQUES, AND SIGNS (U.S. CLS. 100, 101 AND 102).

FIRST USE 1-1-2006; IN COMMERCE 1-1-2006.

CHRISTINA SOBRAL, EXAMINING ATTORNEY

SN 85-375,847. MAPLE LEAF FOODS INC., TORONTO, CANADA, FILED 7-20-2011.

TENDERFLAKE EASY PIE

THE MARK CONSISTS OF STANDARD CHARACTERS WITHOUT CLAIM TO ANY PARTICULAR FONT, STYLE, SIZE, OR COLOR.

NO CLAIM IS MADE TO THE EXCLUSIVE RIGHT TO USE "PIE", APART FROM THE MARK AS SHOWN.

CLASS 29—MEATS AND PROCESSED FOODS

FOR LARD, SHORTENING (U.S. CL. 46).

CLASS 30—STAPLE FOODS

FOR FROZEN PIE SHELLS, FROZEN TART SHELLS, FROZEN PATTY SHELLS, NAMELY, READY TO BAKE PIE, TART AND PATTY SHELLS, AND FROZEN PUFF PASTRY; BAKERY PRODUCTS, NAMELY, ALL TYPES OF BREADS, ROLLS, BUNS, CAKES, COOKIES, MUFFINS, MORNING BUNS, CROISSANTS, BAGELS, FLAT-BREADS, TURNOVERS, CINNAMON ROLLS, DOUGHNUTS, BISCUITS, SCONES; FRUIT BITES, NAMELY, FRUIT-FILLED FLAKY PASTRY; BUTTER TARTS, STRUDEL, PIE KITS, NAMELY, KIT CONTAINING A PIE SHELL, CRUMBLE TOPPING AND SPICE BLEND PACKET, OR TOP AND BOTTOM PIE CRUST AND SPICE BLEND PACKET (U.S. CL. 46).

DANIEL CAPSHAW, EXAMINING ATTORNEY

SN 85-375,903. SELECT JEWELRY, INC., LONG ISLAND CITY, NY. FILED 7-20-2011.

AvantOro

THE MARK CONSISTS OF THE STYLIZED FORM OF THE LETTERS "AVANTORO".

THE WORD(S) "AVANTORO" HAS NO MEANING IN A FOREIGN LANGUAGE.

CLASS 14—JEWELRY

FOR GOLD JEWELRY, NAMELY, RINGS, BRACELETS, CHARMS, PENDANTS, EARRINGS, NECKLACES, BROOCHES, PINS AND CUFFLINKS (U.S. CLS. 2, 27, 28 AND 50).

CLASS 35—ADVERTISING AND BUSINESS

FOR RETAIL AND WHOLESALE STORES FEATURING GOLD JEWELRY, NAMELY, RINGS, BRACELETS, CHARMS, PENDANTS, EARRINGS, NECKLACES, BROOCHES, PINS AND CUFFLINKS (U.S. CLS. 100, 101 AND 102).

BARBARA BROWN, EXAMINING ATTORNEY

SN 85-376,560. LP INNOVATIONS, INC., MILFORD, MA. FILED 7-20-2011.

LPI

THE MARK CONSISTS OF STANDARD CHARACTERS WITHOUT CLAIM TO ANY PARTICULAR FONT, STYLE, SIZE, OR COLOR.

CLASS 41—EDUCATION AND ENTERTAINMENT

FOR LOSS PREVENTION EDUCATION SERVICES, NAMELY, PROVIDING LIVE AND ONLINE TRAINING, EDUCATIONAL PROGRAMS, CLASSES, AND SEMINARS IN THE FIELD OF BUSINESS LOSS PREVENTION (U.S. CLS. 100, 101 AND 107).

FIRST USE 6-15-1998; IN COMMERCE 6-15-1998.

CLASS 45—PERSONAL AND LEGAL SERVICES

FOR LOSS PREVENTION SERVICES FOR BUSINESSES, NAMELY, DEVELOPMENT AND IMPLEMENTATION OF LOSS PREVENTION POLICIES AND PROCEDURES FOR THE REVIEW AND ANALYSIS OF SALES TRANSACTIONS AND RELATED DATA, INVESTIGATIVE SERVICES AND LOSS PREVENTION CONSULTING, NAMELY, SITE SURVEYS AND RISK ANALYSIS; LOSS PREVENTION SERVICES FOR BUSINESSES, NAMELY, BUSINESS OPERATION AUDITS FOR LOSS PREVENTION PURPOSES, INVENTORY PROCESSES AUDITS FOR LOSS PREVENTION PURPOSES, AUDITING PROCESSES FOR DEALING WITH LOSS PREVENTION AND AUDITING PHARMACY COMPLIANCE FOR LOSS PREVENTION PURPOSES; LOSS PREVENTION SERVICES FOR BUSINESSES, NAMELY, MYSTERY SHOPPING SERVICES FOR LOSS PREVENTION PURPOSES (U.S. CLS. 100 AND 101).

FIRST USE 6-15-1998; IN COMMERCE 6-15-1998.
DANIEL CAPSHAW, EXAMINING ATTORNEY

SN 85-377,112. USDS, INC., ROCKVILLE, MD. FILED 7-21-2011.

PROTODX

THE MARK CONSISTS OF STANDARD CHARACTERS WITHOUT CLAIM TO ANY PARTICULAR FONT, STYLE, SIZE, OR COLOR.

CLASS 35—ADVERTISING AND BUSINESS

FOR BUSINESS STRATEGIC PLANNING SERVICES IN THE FIELD OF MEDICAL AND SCIENTIFIC DETECTION AND DIAGNOSTIC TESTS OF OTHERS (U.S. CLS. 100, 101 AND 102).

CLASS 42—SCIENTIFIC AND COMPUTER SERVICES

FOR EVALUATION AND ANALYSIS OF MEDICAL AND SCIENTIFIC DETECTION AND DIAGNOSTIC TESTS OF OTHERS (U.S. CLS. 100 AND 101).

TINA L. SNAPP, EXAMINING ATTORNEY

SN 85-377,103. USDS, INC., ROCKVILLE, MD. FILED 7-21-2011.

PHASEDX

THE MARK CONSISTS OF STANDARD CHARACTERS WITHOUT CLAIM TO ANY PARTICULAR FONT, STYLE, SIZE, OR COLOR.

CLASS 35—ADVERTISING AND BUSINESS

FOR CONSULTING SERVICES IN THE FIELD OF COMMERCIALIZATION AND MARKET ADOPTION OF MEDICAL AND SCIENTIFIC DETECTION AND DIAGNOSTIC TESTS; BUSINESS STRATEGIC PLANNING SERVICES IN THE FIELD OF MEDICAL AND SCIENTIFIC DETECTION AND DIAGNOSTIC TESTS OF OTHERS (U.S. CLS. 100, 101 AND 102).

CLASS 42—SCIENTIFIC AND COMPUTER SERVICES

FOR EVALUATION AND ANALYSIS OF MEDICAL AND SCIENTIFIC DETECTION AND DIAGNOSTIC TESTS OF OTHERS (U.S. CLS. 100 AND 101).

CLASS 45—PERSONAL AND LEGAL SERVICES

FOR REGULATORY COMPLIANCE CONSULTING IN THE FIELD OF MEDICAL AND SCIENTIFIC DETECTION AND DIAGNOSTIC TESTS OF OTHERS (U.S. CLS. 100 AND 101).

TINA L. SNAPP, EXAMINING ATTORNEY

SN 85-377,114. USDS, INC., ROCKVILLE, MD. FILED 7-21-2011.

POSITIONDX

THE MARK CONSISTS OF STANDARD CHARACTERS WITHOUT CLAIM TO ANY PARTICULAR FONT, STYLE, SIZE, OR COLOR.

CLASS 35—ADVERTISING AND BUSINESS

FOR CONSULTING SERVICES IN THE FIELD OF COMMERCIALIZATION AND MARKET ADOPTION OF MEDICAL AND SCIENTIFIC DETECTION AND DIAGNOSTIC TESTS; CONSULTING SERVICES IN THE FIELD OF ADMINISTRATION OF PATIENT REIMBURSEMENT PROGRAMS FOR COSTS OF MEDICAL AND SCIENTIFIC DETECTION AND DIAGNOSTIC TESTS; BUSINESS STRATEGIC PLANNING SERVICES IN THE FIELD OF MEDICAL AND SCIENTIFIC DETECTION AND DIAGNOSTIC TESTS OF OTHERS (U.S. CLS. 100, 101 AND 102).

CLASS 41—EDUCATION AND ENTERTAINMENT

FOR EDUCATION COURSES FOR OTHERS IN THE FIELD OF MEDICAL AND SCIENTIFIC DETECTION AND DIAGNOSTIC TESTS (U.S. CLS. 100, 101 AND 107).

CLASS 42—SCIENTIFIC AND COMPUTER SERVICES

FOR EVALUATION AND ANALYSIS OF MEDICAL AND SCIENTIFIC DETECTION AND DIAGNOSTIC TESTS OF OTHERS (U.S. CLS. 100 AND 101).

CLASS 45—PERSONAL AND LEGAL SERVICES

FOR REGULATORY COMPLIANCE CONSULTING IN THE FIELD OF MEDICAL AND SCIENTIFIC DETECTION AND DIAGNOSTIC TESTS OF OTHERS (U.S. CLS. 100 AND 101).

TINA L. SNAPP, EXAMINING ATTORNEY

SN 85-377,508. OWENS CORNING INTELLECTUAL CAPITAL, LLC, TOLEDO, OH. FILED 7-21-2011.



THE MARK CONSISTS OF THE LETTERS "EMP" IN A BLOCK DESIGN.

CLASS 16—PAPER GOODS AND PRINTED MATTER

FOR CARDBOARD PACKAGING IN THE FORM OF BLOCKS AND BRACES TO POSITION A PRODUCT IN PLACE; CARDBOARD CUSHIONING MATERIAL FOR PACKAGING APPLICATIONS (U.S. CLS. 2, 5, 22, 23, 29, 37, 38 AND 50).

CLASS 17—RUBBER GOODS

FOR GLASS FIBER INSULATION USED AS INTERIOR FILL MATERIAL FOR PACKAGING APPLICATION; THERMAL INSULATION, NAMELY INSULATING MATERIALS (U.S. CLS. 1, 5, 12, 13, 35 AND 50).

JOHN DWYER, EXAMINING ATTORNEY



BEVERLY HILLS LASHES

NO CLAIM IS MADE TO THE EXCLUSIVE RIGHT TO USE "BEVERLY HILLS LASHES", APART FROM THE MARK AS SHOWN.

THE MARK CONSISTS OF A CREST WITH THE LETTERS "BHL". BELOW THERE IS THE STYLIZED TEXT "BEVERLY HILLS LASHES".

CLASS 3—COSMETICS AND CLEANING PREPARATIONS

FOR ADHESIVES FOR AFFIXING FALSE EYELASHES; ARTIFICIAL EYELASHES; COSMETICS; NON-MEDICATED SERUMS FOR USE ON EYELASHES (U.S. CLS. 1, 4, 6, 50, 51 AND 52).

CLASS 41—EDUCATION AND ENTERTAINMENT

FOR TRAINING SERVICES IN THE FIELD OF EYELASH EXTENSION APPLICATION (U.S. CLS. 100, 101 AND 107).

CLASS 44—MEDICAL, BEAUTY AND AGRICULTURAL SERVICES

FOR BEAUTY SALON SERVICES (U.S. CLS. 100 AND 101).

DARRYL SPRUILL, EXAMINING ATTORNEY

SN 85-377,767. SADDLEBACK EDUCATIONAL, INC., COSTA MESA, CA. FILED 7-21-2011.

CARTER HIGH

THE MARK CONSISTS OF STANDARD CHARACTERS WITHOUT CLAIM TO ANY PARTICULAR FONT, STYLE, SIZE, OR COLOR.

NO CLAIM IS MADE TO THE EXCLUSIVE RIGHT TO USE "HIGH", APART FROM THE MARK AS SHOWN.

CLASS 9—ELECTRICAL AND SCIENTIFIC APPARATUS

FOR DOWNLOADABLE ELECTRONIC PUBLICATIONS IN THE NATURE OF ELECTRONIC BOOKS AND TEACHER'S GUIDES IN THE FIELD OF REMEDIAL EDUCATION FOR SECONDARY AND ADULT EDUCATION (U.S. CLS. 21, 23, 26, 36 AND 38).

FIRST USE 0-0-2003; IN COMMERCE 0-0-2003.

CLASS 16—PAPER GOODS AND PRINTED MATTER

FOR SERIES OF FICTION BOOKS AND TEACHER'S GUIDES IN THE FIELD OF REMEDIAL EDUCATION FOR SECONDARY AND ADULT EDUCATION; PRINTED MATTER, NAMELY, BOOKS AND TEACHING GUIDES IN THE FIELD OF REMEDIAL EDUCATION FOR SECONDARY AND ADULT EDUCATION (U.S. CLS. 2, 5, 22, 23, 29, 37, 38 AND 50).

FIRST USE 0-0-2003; IN COMMERCE 0-0-2003.
JULIE GUTTADAURO, EXAMINING ATTORNEY

SN 85-377,887. SADDLEBACK EDUCATIONAL, INC., COSTA MESA, CA. FILED 7-21-2011.

STRANGE BUT TRUE

THE MARK CONSISTS OF STANDARD CHARACTERS WITHOUT CLAIM TO ANY PARTICULAR FONT, STYLE, SIZE, OR COLOR.

CLASS 9—ELECTRICAL AND SCIENTIFIC APPARATUS

FOR DOWNLOADABLE ELECTRONIC PUBLICATIONS IN THE NATURE OF ELECTRONIC BOOKS AND TEACHER'S GUIDES IN THE FIELD OF REMEDIAL EDUCATION FOR SECONDARY AND ADULT EDUCATION (U.S. CLS. 21, 23, 26, 36 AND 38).

FIRST USE 0-0-2006; IN COMMERCE 0-0-2006.

CLASS 16—PAPER GOODS AND PRINTED MATTER

FOR SERIES OF FICTION BOOKS AND TEACHER'S GUIDES IN THE FIELD OF REMEDIAL EDUCATION FOR SECONDARY AND ADULT EDUCATION; PRINTED MATTER, NAMELY, BOOKS AND TEACHING GUIDES IN THE FIELD OF REMEDIAL EDUCATION FOR SECONDARY AND ADULT EDUCATION (U.S. CLS. 2, 5, 22, 23, 29, 37, 38 AND 50).

FIRST USE 0-0-2006; IN COMMERCE 0-0-2006.
JULIE GUTTADAURO, EXAMINING ATTORNEY

SN 85-377,894. SADDLEBACK EDUCATIONAL, INC., COSTA MESA, CA. FILED 7-21-2011.

THINK GREEN

THE MARK CONSISTS OF STANDARD CHARACTERS WITHOUT CLAIM TO ANY PARTICULAR FONT, STYLE, SIZE, OR COLOR.

NO CLAIM IS MADE TO THE EXCLUSIVE RIGHT TO USE "GREEN", APART FROM THE MARK AS SHOWN.

CLASS 9—ELECTRICAL AND SCIENTIFIC APPARATUS

FOR DOWNLOADABLE ELECTRONIC PUBLICATIONS IN THE NATURE OF ELECTRONIC BOOKS AND TEACHER'S GUIDES IN THE FIELD OF REMEDIAL EDUCATION FOR SECONDARY AND ADULT EDUCATION (U.S. CLS. 21, 23, 26, 36 AND 38).

FIRST USE 0-0-2008; IN COMMERCE 0-0-2008.

CLASS 16—PAPER GOODS AND PRINTED MATTER

FOR SERIES OF FICTION BOOKS AND TEACHER'S GUIDES IN THE FIELD OF REMEDIAL EDUCATION FOR SECONDARY AND ADULT EDUCATION; PRINTED MATTER, NAMELY, BOOKS AND TEACHING GUIDES IN THE FIELD OF REMEDIAL EDUCATION FOR SECONDARY AND ADULT EDUCATION (U.S. CLS. 2, 5, 22, 23, 29, 37, 38 AND 50).

FIRST USE 0-0-2008; IN COMMERCE 0-0-2008.
JULIE GUTTADAURO, EXAMINING ATTORNEY

SN 85-378,810. CHARTER SERVICES NEW YORK, INC., WHITE PLAINS, NY. FILED 7-22-2011.

SCOPECLOUD

THE MARK CONSISTS OF STANDARD CHARACTERS WITHOUT CLAIM TO ANY PARTICULAR FONT, STYLE, SIZE, OR COLOR.

CLASS 9—ELECTRICAL AND SCIENTIFIC APPARATUS

FOR DOWNLOADABLE SOFTWARE APPLICATION PROVIDING CONNECTIVITY BETWEEN MEDICAL DIAGNOSTIC EQUIPMENT AND COMPUTER HARDWARE DEVICES FOR STORING, READING, AND DISTRIBUTING MEDICAL DATA AND IMAGES FROM MEDICAL DIAGNOSTIC EQUIPMENT AND COMPUTER HARDWARE DEVICES FOR STORING, READING AND DISTRIBUTING MEDICAL DATA AND IMAGES (U.S. CLS. 21, 23, 26, 36 AND 38).

CLASS 10—MEDICAL APPARATUS

FOR MEDICAL DEVICE FOR COLLECTING, STORING, AND DISTRIBUTING MEDICAL DATA AND IMAGES, NAMELY, ENDOSCOPIC EQUIPMENT (U.S. CLS. 26, 39 AND 44).

CLASS 42—SCIENTIFIC AND COMPUTER SERVICES

FOR PROVIDING AN ONLINE NON-DOWNLOADABLE SOFTWARE APPLICATION PROVIDING CONNECTIVITY BETWEEN MEDICAL DIAGNOSTIC EQUIPMENT AND COMPUTER HARDWARE DEVICES FOR STORING, READING, AND DISTRIBUTING SUCH MEDICAL DATA AND IMAGES (U.S. CLS. 100 AND 101).

REBECCA EISINGER, EXAMINING ATTORNEY

SN 85-380,038. CHURCH UNIVERSAL AND TRIUMPHANT, INC., DBA SUMMIT UNIVERSITY PRESS, GARDINER, MT. FILED 7-25-2011.

**SUMMIT UNIVERSITY PRESS
ESPAÑOL**

THE MARK CONSISTS OF STANDARD CHARACTERS WITHOUT CLAIM TO ANY PARTICULAR FONT, STYLE, SIZE, OR COLOR.

OWNER OF U.S. REG. NOS. 1,075,919 AND 1,076,660.

NO CLAIM IS MADE TO THE EXCLUSIVE RIGHT TO USE "UNIVERSITY PRESS ESPAÑOL", APART FROM THE MARK AS SHOWN.

THE ENGLISH TRANSLATION OF "ESPAÑOL" IN THE MARK IS "SPANISH".

CLASS 9—ELECTRICAL AND SCIENTIFIC APPARATUS

FOR DOWNLOADABLE AUDIO FILES; DOWNLOADABLE AUDIO AND VIDEO RECORDINGS; DOWNLOADABLE MULTIMEDIA FILES; DOWNLOADABLE ELECTRONIC PUBLICATIONS, NAMELY, ELECTRONIC BOOKS, AUDIO BOOKS, ENHANCED ELECTRONIC BOOKS INCORPORATING AUDIO AND VIDEO FILES, BOOKLETS, PAMPHLETS, COURSE CURRICULA AND ELECTRONIC TEMPLATES THAT ALLOW USERS TO GENERATE PROMOTIONAL MATERIALS FOR THEIR OWN EVENTS; DOWNLOADABLE ELECTRONIC NEWSLETTERS; DOWNLOADABLE IMAGE AND MULTIMEDIA FILES CONTAINING ARTWORK, TEXT, AUDIO, VIDEO, GAMES AND INTERNET WEB LINKS; DOWNLOADABLE MP3 FILES AND MP3 RECORDINGS; DOWNLOADABLE WEBCASTS; DOWNLOADABLE WEBINARS; AND DOWNLOADABLE PODCASTS; PRERECORDED CD-ROMS AND DVDS FEATURING ELECTRONIC BOOKS, AUDIO BOOKS, TEXT, NARRATION, MUSICAL AND DRAMATIC PERFORMANCES, MOTION AND NON-MOTION PICTURE FILM AND DIGITAL IMAGES, AND THE SPOKEN WORD, ALL IN THE FIELDS OF RELIGION, PHILOSOPHY AND SPIRITUALITY (U.S. CLS. 21, 23, 26, 36 AND 38).

CLASS 16—PAPER GOODS AND PRINTED MATTER

FOR BOOKS AND PUBLICATIONS, NAMELY, PERIODICAL NEWSPAPERS, NEWSLETTERS, MAGAZINES, PRINTED LESSONS, PAMPHLETS, POSTERS AND PICTURES, ALL IN THE FIELDS OF RELIGION, PHILOSOPHY AND SPIRITUALITY (U.S. CLS. 2, 5, 22, 23, 29, 37, 38 AND 50).

LESLEY LAMOTHE, EXAMINING ATTORNEY

SN 85-381,863. ADITYA WATAL, EDISON, NJ. FILED 7-27-2011.

Guzool

THE MARK CONSISTS OF STANDARD CHARACTERS WITHOUT CLAIM TO ANY PARTICULAR FONT, STYLE, SIZE, OR COLOR.

CLASS 9—ELECTRICAL AND SCIENTIFIC APPARATUS

FOR COMPUTER APPLICATION SOFTWARE FOR USE IN WORD PROCESSING, DATA PROCESSING, USE AS A SPREADSHEET AND DATA STORAGE AND DATA ANALYSIS IN CONNECTION WITH COMPUTER DATA PROCESSING AND DATABASE MANAGEMENT, OPERATING SYSTEMS, DATABASE SERVER, APPLICATION SERVER, VIRTUALIZATION HYPERVISOR, AND COMPUTER NETWORK ROUTERS AND SWITCHES, TELEPHONE ROUTERS AND SWITCHES, MOBILE AND SATELLITE PHONES, TABLET COMPUTERS, PRINTERS, RADAR, PORTABLE MEDIA PLAYERS, HAND HELD COMPUTERS, LAPTOPS, DESKTOP COMPUTERS, DUAL SCREEN LAPTOPS, INTERACTIVE COMPUTER TOUCH SCREENS, AND ELECTRONIC DISPLAY PANELS AND BOARDS IN THE FIELD OF PERSONAL AND PROFESSIONAL INFORMATION MANAGEMENT (U.S. CLS. 21, 23, 26, 36 AND 38).

FIRST USE 2-14-2011; IN COMMERCE 2-14-2011.

CLASS 42—SCIENTIFIC AND COMPUTER SERVICES

FOR COMPUTER PROGRAMMING SERVICES IN THE FIELD OF DATA BASE MANAGEMENT FOR COMPUTERS, COMPUTER OPERATING SYSTEMS, COMPUTER NETWORKS, COMPUTER SERVERS, PRINTERS, TOUCH SCREEN COMPUTERS, COMPUTER DISPLAY UNITS AND TOUCH SCREEN DISPLAYS, NETWORK ROUTERS, NETWORK SWITCHES, TELEPHONE SWITCHES, MOBILE AND SATELLITE PHONES, TABLET COMPUTERS, PRINTERS, AND RADAR (U.S. CLS. 100 AND 101).

FIRST USE 2-14-2011; IN COMMERCE 2-14-2011.

SUSAN RICHARDS, EXAMINING ATTORNEY

SN 85-381,956. PEGGY BROWN CREATIVE CONSULTING, LLC, MILWAUKEE, WI. FILED 7-27-2011.

SIMPLE SHADES

THE MARK CONSISTS OF STANDARD CHARACTERS WITHOUT CLAIM TO ANY PARTICULAR FONT, STYLE, SIZE, OR COLOR.

NO CLAIM IS MADE TO THE EXCLUSIVE RIGHT TO USE "SHADES", APART FROM THE MARK AS SHOWN.

CLASS 11—ENVIRONMENTAL CONTROL APPARATUS

FOR LIGHT DIFFUSERS (U.S. CLS. 13, 21, 23, 31 AND 34).

CLASS 35—ADVERTISING AND BUSINESS

FOR ONLINE RETAIL STORE SERVICES FEATURING HOME GOODS (U.S. CLS. 100, 101 AND 102).

ANDREA BUTLER, EXAMINING ATTORNEY

SN 85-382,485. CONOPCO, INC., ENGLEWOOD CLIFFS, NJ.
FILED 7-27-2011.



NO CLAIM IS MADE TO THE EXCLUSIVE RIGHT TO USE "STORE", APART FROM THE MARK AS SHOWN.

THE COLOR(S) BLUE, LIGHT BLUE AND WHITE IS/ARE CLAIMED AS A FEATURE OF THE MARK.

THE MARK CONSISTS OF THE WORDING "THE PERFECT STORE" APPEARING IN WHITE WITHIN A BLUE RECTANGULAR DESIGN WHICH DEPICTS SEVERAL LIGHT BLUE CONTINENTS ON A PORTION OF A GLOBE WITH A SINGLE WHITE CHEVRON INSIGNIA ABOVE THE "O" AND THE "R".

CLASS 9—ELECTRICAL AND SCIENTIFIC APPARATUS

FOR INTERACTIVE DOWNLOADABLE MULTI-MEDIA, NAMELY, INTERACTIVE MULTIMEDIA COMPUTER PROGRAMS, SOFTWARE RECORDED ON CD-ROM AND DOWNLOADABLE AUDIO FILES, MULTI-MEDIA FILES, TEXT FILES, E-MAILS, WRITTEN DOCUMENTS, AUDIO MATERIAL, VIDEO MATERIAL AND GAMES FEATURING EDUCATIONAL AND BUSINESS MATERIAL; MULTIMEDIA SOFTWARE RECORDED ON CD-ROMS FEATURING EDUCATIONAL AND BUSINESS MATERIAL AND ELECTRONIC PUBLICATIONS, NAMELY, ONLINE BOOKS, MAGAZINES AND MANUALS FEATURING EDUCATIONAL AND BUSINESS MATERIAL RECORDED ON COMPUTER MEDIA (U.S. CLS. 21, 23, 26, 36 AND 38).

CLASS 41—EDUCATION AND ENTERTAINMENT

FOR EDUCATIONAL SERVICES, NAMELY, PROVIDING CLASSES OF INSTRUCTION IN THE FIELD OF BUSINESS; BUSINESS TRAINING CONSULTANCY SERVICES (U.S. CLS. 100, 101 AND 107).

DAVID COLLIER, EXAMINING ATTORNEY

SN 85-382,928. MOOSE CREATIVE PTY LTD, EAST BENTLEIGH, AUSTRALIA, FILED 7-27-2011.

BLINGLES

THE MARK CONSISTS OF STANDARD CHARACTERS WITHOUT CLAIM TO ANY PARTICULAR FONT, STYLE, SIZE, OR COLOR.

PRIORITY CLAIMED UNDER SEC. 44(D) ON AUSTRALIA APPLICATION NO. 1422931, FILED 5-11-2011.

CLASS 16—PAPER GOODS AND PRINTED MATTER

FOR ARTS AND CRAFTS PAINT KITS; PAINT SETS FOR CHILDREN; STICKERS; CRAFT ACTIVITY KITS FOR DECORATING COMPRISING PAINTS, STICKERS, PATTERNED DRAWING TEMPLATES AND PLASTIC EMBELLISHMENTS FOR STICKERS, NAMELY, PLASTIC GEM STONES AND PLASTIC DECORATIONS FOR STICKERS; DESK SETS; ART CRAFT KITS COMPRISING PATTERNED DRAWING TEMPLATES, STICKERS, PAINT, PAINT DISPENSING PENS, PENS FOR APPLYING DECORATIVE GEMS, BONDING BEADS FOR DECORATION PURPOSES, AND PLASTIC GEM STONES AND PLASTIC STICKER DECORATIONS FOR EMBELLISHMENT OF STICKERS AND A DRYING RACK FOR DRYING PROJECTS; DRAWING INSTRUMENTS FOR CREATING MARBLING DESIGNS AND PATTERNS; PLASTIC ADHESIVES FOR STICKERS IN THE NATURE OF DECORATIVE GEM STONES AND EMBELLISHMENTS FOR ADHERING TO STICKERS (U.S. CLS. 2, 5, 22, 23, 29, 37, 38 AND 50).

CLASS 28—TOYS AND SPORTING GOODS

FOR PLASTIC ACTIVITY PLAYSETS FOR DOLLS, MODELLED PLASTIC TOY FIGURINES, FANTASY CHARACTER TOYS, COLLECTIBLE TOY CHARACTERS AND PLASTIC CHARACTER TOYS (U.S. CLS. 22, 23, 38 AND 50).

COLLEEN KEARNEY, EXAMINING ATTORNEY

SN 85-383,128. HILL'S PET NUTRITION, INC., TOPEKA, KS.
FILED 7-28-2011.



THE MARK CONSISTS OF THE WORDS "FOOD SHELTER & LOVE" STACKED ABOVE ONE ANOTHER BELOW A HOUSE-LIKE SHAPED DESIGN THAT CONTAINS A STYLIZED HEART WITH A PET FOOD BOWL BELOW.

CLASS 31—NATURAL AGRICULTURAL PRODUCTS

FOR PET FOOD (U.S. CLS. 1 AND 46).

CLASS 35—ADVERTISING AND BUSINESS

FOR PROMOTIONAL SERVICES, NAMELY, PROVIDING HATS, CLOTHING AND PET FOOD BOWLS FOR THE PURPOSES OF PROMOTING THE CHARITIES OF OTHERS WHICH SEEK TO PROVIDE DISCOUNT PET FOOD TO ANIMAL SHELTERS (U.S. CLS. 100, 101 AND 102).

GRETCHEN ULRICH, EXAMINING ATTORNEY

SN 85-383,325. BLUE CROSS AND BLUE SHIELD ASSOCIATION, AKA BLUECROSS BLUESHIELD ASSOCIATION, CHICAGO, IL. FILED 7-28-2011.

GEOBLUE EXPLORER

THE MARK CONSISTS OF STANDARD CHARACTERS WITHOUT CLAIM TO ANY PARTICULAR FONT, STYLE, SIZE, OR COLOR.

CLASS 36—INSURANCE AND FINANCIAL

FOR PREPAID FINANCING AND ADMINISTRATION OF MEDICAL, HOSPITAL AND RELATED HEALTH CARE SERVICES, NAMELY, COMPREHENSIVE HEALTH CARE BENEFIT PLANS AND PHARMACY BENEFIT PLANS, AND ORGANIZING PREFERRED PROVIDER PROGRAMS IN THE FIELD OF PREPAID HEALTH CARE BENEFIT PLANS (U.S. CLS. 100, 101 AND 102).

CLASS 44—MEDICAL, BEAUTY AND AGRICULTURAL SERVICES

FOR COMPREHENSIVE HEALTH CARE BENEFIT PROGRAMS IN THE NATURE OF MANAGED INTEGRATED HEALTHCARE SERVICES RENDERED THROUGH A NETWORK OF INTERNATIONAL HEALTHCARE PROVIDERS, HEALTH MAINTENANCE ORGANIZATIONS AND PREFERRED PROVIDER ORGANIZATIONS, NAMELY, PHYSICIAN, DENTAL, HOSPITAL, HOME HEALTH CARE, PREVENTIVE HEALTH CARE TREATMENT, PHYSICAL AND MENTAL THERAPY SERVICES (U.S. CLS. 100 AND 101).

DAVID ELTON, EXAMINING ATTORNEY

SN 85-383,328. BLUE CROSS AND BLUE SHIELD ASSOCIATION, AKA BLUECROSS BLUESHIELD ASSOCIATION, CHICAGO, IL. FILED 7-28-2011.

GEOBLUE EXPAT

THE MARK CONSISTS OF STANDARD CHARACTERS WITHOUT CLAIM TO ANY PARTICULAR FONT, STYLE, SIZE, OR COLOR.

NO CLAIM IS MADE TO THE EXCLUSIVE RIGHT TO USE "EXPAT", APART FROM THE MARK AS SHOWN.

CLASS 36—INSURANCE AND FINANCIAL

FOR PREPAID FINANCING AND ADMINISTRATION OF MEDICAL, HOSPITAL AND RELATED HEALTH CARE SERVICES, NAMELY, COMPREHENSIVE HEALTH CARE BENEFIT PLANS AND PHARMACY BENEFIT PLANS, AND ORGANIZING PREFERRED PROVIDER PROGRAMS IN THE FIELD OF PREPAID HEALTH CARE BENEFIT PLANS (U.S. CLS. 100, 101 AND 102).

CLASS 44—MEDICAL, BEAUTY AND AGRICULTURAL SERVICES

FOR COMPREHENSIVE HEALTH CARE BENEFIT PROGRAMS IN THE NATURE OF MANAGED INTEGRATED HEALTHCARE SERVICES RENDERED THROUGH A NETWORK OF INTERNATIONAL HEALTHCARE PROVIDERS, HEALTH MAINTENANCE ORGANIZATIONS AND PREFERRED PROVIDER ORGANIZATIONS, NAMELY, PHYSICIAN, DENTAL, HOSPITAL, HOME HEALTH CARE, PREVENTIVE HEALTH CARE TREATMENT, PHYSICAL AND MENTAL THERAPY SERVICES (U.S. CLS. 100 AND 101).

DAVID ELTON, EXAMINING ATTORNEY

SN 85-383,332. BLUE CROSS AND BLUE SHIELD ASSOCIATION, AKA BLUECROSS BLUESHIELD ASSOCIATION, CHICAGO, IL. FILED 7-28-2011.

GEOBLUE TRAVELER

THE MARK CONSISTS OF STANDARD CHARACTERS WITHOUT CLAIM TO ANY PARTICULAR FONT, STYLE, SIZE, OR COLOR.

NO CLAIM IS MADE TO THE EXCLUSIVE RIGHT TO USE "TRAVELER", APART FROM THE MARK AS SHOWN.

CLASS 36—INSURANCE AND FINANCIAL

FOR PREPAID FINANCING AND ADMINISTRATION OF MEDICAL, HOSPITAL AND RELATED HEALTH CARE SERVICES, NAMELY, COMPREHENSIVE HEALTH CARE BENEFIT PLANS AND PHARMACY BENEFIT PLANS, AND ORGANIZING PREFERRED PROVIDER PROGRAMS IN THE FIELD OF PREPAID HEALTH CARE BENEFIT PLANS (U.S. CLS. 100, 101 AND 102).

CLASS 44—MEDICAL, BEAUTY AND AGRICULTURAL SERVICES

FOR COMPREHENSIVE HEALTH CARE BENEFIT PROGRAMS IN THE NATURE OF MANAGED INTEGRATED HEALTHCARE SERVICES RENDERED THROUGH A NETWORK OF INTERNATIONAL HEALTHCARE PROVIDERS, HEALTH MAINTENANCE ORGANIZATIONS AND PREFERRED PROVIDER ORGANIZATIONS, NAMELY, PHYSICIAN, DENTAL, HOSPITAL, HOME HEALTH CARE, PREVENTIVE HEALTH CARE TREATMENT, PHYSICAL AND MENTAL THERAPY SERVICES (U.S. CLS. 100 AND 101).

DAVID ELTON, EXAMINING ATTORNEY

SN 85-383,335. BLUE CROSS AND BLUE SHIELD ASSOCIATION, AKA BLUECROSS BLUESHIELD ASSOCIATION, CHICAGO, IL. FILED 7-28-2011.

GEOBLUE STUDENT

THE MARK CONSISTS OF STANDARD CHARACTERS WITHOUT CLAIM TO ANY PARTICULAR FONT, STYLE, SIZE, OR COLOR.

NO CLAIM IS MADE TO THE EXCLUSIVE RIGHT TO USE "STUDENT", APART FROM THE MARK AS SHOWN.

CLASS 36—INSURANCE AND FINANCIAL

FOR PREPAID FINANCING AND ADMINISTRATION OF MEDICAL, HOSPITAL AND RELATED HEALTH CARE SERVICES, NAMELY, COMPREHENSIVE HEALTH CARE BENEFIT PLANS AND PHARMACY BENEFIT PLANS, AND ORGANIZING PREFERRED PROVIDER PROGRAMS IN THE FIELD OF PREPAID HEALTH CARE BENEFIT PLANS (U.S. CLS. 100, 101 AND 102).

CLASS 44—MEDICAL, BEAUTY AND AGRICULTURAL SERVICES

FOR COMPREHENSIVE HEALTH CARE BENEFIT PROGRAMS IN THE NATURE OF MANAGED INTEGRATED HEALTHCARE SERVICES RENDERED THROUGH A NETWORK OF INTERNATIONAL HEALTHCARE PROVIDERS, HEALTH MAINTENANCE ORGANIZATIONS AND PREFERRED PROVIDER ORGANIZATIONS, NAMELY, PHYSICIAN, DENTAL, HOSPITAL, HOME HEALTH CARE, PREVENTIVE HEALTH CARE TREATMENT, PHYSICAL AND MENTAL THERAPY SERVICES (U.S. CLS. 100 AND 101).

DAVID ELTON, EXAMINING ATTORNEY

SN 85-384,505. CHARLOTTE RONSON LLC, NEW YORK, NY. FILED 7-29-2011.

CHARLOTTE RONSON

THE MARK CONSISTS OF STANDARD CHARACTERS WITHOUT CLAIM TO ANY PARTICULAR FONT, STYLE, SIZE, OR COLOR.

OWNER OF U.S. REG. NOS. 3,614,032, 3,620,635 AND 3,620,843.

THE NAME(S), PORTRAIT(S), AND/OR SIGNATURE(S) SHOWN IN THE MARK IDENTIFIES A PARTICULAR LIVING INDIVIDUAL, WHOSE CONSENT(S) TO REGISTER IS MADE OF RECORD.

CLASS 9—ELECTRICAL AND SCIENTIFIC APPARATUS

FOR CASES FOR MOBILE PHONES (U.S. CLS. 21, 23, 26, 36 AND 38).

CLASS 18—LEATHER GOODS

FOR ALL-PURPOSE SPORTS BAGS, BEACH BAGS, TOILETRY BAGS SOLD EMPTY, SHOE BAGS FOR TRAVEL, SCHOOL BAGS, MESSENGER BAGS, DUFFEL BAGS, BAGS FOR CARRYING BABIES' ACCESSORIES, HANDBAGS, WALLETS, PURSES, LUGGAGE, BACKPACKS, TRAVEL BAGS, TOTE BAGS, CHANGE PURSES, COSMETIC CASES AND BAGS SOLD EMPTY, AND UMBRELLAS; CARRYING CASES FOR TRAIN AND BUS PASSES, KEY CASES, BUSINESS CARD CASES, LUGGAGE TAGS AND KEY CHAINS, ALL OF THE FOREGOING MADE FROM LEATHER OR IMITATION LEATHER (U.S. CLS. 1, 2, 3, 22 AND 41).

TEJBIR SINGH, EXAMINING ATTORNEY

SN 85-383,341. BLUE CROSS AND BLUE SHIELD ASSOCIATION, AKA BLUECROSS BLUESHIELD ASSOCIATION, CHICAGO, IL. FILED 7-28-2011.

GEOBLUE

THE MARK CONSISTS OF STANDARD CHARACTERS WITHOUT CLAIM TO ANY PARTICULAR FONT, STYLE, SIZE, OR COLOR.

CLASS 36—INSURANCE AND FINANCIAL

FOR PREPAID FINANCING AND ADMINISTRATION OF MEDICAL, HOSPITAL AND RELATED HEALTH CARE SERVICES, NAMELY, COMPREHENSIVE HEALTH CARE BENEFIT PLANS AND PHARMACY BENEFIT PLANS, AND ORGANIZING PREFERRED PROVIDER PROGRAMS IN THE FIELD OF PREPAID HEALTH CARE BENEFIT PLANS (U.S. CLS. 100, 101 AND 102).

CLASS 44—MEDICAL, BEAUTY AND AGRICULTURAL SERVICES

FOR COMPREHENSIVE HEALTH CARE BENEFIT PROGRAMS IN THE NATURE OF MANAGED INTEGRATED HEALTHCARE SERVICES RENDERED THROUGH A NETWORK OF INTERNATIONAL HEALTHCARE PROVIDERS, HEALTH MAINTENANCE ORGANIZATIONS AND PREFERRED PROVIDER ORGANIZATIONS, NAMELY, PHYSICIAN, DENTAL, HOSPITAL, HOME HEALTH CARE, PREVENTIVE HEALTH CARE TREATMENT, PHYSICAL AND MENTAL THERAPY SERVICES (U.S. CLS. 100 AND 101).

DAVID ELTON, EXAMINING ATTORNEY

SN 85-384,792. PALLADIAN HEALTH, LLC, WEST SENECA, NY. FILED 7-29-2011.



OWNER OF U.S. REG. NOS. 3,848,293, 3,882,145 AND 3,944,698.

NO CLAIM IS MADE TO THE EXCLUSIVE RIGHT TO USE "COORDINATED SPINE CARE", APART FROM THE MARK AS SHOWN.

THE COLOR(S) BLUE, WHITE AND GREEN IS/ARE CLAIMED AS A FEATURE OF THE MARK.

THE MARK CONSISTS OF A SOLID BLUE BOX WITH THE WORD "PALLADIAN" IN WHITE LETTERS AT THE TOP CENTER SITUATED ABOVE A WHITE LINE. BELOW THE WHITE LINE IS THE CAPITAL LETTERS "CSC" IN GREEN IN THE MIDDLE CENTER OF THE BLUE BOX SITUATED ABOVE A SECOND WHITE LINE. BELOW THE SECOND WHITE LINE IS THE WORDS "COORDINATED SPINE CARE" IN ALL CAPITAL LETTERS IN WHITE AT THE BOTTOM CENTER OF THE BLUE SQUARE.

CLASS 36—INSURANCE AND FINANCIAL

FOR INSURANCE CONSULTATION, NAMELY, HEALTH CARE UTILIZATION MANAGEMENT SERVICES IN THE FIELD OF SPINE CARE WITH COMPREHENSIVE EVIDENCE-BASED MEDICAL POLICY STATEMENTS (U.S. CLS. 100, 101 AND 102).

FIRST USE 11-1-2010; IN COMMERCE 11-1-2010.

CLASS 41—EDUCATION AND ENTERTAINMENT

FOR PATIENT EDUCATION SERVICES, NAMELY, PROVIDING ON-LINE SEMINARS IN THE FIELD OF SPINE PAIN AND CARE TO PATIENTS; PERSONAL COACHING SERVICES, NAMELY, PROVIDING HEALTH COACHES IN THE FIELD OF SPINE PAIN AND CARE TO PATIENTS; PROVIDING A WEBSITE FEATURING BLOGS AND NON-DOWNLOADABLE PUBLICATIONS IN THE NATURE OF ARTICLES IN THE FIELD OF MANAGING BACK PAIN; PROVIDING A WEB SITE FEATURE NON-DOWNLOADABLE INSTRUCTIONAL VIDEOS IN THE FIELD OF EXERCISE (U.S. CLS. 100, 101 AND 107).

FIRST USE 11-1-2010; IN COMMERCE 11-1-2010.

CLASS 44—MEDICAL, BEAUTY AND AGRICULTURAL SERVICES

FOR HEALTH CARE SERVICES, NAMELY, CHRONIC BACK PAIN MANAGEMENT FEATURING BEHAVIORAL HEALTH PROGRAMS AND HEALTH PLAN CARE MANAGEMENT TEAMS (U.S. CLS. 100 AND 101).

FIRST USE 11-1-2010; IN COMMERCE 11-1-2010.

CHRISTOPHER LAW, EXAMINING ATTORNEY

SN 85-385,816. PALLADIAN HEALTH, LLC, WEST SENECA, NY. FILED 8-1-2011.



OWNER OF U.S. REG. NOS. 3,848,293, 3,944,698 AND OTHERS.

NO CLAIM IS MADE TO THE EXCLUSIVE RIGHT TO USE "EAP" AND "EMPLOYEE ASSISTANCE", APART FROM THE MARK AS SHOWN.

THE COLOR(S) BLUE, WHITE AND PURPLE IS/ARE CLAIMED AS A FEATURE OF THE MARK.

THE MARK CONSISTS OF A SOLID BLUE BOX WITH THE WORD "PALLADIAN" IN WHITE LETTERS AT THE TOP CENTER, SITUATED ABOVE A WHITE LINE. BELOW THE WHITE LINE IS THE CAPITAL LETTERS "EAP" IN PURPLE, IN THE MIDDLE CENTER OF THE BOX, SITUATED ABOVE A SECOND WHITE LINE. BELOW THE SECOND WHITE LINE IS THE WORDS "EMPLOYEE ASSISTANCE" IN ALL CAPITAL LETTERS IN WHITE AT THE BOTTOM CENTER OF THE BLUE BOX.

CLASS 42—SCIENTIFIC AND COMPUTER SERVICES

FOR ONLINE TOOLS, NAMELY, PROVIDING A WEBSITE FEATURING NON-DOWNLOADABLE SOFTWARE FOR USE IN MANAGING BACK PAIN IN THE FIELD OF EMPLOYEE ASSISTANCE PROGRAMS (U.S. CLS. 100 AND 101).

FIRST USE 5-6-2011; IN COMMERCE 5-6-2011.

CLASS 44—MEDICAL, BEAUTY AND AGRICULTURAL SERVICES

FOR EMPLOYEE ASSISTANCE PROGRAM SERVICES, NAMELY, MENTAL HEALTH COUNSELING TO ASSIST WITH PROBLEMS THAT AFFECT WORKPLACE PERFORMANCE, TRAUMA RESPONSE, AND CRITICAL INCIDENT STRESS DEBRIEFINGS PROVIDED TO INDIVIDUALS OR GROUPS (U.S. CLS. 100 AND 101).

FIRST USE 5-6-2011; IN COMMERCE 5-6-2011.

CHRISTOPHER LAW, EXAMINING ATTORNEY

SN 85-387,031. ASSOCIATION OF GOVERNING BOARDS OF UNIVERSITIES AND COLLEGES, AKA AGB, WASHINGTON, DC. FILED 8-2-2011.

AGB University

THE MARK CONSISTS OF STANDARD CHARACTERS WITHOUT CLAIM TO ANY PARTICULAR FONT, STYLE, SIZE, OR COLOR.

OWNER OF U.S. REG. NOS. 2,374,535 AND 3,067,755.

CLASS 16—PAPER GOODS AND PRINTED MATTER

FOR EDUCATIONAL PUBLICATIONS, NAMELY, NEWSLETTERS, MAGAZINES, BOOKS, REPORTS AND SURVEYS IN THE FIELDS OF HIGHER EDUCATION GOVERNANCE AND LEADERSHIP (U.S. CLS. 2, 5, 22, 23, 29, 37, 38 AND 50).

CLASS 35—ADVERTISING AND BUSINESS

FOR CONSULTING SERVICES IN THE FIELD OF HIGHER EDUCATION ADMINISTRATION (U.S. CLS. 100, 101 AND 102).

ODESSA BIBBINS, EXAMINING ATTORNEY

SN 85-388,199. WHOLESOME WAVE FOUNDATION CHARITABLE VENTURES INC., BRIDGEPORT, CT. FILED 8-3-2011.

FVRx

THE MARK CONSISTS OF STANDARD CHARACTERS WITHOUT CLAIM TO ANY PARTICULAR FONT, STYLE, SIZE, OR COLOR.

CLASS 35—ADVERTISING AND BUSINESS

FOR BUSINESS MANAGEMENT SERVICES, NAMELY, PROVIDING INDUSTRY EXPERTISE AND SUPPLIER PARTNERSHIPS FOR THE PURPOSE OF ENABLING UNDERSERVED URBAN AND RURAL COMMUNITIES TO GAIN ACCESS TO FRESH, HEALTHY, LOCALLY GROWN AND RAISED FOODS (U.S. CLS. 100, 101 AND 102).

FIRST USE 3-0-2010; IN COMMERCE 3-0-2010.

CLASS 42—SCIENTIFIC AND COMPUTER SERVICES

FOR SCIENTIFIC RESEARCH INTO THE HEALTH EFFECTS OF FRESH FOOD CONSUMPTION (U.S. CLS. 100 AND 101).

FIRST USE 3-0-2010; IN COMMERCE 3-0-2010.
AHSEN KHAN, EXAMINING ATTORNEY

SN 85-388,250. WHOLESOME WAVE FOUNDATION CHARITABLE VENTURES INC., BRIDGEPORT, CT. FILED 8-3-2011.

**FRUIT AND VEGETABLE
PRESCRIPTION PROGRAM**

THE MARK CONSISTS OF STANDARD CHARACTERS WITHOUT CLAIM TO ANY PARTICULAR FONT, STYLE, SIZE, OR COLOR.

NO CLAIM IS MADE TO THE EXCLUSIVE RIGHT TO USE "FRUIT AND VEGETABLE" AND "PROGRAM", APART FROM THE MARK AS SHOWN.

CLASS 35—ADVERTISING AND BUSINESS

FOR BUSINESS MANAGEMENT SERVICES, NAMELY, PROVIDING INDUSTRY EXPERTISE AND SUPPLIER PARTNERSHIPS FOR THE PURPOSE OF ENABLING UNDERSERVED URBAN AND RURAL COMMUNITIES TO GAIN ACCESS TO FRESH, HEALTHY, LOCALLY GROWN AND RAISED FOODS (U.S. CLS. 100, 101 AND 102).

FIRST USE 3-0-2010; IN COMMERCE 3-0-2010.

CLASS 42—SCIENTIFIC AND COMPUTER SERVICES

FOR SCIENTIFIC RESEARCH INTO THE HEALTH EFFECTS OF FRESH FOOD CONSUMPTION (U.S. CLS. 100 AND 101).

FIRST USE 3-0-2010; IN COMMERCE 3-0-2010.
AHSEN KHAN, EXAMINING ATTORNEY

SN 85-388,278. WHOLESOME WAVE FOUNDATION CHARITABLE VENTURES INC., BRIDGEPORT, CT. FILED 8-3-2011.

WHOLESOME WAVE

THE MARK CONSISTS OF STANDARD CHARACTERS WITHOUT CLAIM TO ANY PARTICULAR FONT, STYLE, SIZE, OR COLOR.

CLASS 35—ADVERTISING AND BUSINESS

FOR BUSINESS MANAGEMENT SERVICES, NAMELY, PROVIDING INDUSTRY EXPERTISE AND SUPPLIER PARTNERSHIPS FOR THE PURPOSE OF ENABLING UNDERSERVED URBAN AND RURAL COMMUNITIES TO GAIN ACCESS TO FRESH, HEALTHY, LOCALLY GROWN AND RAISED FOODS; ADMINISTRATION OF A DISCOUNT PROGRAM WHICH INCREASES THE PURCHASING POWER OF FEDERAL BENEFITS WHEN USED BY PEOPLE IN UNDERSERVED URBAN AND RURAL COMMUNITIES BY ENABLING PARTICIPANTS TO OBTAIN DISCOUNTS ON FRESH LOCALLY GROWN AND PRODUCED FOOD (U.S. CLS. 100, 101 AND 102).

FIRST USE 6-0-2007; IN COMMERCE 6-0-2007.

CLASS 42—SCIENTIFIC AND COMPUTER SERVICES

FOR SCIENTIFIC RESEARCH INTO THE HEALTH EFFECTS OF FRESH FOOD CONSUMPTION (U.S. CLS. 100 AND 101).

FIRST USE 3-0-2010; IN COMMERCE 3-0-2010.
AHSEN KHAN, EXAMINING ATTORNEY

SN 85-388,347. WHOLESOME WAVE FOUNDATION CHARITABLE VENTURES INC., BRIDGEPORT, CT. FILED 8-3-2011.

**NOURISHING NEIGHBORHOODS
ACROSS AMERICA**

THE MARK CONSISTS OF STANDARD CHARACTERS WITHOUT CLAIM TO ANY PARTICULAR FONT, STYLE, SIZE, OR COLOR.

CLASS 35—ADVERTISING AND BUSINESS

FOR BUSINESS MANAGEMENT SERVICES, NAMELY, PROVIDING INDUSTRY EXPERTISE AND SUPPLIER PARTNERSHIPS FOR THE PURPOSE OF ENABLING UNDERSERVED URBAN AND RURAL COMMUNITIES TO GAIN ACCESS TO FRESH, HEALTHY, LOCALLY GROWN AND RAISED FOODS; ADMINISTRATION OF A DISCOUNT PROGRAM WHICH INCREASES THE PURCHASING POWER OF FEDERAL BENEFITS WHEN USED BY PEOPLE IN UNDERSERVED URBAN AND RURAL COMMUNITIES BY ENABLING PARTICIPANTS TO OBTAIN DISCOUNTS ON FRESH, LOCALLY GROWN AND PRODUCED FOOD (U.S. CLS. 100, 101 AND 102).

FIRST USE 3-0-2008; IN COMMERCE 3-0-2008.

CLASS 42—SCIENTIFIC AND COMPUTER SERVICES

FOR SCIENTIFIC RESEARCH INTO THE HEALTH EFFECTS OF FRESH FOOD CONSUMPTION (U.S. CLS. 100 AND 101).

FIRST USE 3-0-2010; IN COMMERCE 3-0-2010.
AHSEN KHAN, EXAMINING ATTORNEY

SN 85-388,783. NCL CORPORATION LTD., MIAMI, FL.
FILED 8-3-2011.

ECO-SMART CRUISING

THE MARK CONSISTS OF STANDARD CHARACTERS WITHOUT CLAIM TO ANY PARTICULAR FONT, STYLE, SIZE, OR COLOR.

OWNER OF U.S. REG. NOS. 2,489,424, 2,834,087 AND 3,248,641.

NO CLAIM IS MADE TO THE EXCLUSIVE RIGHT TO USE "CRUISING", APART FROM THE MARK AS SHOWN.

CLASS 36—INSURANCE AND FINANCIAL

FOR A PROGRAM ALLOWING CRUISE PASSENGERS TO PAY A FEE TO OFFSET THEIR CARBON FOOTPRINT (U.S. CLS. 100, 101 AND 102).

FIRST USE 7-22-2011; IN COMMERCE 7-22-2011.

CLASS 39—TRANSPORTATION AND STORAGE

FOR ARRANGING OF CRUISES; CRUISE SHIP SERVICES (U.S. CLS. 100 AND 105).

FIRST USE 7-22-2011; IN COMMERCE 7-22-2011.
APRIL HESIK, EXAMINING ATTORNEY

SN 85-389,036. PERENELLE, INC., MEMPHIS, TN. FILED 8-3-2011.

Perenelle

THE MARK CONSISTS OF STANDARD CHARACTERS WITHOUT CLAIM TO ANY PARTICULAR FONT, STYLE, SIZE, OR COLOR.

CLASS 3—COSMETICS AND CLEANING PREPARATIONS

FOR BODY AND BEAUTY CARE COSMETICS; CLEANSING CREAMS; COLOGNES, PERFUMES AND COSMETICS; COSMETIC CREAMS; COSMETIC CREAMS FOR SKIN CARE; COSMETIC HAND CREAMS; COSMETIC MASKS; COSMETIC NOURISHING CREAMS; COSMETIC OILS; COSMETIC PREPARATIONS; COSMETIC PREPARATIONS FOR BODY CARE; COSMETIC PREPARATIONS FOR SKIN CARE; COSMETIC PREPARATIONS FOR SKIN RENEWAL; COSMETICS AND COSMETIC PREPARATIONS; COSMETICS IN GENERAL, INCLUDING PERFUMES (U.S. CLS. 1, 4, 6, 50, 51 AND 52).

CLASS 35—ADVERTISING AND BUSINESS

FOR MAIL ORDER CATALOG SERVICES FEATURING HEALTH AND SKIN CARE PRODUCTS; RETAIL APOTHECARY STORE SERVICES; WHOLESALE AND RETAIL STORE SERVICES AND ON-LINE RETAIL AND WHOLESALE STORE SERVICES FEATURING HEALTH AND BEAUTY ITEMS (U.S. CLS. 100, 101 AND 102).

CLASS 41—EDUCATION AND ENTERTAINMENT

FOR CONDUCTING WORKSHOPS AND SEMINARS IN PERSONAL AWARENESS; CONDUCTING WORKSHOPS AND SEMINARS IN SELF AWARENESS; CONDUCTING WORKSHOPS AND SEMINARS IN HEALTH AND BEAUTY; EDUCATIONAL SERVICES, NAMELY, CONDUCTING CLASSES, SEMINARS, CONFERENCES, WORKSHOPS, RETREATS, CAMPS AND FIELD TRIPS IN THE FIELD OF HEALTH AND BEAUTY AND DISTRIBUTION OF TRAINING MATERIAL IN CONNECTION THEREWITH (U.S. CLS. 100, 101 AND 107).

CLASS 44—MEDICAL, BEAUTY AND AGRICULTURAL SERVICES

FOR BEAUTY CONSULTATION SERVICES IN THE SELECTION AND USE OF COSMETICS, FRAGRANCES, BEAUTY AIDS, PERSONAL CARE PRODUCTS, AND BATH, BODY AND BEAUTY PRODUCTS; BEAUTY SPA SERVICES, NAMELY, COSMETIC BODY CARE; COSMETIC FACE CARE SERVICES; COSMETIC SKIN CARE SERVICES; HEALTH SPA SERVICES FOR HEALTH AND WELLNESS OF THE BODY AND SPIRIT, NAMELY, PROVIDING MASSAGE, FACIAL AND BODY TREATMENT SERVICES, COSMETIC BODY CARE SERVICES; NON-INVASIVE COSMETIC MEDICAL PROCEDURES; PROVIDE A WEBSITE FEATURING INFORMATION ABOUT HOLISTIC COSMETIC AND PLASTIC SURGERY PRACTICE (U.S. CLS. 100 AND 101).

MARC LEIPZIG, EXAMINING ATTORNEY

SN 85-389,659. YOUTH VILLAGES, INC., MEMPHIS, TN.
FILED 8-4-2011.

EVIDENTIARY FAMILY RESTORATION

THE MARK CONSISTS OF STANDARD CHARACTERS WITHOUT CLAIM TO ANY PARTICULAR FONT, STYLE, SIZE, OR COLOR.

NO CLAIM IS MADE TO THE EXCLUSIVE RIGHT TO USE "FAMILY", APART FROM THE MARK AS SHOWN.

CLASS 41—EDUCATION AND ENTERTAINMENT

FOR EDUCATION SERVICES IN THE FORM OF PROVIDING ELEMENTARY THROUGH 12TH GRADE CLASSROOM INSTRUCTION AND TRAINING FOR CHILDREN, TEENAGERS, AND YOUNG ADULTS AGING OUT OF FOSTER CARE, ALL WITH SERIOUS BEHAVIORAL OR MENTAL HEALTH ISSUES, IN THE FIELDS OF MODIFYING BEHAVIOR, LEARNING SELF CONTROL, ESTABLISHING LIFE SKILLS, DEVELOPING AND IMPROVING SOCIAL SKILLS, AND PREPARING FOR CAREERS; MENTORING CHILDREN, TEENAGERS, AND YOUNG ADULTS WITH SERIOUS BEHAVIOR OR MENTAL HEALTH ISSUES IN THE FIELDS OF ACADEMIC PERFORMANCE, ESTABLISHING LIFE SKILLS, DEVELOPING AND IMPROVING SOCIAL SKILLS, MODIFYING BEHAVIOR, HOBBIES, BUILDING HEALTHY RELATIONSHIPS, AND DEVELOPING SUPPORT SYSTEMS; PROVIDING CAREER COUNSELING, LIFE SKILLS TRAINING, CAREER PLANNING IN THE NATURE OF VOCATIONAL GUIDANCE, AND CAREER TRAINING FOR TEENAGERS, YOUNG ADULTS, AND MEDICALLY FRAGILE CHILDREN, ALL AS THEY AGE OUT OF FOSTER CARE (U.S. CLS. 100, 101 AND 107).

CLASS 43—HOTEL AND RESTAURANT SERVICES

FOR CHILD CARE; PROVIDING SHORT AND LONG TERM RESIDENTIAL SERVICES TO COURT ORDERED YOUTHS AND TEENAGERS; CHILD WELFARE SERVICES, NAMELY, PROVIDING RESIDENTIAL HOMES AND HOUSING FOR AT-RISK CHILDREN, AT-RISK YOUTH, AND/OR MEDICALLY FRAGILE CHILDREN IN THE NATURE OF GROUP HOMES; CHARITABLE SERVICES, NAMELY, PROVIDING TEMPORARY SHELTER FOR RUNAWAY AND HOMELESS TEENS (U.S. CLS. 100 AND 101).

CLASS 44—MEDICAL, BEAUTY AND AGRICULTURAL SERVICES

FOR PSYCHOLOGICAL COUNSELING FOR CHILDREN AND TEENAGERS WITH SERIOUS BEHAVIORAL OR MENTAL HEALTH ISSUES; PSYCHOLOGICAL COUNSELING OF PARENTS AND FAMILIES IN AN EFFORT TO KEEP AT-RISK CHILDREN AND TEENAGERS AND/OR MEDICALLY FRAGILE CHILDREN IN THE HOME (U.S. CLS. 100 AND 101).

CLASS 45—PERSONAL AND LEGAL SERVICES

FOR FOSTER CARE; ORGANIZING AND CONDUCTING SUPPORT GROUPS FOR CHILDREN AND TEENAGERS WITH SERIOUS BEHAVIORAL OR MENTAL HEALTH ISSUES IN THE FIELDS OF MODIFYING BEHAVIOR, LEARNING SELF CONTROL, DEVELOPING AND IMPROVING SOCIAL SKILLS, PROVIDING EMOTIONAL SUPPORT, AND COPING WITH MENTAL HEALTH ISSUES; ORGANIZING AND CONDUCTING SUPPORT GROUP SERVICES FOR FOSTER PARENTS TO HELP THEM DEAL WITH CHALLENGES RELATED TO CARING FOR FOSTER CHILDREN AND/OR MEDICALLY FRAGILE CHILDREN IN THE HOME IN AN EFFORT TO KEEP THE CHILDREN IN THE HOME; COUNSELING IN THE FIELD OF DEVELOPING, STRENGTHENING AND SUSTAINING WELL-BALANCED FAMILIES AND FAMILY RELATIONSHIPS, NAMELY, COUNSELING OF PARENTS AND FAMILIES IN THE FIELDS OF SOCIAL SKILLS DEVELOPMENT AND IMPROVEMENT, EMOTIONAL SUPPORT, BEHAVIORAL MODIFICATION, AND COPING WITH BEHAVIORAL OR MENTAL HEALTH ISSUES IN AN EFFORT TO KEEP THE CHILDREN IN THE HOME; COUNSELING IN THE FIELD OF DEVELOPING, STRENGTHENING AND SUSTAINING WELL-BALANCED FAMILIES AND FAMILY RELATIONSHIPS, NAMELY, PROVIDING EMOTIONAL COUNSELING AND EMOTIONAL SUPPORT SERVICES IN THE FIELDS OF MODIFYING

BEHAVIOR, LEARNING SELF CONTROL, DEVELOPING AND IMPROVING SOCIAL SKILLS, PROVIDING EMOTIONAL SUPPORT, COPING WITH MENTAL HEALTH ISSUES, AND COPING WITH HEALTH AND MEDICAL ISSUES AND EMOTIONAL COUNSELING IN THE FORM OF BEHAVIORAL SUPPORT SERVICES FOR TROUBLED AND AT-RISK YOUTH AND THEIR BIRTH AND FOSTER FAMILIES IN AN EFFORT TO KEEP THE YOUTH AND CHILDREN IN THE HOME; ADOPTION SERVICES, NAMELY, ADOPTION AGENCIES, ADOPTION COUNSELING, AND ADOPTION PLACEMENT (U.S. CLS. 100 AND 101).

MATTHEW KLINE, EXAMINING ATTORNEY

SN 85-389,662. YOUTH VILLAGES, INC., MEMPHIS, TN. FILED 8-4-2011.

THE FORCE FOR FAMILIES

THE MARK CONSISTS OF STANDARD CHARACTERS WITHOUT CLAIM TO ANY PARTICULAR FONT, STYLE, SIZE, OR COLOR.

NO CLAIM IS MADE TO THE EXCLUSIVE RIGHT TO USE "FAMILIES", APART FROM THE MARK AS SHOWN.

CLASS 41—EDUCATION AND ENTERTAINMENT

FOR EDUCATION SERVICES IN THE FORM OF PROVIDING ELEMENTARY THROUGH 12TH GRADE CLASSROOM INSTRUCTION AND TRAINING FOR CHILDREN, TEENAGERS, AND YOUNG ADULTS AGING OUT OF FOSTER CARE, ALL WITH SERIOUS BEHAVIORAL OR MENTAL HEALTH ISSUES, IN THE FIELDS OF MODIFYING BEHAVIOR, LEARNING SELF CONTROL, ESTABLISHING LIFE SKILLS, DEVELOPING AND IMPROVING SOCIAL SKILLS, AND PREPARING FOR CAREERS; MENTORING CHILDREN, TEENAGERS, AND YOUNG ADULTS WITH SERIOUS BEHAVIOR OR MENTAL HEALTH ISSUES IN THE FIELDS OF ACADEMIC PERFORMANCE, ESTABLISHING LIFE SKILLS, DEVELOPING AND IMPROVING SOCIAL SKILLS, MODIFYING BEHAVIOR, HOBBIES, BUILDING HEALTHY RELATIONSHIPS, AND DEVELOPING SUPPORT SYSTEMS; PROVIDING CAREER COUNSELING, LIFE SKILLS TRAINING, CAREER PLANNING IN THE NATURE OF VOCATIONAL GUIDANCE, AND CAREER TRAINING FOR TEENAGERS, YOUNG ADULTS, AND MEDICALLY FRAGILE CHILDREN, ALL AS THEY AGE OUT OF FOSTER CARE (U.S. CLS. 100, 101 AND 107).

FIRST USE 11-0-2010; IN COMMERCE 11-0-2010.

CLASS 43—HOTEL AND RESTAURANT SERVICES

FOR CHILD CARE; PROVIDING SHORT AND LONG TERM RESIDENTIAL SERVICES TO COURT ORDERED YOUTHS AND TEENAGERS; CHILD WELFARE SERVICES, NAMELY, PROVIDING RESIDENTIAL HOMES AND HOUSING FOR AT-RISK CHILDREN, AT-RISK YOUTH, AND/OR MEDICALLY FRAGILE CHILDREN IN THE NATURE OF GROUP HOMES; CHARITABLE SERVICES, NAMELY, PROVIDING TEMPORARY SHELTER FOR RUNAWAY AND HOMELESS TEENS (U.S. CLS. 100 AND 101).

FIRST USE 11-0-2010; IN COMMERCE 11-0-2010.

CLASS 44—MEDICAL, BEAUTY AND AGRICULTURAL SERVICES

FOR PSYCHOLOGICAL COUNSELING FOR CHILDREN AND TEENAGERS WITH SERIOUS BEHAVIORAL OR MENTAL HEALTH ISSUES; PSYCHOLOGICAL COUNSELING OF PARENTS AND FAMILIES IN AN EFFORT TO KEEP AT-RISK CHILDREN AND TEENAGERS AND/OR MEDICALLY FRAGILE CHILDREN IN THE HOME (U.S. CLS. 100 AND 101).
FIRST USE 11-0-2010; IN COMMERCE 11-0-2010.

CLASS 45—PERSONAL AND LEGAL SERVICES

FOR FOSTER CARE; ORGANIZING AND CONDUCTING SUPPORT GROUPS FOR CHILDREN AND TEENAGERS WITH SERIOUS BEHAVIORAL OR MENTAL HEALTH ISSUES IN THE FIELDS OF MODIFYING BEHAVIOR, LEARNING SELF CONTROL, DEVELOPING AND IMPROVING SOCIAL SKILLS, PROVIDING EMOTIONAL SUPPORT, AND COPING WITH MENTAL HEALTH ISSUES; ORGANIZING AND CONDUCTING SUPPORT GROUP SERVICES FOR FOSTER PARENTS TO HELP THEM DEAL WITH CHALLENGES RELATED TO CARING FOR FOSTER CHILDREN AND/OR MEDICALLY FRAGILE CHILDREN IN THE HOME IN AN EFFORT TO KEEP THE CHILDREN IN THE HOME; COUNSELING IN THE FIELD OF DEVELOPING, STRENGTHENING AND SUSTAINING WELL-BALANCED FAMILIES AND FAMILY RELATIONSHIPS, NAMELY, COUNSELING OF PARENTS AND FAMILIES IN THE FIELDS OF SOCIAL SKILLS DEVELOPMENT AND IMPROVEMENT, EMOTIONAL SUPPORT, BEHAVIORAL MODIFICATION, AND COPING WITH BEHAVIORAL OR MENTAL HEALTH ISSUES IN AN EFFORT TO KEEP THE CHILDREN IN THE HOME; COUNSELING IN THE FIELD OF DEVELOPING, STRENGTHENING AND SUSTAINING WELL-BALANCED FAMILIES AND FAMILY RELATIONSHIPS, NAMELY, PROVIDING EMOTIONAL COUNSELING AND EMOTIONAL SUPPORT SERVICES IN THE FIELDS OF MODIFYING BEHAVIOR, LEARNING SELF CONTROL, DEVELOPING AND IMPROVING SOCIAL SKILLS, PROVIDING EMOTIONAL SUPPORT, COPING WITH MENTAL HEALTH ISSUES, AND COPING WITH HEALTH AND MEDICAL ISSUES AND EMOTIONAL COUNSELING IN THE FORM OF BEHAVIORAL SUPPORT SERVICES FOR TROUBLED AND AT-RISK YOUTH AND THEIR BIRTH AND FOSTER FAMILIES IN AN EFFORT TO KEEP THE YOUTH AND CHILDREN IN THE HOME; ADOPTION SERVICES, NAMELY, ADOPTION AGENCIES, ADOPTION COUNSELING, AND ADOPTION PLACEMENT (U.S. CLS. 100 AND 101).

FIRST USE 11-0-2010; IN COMMERCE 11-0-2010.
MATTHEW KLINE, EXAMINING ATTORNEY

SN 85-389,663. PANITO MOLE INDUSTRIA E COMERCIO DE PADARIA E PASTELARIA, LDA., ALBUFEIRA, PORTUGAL, FILED 8-4-2011.

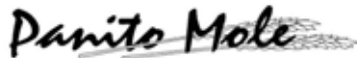

NO CLAIM IS MADE TO THE EXCLUSIVE RIGHT TO USE "MOLE", APART FROM THE MARK AS SHOWN.

THE MARK CONSISTS OF "PANITO MOLE" AND STALKS OF WHEAT.

CLASS 29—MEATS AND PROCESSED FOODS

FOR CANNED COOKED MEAT; MEAT (U.S. CL. 46).

CLASS 30—STAPLE FOODS

FOR BAKERY PRODUCTS; BREAD AND PASTRY; CAKES; CREPES (U.S. CL. 46).

CLASS 35—ADVERTISING AND BUSINESS

FOR RETAIL BAKERY SHOPS; SELF-SERVE RETAIL BAKERY SHOPS; TAKE-OUT BAKERY SERVICES (U.S. CLS. 100, 101 AND 102).

CLASS 43—HOTEL AND RESTAURANT SERVICES

FOR CAFE AND RESTAURANT SERVICES; CARRY-OUT RESTAURANTS; RESTAURANT, BAR AND CATERING SERVICES; TAKE-OUT RESTAURANT SERVICES (U.S. CLS. 100 AND 101).

REBECCA SMITH, EXAMINING ATTORNEY

SN 85-389,915. INTERNATIONAL GYMNASTICS SPORTS-CAMP, INC., STROUDSBURG, PA. FILED 8-4-2011.



THE MARK CONSISTS OF A FORWARD LETTER "K"-LIKE ELEMENT AND A BACKWARD LETTER "K"-LIKE ELEMENT SITUATED NEXT TO EACH OTHER WITH A DOT SPACED WITHIN EACH "K"-LIKE ELEMENT.

CLASS 25—CLOTHING

FOR SPORTS CLOTHES, NAMELY, T-SHIRTS, HATS, SWEATSHIRTS, SWEATPANTS, SHORTS (U.S. CLS. 22 AND 39).

FIRST USE 1-1-1971; IN COMMERCE 1-1-1971.

CLASS 41—EDUCATION AND ENTERTAINMENT

FOR SPORTS CAMP, NAMELY, GYMNASTICS CAMP AND INSTRUCTION (U.S. CLS. 100, 101 AND 107).

FIRST USE 1-1-1971; IN COMMERCE 1-1-1971.

KARANENDRA S. CHHINA, EXAMINING ATTORNEY

SN 85-390,987. FREEMAN CAPITAL COMPANY, LAS VEGAS, NV. FILED 8-5-2011.

FLOORPRINT BY FREEMAN

THE MARK CONSISTS OF STANDARD CHARACTERS WITHOUT CLAIM TO ANY PARTICULAR FONT, STYLE, SIZE, OR COLOR.

OWNER OF U.S. REG. NOS. 2,645,625, 3,673,571 AND OTHERS.

NO CLAIM IS MADE TO THE EXCLUSIVE RIGHT TO USE "FLOORPRINT", APART FROM THE MARK AS SHOWN.

CLASS 16—PAPER GOODS AND PRINTED MATTER

FOR FULL SCALE TEMPLATE FOR INSTALLING TEMPORARY WALLS AND PLACING FURNITURE AT EXHIBITIONS, TRADE SHOWS, CONVENTIONS, AND EVENTS (U.S. CLS. 2, 5, 22, 23, 29, 37, 38 AND 50).
FIRST USE 2-1-2011; IN COMMERCE 2-1-2011.

CLASS 37—CONSTRUCTION AND REPAIR

FOR PROVIDING SERVICES FOR EXHIBITIONS, TRADE SHOWS, CONVENTIONS, AND EVENTS, NAMELY, INSTALLING TEMPORARY WALLS AND PLACING FURNITURE ON A FULL SCALE TEMPLATE AT EXHIBITIONS, TRADE SHOWS, CONVENTIONS, AND EVENTS (U.S. CLS. 100, 103 AND 106).
FIRST USE 2-1-2011; IN COMMERCE 2-1-2011.
TASHIA BUNCH, EXAMINING ATTORNEY

SN 85-392,055. BANK OF AMERICA CORPORATION, CHARLOTTE, NC. FILED 8-8-2011.

MERRILL LYNCH ANSWERS

THE MARK CONSISTS OF STANDARD CHARACTERS WITHOUT CLAIM TO ANY PARTICULAR FONT, STYLE, SIZE, OR COLOR.
OWNER OF U.S. REG. NOS. 1,280,908, 3,462,159 AND 3,894,481.

CLASS 9—ELECTRICAL AND SCIENTIFIC APPARATUS

FOR ELECTRONIC PUBLICATIONS, NAMELY, DOWNLOADABLE NEWSLETTERS IN THE FIELD OF FINANCIAL AND INVESTMENT MATTERS; DOWNLOADABLE WEBCASTS IN THE FIELD OF FINANCIAL AND INVESTMENT MATTERS (U.S. CLS. 21, 23, 26, 36 AND 38).

CLASS 16—PAPER GOODS AND PRINTED MATTER

FOR PUBLICATIONS, NAMELY, NEWSLETTERS AND MAGAZINES IN THE FIELD OF FINANCIAL AND INVESTMENT MATTERS (U.S. CLS. 2, 5, 22, 23, 29, 37, 38 AND 50).

CLASS 36—INSURANCE AND FINANCIAL

FOR FINANCIAL SERVICES, NAMELY, FINANCIAL RESEARCH, FINANCIAL ADVICE; FINANCIAL INFORMATION (U.S. CLS. 100, 101 AND 102).

CLASS 41—EDUCATION AND ENTERTAINMENT

FOR EDUCATIONAL SERVICES, NAMELY, CONDUCTING SEMINARS AND WEBINARS IN THE FIELD OF FINANCIAL EDUCATION (U.S. CLS. 100, 101 AND 107).
FRANK LATTUCA, EXAMINING ATTORNEY

SN 85-392,095. OSBORN, OWEN, DBA CRITTER & GUITARI, PHILADELPHIA, PA. AND CHRISTOPHER KUCINSKI, DBA CRITTER & GUITARI, BROOKLYN, NY. FILED 8-8-2011.

Critter & Guitari

THE MARK CONSISTS OF STANDARD CHARACTERS WITHOUT CLAIM TO ANY PARTICULAR FONT, STYLE, SIZE, OR COLOR.

CLASS 9—ELECTRICAL AND SCIENTIFIC APPARATUS

FOR ELECTRIC AUDIO PLAYBACK UNITS (U.S. CLS. 21, 23, 26, 36 AND 38).
FIRST USE 9-30-2010; IN COMMERCE 9-30-2010.

CLASS 15—MUSICAL INSTRUMENTS

FOR MUSIC SYNTHESIZERS (U.S. CLS. 2, 21 AND 36).
FIRST USE 8-30-2010; IN COMMERCE 8-30-2010.

CLASS 35—ADVERTISING AND BUSINESS

FOR ON-LINE RETAIL STORE SERVICES FEATURING MUSICAL INSTRUMENTS (U.S. CLS. 100, 101 AND 102).
FIRST USE 8-30-2010; IN COMMERCE 8-30-2010.
JAY BESCH, EXAMINING ATTORNEY

SN 85-393,547. WPX ENERGY, INC., TULSA, OK. FILED 8-9-2011.



THE COLOR(S) BLACK, GRAY, DARK BLUE, BLUE, LIGHT BLUE, GREEN, LIGHT GREEN, AND YELLOW IS/ ARE CLAIMED AS A FEATURE OF THE MARK.

THE MARK CONSISTS OF THE STYLIZED BLACK LETTERS "WPX" FOLLOWED BY THE STYLIZED GRAY WORD "ENERGY" ABOVE THREE TRIANGLES ORIGINATING FROM A COMMON POINT, STACKED AND STAGGERED ON TOP OF EACH OTHER IN THE COLORS DARK BLUE, BLUE, LIGHT BLUE, GREEN, LIGHT GREEN, AND YELLOW.

CLASS 40—MATERIAL TREATMENT

FOR GAS PRODUCTION SERVICES; OIL PRODUCTION SERVICES (U.S. CLS. 100, 103 AND 106).

CLASS 42—SCIENTIFIC AND COMPUTER SERVICES

FOR EXPLORATION AND SEARCHING OF OIL AND GAS (U.S. CLS. 100 AND 101).
DAVID TOOLEY, EXAMINING ATTORNEY

SN 85-393,642. KBW ENTERPRISES, LLC, AKA UNCUT SPORTS, GAITHERSBURG, MD. FILED 8-9-2011.



OWNER OF U.S. REG. NO. 3,509,807.

NO CLAIM IS MADE TO THE EXCLUSIVE RIGHT TO USE "SPORTS" AS TO CLASS 25 AND "UNCUT SPORTS" AS TO CLASS 41, APART FROM THE MARK AS SHOWN.

THE STIPPLING IS A FEATURE OF THE MARK AND DOES NOT INDICATE COLOR.

THE MARK CONSISTS OF THE WORDING "UNCUT SPORTS" SET AGAINST A STYLIZED DEPICTION OF A DETERIORATED MOTORCYCLE SPROCKET AND MICROPHONE. THE BACKGROUND OF THE ENTIRE MARK CONTAINS CLOUDED SPOTS.

CLASS 25—CLOTHING

FOR ATHLETIC APPAREL, NAMELY, SHIRTS, PANTS, JACKETS, FOOTWEAR, HATS AND CAPS, ATHLETIC UNIFORMS (U.S. CLS. 22 AND 39).

FIRST USE 8-1-2011; IN COMMERCE 8-1-2011.

CLASS 41—EDUCATION AND ENTERTAINMENT

FOR ENTERTAINMENT IN THE NATURE OF VISUAL AND AUDIO PERFORMANCES, AND MUSICAL, VARIETY, NEWS AND COMEDY SHOWS (U.S. CLS. 100, 101 AND 107).

FIRST USE 8-1-2011; IN COMMERCE 8-1-2011.

JIM RINGLE, EXAMINING ATTORNEY

SN 85-393,871. PRESIGHT HEALTH SOLUTIONS, LLC, ARLINGTON, VA. FILED 8-9-2011.

PreSight

THE MARK CONSISTS OF STANDARD CHARACTERS WITHOUT CLAIM TO ANY PARTICULAR FONT, STYLE, SIZE, OR COLOR.

CLASS 36—INSURANCE AND FINANCIAL

FOR PROVIDING INFORMATION IN INSURANCE MATTERS (U.S. CLS. 100, 101 AND 102).

CLASS 45—PERSONAL AND LEGAL SERVICES

FOR COMPILING AND ANALYZING STATISTICAL HEALTH DATA IN ORDER TO UNCOVER AND IDENTIFY HEALTH CARE FRAUD AND CLAIMS ERRORS (U.S. CLS. 100 AND 101).

ROBERT C. CLARK JR., EXAMINING ATTORNEY

SN 85-395,363. REVOLUTIONARY WAR VETERANS ASSOCIATION, INC., AKA RWVA, MOREHEAD, KY. FILED 8-11-2011.



NO CLAIM IS MADE TO THE EXCLUSIVE RIGHT TO USE "MARKSMANSHIP" AND "HERITAGE" AND "REVOLUTIONARY WAR VETERANS ASSOCIATION", APART FROM THE MARK AS SHOWN.

THE MARK CONSISTS OF AN OVAL SURROUND ENCLOSING THE WORDS "LIBERTY", "REVOLUTIONARY WAR VETERANS ASSOCIATION", "MARKSMANSHIP" AND "HERITAGE" AROUND A DEPICTION OF A MINUTEMAN, NAMELY, CAPTAIN JOHN PARKER, LEADER OF THE LEXINGTON MILITIA ON APRIL 19, 1775.

CLASS 25—CLOTHING

FOR MEN'S, WOMEN'S AND CHILDREN'S CLOTHING, NAMELY, HATS, BASEBALL CAPS, T-SHIRTS, GOLF SHIRTS, SWEATSHIRTS, ALL USED TO PROMOTE ASSOCIATION SERVICES, NAMELY, PROMOTING THE INTEREST AND OPPORTUNITIES FOR MEN, WOMEN AND CHILDREN IN THE FIELDS OF EARLY AMERICAN HERITAGE AND RIFLE MARKSMANSHIP (U.S. CLS. 22 AND 39).

FIRST USE 3-1-2006; IN COMMERCE 3-1-2006.

CLASS 41—EDUCATION AND ENTERTAINMENT

FOR EDUCATIONAL SERVICES, NAMELY, ARRANGING AND CONDUCTING EDUCATIONAL PROGRAMS FOR EXPOSING PARTICIPANTS TO EARLY AMERICAN HISTORY, AMERICAN HERITAGE AND PROVIDING RIFLE MARKSMANSHIP TRAINING (U.S. CLS. 100, 101 AND 107).

FIRST USE 3-1-2006; IN COMMERCE 3-1-2006.

CHRISIE B. KING, EXAMINING ATTORNEY

SN 85-395,818. RADIORAX AVIATION SYSTEMS, INC., LAKE STEVENS, WA. FILED 8-11-2011.

RADIORAX

THE MARK CONSISTS OF STANDARD CHARACTERS WITHOUT CLAIM TO ANY PARTICULAR FONT, STYLE, SIZE, OR COLOR.

SEC. 2(F).

CLASS 12—VEHICLES

FOR KITS COMPRISING RAILS, BRACKETS, ADAPTERS, SPACERS, CAMS, PANELS, DRILL GUIDES, NUTS, AND BOLTS, ALL FOR INSTALLING COCKPIT AVIONICS, SOLD AS A UNIT (U.S. CLS. 19, 21, 23, 31, 35 AND 44).

FIRST USE 5-0-2002; IN COMMERCE 9-0-2002.

CLASS 35—ADVERTISING AND BUSINESS

FOR ON-LINE RETAIL STORE SERVICES FEATURING KITS COMPRISING RAILS, BRACKETS, ADAPTERS, SPACERS, CAMS, PANELS, DRILL GUIDES, NUTS, AND BOLTS, ALL FOR INSTALLING COCKPIT AVIONICS (U.S. CLS. 100, 101 AND 102).

FIRST USE 5-0-2002; IN COMMERCE 9-0-2002.
KALIE KUNG, EXAMINING ATTORNEY

SN 85-396,155. BALD HEAD ISLAND CLUB, BALD HEAD ISLAND, NC. FILED 8-12-2011.



NO CLAIM IS MADE TO THE EXCLUSIVE RIGHT TO USE "BALD HEAD ISLAND CLUB", APART FROM THE MARK AS SHOWN.

THE MARK CONSISTS OF AN IMAGE OF A LIGHTHOUSE SURROUNDED BY LANDSCAPING AND TREES. THE BACKGROUND IS IN HORIZONTAL LINES. THE IMAGE IS SURROUNDED BY A CIRCLE WHICH IS IMMEDIATELY SURROUNDED BY ANOTHER CIRCLE. THE CIRCLE IS IMMEDIATELY SURROUNDED BY A CIRCULAR BAND. INSIDE THE BAND IS THE LITERAL ELEMENT "BALD HEAD ISLAND CLUB" IS WRITTEN. THE BAND IS FURTHER SURROUNDED BY ANOTHER CIRCLE FURTHEST TO THE OUTSIDE.

CLASS 28—TOYS AND SPORTING GOODS

FOR SPORTING GOODS, NAMELY, GOLF BALLS, GOLF CLUBS AND TENNIS RACKETS AND BALLS (U.S. CLS. 22, 23, 38 AND 50).

FIRST USE 8-3-1990; IN COMMERCE 8-3-1990.

CLASS 41—EDUCATION AND ENTERTAINMENT

FOR CLUB SERVICES, NAMELY, GOLF CLUB AND SOCIAL CLUB SERVICES, NAMELY, ARRANGING, ORGANIZING, AND HOSTING SOCIAL EVENTS AND PARTIES FOR CLUB MEMBERS (U.S. CLS. 100, 101 AND 107).

FIRST USE 8-3-1990; IN COMMERCE 8-3-1990.

CLASS 43—HOTEL AND RESTAURANT SERVICES

FOR RESTAURANT SERVICES, DINING SERVICES (U.S. CLS. 100 AND 101).

FIRST USE 8-3-1990; IN COMMERCE 8-3-1990.
MICHAEL WEBSTER, EXAMINING ATTORNEY

SN 85-396,258. INNOVATIVE SCIENCE SOLUTIONS, LLC, DENVER, NJ. FILED 8-12-2011.

INNOVATIVE SCIENCE SOLUTIONS

THE MARK CONSISTS OF STANDARD CHARACTERS WITHOUT CLAIM TO ANY PARTICULAR FONT, STYLE, SIZE, OR COLOR.

NO CLAIM IS MADE TO THE EXCLUSIVE RIGHT TO USE "SCIENCE SOLUTIONS", APART FROM THE MARK AS SHOWN.

CLASS 35—ADVERTISING AND BUSINESS

FOR BUSINESS CONSULTATION RELATING TO PHARMACEUTICAL PRODUCTS, FOODS, MEDICAL DEVICES, COSMETICS, DIETARY SUPPLEMENTS, AND CHEMICAL EXPOSURES (U.S. CLS. 100, 101 AND 102).

FIRST USE 0-0-2000; IN COMMERCE 0-0-2000.

CLASS 42—SCIENTIFIC AND COMPUTER SERVICES

FOR SCIENTIFIC RESEARCH CONSULTING IN THE FIELDS OF PHARMACEUTICAL PRODUCTS, FOODS, MEDICAL DEVICES, COSMETICS, DIETARY SUPPLEMENTS, AND CHEMICAL EXPOSURES (U.S. CLS. 100 AND 101).

FIRST USE 0-0-2000; IN COMMERCE 0-0-2000.
GEOFFREY FOSDICK, EXAMINING ATTORNEY

SN 85-396,332. VOLVO CAR CORPORATION, GOTEBOG, SWEDEN, FILED 8-12-2011.

SERVICE 2.0

THE MARK CONSISTS OF STANDARD CHARACTERS WITHOUT CLAIM TO ANY PARTICULAR FONT, STYLE, SIZE, OR COLOR.

PRIORITY CLAIMED UNDER SEC. 44(D) ON ERPN CMNTY TM OFC APPLICATION NO. 009773722, FILED 3-1-2011, REG. NO. 009773722, DATED 8-10-2011, EXPIRES 3-1-2021.

NO CLAIM IS MADE TO THE EXCLUSIVE RIGHT TO USE "SERVICE", APART FROM THE MARK AS SHOWN.

CLASS 35—ADVERTISING AND BUSINESS

FOR RETAIL STORE SERVICES FEATURING MOTOR VEHICLES PARTS (U.S. CLS. 100, 101 AND 102).

CLASS 37—CONSTRUCTION AND REPAIR

FOR MOTOR VEHICLE REPAIR AND MAINTENANCE SERVICES (U.S. CLS. 100, 103 AND 106).

KATHLEEN LORENZO, EXAMINING ATTORNEY

SN 85-396,348. ENTERTAINMENT PUBLICATIONS, LLC, TROY, MI. FILED 8-12-2011.

ENTERTAINMENT HOTEL BUCKS

THE MARK CONSISTS OF STANDARD CHARACTERS WITHOUT CLAIM TO ANY PARTICULAR FONT, STYLE, SIZE, OR COLOR.

OWNER OF U.S. REG. NOS. 1,909,948, 3,283,711 AND OTHERS.

NO CLAIM IS MADE TO THE EXCLUSIVE RIGHT TO USE "HOTEL BUCKS", APART FROM THE MARK AS SHOWN.

SEC. 2(F) AS TO "ENTERTAINMENT".

CLASS 16—PAPER GOODS AND PRINTED MATTER

FOR BOOKS, BOOKLETS, AND NON-MAGNETICALLY ENCODED PRINTED COUPON AND DISCOUNT CARDS ALL WHICH ENTITLE THE HOLDER TO RECEIVE DISCOUNTS ON DINING, HOTEL ACCOMMODATIONS, CONSUMER MERCHANDISE, TRAVEL, MOVIES, SPORTS, THEATER, AND OTHER LEISURE ACTIVITIES SOLD SEPARATELY OR AS PART OF A UNIT (U.S. CLS. 2, 5, 22, 23, 29, 37, 38 AND 50).
FIRST USE 8-1-2011; IN COMMERCE 8-1-2011.

CLASS 35—ADVERTISING AND BUSINESS

FOR ADVERTISING AND PROMOTIONAL SERVICES, NAMELY, PROMOTING THE GOODS AND SERVICES OF OTHERS THROUGH THE DISTRIBUTION OF COUPONS, AND DISCOUNT OFFERS WHICH ENTITLE THE HOLDER TO RECEIVE DISCOUNTS ON DINING, HOTEL ACCOMMODATIONS, CONSUMER MERCHANDISE, TRAVEL, MOVIES, SPORTS, THEATER AND OTHER LEISURE ACTIVITIES; PROVIDING ADVERTISING SERVICE THROUGH THE DISTRIBUTION OF ADVERTISEMENTS, COUPONS AND DISCOUNT OFFERS FOR DISPLAY ON INTERNET, NAMELY, IN WEBSITES, E-MAILS AND MULTIMEDIA MESSAGES; PROVIDING VIA ON-LINE COMPUTER SERVICES A MEMBERSHIP PROGRAM ENTITLING THE PARTICIPANTS TO RECEIVE DISCOUNTS ON DINING, HOTEL ACCOMMODATIONS, CONSUMER MERCHANDISE, TRAVEL, MOVIES, SPORTS, THEATER AND OTHER LEISURE ACTIVITIES, AND PROVIDING IN CONNECTION THEREWITH AN ON-LINE DIRECTORY OF INFORMATION ABOUT THE DISCOUNT PROGRAM AND PARTICIPATING BUSINESSES (U.S. CLS. 100, 101 AND 102).

FIRST USE 8-1-2011; IN COMMERCE 8-1-2011.

COURTNEY ALVAREZ, EXAMINING ATTORNEY

CLASS 35—ADVERTISING AND BUSINESS

FOR PROFESSIONAL OUTSOURCED HUMAN RESOURCE MANAGEMENT AND BUSINESS ADMINISTRATION ASSISTANCE (U.S. CLS. 100, 101 AND 102).

CLASS 36—INSURANCE AND FINANCIAL

FOR HEALTHCARE INSURANCE SERVICES, NAMELY, ADMINISTRATION OF PRE-PAID HEALTH CARE PLANS (U.S. CLS. 100, 101 AND 102).

BRENDAN MCCAULEY, EXAMINING ATTORNEY

SN 85-396,625. THE DISPATCH PRINTING COMPANY, COLUMBUS, OH. FILED 8-12-2011.

DISPATCH SPORTS EXTRA

THE MARK CONSISTS OF STANDARD CHARACTERS WITHOUT CLAIM TO ANY PARTICULAR FONT, STYLE, SIZE, OR COLOR.

NO CLAIM IS MADE TO THE EXCLUSIVE RIGHT TO USE "SPORTS EXTRA", APART FROM THE MARK AS SHOWN.

CLASS 16—PAPER GOODS AND PRINTED MATTER

FOR PRINTED PUBLICATIONS, NAMELY, MAGAZINES, PERTAINING TO LOCAL AND NATIONAL SPORTS FOR ENTERTAINMENT PURPOSES (U.S. CLS. 2, 5, 22, 23, 29, 37, 38 AND 50).

CLASS 41—EDUCATION AND ENTERTAINMENT

FOR ON-LINE PUBLICATIONS, NAMELY, E-MAGAZINES, PERTAINING TO LOCAL AND NATIONAL SPORTS FOR ENTERTAINMENT PURPOSES (U.S. CLS. 100, 101 AND 107).

ODESSA BIBBINS, EXAMINING ATTORNEY

SN 85-396,671. FORT WAYNE METALS RESEARCH PRODUCTS CORP, FORT WAYNE, IN. FILED 8-12-2011.

SN 85-396,604. ALPHASTAFF, INC., FORT LAUDERDALE, FL. FILED 8-12-2011.

ALLEGRO

THE MARK CONSISTS OF STANDARD CHARACTERS WITHOUT CLAIM TO ANY PARTICULAR FONT, STYLE, SIZE, OR COLOR.



THE MARK CONSISTS OF FOUR INTERLOCKING CIRCLES OR RINGS THAT PROVIDE THE APPEARANCE OF BEING THREE-DIMENSIONAL.

CLASS 6—METAL GOODS

FOR METAL WIRE, MEDICAL GRADE WIRE FOR USE IN THE MANUFACTURE OF MEDICAL DEVICES; BARS, BILLETS, INGOTS, PLATES, SHEETS, AND TUBING ALL OF COMMON METAL AND METAL COMPOSITES (U.S. CLS. 2, 12, 13, 14, 23, 25 AND 50).

CLASS 42—SCIENTIFIC AND COMPUTER SERVICES

FOR SCIENTIFIC LABORATORY SERVICES, NAMELY, TESTING, CHARACTERIZATION AND DEVELOPMENT OF NEW PRODUCTS, METALLURGY, GAS ANALYSIS, CALORIMETRY, CORROSION TESTING, AND MECHANICAL AND FATIGUE TESTING AND ANALYSIS (U.S. CLS. 100 AND 101).

DARRYL SPRULL, EXAMINING ATTORNEY

CLASS 9—ELECTRICAL AND SCIENTIFIC APPARATUS

FOR AUDIO BOOKS IN THE FIELD OF MUSIC, LECTURE, KNOWLEDGE INSTRUCTION, RELIGION, PHILOSOPHY, LITERATURE, ACADEMIC RESEARCH, ART; ELECTRONIC NOTICE BOARDS; COMPUTER HARDWARE; EDUCATIONAL SOFTWARE FEATURING INSTRUCTION IN RELIGION, PHILOSOPHY, LITERATURE, ACADEMIC RESEARCH, ART; COMPUTER INTERFACE BOARDS; DOWNLOADABLE MUSIC AND PICTURES IN THE FIELD OF RELIGION, PHILOSOPHY, LITERATURE, ACADEMIC RESEARCH AND ART VIA THE INTERNET AND WIRELESS DEVICES; DOWNLOADABLE FILMS FEATURING RELIGION, PHILOSOPHY, LITERATURE, ACADEMIC RESEARCH AND ART PROVIDED VIA A VIDEO-ON-DEMAND SERVICE; DOWNLOADABLE MPS FILES, MP3 RECORDINGS, WEBCASTS, AND PODCASTS FEATURING AUDIO BOOKS IN THE FIELD OF RELIGION, PHILOSOPHY, LITERATURE, ACADEMIC RESEARCH AND ART; COMPACT DISKS FEATURING MUSIC, LECTURE, KNOWLEDGE INSTRUCTION; ELECTRONIC DIARIES; ELECTRONIC PUBLICATIONS, NAMELY, BOOK, MANUAL, FEATURING MUSIC, LECTURE, KNOWLEDGE INSTRUCTION, RELIGION, PHILOSOPHY, LITERATURE, ACADEMIC RESEARCH, ART RECORDED ON COMPUTER MEDIA; PERSONAL DIGITAL ASSISTANTS (PDA); HAND-HELD ELECTRONIC DICTIONARIES; DATA CARRIERS CONTAINING STORED TYPOGRAPHIC TYPEFACES; MOTION PICTURE FILMS ABOUT MUSIC, LECTURE, KNOWLEDGE INSTRUCTION, RELIGION, PHILOSOPHY, LITERATURE, ACADEMIC RESEARCH, ART; PRERECORDED VIDEO TAPES FEATURING MUSIC, LECTURE, KNOWLEDGE INSTRUCTION, RELIGION, PHILOSOPHY, LITERATURE, ACADEMIC RESEARCH, ART; AUDIO DISCS FEATURING MUSIC, LECTURE, KNOWLEDGE INSTRUCTION, RELIGION, PHILOSOPHY, LITERATURE, ACADEMIC RESEARCH, ART; AUDIO TAPES FEATURING MUSIC, LECTURE, KNOWLEDGE INSTRUCTION, RELIGION, PHILOSOPHY, LITERATURE, ACADEMIC RESEARCH, ART; SOUND RECORDING APPARATUS; MAGNETIC IDENTIFYING CARDS (U.S. CLS. 21, 23, 26, 36 AND 38).

SN 85-397,071. TRUE WISDOM PUBLISHING CENTER, TAIPEI, TAIWAN, FILED 8-12-2011.



THE COLOR(S) BLACK, DARK PURPLE, AND WHITE IS/ARE CLAIMED AS A FEATURE OF THE MARK.

THE MARK CONSISTS OF A DESIGN OF A RIGHT HUMAN HAND WITH THE MIDDLE FINGER BENT AND SLIGHTLY TOUCHING THE THUMB OVER A WHITE CLOUD DESIGN WITH BOTH THE HAND AND THE CLOUD OUTLINED IN BLACK, ABOVE TWO CHINESE CHARACTERS APPEARING IN BLACK, WITH A BACKGROUND IN DARK PURPLE.

THE NON-LATIN CHARACTERS IN THE MARK TRANSLITERATE TO "CHENG" AND "CHUEH" AND THIS MEANS "PURE" AND "AWAKENING" IN ENGLISH.

CLASS 16—PAPER GOODS AND PRINTED MATTER

FOR OFFICE PAPER STATIONERY; LABEL PAPER; BOOKS IN THE FIELD OF RELIGION, PHILOSOPHY, LITERATURE, ACADEMIC RESEARCH, ART; ENVELOPES; BOOK COVERS; BOOKMARKERS; POSTCARDS; INVITATION CARDS; PRINTED CERTIFICATES; CALENDARS; DICTIONARIES; GENERAL FEATURE MAGAZINES; PRINTED MATTER, NAMELY, PAPER SIGNS, BOOKS, MANUALS, CURRICULUM, NEWSLETTERS, INFORMATIONAL CARDS AND BROCHURES IN THE FIELD OF RELIGION, PHILOSOPHY, LITERATURE, ACADEMIC RESEARCH, ART; LETTER PAPER (FINISHED PRODUCTS); NEWSPAPERS; PENS; FILING FOLDERS, PAPER LABELS AND PRINTED INSTRUCTIONAL MATERIALS FOR ORGANIZING PERSONAL FILES; CONTAINERS FOR STORAGE OR TRANSPORT MADE OF PAPER OR CARDBOARD; GENERAL PURPOSE PLASTIC BAGS; PAINTINGS; ROSARIES; CALENDAR DESK STANDS (U.S. CLS. 2, 5, 22, 23, 29, 37, 38 AND 50).

CLASS 41—EDUCATION AND ENTERTAINMENT

FOR INSTRUCTION IN THE FIELD OF RELIGION, PHILOSOPHY, LITERATURE, ACADEMIC RESEARCH, ART; LIBRARIES; RELIGIOUS INSTRUCTION SERVICES; TEACHING IN THE FIELD OF RELIGION, PHILOSOPHY, LITERATURE, ACADEMIC RESEARCH, ART; PUBLICATION OF ELECTRONIC MAGAZINES, NEWSPAPERS ACCESSIBLE VIA A GLOBAL COMPUTER NETWORK; ON-LINE LIBRARY SERVICES, NAMELY, PROVIDING ELECTRONIC LIBRARY SERVICES WHICH FEATURE NEWSPAPERS, MAGAZINES, PHOTOGRAPHS AND PICTURES VIA AN ON-LINE COMPUTER NETWORK; PUBLICATION OF BOOKS, JOURNALS, MAGAZINES, COLLEGE, PERIODICALS; TRANSLATION SERVICES; ON-LINE ELECTRONIC PUBLISHING OF BOOKS AND PERIODICALS; BOOK

RENTAL; RENTAL OF MAGAZINES; CONDUCTING WORKSHOPS AND SEMINARS IN RELIGION, PHILOSOPHY, LITERATURE, ACADEMIC RESEARCH, ART; ORGANIZING AND HOSTING OF EVENTS FOR CULTURAL PURPOSES; PROVIDING INFORMATION RELATING TO ENTERTAINMENT AND EDUCATION FROM AN ON-LINE COMPUTER DATABASE OR THE INTERNET; PROVIDING INFORMATION, NEWS AND COMMENTARY IN THE FIELD OF ENTERTAINMENT; CONTESTS AND INCENTIVE AWARD PROGRAMS TO ENCOURAGE STUDENTS AND ORGANIZATION MEMBERS TO SET UP AND ACHIEVE GOALS IN ACADEMICS, ATTENDANCE, CITIZENSHIP AND CONDUCT; ARRANGING AND CONDUCTING OF CONCERTS; ENTERTAINMENT TICKET AGENCY SERVICES; AUDIO RECORDING AND PRODUCTION; PRODUCTION OF VIDEO DISCS AND TAPES; RECORD PRODUCTION; PRODUCTION OF RADIO OR TELEVISION PROGRAMS; ADMISSION CONSULTING SERVICES, NAMELY, CONSULTING IN THE FIELD OF COLLEGE ADMISSIONS, SPECIFICALLY, COLLEGE SELECTION, COMPLETING ADMISSIONS APPLICATION, AND PREPARATION FOR ACADEMIC RESEARCH INTERVIEWS; RENTAL OF FACILITIES AND EQUIPMENT FOR THE PRODUCTION OF RADIO AND TELEVISION PROGRAMS, MUSICAL AND THEATRICAL PRODUCTIONS, NAMELY, PERFORMANCE VENUES, STUDIOS, SETS, DRESSING ROOMS; RENTAL OF RECORDS OR SOUND-RECORDED MAGNETIC TAPES; RENTAL OF FILMS; PHOTOGRAPHIC AND VIDEO SERVICES, NAMELY, PHOTOGRAPHIC AND VIDEO CAPTURE; PROVIDING NEWS IN THE NATURE OF CURRENT EVENT REPORTING; SIGN LANGUAGE INTERPRETATION (U.S. CLS. 100, 101 AND 107).

DAVID I, EXAMINING ATTORNEY

SN 85-397,664. PRACTICE GREENHEALTH, RESTON, VA. FILED 8-15-2011.



NO CLAIM IS MADE TO THE EXCLUSIVE RIGHT TO USE "GREENING THE OR", APART FROM THE MARK AS SHOWN.

THE MARK CONSISTS OF THE WORDS "GREENING THE OR" WITH A STYLIZED EKG LINE WITH A STYLIZED LEAF IN THE "O" OF THE "OR".

CLASS 16—PAPER GOODS AND PRINTED MATTER

FOR PRINTED MATERIALS, NAMELY, CASE STUDIES, MANUALS, GUIDES, BROCHURES, PAMPHLETS, INSTRUCTIONAL MATERIALS, AND COURSE MATERIALS ON THE TOPIC OF BEST PRACTICES FOR MAKING HEALTHCARE FACILITIES MORE ENVIRONMENTALLY FRIENDLY (U.S. CLS. 2, 5, 22, 23, 29, 37, 38 AND 50).

FIRST USE 4-0-2010; IN COMMERCE 4-0-2010.

CLASS 41—EDUCATION AND ENTERTAINMENT

FOR EDUCATIONAL SERVICES, NAMELY, CONDUCTING SYMPOSIUMS, CONFERENCES, WORKSHOPS, AND WEBINARS ON BEST PRACTICES FOR MAKING HEALTHCARE FACILITIES MORE ENVIRONMENTALLY FRIENDLY, AND DISTRIBUTION OF COURSE MATERIALS IN CONNECTION THEREWITH (U.S. CLS. 100, 101 AND 107).

FIRST USE 4-0-2010; IN COMMERCE 4-0-2010.

CLASS 44—MEDICAL, BEAUTY AND AGRICULTURAL SERVICES

FOR PROVIDING A WEBSITE FEATURING INFORMATION ON BEST HEALTHCARE AND MEDICAL PRACTICES FOR MAKING HEALTHCARE FACILITIES MORE ENVIRONMENTALLY FRIENDLY (U.S. CLS. 100 AND 101).

FIRST USE 4-0-2010; IN COMMERCE 4-0-2010.
ZACHARY BELLO, EXAMINING ATTORNEY

SN 85-397,603. TYCO VALVES & CONTROLS, INC., HOUSTON, TX. FILED 8-15-2011.

KUNKLE

THE MARK CONSISTS OF STANDARD CHARACTERS WITHOUT CLAIM TO ANY PARTICULAR FONT, STYLE, SIZE, OR COLOR.
OWNER OF U.S. REG. NO. 1,591,699.
SEC. 2(F).

CLASS 7—MACHINERY

FOR SAFETY AND RELIEF VALVES AS PARTS OF MACHINES FOR AIR, GAS, STEAM AND LIQUID APPLICATIONS (U.S. CLS. 13, 19, 21, 23, 31, 34 AND 35).

FIRST USE 12-1-1988; IN COMMERCE 12-1-1988.

CLASS 9—ELECTRICAL AND SCIENTIFIC APPARATUS

FOR AUTOMATIC SAFETY AND RELIEF VALVES FOR AIR, GAS, STEAM AND LIQUID APPLICATIONS (U.S. CLS. 21, 23, 26, 36 AND 38).

FIRST USE 12-1-1988; IN COMMERCE 12-1-1988.
EDWARD NELSON, EXAMINING ATTORNEY

SN 85-397,910. HUNT STRONG, LLC, BROOKSVILLE, FL. FILED 8-15-2011.



NO CLAIM IS MADE TO THE EXCLUSIVE RIGHT TO USE "TRAIN TO HUNT", APART FROM THE MARK AS SHOWN.

THE MARK CONSISTS OF THE WORDS "HUNT STRONG" ARE IN STYLIZED FONT, THE FONT IS TITLED "BLEEDING COWBOYS". THE WORDS "TRAIN TO HUNT"

ARE IN SMALLER FONT THAN THE WORDS "HUNT STRONG", AND ARE IN ALL CAPITAL LETTERS IN BLOCK OUTLINE FORMAT. THE WORDS "TRAIN TO HUNT" ARE LOCATED BELOW THE WORDS "HUNT STRONG", WITH THE "T" OF THE WORD "TRAIN" BEGINNING BETWEEN THE "U" AND THE "N" OF "HUNT" IN "HUNT STRONG", AND THE LETTER "T" IN "HUNT" OF "TRAIN TO HUNT" IS UNDERNEATH THE FIRST PART OF THE "N" OF "STRONG" IN "HUNT STRONG".

SN 85-398,207. SARASIN CONSULTANTS LTD., CENTRAL HONG KONG, CHINA, FILED 8-15-2011.

LEIT

CLASS 25—CLOTHING

FOR HATS; T-SHIRTS (U.S. CLS. 22 AND 39). FIRST USE 4-19-2010; IN COMMERCE 4-19-2010.

THE MARK CONSISTS OF STANDARD CHARACTERS WITHOUT CLAIM TO ANY PARTICULAR FONT, STYLE, SIZE, OR COLOR.

CLASS 41—EDUCATION AND ENTERTAINMENT

FOR EDUCATION SERVICES, NAMELY, PROVIDING SEMINARS IN THE FIELDS OF PHYSICAL FITNESS, PHYSICAL AND MENTAL TRAINING AND EDUCATION SERVICES, NAMELY, PROVIDING CLASSES AND SEMINARS IN THE FIELD OF PREPARATION FOR BECOMING A SUCCESSFUL HUNTER; PERSONAL TRAINER SERVICES (U.S. CLS. 100, 101 AND 107). FIRST USE 4-19-2010; IN COMMERCE 4-19-2010. ROBERT STRUCK, EXAMINING ATTORNEY

CLASS 36—INSURANCE AND FINANCIAL

FOR CONSULTING SERVICES IN THE AREA OF REAL ESTATE INVESTMENT; THE PURCHASE AND MANAGEMENT OF REAL ESTATE FOR OTHERS; REAL ESTATE INVESTMENT MANAGEMENT SERVICES; THE OPERATION OF REAL ESTATE INVESTMENT TRUSTS; REAL ESTATE MANAGEMENT SERVICES; REAL ESTATE BROKERAGE SERVICES; MORTGAGE BROKERAGE SERVICES; REAL ESTATE FINANCING SERVICES; REAL ESTATE TITLE INSURANCE UNDERWRITING SERVICES (U.S. CLS. 100, 101 AND 102).

SN 85-398,065. TAYLOR WESSING LLP, LONDON, UNITED KINGDOM, FILED 8-15-2011.

CLASS 37—CONSTRUCTION AND REPAIR

FOR BUILDING AND CONSTRUCTION SERVICES; REAL ESTATE DEVELOPMENT SERVICES (U.S. CLS. 100, 103 AND 106).

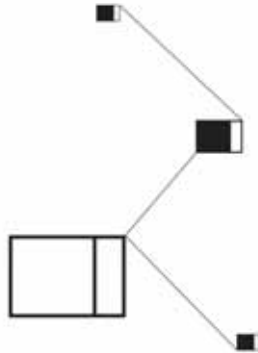

CLASS 42—SCIENTIFIC AND COMPUTER SERVICES

FOR ARCHITECTURAL AND ENGINEERING SERVICES RELATING TO REAL ESTATE DEVELOPMENTS (U.S. CLS. 100 AND 101). MARK T. MULLEN, EXAMINING ATTORNEY

THE MARK CONSISTS OF A SERIES OF BOXES WITH CONNECTING LINES.

SN 85-398,292. TRUE WISDOM PUBLISHING CENTER, TAIPEI, TAIWAN, FILED 8-15-2011.

CLASS 41—EDUCATION AND ENTERTAINMENT

FOR EDUCATIONAL SERVICES, NAMELY, PROVIDING INFORMATION IN THE FIELDS OF BUSINESS, FINANCE AND LAW (U.S. CLS. 100, 101 AND 107). FIRST USE 5-10-2010; IN COMMERCE 5-10-2010.



CLASS 45—PERSONAL AND LEGAL SERVICES

FOR LEGAL SERVICES, NAMELY, PROVIDING LEGAL ADVICE, CONSULTANCY AND REPRESENTATION (U.S. CLS. 100 AND 101). FIRST USE 5-10-2010; IN COMMERCE 5-10-2010. MICHAEL ENGEL, EXAMINING ATTORNEY

THE MARK CONSISTS OF A DESIGN OF A RIGHT HAND OF A HUMAN WITH THE MIDDLE FINGER BENT AND SLIGHTLY TOUCHING THE THUMB OVER A CLOUD DESIGN.

CLASS 9—ELECTRICAL AND SCIENTIFIC APPARATUS

FOR AUDIO BOOKS IN THE FIELD OF MUSIC, LECTURE, KNOWLEDGE INSTRUCTION, RELIGION, PHILOSOPHY, LITERATURE, ACADEMIC RESEARCH, ART; ELECTRONIC NOTICE BOARDS; COMPUTER HARDWARE; EDUCATIONAL SOFTWARE FEATURING INSTRUCTION IN RELIGION, PHILOSOPHY, LITERATURE, ACADEMIC RESEARCH, ART; COMPUTER INTERFACE BOARDS; DOWNLOADABLE MUSIC AND PICTURES IN THE FIELD OF RELIGION, PHILOSOPHY, LITERATURE, ACADEMIC RESEARCH AND ART VIA THE INTERNET AND WIRELESS DEVICES; DOWNLOADABLE FILMS FEATURING RELIGION, PHILOSOPHY, LITERATURE, ACADEMIC RESEARCH AND ART PROVIDED VIA A VIDEO-ON-DEMAND SERVICE; DOWNLOADABLE MPS FILES, MP3 RECORDINGS, WEBCASTS, AND PODCASTS FEATURING AUDIO BOOKS IN THE FIELD OF RELIGION, PHILOSOPHY, LITERATURE, ACADEMIC RESEARCH AND ART; COMPACT DISKS FEATURING MUSIC, LECTURE, KNOWLEDGE INSTRUCTION; ELECTRONIC DIARIES; ELECTRONIC PUBLICATIONS, NAMELY, BOOK, MANUAL, FEATURING MUSIC, LECTURE, KNOWLEDGE INSTRUCTION, RELIGION, PHILOSOPHY, LITERATURE, ACADEMIC RESEARCH, ART RECORDED ON COMPUTER MEDIA; PERSONAL DIGITAL ASSISTANTS (PDA); HAND-HELD ELECTRONIC DICTIONARIES; DATA CARRIERS CONTAINING STORED TYPOGRAPHIC TYPEFACES; MOTION PICTURE FILMS ABOUT MUSIC, LECTURE, KNOWLEDGE INSTRUCTION, RELIGION, PHILOSOPHY, LITERATURE, ACADEMIC RESEARCH, ART; PRERECORDED VIDEO TAPES FEATURING MUSIC, LECTURE, KNOWLEDGE INSTRUCTION, RELIGION, PHILOSOPHY, LITERATURE, ACADEMIC RESEARCH, ART; AUDIO DISCS FEATURING MUSIC, LECTURE, KNOWLEDGE INSTRUCTION, RELIGION, PHILOSOPHY, LITERATURE, ACADEMIC RESEARCH, ART; AUDIO TAPES FEATURING MUSIC, LECTURE, KNOWLEDGE INSTRUCTION, RELIGION, PHILOSOPHY, LITERATURE, ACADEMIC RESEARCH, ART; SOUND RECORDING APPARATUS; MAGNETIC IDENTIFYING CARDS (U.S. CLS. 21, 23, 26, 36 AND 38).

CLASS 16—PAPER GOODS AND PRINTED MATTER

FOR OFFICE PAPER STATIONERY; LABEL PAPER; BOOKS IN THE FIELD OF RELIGION, PHILOSOPHY, LITERATURE, ACADEMIC RESEARCH, ART; ENVELOPES; BOOK COVERS; BOOKMARKERS; POSTCARDS; INVITATION CARDS; PRINTED CERTIFICATES; CALENDARS; DICTIONARIES; GENERAL FEATURE MAGAZINES; PRINTED MATTER, NAMELY, PAPER SIGNS, BOOKS, MANUALS, CURRICULUM, NEWSLETTERS, INFORMATIONAL CARDS AND BROCHURES IN THE FIELD OF RELIGION, PHILOSOPHY, LITERATURE, ACADEMIC RESEARCH, ART; LETTER PAPER (FINISHED PRODUCTS); NEWSPAPERS; PENS; FILING FOLDERS, PAPER LABELS AND PRINTED INSTRUCTIONAL MATERIALS FOR ORGANIZING PERSONAL FILES; CONTAINERS FOR STORAGE OR TRANSPORT MADE OF PAPER OR CARDBOARD; GENERAL PURPOSE PLASTIC BAGS; PAINTINGS; ROSARIES; CALENDAR DESK STANDS (U.S. CLS. 2, 5, 22, 23, 29, 37, 38 AND 50).

CLASS 41—EDUCATION AND ENTERTAINMENT

FOR INSTRUCTION IN THE FIELD OF RELIGION, PHILOSOPHY, LITERATURE, ACADEMIC RESEARCH, ART; LIBRARIES; RELIGIOUS INSTRUCTION SERVICES; TEACHING IN THE FIELD OF RELIGION, PHILOSOPHY, LITERATURE, ACADEMIC RESEARCH, ART; PUBLICATION OF ELECTRONIC MAGAZINES, NEWSPAPERS ACCESSIBLE VIA A GLOBAL COMPUTER NETWORK; ON-LINE LIBRARY SERVICES, NAMELY, PROVIDING ELECTRONIC LIBRARY SERVICES WHICH FEATURE NEWSPAPERS, MAGAZINES, PHOTOGRAPHS AND PICTURES VIA AN ON-LINE COMPUTER NETWORK; PUBLICATION OF BOOKS, JOURNALS, MAGAZINES, COLLEGE, PERIODICALS; TRANSLATION SERVICES; ON-LINE ELECTRONIC PUBLISHING OF BOOKS AND PERIODICALS; BOOK

RENTAL; RENTAL OF MAGAZINES; CONDUCTING WORKSHOPS AND SEMINARS IN RELIGION, PHILOSOPHY, LITERATURE, ACADEMIC RESEARCH, ART; ORGANIZING AND HOSTING OF EVENTS FOR CULTURAL PURPOSES; PROVIDING INFORMATION RELATING TO ENTERTAINMENT AND EDUCATION FROM AN ON-LINE COMPUTER DATABASE OR THE INTERNET; PROVIDING INFORMATION, NEWS AND COMMENTARY IN THE FIELD OF ENTERTAINMENT; CONTESTS AND INCENTIVE AWARD PROGRAMS TO ENCOURAGE STUDENTS AND ORGANIZATION MEMBERS TO SET UP AND ACHIEVE GOALS IN ACADEMICS, ATTENDANCE, CITIZENSHIP AND CONDUCT; ARRANGING AND CONDUCTING OF CONCERTS; ENTERTAINMENT TICKET AGENCY SERVICES; AUDIO RECORDING AND PRODUCTION; PRODUCTION OF VIDEO DISCS AND TAPES; RECORD PRODUCTION; PRODUCTION OF RADIO OR TELEVISION PROGRAMS; ADMISSION CONSULTING SERVICES, NAMELY, CONSULTING IN THE FIELD OF COLLEGE ADMISSIONS, SPECIFICALLY, COLLEGE SELECTION, COMPLETING ADMISSIONS APPLICATION, AND PREPARATION FOR ACADEMIC RESEARCH INTERVIEWS; RENTAL OF FACILITIES AND EQUIPMENT FOR THE PRODUCTION OF RADIO AND TELEVISION PROGRAMS, MUSICAL AND THEATRICAL PRODUCTIONS, NAMELY, PERFORMANCE VENUES, STUDIOS, SETS, DRESSING ROOMS; RENTAL OF RECORDS OR SOUND-RECORDED MAGNETIC TAPES; RENTAL OF FILMS; PHOTOGRAPHIC AND VIDEO SERVICES, NAMELY, PHOTOGRAPHIC AND VIDEO CAPTURE; PROVIDING NEWS IN THE NATURE OF CURRENT EVENT REPORTING; SIGN LANGUAGE INTERPRETATION (U.S. CLS. 100, 101 AND 107).

DAVID I. EXAMINING ATTORNEY

SN 85-398,348. TRUE WISDOM PUBLISHING CENTER, TAIPEI, TAIWAN, FILED 8-15-2011.



THE COLOR(S) BLACK, DARK PURPLE AND WHITE IS/ ARE CLAIMED AS A FEATURE OF THE MARK.

THE MARK CONSISTS OF A DESIGN OF A RIGHT HUMAN HAND WITH THE MIDDLE FINGER BENT AND SLIGHTLY TOUCHING THE THUMB OVER A WHITE CLOUD DESIGN WITH BOTH THE HAND AND THE CLOUD OUTLINED IN BLACK, ABOVE TWO CHINESE CHARACTERS APPEARING IN BLACK, WITH A BACKGROUND IN DARK PURPLE.

THE NON-LATIN CHARACTERS IN THE MARK TRANSLITERATE TO "CHENG" AND "CHIH" AND THIS MEANS "PURE" AND "TALENTED" IN ENGLISH.

CLASS 9—ELECTRICAL AND SCIENTIFIC APPARATUS

FOR AUDIO BOOKS IN THE FIELD OF MUSIC, LECTURE, KNOWLEDGE INSTRUCTION, RELIGION, PHILOSOPHY, LITERATURE, ACADEMIC RESEARCH, ART; ELECTRONIC NOTICE BOARDS; COMPUTER HARDWARE; EDUCATIONAL SOFTWARE FEATURING INSTRUCTION IN RELIGION, PHILOSOPHY, LITERATURE, ACADEMIC RESEARCH, ART; COMPUTER INTERFACE BOARDS; DOWNLOADABLE MUSIC AND PICTURES IN THE FIELD OF RELIGION, PHILOSOPHY, LITERATURE, ACADEMIC RESEARCH AND ART VIA THE INTERNET AND WIRELESS DEVICES; DOWNLOADABLE FILMS FEATURING RELIGION, PHILOSOPHY, LITERATURE, ACADEMIC RESEARCH AND ART PROVIDED VIA A VIDEO-ON-DEMAND SERVICE; DOWNLOADABLE MPS FILES, MP3 RECORDINGS, WEBCASTS, AND PODCASTS FEATURING AUDIO BOOKS IN THE FIELD OF RELIGION, PHILOSOPHY, LITERATURE, ACADEMIC RESEARCH AND ART; COMPACT DISKS FEATURING MUSIC, LECTURE, KNOWLEDGE INSTRUCTION; ELECTRONIC DIARIES; ELECTRONIC PUBLICATIONS, NAMELY, BOOK, MANUAL, FEATURING MUSIC, LECTURE, KNOWLEDGE INSTRUCTION, RELIGION, PHILOSOPHY, LITERATURE, ACADEMIC RESEARCH, ART RECORDED ON COMPUTER MEDIA; PERSONAL DIGITAL ASSISTANTS (PDA); HAND-HELD ELECTRONIC DICTIONARIES; DATA CARRIERS CONTAINING STORED TYPOGRAPHIC TYPEFACES; MOTION PICTURE FILMS ABOUT MUSIC, LECTURE, KNOWLEDGE INSTRUCTION, RELIGION, PHILOSOPHY, LITERATURE, ACADEMIC RESEARCH, ART; PRERECORDED VIDEO TAPES FEATURING MUSIC, LECTURE, KNOWLEDGE INSTRUCTION, RELIGION, PHILOSOPHY, LITERATURE, ACADEMIC RESEARCH, ART; AUDIO DISCS FEATURING MUSIC, LECTURE, KNOWLEDGE INSTRUCTION, RELIGION, PHILOSOPHY, LITERATURE, ACADEMIC RESEARCH, ART; AUDIO TAPES FEATURING MUSIC, LECTURE, KNOWLEDGE INSTRUCTION, RELIGION, PHILOSOPHY, LITERATURE, ACADEMIC RESEARCH, ART; SOUND RECORDING APPARATUS; MAGNETIC IDENTIFYING CARDS (U.S. CLS. 21, 23, 26, 36 AND 38).

CLASS 16—PAPER GOODS AND PRINTED MATTER

FOR OFFICE PAPER STATIONERY; LABEL PAPER; BOOKS IN THE FIELD OF RELIGION, PHILOSOPHY, LITERATURE, ACADEMIC RESEARCH, ART; ENVELOPES; BOOK COVERS; BOOKMARKERS; POSTCARDS; INVITATION CARDS; PRINTED CERTIFICATES; CALENDARS; DICTIONARIES; GENERAL FEATURE MAGAZINES; PRINTED MATTER, NAMELY, PAPER SIGNS, BOOKS, MANUALS, CURRICULUM, NEWSLETTERS, INFORMATIONAL CARDS AND BROCHURES IN THE FIELD OF RELIGION, PHILOSOPHY, LITERATURE, ACADEMIC RESEARCH, ART; LETTER PAPER (FINISHED PRODUCTS); NEWSPAPERS; PENS; FILING FOLDERS, PAPER LABELS AND PRINTED INSTRUCTIONAL MATERIALS FOR ORGANIZING PERSONAL FILES; CONTAINERS FOR STORAGE OR TRANSPORT MADE OF PAPER OR CARDBOARD; GENERAL PURPOSE PLASTIC BAGS; PAINTINGS; ROSARIES; CALENDAR DESK STANDS (U.S. CLS. 2, 5, 22, 23, 29, 37, 38 AND 50).

CLASS 41—EDUCATION AND ENTERTAINMENT

FOR INSTRUCTION IN THE FIELD OF RELIGION, PHILOSOPHY, LITERATURE, ACADEMIC RESEARCH, ART; LIBRARIES; RELIGIOUS INSTRUCTION SERVICES; TEACHING IN THE FIELD OF RELIGION, PHILOSOPHY, LITERATURE, ACADEMIC RESEARCH, ART; PUBLICATION OF ELECTRONIC MAGAZINES, NEWSPAPERS ACCESSIBLE VIA A GLOBAL COMPUTER NETWORK; ON-LINE LIBRARY SERVICES, NAMELY, PROVIDING ELECTRONIC LIBRARY SERVICES WHICH FEATURE NEWSPAPERS, MAGAZINES, PHOTOGRAPHS AND PICTURES VIA AN ON-LINE COMPUTER NETWORK; PUBLICATION OF BOOKS, JOURNALS, MAGAZINES, COLLEGE, PERIODICALS; TRANSLATION SERVICES; ON-LINE ELECTRONIC PUBLISHING OF BOOKS AND PERIODICALS; BOOK

RENTAL; RENTAL OF MAGAZINES; CONDUCTING WORKSHOPS AND SEMINARS IN RELIGION, PHILOSOPHY, LITERATURE, ACADEMIC RESEARCH, ART; ORGANIZING AND HOSTING OF EVENTS FOR CULTURAL PURPOSES; PROVIDING INFORMATION RELATING TO ENTERTAINMENT AND EDUCATION FROM AN ON-LINE COMPUTER DATABASE OR THE INTERNET; PROVIDING INFORMATION, NEWS AND COMMENTARY IN THE FIELD OF ENTERTAINMENT; CONTESTS AND INCENTIVE AWARD PROGRAMS TO ENCOURAGE STUDENTS AND ORGANIZATION MEMBERS TO SET UP AND ACHIEVE GOALS IN ACADEMICS, ATTENDANCE, CITIZENSHIP AND CONDUCT; ARRANGING AND CONDUCTING OF CONCERTS; ENTERTAINMENT TICKET AGENCY SERVICES; AUDIO RECORDING AND PRODUCTION; PRODUCTION OF VIDEO DISCS AND TAPES; RECORD PRODUCTION; PRODUCTION OF RADIO OR TELEVISION PROGRAMS; ADMISSION CONSULTING SERVICES, NAMELY, CONSULTING IN THE FIELD OF COLLEGE ADMISSIONS, SPECIFICALLY, COLLEGE SELECTION, COMPLETING ADMISSIONS APPLICATION, AND PREPARATION FOR ACADEMIC RESEARCH INTERVIEWS; RENTAL OF FACILITIES AND EQUIPMENT FOR THE PRODUCTION OF RADIO AND TELEVISION PROGRAMS, MUSICAL AND THEATRICAL PRODUCTIONS, NAMELY, PERFORMANCE VENUES, STUDIOS, SETS, DRESSING ROOMS; RENTAL OF RECORDS OR SOUND-RECORDED MAGNETIC TAPES; RENTAL OF FILMS; PHOTOGRAPHIC AND VIDEO SERVICES, NAMELY, PHOTOGRAPHIC AND VIDEO CAPTURE; PROVIDING NEWS IN THE NATURE OF CURRENT EVENT REPORTING; SIGN LANGUAGE INTERPRETATION (U.S. CLS. 100, 101 AND 107).

DAVID I. EXAMINING ATTORNEY

SN 85-398,357. ANHING CORPORATION, LOS ANGELES, CA. FILED 8-15-2011.

SARAP

THE MARK CONSISTS OF STANDARD CHARACTERS WITHOUT CLAIM TO ANY PARTICULAR FONT, STYLE, SIZE, OR COLOR.

OWNER OF U.S. REG. NOS. 1,871,459, 1,912,685 AND 2,736,843.

CLASS 29—MEATS AND PROCESSED FOODS

FOR PROCESSED FRUITS, PROCESSED VEGETABLES, FRUIT PRESERVES, PRESERVED VEGETABLES, FRUIT AND VEGETABLE JELLIES AND JAMS, PROCESSED BEANS, SHREDDED COCONUT, PREPARED COCONUT, PROCESSED COCONUT, COCONUT SPREAD IN THE NATURE OF PROCESSED COCONUT, PRESERVED SUGAR PALM, PRESERVED JACKFRUIT, PRESERVED BANANAS, PROCESSED YAMS, PROCESSED SWEET RED BEANS, PROCESSED SWEET WHITE BEANS, PROCESSED GARBANZO BEANS, PICKLED FISH, PRESERVED FISH; CASSAVA, NAMELY, FROZEN WHOLE CASSAVA AND FROZEN GRATED CASSAVA (U.S. CL. 46).

FIRST USE 10-0-1993; IN COMMERCE 10-0-1993.

CLASS 30—STAPLE FOODS

FOR TAPIOCA, NOODLES, ASIAN NOODLES, CORNSTARCH NOODLES, BANANA LEAVES FOR USE AS A FOOD WRAPPER, DOUGH-BASED PASTRY WRAPPERS (U.S. CL. 46).

FIRST USE 9-0-1994; IN COMMERCE 9-0-1994.

CLASS 32—LIGHT BEVERAGES

FOR COCONUT MILK (U.S. CLS. 45, 46 AND 48).
FIRST USE 12-0-1994; IN COMMERCE 12-0-1994.
MYRIAH HABEEB, EXAMINING ATTORNEY

SN 85-399,913. MAJID, INC., NEW YORK, NY. FILED 8-17-2011.

SN 85-398,850. VERMOP SALMON GMBH, GILCHING, FED REP GERMANY, FILED 8-16-2011.

GLASSMAN

THE MARK CONSISTS OF STANDARD CHARACTERS WITHOUT CLAIM TO ANY PARTICULAR FONT, STYLE, SIZE, OR COLOR.

OWNER OF U.S. REG. NO. 2,969,819.

CLASS 8—HAND TOOLS

FOR STEEL RAZOR BLADES FOR CLEANING AND SCRAPING GLASS WINDOWS, WINDOW SILLS, HOT PLATES, FLAGSTONES, TILES, MIRRORS AND TABLES; SMALL HAND-OPERATED HOUSEHOLD AND KITCHEN APPARATUS, NAMELY, SCRAPERS; HAND TOOLS, NAMELY, SCRAPERS FOR USE IN CLEANING FLOORS AND WINDOWS; HAND-OPERATED APPARATUS FOR CLEANING BUILDINGS AND WINDOWS, NAMELY, SCRAPERS (U.S. CLS. 23, 28 AND 44).

CLASS 20—FURNITURE AND ARTICLES NOT OTHERWISE CLASSIFIED

FOR PLASTIC HOLDERS FOR STEEL RAZOR BLADES USED TO CLEAN AND SCRAPE GLASS WINDOWS, WINDOW SILLS, HOTPLATES, FLAGSTONES, TILES, MIRRORS AND TABLES (U.S. CLS. 2, 13, 22, 25, 32 AND 50).

MICHELE SWAIN, EXAMINING ATTORNEY

SN 85-399,304. AUTOBUS LION INC., SAINT-JEROME, QUEBEC, CANADA, FILED 8-16-2011.

360° EVOLUTION

THE MARK CONSISTS OF STANDARD CHARACTERS WITHOUT CLAIM TO ANY PARTICULAR FONT, STYLE, SIZE, OR COLOR.

CLASS 12—VEHICLES

FOR MOTOR VEHICLES, NAMELY, SCHOOL BUSES AND MULTI FUNCTION SCHOOL ACTIVITY BUSES (U.S. CLS. 19, 21, 23, 31, 35 AND 44).

CLASS 35—ADVERTISING AND BUSINESS

FOR DISTRIBUTORSHIPS IN THE FIELD OF MOTOR VEHICLES, NAMELY, BUSES AND MULTI FUNCTION SCHOOL ACTIVITY BUSES; WHOLESALE DISTRIBUTORSHIPS IN THE FIELD OF MOTOR VEHICLES NAMELY, BUSES AND MULTI FUNCTION SCHOOL ACTIVITY BUSES (U.S. CLS. 100, 101 AND 102).

JANET LEE, EXAMINING ATTORNEY

GORGEOUS LOCKS COLLECTION

THE MARK CONSISTS OF STANDARD CHARACTERS WITHOUT CLAIM TO ANY PARTICULAR FONT, STYLE, SIZE, OR COLOR.

NO CLAIM IS MADE TO THE EXCLUSIVE RIGHT TO USE "LOCKS COLLECTION", APART FROM THE MARK AS SHOWN.

CLASS 3—COSMETICS AND CLEANING PREPARATIONS

FOR HAIR CARE PREPARATIONS, NAMELY, SHAMPOO, SHAMPOO WITH NON-PERMANENT HAIR COLORING, CONDITIONER, CONDITIONER WITH NON-PERMANENT HAIR COLORING, POMADES, HAIR SHINE ENHANCER PREPARATIONS, HAIR LIGHTENER AND BLEACHING PREPARATIONS, HAIR SPRAY, MOUSSE, GELS, HAIR STYLING LOTIONS, PERMANENT HAIR COLOR PREPARATIONS, PERMANENT WAVING PREPARATIONS, HAIR RELAXERS, AND NON-MEDICATED SCALP AND HAIR TREATMENTS (U.S. CLS. 1, 4, 6, 50, 51 AND 52).

CLASS 9—ELECTRICAL AND SCIENTIFIC APPARATUS

FOR ELECTRIC CURLING IRONS (U.S. CLS. 21, 23, 26, 36 AND 38).

CLASS 11—ENVIRONMENTAL CONTROL APPARATUS

FOR HAIR DRYERS (U.S. CLS. 13, 21, 23, 31 AND 34).

CLASS 21—HOUSEWARES AND GLASS

FOR HAIRBRUSHES AND COMBS (U.S. CLS. 2, 13, 23, 29, 30, 33, 40 AND 50).

CLASS 26—FANCY GOODS

FOR WIGS, HAIRPIECES, ADD-IN AND ADD-ON HAIR ACCESSORIES CONSTRUCTED PRIMARILY OF SYNTHETIC AND/OR HUMAN HAIR; HAIR EXTENSIONS (U.S. CLS. 37, 39, 40, 42 AND 50).

CLASS 35—ADVERTISING AND BUSINESS

FOR ONLINE RETAIL STORE SERVICES FEATURING HAIR CARE PREPARATIONS, ELECTRIC CURLING IRONS, HAIR DRYERS, HAIRBRUSHES AND COMBS, WIGS, HAIRPIECES AND HAIR ACCESSORIES, HAIR CLIP-ONS, BANG CLIP-ONS, PONY TAIL ENHANCERS, HEADBAND HAIRPIECES AND HAIR-CARE RELATED MERCHANDISE (U.S. CLS. 100, 101 AND 102).

DAVID C. REIHNER, EXAMINING ATTORNEY

SN 85-399,935. MAJID, INC., NEW YORK, NY. FILED 8-17-2011.

IMAN PLATINUM COLLECTION

THE MARK CONSISTS OF STANDARD CHARACTERS WITHOUT CLAIM TO ANY PARTICULAR FONT, STYLE, SIZE, OR COLOR.

OWNER OF U.S. REG. NO. 3,719,993.

NO CLAIM IS MADE TO THE EXCLUSIVE RIGHT TO USE "COLLECTION", APART FROM THE MARK AS SHOWN.

THE NAME "IMAN" IS THAT OF A LIVING INDIVIDUAL WHOSE CONSENT TO REGISTER HER NAME AS A TRADEMARK AND SERVICE MARK IS OF RECORD.

CLASS 18—LEATHER GOODS

FOR HANDBAGS, TOTE BAGS, LEATHER TOTE BAGS, LEATHER SATCHELS, LEATHER HANDBAGS (U.S. CLS. 1, 2, 3, 22 AND 41).

CLASS 25—CLOTHING

FOR WOMEN'S APPAREL, NAMELY, FUR JACKETS, FUR COATS, FUR STOLEES, HATS, GLOVES, SCARVES, WRAPS, JACKETS, COATS, BLAZERS, VESTS (U.S. CLS. 22 AND 39).

CLASS 35—ADVERTISING AND BUSINESS

FOR ONLINE RETAIL STORE SERVICES FEATURING WOMEN'S APPAREL, NAMELY, FUR JACKETS, FUR COATS, FUR STOLEES, HATS, GLOVES, SCARVES, WRAPS, JACKETS, COATS, BLAZERS, VESTS, HANDBAGS, TOTE BAGS, LEATHER TOTE BAGS, LEATHER SATCHELS, LEATHER HANDBAGS AND CLOTHING-RELATED MERCHANDISE (U.S. CLS. 100, 101 AND 102).
DAVID C. REIHNER, EXAMINING ATTORNEY

SN 85-400,342. ANGEL MUSICAL INSTRUMENT CO., LTD., HWASEONG-CITY, REPUBLIC OF KOREA, FILED 8-17-2011.



OWNER OF REPUBLIC OF KOREA REG. NO. 0890605, DATED 11-18-2011, EXPIRES 11-18-2021.

OWNER OF REPUBLIC OF KOREA REG. NO. 0889629, DATED 11-11-2011, EXPIRES 11-11-2021.

NO CLAIM IS MADE TO THE EXCLUSIVE RIGHT TO USE THE NON-LATIN CHARACTERS THAT TRANSLITERATE TO "MUSICAL INSTRUMENT", APART FROM THE MARK AS SHOWN.

THE MARK CONSISTS OF THE STYLIZED LETTERS "A" AND "G" DEPICTED IN MONOGRAM FORM OVER FOUR ASIAN CHARACTERS. ABOVE THE THIRD ASIAN CHARACTER IS THE DESIGN OF A WING OF A BIRD.

THE NON-LATIN CHARACTERS IN THE MARK TRANSLITERATE TO "ANGEL AK KI" AND THIS MEANS "ANGEL MUSICAL INSTRUMENT" IN ENGLISH.

CLASS 15—MUSICAL INSTRUMENTS

FOR PIANO PART, NAMELY, INTENSITY REGULATORS FOR MECHANICAL PIANOS; TUNING APPARATUS FOR MUSICAL INSTRUMENTS; KOREAN ZITHER ALSO KNOWN AS A GAYAGEUM; BAMBOO FLUTES; DOUBLE BASSES; DRUMS; DRUMHEADS; DRUMSTICKS; REEDS; LYRES; MANDOLINS; XYLOPHONES; MUSIC SYNTHESIZERS; MUSICAL BOXES; VIOLINS; CHIN RESTS FOR VIOLINS; CONCERTINA ALSO KNOWN AS BANDONIANS; BARREL ORGANS; BAGPIPES; BUCCIN TROMBONES; BASSES, NAMELY, ELECTRIC BASSES; BASS DRUM STICKS; DRUMS; DRUMSTICKS; VIOLAS; CHINESE PIPA; SAXOPHONES; SHENG; TUNING FORKS; SUONA KNOWN AS CHINESE TRUMPETS; CYMBALS; MUSICAL INSTRUMENTS FOR COURT MUSIC; ACCORDIONS; MUSICAL INSTRUMENTS; KEYBOARDS FOR MUSICAL INSTRUMENTS; MOUTHPIECES FOR MUSICAL INSTRUMENTS; STANDS FOR MUSICAL INSTRUMENTS; VALVES FOR MUSICAL INSTRUMENTS; BRIDGES FOR MUSICAL INSTRUMENTS; BELLOWES FOR MUSICAL INSTRUMENTS; DAMPERS FOR MUSICAL INSTRUMENTS; CATGUT FOR MUSICAL INSTRUMENTS; CASES FOR MUSICAL INSTRUMENTS; KEYS FOR MUSICAL INSTRUMENTS; PEDALS FOR MUSICAL INSTRUMENTS; PICKS FOR STRINGED INSTRUMENTS; STRINGS FOR MUSICAL INSTRUMENTS; PEGS FOR MUSICAL INSTRUMENTS; BOWS FOR MUSICAL INSTRUMENTS; BOW NUTS FOR MUSICAL INSTRUMENTS; STICKS FOR BOWS FOR MUSICAL INSTRUMENTS; SHEET MUSIC STANDS; TURNING APPARATUS FOR SHEET MUSIC; ORGANS; WIND PIPES FOR ORGANS; OBOES; OCARINAS; JANGGU; KOREAN FLUTE; ELECTRIC GUITARS; ELECTRIC ORGANS; ELECTRONIC MUSICAL INSTRUMENTS; ELECTRONIC ORGANS; GONGS; CHIMES; GLOCKENSPIELS; CELLOS; ZITHERS; CARILLONS; CASTANETS; KETTLEDRUMS; KETTLEDRUM FRAMES; CORNETS; CONCERTINAS; CONTRABASS; CHROMAHARPS; CLARINETS; CLARIONS; TOM-TOM DRUMS; TAMBOURINES; TRIANGLES; TROMBONES; TRUMPETS; TIMPANI; BASSOON; PLECTRUMS; FLUTES; PIANOS; PIANO KEYBOARDS; MUSIC ROLLS, NAMELY, PERFORATED MUSIC ROLLS FOR USE IN PLAYER PIANOS; PIANO KEYS; PIANO STRINGS; HARMONIUMS; HARMONICAS; HARPS; HARP STRINGS; HANDBELLS; STRINGED MUSICAL INSTRUMENTS; HORSEHAIR FOR BOWS FOR MUSICAL INSTRUMENTS; CHINESE FIDDLES; HORNS; HUQIN (U.S. CLS. 2, 21 AND 36).

CLASS 16—PAPER GOODS AND PRINTED MATTER

FOR CIGAR BANDS; ADHESIVES FOR HOUSEHOLD PURPOSES; ADHESIVE TAPES FOR HOUSEHOLD PURPOSES; GARBAGE BAGS OF PAPER; GARBAGE BAGS OF PLASTICS; ALUMINUM FOILS FOR COLLECTING GAS RANGE DIRT; BAGS FOR MICROWAVE COOKING; FOILS FOR KITCHENS; LABELS NOT OF TEXTILE, NAMELY, PAPER LABELS; SIGNBOARDS OF PAPER OR CARDBOARD; PLACARDS OF PAPER OR CARDBOARD; FLAGS OF PAPER; PAPER PENNANTS; COVERS OF PAPER FOR FLOWER POTS; FITTED TOILET LID COVERS OF PAPER; STEATITE; EMBROIDERY DESIGN PATTERNS PRINTED ON PAPER; PATTERNS FOR KNITTING; PAPER ROLLS FOR CALCULATING MACHINES; CORRUGATED BOARD; PAPER NAPKINS; ROOFING PAPERBOARD; INKING RIBBON FOR DOCUMENT REPRODUCING MACHINES; WHITE PAPERBOARD; PAPER CONTAINING MICA; OILPAPER FOR FLOOR; PAPERS; PAPER TAPES; PAPER COFFEE FILTERS; BLANK PAPER TAPES AND CARDS FOR THE RECORDING OF COMPUTER PROGRAMS; CARDBOARD; WOOD PULP BOARD; MILLBOARD; PAPIER MACHE; STRAWBOARD; HANDKERCHIEFS OF PAPER; TOWELS OF PAPER; TISSUES OF PAPER; TOILET PAPER; TAGS FOR INDEX CARDS; RUBBER STAMPS; MOISTENERS IN THE

NATURE OF HAND HELD DEVICES FOR WETTING GUMMED PAPER SURFACES; NOTEBOOKS; PAINT BOXES; ERASING PRODUCTS, NAMELY, ERASERS; DESK FILE TRAY FOR SORTING AND COUNTING MONEY; PEN NIBS OF GOLD; RECORD CARDS; LEDGER BOOKS; INK PASTE USED FOR SEALS; STENCILS; STENCIL CASES; STENCIL PLATES; MARKERS; INK STICKS; MEMO BLOCKS; HOLDERS FOR NOTEPADS; MEMO PADS; STATIONERY; DOCUMENT FILES FOR STATIONERY; SEALING COMPOUNDS, NAMELY, SEALING WAX FOR STATIONERY PURPOSES; ENVELOPES; ISINGLASS FOR STATIONERY; INDEX CARDS; STICKERS; PENCIL ORNAMENTS; SEALS; GUMMED CLOTH FOR STATIONERY PURPOSES, NAMELY, BOOKBINDING CLOTH; GUMMED TAPE FOR STATIONERY OR HOUSEHOLD USE; ADHESIVE FOR STATIONERY PURPOSES; ADHESIVE TAPES FOR STATIONERY; ADHESIVE FOILS STATIONERY; BOOK COVERS; CASES FOR STATIONERY; NOTE PADS; FOLDERS; PAPERWEIGHTS; INK STONES; REFILLS FOR BALLPOINT PENS; BALLS FOR BALLPOINT PENS; TIPS FOR BALLPOINT PENS; SEALING STAMPS; BOOKENDS; PROTRACTORS; CHALK STICKS; CHALK HOLDERS; WRITING BRUSHES; STAPLERS; NON-ELECTRONIC CHART POINTERS; ELASTIC BANDS FOR OFFICES; FINGER-STALLS; FINGER MOISTENERS; DESKTOP CABINETS FOR STATIONERY; BINDERS AS OFFICE SUPPLIES; CORRECTING FLUIDS FOR TYPE; SEALS FOR OFFICES; PAPER SHEETS; PAPER CUTTERS; STAPLES FOR OFFICES; CLIPS FOR OFFICES; FILES; PAPER HOLE PUNCHES; PENS; GLUE FOR THE OFFICE; PHOTOGRAPH STANDS; APPARATUS FOR MOUNTING PHOTOGRAPHS, NAMELY, PHOTO MOUNTING CORNERS; PHOTOGRAPHIC ALBUMS; PHOTOGRAPH CORNERS; PAPER FILE JACKETS; LETTER TRAYS; CORRECTION FLUIDS FOR DOCUMENTS; DOCUMENT HOLDERS; STAPLING PRESSES; DOCUMENT PORTFOLIOS; LITHOGRAPHIC STONES; CHALK FOR LITHOGRAPHY; CHECKBOOK HOLDERS; SKETCHBOOKS; SCRAPBOOKS; STAMP STANDS; STAMP PADS; CASES FOR STAMPS; HOLDERS FOR STAMPS; STAPLER HOLDERS; ALBUMS FOR STICKERS; BLOTTERS; THUMB TACKS; ALBUMS FOR STAMPS; BULLDOG CLIPS; ETCHING NEEDLES; PENCILS; PENCIL SHARPENERS ELECTRIC OR NON-ELECTRIC; PENCIL LEADS; PENCIL POINT PROTECTORS; PENCIL LEAD HOLDERS; DECORATIONS FOR PENCILS; PENCIL HOLDERS; PAPER PARCEL TAGS; FRENCH CURVES; EVENT ALBUMS; SEALS; DATE STAMPS; WRITING INK; SPOOLS FOR INKING RIBBONS; INKWELLS; INKSTANDS; INKING PADS; MAGNETIC STAMPS; MAGNETIC BOARDS; PERFORATED CARDS FOR JACQUARD LOOMS; ACCOUNT BOOKS; BOOKMARKERS; ACCOUNT SLIP PADS; ADHESIVE NOTE PADS; ADHESIVE NOTE PAPER; THUMB TACKS FOR DRAWING; DRAWING RULERS; DRAWING SQUARES; COMPASSES FOR DRAWING; TRACING NEEDLES FOR DRAWING PURPOSES; DRAWING PADS; DRAWING PINS; DRAWING T-SQUARES; DRAWING MATERIALS FOR BLACKBOARDS; BOOKBINDING CORDS; ENGRAVING PLATES; PAPER RIBBONS; PAPER PICTURE MOUNTS; BOWS OF PAPER; DRAWER LINERS OF PAPER PERFUMED OR NOT; PAPER-CLIPS; TERRESTRIAL GLOBES; SQUARE RULERS; PRINTED CHARTS; SHEETS OF PLASTICS PLACED UNDER A SHEET OF PAPER WHEN WRITING; BLACKBOARDS; BLACKBOARD ERASERS; PUSH PINS; CARBON PAPER FOR STATIONERY; CANVAS FOR PAINTING; CRAYONS; CLIPBOARDS; ANNOUNCEMENT CARDS; PAPER OR PLASTIC TRANSPARENCIES; PRINTED TRACING PATTERNS; TRACING PAPER; PASTELS; PAPER KNIVES; PEN RESTS; STANDS FOR PENS AND PENCILS; PENS; PENHOLDERS; BOXES FOR PENS; PEN CASES; PEN CLIPS; CORRESPONDENCE RACKS; PAPER CLIPS FOR LETTERS; WRITING PADS; MARKING CHALK; WRITING-BRUSH RACK, NAMELY, PRINTERS' GALLEY RACKS; WRITING INSTRUMENTS; STANDS FOR WRITING IMPLEMENTS; POUCHES FOR WRITING INSTRUMENTS; WRISTBANDS FOR THE RETENTION OF WRITING INSTRUMENTS; WRITING CHALK; WRITING SLATES; WRITING PAPER HOLDERS; NOTEBOARDS; PENCIL OR PEN BOXES; WRITING BOARDS, NAMELY, MEMORANDUM BOARDS; SPONGES AS PAINT APPLICATORS; PAINTBRUSHES; PALETTES FOR PAINTERS; POCKET MEMORANDUM BOOKS; FOOD WRAPPING PLASTIC FILM FOR HOUSEHOLD USE; MONEY CLIPS; PASSPORT HOLDERS; STORAGE CONTAINERS OF PAPER; CARTONS MADE FROM

CORRUGATED FIBRE BOARD; COLLAPSIBLE BOXES OF PAPER; BOXES OF PAPER OR CARDBOARD; PACKAGING CONTAINERS COMPRISED OF STARCH-BASED MATERIALS IN THE NATURE OF A PAPER SUBSTITUTE FOR FOOD, BEVERAGES AND CONSUMER PRODUCTS; BAGS AND SACKS OF PAPER; BOTTLE WRAPPERS OF CARDBOARD OR PAPER; CARDBOARD TUBES; BAGS OF PAPER OR PLASTICS FOR PACKAGING; PAPER SACKS FOR WRAPPING; SACKS OF PLASTICS FOR PACKAGING; PLASTIC BUBBLE PACKS FOR WRAPPING OR PACKAGING; GRAINING COMBS; DECORATORS' PAINTBRUSHES; PAINT BRUSHES; DUPLICATORS, NAMELY, DUPLICATING MACHINES; MIMEOGRAPHS AND MIMEOGRAPH MACHINES; PAPER SHREDDING MACHINES; NUMBERING STAMPS; IMPRINTERS FOR OFFICE USE; ENVELOPE SEALING MACHINES FOR OFFICES; DOCUMENT LAMINATORS FOR OFFICE USE; ELECTRIC STAPLERS FOR OFFICES; ADHESIVE TAPE DISPENSERS; PAPER FOLDING MACHINES AS OFFICE REQUISITES; OBLITERATING STAMPS; HAND LABELING APPLIANCES, NAMELY, HANDHELD LABELING DEVICES; RUBBER STAMP PRINTERS; FRANKING MACHINES; INKING RIBBONS; ELECTRIC AND ELECTRONIC FRANKING MACHINES; OFFICE PERFORMATORS; DRAWING INSTRUMENTS; DRAWING BOARDS; HECTOGRAPHS; ADDRESS STAMPS; ADDRESSING MACHINES; ADDRESS PLATES FOR ADDRESSING MACHINES; PANTOGRAPHS; CARTRIDGE RIBBONS AND CARTRIDGE TAPES FOR PRINTERS; TYPEWRITERS ELECTRIC OR NON-ELECTRIC; TYPEWRITER KEYS; ROLLERS FOR TYPEWRITERS; TYPEWRITER RIBBONS; LETTER-OPENERS; LETTER SEALERS; STEEL LETTER OPENERS; PHOTO-ENGRAVINGS; NUMBERS IN THE NATURE OF VINYL NUMBERS FOR USE IN MAKING SIGNS AND POSTERS; PRINTERS GALLEY RACKS; PRINTING TYPE; ELECTROTYPES; BINDING STRIPS; BOOKBINDING MATERIAL; PRINT WHEELS; PRINT BLOCKS; CORRECTION FLUIDS FOR PRINTING BLOCKS; SEALING WAX; DIAPERS OF CELLULOSE; PAPER DIAPERS; BIBS OF PAPER; CHAPLETS; ADVERTISING DAMPHLETS; GRAPHIC PRINTS; PICTURE POSTCARDS; CALENDARS; ROAD MAPS; MUSICAL GREETING CARDS; BUSINESS CARDS; SUBWAY PASSENGER TICKETS; TELEPHONE CALLING CARDS, NOT MAGNETICALLY ENCODED; CREDIT CARDS, WITHOUT MAGNETIC CODING; PRINTED PLANS; CHECK BOOKS; PASSENGER TICKETS; DAILY PLANNERS; PATTERNS FOR MAKING CLOTHES; GREETING CARDS; POSTCARDS; PRINTED PATTERNS; POSTAGE STAMPS; PRINTED CALENDARS; FORMS PRINTED; PRINTED TIMETABLES; DIARIES; ENTRY TICKETS; POSTERS MADE OF PAPER; GEOGRAPHICAL MAPS; ATLASES; INVITATION CARDS; OCCASION CARDS; PRINTED TICKETS; POSTERS; TEAR-OFF CALENDARS; GRAPHIC REPRODUCTIONS; GRAPHIC REPRESENTATIONS; ART PICTURES; CHROMOLITHOGRAPHS; DECALCOMANIAS; ETCHINGS; PAINTINGS AND CALLIGRAPHIC WORKS OF ART; LITHOGRAPHIC WORKS OF ART; LITHOGRAPHS; AQUARELLES; ART PICTURES; OLEOGRAPHS; TRANSFERS IN THE NATURE OF STICKERS; PORTRAITS; PRINT ENGRAVINGS; PAINTINGS FRAMED OR UNFRAMED; PAINTINGS; PHOTOGRAPHS; BLUEPRINTS; MODELING WAX NOT FOR DENTAL PURPOSES; MODELING MATERIALS, NAMELY, MODELING CLAY AND MODELING PASTE; PLASTICS AS A COMPOUND FOR MODELING; TEACHING MATERIALS, NAMELY, PICTURE BOOKS; LITURGICAL BOOKS; SONG BOOKS; COMIC BOOKS; SCOREBOOKS; WRITING OR DRAWING BOOKS, NAMELY, DRAWING PADS, BLANK WRITING JOURNALS; COPY BOOKS; PRINTED PROSPECTUSES; NEWSPAPERS; COMPOSITION BOOKS; ALMANACS; CARTOON STRIPS; BOOKS FOR USE IN THE TEACHING OF MUSIC, NAMELY, PRINTED MUSIC BOOKS; GENERAL FEATURE MAGAZINES; TELEPHONE DIRECTORIES; ADDRESS BOOKS; SCHOOL WRITING BOOKS (U.S. CLS. 2, 5, 22, 23, 29, 37, 38 AND 50).

CARYN GLASSER, EXAMINING ATTORNEY

SN 85-400,348. PSYCHOLOGICAL SOFTWARE SOLUTIONS, INC., HOUSTON, TX. FILED 8-17-2011.

BEHAVIOR MATTERS

THE MARK CONSISTS OF STANDARD CHARACTERS WITHOUT CLAIM TO ANY PARTICULAR FONT, STYLE, SIZE, OR COLOR.

NO CLAIM IS MADE TO THE EXCLUSIVE RIGHT TO USE "BEHAVIOR", APART FROM THE MARK AS SHOWN.

CLASS 41—EDUCATION AND ENTERTAINMENT

FOR CONTINUING EDUCATION CLASSES IN THE FIELD OF PROFESSIONAL DEVELOPMENT FOR EDUCATORS; EDUCATIONAL RESEARCH SERVICES IN THE FIELD OF MANAGING, TRACKING AND MONITORING STUDENT BEHAVIOR; EDUCATIONAL CONSULTATION SERVICES IN THE FIELD OF MANAGING, TRACKING AND MONITORING STUDENT BEHAVIOR; EDUCATIONAL CONSULTATION IN THE NATURE OF BEHAVIOR SERVICES, NAMELY, MANAGING, TRACKING AND MONITORING STUDENT BEHAVIOR FOR SCHOOLS; EDUCATIONAL CONSULTATION SERVICES IN THE FIELD OF CLASSROOM PROJECT MANAGEMENT, NAMELY, PROVIDING THE CLASSROOM FRAMEWORK FOR IMPLEMENTATION ACTIVITIES FOR BEHAVIOR-RELATED ISSUES (U.S. CLS. 100, 101 AND 107).

CLASS 44—MEDICAL, BEAUTY AND AGRICULTURAL SERVICES

FOR PSYCHOLOGICAL CONSULTATION SERVICES IN THE FIELD OF EDUCATION IN THE NATURE OF MANAGING, TRACKING AND MONITORING STUDENT BEHAVIOR; PSYCHOLOGICAL CONSULTATION IN THE NATURE OF BEHAVIOR ANALYSIS SERVICES, NAMELY, MANAGING, TRACKING AND MONITORING STUDENT BEHAVIOR FOR SCHOOLS (U.S. CLS. 100 AND 101).

TRACY WHITTAKER-BROWN, EXAMINING ATTORNEY

SN 85-400,894. RICOH COMPANY, LTD., TOKYO, JAPAN, FILED 8-18-2011.

Eventjot

THE MARK CONSISTS OF STANDARD CHARACTERS WITHOUT CLAIM TO ANY PARTICULAR FONT, STYLE, SIZE, OR COLOR.

PRIORITY CLAIMED UNDER SEC. 44(D) ON JAPAN APPLICATION NO. 2011-013369, FILED 2-25-2011, REG. NO. 5437408, DATED 9-9-2011, EXPIRES 2-25-2021.

CLASS 9—ELECTRICAL AND SCIENTIFIC APPARATUS

FOR COMPUTER PROGRAMS TO ENABLE TRANSMISSION, ACCESS, ORGANIZATION AND MANAGEMENT OF TEXT MESSAGING, INSTANT MESSAGING, TEXT, WEBLINKS, CHAT, EMAIL, VIDEO, PHOTO SHARING, BLOGGING AND GROUP DISCUSSION ON THE INTERNET; DOWNLOADABLE IMAGE FILES CONTAINING TEXT, PHOTOGRAPHS, AUDIO, VIDEO AND LINKS RELATING TO SOCIAL NETWORKING (U.S. CLS. 21, 23, 26, 36 AND 38).

CLASS 35—ADVERTISING AND BUSINESS

FOR ADVERTISING AND PUBLICITY SERVICES (U.S. CLS. 100, 101 AND 102).

CLASS 38—COMMUNICATION

FOR COMMUNICATION SERVICES, NAMELY, TRANSMISSION OF MESSAGES VIA COMPUTER OR MOBILE PHONE; PROVIDING CHATROOMS ON THE INTERNET; ELECTRONIC BULLETIN BOARD SERVICES POSTED ON THE WEB LOGS OF OTHERS; OTHER ELECTRONIC BULLETIN BOARD SERVICES, NAMELY, PROVIDING TRANSMISSION OF MESSAGES, PHOTOGRAPHS, LINKS AND TEXT AMONG USERS IN THE FIELD OF GENERAL INTEREST; TRANSMISSION OF TEXT, SOUND AND IMAGE BY ON-DEMAND SYSTEM VIA TELECOMMUNICATION NETWORKS; COMMUNICATIONS OF MESSAGE, SOUND AND IMAGE BY MOBILE PHONE; COMMUNICATIONS BY COMPUTER TERMINALS (U.S. CLS. 100, 101 AND 104).

CLASS 41—EDUCATION AND ENTERTAINMENT

FOR PROVIDING A WEBSITE FEATURING INFORMATION ABOUT MUSIC AND MUSIC VIDEOS (U.S. CLS. 100, 101 AND 107).

CLASS 42—SCIENTIFIC AND COMPUTER SERVICES

FOR RENTAL OF WEB SERVER FOR SOCIAL NETWORKING FOR USERS TO EXCHANGE INFORMATION VIA THE INTERNET; RENTAL OF WEB SERVER USED FOR BLOGS PUBLISHED VIA THE INTERNET; PROVIDING NON-DOWNLOADABLE SOFTWARE FOR COMPUTER PROGRAMS USED FOR OPERATING AND ADMINISTRATION OF WEB LOG; RENTAL OF WEB SERVERS (U.S. CLS. 100 AND 101).

CLASS 45—PERSONAL AND LEGAL SERVICES

FOR ONLINE SOCIAL NETWORKING SERVICES, NAMELY, PROVIDING INFORMATION CONCERNING INDIVIDUALS' PROFILES AND DIARY VIA HOMEPAGE ON THE INTERNET AND ELECTRONIC BULLETIN BOARD; ONLINE SOCIAL NETWORKING SERVICES, NAMELY, PROVIDING INFORMATION FOR FRIEND SEARCH AND INTRODUCTION FOR GENERAL USERS THROUGH WEBSITE ON THE INTERNET (U.S. CLS. 100 AND 101).

AHSEN KHAN, EXAMINING ATTORNEY

SN 85-401,976. MATERIAL CONNEXION, INC., NEW YORK, NY. FILED 8-19-2011.

CULTURE & COMMERCE

THE MARK CONSISTS OF STANDARD CHARACTERS WITHOUT CLAIM TO ANY PARTICULAR FONT, STYLE, SIZE, OR COLOR.

NO CLAIM IS MADE TO THE EXCLUSIVE RIGHT TO USE "COMMERCE", APART FROM THE MARK AS SHOWN.

CLASS 35—ADVERTISING AND BUSINESS

FOR BUSINESS MANAGEMENT, MARKETING AND BUSINESS MARKETING CONSULTING SERVICES ON PRODUCT DEVELOPMENT, DESIGN SOURCING, NEW MARKET RESEARCH AND INTERNATIONAL PARTNERSHIPS FOR THE INDUSTRIAL DESIGN INDUSTRY; PERSONAL MANAGEMENT SERVICES FOR CELEBRITIES, INDUSTRIAL DESIGNERS, INTERIOR DESIGNERS, AND ARCHITECTS; BUSINESS MANAGEMENT, NAMELY, MANAGEMENT OF THE PERSONAL BUSINESS AFFAIRS OF OTHERS; ASSISTANCE IN MANAGEMENT OF BUSINESS ACTIVITIES AND EVENTS; PROCURING OF CONTRACTS FOR THE PURCHASE AND SALE OF GOODS AND ARRANGING OF BUYING AND SELLING CONTRACTS FOR THIRD PARTIES, AND ENDORSEMENT SERVICES, NAMELY, PROMOTING THE GOODS AND SERVICES OF OTHERS; PROMOTING THE GOODS AND SERVICES OF OTHERS IN THE FIELDS OF INTERIOR DESIGN, INDUSTRIAL DESIGN AND ARCHITECTURE VIA ELECTRONIC MEDIA; ADVERTISING SERVICES; PROVIDING COMMERCIAL INFORMATION, VIA PRINT AND ELECTRONIC MEDIA, IN THE FIELDS OF DESIGN, ARCHITECTURE, LICENSING AND ENDORSEMENTS; ADVERTISING AND PUBLICITY SERVICES, NAMELY, PROMOTING THE GOODS, SERVICES, BRAND IDENTITY, AND COMMERCIAL INFORMATION AND NEWS OF THIRD PARTIES THROUGH PRINT, AUDIO, VIDEO, DIGITAL AND ON-LINE MEDIA; ADVERTISING, INCLUDING PROMOTION OF PRODUCTS AND SERVICES OF THIRD PARTIES THROUGH SPONSORING ARRANGEMENTS AND LICENSE AGREEMENTS; ADVERTISING CONSULTATION; COMMERCIAL CONSULTANCY; MARKETING CONSULTING; BUSINESS CONSULTING IN THE FIELD OF PROMOTIONAL SPONSORSHIP OF INTERIOR DESIGN, INDUSTRIAL DESIGN AND ARCHITECTURE ACTIVITIES; SALES PROMOTION AND PUBLIC RELATIONS CONSULTING SERVICES; ARRANGING AND CONDUCTING OF TRADE SHOWS, EVENTS, EXHIBITIONS AND PRESENTATIONS FOR PROMOTING THE GOODS AND SERVICES OF OTHERS FOR COMMERCIAL AND ADVERTISING PURPOSES; ARRANGING AND CONDUCTING BUSINESS CONFERENCES; CONDUCTING, ARRANGING AND ORGANIZING TRADE SHOWS AND TRADE FAIRS FOR COMMERCIAL AND ADVERTISING PURPOSES; AND PROJECT MANAGEMENT SERVICES FOR OTHERS FOR BUSINESS PURPOSES IN THE FIELDS OF ARCHITECTURE, INTERIOR DESIGN, URBAN PLANNING DESIGN; BUSINESS DEVELOPMENT SERVICES; MARKETING SERVICES, NAMELY, CONDUCTING CONSUMER TREND ANALYSIS IN THE FIELDS OF MATERIALS, PROCESSES APPLIED TO MATERIALS, INTERIOR DESIGN, INDUSTRIAL DESIGN AND ARCHITECTURE; CONSUMER TRACKING BEHAVIOR RESEARCH, NAMELY, CONSULTING SERVICES RELATED TO TRENDS IN THE FIELDS OF MATERIALS, PROCESSES APPLIED TO MATERIALS, INTERIOR DESIGN, INDUSTRIAL DESIGN AND ARCHITECTURE (U.S. CLS. 100, 101 AND 102).

FIRST USE 1-31-1997; IN COMMERCE 1-31-1997.

CLASS 42—SCIENTIFIC AND COMPUTER SERVICES

FOR PRODUCT DEVELOPMENT CONSULTATION; PROVIDING A WEBSITE FEATURING INFORMATION IN THE FIELD OF INTERIOR DESIGN, INDUSTRIAL DESIGN, ARCHITECTURE, MATERIALS FOR USE IN THE FIELD OF INTERIOR DESIGN, INDUSTRIAL DESIGN AND ARCHITECTURE, AND PROCESSES APPLIED TO SUCH MATERIALS (U.S. CLS. 100 AND 101). FIRST USE 1-31-1997; IN COMMERCE 1-31-1997. STEVEN JACKSON, EXAMINING ATTORNEY

SN 85-402,127. WABTEC HOLDING CORP., WILMERDING, PA. FILED 8-19-2011.

Q-TRON

THE MARK CONSISTS OF STANDARD CHARACTERS WITHOUT CLAIM TO ANY PARTICULAR FONT, STYLE, SIZE, OR COLOR.

CLASS 7—MACHINERY

FOR MECHANICAL ENGINE PARTS FOR LOCOMOTIVES (U.S. CLS. 13, 19, 21, 23, 31, 34 AND 35). FIRST USE 11-0-1994; IN COMMERCE 11-0-1994.

CLASS 9—ELECTRICAL AND SCIENTIFIC APPARATUS

FOR ELECTRONIC EQUIPMENT FOR USE BY THE RAILROAD INDUSTRY, NAMELY, MAIN GENERATOR EXCITATION CONTROLLERS, TEMPERATURE SENSORS, ELECTRIC CURRENT SENSORS AND ELECTRIC REVOLUTION SENSORS; LOCOMOTIVE ENGINE CONTROL SYSTEMS COMPRISED OF MAIN CONTROL UNITS IN THE NATURE OF MICROPROCESSOR BASED CONTROL SYSTEMS THAT USE PROGRAMMED LOGIC TO MONITOR AND CONTROL LOCOMOTIVE SYSTEMS, AUXILIARY CONTROL UNITS IN THE NATURE OF MICROPROCESSOR BASED CONTROL SYSTEMS THAT USE PROGRAMMED LOGIC TO MONITOR AND CONTROL LOCOMOTIVE SYSTEMS, ELECTRIC OPERATOR CONTROL PANELS, AND ELECTRIC TRANSDUCERS, ELECTRICAL SENSORS FOR MEASURING TEMPERATURE, PRESSURE, ELECTRIC CURRENT, VOLTAGE AND SPEED; LOCOMOTIVE EVENT RECORDER AND HEALTH MONITORING SYSTEMS COMPRISED OF ELECTRONIC EVENT RECORDERS, RADIO TRANSCIVERS AND BASE STATIONS; RADIO LOCATION SYSTEMS COMPRISED OF GPS (GLOBAL POSITION SATELLITE) ANTENNAS AND RECEIVERS; LOCOMOTIVE ADHESION CONTROL SYSTEMS COMPRISED OF CONTROL PANELS, NAMELY, ELECTRIC CONTROL PANELS, AND TRANSDUCERS, NAMELY, ELECTRIC CONTROL PANELS; LOCOMOTIVE SPEED SIGNAL SYSTEMS COMPRISED OF AXLE GENERATORS IN THE NATURE OF DEVICES THAT MOUNT TO THE AXLE OF A LOCOMOTIVE AND MEASURE THE ROTATION OF THE AXLE, POWER SUPPLIES, ISOLATION-AMPLIFIERS, TRACTION MOTOR SPEED PROBES IN THE NATURE OF DEVICES INSERTED AT THE TRACTION MOTOR THAT COUNT THE TEETH OF THE BULL GEAR TO DETERMINE THE SPEED OF THE AXLE AND PROBE AMPLIFIER PANELS THAT SPLIT AND DISTRIBUTE THE SIGNALS FROM THE PROBES TO THE VARIOUS INPUTS WHERE THEY ARE NEEDED, ALARM HEADS IN THE NATURE OF SIRENS THAT PRODUCE AND EMIT AN AUDIBLE ALARM, RESET SWITCHES, NAMELY, RESET POWER SWITCHES AND RESET ELECTRIC SWITCHES, AND TRANSDUCERS; LOCOMOTIVE CONTROL SYSTEMS COMPRISED OF ELECTRONIC CONTROL UNITS (ECU), OPERATOR INTERFACE, COMPUTER DISPLAY

UNITS (CDU), TRANSDUCERS, AND BATTERY FIELD DRIVERS; COMPUTER SOFTWARE FOR ANALYZING DATA FROM LOCOMOTIVE SYSTEMS; SPEED INDICATORS AND SPEED CONTROL EQUIPMENT COMPRISED OF SPEED CONTROL PANELS AND ELECTRONIC SIGNAL AMPLIFIER PANELS; LOCOMOTIVE ENGINE CONTROL SYSTEMS COMPRISING SENSORS THAT MONITOR PRESSURE NEEDED FOR BRAKING SYSTEMS, CURRENT TO TRACTION MOTORS, DYNAMIC BRAKING GRIDS, TRACTION MOTOR BLOWERS AND BATTERIES, TEMPERATURE OF THE COOLING WATER SYSTEM, TEMPERATURE OF THE AMBIENT AIR OUTSIDE THE LOCOMOTIVE, AND OIL TEMPERATURE AND OIL PRESSURE, CONTROLLERS FOR PROVIDING MAIN GENERATOR EXCITATION TO POWER THE LOCOMOTIVE, TO TURN ON OR OFF THE COOLING FANS, TO MONITOR TEMPERATURES AND PRESSURES AND CUT BACK OR SHUT DOWN POWER, TO PROVIDE IDLE LIMITING FUNCTIONALITY, TO PROVIDE ON BOARD RECORDING OF ELECTRICAL SIGNALS, AND TO RECORD DATA TO CRASH HARDENED MEMORY MODULES, GOVERNOR ASSIST PUMPS, GOVERNOR MANIFOLDS, ENGINE PROTECTION DEVICE OVERRIDES, WATER TEMPERATURE SENSORS, AIR TEMPERATURE SENSORS, PRESSURE SENSORS, LOAD SHED RELAYS, PRESSURE SWITCHES, DATA RECORDERS, ELECTRONIC OPERATOR DISPLAY INTERFACES AND ALARMS; ELECTRONIC GOVERNOR SYSTEMS COMPRISING MAIN CONTROL UNITS, ELECTRONIC ACTUATORS, ACTUATOR CONTROL UNITS, ELECTRIC CURRENT SENSORS, OPERATOR DISPLAYS, NAMELY, ELECTRONIC OPERATOR DISPLAY INTERFACES, AND BATTERY FIELD DRIVERS COMPRISING PRINTED CIRCUIT BOARDS, ELECTRIC LOAD RESISTOR PANELS, PRESSURE AND TEMPERATURE SENSORS, AND REVOLUTION SENSORS; ENGINE RUN MANAGER SYSTEMS COMPRISING ELECTRIC CONTROLLER SENSORS AND OPERATOR INTERFACE DEVICES IN THE NATURE OF SWITCHES FOR OPERATING LOCOMOTIVE ENGINES, CONTROL UNITS IN THE NATURE OF MICROPROCESSOR-BASED DEVICES THAT MONITOR INPUT FROM LOCOMOTIVE SENSORS AND REACT ACCORDING TO PROGRAMMED PRESETS, AUTO START SIREN PANELS, HIGH VOLTAGE MODULES, DIODE BLOCK ASSEMBLIES, AND LOCOMOTIVE ENGINE START SWITCHES; LOCOMOTIVE TRACTION CONTROL SYSTEMS COMPRISING MOTOR CONTROLLERS, TEMPERATURE SENSORS, OPERATOR INTERFACE DEVICES, AXLE GENERATORS, FLEXIBLE DRIVE SHAFTS FOR LAND VEHICLES, ELECTRIC CURRENT SENSORS, BATTERY FIELD DRIVERS, DOWNLOAD BOXES, SIGNAL CONDITIONING PANELS, PRESSURE SWITCHES FOR MONITORING, CONTROLLING, AND SWITCHING HYDRAULIC OR PNEUMATIC SYSTEMS, ELECTRIC REVOLUTION SENSORS; LOCOMOTIVE SPEED SENSING, CONTROL AND VERIFICATION EQUIPMENT IN THE NATURE OF AXLE GENERATORS, AXLE GENERATOR POWER SUPPLIES, AXLE GENERATOR JUNCTION BOXES, AXLE GENERATOR MOUNTING BRACKETS, AXLE GENERATOR CABLING, TRACTION MOTOR PROBES, TRACTION MOTOR JUNCTION BOXES, TRACTION MOTOR CABLING, DIFFERENTIAL VOLTAGE MODULES, CURRENT TRANSDUCERS, ELECTRONIC SLOW SPEED CONTROLLERS, AND DOPPLER RADAR; ELECTRONIC CONTROLLERS FOR LOCOMOTIVES; COMPUTER SOFTWARE, NAMELY, SOFTWARE TO COLLECT AND DISPLAY INFORMATION FROM LOCOMOTIVES; COMPUTER FIRMWARE FOR COLLECTING AND DISPLAYING INFORMATION FROM LOCOMOTIVES (U.S. CLS. 21, 23, 26, 36 AND 38).

FIRST USE 11-0-1994; IN COMMERCE 11-0-1994.
MICHAEL WIENER, EXAMINING ATTORNEY

SN 85-402,248. MIR ACQUISITION, INC., ANN ARBOR, MI.
FILED 8-19-2011.



NO CLAIM IS MADE TO THE EXCLUSIVE RIGHT TO USE "MOLECULAR IMAGING", APART FROM THE MARK AS SHOWN.

THE MARK CONSISTS OF THE LETTER "M" SURROUNDED BY A CIRCLE WITH A SMALLER CIRCLE ABOVE THE "M" ON THE EDGE OF THE LARGER CIRCLE MAKING PART OF THE "M" APPEAR AS AN "I" ALL NEXT TO THE WORDS "MOLECULAR IMAGING".

CLASS 42—SCIENTIFIC AND COMPUTER SERVICES

FOR SCIENTIFIC AND TECHNOLOGICAL SERVICES AND RESEARCH AND DESIGN RELATING THERETO, NAMELY, SCIENTIFIC RESEARCH AND DEVELOPMENT, AND PROVIDING SCIENTIFIC RESEARCH INFORMATION IN THE FIELDS OF PHARMACEUTICALS, DRUG DEVELOPMENT, LIFE CYCLE MANAGEMENT, CLINICAL RESEARCH AND DEVELOPMENT, DIAGNOSTIC IMAGING AND MOLECULAR MEDICINE; INDUSTRIAL ANALYSIS AND RESEARCH SERVICES IN THE FIELDS OF PHARMACEUTICALS, DRUG DEVELOPMENT, LIFE CYCLE MANAGEMENT, CLINICAL RESEARCH AND DEVELOPMENT, DIAGNOSTIC IMAGING AND MOLECULAR MEDICINE (U.S. CLS. 100 AND 101).

CLASS 44—MEDICAL, BEAUTY AND AGRICULTURAL SERVICES

FOR PROVIDING MEDICAL RESEARCH INFORMATION IN THE FIELDS OF PHARMACEUTICALS, DRUG DEVELOPMENT, LIFE CYCLE MANAGEMENT, CLINICAL RESEARCH AND DEVELOPMENT, DIAGNOSTIC IMAGING AND MOLECULAR MEDICINE; INDUSTRIAL ANALYSIS AND RESEARCH SERVICES IN THE FIELDS OF PHARMACEUTICALS, DRUG DEVELOPMENT, LIFE CYCLE MANAGEMENT, CLINICAL RESEARCH AND DEVELOPMENT, DIAGNOSTIC IMAGING AND MOLECULAR MEDICINE (U.S. CLS. 100 AND 101).

LESLIE RICHARDS, EXAMINING ATTORNEY

SN 85-402,929. MICHIGAN CONSULTING ENTERPRISES LLC, ROCHESTER HILLS, MI. AND VILLARREAL, RAUL, AUBURN HILLS, MI. FILED 8-19-2011.

SN 85-404,942. NATIONAL ELECTRONICS & WATCH CO., LTD., ABERDEEN, HONG KONG, FILED 8-23-2011.



THE MARK CONSISTS OF THE WORD "NO" ABOVE THE IMAGE OF A HOLLERING BABY FACE CRYING TEARS, TWO TEARS ON EACH SIDE OF THE FACE, WITH THE WORDS "CRY BABIES" BELOW, FOLLOWED WITH AN EXCLAMATION MARK "!".

CLASS 14—JEWELRY

FOR RUBBER OR SILICON WRISTBANDS IN THE NATURE OF A BRACELET (U.S. CLS. 2, 27, 28 AND 50). FIRST USE 7-11-2011; IN COMMERCE 7-11-2011.

CLASS 25—CLOTHING

FOR SHORT-SLEEVED OR LONG-SLEEVED T-SHIRTS (U.S. CLS. 22 AND 39). FIRST USE 7-11-2011; IN COMMERCE 7-11-2011. CHRIS WELLS, EXAMINING ATTORNEY

SN 85-403,120. AVROKO HOSPITALITY GROUP, INC., NEW YORK, NY. FILED 8-21-2011.

SAXON + PAROLE

THE MARK CONSISTS OF STANDARD CHARACTERS WITHOUT CLAIM TO ANY PARTICULAR FONT, STYLE, SIZE, OR COLOR.

CLASS 41—EDUCATION AND ENTERTAINMENT

FOR NIGHTCLUB SERVICES (U.S. CLS. 100, 101 AND 107).

CLASS 43—HOTEL AND RESTAURANT SERVICES

FOR RESTAURANT, CATERING, AND BAR SERVICES (U.S. CLS. 100 AND 101). FRANK LATTUCA, EXAMINING ATTORNEY



THE COLOR(S) GRAY AND RED IS/ARE CLAIMED AS A FEATURE OF THE MARK.

THE MARK CONSISTS OF THE WORD "OUTBOUND" IN GRAY WITH THE LETTER "B" IN RED AND STYLIZED LETTERS "OB" APPEARING ABOVE IN GRAY AND RED.

CLASS 9—ELECTRICAL AND SCIENTIFIC APPARATUS

FOR SCIENTIFIC APPARATUS AND INSTRUMENTS, NAMELY, DIVE COMPUTERS; MEASURING APPARATUS AND INSTRUMENTS, NAMELY, THERMOMETERS; APPARATUS FOR RECORDING, TRANSMISSION OR REPRODUCTION OF SOUND OR IMAGES; DATA PROCESSING EQUIPMENT AND COMPUTERS; ALTIMETER; NAVIGATION INSTRUMENTS, NAMELY, COMPASSES; COMPASS DISPLAYS; NAVIGATION COMPASSES; ELECTRONIC DISTANCE METERS; ELECTRONIC TEMPERATURE MONITORS, OTHER THAN FOR MEDICAL USE; AUDIO TIMERS; ELECTRIC TIMERS; ELECTRONIC TIMERS; UNIVERSAL TIMERS; PEDOMETERS; GLOBAL POSITIONING APPARATUS; GLOBAL POSITIONING INSTRUMENTS; COMPUTER DISPLAY MONITORS; COMPUTER MONITORS; COMPUTER MONITORS BEING VISUAL DISPLAY UNITS (U.S. CLS. 21, 23, 26, 36 AND 38).

CLASS 10—MEDICAL APPARATUS

FOR ELECTRONIC BLOOD PRESSURE METERS OTHER THAN FOR MEDICAL USE; ELECTRONIC APPARATUS FOR MONITORING BODY FUNCTIONS, NAMELY, SLEEP MONITORS, FOOT POD SENSORS, HEART RATE SENSORS OTHER THAN FOR MEDICAL USE; ELECTRONIC HEART RATE MONITORS OTHER THAN FOR MEDICAL USE; ELECTRONIC HEART SIGNAL MONITORS OTHER THAN FOR MEDICAL USE (U.S. CLS. 26, 39 AND 44).

CLASS 14—JEWELRY

FOR HOROLOGICAL AND CHRONOMETRIC INSTRUMENTS; SPORTS WATCHES; DIGITAL WATCHES WITH AUTOMATIC TIMERS; DIVERS' WATCHES (U.S. CLS. 2, 27, 28 AND 50). KATHY DE JONGE, EXAMINING ATTORNEY

SN 85-406,629. CALIFORNIA STEM CELL, INC., IRVINE, CA. FILED 8-24-2011.



THE MARK CONSISTS OF TWO PARTIAL CIRCLES, EACH WITH A COMPLETE CIRCLE INSIDE.

CLASS 42—SCIENTIFIC AND COMPUTER SERVICES

FOR SCIENTIFIC STUDY AND RESEARCH IN THE FIELDS OF TREATMENT, DIAGNOSIS OR PROPHYLAXIS OF HUMAN DISEASES, DISORDERS AND CONDITIONS, NAMELY, CANCER, DIABETES, ARTHRITIS, AND WOUND HEALING, AND DISEASES, DISORDERS AND CONDITIONS OF THE CARDIOVASCULAR, HEMATOLOGICAL, NEURAL, NEURONAL AND NERVOUS SYSTEMS; PROVIDING SCIENTIFIC INFORMATION TO PATIENTS, SCIENTISTS, PHYSICIANS AND OTHER HEALTH CARE PROVIDERS IN THE FIELD OF CANCER, DIABETES, ARTHRITIS, WOUND HEALING, CARDIOVASCULAR, HEMATOLOGICAL, NEURAL, NEURONAL AND NERVOUS SYSTEM (U.S. CLS. 100 AND 101).

CLASS 44—MEDICAL, BEAUTY AND AGRICULTURAL SERVICES

FOR PROVIDING MEDICAL INFORMATION TO PATIENTS, SCIENTISTS, PHYSICIANS AND OTHER HEALTH CARE PROVIDERS (U.S. CLS. 100 AND 101).
JANET LEE, EXAMINING ATTORNEY

SN 85-407,394. CALIFORNIA STEM CELL, INC., IRVINE, CA. FILED 8-25-2011.



THE MARK CONSISTS OF TWO PARTIAL CIRCLES, EACH WITH A COMPLETE CIRCLE INSIDE.

CLASS 1—CHEMICALS

FOR CELL CULTURE REAGENTS, NAMELY, GROWTH MEDIA AND CELL GROWTH FACTORS FOR STEM CELLS AND GENERAL CELL POPULATIONS FOR USE IN SCIENTIFIC RESEARCH, DIAGNOSTIC REAGENTS FOR SCIENTIFIC AND RESEARCH USE; CELL LINES AND GROWTH FACTORS FOR SCIENTIFIC AND RESEARCH USE (U.S. CLS. 1, 5, 6, 10, 26 AND 46).

CLASS 5—PHARMACEUTICALS

FOR CELL CULTURE REAGENTS, NAMELY, GROWTH MEDIA AND CELL GROWTH FACTORS FOR STEM CELLS AND GENERAL CELL POPULATIONS FOR MEDICAL AND CLINICAL USE (U.S. CLS. 6, 18, 44, 46, 51 AND 52).
JANET LEE, EXAMINING ATTORNEY

SN 85-407,410. NATIONAL ASSOCIATION OF COLLEGE AND UNIVERSITY ATTORNEYS, WASHINGTON, DC. FILED S.R. 8-25-2011; AM. P.R. 1-13-2012.

THE JOURNAL OF COLLEGE AND UNIVERSITY LAW

THE MARK CONSISTS OF STANDARD CHARACTERS WITHOUT CLAIM TO ANY PARTICULAR FONT, STYLE, SIZE, OR COLOR.
NO CLAIM IS MADE TO THE EXCLUSIVE RIGHT TO USE "JOURNAL", APART FROM THE MARK AS SHOWN.
SEC. 2(F).

CLASS 9—ELECTRICAL AND SCIENTIFIC APPARATUS

FOR DOWNLOADABLE ELECTRONIC PUBLICATIONS, NAMELY, JOURNALS CONCERNING HIGHER EDUCATION LAW AND RELATED TOPICS OF INTEREST TO COLLEGE AND UNIVERSITY COUNSEL (U.S. CLS. 21, 23, 26, 36 AND 38).
FIRST USE 0-0-2004; IN COMMERCE 0-0-2004.

CLASS 16—PAPER GOODS AND PRINTED MATTER

FOR PRINTED PUBLICATIONS, NAMELY, JOURNALS CONCERNING HIGHER EDUCATION LAW AND RELATED TOPICS OF INTEREST TO COLLEGE AND UNIVERSITY COUNSEL (U.S. CLS. 2, 5, 22, 23, 29, 37, 38 AND 50).
FIRST USE 0-0-1973; IN COMMERCE 0-0-1973.
CHRISTINA SOBRAL, EXAMINING ATTORNEY

SN 85-407,577. CALIFORNIA STEM CELL, INC., IRVINE, CA. FILED 8-25-2011.



THE MARK CONSISTS OF TWO PARTIAL CIRCLES, EACH WITH A COMPLETE CIRCLE INSIDE.

CLASS 1—CHEMICALS

FOR KITS FOR DIAGNOSTICS, SCIENTIFIC AND RESEARCH USE COMPRISED OF HIGH PURITY CELL POPULATIONS DERIVED FROM STEM CELL LINES (U.S. CLS. 1, 5, 6, 10, 26 AND 46).

SN 85-408,217. R2 WELLNESS, LLC, VILLA PARK, CA. FILED 8-26-2011.

CLASS 5—PHARMACEUTICALS

FOR THERAPEUTIC, DIAGNOSTIC AND PROPHYLACTIC PREPARATIONS, VACCINES, ADJUVANT, PHARMACEUTICAL PRODUCTS AND AGENTS OF HIGH PURITY CELL POPULATIONS DERIVED FROM STEM CELL LINES FOR THE TREATMENT, DIAGNOSIS OR PROPHYLAXIS OF HUMAN DISEASES, DISORDERS AND CONDITIONS, NAMELY, CANCER, DIABETES, ARTHRITIS, WOUND HEALING, CARDIOVASCULAR, HEMATOLOGICAL, NEURAL, NEUROANAL AND NERVOUS SYSTEM (U.S. CLS. 6, 18, 44, 46, 51 AND 52).

JANET LEE, EXAMINING ATTORNEY

SELECTIVE HEARING

THE MARK CONSISTS OF STANDARD CHARACTERS WITHOUT CLAIM TO ANY PARTICULAR FONT, STYLE, SIZE, OR COLOR.

NO CLAIM IS MADE TO THE EXCLUSIVE RIGHT TO USE "HEARING", APART FROM THE MARK AS SHOWN.

CLASS 9—ELECTRICAL AND SCIENTIFIC APPARATUS

FOR A PROGRAMMABLE ELECTRIC AUDITORY DEVICE TO BE WORN IN OR ON THE HUMAN EAR OR COUPLED TO THE HUMAN EAR BY WIRELESS MEANS TO FILTER AND REDUCE THE INTENSITY OF CERTAIN AUDIBLE SOUNDS SO THAT THE WEARER CAN DISCRIMINATE AND MORE CLEARLY HEAR OTHER SOUNDS NOT FOR MEDICAL USE (U.S. CLS. 21, 23, 26, 36 AND 38).

SN 85-408,169. CHARLOTTE RONSON LLC, NEW YORK, NY. FILED 8-26-2011.

CLASS 10—MEDICAL APPARATUS

FOR A PROGRAMMABLE ELECTRIC AUDITORY DEVICE TO BE WORN IN OR ON THE HUMAN EAR OR COUPLED TO THE HUMAN EAR BY WIRELESS MEANS TO FILTER AND REDUCE THE INTENSITY OF CERTAIN AUDIBLE SOUNDS SO THAT THE WEARER CAN DISCRIMINATE AND MORE CLEARLY HEAR OTHER SOUNDS FOR MEDICAL USE (U.S. CLS. 26, 39 AND 44).

JUSTINE D. PARKER, EXAMINING ATTORNEY

—
I ♥ RONSON

SN 85-408,224. R2 WELLNESS, LLC, VILLA PARK, CA. FILED 8-26-2011.

OWNER OF U.S. REG. NOS. 3,614,032, 3,620,635 AND 3,620,843.

THE NAME(S), PORTRAIT(S), AND/OR SIGNATURE(S) SHOWN IN THE MARK IDENTIFIES A PARTICULAR LIVING INDIVIDUAL, WHOSE CONSENT(S) TO REGISTER IS MADE OF RECORD.

THE MARK CONSISTS OF THE WORDS "I" AND "RONSON" SEPARATED BY A HEART SHAPE.

—
AIDD

THE MARK CONSISTS OF STANDARD CHARACTERS WITHOUT CLAIM TO ANY PARTICULAR FONT, STYLE, SIZE, OR COLOR.

CLASS 9—ELECTRICAL AND SCIENTIFIC APPARATUS

FOR CASES FOR MOBILE PHONES (U.S. CLS. 21, 23, 26, 36 AND 38).

CLASS 9—ELECTRICAL AND SCIENTIFIC APPARATUS

FOR A PROGRAMMABLE ELECTRIC AUDITORY DEVICE TO BE WORN IN OR ON THE HUMAN EAR OR COUPLED TO THE HUMAN EAR BY WIRELESS MEANS TO FILTER AND REDUCE THE INTENSITY OF CERTAIN AUDIBLE SOUNDS SO THAT THE WEARER CAN DISCRIMINATE AND MORE CLEARLY HEAR OTHER SOUNDS NOT FOR MEDICAL USE (U.S. CLS. 21, 23, 26, 36 AND 38).

CLASS 18—LEATHER GOODS

FOR ALL-PURPOSE SPORTS BAGS, BEACH BAGS, TOILETRY BAGS SOLD EMPTY, SHOE BAGS FOR TRAVEL, SCHOOL BAGS, MESSENGER BAGS, DUFFEL BAGS, BAGS FOR CARRYING BABIES' ACCESSORIES, HANDBAGS, WALLETS, PURSES, LUGGAGE, BACKPACKS, TRAVEL BAGS, TOTE BAGS, CHANGE PURSES, COSMETIC CASES AND BAGS SOLD EMPTY, AND UMBRELLAS; CARRYING CASES FOR TRAIN AND BUS PASSES, KEY CASES, BUSINESS CARD CASES, LUGGAGE TAGS AND KEY CHAINS, ALL OF THE FOREGOING MADE FROM LEATHER OR IMITATION LEATHER (U.S. CLS. 1, 2, 3, 22 AND 41).

TEJBIR SINGH, EXAMINING ATTORNEY

CLASS 10—MEDICAL APPARATUS

FOR A PROGRAMMABLE ELECTRIC AUDITORY DEVICE TO BE WORN IN OR ON THE HUMAN EAR OR COUPLED TO THE HUMAN EAR BY WIRELESS MEANS TO FILTER AND REDUCE THE INTENSITY OF CERTAIN AUDIBLE SOUNDS SO THAT THE WEARER CAN DISCRIMINATE AND MORE CLEARLY HEAR OTHER SOUNDS FOR MEDICAL USE (U.S. CLS. 26, 39 AND 44).

JUSTINE D. PARKER, EXAMINING ATTORNEY

SN 85-408,895. ORGANIC OCEAN SEAFOOD INC., VANCOUVER, BC, CANADA, FILED 8-27-2011.

SEAFOOD NATURALLY

THE MARK CONSISTS OF STANDARD CHARACTERS WITHOUT CLAIM TO ANY PARTICULAR FONT, STYLE, SIZE, OR COLOR.

OWNER OF CANADA REG. NO. 769337, DATED 6-10-2010, EXPIRES 6-10-2025.

NO CLAIM IS MADE TO THE EXCLUSIVE RIGHT TO USE "SEAFOOD", APART FROM THE MARK AS SHOWN.

CLASS 29—MEATS AND PROCESSED FOODS

FOR FRESH AND FROZEN SEAFOOD (U.S. CL. 46). FIRST USE 10-31-2008; IN COMMERCE 1-1-2010.

CLASS 35—ADVERTISING AND BUSINESS

FOR WHOLESALE DISTRIBUTORSHIPS FEATURING SEAFOOD (U.S. CLS. 100, 101 AND 102).

FIRST USE 10-31-2008; IN COMMERCE 1-1-2010. MARK T. MULLEN, EXAMINING ATTORNEY

SN 85-409,274. GREAT-WEST LIFE & ANNUITY INSURANCE COMPANY, GREENWOOD VILLAGE, CO. FILED 8-29-2011.

Great-West Financial

THE MARK CONSISTS OF STANDARD CHARACTERS WITHOUT CLAIM TO ANY PARTICULAR FONT, STYLE, SIZE, OR COLOR.

OWNER OF U.S. REG. NOS. 1,683,967, 3,398,240 AND OTHERS.

NO CLAIM IS MADE TO THE EXCLUSIVE RIGHT TO USE "FINANCIAL", APART FROM THE MARK AS SHOWN.

CLASS 35—ADVERTISING AND BUSINESS

FOR FINANCIAL RECORD KEEPING FOR EMPLOYER-SPONSORED DEFINED CONTRIBUTION PLANS AND DEFINED BENEFIT PLANS FOR FINANCIAL INSTITUTIONS (U.S. CLS. 100, 101 AND 102).

CLASS 36—INSURANCE AND FINANCIAL

FOR FINANCIAL ADMINISTRATION OF EMPLOYER-SPONSORED DEFINED CONTRIBUTION AND DEFINED BENEFIT PLANS; ENROLLMENT PROCESSING SERVICES FOR EMPLOYER-SPONSORED DEFINED CONTRIBUTION AND DEFINED BENEFIT PLANS; PROVIDING INFORMATION IN THE FIELD OF EMPLOYER-SPONSORED DEFINED CONTRIBUTION AND DEFINED BENEFIT PLANS; INVESTMENT OF FUNDS FOR OTHERS; FUND MANAGEMENT; INVESTMENT ADVISORY SERVICES; UNDERWRITING, ISSUANCE AND ADMINISTRATION OF INDIVIDUAL AND BUSINESS-OWNED LIFE INSURANCE; ANNUITY UNDERWRITING AND INVESTMENT MANAGEMENT OF AND DISTRIBUTION OF ANNUITIES; ADMINISTRATION OF EMPLOYEE BENEFIT PLANS CONCERNING INSURANCE AND FINANCE; INDIVIDUAL RETIREMENT ACCOUNT SERVICES (U.S. CLS. 100, 101 AND 102).

MICHAEL W. BAIRD, EXAMINING ATTORNEY

SN 85-409,278. GREAT-WEST LIFE & ANNUITY INSURANCE COMPANY, GREENWOOD VILLAGE, CO. FILED 8-29-2011.

Great-West Financial Services

THE MARK CONSISTS OF STANDARD CHARACTERS WITHOUT CLAIM TO ANY PARTICULAR FONT, STYLE, SIZE, OR COLOR.

OWNER OF U.S. REG. NOS. 1,683,967, 3,398,240 AND OTHERS.

NO CLAIM IS MADE TO THE EXCLUSIVE RIGHT TO USE "FINANCIAL SERVICES", APART FROM THE MARK AS SHOWN.

CLASS 35—ADVERTISING AND BUSINESS

FOR FINANCIAL RECORD KEEPING FOR EMPLOYER-SPONSORED DEFINED CONTRIBUTION PLANS AND DEFINED BENEFIT PLANS FOR FINANCIAL INSTITUTIONS (U.S. CLS. 100, 101 AND 102).

CLASS 36—INSURANCE AND FINANCIAL

FOR FINANCIAL ADMINISTRATION OF EMPLOYER-SPONSORED DEFINED CONTRIBUTION AND DEFINED BENEFIT PLANS; ENROLLMENT PROCESSING SERVICES FOR EMPLOYER-SPONSORED DEFINED CONTRIBUTION AND DEFINED BENEFIT PLANS; PROVIDING INFORMATION IN THE FIELD OF EMPLOYER-SPONSORED DEFINED CONTRIBUTION AND DEFINED BENEFIT PLANS; INVESTMENT OF FUNDS FOR OTHERS; FUND MANAGEMENT; INVESTMENT ADVISORY SERVICES; UNDERWRITING, ISSUANCE AND ADMINISTRATION OF INDIVIDUAL AND BUSINESS-OWNED LIFE INSURANCE; ANNUITY UNDERWRITING AND INVESTMENT MANAGEMENT OF AND DISTRIBUTION OF ANNUITIES; ADMINISTRATION OF EMPLOYEE BENEFIT PLANS CONCERNING INSURANCE AND FINANCE; INDIVIDUAL RETIREMENT ACCOUNT SERVICES (U.S. CLS. 100, 101 AND 102).

MICHAEL W. BAIRD, EXAMINING ATTORNEY

SN 85-410,254. IDT TELECOM, INC., NEWARK, NJ. FILED 8-30-2011.

EL COMICO

THE MARK CONSISTS OF STANDARD CHARACTERS WITHOUT CLAIM TO ANY PARTICULAR FONT, STYLE, SIZE, OR COLOR.

THE ENGLISH TRANSLATION OF "EL COMICO" IN THE MARK IS THE COMEDIAN.

CLASS 16—PAPER GOODS AND PRINTED MATTER

FOR PREPAID TELEPHONE CALLING CARDS, NOT MAGNETICALLY ENCODED (U.S. CLS. 2, 5, 22, 23, 29, 37, 38 AND 50).

FIRST USE 8-5-2011; IN COMMERCE 8-5-2011.

CLASS 36—INSURANCE AND FINANCIAL

FOR PREPAID TELEPHONE CALLING CARD AND DEBIT CARD SERVICES (U.S. CLS. 100, 101 AND 102).

FIRST USE 8-5-2011; IN COMMERCE 8-5-2011.

CLASS 38—COMMUNICATION

FOR TELEPHONE TELECOMMUNICATIONS SERVICES PROVIDED VIA PREPAID TELEPHONE CALLING CARDS (U.S. CLS. 100, 101 AND 104).

FIRST USE 8-5-2011; IN COMMERCE 8-5-2011.

EDWARD FENNESSY, EXAMINING ATTORNEY

SN 85-410,427. SCOTT, FRED, ASTON, PA. FILED 8-30-2011.



NO CLAIM IS MADE TO THE EXCLUSIVE RIGHT TO USE "MOO DO BRAND", APART FROM THE MARK AS SHOWN.

THE MARK CONSISTS OF THE WORDING "MOO DO BRAND" OVER THE CHINESE CHARACTER FOR "MOO DO" AND AN ABSTRACT STAR DESIGN THAT ARE MOSTLY WITHIN A CIRCULAR BORDER, ALL SURROUNDED BY A BAMBOO DESIGN BORDER.

THE ENGLISH TRANSLATION OF "MOO DO" IN THE MARK IS "MARTIAL WAY".

THE NON-LATIN CHARACTERS IN THE MARK TRANSLITERATE TO "MOO DO" AND THIS MEANS "MARTIAL WAY" IN ENGLISH.

CLASS 14—JEWELRY

FOR JEWELRY (U.S. CLS. 2, 27, 28 AND 50).

CLASS 25—CLOTHING

FOR MARTIAL ARTS UNIFORMS, BELTS, T-SHIRTS, FOOTWEAR, CAPS, WARM UP JACKETS, PANTS (U.S. CLS. 22 AND 39).

CLASS 26—FANCY GOODS

FOR ORNAMENTAL CLOTH PATCHES FOR CLOTHING (U.S. CLS. 37, 39, 40, 42 AND 50).

LINDA M. KING, EXAMINING ATTORNEY

SN 85-410,618. WOUNDED WARRIOR PROJECT, INC., JACKSONVILLE, FL. FILED 8-30-2011.

SOLDIER RIDE

THE MARK CONSISTS OF STANDARD CHARACTERS WITHOUT CLAIM TO ANY PARTICULAR FONT, STYLE, SIZE, OR COLOR.

OWNER OF U.S. REG. NO. 3,841,207.

NO CLAIM IS MADE TO THE EXCLUSIVE RIGHT TO USE "RIDE", APART FROM THE MARK AS SHOWN.

SEC. 2(F).

CLASS 36—INSURANCE AND FINANCIAL

FOR CHARITABLE FUNDRAISING SERVICES (U.S. CLS. 100, 101 AND 102).

FIRST USE 8-0-2004; IN COMMERCE 8-0-2004.

CLASS 41—EDUCATION AND ENTERTAINMENT

FOR ORGANIZING, ARRANGING, AND CONDUCTING CYCLING EVENTS (U.S. CLS. 100, 101 AND 107).

FIRST USE 0-0-2005; IN COMMERCE 0-0-2005.

LINDSEY RUBIN, EXAMINING ATTORNEY

SN 85-410,784. DSS CORP., SOUTHFIELD, MI. FILED 8-30-2011.

SECONDS SAVE LIVES

THE MARK CONSISTS OF STANDARD CHARACTERS WITHOUT CLAIM TO ANY PARTICULAR FONT, STYLE, SIZE, OR COLOR.

CLASS 9—ELECTRICAL AND SCIENTIFIC APPARATUS

FOR COMPUTER HARDWARE FOR CALL RECORDING SERVICES; COMPUTER SOFTWARE FOR CALL RECORDING SERVICES, NAMELY, AUDIO RECORDING SOFTWARE FOR USE IN THE RECORDING OF TELEPHONE CALLS (U.S. CLS. 21, 23, 26, 36 AND 38).

CLASS 42—SCIENTIFIC AND COMPUTER SERVICES

FOR DESIGN AND DEVELOPMENT OF SOFTWARE AND HARDWARE FOR CALL RECORDING SERVICES; DESIGN, DEVELOPMENT, AND IMPLEMENTATION OF SOFTWARE FOR CALL RECORDING SERVICES; DESIGN, DEVELOPMENT, INSTALLATION AND MAINTENANCE OF COMPUTER SOFTWARE FOR USE IN THE RECORDING OF TELEPHONE CALLS (U.S. CLS. 100 AND 101).

STEVEN PEREZ, EXAMINING ATTORNEY

SN 85-412,708. PERFORMANCE INDICATOR, LLC, LOWELL, MA. FILED 9-1-2011.

DYNAMIC CAMOUFLAGE

THE MARK CONSISTS OF STANDARD CHARACTERS WITHOUT CLAIM TO ANY PARTICULAR FONT, STYLE, SIZE, OR COLOR.

NO CLAIM IS MADE TO THE EXCLUSIVE RIGHT TO USE "CAMOUFLAGE", APART FROM THE MARK AS SHOWN.

CLASS 1—CHEMICALS

FOR CHEMICAL AGENTS FOR IMPREGNATING, BINDING OR COATING OF TEXTILES, FURS AND LEATHER, NON-WOVENS AND FABRICS (U.S. CLS. 1, 5, 6, 10, 26 AND 46).

CLASS 2—PAINTS

FOR INKS, TONERS AND DYES FOR USE WITH OR ON TEXTILES AND FABRICS (U.S. CLS. 6, 11 AND 16).

PAUL E. FAHRENKOPF, EXAMINING ATTORNEY

SN 85-412,892. ONEMAIN FINANCIAL HOLDINGS, INC., WILMINGTON, DE. FILED 9-1-2011.

ONEMAIN REMARKETING

THE MARK CONSISTS OF STANDARD CHARACTERS WITHOUT CLAIM TO ANY PARTICULAR FONT, STYLE, SIZE, OR COLOR.

NO CLAIM IS MADE TO THE EXCLUSIVE RIGHT TO USE "REMARKETING", APART FROM THE MARK AS SHOWN.

CLASS 35—ADVERTISING AND BUSINESS

FOR ARRANGING AND CONDUCTING OF VEHICLE AUCTION SALES (U.S. CLS. 100, 101 AND 102).

CLASS 37—CONSTRUCTION AND REPAIR

FOR VEHICLE RECONDITIONING, MAINTENANCE AND REPAIR SERVICES (U.S. CLS. 100, 103 AND 106).

CLASS 39—TRANSPORTATION AND STORAGE

FOR VEHICLE REPOSSESSION SERVICES, NAMELY, PHYSICAL REMOVAL OF REPOSSESSED VEHICLES FROM DEBTOR'S POSSESSION (U.S. CLS. 100 AND 105).

JAY BESCH, EXAMINING ATTORNEY

SN 85-414,160. JMJ-FM, LLC, DBA FM FOOD & MUSIC ALL-AMERICAN BAR & GRILL, GAHANNA, OH. FILED 9-2-2011.



NO CLAIM IS MADE TO THE EXCLUSIVE RIGHT TO USE "FOOD & MUSIC" AND "ALL-AMERICAN BAR & GRILL" FOR INTERNATIONAL CLASS 43, APART FROM THE MARK AS SHOWN.

THE COLOR(S) WHITE, RED, GRAY IS/ARE CLAIMED AS A FEATURE OF THE MARK.

THE MARK CONSISTS OF THE WORDING "FM FOOD & MUSIC" IN WHITE OVERLAYING A RED CIRCLE, ABOVE THE WORDING "ALL-AMERICAN BAR & GRILL" IN RED ABOVE A MIRROR IMAGE OF THE SAME WORDING IN GRAY. THE COLOR BLACK REPRESENTS BACKGROUND AND IS NOT A FEATURE OF THE MARK.

CLASS 25—CLOTHING

FOR BASEBALL HATS; GOLF SHIRTS; SHIRTS; T-SHIRTS, TANK TOPS; GOLF HATS (U.S. CLS. 22 AND 39).

FIRST USE 8-2-2011; IN COMMERCE 8-2-2011.

CLASS 43—HOTEL AND RESTAURANT SERVICES

FOR RESTAURANT, BAR, AND CATERING SERVICES, AND PROVIDING BANQUET FACILITIES FOR SPECIAL OCCASIONS (U.S. CLS. 100 AND 101).

FIRST USE 8-2-2011; IN COMMERCE 8-2-2011.

JOHN DWYER, EXAMINING ATTORNEY

SN 85-414,299. TOM MIRANDA OUTDOORS, INC., ENGLEWOOD, FL. FILED 9-2-2011.

ADVENTURE BOWHUNTER

THE MARK CONSISTS OF STANDARD CHARACTERS WITHOUT CLAIM TO ANY PARTICULAR FONT, STYLE, SIZE, OR COLOR.

NO CLAIM IS MADE TO THE EXCLUSIVE RIGHT TO USE "BOWHUNTER", APART FROM THE MARK AS SHOWN.

CLASS 9—ELECTRICAL AND SCIENTIFIC APPARATUS

FOR DVDS, VIDEOTAPES, AUDIOTAPES, DOWNLOADABLE VIDEO AND AUDIO FILES ALL IN THE FIELD OF HUNTING; ARCHERY EQUIPMENT, NAMELY, TELESCOPIC BOW SIGHTS; HUNTING BINOCULARS (U.S. CLS. 21, 23, 26, 36 AND 38).

CLASS 25—CLOTHING

FOR CLOTHING, NAMELY, SHIRTS, JACKETS, SWEAT SHIRTS, PANTS, SHORTS, VESTS, BIB OVERALLS, HATS, SOCKS, GLOVES, AND FOOTWEAR; HUNTING CLOTHING, NAMELY, SHIRTS, JACKETS, SWEAT SHIRTS, PANTS, SHORTS, VESTS, BIB OVERALLS, HATS, SOCKS, GLOVES, AND FOOTWEAR (U.S. CLS. 22 AND 39).

CLASS 28—TOYS AND SPORTING GOODS

FOR HUNTING AND ARCHERY EQUIPMENT, NAMELY, QUIVERS AND BOWS; FIREARMS ACCESSORIES, NAMELY, TARGETS AND FIREARMS TARGET LAUNCHERS; ARCHERY AND HUNTING BOWS; ARCHERY AND HUNTING ARM GUARDS; ARCHERY AND HUNTING ARROW FLETCHING DEVICES; ARCHERY AND HUNTING ARROW POINTS; ARCHERY AND HUNTING ARROWS; ARCHERY AND HUNTING BOW CASES; ARCHERY AND HUNTING BOW STRINGS; ARCHERY AND HUNTING NON-TELESCOPIC BOW SIGHTS AND OPEN BOW SIGHTS; ARCHERY AND HUNTING TARGETS; CAMOUFLAGE NETTING USED IN HUNTING; HUNTING BLINDS; HUNTING DECOY BAGS; HUNTING STANDS; HUNTING GAME CALLS; TREE STANDS FOR HUNTING; ANIMAL AND BIRD HUNTING DECOYS; ARCHERY BROADHEADS (U.S. CLS. 22, 23, 38 AND 50).

CLASS 41—EDUCATION AND ENTERTAINMENT

FOR ENTERTAINMENT SERVICES, NAMELY, A TELEVISION SERIES IN THE FIELD OF HUNTING PROVIDED THROUGH SATELLITE TELEVISION, TELEVISION BROADCAST, CABLE TELEVISION; PROVIDING INFORMATION IN THE FIELD OF HUNTING AND FISHING VIA THE INTERNET (U.S. CLS. 100, 101 AND 107).

WILLIAM VERHOSEK, EXAMINING ATTORNEY

SN 85-415,120. HALLER, ZACH, CHICAGO, IL. FILED 9-5-2011.

Found In Town

THE MARK CONSISTS OF STANDARD CHARACTERS WITHOUT CLAIM TO ANY PARTICULAR FONT, STYLE, SIZE, OR COLOR.

CLASS 6—METAL GOODS

FOR METAL KEY CHAINS (U.S. CLS. 2, 12, 13, 14, 23, 25 AND 50).

CLASS 16—PAPER GOODS AND PRINTED MATTER

FOR STICKERS (U.S. CLS. 2, 5, 22, 23, 29, 37, 38 AND 50).

CLASS 20—FURNITURE AND ARTICLES NOT OTHERWISE CLASSIFIED

FOR NON-METAL AND NON-LEATHER KEY CHAINS (U.S. CLS. 2, 13, 22, 25, 32 AND 50).
MARK SPARACINO, EXAMINING ATTORNEY

SN 85-415,406. INTERNATIONAL SCHOOL PSYCHOLOGY ASSOCIATION, CHICAGO, IL. FILED 9-6-2011.



THE MARK CONSISTS OF STYLIZED GREEK LETTER PSI WITH A WIRE GLOBE DESIGN APPEARING DIRECTLY ABOVE.

CLASS 16—PAPER GOODS AND PRINTED MATTER

FOR PUBLICATIONS, NAMELY, ARTICLES, JOURNALS, AND HAND-OUTS IN THE FIELDS OF SCHOOL PSYCHOLOGY, EDUCATIONAL PSYCHOLOGY AND CHILDREN'S RIGHTS (U.S. CLS. 2, 5, 22, 23, 29, 37, 38 AND 50).

FIRST USE 12-31-1982; IN COMMERCE 12-31-1982.

CLASS 35—ADVERTISING AND BUSINESS

FOR ASSOCIATION SERVICES, NAMELY, WORLD-WIDE PROMOTION OF THE INTERESTS OF SCHOOL PSYCHOLOGISTS; ASSOCIATION SERVICES, NAMELY, PROMOTING INTERESTS OF SCHOOL PSYCHOLOGISTS IN THE FIELD OF SCHOOL PSYCHOLOGY AND EDUCATIONAL PSYCHOLOGY; PROMOTING PUBLIC AWARENESS OF MENTAL HEALTH; PUBLIC ADVOCACY TO PROMOTE AWARENESS OF MENTAL HEALTH AND THE EDUCATION OF ALL CHILDREN; ASSOCIATION SERVICES, NAMELY, PROMOTING THE PUBLIC INTEREST AND AWARENESS IN THE USE OF SOUND PSYCHOLOGICAL PRINCIPLES IN EDUCATION; ASSOCIATION SERVICES, NAMELY, PROMOTIONAL SERVICES RELATED TO THE FIELD OF MENTAL HEALTH AND WELL-BEING FOR THE PURPOSE OF FACILITATING AND ENCOURAGING COMMUNICATION AND COOPERATION BETWEEN PROFESSIONALS AND ORGANIZATIONS COMMITTED TO SIMILAR PURPOSES OF IMPROVING CHILDREN'S MENTAL HEALTH AND WELL-BEING; PUBLIC ADVOCACY TO PROMOTE THE IMPORTANCE OF THE PSYCHOLOGICAL RIGHTS OF CHILDREN THROUGHOUT THE WORLD BY PARTICIPATING IN AND CONTRIBUTING TO THE WORK OF INTERNATIONAL ORGANIZATIONS; ASSOCIATION SERVICES, NAMELY, PROMOTING COOPERATION AND FURTHERANCE OF RESEARCH PROJECTS IN THE FIELD OF CHILDREN'S RIGHTS (U.S. CLS. 100, 101 AND 102).

FIRST USE 12-31-1982; IN COMMERCE 12-31-1982.

CLASS 41—EDUCATION AND ENTERTAINMENT

FOR PROVIDING ON-LINE PUBLICATIONS IN THE NATURE OF ARTICLES IN THE FIELDS OF SCHOOL PSYCHOLOGY AND EDUCATIONAL PSYCHOLOGY; PROVIDING ON-LINE PUBLICATIONS, NAMELY, BROCHURES, BOOKLETS, NEWSLETTERS, AND TEACHING MATERIALS IN THE FIELDS OF MENTAL HEALTH AND PSYCHOLOGICAL EDUCATION; ORGANIZATION OF CONFERENCES IN THE FIELD OF INTERNATIONAL CHILDREN'S RIGHTS FOR NON-BUSINESS AND NON-COMMERCIAL PURPOSES; EDUCATIONAL SERVICES, NAMELY, CONDUCTING CLASSES, SEMINARS, CONFERENCES, WORKSHOPS IN THE FIELDS OF EDUCATIONAL PSYCHOLOGY, CHILDREN'S RIGHTS, AND CRISIS MANAGEMENT FOR CRISES PRIMARILY INVOLVING SCHOOL SHOOTINGS, NATURAL DISASTERS AFFECTING SCHOOLS, ACCIDENTS, SUICIDES, DEATHS, BULLYING, AND IN PREVENTION OF VIOLENCE IN SCHOOLS AND DISTRIBUTION OF TRAINING MATERIALS IN CONNECTION THEREWITH; PROVIDING A WEBSITE FEATURING RESOURCES, NAMELY, A WEBSITE FEATURING PRIMARILY NON-DOWNLOADABLE PUBLICATIONS IN THE NATURE OF ARTICLES AND NEWSLETTERS IN THE FIELDS OF SCHOOL PSYCHOLOGY, EDUCATIONAL PSYCHOLOGY AND CHILDREN'S RIGHTS (U.S. CLS. 100, 101 AND 107).
FIRST USE 12-31-1982; IN COMMERCE 12-31-1982.

CLASS 42—SCIENTIFIC AND COMPUTER SERVICES

FOR ACCREDITATION SERVICES, NAMELY, DEVELOPING AND ADMINISTERING STANDARDS AND PROCEDURES FOR CERTIFYING ORGANIZATIONS IN THE FIELD OF SCHOOL PSYCHOLOGY, EDUCATIONAL PSYCHOLOGY AND CHILDREN'S RIGHTS, AND EVALUATING ORGANIZATIONS TO DETERMINE WHETHER THE ORGANIZATIONS CONFORM TO DEVELOPED STANDARDS IN THE FIELD OF SCHOOL PSYCHOLOGY, EDUCATIONAL PSYCHOLOGY AND CHILDREN'S RIGHTS (U.S. CLS. 100 AND 101).
FIRST USE 7-31-2010; IN COMMERCE 7-31-2010.
JAY BESCH, EXAMINING ATTORNEY

SN 85-417,168. SHIFT4 CORPORATION, LAS VEGAS, NV. FILED 9-7-2011.

TOKENIZATION YOUR WAY

THE MARK CONSISTS OF STANDARD CHARACTERS WITHOUT CLAIM TO ANY PARTICULAR FONT, STYLE, SIZE, OR COLOR.

NO CLAIM IS MADE TO THE EXCLUSIVE RIGHT TO USE "TOKENIZATION", APART FROM THE MARK AS SHOWN.

CLASS 36—INSURANCE AND FINANCIAL

FOR PAYMENT PROCESSING SERVICES, INCLUDING CREDIT CARD, DEBIT CARD AND CARD PAYMENT TRANSACTION PROCESSING SERVICES, AND MANAGING ELECTRONIC PAYMENT INFORMATION AND CARDHOLDER PAYMENT DATA VIA AN INTERNET-BASED SYSTEM (U.S. CLS. 100, 101 AND 102).

CLASS 39—TRANSPORTATION AND STORAGE

FOR PROVIDING AN INTERNET-BASED SYSTEM FOR SECURELY STORING ELECTRONIC PAYMENT INFORMATION AND CARDHOLDER PAYMENT DATA (U.S. CLS. 100 AND 105).

CLASS 42—SCIENTIFIC AND COMPUTER SERVICES

FOR COMPUTER SERVICES, NAMELY, PROVIDING ON-LINE SECURITY SERVICES FOR PROCESSING ELECTRONIC PAYMENT TRANSACTIONS BY REPLACING CARDHOLDER PAYMENT DATA WITH A UNIQUE IDENTIFIER ASSOCIATED WITH AN ELECTRONIC PAYMENT TRANSACTION AND ENABLING MERCHANTS TO PROCESS AN ELECTRONIC PAYMENT TRANSACTION USING THE UNIQUE IDENTIFIER (U.S. CLS. 100 AND 101).

DAVID H. STINE, EXAMINING ATTORNEY

SN 85-417,867. DPX GEAR, INC., SAN DIEGO, CA. FILED 9-8-2011.

Mogadishu Yacht Club

THE MARK CONSISTS OF STANDARD CHARACTERS WITHOUT CLAIM TO ANY PARTICULAR FONT, STYLE, SIZE, OR COLOR.

CLASS 25—CLOTHING

FOR BASEBALL CAPS AND HATS; COLLARED SHIRTS; HATS; HOODED SWEAT SHIRTS; LONG-SLEEVED SHIRTS; PIQUE SHIRTS; POLO SHIRTS; SHIRTS; SHIRTS AND SHORT-SLEEVED SHIRTS; SHORT-SLEEVED OR LONG-SLEEVED T-SHIRTS; SPORTS CAPS AND HATS; SWEAT SHIRTS; T-SHIRTS (U.S. CLS. 22 AND 39).

CLASS 26—FANCY GOODS

FOR CLOTH PATCHES FOR CLOTHING; EMBROIDERED PATCHES FOR CLOTHING; ORNAMENTAL CLOTH PATCHES; SHIRT BUTTONS (U.S. CLS. 37, 39, 40, 42 AND 50).

B. PARADEWELAI, EXAMINING ATTORNEY

SN 85-418,278. PUNJAB TRADING, INC., DBA PUNJAB TRADING, AUBURN, WA. FILED 9-8-2011.



THE COLOR(S) RED ON WHITE BACKGROUND IS/ARE CLAIMED AS A FEATURE OF THE MARK.

THE MARK CONSISTS OF A DOUBLE OUTSIDE BOX IN THE SHAPE OF A PARALLELOGRAM WITH OUTER LINE THINNER AND INSIDE THERE ARE WORDS WRITTEN "P-PURE MAZZA" WITH "MAZZA" WRITTEN BOLD AND BIGGER; THE WORDING AND DESIGN ELEMENTS APPEAR IN RED, ALL ON A WHITE BACKGROUND.

CLASS 29—MEATS AND PROCESSED FOODS

FOR EDIBLE OILS (U.S. CL. 46).
FIRST USE 8-1-2011; IN COMMERCE 8-1-2011.

CLASS 32—LIGHT BEVERAGES

FOR FRUIT-BASED BEVERAGES (U.S. CLS. 45, 46 AND 48).
FIRST USE 8-1-2011; IN COMMERCE 8-1-2011.
RON FAIRBANKS, EXAMINING ATTORNEY

CLASS 25—CLOTHING

FOR CLOTHING, NAMELY, CAPS, HATS, SHIRTS AND T-SHIRTS (U.S. CLS. 22 AND 39).

CLASS 35—ADVERTISING AND BUSINESS

FOR ONLINE RETAIL STORE SERVICES FEATURING AN ARRAY OF GENERAL MERCHANDISE (U.S. CLS. 100, 101 AND 102).
DOMINICK J. SALEMI, EXAMINING ATTORNEY

SN 85-418,371. BO-DYN BOBSLED PROJECT, INC., WATERBURY, CT. FILED 9-9-2011.

SN 85-419,698. CAMPANARIO ENTERTAINMENT, LLC, MCALEN, TX. FILED 9-11-2011.

THE NIGHT TRAIN

THE MARK CONSISTS OF STANDARD CHARACTERS WITHOUT CLAIM TO ANY PARTICULAR FONT, STYLE, SIZE, OR COLOR.

CLASS 9—ELECTRICAL AND SCIENTIFIC APPARATUS

FOR PRE-RECORDED DVDS, DIGITAL VERSATILE DISCS, DIGITAL VIDEO DISCS FEATURING LIVE ACTION ENTERTAINMENT AND MOTION PICTURE FILMS ABOUT BOBSLEDDING AND THE DESIGN AND BUILDING OF A BOBSLED FOR COMPETITION (U.S. CLS. 21, 23, 26, 36 AND 38).

CLASS 41—EDUCATION AND ENTERTAINMENT

FOR PRODUCTION, PRESENTATION, DISTRIBUTION, AND RENTAL OF MOTION PICTURE FILMS; PRODUCTION, PRESENTATION, AND RENTAL OF VISUAL RECORDINGS; PRODUCTION OF LIVE-ACTION ENTERTAINMENT SHOWS FOR DISTRIBUTION VIA VISUAL MEDIA AND ELECTRONIC MEANS; ENTERTAINMENT SERVICES RENDERED THROUGH THE MEDIA OF TELEVISION, NAMELY, A TELEVISION SERIES ABOUT SPORTS COMPETITION AND THE HISTORY AND BUILDING OF A BOBSLED (U.S. CLS. 100, 101 AND 107).
B. PARADEWELAI, EXAMINING ATTORNEY

SN 85-419,173. HARLEM GLOBETROTTERS INTERNATIONAL, INC., PHOENIX, AZ. FILED 9-9-2011.

GLOBETROTTER NATION

THE MARK CONSISTS OF STANDARD CHARACTERS WITHOUT CLAIM TO ANY PARTICULAR FONT, STYLE, SIZE, OR COLOR.

OWNER OF U.S. REG. NOS. 2,374,778, 3,286,735 AND 3,352,775.

CLASS 18—LEATHER GOODS

FOR BAGS, NAMELY, TOTE BAGS, ALL-PURPOSE CARRYING BAGS, BACKPACKS AND DUFFLE BAGS (U.S. CLS. 1, 2, 3, 22 AND 41).

JEFE DE JEFES

THE MARK CONSISTS OF STANDARD CHARACTERS WITHOUT CLAIM TO ANY PARTICULAR FONT, STYLE, SIZE, OR COLOR.

THE ENGLISH TRANSLATION OF "JEFE DE JEFES" IN THE MARK IS "BOSS OF BOSSES".

CLASS 9—ELECTRICAL AND SCIENTIFIC APPARATUS

FOR DIGITAL MEDIA, NAMELY, PRE-RECORDED VIDEO CASSETTES, DIGITAL VIDEO DISCS, DIGITAL VERSATILE DISCS, DOWNLOADABLE AUDIO AND VIDEO RECORDINGS, DVDS, AND HIGH DEFINITION DIGITAL DISCS FEATURING DRAMATIC AND MUSICAL PERFORMANCES; PRE-RECORDED CDS, VIDEO TAPES, LASER DISKS AND DVDS FEATURING DRAMATIC AND MUSICAL PERFORMANCES; VIDEO AND COMPUTER GAME PROGRAMS (U.S. CLS. 21, 23, 26, 36 AND 38).

CLASS 41—EDUCATION AND ENTERTAINMENT

FOR ENTERTAINMENT IN THE NATURE OF A DRAMATIC TELEVISION SERIES; PRODUCTION OF DVDS, VIDEOTAPES AND TELEVISION PROGRAMS FEATURING DRAMATIC AND MUSICAL PERFORMANCES (U.S. CLS. 100, 101 AND 107).
AMY KERTGATE, EXAMINING ATTORNEY

SN 85-420,121. INFINITY CLASSICS INTERNATIONAL, INC., LINDEN, NJ. FILED 9-12-2011.

FOOT PETZ

THE MARK CONSISTS OF STANDARD CHARACTERS WITHOUT CLAIM TO ANY PARTICULAR FONT, STYLE, SIZE, OR COLOR.

NO CLAIM IS MADE TO THE EXCLUSIVE RIGHT TO USE "FOOT", APART FROM THE MARK AS SHOWN.

CLASS 3—COSMETICS AND CLEANING PREPARATIONS

FOR FOOT CARE PRODUCTS, NAMELY, NON-MEDICATED FOOT GELS (U.S. CLS. 1, 4, 6, 50, 51 AND 52).

CLASS 25—CLOTHING

FOR CLOTHING, NAMELY, HOSIERY, LINGERIE, UNDERWEAR AND SWIMWEAR (U.S. CLS. 22 AND 39).
FRANK LATTUCA, EXAMINING ATTORNEY

SN 85-420,134. INFINITY CLASSICS INTERNATIONAL, INC., LINDEN, NJ. FILED 9-12-2011.

FOOT PETS

THE MARK CONSISTS OF STANDARD CHARACTERS WITHOUT CLAIM TO ANY PARTICULAR FONT, STYLE, SIZE, OR COLOR.
NO CLAIM IS MADE TO THE EXCLUSIVE RIGHT TO USE "FOOT", APART FROM THE MARK AS SHOWN.

CLASS 3—COSMETICS AND CLEANING PREPARATIONS

FOR FOOT CARE PRODUCTS, NAMELY, NON-MEDICATED FOOT GELS (U.S. CLS. 1, 4, 6, 50, 51 AND 52).

CLASS 25—CLOTHING

FOR CLOTHING, NAMELY, HOSIERY, LINGERIE, UNDERWEAR AND SWIMWEAR (U.S. CLS. 22 AND 39).
FRANK LATTUCA, EXAMINING ATTORNEY

SN 85-420,346. UNITEDHEALTH GROUP INCORPORATED, MINNETONKA, MN. FILED 9-12-2011.

LIFEPRINT

THE MARK CONSISTS OF STANDARD CHARACTERS WITHOUT CLAIM TO ANY PARTICULAR FONT, STYLE, SIZE, OR COLOR.

CLASS 44—MEDICAL, BEAUTY AND AGRICULTURAL SERVICES

FOR PROVIDING HEALTHCARE, NURSING CARE, AND MEDICAL SERVICES; PHYSICAL THERAPY; MEDICAL COUNSELING; CONDUCTING MEDICAL PHYSICAL EVALUATIONS; CONSULTATION IN THE FIELD OF HOME HEALTH TREATMENT PROGRAMS ADAPTED TO INDIVIDUAL PATIENT NEEDS, NAMELY, FACILITATING PATIENT'S TRANSITION FROM POINT OF CARE DELIVERY TO HOME, ASSESSING THE HOME ENVIRONMENT AND THE PATIENT CONDITION, MONITORING A PATIENT'S CONDITION AND REPORTING SAME TO OTHERS TO FACILITATE THEIR PROVISION OF HOME HEALTHCARE SERVICES PROVIDED, AND PHARMACEUTICALS AND EQUIPMENT UTILIZED TO TREAT THE PATIENT; HOSPICE SERVICES; PALLIATIVE CARE SERVICES; HOME HEALTH CARE SERVICES, NAMELY, PHYSICIAN CARE, SKILLED NURSING CARE, PHYSICAL THERAPY, OCCUPATIONAL THERAPY, MENTAL HEALTH SERVICES, DENTAL SERVICES, HEARING AND VISION SCREENING AND TREATMENT, RESPIRATORY THERAPY SERVICES, AND SPEECH THERAPY SERVICES (U.S. CLS. 100 AND 101).

CLASS 45—PERSONAL AND LEGAL SERVICES

FOR CASE MANAGEMENT SERVICES, NAMELY, DEVELOPING AN INDIVIDUALIZED HOME AND COMMUNITY-BASED CARE PLAN FOR PERSONS ELIGIBLE FOR NURSING HOME PLACEMENT, HOSPICE CARE OR CHRONICALLY ILL PATIENTS, COORDINATING FOR SUCH PERSONS THE NECESSARY MEDICAL SERVICES, MENTAL HEALTH SERVICES, DENTAL HYGIENIST SERVICES, HEARING AND VISION SCREENING AND TREATMENT, OCCUPATIONAL THERAPY SERVICES, PHYSICAL THERAPY SERVICES, SPEECH THERAPY SERVICES, HOME HEALTH SERVICES, TRANSPORTATION SERVICES, AND MEDICAL SUPPLIES (U.S. CLS. 100 AND 101).
ESTHER A. BORSUK, EXAMINING ATTORNEY

SN 85-420,538. IHS GLOBAL INC., ENGLEWOOD, CO. FILED 9-12-2011.



OWNER OF U.S. REG. NOS. 1,803,243, 3,174,210 AND OTHERS.
THE COLOR(S) LIGHT AND DARK BLUE AND WHITE IS/ARE CLAIMED AS A FEATURE OF THE MARK IS/ARE CLAIMED AS A FEATURE OF THE MARK.
THE MARK CONSISTS OF "IHS" AND A SPHERE DESIGN. THE COLORS LIGHT AND DARK BLUE APPEAR ON THE SPHERE IN THE BACKGROUND BEHIND THE

LETTERS "IHS", WITH THE DARK BLUE COLOR AROUND THE EDGES OF THE SPHERE TO THE SIDES OF AND ABOVE THE LETTERS "IHS" AND THE LIGHT BLUE COLOR BEHIND THE LETTERS, IN SHADING IN AN OVAL FIGURE ABOVE THE LETTERS, AND BENEATH THE LETTERS AND A LIGHTER BLUE IN THE SHADING UNDER THE SPHERE. THE COLOR WHITE APPEARS IN THE LETTERS "IHS", IN A CIRCULAR FIGURE ABOVE THE LETTER "I" AND IN AN OVAL FIGURE BENEATH THE LETTER "H".

CLASS 9—ELECTRICAL AND SCIENTIFIC APPARATUS

FOR COMPUTER SOFTWARE FOR CREATING SEARCHABLE DATABASES OF INFORMATION AND DATA; COMPUTER SOFTWARE FOR USE IN DATABASE MANAGEMENT AND COMPILING, MONITORING, AND UPDATING INFORMATION AND DATA IN THE FIELDS OF ENVIRONMENTAL COMPLIANCE, ENERGY, NATURAL RESOURCES, SUPPLY CHAIN MANAGEMENT, PRODUCT DESIGN, DEFENSE, SECURITY, PUBLIC SAFETY, ECONOMIC FORECASTING AND ANALYSIS, AEROSPACE, AUTOMOTIVE, AGRICULTURE, CONSTRUCTION, CONSUMER GOODS, RETAIL MARKETS, ELECTRONICS, TELECOMMUNICATIONS, FINANCIAL MANAGEMENT, GOVERNMENT AFFAIRS, HEALTHCARE, PHARMACEUTICALS, MINING, UTILITIES, SHIPPING, TRANSPORTATION, CHEMICALS, AND COMMODITIES; DOWNLOADABLE COMPUTER SOFTWARE FOR USE IN DATABASE MANAGEMENT AND COMPILING, MONITORING, AND UPDATING INFORMATION AND DATA IN THE FIELDS OF ENVIRONMENTAL COMPLIANCE, ENERGY, NATURAL RESOURCES, SUPPLY CHAIN MANAGEMENT, PRODUCT DESIGN, DEFENSE, SECURITY, PUBLIC SAFETY, ECONOMIC FORECASTING AND ANALYSIS, AEROSPACE, AUTOMOTIVE, AGRICULTURE, CONSTRUCTION, CONSUMER GOODS, RETAIL MARKETS, ELECTRONICS, TELECOMMUNICATIONS, FINANCIAL MANAGEMENT, GOVERNMENT AFFAIRS, HEALTHCARE, PHARMACEUTICALS, MINING, UTILITIES, SHIPPING, TRANSPORTATION, CHEMICALS, AND COMMODITIES; DOWNLOADABLE ELECTRONIC NEWSLETTERS IN THE FIELDS OF ENVIRONMENTAL COMPLIANCE, ENERGY, NATURAL RESOURCES, SUPPLY CHAIN MANAGEMENT, PRODUCT DESIGN, DEFENSE, SECURITY, PUBLIC SAFETY, ECONOMIC FORECASTING AND ANALYSIS, AEROSPACE, AUTOMOTIVE, AGRICULTURE, CONSTRUCTION, CONSUMER GOODS, RETAIL MARKETS, ELECTRONICS, TELECOMMUNICATIONS, FINANCIAL MANAGEMENT, GOVERNMENT AFFAIRS, HEALTHCARE, PHARMACEUTICALS, MINING, UTILITIES, SHIPPING, TRANSPORTATION, CHEMICALS, AND COMMODITIES (U.S. CLS. 21, 23, 26, 36 AND 38).

FIRST USE 2-20-2006; IN COMMERCE 2-20-2006.

CLASS 16—PAPER GOODS AND PRINTED MATTER

FOR PRINTED REPORTS IN THE FIELDS OF ENVIRONMENTAL COMPLIANCE, ENERGY, NATURAL RESOURCES, SUPPLY CHAIN MANAGEMENT, PRODUCT DESIGN, DEFENSE, SECURITY, PUBLIC SAFETY, ECONOMIC FORECASTING AND ANALYSIS, AEROSPACE, AUTOMOTIVE, AGRICULTURE, CONSTRUCTION, CONSUMER GOODS, RETAIL MARKETS, ELECTRONICS, TELECOMMUNICATIONS, FINANCIAL MANAGEMENT, GOVERNMENT AFFAIRS, HEALTHCARE, PHARMACEUTICALS, MINING, UTILITIES, SHIPPING, TRANSPORTATION, CHEMICALS, AND COMMODITIES (U.S. CLS. 2, 5, 22, 23, 29, 37, 38 AND 50).

FIRST USE 2-20-2006; IN COMMERCE 2-20-2006.

CLASS 35—ADVERTISING AND BUSINESS

FOR ARRANGING AND CONDUCTING BUSINESS CONFERENCES; BUSINESS CONSULTING AND INFORMATION SERVICES; BUSINESS ADVISORY SERVICES, CONSULTANCY AND INFORMATION; BUSINESS RESEARCH; MARKET RESEARCH AND BUSINESS ANALYSES; MARKET RESEARCH STUDIES (U.S. CLS. 100, 101 AND 102).

FIRST USE 2-20-2006; IN COMMERCE 2-20-2006.

CLASS 41—EDUCATION AND ENTERTAINMENT

FOR ON-LINE ELECTRONIC NEWSLETTERS DELIVERED BY E-MAIL IN THE FIELDS OF ENVIRONMENTAL COMPLIANCE, ENERGY, NATURAL RESOURCES, SUPPLY CHAIN MANAGEMENT, PRODUCT DESIGN, DEFENSE, SECURITY, PUBLIC SAFETY, ECONOMIC FORECASTING AND ANALYSIS, AEROSPACE, AUTOMOTIVE, AGRICULTURE, CONSTRUCTION, CONSUMER GOODS, RETAIL MARKETS, ELECTRONICS, TELECOMMUNICATIONS, FINANCIAL MANAGEMENT, GOVERNMENT AFFAIRS, HEALTHCARE, PHARMACEUTICALS, MINING, UTILITIES, SHIPPING, TRANSPORTATION, CHEMICALS, AND COMMODITIES; PROVIDING ON-LINE NEWSLETTERS IN THE FIELDS OF ENVIRONMENTAL COMPLIANCE, ENERGY, NATURAL RESOURCES, SUPPLY CHAIN MANAGEMENT, PRODUCT DESIGN, DEFENSE, SECURITY, PUBLIC SAFETY, ECONOMIC FORECASTING AND ANALYSIS, AEROSPACE, AUTOMOTIVE, AGRICULTURE, CONSTRUCTION, CONSUMER GOODS, RETAIL MARKETS, ELECTRONICS, TELECOMMUNICATIONS, FINANCIAL MANAGEMENT, GOVERNMENT AFFAIRS, HEALTHCARE, PHARMACEUTICALS, MINING, UTILITIES, SHIPPING, TRANSPORTATION, CHEMICALS, AND COMMODITIES; ARRANGING AND CONDUCTING BUSINESS SEMINARS IN THE FIELDS OF ENVIRONMENTAL COMPLIANCE, ENERGY, NATURAL RESOURCES, SUPPLY CHAIN MANAGEMENT, PRODUCT DESIGN, DEFENSE, SECURITY, PUBLIC SAFETY, ECONOMIC FORECASTING AND ANALYSIS, AEROSPACE, AUTOMOTIVE, AGRICULTURE, CONSTRUCTION, CONSUMER GOODS, RETAIL MARKETS, ELECTRONICS, TELECOMMUNICATIONS, FINANCIAL MANAGEMENT, GOVERNMENT AFFAIRS, HEALTHCARE, PHARMACEUTICALS, MINING, UTILITIES, SHIPPING, TRANSPORTATION, CHEMICALS, AND COMMODITIES; PUBLICATION OF PRINTED MATTER, NAMELY, REPORTS, NEWSLETTERS, AND BOOKS; PUBLISHING OF ELECTRONIC PUBLICATIONS AND BOOKS (U.S. CLS. 100, 101 AND 107).

FIRST USE 2-20-2006; IN COMMERCE 2-20-2006.

CLASS 42—SCIENTIFIC AND COMPUTER SERVICES

FOR PROVIDING A WEB SITE FEATURING NON-DOWNLOADABLE SOFTWARE FOR USE IN DATABASE MANAGEMENT AND COMPILING, MONITORING, AND UPDATING INFORMATION AND DATA IN THE FIELDS OF ENVIRONMENTAL COMPLIANCE, ENERGY, NATURAL RESOURCES, SUPPLY CHAIN MANAGEMENT, PRODUCT DESIGN, DEFENSE, SECURITY, PUBLIC SAFETY, ECONOMIC FORECASTING AND ANALYSIS, AEROSPACE, AUTOMOTIVE, AGRICULTURE, CONSTRUCTION, CONSUMER GOODS, RETAIL MARKETS, ELECTRONICS, TELECOMMUNICATIONS, FINANCIAL MANAGEMENT, GOVERNMENT AFFAIRS, HEALTHCARE, PHARMACEUTICALS, MINING, UTILITIES, SHIPPING, TRANSPORTATION, CHEMICALS, AND COMMODITIES; RESEARCH IN THE FIELD OF ENERGY; RESEARCH IN THE FIELD OF RENEWABLE ENERGY; RESEARCH IN THE FIELD OF INTELLIGENCE AND SECURITY TECHNOLOGY; CONSULTATION AND RESEARCH IN THE FIELD OF AEROSPACE ENGINEERING (U.S. CLS. 100 AND 101).

FIRST USE 2-20-2006; IN COMMERCE 2-20-2006.

EDWARD FENNESSY, EXAMINING ATTORNEY

SN 85-420,617. WORLD FINER FOODS, INC., BLOOMFIELD, NJ. FILED 9-12-2011.



OWNER OF U.S. REG. NOS. 1,060,919 AND 1,275,869.
THE MARK CONSISTS OF "TY LING" STYLIZED TEXT, WITH AN ASIAN SYMBOL ABOVE THE STYLIZED TEXT. THE ENGLISH TRANSLATION OF SYMBOL IN THE MARK IS "TASTE".

THE NON-LATIN CHARACTERS IN THE MARK TRANSLITERATE TO "WEI" AND THIS MEANS "TASTE" IN ENGLISH.

CLASS 29—MEATS AND PROCESSED FOODS

FOR CANNED VEGETABLES; SESAME OIL; SMOKED FISH; SOUPS; SOYBEAN OIL (U.S. CL. 46).
FIRST USE 1-28-1976; IN COMMERCE 1-28-1976.

CLASS 30—STAPLE FOODS

FOR ASIAN NOODLES; COOKIES; MUSTARD; SAUCES; SPICES; VINEGAR (U.S. CL. 46).
FIRST USE 1-28-1976; IN COMMERCE 1-28-1976.
SKYE YOUNG, EXAMINING ATTORNEY

SN 85-421,958. TOTALLY APPS HOLDINGS LIMITED, TORTOLA, BR. VIRGIN ISLANDS, FILED 9-13-2011.



THE MARK CONSISTS OF A FRONTAL VIEW OF A TOY ANIMAL STANDING WITH A HEAD OF HAIR, AND A COMB AND SCISSORS IN ITS HAIR, WEARING CLOTHING THAT HAS AN IMAGE APPEARING AS A FLOWER WITH PEDALS ON THE FRONT.

CLASS 9—ELECTRICAL AND SCIENTIFIC APPARATUS

FOR AMUSEMENT APPARATUS AND GAMES ADAPTED FOR USE WITH TELEVISION RECEIVERS OR WITH VIDEO OR COMPUTER MONITORS; BAGS AND CASES SPECIALLY ADAPTED FOR HOLDING OR CARRYING PORTABLE TELEPHONES AND TELEPHONE EQUIPMENT AND ACCESSORIES; COMPUTER GAME PROGRAMMES DOWNLOADABLE VIA THE INTERNET; COMPUTER GAME SOFTWARE DOWNLOADABLE FROM A GLOBAL COMPUTER NETWORK; COMPUTER GAME SOFTWARE FOR PERSONAL COMPUTERS AND HOME VIDEO GAME CONSOLES; COMPUTER GAME SOFTWARE FOR USE WITH PERSONAL COMPUTERS, HOME VIDEO GAME CONSOLES USED WITH TELEVISIONS AND ARCADE-BASED VIDEO GAME CONSOLES; COMPUTER PROGRAMS FOR VIDEO AND COMPUTER GAMES; COMPUTER SOFTWARE, NAMELY, GAME ENGINE SOFTWARE FOR VIDEO GAME DEVELOPMENT AND OPERATION; DOWNLOADABLE COMPUTER GAME PROGRAMS; DOWNLOADABLE COMPUTER GAME SOFTWARE VIA A GLOBAL COMPUTER NETWORK AND WIRELESS DEVICES; DOWNLOADABLE ELECTRONIC GAME PROGRAMS; DOWNLOADABLE MULTIMEDIA FILE CONTAINING ARTWORK, TEXT, AUDIO, VIDEO, GAMES, AND INTERNET WEB LINKS RELATING TO VIDEO GAMES AND INTERACTIVE VIDEO GAMES; ELECTRONIC GAME SOFTWARE FOR HANDHELD ELECTRONIC DEVICES; INTERACTIVE VIDEO GAME PROGRAMS; INTERACTIVE VIDEO GAMES OF VIRTUAL REALITY COMPRISED OF COMPUTER HARDWARE FOR USE WITH AN EXTERNAL MONITOR AND SOFTWARE; PROTECTIVE COVERS AND CASES FOR CELL PHONES, LAPTOPS AND PORTABLE MEDIA PLAYERS (U.S. CLS. 21, 23, 26, 36 AND 38).

CLASS 16—PAPER GOODS AND PRINTED MATTER

FOR ADHESIVE NOTE PADS; ALBUMS FOR STICKERS; BALL POINT PENS; BINDER CLIPS; BINDERS; BOOK COVERS; BOOKMARKS; BUMPER STICKERS; CALENDAR DESK PADS; CALENDARS AND DIARIES; CARDS, NAMELY, TRADING CARDS, INVITATION CARDS, PRINTED APPOINTMENT REMINDER CARDS, PAPER GIFT CARDS, AND POSTCARDS; CHILDREN'S ACTIVITY BOOKS; CHILDREN'S BOOKS; CHILDREN'S INTERACTIVE EDUCATIONAL BOOKS; CHILDREN'S STORYBOOKS; CHILDREN'S WALL STICKERS AND MURALS; CHILDREN'S ARTS AND CRAFTS PAPER KITS; CHRISTMAS CARDS; COLOURED PENS; COMIC MAGAZINES; COMPUTER GAME INSTRUCTION MANUALS; CRAYONS; DECORATIONS FOR PENCILS; DESK PADS; DESK STANDS AND HOLDERS FOR PENS, PENCILS, AND INK; DISPOSABLE NAPKINS; DRAWING PADS; DRAWING PENCILS; EDUCATIONAL PUBLICATIONS, NAMELY, EDUCATIONAL LEARNING CARDS, FLASH CARDS, ACTIVITY CARDS, WORKBOOKS, TEXTBOOKS, ACTIVITY BOOKS, STORY BOOKS, PUZZLE BOOKS, PRINTED PUZZLES, TEACHER GUIDES, MANUALS, POSTERS AND EDUCATIONAL BOOKLETS IN THE FIELD OF VIDEO GAME CHARACTERS; ELECTRIC PENCIL SHARPENERS; ERASERS; EXTENSIONS AND ATTACHMENTS FOR PENCILS; FELT PENS; FIBERTIP PENS; FOUNTAIN PENS; GEL ROLLER PENS; GIFT BAGS; GIFT BOXES; GIFT WRAP PAPER; GLITTER PENS FOR STATIONERY PURPOSES; GLUE PENS FOR STATIONERY PURPOSES; HIGHLIGHTER PENS; INK PENS; INVITATION CARDS; LOOSE LEAF BINDERS; LUNCH BAGS; MAGAZINE SECTIONS IN THE FIELD OF VIDEO GAMES AND DOWNLOADABLE COMPUTER GAMES; MAGAZINES FEATURING VIDEO GAMES AND DOWNLOADABLE COMPUTER GAMES; MECHANICAL PENCIL SHARPENERS; MECHANICAL PENCILS; MEMO PADS; NOTE PAD HOLDERS; NOTE PADS; PAPER GIFT TAGS; PAPER GIFT WRAP BOWS; PAPER NAPKINS; PAPER PARTY BAGS; PAPER PARTY DECORATIONS; PAPER PARTY FAVORS; PAPER STAPLERS; PARTY GOODIE BAGS OF PAPER OR PLASTIC; PARTY ORNAMENTS OF PAPER; PEN AND PENCIL CASES AND BOXES; PEN AND PENCIL TRAYS; PEN OR PENCIL HOLDERS; PENS; PERSONALIZED COLORING BOOKS FOR CHILDREN; PLASTIC BAGS FOR PACKAGING; PLASTIC SANDWICH BAGS; POCKET CALENDARS; POSTCARDS AND GREETING CARDS; PRINTED CALENDARS;

PRINTED CHILDREN'S COLORING PAGES; PRINTED MATERIALS, NAMELY, NOVELS AND SERIES OF FICTION BOOKS AND SHORT STORIES FEATURING SCENES AND CHARACTERS BASED ON VIDEO GAMES; PRINTED PAMPHLETS, BROCHURES, MANUALS, BOOKS, BOOKLETS, LEAFLETS, FLYERS, INFORMATIONAL SHEETS AND NEWSLETTERS, ADHESIVE BACKED STICKERS, AND KITS COMPRISING ONE OR MORE OF THE FOREGOING MATERIALS IN THE FIELD OF VIDEO GAME CHARACTERS; PROTECTIVE COVERS FOR BOOKS; REMOVABLE TATTOOS; ROLE PLAYING GAME EQUIPMENT IN THE NATURE OF GAME BOOK MANUALS; ROLLER BALL PENS; SCHOOL SUPPLY KITS CONTAINING VARIOUS COMBINATIONS OF SELECTED SCHOOL SUPPLIES, NAMELY, WRITING INSTRUMENTS, PENS, PENCILS, MECHANICAL PENCILS, ERASERS, MARKERS, CRAYONS, HIGHLIGHTER PENS, FOLDERS, NOTEBOOKS, PAPER, PROTRACTORS, PAPER CLIPS, PENCIL SHARPENERS, WRITING GRIPS, GLUE AND BOOK MARKS; SCRATCH PADS; SERIES OF COMPUTER GAME HINT BOOKS; STICKERS AND TRANSFERS; TALKING CHILDREN'S BOOKS; TEAR-OFF CALENDARS; TEMPORARY TATTOOS; THREE-RING BINDERS; TRADING CARDS; WALL CALENDARS; WRITING PADS; IRON-ON, PLASTIC TRANSFERS (U.S. CLS. 2, 5, 22, 23, 29, 37, 38 AND 50).

CLASS 25—CLOTHING

FOR APRONS; BABY BIBS NOT OF PAPER; BABY BODYSUITS; BABY TOPS; BATHING SUITS; BEACH COVER-UPS; BEACHWEAR; BIBS NOT OF PAPER; BLOUSES; BODY SHIRTS; BOOTS; BRIEFS; CAPS; CHILDREN'S AND INFANT'S APPAREL, NAMELY, JUMPERS, OVERALL SLEEPWEAR, PAJAMAS, ROMPERS AND ONE-PIECE GARMENTS; CLOTH DIAPERS; CLOTHING FOR BABIES, TODDLERS AND CHILDREN, TREATED WITH FIRE AND HEAT RETARDANTS, NAMELY, PAJAMAS, JACKETS, SHIRTS, PANTS, JUMPERS; COATS; COSTUMES FOR USE IN CHILDREN'S DRESS UP PLAY; DRESSES; EAR WARMERS; FOOTWEAR; HALLOWEEN COSTUMES; HATS; HEAD WEAR; INFANT AND TODDLER ONE PIECE CLOTHING; INFANT SLEEPERS; INFANT WEAR; INFANT WEARABLE BLANKETS; JUMPERS; KNITTED CAPS; MITTENS; NIGHT GOWNS; NIGHTDRESSES; NIGHTIES; NIGHT-SHIRTS; NIGHTWEAR; ONE-PIECE GARMENTS FOR CHILDREN; PAJAMAS; PARTY HATS; RAIN BOOTS; RAIN COATS; RAINWEAR; SANDALS; SHIRTS; SHIRTS FOR INFANTS, BABIES, TODDLERS AND CHILDREN; SKIRTS AND DRESSES; SLIPPERS; SUNDRESSES; SWIM WEAR; T-SHIRTS; TANK TOPS; TEDDIES; TUNICS; UNDERCLOTHES (U.S. CLS. 22 AND 39).

CLASS 28—TOYS AND SPORTING GOODS

FOR AMUSEMENT APPARATUS INCORPORATING A TELEVISION SCREEN; AMUSEMENT PARK RIDES; APPARATUS FOR ELECTRONIC GAMES OTHER THAN THOSE ADAPTED FOR USE WITH AN EXTERNAL DISPLAY SCREEN OR MONITOR; ARCADE GAMES; BABY RATTLES; BALL-JOINTED DOLLS; BALLOONS; BATH TOYS; BEACH BALLS; BEAN BAG DOLLS; BEAN BAGS; BENDABLE TOYS; BOARD GAMES; BOBBLE-HEAD DOLLS; CHILDREN'S GAME CARDS; CARD GAMES; CASES FOR TOY STRUCTURES; CHILDREN'S MULTIPLE ACTIVITY TOYS; CHRISTMAS TREE ORNAMENTS AND DECORATIONS; CRIB TOYS; DOLLS AND ACCESSORIES THEREFOR; ELECTRONIC EDUCATIONAL GAME MACHINES FOR CHILDREN; ELECTRONIC GAMES OTHER THAN THOSE ADAPTED FOR USE WITH TELEVISION RECEIVERS ONLY; FLYING DISCS; GAME CARDS; HAND PUPPETS; HAND-HELD GAMES WITH LIQUID CRYSTAL DISPLAYS; INFANT TOYS; INFLATABLE TOYS; KITES; MECHANICAL TOYS; MOLDED TOY FIGURES; PAPER DOLLS; PLAY FIGURES; PLUSH DOLLS; PULL TOYS; PUPPETS; RIDE-ON TOYS; SQUEEZE TOYS; STACKING TOYS; STAND ALONE VIDEO GAME MACHINES; STUFFED DOLLS AND ANIMALS; TOY ANIMALS; TOY BALLOONS; TOY BOXES; TOY BUILDING BLOCKS; TOY FIGURES (U.S. CLS. 22, 23, 38 AND 50).

ODESSA BIBBINS, EXAMINING ATTORNEY

SN 85-423,638. SUKUP MANUFACTURING CO., SHEFFIELD, IA. FILED 9-15-2011.



THE MARK CONSISTS OF AN OVAL SHAPE WITH THE WORD "SUKUP" IN STYLIZED LETTERING APPEARING INSIDE THE OVAL.

CLASS 6—METAL GOODS

FOR PREFABRICATED METAL BUILDINGS, INCLUDING GRAIN BINS AND COMPONENT PARTS ASSOCIATED THEREWITH; NON-MECHANICAL METAL HOPPERS FOR MOVING GRAIN (U.S. CLS. 2, 12, 13, 14, 23, 25 AND 50).

FIRST USE 10-1-2001; IN COMMERCE 10-1-2001.

CLASS 7—MACHINERY

FOR AGRICULTURAL IMPLEMENTS, NAMELY, ELEVATORS, CONVEYORS AND MECHANICAL HOPPERS FOR MOVING GRAIN, AND PNEUMATIC GRAIN MOVING AND DRYING SYSTEMS AND COMPONENT PARTS ASSOCIATED THEREWITH (U.S. CLS. 13, 19, 21, 23, 31, 34 AND 35).

FIRST USE 7-1-2000; IN COMMERCE 7-1-2000.

CLASS 11—ENVIRONMENTAL CONTROL APPARATUS

FOR GRAIN DRYERS AND TOWER DRYERS FOR GRAIN (U.S. CLS. 13, 21, 23, 31 AND 34).

FIRST USE 9-1-1998; IN COMMERCE 9-1-1998.

LEIGH LOWRY, EXAMINING ATTORNEY

SN 85-423,681. SUKUP MANUFACTURING CO., SHEFFIELD, IA. FILED 9-15-2011.

SUKUP

THE MARK CONSISTS OF STANDARD CHARACTERS WITHOUT CLAIM TO ANY PARTICULAR FONT, STYLE, SIZE, OR COLOR.

CLASS 6—METAL GOODS

FOR PREFABRICATED METAL BUILDINGS, INCLUDING GRAIN BINS AND COMPONENT PARTS ASSOCIATED THEREWITH; NON-MECHANICAL METAL HOPPERS FOR MOVING GRAIN (U.S. CLS. 2, 12, 13, 14, 23, 25 AND 50).

FIRST USE 10-1-2001; IN COMMERCE 10-1-2001.

CLASS 7—MACHINERY

FOR AGRICULTURAL IMPLEMENTS, NAMELY, ELEVATORS, CONVEYORS AND MECHANICAL HOPPERS FOR MOVING GRAIN, AND PNEUMATIC GRAIN MOVING AND DRYING SYSTEMS AND COMPONENT PARTS ASSOCIATED THEREWITH (U.S. CLS. 13, 19, 21, 23, 31, 34 AND 35).

FIRST USE 7-1-2000; IN COMMERCE 7-1-2000.

CLASS 11—ENVIRONMENTAL CONTROL APPARATUS

FOR GRAIN DRYERS AND TOWER DRYERS FOR GRAIN (U.S. CLS. 13, 21, 23, 31 AND 34).
FIRST USE 9-1-1998; IN COMMERCE 9-1-1998.
LEIGH LOWRY, EXAMINING ATTORNEY

SN 85-426,476. NEW BELGIUM BREWING COMPANY, INC., FORT COLLINS, CO. FILED 9-19-2011.

SN 85-423,908. CIVILIGHT SHENZHEN SEMICONDUCTOR LIGHTING CO., LTD., SHENZHEN, GUANGDONG, CHINA, FILED 9-15-2011.

SUN WHITE

THE MARK CONSISTS OF STANDARD CHARACTERS WITHOUT CLAIM TO ANY PARTICULAR FONT, STYLE, SIZE, OR COLOR.

CLASS 9—ELECTRICAL AND SCIENTIFIC APPARATUS

FOR SIGNAL LANTERNS, NEON SIGNS, FLASHLIGHTS FOR PHOTOGRAPHY, ELECTRIC LIGHT DIMMERS AND REGULATORS, STAGE LIGHTING REGULATORS, BATTERIES FOR LIGHTING, SOLAR BATTERIES, OPTICAL INSPECTION APPARATUS FOR INSPECTION OF SEMICONDUCTOR MATERIALS, NAMELY, SEMICONDUCTOR WAFERS, RETICLES, AND PHOTOMASKS, AND SEMICONDUCTOR APPARATUS (U.S. CLS. 21, 23, 26, 36 AND 38).

CLASS 11—ENVIRONMENTAL CONTROL APPARATUS

FOR LAMP CASINGS (U.S. CLS. 13, 21, 23, 31 AND 34).
EMILY CARLSEN, EXAMINING ATTORNEY

SN 85-425,183. ARAMCO IMPORTS, INC., COMMERCE, CA. FILED 9-16-2011.



THE MARK CONSISTS OF THE WORDING "SOL Y LUNA" DISPLAYED OVER A DEPICTION OF A HALF SUN WITH RAYS.

THE ENGLISH TRANSLATION OF "SOL Y LUNA" IN THE MARK IS "SUN AND MOON".

CLASS 21—HOUSEWARES AND GLASS

FOR POTS, PANS, HOUSEHOLD UTENSILS, NAMELY, ROLLING PINS, SPATULAS, TURNERS; KITCHEN LADLES (U.S. CLS. 2, 13, 23, 29, 30, 33, 40 AND 50).
FIRST USE 12-0-2010; IN COMMERCE 12-0-2010.

CLASS 29—MEATS AND PROCESSED FOODS

FOR CANNED VEGETABLES (U.S. CL. 46).
FIRST USE 10-1-2009; IN COMMERCE 10-1-2009.
EVELYN BRADLEY, EXAMINING ATTORNEY

DIG

THE MARK CONSISTS OF STANDARD CHARACTERS WITHOUT CLAIM TO ANY PARTICULAR FONT, STYLE, SIZE, OR COLOR.

CLASS 16—PAPER GOODS AND PRINTED MATTER

FOR PAPER PRODUCTS, NAMELY, POSTERS, COASTERS, POSTCARDS, STICKERS AND DECALS (U.S. CLS. 2, 5, 22, 23, 29, 37, 38 AND 50).

CLASS 32—LIGHT BEVERAGES

FOR BEER (U.S. CLS. 45, 46 AND 48).
JORDAN BAKER, EXAMINING ATTORNEY

SN 85-426,488. WOODSHILL RECORDS, INC., LOS ANGELES, CA. FILED 9-19-2011.



NO CLAIM IS MADE TO THE EXCLUSIVE RIGHT TO USE "RECORDS", APART FROM THE MARK AS SHOWN.

THE MARK CONSISTS OF THE STYLIZED WORD "WOODSHILL" THAT APPEARS ABOVE THE WORD "RECORDS". THE LETTERS "HILL" IN THE WORD "WOODSHILL" APPEAR WITHIN A SHADED RECTANGLE WITH A SHADED BAR BENEATH.

CLASS 9—ELECTRICAL AND SCIENTIFIC APPARATUS

FOR PRE-RECORDED AUDIO TAPES, DISCS AND CASSETTES, VIDEO TAPES, DISCS AND CASSETTES, DIGITAL AUDIO AND AUDIO VIDEO TAPES AND DISCS, CDS, DVDS, LASER DISCS, AND PHONOGRAPH RECORDS FEATURING MUSIC AND ENTERTAINMENT; MUSICAL SOUND RECORDINGS AND VIDEO RECORDINGS FEATURING MUSIC; DOWNLOADABLE RING TONES, MUSIC, MP3 RECORDINGS FEATURING MUSIC; GRAPHICS, ELECTRONIC GAMES, IMAGES IN THE FIELD OF MUSIC; AND VIDEO RECORDINGS FEATURING MUSIC FOR WIRELESS COMMUNICATION DEVICES (U.S. CLS. 21, 23, 26, 36 AND 38).

CLASS 41—EDUCATION AND ENTERTAINMENT

FOR AUDIO AND SOUND RECORDING AND PRODUCTION; PRODUCTION AND PUBLISHING OF MUSIC; PROVIDING ONLINE ENTERTAINMENT, NAMELY, PROVIDING NON-DOWNLOADABLE SOUND AND VIDEO RECORDINGS IN THE FIELD OF MUSIC AND MUSIC BASED ENTERTAINMENT; ENTERTAINMENT SERVICES, NAMELY, PROVIDING ONLINE NON-DOWNLOADABLE PRERECORDED MUSICAL SOUND AND VIDEO RECORDINGS VIA A GLOBAL COMPUTER NETWORK; RECORD PRODUCTION; VIDEOTAPE PRODUCTION; ENTERTAINMENT IN THE NATURE OF LIVE CONCERTS AND PERFORMANCES BY MUSICAL ARTISTS AND GROUPS; ENTERTAINMENT SERVICES, NAMELY, PERSONAL APPEARANCES BY MUSICAL GROUPS, MUSICAL ARTISTS AND CELEBRITIES; ENTERTAINMENT SERVICES IN THE NATURE OF LIVE PERFORMANCES RENDERED BY MUSICAL ARTISTS THROUGH THE MEDIUM OF RADIO, AND AUDIO AND VIDEO RECORDINGS; ENTERTAINMENT SERVICES, NAMELY, PERFORMANCES BY MUSICAL ARTISTS RENDERED LIVE AND RECORDED FOR FUTURE DISTRIBUTION (U.S. CLS. 100, 101 AND 107).

STEVEN JACKSON, EXAMINING ATTORNEY

SN 85-427,190. PETERSON, ERIC, OAKLAND, CA. FILED 9-20-2011.



THE MARK CONSISTS OF THE WORD "DRAGONLORD" IN STYLIZED LETTERING.

CLASS 9—ELECTRICAL AND SCIENTIFIC APPARATUS

FOR AUDIO AND VIDEO RECORDINGS FEATURING MUSIC AND ARTISTIC PERFORMANCES (U.S. CLS. 21, 23, 26, 36 AND 38).

FIRST USE 8-1-2000; IN COMMERCE 8-1-2000.

CLASS 25—CLOTHING

FOR HATS; HOODED SWEATSHIRTS; T-SHIRTS (U.S. CLS. 22 AND 39).

FIRST USE 8-1-2000; IN COMMERCE 8-1-2000.

JOHN E. MICHOS, EXAMINING ATTORNEY

SN 85-428,918. SUPERIOR FURNITURE SOLUTIONS, INC., DBA MONTAGE FURNITURE SERVICES, ROSEVILLE, MN. FILED 9-22-2011.



THE COLOR(S) BLACK AND GREEN IS/ARE CLAIMED AS A FEATURE OF THE MARK.

THE MARK CONSISTS OF THE WORD "PUREPROTECTION" IN BLACK SPELLED WITH "PURE" IN AN UPPER-CASE SANS SERIF FONT AND "PROTECTION" IN A LOWERCASE SERIFED FONT AND WITHOUT A SPACE BETWEEN THE WORDS. ADDITIONALLY, THERE IS A GREEN LEAF GRAPHIC STARTING BETWEEN THE "P" AND "U" IN "PURE" AND EXTENDING ABOVE THE TEXT.

CLASS 16—PAPER GOODS AND PRINTED MATTER

FOR CARDBOARD PACKAGING; PRINTED VISUALS IN THE NATURE OF PROMOTIONAL MATERIALS (U.S. CLS. 2, 5, 22, 23, 29, 37, 38 AND 50).

FIRST USE 8-1-2010; IN COMMERCE 8-1-2010.

CLASS 35—ADVERTISING AND BUSINESS

FOR PROVIDING CONSUMER PRODUCT INFORMATION VIA THE INTERNET (U.S. CLS. 100, 101 AND 102).

FIRST USE 8-1-2010; IN COMMERCE 8-1-2010.

NAKWAMA ANKRAH, EXAMINING ATTORNEY

SN 85-428,926. TAREK, ANDRE, JUPITER, FL. FILED 9-22-2011.

ANDRÉ JOURDAN

THE MARK CONSISTS OF STANDARD CHARACTERS WITHOUT CLAIM TO ANY PARTICULAR FONT, STYLE, SIZE, OR COLOR.

THE NAME(S), PORTRAIT(S), AND/OR SIGNATURE(S) SHOWN IN THE MARK DOES NOT IDENTIFY A PARTICULAR LIVING INDIVIDUAL.

CLASS 3—COSMETICS AND CLEANING PREPARATIONS

FOR HAIR CARE AND STYLING PRODUCTS, NAMELY, SHAMPOOS, CONDITIONERS, SHINE SERUM, CURL DEFINERS, HAIR GELS, HAIR WAX, HAIR-SPRAYS, MOUSSE, AND HAIR OILS; MANICURE AND PEDICURE PRODUCTS, NAMELY, NAIL HARDENERS, NAIL POLISH, BASE COATS, TOP COATS, NAIL OIL, MASSAGE OILS, CUTICLE OILS, CUTICLE REMOVERS, AND NAIL POLISH REMOVERS; SKIN CARE AND MAKEUP PRODUCTS, NAMELY, CLEANSERS, TONERS, MOISTURIZERS, CREAMS, MASKS, SCRUBS, SUNSCREEN CREAM, LIP GLOSS, LIP LINERS, EYE SHADOWS, EYE LINERS, EYE PENCILS AND MAS-CARAS (U.S. CLS. 1, 4, 6, 50, 51 AND 52).

CLASS 44—MEDICAL, BEAUTY AND AGRICULTURAL SERVICES

FOR HAIR SALON AND SPA SERVICES (U.S. CLS. 100 AND 101).

FIRST USE 6-28-1994; IN COMMERCE 6-28-1994.

NAKWAMA ANKRAH, EXAMINING ATTORNEY

SN 85-429,496. BAYLOR HEALTH CARE SYSTEM, DALLAS, TX. FILED 9-22-2011.

IT'S A GUY THING

THE MARK CONSISTS OF STANDARD CHARACTERS WITHOUT CLAIM TO ANY PARTICULAR FONT, STYLE, SIZE, OR COLOR.

CLASS 41—EDUCATION AND ENTERTAINMENT

FOR EDUCATIONAL SERVICES, NAMELY, PROVIDING LECTURES, PRESENTATIONS AND SEMINARS ABOUT MEN'S HEALTH, ALL PROVIDED AT A HEALTH DAY EVENT (U.S. CLS. 100, 101 AND 107).

FIRST USE 3-0-2007; IN COMMERCE 3-0-2007.

CLASS 44—MEDICAL, BEAUTY AND AGRICULTURAL SERVICES

FOR MEN'S HEALTH SCREENING SERVICES IN THE FIELDS OF CHOLESTEROL, BLOOD PRESSURE, GLUCOSE, SLEEP APNEA, LUNG FUNCTION, BODY MASS INDEX, GENERAL WELLNESS, DIABETES, VISION AND HEARING AND PROVIDING MEN'S HEALTH INFORMATION, ALL PROVIDED AT A HEALTH DAY EVENT (U.S. CLS. 100 AND 101).

FIRST USE 3-0-2007; IN COMMERCE 3-0-2007.

REBECCA GILBERT, EXAMINING ATTORNEY

SN 85-430,196. A LA MODE, INC., OKLAHOMA CITY, OK. FILED 9-23-2011.

workflowGEEKS

THE MARK CONSISTS OF STANDARD CHARACTERS WITHOUT CLAIM TO ANY PARTICULAR FONT, STYLE, SIZE, OR COLOR.

CLASS 36—INSURANCE AND FINANCIAL

FOR PROVIDING ONLINE INFORMATION IN THE FIELD OF REAL ESTATE (U.S. CLS. 100, 101 AND 102).

FIRST USE 4-8-2011; IN COMMERCE 4-8-2011.

CLASS 41—EDUCATION AND ENTERTAINMENT

FOR ONLINE JOURNALS, NAMELY, BLOGS FEATURING STORIES, ARTICLES, AND INFORMATION ABOUT THE REAL ESTATE INDUSTRY (U.S. CLS. 100, 101 AND 107).

FIRST USE 4-8-2011; IN COMMERCE 4-8-2011.

JACLYN KIDWELL WALKER, EXAMINING ATTORNEY

SN 85-430,200. EPICOR SOFTWARE CORPORATION, LIVERMORE, CA. FILED 9-23-2011.

BUSINESS INSPIRED

THE MARK CONSISTS OF STANDARD CHARACTERS WITHOUT CLAIM TO ANY PARTICULAR FONT, STYLE, SIZE, OR COLOR.

NO CLAIM IS MADE TO THE EXCLUSIVE RIGHT TO USE "BUSINESS", APART FROM THE MARK AS SHOWN.

CLASS 9—ELECTRICAL AND SCIENTIFIC APPARATUS

FOR COMPUTER SOFTWARE FOR USE IN SUPPLY CHAIN MANAGEMENT, PRODUCTION MANAGEMENT, LOGISTICS, PROJECT MANAGEMENT, PRODUCT DATA MANAGEMENT, SERVICE MANAGEMENT, SALES MANAGEMENT, CUSTOMER RELATIONSHIP MANAGEMENT, E-COMMERCE, IT SERVICE MANAGEMENT, INVENTORY CONTROL, PREPARING WORK ORDERS AND ORDER PROCESSING, ESTIMATING PURCHASING NEEDS, RESTOCKING, SALES TRACKING, AND WAREHOUSE MANAGEMENT IN THE FIELDS OF RETAIL, MANUFACTURING, DISTRIBUTION, NON-PROFIT ORGANIZATIONS, FINANCIAL ORGANIZATIONS, AGED CARE AND SENIOR LIVING ORGANIZATIONS, HOSPITALITY, GOVERNMENT, EDUCATION, COMMUNICATIONS, TITLE AND ESCROW, BANKING, CREDIT UNIONS, RESEARCH AND DEVELOPMENT, MARKETING, ADVERTISING, MANAGEMENT CONSULTING, ARCHITECTURE, ENGINEERING, CONSTRUCTION AND PROFESSIONAL SERVICES; ELECTRONIC PUBLICATIONS, NAMELY, MANUALS FEATURING INSTRUCTION FOR COMPUTER SOFTWARE FOR USE IN SUPPLY CHAIN MANAGEMENT, PRODUCTION MANAGEMENT, LOGISTICS, PROJECT MANAGEMENT, PRODUCT DATA MANAGEMENT, SERVICE MANAGEMENT, SALES MANAGEMENT, CUSTOMER RELATIONSHIP MANAGEMENT, E-COMMERCE, IT SERVICE MANAGEMENT, INVENTORY CONTROL, PREPARING WORK ORDERS AND ORDER PROCESSING, ESTIMATING PURCHASING NEEDS, RESTOCKING, SALES TRACKING, AND WAREHOUSE MANAGEMENT RECORDED ON COMPUTER MEDIA (U.S. CLS. 21, 23, 26, 36 AND 38).

CLASS 42—SCIENTIFIC AND COMPUTER SERVICES

FOR COMPUTER SERVICES FOR OTHERS IN THE FIELD OF DESIGN, SELECTION, IMPLEMENTATION AND USE OF COMPUTER HARDWARE, COMPUTER SOFTWARE AND NETWORKING SYSTEMS; COMPUTER CONSULTATION SERVICES; COMPUTER PROGRAMMING FOR OTHERS; COMPUTER SOFTWARE UPDATING AND INSTALLATION FOR OTHERS; REPAIR OF COMPUTER SOFTWARE; TECHNICAL SUPPORT SERVICES, NAMELY, TROUBLESHOOTING IN THE NATURE OF DIAGNOSING COMPUTER HARDWARE AND SOFTWARE PROBLEMS; COMPUTER SOFTWARE DESIGN AND DEVELOPMENT FOR OTHERS AND CONSULTATION IN THE MAINTENANCE AND MANAGEMENT THEREOF; UPDATING COMPUTER DATABASES; PROVIDING A WEBSITE FEATURING NON-DOWNLOADABLE SOFTWARE FOR USE IN SUPPLY CHAIN MANAGEMENT, PRODUCTION MANAGEMENT, LOGISTICS, PROJECT MANAGEMENT, PRODUCT DATA MANAGEMENT, SERVICE MANAGEMENT, SALES MANAGEMENT, CUSTOMER RELATIONSHIP MANAGEMENT, E-COMMERCE, IT SERVICE MANAGEMENT, ACCOUNTING, BUSINESS ANALYSIS, LABOR COSTS, FINANCIAL MANAGEMENT, HUMAN RESOURCES MANAGEMENT, EMPLOYEE DATA, INVENTORY CONTROL, PREPARING WORK ORDERS AND ORDER PROCESSING, ESTIMATING PURCHASING NEEDS, RESTOCKING, SALES TRACKING, AND WAREHOUSE MANAGEMENT IN THE FIELDS OF RETAIL, MANUFACTURING, DISTRIBUTION, NON-PROFIT ORGANIZATIONS, FINANCIAL ORGANIZATIONS, AGED CARE AND SENIOR LIVING ORGANIZATIONS, AUTOMOTIVE, LUMBER, HOSPITALITY, GOVERNMENT, EDUCATION, COMMUNICATIONS, TITLE AND ESCROW, BANKING, CREDIT UNIONS, RESEARCH AND DEVELOPMENT, MARKETING, ADVERTISING, MANAGEMENT CONSULTING, ARCHITECTURE, ENGINEERING, CONSTRUCTION AND PROFESSIONAL SERVICES; SOFTWARE AS A SERVICE FOR USE IN SUPPLY CHAIN MANAGEMENT, PRODUCTION MANAGEMENT, LOGISTICS, PROJECT MANAGEMENT, PRODUCT DATA MANAGEMENT, SERVICE MANAGEMENT, SALES MANAGEMENT, CUSTOMER RELATIONSHIP MANAGEMENT, E-COMMERCE, IT SERVICE MANAGEMENT, ACCOUNTING, BUSINESS ANALYSIS, LABOR COSTS, FINANCIAL MANAGEMENT, HUMAN RESOURCES MANAGEMENT, EMPLOYEE DATA, INVENTORY CONTROL,

PREPARING WORK ORDERS AND ORDER PROCESSING, ESTIMATING PURCHASING NEEDS, RESTOCKING, SALES TRACKING, AND WAREHOUSE MANAGEMENT IN THE FIELDS OF RETAIL, MANUFACTURING, DISTRIBUTION, NON-PROFIT ORGANIZATIONS, FINANCIAL ORGANIZATIONS, AGED CARE AND SENIOR LIVING ORGANIZATIONS, AUTOMOTIVE, LUMBER, HOSPITALITY, GOVERNMENT, EDUCATION, COMMUNICATIONS, TITLE AND ESCROW, BANKING, CREDIT UNIONS, RESEARCH AND DEVELOPMENT, MARKETING, ADVERTISING, MANAGEMENT CONSULTING, ARCHITECTURE, ENGINEERING, CONSTRUCTION AND PROFESSIONAL SERVICES (U.S. CLS. 100 AND 101).
ANNE MADDEN, EXAMINING ATTORNEY

SN 85-430,404. AMERIGROUP CORPORATION, VIRGINIA BEACH, VA. FILED 9-23-2011.

REAL STORIES

THE MARK CONSISTS OF STANDARD CHARACTERS WITHOUT CLAIM TO ANY PARTICULAR FONT, STYLE, SIZE, OR COLOR.
OWNER OF U.S. REG. NO. 3,750,487.

CLASS 36—INSURANCE AND FINANCIAL

FOR ADMINISTRATION OF PRE-PAID HEALTH CARE PLANS (U.S. CLS. 100, 101 AND 102).
FIRST USE 5-23-2008; IN COMMERCE 5-23-2008.

CLASS 44—MEDICAL, BEAUTY AND AGRICULTURAL SERVICES

FOR HEALTH CARE IN THE NATURE OF HEALTH MAINTENANCE ORGANIZATIONS (U.S. CLS. 100 AND 101).
FIRST USE 5-23-2008; IN COMMERCE 5-23-2008.
SANDRA BUJA, EXAMINING ATTORNEY

SN 85-431,047. INVASOFT, LLC, TEMPE, AZ. FILED 9-23-2011.

INVASOFT

THE MARK CONSISTS OF STANDARD CHARACTERS WITHOUT CLAIM TO ANY PARTICULAR FONT, STYLE, SIZE, OR COLOR.

CLASS 35—ADVERTISING AND BUSINESS

FOR PROVIDING A WEBSITE USED TO PLACE ONLINE COMMERCIAL ORDERS IN THE FIELD OF MEDICAL EQUIPMENT; ASSET MANAGEMENT SERVICES, NAMELY, REPORTING ON SERVICE HISTORIES, UTILIZATION OF THE MEDICAL ASSETS, END OF PRODUCT LIFE INFORMATION AND REPLACEMENT COSTS ALL RELATED TO MEDICAL DIAGNOSTIC, CLINICAL AND BIOMEDICAL EQUIPMENT (U.S. CLS. 100, 101 AND 102).

CLASS 42—SCIENTIFIC AND COMPUTER SERVICES

FOR SOFTWARE DEVELOPMENT FOR OTHERS IN THE MEDICAL INDUSTRY (U.S. CLS. 100 AND 101).
SALLY SHIH, EXAMINING ATTORNEY

SN 85-432,807. LAMP POST GROUP LLC, CHATTANOOGA, TN. FILED 9-27-2011.

LAMP POST GROUP

THE MARK CONSISTS OF STANDARD CHARACTERS WITHOUT CLAIM TO ANY PARTICULAR FONT, STYLE, SIZE, OR COLOR.

NO CLAIM IS MADE TO THE EXCLUSIVE RIGHT TO USE "GROUP", APART FROM THE MARK AS SHOWN.

CLASS 35—ADVERTISING AND BUSINESS

FOR BUSINESS ADMINISTRATION SERVICES; BUSINESS CONSULTING SERVICES; BUSINESS INCUBATOR SERVICES, NAMELY, BUSINESS MARKETING, BUSINESS MANAGEMENT, AND BUSINESS DEVELOPMENT SERVICES IN THE FORM OF START-UP SUPPORT FOR BUSINESSES OF OTHERS; RENTAL AND LEASING OF OFFICE MACHINERY AND EQUIPMENT (U.S. CLS. 100, 101 AND 102).

FIRST USE 12-1-2010; IN COMMERCE 12-1-2010.

CLASS 36—INSURANCE AND FINANCIAL

FOR FINANCIAL SERVICES, NAMELY, FINANCIAL CONSULTATION, FINANCIAL ANALYSIS, FINANCIAL PLANNING, FINANCIAL MANAGEMENT; VENTURE CAPITAL SERVICES, NAMELY, PROVIDING DEBT AND EQUITY CAPITAL, AND TANGIBLE AND INTANGIBLE ASSET FINANCING; BUSINESS INCUBATOR SERVICES, NAMELY, PROVIDING EQUITY AND DEBT FINANCING TO EMERGING AND START-UP COMPANIES (U.S. CLS. 100, 101 AND 102).

FIRST USE 12-1-2010; IN COMMERCE 12-1-2010.
STEVEN R. FINE, EXAMINING ATTORNEY

SN 85-434,214. DAYCO PRODUCTS, LLC, TULSA, OK. FILED 9-28-2011.



OWNER OF U.S. REG. NO. 3,978,239.
THE MARK CONSISTS OF THREE HASH MARKS.

CLASS 7—MACHINERY

FOR BELTS FOR MOTORS AND ENGINES USED IN INDUSTRIAL MACHINES AND/OR APPLICATIONS, NAMELY, POWER TRANSMISSION BELTS AND DRIVE BELTS (U.S. CLS. 13, 19, 21, 23, 31, 34 AND 35).
FIRST USE 2-11-2008; IN COMMERCE 2-11-2008.

CLASS 12—VEHICLES

FOR BELTS FOR LAND VEHICLES, NAMELY, POWER TRANSMISSION BELTS AND DRIVE BELTS (U.S. CLS. 19, 21, 23, 31, 35 AND 44).
FIRST USE 2-11-2008; IN COMMERCE 2-11-2008.
BRIDGETT SMITH, EXAMINING ATTORNEY

CLASS 41—EDUCATION AND ENTERTAINMENT

FOR ON-LINE JOURNALS, NAMELY, BLOGS FEATURING GAMES AND GAMING RELATED INFORMATION.; PROVIDING A WEBSITE FEATURING BLOGS AND NON-DOWNLOADABLE PUBLICATIONS IN THE NATURE OF GAMES AND GAMING RELATED INFORMATION IN THE FIELD(S) OF HOBBY GAMING (U.S. CLS. 100, 101 AND 107).
FIRST USE 10-1-2000; IN COMMERCE 5-1-2001.
LINDA MICKLEBURGH, EXAMINING ATTORNEY

SN 85-434,293. GREEN HAT PEOPLE AB, STOCKHOLM, SWEDEN, FILED 9-28-2011.



THE COLOR(S) BLACK, RED, AND GREY IS/ARE CLAIMED AS A FEATURE OF THE MARK.
THE MARK CONSISTS OF THE WORDING "NEXT CANVAS" IN BLACK WITH A RED AND GRAY SQUARE SITUATED BEFORE THE WORD "NEXT".

CLASS 42—SCIENTIFIC AND COMPUTER SERVICES

FOR DESIGN AND DEVELOPMENT OF COMPUTER HARDWARE AND COMPUTER SOFTWARE, COMPUTER GAMES AND ON-LINE GAMES AND VISUAL DISPLAYS (U.S. CLS. 100 AND 101).

CLASS 45—PERSONAL AND LEGAL SERVICES

FOR LICENSING OF GAME CONCEPTS, NAMELY, LICENSING OF SOFTWARE, AND KNOW-HOW IN RELATION THERETO (U.S. CLS. 100 AND 101).
LINDA M. KING, EXAMINING ATTORNEY

SN 85-437,436. AMERICAN NATIONAL INSURANCE COMPANY, GALVESTON, TX. FILED 10-3-2011.

HARVEST TO HAND

THE MARK CONSISTS OF STANDARD CHARACTERS WITHOUT CLAIM TO ANY PARTICULAR FONT, STYLE, SIZE, OR COLOR.

CLASS 9—ELECTRICAL AND SCIENTIFIC APPARATUS

FOR COMPUTER APPLICATION SOFTWARE FOR MOBILE PHONES, SMART PHONES, AND HANDHELD COMPUTERS, NAMELY, SOFTWARE FOR PROVIDING AND OBTAINING INFORMATION IN THE FIELD OF AGRICULTURE AND AGRITOURISM, INCLUDING INFORMATION ABOUT PROPRIETORS, FARMS, MARKETS, FARMERS MARKETS, PRODUCTS, FOODS, BEVERAGES, SERVICES AND EVENTS, ALL ORGANIZED BY GEOGRAPHICAL AREA (U.S. CLS. 21, 23, 26, 36 AND 38).
FIRST USE 9-1-2011; IN COMMERCE 9-1-2011.

SN 85-435,947. ZACCARDI, STEVEN, ALFONSE, DBA BATTLEPLAY, CORAL SPRINGS, FL. FILED 9-29-2011.



OWNER OF U.S. REG. NO. 2,626,562.
THE COLOR(S) RED, WHITE, AND BLACK IS/ARE CLAIMED AS A FEATURE OF THE MARK.
THE MARK CONSISTS OF THE WORD "BATTLEPLAY" IN RED LETTERS WITH OUTLINING IN BLACK, THEN WHITE, THEN BLACK AGAIN FROM THE INSIDE OF THE LETTERS OUTWARD; THE LETTER "Y" HAS A TAIL WHICH FORMS AN ARROW AND WHICH REACHES UNDER THE WORD ALL THE WAY TO THE LETTER "B".

CLASS 35—ADVERTISING AND BUSINESS

FOR PROVIDING CONSUMER INFORMATION IN THE FIELD OF AGRICULTURE, NAMELY, INFORMATION ABOUT MARKETS AND FARMERS MARKETS AND CONSUMER INFORMATION ABOUT FOODS AND BEVERAGES, ORGANIZED BY GEOGRAPHICAL AREA (U.S. CLS. 100, 101 AND 102).
FIRST USE 6-27-2011; IN COMMERCE 6-27-2011.
WILLIAM JACKSON, EXAMINING ATTORNEY

SN 85-437,603. THE CHILDREN'S HOME SOCIETY OF FLORIDA, WINTER PARK, FL. FILED 10-3-2011.

**EMBRACING CHILDREN.
INSPIRING LIVES.**

THE MARK CONSISTS OF STANDARD CHARACTERS WITHOUT CLAIM TO ANY PARTICULAR FONT, STYLE, SIZE, OR COLOR.

CLASS 28—TOYS AND SPORTING GOODS

FOR (BASED ON USE IN COMMERCE) BOARD GAMES(BASED ON INTENT TO USE) CARD GAMES; DICE GAMES; PUZZLE GAMES; ROLE PLAYING GAMES; TABLETOP GAMES; TRADING CARD GAMES (U.S. CLS. 22, 23, 38 AND 50).
FIRST USE 10-1-2000; IN COMMERCE 5-1-2001.

CLASS 41—EDUCATION AND ENTERTAINMENT

FOR COUNSELING IN THE FIELD OF EARLY CHILDHOOD EDUCATION (U.S. CLS. 100, 101 AND 107).
FIRST USE 0-0-2003; IN COMMERCE 0-0-2003.

CLASS 44—MEDICAL, BEAUTY AND AGRICULTURAL SERVICES

FOR COUNSELING IN THE FIELD OF DRUG REHABILITATION; COUNSELING IN THE FIELD OF PARENTING AND FOSTER PARENTING CONCERNING THE HEALTH OF CHILDREN; COUNSELING IN THE FIELDS OF CHILD HEALTH AND PHYSICAL DEVELOPMENT, STRESS REDUCTION, ANGER MANAGEMENT AND TREATING DEPRESSION; PSYCHOTHERAPY COUNSELING IN THE FIELD OF CHILD DISCIPLINE (U.S. CLS. 100 AND 101).

FIRST USE 0-0-2003; IN COMMERCE 0-0-2003.

CLASS 45—PERSONAL AND LEGAL SERVICES

FOR PROVIDING ADOPTION PLACEMENT, FOSTER CARE HOMES; COUNSELING IN THE FIELD OF DEVELOPING, STRENGTHENING AND SUSTAINING WELL-BALANCED FAMILIES AND FAMILY RELATIONSHIPS; PROVIDING EMOTIONAL COUNSELING AND EMOTIONAL SUPPORT SERVICES FOR PREGNANT TEENAGERS AND THEIR FAMILIES; COUNSELING IN THE FIELD OF PARENTING AND FOSTER PARENTING CONCERNING INTRAFAMILY RELATIONSHIPS; SPIRITUAL COUNSELING IN THE FIELD OF CHILD DISCIPLINE (U.S. CLS. 100 AND 101).

FIRST USE 0-0-2003; IN COMMERCE 0-0-2003.

DOUGLAS LEE, EXAMINING ATTORNEY

SN 85-439,615. THE K&M CENTER, INC., SANTA MONICA, CA. FILED 10-5-2011.

Targeted Learning Concepts

THE MARK CONSISTS OF STANDARD CHARACTERS WITHOUT CLAIM TO ANY PARTICULAR FONT, STYLE, SIZE, OR COLOR.

NO CLAIM IS MADE TO THE EXCLUSIVE RIGHT TO USE "LEARNING", APART FROM THE MARK AS SHOWN.

CLASS 9—ELECTRICAL AND SCIENTIFIC APPARATUS

FOR DOWNLOADABLE ELECTRONIC PUBLICATIONS, NAMELY, MAGAZINES, BOOKS AND JOURNALS FEATURING ACADEMIC REMEDIATION AND ENRICHMENT IN THE FIELDS OF MATH, SCIENCE, READING AND HISTORY; DOWNLOADABLE INSTRUCTIONAL MATERIALS, NAMELY, WORKBOOKS, FLASH CARDS, WORK SHEETS, CHECK LISTS, STORY BOOKS AND STORY ACTIVITY SHEETS FEATURING ACADEMIC REMEDIATION AND ENRICHMENT IN THE FIELDS OF MATH, SCIENCE, READING AND HISTORY (U.S. CLS. 21, 23, 26, 36 AND 38).

CLASS 16—PAPER GOODS AND PRINTED MATTER

FOR PRINTED PUBLICATIONS, NAMELY, MAGAZINES, BOOKS AND JOURNALS FEATURING ACADEMIC REMEDIATION AND ENRICHMENT IN THE FIELDS OF MATH, SCIENCE, READING AND HISTORY; PRINTED INSTRUCTIONAL MATERIALS COMPRISED OF CARDS AND WORKBOOKS FEATURING ACADEMIC REMEDIATION AND ENRICHMENT IN THE FIELDS OF MATH, SCIENCE, READING AND HISTORY; EDUCATIONAL KITS SOLD AS A UNIT FEATURING ACADEMIC REMEDIATION AND ENRICHMENT IN THE FIELDS OF MATH, SCIENCE, READING AND HISTORY CONSISTING PRIMARILY OF EDUCATIONAL BOOKS, FLASH CARDS AND WORKSHEETS, AND ALSO INCLUDING AN EDUCATIONAL DVD CONTAINING PRERECORDED EDUCATIONAL AND ACADEMIC PROGRAMS IN THE FIELDS OF MATH, SCIENCE, READING AND HISTORY (U.S. CLS. 2, 5, 22, 23, 29, 37, 38 AND 50).

FIRST USE 10-4-2011; IN COMMERCE 10-4-2011.

NATALIE POLZER, EXAMINING ATTORNEY

SN 85-439,819. PARROT, PARIS, FRANCE, FILED 10-5-2011.

ZIK

THE MARK CONSISTS OF STANDARD CHARACTERS WITHOUT CLAIM TO ANY PARTICULAR FONT, STYLE, SIZE, OR COLOR.

PRIORITY CLAIMED UNDER SEC. 44(D) ON FRANCE APPLICATION NO. 11/3851560, FILED 10-5-2011, REG. NO. 010316826, DATED 3-8-2012, EXPIRES 10-5-2021.

CLASS 9—ELECTRICAL AND SCIENTIFIC APPARATUS

FOR EARPHONES, HEADPHONES, AUDIO SPEAKERS, RADIOS, PERSONAL STEREO, STEREO RECEIVERS AND STEREO TUNERS; WIRELESS HEADSETS FOR USE WITH CELLULAR PHONES, PERSONAL STEREO, STEREO RECEIVERS AND COMPUTERS (U.S. CLS. 21, 23, 26, 36 AND 38).

CLASS 28—TOYS AND SPORTING GOODS

FOR AUDIO AND VISUAL HEADSETS FOR USE IN PLAYING VIDEO GAMES, GAMING HEADSETS ADAPTED FOR USE IN PLAYING VIDEO GAME (U.S. CLS. 22, 23, 38 AND 50).

DEIRDRE ROBERTSON, EXAMINING ATTORNEY

SN 85-439,898. THE NASDAQ OMX GROUP, INC., NEW YORK, NY. FILED 10-5-2011.

NOMX

THE MARK CONSISTS OF STANDARD CHARACTERS WITHOUT CLAIM TO ANY PARTICULAR FONT, STYLE, SIZE, OR COLOR.

OWNER OF U.S. REG. NOS. 3,648,625, 3,699,800 AND OTHERS.

CLASS 9—ELECTRICAL AND SCIENTIFIC APPARATUS

FOR SOFTWARE FOR TRADING, UPDATING, CLEARING AND SETTLEMENT OF SECURITIES, FOR OPERATION OF STOCK EXCHANGES OR OTHER FINANCIAL MARKETPLACES, FOR PROVIDING INFORMATION AND ANALYSIS RELATING TO THE SECURITIES MARKET AND SECURITIES (U.S. CLS. 21, 23, 26, 36 AND 38).

CLASS 35—ADVERTISING AND BUSINESS

FOR CALCULATION, RECORDATION, COMPILATION AND SYSTEMATIZATION OF STATISTICS AND INDEXES CONCERNING SECURITIES TRADING, FINANCIAL INTERESTS, PRICES, EXCHANGE RATES AND OTHER ECONOMIC DATA CONCERNING SECURITIES, AND PROVIDING SUCH INFORMATION VIA THE INTERNET (U.S. CLS. 100, 101 AND 102).

CLASS 36—INSURANCE AND FINANCIAL

FOR FINANCIAL SERVICES, NAMELY, CONDUCTING A SECURITIES EXCHANGE, PROVIDING CLEARING AND SETTLEMENT SERVICES FOR STOCKS, EQUITY INDICES, CONTRACTS ON STOCKS, BONDS, OPTIONS, EQUITIES, FUTURES, OTHER SECURITIES AND CURRENCIES; SECURITIES ADMINISTRATION, NAMELY, MANAGEMENT OF PORTFOLIOS COMPRISING SECURITIES; COLLECTING AND PROVIDING FINANCIAL INFORMATION IN THE NATURE OF SECURITIES MARKET DATA, QUOTATIONS, ORDERS, MARKET TRANSACTIONS, AND FINANCIAL INDEX VALUES; LISTING OF SECURITIES AND SECURITIES DERIVATIVES FOR QUOTATION AND TRADING; PROVIDING AND UPDATING AN INDEX OF SECURITIES VALUES AND CLASSIFICATION, ANALYSIS, AND REPORTING THEREOF; FINANCIAL GUARANTEE SERVICES TO GUARANTEE THE VENDOR'S LIABILITY; PROVIDING FINANCIAL AND SECURITIES INFORMATION; SECURITIES EXCHANGE PRICE QUOTATION SERVICES; PROVIDING AN ONLINE DATABASE FEATURING REAL TIME INVESTMENT INFORMATION (U.S. CLS. 100, 101 AND 102).

CLASS 38—COMMUNICATION

FOR PROVIDING ACCESS TO AN ONLINE DATABASE FEATURING REAL TIME INVESTMENT INFORMATION; ELECTRONIC TRANSMISSION OF FINANCIAL INSTRUMENTS MARKET INFORMATION, QUOTATIONS AND ORDERS; PROVIDING COMMUNICATIONS NETWORKS FOR COLLECTION, PROCESSING, DISTRIBUTION AND TRANSMISSION OF FINANCIAL INSTRUMENTS AND MARKET INFORMATION (U.S. CLS. 100, 101 AND 104).

CLASS 42—SCIENTIFIC AND COMPUTER SERVICES

FOR DESIGN, INSTALLATION, MAINTENANCE AND DEVELOPMENT OF SOFTWARE FOR TRADING, CLEARING AND SETTLEMENT AND HANDLING OF SECURITIES, FOR THE OPERATION OF FINANCIAL MARKET PLACES, AND FOR INFORMATION RELATING TO THE STOCK MARKET AND SECURITIES; SOFTWARE SURVEILLANCE SERVICES IN THE NATURE OF SOFTWARE MONITORING SERVICES WHICH TRACK SOFTWARE PERFORMANCE; COMPUTER SOFTWARE CONSULTANCY REGARDING THE TRADING, CLEARING AND SETTLEMENT AND HANDLING OF SECURITIES, THE OPERATION OF FINANCIAL MARKET PLACES AND INFORMATION RELATING TO THE SECURITIES MARKET AND SECURITIES; COMPUTER PROGRAMMING FOR OTHERS (U.S. CLS. 100 AND 101).

CURTIS FRENCH, EXAMINING ATTORNEY

SN 85-439,968. AECI LIMITED, SANDTON, GAUTENG, SOUTH AFRICA, FILED 10-5-2011.

NULANDIS

THE MARK CONSISTS OF STANDARD CHARACTERS WITHOUT CLAIM TO ANY PARTICULAR FONT, STYLE, SIZE, OR COLOR.

CLASS 1—CHEMICALS

FOR CHEMICALS FOR USE IN AGRICULTURE, HORTICULTURE AND FORESTRY EXCEPT FUNGICIDES, HERBICIDES, INSECTICIDES AND PARASITICIDES; CHEMICAL FERTILIZERS; PLANT GROWTH NUTRIENTS, PLANT GROWTH REGULATING PREPARATIONS; MANURES; ADJUVANTS FOR THE MANUFACTURE OF AND USE WITH FUNGICIDES, HERBICIDES AND PESTICIDES (U.S. CLS. 1, 5, 6, 10, 26 AND 46).

CLASS 5—PHARMACEUTICALS

FOR DISINFECTANTS FOR SANITARY PURPOSES; PREPARATIONS FOR KILLING WEEDS AND DESTROYING VERMIN; FUNGICIDES; HERBICIDES; PESTICIDES (U.S. CLS. 6, 18, 44, 46, 51 AND 52).

CAROLYN CATALDO, EXAMINING ATTORNEY

SN 85-440,254. AIDEN INDUSTRIES LLC, ENCINITAS, CA. FILED 10-5-2011.



NO CLAIM IS MADE TO THE EXCLUSIVE RIGHT TO USE "RADIATION RELIEF", APART FROM THE MARK AS SHOWN.

THE MARK CONSISTS OF A LEAF OVER THE "I" IN THE WORD "MIADERM" AND THE WORDING "RADIATION RELIEF" APPEARING BELOW SAID WORD.

CLASS 3—COSMETICS AND CLEANING PREPARATIONS

FOR NON-MEDICATED SKIN LOTIONS FOR PATIENTS UNDER GOING RADIATION THERAPY (U.S. CLS. 1, 4, 6, 50, 51 AND 52).

FIRST USE 4-1-2007; IN COMMERCE 4-1-2007.

CLASS 5—PHARMACEUTICALS

FOR MEDICATED SKIN LOTIONS FOR PATIENTS UNDER GOING RADIATION THERAPY (U.S. CLS. 6, 18, 44, 46, 51 AND 52).

FIRST USE 4-1-2007; IN COMMERCE 4-1-2007.

MARC LEIPZIG, EXAMINING ATTORNEY

SN 85-440,508. GÖTTLICH, HARALD, BISSENDORF, FED REP GERMANY, FILED 10-6-2011.



PRIORITY CLAIMED UNDER SEC. 44(D) ON ERP CMNTY TM OFC APPLICATION NO. 009893405, FILED 4-13-2011, REG. NO. 009893405, DATED 8-30-2011, EXPIRES 4-13-2021.

THE COLOR(S) YELLOW AND BLUE IS/ARE CLAIMED AS A FEATURE OF THE MARK.

THE MARK CONSISTS OF THE STYLIZED LETTER "U" IN YELLOW TO THE LEFT OF THE STYLIZED WORD "BOND" IN BLUE.

CLASS 1—CHEMICALS

FOR CHEMICALS USED IN INDUSTRY AND SCIENCE, IN PARTICULAR IN CONSTRUCTION; UNPROCESSED ARTIFICIAL RESINS; UNPROCESSED PLASTICS; ADHESIVES, IN PARTICULAR WITH AN EPOXY RESIN BASE, ALL FOR USE IN INDUSTRY; HARDENERS BEING CHEMICALS USED IN INDUSTRY, NAMELY, SELF-HARDENING ARTIFICIAL RESIN AND MORTAR COMPOUNDS, IN PARTICULAR FOR ANCHORING FASTENING ELEMENTS; NON-PROCESSED EPOXY RESINS (U.S. CLS. 1, 5, 6, 10, 26 AND 46).

CLASS 6—METAL GOODS

FOR METAL FASTENERS, IN PARTICULAR PEGS, BOLTS, ANCHORS, ANCHORING BOLTS, THREADED RODS, SCREW NUTS, HOOKS, PROFILES, AND TACKS BEING NAILS; PIPE CLIPS, SCREWS, RIVETS, CABLE CLAMPS, WASHERS BEING HARDWARE, INJECTION ANCHOR SLEEVES FOR AFFIXING SCREWS, ALL THE AFORESAID GOODS MADE OF METAL (U.S. CLS. 2, 12, 13, 14, 23, 25 AND 50).

CLASS 16—PAPER GOODS AND PRINTED MATTER

FOR ADHESIVES USED IN STATIONERY AND HOUSEHOLD PURPOSES (U.S. CLS. 2, 5, 22, 23, 29, 37, 38 AND 50).

BRENDAN MCCAULEY, EXAMINING ATTORNEY

SN 85-440,887. GREEN MOUNTAIN COFFEE ROASTERS, INC., WATERBURY, VT. FILED 10-6-2011.

BREWING A BETTER WORLD

THE MARK CONSISTS OF STANDARD CHARACTERS WITHOUT CLAIM TO ANY PARTICULAR FONT, STYLE, SIZE, OR COLOR.

CLASS 35—ADVERTISING AND BUSINESS

FOR CHARITABLE SERVICES, NAMELY, ORGANIZING, CONDUCTING AND SPONSORING COMMUNITY OUTREACH PROJECTS (U.S. CLS. 100, 101 AND 102).
FIRST USE 10-1-2007; IN COMMERCE 10-1-2007.

CLASS 36—INSURANCE AND FINANCIAL

FOR CHARITABLE FUNDRAISING SERVICES; PROVIDING GRANTS FOR CHARITABLE PURPOSES; ELEEMOSYNARY SERVICES IN THE FIELD OF MONETARY DONATIONS (U.S. CLS. 100, 101 AND 102).
FIRST USE 10-1-2007; IN COMMERCE 10-1-2007.
TOBY BULLOFF, EXAMINING ATTORNEY

SN 85-441,758. AMERICAN NATIONAL INSURANCE COMPANY, GALVESTON, TX. FILED 10-7-2011.



THE MARK CONSISTS OF A STYLIZED PLANT IN A MOUND OF SOIL, WITH FOUR LEAVES AND TWO CURLS AT THE TOP OF THE STEM, BEING HELD IN THE PALM OF A HAND.

CLASS 9—ELECTRICAL AND SCIENTIFIC APPARATUS

FOR COMPUTER APPLICATION SOFTWARE FOR MOBILE PHONES, SMART PHONES, AND HANDHELD COMPUTERS, NAMELY, SOFTWARE FOR PROVIDING AND OBTAINING INFORMATION IN THE FIELD OF AGRICULTURE AND AGRITOURISM, INCLUDING INFORMATION ABOUT PROPRIETORS, FARMS, MARKETS, FARMERS MARKETS, PRODUCTS, FOODS, BEVERAGES, SERVICES AND EVENTS, ALL ORGANIZED BY GEOGRAPHICAL AREA (U.S. CLS. 21, 23, 26, 36 AND 38).

FIRST USE 9-1-2011; IN COMMERCE 9-1-2011.

CLASS 35—ADVERTISING AND BUSINESS

FOR PROVIDING CONSUMER INFORMATION IN THE FIELD OF AGRICULTURE, NAMELY, INFORMATION ABOUT MARKETS AND FARMERS MARKETS AND CONSUMER INFORMATION ABOUT FOODS AND BEVERAGES, ORGANIZED BY GEOGRAPHICAL AREA (U.S. CLS. 100, 101 AND 102).

FIRST USE 6-27-2011; IN COMMERCE 6-27-2011.
WILLIAM JACKSON, EXAMINING ATTORNEY

SN 85-441,772. AXIOM EXPRESSIONS, LLC, MIDDLETOWN, PA. FILED 10-7-2011.

TELL TALE GIFT

THE MARK CONSISTS OF STANDARD CHARACTERS WITHOUT CLAIM TO ANY PARTICULAR FONT, STYLE, SIZE, OR COLOR.

NO CLAIM IS MADE TO THE EXCLUSIVE RIGHT TO USE "GIFT", APART FROM THE MARK AS SHOWN.

CLASS 35—ADVERTISING AND BUSINESS

FOR ONLINE RETAIL STORE SERVICES FEATURING GIFTS; ONLINE RETAIL SHOPS FEATURING GIFTS WHICH INCLUDE PERSONALIZED MESSAGES TO BE DELIVERED IN CONNECTION WITH THE GIFTS REGARDING PARTICULAR OCCASIONS, MEMORIES OR EXPERIENCES FOR THE GIFT RECIPIENT (U.S. CLS. 100, 101 AND 102).

CLASS 45—PERSONAL AND LEGAL SERVICES

FOR PREPARATION OF PERSONAL MESSAGES TO BE DELIVERED IN CONNECTION WITH GIFTS REGARDING PARTICULAR OCCASIONS, MEMORIES OR EXPERIENCES FOR THE GIFT RECIPIENT (U.S. CLS. 100 AND 101).

SUE LAWRENCE, EXAMINING ATTORNEY

SN 85-442,226. KEN SWINEHART, ALAMOSA, CO. FILED 10-7-2011.

I Speak Texan

THE MARK CONSISTS OF STANDARD CHARACTERS WITHOUT CLAIM TO ANY PARTICULAR FONT, STYLE, SIZE, OR COLOR.

CLASS 21—HOUSEWARES AND GLASS

FOR CUPS, AND MUGS (U.S. CLS. 2, 13, 23, 29, 30, 33, 40 AND 50).

CLASS 25—CLOTHING

FOR CLOTHING AND APPAREL, NAMELY, T-SHIRTS, SWEATSHIRTS, HATS, BIBS NOT OF PAPER (U.S. CLS. 22 AND 39).

DAVID COLLIER, EXAMINING ATTORNEY

SN 85-442,380. PENNINGTON SEED, INC. OF NEBRASKA, SIDNEY, NE. FILED 10-7-2011.



OWNER OF U.S. REG. NOS. 3,017,484, 3,338,028 AND OTHERS.

NO CLAIM IS MADE TO THE EXCLUSIVE RIGHT TO USE "AQUA GARDEN" AND "WATER GARDENING", APART FROM THE MARK AS SHOWN.

THE MARK CONSISTS OF THE WORDING "PENNINGTON AQUAGARDEN BEAUTIFULLY SIMPLE WATER GARDENING" AND DESIGN. THE TERM "PENNINGTON" APPEARS INSIDE OF A HORIZONTAL SHIELD DESIGN. BELOW IS THE WORDING "AQUAGARDEN". THE STEM OF THE LETTER "Q" IN "AQUAGARDEN" EXTENDS AND CURVES BELOW THE LETTER "G" IN "AQUAGARDEN". BELOW IS THE WORDING "BEAUTIFULLY SIMPLE WATER GARDENING".

CLASS 7—MACHINERY

FOR INDOOR AND/OR OUTDOOR WATER FOUNTAINS AND PONDS, NAMELY, PONDS AND WATER GARDEN AERATION SYSTEMS COMPRISING WATER-PUMPS, AIR COMPRESSORS, AIR BLOWERS AND A FINNED WHEEL FOR PRESSURIZING AND AERATING PONDS AND AQUARIUMS; WATER PUMP UNITS AND COMPONENTS FOR INDOOR AND/OR OUTDOOR WATER FOUNTAINS AND PONDS; WATER FOUNTAIN KITS FOR INDOOR AND/OR OUTDOOR WATER FOUNTAINS AND PONDS, COMPRISED OF WATER FILTERING UNITS, WATER PUMP UNITS, DE-ICING UNITS, AERATION UNITS, NAMELY, A WATER AERATION SYSTEM COMPRISING WATER PUMPS, AIR COMPRESSORS AND AIR BLOWERS; DECORATIVE FLOATATION UNITS, NAMELY, SUBMERSIBLE PUMPS (U.S. CLS. 13, 19, 21, 23, 31, 34 AND 35).

CLASS 9—ELECTRICAL AND SCIENTIFIC APPARATUS

FOR WATER FILTERING UNITS, NAMELY, WATER FILTER CONTROLLERS AND COMPONENTS FOR INDOOR AND/OR OUTDOOR WATER FOUNTAINS AND PONDS (U.S. CLS. 21, 23, 26, 36 AND 38).

CLASS 11—ENVIRONMENTAL CONTROL APPARATUS

FOR LIGHTING FIXTURES AND/OR FOUNTAIN NOZZLES (U.S. CLS. 13, 21, 23, 31 AND 34).

MARLENE BELL, EXAMINING ATTORNEY

SN 85-443,086. CHARGER EQUITIES LLC, SAN ANTONIO, TX. FILED 10-10-2011.

SOJO

THE MARK CONSISTS OF STANDARD CHARACTERS WITHOUT CLAIM TO ANY PARTICULAR FONT, STYLE, SIZE, OR COLOR.

CLASS 35—ADVERTISING AND BUSINESS

FOR RETAIL STORE SERVICES FEATURING A WIDE VARIETY OF CONSUMER GOODS OF OTHERS (U.S. CLS. 100, 101 AND 102).

CLASS 36—INSURANCE AND FINANCIAL

FOR APARTMENT AND OFFICE RENTALS; LEASING OF OFFICE SPACE; LEASING OF REAL ESTATE; LEASING OF SHOPPING MALL SPACE (U.S. CLS. 100, 101 AND 102).

ANNE MADDEN, EXAMINING ATTORNEY

SN 85-443,811. KP PRODUCTS, INC., DBA KIMBERLY PARRY ORGANICS, SAN JUAN CAPISTRANO, CA. FILED 10-10-2011.

SN 85-444,166. ECOLOGICAL LABORATORIES, INC., LYNBROOK, NY. FILED 10-11-2011.

KIMBERLY PARRY

THE MARK CONSISTS OF STANDARD CHARACTERS WITHOUT CLAIM TO ANY PARTICULAR FONT, STYLE, SIZE, OR COLOR.

OWNER OF U.S. REG. NOS. 3,839,999 AND 3,935,808.

THE NAME(S), PORTRAIT(S), AND/OR SIGNATURE(S) SHOWN IN THE MARK IDENTIFIES "KIMBERLY PARRY", WHOSE CONSENT(S) TO REGISTER IS MADE OF RECORD.

CLASS 41—EDUCATION AND ENTERTAINMENT

FOR EDUCATIONAL SERVICES, NAMELY, PROVIDING CLASSES, SEMINARS, WORKSHOPS, PRESENTATIONS AND RETREATS IN THE FIELD OF PROVIDING SPA AND MASSAGE SERVICES; PROVIDING CONTINUING EDUCATIONAL COURSES IN THE FIELD OF PROVIDING SPA AND MASSAGE SERVICES AND RELATED PRODUCTS (U.S. CLS. 100, 101 AND 107).

CLASS 44—MEDICAL, BEAUTY AND AGRICULTURAL SERVICES

FOR PROVIDING A WEBSITE FEATURING INFORMATION ABOUT SPA AND MASSAGE SERVICES AND RELATED PRODUCTS, AND INFORMATION ABOUT PROVIDING SPA AND MASSAGE SERVICES AND RELATED PRODUCTS (U.S. CLS. 100 AND 101).

RONALD MCMORROW, EXAMINING ATTORNEY

SN 85-444,032. SOLAR GROUP, INC., BUFFALO, NY. FILED 10-11-2011.

PARCEL PRO

THE MARK CONSISTS OF STANDARD CHARACTERS WITHOUT CLAIM TO ANY PARTICULAR FONT, STYLE, SIZE, OR COLOR.

NO CLAIM IS MADE TO THE EXCLUSIVE RIGHT TO USE "PARCEL", APART FROM THE MARK AS SHOWN.

CLASS 6—METAL GOODS

FOR METALLIC LOCKABLE CONTAINERS FOR THE RECEIPT OF DELIVERED PACKAGES, ENVELOPES, AND OTHER ARTICLES (U.S. CLS. 2, 12, 13, 14, 23, 25 AND 50).

CLASS 20—FURNITURE AND ARTICLES NOT OTHERWISE CLASSIFIED

FOR LOCKABLE CONTAINERS PRIMARILY OF PLASTIC FOR THE RECEIPT OF DELIVERED PACKAGES, ENVELOPES AND OTHER ARTICLES (U.S. CLS. 2, 13, 22, 25, 32 AND 50).

Laurie Mayes, Examining Attorney



OWNER OF U.S. REG. NO. 1,192,959.

NO CLAIM IS MADE TO THE EXCLUSIVE RIGHT TO USE "MICROBE" AND "HYDROPONICS", APART FROM THE MARK AS SHOWN.

THE MARK CONSISTS OF THE WORDS "MICROBE LIFE HYDROPONICS", WITH THE WORD "LIFE" SHOWN BELOW THE WORD "MICROBE" AND THE WORD "HYDROPONICS" BELOW "LIFE". THE WORD "MICROBE" IS INTERSECTED WITH TWO OVERLAPPING ORBITAL DESIGNS, WITH THE ORBITALS INTERSECTED IN THE UPPER RIGHT AND LEFT ARMS BY SPHERES AND TWO LEAF DESIGNS.

CLASS 1—CHEMICALS

FOR NUTRIENTS AND FERTILIZERS FOR LAWNS, PLANTS, TREES, SHRUBS AND HYDROPONIC PLANTS (U.S. CLS. 1, 5, 6, 10, 26 AND 46).

CLASS 35—ADVERTISING AND BUSINESS

FOR MAIL ORDER CATALOG AND ON LINE STORE SERVICES FEATURING NUTRIENTS AND FERTILIZERS FOR LAWNS, PLANTS, TREES AND HYDROPONIC PLANTS (U.S. CLS. 100, 101 AND 102).

ANTHONY RINKER, EXAMINING ATTORNEY

SN 85-445,546. THE JELLYVISION LAB, INC., CHICAGO, IL. FILED 10-12-2011.

ALEX

THE MARK CONSISTS OF STANDARD CHARACTERS WITHOUT CLAIM TO ANY PARTICULAR FONT, STYLE, SIZE, OR COLOR.

CLASS 36—INSURANCE AND FINANCIAL

FOR PROVIDING INFORMATION IN THE FIELD OF EMPLOYEE FINANCIAL BENEFIT PLANS (U.S. CLS. 100, 101 AND 102).

FIRST USE 9-29-2011; IN COMMERCE 9-29-2011.

CLASS 41—EDUCATION AND ENTERTAINMENT

FOR EDUCATION SERVICES, NAMELY, PROVIDING ON-LINE TUTORING IN THE FIELD OF EMPLOYEE BENEFITS (U.S. CLS. 100, 101 AND 107).

FIRST USE 9-29-2011; IN COMMERCE 9-29-2011.
KATHERINE CHANG, EXAMINING ATTORNEY

SN 85-445,809. THE MBA TOUR, INC., CONCORD, MA.
FILED 10-12-2011.

THE MBA TOUR

THE MARK CONSISTS OF STANDARD CHARACTERS WITHOUT CLAIM TO ANY PARTICULAR FONT, STYLE, SIZE, OR COLOR.

OWNER OF U.S. REG. NO. 3,984,942.

NO CLAIM IS MADE TO THE EXCLUSIVE RIGHT TO USE "MBA" IN INTERNATIONAL CLASSES 35 AND 41 OR "TOUR" IN INTERNATIONAL CLASS 39, APART FROM THE MARK AS SHOWN.

CLASS 35—ADVERTISING AND BUSINESS

FOR PROMOTING GRADUATE SCHOOL BUSINESS PROGRAMS FOR OTHERS; EVENT PLANNING AND MANAGEMENT FOR PROMOTING GRADUATE SCHOOL BUSINESS PROGRAMS FOR OTHERS; MATCHING GRADUATE BUSINESS SCHOOLS WITH POTENTIAL SCHOOL APPLICANTS BY MEANS OF CONDUCTING SURVEYS (U.S. CLS. 100, 101 AND 102).
FIRST USE 0-0-1993; IN COMMERCE 0-0-1993.

CLASS 39—TRANSPORTATION AND STORAGE

FOR ORGANIZATION OF TRAVEL PACKAGES FOR BUSINESS SCHOOL REPRESENTATIVES CONSISTING PRIMARILY OF ORGANIZATION OF TRAVEL AND ALSO INCLUDING MAKING HOTEL BOOKINGS (U.S. CLS. 100 AND 105).
FIRST USE 0-0-1993; IN COMMERCE 0-0-1993.

CLASS 41—EDUCATION AND ENTERTAINMENT

FOR ARRANGING AND ORGANIZING EDUCATIONAL CONFERENCES, PANELS, WORKSHOPS, AND PRESENTATIONS IN THE FIELD OF BUSINESS SCHOOL PROGRAMS AND ADMISSIONS; PROVIDING ON-LINE INFORMATION IN THE FIELD OF GRADUATE BUSINESS SCHOOL PROGRAMS AND ADMISSIONS; PROVIDING ON-LINE NEWSLETTERS IN THE FIELD OF GRADUATE BUSINESS SCHOOL PROGRAMS AND ADMISSIONS (U.S. CLS. 100, 101 AND 107).
FIRST USE 0-0-1993; IN COMMERCE 0-0-1993.

LEIGH LOWRY, EXAMINING ATTORNEY

SN 85-446,237. GLOCAL, INC., DETROIT, MI. FILED 10-13-2011.



THE MARK CONSISTS OF THE TERM "GLOCAL" IN STYLIZED FORMAT.

CLASS 9—ELECTRICAL AND SCIENTIFIC APPARATUS

FOR DOWNLOADABLE AUDIO, VIDEO AND AUDIO-VISUAL MEDIA CONTENT IN THE FIELDS OF NEWS, CURRENT EVENTS, SPORTS, WEATHER, TELEVISION, MOVIES, RADIO, TECHNOLOGY, FINANCE, MUSIC, HEALTH, BEAUTY, FITNESS AND THE ARTS; COMPUTER SOFTWARE FOR STREAMING AUDIO, VIDEO AND AUDIO-VISUAL MEDIA CONTENT VIA A GLOBAL COMPUTER NETWORK, WIRELESS NETWORK, MOBILE DIGITAL ELECTRONIC DEVICE OR OTHER ELECTRONIC OR DIGITAL COMMUNICATIONS NETWORK OR DIGITAL COMMUNICATIONS DEVICE; COMPUTER SOFTWARE, NAMELY, DOWNLOADABLE PLAYERS FOR AUDIO, VIDEO AND AUDIO-VISUAL MEDIA CONTENT; COMPUTER SOFTWARE, NAMELY, SOFTWARE TOOLS FOR EDITING OF AUDIO, VIDEO AND AUDIO-VISUAL CONTENT, VIDEO SEARCH AND ANNOTATION SOFTWARE, CONTENT PROTECTION SOFTWARE, AD TRACKING AND OPTIMIZATION SOFTWARE, AND SOFTWARE PLATFORM FOR PROVIDING PROGRAMMATIC INTERFACES FOR THIRD PARTIES TO ACCESS WEBSITE CONTENT AND DATA; DOWNLOADABLE SOFTWARE TO ENABLE UPLOADING, POSTING, SHOWING, DISPLAYING, TAGGING, BLOGGING, SHARING AND OTHERWISE PROVIDING ELECTRONIC MEDIA OR INFORMATION OVER A GLOBAL COMPUTER NETWORK, WIRELESS NETWORK, MOBILE DIGITAL ELECTRONIC DEVICE OR OTHER ELECTRONIC OR DIGITAL COMMUNICATIONS NETWORK OR DIGITAL COMMUNICATIONS DEVICE (U.S. CLS. 21, 23, 26, 36 AND 38).

CLASS 35—ADVERTISING AND BUSINESS

FOR ONLINE BANNER ADVERTISING AND MARKETING SERVICES; DEVELOPING AND PROVIDING ONLINE MARKETING PROGRAMS FOR ADVERTISERS, MARKETERS, AND CONTENT PROVIDERS; PROVIDING A WEBSITE WHERE ADVERTISERS, MARKETERS, AND CONTENT PROVIDERS CAN REACH, ENGAGE, AND INTERACT WITH ONLINE USERS FOR THE PURPOSES OF PROMOTION, MARKETING OR ADVERTISING (U.S. CLS. 100, 101 AND 102).

CLASS 38—COMMUNICATION

FOR BROADCASTING AND STREAMING OF AUDIO, VIDEO AND AUDIO-VISUAL MEDIA CONTENT IN THE FIELDS OF NEWS, CURRENT EVENTS, SPORTS, WEATHER, TELEVISION, MOVIES, RADIO, TECHNOLOGY, FINANCE, MUSIC, HEALTH, BEAUTY, FITNESS AND THE ARTS VIA A GLOBAL COMPUTER NETWORK, WIRELESS NETWORK, MOBILE DIGITAL ELECTRONIC DEVICE OR OTHER ELECTRONIC OR DIGITAL COMMUNICATIONS NETWORK OR DIGITAL COMMUNICATIONS DEVICE; AUDIO AND VIDEO BROADCASTING SERVICES FEATURING THE UPLOADED, POSTED AND TAGGED CONTENT OF OTHERS; AUDIO AND VIDEO BROADCASTING SERVICES, NAMELY, ELECTRONICALLY TRANSMITTING AUDIO, VIDEO AND AUDIO-VISUAL MEDIA; TRANSMISSION OF DOWNLOADABLE VIDEO, AUDIO AND AUDIO-VISUAL MEDIA CONTENT; PROVIDING ON-LINE ELECTRONIC BULLETIN BOARDS, CHAT ROOMS, FORUMS FOR TRANSMISSION OF MESSAGES IN THE FIELDS OF VIDEO, NEWS, CURRENT EVENTS, SPORTS, WEATHER, TELEVISION, MOVIES, RADIO, TECHNOLOGY, FINANCE, MUSIC, HEALTH, BEAUTY, FITNESS AND THE ARTS; VIDEO-ON-DEMAND TRANSMISSION SERVICES; WEB MESSAGING SERVICES; WEBCASTING SERVICES (U.S. CLS. 100, 101 AND 104).

CLASS 42—SCIENTIFIC AND COMPUTER SERVICES

FOR HOSTING OF AUDIO, VIDEO AND AUDIO-VISUAL MEDIA CONTENT ON THE INTERNET OR OTHER GLOBAL COMPUTER NETWORK; HOSTING AND MAINTAINING AN ONLINE PLATFORM FEATURING AUDIO, VIDEO AND AUDIO-VISUAL MEDIA CONTENT IN THE FIELDS OF NEWS, CURRENT EVENTS, SPORTS, WEATHER, TELEVISION, MOVIES, RADIO, TECHNOLOGY, FINANCE, MUSIC, HEALTH, BEAUTY, FITNESS AND THE ARTS; PROVIDING PROGRAMMATIC INTERFACES FOR THIRD PARTIES TO ACCESS WEBSITE CONTENT AND DATA; PROVIDING A WEBHOSTING PLATFORM FOR THE AGGREGATION OF AUDIO, VIDEO AND AUDIO-VISUAL MEDIA CONTENT IN THE FIELDS OF NEWS, CURRENT EVENTS, SPORTS, WEATHER, TELEVISION, MOVIES, RADIO, TECHNOLOGY, FINANCE, MUSIC, HEALTH, BEAUTY, FITNESS AND THE ARTS VIA A GLOBAL COMPUTER NETWORK, WIRELESS NETWORK, MOBILE DIGITAL ELECTRONIC DEVICE OR OTHER ELECTRONIC OR DIGITAL COMMUNICATIONS NETWORK OR DIGITAL COMMUNICATIONS DEVICE; PROVIDING TEMPORARY USE OF NON-DOWNLOADABLE SOFTWARE TO ENABLE UPLOADING, CAPTURING, POSTING, SHOWING, EDITING, PLAYING, STREAMING, VIEWING, PREVIEWING, DISPLAYING, TAGGING, BLOGGING, SHARING, MANIPULATING, DISTRIBUTING, PUBLISHING, REPRODUCING, AND OTHERWISE PROVIDING ELECTRONIC MEDIA, MULTIMEDIA CONTENT, VIDEOS, MOVIES, PICTURES, IMAGES, TEXT, PHOTOS, USER-GENERATED CONTENT, AUDIO CONTENT AND INFORMATION VIA A GLOBAL COMPUTER NETWORK, WIRELESS NETWORK, MOBILE DIGITAL ELECTRONIC DEVICE OR OTHER ELECTRONIC OR DIGITAL COMMUNICATIONS NETWORK OR DIGITAL COMMUNICATIONS DEVICE (U.S. CLS. 100 AND 101).

JAMES A. RAUEN, EXAMINING ATTORNEY

CLASS 5—PHARMACEUTICALS

FOR MEDICATED SKIN CARE PREPARATIONS; MEDICATED SUNSCREENS; MEDICATED FACIAL CARE PRODUCTS, NAMELY, CLEANSERS, MOISTURIZERS, LOTIONS, CREAMS; MEDICATED BODY CARE PRODUCTS, NAMELY, CLEANSERS, MOISTURIZERS, LOTIONS, CREAMS; MEDICATED INGREDIENTS SOLD AS INTEGRAL COMPONENTS OF SKIN CARE PREPARATIONS, COSMETICS, SUN SCREENS, FACIAL PRODUCTS, AND BODY CARE PRODUCTS, NAMELY, CLEANSERS, MOISTURIZERS, LOTIONS, CREAMS (U.S. CLS. 6, 18, 44, 46, 51 AND 52).

CLASS 44—MEDICAL, BEAUTY AND AGRICULTURAL SERVICES

FOR PROVIDING INFORMATION IN THE FIELD OF BEAUTY CARE AND AGEING (U.S. CLS. 100 AND 101).
ANNE MADDEN, EXAMINING ATTORNEY

SN 85-446,560. ONE BEAT HOLDINGS, INC., NEW YORK, NY. FILED 10-13-2011.

ONE BEAT

THE MARK CONSISTS OF STANDARD CHARACTERS WITHOUT CLAIM TO ANY PARTICULAR FONT, STYLE, SIZE, OR COLOR.

SN 85-446,373. JOHNSON & JOHNSON, NEW BRUNSWICK, NJ. FILED 10-13-2011.

HEXINOL

THE MARK CONSISTS OF STANDARD CHARACTERS WITHOUT CLAIM TO ANY PARTICULAR FONT, STYLE, SIZE, OR COLOR.

CLASS 3—COSMETICS AND CLEANING PREPARATIONS

FOR SKIN CARE PREPARATIONS; COSMETICS; SUN SCREENS; FACIAL PRODUCTS, NAMELY, CLEANSERS, MOISTURIZERS, LOTIONS, CREAMS; BODY CARE PRODUCTS, NAMELY, CLEANSERS, MOISTURIZERS, LOTIONS, CREAMS; NON-MEDICATED INGREDIENTS SOLD AS INTEGRAL COMPONENTS OF SKIN CARE PREPARATIONS, COSMETICS, SUN SCREENS, FACIAL PRODUCTS, AND BODY CARE PRODUCTS, NAMELY, CLEANSERS, MOISTURIZERS, LOTIONS, CREAMS (U.S. CLS. 1, 4, 6, 50, 51 AND 52).

CLASS 38—COMMUNICATION

FOR TELEVISION BROADCASTING; CABLE TELEVISION BROADCASTING; SATELLITE TELEVISION BROADCASTING; STREAMING OF MULTIMEDIA MATERIAL VIA A COMPUTER NETWORK; VIDEO ON DEMAND TRANSMISSION SERVICES (U.S. CLS. 100, 101 AND 104).

CLASS 41—EDUCATION AND ENTERTAINMENT

FOR ENTERTAINMENT SERVICES, NAMELY, AN ON-LINE NONDOWNLOADABLE SERIES OF PROGRAMS, WEBISODES, VIDEO CLIPS, SEGMENTS, AND INTERSTITIALS FEATURING INFORMATION ABOUT POPULAR CULTURE, ENTERTAINMENT, FASHION, CULTURE, MUSIC, AND TOPICS OF GENERAL INTEREST; PRODUCTION AND DISTRIBUTION OF TELEVISION PROGRAMS; PRODUCTION AND DISTRIBUTION OF CABLE TELEVISION PROGRAMS; ENTERTAINMENT SERVICES IN THE NATURE OF TELEVISION PROGRAMMING; PRODUCTION OF MULTIMEDIA CONTENT FOR ONLINE DISTRIBUTION; ENTERTAINMENT SERVICES, NAMELY, THE PRODUCTION AND DISTRIBUTION OF WEBISODES, MULTIMEDIA CONTENT, VIDEOS, SEGMENTS, AND INTERSTITIALS; PROVIDING A WEBSITE FEATURING INFORMATION ABOUT POPULAR CULTURE, ENTERTAINMENT, CULTURE, AND MUSIC (U.S. CLS. 100, 101 AND 107).

CLASS 45—PERSONAL AND LEGAL SERVICES

FOR PROVIDING A WEBSITE FEATURING INFORMATION ABOUT FASHION (U.S. CLS. 100 AND 101).
JUSTINE D. PARKER, EXAMINING ATTORNEY

SN 85-446,893. BEAUTY UNITES, LLC, WASHINGTON, DC.
FILED 10-13-2011.

beautyunites
feel the power

THE MARK CONSISTS OF STANDARD CHARACTERS WITHOUT CLAIM TO ANY PARTICULAR FONT, STYLE, SIZE, OR COLOR.

CLASS 35—ADVERTISING AND BUSINESS

FOR PROVIDING CONSUMER INFORMATION AND RELATED NEWS ABOUT BEAUTY, WELLNESS AND LIFESTYLE (U.S. CLS. 100, 101 AND 102).

CLASS 42—SCIENTIFIC AND COMPUTER SERVICES

FOR COMPUTER SERVICES, NAMELY, CREATING AN ON-LINE COMMUNITY FOR REGISTERED USERS TO PROVIDE AND RECEIVE FEEDBACK TO AND FROM THEIR PEERS, FROM VIRTUAL COMMUNITIES, ENGAGE IN SOCIAL NETWORKING, POST, EXCHANGE AND VIEW INFORMATION, RATINGS, REVIEWS AND COMMENTARY ABOUT BEAUTY, WELLNESS AND LIFESTYLE MATTERS, BEAUTY, WELLNESS AND LIFESTYLE PRODUCTS AND SERVICES; HOSTING AN ONLINE COMMUNITY WEBSITE FEATURING A FORUM THAT ALLOWS USERS TO POST, EXCHANGE AND VIEW INFORMATION, RATINGS, REVIEWS AND COMMENTARY ABOUT BEAUTY, WELLNESS AND LIFESTYLE MATTERS, BEAUTY, WELLNESS AND LIFESTYLE PRODUCTS AND SERVICES, FORM VIRTUAL COMMUNITIES AND ENGAGE IN SOCIAL NETWORKING; PROVIDING A WEBSITE THAT GIVES COMPUTER USERS THE ABILITY TO POST, EXCHANGE AND VIEW INFORMATION, RATINGS, REVIEWS AND COMMENTARY ABOUT BEAUTY, WELLNESS AND LIFESTYLE (U.S. CLS. 100 AND 101).

CLASS 44—MEDICAL, BEAUTY AND AGRICULTURAL SERVICES

FOR PROVIDING INFORMATION ABOUT BEAUTY, WELLNESS AND LIVING A HEALTHY LIFESTYLE VIA THE INTERNET (U.S. CLS. 100 AND 101).

CLASS 45—PERSONAL AND LEGAL SERVICES

FOR ON-LINE SOCIAL NETWORKING SERVICES (U.S. CLS. 100 AND 101).
JORDAN BAKER, EXAMINING ATTORNEY

SN 85-447,504. JOHNSON & JOHNSON, NEW BRUNSWICK, NJ. FILED 10-14-2011.

HEXINOL

THE MARK CONSISTS OF STYLIZED WORD "HEXINOL".

CLASS 3—COSMETICS AND CLEANING PREPARATIONS

FOR SKIN CARE PREPARATIONS; COSMETICS; SUN SCREENS; FACIAL PRODUCTS, NAMELY, CLEANSERS, MOISTURIZERS, LOTIONS, CREAMS; BODY CARE PRODUCTS, NAMELY, CLEANSERS, MOISTURIZERS, LOTIONS, CREAMS; NON-MEDICATED INGREDIENTS SOLD AS INTEGRAL COMPONENTS OF SKIN CARE PREPARATIONS, COSMETICS, SUN SCREENS, FACIAL PRODUCTS, AND BODY CARE PRODUCTS, NAMELY, CLEANSERS, MOISTURIZERS, LOTIONS, CREAMS (U.S. CLS. 1, 4, 6, 50, 51 AND 52).

CLASS 5—PHARMACEUTICALS

FOR MEDICATED SKIN CARE PREPARATIONS; MEDICATED SUNSCREENS; MEDICATED FACIAL CARE PRODUCTS, NAMELY, CLEANSERS, MOISTURIZERS, LOTIONS, CREAMS; MEDICATED BODY CARE PRODUCTS, NAMELY, CLEANSERS, MOISTURIZERS, LOTIONS, CREAMS; MEDICATED INGREDIENTS SOLD AS INTEGRAL COMPONENTS OF SKIN CARE PREPARATIONS, COSMETICS, SUN SCREENS, FACIAL PRODUCTS, AND BODY CARE PRODUCTS, NAMELY, CLEANSERS, MOISTURIZERS, LOTIONS, CREAMS (U.S. CLS. 6, 18, 44, 46, 51 AND 52).

CLASS 44—MEDICAL, BEAUTY AND AGRICULTURAL SERVICES

FOR PROVIDING INFORMATION IN THE FIELD OF BEAUTY CARE AND AGEING (U.S. CLS. 100 AND 101).
ANNE MADDEN, EXAMINING ATTORNEY

SN 85-447,780. TOPMAX INTERNATIONAL, INC., DBA KIDMEMORYUSA.COM, GREAT NECK, NY. FILED 10-14-2011.



THE MARK CONSISTS OF FOUR SPHERICAL SHAPES OF INCREASING SIZE BRACKETING BELOW A HIGHLY STYLIZED WALKING PERSON FOLLOWED BY CAPITAL LETTERS SPELLING "KIDMEMORY" WHERE THE FIRST CAPITAL LETTER "M" FORMS A PART OF THE FIRST CAPITAL LETTER "E".

CLASS 18—LEATHER GOODS

FOR KNAPSACKS (U.S. CLS. 1, 2, 3, 22 AND 41).
FIRST USE 1-25-2011; IN COMMERCE 7-7-2011.

CLASS 25—CLOTHING

FOR ATHLETIC SHOES (U.S. CLS. 22 AND 39).
FIRST USE 1-25-2011; IN COMMERCE 7-7-2011.
KELLY BOULTON, EXAMINING ATTORNEY

SN 85-447,959. GREEN HAMMER, INC., PORTLAND, OR.
FILED 10-14-2011.

GREEN HAMMER

THE MARK CONSISTS OF STANDARD CHARACTERS WITHOUT CLAIM TO ANY PARTICULAR FONT, STYLE, SIZE, OR COLOR.
OWNER OF U.S. REG. NO. 3,691,733.

CLASS 37—CONSTRUCTION AND REPAIR

FOR GENERAL CONTRACTOR SERVICES, NAMELY, CONSTRUCTION AND REMODELING OF RESIDENTIAL AND COMMERCIAL BUILDINGS AND WORK SPACES; TESTING AND MODELING SERVICES FOR HOME, OFFICE, AND WORKSPACE ENERGY EFFICIENCY, NAMELY, ENERGY ASSESSMENT SERVICES FOR THE PURPOSE OF DETERMINING IMPROVEMENTS NEEDED TO HOME, OFFICE AND WORKSPACE FACILITIES TO IMPROVE ENERGY USE AND EFFICIENCY (U.S. CLS. 100, 103 AND 106).
FIRST USE 11-1-2002; IN COMMERCE 11-1-2002.

CLASS 42—SCIENTIFIC AND COMPUTER SERVICES

FOR ARCHITECTURAL DESIGN; ENGINEERING SERVICES (U.S. CLS. 100 AND 101).
FIRST USE 0-0-2007; IN COMMERCE 0-0-2007.
AMY KERTGATE, EXAMINING ATTORNEY

SN 85-448,054. NORRIS, CARLOS RAY, DALLAS, TX. FILED
10-14-2011.

WWCND

THE MARK CONSISTS OF STANDARD CHARACTERS WITHOUT CLAIM TO ANY PARTICULAR FONT, STYLE, SIZE, OR COLOR.

OWNER OF U.S. REG. NOS. 2,864,474, 3,780,118 AND OTHERS.

CLASS 9—ELECTRICAL AND SCIENTIFIC APPARATUS

FOR MOUSEPADS, MAGNETS (U.S. CLS. 21, 23, 26, 36 AND 38).

CLASS 14—JEWELRY

FOR JEWELRY (U.S. CLS. 2, 27, 28 AND 50).

CLASS 16—PAPER GOODS AND PRINTED MATTER

FOR STICKERS, NOTEBOOKS, NOTEPADS, FOLDERS, BOOKMARKS, PRINTS, POSTERS, STATIONERY, CALENDARS, GREETING CARDS (U.S. CLS. 2, 5, 22, 23, 29, 37, 38 AND 50).

CLASS 18—LEATHER GOODS

FOR MESSENGER BAGS, TOTE BAGS, BACKPACKS (U.S. CLS. 1, 2, 3, 22 AND 41).

CLASS 20—FURNITURE AND ARTICLES NOT OTHERWISE CLASSIFIED

FOR NON-METAL AND NON-LEATHER KEY CHAINS; PLASTIC KEY CHAINS; FABRIC KEY CHAINS (U.S. CLS. 2, 13, 22, 25, 32 AND 50).

CLASS 21—HOUSEWARES AND GLASS

FOR CUPS, MUGS, SPORTS BOTTLES (U.S. CLS. 2, 13, 23, 29, 30, 33, 40 AND 50).

CLASS 25—CLOTHING

FOR CLOTHING, NAMELY, T-SHIRTS, SWEATSHIRTS, FLEECE PULLOVERS, SHIRTS, PANTS AND HATS (U.S. CLS. 22 AND 39).

CLASS 26—FANCY GOODS

FOR NOVELTY BUTTONS (U.S. CLS. 37, 39, 40, 42 AND 50).
WILLIAM BRECKENFELD, EXAMINING ATTORNEY

SN 85-448,093. MAIONICA, MOISES, WESTON, FL. FILED
10-14-2011.



THE MARK CONSISTS OF A RECTANGLE WITH A SOLID UPPER HALF CARRYING A FISHING BOAT WITH A BILLFISH ON A FISHING LINE ABOVE THE LETTERS "OFL" ON THE BOTTOM PORTION OF THE RECTANGLE.

CLASS 25—CLOTHING

FOR CLOTHING, NAMELY, T-SHIRTS, SHIRTS, SWEATSHIRTS, SWIMWEAR, SHORTS, PANTS, HATS, CAPS, FOOTWEAR, JACKETS (U.S. CLS. 22 AND 39).

CLASS 28—TOYS AND SPORTING GOODS

FOR FISHING EQUIPMENT, NAMELY, FISHING LURES; FISHING POLES; FISHING REELS; FISHING TACKLE (U.S. CLS. 22, 23, 38 AND 50).

CLASS 35—ADVERTISING AND BUSINESS

FOR ONLINE PROMOTIONAL SERVICES FOR FISHING TOURNAMENTS; MANAGING FISHING TOURNAMENTS, NAMELY, PROVIDING ONLINE REGISTRATION SERVICES FOR FISHING TOURNAMENTS (U.S. CLS. 100, 101 AND 102).

CLASS 41—EDUCATION AND ENTERTAINMENT

FOR ENTERTAINMENT SERVICES, NAMELY, ORGANIZING AND CONDUCTING FISHING TOURNAMENTS IN OPEN WATERS; TELEVISION PROGRAM SERIES FEATURING FISHING TOURNAMENTS; PROVIDING ENTERTAINMENT WEBCASTS IN THE FIELD OF FISHING TOURNAMENTS (U.S. CLS. 100, 101 AND 107).

SANDRA BUJA, EXAMINING ATTORNEY

SN 85-448,559. COMMISSION ON ACCREDITATION FOR LAW ENFORCEMENT AGENCIES, INC., GAINESVILLE, VA. FILED 10-17-2011.



OWNER OF U.S. REG. NOS. 2,114,083, 2,560,758 AND 2,761,838.

NO CLAIM IS MADE TO THE EXCLUSIVE RIGHT TO USE "LAW ENFORCEMENT ACCREDITATION", APART FROM THE MARK AS SHOWN.

THE MARK CONSISTS OF A CENTRAL DESIGN OF A HERALDIC EAGLE HOLDING A LEAFED BRANCH IN ONE CLAW AND THREE ARROWS IN THE OTHER. THE EAGLE IS SURROUNDED BY A WREATH OF TWO LAUREL BRANCHES SEPARATED BY A STAR. THE TERM "CALEA" IN STYLIZED FONT OVERLAYS THE EAGLE DESIGN. THE TOP OF THE MARK IS FRAMED BY A BANNER-LIKE BORDER WITH THE WORDS "LAW ENFORCEMENT" IN STYLIZED FONT. A SIMILAR BORDER BEARING THE WORD "ACCREDITATION" IN STYLIZED FONT IS PLACED BELOW THE CENTRAL DESIGN.

SN 85-448,170. MALONE UNIVERSITY, CANTON, OH. FILED 10-14-2011.



NO CLAIM IS MADE TO THE EXCLUSIVE RIGHT TO USE "1892" OR "UNIVERSITY", APART FROM THE MARK AS SHOWN.

THE MARK CONSISTS OF TWO-PIECE FORKED BANNER WITH REVERSE IMAGE OF THE NUMBER "1892" ON TOP COMPONENT AND REVERSE-IMAGE TORCH ON BOTTOM COMPONENT; ALL NEXT TO THE WORDS "MALONE UNIVERSITY" UNDERLINED AND PLACED ABOVE THE WORDS "CHRIST'S KINGDOM FIRST".

CLASS 25—CLOTHING

FOR CLOTHING, NAMELY, SHIRTS, BLOUSES, SWEAT SHIRTS, T-SHIRTS, POLO SHIRTS (U.S. CLS. 22 AND 39).

FIRST USE 10-3-2008; IN COMMERCE 10-3-2008.

CLASS 41—EDUCATION AND ENTERTAINMENT

FOR EDUCATIONAL SERVICES, NAMELY, PROVIDING COURSES OF INSTRUCTION AT THE UNIVERSITY LEVEL AND DISTRIBUTING COURSE MATERIALS (U.S. CLS. 100, 101 AND 107).

FIRST USE 10-3-2008; IN COMMERCE 10-3-2008.
SEAN CROWLEY, EXAMINING ATTORNEY

CLASS 9—ELECTRICAL AND SCIENTIFIC APPARATUS

FOR DIGITAL MEDIA, NAMELY, PRERECORDED DIGITAL VIDEO DISCS, DIGITAL VERSATILE DISCS, DOWNLOADABLE AUDIO AND VIDEO RECORDINGS, DVDS, AND HIGH DEFINITION DIGITAL DISCS FEATURING INFORMATION IN THE FIELD OF LAW ENFORCEMENT (U.S. CLS. 21, 23, 26, 36 AND 38).

CLASS 14—JEWELRY

FOR LAPEL PINS DISTRIBUTED TO CUSTOMERS INVOLVED IN LAW ENFORCEMENT ACCREDITATION PROGRAMS PROVIDED BY THE COMMISSION ON ACCREDITATION FOR LAW ENFORCEMENT AGENCIES, INC (U.S. CLS. 2, 27, 28 AND 50).

CLASS 16—PAPER GOODS AND PRINTED MATTER

FOR DECALS; PUBLICATIONS, NAMELY, BROCHURES, MAGAZINES, PRINTED PRESENTATIONS, PERIODICALLY ISSUED STANDARDS MANUALS AND PRINTED VISUALS IN THE NATURE OF INFORMATION GRAPHICS IN THE FIELD OF LAW ENFORCEMENT AND INSPECTIONS TO DETERMINE COMPLIANCE WITH STANDARDS AND PRACTICES IN THE FIELD OF LAW ENFORCEMENT; CONFERENCE BOOKLETS IN THE FIELD OF LAW ENFORCEMENT; PRINTED AWARD CERTIFICATES; PERIODICALLY ISSUED PRINTED STANDARDS GUIDES IN THE FIELD OF LAW ENFORCEMENT (U.S. CLS. 2, 5, 22, 23, 29, 37, 38 AND 50).

CLASS 41—EDUCATION AND ENTERTAINMENT

FOR EDUCATIONAL SERVICES, NAMELY, CONDUCTING CONFERENCES, WORKSHOPS AND PRESENTATIONS IN THE FIELD OF LAW ENFORCEMENT (U.S. CLS. 100, 101 AND 107).

CLASS 42—SCIENTIFIC AND COMPUTER SERVICES

FOR ACCREDITATION SERVICES, NAMELY, SETTING AND PROVIDING STANDARDS FOR THE FIELD OF LAW ENFORCEMENT AND EVALUATING LAW ENFORCEMENT ORGANIZATIONS TO DETERMINE WHETHER THE ORGANIZATIONS CONFORM TO ESTABLISHED STANDARDS (U.S. CLS. 100 AND 101).

CLASS 45—PERSONAL AND LEGAL SERVICES

FOR REVIEWING STANDARDS AND PRACTICES TO ASSURE COMPLIANCE WITH LAWS AND REGULATIONS IN THE FIELD OF LAW ENFORCEMENT; PROVIDING A WEBSITE FEATURING INFORMATION IN THE FIELD OF LAW ENFORCEMENT (U.S. CLS. 100 AND 101).

STEVEN PEREZ, EXAMINING ATTORNEY

SN 85-448,606. MEXILINK, INC., HOUSTON, TX. FILED 10-17-2011.



NO CLAIM IS MADE TO THE EXCLUSIVE RIGHT TO USE "INCORPORATED", APART FROM THE MARK AS SHOWN.

THE COLOR(S) BLACK, WHITE, RED AND GREEN IS/ARE CLAIMED AS A FEATURE OF THE MARK.

THE MARK CONSISTS OF TWO CONSECUTIVE ARROWS THAT CURVE COUNTER-CLOCKWISE, EACH INDEPENDENTLY FORMING A SEMI-CIRCLE AND TOGETHER A FULL CIRCLE. THE ARROW ON THE LEFT IS GREEN AND THE ARROW ON THE RIGHT IS RED. BOTH ARROWS ARE OUTLINED IN WHITE, WITH BLACK SHADOWING. BELOW THE ARROWS ARE THE WORDS "MEXILINK" IN THIN BLACK BUBBLE LETTERS, AND THE WORD "INCORPORATED" IN GREEN BLOCK LETTERS.

CLASS 35—ADVERTISING AND BUSINESS

FOR IMPORT AGENCY SERVICES IN THE FIELD OF GENERAL CONSUMER MERCHANDISE; MARKETING OF CONSUMER PRODUCTS FOR OTHERS; RETAIL STORE SERVICES FEATURING GENERAL CONSUMER MERCHANDISE; SAMPLE DISTRIBUTION OF GENERAL CONSUMER PRODUCTS (U.S. CLS. 100, 101 AND 102).

CLASS 39—TRANSPORTATION AND STORAGE

FOR DISTRIBUTION, NAMELY, DELIVERY OF GENERAL CONSUMER MERCHANDISE; STORAGE OF GENERAL CONSUMER MERCHANDISE (U.S. CLS. 100 AND 105).

ELLEN PERKINS, EXAMINING ATTORNEY

SN 85-448,736. LCI GLOBAL SUPPLY CHAIN MANAGEMENT SOLUTIONS, INC., AUSTIN, TX. FILED 10-17-2011.

MACROLYNK

THE MARK CONSISTS OF STANDARD CHARACTERS WITHOUT CLAIM TO ANY PARTICULAR FONT, STYLE, SIZE, OR COLOR.

CLASS 42—SCIENTIFIC AND COMPUTER SERVICES

FOR SOFTWARE AS A SERVICE (SAAS) SERVICES USED IN CONNECTION WITH A SUPPLY CHAIN EXECUTION AND COLLABORATION SYSTEM FEATURING SOFTWARE APPLICATIONS FOR MANAGING INVENTORY, MANAGING SUPPLY CHAINS, MANAGING TRADE ZONES, MANAGING ORDERS, MANAGING ACCOUNTS PAYABLE, MANAGING VENDORS, MANAGING BUSINESS NETWORKS, MANAGING TRANSPORTATION OF GOODS, MANAGING TRADE TRANSACTIONS, AND MANAGING IMPORT-EXPORT OPERATIONS (U.S. CLS. 100 AND 101).

CLASS 45—PERSONAL AND LEGAL SERVICES

FOR ONLINE SOCIAL NETWORKING SERVICES (U.S. CLS. 100 AND 101).

EMILY CARLSEN, EXAMINING ATTORNEY

SN 85-449,999. GRACE ADVENTURES, SILVER LAKE, MI. FILED 10-18-2011.

GRACE ADVENTURES

THE MARK CONSISTS OF STANDARD CHARACTERS WITHOUT CLAIM TO ANY PARTICULAR FONT, STYLE, SIZE, OR COLOR.

CLASS 41—EDUCATION AND ENTERTAINMENT

FOR EDUCATIONAL SERVICES, NAMELY, PROVIDING LEADERSHIP DEVELOPMENT TRAINING; PROVIDING LEADERSHIP TRAINING AND CONSULTING FOR CHILDREN, ADULTS, PARENTS AND FAMILIES TO DEVELOP AND ENHANCE THE SPIRITUAL LIVES OF INDIVIDUALS; PROVIDING RECREATIONAL CAMPS FOR CHILDREN, ADULTS, PARENTS AND FAMILIES TO DEVELOP AND ENHANCE THE SPIRITUAL LIVES OF INDIVIDUAL (U.S. CLS. 100, 101 AND 107).

FIRST USE 7-31-1999; IN COMMERCE 7-31-1999.

CLASS 45—PERSONAL AND LEGAL SERVICES

FOR MINISTERIAL SERVICES, NAMELY, PROVIDING GATHERINGS AND RETREATS FOR CHILDREN, ADULTS, PARENTS AND FAMILIES TO DEVELOP AND ENHANCE THE SPIRITUAL LIVES OF INDIVIDUALS (U.S. CLS. 100 AND 101).

FIRST USE 7-31-1999; IN COMMERCE 7-31-1999.
JORDAN BAKER, EXAMINING ATTORNEY

SN 85-450,616. ULLIANCE, INC., TROY, MI. FILED 10-19-2011.

ULLIANCE

THE MARK CONSISTS OF STANDARD CHARACTERS WITHOUT CLAIM TO ANY PARTICULAR FONT, STYLE, SIZE, OR COLOR.

THE WORDING "ULLIANCE" HAS NO MEANING IN A FOREIGN LANGUAGE.

CLASS 35—ADVERTISING AND BUSINESS

FOR EMPLOYMENT OUTPLACEMENT AND CAREER TRANSITION SERVICES; PROVIDING REFERRAL SERVICES TO ASSIST EMPLOYEES WITH PERSONAL, MEDICAL, AND WORK-LIFE CONCERNS; PROVIDING ASSISTANCE, FITNESS EVALUATION AND CONSULTATION TO CORPORATE CLIENTS AND THEIR EMPLOYEES IN ORDER FOR THEM TO MAKE HEALTH, WELLNESS AND NUTRITIONAL CHANGES IN THEIR DAILY LIVING TO INCREASE PRODUCTIVITY AND LOWER HEALTH CARE COSTS (U.S. CLS. 100, 101 AND 102).

CLASS 41—EDUCATION AND ENTERTAINMENT

FOR TRAINING SERVICES IN THE FIELD OF HUMAN EFFECTIVENESS TO PROVIDE CORPORATE CLIENTS, THEIR EMPLOYEES, AND OTHER INDIVIDUALS WITH SKILLS AND TOOLS TO IMPROVE THEIR PROFESSIONAL AND PERSONAL GROWTH AND DEVELOPMENT (U.S. CLS. 100, 101 AND 107).

CLASS 43—HOTEL AND RESTAURANT SERVICES

FOR PROVIDING INFORMATION VIA THE INTERNET RELATING TO ELDER CARE (U.S. CLS. 100 AND 101).

CLASS 44—MEDICAL, BEAUTY AND AGRICULTURAL SERVICES

FOR BEHAVIORAL HEALTH SERVICES; COUNSELING SERVICES IN THE FIELDS OF HEALTH, NUTRITION AND LIFESTYLE WELLNESS; PROVIDING ASSISTANCE, FITNESS EVALUATION AND CONSULTATION TO CORPORATE CLIENTS TO HELP THEIR EMPLOYEES MAKE HEALTH, WELLNESS AND NUTRITIONAL CHANGES IN THEIR DAILY LIVING TO IMPROVE HEALTH; PROVIDING EMPLOYEE ASSISTANCE PROGRAMS IN THE NATURE OF MANAGED BEHAVIORAL HEALTHCARE PROGRAMS FOR MEMBERS OF CONTRACTING GROUPS; PROVIDING INFORMATION VIA THE INTERNET RELATING TO HEALTH, WELL-BEING, NUTRITION, AND FAMILY HEALTH MATTERS; EMPLOYEE ASSISTANCE PROGRAMS IN THE NATURE OF PSYCHOLOGICAL EVALUATION AND COUNSELING; PROVIDING ASSISTANCE, FITNESS EVALUATION AND CONSULTATION TO INDIVIDUALS TO HELP THEM MAKE HEALTH, WELLNESS AND NUTRITIONAL CHANGES IN THEIR DAILY LIVING TO IMPROVE HEALTH; MENTAL HEALTH SERVICES; CHEMICAL DEPENDENCY AND SUBSTANCE ABUSE TREATMENT CONSULTATION SERVICES; ENERGY HEALING SERVICES, NAMELY, STRESS MANAGEMENT AND STRESS REDUCTION COUNSELING FOR INDIVIDUALS TO ENHANCE THEIR LIVES; PSYCHOLOGICAL ASSESSMENT AND PSYCHOTHERAPEUTIC COUNSELING SERVICES; CONSULTING IN THE FIELD OF HEALTH AND WELLNESS TO BRING ABOUT PERSONAL HAPPINESS AND WELL-BEING (U.S. CLS. 100 AND 101).

CLASS 45—PERSONAL AND LEGAL SERVICES

FOR PROVIDING PERSONAL SUPPORT SERVICES FOR EMPLOYEES AND RETIREES OF CORPORATE CLIENTS AND THEIR FAMILIES, NAMELY, EMOTIONAL COUNSELING AND EMOTIONAL SUPPORT; SECURITY SERVICES, NAMELY, THREAT SIMULATION VULNERABILITY ANALYSIS AND MITIGATION AND EMERGENCY AND CRISIS MANAGEMENT RESPONSE (U.S. CLS. 100 AND 101).
DAVID TOOLEY, EXAMINING ATTORNEY

SN 85-451,177. BAYLOR HEALTH CARE SYSTEM, DALLAS, TX. FILED 10-19-2011.

FOR WOMEN FOR LIFE

THE MARK CONSISTS OF STANDARD CHARACTERS WITHOUT CLAIM TO ANY PARTICULAR FONT, STYLE, SIZE, OR COLOR.

OWNER OF U.S. REG. NOS. 2,710,027, 2,710,036 AND 3,686,990.

CLASS 41—EDUCATION AND ENTERTAINMENT

FOR EDUCATIONAL SERVICES, NAMELY, PROVIDING LECTURES, PRESENTATIONS AND SEMINARS ABOUT WOMEN'S HEALTH, ALL PROVIDED AT A HEALTH DAY EVENT (U.S. CLS. 100, 101 AND 107).
FIRST USE 4-5-2003; IN COMMERCE 4-5-2003.

CLASS 44—MEDICAL, BEAUTY AND AGRICULTURAL SERVICES

FOR WOMEN'S HEALTH SCREENING SERVICES IN THE FIELDS OF CHOLESTEROL, BLOOD PRESSURE, GLUCOSE, SLEEP APNEA, LUNG FUNCTION, BODY MASS INDEX, GENERAL WELLNESS, GYNECOLOGY, DIABETES, VISION AND HEARING AND PROVIDING HEALTH INFORMATION, ALL PROVIDED AT A HEALTH DAY EVENT (U.S. CLS. 100 AND 101).
FIRST USE 4-5-2003; IN COMMERCE 4-5-2003.
REBECCA GILBERT, EXAMINING ATTORNEY

SN 85-451,695. GET IN TOUCH, HENDERSON, NV. FILED 10-20-2011.



NO CLAIM IS MADE TO THE EXCLUSIVE RIGHT TO USE "THERAPEUTICS", APART FROM THE MARK AS SHOWN.

THE MARK CONSISTS OF A PEACE SYMBOL NEXT TO THE WORD "SPHERE" AND ABOVE THE WORD "THERAPEUTIX". "SPHERE THERAPEUTIX" IS IN A STYLIZED FONT.

CLASS 41—EDUCATION AND ENTERTAINMENT

FOR YOGA INSTRUCTION (U.S. CLS. 100, 101 AND 107).

CLASS 44—MEDICAL, BEAUTY AND AGRICULTURAL SERVICES

FOR BODYWORK THERAPY; MESSAGE THERAPY SERVICES (U.S. CLS. 100 AND 101).
AHSEN KHAN, EXAMINING ATTORNEY

SN 85-452,194. AGENCY SPORTS MANAGEMENT, LLC, DIX HILLS, NY. FILED 10-20-2011.



NO CLAIM IS MADE TO THE EXCLUSIVE RIGHT TO USE "BRANDS", APART FROM THE MARK AS SHOWN.

THE MARK CONSISTS OF A WHITE HEXAGON WITH THE WORDS "BAZANT BRANDS" CONTAINED THEREIN; THE DIACRITICAL MARK CARON APPEARS OVER THE LETTER "Z".

THE ENGLISH TRANSLATION OF THE WORD "BAZANT" IN THE MARK IS "PHEASANT".

CLASS 11—ENVIRONMENTAL CONTROL APPARATUS

FOR NON-ELECTRIC POCKET WARMERS, NAMELY, CHEMICALLY-ACTIVATED HEATING PACKETS FOR WARMING HANDS, TOES, AND BODY (U.S. CLS. 13, 21, 23, 31 AND 34).

FIRST USE 1-0-2010; IN COMMERCE 1-0-2010.

CLASS 20—FURNITURE AND ARTICLES NOT OTHERWISE CLASSIFIED

FOR DISPLAY CASES (U.S. CLS. 2, 13, 22, 25, 32 AND 50).

FIRST USE 1-0-2010; IN COMMERCE 1-0-2010.
RON FAIRBANKS, EXAMINING ATTORNEY

SN 85-452,869. M.S.R. IMPORTS, INC., PENNSAUKEN, NJ. FILED 10-21-2011.



NO CLAIM IS MADE TO THE EXCLUSIVE RIGHT TO USE "KITCHEN", APART FROM THE MARK AS SHOWN.

THE MARK CONSISTS OF THE WORDS "OLD HOME KITCHEN" POSITIONED AROUND THE DESIGN OF A HOUSE THAT IS SURROUNDED BY A PARTIAL CIRCLE.

CLASS 8—HAND TOOLS

FOR KITCHEN AND HOUSEHOLD PRODUCTS, NAMELY, HAND-OPERATED KITCHEN APPLIANCE FOR CHOPPING FOOD (U.S. CLS. 23, 28 AND 44).

CLASS 9—ELECTRICAL AND SCIENTIFIC APPARATUS

FOR KITCHEN AND HOUSEHOLD PRODUCTS, NAMELY, GLASS MEASURING CUPS; 2-CUP GLASS MEASURING CUPS WITH HANDLES; STAINLESS STEEL DIGITAL TIMERS (U.S. CLS. 21, 23, 26, 36 AND 38).

CLASS 11—ENVIRONMENTAL CONTROL APPARATUS

FOR KITCHEN AND HOUSEHOLD PRODUCTS, NAMELY, ELECTRIC TOASTER GRILLER SANDWICH MAKERS; MICROWAVE OVENS FOR HOUSEHOLD PURPOSES, NAMELY, MICROWAVE TRIPLE COOKERS; MINI OUTDOOR PLANT LIGHTS (U.S. CLS. 13, 21, 23, 31 AND 34).

CLASS 20—FURNITURE AND ARTICLES NOT OTHERWISE CLASSIFIED

FOR KITCHEN AND HOUSEHOLD PRODUCTS, NAMELY, CUT-TO-SIZE SINK MATS (U.S. CLS. 2, 13, 22, 25, 32 AND 50).

CLASS 21—HOUSEWARES AND GLASS

FOR KITCHEN AND HOUSEHOLD PRODUCTS, NAMELY, BASTER SETS COMPRISED OF A FOOD BASTER, CLEANING BRUSH AND AN INJECTION NEEDLE; TOASTER OVEN PANS, NON-METAL WAVY FLAG DÉVILED EGG TRAYS, SNOWMAN LAZY SUSANS; BAKEWARE, NAMELY, BROWN RAMEKINS AND CHRISTMAS RAMEKINS; DESSERT PLATES, NAMELY, TULIP CUPCAKE HOLDERS; UNIVERSAL SEE THROUGH PAN LIDS, SCOOPS FOR SERVING FOOD, 24 CUP MINI MUFFIN PANS, DECORATING PLUNGER SETS COMPRISED PRIMARILY OF DECORATING TUBES, COUPLERS AND TIPS; DRINKING GLASSES, NAMELY, STACKING TUMBLERS AND LIGHTHOUSE TUMBLERS; GLASS BOTTOM SPRINGFORM PANS, BUNDT CAKE PANS WITH CARRIERS, ROASTER PANS WITH RACKS, ROUND WHOOPIE PIES PANS, HEART SHAPED WHOOPIE PIES PANS, 24 CUP MINI MUFFIN PANS, HOLIDAY COOKIE PRESSES; SNOWMAN DIVIDED CAKE AND PIE SERVERS WITH LIDS; CHRISTMAS DESIGNED PASTRY BAGS, LOAF PANS; ABRASIVE SPONGES FOR SCRUBBING THE SKIN, NAMELY, HEEL SCRUBBERS; SILICONE MICROWAVE MATS; FOLDABLE PLASTIC WATER BOTTLES SOLD EMPTY, PINWHEEL COOKIE CUTTERS, COLLAPSIBLE LOAF PANS, FRESH KEEPER BOWL COVERS; LOCK-LID FOOD CONTAINER SETS COMPRISED PRIMARILY OF LOCKABLE NON-METAL HOUSEHOLD CONTAINERS FOR FOOD; REUSABLE STAINLESS STEEL WATER BOTTLES SOLD EMPTY, BUTTERFLY MICROWAVE POT SETS (U.S. CLS. 2, 13, 23, 29, 30, 33, 40 AND 50).

RONALD MCMORROW, EXAMINING ATTORNEY

SN 85-453,529. FTS INTERNATIONAL SERVICES, LLC,
FORT WORTH, TX. FILED 10-21-2011.



THE MARK CONSISTS OF A STYLIZED LETTER "F" THAT IS FORMED BY INTERLOCKING AND OUTLINED AND CURVED RECTANGULAR DESIGN ELEMENTS. THE LETTER "F" IS LOCATED WITHIN A SQUARE DESIGN ELEMENT WITH CURVED BORDERS.

CLASS 1—CHEMICALS

FOR PROPPANT FOR USE IN OIL WELL AND GAS WELL HYDRAULIC FRACTURING OPERATIONS; CHEMICALS AND CHEMICAL ADDITIVES FOR DRILLING FLUID USED IN OIL AND GAS DRILLING AND ENHANCED RECOVERY OPERATIONS (U.S. CLS. 1, 5, 6, 10, 26 AND 46).

FIRST USE 1-1-2012; IN COMMERCE 1-1-2012.

CLASS 40—MATERIAL TREATMENT

FOR OIL AND GAS WELL TREATMENT (U.S. CLS. 100, 103 AND 106).

FIRST USE 1-1-2012; IN COMMERCE 1-1-2012.

BRIAN PINO, EXAMINING ATTORNEY

SN 85-453,547. FTS INTERNATIONAL SERVICES, LLC,
FORT WORTH, TX. FILED 10-21-2011.



THE COLOR(S) GREEN AND YELLOW IS/ARE CLAIMED AS A FEATURE OF THE MARK.

THE MARK CONSISTS OF A STYLIZED YELLOW LETTER "F" COMPRISED OF RECTANGLES AND SQUARE IN A GREEN SQUARE WITH A YELLOW SQUARE BORDER.

CLASS 1—CHEMICALS

FOR PROPPANT FOR USE IN OIL WELL AND GAS WELL HYDRAULIC FRACTURING OPERATIONS; CHEMICALS AND CHEMICAL ADDITIVES FOR DRILLING FLUID USED IN OIL AND GAS DRILLING AND ENHANCED RECOVERY OPERATIONS (U.S. CLS. 1, 5, 6, 10, 26 AND 46).

FIRST USE 2-1-2012; IN COMMERCE 2-1-2012.

CLASS 40—MATERIAL TREATMENT

FOR OIL AND GAS WELL TREATMENT (U.S. CLS. 100, 103 AND 106).

FIRST USE 2-1-2012; IN COMMERCE 2-1-2012.

BRIAN PINO, EXAMINING ATTORNEY

SN 85-453,754. SUBTRACTIVE, INC., SANTA MONICA, CA.
FILED 10-21-2011.

MEAT WALLET

THE MARK CONSISTS OF STANDARD CHARACTERS WITHOUT CLAIM TO ANY PARTICULAR FONT, STYLE, SIZE, OR COLOR.

CLASS 25—CLOTHING

FOR (BASED ON INTENT TO USE) CLOTHING, NAMELY, HATS, CAPS, T-SHIRTS, SWEATSHIRTS, SWEAT PANTS, TOPS, SHIRTS, JACKETS, DRESSES, SKIRTS, BLOUSES, UNDERGARMENTS, LINGERIE, WRIST BANDS, HEADBANDS, GLOVES, SHOES, BEACHWEAR, SHORTS, TIES, PANTS, VESTS, BELTS, SWEATERS, SUITS, PULLOVERS, JEANS, LOUNGE WEAR, SOCKS, SCARVES, RAINWEAR, SPORTS JERSEYS, SWIM WEAR AND TANK TOPS (U.S. CLS. 22 AND 39).

CLASS 41—EDUCATION AND ENTERTAINMENT

FOR (BASED ON USE IN COMMERCE) ENTERTAINMENT SERVICES IN THE NATURE OF AN ONGOING ANIMATED TELEVISION PROGRAM FEATURING COMEDY ENTERTAINMENT FOR ADULTS AND CHILDREN; PROVIDING ENTERTAINMENT INFORMATION ABOUT ANIMATED TELEVISION PROGRAMS FEATURING COMEDY ENTERTAINMENT FOR ADULTS AND CHILDREN; PRODUCTION AND DISTRIBUTION OF ANIMATED TELEVISION PROGRAMS; DISTRIBUTION OF ENTERTAINMENT, NAMELY, OF AN ONGOING ANIMATED TELEVISION PROGRAM FEATURING COMEDY ENTERTAINMENT FOR ADULTS AND CHILDREN; PROGRAM SCHEDULING INFORMATION BY MEANS OF A GLOBAL COMMUNICATION NETWORK; FAN CLUB SERVICES (U.S. CLS. 100, 101 AND 107).

FIRST USE 5-1-2009; IN COMMERCE 1-1-2010.

Laurie Mayes, Examining Attorney

SN 85-454,147. RETIREMENT INCOME INDUSTRY ASSOCIATION, BOSTON, MA. FILED 10-24-2011.

SN 85-454,230. GENERAL MOTORS FINANCIAL COMPANY, INC., FORT WORTH, TX. FILED 10-24-2011.



The
Right →
Lease

NO CLAIM IS MADE TO THE EXCLUSIVE RIGHT TO USE "LEASE", APART FROM THE MARK AS SHOWN.

THE MARK CONSISTS OF THE WORDS "THE RIGHT LEASE" WITH THE "T" IN THE WORD "RIGHT" FORMING AN ARROW AT THE BOTTOM.

CLASS 36—INSURANCE AND FINANCIAL

FOR OFFERING CONSUMER VEHICLE LEASES TO AUTOMOBILE DEALERS (U.S. CLS. 100, 101 AND 102).
FIRST USE 10-11-2011; IN COMMERCE 10-11-2011.

CLASS 41—EDUCATION AND ENTERTAINMENT

FOR CONDUCTING VEHICLE LEASING WORKSHOPS FOR DEALER PRINCIPALS, GENERAL MANAGERS, SALES MANAGERS AND FINANCE MANAGERS (U.S. CLS. 100, 101 AND 107).
FIRST USE 10-11-2011; IN COMMERCE 10-11-2011.
STEVEN JACKSON, EXAMINING ATTORNEY

NO CLAIM IS MADE TO THE EXCLUSIVE RIGHT TO USE "THE RETIREMENT MANAGEMENT JOURNAL", APART FROM THE MARK AS SHOWN.

THE COLOR(S) NAVY BLUE AND BURNT SIENNA IS/ARE CLAIMED AS A FEATURE OF THE MARK.

THE MARK CONSISTS OF AN OPEN SWIRL ACROSS THE STYLIZED LETTERS "RMJ" VIGNETTING FROM NAVY BLUE AT THE LEFT EDGE TO BURNT SIENNA AT THE RIGHT EDGE OF THE STYLIZED LETTERS AND A SWIRL TO THE RIGHT OF THE STYLIZED LETTERS VIGNETTING FROM NAVY BLUE AT THE LEFT EDGE TO BURNT SIENNA AT THE RIGHT EDGE OF THE SWIRL BENEATH THE WORDS "THE VIEW ACROSS THE SILOS" IN BURNT SIENNA UPPER AND LOWER CASE LETTERS AND ABOVE THE WORDS "THE RETIREMENT MANAGEMENT JOURNAL" NAVY BLUE UPPER AND LOWER CASE LETTERS.

CLASS 16—PAPER GOODS AND PRINTED MATTER

FOR PRINTED PERIODICALS IN THE FIELD OF RETIREMENT INCOME PLANNING, MANAGEMENT AND POLICY FORMULATION (U.S. CLS. 2, 5, 22, 23, 29, 37, 38 AND 50).

FIRST USE 3-21-2011; IN COMMERCE 3-21-2011.

CLASS 41—EDUCATION AND ENTERTAINMENT

FOR PROVIDING AN ON-LINE PUBLICATION IN THE NATURE OF ARTICLES, ESSAYS AND PAPERS IN THE FIELD OF RETIREMENT INCOME, PLANNING AND RETIREMENT, MANAGEMENT AND POLICY FORMULATION (U.S. CLS. 100, 101 AND 107).

FIRST USE 3-21-2011; IN COMMERCE 3-21-2011.
KATHERINE E. HALMEN, EXAMINING ATTORNEY

SN 85-454,395. GREAT LAKES HEALTH INFORMATION EXCHANGE, OKEMOS, MI. FILED 10-24-2011.



NO CLAIM IS MADE TO THE EXCLUSIVE RIGHT TO USE "GREAT LAKES" AND "HEALTH INFORMATION EXCHANGE", APART FROM THE MARK AS SHOWN.

THE MARK CONSISTS OF THE WORDS "GREAT LAKES HEALTH INFORMATION EXCHANGE" WITH INTERCONNECTING ARCS ADJACENT THE "T" IN "GREAT", THE "S" IN "LAKES" AND EXTENDING UNDER THE WORD "EXCHANGE".

CLASS 38—COMMUNICATION

FOR PROVIDING MULTIPLE USE ACCESS TO ELECTRONIC COMMUNICATION TO HEALTH CARE PROVIDERS FOR THE SECURE EXCHANGE AND DISSEMINATION OF HEALTH CARE INFORMATION (U.S. CLS. 100, 101 AND 104).

FIRST USE 5-19-2011; IN COMMERCE 5-19-2011.

CLASS 42—SCIENTIFIC AND COMPUTER SERVICES

FOR PROVIDING AN ELECTRONIC ONLINE SYSTEM FEATURING TECHNOLOGY THAT ENABLES HEALTH CARE PROVIDERS TO SECURELY GENERATE, MANAGE AND EXCHANGE MEDICAL INFORMATION AND DOCUMENTS (U.S. CLS. 100 AND 101).

FIRST USE 5-19-2011; IN COMMERCE 5-19-2011.

CLASS 44—MEDICAL, BEAUTY AND AGRICULTURAL SERVICES

FOR PROVIDING AN INTERNET WEBSITE FEATURING HEALTH CARE INFORMATION FROM REMOTE LOCATIONS THAT IS SECURELY EXCHANGED AND ACCESSED BY HEALTH CARE PROVIDERS (U.S. CLS. 100 AND 101).

FIRST USE 5-19-2011; IN COMMERCE 5-19-2011.

AMY KELLY, EXAMINING ATTORNEY

SN 85-454,514. JETEX FZCO, DUBAI, UNITED ARAB EMIR., FILED 10-24-2011.

JETEX

THE MARK CONSISTS OF STANDARD CHARACTERS WITHOUT CLAIM TO ANY PARTICULAR FONT, STYLE, SIZE, OR COLOR.

CLASS 37—CONSTRUCTION AND REPAIR

FOR AIRCRAFT FLIGHT-SUPPORT SERVICES, NAMELY, GROUND-SUPPORT SERVICES FOR AIRCRAFT, NAMELY, AIRCRAFT FUELING, AIRCRAFT DE-ICING, AIRCRAFT INTERIOR AND EXTERIOR CLEANING SERVICES; DELIVERING FUEL AND WATER TO AIRCRAFT, PUSHING AND PULLING IN AIRCRAFT, AND PREPARING FLIGHT PLANS AND ARRANGING OVERFLY AND LANDING PERMITS (U.S. CLS. 100, 103 AND 106).

FIRST USE 1-25-2010; IN COMMERCE 1-25-2010.

CLASS 39—TRANSPORTATION AND STORAGE

FOR AIRCRAFT GROUND HANDLING AND COORDINATION AND FIXED-BASE OPERATIONS IN THE NATURE OF ESCORTING PASSENGERS AND FLIGHT CREW THROUGH AIRPORT FACILITIES, DELIVERING FUEL AND WATER TO AIRCRAFT, PUSHING AND PULLING IN AIRCRAFT, PREPARING FLIGHT PLANS AND ARRANGING OVERFLY AND LANDING PERMITS; TRAVEL SERVICES FOR GENERAL AVIATION, NAMELY, PREPARING COMPUTERIZED FLIGHT PLANS, AND ARRANGING FOR OVERFLY AND LANDING PERMITS, AND HOTEL ACCOMMODATIONS (U.S. CLS. 100 AND 105).

FIRST USE 1-25-2010; IN COMMERCE 1-25-2010.

DAVID I, EXAMINING ATTORNEY

SN 85-454,706. ORE INTERNATIONAL, INC., CERRITOS, CA. FILED 10-24-2011.

ORE INTERNATIONAL

THE MARK CONSISTS OF STANDARD CHARACTERS WITHOUT CLAIM TO ANY PARTICULAR FONT, STYLE, SIZE, OR COLOR.

NO CLAIM IS MADE TO THE EXCLUSIVE RIGHT TO USE "INTERNATIONAL", APART FROM THE MARK AS SHOWN.

CLASS 11—ENVIRONMENTAL CONTROL APPARATUS

FOR LAMPS, NAMELY, TABLE LAMPS, FLOOR LAMPS, DESK LAMPS; DECORATIVE FOUNTAINS, NAMELY, FLOOR AND TABLETOP FOUNTAINS, ORNAMENTAL FOUNTAINS (U.S. CLS. 13, 21, 23, 31 AND 34).

FIRST USE 1-5-2004; IN COMMERCE 1-5-2004.

CLASS 20—FURNITURE AND ARTICLES NOT OTHERWISE CLASSIFIED

FOR FURNITURE, NAMELY, CHESTS, DRESSERS, ACCENT TABLES, SIDE TABLES, END TABLES, TABLES, PEDESTAL TABLES, OCCASIONAL TABLES, PHONE TABLES, COFFEE TABLES, MAGAZINE TABLES, PLANT STANDS, UMBRELLA STANDS, TOWEL STANDS, CORNER HAT STANDS, TABLE TOPS, MAGAZINE RACKS, FOOT STOOLS WITH STORAGE, DINETTE SETS IN THE NATURE OF DINING ROOM TABLES AND CHAIRS, VANITY TABLES, MIRROR DRESSERS, SIDEBOARDS, WRITING SURFACE TABLES, DESKS, BOOKSHELVES, BOOKCASES, MEDIA STORAGE TOWERS IN THE NATURE OF SHELVES, MEDIA WALL STORAGE RACKS, NON-METAL WALL HANGERS FOR PICTURES AND MIRRORS, SHOE RACKS, NON-METAL KEY HOLDERS, CHAIRS, DESKS, ENTERTAINMENT CONSOLE TABLES, TV STANDS, MEDIA TELEVISION STANDS, CORNER CABINETS, NIGHTSTANDS, SOFAS, SLEEPER SOFAS, LOVE SEATS, ACCENT CHAIRS, ARMCHAIRS, SIDE CHAIRS, SLEEPER SOFAS WITH STORAGE, OTTOMANS, SWIVEL CHAIRS, ROOM DIVIDERS, OUTDOOR FURNITURE, LAWN CHAIRS, COAT HANGERS WITH WHEELS, WINE RACK WITH WHEELS, KITCHEN CART IN THE NATURE OF TEA AND COFFEE CARTS, KITCHEN FURNITURE WORK CENTER CONTAINING STORAGE IN THE NATURE OF A KITCHEN ISLAND, WINE TABLES, BAR STOOLS, STOOLS, TOY STORAGE RACKS, HIGH CHAIRS, CHILDREN'S FURNITURE, PICNIC TABLES, ARM CHAIRS; BEAN BAG CHAIRS; BOOSTER CHAIRS, COAT RACKS, WINE RACKS, AND SERVING TROLLEYS (U.S. CLS. 2, 13, 22, 25, 32 AND 50).

FIRST USE 1-5-2004; IN COMMERCE 1-5-2004.

TARAH HARDY, EXAMINING ATTORNEY

SN 85-454,707. ROWLEY, CYNTHIA, NEW YORK, NY. FILED 10-24-2011.

CR BY CYNTHIA ROWLEY

THE MARK CONSISTS OF STANDARD CHARACTERS WITHOUT CLAIM TO ANY PARTICULAR FONT, STYLE, SIZE, OR COLOR.

OWNER OF U.S. REG. NOS. 3,300,792, 3,944,583 AND OTHERS.

THE NAME "CYNTHIA ROWLEY" IDENTIFIES A LIVING INDIVIDUAL WHOSE CONSENT IS OF RECORD.

CLASS 18—LEATHER GOODS

FOR HANDBAGS (U.S. CLS. 1, 2, 3, 22 AND 41).
FIRST USE 8-0-2011; IN COMMERCE 8-0-2011.

CLASS 25—CLOTHING

FOR CLOTHING, NAMELY, SHOES, PANTS, DRESSES, SKIRTS, SHIRTS AND SWEATERS (U.S. CLS. 22 AND 39).

FIRST USE 8-0-2011; IN COMMERCE 8-0-2011.
AISHA SALEM, EXAMINING ATTORNEY



SN 85-454,748. GROOVBOSTON, LLC, WOBURN, MA.
FILED 10-24-2011.



THE MARK CONSISTS OF A DESIGN OF HEADPHONES AND FLAMES.

CLASS 25—CLOTHING

FOR CLOTHING, NAMELY, T-SHIRTS (U.S. CLS. 22 AND 39).
FIRST USE 8-26-2011; IN COMMERCE 8-26-2011.

CLASS 41—EDUCATION AND ENTERTAINMENT

FOR ENTERTAINMENT SERVICES IN THE NATURE OF DISC JOCKEYS FOR SPECIAL EVENTS; ARRANGING AND CONDUCTING MOBILE NIGHTCLUB EVENTS (U.S. CLS. 100, 101 AND 107).

FIRST USE 8-26-2011; IN COMMERCE 8-26-2011.
KATHLEEN LORENZO, EXAMINING ATTORNEY

SN 85-455,662. DAVE & BUSTER'S I, L.P., DALLAS, TX.
FILED 10-25-2011.

OWNER OF U.S. REG. NOS. 1,491,691, 3,176,873 AND OTHERS.

THE COLOR(S) ORANGE, WHITE AND BLUE IS/ARE CLAIMED AS A FEATURE OF THE MARK.

THE MARK CONSISTS OF "DAVE" ABOVE THE WORD "AND", WHICH WORD HAS ORANGE LINES EXTENDING TO ITS LEFT AND RIGHT, BOTH OF WHICH DESIGNATIONS ARE IN SCRIPT TYPE, UNDER WHICH IS "BUSTER'S" IN BLOCK LETTERS, ALL OF WHICH DESIGNATIONS ARE PRESENTED IN WHITE LETTERING CONTAINED WITHIN A CIRCLE THE CENTER PORTION OF WHICH IS BLUE AROUND WHICH THERE IS A WHITE RING WITHIN AN OUTER BLUE RING.

CLASS 21—HOUSEWARES AND GLASS

FOR PORCELAIN COFFEE MUGS AND EARTHENWARE MUGS, BEVERAGE CONTAINERS, NAMELY, THERMAL INSULATED CONTAINERS, SHOT GLASSES, PLASTIC CUPS SOLD AS A UNIT WITH DRINKING STRAWS, DRINKING GLASSES, PLASTIC TUMBLERS (U.S. CLS. 2, 13, 23, 29, 30, 33, 40 AND 50).

CLASS 25—CLOTHING

FOR CLOTHING, NAMELY, T-SHIRTS, SWEATSHIRTS, BOXER SHORTS, BOXER BRIEFS, POLO SHIRTS, BASEBALL CAPS (U.S. CLS. 22 AND 39).

CLASS 28—TOYS AND SPORTING GOODS

FOR GAMES, PLAYTHINGS AND SPORTING ARTICLES, NAMELY, BASKETBALLS, SOCCER BALLS, FLYING DISCS, PLAYGROUND BALLS (U.S. CLS. 22, 23, 38 AND 50).

CLASS 41—EDUCATION AND ENTERTAINMENT

FOR PROVIDING ENTERTAINMENT SERVICES IN THE NATURE OF INDOOR AMUSEMENT COMPLEXES (U.S. CLS. 100, 101 AND 107).

CLASS 43—HOTEL AND RESTAURANT SERVICES

FOR RESTAURANT AND BAR SERVICES (U.S. CLS. 100 AND 101).
CHERYL CLAYTON, EXAMINING ATTORNEY

SN 85-456,238. THE NASDAQ OMX GROUP, INC., NEW YORK, NY. FILED 10-26-2011.

NASDAQ OMX NORDIC

THE MARK CONSISTS OF STANDARD CHARACTERS WITHOUT CLAIM TO ANY PARTICULAR FONT, STYLE, SIZE, OR COLOR.

OWNER OF U.S. REG. NOS. 922,973, 2,156,075 AND OTHERS.

NO CLAIM IS MADE TO THE EXCLUSIVE RIGHT TO USE "NORDIC", APART FROM THE MARK AS SHOWN.

CLASS 9—ELECTRICAL AND SCIENTIFIC APPARATUS

FOR SOFTWARE FOR TRADING, UPDATING, CLEARING AND SETTLEMENT OF SECURITIES, FOR OPERATION OF STOCK EXCHANGES OR OTHER FINANCIAL MARKETPLACES, FOR PROVIDING INFORMATION AND ANALYSIS RELATING TO THE SECURITIES MARKET AND SECURITIES (U.S. CLS. 21, 23, 26, 36 AND 38).

CLASS 35—ADVERTISING AND BUSINESS

FOR CALCULATION, RECORDATION, COMPILATION AND SYSTEMATIZATION OF STATISTICS AND INDEXES CONCERNING SECURITIES TRADING, FINANCIAL INTERESTS, PRICES, EXCHANGE RATES AND OTHER ECONOMIC DATA CONCERNING SECURITIES, AND PROVIDING SUCH INFORMATION VIA THE INTERNET (U.S. CLS. 100, 101 AND 102).

CLASS 36—INSURANCE AND FINANCIAL

FOR FINANCIAL SERVICES, NAMELY, CONDUCTING A SECURITIES EXCHANGE, PROVIDING CLEARING AND SETTLEMENT SERVICES FOR STOCKS, EQUITY INDICES, CONTRACTS ON STOCKS, BONDS, OPTIONS, EQUITIES, FUTURES, OTHER SECURITIES AND CURRENCIES; SECURITIES ADMINISTRATION, NAMELY, MANAGEMENT OF PORTFOLIOS COMPRISING SECURITIES; COLLECTING AND PROVIDING FINANCIAL INFORMATION IN THE NATURE OF SECURITIES MARKET DATA, QUOTATIONS, ORDERS, MARKET TRANSACTIONS, AND FINANCIAL INDEX VALUES; LISTING OF SECURITIES AND SECURITIES DERIVATIVES FOR QUOTATION AND TRADING; PROVIDING AND UPDATING AN INDEX OF SECURITIES VALUES AND CLASSIFICATION, ANALYSIS, AND REPORTING THEREOF; FINANCIAL GUARANTEE SERVICES TO GUARANTEE THE VENDOR'S LIABILITY; PROVIDING FINANCIAL AND SECURITIES INFORMATION; SECURITIES EXCHANGE PRICE QUOTATION SERVICES; PROVIDING AN ONLINE DATABASE FEATURING REAL TIME INVESTMENT INFORMATION (U.S. CLS. 100, 101 AND 102).

CLASS 38—COMMUNICATION

FOR PROVIDING ACCESS TO AN ONLINE DATABASE FEATURING REAL TIME INVESTMENT INFORMATION; ELECTRONIC TRANSMISSION OF FINANCIAL INSTRUMENTS MARKET INFORMATION, QUOTATIONS AND ORDERS; PROVIDING COMMUNICATIONS NETWORKS FOR COLLECTION, PROCESSING, DISTRIBUTION AND TRANSMISSION OF FINANCIAL INSTRUMENTS AND MARKET INFORMATION (U.S. CLS. 100, 101 AND 104).

CLASS 42—SCIENTIFIC AND COMPUTER SERVICES

FOR DESIGN, INSTALLATION, MAINTENANCE AND DEVELOPMENT OF SOFTWARE FOR TRADING, CLEARING AND SETTLEMENT AND HANDLING OF SECURITIES, FOR THE OPERATION OF FINANCIAL MARKET PLACES, AND FOR INFORMATION RELATING TO THE STOCK MARKET AND SECURITIES; SOFTWARE SURVEILLANCE SERVICES IN THE NATURE OF SOFTWARE MONITORING SERVICES WHICH TRACK SOFTWARE PERFORMANCE; COMPUTER SOFTWARE CONSULTANCY REGARDING THE TRADING, CLEARING AND SETTLEMENT AND HANDLING OF SECURITIES, THE OPERATION OF FINANCIAL MARKET PLACES AND INFORMATION RELATING TO THE SECURITIES MARKET AND SECURITIES; COMPUTER PROGRAMMING FOR OTHERS (U.S. CLS. 100 AND 101).

CURTIS FRENCH, EXAMINING ATTORNEY

SN 85-457,464. BRADFORD COMPANY, HOLLAND, MI. FILED 10-27-2011.

GREENSTREEM

THE MARK CONSISTS OF STANDARD CHARACTERS WITHOUT CLAIM TO ANY PARTICULAR FONT, STYLE, SIZE, OR COLOR.

CLASS 37—CONSTRUCTION AND REPAIR

FOR RECYCLING SERVICES, NAMELY, COLLECTION OF PACKAGING MATERIALS FOR REPROCESSING AND RESALE TO CUSTOMERS (U.S. CLS. 100, 103 AND 106).

FIRST USE 6-1-1998; IN COMMERCE 6-1-1998.

CLASS 40—MATERIAL TREATMENT

FOR RECYCLING SERVICES, NAMELY, RECYCLING AND REPROCESSING OF PACKAGING MATERIALS FOR REUSE (U.S. CLS. 100, 103 AND 106).

FIRST USE 6-1-1998; IN COMMERCE 6-1-1998.

ALYSSA STEEL, EXAMINING ATTORNEY

SN 85-458,392. CELLFREE SCIENCES CO., LTD., KANAGAWA-KEN, JAPAN, FILED 10-27-2011.



OWNER OF U.S. REG. NO. 3,018,593.

NO CLAIM IS MADE TO THE EXCLUSIVE RIGHT TO USE "CELL FREE SCIENCES", APART FROM THE MARK AS SHOWN.

THE COLOR(S) YELLOW, ORANGE, BLACK AND BLUE IS/ARE CLAIMED AS A FEATURE OF THE MARK.

THE MARK CONSISTS OF THE STYLIZED LETTERS "C", "F", "S", DRAWN IN BLUE. THE WORDING "CELL-FREE SCIENCES" IS DRAWN IN BLACK AND BENEATH THE LETTERS "C", "F", "S". TO THE LEFT OF THE LITERAL PORTION OF THE MARK, FOUR IRREGULAR CIRCLES ARE DRAWN, THE LEFT HEMISPHERE OF EACH CIRCLE IS DRAWN IN ORANGE; THE RIGHT SIDE IN YELLOW. THE CIRCLES INCREASE IN SIZE AS THEY ASCEND FROM THE LOWER PORTION TO THE UPPER RIGHT HAND CORNER OF THE MARK.

CLASS 1—CHEMICALS

FOR CHEMICAL REAGENTS FOR RESEARCH PURPOSES (U.S. CLS. 1, 5, 6, 10, 26 AND 46).
FIRST USE 7-0-2006; IN COMMERCE 7-0-2006.

CLASS 9—ELECTRICAL AND SCIENTIFIC APPARATUS

FOR AUTOMATIC PROTEIN SYNTHESIZERS (U.S. CLS. 21, 23, 26, 36 AND 38).
FIRST USE 7-0-2006; IN COMMERCE 7-0-2006.
LINDA ORNDORFF, EXAMINING ATTORNEY

SN 85-459,274. OBSHCHESTVO S OGRANICHENNOY OT-VETSTVENNOSTYU "RUSINVEST", MYTISHCHI, RUSSIAN FED., FILED 10-28-2011.



BUHALO

THE COLOR(S) BLACK, WHITE, GRAY, DARK GRAY, SILVER, YELLOW-GREEN, BROWN, BEIGE, AND GOLD IS/ARE CLAIMED AS A FEATURE OF THE MARK.

THE MARK CONSISTS OF A DESIGN OF A BITTERN WITH BLACK, GRAY, DARK GRAY, SILVER, YELLOW-GREEN, BROWN, AND BEIGE COLORED FEATHERS WITH A BROWN BEAK, A WHITE AND BLACK EYE, AND A BLACK OUTLINE WITH THE STYLIZED WORDING "BUHALO" IN STYLIZED FONT IN GOLD LOCATED BELOW THE DESIGN.

THE ENGLISH TRANSLATION OF "BUHALO" IN THE MARK IS "BITTERN".

CLASS 32—LIGHT BEVERAGES

FOR NONALCOHOLIC APERITIFS; BOTTLED WATER, KVASS, NONALCOHOLIC COCKTAILS; LEMONADES; NONALCOHOLIC BEVERAGES, NAMELY, SODA POP, FRUIT JUICE; ISOTONIC BEVERAGES; NONALCOHOLIC HONEY-BASED BEVERAGES; WHEY BEVERAGES; NONALCOHOLIC FRUIT JUICE BEVERAGES; NONALCOHOLIC FRUIT NECTARS; ORGEAT; BEER; NONALCOHOLIC BEER; SARSAPARILLA; NONALCOHOLIC CIDER; VEGETABLE JUICES; FRUIT JUICES; ESSENCES FOR MAKING LIQUEURS; ESSENCES FOR MAKING MINERAL WATER; PREPARATIONS FOR MAKING BEVERAGES, NAMELY, SODA POP, FRUIT JUICE; MUST; SHERBETS; NONALCOHOLIC FRUIT EXTRACTS; EXTRACTS OF HOPS FOR MAKING BEER; ESSENCES FOR MAKING NON-ALCOHOLIC BEVERAGES (U.S. CLS. 45, 46 AND 48).

CLASS 33—WINES AND SPIRITS

FOR APERITIFS; BRANDY; WINES; PIQUETTE; WHISKY; VODKA; GIN; DIGESTER LIQUEURS AND SPIRITS; PREPARED ALCOHOLIC COCKTAILS; LIQUEURS; ALCOHOLIC BEVERAGES, EXCEPT BEER; ALCOHOLIC BEVERAGES CONTAINING FRUIT; SPIRITS; DISTILLED SPIRITS; MEAD AND HYDROMEL; PEPPERMINT LIQUEURS; ALCOHOLIC BITTERS; RUM; SAKE; HARD CIDER; ALCOHOLIC BEVERAGES MADE FROM RICE; ALCOHOLIC EXTRACTS; FRUIT EXTRACTS, ALCOHOLIC; ALCOHOLIC ESSENCES (U.S. CLS. 47 AND 49).

DAVID TOOLEY, EXAMINING ATTORNEY

SN 85-459,438. AIRLINES MERCHANDISING WHOLESALE, INC., HONOLULU, HI. FILED 10-28-2011.



NO CLAIM IS MADE TO THE EXCLUSIVE RIGHT TO USE "MAUI", APART FROM THE MARK AS SHOWN.

THE MARK CONSISTS OF THE STYLIZED LETTERS "MP" ABOVE THE WORDING "MAUI PURE" WITHIN A MULTIPLE BORDER RECTANGULAR CARRIER.

CLASS 3—COSMETICS AND CLEANING PREPARATIONS

FOR COSMETIC PREPARATIONS FOR SKIN FEATURING BOTANICAL EXTRACTS; COSMETIC PREPARATIONS FOR SKIN FEATURING NONI EXTRACTS; COSMETICS; COSMETIC OILS; COSMETIC CREAMS; COSMETIC GELS; COSMETIC LOTIONS; COSMETIC PREPARATIONS FOR SKIN RENEWAL; COSMETIC PREPARATIONS FOR BODY CARE; COSMETIC SOAPS; COSMETIC SUNTAN LOTIONS; COSMETIC SUN-PROTECTING PREPARATIONS; COSMETIC SUN-TANNING PREPARATIONS; NUTRITIONAL OILS FOR COSMETIC PURPOSES; FACE CREAMS FOR COSMETIC USE; SKIN CREAMS FOR COSMETIC USE; SKIN AND BODY TOPICAL LOTIONS; CREAMS AND OILS FOR COSMETIC USE; SOAPS; TOPICAL SKIN SPRAYS FOR COSMETIC PURPOSES; MASSAGE LOTION; FACIAL TONER; SHAMPOO; HAIR CONDITIONER; SKIN MASKS; AFTER-SUN GELS; AFTER SUN CREAMS; BODY, FACIAL AND HAND SCRUBS; SKIN TONER; BODY WASHES; CREAM FACIAL CLEANSERS; CREAM SKIN CLEANSERS; GEL FACIAL CLEANSERS; GEL BODY CLEANSERS FOR THE SKIN; BATH SALTS; FACIAL CREAMS AND GELS FOR SKIN LIFTING PURPOSES; EYE LOTIONS FOR CONTOUR PURPOSES; ANTI-WRINKLE CREAMS; AND ANTI-WRINKLE GELS (U.S. CLS. 1, 4, 6, 50, 51 AND 52).
FIRST USE 10-1-2011; IN COMMERCE 10-1-2011.

CLASS 5—PHARMACEUTICALS

FOR NUTRICEUTICALS FOR USE AS A DIETARY SUPPLEMENT; DIETARY SUPPLEMENTS; NUTRITIONAL SUPPLEMENTS; NUTRITIONAL ADDITIVES FOR MEDICAL PURPOSES FOR USE IN FOODS AND DIETARY SUPPLEMENTS FOR HUMAN CONSUMPTION; NON-MEDICATED ADDITIVES FOR ANIMAL FEED FOR USE AS NUTRITIONAL SUPPLEMENTS; DIETARY SUPPLEMENTAL DRINKS; FOOD SUPPLEMENTS; FOOD SUPPLEMENTS, NAMELY, ANTI-OXIDANTS; HERBAL SUPPLEMENTS; HOMEOPATHIC SUPPLEMENTS; NUTRITIONAL SUPPLEMENTS IN LOTION FORM SOLD AS A COMPONENT OF NUTRITIONAL SKIN CARE PRODUCTS; POWDERED NUTRITIONAL SUPPLEMENT DRINK MIX; VITAMIN AND MINERAL SUPPLEMENTS (U.S. CLS. 6, 18, 44, 46, 51 AND 52).

FIRST USE 10-1-2011; IN COMMERCE 10-1-2011.
SALLY SHIH, EXAMINING ATTORNEY

SN 85-459,789. EXCELLENT TREASURE TECHNOLOGIES LIMITED, SUNNYVALE, CA. FILED 10-30-2011.

LIBPPE

THE MARK CONSISTS OF THE WORDING "LIBPPE" IN STYLIZED FONT.

CLASS 9—ELECTRICAL AND SCIENTIFIC APPARATUS

FOR STANDS FOR PHOTOGRAPHIC APPARATUS (U.S. CLS. 21, 23, 26, 36 AND 38).

CLASS 11—ENVIRONMENTAL CONTROL APPARATUS

FOR LAMP CASINGS; LAMP MANTLES; LED (LIGHT EMITTING DIODE) LIGHTING FIXTURES; LIGHT DIFFUSERS; LIGHTING APPARATUS, NAMELY, LIGHTING INSTALLATIONS (U.S. CLS. 13, 21, 23, 31 AND 34).
SUSAN STIGLITZ, EXAMINING ATTORNEY

SN 85-460,403. BUNZL DISTRIBUTION USA, INC., CREVE COEUR, MO. FILED 10-31-2011.

HI-VALU

THE MARK CONSISTS OF STANDARD CHARACTERS WITHOUT CLAIM TO ANY PARTICULAR FONT, STYLE, SIZE, OR COLOR.

OWNER OF U.S. REG. NOS. 3,613,902, 3,626,948 AND OTHERS.

CLASS 3—COSMETICS AND CLEANING PREPARATIONS

FOR HAND SOAP, ANTIMICROBIAL SOAP, LIQUID SOAPS (U.S. CLS. 1, 4, 6, 50, 51 AND 52).
FIRST USE 8-31-2011; IN COMMERCE 8-31-2011.

CLASS 21—HOUSEWARES AND GLASS

FOR DISPENSERS FOR LIQUID SOAP (U.S. CLS. 2, 13, 23, 29, 30, 33, 40 AND 50).

FIRST USE 8-31-2011; IN COMMERCE 8-31-2011.
ANN E. SAPPENFIELD, EXAMINING ATTORNEY

SN 85-461,965. NEST LABS, INC., PALO ALTO, CA. FILED 11-1-2011.



PRIORITY CLAIMED UNDER SEC. 44(D) ON JAMAICA APPLICATION NO. 58662, FILED 8-15-2011.

THE MARK CONSISTS OF SILHOUETTE OF HOUSE WITH ARCH FOR FRONT DOOR.

CLASS 9—ELECTRICAL AND SCIENTIFIC APPARATUS

FOR THERMOSTATS; CLIMATE CONTROL SYSTEM CONSISTING OF A DIGITAL THERMOSTAT THAT CAN BE CONTROLLED WIRELESSLY FROM A REMOTE LOCATION; SOFTWARE APPLICATION FOR USE ON COMPUTERS AND HAND-HELD DEVICES TO CONTROL CLIMATE AND ENERGY USAGE IN HOMES AND BUSINESSES FROM A REMOTE LOCATION (U.S. CLS. 21, 23, 26, 36 AND 38).

CLASS 35—ADVERTISING AND BUSINESS

FOR PROMOTIONAL SERVICES, NAMELY, CREATING ADVERTISING MESSAGES AND CREATING PROMOTIONAL INCENTIVES FOR ENERGY USERS TO REDUCE THEIR ENERGY USE (U.S. CLS. 100, 101 AND 102).

CLASS 38—COMMUNICATION

FOR ELECTRONIC TRANSMISSION OF MESSAGES (U.S. CLS. 100, 101 AND 104).

SUSAN LESLIE DUBOIS, EXAMINING ATTORNEY

SN 85-462,143. ORIND SPECIAL REFRACTORIES PVT. LTD., MUMBAI, MAHARASHTRA, INDIA, FILED 11-2-2011.

ORIBON

THE MARK CONSISTS OF STANDARD CHARACTERS WITHOUT CLAIM TO ANY PARTICULAR FONT, STYLE, SIZE, OR COLOR.

CLASS 8—HAND TOOLS

FOR LADLES, NAMELY, FOUNDRY LADLES FOR USE IN STEEL PLANTS (U.S. CLS. 23, 28 AND 44).

CLASS 19—NON-METALLIC BUILDING MATERIALS

FOR MAGNESIA CARBON BRICKS FOR BASIC OXY-GEN FURNACE AND ELECTRIC ARC FURNACES IN STEEL PLANTS (U.S. CLS. 1, 12, 33 AND 50).
ELLEN PERKINS, EXAMINING ATTORNEY

SN 85-463,415. PATRICK HENRY BREWING COMPANY, LAS VEGAS, NV. FILED 11-3-2011.

**PATRICK HENRY BREWING
COMPANY**

THE MARK CONSISTS OF STANDARD CHARACTERS WITHOUT CLAIM TO ANY PARTICULAR FONT, STYLE, SIZE, OR COLOR.

NO CLAIM IS MADE TO THE EXCLUSIVE RIGHT TO USE "BREWING COMPANY", APART FROM THE MARK AS SHOWN.

THE NAME "PATRICK HENRY" DOES NOT IDENTIFY A LIVING INDIVIDUAL.

CLASS 30—STAPLE FOODS

FOR COFFEE; TEA AND BEVERAGES MADE WITH TEA (U.S. CL. 46).

CLASS 32—LIGHT BEVERAGES

FOR BEER AND ALE; SOFT DRINKS; FRUIT BEVERAGES; FRUIT-FLAVORED BEVERAGES; ENERGY DRINKS; SPORTS DRINKS (U.S. CLS. 45, 46 AND 48).

CLASS 43—HOTEL AND RESTAURANT SERVICES

FOR PUBS; RESTAURANT AND BAR SERVICES (U.S. CLS. 100 AND 101).
CHRISTINA SOBRAL, EXAMINING ATTORNEY

SN 85-464,140. IHS GLOBAL INC., ENGLEWOOD, CO. FILED 11-3-2011.

**ADVANCING DECISIONS THAT
ADVANCE THE WORLD**

THE MARK CONSISTS OF STANDARD CHARACTERS WITHOUT CLAIM TO ANY PARTICULAR FONT, STYLE, SIZE, OR COLOR.

CLASS 9—ELECTRICAL AND SCIENTIFIC APPARATUS

FOR COMPUTER SOFTWARE FOR CREATING SEARCHABLE DATABASES OF INFORMATION AND DATA; COMPUTER SOFTWARE FOR USE IN DATABASE MANAGEMENT AND COMPILING, MONITORING, AND UPDATING INFORMATION AND DATA IN THE FIELDS OF ENVIRONMENTAL COMPLIANCE, ENERGY, NATURAL RESOURCES, SUPPLY CHAIN MANAGEMENT, PRODUCT DESIGN, DEFENSE, SECURITY, PUBLIC SAFETY, ECONOMIC FORECASTING AND ANALYSIS, AEROSPACE, AUTOMOTIVE, AGRICULTURE, CONSTRUCTION, CONSUMER GOODS, RETAIL MARKETS, ELECTRONICS, TELECOMMUNICATIONS, FINANCIAL MANAGEMENT, GOVERNMENT AFFAIRS, HEALTHCARE, PHARMACEUTICALS, MINING, UTILITIES, SHIPPING, TRANSPORTATION, CHEMICALS, AND COMMODITIES; DOWNLOADABLE COMPUTER SOFTWARE FOR USE IN DATABASE MANAGEMENT AND COMPILING, MONITORING, AND UPDATING INFORMATION AND DATA IN THE FIELDS OF ENVIRONMENTAL COMPLIANCE, ENERGY, NATURAL RESOURCES, SUPPLY CHAIN MANAGEMENT, PRODUCT DESIGN, DEFENSE, SECURITY, PUBLIC SAFETY, ECONOMIC FORECASTING AND ANALYSIS, AEROSPACE, AUTOMOTIVE, AGRICULTURE, CONSTRUCTION, CONSUMER GOODS, RETAIL MARKETS, ELECTRONICS, TELECOMMUNICATIONS, FINANCIAL MANAGEMENT, GOVERNMENT AFFAIRS, HEALTHCARE, PHARMACEUTICALS, MINING, UTILITIES, SHIPPING, TRANSPORTATION, CHEMICALS, AND COMMODITIES; DOWNLOADABLE ELECTRONIC NEWSLETTERS IN THE FIELDS OF ENVIRONMENTAL COMPLIANCE, ENERGY, NATURAL RESOURCES, SUPPLY CHAIN MANAGEMENT, PRODUCT DESIGN, DEFENSE, SECURITY, PUBLIC SAFETY, ECONOMIC FORECASTING AND ANALYSIS, AEROSPACE, AUTOMOTIVE, AGRICULTURE, CONSTRUCTION, CONSUMER GOODS, RETAIL MARKETS, ELECTRONICS, TELECOMMUNICATIONS, FINANCIAL MANAGEMENT, GOVERNMENT AFFAIRS, HEALTHCARE, PHARMACEUTICALS, MINING, UTILITIES, SHIPPING, TRANSPORTATION, CHEMICALS, AND COMMODITIES (U.S. CLS. 21, 23, 26, 36 AND 38).

CLASS 16—PAPER GOODS AND PRINTED MATTER

FOR PRINTED REPORTS IN THE FIELDS OF ENVIRONMENTAL COMPLIANCE, ENERGY, NATURAL RESOURCES, SUPPLY CHAIN MANAGEMENT, PRODUCT DESIGN, DEFENSE, SECURITY, PUBLIC SAFETY, ECONOMIC FORECASTING AND ANALYSIS, AEROSPACE, AUTOMOTIVE, AGRICULTURE, CONSTRUCTION, CONSUMER GOODS, RETAIL MARKETS, ELECTRONICS, TELECOMMUNICATIONS, FINANCIAL MANAGEMENT, GOVERNMENT AFFAIRS, HEALTHCARE, PHARMACEUTICALS, MINING, UTILITIES, SHIPPING, TRANSPORTATION, CHEMICALS, AND COMMODITIES (U.S. CLS. 2, 5, 22, 23, 29, 37, 38 AND 50).
EDWARD FENNESSY, EXAMINING ATTORNEY

SN 85-464,696. PURA STAINLESS, LLC, SANTA BARBARA, CA. FILED 11-4-2011.



THE MARK CONSISTS OF TWO RAINDROPS WITH THE LARGER IMAGE ON THE BOTTOM LEFT HAND CORNER AND A SMALLER IMAGE AT THE TOP RIGHT HAND CORNER.

CLASS 10—MEDICAL APPARATUS

FOR BABY BOTTLES; SLEEVES FOR BABY BOTTLES; BABY BOTTLE ACCESSORIES, NAMELY, NIPPLES, SPOUTS, BOTTLE COLLARS, TRAVEL AND STORAGE CAPS; STAINLESS STEEL BABY BOTTLES SOLD EMPTY (U.S. CLS. 26, 39 AND 44).

CLASS 21—HOUSEWARES AND GLASS

FOR STAINLESS STEEL BEVERAGE BOTTLES SOLD EMPTY (U.S. CLS. 2, 13, 23, 29, 30, 33, 40 AND 50).
JOHN HWANG, EXAMINING ATTORNEY

SN 85-465,336. CONNAT, INC., CORONA, CA. FILED 11-5-2011.



THE COLOR(S) LIGHT BLUE AND MAGENTA IS/ARE CLAIMED AS A FEATURE OF THE MARK.

THE MARK CONSISTS OF THE WORD "CONNAT" IN MAGENTA. A LIGHT BLUE CIRCLE WITH A POINT REMINISCENT OF A THOUGHT OR SPEECH CLOUD IS AROUND THE LETTER "C" WHICH IS BROKEN AT THE LETTER "O".

THE WORDING "CONNAT" HAS NO MEANING IN A FOREIGN LANGUAGE.

CLASS 9—ELECTRICAL AND SCIENTIFIC APPARATUS

FOR COMPUTER APPLICATION SOFTWARE FOR MOBILE COMPUTERS, NAMELY, SOFTWARE FOR FACILITATING ONLINE SERVICES FOR SOCIAL NETWORKING, BUILDING SOCIAL NETWORKING AND FOR ALLOWING DATA RETRIEVAL, UPLOAD, DOWNLOAD, ACCESS AND MANAGEMENT, DISPLAYING AND SHARING A USER'S LOCATION AND FINDING, LOCATING, AND INTERACTING WITH OTHER USERS AND PLACES; COMPUTER GAME SOFTWARE DOWNLOADABLE FROM A GLOBAL COMPUTER NETWORK; COMPUTER GAME SOFTWARE FOR USE ON MOBILE AND CELLULAR PHONES; COMPUTER SOFTWARE FOR APPLICATION AND DATABASE INTEGRATION; COMPUTER SOFTWARE FOR CREATING SEARCHABLE DATABASES OF INFORMATION AND DATA; COMPUTER SOFTWARE FOR PROCESSING DIGITAL IMAGES; DOWNLOADABLE MOBILE APPLICATION GRAPHICS SOFTWARE FOR CREATING AND ADDING STYLIZED ICONS TO USER INTERFACE SOFTWARE; DOWNLOADABLE COMPUTER SOFTWARE FOR DISPLAYING AND SHARING A USER'S LOCATION AND FINDING, LOCATING, AND INTERACTING WITH OTHER USERS AND PLACES; DOWNLOADABLE IMAGE FILES CONTAINING IMAGES OF ANIMALS, AUTOMOBILES, BUILDINGS, CARTOON CHARACTERS, COMPUTERS AND COMPUTER PERIPHERAL DEVICES, FOOD PRODUCTS, LANDSCAPES, PEOPLE, PLANTS, PLAYING CARDS, MACHINES AND POINTS OF INTEREST UPLOADED BY USERS FOR USE IN PERSONAL PROFILES (U.S. CLS. 21, 23, 26, 36 AND 38).

CLASS 35—ADVERTISING AND BUSINESS

FOR ADVERTISEMENT VIA MOBILE PHONE NETWORKS; ADVERTISING AGENCIES; ADVERTISING AND MARKETING; ADVERTISING AND MARKETING SERVICES PROVIDED BY MEANS OF INDIRECT METHODS OF MARKETING COMMUNICATIONS, NAMELY, SOCIAL MEDIA, SEARCH ENGINE MARKETING, INQUIRY MARKETING, INTERNET MARKETING, MOBILE MARKETING, BLOGGING AND OTHER FORMS OF PASSIVE, SHARABLE OR VIRAL COMMUNICATIONS CHANNELS; ADVERTISING AND MARKETING SERVICES, NAMELY, PROMOTING THE GOODS AND SERVICES OF OTHERS; ADVERTISING AND PROMOTIONAL SERVICES; ADVERTISING BY TRANSMISSION OF ON-LINE PUBLICITY FOR THIRD PARTIES THROUGH ELECTRONIC COMMUNICATIONS NETWORKS; ADVERTISING ON THE INTERNET FOR OTHERS; ADVERTISING SERVICES; ADVERTISING SERVICES, NAMELY, PROMOTING AND MARKETING THE GOODS AND SERVICES OF OTHERS THROUGH ALL PUBLIC COMMUNICATION MEANS; ADVERTISING, MARKETING AND PROMOTION SERVICES; ADVERTISING, PROMOTION, AND MARKETING SERVICES, NAMELY, PROVIDING ADVERTISING SPACE VIA THE GLOBAL COMPUTER NETWORK AND AD SERVING IN THE NATURE OF PLACING ADVERTISEMENTS ON WEBSITES FOR OTHERS USING SPECIALIZED COMPUTER SOFTWARE; ADVERTISING, PROMOTION AND MARKETING SERVICES UTILIZING A SOFTWARE APPLICATION FOR USERS TO RECEIVE PROMOTIONAL ITEMS CONSISTING OF COUPONS, REBATES, DISCOUNTS OR SPECIAL OFFERINGS ON GOODS AND/OR SERVICES PROVIDED BY OTHERS; ORGANIZING AND ARRANGING CONTESTS AND INCENTIVE AWARD PROGRAMS TO PROMOTE THE SALE OF PRODUCTS AND SERVICES OF OTHERS FOR OTHERS; COMPUTERIZED ON-LINE ORDERING FEATURING GENERAL MERCHANDISE AND GENERAL CONSUMER GOODS; CONDUCTING MARKET SURVEYS; ELECTRONIC COMMERCE SERVICES, NAMELY, PROVIDING INFORMATION ABOUT PRODUCTS VIA TELECOMMUNICATION NETWORKS FOR ADVERTISING AND SALES PURPOSES; INTERNET ADVERTISING SERVICES; MARKET ANALYSIS AND RESEARCH SERVICES; ON-LINE ADVERTISING AND MARKETING SERVICES; ON-LINE ADVERTISING ON COMPUTER COMMUNICATION NETWORKS; ON-LINE ADVERTISING ON COMPUTER NETWORKS; ON-LINE ADVERTISING SERVICES FOR OTHERS; ONLINE ADVERTISEMENTS; ONLINE ADVERTISING AND PROMOTIONAL SERVICES; ONLINE ADVERTISING VIA A COMPUTER COMMUNICATIONS NETWORK;

ONLINE SERVICE FOR CONNECTING SOCIAL NETWORK USERS WITH RETAILERS FOR THE PURPOSE OF FACILITATING DISCOUNTED PURCHASES; PROMOTING AND MARKETING THE GOODS AND SERVICES OF OTHERS BY DISTRIBUTING ADVERTISING MATERIAL, COUPONS AND DISCOUNT OFFERS VIA TEXT MESSAGES; PROMOTING THE GOODS AND SERVICES OF OTHERS BY MEANS OF DISTRIBUTING ADVERTISING ON THE INTERNET; PROMOTING THE GOODS AND SERVICES OF OTHERS BY MEANS OF WORD-OF-MOUTH AND NONTRADITIONAL MARKETING PROGRAMS; PROMOTING THE GOODS AND SERVICES OF OTHERS BY PROVIDING A WEBSITE FEATURING COUPONS, REBATES, PRICE-COMPARISON INFORMATION, PRODUCT REVIEWS, LINKS TO THE RETAIL WEBSITES OF OTHERS, AND DISCOUNT INFORMATION; PROMOTING THE GOODS AND SERVICES OF OTHERS BY PROVIDING A WEBSITE FEATURING USER UPLOADED MATERIALS, AND LINKS TO THE WEBSITES OF OTHERS; PROMOTING THE GOODS AND SERVICES OF OTHERS BY PROVIDING AN INTERACTIVE WEBSITE WHERE USERS CAN INCREASE THE CURRENT VALUE OF AN ONLINE DISCOUNT BEING OFFERED BY PURCHASING THE GOODS AND SERVICES ASSOCIATED WITH THAT DISCOUNT IN THE FORM OF AN ONLINE COUPON, VOUCHER OR GIFT CARD; PROMOTING THE GOODS AND SERVICES OF OTHERS VIA A GLOBAL COMPUTER NETWORK; PROVISION OF ADVERTISING SPACE BY ELECTRONIC MEANS AND GLOBAL INFORMATION NETWORKS (U.S. CLS. 100, 101 AND 102).

CLASS 38—COMMUNICATION

FOR BROADCASTING SERVICES, NAMELY, TRANSMISSION OF ADVERTISING PROGRAMS AND MEDIA ADVERTISING COMMUNICATIONS VIA DIGITAL COMMUNICATIONS NETWORKS; CHAT ROOM SERVICES FOR SOCIAL NETWORKING; COMMUNICATION BY MOBILE TELEPHONE; COMMUNICATION SERVICES, NAMELY, ELECTRONIC TRANSMISSION OF DATA AND DOCUMENTS AMONG USERS OF COMPUTERS; COMMUNICATION SERVICES, NAMELY, PROVIDING ELECTRONIC TRANSMISSION OF INFORMATION STORED IN A DATABASE VIA INTERACTIVELY COMMUNICATING COMPUTER SYSTEMS; COMMUNICATIONS VIA MULTINATIONAL TELECOMMUNICATION NETWORKS; COMPUTER AIDED TRANSMISSION OF INFORMATION AND IMAGES; COMPUTER SERVICES, NAMELY, PROVIDING ON-LINE FACILITIES FOR REAL-TIME INTERACTION WITH OTHER COMPUTER USERS CONCERNING TOPICS OF EDUCATION; COMPUTER-AIDED TRANSMISSION OF MESSAGES; COMPUTER-AIDED TRANSMISSION OF MESSAGES AND IMAGES; DATA TRANSMISSION AND RECEPTION SERVICES VIA TELECOMMUNICATION MEANS; ELECTRONIC DATA TRANSMISSION; ELECTRONIC MESSAGE SENDING; ELECTRONIC MESSAGE TRANSMISSION; ELECTRONIC STORE-AND-FORWARD MESSAGING; ELECTRONIC TRANSMISSION OF MESSAGES; ELECTRONIC TRANSMISSION OF MESSAGES AND DATA; ELECTRONIC, ELECTRIC, AND DIGITAL TRANSMISSION OF VOICE, DATA, IMAGES, SIGNALS, AND MESSAGES; INSTANT MESSAGING SERVICES; MESSAGE COLLECTION AND TRANSMISSION; MESSAGE SENDING, RECEIVING AND FORWARDING; ON-LINE SERVICES, NAMELY, MESSAGE SENDING; PROVIDING E-MAIL AND INSTANT MESSAGING SERVICES; PROVIDING ON-LINE CHAT ROOMS AND ELECTRONIC BULLETIN BOARDS FOR TRANSMISSION OF MESSAGES AMONG USERS IN THE FIELD OF GENERAL INTEREST; PROVIDING ON-LINE CHAT ROOMS FOR SOCIAL NETWORKING; PROVIDING ON-LINE CHAT ROOMS FOR TRANSMISSION OF MESSAGES AMONG COMPUTER USERS CONCERNING COLLEGIATE LIFE, CLASSIFIEDS, VIRTUAL COMMUNITY, SOCIAL NETWORKING AND TRACKING OF TRENDS; PROVIDING VIRTUAL CHAT ROOMS ESTABLISHED VIA TEXT MESSAGING; TRANSMISSION OF INFORMATION BY ELECTRONIC COMMUNICATIONS NETWORKS; TRANSMISSION OF MESSAGES; TRANSMISSION OF SHORT MESSAGES; WEB MESSAGING (U.S. CLS. 100, 101 AND 104).

CLASS 42—SCIENTIFIC AND COMPUTER SERVICES

FOR COMPUTER HARDWARE AND SOFTWARE DESIGN; COMPUTER PROGRAMMING; COMPUTER PROGRAMMING AND SOFTWARE DESIGN; COMPUTER PROGRAMMING SERVICES FOR CUSTOMERS THAT ENABLES THE CUSTOMER'S DIGITAL DEVICES TO PROCESS NATURAL LANGUAGE QUERIES FROM END USERS; COMPUTER PROGRAMMING SERVICES FOR INCORPORATING STYLIZED ICONS FOR DISPLAYING AND SHARING A USER'S LOCATION AND FINDING, LOCATING, AND INTERACTING WITH OTHER USERS AND PLACES; COMPUTER PROGRAMMING SERVICES, NAMELY, PROGRAMMING A MOBILE APPLICATION FOR OTHERS FOR CONDUCTING INTERACTIVE DISCUSSIONS VIA COMMUNICATION NETWORK; COMPUTER SERVICES, NAMELY, CREATING AN ON-LINE COMMUNITY FOR REGISTERED USERS TO PARTICIPATE IN DISCUSSIONS, GET FEEDBACK FROM THEIR PEERS, FORM VIRTUAL COMMUNITIES, AND ENGAGE IN SOCIAL NETWORKING SERVICES IN THE FIELD OF SOCIAL NETWORKING; COMPUTER SERVICES, NAMELY, CREATING AN ON-LINE COMMUNITY FOR REGISTERED USERS TO DISPLAY AND SHARE A USER'S LOCATION AND FINDING, LOCATING, AND INTERACTING WITH OTHER USERS AND PLACES TO ENABLE USERS WITH MORE PHYSICAL AND VIRTUAL INTERACTION VIA COMPUTER NETWORK; COMPUTER SOFTWARE DESIGN; COMPUTER SOFTWARE DESIGN AND UPDATING; COMPUTER SOFTWARE DEVELOPMENT; COMPUTER SOFTWARE DEVELOPMENT AND COMPUTER PROGRAMMING DEVELOPMENT FOR OTHERS; COMPUTER SOFTWARE DEVELOPMENT IN THE FIELD OF MOBILE APPLICATIONS; COMPUTER SOFTWARE DEVELOPMENT IN THE FIELD OF SOCIAL NETWORKING; COMPUTER SOFTWARE DEVELOPMENT, COMPUTER PROGRAMMING AND MAINTENANCE OF COMPUTER SOFTWARE FOR SOCIAL NETWORKING AND THE EXCHANGE OF MESSAGES AND DATA; COMPUTER SOFTWARE INSTALLATION AND MAINTENANCE; CREATING OF COMPUTER PROGRAMS; CREATING, MAINTAINING, AND MODERNIZING COMPUTER SOFTWARE; DATA MINING; DATA WAREHOUSING; DATABASE DESIGN AND DEVELOPMENT; DESIGN AND DEVELOPMENT OF COMPUTER SOFTWARE; DESIGN AND DEVELOPMENT OF COMPUTERS AND PROGRAMS FOR COMPUTERS; DESIGN AND DEVELOPMENT OF ON-LINE COMPUTER SOFTWARE SYSTEMS; DESIGN AND WRITING OF COMPUTER SOFTWARE; DESIGN, DEVELOPMENT, AND IMPLEMENTATION OF SOFTWARE FOR PROVIDING SOCIAL NETWORKING FOR REGISTERED USERS TO LOOK FOR OTHERS WITH COMMON INTEREST AT A LOCATION NEARBY TO PROVIDE MORE PHYSICAL INTERACTION AMONG THEM; DESIGN, DEVELOPMENT, INSTALLATION AND MAINTENANCE OF COMPUTER SOFTWARE; DESIGN, INSTALLATION, UPDATING AND MAINTENANCE OF COMPUTER SOFTWARE; DESIGN, MAINTENANCE, DEVELOPMENT AND UPDATING OF COMPUTER SOFTWARE; DEVELOPMENT, UPDATING AND MAINTENANCE OF SOFTWARE AND DATA BASES; MAINTENANCE OF SOFTWARE FOR INTERNET ACCESS; PLANNING AND DEVELOPMENT OF ELECTRONIC COMMUNICATIONS NETWORKS; PROVIDING A MEMBERS-ONLY WEBSITE FEATURING TECHNOLOGY WHICH PROVIDES MEMBERS WITH THE ABILITY TO ACCESS A DATABASE THROUGH COMPUTER AND MOBILE PHONE VIA COMPUTER NETWORKS; SOFTWARE DESIGN AND DEVELOPMENT; WRITING AND UPDATING COMPUTER SOFTWARE (U.S. CLS. 100 AND 101).

CLASS 45—PERSONAL AND LEGAL SERVICES

FOR COMPUTER DATING SERVICES; CONDUCTING ON-LINE PERSONAL LIFESTYLE PERFORMANCE ASSESSMENTS AND SKILL ENHANCEMENT PROGRAMS BASED ON PRINCIPLES OF EMOTIONAL INTELLIGENCE, BY MEANS OF PERFORMANCE TRACKING, REWARD AND INCENTIVE PROGRAMS; INTERNET-BASED SOCIAL NETWORKING SERVICES; LICENSING OF COMPUTER SOFTWARE; LICENSING OF INTELLECTUAL PROPERTY; LICENSING OF SOFTWARE FOR MANAGEMENT OF INTELLECTUAL PROPERTY; ON-LINE SOCIAL NETWORKING SERVICES; ONLINE SOCIAL NETWORKING SERVICES PROVIDED THROUGH A COMMUNITY WEBSITE; SOCIAL NETWORKING SERVICES IN THE FIELD OF PERSONAL DEVELOPMENT, NAMELY, SELF IMPROVEMENT, SELF-FULFILLMENT, CHARITABLE, PHILANTHROPIC, VOLUNTEER, PUBLIC AND COMMUNITY SERVICES, AND HUMANITARIAN ACTIVITIES PROVIDED VIA A WEBSITE (U.S. CLS. 100 AND 101).
NELSON SNYDER, EXAMINING ATTORNEY

CLASS 3—COSMETICS AND CLEANING PREPARATIONS

FOR NON-MEDICATED SKIN CARE PRODUCTS, SOAPS, BODY SCRUBS, FACIAL SCRUBS, FOOT SCRUBS, HAND SCRUBS, BODY OILS, SKIN TONERS, SKIN MOISTURIZERS, ALL OF THE FORGOING MADE FROM ALL NATURAL INGREDIENTS (U.S. CLS. 1, 4, 6, 50, 51 AND 52).
FIRST USE 10-1-2011; IN COMMERCE 10-20-2011.

CLASS 4—LUBRICANTS AND FUELS

FOR ECO-SOY CANDLES (U.S. CLS. 1, 6 AND 15).
FIRST USE 10-1-2011; IN COMMERCE 10-20-2011.
BRENDAN MCCAULEY, EXAMINING ATTORNEY

SN 85-466,062. TRANS FAMILY, INC., SAN GABRIEL, CA. FILED 11-7-2011.

SN 85-465,399. TUCKER-JOHNSON, BRENDA, DBA BRENDA'S BODY, OAKLAND, CA. FILED 11-5-2011.

BA MIEN



THE MARK CONSISTS OF STANDARD CHARACTERS WITHOUT CLAIM TO ANY PARTICULAR FONT, STYLE, SIZE, OR COLOR.
THE ENGLISH TRANSLATION OF "BA MIEN" IN THE MARK IS "THREE REGIONS".

CLASS 16—PAPER GOODS AND PRINTED MATTER

FOR RICE PAPER (U.S. CLS. 2, 5, 22, 23, 29, 37, 38 AND 50).

CLASS 29—MEATS AND PROCESSED FOODS

FOR FROZEN FRUITS, SEAFOOD (U.S. CL. 46).

CLASS 30—STAPLE FOODS

FOR RICE (U.S. CL. 46).
DANNEAN HETZEL, EXAMINING ATTORNEY

SN 85-466,337. UNITEUS ENTERTAINMENT LLC, PASADENA, CA. FILED 11-7-2011.

UNITEUS

THE MARK CONSISTS OF STANDARD CHARACTERS WITHOUT CLAIM TO ANY PARTICULAR FONT, STYLE, SIZE, OR COLOR.

OWNER OF U.S. REG. NO. 3,243,338.
NO CLAIM IS MADE TO THE EXCLUSIVE RIGHT TO USE "100 % PURE & ALL NATURAL" FOR INTERNATIONAL CLASSES 3 AND 4 AND "BODY" FOR INTERNATIONAL CLASS 3, APART FROM THE MARK AS SHOWN.
THE COLOR(S) MINT, SAGE, AND FOREST GREEN, BLACK, WHITE, LIGHT AND DARK BEIGE, AND REDDISH PINK IS/ARE CLAIMED AS A FEATURE OF THE MARK.
THE MARK CONSISTS OF AN OVAL SHAPE OUTLINED IN MINT, SAGE, AND FOREST GREEN WITH A SAGE GREEN INTERIOR AND AREAS OF WHITE IN THE UPPER RIGHT AND LOWER LEFT CORNERS. THERE IS A SMALLER OVAL AT THE TOP AND INSIDE OF THE LARGER OVAL. THE INSIDE OF THE SMALLER OVAL CONTAINS THE TOP HALF OF A NEUTRAL HUMAN BODY IN SHADES OF LIGHT AND DARK BEIGE WITH ARMS CROSSING OVER THE CHEST AND HANDS RESTING ON OPPOSITE SHOULDERS. THE AREA INSIDE THE SMALLER OVAL BEHIND THE BODY IS BLACK. THE SMALLER OVAL IS OUTLINED IN BLACK WITH A WHITE INNER LINE. BELOW IN SMALLER OVAL ARE THE WORDS CENTERED AND IN 5 LINES - "100% PURE" (1ST LINE); "& ALL NATURAL" (2ND LINE); "BY" (3RD LINE); "BRENDA'S BODY" (4TH LINE); "SKIN CARE PRODUCTS FOR ANYBODY WITH SKIN" (5TH LINE). LINES 1, 2, AND 3 ARE IN MINT GREEN AND LINES 4 AND 5 ARE IN REDDISH PINK.

CLASS 9—ELECTRICAL AND SCIENTIFIC APPARATUS

FOR PRE-RECORDED DVDS, VIDEO TAPES, AND CDS FEATURING CONTENT IN THE NATURE OF TELEVISION PROGRAMS AND MOTION PICTURE FILMS FEATURING GENERAL ENTERTAINMENT, MUSICAL RECORDINGS, SOUNDTRACKS, MUSIC CONCERTS AND THEATRICAL STAGE PLAYS (U.S. CLS. 21, 23, 26, 36 AND 38).

CLASS 41—EDUCATION AND ENTERTAINMENT

FOR PRODUCTION AND DISTRIBUTION OF MOTION PICTURE FILMS AND TELEVISION PROGRAMS; PRODUCTION OF LIVE ENTERTAINMENT EVENTS IN THE NATURE OF THEATRICAL STAGE PLAYS AND MUSIC CONCERTS; PRODUCTION OF MUSICAL RECORDINGS (U.S. CLS. 100, 101 AND 107).
JOHN WILKE, EXAMINING ATTORNEY

SN 85-467,108. NEW GENERATION DEVICES, INC., GLEN ROCK, NJ. FILED 11-8-2011.

COLLAVET

THE MARK CONSISTS OF STANDARD CHARACTERS WITHOUT CLAIM TO ANY PARTICULAR FONT, STYLE, SIZE, OR COLOR.

CLASS 5—PHARMACEUTICALS

FOR COLLAGEN DRESSINGS FOR ANIMALS FOR MEDICAL AND SURGICAL USE (U.S. CLS. 6, 18, 44, 46, 51 AND 52).

CLASS 10—MEDICAL APPARATUS

FOR COLLAGEN IMPLANTS FOR SURGICAL USE IN ANIMALS FOR WOUND HEALING; COLLAGEN IMPLANTS FOR SURGICAL USE IN ANIMALS FOR LOCAL DELIVERY OF MEDICINE AND THERAPEUTIC SUBSTANCES; COLLAGEN IMPLANTS FOR HEMOSTATIC APPLICATIONS (U.S. CLS. 26, 39 AND 44).
RUSS HERMAN, EXAMINING ATTORNEY

SN 85-467,269. SAGAMORE PARTNERS, LLC, ROGERS, MN. FILED 11-8-2011.

INNOVATING WITH METAL

THE MARK CONSISTS OF STANDARD CHARACTERS WITHOUT CLAIM TO ANY PARTICULAR FONT, STYLE, SIZE, OR COLOR.
NO CLAIM IS MADE TO THE EXCLUSIVE RIGHT TO USE "METAL", APART FROM THE MARK AS SHOWN.

CLASS 6—METAL GOODS

FOR METAL CONSTRUCTION PRODUCTS FOR USE IN BUILDINGS, NAMELY, INTERIOR AND EXTERIOR BUILDING PANELS, COLUMN COVERS, SUN SCREENS AND FLAT METAL SHEETING (U.S. CLS. 2, 12, 13, 14, 23, 25 AND 50).
FIRST USE 10-4-2011; IN COMMERCE 10-4-2011.

CLASS 37—CONSTRUCTION AND REPAIR

FOR TECHNICAL CONSULTATION IN THE FIELD OF BUILDING CONSTRUCTION (U.S. CLS. 100, 103 AND 106).
FIRST USE 4-10-2011; IN COMMERCE 4-10-2011.

CLASS 40—MATERIAL TREATMENT

FOR METAL FABRICATION AND FINISHING SERVICES, NAMELY, IN THE FIELD OF BUILDING CONSTRUCTION PRODUCTS (U.S. CLS. 100, 103 AND 106).
FIRST USE 10-4-2011; IN COMMERCE 10-4-2011.

CLASS 42—SCIENTIFIC AND COMPUTER SERVICES

FOR ENGINEERING DESIGN SERVICES IN THE FIELD OF BUILDING CONSTRUCTION PRODUCTS AND BUILDING PRODUCT INSTALLATION DESIGN (U.S. CLS. 100 AND 101).
FIRST USE 10-4-2011; IN COMMERCE 10-4-2011.
PAUL MORENO, EXAMINING ATTORNEY

SN 85-467,604. SWISS-AMERICAN, INC., ST. LOUIS, MO. FILED 11-8-2011.

Mont Blanc

THE MARK CONSISTS OF STANDARD CHARACTERS WITHOUT CLAIM TO ANY PARTICULAR FONT, STYLE, SIZE, OR COLOR.
THE ENGLISH TRANSLATION OF THE WORDS "MONT BLANC" IN THE MARK IS "WHITE MOUNTAIN".

CLASS 29—MEATS AND PROCESSED FOODS

FOR CHEESE (U.S. CL. 46).

CLASS 30—STAPLE FOODS

FOR CRACKERS (U.S. CL. 46).
ALICE BENMAMAN, EXAMINING ATTORNEY

SN 85-467,749. JABARA, GARY, NEWPORT BEACH, CA. FILED 11-8-2011.

BLACK BALL SURF COMPANY

THE MARK CONSISTS OF STANDARD CHARACTERS WITHOUT CLAIM TO ANY PARTICULAR FONT, STYLE, SIZE, OR COLOR.

NO CLAIM IS MADE TO THE EXCLUSIVE RIGHT TO USE "SURF COMPANY", APART FROM THE MARK AS SHOWN.

CLASS 9—ELECTRICAL AND SCIENTIFIC APPARATUS

FOR EYEWEAR, NAMELY, SUNGLASSES, PROTECTIVE EYEWEAR, SWIMMING GOGGLES AND MASKS; EYEGGLASS CHAINS AND CORDS; EYEGGLASS CASES; NOSE CLIPS FOR SWIMMING; EAR PLUGS FOR SWIMMING (U.S. CLS. 21, 23, 26, 36 AND 38).

CLASS 16—PAPER GOODS AND PRINTED MATTER

FOR STICKERS AND TRANSFERS; MOUNTED AND UNMOUNTED POSTERS; POSTCARDS (U.S. CLS. 2, 5, 22, 23, 29, 37, 38 AND 50).

CLASS 25—CLOTHING

FOR CLOTHING, NAMELY, T-SHIRTS, SHIRTS, BUTTON FRONT SHIRTS, COLLARED SHIRTS, POLO SHIRTS, BLOUSES, TANK TOPS, HALTER TOPS, PULL-OVERS, CAMISOLES, SLEEVELESS SHIRTS, JERSEYS, SWEATSHIRTS, HOODED SWEATSHIRTS, ZIPPERED SWEATSHIRTS, SWEATERS, BELTS, SHORTS, BOXER SHORTS, BOARD SHORTS, JEANS, PANTS, CAPRIS, LEGGINGS, BEACHWEAR, DRESSES, SKIRTS, SKORTS, SARONGS, SWIMSUITS, BIKINIS, TANKINIS, BODY SUITS, UNDER GARMENTS, COVER-UPS, JACKETS, WIND RESISTANT JACKETS, COATS, PANTS, JUMPERS, SCARVES, WETSUITS, RASH GUARDS AND PROTECTIVE BODY GUARDS TO PREVENT WETSUIT CHAFING, SUN PROTECTIVE CLOTHING WITH SPF, NAMELY, SHIRTS, PANTS, SHORTS, RASH GUARDS, TOPS, TANK TOPS, BIKINIS, HALTER TOPS; HEADWEAR, NAMELY, HATS, BASEBALL CAPS, KNITTED CAPS, BEANIES; FOOTWEAR, NAMELY, TIGHTS, SOCKS, SHOES, SANDALS, FLIP FLOPS, BEACH SHOES, SLIPPERS AND BOOTS (U.S. CLS. 22 AND 39).

CLASS 28—TOYS AND SPORTING GOODS

FOR SURFBOARDS; SURF AND SWIM FINS; SURFBOARD HOLDER WORN ON THE BODY; SURFBOARD LEASHES; SURFBOARD REPAIR PATCHES; SURFBOARD STORAGE RACKS; SURFBOARD TRACTION PADS; SURFBOARD WAX (U.S. CLS. 22, 23, 38 AND 50).
TOBY BULLOFF, EXAMINING ATTORNEY

SN 85-467,803. MACHEREY-NAGEL GMBH & CO. KG HANDELSGESELLSCHAFT, DBA MACHEREY-NAGEL, DUEREN, FED REP GERMANY, FILED 11-9-2011.

NUCLEOSHELL

THE MARK CONSISTS OF STANDARD CHARACTERS WITHOUT CLAIM TO ANY PARTICULAR FONT, STYLE, SIZE, OR COLOR.

THE WORDING "NUCLEOSHELL" HAS NO MEANING IN A FOREIGN LANGUAGE.

CLASS 1—CHEMICALS

FOR SYNTHETIC AMORPHOUS SILICA GEL FOR FURTHER PROCESSING IN CONNECTION WITH THE MANUFACTURE OF FINISHED GOODS (U.S. CLS. 1, 5, 6, 10, 26 AND 46).

FIRST USE 2-1-2011; IN COMMERCE 4-1-2011.

CLASS 9—ELECTRICAL AND SCIENTIFIC APPARATUS

FOR CHROMATOGRAPHY COLUMNS (U.S. CLS. 21, 23, 26, 36 AND 38).

FIRST USE 2-1-2011; IN COMMERCE 4-1-2011.

BILL DAWE, EXAMINING ATTORNEY

SN 85-467,844. APOLLO SECURITY INTERNATIONAL, INC., WALPOLE, MA. FILED 11-9-2011.

APOLLO INTERNATIONAL

THE MARK CONSISTS OF STANDARD CHARACTERS WITHOUT CLAIM TO ANY PARTICULAR FONT, STYLE, SIZE, OR COLOR.

OWNER OF U.S. REG. NOS. 2,446,292 AND 2,554,862.

NO CLAIM IS MADE TO THE EXCLUSIVE RIGHT TO USE "INTERNATIONAL", APART FROM THE MARK AS SHOWN.

CLASS 41—EDUCATION AND ENTERTAINMENT

FOR EDUCATIONAL SERVICES, NAMELY, DEVELOPING AND CONDUCTING TRAINING IN THE FIELD OF PHYSICAL AND PERSONAL SECURITY AND RELATED POLICIES THERETO (U.S. CLS. 100, 101 AND 107).

CLASS 45—PERSONAL AND LEGAL SERVICES

FOR SECURITY GUARD SERVICES; SECURITY GUARDING FOR FACILITIES; SECURITY SERVICES, NAMELY, PROVIDING SECURITY ASSESSMENTS OF PHYSICAL LOCATIONS AND WORKING ENVIRONMENTS; SECURITY CONSULTANCY; SECURITY SERVICES, NAMELY, FOR THE PROTECTION OF PROPERTY AND INDIVIDUALS; PROVISION OF INFORMATION, ADVICE AND CONSULTANCY IN RELATION TO SECURITY SERVICES FOR THE PROTECTION OF PROPERTY AND INDIVIDUALS; SECURITY SERVICES FOR CONTROLLING ADMISSION TO BUILDINGS AND PUBLIC PLACES; SECURITY SAFETY MANAGEMENT, NAMELY, PROVIDING SECURITY ASSESSMENTS FOR BUSINESS AND GOVERNMENTAL AGENCIES; SECURITY DUE DILIGENCE SERVICES, NAMELY DETAILED INVESTIGATIVE REPORTS FOR INDIVIDUALS OR BUSINESSES TRAVELING OR OPENING AN OFFICE OVERSEAS, IN THE NATURE OF DETAILED FOREIGN COUNTRY BRIEFINGS, VETTING OF LOCAL PERSONNEL, ESTABLISHING HOST COUNTRY GOVERNMENT CONTACTS, AND PROVIDING INFORMATION ON SUSTAINABLE SECURITY MEASURES OVERSEAS; INTELLECTUAL PROPERTY CONSULTANCY; INVESTIGATION SERVICES INVOLVING INFRINGEMENTS OF INTELLECTUAL PROPERTY RIGHTS AND FOR ASSET PROTECTION; SECURITY SERVICES, NAMELY, PROVIDING EXECUTIVE PROTECTION (U.S. CLS. 100 AND 101).

WILLIAM VERHOSEK, EXAMINING ATTORNEY

SN 85-468,240. ULLIANCE, INC., TROY, MI. FILED 11-9-2011.



THE STIPLING IS FOR SHADING PURPOSES ONLY. THE MARK CONSISTS OF FOUR BUILDING BLOCKS STACKED IN A SQUARE CASTING A SHADOW ALL TO THE LEFT OF THE STYLIZED WORD "ULLIANCE" ABOVE THE STYLIZED WORDING "ENHANCING PEOPLE. IMPROVING BUSINESS".

THE WORDING "ULLIANCE" HAS NO MEANING IN A FOREIGN LANGUAGE.

CLASS 35—ADVERTISING AND BUSINESS

FOR EMPLOYMENT OUTPLACEMENT AND CAREER TRANSITION SERVICES; PROVIDING REFERRAL SERVICES TO ASSIST EMPLOYEES WITH PERSONAL, MEDICAL, AND WORK-LIFE CONCERNS; PROVIDING ASSISTANCE, FITNESS EVALUATION AND CONSULTATION TO CORPORATE CLIENTS AND THEIR EMPLOYEES IN ORDER FOR THEM TO MAKE HEALTH, WELLNESS AND NUTRITIONAL CHANGES IN THEIR DAILY LIVING TO INCREASE PRODUCTIVITY AND LOWER HEALTH CARE COSTS (U.S. CLS. 100, 101 AND 102).

CLASS 41—EDUCATION AND ENTERTAINMENT

FOR TRAINING SERVICES IN THE FIELD OF HUMAN EFFECTIVENESS TO PROVIDE CORPORATE CLIENTS, THEIR EMPLOYEES, AND OTHER INDIVIDUALS WITH SKILLS AND TOOLS TO IMPROVE THEIR PROFESSIONAL AND PERSONAL GROWTH AND DEVELOPMENT (U.S. CLS. 100, 101 AND 107).

CLASS 43—HOTEL AND RESTAURANT SERVICES

FOR PROVIDING INFORMATION VIA THE INTERNET RELATING TO ELDER CARE (U.S. CLS. 100 AND 101).

CLASS 44—MEDICAL, BEAUTY AND AGRICULTURAL SERVICES

FOR BEHAVIORAL HEALTH SERVICES; COUNSELING SERVICES IN THE FIELDS OF HEALTH, NUTRITION AND LIFESTYLE WELLNESS; PROVIDING ASSISTANCE, FITNESS EVALUATION AND CONSULTATION TO CORPORATE CLIENTS TO HELP THEIR EMPLOYEES MAKE HEALTH, WELLNESS AND NUTRITIONAL CHANGES IN THEIR DAILY LIVING TO IMPROVE HEALTH; PROVIDING EMPLOYEE ASSISTANCE PROGRAMS IN THE NATURE OF MANAGED BEHAVIORAL HEALTHCARE PROGRAMS FOR MEMBERS OF CONTRACTING GROUPS; PROVIDING INFORMATION VIA THE INTERNET RELATING TO HEALTH, WELL-BEING, NUTRITION, AND FAMILY HEALTH MATTERS; EMPLOYEE ASSISTANCE PROGRAMS IN THE NATURE OF PSYCHOLOGICAL EVALUATION AND COUNSELING; PROVIDING ASSISTANCE, FITNESS EVALUATION AND CONSULTATION TO INDIVIDUALS TO HELP THEM MAKE HEALTH, WELLNESS AND NUTRITIONAL CHANGES IN THEIR DAILY LIVING TO IMPROVE HEALTH; MENTAL HEALTH SERVICES; CHEMICAL DEPENDENCY AND SUBSTANCE ABUSE TREATMENT CONSULTATION SERVICES; ENERGY HEALING SERVICES, NAMELY, STRESS MANAGEMENT AND STRESS REDUCTION COUNSELING FOR INDIVIDUALS TO ENHANCE THEIR LIVES; PSYCHOLOGICAL ASSESSMENT AND PSYCHOTHERAPEUTIC COUNSELING SERVICES; CONSULTING IN THE FIELD OF HEALTH AND WELLNESS TO BRING ABOUT PERSONAL HAPPINESS AND WELL-BEING (U.S. CLS. 100 AND 101).

CLASS 45—PERSONAL AND LEGAL SERVICES

FOR PROVIDING PERSONAL SUPPORT SERVICES FOR EMPLOYEES AND RETIREES OF CORPORATE CLIENTS AND THEIR FAMILIES, NAMELY, EMOTIONAL COUNSELING AND EMOTIONAL SUPPORT; SECURITY SERVICES, NAMELY, THREAT SIMULATION VULNERABILITY ANALYSIS AND MITIGATION AND EMERGENCY AND CRISIS MANAGEMENT RESPONSE (U.S. CLS. 100 AND 101).

DAVID TOOLEY, EXAMINING ATTORNEY

SN 85-469,076. DEPALMA ENTERPRISES, INC., SAN CLEMENTE, CA. FILED 11-10-2011.

ULTIMATE INNOVATIONS BY THE DEPALMAS

THE MARK CONSISTS OF STANDARD CHARACTERS WITHOUT CLAIM TO ANY PARTICULAR FONT, STYLE, SIZE, OR COLOR.

CLASS 14—JEWELRY

FOR WATCHES (U.S. CLS. 2, 27, 28 AND 50).

CLASS 17—RUBBER GOODS

FOR GARDEN HOSES (U.S. CLS. 1, 5, 12, 13, 35 AND 50).

CLASS 20—FURNITURE AND ARTICLES NOT OTHERWISE CLASSIFIED

FOR NON-METAL DECORATIVE LAWN ORNAMENTATION, WHIMSICAL GARDEN NOVELTIES, NAMELY WINDMILLS NOT MADE OF METAL (U.S. CLS. 2, 13, 22, 25, 32 AND 50).

CLASS 21—HOUSEWARES AND GLASS

FOR SPRAY NOZZLES FOR GARDEN HOSES, SPRAYER WANDS FOR GARDEN HOSES, SPRAYERS ATTACHED TO GARDEN HOSES; ELECTRIC JEWELRY BRUSHES (U.S. CLS. 2, 13, 23, 29, 30, 33, 40 AND 50).
MICHAEL ENGEL, EXAMINING ATTORNEY

SN 85-469,679. MILLIONINONE FZE, AL HAMRA, UNITED ARAB EMIR., FILED 11-10-2011.

MILLIONINONE

THE MARK CONSISTS OF STANDARD CHARACTERS WITHOUT CLAIM TO ANY PARTICULAR FONT, STYLE, SIZE, OR COLOR.

CLASS 38—COMMUNICATION

FOR PROVIDING ON-LINE CHAT ROOMS, LISTSERVERS, AND ON-LINE FORUMS FOR TRANSMISSION OF MESSAGES AMONG COMPUTER USERS CONCERNING USER-DEFINED CONTENT; PROVIDING ON-LINE CHAT ROOMS AND ELECTRONIC BULLETIN BOARDS FOR TRANSMISSION OF MESSAGES (U.S. CLS. 100, 101 AND 104).

FIRST USE 9-20-2011; IN COMMERCE 10-15-2011.

CLASS 42—SCIENTIFIC AND COMPUTER SERVICES

FOR COMPUTER SERVICES, NAMELY, CREATING AN ON-LINE COMMUNITY FOR REGISTERED USERS TO PARTICIPATE IN DISCUSSIONS, GET FEEDBACK FROM THEIR PEERS, FORM VIRTUAL COMMUNITIES, AND ENGAGE IN SOCIAL NETWORKING; APPLICATION SERVICE PROVIDER (ASP) FEATURING SOFTWARE TO ENABLE UPLOADING, POSTING, SHOWING, DISPLAYING, TAGGING, BLOGGING, SHARING, ELECTRONICALLY TRANSMITTING INFORMATION, AUDIO, AND VIDEO CLIPS OR OTHERWISE PROVIDING ELECTRONIC MEDIA OR INFORMATION OVER THE INTERNET OR OTHER COMMUNICATIONS NETWORK; HOSTING ONLINE WEB FACILITIES FOR OTHERS FOR REAL-TIME INTERACTIVE DISCUSSIONS, SHARING ONLINE CONTENT BETWEEN AND AMONG USERS OF COMPUTERS, MOBILE AND HAND-HELD COMPUTERS AND WIRED AND WIRELESS COMMUNICATIONS DEVICES (U.S. CLS. 100 AND 101).

FIRST USE 9-20-2011; IN COMMERCE 10-15-2011.
KELLY BOULTON, EXAMINING ATTORNEY

SN 85-469,784. KDE DIRECT, WASHOUGAL, WA. FILED 11-10-2011.

KDE Direct

THE MARK CONSISTS OF STANDARD CHARACTERS WITHOUT CLAIM TO ANY PARTICULAR FONT, STYLE, SIZE, OR COLOR.

CLASS 7—MACHINERY

FOR ELECTRIC MOTORS FOR TOYS; MINIATURE ELECTRIC MOTORS FOR TOYS; MINIATURE MOTORS FOR USE IN MOTORIZED TOYS (U.S. CLS. 13, 19, 21, 23, 31, 34 AND 35).

FIRST USE 5-1-2008; IN COMMERCE 5-1-2008.

CLASS 28—TOYS AND SPORTING GOODS

FOR REMOTE CONTROL TOY GLIDER, AIRPLANE, SAILPLANE, AND HELICOPTER EQUIPMENT AND PARTS, NAMELY, ROTOR HEAD MECHANICS, TAIL PITCH CONTROL ASSEMBLIES, BRUSHLESS MOTORS AND MOUNTS, BATTERY SUPPORTS, MAIN ROTOR BEARING BLOCKS, FRAME BRACES, AND TRANSMISSION COMPONENTS (U.S. CLS. 22, 23, 38 AND 50).

FIRST USE 5-1-2008; IN COMMERCE 5-1-2008.

GIANCARLO CASTRO, EXAMINING ATTORNEY

SN 85-470,447. THE ELECTORAL BRAND COMPANY LIMITED, CHRISTCHURCH, NEW ZEALAND, FILED 11-11-2011.



NO CLAIM IS MADE TO THE EXCLUSIVE RIGHT TO USE "SAXON" AND "1765", APART FROM THE MARK AS SHOWN.

THE MARK CONSISTS OF THE WORD "SAXXON" ABOVE A DRAGON IN A SHIELD DEVICE, AND THE NUMERALS "1765" CENTERED BENEATH THE SHIELD.

CLASS 22—CORDAGE AND FIBERS

FOR RAW FIBROUS TEXTILE MATERIALS; ANIMAL FIBERS, NAMELY, ANIMAL HAIR; SHEEP HAIR, FLEECE WOOL AND WOOL; RAW WOOL, NAMELY, WOOL FLOCKS, WOOL PACKS, WOOL TOPS, SHORN WOOL; RAW, TREATED, COMBED OR CARDED WOOL, AND ALL OF THE FOREGOING MADE IN WHOLE OR IN SUBSTANTIAL PART OF SAXON WOOL (U.S. CLS. 1, 2, 7, 19, 22, 42 AND 50).

CLASS 23—YARNS AND THREADS

FOR YARNS AND THREADS, AND ALL OF THE FOREGOING MADE IN WHOLE OR IN SUBSTANTIAL PART OF SAXON WOOL (U.S. CL. 43).

MARK SPARACINO, EXAMINING ATTORNEY

SN 85-470,885. AIRCRAFT TECHNICAL PUBLISHERS, BRISBANE, CA. FILED 11-11-2011.

ATP  **AVIATION HUB**

OWNER OF U.S. REG. NOS. 1,617,116, 1,855,117 AND 2,298,462.

NO CLAIM IS MADE TO THE EXCLUSIVE RIGHT TO USE "AVIATION HUB", APART FROM THE MARK AS SHOWN.

CLASS 37—CONSTRUCTION AND REPAIR

FOR PROVIDING A WEB-BASED ONLINE PORTAL FEATURING MAINTENANCE REFERENCE LIBRARIES, MAINTENANCE LIBRARIES AND TECHNICAL INFORMATION RELATING TO AIRCRAFT PARTS AND THEIR INSTALLATION AND MAINTENANCE, ALL IN THE FIELD OF AVIATION (U.S. CLS. 100, 103 AND 106).

FIRST USE 9-16-2011; IN COMMERCE 9-16-2011.

CLASS 42—SCIENTIFIC AND COMPUTER SERVICES

FOR PROVIDING A WEB-BASED ONLINE PORTAL FEATURING SOFTWARE AS A SERVICE (SAAS) SERVICES FEATURING SOFTWARE FOR ACCESSING REFERENCE LIBRARIES, GLOBAL REGULATORY LIBRARIES, MAINTENANCE LIBRARIES, INFORMATION RELATING TO FAA AND GLOBAL REGULATORY SAFETY, COMPLIANCE AND CONFORMANCE, INFORMATION RELATING TO AIRCRAFT PARTS, ALL IN THE FIELD OF AVIATION (U.S. CLS. 100 AND 101).

FIRST USE 9-16-2011; IN COMMERCE 9-16-2011.

CLASS 45—PERSONAL AND LEGAL SERVICES

FOR PROVIDING A WEB-BASED ONLINE PORTAL FEATURING GLOBAL REGULATORY LIBRARIES AND REGULATORY INFORMATION RELATING TO FAA AND GLOBAL REGULATORY SAFETY, COMPLIANCE AND CONFORMANCE, ALL IN THE FIELD OF AVIATION (U.S. CLS. 100 AND 101).

FIRST USE 9-16-2011; IN COMMERCE 9-16-2011.

MARK RADEMACHER, EXAMINING ATTORNEY

SN 85-471,013. INTERNATIONAL CONSULTING ACQUISITION CORPORATION, DBA STA CONSULTING, AUSTIN, TX. FILED 11-11-2011.

STA CONSULTING

THE MARK CONSISTS OF STANDARD CHARACTERS WITHOUT CLAIM TO ANY PARTICULAR FONT, STYLE, SIZE, OR COLOR.

NO CLAIM IS MADE TO THE EXCLUSIVE RIGHT TO USE "CONSULTING", APART FROM THE MARK AS SHOWN.

CLASS 35—ADVERTISING AND BUSINESS

FOR BUSINESS CONSULTING IN THE FIELD OF INFORMATION TECHNOLOGY, ENTERPRISE RESOURCE MANAGEMENT, AND OTHER ENTERPRISE AND ADMINISTRATIVE MANAGEMENT SYSTEMS (U.S. CLS. 100, 101 AND 102).

CLASS 42—SCIENTIFIC AND COMPUTER SERVICES

FOR CONSULTING IN THE FIELD OF DESIGN, SELECTION, IMPLEMENTATION AND USE OF COMPUTER HARDWARE AND SOFTWARE SYSTEMS FOR OTHERS (U.S. CLS. 100 AND 101).

DAVID H. STINE, EXAMINING ATTORNEY

SN 85-471,016. INTERNATIONAL CONSULTING ACQUISITION CORPORATION, DBA STA CONSULTING, AUSTIN, TX. FILED 11-11-2011.



NO CLAIM IS MADE TO THE EXCLUSIVE RIGHT TO USE "CONSULTING", APART FROM THE MARK AS SHOWN.

THE MARK CONSISTS OF THE WORDS "STA" WITH "CONSULTING" POSITIONED BELOW AND A BUILDING DOME POSITIONED ABOVE.

CLASS 35—ADVERTISING AND BUSINESS

FOR BUSINESS CONSULTING IN THE FIELD OF INFORMATION TECHNOLOGY, ENTERPRISE RESOURCE MANAGEMENT, AND OTHER ENTERPRISE AND ADMINISTRATIVE MANAGEMENT SYSTEMS (U.S. CLS. 100, 101 AND 102).

CLASS 42—SCIENTIFIC AND COMPUTER SERVICES

FOR CONSULTING IN THE FIELD OF DESIGN, SELECTION, IMPLEMENTATION AND USE OF COMPUTER HARDWARE AND SOFTWARE SYSTEMS FOR OTHERS (U.S. CLS. 100 AND 101).

DAVID H. STINE, EXAMINING ATTORNEY

SN 85-471,207. PROTICA INC., WHITEHALL, PA. FILED 11-13-2011.

Milksicle

THE MARK CONSISTS OF STANDARD CHARACTERS WITHOUT CLAIM TO ANY PARTICULAR FONT, STYLE, SIZE, OR COLOR.

CLASS 5—PHARMACEUTICALS

FOR DIETARY AND NUTRITIONAL SUPPLEMENTS CONTAINING MILK DERIVED INGREDIENTS (U.S. CLS. 6, 18, 44, 46, 51 AND 52).

CLASS 30—STAPLE FOODS

FOR FROZEN CONFECTIONS (U.S. CL. 46).
SHARON MEIER, EXAMINING ATTORNEY

SN 85-471,641. LOS ALTOS FOOD PRODUCTS, INC., CITY OF INDUSTRY, CA. FILED 11-14-2011.

Mi Granjita

THE MARK CONSISTS OF STANDARD CHARACTERS WITHOUT CLAIM TO ANY PARTICULAR FONT, STYLE, SIZE, OR COLOR.

THE ENGLISH TRANSLATION OF "MI GRANJITA" IN THE MARK IS "MY LITTLE FARM."

CLASS 29—MEATS AND PROCESSED FOODS

FOR (BASED ON USE IN COMMERCE) CHEESE (BASED ON INTENT TO USE) CHICHARRON; FRUIT PASTE; MEAT; PICKLED PIGS' FEET; PORK RINDS; YOGURT (U.S. CL. 46).

FIRST USE 9-17-2009; IN COMMERCE 9-29-2009.

CLASS 30—STAPLE FOODS

FOR FLAN; FLAVORED, SWEETENED GELATIN DESSERTS; ICE CREAM; RICE-BASED PUDDING DESSERT (ARROZ CON LECHE); SAUCES; SOPES; TAMALES (U.S. CL. 46).

LINDA LAVACHE, EXAMINING ATTORNEY

SN 85-471,699. BEKA MEDIA, LLC, NORTH MIAMI, FL. FILED 11-14-2011.



NO CLAIM IS MADE TO THE EXCLUSIVE RIGHT TO USE "SPANGLISH", APART FROM THE MARK AS SHOWN.

THE MARK CONSISTS OF THE ARTISTIC RENDERING OF AN OPEN MOUTH APPEARING ABOVE THE STYLIZED WORDS "SPAN" AND "GLISH". CURVED LINES APPEAR ABOVE AND BELOW THE WORD "SPAN" AND BELOW THE WORD "GLISH".

CLASS 9—ELECTRICAL AND SCIENTIFIC APPARATUS

FOR PRE-RECORDED CDS FEATURING MUSIC; AUDIO RECORDINGS FEATURING MUSIC; DIGITAL MUSIC DOWNLOADABLE FROM THE INTERNET (U.S. CLS. 21, 23, 26, 36 AND 38).

FIRST USE 11-7-2011; IN COMMERCE 11-7-2011.

CLASS 35—ADVERTISING AND BUSINESS

FOR PROVIDING MARKETING AND PROMOTION OF SPECIAL EVENTS; PROVIDING MARKETING AND ADVERTISING SERVICES (U.S. CLS. 100, 101 AND 102).

FIRST USE 11-7-2011; IN COMMERCE 11-7-2011.

CLASS 41—EDUCATION AND ENTERTAINMENT

FOR MUSIC PRODUCTION SERVICES, RECORD PRODUCTION (U.S. CLS. 100, 101 AND 107).

FIRST USE 11-7-2011; IN COMMERCE 11-7-2011.

SANDRA BUJA, EXAMINING ATTORNEY

SN 85-471,756. OOHLALA MOBILE INC., LASALLE, CANADA, FILED 11-14-2011.

OOHLALA

THE MARK CONSISTS OF STANDARD CHARACTERS WITHOUT CLAIM TO ANY PARTICULAR FONT, STYLE, SIZE, OR COLOR.

CLASS 9—ELECTRICAL AND SCIENTIFIC APPARATUS

FOR COMPUTER APPLICATION SOFTWARE FOR MOBILE PHONES AND HANDHELD COMPUTERS, NAMELY, SOFTWARE FOR SOCIAL NETWORKING, PROVIDING DISCOUNTS ON THE GOODS AND SERVICES OF OTHERS, PROMOTING THE GOODS AND SERVICES OF OTHERS, REAL-TIME CHAT, PHOTO SHARING AND COMPUTER GAMES (U.S. CLS. 21, 23, 26, 36 AND 38).

FIRST USE 10-8-2011; IN COMMERCE 10-8-2011.

CLASS 42—SCIENTIFIC AND COMPUTER SERVICES

FOR PROVIDING A WEBSITE FEATURING ON-LINE NON-DOWNLOADABLE SOFTWARE THAT ENABLES USERS TO ENGAGE IN SOCIAL NETWORKING, FIND DISCOUNTS ON THE GOODS AND SERVICES OF OTHERS, RECEIVE PROMOTIONS ON THE GOODS AND SERVICES OF OTHERS, CONDUCT REAL-TIME CHAT, AND ENGAGE IN PHOTO-SHARING (U.S. CLS. 100 AND 101).

FIRST USE 10-8-2011; IN COMMERCE 10-8-2011.

CHARLES L. JENKINS, EXAMINING ATTORNEY

SN 85-471,885. RENOVIA S.A.C., INDEPENDENCIA, PERU,
FILED 11-14-2011.



OWNER OF PERU REG. NO. 00000918, DATED 4-22-2010,
EXPIRES 4-22-2020.

THE MARK CONSISTS OF A TIRE WITH AN OPENING FOLLOWED BY THE WORD "RENOVA" IN STYLIZED LETTERS. AN ARROW EXTENDING FROM THE LOWER INNER AREA OF THE TIRE POINTS UPWARDS TOWARDS THE LETTER "R" OF THE WORD "RENOVA".

THE ENGLISH TRANSLATION OF THE WORD "RENOVA" IN THE MARK IS "TO RENEW".

CLASS 12—VEHICLES

FOR TIRES; PNEUMATIC VEHICLE TIRES; VEHICLE WHEELS; REPAIRED TIRES; REPAIRED PNEUMATIC VEHICLE TIRES; REPAIRED VEHICLE WHEELS; RETREADED TIRES; RETREADED PNEUMATIC VEHICLE TIRES; RETREADED VEHICLE WHEELS (U.S. CLS. 19, 21, 23, 31, 35 AND 44).

CLASS 17—RUBBER GOODS

FOR RUBBER MATERIALS, RUBBER COMPOUNDS AND RUBBER MIXTURES FOR THE MANUFACTURE, REPAIR AND RETREADING OF TIRES, PNEUMATIC TIRES AND WHEELS, NAMELY, RAW OR SEMI-WORKED RUBBER FOR USE IN THE MANUFACTURE, REPAIR AND RETREADING OF VEHICLE TIRES, PNEUMATIC VEHICLE TIRES AND VEHICLE WHEELS; RUBBER MATERIALS, RUBBER COMPOUNDS AND RUBBER MIXTURES FOR THE MANUFACTURE OF PRODUCTS USED TO REPAIR AND RETREAD TIRES, PNEUMATIC TIRES AND WHEELS, NAMELY, RAW OR SEMI-WORKED RUBBER FOR USE IN THE MANUFACTURE, REPAIR AND RETREADING OF VEHICLE TIRES, PNEUMATIC VEHICLE TIRES AND VEHICLE WHEELS (U.S. CLS. 1, 5, 12, 13, 35 AND 50).

CLASS 37—CONSTRUCTION AND REPAIR

FOR REPAIR AND RETREADING OF ALL TYPES OF TIRES, PNEUMATIC TIRES AND VEHICLE WHEELS (U.S. CLS. 100, 103 AND 106).

MICHAEL TANNER, EXAMINING ATTORNEY

SN 85-472,201. TECO ELECTRIC & MACHINERY CO., LTD.,
TAIPEI, TAIWAN, FILED 11-14-2011.



THE MARK CONSISTS OF THE WORDS "TECO" WITH SPIRAL DESIGN ON THE LETTER "O".

CLASS 7—MACHINERY

FOR ENGINES AND MOTORS FOR THE GENERATION OF ELECTRICITY; WINDMILLS FOR GENERATING ELECTRICITY; WIND-POWERED GENERATORS; SOLAR-POWERED GENERATORS; WATER-POWERED GENERATORS; WIND TURBINES; BLADES OF WIND POWER GENERATOR (U.S. CLS. 13, 19, 21, 23, 31, 34 AND 35).

FIRST USE 3-23-2010; IN COMMERCE 3-23-2010.

CLASS 9—ELECTRICAL AND SCIENTIFIC APPARATUS

FOR ELECTRIC SWITCHGEARS AND VOLTAGE REGULATORS FOR ELECTRIC POWER; PHOTOVOLTAIC CELLS AND MODULES; SOLAR PANELS FOR PRODUCTION OF ELECTRICITY; PHOTOVOLTAIC INVERTERS; SOLAR CELLS; ELECTRICAL POWER CONVERTERS; WIND-SOLAR HYBRID PHOTOVOLTAIC MODULES; POWER DISTRIBUTION AND POWER CONTROL SWITCHBOARDS (U.S. CLS. 21, 23, 26, 36 AND 38).

FIRST USE 8-23-2010; IN COMMERCE 8-23-2010.

MARK T. MULLEN, EXAMINING ATTORNEY

SN 85-472,413. LA CENTRO AMERICANA CORP., BAY SHORE, NY. FILED 11-14-2011.

EL VIÑERO

THE MARK CONSISTS OF STANDARD CHARACTERS WITHOUT CLAIM TO ANY PARTICULAR FONT, STYLE, SIZE, OR COLOR.

THE ENGLISH TRANSLATION OF "EL VIÑERO" IN THE MARK IS "THE GARDENER".

CLASS 29—MEATS AND PROCESSED FOODS

FOR PROCESSED BEANS, DRIED BEANS, FROZEN YELLOW CHERRIES AND FROZEN PLUMS (U.S. CL. 46).

CLASS 30—STAPLE FOODS

FOR RICE, BEAN PASTE, SUGARED BEANS, BARLEY FOUR, BROWN SUGAR AND CORN TAMALES (U.S. CL. 46).

CHRISTINA SOBRAL, EXAMINING ATTORNEY

SN 85-472,574. FAIR TRADE SERVICES, L.L.C., BRENTWOOD, TN. FILED 11-15-2011.



THE COLOR(S) RED, BLACK AND WHITE IS/ARE CLAIMED AS A FEATURE OF THE MARK.

THE MARK CONSISTS OF A FIVE SIDED RED BOX WITH UNEQUAL LENGTHS WITH OUTLINES IN BLACK AND WHITE; THE LETTERS "FT" APPEAR IN WHITE IN THE CENTER OF THE BOX.

CLASS 9—ELECTRICAL AND SCIENTIFIC APPARATUS

FOR MUSICAL SOUND RECORDINGS; AUDIOVISUAL RECORDINGS AND DVDS FEATURING MUSIC VIDEOS, DOWNLOADABLE MUSICAL SOUND RECORDINGS, DOWNLOADABLE AUDIOVISUAL RECORDINGS FEATURING MUSIC VIDEOS (U.S. CLS. 21, 23, 26, 36 AND 38).

FIRST USE 5-27-2011; IN COMMERCE 5-27-2011.

CLASS 41—EDUCATION AND ENTERTAINMENT

FOR PROVIDING A WEBSITE WITH INFORMATION ON MUSIC AND ENTERTAINMENT (U.S. CLS. 100, 101 AND 107).

FIRST USE 5-27-2011; IN COMMERCE 5-27-2011.
CHARLOTTE CORWIN, EXAMINING ATTORNEY

SN 85-474,118. EXABLOX CORPORATION, MOUNTAIN VIEW, CA. FILED 11-16-2011.

SMARTONE

THE MARK CONSISTS OF STANDARD CHARACTERS WITHOUT CLAIM TO ANY PARTICULAR FONT, STYLE, SIZE, OR COLOR.

CLASS 35—ADVERTISING AND BUSINESS

FOR PROVIDING A WEB SITE WHERE USERS CAN ACCESS INFORMATION, NAMELY, CONSUMER PRODUCT INFORMATION AND COMPANY INFORMATION FOR MANUFACTURERS AND RETAILERS OF COMPUTER PRODUCTS AND SERVICES FOR COMMERCIAL PURPOSES (U.S. CLS. 100, 101 AND 102).

CLASS 42—SCIENTIFIC AND COMPUTER SERVICES

FOR COMPUTER SERVICES, NAMELY, PROVIDING A WEB SITE FEATURING TECHNOLOGY THAT ENABLES CUSTOMERS TO CONFIGURE AND MANAGE STORAGE DEVICES, OBTAIN TELEMETRY DATA, AND CONDUCT PERFORMANCE ANALYSIS OF STORAGE DEVICES (U.S. CLS. 100 AND 101).

JULIE GUTTADAURO, EXAMINING ATTORNEY

SN 85-474,468. ADVANCED ICE CREAM TECHNOLOGIES CORP., SAN DIEGO, CA. FILED 11-16-2011.

BARDOT

THE MARK CONSISTS OF STANDARD CHARACTERS WITHOUT CLAIM TO ANY PARTICULAR FONT, STYLE, SIZE, OR COLOR.

CLASS 30—STAPLE FOODS

FOR ICE CREAM AND ICE CREAM BARS (U.S. CL. 46).

CLASS 35—ADVERTISING AND BUSINESS

FOR RETAIL STORE SERVICES SELLING ICE CREAM, ICE CREAM BARS AND ICE CREAM PRODUCTS (U.S. CLS. 100, 101 AND 102).

ANGELA DUONG, EXAMINING ATTORNEY

SN 85-474,860. AERO INDUSTRIES, INC., INDIANAPOLIS, IN. FILED 11-17-2011.

LENGTH LOCK

THE MARK CONSISTS OF STANDARD CHARACTERS WITHOUT CLAIM TO ANY PARTICULAR FONT, STYLE, SIZE, OR COLOR.

NO CLAIM IS MADE TO THE EXCLUSIVE RIGHT TO USE "LOCK", APART FROM THE MARK AS SHOWN.

CLASS 6—METAL GOODS

FOR METAL LOCKING MECHANISMS FOR DRUM OR ROLLER MOUNTED DEPLOYABLE FLEXIBLE COVER SYSTEMS AND TARPING SYSTEMS FOR USE ON TRUCK BODIES, DUMP BODIES AND TRANSPORTABLE OPEN-TOPPED CONTAINERS (U.S. CLS. 2, 12, 13, 14, 23, 25 AND 50).

CLASS 20—FURNITURE AND ARTICLES NOT OTHERWISE CLASSIFIED

FOR NON-METAL LOCKING MECHANISMS FOR DRUM OR ROLLER MOUNTED DEPLOYABLE FLEXIBLE COVER SYSTEMS AND TARPING SYSTEMS FOR USE ON TRUCK BODIES, DUMP BODIES AND TRANSPORTABLE OPEN-TOPPED CONTAINERS (U.S. CLS. 2, 13, 22, 25, 32 AND 50).

GINA HAYES, EXAMINING ATTORNEY

SN 85-475,132. FUNERALWISE, LLC, WILMETTE, IL. FILED 11-17-2011.

SN 85-475,194. FUNERALWISE, LLC, WILMETTE, IL. FILED 11-17-2011.

FUNERALWISE

THE MARK CONSISTS OF STANDARD CHARACTERS WITHOUT CLAIM TO ANY PARTICULAR FONT, STYLE, SIZE, OR COLOR.



CLASS 35—ADVERTISING AND BUSINESS

FOR ADVERTISING, MARKETING, PROMOTIONAL, AND INFORMATION DISTRIBUTION SERVICES, NAMELY, PROVIDING ADVERTISING SPACE VIA THE GLOBAL COMPUTER NETWORK; PROMOTING THE GOODS AND SERVICES OF OTHERS OVER THE INTERNET; PROVIDING ONLINE WEBSITE AND INFORMATIONAL GUIDES FEATURING THE GOODS AND SERVICES OF OTHER VENDORS VIA THE INTERNET IN THE FIELDS OF FUNERALS, FUNERAL PLANNING AND ARRANGEMENTS, FUNERAL AND MEMORIAL SERVICES, FINANCIAL PLANNING, RETIREMENT PLANNING, GRIEF SUPPORT, BEREAVEMENT, MEMORIALIZATION, LIFE STORIES, PET LOSS, END OF LIFE, ELDERLY CARE, LIFE PLANNING, AND DEATH PLANNING TOPICS; PROVIDING ONLINE DIRECTORY INFORMATION FEATURING INFORMATION IN THE FIELDS OF FUNERALS, FUNERAL PLANNING AND ARRANGEMENTS, FUNERAL AND MEMORIAL SERVICES, FINANCIAL PLANNING, RETIREMENT PLANNING, GRIEF SUPPORT, BEREAVEMENT, MEMORIALIZATION, LIFE STORIES, PET LOSS, END OF LIFE, ELDERLY CARE, LIFE PLANNING, AND DEATH PLANNING TOPICS; ON-LINE RETAIL STORE SERVICES FEATURING FUNERAL AND MEMORIAL GOODS (U.S. CLS. 100, 101 AND 102).

FIRST USE 4-4-2001; IN COMMERCE 4-4-2001.

CLASS 42—SCIENTIFIC AND COMPUTER SERVICES

FOR COMPUTER SERVICES, NAMELY, HOSTING ON-LINE WEB FACILITIES FOR OTHERS AND ONLINE PORTALS FEATURING NON-DOWNLOADABLE SOFTWARE THAT ENABLES USERS TO ACCESS PRODUCTS AND SERVICES RELATING TO FUNERALS, FUNERAL PLANNING AND ARRANGEMENTS, FUNERAL AND MEMORIAL SERVICES, FINANCIAL PLANNING, RETIREMENT PLANNING, GRIEF SUPPORT, BEREAVEMENT, MEMORIALIZATION, LIFE STORIES, PET LOSS, END OF LIFE, ELDERLY CARE, LIFE PLANNING, AND DEATH PLANNING; HOSTING AN ONLINE WEBSITE FEATURING FUNERALS, FUNERAL PLANNING AND ARRANGEMENTS, FUNERAL AND MEMORIAL SERVICES, FINANCIAL PLANNING, RETIREMENT PLANNING, GRIEF SUPPORT, BEREAVEMENT, MEMORIALIZATION, LIFE STORIES, PET LOSS, END OF LIFE, ELDERLY CARE, LIFE PLANNING, AND DEATH PLANNING TOPICS (U.S. CLS. 100 AND 101).

FIRST USE 4-4-2001; IN COMMERCE 4-4-2001.

CLASS 45—PERSONAL AND LEGAL SERVICES

FOR PROVIDING ON-LINE COMPUTER DATABASES AND ON-LINE SEARCHABLE DATABASES IN THE FIELDS OF FUNERALS, FUNERAL PLANNING AND ARRANGEMENTS, FUNERAL AND MEMORIAL SERVICES, GRIEF SUPPORT SERVICES, BEREAVEMENT SERVICES, MEMORIALIZATION SERVICES, PERSONAL LIFE STORIES, GRIEF SUPPORT AND BEREAVEMENT SERVICES RELATED TO PET LOSS (U.S. CLS. 100 AND 101).

FIRST USE 4-4-2011; IN COMMERCE 4-4-2011.
LINDA POWELL, EXAMINING ATTORNEY

THE MARK CONSISTS OF THE LITERAL ELEMENT "FUNERALWISE.COM" WITH AN ELLIPTIC PARTIAL CIRCLE EMPHASIS TO THE LITERAL MARK COMPONENT "WISE" AND A FILLED CIRCULAR DOTTING OF THE ALPHABETIC LETTER "I" OF THE LITERAL MARK COMPONENT "WISE".

CLASS 35—ADVERTISING AND BUSINESS

FOR ADVERTISING, MARKETING, PROMOTIONAL, AND INFORMATION DISTRIBUTION SERVICES, NAMELY, PROVIDING ADVERTISING SPACE VIA THE GLOBAL COMPUTER NETWORK; PROMOTING THE GOODS AND SERVICES OF OTHERS OVER THE INTERNET; PROVIDING ONLINE WEBSITE AND INFORMATIONAL GUIDES FEATURING THE GOODS AND SERVICES OF OTHER VENDORS VIA THE INTERNET IN THE FIELDS OF FUNERALS, FUNERAL PLANNING AND ARRANGEMENTS, FUNERAL AND MEMORIAL SERVICES, FINANCIAL PLANNING, RETIREMENT PLANNING, GRIEF SUPPORT, BEREAVEMENT, MEMORIALIZATION, LIFE STORIES, PET LOSS, END OF LIFE, ELDERLY CARE, LIFE PLANNING, AND DEATH PLANNING TOPICS; PROVIDING ONLINE DIRECTORY INFORMATION FEATURING INFORMATION IN THE FIELDS OF FUNERALS, FUNERAL PLANNING AND ARRANGEMENTS, FUNERAL AND MEMORIAL SERVICES, FINANCIAL PLANNING, RETIREMENT PLANNING, GRIEF SUPPORT, BEREAVEMENT, MEMORIALIZATION, LIFE STORIES, PET LOSS, END OF LIFE, ELDERLY CARE, LIFE PLANNING, AND DEATH PLANNING TOPICS; ON-LINE RETAIL STORE SERVICES FEATURING FUNERAL AND MEMORIAL GOODS (U.S. CLS. 100, 101 AND 102).

FIRST USE 4-4-2001; IN COMMERCE 4-4-2001.

CLASS 42—SCIENTIFIC AND COMPUTER SERVICES

FOR COMPUTER SERVICES, NAMELY, HOSTING ON-LINE WEB FACILITIES FOR OTHERS AND ONLINE PORTALS FEATURING NON-DOWNLOADABLE SOFTWARE THAT ENABLES USERS TO ACCESS PRODUCTS AND SERVICES RELATING TO FUNERALS, FUNERAL PLANNING AND ARRANGEMENTS, FUNERAL AND MEMORIAL SERVICES, FINANCIAL PLANNING, RETIREMENT PLANNING, GRIEF SUPPORT, BEREAVEMENT, MEMORIALIZATION, LIFE STORIES, PET LOSS, END OF LIFE, ELDERLY CARE, LIFE PLANNING, AND DEATH PLANNING; HOSTING AN ONLINE WEBSITE FEATURING FUNERALS, FUNERAL PLANNING AND ARRANGEMENTS, FUNERAL AND MEMORIAL SERVICES, FINANCIAL PLANNING, RETIREMENT PLANNING, GRIEF SUPPORT, BEREAVEMENT, MEMORIALIZATION, LIFE STORIES, PET LOSS, END OF LIFE, ELDERLY CARE, LIFE PLANNING, AND DEATH PLANNING TOPICS (U.S. CLS. 100 AND 101).

FIRST USE 4-4-2001; IN COMMERCE 4-4-2001.

CLASS 45—PERSONAL AND LEGAL SERVICES

FOR PROVIDING ON-LINE COMPUTER DATABASES AND ON-LINE SEARCHABLE DATABASES IN THE FIELDS OF FUNERALS, FUNERAL PLANNING AND ARRANGEMENTS, FUNERAL AND MEMORIAL SERVICES, GRIEF SUPPORT SERVICES, BEREAVEMENT SERVICES, MEMORIALIZATION SERVICES, PERSONAL LIFE STORIES, GRIEF SUPPORT AND BEREAVEMENT SERVICES RELATED TO PET LOSS (U.S. CLS. 100 AND 101).

FIRST USE 4-4-2001; IN COMMERCE 4-4-2001.
LINDA POWELL, EXAMINING ATTORNEY

SN 85-475,470. HERRING BROADCASTING COMPANY, INC., SAN DIEGO, CA. FILED 11-17-2011.



THE MARK CONSISTS OF THE LETTER "W" FRAMED ON THE BOTTOM BY FOUR STALKS OF WHEAT.

SN 85-475,238. KAY YOW CANCER FOUNDATION, INC., AKA KAY YOW CANCER FUND, CARY, NC. FILED 11-17-2011.



CLASS 38—COMMUNICATION

FOR CABLE AND TELEVISION BROADCASTING SERVICES; INTERNET AND CLOUD BASED VIDEO TRANSMISSION SERVICES; TRANSMISSION OF TELEVISION PROGRAMS VIA INTERNET AND COMPUTER NETWORKS; PROVIDING ON-LINE CHAT ROOMS FOR SOCIAL NETWORKING (U.S. CLS. 100, 101 AND 104).

FIRST USE 8-4-2009; IN COMMERCE 8-4-2009.

CLASS 41—EDUCATION AND ENTERTAINMENT

FOR ENTERTAINMENT PRODUCTION AND RECORDING SERVICES OVER TELEVISION, SATELLITE, INTERNET OF VIDEO PROGRAMS RELATING TO LIFESTYLE; PROVIDING LIFESTYLE AND ENTERTAINMENT INFORMATION (U.S. CLS. 100, 101 AND 107).

FIRST USE 8-4-2009; IN COMMERCE 8-4-2009.
JOHN HWANG, EXAMINING ATTORNEY

OWNER OF U.S. REG. NOS. 3,635,696, 4,002,312 AND OTHERS.

THE COLOR(S) PINK, BLACK AND WHITE IS/ARE CLAIMED AS A FEATURE OF THE MARK.

THE MARK CONSISTS OF THE WORDS AND NUMERAL "PLAY 4KAY" IN WHICH THE WORDS "PLAY" AND "KAY" ARE IN A STYLIZED PINK FONT PARTIALLY OUTLINED IN BLACK AND THE NUMERAL "4" APPEARS IN BLACK COMPLETELY OUTLINED IN PINK AND WHITE WITH ANOTHER PINK OUTLINE THAT DOES NOT TOUCH THE NUMERAL AND A PINK TRIANGLE INSIDE THE FIELD OF THE TRIANGLE IN THE NUMERAL. THE LETTER "Y" CONSISTS OF A FANCIFUL PINK RIBBON PARTIALLY OUTLINED IN BLACK.

CLASS 35—ADVERTISING AND BUSINESS

FOR PROMOTING THE PUBLIC AWARENESS OF THE NEED FOR FINDING A CURE FOR CANCER, CANCER RESEARCH AND ASSISTING THE UNDER-SERVED (U.S. CLS. 100, 101 AND 102).

FIRST USE 9-1-2011; IN COMMERCE 9-1-2011.

CLASS 36—INSURANCE AND FINANCIAL

FOR CHARITABLE FUND RAISING SERVICES (U.S. CLS. 100, 101 AND 102).

FIRST USE 9-1-2011; IN COMMERCE 9-1-2011.
CHRISTOPHER LAW, EXAMINING ATTORNEY

SN 85-475,894. SENFTNER, INDIRA CESARINE, DBA XXXX MAGAZINE, NEW YORK, NY. FILED 11-17-2011.



THE MARK CONSISTS OF THE STYLIZED LETTERS "XXXX".

CLASS 16—PAPER GOODS AND PRINTED MATTER

FOR MAGAZINES FEATURING FILM, CREATIVE AND PERFORMING ARTS, BEAUTY, FASHION TRENDS AND STYLES (U.S. CLS. 2, 5, 22, 23, 29, 37, 38 AND 50).

FIRST USE 12-1-2008; IN COMMERCE 4-1-2009.

CLASS 41—EDUCATION AND ENTERTAINMENT

FOR MULTIMEDIA PRODUCTION COMPANY PROVIDING SERVICES IN FILM PRODUCTION; ON-LINE JOURNALS, NAMELY, BLOGS, FEATURING INFORMATION ON CREATIVE AND PERFORMING ARTS, BEAUTY, FASHION TRENDS AND STYLES (U.S. CLS. 100, 101 AND 107).

FIRST USE 12-1-2008; IN COMMERCE 4-1-2009.
 NAAKWAMA ANKRAH, EXAMINING ATTORNEY

SN 85-476,086. VIZIBILITY INC., NEW YORK, NY. FILED 11-18-2011.



THE MARK CONSISTS OF A ROUND SHAPE CONSISTING OF CIRCLES OF VARIOUS SIZES.

SN 85-476,079. VIZIBILITY INC., NEW YORK, NY. FILED 11-18-2011.

VIZIBILITY

THE MARK CONSISTS OF STANDARD CHARACTERS WITHOUT CLAIM TO ANY PARTICULAR FONT, STYLE, SIZE, OR COLOR.

CLASS 35—ADVERTISING AND BUSINESS

FOR ONLINE PROMOTIONAL AND MARKETING SERVICES IN THE NATURE OF PERSONAL AND COMMERCIAL IDENTITY SERVICES, NAMELY, PROMOTING INDIVIDUAL IDENTITIES, BRAND IDENTITIES AND COMMERCIAL INFORMATION (U.S. CLS. 100, 101 AND 102).

FIRST USE 1-19-2010; IN COMMERCE 1-19-2010.

CLASS 42—SCIENTIFIC AND COMPUTER SERVICES

FOR NON-DOWNLOADABLE COMPUTER SOFTWARE IN THE NATURE OF A SOLUTION TO CURATE AND ORGANIZE ONLINE CONTENT TO PROMOTE INDIVIDUAL IDENTITIES, BRAND IDENTITIES AND COMMERCIAL INFORMATION; PROVIDING A WEBSITE THAT ALLOWS USERS TO ORGANIZE AND CURATE ONLINE CONTENT TO PROMOTE INDIVIDUAL IDENTITIES, BRAND IDENTITIES AND COMMERCIAL INFORMATION (U.S. CLS. 100 AND 101).

FIRST USE 1-19-2010; IN COMMERCE 1-19-2010.
 ALAIN LAPTEY, EXAMINING ATTORNEY

CLASS 35—ADVERTISING AND BUSINESS

FOR ONLINE PROMOTIONAL AND MARKETING SERVICES IN THE NATURE OF PERSONAL AND COMMERCIAL IDENTITY SERVICES, NAMELY, PROMOTING INDIVIDUAL IDENTITIES, BRAND IDENTITIES AND COMMERCIAL INFORMATION (U.S. CLS. 100, 101 AND 102).

FIRST USE 1-19-2010; IN COMMERCE 1-19-2010.

CLASS 42—SCIENTIFIC AND COMPUTER SERVICES

FOR NON-DOWNLOADABLE COMPUTER SOFTWARE IN THE NATURE OF A SOLUTION TO CURATE AND ORGANIZE ONLINE CONTENT TO PROMOTE INDIVIDUAL IDENTITIES, BRAND IDENTITIES AND COMMERCIAL INFORMATION; PROVIDING A WEBSITE THAT ALLOWS USERS TO ORGANIZE AND CURATE ONLINE CONTENT TO PROMOTE INDIVIDUAL IDENTITIES, BRAND IDENTITIES AND COMMERCIAL INFORMATION (U.S. CLS. 100 AND 101).

FIRST USE 1-19-2010; IN COMMERCE 1-19-2010.
 ALAIN LAPTEY, EXAMINING ATTORNEY

SN 85-476,847. TRANS FAMILY, INC., SAN GABRIEL, CA. FILED 11-18-2011.

4 MUA

THE MARK CONSISTS OF STANDARD CHARACTERS WITHOUT CLAIM TO ANY PARTICULAR FONT, STYLE, SIZE, OR COLOR.

THE ENGLISH TRANSLATION OF THE "VIETNAMESE" WORD "4 MUA" IN THE MARK IS "4 SEASONS".

CLASS 16—PAPER GOODS AND PRINTED MATTER

FOR RICE PAPER (U.S. CLS. 2, 5, 22, 23, 29, 37, 38 AND 50).

CLASS 29—MEATS AND PROCESSED FOODS

FOR FROZEN FRUITS, SEAFOOD (U.S. CL. 46).

CLASS 30—STAPLE FOODS

FOR RICE (U.S. CL. 46).
DANNEAN HETZEL, EXAMINING ATTORNEY

SN 85-476,902. TRANS FAMILY, INC., SAN GABRIEL, CA.
FILED 11-18-2011.

BON MUA

THE MARK CONSISTS OF STANDARD CHARACTERS WITHOUT CLAIM TO ANY PARTICULAR FONT, STYLE, SIZE, OR COLOR.
THE ENGLISH TRANSLATION OF THE VIETNAMESE WORD "BON MUA" IN THE MARK IS "4 SEASONS".

CLASS 16—PAPER GOODS AND PRINTED MATTER

FOR RICE PAPER (U.S. CLS. 2, 5, 22, 23, 29, 37, 38 AND 50).

CLASS 29—MEATS AND PROCESSED FOODS

FOR FROZEN FRUITS, SEAFOOD (U.S. CL. 46).

CLASS 30—STAPLE FOODS

FOR RICE (U.S. CL. 46).
DANNEAN HETZEL, EXAMINING ATTORNEY

SN 85-477,259. PASSRULES CANADIAN SECURITY INC.,
MANITOBA R2H 1N5, CANADA, FILED 11-20-2011.

ENTERPRISE SENTINEL

THE MARK CONSISTS OF STANDARD CHARACTERS WITHOUT CLAIM TO ANY PARTICULAR FONT, STYLE, SIZE, OR COLOR.

NO CLAIM IS MADE TO THE EXCLUSIVE RIGHT TO USE "ENTERPRISE", APART FROM THE MARK AS SHOWN.

CLASS 9—ELECTRICAL AND SCIENTIFIC APPARATUS

FOR COMPUTER SOFTWARE FOR CONTROLLING AND MANAGING ACCESS SOFTWARE APPLICATIONS AND COMPUTER RESOURCES; COMPUTER SERVERS; PERSONAL DIGITAL ASSISTANT DEVICES; CELLULAR TELEPHONES; ATM MACHINES; CREDIT AND DEBIT CARD SCANNERS AND PROCESSORS; COMPUTERIZED NON-BIOMETRIC USER AUTHENTICATION SOFTWARE TO PROVIDE SECURE ACCESS TO ELECTRONIC DEVICES (U.S. CLS. 21, 23, 26, 36 AND 38).

CLASS 45—PERSONAL AND LEGAL SERVICES

FOR IDENTIFICATION VERIFICATION SERVICES, NAMELY, PROVIDING AUTHENTICATION OF PERSONAL IDENTIFICATION INFORMATION (U.S. CLS. 100 AND 101).
ANGELA M. MICHELI, EXAMINING ATTORNEY

SN 85-477,280. TERRY, JOHN, BRUCE, AKA BRUCE TERRY, MADEIRA BEACH, FL. FILED 11-20-2011.

Pinz & Needlz

THE MARK CONSISTS OF STANDARD CHARACTERS WITHOUT CLAIM TO ANY PARTICULAR FONT, STYLE, SIZE, OR COLOR.

CLASS 16—PAPER GOODS AND PRINTED MATTER

FOR DECORATIVE DECALS FOR VEHICLE WINDOWS AND VEHICLE BODY EXTERIORS THAT ARE BASED ON IMAGES OF TATTOOS (U.S. CLS. 2, 5, 22, 23, 29, 37, 38 AND 50).

CLASS 41—EDUCATION AND ENTERTAINMENT

FOR ENTERTAINMENT IN THE NATURE OF AN ONGOING SPECIAL VARIETY, NEWS, MUSIC OR COMEDY SHOW FEATURING TATTOO AND PIERCING PARLORS ACROSS AMERICA BROADCAST OVER TELEVISION, THE INTERNET, SATELLITE, AUDIO, AND VIDEO MEDIA ; NIGHT CLUBS (U.S. CLS. 100, 101 AND 107).

CLASS 43—HOTEL AND RESTAURANT SERVICES

FOR BAR SERVICES (U.S. CLS. 100 AND 101).

CLASS 44—MEDICAL, BEAUTY AND AGRICULTURAL SERVICES

FOR TATTOO AND BODY PIERCING SERVICES; BEAUTY SALON AND NAIL CARE SALON (U.S. CLS. 100 AND 101).

ANGELA M. MICHELI, EXAMINING ATTORNEY

SN 85-477,356. KAIZEN PRODUCTS, LP, DALLAS, TX.
FILED 11-20-2011.

Walk With Jesus Collection

THE MARK CONSISTS OF STANDARD CHARACTERS WITHOUT CLAIM TO ANY PARTICULAR FONT, STYLE, SIZE, OR COLOR.

NO CLAIM IS MADE TO THE EXCLUSIVE RIGHT TO USE "COLLECTION", APART FROM THE MARK AS SHOWN.

CLASS 16—PAPER GOODS AND PRINTED MATTER

FOR STATIONERY ITEMS, NAMELY, PENCILS, PENS, ERASERS, PAPER CLIPS, NOTE BOOKS, CALENDARS (U.S. CLS. 2, 5, 22, 23, 29, 37, 38 AND 50).

CLASS 25—CLOTHING

FOR HATS, BANDANAS, AND GENERAL HEADGEAR, NAMELY, CAPS, VISORS (U.S. CLS. 22 AND 39).
KARANENDRA S. CHHINA, EXAMINING ATTORNEY

SN 85-477,384. TIDAL SURGE LURES, DBA TIDAL SURGE LURES, HIGHLANDS, TX. FILED 11-21-2011.



NO CLAIM IS MADE TO THE EXCLUSIVE RIGHT TO USE "LURES", APART FROM THE MARK AS SHOWN.

THE MARK CONSISTS OF THE STYLIZED WORDING "TIDAL SURGE LURES" ARCHED ABOVE THE DESIGN OF A FISH.

CLASS 25—CLOTHING

FOR FISHING SHIRTS; SPORTS CAPS AND HATS (U.S. CLS. 22 AND 39).
FIRST USE 8-1-2010; IN COMMERCE 9-1-2010.

CLASS 28—TOYS AND SPORTING GOODS

FOR ARTIFICIAL FISHING LURES (U.S. CLS. 22, 23, 38 AND 50).
FIRST USE 8-1-2010; IN COMMERCE 9-1-2010.
KELLEY WELLS, EXAMINING ATTORNEY

SN 85-477,419. VEGA GARCIA-DONAS, MARIA DOLORES, MADRID 28020, SPAIN, AND VEGA GARCIA-DONAS, MARIA JOSEFA, MADRID 28020, SPAIN, FILED 11-21-2011.

ALMATRICH I

THE MARK CONSISTS OF STANDARD CHARACTERS WITHOUT CLAIM TO ANY PARTICULAR FONT, STYLE, SIZE, OR COLOR.

THE WORDING "ALMATRICH I" HAS NO MEANING IN A FOREIGN LANGUAGE.

CLASS 25—CLOTHING

FOR BATHING COSTUMES; BATHING SUITS; BELTS; CARDIGANS; CHILDREN'S AND INFANT'S APPAREL, NAMELY, JUMPERS, OVERALL SLEEPWEAR, PAJAMAS, ROMPERS AND ONE-PIECE GARMENTS; CHILDREN'S HEADWEAR; COATS; DRESS SHIRTS; DRESS SUITS; DRESSES; FINISHED TEXTILE LININGS FOR GARMENTS; FOOTWEAR; FOOTWEAR FOR MEN; FOOTWEAR FOR MEN AND WOMEN; GLOVES; HATS; HEAD WEAR; LEATHER JACKETS; LEGGINGS; LEOTARDS AND TIGHTS FOR WOMEN; MEN AND CHILDREN OF NYLON, COTTON OR OTHER TEXTILE FIBERS; MEN'S AND WOMEN'S JACKETS, COATS, TROUSERS, VESTS; MEN'S SUITS, WOMEN'S SUITS; ONE PIECE GARMENT FOR INFANTS AND TODDLERS; ONE-PIECE GARMENTS FOR CHILDREN; SCARVES; SLEEPING GARMENTS; SLEEPWEAR; UNDERGARMENTS; UNDERWEAR; WOMEN'S CEREMONIAL DRESSES; WOMEN'S CLOTHING, NAMELY, SHIRTS, DRESSES, SKIRTS, BLOUSES; WOMEN'S SHOES (U.S. CLS. 22 AND 39).

CLASS 35—ADVERTISING AND BUSINESS

FOR RETAIL STORE SERVICES FEATURING A WIDE VARIETY OF CONSUMER GOODS OF OTHERS; RETAIL STORE SERVICES FEATURING ALL KINDS OF CLOTHING, TEXTILES, FOOTWEAR, HANDBAGS, COSTUME JEWELLERY AND FASHION ACCESSORIES; RETAIL STORE SERVICES FEATURING ALL KINDS OF CLOTHING, TEXTILES, FOOTWEAR, HANDBAGS, COSTUME JEWELLERY AND FASHION ACCESSORIES ACCESSIBLE ON-LINE AND BY TELEPHONE, FACSIMILE AND MAIL ORDER; RETAIL STORE SERVICES, AVAILABLE THROUGH COMPUTER COMMUNICATIONS AND INTERACTIVE TELEVISION, FEATURING ALL KINDS OF CLOTHING, TEXTILES, FOOTWEAR, HANDBAGS, COSTUME JEWELLERY AND FASHION ACCESSORIES; RETAIL STORE SERVICES OF ALL KINDS OF CLOTHING, TEXTILES, FOOTWEAR, HANDBAGS, COSTUME JEWELLERY AND FASHION ACCESSORIES; VENDING IN THE FIELD OF ALL KINDS OF CLOTHING, TEXTILES, FOOTWEAR, HANDBAGS, COSTUME JEWELLERY AND FASHION ACCESSORIES; WEB-BASED CATALOGUE SERVICES FEATURING ALL KINDS OF CLOTHING, TEXTILES, FOOTWEAR, HANDBAGS, COSTUME JEWELLERY AND FASHION ACCESSORIES; WHOLESALE DISTRIBUTORSHIPS FEATURING ALL KINDS OF CLOTHING, TEXTILES, FOOTWEAR, HANDBAGS, COSTUME JEWELLERY AND FASHION ACCESSORIES; WHOLESALE STORE SERVICES FEATURING ALL KINDS OF CLOTHING, TEXTILES, FOOTWEAR, HANDBAGS, COSTUME JEWELLERY AND FASHION ACCESSORIES (U.S. CLS. 100, 101 AND 102).

CLASS 39—TRANSPORTATION AND STORAGE

FOR DISTRIBUTION SERVICES, NAMELY, DELIVERY OF ALL KINDS OF CLOTHING, TEXTILES, FOOTWEAR, HANDBAGS, COSTUME JEWELLERY AND FASHION ACCESSORIES; STORAGE AND DELIVERY OF GOODS; STORAGE OF CLOTHES; TRANSPORT AND STORAGE OF GOODS (U.S. CLS. 100 AND 105).

MARGER Y A. TIERNEY, EXAMINING ATTORNEY

SN 85-479,423. KIHEI ICE INC., KIHEI, HI. FILED 11-22-2011.

TINA L. SNAPP, EXAMINING ATTORNEY



NO CLAIM IS MADE TO THE EXCLUSIVE RIGHT TO USE "LOCAL ICE & H2O", APART FROM THE MARK AS SHOWN.

THE MARK CONSISTS OF THE STYLIZED WORDING "LOCAL ICE & H2O" AS WELL AS THE DEPICTION OF SNOW AND ICE. THE WORDING "LOCAL" APPEARS VERTICALLY WITH THE WORDING "ICE" APPEARING HORIZONTALLY CENTERED ON THE LETTER "C" IN "LOCAL" WITH THE TERM "& H2O" APPEARING TO THE RIGHT OF THE LETTER "A" IN "LOCAL". THE DEPICTION OF SNOW AND ICE APPEARS ON THE TOP OF WORD "ICE".

CLASS 30—STAPLE FOODS

FOR ICE (U.S. CL. 46).
FIRST USE 4-1-2011; IN COMMERCE 4-11-2011.

CLASS 35—ADVERTISING AND BUSINESS

FOR PROVIDING VENDING MACHINES FEATURING ICE AND WATER (U.S. CLS. 100, 101 AND 102).
FIRST USE 4-1-2011; IN COMMERCE 4-11-2011.
MICHAEL TANNER, EXAMINING ATTORNEY

SN 85-479,738. ALLSTATE INSURANCE COMPANY, NORTHBROOK, IL. FILED 11-23-2011.

DRIVE HAPPY SAVE SMART

THE MARK CONSISTS OF STANDARD CHARACTERS WITHOUT CLAIM TO ANY PARTICULAR FONT, STYLE, SIZE, OR COLOR.

CLASS 36—INSURANCE AND FINANCIAL

FOR INSURANCE UNDERWRITING SERVICES IN THE FIELD OF AUTO PROTECTION, EXCESS WEAR AND TEAR PROTECTION, GAP, VEHICLE SERVICE CONTRACTS AND CREDIT LIFE INSURANCE; PREPAID PREVENTIVE MAINTENANCE SERVICE PLANS FOR AUTOMOBILES (U.S. CLS. 100, 101 AND 102).

CLASS 37—CONSTRUCTION AND REPAIR

FOR AUTOMOTIVE MAINTENANCE AND REPAIR; EMERGENCY ROADSIDE ASSISTANCE SERVICES; NAMELY, RESPONDING TO CALLS FOR ROADSIDE ASSISTANCE, FLAT TIRE CHANGING, EMERGENCY FUEL SUPPLYING, AND BATTERY JUMP STARTING (U.S. CLS. 100, 103 AND 106).

SN 85-480,498. JELSLEEP LLC, NORTHFIELD, IL. FILED 11-23-2011.

no cover-up guarantee

THE MARK CONSISTS OF STANDARD CHARACTERS WITHOUT CLAIM TO ANY PARTICULAR FONT, STYLE, SIZE, OR COLOR.

CLASS 20—FURNITURE AND ARTICLES NOT OTHERWISE CLASSIFIED

FOR MATTRESSES AND PILLOWS (U.S. CLS. 2, 13, 22, 25, 32 AND 50).

CLASS 24—FABRICS

FOR BEDDING ARTICLES, NAMELY, SHEETS, MATTRESS PADS, COMFORTERS, AND TICKING FABRIC FOR MATTRESSES (U.S. CLS. 42 AND 50).
COLLEEN KEARNEY, EXAMINING ATTORNEY

SN 85-480,635. WORLD COVENANT MINISTRIES, INC., HALTOM CITY, TX. FILED 11-24-2011.

THE JOSEPH STOREHOUSE

THE MARK CONSISTS OF STANDARD CHARACTERS WITHOUT CLAIM TO ANY PARTICULAR FONT, STYLE, SIZE, OR COLOR.

NO CLAIM IS MADE TO THE EXCLUSIVE RIGHT TO USE "STOREHOUSE", APART FROM THE MARK AS SHOWN.

CLASS 35—ADVERTISING AND BUSINESS

FOR CHARITABLE SERVICES, NAMELY, COORDINATION OF THE PROCUREMENT AND DISTRIBUTION OF FOOD DONATIONS FROM MANUFACTURERS, WHOLESALERS, RETAILERS, AND GOVERNMENT AGENCIES TO ORGANIZATIONS PROVIDING FREE FOOD TO NEEDY PEOPLE (U.S. CLS. 100, 101 AND 102).
FIRST USE 3-1-2011; IN COMMERCE 6-7-2011.

CLASS 43—HOTEL AND RESTAURANT SERVICES

FOR CHARITABLE SERVICES, NAMELY, PROVIDING FOOD TO NEEDY PERSONS (U.S. CLS. 100 AND 101).
FIRST USE 3-1-2011; IN COMMERCE 6-7-2011.
EVELYN BRADLEY, EXAMINING ATTORNEY

SN 85-481,915. MIXON FRUIT FARMS, INC., BRADENTON, FL. FILED 11-28-2011.

MIXON'S IN THE GROVE

THE MARK CONSISTS OF STANDARD CHARACTERS WITHOUT CLAIM TO ANY PARTICULAR FONT, STYLE, SIZE, OR COLOR.

CLASS 41—EDUCATION AND ENTERTAINMENT

FOR PROVIDING FACILITIES FOR RECREATION ACTIVITIES (U.S. CLS. 100, 101 AND 107).
FIRST USE 11-1-2008; IN COMMERCE 11-1-2008.

CLASS 45—PERSONAL AND LEGAL SERVICES

FOR PROVIDING FACILITIES FOR WEDDING CEREMONIES (U.S. CLS. 100 AND 101).
FIRST USE 11-1-2008; IN COMMERCE 11-1-2008.
TARAH HARDY, EXAMINING ATTORNEY

SN 85-482,038. PIPE DREAMS INC., NORTH HOLLYWOOD, CA. FILED 11-28-2011.

MARK SALLING

THE MARK CONSISTS OF STANDARD CHARACTERS WITHOUT CLAIM TO ANY PARTICULAR FONT, STYLE, SIZE, OR COLOR.

THE NAME(S), PORTRAIT(S), AND/OR SIGNATURE(S) SHOWN IN THE MARK IDENTIFIES "MARK SALLING", WHOSE CONSENT(S) TO REGISTER IS MADE OF RECORD.

CLASS 9—ELECTRICAL AND SCIENTIFIC APPARATUS

FOR SERIES OF SOUND RECORDINGS AND AUDIO-VISUAL RECORDINGS FEATURING MUSIC, MUSIC-BASED ENTERTAINMENT, MUSICAL PERFORMANCES, DRAMATIC PERFORMANCES AND COMEDIC PERFORMANCES BY AN ACTOR, MUSICIAN OR A MUSICAL GROUP; DOWNLOADABLE SOUND RECORDINGS AND AUDIO-VISUAL RECORDINGS VIA A GLOBAL COMPUTER NETWORK AND WIRELESS DEVICES FEATURING MUSIC, MUSIC-BASED ENTERTAINMENT, MUSICAL PERFORMANCES, DRAMATIC PERFORMANCES AND COMEDIC PERFORMANCES BY AN ACTOR, MUSICIAN OR A MUSICAL GROUP; DOWNLOADABLE RINGTONES VIA A GLOBAL COMPUTER NETWORK AND WIRELESS DEVICES; COMPUTER APPLICATION SOFTWARE FOR MOBILE PHONES, NAMELY, FOR ELECTRONIC STORAGE OF DATA AND GRAPHICS, FOR DOWNLOADING AND PLAYING SOUND RECORDINGS AND AUDIO-VISUAL RECORDINGS AND FOR THE RECEIPT AND TRANSMISSION OF MESSAGES; VINYL COVERS SPECIALLY ADAPTED FOR WIRELESS DEVICES IN THE NATURE OF CELL PHONES, PDAS, MP3 PLAYERS, LAPTOPS AND GAMING DEVICES; HEADPHONES (U.S. CLS. 21, 23, 26, 36 AND 38).
FIRST USE 1-1-2001; IN COMMERCE 3-1-2010.

CLASS 16—PAPER GOODS AND PRINTED MATTER

FOR PAMPHLETS AND JOURNALS IN THE FIELD OF CELEBRITY MERCHANDISE, WRITING INSTRUMENTS, ERASERS, PENCIL SHARPENERS, STICKERS, MOUNTED AND UNMOUNTED PHOTOGRAPHS, PHOTOGRAPH ALBUMS, AUTOGRAPH ALBUMS, DIARIES, CALENDARS, POSTERS, NOTE PADS AND NOTEBOOKS, BINDERS, FILE FOLDERS, PAPER AND CARDBOARD FILE JACKETS, PEN CASES, PENCIL CASES, WRAPPING PAPER, NOTE CARDS, POST CARDS, GIFT CARDS, FILE CARDS, PRINTED LABELS, GREETING CARDS, SHEET MUSIC, STATIONERY (U.S. CLS. 2, 5, 22, 23, 29, 37, 38 AND 50).

CLASS 25—CLOTHING

FOR CLOTHING, NAMELY, HATS, CAPS, T-SHIRTS, SWEATSHIRTS, SWEATPANTS, TOPS, SHIRTS, JACKETS, DRESSES, SKIRTS, BLOUSES, UNDERGARMENTS, LINGERIE, WRIST BANDS, HEADBANDS, SUN VISORS, GLOVES, SHOES, BEACHWEAR, SHORTS, TIES, PANTS, VESTS, BELTS, SWEATERS, SUITS, PULLOVERS, JEANS, LOUNGEWEAR, SOCKS, SCARVES, RAINWEAR, SPORTS JERSEYS, SWIMWEAR AND TANK TOPS (U.S. CLS. 22 AND 39).

FIRST USE 1-1-2010; IN COMMERCE 1-1-2010.

CLASS 38—COMMUNICATION

FOR PROVIDING ON-LINE CHAT ROOMS FOR TRANSMISSION OF MESSAGES AMONG COMPUTER AND MOBILE DEVICE USERS CONCERNING AN ACTOR, MUSICIAN OR MUSICAL GROUP (U.S. CLS. 100, 101 AND 104).

CLASS 41—EDUCATION AND ENTERTAINMENT

FOR ENTERTAINMENT SERVICES, NAMELY, LIVE ENTERTAINMENT COMPRISING MUSICAL PERFORMANCES, DRAMATIC PERFORMANCES AND COMEDIC PERFORMANCES BY AN ACTOR, MUSICIAN OR A MUSICAL GROUP; AUDIO AND VIDEO PRODUCTION AND RECORDING SERVICES; PROVIDING NON-DOWNLOADABLE SOUND RECORDINGS AND AUDIO-VISUAL RECORDINGS FEATURING PERFORMANCES BY AN ACTOR, MUSICIAN OR MUSICAL GROUP BY MEANS OF A GLOBAL COMPUTER NETWORK AND MOBILE DEVICES; PROVIDING INFORMATION ABOUT ENTERTAINMENT SERVICES PERFORMED BY AN ACTOR, MUSICIAN, MUSICAL GROUP AND IN FILMS; ARRANGING, ORGANIZING AND CONDUCTING CULTURAL EVENTS AND ENTERTAINMENT EVENTS IN THE NATURE OF LIVE ENTERTAINMENT COMPRISING LIVE MUSICAL PERFORMANCES, LIVE DRAMATIC PERFORMANCES AND LIVE COMEDIC PERFORMANCES BY AN ACTOR, MUSICIAN OR MUSICAL GROUP, FAN CLUB PARTIES AND MEET AND GREET SOCIAL PARTIES WITH AN ACTOR, MUSICIAN OR MUSICAL GROUP; ENTERTAINMENT INFORMATION, NAMELY, PROVIDING A WEBSITE, BLOGS AND ONLINE JOURNALS FEATURING ENTERTAINMENT INFORMATION ABOUT AN ACTOR, MUSICIAN OR MUSICAL GROUP AND THEIR TOURS, LIVE AND RECORDED PERFORMANCES, APPEARANCES, NEWS, BIOGRAPHICAL AND OTHER PERSONAL INFORMATION, PHOTOGRAPHS AND OTHER ENTERTAINMENT INFORMATION; PROVIDING A WEBSITE FEATURING MUSICAL PERFORMANCES, DRAMATIC PERFORMANCES AND COMEDIC PERFORMANCES BY AN ACTOR, MUSICIAN OR A MUSICAL GROUP, VIDEOS AND OTHER MULTIMEDIA MATERIALS ON REGARDING AN ACTOR, MUSICIAN OR MUSICAL GROUP; FAN CLUB SERVICES (U.S. CLS. 100, 101 AND 107).

FIRST USE 2-1-2006; IN COMMERCE 2-1-2006.
TARAH HARDY, EXAMINING ATTORNEY

SN 85-482,216. ROAD HERO, INC., SAN FRANCISCO, CA. FILED 11-29-2011.

SN 85-482,416. FREEHAVEN INVESTMENTS LTD., CHARLESTOWN, ST.KITTS-NEVIS, FILED 11-29-2011.

ROAD HERO

THE MARK CONSISTS OF STANDARD CHARACTERS WITHOUT CLAIM TO ANY PARTICULAR FONT, STYLE, SIZE, OR COLOR.

NO CLAIM IS MADE TO THE EXCLUSIVE RIGHT TO USE "ROAD", APART FROM THE MARK AS SHOWN.

CLASS 9—ELECTRICAL AND SCIENTIFIC APPARATUS

FOR COMPUTER APPLICATION SOFTWARE FOR RECEIVING, PROCESSING AND TRANSMITTING USER-CREATED CONTENT REGARDING THE DRIVING ACTIVITIES OF OTHERS; COMPUTER APPLICATION SOFTWARE FOR TRANSMITTING AUDIO, VIDEO AND TEXT MESSAGES (U.S. CLS. 21, 23, 26, 36 AND 38).

FIRST USE 12-15-2011; IN COMMERCE 12-15-2011.

CLASS 35—ADVERTISING AND BUSINESS

FOR COLLECTION AND COMPILATION OF USER-CREATED INFORMATION, NAMELY, RATINGS AND REPORTS REGARDING THE DRIVING ACTIVITIES OF OTHERS, INTO COMPUTER DATABASES (U.S. CLS. 100, 101 AND 102).

FIRST USE 12-15-2011; IN COMMERCE 12-15-2011. LAKEISHA LEWIS, EXAMINING ATTORNEY

SN 85-482,258. THE SIKH COALITION, NEW YORK, NY. FILED 11-29-2011.

THE SIKH COALITION

THE MARK CONSISTS OF STANDARD CHARACTERS WITHOUT CLAIM TO ANY PARTICULAR FONT, STYLE, SIZE, OR COLOR.

NO CLAIM IS MADE TO THE EXCLUSIVE RIGHT TO USE "COALITION", APART FROM THE MARK AS SHOWN. SEC. 2(F).

CLASS 35—ADVERTISING AND BUSINESS

FOR ASSOCIATION SERVICES, NAMELY, PROMOTING THE INTERESTS OF SIKHS BY ADVOCATING FOR LAW AND POLICIES THAT ARE RESPECTFUL OF HUMAN RIGHTS AND PROMOTE APPRECIATION FOR DIVERSITY (U.S. CLS. 100, 101 AND 102).

FIRST USE 10-12-2001; IN COMMERCE 10-12-2001.

CLASS 45—PERSONAL AND LEGAL SERVICES

FOR PROVIDING LEGAL SERVICES TO PERSONS WHOSE CIVIL OR HUMAN RIGHTS HAVE BEEN VIOLATED (U.S. CLS. 100 AND 101).

FIRST USE 10-12-2001; IN COMMERCE 10-12-2001. ANDREA HACK, EXAMINING ATTORNEY

VASYLI THINK TANK

THE MARK CONSISTS OF STANDARD CHARACTERS WITHOUT CLAIM TO ANY PARTICULAR FONT, STYLE, SIZE, OR COLOR.

OWNER OF U.S. REG. NOS. 2,727,758 AND 3,925,852.

NO CLAIM IS MADE TO THE EXCLUSIVE RIGHT TO USE "THINK TANK", APART FROM THE MARK AS SHOWN.

CLASS 41—EDUCATION AND ENTERTAINMENT

FOR EDUCATION SERVICES, NAMELY, CONDUCTING SEMINARS, CLASSES, WORKSHOPS, CONFERENCES AND TRAINING IN THE FIELD OF LOWER LIMB BIOMECHANICS (U.S. CLS. 100, 101 AND 107).

CLASS 42—SCIENTIFIC AND COMPUTER SERVICES

FOR CONDUCTING RESEARCH, CLINICAL TRIALS AND PRODUCT DEVELOPMENT IN THE FIELD OF LOWER LIMB BIOMECHANICS (U.S. CLS. 100 AND 101).

ANN E. SAPPENFIELD, EXAMINING ATTORNEY

SN 85-482,675. IDIGITAL VIDEO PRODUCTIONS, LLC, CHARLOTTE, NC. FILED 11-29-2011.



NO CLAIM IS MADE TO THE EXCLUSIVE RIGHT TO USE "IDIGITAL VIDEO SERVICES", APART FROM THE MARK AS SHOWN.

THE COLOR(S) BLUE AND WHITE IS/ARE CLAIMED AS A FEATURE OF THE MARK.

THE MARK CONSISTS OF A BLUE CIRCLE WITH A WHITE ARROW POINTING TO THE RIGHT LOCATED TO THE LEFT OF THE WORDS "IDIGITAL VIDEO SERVICES". THE WORD "IDIGITAL" IS WRITTEN WITH WHITE TYPE WITH A BLUE OUTLINE AND THE WORDS "VIDEO SERVICES" ARE BELOW THAT IN BLUE TYPE.

CLASS 41—EDUCATION AND ENTERTAINMENT

FOR VIDEO PRODUCTION SERVICES FOR TELEVISION, VIDEOTAPES, VIDEO DISCS, AND STREAMING INTERNET VIDEO (U.S. CLS. 100, 101 AND 107).

FIRST USE 11-11-2011; IN COMMERCE 11-11-2011.

CLASS 42—SCIENTIFIC AND COMPUTER SERVICES

FOR COMPUTER SERVICES, NAMELY, PLANNING, DESIGN, DEVELOPMENT, MAINTENANCE, AND OPTIMIZATION OF ONLINE SOCIAL MEDIA WEBSITES, BLOGS, AND OTHER WEBSITES; CONSULTATION SERVICES IN THE FIELD OF SEARCH ENGINE OPTIMIZATION AND VIDEO OPTIMIZATION (U.S. CLS. 100 AND 101).

FIRST USE 11-11-2011; IN COMMERCE 11-11-2011. JOHN HWANG, EXAMINING ATTORNEY

SN 85-483,156. NEW DREAM NETWORK, LLC, BREA, CA.
FILED 11-29-2011.

DreamCompute

THE MARK CONSISTS OF STANDARD CHARACTERS WITHOUT CLAIM TO ANY PARTICULAR FONT, STYLE, SIZE, OR COLOR.

OWNER OF U.S. REG. NOS. 2,664,983, 3,058,368 AND 3,467,780.

CLASS 38—COMMUNICATION

FOR PROVIDING ACCESS TO VIRTUAL COMPUTING ENVIRONMENTS AND CLOUD COMPUTING RESOURCES; PROVIDING ACCESS TO VIRTUAL COMPUTING ENVIRONMENTS CONSISTING OF VIRTUALIZED COMPUTER HARDWARE, COMPUTER SOFTWARE AND DATA STORAGE FACILITIES THROUGH THE INTERNET (U.S. CLS. 100, 101 AND 104).

CLASS 42—SCIENTIFIC AND COMPUTER SERVICES

FOR COMPUTER SERVICES, NAMELY, APPLICATION SERVICE PROVIDER SERVICES FOR THIRD PARTIES FEATURING REMOTE HOSTING OF OPERATING SYSTEMS AND COMPUTER APPLICATIONS; CLOUD COMPUTING, NAMELY, PROVIDING VIRTUAL COMPUTER SYSTEMS AND VIRTUAL COMPUTER ENVIRONMENTS THROUGH CLOUD COMPUTING; COMPUTER SERVICES, NAMELY, PROVIDING A VIRTUAL COMPUTING ENVIRONMENT ACCESSIBLE VIA THE INTERNET FOR REGISTERED USERS FOR THE PURPOSE OF USING COMPUTING AND DATA STORAGE FACILITIES OF VARIABLE CAPACITY; RENTAL OF DATABASE SERVERS TO THIRD PARTIES ACCESSIBLE VIA THE INTERNET; RENTAL OF DATABASE SERVERS OF VARIABLE CAPACITY TO THIRD PARTIES VIA THE INTERNET (U.S. CLS. 100 AND 101).

GINA HAYES, EXAMINING ATTORNEY

SN 85-483,495. PROMOTORA APARTAMENTOS DANN S.A.,
BOTOTA D.C., COLOMBIA, FILED 11-30-2011.



NO CLAIM IS MADE TO THE EXCLUSIVE RIGHT TO USE "HOTELS", APART FROM THE MARK AS SHOWN.

THE MARK CONSISTS OF THE STYLIZED WORDING "HOTELS DANN", HAVING THE LETTER "H" FORMING A PORTION OF THE LETTER "D" IN "DANN" AND THE DESIGN OF AN OVAL CARRIER AROUND ALL OF THE WORDING.

CLASS 16—PAPER GOODS AND PRINTED MATTER

FOR BOOKS AND PUBLICATIONS, NAMELY, MAGAZINES, BROCHURES, JOURNALS, AND NEWSLETTERS IN THE FIELD OF TRAVEL, ENTERTAINMENT, ACCOMMODATIONS, AMENITIES, DINING, AND NEWS; STATIONERY; POSTCARDS; PRINTED MATTER, NAMELY, ALMANACS, ANNOUNCEMENT CARDS, PAPER BAGS AND PLASTIC BAGS FOR GENERAL USE, BIBS OF PAPER, LOOSE-LEAF BINDERS, BOOKMARKERS, CALENDARS, ENVELOPES, FACE TOWELS OF PAPER, GARBAGE BAGS OF PAPER AND OF PLASTIC, GEOGRAPHICAL MAPS, HANDKERCHIEFS OF PAPER, TABLE NAPKINS OF PAPER, PAPER SHEETS FOR NOTETAKING, POSTCARDS, POSTERS, STICKERS, TEAR-OFF CALENDARS, PRINTED TICKETS, PRINTED TIMETABLES, PAPER LABELS; PRINTED MATTER IN THE NATURE OF CARDS, NAMELY, BUSINESS CARDS, CARDS BEARING UNIVERSAL GREETINGS, CORRESPONDENCE CARDS, FILE CARDS, FLASH CARDS, NON-MAGNETICALLY ENCODED PAPER AND PLASTIC GIFT CARDS, GREETING CARDS, INVITATION CARDS (U.S. CLS. 2, 5, 22, 23, 29, 37, 38 AND 50).

CLASS 35—ADVERTISING AND BUSINESS

FOR BUSINESS MANAGEMENT; BUSINESS ADMINISTRATION (U.S. CLS. 100, 101 AND 102).

CLASS 39—TRANSPORTATION AND STORAGE

FOR TRANSPORT OF PERSONS AND GOODS; PACKING OF GOODS FOR TRANSPORTATION AND STORAGE OF GOODS; TRAVEL ARRANGEMENT (U.S. CLS. 100 AND 105).

CLASS 43—HOTEL AND RESTAURANT SERVICES

FOR PROVIDING OF FOOD AND DRINK SERVICES; PROVIDING TEMPORARY ACCOMMODATIONS; RENTAL OF TEMPORARY ACCOMMODATIONS; RESERVATION FOR TEMPORARY ACCOMMODATIONS; BAR SERVICES; CAFES; CAFETERIAS; CATERING; HOTELS; MAKING HOTEL RESERVATIONS FOR OTHERS; RENTAL OF MEETING ROOMS; RENTAL OF CHAIRS, TABLES, TABLE LINEN, GLASSWARE; RESTAURANTS; SELF-SERVICE RESTAURANT (U.S. CLS. 100 AND 101).

JEFFERY COWARD, EXAMINING ATTORNEY

SN 85-483,683. HENKEL AG & CO. KGAA, DUESSELDORF,
FED REP GERMANY, FILED 11-30-2011.

AQUENCE

THE MARK CONSISTS OF STANDARD CHARACTERS WITHOUT CLAIM TO ANY PARTICULAR FONT, STYLE, SIZE, OR COLOR.

OWNER OF U.S. REG. NO. 3,454,062.

CLASS 1—CHEMICALS

FOR CHEMICALS USED IN INDUSTRY; ADHESIVES USED IN INDUSTRY; DEGREASING AGENTS NOT FOR HOUSEHOLD USE (U.S. CLS. 1, 5, 6, 10, 26 AND 46).

CLASS 3—COSMETICS AND CLEANING PREPARATIONS

FOR INDUSTRIAL CLEANING PREPARATIONS (U.S. CLS. 1, 4, 6, 50, 51 AND 52).
KATHLEEN LORENZO, EXAMINING ATTORNEY

CLASS 36—INSURANCE AND FINANCIAL

FOR REAL ESTATE CONSULTATION (U.S. CLS. 100, 101 AND 102).
FIRST USE 11-1-2011; IN COMMERCE 11-1-2011.
EDWARD FENNESSY, EXAMINING ATTORNEY

SN 85-484,515. TRIANGLE WEALTH MANAGEMENT LLC, CARY, NC. FILED 12-1-2011.

SN 85-484,911. BIO-MICROBICS, INC., SHAWNEE, KS. FILED 12-1-2011.

GREEDOMETER

THE MARK CONSISTS OF STANDARD CHARACTERS WITHOUT CLAIM TO ANY PARTICULAR FONT, STYLE, SIZE, OR COLOR.

CLASS 9—ELECTRICAL AND SCIENTIFIC APPARATUS

FOR DOWNLOADABLE ELECTRONIC PUBLICATIONS IN THE NATURE OF NEWSLETTERS AND BOOKS IN THE FIELD OF ECONOMICS, FINANCES, AND INVESTMENTS (U.S. CLS. 21, 23, 26, 36 AND 38).

CLASS 16—PAPER GOODS AND PRINTED MATTER

FOR SERIES OF BOOKS IN THE FIELD OF ECONOMICS, FINANCES, AND INVESTMENTS (U.S. CLS. 2, 5, 22, 23, 29, 37, 38 AND 50).

CLASS 41—EDUCATION AND ENTERTAINMENT

FOR NON-DOWNLOADABLE ELECTRONIC PUBLICATIONS IN THE NATURE OF NEWSLETTERS IN THE FIELD OF ECONOMICS, FINANCES, AND INVESTMENTS (U.S. CLS. 100, 101 AND 107).
WILLIAM VERHOSEK, EXAMINING ATTORNEY

SN 85-484,662. LIVE WITHOUT BOUNDS, LLC, CASTLE ROCK, CO. FILED 12-1-2011.

Live Without Bounds

THE MARK CONSISTS OF STANDARD CHARACTERS WITHOUT CLAIM TO ANY PARTICULAR FONT, STYLE, SIZE, OR COLOR.

CLASS 35—ADVERTISING AND BUSINESS

FOR PROVIDING REAL ESTATE LEADS FOR PROSPECTIVE PURCHASERS AND OR RENTERS; ADVERTISING OF REAL ESTATE; PROVIDING ONLINE VIDEO TOURS FOR PROSPECTIVE PURCHASERS AND OR RENTERS (U.S. CLS. 100, 101 AND 102).

MIGHTY MIKE

THE MARK CONSISTS OF STANDARD CHARACTERS WITHOUT CLAIM TO ANY PARTICULAR FONT, STYLE, SIZE, OR COLOR.

CLASS 1—CHEMICALS

FOR BACTERIA TABLETS FOR WATER TREATMENT (U.S. CLS. 1, 5, 6, 10, 26 AND 46).
FIRST USE 9-0-2008; IN COMMERCE 9-0-2008.

CLASS 3—COSMETICS AND CLEANING PREPARATIONS

FOR LAUNDRY DETERGENTS; ALL PURPOSE CLEANERS (U.S. CLS. 1, 4, 6, 50, 51 AND 52).
FIRST USE 9-0-2008; IN COMMERCE 9-0-2008.
AMY KELLY, EXAMINING ATTORNEY

SN 85-485,161. FINANCIAL STRAIGHT TALK, LLC, CHICAGO, IL. FILED 12-1-2011.

Financial Straight Talk

THE MARK CONSISTS OF STANDARD CHARACTERS WITHOUT CLAIM TO ANY PARTICULAR FONT, STYLE, SIZE, OR COLOR.
NO CLAIM IS MADE TO THE EXCLUSIVE RIGHT TO USE "FINANCIAL", APART FROM THE MARK AS SHOWN.

CLASS 9—ELECTRICAL AND SCIENTIFIC APPARATUS

FOR DIGITAL MEDIA, NAMELY, WEB VIDEOS, STREAMING VIDEOS, DVDS, CDS FEATURING FINANCIAL ADVISING, FINANCIAL EDUCATION, AND FINANCIAL PLANNING; DOWNLOADABLE MOTION PICTURES AND TELEVISION SHOWS ABOUT FINANCIAL ADVISING, FINANCIAL EDUCATION, AND FINANCIAL PLANNING (U.S. CLS. 21, 23, 26, 36 AND 38).
FIRST USE 9-1-1988; IN COMMERCE 9-1-1988.

CLASS 41—EDUCATION AND ENTERTAINMENT

FOR CONTINUING PUBLIC SERVICE PROGRAMS IN THE FIELD OF FINANCIAL ADVISING, FINANCIAL EDUCATION, AND FINANCIAL PLANNING PRODUCED AND DISTRIBUTED OVER TELEVISION, SATELLITE, FILM, AUDIO, VIDEO, INTERNET, AND 3-D VIRTUAL REALITY MEDIA; EDUCATIONAL AND ENTERTAINMENT SERVICES, NAMELY, A CONTINUING PROGRAM ABOUT FINANCIAL ADVISING, FINANCIAL EDUCATION, AND FINANCIAL PLANNING ACCESSIBLE BY RADIO, TELEVISION, SATELLITE, AUDIO, VIDEO AND COMPUTER NETWORKS; ENTERTAINMENT IN THE NATURE OF AN ON-GOING SPECIAL VARIETY, NEWS, MUSIC OR COMEDY SHOW FEATURING FINANCIAL ADVISING, FINANCIAL EDUCATION, AND FINANCIAL PLANNING BROADCAST OVER TELEVISION, SATELLITE, AUDIO, AND VIDEO MEDIA; ENTERTAINMENT IN THE NATURE OF ON-GOING TELEVISION PROGRAMS IN THE FIELD OF FINANCIAL ADVISING, FINANCIAL EDUCATION, AND FINANCIAL PLANNING; ENTERTAINMENT IN THE NATURE OF TELEVISION NEWS SHOWS; ENTERTAINMENT SERVICES, NAMELY, PRODUCTION AND DISTRIBUTION OF ONGOING TELEVISION PROGRAMS IN THE FIELD OF FINANCIAL ADVISING, FINANCIAL EDUCATION, AND FINANCIAL PLANNING; ENTERTAINMENT SERVICES, NAMELY, PROVIDING ON-GOING TELEVISION PROGRAMS IN THE FIELD OF FINANCIAL ADVISING, FINANCIAL EDUCATION, AND FINANCIAL PLANNING VIA A GLOBAL COMPUTER NETWORK; ONLINE JOURNALS, NAMELY, BLOGS FEATURING FINANCIAL ADVISING, FINANCIAL EDUCATION, AND FINANCIAL PLANNING; PRODUCTION OF CABLE TELEVISION PROGRAMS (U.S. CLS. 100, 101 AND 107).

FIRST USE 9-1-1988; IN COMMERCE 9-1-1988.

WILLIAM ROSSMAN, EXAMINING ATTORNEY

SN 85-485,986. PASSRULLES CANADIAN SECURITY INC., MANITOBA R2H 1N5, CANADA, FILED 12-2-2011.

DESKTOP SENTINEL

THE MARK CONSISTS OF STANDARD CHARACTERS WITHOUT CLAIM TO ANY PARTICULAR FONT, STYLE, SIZE, OR COLOR.

NO CLAIM IS MADE TO THE EXCLUSIVE RIGHT TO USE "DESKTOP", APART FROM THE MARK AS SHOWN.

CLASS 9—ELECTRICAL AND SCIENTIFIC APPARATUS

FOR COMPUTER SOFTWARE FOR CONTROLLING AND MANAGING ACCESS SOFTWARE APPLICATIONS AND COMPUTER RESOURCES; COMPUTER SERVERS; PERSONAL DIGITAL ASSISTANT DEVICES; CELLULAR TELEPHONES; ATM MACHINES; CREDIT AND DEBIT CARD SCANNERS AND PROCESSORS; COMPUTERIZED NON-BIOMETRIC USER AUTHENTICATION SOFTWARE TO PROVIDE SECURE ACCESS TO ELECTRONIC DEVICES (U.S. CLS. 21, 23, 26, 36 AND 38).

CLASS 45—PERSONAL AND LEGAL SERVICES

FOR IDENTIFICATION VERIFICATION SERVICES, NAMELY, PROVIDING AUTHENTICATION OF PERSONAL IDENTIFICATION INFORMATION (U.S. CLS. 100 AND 101).

ANGELA M. MICHELI, EXAMINING ATTORNEY

SN 85-486,247. WENDELN, ULRICH, GARREL, FED REP GERMANY, FILED 12-2-2011.

GOLDEN MILL

THE MARK CONSISTS OF STANDARD CHARACTERS WITHOUT CLAIM TO ANY PARTICULAR FONT, STYLE, SIZE, OR COLOR.

CLASS 22—CORDAGE AND FIBERS

FOR TEXTILE PACKAGING BAGS MADE FROM SUNFLOWER SEED SKIN (U.S. CLS. 1, 2, 7, 19, 22, 42 AND 50).

CLASS 29—MEATS AND PROCESSED FOODS

FOR NATURAL SUNFLOWER SEEDS; ROASTED SUNFLOWER SEEDS; SWEETENED SUNFLOWER SEEDS; SALTED SUNFLOWER SEEDS; EDIBLE OILS (U.S. CL. 46).

CLASS 30—STAPLE FOODS

FOR CHOCOLATE BARS; MUESLI BARS MADE FROM SUNFLOWER SEEDS; CAKES; PASTRY; COOKIES (U.S. CL. 46).

CURTIS FRENCH, EXAMINING ATTORNEY

SN 85-486,656. EXHALE PREMIUM BEVERAGES, INC., MIAMI, FL. FILED 12-4-2011.

INHALE PREMIUM BEVERAGES

THE MARK CONSISTS OF STANDARD CHARACTERS WITHOUT CLAIM TO ANY PARTICULAR FONT, STYLE, SIZE, OR COLOR.

NO CLAIM IS MADE TO THE EXCLUSIVE RIGHT TO USE "PREMIUM BEVERAGES", APART FROM THE MARK AS SHOWN.

CLASS 32—LIGHT BEVERAGES

FOR LIGHT BEVERAGES, NAMELY, ENERGY DRINKS, FRUIT BEVERAGES, FRUIT DRINKS AND FRUIT JUICES, FRUIT FLAVORED DRINKS AND FRUIT JUICES AND FRUIT DRINKS; BEERS; MINERAL AND AERATED WATERS AND OTHER NON-ALCOHOLIC DRINKS, NAMELY, NON-ALCOHOLIC BEVERAGES CONTAINING FRUIT JUICES, NON-ALCOHOLIC BEVERAGES WITH TEA FLAVOR, NON-ALCOHOLIC DRINKS, NAMELY ENERGY SHOTS, SYRUPS FOR MAKING BEVERAGES (U.S. CLS. 45, 46 AND 48).

CLASS 33—WINES AND SPIRITS

FOR ALCOHOLIC BEVERAGES EXCEPT BEERS, ALCOHOLIC ENERGY DRINKS, SPIRITS, WINE, WINE COOLERS (U.S. CLS. 47 AND 49).

ALLISON SCHRODY, EXAMINING ATTORNEY

SN 85-486,768. BUNZL DISTRIBUTION USA, INC., CREVE COEUR, MO. FILED 12-5-2011.

SN 85-487,765. O'SHEA, KATHERINE, DENVER, CO. FILED 12-6-2011.

HI-VALU

THE MARK CONSISTS OF STANDARD CHARACTERS WITHOUT CLAIM TO ANY PARTICULAR FONT, STYLE, SIZE, OR COLOR.

OWNER OF U.S. REG. NOS. 3,613,902, 3,626,948 AND OTHERS.

CLASS 20—FURNITURE AND ARTICLES NOT OTHERWISE CLASSIFIED

FOR PLASTIC CONTAINERS AND COVERS FOR THE FOOD INDUSTRY (U.S. CLS. 2, 13, 22, 25, 32 AND 50).

CLASS 21—HOUSEWARES AND GLASS

FOR PLASTIC CUPS; PLASTIC CUPS WITH LIDS (U.S. CLS. 2, 13, 23, 29, 30, 33, 40 AND 50).

ANN E. SAPPENFIELD, EXAMINING ATTORNEY

SN 85-487,590. THE ASSOCIATION OF BONE AND JOINT SURGEONS, ROSEMONT, IL. FILED 12-5-2011.

ABJS

THE MARK CONSISTS OF STANDARD CHARACTERS WITHOUT CLAIM TO ANY PARTICULAR FONT, STYLE, SIZE, OR COLOR.

CLASS 35—ADVERTISING AND BUSINESS

FOR ASSOCIATION SERVICES, NAMELY, PROMOTING THE INTERESTS OF ORTHOPAEDIC SURGEONS (U.S. CLS. 100, 101 AND 102).

FIRST USE 0-0-1989; IN COMMERCE 0-0-1989.

CLASS 41—EDUCATION AND ENTERTAINMENT

FOR EDUCATIONAL SERVICES, NAMELY, CONDUCTING SEMINARS, CONFERENCES AND WORKSHOPS IN THE FIELD OF ORTHOPAEDIC CARE AND SURGERY; AND PROVIDING RECOGNITION BY THE WAY OF AWARDS FOR THE DEMONSTRATION OF EXCELLENCE IN MUSCULOSKELETAL RESEARCH (U.S. CLS. 100, 101 AND 107).

FIRST USE 0-0-1989; IN COMMERCE 0-0-1989.
DAWN HAN, EXAMINING ATTORNEY

CRAFTY LADIES BEER CLUB

THE MARK CONSISTS OF STANDARD CHARACTERS WITHOUT CLAIM TO ANY PARTICULAR FONT, STYLE, SIZE, OR COLOR.

NO CLAIM IS MADE TO THE EXCLUSIVE RIGHT TO USE "LADIES BEER CLUB", APART FROM THE MARK AS SHOWN.

CLASS 21—HOUSEWARES AND GLASS

FOR DRINKING PINT GLASSES; MUGS; BOTTLE OPENERS; COASTERS NOT OF PAPER AND NOT BEING TABLE LINEN (U.S. CLS. 2, 13, 23, 29, 30, 33, 40 AND 50).

CLASS 25—CLOTHING

FOR CLOTHING, NAMELY, TOPS, BOTTOMS, T-SHIRTS, HATS (U.S. CLS. 22 AND 39).

CLASS 35—ADVERTISING AND BUSINESS

FOR CLUB SERVICES, NAMELY, PROMOTING THE INTERESTS OF BEER ENTHUSIASTS (U.S. CLS. 100, 101 AND 102).

CLASS 39—TRANSPORTATION AND STORAGE

FOR ARRANGING, ORGANIZING, AND CONDUCTING BEER-RELATED FIELD TRIPS; ARRANGING OF BREWERY TOURS (U.S. CLS. 100 AND 105).

ANDREA HACK, EXAMINING ATTORNEY

SN 85-488,523. NEONATAL THERAPY SOLUTIONS LLC, DALLAS, TX. FILED 12-6-2011.



NO CLAIM IS MADE TO THE EXCLUSIVE RIGHT TO USE "NEONATAL THERAPY SOLUTIONS", APART FROM THE MARK AS SHOWN.

THE COLOR(S) BLACK, PURPLE AND GREEN IS/ARE CLAIMED AS A FEATURE OF THE MARK.

THE MARK CONSISTS OF A GRAPHICAL DEPICTION OF A SMALL SEEDLING IN THE COLOR PURPLE WITH A LEAF IN THE COLOR GREEN ABOVE THE WORDS "NEONATAL THERAPY" IN THE COLOR PURPLE ABOVE THE TERM "SOLUTIONS" IN THE COLOR GREEN ALL OF WHICH IS ON A BLACK BACKGROUND.

CLASS 41—EDUCATION AND ENTERTAINMENT

FOR EDUCATIONAL SERVICES, NAMELY, CONDUCTING WORKSHOPS, LECTURES AND SEMINARS IN THE FIELDS OF DEVELOPMENTAL INTERVENTIONS AND FEEDING FOR MEDICAL PROFESSIONALS IN THE NEONATAL INTENSIVE CARE UNIT AND DISTRIBUTION OF TRAINING MATERIALS IN CONNECTION THEREWITH; MENTORING SERVICES IN THE FIELDS OF DEVELOPMENTAL INTERVENTIONS AND FEEDING FOR MEDICAL PROFESSIONALS IN THE NEONATAL INTENSIVE CARE UNIT; COACHING SERVICES IN THE FIELDS OF DEVELOPMENTAL INTERVENTIONS AND FEEDING FOR MEDICAL PROFESSIONALS IN THE NEONATAL INTENSIVE CARE UNIT (U.S. CLS. 100, 101 AND 107).

FIRST USE 9-0-2010; IN COMMERCE 9-0-2010.

CLASS 44—MEDICAL, BEAUTY AND AGRICULTURAL SERVICES

FOR PROFESSIONAL AND MEDICAL CONSULTING SERVICES IN THE FIELDS OF DEVELOPMENTAL MEDICAL INTERVENTIONS AND FEEDING FOR MEDICAL PROFESSIONALS IN THE NEONATAL INTENSIVE CARE UNIT (U.S. CLS. 100 AND 101).

FIRST USE 9-0-2010; IN COMMERCE 9-0-2010.
PRISCILLA MILTON, EXAMINING ATTORNEY

SN 85-488,534. CHADDOCK, CYNTHIA, TEMPE, AZ. FILED 12-6-2011.

E & E GRAPHIC INNOVATIONS

THE MARK CONSISTS OF STANDARD CHARACTERS WITHOUT CLAIM TO ANY PARTICULAR FONT, STYLE, SIZE, OR COLOR.

NO CLAIM IS MADE TO THE EXCLUSIVE RIGHT TO USE "GRAPHIC", APART FROM THE MARK AS SHOWN.

CLASS 16—PAPER GOODS AND PRINTED MATTER

FOR GRAPHIC ART REPRODUCTIONS; FRAMED GRAPHIC ART REPRODUCTIONS (U.S. CLS. 2, 5, 22, 23, 29, 37, 38 AND 50).

CLASS 42—SCIENTIFIC AND COMPUTER SERVICES

FOR GRAPHIC ARTS DESIGNING (U.S. CLS. 100 AND 101).

CHRISTOPHER LAW, EXAMINING ATTORNEY

SN 85-488,726. AQUATACTICS LLC, KIRKLAND, WA. FILED 12-6-2011.

AQUATACTICS

THE MARK CONSISTS OF STANDARD CHARACTERS WITHOUT CLAIM TO ANY PARTICULAR FONT, STYLE, SIZE, OR COLOR.

CLASS 5—PHARMACEUTICALS

FOR VETERINARY BIOLOGICS AND PHARMACEUTICALS FOR THE TREATMENT OF FISH (U.S. CLS. 6, 18, 44, 46, 51 AND 52).

CLASS 44—MEDICAL, BEAUTY AND AGRICULTURAL SERVICES

FOR VETERINARY SERVICES (U.S. CLS. 100 AND 101).

COLLEEN KEARNEY, EXAMINING ATTORNEY

SN 85-489,094. HUNT GEEK, INC., WARSAW, IL. FILED 12-7-2011.



THE COLOR(S) GREEN, ORANGE, BLACK, WHITE, BROWN, CREAM, GRAY AND BLUE IS/ARE CLAIMED AS A FEATURE OF THE MARK.

THE MARK CONSISTS OF GREEN AND GRAY CIRCLE WITH A BLUE BACKGROUND. "HUNT GEEK" IS IN ORANGE STYLIZED LETTERS WITHIN A WHITE BOX AT THE BOTTOM WITH A BLACK HAired PERSON WITH CREAM SKIN, BLACK AND WHITE EYES, A GREEN SHIRT, GRAY GLASSES, A BROWN PENCIL BEHIND HIS EAR AND WHITE TEETH.

CLASS 9—ELECTRICAL AND SCIENTIFIC APPARATUS

FOR CAMERAS; DOWNLOADABLE SOFTWARE FOR HUNT INFORMATION, SERVICES AND PRODUCTS; DOWNLOADABLE SOFTWARE IN THE NATURE OF A MOBILE APPLICATION FOR HUNT INFORMATION, SERVICES AND PRODUCTS; ENVIRONMENTAL ENCLOSURES, NAMELY, STRUCTURES SPECIALLY ADAPTED TO HOLD AND PROTECT CAMERAS FROM OUTDOOR ELEMENTS AND TAMPERING; FLOATING FISH WEIGHING SCALES; HUNTING BINOCULARS; LASER POINTING DEVICE FOR USE WITH FIREARMS; RIFLE SCOPES; VEHICLE SAFETY EQUIPMENT, NAMELY, ELECTRONIC DEER ALERTS; VIDEO CAMERAS (U.S. CLS. 21, 23, 26, 36 AND 38).

CLASS 28—TOYS AND SPORTING GOODS

FOR ANIMAL HUNTING DECOYS; CAMOUFLAGE NETTING USED IN HUNTING; CAMOUFLAGE SCREENS FOR HUNTING PURPOSES; CAMOUFLAGE TAPE USED IN HUNTING; ELECTRONIC ANIMAL CALLS FOR RECREATION AND HUNTING ACTIVITIES; ELECTRONIC HUNTING GAME CALL WITH INTERCHANGEABLE SOUND CARTRIDGES; FIREARM TARGETS; FISH BITE ALARM AND STRIKE INDICATOR; FISH CAGES FOR USE IN RECREATIONAL FISHING; FISH HOOK REMOVERS; FISH HOOKS; FISHING BAIT HOLDER; FISHING FLIES; FISHING FLY BOXES; FISHING RODS; GAME STRAPS USED IN BIRD HUNTING; HUNTING ARROW POINTS; HUNTING BOWS; HUNTING DECOY BAGS; HUNTING EQUIPMENT, NAMELY, SCENT DISPENSER FOR ATTRACTING OR REPELLING ANIMALS; HUNTING STANDS; LINES FOR FISHING; LURES FOR HUNTING; SCENT ELIMINATING POWDER FOR USE ASSOCIATED WITH HUNTING AND OUTDOOR RECREATION; TARGET LAUNCHERS FOR FIREARM, SKEETS, CLAY PIGEONS (U.S. CLS. 22, 23, 38 AND 50).

CLASS 41—EDUCATION AND ENTERTAINMENT

FOR ENTERTAINMENT IN THE NATURE OF ONGOING TELEVISION PROGRAMS IN THE FIELD OF HUNTING (U.S. CLS. 100, 101 AND 107).

DAVID H. STINE, EXAMINING ATTORNEY

SN 85-489,233. ARCHETYPES, INC., NEW YORK, NY. FILED 12-7-2011.

ARCHETYPE.ME

THE MARK CONSISTS OF STANDARD CHARACTERS WITHOUT CLAIM TO ANY PARTICULAR FONT, STYLE, SIZE, OR COLOR.

CLASS 4—LUBRICANTS AND FUELS

FOR CANDLE-MAKING KITS; CANDLES; FIRE LIGHTERS; PATIO TORCHES (U.S. CLS. 1, 6 AND 15).

CLASS 8—HAND TOOLS

FOR DISPOSABLE RAZORS; DISPOSABLE TABLEWARE, NAMELY, KNIVES, FORKS AND SPOONS; EYELASH CURLERS; FIREPLACE TOOL SETS SOLD AS A UNIT; GARDENING TOOLS, NAMELY, TROWELS, SHEARS, AND MANUALLY OPERATED PRUNERS; MANICURE SETS; SCISSORS; TABLEWARE, NAMELY, KNIVES, FORKS AND SPOONS; AND ELECTRIC HAND-HELD HAIR STYLING IRONS (U.S. CLS. 23, 28 AND 44).

CLASS 9—ELECTRICAL AND SCIENTIFIC APPARATUS

FOR DECORATIVE MAGNETS; EYEGLASS CHAINS AND CORDS; EYEWEAR; EYEWEAR CASES (U.S. CLS. 21, 23, 26, 36 AND 38).

CLASS 14—JEWELRY

FOR CLOCKS; JEWELRY; JEWELRY BOXES; JEWELRY CASES; JEWELRY ORGANIZERS; WATCHES (U.S. CLS. 2, 27, 28 AND 50).

CLASS 16—PAPER GOODS AND PRINTED MATTER

FOR ART PADS; ART PAPER; ARTISTS' BRUSHES; ARTISTS' PENCILS; ARTISTS' PENS; ARTS AND CRAFT CLAY KITS; ARTS AND CRAFT PAINT KITS; BABY BOOKS; BLANK JOURNALS; CALENDARS; COLORING BOOKS; COSMETIC PENCIL SHARPENERS; CRAYONS; DECORATIVE PAPER BOWS FOR WRAPPING; FRAMED ART PRINTS; GIFT BAGS; GIFT BOXES; GIFT WRAPPING PAPER; GREETING CARDS; LETTER OPENERS; MAGAZINES IN THE FIELD OF NUTRITION, FITNESS, SEXUALITY, PSYCHOLOGICAL SELF-IMPROVEMENT, PERSONALITY IDENTIFICATION AND MATCHING, PERSONAL RELATIONSHIPS AND DATING, SPIRITUALITY, HOROSCOPES AND ASTROLOGY, FASHION, MUSIC, AND REVIEWS AND RECOMMENDATIONS FOR BOOKS; MARKERS; NOTE CARDS; PAPER NAPKINS; PAPER TABLE LINENS; PHOTOGRAPH ALBUMS; PRINTED INVITATIONS; SCRAPBOOK ALBUMS; SERIES OF NON-FICTION BOOKS IN THE FIELD OF NUTRITION, FITNESS, SEXUALITY, PSYCHOLOGICAL SELF-IMPROVEMENT, PERSONALITY IDENTIFICATION AND MATCHING, PERSONAL RELATIONSHIPS AND DATING, SPIRITUALITY, HOROSCOPES AND ASTROLOGY, FASHION, MUSIC, AND REVIEWS AND RECOMMENDATIONS FOR BOOKS (U.S. CLS. 2, 5, 22, 23, 29, 37, 38 AND 50).

CLASS 18—LEATHER GOODS

FOR ALL-PURPOSE CARRYING BAGS; BACKPACKS; BRIEFCASES; BUSINESS CARD CASES; CLUTCH PURSES; COLLARS FOR PETS; COSMETIC BAGS SOLD EMPTY; DOG CLOTHING; DOG LEASHES; HANDBAGS; IMITATION LEATHER KEY CHAINS; KEY CASES; KEY WALLETS; LEATHER KEY CASES; LEATHER KEY CHAINS; LUGGAGE; LUGGAGE TAGS; UMBRELLAS; WALLETS; WRISTLET BAGS (U.S. CLS. 1, 2, 3, 22 AND 41).

CLASS 21—HOUSEWARES AND GLASS

FOR BAKEWARE; BASKETS OF WICKER; BATH BRUSHES; BATH SPONGES; BEVERAGE GLASSWARE; BIRD FEEDERS; BIRD HOUSES; BOWLS; BREAD BOXES; BROOMS; CANDLE HOLDERS; CANDLE SNUFFERS; CANDLESTICKS; CARAFES; CERAMIC FIGURINES; CLEANING SPONGES; COASTERS, NOT OF PAPER AND OTHER THAN TABLE LINEN; CONTAINERS FOR HOUSEHOLD USE; COSMETIC BRUSHES; DECANTERS; DECORATIVE PLATES; DINNERWARE; DISPENSERS FOR FACIAL TISSUES; DISPENSERS FOR LIQUID SOAP; DISPENSERS FOR PAPER TOWELS; DISPOSABLE DINNERWARE, NAMELY, PLATES AND SERVINGWARE; DUST PANS; FACIAL SPONGES FOR APPLYING MAKE-UP; FEATHER DUSTERS; FLOWER BASKETS; FLOWER POTS; GARDENING GLOVES; GLASS JARS; HAIR BRUSHES; HAIR COMBS; LAUNDRY BASKETS; NAPKIN RINGS; OVENWARE; PET BRUSHES; PET FEEDING DISHES; PET TREAT JARS; PICNIC BASKETS SOLD EMPTY; PLASTIC WATER BOTTLES SOLD EMPTY; SALT AND PEPPER MILLS; SALT AND PEPPER SHAKERS; SERVINGWARE FOR SERVING FOOD AND DRINKS; STAINED GLASS; VASES (U.S. CLS. 2, 13, 23, 29, 30, 33, 40 AND 50).

CLASS 22—CORDAGE AND FIBERS

FOR LAUNDRY BAGS; MULTI-PURPOSE CLOTH BAGS; SHOE BAGS FOR STORAGE (U.S. CLS. 1, 2, 7, 19, 22, 42 AND 50).

CLASS 24—FABRICS

FOR BATH GLOVES; BATH LINEN; BATH TOWELS; BEACH TOWELS; BED BLANKETS; BED LINEN; BED PADS; BED SPREADS; BED THROWS; COMFORTERS; COVERLETS; CURTAINS; HANDKERCHIEFS; KITCHEN LINENS; KITCHEN TOWELS; SHOWER CURTAIN LINERS; SHOWER CURTAINS; TABLE LINEN; TABLE PADS; TEXTILE WALL HANGINGS; VINYL PLACE MATS (U.S. CLS. 42 AND 50).

CLASS 26—FANCY GOODS

FOR ARTIFICIAL FLOWER ARRANGEMENTS IN CONTAINERS; ARTIFICIAL FRUIT; ARTIFICIAL PLANTS; ARTIFICIAL TOPIARIES; ARTIFICIAL WREATHS; BOWS FOR WRAPPING; DECORATIVE RIBBONS (U.S. CLS. 37, 39, 40, 42 AND 50).

SN 85-489,237. ARCHETYPES, INC., NEW YORK, NY. FILED 12-7-2011.

CLASS 27—FLOOR COVERINGS

FOR AREA RUGS; BATH MATS; DOOR MATS; NON-TEXTILE WALL HANGINGS; PET FEEDING MATS; WALLCOVERINGS (U.S. CLS. 19, 20, 37, 42 AND 50).

ARCHETYPES.ME**CLASS 28—TOYS AND SPORTING GOODS**

FOR ACTION FIGURES AND ACCESSORIES THEREFOR; BATHTUB TOYS; BATTERY OPERATED ACTION TOYS; BENDABLE TOYS; BOARD GAMES; BUBBLE MAKING WAND AND SOLUTION SETS; CARD GAMES; CHILDREN'S MULTIPLE ACTIVITY TOYS; CHRISTMAS STOCKINGS; CHRISTMAS TREE ORNAMENTS AND DECORATIONS; CHRISTMAS TREE SKIRTS; CRIB TOYS; DOLLS AND ACCESSORIES THEREFOR; ELECTRONIC LEARNING TOYS; MECHANICAL TOYS; PET TOYS; PUZZLES; STUFFED AND PLUSH TOYS; TOY ANIMALS AND ACCESSORIES THEREFOR; TOY BAKEWARE AND COOKWARE; TOY BUILDING BLOCKS (U.S. CLS. 22, 23, 38 AND 50).

THE MARK CONSISTS OF STANDARD CHARACTERS WITHOUT CLAIM TO ANY PARTICULAR FONT, STYLE, SIZE, OR COLOR.

CLASS 4—LUBRICANTS AND FUELS

FOR CANDLE-MAKING KITS; CANDLES; FIRE LIGHTERS; PATIO TORCHES (U.S. CLS. 1, 6 AND 15).

CLASS 8—HAND TOOLS

FOR DISPOSABLE RAZORS; DISPOSABLE TABLEWARE, NAMELY, KNIVES, FORKS AND SPOONS; EYELASH CURLERS; FIREPLACE TOOL SETS SOLD AS A UNIT; GARDENING TOOLS, NAMELY, TROWELS, SHEARS, AND MANUALLY OPERATED PRUNERS; MANICURE SETS; SCISSORS; TABLEWARE, NAMELY, KNIVES, FORKS AND SPOONS; AND ELECTRIC HAND-HELD HAIR STYLING IRONS (U.S. CLS. 23, 28 AND 44).

CLASS 35—ADVERTISING AND BUSINESS

FOR RETAIL STORE SERVICES FEATURING BOOKS, MUSIC, HANDBAGS, JEWELRY, FOOD, BEVERAGES, DINING AND KITCHEN UTENSILS AND LINENS, BAKEWARE, COOKWARE, FURNITURE, BATH AND BEDDING LINENS, GARDENING TOOLS, CANDLES, EYEWEAR, CLOCKS, LUGGAGE, PAPER GOODS, ARTWORK, TOYS, EXERCISE EQUIPMENT, ELECTRONICS, AND APPLIANCES; NONE OF THE AFOREMENTIONED GOODS BEING RELATED TO ARCHITECTURE AND DESIGN (U.S. CLS. 100, 101 AND 102).

CLASS 9—ELECTRICAL AND SCIENTIFIC APPARATUS

FOR DECORATIVE MAGNETS; EYEGLOSS CHAINS AND CORDS; EYEWEAR; EYEWEAR CASES (U.S. CLS. 21, 23, 26, 36 AND 38).

CLASS 14—JEWELRY

FOR CLOCKS; JEWELRY; JEWELRY BOXES; JEWELRY CASES; JEWELRY ORGANIZERS; WATCHES (U.S. CLS. 2, 27, 28 AND 50).

CLASS 41—EDUCATION AND ENTERTAINMENT

FOR CONDUCTING WORKSHOPS AND SEMINARS IN THE FIELDS OF NUTRITION, FITNESS, SEXUALITY, PSYCHOLOGICAL SELF-IMPROVEMENT, PERSONALITY IDENTIFICATION AND MATCHING, PERSONAL RELATIONSHIPS AND DATING, SPIRITUALITY, HOROSCOPES AND ASTROLOGY, FASHION, MUSIC AND REVIEWS AND RECOMMENDATIONS FOR BOOKS; PROVIDING A WEBSITE FEATURING BLOGS AND NON-DOWNLOADABLE PUBLICATIONS IN THE NATURE OF ARTICLES IN THE FIELDS OF NUTRITION, FITNESS, SEXUALITY, PSYCHOLOGICAL SELF-IMPROVEMENT, PERSONALITY IDENTIFICATION AND MATCHING, PERSONAL RELATIONSHIPS AND DATING, SPIRITUALITY, HOROSCOPES AND ASTROLOGY, FASHION, MUSIC, AND REVIEWS AND RECOMMENDATIONS FOR BOOKS (U.S. CLS. 100, 101 AND 107).

CLASS 16—PAPER GOODS AND PRINTED MATTER

FOR ART PADS; ART PAPER; ARTISTS' BRUSHES; ARTISTS' PENCILS; ARTISTS' PENS; ARTS AND CRAFT CLAY KITS; ARTS AND CRAFT PAINT KITS; BABY BOOKS; BLANK JOURNALS; CALENDARS; COLORING BOOKS; COSMETIC PENCIL SHARPENERS; CRAYONS; DECORATIVE PAPER BOWS FOR WRAPPING; FRAMED ART PRINTS; GIFT BAGS; GIFT BOXES; GIFT WRAPPING PAPER; GREETING CARDS; LETTER OPENERS; MAGAZINES IN THE FIELD OF NUTRITION, FITNESS, SEXUALITY, PSYCHOLOGICAL SELF-IMPROVEMENT, PERSONALITY IDENTIFICATION AND MATCHING, PERSONAL RELATIONSHIPS AND DATING, SPIRITUALITY, HOROSCOPES AND ASTROLOGY, FASHION, MUSIC, AND REVIEWS AND RECOMMENDATIONS FOR BOOKS; MARKERS; NOTE CARDS; PAPER NAPKINS; PAPER TABLE LINENS; PHOTOGRAPH ALBUMS; PRINTED INVITATIONS; SCRAPBOOK ALBUMS; SERIES OF NON-FICTION BOOKS IN THE FIELD OF NUTRITION, FITNESS, SEXUALITY, PSYCHOLOGICAL SELF-IMPROVEMENT, PERSONALITY IDENTIFICATION AND MATCHING, PERSONAL RELATIONSHIPS AND DATING, SPIRITUALITY, HOROSCOPES AND ASTROLOGY, FASHION, MUSIC, AND REVIEWS AND RECOMMENDATIONS FOR BOOKS (U.S. CLS. 2, 5, 22, 23, 29, 37, 38 AND 50).

CLASS 45—PERSONAL AND LEGAL SERVICES

FOR PERSONAL LIFESTYLE CONSULTING SERVICES (U.S. CLS. 100 AND 101).
JEFFERY COWARD, EXAMINING ATTORNEY

CLASS 18—LEATHER GOODS

FOR ALL-PURPOSE CARRYING BAGS; BACKPACKS; BRIEFCASES; BUSINESS CARD CASES; CLUTCH PURSES; COLLARS FOR PETS; COSMETIC BAGS SOLD EMPTY; DOG CLOTHING; DOG LEASHES; HANDBAGS; IMITATION LEATHER KEY CHAINS; KEY CASES; KEY WALLETS; LEATHER KEY CASES; LEATHER KEY CHAINS; LUGGAGE; LUGGAGE TAGS; UMBRELLAS; WALLETS; WRISTLET BAGS (U.S. CLS. 1, 2, 3, 22 AND 41).

CLASS 21—HOUSEWARES AND GLASS

FOR BAKEWARE; BASKETS OF WICKER; BATH BRUSHES; BATH SPONGES; BEVERAGE GLASSWARE; BIRD FEEDERS; BIRD HOUSES; BOWLS; BREAD BOXES; BROOMS; CANDLE HOLDERS; CANDLE SNUFFERS; CANDLESTICKS; CARAFES; CERAMIC FIGURINES; CLEANING SPONGES; COASTERS, NOT OF PAPER AND OTHER THAN TABLE LINEN; CONTAINERS FOR HOUSEHOLD USE; COSMETIC BRUSHES; DECANTERS; DECORATIVE PLATES; DINNERWARE; DISPENSERS FOR FACIAL TISSUES; DISPENSERS FOR LIQUID SOAP; DISPENSERS FOR PAPER TOWELS; DISPOSABLE DINNERWARE, NAMELY, PLATES AND SERVINGWARE; DUST PANS; FACIAL SPONGES FOR APPLYING MAKE-UP; FEATHER DUSTERS; FLOWER BASKETS; FLOWER POTS; GARDENING GLOVES; GLASS JARS; HAIR BRUSHES; HAIR COMBS; LAUNDRY BASKETS; NAPKIN RINGS; OVENWARE; PET BRUSHES; PET FEEDING DISHES; PET TREAT JARS; PICNIC BASKETS SOLD EMPTY; PLASTIC WATER BOTTLES SOLD EMPTY; SALT AND PEPPER MILLS; SALT AND PEPPER SHAKERS; SERVINGWARE FOR SERVING FOOD AND DRINKS; STAINED GLASS; VASES (U.S. CLS. 2, 13, 23, 29, 30, 33, 40 AND 50).

CLASS 22—CORDAGE AND FIBERS

FOR LAUNDRY BAGS; MULTI-PURPOSE CLOTH BAGS; SHOE BAGS FOR STORAGE (U.S. CLS. 1, 2, 7, 19, 22, 42 AND 50).

CLASS 24—FABRICS

FOR BATH GLOVES; BATH LINEN; BATH TOWELS; BEACH TOWELS; BED BLANKETS; BED LINEN; BED PADS; BED SPREADS; BED THROWS; COMFORTERS; COVERLETS; CURTAINS; HANDKERCHIEFS; KITCHEN LINENS; KITCHEN TOWELS; SHOWER CURTAIN LINERS; SHOWER CURTAINS; TABLE LINEN; TABLE PADS; TEXTILE WALL HANGINGS; VINYL PLACE MATS (U.S. CLS. 42 AND 50).

CLASS 26—FANCY GOODS

FOR ARTIFICIAL FLOWER ARRANGEMENTS IN CONTAINERS; ARTIFICIAL FRUIT; ARTIFICIAL PLANTS; ARTIFICIAL TOPIARIES; ARTIFICIAL WREATHS; BOWS FOR WRAPPING; DECORATIVE RIBBONS (U.S. CLS. 37, 39, 40, 42 AND 50).

CLASS 27—FLOOR COVERINGS

FOR AREA RUGS; BATH MATS; DOOR MATS; NON-TEXTILE WALL HANGINGS; PET FEEDING MATS; WALLCOVERINGS (U.S. CLS. 19, 20, 37, 42 AND 50).

CLASS 28—TOYS AND SPORTING GOODS

FOR ACTION FIGURES AND ACCESSORIES THEREFOR; BATHTUB TOYS; BATTERY OPERATED ACTION TOYS; BENDABLE TOYS; BOARD GAMES; BUBBLE MAKING WAND AND SOLUTION SETS; CARD GAMES; CHILDREN'S MULTIPLE ACTIVITY TOYS; CHRISTMAS STOCKINGS; CHRISTMAS TREE ORNAMENTS AND DECORATIONS; CHRISTMAS TREE SKIRTS; CRIB TOYS; DOLLS AND ACCESSORIES THEREFOR; ELECTRONIC LEARNING TOYS; MECHANICAL TOYS; PET TOYS; PUZZLES; STUFFED AND PLUSH TOYS; TOY ANIMALS AND ACCESSORIES THEREFOR; TOY BAKEWARE AND COOKWARE; TOY BUILDING BLOCKS (U.S. CLS. 22, 23, 38 AND 50).

CLASS 35—ADVERTISING AND BUSINESS

FOR RETAIL STORE SERVICES FEATURING BOOKS, MUSIC, HANDBAGS, JEWELRY, FOOD, BEVERAGES, DINING AND KITCHEN UTENSILS AND LINENS, BAKEWARE, COOKWARE, FURNITURE, BATH AND BEDDING LINENS, GARDENING TOOLS, CANDLES, EYEWEAR, CLOCKS, LUGGAGE, PAPER GOODS, ARTWORK, TOYS, EXERCISE EQUIPMENT, ELECTRONICS, AND APPLIANCES; NONE OF THE AFOREMENTIONED GOODS BEING RELATED TO ARCHITECTURE AND DESIGN (U.S. CLS. 100, 101 AND 102).

CLASS 41—EDUCATION AND ENTERTAINMENT

FOR CONDUCTING WORKSHOPS AND SEMINARS IN THE FIELDS OF NUTRITION, FITNESS, SEXUALITY, PSYCHOLOGICAL SELF-IMPROVEMENT, PERSONALITY IDENTIFICATION AND MATCHING, PERSONAL RELATIONSHIPS AND DATING, SPIRITUALITY, HOROSCOPES AND ASTROLOGY, FASHION, MUSIC AND REVIEWS AND RECOMMENDATIONS FOR BOOKS; PROVIDING A WEBSITE FEATURING BLOGS AND NON-DOWNLOADABLE PUBLICATIONS IN THE NATURE OF ARTICLES IN THE FIELDS OF NUTRITION, FITNESS, SEXUALITY, PSYCHOLOGICAL SELF-IMPROVEMENT, PERSONALITY IDENTIFICATION AND MATCHING, PERSONAL RELATIONSHIPS AND DATING, SPIRITUALITY, HOROSCOPES AND ASTROLOGY, FASHION, MUSIC, AND REVIEWS AND RECOMMENDATIONS FOR BOOKS (U.S. CLS. 100, 101 AND 107).

CLASS 45—PERSONAL AND LEGAL SERVICES

FOR PERSONAL LIFESTYLE CONSULTING SERVICES (U.S. CLS. 100 AND 101).

JEFFERY COWARD, EXAMINING ATTORNEY

SN 85-489,396. HAN LION GROUP LIMITED, ROAD TOWN, TORTOLA, BR. VIRGIN ISLANDS, FILED 12-7-2011.



漢獅
HAN LION

THE MARK CONSISTS OF A STYLIZED LION'S FACE WITHIN A SQUARE; THE WORDS "HAN LION" TO THE RIGHT OF THE SQUARE, AND CHINESE CHARACTERS ABOVE THE WORDS "HAN LION".

THE ENGLISH TRANSLATION OF "HAN LION" IN THE MARK IS CHINESE LION.

THE NON-LATIN CHARACTERS IN THE MARK TRANSLITERATE TO "HAN LION" AND THIS MEANS CHINESE LION IN ENGLISH.

CLASS 5—PHARMACEUTICALS

FOR DIETETIC SUBSTANCES ADAPTED FOR MEDICAL USE, DIETARY NUTRITIONAL SUPPLEMENTS FOR MEDICAL USE; MINERAL FOOD-SUPPLEMENTS; VITAMIN SUPPLEMENTS; NUTRITIONAL SUPPLEMENTS; CAPSULES OF HERBS FOR MEDICAL USE; EXTRACTS OF MEDICINAL HERBS AND MEDICINAL PLANTS; HERBAL PREPARATIONS FOR MEDICINAL PURPOSES; HERBAL TEA FOR MEDICINAL USE; MEDICINAL HERBS; MEDICINAL HERBAL INFUSIONS; AROMATIC TEAS FOR MEDICINAL USE; ARTIFICIAL TEA FOR MEDICINAL USE; FRUIT FLAVORED TEA FOR MEDICINAL USE; FRUIT TEA MEDICINAL PURPOSES; MEDICINAL TEA; MEDICINAL BEVERAGES; TONICS MEDICINAL BASED ON PLANT EXTRACTS; ASTHMATIC TEA (U.S. CLS. 6, 18, 44, 46, 51 AND 52).

CLASS 30—STAPLE FOODS

FOR COFFEE, COCOA, SUGAR, ARTIFICIAL COFFEE (U.S. CL. 46).
GINA HAYES, EXAMINING ATTORNEY

SN 85-489,678. ARCHETYPES, INC., NEW YORK, NY. FILED 12-7-2011.

ARCHETYPES

THE MARK CONSISTS OF STANDARD CHARACTERS WITHOUT CLAIM TO ANY PARTICULAR FONT, STYLE, SIZE, OR COLOR.

CLASS 16—PAPER GOODS AND PRINTED MATTER

FOR MAGAZINES IN THE FIELD OF NUTRITION, FITNESS, SEXUALITY, PSYCHOLOGICAL SELF-IMPROVEMENT, PERSONAL IDENTIFICATION AND MATCHING, PERSONAL RELATIONSHIPS AND DATING, SPIRITUALITY, HOROSCOPES AND ASTROLOGY, FASHION, MUSIC, AND REVIEWS AND RECOMMENDATIONS FOR BOOKS; SERIES OF NON-FICTION BOOKS IN THE FIELD OF NUTRITION, FITNESS, SEXUALITY, PSYCHOLOGICAL SELF-IMPROVEMENT, PERSONAL IDENTIFICATION AND MATCHING, PERSONAL RELATIONSHIPS AND DATING, SPIRITUALITY, HOROSCOPES AND ASTROLOGY, FASHION, MUSIC, AND REVIEWS AND RECOMMENDATIONS FOR BOOKS (U.S. CLS. 2, 5, 22, 23, 29, 37, 38 AND 50).

CLASS 41—EDUCATION AND ENTERTAINMENT

FOR CONDUCTING WORKSHOPS AND SEMINARS IN THE FIELDS OF NUTRITION, FITNESS, SEXUALITY, PSYCHOLOGICAL SELF-IMPROVEMENT, PERSONAL IDENTIFICATION AND MATCHING, PERSONAL RELATIONSHIPS AND DATING, SPIRITUALITY, HOROSCOPES AND ASTROLOGY, FASHION, MUSIC, AND REVIEWS AND RECOMMENDATIONS FOR BOOKS; PROVIDING A WEBSITE FEATURING BLOGS AND NON-DOWNLOADABLE PUBLICATIONS IN THE NATURE OF ARTICLES IN THE FIELDS OF NUTRITION, FITNESS, SEXUALITY, PSYCHOLOGICAL SELF-IMPROVEMENT, PERSONAL IDENTIFICATION AND MATCHING, PERSONAL RELATIONSHIPS AND DATING, SPIRITUALITY, HOROSCOPES AND ASTROLOGY, FASHION, MUSIC, AND REVIEWS AND RECOMMENDATIONS FOR BOOKS (U.S. CLS. 100, 101 AND 107).

CLASS 45—PERSONAL AND LEGAL SERVICES

FOR PERSONAL LIFESTYLE CONSULTING SERVICES (U.S. CLS. 100 AND 101).
JEFFERY COWARD, EXAMINING ATTORNEY

SN 85-490,174. ROYAL ADHESIVES AND SEALANTS, LLC, SOUTH BEND, IN. FILED 12-8-2011.



OWNER OF U.S. REG. NO. 2,967,536.
NO CLAIM IS MADE TO THE EXCLUSIVE RIGHT TO USE "ADHESIVES & SEALANTS", APART FROM THE MARK AS SHOWN.

THE MARK CONSISTS OF THE WORD "ROYAL" DISPLAYED ABOVE A LINE WITH THE PHRASE "ADHESIVES & SEALANTS" DISPLAYED UNDERNEATH THE LINE. A CIRCULAR IMAGE COMPRISED OF TWO CURVED LINES IS DISPLAYED TO THE LEFT OF THE TEXT.

CLASS 1—CHEMICALS

FOR ADHESIVE MATERIALS, NAMELY, ADHESIVES FOR BONDING MATERIALS IN THE TRANSPORTATION, MARINE, AEROSPACE, DEFENSE, AUTOMOTIVE, ELECTRONICS, FLOORING AND HVAC INDUSTRIES (U.S. CLS. 1, 5, 6, 10, 26 AND 46).

CLASS 17—RUBBER GOODS

FOR ADHESIVE MATERIALS, NAMELY, SEALANTS FOR BONDING MATERIALS IN THE TRANSPORTATION, MARINE, AEROSPACE, DEFENSE, AUTOMOTIVE, ELECTRONICS, FLOORING AND HVAC INDUSTRIES (U.S. CLS. 1, 5, 12, 13, 35 AND 50).
C. DIONNE CLYBURN, EXAMINING ATTORNEY

SN 85-490,287. KATHIE'S KITCHEN LLC, BRANFORD, CT. FILED 12-8-2011.



NO CLAIM IS MADE TO THE EXCLUSIVE RIGHT TO USE "KITCHEN", APART FROM THE MARK AS SHOWN.
THE NAME(S), PORTRAIT(S), AND/OR SIGNATURE(S) SHOWN IN THE MARK IDENTIFIES KATHLEEN PELLICIO, WHOSE CONSENT(S) TO REGISTER IS MADE OF RECORD.

THE MARK CONSISTS OF AN IMAGE OF A WOMAN'S HEAD CONTAINED WITHIN A CIRCULAR BORDER WHICH INCLUDES A LOWER SEMICIRCULAR CURVED LINE AND THE WORDS "KATHIE'S KITCHEN" IN AN UPPER SEMICIRCULAR CURVED POSITION IN A SCRIPT FONT.

SN 85-490,512. ENTERCOM COMMUNICATIONS CORP., BALA CYNWYD, PA. FILED 12-8-2011.

CLASS 29—MEATS AND PROCESSED FOODS

FOR (BASED ON USE IN COMMERCE) ROASTED SHELLED PUMPKIN SEEDS; PUMPKIN SEED BASED PROTEIN BARS; MIXED SEEDS; DRIED FRUITS (U.S. CL. 46).

FIRST USE 7-0-2011; IN COMMERCE 7-0-2011.

STAR 106.5

CLASS 30—STAPLE FOODS

FOR (BASED ON INTENT TO USE) CRUMBLE TOPPING MIX; PIE CRUST MIX; CAKE MIXES; COOKIE MIXES; PIE CRUSTS; PIES (U.S. CL. 46).

CHRIS WELLS, EXAMINING ATTORNEY

THE MARK CONSISTS OF STANDARD CHARACTERS WITHOUT CLAIM TO ANY PARTICULAR FONT, STYLE, SIZE, OR COLOR.

NO CLAIM IS MADE TO THE EXCLUSIVE RIGHT TO USE "106.5", APART FROM THE MARK AS SHOWN.

CLASS 38—COMMUNICATION

FOR RADIO BROADCASTING SERVICES (U.S. CLS. 100, 101 AND 104).

FIRST USE 12-9-2011; IN COMMERCE 12-9-2011.

SN 85-490,343. YORKTOWN TECHNOLOGIES, L.P., AUSTIN, TX. FILED 12-8-2011.

CLASS 41—EDUCATION AND ENTERTAINMENT

FOR ENTERTAINMENT SERVICES, NAMELY, PRODUCTION OF RADIO PROGRAMS, RADIO PROGRAMMING; RADIO ENTERTAINMENT SERVICES, NAMELY, ONGOING RADIO PROGRAMS IN THE FIELDS OF ENTERTAINMENT AND MUSIC (U.S. CLS. 100, 101 AND 107).

FIRST USE 12-9-2011; IN COMMERCE 12-9-2011.

JAY BESCH, EXAMINING ATTORNEY



SN 85-490,547. NUTRITION & FITNESS, INC., FAYETTEVILLE, NC. FILED 12-8-2011.

OWNER OF U.S. REG. NOS. 3,042,917, 4,106,117 AND OTHERS.

THE COLOR(S) GREEN, RED AND ORANGE IS/ARE CLAIMED AS A FEATURE OF THE MARK.

THE MARK CONSISTS OF THE STYLIZED TEXT "GLO-FISH" WHERE "GLO" IS IN GREEN AND "FISH" IS IN RED ABOVE THE STYLIZED TEXT "EXPERIENCE THE GLO!" IN ORANGE WHERE A GREEN FISH FORMS THE DOT OF THE "I" IN "FISH" WITH ONE ORANGE STAR SHAPE ABOVE THE FISH AND ONE RED STAR SHAPE ABOVE AND TO THE RIGHT OF THE FISH.

EMU IT

CLASS 21—HOUSEWARES AND GLASS

FOR AQUARIUM KITS CONSISTING OF AQUARIUM WATER TANKS FOR LIVE FISH, AQUARIUM COVERS, AERATORS FOR AQUARIUMS, AIR-INTAKE TUBES FOR AQUARIUMS, AQUARIUM FILTRATION APPARATUS, AQUARIUM LIGHTING, COMPRESSED AIR PUMPS, AND AQUARIUM WATER CONDITIONER (U.S. CLS. 2, 13, 23, 29, 30, 33, 40 AND 50).

FIRST USE 11-17-2010; IN COMMERCE 11-17-2010.

THE MARK CONSISTS OF STANDARD CHARACTERS WITHOUT CLAIM TO ANY PARTICULAR FONT, STYLE, SIZE, OR COLOR.

CLASS 3—COSMETICS AND CLEANING PREPARATIONS

FOR NON-MEDICATED SKIN CARE PREPARATIONS, NAMELY, CREAMS CONTAINING EMU OIL (U.S. CLS. 1, 4, 6, 50, 51 AND 52).

CLASS 31—NATURAL AGRICULTURAL PRODUCTS

FOR LIVE FISH (U.S. CLS. 1 AND 46).

FIRST USE 8-6-2008; IN COMMERCE 8-6-2008.
BILL DAWE, EXAMINING ATTORNEY

CLASS 5—PHARMACEUTICALS

FOR TOPICAL OINTMENT CONTAINING EMU OIL FOR USE IN RELIEVING JOINT OR MUSCLE PAIN (U.S. CLS. 6, 18, 44, 46, 51 AND 52).

MICHAEL WIENER, EXAMINING ATTORNEY

SN 85-490,667. DELL INC., ROUND ROCK, TX. FILED 12-8-2011.

MORE YOU

THE MARK CONSISTS OF STANDARD CHARACTERS WITHOUT CLAIM TO ANY PARTICULAR FONT, STYLE, SIZE, OR COLOR.

CLASS 9—ELECTRICAL AND SCIENTIFIC APPARATUS

FOR COMPUTER HARDWARE AND COMPUTER PERIPHERALS (U.S. CLS. 21, 23, 26, 36 AND 38).
FIRST USE 7-30-2011; IN COMMERCE 7-30-2011.

CLASS 35—ADVERTISING AND BUSINESS

FOR RETAIL STORE SERVICES FEATURING CONSUMER ELECTRONICS ACCESSIBLE ON-LINE AND BY TELEPHONE, FACSIMILE AND MAIL ORDER (U.S. CLS. 100, 101 AND 102).
FIRST USE 7-30-2011; IN COMMERCE 7-30-2011.

CLASS 40—MATERIAL TREATMENT

FOR CUSTOM MANUFACTURE OF COMPUTERS FOR OTHERS (U.S. CLS. 100, 103 AND 106).
FIRST USE 7-30-2011; IN COMMERCE 7-30-2011.
ALLISON HOLTZ, EXAMINING ATTORNEY

SN 85-490,673. INTEGRATIVE NUTRITION, INC., NEW YORK, NY. FILED 12-8-2011.



OWNER OF U.S. REG. NOS. 2,956,412, 3,354,697 AND 3,362,440.

NO CLAIM IS MADE TO THE EXCLUSIVE RIGHT TO USE "INSTITUTE" AND "NUTRITION", APART FROM THE MARK AS SHOWN.

THE COLOR(S) RED AND BLACK IS/ARE CLAIMED AS A FEATURE OF THE MARK.

THE MARK CONSISTS OF A RED SPIRAL TO THE LEFT OF THE WORDS "INSTITUTE FOR INTEGRATIVE NUTRITION" IN BLACK; THE COLOR WHITE IN THE MARK REPRESENTS BACKGROUND AND IS NOT PART OF THE MARK.

CLASS 9—ELECTRICAL AND SCIENTIFIC APPARATUS

FOR COMPUTER APPLICATION SOFTWARE FOR MOBILE PHONES, PORTABLE MEDIA PLAYERS, HANDHELD COMPUTERS, DESKTOP COMPUTERS, PORTABLE COMPUTERS, TABLET COMPUTERS, WIRELESS INTELLIGENT DEVICES, IPTV, INTERNET SET-TOP BOXES, NAMELY, SOFTWARE FOR BUSINESS AND EDUCATION IN THE FIELDS OF HEALTH AND NUTRITION; COMPUTER SOFTWARE THAT PROVIDES WEB-BASED ACCESS TO APPLICATIONS AND SERVICES THROUGH A WEB OPERATING SYSTEM OR PORTAL INTERFACE; DOWNLOADABLE SOFTWARE IN THE NATURE OF A MOBILE APPLICATION FOR BUSINESS AND EDUCATION IN THE FIELDS OF HEALTH AND NUTRITION; DOWNLOADABLE COMPUTER SOFTWARE FOR BUSINESS AND EDUCATION IN THE FIELDS OF HEALTH AND NUTRITION; DOWNLOADABLE VIDEOS CONTAINING INFORMATION IN THE FIELDS OF HEALTH AND NUTRITION (U.S. CLS. 21, 23, 26, 36 AND 38).
FIRST USE 5-1-2011; IN COMMERCE 5-1-2011.

CLASS 21—HOUSEWARES AND GLASS

FOR HOUSEHOLD OR KITCHEN UTENSILS AND CONTAINERS, NAMELY, REUSABLE STAINLESS STEEL WATER BOTTLES SOLD EMPTY AND BEVERAGE GLASSWARE (U.S. CLS. 2, 13, 23, 29, 30, 33, 40 AND 50).
FIRST USE 1-28-2011; IN COMMERCE 1-28-2011.

CLASS 22—CORDAGE AND FIBERS

FOR MULTI-PURPOSE BAGS MADE OF CLOTH OR WOVEN PLASTIC (U.S. CLS. 1, 2, 7, 19, 22, 42 AND 50).
FIRST USE 9-17-2011; IN COMMERCE 9-17-2011.

CLASS 35—ADVERTISING AND BUSINESS

FOR MANAGEMENT AND BUSINESS CONSULTING SERVICES IN THE FIELDS OF HEALTH AND NUTRITION, COACHING AND CONSULTING (U.S. CLS. 100, 101 AND 102).
FIRST USE 2-4-2009; IN COMMERCE 2-4-2009.

CLASS 38—COMMUNICATION

FOR PROVIDING ON-LINE FORUMS FOR TRANSMISSION OF MESSAGES AMONG COMPUTER USERS CONCERNING HEALTH AND NUTRITION (U.S. CLS. 100, 101 AND 104).
FIRST USE 2-4-2009; IN COMMERCE 2-4-2009.

CLASS 41—EDUCATION AND ENTERTAINMENT

FOR EDUCATIONAL SERVICES, NAMELY, CONDUCTING CLASSES, COURSES, SEMINARS, CONFERENCES, TELECONFERENCES, WORKSHOPS AND PODCASTS, ALL IN THE FIELDS OF HEALTH AND NUTRITION; PUBLISHING OF BOOKS AND MAGAZINES; ONLINE JOURNALS, NAMELY, BLOGS IN THE FIELDS OF HEALTH AND NUTRITION (U.S. CLS. 100, 101 AND 107).
FIRST USE 1-1-2010; IN COMMERCE 1-1-2010.

CLASS 42—SCIENTIFIC AND COMPUTER SERVICES

FOR DESIGN, CREATION, HOSTING, MAINTENANCE OF WEBSITES FOR OTHERS (U.S. CLS. 100 AND 101).
FIRST USE 2-4-2009; IN COMMERCE 2-4-2009.

CLASS 43—HOTEL AND RESTAURANT SERVICES

FOR CONSULTING SERVICES IN THE FIELD OF CULINARY ARTS; PROVIDING A DATABASE IN THE FIELDS OF RECIPES AND COOKING INFORMATION (U.S. CLS. 100 AND 101).

FIRST USE 2-4-2009; IN COMMERCE 2-4-2009.

CLASS 44—MEDICAL, BEAUTY AND AGRICULTURAL SERVICES

FOR FOOD NUTRITION CONSULTATION AND HEALTH COUNSELING; DISSEMINATION OF HEALTH AND NUTRITION INFORMATION ON THE INTERNET (U.S. CLS. 100 AND 101).

FIRST USE 11-14-2011; IN COMMERCE 11-14-2011.

VIVIAN MICZNIK FIRST, EXAMINING ATTORNEY

CLASS 42—SCIENTIFIC AND COMPUTER SERVICES

FOR PROVIDING TEMPORARY USE OF ONLINE, NON-DOWNLOADABLE SOFTWARE TO RECORD, STORE, SEARCH, DISTRIBUTE, SHARE, PLAY, AND MANAGE MEDIA CONTENT AND DATA TO AND BETWEEN COMPUTERS, ELECTRONIC STORAGE DEVICES, MEDIA PLAYERS AND RECORDERS, TELEVISION SET-TOP BOXES, VIDEO GAME CONSOLES, AND MOBILE, PORTABLE AND HANDHELD ELECTRONIC DEVICES, ALL IN CONNECTION WITH DIGITAL STOREFRONTS (U.S. CLS. 100 AND 101).

ELLEN BURNS, EXAMINING ATTORNEY

SN 85-491,134. LITE-ON IT CORPORATION, TAIPEI CITY, TAIWAN, FILED 12-8-2011.

SN 85-491,099. ROVI TECHNOLOGIES CORPORATION, SANTA CLARA, CA. FILED 12-8-2011.

ROVI ENTERTAINMENT STORE

THE MARK CONSISTS OF STANDARD CHARACTERS WITHOUT CLAIM TO ANY PARTICULAR FONT, STYLE, OR COLOR.

NO CLAIM IS MADE TO THE EXCLUSIVE RIGHT TO USE "ENTERTAINMENT STORE", APART FROM THE MARK AS SHOWN.

CLASS 9—ELECTRICAL AND SCIENTIFIC APPARATUS

FOR DOWNLOADABLE MOTION PICTURE FILMS AND TELEVISION SERIES IN A VARIETY OF GENRES, FEATURING ACTION, ADVENTURE, ANIMATION, COMEDY, DOCUMENTARY, DRAMA, FAMILY, FANTASY, MUSIC, NEWS, REALITY, ROMANCE, SCIENCE FICTION AND SPORTS; DOWNLOADABLE MUSIC, MUSIC VIDEOS AND OTHER AUDIO AND VISUAL RECORDINGS FEATURING MUSIC; DOWNLOADABLE VIDEO GAMES AND COMPUTER GAME SOFTWARE; COMPUTER SOFTWARE TO RECORD, STORE, SEARCH, DISTRIBUTE, SHARE, PLAY, AND MANAGE MEDIA CONTENT AND DATA TO AND BETWEEN COMPUTERS, ELECTRONIC STORAGE DEVICES, MEDIA PLAYERS AND RECORDERS, TELEVISION SET-TOP BOXES, VIDEO GAMES CONSOLES AND MOBILE, PORTABLE AND HANDHELD ELECTRONIC DEVICES, ALL IN CONNECTION WITH DIGITAL STOREFRONTS (U.S. CLS. 21, 23, 26, 36 AND 38).

CLASS 38—COMMUNICATION

FOR VIDEO STREAMING SERVICES VIA THE INTERNET AND ELECTRONIC AND COMPUTER DEVICES FEATURING MOTION PICTURE FILMS AND TELEVISION SERIES IN A VARIETY OF GENRES, MUSIC, MUSIC VIDEOS AND OTHER AUDIO AND VISUAL RECORDINGS FEATURING MUSIC, GAMES AND OTHER MULTIMEDIA CONTENT, ALL IN CONNECTION WITH DIGITAL STOREFRONTS (U.S. CLS. 100, 101 AND 104).

MED-ON

THE MARK CONSISTS OF STANDARD CHARACTERS WITHOUT CLAIM TO ANY PARTICULAR FONT, STYLE, SIZE, OR COLOR.

CLASS 5—PHARMACEUTICALS

FOR AMINO ACIDS FOR MEDICAL OR VETERINARY PURPOSES; BACTERIAL AND BACTERIOLOGICAL PREPARATIONS FOR MEDICAL OR VETERINARY PURPOSES; BIOCHEMICAL PREPARATIONS FOR MEDICAL OR VETERINARY PURPOSES, NAMELY, PREPARATIONS FOR BLOOD ANALYSIS AND BODY FLUID ANALYSIS; BIOLOGICAL AND CHEMICAL PREPARATIONS AND REAGENTS FOR MEDICAL OR VETERINARY USE, NAMELY, REAGENTS FOR BIOCHEMISTRY ANALYSIS, IMMUNOASSAY AND NUCLEIC ACID TESTING; BIOLOGICAL INDICATORS FOR MONITORING STERILIZATION PROCESSES FOR MEDICAL OR VETERINARY PURPOSES; BIOLOGICAL TISSUE CULTURES FOR VETERINARY PURPOSES; CHEMICAL REAGENTS FOR MEDICAL OR VETERINARY PURPOSES; CLINICAL MEDICAL REAGENTS FOR PROCESSING HUMAN WHOLE BLOOD AND ITS COMPONENTS FOR USE IN BLOOD TRANSFUSIONS STORED IN BAGS, BOTTLES, SYRINGES AND OTHER SUCH CONTAINERS USED TO STORE SUCH SUBSTANCES IN THE MEDICAL FIELD; DIAGNOSTIC PREPARATIONS FOR MEDICAL OR VETERINARY PURPOSES; DIAGNOSTIC REAGENTS AND CONTRAST MEDIA FOR MEDICAL USE; DRUG TESTING KITS COMPRISED OF MEDICAL DIAGNOSTIC REAGENTS AND ASSAYS FOR TESTING BODY FLUIDS; ELECTROPHORESIS GELS FOR MEDICAL OR VETERINARY PURPOSES; GREASES AND PETROLEUM JELLY FOR MEDICAL OR VETERINARY PURPOSES; MEDICAL DIAGNOSTIC REAGENTS AND ASSAYS FOR TESTING OF BODY FLUIDS; MEDICAL DIAGNOSTIC REAGENTS AND ASSAYS FOR TESTING BODY FLUIDS FOR MICROORGANISMS; MEDICAL DIAGNOSTIC REAGENTS FOR THE ANALYSIS OF BODY FLUIDS; MOLECULAR COMPLEX FOR THE DELIVERY OF NON-RADICAL OXYGEN FOR MEDICINAL, SURGICAL, THERAPEUTIC OR VETERINARY PURPOSES; NUCLEIC ACID SEQUENCES AND CHEMICAL REAGENTS FOR MEDICAL AND VETERINARY PURPOSES; PLANT EXTRACTS FOR MEDICAL, VETERINARY AND PHARMACEUTICAL PURPOSES; REAGENTS AND MEDIA FOR MEDICAL AND VETERINARY DIAGNOSTIC PURPOSES; REAGENTS FOR MEDICAL USE (U.S. CLS. 6, 18, 44, 46, 51 AND 52).

CLASS 10—MEDICAL APPARATUS

FOR BLOOD PRESSURE AND DIABETIC DIAGNOSTIC MEDICAL DEVICES; BREATH GAS ANALYZERS FOR MEDICAL DIAGNOSTICS; CYTOMETERS FOR MEDICAL DIAGNOSTIC USE; DIAGNOSTIC APPARATUS FOR THE DETECTION OF PERIODONTAL DISEASE; DIAGNOSTIC APPARATUS FOR THE DETECTION OF CANCER; DIAGNOSTIC KITS CONSISTING PRIMARILY OF PROBES, BUFFERS AND REAGENTS FOR USE IN MICROBIAL TESTING; DYNAMOMETERS FOR DIAGNOSTIC MUSCLE STRENGTH TESTING; ELECTROMAGNETIC MEDICAL DIAGNOSTIC IMAGING APPARATUS; FLOW CYTOMETERS AND FLOW-BASED ANALYZERS PROVIDING CELL AND PARTICLE ANALYSIS, DETECTION, OR COUNTING FOR MEDICAL, CLINICAL, MEDICAL DIAGNOSTIC, AND THERAPEUTIC USES; FLOW CYTOMETERS FOR MEDICAL DIAGNOSTIC USES; HEMATOLOGY ANALYZERS FOR MEDICAL DIAGNOSTIC USES; INSTRUMENT AND APPARATUS SYSTEMS FOR MEDICAL DIAGNOSTIC USES CONSISTING OF FLOW CYTOMETERS, HEMATOLOGY ANALYZERS, SAMPLE PREPARATION DEVICE, AND RELATED DATA MANAGEMENT SOFTWARE SOLD AS A UNIT; MEDICAL APPARATUS AND INSTRUMENTS FOR DIAGNOSTIC RADIOPHARMACEUTICAL USE; MEDICAL APPARATUS AND INSTRUMENT FOR DIAGNOSTIC USE, NAMELY, APPARATUS FOR MEDICAL DIAGNOSTIC TESTING IN THE FIELDS OF CANCER OR OTHER TISSUE-BASED DIAGNOSTIC TESTING, CYTOLOGY AND CELL-BASED TESTING; MEDICAL DIAGNOSTIC APPARATUS, ANALYTICAL APPARATUS FOR MEDICAL PURPOSES AND BLOOD PRESSURE MEASURING APPARATUS; MEDICAL DIAGNOSTIC APPARATUS FOR DETECTING CANCER; MEDICAL DIAGNOSTIC INSTRUMENTS FOR THE ANALYSIS OF BODY FLUIDS; MEDICAL DOSE METER THAT MEASURES THE TOTAL RADIATION DOSE RECEIVED BY A PATIENT DURING A DIAGNOSTIC PROCEDURE; MEDICAL INSTRUMENT FOR CARDIOVASCULAR DIAGNOSTICS; MRI DIAGNOSTIC APPARATUS; NUCLEAR MEDICINE DIAGNOSTIC IMAGING APPARATUS; ORGANOLEPTIC DIAGNOSTIC TESTING APPARATUS FOR MEDICAL, DENTAL OR COSMETIC USE; ORTHOPEDIC APPARATUS AND INSTRUMENTS FOR DIAGNOSTIC AND THERAPEUTIC USE; ORTHOPEDIC DEVICES FOR DIAGNOSTIC AND THERAPEUTIC USE; RADIOLOGICAL APPARATUS FOR DIAGNOSTIC AND MEDICAL PURPOSES, NAMELY, MAGNETIC RESONANCE IMAGER; RADIOLOGICAL APPARATUS FOR DIAGNOSTIC AND MEDICAL PURPOSES, NAMELY, A HELIUM-3 POLARIZER USED FOR MAGNETIC RESONANCE IMAGING (MRI) OF THE LUNGS; SAMPLE PREPARATION DEVICE FOR MEDICAL DIAGNOSTIC USES; ULTRASONIC BONE DENSITOMETER WITH COMPUTER, PRINTER, AND COMPUTER SOFTWARE FOR USE THEREWITH, SOLD AS A UNIT, FOR MEDICAL DIAGNOSTIC USE; ULTRASONIC MEDICAL DIAGNOSTIC APPARATUS; ULTRASOUND DIAGNOSTIC APPARATUS; X-RAY DIAGNOSTIC APPARATUS (U.S. CLS. 26, 39 AND 44).

JASON BLAIR, EXAMINING ATTORNEY

THE MARK CONSISTS OF THE WORD "GRASP" IN STYLIZED LOWER-CASE LETTERS, THE "G" BEING IN THE COLOR TEAL, THE "R" IN THE COLOR ORANGE, THE "A" IN THE COLOR GREEN, THE "S" IN THE COLOR BLUE, AND THE "P" IN THE COLOR PURPLE, WITH THE WORD "SYSTEMS" IN ALL CAPITAL LETTERS IN THE COLOR BLUE "AND" CENTERED BENEATH THE LETTERS "A" AND "S", ALL TO THE LEFT OF A SET OF HANGING SCALES IN THE COLORS GREEN AND PURPLE.

CLASS 9—ELECTRICAL AND SCIENTIFIC APPARATUS

FOR COMPUTER SOFTWARE USED FOR WORKLOAD MANAGEMENT AND STAFFING OF HEALTHCARE PERSONNEL, AND INSTRUCTION MANUALS, SOLD AS A UNIT (U.S. CLS. 21, 23, 26, 36 AND 38).

FIRST USE 7-1-2011, THE MARK WAS FIRST USED ANYWHERE IN A DIFFERENT FORM OTHER THAN THAT SOUGHT TO BE REGISTERED AT LEAST AS EARLY AS 09/01/1976; IN COMMERCE 7-1-2011, THE MARK WAS FIRST USED IN COMMERCE IN A DIFFERENT FORM OTHER THAN THAT SOUGHT TO BE REGISTERED AT LEAST AS EARLY AS 01/01/1977.

CLASS 16—PAPER GOODS AND PRINTED MATTER

FOR PRINTED MATTER, NAMELY, INSTRUCTIONAL BOOKS, COURSE AND TRAINING MATERIALS AND MANUALS DEALING WITH NURSING WORKLOAD MANAGEMENT, AND MANUALS RELATING TO COMPUTER SOFTWARE CONCERNING NURSING WORKLOAD MANAGEMENT AND STAFFING (U.S. CLS. 2, 5, 22, 23, 29, 37, 38 AND 50).

FIRST USE 7-1-2011, THE MARK WAS FIRST USED ANYWHERE IN A DIFFERENT FORM OTHER THAN THAT SOUGHT TO BE REGISTERED AT LEAST AS EARLY AS 09/01/1976; IN COMMERCE 7-1-2011, THE MARK WAS FIRST USED IN COMMERCE IN A DIFFERENT FORM OTHER THAN THAT SOUGHT TO BE REGISTERED AT LEAST AS EARLY AS 01/01/1977.

SN 85-491,671. GRASP SYSTEMS INTERNATIONAL, INC., FORT COLLINS, CO. FILED 12-9-2011.



OWNER OF U.S. REG. NOS. 1,278,011, 1,730,810 AND OTHERS.

NO CLAIM IS MADE TO THE EXCLUSIVE RIGHT TO USE "SYSTEMS", APART FROM THE MARK AS SHOWN.

THE COLOR(S) TEAL, ORANGE, GREEN, BLUE, AND PURPLE IS/ARE CLAIMED AS A FEATURE OF THE MARK.

CLASS 35—ADVERTISING AND BUSINESS

FOR HEALTHCARE WORKLOAD MANAGEMENT CONSULTING SERVICES FOR HEALTHCARE PROVIDERS (U.S. CLS. 100, 101 AND 102).

FIRST USE 7-1-2011, THE MARK WAS FIRST USED ANYWHERE IN A DIFFERENT FORM OTHER THAN THAT SOUGHT TO BE REGISTERED AT LEAST AS EARLY AS 09/01/1976; IN COMMERCE 7-1-2011, THE MARK WAS FIRST USED IN COMMERCE IN A DIFFERENT FORM OTHER THAN THAT SOUGHT TO BE REGISTERED AT LEAST AS EARLY AS 01/01/1977.

KIMBERLY PERRY, EXAMINING ATTORNEY

SN 85-492,389. WESTERN HERITAGE FOUNDATION, CEDAR CITY, UT. FILED 12-11-2011.



THE MARK CONSISTS OF A RIDER ON HORSEBACK MOVING AWAY FROM THE VIEWER. THE RIDER IS LOOKING BACK AND DOWN AND AT A DOG.

CLASS 14—JEWELRY

FOR BROACHES; BRONZE JEWELRY; COSTUME JEWELRY; JEWELRY; JEWELRY BROOCHES; JEWELRY FOR ATTACHMENT TO CLOTHING; LAPEL PINS; ORNAMENTAL LAPEL PINS; ORNAMENTAL PINS; PINS BEING JEWELRY (U.S. CLS. 2, 27, 28 AND 50).

FIRST USE 6-6-2006; IN COMMERCE 6-6-2006.

CLASS 25—CLOTHING

FOR COLLARED SHIRTS; GOLF SHIRTS; HOODED SWEAT SHIRTS; LONG-SLEEVED SHIRTS; OPEN-NECKED SHIRTS; POLO SHIRTS; SHIRTS AND SHORT-SLEEVED SHIRTS; SHORT-SLEEVED OR LONG-SLEEVED T-SHIRTS; T-SHIRTS; WIND SHIRTS (U.S. CLS. 22 AND 39).

FIRST USE 6-6-2006; IN COMMERCE 6-6-2006.
JUSTINE D. PARKER, EXAMINING ATTORNEY

SN 85-492,894. TONER, JAMES C., MORGANTON, NC. FILED 12-12-2011.



OWNER OF U.S. REG. NO. 3,278,392.
NO CLAIM IS MADE TO THE EXCLUSIVE RIGHT TO USE "EST. 2001", APART FROM THE MARK AS SHOWN.
THE MARK CONSISTS OF THE TERM "BONERFIDE" AND THE DESIGN OF A BONE OVER A CIRCLE THAT HAS THE TERM "HARDWEAR" ON THE TOP OUTER RIM AND THE TERM "EST. 2001" ON THE LOWER OUTER RIM.

CLASS 16—PAPER GOODS AND PRINTED MATTER

FOR DECALS, STICKERS AND REMOVABLE TATTOOS (U.S. CLS. 2, 5, 22, 23, 29, 37, 38 AND 50).

CLASS 25—CLOTHING

FOR CLOTHING, NAMELY, T-SHIRTS, SHIRTS, BOXER SHORTS, HOODED SWEATSHIRTS, JACKETS, HATS, DO RAGS AND CAPS (U.S. CLS. 22 AND 39).
JASON TURNER, EXAMINING ATTORNEY

SN 85-493,256. MASTERS PHARMACEUTICAL, INC., CINCINNATI, OH. FILED 12-12-2011.



OWNER OF U.S. REG. NOS. 3,066,591 AND 3,538,465.
THE MARK CONSISTS OF THE STYLIZED WORDING "MASTERS" AT THE LOWER RIGHT OF THE DESIGN OF A GREEK CROSS THAT CONTAINS A STYLIZED LETTER "M".

CLASS 35—ADVERTISING AND BUSINESS

FOR WHOLESALE DISTRIBUTORSHIP SERVICES IN THE FIELD OF MEDICAL, PHARMACEUTICAL, AND HEALTH-RELATED PRODUCTS (U.S. CLS. 100, 101 AND 102).

FIRST USE 4-23-2007; IN COMMERCE 4-23-2007.

CLASS 39—TRANSPORTATION AND STORAGE

FOR WAREHOUSING SERVICES, NAMELY, STORAGE, DISTRIBUTION, PICK-UP, PACKING, AND SHIPPING OF MEDICAL, PHARMACEUTICAL, AND HEALTH-RELATED PRODUCTS (U.S. CLS. 100 AND 105).

FIRST USE 4-23-2007; IN COMMERCE 4-23-2007.
DAWN HAN, EXAMINING ATTORNEY

SN 85-493,257. MASTERS PHARMACEUTICAL, INC., CINCINNATI, OH. FILED 12-12-2011.



OWNER OF U.S. REG. NOS. 3,066,591 AND 3,538,465.
NO CLAIM IS MADE TO THE EXCLUSIVE RIGHT TO USE "TPL", APART FROM THE MARK AS SHOWN.
THE MARK CONSISTS OF THE DESIGN OF A STRIPED ORB THAT INCLUDES IN ITS MIDDLE A STRIPE ENDING IN AN ARROWHEAD. THIS DESIGN APPEARS TO THE LEFT OF THE STYLIZED WORDING "MASTERS TPL".

CLASS 35—ADVERTISING AND BUSINESS

FOR BUSINESS MANAGEMENT SERVICES FOR HEALTHCARE MANUFACTURERS AND HEALTHCARE PRODUCT OWNERS, NAMELY, SUPPLY CHAIN LOGISTICS, REVERSE LOGISTICS AND LIQUIDATION OF GOODS OF OTHERS, FREIGHT LOGISTICS MANAGEMENT, LOGISTICS MANAGEMENT, CUSTOMER SERVICE MANAGEMENT FOR OTHERS, ORDER FULFILLMENT, TELEPHONE ORDERING SERVICES, ORDER-TO-CASH BILLING, INVOICING, ACCOUNTS RECEIVABLE SERVICES, BUSINESS MANAGEMENT, RETURN MANAGEMENT IN THE NATURE OF MANAGEMENT OF RETURNED AND RECALLED MERCHANDISE, AND TRANSPORTATION LOGISTICS SERVICES IN THE NATURE OF ARRANGING THE TRANSPORTATION OF GOODS FOR OTHERS, ALL IN THE FIELDS OF HEALTHCARE, PHARMACEUTICALS, NUTRITIONAL HEALTH PRODUCTS, MEDICAL DEVICES AND EQUIPMENT, CONSUMER HEALTH PRODUCTS, AND NATURAL HEALTH PRODUCTS (U.S. CLS. 100, 101 AND 102).

FIRST USE 2-28-2011; IN COMMERCE 2-28-2011.

CLASS 39—TRANSPORTATION AND STORAGE

FOR WAREHOUSING SERVICES, NAMELY, STORAGE, DISTRIBUTION, AND PACKING FOR SHIPMENT FOR OTHERS; LOGISTICS SERVICES, NAMELY, TRANSPORTATION AND DELIVERY OF FREIGHT BY TRUCK, ALL OF THE FOREGOING IN THE FIELDS OF HEALTHCARE, PHARMACEUTICALS, NUTRITIONAL HEALTH PRODUCTS, MEDICAL DEVICES AND EQUIPMENT, CONSUMER HEALTH PRODUCTS, AND NATURAL HEALTH PRODUCTS (U.S. CLS. 100 AND 105).

FIRST USE 2-28-2011; IN COMMERCE 2-28-2011.
DAWN HAN, EXAMINING ATTORNEY

SN 85-493,337. JUSTGOODNEWS.BIZ LLC, EDMOND, OK.
FILED 12-12-2011.

JUSTGOODNEWS.BIZ

THE MARK CONSISTS OF STANDARD CHARACTERS WITHOUT CLAIM TO ANY PARTICULAR FONT, STYLE, SIZE, OR COLOR.

CLASS 35—ADVERTISING AND BUSINESS

FOR ADVERTISING, MARKETING AND PROMOTION SERVICES; ONLINE ADVERTISING, MARKETING AND PROMOTION SERVICES; INTERNET ADVERTISING SERVICES (U.S. CLS. 100, 101 AND 102).

CLASS 41—EDUCATION AND ENTERTAINMENT

FOR NEWS SYNDICATION, NAMELY, NEWS SYNDICATION REPORTING; PROVIDING NEWS IN THE NATURE OF CURRENT EVENT REPORTING; PROVIDING INFORMATION, NEWS AND COMMENTARY IN THE FIELD OF CURRENT EVENTS RELATING TO PROMOTING BUSINESS AND TOURISM; NEWS AGENCY SERVICES, NAMELY, GATHERING AND DISSEMINATION OF NEWS (U.S. CLS. 100, 101 AND 107).

ELLEN PERKINS, EXAMINING ATTORNEY

SN 85-493,471. SOLARWINDS WORLDWIDE, LLC, AUSTIN, TX. FILED 12-12-2011.

DAMEWARE

THE MARK CONSISTS OF STANDARD CHARACTERS WITHOUT CLAIM TO ANY PARTICULAR FONT, STYLE, SIZE, OR COLOR.

CLASS 9—ELECTRICAL AND SCIENTIFIC APPARATUS

FOR COMPUTER SOFTWARE FOR USE WITH NETWORK MANAGEMENT; REMOTE SYSTEM MANAGEMENT SOFTWARE TO ASSIST WITH MANAGEMENT OF DOMAINS, WORKSTATIONS, DISK DRIVES, EVENT LOGS, LOCAL GROUPS, GLOBAL GROUPS, DOMAIN MEMBERS, OPEN FILES, PRINTERS, PROCESSES, PROPERTIES, REGISTRIES, SOFTWARE, TERMINAL SERVICES/REMOTE DESKTOP PROTOCOL (RDP), AND USERS; COMPUTER SOFTWARE FOR USE WITH TROUBLESHOOTING COMPUTERS AND COMPUTER NETWORKS; COMPUTER SOFTWARE FOR USE WITH EXPORTING DATA FROM COMPUTERS AND COMPUTER NETWORKS (U.S. CLS. 21, 23, 26, 36 AND 38).

FIRST USE 0-0-1999; IN COMMERCE 0-0-1999.

CLASS 42—SCIENTIFIC AND COMPUTER SERVICES

FOR SOFTWARE AS A SERVICE (SAAS) SERVICES FEATURING SOFTWARE FOR MONITORING, IDENTIFYING, AND ANALYZING INTERNET DATA; PROVIDING TELEPHONE AND EMAIL TECHNICAL SUPPORT, NAMELY, TROUBLESHOOTING OF COMPUTER SOFTWARE PROBLEMS; UPDATING OF COMPUTER SOFTWARE FOR OTHERS, NAMELY, PROVIDING NEW VERSIONS AND BUG FIXES OF COMPUTER SOFTWARE (U.S. CLS. 100 AND 101).

FIRST USE 0-0-1999; IN COMMERCE 0-0-1999.
BRIAN CALLAGHAN, EXAMINING ATTORNEY

SN 85-493,885. RHEE BROS., INC., HANOVER, MD. FILED 12-13-2011.



THE MARK CONSISTS OF THE STYLIZED WORD "MATSARANG" BELOW THREE SQUARES WITH CURVED CORNERS, EACH CONTAINING A KOREAN LETTER.

THE ENGLISH TRANSLATION OF "MATSARANG" IN THE MARK IS "FLAVOR LOVE".

THE NON-LATIN CHARACTERS IN THE MARK TRANSLITERATE TO "MATSARANG" AND THIS TRANSLATES TO "FLAVOR LOVE" IN ENGLISH.

CLASS 29—MEATS AND PROCESSED FOODS

FOR PROCESSED FOOD, NAMELY, FISH ROE, FISH CAKE; DRIED FRUIT AND VEGETABLES; PICKLED RADISH, PICKLED GARLIC STEM, PICKLED GREEN PEPPER (U.S. CL. 46).

FIRST USE 2-5-2006; IN COMMERCE 2-5-2006.

CLASS 30—STAPLE FOODS

FOR NOODLES; SWEET RICE; COOKED RICE; SPICE, NAMELY, RED PEPPER (U.S. CL. 46).
FIRST USE 2-1-2006; IN COMMERCE 2-1-2006.
HOWARD B. LEVINE, EXAMINING ATTORNEY

SN 85-494,066. PARK NICOLLET HEALTH SERVICES, ST. LOUIS PARK, MN. FILED 12-13-2011.

PARK NICOLLET BE WELL

THE MARK CONSISTS OF STANDARD CHARACTERS WITHOUT CLAIM TO ANY PARTICULAR FONT, STYLE, SIZE, OR COLOR.
OWNER OF U.S. REG. NOS. 2,566,532, 3,439,006 AND OTHERS.

CLASS 9—ELECTRICAL AND SCIENTIFIC APPARATUS

FOR DOWNLOADABLE ELECTRONIC PERIODICALS IN THE FIELDS OF WOMEN'S HEALTH, HEALTHY LIFESTYLES, AND HEALTH CARE (U.S. CLS. 21, 23, 26, 36 AND 38).
FIRST USE 6-0-2011; IN COMMERCE 6-0-2011.

CLASS 16—PAPER GOODS AND PRINTED MATTER

FOR PRINTED PUBLICATIONS, NAMELY, MAGAZINES IN THE FIELDS OF WOMEN'S HEALTH, HEALTHY LIFESTYLES, AND HEALTH CARE (U.S. CLS. 2, 5, 22, 23, 29, 37, 38 AND 50).
FIRST USE 6-0-2011; IN COMMERCE 6-0-2011.
DEBORAH LOBO, EXAMINING ATTORNEY

SN 85-494,076. PARK NICOLLET HEALTH SERVICES, ST. LOUIS PARK, MN. FILED 12-13-2011.



OWNER OF U.S. REG. NOS. 2,566,532, 3,439,006 AND OTHERS.
THE MARK CONSISTS OF THE WORDING "PARK NICOLLET" POSITIONED ABOVE THE WORD "BE" POSITIONED TO THE LEFT AND ABOVE THE WORD "WELL", ALL IN STYLIZED FONT.

CLASS 9—ELECTRICAL AND SCIENTIFIC APPARATUS

FOR DOWNLOADABLE ELECTRONIC PERIODICALS IN THE FIELDS OF WOMEN'S HEALTH, HEALTHY LIFESTYLES, AND HEALTH CARE (U.S. CLS. 21, 23, 26, 36 AND 38).
FIRST USE 6-0-2011; IN COMMERCE 6-0-2011.

CLASS 16—PAPER GOODS AND PRINTED MATTER

FOR PRINTED PUBLICATIONS, NAMELY, MAGAZINES IN THE FIELDS OF WOMEN'S HEALTH, HEALTHY LIFESTYLES, AND HEALTH CARE (U.S. CLS. 2, 5, 22, 23, 29, 37, 38 AND 50).
FIRST USE 6-0-2011; IN COMMERCE 6-0-2011.
DEBORAH LOBO, EXAMINING ATTORNEY

SN 85-494,157. INVIVOSCIENCES, LLC, MCFARLAND, WI. FILED 12-13-2011.

INVIVOSCIENCES

THE MARK CONSISTS OF STANDARD CHARACTERS WITHOUT CLAIM TO ANY PARTICULAR FONT, STYLE, SIZE, OR COLOR.

CLASS 9—ELECTRICAL AND SCIENTIFIC APPARATUS

FOR CLINICAL AND LABORATORY ANALYZERS FOR MEASURING, TESTING AND ANALYZING BIOLOGICAL TISSUES; CELL CULTURE APPARATUS FOR CLINICAL AND LABORATORY USE, NAMELY, CELL CULTURE CHAMBERS AND CELL CULTURE SUPPORTS (U.S. CLS. 21, 23, 26, 36 AND 38).
FIRST USE 12-31-2001; IN COMMERCE 1-30-2008.

CLASS 42—SCIENTIFIC AND COMPUTER SERVICES

FOR CLINICAL AND LABORATORY SERVICES RELATED TO PREPARATION OF BIOLOGICAL TISSUES FOR OTHERS, NAMELY, THREE-DIMENSIONAL TISSUES FROM CELLS; CLINICAL AND LABORATORY SERVICES FOR OTHERS, NAMELY, USING THREE-DIMENSIONAL BIOLOGICAL TISSUES FOR USE IN DEVELOPING SCREENING ASSAYS, AND DIAGNOSTIC ASSAYS, AND IN PRODUCT DEVELOPMENT (U.S. CLS. 100 AND 101).
FIRST USE 12-31-2001; IN COMMERCE 12-31-2008.
ALYSSA STEEL, EXAMINING ATTORNEY

SN 85-494,214. EVERSTONE PTY. LTD., SYDNEY, AUSTRALIA, FILED 12-13-2011.



OWNER OF U.S. REG. NO. 3,308,399.
THE MARK CONSISTS OF THE LETTERS "ES" ARRANGED INTO A FANCIFUL SQUARE SHAPE.

CLASS 6—METAL GOODS

FOR METAL DOOR PANELS AND FRAMES HAVING A DECORATIVE METALLIC FINISH AND APPEARANCE; BUILDING MATERIALS, NAMELY, COMPOSITE PANELS COMPOSED PRIMARILY OF METAL WITH A DECORATIVE FINISH AND METALLIC APPEARANCE USED AS BUILDING MATERIALS (U.S. CLS. 2, 12, 13, 14, 23, 25 AND 50).

FIRST USE 7-15-2005; IN COMMERCE 7-15-2005.

CLASS 19—NON-METALLIC BUILDING MATERIALS

FOR BALUSTRADES; BRICKS; BUILDING MATERIALS NOT OF METAL, NAMELY, COUNTERTOPS FOR FURTHER INSTALLATION, FASCIA AND SOFFITS; BUILDING MATERIALS, HAVING DECORATIVE NON-METALLIC FINISHES, NAMELY, GLASS, NON-METAL MOLDINGS, NON-METAL TRIM; PORTLAND CEMENT; ROOFING CEMENT; SLAG-LIME; CEMENT MIXES; CEMENT POSTS; CLADDING NOT OF METAL FOR CONSTRUCTION AND BUILDING; COATINGS OTHER THAN PAINTS FOR USE IN BUILDING FOR USE WITH METAL, TIMBER, CONCRETE AND PLASTERBOARD, NAMELY, ASPHALT ROOF COVERINGS, BITUMINOUS ROOF COVERINGS; CONCRETE; CONCRETE BUILDING ELEMENTS AND STRUCTURES HAVING NON-METALLIC AND METALLIC DECORATIVE APPEARANCE, NAMELY, BEAMS, BLOCKS, BOLLARDS, POSTS, PANELS AND SLABS; PRE-FABRICATED NONMETAL ARCHITECTURAL COLUMNS; CONSTRUCTION MATERIALS NOT OF METAL, NAMELY, FIBERGLASS PANELS, FIBERGLASS BOARDS, UNDERLAYS OF AGGLOMERATED CORKS, TOILET PARTITIONS AND EXTERIOR PANELS; COVERINGS NOT OF METAL FOR BUILDING, NAMELY, FOR CEILINGS, FOR ROOFS, CORK TILES FOR WALL AND CEILING COVERS; DOORS, DOOR PANELS OR FRAMES NOT OF METAL; NON-METAL DOORS, NON-METAL DECORATIVE MOLDINGS AND TRIM, NAMELY, BUILDING FACINGS; FLOOR BOARDS; BAMBOO FLOORING; HARDWOOD FLOORING; VINYL FLOORING; WOODEN FLOORING; BUILDING GLASS; GLASS BRICKS; DECORATIVE GLASS FOR BUILDINGS; MANTELPIECES; CONSTRUCTION MATERIALS, NAMELY, NONMETAL TOILET PARTITIONS; TIMBER DOOR, FLOOR AND EXTERIOR PANELS FOR BUILDING, NAMELY, TIMBER PANELS HAVING A DECORATIVE METALLIC FINISH AND APPEARANCE; PAVING BLOCKS, STONES, TILES AND SLABS; ASPHALT PAVING COMPOSITIONS; WORKS OF STONEMASONRY, NAMELY, BUSTS AND FIGURES OF STONE, CONCRETE, OR MARBLE; WALL CLADDING NOT OF METAL; NON-METAL DOOR PANELS; NON-METAL FLOOR PANELS; NON-METAL CEILING PANELS; NON-METAL ROOFING PANELS; NON-METAL DOOR PANELS WITH A DECORATIVE METALLIC FINISH AND APPEARANCE; NON-METAL FLOOR PANELS WITH A DECORATIVE METALLIC FINISH AND APPEARANCE; NON-METAL CEILING PANELS WITH A DECORATIVE METALLIC FINISH AND APPEARANCE; NON-METAL ROOFING PANELS WITH A DECORATIVE METALLIC FINISH AND APPEARANCE; WINDOWS AND WINDOW FRAMES NOT OF METAL; WORKS OF ART OF STONE, CONCRETE OR MARBLE; NON-METAL TILES, NAMELY, CERAMIC TILES, GLASS TILES, PORCELAIN TILES, TERRACOTTA TILES, SLATE TILES AND STONE TILES; FLOOR, WALL, KITCHEN, BATHROOM, OUTDOOR AND DECORATIVE TILES OF CERAMIC, GLASS, PORCELAIN, TERRACOTTA, SLATE AND STONE; DECORATIVE COMPOSITE TILES COMPRISED PRIMARILY OF ONE OR MORE LAYERS OF CERAMIC, GLASS, RESIN OR FOIL WITH A DECORATIVE FINISH AND METALLIC APPEARANCE USED AS BUILDING MATERIALS; CERAMIC OR PORCELAIN TILES HAVING A COATING WITH METAL PARTICLES; GLASS TILES HAVING A FOIL BACKING OR LAYER; MOSAIC ART TILES MADE OF MARBLE, NATURAL STONE AND STONE TILE WITH ONE OR MORE METALLIC FOIL LAYERS; GLASS MOSAICS FOR USE IN BUILDING CONSTRUCTION; DECORATIVE GLASS PANELS OR TILES AND GLASS MOSAICS FOR USE IN BUILDING CONSTRUCTION; DECORATIVE NATURAL STONE AND NATURAL TILE PANELS AND MOSAICS; NON-METAL DOOR, FLOOR AND CEILING PANELS HAVING A DECORATIVE METALLIC APPEARANCE; ASSEMBLED DEC-

ORATIVE GLASS PANELS OR TILES AND GLASS MOSAICS FOR USE IN BUILDING CONSTRUCTION; ASSEMBLED DECORATIVE NATURAL STONE AND NATURAL TILE PANELS AND MOSAICS (U.S. CLS. 1, 12, 33 AND 50).

FIRST USE 7-15-2005; IN COMMERCE 7-15-2005.
MICHAEL KEATING, EXAMINING ATTORNEY

SN 85-495,474. SERVPRO INTELLECTUAL PROPERTY, INC., GALLATIN, TN. FILED 12-14-2011.

REAL GREEN

THE MARK CONSISTS OF STANDARD CHARACTERS WITHOUT CLAIM TO ANY PARTICULAR FONT, STYLE, SIZE, OR COLOR.

NO CLAIM IS MADE TO THE EXCLUSIVE RIGHT TO USE "GREEN", APART FROM THE MARK AS SHOWN.

CLASS 35—ADVERTISING AND BUSINESS

FOR BUSINESS CONSULTING AND ADVISORY SERVICES IN THE FIELDS OF ADVISING BUSINESSES ON ISSUES OF ENVIRONMENTAL CONSERVATION, PRESERVATION, SUSTAINABILITY, IMPACT AND RESTORATION (U.S. CLS. 100, 101 AND 102).

CLASS 42—SCIENTIFIC AND COMPUTER SERVICES

FOR CONSULTING SERVICES IN THE FIELD OF ENVIRONMENTAL ASSESSMENT AND PLANNING (U.S. CLS. 100 AND 101).

CLASS 45—PERSONAL AND LEGAL SERVICES

FOR CONSULTING SERVICES IN THE FIELD OF REVIEWING PRACTICES TO ENSURE COMPLIANCE WITH ENVIRONMENTAL LAWS AND REGULATIONS (U.S. CLS. 100 AND 101).

JASON TURNER, EXAMINING ATTORNEY

SN 85-495,656. OS&E INC., NEWBURYPORT, MA. FILED 12-14-2011.

OS&e Inc

THE MARK CONSISTS OF STANDARD CHARACTERS WITHOUT CLAIM TO ANY PARTICULAR FONT, STYLE, SIZE, OR COLOR.

NO CLAIM IS MADE TO THE EXCLUSIVE RIGHT TO USE "INC", APART FROM THE MARK AS SHOWN.

CLASS 35—ADVERTISING AND BUSINESS

FOR PROCUREMENT SERVICES, NAMELY, PURCHASING TABLEWARE, GLASSWARE, BARWARE, TOILETRIES, OFFICE EQUIPMENT, CLEANING SUPPLIES, LINENS, ARTWORK, FLOOR COVERINGS, BEDDING, APPLIANCES AND POOL EQUIPMENT, FOR OTHERS IN THE HOSPITALITY INDUSTRY, RESORT AND SPA INDUSTRY, AND TEMPORARY AND ASSISTED LIVING INDUSTRY; PROVIDING ONLINE ORDERING SERVICES IN THE FIELDS OF HOSPITALITY AND BUSINESS FURNISHINGS, SUPPLIES AND EQUIPMENT; AND RENDERING CONSULTATION SERVICES RELATING TO THE AFORESAID SERVICES; PROVIDING ONLINE ORDERING AND RETAIL STORE SERVICES IN THE FIELDS OF HOSPITALITY INDUSTRY, RESORT AND SPA INDUSTRY, AND TEMPORARY AND ASSISTED LIVING EQUIPMENT AND SUPPLIES (U.S. CLS. 100, 101 AND 102).

FIRST USE 9-1-2010; IN COMMERCE 9-1-2010.

CLASS 39—TRANSPORTATION AND STORAGE

FOR WAREHOUSING SERVICES, NAMELY, STORAGE, DISTRIBUTION, PACKING AND SHIPPING OF TABLEWARE, GLASSWARE, BARWARE, TOILETRIES, OFFICE EQUIPMENT, CLEANING SUPPLIES, LINENS, ARTWORK, FLOOR COVERINGS, BEDDING, APPLIANCES AND POOL EQUIPMENT (U.S. CLS. 100 AND 105).

FIRST USE 10-1-2011; IN COMMERCE 10-1-2011.

CLASS 42—SCIENTIFIC AND COMPUTER SERVICES

FOR PROVIDING ONLINE NONDOWNLOADABLE SOFTWARE FOR USE IN BUSINESS PURCHASING AND PROCUREMENT, REQUISITIONING, PURCHASE ORDER CREATION AND STORING AND MANAGING PURCHASE LISTS (U.S. CLS. 100 AND 101).

FIRST USE 10-1-2011; IN COMMERCE 10-1-2011.

PAM WILLIS, EXAMINING ATTORNEY

SN 85-495,768. THEOS MEDICAL SYSTEMS, SANTA CLARA, CA. FILED 12-15-2011.



The logo for CHÜMMIE features the word "CHÜMMIE" in a bold, sans-serif font. The letter "U" is replaced by a stylized smiley face with two dots for eyes and a curved line for a mouth. The "Ü" has a blue dot above it.

OWNER OF U.S. REG. NO. 3,941,471.
THE COLOR(S) BLUE AND GRAY IS/ARE CLAIMED AS A FEATURE OF THE MARK.

THE MARK CONSISTS OF THE STYLIZED WORD "CHÜMMIE" WHERE THE LETTER "U" IS REPLACED BY A SMILE SIGN WITH GRAY EYES AND A BLUE MOUTH AND WITH THE REST OF THE LETTERS IN THE WORD IN GRAY.

CLASS 9—ELECTRICAL AND SCIENTIFIC APPARATUS

FOR MONITORING DEVICES FOR DETECTING URINE, FECES, BLOOD IN INFANTS, CHILDREN, AND ADULTS; MOISTURE DETECTION SENSORS WITH ALARM UNIT FOR USE IN POTTY TRAINING, BED-WETTING TREATMENT, AND IN CONTINENCE MANAGEMENT IN ADULTS; ELECTRONIC DEVICES FOR ASSISTING CARE GIVING FOR SENIORS OR PEOPLE NEEDING ASSISTANCE COMPRISED OF SENSORS FOR DETERMINING STATUS OF PERSON AND APPARATUS FOR SENDING ELECTRONIC ALERTS TO CARE GIVERS (U.S. CLS. 21, 23, 26, 36 AND 38).

FIRST USE 1-1-2011; IN COMMERCE 1-1-2011.

CLASS 10—MEDICAL APPARATUS

FOR PATIENT MONITORING SENSORS AND ALARMS, NAMELY, ELECTROCHEMICAL SENSORS FOR DETECTION OF URINE, FECES, BLOOD IN INFANTS, CHILDREN, AND ADULTS FOR MEDICAL PURPOSES (U.S. CLS. 26, 39 AND 44).

FIRST USE 1-1-2011; IN COMMERCE 1-1-2011.

KELLEY WELLS, EXAMINING ATTORNEY

SN 85-496,257. GUILIN BODA AUTOMOBILE TECHNOLOGY CO., LTD., GUILIN, CHINA, FILED 12-15-2011.



NO CLAIM IS MADE TO THE EXCLUSIVE RIGHT TO USE "FOUR WHEEL ALIGNMENT", APART FROM THE MARK AS SHOWN.

THE MARK CONSISTS OF THE CAPITALIZED LETTERS "APLBODA" UNDER THREE CHINESE CHARACTERS WITH A DOT BETWEEN THE CHARACTERS. TO THE RIGHT OF THESE CHARACTERS IS THE STYLIZED LETTERING "APL" WITH A BORDER. THE "A" IS PARTIALLY SURROUNDED BY A CIRCULAR DESIGN RESEMBLING TIRE TREAD. BENEATH THE "APL" ARE THE WORDS "FOUR WHEEL ALIGNMENT".

THE NON-LATIN CHARACTERS IN THE MARK TRANSLITERATE TO APOLO AND THIS HAS NO MEANING IN A FOREIGN LANGUAGE.

CLASS 7—MACHINERY

FOR CAR LIFTS; POWERED TIRE CHANGER MACHINES FOR LAND VEHICLES (U.S. CLS. 13, 19, 21, 23, 31, 34 AND 35).

FIRST USE 7-1-2008; IN COMMERCE 7-1-2008.

CLASS 9—ELECTRICAL AND SCIENTIFIC APPARATUS

FOR VEHICLE WHEEL ALIGNMENT MACHINE; TIRE BALANCING MACHINES FOR LAND VEHICLES (U.S. CLS. 21, 23, 26, 36 AND 38).

FIRST USE 7-1-2008; IN COMMERCE 7-1-2008.

AISHA CLARKE, EXAMINING ATTORNEY

SN 85-496,346. THE BOSTON SOCIETY OF ARCHITECTS, BOSTON, MA. FILED 12-15-2011.



The logo for ABX consists of the letters "ABX" in a bold, serif font.

THE MARK CONSISTS OF STANDARD CHARACTERS WITHOUT CLAIM TO ANY PARTICULAR FONT, STYLE, SIZE, OR COLOR.

CLASS 35—ADVERTISING AND BUSINESS

FOR ORGANIZING, PROMOTING, AND CONDUCTING TRADE SHOWS, EXHIBITIONS, AND EVENTS IN THE FIELD OF ARCHITECTURE, DESIGN, AND CONSTRUCTION, FOR BUSINESS PURPOSES (U.S. CLS. 100, 101 AND 102).

CLASS 41—EDUCATION AND ENTERTAINMENT

FOR EDUCATIONAL SERVICES, NAMELY, DEVELOPING, PROMOTING, AND CONDUCTING EDUCATIONAL CONFERENCES AND PROGRAMS AND PROVIDING WORKSHOPS IN THE FIELD OF ARCHITECTURE, DESIGN, AND CONSTRUCTION (U.S. CLS. 100, 101 AND 107).

HELENE LIWINSKI, EXAMINING ATTORNEY

SN 85-498,591. IPWORLD TV INC, SANTA ANA, CA. FILED 12-19-2011.

SN 85-497,566. EYE INJECTION KITS INTERNATIONAL, INC., EL PASO, TX. FILED 12-16-2011.



AMD AGE-RELATED
MACULAR
DEGENERATION
Convenience Kit

NO CLAIM IS MADE TO THE EXCLUSIVE RIGHT TO USE "AMD AGE-RELATED MACULAR DEGENERATION" AND "KIT", APART FROM THE MARK AS SHOWN.

THE COLOR(S) PINK, BLUE, AND BLACK IS/ARE CLAIMED AS A FEATURE OF THE MARK.

THE MARK CONSISTS OF THE WORDING "AMD" IN PINK, THE WORDING "CONVENIENCE KIT" IN BLACK, AND THE WORDING "AGE-RELATED MACULAR DEGENERATION" IN BLUE. THE WORD "AMD" IS ABOVE THE LETTERS "CONVENI" IN THE WORD "CONVENIENCE". THE WORDING "AGE-RELATED MACULAR DEGENERATION" IS ABOVE THE LETTERS "ENCE KIT" IN THE WORDING "CONVENIENCE KIT" AND TO THE RIGHT OF THE WORD "AMD". THERE IS A BLUE CURVED LINE UNDERNEATH THE WORDING "CONVENIENCE KIT".

CLASS 5—PHARMACEUTICALS

FOR SURGICAL EYE CARE KITS COMPOSED OF COTTON SWABS FOR MEDICAL PURPOSES, NAMELY, COTTON TIP APPLICATORS; EYEDROPS, NAMELY, DILATING DROPS, NUMBING DROPS, BETADINE DROPS, AND ANTIBIOTIC DROPS; ANTISEPTIC WIPES, INCLUDING PROVIDONE-IODINE PREP PADS (U.S. CLS. 6, 18, 44, 46, 51 AND 52).

CLASS 10—MEDICAL APPARATUS

FOR SURGICAL EYE CARE KITS COMPOSED OF SYRINGES, FORCEPS, INFANT EYE SPECULUM, PROBE, DRAPE CLOTH, DROPPER, LATEX MEDICAL GLOVES, FACEMASKS FOR USE BY HEALTH CARE PROVIDERS, NAMELY, EARLOOP FACE MASKS; FORCEPS FOR MEDICAL USES, NAMELY SURGICAL FORCEPS (U.S. CLS. 26, 39 AND 44).

MARY ROSSMAN, EXAMINING ATTORNEY



THE COLOR(S) YELLOW, DARK GREEN, BROWN, BURGUNDY, BLUE, RED, TURQUOISE, PURPLE, PINK, LIME GREEN, ORANGE AND LIGHT GREEN IS/ARE CLAIMED AS A FEATURE OF THE MARK.

THE MARK CONSISTS OF A GLOBE DESIGN IN FIFTEEN SECTIONS WITH THE FOLLOWING ALTERNATING COLORS BEGINNING LEFT TO RIGHT AT THE TOP OF THE GLOBE TO THE BOTTOM: YELLOW, DARK GREEN, BROWN, BURGUNDY, BLUE, RED, TURQUOISE, PURPLE, PINK, LIME GREEN, ORANGE, LIGHT GREEN, DARK GREEN, BURGUNDY, PURPLE AND TURQUOISE.

CLASS 9—ELECTRICAL AND SCIENTIFIC APPARATUS

FOR AUDIO AND VIDEO RECORDINGS FEATURING TELEVISION PROGRAMS; DIGITAL ENTERTAINMENT SYSTEMS FOR WATCHING, STORING AND SHARING DIGITAL CONTENT ON A HOME COMPUTER NETWORK; DIGITAL MUSIC DOWNLOADABLE FROM THE INTERNET; DOWNLOADABLE MULTIMEDIA FILE CONTAINING ARTWORK, TEXT, AUDIO, VIDEO, GAMES, AND INTERNET WEB LINKS RELATING TO TELEVISION PROGRAMS; INTEROPERABLE COMMUNICATION SYSTEM DESIGNED TO PROVIDE RADIO, STREAMING VIDEO, WIRELESS INTERNET, AND VOIP PHONE; TELECOMMUNICATIONS HARDWARE AND SOFTWARE FOR MONITORING AND ALERTING REMOTE SENSOR STATUS VIA THE INTERNET; WIRELESS TELEVISION SET FOR PROVIDING VIDEO CONFERENCING AND TELEPHONE SERVICE OVER THE INTERNET (U.S. CLS. 21, 23, 26, 36 AND 38).

CLASS 41—EDUCATION AND ENTERTAINMENT

FOR ENTERTAINMENT SERVICES IN THE NATURE OF AN ONGOING IPTV (INTERNET PROTOCOL TELEVISION), TELEVISION PROGRAMMING SEGMENTS IN THE FIELD OF POSITIVE PSYCHOLOGY, PERSONAL RELATIONSHIPS, THE ART AND SCIENCE OF HAPPINESS (U.S. CLS. 100, 101 AND 107).

LESLEY LAMOTHE, EXAMINING ATTORNEY

SN 85-498,922. FARMWORKER JUSTICE, WASHINGTON, DC. FILED 12-19-2011.

JUSTICIA CAMPESINA

THE MARK CONSISTS OF STANDARD CHARACTERS WITHOUT CLAIM TO ANY PARTICULAR FONT, STYLE, SIZE, OR COLOR.

THE ENGLISH TRANSLATION OF "JUSTICIA CAMPESINA" IN THE MARK IS FARMWORKER JUSTICE. SEC. 2(F).

CLASS 16—PAPER GOODS AND PRINTED MATTER

FOR PRINTED BROCHURES, NEWSLETTERS, PAMPHLETS, NEWS RELEASES, AND MAGAZINES IN THE FIELD OF ISSUES OF CONCERN TO AGRICULTURAL WORKERS (U.S. CLS. 2, 5, 22, 23, 29, 37, 38 AND 50).

FIRST USE 10-31-2005; IN COMMERCE 10-31-2005.

CLASS 35—ADVERTISING AND BUSINESS

FOR PUBLIC ADVOCACY TO PROMOTE AWARENESS OF ISSUES OF CONCERN TO AGRICULTURAL WORKERS; ADVOCACY FOR AND PROMOTION OF HEALTH AND SAFETY MEASURES TO IMPROVE THE LIVES OF AGRICULTURAL WORKERS (U.S. CLS. 100, 101 AND 102).

FIRST USE 10-31-2005; IN COMMERCE 10-31-2005.

CLASS 41—EDUCATION AND ENTERTAINMENT

FOR EDUCATIONAL SERVICES, NAMELY, CONDUCTING CLASSES, SEMINARS, CONFERENCES, AND WORKSHOPS IN THE FIELD OF ISSUES OF CONCERN TO AGRICULTURAL WORKERS (U.S. CLS. 100, 101 AND 107).

FIRST USE 10-31-2005; IN COMMERCE 10-31-2005. DEZMONA MIZELLE, EXAMINING ATTORNEY

SN 85-498,924. FARMWORKER JUSTICE, WASHINGTON, DC. FILED 12-19-2011.

PODER SANO

THE MARK CONSISTS OF STANDARD CHARACTERS WITHOUT CLAIM TO ANY PARTICULAR FONT, STYLE, SIZE, OR COLOR.

NO CLAIM IS MADE TO THE EXCLUSIVE RIGHT TO USE "SANO", APART FROM THE MARK AS SHOWN.

THE ENGLISH TRANSLATION OF "PODER SANO" IN THE MARK IS HEALTH EMPOWERMENT.

CLASS 16—PAPER GOODS AND PRINTED MATTER

FOR PRINTED BROCHURES, NEWSLETTERS, PAMPHLETS, NEWS RELEASES, AND MAGAZINES IN THE FIELD OF HEALTH MATTERS FOR AGRICULTURAL WORKERS (U.S. CLS. 2, 5, 22, 23, 29, 37, 38 AND 50).

FIRST USE 10-31-2009; IN COMMERCE 10-31-2009.

CLASS 41—EDUCATION AND ENTERTAINMENT

FOR EDUCATIONAL SERVICES, NAMELY, CONDUCTING CLASSES, SEMINARS, CONFERENCES, AND WORKSHOPS IN THE FIELD OF HEALTH MATTERS FOR AGRICULTURAL WORKERS (U.S. CLS. 100, 101 AND 107).

FIRST USE 10-31-2009; IN COMMERCE 10-31-2009. DEZMONA MIZELLE, EXAMINING ATTORNEY

SN 85-498,996. TACO BELL CORP., IRVINE, CA. FILED 12-19-2011.

CANTINA BURRITO BOWL

THE MARK CONSISTS OF STANDARD CHARACTERS WITHOUT CLAIM TO ANY PARTICULAR FONT, STYLE, SIZE, OR COLOR.

NO CLAIM IS MADE TO THE EXCLUSIVE RIGHT TO USE "BURRITO BOWL", APART FROM THE MARK AS SHOWN.

CLASS 29—MEATS AND PROCESSED FOODS

FOR REFRIED BEANS; SEASONED MEAT, CHEESE AND VEGETABLES FOR MAKING TACOS; TACO SALAD (U.S. CL. 46).

CLASS 30—STAPLE FOODS

FOR TACOS; BURRITOS; TOSTADOS; ENCHILADAS; FAJITAS; TORTILLAS; SALSA; PICANTE SAUCE; TACO SEASONING MIX; SPICES; TACO SHELLS; TACO SAUCE; TORTILLA CHIPS; MEXICAN PIZZA; PREPARED FRIED FLOUR TORTILLA CONFECTIONS; COMBINATION ENCHILADA AND BURRITO CONFECTIONS; FRIED FLOUR TORTILLA CONFECTIONS (U.S. CL. 46).

CHRISTOPHER SIDOTI, EXAMINING ATTORNEY

SN 85-499,027. BUNZL DISTRIBUTIONUSA, INC., CREVE COEUR, MO. FILED 12-19-2011.

The logo for HI-VALU features the word "HI" in a large, bold, black sans-serif font. To the right of "HI" is a stylized hyphen that forms the top of a checkmark. To the right of the checkmark is the word "VALU" in a smaller, bold, black sans-serif font.

OWNER OF U.S. REG. NOS. 3,613,902, 3,626,948 AND OTHERS.

THE MARK CONSISTS OF THE TERMS "HI" AND "VALU", JOINED WITH A HYPHEN.

CLASS 20—FURNITURE AND ARTICLES NOT OTHERWISE CLASSIFIED

FOR PLASTIC CONTAINERS AND COVERS FOR THE FOOD INDUSTRY (U.S. CLS. 2, 13, 22, 25, 32 AND 50).

CLASS 21—HOUSEWARES AND GLASS

FOR PLASTIC CUPS; PLASTIC CUPS WITH LIDS (U.S. CLS. 2, 13, 23, 29, 30, 33, 40 AND 50).
ANN E. SAPPENFIELD, EXAMINING ATTORNEY

SN 85-499,910. CONCEPTION ABBEY, CONCEPTION, MO.
FILED 12-20-2011.

CONCEPTION ABBEY

THE MARK CONSISTS OF STANDARD CHARACTERS WITHOUT CLAIM TO ANY PARTICULAR FONT, STYLE, SIZE, OR COLOR.

NO CLAIM IS MADE TO THE EXCLUSIVE RIGHT TO USE "ABBHEY", APART FROM THE MARK AS SHOWN.

CLASS 41—EDUCATION AND ENTERTAINMENT

FOR EDUCATIONAL SERVICES, NAMELY, PROVIDING CLASSES IN THE FIELD OF SPIRITUAL GUIDANCE, ACADEMIC TRAINING AND CHARACTER FORMATION TO YOUNG MEN CONSIDERING A PRIESTLY VOCATION; RELIGIOUS INSTRUCTION SERVICES (U.S. CLS. 100, 101 AND 107).
FIRST USE 0-0-1882; IN COMMERCE 0-0-1882.

CLASS 45—PERSONAL AND LEGAL SERVICES

FOR CONDUCTING RELIGIOUS PRAYER SERVICES; RELIGIOUS AND SPIRITUAL SERVICES, NAMELY, PROVIDING GATHERINGS AND RETREATS TO DEVELOP AND ENHANCE THE SPIRITUAL LIVES OF INDIVIDUALS; RELIGIOUS SERVICES, NAMELY, PRAYER MEETINGS; MINISTERIAL SERVICES, NAMELY, PROVIDING PASTORAL CARE TO PARISHES, HOSPITALS, RELIGIOUS HOUSES, AND SCHOOLS; SPIRITUAL COUNSELING, NAMELY, PROVIDING SPIRITUAL GUIDANCE AND CHARACTER FORMATION TO YOUNG MEN CONSIDERING A PRIESTLY VOCATION (U.S. CLS. 100 AND 101).
FIRST USE 0-0-1882; IN COMMERCE 0-0-1882.

ANNE E. GUSTASON, EXAMINING ATTORNEY

SN 85-500,153. O'NEAL STEEL, INC., BIRMINGHAM, AL.
FILED 12-20-2011.

metalwest

THE MARK CONSISTS OF THE WORD "METALWEST" IN LOWER-CASE LETTERS WITH A HORIZONTAL LINE ACROSS THE LOWER PORTION OF THE MARK.

CLASS 35—ADVERTISING AND BUSINESS

FOR DISTRIBUTORSHIP SERVICES IN THE FIELD OF METAL AND METAL ALLOY SHEETS, TUBES, RODS, BARS, PLATES, AND COILS (U.S. CLS. 100, 101 AND 102).
FIRST USE 0-0-1986; IN COMMERCE 0-0-1986.

CLASS 40—MATERIAL TREATMENT

FOR INTERMEDIATE PROCESSING OF METAL AND METAL ALLOY SHEETS, TUBES, BARS, PLATES, AND COILS, NAMELY, CUTTING, SLITTING, LEVELING, BLANKING, AND SHEARING (U.S. CLS. 100, 103 AND 106).

FIRST USE 0-0-1986; IN COMMERCE 0-0-1986.
STEVEN JACKSON, EXAMINING ATTORNEY

SN 85-500,253. TENET HEALTHSYSTEM MEDICAL, INC., DALLAS, TX. FILED 12-20-2011.



NO CLAIM IS MADE TO THE EXCLUSIVE RIGHT TO USE "QUALITY", "SERVICE", "SAFETY" AND "OUTCOMES", APART FROM THE MARK AS SHOWN.

THE COLOR(S) GRAY, YELLOW, ORANGE, BLUE, RED, GREEN IS/ARE CLAIMED AS A FEATURE OF THE MARK.

THE MARK CONSISTS OF "C2Q" IN GRAY IN THE CENTER SURROUNDED BY FOUR COLORED CIRCULAR ARROWS, FROM THE TOP AND MOVING CLOCK-WISE, THE ARROWS ARE YELLOW/ORANGE, BLUE, RED & FINALLY GREEN WITH THE WORDS "QUALITY" IN ORANGE FOLLOWED BY AN ORANGE MIDDLE-DOT, "SERVICE" IN BLUE FOLLOWED BY A BLUE MIDDLE-DOT, "SAFETY" IN RED FOLLOWED BY A RED MIDDLE-DOT AND "OUTCOMES" IN GREEN FOLLOWED BY A GREEN MIDDLE-DOT. ALL OF THE WORDING CURVES AROUND THE ARROWS IN A CIRCULAR SHAPE.

CLASS 41—EDUCATION AND ENTERTAINMENT

FOR EDUCATIONAL SERVICES, NAMELY, PROVIDING EDUCATIONAL PROGRAMS TO MEDICAL PROFESSIONALS DESIGNED TO ENHANCE THE OVERALL QUALITY, CONTROL AND PRODUCTIVITY OF THE CARE DELIVERY PROCESS, AND PROVIDING INCENTIVES TO HOSPITALS AND MEDICAL PROFESSIONALS TO DEMONSTRATE EXCELLENCE IN THE FIELD OF PATIENT CARE THROUGH THE ISSUANCE OF AWARDS (U.S. CLS. 100, 101 AND 107).

CLASS 44—MEDICAL, BEAUTY AND AGRICULTURAL SERVICES

FOR HEALTHCARE SERVICES (U.S. CLS. 100 AND 101).
MATTHEW MCDOWELL, EXAMINING ATTORNEY

SN 85-500,630. COLLECTORSHOP.COM, LLC, DIX HILLS, NY. FILED 12-21-2011.

SN 85-500,780. RAW TOYS LLC, ST. PAUL, MN. FILED 12-21-2011.

COLLECTORZOO

THE MARK CONSISTS OF STANDARD CHARACTERS WITHOUT CLAIM TO ANY PARTICULAR FONT, STYLE, SIZE, OR COLOR.

CLASS 35—ADVERTISING AND BUSINESS

FOR ON-LINE TRADING SERVICES IN WHICH SELLER POSTS PRODUCTS TO BE OFFERED FOR SALE VIA THE INTERNET; ON-LINE TRADING SERVICES IN WHICH POTENTIAL BUYERS SEARCH FOR PRODUCTS SOUGHT TO BE PURCHASED VIA THE INTERNET; PROVIDING A COMMERCIAL WEBSITE FOR SELLERS TO DISPLAY COLLECTIONS AND COLLECTIBLES FOR THE PURPOSE OF CONNECTING SELLERS WITH BUYERS; PROMOTION SERVICES, NAMELY, PROVIDING A WEBSITE PROMOTING COLLECTIONS OF OTHERS, COLLECTORS' GOODS, AND COLLECTIBLES OF OTHERS; PROMOTING THE GOODS OF OTHERS BY PROVIDING A COMMUNITY-DRIVEN WEBSITE FEATURING USER-SUBMITTED CONTENT IN THE NATURE OF IMAGES AND CONSUMER INFORMATION ABOUT COLLECTIONS AND COLLECTIBLE ITEMS; PROVIDING A WEBSITE FEATURING A SEARCHABLE DATABASE OF COLLECTIBLE PRODUCTS FOR PURPOSES OF CALCULATING THE PRICE OR INDEX VALUE OF SUCH PRODUCTS (U.S. CLS. 100, 101 AND 102).

CLASS 38—COMMUNICATION

FOR PROVIDING AN ON-LINE FORUM FOR USERS TO DISCUSS COLLECTIBLE PRODUCTS; PROVIDING AN ON-LINE FORUM FOR USERS TO DISCUSS BUYING AND SELLING COLLECTIBLE PRODUCTS (U.S. CLS. 100, 101 AND 104).

CLASS 42—SCIENTIFIC AND COMPUTER SERVICES

FOR PROVIDING A WEBSITE FEATURING TECHNOLOGY THAT ENABLES USERS TO ORGANIZE, STORE AND MANAGE AN INVENTORY OF PRODUCTS; PROVIDING A WEBSITE FEATURING NON-DOWNLOADABLE SOFTWARE FOR CREATING, MANAGING, ORGANIZING, PROMOTING, ADVERTISING, SEARCHING, AND SHARING INFORMATION RELATED TO COLLECTIBLE ITEMS, COLLECTORS OR COLLECTIONS OF ITEMS; PROVIDING A WEBSITE FEATURING ON-LINE NON-DOWNLOADABLE SOFTWARE THAT ENABLES USERS TO BUY PRODUCTS POSTED FOR SALE; COMPUTER SERVICES, NAMELY, CREATING AN ON-LINE COMMUNITY FOR USERS TO CREATE, MANAGE, ORGANIZE, PROMOTE, ADVERTISE, SEARCH, AND SHARE INFORMATION RELATED TO COLLECTIBLE ITEMS, COLLECTORS, OR COLLECTIONS OF COLLECTIBLE ITEMS; PROVIDING A WEBSITE FEATURING ON-LINE NON-DOWNLOADABLE SOFTWARE THAT ENABLES USERS TO POST PRODUCTS FOR SALE TO OTHERS; CLOUD COMPUTING FEATURING SOFTWARE FOR USE IN CREATING, MANAGING, ORGANIZING, PROMOTING, ADVERTISING, SEARCHING, AND SHARING INFORMATION RELATED TO COLLECTIBLE ITEMS, COLLECTORS, OR COLLECTIONS OF ITEMS (U.S. CLS. 100 AND 101).
YAT SYE, LEE, EXAMINING ATTORNEY

RAW TOYS

THE MARK CONSISTS OF STANDARD CHARACTERS WITHOUT CLAIM TO ANY PARTICULAR FONT, STYLE, SIZE, OR COLOR.

NO CLAIM IS MADE TO THE EXCLUSIVE RIGHT TO USE "TOYS", APART FROM THE MARK AS SHOWN.

CLASS 28—TOYS AND SPORTING GOODS

FOR CHILDREN'S EDUCATIONAL TOYS AND GAMES FOR COGNITIVE AND MOTOR SKILLS DEVELOPMENT; BOARD AND CARD GAMES; HOBBY CRAFT KITS COMPRISING RECYCLABLE CRAFT PAPER, CRAFT CARDBOARD, ADHESIVE TAPE, ADHESIVE STICKERS, CRAFT GLUE, STRING, YARN, THREAD, RIBBONS, FABRIC, PAPER AND CARDBOARD TUBES, PAPER AND CARDBOARD BOXES, ELASTIC BANDS, FUNNELS AND TONGUE DEPRESSORS (U.S. CLS. 22, 23, 38 AND 50).

CLASS 35—ADVERTISING AND BUSINESS

FOR RETAIL STORE AND ON-LINE RETAIL STORE SERVICES FEATURING TOYS, HOBBY CRAFT KITS AND GAMES (U.S. CLS. 100, 101 AND 102).

LINDA ORNDORFF, EXAMINING ATTORNEY

SN 85-501,012. L&L WINGS, INC., NEW YORK, NY. FILED 12-21-2011.

WINGS

THE MARK CONSISTS OF STANDARD CHARACTERS WITHOUT CLAIM TO ANY PARTICULAR FONT, STYLE, SIZE, OR COLOR.

OWNER OF U.S. REG. NO. 3,458,144.

CLASS 24—FABRICS

FOR BEACH TOWELS (U.S. CLS. 42 AND 50).
FIRST USE 3-1-1990; IN COMMERCE 3-1-1990.

CLASS 25—CLOTHING

FOR MEN'S, WOMEN'S AND CHILDREN'S CLOTHING, NAMELY, SWEAT PANTS, SWEATSHIRTS, TEE SHIRTS, TANK TOPS, SHIRTS, SHORTS, DRESSES, SKIRTS, PANTS, JACKETS, SWEATERS, SWIMSUITS, SWIMSUIT COVER-UPS, AND PAREOS; BEACH SHOES, NAMELY, SANDALS, THONGS AND SLIPPERS; SOCKS, NAMELY, AQUA SOCKS; HEAD WEAR, NAMELY, SWIM CAPS, HATS, CAPS, HEADBANDS, BANDANAS, AND KERCHIEFS; ACCESSORIES, NAMELY, WRISTBANDS, VESTS, SHAWLS, SCARVES AND BELTS (U.S. CLS. 22 AND 39).

FIRST USE 2-1-1978; IN COMMERCE 2-1-1978.

CLASS 35—ADVERTISING AND BUSINESS

FOR RETAIL STORE SERVICES FEATURING BODY BOARDS, SWIM BOARDS, SWIM FLOATS, BEACH UMBRELLAS, BEACH TOWELS, SCUBA DIVING EQUIPMENT, SWIM GOGGLES, BEACH MATS, COSTUME JEWELRY, SOUVENIRS, GIFT ITEMS, CANDY AND BOTTLED WATER (U.S. CLS. 100, 101 AND 102).

FIRST USE 2-1-1978; IN COMMERCE 2-1-1978.
COLLEEN DOMBROW, EXAMINING ATTORNEY

SN 85-501,442. FUTURE DONTICS, INC., LOS ANGELES, CA.
FILED 12-21-2011.

1-800-DENTIST

OWNER OF U.S. REG. NOS. 1,663,616, 3,371,531 AND OTHERS.

THE COLOR(S) BLUE IS/ARE CLAIMED AS A FEATURE OF THE MARK.

THE MARK CONSISTS OF BLUE STYLIZED LETTERING OF THE MARK "1-800-DENTIST".
SEC. 2(F).

CLASS 35—ADVERTISING AND BUSINESS

FOR PROVIDING ONLINE REFERRALS OF DENTAL PROFESSIONALS AND REFERRALS IN THE FIELD OF DENTISTRY; PROVIDING ONLINE MARKETING SERVICES FOR DENTAL PROFESSIONALS; ADVERTISING AGENCY SERVICES RENDERED TO DENTISTS (U.S. CLS. 100, 101 AND 102).

FIRST USE 2-18-2006; IN COMMERCE 2-18-2006.

CLASS 44—MEDICAL, BEAUTY AND AGRICULTURAL SERVICES

FOR PROVIDING INFORMATION IN THE FIELD OF DENTISTRY VIA AN ELECTRONIC COMMUNICATIONS NETWORK (U.S. CLS. 100 AND 101).

FIRST USE 2-18-2006; IN COMMERCE 2-18-2006.
JIM RINGLE, EXAMINING ATTORNEY

SN 85-501,636. PROJECT ODA, INC., NEW YORK, NY.
FILED 12-21-2011.

viggle

THE MARK CONSISTS OF THE TERM "VIGGLE" IN STYLIZED LETTERS.

CLASS 9—ELECTRICAL AND SCIENTIFIC APPARATUS

FOR SOFTWARE FOR: DISPLAYING ADVERTISING AND MARKETING INFORMATION; ENABLING CONSUMERS TO RECEIVE LOYALTY AND PROMOTIONAL REWARDS AND INCENTIVES; ENABLING CONSUMER PARTICIPATION IN INTERACTIVE LOYALTY AND REWARDS PROGRAMS; ENABLING MEDIA IDENTIFICATION AND RECOGNITION; RECEIVING AND DISPLAYING PROMOTIONS, INTERNET LINKS, LOYALTY REWARDS AND OTHER INFORMATION ON A MOBILE DEVICE; ENABLING USERS TO UPLOAD, DOWNLOAD, POST, SHOW, DISPLAY, TAG, DISCUSS, SHARE OR PROVIDE ELECTRONIC MEDIA OR INFORMATION VIA A COMMUNICATIONS NETWORK; ENABLING USERS TO UPLOAD, DOWNLOAD, DISPLAY, VIEW, RECEIVE, POST AND SHARE DATA AND INFORMATION FOR SOCIAL NETWORKING PURPOSES; ENABLING USERS TO PERFORM ELECTRONIC TRANSACTIONS VIA A MOBILE COMMUNICATION NETWORK; PROVIDING LOYALTY ACCOUNT MANAGEMENT, REWARD REDEMPTION, AND LOCATION-BASED COMMERCE SERVICES; ENABLING TRANSMISSION AND RECEIPT OF ADVERTISING AND PROMOTIONS; SOCIAL NETWORKING; ENABLING CONSUMER INTERACTION WITH VARIOUS FORMS OF MEDIA AND ENTERTAINMENT; ENABLING CONSUMER PARTICIPATION IN INTERACTIVE LOYALTY AND REWARDS PROGRAMS, AND CONSUMER INTERACTION WITHIN A SOCIAL NETWORKING ENVIRONMENT; AND ENABLING ELECTRONIC TRANSACTIONS VIA ONE OR MORE COMMUNICATION NETWORKS, LOYALTY ACCOUNT MANAGEMENT, REWARD REDEMPTION, LOCATION-BASED COMMERCE; ENABLING RECOGNITION OF AUDIO/VISUAL SAMPLES DETECTED IN A USER'S ENVIRONMENT; RECEIVING, AND DISPLAYING PROMOTIONS, INTERNET LINKS, LOYALTY REWARDS AND OTHER INFORMATION IN RESPONSE TO RECOGNITION AND IDENTIFICATION OF AUDIO/VISUAL CONTENT; RECOGNIZING AND IDENTIFYING AUDIO/VISUAL CONTENT (U.S. CLS. 21, 23, 26, 36 AND 38).

CLASS 35—ADVERTISING AND BUSINESS

FOR ADVERTISING, MARKETING AND PROMOTIONAL SERVICES; ADVERTISING, INCLUDING PROMOTION RELATING TO THE SALE OF ARTICLES AND SERVICES FOR THIRD PARTIES BY THE TRANSMISSION OF ADVERTISING MATERIAL AND THE DISSEMINATION OF ADVERTISING MESSAGES VIA DIGITAL COMMUNICATIONS NETWORKS; ADVERTISING, MARKETING AND PROMOTIONAL SERVICES IN THE NATURE OF E-MAIL AND TEXT MESSAGE CAMPAIGNS FOR OTHERS BASED ON INDIVIDUAL CONSUMERS' MEDIA CONSUMPTION AND AUDIO/VISUAL EXPERIENCES; ADVERTISING VIA ELECTRONIC MEDIA AND SPECIFICALLY VIA DIGITAL COMMUNICATIONS NETWORKS; ADVERTISING AND COMMERCIAL INFORMATION SERVICES VIA MOBILE PHONES AND OTHER HANDHELD TELECOMMUNICATIONS DEVICES; PROVIDING ADVERTISING SERVICE TO DISTRIBUTE ADVERTISEMENTS FOR DISPLAY ON MOBILE PHONES AND OTHER HANDHELD TELECOMMUNICATION DEVICES, NAMELY, IN WEBSITES, SOCIAL CONVERSATIONS OVER THE INTERNET, E-MAILS, BLOGS, INSTANT MESSAGES, TEXT MESSAGES, MULTIMEDIA MESSAGES, AND OTHER ELECTRONIC MESSAGES; ADVERTISING AND PROMOTION SERVICES AND RELATED CONSULTING; ADVERTISING SERVICES FOR THE PROMOTION OF GOODS AND SERVICES; ADVERTISING SERVICES, NAMELY, PROVIDING ADVERTISING SPACE ON MOBILE APPLICATIONS ACCESSIBLE VIA DIGITAL COMMUNICATIONS NETWORKS; PROMOTING THE GOODS AND SERVICES OF OTHERS BY DISSEMINATING ADVERTISEMENTS VIA A GLOBAL COMPUTER NETWORK AND VIA DIGITAL COMMUNICATIONS NETWORKS TO WEB BROWSERS AND MOBILE APPLICATIONS; DISSEMINATION OF ADVERTISING FOR OTHERS VIA WIRELESS TELECOMMUNICATIONS NETWORKS; ELECTRONIC COMMERCE SERVICES, NAMELY, PROVIDING INFORMATION ABOUT PRODUCTS AND SERVICES OF OTHERS VIA DIGITAL COMMUNICATIONS NETWORKS FOR ADVERTISING AND SALES PURPOSES; MARKETING, ADVERTISING, AND PROMOTING THE RETAIL

GOODS AND SERVICES OF OTHERS TO WIRELESS ELECTRONIC DEVICES; CUSTOMER LOYALTY SERVICES AND CUSTOMER CLUB SERVICES, FOR COMMERCIAL, PROMOTIONAL AND/OR ADVERTISING PURPOSES; PROVIDING INCENTIVE AWARD PROGRAMS FOR CUSTOMERS BY PROVIDING REWARDS AND PROMOTIONS FOR THE PURPOSE OF PROMOTING AND REWARDING LOYALTY; PROVIDING INCENTIVE AWARD PROGRAMS FOR CUSTOMERS THROUGH THE ISSUANCE AND PROCESSING OF COUPONS, IN RESPONSE TO THE INDIVIDUAL CONSUMERS' MEDIA CONSUMPTION AND AUDIO/VISUAL EXPERIENCES; CONSUMER LOYALTY SERVICES FOR COMMERCIAL, PROMOTIONAL, AND/OR ADVERTISING PURPOSES, NAMELY, ADMINISTRATION OF LOYALTY AND REWARDS PROGRAMS THAT ALLOWS CONSUMERS TO REDEEM POINTS, REWARDS AND OTHER PROMOTIONAL OFFERS IN RESPONSE TO THE INDIVIDUAL CONSUMERS' MEDIA CONSUMPTION AND AUDIO/VISUAL EXPERIENCES (U.S. CLS. 100, 101 AND 102).

CLASS 38—COMMUNICATION

FOR BROADCASTING SERVICES, NAMELY, TRANSMISSION OF INFORMATION VIA DIGITAL COMMUNICATIONS NETWORKS; DELIVERY OF MESSAGES BY ELECTRONIC TRANSMISSION; ELECTRONIC TRANSMISSION OF MESSAGES AND DATA; TRANSMISSION OF INFORMATION BY DIGITAL COMMUNICATIONS NETWORKS; TRANSMISSION OF MESSAGES; TRANSMISSION OF MESSAGES OVER ELECTRONIC MEDIA; TRANSMISSION OF SMS MESSAGES; ELECTRONIC MESSAGING; DELIVERY OF INFORMATION VIA TELEPHONE OR MOBILE PHONE; DELIVERY OF AUDIO/VISUAL CONTENT VIA TELEPHONE OR MOBILE PHONE; TRANSMISSION TO CONSUMERS OF INFORMATION, INTERNET LINKS, AND ELECTRONIC DATA IN RESPONSE TO RECOGNITION AND IDENTIFICATION OF AUDIO/VISUAL CONTENT; ELECTRONIC TRANSMISSION TO CONSUMERS OF INFORMATION, SALES OFFERS, PROMOTIONS, REWARDS AND/OR COMPETITIONS IN RESPONSE TO RECOGNITION AND IDENTIFICATION OF AUDIO/VISUAL CONTENT; ELECTRONIC TRANSMISSION OF STREAMED AND DOWNLOADABLE AUDIO AND VIDEO FILES, AND TEXT FILES, VIA COMMUNICATIONS NETWORKS (U.S. CLS. 100, 101 AND 104).

CLASS 42—SCIENTIFIC AND COMPUTER SERVICES

FOR DEVELOPING AND MANAGING APPLICATION SOFTWARE AND DATABASES FOR DELIVERY OF CONTENT PROVIDED BY BRAND-OWNERS AND BUSINESSES; COMPUTER SERVICES, NAMELY, PROVIDING ONLINE NONDOWNLOADABLE SOFTWARE FOR DELIVERY OF MULTI-MEDIA CONTENT TO INDIVIDUAL CONSUMERS IN RESPONSE TO SUCH INDIVIDUAL CONSUMERS' MEDIA CONSUMPTION AND AUDIO/VISUAL EXPERIENCES; COMPUTER SERVICES, NAMELY, HOSTING, MANAGING, DEVELOPING, ANALYZING, AND MAINTAINING SOFTWARE APPLICATIONS, SOFTWARE, AND WEB SITES FOR THE PURPOSE OF ADVERTISING, MARKETING AND PROMOTING THE GOODS AND SERVICES OF OTHERS; COMPUTER SERVICES, NAMELY, MAINTAINING SOFTWARE APPLICATIONS, SOFTWARE AND WEB SITES FOR THE PURPOSE OF ADVERTISING, MARKETING AND PROMOTING THE GOODS AND SERVICES OF OTHERS, NAMELY, OPERATION OF A COMPUTER NETWORK INFRASTRUCTURE FOR DISSEMINATION OF ADVERTISING FOR OTHERS VIA WIRELESS TELECOMMUNICATIONS NETWORKS; COMPUTER SERVICE, NAMELY, ACTING AS AN APPLICATION SERVICE PROVIDER IN THE FIELD OF INFORMATION AND DATABASE MANAGEMENT TO HOST COMPUTER APPLICATION SOFTWARE FOR THE PURPOSE OF DELIVERING MULTI-MEDIA CONTENT TO INDIVIDUAL CONSUMERS IN RESPONSE TO SUCH INDIVIDUAL CONSUMERS' MEDIA CONSUMPTION AND AUDIO/VISUAL EXPERIENCES (U.S. CLS. 100 AND 101).

TARAH HARDY, EXAMINING ATTORNEY

SN 85-501.638. PROJECT ODA, INC., NEW YORK, NY.
FILED 12-21-2011.



THE MARK CONSISTS OF A STYLIZED DESIGN OF A BUBBLE SHAPED LETTER "V" WITH THE TERM "VIGGLE" IN STYLIZED LETTERS BELOW IT.

CLASS 9—ELECTRICAL AND SCIENTIFIC APPARATUS

FOR SOFTWARE FOR: DISPLAYING ADVERTISING AND MARKETING INFORMATION; ENABLING CONSUMERS TO RECEIVE LOYALTY AND PROMOTIONAL REWARDS AND INCENTIVES; ENABLING CONSUMER PARTICIPATION IN INTERACTIVE LOYALTY AND REWARDS PROGRAMS; ENABLING MEDIA IDENTIFICATION AND RECOGNITION; RECEIVING AND DISPLAYING PROMOTIONS, INTERNET LINKS, LOYALTY REWARDS AND OTHER INFORMATION ON A MOBILE DEVICE; ENABLING USERS TO UPLOAD, DOWNLOAD, POST, SHOW, DISPLAY, TAG, DISCUSS, SHARE OR PROVIDE ELECTRONIC MEDIA OR INFORMATION VIA A COMMUNICATIONS NETWORK; ENABLING USERS TO UPLOAD, DOWNLOAD, DISPLAY, VIEW, RECEIVE, POST AND SHARE DATA AND INFORMATION FOR SOCIAL NETWORKING PURPOSES; ENABLING USERS TO PERFORM ELECTRONIC TRANSACTIONS VIA A MOBILE COMMUNICATION NETWORK; PROVIDING LOYALTY ACCOUNT MANAGEMENT, REWARD REDEMPTION, AND LOCATION-BASED COMMERCE SERVICES; ENABLING TRANSMISSION AND RECEIPT OF ADVERTISING AND PROMOTIONS; SOCIAL NETWORKING; ENABLING CONSUMER INTERACTION WITH VARIOUS FORMS OF MEDIA AND ENTERTAINMENT; ENABLING CONSUMER PARTICIPATION IN INTERACTIVE LOYALTY AND REWARDS PROGRAMS, AND CONSUMER INTERACTION WITHIN A SOCIAL NETWORKING ENVIRONMENT; AND ENABLING ELECTRONIC TRANSACTIONS VIA ONE OR MORE COMMUNICATION NETWORKS, LOYALTY ACCOUNT MANAGEMENT, REWARD REDEMPTION, LOCATION-BASED COMMERCE; ENABLING RECOGNITION OF AUDIO/VISUAL SAMPLES DETECTED IN A USER'S ENVIRONMENT; RECEIVING, AND DISPLAYING PROMOTIONS, INTERNET LINKS, LOYALTY REWARDS AND OTHER INFORMATION IN RESPONSE TO RECOGNITION AND IDENTIFICATION OF AUDIO/VISUAL CONTENT; RECOGNIZING AND IDENTIFYING AUDIO/VISUAL CONTENT (U.S. CLS. 21, 23, 26, 36 AND 38).

CLASS 35—ADVERTISING AND BUSINESS

FOR ADVERTISING, MARKETING AND PROMOTIONAL SERVICES; ADVERTISING, INCLUDING PROMOTION RELATING TO THE SALE OF ARTICLES AND SERVICES FOR THIRD PARTIES BY THE TRANSMISSION OF ADVERTISING MATERIAL AND THE DISSEMINATION OF ADVERTISING MESSAGES VIA DIGITAL COMMUNICATIONS NETWORKS; ADVERTISING, MARKETING AND PROMOTIONAL SERVICES IN THE NATURE OF E-MAIL AND TEXT MESSAGE CAMPAIGNS FOR OTHERS BASED ON INDIVIDUAL CONSUMERS' MEDIA CONSUMPTION AND AUDIO/VISUAL EXPERIENCES; ADVERTISING VIA ELECTRONIC MEDIA AND SPECIFICALLY VIA DIGITAL COMMUNICATIONS NETWORKS; ADVERTISING AND COMMERCIAL INFORMATION SERVICES VIA MOBILE PHONES AND OTHER HANDHELD TELECOMMUNICATIONS DEVICES; PROVIDING ADVERTISING SER-

VICE TO DISTRIBUTE ADVERTISEMENTS FOR DISPLAY ON MOBILE PHONES AND OTHER HANDHELD TELECOMMUNICATION DEVICES, NAMELY, IN WEBSITES, SOCIAL CONVERSATIONS OVER THE INTERNET, E-MAILS, BLOGS, INSTANT MESSAGES, TEXT MESSAGES, MULTIMEDIA MESSAGES, AND OTHER ELECTRONIC MESSAGES; ADVERTISING AND PROMOTION SERVICES AND RELATED CONSULTING; ADVERTISING SERVICES FOR THE PROMOTION OF GOODS AND SERVICES; ADVERTISING SERVICES, NAMELY, PROVIDING ADVERTISING SPACE ON MOBILE APPLICATIONS ACCESSIBLE VIA DIGITAL COMMUNICATIONS NETWORKS; PROMOTING THE GOODS AND SERVICES OF OTHERS BY DISSEMINATING ADVERTISEMENTS VIA A GLOBAL COMPUTER NETWORK AND VIA DIGITAL COMMUNICATIONS NETWORKS TO WEB BROWSERS AND MOBILE APPLICATIONS; DISSEMINATION OF ADVERTISING FOR OTHERS VIA WIRELESS TELECOMMUNICATIONS NETWORKS; ELECTRONIC COMMERCE SERVICES, NAMELY, PROVIDING INFORMATION ABOUT PRODUCTS AND SERVICES OF OTHERS VIA DIGITAL COMMUNICATIONS NETWORKS FOR ADVERTISING AND SALES PURPOSES; MARKETING, ADVERTISING, AND PROMOTING THE RETAIL GOODS AND SERVICES OF OTHERS TO WIRELESS ELECTRONIC DEVICES; CUSTOMER LOYALTY SERVICES AND CUSTOMER CLUB SERVICES, FOR COMMERCIAL, PROMOTIONAL AND/OR ADVERTISING PURPOSES; PROVIDING INCENTIVE AWARD PROGRAMS FOR CUSTOMERS BY PROVIDING REWARDS AND PROMOTIONS FOR THE PURPOSE OF PROMOTING AND REWARDING LOYALTY; PROVIDING INCENTIVE AWARD PROGRAMS FOR CUSTOMERS THROUGH THE ISSUANCE AND PROCESSING OF COUPONS, IN RESPONSE TO THE INDIVIDUAL CONSUMERS' MEDIA CONSUMPTION AND AUDIO/VISUAL EXPERIENCES; CONSUMER LOYALTY SERVICES FOR COMMERCIAL, PROMOTIONAL, AND/OR ADVERTISING PURPOSES, NAMELY, ADMINISTRATION OF LOYALTY AND REWARDS PROGRAMS THAT ALLOWS CONSUMERS TO REDEEM POINTS, REWARDS AND OTHER PROMOTIONAL OFFERS IN RESPONSE TO THE INDIVIDUAL CONSUMERS' MEDIA CONSUMPTION AND AUDIO/VISUAL EXPERIENCES (U.S. CLS. 100, 101 AND 102).

CLASS 42—SCIENTIFIC AND COMPUTER SERVICES

FOR DEVELOPING AND MANAGING APPLICATION SOFTWARE AND DATABASES FOR DELIVERY OF CONTENT PROVIDED BY BRAND-OWNERS AND BUSINESSES; COMPUTER SERVICES, NAMELY, PROVIDING ONLINE NONDOWNLOADABLE SOFTWARE FOR DELIVERY OF MULTI-MEDIA CONTENT TO INDIVIDUAL CONSUMERS IN RESPONSE TO SUCH INDIVIDUAL CONSUMERS' MEDIA CONSUMPTION AND AUDIO/VISUAL EXPERIENCES; COMPUTER SERVICES, NAMELY, HOSTING, MANAGING, DEVELOPING, ANALYZING, AND MAINTAINING SOFTWARE APPLICATIONS, SOFTWARE, AND WEB SITES FOR THE PURPOSE OF ADVERTISING, MARKETING AND PROMOTING THE GOODS AND SERVICES OF OTHERS; COMPUTER SERVICES, NAMELY, MAINTAINING SOFTWARE APPLICATIONS, SOFTWARE AND WEB SITES FOR THE PURPOSE OF ADVERTISING, MARKETING AND PROMOTING THE GOODS AND SERVICES OF OTHERS, NAMELY, OPERATION OF A COMPUTER NETWORK INFRASTRUCTURE FOR DISSEMINATION OF ADVERTISING FOR OTHERS VIA WIRELESS TELECOMMUNICATIONS NETWORKS; COMPUTER SERVICE, NAMELY, ACTING AS AN APPLICATION SERVICE PROVIDER IN THE FIELD OF INFORMATION AND DATABASE MANAGEMENT TO HOST COMPUTER APPLICATION SOFTWARE FOR THE PURPOSE OF DELIVERING MULTI-MEDIA CONTENT TO INDIVIDUAL CONSUMERS IN RESPONSE TO SUCH INDIVIDUAL CONSUMERS' MEDIA CONSUMPTION AND AUDIO/VISUAL EXPERIENCES (U.S. CLS. 100 AND 101).

TARAH HARDY, EXAMINING ATTORNEY

SN 85-501,774. THE W.E. BASSETT COMPANY, SHELTON, CT. FILED 12-22-2011.

PEDX

CLASS 38—COMMUNICATION

FOR BROADCASTING SERVICES, NAMELY, TRANSMISSION OF INFORMATION VIA DIGITAL COMMUNICATIONS NETWORKS; DELIVERY OF MESSAGES BY ELECTRONIC TRANSMISSION; ELECTRONIC TRANSMISSION OF MESSAGES AND DATA; TRANSMISSION OF INFORMATION BY DIGITAL COMMUNICATIONS NETWORKS; TRANSMISSION OF MESSAGES; TRANSMISSION OF MESSAGES OVER ELECTRONIC MEDIA; TRANSMISSION OF SMS MESSAGES; ELECTRONIC MESSAGING; DELIVERY OF INFORMATION VIA TELEPHONE OR MOBILE PHONE; DELIVERY OF AUDIO/VISUAL CONTENT VIA TELEPHONE OR MOBILE PHONE; TRANSMISSION TO CONSUMERS OF INFORMATION, INTERNET LINKS, AND ELECTRONIC DATA IN RESPONSE TO RECOGNITION AND IDENTIFICATION OF AUDIO/VISUAL CONTENT; ELECTRONIC TRANSMISSION TO CONSUMERS OF INFORMATION, SALES OFFERS, PROMOTIONS, REWARDS AND/OR COMPETITIONS IN RESPONSE TO RECOGNITION AND IDENTIFICATION OF AUDIO/VISUAL CONTENT; ELECTRONIC TRANSMISSION OF STREAMED AND DOWNLOADABLE AUDIO AND VIDEO FILES, AND TEXT FILES, VIA COMMUNICATIONS NETWORKS (U.S. CLS. 100, 101 AND 104).

THE MARK CONSISTS OF STANDARD CHARACTERS WITHOUT CLAIM TO ANY PARTICULAR FONT, STYLE, SIZE, OR COLOR.

OWNER OF U.S. REG. NO. 3,228,478.

CLASS 3—COSMETICS AND CLEANING PREPARATIONS

FOR PEDICURE IMPLEMENTS, NAMELY, FOOT FILES IN THE NATURE OF FOOT SMOOTHING STONES (U.S. CLS. 1, 4, 6, 50, 51 AND 52).

FIRST USE 12-12-2005; IN COMMERCE 12-12-2005.

CLASS 8—HAND TOOLS

FOR PEDICURE IMPLEMENTS, NAMELY, NAIL CLIPPERS, NAIL NIPPERS, NAIL SCISSORS, NAIL FILES, AND FOOT SMOOTHERS IN THE NATURE OF FOOT FILES AND FOOT SCRAPERS (U.S. CLS. 23, 28 AND 44).

FIRST USE 12-12-2005; IN COMMERCE 12-12-2005.
ELLEN PERKINS, EXAMINING ATTORNEY

SN 85-501,962. MOTION LACROSSE, LLC, WAYNE, PA.
FILED 12-22-2011.

MOTION LACROSSE

NO CLAIM IS MADE TO THE EXCLUSIVE RIGHT TO USE "LACROSSE", APART FROM THE MARK AS SHOWN. THE COLOR(S) PURPLE AND BLACK IS/ARE CLAIMED AS A FEATURE OF THE MARK.

THE MARK CONSISTS OF THE WORDS "MOTION LACROSSE" STYLIZED AND IN PURPLE WITH A BLACK LINE UNDERNEATH.

CLASS 25—CLOTHING

FOR CLOTHING, NAMELY, SHIRTS, T-SHIRTS, TANK TOPS, SKIRTS, SKORTS, ATHLETIC PINNIES IN THE NATURE OF SCRIMMAGE VESTS FOR USE IN SPORTS, SWEAT SHIRTS, JACKET, SWEAT PANTS, SHORTS, COMPRESSION SHORTS, CAPS, HATS, VISORS, SOCKS AND SWEAT BANDS (U.S. CLS. 22 AND 39).

FIRST USE 12-17-2010; IN COMMERCE 12-17-2010.

CLASS 41—EDUCATION AND ENTERTAINMENT

FOR AMATEUR YOUTH SPORTS SERVICES, NAMELY, ORGANIZING AND PROVIDING YOUTH SPORTS ACTIVITIES; LACROSSE EDUCATION AND ENTERTAINMENT SERVICES, NAMELY, THE OPERATION OF LACROSSE CAMPS AND CLINICS AND TEAMS AND THE ORGANIZATION OF LACROSSE COMPETITIONS (U.S. CLS. 100, 101 AND 107).

FIRST USE 12-17-2010; IN COMMERCE 12-17-2010.

ALAIN LAPTEK, EXAMINING ATTORNEY

SN 85-502,312. BRYN MAWR COMMUNICATIONS II, LLC,
WAYNE, PA. FILED 12-22-2011.

CARDIAC INTERVENTIONS TODAY

THE MARK CONSISTS OF STANDARD CHARACTERS WITHOUT CLAIM TO ANY PARTICULAR FONT, STYLE, SIZE, OR COLOR.

NO CLAIM IS MADE TO THE EXCLUSIVE RIGHT TO USE "CARDIAC INTERVENTIONS", APART FROM THE MARK AS SHOWN.

CLASS 9—ELECTRICAL AND SCIENTIFIC APPARATUS

FOR DOWNLOADABLE ELECTRONIC PUBLICATIONS, NAMELY, MEDICAL JOURNALS AND MAGAZINES IN THE FIELD OF CARDIOLOGY (U.S. CLS. 21, 23, 26, 36 AND 38).

FIRST USE 3-31-2007; IN COMMERCE 3-31-2007.

CLASS 16—PAPER GOODS AND PRINTED MATTER

FOR MEDICAL JOURNALS AND MAGAZINES IN THE FIELD OF CARDIOLOGY (U.S. CLS. 2, 5, 22, 23, 29, 37, 38 AND 50).

FIRST USE 3-31-2007; IN COMMERCE 3-31-2007.

CLASS 44—MEDICAL, BEAUTY AND AGRICULTURAL SERVICES

FOR ONLINE WEBSITE FEATURING INFORMATION IN THE FIELD OF MEDICAL THERAPIES AND PROCEDURES (U.S. CLS. 100 AND 101).

FIRST USE 3-31-2007; IN COMMERCE 3-31-2007.

ALAIN LAPTEK, EXAMINING ATTORNEY

SN 85-502,475. PULSAR INFORMATICS, INC., PHILADELPHIA, PA. FILED 12-22-2011.

JOGGLE

THE MARK CONSISTS OF STANDARD CHARACTERS WITHOUT CLAIM TO ANY PARTICULAR FONT, STYLE, SIZE, OR COLOR.

CLASS 41—EDUCATION AND ENTERTAINMENT

FOR ENTERTAINMENT SERVICES FEATURING A SERIES OF COGNITIVE AND PSYCHOLOGICAL TESTS, TASKS, AND ASSESSMENTS IN THE FIELD OF NEUROBEHAVIORAL SCIENCE, DELIVERED BY COMPUTER BY MEANS OF INTERNET-BASED PORTALS, PERSONAL COMPUTERS, AND MOBILE DEVICES, ASSOCIATED WITH QUANTIFYING HUMAN BRAIN PERFORMANCE (U.S. CLS. 100, 101 AND 107).

CLASS 44—MEDICAL, BEAUTY AND AGRICULTURAL SERVICES

FOR A SERIES OF COGNITIVE AND PSYCHOLOGICAL TESTS, TASKS, AND ASSESSMENTS IN THE FIELD OF NEUROBEHAVIORAL SCIENCE, DELIVERED BY MEANS OF COMPUTER, INTERNET WEB-BASED PORTALS, PERSONAL COMPUTERS, AND MOBILE DEVICES, ASSOCIATED WITH QUANTIFYING HUMAN BRAIN PERFORMANCE TO FOSTER BRAIN FITNESS, TO ASSIST IN MEDICAL DIAGNOSIS AND MONITORING, AND TO EDUCATE INDIVIDUALS REGARDING COGNITIVE HEALTH ASPECTS RELATED TO BRAIN FUNCTION; EDUCATIONAL HEALTH SERVICES FEATURING A SERIES OF COGNITIVE AND PSYCHOLOGICAL TESTS, TASKS, AND ASSESSMENTS IN THE FIELD OF NEUROBEHAVIORAL SCIENCE, DELIVERED BY MEANS OF COMPUTER, INTERNET WEB-BASED PORTALS, PERSONAL COMPUTERS, AND MOBILE DEVICES, ASSOCIATED WITH QUANTIFYING HUMAN BRAIN PERFORMANCE TO FOSTER BRAIN FITNESS (U.S. CLS. 100 AND 101).

THOMAS MANOR, EXAMINING ATTORNEY

SN 85-502,545. CROSS MEDIAPRODUCTIONS, LLC, NEW YORK, NY. FILED 12-22-2011.

TV MEDIA INSIGHTS

THE MARK CONSISTS OF STANDARD CHARACTERS WITHOUT CLAIM TO ANY PARTICULAR FONT, STYLE, SIZE, OR COLOR.

NO CLAIM IS MADE TO THE EXCLUSIVE RIGHT TO USE "TV MEDIA", APART FROM THE MARK AS SHOWN.

CLASS 35—ADVERTISING AND BUSINESS

FOR PROVIDING AN ON-LINE SEARCHABLE DATABASE FEATURING CLASSIFIED AD LISTINGS AND EMPLOYMENT OPPORTUNITIES (U.S. CLS. 100, 101 AND 102).

FIRST USE 9-6-2011; IN COMMERCE 9-6-2011.

CLASS 38—COMMUNICATION

FOR PROVIDING ON-LINE FORUMS FOR TRANSMISSION OF MESSAGES AMONG COMPUTER USERS CONCERNING TELEVISION AND MEDIA (U.S. CLS. 100, 101 AND 104).

FIRST USE 9-6-2011; IN COMMERCE 9-6-2011.

CLASS 41—EDUCATION AND ENTERTAINMENT

FOR PROVIDING INFORMATION, NEWS AND COMMENTARY IN THE FIELD OF TELEVISION AND MEDIA; PROVIDING ON-LINE INFORMATION, NEWS AND COMMENTARY IN THE FIELD OF TELEVISION AND MEDIA; ON-LINE ELECTRONIC NEWSLETTERS DELIVERED BY E-MAIL IN THE FIELD OF TELEVISION AND MEDIA; ON-LINE JOURNALS, NAMELY, BLOGS FEATURING TELEVISION AND MEDIA INFORMATION; ENTERTAINMENT SERVICES, NAMELY, PROVIDING PODCASTS IN THE FIELD OF TELEVISION AND MEDIA; PROVIDING A WEBSITE FEATURING NON-DOWNLOADABLE VIDEOS IN THE FIELD OF TELEVISION AND MEDIA (U.S. CLS. 100, 101 AND 107).

FIRST USE 9-6-2011; IN COMMERCE 9-6-2011.

CHERYL CLAYTON, EXAMINING ATTORNEY

SN 85-502,561, 10,000 DEGREES, FORMERLY MARIN EDUCATION FUND, SAN RAFAEL, CA. FILED 12-22-2011.

10,000 Degrees

THE MARK CONSISTS OF STANDARD CHARACTERS WITHOUT CLAIM TO ANY PARTICULAR FONT, STYLE, SIZE, OR COLOR.

NO CLAIM IS MADE TO THE EXCLUSIVE RIGHT TO USE "DEGREES" IN INTERNATIONAL CLASS 36, APART FROM THE MARK AS SHOWN.

CLASS 21—HOUSEWARES AND GLASS

FOR ALUMINUM WATER BOTTLES SOLD EMPTY; COFFEE MUGS; SPORTS BOTTLES SOLD EMPTY (U.S. CLS. 2, 13, 23, 29, 30, 33, 40 AND 50).

FIRST USE 4-28-2010; IN COMMERCE 4-28-2010.

CLASS 25—CLOTHING

FOR HOODED SWEAT SHIRTS; SHORT-SLEEVED OR LONG-SLEEVED T-SHIRTS; T-SHIRTS (U.S. CLS. 22 AND 39).

FIRST USE 4-28-2010; IN COMMERCE 4-28-2010.

CLASS 36—INSURANCE AND FINANCIAL

FOR CHARITABLE FOUNDATION SERVICES, NAMELY, PROVIDING FUNDRAISING ACTIVITIES, FUNDING, SCHOLARSHIPS AND/OR FINANCIAL ASSISTANCE FOR STUDENTS IN NEED, TO SUCCESSFULLY ACCESS, PURSUE AND COMPLETE HIGHER EDUCATION (U.S. CLS. 100, 101 AND 102).

FIRST USE 4-28-2010; IN COMMERCE 4-28-2010.

JEAN IM, EXAMINING ATTORNEY

SN 85-502,951, PAMPADOUR LLC, GREAT NECK, NY, NY. FILED 12-23-2011.

pamp it

THE MARK CONSISTS OF STANDARD CHARACTERS WITHOUT CLAIM TO ANY PARTICULAR FONT, STYLE, SIZE, OR COLOR.

CLASS 9—ELECTRICAL AND SCIENTIFIC APPARATUS

FOR COMPUTER SOFTWARE FOR THE COLLECTION, EDITING, ORGANIZING, MODIFYING, BOOK MARKING, TRANSMISSION, STORAGE AND SHARING OF DATA AND INFORMATION (U.S. CLS. 21, 23, 26, 36 AND 38).

CLASS 35—ADVERTISING AND BUSINESS

FOR ADVERTISING AND MARKETING SERVICES PROVIDED BY MEANS OF INDIRECT METHODS OF MARKETING COMMUNICATIONS, NAMELY, SOCIAL MEDIA, SEARCH ENGINE MARKETING, INQUIRY MARKETING, INTERNET MARKETING, MOBILE MARKETING, BLOGGING AND OTHER FORMS OF PASSIVE, SHARABLE OR VIRAL COMMUNICATIONS CHANNELS; OPERATING AN ON-LINE SHOPPING SITE IN THE FIELD OF HEALTH AND BEAUTY AIDS FEATURING ONLINE MERCHANDISE DISPLAYS OF INDIVIDUAL AND COMBINATIONS OF HEALTH AND BEAUTY AID PRODUCTS, PROMOTING THE GOODS AND SERVICES OF OTHERS BY MEANS OF OPERATING AN ONLINE SHOPPING WEBSITE WITH LINKS TO THE RETAIL WEBSITES OF OTHERS; PROVISION OF A WEBSITE FEATURING COMMERCIAL INFORMATION ON SHOPPING (U.S. CLS. 100, 101 AND 102).

CLASS 38—COMMUNICATION

FOR TELECOMMUNICATION SERVICES, NAMELY, TRANSMISSION OF VOICE, DATA, GRAPHICS, IMAGES, AUDIO AND VIDEO BY MEANS OF TELECOMMUNICATIONS NETWORKS, WIRELESS COMMUNICATION NETWORKS, AND THE INTERNET (U.S. CLS. 100, 101 AND 104).

CLASS 41—EDUCATION AND ENTERTAINMENT

FOR ON-LINE JOURNALS, NAMELY, BLOGS FEATURING USER AND NON-USER DEFINED CONTENT IN THE FIELD OF HEALTH AND BEAUTY AIDS (U.S. CLS. 100, 101 AND 107).

CLASS 42—SCIENTIFIC AND COMPUTER SERVICES

FOR COMPUTER SERVICES, NAMELY, PROVIDING CUSTOMIZED WEB PAGES FEATURING USER-DEFINED INFORMATION; PROVIDING A WEB SITE FEATURING TECHNOLOGY THAT ENABLES INTERNET USERS TO CREATE, BOOKMARK, ANNOTATE, AND PUBLICLY SHARE DATA; PROVIDING A WEBSITE THAT GIVES USERS THE ABILITY TO CREATE CUSTOMIZED WEB PAGES FEATURING USER-DEFINED INFORMATION (U.S. CLS. 100 AND 101).

CLASS 45—PERSONAL AND LEGAL SERVICES

FOR INTERNET-BASED SOCIAL NETWORKING SERVICES (U.S. CLS. 100 AND 101).

LINDA M. KING, EXAMINING ATTORNEY

SN 85-502,973. PAMPADOUR LLC, GREAT NECK, NY.
FILED 12-23-2011.

SN 85-502,991. ROY HAKIMIAN, GREAT NECK, NY. FILED
12-23-2011.

adour it

THE MARK CONSISTS OF STANDARD CHARACTERS WITHOUT CLAIM TO ANY PARTICULAR FONT, STYLE, SIZE, OR COLOR.

CLASS 9—ELECTRICAL AND SCIENTIFIC APPARATUS

FOR COMPUTER SOFTWARE FOR THE COLLECTION, EDITING, ORGANIZING, MODIFYING, BOOK MARKING, TRANSMISSION, STORAGE AND SHARING OF DATA AND INFORMATION (U.S. CLS. 21, 23, 26, 36 AND 38).

CLASS 35—ADVERTISING AND BUSINESS

FOR ADVERTISING AND MARKETING SERVICES PROVIDED BY MEANS OF INDIRECT METHODS OF MARKETING COMMUNICATIONS, NAMELY, SOCIAL MEDIA, SEARCH ENGINE MARKETING, INQUIRY MARKETING, INTERNET MARKETING, MOBILE MARKETING, BLOGGING AND OTHER FORMS OF PASSIVE, SHARABLE OR VIRAL COMMUNICATIONS CHANNELS; OPERATING AN ON-LINE SHOPPING SITE IN THE FIELD OF HEALTH AND BEAUTY AIDS FEATURING ONLINE MERCHANDISE DISPLAYS OF INDIVIDUAL AND COMBINATIONS OF HEALTH AND BEAUTY AID PRODUCTS, PROMOTING THE GOODS AND SERVICES OF OTHERS BY MEANS OF OPERATING AN ONLINE SHOPPING MALL WITH LINKS TO THE RETAIL WEBSITES OF OTHERS; PROVISION OF A WEBSITE FEATURING COMMERCIAL INFORMATION ON SHOPPING (U.S. CLS. 100, 101 AND 102).

CLASS 38—COMMUNICATION

FOR TELECOMMUNICATION SERVICES, NAMELY, TRANSMISSION OF VOICE, DATA, GRAPHICS, IMAGES, AUDIO AND VIDEO BY MEANS OF TELECOMMUNICATIONS NETWORKS, WIRELESS COMMUNICATION NETWORKS, AND THE INTERNET (U.S. CLS. 100, 101 AND 104).

CLASS 41—EDUCATION AND ENTERTAINMENT

FOR ON-LINE JOURNALS, NAMELY, BLOGS FEATURING USER AND NON-USER DEFINED CONTENT IN THE FIELD OF HEALTH AND BEAUTY AIDS (U.S. CLS. 100, 101 AND 107).

CLASS 42—SCIENTIFIC AND COMPUTER SERVICES

FOR COMPUTER SERVICES, NAMELY, PROVIDING CUSTOMIZED WEB PAGES FEATURING USER-DEFINED INFORMATION; PROVIDING A WEB SITE FEATURING TECHNOLOGY THAT ENABLES INTERNET USERS TO CREATE, BOOKMARK, ANNOTATE, AND PUBLICLY SHARE DATA (U.S. CLS. 100 AND 101).

CLASS 45—PERSONAL AND LEGAL SERVICES

FOR INTERNET-BASED SOCIAL NETWORKING SERVICES (U.S. CLS. 100 AND 101).
LINDA M. KING, EXAMINING ATTORNEY

pampadour

THE MARK CONSISTS OF STANDARD CHARACTERS WITHOUT CLAIM TO ANY PARTICULAR FONT, STYLE, SIZE, OR COLOR.

CLASS 42—SCIENTIFIC AND COMPUTER SERVICES

FOR PROVIDING A WEB SITE FEATURING TECHNOLOGY THAT ENABLES INTERNET USERS TO CREATE, BOOKMARK, ANNOTATE, AND PUBLICLY SHARE DATA (U.S. CLS. 100 AND 101).

CLASS 45—PERSONAL AND LEGAL SERVICES

FOR INTERNET-BASED SOCIAL NETWORKING SERVICES (U.S. CLS. 100 AND 101).
LINDA M. KING, EXAMINING ATTORNEY

SN 85-503,107. PAMPADOUR LLC, GREAT NECK, NY.
FILED 12-23-2011.

pamp

THE MARK CONSISTS OF STANDARD CHARACTERS WITHOUT CLAIM TO ANY PARTICULAR FONT, STYLE, SIZE, OR COLOR.

CLASS 9—ELECTRICAL AND SCIENTIFIC APPARATUS

FOR COMPUTER SOFTWARE FOR THE COLLECTION, EDITING, ORGANIZING, MODIFYING, BOOK MARKING, TRANSMISSION, STORAGE AND SHARING OF DATA AND INFORMATION (U.S. CLS. 21, 23, 26, 36 AND 38).

CLASS 35—ADVERTISING AND BUSINESS

FOR ADVERTISING AND MARKETING SERVICES PROVIDED BY MEANS OF INDIRECT METHODS OF MARKETING COMMUNICATIONS, NAMELY, SOCIAL MEDIA, SEARCH ENGINE MARKETING, INQUIRY MARKETING, INTERNET MARKETING, MOBILE MARKETING, BLOGGING AND OTHER FORMS OF PASSIVE, SHARABLE OR VIRAL COMMUNICATIONS CHANNELS; OPERATING AN ON-LINE SHOPPING SITE IN THE FIELD OF HEALTH AND BEAUTY AIDS FEATURING ONLINE MERCHANDISE DISPLAYS OF INDIVIDUAL AND COMBINATIONS OF HEALTH AND BEAUTY AID PRODUCTS, PROMOTING THE GOODS AND SERVICES OF OTHERS BY MEANS OF OPERATING AN ONLINE SHOPPING WEBSITE WITH LINKS TO THE RETAIL WEBSITES OF OTHERS; PROVISION OF A WEBSITE FEATURING COMMERCIAL INFORMATION ON SHOPPING (U.S. CLS. 100, 101 AND 102).

CLASS 38—COMMUNICATION

FOR TELECOMMUNICATION SERVICES, NAMELY, TRANSMISSION OF VOICE, DATA, GRAPHICS, IMAGES, AUDIO AND VIDEO BY MEANS OF TELECOMMUNICATIONS NETWORKS, WIRELESS COMMUNICATION NETWORKS, AND THE INTERNET (U.S. CLS. 100, 101 AND 104).

CLASS 41—EDUCATION AND ENTERTAINMENT

FOR ON-LINE JOURNALS, NAMELY, BLOGS FEATURING USER AND NON-USER DEFINED CONTENT IN THE FIELD OF HEALTH AND BEAUTY AIDS (U.S. CLS. 100, 101 AND 107).

CLASS 42—SCIENTIFIC AND COMPUTER SERVICES

FOR COMPUTER SERVICES, NAMELY, PROVIDING CUSTOMIZED WEB PAGES FEATURING USER-DEFINED INFORMATION; PROVIDING A WEB SITE FEATURING TECHNOLOGY THAT ENABLES INTERNET USERS TO CREATE, BOOKMARK, ANNOTATE, AND PUBLICLY SHARE DATA; PROVIDING A WEBSITE THAT GIVES USERS THE ABILITY TO CREATE CUSTOMIZED WEB PAGES FEATURING USER-DEFINED INFORMATION (U.S. CLS. 100 AND 101).

CLASS 45—PERSONAL AND LEGAL SERVICES

FOR INTERNET-BASED SOCIAL NETWORKING SERVICES (U.S. CLS. 100 AND 101).
LINDA M. KING, EXAMINING ATTORNEY

SN 85-503,153. RH CAPITAL ASSOCIATES LLC, ANCRAMDALE, NY. FILED 12-23-2011.

OPTHOQUEST

THE MARK CONSISTS OF STANDARD CHARACTERS WITHOUT CLAIM TO ANY PARTICULAR FONT, STYLE, SIZE, OR COLOR.

CLASS 5—PHARMACEUTICALS

FOR DIETARY AND NUTRITIONAL SUPPLEMENTS; EYE DROPS (U.S. CLS. 6, 18, 44, 46, 51 AND 52).

CLASS 10—MEDICAL APPARATUS

FOR EYE TESTING INSTRUMENTS; OPHTHALMIC DIAGNOSTIC INSTRUMENTS; AND MEDICAL DEVICE FOR TRACKING FOR TRACKING EYE POSITIONS AND EYE MOVEMENT AND SOFTWARE SOLD AS A UNIT THEREWITH (U.S. CLS. 26, 39 AND 44).
KATHERINE STOIDES, EXAMINING ATTORNEY

SN 85-504,157. RAKSHA INTERNATIONAL, INC., SAN MATEO, CA. FILED 12-27-2011.



NO CLAIM IS MADE TO THE EXCLUSIVE RIGHT TO USE "CARE HOMES", APART FROM THE MARK AS SHOWN.

THE MARK CONSISTS OF AN IMAGE OF A LOTUS PLANT PLUS THE WORDS "RAKSHA CARE HOMES".

CLASS 43—HOTEL AND RESTAURANT SERVICES

FOR PROVIDING ASSISTED LIVING FACILITIES; PROVIDING ASSISTED LIVING CARE, PROGRAMS AND FACILITIES, NAMELY, RETIREMENT HOMES; PROVIDING ASSISTED LIVING ACCOMMODATION SERVICES FOR SENIOR ADULTS, THE ELDERLY AND INDIVIDUALS WITH DISABILITIES; AGED CARE, NAMELY, PROVIDING ELDER CARE SERVICES; PROVIDING RESPITE CARE IN THE NATURE OF PROVIDING TEMPORARY ACCOMMODATION AND PROVIDING ELDER CARE FOR SENIOR ADULTS AND THE ELDERLY; PROVIDING MEALS FOR SENIOR ADULTS AND THE ELDERLY (U.S. CLS. 100 AND 101).
FIRST USE 7-31-2005; IN COMMERCE 7-31-2005.

CLASS 45—PERSONAL AND LEGAL SERVICES

FOR SUPPORT SERVICES FOR SENIOR ADULTS AND THE ELDERLY, NAMELY, GERIATRIC CARE MANAGEMENT SERVICES IN THE NATURE OF THE COORDINATION OF NECESSARY SERVICES AND PERSONAL CARE FOR OLDER INDIVIDUALS; PERSONAL CARE AND HOSPITALITY SERVICES, NAMELY, ASSISTANCE WITH ACTIVITIES OF DAILY LIVING, SUCH AS BATHING, GROOMING AND PERSONAL MOBILITY FOR SENIOR ADULTS AND THE ELDERLY; PROVIDING NON-MEDICAL ASSISTED LIVING SERVICES FOR PERSONAL PURPOSES IN THE NATURE OF SCHEDULING APPOINTMENTS, MAIL SORTING, MAIL HANDLING, AND MAIL RECEIVING (U.S. CLS. 100 AND 101).

FIRST USE 7-31-2005; IN COMMERCE 7-31-2005.
JENNIFER WILLISTON, EXAMINING ATTORNEY

SN 85-504,235. KATHLEEN M. TOMPKINS, PORT LUDLOW, WA. FILED 12-27-2011.

ABC KIDS

THE MARK CONSISTS OF STANDARD CHARACTERS WITHOUT CLAIM TO ANY PARTICULAR FONT, STYLE, SIZE, OR COLOR.

NO CLAIM IS MADE TO THE EXCLUSIVE RIGHT TO USE "KIDS", APART FROM THE MARK AS SHOWN.

CLASS 9—ELECTRICAL AND SCIENTIFIC APPARATUS

FOR COMPUTER SOFTWARE IN THE FIELDS OF EARLY CHILDHOOD EDUCATION, SPECIAL EDUCATION AND TEACHING ENGLISH AS A SECOND LANGUAGE (U.S. CLS. 21, 23, 26, 36 AND 38).

CLASS 16—PAPER GOODS AND PRINTED MATTER

FOR PRINTED MATERIALS, NAMELY, EDUCATIONAL, INSTRUCTIONAL AND TEACHING MATERIAL IN THE FIELDS OF EARLY CHILDHOOD EDUCATION, SPECIAL EDUCATION AND TEACHING ENGLISH AS A SECOND LANGUAGE (U.S. CLS. 2, 5, 22, 23, 29, 37, 38 AND 50).

ARETHA SOMERVILLE, EXAMINING ATTORNEY

SN 85-504,545. ORLEANS ARIZONA, INC., WILMINGTON, DE. FILED 12-27-2011.

ORLEANS HOMES

THE MARK CONSISTS OF STANDARD CHARACTERS WITHOUT CLAIM TO ANY PARTICULAR FONT, STYLE, SIZE, OR COLOR.

NO CLAIM IS MADE TO THE EXCLUSIVE RIGHT TO USE "HOMES", APART FROM THE MARK AS SHOWN.

CLASS 35—ADVERTISING AND BUSINESS

FOR REAL ESTATE SALES MANAGEMENT; REAL ESTATE MARKETING SERVICES IN THE FIELD OF HOMES, INCLUDING SINGLE FAMILY, ATTACHED AND DETACHED HOMES, MULTIFAMILY HOMES, CONDOMINIUMS AND APARTMENTS (U.S. CLS. 100, 101 AND 102).

CLASS 37—CONSTRUCTION AND REPAIR

FOR RESIDENTIAL HOMEBUILDING SERVICES, NAMELY, CONSTRUCTION OF NEW RESIDENCES, INCLUDING HOMES; REAL ESTATE DEVELOPMENT; CONSTRUCTION PLANNING; LAND DEVELOPMENT SERVICES, NAMELY, PLANNING AND LAYING OUT RESIDENTIAL COMMUNITIES; CONSTRUCTION SERVICES, NAMELY, CONSTRUCTION OF HOMES, INCLUDING SINGLE FAMILY, ATTACHED AND DETACHED HOMES, MULTIFAMILY HOMES, CONDOMINIUMS AND APARTMENTS (U.S. CLS. 100, 103 AND 106).

JAMES GRIFFIN, EXAMINING ATTORNEY

SN 85-504,755. TENNIS CORPORATION OF AMERICA, CHICAGO, IL. FILED 12-28-2011.

TENNIS EXPLORERS

THE MARK CONSISTS OF STANDARD CHARACTERS WITHOUT CLAIM TO ANY PARTICULAR FONT, STYLE, SIZE, OR COLOR.

NO CLAIM IS MADE TO THE EXCLUSIVE RIGHT TO USE "TENNIS", APART FROM THE MARK AS SHOWN.

CLASS 28—TOYS AND SPORTING GOODS

FOR SPORTS EQUIPMENT FOR TENNIS, NAMELY, RACQUETS, RACQUET CASES, RACQUET COVERS, AND BACKPACKS SPECIFICALLY ADAPTED AND DESIGNED FOR CARRYING TENNIS EQUIPMENT; TOYS, NAMELY, RUBBER BALLS AND STUFFED TOY ANIMALS (U.S. CLS. 22, 23, 38 AND 50).

CLASS 41—EDUCATION AND ENTERTAINMENT

FOR PROVIDING INSTRUCTIONS AND TRAINING PROGRAMS FOR THE DEVELOPMENT OF RACQUET SPORT SKILLS (U.S. CLS. 100, 101 AND 107).

DEBORAH LOBO, EXAMINING ATTORNEY

SN 85-504,775. TENNIS CORPORATION OF AMERICA, CHICAGO, IL. FILED 12-28-2011.



NO CLAIM IS MADE TO THE EXCLUSIVE RIGHT TO USE "TENNIS", "MIDTOWN" AND THE REPRESENTATION OF THE TENNIS BALL, APART FROM THE MARK AS SHOWN.

THE MARK CONSISTS OF A DRAGON IMAGE IN FRONT OF A GLOBE WITH A TENNIS BALL ENCIRCLING THE GLOBE AND EXTENDING FROM THE WORDS "TENNIS EXPLORERS" UNDERNEATH THE DRAGON IMAGE. THE WORD "MIDTOWN" APPEARS UNDERNEATH THE WORDS "TENNIS EXPLORERS".

CLASS 25—CLOTHING

FOR ATHLETIC APPAREL, NAMELY, SHIRTS (U.S. CLS. 22 AND 39).

CLASS 28—TOYS AND SPORTING GOODS

FOR SPORTS EQUIPMENT FOR TENNIS, NAMELY, RACQUETS, RACQUET CASES, RACQUET COVERS, AND BACKPACKS SPECIFICALLY ADAPTED AND DESIGNED FOR CARRYING TENNIS EQUIPMENT; TOYS, NAMELY, RUBBER BALLS AND STUFFED TOY ANIMALS (U.S. CLS. 22, 23, 38 AND 50).

CLASS 41—EDUCATION AND ENTERTAINMENT

FOR PROVIDING INSTRUCTIONS AND TRAINING PROGRAMS FOR THE DEVELOPMENT OF RACQUET SPORT SKILLS (U.S. CLS. 100, 101 AND 107).

DEBORAH LOBO, EXAMINING ATTORNEY

SN 85-505,547. SANOFI, PARIS, FRANCE, FILED 12-29-2011.

SN 85-506,428. PETER CHRISTIAN'S SPECIALTY FOOD AND GIFTS, LLC, CONCORD, NH. FILED 12-30-2011.

NOTIRIS

THE MARK CONSISTS OF STANDARD CHARACTERS WITHOUT CLAIM TO ANY PARTICULAR FONT, STYLE, SIZE, OR COLOR.

PRIORITY CLAIMED UNDER SEC. 44(D) ON FRANCE APPLICATION NO. 11/3845058, FILED 7-8-2011, REG. NO. 11/384058, DATED 7-8-2011, EXPIRES 7-8-2021.

THE WORDING "NOTIRIS" HAS NO MEANING IN A FOREIGN LANGUAGE.

CLASS 9—ELECTRICAL AND SCIENTIFIC APPARATUS

FOR COMPUTER SOFTWARE AND MOBILE SOFTWARE APPLICATION FOR PROVIDING INFORMATION ON PHARMACEUTICAL PRODUCTS, OR INFORMATION IN THE FIELD OF HEALTHCARE; BARCODE SCANNERS; COMPUTER SOFTWARE AND MOBILE SOFTWARE APPLICATION FEATURING A SPEECH SYNTHESIZER WHICH VOCALIZES INFORMATION ON PHARMACEUTICAL PRODUCTS, DISEASES, AND MEDICAL CONDITIONS IN THE FIELD OF HEALTHCARE (U.S. CLS. 21, 23, 26, 36 AND 38).

CLASS 44—MEDICAL, BEAUTY AND AGRICULTURAL SERVICES

FOR PROVIDING INFORMATION TO HEALTHCARE PROFESSIONALS AND PATIENTS ABOUT HEALTHCARE AND IN PARTICULAR ABOUT PHARMACEUTICALS (U.S. CLS. 100 AND 101).

AISHA SALEM, EXAMINING ATTORNEY

SN 85-506,018. DOCMAGIC, INC., CARSON, CA. FILED 12-29-2011.

FREESIGN

THE MARK CONSISTS OF STANDARD CHARACTERS WITHOUT CLAIM TO ANY PARTICULAR FONT, STYLE, SIZE, OR COLOR.

CLASS 36—INSURANCE AND FINANCIAL

FOR FINANCIAL SERVICES; PREPARATION OF FINANCIAL LOAN DOCUMENTS FOR OTHERS; ELECTRONIC LOAN PREPARATION FOR OTHERS; FACILITATING THE PREPARATION AND EXECUTION OF ELECTRONIC SIGNATURES BY OTHERS FOR THE DOCUMENTATION OF LOANS (U.S. CLS. 100, 101 AND 102).

CLASS 38—COMMUNICATION

FOR ELECTRONIC DELIVERY OF LOAN DOCUMENTS AND OF ELECTRONIC SIGNATURES FOR SUCH LOAN DOCUMENTS (U.S. CLS. 100, 101 AND 104).

LAKEISHA LEWIS, EXAMINING ATTORNEY

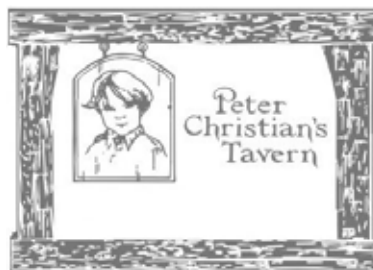

THE NAME(S), PORTRAIT(S), AND/OR SIGNATURE(S) SHOWN IN THE MARK IDENTIFIES PETER CHRISTIAN WASHBURN, WHOSE CONSENT(S) TO REGISTER IS MADE OF RECORD.

THE MARK CONSISTS OF A STYLIZED WOODEN BORDER WITH A SIGN HANGING FROM THE INSIDE LEFT CORNER CONTAINING THE IMAGE OF A YOUNG PERSON, AND TO THE RIGHT OF WHICH APPEARS THE WORDING "PETER CHRISTIAN'S TAVERN".

CLASS 30—STAPLE FOODS

FOR MUSTARD (U.S. CL. 46).
FIRST USE 7-2-1973; IN COMMERCE 7-2-1973.

CLASS 32—LIGHT BEVERAGES

FOR SOFT DRINKS, NAMELY, SODAS (U.S. CLS. 45, 46 AND 48).
FIRST USE 7-2-1973; IN COMMERCE 7-2-1973.
JEFFREY LOOK, EXAMINING ATTORNEY

SN 85-506,488. BENNET OMALU PATHOLOGY, INC., LODI, CA. FILED 12-30-2011.

Bennet Omalu Pathology

THE MARK CONSISTS OF STANDARD CHARACTERS WITHOUT CLAIM TO ANY PARTICULAR FONT, STYLE, SIZE, OR COLOR.

NO CLAIM IS MADE TO THE EXCLUSIVE RIGHT TO USE "PATHOLOGY", APART FROM THE MARK AS SHOWN.

THE NAME "BENNET OMALU" IDENTIFIES A LIVING INDIVIDUAL WHOSE CONSENT IS OF RECORD.

CLASS 42—SCIENTIFIC AND COMPUTER SERVICES

FOR CONSULTING SERVICES IN THE FIELDS OF FORENSIC SCIENCE (U.S. CLS. 100 AND 101).
FIRST USE 11-3-2011; IN COMMERCE 11-3-2011.

CLASS 44—MEDICAL, BEAUTY AND AGRICULTURAL SERVICES

FOR CONSULTING SERVICES IN THE FIELD OF MEDICAL CARE (U.S. CLS. 100 AND 101).
FIRST USE 11-3-2011; IN COMMERCE 11-3-2011.

CLASS 45—PERSONAL AND LEGAL SERVICES

FOR CONSULTING SERVICES CONCERNING LEGAL MATTERS IN THE MEDICAL FIELD; EXPERT WITNESS SERVICES IN LEGAL MATTERS IN THE FIELD OF FORENSIC SCIENCE, NEUROPATHOLOGY, ANATOMIC PATHOLOGY, CLINICAL PATHOLOGY, PUBLIC HEALTH MANAGEMENT AND EPIDEMIOLOGY (U.S. CLS. 100 AND 101).

FIRST USE 11-3-2011; IN COMMERCE 11-3-2011.
BRENDAN REGAN, EXAMINING ATTORNEY

SN 85-506,611. DIGITECH SYSTEMS, INC., GREENWOOD VILLAGE, CO. FILED 12-30-2011.



THE MARK CONSISTS OF AN OUTLINE DRAWING OF THE BODY OF A PERSON WITH ONE FINGER OF ONE HAND HELD UP NEXT TO A DRAWING OF A DOCUMENT WITH LINES.

SN 85-506,496. VIVID LEARNING SYSTEMS, INC., PASCO, WA. FILED 12-30-2011.

ROGO

THE MARK CONSISTS OF STANDARD CHARACTERS WITHOUT CLAIM TO ANY PARTICULAR FONT, STYLE, SIZE, OR COLOR.

THE ENGLISH TRANSLATION OF "ROGO" IN THE MARK IS "TO INQUIRE", "TO ASK", OR "TO HEAR".

CLASS 39—TRANSPORTATION AND STORAGE

FOR DOCUMENT DELIVERY; ELECTRONIC STORAGE OF FILES AND DOCUMENTS; ELECTRONIC STORAGE OF DATA, IMAGES, DOCUMENTS, FILES, AND INFORMATION; STORAGE OF ELECTRONIC MEDIA, NAMELY, IMAGES, TEXT AND AUDIO DATA; STORAGE SERVICES FOR ARCHIVING DATABASES, IMAGES AND OTHER ELECTRONIC DATA (U.S. CLS. 100 AND 105).

CLASS 42—SCIENTIFIC AND COMPUTER SERVICES

FOR COMPUTER SERVICES, NAMELY, ACTING AS AN APPLICATION SERVICE PROVIDER IN THE FIELD OF INFORMATION MANAGEMENT TO HOST COMPUTER APPLICATION SOFTWARE FOR THE PURPOSE OF COLLECTING, EDITING, ORGANIZING, MODIFYING, BOOK MARKING, TRANSMISSION, STORAGE AND SHARING OF DATA AND INFORMATION (U.S. CLS. 100 AND 101).

CHRISTINE MARTIN, EXAMINING ATTORNEY

SN 85-506,684. ASTRO STUDIOS, INC., SAN FRANCISCO, CA. FILED 12-30-2011.

CLASS 35—ADVERTISING AND BUSINESS

FOR BRAND CONCEPT AND BRAND DEVELOPMENT SERVICES FOR CORPORATE AND INDIVIDUAL CLIENTS (U.S. CLS. 100, 101 AND 102).

CLASS 41—EDUCATION AND ENTERTAINMENT

FOR TRAINING SERVICES IN THE FIELD OF SAFETY, WORKPLACE COMPLIANCE, AND PROFESSIONAL DEVELOPMENT; DEVELOPING TRAINING SYSTEMS AND LEARNING METHODOLOGIES FOR OTHERS (U.S. CLS. 100, 101 AND 107).

CLASS 42—SCIENTIFIC AND COMPUTER SERVICES

FOR MULTIDISCIPLINARY VISUAL DESIGN SERVICES (U.S. CLS. 100 AND 101).
BRENDAN REGAN, EXAMINING ATTORNEY



THE MARK CONSISTS OF A STYLIZED LETTER "A" INSIDE A SHADED SQUARE.

CLASS 35—ADVERTISING AND BUSINESS

FOR CONCEPT AND BRAND DEVELOPMENT SERVICES FOR OTHERS AND BRAND POSITIONING SERVICES (U.S. CLS. 100, 101 AND 102).

CLASS 42—SCIENTIFIC AND COMPUTER SERVICES

FOR PRODUCT DEVELOPMENT SERVICES; NEW PRODUCT DESIGN AND DEVELOPMENT SERVICES; GRAPHIC DESIGN SERVICES; COMPUTER USER INTERFACE DESIGN SERVICES FOR OTHERS; COMPUTER AIDED DESIGN FOR OTHERS (U.S. CLS. 100 AND 101).

RUSS HERMAN, EXAMINING ATTORNEY

SN 85-506,938. BLAKE LINDEMANN, BEVERLY HILLS, CA. FILED 12-31-2011.



THE MARK CONSISTS OF THE NON-SENSE WORD "BUNDELOW" WITH THE "O" REPRESENTED AS A BUBBLE WITH THREE BUBBLES OF DECREASING SIZE DIRECTLY ABOVE IT. THE "W" IS ITALICIZED WITH THREE BUBBLES OF INCREASING SIZE DIRECTLY ABOVE IT.

CLASS 9—ELECTRICAL AND SCIENTIFIC APPARATUS

FOR COMPUTER APPLICATION SOFTWARE FOR MOBILE PHONE AND MOBILE DIGITAL DEVICES, NAMELY, SOFTWARE THAT ALLOWS USERS TO ACCESS COUPONS, REBATES, PRICE-COMPARISON INFORMATION, PRODUCT REVIEWS, LINKS TO THE RETAIL WEBSITES OF OTHERS, DISCOUNT INFORMATION, ADVERTISING, SWEEPSTAKES, CONTESTS, SPECIAL OFFERS, AND INCENTIVE REWARD PROGRAMS (U.S. CLS. 21, 23, 26, 36 AND 38).

FIRST USE 1-12-2011; IN COMMERCE 7-20-2011.

CLASS 35—ADVERTISING AND BUSINESS

FOR PROMOTING THE GOODS AND SERVICES OF OTHERS BY PROVIDING A WEBSITE FEATURING COUPONS, REBATES, PRICE COMPARISON INFORMATION, PRODUCT REVIEWS, LINKS TO THE RETAIL WEBSITES OF OTHERS, DISCOUNT INFORMATION, ADVERTISING, SWEEPSTAKES, CONTESTS, SPECIAL OFFERS, AND INCENTIVE REWARD PROGRAMS (U.S. CLS. 100, 101 AND 102).

FIRST USE 1-12-2011; IN COMMERCE 4-12-2011.
B. PARADEWELAI, EXAMINING ATTORNEY

SN 85-506,953. BLAKE LINDEMANN, BEVERLY HILLS, CA. FILED 12-31-2011.



THE COLOR(S) BLUE, WHITE AND GREEN IS/ARE CLAIMED AS A FEATURE OF THE MARK.

THE MARK CONSISTS OF THE WHITE LETTER "B" IN LOWER CASE WITH A BLUE BUBBLE IN THE CENTER OF THE "B" WITH TWO ADDITIONAL BLUE BUBBLES ON THE BOTTOM RIGHT OF THE "B". THE "B" IS IN THE CENTER OF A GREEN SQUARE WITH GREEN AND BLUE TRANSLUCENT BUBBLES THROUGHOUT. THE GREEN SQUARE IS BORDERED BY A WHITE AND BLUE MARGIN WITH ROUNDED CORNERS.

CLASS 9—ELECTRICAL AND SCIENTIFIC APPARATUS

FOR COMPUTER APPLICATION SOFTWARE FOR MOBILE PHONE AND MOBILE DIGITAL DEVICES, NAMELY, SOFTWARE THAT ALLOWS USERS TO ACCESS COUPONS, REBATES, PRICE-COMPARISON INFORMATION, PRODUCT REVIEWS, LINKS TO THE RETAIL WEBSITES OF OTHERS, DISCOUNT INFORMATION, ADVERTISING, SWEEPSTAKES, CONTESTS, SPECIAL OFFERS, AND INCENTIVE REWARD PROGRAMS (U.S. CLS. 21, 23, 26, 36 AND 38).

FIRST USE 7-20-2011; IN COMMERCE 7-20-2011.

CLASS 35—ADVERTISING AND BUSINESS

FOR PROMOTING THE GOODS AND SERVICES OF OTHERS BY PROVIDING A WEBSITE FEATURING COUPONS, REBATES, PRICE COMPARISON INFORMATION, PRODUCT REVIEWS, LINKS TO THE RETAIL WEBSITES OF OTHERS, DISCOUNT INFORMATION, ADVERTISING, SWEEPSTAKES, CONTESTS, SPECIAL OFFERS, AND INCENTIVE REWARD PROGRAMS (U.S. CLS. 100, 101 AND 102).

FIRST USE 12-10-2011; IN COMMERCE 12-10-2011.

B. PARADEWELAI, EXAMINING ATTORNEY

SN 85-506,984. INTERNATIONAL MENTORS, INC., ELLENWOOD, GA. FILED 12-31-2011.



THE COLOR(S) LIGHT BLUE, WHITE, DARK BLUE AND GRAY IS/ARE CLAIMED AS A FEATURE OF THE MARK.

THE MARK CONSISTS OF THE WORDING "HEAVEN BOUND" IN THE COLORS LIGHT BLUE FADING TO THE COLOR WHITE, THE WORDING "A STUDY GUIDE TO THE WORD OF GOD" APPEARS IN THE COLOR DARK BLUE, A STYLIZED GRAY ROCK AND THE BACKGROUND IS LIGHT BLUE WITH WHITE CLOUDS.

CLASS 9—ELECTRICAL AND SCIENTIFIC APPARATUS

FOR EDUCATIONAL SOFTWARE FEATURING INSTRUCTION IN BIBLICAL LIFE CHOICES (U.S. CLS. 21, 23, 26, 36 AND 38).

SN 85-507,131. GYMETRIX LTD., SOUTHAMPTON, UNITED KINGDOM, FILED 1-2-2012.

CLASS 41—EDUCATION AND ENTERTAINMENT

FOR ENTERTAINMENT SERVICES, NAMELY, PROVIDING ONLINE COMPUTER GAMES THAT HELP MAINTAIN AN ACTIVE BRAIN AND THUS IMPROVE MEMORY, SPEED OF PROCESSING, AND THAT PROVIDE A VARIETY OF COGNITIVE BENEFITS THAT POSITIVELY IMPACT QUALITY OF LIFE; PROVIDING ON-LINE RELIGIOUS INSTRUCTION PROMOTING CHRISTIAN AND FAMILY VALUES (U.S. CLS. 100, 101 AND 107).

GYMETRIX

THE MARK CONSISTS OF STANDARD CHARACTERS WITHOUT CLAIM TO ANY PARTICULAR FONT, STYLE, SIZE, OR COLOR.

OWNER OF UNITED KINGDOM REG. NO. 2518670, DATED 6-17-2009, EXPIRES 6-17-2019.

CLASS 45—PERSONAL AND LEGAL SERVICES

FOR PROVIDING A WEBSITE FEATURING INFORMATION ABOUT RELIGIOUS BELIEF SYSTEMS (U.S. CLS. 100 AND 101).
JAY FLOWERS, EXAMINING ATTORNEY

CLASS 9—ELECTRICAL AND SCIENTIFIC APPARATUS

FOR COMPUTER HARDWARE AND SOFTWARE FOR MONITORING USAGE OF FITNESS EQUIPMENT AND FOR CONDUCTING RESEARCH AND PROVIDING ANALYSIS ON THE USAGE OF FITNESS EQUIPMENT (U.S. CLS. 21, 23, 26, 36 AND 38).

SN 85-507,046. MEMOSOFT CO., ALEXANDRIA, EGYPT, FILED 1-1-2012.

CLASS 42—SCIENTIFIC AND COMPUTER SERVICES

FOR INFORMATION TECHNOLOGY CONSULTANCY SERVICES; PROVIDING RESEARCH SERVICES IN THE FIELD OF USAGE OF GYM EQUIPMENT; COMPUTER SOFTWARE PROGRAMMING SERVICES; COMPUTER SOFTWARE CREATION AND DESIGN; MEASUREMENT EVALUATIONS IN THE FIELD OF FITNESS EQUIPMENT USAGE (U.S. CLS. 100 AND 101).
CHRIS WELLS, EXAMINING ATTORNEY

travelfox

THE MARK CONSISTS OF STANDARD CHARACTERS WITHOUT CLAIM TO ANY PARTICULAR FONT, STYLE, SIZE, OR COLOR.

SN 85-507,152. PERFECTION MIGHTY INDUSTRIAL CO., LTD., TAICHUNG, TAIWAN, FILED 1-2-2012.

CLASS 35—ADVERTISING AND BUSINESS

FOR AD SERVING, NAMELY, PLACING ADVERTISEMENTS ON WEBSITES FOR OTHERS USING SPECIALIZED COMPUTER SOFTWARE; ON-LINE PRICE MONITORING AND ADJUSTING FOR CUSTOMERS OF TRAVEL RELATED PURCHASES; ON-LINE PROMOTION OF COMPUTER NETWORKS AND WEBSITES; PROMOTING THE GOODS AND SERVICES OF OTHERS BY PROVIDING A WEBSITE FEATURING COUPONS, REBATES, PRICE-COMPARISON INFORMATION, PRODUCT REVIEWS, LINKS TO THE RETAIL WEBSITES OF OTHERS, AND DISCOUNT INFORMATION; PROMOTING THE GOODS AND SERVICES OF OTHERS BY PROVIDING A WEBSITE FEATURING TRAVEL (U.S. CLS. 100, 101 AND 102).



CLASS 39—TRANSPORTATION AND STORAGE

FOR BOOKING OF TRAVEL TICKETS; ORGANISATION OF TRAVEL; ORGANIZATION OF EXCURSIONS, SIGHTSEEING TOURS, HOLIDAYS, TOURS AND TRAVEL; ORGANIZATION OF TRAVEL AND BOAT TRIPS; PROVISION OF TRAVEL INFORMATION; TRAVEL INFORMATION (U.S. CLS. 100 AND 105).
JUSTINE D. PARKER, EXAMINING ATTORNEY

THE MARK CONSISTS OF A CIRCLE SURROUNDED BY A CONCENTRIC ARC OF ABOUT 270 DEGREES, WHEREIN THE CIRCLE CONTAINS A VERTICAL BAR SHAPE AND TWO INVERTED DROP-LIKE SHAPES SYMMETRICALLY ARRANGED AT THE LOWER END OF THE BAR SHAPE.

CLASS 17—RUBBER GOODS

FOR PACKING MATERIALS OF RUBBER AND PLASTICS FOR FORMING SEALS; INSULATING ADHESIVE TAPES FOR INDUSTRIAL OR COMMERCIAL PACKING USE; MICA; MICA POWDER FOR USE IN THE MANUFACTURE OF ELECTRONIC INSTRUMENTS; HEAT INSULATING BOARDS; SOUNDPROOFING MATERIALS FOR BUILDINGS, NAMELY, SOUND-PROOF BOARDS AND SOUND-PROOF BOARDS CONTAINING OR MADE WITH FIRE PROOF MATERIALS; RUBBER SHEETS; INJECTING PLASTIC FOR USE IN MANUFACTURE; PROCESSED PLASTIC POWDER FOR USE IN MANUFACTURING; PROCESSED PLASTIC GRANULE FOR USE IN MANUFACTURING; SYNTHETIC RUBBERS; ADHESIVE-COATED PLASTIC SHEETS; NON-METAL PIPE CONNECTORS AND PIPE CAPS (U.S. CLS. 1, 5, 12, 13, 35 AND 50).

CLASS 18—LEATHER GOODS

FOR LEATHER, IMITATIONS LEATHER AND FURS SOLD IN BULK; LEATHER GOODS, NAMELY, HANDBAGS, WALLETS, TRAVEL BAGS, LUGGAGE, BUSINESS AND CREDIT CARD CASES, BRIEF CASE TYPE PORTFOLIOS, ATTACHE CASES, CHANGE PURSES, SUITCASES, TOTE BAGS, MAKE-UP BAGS SOLD EMPTY, VANITY CASES SOLD EMPTY, GARMENT BAGS AND SHOE BAGS FOR TRAVEL (U.S. CLS. 1, 2, 3, 22 AND 41).

CLASS 24—FABRICS

FOR BED BLANKETS; COVERLETS; BED SPREADS; CURTAINS MADE OF TEXTILE FABRICS; PILLOWCASES; PILLOW SLIPS; QUILTS; TEXTILE WALL HANGINGS; BED SHEETS; KNITTED FABRICS; QUILTS OF TEXTILE; TEXTILE FABRICS FOR THE MANUFACTURE OF CLOTHING (U.S. CLS. 42 AND 50).
DANIEL CAPSHAW, EXAMINING ATTORNEY

SN 85-507,215. RUSS, CHARLES J., TAYLORS, SC. FILED 1-2-2012.

SIDEMEAT

THE MARK CONSISTS OF STANDARD CHARACTERS WITHOUT CLAIM TO ANY PARTICULAR FONT, STYLE, SIZE, OR COLOR.

CLASS 25—CLOTHING

FOR T-SHIRTS, SWEATSHIRTS, SWEATPANTS AND HATS (U.S. CLS. 22 AND 39).

CLASS 41—EDUCATION AND ENTERTAINMENT

FOR PROVIDING A WEBSITE FEATURING NON-DOWNLOADABLE INSTRUCTIONAL VIDEOS IN THE FIELDS OF EXERCISE AND FITNESS; PROVIDING A WEBSITE FEATURING NON-DOWNLOADABLE PUBLICATIONS IN THE NATURE OF ARTICLES IN THE FIELDS OF EXERCISE AND FITNESS (U.S. CLS. 100, 101 AND 107).
AMY KERTGATE, EXAMINING ATTORNEY

SN 85-507,514. HARVEY'S MILLING CO., INC., CARSON CITY, MI. FILED 1-3-2012.



OWNER OF U.S. REG. NO. 3,501,188.

NO CLAIM IS MADE TO THE EXCLUSIVE RIGHT TO USE "AGRICULTURAL SOLUTIONS", APART FROM THE MARK AS SHOWN.

THE MARK CONSISTS OF THE TERMS "HARVEY'S AGRICULTURAL SOLUTIONS" TO THE LEFT OF WHICH ARE TWO ARROWS.

CLASS 35—ADVERTISING AND BUSINESS

FOR RETAIL STORE SERVICES FOR AGRICULTURAL PRODUCTS, NAMELY, ANIMAL FEED, FENCING, CLOTHING, AND PESTICIDES, FOR FARM USE (U.S. CLS. 100, 101 AND 102).

FIRST USE 4-11-2008; IN COMMERCE 4-11-2008.

CLASS 44—MEDICAL, BEAUTY AND AGRICULTURAL SERVICES

FOR CONSULTING IN THE FIELD OF AGRONOMY; CONSULTING REGARDING FERTILIZER, FEED, SEED AND CROP PROTECTION; AGRICULTURAL ADVICE; PROVIDING INFORMATION IN THE FIELDS OF FERTILIZER, FEED AND SEED; AGRICULTURAL SOIL MANAGEMENT FOR RAISING CROPS (U.S. CLS. 100 AND 101).

FIRST USE 4-11-2008; IN COMMERCE 4-11-2008.

LINDA POWELL, EXAMINING ATTORNEY

SN 85-507,598. BIO COSMETICS, S.L., 28023 MADRID, SPAIN, FILED 1-3-2012.

air-lift

OWNER OF ERPN CMNTY TM OFC REG. NO. 3486181, DATED 3-4-2005, EXPIRES 10-30-2013.

OWNER OF U.S. REG. NOS. 2,471,012 AND 2,703,345.

THE MARK CONSISTS OF THE WORDS "AIR-LIFT" IN A STYLIZED FONT.

CLASS 3—COSMETICS AND CLEANING PREPARATIONS

FOR TOOTHPASTE; NON-MEDICATED MOUTH WASH AND RINSE; BREATH FRESHENER SPRAY; BREATH-FRESHENING CONFECTIONERY, NAMELY, GUM AND CANDY (U.S. CLS. 1, 4, 6, 50, 51 AND 52).

CLASS 5—PHARMACEUTICALS

FOR PHARMACEUTICALS, NAMELY, PILLS, ANTI-CAVITY MOUTH RINSES, GARGLES AND TOOTHPASTE FOR THE TREATMENT OF BAD BREATH (U.S. CLS. 6, 18, 44, 46, 51 AND 52).

GEOFFREY FOSDICK, EXAMINING ATTORNEY

SN 85-507.603. TORRES, JEANNINE, ORANGE, CA. AND GETTMAN, MIKE, ORANGE, CA. FILED 1-3-2012.

The Parent Tree

THE MARK CONSISTS OF STANDARD CHARACTERS WITHOUT CLAIM TO ANY PARTICULAR FONT, STYLE, SIZE, OR COLOR.

NO CLAIM IS MADE TO THE EXCLUSIVE RIGHT TO USE "PARENT", APART FROM THE MARK AS SHOWN.

CLASS 35—ADVERTISING AND BUSINESS

FOR RETAIL STORE SERVICES FEATURING A WIDE VARIETY OF CONSUMER GOODS OF OTHERS (U.S. CLS. 100, 101 AND 102).

CLASS 41—EDUCATION AND ENTERTAINMENT

FOR EDUCATION SERVICES, NAMELY, PROVIDING CLASSES IN THE FIELD OF PRE-NATAL AND POST-NATAL EDUCATION; PHYSICAL FITNESS INSTRUCTION (U.S. CLS. 100, 101 AND 107).

MELISSA VALLILLO, EXAMINING ATTORNEY

SN 85-507.706. TEKSYSTEMS, INC., HANOVER, MD. FILED 1-3-2012.

FLEXIBLE SOLUTIONS.
UNCOMPROMISING PERFORMANCE.

THE MARK CONSISTS OF STANDARD CHARACTERS WITHOUT CLAIM TO ANY PARTICULAR FONT, STYLE, SIZE, OR COLOR.

CLASS 35—ADVERTISING AND BUSINESS

FOR EMPLOYMENT AGENCY SERVICES, NAMELY, FILLING THE TEMPORARY AND PERMANENT STAFFING NEEDS OF BUSINESSES; EMPLOYMENT HIRING, RECRUITING, PLACEMENT, STAFFING AND CAREER NETWORKING SERVICES; EMPLOYMENT OUTPLACEMENT SERVICES; EMPLOYMENT STAFFING IN THE FIELD OF INFORMATION TECHNOLOGY; HUMAN CAPITAL MANAGEMENT OUTSOURCING SERVICES; MANAGEMENT OF TELEPHONE CALL CENTERS FOR OTHERS; OUTSOURCING IN THE FIELD OF INFORMATION TECHNOLOGY SYSTEMS; PERSONNEL RECRUITMENT SERVICES AND EMPLOYMENT AGENCIES; PROVIDING AN ON-LINE SEARCHABLE DATABASE FEATURING EMPLOYMENT OPPORTUNITIES; PROVIDING ONLINE BUSINESS MANAGEMENT SERVICES INCLUDING ACCOUNTING, MARKETING, BUSINESS PROJECT MANAGEMENT, AND BUSINESS DEVELOPMENT; TEMPORARY EMPLOYMENT AGENCIES (U.S. CLS. 100, 101 AND 102).

CLASS 42—SCIENTIFIC AND COMPUTER SERVICES

FOR COMPUTER PROJECT MANAGEMENT SERVICES; COMPUTER SOFTWARE INSTALLATION AND MAINTENANCE; COMPUTER TECHNOLOGY SUPPORT SERVICES, NAMELY, HELP DESK SERVICES; CONSULTING SERVICES IN THE FIELD OF CLOUD COMPUTING; CONSULTING SERVICES IN THE FIELD OF COMPUTER-BASED INFORMATION SYSTEMS FOR BUSINESSES; DESIGN, DEVELOPMENT AND IMPLEMENTATION OF SOFTWARE; INTEGRATION OF COMPUTER SYSTEMS AND NETWORKS; TECHNOLOGICAL CONSULTATION IN THE TECHNOLOGY FIELD OF INFORMATION TECHNOLOGY SYSTEMS (U.S. CLS. 100 AND 101).

TOBY BULLOFF, EXAMINING ATTORNEY

SN 85-507.715. TEKSYSTEMS, INC., HANOVER, MD. FILED 1-3-2012.

OUR PEOPLE MAKE IT POSSIBLE

THE MARK CONSISTS OF STANDARD CHARACTERS WITHOUT CLAIM TO ANY PARTICULAR FONT, STYLE, SIZE, OR COLOR.

CLASS 35—ADVERTISING AND BUSINESS

FOR EMPLOYMENT AGENCY SERVICES, NAMELY, FILLING THE TEMPORARY AND PERMANENT STAFFING NEEDS OF BUSINESSES; EMPLOYMENT HIRING, RECRUITING, PLACEMENT, STAFFING AND CAREER NETWORKING SERVICES; EMPLOYMENT OUTPLACEMENT SERVICES; EMPLOYMENT STAFFING IN THE FIELD OF INFORMATION TECHNOLOGY; HUMAN CAPITAL MANAGEMENT OUTSOURCING SERVICES; MANAGEMENT OF TELEPHONE CALL CENTERS FOR OTHERS; OUTSOURCING IN THE FIELD OF INFORMATION TECHNOLOGY SYSTEMS; PERSONNEL RECRUITMENT SERVICES AND EMPLOYMENT AGENCIES; PROVIDING AN ON-LINE SEARCHABLE DATABASE FEATURING EMPLOYMENT OPPORTUNITIES; PROVIDING ONLINE BUSINESS MANAGEMENT SERVICES INCLUDING ACCOUNTING, MARKETING, BUSINESS PROJECT MANAGEMENT, AND BUSINESS DEVELOPMENT; TEMPORARY EMPLOYMENT AGENCIES (U.S. CLS. 100, 101 AND 102).

CLASS 42—SCIENTIFIC AND COMPUTER SERVICES

FOR COMPUTER PROJECT MANAGEMENT SERVICES; COMPUTER SOFTWARE INSTALLATION AND MAINTENANCE; COMPUTER TECHNOLOGY SUPPORT SERVICES, NAMELY, HELP DESK SERVICES; CONSULTING SERVICES IN THE FIELD OF CLOUD COMPUTING; CONSULTING SERVICES IN THE FIELD OF COMPUTER-BASED INFORMATION SYSTEMS FOR BUSINESSES; DESIGN, DEVELOPMENT AND IMPLEMENTATION OF SOFTWARE; INTEGRATION OF COMPUTER SYSTEMS AND NETWORKS; TECHNOLOGICAL CONSULTATION IN THE TECHNOLOGY FIELD OF INFORMATION TECHNOLOGY SYSTEMS (U.S. CLS. 100 AND 101).

TOBY BULLOFF, EXAMINING ATTORNEY

SN 85-507,767. TEKSYSTEMS, INC., HANOVER, MD. FILED 1-3-2012.

BRINGING IT TOGETHER

THE MARK CONSISTS OF STANDARD CHARACTERS WITHOUT CLAIM TO ANY PARTICULAR FONT, STYLE, SIZE, OR COLOR.

CLASS 35—ADVERTISING AND BUSINESS

FOR EMPLOYMENT AGENCY SERVICES, NAMELY, FILLING THE TEMPORARY AND PERMANENT STAFFING NEEDS OF BUSINESSES; EMPLOYMENT HIRING, RECRUITING, PLACEMENT, STAFFING AND CAREER NETWORKING SERVICES; EMPLOYMENT OUTPLACEMENT SERVICES; EMPLOYMENT STAFFING IN THE FIELD OF INFORMATION TECHNOLOGY; HUMAN CAPITAL MANAGEMENT OUTSOURCING SERVICES; MANAGEMENT OF TELEPHONE CALL CENTERS FOR OTHERS; OUTSOURCING IN THE FIELD OF INFORMATION TECHNOLOGY SYSTEMS; PERSONNEL RECRUITMENT SERVICES AND EMPLOYMENT AGENCIES; PROVIDING AN ON-LINE SEARCHABLE DATABASE FEATURING EMPLOYMENT OPPORTUNITIES; PROVIDING ONLINE BUSINESS MANAGEMENT SERVICES INCLUDING ACCOUNTING, MARKETING, BUSINESS PROJECT MANAGEMENT, AND BUSINESS DEVELOPMENT; TEMPORARY EMPLOYMENT AGENCIES (U.S. CLS. 100, 101 AND 102).

CLASS 42—SCIENTIFIC AND COMPUTER SERVICES

FOR COMPUTER PROJECT MANAGEMENT SERVICES; COMPUTER SOFTWARE INSTALLATION AND MAINTENANCE; COMPUTER TECHNOLOGY SUPPORT SERVICES, NAMELY, HELP DESK SERVICES; CONSULTING SERVICES IN THE FIELD OF CLOUD COMPUTING; CONSULTING SERVICES IN THE FIELD OF COMPUTER-BASED INFORMATION SYSTEMS FOR BUSINESSES; DESIGN, DEVELOPMENT AND IMPLEMENTATION OF SOFTWARE; INTEGRATION OF COMPUTER SYSTEMS AND NETWORKS; TECHNOLOGICAL CONSULTATION IN THE TECHNOLOGY FIELD OF INFORMATION TECHNOLOGY SYSTEMS (U.S. CLS. 100 AND 101).

TOBY BULLOFF, EXAMINING ATTORNEY

SN 85-507,842. GO WIRELINE LLC, AKA GO WIRELINE, WILLISTON, ND. FILED 1-3-2012.

Go Wireline

THE MARK CONSISTS OF STANDARD CHARACTERS WITHOUT CLAIM TO ANY PARTICULAR FONT, STYLE, SIZE, OR COLOR.

NO CLAIM IS MADE TO THE EXCLUSIVE RIGHT TO USE "WIRELINE", APART FROM THE MARK AS SHOWN.

CLASS 37—CONSTRUCTION AND REPAIR

FOR CEMENTING SERVICES FOR OIL AND GAS WELLS; WIRELINING FOR OIL WELLS (U.S. CLS. 100, 103 AND 106).

FIRST USE 5-22-2011; IN COMMERCE 5-22-2011.

CLASS 40—MATERIAL TREATMENT

FOR OIL PRODUCTION SERVICES; OIL WELL PROSPECTING, NAMELY, PERFORATION AND SPILL TREATMENT (U.S. CLS. 100, 103 AND 106).

FIRST USE 5-22-2011; IN COMMERCE 5-22-2011.

CLASS 42—SCIENTIFIC AND COMPUTER SERVICES

FOR OIL PROSPECTING, NAMELY, WELL LOGGING AND TESTING; WELL LOGGING (U.S. CLS. 100 AND 101).

FIRST USE 5-22-2011; IN COMMERCE 5-22-2011.

JOHN HWANG, EXAMINING ATTORNEY

SN 85-507,902. NEW BELGIUM BREWING COMPANY, INC., FORT COLLINS, CO. FILED 1-3-2012.

RED HOPTOBER

THE MARK CONSISTS OF STANDARD CHARACTERS WITHOUT CLAIM TO ANY PARTICULAR FONT, STYLE, SIZE, OR COLOR.

CLASS 16—PAPER GOODS AND PRINTED MATTER

FOR PAPER GOODS, NAMELY, DECALS, POSTERS, PAPER COASTERS, AND POSTCARDS (U.S. CLS. 2, 5, 22, 23, 29, 37, 38 AND 50).

CLASS 25—CLOTHING

FOR CLOTHING, NAMELY, SHIRTS, T-SHIRTS, SWEATSHIRTS, HATS, CAPS, JERSEYS, JACKETS, FLEECE PULLOVERS, AND SOCKS (U.S. CLS. 22 AND 39).

CLASS 32—LIGHT BEVERAGES

FOR BEER (U.S. CLS. 45, 46 AND 48).

DOMINIC FATHY, EXAMINING ATTORNEY

SN 85-507,969. PMP RESOUORCES, LLC, BELLINGHAM, MA. FILED 1-3-2012.

SecZetta

THE MARK CONSISTS OF STANDARD CHARACTERS WITHOUT CLAIM TO ANY PARTICULAR FONT, STYLE, SIZE, OR COLOR.

CLASS 42—SCIENTIFIC AND COMPUTER SERVICES

FOR COMPUTER SECURITY AND INFORMATION TECHNOLOGY CONSULTING SERVICES IN THE FIELD OF INFORMATION SECURITY RISK MANAGEMENT FOR PRIVATE BUSINESSES, GOVERNMENTS, AND OTHER ORGANIZATIONS (U.S. CLS. 100 AND 101).

FIRST USE 7-21-2011; IN COMMERCE 7-21-2011.

CLASS 45—PERSONAL AND LEGAL SERVICES

FOR REGULATORY COMPLIANCE CONSULTING SERVICES IN THE FIELD OF INFORMATION SECURITY FOR PRIVATE BUSINESSES, GOVERNMENTS, AND OTHER ORGANIZATIONS (U.S. CLS. 100 AND 101).

FIRST USE 7-21-2011; IN COMMERCE 7-21-2011.
JUDITH HELFMAN, EXAMINING ATTORNEY

SN 85-507,983. MOLES FAMILY SERVICES, INC., FERNDALE, WA. FILED 1-3-2012.

The Natural Way

THE MARK CONSISTS OF STANDARD CHARACTERS WITHOUT CLAIM TO ANY PARTICULAR FONT, STYLE, SIZE, OR COLOR.

CLASS 16—PAPER GOODS AND PRINTED MATTER

FOR ORGANIZATIONAL KITS CONTAINING CALENDARS, STATIONERY, PLANNING FOLDERS, TEMPLATES AND PRINTED GUIDELINES FOR PLANNING SOCIAL EVENTS (U.S. CLS. 2, 5, 22, 23, 29, 37, 38 AND 50).

CLASS 35—ADVERTISING AND BUSINESS

FOR EVENT PLANNING AND MANAGEMENT FOR MARKETING, BRANDING, PROMOTING OR ADVERTISING THE GOODS AND SERVICES OF OTHERS (U.S. CLS. 100, 101 AND 102).

CLASS 36—INSURANCE AND FINANCIAL

FOR PRE-PAID FUNERAL EXPENSE SERVICES (U.S. CLS. 100, 101 AND 102).

CLASS 41—EDUCATION AND ENTERTAINMENT

FOR SPECIAL EVENT PLANNING FOR SOCIAL ENTERTAINMENT PURPOSES (U.S. CLS. 100, 101 AND 107).

CLASS 45—PERSONAL AND LEGAL SERVICES

FOR FUNERAL SERVICES ACCOMPANYING CREMATION; PET FUNERAL SERVICES ACCOMPANYING CREMATION (U.S. CLS. 100 AND 101).
MICHAEL SOUDERS, EXAMINING ATTORNEY

SN 85-508,035. PDB SPORTS, LTD., ENGLEWOOD, CO. FILED 1-3-2012.

MILE HIGH MAGIC

THE MARK CONSISTS OF STANDARD CHARACTERS WITHOUT CLAIM TO ANY PARTICULAR FONT, STYLE, SIZE, OR COLOR.

NO CLAIM IS MADE TO THE EXCLUSIVE RIGHT TO USE "MILE HIGH", APART FROM THE MARK AS SHOWN.

CLASS 25—CLOTHING

FOR MEN'S, WOMEN'S AND CHILDREN'S CLOTHING, NAMELY, FLEECE TOPS AND BOTTOMS, CAPS, HEADWEAR, T-SHIRTS, SWEATSHIRTS, SHORTS, TANK TOPS, SWEATERS, PANTS, JACKETS, TURTLENECKS, JUMPSUITS, GOLF SHIRTS, JERSEYS, WRISTBANDS, WARM UP SUITS, SWIMWEAR, WIND RESISTANT JACKETS, RAINCOATS, PARKAS, PONCHOS, TIES, SUSPENDERS, CLOTH BIBS, SLEEPWEAR, NAMELY, ROBES, NIGHT SHIRTS AND PAJAMAS, GLOVES, MITTENS, KNIT HATS, SCARVES, APRONS, HEADBANDS, EAR MUFFS AND UNDERWEAR (U.S. CLS. 22 AND 39).

FIRST USE 8-31-2011; IN COMMERCE 8-31-2011.

CLASS 41—EDUCATION AND ENTERTAINMENT

FOR ENTERTAINMENT IN THE NATURE OF PROFESSIONAL FOOTBALL GAMES (U.S. CLS. 100, 101 AND 107).

FIRST USE 8-31-2011; IN COMMERCE 8-31-2011.

MARK RADEMACHER, EXAMINING ATTORNEY

SN 85-508,051. PRETEND LLC, VENICE, CA. FILED 1-3-2012.

STEREOID

THE MARK CONSISTS OF STANDARD CHARACTERS WITHOUT CLAIM TO ANY PARTICULAR FONT, STYLE, SIZE, OR COLOR.

CLASS 9—ELECTRICAL AND SCIENTIFIC APPARATUS

FOR COMPUTER SOFTWARE FOR CREATING, EDITING, AND MANIPULATING VISUAL EFFECTS, 3D CONTENT, VIDEO AND IMAGES; COMPUTER SOFTWARE FOR MULTI-VIEW IMAGE CORRECTION AND DEPTH MANIPULATION IN 3D CONTENT, VIDEO, AND IMAGES (U.S. CLS. 21, 23, 26, 36 AND 38).

CLASS 42—SCIENTIFIC AND COMPUTER SERVICES

FOR CLOUD COMPUTING FEATURING SOFTWARE FOR USE IN CREATING, EDITING, AND MANIPULATING VISUAL EFFECTS, 3D CONTENT, VIDEO, AND IMAGES; CLOUD COMPUTING FEATURING SOFTWARE FOR USE IN MULTI-VIEW IMAGE CORRECTION AND DEPTH MANIPULATION IN 3D CONTENT, VIDEO, AND IMAGES; TECHNICAL SUPPORT SERVICES, NAMELY, ADMINISTRATION AND TROUBLESHOOTING OF PROBLEMS RELATING TO THE AFOREMENTIONED COMPUTER SOFTWARE (U.S. CLS. 100 AND 101).

KATHERINE CHANG, EXAMINING ATTORNEY

SN 85-508,065. PASCAL VENTURES, LLC, LAS VEGAS, NV. FILED 1-3-2012.

SCAN, SPIN & WIN

THE MARK CONSISTS OF STANDARD CHARACTERS WITHOUT CLAIM TO ANY PARTICULAR FONT, STYLE, SIZE, OR COLOR.

CLASS 9—ELECTRICAL AND SCIENTIFIC APPARATUS

FOR DOWNLOADABLE SOFTWARE IN THE NATURE OF A MOBILE APPLICATION FOR PLAYING A MOBILE GAME THAT OFFERS CONSUMERS PRIZES AND PROMOTIONAL DEALS WHEN THEY VISIT PARTICIPATING LOCATIONS (U.S. CLS. 21, 23, 26, 36 AND 38).

CLASS 35—ADVERTISING AND BUSINESS

FOR ADVERTISING, MARKETING, AND PROMOTING THE GOODS AND SERVICES OF OTHERS VIA THE INTERNET AND THROUGH A MOBILE PHONE GAME (U.S. CLS. 100, 101 AND 102).

CLASS 41—EDUCATION AND ENTERTAINMENT

FOR ELECTRONIC GAMES SERVICES PROVIDED BY MEANS OF THE INTERNET (U.S. CLS. 100, 101 AND 107).

LAURIE KAUFMAN, EXAMINING ATTORNEY

SN 85-508,100. LEE, MICHAEL S., SCHAUMBURG, IL. FILED 1-3-2012.



BIBIMBAP

NO CLAIM IS MADE TO THE EXCLUSIVE RIGHT TO USE "BIBIMBAP", APART FROM THE MARK AS SHOWN. THE COLOR(S) BLACK AND RED IS/ARE CLAIMED AS A FEATURE OF THE MARK.

THE MARK CONSISTS OF THE LETTER "I" IN THE COLOR BLACK FOLLOWED BY A HEART SHAPE IN THE COLOR RED. BELOW THE LETTER "I" IN THE COLOR BLACK AND WITH THE RED HEART SHAPE ARE THE LETTERS "BIBIMBAP" ALL IN THE COLOR BLACK.

THE ENGLISH TRANSLATION OF "BIBIMBAP" IN THE MARK IS "MIXED RICE VEGETABLES AND BEEF" OR "OTHER MEAT BOWL DISH".

CLASS 35—ADVERTISING AND BUSINESS

FOR ADVICE IN THE RUNNING OF ESTABLISHMENTS AS FRANCHISES; BUSINESS MANAGEMENT ADVISORY SERVICES RELATING TO FRANCHISING; FRANCHISING, NAMELY, OFFERING BUSINESS MANAGEMENT ASSISTANCE IN THE ESTABLISHMENT AND/OR OPERATION OF RESTAURANTS (U.S. CLS. 100, 101 AND 102).

FIRST USE 12-31-2011; IN COMMERCE 12-31-2011.

CLASS 43—HOTEL AND RESTAURANT SERVICES

FOR RESTAURANT AND CAFE SERVICES; RESTAURANT SERVICES; RESTAURANT SERVICES FEATURING KOREAN CUISINE; RESTAURANT SERVICES, INCLUDING SIT-DOWN SERVICE OF FOOD AND TAKE-OUT RESTAURANT SERVICES; TAKE-OUT RESTAURANT SERVICES (U.S. CLS. 100 AND 101).

FIRST USE 12-31-2011; IN COMMERCE 12-31-2011.

WILLIAM ROSSMAN, EXAMINING ATTORNEY

SN 85-508,325. DOUGLAS, CHRIS, SANFORD, NC. FILED 1-4-2012.

WHITETAIL MAESTRO

THE MARK CONSISTS OF STANDARD CHARACTERS WITHOUT CLAIM TO ANY PARTICULAR FONT, STYLE, SIZE, OR COLOR.

NO CLAIM IS MADE TO THE EXCLUSIVE RIGHT TO USE "WHITETAIL", APART FROM THE MARK AS SHOWN.

CLASS 9—ELECTRICAL AND SCIENTIFIC APPARATUS

FOR DIGITAL MEDIA, NAMELY, PRERECORDED DIGITAL VIDEO DISKS FEATURING WILD GAME HUNTING, OUTDOOR RECREATION AND SPORTSMAN TOPICS (U.S. CLS. 21, 23, 26, 36 AND 38).

CLASS 41—EDUCATION AND ENTERTAINMENT

FOR ENTERTAINMENT SERVICES, NAMELY, AN ON-GOING SERIES FEATURING WILD GAME HUNTING, OUTDOOR RECREATION AND SPORTSMAN TOPICS PROVIDED THROUGH TELEVISION (U.S. CLS. 100, 101 AND 107).

APRIL ROACH, EXAMINING ATTORNEY

SN 85-508,342. DOUGLAS, CHRIS, SANFORD, NC. FILED 1-4-2012.

BOW MAESTRO

THE MARK CONSISTS OF STANDARD CHARACTERS WITHOUT CLAIM TO ANY PARTICULAR FONT, STYLE, SIZE, OR COLOR.

NO CLAIM IS MADE TO THE EXCLUSIVE RIGHT TO USE "BOW", APART FROM THE MARK AS SHOWN.

CLASS 9—ELECTRICAL AND SCIENTIFIC APPARATUS

FOR DIGITAL MEDIA, NAMELY, PRERECORDED DIGITAL VIDEO DISKS FEATURING WILD GAME HUNTING, OUTDOOR RECREATION AND SPORTSMAN TOPICS (U.S. CLS. 21, 23, 26, 36 AND 38).

CLASS 41—EDUCATION AND ENTERTAINMENT

FOR ENTERTAINMENT SERVICES, NAMELY, AN ON-GOING SERIES FEATURING WILD GAME HUNTING, OUTDOOR RECREATION AND SPORTSMAN TOPICS PROVIDED THROUGH TELEVISION (U.S. CLS. 100, 101 AND 107).

APRIL ROACH, EXAMINING ATTORNEY

SN 85-508,410. YRC WORLDWIDE INC., OVERLAND PARK, KS. FILED 1-4-2012.



OWNER OF U.S. REG. NOS. 3,266,262, 3,809,215 AND OTHERS.

NO CLAIM IS MADE TO THE EXCLUSIVE RIGHT TO USE "FREIGHT", APART FROM THE MARK AS SHOWN.

THE MARK CONSISTS OF THE LETTERS "YRC" ABOVE A TRILATERAL DESIGN, THAT IS DIVIDED INTO TWO PARTS BY A SMALLER TRILATERAL DESIGN, WITH THE WORD "FREIGHT" BELOW THE TRILATERAL DESIGNS.

CLASS 35—ADVERTISING AND BUSINESS

FOR BUSINESS CONSULTING SERVICES RELATING TO PRODUCT DISTRIBUTION, OPERATIONS MANAGEMENT SERVICES, LOGISTICS, REVERSE LOGISTICS, SUPPLY CHAIN, AND PRODUCTION SYSTEMS AND DISTRIBUTION SOLUTIONS; BUSINESS MANAGEMENT SERVICES, NAMELY, MANAGING LOGISTICS, REVERSE LOGISTICS, SUPPLY CHAIN SERVICES, SUPPLY CHAIN VISIBILITY AND SYNCHRONIZATION, SUPPLY AND DEMAND FORECASTING AND PRODUCT DISTRIBUTION PROCESSES FOR OTHERS; TRANSPORTATION LOGISTICS SERVICES, NAMELY, ARRANGING THE TRANSPORTATION OF GOODS FOR OTHERS; TRANSPORTATION LOGISTICS SERVICES, NAMELY, PLANNING AND SCHEDULING SHIPMENTS FOR USERS OF TRANSPORTATION SERVICES; COMPUTERIZED TRACKING AND TRACING OF PACKAGES IN TRANSIT; INFORMATION MANAGEMENT SERVICES, NAMELY, SHIPMENT PROCESSING, PREPARING SHIPPING DOCUMENTS AND INVOICES, TRACKING DOCUMENTS, PACKAGES AND FREIGHT OVER COMPUTER NETWORKS, INTRANETS AND INTERNETS; MONITORING AND TRACKING OF PACKAGE SHIPMENTS; PROVIDING ELECTRONIC TRACKING OF FREIGHT INFORMATION TO OTHERS; TRACKING, LOCATING AND MONITORING OF VEHICLES, MARITIME VESSELS AND AIRCRAFT SERVICES; CUSTOMS CLEARANCE SERVICES; ARRANGING FOR PICKUP, DELIVERY, STORAGE AND TRANSPORTATION OF DOCUMENTS, PACKAGES, FREIGHT AND PARCELS VIA GROUND AND AIR CARRIERS; ORDER FULFILLMENT SERVICES (U.S. CLS. 100, 101 AND 102).

CLASS 39—TRANSPORTATION AND STORAGE

FOR DOMESTIC AND INTERNATIONAL COMMON CARRIER FREIGHT TRANSPORTATION BY MEANS OF TRUCK, AIR, OR SEA, AND DOMESTIC AND INTERNATIONAL FREIGHT FORWARDING SERVICES; SUPPLY CHAIN, LOGISTICS AND REVERSE LOGISTICS SERVICES, NAMELY, STORAGE, TRANSPORTATION AND DELIVERY OF DOCUMENTS, PACKAGES, RAW MATERIALS, AND OTHER FREIGHT FOR OTHERS BY AIR, RAIL, SHIP OR TRUCK; WAREHOUSING SERVICES, NAMELY, STORAGE, DISTRIBUTION, PICK-UP, AND PACKING FOR SHIPMENT OF DOCUMENTS, PACKAGES, RAW MATERIALS, AND OTHER FREIGHT FOR OTHERS (U.S. CLS. 100 AND 105).

BRIAN NEVILLE, EXAMINING ATTORNEY

SN 85-508,429. YRC WORLDWIDE INC., OVERLAND PARK, KS. FILED 1-4-2012.



OWNER OF U.S. REG. NOS. 3,266,262, 3,809,215 AND OTHERS.

NO CLAIM IS MADE TO THE EXCLUSIVE RIGHT TO USE "FREIGHT", APART FROM THE MARK AS SHOWN.

THE COLOR(S) ORANGE, BLUE, AND WHITE IS/ARE CLAIMED AS A FEATURE OF THE MARK.

THE MARK CONSISTS OF THE LETTERS "YRC" IN BLUE, ABOVE A TRILATERAL DESIGN IN WHITE, THAT IS DIVIDED INTO TWO PARTS BY A SMALLER TRILATERAL DESIGN IN ORANGE, WITH THE WORD "FREIGHT" IN BLUE BELOW THE TRILATERAL DESIGNS, ALL INCLUDED WITHIN AN ORANGE RECTANGLE.

SN 85-508,470. YRC WORLDWIDE INC., OVERLAND PARK, KS. FILED 1-4-2012.

CLASS 35—ADVERTISING AND BUSINESS

FOR BUSINESS CONSULTING SERVICES RELATING TO PRODUCT DISTRIBUTION, OPERATIONS MANAGEMENT SERVICES, LOGISTICS, REVERSE LOGISTICS, SUPPLY CHAIN, AND PRODUCTION SYSTEMS AND DISTRIBUTION SOLUTIONS; BUSINESS MANAGEMENT SERVICES, NAMELY, MANAGING LOGISTICS, REVERSE LOGISTICS, SUPPLY CHAIN SERVICES, SUPPLY CHAIN VISIBILITY AND SYNCHRONIZATION, SUPPLY AND DEMAND FORECASTING AND PRODUCT DISTRIBUTION PROCESSES FOR OTHERS; TRANSPORTATION LOGISTICS SERVICES, NAMELY, ARRANGING THE TRANSPORTATION OF GOODS FOR OTHERS; TRANSPORTATION LOGISTICS SERVICES, NAMELY, PLANNING AND SCHEDULING SHIPMENTS FOR USERS OF TRANSPORTATION SERVICES; COMPUTERIZED TRACKING AND TRACING OF PACKAGES IN TRANSIT; INFORMATION MANAGEMENT SERVICES, NAMELY, SHIPMENT PROCESSING, PREPARING SHIPPING DOCUMENTS AND INVOICES, TRACKING DOCUMENTS, PACKAGES AND FREIGHT OVER COMPUTER NETWORKS, INTRANETS AND INTERNETS; MONITORING AND TRACKING OF PACKAGE SHIPMENTS; PROVIDING ELECTRONIC TRACKING OF FREIGHT INFORMATION TO OTHERS; TRACKING, LOCATING AND MONITORING OF VEHICLES, MARITIME VESSELS AND AIRCRAFT SERVICES; CUSTOMS CLEARANCE SERVICES; ARRANGING FOR PICKUP, DELIVERY, STORAGE AND TRANSPORTATION OF DOCUMENTS, PACKAGES, FREIGHT AND PARCELS VIA GROUND AND AIR CARRIERS; ORDER FULFILLMENT SERVICES (U.S. CLS. 100, 101 AND 102).

CLASS 39—TRANSPORTATION AND STORAGE

FOR DOMESTIC AND INTERNATIONAL COMMON CARRIER FREIGHT TRANSPORTATION BY MEANS OF TRUCK, AIR, OR SEA, AND DOMESTIC AND INTERNATIONAL FREIGHT FORWARDING SERVICES; SUPPLY CHAIN, LOGISTICS AND REVERSE LOGISTICS SERVICES, NAMELY, STORAGE, TRANSPORTATION AND DELIVERY OF DOCUMENTS, PACKAGES, RAW MATERIALS, AND OTHER FREIGHT FOR OTHERS BY AIR, RAIL, SHIP OR TRUCK; WAREHOUSING SERVICES, NAMELY, STORAGE, DISTRIBUTION, PICK-UP, AND PACKING FOR SHIPMENT OF DOCUMENTS, PACKAGES, RAW MATERIALS, AND OTHER FREIGHT FOR OTHERS (U.S. CLS. 100 AND 105).

BRIAN NEVILLE, EXAMINING ATTORNEY



OWNER OF U.S. REG. NOS. 3,266,262, 3,809,215 AND OTHERS.

NO CLAIM IS MADE TO THE EXCLUSIVE RIGHT TO USE "FREIGHT", APART FROM THE MARK AS SHOWN.

THE COLOR(S) BLUE, WHITE, AND ORANGE IS/ARE CLAIMED AS A FEATURE OF THE MARK.

THE MARK CONSISTS OF THE LETTERS "YRC" IN WHITE ABOVE A TRILATERAL DESIGN IN ORANGE, THAT IS DIVIDED INTO TWO PARTS BY A SMALLER TRILATERAL DESIGN IN BLUE, WITH THE WORD "FREIGHT" IN WHITE BELOW THE TRILATERAL DESIGNS, ALL INCLUDED WITHIN A BLUE RECTANGLE.

CLASS 35—ADVERTISING AND BUSINESS

FOR BUSINESS CONSULTING SERVICES RELATING TO PRODUCT DISTRIBUTION, OPERATIONS MANAGEMENT SERVICES, LOGISTICS, REVERSE LOGISTICS, SUPPLY CHAIN, AND PRODUCTION SYSTEMS AND DISTRIBUTION SOLUTIONS; BUSINESS MANAGEMENT SERVICES, NAMELY, MANAGING LOGISTICS, REVERSE LOGISTICS, SUPPLY CHAIN SERVICES, SUPPLY CHAIN VISIBILITY AND SYNCHRONIZATION, SUPPLY AND DEMAND FORECASTING AND PRODUCT DISTRIBUTION PROCESSES FOR OTHERS; TRANSPORTATION LOGISTICS SERVICES, NAMELY, ARRANGING THE TRANSPORTATION OF GOODS FOR OTHERS; TRANSPORTATION LOGISTICS SERVICES, NAMELY, PLANNING AND SCHEDULING SHIPMENTS FOR USERS OF TRANSPORTATION SERVICES; COMPUTERIZED TRACKING AND TRACING OF PACKAGES IN TRANSIT; INFORMATION MANAGEMENT SERVICES, NAMELY, SHIPMENT PROCESSING, PREPARING SHIPPING DOCUMENTS AND INVOICES, TRACKING DOCUMENTS, PACKAGES AND FREIGHT OVER COMPUTER NETWORKS, INTRANETS AND INTERNETS; MONITORING AND TRACKING OF PACKAGE SHIPMENTS; PROVIDING ELECTRONIC TRACKING OF FREIGHT INFORMATION TO OTHERS; TRACKING, LOCATING AND MONITORING OF VEHICLES, MARITIME VESSELS AND AIRCRAFT SERVICES; CUSTOMS CLEARANCE SERVICES; ARRANGING FOR PICKUP, DELIVERY, STORAGE AND TRANSPORTATION OF DOCUMENTS, PACKAGES, FREIGHT AND PARCELS VIA GROUND AND AIR CARRIERS; ORDER FULFILLMENT SERVICES (U.S. CLS. 100, 101 AND 102).

CLASS 39—TRANSPORTATION AND STORAGE

FOR DOMESTIC AND INTERNATIONAL COMMON CARRIER FREIGHT TRANSPORTATION BY MEANS OF TRUCK, AIR, OR SEA, AND DOMESTIC AND INTERNATIONAL FREIGHT FORWARDING SERVICES; SUPPLY CHAIN, LOGISTICS AND REVERSE LOGISTICS SERVICES, NAMELY, STORAGE, TRANSPORTATION AND DELIVERY OF DOCUMENTS, PACKAGES, RAW MATERIALS, AND OTHER FREIGHT FOR OTHERS BY AIR, RAIL, SHIP OR TRUCK; WAREHOUSING SERVICES, NAMELY, STORAGE, DISTRIBUTION, PICK-UP, AND PACKING FOR SHIPMENT OF DOCUMENTS, PACKAGES, RAW MATERIALS, AND OTHER FREIGHT FOR OTHERS (U.S. CLS. 100 AND 105).

BRIAN NEVILLE, EXAMINING ATTORNEY

SN 85-508,485. JAMBA JUICE COMPANY, EMERYVILLE, CA. FILED 1-4-2012.

ZUKA JUICE

THE MARK CONSISTS OF STANDARD CHARACTERS WITHOUT CLAIM TO ANY PARTICULAR FONT, STYLE, SIZE, OR COLOR.

NO CLAIM IS MADE TO THE EXCLUSIVE RIGHT TO USE "JUICE", APART FROM THE MARK AS SHOWN.

CLASS 32—LIGHT BEVERAGES

FOR FRUIT JUICES AND FRUIT DRINKS; VEGETABLE JUICES AND VEGETABLE DRINKS; SMOOTHIES (U.S. CLS. 45, 46 AND 48).

CLASS 43—HOTEL AND RESTAURANT SERVICES

FOR RESTAURANT SERVICES; SNACK BAR SERVICES; JUICE BAR SERVICES (U.S. CLS. 100 AND 101).
SANJEEV VOHRA, EXAMINING ATTORNEY

SN 85-508,558. HEB GROCERY COMPANY LP, SAN ANTONIO, TX. FILED 1-4-2012.

HILL COUNTRY ESSENTIALS

THE MARK CONSISTS OF STANDARD CHARACTERS WITHOUT CLAIM TO ANY PARTICULAR FONT, STYLE, SIZE, OR COLOR.

OWNER OF U.S. REG. NOS. 3,681,033 AND 3,681,034.

CLASS 5—PHARMACEUTICALS

FOR BABY AND INFANT DIAPERS (U.S. CLS. 6, 18, 44, 46, 51 AND 52).
FIRST USE 1-17-2011; IN COMMERCE 1-17-2011.

CLASS 16—PAPER GOODS AND PRINTED MATTER

FOR DISPOSABLE TRAINING PANTS (U.S. CLS. 2, 5, 22, 23, 29, 37, 38 AND 50).

FIRST USE 1-17-2011; IN COMMERCE 1-17-2011.

JUDITH HELFMAN, EXAMINING ATTORNEY

SN 85-508,571. GLOVER, CHARLENE W, ALBANY, GA. FILED 1-4-2012.



THE COLOR(S) SILVER IS/ARE CLAIMED AS A FEATURE OF THE MARK.

THE MARK CONSISTS OF A CROSS IN SILVER WITH THE CURVED WORDING "CHRIST CENTERED" IN SILVER OVER THE TOP OF THE CROSS AND THE CURVED WORDING "CROSS FOCUSED" IN SILVER ON EITHER SIDE OF THE LOWER PART OF THE CROSS. THE GRAY AREA REPRESENTS BACKGROUND AND IS NOT CLAIMED AS A FEATURE OF THE MARK.

CLASS 14—JEWELRY

FOR ALARM CLOCKS; AMULETS; ANKLE BRACELETS; BANGLE BRACELETS; BEADS FOR MAKING JEWELRY; BRACELETS; BRACELETS AND JEWELRY FEATURING ELECTRONIC CHIPS FOR ATTRACTING ENERGY TO THE BODY WHEREIN THE ELECTRONIC CHIPS INCREASE IN POWER IN THE PRESENCE OF ELECTROMAGNETIC FIELDS, FOR THE PURPOSE OF RE-BALANCING THE HUMAN ENERGY FIELD; BROACHES; BRONZE JEWELRY; BROOCHES; CASES FOR WATCHES AND CLOCKS; CHARMS; CHARMS FOR COLLAR JEWELRY AND BRACELET; CLIP EARRINGS; CLOCKS; CLOCKS AND WATCHES; COMMEMORATIVE COINS; COSTUME JEWELRY; DESK CLOCKS; DIAMOND JEWELRY; EAR STUDS; EARRINGS; FANCY KEYRINGS OF PRECIOUS METALS; FLOOR CLOCKS; GEMSTONE JEWELRY; GOLD THREAD JEWELRY; HAIR JEWELRY IN THE NATURE OF JEWELRY FOR USE IN THE HAIR; IVORY JEWELRY; JEWELRY CHAIN OF PRECIOUS METAL FOR BRACELETS; JEWELLERY, CLOCKS AND WATCHES; JEWELRY; JEWELRY AND IMITATION JEWELRY; JEWELRY BOXES; JEWELRY BOXES NOT OF METAL; JEWELRY BOXES OF METAL; JEWELRY BOXES OF PRECIOUS METAL; JEWELRY BROOCHES; JEWELRY CASES; JEWELRY CASES NOT OF PRECIOUS METAL; JEWELRY CASKETS; JEWELRY CASKETS OF PRECIOUS METAL; JEWELRY DISHES; JEWELRY FOR THE HEAD; JEWELRY IN THE NATURE OF ARMBANDS; JEWELRY MAKING KITS; JEWELRY ORGANIZERS; JEWELRY PINS FOR USE ON HATS; JEWELRY RING HOLDERS; JEWELRY STICKPINS; JEWELRY WATCHES; JEWELRY, NAMELY, AMULETS; JEWELRY, NAMELY, ANKLETS; JEWELRY, NAMELY, ARM CUFFS; JEWELRY, NAMELY, BRACELETS, WRISTBANDS AND NECKLACES THAT ALSO PROVIDES NOTIFICATION TO THE WEARER OF A PENDING MEDICAL RELATED TASK; JEWELRY, NAMELY, CROSSES; JEWELRY, NAMELY, MAGNETIC NECKLACES; JEWELRY, NAMELY, MAGNETIC PENDANTS; JEWELRY, NAMELY, PRECIOUS METAL PLATED REAL LEAVES

AND FLOWERS; JEWELRY, NAMELY, STONE PENDANTS; KEY CHAINS AS JEWELLERY; LEATHER JEWELRY AND ACCESSORY BOXES; METAL WIRE FOR USE IN THE MAKING OF JEWELRY, NAMELY, JEWELRY CABLE; MUSICAL JEWELRY BOXES; NECKLACES; NYLON ANKLE BRACELETS; NYLON BRACELETS; PINS BEING JEWELRY; PLASTIC BRACELETS IN THE NATURE OF JEWELRY; RINGS; RINGS BEING JEWELRY; SLAP BRACELETS; SLAPBAND BRACELETS; SMALL CLOCKS; STAINLESS STEEL JEWELRY BRACELETS; TABLE CLOCKS; TRAVEL CLOCKS; WALL CLOCKS; WATCH BRACELETS; WATCHES AND CLOCKS; WATCHES AND JEWELRY; WATCHES, CLOCKS, JEWELLERY AND IMITATION JEWELLERY; WATCHES, CLOCKS, JEWELRY AND IMITATION JEWELRY; WOMEN'S JEWELRY; WOODEN JEWELLERY BOXES (U.S. CLS. 2, 27, 28 AND 50).

SN 85-508,573. MIKE THOMPSON RECREATIONAL VEHICLE, SANTA FE SPRINGS, CA. FILED 1-4-2012.

TRAVELAND USA

THE MARK CONSISTS OF STANDARD CHARACTERS WITHOUT CLAIM TO ANY PARTICULAR FONT, STYLE, SIZE, OR COLOR.

NO CLAIM IS MADE TO THE EXCLUSIVE RIGHT TO USE "USA", APART FROM THE MARK AS SHOWN.

CLASS 35—ADVERTISING AND BUSINESS

FOR RECREATIONAL VEHICLE DEALERSHIPS (U.S. CLS. 100, 101 AND 102).

CLASS 37—CONSTRUCTION AND REPAIR

FOR RECREATIONAL VEHICLE REPAIR SERVICES (U.S. CLS. 100, 103 AND 106).

JUDITH HELFMAN, EXAMINING ATTORNEY

CLASS 25—CLOTHING

FOR ATHLETIC APPAREL, NAMELY, SHIRTS, PANTS, JACKETS, FOOTWEAR, HATS AND CAPS; ATHLETIC UNIFORMS; ATHLETIC SHOES; BABIES' PANTS; BASEBALL CAPS AND HATS; BELTS; BIBS NOT OF CLOTH OR PAPER; BODY SHIRTS; BUTTON DOWN SHIRTS; BUTTON-FRONT ALOHA SHIRTS; CAMP SHIRTS; CAPRI PANTS; CARGO PANTS; CHILDREN'S AND INFANTS' CLOTH BIBS; CHILDREN'S CLOTH EATING BIBS; CLOTH BIBS FOR ADULT DINERS; CLOTHING EXTENSION USED TO EXTEND THE NORMAL SIZE RANGE OF CLOTHING ITEMS TO ACCOMMODATE PREGNANCY SIZE CHANGES; CLOTHING FOR ATHLETIC USE, NAMELY, PADDED SHIRTS; CLOTHING FOR BABIES, TODDLERS AND CHILDREN, TREATED WITH FIRE AND HEAT RETARDANTS, NAMELY, PAJAMAS, JACKETS, SHIRTS, PANTS, JUMPERS; CLOTHING SHIELDS, NAMELY, PADS APPLIED TO THE UNDERARMS OF SHIRTS, BLOUSES AND SWEATERS; COLLARED SHIRTS; CROP PANTS; DENIMS; DRESS PANTS; DRESS SHIRTS; DUSTERS BEING CLOTHING; EYESHADES; FLOOD PANTS; GLOVES AS CLOTHING; HAT BANDS; HATS; HATS FOR INFANTS, BABIES, TODDLERS AND CHILDREN; HEADBANDS FOR CLOTHING; HOODED SWEAT SHIRTS; HOODS; INFANT AND TODDLER ONE PIECE CLOTHING; INFANTS' SHOES AND BOOTS; JACKETS; JERSEYS; KNIT SHIRTS; LEATHER BELTS; LEATHER HATS; LEATHER SHOES; LEISURE SHOES; LONG-SLEEVED SHIRTS; MANTLES; MUFFLERS; NIGHT SHIRTS; NON-DISPOSABLE CLOTH TRAINING PANTS; OPEN-NECKED SHIRTS; OVER SHIRTS; PANTS; PARTY HATS BEING CLOTHING; PIQUE SHIRTS; POLO SHIRTS; RAIN HATS; RIDING SHOES; RUBBER SHOES; RUGBY SHIRTS; RUNNING SHOES; SHIRTS; SHIRTS AND SHORT-SLEEVED SHIRTS; SHIRTS AND SLIPS; SHIRTS FOR INFANTS, BABIES, TODDLERS AND CHILDREN; SHIRTS FOR SUITS; SHOE ACCESSORIES, NAMELY, FITTED DECORATIVE COVERS FOR SHOES; SHOE COVERS FOR USE WHEN WEARING SHOES; SHORT SETS; SHORT-SLEEVED OR LONG-SLEEVED T-SHIRTS; SHOULDER WRAPS; SHOULDER WRAPS FOR CLOTHING; SLEEP PANTS; SLEEP SHIRTS; SLEEVES WORN SEPARATE AND APART FROM BLOUSES, SHIRTS AND OTHER TOPS; SMALL HATS; SPORTS CAPS AND HATS; SWEAT SHIRTS; T-SHIRTS; TOPS; TRAVEL CLOTHING CONTAINED IN A PACKAGE COMPRISING REVERSIBLE JACKETS, PANTS, SKIRTS, TOPS AND A BELT OR SCARF; TURTLE NECK SHIRTS; WEARABLE GARMENTS AND CLOTHING, NAMELY, SHIRTS; WOMEN'S CLOTHING, NAMELY, SHIRTS, DRESSES, SKIRTS, BLOUSES; WOMEN'S HATS AND HOODS; WOMEN'S SHOES; WOOLLY HATS; WRAPS; WRIST BANDS; WRISTBANDS (U.S. CLS. 22 AND 39).

KATHY DE JONGE, EXAMINING ATTORNEY

SN 85-508,659. WINEASE, LLC, DELANO, MN. FILED 1-4-2012.

FLAIR

THE MARK CONSISTS OF STANDARD CHARACTERS WITHOUT CLAIM TO ANY PARTICULAR FONT, STYLE, SIZE, OR COLOR.

OWNER OF U.S. REG. NO. 2,339,119.

CLASS 16—PAPER GOODS AND PRINTED MATTER

FOR PRINTED PUBLICATIONS, NAMELY, NEWSLETTERS IN THE FIELD OF THE EQUINE INDUSTRY; STICKERS; PAPER GIFT BAGS (U.S. CLS. 2, 5, 22, 23, 29, 37, 38 AND 50).

CLASS 41—EDUCATION AND ENTERTAINMENT

FOR PROVIDING A WEB SITE FEATURING INFORMATION FOR THE EQUINE INDUSTRY, NAMELY, INFORMATION ON EQUINE TRAINING, EQUINE SPORTING EVENTS, EQUINE COMPETITORS AND EQUINE HEALTHCARE (U.S. CLS. 100, 101 AND 107).

JAY FLOWERS, EXAMINING ATTORNEY

SN 85-508,668. THE ADVISORY BOARD COMPANY, WASHINGTON, DC. FILED 1-4-2012.

CRIMSON POPULATION RISK MANAGEMENT

THE MARK CONSISTS OF STANDARD CHARACTERS WITHOUT CLAIM TO ANY PARTICULAR FONT, STYLE, SIZE, OR COLOR.

OWNER OF U.S. REG. NO. 3,638,249.

NO CLAIM IS MADE TO THE EXCLUSIVE RIGHT TO USE "POPULATION RISK MANAGEMENT", APART FROM THE MARK AS SHOWN.

CLASS 35—ADVERTISING AND BUSINESS

FOR BUSINESS CONSULTING AND INFORMATION SERVICES IN THE FIELD OF EMPLOYEE HEALTH CARE BENEFITS SAVINGS OPPORTUNITIES FOR SELF-INSURED EMPLOYERS (U.S. CLS. 100, 101 AND 102).

FIRST USE 4-0-2011; IN COMMERCE 4-0-2011.

CLASS 42—SCIENTIFIC AND COMPUTER SERVICES

FOR PROVIDING TEMPORARY USE OF ONLINE, NON-DOWNLOADABLE COMPUTER SOFTWARE FOR RISK MANAGEMENT IN THE FIELD OF BUSINESS INTELLIGENCE RELATED TO EMPLOYEE HEALTH CARE BENEFITS SAVINGS OPPORTUNITIES FOR SELF-INSURED EMPLOYERS (U.S. CLS. 100 AND 101).

FIRST USE 4-0-2011; IN COMMERCE 4-0-2011.

JAY FLOWERS, EXAMINING ATTORNEY

SN 85-508,806. COHEN, EMILY, DENVER, CO. FILED 1-4-2012.

SOCIAL REALTY

THE MARK CONSISTS OF STANDARD CHARACTERS WITHOUT CLAIM TO ANY PARTICULAR FONT, STYLE, SIZE, OR COLOR.

NO CLAIM IS MADE TO THE EXCLUSIVE RIGHT TO USE "SOCIAL" FOR INTERNATIONAL CLASS 35 AND "REALTY" FOR INTERNATIONAL CLASS 36, APART FROM THE MARK AS SHOWN.

CLASS 35—ADVERTISING AND BUSINESS

FOR ADVERTISING AND MARKETING SERVICES; SOCIAL MEDIA ADVERTISING AND RELATED CONSULTING; ADVERTISING AND MARKETING CONSULTANCY; BUSINESS MANAGEMENT CONSULTANCY; ASSISTANCE, ADVISORY SERVICES AND CONSULTANCY WITH REGARD TO BUSINESS PLANNING, BUSINESS ANALYSIS, BUSINESS MANAGEMENT, BUSINESS ORGANIZATION, MARKETING AND CUSTOMER ANALYSIS (U.S. CLS. 100, 101 AND 102).

CLASS 36—INSURANCE AND FINANCIAL

FOR PROVIDING REAL ESTATE LISTING SERVICES, LISTINGS OF REAL ESTATE AVAILABLE FOR LEASE, AND REAL ESTATE INFORMATION VIA THE INTERNET; LEASING OF REAL ESTATE; REAL ESTATE AGENCIES; REAL ESTATE BROKERS; REAL ESTATE MANAGEMENT; RENTAL OF OFFICES (U.S. CLS. 100, 101 AND 102).

APRIL ROACH, EXAMINING ATTORNEY

SN 85-508,926. NUSCALE POWER, LLC, PORTLAND, OR. FILED 1-4-2012.

NUSCALE POWER

THE MARK CONSISTS OF STANDARD CHARACTERS WITHOUT CLAIM TO ANY PARTICULAR FONT, STYLE, SIZE, OR COLOR.

NO CLAIM IS MADE TO THE EXCLUSIVE RIGHT TO USE "POWER", APART FROM THE MARK AS SHOWN.

CLASS 11—ENVIRONMENTAL CONTROL APPARATUS

FOR NUCLEAR REACTORS (U.S. CLS. 13, 21, 23, 31 AND 34).

CLASS 35—ADVERTISING AND BUSINESS

FOR MANAGEMENT AND BUSINESS CONSULTING SERVICES IN THE FIELD OF NUCLEAR ENERGY; PROCUREMENT, NAMELY, PURCHASING POWER PLANT COMPONENTS FOR OTHERS; REGULATORY SUBMISSION MANAGEMENT, NAMELY, ASSISTING OTHERS IN PREPARING AND FILING APPLICATIONS FOR NEW NUCLEAR POWER PLANTS WITH GOVERNMENTAL REGULATORY BODIES; CONSULTING SERVICES IN THE FIELD OF MANAGEMENT OF NUCLEAR POWER PLANTS; CONSULTING SERVICES IN THE FIELD OF MANAGEMENT OF THE DESIGN, LICENSING, OPERATION, MAINTENANCE, AND DECOMMISSIONING OF NUCLEAR POWER PLANTS (U.S. CLS. 100, 101 AND 102).

CLASS 37—CONSTRUCTION AND REPAIR

FOR CONSULTING SERVICES IN THE FIELD OF REPAIR AND MAINTENANCE OF NUCLEAR ENERGY POWER PLANTS; CONSULTING SERVICES IN THE FIELD OF CONSTRUCTION OF NUCLEAR POWER PLANTS (U.S. CLS. 100, 103 AND 106).

CLASS 41—EDUCATION AND ENTERTAINMENT

FOR EDUCATIONAL SERVICES, NAMELY, DEVELOPING CURRICULUM AND TRAINING MATERIALS FOR OTHERS IN THE FIELD OF OPERATION, MAINTENANCE, REFUELING AND CALIBRATION OF NUCLEAR POWER PLANTS; TRAINING SERVICES IN THE FIELD OF OPERATION, MAINTENANCE, REFUELING AND CALIBRATION OF NUCLEAR POWER PLANTS; CONSULTING SERVICES IN THE FIELD OF TRAINING FOR THE OPERATION, MAINTENANCE, REFUELING AND CALIBRATION OF NUCLEAR POWER PLANTS (U.S. CLS. 100, 101 AND 107).

CLASS 42—SCIENTIFIC AND COMPUTER SERVICES

FOR CONSULTING SERVICES IN THE FIELD OF DESIGN, PLANNING, IMPLEMENTATION, AND OPERATION OF NUCLEAR POWER PLANTS; CONSULTING SERVICES IN THE FIELD OF REFUELING, AND CALIBRATING NUCLEAR POWER PLANTS; NUCLEAR ENGINEERING; DESIGNING PLANT COMPONENTS AND EQUIPMENT FOR NUCLEAR POWER PLANTS (U.S. CLS. 100 AND 101).

MATTHEW PAPPAS, EXAMINING ATTORNEY

CLASS 16—PAPER GOODS AND PRINTED MATTER

FOR GLUE FOR STATIONERY OR HOUSEHOLD USE (U.S. CLS. 2, 5, 22, 23, 29, 37, 38 AND 50).

FIRST USE 10-11-2011; IN COMMERCE 10-11-2011.

NAKIA HENRY, EXAMINING ATTORNEY

SN 85-508,980. CICLOVIDA BAGS, PORTLAND, OR. FILED 1-5-2012.

SN 85-509,229. NEOPOINT TECHNOLOGIES LTD., GIBRALTAR, GIBRALTAR, FILED 1-5-2012.

Ciclovida Bags

THE MARK CONSISTS OF STANDARD CHARACTERS WITHOUT CLAIM TO ANY PARTICULAR FONT, STYLE, SIZE, OR COLOR.

NO CLAIM IS MADE TO THE EXCLUSIVE RIGHT TO USE "BAGS", APART FROM THE MARK AS SHOWN.

THE ENGLISH TRANSLATION OF THE WORD "CICLOVIDA" IN THE MARK IS LIFECYCLE OR CYCLE OF LIFE.

CLASS 12—VEHICLES

FOR PANNIER BAGS FOR BICYCLES (U.S. CLS. 19, 21, 23, 31, 35 AND 44).

CLASS 16—PAPER GOODS AND PRINTED MATTER

FOR LUNCH BAGS MADE OF TEXTILE (U.S. CLS. 2, 5, 22, 23, 29, 37, 38 AND 50).

CLASS 18—LEATHER GOODS

FOR MESSENGER BAGS (U.S. CLS. 1, 2, 3, 22 AND 41).
DANIEL CAPSHAW, EXAMINING ATTORNEY

SN 85-509,192. PURPLE COWS, INC., PROVO, UT. FILED 1-5-2012.

Moo Glue

THE MARK CONSISTS OF STANDARD CHARACTERS WITHOUT CLAIM TO ANY PARTICULAR FONT, STYLE, SIZE, OR COLOR.

NO CLAIM IS MADE TO THE EXCLUSIVE RIGHT TO USE "GLUE", APART FROM THE MARK AS SHOWN.

CLASS 1—CHEMICALS

FOR GLUE FOR USE IN HANDMADE CRAFT INDUSTRY (U.S. CLS. 1, 5, 6, 10, 26 AND 46).
FIRST USE 10-11-2011; IN COMMERCE 10-11-2011.

3 WOW

THE MARK CONSISTS OF STANDARD CHARACTERS WITHOUT CLAIM TO ANY PARTICULAR FONT, STYLE, SIZE, OR COLOR.

CLASS 9—ELECTRICAL AND SCIENTIFIC APPARATUS

FOR COMPUTER GAME PROGRAMS; COMPUTER GAME PROGRAMS DOWNLOADABLE VIA THE INTERNET; COMPUTER GAME SOFTWARE; COMPUTER GAME SOFTWARE FOR GAMING MACHINES INCLUDING SLOT MACHINES OR VIDEO LOTTERY TERMINALS; COMPUTER GAME SOFTWARE FOR PERSONAL COMPUTERS AND HOME VIDEO GAME CONSOLES; COMPUTER GAME SOFTWARE FOR USE ON MOBILE AND CELLULAR PHONES; INTERACTIVE MULTIMEDIA COMPUTER GAME PROGRAM; VISUAL RECORDINGS AND AUDIOVISUAL RECORDINGS FEATURING MUSIC AND ANIMATION; COMPUTER CURSOR CONTROL DEVICES, NAMELY, DIGITIZER TABLETS; TABLET COMPUTER; MOBILE TELEPHONES (U.S. CLS. 21, 23, 26, 36 AND 38).

CLASS 41—EDUCATION AND ENTERTAINMENT

FOR ELECTRONIC GAME SERVICES, NAMELY, PROVIDING ONLINE COMPUTER GAMES, PROVIDING A COMPUTER GAME THAT MAY BE ACCESSED BY USERS ON A GLOBAL NETWORK OR THE INTERNET, PROVIDING A COMPUTER GAME THAT MAY BE ACCESSED NETWORK-WIDE BY NETWORK USERS, PROVIDING ONLINE INTERACTIVE COMPUTER GAMES VIA THE INTERNET OR ELECTRONIC COMMUNICATION NETWORKS, AND PROVIDING ONLINE ELECTRONIC GAMES ACCESSIBLE VIA HANDHELD GAME APPARATUS; INTERNET LOTTERY, GAMBLING, CASINO GAMING, AND BETTING POOL SERVICES; PROVIDING ON-LINE LOTTERY CARD GAMES, NAMELY, ELECTRONIC INSTANT CARD GAMES AND SCRATCH CARD GAMES; PRODUCTION OF VIDEO AND COMPUTER GAME SOFTWARE; ENTERTAINMENT SERVICES IN THE NATURE OF RECORDING, PRODUCTION AND POST-PRODUCTION SERVICES IN THE FIELD OF ONLINE GAMES AND NON-DOWNLOADABLE GAMES (U.S. CLS. 100, 101 AND 107).

CLASS 42—SCIENTIFIC AND COMPUTER SERVICES

FOR PROVIDING ON-LINE NON-DOWNLOADABLE INTERACTIVE GAMING SOFTWARE, AND A WEBSITE FEATURING ON-LINE NON-DOWNLOADABLE INTERACTIVE GAMING SOFTWARE; DESIGN AND DEVELOPMENT OF COMPUTER GAME SOFTWARE, DESIGNING AND DEVELOPING COMPUTER GAME SOFTWARE AND VIDEO GAME SOFTWARE FOR USE WITH COMPUTERS, VIDEO GAME PROGRAM SYSTEMS AND COMPUTER NETWORKS, COMPUTER SERVICES, NAMELY, HOSTING AN INTERACTIVE WEB SITE THAT ALLOWS USERS TO PARTICIPATE IN ONLINE GAMES; COMPUTER PROGRAMMING OF COMPUTER GAMES; COMPUTER GRAPHICS DESIGN SERVICES, DESIGN AND DEVELOPMENT OF COMPUTER SOFTWARE AND GRAPHIC ARTS; COMPUTER SERVICES, NAMELY, ELECTRONIC DIGITIZING OF VISUAL MATERIAL, NAMELY, PHOTOGRAPHIC IMAGES, ARTWORK, PAINTINGS; COMPUTER SERVICES, NAMELY, CREATING AN ON-LINE VIRTUAL ENVIRONMENT FOR ELECTRONIC SLOT MACHINES, ELECTRONIC INSTANT CARD GAMES AND SCRATCH CARD GAMES; PROVIDING VIRTUAL COMPUTER SYSTEMS AND VIRTUAL COMPUTER ENVIRONMENTS THROUGH CLOUD COMPUTING; COMPUTER SERVICES, NAMELY, INTERACTIVE HOSTING SERVICES WHICH ALLOW THE USER TO PUBLISH AND SHARE THEIR OWN CONTENT AND IMAGES ONLINE; SPECIAL EFFECTS ANIMATION SERVICES FOR FILM, VIDEO AND COMPUTER GAMES; DESIGN AND DEVELOPMENT OF MULTIMEDIA PRODUCTS, PROGRAMMING OF MULTIMEDIA APPLICATIONS; HOSTING WEBSITES ON THE INTERNET; CREATION, DESIGN, DEVELOPMENT AND MAINTENANCE OF WEB SITES FOR THIRD PARTIES; HOSTING INTERNET SITES FOR THIRD PARTIES (U.S. CLS. 100 AND 101).

KAPIL BHANOT, EXAMINING ATTORNEY

CLASS 41—EDUCATION AND ENTERTAINMENT

FOR ELECTRONIC GAME SERVICES, NAMELY, PROVIDING ONLINE COMPUTER GAMES, PROVIDING A COMPUTER GAME THAT MAY BE ACCESSED BY USERS ON A GLOBAL NETWORK OR THE INTERNET, PROVIDING A COMPUTER GAME THAT MAY BE ACCESSED NETWORK-WIDE BY NETWORK USERS, PROVIDING ONLINE INTERACTIVE COMPUTER GAMES VIA THE INTERNET OR ELECTRONIC COMMUNICATION NETWORKS, AND PROVIDING ONLINE ELECTRONIC GAMES ACCESSIBLE VIA HANDHELD GAME APPARATUS; INTERNET LOTTERY, GAMBLING, CASINO GAMING, AND BETTING POOL SERVICES; PROVIDING ON-LINE LOTTERY CARD GAMES, NAMELY, ELECTRONIC INSTANT CARD GAMES AND SCRATCH CARD GAMES; PRODUCTION OF VIDEO AND COMPUTER GAME SOFTWARE; ENTERTAINMENT SERVICES IN THE NATURE OF RECORDING, PRODUCTION AND POST-PRODUCTION SERVICES IN THE FIELD OF ONLINE GAMES AND NON-DOWNLOADABLE GAMES (U.S. CLS. 100, 101 AND 107).

CLASS 42—SCIENTIFIC AND COMPUTER SERVICES

FOR PROVIDING ON-LINE NON-DOWNLOADABLE INTERACTIVE GAMING SOFTWARE, AND A WEBSITE FEATURING ON-LINE NON-DOWNLOADABLE INTERACTIVE GAMING SOFTWARE; DESIGN AND DEVELOPMENT OF COMPUTER GAME SOFTWARE, DESIGNING AND DEVELOPING COMPUTER GAME SOFTWARE AND VIDEO GAME SOFTWARE FOR USE WITH COMPUTERS, VIDEO GAME PROGRAM SYSTEMS AND COMPUTER NETWORKS, COMPUTER SERVICES, NAMELY, HOSTING AN INTERACTIVE WEB SITE THAT ALLOWS USERS TO PARTICIPATE IN ONLINE GAMES; COMPUTER PROGRAMMING OF COMPUTER GAMES; COMPUTER GRAPHICS DESIGN SERVICES, DESIGN AND DEVELOPMENT OF COMPUTER SOFTWARE AND GRAPHIC ARTS; COMPUTER SERVICES, NAMELY, ELECTRONIC DIGITIZING OF VISUAL MATERIAL, NAMELY, PHOTOGRAPHIC IMAGES, ARTWORK, PAINTINGS; COMPUTER SERVICES, NAMELY, CREATING AN ON-LINE VIRTUAL ENVIRONMENT FOR ELECTRONIC SLOT MACHINES, ELECTRONIC INSTANT CARD GAMES AND SCRATCH CARD GAMES; PROVIDING VIRTUAL COMPUTER SYSTEMS AND VIRTUAL COMPUTER ENVIRONMENTS THROUGH CLOUD COMPUTING; COMPUTER SERVICES, NAMELY, INTERACTIVE HOSTING SERVICES WHICH ALLOW THE USER TO PUBLISH AND SHARE THEIR OWN CONTENT AND IMAGES ONLINE; SPECIAL EFFECTS ANIMATION SERVICES FOR FILM, VIDEO AND COMPUTER GAMES; DESIGN AND DEVELOPMENT OF MULTIMEDIA PRODUCTS, PROGRAMMING OF MULTIMEDIA APPLICATIONS; HOSTING WEBSITES ON THE INTERNET; CREATION, DESIGN, DEVELOPMENT AND MAINTENANCE OF WEB SITES FOR THIRD PARTIES; HOSTING INTERNET SITES FOR THIRD PARTIES (U.S. CLS. 100 AND 101).

KAPIL BHANOT, EXAMINING ATTORNEY

SN 85-509,239. NEOPOINT TECHNOLOGIES LTD., GIBRALTAR, GIBRALTAR, FILED 1-5-2012.

SUPER 3 WOW

THE MARK CONSISTS OF STANDARD CHARACTERS WITHOUT CLAIM TO ANY PARTICULAR FONT, STYLE, SIZE, OR COLOR.

CLASS 9—ELECTRICAL AND SCIENTIFIC APPARATUS

FOR COMPUTER GAME PROGRAMS; COMPUTER GAME PROGRAMS DOWNLOADABLE VIA THE INTERNET; COMPUTER GAME SOFTWARE; COMPUTER GAME SOFTWARE FOR GAMING MACHINES INCLUDING SLOT MACHINES OR VIDEO LOTTERY TERMINALS; COMPUTER GAME SOFTWARE FOR PERSONAL COMPUTERS AND HOME VIDEO GAME CONSOLES; COMPUTER GAME SOFTWARE FOR USE ON MOBILE AND CELLULAR PHONES; INTERACTIVE MULTIMEDIA COMPUTER GAME PROGRAM; VISUAL RECORDINGS AND AUDIOVISUAL RECORDINGS FEATURING MUSIC AND ANIMATION; COMPUTER CURSOR CONTROL DEVICES, NAMELY, DIGITIZER TABLETS; TABLET COMPUTER; MOBILE TELEPHONES (U.S. CLS. 21, 23, 26, 36 AND 38).

SN 85-509,248. NEOPOINT TECHNOLOGIES LTD., GIBRALTAR, GIBRALTAR, FILED 1-5-2012.

QUICK PLAY

THE MARK CONSISTS OF STANDARD CHARACTERS WITHOUT CLAIM TO ANY PARTICULAR FONT, STYLE, SIZE, OR COLOR.

CLASS 9—ELECTRICAL AND SCIENTIFIC APPARATUS

FOR COMPUTER GAME PROGRAMS; COMPUTER GAME PROGRAMS DOWNLOADABLE VIA THE INTERNET; COMPUTER GAME SOFTWARE; COMPUTER GAME SOFTWARE FOR GAMING MACHINES INCLUDING SLOT MACHINES OR VIDEO LOTTERY TERMINALS; COMPUTER GAME SOFTWARE FOR PERSONAL COMPUTERS AND HOME VIDEO GAME CONSOLES; COMPUTER GAME SOFTWARE FOR USE ON MOBILE AND CELLULAR PHONES; INTERACTIVE MULTIMEDIA COMPUTER GAME PROGRAM; VISUAL RECORDINGS AND AUDIOVISUAL RECORDINGS FEATURING MUSIC AND ANIMATION; COMPUTER CURSOR CONTROL DEVICES, NAMELY, DIGITIZER TABLETS; TABLET COMPUTER; MOBILE TELEPHONES (U.S. CLS. 21, 23, 26, 36 AND 38).

SN 85-509,254. NEOPOINT TECHNOLOGIES LTD., GIBRALTAR, GIBRALTAR, FILED 1-5-2012.

CLASS 41—EDUCATION AND ENTERTAINMENT

FOR ELECTRONIC GAME SERVICES, NAMELY, PROVIDING ONLINE COMPUTER GAMES, PROVIDING A COMPUTER GAME THAT MAY BE ACCESSED BY USERS ON A GLOBAL NETWORK OR THE INTERNET, PROVIDING A COMPUTER GAME THAT MAY BE ACCESSED NETWORK-WIDE BY NETWORK USERS, PROVIDING ONLINE INTERACTIVE COMPUTER GAMES VIA THE INTERNET OR ELECTRONIC COMMUNICATION NETWORKS, AND PROVIDING ONLINE ELECTRONIC GAMES ACCESSIBLE VIA HANDHELD GAME APPARATUS; INTERNET LOTTERY, GAMBLING, CASINO GAMING, AND BETTING POOL SERVICES; PROVIDING ON-LINE LOTTERY CARD GAMES, NAMELY, ELECTRONIC INSTANT CARD GAMES AND SCRATCH CARD GAMES; PRODUCTION OF VIDEO AND COMPUTER GAME SOFTWARE; ENTERTAINMENT SERVICES IN THE NATURE OF RECORDING, PRODUCTION AND POST-PRODUCTION SERVICES IN THE FIELD OF ONLINE GAMES AND NON-DOWNLOADABLE GAMES (U.S. CLS. 100, 101 AND 107).

CLASS 42—SCIENTIFIC AND COMPUTER SERVICES

FOR PROVIDING ON-LINE NON-DOWNLOADABLE INTERACTIVE GAMING SOFTWARE, AND A WEBSITE FEATURING ON-LINE NON-DOWNLOADABLE INTERACTIVE GAMING SOFTWARE; DESIGN AND DEVELOPMENT OF COMPUTER GAME SOFTWARE, DESIGNING AND DEVELOPING COMPUTER GAME SOFTWARE AND VIDEO GAME SOFTWARE FOR USE WITH COMPUTERS, VIDEO GAME PROGRAM SYSTEMS AND COMPUTER NETWORKS, COMPUTER SERVICES, NAMELY, HOSTING AN INTERACTIVE WEB SITE THAT ALLOWS USERS TO PARTICIPATE IN ONLINE GAMES; COMPUTER PROGRAMMING OF COMPUTER GAMES; COMPUTER GRAPHICS DESIGN SERVICES, DESIGN AND DEVELOPMENT OF COMPUTER SOFTWARE AND GRAPHIC ARTS; COMPUTER SERVICES, NAMELY, ELECTRONIC DIGITIZING OF VISUAL MATERIAL, NAMELY, PHOTOGRAPHIC IMAGES, ARTWORK, PAINTINGS; COMPUTER SERVICES, NAMELY, CREATING AN ON-LINE VIRTUAL ENVIRONMENT FOR ELECTRONIC SLOT MACHINES, ELECTRONIC INSTANT CARD GAMES AND SCRATCH CARD GAMES; PROVIDING VIRTUAL COMPUTER SYSTEMS AND VIRTUAL COMPUTER ENVIRONMENTS THROUGH CLOUD COMPUTING; COMPUTER SERVICES, NAMELY, INTERACTIVE HOSTING SERVICES WHICH ALLOW THE USER TO PUBLISH AND SHARE THEIR OWN CONTENT AND IMAGES ONLINE; SPECIAL EFFECTS ANIMATION SERVICES FOR FILM, VIDEO AND COMPUTER GAMES; DESIGN AND DEVELOPMENT OF MULTIMEDIA PRODUCTS, PROGRAMMING OF MULTIMEDIA APPLICATIONS; HOSTING WEBSITES ON THE INTERNET; CREATION, DESIGN, DEVELOPMENT AND MAINTENANCE OF WEBSITES FOR THIRD PARTIES; HOSTING INTERNET SITES FOR THIRD PARTIES (U.S. CLS. 100 AND 101).

KAPIL BHANOT, EXAMINING ATTORNEY

LEGEND OF TERRA

THE MARK CONSISTS OF STANDARD CHARACTERS WITHOUT CLAIM TO ANY PARTICULAR FONT, STYLE, SIZE, OR COLOR.

CLASS 9—ELECTRICAL AND SCIENTIFIC APPARATUS

FOR COMPUTER GAME PROGRAMS; COMPUTER GAME PROGRAMS DOWNLOADABLE VIA THE INTERNET; COMPUTER GAME SOFTWARE; COMPUTER GAME SOFTWARE FOR GAMING MACHINES INCLUDING SLOT MACHINES OR VIDEO LOTTERY TERMINALS; COMPUTER GAME SOFTWARE FOR PERSONAL COMPUTERS AND HOME VIDEO GAME CONSOLES; COMPUTER GAME SOFTWARE FOR USE ON MOBILE AND CELLULAR PHONES; INTERACTIVE MULTIMEDIA COMPUTER GAME PROGRAM; VISUAL RECORDINGS AND AUDIOVISUAL RECORDINGS FEATURING MUSIC AND ANIMATION; COMPUTER CURSOR CONTROL DEVICES, NAMELY, DIGITIZER TABLETS; TABLET COMPUTER; MOBILE TELEPHONES (U.S. CLS. 21, 23, 26, 36 AND 38).

CLASS 41—EDUCATION AND ENTERTAINMENT

FOR ELECTRONIC GAME SERVICES, NAMELY, PROVIDING ONLINE COMPUTER GAMES, PROVIDING A COMPUTER GAME THAT MAY BE ACCESSED BY USERS ON A GLOBAL NETWORK OR THE INTERNET, PROVIDING A COMPUTER GAME THAT MAY BE ACCESSED NETWORK-WIDE BY NETWORK USERS, PROVIDING ONLINE INTERACTIVE COMPUTER GAMES VIA THE INTERNET OR ELECTRONIC COMMUNICATION NETWORKS, AND PROVIDING ONLINE ELECTRONIC GAMES ACCESSIBLE VIA HANDHELD GAME APPARATUS; INTERNET LOTTERY, GAMBLING, CASINO GAMING, AND BETTING POOL SERVICES; PROVIDING ON-LINE LOTTERY CARD GAMES, NAMELY, ELECTRONIC INSTANT CARD GAMES AND SCRATCH CARD GAMES; PRODUCTION OF VIDEO AND COMPUTER GAME SOFTWARE; ENTERTAINMENT SERVICES IN THE NATURE OF RECORDING, PRODUCTION AND POST-PRODUCTION SERVICES IN THE FIELD OF ONLINE GAMES AND NON-DOWNLOADABLE GAMES (U.S. CLS. 100, 101 AND 107).

CLASS 42—SCIENTIFIC AND COMPUTER SERVICES

FOR PROVIDING ON-LINE NON-DOWNLOADABLE INTERACTIVE GAMING SOFTWARE, AND A WEBSITE FEATURING ON-LINE NON-DOWNLOADABLE INTERACTIVE GAMING SOFTWARE; DESIGN AND DEVELOPMENT OF COMPUTER GAME SOFTWARE, DESIGNING AND DEVELOPING COMPUTER GAME SOFTWARE AND VIDEO GAME SOFTWARE FOR USE WITH COMPUTERS, VIDEO GAME PROGRAM SYSTEMS AND COMPUTER NETWORKS, COMPUTER SERVICES, NAMELY, HOSTING AN INTERACTIVE WEB SITE THAT ALLOWS USERS TO PARTICIPATE IN ONLINE GAMES; COMPUTER PROGRAMMING OF COMPUTER GAMES; COMPUTER GRAPHICS DESIGN SERVICES, DESIGN AND DEVELOPMENT OF COMPUTER SOFTWARE AND GRAPHIC ARTS; COMPUTER SERVICES, NAMELY, ELECTRONIC DIGITIZING OF VISUAL MATERIAL, NAMELY, PHOTOGRAPHIC IMAGES, ARTWORK, PAINTINGS; COMPUTER SERVICES, NAMELY, CREATING AN ON-LINE VIRTUAL ENVIRONMENT FOR ELECTRONIC SLOT MACHINES, ELECTRONIC INSTANT CARD GAMES AND SCRATCH CARD GAMES; PROVIDING VIRTUAL COMPUTER SYSTEMS AND VIRTUAL COMPUTER ENVIRONMENTS THROUGH CLOUD COMPUTING; COMPUTER SERVICES, NAMELY, INTERACTIVE HOSTING SERVICES WHICH ALLOW THE USER TO PUBLISH AND SHARE THEIR OWN CONTENT AND IMAGES ONLINE; SPECIAL EFFECTS ANIMATION SERVICES FOR FILM, VIDEO AND COMPUTER GAMES; DESIGN AND DEVELOPMENT OF MULTIMEDIA PRODUCTS, PROGRAMMING OF MULTIMEDIA APPLICATIONS; HOSTING WEBSITES ON THE INTERNET; CREATION, DESIGN, DEVELOPMENT AND MAINTENANCE OF WEBSITES FOR THIRD PARTIES; HOSTING INTERNET SITES FOR THIRD PARTIES (U.S. CLS. 100 AND 101).

KAPIL BHANOT, EXAMINING ATTORNEY

CLASS 41—EDUCATION AND ENTERTAINMENT

FOR ELECTRONIC GAME SERVICES, NAMELY, PROVIDING ONLINE COMPUTER GAMES, PROVIDING A COMPUTER GAME THAT MAY BE ACCESSED BY USERS ON A GLOBAL NETWORK OR THE INTERNET, PROVIDING A COMPUTER GAME THAT MAY BE ACCESSED NETWORK-WIDE BY NETWORK USERS, PROVIDING ONLINE INTERACTIVE COMPUTER GAMES VIA THE INTERNET OR ELECTRONIC COMMUNICATION NETWORKS, AND PROVIDING ONLINE ELECTRONIC GAMES ACCESSIBLE VIA HANDHELD GAME APPARATUS; INTERNET LOTTERY, GAMBLING, CASINO GAMING, AND BETTING POOL SERVICES; PROVIDING ON-LINE LOTTERY CARD GAMES, NAMELY, ELECTRONIC INSTANT CARD GAMES AND SCRATCH CARD GAMES; PRODUCTION OF VIDEO AND COMPUTER GAME SOFTWARE; ENTERTAINMENT SERVICES IN THE NATURE OF RECORDING, PRODUCTION AND POST-PRODUCTION SERVICES IN THE FIELD OF ONLINE GAMES AND NON-DOWNLOADABLE GAMES (U.S. CLS. 100, 101 AND 107).

CLASS 42—SCIENTIFIC AND COMPUTER SERVICES

FOR PROVIDING ON-LINE NON-DOWNLOADABLE INTERACTIVE GAMING SOFTWARE, AND A WEBSITE FEATURING ON-LINE NON-DOWNLOADABLE INTERACTIVE GAMING SOFTWARE; DESIGN AND DEVELOPMENT OF COMPUTER GAME SOFTWARE, DESIGNING AND DEVELOPING COMPUTER GAME SOFTWARE AND VIDEO GAME SOFTWARE FOR USE WITH COMPUTERS, VIDEO GAME PROGRAM SYSTEMS AND COMPUTER NETWORKS, COMPUTER SERVICES, NAMELY, HOSTING AN INTERACTIVE WEB SITE THAT ALLOWS USERS TO PARTICIPATE IN ONLINE GAMES; COMPUTER PROGRAMMING OF COMPUTER GAMES; COMPUTER GRAPHICS DESIGN SERVICES, DESIGN AND DEVELOPMENT OF COMPUTER SOFTWARE AND GRAPHIC ARTS; COMPUTER SERVICES, NAMELY, ELECTRONIC DIGITIZING OF VISUAL MATERIAL, NAMELY, PHOTOGRAPHIC IMAGES, ARTWORK, PAINTINGS; COMPUTER SERVICES, NAMELY, CREATING AN ON-LINE VIRTUAL ENVIRONMENT FOR ELECTRONIC SLOT MACHINES, ELECTRONIC INSTANT CARD GAMES AND SCRATCH CARD GAMES; PROVIDING VIRTUAL COMPUTER SYSTEMS AND VIRTUAL COMPUTER ENVIRONMENTS THROUGH CLOUD COMPUTING; COMPUTER SERVICES, NAMELY, INTERACTIVE HOSTING SERVICES WHICH ALLOW THE USER TO PUBLISH AND SHARE THEIR OWN CONTENT AND IMAGES ONLINE; SPECIAL EFFECTS ANIMATION SERVICES FOR FILM, VIDEO AND COMPUTER GAMES; DESIGN AND DEVELOPMENT OF MULTIMEDIA PRODUCTS, PROGRAMMING OF MULTIMEDIA APPLICATIONS; HOSTING WEBSITES ON THE INTERNET; CREATION, DESIGN, DEVELOPMENT AND MAINTENANCE OF WEBSITES FOR THIRD PARTIES; HOSTING INTERNET SITES FOR THIRD PARTIES (U.S. CLS. 100 AND 101).

KAPIL BHANOT, EXAMINING ATTORNEY

SN 85-509,266. NEOPOINT TECHNOLOGIES LTD., GIBRALTAR, GIBRALTAR, FILED 1-5-2012.

7TH HEAVEN

THE MARK CONSISTS OF STANDARD CHARACTERS WITHOUT CLAIM TO ANY PARTICULAR FONT, STYLE, SIZE, OR COLOR.

CLASS 9—ELECTRICAL AND SCIENTIFIC APPARATUS

FOR COMPUTER GAME PROGRAMS; COMPUTER GAME PROGRAMS DOWNLOADABLE VIA THE INTERNET; COMPUTER GAME SOFTWARE; COMPUTER GAME SOFTWARE FOR GAMING MACHINES INCLUDING SLOT MACHINES OR VIDEO LOTTERY TERMINALS; COMPUTER GAME SOFTWARE FOR PERSONAL COMPUTERS AND HOME VIDEO GAME CONSOLES; COMPUTER GAME SOFTWARE FOR USE ON MOBILE AND CELLULAR PHONES; INTERACTIVE MULTIMEDIA COMPUTER GAME PROGRAM; VISUAL RECORDINGS AND AUDIOVISUAL RECORDINGS FEATURING MUSIC AND ANIMATION; COMPUTER CURSOR CONTROL DEVICES, NAMELY, DIGITIZER TABLETS; TABLET COMPUTER; MOBILE TELEPHONES (U.S. CLS. 21, 23, 26, 36 AND 38).

SN 85-509,407. SUGAR DIGITAL, LLC, SAN FRANCISCO, CA. FILED 1-5-2012.

SUGAR DIGITAL

THE MARK CONSISTS OF STANDARD CHARACTERS WITHOUT CLAIM TO ANY PARTICULAR FONT, STYLE, SIZE, OR COLOR.

NO CLAIM IS MADE TO THE EXCLUSIVE RIGHT TO USE "DIGITAL", APART FROM THE MARK AS SHOWN.

CLASS 40—MATERIAL TREATMENT

FOR DIGITAL PHOTO PRINTING SERVICES; DIGITAL PRINTING; PHOTOGRAPHIC RETOUCHING (U.S. CLS. 100, 103 AND 106).

FIRST USE 12-7-2005; IN COMMERCE 2-16-2006.

CLASS 41—EDUCATION AND ENTERTAINMENT

FOR DIGITAL IMAGING SERVICES; PHOTOGRAPHIC COMPUTER IMAGING (U.S. CLS. 100, 101 AND 107).

FIRST USE 12-7-2005; IN COMMERCE 2-16-2006.

CLASS 42—SCIENTIFIC AND COMPUTER SERVICES

FOR COMPUTER GRAPHICS SERVICES; CONSULTING SERVICES IN THE FIELD OF THE DESIGN OF ARTWORK, PHOTOGRAPHS AND IMAGES, THROUGH THE USE OF ELECTRONIC DIGITIZED COLOR IMAGING, ELECTRONIC IMAGING ALTERATION AND RETOUCHING; CUSTOM DESIGN AND DEVELOPMENT OF ARTWORK, PHOTOGRAPHS AND IMAGES, THROUGH THE USE OF ELECTRONIC DIGITIZED COLOR IMAGING, ELECTRONIC IMAGING ALTERATION AND RETOUCHING; DESIGN FOR OTHERS IN THE FIELD OF ADVERTISING, RELATING TO ARTWORK, PHOTOGRAPHS AND IMAGES, THROUGH THE USE OF ELECTRONIC DIGITIZED COLOR IMAGING, ELECTRONIC IMAGING ALTERATION AND RETOUCHING; DESIGN FOR OTHERS IN THE FIELD OF ADVERTISING, RELATING TO ARTWORK, PHOTOGRAPHS AND IMAGES, THROUGH THE USE OF ELECTRONIC DIGITIZED COLOR IMAGING, ELECTRONIC IMAGING ALTERATION AND RETOUCHING; DESIGN FOR OTHERS IN THE FIELD OF ADVERTISING, RELATING TO ARTWORK, PHOTOGRAPHS AND IMAGES, THROUGH THE USE OF ELECTRONIC DIGITIZED COLOR IMAGING, ELECTRONIC IMAGING ALTERATION AND RETOUCHING; DESIGN FOR OTHERS IN THE FIELD OF ADVERTISING, RELATING TO ARTWORK, PHOTOGRAPHS AND IMAGES, THROUGH THE USE OF ELECTRONIC DIGITIZED COLOR IMAGING, ELECTRONIC IMAGING ALTERATION AND RETOUCHING (U.S. CLS. 100 AND 101).

FIRST USE 12-7-2005; IN COMMERCE 2-16-2006.
SUSAN LESLIE DUBOIS, EXAMINING ATTORNEY

SN 85-509,526. THOUGHTFUL PRESENCE, INC., FORMERLY MY THOUGHTFUL SHOPPER, INC., NILES, IL. FILED 1-5-2012.

Thoughtful Presence

THE MARK CONSISTS OF STANDARD CHARACTERS WITHOUT CLAIM TO ANY PARTICULAR FONT, STYLE, SIZE, OR COLOR.

CLASS 35—ADVERTISING AND BUSINESS

FOR ON-LINE RETAIL GIFT SHOPS (U.S. CLS. 100, 101 AND 102).

FIRST USE 11-1-2011; IN COMMERCE 12-14-2011.

CLASS 45—PERSONAL AND LEGAL SERVICES

FOR PREPARATION OF CUSTOMIZED GIFT BASKETS; PREPARATION OF CUSTOMIZED GIFT BASKETS WITH SELECTED ITEMS REGARDING A PARTICULAR OCCASION OR THEME; PREPARATION OF CUSTOMIZED GIFT BOXES (U.S. CLS. 100 AND 101).

FIRST USE 11-1-2011; IN COMMERCE 12-14-2011.
SANJEEV VOHRA, EXAMINING ATTORNEY

SN 85-509,553. TRENT HICKIE, MELVILLE, SASKATCHEWAN, CANADA, FILED 1-5-2012.

MANIAC

THE MARK CONSISTS OF STANDARD CHARACTERS WITHOUT CLAIM TO ANY PARTICULAR FONT, STYLE, SIZE, OR COLOR.

CLASS 25—CLOTHING

FOR CLOTHING, NAMELY, SHIRTS, JERSEYS AND HATS (U.S. CLS. 22 AND 39).

FIRST USE 6-9-1990; IN COMMERCE 6-9-1990.

CLASS 28—TOYS AND SPORTING GOODS

FOR TOYS, NAMELY, TOY TRUCKS, TOY MODEL TRUCKS AND TOY DIE CAST COLLECTIBLE TRUCKS (U.S. CLS. 22, 23, 38 AND 50).

FIRST USE 11-0-2003; IN COMMERCE 11-0-2003.

CLASS 41—EDUCATION AND ENTERTAINMENT

FOR ENTERTAINMENT SERVICES, NAMELY, PERFORMING AND COMPETING IN MOTOR SPORTS EVENTS IN THE NATURE OF MONSTER TRUCK EXHIBITIONS (U.S. CLS. 100, 101 AND 107).

FIRST USE 6-9-1990; IN COMMERCE 6-9-1990.
JESSICA A. POWERS, EXAMINING ATTORNEY

SN 85-509,558. MAPCO, INC., BOISE, ID. FILED 1-5-2012.



THE MARK CONSISTS OF THE WORD "FAN METER" ON TOP OF A SCALE DESIGN. BELOW THE SCALE AND ABOVE THE ORIGIN OF THE INDICATOR ARM IS THE WORDING "LOW MED HIGH".

CLASS 25—CLOTHING

FOR CLOTHING, NAMELY, T-SHIRTS AND SWEATSHIRTS (U.S. CLS. 22 AND 39).

CLASS 26—FANCY GOODS

FOR BUTTONS (U.S. CLS. 37, 39, 40, 42 AND 50).
JESSICA A. POWERS, EXAMINING ATTORNEY

SN 85-509,568. THE NERDEL COMPANY, LLC, POMPANO BEACH, FL. FILED 1-5-2012.

ZEPPETS

THE MARK CONSISTS OF STANDARD CHARACTERS WITHOUT CLAIM TO ANY PARTICULAR FONT, STYLE, SIZE, OR COLOR.

CLASS 16—PAPER GOODS AND PRINTED MATTER

FOR CHILDREN'S FICTION BOOKS, CHILDREN'S ACTIVITY BOOKS, CHILDREN'S PICTURE BOOKS, COLORING BOOKS (U.S. CLS. 2, 5, 22, 23, 29, 37, 38 AND 50).

CLASS 25—CLOTHING

FOR CLOTHING, NAMELY, SHIRTS, SWEAT SHIRTS, T-SHIRTS, HATS (U.S. CLS. 22 AND 39).

CLASS 28—TOYS AND SPORTING GOODS

FOR TOYS, NAMELY, PUPPETS, PLUSH DOLLS, STUFFED TOYS (U.S. CLS. 22, 23, 38 AND 50).

CLASS 41—EDUCATION AND ENTERTAINMENT

FOR ENTERTAINMENT SERVICES IN THE NATURE OF PUPPETS SHOWS (U.S. CLS. 100, 101 AND 107).
MIDGE BUTLER, EXAMINING ATTORNEY

SN 85-509,590. 888 EXPORTS, INC., CRYSTAL LAKE, IL. FILED 1-5-2012.

Lucky Cat

THE MARK CONSISTS OF STANDARD CHARACTERS WITHOUT CLAIM TO ANY PARTICULAR FONT, STYLE, SIZE, OR COLOR.

NO CLAIM IS MADE TO THE EXCLUSIVE RIGHT TO USE "CAT", APART FROM THE MARK AS SHOWN.

CLASS 18—LEATHER GOODS

FOR CLOTHING FOR DOMESTIC PETS; COLLARS FOR PETS; PET CLOTHING; PET COLLAR ACCESSORIES, NAMELY, BELLS, SILENCERS, SAFETY LIGHTS AND BLINKERS, PENDANTS AND CHARMS; PET COLLAR ACCESSORIES, NAMELY, BOWS AND CHARMS; PET COLLAR ACCESSORIES, NAMELY, CHARMS; PET HAIR ORNAMENTS; PET PRODUCTS IN THE NATURE OF A RESTRAINING DEVICE, NAMELY, TIE-OUT STAKES AND TIE-OUT CHAINS; PET PRODUCTS, NAMELY, PET RESTRAINING DEVICES CONSISTING OF LEASHES, COLLARS, HARNESSES, RESTRAINING STRAPS, AND LEASHES WITH LOCKING DEVICES; PET TAGS SPECIALLY ADAPTED FOR ATTACHING TO PET LEASHES OR COLLARS (U.S. CLS. 1, 2, 3, 22 AND 41).

CLASS 28—TOYS AND SPORTING GOODS

FOR PET TOYS; PET TOYS CONTAINING CATNIP; PET TOYS MADE OF ROPE; TOYS FOR DOMESTIC PETS (U.S. CLS. 22, 23, 38 AND 50).

CLASS 31—NATURAL AGRICULTURAL PRODUCTS

FOR CONSUMABLE PET CHEWS; PET FOOD; PET TREATS (U.S. CLS. 1 AND 46).
CHRISTINA SOBRAL, EXAMINING ATTORNEY

SN 85-509,598. THOUGHTFUL PRESENCE, INC., FORMERLY MY THOUGHTFUL SHOPPER, INC., NILES, IL. FILED 1-5-2012.



THE COLOR(S) YELLOW, PINK, BLUE, AND WHITE IS/ ARE CLAIMED AS A FEATURE OF THE MARK.

THE MARK CONSISTS OF A WOMAN WEARING A YELLOW SHIRT, BLUE PANTS AND PINK SHOES HOLDING A PINK GIFT IN HER RIGHT HAND AND A BASKET WITH A WHITE AND PINK GIFT AND A PINK GIFT IN HER LEFT HAND STANDING NEXT TO A PINK SQUARE RIBBON AND BOW SURROUNDING THE WORDS "THOUGHTFUL PRESENCE" IN BLUE ITALICIZED SCRIPT WITH A WHITE BACKGROUND.

CLASS 35—ADVERTISING AND BUSINESS

FOR ON-LINE RETAIL GIFT SHOPS (U.S. CLS. 100, 101 AND 102).
FIRST USE 11-1-2011; IN COMMERCE 12-14-2011.

CLASS 45—PERSONAL AND LEGAL SERVICES

FOR PREPARATION OF CUSTOMIZED GIFT BASKETS; PREPARATION OF CUSTOMIZED GIFT BASKETS WITH SELECTED ITEMS REGARDING A PARTICULAR OCCASION OR THEME; PREPARATION OF CUSTOMIZED GIFT BOXES (U.S. CLS. 100 AND 101).
FIRST USE 11-1-2011; IN COMMERCE 12-14-2011.
SANJEEV VOHRA, EXAMINING ATTORNEY

SN 85-509,611. STRATEGIC STORAGE HOLDINGS, LLC,
LADERA RANCH, CA. FILED 1-5-2012.

JEFFREY LOOK, EXAMINING ATTORNEY

THE SMARTER WAY

THE MARK CONSISTS OF STANDARD CHARACTERS WITHOUT CLAIM TO ANY PARTICULAR FONT, STYLE, SIZE, OR COLOR.

CLASS 35—ADVERTISING AND BUSINESS

FOR PROVIDING RETAIL STORE SERVICES FEATURING STORAGE SUPPLIES INCLUDING BOXES, PACKAGING TAPE AND DISPENSERS, PADLOCKS AND CYLINDER LOCKS (U.S. CLS. 100, 101 AND 102).

CLASS 39—TRANSPORTATION AND STORAGE

FOR STORAGE OF GOODS; STORAGE OF VEHICLES, NAMELY, STORAGE OF CARS, RECREATIONAL VEHICLES, BOATS, AND AIRCRAFT OF OTHERS; STORAGE OF FILES AND DOCUMENTS OF OTHERS; PHYSICAL STORAGE OF ELECTRONICALLY-STORED DATA OR DOCUMENTS; STORAGE OF PERSONAL PROPERTY OF OTHERS; PROVIDING SELF-STORAGE FACILITIES FOR OTHERS; PROVIDING RENTAL STORAGE SPACES FOR OTHERS; WAREHOUSING SERVICES FOR GOODS OF OTHERS; PROVIDING CONTAINERS FOR STORAGE OF GOODS OF OTHERS; AND PROVIDING PICKUP, DELIVERY AND STORAGE OF GOODS OF OTHERS (U.S. CLS. 100 AND 105).

JEFFREY LOOK, EXAMINING ATTORNEY

SN 85-509,615. STRATEGIC STORAGE HOLDINGS, LLC,
LADERA RANCH, CA. FILED 1-5-2012.

GOODBYE CLUTTER, HELLO FLOOR!

THE MARK CONSISTS OF STANDARD CHARACTERS WITHOUT CLAIM TO ANY PARTICULAR FONT, STYLE, SIZE, OR COLOR.

CLASS 35—ADVERTISING AND BUSINESS

FOR PROVIDING RETAIL STORE SERVICES FEATURING STORAGE SUPPLIES INCLUDING BOXES, PACKAGING TAPE AND DISPENSERS, PADLOCKS AND CYLINDER LOCKS (U.S. CLS. 100, 101 AND 102).

CLASS 39—TRANSPORTATION AND STORAGE

FOR STORAGE OF GOODS; STORAGE OF VEHICLES, NAMELY, STORAGE OF CARS, RECREATIONAL VEHICLES, BOATS, AND AIRCRAFT OF OTHERS; STORAGE OF FILES AND DOCUMENTS OF OTHERS; PHYSICAL STORAGE OF ELECTRONICALLY-STORED DATA OR DOCUMENTS; STORAGE OF PERSONAL PROPERTY OF OTHERS; PROVIDING SELF-STORAGE FACILITIES FOR OTHERS; PROVIDING RENTAL STORAGE SPACES FOR OTHERS; WAREHOUSING SERVICES FOR GOODS OF OTHERS; PROVIDING CONTAINERS FOR STORAGE OF GOODS OF OTHERS; AND PROVIDING PICKUP, DELIVERY AND STORAGE OF GOODS OF OTHERS (U.S. CLS. 100 AND 105).

SN 85-509,673. 888 EXPORTS, INC., CRYSTAL LAKE, IL.
FILED 1-5-2012.

Lucky Bird

THE MARK CONSISTS OF STANDARD CHARACTERS WITHOUT CLAIM TO ANY PARTICULAR FONT, STYLE, SIZE, OR COLOR.

NO CLAIM IS MADE TO THE EXCLUSIVE RIGHT TO USE "BIRD", APART FROM THE MARK AS SHOWN.

CLASS 21—HOUSEWARES AND GLASS

FOR BIRD CAGES; BIRD CAGES FOR DOMESTIC BIRDS; BIRD FEEDERS; BIRD FEEDING TABLES; BIRD HOUSES; GRAVEL PAPER FOR BIRD CAGES; OUTDOOR SWINGS FOR BIRDS; PERCHES FOR BIRD CAGES (U.S. CLS. 2, 13, 23, 29, 30, 33, 40 AND 50).

CLASS 31—NATURAL AGRICULTURAL PRODUCTS

FOR BIRD FOOD; BIRD SEED; BIRD TREATS (U.S. CLS. 1 AND 46).

CHRISTINA SOBRAL, EXAMINING ATTORNEY

SN 85-509,684. HELIOSONE, LLC, LEWES, DE. FILED 1-5-2012.

Heliosone

THE MARK CONSISTS OF STANDARD CHARACTERS WITHOUT CLAIM TO ANY PARTICULAR FONT, STYLE, SIZE, OR COLOR.

CLASS 7—MACHINERY

FOR MODULAR POWER STATION FOR POWER GENERATION (U.S. CLS. 13, 19, 21, 23, 31, 34 AND 35).

CLASS 39—TRANSPORTATION AND STORAGE

FOR TRANSPORTATION SERVICES, NAMELY LONG-TERM OPERATION OF ADVANCED TOLL EXPRESSWAYS WORLDWIDE; TRANSPORTATION SERVICES, NAMELY OPERATION OF BULK CARRIERS AND TANKSHIPS (U.S. CLS. 100 AND 105).

CLASS 42—SCIENTIFIC AND COMPUTER SERVICES

FOR DESIGN OF BULK CARRIERS AND TANKSHIPS; DESIGN OF ADVANCED TOLL EXPRESSWAYS WORLDWIDE, INCORPORATING PROPRIETARY ELEMENTS RELATING TO TERRAIN PREPARATION, ROADWAY UNDERSTRUCTURE, PAVEMENT COMPOSITION AND INSTALLATION, INTERCHANGE, TUNNEL, AND TOLL COLLECTION DESIGNS (U.S. CLS. 100 AND 101).

JEFF DEFORD, EXAMINING ATTORNEY

CLASS 16—PAPER GOODS AND PRINTED MATTER

FOR PUBLICATIONS, NAMELY, BROCHURES, BOOKLETS, AND TEACHING MATERIALS IN THE FIELD OF NUTRITION; PRINTED PAMPHLETS, MANUALS, BOOKS, LEAFLETS, FLYERS, INFORMATIONAL SHEETS AND NEWSLETTERS, IN THE FIELD OF HEALTH, NUTRITION AND FITNESS (U.S. CLS. 2, 5, 22, 23, 29, 37, 38 AND 50).

CLASS 44—MEDICAL, BEAUTY AND AGRICULTURAL SERVICES

FOR PROVIDING A WEBSITE FEATURING INFORMATION ON HEALTH AND NUTRITION; COUNSELING SERVICES IN THE FIELDS OF HEALTH, NUTRITION AND LIFESTYLE WELLNESS (U.S. CLS. 100 AND 101).

TARAH HARDY, EXAMINING ATTORNEY

SN 85-509,732. ABBOTT LABORATORIES, ABBOTT PARK, IL. FILED 1-5-2012.

PUT MORE LIFE IN YOUR YEARS

THE MARK CONSISTS OF STANDARD CHARACTERS WITHOUT CLAIM TO ANY PARTICULAR FONT, STYLE, SIZE, OR COLOR.

CLASS 16—PAPER GOODS AND PRINTED MATTER

FOR NEWSLETTERS IN THE FIELD OF NUTRITION; PUBLICATIONS, NAMELY, BROCHURES, BOOKLETS, AND TEACHING MATERIALS IN THE FIELD OF NUTRITION (U.S. CLS. 2, 5, 22, 23, 29, 37, 38 AND 50).

CLASS 44—MEDICAL, BEAUTY AND AGRICULTURAL SERVICES

FOR PROVIDING A WEBSITE FEATURING INFORMATION ON HEALTH AND NUTRITION (U.S. CLS. 100 AND 101).

YAT SYE, LEE, EXAMINING ATTORNEY

SN 85-509,737. ZONEPERFECT NUTRITION COMPANY, ABBOTT PARK, IL. FILED 1-5-2012.

FLAVORFUEL

THE MARK CONSISTS OF STANDARD CHARACTERS WITHOUT CLAIM TO ANY PARTICULAR FONT, STYLE, SIZE, OR COLOR.

CLASS 5—PHARMACEUTICALS

FOR VITAMIN AND MINERAL SUPPLEMENTS; VITAMIN AND MINERAL FORMED AND PACKAGED AS BARS; NUTRITIONAL AND DIETARY SUPPLEMENTS FORMED AND PACKAGED AS BARS (U.S. CLS. 6, 18, 44, 46, 51 AND 52).

SN 85-509,735. ZONEPERFECT NUTRITION COMPANY, ABBOTT PARK, IL. FILED 1-5-2012.

ZONE PERFECT FLAVORFUEL

THE MARK CONSISTS OF STANDARD CHARACTERS WITHOUT CLAIM TO ANY PARTICULAR FONT, STYLE, SIZE, OR COLOR.

OWNER OF U.S. REG. NOS. 2,294,807 AND 2,408,977.

CLASS 16—PAPER GOODS AND PRINTED MATTER

FOR PUBLICATIONS, NAMELY, BROCHURES, BOOKLETS, AND TEACHING MATERIALS IN THE FIELD OF NUTRITION; PRINTED PAMPHLETS, MANUALS, BOOKS, LEAFLETS, FLYERS, INFORMATIONAL SHEETS AND NEWSLETTERS, IN THE FIELD OF HEALTH, NUTRITION AND FITNESS (U.S. CLS. 2, 5, 22, 23, 29, 37, 38 AND 50).

CLASS 44—MEDICAL, BEAUTY AND AGRICULTURAL SERVICES

FOR PROVIDING A WEB SITE FEATURING INFORMATION ON HEALTH AND NUTRITION; COUNSELING SERVICES IN THE FIELDS OF HEALTH, NUTRITION AND LIFESTYLE WELLNESS (U.S. CLS. 100 AND 101).

TARAH HARDY, EXAMINING ATTORNEY

CLASS 5—PHARMACEUTICALS

FOR VITAMIN AND MINERAL SUPPLEMENTS; VITAMIN AND MINERAL FORMED AND PACKAGED AS BARS; NUTRITIONAL AND DIETARY SUPPLEMENTS FORMED AND PACKAGED AS BARS (U.S. CLS. 6, 18, 44, 46, 51 AND 52).

SN 85-509,824. CCT TELECOMMUNICATIONS, INC., DBA CORNERSTONE PRODUCTS GROUP, LODI, CA. FILED 1-5-2012.

SN 85-509,915. GORDY, SKYLER, LOS ANGELES, CA. FILED 1-5-2012.



NO CLAIM IS MADE TO THE EXCLUSIVE RIGHT TO USE "ILLUMINATIONS", APART FROM THE MARK AS SHOWN.

THE MARK CONSISTS OF THE LITERAL ELEMENTS "EI ESSENTIAL ILLUMINATIONS" WITH THE "EI" PORTION APPEARING IN A LARGER FONT TO THE LEFT OF THE LITERAL ELEMENTS "ESSENTIAL" APPEARING OVER- TOP OF "ILLUMINATIONS".

CLASS 9—ELECTRICAL AND SCIENTIFIC APPARATUS

FOR LIGHT SYSTEMS COMPRISING LIGHT SENSORS AND SWITCHES; LIGHTING CONTROLS (U.S. CLS. 21, 23, 26, 36 AND 38).

CLASS 11—ENVIRONMENTAL CONTROL AP- PARATUS

FOR CEILING LIGHTS; ELECTRIC LIGHTING FIX- TURES; LIGHTING FIXTURES (U.S. CLS. 13, 21, 23, 31 AND 34).

THOMAS MANOR, EXAMINING ATTORNEY

SN 85-509,911. GORDY, SKYLER, LOS ANGELES, CA. FILED 1-5-2012.

Big Bad U

THE MARK CONSISTS OF STANDARD CHARACTERS WITHOUT CLAIM TO ANY PARTICULAR FONT, STYLE, SIZE, OR COLOR.

CLASS 25—CLOTHING

FOR CAPS; T-SHIRTS; TOPS (U.S. CLS. 22 AND 39).

CLASS 41—EDUCATION AND ENTERTAIN- MENT

FOR ENTERTAINMENT SERVICES IN THE NATURE OF LIVE MUSICAL PERFORMANCES (U.S. CLS. 100, 101 AND 107).

BRENDAN REGAN, EXAMINING ATTORNEY

Who Came To Party

THE MARK CONSISTS OF STANDARD CHARACTERS WITHOUT CLAIM TO ANY PARTICULAR FONT, STYLE, SIZE, OR COLOR.

CLASS 25—CLOTHING

FOR CAPS; T-SHIRTS; TOPS (U.S. CLS. 22 AND 39).

CLASS 41—EDUCATION AND ENTERTAIN- MENT

FOR ENTERTAINMENT SERVICES IN THE NATURE OF LIVE MUSICAL PERFORMANCES (U.S. CLS. 100, 101 AND 107).

BRENDAN REGAN, EXAMINING ATTORNEY

SN 85-509,920. CLIF BAR & COMPANY, EMERYVILLE, CA. FILED 1-5-2012.



THE MARK CONSISTS OF THE WORD "SEED" IN STYLIZED LETTERS SHOWN ABOVE THE WORD "MAT- TERS".

CLASS 35—ADVERTISING AND BUSINESS

FOR PUBLIC ADVOCACY TO PROMOTE AWARE- NESS OF CONSERVING AND IMPROVING ORGANIC CROP GENETIC DIVERSITY (U.S. CLS. 100, 101 AND 102).

FIRST USE 10-0-2010; IN COMMERCE 10-0-2010.

CLASS 36—INSURANCE AND FINANCIAL

FOR CHARITABLE FOUNDATION SERVICES, NAMELY, PROVIDING FUNDRAISING ACTIVITIES, FUNDING, AND/OR FINANCIAL ASSISTANCE FOR CONSERVING AND IMPROVING ORGANIC CROP GE- NETIC DIVERSITY (U.S. CLS. 100, 101 AND 102).

FIRST USE 10-0-2010; IN COMMERCE 10-0-2010.

TEJBIR SINGH, EXAMINING ATTORNEY

SN 85-509,940. SALLY STEADMAN AS TRUSTEE OF THE STEADMAN INTELLECTUAL PROPERTY TRUST, SANDHURST, VICTORIA, AUSTRALIA, FILED 1-5-2012.

EUHYDRIT

THE MARK CONSISTS OF STANDARD CHARACTERS WITHOUT CLAIM TO ANY PARTICULAR FONT, STYLE, SIZE, OR COLOR.

PRIORITY CLAIMED UNDER SEC. 44(D) ON AUSTRALIA APPLICATION NO. 1435219, FILED 7-8-2011, REG. NO. 1435219, DATED 7-8-2011, EXPIRES 7-8-2021.

CLASS 21—HOUSEWARES AND GLASS

FOR DISPOSABLE DRINKING VESSELS OF PAPER; DISPOSABLE DRINKING VESSELS OF PLASTIC; DISPOSABLE DRINKING VESSELS OF POLYSTYRENE; DRINKING CONTAINERS; DRINKING CUPS; DRINKING FLASKS; DRINKING VESSELS; JUGS; CONTAINERS FOR HOUSEHOLD OR KITCHEN USE; BEVERAGE GLASSWARE; BOTTLES, SOLD EMPTY (U.S. CLS. 2, 13, 23, 29, 30, 33, 40 AND 50).

CLASS 32—LIGHT BEVERAGES

FOR AERATED AND MINERAL WATERS; AERATED SPRING WATERS; AERATED WATER; DRINKING WATER; MINERAL WATER; WATER BEVERAGES; FRUIT DRINKS; SOFT DRINKS; SPORTS DRINKS; FRUIT JUICES (U.S. CLS. 45, 46 AND 48).
EMILY CHUO, EXAMINING ATTORNEY

SN 85-509,942. ONE KINGS LANE, INC., SAN FRANCISCO, CA. FILED 1-5-2012.

LIVE. LOVE. HOME.

THE MARK CONSISTS OF STANDARD CHARACTERS WITHOUT CLAIM TO ANY PARTICULAR FONT, STYLE, SIZE, OR COLOR.

NO CLAIM IS MADE TO THE EXCLUSIVE RIGHT TO USE "HOME", APART FROM THE MARK AS SHOWN.

CLASS 35—ADVERTISING AND BUSINESS

FOR ON-LINE RETAIL STORE SERVICES FEATURING A WIDE VARIETY OF CONSUMER GOODS INCLUDING HOUSEHOLD AND LIFESTYLE PRODUCTS (U.S. CLS. 100, 101 AND 102).
FIRST USE 12-19-2011; IN COMMERCE 12-19-2011.

CLASS 41—EDUCATION AND ENTERTAINMENT

FOR PROVIDING A WEBSITE FEATURING BLOGS AND NON-DOWNLOADABLE PUBLICATIONS IN THE NATURE OF ARTICLES AND MAGAZINES IN THE FIELDS OF HOME DÉCOR, INTERIOR DESIGN, NOTABLE DESIGNERS AND RETAILERS, LIFESTYLE, DECORATING, ENTERTAINING, TRAVEL, ART, FOOD, BEVERAGES, AND RECIPES; ENTERTAINMENT SERVICES, NAMELY, PROVIDING ON-LINE NON-DOWNLOADABLE VIDEOS IN THE FIELDS OF HOME DÉCOR, INTERIOR DESIGN, NOTABLE DESIGNERS AND RETAILERS, LIFESTYLE, DECORATING, ENTERTAINING, TRAVEL, ART, FOOD, BEVERAGES, AND RECIPES (U.S. CLS. 100, 101 AND 107).

FIRST USE 12-19-2011; IN COMMERCE 12-19-2011.
EMILY CHUO, EXAMINING ATTORNEY

SN 85-509,984. LAERA, VITO, FORT LAUDERDALE, FL. FILED 1-5-2012.

ARIACQUA

THE MARK CONSISTS OF STANDARD CHARACTERS WITHOUT CLAIM TO ANY PARTICULAR FONT, STYLE, SIZE, OR COLOR.

THE WORDING "ARIACQUA" HAS NO MEANING IN A FOREIGN LANGUAGE.

CLASS 7—MACHINERY

FOR FOOD WASTE DISPOSALS; FOOD WASTE DISPOSERS; GARBAGE DISPOSALS (U.S. CLS. 13, 19, 21, 23, 31, 34 AND 35).

FIRST USE 1-1-2006; IN COMMERCE 1-1-2006.

CLASS 11—ENVIRONMENTAL CONTROL APPARATUS

FOR KITCHEN SINKS; PLUMBING FITTINGS, NAMELY, DRAINS; PLUMBING FITTINGS, NAMELY, SINK STRAINERS; PLUMBING SUPPLIES, NAMELY, SINK STRAINERS; SINKS; TAP WATER FAUCETS; TAPS (U.S. CLS. 13, 21, 23, 31 AND 34).

FIRST USE 1-1-2006; IN COMMERCE 1-1-2006.
WON TEAK OH, EXAMINING ATTORNEY

SN 85-510,026. FACT FIBER, INC, ALLSTON, MA. FILED 1-6-2012.

Reach For Care

THE MARK CONSISTS OF STANDARD CHARACTERS WITHOUT CLAIM TO ANY PARTICULAR FONT, STYLE, SIZE, OR COLOR.

CLASS 9—ELECTRICAL AND SCIENTIFIC APPARATUS

FOR COMPUTER SOFTWARE FOR CONTROLLING AND MANAGING PATIENT MEDICAL INFORMATION; DOWNLOADABLE SCIENTIFIC AND MEDICAL DATA VIA THE INTERNET (U.S. CLS. 21, 23, 26, 36 AND 38).

CLASS 35—ADVERTISING AND BUSINESS

FOR ADVERTISING AND MARKETING SERVICES PROVIDED BY MEANS OF INDIRECT METHODS OF MARKETING COMMUNICATIONS, NAMELY, SOCIAL MEDIA, SEARCH ENGINE MARKETING, INQUIRY MARKETING, INTERNET MARKETING, MOBILE MARKETING, BLOGGING AND OTHER FORMS OF PASSIVE, SHARABLE OR VIRAL COMMUNICATIONS CHANNELS; BUSINESS ASSISTANCE SERVICES, NAMELY, ASSISTING HEALTH CARE FACILITIES AND OTHER COMPANIES WITH CUSTOMER FOLLOW-UP TO IMPROVE CUSTOMER OUTCOMES AND SATISFACTION THROUGH THE USE OF TELECOMMUNICATION DEVICES AND COMPUTER NETWORKS WITH AUTOMATED INTERACTION AND DATA FEEDBACK, MONITORING AND COMPILATION CAPACITY; BUSINESS SERVICES PROVIDED TO THE HEALTHCARE INDUSTRY, NAMELY, THE COLLECTION, REPORTING, AND ANALYSIS OF HEALTHCARE QUALITY DATA FOR BUSINESS PURPOSES; COLLECTING AND ANALYZING CLAIMS DATA FROM HEALTHCARE ORGANIZATIONS FOR BUSINESS PURPOSES; ELECTRONIC DATA COLLECTION AND DATA SUBMISSION SERVICES FOR BUSINESS PURPOSES IN THE FIELDS OF MEDICINE AND HEALTHCARE; ONLINE MEDIA MONITORING SERVICES USING COMPUTER SOFTWARE TO AUTOMATICALLY MONITOR INTERNET WEBSITES AND ONLINE PUBLICATIONS FOR CUSTOMER-SPECIFIED TOPICS AND TO CAPTURE RELEVANT CONTENT ON THOSE TOPICS, AND PROVIDING DOCUMENTATION AND ANALYSIS OF THAT ONLINE CONTENT TO OTHERS FOR BUSINESS PURPOSES (U.S. CLS. 100, 101 AND 102).

IRA J. GOODSaid, EXAMINING ATTORNEY

CLASS 25—CLOTHING

FOR A-SHIRTS; APPAREL FOR DANCERS, NAMELY, TEE SHIRTS, SWEATSHIRTS, PANTS, LEGGINGS, SHORTS AND JACKETS; ATHLETIC APPAREL, NAMELY, SHIRTS, PANTS, JACKETS, FOOTWEAR, HATS AND CAPS, ATHLETIC UNIFORMS; BODY SHIRTS; BUTTON DOWN SHIRTS; BUTTON-FRONT ALOHA SHIRTS; CAMOUFLAGE SHIRTS; CAMP SHIRTS; CLOTHING FOR ATHLETIC USE, NAMELY, PADDED SHIRTS; CLOTHING FOR BABIES, TODDLERS AND CHILDREN, TREATED WITH FIRE AND HEAT RETARDANTS, NAMELY, PAJAMAS, JACKETS, SHIRTS, PANTS, JUMPERS; CLOTHING SHIELDS, NAMELY, PADS APPLIED TO THE UNDERARMS OF SHIRTS, BLOUSES AND SWEATERS; COLLARED SHIRTS; DRESS SHIRTS; FISHING SHIRTS; GOLF PANTS, SHIRTS AND SKIRTS; GOLF SHIRTS; HOODED SWEAT SHIRTS; HUNTING SHIRTS; KNIT SHIRTS; LEATHER SHIRTS; LONG-SLEEVED SHIRTS; MATERNITY CLOTHING, NAMELY, SHIRTS; MOISTURE-WICKING SPORTS SHIRTS; NIGHT SHIRTS; OPEN-NECKED SHIRTS; OVER SHIRTS; PIQUE SHIRTS; POLO SHIRTS; RUGBY SHIRTS; SCIENTIFIC AND TECHNOLOGICAL APPAREL, NAMELY, SHIRTS, PANTS, JACKETS, FOOTWEAR, HATS AND CAPS, UNIFORMS; SHIRT FRONTS; SHIRT INSERTS, NAMELY, DICKIES; SHIRT YOKES; SHIRTS; SHIRTS AND SHORT-SLEEVED SHIRTS; SHIRTS AND SLIPS; SHIRTS FOR INFANTS, BABIES, TODDLERS AND CHILDREN; SHIRTS FOR SUITS; SHORT-SLEEVED OR LONG-SLEEVED T-SHIRTS; SHORT-SLEEVED SHIRTS; SLEEP SHIRTS; SLEEVES WORN SEPARATE AND APART FROM BLOUSES, SHIRTS AND OTHER TOPS; SNAP CROTCH SHIRTS FOR INFANTS AND TODDLERS; SPORT SHIRTS; SPORTS SHIRTS; SPORTS SHIRTS WITH SHORT SLEEVES; SUN PROTECTIVE CLOTHING, NAMELY, SHIRTS; SWEAT SHIRTS; T-SHIRTS; T-SHIRTS FOR ADULTS AND CHILDREN; TEE SHIRTS; TRIATHLON CLOTHING, NAMELY, TRIATHLON TIGHTS, TRIATHLON SHORTS, TRIATHLON SINGLETS, TRIATHLON SHIRTS, TRIATHLON SUITS; TURLE NECK SHIRTS; WEARABLE GARMENTS AND CLOTHING, NAMELY, SHIRTS; WIND SHIRTS; WOMEN'S CLOTHING, NAMELY, SHIRTS, DRESSES, SKIRTS, BLOUSES; YOGA SHIRTS (U.S. CLS. 22 AND 39).

FIRST USE 1-1-2012; IN COMMERCE 1-1-2012.

CLASS 32—LIGHT BEVERAGES

FOR ALOE JUICE BEVERAGES; APPLE JUICE BEVERAGES; AROMATIZED BEVERAGES BASED ON FRUIT, PROTEIN, CORDIAL, SUGAR AND OTHER FLUID NUTRIENTS, NAMELY, CARBOHYDRATES DRINKS FOR USE AS A FOOD FILLERS; AROMATIZED BEVERAGES BASED ON FRUIT, PROTEIN, CORDIAL, SUGAR AND OTHER FLUID NUTRIENTS, NAMELY, PROTEIN DRINKS FOR USE AS A FOOD FILLERS AND NOT FOR USE AS A MEAL REPLACEMENT; BEAUTY BEVERAGES, NAMELY, FRUIT JUICES AND ENERGY DRINKS CONTAINING NUTRITIONAL SUPPLEMENTS; BREWED MALT-BASED ALCOHOLIC BEVERAGE IN THE NATURE OF A BEER; COCONUT-BASED BEVERAGES; COCONUT-BASED NON-ALCOHOLIC BEVERAGES; CONCENTRATES AND POWDERS USED IN THE PREPARATION OF ENERGY DRINKS AND FRUIT-FLAVORED BEVERAGES; CONCENTRATES, SYRUPS OR POWDERS FOR MAKING SOFT DRINKS OR TEA-FLAVORED BEVERAGES; CORN-BASED BEVERAGES NOT FOR FOOD PURPOSES (CHICHA MORADA); ESSENCES FOR MAKING NON-ALCOHOLIC BEVERAGES; FROZEN CARBONATED BEVERAGES; FROZEN FRUIT BEVERAGES; FROZEN FRUIT-BASED BEVERAGES; FRUIT BEVERAGES; FRUIT CONCENTRATES AND PUREES USED AS INGREDIENTS OF BEVERAGES; FRUIT-BASED BEVERAGES; FRUIT-FLAVORED BEVERAGES; FRUIT-FLAVOURED BEVERAGES; GRAPE JUICE BEVERAGES; ICED FRUIT BEVERAGES; ISOTONIC BEVERAGES; KVASS; LEMON JUICE FOR USE IN THE PREPARATION OF BEVERAGES; MALT SYRUP FOR BEVERAGES; MILK OF ALMONDS FOR BEVERAGE; NON-ALCOHOLIC BEVERAGES CONTAINING FRUIT JUICES; NON-ALCOHOLIC BEVERAGES WITH TEA FLAVOR; NON-ALCOHOLIC BEVERAGES, NAMELY, CARBONATED BEVERAGES; NON-ALCOHOLIC FRUIT EXTRACTS USED IN THE PREPARATION OF BEVERAGES; NON-

SN 85-510,032. DELISHAST, LLC, DIAMOND BAR, CA. FILED 1-6-2012.

Just Enjoy It!

THE MARK CONSISTS OF STANDARD CHARACTERS WITHOUT CLAIM TO ANY PARTICULAR FONT, STYLE, SIZE, OR COLOR.

ALCOHOLIC FRUIT JUICE BEVERAGES; NON-ALCOHOLIC HONEY-BASED BEVERAGES; NON-ALCOHOLIC MALT BEVERAGE; NON-ALCOHOLIC RICE-BASED BEVERAGES NOT BEING MILK SUBSTITUTES; NON-CARBONATED, NON-ALCOHOLIC FROZEN FLAVORED BEVERAGES; OAT-BASED BEVERAGES WITH FRUIT JUICE NOT FOR FOOD PURPOSES; OAT-BASED BEVERAGES WITH MILK NOT FOR FOOD PURPOSES; ORANGE JUICE BEVERAGES; PEANUT MILK; PINEAPPLE JUICE BEVERAGES; POWDERS USED IN THE PREPARATION OF FRUIT-BASED BEVERAGES; POWDERS USED IN THE PREPARATION OF ISOTONIC SPORTS DRINKS AND SPORTS BEVERAGES; PREPARATIONS FOR MAKING BEVERAGES, NAMELY, FRUIT FLAVORED DRINKS; PREPARED ENTREES CONSISTING OF FRUIT DRINKS AND FRUIT JUICES, FRUIT-BASED BEVERAGES, NON-ALCOHOLIC BEVERAGES CONTAINING FRUIT JUICES, NON-ALCOHOLIC FRUIT EXTRACTS USED IN THE PREPARATION OF BEVERAGES, NON-ALCOHOLIC FRUIT JUICE BEVERAGES, VEGETABLE JUICES, VEGETABLE-FRUIT JUICES AND SMOOTHIES; SARPARRILLA; SCENTED WATER FOR MAKING BEVERAGES; SHERBETS; SMOOTHIES; SORBETS IN THE FORM OF BEVERAGES; SORBETS IN THE NATURE OF BEVERAGES; SOY-BASED BEVERAGES NOT BEING MILK SUBSTITUTES; SYRUP SUBSTITUTES FOR MAKING BEVERAGES; SYRUPS FOR BEVERAGES; SYRUPS FOR MAKING BEVERAGES; SYRUPS FOR MAKING NON-ALCOHOLIC BEVERAGES; SYRUPS FOR MAKING WHEY-BASED BEVERAGES; TOMATO JUICE; TOMATO JUICE BEVERAGES; VEGETABLE JUICE; VEGETABLE JUICES; WATER BEVERAGES; WHEY BEVERAGES (U.S. CLS. 45, 46 AND 48).
 FIRST USE 1-1-2012; IN COMMERCE 1-1-2012.
 MARK T. MULLEN, EXAMINING ATTORNEY

CLASS 41—EDUCATION AND ENTERTAINMENT

FOR AMUSEMENT PARKS FEATURING LOCATIONS AND EQUIPMENT FOR ZIP LINES, SWING LINES, TREE TO TREE OBSTACLE COURSES, HIGH ROPE COURSES, CLIMBING COURSES, TIGHT ROPES, SUSPENSION BRIDGES, ROPE SWINGS, AND CLIMBING NETS; EDUCATIONAL SERVICES, PROVIDING COURSES OF INSTRUCTION, SEMINARS, WORKSHOPS IN THE FIELD OF ADVENTURE AND OBSTACLE COURSES; RECREATIONAL AND ENTERTAINMENT SERVICES, NAMELY, PROVIDING HIGH-WIRE ROPE-BRIDGE OUTDOOR ACTIVITIES; PROVIDING HIGH-WIRE ROPE-BRIDGE COURSE FACILITIES; PROVIDING SWINGS AND ZIP WIRE COURSE FACILITIES; PROVIDING ROPE-BRIDGES AND SWINGS AND ZIP WIRES FOR ENTERTAINMENT PURPOSE; PROVIDING THEME PARK SERVICES; PROVIDING ADVENTURE PARK FACILITIES FOR RECREATION ACTIVITIES; ENTERTAINMENT SERVICES, NAMELY, PROVIDING OUTDOOR ENVIRONMENTS WITH ADVENTURE COURSE AND TREE-TOP CHALLENGING ACTIVITIES IN WHICH USERS CAN INTERACT FOR RECREATIONAL, LEISURE OR ENTERTAINMENT PURPOSES; RECREATIONAL AND ENTERTAINMENT SERVICES WITHIN A COMBINATION RECREATIONAL AND AMUSEMENT PARK ENVIRONMENT FEATURING AERIAL WALKWAYS, HIGH WIRE COURSES, HIGH ROPES, FOREST ADVENTURE COURSES, TRAINING SERVICES IN THE FIELD OF OBSTACLE COURSES (U.S. CLS. 100, 101 AND 107).
 FIRST USE 10-1-2010; IN COMMERCE 10-1-2010.

CLASS 42—SCIENTIFIC AND COMPUTER SERVICES

FOR LANDSCAPE ARCHITECTURE AND OUTDOOR ATTRACTION DESIGN; CUSTOM DESIGN OF RECREATIONAL SITES, NAMELY, PLAYGROUNDS, PARKS, OUTDOOR OBSTACLE COURSES, TREE TOP COURSES, ZIP LINES, SWING LINES, TREE TO TREE OBSTACLE COURSES, HIGH ROPE COURSES, CLIMBING COURSES, TIGHT ROPES, SUSPENSION BRIDGES, ROPE SWINGS, AND CLIMBING NETS; SAFETY AND ACCESSIBILITY CONSULTATION SERVICES IN THE FIELD OF THE DESIGN OF PLAYGROUNDS, PARKS, OUTDOOR OBSTACLE COURSE, TREE TOP COURSES, ZIP LINES, SWING LINES, TREE TO TREE OBSTACLE COURSES, HIGH ROPE COURSES, CLIMBING COURSES, TIGHT ROPES, SUSPENSION BRIDGES, ROPE SWINGS, CLIMBING NETS AND EQUIPMENT AND ACCESSORIES THEREFOR (U.S. CLS. 100 AND 101).
 FIRST USE 10-1-2010; IN COMMERCE 10-1-2010.
 JANICE L. MCMORROW, EXAMINING ATTORNEY

SN 85-510,109. DEEP FOREST CHALLENGE, LLC, SAN JOSE, CA. FILED 1-6-2012.

Deep Forest Challenge

THE MARK CONSISTS OF STANDARD CHARACTERS WITHOUT CLAIM TO ANY PARTICULAR FONT, STYLE, SIZE, OR COLOR.
 NO CLAIM IS MADE TO THE EXCLUSIVE RIGHT TO USE "FOREST CHALLENGE", APART FROM THE MARK AS SHOWN.

SN 85-510,147. DEEP FOREST CHALLENGE, LLC, SAN JOSE, CA. FILED 1-6-2012.

CLASS 37—CONSTRUCTION AND REPAIR

FOR CONSTRUCTION SERVICES, NAMELY, PLANING AND LAYING OUT OF RECREATIONAL SITES, NAMELY, PLAYGROUNDS, PARKS, OUTDOOR OBSTACLE COURSES, TREE TOP COURSES, ZIP LINES, SWING LINES, TREE TO TREE OBSTACLE COURSES, HIGH ROPE COURSES, CLIMBING COURSES, TIGHT ROPES, SUSPENSION BRIDGES, ROPE SWINGS, AND CLIMBING NETS; CONSTRUCTION AND INSTALLATION OF PLAYGROUNDS, PARKS, OUTDOOR OBSTACLE COURSES, TREE TOP COURSES, ZIP LINES, SWING LINES, TREE TO TREE OBSTACLE COURSES, HIGH ROPE COURSES, CLIMBING COURSES, TIGHT ROPES, SUSPENSION BRIDGES, ROPE SWINGS, CLIMBING NETS AND EQUIPMENT AND ACCESSORIES THEREFOR (U.S. CLS. 100, 103 AND 106).
 FIRST USE 10-1-2010; IN COMMERCE 10-1-2010.

Swing out of your comfort zone

THE MARK CONSISTS OF STANDARD CHARACTERS WITHOUT CLAIM TO ANY PARTICULAR FONT, STYLE, SIZE, OR COLOR.

CLASS 37—CONSTRUCTION AND REPAIR

FOR CONSTRUCTION SERVICES, NAMELY, PLANNING AND LAYING OUT OF RECREATIONAL SITES, NAMELY, PLAYGROUNDS, PARKS, OUTDOOR OBSTACLE COURSES, TREE TOP COURSES, ZIP LINES, SWING LINES, TREE TO TREE OBSTACLE COURSES, HIGH ROPE COURSES, CLIMBING COURSES, TIGHT ROPES, SUSPENSION BRIDGES, ROPE SWINGS, AND CLIMBING NETS; CONSTRUCTION AND INSTALLATION OF PLAYGROUNDS, PARKS, OUTDOOR OBSTACLE COURSES, TREE TOP COURSES, ZIP LINES, SWING LINES, TREE TO TREE OBSTACLE COURSES, HIGH ROPE COURSES, CLIMBING COURSES, TIGHT ROPES, SUSPENSION BRIDGES, ROPE SWINGS, CLIMBING NETS AND EQUIPMENT AND ACCESSORIES THEREFOR (U.S. CLS. 100, 103 AND 106).

FIRST USE 10-1-2010; IN COMMERCE 10-1-2010.

CLASS 41—EDUCATION AND ENTERTAINMENT

FOR AMUSEMENT PARKS FEATURING LOCATIONS AND EQUIPMENT FOR ZIP LINES, SWING LINES, TREE TO TREE OBSTACLE COURSES, HIGH ROPE COURSES, CLIMBING COURSES, TIGHT ROPES, SUSPENSION BRIDGES, ROPE SWINGS, AND CLIMBING NETS; EDUCATIONAL SERVICES, PROVIDING COURSES OF INSTRUCTION, SEMINARS, WORKSHOPS IN THE FIELD OF ADVENTURE AND OBSTACLE COURSES; RECREATIONAL AND ENTERTAINMENT SERVICES, NAMELY, PROVIDING HIGH-WIRE ROPE-BRIDGE OUTDOOR ACTIVITIES; PROVIDING HIGH-WIRE ROPE-BRIDGE COURSE FACILITIES; PROVIDING SWINGS AND ZIP WIRE COURSE FACILITIES; PROVIDING ROPE-BRIDGES AND SWINGS AND ZIP WIRES FOR ENTERTAINMENT PURPOSE; PROVIDING THEME PARK SERVICES; PROVIDING ADVENTURE PARK FACILITIES FOR RECREATION ACTIVITIES; ENTERTAINMENT SERVICES, NAMELY, PROVIDING OUTDOOR ENVIRONMENTS WITH ADVENTURE COURSE AND TREETOP CHALLENGING ACTIVITIES IN WHICH USERS CAN INTERACT FOR RECREATIONAL, LEISURE OR ENTERTAINMENT PURPOSES; RECREATIONAL AND ENTERTAINMENT SERVICES WITHIN A COMBINATION RECREATIONAL AND AMUSEMENT PARK ENVIRONMENT FEATURING AERIAL WALKWAYS, HIGH WIRE COURSES, HIGH ROPES, FOREST ADVENTURE COURSES, TRAINING SERVICES IN THE FIELD OF OBSTACLE COURSES (U.S. CLS. 100, 101 AND 107).

FIRST USE 10-1-2010; IN COMMERCE 10-1-2010.

CLASS 42—SCIENTIFIC AND COMPUTER SERVICES

FOR LANDSCAPE ARCHITECTURE AND OUTDOOR ATTRACTION DESIGN; CUSTOM DESIGN OF RECREATIONAL SITES, NAMELY, PLAYGROUNDS, PARKS, OUTDOOR OBSTACLE COURSES, TREE TOP COURSES, ZIP LINES, SWING LINES, TREE TO TREE OBSTACLE COURSES, HIGH ROPE COURSES, CLIMBING COURSES, TIGHT ROPES, SUSPENSION BRIDGES, ROPE SWINGS, AND CLIMBING NETS; SAFETY AND ACCESSIBILITY CONSULTATION SERVICES IN THE FIELD OF THE DESIGN OF PLAYGROUNDS, PARKS, OUTDOOR OBSTACLE COURSE, TREE TOP COURSES, ZIP LINES, SWING LINES, TREE TO TREE OBSTACLE COURSES, HIGH ROPE COURSES, CLIMBING COURSES, TIGHT ROPES, SUSPENSION BRIDGES, ROPE SWINGS, CLIMBING NETS AND EQUIPMENT AND ACCESSORIES THEREFOR (U.S. CLS. 100 AND 101).

FIRST USE 10-1-2010; IN COMMERCE 10-1-2010.

JANICE L. MCMORROW, EXAMINING ATTORNEY

SN 85-510,225. OLIVER PEOPLES, INC., WEST HOLLYWOOD, CA. FILED 1-6-2012.

OLIVER PEOPLES

THE MARK CONSISTS OF STANDARD CHARACTERS WITHOUT CLAIM TO ANY PARTICULAR FONT, STYLE, SIZE, OR COLOR.

OWNER OF U.S. REG. NOS. 2,005,096 AND 2,600,900.

THE NAME "OLIVER PEOPLES" DOES NOT IDENTIFY A LIVING INDIVIDUAL.

CLASS 9—ELECTRICAL AND SCIENTIFIC APPARATUS

FOR SUNGLASSES, EYEGLASSES AND EYEWEAR ACCESSORIES, NAMELY CASES, CORDS AND STRAPS (U.S. CLS. 21, 23, 26, 36 AND 38).

FIRST USE 11-30-1986; IN COMMERCE 11-30-1986.

CLASS 35—ADVERTISING AND BUSINESS

FOR RETAIL STORE SERVICES, MAIL ORDER CATALOG SERVICES AND ONLINE RETAIL STORE SERVICES ALL FEATURING SUNGLASSES, EYEGLASSES AND EYEWEAR ACCESSORIES, NAMELY CASES, CORDS AND STRAPS (U.S. CLS. 100, 101 AND 102).

FIRST USE 11-30-1986; IN COMMERCE 11-30-1986.

FRANK LATTUCA, EXAMINING ATTORNEY

SN 85-510,244. OLIVER PEOPLES, INC., WEST HOLLYWOOD, CA. FILED 1-6-2012.



OWNER OF U.S. REG. NOS. 1,913,440 AND 2,600,900.
THE MARK CONSISTS OF FANCIFUL REPRESENTATIONS OF EYEGLASSES.

CLASS 9—ELECTRICAL AND SCIENTIFIC APPARATUS

FOR SUNGLASSES, EYEGLASSES AND EYEWEAR ACCESSORIES, NAMELY CASES, CORDS AND STRAPS (U.S. CLS. 21, 23, 26, 36 AND 38).

FIRST USE 11-30-1986; IN COMMERCE 11-30-1986.

CLASS 35—ADVERTISING AND BUSINESS

FOR RETAIL STORE SERVICES, MAIL ORDER CATALOG SERVICES AND ONLINE RETAIL STORE SERVICES ALL FEATURING SUNGLASSES, EYEGLASSES AND EYEGLASS ACCESSORIES, NAMELY CASES, CORDS AND STRAPS (U.S. CLS. 100, 101 AND 102).

FIRST USE 11-30-1986; IN COMMERCE 11-30-1986.

FRANK LATTUCA, EXAMINING ATTORNEY

SN 85-510,258. BEACON PARTNERS, INC., WEYMOUTH, MA. FILED 1-6-2012.

SN 85-510,281. HAWAIIAN JELLYS, LLC., WAIKOLOA, HI. FILED 1-6-2012.

PILLARS

THE MARK CONSISTS OF STANDARD CHARACTERS WITHOUT CLAIM TO ANY PARTICULAR FONT, STYLE, SIZE, OR COLOR.

CLASS 9—ELECTRICAL AND SCIENTIFIC APPARATUS

FOR DOWNLOADABLE COMPUTER SOFTWARE IN THE HEALTHCARE FIELD FOR TASK MANAGEMENT, TIME TRACKING, ISSUE TRACKING, RESOURCE PLANNING, AND MANAGING WORKFLOW, FOR USE BY HEALTHCARE FACILITIES, CLINICIANS, AND OTHER HEALTHCARE PERSONNEL (U.S. CLS. 21, 23, 26, 36 AND 38).

CLASS 42—SCIENTIFIC AND COMPUTER SERVICES

FOR SOFTWARE AS A SERVICE (SAAS) SERVICES FEATURING SOFTWARE IN THE HEALTHCARE FIELD FOR TASK MANAGEMENT, TIME TRACKING, ISSUE TRACKING, RESOURCE PLANNING, AND MANAGING WORKFLOW, FOR USE BY HEALTHCARE FACILITIES, CLINICIANS, AND OTHER HEALTHCARE PERSONNEL (U.S. CLS. 100 AND 101).

CHRIS WELLS, EXAMINING ATTORNEY

SN 85-510,268. LUXOTTICA RETAIL NORTH AMERICA INC., MASON, OH. FILED 1-6-2012.

SUNSOURCE

THE MARK CONSISTS OF STANDARD CHARACTERS WITHOUT CLAIM TO ANY PARTICULAR FONT, STYLE, SIZE, OR COLOR.

CLASS 35—ADVERTISING AND BUSINESS

FOR RETAIL OPTICAL STORE SERVICES (U.S. CLS. 100, 101 AND 102).

CLASS 44—MEDICAL, BEAUTY AND AGRICULTURAL SERVICES

FOR OPTICIAN AND OPTOMETRIC SERVICES (U.S. CLS. 100 AND 101).

CHRIS WELLS, EXAMINING ATTORNEY

JellyBugs

THE MARK CONSISTS OF STANDARD CHARACTERS WITHOUT CLAIM TO ANY PARTICULAR FONT, STYLE, SIZE, OR COLOR.

CLASS 25—CLOTHING

FOR FLIP FLOPS (U.S. CLS. 22 AND 39).

CLASS 28—TOYS AND SPORTING GOODS

FOR PLUSH TOYS (U.S. CLS. 22, 23, 38 AND 50).

BRENDAN REGAN, EXAMINING ATTORNEY

SN 85-510,307. PEPSICO, INC., PURCHASE, NY. FILED 1-6-2012.

SOUNDTRACK YOUR SUMMER

THE MARK CONSISTS OF STANDARD CHARACTERS WITHOUT CLAIM TO ANY PARTICULAR FONT, STYLE, SIZE, OR COLOR.

CLASS 29—MEATS AND PROCESSED FOODS

FOR NUT-BASED SNACK FOODS; POTATO-BASED SNACK FOODS; PROCESSED EDIBLE SEEDS; SNACK DIPS; SOY-BASED SNACK FOODS (U.S. CL. 46).

CLASS 30—STAPLE FOODS

FOR CHEESE FLAVORED PUFFED CORN SNACKS; CORN-BASED SNACK FOODS; CRACKERS; FLOUR-BASED CHIPS; GRAIN-BASED SNACK FOODS; PRETZELS; SALSA; WHEAT-BASED SNACK FOODS (U.S. CL. 46).

CLASS 32—LIGHT BEVERAGES

FOR SOFT DRINKS (U.S. CLS. 45, 46 AND 48).

JENNIFER VASQUEZ, EXAMINING ATTORNEY

SN 85-510,377. TRATTNER, STEVEN, SUNNY ISLES BEACH, FL. FILED 1-6-2012.

VetNet Laboratories

THE MARK CONSISTS OF STANDARD CHARACTERS WITHOUT CLAIM TO ANY PARTICULAR FONT, STYLE, SIZE, OR COLOR.

NO CLAIM IS MADE TO THE EXCLUSIVE RIGHT TO USE "LABORATORIES", APART FROM THE MARK AS SHOWN.

SN 85-510,504. BUSTOUT POKER, LLC, COLUMBIA, SC. FILED 1-6-2012.

CLASS 42—SCIENTIFIC AND COMPUTER SERVICES

FOR VETERINARY LABORATORY SERVICES (U.S. CLS. 100 AND 101).

CLASS 44—MEDICAL, BEAUTY AND AGRICULTURAL SERVICES

FOR VETERINARY SERVICES (U.S. CLS. 100 AND 101).

ELI HELLMAN, EXAMINING ATTORNEY

LIVE AND LET GRIND

THE MARK CONSISTS OF STANDARD CHARACTERS WITHOUT CLAIM TO ANY PARTICULAR FONT, STYLE, SIZE, OR COLOR.

CLASS 14—JEWELRY

FOR RUBBER OR SILICON WRISTBANDS IN THE NATURE OF A BRACELET (U.S. CLS. 2, 27, 28 AND 50).

CLASS 25—CLOTHING

FOR HATS; HOODED SWEATSHIRTS; T-SHIRTS (U.S. CLS. 22 AND 39).

FRANK LATTUCA, EXAMINING ATTORNEY

SN 85-510,435. QUINTILES TRANSNATIONAL CORP., DURHAM, NC. FILED 1-6-2012.

SN 85-510,569. FOOD MARKETING INSTITUTE, ALEXANDRIA, VA. FILED 1-6-2012.

QUINEXSYN

THE MARK CONSISTS OF STANDARD CHARACTERS WITHOUT CLAIM TO ANY PARTICULAR FONT, STYLE, SIZE, OR COLOR.



CLASS 35—ADVERTISING AND BUSINESS

FOR MANUFACTURERS' AND INDEPENDENT SALES REPRESENTATIVES IN THE FIELDS OF PHARMACEUTICALS, HEALTHCARE, PHARMACOGENOMIC, BIOTECHNICAL AND MEDICAL PRODUCTS AND DEVICES; MARKETING SERVICES FOR OTHERS, NAMELY, CREATING AND MANAGING PRODUCT SALES AND PRODUCT LAUNCH PROGRAMS IN THE FIELDS OF PHARMACEUTICALS, HEALTHCARE, PHARMACOGENOMIC, BIOTECHNICAL AND MEDICAL PRODUCTS AND DEVICES; BUSINESS MARKETING CONSULTING SERVICES IN THE FIELDS OF PHARMACEUTICALS, HEALTHCARE, PHARMACOGENOMIC, BIOTECHNICAL AND MEDICAL PRODUCTS AND DEVICES; MARKET RESEARCH AND ANALYSIS SERVICES IN THE FIELDS OF PHARMACEUTICALS, HEALTHCARE, PHARMACOGENOMIC, BIOTECHNICAL, AND MEDICAL PRODUCTS AND DEVICES (U.S. CLS. 100, 101 AND 102).

CLASS 41—EDUCATION AND ENTERTAINMENT

FOR EDUCATIONAL AND TRAINING SERVICES, NAMELY, CONDUCTING TRAINING PROGRAMS, SEMINARS, CLASSES, CONFERENCES AND WORKSHOPS IN THE FIELDS OF HEALTH MANAGEMENT AND DISEASE MANAGEMENT, PHARMACEUTICAL SALES SKILLS, AND PHARMACEUTICAL AND HEALTH PRODUCTS, AND DISTRIBUTING COURSE MATERIALS IN CONNECTION THEREWITH (U.S. CLS. 100, 101 AND 107).

RAUL CORDOVA, EXAMINING ATTORNEY

OWNER OF U.S. REG. NOS. 1,118,214, 1,151,682 AND 3,100,261.

THE MARK CONSISTS OF THE STYLIZED LETTERS "FMI" IN A SOLID RECTANGULAR BOX TO THE LEFT OF A RECTANGULAR BOX WITH BAR CODES INSIDE, WHICH APPEAR ABOVE THE WORDS "THE VOICE OF FOOD RETAIL", WHICH APPEARS ABOVE THE WORDS "FEEDING FAMILIES" AND "ENRICHING LIVES" SEPARATED BY A GROCERY CART IMAGE.

CLASS 16—PAPER GOODS AND PRINTED MATTER

FOR REPORTS OF INTEREST TO THE FOOD AND GROCERY INDUSTRY (U.S. CLS. 2, 5, 22, 23, 29, 37, 38 AND 50).

CLASS 35—ADVERTISING AND BUSINESS

FOR ASSOCIATION SERVICES, NAMELY, PROMOTING THE INTERESTS OF THE FOOD AND GROCERY INDUSTRY (U.S. CLS. 100, 101 AND 102).

CLASS 41—EDUCATION AND ENTERTAINMENT

FOR EDUCATIONAL SERVICES, NAMELY, CONDUCTING CONFERENCES AND SEMINARS FOR THE FOOD AND GROCERY INDUSTRY (U.S. CLS. 100, 101 AND 107).

JENNIFER VASQUEZ, EXAMINING ATTORNEY

SN 85-510,780. LEIGH'S OF WESTERN MICHIGAN, INC., GRAND RAPIDS, MI. FILED 1-6-2012.

LEIGH'S

THE MARK CONSISTS OF STANDARD CHARACTERS WITHOUT CLAIM TO ANY PARTICULAR FONT, STYLE, SIZE, OR COLOR.

CLASS 35—ADVERTISING AND BUSINESS

FOR RETAIL STORE AND ON-LINE RETAIL STORE SERVICES IN THE FIELD OF APPAREL, FOOTWEAR, FASHION ACCESSORIES, COSMETICS, GIFTS, AND BATH, BODY AND PERSONAL CARE PRODUCTS; PRE-PAID GIFT CARD SERVICES, NAMELY, ISSUING GIFT CARD CERTIFICATES THAT MAY BE REDEEMED FOR GOODS OR SERVICES; RETAIL DEPARTMENT STORES (U.S. CLS. 100, 101 AND 102).
FIRST USE 1-17-1975; IN COMMERCE 1-17-1975.

CLASS 45—PERSONAL AND LEGAL SERVICES

FOR PERSONAL SHOPPING FOR OTHERS; PERSONAL GIFT SELECTION FOR OTHERS; PERSONAL FASHION CONSULTING SERVICES; PERSONAL WARDROBE STYLING SERVICES (U.S. CLS. 100 AND 101).
FIRST USE 1-17-1975; IN COMMERCE 1-17-1975.
ANDREW LEASER, EXAMINING ATTORNEY

SN 85-510,784. ALCOHOL COUNTERMEASURE SYSTEMS (INTERNATIONAL) INC., TORONTO, ONTARIO, CANADA, FILED 1-6-2012.

ALCOLOCK

THE MARK CONSISTS OF STANDARD CHARACTERS WITHOUT CLAIM TO ANY PARTICULAR FONT, STYLE, SIZE, OR COLOR.
OWNER OF U.S. REG. NO. 4,123,395.

CLASS 37—CONSTRUCTION AND REPAIR

FOR INSTALLATION AND REPAIR SERVICES OF DEVICES FOR DISABLING A VEHICLE IN RESPONSE TO A DETECTION OF ALCOHOL IN THE BLOOD OF ITS PURPORTED OPERATOR, DEVICES FOR DISABLING A VEHICLE IN RESPONSE TO A MEASUREMENT OF ALCOHOL IN EXCESS OF A SAFETY THRESHOLD IN THE BLOOD OF ITS PURPORTED OPERATOR, AND BREATH ALCOHOL TESTERS (U.S. CLS. 100, 103 AND 106).

CLASS 42—SCIENTIFIC AND COMPUTER SERVICES

FOR COMPLIANCE MONITORING SERVICES, NAMELY, MONITORING, INSPECTING, AND TESTING OF THE FUNCTIONING AND USE OF DEVICES FOR DISABLING A VEHICLE IN RESPONSE TO A DETECTION OF ALCOHOL IN THE BLOOD OF ITS PURPORTED OPERATOR, DEVICES FOR DISABLING A VEHICLE IN RESPONSE TO A MEASUREMENT OF ALCOHOL IN EXCESS OF A SAFETY THRESHOLD IN THE BLOOD OF ITS PURPORTED OPERATOR, AND BREATH ALCOHOL TESTERS (U.S. CLS. 100 AND 101).
ANDREW LEASER, EXAMINING ATTORNEY

SN 85-510,785. EXXON MOBIL CORPORATION, IRVING, TX. FILED 1-6-2012.

ENERGY LIVES HERE

THE MARK CONSISTS OF STANDARD CHARACTERS WITHOUT CLAIM TO ANY PARTICULAR FONT, STYLE, SIZE, OR COLOR.

CLASS 40—MATERIAL TREATMENT

FOR PROVIDING INFORMATION IN THE FIELDS OF OIL AND NATURAL GAS PRODUCTION AND REFINING (U.S. CLS. 100, 103 AND 106).

CLASS 42—SCIENTIFIC AND COMPUTER SERVICES

FOR PROVIDING INFORMATION IN THE FIELD OF OIL AND NATURAL GAS EXPLORATION (U.S. CLS. 100 AND 101).
ANDREW LEASER, EXAMINING ATTORNEY

SN 85-510,845. JOHN & COOK'S REAL PIT BBQ L.L.C., LAWTON, OK. FILED 1-6-2012.



NO CLAIM IS MADE TO THE EXCLUSIVE RIGHT TO USE "REAL PIT BAR-B-QUE" "PORK" "BEEF" "SINCE 1936", APART FROM THE MARK AS SHOWN.

THE COLOR(S) YELLOW, BLUE, TAN, GREEN, GRAY, WHITE AND ORANGE IS/ARE CLAIMED AS A FEATURE OF THE MARK.

THE MARK CONSISTS OF A GRAY BANNER WITH TAN OUTLINE WITH THE WORDS "JOHN & COOK'S" IN YELLOW AND ORANGE OVER THE BANNER, WITH A

BLUE CIRCLE BELOW THE BANNER HAVING A TAN SCROLLED OUTLINE, WITH THE INTERIOR OF THE CIRCLE CONTAINING A TAN PIG WEARING A WHITE CHEF HAT AND WHITE COAT AND CARRYING A GRAY BUTCHER KNIFE, WITH THE PIG SURROUNDED BY ORANGE FLAMES AND THE WORDS "REAL PIT" IN YELLOW AND ORANGE, THE BLUE CIRCLE CONTAINING THE PIG IS FLANKED ON EITHER SIDE BY A GREEN SWIRLED LEAF, AND ALONG THE BOTTOM PORTION OF THE BLUE CIRCLE IS ANOTHER BANNER CONTAINING THE WORDS "PORK BAR-B-QUE BEEF" WITH THE WORDS "PORK" AND "BEEF" IN WHITE AND "BAR-B-QUE" IN YELLOW AND ORANGE, WITH THE BANNER BEING BLUE AND OUTLINED IN TAN AND GREEN, AND BELOW THE BLUE BANNER IS A GREEN, ORANGE AND YELLOW SCROLLED BANNER CONTAINING THE WORDS "SINCE 1936" IN TAN. THE ENTIRE MARK IS ON A TRANSPARENT BACKGROUND.

SN 85-510,886. FOOD MARKETING INSTITUTE, ALEXANDRIA, VA. FILED 1-6-2012.

THE VOICE OF FOOD RETAIL 

THE MARK CONSISTS OF THE WORDS "THE VOICE OF FOOD RETAIL" WITH A SHOPPING CART IMAGE TO THE RIGHT.

CLASS 29—MEATS AND PROCESSED FOODS

FOR SAUSAGES (U.S. CL. 46).

CLASS 16—PAPER GOODS AND PRINTED MATTER

FOR REPORTS OF INTEREST TO THE FOOD AND GROCERY INDUSTRY (U.S. CLS. 2, 5, 22, 23, 29, 37, 38 AND 50).

CLASS 30—STAPLE FOODS

FOR BARBECUE SAUCE (U.S. CL. 46).
DAVID MURRAY, EXAMINING ATTORNEY

CLASS 35—ADVERTISING AND BUSINESS

FOR ASSOCIATION SERVICES, NAMELY, PROMOTING THE INTERESTS OF THE FOOD AND GROCERY INDUSTRY (U.S. CLS. 100, 101 AND 102).

SN 85-510,861. FOOD MARKETING INSTITUTE, ALEXANDRIA, VA. FILED 1-6-2012.

CLASS 41—EDUCATION AND ENTERTAINMENT

FOR EDUCATIONAL SERVICES, NAMELY, CONDUCTING CONFERENCES AND SEMINARS FOR THE FOOD AND GROCERY INDUSTRY (U.S. CLS. 100, 101 AND 107).
JENNIFER VASQUEZ, EXAMINING ATTORNEY



SN 85-510,902. FOOD MARKETING INSTITUTE, ALEXANDRIA, VA. FILED 1-6-2012.

Feeding Families  **Enriching Lives**

OWNER OF U.S. REG. NOS. 1,118,214, 1,151,682 AND 3,100,261.

THE MARK CONSISTS OF THE STYLIZED LETTERS "FMI" IN A SOLID RECTANGULAR BOX TO THE LEFT OF A RECTANGULAR BOX WITH BAR CODES INSIDE.

THE MARK CONSISTS OF THE WORDS "FEEDING FAMILIES" AND "ENRICHING LIVES" SEPARATED BY A SHOPPING CART IMAGE.

CLASS 16—PAPER GOODS AND PRINTED MATTER

FOR REPORTS OF INTEREST TO THE FOOD AND GROCERY INDUSTRY (U.S. CLS. 2, 5, 22, 23, 29, 37, 38 AND 50).

CLASS 16—PAPER GOODS AND PRINTED MATTER

FOR REPORTS OF INTEREST TO THE FOOD AND GROCERY INDUSTRY (U.S. CLS. 2, 5, 22, 23, 29, 37, 38 AND 50).

CLASS 35—ADVERTISING AND BUSINESS

FOR ASSOCIATION SERVICES, NAMELY, PROMOTING THE INTERESTS OF THE FOOD AND GROCERY INDUSTRY (U.S. CLS. 100, 101 AND 102).

CLASS 35—ADVERTISING AND BUSINESS

FOR ASSOCIATION SERVICES, NAMELY, PROMOTING THE INTERESTS OF THE FOOD AND GROCERY INDUSTRY (U.S. CLS. 100, 101 AND 102).

CLASS 41—EDUCATION AND ENTERTAINMENT

FOR EDUCATIONAL SERVICES, NAMELY, CONDUCTING CONFERENCES AND SEMINARS FOR THE FOOD AND GROCERY INDUSTRY (U.S. CLS. 100, 101 AND 107).
JENNIFER VASQUEZ, EXAMINING ATTORNEY

CLASS 41—EDUCATION AND ENTERTAINMENT

FOR EDUCATIONAL SERVICES, NAMELY, CONDUCTING CONFERENCES AND SEMINARS FOR THE FOOD AND GROCERY INDUSTRY (U.S. CLS. 100, 101 AND 107).
JENNIFER VASQUEZ, EXAMINING ATTORNEY

SN 85-510,914. FOOD MARKETING INSTITUTE, ALEXANDRIA, VA. FILED 1-6-2012.

SN 85-510,995. SKINNY LIZARD DESIGNS, INC., LOS ANGELES, CA. FILED 1-6-2012.

FEEDING FAMILIES AND ENRICHING LIVES

THE MARK CONSISTS OF STANDARD CHARACTERS WITHOUT CLAIM TO ANY PARTICULAR FONT, STYLE, SIZE, OR COLOR.

CLASS 16—PAPER GOODS AND PRINTED MATTER

FOR REPORTS OF INTEREST TO THE FOOD AND GROCERY INDUSTRY (U.S. CLS. 2, 5, 22, 23, 29, 37, 38 AND 50).

CLASS 35—ADVERTISING AND BUSINESS

FOR ASSOCIATION SERVICES, NAMELY, PROMOTING THE INTERESTS OF THE FOOD AND GROCERY INDUSTRY (U.S. CLS. 100, 101 AND 102).

CLASS 41—EDUCATION AND ENTERTAINMENT

FOR EDUCATIONAL SERVICES, NAMELY, CONDUCTING CONFERENCES AND SEMINARS FOR THE FOOD AND GROCERY INDUSTRY (U.S. CLS. 100, 101 AND 107).

JENNIFER VASQUEZ, EXAMINING ATTORNEY

SN 85-510,926. FOOD MARKETING INSTITUTE, ALEXANDRIA, VA. FILED 1-6-2012.

THE VOICE OF FOOD RETAIL

THE MARK CONSISTS OF STANDARD CHARACTERS WITHOUT CLAIM TO ANY PARTICULAR FONT, STYLE, SIZE, OR COLOR.

CLASS 16—PAPER GOODS AND PRINTED MATTER

FOR REPORTS OF INTEREST TO THE FOOD AND GROCERY INDUSTRY (U.S. CLS. 2, 5, 22, 23, 29, 37, 38 AND 50).

CLASS 35—ADVERTISING AND BUSINESS

FOR ASSOCIATION SERVICES, NAMELY, PROMOTING THE INTERESTS OF THE FOOD AND GROCERY INDUSTRY (U.S. CLS. 100, 101 AND 102).

CLASS 41—EDUCATION AND ENTERTAINMENT

FOR EDUCATIONAL SERVICES, NAMELY, CONDUCTING CONFERENCES AND SEMINARS FOR THE FOOD AND GROCERY INDUSTRY (U.S. CLS. 100, 101 AND 107).

JENNIFER VASQUEZ, EXAMINING ATTORNEY

DOUGLAS DUNNAM

THE MARK CONSISTS OF STANDARD CHARACTERS WITHOUT CLAIM TO ANY PARTICULAR FONT, STYLE, SIZE, OR COLOR.

THE NAME "DOUGLAS DUNNAM" IDENTIFIES A LIVING INDIVIDUAL WHOSE CONSENT IS OF RECORD.

CLASS 14—JEWELRY

FOR WATCH BANDS AND STRAPS, WATCHES, BRACELETS, NECKLACES, RINGS (U.S. CLS. 2, 27, 28 AND 50).

CLASS 15—MUSICAL INSTRUMENTS

FOR GUITAR STRAPS (U.S. CLS. 2, 21 AND 36).

CLASS 18—LEATHER GOODS

FOR LEATHER BAGS, LEATHER WALLETS, BANDS OF LEATHER, KEY RINGS OF LEATHER, KEY CHAINS OF LEATHER (U.S. CLS. 1, 2, 3, 22 AND 41).

CLASS 25—CLOTHING

FOR BELTS, BELTS OF LEATHER, PANTS, T-SHIRTS, JACKETS, COATS, HATS (U.S. CLS. 22 AND 39).

LINDA M. KING, EXAMINING ATTORNEY

SN 85-511,009. STS MEDIA, INC., UNIVERSAL CITY, CA. FILED 1-6-2012.

FREEDOMPOP

THE MARK CONSISTS OF STANDARD CHARACTERS WITHOUT CLAIM TO ANY PARTICULAR FONT, STYLE, SIZE, OR COLOR.

CLASS 9—ELECTRICAL AND SCIENTIFIC APPARATUS

FOR MODEMS (U.S. CLS. 21, 23, 26, 36 AND 38).

CLASS 38—COMMUNICATION

FOR TELECOMMUNICATIONS SERVICES, NAMELY, PROVIDING INTERNET ACCESS VIA WIRELESS BROADBAND NETWORKS; WIRELESS BROADBAND COMMUNICATION SERVICES (U.S. CLS. 100, 101 AND 104).

LAURIE MAYES, EXAMINING ATTORNEY

SN 85-511,033. TEALEAF TECHNOLOGY, INC., SAN FRANCISCO, CA. FILED 1-6-2012.

MOBILITEA

THE MARK CONSISTS OF STANDARD CHARACTERS WITHOUT CLAIM TO ANY PARTICULAR FONT, STYLE, SIZE, OR COLOR.

CLASS 9—ELECTRICAL AND SCIENTIFIC APPARATUS

FOR COMPUTER SOFTWARE FOR CAPTURING AND ANALYZING INTERNET-RELATED AND CLIENT/SERVER-RELATED CUSTOMER EXPERIENCE DATA (U.S. CLS. 21, 23, 26, 36 AND 38).

CLASS 42—SCIENTIFIC AND COMPUTER SERVICES

FOR COMPUTER SERVICES FOR CAPTURING AND ANALYZING INTERNET-RELATED AND CLIENT/SERVER-RELATED CUSTOMER EXPERIENCE DATA (U.S. CLS. 100 AND 101).

JAY FLOWERS, EXAMINING ATTORNEY

SN 85-511,112. BEDNARCIC CONSULTING LLC, EAST GREENWICH, RI. FILED 1-7-2012.

DCIQ

THE MARK CONSISTS OF STANDARD CHARACTERS WITHOUT CLAIM TO ANY PARTICULAR FONT, STYLE, SIZE, OR COLOR.

CLASS 9—ELECTRICAL AND SCIENTIFIC APPARATUS

FOR COMPUTER HARDWARE AND SOFTWARE SYSTEM FOR REMOTELY MONITORING ENVIRONMENTAL CONDITIONS AND CONTROLLING DEVICES WITHIN A BUILDING, FACILITY, GROUNDS, OR DESIGNATED SPATIAL AREA (U.S. CLS. 21, 23, 26, 36 AND 38).

CLASS 42—SCIENTIFIC AND COMPUTER SERVICES

FOR SOFTWARE AS A SERVICE (SAAS) SERVICES FEATURING SOFTWARE FOR DIAGNOSING AND MONITORING DATA CENTER HARDWARE AND SOFTWARE; TECHNICAL CONSULTING SERVICES IN THE FIELDS OF DATACENTER ARCHITECTURE, PUBLIC AND PRIVATE CLOUD COMPUTING SOLUTIONS, AND EVALUATION AND IMPLEMENTATION OF INTERNET TECHNOLOGY AND SERVICES; TECHNICAL SUPPORT SERVICES, NAMELY, REMOTE ADMINISTRATION AND MANAGEMENT OF IN-HOUSE AND HOSTED DATACENTER DEVICES, DATABASES AND SOFTWARE APPLICATIONS (U.S. CLS. 100 AND 101).

SUNG IN, EXAMINING ATTORNEY

SN 85-511,156. SAKU LLC, CUPERTINO, CA. FILED 1-7-2012.

kiddoBLOOM



THE MARK CONSISTS OF STYLIZED FROG WITH STYLIZED WORDING "KIDDOBLOOM", THE LETTERS "OO" IN "KIDDOBLOOM" ALSO SERVE AS THE EYES OF THE FROG.

CLASS 8—HAND TOOLS

FOR CUTLERY, NAMELY, SPOONS, FORKS, AND KNIVES; STAINLESS STEEL TABLE KNIVES, FORKS AND SPOONS (U.S. CLS. 23, 28 AND 44).

CLASS 21—HOUSEWARES AND GLASS

FOR DESSERT PLATES; DINNERWARE, NAMELY, PLATES, CUPS, AND SAUCERS; DRINKING CUPS FOR CHILDREN AND PARTS AND FITTINGS THEREFOR, NAMELY, DRINKING CUPS FOR CHILDREN SOLD AS A UNIT WITH NON-INSULATED LIDS; LUNCH BOXES; POTTIES FOR CHILDREN (U.S. CLS. 2, 13, 23, 29, 30, 33, 40 AND 50).

CLASS 25—CLOTHING

FOR CHILDREN'S AND INFANT'S APPAREL, NAMELY, JUMPERS, OVERALL SLEEPWEAR, PAJAMAS, ROMPERS AND ONE-PIECE GARMENTS; CHILDREN'S HEADWEAR; LEOTARDS AND TIGHTS FOR WOMEN, MEN AND CHILDREN OF NYLON, COTTON OR OTHER TEXTILE FIBERS; SHIRTS FOR INFANTS, BABIES, TODDLERS AND CHILDREN (U.S. CLS. 22 AND 39).

LUCY ARANT, EXAMINING ATTORNEY

SN 85-511,175. JOBY, INC., PETALUMA, CA. FILED 1-7-2012.

JOBY



THE MARK CONSISTS OF THE LETTERS "JOBY" AND A CIRCULAR DESIGN CONSISTING OF EIGHT (8) CIRCLES THAT ARE TOTALLY SHADED.

CLASS 9—ELECTRICAL AND SCIENTIFIC APPARATUS

FOR TRIPODS DESIGNED FOR USE WITH CAMERAS, VIDEOCAMERAS, MOBILE TELEPHONES, HANDHELD MOBILE DIGITAL ELECTRONIC DEVICES, COMPUTER NOTEBOOKS, COMPUTER PADS, COMPUTER TABLETS AND COMPUTER PLAYBOOKS; STANDS AND CASES DESIGNED FOR USE WITH MOBILE TELEPHONES, COMPUTER NOTEBOOKS, COMPUTER PADS, COMPUTER TABLETS AND COMPUTER PLAYBOOKS; FLEXIBLE BALLHEADS AND BUBBLE LEVEL CLIPS DESIGNED FOR USE WITH TRIPODS; TRIPODS DESIGNED FOR USE WITH PHOTOGRAPHY LIGHTING EQUIPMENT; FLASHLIGHTS DESIGNED FOR USE WITH PHOTOGRAPHY EQUIPMENT, SPOT LIGHTS DESIGNED FOR USE WITH PHOTOGRAPHY EQUIPMENT, AND LANTERNS DESIGNED FOR USE WITH PHOTOGRAPHY EQUIPMENT (U.S. CLS. 21, 23, 26, 36 AND 38).

FIRST USE 11-30-2011; IN COMMERCE 11-30-2011.

CLASS 11—ENVIRONMENTAL CONTROL APPARATUS

FOR CONSUMER ELECTRONIC DEVICES, NAMELY PORTABLE LIGHTING FIXTURES IN THE NATURE OF A FLEXIBLE TRIPOD WITH A LIGHT MOUNTED THEREON AND A FLEXIBLE ARM WITH A LIGHT MOUNTED THEREON, TRANSFORMABLE LIGHT FOR USE AS A LANTERN AND AS A PORTABLE HEADLAMP FOR RECREATIONAL USE (U.S. CLS. 13, 21, 23, 31 AND 34).

FIRST USE 11-30-2011; IN COMMERCE 11-30-2011.
BRIAN NEVILLE, EXAMINING ATTORNEY

SN 85-511,269. HORSE WHISPERS, LLC, CAREFREE, AZ.
FILED 1-8-2012.



THE MARK CONSISTS OF TWO CONCENTRIC OVALS WITH THE WORD "HORSE" APPEARING IN CAPITAL LETTERS AT THE TOP OF THE MARK BETWEEN THE TWO OVALS AND WITH DOTS APPEARING BETWEEN EACH OF THE LETTERS IN THE WORD "HORSE". THE WORD "WHISPERS" APPEARS AT THE BOTTOM OF THE MARK BETWEEN THE TWO OVALS IN STYLIZED LETTERS. A FILIGREE DESIGN APPEARS IN BETWEEN THE TWO OVALS NEXT TO EACH SIDE OF THE INNER OVAL WITH A DOT SURROUNDED BY AN OUTER CIRCLE APPEARING ON THE OUTSIDE OF EACH FILIGREE DESIGN. AN IMAGE OF A HORSE HEAD AND AN IMAGE OF A FEMALE APPEAR IN THE INNER OVAL WITH THE MANE OF THE HORSE AND HAIR OF THE FEMALE APPEARING INTERTWINED.

SN 85-511,233. REMOTE MEDICINE INC., SEATTLE, WA.
FILED 1-7-2012.

WHEN THE HOSPITAL IS NOT AN OPTION

THE MARK CONSISTS OF STANDARD CHARACTERS WITHOUT CLAIM TO ANY PARTICULAR FONT, STYLE, SIZE, OR COLOR.

CLASS 25—CLOTHING

FOR T-SHIRTS (U.S. CLS. 22 AND 39).

CLASS 35—ADVERTISING AND BUSINESS

FOR BUSINESS CONSULTING SERVICES IN THE FIELD OF CONSULTING FOR INDIVIDUALS AND BUSINESSES WITH GEOGRAPHICALLY REMOTE BUSINESS INTERESTS; ON-LINE RETAIL STORE SERVICES FEATURING MEDICAL EQUIPMENT, NAMELY, MEDICAL REFERENCE BOOKS, OVER-THE-COUNTER MEDICATIONS, DENTAL SUPPLIES, EQUIPMENT BAGS AND CASES, FIRST AID KITS AND MODULES, SURGICAL EQUIPMENT, RESCUE EQUIPMENT, NURSING AND LONG TERM CARE EQUIPMENT, MONITORS AND DEFIBRILLATORS, APPAREL, PATCHES, AND UNIFORMS, MEDICAL CLINIC FURNITURE AND FIXTURES (U.S. CLS. 100, 101 AND 102).

FIRST USE 9-1-2005; IN COMMERCE 9-1-2005.

CLASS 41—EDUCATION AND ENTERTAINMENT

FOR EDUCATION SERVICES, NAMELY, PROVIDING TRAINING AND TEACHING IN THE FIELD OF FIRST AID, EMERGENCY MEDICAL SERVICES, EMERGENCY RESPONSE SERVICE, EMERGENCY MEDICAL TECHNICIANS AS IT RELATES TO EMERGENCY SITUATIONS IN REMOTE GEOGRAPHIC SETTINGS FOR PURPOSES OF CERTIFICATION AND RECERTIFICATION (U.S. CLS. 100, 101 AND 107).

FIRST USE 9-1-2005; IN COMMERCE 9-1-2005.

CLASS 44—MEDICAL, BEAUTY AND AGRICULTURAL SERVICES

FOR MEDICAL SERVICES, NAMELY, TELEMEDICINE AND EMERGENCY MEDICAL SERVICES PROVIDED DURING EVACUATION; ONSITE MEDICAL SERVICES, NAMELY, ONSITE MEDICAL AND EMERGENCY MEDICAL SERVICES AS A MEANS OF RESCUE SUPPORT (U.S. CLS. 100 AND 101).

FIRST USE 9-1-2005; IN COMMERCE 9-1-2005.
NATALIE POLZER, EXAMINING ATTORNEY

CLASS 20—FURNITURE AND ARTICLES NOT OTHERWISE CLASSIFIED

FOR FIGURINES OF RESIN (U.S. CLS. 2, 13, 22, 25, 32 AND 50).

CLASS 21—HOUSEWARES AND GLASS

FOR FIGURINES OF CHINA, CRYSTAL, EARTHENWARE, GLASS, PORCELAIN, CERAMIC; CERAMIC BOXES (U.S. CLS. 2, 13, 23, 29, 30, 33, 40 AND 50).

DOMINICK J. SALEMI, EXAMINING ATTORNEY

SN 85-511,507. EARTHSEAWARRIOR, LLC, ROCKVILLE, MD. FILED 1-9-2012.

EARTHSEAWARRIOR

THE MARK CONSISTS OF STANDARD CHARACTERS WITHOUT CLAIM TO ANY PARTICULAR FONT, STYLE, SIZE, OR COLOR.

CLASS 11—ENVIRONMENTAL CONTROL APPARATUS

FOR ELECTRIC LAMPS AND LIGHTING FIXTURES (U.S. CLS. 13, 21, 23, 31 AND 34).
FIRST USE 4-5-2010; IN COMMERCE 9-0-2010.

CLASS 21—HOUSEWARES AND GLASS

FOR WORKS OF ART OF CHINA, CRYSTAL, GLASS, PORCELAIN, AND CERAMIC (U.S. CLS. 2, 13, 23, 29, 30, 33, 40 AND 50).

FIRST USE 4-5-2010; IN COMMERCE 9-0-2010.
JOHN GARTNER, EXAMINING ATTORNEY

SN 85-511,659. YOTTAVOTE, INC., SMYRNA, GA. FILED 1-9-2012.

SN 85-511,792. TIP OR SKIP, INC., NEW YORK, NY. FILED 1-9-2012.

YOTTAVOTE

THE MARK CONSISTS OF STANDARD CHARACTERS WITHOUT CLAIM TO ANY PARTICULAR FONT, STYLE, SIZE, OR COLOR.

CLASS 25—CLOTHING

FOR BLOUSES; CAPS; HATS; JACKETS; LEISURE SUITS; PANTS; SHIRTS; SKIRTS; SWEATERS; TOPS; WEARABLE GARMENTS AND CLOTHING, NAMELY, SHIRTS (U.S. CLS. 22 AND 39).

CLASS 35—ADVERTISING AND BUSINESS

FOR ADVERTISING AND MARKETING SERVICES PROVIDED BY MEANS OF INDIRECT METHODS OF MARKETING COMMUNICATIONS, NAMELY, SOCIAL MEDIA, SEARCH ENGINE MARKETING, INQUIRY MARKETING, INTERNET MARKETING, MOBILE MARKETING, BLOGGING AND OTHER FORMS OF PASSIVE, SHARABLE OR VIRAL COMMUNICATIONS CHANNELS; COMPUTERIZED MARKET RESEARCH SERVICES; CONDUCTING BUSINESS AND MARKET RESEARCH SURVEYS; CONSUMER SURVEY SERVICES; MARKET OPINION POLLING STUDIES (U.S. CLS. 100, 101 AND 102).

PRISCILLA MILTON, EXAMINING ATTORNEY

SN 85-511,691. TRE IMPORTS, LLC, DBA STERI-CLENS, LAKE ZURICH, IL. FILED 1-9-2012.

Steri-Clens

THE MARK CONSISTS OF STANDARD CHARACTERS WITHOUT CLAIM TO ANY PARTICULAR FONT, STYLE, SIZE, OR COLOR.

CLASS 3—COSMETICS AND CLEANING PREPARATIONS

FOR ALCOHOL FOR CLEANING PURPOSES; ALL PURPOSE CLEANING PREPARATIONS (U.S. CLS. 1, 4, 6, 50, 51 AND 52).

CLASS 5—PHARMACEUTICALS

FOR CLEANSING SOLUTIONS FOR MEDICAL USE (U.S. CLS. 6, 18, 44, 46, 51 AND 52).

ELLEN PERKINS, EXAMINING ATTORNEY

TIP OR SKIP

THE MARK CONSISTS OF STANDARD CHARACTERS WITHOUT CLAIM TO ANY PARTICULAR FONT, STYLE, SIZE, OR COLOR.

CLASS 9—ELECTRICAL AND SCIENTIFIC APPARATUS

FOR COMPUTER SOFTWARE FOR UPLOADING, DOWNLOADING, ACCESSING, POSTING, DISPLAYING, TAGGING, STREAMING, LINKING AND SHARING DATA WITH OTHERS (U.S. CLS. 21, 23, 26, 36 AND 38).

CLASS 35—ADVERTISING AND BUSINESS

FOR ADVERTISING SERVICES, NAMELY, PROMOTING THE GOODS AND SERVICES OF OTHERS VIA COMPUTER AND COMMUNICATION NETWORKS (U.S. CLS. 100, 101 AND 102).

CLASS 42—SCIENTIFIC AND COMPUTER SERVICES

FOR PROVIDING A WEBSITE FEATURING TECHNOLOGY FOR UPLOADING, DOWNLOADING, ACCESSING, POSTING, DISPLAYING, TAGGING, STREAMING, LINKING AND SHARING DATA WITH OTHERS; PROVIDING A WEB SITE FEATURING TECHNOLOGY THAT ENABLES ONLINE USERS TO CREATE PERSONAL PAGES FEATURING INFORMATION FOR SHARING WITH OTHERS (U.S. CLS. 100 AND 101).

CLASS 45—PERSONAL AND LEGAL SERVICES

FOR ONLINE SOCIAL NETWORKING SERVICES (U.S. CLS. 100 AND 101).

ZHALEH DELANEY, EXAMINING ATTORNEY

SN 85-511,817. LASHDIP, LLC, CHICAGO, IL. FILED 1-9-2012.



OWNER OF U.S. REG. NO. 4,048,706.

THE MARK CONSISTS OF THE WORD "LASHDIP" HAVING THREE ARCHED WEDGES IN THE SHAPE OF EYELASHES DISPOSED ABOVE AND TO THE LEFT OF THE WORD, WHEREIN THE RIGHT-MOST POINT OF THE RIGHT-MOST WEDGE IS POSITIONED ABOVE THE "A" IN "LASHDIP", THE RIGHT-MOST POINT OF THE MIDDLE WEDGE IS POSITIONED SLIGHTLY HIGHER AND TO THE LEFT OF THE RIGHT-MOST WEDGE, AND THE RIGHT-MOST POINT OF THE LEFT-MOST WEDGE IS POSITIONED SLIGHTLY HIGHER AND TO THE LEFT OF THE MIDDLE WEDGE; WHEREIN THE "LASH" PORTION OF "LASHDIP" IS IN BOLD TYPEFACE AND THE "DIP" PORTION OF "LASHDIP" IS NOT IN BOLD; AND WHEREIN THERE IS A SUBTLE REFLECTION OF THE WORD "LASHDIP" DISPOSED BELOW THE WORD "LASHDIP".

CLASS 3—COSMETICS AND CLEANING PREPARATIONS

FOR SEMI-PERMANENT COSMETIC PREPARATIONS FOR EYELASHES (U.S. CLS. 1, 4, 6, 50, 51 AND 52).
FIRST USE 10-31-2010; IN COMMERCE 10-31-2010.

CLASS 41—EDUCATION AND ENTERTAINMENT

FOR EDUCATION SERVICES, NAMELY, PROVIDING CLASSES, SEMINARS, AND WORKSHOPS IN THE FIELD OF SEMI-PERMANENT COSMETIC EYELASH TREATMENTS AND THE APPLICATION OF SEMI-PERMANENT COSMETIC EYELASH TREATMENTS (U.S. CLS. 100, 101 AND 107).
FIRST USE 9-24-2010; IN COMMERCE 9-24-2010.

CLASS 44—MEDICAL, BEAUTY AND AGRICULTURAL SERVICES

FOR SALON SERVICES, NAMELY, APPLICATION OF SEMI-PERMANENT COSMETIC EYELASH TREATMENTS (U.S. CLS. 100 AND 101).
FIRST USE 6-30-2010; IN COMMERCE 6-30-2010.
ELI HELLMAN, EXAMINING ATTORNEY

CLASS 18—LEATHER GOODS

FOR LEATHER AND IMITATION LEATHER GOODS, NAMELY, HANDBAGS, SHOULDER-STRAP BAGS, SHOULDER BAGS (U.S. CLS. 1, 2, 3, 22 AND 41).
FIRST USE 1-15-2010; IN COMMERCE 1-15-2010.

CLASS 25—CLOTHING

FOR CLOTHING, NAMELY, DRESSES; LEATHER SKIRTS; PANTS; SHIRTS; SHOES; SKIRTS, T-SHIRTS, VESTS, COATS, LEATHER JACKETS AND BELTS (U.S. CLS. 22 AND 39).
FIRST USE 2-20-2008; IN COMMERCE 2-20-2008.
KATHERINE M. DUBRAY, EXAMINING ATTORNEY

SN 85-512,006. DESIGN SUPPORT GROUP, INC., CORAL SPRINGS, FL. FILED 1-9-2012.

MOTORIZATION WITHOUT COMPLICATION

THE MARK CONSISTS OF STANDARD CHARACTERS WITHOUT CLAIM TO ANY PARTICULAR FONT, STYLE, SIZE, OR COLOR.

CLASS 37—CONSTRUCTION AND REPAIR

FOR INSTALLATION OF WINDOW TREATMENTS (U.S. CLS. 100, 103 AND 106).

CLASS 42—SCIENTIFIC AND COMPUTER SERVICES

FOR DESIGN OF WINDOW TREATMENTS FOR OTHERS (U.S. CLS. 100 AND 101).
LAKEISHA LEWIS, EXAMINING ATTORNEY

SN 85-512,095. WINSTEAD, JANNIS, B, BROOKLYN, NY. FILED 1-9-2012.

JANWINS

THE MARK CONSISTS OF STANDARD CHARACTERS WITHOUT CLAIM TO ANY PARTICULAR FONT, STYLE, SIZE, OR COLOR.

CLASS 41—EDUCATION AND ENTERTAINMENT

FOR PHYSICAL FITNESS TRAINING OF INDIVIDUALS AND GROUPS (U.S. CLS. 100, 101 AND 107).

SN 85-511,920. PEPSICO-STRAUSS FRESH DIPS & SPREADS INTERNATIONAL GMBH, CANTON OF BERNE, SWITZERLAND, FILED 1-9-2012.

FOOD THAT BRINGS THE WORLD TOGETHER

THE MARK CONSISTS OF STANDARD CHARACTERS WITHOUT CLAIM TO ANY PARTICULAR FONT, STYLE, SIZE, OR COLOR.

CLASS 29—MEATS AND PROCESSED FOODS

FOR VEGETABLE-BASED SPREADS AND DIPS; VEGETABLE SALADS; DAIRY-BASED SPREADS; LEGUME-BASED SPREADS; DAIRY-BASED DIPS; GUACAMOLE; HUMMUS (U.S. CL. 46).

CLASS 30—STAPLE FOODS

FOR SALSA (U.S. CL. 46).
MARK SPARACINO, EXAMINING ATTORNEY

SN 85-511,983. HICKEY-FISCH, LLC, NEW YORK, NY. FILED 1-9-2012.

VEDA

THE MARK CONSISTS OF STANDARD CHARACTERS WITHOUT CLAIM TO ANY PARTICULAR FONT, STYLE, SIZE, OR COLOR.

CLASS 44—MEDICAL, BEAUTY AND AGRICULTURAL SERVICES

FOR PHYSICAL REHABILITATION; PHYSICAL THERAPY EVALUATION, IDENTIFICATION, AND MANAGEMENT OF MOVEMENT DYSFUNCTION TO RESTORE, MAINTAIN, AND PROMOTE OPTIMAL PHYSICAL FUNCTION PREVENTING THE ONSET, SYMPTOMS AND PROGRESSION OF IMPAIRMENTS, FUNCTIONAL LIMITATIONS, AND DISABILITIES RESULTING FROM DISEASE, DISORDERS, CONDITIONS, OR INJURIES (U.S. CLS. 100 AND 101).

JAMES GRIFFIN, EXAMINING ATTORNEY

SN 85-512,264. STARLIGHT ACCESSORIES, INC., NEW YORK, NY. FILED 1-9-2012.

WE CARE

SN 85-512,124. DIAL GLOBAL, INC., NEW YORK, NY. FILED 1-9-2012.



THE MARK CONSISTS OF THE LETTERS "DG" INSERTED IN A CIRCLE FOLLOWED BY "DIALGLOBAL".

CLASS 35—ADVERTISING AND BUSINESS

FOR PRODUCTION OF ADVERTISING AND PROMOTIONAL MATERIALS (U.S. CLS. 100, 101 AND 102). FIRST USE 10-0-2011; IN COMMERCE 10-0-2011.

CLASS 41—EDUCATION AND ENTERTAINMENT

FOR PRODUCTION AND DISTRIBUTION OF RADIO PROGRAMS; RADIO ENTERTAINMENT PRODUCTION; AND RADIO PROGRAM SYNDICATION (U.S. CLS. 100, 101 AND 107).

FIRST USE 10-0-2011; IN COMMERCE 10-0-2011.
NATALIE POLZER, EXAMINING ATTORNEY

SN 85-512,134. TREMONT-MORGAN, SONJA, NEW YORK, NY. FILED 1-9-2012.

Sonja In The City

THE MARK CONSISTS OF STANDARD CHARACTERS WITHOUT CLAIM TO ANY PARTICULAR FONT, STYLE, SIZE, OR COLOR.

CLASS 41—EDUCATION AND ENTERTAINMENT

FOR SPECIAL EVENT PLANNING FOR SOCIAL ENTERTAINMENT PURPOSES (U.S. CLS. 100, 101 AND 107).

CLASS 43—HOTEL AND RESTAURANT SERVICES

FOR CATERING SERVICES (U.S. CLS. 100 AND 101).
KELLY TRUSILO, EXAMINING ATTORNEY

THE MARK CONSISTS OF STANDARD CHARACTERS WITHOUT CLAIM TO ANY PARTICULAR FONT, STYLE, SIZE, OR COLOR.

CLASS 9—ELECTRICAL AND SCIENTIFIC APPARATUS

FOR EYEWEAR, NAMELY, SUNGLASSES AND READING GLASSES (U.S. CLS. 21, 23, 26, 36 AND 38).

CLASS 18—LEATHER GOODS

FOR BACKPACKS; HANDBAGS, PURSES AND WALLETS; HOBO BAGS; SATCHELS; SLING BAGS; TOTE BAGS; WRISTLET BAGS (U.S. CLS. 1, 2, 3, 22 AND 41).
ESTHER A. BORSUK, EXAMINING ATTORNEY

SN 85-512,308. STEELE, JOHNNY, ATLANTA, GA. FILED 1-9-2012.

It's Never Right To Do Wrong

THE MARK CONSISTS OF STANDARD CHARACTERS WITHOUT CLAIM TO ANY PARTICULAR FONT, STYLE, SIZE, OR COLOR.

CLASS 21—HOUSEWARES AND GLASS

FOR COFFEE CUPS, TEA CUPS AND MUGS (U.S. CLS. 2, 13, 23, 29, 30, 33, 40 AND 50).

CLASS 25—CLOTHING

FOR SHIRTS; WEARABLE GARMENTS AND CLOTHING, NAMELY, SHIRTS (U.S. CLS. 22 AND 39).

CLASS 40—MATERIAL TREATMENT

FOR CUSTOM IMPRINTING OF CLOTHINGS, ACCESSORIES AND MUGS WITH MESSAGES; IMPRINTING MESSAGES ON WEARING APPAREL, ACCESSORIES AND MUGS; T-SHIRT EMBROIDERING SERVICES (U.S. CLS. 100, 103 AND 106).

RUSS HERMAN, EXAMINING ATTORNEY

SN 85-512,329. MICHAEL T. KASSERIS, BELMONT, MA.
FILED 1-9-2012.

SN 85-512,790. DAVID BURR, 21126 VANOWEN STREET,
CA. FILED 1-10-2012.

VITAFLAVOR

THE MARK CONSISTS OF STANDARD CHARACTERS WITHOUT CLAIM TO ANY PARTICULAR FONT, STYLE, SIZE, OR COLOR.

CLASS 5—PHARMACEUTICALS

FOR FLAVOR ENHANCED VITAMIN POWDER FOR FOOD (U.S. CLS. 6, 18, 44, 46, 51 AND 52).

CLASS 29—MEATS AND PROCESSED FOODS

FOR BROTH; STOCK (U.S. CL. 46).

CLASS 30—STAPLE FOODS

FOR FLAVORINGS; SAUCE MIXES; INSTANT NOODLES (U.S. CL. 46).
DANNEAN HETZEL, EXAMINING ATTORNEY

VIVID AQUARIUMS

THE MARK CONSISTS OF STANDARD CHARACTERS WITHOUT CLAIM TO ANY PARTICULAR FONT, STYLE, SIZE, OR COLOR.

NO CLAIM IS MADE TO THE EXCLUSIVE RIGHT TO USE "AQUARIUMS", APART FROM THE MARK AS SHOWN.

CLASS 31—NATURAL AGRICULTURAL PRODUCTS

FOR AQUARIUM FISH; LIVE AQUARIUM CORAL (U.S. CLS. 1 AND 46).
FIRST USE 12-9-2004; IN COMMERCE 12-9-2004.

CLASS 37—CONSTRUCTION AND REPAIR

FOR MAINTENANCE OF AQUARIUMS (U.S. CLS. 100, 103 AND 106).
FIRST USE 12-9-2004; IN COMMERCE 12-9-2004.
JANICE KIM, EXAMINING ATTORNEY

SN 85-512,629. TURKELL, MICHAEL HARLAN, BROOKLYN, NY. FILED 1-10-2012.

SN 85-512,802. BBDO WORLDWIDE INC., NEW YORK, NY.
FILED 1-10-2012.

BACK OF THE HOUSE

THE MARK CONSISTS OF STANDARD CHARACTERS WITHOUT CLAIM TO ANY PARTICULAR FONT, STYLE, SIZE, OR COLOR.

CLASS 16—PAPER GOODS AND PRINTED MATTER

FOR UNMOUNTED AND MOUNTED PHOTOGRAPHS (U.S. CLS. 2, 5, 22, 23, 29, 37, 38 AND 50).
FIRST USE 11-6-2005; IN COMMERCE 11-6-2005.

CLASS 41—EDUCATION AND ENTERTAINMENT

FOR PHOTOGRAPHY SERVICES (U.S. CLS. 100, 101 AND 107).
FIRST USE 6-24-2003; IN COMMERCE 6-24-2003.
MARY CRAWFORD, EXAMINING ATTORNEY

SongTogether

THE MARK CONSISTS OF STANDARD CHARACTERS WITHOUT CLAIM TO ANY PARTICULAR FONT, STYLE, SIZE, OR COLOR.

CLASS 9—ELECTRICAL AND SCIENTIFIC APPARATUS

FOR MUSIC COMPOSITION SOFTWARE (U.S. CLS. 21, 23, 26, 36 AND 38).

CLASS 41—EDUCATION AND ENTERTAINMENT

FOR ENTERTAINMENT SERVICES, NAMELY, AN ON-LINE ACTIVITY TO CREATE MUSIC AND SONGS; MUSIC COMPOSITION SERVICES; LYRIC AND SONG WRITING; MULTIMEDIA ENTERTAINMENT SERVICES IN THE NATURE OF CREATING, RECORDING AND PRODUCING MUSIC AND SONGS (U.S. CLS. 100, 101 AND 107).
JANICE KIM, EXAMINING ATTORNEY

SN 85-512,909. BLUEPRINTCLEANSE LLC, NEW YORK, NY.
FILED 1-10-2012.

BluePrintOrganics

THE MARK CONSISTS OF STANDARD CHARACTERS WITHOUT CLAIM TO ANY PARTICULAR FONT, STYLE, SIZE, OR COLOR.

CLASS 29—MEATS AND PROCESSED FOODS

FOR SOUPS; VEGETABLE PUREE; VEGETABLE SALADS; VEGETABLE-BASED FOOD BEVERAGES; VEGETABLE-BASED RAW FOOD BARS; VEGETABLE-BASED SNACK FOODS; PREPARED VEGETABLE-BASED ENTREES; ALL THE FOREGOING INCORPORATING ORGANIC INGREDIENTS (U.S. CL. 46).

CLASS 32—LIGHT BEVERAGES

FOR COCONUT WATER; COCONUT-BASED BEVERAGES; COCONUT-BASED NON-ALCOHOLIC BEVERAGES; FRUIT BEVERAGES; FRUIT DRINKS AND FRUIT JUICES; FRUIT DRINKS AND JUICES; FRUIT JUICES; FRUIT JUICES AND FRUIT DRINKS; FRUIT-BASED BEVERAGES; MILK OF ALMONDS FOR BEVERAGE; NON-ALCOHOLIC BEVERAGES CONTAINING FRUIT JUICES; NON-ALCOHOLIC FRUIT EXTRACTS USED IN THE PREPARATION OF BEVERAGES; NON-ALCOHOLIC FRUIT JUICE BEVERAGES; PREPARED ENTREES CONSISTING OF FRUIT DRINKS AND FRUIT JUICES, FRUIT-BASED BEVERAGES, NON-ALCOHOLIC BEVERAGES CONTAINING FRUIT JUICES, NON-ALCOHOLIC FRUIT EXTRACTS USED IN THE PREPARATION OF BEVERAGES, NON-ALCOHOLIC FRUIT JUICE BEVERAGES, VEGETABLE JUICES, VEGETABLE-FRUIT JUICES AND SMOOTHIES; SMOOTHIES; VEGETABLE DRINKS; VEGETABLE JUICE; VEGETABLE JUICES; VEGETABLE-FRUIT JUICES; ALL THE FOREGOING INCORPORATING ORGANIC INGREDIENTS (U.S. CLS. 45, 46 AND 48).

CHRISTOPHER LAW, EXAMINING ATTORNEY

SN 85-512,967. REDDING LIFE CARE, LLC, NEW HAVEN, CT. FILED 1-10-2012.

MEADOW RIDGE

THE MARK CONSISTS OF STANDARD CHARACTERS WITHOUT CLAIM TO ANY PARTICULAR FONT, STYLE, SIZE, OR COLOR.

CLASS 43—HOTEL AND RESTAURANT SERVICES

FOR PROVIDING ASSISTED LIVING FACILITIES; PROVIDING INDEPENDENT LIVING RESIDENCES AND LIVING FACILITIES; ASSISTED LIVING SERVICES; RETIREMENT HOME SERVICES (U.S. CLS. 100 AND 101).

FIRST USE 0-0-2001; IN COMMERCE 0-0-2001.

CLASS 44—MEDICAL, BEAUTY AND AGRICULTURAL SERVICES

FOR PROVIDING LONG-TERM CARE FACILITIES FOR SENIORS (U.S. CLS. 100 AND 101).
FIRST USE 0-0-2001; IN COMMERCE 0-0-2001.
APRIL ROACH, EXAMINING ATTORNEY

SN 85-513,070. NAPCO, INC., BATTAVIA, IL. FILED 1-10-2012.

FROM THE EARTH TO THE
CUP...GIVE THE WORLD GREAT
COFFEE AT A GREAT VALUE.

THE MARK CONSISTS OF STANDARD CHARACTERS WITHOUT CLAIM TO ANY PARTICULAR FONT, STYLE, SIZE, OR COLOR.

CLASS 30—STAPLE FOODS

FOR COFFEE, COCOA, HERBAL FOOD BEVERAGES, HERBAL INFUSIONS (U.S. CL. 46).

CLASS 32—LIGHT BEVERAGES

FOR ENERGY DRINKS (U.S. CLS. 45, 46 AND 48).
RAUL CORDOVA, EXAMINING ATTORNEY

SN 85-513,203. SYNGENTA PARTICIPATIONS AG, BASEL, SWITZERLAND, FILED 1-10-2012.

Clarelle

THE MARK CONSISTS OF STANDARD CHARACTERS WITHOUT CLAIM TO ANY PARTICULAR FONT, STYLE, SIZE, OR COLOR.

CLASS 1—CHEMICALS

FOR PLANT GROWTH REGULATORS FOR COMMERCIAL OR AGRICULTURAL USE, NAMELY, TURF GROWTH REGULATOR (U.S. CLS. 1, 5, 6, 10, 26 AND 46).

CLASS 5—PHARMACEUTICALS

FOR FUNGICIDES FOR COMMERCIAL, DOMESTIC OR AGRICULTURAL USE (U.S. CLS. 6, 18, 44, 46, 51 AND 52).

JAMES STEIN, EXAMINING ATTORNEY

SN 85-513,219. RUSSELL JR., WILLIAM A., ARLINGTON, VA. FILED 1-10-2012.

SN 85-513,299. NATIONAL ASSOCIATION OF REALTORS, CHICAGO, IL. FILED 1-10-2012.

ArcTrak

THE MARK CONSISTS OF STANDARD CHARACTERS WITHOUT CLAIM TO ANY PARTICULAR FONT, STYLE, SIZE, OR COLOR.

CLASS 9—ELECTRICAL AND SCIENTIFIC APPARATUS

FOR COMPUTER SOFTWARE FOR USING A DIGITALLY EMBEDDED RFID TRACKING ALGORITHM TO SEQUENTIALLY UPDATE LOCATION AND EQUIPMENT IDENTIFICATION WHERE A DIGITAL FILE HAS BEEN OPENED AT EACH LOCATION WHERE IT IS ENTERED IN THE INTERNET (U.S. CLS. 21, 23, 26, 36 AND 38).

CLASS 42—SCIENTIFIC AND COMPUTER SERVICES

FOR PROVIDING TEMPORARY USE OF ON-LINE NON-DOWNLOADABLE SOFTWARE FOR USING A DIGITALLY EMBEDDED RFID TRACKING ALGORITHM TO SEQUENTIALLY UPDATE LOCATION AND EQUIPMENT IDENTIFICATION WHERE A DIGITAL FILE HAS BEEN OPENED AT EACH LOCATION WHERE IT IS ENTERED IN THE INTERNET (U.S. CLS. 100 AND 101).

EDWARD NELSON, EXAMINING ATTORNEY

SN 85-513,231. GOOD LIFE BEVERAGES, INC., BOSTON, MA. FILED 1-10-2012.

BCALM

THE MARK CONSISTS OF STANDARD CHARACTERS WITHOUT CLAIM TO ANY PARTICULAR FONT, STYLE, SIZE, OR COLOR.

CLASS 30—STAPLE FOODS

FOR HERBAL FOOD BEVERAGES (U.S. CL. 46).

CLASS 32—LIGHT BEVERAGES

FOR NON-ALCOHOLIC BEVERAGES, NAMELY, CARBONATED BEVERAGES (U.S. CLS. 45, 46 AND 48).

FRANK LATTUCA, EXAMINING ATTORNEY

RPR

THE MARK CONSISTS OF STANDARD CHARACTERS WITHOUT CLAIM TO ANY PARTICULAR FONT, STYLE, SIZE, OR COLOR.

CLASS 35—ADVERTISING AND BUSINESS

FOR PROVIDING AN ON-LINE COMPUTER DATABASE FEATURING REAL PROPERTY TAX INFORMATION (U.S. CLS. 100, 101 AND 102).

FIRST USE 11-15-2010; IN COMMERCE 11-15-2010.

CLASS 36—INSURANCE AND FINANCIAL

FOR PROVIDING AN ON-LINE COMPUTER DATABASE FEATURING REAL PROPERTY VALUATION AND REAL ESTATE MULTIPLE LISTING INFORMATION (U.S. CLS. 100, 101 AND 102).

FIRST USE 11-15-2010; IN COMMERCE 11-15-2010.

CLASS 37—CONSTRUCTION AND REPAIR

FOR PROVIDING AN ON-LINE COMPUTER DATABASE FEATURING REAL PROPERTY SITE SELECTION INFORMATION (U.S. CLS. 100, 103 AND 106).

FIRST USE 11-15-2010; IN COMMERCE 11-15-2010.

KRISTINA MORRIS, EXAMINING ATTORNEY

SN 85-513,311. STROTHEIDE, JASON, CHESTERFIELD, MO. FILED 1-10-2012.

CHIROTHIN

THE MARK CONSISTS OF STANDARD CHARACTERS WITHOUT CLAIM TO ANY PARTICULAR FONT, STYLE, SIZE, OR COLOR.

CLASS 5—PHARMACEUTICALS

FOR DIETARY AND NUTRITIONAL SUPPLEMENTS USED FOR WEIGHT LOSS (U.S. CLS. 6, 18, 44, 46, 51 AND 52).

FIRST USE 12-6-2011; IN COMMERCE 12-6-2011.

CLASS 44—MEDICAL, BEAUTY AND AGRICULTURAL SERVICES

FOR PROVIDING WEIGHT LOSS PROGRAM SERVICES; PROVIDING A WEBSITE FEATURING INFORMATION AND ADVICE IN THE FIELDS OF DIET, WEIGHT LOSS, DIET PLANNING AND LIFESTYLE WELLNESS; HEALTH SPA SERVICES, NAMELY, PROVIDING WEIGHT LOSS PROGRAMS; WEIGHT MANAGEMENT SERVICES, NAMELY, PROVIDING WEIGHT LOSS AND/OR WEIGHT MAINTENANCE PROGRAMS (U.S. CLS. 100 AND 101).

FIRST USE 12-6-2011; IN COMMERCE 12-6-2011.

BRIAN PINO, EXAMINING ATTORNEY

SN 85-513,332. HAAS, TARYN, HOBART, IN. FILED 1-10-2012.

NATRYL 1

THE MARK CONSISTS OF STANDARD CHARACTERS WITHOUT CLAIM TO ANY PARTICULAR FONT, STYLE, SIZE, OR COLOR.

CLASS 16—PAPER GOODS AND PRINTED MATTER

FOR PAINTINGS; FRAMED PAINTINGS; PHOTOGRAPHS (U.S. CLS. 2, 5, 22, 23, 29, 37, 38 AND 50).

CLASS 41—EDUCATION AND ENTERTAINMENT

FOR PHOTOGRAPHY SERVICES (U.S. CLS. 100, 101 AND 107).
PAM WILLIS, EXAMINING ATTORNEY

SN 85-513,371. BIOMED REALTY TRUST, INC., SAN DIEGO, CA. FILED 1-10-2012.

TRUE CREATIVE UNSTOPPABLE

THE MARK CONSISTS OF STANDARD CHARACTERS WITHOUT CLAIM TO ANY PARTICULAR FONT, STYLE, SIZE, OR COLOR.

CLASS 36—INSURANCE AND FINANCIAL

FOR REAL ESTATE ACQUISITION, LEASING, AND MANAGEMENT SERVICES; REAL ESTATE INVESTMENT SERVICES; REAL ESTATE INVESTMENT TRUST SERVICES (U.S. CLS. 100, 101 AND 102).

CLASS 37—CONSTRUCTION AND REPAIR

FOR REAL ESTATE DEVELOPMENT (U.S. CLS. 100, 103 AND 106).
DOMINIC FATHY, EXAMINING ATTORNEY

SN 85-513,374. BIOMED REALTY TRUST, INC., SAN DIEGO, CA. FILED 1-10-2012.

CREATING OPTIMAL ENVIRONMENTS THAT FOSTER LIFE SCIENCE SUCCESSES

THE MARK CONSISTS OF STANDARD CHARACTERS WITHOUT CLAIM TO ANY PARTICULAR FONT, STYLE, SIZE, OR COLOR.

CLASS 36—INSURANCE AND FINANCIAL

FOR REAL ESTATE ACQUISITION, LEASING, AND MANAGEMENT SERVICES; REAL ESTATE INVESTMENT SERVICES; REAL ESTATE INVESTMENT TRUST SERVICES (U.S. CLS. 100, 101 AND 102).

CLASS 37—CONSTRUCTION AND REPAIR

FOR REAL ESTATE DEVELOPMENT (U.S. CLS. 100, 103 AND 106).
DOMINIC FATHY, EXAMINING ATTORNEY

SN 85-513,379. BIOMED REALTY TRUST, INC., SAN DIEGO, CA. FILED 1-10-2012.

TRUSTED EXPERTISE AND VALUABLE RELATIONSHIPS BUILD BREAKTHROUGH PERFORMANCE

THE MARK CONSISTS OF STANDARD CHARACTERS WITHOUT CLAIM TO ANY PARTICULAR FONT, STYLE, SIZE, OR COLOR.

CLASS 36—INSURANCE AND FINANCIAL

FOR REAL ESTATE ACQUISITION, LEASING, AND MANAGEMENT SERVICES; REAL ESTATE INVESTMENT SERVICES; REAL ESTATE INVESTMENT TRUST SERVICES (U.S. CLS. 100, 101 AND 102).

CLASS 37—CONSTRUCTION AND REPAIR

FOR REAL ESTATE DEVELOPMENT (U.S. CLS. 100, 103 AND 106).
DOMINIC FATHY, EXAMINING ATTORNEY

SN 85-513,424. ITER9, LLC, LOS ANGELES, CA. FILED 1-10-2012.

frax

THE MARK CONSISTS OF STANDARD CHARACTERS WITHOUT CLAIM TO ANY PARTICULAR FONT, STYLE, SIZE, OR COLOR.

CLASS 9—ELECTRICAL AND SCIENTIFIC APPARATUS

FOR DOWN-LOADABLE SOFTWARE FOR DIGITAL DESIGN (U.S. CLS. 21, 23, 26, 36 AND 38).

CLASS 42—SCIENTIFIC AND COMPUTER SERVICES

FOR NON-DOWNLOADABLE SOFTWARE FOR OBTAINING DIGITAL ARTWORK (U.S. CLS. 100 AND 101).
BENJAMIN OKEKE, EXAMINING ATTORNEY

SN 85-513,443. BARTON G. WEISS, MIAMI, FL. FILED 1-10-2012.

SN 85-513,584. ENTERPRISE MEDIA GROUP, INC., NEW YORK, NY. FILED 1-11-2012.



THE MARK CONSISTS OF THE WORD "VAULT" IN STYLIZED TEXT WITH A RECTANGULAR BORDER.

CLASS 16—PAPER GOODS AND PRINTED MATTER

FOR MAGAZINES FEATURING FASHION, NIGHTLIFE, ENTERTAINMENT, MOVIES, MUSIC, BOOKS, ECOLOGY, ARTS, RESTAURANTS, TRAVEL, HOME ENTERTAINING, AND HOME DESIGN (U.S. CLS. 2, 5, 22, 23, 29, 37, 38 AND 50).

CLASS 41—EDUCATION AND ENTERTAINMENT

FOR PROVIDING NON-DOWNLOADABLE ONLINE MAGAZINES FEATURING FASHION, NIGHTLIFE, ENTERTAINMENT, MOVIES, MUSIC, BOOKS, ECOLOGY, ARTS, RESTAURANTS, TRAVEL, HOME ENTERTAINING, AND HOME DESIGN (U.S. CLS. 100, 101 AND 107).
JAY FLOWERS, EXAMINING ATTORNEY

SN 85-513,496. GVS TECHNOLOGIES, LLC, ELKHART, IN. FILED 1-11-2012.



THE MARK CONSISTS OF CAPITAL LETTERS "GVS" WITH EIGHT ROUND, SOLID CIRCLES IN A STACKED DESIGN TO THE UPPER LEFT OF THE "G".

CLASS 12—VEHICLES

FOR LIGHT AND MEDIUM DUTY RECREATIONAL LAND VEHICLE AND AUTOMOTIVE AXLE AND SUSPENSION COMPONENTS AND SYSTEMS, NAMELY, SPINDLES, GENERATOR SHAFTS, KING PINS, AXLE SHAFTS, DOUBLE ENDED SPINDLES, BENT SPINDLES, TORSION SPINDLES, BEARING HOUSINGS, VALVE BODIES, SUSPENSION BLOCKS, BUSHINGS (U.S. CLS. 19, 21, 23, 31, 35 AND 44).
FIRST USE 1-0-2006; IN COMMERCE 1-0-2006.

CLASS 40—MATERIAL TREATMENT

FOR MACHINE SHOP SERVICES, NAMELY, MACHINING PARTS FOR OTHERS (U.S. CLS. 100, 103 AND 106).
FIRST USE 1-0-2006; IN COMMERCE 1-0-2006.
WILLIAM JACKSON, EXAMINING ATTORNEY

BASELINE

THE MARK CONSISTS OF STANDARD CHARACTERS WITHOUT CLAIM TO ANY PARTICULAR FONT, STYLE, SIZE, OR COLOR.

CLASS 16—PAPER GOODS AND PRINTED MATTER

FOR PUBLICATIONS, NAMELY, MAGAZINES IN THE FIELDS OF INFORMATION TECHNOLOGY (U.S. CLS. 2, 5, 22, 23, 29, 37, 38 AND 50).
FIRST USE 10-29-2001; IN COMMERCE 10-29-2001.

CLASS 41—EDUCATION AND ENTERTAINMENT

FOR PROVIDING ON-LINE PUBLICATIONS IN THE NATURE OF MAGAZINES IN THE FIELD OF INFORMATION TECHNOLOGY (U.S. CLS. 100, 101 AND 107).
FIRST USE 10-29-2001; IN COMMERCE 10-29-2001.
DEBRA LEE, EXAMINING ATTORNEY

SN 85-513,604. FOOD MARKETING INSTITUTE, ALEXANDRIA, VA. FILED 1-11-2012.



OWNER OF U.S. REG. NOS. 1,118,214, 1,151,682 AND 3,100,261.

THE MARK CONSISTS OF THE STYLIZED LETTERS "FMI" IN A SOLID RECTANGULAR BOX TO THE LEFT OF A RECTANGULAR BOX WITH BAR CODES INSIDE, WHICH APPEAR ABOVE THE WORDS "THE VOICE OF FOOD RETAIL" FOLLOWED BY A GROCERY CART IMAGE.

CLASS 16—PAPER GOODS AND PRINTED MATTER

FOR REPORTS OF INTEREST TO THE FOOD AND GROCERY INDUSTRY (U.S. CLS. 2, 5, 22, 23, 29, 37, 38 AND 50).

CLASS 35—ADVERTISING AND BUSINESS

FOR ASSOCIATION SERVICES, NAMELY, PROMOTING THE INTERESTS OF THE FOOD AND GROCERY INDUSTRY (U.S. CLS. 100, 101 AND 102).

CLASS 41—EDUCATION AND ENTERTAINMENT

FOR EDUCATIONAL SERVICES, NAMELY, CONDUCTING CONFERENCES AND SEMINARS FOR THE FOOD AND GROCERY INDUSTRY (U.S. CLS. 100, 101 AND 107).
JENNIFER VASQUEZ, EXAMINING ATTORNEY

SN 85-513,609. DAVID GOULD, DELTA, BC, CANADA, FILED 1-11-2012.



THE MARK CONSISTS OF AN OUTLINE OF A TRISKELEON HAVING SIX SOLID LINES PROJECTING OUTWARDLY THEREFROM WITH SCOOPS AT THE OUTWARD END OF SUCH SOLID LINES.

CLASS 9—ELECTRICAL AND SCIENTIFIC APPARATUS

FOR EYEWEAR, HELMETS FOR MOTORCYCLISTS, MOTORCYCLE GOGGLES, MOTOR CYCLE HELMETS, SUNGLASSES (U.S. CLS. 21, 23, 26, 36 AND 38).
FIRST USE 11-1-2011; IN COMMERCE 11-1-2011.

CLASS 25—CLOTHING

FOR ATHLETIC APPAREL, NAMELY, SHIRTS, PANTS, JACKETS, FOOTWEAR, HATS AND CAPS, ATHLETIC UNIFORMS; BASEBALL CAPS AND HATS; BELTS FOR CLOTHING; BELTS MADE OF LEATHER; BOOTS FOR MOTORCYCLING; HEADWEAR, NAMELY, CAPS; CAPS WITH VISORS; GLOVES; HOODED SWEATSHIRTS; CLOTHING, NAMELY, JACKETS; LEATHER COATS; LEATHER BOOTS; LEATHER PANTS; LADIES' BOOTS; POLO SHIRTS; SHIRTS AND SHORT-SLEEVED SHIRTS; SHIRTS FOR INFANTS, BABIES, TODDLERS AND CHILDREN; SKULL CAPS; HEADWEAR, NAMELY SKULLIES; T-SHIRTS (U.S. CLS. 22 AND 39).
FIRST USE 11-1-2011; IN COMMERCE 11-1-2011.
DAVID C. REIHNER, EXAMINING ATTORNEY

SN 85-513,652. SWIHART, CLARK, TURLOCK, CA. AND BLEMASTER, JEFFREY, TURLOCK, CA. FILED 1-11-2012.

MY FAVORITE COLOR IS GAY

THE MARK CONSISTS OF STANDARD CHARACTERS WITHOUT CLAIM TO ANY PARTICULAR FONT, STYLE, SIZE, OR COLOR.

CLASS 16—PAPER GOODS AND PRINTED MATTER

FOR BUMPER STICKERS; DECALS; DECORATIVE DECALS FOR VEHICLE WINDOWS; MAGNETIC BUMPER STICKERS; STICKERS; STICKERS AND DECALOMANIAS (U.S. CLS. 2, 5, 22, 23, 29, 37, 38 AND 50).

CLASS 25—CLOTHING

FOR APPAREL, NAMELY, T-SHIRTS, SHIRTS, PANTS, SHORTS, SKIRTS, DRESSES, JACKETS, FOOTWEAR, HATS, CAPS, VISORS, UNDERGARMENTS, AND SOCKS; ATHLETIC APPAREL, NAMELY, SHIRTS, T-SHIRTS, SWEATSHIRTS, BODY SHIRTS, PANTS, SWEATPANTS, SHORTS, SWEAT SHORTS, JACKETS, FOOTWEAR, HATS, CAPS, VISORS, AND ATHLETIC UNIFORMS (U.S. CLS. 22 AND 39).
ANNE E. GUSTASON, EXAMINING ATTORNEY

SN 85-513,673. TOLEDO ZOOLOGICAL SOCIETY, TOLEDO, OH. FILED 1-11-2012.



OWNER OF U.S. REG. NOS. 1,514,683, 1,518,383 AND OTHERS.

NO CLAIM IS MADE TO THE EXCLUSIVE RIGHT TO USE "ZOO", APART FROM THE MARK AS SHOWN.

THE MARK CONSISTS OF THE STYLIZED WORDING "TOLEDO ZOO" WITH THE "OO" APPEARING AS INCOMPLETE CIRCLES WITH SMALLER COMPLETE CIRCLES ON THEM GIVING THE APPEARANCE OF ANIMAL EYES.
SEC. 2(F) AS TO "TOLEDO ZOO".

CLASS 41—EDUCATION AND ENTERTAINMENT

FOR EDUCATION SERVICES, NAMELY, PROVIDING CLASSES, SEMINARS, CONFERENCES, WORKSHOPS AND LECTURES IN THE FIELD OF ANIMALS, ZOOLOGY, ENVIRONMENT AND WILDLIFE CONSERVATION; EDUCATION SERVICES, NAMELY, GUIDED TOURS OF ZOOS, GARDENS AND ANIMAL WILDLIFE AREAS IN THE FIELDS OF ANIMALS, ZOOLOGY, ENVIRONMENT AND WILDLIFE CONSERVATION; EDUCATIONAL AND ENTERTAINMENT SERVICES FOR CHILDREN, NAMELY, PROVIDING INTERACTIVE PLAY AREAS, INSTRUCTIONAL CLASSES IN THE FIELD OF ANIMALS AND SOCIAL GATHERINGS FOR CHILDREN; EDUCATIONAL SERVICES, NAMELY, PROVIDING EDUCATIONAL SPEAKERS IN THE FIELD OF ANIMALS, ZOOLOGY, ENVIRONMENT AND WILDLIFE CONSERVATION; GUIDED TOURS OF ZOO; PROVIDING EDUCATIONAL DEMONSTRATIONS; ZOOLOGICAL GARDEN SERVICES; ZOOS (U.S. CLS. 100, 101 AND 107).

FIRST USE 1-2-2012, THE MARK WAS FIRST USED ANYWHERE IN A DIFFERENT FORM OTHER THAN THAT SOUGHT TO BE REGISTERED AT LEAST AS EARLY AS 00/00/1899.; IN COMMERCE 1-2-2012, THE MARK WAS FIRST USED IN COMMERCE IN A DIFFERENT FORM OTHER THAN THAT SOUGHT TO BE REGISTERED AT LEAST AS EARLY AS 00/00/1899..

CLASS 42—SCIENTIFIC AND COMPUTER SERVICES

FOR BIOLOGICAL RESEARCH; RESEARCH IN THE FIELD OF ZOOLOGY, AND ENVIRONMENTAL AND WILDLIFE CONSERVATION; SCIENTIFIC RESEARCH INFORMATION IN THE FIELD OF WILDLIFE PRESERVATION; ZOOLOGICAL RESEARCH AND CONSULTATION (U.S. CLS. 100 AND 101).

FIRST USE 1-10-2012; IN COMMERCE 1-10-2012.
COURTNEY ALVAREZ, EXAMINING ATTORNEY

SN 85-513,678. SWIHART, CLARK, TURLOCK, CA. AND BLEMASTER, JEFFREY, TURLOCK, CA. FILED 1-11-2012.

HAVE A NICE GAY

THE MARK CONSISTS OF STANDARD CHARACTERS WITHOUT CLAIM TO ANY PARTICULAR FONT, STYLE, SIZE, OR COLOR.

CLASS 16—PAPER GOODS AND PRINTED MATTER

FOR BUMPER STICKERS; DECALS; DECORATIVE DECALS FOR VEHICLE WINDOWS; MAGNETIC BUMPER STICKERS; STICKERS; STICKERS AND DECALCOMANIAS (U.S. CLS. 2, 5, 22, 23, 29, 37, 38 AND 50).

CLASS 25—CLOTHING

FOR APPAREL, NAMELY, T-SHIRTS, SHIRTS, PANTS, SHORTS, SKIRTS, DRESSES, JACKETS, FOOTWEAR, HATS, CAPS, VISORS, UNDERGARMENTS, AND SOCKS; ATHLETIC APPAREL, NAMELY, SHIRTS, T-SHIRTS, SWEATSHIRTS, BODY SHIRTS, PANTS, SWEATPANTS, SHORTS, SWEAT SHORTS, JACKETS, FOOTWEAR, HATS, CAPS, VISORS, AND ATHLETIC UNIFORMS (U.S. CLS. 22 AND 39).

ANNE E. GUSTASON, EXAMINING ATTORNEY

SN 85-513,735. MAMALAW MEDIA GROUP, SILVER SPRING, MD. FILED 1-11-2012.

MAMALAW

THE MARK CONSISTS OF STANDARD CHARACTERS WITHOUT CLAIM TO ANY PARTICULAR FONT, STYLE, SIZE, OR COLOR.

CLASS 35—ADVERTISING AND BUSINESS

FOR ADVERTISING, MARKETING AND PROMOTION SERVICES THROUGH ALL PUBLIC COMMUNICATION MEANS, PARTICULARLY SPECIALIZING IN THE USE OF MOBILE, SOCIAL, AND PRINT MEDIA; PROVIDING ADVERTISING SERVICE TO DISTRIBUTE ADVERTISEMENTS FOR DISPLAY ON THE INTERNET, NAMELY, IN WEBSITES, BLOGS, SOCIAL NETWORKS, SOCIAL CONVERSATIONS OVER THE INTERNET, EMAILS, MICROBLOGS, ELECTRONIC MESSAGES, INSTANT MESSAGES, TEXT MESSAGES, MULTIMEDIA MESSAGES, STATUS UPDATES, FORUMS, AND ELECTRONIC BULLETIN BOARDS (U.S. CLS. 100, 101 AND 102).

FIRST USE 3-0-2006; IN COMMERCE 3-0-2006.

CLASS 41—EDUCATION AND ENTERTAINMENT

FOR ONLINE JOURNALS, NAMELY, BLOGS FEATURING CONTENT RELATED TO TOPICS CONCERNING WOMEN, MARRIAGE, PARENTING, FAMILY, PERSONAL RELATIONSHIPS, HEALTH, WELLNESS, FITNESS, CAREERS AND WORK-LIFE BALANCE, FASHION, ENTREPRENEURSHIP AND BUSINESS, PERSONAL FINANCE, POLITICS, RELIGION, TECHNOLOGY, TRAVEL AND ENTERTAINMENT, RECREATION, AND ISSUES OF INTEREST TO FEMALE BLOGGERS; PROVIDING INFORMATION, NEWS, AND COMMENTARY IN THE FIELDS OF SOCIAL MEDIA, ESSAY FICTION, AND NON-FICTION WRITING, AND JOURNALISM; EDUCATIONAL AND EVENT SERVICES, NAMELY, CONDUCTING SEMINARS, CONFERENCES, WORKSHOPS, AND SOCIAL EVENTS FOCUSING ON SOCIAL MEDIA, DIVERSITY IN SOCIAL MEDIA, MARKETING TO WOMEN, AND TOPICS CONCERNING WOMEN AND WOMEN BLOGGERS (U.S. CLS. 100, 101 AND 107).

FIRST USE 3-0-2009; IN COMMERCE 3-0-2009.

JAY FLOWERS, EXAMINING ATTORNEY

SN 85-513,752. COLLINS, CAROLINE, BATON ROUGE, LA. FILED 1-11-2012.

BB & PF

THE MARK CONSISTS OF STANDARD CHARACTERS WITHOUT CLAIM TO ANY PARTICULAR FONT, STYLE, SIZE, OR COLOR.

CLASS 29—MEATS AND PROCESSED FOODS

FOR FRIED PLANTAIN (U.S. CL. 46).

CLASS 30—STAPLE FOODS

FOR BEAN PASTE; HAMBURGER SANDWICHES (U.S. CL. 46).

ALLISON SCHRODY, EXAMINING ATTORNEY

SN 85-513,756. BOSS LADY MANAGEMENT TEAM, LLC, DENVER, CO. FILED 1-11-2012.

BARKSTORM

THE MARK CONSISTS OF STANDARD CHARACTERS WITHOUT CLAIM TO ANY PARTICULAR FONT, STYLE, SIZE, OR COLOR.

CLASS 18—LEATHER GOODS

FOR PET APPAREL (U.S. CLS. 1, 2, 3, 22 AND 41).

CLASS 31—NATURAL AGRICULTURAL PRODUCTS

FOR NUTRITIONAL FOOD AND TREATS FOR PETS (U.S. CLS. 1 AND 46).

SUSAN RICHARDS, EXAMINING ATTORNEY

SN 85-514,052. MICHAEL I. KIRSCH, SYOSSET, NY. FILED 1-11-2012.

GRANDFATHER

THE MARK CONSISTS OF STANDARD CHARACTERS WITHOUT CLAIM TO ANY PARTICULAR FONT, STYLE, SIZE, OR COLOR.

CLASS 9—ELECTRICAL AND SCIENTIFIC APPARATUS

FOR DOWNLOADABLE MUSICAL SOUND RECORDINGS (U.S. CLS. 21, 23, 26, 36 AND 38).
FIRST USE 1-1-2007; IN COMMERCE 1-1-2007.

CLASS 25—CLOTHING

FOR T-SHIRTS (U.S. CLS. 22 AND 39).
FIRST USE 1-1-2007; IN COMMERCE 1-1-2007.

CLASS 41—EDUCATION AND ENTERTAINMENT

FOR ENTERTAINMENT SERVICES IN THE NATURE OF LIVE MUSICAL PERFORMANCES (U.S. CLS. 100, 101 AND 107).
FIRST USE 1-1-2007; IN COMMERCE 1-1-2007.
ELI HELLMAN, EXAMINING ATTORNEY

SN 85-514,132. ONELOUDER APPS, INC., KANSAS CITY, MO. FILED 1-11-2012.

ONECHAT

THE MARK CONSISTS OF STANDARD CHARACTERS WITHOUT CLAIM TO ANY PARTICULAR FONT, STYLE, SIZE, OR COLOR.

CLASS 9—ELECTRICAL AND SCIENTIFIC APPARATUS

FOR SOFTWARE AND DOWNLOADABLE SOFTWARE FOR ACCESSING INFORMATION ON GLOBAL COMPUTER NETWORKS; SOFTWARE AND DOWNLOADABLE SOFTWARE THAT ALLOWS FOR INTERACTION BETWEEN AND AMONG USERS OF COMPUTERS, MOBILE AND HANDHELD COMPUTERS, AND WIRED AND WIRELESS COMMUNICATION DEVICES AND PROVIDES THE MEANS TO TRANSMIT, SYNDICATE, DISTRIBUTE, TAG, ORGANIZE, AGGREGATE AND MANAGE WEB LINKS, BLOGS, NEWS CONTENT, SOCIAL MEDIA CONTENT, TEXT MESSAGES, IMAGES, AUDIO, VIDEO AND AGGREGATED CONTENT FEEDS, OVER THE INTERNET, WIRELESS AND OTHER COMMUNICATIONS NETWORKS (U.S. CLS. 21, 23, 26, 36 AND 38).

CLASS 42—SCIENTIFIC AND COMPUTER SERVICES

FOR SOFTWARE AS A SERVICE (SAAS) SERVICES FEATURING SOFTWARE FOR INTERACTION BETWEEN AND AMONG USERS OF COMPUTERS, MOBILE AND HANDHELD COMPUTERS, AND WIRED AND WIRELESS COMMUNICATION DEVICES AND PROVIDES THE MEANS TO TRANSMIT, SYNDICATE, DISTRIBUTE, TAG, ORGANIZE, AGGREGATE AND MANAGE WEB LINKS, BLOGS, SOCIAL MEDIA CONTENT, TEXT MESSAGES, IMAGES, AUDIO, VIDEO AND AGGREGATED CONTENT FEEDS, OVER THE INTERNET, WIRELESS AND OTHER COMMUNICATIONS NETWORK (U.S. CLS. 100 AND 101).
MIDGE BUTLER, EXAMINING ATTORNEY

SN 85-514,171. MOTORS ACCEPTANCE CORPORATION, COLUMBUS, GA. FILED 1-11-2012.

MOTORMAX

THE MARK CONSISTS OF STANDARD CHARACTERS WITHOUT CLAIM TO ANY PARTICULAR FONT, STYLE, SIZE, OR COLOR.

CLASS 35—ADVERTISING AND BUSINESS

FOR AUTOMOBILE DEALERSHIPS (U.S. CLS. 100, 101 AND 102).
FIRST USE 1-16-1998; IN COMMERCE 1-16-1998.

CLASS 36—INSURANCE AND FINANCIAL

FOR AUTOMOTIVE FINANCING SERVICES (U.S. CLS. 100, 101 AND 102).
FIRST USE 1-16-1998; IN COMMERCE 1-16-1998.
CAROLYN CATALDO, EXAMINING ATTORNEY

SN 85-514,204. PACIFIC COAST FEATHER COMPANY, SEATTLE, WA. FILED 1-11-2012.

CUDDLESOFT

THE MARK CONSISTS OF STANDARD CHARACTERS WITHOUT CLAIM TO ANY PARTICULAR FONT, STYLE, SIZE, OR COLOR.

CLASS 20—FURNITURE AND ARTICLES NOT OTHERWISE CLASSIFIED

FOR PILLOWS AND FEATHERBEDS (U.S. CLS. 2, 13, 22, 25, 32 AND 50).
FIRST USE 8-1-2005; IN COMMERCE 8-1-2005.

CLASS 24—FABRICS

FOR COMFORTERS (U.S. CLS. 42 AND 50).
FIRST USE 9-1-2005; IN COMMERCE 9-1-2005.
TEJBIR SINGH, EXAMINING ATTORNEY

SN 85-514,205. PHYSICIANS REFERENCE LABORATORY, L.L.C., OVERLAND PARK, KS. FILED 1-11-2012.

SN 85-514,397. MEMPHIS PUBLISHING COMPANY, CINCINNATI, OH. FILED 1-11-2012.

PinkLab

THE MARK CONSISTS OF STANDARD CHARACTERS WITHOUT CLAIM TO ANY PARTICULAR FONT, STYLE, SIZE, OR COLOR.

CLASS 42—SCIENTIFIC AND COMPUTER SERVICES

FOR MEDICAL LABORATORY SERVICES (U.S. CLS. 100 AND 101).
FIRST USE 5-20-2011; IN COMMERCE 5-20-2011.

CLASS 44—MEDICAL, BEAUTY AND AGRICULTURAL SERVICES

FOR MEDICAL DIAGNOSTIC TESTING, MONITORING AND REPORTING SERVICES (U.S. CLS. 100 AND 101).
FIRST USE 5-20-2011; IN COMMERCE 5-20-2011.
WILLIAM VERHOSEK, EXAMINING ATTORNEY

SN 85-514,353. GLÜCK HOLDINGS, LLC, SUGAR LAND, TX. FILED 1-11-2012.

EVERY TREAT HELPS A KID

THE MARK CONSISTS OF STANDARD CHARACTERS WITHOUT CLAIM TO ANY PARTICULAR FONT, STYLE, SIZE, OR COLOR.

CLASS 30—STAPLE FOODS

FOR CEREAL-BASED SNACK FOODS; COOKIES; POWDERED FLAVORINGS FOR MILK DRINKS; PASTRIES; CORN-BASED SNACK FOODS; GRAIN-BASED SNACK FOODS; WHEAT-BASED SNACK FOODS (U.S. CL. 46).

CLASS 32—LIGHT BEVERAGES

FOR POWDERS OR CONCENTRATES USED IN THE PREPARATION OF SOFT DRINKS (U.S. CLS. 45, 46 AND 48).
TEJBIR SINGH, EXAMINING ATTORNEY

THE COMMERCIAL APPEAL

THE MARK CONSISTS OF STANDARD CHARACTERS WITHOUT CLAIM TO ANY PARTICULAR FONT, STYLE, SIZE, OR COLOR.

CLASS 16—PAPER GOODS AND PRINTED MATTER

FOR NEWSPAPERS (U.S. CLS. 2, 5, 22, 23, 29, 37, 38 AND 50).
FIRST USE 7-1-1894; IN COMMERCE 7-1-1894.

CLASS 41—EDUCATION AND ENTERTAINMENT

FOR PROVIDING AN INTERACTIVE COMPUTER DATABASE CONTAINING INFORMATION IN THE FIELD OF SPORTS, ENTERTAINMENT, FINE ARTS AND LOCAL AND NATIONAL NEWS (U.S. CLS. 100, 101 AND 107).
FIRST USE 2-1-1997; IN COMMERCE 2-1-1997.
MIDGE BUTLER, EXAMINING ATTORNEY

SN 85-514,485. ESPINOZA, VERONICA, WAXAHACHIE, TX. FILED 1-11-2012.

Yummy Perfection

THE MARK CONSISTS OF STANDARD CHARACTERS WITHOUT CLAIM TO ANY PARTICULAR FONT, STYLE, SIZE, OR COLOR.

CLASS 30—STAPLE FOODS

FOR BAKERY GOODS; CANDY (U.S. CL. 46).

CLASS 35—ADVERTISING AND BUSINESS

FOR RETAIL BAKERY SHOPS (U.S. CLS. 100, 101 AND 102).
FIRST USE 10-10-2011; IN COMMERCE 10-10-2011.
JENNIFER VASQUEZ, EXAMINING ATTORNEY

SN 85-514,493. GIBSON, JR., THOMAS E., CLERMONT, FL. FILED 1-11-2012.

Lagoon Life

THE MARK CONSISTS OF STANDARD CHARACTERS WITHOUT CLAIM TO ANY PARTICULAR FONT, STYLE, SIZE, OR COLOR.

CLASS 16—PAPER GOODS AND PRINTED MATTER

FOR BUMPER STICKERS (U.S. CLS. 2, 5, 22, 23, 29, 37, 38 AND 50).

CLASS 25—CLOTHING

FOR BASEBALL CAPS AND HATS; SHORT-SLEEVED OR LONG-SLEEVED T-SHIRTS (U.S. CLS. 22 AND 39).
CHRISTINE MARTIN, EXAMINING ATTORNEY

SN 85-514,819. PLACECOL COSMETICS (PROPRIETARY) LIMITED, CENTURION, SOUTH AFRICA, FILED 1-12-2012.



SN 85-514,657. LSI CORPORATION, MILPITAS, PA. FILED 1-12-2012.

CAPS

THE MARK CONSISTS OF STANDARD CHARACTERS WITHOUT CLAIM TO ANY PARTICULAR FONT, STYLE, SIZE, OR COLOR.

CLASS 35—ADVERTISING AND BUSINESS

FOR MARKETING SERVICES, NAMELY, PROMOTING OR ADVERTISING THE GOODS AND SERVICES OF OTHERS (U.S. CLS. 100, 101 AND 102).
FIRST USE 11-8-2011; IN COMMERCE 11-8-2011.

CLASS 42—SCIENTIFIC AND COMPUTER SERVICES

FOR TECHNICAL SUPPORT SERVICES, NAMELY, COMPUTER HARDWARE AND SOFTWARE COMPATIBILITY TESTING FOR OTHERS (U.S. CLS. 100 AND 101).
FIRST USE 11-8-2011; IN COMMERCE 11-8-2011.
DAWN FELDMAN, EXAMINING ATTORNEY

SN 85-514,736. GABRIEL FIRST CORPORATION, EAST ROCHESTER, NY. FILED 1-12-2012.

FAST-1-2-3

THE MARK CONSISTS OF STANDARD CHARACTERS WITHOUT CLAIM TO ANY PARTICULAR FONT, STYLE, SIZE, OR COLOR.

CLASS 1—CHEMICALS

FOR DETERGENTS FOR INDUSTRIAL USE (U.S. CLS. 1, 5, 6, 10, 26 AND 46).
FIRST USE 10-1-1992; IN COMMERCE 10-1-1992.

CLASS 3—COSMETICS AND CLEANING PREPARATIONS

FOR DETERGENTS FOR HOUSEHOLD USE (U.S. CLS. 1, 4, 6, 50, 51 AND 52).
FIRST USE 10-1-1992; IN COMMERCE 10-1-1992.
ERIN FALK, EXAMINING ATTORNEY

THE MARK CONSISTS OF THE STYLIZED WORD "PLACECOL" WITH A LEAF DESIGN ABOVE THE LETTER "E".

CLASS 3—COSMETICS AND CLEANING PREPARATIONS

FOR NON-MEDICATED PREPARATIONS ALL FOR THE CARE OF SKIN, HAIR AND SCALP; HAND CARE PREPARATIONS, NAMELY, HAND CREAM AND LOTION; NAIL CARE PREPARATIONS, NAMELY NAIL POLISHES AND VARNISHES, NAIL GLITTER, COLOR LIQUID FOR DECORATING NAILS, NAIL HARDENERS, NAIL POLISH REMOVERS, CUTICLE CONDITIONERS AND CREAMS; ARTIFICIAL NAILS AND ARTIFICIAL NAIL CARE PREPARATIONS AND KITS; ADHESIVES FOR ATTACHING ARTIFICIAL NAILS; GEL PAINTS FOR SCULPTURING AND DECORATING NAILS; EMERY BOARDS; CLEANING PREPARATIONS FOR NAIL BRUSHES; SOAPS; PERFUMERY, OILS FOR COSMETIC PURPOSES, COSMETICS; MASKS AND SCRUBS FOR BODY AND FACE, NON-MEDICATED SUN CARE PREPARATIONS (U.S. CLS. 1, 4, 6, 50, 51 AND 52).

CLASS 44—MEDICAL, BEAUTY AND AGRICULTURAL SERVICES

FOR HYGIENIC AND BEAUTY CARE FOR HUMAN BEINGS NAMELY SPA, BEAUTY SALON AND NAIL SALON SERVICES, LASER SKIN ENHANCEMENT PROCEDURES, MASSAGE AND BODY WAXING SERVICES, PEDICURES AND MANICURES (U.S. CLS. 100 AND 101).
MATTHEW KLINE, EXAMINING ATTORNEY

SN 85-515,155. ZELDA'S SONG, LLC, FAIRFIELD, CT. FILED 1-12-2012.



THE MARK CONSISTS OF THE LETTERS "ZS" INSIDE A HEART WITH A STRIPED BORDER.

CLASS 14—JEWELRY

FOR JEWELRY; LEATHER JEWELRY AND ACCESSORY BOXES (U.S. CLS. 2, 27, 28 AND 50).

CLASS 18—LEATHER GOODS

FOR ALL-PURPOSE CARRYING BAGS; BRIEFCASE-TYPE LEATHER BUSINESS FOLDERS; DOG COLLARS; LEATHER KEY CASES; LEATHER KEY CHAINS; LEATHER LEADS; LEATHER LEASHES; TOTE BAGS (U.S. CLS. 1, 2, 3, 22 AND 41).

CLASS 25—CLOTHING

FOR JACKETS; SHIRTS; WRIST BANDS (U.S. CLS. 22 AND 39).
BRENDAN REGAN, EXAMINING ATTORNEY

SN 85-515,212. ATTORNEYS' TITLE GUARANTY FUND, INC., CHICAGO, IL. FILED 1-12-2012.

AUCTIONS BY ATG

THE MARK CONSISTS OF STANDARD CHARACTERS WITHOUT CLAIM TO ANY PARTICULAR FONT, STYLE, SIZE, OR COLOR.

OWNER OF U.S. REG. NOS. 1,611,540, 3,361,907 AND OTHERS.

NO CLAIM IS MADE TO THE EXCLUSIVE RIGHT TO USE "AUCTIONS", APART FROM THE MARK AS SHOWN.

CLASS 35—ADVERTISING AND BUSINESS

FOR REAL ESTATE AUCTIONS (U.S. CLS. 100, 101 AND 102).

CLASS 36—INSURANCE AND FINANCIAL

FOR REAL ESTATE ACQUISITION SERVICES; REAL ESTATE BROKERAGE; REAL ESTATE CONSULTATION; REAL ESTATE INVESTMENT SERVICES; REAL ESTATE VALUATIONS (U.S. CLS. 100, 101 AND 102).

CLASS 45—PERSONAL AND LEGAL SERVICES

FOR REAL ESTATE CLOSING SERVICES (U.S. CLS. 100 AND 101).
AMY KELLY, EXAMINING ATTORNEY

SN 85-515,235. MAINTENANCE RESOURCE INC., DBA FACILITIES RESOURCE GROUP, GRANDVILLE, MI. FILED 1-12-2012.

LUXEVO

THE MARK CONSISTS OF STANDARD CHARACTERS WITHOUT CLAIM TO ANY PARTICULAR FONT, STYLE, SIZE, OR COLOR.

CLASS 11—ENVIRONMENTAL CONTROL APPARATUS

FOR LED (LIGHT EMITTING DIODE) LIGHTING FIXTURES AND LAMPS (U.S. CLS. 13, 21, 23, 31 AND 34).

CLASS 39—TRANSPORTATION AND STORAGE

FOR DISTRIBUTION SERVICES, NAMELY, DELIVERY OF LED (LIGHT EMITTING DIODE) FIXTURES AND LAMPS (U.S. CLS. 100 AND 105).
ADA HAN, EXAMINING ATTORNEY

SN 85-515,262. DALY, ERIC A., LAS VEGAS, NV. FILED 1-12-2012.

No Bain - No Pain

THE MARK CONSISTS OF STANDARD CHARACTERS WITHOUT CLAIM TO ANY PARTICULAR FONT, STYLE, SIZE, OR COLOR.

CLASS 16—PAPER GOODS AND PRINTED MATTER

FOR BUMPER STICKERS; PRINTED PAMPHLETS, BROCHURES, MANUALS, BOOKS, BOOKLETS, LEAFLETS, FLYERS, INFORMATIONAL SHEETS AND NEWSLETTERS, ADHESIVE BACKED STICKERS, AND KITS COMPRISING ONE OR MORE OF THE FOREGOING MATERIALS IN THE FIELD OF POLITICS (U.S. CLS. 2, 5, 22, 23, 29, 37, 38 AND 50).

CLASS 25—CLOTHING

FOR T-SHIRTS; T-SHIRTS FOR CAMPAIGN (U.S. CLS. 22 AND 39).

CLASS 26—FANCY GOODS

FOR CAMPAIGN BUTTONS (U.S. CLS. 37, 39, 40, 42 AND 50).
NAKIA HENRY, EXAMINING ATTORNEY

SN 85-515,376. FORMULA 21 LLC, DRAPER, UT. FILED 1-12-2012.

iSugar

THE MARK CONSISTS OF STANDARD CHARACTERS WITHOUT CLAIM TO ANY PARTICULAR FONT, STYLE, SIZE, OR COLOR.

CLASS 5—PHARMACEUTICALS

FOR DIETARY AND NUTRITIONAL SUPPLEMENTS USED FOR WEIGHT LOSS (U.S. CLS. 6, 18, 44, 46, 51 AND 52).

CLASS 30—STAPLE FOODS

FOR NATURAL SWEETENER (U.S. CL. 46).
BRIAN NEVILLE, EXAMINING ATTORNEY

SN 85-515,404. SAINT LUCAS OF NORTH AMERICA LLC,
CORAM, NY. FILED 1-12-2012.

Saint Lucas

THE MARK CONSISTS OF STANDARD CHARACTERS
WITHOUT CLAIM TO ANY PARTICULAR FONT, STYLE,
SIZE, OR COLOR.

CLASS 18—LEATHER GOODS

FOR TOTE BAGS; WALLETS (U.S. CLS. 1, 2, 3, 22 AND
41).
FIRST USE 9-15-2011; IN COMMERCE 9-15-2011.

CLASS 25—CLOTHING

FOR BELTS; TIES (U.S. CLS. 22 AND 39).
FIRST USE 9-15-2011; IN COMMERCE 9-15-2011.
MARIA-VICTORIA SUAREZ, EXAMINING ATTORNEY

SN 85-515,449. COUGHLAN COMPANIES, INC., NORTH
MANKATO, MN. FILED 1-12-2012.

CAPSTONE

THE MARK CONSISTS OF STANDARD CHARACTERS
WITHOUT CLAIM TO ANY PARTICULAR FONT, STYLE,
SIZE, OR COLOR.

CLASS 9—ELECTRICAL AND SCIENTIFIC APPARATUS

FOR DOWNLOADABLE ELECTRONIC PUBLICATIONS IN THE NATURE OF BOOKS IN THE FIELD OF FICTION AND NON-FICTION BOOKS ON A VARIETY OF TOPICS; DOWNLOADABLE BOOKS VIA THE INTERNET AND WIRELESS DEVICES; ELECTRONIC PUBLICATIONS, NAMELY, E-BOOKS FEATURING INFORMATION OF INTEREST TO CHILDREN AND YOUNG ADULTS RECORDED ON COMPUTER MEDIA (U.S. CLS. 21, 23, 26, 36 AND 38).
FIRST USE 11-1-2010; IN COMMERCE 11-1-2010.

CLASS 16—PAPER GOODS AND PRINTED MATTER

FOR BOOKS IN THE FIELD OF EDUCATIONAL READERS ON A VARIETY OF TOPICS FOR SCHOOL AGE CHILDREN; CHILDREN'S BOOKS; NON-FICTION BOOKS ON A VARIETY OF TOPICS; SERIES OF FICTION AND NON-FICTION BOOKS ON A VARIETY OF TOPICS (U.S. CLS. 2, 5, 22, 23, 29, 37, 38 AND 50).
FIRST USE 5-28-2009; IN COMMERCE 5-28-2009.

CLASS 41—EDUCATION AND ENTERTAINMENT

FOR BOOK PUBLISHING; ON-LINE PUBLICATION OF E-BOOKS AND DIGITAL CONTENT; PROVIDING ON-LINE PUBLICATIONS IN THE NATURE OF AN E-BOOK IN THE FIELD OF BOOKS FOR CHILDREN AND YOUNG ADULTS; PUBLISHING OF ELECTRONIC PUBLICATIONS (U.S. CLS. 100, 101 AND 107).
FIRST USE 11-1-2010; IN COMMERCE 11-1-2010.
HENRY S. ZAK, EXAMINING ATTORNEY

SN 85-515,459. COUGHLAN COMPANIES, INC., NORTH
MANKATO, MN. FILED 1-12-2012.

THE COLOR(S) PURPLE AND RED IS/ARE CLAIMED AS
A FEATURE OF THE MARK.

THE MARK CONSISTS OF THE WORD "CAPSTONE" IN
LOWER CASE LETTERS, WITH THE LETTERS "C", "A", "P",
"S", "T", "N" AND "E" IN PURPLE AND THE LETTER "O"
IN RED.

CLASS 9—ELECTRICAL AND SCIENTIFIC APPARATUS

FOR DOWNLOADABLE ELECTRONIC PUBLICATIONS IN THE NATURE OF BOOKS IN THE FIELD OF FICTION AND NON-FICTION BOOKS ON A VARIETY OF TOPICS; DOWNLOADABLE BOOKS VIA THE INTERNET AND WIRELESS DEVICES; ELECTRONIC PUBLICATIONS, NAMELY, E-BOOKS FEATURING INFORMATION OF INTEREST TO CHILDREN AND YOUNG ADULTS RECORDED ON COMPUTER MEDIA (U.S. CLS. 21, 23, 26, 36 AND 38).
FIRST USE 11-1-2010; IN COMMERCE 11-1-2010.

CLASS 16—PAPER GOODS AND PRINTED MATTER

FOR BOOKS IN THE FIELD OF EDUCATIONAL READERS ON A VARIETY OF TOPICS FOR SCHOOL AGE CHILDREN; CHILDREN'S BOOKS; NON-FICTION BOOKS ON A VARIETY OF TOPICS; SERIES OF FICTION AND NON-FICTION BOOKS ON A VARIETY OF TOPICS (U.S. CLS. 2, 5, 22, 23, 29, 37, 38 AND 50).
FIRST USE 5-28-2009; IN COMMERCE 5-28-2009.

CLASS 41—EDUCATION AND ENTERTAINMENT

FOR BOOK PUBLISHING; ON-LINE PUBLICATION OF E-BOOKS AND DIGITAL CONTENT; PROVIDING ON-LINE PUBLICATIONS IN THE NATURE OF AN E-BOOK IN THE FIELD OF BOOKS FOR CHILDREN AND YOUNG ADULTS; PUBLISHING OF ELECTRONIC PUBLICATIONS (U.S. CLS. 100, 101 AND 107).
FIRST USE 11-1-2010; IN COMMERCE 11-1-2010.
HENRY S. ZAK, EXAMINING ATTORNEY

SN 85-515,505. IT'S ALL MADE UP, INC., HAGUE, NY.
FILED 1-12-2012.

The Bigger Game

THE MARK CONSISTS OF STANDARD CHARACTERS WITHOUT CLAIM TO ANY PARTICULAR FONT, STYLE, SIZE, OR COLOR.

OWNER OF U.S. REG. NO. 3,802,090.

CLASS 16—PAPER GOODS AND PRINTED MATTER

FOR EDUCATIONAL KITS SOLD AS A UNIT IN THE FIELD OF PROFESSIONAL GROWTH AND TRANSFORMATION CONSISTING PRIMARILY OF PRINTED INSTRUCTIONAL AND TEACHING MATERIAL AND ALSO INCLUDING DVDS (U.S. CLS. 2, 5, 22, 23, 29, 37, 38 AND 50).

FIRST USE 8-4-2002; IN COMMERCE 8-4-2002.

CLASS 41—EDUCATION AND ENTERTAINMENT

FOR EDUCATIONAL SERVICES, NAMELY, CONDUCTING CLASSES, WORKSHOPS, AND TRAINING SESSIONS IN THE FIELD OF PROFESSIONAL GROWTH AND TRANSFORMATION AND DISTRIBUTION OF COURSE MATERIAL IN CONNECTION THEREWITH (U.S. CLS. 100, 101 AND 107).

FIRST USE 8-4-2002; IN COMMERCE 8-4-2002.

KIMBERLY PERRY, EXAMINING ATTORNEY

SN 85-515,547. MANAGER TOOLS LLC, FREDERICKSBURG, TX. FILED 1-12-2012.

EVERY PROFESSIONAL PRODUCTIVE

THE MARK CONSISTS OF STANDARD CHARACTERS WITHOUT CLAIM TO ANY PARTICULAR FONT, STYLE, SIZE, OR COLOR.

CLASS 9—ELECTRICAL AND SCIENTIFIC APPARATUS

FOR DIGITAL MEDIA, NAMELY, AUDIO FILES, TEXT FILES, MULTIMEDIA FILES, PODCASTS AND APPLICATION FILES FEATURING AUDIO, TEXT, MULTIMEDIA AND APPLICATION BASED EDUCATIONAL MATERIALS IN THE FIELD OF MANAGEMENT, BUSINESS MANAGEMENT, LEADERSHIP, PERSONAL DEVELOPMENT, COMMUNICATION, BEHAVIOR, RESUME WRITING, INTERVIEWING AND CAREER PLANNING; DOWNLOADABLE PODCASTS IN THE FIELD OF MANAGEMENT, BUSINESS MANAGEMENT, LEADERSHIP, PERSONAL DEVELOPMENT, COMMUNICATIONS, BEHAVIOR, RESUME WRITING, INTERVIEWING AND CAREER PLANNING (U.S. CLS. 21, 23, 26, 36 AND 38).

FIRST USE 5-31-2011; IN COMMERCE 5-31-2011.

CLASS 41—EDUCATION AND ENTERTAINMENT

FOR EDUCATIONAL SERVICES, NAMELY, CONDUCTING CLASSES, SEMINARS, CONFERENCES, WORKSHOPS, PODCASTS, ON-LINE FORUMS, CONFERENCE CALLS AND COACHING SESSIONS IN THE FIELDS OF MANAGEMENT, BUSINESS MANAGEMENT, LEADERSHIP, PERSONAL DEVELOPMENT, COMMUNICATION, BEHAVIOR, RESUME WRITING, INTERVIEWING AND CAREER PLANNING AND DISTRIBUTION OF TRAINING MATERIALS IN CONNECTION THEREWITH (U.S. CLS. 100, 101 AND 107).

FIRST USE 5-31-2011; IN COMMERCE 5-31-2011.

NAAKWAMA ANKRAH, EXAMINING ATTORNEY

SN 85-515,549. MANAGER TOOLS LLC, FREDERICKSBURG, TX. FILED 1-12-2012.

EVERY MANAGER EFFECTIVE

THE MARK CONSISTS OF STANDARD CHARACTERS WITHOUT CLAIM TO ANY PARTICULAR FONT, STYLE, SIZE, OR COLOR.

CLASS 9—ELECTRICAL AND SCIENTIFIC APPARATUS

FOR DIGITAL MEDIA, NAMELY, AUDIO FILES, TEXT FILES, MULTIMEDIA FILES, PODCASTS AND APPLICATION FILES FEATURING AUDIO, TEXT, MULTIMEDIA AND APPLICATION BASED EDUCATIONAL MATERIALS IN THE FIELD OF MANAGEMENT, BUSINESS MANAGEMENT, LEADERSHIP, PERSONAL DEVELOPMENT, COMMUNICATION, BEHAVIOR, RESUME WRITING, INTERVIEWING AND CAREER PLANNING; DOWNLOADABLE PODCASTS IN THE FIELD OF MANAGEMENT, BUSINESS MANAGEMENT, LEADERSHIP, PERSONAL DEVELOPMENT, COMMUNICATIONS, BEHAVIOR, RESUME WRITING, INTERVIEWING AND CAREER PLANNING (U.S. CLS. 21, 23, 26, 36 AND 38).

FIRST USE 5-31-2011; IN COMMERCE 5-31-2011.

CLASS 41—EDUCATION AND ENTERTAINMENT

FOR EDUCATIONAL SERVICES, NAMELY, CONDUCTING CLASSES, SEMINARS, CONFERENCES, WORKSHOPS, PODCASTS, ON-LINE FORUMS, CONFERENCE CALLS AND COACHING SESSIONS IN THE FIELDS OF MANAGEMENT, BUSINESS MANAGEMENT, LEADERSHIP, PERSONAL DEVELOPMENT, COMMUNICATION, BEHAVIOR, RESUME WRITING, INTERVIEWING AND CAREER PLANNING AND DISTRIBUTION OF TRAINING MATERIALS IN CONNECTION THEREWITH (U.S. CLS. 100, 101 AND 107).

FIRST USE 5-31-2011; IN COMMERCE 5-31-2011.

NAAKWAMA ANKRAH, EXAMINING ATTORNEY

SN 85-515,600. ATTORNEYS' TITLE GUARANTY FUND, INC., CHICAGO, IL. FILED 1-13-2012.



THE MARK CONSISTS OF TWO INVERTED CHEVRONS REPRESENTING STYLIZED ROOFTOPS WITH A CHIMNEY ON THE LEFT AND A RECTANGLE LOCATED BELOW THE INTERSECTION OF THE TWO CHEVRONS.

CLASS 35—ADVERTISING AND BUSINESS

FOR REAL ESTATE AUCTIONS (U.S. CLS. 100, 101 AND 102).

CLASS 36—INSURANCE AND FINANCIAL

FOR REAL ESTATE ACQUISITION SERVICES; REAL ESTATE BROKERAGE; REAL ESTATE CONSULTATION; REAL ESTATE INVESTMENT SERVICES; REAL ESTATE VALUATIONS (U.S. CLS. 100, 101 AND 102).

CLASS 45—PERSONAL AND LEGAL SERVICES

FOR REAL ESTATE CLOSING SERVICES (U.S. CLS. 100 AND 101).
AMY KELLY, EXAMINING ATTORNEY

SN 85-515,675. ESTES EXPRESS LINES, RICHMOND, VA. FILED 1-13-2012.

LEVEL² LOGISTICS

NO CLAIM IS MADE TO THE EXCLUSIVE RIGHT TO USE "LOGISTICS", APART FROM THE MARK AS SHOWN. THE MARK CONSISTS OF THE EXPRESSION "LEVEL² LOGISTICS" WITH THE ONLY STYLIZATION CLAIMED BEING THAT THE NUMBER "2" IS PRESENTED IN SUPERSCRIPIT.

CLASS 35—ADVERTISING AND BUSINESS

FOR LOGISTICS MANAGEMENT IN THE FIELD OF FREIGHT TRANSPORTATION AND SUPPLY CHAIN MANAGEMENT (U.S. CLS. 100, 101 AND 102).

CLASS 39—TRANSPORTATION AND STORAGE

FOR FREIGHT TRANSPORTATION BY TRUCK, AIR AND SEA; FREIGHT BROKERAGE; FREIGHT FORWARDING; TRANSPORTATION AND DELIVERY SERVICES, NAMELY, GUARANTEED EXPRESS DELIVERY OF GOODS BY TRUCK AND AIR; PROVIDING CUSTOMIZED FREIGHT PACKING, CARGO HANDLING, TRANSPORT OF GOODS BY TRUCK, AIR AND SEA; AND THE LEASING OF TRUCKS AND TRAILERS FOR FREIGHT TRANSPORTATION (U.S. CLS. 100 AND 105).
RENEE MCCRAY, EXAMINING ATTORNEY

SN 85-515,679. ESTES EXPRESS LINES, RICHMOND, VA. FILED 1-13-2012.

LEVEL² LOGISTICS

THE MARK CONSISTS OF STANDARD CHARACTERS WITHOUT CLAIM TO ANY PARTICULAR FONT, STYLE, SIZE, OR COLOR.

NO CLAIM IS MADE TO THE EXCLUSIVE RIGHT TO USE "LOGISTICS", APART FROM THE MARK AS SHOWN.

CLASS 35—ADVERTISING AND BUSINESS

FOR LOGISTICS MANAGEMENT IN THE FIELD OF FREIGHT TRANSPORTATION AND SUPPLY CHAIN MANAGEMENT (U.S. CLS. 100, 101 AND 102).

CLASS 39—TRANSPORTATION AND STORAGE

FOR FREIGHT TRANSPORTATION BY TRUCK, AIR AND SEA; FREIGHT BROKERAGE; FREIGHT FORWARDING; TRANSPORTATION AND DELIVERY SERVICES, NAMELY, GUARANTEED EXPRESS DELIVERY OF GOODS BY TRUCK AND AIR; PROVIDING CUSTOMIZED FREIGHT PACKING, CARGO HANDLING, TRANSPORT OF GOODS BY TRUCK, AIR AND SEA; AND THE LEASING OF TRUCKS AND TRAILERS FOR FREIGHT TRANSPORTATION (U.S. CLS. 100 AND 105).
RENEE MCCRAY, EXAMINING ATTORNEY

SN 85-515,700. STREETSBORO CITY SCHOOL DISTRICT BOARD OF EDUCATION, STREETSBORO, OH. FILED 1-13-2012.



THE COLOR(S) BLUE AND YELLOW IS/ARE CLAIMED AS A FEATURE OF THE MARK.

THE MARK CONSISTS OF A BLUE OPEN ENDED ROCKET SHIP WITH A BLUE PLUME COMING OUT OF THE OPEN END, PASSING DIAGONALLY NORTHEAST THROUGH A YELLOW RING.

SN 85-515,839. HUYNH, HOWARD, LOS ANGELES, CA. FILED 1-13-2012.

CLASS 16—PAPER GOODS AND PRINTED MATTER

FOR BOOK COVERS; CALENDARS; DECALS; FOLDERS; NOTEBOOKS; PENCILS; PENS; POSTERS; STICKERS (U.S. CLS. 2, 5, 22, 23, 29, 37, 38 AND 50).

CLASS 21—HOUSEWARES AND GLASS

FOR CUPS AND MUGS; SPORTS BOTTLES SOLD EMPTY (U.S. CLS. 2, 13, 23, 29, 30, 33, 40 AND 50).

CLASS 24—FABRICS

FOR AFGHANS; BANNERS AND FLAGS OF TEXTILE; BLANKET THROWS; CLOTH BANNERS; TOWELS (U.S. CLS. 42 AND 50).

CLASS 25—CLOTHING

FOR ATHLETIC APPAREL, NAMELY, SHIRTS, PANTS, JACKETS, FOOTWEAR, HATS AND CAPS, ATHLETIC UNIFORMS; COATS; GOLF SHIRTS; GYM SHORTS; PONCHOS; SWEATPANTS; SWEATSHIRTS; T-SHIRTS; UNIFORMS; WARM-UP SUITS (U.S. CLS. 22 AND 39).

CLASS 26—FANCY GOODS

FOR EMBROIDERED EMBLEMS; EMBROIDERED PATCHES FOR CLOTHING (U.S. CLS. 37, 39, 40, 42 AND 50).

WILLIAM BRECKENFELD, EXAMINING ATTORNEY

SN 85-515,704. TRACEY MALLET LIFESTYLES, LLC, PASADENA, CA. FILED 1-13-2012.

FuseDance

THE MARK CONSISTS OF STANDARD CHARACTERS WITHOUT CLAIM TO ANY PARTICULAR FONT, STYLE, SIZE, OR COLOR.

CLASS 9—ELECTRICAL AND SCIENTIFIC APPARATUS

FOR DVDS FEATURING EXERCISE AND FITNESS (U.S. CLS. 21, 23, 26, 36 AND 38).

CLASS 41—EDUCATION AND ENTERTAINMENT

FOR PHYSICAL FITNESS CONDITIONING CLASSES (U.S. CLS. 100, 101 AND 107).

WILLIAM BRECKENFELD, EXAMINING ATTORNEY



NO CLAIM IS MADE TO THE EXCLUSIVE RIGHT TO USE "HOME DECOR", APART FROM THE MARK AS SHOWN.

THE MARK CONSISTS OF A SINGLE LATTICE BLOCK WITH EIGHT INTERLOCKING LINES. BELOW THE BLOCK IS THE STYLIZED TEXT "LOFT209" ABOVE THE STYLIZED TEXT "HOME DECOR".

CLASS 20—FURNITURE AND ARTICLES NOT OTHERWISE CLASSIFIED

FOR DOG BEDS; PILLOWS (U.S. CLS. 2, 13, 22, 25, 32 AND 50).

FIRST USE 3-0-2011; IN COMMERCE 3-0-2011.

CLASS 24—FABRICS

FOR BED BLANKETS; BEDSHEETS; TABLE LINEN OF TEXTILE; THROWS (U.S. CLS. 42 AND 50).

FIRST USE 3-0-2011; IN COMMERCE 3-0-2011.

BRIDGETT SMITH, EXAMINING ATTORNEY

SN 85-515,842. TIEDAY FRIDAY, LLC, CARY, NC. FILED 1-13-2012.

TieDay Friday

THE MARK CONSISTS OF STANDARD CHARACTERS WITHOUT CLAIM TO ANY PARTICULAR FONT, STYLE, SIZE, OR COLOR.

CLASS 25—CLOTHING

FOR TIES (U.S. CLS. 22 AND 39).

FIRST USE 10-10-2011; IN COMMERCE 10-10-2011.

CLASS 35—ADVERTISING AND BUSINESS

FOR RETAIL STORE SERVICES FEATURING NECKTIES AND NECKTIE ACCESSORIES (U.S. CLS. 100, 101 AND 102).

FIRST USE 10-10-2011; IN COMMERCE 10-10-2011.

DARRYL SPRUILL, EXAMINING ATTORNEY

SN 85-515,844. DAON HOLDINGS LIMITED, GRAND CAYMAN, CAYMAN ISLANDS, FILED 1-13-2012.

TrustX

THE MARK CONSISTS OF STANDARD CHARACTERS WITHOUT CLAIM TO ANY PARTICULAR FONT, STYLE, SIZE, OR COLOR.

CLASS 9—ELECTRICAL AND SCIENTIFIC APPARATUS

FOR COMPUTER SOFTWARE FOR AUTHENTICATION OR IDENTIFICATION PURPOSES BY MEANS OF STORAGE OF BIOMETRIC FEATURES AND COMPARISON OF THE STORED FEATURES AND FOR PROTECTING NETWORK ACCESSIBLE INFORMATION ASSOCIATED WITH INDIVIDUALS (U.S. CLS. 21, 23, 26, 36 AND 38).

CLASS 42—SCIENTIFIC AND COMPUTER SERVICES

FOR AUTHENTICATION TECHNOLOGY SERVICES, NAMELY, PROVIDING SECURE SERVER AND MOBILE DEVICE TECHNOLOGY SERVICES USING BIOMETRIC FEATURES STORED ON A COMPUTER NETWORK TO VALIDATE IDENTITIES AND PROTECTING NETWORK ACCESSIBLE INFORMATION ASSOCIATED WITH INDIVIDUALS (U.S. CLS. 100 AND 101).

CLASS 45—PERSONAL AND LEGAL SERVICES

FOR PROVIDING USER AUTHENTICATION SERVICES IN THE NATURE OF PROVIDING AUTHENTICATION OF INDIVIDUAL IDENTITY INFORMATION USING BIOMETRIC FEATURES STORED ON COMPUTER NETWORKS IN ORDER TO PROTECT NETWORK ACCESSIBLE INFORMATION ASSOCIATED WITH INDIVIDUALS (U.S. CLS. 100 AND 101).

DARRYL SPRULL, EXAMINING ATTORNEY

SN 85-515,910. THOUGHTS MATTER LLC, NEW YORK, NY. FILED 1-13-2012.

THOUGHTS MATTER

THE MARK CONSISTS OF STANDARD CHARACTERS WITHOUT CLAIM TO ANY PARTICULAR FONT, STYLE, SIZE, OR COLOR.

CLASS 14—JEWELRY

FOR RUBBER OR SILICON WRISTBANDS IN THE NATURE OF A BRACELET, JEWELRY, WATCHES (U.S. CLS. 2, 27, 28 AND 50).

CLASS 18—LEATHER GOODS

FOR BACKPACKS, FANNY PACKS, TOTE BAGS, HANDBAGS, WALLETS, SATCHELS, BEACH BAGS, UMBRELLAS, COLLARS FOR PETS, CHARMS FOR PET COLLARS, DOG APPAREL, DOG LEADS, DOG SHOES (U.S. CLS. 1, 2, 3, 22 AND 41).

CLASS 25—CLOTHING

FOR T-SHIRTS, SWEAT SHIRTS, HEADWEAR, LEGGINGS, SWEAT PANTS, JACKETS (U.S. CLS. 22 AND 39).

MARK RADEMACHER, EXAMINING ATTORNEY

SN 85-515,916. WILLIAM EARL RUSSELL, TUNNEL HILL, GA. FILED 1-13-2012.

EASY REST

THE MARK CONSISTS OF STANDARD CHARACTERS WITHOUT CLAIM TO ANY PARTICULAR FONT, STYLE, SIZE, OR COLOR.

OWNER OF U.S. REG. NO. 1,876,674.

CLASS 20—FURNITURE AND ARTICLES NOT OTHERWISE CLASSIFIED

FOR BED PILLOWS; PILLOWS (U.S. CLS. 2, 13, 22, 25, 32 AND 50).

FIRST USE 1-1-1980; IN COMMERCE 1-1-1980.

CLASS 24—FABRICS

FOR BED BLANKETS; BED COVERS; BED LINEN; BED SHEETS; BED SPREADS; COMFORTERS; FITTED BED SHEETS; FLAT BED SHEETS; MATTRESS COVERS; PILLOW CASES; PILLOW COVERS (U.S. CLS. 42 AND 50).

WILLIAM BRECKENFELD, EXAMINING ATTORNEY

SN 85-515,925. ANDERSON, DARIN, BRONX, NY. FILED 1-13-2012.

SEX IT UP

THE MARK CONSISTS OF STANDARD CHARACTERS WITHOUT CLAIM TO ANY PARTICULAR FONT, STYLE, SIZE, OR COLOR.

CLASS 25—CLOTHING

FOR JACKETS; PANTS; SHIRTS; SHOES; SHORTS; SNEAKERS; SWIMSUITS; UNDERWEAR (U.S. CLS. 22 AND 39).

CLASS 32—LIGHT BEVERAGES

FOR BEER; NON-ALCOHOLIC COCKTAIL MIXES (U.S. CLS. 45, 46 AND 48).

CLASS 33—WINES AND SPIRITS

FOR ALCOHOLIC COCKTAIL MIXES; BRANDY; GIN; RUM; SCOTCH; TEQUILA; VODKA; WHISKEY; WINE; WINE COOLERS (U.S. CLS. 47 AND 49).

THOMAS MANOR, EXAMINING ATTORNEY

SN 85-515,984. BRAD MCLAWS, PARK CITY, UT. FILED 1-13-2012.

Stratov8

THE MARK CONSISTS OF STANDARD CHARACTERS WITHOUT CLAIM TO ANY PARTICULAR FONT, STYLE, SIZE, OR COLOR.

CLASS 35—ADVERTISING AND BUSINESS

FOR BUSINESS CONSULTATION IN THE FIELD OF BUSINESS MANAGEMENT SERVICES TO ALL TYPES OF ORGANIZATIONS OR INDIVIDUALS; BUSINESS RESEARCH SERVICES IN THE FIELD OF MARKET RESEARCH AND BUSINESS INTELLIGENCE; MARKET RESEARCH SERVICES (U.S. CLS. 100, 101 AND 102).
FIRST USE 1-13-2012; IN COMMERCE 1-13-2012.

CLASS 41—EDUCATION AND ENTERTAINMENT

FOR BUSINESS TRAINING IN THE FIELD OF BUSINESS MANAGEMENT TO ALL TYPES OF ORGANIZATIONS (U.S. CLS. 100, 101 AND 107).
FIRST USE 1-13-2012; IN COMMERCE 1-13-2012.
KRISTINA MORRIS, EXAMINING ATTORNEY

SN 85-516,041. AMERICAN SHARED HOSPITAL SERVICES, SAN FRANCISCO, CA. FILED 1-13-2012.

THE OPERATING ROOM FOR THE
21ST CENTURY

THE MARK CONSISTS OF STANDARD CHARACTERS WITHOUT CLAIM TO ANY PARTICULAR FONT, STYLE, SIZE, OR COLOR.

CLASS 35—ADVERTISING AND BUSINESS

FOR MANAGEMENT SERVICES, NAMELY, STAFFING SERVICES AND EXPERT PRODUCTIVITY ANALYSIS CONSULTING SERVICES, ALL IN THE FIELD OF SURGICAL SUITES; BUSINESS CONSULTING, DISTRIBUTORSHIP SERVICES IN THE FIELD OF MEDICAL EQUIPMENT, SURGICAL SUITE LIGHTING EQUIPMENT, OPERATING ROOM LIGHTING EQUIPMENT, SURGICAL SUITE SANITATION EQUIPMENT, OPERATING ROOM SANITATION EQUIPMENT, SURGICAL SUITES EQUIPMENT, AND RELATED OPERATING ROOM EQUIPMENT; RETAIL STORE AND ONLINE RETAIL STORE SERVICES FEATURING SURGICAL SUITE EQUIPMENT, MEDICAL EQUIPMENT, SURGICAL SUITE LIGHTING AND SANITATION EQUIPMENT AND OPERATING ROOM LIGHTING AND SANITATION EQUIPMENT; CONSULTING SERVICES IN THE BUSINESS FIELD OF FACILITIES MANAGEMENT OF TECHNICAL OPERATIONS, NAMELY, PROVIDING, USING AND OPERATING SURGICAL SUITE FACILITIES, SURGICAL SUITE EQUIPMENT, MEDICAL EQUIPMENT, SURGICAL SUITE LIGHTING AND SANITATION EQUIPMENT, AND OPERATING ROOM LIGHTING AND SANITATION EQUIPMENT (U.S. CLS. 100, 101 AND 102).

CLASS 44—MEDICAL, BEAUTY AND AGRICULTURAL SERVICES

FOR LEASING OF SURGICAL SUITES AND MEDICAL EQUIPMENT (U.S. CLS. 100 AND 101).
ELISSA GARBER KON, EXAMINING ATTORNEY

SN 85-516,064. DISCALCED, INC., BROOKLYN, NY. FILED 1-13-2012.

DISCALCED

THE MARK CONSISTS OF STANDARD CHARACTERS WITHOUT CLAIM TO ANY PARTICULAR FONT, STYLE, SIZE, OR COLOR.

CLASS 9—ELECTRICAL AND SCIENTIFIC APPARATUS

FOR VIDEO RECORDINGS OF DANCE PERFORMANCES; MUSICAL SOUND RECORDINGS (U.S. CLS. 21, 23, 26, 36 AND 38).

CLASS 41—EDUCATION AND ENTERTAINMENT

FOR PROVIDING COMMUNITY OUTREACH PROGRAMS IN THE FIELD OF DANCE, NAMELY, ORGANIZING COMMUNITY CULTURAL EVENTS; EDUCATIONAL SERVICES, NAMELY, CONDUCTING CLASSES, SEMINARS, CONFERENCES AND WORKSHOPS OF INSTRUCTION IN THE FIELD OF DANCE, YOUTH DEVELOPMENT AND LEADERSHIP, AND DISTRIBUTING COURSE MATERIALS IN CONNECTION THEREWITH; ENTERTAINMENT IN THE NATURE OF LIVE DANCE PERFORMANCES; PROVIDING ENTERTAINMENT INFORMATION IN THE FIELD OF DANCE AND DANCE PERFORMANCES; DANCE SCHOOLS; AND DANCE STUDIOS (U.S. CLS. 100, 101 AND 107).

COLLEEN KEARNEY, EXAMINING ATTORNEY

SN 85-516,137. LAWZAM LLC, LEWES, DE. FILED 1-13-2012.

LAWZAM

THE MARK CONSISTS OF STANDARD CHARACTERS WITHOUT CLAIM TO ANY PARTICULAR FONT, STYLE, SIZE, OR COLOR.

CLASS 38—COMMUNICATION

FOR PROVIDING SECURE ON-LINE FORUMS FOR THE TRANSMISSION OF MESSAGES AND LIVE COMMUNICATIONS AMONG LEGAL PROFESSIONALS, PROSPECTIVE CLIENTS AND CLIENTS CONCERNING LEGAL CASES, LEGAL CASE MANAGEMENT AND THE LEGAL FIELD ON GLOBAL COMPUTER NETWORKS (U.S. CLS. 100, 101 AND 104).

CLASS 45—PERSONAL AND LEGAL SERVICES

FOR LEGAL SERVICES (U.S. CLS. 100 AND 101).
LIEF MARTIN, EXAMINING ATTORNEY

SN 85-516,148. UNPLUGGED GOODS, DBA UNPLUGGED GOODS, PORTOLA VALLEY, CA. FILED 1-13-2012.

Unplugged

THE MARK CONSISTS OF STANDARD CHARACTERS WITHOUT CLAIM TO ANY PARTICULAR FONT, STYLE, SIZE, OR COLOR.

CLASS 9—ELECTRICAL AND SCIENTIFIC APPARATUS

FOR BRIEFCASES SPECIALLY ADAPTED FOR HOLDING LAPTOP COMPUTERS (U.S. CLS. 21, 23, 26, 36 AND 38).

CLASS 21—HOUSEWARES AND GLASS

FOR CLOTH FOR WIPING OR DUSTING (U.S. CLS. 2, 13, 23, 29, 30, 33, 40 AND 50).

CLASS 22—CORDAGE AND FIBERS

FOR CABLE TIES AND STRAPS FOR FASTENING AND SECURING OBJECTS SUCH AS BUNDLES OF WIRE TOGETHER (U.S. CLS. 1, 2, 7, 19, 22, 42 AND 50).
ANDREW LEASER, EXAMINING ATTORNEY

SN 85-516,192. WOMEN BUSINESS LEADERS OF THE U.S. HEALTH CARE INDUSTRY FOUNDATION, WASHINGTON, DC. FILED 1-13-2012.



OWNER OF U.S. REG. NOS. 3,376,987, 3,513,058 AND 3,545,718.

THE MARK CONSISTS OF THE LETTERS "W", "B" AND "L" ABOVE THE TERM "WOMEN LEADING HEALTH CARE WWW.WBL.ORG" IN A SMALLER FONT, ALL OF WHICH APPEARS TO THE LEFT OF A STYLIZED DEPICTION OF TWO PEOPLE WITH RAISED ARMS THAT FORM THE LETTER "W" INSIDE OF TWO CONCENTRIC CIRCLES.

CLASS 35—ADVERTISING AND BUSINESS

FOR ASSOCIATION SERVICES, NAMELY, PROMOTING THE INTERESTS OF WOMEN IN THE FIELDS OF HEALTH CARE OR BUSINESS (U.S. CLS. 100, 101 AND 102).

FIRST USE 12-7-2010; IN COMMERCE 3-23-2011.

CLASS 41—EDUCATION AND ENTERTAINMENT

FOR ARRANGING AND CONDUCTING OF CONFERENCES, WORKSHOPS, CLASSES AND SEMINARS IN THE FIELD OF HEALTH CARE; ARRANGING AND CONDUCTING OF WORKSHOPS, CLASSES, SEMINARS AND EDUCATIONAL CONFERENCES IN THE FIELD OF BUSINESS (U.S. CLS. 100, 101 AND 107).
FIRST USE 12-7-2010; IN COMMERCE 3-23-2011.
MICHAEL KEATING, EXAMINING ATTORNEY

SN 85-516,283. TOPCO HOLDINGS, INC., SKOKIE, IL. FILED 1-13-2012.

TOP FRESH

THE MARK CONSISTS OF STANDARD CHARACTERS WITHOUT CLAIM TO ANY PARTICULAR FONT, STYLE, SIZE, OR COLOR.

OWNER OF U.S. REG. NO. 761,016.

NO CLAIM IS MADE TO THE EXCLUSIVE RIGHT TO USE "FRESH", APART FROM THE MARK AS SHOWN.

CLASS 21—HOUSEWARES AND GLASS

FOR FLORAL ITEMS, NAMELY, DECORATIVE FLOWER AND PLANT CONTAINERS, BOWLS, POTS, PLANTERS, VASES; FLOWER BASKETS (U.S. CLS. 2, 13, 23, 29, 30, 33, 40 AND 50).

CLASS 31—NATURAL AGRICULTURAL PRODUCTS

FOR LIVE PLANTS AND FLOWERS, CUT LIVE FLOWERS, LIVE FLOWER WREATHS, DRIED FLOWER ARRANGEMENTS, FLORAL-BASED CENTERPIECES, NAMELY, DRIED FLOWER ARRANGEMENTS AND LIVE FLOWER ARRANGEMENTS (U.S. CLS. 1 AND 46).

CLASS 35—ADVERTISING AND BUSINESS

FOR RETAIL FLORIST SHOPS, ONLINE RETAIL STORE SERVICES FEATURING FLOWERS (U.S. CLS. 100, 101 AND 102).

GENE MACIOL, EXAMINING ATTORNEY

SN 85-516,310. BNP MEDIA II, LLC, TROY, MI. FILED 1-13-2012.

ORANGETAP

THE MARK CONSISTS OF STANDARD CHARACTERS WITHOUT CLAIM TO ANY PARTICULAR FONT, STYLE, SIZE, OR COLOR.

CLASS 41—EDUCATION AND ENTERTAINMENT

FOR PUBLISHING OF JOURNALS, MAGAZINES, PERIODICALS, BOOKS, NEWSLETTERS, AND ELECTRONIC PUBLICATIONS (U.S. CLS. 100, 101 AND 107).

CLASS 42—SCIENTIFIC AND COMPUTER SERVICES

FOR WEBSITE DESIGN AND DEVELOPMENT FOR OTHERS (U.S. CLS. 100 AND 101).
CHRISTINE MARTIN, EXAMINING ATTORNEY

SN 85-516,506. JIMMY JOHN'S ENTERPRISES, LLC, CHAMPAIGN, IL. FILED 1-13-2012.

CLICK. ORDER. EAT.

THE MARK CONSISTS OF STANDARD CHARACTERS WITHOUT CLAIM TO ANY PARTICULAR FONT, STYLE, SIZE, OR COLOR.

CLASS 35—ADVERTISING AND BUSINESS

FOR ON-LINE ORDERING SERVICES IN THE FIELD OF RESTAURANT TAKE-OUT AND DELIVERY (U.S. CLS. 100, 101 AND 102).
FIRST USE 12-28-2011; IN COMMERCE 12-28-2011.

CLASS 43—HOTEL AND RESTAURANT SERVICES

FOR RESTAURANT SERVICES, INCLUDING SIT-DOWN SERVICE OF FOOD AND TAKE-OUT RESTAURANT SERVICES (U.S. CLS. 100 AND 101).
FIRST USE 12-28-2011; IN COMMERCE 12-28-2011.
JORDAN BAKER, EXAMINING ATTORNEY

SN 85-517,673. GOOD SPORTS, INC., AKA HOT LEATHERS, MANCHESTER, CT. FILED 1-17-2012.

LACONIA MOTORCYCLE WEEK

THE MARK CONSISTS OF STANDARD CHARACTERS WITHOUT CLAIM TO ANY PARTICULAR FONT, STYLE, SIZE, OR COLOR.

NO CLAIM IS MADE TO THE EXCLUSIVE RIGHT TO USE "MOTORCYCLE WEEK", APART FROM THE MARK AS SHOWN.

CLASS 14—JEWELRY

FOR BADGES OF PRECIOUS METAL; BRACELETS; EARRINGS; KEY RINGS OF PRECIOUS METALS; KEY RINGS NOT OF PRECIOUS METALS; NECKLACES; RINGS; ORNAMENTAL PINS; PINS BEING JEWELRY; TIE PINS; LAPEL PINS; SHOE ORNAMENTS OF PRECIOUS METAL (U.S. CLS. 2, 27, 28 AND 50).
FIRST USE 6-11-2005; IN COMMERCE 6-11-2005.

CLASS 26—FANCY GOODS

FOR PATCHES, NAMELY, CLOTH PATCHES, EMBROIDERED PATCHES FOR SEWING, HEAT ADHESIVE CLOTH PATCHES FOR DECORATION OF CLOTHING; ORNAMENTAL BADGES, NAMELY, ORNAMENTAL NOVELTY PINS; BELT BUCKLES NOT OF PRECIOUS METAL FOR CLOTHING; HAT ORNAMENTS NOT OF PRECIOUS METAL; BOOT ORNAMENTS OF PRECIOUS METAL; SHOE ORNAMENTS NOT OF PRECIOUS METAL; BOOT ORNAMENTS NOT OF PRECIOUS METAL (U.S. CLS. 37, 39, 40, 42 AND 50).
FIRST USE 6-11-2005; IN COMMERCE 6-11-2005.
ESTHER A. BORSUK, EXAMINING ATTORNEY

SN 85-517,678. GOOD SPORTS, INC., AKA HOT LEATHERS, MANCHESTER, CT. FILED 1-17-2012.

LACONIA BIKE WEEK

THE MARK CONSISTS OF STANDARD CHARACTERS WITHOUT CLAIM TO ANY PARTICULAR FONT, STYLE, SIZE, OR COLOR.

NO CLAIM IS MADE TO THE EXCLUSIVE RIGHT TO USE "BIKE WEEK", APART FROM THE MARK AS SHOWN.

CLASS 14—JEWELRY

FOR BADGES OF PRECIOUS METAL; BRACELETS; EARRINGS; KEY RINGS OF PRECIOUS METALS; KEY RINGS NOT OF PRECIOUS METALS; NECKLACES; RINGS; ORNAMENTAL PINS; PINS BEING JEWELRY; TIE PINS; LAPEL PINS; SHOE ORNAMENTS OF PRECIOUS METAL (U.S. CLS. 2, 27, 28 AND 50).
FIRST USE 6-11-2005; IN COMMERCE 6-11-2005.

CLASS 26—FANCY GOODS

FOR PATCHES, NAMELY, CLOTH PATCHES, EMBROIDERED PATCHES FOR SEWING, HEAT ADHESIVE CLOTH PATCHES FOR DECORATION OF CLOTHING; ORNAMENTAL BADGES, NAMELY, ORNAMENTAL NOVELTY PINS; BELT BUCKLES NOT OF PRECIOUS METAL FOR CLOTHING; HAT ORNAMENTS NOT OF PRECIOUS METAL; BOOT ORNAMENTS OF PRECIOUS METAL; SHOE ORNAMENTS NOT OF PRECIOUS METAL; BOOT ORNAMENTS NOT OF PRECIOUS METAL (U.S. CLS. 37, 39, 40, 42 AND 50).
FIRST USE 6-11-2005; IN COMMERCE 6-11-2005.
ESTHER A. BORSUK, EXAMINING ATTORNEY

SN 85-518,118. BRYN MAWR COMMUNICATIONS LLC, WAYNE, PA. FILED 1-17-2012.

CATARACT & REFRACTIVE SURGERY TODAY

THE MARK CONSISTS OF STANDARD CHARACTERS WITHOUT CLAIM TO ANY PARTICULAR FONT, STYLE, SIZE, OR COLOR.

NO CLAIM IS MADE TO THE EXCLUSIVE RIGHT TO USE "CATARACT & REFRACTIVE SURGERY", APART FROM THE MARK AS SHOWN.

CLASS 9—ELECTRICAL AND SCIENTIFIC APPARATUS

FOR DOWNLOADABLE ELECTRONIC PUBLICATIONS, NAMELY, MEDICAL JOURNALS AND MAGAZINES IN THE FIELD OF EYE CARE AND MEDICINE (U.S. CLS. 21, 23, 26, 36 AND 38).

FIRST USE 3-1-2001; IN COMMERCE 3-1-2001.

CLASS 16—PAPER GOODS AND PRINTED MATTER

FOR MEDICAL JOURNALS AND MAGAZINES IN THE FIELD OF EYE CARE AND MEDICINE (U.S. CLS. 2, 5, 22, 23, 29, 37, 38 AND 50).

FIRST USE 3-1-2001; IN COMMERCE 3-1-2001.

CLASS 44—MEDICAL, BEAUTY AND AGRICULTURAL SERVICES

FOR ONLINE WEBSITE FEATURING INFORMATION IN THE FIELD OF EYE CARE AND MEDICINE (U.S. CLS. 100 AND 101).

FIRST USE 3-1-2001; IN COMMERCE 3-1-2001.

ALAIN LAPTER, EXAMINING ATTORNEY

SN 85-518,184. BRYN MAWR COMMUNICATIONS II, LLC, WAYNE, PA. FILED 1-17-2012.

ENDOVASCULAR TODAY

THE MARK CONSISTS OF STANDARD CHARACTERS WITHOUT CLAIM TO ANY PARTICULAR FONT, STYLE, SIZE, OR COLOR.

NO CLAIM IS MADE TO THE EXCLUSIVE RIGHT TO USE "ENDOVASCULAR", APART FROM THE MARK AS SHOWN.

CLASS 9—ELECTRICAL AND SCIENTIFIC APPARATUS

FOR DOWNLOADABLE ELECTRONIC PUBLICATIONS, NAMELY, MEDICAL JOURNALS AND MAGAZINES IN THE FIELD OF ENDOVASCULAR THERAPIES AND PROCEDURES (U.S. CLS. 21, 23, 26, 36 AND 38).

FIRST USE 12-1-2001; IN COMMERCE 12-1-2001.

CLASS 16—PAPER GOODS AND PRINTED MATTER

FOR MEDICAL JOURNALS AND MAGAZINES IN THE FIELD OF ENDOVASCULAR THERAPIES AND PROCEDURES (U.S. CLS. 2, 5, 22, 23, 29, 37, 38 AND 50).

FIRST USE 12-1-2001; IN COMMERCE 12-1-2001.

CLASS 44—MEDICAL, BEAUTY AND AGRICULTURAL SERVICES

FOR ONLINE WEBSITE FEATURING INFORMATION IN THE FIELD OF MEDICAL THERAPIES AND PROCEDURES (U.S. CLS. 100 AND 101).

FIRST USE 12-1-2001; IN COMMERCE 12-1-2001.

ALAIN LAPTER, EXAMINING ATTORNEY

SN 85-518,215. BRYN MAWR COMMUNICATIONS LLC, WAYNE, PA. FILED 1-17-2012.

RETINA TODAY

THE MARK CONSISTS OF STANDARD CHARACTERS WITHOUT CLAIM TO ANY PARTICULAR FONT, STYLE, SIZE, OR COLOR.

NO CLAIM IS MADE TO THE EXCLUSIVE RIGHT TO USE "RETINA", APART FROM THE MARK AS SHOWN.

CLASS 9—ELECTRICAL AND SCIENTIFIC APPARATUS

FOR DOWNLOADABLE ELECTRONIC PUBLICATIONS, NAMELY, MEDICAL JOURNALS AND MAGAZINES IN THE FIELD OF EYE CARE AND MEDICINE (U.S. CLS. 21, 23, 26, 36 AND 38).

FIRST USE 10-15-2005; IN COMMERCE 10-15-2005.

CLASS 16—PAPER GOODS AND PRINTED MATTER

FOR MEDICAL JOURNALS AND MAGAZINES IN THE FIELD OF EYE CARE AND MEDICINE (U.S. CLS. 2, 5, 22, 23, 29, 37, 38 AND 50).

FIRST USE 10-15-2005; IN COMMERCE 10-15-2005.

CLASS 44—MEDICAL, BEAUTY AND AGRICULTURAL SERVICES

FOR ONLINE WEBSITE FEATURING INFORMATION IN THE FIELD OF EYE CARE AND MEDICINE (U.S. CLS. 100 AND 101).

FIRST USE 10-15-2005; IN COMMERCE 10-15-2005.

ALAIN LAPTER, EXAMINING ATTORNEY

SN 85-518,257. ADVANCE MAGAZINE PUBLISHERS INC., NEW YORK, NY. FILED 1-17-2012.

SELF WORKOUT IN THE PARK

THE MARK CONSISTS OF STANDARD CHARACTERS WITHOUT CLAIM TO ANY PARTICULAR FONT, STYLE, SIZE, OR COLOR.

OWNER OF U.S. REG. NOS. 1,663,404, 2,027,989 AND OTHERS.

NO CLAIM IS MADE TO THE EXCLUSIVE RIGHT TO USE "WORKOUT IN THE PARK", APART FROM THE MARK AS SHOWN.

CLASS 9—ELECTRICAL AND SCIENTIFIC APPARATUS

FOR SOFTWARE APPLICATIONS FOR USE IN CONNECTION WITH SMART PHONES, PDA DEVICES, TABLET COMPUTERS AND OTHER PORTABLE AND HANDHELD ELECTRONIC DEVICES, NAMELY, SOFTWARE FOR ACCESSING, VIEWING INTERACTING WITH AND DOWNLOADING CONTENT FROM MAGAZINES AND WEBSITES AND COMMUNICATIONS WITH OTHERS ABOUT EXERCISE, FITNESS, NUTRITION, SPORTS AND GAMES (U.S. CLS. 21, 23, 26, 36 AND 38).

CLASS 41—EDUCATION AND ENTERTAINMENT

FOR PHYSICAL EDUCATIONAL SERVICES, NAMELY, ORGANIZING CLASSES, LECTURES AND LIVE EVENTS IN THE FIELD OF EXERCISE, AEROBICS, STATIONARY BICYCLING, YOGA, RUNNING, AND HEALTH, FITNESS, DIET AND NUTRITION ISSUES (U.S. CLS. 100, 101 AND 107).

JULIE VEPPUMTHARA, EXAMINING ATTORNEY

SN 85-518,321. GLOFIN LIMITED, BELIZE CITY, BELIZE, FILED 1-17-2012.



THE MARK CONSISTS OF A STYLIZED "T" ON TOP OF A STYLIZED "W" NEXT TO THE STYLIZED WORD "TRADERWORLD".

CLASS 36—INSURANCE AND FINANCIAL

FOR FINANCIAL SERVICES, NAMELY, PROVIDING FOR THE EXCHANGE OF FOREIGN CURRENCY, COMMODITIES, FINANCIAL DERIVATIVES, INTEREST RATE PRODUCTS, AND EQUITIES VIA THE INTERNET AND INTRANET SYSTEMS; FINANCIAL SERVICES, NAMELY, PROVIDING INFORMATION IN THE FIELDS OF FOREIGN CURRENCY, COMMODITIES, FINANCIAL DERIVATIVES, INTEREST RATE PRODUCTS, AND EQUITIES VIA THE INTERNET AND INTRANET SYSTEMS (U.S. CLS. 100, 101 AND 102).

CLASS 41—EDUCATION AND ENTERTAINMENT

FOR ON-LINE GAMBLING (U.S. CLS. 100, 101 AND 107).

ROBERT C. CLARK JR., EXAMINING ATTORNEY

SN 85-518,356. RESONANT SYSTEMS, INC, SEATTLE, WA. FILED 1-17-2012.



THE MARK CONSISTS OF STANDARD CHARACTERS WITHOUT CLAIM TO ANY PARTICULAR FONT, STYLE, SIZE, OR COLOR.

CLASS 7—MACHINERY

FOR LINEAR MOTORS (U.S. CLS. 13, 19, 21, 23, 31, 34 AND 35).

CLASS 10—MEDICAL APPARATUS

FOR ADULT SEXUAL STIMULATION AIDS, NAMELY, VIBRATORS; ELECTRIC MASSAGE APPLIANCES, NAMELY, ELECTRIC VIBRATING MASSAGER; MASSAGE APPARATUS; MASSAGE APPARATUS; MASSAGE APPARATUS; MASSAGING APPARATUS FOR PERSONAL USE (U.S. CLS. 26, 39 AND 44).

ALEX KEAM, EXAMINING ATTORNEY

SN 85-518,544. ZO SKIN HEALTH, INC., IRVINE, CA. FILED 1-17-2012.



THE MARK CONSISTS OF STANDARD CHARACTERS WITHOUT CLAIM TO ANY PARTICULAR FONT, STYLE, SIZE, OR COLOR.

OWNER OF U.S. REG. NOS. 3,443,711 AND 3,443,712.

NO CLAIM IS MADE TO THE EXCLUSIVE RIGHT TO USE "MEDICAL", APART FROM THE MARK AS SHOWN.

CLASS 3—COSMETICS AND CLEANING PREPARATIONS

FOR ANTI-AGING CREAMS; ANTI-WRINKLE CREAMS; COSMETIC CREAMS FOR SKIN CARE; SKIN TONERS; SKIN WHITENING CREAMS (U.S. CLS. 1, 4, 6, 50, 51 AND 52).

CLASS 5—PHARMACEUTICALS

FOR ACNE MEDICATIONS; MEDICATED CREAMS FOR TREATING DERMATOLOGICAL CONDITIONS (U.S. CLS. 6, 18, 44, 46, 51 AND 52).

SHARON MEIER, EXAMINING ATTORNEY

SN 85-518,603. EXAMWORKS, INC., ATLANTA, GA. FILED 1-17-2012.



THE MARK CONSISTS OF STANDARD CHARACTERS WITHOUT CLAIM TO ANY PARTICULAR FONT, STYLE, SIZE, OR COLOR.

CLASS 35—ADVERTISING AND BUSINESS

FOR COST CONTAINMENT SERVICES IN THE FIELDS OF HEALTHCARE AND MEDICINE; MEDICAL REVIEW AND UTILIZATION SERVICES IN THE NATURE OF REVIEWING MEDICAL AND INSURANCE CASES; REFERRAL SERVICES IN THE NATURE OF PROVIDING REFERRALS FOR INDEPENDENT MEDICAL EXAMINATIONS AND ASSESSMENTS (U.S. CLS. 100, 101 AND 102).

FIRST USE 0-0-1987; IN COMMERCE 0-0-1987.

CLASS 36—INSURANCE AND FINANCIAL

FOR MEDICAL INSURANCE CASE AND UTILIZATION REVIEW AND INSURANCE CLAIMS ADJUSTMENT SERVICES FOR HEALTHCARE PURCHASERS AND PAYORS AND PROVIDERS AND MEDICARE BENEFICIARIES (U.S. CLS. 100, 101 AND 102).

FIRST USE 0-0-1987; IN COMMERCE 0-0-1987.
CURTIS FRENCH, EXAMINING ATTORNEY

CLASS 44—MEDICAL, BEAUTY AND AGRICULTURAL SERVICES

FOR PHYSICAL THERAPY SERVICES (U.S. CLS. 100 AND 101).

FIRST USE 9-30-1993; IN COMMERCE 9-30-1993.
DEBORAH LOBO, EXAMINING ATTORNEY

SN 85-518,887. THE ADVISORY BOARD COMPANY, WASHINGTON, DC. FILED 1-18-2012.

SURGICAL PROFITABILITY COMPASS

THE MARK CONSISTS OF STANDARD CHARACTERS WITHOUT CLAIM TO ANY PARTICULAR FONT, STYLE, SIZE, OR COLOR.

NO CLAIM IS MADE TO THE EXCLUSIVE RIGHT TO USE "SURGICAL PROFITABILITY", APART FROM THE MARK AS SHOWN.

CLASS 35—ADVERTISING AND BUSINESS

FOR HEALTH CARE MANAGEMENT CONSULTATION AND RESEARCH FOR OTHERS CONCERNING THE MANAGEMENT OF HEALTH CARE FACILITIES (U.S. CLS. 100, 101 AND 102).

CLASS 42—SCIENTIFIC AND COMPUTER SERVICES

FOR PROVIDING TEMPORARY USE OF ONLINE NON-DOWNLOADABLE SOFTWARE FOR ANALYSIS OF DATA IN THE FIELD OF BUSINESS INTELLIGENCE (U.S. CLS. 100 AND 101).

JAY FLOWERS, EXAMINING ATTORNEY

SN 85-519,867. TENNIS CORPORATION OF AMERICA, CHICAGO, IL. FILED 1-19-2012.



OWNER OF U.S. REG. NOS. 3,438,074, 3,442,675 AND 3,455,532.

NO CLAIM IS MADE TO THE EXCLUSIVE RIGHT TO USE "SPORTS CARE", APART FROM THE MARK AS SHOWN.

THE MARK CONSISTS OF A CAPITAL "S" INSIDE TWO OFF-SET SQUARES, WITH THE WORDS "SPORTS CARE" TO THE RIGHT OF THE "S" AND SQUARES.

CLASS 41—EDUCATION AND ENTERTAINMENT

FOR ENTERTAINMENT SERVICES, NAMELY, PROVIDING CLUB FACILITIES FOR RECREATION AND FITNESS ACTIVITIES (U.S. CLS. 100, 101 AND 107).

FIRST USE 9-30-1993; IN COMMERCE 9-30-1993.

SN 85-520,290. LABONVILLE, INC., GORHAM, NH. FILED 1-19-2012.



NO CLAIM IS MADE TO THE EXCLUSIVE RIGHT TO USE "INC.", APART FROM THE MARK AS SHOWN.

THE MARK CONSISTS OF TREES CONTAINING THE WORDS "LABONVILLE INC.".

CLASS 8—HAND TOOLS

FOR TOOL BELTS; TOOL POUCHES FOR ATTACHMENT TO TOOL BELTS (U.S. CLS. 23, 28 AND 44).

FIRST USE 1-1-1973; IN COMMERCE 1-1-1973.

CLASS 9—ELECTRICAL AND SCIENTIFIC APPARATUS

FOR CLOTHING FOR PROTECTION AGAINST ACCIDENTS; EYEWEAR; PROTECTIVE EAR COVERINGS; PROTECTIVE EYEWEAR; PROTECTIVE FACE-SHIELDS FOR PROTECTIVE HELMETS; PROTECTIVE GLASSES; PROTECTIVE HELMETS; PROTECTIVE INDUSTRIAL BOOTS; PROTECTIVE WORK GLOVES; REFLECTIVE AND ILLUMINATED CLOTHING FOR SAFETY PURPOSES (U.S. CLS. 21, 23, 26, 36 AND 38).

FIRST USE 1-1-1973; IN COMMERCE 1-1-1973.

CLASS 25—CLOTHING

FOR BIB OVERALLS; BOOTS; CHAPS; HATS; HOODS; JACKETS; PANTS; SCARVES; SUSPENDERS; SWEAT-SHIRTS; TEE SHIRTS; VESTS; WEARABLE GARMENTS AND CLOTHING, NAMELY, SHIRTS (U.S. CLS. 22 AND 39).

FIRST USE 1-1-1973; IN COMMERCE 1-1-1973.

CLASS 35—ADVERTISING AND BUSINESS

FOR ON-LINE RETAIL STORE SERVICES FEATURING CLOTHING, PROTECTIVE GEAR AND SAFETY GEAR AND SIGNS; RETAIL STORE SERVICES FEATURING CLOTHING, PROTECTIVE GEAR AND SAFETY GEAR AND SIGNS (U.S. CLS. 100, 101 AND 102).

FIRST USE 1-1-1973; IN COMMERCE 1-1-1973.

Laurie Mayes, Examining Attorney

SN 85-520,340. LABONVILLE, INC., GORHAM, NH. FILED 1-19-2012.

SN 85-520,401. MIAMI CHILDREN'S HEALTH SYSTEMS, INC., MIAMI, FL. FILED 1-19-2012.



NO CLAIM IS MADE TO THE EXCLUSIVE RIGHT TO USE "ORIGINAL PRODUCT" AND "INC.", APART FROM THE MARK AS SHOWN.

THE MARK CONSISTS OF TREES CONTAINING THE WORDS "LABONVILLE INC." SURROUNDED BY A SPROCKET OR GEAR SHAPED DESIGN CONTAINING THE WORDS "ORIGINAL PRODUCT".

CLASS 8—HAND TOOLS

FOR TOOL BELTS; TOOL POUCHES FOR ATTACHMENT TO TOOL BELTS (U.S. CLS. 23, 28 AND 44). FIRST USE 1-1-1973; IN COMMERCE 1-1-1973.

CLASS 9—ELECTRICAL AND SCIENTIFIC APPARATUS

FOR CLOTHING FOR PROTECTION AGAINST ACCIDENTS; EYEWEAR; PROTECTIVE EAR COVERINGS; PROTECTIVE EYEWEAR; PROTECTIVE FACE-SHIELDS FOR PROTECTIVE HELMETS; PROTECTIVE GLASSES; PROTECTIVE HELMETS; PROTECTIVE INDUSTRIAL BOOTS; PROTECTIVE WORK GLOVES; REFLECTIVE AND ILLUMINATED CLOTHING FOR SAFETY PURPOSES (U.S. CLS. 21, 23, 26, 36 AND 38). FIRST USE 1-1-1973; IN COMMERCE 1-1-1973.

CLASS 25—CLOTHING

FOR BIB OVERALLS; BOOTS; CHAPS; HATS; HOODS; JACKETS; PANTS; SCARVES; SUSPENDERS; SWEAT-SHIRTS; TEE SHIRTS; VESTS; WEARABLE GARMENTS AND CLOTHING, NAMELY, SHIRTS (U.S. CLS. 22 AND 39). FIRST USE 1-1-1973; IN COMMERCE 1-1-1973.

CLASS 35—ADVERTISING AND BUSINESS

FOR ON-LINE RETAIL STORE SERVICES FEATURING CLOTHING, PROTECTIVE GEAR, AND SAFETY GEAR AND SIGNS; RETAIL STORE SERVICES FEATURING CLOTHING, PROTECTIVE GEAR, AND SAFETY GEAR AND SIGNS (U.S. CLS. 100, 101 AND 102). FIRST USE 1-1-1973; IN COMMERCE 1-1-1973. LAURIE MAYES, EXAMINING ATTORNEY



OWNER OF U.S. REG. NO. 3,802,149. THE MARK CONSISTS OF A FIGURE OF A CHILD IN FRONT OF A GLOBE WITH MERIDIANS AND PARALLELS TO THE LEFT OF THE STYLIZED WORDING "LEAN NEXT", AND THE WORDING "LEAN" CONTAINING AN ARROW FORMING PART OF THE LETTERS "E" AND "A".

CLASS 35—ADVERTISING AND BUSINESS

FOR ON-LINE RETAIL STORE SERVICES FEATURING EDUCATIONAL MATERIALS AND TOOL-KITS IN THE FIELD OF HEALTHCARE SERVICES INDUSTRY; RETAIL STORE SERVICES FEATURING EDUCATIONAL MATERIALS AND TOOL-KITS IN THE FIELD OF HEALTHCARE SERVICES INDUSTRY (U.S. CLS. 100, 101 AND 102).

CLASS 41—EDUCATION AND ENTERTAINMENT

FOR EDUCATION SERVICES, NAMELY, PROVIDING PROCESS IMPROVEMENT CLASSES, SEMINARS, AND WORKSHOPS IN THE FIELD OF HEALTHCARE SERVICES INDUSTRY (U.S. CLS. 100, 101 AND 107). DEZMONA MIZELLE, EXAMINING ATTORNEY

SN 85-521,114. ONBOARD RESEARCH CORPORATION, DALLAS, TX. FILED 1-20-2012.

Freedom One

THE MARK CONSISTS OF STANDARD CHARACTERS WITHOUT CLAIM TO ANY PARTICULAR FONT, STYLE, SIZE, OR COLOR.

CLASS 9—ELECTRICAL AND SCIENTIFIC APPARATUS

FOR APPARATUS FOR WIRELESS TRANSMISSION OF ACOUSTIC INFORMATION; DEVICES FOR WIRELESS RADIO TRANSMISSION; ELECTRONIC EFFECT PEDALS FOR USE WITH SOUND AMPLIFIERS; GUITAR EFFECTS PROCESSORS; WIRELESS TRANSCIEVER RADIO; WIRELESS TRANSMITTERS AND RECEIVERS (U.S. CLS. 21, 23, 26, 36 AND 38). FIRST USE 1-20-2011; IN COMMERCE 1-19-2012.

CLASS 15—MUSICAL INSTRUMENTS

FOR ELECTRIC AND ELECTRONIC MUSICAL INSTRUMENTS; ELECTRONIC EFFECTS PEDALS FOR USE WITH MUSICAL INSTRUMENTS; FOOT PEDALS FOR USE IN CONNECTION WITH MUSICAL INSTRUMENTS; GUITAR PEDALS; SOUND EFFECT PEDALS FOR MUSICAL INSTRUMENTS; TUNERS FOR MUSICAL INSTRUMENTS; TUNING APPARATUS FOR MUSICAL INSTRUMENTS (U.S. CLS. 2, 21 AND 36). FIRST USE 1-20-2011; IN COMMERCE 1-19-2012. ESTHER BELENKER, EXAMINING ATTORNEY

SN 85-521,207. RED CUP LIVING, LLC, PHOENIX, AZ.
FILED 1-20-2012.

SN 85-522,749. IRIDIUM SATELLITE LLC, MCLEAN, VA.
FILED 1-23-2012.

RED CUP SNACKS

THE MARK CONSISTS OF STANDARD CHARACTERS WITHOUT CLAIM TO ANY PARTICULAR FONT, STYLE, SIZE, OR COLOR.

NO CLAIM IS MADE TO THE EXCLUSIVE RIGHT TO USE "SNACKS", APART FROM THE MARK AS SHOWN.

CLASS 29—MEATS AND PROCESSED FOODS

FOR PROCESSED NUTS; ROASTED NUTS; PROCESSED PEANUTS; SNACK MIX CONSISTING PRIMARILY OF PROCESSED NUTS AND SALTED SQUASH SEEDS AND ALSO INCLUDING TOASTED CORN; PROCESSED OLIVES; TRAIL MIX CONSISTING PRIMARILY OF PROCESSED NUTS AND SEEDS; WASABI PEAS; POTATO CHIPS; VEGETABLE CHIPS, STICKS AND CRISPS; CHEESE IN STICK FORM (U.S. CL. 46).

FIRST USE 1-19-2012; IN COMMERCE 1-19-2012.

CLASS 30—STAPLE FOODS

FOR PRETZELS; PROCESSED POPCORN; TOASTED CORN KERNELS; CORN CHIPS; CHEESE FLAVORED SNACKS, NAMELY, CHEESE CRISPS; TORTILLA CHIPS; RICE-BASED FOOD SNACKS (U.S. CL. 46).

FIRST USE 1-19-2012; IN COMMERCE 1-19-2012.
ANGELA M. MICHELI, EXAMINING ATTORNEY

SN 85-521,735. TD AMERITRADE IP COMPANY, INC.,
OMAHA, NE. FILED 1-20-2012.

SNAPSTOCK

THE MARK CONSISTS OF STANDARD CHARACTERS WITHOUT CLAIM TO ANY PARTICULAR FONT, STYLE, SIZE, OR COLOR.

CLASS 9—ELECTRICAL AND SCIENTIFIC APPARATUS

FOR COMPUTER SOFTWARE RELATED TO FINANCIAL INFORMATION, INVESTMENT, AND TRADING; DOWNLOADABLE SOFTWARE FOR USE IN ACCESSING SECURITIES AND INVESTMENT INFORMATION VIA MOBILE PHONES, HANDHELD COMPUTERS, AND MOBILE DEVICES; DOWNLOADABLE SOFTWARE FOR USE IN TRADING SECURITIES VIA MOBILE PHONES, HANDHELD COMPUTERS, AND MOBILE DEVICES (U.S. CLS. 21, 23, 26, 36 AND 38).

CLASS 36—INSURANCE AND FINANCIAL

FOR FINANCIAL SERVICES, NAMELY, PROVIDING SECURITIES AND INVESTMENT INFORMATION; COMMODITY TRADING FOR OTHERS; PROVIDING SECURITIES AND INVESTMENT INFORMATION VIA MOBILE PHONES, HANDHELD COMPUTERS, AND MOBILE DEVICES (U.S. CLS. 100, 101 AND 102).

TARAH HARDY, EXAMINING ATTORNEY



THE MARK CONSISTS OF A PARTIAL CIRCLE WITH TWO SETS OF LINES THAT APPEAR TO BE CONVERGING. TO THE RIGHT OF THE DESIGN ELEMENT IS THE WORD "AIREON" WRITTEN IN A STYLIZED FORMAT.

CLASS 9—ELECTRICAL AND SCIENTIFIC APPARATUS

FOR AIR TRAFFIC CONTROL AND MONITORING DEVICES, NAMELY, AIR TRAFFIC CONTROL RADIO EQUIPMENT (U.S. CLS. 21, 23, 26, 36 AND 38).

CLASS 38—COMMUNICATION

FOR SATELLITE COMMUNICATION SERVICES (U.S. CLS. 100, 101 AND 104).

CLASS 39—TRANSPORTATION AND STORAGE

FOR AIR TRAFFIC CONTROL SERVICES; AIR TRAFFIC CONTROL SERVICES FEATURING AIR TRAFFIC MONITORING (U.S. CLS. 100 AND 105).

EMILY CHUO, EXAMINING ATTORNEY

SN 85-524,424. GIANT SPORTS PRODUCTS LLC, BRICK, NJ.
FILED 1-24-2012.

GIANT SPORTS PRODUCTS

THE MARK CONSISTS OF STANDARD CHARACTERS WITHOUT CLAIM TO ANY PARTICULAR FONT, STYLE, SIZE, OR COLOR.

NO CLAIM IS MADE TO THE EXCLUSIVE RIGHT TO USE "SPORTS PRODUCTS", APART FROM THE MARK AS SHOWN.

CLASS 5—PHARMACEUTICALS

FOR DIETARY AND NUTRITIONAL SUPPLEMENTS; DIETARY AND NUTRITIONAL SUPPLEMENTS FOR ENDURANCE SPORTS; DIETARY AND NUTRITIONAL SUPPLEMENTS USED FOR WEIGHT LOSS; DIETARY BEVERAGE SUPPLEMENTS FOR HUMAN CONSUMPTION IN LIQUID AND DRY MIX FORM FOR THERAPEUTIC PURPOSES; DIETARY FOOD SUPPLEMENTS; DIETARY SUPPLEMENTAL DRINKS; DIETARY SUPPLEMENTAL DRINKS IN THE NATURE OF VITAMIN AND MINERAL BEVERAGES; DIETARY SUPPLEMENTS; DIETARY SUPPLEMENTS FOR CONTROLLING CHOLESTEROL; DIETARY SUPPLEMENTS FOR HUMAN CONSUMPTION; DIETARY SUPPLEMENTS IN THE NATURE OF WEIGHT LOSS POWDERS; FOOD SUPPLEMENTS; HEALTH FOOD SUPPLEMENTS; HERBAL SUPPLEMENTS; LIQUID NUTRITIONAL SUPPLEMENT; LIQUID VITAMIN SUPPLEMENTS; NATURAL HERBAL SUPPLEMENTS; NATURAL SUPPLEMENTS FOR TREATING ERECTILE DYSFUNCTION; NUTRACEUTICALS FOR USE AS A DIETARY SUPPLEMENT; NUTRITIONAL AND DIETARY SUPPLEMENTS FORMED AND PACKAGED AS BARS; NUTRITIONAL SUPPLEMENT ENERGY BARS; NUTRITIONAL SUPPLEMENT IN THE NATURE OF A NUTRIENT-DENSE, PROTEIN-BASED DRINK MIX; NUTRITIONAL SUPPLEMENT SHAKES; NUTRITIONAL SUPPLEMENTS; NUTRITIONAL SUPPLEMENTS, NAMELY, CARBOHYDRATES IN POWDERED FORM; NUTRITIONAL SUPPLEMENTS, NAMELY, PROBIOTIC COMPOSITIONS; POWDERED FRUIT-FLAVORED DIETARY SUPPLEMENT DRINK MIX; POWDERED NUTRITIONAL SUPPLEMENT CONCENTRATE; POWDERED NUTRITIONAL SUPPLEMENT DRINK MIX; POWDERED NUTRITIONAL SUPPLEMENT DRINK MIX AND CONCENTRATE; PROTEIN DIETARY SUPPLEMENTS; PROTEIN SUPPLEMENTS; VITAMIN AND MINERAL SUPPLEMENTS; VITAMIN SUPPLEMENTS; WEIGHT MANAGEMENT SUPPLEMENTS; WHEY PROTEIN SUPPLEMENTS (U.S. CLS. 6, 18, 44, 46, 51 AND 52).

CLASS 35—ADVERTISING AND BUSINESS

FOR BUSINESS CONSULTATION AND MANAGEMENT REGARDING MARKETING ACTIVITIES AND LAUNCHING OF NEW PRODUCTS; BUSINESS CONSULTATION; BUSINESS DEVELOPMENT SERVICES; BUSINESS EFFICIENCY ADVICE AND EXPERT SERVICES; BUSINESS MANAGEMENT AND ENTERPRISE ORGANIZATION CONSULTANCY; BUSINESS MARKETING AND MERCHANDISING DISPLAY SERVICES; BUSINESS PLANNING; BUSINESS RESEARCH IN THE FIELD OF DIETARY SUPPLEMENTS; BUSINESS SERVICES, NAMELY, COMBINED STRATEGIC GOODS OR SERVICES SOURCING AND COOPERATIVE PURCHASING FOR OTHERS; BUSINESS SERVICES, NAMELY, FORMULATION OF BEST PRACTICES FOR DIETARY SUPPLEMENTS; BUSINESS STRATEGIC PLANNING SERVICES; BUSINESS STRATEGY DEVELOPMENT SERVICES; DEVELOPING PROMOTIONAL CAMPAIGNS FOR BUSINESS; GENERAL BUSINESS NETWORKING REFERRAL SERVICES, NAMELY, PROMOTING THE GOODS AND SERVICES OF OTHERS BY PASSING BUSINESS LEADS AND REFERRALS AMONG GROUP MEMBERS; MANAGEMENT AND BUSINESS CONSULTING SERVICES IN THE FIELD OF DIETARY SUPPLEMENTS; MANAGEMENT AND OPERATION ASSISTANCE TO COMMERCIAL BUSINESSES; MARKETING CONSULTATION IN THE FIELD OF DIETARY SUPPLEMENTS; MARKETING SERVICES; ON-LINE ADVERTISING AND MARKETING SERVICES; PROMOTING, ADVERTISING AND MARKETING OF THE BRANDS, PRODUCTS, SERVICES AND ONLINE WEBSITES OF INDIVIDUALS, BUSINESSES AND NONPROFIT ORGANIZATIONS; PROMOTION OF BUSINESS OPPORTUNITIES; PROMOTIONAL SERVICES, NAMELY, GUERRILLA MARKETING SERVICES; PROVISION OF INFORMATION CONCERNING COMMERCIAL SALES; PUBLICITY AND SALES PROMOTION RELATING TO GOODS AND SERVICES, OFFERED AND ORDERED BY TELECOMMUNICATION OR THE ELECTRONIC WAY; PUBLICITY AND SALES PROMOTION SERVICES; RETAIL SERVICES BY DIRECT SOLICITATION BY SALES AGENTS IN THE FIELD OF DIETARY SUPPLEMENTS; SALES PROMOTION SERVICES (U.S. CLS. 100, 101 AND 102).

IRA J. GOODSaid, EXAMINING ATTORNEY

SN 85-525,768. HONEYWELL INTERNATIONAL INC., MORRISTOWN, NJ. FILED 1-26-2012.

ATTUNE

THE MARK CONSISTS OF STANDARD CHARACTERS WITHOUT CLAIM TO ANY PARTICULAR FONT, STYLE, SIZE, OR COLOR.

CLASS 9—ELECTRICAL AND SCIENTIFIC APPARATUS

FOR COMPUTER HARDWARE AND SOFTWARE FOR REMOTELY MONITORING ENVIRONMENTAL CONDITIONS AND CONTROLLING DEVICES WITHIN A BUILDING, FACILITY, GROUNDS, OR DESIGNATED SPATIAL AREA; COMPUTER SOFTWARE THAT COLLECTS AND ANALYZES DATA AND PROVIDES RECOMMENDATIONS FOR THE OPTIMIZATION OF BUILDINGS, FACILITIES, GROUNDS, OR DESIGNATED SPATIAL AREAS (U.S. CLS. 21, 23, 26, 36 AND 38).

CLASS 35—ADVERTISING AND BUSINESS

FOR BUSINESS SERVICES, NAMELY, FACILITIES MANAGEMENT OF TECHNICAL OPERATIONS; CONSULTING SERVICES IN THE FIELD OF ENERGY EFFICIENCY FOR COMMERCIAL AND INSTITUTIONAL FACILITIES (U.S. CLS. 100, 101 AND 102).

CLASS 38—COMMUNICATION

FOR PROVIDING ACCESS TO THE INTERNET FOR PURPOSES OF MANAGING THE ENVIRONMENT AND CONTROLLING DEVICES WITHIN A BUILDING, FACILITY, GROUNDS, OR DESIGNATED SPATIAL AREA (U.S. CLS. 100, 101 AND 104).

CLASS 42—SCIENTIFIC AND COMPUTER SERVICES

FOR PROVIDING AN INTERNET WEBSITE PORTAL FOR MANAGING THE ENVIRONMENT AND CONTROLLING DEVICES WITHIN A BUILDING, FACILITY, GROUNDS, OR DESIGNATED SPATIAL AREA (U.S. CLS. 100 AND 101).

TINA L. SNAPP, EXAMINING ATTORNEY

SN 85-526,875. BBIP, LLC, MIAMI, FL. FILED 1-27-2012.

Brown Bunnies

THE MARK CONSISTS OF STANDARD CHARACTERS WITHOUT CLAIM TO ANY PARTICULAR FONT, STYLE, SIZE, OR COLOR.

CLASS 9—ELECTRICAL AND SCIENTIFIC APPARATUS

FOR PRE-RECORDED DVDS FEATURING ADULT ENTERTAINMENT (U.S. CLS. 21, 23, 26, 36 AND 38).

FIRST USE 5-31-2010; IN COMMERCE 11-2-2010.

CLASS 41—EDUCATION AND ENTERTAINMENT

FOR ENTERTAINMENT SERVICES, NAMELY, PROVIDING A WEB SITE FEATURING PHOTOGRAPHIC, AUDIO, VIDEO AND PROSE PRESENTATIONS FEATURING ADULT-ORIENTED SUBJECT MATTER (U.S. CLS. 100, 101 AND 107).

FIRST USE 5-31-2010; IN COMMERCE 5-31-2010.
DAVID I, EXAMINING ATTORNEY

SN 85-527,542. SUTIRCOMED PRESS & PUBLISHING CO., INC., WOODRIDGE, NY. FILED 1-27-2012.

LION LEV

THE MARK CONSISTS OF STANDARD CHARACTERS WITHOUT CLAIM TO ANY PARTICULAR FONT, STYLE, SIZE, OR COLOR.

THE NAME(S), PORTRAIT(S), AND/OR SIGNATURE(S) SHOWN IN THE MARK IDENTIFIES "LION LEV", WHOSE CONSENT(S) TO REGISTER IS MADE OF RECORD.

CLASS 16—PAPER GOODS AND PRINTED MATTER

FOR PRINTED PUBLICATIONS, NAMELY, POSTERS, BOOKS, COMIC BOOKS, PAMPHLETS, LEAFLETS, DVD AND CD JEWEL CASE INSERTS, MAGAZINES, MANUALS AND NEWSLETTERS IN THE FIELDS OF MUSIC, LITERATURE, SCIENCE, MATHEMATICS, ART, HISTORY AND ENTERTAINMENT (U.S. CLS. 2, 5, 22, 23, 29, 37, 38 AND 50).

FIRST USE 9-4-2005; IN COMMERCE 12-9-2007.

CLASS 41—EDUCATION AND ENTERTAINMENT

FOR PROVIDING ONLINE PUBLICATIONS, NAMELY, POSTERS, BOOKS, COMIC BOOKS, STORYBOARDS, MAGAZINES, LEAFLETS AND BOOKLETS IN THE NATURE OF DVD AND CD JEWEL CASE INSERTS, ALL NON-DOWNLOADABLE, IN ILLUSTRATED FORM FEATURING A FICTITIOUS CHARACTER OR CHARACTERS IN THE FIELDS OF MUSIC, LITERATURE, SCIENCE, MATHEMATICS, ART, HISTORY AND ENTERTAINMENT; PROVIDING NON-DOWNLOADABLE VIDEOS AND AUDIO RECORDINGS, NAMELY, VIDEOS AND AUDIO RECORDINGS ABOUT PIANO MUSIC AND PIANO PLAYING, VIDEOS AND AUDIO RECORDINGS OF PIANO PERFORMANCES (U.S. CLS. 100, 101 AND 107).

FIRST USE 9-4-2005; IN COMMERCE 12-9-2007.
ROSELLE HERRERA, EXAMINING ATTORNEY

SN 85-527,714. NIKE, INC., BEAVERTON, OR. FILED 1-27-2012.

NIKEFUEL

THE MARK CONSISTS OF STANDARD CHARACTERS WITHOUT CLAIM TO ANY PARTICULAR FONT, STYLE, SIZE, OR COLOR.

OWNER OF U.S. REG. NOS. 2,196,735, 3,618,440 AND OTHERS.

CLASS 10—MEDICAL APPARATUS

FOR HEALTH MONITORING DEVICES, NAMELY, PEDOMETERS, METABOLIC MONITORS, CALORIE MONITORS, AND BODY FAT MONITORS (U.S. CLS. 26, 39 AND 44).

CLASS 14—JEWELRY

FOR WATCHES; BRACELETS; WATCHES AND BRACELETS INCORPORATING FUNCTIONS FOR MONITORING AND REPORTING FITNESS, TRAINING, AND ACTIVITY DATA, NAMELY, TIME, DISTANCE, PACE, BODY RATE, WEIGHT MANAGEMENT, CALORIES BURNED, AND CUMULATIVE ACTIVITY LEVEL; WATCHES AND BRACELETS THAT COMMUNICATE DATA TO PERSONAL DIGITAL ASSISTANTS, SMART PHONES, AND PERSONAL COMPUTERS THROUGH INTERNET WEBSITES AND OTHER COMPUTER AND ELECTRONIC COMMUNICATION NETWORKS (U.S. CLS. 2, 27, 28 AND 50).

JAY FLOWERS, EXAMINING ATTORNEY

SN 85-528,494. ABBOTT LABORATORIES, ABBOTT PARK, IL. FILED 1-30-2012.

DESIGNED WITH A MAN IN MIND

THE MARK CONSISTS OF STANDARD CHARACTERS WITHOUT CLAIM TO ANY PARTICULAR FONT, STYLE, SIZE, OR COLOR.

CLASS 16—PAPER GOODS AND PRINTED MATTER

FOR PRINTED MATERIALS, NAMELY, LEAFLETS, BROCHURES AND PAMPHLETS, ON THE TOPIC OF TESTOSTERONE DEFICIENCY OR TESTOSTERONE REPLACEMENT THERAPY (U.S. CLS. 2, 5, 22, 23, 29, 37, 38 AND 50).

CLASS 44—MEDICAL, BEAUTY AND AGRICULTURAL SERVICES

FOR PROVIDING INFORMATION ON THE TOPIC OF TESTOSTERONE DEFICIENCY OR TESTOSTERONE REPLACEMENT THERAPY (U.S. CLS. 100 AND 101).

YAT SYE, LEE, EXAMINING ATTORNEY

SN 85-530,048. ABLE PLANET, INCORPORATED, DENVER, CO. FILED 1-31-2012.

ABLE PLANET FOUNDATION

THE MARK CONSISTS OF STANDARD CHARACTERS WITHOUT CLAIM TO ANY PARTICULAR FONT, STYLE, SIZE, OR COLOR.

OWNER OF U.S. REG. NOS. 3,563,428, 3,563,429 AND 4,107,174.

NO CLAIM IS MADE TO THE EXCLUSIVE RIGHT TO USE "FOUNDATION", APART FROM THE MARK AS SHOWN.

SN 85-531,824. TENNIS CORPORATION OF AMERICA, CHICAGO, IL. FILED 2-2-2012.

CLASS 35—ADVERTISING AND BUSINESS

FOR PROMOTING PUBLIC AWARENESS OF SENSORY AND COGNITIVE IMPAIRMENTS AND SOLUTIONS AVAILABLE FOR MANAGING SUCH IMPAIRMENTS (U.S. CLS. 100, 101 AND 102).

CLASS 41—EDUCATION AND ENTERTAINMENT

FOR EDUCATIONAL SERVICES, NAMELY, WORKSHOPS, SEMINARS AND ONLINE PROGRAMS TO TRAIN PEOPLE WITH ALL LEVELS OF HEARING AND THEIR SUPPORT PERSONS TO UNDERSTAND HEARING LOSS AND THE USE OF TECHNOLOGY THAT WILL ENABLE THEM TO OVERCOME BARRIERS THAT MAY PROHIBIT THEM FROM PARTICIPATING IN MORE ACTIVE LIFESTYLES BY FOUNDATION STAFF (U.S. CLS. 100, 101 AND 107).
ALYSSA STEEL, EXAMINING ATTORNEY



THE MARK CONSISTS OF A DRAGON IMAGE.

CLASS 28—TOYS AND SPORTING GOODS

FOR SPORTS EQUIPMENT FOR TENNIS, NAMELY, RACQUETS, RACQUET CASES, RACQUET COVERS, AND BACKPACKS SPECIFICALLY ADAPTED AND DESIGNED FOR CARRYING TENNIS EQUIPMENT; TOYS, NAMELY, RUBBER BALLS AND STUFFED TOY ANIMALS (U.S. CLS. 22, 23, 38 AND 50).

SN 85-531,369. CHESAPEAKE ENERGY CORPORATION, OKLAHOMA CITY, OK. FILED 2-1-2012.

CLASS 41—EDUCATION AND ENTERTAINMENT

FOR PROVIDING INSTRUCTIONS AND TRAINING PROGRAMS FOR THE DEVELOPMENT OF RACQUET SPORT SKILLS (U.S. CLS. 100, 101 AND 107).
DEBORAH LOBO, EXAMINING ATTORNEY

NOMAC DRILLING

SN 85-532,657. NEW NICHE, LLC, STEAMBOAT SPRINGS, CO. FILED 2-2-2012.

THE MARK CONSISTS OF STANDARD CHARACTERS WITHOUT CLAIM TO ANY PARTICULAR FONT, STYLE, SIZE, OR COLOR.

NO CLAIM IS MADE TO THE EXCLUSIVE RIGHT TO USE "DRILLING", APART FROM THE MARK AS SHOWN.

CLASS 37—CONSTRUCTION AND REPAIR

FOR OIL AND GAS DRILLING (U.S. CLS. 100, 103 AND 106).
FIRST USE 2-7-2001; IN COMMERCE 2-7-2001.

CLASS 42—SCIENTIFIC AND COMPUTER SERVICES

FOR EXPLORATION AND SEARCHING OF OIL AND GAS (U.S. CLS. 100 AND 101).
FIRST USE 2-7-2001; IN COMMERCE 2-7-2001.
KATHERINE CHANG, EXAMINING ATTORNEY

JOURNEY'S END

THE MARK CONSISTS OF STANDARD CHARACTERS WITHOUT CLAIM TO ANY PARTICULAR FONT, STYLE, SIZE, OR COLOR.

CLASS 18—LEATHER GOODS

FOR PURSES (U.S. CLS. 1, 2, 3, 22 AND 41).
FIRST USE 2-1-2012; IN COMMERCE 2-1-2012.

CLASS 25—CLOTHING

FOR SCARVES (U.S. CLS. 22 AND 39).
FIRST USE 2-1-2012; IN COMMERCE 2-1-2012.
ROBERT C. CLARK JR., EXAMINING ATTORNEY

SN 85-532,941. ALEDA FITNESS INC., PORTLAND, OR.
FILED 2-3-2012.

SN 85-533,264. SISCO TEXTILES N.V., WILLEMSTAD, CUR-
ACAO, FILED 2-3-2012.

Meet The Most Remarkable You

THE MARK CONSISTS OF STANDARD CHARACTERS
WITHOUT CLAIM TO ANY PARTICULAR FONT, STYLE,
SIZE, OR COLOR.

CLASS 41—EDUCATION AND ENTERTAIN- MENT

FOR PROVIDING FITNESS AND EXERCISE FACIL-
ITIES (U.S. CLS. 100, 101 AND 107).

CLASS 44—MEDICAL, BEAUTY AND AGRI- CULTURAL SERVICES

FOR CONSULTING IN THE FIELD OF HEALTH AND
WELLNESS TO BRING ABOUT PERSONAL HAPPINESS
(U.S. CLS. 100 AND 101).

JASON BLAIR, EXAMINING ATTORNEY

SN 85-533,259. SISCO TEXTILES N.V., WILLEMSTAD, CUR-
ACAO, FILED 2-3-2012.

COLDWATER CLASSIC

THE MARK CONSISTS OF STANDARD CHARACTERS
WITHOUT CLAIM TO ANY PARTICULAR FONT, STYLE,
SIZE, OR COLOR.

NO CLAIM IS MADE TO THE EXCLUSIVE RIGHT TO
USE "CLASSIC", APART FROM THE MARK AS SHOWN.

CLASS 9—ELECTRICAL AND SCIENTIFIC APPARATUS

FOR DOWNLOADABLE SOFTWARE PROVIDING
SPORTS NEWS AND PHOTOS AND VIDEOS OF SPORTS
AND SURFING COMPETITIONS (U.S. CLS. 21, 23, 26, 36
AND 38).

FIRST USE 3-1-2010; IN COMMERCE 3-1-2010.

CLASS 41—EDUCATION AND ENTERTAIN- MENT

FOR ENTERTAINMENT SERVICES, NAMELY, ORGA-
NIZING, CONDUCTING AND SPONSORING SPORTS
EVENTS, SURFING EVENTS AND SURFING COMPETI-
TIONS; ENTERTAINMENT SERVICES, NAMELY, PRO-
VIDING WEBCASTS AND ONLINE VIDEOS ON SPORTS
NEWS AND PHOTOS AND VIDEOS OF SURFING AND
SPORTS EVENTS (U.S. CLS. 100, 101 AND 107).

FIRST USE 1-31-1999; IN COMMERCE 1-31-1999.
LESLEY LAMOTHE, EXAMINING ATTORNEY

CWC

THE MARK CONSISTS OF STANDARD CHARACTERS
WITHOUT CLAIM TO ANY PARTICULAR FONT, STYLE,
SIZE, OR COLOR.

CLASS 9—ELECTRICAL AND SCIENTIFIC APPARATUS

FOR DOWNLOADABLE SOFTWARE PROVIDING
SPORTS NEWS AND PHOTOS AND VIDEOS OF SPORTS
AND SURFING COMPETITIONS (U.S. CLS. 21, 23, 26, 36
AND 38).

FIRST USE 3-1-2010; IN COMMERCE 3-1-2010.

CLASS 41—EDUCATION AND ENTERTAIN- MENT

FOR ENTERTAINMENT SERVICES, NAMELY, ORGA-
NIZING, CONDUCTING AND SPONSORING SPORTS
EVENTS, SURFING EVENTS AND SURFING COMPETI-
TIONS; ENTERTAINMENT SERVICES, NAMELY, PRO-
VIDING WEBCASTS AND ONLINE VIDEOS ON SPORTS
NEWS AND PHOTOS AND VIDEOS OF SURFING AND
SPORTS EVENTS (U.S. CLS. 100, 101 AND 107).

FIRST USE 1-31-1999; IN COMMERCE 1-31-1999.
LESLEY LAMOTHE, EXAMINING ATTORNEY

SN 85-535,311. ALLERGAN, INC., IRVINE, CA. FILED 2-6-
2012.

OPTOMETRY JUMPSTART

THE MARK CONSISTS OF STANDARD CHARACTERS
WITHOUT CLAIM TO ANY PARTICULAR FONT, STYLE,
SIZE, OR COLOR.

OWNER OF U.S. REG. NO. 3,874,883.

NO CLAIM IS MADE TO THE EXCLUSIVE RIGHT TO
USE "OPTOMETRY", APART FROM THE MARK AS
SHOWN.

CLASS 16—PAPER GOODS AND PRINTED MATTER

FOR PRINTED PAMPHLETS, BROCHURES, MAN-
UALS, LEAFLETS, FLYERS, AND INFORMATIONAL
SHEETS AND NEWSLETTERS IN THE FIELD OF EYE
CARE (U.S. CLS. 2, 5, 22, 23, 29, 37, 38 AND 50).

CLASS 35—ADVERTISING AND BUSINESS

FOR SAMPLE DISTRIBUTION IN THE FIELD OF EYE
CARE (U.S. CLS. 100, 101 AND 102).

CLASS 44—MEDICAL, BEAUTY AND AGRI- CULTURAL SERVICES

FOR PROVIDING MEDICAL INFORMATION TO
OPHTHALMOLOGISTS IN THE FIELD OF EYE CARE
(U.S. CLS. 100 AND 101).

JIM RINGLE, EXAMINING ATTORNEY

SN 85-535,977. SUSSMAN-AUTOMATIC CORPORATION, LONG ISLAND CITY, NY. FILED 2-7-2012.

SN 85-537,125. FERNO-WASHINGTON, INC., WILMINGTON, OH. FILED 2-8-2012.

STEAM IN A BOX

THE MARK CONSISTS OF STANDARD CHARACTERS WITHOUT CLAIM TO ANY PARTICULAR FONT, STYLE, SIZE, OR COLOR.

CLASS 9—ELECTRICAL AND SCIENTIFIC APPARATUS

FOR ELECTRONIC CONTROLS FOR STEAM BATHS (U.S. CLS. 21, 23, 26, 36 AND 38).

CLASS 11—ENVIRONMENTAL CONTROL APPARATUS

FOR STEAM BATHS (U.S. CLS. 13, 21, 23, 31 AND 34).
CAROLINE WOOD, EXAMINING ATTORNEY

SN 85-536,343. ORDER OF ST. BENEDICT, COLLEGEVILLE, MN. FILED 2-7-2012.

GIVE US THIS DAY

THE MARK CONSISTS OF STANDARD CHARACTERS WITHOUT CLAIM TO ANY PARTICULAR FONT, STYLE, SIZE, OR COLOR.
OWNER OF U.S. REG. NO. 4,023,940.

CLASS 9—ELECTRICAL AND SCIENTIFIC APPARATUS

FOR DOWNLOADABLE ELECTRONIC PUBLICATIONS, NAMELY, PERIODICALS IN THE FIELD OF PRAYERS (U.S. CLS. 21, 23, 26, 36 AND 38).
FIRST USE 8-1-2011; IN COMMERCE 8-1-2011.

CLASS 41—EDUCATION AND ENTERTAINMENT

FOR ELECTRONIC NON-DOWNLOADABLE PUBLICATIONS, NAMELY, PERIODICALS IN THE FIELD OF PRAYERS (U.S. CLS. 100, 101 AND 107).
FIRST USE 8-1-2011; IN COMMERCE 8-1-2011.
DARRYL SPRUILL, EXAMINING ATTORNEY

INSPIRATION FOR LIFE

THE MARK CONSISTS OF STANDARD CHARACTERS WITHOUT CLAIM TO ANY PARTICULAR FONT, STYLE, SIZE, OR COLOR.

CLASS 9—ELECTRICAL AND SCIENTIFIC APPARATUS

FOR OXYGEN REGULATORS; FLOW METERS; CONTROL VALVES FOR REGULATING THE FLOW OF GASES; OXYGEN ADMINISTRATORS, NAMELY AN ASSEMBLAGE OF MULTIPLE CONTROL VALVES USED FOR REGULATING THE FLOW OF OXYGEN TO MULTIPLE PATIENTS (U.S. CLS. 21, 23, 26, 36 AND 38).

CLASS 10—MEDICAL APPARATUS

FOR OXYGEN INHALATORS, VALVES BEING PARTS OF MEDICAL DEVICES, NAMELY, OXYGEN INHALATORS, OXYGEN CONSERVERS FOR MEDICAL USE; RESUSCITATORS; CPR (CARDIOPULMONARY RESUSCITATION) MASKS; OXYGEN MASKS FOR MEDICAL USE; RESPIRATORY MASKS FOR MEDICAL PURPOSES; PORTABLE MEDICAL OXYGEN CYLINDERS; BRACKETS FOR HOLDING PORTABLE MEDICAL OXYGEN CYLINDERS; HOLDERS USED TO ATTACH PORTABLE MEDICAL OXYGEN CYLINDERS TO AMBULANCE COT RAILS; MEDICAL APPARATUS FOR DIAGNOSING OR TREATING RESPIRATORY CONDITIONS, NAMELY, RESPIRATORY ASPIRATORS; MEDICAL APPARATUS FOR DIAGNOSING AND TREATING RESPIRATORY CONDITIONS, NAMELY, PORTABLE VACUUM SUCTION UNITS, CONSISTING OF A PUMP AND COLLECTION JAR FOR USE IN ASPIRATION; MEDICAL INTUBATION EQUIPMENT; ENDOTRACHEAL TUBES; ESOPHAGEAL DETECTION DEVICE FOR USE IN VERIFYING PROPER PLACEMENT OF ENDOTRACHEAL TUBES; SECURING DEVICES FOR ENDOTRACHEAL TUBES; BACKPACKS FOR MEDICAL PURPOSES, NAMELY, BACKPACKS SPECIALLY EQUIPPED WITH A PORTABLE MEDICAL OXYGEN CYLINDER AND OXYGEN REGULATOR; KITS CONSISTING OF A WATER-TIGHT, HARDSHELL CASE, CONTAINING A PORTABLE MEDICAL OXYGEN CYLINDER, OXYGEN REGULATOR, TUBING AND OXYGEN MASK (U.S. CLS. 26, 39 AND 44).
JAMES LOVELACE, EXAMINING ATTORNEY

SN 85-539,217. STANLEY LOGISTICS, L.L.C., NEW BRITAIN, CT. FILED 2-10-2012.

DESIGNED FOR PRODUCTIVITY. BUILT TO LAST.

THE MARK CONSISTS OF STANDARD CHARACTERS WITHOUT CLAIM TO ANY PARTICULAR FONT, STYLE, SIZE, OR COLOR.

CLASS 7—MACHINERY

FOR PNEUMATIC NAILERS AND STAPLERS (U.S. CLS. 13, 19, 21, 23, 31, 34 AND 35).

CLASS 8—HAND TOOLS

FOR HAND TOOLS, NAMELY, CHALK LINE REELS, SCREWDRIVERS, HAMMERS, CHISELS, AND WRENCHES; SCISSORS FOR CUTTING STEEL, UTILITY KNIVES, BLADES FOR UTILITY KNIVES, AND HAND-HELD SAWS (U.S. CLS. 23, 28 AND 44).

CLASS 9—ELECTRICAL AND SCIENTIFIC APPARATUS

FOR TAPE MEASURES AND BUBBLE LEVELS (U.S. CLS. 21, 23, 26, 36 AND 38).

CLASS 18—LEATHER GOODS

FOR TOOL BAGS SOLD EMPTY (U.S. CLS. 1, 2, 3, 22 AND 41).

CLASS 20—FURNITURE AND ARTICLES NOT OTHERWISE CLASSIFIED

FOR CONTAINERS OF PLASTIC FOR TOOL STORAGE (U.S. CLS. 2, 13, 22, 25, 32 AND 50).
ALAIN LAPTER, EXAMINING ATTORNEY

SN 85-541,315. DARK HORSE DISTILLERY, LLC, SHAWNEE, KS. FILED 2-13-2012.



THE MARK CONSISTS OF A STYLIZED DEPICTION OF A HORSE HEAD DIVIDED VERTICALLY AND SYMMETRICALLY WITH ONE SIDE OF ONE COLOR AND THE OTHER SIDE OF A DIFFERENT COLOR AND INCLUDING A CURVED SECTION IN THE LOWER PORTION OF THE HORSE HEAD EXTENDING ACROSS BOTH SIDES.

CLASS 25—CLOTHING

FOR HATS; T-SHIRTS (U.S. CLS. 22 AND 39).

CLASS 33—WINES AND SPIRITS

FOR DISTILLED SPIRITS (U.S. CLS. 47 AND 49).
FRANK LATTUCA, EXAMINING ATTORNEY

SN 85-540,880. ATLEISURE, LLC, FORMERLY SOUTHERN CASUAL LIVING, LLC, ATLANTA, GA. FILED 2-13-2012.



THE MARK CONSISTS OF A STYLIZED WORD "ATLEISURE"; FIVE TREES; AND THE WORDS "CREATE YOUR ESCAPE" UNDER A LINE.

CLASS 6—METAL GOODS

FOR GAZEBOS PRIMARILY OF METAL; METAL GAZEBOS (U.S. CLS. 2, 12, 13, 14, 23, 25 AND 50).

CLASS 11—ENVIRONMENTAL CONTROL APPARATUS

FOR FIRE TABLE (U.S. CLS. 13, 21, 23, 31 AND 34).

CLASS 18—LEATHER GOODS

FOR PATIO UMBRELLAS; UMBRELLA BASES; UMBRELLA FRAMES (U.S. CLS. 1, 2, 3, 22 AND 41).

CLASS 20—FURNITURE AND ARTICLES NOT OTHERWISE CLASSIFIED

FOR PATIO FURNITURE (U.S. CLS. 2, 13, 22, 25, 32 AND 50).
DEZMONA MIZELLE, EXAMINING ATTORNEY

SN 85-542,511. ORLEANS ARIZONA, INC., WILMINGTON, DE. FILED 2-14-2012.

GET YOUR HAPPY ON

THE MARK CONSISTS OF STANDARD CHARACTERS WITHOUT CLAIM TO ANY PARTICULAR FONT, STYLE, SIZE, OR COLOR.

CLASS 35—ADVERTISING AND BUSINESS

FOR REAL ESTATE SALES MANAGEMENT; REAL ESTATE MARKETING SERVICES IN THE FIELD OF HOMES, INCLUDING SINGLE FAMILY, ATTACHED AND DETACHED HOMES, MULTIFAMILY HOMES, CONDOMINIUMS AND APARTMENTS (U.S. CLS. 100, 101 AND 102).

CLASS 37—CONSTRUCTION AND REPAIR

FOR RESIDENTIAL HOMEBUILDING SERVICES, NAMELY, CONSTRUCTION OF NEW RESIDENCES, INCLUDING HOMES; REAL ESTATE DEVELOPMENT; CONSTRUCTION PLANNING; LAND DEVELOPMENT SERVICES, NAMELY PLANNING AND LAYING OUT RESIDENTIAL COMMUNITIES; CONSTRUCTION SERVICES, NAMELY CONSTRUCTION OF HOMES, INCLUDING SINGLE FAMILY, ATTACHED AND DETACHED HOMES, MULTIFAMILY HOMES, CONDOMINIUMS AND APARTMENTS (U.S. CLS. 100, 103 AND 106).
JAMES GRIFFIN, EXAMINING ATTORNEY

SN 85-543,239. TACO BELL CORP., IRVINE, CA. FILED 2-15-2012.

SN 85-547,516. INDIAN MOTORCYCLE INTERNATIONAL, LLC, MEDINA, MN. FILED 2-20-2012.

LIVE MÁS

THE MARK CONSISTS OF STANDARD CHARACTERS WITHOUT CLAIM TO ANY PARTICULAR FONT, STYLE, SIZE, OR COLOR.

THE ENGLISH TRANSLATION OF "LIVE MÁS" IN THE MARK IS "LIVE MORE".

CLASS 29—MEATS AND PROCESSED FOODS

FOR TACO SALADS (U.S. CL. 46).

CLASS 30—STAPLE FOODS

FOR TACOS, TOSTADAS, FAJITAS, BURRITOS, ENCHILADAS, TORTILLAS, NACHOS, PREPARED ENTREES CONSISTING PRIMARILY OF RICE, MEXICAN PIZZA, PREPARED FRIED FLOUR TORTILLA CONFECTIONS, TACO SEASONING MIX, TACO SHELLS, TACO DINNER KITS CONSISTING OF TACO SHELLS, TACO SAUCE AND SEASONING MIX, TORTILLA CHIPS, SALSA, ALL FOR CONSUMPTION ON OR OFF THE PREMISES (U.S. CL. 46).

CHRISTOPHER SIDOTI, EXAMINING ATTORNEY

SN 85-545,179. QUALCOMM INCORPORATED, SAN DIEGO, CA. FILED 2-16-2012.



THE MARK CONSISTS OF THE LETTERS "MD" IN STYLIZED FORM INSIDE A CIRCLE, WHICH IS SHADED.

CLASS 35—ADVERTISING AND BUSINESS

FOR SPECIAL EVENT PLANNING FOR BUSINESS PURPOSES, NAMELY, FOR INFLUENCING AND SHAPING THE MOBILE ECOSYSTEM IN THE TELECOMMUNICATIONS FIELD (U.S. CLS. 100, 101 AND 102).

CLASS 41—EDUCATION AND ENTERTAINMENT

FOR ARRANGING AND CONDUCTING EDUCATIONAL CONFERENCES; PROVIDING A WEBSITE FEATURING BLOGS AND NON-DOWNLOADABLE PUBLICATIONS IN THE NATURE OF ARTICLES IN THE FIELD OF TELECOMMUNICATIONS (U.S. CLS. 100, 101 AND 107).

MICHAEL ENGEL, EXAMINING ATTORNEY

INDIAN MOTORCYCLE

THE MARK CONSISTS OF STANDARD CHARACTERS WITHOUT CLAIM TO ANY PARTICULAR FONT, STYLE, SIZE, OR COLOR.

OWNER OF U.S. REG. NO. 2,927,365.

NO CLAIM IS MADE TO THE EXCLUSIVE RIGHT TO USE "MOTORCYCLE", APART FROM THE MARK AS SHOWN.

CLASS 9—ELECTRICAL AND SCIENTIFIC APPARATUS

FOR MOTORCYCLE HELMETS; MOTORCYCLE GOGGLES; DECORATIVE MAGNETS; LUMINOUS SIGNS (U.S. CLS. 21, 23, 26, 36 AND 38).

CLASS 12—VEHICLES

FOR MOTORCYCLES AND STRUCTURAL PARTS THEREFOR; MOTORCYCLE SADDLEBAGS (U.S. CLS. 19, 21, 23, 31, 35 AND 44).

CLASS 16—PAPER GOODS AND PRINTED MATTER

FOR POSTERS, PICTURES, DECALS, STICKERS, STATIONERY, POSTCARDS, PENS, PRINTED PAPER SIGNS, CALENDARS, BROCHURES ABOUT MOTORCYCLES AND MOTORCYCLE ACCESSORIES, PRINTS IN THE NATURE OF PHOTOGRAPHS AND PICTURES (U.S. CLS. 2, 5, 22, 23, 29, 37, 38 AND 50).

CLASS 25—CLOTHING

FOR CLOTHING, NAMELY, FOOTWEAR, SHIRTS, JACKETS, HATS, GLOVES, VESTS, PANTS (U.S. CLS. 22 AND 39).

CLASS 28—TOYS AND SPORTING GOODS

FOR MODEL TOY VEHICLES, RIDE-ON TOYS, TOY MOTORCYCLES; SPORTS BAGS SPECIALLY ADAPTED FOR MOTORCYCLE SPORTS EQUIPMENT (U.S. CLS. 22, 23, 38 AND 50).

KATHLEEN M. VANSTON, EXAMINING ATTORNEY

SN 85-547,768. CLINICAL CARE TARGETED COMMUNICATIONS GROUP, LLC, PLAINSBORO, NJ. FILED 2-20-2012.

TRANSLATING EVIDENCE-BASED RESEARCH INTO VALUE-BASED DECISIONS

THE MARK CONSISTS OF STANDARD CHARACTERS WITHOUT CLAIM TO ANY PARTICULAR FONT, STYLE, SIZE, OR COLOR.

CLASS 16—PAPER GOODS AND PRINTED MATTER

FOR PRINTED PUBLICATIONS, NAMELY, JOURNALS, NEWSLETTERS, MONOGRAPHS AND PRINTED SUPPLEMENTS TO SUCH PRINTED PUBLICATIONS IN THE FIELDS OF PHARMACY AND MEDICINE (U.S. CLS. 2, 5, 22, 23, 29, 37, 38 AND 50).

FIRST USE 4-16-2009; IN COMMERCE 4-16-2009.

CLASS 41—EDUCATION AND ENTERTAINMENT

FOR PROVIDING A WEBSITE FEATURING RESOURCES, NAMELY, NON-DOWNLOADABLE PUBLICATIONS IN THE NATURE OF MAGAZINES, JOURNALS, MONOGRAPHS, SUPPLEMENTS, AND ARTICLES IN THE FIELD OF PHARMACY AND MEDICINE (U.S. CLS. 100, 101 AND 107).

FIRST USE 4-16-2009; IN COMMERCE 4-16-2009.
EUGENIA MARTIN, EXAMINING ATTORNEY

SN 85-550,340. LIONS GATE ENTERTAINMENT, INC., SANTA MONICA, CA. FILED 2-22-2012.

DISTRICT 12

THE MARK CONSISTS OF STANDARD CHARACTERS WITHOUT CLAIM TO ANY PARTICULAR FONT, STYLE, SIZE, OR COLOR.

CLASS 6—METAL GOODS

FOR METAL KEY CHAINS; METAL DOG TAGS (U.S. CLS. 2, 12, 13, 14, 23, 25 AND 50).

CLASS 9—ELECTRICAL AND SCIENTIFIC APPARATUS

FOR MOBILE PHONE COVERS, SMART PHONE COVERS, MAGNETS, SOUND RECORDED MAGNETIC SHEETS, HEADPHONES, BACKPACKS ADAPTED FOR HOLDING COMPUTERS; CAMERA CASES; LAPTOP CARRYING CASES; MOUSEPADS (U.S. CLS. 21, 23, 26, 36 AND 38).

CLASS 11—ENVIRONMENTAL CONTROL APPARATUS

FOR INCANDESCENT LIGHT BULBS (U.S. CLS. 13, 21, 23, 31 AND 34).

CLASS 14—JEWELRY

FOR JEWELRY, LAPEL PINS, KEY CHAINS AS JEWELLERY, NECKLACES, EARRINGS, BRACELETS, PENDANTS, WRIST WATCHES (U.S. CLS. 2, 27, 28 AND 50).

CLASS 16—PAPER GOODS AND PRINTED MATTER

FOR FOLDERS, BOOKMARKS, STATIONERY SETS CONSISTING OF PAPER AND ENVELOPES, INK STAMPS, FLIP BOOKS, BOOKENDS, PENCIL CASES, GREETING CARDS, NOTEBOOKS, POSTERS, PENS, BLANK JOURNALS, STICKERS, DECALS, PENCIL SHARPENERS, ERASERS, FOLDING RULERS (U.S. CLS. 2, 5, 22, 23, 29, 37, 38 AND 50).

CLASS 18—LEATHER GOODS

FOR SHOULDER BAGS, SACK BAGS IN THE NATURE OF HANDBAGS, BACKPACKS, UMBRELLAS, REUSABLE SHOPPING BAGS, DUFFEL BAGS, WALLETS (U.S. CLS. 1, 2, 3, 22 AND 41).

CLASS 20—FURNITURE AND ARTICLES NOT OTHERWISE CLASSIFIED

FOR PICTURES FRAMES, MIRRORS, PLASTIC KEY-CHAINS, NON-METAL DOG TAGS, NON-METAL CLIPS FOR SEALING BAGS (U.S. CLS. 2, 13, 22, 25, 32 AND 50).

CLASS 21—HOUSEWARES AND GLASS

FOR TEA LIGHT CANDLE HOLDERS, GLASS CANDLE HOLDERS, MUGS, LUNCHBOXES WITH DRINKING CUPS (U.S. CLS. 2, 13, 23, 29, 30, 33, 40 AND 50).

CLASS 22—CORDAGE AND FIBERS

FOR LANYARDS FOR HOLDING BADGES (U.S. CLS. 1, 2, 7, 19, 22, 42 AND 50).

CLASS 24—FABRICS

FOR PILLOW CASES, BED SHEETS, BEACH TOWELS, BED THROWS (U.S. CLS. 42 AND 50).

CLASS 25—CLOTHING

FOR T-SHIRTS, SWEATSHIRTS, HOODED SWEATSHIRTS, JACKETS, SHIRTS, PAJAMAS, SOCKS, WRISTBANDS, BEANIES, FLIP FLOPS, CAPS (U.S. CLS. 22 AND 39).

CLASS 26—FANCY GOODS

FOR SHOE LACES, BELT BUCKLES (U.S. CLS. 37, 39, 40, 42 AND 50).

CLASS 28—TOYS AND SPORTING GOODS

FOR PUZZLES, MODELED PLASTIC TOY FIGURINES, BOARD GAMES, ARCHERY BOWS, GAME CARDS (U.S. CLS. 22, 23, 38 AND 50).
KHANH LE, EXAMINING ATTORNEY

SN 85-550,706. V&V SUPREMO FOODS, INC., CHICAGO, IL. FILED 2-23-2012.

PUT A LITTLE LOVE

THE MARK CONSISTS OF STANDARD CHARACTERS WITHOUT CLAIM TO ANY PARTICULAR FONT, STYLE, SIZE, OR COLOR.

CLASS 29—MEATS AND PROCESSED FOODS

FOR CHEESE, SOUR CREAM, CREAMS, YOGURT, MEATS, UNFLAVORED AND UNSWEETENED GELATINS (U.S. CL. 46).

CLASS 30—STAPLE FOODS

FOR SOPES, FLAVORED AND SWEETENED GELATINS (U.S. CL. 46).
JOHN GARTNER, EXAMINING ATTORNEY

SN 85-550,712. V&V SUPREMO FOODS, INC., CHICAGO, IL. FILED 2-23-2012.

Put a little  **...**

OWNER OF U.S. REG. NO. 3,978,989.
THE MARK CONSISTS OF THE WORDS "PUT A LITTLE" FOLLOWED BY A HEART DESIGN AND THREE DOTS.

CLASS 29—MEATS AND PROCESSED FOODS

FOR CHEESE, SOUR CREAM, CREAMS, YOGURT, MEATS, UNFLAVORED AND UNSWEETENED GELATINS (U.S. CL. 46).

CLASS 30—STAPLE FOODS

FOR SOPEs, FLAVORED AND SWEETENED GELATINS (U.S. CL. 46).
JOHN GARTNER, EXAMINING ATTORNEY

SN 85-550,727. V&V SUPREMO FOODS, INC., CHICAGO, IL. FILED 2-23-2012.

PONLE AMOR

THE MARK CONSISTS OF STANDARD CHARACTERS WITHOUT CLAIM TO ANY PARTICULAR FONT, STYLE, SIZE, OR COLOR.

OWNER OF U.S. REG. NO. 3,978,989.
THE ENGLISH TRANSLATION OF "PONLE AMOR" IS PUT LOVE.

CLASS 29—MEATS AND PROCESSED FOODS

FOR CHEESE, SOUR CREAM, CREAMS, YOGURT, MEATS, UNFLAVORED AND UNSWEETENED GELATINS (U.S. CL. 46).

CLASS 30—STAPLE FOODS

FOR SOPEs, FLAVORED AND SWEETENED GELATINS (U.S. CL. 46).
JOHN GARTNER, EXAMINING ATTORNEY

SN 85-550,737. V&V SUPREMO FOODS, INC., CHICAGO, IL. FILED 2-23-2012.

Ponle  **...**

OWNER OF U.S. REG. NO. 3,978,989.
THE MARK CONSISTS OF THE WORD "PONLE" FOLLOWED BY A HEART DESIGN AND THREE DOTS.
THE ENGLISH TRANSLATION OF "PONLE" IS PUT.

CLASS 29—MEATS AND PROCESSED FOODS

FOR CHEESE, SOUR CREAM, CREAMS, YOGURT, MEATS, UNFLAVORED AND UNSWEETENED GELATINS (U.S. CL. 46).

CLASS 30—STAPLE FOODS

FOR SOPEs, FLAVORED AND SWEETENED GELATINS (U.S. CL. 46).
JOHN GARTNER, EXAMINING ATTORNEY

SN 85-553,507. ROCKET DOG BRANDS LLC, HAYWARD, CA. FILED 2-27-2012.

ROCKET DOG

THE MARK CONSISTS OF STANDARD CHARACTERS WITHOUT CLAIM TO ANY PARTICULAR FONT, STYLE, SIZE, OR COLOR.

OWNER OF U.S. REG. NOS. 2,588,957, 3,595,180 AND OTHERS.

CLASS 14—JEWELRY

FOR JEWELRY, EARRINGS, WATCHES (U.S. CLS. 2, 27, 28 AND 50).

CLASS 18—LEATHER GOODS

FOR LEATHER AND IMITATION LEATHER ACCESSORIES, NAMELY, PURSES, HANDBAGS, TOTE BAGS, BOOK BAGS, BACKPACKS, SPORTS BAGS, RUCKSACKS, BUM BAGS, BRIEFCASES, WALLETS, KEY CASES, AND LUGGAGE; ACCESSORIES, NAMELY, PURSES, HANDBAGS, TOTE BAGS, BOOK BAGS, BACKPACKS, SPORTS BAGS, RUCKSACKS, BUM BAGS, BRIEFCASES, WALLETS, KEY CASES AND LUGGAGE (U.S. CLS. 1, 2, 3, 22 AND 41).
WILLIAM VERHOSEK, EXAMINING ATTORNEY

SN 85-553,950. SYNGENTA PARTICIPATIONS AG, BASEL, SWITZERLAND, FILED 2-27-2012.

Adage

THE MARK CONSISTS OF STANDARD CHARACTERS WITHOUT CLAIM TO ANY PARTICULAR FONT, STYLE, SIZE, OR COLOR.

CLASS 1—CHEMICALS

FOR CHEMICALS USED IN AGRICULTURE, HORTICULTURE AND FORESTRY, NAMELY, SEED TREATMENT PREPARATIONS (U.S. CLS. 1, 5, 6, 10, 26 AND 46).

CLASS 5—PHARMACEUTICALS

FOR PESTICIDES, HERBICIDES, FUNGICIDES, AND INSECTICIDES (U.S. CLS. 6, 18, 44, 46, 51 AND 52).
JAMES STEIN, EXAMINING ATTORNEY

SN 85-554,795. MONSTER ENERGY COMPANY, CORONA, CA. FILED 2-28-2012.

SN 85-560,529. WAL-MART STORES, INC., BENTONVILLE, AR. FILED 3-5-2012.

MONSTERCCINO

THE MARK CONSISTS OF STANDARD CHARACTERS WITHOUT CLAIM TO ANY PARTICULAR FONT, STYLE, SIZE, OR COLOR.

CLASS 5—PHARMACEUTICALS

FOR NUTRITIONAL SUPPLEMENTS IN LIQUID FORM (U.S. CLS. 6, 18, 44, 46, 51 AND 52).

CLASS 30—STAPLE FOODS

FOR READY TO DRINK COFFEE, ICED COFFEE AND COFFEE BASED BEVERAGES; READY TO DRINK FLAVORED COFFEE, ICED COFFEE AND COFFEE BASED BEVERAGES (U.S. CL. 46).

CLASS 32—LIGHT BEVERAGES

FOR NON-ALCOHOLIC BEVERAGES, NAMELY, ENERGY DRINKS AND DRINKS ENHANCED WITH VITAMINS, MINERALS, NUTRIENTS, AMINO ACIDS AND/OR HERBS, BUT EXCLUDING PERISHABLE BEVERAGE PRODUCTS THAT CONTAIN FRUIT JUICE OR SOY, WHETHER SUCH PRODUCTS ARE PASTEURIZED OR NOT (U.S. CLS. 45, 46 AND 48).

GEOFFREY FOSDICK, EXAMINING ATTORNEY

SN 85-559,198. VULCAN INC., SEATTLE, WA. FILED 3-2-2012.

UNDERTHINKERS

THE MARK CONSISTS OF STANDARD CHARACTERS WITHOUT CLAIM TO ANY PARTICULAR FONT, STYLE, SIZE, OR COLOR.

CLASS 9—ELECTRICAL AND SCIENTIFIC APPARATUS

FOR PRE-RECORDED CDS FEATURING MUSIC (U.S. CLS. 21, 23, 26, 36 AND 38).

CLASS 41—EDUCATION AND ENTERTAINMENT

FOR ENTERTAINMENT, NAMELY, LIVE PERFORMANCES BY A MUSICAL BAND (U.S. CLS. 100, 101 AND 107).

DAVID I, EXAMINING ATTORNEY

PRICE EDGE

THE MARK CONSISTS OF STANDARD CHARACTERS WITHOUT CLAIM TO ANY PARTICULAR FONT, STYLE, SIZE, OR COLOR.

CLASS 3—COSMETICS AND CLEANING PREPARATIONS

FOR LAUNDRY PRODUCTS, NAMELY, BLEACHING PREPARATIONS, ANTI-STATIC DRYER SHEETS, FABRIC SOFTENERS FOR DOMESTIC USE, AND STAIN REMOVERS; DISHWASHING DETERGENT, LAUNDRY DETERGENT (U.S. CLS. 1, 4, 6, 50, 51 AND 52).

CLASS 11—ENVIRONMENTAL CONTROL APPARATUS

FOR LIGHT BULBS (U.S. CLS. 13, 21, 23, 31 AND 34).

CLASS 29—MEATS AND PROCESSED FOODS

FOR EDIBLE OILS, NAMELY, COOKING OIL, COOKING SPRAY, SHORTENING, OLIVE OIL; VEGETABLE OIL SPREAD, BUTTER, MARGARINE; BROTH; MEAT; PROCESSED MEAT, FISH, AND POULTRY; FROZEN MEAT, FISH, AND POULTRY; FROZEN PRE-COOKED BREADED MEAT, FISH, AND POULTRY; CANNED MEAT, FISH, AND POULTRY; SAUSAGES; BRAT-WURSTS; LUNCHMEATS; BACON; BACON BITS BEING FOOD; IMITATION BACON BITS BEING FOOD; CHILI WITH OR WITHOUT BEANS; CHICKEN AND DUMPLINGS; SOUPS AND FROZEN, PREPARED, AND PACKAGED ENTREES CONSISTING PRIMARILY OF VEGETABLES AND/OR MEAT; BEEF STEW; SOUPS AND SOUP MIXES; PREPARED ENTREES CONSISTING PRIMARILY OF BEEF OR PORK OR POULTRY OR FISH AND/OR VEGETABLES; PICKLES; PROCESSED PEPPERS; PROCESSED OLIVES; PROCESSED MUSHROOMS; STIR FRY VEGETABLES, NAMELY, FROZEN OR PROCESSED VEGETABLES; FROZEN VEGETABLES; CANNED CUT VEGETABLES; CANNED SLICED VEGETABLES; TOMATO PUREE; TOMATO PASTE; PROCESSED BEETS; PROCESSED BEANS; REFRIED BEANS; CANNED PORK AND BEANS; BAKED BEANS; CANNED FRANKFURTERS AND BEANS; DRIED BEANS; PROCESSED CACTUS FOR FOOD PURPOSES; DRIED POTATO FLAKES; DEHYDRATED POTATO PRODUCTS, NAMELY, SCALLOPED POTATOES; AU GRATIN POTATOES; FRENCH FRIED ONIONS; FORTIFIED AND FLAVORED INSTANT MILK DRINK, NAMELY, MILK POWDER; SOY MILK; FLAVORED SOY MILK; SOY SPREAD, NAMELY, SOYBEAN OIL; DAIRY PRODUCTS, NAMELY, MILK, POWDERED MILK FOR FOOD CONSUMPTION, EVAPORATED MILK, CONDENSED MILK, ORGANIC MILK, YOGURT, HALF AND HALF, WHIPPING CREAM, BUTTERMILK, SOUR CREAM, CHEESES, CREAM CHEESE, COTTAGE CHEESE AND CHEESE SPREADS; DAIRY AND NON-DAIRY WHIPPED TOPPING; DAIRY-BASED DIPS; NON-DAIRY CREAMER; FRUIT-BASED FILLING FOR CAKES AND PIES; PROCESSED, CANNED, FROZEN AND DRIED FRUIT; CRANBERRY SAUCE; APPLE SAUCE; FRUIT-BASED SNACK FOODS; JAMS, JELLIES AND FRUIT PRESERVES; FRUIT BUTTERS; PEANUT BUTTER; FLAKED COCONUT; PROCESSED EDIBLE SEEDS; ROASTED OR PROCESSED PEANUTS, ALMONDS, CASHEWS; BEEF JERKY; POTATO CHIPS, SNACK MIX CONSISTING PRIMARILY OF PROCESSED FRUITS, PROCESSED NUTS AND/OR RAISINS; CHEESE AND CRACKER COMBINATIONS; FROZEN PREPARED ENTREES CONSISTING OF MEAT, FISH, OR POULTRY; FROZEN PREPARED MEALS CONSISTING PRIMARILY OF MEAT, FISH, OR POULTRY; FROZEN ONION RINGS; FROZEN FRENCH FRIES AND OTHER FRO-

ZEN POTATO PRODUCTS, NAMELY, BATTERED POTATOES, POTATO PATTIES, POTATO NUGGETS, POTATO LOGS, AND HASH BROWNS; FROZEN FRENCH FRIED SWEET POTATOES; READY-TO-EAT NUT BASED FOOD BARS; PACKAGED MEALS CONSISTING PRIMARILY OF POTATOES WITH SPICES AND SAUCE MIXES; FROZEN, PREPARED OR PACKAGED MEALS CONSISTING PRIMARILY OF MEAT AND/OR VEGETABLES (U.S. CL. 46).

CLASS 30—STAPLE FOODS

FOR ICE CREAM, MAYONNAISE, PASTA; FRESH AND FROZEN PIE SHELLS; FROZEN WAFFLES; BAKERY MIXES; FROZEN PREPARED ENTREES CONSISTING PRIMARILY OF PASTA; BOXED MACARONI AND CHEESE DINNERS; SPAGHETTI SAUCE AND SPAGHETTI SAUCE MIXES; GRAVY MIXES; SEASONINGS AND SEASONING MIXES; BAKING SODA; FOOD FLAVORINGS AND EXTRACTS USED AS FLAVORING; SAUCES, NAMELY, SPAGHETTI SAUCE, TARTAR SAUCE, PIZZA SAUCE, CHILI SAUCE, HOT SAUCE, SLOPPY JOE SAUCE, ALFREDO SAUCE; PICANTE SAUCE; TACO SAUCE; STEAK SAUCE; BARBEQUE SAUCE; SOY SAUCE; WORCESTERSHIRE SAUCE, TOMATO SAUCE, AND DIPPING SAUCES; FROZEN, PREPARED OR PACKAGED ENTREES CONSISTING PRIMARILY OF PASTA OR RICE; FROZEN, PREPARED OR PACKAGED MEALS CONSISTING PRIMARILY OF PASTA OR RICE; DRIED PASTA; RICE; RICE MIXES; STUFFING MIXES CONTAINING BREAD; BREAD CRUMBS; FROZEN PIZZA; SALT; PEPPER; BAKING SPICES; SEASONINGS; DRY SEASONING MIXES FOR GRAVY, SPAGHETTI, STEWS, SLOPPY JOES, TACOS, FAJITAS, AND CHILI; MEAT SEASONINGS SOLD TOGETHER WITH A ROASTING BAG; SEASONED COATING FOR MEAT, FISH, POULTRY; IMITATION VANILLA; VANILLA EXTRACT; VINEGAR; FLAVORED VINEGAR; NO CALORIE SUGAR SUBSTITUTES; SUGAR; BROWN SUGAR; POWDERED SUGAR; FLOUR; CORN STARCH FOR FOOD; BAKING POWDER; HOMINY; FROZEN FRENCH TOAST STICKS; FROZEN PANCAKES; FROZEN FRENCH TOAST; FROZEN WAFFLE STICKS; SYRUP, NAMELY, CORN SYRUP; MAPLE SYRUP; PANCAKE SYRUP; HONEY; NOODLES; PACKAGED MEALS CONSISTING PRIMARILY OF NOODLES AND SPICES; INSTANT NOODLES; BOXED MACARONI AND CHEESE; MUSTARD; HONEY MUSTARD; DIJON MUSTARD; MUSTARD WITH HORSERADISH; HONEY MUSTARD SAUCE; TOASTER PASTRIES; CORN TORTILLA BAKING MIX; CORN MEAL; BREAD AND BUNS; BREAD ROLLS; BREAD MIXES; FROZEN BREADS; CORNBREAD BAKING MIX; MUFFIN MIX; PIZZA DOUGH MIX; PANCAKE, WAFFLE, AND BISCUIT MIXES; CAKE MIXES; BROWNIE MIXES; MIXES FOR BAKERY GOODS; FROSTING; FLAVORED, SWEETENED GELATINS; OATMEAL; INSTANT OATMEAL; GRITS; BREAKFAST CEREALS; TEA BAGS; READY-TO-DRINK TEA; MIXES IN THE NATURE OF CONCENTRATES OR POWDERS USED IN THE PREPARATION OF TEA-BASED BEVERAGES; COFFEE; INSTANT COFFEE; CAPPUCCINO MIX; HOT COCOA MIX; CHOCOLATE MIX TO PREPARE INSTANT CHOCOLATE MILK BEVERAGES; CHEESE-STUFFED BREAD; CRACKERS; GRAHAM CRACKERS; CRACKER SANDWICHES WITH A PEANUT BUTTER FILLING; COOKIES; POPCORN; CEREAL-BASED SNACK BARS; GRANOLA-BASED SNACK BARS; GRAIN-BASED SNACK BARS ALSO CONTAINING DRIED FRUIT; MICROWAVE POPCORN; POPPING CORN; ICE CREAM; SHERBET; ICE CREAM BARS AND SANDWICHES; CONES FOR ICE CREAM; FROZEN CONFECTIONS; FROZEN FUDGE BARS, ICE POPS; CHOCOLATE-FLAVORED SYRUP; STRAWBERRY-FLAVORED SYRUP; SNACK MIX CONSISTING PRIMARILY OF CRACKERS, PRETZELS, WITH EDIBLE SEEDS AND NUTS; SNACK MIX CONSISTING PRIMARILY OF CANDY POPCORN WITH NUTS; PRETZELS; CORN CHIPS; CHEESE FLAVORED PUFFED CORN SNACKS; CHEESE FLAVORED SNACKS, NAMELY, CHEESE CURLS; PICKLE RELISH; GRAVY; SALSA; SALSA CON QUESO (CHEESE SAUCE); CHEESE SAUCE; CHEESE SAUCE PACKAGED IN AN AEROSOL CONTAINER; CANDY; CANDY BARS; CHOCOLATE CANDIES; CANDY WITH CARAMEL; CANDY MINTS; GUMMY CANDIES; SUGARLESS CANDIES; CANDY DECORATIONS FOR CAKES; CHOCOLATE CHIPS; SALAD DRESSINGS; MAYONNAISE; TORTILLAS; TACO SHELLS; REFRIGERATED AND/OR FROZEN

DOUGH TO BAKE BISCUITS, CRESCENT ROLLS, DINNERS ROLLS, CROISSANTS, CINNAMON ROLLS, DANISH PASTRIES, AND PIE SHELLS, PIZZA CRUST DOUGH, AND COOKIE DOUGH; GRAHAM CRACKER PIE CRUSTS; POT PIES; RAVIOLI; SPAGHETTI AND MEATBALLS; DOUGH-BASED POCKETS WITH FILLING CONSISTING PRIMARILY OF SAUCE, MEATS, VEGETABLES AND CHEESE; PUDDINGS; INSTANT PUDDING MIXES; KETCHUP; MARSHMALLOWS; MARSHMALLOW CREME TOPPING; MINCED GARLIC (U.S. CL. 46).

CLASS 32—LIGHT BEVERAGES

FOR DRINKING WATER; FRUIT DRINKS AND JUICES; FRUIT JUICE CONCENTRATES; PREPARATIONS FOR MAKING BEVERAGES, NAMELY, FLAVORED WATERS, FRUIT DRINKS AND FRUIT JUICES; VEGETABLE JUICES; SOFT DRINKS (U.S. CLS. 45, 46 AND 48).

JUDITH HELFMAN, EXAMINING ATTORNEY

SN 85-560,644, WAL-MART STORES, INC., BENTONVILLE, AR. FILED 3-5-2012.

WALMART ENTERTAINMENT

THE MARK CONSISTS OF STANDARD CHARACTERS WITHOUT CLAIM TO ANY PARTICULAR FONT, STYLE, SIZE, OR COLOR.

OWNER OF U.S. REG. NOS. 1,783,039, 3,757,586 AND OTHERS.

NO CLAIM IS MADE TO THE EXCLUSIVE RIGHT TO USE "ENTERTAINMENT", APART FROM THE MARK AS SHOWN.

CLASS 9—ELECTRICAL AND SCIENTIFIC APPARATUS

FOR SET TOP BOXES, COMPUTER PERIPHERALS, AND SOFTWARE FOR USE IN THE TRANSMISSION, STORAGE AND PLAYBACK OF AUDIO AND VIDEO CONTENT; COMPUTER SOFTWARE FOR THE TRANSMISSION, STORAGE AND PLAYBACK OF AUDIO AND VIDEO CONTENT, SOLD AS A COMPONENT PART OF COMPUTERS; SOFTWARE FOR THE TRANSMISSION, STORAGE AND PLAYBACK OF AUDIO AND VIDEO CONTENT, SOLD AS A COMPONENT PART OF TELEVISIONS (U.S. CLS. 21, 23, 26, 36 AND 38).

CLASS 35—ADVERTISING AND BUSINESS

FOR PROVIDING INFORMATION TO ASSIST CONSUMERS WITH THE SELECTION AND PURCHASE OF MULTIMEDIA PRODUCTS, INCLUDING THOSE FEATURING MOTION PICTURES, THROUGH ONLINE RETAIL ORDERING; RETAIL STORE SERVICES FEATURING MULTIMEDIA PRODUCTS, AND MULTIMEDIA PROGRAMS, FILES, APPLICATIONS AND RECORDINGS CONTAINING ENTERTAINMENT-BASED MATERIAL (U.S. CLS. 100, 101 AND 102).

CLASS 38—COMMUNICATION

FOR AUDIO AND VIDEO BROADCASTING SERVICES, BROADCASTING AUDIO AND VIDEO CONTENT OVER GLOBAL COMPUTER NETWORKS, VIDEO-ON-DEMAND TRANSMISSION SERVICES, PAY-PER-VIEW VIDEO AND AUDIO TRANSMISSION SERVICES, STREAMING OF AUDIO AND VISUAL CONTENT VIA GLOBAL AND LOCAL COMPUTER NETWORKS (U.S. CLS. 100, 101 AND 104).

CLASS 41—EDUCATION AND ENTERTAINMENT

FOR PROVIDING INFORMATION ABOUT ENTERTAINMENT-BASED AND EDUCATIONAL MULTIMEDIA CONTENT AND RECORDINGS, DIGITAL FILES, AND SCHEDULED AND PAY-PER-VIEW BROADCAST MEDIA PROGRAMMING TO ASSIST RETAIL CONSUMERS (U.S. CLS. 100, 101 AND 107).

JUDITH HELFMAN, EXAMINING ATTORNEY

SN 85-560,669. WAL-MART STORES, INC., BENTONVILLE, AR. FILED 3-5-2012.



OWNER OF U.S. REG. NOS. 2,891,003, 3,612,345 AND OTHERS.

NO CLAIM IS MADE TO THE EXCLUSIVE RIGHT TO USE "ENTERTAINMENT", APART FROM THE MARK AS SHOWN.

THE MARK CONSISTS OF THE WORDS "WALMART ENTERTAINMENT" IN STYLIZED LETTERING, WITH THE FINAL LETTER "T" IN "ENTERTAINMENT" CONTINUING TO FORM THE LINE DESIGN OF A PARTIAL CLOUD WITH AN ARROW POINTING LEFT AT OTHER END OF THE LINE DESIGN, AND WITHIN THE CLOUD IS A DESIGN OF SIX RAYS POSITIONED TO CREATE A FANCIFUL REPRESENTATION OF A SPARK.

CLASS 9—ELECTRICAL AND SCIENTIFIC APPARATUS

FOR SET TOP BOXES, COMPUTER PERIPHERALS, AND SOFTWARE FOR USE IN THE TRANSMISSION, STORAGE AND PLAYBACK OF AUDIO AND VIDEO CONTENT; COMPUTER SOFTWARE FOR THE TRANSMISSION, STORAGE AND PLAYBACK OF AUDIO AND VIDEO CONTENT, SOLD AS A COMPONENT PART OF COMPUTERS; SOFTWARE FOR THE TRANSMISSION, STORAGE AND PLAYBACK OF AUDIO AND VIDEO CONTENT, SOLD AS A COMPONENT PART OF TELEVISIONS (U.S. CLS. 21, 23, 26, 36 AND 38).

CLASS 35—ADVERTISING AND BUSINESS

FOR PROVIDING INFORMATION TO ASSIST CONSUMERS WITH THE SELECTION AND PURCHASE OF MULTIMEDIA PRODUCTS, INCLUDING THOSE FEATURING MOTION PICTURES, THROUGH ONLINE RETAIL ORDERING; RETAIL STORE SERVICES FEATURING MULTIMEDIA PRODUCTS, AND MULTIMEDIA PROGRAMS, FILES, APPLICATIONS AND RECORDINGS CONTAINING ENTERTAINMENT-BASED MATERIAL (U.S. CLS. 100, 101 AND 102).

CLASS 38—COMMUNICATION

FOR AUDIO AND VIDEO BROADCASTING SERVICES, BROADCASTING AUDIO AND VIDEO CONTENT OVER GLOBAL COMPUTER NETWORKS, VIDEO-ON-DEMAND TRANSMISSION SERVICES, PAY-PER-VIEW VIDEO AND AUDIO TRANSMISSION SERVICES, STREAMING OF AUDIO AND VISUAL CONTENT VIA GLOBAL AND LOCAL COMPUTER NETWORKS (U.S. CLS. 100, 101 AND 104).

CLASS 41—EDUCATION AND ENTERTAINMENT

FOR PROVIDING INFORMATION ABOUT ENTERTAINMENT-BASED AND EDUCATIONAL MULTIMEDIA CONTENT AND RECORDINGS, DIGITAL FILES, AND SCHEDULED AND PAY-PER-VIEW BROADCAST MEDIA PROGRAMMING TO ASSIST RETAIL CONSUMERS (U.S. CLS. 100, 101 AND 107).

JUDITH HELFMAN, EXAMINING ATTORNEY

SN 85-564,082. LETTUCE ENTERTAIN YOU ENTERPRISES, INC., CHICAGO, IL. FILED 3-8-2012.



NO CLAIM IS MADE TO THE EXCLUSIVE RIGHT TO USE "DONUTS & COFFEE", APART FROM THE MARK AS SHOWN.

THE MARK CONSISTS OF A CIRCLE DESIGN WITH A BANNER WITH THE WORDS "DO-RITE" IN THE UPPER HALF OF THE CIRCLE DESIGN AND THE WORD "DONUTS" IN THE LOWER HALF OF THE CIRCLE DESIGN WITH THE WORDS "& COFFEE" INSIDE OF THE BANNER.

CLASS 30—STAPLE FOODS

FOR DONUTS (U.S. CL. 46).
FIRST USE 2-23-2012; IN COMMERCE 2-23-2012.

CLASS 43—HOTEL AND RESTAURANT SERVICES

FOR RESTAURANT SERVICES (U.S. CLS. 100 AND 101).
FIRST USE 2-23-2012; IN COMMERCE 2-23-2012.
KAREN K. BUSH, EXAMINING ATTORNEY

SN 85-569,126. PARI PHARMA GMBH, STARNBERG, FED REP GERMANY, FILED 3-14-2012.

LAMIRA

THE MARK CONSISTS OF STANDARD CHARACTERS WITHOUT CLAIM TO ANY PARTICULAR FONT, STYLE, SIZE, OR COLOR.

CLASS 5—PHARMACEUTICALS

SN 85-571,839. SANOFI, 75008 PARIS, FRANCE, FILED 3-16-2012.

FOR PHARMACEUTICAL PREPARATIONS FOR USE IN RESPIRATORY THERAPY AND SYSTEMATIC THERAPY VIA THE RESPIRATORY TRACT FOR TREATMENT OF RESPIRATORY DISEASES AND DISEASES OF THE LUNGS AND NASAL PASSAGES (U.S. CLS. 6, 18, 44, 46, 51 AND 52).

CLASS 10—MEDICAL APPARATUS

FOR MEDICAL DEVICES FOR APPLICATION OF SUBSTANCES INTO THE LUNGS, NAMELY NEBULIZERS, INHALERS, COMPRESSORS USED IN THE TREATMENT OF RESPIRATORY DISEASES (U.S. CLS. 26, 39 AND 44).

MICHAEL SOUDERS, EXAMINING ATTORNEY

BGtech

THE MARK CONSISTS OF STANDARD CHARACTERS WITHOUT CLAIM TO ANY PARTICULAR FONT, STYLE, SIZE, OR COLOR.

OWNER OF U.S. REG. NOS. 3,787,454 AND 4,022,862.

CLASS 9—ELECTRICAL AND SCIENTIFIC APPARATUS

FOR SOFTWARE INTENDED FOR DIABETIC PATIENTS FOR RECORDING BLOOD TEST RESULTS FROM A BLOOD GLUCOSE MONITOR (U.S. CLS. 21, 23, 26, 36 AND 38).

SN 85-570,044. BRYN MAWR COMMUNICATIONS III, LLC, WAYNE, PA. FILED 3-15-2012.

CLASS 10—MEDICAL APPARATUS

FOR MEDICAL APPARATUS, NAMELY, BLOOD GLUCOSE METER KITS COMPRISING BLOOD GLUCOSE METERS, STRIPS FOR MEASURING BLOOD GLUCOSE CONCENTRATIONS, CONTROL SOLUTION, AND LANCETS (U.S. CLS. 26, 39 AND 44).

DAVID COLLIER, EXAMINING ATTORNEY

Modern Aesthetics

SN 85-577,282. SPC RESOURCES, INC., HARTSVILLE, SC. FILED 3-22-2012.

THE MARK CONSISTS OF STANDARD CHARACTERS WITHOUT CLAIM TO ANY PARTICULAR FONT, STYLE, SIZE, OR COLOR.

NO CLAIM IS MADE TO THE EXCLUSIVE RIGHT TO USE "AESTHETICS", APART FROM THE MARK AS SHOWN.

CLASS 9—ELECTRICAL AND SCIENTIFIC APPARATUS

FOR DOWNLOADABLE ELECTRONIC PUBLICATIONS, NAMELY, MEDICAL JOURNALS AND MAGAZINES IN THE FIELD OF DERMATOLOGY AND COSMETIC-AESTHETIC DERMATOLOGY (U.S. CLS. 21, 23, 26, 36 AND 38).

CLASS 16—PAPER GOODS AND PRINTED MATTER

FOR MEDICAL JOURNALS AND MAGAZINES IN THE FIELD OF DERMATOLOGY AND COSMETIC-AESTHETIC DERMATOLOGY (U.S. CLS. 2, 5, 22, 23, 29, 37, 38 AND 50).

CLASS 44—MEDICAL, BEAUTY AND AGRICULTURAL SERVICES

FOR ONLINE WEBSITES FEATURING INFORMATION IN THE FIELD OF DERMATOLOGY AND COSMETIC-AESTHETIC DERMATOLOGY (U.S. CLS. 100 AND 101).

ALAIN LAPTER, EXAMINING ATTORNEY

RCS

THE MARK CONSISTS OF STANDARD CHARACTERS WITHOUT CLAIM TO ANY PARTICULAR FONT, STYLE, SIZE, OR COLOR.

CLASS 16—PAPER GOODS AND PRINTED MATTER

FOR PAPER PRODUCTS, NAMELY, PAPER BASED CORES USED FOR WINDING FILM OR TEXTILE PRODUCTS (U.S. CLS. 2, 5, 22, 23, 29, 37, 38 AND 50).

CLASS 20—FURNITURE AND ARTICLES NOT OTHERWISE CLASSIFIED

FOR PLASTIC CORES USED TO FACILITATE ROLL WINDING FOR FILM AND TEXTILE PRODUCTS (U.S. CLS. 2, 13, 22, 25, 32 AND 50).

JAMES LOVELACE, EXAMINING ATTORNEY

SN 85-580,695. PASKENTA BAND OF NOMLAKI INDIANS, ORLAND, CA. FILED 3-27-2012.

ROLLING HILLS CASINO

THE MARK CONSISTS OF STANDARD CHARACTERS WITHOUT CLAIM TO ANY PARTICULAR FONT, STYLE, SIZE, OR COLOR.

NO CLAIM IS MADE TO THE EXCLUSIVE RIGHT TO USE "CASINO", APART FROM THE MARK AS SHOWN.

CLASS 35—ADVERTISING AND BUSINESS

FOR ARRANGING AND CONDUCTING INCENTIVE REWARD PROGRAMS TO PROMOTE THE SALE OF CASINO SERVICES; ORGANIZING AND PROVIDING FACILITIES FOR BUSINESS MEETINGS (U.S. CLS. 100, 101 AND 102).

FIRST USE 7-30-2002; IN COMMERCE 7-30-2002.

CLASS 41—EDUCATION AND ENTERTAINMENT

FOR CASINO SERVICES; PROVIDING CASINO SERVICES FEATURING A CASINO PLAYERS REWARDS PROGRAM; CONDUCTING AND PROVIDING FACILITIES FOR SPECIAL EVENTS FEATURING CASINO AND GAMING CONTESTS AND TOURNAMENTS; HUNTING GUIDE SERVICES; PROVIDING FACILITIES FOR HUNTING; RECREATION SERVICES, NAMELY, PROVIDING HUNTING PRESERVES; GOLF COURSES; AMUSEMENT ARCADE SERVICES; PROVIDING FACILITIES FOR SPORTS AND ENTERTAINMENT EVENTS; ENTERTAINMENT SERVICES, NAMELY, ORGANIZING AND CONDUCTING SOCIAL MEETINGS, PARTIES AND SOCIAL REUNIONS; ARRANGING AND ORGANIZING SOCIAL ENTERTAINMENT EVENTS, NAMELY, SOCIAL MEETINGS, PARTIES AND SOCIAL REUNIONS; ARRANGING AND CONDUCTING SPECIAL EVENTS FOR SOCIAL ENTERTAINMENT PURPOSES (U.S. CLS. 100, 101 AND 107).

FIRST USE 7-30-2002; IN COMMERCE 7-30-2002.
KATHY DE JONGE, EXAMINING ATTORNEY

SN 85-583,684. NITTANY CORPORATION, WILMINGTON, DE. FILED 3-29-2012.

JOHN
COPE'S

THE NAME "JOHN COPE'S" DOES NOT IDENTIFY A LIVING INDIVIDUAL.

THE MARK CONSISTS OF THE WORDS "JOHN COPE'S" IN STYLIZED FORM.

CLASS 29—MEATS AND PROCESSED FOODS

FOR DRIED CORN (U.S. CL. 46).

CLASS 30—STAPLE FOODS

FOR APPLE FRITTERS; CORN FRITTERS (U.S. CL. 46).
FRED CARL, EXAMINING ATTORNEY

SN 85-583,685. NITTANY CORPORATION, WILMINGTON, DE. FILED 3-29-2012.



OWNER OF U.S. REG. NO. 2,547,310.
THE MARK CONSISTS OF THE STYLIZED IMAGE OF AN AMISH MAN'S FACE.

CLASS 29—MEATS AND PROCESSED FOODS

FOR DRIED CORN (U.S. CL. 46).

CLASS 30—STAPLE FOODS

FOR APPLE FRITTERS; CORN FRITTERS (U.S. CL. 46).
FRED CARL, EXAMINING ATTORNEY

SN 85-584,473. INTERNATIONAL PAPER COMPANY, MEMPHIS, TN. FILED 3-30-2012.

COLOR IS FOREVER

THE MARK CONSISTS OF STANDARD CHARACTERS WITHOUT CLAIM TO ANY PARTICULAR FONT, STYLE, SIZE, OR COLOR.

CLASS 16—PAPER GOODS AND PRINTED MATTER

FOR PAPER AND PAPERBOARD; ROLL PAPER; CUT-SIZE PAPER; PAPER AND PAPERBOARD FOR PRINTING; PAPER FOR PUBLICATION, COPYING AND WRITING; COVER PAPER; BOND PAPER; DIGITAL PRINTING PAPER; DIGITAL INKJET PRINTING PAPER; DIGITAL INKJET PRINTING PAPER WITH PIGMENT-BASED INKJET INK; DIGITAL INKJET PRINTING PAPER WITH DYE-BASED INKJET INK; OFFSET PAPER; INKJET PAPER; LASER PAPER; MULTI-PURPOSE PAPER; COMPUTER AND FORMS PAPER; COATED AND UNCOATED PRINTING PAPER; PAPER FOR FAXING AND WRITING; COATED AND UNCOATED PAPERBOARD; COATED AND UNCOATED FREE SHEET PAPER (U.S. CLS. 2, 5, 22, 23, 29, 37, 38 AND 50).

CLASS 35—ADVERTISING AND BUSINESS

FOR BUSINESS CONSULTATION SERVICES IN THE FIELD OF THE PRINTING AND PAPER INDUSTRY (U.S. CLS. 100, 101 AND 102).

MARC LEIPZIG, EXAMINING ATTORNEY

SN 85-588,632. UNITED STATES POSTAL SERVICE, WASHINGTON, DC. FILED 4-4-2012.



SN 85-585,015. CORPORACION BELLEZA JUVENIL S.A., SAN JOSE, COSTA RICA, FILED 3-30-2012.



NO CLAIM IS MADE TO THE EXCLUSIVE RIGHT TO USE "SELF-SERVICE SHIP AND MAIL CENTER", APART FROM THE MARK AS SHOWN.

THE MARK CONSISTS OF THE WORDS "SELF-SERVICE" OVER THE WORDING "SHIP AND MAIL CENTER" DIVIDED BY A LINE. A DESIGN CONSISTING OF A STYLIZED PERSON IN FRONT OF A KIOSK APPEARS TO THE RIGHT OF THE WORDING.

CLASS 35—ADVERTISING AND BUSINESS

FOR PROVIDING INFORMATION IN THE FIELD OF MAIL SORTING, HANDLING AND RECEIVING; VENDING MACHINE SERVICES IN THE FIELD OF STAMPS, STATIONERY, AND OTHER PHILATELIC PRODUCTS (U.S. CLS. 100, 101 AND 102).

FIRST USE 10-14-2011; IN COMMERCE 10-14-2011.

CLASS 39—TRANSPORTATION AND STORAGE

FOR PROVIDING INFORMATION IN THE FIELD OF MAIL DELIVERY (U.S. CLS. 100 AND 105).

FIRST USE 10-14-2011; IN COMMERCE 10-14-2011.

JEFFERY COWARD, EXAMINING ATTORNEY

SN 85-588,734. HERSHEY CHOCOLATE & CONFECTIONERY CORPORATION, WHEAT RIDGE, CO. FILED 4-4-2012.

HEREWEARE

OWNER OF U.S. REG. NO. 3,469,381.

THE MARK CONSISTS OF THE STYLIZED WORDING "REVER" HAVING A LEAF OVER THE LETTER "V". THE TERMS "DISCOVER UNIQUENESS" ARE BELOW THE WORDING "REVER".

THE ENGLISH TRANSLATION OF "REVER" IN THE MARK IS "TO DREAM".

CLASS 18—LEATHER GOODS

FOR WALLETS, PURSES (U.S. CLS. 1, 2, 3, 22 AND 41).

CLASS 25—CLOTHING

FOR MEN'S, WOMEN'S AND CHILDREN'S APPAREL, NAMELY, KNIT SHIRTS, T-SHIRTS, SPORTS SHIRTS, POLO SHIRTS, DRESS SHIRTS, BLOUSES, SWEATSHIRTS, SHAWLS, SHOULDER WRAPS, STOLES, JACKETS, VESTS, PANTS, SWEATPANTS, SHORTS, SWIMWEAR, SCARVES, NECKTIES, NECKERCHIEFS, BOWTIES, SASHES, BANDANAS, UNDERWEAR, BRAS, PANTIES, PANTY HOSES, CAMISOLES, SLIPS, NIGHTGOWNS, PAJAMAS, ROBES, OTHER SLEEPWEAR, BELTS, GLOVES, MITTENS, SOCKS, STOCKINGS, WRISTBANDS, CUMMERBUNDS, SUSPENDERS; FOOTWEAR, NAMELY SHOES, BOOTS, SLIPPERS; HEADWEAR, NAMELY HATS, CAPS, VISORS, BANDANAS (U.S. CLS. 22 AND 39).

MELISSA VALLILLO, EXAMINING ATTORNEY

THE MARK CONSISTS OF STANDARD CHARACTERS WITHOUT CLAIM TO ANY PARTICULAR FONT, STYLE, SIZE, OR COLOR.

OWNER OF U.S. REG. NOS. 2,028,403, 2,210,397 AND 2,210,398.

CLASS 16—PAPER GOODS AND PRINTED MATTER

FOR PAPER CANDY WRAPPERS (U.S. CLS. 2, 5, 22, 23, 29, 37, 38 AND 50).

FIRST USE 9-18-2002; IN COMMERCE 9-18-2002.

CLASS 30—STAPLE FOODS

FOR CANDY (U.S. CL. 46).

FIRST USE 9-18-2002; IN COMMERCE 9-18-2002.

SAMUEL E. SHARPER JR., EXAMINING ATTORNEY

SN 85-588,901. WINFIELD SOLUTIONS, LLC, SHOREVIEW, MN. FILED 4-4-2012.

COASTAL TIDE

THE MARK CONSISTS OF STANDARD CHARACTERS WITHOUT CLAIM TO ANY PARTICULAR FONT, STYLE, SIZE, OR COLOR.

CLASS 1—CHEMICALS

FOR WETTING AGENTS (U.S. CLS. 1, 5, 6, 10, 26 AND 46).

CLASS 2—PAINTS

FOR SYNTHETIC DYES (U.S. CLS. 6, 11 AND 16).
JIM RINGLE, EXAMINING ATTORNEY

SN 85-591,256. VENICE BEACH BREWING COMPANY LLC, DBA VENICE BEACH BEER COMPANY, VENICE, CA. FILED 4-6-2012.

Shut up and drink it.

THE MARK CONSISTS OF STANDARD CHARACTERS WITHOUT CLAIM TO ANY PARTICULAR FONT, STYLE, SIZE, OR COLOR.

CLASS 25—CLOTHING

FOR ATHLETIC APPAREL, NAMELY, SHIRTS, PANTS, JACKETS, FOOTWEAR, HATS AND CAPS, ATHLETIC UNIFORMS (U.S. CLS. 22 AND 39).

CLASS 32—LIGHT BEVERAGES

FOR BEER (U.S. CLS. 45, 46 AND 48).
KAREN K. BUSH, EXAMINING ATTORNEY

SN 85-593,430. MEADWESTVACO CORPORATION, RICHMOND, VA. FILED 4-10-2012.

MEAD

THE MARK CONSISTS OF STANDARD CHARACTERS WITHOUT CLAIM TO ANY PARTICULAR FONT, STYLE, SIZE, OR COLOR.
OWNER OF U.S. REG. NOS. 1,201,126, 3,551,367 AND OTHERS.

CLASS 16—PAPER GOODS AND PRINTED MATTER

FOR DRY ERASE WRITING BOARD FITTED WITH FABRIC POCKET FOR STORAGE; BINDERS FITTED WITH MAGNETS FOR AFFIXATION TO LOCKER; MAGNETIC PENCIL CUP; PHOTO ALBUM THAT UNFOLDS FOR AFFIXATION TO LOCKER (U.S. CLS. 2, 5, 22, 23, 29, 37, 38 AND 50).

CLASS 20—FURNITURE AND ARTICLES NOT OTHERWISE CLASSIFIED

FOR SHELVING FOR LOCKERS; HANGING LOCKER SHELVING MADE OF FABRIC; LOCKER MIRRORS, AND LOCKER MIRRORS FITTED WITH FABRIC POCKET FOR STORAGE; LOCKER ORGANIZER COMPRISED OF MIRROR, DRY ERASE WHITE BOARD AND PENCIL CUP; NON-METAL FABRIC STORAGE BIN ORGANIZER; NON-METAL FABRIC LOCKER ORGANIZER (U.S. CLS. 2, 13, 22, 25, 32 AND 50).
TASNEEM HUSSAIN, EXAMINING ATTORNEY

SN 85-593,506. MEADWESTVACO CORPORATION, RICHMOND, VA. FILED 4-10-2012.

MEAD

THE MARK CONSISTS OF STANDARD CHARACTERS WITHOUT CLAIM TO ANY PARTICULAR FONT, STYLE, SIZE, OR COLOR.
OWNER OF U.S. REG. NOS. 1,201,126, 3,551,367 AND OTHERS.

CLASS 21—HOUSEWARES AND GLASS

FOR COLLAPSIBLE FABRIC STORAGE CONTAINER FOR DOMESTIC USE (U.S. CLS. 2, 13, 23, 29, 30, 33, 40 AND 50).

CLASS 22—CORDAGE AND FIBERS

FOR ALL PURPOSE STRAPS (U.S. CLS. 1, 2, 7, 19, 22, 42 AND 50).
TASNEEM HUSSAIN, EXAMINING ATTORNEY

SN 85-976,362. FEDERACIÓN MEXICANA DE FÚTBOL ASOCIACIÓN, A.C., MEXICO CITY 06700, MEXICO, FILED 10-18-2010.

PRIMERA DIVISIÓN DEL FÚTBOL MEXICANO

THE MARK CONSISTS OF STANDARD CHARACTERS WITHOUT CLAIM TO ANY PARTICULAR FONT, STYLE, SIZE, OR COLOR.
OWNER OF MEXICO REG. NO. 1204461, DATED 2-28-2011, EXPIRES 11-8-2020.
OWNER OF MEXICO REG. NO. 1204462, DATED 2-28-2011, EXPIRES 11-8-2020.
OWNER OF MEXICO REG. NO. 1204463, DATED 2-28-2011, EXPIRES 11-8-2020.
OWNER OF U.S. REG. NO. 3,882,841.

NO CLAIM IS MADE TO THE EXCLUSIVE RIGHT TO USE "FÚTBOL MEXICANO", APART FROM THE MARK AS SHOWN.

THE ENGLISH TRANSLATION OF "PRIMERA DIVISIÓN DEL FUTBOL MEXICANO" IS FIRST DIVISION OF MEXICAN FOOTBALL.

CLASS 25—CLOTHING

FOR FOOTWEAR AND SPORTING FOOTWEAR; MEN'S, WOMEN'S AND CHILDREN'S CLOTHING, NAMELY, FLEECE TOPS AND BOTTOMS, CAPS, HEADWEAR, T-SHIRTS, SWEATSHIRTS, SHORTS, TANK TOPS, SWEATERS, PANTS, JACKETS, TURTLENECKS, JUMPSUITS, GOLF SHIRTS, WOVEN SHIRTS, KNIT SHIRTS, JERSEYS, WRISTBANDS, WARM UP SUITS, SWIMWEAR, WIND RESISTANT JACKETS, RAINCOATS, PARKAS, PONCHOS, GLOVES, TIES, SUSPENDERS, CLOTH BIBS, SLEEPWEAR, NAMELY, ROBES, NIGHT SHIRTS AND PAJAMAS, MITTENS, KNIT HATS AND CAPS, SCARVES, APRONS, HEADBANDS, EAR MUFFS, UNDERWEAR (U.S. CLS. 22 AND 39).

CLASS 28—TOYS AND SPORTING GOODS

FOR DECORATIONS FOR CHRISTMAS TREES; GAMES AND PLAYTHINGS, NAMELY, BOARD GAMES, TOY PENNANTS, BALLOONS, TOYS AND SPORTING GOODS, NAMELY, PLUSH TOYS, STUFFED ANIMALS, PLAY FIGURES, GOLF BALLS, GOLF BAGS, GOLF CLUB COVERS, BOWLING BAGS, SOCCER BALLS, TOY BANKS, HAND HELD UNIT FOR PLAYING ELECTRONIC GAMES, HAND HELD UNIT FOR PLAYING VIDEO GAMES; TOY AND DECORATIVE WINDSOCKS, KITES, TOY TRUCKS (U.S. CLS. 22, 23, 38 AND 50).

CLASS 32—LIGHT BEVERAGES

FOR BEER; MINERAL AND AERATED WATERS AND OTHER NON-ALCOHOLIC DRINKS, NAMELY, SOFT DRINKS, SODAS, JUICES, DRINKING WATER, FLAVORED WATER, LEMONADES, FRUIT PUNCHES; FRUIT DRINKS AND FRUIT JUICES; SYRUPS AND PREPARATIONS FOR MAKING BEVERAGES, NAMELY, FRUIT DRINKS (U.S. CLS. 45, 46 AND 48).
GIANCARLO CASTRO, EXAMINING ATTORNEY

SN 85-976,526. SAM SANCHEZ, CHICAGO, IL. FILED 6-17-2011.

MOE'S CANTINA

THE MARK CONSISTS OF STANDARD CHARACTERS WITHOUT CLAIM TO ANY PARTICULAR FONT, STYLE, SIZE, OR COLOR.

NO CLAIM IS MADE TO THE EXCLUSIVE RIGHT TO USE "CANTINA", APART FROM THE MARK AS SHOWN.

CLASS 25—CLOTHING

FOR CLOTHING, NAMELY, SHIRTS, SWEATSHIRTS, JACKETS, SCARVES, SHORTS, SWEAT PANTS; HEADGEAR, NAMELY, HATS, VISORS (U.S. CLS. 22 AND 39).

CLASS 35—ADVERTISING AND BUSINESS

FOR FRANCHISING SERVICES, NAMELY, OFFERING BUSINESS MANAGEMENT ASSISTANCE IN THE ESTABLISHMENT AND OPERATION OF A BAR AND CONCERT VENUE (U.S. CLS. 100, 101 AND 102).

CLASS 41—EDUCATION AND ENTERTAINMENT

FOR ARRANGING AND CONDUCTING OF CONCERTS (U.S. CLS. 100, 101 AND 107).

CLASS 43—HOTEL AND RESTAURANT SERVICES

FOR BAR SERVICES (U.S. CLS. 100 AND 101).
ESTHER BELENKER, EXAMINING ATTORNEY

SN 85-976,527. SAM SANCHEZ, CHICAGO, IL. FILED 6-17-2011.

moe's cantina

NO CLAIM IS MADE TO THE EXCLUSIVE RIGHT TO USE "CANTINA", APART FROM THE MARK AS SHOWN. THE MARK CONSISTS OF THE WORDING "MOE'S CANTINA" IN STYLIZED FONT.

CLASS 25—CLOTHING

FOR CLOTHING, NAMELY, SHIRTS, SWEATSHIRTS, JACKETS, SCARVES, SHORTS, SWEAT PANTS; HEADGEAR, NAMELY, HATS, VISORS (U.S. CLS. 22 AND 39).

CLASS 35—ADVERTISING AND BUSINESS

FOR FRANCHISING SERVICES, NAMELY, OFFERING BUSINESS MANAGEMENT ASSISTANCE IN THE ESTABLISHMENT AND OPERATION OF A BAR AND CONCERT VENUE (U.S. CLS. 100, 101 AND 102).

CLASS 41—EDUCATION AND ENTERTAINMENT

FOR ARRANGING AND CONDUCTING OF CONCERTS (U.S. CLS. 100, 101 AND 107).

CLASS 43—HOTEL AND RESTAURANT SERVICES

FOR BAR SERVICES (U.S. CLS. 100 AND 101).
ESTHER BELENKER, EXAMINING ATTORNEY

SN 85-976,657. SKYDIVING SCHOOL, INC., DBA SKYDIVE HAWAII, HONOLULU, HI. FILED 7-18-2011.

SN 85-976,663. THE LAST GREEN VALLEY, DANIELSON, CT. FILED 4-11-2011.

SKYDIVE HAWAII

THE MARK CONSISTS OF STANDARD CHARACTERS WITHOUT CLAIM TO ANY PARTICULAR FONT, STYLE, SIZE, OR COLOR.

NO CLAIM IS MADE TO THE EXCLUSIVE RIGHT TO USE "SKYDIVE" FOR CLASS 35 ONLY, APART FROM THE MARK AS SHOWN.
SEC. 2(F).

CLASS 9—ELECTRICAL AND SCIENTIFIC APPARATUS

FOR BLANK RECORDABLE CD-RS AND DVD-RS; BLANK RECORDABLE DVDS; BLANK USB FLASH DRIVES; COMPUTER STORAGE DEVICES, NAMELY, BLANK FLASH DRIVES; EYEGLOSS CORDS (U.S. CLS. 21, 23, 26, 36 AND 38).

FIRST USE 1-1-1998; IN COMMERCE 1-1-1998.

CLASS 14—JEWELRY

FOR LAPEL PINS; ORNAMENTAL LAPEL PINS; ORNAMENTAL PINS; PINS BEING JEWELRY (U.S. CLS. 2, 27, 28 AND 50).

FIRST USE 1-1-1996; IN COMMERCE 1-1-1996.

CLASS 16—PAPER GOODS AND PRINTED MATTER

FOR DECALS; PAPER WEIGHTS; REMOVABLE TATTOOS; STICKERS; STICKERS AND DECALCOMANIAS; STICKERS AND TRANSFERS; TEMPORARY TATTOOS (U.S. CLS. 2, 5, 22, 23, 29, 37, 38 AND 50).

FIRST USE 7-1-2001; IN COMMERCE 7-1-2001.

CLASS 21—HOUSEWARES AND GLASS

FOR COFFEE CUPS, TEA CUPS AND MUGS; COFFEE MUGS; CUPS AND MUGS; MUGS (U.S. CLS. 2, 13, 23, 29, 30, 33, 40 AND 50).

FIRST USE 1-1-2005; IN COMMERCE 1-1-2005.

CLASS 25—CLOTHING

FOR BASEBALL CAPS; BASEBALL CAPS AND HATS; CAPS; CAPS WITH VISORS; CARGO PANTS; PANTS; SHORT-SLEEVED OR LONG-SLEEVED T-SHIRTS; T-SHIRTS (U.S. CLS. 22 AND 39).

FIRST USE 7-1-1998; IN COMMERCE 7-1-1998.

CLASS 26—FANCY GOODS

FOR CLOTH PATCHES FOR CLOTHING; EMBROIDERED PATCHES FOR CLOTHING; ORNAMENTAL CLOTH PATCHES (U.S. CLS. 37, 39, 40, 42 AND 50).

FIRST USE 7-1-1998; IN COMMERCE 7-1-1998.

CLASS 35—ADVERTISING AND BUSINESS

FOR RETAIL CLOTHING STORES; RETAIL SPORTING GOODS STORES; RETAIL STORE AND ON-LINE RETAIL STORE SERVICES FEATURING SKYDIVING GEAR, SKYDIVING EQUIPMENT, AND PARACHUTE RIGGING; RETAIL STORES FEATURING SKYDIVING GEAR, SKYDIVING EQUIPMENT, AND PARACHUTE RIGGING (U.S. CLS. 100, 101 AND 102).

FIRST USE 1-1-2005; IN COMMERCE 1-1-2005.
TEJBIR SINGH, EXAMINING ATTORNEY



The logo for "The Last Green Valley" features the words "The Last" in blue, "Green" in green, and "Valley" in blue. The "V" in "Valley" is stylized with a green-to-blue gradient.

THE COLOR(S) BLUE AND GREEN IS/ARE CLAIMED AS A FEATURE OF THE MARK.

THE MARK CONSISTS OF THE WORDS "THE", "LAST" AND "VALLEY" PRESENTED IN BLUE FONT AND THE WORD "GREEN" PRESENTED IN GREEN FONT.

CLASS 16—PAPER GOODS AND PRINTED MATTER

FOR PRINTED INSTRUCTIONAL, EDUCATIONAL AND TEACHING MATERIALS IN THE FIELDS OF NATURAL RESOURCE PROTECTION, CULTURAL RESOURCE PROTECTION, ECONOMIC DEVELOPMENT AND COMMUNITY REVITALIZATION IN THE NEW ENGLAND AREA DEFINED BY THE QUINEBAUG AND SHETUCKET RIVERS SYSTEMS; PRINTED MATTER, NAMELY, LEAFLETS, BROCHURES, VISITOR'S GUIDES, AND PRINTED PERIODICALS IN THE FIELD OF TOURISM IN THE NEW ENGLAND AREA DEFINED BY THE QUINEBAUG AND SHETUCKET RIVERS SYSTEMS; EDUCATIONAL PRINTED MATERIAL, NAMELY, NEWSLETTERS, PRESS RELEASES, PRINTED SPEECHES, AND BROCHURES IN THE FIELD OF NATURAL RESOURCE PROTECTION, CULTURAL RESOURCE PROTECTION, ECONOMIC DEVELOPMENT, AND COMMUNITY REVITALIZATION IN THE NEW ENGLAND AREA DEFINED BY THE QUINEBAUG AND SHETUCKET RIVERS SYSTEMS; EDUCATIONAL PRINTED MATERIAL, NAMELY, POSTERS, MAPS, AND PHOTOGRAPHS OF THE NEW ENGLAND AREA DEFINED BY THE QUINEBAUG AND SHETUCKET RIVERS SYSTEMS (U.S. CLS. 2, 5, 22, 23, 29, 37, 38 AND 50).

FIRST USE 11-1-2008; IN COMMERCE 11-1-2008.

CLASS 35—ADVERTISING AND BUSINESS

FOR CHARITABLE SERVICES, NAMELY, PROMOTING PUBLIC AWARENESS OF NATURAL RESOURCE PROTECTION, CULTURAL RESOURCE PROTECTION, ECONOMIC DEVELOPMENT, AND COMMUNITY REVITALIZATION IN THE NEW ENGLAND AREA DEFINED BY THE QUINEBAUG AND SHETUCKET RIVERS SYSTEMS; CHARITABLE SERVICES, NAMELY, ORGANIZING AND CONDUCTING VOLUNTEER PROGRAMS AND COMMUNITY SERVICE PROJECTS IN THE NEW ENGLAND AREA DEFINED BY THE QUINEBAUG AND SHETUCKET RIVERS SYSTEMS; CHARITABLE SERVICES, NAMELY, PROMOTING ENVIRONMENTAL AWARENESS TO THE PUBLIC IN THE NEW ENGLAND AREA DEFINED BY THE QUINEBAUG AND SHETUCKET RIVERS SYSTEMS; PROMOTING THE COLLABORATION AND EXCHANGE OF INFORMATION AND RESOURCES WITHIN THE SCIENTIFIC, RESEARCH AND PROVIDER COMMUNITIES TO ACHIEVE ADVANCES IN NATURAL RESOURCE PROTECTION, CULTURAL RESOURCE PROTECTION, ECONOMIC DEVELOPMENT AND COMMUNITY REVITALIZATION IN THE NEW ENGLAND AREA DEFINED BY THE QUINEBAUG AND SHETUCKET RIVERS SYSTEMS; WRITING OF GRANT PROPOSALS FOR NOT-FOR PROFIT ORGANIZATIONS, EDUCATIONAL INSTITUTIONS AND OTHER COMMUNITY ORGANIZATIONS IN THE NEW ENGLAND AREA DEFINED BY THE QUINEBAUG AND SHETUCKET RIVERS SYSTEMS; ADMINISTRATION AND MANAGEMENT OF RESEARCH GRANTS IN THE NEW ENGLAND AREA DEFINED BY THE QUINEBAUG AND SHETUCKET RIVERS SYSTEMS; ADVERTISING, MARKETING AND PROMOTIONAL SERVICES IN THE NEW ENGLAND AREA DEFINED BY THE QUINEBAUG AND SHETUCKET RIVERS SYSTEMS; DISSEMINATION OF ADVERTISING AND MARKETING MATERIAL TO PROMOTE NATURAL RESOURCE PROTECTION, CULTURAL RESOURCE PROTECTION, ECONOMIC DEVELOPMENT, AND COMMUNITY REVITALIZATION IN THE NEW ENGLAND AREA DEFINED BY THE QUINEBAUG AND SHETUCKET RIVERS SYSTEMS.

OPMENT AND COMMUNITY REVITALIZATION IN THE NEW ENGLAND AREA DEFINED BY THE QUINEBAUG AND SHETUCKET RIVERS SYSTEMS; PROVIDING A WEBSITE FEATURING INFORMATION TO PROMOTE THE ECONOMIC DEVELOPMENT AND COMMUNITY REVITALIZATION IN THE NEW ENGLAND AREA DEFINED BY THE QUINEBAUG AND SHETUCKET RIVERS SYSTEMS; CHARITABLE SERVICES, NAMELY, ORGANIZING AND CONDUCTING VOLUNTEER PROGRAMS TO MONITOR WATER QUALITY IN THE NEW ENGLAND AREA DEFINED BY THE QUINEBAUG AND SHETUCKET RIVERS SYSTEMS; CHARITABLE SERVICES, NAMELY, ORGANIZING COMMUNITY SERVICE PROJECTS RELATING TO RIVER, TRAIL AND EARTH DAY CLEANUPS IN THE NEW ENGLAND AREA DEFINED BY THE QUINEBAUG AND SHETUCKET RIVERS SYSTEMS; PROVIDING INFORMATION TO PROMOTE THE ECONOMIC DEVELOPMENT AND COMMUNITY REVITALIZATION IN THE NEW ENGLAND AREA DEFINED BY THE QUINEBAUG AND SHETUCKET RIVERS SYSTEMS; CHARITABLE SERVICES, NAMELY, COORDINATION OF NON-MONETARY CONTRIBUTIONS TO CHARITIES AND NON-PROFITS IN THE NEW ENGLAND AREA DEFINED BY THE QUINEBAUG AND SHETUCKET RIVERS SYSTEMS (U.S. CLS. 100, 101 AND 102).

FIRST USE 11-1-2008; IN COMMERCE 11-1-2008.

CLASS 36—INSURANCE AND FINANCIAL

FOR CHARITABLE FUNDRAISING SERVICES IN THE NEW ENGLAND AREA DEFINED BY THE QUINEBAUG AND SHETUCKET RIVERS SYSTEMS; CHARITABLE FUNDRAISING SERVICES BY MEANS OF ORGANIZING AND CONDUCTING SPECIAL EVENTS AND SEASONAL EVENTS IN THE NEW ENGLAND AREA DEFINED BY THE QUINEBAUG AND SHETUCKET RIVERS SYSTEMS; CHARITABLE FUNDRAISING SERVICES BY MEANS OF RUNNING AND WALKING EVENTS IN THE NEW ENGLAND AREA DEFINED BY THE QUINEBAUG AND SHETUCKET RIVERS SYSTEMS; CHARITABLE FUNDRAISING SERVICES BY MEANS OF ORGANIZING AND CONDUCTING PROJECTS TO PROMOTE AWARENESS OF NATURAL RESOURCE PROTECTION, CULTURAL RESOURCE PROTECTION, ECONOMIC DEVELOPMENT, AND COMMUNITY REVITALIZATION IN THE NEW ENGLAND AREA DEFINED BY THE QUINEBAUG AND SHETUCKET RIVERS SYSTEMS; CHARITABLE FUNDRAISING SERVICES BY MEANS OF SELLING GOODS TO RAISE FUNDS IN THE NEW ENGLAND AREA DEFINED BY THE QUINEBAUG AND SHETUCKET RIVERS SYSTEMS; CHARITABLE SERVICES, NAMELY, GRANTING FUNDS TO ORGANIZATIONS AND INDIVIDUALS SEEKING TO PROMOTE NATURAL RESOURCE PROTECTION, CULTURAL RESOURCE PROTECTION, ECONOMIC DEVELOPMENT AND COM-

MUNITY REVITALIZATION IN THE NEW ENGLAND AREA DEFINED BY THE QUINEBAUG AND SHETUCKET RIVERS SYSTEMS; ACCEPTING AND ADMINISTERING MONETARY CHARITABLE CONTRIBUTIONS IN THE NEW ENGLAND AREA DEFINED BY THE QUINEBAUG AND SHETUCKET RIVERS SYSTEMS; PROVIDING GRANTS FOR ENVIRONMENTAL, NATURAL RESOURCE PRESERVATION, ECONOMIC PRESERVATION AND CULTURAL AWARENESS PROJECTS IN THE NEW ENGLAND AREA DEFINED BY THE QUINEBAUG AND SHETUCKET RIVERS SYSTEMS (U.S. CLS. 100, 101 AND 102).

FIRST USE 11-1-2008; IN COMMERCE 11-1-2008.

CLASS 41—EDUCATION AND ENTERTAINMENT

FOR ORGANIZING COMMUNITY SPORTING AND CULTURAL EVENTS IN THE NEW ENGLAND AREA DEFINED BY THE QUINEBAUG AND SHETUCKET RIVERS SYSTEMS; EDUCATIONAL SERVICES, NAMELY, PROVIDING INFORMATION ABOUT EDUCATION RELATING TO TEACHING OF NATURAL RESOURCE PROTECTION, CULTURAL RESOURCE PROTECTION, ECONOMIC DEVELOPMENT AND COMMUNITY REVITALIZATION TO STUDENTS IN THE NEW ENGLAND AREA DEFINED BY THE QUINEBAUG AND SHETUCKET RIVERS SYSTEMS; EDUCATIONAL SERVICES, NAMELY, CONDUCTING PROGRAMS IN THE FIELDS OF NATURAL RESOURCE PROTECTION, CULTURAL RESOURCE PROTECTION, ECONOMIC DEVELOPMENT AND COMMUNITY REVITALIZATION IN THE NEW ENGLAND AREA DEFINED BY THE QUINEBAUG AND SHETUCKET RIVERS SYSTEMS; EDUCATIONAL SERVICES, NAMELY, PROVIDING SPEECHES IN THE NATURE OF LECTURES, CONFERENCES AND WORKSHOPS IN THE FIELDS OF NATURAL RESOURCE PROTECTION, CULTURAL RESOURCE PROTECTION, ECONOMIC DEVELOPMENT AND COMMUNITY REVITALIZATION IN THE NEW ENGLAND AREA DEFINED BY THE QUINEBAUG AND SHETUCKET RIVERS SYSTEMS; PROVIDING ONLINE NEWSLETTERS IN THE FIELDS OF NATURAL RESOURCE PROTECTION, CULTURAL RESOURCE PROTECTION, ECONOMIC DEVELOPMENT AND COMMUNITY REVITALIZATION IN THE NEW ENGLAND AREA DEFINED BY THE QUINEBAUG AND SHETUCKET RIVERS SYSTEMS; DEVELOPMENT AND DISSEMINATION OF EDUCATIONAL MATERIALS OF OTHERS, NAMELY, E-NEWSLETTERS AND DIGITAL RECORDINGS IN THE FIELDS OF NATURAL RESOURCE PROTECTION, CULTURAL RESOURCE PROTECTION, ECONOMIC DEVELOPMENT AND COMMUNITY REVITALIZATION IN THE NEW ENGLAND AREA DEFINED BY THE QUINEBAUG AND SHETUCKET RIVERS SYSTEMS (U.S. CLS. 100, 101 AND 107).

FIRST USE 11-1-2008; IN COMMERCE 11-1-2008.

B. PARADEWELAI, EXAMINING ATTORNEY

* * * * *

SECTION 2.— INTERNATIONAL CLASSIFICATION

The short titles associated below with the international class numbers are terms designed merely for quick identification and are not an official part of the international classification. The full names of international classes are given in section 6.1 of the trademark rules of practice.

The designation "U.S. Cl." appearing in this section refers to the U.S. class in effect prior to Sep. 1, 1973 rather than the international class which applies to applications filed on or after that date. For adoption of international classification see notice in the OFFICIAL GAZETTE of Jun. 26, 1973 (911 O.G. TM 210).

Application in one class

CLASS 1—CHEMICALS

SN 76-704,865. VAN HEES GMBH, 65396 WALLUF, FED REP GERMANY, FILED 10-13-2010.

CLASS 1—(Continued).

SN 76-708,537. ENVIRONMENTAL ALTERNATIVES INC., KEENE, NH. FILED 7-29-2011.

Rad - Release

BOMBAL

THE MARK CONSISTS OF STANDARD CHARACTERS WITHOUT CLAIM TO ANY PARTICULAR FONT, STYLE, SIZE, OR COLOR.

FOR A RADIOLOGICAL DECONTAMINATION SOLUTION IN THE FIELD OF CHEMISTRY USED TO DECONTAMINATE CUSTOMER'S ASSETS (U.S. CLS. 1, 5, 6, 10, 26 AND 46).

FIRST USE 9-1-2007; IN COMMERCE 9-1-2007.

NAKWAMA ANKRAH, EXAMINING ATTORNEY

THE MARK CONSISTS OF STANDARD CHARACTERS WITHOUT CLAIM TO ANY PARTICULAR FONT, STYLE, SIZE, OR COLOR.

FOR CHEMICAL COMPOSITIONS FOR KEEPING FRESH AND PRESERVING LIVER SAUSAGES, SAUSAGE AND GERMAN SALAMI, FOR USE IN SAUSAGE SUBSTANCES, FOR INHIBITING BACTERIA GROWTH, AS ADDITIVE SUBSTANCES FOR BLANCHING OR COOKING WATER WHEN TREATING SAUSAGE INGREDIENTS, FOR IMMERSING COOKED OR SMOKED SAUSAGE PRODUCTS AND CANNED SAUSAGES, FOR PRESERVATION, AS PRODUCTS AGAINST MILDEW AND AS PRODUCTS FOR TREATMENT OF SAUSAGE CASINGS, IN ORDER TO MAKE THEM STERILE AND SMOOTH, ALL OF THE AFORESAID FOR USE IN MANUFACTURING SAUSAGE FOOD PRODUCTS; CHEMICAL COMPOSITIONS FOR PRESERVING, EMULSIFYING, CURING, MATURING AND PRESERVING MEAT PRODUCTS; AND COMPOSITIONS FOR PRESERVING FOODSTUFFS; COMPOSITIONS FOR USE IN THE MANUFACTURE OF FOOD, NAMELY, COMPOSITIONS FOR INFLUENCING THE CONSISTENCY AND COLOR OF MEAT AND MEAT PRODUCTS; COMPOSITIONS FOR TENDERIZING MEAT; LACTOSE PRODUCTS, NAMELY, LACTOSE TO BE USED IN THE MANUFACTURE OF FOODSTUFFS (U.S. CLS. 1, 5, 6, 10, 26 AND 46).

FIRST USE 0-0-2002; IN COMMERCE 0-0-2002.

BRIAN NEVILLE, EXAMINING ATTORNEY

SN 76-710,055. MALVERN MINERALS COMPANY, HOT SPRINGS, AR. FILED 12-19-2011.

NOVACITE

THE MARK CONSISTS OF STANDARD CHARACTERS WITHOUT CLAIM TO ANY PARTICULAR FONT, STYLE, SIZE, OR COLOR.

OWNER OF U.S. REG. NO. 698,758. FOR RAW POWDERED SILICA FOR INDUSTRIAL USE (U.S. CLS. 1, 5, 6, 10, 26 AND 46).

FIRST USE 0-0-1944; IN COMMERCE 0-0-1944.

TINA BROWN, EXAMINING ATTORNEY

CLASS 1—(Continued).

SN 79-099,966. TECHNO SEMICHEM CO., LTD., GYEONG-GI-DO, REPUBLIC OF KOREA, FILED 4-26-2011.



The logo for "soulbrain" features the word "soul" in a blue, lowercase, sans-serif font, followed by "brain" in a grey, lowercase, sans-serif font. The "l" in "soul" and the "b" in "brain" are connected.

OWNER OF INTERNATIONAL REGISTRATION 1084033 DATED 4-26-2011, EXPIRES 4-26-2021.

THE COLOR(S) BLUE, PURPLE AND GREY IS/ARE CLAIMED AS A FEATURE OF THE MARK.

THE WORDS "SOUL" ARE IN BLUE; THE WORDS "BRAIN" IN GREY; A PART OF "L" OF "SOUL" OVERLAPPED WITH "B" OF "BRAIN" IS IN PURPLE.

FOR CAUSTIC ALKALI; CAUSTIC SODA FOR INDUSTRIAL PURPOSES; DIOXIDE OF HYDROGEN FOR INDUSTRIAL USE; GLYCERINE FOR INDUSTRIAL PURPOSES; CHEMICAL PREPARATIONS FOR INDUSTRIAL OR SCIENTIFIC PURPOSES; CAUSTICS FOR INDUSTRIAL PURPOSES, NAMELY, CAUSTIC SODA; INDUSTRIAL CHEMICALS; SALTS FOR INDUSTRIAL PURPOSES, NAMELY, MAGNESIUM SALTS; ACETATES, BEING CHEMICALS, FOR INDUSTRIAL PURPOSE; CARBON BLACK FOR INDUSTRIAL PURPOSES; PERCHLORATES, NAMELY, AMMONIUM PERCHLORATE; SILICON; SODIUM SALTS AS CHEMICAL PREPARATIONS; ACID PROOF CHEMICAL COMPOSITIONS, NAMELY, METAL PLATING CHEMICAL COMPOSITIONS; POTASSIUM DIOXALATE; ANHYDRIDES; ANTIFREEZING AGENTS, NAMELY, ANTIFREEZE; FLUORINE IN THE NATURE OF FLUORINE RESINS; FLUORSPAR COMPOUNDS; HYDROFLUORIC ACID; BORAX; BORATES; SORREL SALT; LITHIA, BEING LITHIUM OXIDE; CHROMIUM OXIDE; SALICYLIC ACID FOR INDUSTRIAL USES; ALUMINUM HYDRATE; CALCIUM HYDROXIDE; HYDROGEN; SALTS OF ALKALINE METALS; ALKALIES; ALKALINE-EARTH METALS; ALCOHOL, NAMELY, ALCOHOL FOR INDUSTRIAL PURPOSES; ETHYL ALCOHOL; AMMONIUM SALTS FOR INDUSTRIAL PURPOSES; CHEMICAL PREPARATIONS, EXCEPT PIGMENTS, FOR THE MANUFACTURE OF ENAMEL; HYDROCHLORATES; CHLORIDES, NAMELY, ALUMINUM CHLORIDE; SAL AMMONIAC; OXALIC ACID; IODIC ACID; FLOCCULANTS; CHEMICAL PREPARATIONS, NAMELY, ION EXCHANGERS; PHOSPHORIC ACID; AUTOMOBILE BODY FILLERS; CHEMICAL ADDITIVES TO MOTOR FUEL; BATTERY ANTI-SULPHURIZING AGENTS, NAMELY, BATTERY ELECTROLYTES; DETERGENTS FOR USE IN MANUFACTURING PROCESSES; NITRIC ACID; NITRATES, NAMELY, IRON NITRATE; HYPOCHLORITE OF SODA; IRON SALTS; CHEMICALS, NAMELY, ACETATES; CALCIUM SALTS; CHEMICAL REAGENTS OTHER THAN FOR MEDICAL OR VETERINARY PURPOSES; BROMINE FOR CHEMICAL PURPOSES; SULPHURIC ACID; COPPER SULPHATE VITRIOL; ETCHANT FOR SEMICONDUCTOR MANUFACTURING PROCESSES; ETCHANT FOR LCD MANUFACTURING PROCESSES; ETCHANT FOR TFT-LCD MANUFACTURING PROCESSES; THIN FILMS FOR SEMICONDUCTOR MANUFACTURING; NITRIDE THIN FILMS; EPI-SILICON THIN FILMS; ABRASIVE COMPOSITION USED IN MANUFACTURE OF SEMICONDUCTOR MANUFACTURING PROCESSES; ELECTROLYTES, NAMELY, BATTERY ELECTROLYTES (U.S. CLS. 1, 5, 6, 10, 26 AND 46).

DAVID HOFFMAN, EXAMINING ATTORNEY

CLASS 1—(Continued).

SN 79-100,263. DANISCO US INC., UNITED STATES, FILED 5-27-2011.



The logo for "TRIO" consists of the word "TRIO" in a large, bold, black, serif font.

THE MARK CONSISTS OF STANDARD CHARACTERS WITHOUT CLAIM TO ANY PARTICULAR FONT, STYLE, SIZE, OR COLOR.

PRIORITY DATE OF 5-24-2011 IS CLAIMED.

OWNER OF INTERNATIONAL REGISTRATION 1084811 DATED 5-27-2011, EXPIRES 5-27-2021.

FOR ENZYMES FOR USE IN THE PROCESSING OF GRAINS FOR THE MANUFACTURE OF BIOFUELS, BIOCHEMICALS AND PRODUCTS, NAMELY, BIOCHEMICAL CATALYSTS FROM RENEWABLE CARBON FEEDSTOCKS, AND ENZYMES FOR USE IN THE CONVERSION OF CELLULOSIC BIOMASS TO SUGARS AND OTHER FOOD PRODUCTS (U.S. CLS. 1, 5, 6, 10, 26 AND 46).

MARLENE BELL, EXAMINING ATTORNEY

SN 79-102,675. CLARIANT AG, SWITZERLAND, FILED 8-11-2011.



The logo for "PERLOGEN" consists of the word "PERLOGEN" in a large, bold, black, sans-serif font.

THE MARK CONSISTS OF STANDARD CHARACTERS WITHOUT CLAIM TO ANY PARTICULAR FONT, STYLE, SIZE, OR COLOR.

PRIORITY DATE OF 3-10-2011 IS CLAIMED.

OWNER OF INTERNATIONAL REGISTRATION 1091004 DATED 8-11-2011, EXPIRES 8-11-2021.

FOR CHEMICAL PRODUCTS, NAMELY, CHEMICAL PREPARATIONS FOR USE IN INDUSTRIAL AND SCIENTIFIC PURPOSES (U.S. CLS. 1, 5, 6, 10, 26 AND 46).

CARYN GLASSER, EXAMINING ATTORNEY

SN 79-111,296. JSR CORPORATION, JAPAN, FILED 1-10-2012.



The logo for "Omnisphere" consists of the word "Omnisphere" in a large, black, serif font with a thin outline.

THE MARK CONSISTS OF STANDARD CHARACTERS WITHOUT CLAIM TO ANY PARTICULAR FONT, STYLE, SIZE, OR COLOR.

OWNER OF INTERNATIONAL REGISTRATION 1111938 DATED 1-10-2012, EXPIRES 1-10-2022.

FOR CHEMICAL PREPARATIONS FOR SCIENTIFIC PURPOSES, OTHER THAN FOR MEDICAL OR VETERINARY USE; CHEMICAL REAGENTS FOR ISOLATION, DETECTION, MEASUREMENT AND ANALYSIS OF BIOLOGICAL EXTRACTS, BIOLOGICAL ANALYTES, OR BIOLOGICAL MATERIALS SUCH AS NUCLEIC ACID, PROTEIN, POLYPEPTIDE OR ANTIBODY; INDUSTRIAL CHEMICALS; SYNTHETIC RESIN PARTICLES OR NATURALLY-DERIVED RESIN PARTICLES DISPERSED IN WATER OR ORGANIC SOLVENTS; SYNTHETIC RESIN PARTICLES OR NATURALLY-DERIVED RESIN PARTICLES IN THE FORM OF POWDER (U.S. CLS. 1, 5, 6, 10, 26 AND 46).

ADA HAN, EXAMINING ATTORNEY

CLASS 1—(Continued).

SN 85-213,905. AGILEX FLAVOR & FRAGRANCES, PISCATAWAY, NJ. FILED 1-10-2011.

DUOGEL

THE MARK CONSISTS OF STANDARD CHARACTERS WITHOUT CLAIM TO ANY PARTICULAR FONT, STYLE, SIZE, OR COLOR.

FOR COMPONENTS USED IN THE MANUFACTURE OF INDUSTRIAL AND CONSUMER FRAGRANCED PRODUCTS, NAMELY, FRAGRANCES FOR USE IN MANUFACTURING AIR FRESHENERS, POTPOURRI AND INSECT REPELLANT IN THE NATURE OF FRAGRANCED GELS (U.S. CLS. 1, 5, 6, 10, 26 AND 46).

TRACY FLETCHER, EXAMINING ATTORNEY

CLASS 1—(Continued).

SN 85-348,286. CYTOZYME LABORATORIES, INC., SALT LAKE CITY, UT. FILED 6-16-2011.

CROP+

THE MARK CONSISTS OF STANDARD CHARACTERS WITHOUT CLAIM TO ANY PARTICULAR FONT, STYLE, SIZE, OR COLOR.

FOR PLANT GROWTH NUTRIENTS; PLANT NUTRITION PREPARATIONS; PREPARATIONS FOR FORTIFYING PLANTS; AND FERTILIZERS (U.S. CLS. 1, 5, 6, 10, 26 AND 46).

FIRST USE 2-0-1977; IN COMMERCE 2-11-1977.

ANDREA HACK, EXAMINING ATTORNEY

SN 85-344,939. VIRENT ENERGY SYSTEMS, INC., MADISON, WI. FILED 6-13-2011.

BIOFORM PX

THE MARK CONSISTS OF STANDARD CHARACTERS WITHOUT CLAIM TO ANY PARTICULAR FONT, STYLE, SIZE, OR COLOR.

OWNER OF U.S. REG. NO. 3,418,993.

NO CLAIM IS MADE TO THE EXCLUSIVE RIGHT TO USE "PX", APART FROM THE MARK AS SHOWN.

FOR CHEMICALS FOR USE IN INDUSTRY, NAMELY, CHEMICALS FOR USE IN THE MANUFACTURE OF PLASTICS (U.S. CLS. 1, 5, 6, 10, 26 AND 46).

MAUREEN DALL, EXAMINING ATTORNEY

SN 85-364,941. SL PARKHURST CORPORATION, ROUND ROCK, TX. FILED 7-7-2011.

Novexium

THE MARK CONSISTS OF STANDARD CHARACTERS WITHOUT CLAIM TO ANY PARTICULAR FONT, STYLE, SIZE, OR COLOR.

OWNER OF U.S. REG. NO. 2,847,494.

FOR CHEMICAL PREPARATIONS IN THE NATURE OF FILTERING MATERIALS FOR THE ELIMINATION OF MALODORANT GASES PRESENT IN CONSUMER, COMMERCIAL AND INDUSTRIAL ENVIRONMENTS (U.S. CLS. 1, 5, 6, 10, 26 AND 46).

FIRST USE 10-1-2001; IN COMMERCE 2-1-2002.

ANTHONY RINKER, EXAMINING ATTORNEY

SN 85-347,910. CYTOZYME LABORATORIES, INC., SALT LAKE CITY, UT. FILED 6-16-2011.

SEED+

THE MARK CONSISTS OF STANDARD CHARACTERS WITHOUT CLAIM TO ANY PARTICULAR FONT, STYLE, SIZE, OR COLOR.

FOR PLANT GROWTH NUTRIENTS FOR TREATMENT OF SEEDS FOR USE IN AGRICULTURE, HORTICULTURE AND FORESTRY, PLANT NUTRITION PREPARATIONS FOR THE TREATMENT OF SEEDS (U.S. CLS. 1, 5, 6, 10, 26 AND 46).

FIRST USE 6-0-1976; IN COMMERCE 6-0-1976.

ANDREA HACK, EXAMINING ATTORNEY

SN 85-381,487. CRI CATALYST COMPANY, HOUSTON, TX. FILED 7-26-2011.

HI-PZ25

THE MARK CONSISTS OF STANDARD CHARACTERS WITHOUT CLAIM TO ANY PARTICULAR FONT, STYLE, SIZE, OR COLOR.

FOR ZEOLITE USED AS CATALYST FOR CHEMICAL AND BIOCHEMICAL PROCESSES (U.S. CLS. 1, 5, 6, 10, 26 AND 46).

DOMINICK J. SALEMI, EXAMINING ATTORNEY

CLASS 1—(Continued).

SN 85-402,759. FIBREK RECYCLING U.S., INC., MENOMINEE, MI. FILED 8-19-2011.

MOUNTAIN PULP

THE MARK CONSISTS OF STANDARD CHARACTERS WITHOUT CLAIM TO ANY PARTICULAR FONT, STYLE, SIZE, OR COLOR.
NO CLAIM IS MADE TO THE EXCLUSIVE RIGHT TO USE "PULP", APART FROM THE MARK AS SHOWN.
FOR PAPER PULP (U.S. CLS. 1, 5, 6, 10, 26 AND 46).
FIRST USE 5-1-1998; IN COMMERCE 5-1-1998.
LINDA ESTRADA, EXAMINING ATTORNEY

SN 85-434,936. PERMEATOR DISTRIBUTORS, LLC, HUDSONVILLE, MI. FILED 9-29-2011.



NO CLAIM IS MADE TO THE EXCLUSIVE RIGHT TO USE "FIRE", APART FROM THE MARK AS SHOWN.
THE COLOR(S) RED, BLUE AND BLACK IS/ARE CLAIMED AS A FEATURE OF THE MARK.
THE MARK CONSISTS OF THE WORD "FIRE" IN RED AND OUTLINED IN BLACK FOLLOWED BY THE WORD "CAP" IN BLUE AND THE WORD "PLUS" IN RED; SURROUNDING THE WORDING IS A SWIRL TYPE DESIGN THAT FORMS AN INCOMPLETE OVAL AND THAT GOES FROM BLUE TO LIGHTER BLUE FROM LEFT TO RIGHT AND IS OUTLINED IN BLACK.
FOR FIRE SUPPRESSION COMPOSITIONS (U.S. CLS. 1, 5, 6, 10, 26 AND 46).
FIRST USE 7-1-2011; IN COMMERCE 7-1-2011.
MARY CRAWFORD, EXAMINING ATTORNEY

CLASS 1—(Continued).

SN 85-437,803. ECOLOGICAL LABORATORIES, INC., LYNBROOK, NY. FILED 10-3-2011.



OWNER OF U.S. REG. NO. 1,192,959.
NO CLAIM IS MADE TO THE EXCLUSIVE RIGHT TO USE "MICROBE", APART FROM THE MARK AS SHOWN.
THE MARK CONSISTS OF THE WORDS "MICROBE LIFE", WITH THE WORD "LIFE" SHOWN BELOW THE WORD "MICROBE". THE WORD "MICROBE" IS INTERSECTED WITH TWO OVERLAPPING ORBITAL DESIGNS, WITH THE ORBITALS INTERSECTED IN THE UPPER RIGHT AND LEFT ARMS BY SPHERES AND TWO LEAF DESIGNS.
FOR NUTRIENTS AND FERTILIZERS FOR LAWNS, PLANTS, TREES, SHRUBS AND HYDROPONIC PLANTS (U.S. CLS. 1, 5, 6, 10, 26 AND 46).
ANTHONY RINKER, EXAMINING ATTORNEY

SN 85-452,278. PILOT TRAVEL CENTERS LLC, KNOXVILLE, TN. FILED S.R. 10-20-2011; AM. P.R. 4-17-2012.

Life just got easier.
One swipe
One card
One pump

THE MARK CONSISTS OF STANDARD CHARACTERS WITHOUT CLAIM TO ANY PARTICULAR FONT, STYLE, SIZE, OR COLOR.
FOR DIESEL EXHAUST FLUID (U.S. CLS. 1, 5, 6, 10, 26 AND 46).
FIRST USE 9-1-2011; IN COMMERCE 9-1-2011.
CORY BOONE, EXAMINING ATTORNEY

CLASS 1—(Continued).

SN 85-457,298. INNOLEO LLC, TWINSBURG, OH. FILED 10-26-2011.

INNOLEATE

THE MARK CONSISTS OF STANDARD CHARACTERS WITHOUT CLAIM TO ANY PARTICULAR FONT, STYLE, SIZE, OR COLOR.

FOR CHEMICALS, NAMELY, OLEOCHEMICALS, BIO-BASED CHEMICALS, AND DERIVATIVES THEREOF FOR USE IN INDUSTRIAL AND CONSUMER PRODUCT APPLICATIONS; OLEOCHEMICALS, BIOBASED CHEMICALS, AND DERIVATIVES THEREOF DERIVED FROM PLANTS FOR USE IN INDUSTRIAL AND CONSUMER PRODUCT APPLICATIONS; CHEMICALS, NAMELY, CASTOR OIL DERIVATIVES, PALM OIL DERIVATIVE, COCONUT OIL DERIVATIVES, SOY BEAN OIL DERIVATIVES, FATTY ACID DERIVATIVES, ESTERS, DIBASIC FATTY ACID ESTERS, SURFACTANTS, FATTY ACID ETHOXYLATES, CASTOR OIL ETHOXYLATES, METHYL 12-HYDROXY STEARATE, METHYL RICINOLEATE, DI-METHYL SEBACATE, DI-BUTYL SEBACATE, DI-OCTYL SEBACATE, ZINC RICINOLEATE, ZINC UNDECYLENATE, ACETIC ANHYDRIDE DERIVATIVES FOR USE IN THE INDUSTRIAL AND CONSUMER PRODUCT APPLICATIONS (U.S. CLS. 1, 5, 6, 10, 26 AND 46).

ASMAT KHAN, EXAMINING ATTORNEY

SN 85-457,303. INNOLEO LLC, TWINSBURG, OH. FILED 10-26-2011.

INNOLAMIDE

THE MARK CONSISTS OF STANDARD CHARACTERS WITHOUT CLAIM TO ANY PARTICULAR FONT, STYLE, SIZE, OR COLOR.

FOR CHEMICALS, NAMELY, OLEOCHEMICALS, BIO-BASED CHEMICALS, AND DERIVATIVES THEREOF FOR USE IN INDUSTRIAL AND CONSUMER PRODUCT APPLICATIONS; OLEOCHEMICALS, BIOBASED CHEMICALS, AND DERIVATIVES THEREOF DERIVED FROM PLANTS FOR USE IN INDUSTRIAL AND CONSUMER PRODUCT APPLICATIONS; CHEMICALS, NAMELY, CASTOR OIL DERIVATIVES, PALM OIL DERIVATIVE, COCONUT OIL DERIVATIVES, SOY BEAN OIL DERIVATIVES, FATTY ACID DERIVATIVES, FATTY AMIDES, BISAMIDES FOR USE IN INDUSTRIAL AND CONSUMER PRODUCT APPLICATIONS (U.S. CLS. 1, 5, 6, 10, 26 AND 46).

ASMAT KHAN, EXAMINING ATTORNEY

CLASS 1—(Continued).

SN 85-466,408. DENKI KAGAKU KOGYO KABUSHIKI KAISHA, CHUO-KU, TOKYO., JAPAN, FILED 11-7-2011.

DENKA MBS

OWNER OF U.S. REG. NOS. 896,712, 3,754,853 AND OTHERS.

THE MARK CONSISTS OF THE WORDS "DENKA MBS" WRITTEN IN A STYLIZED FORMAT.

FOR UNPROCESSED PLASTICS IN ALL FORMS; METHYL METHACRYLATE BUTADIENE-STYRENE COPOLYMER RESINS; POLYMERIZATION PLASTICS (U.S. CLS. 1, 5, 6, 10, 26 AND 46).

SUE LAWRENCE, EXAMINING ATTORNEY

SN 85-487,174. OMS INVESTMENTS, INC., LOS ANGELES, CA. FILED 12-5-2011.

NATURE'S CARE

THE MARK CONSISTS OF STANDARD CHARACTERS WITHOUT CLAIM TO ANY PARTICULAR FONT, STYLE, SIZE, OR COLOR.

OWNER OF U.S. REG. NOS. 3,250,568 AND 3,375,928.

FOR FERTILIZERS, PLANT FOODS; PLANT GROWTH REGULATORY PREPARATIONS AND SUBSTANCES, PLANT GROWTH STIMULANTS AND ENHANCERS; SOIL CONDITIONERS FOR DOMESTIC AND HORTICULTURAL USE, SOIL AMENDMENTS, SOIL ADDITIVES, SOIL WETTING AGENTS, GROWING MEDIA FOR PLANTS, GARDEN SOILS, PLANTING SOILS, POTTING SOILS, COMPOST, HUMUS, LOAM, MANURE AND PEAT (U.S. CLS. 1, 5, 6, 10, 26 AND 46).

ROBIN MITTLER, EXAMINING ATTORNEY

SN 85-487,740. TWO LITTLE FISHIES, INC., MIAMI GARDENS, FL. FILED 12-6-2011.

CDX

THE MARK CONSISTS OF STANDARD CHARACTERS WITHOUT CLAIM TO ANY PARTICULAR FONT, STYLE, SIZE, OR COLOR.

FOR AQUARIUM FILTER MEDIA, NAMELY, CHEMICALS USED FOR THE ADSORPTION OF CO₂ (U.S. CLS. 1, 5, 6, 10, 26 AND 46).

GINA FINK, EXAMINING ATTORNEY

CLASS 1—(Continued).

SN 85-493,960. KASTALON, INC., ALSIP, IL. FILED 12-13-2011.

ELASTALON

THE MARK CONSISTS OF STANDARD CHARACTERS WITHOUT CLAIM TO ANY PARTICULAR FONT, STYLE, SIZE, OR COLOR.

FOR CHEMICAL PREPARATIONS AND CHEMICAL COMPOSITIONS FOR INDUSTRIAL USE, NAMELY, UNPROCESSED PLASTIC MATERIALS FOR USE IN THE PLASTICS INDUSTRY (U.S. CLS. 1, 5, 6, 10, 26 AND 46).

FIRST USE 11-30-2011; IN COMMERCE 11-30-2011.
THOMAS MANOR, EXAMINING ATTORNEY

SN 85-496,393. OXITENO S.A. INDÚSTRIA E COMÉRCIO, SÃO PAULO, BRAZIL, FILED 12-15-2011.



THE COLOR(S) BLUE, GREEN AND ORANGE IS/ARE CLAIMED AS A FEATURE OF THE MARK.

THE MARK CONSISTS OF THE WORD "GREEN" IN LOWER CASE BLUE LETTERS DIRECTLY BEFORE THE WORD "FORMANCE" IN DARKER BLUE LOWER CASE LETTERS, ALL DIRECTLY BELOW AN ABSTRACT LEAF COMPOSED OF THREE CONCENTRIC OVAL-LIKE SHAPES, THE FIRST OF WHICH IS DARK GREEN, THE SECOND OF WHICH IS MEDIUM GREEN WITH A BLUE INTERIOR AND THE THIRD OF WHICH IS LIGHT GREEN WITH AN ORANGE INTERIOR. THE COLOR WHITE IS BACKGROUND ONLY AND IS NOT PART OF THE MARK. THE COLORS BLACK, WHITE AND/OR GRAY REPRESENT BACKGROUND, OUTLINING, SHADING AND/OR TRANSPARENT AREAS AND ARE NOT PART OF THE MARK.

FOR CHEMICALS USED IN THE MANUFACTURE OF INDUSTRIAL PRODUCTS, NAMELY, ETHYLENE OXIDE, ETHYLENE GLYCOLS, ETHANOLAMINES, GLYCOL ETHERS, ALCOHOL AND ETHER ACETATES, ETHOXYLATES, PROPOXYLATES, ETHOXYLATES/PROPOXYLATES, NONIONIC SURFACTANTS, ANIONIC SURFACTANTS, AMPHOTERIC SURFACTANTS, NATURAL ALCOHOLS, NONYLPHENOL, FATTY ESTERS, OXYGENATED SOLVENTS, BLENDS AGRO-CHEMICALS, EMULSIFIERS, SURFACE-ACTIVE PREPARATIONS, SULFATED ALCOHOLS, ALKYL BENZENE SULFONATES, NAPHTALENE SULFONATES, BETAINES, CATALYSTS AND METHYL ETHYL KETONE; ENGINE COOLING FLUIDS AND BRAKE FLUIDS (U.S. CLS. 1, 5, 6, 10, 26 AND 46).

EDWARD FENNESSY, EXAMINING ATTORNEY

CLASS 1—(Continued).

SN 85-498,947. COE, KIERAN D, MONTGOMERY, AL. AND LONG, VICTOR M., MILLBROOK, AL. FILED 12-19-2011.

No Shoe Blues

THE MARK CONSISTS OF STANDARD CHARACTERS WITHOUT CLAIM TO ANY PARTICULAR FONT, STYLE, SIZE, OR COLOR.

NO CLAIM IS MADE TO THE EXCLUSIVE RIGHT TO USE "SHOE", APART FROM THE MARK AS SHOWN.

FOR STAIN REPELLENTS FOR SHOES (U.S. CLS. 1, 5, 6, 10, 26 AND 46).

TINA L. SNAPP, EXAMINING ATTORNEY

SN 85-500,959. DENKI KAGAKU KOGYO KABUSHIKI KAISHA, CHUO-KU, TOKYO, JAPAN, FILED 12-21-2011.

MALECCA

THE MARK CONSISTS OF STANDARD CHARACTERS WITHOUT CLAIM TO ANY PARTICULAR FONT, STYLE, SIZE, OR COLOR.

FOR UNPROCESSED PLASTICS IN ALL FORMS; ACRYLONITRILE BUTADIENE STYRENE COPOLYMER RESINS; POLYMERIZATION PLASTICS (U.S. CLS. 1, 5, 6, 10, 26 AND 46).

FIRST USE 1-1-2006; IN COMMERCE 1-1-2006.
SUE LAWRENCE, EXAMINING ATTORNEY

CLASS 1—(Continued).

SN 85-501,411. COMMAX INC., SCHAUMBURG, IL. FILED 12-21-2011.



THE MARK CONSISTS OF THE ITALICIZED UPPER-CASE "EL WORLD". THE LEFT SIDE OF LETTER "O" IS SURROUNDED BY FIRE FLAME AND A MAPLE LEAF IS IN THE MIDDLE OF LETTER "O".

FOR AUTOMOTIVE CARE CHEMICALS, NAMELY, FUEL DRYER AND ANTIFREEZE, STARTING FLUID, POWER STEERING FLUID, AUTOMOBILE TIRE INFLATOR SEALER, CHEMICAL FUEL INJECTOR CLEANER ADDITIVE, CHEMICAL FUEL ADDITIVE TREATMENT, NAMELY, LEAD SUBSTITUTE, CHEMICAL FUEL ADDITIVE STABILIZER TREATMENT, BRAKE FLUID, CHEMICAL OCTANE BOOSTER FUEL ADDITIVE, GAS LINE ANTIFREEZE, RADIATOR FLUSH, AUTOMOBILE COOLING SYSTEM LEAK SEALANT, CHEMICAL GASOLINE TREATMENT ADDITIVE, WINDSHIELD DEICER FLUID, RADIATOR AND COOLING SYSTEM LEAK SEALANT, CHEMICAL FUEL INJECTION CLEANER ADDITIVE AND GASOLINE DRYER, TRANSMISSION LEAK SEALANT, POWER STEERING LEAK SEALANT, ENGINE LEAK SEALANT, CHEMICAL DIESEL FUEL ADDITIVE STABILIZER TREATMENT, CHEMICAL INTERNAL ENGINE CORROSION INHIBITORS, CHEMICAL FUEL ADDITIVE, NAMELY, ENGINE EMISSION REDUCER, CHEMICAL FUEL ADDITIVE, NAMELY, DIESEL FUEL CONDITIONER, CHEMICAL MOTOR OIL ADDITIVE TREATMENT, CHEMICAL MOTOR OIL ADDITIVE, NAMELY, ENGINE FRICTION REDUCER, CHEMICAL RADIATOR CORROSION INHIBITORS, CHEMICAL DIESEL FUEL ADDITIVE TO PREVENT GELLING, CHEMICAL DIESEL FUEL ADDITIVE CONDITIONER, AIR BRAKE ANTIFREEZE, CHEMICAL DIESEL FUEL ADDITIVE TREATMENT, AND LOCK DEICER FLUID (U.S. CLS. 1, 5, 6, 10, 26 AND 46).

FIRST USE 10-1-2011; IN COMMERCE 10-1-2011.
DAVID MURRAY, EXAMINING ATTORNEY

SN 85-506,974. VERSAFLEX, INC., KANSAS CITY, KS. FILED 12-31-2011.

DZOLV

THE MARK CONSISTS OF STANDARD CHARACTERS WITHOUT CLAIM TO ANY PARTICULAR FONT, STYLE, SIZE, OR COLOR.

SEC. 2(F).

FOR CHEMICAL PREPARATIONS, NAMELY, CLEANING SOLVENTS IN THE NATURE OF WATER SOLUBLE, HIGH FLASHPOINT SOLUTIONS FOR REMOVING UNCURED POLYMERIC RESINS AND SOLUTIONS FOR REMOVING UNCURED POLYUREA, POLYURETHANE, EPOXY AND POLYESTER RESINS (U.S. CLS. 1, 5, 6, 10, 26 AND 46).

FIRST USE 4-1-1995; IN COMMERCE 4-1-1995.
KRISTIN DAHLING, EXAMINING ATTORNEY

CLASS 1—(Continued).

SN 85-507,077. GENEFORGE LIMITED, HONG KONG, HONG KONG, FILED 1-2-2012.

GENEFORGE

THE MARK CONSISTS OF STANDARD CHARACTERS WITHOUT CLAIM TO ANY PARTICULAR FONT, STYLE, SIZE, OR COLOR.

FOR ENZYMES FOR THE PRODUCTION OF BIO-FUELS AND OTHER PRODUCTS FROM RENEWABLE CARBON FEEDSTOCKS, AS WELL AS ENZYMES FOR THE CONVERSION OF CELLULOSIC BIOMASS TO SUGARS AND OTHER PRODUCTS (U.S. CLS. 1, 5, 6, 10, 26 AND 46).

FIRST USE 11-13-2009; IN COMMERCE 11-13-2009.
MATTHEW KLINE, EXAMINING ATTORNEY

SN 85-508,020. INTO GREAT BRANDS, INC, GAHANNA, OH. FILED 1-3-2012.

QUICK FIX

THE MARK CONSISTS OF STANDARD CHARACTERS WITHOUT CLAIM TO ANY PARTICULAR FONT, STYLE, SIZE, OR COLOR.

FOR CHEMICAL ADDITIVE FOR OILS (U.S. CLS. 1, 5, 6, 10, 26 AND 46).

FIRST USE 6-24-2011; IN COMMERCE 12-29-2011.
KELLY TRUSILO, EXAMINING ATTORNEY

SN 85-511,520. REAL, JOSELITO G, WOODLAND, CA. FILED 1-9-2012.

X-Frost

THE MARK CONSISTS OF STANDARD CHARACTERS WITHOUT CLAIM TO ANY PARTICULAR FONT, STYLE, SIZE, OR COLOR.

FOR CHEMICAL FERTILIZERS; CHEMICALLY CONVERTED COMPOUND FERTILIZERS; COMPLEX FERTILIZER; COMPLEX FERTILIZERS; FERTILIZERS; FERTILIZERS AND MANURES; FERTILIZERS FOR AGRICULTURAL USE; FERTILIZERS FOR DOMESTIC USE; FERTILIZING PREPARATIONS; HUMIC ACID SOLD AS AN INGREDIENT OF FERTILIZER AND SOIL CONDITIONING PREPARATIONS; MARINE FERTILIZER; MIXED FERTILIZERS; NATURAL FERTILIZERS; NON-CHEMICAL BIO-FERTILIZERS; NUTRITIVE ADDITIVE TO ENHANCE THE BIOLOGICAL ACTIVITY OF WATER, SOIL, SEEDS AND PLANTS FOR PURPOSES OF FERTILIZATION AND BIOREMEDIATION OF POLLUTANTS; UREA FERTILIZER (U.S. CLS. 1, 5, 6, 10, 26 AND 46).

FIRST USE 12-15-2010; IN COMMERCE 1-15-2011.
JENNIFER VASQUEZ, EXAMINING ATTORNEY

CLASS 1—(Continued).

SN 85-512,105. REAL, JOSELITO G, WOODLAND, CA. FILED 1-9-2012.

MX-42

THE MARK CONSISTS OF STANDARD CHARACTERS WITHOUT CLAIM TO ANY PARTICULAR FONT, STYLE, SIZE, OR COLOR.

FOR BOTANICAL EXTRACTS FOR USE IN MAKING COSMETICS; CHEMICALLY CONVERTED COMPOUND FERTILIZERS; COMPLEX FERTILIZER; COMPLEX FERTILIZERS; COMPOST; FERMENTATION EXTRACT; FERTILIZERS; FERTILIZERS AND MANURES; FERTILIZERS FOR AGRICULTURAL USE; FERTILIZERS FOR DOMESTIC USE; FERTILIZING PREPARATIONS; FOOD SUPPLEMENTS FOR AGRICULTURAL PRODUCTS AND OTHER PLANTS; GROWING MEDIA FOR PLANTS; HUMIC ACID SOLD AS AN INGREDIENT OF FERTILIZER AND SOIL CONDITIONING PREPARATIONS; MARINE FERTILIZER; MIXED FERTILIZERS; NATURAL FERTILIZERS; NON-CHEMICAL BIO-FERTILIZERS; NUTRITIVE ADDITIVE TO ENHANCE THE BIOLOGICAL ACTIVITY OF WATER, SOIL, SEEDS AND PLANTS FOR PURPOSES OF FERTILIZATION AND BIOREMEDIATION OF POLLUTANTS; ODOR ELIMINATING TABLETS COMPRISED OF MICROORGANISMS AND ENZYMES TO BE DISSOLVED IN WATER AND USED TO DIGEST ORGANIC WASTE; ORGANIC SOIL ENHANCEMENT POWDERS AND PREPARATIONS; PLANT AND HERB EXTRACTS FOR USE IN THE MANUFACTURE OF COSMETICS; PLANT EXTRACTS FOR USE IN THE MANUFACTURE OF CREAMS, LOTIONS AND COSMETIC PRODUCTS; PLANT EXTRACTS, NAMELY MORINGA, USED IN THE MANUFACTURE OF ORGANIC FERTILIZER; PLANT FOOD; PLANT GROWTH NUTRIENTS; PLANT GROWTH REGULATING PREPARATIONS; PLANT GROWTH REGULATORS FOR AGRICULTURAL USE; PLANT HORMONES (PHYTOHORMONES); PLANT NUTRITION PREPARATIONS; PREPARATIONS FOR FORTIFYING PLANTS; SUBSTANCES FOR REGULATING PLANT GROWTH (U.S. CLS. 1, 5, 6, 10, 26 AND 46).

JENNIFER VASQUEZ, EXAMINING ATTORNEY

SN 85-512,443. LOCKERROOM MARKETING LTD, DELTA, CANADA, FILED 1-10-2012.

ROCHEFORT

THE MARK CONSISTS OF STANDARD CHARACTERS WITHOUT CLAIM TO ANY PARTICULAR FONT, STYLE, SIZE, OR COLOR.

FOR LEATHER CLEANERS (U.S. CLS. 1, 5, 6, 10, 26 AND 46).

JIM RINGLE, EXAMINING ATTORNEY

CLASS 1—(Continued).

SN 85-513,521. GREEN FUTURE SOIL PRODUCTS LLC, ARCATA, CA. FILED 1-11-2012.

GREEN FUTURE INFINITY

THE MARK CONSISTS OF STANDARD CHARACTERS WITHOUT CLAIM TO ANY PARTICULAR FONT, STYLE, SIZE, OR COLOR.

FOR POTTING SOIL (U.S. CLS. 1, 5, 6, 10, 26 AND 46). ALLISON HOLTZ, EXAMINING ATTORNEY

SN 85-513,613. MIDTECH R & D, INC., FAIRMONT, MN. FILED 1-11-2012.

HARVEST MAX

THE MARK CONSISTS OF STANDARD CHARACTERS WITHOUT CLAIM TO ANY PARTICULAR FONT, STYLE, SIZE, OR COLOR.

FOR FERTILIZERS (U.S. CLS. 1, 5, 6, 10, 26 AND 46). KELLY TRUSILO, EXAMINING ATTORNEY

SN 85-513,632. MIDTECH R & D, INC., FAIRMONT, MN. FILED 1-11-2012.



THE MARK CONSISTS OF THE IMAGE OF A LEAF ABOVE THE WORDS "HARVEST MAX" IN STYLIZED LETTERS.

FOR FERTILIZERS (U.S. CLS. 1, 5, 6, 10, 26 AND 46). KELLY TRUSILO, EXAMINING ATTORNEY

CLASS 1—(Continued).

SN 85-514,039. PRIMERATURF, INC., NORTH RIDGEVILLE, OH. FILED 1-11-2012.

INVOKE

THE MARK CONSISTS OF STANDARD CHARACTERS WITHOUT CLAIM TO ANY PARTICULAR FONT, STYLE, SIZE, OR COLOR.

FOR NON-IONIC SURFACTANT FOR SPRAY APPLICATIONS ON TURF AND AGRICULTURAL CROPS (U.S. CLS. 1, 5, 6, 10, 26 AND 46).

BARBARA A. GOLD, EXAMINING ATTORNEY

SN 85-514,058. PRIMERATURF, INC., NORTH RIDGEVILLE, OH. FILED 1-11-2012.

CASTOFF

THE MARK CONSISTS OF STANDARD CHARACTERS WITHOUT CLAIM TO ANY PARTICULAR FONT, STYLE, SIZE, OR COLOR.

FOR DEFOAMING AGENT TO REDUCE FOAM IN SPRAYERS USED FOR TURF AND AGRICULTURAL APPLICATIONS (U.S. CLS. 1, 5, 6, 10, 26 AND 46).

BARBARA A. GOLD, EXAMINING ATTORNEY

SN 85-514,080. VR LABORATORIES, LLC, BONITA SPRINGS, FL. FILED 1-11-2012.

GTE-125

THE MARK CONSISTS OF STANDARD CHARACTERS WITHOUT CLAIM TO ANY PARTICULAR FONT, STYLE, SIZE, OR COLOR.

FOR BOTANICAL EXTRACTS FOR USE IN THE MANUFACTURE OF NUTRACEUTICALS; BOTANICAL EXTRACTS FOR USE IN THE MANUFACTURE OF NUTRACEUTICALS AND PHARMACEUTICALS; BOTANICAL EXTRACTS FOR USE IN THE MANUFACTURE OF NUTRACEUTICALS AND PHARMACEUTICALS; CHEMICAL EXTRACTS AND ACTIVE PRINCIPLES EXTRACTED FROM MEDICINAL PLANTS FOR USE IN THE MANUFACTURE OF NUTRACEUTICALS AND PHARMACEUTICALS, NAMELY, CHEMICAL AGENTS MADE FROM BOTANICAL EXTRACTS; CHEMICAL EXTRACTS AND ACTIVE PRINCIPLES EXTRACTED FROM MEDICINAL PLANTS FOR USE IN THE PHARMACEUTICAL INDUSTRY, NAMELY, CHEMICAL AGENTS MADE FROM BOTANICAL EXTRACTS OR ASSOCIATION OF CHEMICAL EXTRACTS FOR USE IN THE MANUFACTURE OF PHARMACEUTICAL OR NUTRACEUTICAL PRODUCTS; BOTANICAL EXTRACTS FOR USE IN THE MANUFACTURE OF MEDICATED PREPARATIONS IN THE FORM OF LOTIONS, CREAMS, AND TOPICAL ANALGESICS AND ANESTHETICS, TABLETS, CAPSULES, PILLS, LOZENGES,

CLASS 1—(Continued).

INHALERS, TINCTURE, SUPPOSITORIES AND AMPULE FOR INJECTION; BOTANICAL EXTRACTS USED IN THE MANUFACTURE OF PHARMACEUTICAL PREPARATIONS IN THE FORM OF LOTIONS, CREAMS, AND TOPICAL ANALGESICS AND ANESTHETICS, TABLETS, CAPSULES, PILLS, TINCTURE, SUPPOSITORIES AND AMPULE FOR INJECTION; BOTANICAL EXTRACTS FOR USE IN THE MANUFACTURE OF PHARMACEUTICAL PREPARATIONS IN THE FORM OF LOTIONS, CREAMS, AND TOPICAL ANALGESICS AND ANESTHETICS, TABLETS, CAPSULES, PILLS, TINCTURE, SUPPOSITORIES AND AMPULE FOR INJECTION; BOTANICALS AND BOTANICAL BLENDS, HERBALS AND HERBAL BLENDS, BOTANICAL EXTRACTS AND BOTANICAL EXTRACT BLENDS, FLAVOR EXTRACTS AND FLAVOR EXTRACT BLENDS, ALGAL EXTRACTS AND ALGAL EXTRACT BLENDS, ALL FOR USE IN THE MANUFACTURE OF NUTRITIONAL SUPPLEMENTS AND VITAMINS; ALGAL EXTRACTS OR ALGAL EXTRACT BLENDS FOR USE IN THE MANUFACTURE OF NUTRITIONAL AND DIETARY SUPPLEMENTS; ALGAL EXTRACTS AND ALGAL EXTRACT BLENDS, ALL FOR USE IN THE MANUFACTURE OF NUTRITIONAL SUPPLEMENTS AND VITAMINS; MUSHROOM, FUNGUS, AND SPORE EXTRACTS FOR USE IN FOOD MANUFACTURE (U.S. CLS. 1, 5, 6, 10, 26 AND 46).

MARC LEIPZIG, EXAMINING ATTORNEY

SN 85-514,935. CYBERBOND, LLC, BATAVIA, IL. FILED 1-12-2012.

CYBERPRIME

THE MARK CONSISTS OF STANDARD CHARACTERS WITHOUT CLAIM TO ANY PARTICULAR FONT, STYLE, SIZE, OR COLOR.

FOR PRIMERS FOR USE WITH CYANOACRYLATE ADHESIVES (U.S. CLS. 1, 5, 6, 10, 26 AND 46).

FIRST USE 2-0-2004; IN COMMERCE 2-0-2004.

FRANK LATTUCA, EXAMINING ATTORNEY

SN 85-515,817. HOLT CONCEPTS LLC, HAMPSTEAD, NC. FILED 1-13-2012.

Holt's AquaXtend

THE MARK CONSISTS OF STANDARD CHARACTERS WITHOUT CLAIM TO ANY PARTICULAR FONT, STYLE, SIZE, OR COLOR.

FOR SOIL ADDITIVES (U.S. CLS. 1, 5, 6, 10, 26 AND 46).

FIRST USE 8-1-2011; IN COMMERCE 9-13-2011.

WILLIAM JACKSON, EXAMINING ATTORNEY

CLASS 1—(Continued).

SN 85-519,677. FERTILIZER COMPANY OF ARIZONA, INC., AKA FERTIZONA, CASA GRANDE, AZ. FILED S.R. 1-18-2012; AM. P.R. 1-26-2012.

FURST

THE MARK CONSISTS OF STANDARD CHARACTERS WITHOUT CLAIM TO ANY PARTICULAR FONT, STYLE, SIZE, OR COLOR.

FOR FERTILIZERS (U.S. CLS. 1, 5, 6, 10, 26 AND 46).
FIRST USE 6-29-2006; IN COMMERCE 11-20-2006.
MATTHEW EINSTEIN, EXAMINING ATTORNEY

SN 85-520,794. GROWER'S SECRET, INC., HONOLULU, HI. FILED 1-19-2012.

Lush 'N Plush

THE MARK CONSISTS OF STANDARD CHARACTERS WITHOUT CLAIM TO ANY PARTICULAR FONT, STYLE, SIZE, OR COLOR.

FOR FERTILIZERS; ORGANIC GROWING MEDIA PRODUCED FROM FERMENTED EDIBLE MUSHROOMS FOR USE AS A PLANT GROWTH ACCELERANT, GROWTH STIMULANT AND GROWTH ENERGIZER (U.S. CLS. 1, 5, 6, 10, 26 AND 46).
DAWN FELDMAN, EXAMINING ATTORNEY

SN 85-535,985. ESSENTIAL WATER SOLUTIONS INC., STORY CITY, IA. FILED 2-7-2012.



THE COLOR(S) BLUE, WHITE AND BLUE-GREEN COLOR IS/ARE CLAIMED AS A FEATURE OF THE MARK.

THE MARK CONSISTS OF THE LITERAL ELEMENT "ESSENTIALWATERSOLUTIONS" WHEREIN A DROP OF WATER SEEMINGLY DRIPPING INTO A POOL OF WATER CAUSING RIPPLES, DROP AND RIPPLES ARE IN COMBINATION OF BLUE, WHITE AND BLUE-GREEN COLOR BELOW WHICH THE WORDING "ESSENTIAL" AND "SOLUTIONS" IN BLUE AND THE WORD "WATER" IN BLUE-GREEN COLOR OF "ESSENTIALWATERSOLUTIONS" ARE WRITTEN AS SHOWN IN THE MARK.

FOR CHEMICALS FOR USE IN PURIFICATION OF WATER; CHEMICALS FOR THE TREATMENT OF WATER AND WASTEWATER (U.S. CLS. 1, 5, 6, 10, 26 AND 46).

FIRST USE 1-1-2012; IN COMMERCE 1-1-2012.

JANICE L. MCMORROW, EXAMINING ATTORNEY

CLASS 1—(Continued).

SN 85-547,156. WINFIELD SOLUTIONS, LLC, SHOREVIEW, MN. FILED 2-20-2012.

DROPLEX

THE MARK CONSISTS OF STANDARD CHARACTERS WITHOUT CLAIM TO ANY PARTICULAR FONT, STYLE, SIZE, OR COLOR.

FOR ADJUVANTS FOR USE WITH INSECTICIDES, PESTICIDES, AND AGRICULTURAL CHEMICALS, NAMELY, PLANT GROWTH REGULATORS AND CROP PROTECTION CHEMICALS FOR AGRICULTURAL USE (U.S. CLS. 1, 5, 6, 10, 26 AND 46).

JIM RINGLE, EXAMINING ATTORNEY

SN 85-561,848. WINFIELD SOLUTIONS, LLC, SHOREVIEW, MN. FILED 3-6-2012.

ATMOS

THE MARK CONSISTS OF STANDARD CHARACTERS WITHOUT CLAIM TO ANY PARTICULAR FONT, STYLE, SIZE, OR COLOR.

FOR ADJUVANT FOR USE WITH AGRICULTURAL CHEMICALS (U.S. CLS. 1, 5, 6, 10, 26 AND 46).

JIM RINGLE, EXAMINING ATTORNEY

CLASS 2—PAINTS

SN 79-105,100. SHANGHAI EXCILON CHEMICAL CO., LTD., SHANGHAI, CHINA, FILED 9-26-2011.

excilon

PRIORITY DATE OF 4-15-2011 IS CLAIMED.

OWNER OF INTERNATIONAL REGISTRATION 1096883 DATED 9-26-2011, EXPIRES 9-26-2021.

THE MARK CONSISTS OF THE WORDING "EXCILON" IN LOWER CASE LETTERS IN A STYLIZED FONT.

THE WORDING "EXCILON" HAS NO MEANING IN A FOREIGN LANGUAGE.

FOR WHITES AND BLACKS, NAMELY, COLORANTS AND PAINTS; PRINTING INK; PAINTS; BACTERICIDAL PAINTS; CERAMIC PAINTS; FIREPROOF PAINTS; PRIMERS; NON-STICKY CHEMICAL COATING FOR NON-STICK PANS IN THE NATURE OF PAINT; PROTECTIVE PREPARATIONS FOR METALS, NAMELY, EXTERIOR SURFACE PROTECTIVE COATINGS (U.S. CLS. 6, 11 AND 16).

SEAN CROWLEY, EXAMINING ATTORNEY

CLASS 2—(Continued).

SN 85-285,436. COLART FINE ART & GRAPHICS LTD, HARROW, MIDDLESEX, UNITED KINGDOM, FILED 4-4-2011.



OWNER OF U.S. REG. NOS. 1,140,150, 1,621,854 AND OTHERS.

NO CLAIM IS MADE TO THE EXCLUSIVE RIGHT TO USE "ARTISTS' OIL COLOUR", APART FROM THE MARK AS SHOWN.

THE MARK CONSISTS OF THE STYLIZED WORDING "WINSOR & NEWTON" ARCHED ABOVE THE DESIGN OF A GRIFFIN WITH OPEN SIDED ARCHED TRIANGLES ON BOTH SIDES OF THE GRIFFIN DESIGN WITH THE STYLIZED WORDING "ARTISTS'" BELOW THE DESIGN AND THE STYLIZED WORDING "OIL COLOUR" BELOW "ARTISTS'".

FOR COLOURS, NAMELY, PAINTS FOR ARTISTS; PAINTS; DYESTUFFS; NATURAL RESINS; COLOR PIGMENTS; COLOURING MATTERS, NAMELY, COLORANTS FOR USE IN PAINTS AND COLOURS; OIL COLOURS; OIL COLOUR PAINTS (U.S. CLS. 6, 11 AND 16).

KELLEY WELLS, EXAMINING ATTORNEY

SN 85-353,643. GARDNER ASPHALT CORPORATION, TAMPA, FL. FILED 6-22-2011.

POLYCRYL

THE MARK CONSISTS OF STANDARD CHARACTERS WITHOUT CLAIM TO ANY PARTICULAR FONT, STYLE, SIZE, OR COLOR.

FOR FLUID-APPLIED POLYMER AND ELASTOMERIC COATINGS FOR USE ON ROOFS, WALLS AND FOUNDATIONS (U.S. CLS. 6, 11 AND 16).

RONALD MCMORROW, EXAMINING ATTORNEY

SN 85-353,644. GARDNER ASPHALT CORPORATION, TAMPA, FL. FILED 6-22-2011.

THERMOCRYL

THE MARK CONSISTS OF STANDARD CHARACTERS WITHOUT CLAIM TO ANY PARTICULAR FONT, STYLE, SIZE, OR COLOR.

FOR FLUID-APPLIED POLYMER AND ELASTOMERIC COATINGS FOR USE ON ROOFS, WALLS AND FOUNDATIONS (U.S. CLS. 6, 11 AND 16).

RONALD MCMORROW, EXAMINING ATTORNEY

CLASS 2—(Continued).

SN 85-353,646. GARDNER ASPHALT CORPORATION, TAMPA, FL. FILED 6-22-2011.

UREACRYL

THE MARK CONSISTS OF STANDARD CHARACTERS WITHOUT CLAIM TO ANY PARTICULAR FONT, STYLE, SIZE, OR COLOR.

FOR FLUID-APPLIED POLYMER, URETHANE AND ELASTOMERIC COATINGS FOR USE ON ROOFS, WALLS AND FOUNDATIONS (U.S. CLS. 6, 11 AND 16).

RONALD MCMORROW, EXAMINING ATTORNEY

SN 85-353,648. GARDNER ASPHALT CORPORATION, TAMPA, FL. FILED 6-23-2011.

ELASTOCRYL

THE MARK CONSISTS OF STANDARD CHARACTERS WITHOUT CLAIM TO ANY PARTICULAR FONT, STYLE, SIZE, OR COLOR.

FOR FLUID-APPLIED ACRYLIC AND ELASTOMERIC COATINGS FOR USE ON ROOFS, WALLS AND FOUNDATIONS (U.S. CLS. 6, 11 AND 16).

RONALD MCMORROW, EXAMINING ATTORNEY

SN 85-356,822. STONCOR GROUP, INC., MAPLE SHADE, NJ. FILED 6-27-2011.

SAFE-T-GRIP

THE MARK CONSISTS OF STANDARD CHARACTERS WITHOUT CLAIM TO ANY PARTICULAR FONT, STYLE, SIZE, OR COLOR.

FOR EPOXY COATING FOR ASPHALT, CONCRETE, METAL AND WOOD SURFACES (U.S. CLS. 6, 11 AND 16).

FIRST USE 5-4-2007; IN COMMERCE 5-4-2007.

DAVID C. REIHNER, EXAMINING ATTORNEY

CLASS 2—(Continued).

SN 85-432,328. AMERICOATS, FRANKLIN PARK, IL. FILED 9-26-2011.

AMERISHIELD

THE MARK CONSISTS OF STANDARD CHARACTERS WITHOUT CLAIM TO ANY PARTICULAR FONT, STYLE, SIZE, OR COLOR.

FOR POWDER COATINGS IN THE NATURE OF A CLEAR FINISH USED TO COAT ALUMINUM EXTRUSIONS TO PREVENT SCRATCHING, CHIPPING, STAINING OR OTHERWISE BEING DAMAGED BY HEAT OR OTHER ELEMENTS (U.S. CLS. 6, 11 AND 16).

AMY ALFIERI, EXAMINING ATTORNEY

CLASS 2—(Continued).

SN 85-490,175. ROYAL ADHESIVES AND SEALANTS, LLC, SOUTH BEND, IN. FILED 12-8-2011.



NO CLAIM IS MADE TO THE EXCLUSIVE RIGHT TO USE "COATINGS & SPECIALTY POLYMERS", APART FROM THE MARK AS SHOWN.

THE MARK CONSISTS OF THE WORD "ROYAL" DISPLAYED ABOVE A LINE WITH THE PHRASE "COATINGS & SPECIALTY POLYMERS" DISPLAYED UNDERNEATH THE LINE. A CIRCULAR IMAGE COMPRISED OF TWO CURVED LINES IS DISPLAYED TO THE LEFT OF THE TEXT.

FOR PROTECTIVE COATING, NAMELY, A POLYMERIC COATING (U.S. CLS. 6, 11 AND 16).

C. DIONNE CLYBURN, EXAMINING ATTORNEY

SN 85-445,834. RENAISSANCE COATING CONSULTANTS, LLC, PLYMOUTH, MN. FILED 10-12-2011.

COLORS BY DREW

THE MARK CONSISTS OF STANDARD CHARACTERS WITHOUT CLAIM TO ANY PARTICULAR FONT, STYLE, SIZE, OR COLOR.

NO CLAIM IS MADE TO THE EXCLUSIVE RIGHT TO USE "COLORS", APART FROM THE MARK AS SHOWN.

FOR DECORATIVE COATING COMPOSITIONS IN THE NATURE OF PAINT FOR ARCHITECTURAL APPLICATIONS (U.S. CLS. 6, 11 AND 16).

FIRST USE 8-15-2010; IN COMMERCE 8-15-2010.

ELLEN PERKINS, EXAMINING ATTORNEY

SN 85-509,880. GAMBLIN HOLDINGS, LLC, PORTLAND, OR. FILED 1-5-2012.

CREATE WITHOUT COMPROMISE

THE MARK CONSISTS OF STANDARD CHARACTERS WITHOUT CLAIM TO ANY PARTICULAR FONT, STYLE, SIZE, OR COLOR.

FOR OIL PAINTS FOR USE BY ARTISTS; INTAGLIO AND RELIEF PRINTING INKS FOR USE BY ARTISTS; OIL PAINTING MEDIUMS IN THE NATURE OF GELS, FLUIDS AND SOLVENTS USED TO MODIFY THE WORKING PROPERTIES OF OIL COLORS (U.S. CLS. 6, 11 AND 16).

JAMES A. RAUEN, EXAMINING ATTORNEY

SN 85-458,497. KRINGS COATING SYSTEMS LLC, NEW ALBANY, OH. FILED 10-27-2011.

ZOWO-TEC

THE MARK CONSISTS OF STANDARD CHARACTERS WITHOUT CLAIM TO ANY PARTICULAR FONT, STYLE, SIZE, OR COLOR.

OWNER OF U.S. REG. NO. 4,098,812.

FOR PRESERVATIVE COATINGS FOR WOOD SURFACES AND WOOD FURNITURE (U.S. CLS. 6, 11 AND 16).

ERIN FALK, EXAMINING ATTORNEY

SN 85-509,887. GAMBLIN HOLDINGS, LLC, PORTLAND, OR. FILED 1-5-2012.

PAINT LIKE YOU MEAN IT

THE MARK CONSISTS OF STANDARD CHARACTERS WITHOUT CLAIM TO ANY PARTICULAR FONT, STYLE, SIZE, OR COLOR.

FOR OIL PAINTS FOR USE BY ARTISTS; INTAGLIO AND RELIEF PRINTING INKS FOR USE BY ARTISTS; OIL PAINTING MEDIUMS IN THE NATURE OF GELS, FLUIDS AND SOLVENTS USED TO MODIFY THE WORKING PROPERTIES OF OIL COLORS (U.S. CLS. 6, 11 AND 16).

JAMES A. RAUEN, EXAMINING ATTORNEY

CLASS 2—(Continued).

SN 85-513,750. THE VALSPAR CORPORATION, MINNEAPOLIS, MN. FILED 1-11-2012.

LOVE YOUR COLOR

THE MARK CONSISTS OF STANDARD CHARACTERS WITHOUT CLAIM TO ANY PARTICULAR FONT, STYLE, SIZE, OR COLOR.

FOR INTERIOR AND EXTERIOR COATINGS, NAMELY, PAINTS, STAINS, VARNISHES AND PRIMERS (U.S. CLS. 6, 11 AND 16).

ALLISON SCHRODY, EXAMINING ATTORNEY

SN 85-531,715. AKZO NOBEL COATINGS INTERNATIONAL B.V., ARNHEM, NETHERLANDS, FILED 2-2-2012.

THE MARK OF TRUE CRAFTSMANSHIP

THE MARK CONSISTS OF STANDARD CHARACTERS WITHOUT CLAIM TO ANY PARTICULAR FONT, STYLE, SIZE, OR COLOR.

FOR COATINGS, NAMELY, WOOD FINISHES AND STAINS (U.S. CLS. 6, 11 AND 16).

WILLIAM VERHOSEK, EXAMINING ATTORNEY

SN 85-545,616. AKZO NOBEL COATINGS INTERNATIONAL B.V., ARNHEM, NETHERLANDS, FILED 2-17-2012.

VARICURE

THE MARK CONSISTS OF STANDARD CHARACTERS WITHOUT CLAIM TO ANY PARTICULAR FONT, STYLE, SIZE, OR COLOR.

OWNER OF U.S. REG. NO. 4,118,673.
FOR PRIMER (U.S. CLS. 6, 11 AND 16).

WILLIAM VERHOSEK, EXAMINING ATTORNEY

CLASS 3—COSMETICS AND CLEANING PREPARATIONS

SN 77-517,867. LAURICE EL BADRY RAHME LTD., DBA LAURICE & CO., NEW YORK, NY. FILED 7-9-2008.

BOND NO. 9'S DUBAI

THE MARK CONSISTS OF STANDARD CHARACTERS WITHOUT CLAIM TO ANY PARTICULAR FONT, STYLE, SIZE, OR COLOR.

OWNER OF U.S. REG. NOS. 2,742,675, 3,184,312 AND 3,235,717.

NO CLAIM IS MADE TO THE EXCLUSIVE RIGHT TO USE "DUBAI", APART FROM THE MARK AS SHOWN.

FOR FRAGRANCES FOR PERSONAL USE, NAMELY, PERFUMES, COLOGNES, AFTER BATH SPLASHES, BODY SPRAYS, SHOWER GELS, SOAPS, BODY LOTIONS, MASSAGE OILS, COSMETICS, NAMELY, NON-MEDICATED SKIN CARE PREPARATIONS, MAKEUP, LIPSTICK, FOUNDATION POWDER, EYESHADOW, NAIL POLISH, MASCARA AND EYE PENCIL (U.S. CLS. 1, 4, 6, 50, 51 AND 52).

CIMMERIAN COLEMAN, EXAMINING ATTORNEY

SN 77-527,989. UNIGEN CO., LTD., CHUNGCHEONGNAM-DO, REPUBLIC OF KOREA, FILED 7-22-2008.

UNIFLAVON

THE MARK CONSISTS OF STANDARD CHARACTERS WITHOUT CLAIM TO ANY PARTICULAR FONT, STYLE, SIZE, OR COLOR.

OWNER OF REPUBLIC OF KOREA REG. NO. 0775561, DATED 1-12-2009, EXPIRES 1-12-2019.

FOR COSMETIC PREPARATIONS FOR BATHS, COSMETIC CREAMS, BODY LOTIONS, SUNSCREEN LOTIONS, SUNSCREEN CREAMS, SKIN LOTIONS, COSMETIC PREPARATIONS FOR SKIN CARE, SKIN CREAMS, SKIN CLEANSERS, EYE LOTIONS, EYE CREAMS, AFTER-SHAVE LOTIONS, COSMETIC PREPARATIONS FOR ULTRAVIOLET PROTECTION, FACIAL LOTIONS, SKIN WHITENING CREAMS, NOURISHING CREAMS FOR COSMETIC PURPOSES, LOTIONS FOR COSMETIC PURPOSES, COSMETIC SOAPS (U.S. CLS. 1, 4, 6, 50, 51 AND 52).

DAVID H. STINE, EXAMINING ATTORNEY

CLASS 3—(Continued).

SN 77-527,991. UNIGEN CO., LTD., CHUNGCHEONGNAM-DO, REPUBLIC OF KOREA, FILED 7-22-2008.

PURINOL

THE MARK CONSISTS OF STANDARD CHARACTERS WITHOUT CLAIM TO ANY PARTICULAR FONT, STYLE, SIZE, OR COLOR.

OWNER OF REPUBLIC OF KOREA REG. NO. 0772881, DATED 12-17-2008, EXPIRES 12-17-2018.

FOR COSMETIC PREPARATIONS FOR BATHS, COSMETIC CREAMS, BODY LOTIONS, SUNSCREEN LOTIONS, SUNSCREEN CREAMS, SKIN LOTIONS, COSMETIC PREPARATIONS FOR SKIN CARE, SKIN CREAMS, SKIN CLEANSERS, EYE LOTIONS, EYE CREAMS, AFTER-SHAVE LOTIONS, COSMETIC PREPARATIONS FOR ULTRAVIOLET PROTECTION, FACIAL LOTIONS, SKIN WHITENING CREAMS, NOURISHING CREAMS FOR COSMETIC PURPOSES, LOTIONS FOR COSMETIC PURPOSES, COSMETIC SOAPS (U.S. CLS. 1, 4, 6, 50, 51 AND 52).

DAVID H. STINE, EXAMINING ATTORNEY

SN 77-650,682. AMOREPACIFIC CORPORATION, SEOUL, REPUBLIC OF KOREA, FILED 1-15-2009.

ART PLAY

THE MARK CONSISTS OF STANDARD CHARACTERS WITHOUT CLAIM TO ANY PARTICULAR FONT, STYLE, SIZE, OR COLOR.

PRIORITY CLAIMED UNDER SEC. 44(D) ON REPUBLIC OF KOREA APPLICATION NO. 40-2008-0036, FILED 7-24-2008, REG. NO. 0792223, DATED 6-15-2009, EXPIRES 6-15-2019.

FOR FLAVORINGS FOR CAKES MADE OF ESSENTIAL OILS; FLAVORINGS FOR FOODS MADE OF ESSENTIAL OILS; FLAVORINGS FOR BEVERAGES MADE OF ESSENTIAL OILS; COLOR-BRIGHTENING PREPARATIONS FOR HOUSEHOLD PURPOSES FOR LAUNDRY; ANTISTATIC PREPARATIONS FOR HOUSEHOLD PURPOSES; RUST REMOVING PREPARATIONS; PAINT STRIPPING PREPARATIONS; LACQUER-REMOVING PREPARATIONS; NON-SLIPPING WAX FOR FLOORS; NON-SLIPPING LIQUIDS FOR FLOORS; LAUNDRY GLAZE; FABRIC SOFTENERS FOR LAUNDRY USE; WASHING SODA FOR CLEANING; LAUNDRY WAX; BLUING FOR LAUNDRY; BLEACHING PREPARATIONS FOR LAUNDRY USE; SODA LYE; AMMONIA FOR CLEANING PURPOSES; STAIN REMOVERS; CANNED PRESSURIZED AIR FOR CLEANING AND DUSTING PURPOSES; FLOOR WAX REMOVERS; DEGREASING PREPARATION IN THE NATURE OF TURPENTINE AND OIL OF TURPENTINE NOT USED IN THE MANUFACTURING PROCESS FOR HOUSEHOLD USE; BLEACHING SODA FOR HOUSEHOLD USE; BLEACHING SALTS FOR HOUSEHOLD USE; BLEACHING PREPARATIONS FOR HOUSEHOLD USE; STARCH GLAZE FOR LAUNDRY PURPOSES; LAUNDRY STARCH; NAIL ENAMEL REMOVERS; EYEBROW PENCILS; EYEBROW COSMETICS; LOOSE FACE POWDER; ROUGE; LIQUID ROUGE; SACHETS FOR PERFUMING LINEN; LIP LINER; LIPSTICKS; GELS FOR MASSAGE; OILS FOR MASSAGE; MASCARA; NAIL VARNISH; NAIL ENAMEL; VARNISH-REMOVING PREPARATIONS; HAIR OILS; MAKE-UP FOUNDATIONS; MAKE-UP PREPARATIONS; GELS FOR

CLASS 3—(Continued).

SHAVING; SHAVING PREPARATIONS; HAIR DRYING PREPARATIONS; NON-MEDICATED PREPARATIONS FOR HAIR PRESERVATION AND MANAGEMENT; HAIR DYES; HAIR COLORANTS; MASCARA FOR HAIR; WAVING PREPARATIONS FOR THE HAIR; NON-MEDICATED POWDERS FOR THE CARE OF HAIR; POMADES FOR HAIR; BLEACHING PREPARATION FOR HAIR; HAIR CREAMS; DECOLORANT FOR HAIR; BATH SALTS; BEAUTY CREAMS; BODY LOTIONS; BODY MILKS; BODY OILS; BODY CREAMS; SACHET FOR PERFUMING; VANISHING CREAMS FOR COSMETIC PURPOSES; BATH GELS; BATH LOTIONS; BATH BEADS; BATH OILS; BATH FOAMS; WHITE MAKE-UP POWDER; BAY RUMS; BABY OILS; BABY POWDERS; CHEEK COLORS; BLUSHERS; BLUSH PENCILS; PERFUME IN THE FORM OF POWDER; BATH SALTS NOT FOR MEDICAL PURPOSES; SUN-TANNING PREPARATIONS NOT FOR MEDICAL PURPOSES; SKIN CREAMS NOT FOR MEDICAL PURPOSES; SAFROL IN THE NATURE OF ESSENTIAL OIL; SHOWER AND BATH GELS; SHOWER GELS; SHOWER CREAMS; SHOWER FOAMS AND BATH FOAMS; COSMETIC PREPARATIONS AGAINST SUNBURN; SUN-BLOCK LOTIONS; SUNSCREEN LOTIONS; SUNSCREEN CREAMS; SUN-TANNING LOTIONS; COSMETIC SUN-TANNING PREPARATIONS; SUN-TANNING CREAMS; SHAVING LOTIONS; SHAVING CREAMS; SHAVING FOAMS; COSMETIC PREPARATIONS FOR EYELASHES; LOTIONS FOR STRENGTHENING THE NAILS; NAIL POLISHING POWDER; NAIL CARE PREPARATIONS; NAIL COLORANTS; NAIL DECOLORANT; SKIN LOTIONS; COSMETIC PREPARATIONS FOR SKIN CARE; SKIN CREAMS; SKIN CLEANSER; EYE LINERS; EYE LOTIONS; EYE MAKE-UP REMOVERS; EYE SHADOWS; EYE CREAMS; EYE PENCILS; COSMETICS FOR PETS; AFTER SUN CREAMS; AFTER-SHAVE LOTIONS; AFTER-SHAVE EMULSIONS; AFTER-SHAVE CREAMS; LIQUID PERFUMES; EAU DE COLOGNE; EAU DE PERFUME; EAU DE TOILETTE; COSMETIC OILS FOR EPIDERMIS; HAIR CONDITIONERS FOR BABIES; DEODORANTS FOR PERSONAL USE; ESSENTIAL OILS FOR PERSONAL USE; TOILET WATERS; COSMETIC PREPARATIONS FOR DRY SKIN DURING PREGNANCY; COSMETIC PREPARATIONS FOR SLIMMING PURPOSES; COLD CREAMS; COLD WAVING SOLUTIONS; SOLID FACE POWDER FOR COMPACTS; MUSTACHE WAX; CLEANSING MILK; DEPILATORY WAX; DEPILATORY PREPARATIONS; TALCUM POWDER; LOTIONS FOR BEARDS; BEARD DYES; PERMANENT WAVE PREPARATIONS; NEUTRALIZERS FOR PERMANENT WAVING; FOUNDATIONS; CREAMY FOUNDATION; PERMANENT WAVING LOTIONS; PERFUMED TALCUM POWDER; PERFUMED PASTE; PERFUMED CREAMS; FACIAL LOTION; FACIAL CLEANSING MILKS; FACIAL CREAMS; FACIAL MILKS AND LOTIONS; FACE AND BODY LOTIONS; FACE AND BODY MILKS; COSMETICS FOR FACE AND BODY; COSMETIC LOTIONS FOR FACE AND BODY CARE; FACE AND BODY CREAMS; FACE POWDER PASTES; POMADES; PRESSED FACE POWDER; PRE-SHAVE CREAMS; SKIN WHITENING CREAMS; HAND CREAMS; SACHETS; PERFUMES; HAIR GELS; HAIR GLAZE; HAIR NOURISHER; HAIR LACQUERS; HAIR LOTIONS; HAIR MOISTURIZERS; HAIR MOUSSE; HAIR BALSAM; HAIR STYLING GELS; HAIR STYLING SPRAY; HAIR SPRAY; HAIR CONDITIONER; HAIR CONDITIONING OIL; HAIR CARE LOTIONS; BATH OILS FOR HAIR CARE; HAIR CARE CREAMS; HAIR CREAMS; HAIR TONICS; HELIOTROPINE IN THE NATURE OF AN ESSENTIAL OIL; GREASES FOR COSMETIC PURPOSES; NOURISHING CREAMS FOR COSMETIC PURPOSES; LOTIONS FOR COSMETIC PURPOSES; ROUGES FOR COSMETIC PURPOSES; SKIN MASK FOR COSMETIC PURPOSES; NAIL ENAMELS FOR COSMETIC PURPOSES; OIL CLEANSERS FOR PERSONAL USE; BATH POWDERS FOR COSMETIC PURPOSES; PETROLEUM JELLY FOR COSMETIC PURPOSES; ANTIPERSPIRANTS FOR COSMETIC PURPOSES; PERSPIRATION SUPPRESSANT FOR COSMETIC PURPOSES; BATH OILS FOR COSMETIC PURPOSES; WHITE MAKE-UP POWDER FOR COSMETIC PURPOSES; AFTER SUN MILK LOTIONS FOR COSMETIC PURPOSES; SUN TANNING OILS FOR COSMETIC PURPOSES; SUN-TANNING PREPARATIONS FOR COSMETIC PURPOSES; ASTRINGENTS FOR COSMETIC PURPOSES; SKIN MILK LOTIONS FOR COSMETIC PURPOSES; SKIN FRESHENER

CLASS 3—(Continued).

WATER FOR COSMETIC PURPOSES; ALMOND MILK FOR COSMETIC PURPOSES; LIQUID FOUNDATION FOR COSMETIC PURPOSES; FACE POWDER FOR COSMETIC PURPOSES; PENCILS FOR COSMETIC PURPOSES; OILS FOR COSMETIC PURPOSES; BATH SALTS FOR COSMETIC PURPOSES; CLEANSING CREAMS FOR COSMETIC PURPOSES; CLEANSING MILK FOR COSMETIC PURPOSES; CREAMS FOR COSMETIC PURPOSES; TALCUM POWDER FOR COSMETIC PURPOSES; MAKE-UP POWDER FOR COSMETIC PURPOSES; FACE CREAMS FOR COSMETIC PURPOSES; POMADES FOR COSMETIC PURPOSES; BLEACHING PREPARATIONS FOR COSMETIC PURPOSES; HAND CREAMS FOR COSMETIC PURPOSES; MAKE-UP REMOVING LOTIONS; MAKE-UP REMOVING MILKS; MAKE-UP REMOVING PREPARATIONS; GAULTHERIA OIL IN THE NATURE OF AN ESSENTIAL OIL; FRAGRANCE FOR HOUSEHOLD PURPOSE; EXTRACTS OF FLOWERS IN THE NATURE OF PERFUMES; BASES FOR FLOWER PERFUMES IN THE NATURE OF AN ESSENTIAL OIL; LAVENDER OIL; ESSENTIAL OILS OF LEMON; PERFUMERY, NAMELY, ELECAMPANE; MINT ESSENCE IN THE NATURE OF AN ESSENTIAL OIL; VANILLA PERFUMERY; PEPPERMINT OIL PERFUMERY; SCENTED WOOD; BERGAMOT OIL; MIXED PERFUMERY; ESSENTIAL OILS OF CEDARWOOD; JOSS STICKS; ESSENTIAL OILS OF CITRON; AMBER PERFUME; ETHEREAL OILS; AMBERGRIS; IONONE PERFUME; FRAGRANCES FOR AUTOMOBILES; JASMINE OIL FOR PERSONAL USE; ROSE OIL FOR COSMETIC PURPOSES; PERFUMERY IN THE NATURE OF GERANIOL; COMPOUND PERFUMERY; NATURAL PERFUMERY; CLOVE OIL IN THE NATURE OF ESSENTIAL OILS; TERPENE IN THE NATURE OF ESSENTIAL OILS; POTPOURRI; SYNTHETIC MUSK; SYNTHETIC PERFUMERY; INCENSE; PERFUMERY; OILS FOR PERFUMES AND SCENTS; MINT ESSENTIAL OILS FOR PERFUMERY; MUSK FOR PERFUMERY; NATURAL MUSK FOR PERFUMERY; ESSENTIAL OIL FOR USE IN MANUFACTURING OF COSMETICS; FUMIGATION PREPARATIONS, NAMELY, FUMIGATING INCENSES; ADHESIVES FOR AFFIXING FALSE HAIR; FALSE EYELASHES; ADHESIVES FOR AFFIXING FALSE EYELASHES; FALSE NAILS; TISSUES IMPREGNATED WITH COSMETIC LOTIONS; BEAUTY MASKS; COTTON STICKS FOR COSMETIC PURPOSES; DECORATIVE TRANSFERS FOR COSMETIC PURPOSES; ADHESIVES FOR COSMETIC PURPOSES; COTTON WOOL FOR COSMETIC PURPOSES; SOAP POWDER; SOAPS FOR HOUSEHOLD PURPOSES; DETERGENTS PREPARED FROM PETROLEUM FOR HOUSEHOLD CLEANING USE; DETERGENT FOR HOUSEHOLD PURPOSES; SCRUBBING POWDER, NAMELY, SCOURING POWDERS; PREPARATIONS FOR CLEANING WASTE PIPES; WALLPAPER CLEANING PREPARATIONS; DETERGENTS PREPARED FROM PETROLEUM; SOAP FOR BRIGHTENING TEXTILE; SKIN POLISHING RICE BRAN; NON-MEDICATED DOUCHE; OILS FOR CLEANING PURPOSES; LAUNDRY DETERGENTS CONTAINING QUILLAIA BARK; LAUNDRY SOAPS; LAUNDRY SOAKING PREPARATIONS; DISINFECTANT SOAP; DETERGENTS FOR DISHWASHER; DISH WASHING LIQUID DETERGENTS; DISH DETERGENTS; GLASS CLEANING PREPARATIONS; WINDSHIELD CLEANING LIQUIDS; DETERGENTS FOR AUTOMOBILES; TOILET BOWL DETERGENTS; CAKES OF TOILET SOAP; SHAVING MOUSSE; SHAVING SOAP; BATH SOAPS; LIQUID SOAPS; BEAUTY SOAPS; BODY CREAM SOAPS; SOAPS FOR BODY CARE; SOAP FOR FOOT PERSPIRATION; ANTIPERSPIRANT SOAP; DEODORANT SOAP; SHAMPOOS; HAND CLEANING PREPARATIONS; ALMOND SOAP; SHAMPOOS FOR PETS; LIQUID BATH SOAPS; MEDICATED SOAP OTHER THAN FOR MEDICAL PURPOSE; SHAMPOO FOR BABY; SOAPS FOR PERSONAL USE; LIQUID SOAPS USED IN FOOT BATH; SOAPS IN THE FORM OF PAPER; CREAM SOAPS; FACIAL WASHES; HAND CLEANING PREPARATIONS; PERFUMED SOAP; HAIR RINSES; COSMETIC SOAPS; BREATH FRESHENING SPRAYS; MOUTH WASHES NOT FOR MEDICAL PURPOSES; TOOTH PASTE IN SOFT CAKE; NON-MEDICATED DENTAL RINSES; DENTURE POLISHES; PREPARATIONS FOR CLEANING DENTURES; DENTAL BLEACHING GELS; TOOTH POWDERS; TOOTH CLEANING LOTIONS; TOOTH CLEANING PREPARATIONS; TOOTH PASTE; SHOE POLISH; SHOE WAX; SHOE CREAMS; COBBLERS'

CLASS 3—(Continued).

WAX; POLISH FOR FURNITURE; POLISH FOR FURNITURE AND FLOORING; LEATHER POLISHES; WAXES FOR LEATHER; CREAMS FOR LEATHER; POLISHING WAX; SHINING PREPARATIONS; POLISHING PAPER; POLISH FOR FLOORING; FLOOR WAX; LIQUID FLOOR WAXES; PREPARATIONS TO MAKE THE LEAVES OF PLANTS SHINY; AUTOMOBILE POLISHES; TAILORS' WAX; PARQUET FLOOR WAX; EMERY BOARDS; EMERY PAPER; EMERY CLOTH; SANDPAPER; SANDCLOTH, NAMELY, ABRASIVE CLOTH; POLISHING STONES; ABRASIVE SHEETS; PUMICE STONE FOR PERSONAL USE; ABRASIVE ROLLS; ABRASIVE SAND; GLASS CLOTH; SCOURING SOLUTIONS; ABRASIVE PAPER; ABRASIVE CLOTH (U.S. CLS. 1, 4, 6, 50, 51 AND 52).

JASON BLAIR, EXAMINING ATTORNEY

SN 77-870,019. HENKEL AG & CO. KGAA, DUESSELDORF, FED REP GERMANY, FILED 11-11-2009.

POOF ERASER

THE MARK CONSISTS OF STANDARD CHARACTERS WITHOUT CLAIM TO ANY PARTICULAR FONT, STYLE, SIZE, OR COLOR.

NO CLAIM IS MADE TO THE EXCLUSIVE RIGHT TO USE "POOF", APART FROM THE MARK AS SHOWN.

FOR HAIR STYLING PREPARATIONS (U.S. CLS. 1, 4, 6, 50, 51 AND 52).

JESSICA FATHY, EXAMINING ATTORNEY

SN 77-914,375. MIA BELLEZZA LLC, BUFORD, GA. FILED 1-19-2010.

MiA BelleZZa

THE MARK CONSISTS OF STANDARD CHARACTERS WITHOUT CLAIM TO ANY PARTICULAR FONT, STYLE, SIZE, OR COLOR.

THE ENGLISH TRANSLATION OF THE MARK IS MY BEAUTY.

FOR ADHESIVES FOR COSMETIC USE; AFTER-SUN GELS; AFTER-SUN MILKS; AFTER-SUN OILS; ALOE VERA GEL FOR COSMETIC PURPOSES; ASTRINGENTS FOR COSMETIC PURPOSES; BATH OILS FOR COSMETIC PURPOSES; BATH POWDER; BLEACHING PREPARATIONS FOR COSMETIC PURPOSES; BODY AND BEAUTY CARE COSMETICS; CHALK FOR COSMETIC USE; CLEANER FOR COSMETIC BRUSHES; CLEANSING CREAMS; COCOA BUTTER FOR COSMETIC PURPOSES; COLOGNES, PERFUMES AND COSMETICS; COLORING PREPARATIONS FOR COSMETIC PURPOSES; CONCEALERS; COSMETIC BALLS; COSMETIC CREAMS; COSMETIC CREAMS FOR SKIN CARE; COSMETIC FACIAL BLOTTERING PAPERS; COSMETIC HAIR DRESSING PREPARATIONS; COSMETIC HAIR REGROWTH INHIBITING PREPARATIONS; COSMETIC MASKS; COSMETIC MILKS; COSMETIC OILS; COSMETIC OILS FOR THE EPIDERMIS; COSMETIC OLIVE OIL FOR THE FACE AND BODY; COSMETIC PADS; COSMETIC PENCILS; COSMETIC PREPARATIONS; COSMETIC PREPARATIONS AGAINST SUNBURN; COSMETIC PREPARATIONS FOR BODY CARE; COSMETIC PREPARATIONS FOR EYE LASHES; COSMETIC PRE-

CLASS 3—(Continued).

PARATIONS FOR SKIN RENEWAL; COSMETIC PREPARATIONS FOR SLIMMING PURPOSES; COSMETIC PREPARATIONS FOR THE CARE OF MOUTH AND TEETH; COSMETIC PREPARATIONS FOR THE HAIR AND SCALP; COSMETIC PREPARATIONS, NAMELY, FIRING CREAMS; COSMETIC PREPARATIONS, NAMELY, FIRING LOTIONS; COSMETIC PREPARATIONS, NAMELY, SKIN BALSAMS; COSMETIC PRODUCTS IN THE FORM OF AEROSOLS FOR SKIN CARE; COSMETIC PRODUCTS IN THE FORM OF AEROSOLS FOR SKINCARE; COSMETIC PRODUCTS TAKEN ORALLY, NAMELY, PILLS THAT INDUCE BRONZING OF THE SKIN; COSMETIC ROUGES; COSMETIC SOAPS; COSMETIC SUN-PROTECTING PREPARATIONS; COSMETIC SUN-TANNING PREPARATIONS; COSMETIC SUNTAN LOTIONS; COSMETIC SUNTAN PREPARATIONS; COSMETICS; COSMETICS AND COSMETIC PREPARATIONS; COSMETICS AND MAKE-UP; COSMETICS FOR ANIMALS; COSMETICS IN GENERAL, INCLUDING PERFUMES; COSMETICS IN THE FORM OF MILKS, LOTIONS AND EMULSIONS; COSMETICS, NAMELY, COMPACTS; COSMETICS, NAMELY, LIP PRIMER; COSMETICS, NAMELY, LIP REPAIRERS; COTTON BALLS FOR COSMETIC PURPOSES; COTTON BUDS FOR COSMETIC PURPOSES; COTTON FOR COSMETIC PURPOSES; COTTON PUFFS FOR COSMETIC PURPOSES; COTTON STICKS FOR COSMETIC PURPOSES; COTTON SWABS FOR COSMETIC PURPOSES; COTTON WOOL AND COTTON STICKS FOR COSMETIC PURPOSES; COTTON WOOL FOR COSMETIC PURPOSES; DECORATIVE TRANSFERS AND SKIN JEWELS FOR COSMETIC PURPOSES; EYE COMPRESSES FOR COSMETIC PURPOSES; EYEBROW COSMETICS; FACE CREAMS AND CLEANSERS CONTAINING BENZOYL PEROXIDE FOR COSMETIC PURPOSES; FACE CREAMS FOR COSMETIC USE; FOAMS CONTAINING COSMETICS AND SUNSCREENS; GAUZE FOR COSMETIC PURPOSES; GIFT BASKETS CONTAINING NON-MEDICATED BATH PREPARATIONS AND COSMETIC PREPARATIONS; GLITTER FOR COSMETIC PURPOSES; GRAPE SEED OIL FOR COSMETIC USE; GREASES FOR COSMETIC PURPOSES; HENNA FOR COSMETIC PURPOSES; IMPREGNATED CLEANING PADS IMPREGNATED WITH COSMETICS; LOTIONS FOR COSMETIC PURPOSES; MILK FOR COSMETIC PURPOSES; MINERAL POWDER FOR USE IN COSMETIC BODY WRAP APPLICATIONS; NAIL VARNISH FOR COSMETIC PURPOSES; NON-MEDICATED COSMETIC SKIN CARE PREPARATIONS CONSISTING OF ORGANIC COCONUT VIRGIN OIL AND COCONUT VIRGIN OIL; NON-MEDICATED HAIR TREATMENT PREPARATIONS FOR COSMETIC PURPOSES; NUTRITIONAL OILS FOR COSMETIC PURPOSES; OILS FOR COSMETIC PURPOSES; PARAFFIN WAX FOR COSMETIC PURPOSES; PENCILS FOR COSMETIC PURPOSES; PERFUME OILS FOR THE MANUFACTURE OF COSMETIC PREPARATIONS; PETROLEUM JELLY FOR COSMETIC PURPOSES; PLANT AND HERB EXTRACTS SOLD AS COMPONENTS OF COSMETICS; PRE-MOISTENED COSMETIC TISSUES; PRE-MOISTENED COSMETIC TOWELLETTES; PRE-MOISTENED COSMETIC WIPES; PRIVATE LABEL COSMETICS; RETINOL CREAM FOR COSMETIC PURPOSES; ROSE OIL FOR COSMETIC PURPOSES; SELF-TANNING PREPARATIONS; SHEA BUTTER FOR COSMETIC PURPOSES; SKIN AND BODY TOPICAL LOTIONS, CREAMS AND OILS FOR COSMETIC USE; SKIN CONDITIONING CREAMS FOR COSMETIC PURPOSES; SKIN FRESHENERS; SOAPS; SOLID POWDER FOR COMPACTS; SUNTAN OILS FOR COSMETIC PURPOSES; TANNING AND AFTER-SUN MILKS, GELS AND OILS; TANNING GELS; TANNING MILKS; TANNING OILS; TEETH WHITENING STRIPS IMPREGNATED WITH TEETH WHITENING PREPARATIONS; TISSUES IMPREGNATED WITH COSMETIC LOTIONS; TONERS; TOOTH WHITENERS FOR COSMETIC PURPOSES COMPRISED OF NEUTRAL SODIUM FLUORIDE SUSTAINED RELEASE GEL; TOPICAL SKIN SPRAYS FOR COSMETIC PURPOSES; WRINKLE-MINIMIZING COSMETIC PREPARATIONS FOR TOPICAL FACIAL USE (U.S. CLS. 1, 4, 6, 50, 51 AND 52).

FIRST USE 10-1-2009; IN COMMERCE 10-1-2009.

LEIGH CAROLINE CASE, EXAMINING ATTORNEY

CLASS 3—(Continued).

SN 78-515,530. CAKE BEAUTY INC., TORONTO, CANADA, FILED 11-11-2004.

CITRUS SQUEEZE

THE MARK CONSISTS OF STANDARD CHARACTERS WITHOUT CLAIM TO ANY PARTICULAR FONT, STYLE, SIZE, OR COLOR.

PRIORITY CLAIMED UNDER SEC. 44(D) ON CANADA APPLICATION NO. 1236451, FILED 11-6-2004.

NO CLAIM IS MADE TO THE EXCLUSIVE RIGHT TO USE "CITRUS", APART FROM THE MARK AS SHOWN.

FOR COSMETICS AND BODY CARE PRODUCTS, NAMELY, BODY SCRUBS; (BASED ON INTENT TO USE) COSMETICS AND BODY CARE PRODUCTS, NAMELY, MAKEUP, BODY, FACE, HAND AND FOOT LOTIONS, BODY MISTS, BODY SPRAYS, BODY POWDERS, BODY, FACE, HAND AND FOOT CREAMS, BODY, BATH AND COSMETIC OILS, NAIL POLISHES, PERSONAL USE FRAGRANCES, PERFUMES, BATH AND SHOWER GELS, SKIN MOISTURIZERS, SKIN CLEANSERS, BEAUTY, BODY AND SKIN MASKS, SUN BLOCKS, SUN SCREENS, SKIN EMOLLIENTS, SKIN TONERS, BODY MOUSSE, FACIAL SCRUBS, BUBBLE BATH, BATH AND SHOWER FOAMS, HAIR SHAMPOOS AND CONDITIONERS (U.S. CLS. 1, 4, 6, 50, 51 AND 52).

FIRST USE 8-31-2001; IN COMMERCE 8-31-2001.

LAURIE MAYES, EXAMINING ATTORNEY

SN 79-086,363. SARL CHATEAU BERGER COSMETIQUES, F-13007 MARSEILLE, FRANCE, FILED 7-21-2010.

CHATEAU BERGER

THE MARK CONSISTS OF STANDARD CHARACTERS WITHOUT CLAIM TO ANY PARTICULAR FONT, STYLE, SIZE, OR COLOR.

OWNER OF INTERNATIONAL REGISTRATION 1006099 DATED 4-2-2009, EXPIRES 4-2-2019.

FOR BLEACHING PREPARATIONS FOR LAUNDRY USE; SUBSTANCES FOR LAUNDRY USE, NAMELY, LAUNDRY SOAP, LAUNDRY STARCH, LAUNDRY DETERGENT, LAUNDRY FABRIC CONDITIONER; CLEANING, POLISHING, SCOURING AND ABRASIVE PREPARATIONS; SOAPS; PERFUMES, ESSENTIAL OILS, COSMETICS, HAIR LOTIONS; MAKE-UP REMOVERS, LIPSTICK, BEAUTY MASKS; AND SHAVING PREPARATIONS (U.S. CLS. 1, 4, 6, 50, 51 AND 52).

KEVIN CORWIN, EXAMINING ATTORNEY

SN 79-100,310. PB TRADEMARK, FRANCE, FILED 6-23-2011.

MONTANA PARFUM DE PEAU

OWNER OF INTERNATIONAL REGISTRATION 0759188 DATED 4-17-2001, EXPIRES 4-17-2021.

NO CLAIM IS MADE TO THE EXCLUSIVE RIGHT TO USE "PARFUM", APART FROM THE MARK AS SHOWN.

THE ENGLISH TRANSLATION OF "PARFUM DE PEAU" IN THE MARK IS "SCENT OF SKIN".

FOR SOAPS; PERFUMERY, ESSENTIAL OILS, COSMETICS, HAIR LOTIONS; DENTIFRICES (U.S. CLS. 1, 4, 6, 50, 51 AND 52).

JAMES GRIFFIN, EXAMINING ATTORNEY

CLASS 3—(Continued).

SN 79-101,978. BIELEND A KOSMETYKI NATURALNE SP. Z O.O., POLAND, FILED 8-4-2011.

BIELEND A

THE MARK CONSISTS OF STANDARD CHARACTERS WITHOUT CLAIM TO ANY PARTICULAR FONT, STYLE, SIZE, OR COLOR.

OWNER OF INTERNATIONAL REGISTRATION 1089179 DATED 8-4-2011, EXPIRES 8-4-2021.

THE WORD "BIELEND A" HAS NO MEANING IN A FOREIGN LANGUAGE.

FOR BEAUTY COSMETICS, BODY CARE COSMETICS, PERFUMERY AND DEODORANTS, MAKE-UP AND MAKE-UP REMOVING OILS AND PREPARATIONS, CLEANING PREPARATIONS, COSMETIC PREPARATIONS FOR SLIMMING PURPOSES, PROFESSIONAL COSMETICS, HAIR STYLING COSMETICS (U.S. CLS. 1, 4, 6, 50, 51 AND 52).

LINDA MICKLEBURGH, EXAMINING ATTORNEY

CLASS 3—(Continued).

SN 79-103,387. CARTIER INTERNATIONAL AG, SWITZERLAND, FILED 9-20-2011.

DECLARATION D'UN SOIR

THE MARK CONSISTS OF STANDARD CHARACTERS WITHOUT CLAIM TO ANY PARTICULAR FONT, STYLE, SIZE, OR COLOR.

PRIORITY DATE OF 4-29-2011 IS CLAIMED.

OWNER OF INTERNATIONAL REGISTRATION 1092944 DATED 9-20-2011, EXPIRES 9-20-2021.

OWNER OF U.S. REG. NO. 2,516,842.

THE ENGLISH TRANSLATION OF THE WORDS "DECLARATION D'UN SOIR" IN THE MARK IS DECLARATION OF A NIGHT.

FOR SOAP; PERFUMERY, ESSENTIAL OILS, COSMETICS, HAIR LOTIONS (U.S. CLS. 1, 4, 6, 50, 51 AND 52).

JOSETTE BEVERLY, EXAMINING ATTORNEY

SN 79-103,166. SLAWOMIR WOS, POLAND, FILED 8-22-2011.



OWNER OF INTERNATIONAL REGISTRATION 1092393 DATED 8-22-2011, EXPIRES 8-22-2021.

THE COLOR(S) BLUE, WHITE IS/ARE CLAIMED AS A FEATURE OF THE MARK.

THE MARK CONSISTS OF A BLUE OVAL WITH THE LETTERS "E" AND "F" INSIDE IT IN WHITE AND THE WORD "EXCLUSIVE" IN BLUE UNDER THE OVAL.

FOR FOOT AND HAND CARE PREPARATIONS, NAMELY, NON-MEDICATED FOOT AND HAND LOTIONS; NAIL VARNISHES AND POLISHES; SCRUBS, SOAPS (U.S. CLS. 1, 4, 6, 50, 51 AND 52).

AISHA CLARKE, EXAMINING ATTORNEY

SN 79-104,685. COSWELL S.P.A., ITALY, FILED 10-5-2010.

BIONSEN

OWNER OF INTERNATIONAL REGISTRATION 0539159 DATED 7-17-1989, EXPIRES 7-17-2019.

THE WORDING "BIONSEN" HAS NO MEANING IN A FOREIGN LANGUAGE.

FOR BLEACHING PREPARATIONS, LAUNDRY DETERGENTS AND FABRIC SOFTENERS FOR LAUNDRY USE; CLEANING, POLISHING, SCOURING AND ABRASIVE PREPARATIONS; SOAPS; PERFUMERY, ESSENTIAL OILS, COSMETICS, HAIR LOTIONS; DENTIFRICES (U.S. CLS. 1, 4, 6, 50, 51 AND 52).

ELISSA GARBER KON, EXAMINING ATTORNEY

CLASS 3—(Continued).

SN 79-106,532. GAULME, FRANCE, FILED 10-18-2011.



OWNER OF INTERNATIONAL REGISTRATION 1100073 DATED 10-18-2011, EXPIRES 10-18-2021.

NO CLAIM IS MADE TO THE EXCLUSIVE RIGHT TO USE "COLLECTION", APART FROM THE MARK AS SHOWN.

THE NAME(S), PORTRAIT(S), AND/OR SIGNATURE(S) SHOWN IN THE MARK IDENTIFIES "JEAN PAUL GAULTIER", WHOSE CONSENT(S) TO REGISTER IS MADE OF RECORD.

THE MARK CONSISTS OF THE TERMS "JEAN PAUL" WITH THE TERM "GAULTIER" APPEARING UNDERNEATH AND ON AN UPWARD INCLINE. UNDERNEATH THIS IS THE TERM "'CLASSIQUE'" IN QUOTES, WITH AN "X" UNDERNEATH "'CLASSIQUE'" AND THE WORDING "COLLECTION" APPEARING TO THE LOWER RIGHT OF THE "X".

FOR SOAP; PERFUMERY, PERFUMES, TOILET WATER, EAUX DE PARFUM, ESSENTIAL OILS, COSMETICS, EYELASH COSMETICS, EYEBROW COSMETICS, EYE COSMETICS, LIP COSMETICS, COSMETIC PREPARATIONS FOR THE SKIN, PREPARATIONS NOT FOR MEDICAL PURPOSES FOR SKIN CARE; HAIR LOTIONS, DENTIFRICES, DEODORANTS FOR PERSONAL USE, COSMETIC MILK, TALC, NAMELY, TALCUM POWDER, COSMETIC BODY OILS, BODY CREAM NOT FOR MEDICAL PURPOSES, MAKE-UP PREPARATIONS, SHAVING PREPARATIONS, SHAVING FOAMS, SHAVING GELS, AFTER-SHAVE LOTIONS, SHAVING SOAPS, COSMETIC KITS, SHAMPOOS; OILS, NAMELY, COSMETIC OILS AND ESSENTIAL OILS, BATH SALTS, BATH LOTIONS NOT FOR MEDICAL PURPOSES (U.S. CLS. 1, 4, 6, 50, 51 AND 52).
JANICE KIM, EXAMINING ATTORNEY

SN 79-106,588. KEYLINE BRANDS LIMITED, HOUNSLOW, MIDDLESEX TW3 1HY, UNITED KINGDOM, FILED 10-19-2011.

PRO:VOKE

THE MARK CONSISTS OF STANDARD CHARACTERS WITHOUT CLAIM TO ANY PARTICULAR FONT, STYLE, SIZE, OR COLOR.

OWNER OF INTERNATIONAL REGISTRATION 1100238 DATED 10-19-2011, EXPIRES 10-19-2021.

FOR NON-MEDICATED HAIR TREATMENT PREPARATIONS; HAIR COLORING AND CONDITIONING PREPARATIONS; SHAMPOO, HAIR CONDITIONER, HAIR SPRAY, HAIR WAX, HAIR STYLING PREPARATIONS (U.S. CLS. 1, 4, 6, 50, 51 AND 52).

ANDREA K. NADELMAN, EXAMINING ATTORNEY

CLASS 3—(Continued).

SN 79-106,722. COTY GERMANY GMBH, FED REP GERMANY, FILED 10-24-2011.

NEW YORK MUSE

THE MARK CONSISTS OF STANDARD CHARACTERS WITHOUT CLAIM TO ANY PARTICULAR FONT, STYLE, SIZE, OR COLOR.

PRIORITY DATE OF 4-29-2011 IS CLAIMED.

OWNER OF INTERNATIONAL REGISTRATION 1100576 DATED 10-24-2011, EXPIRES 10-24-2021.

NO CLAIM IS MADE TO THE EXCLUSIVE RIGHT TO USE "NEW YORK", APART FROM THE MARK AS SHOWN.

FOR TOILET SOAPS, PERFUMES; EAU DE COLOGNE; EAU DE TOILETTE; COSMETICS; ESSENTIAL OILS FOR PERSONAL USE; PERFUMED MILK FOR FACE AND BODY, PERFUMED LOTIONS FOR FACE AND BODY, PERFUMED CREAMS FOR FACE AND BODY, PERFUMED EMULSIONS FOR FACE AND BODY, PERFUMED GELS FOR FACE AND BODY; DEODORANTS FOR PERSONAL USE (PERFUMERY ARTICLES); COSMETIC HAIR LOTIONS (U.S. CLS. 1, 4, 6, 50, 51 AND 52).

KELLY TRUSILO, EXAMINING ATTORNEY

SN 85-081,437. WHISH BODY PRODUCTS, L.L.C., SCOTTSDALE, AZ. FILED 7-9-2010.

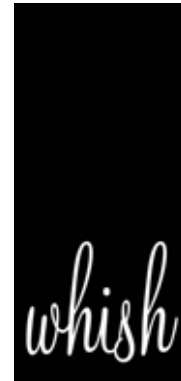

OWNER OF U.S. REG. NO. 3,595,393.

THE MARK CONSISTS OF A RECTANGLE WITH THE WORDS "WHISH" WRITTEN AT THE BOTTOM OF ONE SIDE OF THE RECTANGLE.

FOR BODY LOTION; BODY LOTIONS; SHAVING CREAM; SHAVING CREAMS (U.S. CLS. 1, 4, 6, 50, 51 AND 52).

FIRST USE 5-9-2006; IN COMMERCE 5-9-2006.

DANNEAN HETZEL, EXAMINING ATTORNEY

CLASS 3—(Continued).

SN 85-226,613. CHANEL, INC., NEW YORK, NY. FILED 1-26-2011.

CLASS 3—(Continued).

SN 85-315,710. UNIVERSAL COMPANIES INC., ABINGDON, VA. FILED 5-9-2011.

TXC

THE MARK CONSISTS OF STANDARD CHARACTERS WITHOUT CLAIM TO ANY PARTICULAR FONT, STYLE, SIZE, OR COLOR.

FOR MOLECULAR BASED SKIN BRIGHTENING AGENT USED AS A COMPONENT IN COSMETICS AND NON-MEDICATED SKIN CARE PREPARATIONS (U.S. CLS. 1, 4, 6, 50, 51 AND 52).

RUSS HERMAN, EXAMINING ATTORNEY



SN 85-263,643. ALINTER S.A., CURRIDABAT, SAN JOSÉ, COSTA RICA, FILED 3-10-2011.

Irex

THE MARK CONSISTS OF STANDARD CHARACTERS WITHOUT CLAIM TO ANY PARTICULAR FONT, STYLE, SIZE, OR COLOR.

FOR DETERGENT SOAP; DETERGENTS FOR HOUSEHOLD USE; LAUNDRY DETERGENT (U.S. CLS. 1, 4, 6, 50, 51 AND 52).

FIRST USE 1-1-1950; IN COMMERCE 1-1-2011.
DAVID ELTON, EXAMINING ATTORNEY

NO CLAIM IS MADE TO THE EXCLUSIVE RIGHT TO USE "ECO-FRIENDLY PARAFFIN ALTERNATIVE", APART FROM THE MARK AS SHOWN.

THE COLOR(S) BROWN AND GREEN IS/ARE CLAIMED AS A FEATURE OF THE MARK.

THE MARK CONSISTS OF , ON A FIRST LINE, THE LETTERS "EC" IN BROWN NEXT TO A ROUND, BROWN GLOBE ON WHICH IS SUPERIMPOSED GREEN IMAGES OF CONTINENTS AND WHICH IS FOLLOWED BY A BROWN HYPHEN AND THE BROWN LETTERS "FIN" AND, ON A SECOND LINE, THE WORDS "ECO-FRIENDLY PARAFFIN ALTERNATIVE".

FOR NON-MEDICATED SKIN CARE PREPARATIONS, NOT CONTAINING PARAFFIN, NAMELY, A COMBINATION OF PLANT-BASED INGREDIENTS AND ESSENTIAL OILS (U.S. CLS. 1, 4, 6, 50, 51 AND 52).

FIRST USE 2-5-2010; IN COMMERCE 2-5-2010.
ALLISON HOLTZ, EXAMINING ATTORNEY

CLASS 3—(Continued).

SN 85-317,577. HOLISTIC SKIN CARE PRODUCTS LTD., CREEMORE, ONTARIO, CANADA, FILED 5-10-2011.

DERMEOPATHICS

THE MARK CONSISTS OF STANDARD CHARACTERS WITHOUT CLAIM TO ANY PARTICULAR FONT, STYLE, SIZE, OR COLOR.

OWNER OF CANADA REG. NO. TMA458,942, DATED 6-7-1996, RENEWED AS REG. NO. TMA458,942, DATED 6-7-2011, EXPIRES 6-7-2026.

FOR BEAUTY CREAMS FOR BODY CARE; BODY AND BEAUTY CARE COSMETICS; COSMETIC CREAMS FOR SKIN CARE; DEODORANTS FOR BODY CARE; EXFOLIANTS FOR BODY; HAIR CARE PREPARATIONS; LOTIONS FOR FACE AND BODY CARE; LOTIONS FOR FACE, BODY; MOISTURIZING PREPARATIONS FOR THE SKIN; MOISTURIZING SOLUTIONS FOR THE SKIN; NON-MEDICATED CLEANSERS FOR PERSONAL USE, NAMELY, FACE; NON-MEDICATED HERBAL BODY CARE PRODUCTS, NAMELY, BODY OILS, SALVES, AND LIP BALMS; NON-MEDICATED SKIN CARE CREAMS AND LOTIONS; NON-MEDICATED SKIN CARE PREPARATIONS, NAMELY, CREAMS, LOTIONS, GELS, TONERS, CLEANSERS AND PEELS; NON-MEDICATED SKIN CARE PREPARATIONS, NAMELY, FACE, BODY; NON-MEDICATED SKIN CREAM FOR GENERAL SKIN RASH AND IRRITATION RESULTING FROM SKIN SHINGLES; NON-MEDICATED SKIN TONERS; SKIN CARE PREPARATION, NAMELY, BODY POLISH; SKIN CARE PREPARATIONS, NAMELY, SKIN PEELS; SKIN CLEANSERS; SKIN CLEANSING CREAM; SKIN CLEANSING LOTION; SKIN CREAM; SKIN CREAMS; SKIN CREAMS IN LIQUID AND IN SOLID FORM; SKIN EMOLLIENTS; SKIN FRESHENERS; SKIN GELS FOR ACCELERATING, ENHANCING OR EXTENDING TANS; SKIN LOTION; SKIN LOTIONS; SKIN MASKS; SKIN MOISTURIZER; SKIN MOISTURIZER MASKS; SKIN MOISTURIZING GEL; SKIN SOAP; SKIN TONERS; SOAPS FOR BODY CARE; SUN CARE LOTIONS (U.S. CLS. 1, 4, 6, 50, 51 AND 52).

SALLY SHIH, EXAMINING ATTORNEY

SN 85-327,999. WONDER MARKETING, INC., SANTA BARBARA, CA. FILED 5-23-2011.

PRECIOUS MINERALS

THE MARK CONSISTS OF STANDARD CHARACTERS WITHOUT CLAIM TO ANY PARTICULAR FONT, STYLE, SIZE, OR COLOR.

NO CLAIM IS MADE TO THE EXCLUSIVE RIGHT TO USE "MINERALS", APART FROM THE MARK AS SHOWN.

FOR AGE SPOT REDUCING CREAMS; ANTI AGING CREAMS; ANTI-WRINKLE CREAMS; NON-MEDICATED SKIN CREAMS WITH ESSENTIAL OILS FOR USE IN AROMATHERAPY; ASTRINGENTS FOR COSMETIC USE; BATH AND BODY GELS NOT FOR MEDICAL PURPOSES, BATH BEADS, BUBBLE BATHS, BATH OIL, BATH SALTS, BLUSH, BODY GLITTER, NON-MEDICATED SKIN CARE PREPARATION, NAMELY, BODY MIST, BODY OIL, BODY SCRUB, BODY WASH, SKIN BRONZERS; BEAUTY MASKS; BEDTIME BODY LOTION; BODY AND BEAUTY CARE COSMETICS; BODY CLEANSERS; BODY CREAMS; BODY LOTIONS; BODY OILS; BODY SCRUBS; BODY

CLASS 3—(Continued).

SOAPS; BODY SPRAYS; BATH AND BODY POWDER, SKIN BRONZING CREAMS IN THE FORM OF BRONZING STICKS, COLD CREAM; BODY WASH; COLOGNE, CREAMS, GELS, AND SPRAYS FOR THE FACE AND BODY, CONCEALERS, COSMETICS, COSMETIC CLEANSING CREAMS; COSMETIC CREAMS FOR SKIN CARE; COSMETIC OILS; COSMETIC PREPARATIONS FOR BATHS, NAMELY, BATH OILS, BATH GELS, BATH SALTS, BATH PEARLS, BATH LOTIONS, BATH MILK, BATH CRYSTALS, BATH POWDERS, FOAM BATH, MAKE-UP PREPARATIONS, NAMELY, EYE SHADOW, FACE POWDER, COSMETIC PENCILS; COSMETIC PREPARATIONS FOR BODY CARE; COSMETIC PRODUCTS IN THE FORM OF AEROSOLS FOR SKINCARE; COSMETICS, COSMETIC CLEANSING CREAMS; CUTICLE CREAMS AND CONDITIONERS, DEODORANT FOR PERSONAL USE AND ANTI-PERSPIRANTS, EXFOLIATING PREPARATIONS FOR THE SKIN NOT FOR MEDICAL PURPOSES, EYE GELS, EYE SHADOW, EYE LINING PENCILS, LIQUID EYE LINERS, EYE MAKE-UP, MASCARA, EYEBROW PENCILS, EYE MAKE-UP REMOVER, ESSENTIAL OILS FOR AROMATHERAPY; ESSENTIAL OILS FOR PERSONAL USE; EYE CREAMS; EYE MAKEUP REMOVER; FACE CREAMS FOR COSMETIC USE; FACE CREAMS FOR COSMETIC USE; FACIAL CLEANSERS; FACIAL CREAMS, FACIAL MOISTURIZERS, FACIAL SCRUBS, FACIAL TONERS, AND ASTRINGENTS FOR COSMETIC USE; FACIAL GELS; FACIAL MOUSSE; FOAMS CONTAINING COSMETICS AND SUNSCREENS; HAIR CARE PRODUCTS AND HAIR PREPARATIONS, NAMELY, SHAMPOOS, HAIR RINSES, CONDITIONERS, HAIR SPRAY, HAIR MASKS, HAIR TINTING PREPARATIONS, PRE-SHAMPOO HAIR CARE TREATMENT PREPARATIONS; HAIR GLITTER, HAIR GEL, HAIR SPRAY, HAIR CARE PRODUCTS AND HAIR PREPARATIONS, NAMELY, HAIR SHAMPOOS, SHAMPOOS, SHAMPOO-CONDITIONERS, HAIR CONDITIONERS, HAIR MASKS, GELS, CREAMS, LOTIONS, POMADES AND MOUSSES, HAIR COLOR, HAIR COLOR REMOVERS, HAIR TINTING PREPARATIONS, PRE-SHAMPOO HAIR TREATMENT PREPARATIONS, LIPSTICK, LIP GLOSS, LIP LINERS, LIP BALMS, NON-MEDICATED SKIN CARE PREPARATIONS, NAMELY, MOISTURIZING LOTIONS AND CREAMS; HAND AND NAIL CARE PREPARATIONS, NAMELY, HAND CREAMS AND LOTIONS, NAIL CREAMS, CUTICLE CREAMS AND CUTICLE CONDITIONERS; HAND SOAPS; LIP BALMS; LIP CREAMS; LIQUID SOAPS FOR HANDS, FACE AND BODY; MAKE UP REMOVING PREPARATIONS; MEDICATED FACIAL AND HAND SOAPS; NIGHT CREAM; AGE SPOT REDUCING CREAMS, NAMELY, NON MEDICATED BLEMISH AND SPOT TREATMENTS, NAMELY, FACIAL CREAMS, FACIAL CLEANSERS, FACIAL MOISTURIZERS, FACIAL TONERS, AND ASTRINGENTS FOR COSMETIC USE; NON-MEDICATED FOOT CREAMS AND POWDERS; NON-MEDICATED FOOT SOAKS, FRAGRANT BODY SPLASH, NON-MEDICATED SKIN CARE PREPARATION, NAMELY, FRAGRANT BODY MIST, FOUNDATION MAKEUP FOR THE FACE AND BODY; NON-MEDICATED SKIN CARE PREPARATIONS, NAMELY, MOISTURIZING LOTIONS AND CREAMS; PERFUMERY AND FRAGRANCES FOR PERSONAL USE, NAMELY, PERFUME, COLOGNES, EAU DE COLOGNE, EAU DE PARFUM, EAU DE TOILETTE, AFTER SHAVE GEL AND AFTER SHAVE LOTION; PERFUMERY, ESSENTIAL OILS, COSMETICS, HAIR LOTIONS; SHAVING CREAM, SHAVING GELS, SHOWER CREAM, SHOWER GEL, SKIN BRONZING CREAM, SOAP FOR THE BODY, SOAP FOR THE FACE, SOAP FOR THE HANDS, AND TALCUM POWDER, SKIN EXFOLIANTS; SHAVING CREAMS; SKIN CLEANSERS; SKIN CLEANSING BARS; SKIN CLEANSING SOAP BARS; SKIN EXFOLIANTS; SKIN EXFOLIATING CREAM NOT FOR MEDICAL PURPOSES; SOAPS; SOAPS IN LIQUID, SOLID OR GEL FORM, BODY CREAM SOAP, COSMETIC SOAPS, CREAM SOAPS, HAND SOAPS, PERFUMED SOAP, SKIN SOAP, SOAPS FOR BODY CARE, SOAPS FOR PERSONAL USE; SKIN TONERS (U.S. CLS. 1, 4, 6, 50, 51 AND 52).

PAUL MORENO, EXAMINING ATTORNEY

CLASS 3—(Continued).

SN 85-339,869. LABORATOIRES DARPHIN S.A.S., PARIS, FRANCE, FILED 6-7-2011.

CLASS 3—(Continued).

SN 85-340,792. ROGER & GALLET, ASNIERES SUR SEINE, FRANCE, FILED 6-8-2011.

LINE POLISH COMPLEX

THE MARK CONSISTS OF STANDARD CHARACTERS WITHOUT CLAIM TO ANY PARTICULAR FONT, STYLE, SIZE, OR COLOR.

NO CLAIM IS MADE TO THE EXCLUSIVE RIGHT TO USE "COMPLEX", APART FROM THE MARK AS SHOWN. FOR NON-MEDICATED SKIN CARE PREPARATIONS (U.S. CLS. 1, 4, 6, 50, 51 AND 52).

RUSS HERMAN, EXAMINING ATTORNEY

L'EAU IMAGINAIRE

THE MARK CONSISTS OF STANDARD CHARACTERS WITHOUT CLAIM TO ANY PARTICULAR FONT, STYLE, SIZE, OR COLOR.

PRIORITY CLAIMED UNDER SEC. 44(D) ON FRANCE APPLICATION NO. 113833037, FILED 5-20-2011, REG. NO. 11/3833037, DATED 9-30-2011, EXPIRES 5-20-2021.

THE ENGLISH TRANSLATION OF "L'EAU IMAGINAIRE" IN THE MARK IS THE IMAGINARY WATER.

FOR PERFUME, EAU DE TOILETTE; GELS, SALTS FOR THE BATH AND THE SHOWER NOT FOR MEDICAL PURPOSE; TOILET SOAPS, BODY DEODORANTS; COSMETICS, NAMELY, CREAMS, MILKS, LOTIONS, GELS AND POWDERS FOR THE FACE, THE BODY AND THE HANDS; NON-MEDICATED SUN CARE PREPARATIONS; MAKEUP PREPARATIONS; SHAMPOOS; GELS, SPRAYS, MOUSSES AND NON-MEDICATED BALMS FOR HAIR STYLING AND HAIR CARE; HAIR LACQUERS; HAIR COLORING AND HAIR DECOLORANT PREPARATIONS; PERMANENT WAVING AND CURLING PREPARATIONS; ESSENTIAL OILS FOR PERSONAL USE (U.S. CLS. 1, 4, 6, 50, 51 AND 52).

MATTHEW EINSTEIN, EXAMINING ATTORNEY

SN 85-339,881. TOO FACED COSMETICS, LLC, IRVINE, CA, FILED 6-7-2011.

NATURAL EYE

THE MARK CONSISTS OF STANDARD CHARACTERS WITHOUT CLAIM TO ANY PARTICULAR FONT, STYLE, SIZE, OR COLOR.

OWNER OF U.S. REG. NO. 4,117,855. NO CLAIM IS MADE TO THE EXCLUSIVE RIGHT TO USE "EYE", APART FROM THE MARK AS SHOWN. FOR COSMETICS (U.S. CLS. 1, 4, 6, 50, 51 AND 52). FIRST USE 6-0-2009; IN COMMERCE 6-0-2009. TOBY BULLOFF, EXAMINING ATTORNEY

SN 85-341,013. BUMBLE AND BUMBLE, LLC, NEW YORK, NY, FILED 6-8-2011.

SN 85-340,556. R. EXPO (USA) LTD., INC., AUBURN, WA, FILED 6-7-2011.

SWAGAT**DEDICATED TO THE CRAFT OF
HAIRDRESSING**

THE MARK CONSISTS OF STANDARD CHARACTERS WITHOUT CLAIM TO ANY PARTICULAR FONT, STYLE, SIZE, OR COLOR.

OWNER OF U.S. REG. NO. 3,398,148. THE ENGLISH TRANSLATION OF THE WORD "SWAGAT" IN THE MARK IS WELCOME. FOR INCENSE (U.S. CLS. 1, 4, 6, 50, 51 AND 52). FIRST USE 12-1-1988; IN COMMERCE 12-1-1988. TAMARA FRAZIER, EXAMINING ATTORNEY

THE MARK CONSISTS OF STANDARD CHARACTERS WITHOUT CLAIM TO ANY PARTICULAR FONT, STYLE, SIZE, OR COLOR.

FOR HAIR CARE PREPARATIONS (U.S. CLS. 1, 4, 6, 50, 51 AND 52). FIRST USE 10-31-2009; IN COMMERCE 10-31-2009. MARLENE BELL, EXAMINING ATTORNEY

CLASS 3—(Continued).

SN 85-346,721. ESTHER'S BEAUTY SECRETS, LLC, RIVERDALE, GA. FILED 6-15-2011.

EBS Esther's Beauty Secrets

THE MARK CONSISTS OF STANDARD CHARACTERS WITHOUT CLAIM TO ANY PARTICULAR FONT, STYLE, SIZE, OR COLOR.

NO CLAIM IS MADE TO THE EXCLUSIVE RIGHT TO USE "BEAUTY", APART FROM THE MARK AS SHOWN.

FOR BODY OILS; BODY SCRUB; BODY WASH; HAIR CARE PREPARATIONS; LIP BALM; SKIN CARE PREPARATIONS, NAMELY, BODY BALM (U.S. CLS. 1, 4, 6, 50, 51 AND 52).

FIRST USE 11-2-2010; IN COMMERCE 11-2-2010.
LINDA ORNDORFF, EXAMINING ATTORNEY

CLASS 3—(Continued).

SN 85-353,089. O'ROURKE HOLDINGS LLC, TOPANGA, CA. FILED 6-22-2011.



THE MARK CONSISTS OF A HEART CONTAINING TWO CHAIN LINKS IN THE LEFT SIDE. JUST ABOVE THE SHAPE OF THE HEART THERE IS A DOMED STRUCTURE. INSIDE THE HEART AND THE DOME STRUCTURE, THERE ARE NUMEROUS RANDOMLY ARRANGED DOTS REPRESENTING CRYSTALS.

FOR HAIR CARE PRODUCTS, NAMELY, SHAMPOO, CONDITIONER, HAIR SPRAY, HAIR MOUSSE; HAIR CARE PREPARATIONS; HAIR STYLING PREPARATIONS (U.S. CLS. 1, 4, 6, 50, 51 AND 52).

FIRST USE 12-0-2010; IN COMMERCE 12-0-2010.
ESTHER A. BORSUK, EXAMINING ATTORNEY

SN 85-350,811. VIRANSKI-USA, INC., SUGAR LAND, TX. FILED 6-20-2011.

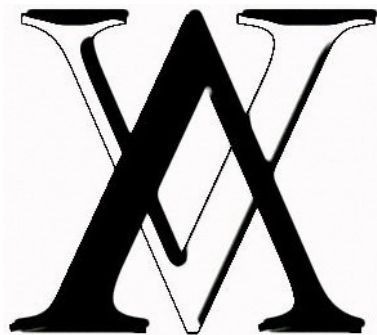

THE MARK CONSISTS OF TWO OVERLAPPING LETTER "V"'S.

FOR COLOGNES, PERFUMES AND COSMETICS (U.S. CLS. 1, 4, 6, 50, 51 AND 52).

SARA BENJAMIN, EXAMINING ATTORNEY

SN 85-353,359. KAZ AMOR, INC., DBA VOCE HAIRCARE, LOS ANGELES, CA. FILED 6-22-2011.

Voce haircare

SN 85-352,652. COLGATE-PALMOLIVE COMPANY, NEW YORK, NY. FILED 6-22-2011.



THE MARK CONSISTS OF A SHIELD DESIGN WITH THE WORD "ADVANCED" TO THE RIGHT OF THE DESIGN. FOR TOOTHPASTE (U.S. CLS. 1, 4, 6, 50, 51 AND 52).
JAY FLOWERS, EXAMINING ATTORNEY

THE MARK CONSISTS OF STANDARD CHARACTERS WITHOUT CLAIM TO ANY PARTICULAR FONT, STYLE, SIZE, OR COLOR.

NO CLAIM IS MADE TO THE EXCLUSIVE RIGHT TO USE "HAIRCARE", APART FROM THE MARK AS SHOWN.

THE ENGLISH TRANSLATION OF "VOCE" IN THE MARK IS "VOICE".

FOR HAIR SHAMPOOS AND CONDITIONERS; HAIR STYLING PREPARATIONS (U.S. CLS. 1, 4, 6, 50, 51 AND 52).

WILLIAM VERHOSEK, EXAMINING ATTORNEY

CLASS 3—(Continued).

SN 85-357,351. SANTE SEMPRINI CESARI, UNION CITY, NJ. FILED 6-27-2011.



THE COLOR(S) BLACK AND PINK IS/ARE CLAIMED AS A FEATURE OF THE MARK.

THE MARK CONSISTS OF THE STYLIZED WORDING VERSUM WITH "VERSU" IN BLACK AND M IN PINK. AT THE BEGINNING OF THE WORD THERE IS A PINK WAVY LINE CONTINUING BELOW THE WORDING "VERSU".

THE WORDING "VERSUM" HAS NO MEANING IN A FOREIGN LANGUAGE.

FOR HAIR BLEACHING PREPARATIONS; HAIR CARE CREAMS; HAIR CARE LOTIONS; HAIR GEL AND HAIR MOUSSE; HAIR LACQUERS; HAIR LOTION; HAIR SHAMPOOS AND CONDITIONERS; HAIR SPRAY; HAIR WAVING LOTION; HAIR WAX; NON-MEDICATED HAIR SERUMS (U.S. CLS. 1, 4, 6, 50, 51 AND 52).
SALLY SHIH, EXAMINING ATTORNEY

SN 85-357,771. L'OREAL, PARIS, FRANCE, FILED 6-28-2011.

FOUNDATION INSIDE

THE MARK CONSISTS OF STANDARD CHARACTERS WITHOUT CLAIM TO ANY PARTICULAR FONT, STYLE, SIZE, OR COLOR.

PRIORITY CLAIMED UNDER SEC. 44(D) ON FRANCE APPLICATION NO. 11/3840520, FILED 6-21-2011.

NO CLAIM IS MADE TO THE EXCLUSIVE RIGHT TO USE "FOUNDATION", APART FROM THE MARK AS SHOWN.

FOR PERFUME, EAU DE TOILETTE; GELS, SALTS FOR THE BATH AND THE SHOWER NOT FOR MEDICAL PURPOSE; TOILET SOAPS, BODY DEODORANTS; COSMETICS, NAMELY, CREAMS, MILKS, LOTIONS, GELS AND POWDERS FOR THE FACE, THE BODY AND THE HANDS; NON-MEDICATED SUN CARE PREPARATIONS; MAKEUP PREPARATIONS; SHAMPOOS; GELS, SPRAYS, MOUSSES AND BALMS FOR HAIR STYLING AND HAIR CARE; HAIR LACQUERS; HAIR COLOURING AND HAIR DECOLORANT PREPARATIONS; PERMANENT WAVING AND CURLING PREPARATIONS; ESSENTIAL OILS FOR PERSONAL USE (U.S. CLS. 1, 4, 6, 50, 51 AND 52).

RENEE MCCRAY, EXAMINING ATTORNEY

CLASS 3—(Continued).

SN 85-358,106. L'OPÉRA DE PARIS INC, DBA L'OPÉRA COSMETICS, SUGARLAND, TX. FILED 6-28-2011.



THE MARK CONSISTS OF THE STYLIZED LETTERS "LP" WITHIN A SQUARE BACKGROUND.

FOR COSMETICS, NAMELY, FACIAL MOISTURIZERS, FACIAL CLEANSERS, EYE CREAM, FACE POWDER, MAKEUP FOUNDATION, EXFOLIATING SCRUB CREAMS FOR FACE AND BODY (U.S. CLS. 1, 4, 6, 50, 51 AND 52).

FIRST USE 1-2-1996; IN COMMERCE 1-2-1996.
HENRY S. ZAK, EXAMINING ATTORNEY

SN 85-360,239. LOTTA LUV, LLC, NEW YORK, NY. FILED 6-30-2011.

MUD IN YOUR FACE

THE MARK CONSISTS OF STANDARD CHARACTERS WITHOUT CLAIM TO ANY PARTICULAR FONT, STYLE, SIZE, OR COLOR.

FOR COSMETIC SKIN FRESHENERS; FACIAL MASKS; MOISTURIZING SOLUTIONS FOR THE SKIN; SKIN MASKS (U.S. CLS. 1, 4, 6, 50, 51 AND 52).

MARGARET POWER, EXAMINING ATTORNEY

CLASS 3—(Continued).

SN 85-365,696. TY LOKE, LLC, NEW YORK, NY. FILED 7-7-2011.

THE TYRA BANKS COMPANY

THE MARK CONSISTS OF STANDARD CHARACTERS WITHOUT CLAIM TO ANY PARTICULAR FONT, STYLE, SIZE, OR COLOR.

OWNER OF U.S. REG. NOS. 3,706,987 AND 3,776,318.

NO CLAIM IS MADE TO THE EXCLUSIVE RIGHT TO USE "COMPANY", APART FROM THE MARK AS SHOWN.

THE NAME "TYRA BANKS" IDENTIFIES A LIVING INDIVIDUAL WHOSE CONSENT IS OF RECORD.

FOR COSMETICS; FACIAL MAKEUP, CONCEALERS, BLUSHERS, FACIAL POWDERS, FOUNDATION MAKEUP, EYE MAKEUP, EYE PENCILS, EYEBROW PENCILS, MASCARA, FALSE EYELASHES, FACE AND BODY GLITTER, COSMETIC COMPACTS, COSMETIC PENCILS, LIPSTICK, LIPSTICK CASES, LIPSTICK HOLDERS, LIP GLOSS, LIP POMADES, LIP PENCILS, MAKEUP REMOVERS, MAKEUP APPLICATORS IN THE NATURE OF COTTON SWABS FOR COSMETIC PURPOSES, EYE CREAMS, FACIAL CLEANSERS, SKIN TONERS, FACIAL EXFOLIANTS AND SCRUBS, FACIAL CREAMS, FACIAL MOISTURIZERS, FACIAL LOTIONS AND NON-MEDICATED FACIAL TREATMENTS IN THE NATURE OF FACIAL EMULSIONS AND FACIAL MASKS, WRINKLE REMOVING SKIN CARE PREPARATIONS, NAIL POLISHES, NAIL POLISH BASE COAT, NAIL POLISH TOP COAT, NAIL STRENGTHENERS, NAIL HARDENERS, NAIL POLISH REMOVERS, NAIL CREAMS, CUTICLE REMOVING PREPARATIONS, NAIL TIPS, AND NAIL BUFFING PREPARATIONS; BEAUTY MILKS, SKIN MOISTURIZERS AND SKIN MOISTURIZER MASKS, SKIN CONDITIONERS, HAND CREAMS, MASSAGE OILS, ESSENTIAL OILS FOR PERSONAL USE, TALCUM POWDER, PERFUMED POWDERS, BATH BEADS, BATH CRYSTALS, BATH FOAM, BATH GELS, BATH OILS, BATH POWDERS, BATH SALTS, FACIAL WASHES, SKIN CLEANSERS, SKIN LIGHTERS, BODY SCRUBS, BODY FRAGRANCES, FRAGRANCES FOR PERSONAL USE, BODY AND HAND LOTIONS, BODY GELS, SHOWER GELS, BODY OILS, BODY POWDERS, BODY EXFOLIANTS, BODY MASKS, BODY MASK CREAMS AND LOTIONS, SHAVING PREPARATIONS, AFTER SHAVE LOTIONS, SHAVING BALM, SHAVING CREAM, SHAVING GEL, SKIN ABRASIVE PREPARATIONS, NON-MEDICATED SKIN CREAMS AND SKIN LOTIONS FOR RELIEVING RAZOR BURNS, NON-MEDICATED LIP CARE PREPARATIONS, LIP CREAM, SUNSCREEN PREPARATIONS, SUNTANNING PREPARATIONS AND AFTER-SUN LOTIONS; COSMETIC SUN-PROTECTING PREPARATIONS; SUN TAN OILS; SELF-TANNING PREPARATIONS, NAMELY, SELF TANNING MILK AND CREAM, ACCELERATED TANNING CREAM, SELF-TANNING LOTIONS, GELS AND SPRAYS; NON-MEDICATED OINTMENTS FOR THE TREATMENT OF SUNBURNS; NON-MEDICATED TOILETRIES; PERFUME, PERFUME OILS, COLOGNE, EAU DE TOILETTE, EAU DE PERFUME, EAU DE COLOGNE AND TOILETTE WATER; TOOTHPASTE, DEODORANT AND ANTIPERSPIRANT; COSMETIC SOAPS, PERFUMED SOAPS, LIQUID SOAPS, HAND, FACIAL AND BATH SOAPS, DEODORANT SOAPS, SHAVING SOAPS, SOAP POWDER, TOILET SOAPS, SOAPS FOR BODY CARE, AND SOAPS FOR PERSONAL USE; COSMETIC PADS, PRE-MOISTENED COSMETIC WIPES, PRE-MOISTENED COSMETIC TISSUES AND TOWELETTES; COTTON STICKS FOR COSMETIC PURPOSES; ALL PURPOSE COTTON SWABS FOR PERSONAL USE AND COSMETIC PURPOSES; NON-MEDICATED TOPICAL SKIN CREAMS, OINTMENTS, GELS, TONERS, AND LOTIONS; TOPICAL SKIN SPRAYS FOR COSMETIC PURPOSES; AROMATIC SKIN CREAMS, LOTIONS AND OILS; HAIR CARE PRODUCTS, NAMELY, SHAMPOOS, CONDITIONERS, MOUSSE, GELS, FROSTS, CREAMS, RINSES, SPRAYS, HAIR COLOR, HAIR WAVING LOTION, PERMANENT WAVE PREPARATIONS, HAIR

CLASS 3—(Continued).

LIGHTENERS, HAIR DYES, HAIR EMOLLIENTS, HAIR MASCARA, HAIR POMADES, HAIR COLOR REMOVERS, HAIR RELAXING PREPARATIONS, HAIR STYLING PREPARATIONS, HAIR REMOVING CREAM, AND HAIR CARE PREPARATIONS; ASTRINGENTS FOR COSMETIC PURPOSES; BABY WIPES; DISPOSABLE WIPES IMPREGNATED WITH CHEMICALS OR COMPOUNDS FOR PERSONAL HYGIENE AND HOUSEHOLD USE; INCENSE; ROOM FRAGRANCES; FRAGRANCE EMITTING WICKS FOR ROOM FRAGRANCES; SACHETS; SACHET-LIKE EYE PILLOWS CONTAINING FRAGRANCES; SCENTED CERAMIC STONES; SCENTED LINEN SPRAYS AND SCENTED ROOM SPRAYS; SCENTED OILS USED TO PRODUCE AROMAS WHEN HEATED; SCENTED PINE CONES; POTPOURRI; AROMATIC PILLOWS COMPRISING POTPOURRI IN FABRIC CONTAINERS (U.S. CLS. 1, 4, 6, 50, 51 AND 52).

EVELYN BRADLEY, EXAMINING ATTORNEY

SN 85-367,117. PRODUCT INNOVATION RESEARCH LLC, DALLAS, TX. FILED 7-8-2011.

Plums the Word

THE MARK CONSISTS OF STANDARD CHARACTERS WITHOUT CLAIM TO ANY PARTICULAR FONT, STYLE, SIZE, OR COLOR.

NO CLAIM IS MADE TO THE EXCLUSIVE RIGHT TO USE "PLUMS", APART FROM THE MARK AS SHOWN.

FOR INDOOR TANNING PRODUCTS, NAMELY, NON-MEDICATED SKIN TAN DARKENING LOTIONS AND SKIN MOISTURIZERS (U.S. CLS. 1, 4, 6, 50, 51 AND 52).

WARREN L. OLANDRIA, EXAMINING ATTORNEY

SN 85-367,639. SAFE CLEANERS, LLC, WYOMING, MI. FILED 7-11-2011.



THE COLOR(S) GREEN, OLIVE GREEN, BLACK AND TEAL IS/ARE CLAIMED AS A FEATURE OF THE MARK.

THE MARK CONSISTS OF THREE LEAF PATTERN ONE OF THE LEAVES BEING GREEN, ANOTHER BEING OLIVE GREEN AND THE THIRD BEING TEAL. THE WORD "SAFE" BEING IN BLACK AND THE WORD "CLEANERS" BEING GREEN. THE "S" AND "C" ARE UPPER CASE.

FOR ALL-PURPOSE CLEANERS (U.S. CLS. 1, 4, 6, 50, 51 AND 52).

FIRST USE 3-4-2008; IN COMMERCE 3-4-2008.

DAVID TAYLOR, EXAMINING ATTORNEY

CLASS 3—(Continued).

SN 85-371,719. O'ROURKE HOLDINGS LLC, TOPANGA, CA.
FILED 7-14-2011.

CLASS 3—(Continued).

SN 85-382,894. PRINCE, SYMONE, NEW YORK, NY. FILED
7-27-2011.

STRAIGHT HAIR ROCKS

THE MARK CONSISTS OF STANDARD CHARACTERS WITHOUT CLAIM TO ANY PARTICULAR FONT, STYLE, SIZE, OR COLOR.

NO CLAIM IS MADE TO THE EXCLUSIVE RIGHT TO USE "STRAIGHT HAIR", APART FROM THE MARK AS SHOWN.

FOR HAIR CARE PRODUCTS, NAMELY, SHAMPOO, CONDITIONER, HAIR SPRAY, HAIR MOUSSE; HAIR CARE PREPARATIONS; HAIR STYLING PREPARATIONS (U.S. CLS. 1, 4, 6, 50, 51 AND 52).
ESTHER A. BORSUK, EXAMINING ATTORNEY

SYMONE PRINCE BEAUTY

SN 85-371,759. O'ROURKE HOLDINGS LLC, TOPANGA, CA.
FILED 7-14-2011.

HEALTHY HAIR ROCKS

THE MARK CONSISTS OF STANDARD CHARACTERS WITHOUT CLAIM TO ANY PARTICULAR FONT, STYLE, SIZE, OR COLOR.

NO CLAIM IS MADE TO THE EXCLUSIVE RIGHT TO USE "HEALTHY HAIR", APART FROM THE MARK AS SHOWN.

FOR HAIR CARE PRODUCTS, NAMELY, SHAMPOO, CONDITIONER, HAIR SPRAY, HAIR MOUSSE; HAIR CARE PREPARATIONS; HAIR STYLING PREPARATIONS (U.S. CLS. 1, 4, 6, 50, 51 AND 52).
ESTHER A. BORSUK, EXAMINING ATTORNEY

THE MARK CONSISTS OF STANDARD CHARACTERS WITHOUT CLAIM TO ANY PARTICULAR FONT, STYLE, SIZE, OR COLOR.

NO CLAIM IS MADE TO THE EXCLUSIVE RIGHT TO USE "BEAUTY", APART FROM THE MARK AS SHOWN.

THE NAME(S), PORTRAIT(S), AND/OR SIGNATURE(S) SHOWN IN THE MARK IDENTIFIES "SYMONE PRINCE", WHOSE CONSENT(S) TO REGISTER IS MADE OF RECORD.

FOR ARTIFICIAL EYELASHES; BEAUTY SERUMS; BODY SCRUB; COSMETICS; COSMETICS AND COSMETIC PREPARATIONS; COSMETICS AND MAKE-UP; COSMETICS, NAMELY, LIP PRIMER; CREAMY FOUNDATION; DUSTING POWDER; EYE CREAM; EYE MAKE-UP; EYE MAKE-UP REMOVER; EYE SHADOWS; EYEBROW COSMETICS; EYES PENCILS; FACE POWDER; FACIAL CLEANSERS; FACIAL SCRUBS; FOUNDATION; LIP GLOSS; LIP LINER; LIPSTICK; LIQUID FOUNDATION (MIZU-OSHIROI); LOOSE FACE POWDER; MAKE UP FOUNDATIONS; MAKE-UP POWDER; MASCARA; MINERAL POWDER FOR USE IN COSMETIC BODY WRAP APPLICATIONS; POWDER FOR MAKE-UP; PRESSED FACE POWDER; SKIN CLEANSERS; SKIN MOISTURIZER; SKIN MOISTURIZER MASKS; SKIN TONERS (U.S. CLS. 1, 4, 6, 50, 51 AND 52).
SHARON MEIER, EXAMINING ATTORNEY

CLASS 3—(Continued).

SN 85-382,924. PRINCE, SYMONE, NEW YORK, NY. FILED 7-27-2011.



THE MARK CONSISTS OF THE LETTERS "SPB" WITHIN AN OVAL WITH A RIBBON ON TOP OF THE OVAL.

FOR ARTIFICIAL EYELASHES; BEAUTY MASKS; BEAUTY SERUMS; COSMETIC PREPARATIONS FOR BODY CARE; COSMETIC PREPARATIONS FOR EYE LASHES; COSMETIC PREPARATIONS FOR SKIN CARE; COSMETIC PREPARATIONS, NAMELY, SKIN BALMS; COSMETICS; COSMETICS AND COSMETIC PREPARATIONS; COSMETICS AND MAKE-UP; COSMETICS, NAMELY, LIP PRIMER; CREAMY FOUNDATION; EYE LINER; EYE MAKE-UP; EYE PENCILS; EYE-SHADOW; EYEBROW COLORS; EYEBROW COSMETICS; EYEBROW PENCILS; EYES MAKE-UP; FACE POWDER; FACIAL CLEANSERS; FOUNDATION; LIP GLOSS; LIP LINER; LIPSTICK; LOOSE FACE POWDER; MAKE UP FOUNDATIONS; MAKE-UP; MAKE-UP POWDER; MAKE-UP REMOVER; MASCARA; POWDER FOR MAKE-UP; PRESSED FACE POWDER; SKIN CARE PRODUCTS, NAMELY, NON-MEDICATED SKIN SERUM; SKIN TONERS (U.S. CLS. 1, 4, 6, 50, 51 AND 52).
SHARON MEIER, EXAMINING ATTORNEY

SN 85-394,518. I-LABS, L.L.C., HUNTINGTON BEACH, CA. FILED 8-10-2011.

California Mango

THE MARK CONSISTS OF STANDARD CHARACTERS WITHOUT CLAIM TO ANY PARTICULAR FONT, STYLE, SIZE, OR COLOR.

SEC. 2(F).
FOR BATH GEL; BEAUTY LOTIONS; CUTICLE CONDITIONERS; CUTICLE CREAM; EXFOLIANT CREAMS (U.S. CLS. 1, 4, 6, 50, 51 AND 52).
FIRST USE 7-15-1991; IN COMMERCE 7-15-1991.
ANDREA BUTLER, EXAMINING ATTORNEY

CLASS 3—(Continued).

SN 85-419,236. AMAZING CONCEALER COSMETICS, INC., LIBERTYVILLE, IL. FILED 9-9-2011.

FACE-ICS

THE MARK CONSISTS OF STANDARD CHARACTERS WITHOUT CLAIM TO ANY PARTICULAR FONT, STYLE, SIZE, OR COLOR.

FOR COSMETICS, NAMELY, FACE MAKEUP, CONCEALER, FACE POWDER, EYE MAKEUP, MASCARA, EYE SHADOW, EYELINER, EYE SHADOW BASE AND PRIMER, NON-MEDICATED LIP TREATMENT PREPARATIONS, LIPSTICK, LIP GLOSS, SKIN BRONZER, LIP LINER, BLUSH, FACE LOTION, BROW POWDER, FACE PRIMER, AND MAKEUP KITS COMPRISING OF ONE OR MORE OF THE FOREGOING (U.S. CLS. 1, 4, 6, 50, 51 AND 52).
JIM RINGLE, EXAMINING ATTORNEY

SN 85-419,577. BIO NAZA COSMETIC PRODUCTS, INC., AKA BIONAZA COSMETICS, BOCA RATON, FL. FILED 9-10-2011.



OWNER OF U.S. REG. NO. 4,059,642.
THE COLOR(S) WHITE AND BROWN IS/ARE CLAIMED AS A FEATURE OF THE MARK.

THE MARK CONSISTS OF THE STYLIZED WORD "CHOCOHAIR" IN BROWN IN CAPITAL LETTERS ON A WHITE BACKGROUND.

FOR HAIR CARE KITS COMPRISING NON-MEDICATED HAIR CARE PREPARATIONS, NAMELY, KERATIN, SHAMPOO, CONDITIONER, AND HAIR LOTION (U.S. CLS. 1, 4, 6, 50, 51 AND 52).
FIRST USE 3-10-2006; IN COMMERCE 3-10-2006.
MARY CRAWFORD, EXAMINING ATTORNEY

SN 85-434,172. CONAIR CORPORATION, STAMFORD, CT. FILED 9-28-2011.

Soho

THE MARK CONSISTS OF STANDARD CHARACTERS WITHOUT CLAIM TO ANY PARTICULAR FONT, STYLE, SIZE, OR COLOR.

OWNER OF U.S. REG. NOS. 3,125,342 AND 3,960,263.
FOR FALSE EYELASHES (U.S. CLS. 1, 4, 6, 50, 51 AND 52).
PAULA MAHONEY, EXAMINING ATTORNEY

CLASS 3—(Continued).

SN 85-436,361. KARI ELLEN LLC, CHEVY CHASE, MD.
FILED 9-30-2011.

KARI ELLEN

THE MARK CONSISTS OF STANDARD CHARACTERS WITHOUT CLAIM TO ANY PARTICULAR FONT, STYLE, SIZE, OR COLOR.

THE NAME "KARI ELLEN" IDENTIFIES A LIVING INDIVIDUAL WHOSE CONSENT IS OF RECORD. FOR COSMETICS (U.S. CLS. 1, 4, 6, 50, 51 AND 52). FIRST USE 9-30-2011; IN COMMERCE 9-30-2011. GRETTA YAO, EXAMINING ATTORNEY

SN 85-441,151. LANCOME PARFUMS ET BEAUTE & CIE,
PARIS, FRANCE, FILED 10-6-2011.

OMBRE NUE

THE MARK CONSISTS OF STANDARD CHARACTERS WITHOUT CLAIM TO ANY PARTICULAR FONT, STYLE, SIZE, OR COLOR.

OWNER OF FRANCE REG. NO. 11/3836096, DATED 6-1-2011, EXPIRES 6-1-2021.

NO CLAIM IS MADE TO THE EXCLUSIVE RIGHT TO USE "OMBRE", APART FROM THE MARK AS SHOWN.

THE ENGLISH TRANSLATION OF "OMBRE NUE" IN THE MARK IS "NAKED SHADOW".

FOR COSMETICS AND MAKEUP PREPARATIONS (U.S. CLS. 1, 4, 6, 50, 51 AND 52).

SUE LAWRENCE, EXAMINING ATTORNEY

SN 85-441,525. IBLANC, INC., YORBA LINDA, CA. FILED 10-7-2011.

iBlanc

THE MARK CONSISTS OF STANDARD CHARACTERS WITHOUT CLAIM TO ANY PARTICULAR FONT, STYLE, SIZE, OR COLOR.

THE ENGLISH TRANSLATION OF "BLANC" IN THE MARK IS "WHITE", "CLEAR".

FOR ANTI-AGING MOISTURIZER (U.S. CLS. 1, 4, 6, 50, 51 AND 52).

MATTHEW EINSTEIN, EXAMINING ATTORNEY

CLASS 3—(Continued).

SN 85-442,410. LANCOME PARFUMS ET BEAUTE & CIE,
PARIS, FRANCE, FILED 10-7-2011.

VERNIS IN LOVE

THE MARK CONSISTS OF STANDARD CHARACTERS WITHOUT CLAIM TO ANY PARTICULAR FONT, STYLE, SIZE, OR COLOR.

OWNER OF FRANCE REG. NO. 113838244, DATED 6-10-2011, EXPIRES 6-10-2021.

NO CLAIM IS MADE TO THE EXCLUSIVE RIGHT TO USE "VARNISH", APART FROM THE MARK AS SHOWN.

THE ENGLISH TRANSLATION OF "VERNIS" IN THE MARK IS "VARNISH".

FOR COSMETICS AND MAKEUP PREPARATIONS (U.S. CLS. 1, 4, 6, 50, 51 AND 52).

SUE LAWRENCE, EXAMINING ATTORNEY

SN 85-445,025. G-WIZ CONSTRUCTION INC., MYRTLE BEACH, SC. FILED 10-12-2011.

TOURISTSEASONING

THE MARK CONSISTS OF STANDARD CHARACTERS WITHOUT CLAIM TO ANY PARTICULAR FONT, STYLE, SIZE, OR COLOR.

FOR COSMETICS, NAMELY, COSMETIC SUNTAN LOTIONS, COSMETIC SUNTAN PREPARATIONS, SUNSCREEN CREAM AND NON-MEDICATED LIP PROTECTORS (U.S. CLS. 1, 4, 6, 50, 51 AND 52).

JUSTINE D. PARKER, EXAMINING ATTORNEY

SN 85-445,239. DIRECT 2U WHOLESALE LLC, LUTZ, FL. FILED 10-12-2011.

WattsBeauty

THE MARK CONSISTS OF STANDARD CHARACTERS WITHOUT CLAIM TO ANY PARTICULAR FONT, STYLE, SIZE, OR COLOR.

FOR NON-MEDICATED HAIR, SKIN, AND BODY TOPICAL LOTIONS, CREAMS AND OILS FOR COSMETIC USE CONSISTING OF ORGANIC ARGAN VIRGIN OIL AND ARGAN VIRGIN OIL (U.S. CLS. 1, 4, 6, 50, 51 AND 52).

FIRST USE 3-16-2008; IN COMMERCE 3-16-2008.

JOHN DWYER, EXAMINING ATTORNEY

CLASS 3—(Continued).

SN 85-451,268. L'OREAL USA CREATIVE, INC., NEW YORK, NY. FILED 10-19-2011.

DREAM BOUNCY BRONZER

THE MARK CONSISTS OF STANDARD CHARACTERS WITHOUT CLAIM TO ANY PARTICULAR FONT, STYLE, SIZE, OR COLOR.
OWNER OF U.S. REG. NOS. 2,950,384, 4,126,698 AND OTHERS.

NO CLAIM IS MADE TO THE EXCLUSIVE RIGHT TO USE "BRONZER", APART FROM THE MARK AS SHOWN. FOR MAKEUP (U.S. CLS. 1, 4, 6, 50, 51 AND 52).
BARBARA BROWN, EXAMINING ATTORNEY

SN 85-453,217. HIGHWOOD INTERNATIONAL LLC, DBA ESTHER P, WILMINGTON, DE. FILED 10-21-2011.



THE NAME(S), PORTRAIT(S), AND/OR SIGNATURE(S) SHOWN IN THE MARK DOES NOT IDENTIFY A PARTICULAR LIVING INDIVIDUAL.

THE COLOR(S) BLUE, GREEN AND WHITE IS/ARE CLAIMED AS A FEATURE OF THE MARK.

THE MARK CONSISTS OF A STYLIZED GREEN AND WHITE JASMINE FLOWER FOLLOWED BY THE BLUE HAND-WRITTEN STYLIZED NAME "ESTHER P" UNDERLINED IN GREEN, AND THE GREEN LETTER "P" TOPPED BY A GREEN BUTTERFLY. ALL LETTERING IS IN LOWER CASE.

FOR COLOGNES, PERFUMES AND COSMETICS (U.S. CLS. 1, 4, 6, 50, 51 AND 52).

MARK T. MULLEN, EXAMINING ATTORNEY

CLASS 3—(Continued).

SN 85-456,326. DYER, SHAWN, HOUSTON, TX. FILED 10-26-2011.

NATURAL CURLZ



ANOINTED HAIR OIL

NO CLAIM IS MADE TO THE EXCLUSIVE RIGHT TO USE "NATURAL CURLS" AND "ANOINTED HAIR OIL", APART FROM THE MARK AS SHOWN.

THE MARK CONSISTS OF AN OUTLINED CIRCLE CARRYING THE TERMS "NC" WITH STYLIZED WAVY BANDS OF HAIR ABOVE AND BELOW THE CIRCLE; THE TERMS "NATURAL CURLZ" APPEARS ABOVE THE DESIGN, AND "ANOINTED HAIR OIL" BELOW THE DESIGN. FOR HAIR STYLING PREPARATIONS (U.S. CLS. 1, 4, 6, 50, 51 AND 52).

FIRST USE 8-11-2011; IN COMMERCE 8-16-2011.
ANTHONY RINKER, EXAMINING ATTORNEY

SN 85-457,724. L'OREAL USA CREATIVE, INC., NEW YORK, NY. FILED 10-27-2011.

MASTER DUO

THE MARK CONSISTS OF STANDARD CHARACTERS WITHOUT CLAIM TO ANY PARTICULAR FONT, STYLE, SIZE, OR COLOR.

NO CLAIM IS MADE TO THE EXCLUSIVE RIGHT TO USE "DUO", APART FROM THE MARK AS SHOWN.

FOR EYELINER (U.S. CLS. 1, 4, 6, 50, 51 AND 52).
DAVID H. STINE, EXAMINING ATTORNEY

CLASS 3—(Continued).

SN 85-460,915. BKB AUTOMOTIVE COSMETICS, INC.,
NORTH HOLLYWOOD, CA. FILED 10-31-2011.



NO CLAIM IS MADE TO THE EXCLUSIVE RIGHT TO
USE "EST. 1926", APART FROM THE MARK AS SHOWN.

THE MARK CONSISTS OF A CIRCLE WITH THE WORDS
"BEAUTY-SHINE" WRITTEN AT A SLANT OVER THE TOP
OF THE CIRCLE, THE WORD "THE" IS AT THE TOP OF
THE CIRCLE AND THE WORD "METHOD" IS AT THE
BOTTOM OF THE CIRCLE, THREE HORIZONTAL LINES
ARE TO THE TOP LEFT OF THE CIRCLE, THREE
HORIZONTAL LINES ARE TO THE BOTTOM RIGHT OF
THE CIRCLE, THE WORDS "EST. 1926" ARE CONTAINED
WITHIN THE CIRCLE AT THE BOTTOM.

FOR AUTOMOTIVE POLISHES, WAXES, AND
CLEANSING PREPARATIONS; DRESSING FOR AUTO-
MOTIVE TIRES AND RUBBER (U.S. CLS. 1, 4, 6, 50, 51
AND 52).

FIRST USE 12-31-1926; IN COMMERCE 12-31-1926.
TARAH HARDY, EXAMINING ATTORNEY

SN 85-460,922. BKB AUTOMOTIVE COSMETICS, INC.,
NORTH HOLLYWOOD, CA. FILED 10-31-2011.

DOUBLE TOUGH

THE MARK CONSISTS OF STANDARD CHARACTERS
WITHOUT CLAIM TO ANY PARTICULAR FONT, STYLE,
SIZE, OR COLOR.

FOR COMBINATION PROTECTIVE AUTOMOBILE,
BOAT, AND AIRCRAFT, DRESSING, SURFACE CON-
DITIONER, AND COATING FOR RUBBER, VINYL AND
LEATHER (U.S. CLS. 1, 4, 6, 50, 51 AND 52).

FIRST USE 7-31-1989; IN COMMERCE 7-31-1989.
TARAH HARDY, EXAMINING ATTORNEY

CLASS 3—(Continued).

SN 85-460,935. BKB AUTOMOTIVE COSMETICS, INC.,
NORTH HOLLYWOOD, CA. FILED 10-31-2011.



NO CLAIM IS MADE TO THE EXCLUSIVE RIGHT TO
USE "SINCE 1926", APART FROM THE MARK AS SHOWN.

THE MARK CONSISTS OF A SMILING CAR POSI-
TIONED OVER A CIRCLE, AN AIRPLANE FLYING
THROUGH THE CIRCLE OVER THE SMILING CAR, AND
THE WORDS "BEAUTY SHINE SINCE 1926" ENCLOSED
WITHIN THE CIRCLE.

FOR AUTOMOTIVE POLISHES, WAXES, AND
CLEANSING PREPARATIONS; DRESSING FOR AUTO-
MOTIVE TIRES AND RUBBER (U.S. CLS. 1, 4, 6, 50, 51
AND 52).

FIRST USE 12-31-1959; IN COMMERCE 12-31-1959.
TARAH HARDY, EXAMINING ATTORNEY

SN 85-469,192. VENUS LABORATORIES, INC., DBA EARTH
FRIENDLY PRODUCTS, ADDISON, IL. FILED 11-10-2011.

PARSLEY PLUS

THE MARK CONSISTS OF STANDARD CHARACTERS
WITHOUT CLAIM TO ANY PARTICULAR FONT, STYLE,
SIZE, OR COLOR.

NO CLAIM IS MADE TO THE EXCLUSIVE RIGHT TO
USE "PARSLEY", APART FROM THE MARK AS SHOWN.

FOR ALL SURFACE CLEANER (U.S. CLS. 1, 4, 6, 50, 51
AND 52).

FIRST USE 2-16-2001; IN COMMERCE 2-16-2001.
JASON BLAIR, EXAMINING ATTORNEY

SN 85-471,568. MENPER DISTRIBUTORS, INC., MIAMI, FL.
FILED 11-14-2011.

CREPE DE PERLE

THE MARK CONSISTS OF STANDARD CHARACTERS
WITHOUT CLAIM TO ANY PARTICULAR FONT, STYLE,
SIZE, OR COLOR.

THE ENGLISH TRANSLATION OF "CREPE DE PERLE"
IN THE MARK IS "PEARL CREPE".

FOR BEAUTY CREAMS (U.S. CLS. 1, 4, 6, 50, 51 AND
52).

FIRST USE 11-28-1978; IN COMMERCE 11-28-1978.
MICHAEL WEBSTER, EXAMINING ATTORNEY

CLASS 3—(Continued).

SN 85-474,210. FISCHBACH, RONALD, GRANADA HILLS, CA. FILED 11-16-2011.

INFINITELY CLEAN

THE MARK CONSISTS OF STANDARD CHARACTERS WITHOUT CLAIM TO ANY PARTICULAR FONT, STYLE, SIZE, OR COLOR.

NO CLAIM IS MADE TO THE EXCLUSIVE RIGHT TO USE "CLEAN", APART FROM THE MARK AS SHOWN.

FOR NATURAL LIQUID PERSONAL CARE CLEANLINESS PRODUCTS, NAMELY, ORGANIC SOAPS, SKIN CLEANSERS, DEODORANTS, SKIN MOISTURIZERS, AND SKIN CONDITIONERS (U.S. CLS. 1, 4, 6, 50, 51 AND 52).

KARANENDRA S. CHHINA, EXAMINING ATTORNEY

CLASS 3—(Continued).

SN 85-482,123. X2 INC., BEVERLY HILLS, CA. FILED 11-28-2011.

Zipper Clean Wipes

THE MARK CONSISTS OF STANDARD CHARACTERS WITHOUT CLAIM TO ANY PARTICULAR FONT, STYLE, SIZE, OR COLOR.

NO CLAIM IS MADE TO THE EXCLUSIVE RIGHT TO USE "CLEAN WIPES", APART FROM THE MARK AS SHOWN.

FOR ALL PURPOSE CLEANING PREPARATIONS; AUTOMOBILE CARPET AND UPHOLSTERY CLEANING PREPARATIONS; AUTOMOBILE TIRE CLEANING AND POLISHING PREPARATIONS; AUTOMOBILE, TIRE, GLASS AND WHEEL CLEANING PREPARATIONS; AUTOMOTIVE CLEANING PREPARATIONS; CLEANING AGENTS AND PREPARATIONS; CLEANING AGENTS FOR CLEANING SURFACES; CLEANING AND POLISHING PREPARATIONS; CLEANING AND WASHING PREPARATIONS; CLEANING PREPARATIONS; CLEANING PREPARATIONS FOR CLEANING SURFACES; CLEANING PREPARATIONS FOR HOUSEHOLD PURPOSES; CLEANING, POLISHING AND SCOURING PREPARATIONS; CLEANING, SCOURING AND POLISHING PREPARATIONS AND SUBSTANCES; CLEANING, WASHING AND POLISHING PREPARATIONS; CLOTHS IMPREGNATED WITH A DETERGENT FOR CLEANING; DISPOSABLE WIPES IMPREGNATED WITH CLEANING CHEMICALS OR COMPOUNDS FOR INDUSTRIAL AND COMMERCIAL USE; DRYER SHEETS IMPREGNATED WITH CLEANING GEL AND BAGS FOR USE IN CONNECTION THEREWITH; FOAM CLEANING PREPARATIONS; GENERAL PURPOSE CLEANING, POLISHING, AND ABRASIVE LIQUIDS AND POWDERS; GLASS CLEANING PREPARATIONS; HAND CLEANERS; HAND CLEANING PREPARATIONS; HOUSEHOLD CLEANING PREPARATIONS; IMPREGNATED CLEANING CLOTHS; IMPREGNATED CLEANING PADS IMPREGNATED WITH TOILET PREPARATIONS; IMPREGNATED CLEANING, DUSTING OR POLISHING CLOTHS; LEATHER CLEANING PREPARATIONS; METAL POLISHING AND CLEANING PREPARATIONS; PREPARATIONS FOR CLEANING, PROTECTING AND PRESERVING VEHICLE SURFACES; SPONGES IMPREGNATED WITH MARINE AND AUTOMOTIVE WAXES AND WASHES; WASHING POWDER; WASHING-UP LIQUIDS; WATERLESS SPRAY FOR THE CLEANING AND WAXING OF VEHICLES; WINDSCREEN CLEANING LIQUIDS; WINDSHIELD WASHING FLUID (U.S. CLS. 1, 4, 6, 50, 51 AND 52).

FIRST USE 6-7-2008; IN COMMERCE 9-14-2008.

MARGARET POWER, EXAMINING ATTORNEY

SN 85-476,931. L'OREAL, PARIS, FRANCE, FILED 11-18-2011.

REVITALIFT CLINICAL

THE MARK CONSISTS OF STANDARD CHARACTERS WITHOUT CLAIM TO ANY PARTICULAR FONT, STYLE, SIZE, OR COLOR.

OWNER OF U.S. REG. NOS. 2,602,468 AND 3,647,591.

NO CLAIM IS MADE TO THE EXCLUSIVE RIGHT TO USE "CLINICAL", APART FROM THE MARK AS SHOWN. FOR NON-MEDICATED SKINCARE PREPARATIONS (U.S. CLS. 1, 4, 6, 50, 51 AND 52).

MARC LEIPZIG, EXAMINING ATTORNEY

SN 85-477,465. THE COLOMER GROUP SPAIN, S.L., BARCELONA, SPAIN, FILED 11-21-2011.

CONARTE

THE MARK CONSISTS OF STANDARD CHARACTERS WITHOUT CLAIM TO ANY PARTICULAR FONT, STYLE, SIZE, OR COLOR.

FOR HAIR CARE LOTIONS, HAIR CARE PREPARATIONS, HAIR CLEANING PREPARATIONS, HAIR CONDITIONER, SHAMPOOS, HAIR MASKS, HAIR CREAMS, HAIR COLORING PREPARATIONS, HAIR DYES, HAIR GELS, HAIR WAXES, HAIR MOUSSE, HAIR SPRAYS, HAIR OILS, HAIR WAVING PREPARATIONS, HAIR EMOLLIENTS, AND NON MEDICATED HAIR SERUM (U.S. CLS. 1, 4, 6, 50, 51 AND 52).

GENE MACIOL, EXAMINING ATTORNEY

CLASS 3—(Continued).

SN 85-483,811. 2 J-A 1476, S.L., ASPE, SPAIN, FILED 11-30-2011.



NO CLAIM IS MADE TO THE EXCLUSIVE RIGHT TO USE "BRONCEADO", APART FROM THE MARK AS SHOWN.

THE COLOR(S) BROWN AND ORANGE IS/ARE CLAIMED AS A FEATURE OF THE MARK.

THE MARK CONSISTS OF THE WORD "BRONCEADO" IN BROWN, WITH THE WORDING "DEL MEDITERRANEO" IN ORANGE BELOW IT. ABOVE THE LETTERS "CE" IN "BRONCEADO" ARE THREE ORANGE OVULAR SHAPES ELONGATED DIAGONALLY. TO THE UPPER RIGHT AND UPPER LEFT CORNER OF THE MARK IS AN ORANGE HALO EFFECT.

THE ENGLISH TRANSLATION OF "BRONCEADO DEL MEDITERRANEO" IN THE MARK IS "MEDITERRANEAN SUNTAN".

FOR SOAPS; PERFUMERY; ESSENTIAL OILS; COSMETICS (U.S. CLS. 1, 4, 6, 50, 51 AND 52).

JASON BLAIR, EXAMINING ATTORNEY

CLASS 3—(Continued).

SN 85-485,140. WANG, DEYOU, MARKHAM, ONTARIO, CANADA, FILED 12-1-2011.

Scalpology

THE MARK CONSISTS OF STANDARD CHARACTERS WITHOUT CLAIM TO ANY PARTICULAR FONT, STYLE, SIZE, OR COLOR.

FOR HAIR CARE PRODUCTS, NAMELY, SHAMPOO, CONDITIONER, HAIRSPRAY, HAIR STYLING GEL, HAIR MOUSSE; NON-MEDICATED SKIN PRODUCTS, NAMELY, FACIAL CREAMS, BODY LOTIONS, SKIN MOISTURIZERS, SKIN TONERS, SKIN ASTRINGENTS, SKIN CLEANSERS, FOUNDATIONS, PRESSED FACE POWERS, BLUSHES, EYE LINERS, EYEBROW PENCILS, EYE SHADOWS, MASCARAS, LIPSTICKS, LIP LINERS, FACIAL MASKS, PERFUME, LIQUID SOAPS, SHOWER AND BATH GELS (U.S. CLS. 1, 4, 6, 50, 51 AND 52).

ERIN FALK, EXAMINING ATTORNEY

SN 85-486,794. L'OREAL, PARIS, FRANCE, FILED 12-5-2011.

MOROCCAN SLEEK

THE MARK CONSISTS OF STANDARD CHARACTERS WITHOUT CLAIM TO ANY PARTICULAR FONT, STYLE, SIZE, OR COLOR.

OWNER OF U.S. REG. NOS. 3,932,496 AND 4,032,448.

NO CLAIM IS MADE TO THE EXCLUSIVE RIGHT TO USE "MOROCCAN", APART FROM THE MARK AS SHOWN.

FOR HAIR CARE PREPARATIONS (U.S. CLS. 1, 4, 6, 50, 51 AND 52).

MARC LEIPZIG, EXAMINING ATTORNEY

SN 85-485,064. WANG, DEYOU, MARKHAM, ONTARIO, CANADA, FILED 12-1-2011.

Easycare

THE MARK CONSISTS OF STANDARD CHARACTERS WITHOUT CLAIM TO ANY PARTICULAR FONT, STYLE, SIZE, OR COLOR.

FOR HAIR CARE PRODUCTS, NAMELY, SHAMPOO, CONDITIONER, HAIRSPRAY, HAIR STYLING GEL, HAIR MOUSSE; NON-MEDICATED SKIN PRODUCTS, NAMELY, FACIAL CREAMS, BODY LOTIONS, SKIN MOISTURIZERS, SKIN TONERS, SKIN ASTRINGENTS, SKIN CLEANSERS, FOUNDATIONS, PRESSED FACE POWERS, BLUSHES, EYE LINERS, EYEBROW PENCILS, EYE SHADOWS, MASCARAS, LIPSTICKS, LIP LINERS, FACIAL MASKS, PERFUME, LIQUID SOAPS, SHOWER AND BATH GELS (U.S. CLS. 1, 4, 6, 50, 51 AND 52).

ERIN FALK, EXAMINING ATTORNEY

SN 85-492,700. AMDERM, CORP, MIAMI, FL. FILED 12-12-2011.

PLACENTIQUE

THE MARK CONSISTS OF STANDARD CHARACTERS WITHOUT CLAIM TO ANY PARTICULAR FONT, STYLE, SIZE, OR COLOR.

FOR BODY CREAMS (U.S. CLS. 1, 4, 6, 50, 51 AND 52).

FIRST USE 7-15-2011; IN COMMERCE 7-15-2011.

SUNG IN, EXAMINING ATTORNEY

CLASS 3—(Continued).

SN 85-493,232. CONOPCO, INC., ENGLEWOOD CLIFFS, NJ. FILED 12-12-2011.

PRECIOUS BLOOM

THE MARK CONSISTS OF STANDARD CHARACTERS WITHOUT CLAIM TO ANY PARTICULAR FONT, STYLE, SIZE, OR COLOR.

FOR SOAPS FOR PERSONAL USE, LIQUID HAND SOAP, BODY WASH, AND SHOWER GEL (U.S. CLS. 1, 4, 6, 50, 51 AND 52).

SAMUEL E. SHARPER JR., EXAMINING ATTORNEY

SN 85-493,699. ENVIRON SKIN CARE (PROPRIETARY) LIMITED, WESTERN CAPE, SOUTH AFRICA, FILED 12-13-2011.

ENVIRON COOL PEEL

THE MARK CONSISTS OF STANDARD CHARACTERS WITHOUT CLAIM TO ANY PARTICULAR FONT, STYLE, SIZE, OR COLOR.

OWNER OF U.S. REG. NOS. 3,725,003 AND 3,731,939.

NO CLAIM IS MADE TO THE EXCLUSIVE RIGHT TO USE "PEEL", APART FROM THE MARK AS SHOWN.

FOR SOAPS, NAMELY, SOAPS FOR PERSONAL USE; PERFUMERY, ESSENTIAL OILS, COSMETICS (U.S. CLS. 1, 4, 6, 50, 51 AND 52).

LUCY ARANT, EXAMINING ATTORNEY

SN 85-493,895. AMOREPACIFIC CORPORATION, SEOUL, REPUBLIC OF KOREA, FILED 12-13-2011.

Sulwhasoo Camellia Hair Oil

THE MARK CONSISTS OF STANDARD CHARACTERS WITHOUT CLAIM TO ANY PARTICULAR FONT, STYLE, SIZE, OR COLOR.

OWNER OF U.S. REG. NOS. 3,674,914, 3,962,642 AND OTHERS.

NO CLAIM IS MADE TO THE EXCLUSIVE RIGHT TO USE "CAMELLIA HAIR OIL", APART FROM THE MARK AS SHOWN.

THE WORDING "SULWHASOO" HAS NO MEANING IN A FOREIGN LANGUAGE.

FOR HAIR CONDITIONERS CONTAINING CAMELLIA OIL; HAIR CREAMS CONTAINING CAMELLIA OIL; HAIR GELS CONTAINING CAMELLIA OIL; HAIR LOTIONS CONTAINING CAMELLIA OIL; HAIR OILS CONTAINING CAMELLIA OIL; HAIR SHAMPOOS CONTAINING CAMELLIA OIL; NON-MEDICATED HAIR SERUMS CONTAINING CAMELLIA OIL; OILS FOR HAIR CONDITIONING CONTAINING CAMELLIA OIL (U.S. CLS. 1, 4, 6, 50, 51 AND 52).

WILLIAM P. SHANAHAN, EXAMINING ATTORNEY

CLASS 3—(Continued).

SN 85-495,758. MODERN BEAUTY, LTD., GARDEN GROVE, CA. FILED 12-15-2011.



THE MARK CONSISTS OF THE STYLIZED WORDING "ACT 5" INCORPORATING THE REPRESENTATION OF FILM REELS ON THE WORDING.

FOR COSMETIC PREPARATIONS; COSMETICS; MAKE-UP; NON-MEDICATED SKIN CARE PREPARATIONS (U.S. CLS. 1, 4, 6, 50, 51 AND 52).

BRIAN NEVILLE, EXAMINING ATTORNEY

SN 85-498,584. CMS WATER WORKS, LLC, HERMOSA BEACH, CA. FILED 12-19-2011.

**C M S Collagen Moisturizer
Spray**

THE MARK CONSISTS OF STANDARD CHARACTERS WITHOUT CLAIM TO ANY PARTICULAR FONT, STYLE, SIZE, OR COLOR.

NO CLAIM IS MADE TO THE EXCLUSIVE RIGHT TO USE "COLLAGEN MOISTURIZER SPRAY", APART FROM THE MARK AS SHOWN.

FOR MOISTURIZING SOLUTIONS FOR THE SKIN (U.S. CLS. 1, 4, 6, 50, 51 AND 52).

FIRST USE 1-1-1985; IN COMMERCE 1-1-1985.

STEVEN R. FINE, EXAMINING ATTORNEY

SN 85-501,905. PRODUCT QUEST MANUFACTURING LLC, HOLLY HILL, FL. FILED 12-22-2011.

DERMANATED

THE MARK CONSISTS OF STANDARD CHARACTERS WITHOUT CLAIM TO ANY PARTICULAR FONT, STYLE, SIZE, OR COLOR.

FOR NON-MEDICATED COSMETICS, NAMELY, SKIN AND FACIAL CLEANSERS, CREAMS AND SERUMS; NON-MEDICATED EYE CREAMS; NON-MEDICATED ANTI-AGING SKIN CARE PREPARATIONS; NON-MEDICATED TOPICAL SKIN CARE PREPARATIONS (U.S. CLS. 1, 4, 6, 50, 51 AND 52).

GRETTA YAO, EXAMINING ATTORNEY

CLASS 3—(Continued).

SN 85-503,417. OLE HENRIKSEN OF DENMARK, INC., VAN NUYS, CA. FILED 12-23-2011.

advanced hydration complex

THE MARK CONSISTS OF STANDARD CHARACTERS WITHOUT CLAIM TO ANY PARTICULAR FONT, STYLE, SIZE, OR COLOR.

NO CLAIM IS MADE TO THE EXCLUSIVE RIGHT TO USE "HYDRATION COMPLEX", APART FROM THE MARK AS SHOWN.

FOR NON-MEDICATED SKIN CARE PREPARATIONS (U.S. CLS. 1, 4, 6, 50, 51 AND 52).

GIANCARLO CASTRO, EXAMINING ATTORNEY

CLASS 3—(Continued).

SN 85-503,527. ZABEK, JOLENE, LAKE FOREST, CA. FILED 12-23-2011.

Dominus Rx Fine Skin Care
For Men

THE MARK CONSISTS OF STANDARD CHARACTERS WITHOUT CLAIM TO ANY PARTICULAR FONT, STYLE, SIZE, OR COLOR.

NO CLAIM IS MADE TO THE EXCLUSIVE RIGHT TO USE "RX FINE SKIN CARE FOR MEN", APART FROM THE MARK AS SHOWN.

FOR ANTI-AGING CLEANSER; ANTI-AGING CREAM; ANTI-AGING MOISTURIZER; ANTI-AGING TONER; BODY SCRUB; COSMETIC PREPARATIONS FOR EYE LASHES; COSMETIC SUNSCREEN PREPARATIONS; EXFOLIATING PAD CONTAINING A GLYCOLIC INGREDIENT NOT FOR MEDICAL PURPOSES; FACIAL CLEANING PREPARATION, NAMELY, SALICYLIC ACNE CLEANSER NOT FOR MEDICAL PURPOSES; NON-MEDICATED ACNE TREATMENT PREPARATIONS; NON-MEDICATED ANTI-AGING SERUM; NON-MEDICATED SKIN CARE PREPARATIONS, NAMELY, CREAMS, LOTIONS, GELS, TONERS, CLEANSERS AND PEELS; NON-MEDICATED SKIN CARE PREPARATIONS, NAMELY, SKIN SERUM; RETINOL CREAM FOR COSMETIC PURPOSES; SKIN CLEANSERS; SKIN MASKS; SKIN MOISTURIZER; SKIN TONERS; SKIN WHITENING CREAMS; SKIN WHITENING PREPARATIONS; SUNSCREEN CREAM; WATERPROOF SUNSCREEN (U.S. CLS. 1, 4, 6, 50, 51 AND 52).

RON FAIRBANKS, EXAMINING ATTORNEY

SN 85-503,454. OLE HENRIKSEN OF DENMARK, INC., VAN NUYS, CA. FILED 12-23-2011.

truth crème

THE MARK CONSISTS OF STANDARD CHARACTERS WITHOUT CLAIM TO ANY PARTICULAR FONT, STYLE, SIZE, OR COLOR.

OWNER OF U.S. REG. NOS. 3,173,981, 3,946,302 AND OTHERS.

NO CLAIM IS MADE TO THE EXCLUSIVE RIGHT TO USE "CRÈME", APART FROM THE MARK AS SHOWN.

FOR NON-MEDICATED SKIN CARE PREPARATIONS (U.S. CLS. 1, 4, 6, 50, 51 AND 52).

GIANCARLO CASTRO, EXAMINING ATTORNEY

SN 85-504,109. AGBANGA KARITE LLC, DBA ALAFFIA, OLYMPIA, WA. FILED 12-27-2011.

EVERYDAY COCONUT

THE MARK CONSISTS OF STANDARD CHARACTERS WITHOUT CLAIM TO ANY PARTICULAR FONT, STYLE, SIZE, OR COLOR.

OWNER OF U.S. REG. NO. 3,719,887.

NO CLAIM IS MADE TO THE EXCLUSIVE RIGHT TO USE "COCONUT", APART FROM THE MARK AS SHOWN.

FOR BODY LOTION; BODY WASH; HAIR CONDITIONER; SHAMPOOS; SHOWER GEL (U.S. CLS. 1, 4, 6, 50, 51 AND 52).

SHARON MEIER, EXAMINING ATTORNEY

CLASS 3—(Continued).

SN 85-506,215. MEI-CHI-NA HSINYEN CO., LTD., TAIPEI CITY, TAIWAN, FILED 12-30-2011.



THE MARK CONSISTS OF A COMBINATION OF TWO STYLIZED CHARACTERS "J" AND "B" AND A STYLIZED CROWN.

FOR FACE CREAMS; PRESSED FACE POWDER; LOOSE FACE POWDER; BLUSH; LIPSTICKS; LIP BALM; FOUNDATIONS; COSMETIC CLEANSING CREAMS; CLEANSING MILK; CLEANSING MILK FOR TOILET PURPOSES; EYE SHADOWS; EYE LINER; EYE LOTIONS; MASCARAS; NAIL VARNISHES; EYEBROW PENCILS; FALSE EYELASHES; NAIL ENAMEL REMOVERS; COSMETICS; MAKE-UP POWDER; BEAUTY MASKS; EYE CREAM; EYEBROW COSMETICS; FACIAL CONCEALER; MAKE-UP REMOVING LOTIONS; SKIN CREAMS; SKIN CLEANSING CREAM; SUN-BLOCK LOTIONS; CREAMY FOUNDATION; COSMETIC CREAMS FOR SKIN CARE; LIP GLOSS; MAKE-UP REMOVER; FACIAL CLEANSERS; ESSENTIAL OILS (U.S. CLS. 1, 4, 6, 50, 51 AND 52).

LINDA LAVACHE, EXAMINING ATTORNEY

SN 85-506,236. GREENOLOGY PRODUCTS, INC., RALEIGH, NC. FILED 12-30-2011.

MEADOW BREEZE

THE MARK CONSISTS OF STANDARD CHARACTERS WITHOUT CLAIM TO ANY PARTICULAR FONT, STYLE, SIZE, OR COLOR.

FOR CLEANING PREPARATIONS, NAMELY, LAUNDRY DETERGENTS, FABRIC SOFTENERS, DISH DETERGENTS, DISPOSABLE WIPES IMPREGNATED WITH CLEANING PREPARATIONS FOR HOUSEHOLD, COMMERCIAL, AND INDUSTRIAL USE, AND CLEANERS FOR USE ON HARD SURFACES (U.S. CLS. 1, 4, 6, 50, 51 AND 52).

BRENDAN REGAN, EXAMINING ATTORNEY

CLASS 3—(Continued).

SN 85-506,427. PHYSICIANS FORMULA, INC., AZUSA, CA. FILED 12-30-2011.

SEXY BOOSTER

THE MARK CONSISTS OF STANDARD CHARACTERS WITHOUT CLAIM TO ANY PARTICULAR FONT, STYLE, SIZE, OR COLOR.

FOR COSMETICS (U.S. CLS. 1, 4, 6, 50, 51 AND 52).
JEFFREY LOOK, EXAMINING ATTORNEY

SN 85-506,744. RUTH EMEN, DBA TREETEA COMPANY, BELLEVUE, WA. FILED 12-31-2011.



NO CLAIM IS MADE TO THE EXCLUSIVE RIGHT TO USE "COMPANY", APART FROM THE MARK AS SHOWN. THE COLOR(S) BLACK AND GREEN IS/ARE CLAIMED AS A FEATURE OF THE MARK.

THE MARK CONSISTS OF A BLACK LEAF SHAPED LIKE A SHIELD CONTAINING THE BLACK LETTER "T", AND THE BLACK WORDING "TREETEA" WITH A CURVED LETTER "T" AND WITH A GREEN LEAF ATTACHED, AND A BLACK UNDERLINE, AND THE BLACK WORDING "COMPANY".

FOR BAR SOAP; HAND SOAPS; HANDMADE SOAP BARS; NATURAL SOAP BARS; SOAPS FOR BODY CARE (U.S. CLS. 1, 4, 6, 50, 51 AND 52).

FIRST USE 9-0-2011; IN COMMERCE 12-0-2011.
TOBY BULLOFF, EXAMINING ATTORNEY

SN 85-506,902. SUSAN TABAK, LLC, NEW YORK, NY. FILED 12-31-2011.

Sortir Le Soir

THE MARK CONSISTS OF STANDARD CHARACTERS WITHOUT CLAIM TO ANY PARTICULAR FONT, STYLE, SIZE, OR COLOR.

THE ENGLISH TRANSLATION OF "SORTIR LE SOIR" IN THE MARK IS "GO PUT IN THE NIGHT".

FOR PERFUME (U.S. CLS. 1, 4, 6, 50, 51 AND 52).
IRA J. GOODSaid, EXAMINING ATTORNEY

CLASS 3—(Continued).

SN 85-507,162. QUALITY BRANDS LLC, CARMEL, IN.
FILED 1-2-2012.

DOES SHE . . . OR DOESN'T SHE?

THE MARK CONSISTS OF STANDARD CHARACTERS WITHOUT CLAIM TO ANY PARTICULAR FONT, STYLE, SIZE, OR COLOR.

FOR 3-IN-1 HAIR CONDITIONERS; 3-IN-1 HAIR SHAMPOOS; ANTI-BACTERIAL SOAP; BAR SOAP; HAIR COLOR REMOVERS; HAIR COLORING PREPARATIONS; HAIR CONDITIONERS; HAIR CREAMS; HAIR DYES; HAIR FROSTS; HAIR GEL; HAIR MOUSSE; HAIR SHAMPOO; HAND SOAPS; LIQUID SOAP (U.S. CLS. 1, 4, 6, 50, 51 AND 52).

JESSICA A. POWERS, EXAMINING ATTORNEY

SN 85-507,743. L'OREAL USA CREATIVE, INC., NEW YORK, NY. FILED 1-3-2012.

CONTROL ADDICT

THE MARK CONSISTS OF STANDARD CHARACTERS WITHOUT CLAIM TO ANY PARTICULAR FONT, STYLE, SIZE, OR COLOR.

FOR HAIR STYLING PREPARATION (U.S. CLS. 1, 4, 6, 50, 51 AND 52).

KEVIN DINALLO, EXAMINING ATTORNEY

SN 85-507,994. ESSENCIA SKIN CARE, LLC, DBA VERIDATTA COLLECTION, ENCINITAS, CA. FILED 1-3-2012.

Veridatta Collection

THE MARK CONSISTS OF STANDARD CHARACTERS WITHOUT CLAIM TO ANY PARTICULAR FONT, STYLE, SIZE, OR COLOR.

NO CLAIM IS MADE TO THE EXCLUSIVE RIGHT TO USE "COLLECTION", APART FROM THE MARK AS SHOWN.

THE WORDING "VERIDATTA" HAS NO MEANING IN A FOREIGN LANGUAGE.

FOR ANTIBACTERIAL SKIN SOAPS; AROMATIC BODY CARE PRODUCTS, NAMELY, BODY LOTION, SHOWER GEL, CUTICLE CREAM, SHAMPOO, CONDITIONER, NON-MEDICATED LIP BALM, SOAP, BODY POLISH, BODY AND FOOT SCRUB AND NON-MEDICATED FOOT CREAM; BEAUTY CREAMS FOR BODY CARE; BODY AND BEAUTY CARE COSMETICS; CLOTHS OR TISSUES IMPREGNATED WITH A SKIN CLEANSER; CONCEALERS FOR FACE, BODY, AND SKIN; CONDITIONERS; COSMETIC CREAMS FOR SKIN CARE; COSMETIC PREPARATIONS FOR BODY CARE; COSMETIC PREPARATIONS FOR PROTECTING THE SKIN FROM THE SUN'S RAYS; COSMETIC PREPARATIONS FOR SKIN CARE; COSMETIC PREPARATIONS

CLASS 3—(Continued).

FOR SKIN RENEWAL; COSMETIC PREPARATIONS FOR THE CARE OF MOUTH AND TEETH; COSMETIC PREPARATIONS, NAMELY, SKIN BALSAMS; COSMETIC PRODUCTS IN THE FORM OF AEROSOLS FOR SKIN CARE; COSMETIC PRODUCTS IN THE FORM OF AEROSOLS FOR SKINCARE; COSMETIC SKIN FRESHENERS; DEODORANTS FOR BODY CARE; EXFOLIANTS FOR SKIN, FACE, AND BODY; FRAGRANCED BODY CARE PREPARATIONS, NAMELY, LOTIONS, SHAMPOOS, CONDITIONERS, CREAMS, PERFUME, COLOGNE; FRAGRANCED FACE CARE PREPARATIONS, NAMELY, CREAMS, LOTIONS, GELS, SCRUBS, PERFUMES, COLOGNE; FRAGRANCED SKIN CARE PREPARATIONS, NAMELY, CREAMS, LOTIONS, GELS, SCRUBS, PERFUMES, COLOGNE; HAIR CARE CREAMS; HAIR CARE KITS COMPRISING NON-MEDICATED HAIR CARE PREPARATIONS, NAMELY, SHAMPOOS, CONDITIONERS, CREAMS, GELS; HAIR CARE LOTIONS; HAIR CARE PREPARATIONS; HAIR CARE PREPARATIONS CONSISTING OF ORGANIC COCONUT VIRGIN OIL AND COCONUT VIRGIN OIL; HAIR CARE PRODUCTS, NAMELY, HEAT PROTECTION SPRAYS; LOTIONS FOR FACE AND BODY CARE; LOTIONS FOR SKIN, LIPS, FACE, AND BODY; MOISTURIZING PREPARATIONS FOR THE SKIN; MOISTURIZING SOLUTIONS FOR THE SKIN; MOUSSE FOR HAIR; NAIL CARE KITS COMPRISING NAIL POLISH; NAIL CARE PREPARATIONS; NAIL CARE PREPARATIONS, NAMELY, NAIL SOFTENERS; NATURAL COCOA BUTTER BASED PERSONAL CARE PRODUCTS, NAMELY, BODY LOTION, SHOWER GEL, SOAP, BODY POLISH, BODY AND FOOT SCRUB AND NON-MEDICATED SKIN CREAMS; NON-MEDICATED BALMS FOR USE ON SKIN, FACE, LIPS, AND BODY; NON-MEDICATED COSMETIC SKIN CARE PREPARATIONS CONSISTING OF ORGANIC COCONUT VIRGIN OIL AND COCONUT VIRGIN OIL; NON-MEDICATED HERBAL BODY CARE PRODUCTS, NAMELY, BODY OILS, SALVES, AND LIP BALMS; NON-MEDICATED HERBAL BODY CARE PRODUCTS, NAMELY, LOTIONS, SHAMPOOS, CONDITIONERS, CREAMS, BRONZERS, CLEANSERS, SCRUBS; NON-MEDICATED LIP CARE PREPARATIONS; NON-MEDICATED PREPARATIONS ALL FOR THE CARE OF SKIN, HAIR AND SCALP; NON-MEDICATED SERUMS FOR USE ON FACE AND BODY; NON-MEDICATED SKIN CARE CREAMS AND LOTIONS; NON-MEDICATED SKIN CARE PREPARATION, NAMELY, BODY MIST; NON-MEDICATED SKIN CARE PREPARATIONS; NON-MEDICATED SKIN CARE PREPARATIONS, NAMELY, CREAMS, LOTIONS, GELS, TONERS, CLEANSERS AND PEELS; NON-MEDICATED SKIN CARE PREPARATIONS, NAMELY, LOTIONS, CREAMS, BRONZERS, CLEANSERS, SCRUBS; NON-MEDICATED SKIN CREAM FOR GENERAL SKIN RASH AND IRRITATION RESULTING FROM SKIN SHINGLES; NON-MEDICATED SKIN CREAMS; NON-MEDICATED SKIN CREAMS WITH ESSENTIAL OILS FOR USE IN AROMATHERAPY; NON-MEDICATED SKIN TONERS; NON-MEDICATED STIMULATING LOTIONS FOR THE SKIN; NON-MEDICATED SUN CARE PREPARATIONS; OIL BATHS FOR HAIR CARE; SKIN ABRASIVE PREPARATIONS; SKIN AND BODY TOPICAL LOTIONS, CREAMS AND OILS FOR COSMETIC USE; SKIN BRONZER; SKIN BRONZING CREAMS; SKIN CARE PREPARATION, NAMELY, BODY POLISH; SKIN CARE PREPARATIONS, NAMELY, BODY BALM; SKIN CARE PREPARATIONS, NAMELY, CHEMICAL PEELS FOR SKIN; SKIN CARE PREPARATIONS, NAMELY, FRUIT ACID PEELS FOR SKIN; SKIN CARE PREPARATIONS, NAMELY, SKIN PEELS; SKIN CARE PRODUCTS, NAMELY, NON-MEDICATED SKIN SERUM; SKIN CLARIFIERS; SKIN CLEANSER IN LIQUID SPRAY FORM FOR USE AS A BABY WIPE ALTERNATIVE; SKIN CLEANSERS; SKIN CLEANSING CREAM; SKIN CLEANSING LOTION; SKIN CONDITIONERS; SKIN CONDITIONING CREAMS FOR COSMETIC PURPOSES; SKIN CREAM; SKIN CREAMS; SKIN CREAMS IN LIQUID AND IN SOLID FORM; SKIN CREAMS IN LIQUID AND SOLID FORM; SKIN CREAMS IN LIQUID AND SOLID FORM; SKIN EMOLLIENTS; SKIN FRESHENERS; SKIN GELS FOR ACCELERATING, ENHAN-

CLASS 3—(Continued).

CING OR EXTENDING TANS; SKIN LIGHTENERS; SKIN LIGHTENING CREAMS; SKIN LOTION; SKIN LOTIONS; SKIN MASKS; SKIN MOISTURIZER; SKIN MOISTURIZER MASKS; SKIN MOISTURIZING GEL; SKIN POLISHING RICE BRAN (ARAI-NUKA); SKIN SOAP; SKIN TEXTURIZERS; SKIN TONERS; SKIN WHITENING CREAMS; SKIN WHITENING PREPARATIONS; SOAPS FOR BODY CARE; SUN CARE LOTIONS; TOPICAL SKIN SPRAYS FOR COSMETIC PURPOSES; WIPES IMPREGNATED WITH A SKIN CLEANSER; WRINKLE REMOVING SKIN CARE PREPARATIONS (U.S. CLS. 1, 4, 6, 50, 51 AND 52).

FIRST USE 1-1-2012; IN COMMERCE 1-1-2012.
DOMINIC FATHY, EXAMINING ATTORNEY

SN 85-508,019. ESSENCIA SKIN CARE, LLC, DBA VERIDATTA COLLECTION, ENCINITAS, CA. FILED 1-3-2012.

Veridatta

THE MARK CONSISTS OF STANDARD CHARACTERS WITHOUT CLAIM TO ANY PARTICULAR FONT, STYLE, SIZE, OR COLOR.

THE WORDING IN THE MARK HAS NO FOREIGN SIGNIFICANCE.

FOR ANTIBACTERIAL SKIN SOAPS; AROMATIC BODY CARE PRODUCTS, NAMELY, BODY LOTION, SHOWER GEL, CUTICLE CREAM, SHAMPOO, CONDITIONER, NON-MEDICATED LIP BALM, SOAP, BODY POLISH, BODY AND FOOT SCRUB AND NON-MEDICATED FOOT CREAM; BEAUTY CREAMS FOR BODY CARE; BODY AND BEAUTY CARE COSMETICS; CLOTHS OR TISSUES IMPREGNATED WITH A SKIN CLEANSER; CONCEALERS FOR SKIN, HAIR, NAILS; CONDITIONERS; COSMETIC CREAMS FOR SKIN CARE; COSMETIC PREPARATIONS FOR BODY CARE; COSMETIC PREPARATIONS FOR PROTECTING THE SKIN FROM THE SUN'S RAYS; COSMETIC PREPARATIONS FOR SKIN CARE; COSMETIC PREPARATIONS FOR SKIN RENEWAL; COSMETIC PREPARATIONS FOR THE CARE OF MOUTH AND TEETH; COSMETIC PREPARATIONS, NAMELY, SKIN BALSAMS; COSMETIC PRODUCTS IN THE FORM OF AEROSOLS FOR SKIN CARE; COSMETIC PRODUCTS IN THE FORM OF AEROSOLS FOR SKINCARE; COSMETIC SKIN FRESHENERS; DEODORANTS FOR BODY CARE; EXFOLIANTS FOR SKIN, BODY, HAIR, FACE, NAILS; FRAGRANCED BODY CARE PREPARATIONS, NAMELY, LOTIONS, CREAMS, PERFUMES, COLOGNE, SCRUBS, SHAMPOOS, CONDITIONERS; FRAGRANCED FACE CARE PREPARATIONS, NAMELY, LOTIONS, CREAMS, PERFUMES, COLOGNE, SCRUBS; FRAGRANCED SKIN CARE PREPARATIONS, NAMELY, LOTIONS, CREAMS, PERFUMES, COLOGNE, SCRUBS; HAIR CARE CREAMS; HAIR CARE KITS COMPRISING NON-MEDICATED HAIR CARE PREPARATIONS, NAMELY, SHAMPOOS, CONDITIONERS, CREAMS, GELS; HAIR CARE LOTIONS; HAIR CARE PREPARATIONS; HAIR CARE PREPARATIONS CONSISTING OF ORGANIC COCONUT VIRGIN OIL AND COCONUT VIRGIN OIL; HAIR CARE PRODUCTS, NAMELY, HEAT PROTECTION SPRAYS; LOTIONS FOR FACE AND BODY CARE; LOTIONS FOR SKIN, HAIR, FACE, LIPS, BODY; MOISTURIZING PREPARATIONS FOR THE SKIN; MOISTURIZING SOLUTIONS FOR THE SKIN; MOUSSE FOR HAIR; NAIL CARE KITS COMPRISING NAIL POLISH; NAIL CARE PREPARATIONS; NAIL CARE PREPARATIONS, NAMELY, NAIL SOFTENERS; NATURAL COCOA BUTTER BASED PERSONAL CARE PRODUCTS, NAMELY, BODY LOTION, SHOWER GEL, SOAP, BODY POLISH, BODY AND FOOT SCRUB AND NON-MEDICATED SKIN CREAMS; NON-MEDICATED BALMS FOR USE ON SKIN, HAIR, FACE, LIPS, BODY; NON-MEDICATED CLEANSERS FOR PERSONAL USE, NAMELY, SKIN CLEANSERS; NON-MEDICATED

CLASS 3—(Continued).

CLEANSERS, NAMELY, SKIN CLEANSERS; NON-MEDICATED COSMETIC SKIN CARE PREPARATIONS CONSISTING OF ORGANIC COCONUT VIRGIN OIL AND COCONUT VIRGIN OIL; NON-MEDICATED HERBAL BODY CARE PRODUCTS, NAMELY, BODY OILS, SALVES, AND LIP BALMS; NON-MEDICATED HERBAL BODY CARE PRODUCTS, NAMELY, LOTIONS, CREAMS, SHAMPOOS, CONDITIONERS, SCRUBS, CLEANSERS; NON-MEDICATED LIP CARE PREPARATIONS; NON-MEDICATED PREPARATIONS ALL FOR THE CARE OF SKIN, HAIR AND SCALP; NON-MEDICATED SERUMS FOR USE ON SKIN, HAIR, BODY, FACE, LIPS; NON-MEDICATED SKIN CARE CREAMS AND LOTIONS; NON-MEDICATED SKIN CARE PREPARATION, NAMELY, BODY MIST; NON-MEDICATED SKIN CARE PREPARATIONS; NON-MEDICATED SKIN CARE PREPARATIONS, NAMELY, CREAMS, LOTIONS, GELS, TONERS, CLEANERS AND PEELS; NON-MEDICATED SKIN CARE PREPARATIONS, NAMELY, LOTIONS, CREAMS, SCRUBS, CLEANSERS; NON-MEDICATED SKIN CREAM FOR GENERAL SKIN RASH AND IRRITATION RESULTING FROM SKIN SHINGLES; NON-MEDICATED SKIN CREAMS; NON-MEDICATED SKIN CREAMS WITH ESSENTIAL OILS FOR USE IN AROMATHERAPY; NON-MEDICATED SKIN TONERS; NON-MEDICATED STIMULATING LOTIONS FOR THE SKIN; NON-MEDICATED SUN CARE PREPARATIONS; OIL BATHS FOR HAIR CARE; PATCHES CONTAINING SUN SCREEN AND SUN BLOCK FOR USE ON THE SKIN; SEAWATER-BASED SKIN CARE PREPARATIONS FOR SKIN RENEWAL; SKIN ABRASIVE PREPARATIONS; SKIN AND BODY TOPICAL LOTIONS, CREAMS AND OILS FOR COSMETIC USE; SKIN BRONZER; SKIN BRONZING CREAMS; SKIN CARE PREPARATION, NAMELY, BODY POLISH; SKIN CARE PREPARATIONS, NAMELY, BODY BALM; SKIN CARE PREPARATIONS, NAMELY, CHEMICAL PEELS FOR SKIN; SKIN CARE PREPARATIONS, NAMELY, FRUIT ACID PEELS FOR SKIN; SKIN CARE PREPARATIONS, NAMELY, SKIN PEELS; SKIN CARE PRODUCTS, NAMELY, NON-MEDICATED SKIN SERUM; SKIN CLARIFIERS; SKIN CLEANSER IN LIQUID SPRAY FORM FOR USE AS A BABY WIPE ALTERNATIVE; SKIN CLEANSERS; SKIN CLEANSING CREAM; SKIN CLEANSING LOTION; SKIN CONDITIONERS; SKIN CONDITIONING CREAMS FOR COSMETIC PURPOSES; SKIN CREAM; SKIN CREAMS; SKIN CREAMS IN LIQUID AND IN SOLID FORM; SKIN CREAMS IN LIQUID AND SOLID; SKIN CREAMS IN LIQUID AND SOLID FORM; SKIN EMOLLIENTS; SKIN FRESHENERS; SKIN GELS FOR ACCELERATING, ENHANCING OR EXTENDING TANS; SKIN LIGHTENERS; SKIN LIGHTENING CREAMS; SKIN LOTION; SKIN LOTIONS; SKIN MASKS; SKIN MOISTURIZER; SKIN MOISTURIZER MASKS; SKIN MOISTURIZING GEL; SKIN POLISHING RICE BRAN (ARAI-NUKA); SKIN SOAP; SKIN TONERS (U.S. CLS. 1, 4, 6, 50, 51 AND 52).

FIRST USE 1-1-2012; IN COMMERCE 1-1-2012.
DOMINIC FATHY, EXAMINING ATTORNEY

CLASS 3—(Continued).

SN 85-508,666. SUSANNE LANGMUIR, TORONTO, ONTARIO, CANADA, AND DOUG LANGMUIR, TORONTO, ONTARIO, CANADA, FILED 1-4-2012.

CLASS 3—(Continued).

SN 85-509,577. AKIRO, LLC, NEW YORK, NY. FILED 1-5-2012.

PLANTS NOT PETROLEUM

THE MARK CONSISTS OF STANDARD CHARACTERS WITHOUT CLAIM TO ANY PARTICULAR FONT, STYLE, SIZE, OR COLOR.

FOR BLUSH; COSMETIC PREPARATIONS; EYE LINER; EYE MAKE-UP REMOVER; EYE PENCILS; EYE SHADOW; FACE AND BODY BEAUTY CREAMS; LIP BALM; LIP GLOSS; LIP LINER; LIPSTICK; MAKE-UP; MAKE-UP PENCILS; NAIL POLISH; NAIL POLISH REMOVER (U.S. CLS. 1, 4, 6, 50, 51 AND 52).

JAY FLOWERS, EXAMINING ATTORNEY

SN 85-509,091. SEATEX, LTD., ROSENBERG, TX. FILED 1-5-2012.

EVO BLEND

THE MARK CONSISTS OF STANDARD CHARACTERS WITHOUT CLAIM TO ANY PARTICULAR FONT, STYLE, SIZE, OR COLOR.

NO CLAIM IS MADE TO THE EXCLUSIVE RIGHT TO USE "BLEND", APART FROM THE MARK AS SHOWN.

FOR CLEANER AND DEGREASER FOR USE ON FLOORS, KITCHEN EQUIPMENT, AND SOILED SURFACES (U.S. CLS. 1, 4, 6, 50, 51 AND 52).

FIRST USE 8-25-2011; IN COMMERCE 8-25-2011.

RONALD MCMORROW, EXAMINING ATTORNEY

SN 85-509,541. AKIRO, LLC, NEW YORK, NY. FILED 1-5-2012.

**MISS JESSIE'S PILLOW SOFT
CURLS**

THE MARK CONSISTS OF STANDARD CHARACTERS WITHOUT CLAIM TO ANY PARTICULAR FONT, STYLE, SIZE, OR COLOR.

OWNER OF U.S. REG. NOS. 3,252,986 AND 3,482,013.

NO CLAIM IS MADE TO THE EXCLUSIVE RIGHT TO USE "CURLS", APART FROM THE MARK AS SHOWN.

THE MARK DOES NOT IDENTIFY ANY PARTICULAR LIVING INDIVIDUAL.

FOR NON-MEDICATED HAIR CARE PREPARATIONS IN THE FORM OF LIQUID, GEL, OR CREAM (U.S. CLS. 1, 4, 6, 50, 51 AND 52).

GENE MACIOL, EXAMINING ATTORNEY

PILLOW SOFT CURLS

THE MARK CONSISTS OF STANDARD CHARACTERS WITHOUT CLAIM TO ANY PARTICULAR FONT, STYLE, SIZE, OR COLOR.

NO CLAIM IS MADE TO THE EXCLUSIVE RIGHT TO USE "CURLS", APART FROM THE MARK AS SHOWN.

FOR NON-MEDICATED HAIR CARE PREPARATIONS IN THE FORM OF LIQUID, GEL, OR CREAM (U.S. CLS. 1, 4, 6, 50, 51 AND 52).

GENE MACIOL, EXAMINING ATTORNEY

SN 85-509,657. GUERILLA BEEKEEPERS, LLC, SILVERADO, CA. FILED 1-5-2012.

GUERILLA BEEKEEPERS

THE MARK CONSISTS OF STANDARD CHARACTERS WITHOUT CLAIM TO ANY PARTICULAR FONT, STYLE, SIZE, OR COLOR.

FOR COSMETICS; NON-MEDICATED SKIN CARE PREPARATIONS; NON-MEDICATED SKIN CREAMS (U.S. CLS. 1, 4, 6, 50, 51 AND 52).

FIRST USE 5-14-2011; IN COMMERCE 5-14-2011.

JEFFREY LOOK, EXAMINING ATTORNEY

CLASS 3—(Continued).

SN 85-509,749. SPRAY LA VIE INTERNATIONAL, LLC, FENTON, MO. FILED 1-5-2012.

CLASS 3—(Continued).

SN 85-509,766. NEMAT INTERNATIONAL INC., FREMONT, CA. FILED 1-5-2012.

OOH LA LA VIE

96 MAJMUA

THE MARK CONSISTS OF STANDARD CHARACTERS WITHOUT CLAIM TO ANY PARTICULAR FONT, STYLE, SIZE, OR COLOR.

THE ENGLISH TRANSLATION OF "LA VIE" IN THE MARK IS "THE LIFE".

FOR AFTER-SUN LOTIONS; AGE RETARDANT LOTION; AROMATIC BODY CARE PRODUCTS, NAMELY, BODY LOTION, SHOWER GEL, CUTICLE CREAM, SHAMPOO, CONDITIONER, NON-MEDICATED LIP BALM, SOAP, BODY POLISH, BODY AND FOOT SCRUB AND NON-MEDICATED FOOT CREAM; BEAUTY LOTIONS; BODY LOTIONS; BODY MASK LOTION; COSMETIC PREPARATIONS, NAMELY, FIRING LOTIONS; EYE LOTIONS; FACIAL LOTION; HAND LOTIONS; LOTIONS FOR CELLULITE REDUCTION; LOTIONS FOR COSMETIC PURPOSES; MAKE-UP REMOVING LOTIONS; NON-MEDICATED SKIN CARE CREAMS AND LOTIONS; NON-MEDICATED STIMULATING LOTIONS FOR THE SKIN; SCENTED BODY LOTIONS AND CREAMS; SKIN AND BODY TOPICAL LOTIONS, CREAMS AND OILS FOR COSMETIC USE; SKIN CLEANSING LOTION; SUN CARE LOTIONS; SUN-BLOCK LOTIONS (U.S. CLS. 1, 4, 6, 50, 51 AND 52).

LINDA E. BLOHM, EXAMINING ATTORNEY

THE MARK CONSISTS OF STANDARD CHARACTERS WITHOUT CLAIM TO ANY PARTICULAR FONT, STYLE, SIZE, OR COLOR.

THE ENGLISH TRANSLATION OF "MAJMUA" IN THE MARK IS "GATHERING".

FOR AROMATIC ESSENTIAL OILS; AROMATIC OILS; COSMETIC OILS; COSMETIC OILS FOR THE EPIDERMIS; ESSENTIAL OILS; ESSENTIAL OILS FOR AROMATHERAPY USE; ESSENTIAL OILS FOR PERSONAL USE; ESSENTIAL OILS FOR USE IN AROMATHERAPY; ESSENTIAL OILS FOR USE IN MANUFACTURING OF COLOGNES, PERFUMES, EAU DE PERFUME, EAU DE TOILETTE, SOAPS, CANDLES, INCENSE, POTPOURRI, INCENSE STICKS, REED DIFFUSERS, DIFFER FRAGRANCES, DIFFUSER OILS, ROOM FRAGRANCES, BODY LOTIONS, BODY CREAMS, BODY SPRAYS, LINEN SPRAYS, MASSAGE LOTIONS, MASSAGE OILS; ESSENTIAL OILS FOR USE IN THE MANUFACTURE OF SCENTED PRODUCTS; ETHEREAL ESSENCES; ETHEREAL OILS; FRAGRANCES; FRAGRANCES AND PERFUMERY; FRAGRANCES FOR PERSONAL USE; INCENSE; INCENSE STICKS; LIQUID PERFUMES; NATURAL ESSENTIAL OILS; OILS FOR PERFUMES AND SCENTS; PERFUME; PERFUME OILS; PERFUME OILS FOR THE MANUFACTURE OF COSMETIC PREPARATIONS; PERFUMES; PERFUMES AND COLOGNES; ROOM FRAGRANCE REFILLS FOR NON-ELECTRIC ROOM FRAGRANCE DISPENSERS; ROOM FRAGRANCES; ROOM FRAGRANCING PREPARATIONS; ROSE OIL FOR COSMETIC PURPOSES; SCENTED BODY SPRAY; SCENTED LINEN SPRAYS; SCENTED OILS; SCENTED OILS USED TO PRODUCE AROMAS WHEN HEATED; SCENTED ROOM SPRAYS; SYNTHETIC PERFUMERY (U.S. CLS. 1, 4, 6, 50, 51 AND 52). FIRST USE 7-1-1990; IN COMMERCE 7-1-1990.

WILLIAM ROSSMAN, EXAMINING ATTORNEY

CLASS 3—(Continued).

SN 85-509,857. DC COMICS, NEW YORK, NY. FILED 1-5-2012.



OWNER OF U.S. REG. NO. 2,051,606.
NO CLAIM IS MADE TO THE EXCLUSIVE RIGHT TO USE "COMICS", APART FROM THE MARK AS SHOWN.

THE MARK CONSISTS OF THE LETTER "D" FLIPPING BACK TO REVEAL THE LETTER "C" AND "DC COMICS".

FOR COSMETICS, NAMELY, LIPSTICK, LIP GLOSS AND NON-MEDICATED LIP BALM; MASCARA; NAIL ENAMEL; FACE POWDER, FACE CREAM, SKIN LOTION AND SKIN GEL; BODY POWDER; BATH OIL, BATH GEL AND NON-MEDICATED BATH SALTS; HAND CREAM AND LOTION; BODY CREAM AND LOTION; SUNSCREEN PREPARATION, NAMELY, CREAM AND LOTION; SHAVING CREAM AND AFTER-SHAVE LOTION, SKIN CLEANSER AND NON-MEDICATED BODY SOAKS; BODY DEODORANT, COLOGNE AND PERFUME; TOOTHPASTE; SOAPS, NAMELY, LIQUID BATH SOAP, GEL SOAP AND BAR SOAP; DETERGENT SOAP, NAMELY, LIQUID AND POWDER; FABRIC SOFTENER; DEODORANT SOAP, SKIN SOAP; AND SHAMPOO AND SHAMPOO CONDITIONER (U.S. CLS. 1, 4, 6, 50, 51 AND 52).
PAUL MORENO, EXAMINING ATTORNEY

SN 85-510,191. L'OREAL, PARIS, FRANCE, FILED 1-6-2012.

MICRO-REPAIR X3

THE MARK CONSISTS OF STANDARD CHARACTERS WITHOUT CLAIM TO ANY PARTICULAR FONT, STYLE, SIZE, OR COLOR.

FOR NON-MEDICATED FACIAL SKINCARE PREPARATIONS (U.S. CLS. 1, 4, 6, 50, 51 AND 52).
ALEX KEAM, EXAMINING ATTORNEY

CLASS 3—(Continued).

SN 85-510,302. MARUT ENTERPRISES LLC, MIAMI BEACH, FL. FILED 1-6-2012.

BIZWIPES

THE MARK CONSISTS OF STANDARD CHARACTERS WITHOUT CLAIM TO ANY PARTICULAR FONT, STYLE, SIZE, OR COLOR.

FOR DISPOSABLE WIPES IMPREGNATED WITH CHEMICALS OR COMPOUNDS FOR PERSONAL HYGIENE (U.S. CLS. 1, 4, 6, 50, 51 AND 52).

ELLEN B. AWRICH, EXAMINING ATTORNEY

SN 85-510,353. MGM RESORTS INTERNATIONAL, LAS VEGAS, NV. FILED 1-6-2012.

MGM GRAND

THE MARK CONSISTS OF STANDARD CHARACTERS WITHOUT CLAIM TO ANY PARTICULAR FONT, STYLE, SIZE, OR COLOR.

OWNER OF U.S. REG. NOS. 2,540,402, 3,908,061 AND OTHERS.

FOR BODY LOTION, SKIN LOTION, FACIAL LOTION, BATH AND SHOWER GELS, BATH OILS, BATH SALTS, BATH SOAPS, AROMA THERAPY OILS, HAIR SHAMPOO AND CONDITIONER (U.S. CLS. 1, 4, 6, 50, 51 AND 52).

KIMBERLY PERRY, EXAMINING ATTORNEY

SN 85-510,514. GRAYSON O COMPANY, KANNAPOLIS, NC. FILED 1-6-2012.



THE MARK CONSISTS OF A FLOWER DESIGN, FOR HAIR CARE PREPARATIONS (U.S. CLS. 1, 4, 6, 50, 51 AND 52).

FIRST USE 12-31-2011; IN COMMERCE 12-31-2011.
LEIGH LOWRY, EXAMINING ATTORNEY

CLASS 3—(Continued).

SN 85-510,515. DJF ENTERPRISES, NEW YORK, NY. FILED 1-6-2012.

MEGATINT

THE MARK CONSISTS OF STANDARD CHARACTERS WITHOUT CLAIM TO ANY PARTICULAR FONT, STYLE, SIZE, OR COLOR.
FOR COSMETICS (U.S. CLS. 1, 4, 6, 50, 51 AND 52).
DEBRA LEE, EXAMINING ATTORNEY

CLASS 3—(Continued).

SN 85-510,668. PLANT EXTRACTS INTERNATIONAL INCORPORATED, HOPKINS, MN. FILED 1-6-2012.

AETHEREO

THE MARK CONSISTS OF STANDARD CHARACTERS WITHOUT CLAIM TO ANY PARTICULAR FONT, STYLE, SIZE, OR COLOR.
FOR ESSENTIAL OILS AND ESSENTIAL OIL BLENDS (U.S. CLS. 1, 4, 6, 50, 51 AND 52).
FIRST USE 1-4-2012; IN COMMERCE 1-4-2012.
LAURIE MAYES, EXAMINING ATTORNEY

SN 85-510,574. POPPY KING PROJECTS LLC, NEW YORK, NY. FILED 1-6-2012.

LIQUID LACE

THE MARK CONSISTS OF STANDARD CHARACTERS WITHOUT CLAIM TO ANY PARTICULAR FONT, STYLE, SIZE, OR COLOR.
FOR COSMETICS; FRAGRANCES; TEMPORARY TATTOO SPRAYS AND STENCILS SOLD AS A UNIT; BODY GLITTER (U.S. CLS. 1, 4, 6, 50, 51 AND 52).
AMY KELLY, EXAMINING ATTORNEY

SN 85-510,693. BENEFIT COSMETICS LLC, SAN FRANCISCO, CA. FILED 1-6-2012.

SUNBEAM

THE MARK CONSISTS OF STANDARD CHARACTERS WITHOUT CLAIM TO ANY PARTICULAR FONT, STYLE, SIZE, OR COLOR.
PRIORITY CLAIMED UNDER SEC. 44(D) ON ERPNCMNTY TM OFC APPLICATION NO. 10530806, FILED 12-28-2011.
FOR COSMETICS; FACIAL HIGHLIGHTER (U.S. CLS. 1, 4, 6, 50, 51 AND 52).
BRIAN CALLAGHAN, EXAMINING ATTORNEY

SN 85-510,644. ROMANE FRAGRANCES, LLC, WILLOWBROOK, IL. FILED 1-6-2012.

CONTRABAND

THE MARK CONSISTS OF STANDARD CHARACTERS WITHOUT CLAIM TO ANY PARTICULAR FONT, STYLE, SIZE, OR COLOR.
FOR BODY CREAMS; BODY LOTIONS; BODY WASH; FRAGRANCES FOR PERSONAL USE; SHAVING CREAM; SHOWER GELS; SKIN LOTIONS; SOAPS FOR BODY CARE (U.S. CLS. 1, 4, 6, 50, 51 AND 52).
THEODORE MCBRIDE, EXAMINING ATTORNEY

SN 85-511,037. DISNEY ENTERPRISES, INC., BURBANK, CA. FILED 1-6-2012.

MAGIC OF HEALTHY LIVING

THE MARK CONSISTS OF STANDARD CHARACTERS WITHOUT CLAIM TO ANY PARTICULAR FONT, STYLE, SIZE, OR COLOR.
FOR COSMETICS; DENTIFRICES; NON-MEDICATED TOILETRIES; FRAGRANCES; PERFUMES (U.S. CLS. 1, 4, 6, 50, 51 AND 52).
PAUL MORENO, EXAMINING ATTORNEY

CLASS 3—(Continued).

SN 85-511,355. U4IA SALON, LLC, LAVEEN, AZ. FILED 1-8-2012.

U4IA

THE MARK CONSISTS OF STANDARD CHARACTERS WITHOUT CLAIM TO ANY PARTICULAR FONT, STYLE, SIZE, OR COLOR.

FOR BATH SOAPS IN LIQUID, SOLID OR GEL FORM; COSMETICS; HAIR SHAMPOOS AND CONDITIONERS (U.S. CLS. 1, 4, 6, 50, 51 AND 52).

FIRST USE 9-1-2010; IN COMMERCE 9-1-2010.
JEFF DEFORD, EXAMINING ATTORNEY

CLASS 3—(Continued).

SN 85-512,116. MAUER, HELMUT, SHOREWOOD, MN. FILED 1-9-2012.

GLOVE-NECK

THE MARK CONSISTS OF STANDARD CHARACTERS WITHOUT CLAIM TO ANY PARTICULAR FONT, STYLE, SIZE, OR COLOR.

FOR SANDING APPARATUS IN THE FORM OF A GLOVE (U.S. CLS. 1, 4, 6, 50, 51 AND 52).

KELLY TRUSILO, EXAMINING ATTORNEY

SN 85-511,511. HEM CORPORATION PRIVATE LIMITED, MULUND (E), MUMBAI, INDIA, FILED 1-9-2012.

MADHUR

THE MARK CONSISTS OF STANDARD CHARACTERS WITHOUT CLAIM TO ANY PARTICULAR FONT, STYLE, SIZE, OR COLOR.

THE ENGLISH TRANSLATION OF "MADHUR" IN THE MARK IS SWEET.

FOR INCENSE AND INCENSE STICKS; INCENSE CONES; INCENSE DHOOP; PERFUME OILS; SCENTED OILS; BATH SOAPS (U.S. CLS. 1, 4, 6, 50, 51 AND 52).

LINDA E. BLOHM, EXAMINING ATTORNEY

SN 85-512,274. ILU BEAUTY, INC., SHERMAN OAKS, CA. FILED 1-9-2012.

Elemān

THE MARK CONSISTS OF STANDARD CHARACTERS WITHOUT CLAIM TO ANY PARTICULAR FONT, STYLE, SIZE, OR COLOR.

THE ENGLISH TRANSLATION OF "ELEMEN" IS "ELEMENT".

FOR HAIR CARE PRODUCTS, NAMELY, HAIR COLOR, HAIR COLOR REMOVERS, HAIR BLEACHING PREPARATIONS, HAIR STRAIGHTENING PREPARATIONS, HAIR CURLING PREPARATIONS, PREPARATIONS FOR PERMANENT HAIR WAVES, HAIR WAVING LOTION, NON-MEDICATED HAIR SERUMS, HAIR STYLING PREPARATIONS, HAIR STYLING SPRAY, HAIR STYLING GEL, HAIR SHEEN SPRAY, HAIR GEL, HAIR MOUSSE, STYLING CLAY FOR HAIR, STYLING FOAM FOR HAIR, STYLING PASTE FOR HAIR, HAIR RINSES, HAIR SHAMPOO, HAIR CONDITIONER, HAIR REMOVING CREAM, WAX FOR REMOVING BODY HAIR; COSMETICS, NAMELY, COSMETIC CREAMS FOR SKIN CARE, NON-MEDICATED SKIN CARE PREPARATIONS, NAMELY, CREAMS, LOTIONS, GELS, TONERS, CLEANERS AND PEELS, SKIN BRONZING CREAMS, SKIN CLEANSING CREAM, SKIN CONDITIONING CREAMS FOR COSMETIC PURPOSES, SKIN MASKS, SKIN LIGHTENING CREAMS, HAND CREAM, VANISHING CREAM, CUTICLE CREAM, NAIL CREAM, SHAVING CREAM, ANTI-WRINKLE CREAM, ANTI-AGING CREAM, BODY CREAM, COLD CREAM, EYE GEL, SKIN FACIAL MOUSSE, SKIN SOAP, LIQUID SOAPS FOR HANDS, FACE AND BODY, SOAPS FOR BODY CARE, FOUNDATION MAKE-UP, FACIAL CONCEALER, BATH POWDER, BODY POWDER, FACE POWDER, TALCUM POWDER, BATH GEL, SHAVING GEL, SHOWER GEL, SUN TAN GEL, SCENTED BODY SPRAY, COSMETICS AND MAKE-UP, COMPACTS CONTAINING MAKE-UP, FACIAL MAKE-UP, EYE MAKE-UP, MAKE-UP REMOVER, LIPSTICK, LIP GLOSS, LIP CREAM, LIP BALM, NAIL POLISH, NAIL POLISH REMOVER (U.S. CLS. 1, 4, 6, 50, 51 AND 52).

RONALD MCMORROW, EXAMINING ATTORNEY

SN 85-512,038. THE SUN PRODUCTS CORPORATION, WILTON, CT. FILED 1-9-2012.

MICRO-CLEANERS

THE MARK CONSISTS OF STANDARD CHARACTERS WITHOUT CLAIM TO ANY PARTICULAR FONT, STYLE, SIZE, OR COLOR.

FOR LAUNDRY DETERGENT (U.S. CLS. 1, 4, 6, 50, 51 AND 52).

JOHN WILKE, EXAMINING ATTORNEY

CLASS 3—(Continued).

SN 85-512,276. VALINSKY, JESSE, MIAMI SHORES, FL.
FILED 1-9-2012.

Swagoo

THE MARK CONSISTS OF STANDARD CHARACTERS
WITHOUT CLAIM TO ANY PARTICULAR FONT, STYLE,
SIZE, OR COLOR.
FOR HAIR POMADES (U.S. CLS. 1, 4, 6, 50, 51 AND
52).
RONALD MCMORROW, EXAMINING ATTORNEY

CLASS 3—(Continued).

SN 85-512,398. STANMAR INTERNATIONAL USA INC.,
SAN DIEGO, CA. FILED 1-10-2012.

FUNFOAM

THE MARK CONSISTS OF STANDARD CHARACTERS
WITHOUT CLAIM TO ANY PARTICULAR FONT, STYLE,
SIZE, OR COLOR.
FOR BATH WASH (U.S. CLS. 1, 4, 6, 50, 51 AND 52).
FIRST USE 1-1-2012; IN COMMERCE 1-1-2012.
MICHAEL WEBSTER, EXAMINING ATTORNEY

SN 85-512,333. KRISTI CARRELL, LITTLETON, CO. FILED
1-9-2012.

Chandler Farm

THE MARK CONSISTS OF STANDARD CHARACTERS
WITHOUT CLAIM TO ANY PARTICULAR FONT, STYLE,
SIZE, OR COLOR.
FOR BODY LOTIONS; BODY WASH; LOTIONS FOR
FACE AND BODY CARE (U.S. CLS. 1, 4, 6, 50, 51 AND
52).
FIRST USE 7-2-2007; IN COMMERCE 5-22-2008.
DANIEL CAPSHAW, EXAMINING ATTORNEY

SN 85-512,435. LOCKERROOM MARKETING LTD, DELTA,
CANADA, FILED 1-10-2012.

AMSTERDAM

THE MARK CONSISTS OF STANDARD CHARACTERS
WITHOUT CLAIM TO ANY PARTICULAR FONT, STYLE,
SIZE, OR COLOR.
FOR LEATHER CLEANERS (U.S. CLS. 1, 4, 6, 50, 51
AND 52).
JIM RINGLE, EXAMINING ATTORNEY

SN 85-512,337. SKINTINUUM, LLC, DENVER, CO. FILED 1-
9-2012.

TECNICHE

THE MARK CONSISTS OF STANDARD CHARACTERS
WITHOUT CLAIM TO ANY PARTICULAR FONT, STYLE,
SIZE, OR COLOR.
OWNER OF U.S. REG. NO. 3,823,143.
FOR COSMETICS (U.S. CLS. 1, 4, 6, 50, 51 AND 52).
FIRST USE 1-5-2012; IN COMMERCE 1-5-2012.
JOHN WILKE, EXAMINING ATTORNEY

SN 85-512,438. KINGDOM ANIMALIA, LLC, VENICE, CA.
FILED 1-10-2012.

IMMACULATE

THE MARK CONSISTS OF STANDARD CHARACTERS
WITHOUT CLAIM TO ANY PARTICULAR FONT, STYLE,
SIZE, OR COLOR.
FOR COSMETICS, NAMELY, A TINTED LIQUID
POWDER FOUNDATION FOR FACIAL USE (U.S. CLS.
1, 4, 6, 50, 51 AND 52).
MARILYN IZZI, EXAMINING ATTORNEY

CLASS 3—(Continued).

SN 85-512,449. LOCKERROOM MARKETING LTD, DELTA, CANADA, FILED 1-10-2012.

BLUE BOY

THE MARK CONSISTS OF STANDARD CHARACTERS WITHOUT CLAIM TO ANY PARTICULAR FONT, STYLE, SIZE, OR COLOR.

FOR LEATHER CLEANERS (U.S. CLS. 1, 4, 6, 50, 51 AND 52).

JIM RINGLE, EXAMINING ATTORNEY

CLASS 3—(Continued).

SN 85-512,751. NIOXIN RESEARCH LABORATORIES, INC., LITHIA SPRINGS, GA. FILED 1-10-2012.

CRYSTALLINE INFUSION

THE MARK CONSISTS OF STANDARD CHARACTERS WITHOUT CLAIM TO ANY PARTICULAR FONT, STYLE, SIZE, OR COLOR.

FOR HAIR CARE PREPARATIONS (U.S. CLS. 1, 4, 6, 50, 51 AND 52).

FIRST USE 7-31-2009; IN COMMERCE 7-31-2009.
WANDA KAY PRICE, EXAMINING ATTORNEY

SN 85-512,726. THE PROCTER & GAMBLE COMPANY, CINCINNATI, OH. FILED 1-10-2012.

ESSENTIAL POWER

THE MARK CONSISTS OF STANDARD CHARACTERS WITHOUT CLAIM TO ANY PARTICULAR FONT, STYLE, SIZE, OR COLOR.

FOR COSMETICS, NAMELY SOAPS, LIPSTICKS, FOUNDATIONS, BLUSHERS, AND POWDERS; PERFUME AND ESSENTIAL OILS FOR PERSONAL USE; NON-MEDICATED SKIN CARE PREPARATIONS FOR THE CLEANING, CARE AND BEAUTIFICATION OF THE SKIN (U.S. CLS. 1, 4, 6, 50, 51 AND 52).

DAVID COLLIER, EXAMINING ATTORNEY

SN 85-512,885. ARCH PERSONAL CARE PRODUCTS, L.P., SOUTH PLAINFIELD, NJ. FILED 1-10-2012.

VIVILLUME

THE MARK CONSISTS OF STANDARD CHARACTERS WITHOUT CLAIM TO ANY PARTICULAR FONT, STYLE, SIZE, OR COLOR.

FOR COSMETIC PREPARATIONS TO FACILITATE BILIRUBIN DEGRADATION (U.S. CLS. 1, 4, 6, 50, 51 AND 52).

CHRISTOPHER BUONGIORNO, EXAMINING ATTORNEY

SN 85-512,743. GCOOL -TECH USA LLC, TAMARACC, FL. FILED 1-10-2012.

GeeWipes

THE MARK CONSISTS OF STANDARD CHARACTERS WITHOUT CLAIM TO ANY PARTICULAR FONT, STYLE, SIZE, OR COLOR.

FOR WIPES IMPREGNATED WITH A CLEANING PREPARATION (U.S. CLS. 1, 4, 6, 50, 51 AND 52).

WANDA KAY PRICE, EXAMINING ATTORNEY

SN 85-513,218. ROMANE FRAGRANCES, LLC, WILLOW-BROOK, IL. FILED 1-10-2012.

UNDENIABLE

THE MARK CONSISTS OF STANDARD CHARACTERS WITHOUT CLAIM TO ANY PARTICULAR FONT, STYLE, SIZE, OR COLOR.

FOR BODY CREAMS; BODY LOTIONS; BODY WASH; FRAGRANCES FOR PERSONAL USE; SHAVING LOTIONS; SHOWER GELS; SKIN LOTIONS; SOAPS FOR BODY CARE (U.S. CLS. 1, 4, 6, 50, 51 AND 52).

THEODORE MCBRIDE, EXAMINING ATTORNEY

CLASS 3—(Continued).

SN 85-513,483. AMBERGILL MANUFACTURING INTERNATIONAL LLC, BROOKLYN, NY. FILED 1-10-2012.

TAUN

THE MARK CONSISTS OF STANDARD CHARACTERS WITHOUT CLAIM TO ANY PARTICULAR FONT, STYLE, SIZE, OR COLOR.

FOR ANTI-AGING MOISTURIZER (U.S. CLS. 1, 4, 6, 50, 51 AND 52).
FIRST USE 8-9-2011; IN COMMERCE 1-3-2012.
CHRIS WELLS, EXAMINING ATTORNEY

SN 85-513,541. THE SHERWIN-WILLIAMS COMPANY, CLEVELAND, OH. FILED 1-11-2012.

SHINE LAST

THE MARK CONSISTS OF STANDARD CHARACTERS WITHOUT CLAIM TO ANY PARTICULAR FONT, STYLE, SIZE, OR COLOR.

NO CLAIM IS MADE TO THE EXCLUSIVE RIGHT TO USE "SHINE", APART FROM THE MARK AS SHOWN.
FOR AUTOMOBILE TIRE CLEANING AND POLISHING PREPARATIONS (U.S. CLS. 1, 4, 6, 50, 51 AND 52).
FLORENTINA BLANDU, EXAMINING ATTORNEY

SN 85-513,672. WOLFMAMA LLC, WESTON, CT. FILED 1-11-2012.

Just Breeze

THE MARK CONSISTS OF STANDARD CHARACTERS WITHOUT CLAIM TO ANY PARTICULAR FONT, STYLE, SIZE, OR COLOR.

FOR ROOM FRAGRANCES (U.S. CLS. 1, 4, 6, 50, 51 AND 52).
FIRST USE 9-1-2011; IN COMMERCE 12-1-2011.
BILL DAWE, EXAMINING ATTORNEY

CLASS 3—(Continued).

SN 85-513,720. FOODFORCE ENTERPRISE, INC., CHESTERFIELD, MO. FILED 1-11-2012.

The image shows the number '168' in a bold, three-dimensional font. The digits are white with a grey shadow on the right side, giving them a 3D appearance. The '1' is slightly taller than the '6' and '8'. The '6' and '8' are connected at the top.

THE MARK CONSISTS OF THE WORDING "168" APPEARING IN A DOWNWARD SEMI-ARC AND SLIGHTLY TWISTED WITH THE WORDING SHADED TO APPEAR THREE-DIMENSIONAL.

FOR ALL PURPOSE CLEANING PREPARATION WITH DEODORIZING PROPERTIES; ALL PURPOSE CLEANING PREPARATIONS; AUTOMOBILE, TIRE, GLASS AND WHEEL CLEANING PREPARATIONS; CLEANING AGENTS AND PREPARATIONS; CLEANING AGENTS FOR CLEANING SURFACES; CLEANING AND POLISHING PREPARATIONS; CLEANING AND WASHING PREPARATIONS; CLEANING PREPARATIONS; CLEANING PREPARATIONS FOR CLEANING SURFACES; CLEANING PREPARATIONS FOR CLEANSING DRAINS; CLEANING PREPARATIONS FOR HOUSEHOLD PURPOSES; CLEANING PREPARATIONS FOR HANDS, OVENS, GLASS SURFACES; CLEANING PREPARATIONS THAT ELIMINATE BACTERIA THAT CAUSE PRODUCTS TO AGE OR PRODUCE FOUL ODORS; CLEANING, POLISHING AND SCOURING PREPARATIONS; CLEANING, SCOURING AND POLISHING PREPARATIONS AND SUBSTANCES; CLEANING, WASHING AND POLISHING PREPARATIONS; FOAM CLEANING PREPARATIONS; GENERAL PURPOSE CLEANING, POLISHING, AND ABRASIVE LIQUIDS AND POWDERS; GLASS CLEANING PREPARATIONS; HAND CLEANERS; HAND CLEANING GELS; HAND CLEANING PREPARATIONS; HOUSEHOLD CLEANING PREPARATIONS; METAL POLISHING AND CLEANING PREPARATIONS (U.S. CLS. 1, 4, 6, 50, 51 AND 52).

FIRST USE 5-11-2011; IN COMMERCE 7-21-2011.
JENNY PARK, EXAMINING ATTORNEY

SN 85-513,743. WOLFMAMA LLC, WESTON, CT. FILED 1-11-2012.

Montana Wind

THE MARK CONSISTS OF STANDARD CHARACTERS WITHOUT CLAIM TO ANY PARTICULAR FONT, STYLE, SIZE, OR COLOR.

FOR ROOM FRAGRANCES (U.S. CLS. 1, 4, 6, 50, 51 AND 52).
FIRST USE 9-1-2011; IN COMMERCE 12-1-2011.
BILL DAWE, EXAMINING ATTORNEY

CLASS 3—(Continued).

SN 85-513,808. KRACIE HOME PRODUCTS, LTD., TOKYO, JAPAN, FILED 1-11-2012.

潤肌日和

THE MARK CONSISTS OF JAPANESE CHARACTERS. THE NON-LATIN CHARACTERS IN THE MARK TRANSLITERATE TO URUHADABIYAORI, AND THIS HAS NO MEANING IN A FOREIGN LANGUAGE.

FOR SOAPS FOR PERSONAL USE, SOAPS FOR HAND CARE, SOAPS FOR FACE CARE, SOAPS FOR BODY CARE, SOAPS FOR SKIN CARE, BATH SOAP, BEAUTY SOAP, COSMETIC SOAP, DEODORANT SOAP, MEDICATED SOAP, PERFUMED SOAP, TOILET SOAP, HAIR SHAMPOO, HAIR RINSE, HAIR CONDITIONER, FACIAL CLEANSING CREAM, SKIN CLEANSING CREAM, FACIAL CLEANSING LOTION, SKIN LOTION, FACIAL CLEANSING GEL, SKIN CLEANING GEL (U.S. CLS. 1, 4, 6, 50, 51 AND 52).

TEJBIR SINGH, EXAMINING ATTORNEY

CLASS 3—(Continued).

SN 85-513,878. GRAHAM, MICHAEL, SHELBY TOWNSHIP, MI. FILED 1-11-2012.

SOLEUS

THE MARK CONSISTS OF STANDARD CHARACTERS WITHOUT CLAIM TO ANY PARTICULAR FONT, STYLE, SIZE, OR COLOR.

FOR COSMETIC CREAMS FOR SKIN CARE; COSMETIC PREPARATIONS FOR SKIN CARE; COSMETIC PREPARATIONS, NAMELY, SKIN BALSAMS; LOTIONS FOR SKIN; MOISTURIZING PREPARATIONS FOR THE SKIN; MOISTURIZING SOLUTIONS FOR THE SKIN; NON-MEDICATED SKIN CARE CREAMS AND LOTIONS; NON-MEDICATED SKIN CARE PREPARATIONS; NON-MEDICATED SKIN CREAMS; NON-MEDICATED STIMULATING LOTIONS FOR THE SKIN; NON-MEDICATED SKIN CARE PREPARATIONS; SKIN AND BODY TOPICAL LOTIONS, CREAMS AND OILS FOR COSMETIC USE; SKIN CREAMS; SKIN LOTIONS (U.S. CLS. 1, 4, 6, 50, 51 AND 52).

KIMBERLY PERRY, EXAMINING ATTORNEY

SN 85-513,904. VOLUME DISTRIBUTORS, INC., VERNON, CA. FILED 1-11-2012.

Soulevé
Spa

SN 85-513,849. MARTHA GALILEA MONTIJO TORRES, MEICO, D.F., MEXICO, FILED 1-11-2012.

GALILEA

THE MARK CONSISTS OF STANDARD CHARACTERS WITHOUT CLAIM TO ANY PARTICULAR FONT, STYLE, SIZE, OR COLOR.

THE NAME(S), PORTRAIT(S), AND/OR SIGNATURE(S) SHOWN IN THE MARK IDENTIFIES MARTHA GALILEA MONTIJO TORRES, WHOSE CONSENT(S) TO REGISTER IS MADE OF RECORD.

FOR PERFUMERY (U.S. CLS. 1, 4, 6, 50, 51 AND 52).
KELLY TRUSILO, EXAMINING ATTORNEY

NO CLAIM IS MADE TO THE EXCLUSIVE RIGHT TO USE "SPA", APART FROM THE MARK AS SHOWN.

THE MARK CONSISTS OF THE WORDING "SOULEVÉ SPA", THE WORD "SOULEVÉ" DEPICTING A STYLIZED LETTER "O" AS A LEAF DESIGN, THE LEAF HAVING VEINS AND PETIOLE, AND THE SECOND OCCURRENCE OF THE LETTER "E" ACCENTED ABOVE WITH A STYLIZED ACUTE.

THE ENGLISH TRANSLATION OF "SOULEVE" IN THE MARK IS "RAISED".

FOR SHAMPOO, HAIR CONDITIONER, BODY WASH FOR HUMANS, SKIN LOTION, HAIR GEL, HAIR SPRAY, HAIR MOUSSE, FACE SCRUB, FACE WASH, AFTER-SHAVE CREAM, PRE-SHAVE CREAM, PRE-SHAVE GEL, SKIN MOISTURIZER, DEODORANT FOR BODY CARE, HAND SOAP (U.S. CLS. 1, 4, 6, 50, 51 AND 52).

BRIDGETT SMITH, EXAMINING ATTORNEY

CLASS 3—(Continued).

SN 85-514,166. APIS, LLC, MINNEAPOLIS, MN. FILED 1-11-2012.

WORKER B

THE MARK CONSISTS OF STANDARD CHARACTERS WITHOUT CLAIM TO ANY PARTICULAR FONT, STYLE, SIZE, OR COLOR.

FOR BODY LOTION; COSMETIC PREPARATIONS; FRAGRANCED FACIAL MOISTURIZER; LIP BALM; MOISTURIZING PREPARATIONS FOR THE SKIN; NON-MEDICATED BALMS FOR USE ON FACE, HANDS AND FEET; NON-MEDICATED LIP CARE PREPARATIONS; NON-MEDICATED SKIN CARE PREPARATIONS (U.S. CLS. 1, 4, 6, 50, 51 AND 52).

FIRST USE 8-25-2010; IN COMMERCE 10-25-2010.
JORDAN BAKER, EXAMINING ATTORNEY

CLASS 3—(Continued).

SN 85-514,244. APIS, LLC, MINNEAPOLIS, MN. FILED 1-11-2012.



THE MARK CONSISTS OF THE IMAGE OF A HONEY BEE ABOVE THE WORD "WORKER" IN LOWER CASE LETTERING SLIGHTLY ARCHED ABOVE THE CAPITAL LETTER "B" ALL WITHIN A VERTICALLY-ORIENTED BANNER OUTLINED BY A SOLID DOUBLE-LINED BORDER.

FOR BODY LOTION; COSMETIC PREPARATIONS; FRAGRANCED SKIN CARE PREPARATIONS, NAMELY, LIP AND SKIN MOISTURIZERS, LOTIONS, BALMS AND CREAMS; LIP BALM; MOISTURIZING PREPARATIONS FOR THE SKIN; NON-MEDICATED BALMS FOR USE ON FACE, HANDS AND FEET; NON-MEDICATED LIP CARE PREPARATIONS; NON-MEDICATED SKIN CARE PREPARATIONS (U.S. CLS. 1, 4, 6, 50, 51 AND 52).

FIRST USE 8-25-2010; IN COMMERCE 10-25-2010.
JORDAN BAKER, EXAMINING ATTORNEY

SN 85-514,184. JAO, LTD., HATFIELD, PA. FILED 1-11-2012.

LIPJAO

THE MARK CONSISTS OF STANDARD CHARACTERS WITHOUT CLAIM TO ANY PARTICULAR FONT, STYLE, SIZE, OR COLOR.

OWNER OF U.S. REG. NOS. 2,185,167 AND 2,374,761.
FOR LIP BALM (U.S. CLS. 1, 4, 6, 50, 51 AND 52).
FIRST USE 6-24-2005; IN COMMERCE 6-24-2005.
JOHN HWANG, EXAMINING ATTORNEY

SN 85-514,328. COCO COSMETICS INC, HIALEAH, FL. FILED 1-11-2012.

**BEE COLLECTED. BE
NOURISHED. WORKER B.**

THE MARK CONSISTS OF STANDARD CHARACTERS WITHOUT CLAIM TO ANY PARTICULAR FONT, STYLE, SIZE, OR COLOR.

FOR BODY LOTION; COSMETIC PREPARATIONS; FRAGRANCED SKIN CARE PREPARATIONS, NAMELY, LIP AND SKIN MOISTURIZERS, LOTIONS, BALMS AND CREAMS; LIP BALM; MOISTURIZING PREPARATIONS FOR THE SKIN; NON-MEDICATED BALMS FOR USE ON FACE, HANDS AND FEET; NON-MEDICATED LIP CARE PREPARATIONS; NON-MEDICATED SKIN CARE PREPARATIONS (U.S. CLS. 1, 4, 6, 50, 51 AND 52).

FIRST USE 8-25-2010; IN COMMERCE 10-25-2010.
JORDAN BAKER, EXAMINING ATTORNEY

La La Love

THE MARK CONSISTS OF STANDARD CHARACTERS WITHOUT CLAIM TO ANY PARTICULAR FONT, STYLE, SIZE, OR COLOR.

FOR COLOGNES, PERFUMES AND COSMETICS; BODY OIL; BODY WASH; BODY LOTION; BODY PERFUME; COSMETIC SOAPS; BAR SOAP; SHOWER GEL (U.S. CLS. 1, 4, 6, 50, 51 AND 52).

RICHARD WHITE, EXAMINING ATTORNEY

CLASS 3—(Continued).

SN 85-514,331. COCO COSMETICS INC., HIALEAH, FL. FILED 1-11-2012.

Love Temptation

THE MARK CONSISTS OF STANDARD CHARACTERS WITHOUT CLAIM TO ANY PARTICULAR FONT, STYLE, SIZE, OR COLOR.

FOR COLOGNES, PERFUMES AND COSMETICS ; BODY OIL, BODY WASH, BODY LOTION, BODY PERFUME, COSMETIC SOAPS, BAR SOAP, SHOWER GEL (U.S. CLS. 1, 4, 6, 50, 51 AND 52).

LESLEY LAMOTHE, EXAMINING ATTORNEY

SN 85-514,461. INOCENCIA PAULINO, FRISCO, TX. FILED 1-11-2012.

DELINO

THE MARK CONSISTS OF STANDARD CHARACTERS WITHOUT CLAIM TO ANY PARTICULAR FONT, STYLE, SIZE, OR COLOR.

FOR BLEACHING PREPARATIONS FOR THE HAIR; COSMETIC HAIR DRESSING PREPARATIONS; COSMETIC PREPARATIONS FOR THE HAIR AND SCALP; HAIR BLEACH; HAIR CARE CREAMS; HAIR CARE LOTIONS; HAIR CARE PREPARATIONS; HAIR COLOR; HAIR CONDITIONER; HAIR GEL AND HAIR MOUSSE; HAIR OILS; HAIR RINSES; HAIR SHAMPOO; HAIR SPRAY; HYDROGEN PEROXIDE FOR USE ON THE HAIR (U.S. CLS. 1, 4, 6, 50, 51 AND 52).

LINDA ESTRADA, EXAMINING ATTORNEY

SN 85-514,505. HEADBLADE, INC., CULVER CITY, CA. FILED 1-11-2012.

HEADBLADE

THE MARK CONSISTS OF STANDARD CHARACTERS WITHOUT CLAIM TO ANY PARTICULAR FONT, STYLE, SIZE, OR COLOR.

OWNER OF U.S. REG. NOS. 3,062,992, 3,253,546 AND 3,563,311.

FOR TOILETRIES, NAMELY, SHAVING CREAM, MOISTURIZING CREAM, SOAPS, SUNSCREEN CREAM, BODY WASH, SELF-TANNING PREPARATIONS, WIPES IMPREGNATED WITH A CLEANING PREPARATION AND AFTER-TAN MOISTURIZER (U.S. CLS. 1, 4, 6, 50, 51 AND 52).

FIRST USE 4-4-2003; IN COMMERCE 4-4-2003.

PAM WILLIS, EXAMINING ATTORNEY

CLASS 3—(Continued).

SN 85-514,530. DIORA PROFESSIONNEL LLC, HALLANDALE BEACH, FL. FILED 1-11-2012.

KERATHERAPY

THE MARK CONSISTS OF STANDARD CHARACTERS WITHOUT CLAIM TO ANY PARTICULAR FONT, STYLE, SIZE, OR COLOR.

FOR CONDITIONERS; COSMETIC HAIR DRESSING PREPARATIONS; HAIR CARE CREAMS; HAIR CARE PREPARATIONS; HAIR CONDITIONER; HAIR CONDITIONERS; HAIR CREAMS; HAIR CURLING PREPARATIONS; HAIR GEL; HAIR GEL AND HAIR MOUSSE; HAIR GELS; HAIR MASKS; HAIR MOUSSE; HAIR MOUSSES; HAIR POMADES; HAIR PRODUCTS, NAMELY, THICKENING CONTROL CREAMS; HAIR RINSES; HAIR RINSES; HAIR SHAMPOO; HAIR SHAMPOOS AND CONDITIONERS; HAIR SHEEN SPRAY; HAIR SPRAY; HAIR SPRAYS; HAIR SPRAYS AND HAIR GELS; HAIR STRAIGHTENING PREPARATIONS; HAIR STYLING GEL; HAIR STYLING PREPARATIONS; HAIR STYLING SPRAY; HAIR TONIC; HAIR TONICS; HAIR WAX; HAIRSPRAY; SHAMPOO-CONDITIONERS; SHAMPOOS; STYLING FOAM FOR HAIR; STYLING GELS; STYLING LOTIONS; STYLING MOUSSE; STYLING PASTE FOR HAIR (U.S. CLS. 1, 4, 6, 50, 51 AND 52).

FIRST USE 1-12-2011; IN COMMERCE 1-12-2011.

JOHN DALIER, EXAMINING ATTORNEY

SN 85-514,540. DIORA PROFESSIONNEL, HALLANDALE BEACH, FL. FILED 1-11-2012.

DIORA

THE MARK CONSISTS OF STANDARD CHARACTERS WITHOUT CLAIM TO ANY PARTICULAR FONT, STYLE, SIZE, OR COLOR.

FOR CONDITIONERS; COSMETIC HAIR DRESSING PREPARATIONS; HAIR CARE CREAMS; HAIR CARE PREPARATIONS CONSISTING OF ORGANIC COCONUT VIRGIN OIL AND COCONUT VIRGIN OIL; HAIR CONDITIONER; HAIR CONDITIONERS; HAIR CREAMS; HAIR CURLING PREPARATIONS; HAIR GEL; HAIR GEL AND HAIR MOUSSE; HAIR GELS; HAIR MASKS; HAIR MOUSSE; HAIR MOUSSES; HAIR POMADES; HAIR PRODUCTS, NAMELY, THICKENING CONTROL CREAMS; HAIR RINSES; HAIR RINSES; HAIR SHAMPOO; HAIR SHAMPOOS AND CONDITIONERS; HAIR SHEEN SPRAY; HAIR SPRAY; HAIR SPRAYS; HAIR SPRAYS AND HAIR GELS; HAIR STRAIGHTENING PREPARATIONS; HAIR STYLING GEL; HAIR STYLING PREPARATIONS; HAIR STYLING SPRAY; HAIR TONIC; HAIR TONICS; HAIR WAX; HAIRSPRAY; SHAMPOO-CONDITIONERS; SHAMPOOS; STYLING FOAM FOR HAIR; STYLING GELS; STYLING LOTIONS; STYLING MOUSSE; STYLING PASTE FOR HAIR (U.S. CLS. 1, 4, 6, 50, 51 AND 52).

FIRST USE 1-12-2011; IN COMMERCE 1-12-2011.

Laurie Mayes, EXAMINING ATTORNEY

CLASS 3—(Continued).

SN 85-514,692. L'OREAL USA CREATIVE, INC., NEW YORK, NY. FILED 1-12-2012.

INSTANT POLISHING PREP

THE MARK CONSISTS OF STANDARD CHARACTERS WITHOUT CLAIM TO ANY PARTICULAR FONT, STYLE, SIZE, OR COLOR.

OWNER OF U.S. REG. NO. 3,164,268. SEC. 2(F). FOR HAIR DETANGLING SPRAY (U.S. CLS. 1, 4, 6, 50, 51 AND 52). FIRST USE 6-0-2006; IN COMMERCE 6-0-2006. KEVIN DINALLO, EXAMINING ATTORNEY

SN 85-514,705. MMS MARKETING SOLUTIONS, INC., GARDEN CITY, NY. FILED 1-12-2012.

CRUNKERS

THE MARK CONSISTS OF STANDARD CHARACTERS WITHOUT CLAIM TO ANY PARTICULAR FONT, STYLE, SIZE, OR COLOR.

FOR POTPOURRI (U.S. CLS. 1, 4, 6, 50, 51 AND 52). FIRST USE 10-30-2011; IN COMMERCE 10-30-2011. LAKEISHA LEWIS, EXAMINING ATTORNEY

SN 85-515,393. MEXON LTD., PLOVDIV, BULGARIA, FILED 1-12-2012.

Medix

THE MARK CONSISTS OF STANDARD CHARACTERS WITHOUT CLAIM TO ANY PARTICULAR FONT, STYLE, SIZE, OR COLOR.

FOR BLEACHING PREPARATIONS FOR LAUNDRY USE; CLEANING, POLISHING AND SCOURING PREPARATIONS; COSMETICS; DENTIFRICES; ESSENTIAL OILS; GENERAL PURPOSE CLEANING, POLISHING, AND ABRASIVE LIQUIDS AND POWDERS; HAIR LOTIONS; PERFUMERY (U.S. CLS. 1, 4, 6, 50, 51 AND 52). SUSAN LESLIE DUBOIS, EXAMINING ATTORNEY

CLASS 3—(Continued).

SN 85-517,722. MEDLINE INDUSTRIES, INC., MUNDELEIN, IL. FILED 1-17-2012.

FLIP 'N SEAL

THE MARK CONSISTS OF STANDARD CHARACTERS WITHOUT CLAIM TO ANY PARTICULAR FONT, STYLE, SIZE, OR COLOR.

FOR DISPOSABLE WIPES IMPREGNATED WITH CLEANSING CHEMICALS OR COMPOUNDS FOR PERSONAL HYGIENE (U.S. CLS. 1, 4, 6, 50, 51 AND 52). ROBERT STRUCK, EXAMINING ATTORNEY

SN 85-521,797. ROMANE FRAGRANCES, LLC, ELMHURST, IL. FILED 1-20-2012.

GYPSY KISS

THE MARK CONSISTS OF STANDARD CHARACTERS WITHOUT CLAIM TO ANY PARTICULAR FONT, STYLE, SIZE, OR COLOR.

FOR BODY CREAMS; BODY LOTIONS; BODY WASH; FRAGRANCES FOR PERSONAL USE; SHOWER GELS; SKIN LOTIONS; SOAPS FOR BODY CARE (U.S. CLS. 1, 4, 6, 50, 51 AND 52). THEODORE MCBRIDE, EXAMINING ATTORNEY

SN 85-525,164. SR HOLDINGS, LLC, LEXINGTON, MA. FILED 1-25-2012.



OWNER OF U.S. REG. NOS. 1,810,853 AND 1,860,428. THE MARK CONSISTS OF A STYLIZED IMAGE OF A SAILBOAT WITH TWO SETS OF WAVES, SURROUNDED BY A SQUARE DESIGN.

FOR SHOE CREAMS AND POLISHES (U.S. CLS. 1, 4, 6, 50, 51 AND 52). CURTIS FRENCH, EXAMINING ATTORNEY

CLASS 3—(Continued).

SN 85-525,265. THE SUN PRODUCTS CORPORATION, WILTON, CT. FILED 1-25-2012.

SUN

THE MARK CONSISTS OF STANDARD CHARACTERS WITHOUT CLAIM TO ANY PARTICULAR FONT, STYLE, SIZE, OR COLOR.

OWNER OF U.S. REG. NOS. 569,580, 4,019,917 AND OTHERS.

FOR DISH DETERGENT (U.S. CLS. 1, 4, 6, 50, 51 AND 52).

FIRST USE 6-13-1951; IN COMMERCE 6-13-1951.
JOHN WILKE, EXAMINING ATTORNEY

CLASS 3—(Continued).

SN 85-526,144. INTELLIGENT NUTRIENTS, LLC, MINNEAPOLIS, MN. FILED 1-26-2012.

Intelligent Nutrients

THE MARK CONSISTS OF STANDARD CHARACTERS WITHOUT CLAIM TO ANY PARTICULAR FONT, STYLE, SIZE, OR COLOR.

OWNER OF U.S. REG. NOS. 3,161,714, 4,097,242 AND OTHERS.

NO CLAIM IS MADE TO THE EXCLUSIVE RIGHT TO USE "NUTRIENTS", APART FROM THE MARK AS SHOWN.

FOR COSMETICS, NAMELY, EYE SHADOW, FOUNDATION, BLUSH, FACE POWDER, CONCEALER, EYE PENCILS, MAKEUP PENCILS FOR LIPS AND MASCARA; PERSONAL HYGIENE PRODUCTS, NAMELY, BODY LOTIONS, SKIN CREAMS, SKIN LOTIONS, SKIN EMOLLIENTS, SKIN MOISTURIZING OILS AND LOTIONS; HOUSEHOLD CLEANING PREPARATIONS, NAMELY, ALL PURPOSE CLEANERS, CLEANERS FOR USE ON DISHES, CLEANERS FOR USE ON FABRIC AND CLEANERS FOR USE ON FLOORS, WALLS, WINDOWS AND BATHROOMS; INCENSE (U.S. CLS. 1, 4, 6, 50, 51 AND 52).

AHSEN KHAN, EXAMINING ATTORNEY

SN 85-526,140. ROUX LABORATORIES, INC., JACKSONVILLE, FL. FILED 1-26-2012.

EXOTIC SHINE

THE MARK CONSISTS OF STANDARD CHARACTERS WITHOUT CLAIM TO ANY PARTICULAR FONT, STYLE, SIZE, OR COLOR.

NO CLAIM IS MADE TO THE EXCLUSIVE RIGHT TO USE "SHINE", APART FROM THE MARK AS SHOWN.

FOR CONDITIONERS; HAIR COLOR; HAIR STYLING PREPARATIONS; NON-MEDICATED HAIR TREATMENT PREPARATIONS FOR COSMETIC PURPOSES; SHAMPOOS (U.S. CLS. 1, 4, 6, 50, 51 AND 52).

ALYSSA STEEL, EXAMINING ATTORNEY

SN 85-527,240. THE SUN PRODUCTS CORPORATION, WILTON, CT. FILED 1-27-2012.

EXHILARATIONS

THE MARK CONSISTS OF STANDARD CHARACTERS WITHOUT CLAIM TO ANY PARTICULAR FONT, STYLE, SIZE, OR COLOR.

OWNER OF U.S. REG. NO. 3,309,341.
FOR FABRIC SOFTENER (U.S. CLS. 1, 4, 6, 50, 51 AND 52).

FIRST USE 7-31-2006; IN COMMERCE 7-31-2006.
JOHN WILKE, EXAMINING ATTORNEY

CLASS 3—(Continued).

SN 85-527,286. GREENOLOGY PRODUCTS, INC., RALEIGH, NC. FILED 1-27-2012.



THE MARK CONSISTS OF STYLIZED CURSIVE FONT DEPICTING THE LITERAL ELEMENT "GREAT" BETWEEN THE LITERAL ELEMENTS "CONCEN" AND "ED!" IN A DIFFERENT STYLIZED FONT.

FOR CLEANING PREPARATIONS, NAMELY, LAUNDRY DETERGENT; CLEANING PREPARATIONS, NAMELY, FABRIC SOFTENER, STAIN REMOVING PREPARATIONS, AND DISHWASHING DETERGENT (U.S. CLS. 1, 4, 6, 50, 51 AND 52).

FIRST USE 1-13-2012; IN COMMERCE 1-13-2012.
BRENDAN REGAN, EXAMINING ATTORNEY

CLASS 3—(Continued).

SN 85-528,868. JOHNSON & JOHNSON, NEW BRUNSWICK, NJ. FILED 1-30-2012.



THE MARK CONSISTS OF A STYLIZED PROTRUDING LIP ON THE UPPER LEFT SIDE OF A BOTTLE THAT CONTINUES ON AS A RAISED, THREE-DIMENSIONAL RIDGE TOWARDS THE RIGHT. THE RAISED RIDGE ENDS NEAR THE RIGHT SIDE OF THE BOTTLE. SLOPES DOWNWARDS, AND LEADS INTO A THIN, INDENTED GROOVE THAT EXTENDS TOWARDS THE BOTTOM OF THE BOTTLE AND TAPERS INTO A POINT.

SEC. 2(F).
FOR NON-MEDICATED SKIN CARE PREPARATIONS (U.S. CLS. 1, 4, 6, 50, 51 AND 52).
FIRST USE 8-16-2006; IN COMMERCE 8-16-2006.
CARYN GLASSER, EXAMINING ATTORNEY

SN 85-527,294. GREENOLOGY PRODUCTS, INC., RALEIGH, NC. FILED 1-27-2012.



SN 85-539,930. PRODUCT INNOVATIONS RESEARCH LLC, DALLAS, TX. FILED 2-10-2012.

Discover the Miracle of
Hempz

OWNER OF U.S. REG. NO. 4,116,321.
NO CLAIM IS MADE TO THE EXCLUSIVE RIGHT TO USE "PUMP", APART FROM THE MARK AS SHOWN.

THE MARK CONSISTS OF LITERAL ELEMENTS "PERFECT" STACKED ON TOP OF THE LITERAL ELEMENTS "PUMP" IN A STYLIZED FONT WITH A LINE WITH CURLING ENDS AND WATER DROPS EXTENDING FROM THE "F" OVER "ECT" IN "PERFECT".

FOR CLEANING PREPARATIONS, NAMELY, LAUNDRY DETERGENT; CLEANING PREPARATIONS, NAMELY, FABRIC SOFTENER, STAIN REMOVING PREPARATIONS, AND DISHWASHING DETERGENT (U.S. CLS. 1, 4, 6, 50, 51 AND 52).

FIRST USE 1-13-2012; IN COMMERCE 1-13-2012.
BRENDAN REGAN, EXAMINING ATTORNEY

THE MARK CONSISTS OF STANDARD CHARACTERS WITHOUT CLAIM TO ANY PARTICULAR FONT, STYLE, SIZE, OR COLOR.

FOR HAIR CARE PRODUCTS, NAMELY, SHAMPOOS, CONDITIONERS, HAIR STYLING GEL, SPRAY AND MOUSSE TO CONTROL CURLS, HAIR STYLING GEL, SPRAY AND MOUSSE TO BOOST CURLS, STYLING MOUSSE, STYLING GLUE, FIRM HOLD HAIR SPRAY AND FINISHING SPRAY (U.S. CLS. 1, 4, 6, 50, 51 AND 52).

FIRST USE 1-1-2011; IN COMMERCE 1-1-2011.
DANIEL CAPSHAW, EXAMINING ATTORNEY

CLASS 3—(Continued).

SN 85-540,700. L'OREAL, PARIS, FRANCE, FILED 2-13-2012.

VOLUMCEUTIC

THE MARK CONSISTS OF STANDARD CHARACTERS WITHOUT CLAIM TO ANY PARTICULAR FONT, STYLE, SIZE, OR COLOR.

PRIORITY CLAIMED UNDER SEC. 44(D) ON FRANCE APPLICATION NO. 113853265, FILED 8-17-2011, REG. NO. 113853265, DATED 8-17-2011, EXPIRES 8-17-2021.

OWNER OF U.S. REG. NOS. 2,472,845, 2,515,520 AND 3,720,945.

FOR SHAMPOOS; PRODUCTS FOR HAIR STYLING AND HAIR CARE, NAMELY, GELS, POWDERS, MOUSSES, BALMS, CREAM, WAX, SERUMS, LOTIONS AND MASKS; HAIR LACQUERS; HAIR COLOURING AND HAIR DECOLORANT PREPARATIONS; PROTECTIVE COLORING PREPARATIONS FOR TREATED HAIR; PERMANENT WAVING AND CURLING PREPARATIONS; ESSENTIAL OILS FOR PERSONAL USE (U.S. CLS. 1, 4, 6, 50, 51 AND 52).

ALEX KEAM, EXAMINING ATTORNEY

SN 85-542,136. BENEFIT COSMETICS LLC, SAN FRANCISCO, CA. FILED 2-14-2012.

UNDER MY SPELL NOELLE

THE MARK CONSISTS OF STANDARD CHARACTERS WITHOUT CLAIM TO ANY PARTICULAR FONT, STYLE, SIZE, OR COLOR.

FOR FRAGRANCES AND PERFUMERY (U.S. CLS. 1, 4, 6, 50, 51 AND 52).

BRIAN CALLAGHAN, EXAMINING ATTORNEY

SN 85-543,383. ROMANE FRAGRANCES, LLC, WILLOW-BROOK, IL. FILED 2-15-2012.

PINK CAMO

THE MARK CONSISTS OF STANDARD CHARACTERS WITHOUT CLAIM TO ANY PARTICULAR FONT, STYLE, SIZE, OR COLOR.

FOR BODY LOTIONS; BODY SPRAYS; BODY WASH; PERFUME (U.S. CLS. 1, 4, 6, 50, 51 AND 52).

THEODORE MCBRIDE, EXAMINING ATTORNEY

CLASS 3—(Continued).

SN 85-544,901. ROMANE FRAGRANCES, LLC, WILLOW-BROOK, IL. FILED 2-16-2012.

TRU BLOOMS

THE MARK CONSISTS OF STANDARD CHARACTERS WITHOUT CLAIM TO ANY PARTICULAR FONT, STYLE, SIZE, OR COLOR.

FOR BODY LOTIONS; BODY SPRAYS; FRAGRANCES FOR PERSONAL USE (U.S. CLS. 1, 4, 6, 50, 51 AND 52).

THEODORE MCBRIDE, EXAMINING ATTORNEY

SN 85-549,948. THE SUN PRODUCTS CORPORATION, WILTON, CT. FILED 2-22-2012.

SKINSMART

THE MARK CONSISTS OF STANDARD CHARACTERS WITHOUT CLAIM TO ANY PARTICULAR FONT, STYLE, SIZE, OR COLOR.

FOR LAUNDRY DETERGENT (U.S. CLS. 1, 4, 6, 50, 51 AND 52).

JOHN WILKE, EXAMINING ATTORNEY

SN 85-556,086. YZY INC, MIAMI, FL. FILED 2-29-2012.

ISENSE

THE MARK CONSISTS OF STANDARD CHARACTERS WITHOUT CLAIM TO ANY PARTICULAR FONT, STYLE, SIZE, OR COLOR.

FOR PERFUMES AND COLOGNES; PERFUMES, AFTERSHAVES AND COLOGNES; PERFUMES, EAU DE COLOGNES AND AFTERSHAVES (U.S. CLS. 1, 4, 6, 50, 51 AND 52).

KHANH LE, EXAMINING ATTORNEY

CLASS 3—(Continued).

SN 85-556,498. PRO BREATH MD LLC, DBA DENTIST SELECT, SAYREVILLE, NJ. FILED 2-29-2012.

ENHANCEMINT

THE MARK CONSISTS OF STANDARD CHARACTERS WITHOUT CLAIM TO ANY PARTICULAR FONT, STYLE, SIZE, OR COLOR.

FOR DENTIFRICES AND MOUTHWASHES; MOUTHWASH; NON-MEDICATED MOUTHWASHES; TOOTH PASTE AND MOUTHWASHES (U.S. CLS. 1, 4, 6, 50, 51 AND 52).

STEVEN JACKSON, EXAMINING ATTORNEY

CLASS 3—(Continued).

SN 85-570,541. ROMANE FRAGRANCES, LLC, WILLOW-BROOK, IL. FILED 3-15-2012.

INVINCIBLE

THE MARK CONSISTS OF STANDARD CHARACTERS WITHOUT CLAIM TO ANY PARTICULAR FONT, STYLE, SIZE, OR COLOR.

OWNER OF U.S. REG. NO. 3,944,520. FOR BODY SPRAYS; DEODORANT FOR PERSONAL USE; LOTIONS FOR SKIN (U.S. CLS. 1, 4, 6, 50, 51 AND 52).

THEODORE MCBRIDE, EXAMINING ATTORNEY

SN 85-557,851. MARUT ENTERPRISES LLC, MIAMI BEACH, FL. FILED 3-1-2012.

PRIVATE POWDER

THE MARK CONSISTS OF STANDARD CHARACTERS WITHOUT CLAIM TO ANY PARTICULAR FONT, STYLE, SIZE, OR COLOR.

NO CLAIM IS MADE TO THE EXCLUSIVE RIGHT TO USE "POWDER", APART FROM THE MARK AS SHOWN.

FOR BODY POWDER; FACE POWDER (U.S. CLS. 1, 4, 6, 50, 51 AND 52).

ELLEN B. AWRICH, EXAMINING ATTORNEY

SN 85-976,567. THEOCORP HOLDING COMPANY, LLC, METAIRIE, LA. FILED 9-14-2011.



THE MARK CONSISTS OF THE WORD "THEODENT" WITHIN AN ORNATE LINE DESIGN SURROUNDING THE WORD AND HAVING A COCOA BEAN POSITIONED ABOVE THE WORD "THEODENT" IN A SEPARATE ORNATE OVAL.

FOR DENTAL CARE PRODUCTS, NAMELY, TOOTH-PASTE HAVING COMPOUNDS CONTAINING NATURAL OR SYNTHESIZED THEOBROMINE (U.S. CLS. 1, 4, 6, 50, 51 AND 52).

FIRST USE 1-2-2012; IN COMMERCE 1-2-2012. MAYUR VAGHANI, EXAMINING ATTORNEY

SN 85-559,023. RESTORATION SOFTWARE, LTD, ENCINITAS, CA. FILED 3-2-2012.

ANGELLIFT

THE MARK CONSISTS OF STANDARD CHARACTERS WITHOUT CLAIM TO ANY PARTICULAR FONT, STYLE, SIZE, OR COLOR.

FOR BODY AND BEAUTY CARE COSMETICS; COSMETIC CREAMS; COSMETIC CREAMS FOR SKIN CARE; COSMETIC NOURISHING CREAMS; COSMETIC PREPARATIONS; COSMETIC PREPARATIONS AGAINST SUNBURN; COSMETIC PREPARATIONS FOR BODY CARE; COSMETIC PREPARATIONS FOR PROTECTING THE SKIN FROM THE SUN'S RAYS; COSMETIC PREPARATIONS FOR SKIN CARE; COSMETIC PREPARATIONS FOR SKIN RENEWAL; COSMETIC PREPARATIONS FOR THE CARE OF MOUTH AND TEETH; COSMETIC PREPARATIONS, NAMELY, FIRMLYING CREAMS; COSMETIC PREPARATIONS, NAMELY, SKIN BALSAMS (U.S. CLS. 1, 4, 6, 50, 51 AND 52).

ADA HAN, EXAMINING ATTORNEY

SN 85-976,569. THEOCORP HOLDING COMPANY, LLC, METAIRIE, LA. FILED 9-21-2011.

FROM CHOCOLATE...THE SWEETEST DISCOVERY

THE MARK CONSISTS OF STANDARD CHARACTERS WITHOUT CLAIM TO ANY PARTICULAR FONT, STYLE, SIZE, OR COLOR.

NO CLAIM IS MADE TO THE EXCLUSIVE RIGHT TO USE "CHOCOLATE", APART FROM THE MARK AS SHOWN.

FOR DENTAL CARE PRODUCTS, NAMELY, TOOTH-PASTE HAVING COMPOUNDS CONTAINING NATURAL OR SYNTHESIZED THEOBROMINE (U.S. CLS. 1, 4, 6, 50, 51 AND 52).

FIRST USE 1-2-2012; IN COMMERCE 1-2-2012. MAYUR VAGHANI, EXAMINING ATTORNEY

CLASS 4—LUBRICANTS AND FUELS

SN 79-111,436. ZF FRIEDRICHSHAFEN AG, FED REP GERMANY, FILED 1-20-2012.

LIFEGUARD

THE MARK CONSISTS OF STANDARD CHARACTERS WITHOUT CLAIM TO ANY PARTICULAR FONT, STYLE, SIZE, OR COLOR.

PRIORITY DATE OF 7-30-2011 IS CLAIMED.
OWNER OF INTERNATIONAL REGISTRATION 1112338 DATED 1-20-2012, EXPIRES 1-20-2022.
FOR INDUSTRIAL OILS AND GREASES; LUBRICANTS (U.S. CLS. 1, 6 AND 15).
GINA HAYES, EXAMINING ATTORNEY

SN 85-330,413. LATINA MEDIA VENTURES LLC, NEW YORK, NY. FILED 5-25-2011.

GOOD LIVING BY LATINA

THE MARK CONSISTS OF STANDARD CHARACTERS WITHOUT CLAIM TO ANY PARTICULAR FONT, STYLE, SIZE, OR COLOR.

THE ENGLISH TRANSLATION OF "LATINA" IN THE MARK IS LATIN OR LATIN WOMAN.
FOR SCENTED CANDLES (U.S. CLS. 1, 6 AND 15).
STEPHANIE ALI, EXAMINING ATTORNEY

SN 85-334,110. DIAS COMPAN SILVA FERNANDO, SAO PAULO, BRAZIL, FILED 5-31-2011.



NO CLAIM IS MADE TO THE EXCLUSIVE RIGHT TO USE "ECO", APART FROM THE MARK AS SHOWN.

THE MARK CONSISTS OF A SUN DESIGN WITH RAYS COMING OUT FROM THE CENTER BELOW OF WHICH APPEARS THE WORDING "ECO TOK" IN STYLIZED LETTERS.

THE WORDING "ECO TOK" HAS NO MEANING IN A FOREIGN LANGUAGE.

FOR FIREWOOD; BRIQUETTE FUEL; WOOD GRAIN FOR FIRE, NAMELY, KINDLING (U.S. CLS. 1, 6 AND 15).

SHANNON TWOHIG, EXAMINING ATTORNEY

CLASS 4—(Continued).

SN 85-400,495. CASTROL LIMITED, SWINDON, WILTSHIRE, UNITED KINGDOM, FILED 8-17-2011.



THE COLOR(S) GREEN, GRAY, WHITE AND BLACK IS/ARE CLAIMED AS A FEATURE OF THE MARK.

THE MARK CONSISTS OF A THREE-DIMENSIONAL DESIGN OF A MOLECULAR MODEL WITH OVERALL TRIANGULAR SHAPE, CONSISTING OF THREE GREEN SPHERES OF VARYING SHADES OF GREEN TO REPRESENT SHADOW AND INCLUDING SOME WHITE CURVED RECTANGULAR SHAPES REPRESENTING SHINY AREA. THE SPHERES FORMING THE CORNERS OF A TRIANGLE AND CONNECTED BY THREE CYLINDRICAL RODS SHOWN IN BOTH WHITE AND GRAY TO REPRESENT SHINE AND SHADOW, WITH A TOUCH OF BLACK WHERE EACH CYLINDRICAL ROD INTERSECTS WITH EACH GREEN SPHERE. THE WHITE AREA ON THE INSIDE OF THE TRIANGULAR MOLECULE REPRESENTS TRANSPARENT BACKGROUND AND IS NOT CLAIMED AS A FEATURE OF THE MARK.

FOR LUBRICANTS FOR MOTOR VEHICLES (U.S. CLS. 1, 6 AND 15).

JENNIFER DIXON, EXAMINING ATTORNEY

SN 85-418,970. AZTECH LUBRICANTS LLC, WAYNE, OK. FILED 9-9-2011.

EZDraw

THE MARK CONSISTS OF STANDARD CHARACTERS WITHOUT CLAIM TO ANY PARTICULAR FONT, STYLE, SIZE, OR COLOR.

FOR INDUSTRIAL LUBRICANTS (U.S. CLS. 1, 6 AND 15).

FIRST USE 3-0-2005; IN COMMERCE 3-0-2005.

MARTHA SANTOMARTINO, EXAMINING ATTORNEY

CLASS 4—(Continued).

SN 85-445,381. LEI, DA, HEMET, CA. FILED 10-12-2011.

E85plus

THE MARK CONSISTS OF STANDARD CHARACTERS WITHOUT CLAIM TO ANY PARTICULAR FONT, STYLE, SIZE, OR COLOR.

FOR ETHANOL FUELS COMPRISED OF 85% ETHANOL AND 15% GASOLINE (U.S. CLS. 1, 6 AND 15).
MICHAEL LITZAU, EXAMINING ATTORNEY

CLASS 4—(Continued).

SN 85-507,754. OIL ASSOCIATES INC., CLEVELAND, OH. FILED 1-3-2012.

POLYMEROL

THE MARK CONSISTS OF STANDARD CHARACTERS WITHOUT CLAIM TO ANY PARTICULAR FONT, STYLE, SIZE, OR COLOR.

FOR FUEL OILS; FUELS; HYDROCARBON FUELS; LIQUID FUELS; AND MINERAL OILS AND GREASES FOR INDUSTRIAL PURPOSES (U.S. CLS. 1, 6 AND 15).
FIRST USE 12-21-2011; IN COMMERCE 12-21-2011.
MAYUR VAGHANI, EXAMINING ATTORNEY

SN 85-510,057. STARMAX ENTERPRISES INC, LOS ANGELES, CA. FILED 1-6-2012.

SN 85-466,392. BARDAHL MANUFACTURING CORPORATION, SEATTLE, WA. FILED 11-7-2011.

**MAGNUM BUTANE**

THE MARK CONSISTS OF STANDARD CHARACTERS WITHOUT CLAIM TO ANY PARTICULAR FONT, STYLE, SIZE, OR COLOR.

NO CLAIM IS MADE TO THE EXCLUSIVE RIGHT TO USE "BUTANE", APART FROM THE MARK AS SHOWN.
FOR BUTANE REFILL FOR LIGHTERS, GAS STOVES (U.S. CLS. 1, 6 AND 15).

FIRST USE 3-29-2011; IN COMMERCE 3-30-2011.
JOHN HWANG, EXAMINING ATTORNEY

SN 85-510,714. MARC CALLON, MURRIETA, CA. FILED 1-6-2012.

OWNER OF U.S. REG. NOS. 526,554, 960,245 AND OTHERS.

NO CLAIM IS MADE TO THE EXCLUSIVE RIGHT TO USE "BIO", APART FROM THE MARK AS SHOWN.

THE MARK CONSISTS OF THE WORDS "BARDAHL", "ECO", AND "BIO", TOGETHER WITH THE DESIGN OF A PLANT, APPEARING BELOW THESE WORDS, WHOSE STEM FORMS A DESIGN OF A POLE TO A CHECKERED FLAG ABOVE THESE WORDS, BOTH DESIGNS FORMING PART OF THE "R" IN THE WORD "BARDAHL".

FOR LUBRICATING OILS AND GREASES; INDUSTRIAL OILS AND INDUSTRIAL GREASES; MOTOR OIL; NON-CHEMICAL ADDITIVES FOR FUEL AND MOTOR OIL (U.S. CLS. 1, 6 AND 15).

CHRISTOPHER SIDOTI, EXAMINING ATTORNEY

Fire N A Can

THE MARK CONSISTS OF STANDARD CHARACTERS WITHOUT CLAIM TO ANY PARTICULAR FONT, STYLE, SIZE, OR COLOR.

FOR COLORED FIRE TORCHES; FIRE LIGHTERS; SOLID FIRE STARTERS (U.S. CLS. 1, 6 AND 15).

FIRST USE 1-1-2012; IN COMMERCE 1-1-2012.

MARK SPARACINO, EXAMINING ATTORNEY

CLASS 4—(Continued).

SN 85-511,068. BIESEL GREENTECH CORPORATION, LAS VEGAS, NV. FILED 1-7-2012.

BIESEL

THE MARK CONSISTS OF STANDARD CHARACTERS WITHOUT CLAIM TO ANY PARTICULAR FONT, STYLE, SIZE, OR COLOR.
FOR BIODIESEL FUEL (U.S. CLS. 1, 6 AND 15).
JOHN DALIER, EXAMINING ATTORNEY

SN 85-511,351. INDUSTRIAL SECRET LLC, LODI, CA. FILED 1-8-2012.

Eat The Candle

THE MARK CONSISTS OF STANDARD CHARACTERS WITHOUT CLAIM TO ANY PARTICULAR FONT, STYLE, SIZE, OR COLOR.
FOR AROMATHERAPY FRAGRANCE CANDLES; BEESWAX FOR USE IN THE MANUFACTURE OF CANDLES; CANDLE CONTAINED IN A CLAMSHELL; CANDLES AND WICKS FOR CANDLES FOR LIGHTING; CANDLES BEING OF WAX OR LIQUID, FOR THE ILLUMINATION OF CARVED PUMPKINS, MINI-PUMPKINS, GOURDS, AND OTHER FRUITS AND VEGETABLES; CANDLES FOR LIGHTING; WICKS FOR CANDLES; WICKS FOR CANDLES FOR LIGHTING (U.S. CLS. 1, 6 AND 15).
DOMINIC FATHY, EXAMINING ATTORNEY

SN 85-513,478. QUICKSTOVE, LLC, PLEASANT GROVE, UT. FILED 1-10-2012.

QUICKSTOVE

THE MARK CONSISTS OF STANDARD CHARACTERS WITHOUT CLAIM TO ANY PARTICULAR FONT, STYLE, SIZE, OR COLOR.
FOR FUEL PRODUCTS FOR STOVES, NAMELY, WOOD PELLETS, CORN AND GRAINS; FUELS; FUELS FROM BIOLOGICAL SOURCES; WOOD CHIPS FOR USE AS FUEL (U.S. CLS. 1, 6 AND 15).
FIRST USE 6-1-2011; IN COMMERCE 6-1-2011.
CHRIS WELLS, EXAMINING ATTORNEY

CLASS 4—(Continued).

SN 85-516,031. FIRSTPOWER GROUP LLC, TWINSBURG, OH. FILED 1-13-2012.



THE MARK CONSISTS OF THE LETTERS "EZ" WITH AN IMAGE OF A DROPLET TO THE RIGHT OF THE LETTERS "EZ" WITH THE WORD "REACH" BENEATH IT.
FOR LUBRICANTS, NAMELY OIL (U.S. CLS. 1, 6 AND 15).
FIRST USE 9-16-2011; IN COMMERCE 9-16-2011.
MARK RADEMACHER, EXAMINING ATTORNEY

SN 85-533,720. TOPCO HOLDINGS, INC., SKOKIE, IL. FILED 2-3-2012.

OVER THE TOP

THE MARK CONSISTS OF STANDARD CHARACTERS WITHOUT CLAIM TO ANY PARTICULAR FONT, STYLE, SIZE, OR COLOR.
FOR CANDLES (U.S. CLS. 1, 6 AND 15).
GENE MACIOL, EXAMINING ATTORNEY

CLASS 5—PHARMACEUTICALS

SN 76-053,356. BEALE, PAX, SAN FRANCISCO, CA. FILED 5-18-2000.

CARDIOSOY

FOR VITAMINS AND NUTRITIONAL SUPPLEMENTS CONTAINING SOY (U.S. CLS. 6, 18, 44, 46, 51 AND 52).
FIRST USE 3-11-2000; IN COMMERCE 3-11-2000.
BRIDGETT SMITH, EXAMINING ATTORNEY

CLASS 5—(Continued).

SN 76-702,871. OLDE GRANDDAD INDUSTRIES, INC., KEARNY, NJ. FILED 5-10-2010.



OWNER OF U.S. REG. NOS. 3,987,471 AND 3,987,472. THE COLOR(S) BLACK AND GOLD IS/ARE CLAIMED AS A FEATURE OF THE MARK.

THE MARK CONSISTS OF A DESIGN OF AN ISLAND SCENE CONSISTING OF TWO PALM TREES AND AN OUTLINE OF A RISING SUN ALL IN BLACK. THE WORDS "PARADISE ISLAND" APPEAR ACROSS THE DESIGN ELEMENT AND ARE IN GOLD OUTLINED IN BLACK. BELOW THE DESIGN ELEMENT ARE THE WORDS "WHERE THE AIR IS FRESH AND THE PEOPLE CARE." ALL IN BLACK.

FOR FRAGRANCE PRODUCTS FOR LAND VEHICLES, AIRCRAFT, MARINE CRAFT, PERSONAL, COMMERCIAL, INDUSTRIAL AND HOME USE, NAMELY, AIR FRESHENERS (U.S. CLS. 6, 18, 44, 46, 51 AND 52).

FIRST USE 3-0-1998; IN COMMERCE 3-0-1998. NELSON SNYDER, EXAMINING ATTORNEY

CLASS 5—(Continued).

SN 77-508,690. TEVA WOMEN'S HEALTH, INC., CINCINNATI, OH. FILED 6-26-2008.

AVIDA

THE MARK CONSISTS OF STANDARD CHARACTERS WITHOUT CLAIM TO ANY PARTICULAR FONT, STYLE, SIZE, OR COLOR.

THE ENGLISH TRANSLATION OF THE WORD "AVIDA" IN THE MARK IS "AVID".

FOR PHARMACEUTICALS, NAMELY, CONTRACEPTIVES, ORAL CONTRACEPTIVES, HORMONE REPLACEMENT THERAPIES, AND HORMONAL AGENTS FOR TREATING DISORDERS AND CONDITIONS RELATED TO WOMEN'S HEALTH (U.S. CLS. 6, 18, 44, 46, 51 AND 52).

FRED CARL, EXAMINING ATTORNEY

SN 76-707,300. WALLS, CLAUDINE SOPHIA, NORTH LAUDERDALE, FL. FILED 4-18-2011.

oops!

THE MARK CONSISTS OF THE STYLIZED WORD "OOPS!".

FOR HAND-SANITIZING PREPARATIONS AND AIR DEODORIZER (U.S. CLS. 6, 18, 44, 46, 51 AND 52). PAUL MORENO, EXAMINING ATTORNEY

SN 77-902,555. PROSYNTHESIS LABORATORIES, INC., STERLING, VA. FILED 12-30-2009.

CHINA ♦ FREE

SN 77-484,110. MEDTRADE PRODUCTS LIMITED, CREWE, CHESHIRE, UNITED KINGDOM, FILED 5-27-2008.

AQUANOVA

THE MARK CONSISTS OF STANDARD CHARACTERS WITHOUT CLAIM TO ANY PARTICULAR FONT, STYLE, SIZE, OR COLOR.

OWNER OF ERPN CMNTY TM OFC REG. NO. 006927354, DATED 2-16-2009, EXPIRES 5-21-2018.

FOR WOUND DRESSINGS; WOUND HEALING DRESSINGS; WOUND HEALING PREPARATIONS; PLASTERS FOR MEDICAL PURPOSES (U.S. CLS. 6, 18, 44, 46, 51 AND 52).

KEVON CHISOLM, EXAMINING ATTORNEY

NO CLAIM IS MADE TO THE EXCLUSIVE RIGHT TO USE "CHINA FREE", APART FROM THE MARK AS SHOWN.

THE MARK CONSISTS OF THE WORDS "CHINA" AND "FREE" SEPARATED BY A SQUARE ROTATED 45 DEGREES SO THAT SUCH SQUARE APPEARS LIKE A DIAMOND AND SUBSTITUTES FOR A HYPHEN BETWEEN THE TWO WORDS, THE LOWEST CORNER OF SAID SQUARE BEING TANGENT TO THE IMAGINARY HORIZONTAL LINE THAT WOULD INTERSECT THE BOTTOM OF EACH OF THE LETTERS IN THE TWO WORDS.

FOR VITAMIN AND MINERAL SUPPLEMENTS (U.S. CLS. 6, 18, 44, 46, 51 AND 52).

ROBERT L. LORENZO, EXAMINING ATTORNEY

CLASS 5—(Continued).

SN 78-836,892. GENENEWS LIMITED, RICHMOND HILL, ONTARIO, CANADA, FILED 3-14-2006.

COLONSENTRY

THE MARK CONSISTS OF STANDARD CHARACTERS WITHOUT CLAIM TO ANY PARTICULAR FONT, STYLE, SIZE, OR COLOR.

PRIORITY CLAIMED UNDER SEC. 44(D) ON CANADA APPLICATION NO. 1293250, FILED 3-10-2006, REG. NO. TMA820607, DATED 3-23-2012, EXPIRES 3-23-2027.

FOR DIAGNOSTIC TESTING KITS FOR CLINICAL OR MEDICAL LABORATORY USE, COMPRISING PREPARATIONS, NAMELY, CLINICAL MEDICAL REAGENTS FOR USE IN DETECTING GENE EXPRESSION PRODUCTS, NAMELY, RIBONUCLEIC ACID (RNA) OR PROTEINS, AS AN INDICATION OF BODY STATE, NAMELY, BODY HEALTH CONDITIONS IN THE NATURE OF DISEASE OR RESPONSE TO THERAPEUTIC TREATMENT (U.S. CLS. 6, 18, 44, 46, 51 AND 52).

RAUL CORDOVA, EXAMINING ATTORNEY

SN 79-099,234. STALLERGENES SA, ANTONY, FRANCE, FILED 6-6-2011.

DEMITIS

THE MARK CONSISTS OF STANDARD CHARACTERS WITHOUT CLAIM TO ANY PARTICULAR FONT, STYLE, SIZE, OR COLOR.

OWNER OF INTERNATIONAL REGISTRATION 1027555 DATED 12-24-2009, EXPIRES 12-24-2019.

FOR PHARMACEUTICAL PREPARATIONS FOR THE TREATMENT OF ALLERGIES; VETERINARY PREPARATIONS FOR DOMESTIC AND WILD ANIMALS FOR THE TREATMENT OF ALLERGIES; MEDICINES IN THE FORM OF TABLETS FOR THE TREATMENT OF ALLERGIES (U.S. CLS. 6, 18, 44, 46, 51 AND 52).

JOHN DWYER, EXAMINING ATTORNEY

CLASS 5—(Continued).

SN 79-102,533. IXODES AG, CH-8044 ZÜRICH, SWITZERLAND, FILED 8-15-2011.

Ixogel

THE MARK CONSISTS OF STANDARD CHARACTERS WITHOUT CLAIM TO ANY PARTICULAR FONT, STYLE, SIZE, OR COLOR.

PRIORITY DATE OF 5-10-2011 IS CLAIMED.

OWNER OF INTERNATIONAL REGISTRATION 1090746 DATED 8-15-2011, EXPIRES 8-15-2021.

FOR PHARMACEUTICAL AND VETERINARY PRODUCTS, NAMELY, PHARMACEUTICAL AND VETERINARY PREPARATIONS FOR THE TREATMENT OF LYME DISEASE, LYME BORRELIOSIS, WOUNDS OR FOR SANITARY STERILIZING; PHARMACEUTICAL AND VETERINARY PREPARATIONS FOR PREVENTING LYME DISEASE, LYME BORRELIOSIS, WOUNDS OR FOR SANITARY STERILIZING TO PREVENT INFECTION; MEDICAL PLASTERS (U.S. CLS. 6, 18, 44, 46, 51 AND 52).

CHRISTOPHER LAW, EXAMINING ATTORNEY

SN 79-103,570. MEDAC GESELLSCHAFT FÜR KLINISCHE SPEZIALPRÄPARATE MBH, 22880 WEDEL, FED REP GERMANY, FILED 9-1-2011.

Spectrila

THE MARK CONSISTS OF STANDARD CHARACTERS WITHOUT CLAIM TO ANY PARTICULAR FONT, STYLE, SIZE, OR COLOR.

OWNER OF INTERNATIONAL REGISTRATION 1093317 DATED 9-1-2011, EXPIRES 9-1-2021.

THE WORD(S) "SPECTRILA" HAS NO MEANING IN A FOREIGN LANGUAGE.

FOR PHARMACEUTICAL PREPARATIONS FOR TREATING CANCER AND AUTO-IMMUNE DISEASES; MEDICINES FOR TREATING CANCER AND AUTO-IMMUNE DISEASES; CHEMICAL PREPARATIONS FOR MEDICAL PURPOSES, NAMELY, CHEMICAL REAGENTS FOR DIAGNOSTIC PURPOSES; MEDICAL PLASTERS; SURGICAL DRESSINGS; ALL PURPOSE DISINFECTANTS (U.S. CLS. 6, 18, 44, 46, 51 AND 52).

MICHAEL SOUDERS, EXAMINING ATTORNEY

CLASS 5—(Continued).

SN 79-106,758. VOCO GMBH, FED REP GERMANY, FILED 11-14-2011.

x-tra base

THE MARK CONSISTS OF STANDARD CHARACTERS WITHOUT CLAIM TO ANY PARTICULAR FONT, STYLE, SIZE, OR COLOR.

PRIORITY DATE OF 5-19-2011 IS CLAIMED. OWNER OF INTERNATIONAL REGISTRATION 1100656 DATED 11-14-2011, EXPIRES 11-14-2021.

NO CLAIM IS MADE TO THE EXCLUSIVE RIGHT TO USE "BASE", APART FROM THE MARK AS SHOWN.

FOR MATERIALS FOR DENTAL MEDICINE, NAMELY, DENTAL COMPOSITES AND DENTAL FILLING MATERIALS (U.S. CLS. 6, 18, 44, 46, 51 AND 52).
GINA FINK, EXAMINING ATTORNEY

SN 79-110,410. TOKUYAMA CORPORATION, JAPAN, FILED 1-18-2012.

E S T E L I N K

THE MARK CONSISTS OF STANDARD CHARACTERS WITHOUT CLAIM TO ANY PARTICULAR FONT, STYLE, SIZE, OR COLOR.

PRIORITY DATE OF 1-10-2012 IS CLAIMED. OWNER OF INTERNATIONAL REGISTRATION 1110078 DATED 1-18-2012, EXPIRES 1-18-2022.

FOR BONDING AND PRIMER MATERIALS FOR DENTAL PURPOSE; DENTAL CEMENTS; ADHESIVES FOR DENTURES; DENTAL ADHESIVES; DENTAL ETCHING AGENTS; TOOTH FILLING MATERIALS; DENTAL COMPOSITE RESINS (U.S. CLS. 6, 18, 44, 46, 51 AND 52).
ALLISON HOLTZ, EXAMINING ATTORNEY

SN 79-111,027. NOVARTIS AG, SWITZERLAND, FILED 3-6-2012.

SAM

THE MARK CONSISTS OF STANDARD CHARACTERS WITHOUT CLAIM TO ANY PARTICULAR FONT, STYLE, SIZE, OR COLOR.

PRIORITY DATE OF 9-21-2011 IS CLAIMED. OWNER OF INTERNATIONAL REGISTRATION 1111428 DATED 3-6-2012, EXPIRES 3-6-2022.

FOR VACCINES (U.S. CLS. 6, 18, 44, 46, 51 AND 52).
CHRISTINE MARTIN, EXAMINING ATTORNEY

CLASS 5—(Continued).

SN 85-011,652. BIO-ENGINEERED SUPPLEMENTS & NUTRITION, INC., EVANSTON, IL. FILED 4-12-2010.



NO CLAIM IS MADE TO THE EXCLUSIVE RIGHT TO USE THE THREE-DIMENSIONAL SHAPE OF THE PRODUCT BOTTLE OR PACKAGING, APART FROM THE MARK AS SHOWN.

THE COLOR(S) RED AND SILVER/GRAY IS/ARE CLAIMED AS A FEATURE OF THE MARK.

THE MARK CONSISTS OF A RED LABEL BORDERED ON THE TOP AND BOTTOM BY HORIZONTAL SILVER-COLORED BANDS AFFIXED TO A RED STRAIGHT-WALLED CONTAINER CURVING INWARD AT THE TOP AND BOTTOM TO A GRAY LID AND BASE OF LESSER DIAMETER. THE CONTAINER AND LID ARE DEPICTED IN BROKEN LINES AND ARE NOT CLAIMED AS FEATURES OF THE MARK, BUT ARE ILLUSTRATED TO SHOW PLACEMENT OF THE MARK.

SEC. 2(F).
FOR DIETARY SUPPLEMENTS (U.S. CLS. 6, 18, 44, 46, 51 AND 52).

FIRST USE 11-1-2005; IN COMMERCE 11-1-2005.
DEZMONA MIZELLE, EXAMINING ATTORNEY

SN 85-104,289. DOBIAS, PETER, NORTH VANCOUVER, BC, CANADA, FILED 8-10-2010.

Green Min

THE MARK CONSISTS OF STANDARD CHARACTERS WITHOUT CLAIM TO ANY PARTICULAR FONT, STYLE, SIZE, OR COLOR.

PRIORITY CLAIMED UNDER SEC. 44(D) ON CANADA APPLICATION NO. 1467568, FILED 5-13-2010, REG. NO. TMA816,269, DATED 1-26-2012, EXPIRES 1-26-2027.

FOR ANIMAL FEED SUPPLEMENTS, NAMELY, NUTRITIONAL PET FOOD ADDITIVES; DIETARY AND NUTRITIONAL SUPPLEMENTS FOR ANIMALS AND PETS, NAMELY, NUTRITIONAL PET FOOD ADDITIVES; DIETARY FOOD SUPPLEMENTS FOR ANIMALS AND PETS, NAMELY, NUTRITIONAL PET FOOD ADDITIVES; DIETARY SUPPLEMENTS FOR ANIMALS, NAMELY, NUTRITIONAL PET FOOD ADDITIVES; FEED SUPPLEMENTS FOR DOGS, CATS, NAMELY, PET FOOD ADDITIVES; FOOD SUPPLEMENTS AND MINERAL FOOD SUPPLEMENTS FOR ANIMALS AND PETS, NAMELY, NUTRITIONAL PET FOOD ADDITIVES (U.S. CLS. 6, 18, 44, 46, 51 AND 52).
SAIMA MAKHDOOM, EXAMINING ATTORNEY

CLASS 5—(Continued).

SN 85-183,029. NUTRIENT SCIENCES, INC., PORT ST. LUCIE, FL. FILED 11-23-2010.

Kymera

THE MARK CONSISTS OF STANDARD CHARACTERS WITHOUT CLAIM TO ANY PARTICULAR FONT, STYLE, SIZE, OR COLOR.

THE WORDING "KYMERA" HAS NO MEANING IN A FOREIGN LANGUAGE.

FOR DIETARY AND NUTRITIONAL SUPPLEMENTS (U.S. CLS. 6, 18, 44, 46, 51 AND 52).

FIRST USE 7-27-2009; IN COMMERCE 7-27-2009.
GISELLE AGOSTO, EXAMINING ATTORNEY

SN 85-183,446. HYGENIC INTANGIBLE PROPERTY HOLDING CO., AKRON, OH. FILED 11-23-2010.

YOUR NATURAL CHOICE FOR
PAIN RELIEF

THE MARK CONSISTS OF STANDARD CHARACTERS WITHOUT CLAIM TO ANY PARTICULAR FONT, STYLE, SIZE, OR COLOR.

FOR TOPICAL ANALGESICS (U.S. CLS. 6, 18, 44, 46, 51 AND 52).

MARCIE MILONE, EXAMINING ATTORNEY

CLASS 5—(Continued).

SN 85-185,052. ONYX PHARMACEUTICALS, INC., SOUTH SAN FRANCISCO, CA. FILED 11-24-2010.



OWNER OF U.S. REG. NOS. 2,791,902, 3,063,997 AND OTHERS.

NO CLAIM IS MADE TO THE EXCLUSIVE RIGHT TO USE "PHARMACEUTICALS", APART FROM THE MARK AS SHOWN.

THE COLOR(S) RED AND BLACK IS/ARE CLAIMED AS A FEATURE OF THE MARK.

THE MARK CONSISTS OF TWO CURVED RED LINES THAT PARTIALLY INTERSECT AT ONE POINT WITH THE WORDS "ONYX PHARMACEUTICALS" TO THE RIGHT OF THE CURVED LINES. THE COLOR BLACK APPEARS IN THE TEXT OF THE WORDING "ONYX PHARMACEUTICALS".

FOR HUMAN AND VETERINARY PHARMACEUTICALS FOR USE IN THE PREVENTION AND TREATMENT OF CANCER, ONCOLOGY, TUMORS, SOLID AND HEMATOLOGICAL TUMORS AND GROWTHS, HEMATOLOGICAL AND HEMOLYTIC DISEASES AND DISORDERS, AMYLODIOSIS, METABOLIC DISEASES AND DISORDERS, LUPUS, AND INFLAMMATION AND AUTOIMMUNE DISEASES AND DISORDERS (U.S. CLS. 6, 18, 44, 46, 51 AND 52).

ELI HELLMAN, EXAMINING ATTORNEY

SN 85-193,912. VICAR OPERATING, INC., LOS ANGELES, CA. FILED 12-9-2010.

ACUGUARD

THE MARK CONSISTS OF STANDARD CHARACTERS WITHOUT CLAIM TO ANY PARTICULAR FONT, STYLE, SIZE, OR COLOR.

FOR ANTI-FLEA TABLETS FOR DOGS (U.S. CLS. 6, 18, 44, 46, 51 AND 52).

FIRST USE 3-21-2011; IN COMMERCE 3-21-2011.
EVELYN BRADLEY, EXAMINING ATTORNEY

CLASS 5—(Continued).

SN 85-206,689. EARTH-KIND, INC., BISMARCK, ND. FILED 12-28-2010.

FRESH CAB

THE MARK CONSISTS OF STANDARD CHARACTERS WITHOUT CLAIM TO ANY PARTICULAR FONT, STYLE, SIZE, OR COLOR.

FOR AIR FRESHENERS; ANIMAL REPELLANTS (U.S. CLS. 6, 18, 44, 46, 51 AND 52).
FIRST USE 6-30-1998; IN COMMERCE 6-30-1998.
ROBERT C. CLARK JR., EXAMINING ATTORNEY



SN 85-206,906. XEMED LLC, DURHAM, NH. FILED 12-28-2010.

MAGNIXENE

THE MARK CONSISTS OF STANDARD CHARACTERS WITHOUT CLAIM TO ANY PARTICULAR FONT, STYLE, SIZE, OR COLOR.

FOR CONTRAST MEDIA FOR IN-VIVO IMAGING; CONTRAST MEDIA FOR USE WITH IMAGING MEDICAL EQUIPMENT; IMAGING AGENTS FOR MAGNETIC RESONANCE IMAGING (MRI) (U.S. CLS. 6, 18, 44, 46, 51 AND 52).
FIRST USE 1-1-2007; IN COMMERCE 6-1-2008.
JOSETTE BEVERLY, EXAMINING ATTORNEY



SN 85-227,039. LIQUID ASSETS COMPANY, LLC, BEVERLY HILLS, CA. FILED 1-26-2011.

SPLASH

THE MARK CONSISTS OF STANDARD CHARACTERS WITHOUT CLAIM TO ANY PARTICULAR FONT, STYLE, SIZE, OR COLOR.

FOR DIETARY AND NUTRITIONAL SUPPLEMENTS CONTAINING STEVIA FOR USE AS A SUGAR SUBSTITUTE (U.S. CLS. 6, 18, 44, 46, 51 AND 52).
GRETTA YAO, EXAMINING ATTORNEY

CLASS 5—(Continued).

SN 85-248,481. MERZ PHARMA GMBH & CO. KGAA, FRANKFURT AM MAIN, FED REP GERMANY, FILED 2-22-2011.

PANTOGAR

THE MARK CONSISTS OF STANDARD CHARACTERS WITHOUT CLAIM TO ANY PARTICULAR FONT, STYLE, SIZE, OR COLOR.

OWNER OF FED REP GERMANY REG. NO. 30087050, DATED 6-19-2001, RENEWED AS REG. NO. 30087050, DATED 11-30-2010, EXPIRES 11-30-2020.

FOR PHARMACEUTICAL PREPARATIONS FOR THE TREATMENT OF HAIR LOSS, NAMELY, ALOPECIA, DIFFUSE HAIR LOSS, NAMELY, DIFFUSE ALOPECIA, HAIR STRUCTURE LESIONS, PROPHYLAXIS OF PRE-MATURE HAIR GREYING, NON-INFECTIOUS DISORDERS OF THE NAILS AND DISTURBANCES IN NAIL GROWTH, AND BRITTLE NAILS (U.S. CLS. 6, 18, 44, 46, 51 AND 52).
HEATHER THOMPSON, EXAMINING ATTORNEY



SN 85-316,963. NANOBIO CORPORATION, ANN ARBOR, MI. FILED 5-10-2011.

NANOSAFE

THE MARK CONSISTS OF STANDARD CHARACTERS WITHOUT CLAIM TO ANY PARTICULAR FONT, STYLE, SIZE, OR COLOR.

FOR ANTI-MICROBIAL, ANTI-SPORICIDAL, ANTI-VIRAL, ANTI-FUNGAL AND ANTI-BACTERIAL PREPARATIONS, SOLUTIONS, AND EMULSIONS FOR USE AS A DISINFECTANT, SANITIZER, AND DECONTAMINANT OF SURFACES, CLOTHING, TEXTILES, SKIN, AND MUCOSAL MEMBRANES, AND FOR USE AS AN INTEGRAL COMPONENT IN DISINFECTANTS, SANITIZERS, AND DECONTAMINANTS FOR SURFACES, CLOTHING, TEXTILES, SKIN AND MUCOSAL MEMBRANES (U.S. CLS. 6, 18, 44, 46, 51 AND 52).
RICHARD WHITE, EXAMINING ATTORNEY



SN 85-329,584. BISCO, INC., SCHAUMBURG, IL. FILED 5-25-2011.

SELECT HV ETCH

THE MARK CONSISTS OF STANDARD CHARACTERS WITHOUT CLAIM TO ANY PARTICULAR FONT, STYLE, SIZE, OR COLOR.

NO CLAIM IS MADE TO THE EXCLUSIVE RIGHT TO USE "HV ETCH", APART FROM THE MARK AS SHOWN.
FOR DENTAL MATERIALS, NAMELY, COMPOSITIONS FOR ETCHING TOOTH DENTIN AND ENAMEL (U.S. CLS. 6, 18, 44, 46, 51 AND 52).
TINA L. SNAPP, EXAMINING ATTORNEY

CLASS 5—(Continued).

SN 85-329,599. BISCO, INC., SCHAUMBURG, IL. FILED 5-25-2011.

SELECT HV

THE MARK CONSISTS OF STANDARD CHARACTERS WITHOUT CLAIM TO ANY PARTICULAR FONT, STYLE, SIZE, OR COLOR.

NO CLAIM IS MADE TO THE EXCLUSIVE RIGHT TO USE "HV", APART FROM THE MARK AS SHOWN.

FOR DENTAL MATERIALS, NAMELY, COMPOSITIONS FOR ETCHING TOOTH DENTIN AND ENAMEL (U.S. CLS. 6, 18, 44, 46, 51 AND 52).

TINA L. SNAPP, EXAMINING ATTORNEY

SN 85-333,060. KORET, S.A. DE C.V., SAN SALVADOR, EL SALVADOR, FILED 5-28-2011.

DESESTRESS PLUS

THE MARK CONSISTS OF STANDARD CHARACTERS WITHOUT CLAIM TO ANY PARTICULAR FONT, STYLE, SIZE, OR COLOR.

FOR DIETARY SUPPLEMENTS, NAMELY, A COMBINATION OF VITAMIN AND MINERAL SUPPLEMENTS COMPOSED IN SUBSTANTIAL PART OF VITAMIN B12 (U.S. CLS. 6, 18, 44, 46, 51 AND 52).

ARETHA SOMERVILLE, EXAMINING ATTORNEY

SN 85-333,069. KORET, S.A. DE C.V., SAN SALVADOR, EL SALVADOR, FILED 5-28-2011.

FORTACHON

THE MARK CONSISTS OF STANDARD CHARACTERS WITHOUT CLAIM TO ANY PARTICULAR FONT, STYLE, SIZE, OR COLOR.

FOR VITAMINS (U.S. CLS. 6, 18, 44, 46, 51 AND 52).

ARETHA SOMERVILLE, EXAMINING ATTORNEY

CLASS 5—(Continued).

SN 85-339,889. PHARMA SCIENCE NUTRIENTS, INC., OCALA, FL. FILED 6-7-2011.

ACTI FLAX

THE MARK CONSISTS OF STANDARD CHARACTERS WITHOUT CLAIM TO ANY PARTICULAR FONT, STYLE, SIZE, OR COLOR.

NO CLAIM IS MADE TO THE EXCLUSIVE RIGHT TO USE "FLAX", APART FROM THE MARK AS SHOWN.

FOR NUTRITIONAL, FOOD AND DIETARY SUPPLEMENTS CONTAINING ACTIVE FLAX INGREDIENTS; AND INGREDIENTS FOR NUTRITIONAL, FOOD AND DIETARY SUPPLEMENTS CONTAINING ACTIVE FLAX (U.S. CLS. 6, 18, 44, 46, 51 AND 52).

FIRST USE 3-6-2006; IN COMMERCE 11-1-2007.

HENRY S. ZAK, EXAMINING ATTORNEY

SN 85-349,642. ACIONT INC., SALT LAKE CITY, UT. FILED 6-17-2011.

VISULEX

THE MARK CONSISTS OF STANDARD CHARACTERS WITHOUT CLAIM TO ANY PARTICULAR FONT, STYLE, SIZE, OR COLOR.

FOR DRUG DELIVERY AGENTS, NAMELY GELS FOR USE IN DELIVERING A WIDE VARIETY OF PHARMACEUTICALS AND DRUGS INTO THE BODY; PHARMACEUTICAL PREPARATIONS, NAMELY, GELS FOR MEDICAL AND THERAPEUTIC USE FOR THE TREATMENT OF ALLERGIES, CANCER, CARDIOVASCULAR DISORDERS, CENTRAL NERVOUS SYSTEM DISORDERS, DERMATOLOGICAL DISORDERS, DISEASES OF THE MOUTH, EAR, NOSE AND THROAT DISORDERS, HAIR AND NAIL DISORDERS, DIABETES, ENDOCRINOLOGICAL DISORDERS, GASTROINTESTINAL DISORDERS, GYNECOLOGICAL DISORDERS, HEMATOLOGICAL DISORDERS, HORMONAL DISORDERS, HYPOGONADISM, IMMUNE SYSTEM DISORDERS, MALNUTRITION, MENOPAUSE, OBESITY, OCULAR DISORDERS, PULMONARY AND RESPIRATORY DISORDERS, REPRODUCTIVE AND FERTILITY DISORDERS, RHEUMATOLOGICAL DISORDERS, INFECTIOUS DISEASES, VIRUSES, BACTERIOLOGICAL DISORDERS, FUNGAL DISORDERS, PARASITIC DISORDERS, SOFT TISSUE DISORDERS, SUBSTANCE ABUSE AND ADDICTIONS, UROLOGICAL DISORDERS (U.S. CLS. 6, 18, 44, 46, 51 AND 52).

KARANENDRA S. CHHINA, EXAMINING ATTORNEY

CLASS 5—(Continued).

SN 85-357,066. PARADISE HERBS & ESSENTIALS, INC., HUNTINGTON BEACH, CA. FILED 6-27-2011.

MONROE LABS

THE MARK CONSISTS OF STANDARD CHARACTERS WITHOUT CLAIM TO ANY PARTICULAR FONT, STYLE, SIZE, OR COLOR.

NO CLAIM IS MADE TO THE EXCLUSIVE RIGHT TO USE "LABS", APART FROM THE MARK AS SHOWN.

FOR NUTRITIONAL SUPPLEMENTS (U.S. CLS. 6, 18, 44, 46, 51 AND 52).

JULIE WATSON, EXAMINING ATTORNEY

SN 85-358,733. BIOMIMETIC THERAPEUTICS, INC., FRANKLIN, TN. FILED 6-28-2011.



NO CLAIM IS MADE TO THE EXCLUSIVE RIGHT TO USE "BIOMIMETIC", APART FROM THE MARK AS SHOWN.

THE MARK CONSISTS OF THE WORD "BIOMIMETIC" AND TO THE LEFT OF THE WORD IS A DESIGN MADE UP OF THREE INVERTED TRIANGLES.

FOR BIOLOGIC PREPARATIONS FOR USE IN ORTHOPEDIC THERAPIES TO STIMULATE AND REGENERATE BONES, TENDONS, CARTILAGE AND LIGAMENTS (U.S. CLS. 6, 18, 44, 46, 51 AND 52).

JULIE WATSON, EXAMINING ATTORNEY

SN 85-362,678. GRANATSTEIN, CAROL-ANN, TORONTO, ONTARIO, CANADA, FILED 7-4-2011.

AROMACENTRIC

THE MARK CONSISTS OF STANDARD CHARACTERS WITHOUT CLAIM TO ANY PARTICULAR FONT, STYLE, SIZE, OR COLOR.

FOR PREPARATIONS, CREAMS, LOTIONS AND SPRAYS FOR IMPROVING AND MAINTAINING HEALTH FOR ACHIEVING THE HEALTH GOAL OF RELIEVING STRESS AND INCREASING VITALITY (U.S. CLS. 6, 18, 44, 46, 51 AND 52).

JAMES GRIFFIN, EXAMINING ATTORNEY

CLASS 5—(Continued).

SN 85-382,190. NUVITAE, INC., JACKSONVILLE, FL. FILED 7-27-2011.

FULL CORE

THE MARK CONSISTS OF STANDARD CHARACTERS WITHOUT CLAIM TO ANY PARTICULAR FONT, STYLE, SIZE, OR COLOR.

FOR DIETARY SUPPLEMENT BEVERAGE FOR APETITE CONTROL; DIETARY SUPPLEMENTAL DRINKS; DIETARY SUPPLEMENTAL DRINKS IN THE NATURE OF VITAMIN AND MINERAL BEVERAGES; NUTRITIONALLY FORTIFIED BEVERAGES (U.S. CLS. 6, 18, 44, 46, 51 AND 52).

FIRST USE 9-12-2007; IN COMMERCE 9-12-2007.

LESLEY LAMOTHE, EXAMINING ATTORNEY

SN 85-383,969. MAYDAY INDUSTRIES INC., WESTMINSTER, CA. FILED 7-28-2011.

Mayday Industries

THE MARK CONSISTS OF STANDARD CHARACTERS WITHOUT CLAIM TO ANY PARTICULAR FONT, STYLE, SIZE, OR COLOR.

OWNER OF U.S. REG. NO. 3,334,783.

NO CLAIM IS MADE TO THE EXCLUSIVE RIGHT TO USE "INDUSTRIES", APART FROM THE MARK AS SHOWN.

FOR EMERGENCY AND DISASTER KITS AND PACKS COMPRISING FIRST AID KITS, WET NAPS, WATER, FOOD RATIONS, FLASHLIGHT, LIGHT STICKS, MATCHES, THERMAL BLANKETS, TARPS, PORTABLE TOILETS, TOILET PAPER, DISINFECTANTS, RADIOS, WALKIE TALKIES, WHISTLES, UTILITY KNIVES, PRY BARS, MULTI-PURPOSE POCKET TOOLS, WRENCHES, MASKS, ROPES, DISTRESS BANNERS, SAFETY VESTS, STRETCHERS, CPR MOUTHPIECES, AND TRAUMA DRESSINGS ALL SOLD AS A UNIT (U.S. CLS. 6, 18, 44, 46, 51 AND 52).

FIRST USE 1-1-1995; IN COMMERCE 1-1-1995.

SHANNON TWOHIG, EXAMINING ATTORNEY

SN 85-390,860. LIVING FUEL, INC., TAMPA, FL. FILED 8-5-2011.

Super Essentials

THE MARK CONSISTS OF STANDARD CHARACTERS WITHOUT CLAIM TO ANY PARTICULAR FONT, STYLE, SIZE, OR COLOR.

SEC. 2(F).

FOR NUTRITIONAL SUPPLEMENT (U.S. CLS. 6, 18, 44, 46, 51 AND 52).

FIRST USE 0-0-2005; IN COMMERCE 0-0-2005.

C. DIONNE CLYBURN, EXAMINING ATTORNEY

CLASS 5—(Continued).

SN 85-399,482. IVY THERAPEUTICS, INC., FORT LEE, NJ. FILED 8-16-2011.



NO CLAIM IS MADE TO THE EXCLUSIVE RIGHT TO USE "THERAPEUTICS", APART FROM THE MARK AS SHOWN.

THE MARK CONSISTS OF THE WORD "THERAPEUTICS" WRITTEN UNDERNEATH THE WORD "IVY"; THE DOT OF THE "I" IN "IVY" CONTAINS WHITE GRADUATION LINES.

FOR HOUSEMARK FOR A FULL LINE OF PHARMACEUTICAL PREPARATIONS EXCLUDING HOMEOPATHIC PHARMACEUTICALS FOR USE IN THE TREATMENT AND PREVENTION OF POISON IVY, OAK, AND SUMAC (U.S. CLS. 6, 18, 44, 46, 51 AND 52). WARREN L. OLANDRIA, EXAMINING ATTORNEY

SN 85-403,783. NUTRI/SYSTEM IPHC, INC., WILMINGTON, DE. FILED 8-22-2011.

REAL BALANCED NUTRITION

THE MARK CONSISTS OF STANDARD CHARACTERS WITHOUT CLAIM TO ANY PARTICULAR FONT, STYLE, SIZE, OR COLOR.

NO CLAIM IS MADE TO THE EXCLUSIVE RIGHT TO USE "BALANCED NUTRITION", APART FROM THE MARK AS SHOWN.

FOR MEAL REPLACEMENT SHAKES; MEAL REPLACEMENT AND DIETARY SUPPLEMENT DRINK MIXES; MEAL REPLACEMENT BARS; MEAL REPLACEMENT DRINKS; MEAL REPLACEMENT POWDERS; MEAL REPLACEMENT SNACKS; DIETARY AND NUTRITIONAL SUPPLEMENTS; DIETARY DRINK MIX FOR USE AS A MEAL REPLACEMENT; DIETARY SUPPLEMENTAL DRINKS; ENERGY BOOSTING BARS FOR USE AS A MEAL SUBSTITUTE; FOOD SUPPLEMENTS; LIQUID NUTRITIONAL SUPPLEMENTS; MINERAL SUPPLEMENTS; MULTI-VITAMIN PREPARATIONS; NUTRACEUTICALS FOR USE AS A DIETARY SUPPLEMENT (U.S. CLS. 6, 18, 44, 46, 51 AND 52).

CHARLOTTE CORWIN, EXAMINING ATTORNEY

CLASS 5—(Continued).

SN 85-403,858. NUTRI/SYSTEM IPHC, INC., WILMINGTON, DC. FILED 8-22-2011.

NUTRISYSTEM EVERYDAY

THE MARK CONSISTS OF STANDARD CHARACTERS WITHOUT CLAIM TO ANY PARTICULAR FONT, STYLE, SIZE, OR COLOR.

OWNER OF U.S. REG. NOS. 1,297,847, 2,945,918 AND OTHERS.

FOR MEAL REPLACEMENT SHAKES; MEAL REPLACEMENT AND DIETARY SUPPLEMENT DRINK MIXES; MEAL REPLACEMENT BARS; MEAL REPLACEMENT DRINKS; MEAL REPLACEMENT POWDERS; MEAL REPLACEMENT SNACKS; DIETARY AND NUTRITIONAL SUPPLEMENTS; DIETARY DRINK MIX FOR USE AS A MEAL REPLACEMENT; DIETARY SUPPLEMENTAL DRINKS; ENERGY BOOSTING BARS FOR USE AS A MEAL SUBSTITUTE; FOOD SUPPLEMENTS; LIQUID NUTRITIONAL SUPPLEMENTS; MINERAL SUPPLEMENTS; MULTI VITAMIN PREPARATIONS; NUTRACEUTICALS FOR USE AS A DIETARY SUPPLEMENT (U.S. CLS. 6, 18, 44, 46, 51 AND 52).

CHARLOTTE CORWIN, EXAMINING ATTORNEY

SN 85-409,964. RESEARCH SPORTS NUTRITION, LLC, TEMPE, AZ. FILED 8-29-2011.

Ultra Reps

THE MARK CONSISTS OF STANDARD CHARACTERS WITHOUT CLAIM TO ANY PARTICULAR FONT, STYLE, SIZE, OR COLOR.

NO CLAIM IS MADE TO THE EXCLUSIVE RIGHT TO USE "REPS", APART FROM THE MARK AS SHOWN.

FOR DIETARY AND NUTRITIONAL SUPPLEMENTS (U.S. CLS. 6, 18, 44, 46, 51 AND 52).

FIRST USE 8-22-2011; IN COMMERCE 8-22-2011.

ALICIA COLLINS, EXAMINING ATTORNEY

SN 85-416,656. HEB GROCERY COMPANY LP, SAN ANTONIO, TX. FILED 9-7-2011.



OWNER OF U.S. REG. NOS. 3,177,895, 3,326,770 AND OTHERS.

THE MARK CONSISTS OF "H E BUDDY" WITH SMALL INCONSPICUOUS CIRCLES AFTER THE "H" AND "E".

FOR NUTRITIONAL FORTIFIED BEVERAGES (U.S. CLS. 6, 18, 44, 46, 51 AND 52).

FIRST USE 1-0-2006; IN COMMERCE 1-0-2006.

MARILYN IZZI, EXAMINING ATTORNEY

CLASS 5—(Continued).

SN 85-421,073. GLAXO GROUP LIMITED, GREENFORD, MIDDLESEX, UNITED KINGDOM, FILED 9-13-2011.

ALUCEED

THE MARK CONSISTS OF STANDARD CHARACTERS WITHOUT CLAIM TO ANY PARTICULAR FONT, STYLE, SIZE, OR COLOR.

FOR PHARMACEUTICAL PREPARATIONS AND SUBSTANCES FOR THE TREATMENT OF DAMAGED SKIN AND TISSUE; PHARMACEUTICAL PREPARATIONS AND SUBSTANCES FOR THE TREATMENT OF INFECTIOUS DISEASES, BLOOD DISORDERS, PAIN, INFLAMMATION, SEPSIS, ALOPECIA, OBESITY AND COGNITIVE DISORDERS; PHARMACEUTICAL PREPARATIONS AND SUBSTANCES FOR THE TREATMENT OF VIRAL, METABOLIC, ENDOCRINE, MUSCULOSKELETAL, CARDIOVASCULAR, CARDIO-PULMONARY, GENITOURINARY, SEXUAL DYSFUNCTION, ONCOLOGICAL, HEPATOLOGICAL, OPHTHALMIC, RESPIRATORY, NEUROLOGICAL, GASTROINTESTINAL, HORMONAL, DERMATOLOGICAL, PSYCHIATRIC AND IMMUNE SYSTEM RELATED DISEASES AND DISORDERS; VACCINES (U.S. CLS. 6, 18, 44, 46, 51 AND 52).

MARK T. MULLEN, EXAMINING ATTORNEY

SN 85-424,305. ENDOMAGNETICS LIMITED, CAMBRIDGE, UNITED KINGDOM, FILED 9-16-2011.

SIENNA

THE MARK CONSISTS OF STANDARD CHARACTERS WITHOUT CLAIM TO ANY PARTICULAR FONT, STYLE, SIZE, OR COLOR.

PRIORITY CLAIMED UNDER SEC. 44(D) ON ERPN CMNTY TM OFC APPLICATION NO. 10258853, FILED 9-12-2011, REG. NO. 10258853, DATED 2-15-2012, EXPIRES 9-12-2021.

FOR INJECTABLE MAGNETIC PREPARATIONS FOR USE IN CANCER STAGING OR SCREENING; INJECTABLE MAGNETIC PREPARATIONS FOR USE IN MEDICAL DIAGNOSIS (U.S. CLS. 6, 18, 44, 46, 51 AND 52).

TINA L. SNAPP, EXAMINING ATTORNEY

CLASS 5—(Continued).

SN 85-426,004. SCHWABE NORTH AMERICA, INC., GREEN BAY, WI. FILED 9-19-2011.



OWNER OF U.S. REG. NOS. 3,864,939 AND 4,001,400. NO CLAIM IS MADE TO THE EXCLUSIVE RIGHT TO USE "PROBIOTIC", APART FROM THE MARK AS SHOWN. THE MARK CONSISTS OF A SPHERE SHAPED PEARL DESIGN WITH THE WORDS "PROBIOTIC PEARLS" DIRECTLY BELOW THE SPHERE DESIGN.

FOR DIETARY AND NUTRITIONAL SUPPLEMENTS CONTAINING PROBIOTICS (U.S. CLS. 6, 18, 44, 46, 51 AND 52).

JASON BLAIR, EXAMINING ATTORNEY

SN 85-427,983. ALTO PHARMACEUTICALS, INC., TAMPA, FL. FILED 9-21-2011.

ALTO PHARMACEUTICALS, INC.

THE MARK CONSISTS OF STANDARD CHARACTERS WITHOUT CLAIM TO ANY PARTICULAR FONT, STYLE, SIZE, OR COLOR.

NO CLAIM IS MADE TO THE EXCLUSIVE RIGHT TO USE "PHARMACEUTICALS, INC.", APART FROM THE MARK AS SHOWN.

FOR DIETARY AND NUTRITIONAL SUPPLEMENTS; NUTRITIONAL SUPPLEMENTS; NUTRITIONAL SUPPLEMENTS IN THE FORM OF CAPSULES; VITAMIN SUPPLEMENTS; VITAMIN TABLETS; VITAMINS (U.S. CLS. 6, 18, 44, 46, 51 AND 52).

FIRST USE 10-9-1968; IN COMMERCE 10-9-1968.

TASHIA BUNCH, EXAMINING ATTORNEY

SN 85-430,433. DANILO CASADEI MASSARI, 35100 PADOVA, ITALY, FILED 9-23-2011.

PRIMARY MEDICINES

THE MARK CONSISTS OF STANDARD CHARACTERS WITHOUT CLAIM TO ANY PARTICULAR FONT, STYLE, SIZE, OR COLOR.

OWNER OF ERPN CMNTY TM OFC REG. NO. 009533274, DATED 9-15-2011, EXPIRES 11-18-2020.

NO CLAIM IS MADE TO THE EXCLUSIVE RIGHT TO USE "MEDICINES", APART FROM THE MARK AS SHOWN.

FOR SANITARY PREPARATIONS FOR MEDICAL PURPOSES; BABY FOOD; MEDICAL PLASTERS, MEDICAL DRESSINGS; MATERIAL FOR STOPPING TEETH, DENTAL WAX; DISINFECTANTS FOR HYGIENE PURPOSES, ALL PURPOSE DISINFECTANTS; PREPARATIONS FOR DESTROYING VERMIN; FUNGICIDES, HERBICIDES (U.S. CLS. 6, 18, 44, 46, 51 AND 52).

MICHAEL KEATING, EXAMINING ATTORNEY

CLASS 5—(Continued).

SN 85-445,003. HAUS BIOCEUTICALS, INC., OKLAHOMA CITY, OK. FILED 10-12-2011.

Metaderm

THE MARK CONSISTS OF STANDARD CHARACTERS WITHOUT CLAIM TO ANY PARTICULAR FONT, STYLE, SIZE, OR COLOR.

FOR MULTIPURPOSE TOPICAL PHARMACEUTICAL PREPARATIONS FOR THE PREVENTION AND TREATMENT OF INFLAMMATORY SKIN DISEASES, NAMELY, TOPICAL MEDICATED SPRAY FOR THE TREATMENT OF ECZEMA (U.S. CLS. 6, 18, 44, 46, 51 AND 52).

AHSEN KHAN, EXAMINING ATTORNEY

SN 85-448,284. MEGA WAY, LLC, SANTA FE, NM. FILED 10-15-2011.

MEGA WAY SHAKES

THE MARK CONSISTS OF STANDARD CHARACTERS WITHOUT CLAIM TO ANY PARTICULAR FONT, STYLE, SIZE, OR COLOR.

NO CLAIM IS MADE TO THE EXCLUSIVE RIGHT TO USE "SHAKES", APART FROM THE MARK AS SHOWN.

FOR PROTEIN SUPPLEMENTS (U.S. CLS. 6, 18, 44, 46, 51 AND 52).

NAAKWAMA ANKRAH, EXAMINING ATTORNEY

CLASS 5—(Continued).

SN 85-450,756. KEMP, LEE, PALATINE, IL. FILED 10-19-2011.



THE NAME(S), PORTRAIT(S), AND/OR SIGNATURE(S) SHOWN IN THE MARK IDENTIFIES "LEE KEMP", WHOSE CONSENT(S) TO REGISTER IS MADE OF RECORD.

THE MARK CONSISTS OF "FORZA BY LEE KEMP" WITH A DESIGN CONSISTING OF TWO CIRCLES DIVIDED BY A LINE, APPEARING TO THE LEFT OF THE WORD "FORZA". ALL THE FOREMENTIONED APPEARS WITHIN A RECTANGULAR DESIGN.

THE ENGLISH TRANSLATION OF "FORZA" IN THE MARK IS "FORCE".

FOR DIETARY AND NUTRITIONAL SUPPLEMENTS; DIETARY AND NUTRITIONAL SUPPLEMENTS FOR ENDURANCE SPORTS; DIETARY AND NUTRITIONAL SUPPLEMENTS USED FOR WEIGHT LOSS; LIQUID NUTRITIONAL SUPPLEMENT; NUTRITIONAL AND DIETARY SUPPLEMENTS FORMED AND PACKAGED AS BARS; NUTRITIONAL DRINK MIX FOR USE AS A MEAL REPLACEMENT; NUTRITIONAL DRINKS USED FOR MEAL REPLACEMENT; NUTRITIONAL ENERGY BARS FOR USE AS A MEAL SUBSTITUTE; NUTRITIONAL FOOD BARS FOR USE AS A MEAL REPLACEMENT; NUTRITIONAL SHAKES FOR USE AS A MEAL SUBSTITUTE; NUTRITIONAL SUPPLEMENTS (U.S. CLS. 6, 18, 44, 46, 51 AND 52).

DAVID COLLIER, EXAMINING ATTORNEY

SN 85-459,251. FF AWAY, LLC, NORTH BABYLON, NY. FILED 10-28-2011.

FRUIT FLY BAR PRO

THE MARK CONSISTS OF STANDARD CHARACTERS WITHOUT CLAIM TO ANY PARTICULAR FONT, STYLE, SIZE, OR COLOR.

NO CLAIM IS MADE TO THE EXCLUSIVE RIGHT TO USE "FRUIT FLY", APART FROM THE MARK AS SHOWN. FOR INSECTICIDE FOR DOMESTIC AND COMMERCIAL USE (U.S. CLS. 6, 18, 44, 46, 51 AND 52).

FIRST USE 10-13-2011; IN COMMERCE 10-13-2011. HEATHER BIDDULPH, EXAMINING ATTORNEY

CLASS 5—(Continued).

SN 85-459,997. THE PROCTER & GAMBLE COMPANY, CINCINNATI, OH. FILED 10-31-2011.

METAMUCIL MULTHEALTH FIBER

THE MARK CONSISTS OF STANDARD CHARACTERS WITHOUT CLAIM TO ANY PARTICULAR FONT, STYLE, SIZE, OR COLOR.

OWNER OF U.S. REG. NOS. 3,094,217, 3,874,786 AND OTHERS.

NO CLAIM IS MADE TO THE EXCLUSIVE RIGHT TO USE "FIBER", APART FROM THE MARK AS SHOWN.

FOR DIETARY SUPPLEMENTS CONTAINING FIBERS (U.S. CLS. 6, 18, 44, 46, 51 AND 52).

FIRST USE 8-2-2010; IN COMMERCE 8-2-2010. ZACHARY BELLO, EXAMINING ATTORNEY

SN 85-464,594. MEDIX HEALTH LLC, WEST PALM BEACH, FL. FILED 11-4-2011.

Glucose Reduce

THE MARK CONSISTS OF STANDARD CHARACTERS WITHOUT CLAIM TO ANY PARTICULAR FONT, STYLE, SIZE, OR COLOR.

NO CLAIM IS MADE TO THE EXCLUSIVE RIGHT TO USE "GLUCOSE", APART FROM THE MARK AS SHOWN.

FOR DIETARY SUPPLEMENT; DIETARY SUPPLEMENT FOR HELPING TO MAINTAIN HEALTHY BLOOD GLUCOSE LEVELS (U.S. CLS. 6, 18, 44, 46, 51 AND 52).

FIRST USE 8-24-2011; IN COMMERCE 8-24-2011. AMY KELLY, EXAMINING ATTORNEY

SN 85-465,720. EMCYTE CORP., FORT MYERS, FL. FILED 11-7-2011.

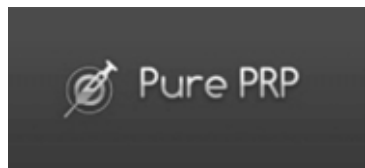

NO CLAIM IS MADE TO THE EXCLUSIVE RIGHT TO USE "PURE PRP", APART FROM THE MARK AS SHOWN.

THE MARK CONSISTS OF THE WORDING "PURE PRP" LOCATED TO THE RIGHT OF THE IMAGE OF A PARTIALLY FILLED SYRINGE PLACED IN THE MIDDLE OF A BULLSEYE DESIGN; THE WORDING AND DESIGN ELEMENTS ARE LOCATED IN THE CENTER OF A RECTANGULAR DESIGN.

FOR THERAPEUTIC AND REGENERATIVE PRODUCTS, NAMELY, BLOOD COMPONENTS IN THE NATURE OF PLATELET RICH PLASMA AND PLATELETS; BLOOD COMPONENTS, NAMELY, PLATELET RICH PLASMA AND STEM CELLS FOR MEDICAL USE (U.S. CLS. 6, 18, 44, 46, 51 AND 52).

KIMBERLY FRYE, EXAMINING ATTORNEY

CLASS 5—(Continued).

SN 85-469,663. TRU RX LLC, EAGLE, ID. FILED 11-10-2011.

VET GUARD

THE MARK CONSISTS OF STANDARD CHARACTERS WITHOUT CLAIM TO ANY PARTICULAR FONT, STYLE, SIZE, OR COLOR.

NO CLAIM IS MADE TO THE EXCLUSIVE RIGHT TO USE "VET", APART FROM THE MARK AS SHOWN.

FOR PREPARATIONS TO TREAT OR PREVENT FLEAS AND TICKS ON PETS (U.S. CLS. 6, 18, 44, 46, 51 AND 52).

TASNEEM HUSSAIN, EXAMINING ATTORNEY

SN 85-469,785. TRU RX LLC, EAGLE, ID. FILED 11-10-2011.

VET GUARD PLUS

THE MARK CONSISTS OF STANDARD CHARACTERS WITHOUT CLAIM TO ANY PARTICULAR FONT, STYLE, SIZE, OR COLOR.

NO CLAIM IS MADE TO THE EXCLUSIVE RIGHT TO USE "VET", APART FROM THE MARK AS SHOWN.

FOR PREPARATIONS TO TREAT OR PREVENT FLEAS AND TICKS, AND THE EGGS OF THESE INSECTS, ON PETS (U.S. CLS. 6, 18, 44, 46, 51 AND 52).

TASNEEM HUSSAIN, EXAMINING ATTORNEY

SN 85-480,124. STEMTECH INTERNATIONAL, INC., SAN CLEMENTE, CA. FILED 11-23-2011.



THE COLOR(S) BLACK AND PURPLE (PANTONE COLOR CODE 2587) IS/ARE CLAIMED AS A FEATURE OF THE MARK.

THE MARK CONSISTS OF FULL SIZED AND CAPITALIZED ENGLISH LETTERS "SE" IN BLACK AND BLOCK STYLE PRINT FOLLOWED BY A HALF SIZED AND FLYING NUMERAL "2" IN PURPLE (PANTONE COLOR CODE 2587) AND CURSIVE STYLE PRINT THAT IS IN REGISTER WITH THE UPPER TWO PRONGS OF THE LETTER "E".

FOR DIETARY AND NUTRITIONAL SUPPLEMENTS FOR THE PURPOSE OF SUPPORTING THE RELEASE OF ADULT STEM CELLS (U.S. CLS. 6, 18, 44, 46, 51 AND 52).

FIRST USE 11-21-2011; IN COMMERCE 11-21-2011. LINDA MICKLEBURGH, EXAMINING ATTORNEY

CLASS 5—(Continued).

SN 85-480,138. ANDREW LOREN KLAMER, LOS ANGELES, CA. FILED 11-23-2011.

METROPOLITAN

THE MARK CONSISTS OF STANDARD CHARACTERS WITHOUT CLAIM TO ANY PARTICULAR FONT, STYLE, SIZE, OR COLOR.

FOR SANITIZING PREPARATIONS, NAMELY, HAND SANITIZERS HAVING ANTI-MICROBIAL AND ANTI-BACTERIAL PROPERTIES; GERMICIDES (U.S. CLS. 6, 18, 44, 46, 51 AND 52).

SHAILA SETTLES, EXAMINING ATTORNEY

SN 85-480,615. JACOBSON, CORINNE, TUSTIN, CA. FILED 11-23-2011.

CALCI-LITE

THE MARK CONSISTS OF STANDARD CHARACTERS WITHOUT CLAIM TO ANY PARTICULAR FONT, STYLE, SIZE, OR COLOR.

FOR CALCIUM SUPPLEMENTS; DIETARY AND NUTRITIONAL SUPPLEMENTS; DIETARY SUPPLEMENTAL DRINKS; DIETARY SUPPLEMENTAL DRINKS IN THE NATURE OF VITAMIN AND MINERAL BEVERAGES; DIETARY SUPPLEMENTS; DIETARY SUPPLEMENTS FOR HUMAN CONSUMPTION; FOOD SUPPLEMENTS; HEALTH FOOD SUPPLEMENTS; LIQUID VITAMIN SUPPLEMENTS (U.S. CLS. 6, 18, 44, 46, 51 AND 52).

FIRST USE 11-21-2011; IN COMMERCE 11-21-2011.
HEATHER BIDDULPH, EXAMINING ATTORNEY

SN 85-481,331. A. NATTERMANN & CIE. GMBH, KÖLN, FED REP GERMANY, FILED 11-28-2011.

Ferrlecit
*sodium ferric gluconate
complex in sucrose injection*

OWNER OF U.S. REG. NOS. 2,408,958, 4,088,357 AND 4,091,467.

NO CLAIM IS MADE TO THE EXCLUSIVE RIGHT TO USE "SODIUM FERRIC GLUCONATE COMPLEX IN SUCROSE INJECTION", APART FROM THE MARK AS SHOWN.

THE MARK CONSISTS OF THE LITERAL ELEMENT "FERRLECIT" UNDER WHICH THE LITERAL ELEMENT "SODIUM FERRIC GLUCONATE COMPLEX IN SUCROSE INJECTION" APPEARS, ON TWO LINES.

FOR PHARMACEUTICAL PREPARATIONS CONTAINING SODIUM FERRIC GLUCONATE COMPLEX IN A SUCROSE INJECTION FOR THE TREATMENT OF IRON DEFICIENCY (U.S. CLS. 6, 18, 44, 46, 51 AND 52).

FIRST USE 6-0-1999; IN COMMERCE 6-0-1999.
KATHLEEN M. VANSTON, EXAMINING ATTORNEY

CLASS 5—(Continued).

SN 85-481,728. IPSEN SA, BOULOGNE BILLANCOURT, FRANCE, FILED 11-28-2011.

**IPSEN INNOVATION FOR
PATIENT CARE**

THE MARK CONSISTS OF STANDARD CHARACTERS WITHOUT CLAIM TO ANY PARTICULAR FONT, STYLE, SIZE, OR COLOR.

OWNER OF U.S. REG. NOS. 3,055,541, 3,095,774 AND 3,868,710.

NO CLAIM IS MADE TO THE EXCLUSIVE RIGHT TO USE "PATIENT CARE", APART FROM THE MARK AS SHOWN.

FOR PHARMACEUTICAL PREPARATIONS FOR THE TREATMENT OF ONCOLOGY, ENDOCRINOLOGY, NEUROLOGY, HEMATOLOGY, GASTROENTEROLOGY, CARDIOVASCULAR AND COGNITIVE DISORDERS (U.S. CLS. 6, 18, 44, 46, 51 AND 52).

LINDA ESTRADA, EXAMINING ATTORNEY

SN 85-483,524. INTERCON CHEMICAL COMPANY, ST. LOUIS, MO. FILED 11-30-2011.

BIOSTAT

THE MARK CONSISTS OF STANDARD CHARACTERS WITHOUT CLAIM TO ANY PARTICULAR FONT, STYLE, SIZE, OR COLOR.

FOR AIR SANITIZING PREPARATION (U.S. CLS. 6, 18, 44, 46, 51 AND 52).

SCOTT BIBB, EXAMINING ATTORNEY

SN 85-484,824. B POSITIVE NATIONAL BLOOD SERVICES, INC., CHERRY HILL, NJ. FILED 12-1-2011.

**B POSITIVE NATIONAL BLOOD
SERVICES**

THE MARK CONSISTS OF STANDARD CHARACTERS WITHOUT CLAIM TO ANY PARTICULAR FONT, STYLE, SIZE, OR COLOR.

NO CLAIM IS MADE TO THE EXCLUSIVE RIGHT TO USE "NATIONAL BLOOD SERVICES", APART FROM THE MARK AS SHOWN.

FOR BLOOD PLASMA (U.S. CLS. 6, 18, 44, 46, 51 AND 52).

JEFFERY COWARD, EXAMINING ATTORNEY

CLASS 5—(Continued).

SN 85-485,454. ALTATHERA PHARMACEUTICALS LLC, CHICAGO, IL. FILED 12-1-2011.

ALTATHERA

THE MARK CONSISTS OF STANDARD CHARACTERS WITHOUT CLAIM TO ANY PARTICULAR FONT, STYLE, SIZE, OR COLOR.

FOR PHARMACEUTICAL PREPARATIONS FOR HUMAN AND ANIMAL USE FOR TREATING CARDIOVASCULAR, NEUROLOGICAL, GASTROINTESTINAL, AND IMMUNE SYSTEM RELATED DISORDERS (U.S. CLS. 6, 18, 44, 46, 51 AND 52).

LIEF MARTIN, EXAMINING ATTORNEY

CLASS 5—(Continued).

SN 85-489,006. AUTO EXPRESSIONS, LLC, COMPTON, CA. FILED 12-7-2011.



OWNER OF U.S. REG. NO. 3,948,233.

NO CLAIM IS MADE TO THE EXCLUSIVE RIGHT TO USE "SCENTS", APART FROM THE MARK AS SHOWN.

THE MARK CONSISTS OF THE WORD "SCENTS" WITH A PAIR OF WAVES ABOVE THE WORD.

FOR AIR FRESHENERS (U.S. CLS. 6, 18, 44, 46, 51 AND 52).

ANN E. SAPPENFIELD, EXAMINING ATTORNEY

SN 85-487,353. WDC, LLC, CRYSTAL LAKE, IL. FILED 12-5-2011.

CARTILAGE CAULK

THE MARK CONSISTS OF STANDARD CHARACTERS WITHOUT CLAIM TO ANY PARTICULAR FONT, STYLE, SIZE, OR COLOR.

NO CLAIM IS MADE TO THE EXCLUSIVE RIGHT TO USE "CARTILAGE", APART FROM THE MARK AS SHOWN.

FOR NUTRITIONAL SUPPLEMENTS (U.S. CLS. 6, 18, 44, 46, 51 AND 52).

GINA FINK, EXAMINING ATTORNEY

SN 85-490,600. NATIVO HEALTH SCIENCES, INC., FORT COLLINS, CO. FILED 12-8-2011.

NATIVO

THE MARK CONSISTS OF STANDARD CHARACTERS WITHOUT CLAIM TO ANY PARTICULAR FONT, STYLE, SIZE, OR COLOR.

THE ENGLISH TRANSLATION OF "NATIVO" IN THE MARK IS "NATIVE".

FOR ALL-NATURAL NUTRITIONAL FOOD SUPPLEMENTS FOR DOGS (U.S. CLS. 6, 18, 44, 46, 51 AND 52).

WANDA KAY PRICE, EXAMINING ATTORNEY

SN 85-487,727. FACT PRODUCTS INC., HOLLADAY, UT. FILED 12-6-2011.

RELOAD

THE MARK CONSISTS OF STANDARD CHARACTERS WITHOUT CLAIM TO ANY PARTICULAR FONT, STYLE, SIZE, OR COLOR.

FOR NUTRITIONAL SUPPLEMENT, MULTIVITAMINS, MULTI-MINERAL SUPPLEMENTS AND ANTIOXIDANT SUPPLEMENTS FOR MEN AND WOMEN (U.S. CLS. 6, 18, 44, 46, 51 AND 52).

JENNIFER VASQUEZ, EXAMINING ATTORNEY

SN 85-491,112. MACHIN MARKETING INC., MANHATTAN BEACH, CA. FILED 12-8-2011.



NO CLAIM IS MADE TO THE EXCLUSIVE RIGHT TO USE "DELIVERY STRIPS", APART FROM THE MARK AS SHOWN.

THE MARK CONSISTS OF LIGHTNING BOLTS WITH AN EDIBLE FILM STRIP IN THE CENTER OF THE BOLTS, AND THE TEXT "EVOLUTION DELIVERY STRIPS".

FOR DIETARY AND NUTRITIONAL SUPPLEMENTS (U.S. CLS. 6, 18, 44, 46, 51 AND 52).

LOURDES AYALA, EXAMINING ATTORNEY

CLASS 5—(Continued).

SN 85-491,921. QORE SYSTEMS, LLC, TEMPE, AZ. FILED 12-9-2011.

Purify Your World.

THE MARK CONSISTS OF STANDARD CHARACTERS WITHOUT CLAIM TO ANY PARTICULAR FONT, STYLE, SIZE, OR COLOR.

FOR ANTIMICROBIAL COATINGS TO TREAT THE GROWTH OF MOLD, MILDEW, BACTERIA AND FUNGUS ON VARIOUS SURFACES (U.S. CLS. 6, 18, 44, 46, 51 AND 52).

FIRST USE 12-1-2011; IN COMMERCE 12-1-2011.
ANDREW LEASER, EXAMINING ATTORNEY

SN 85-500,064. MERCK SHARP & DOHME CORP., WHITEHOUSE STATION, NJ. FILED 12-20-2011.

CESLEM

THE MARK CONSISTS OF STANDARD CHARACTERS WITHOUT CLAIM TO ANY PARTICULAR FONT, STYLE, SIZE, OR COLOR.

FOR PHARMACEUTICAL PREPARATIONS FOR THE TREATMENT OF NEUROLOGICAL DISORDERS, AND DISEASES AND DISORDERS OF THE CENTRAL NERVOUS SYSTEM (U.S. CLS. 6, 18, 44, 46, 51 AND 52).

SANJEEV VOHRA, EXAMINING ATTORNEY

SN 85-500,107. MERCK SHARP & DOHME CORP., WHITEHOUSE STATION, NJ. FILED 12-20-2011.

NYXUVA

THE MARK CONSISTS OF STANDARD CHARACTERS WITHOUT CLAIM TO ANY PARTICULAR FONT, STYLE, SIZE, OR COLOR.

FOR PHARMACEUTICAL PREPARATIONS FOR THE TREATMENT OF NEUROLOGICAL DISORDERS, AND DISEASES AND DISORDERS OF THE CENTRAL NERVOUS SYSTEM (U.S. CLS. 6, 18, 44, 46, 51 AND 52).

SANJEEV VOHRA, EXAMINING ATTORNEY

CLASS 5—(Continued).

SN 85-500,131. MERCK SHARP & DOHME CORP., WHITEHOUSE STATION, NJ. FILED 12-20-2011.

VISPLI

THE MARK CONSISTS OF STANDARD CHARACTERS WITHOUT CLAIM TO ANY PARTICULAR FONT, STYLE, SIZE, OR COLOR.

FOR PHARMACEUTICAL PREPARATIONS FOR THE TREATMENT OF NEUROLOGICAL DISORDERS, AND DISEASES AND DISORDERS OF THE CENTRAL NERVOUS SYSTEM (U.S. CLS. 6, 18, 44, 46, 51 AND 52).

SANJEEV VOHRA, EXAMINING ATTORNEY

SN 85-501,677. CAMPBELL, ROBERT, SANTA FE, NM. FILED 12-22-2011.

BRINGING HERBAL TREASURES
FROM AROUND THE WORLD

THE MARK CONSISTS OF STANDARD CHARACTERS WITHOUT CLAIM TO ANY PARTICULAR FONT, STYLE, SIZE, OR COLOR.

FOR MEDICINAL HERBS; HERBAL DIETARY AND NUTRITIONAL SUPPLEMENTS (U.S. CLS. 6, 18, 44, 46, 51 AND 52).

FIRST USE 9-1-2003; IN COMMERCE 9-1-2003.
JENNIFER VASQUEZ, EXAMINING ATTORNEY

SN 85-502,057. CHERRY CAPITAL SERVICES, INC., TRAVERSE CITY, MI. FILED 12-22-2011.

MONTMORENCY CHERRYFLEX

THE MARK CONSISTS OF STANDARD CHARACTERS WITHOUT CLAIM TO ANY PARTICULAR FONT, STYLE, SIZE, OR COLOR.

OWNER OF U.S. REG. NO. 2,936,726.

NO CLAIM IS MADE TO THE EXCLUSIVE RIGHT TO USE "MONTMORENCY", APART FROM THE MARK AS SHOWN.

FOR DIETARY SUPPLEMENTS CONTAINING CHERRIES (U.S. CLS. 6, 18, 44, 46, 51 AND 52).

FIRST USE 3-3-2003; IN COMMERCE 3-3-2003.

ELISSA GARBER KON, EXAMINING ATTORNEY

CLASS 5—(Continued).

SN 85-502,635. MADRE LABS, INC., SIERRA MADRE, CA. FILED 12-22-2011.

Zoi Research

THE MARK CONSISTS OF STANDARD CHARACTERS WITHOUT CLAIM TO ANY PARTICULAR FONT, STYLE, SIZE, OR COLOR.

NO CLAIM IS MADE TO THE EXCLUSIVE RIGHT TO USE "RESEARCH", APART FROM THE MARK AS SHOWN. FOR DIETARY FOOD SUPPLEMENTS (U.S. CLS. 6, 18, 44, 46, 51 AND 52).

THEODORE MCBRIDE, EXAMINING ATTORNEY

CLASS 5—(Continued).

SN 85-506,268. PRESCOTT VENTURES LLC, FRANKLIN, TN. FILED 12-30-2011.

Memory Defense

THE MARK CONSISTS OF STANDARD CHARACTERS WITHOUT CLAIM TO ANY PARTICULAR FONT, STYLE, SIZE, OR COLOR.

NO CLAIM IS MADE TO THE EXCLUSIVE RIGHT TO USE "MEMORY", APART FROM THE MARK AS SHOWN. FOR VITAMIN AND MINERAL SUPPLEMENTS (U.S. CLS. 6, 18, 44, 46, 51 AND 52).

FIRST USE 4-0-2010; IN COMMERCE 4-0-2010. HAI-LY LAM, EXAMINING ATTORNEY

SN 85-506,400. MAGVERZ, INC., SANTA MONICA, CA. FILED 12-30-2011.



SN 85-505,722. CABADOS, RICK, CARLSBAD, CA. FILED 12-29-2011.



OWNER OF U.S. REG. NO. 3,256,185. THE COLOR(S) GRAY, BLUE, GREEN AND WHITE IS/ARE CLAIMED AS A FEATURE OF THE MARK.

THE MARK CONSISTS OF THE WORD "HYDRACIDE" IN GRAY, BELOW A STYLIZED FLOWER WITH GREEN AND WHITE PETALS AND A BLUE AND WHITE STYLIZED WATER DROPLET AS THE FLOWER.

FOR AGRICULTURAL PESTICIDES; ANTI-INSECT SPRAY; DOMESTIC PESTICIDES; HERBICIDES, INSECTICIDES, PESTICIDES AND FUNGICIDES FOR HOME, GARDEN AND LAWN USE AND FOR PROFESSIONAL USE; INSECT EXTERMINATING AGENTS; INSECT REPELLENT AGENTS; INSECT REPELLENTS; INSECT-REPELLENTS; MOLD INHIBITOR FOR TREATING MOLD ON PLANTS, FOODS, MEDICAL EQUIPMENT, AND FOR PERSONAL HYGIENE USES; MOLD INHIBITORS FOR TREATING MOLD GROWTH IN AND AROUND BUILDINGS; PESTICIDES; PESTICIDES FOR AGRICULTURAL USE (U.S. CLS. 6, 18, 44, 46, 51 AND 52).

FIRST USE 12-1-2011; IN COMMERCE 12-20-2011. ROSELLE HERRERA, EXAMINING ATTORNEY

THE COLOR(S) GREEN AND LIGHT GREEN IS/ARE CLAIMED AS A FEATURE OF THE MARK.

THE MARK CONSISTS OF STYLIZED "V" THAT IS LIGHT GREEN AND GREEN ON THE INTERIOR WITH A LIGHT GREEN AND GREEN LEAF OVERLAID ON THE "V". TO THE RIGHT OF THE "V" IS THE WORDING "VITAVERZ", WHERE "VITA" APPEARS IN LIGHT GREEN AND "VERZ" APPEARS GREEN.

FOR DIETARY AND NUTRITIONAL SUPPLEMENTS (U.S. CLS. 6, 18, 44, 46, 51 AND 52). MARC LEIPZIG, EXAMINING ATTORNEY

SN 85-506,755. NUSPECIES CORPORATION, STORMVILLE, NY. FILED 12-31-2011.

eLNU

THE MARK CONSISTS OF STANDARD CHARACTERS WITHOUT CLAIM TO ANY PARTICULAR FONT, STYLE, SIZE, OR COLOR.

FOR DIETARY AND NUTRITIONAL SUPPLEMENTS; MINERAL NUTRITIONAL SUPPLEMENTS (U.S. CLS. 6, 18, 44, 46, 51 AND 52).

MATTHEW EINSTEIN, EXAMINING ATTORNEY

CLASS 5—(Continued).

SN 85-507,732. DE LA MONJA AVILA MARCOS, GUADAJAJARA, MEXICO, FILED 1-3-2012.



OWNER OF U.S. REG. NO. 4,027,074.
THE COLOR(S) BLUE AND LIGHT BLUE IS/ARE CLAIMED AS A FEATURE OF THE MARK.

THE MARK CONSISTS OF THE LETTERS "ENER" IN BLUE, THE WORD "PET" IN LIGHT BLUE, AND THE LETTERS "IC" IN BLUE. THE WORD IS BROKEN DOWN IN TWO LINES. THE TOP LINE CONTAINING THE LETTERS "ENER" AND THE BOTTOM LINE CONTAINING THE LETTERS "PETIC".

FOR DIETARY SUPPLEMENTS FOR ANIMALS; DIETARY SUPPLEMENTS FOR PETS; VITAMINS AND DIETARY FOOD SUPPLEMENTS FOR ANIMALS (U.S. CLS. 6, 18, 44, 46, 51 AND 52).

FIRST USE 5-1-2011; IN COMMERCE 5-1-2011.
THOMAS MANOR, EXAMINING ATTORNEY

SN 85-507,766. STUART CONSUMER PRODUCT LABS INC., NEW YORK CITY, NY. FILED 1-3-2012.



restorSLIM

THE MARK CONSISTS OF STANDARD CHARACTERS WITHOUT CLAIM TO ANY PARTICULAR FONT, STYLE, SIZE, OR COLOR.

FOR DIETARY AND NUTRITIONAL SUPPLEMENTS; DIETARY FOOD SUPPLEMENTS; FOOD SUPPLEMENTS; HERBAL SUPPLEMENTS; HOMEOPATHIC SUPPLEMENTS; MINERAL SUPPLEMENTS; NUTRITIONAL SUPPLEMENTS; VITAMIN SUPPLEMENTS (U.S. CLS. 6, 18, 44, 46, 51 AND 52).

JOHN HWANG, EXAMINING ATTORNEY

CLASS 5—(Continued).

SN 85-507,806. NEVOA LIFE SCIENCES, LLC, SCOTTSDALE, AZ. FILED 1-3-2012.

DR. EMMO'S

THE MARK CONSISTS OF STANDARD CHARACTERS WITHOUT CLAIM TO ANY PARTICULAR FONT, STYLE, SIZE, OR COLOR.

THE NAME(S), PORTRAIT(S), AND/OR SIGNATURE(S) SHOWN IN THE MARK DOES NOT IDENTIFY A PARTICULAR LIVING INDIVIDUAL.

FOR FIRST AID PRODUCTS FOR PETS, NAMELY, NATURAL, TOPICAL ANTIBACTERIAL SUBSTANCES FOR MEDICAL PURPOSES, FOR USE ON PETS; VETERINARY PHARMACEUTICAL PREPARATIONS, IN THE FORM OF CREAMS, LOTIONS, GELS, AND SPRAYS, FOR HEALING OF WOUNDS AND TREATING SKIN AND EAR DISORDERS (U.S. CLS. 6, 18, 44, 46, 51 AND 52).

FIRST USE 7-1-2011; IN COMMERCE 9-19-2011.
MICHAEL GAFFAR, EXAMINING ATTORNEY

SN 85-507,813. NEVOA LIFE SCIENCES, LLC, SCOTTSDALE, AZ. FILED 1-3-2012.



NO CLAIM IS MADE TO THE EXCLUSIVE RIGHT TO USE "SAFE FOR ALL PETS", APART FROM THE MARK AS SHOWN.

THE MARK CONSISTS OF A CIRCLE WITH A SERATED EDGE CONTAINING THE FACE OF A DOG IN THE CENTER WITH THE WORDS "SAFE FOR ALL PETS" UNDERNEATH THE FACE.

FOR FIRST AID PRODUCTS FOR PETS, NAMELY, NATURAL, TOPICAL ANTIBACTERIAL SUBSTANCES FOR MEDICAL PURPOSES, FOR USE ON PETS, WHICH PRODUCTS ARE SAFE FOR USE BY ALL TYPES OF PETS; VETERINARY PHARMACEUTICAL PREPARATIONS, IN THE FORM OF CREAMS, LOTIONS, GELS, AND SPRAYS, FOR HEALING OF WOUNDS AND TREATING SKIN AND EAR DISORDERS, WHICH PREPARATIONS ARE SAFE FOR USE BY ALL TYPES OF PETS (U.S. CLS. 6, 18, 44, 46, 51 AND 52).

FIRST USE 7-1-2011; IN COMMERCE 9-19-2011.
MICHAEL GAFFAR, EXAMINING ATTORNEY

CLASS 5—(Continued).

SN 85-508,927. VENTRIA BIOSCIENCE, FORT COLLINS, CO. FILED 1-4-2012.



THE MARK CONSISTS OF THE WORD "OPTIBUMIN" UNDER A TAPERING ARC WHOSE WIDER END BEGINS AT THE TOP RIGHT OF THE LETTER "O".

FOR RECOMBINANT ALBUMIN FOR USE AS A BIOLOGICAL THERAPEUTIC AND AS AN EXCIPIENT IN PHARMACEUTICAL PREPARATIONS, CELLULAR THERAPIES, GENE THERAPIES AND VACCINES AS WELL AS A REAGENT USED FOR IN VITRO FERTILIZATION, MEDICAL DEVICES, TISSUE SEALANTS, TISSUE AND CELL CRYOPRESERVATION, BLOOD DETOXIFICATION AND BIOMEDICAL RESEARCH AND DEVELOPMENT (U.S. CLS. 6, 18, 44, 46, 51 AND 52).

DAVID MURRAY, EXAMINING ATTORNEY

SN 85-508,931. VENTRIA BIOSCIENCE, FORT COLLINS, CO. FILED 1-4-2012.

OPTIBUMIN

THE MARK CONSISTS OF STANDARD CHARACTERS WITHOUT CLAIM TO ANY PARTICULAR FONT, STYLE, SIZE, OR COLOR.

FOR RECOMBINANT ALBUMIN FOR USE AS A BIOLOGICAL THERAPEUTIC AND AS AN EXCIPIENT IN PHARMACEUTICAL PREPARATIONS, CELLULAR THERAPIES, GENE THERAPIES AND VACCINES AS WELL AS A REAGENT USED FOR IN VITRO FERTILIZATION, MEDICAL DEVICES, TISSUE SEALANTS, TISSUE AND CELL CRYOPRESERVATION, BLOOD DETOXIFICATION AND BIOMEDICAL RESEARCH AND DEVELOPMENT (U.S. CLS. 6, 18, 44, 46, 51 AND 52).

DAVID MURRAY, EXAMINING ATTORNEY

SN 85-509,200. GENERAL MEDIA COMMUNICATIONS, INC., BOCA RATON, FL. FILED 1-5-2012.

PENTHOUSE

THE MARK CONSISTS OF STANDARD CHARACTERS WITHOUT CLAIM TO ANY PARTICULAR FONT, STYLE, SIZE, OR COLOR.

OWNER OF U.S. REG. NOS. 3,548,339, 3,779,465 AND OTHERS.

FOR NUTRITIONAL SUPPLEMENTS (U.S. CLS. 6, 18, 44, 46, 51 AND 52).

FIRST USE 8-0-2011; IN COMMERCE 8-0-2011.

KATHLEEN M. VANSTON, EXAMINING ATTORNEY

CLASS 5—(Continued).

SN 85-509,532. AGRI LABORATORIES, LTD., ST. JOSEPH, MO. FILED 1-5-2012.

Medallion

THE MARK CONSISTS OF STANDARD CHARACTERS WITHOUT CLAIM TO ANY PARTICULAR FONT, STYLE, SIZE, OR COLOR.

FOR VACCINES FOR CATTLE (U.S. CLS. 6, 18, 44, 46, 51 AND 52).

DOMINICK J. SALEMI, EXAMINING ATTORNEY

SN 85-509,599. MCGUFF PHARMACEUTICALS, INC., SANTA ANA, CA. FILED 1-5-2012.

DELALUTIN

THE MARK CONSISTS OF STANDARD CHARACTERS WITHOUT CLAIM TO ANY PARTICULAR FONT, STYLE, SIZE, OR COLOR.

FOR PHARMACEUTICAL PREPARATIONS, NAMELY, PROGESTERONE PREPARATIONS (U.S. CLS. 6, 18, 44, 46, 51 AND 52).

SANJEEV VOHRA, EXAMINING ATTORNEY

SN 85-509,836. OTSUKA PHARMACEUTICAL CO., LTD., TOKYO, JAPAN, FILED 1-5-2012.

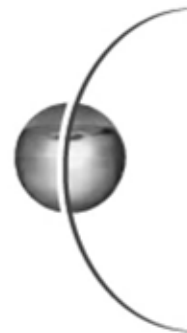

PRIORITY CLAIMED UNDER SEC. 44(D) ON JAPAN APPLICATION NO. 2011-068517. FILED 9-26-2011, REG. NO. 5482177, DATED 3-30-2012, EXPIRES 3-30-2022.

THE MARK CONSISTS OF A SPHERE WITH AN INTERSECTING ARC OR SEMI-CIRCLE DESIGN.

FOR PHARMACEUTICAL PREPARATIONS FOR THE TREATMENT OF EYE DISEASES AND CONDITIONS (U.S. CLS. 6, 18, 44, 46, 51 AND 52).

KEVON CHISOLM, EXAMINING ATTORNEY

CLASS 5—(Continued).

SN 85-509,869. DC COMICS, NEW YORK, NY. FILED 1-5-2012.



OWNER OF U.S. REG. NO. 2,051,606.
NO CLAIM IS MADE TO THE EXCLUSIVE RIGHT TO USE "COMICS", APART FROM THE MARK AS SHOWN.
THE MARK CONSISTS OF THE LETTER "D" FLIPPING BACK TO REVEAL THE LETTER "C" AND "DC COMICS", FOR PHARMACEUTICALS, NAMELY, VITAMINS AND MINERAL SUPPLEMENTS; ADHESIVE BANDAGES (U.S. CLS. 6, 18, 44, 46, 51 AND 52).
PAUL MORENO, EXAMINING ATTORNEY

SN 85-509,875. BENEBIOS, GARDEN GROVE, CA. FILED 1-5-2012.

BioFed

THE MARK CONSISTS OF STANDARD CHARACTERS WITHOUT CLAIM TO ANY PARTICULAR FONT, STYLE, SIZE, OR COLOR.
FOR PROBIOTIC ANIMAL FEED (U.S. CLS. 6, 18, 44, 46, 51 AND 52).
FIRST USE 12-21-2011; IN COMMERCE 12-21-2011.
REBECCA GILBERT, EXAMINING ATTORNEY

SN 85-509,886. SIX MONTH SMILES, INC., SCOTTSVILLE, NY. FILED 1-5-2012.

ORTHOMAX

THE MARK CONSISTS OF STANDARD CHARACTERS WITHOUT CLAIM TO ANY PARTICULAR FONT, STYLE, SIZE, OR COLOR.
FOR DENTAL CEMENT (U.S. CLS. 6, 18, 44, 46, 51 AND 52).
FIRST USE 5-30-2011; IN COMMERCE 5-30-2011.
JAMES A. RAUEN, EXAMINING ATTORNEY

CLASS 5—(Continued).

SN 85-509,891. SIX MONTH SMILES, INC., SCOTTSVILLE, NY. FILED 1-5-2012.

ORTHOFLOW

THE MARK CONSISTS OF STANDARD CHARACTERS WITHOUT CLAIM TO ANY PARTICULAR FONT, STYLE, SIZE, OR COLOR.
FOR DENTAL CEMENT; DENTAL COMPOSITE MATERIALS (U.S. CLS. 6, 18, 44, 46, 51 AND 52).
FIRST USE 5-30-2011; IN COMMERCE 5-30-2011.
JAMES A. RAUEN, EXAMINING ATTORNEY

SN 85-510,014. 5 STAR LABS LLC, GAINESVILLE, VA. FILED 1-5-2012.

PR 90

THE MARK CONSISTS OF STANDARD CHARACTERS WITHOUT CLAIM TO ANY PARTICULAR FONT, STYLE, SIZE, OR COLOR.
FOR PREPARATION FOR THE RELIEF OF PAIN (U.S. CLS. 6, 18, 44, 46, 51 AND 52).
BRENDAN REGAN, EXAMINING ATTORNEY

SN 85-510,076. OSMOTICA HOLDINGS CORPORATION, PANAMA 5, PANAMA, FILED 1-6-2012.

ELATIVA

THE MARK CONSISTS OF STANDARD CHARACTERS WITHOUT CLAIM TO ANY PARTICULAR FONT, STYLE, SIZE, OR COLOR.
FOR PHARMACEUTICAL PREPARATIONS FOR USE IN THE TREATMENT OF DEPRESSION (U.S. CLS. 6, 18, 44, 46, 51 AND 52).
MATTHEW KLINE, EXAMINING ATTORNEY

CLASS 5—(Continued).

SN 85-510,077. OSMOTICA HOLDINGS CORPORATION, PANAMA 5, PANAMA, FILED 1-6-2012.

CLASS 5—(Continued).

SN 85-510,144. TRUTEK CORP., HILLSBOROUGH, NJ. FILED 1-6-2012.

SENORI

THE MARK CONSISTS OF STANDARD CHARACTERS WITHOUT CLAIM TO ANY PARTICULAR FONT, STYLE, SIZE, OR COLOR.

FOR PHARMACEUTICAL PREPARATIONS FOR USE IN THE TREATMENT OF DEPRESSION (U.S. CLS. 6, 18, 44, 46, 51 AND 52).

MATTHEW KLINE, EXAMINING ATTORNEY

NASALGUARD ALLERGIE WIPES

THE MARK CONSISTS OF STANDARD CHARACTERS WITHOUT CLAIM TO ANY PARTICULAR FONT, STYLE, SIZE, OR COLOR.

OWNER OF U.S. REG. NOS. 2,758,780 AND 4,119,181. NO CLAIM IS MADE TO THE EXCLUSIVE RIGHT TO USE "ALLERGY WIPES", APART FROM THE MARK AS SHOWN.

FOR ALLERGY MEDICATIONS; ALLERGY RELIEF MEDICATION; ALLERGY TABLETS; ANTISEPTIC WIPES; DIAGNOSTIC TEST PATCH FOR APPLICATION TO THE SKIN FOR DETERMINING ALLERGIES; DISPOSABLE SANITIZING WIPES; MEDICATED PRE-MOISTENED WIPES; NON-MEDICATED TOPICAL GEL FOR THE PREVENTION AND TREATMENT OF ALLERGIES; NON-MEDICATED TOPICAL GEL FOR THE PREVENTION AND TREATMENT OF COLD AND FLU; PRE-MOISTENED MEDICATED WIPES; SANITIZING WIPES (U.S. CLS. 6, 18, 44, 46, 51 AND 52).

LINDA E. BLOHM, EXAMINING ATTORNEY

SN 85-510,120. TRUTEK CORP., HILLSBOROUGH, NJ. FILED 1-6-2012.

SN 85-510,158. TRUTEK CORP., HILLSBOROUGH, NJ. FILED 1-6-2012.

NASALGUARD WIPES

THE MARK CONSISTS OF STANDARD CHARACTERS WITHOUT CLAIM TO ANY PARTICULAR FONT, STYLE, SIZE, OR COLOR.

OWNER OF U.S. REG. NOS. 2,758,780 AND 4,119,181. NO CLAIM IS MADE TO THE EXCLUSIVE RIGHT TO USE "WIPES", APART FROM THE MARK AS SHOWN.

FOR ALLERGY MEDICATIONS; ALLERGY RELIEF MEDICATION; ALLERGY TABLETS; ANTISEPTIC WIPES; DIAGNOSTIC TEST PATCH FOR APPLICATION TO THE SKIN FOR DETERMINING ALLERGIES; DISPOSABLE SANITIZING WIPES; MEDICATED PRE-MOISTENED WIPES; NON-MEDICATED TOPICAL GEL FOR THE PREVENTION AND TREATMENT OF ALLERGIES; NON-MEDICATED TOPICAL GEL FOR THE PREVENTION AND TREATMENT OF COLD AND FLU; PRE-MOISTENED MEDICATED WIPES; SANITIZING WIPES (U.S. CLS. 6, 18, 44, 46, 51 AND 52).

LINDA E. BLOHM, EXAMINING ATTORNEY

NASALGUARD COLD & FLU WIPES

THE MARK CONSISTS OF STANDARD CHARACTERS WITHOUT CLAIM TO ANY PARTICULAR FONT, STYLE, SIZE, OR COLOR.

OWNER OF U.S. REG. NOS. 2,758,780 AND 4,119,181. NO CLAIM IS MADE TO THE EXCLUSIVE RIGHT TO USE "COLD & FLU WIPES", APART FROM THE MARK AS SHOWN.

FOR ALLERGY MEDICATIONS; ALLERGY RELIEF MEDICATION; ALLERGY TABLETS; ANTISEPTIC WIPES; DIAGNOSTIC TEST PATCH FOR APPLICATION TO THE SKIN FOR DETERMINING ALLERGIES; DISPOSABLE SANITIZING WIPES; MEDICATED PRE-MOISTENED WIPES; NON-MEDICATED TOPICAL GEL FOR THE PREVENTION AND TREATMENT OF ALLERGIES; NON-MEDICATED TOPICAL GEL FOR THE PREVENTION AND TREATMENT OF COLD AND FLU; PRE-MOISTENED MEDICATED WIPES; SANITIZING WIPES (U.S. CLS. 6, 18, 44, 46, 51 AND 52).

LINDA E. BLOHM, EXAMINING ATTORNEY

CLASS 5—(Continued).

SN 85-510,160. CHEMSMART, LLC, CANTON, MA. FILED 1-6-2012.

CHEMIGEL

THE MARK CONSISTS OF STANDARD CHARACTERS WITHOUT CLAIM TO ANY PARTICULAR FONT, STYLE, SIZE, OR COLOR.

FOR DRUG DELIVERY AGENTS CONSISTING OF COMPOUNDS THAT FACILITATE DELIVERY OF A WIDE RANGE OF PHARMACEUTICALS FOR HUMAN AND VETERINARY USE; DRUG DELIVERY AGENTS CONSISTING OF COMPOUNDS FOR TRANSDERMAL, TRANSMUCOSAL, OR TRANSBUCCAL DELIVERY OF THERAPEUTICALLY ACTIVE AND INACTIVE CHEMICAL COMPOUNDS FOR HUMAN AND VETERINARY USE; DRUG DELIVERY AGENTS CONSISTING OF PERMEATION-ENHANCING COMPOUNDS FOR USE IN DRUG DELIVERY AGENTS FOR HUMAN AND VETERINARY USE (U.S. CLS. 6, 18, 44, 46, 51 AND 52).
MELISSA VALLILLO, EXAMINING ATTORNEY

SN 85-510,205. SLEEP CARE OF AMERICA, LLC, COLUMBUS, OH. FILED 1-6-2012.

RevitaSleep

THE MARK CONSISTS OF STANDARD CHARACTERS WITHOUT CLAIM TO ANY PARTICULAR FONT, STYLE, SIZE, OR COLOR.

FOR DIETARY AND NUTRITIONAL SUPPLEMENTS; DIETARY SUPPLEMENT BEVERAGE FOR SLEEP AND RELAXATION; DIETARY SUPPLEMENTAL DRINKS; DIETARY SUPPLEMENTS; DIETARY SUPPLEMENTS FOR HUMAN CONSUMPTION (U.S. CLS. 6, 18, 44, 46, 51 AND 52).

ALEX KEAM, EXAMINING ATTORNEY

SN 85-510,681. QARE, LTD., NASSAU, BAHAMAS, FILED 1-6-2012.

QARE

THE MARK CONSISTS OF STANDARD CHARACTERS WITHOUT CLAIM TO ANY PARTICULAR FONT, STYLE, SIZE, OR COLOR.

FOR TOPICAL MEDICATED CREAM FOR MALE GENITALS TO PREVENT HERPES, HIV AND HPV (U.S. CLS. 6, 18, 44, 46, 51 AND 52).

KATHERINE M. DUBRAY, EXAMINING ATTORNEY

CLASS 5—(Continued).

SN 85-510,730. SYNGENTA PARTICIPATIONS AG, BASEL, SWITZERLAND, FILED 1-6-2012.

Cerno

THE MARK CONSISTS OF STANDARD CHARACTERS WITHOUT CLAIM TO ANY PARTICULAR FONT, STYLE, SIZE, OR COLOR.

FOR PREPARATIONS FOR DESTROYING VERMIN; FUNGICIDES, HERBICIDES, INSECTICIDES, PESTICIDES FOR COMMERCIAL, AGRICULTURAL AND DOMESTIC USE (U.S. CLS. 6, 18, 44, 46, 51 AND 52).

JAMES STEIN, EXAMINING ATTORNEY

SN 85-510,842. CLINICAL THERAPEUTIC SOLUTIONS, WALL, NJ. FILED 1-6-2012.

CLARUS ANTIFUNGAL CREAM

THE MARK CONSISTS OF STANDARD CHARACTERS WITHOUT CLAIM TO ANY PARTICULAR FONT, STYLE, SIZE, OR COLOR.

NO CLAIM IS MADE TO THE EXCLUSIVE RIGHT TO USE "ANTIFUNGAL CREAM", APART FROM THE MARK AS SHOWN.

FOR TOPICAL ANTIFUNGAL CREAM DESIGNED TO TREAT ATHLETE'S FOOT AND RINGWORM (U.S. CLS. 6, 18, 44, 46, 51 AND 52).

LINDA E. BLOHM, EXAMINING ATTORNEY

SN 85-510,858. CLINICAL THERAPEUTIC SOLUTIONS, WALL, NJ. FILED 1-6-2012.

CLARUS ANTIFUNGAL SOLUTION

THE MARK CONSISTS OF STANDARD CHARACTERS WITHOUT CLAIM TO ANY PARTICULAR FONT, STYLE, SIZE, OR COLOR.

NO CLAIM IS MADE TO THE EXCLUSIVE RIGHT TO USE "ANTIFUNGAL SOLUTION", APART FROM THE MARK AS SHOWN.

FOR TOPICAL ANTIFUNGAL CREAMS, PREPARATIONS, AND SOLUTIONS FOR TREATING TOENAIL FUNGUS (U.S. CLS. 6, 18, 44, 46, 51 AND 52).

LINDA E. BLOHM, EXAMINING ATTORNEY

CLASS 5—(Continued).

SN 85-510,936. ESSENTIAL WATER SOLUTIONS INC.,
STORY CITY, IA. FILED 1-6-2012.

OXY BLAST PLUS

THE MARK CONSISTS OF STANDARD CHARACTERS
WITHOUT CLAIM TO ANY PARTICULAR FONT, STYLE,
SIZE, OR COLOR.

FOR ANIMAL FEED SUPPLEMENTS; AND ANIMAL
FEED ADDITIVES, NAMELY, ENZYMES FOR USE IN
ANIMAL FEEDS TO ASSIST IN DIGESTION (U.S. CLS. 6,
18, 44, 46, 51 AND 52).

FIRST USE 6-16-2005; IN COMMERCE 6-16-2005.
JANICE L. MCMORROW, EXAMINING ATTORNEY

SN 85-511,468. MENTIS, DIMITRIOS, PLANTATION, FL.
FILED 1-9-2012.

BEAUTYCOMPLEX

THE MARK CONSISTS OF STANDARD CHARACTERS
WITHOUT CLAIM TO ANY PARTICULAR FONT, STYLE,
SIZE, OR COLOR.

FOR VITAMIN SUPPLEMENTS (U.S. CLS. 6, 18, 44, 46,
51 AND 52).

FIRST USE 7-1-2011; IN COMMERCE 7-1-2011.
ROSELLE HERRERA, EXAMINING ATTORNEY

SN 85-511,568. MENTIS, DIMITRIOS, PLANTATION, FL.
FILED 1-9-2012.

BEAUTYCLEANSE

THE MARK CONSISTS OF STANDARD CHARACTERS
WITHOUT CLAIM TO ANY PARTICULAR FONT, STYLE,
SIZE, OR COLOR.

FOR DIETARY SUPPLEMENTS FOR DETOXIFICA-
TION (U.S. CLS. 6, 18, 44, 46, 51 AND 52).

FIRST USE 7-1-2011; IN COMMERCE 7-1-2011.
ROSELLE HERRERA, EXAMINING ATTORNEY

CLASS 5—(Continued).

SN 85-511,758. NEWPORT LABORATORIES, INC.,
WORTHINGTON, MN. FILED 1-9-2012.

PRIMAVANT

THE MARK CONSISTS OF STANDARD CHARACTERS
WITHOUT CLAIM TO ANY PARTICULAR FONT, STYLE,
SIZE, OR COLOR.

FOR ANTIGEN ADJUVANTS FOR USE IN VETERIN-
ARY VACCINES (U.S. CLS. 6, 18, 44, 46, 51 AND 52).

MEGHAN REINHART, EXAMINING ATTORNEY

SN 85-511,900. CLINICAL THERAPEUTIC SOLUTIONS,
WALL, NJ. FILED 1-9-2012.

CLARUS ANTIFUNGAL SOLUTION

THE MARK CONSISTS OF STANDARD CHARACTERS
WITHOUT CLAIM TO ANY PARTICULAR FONT, STYLE,
SIZE, OR COLOR.

NO CLAIM IS MADE TO THE EXCLUSIVE RIGHT TO
USE "ANTIFUNGAL SOLUTION", APART FROM THE
MARK AS SHOWN.

FOR TOPICAL ANTIFUNGAL OIL BASED SOLUTION
DESIGNED TO TREAT ATHLETE'S FOOT AND RING-
WORM (U.S. CLS. 6, 18, 44, 46, 51 AND 52).

LINDA E. BLOHM, EXAMINING ATTORNEY

SN 85-512,137. BE-WARM LLC, TROY, MI. FILED 1-9-2012.

BE-WARM

THE MARK CONSISTS OF STANDARD CHARACTERS
WITHOUT CLAIM TO ANY PARTICULAR FONT, STYLE,
SIZE, OR COLOR.

FOR DIETARY SUPPLEMENTS FOR INCREASING
HUMAN TOLERANCE TO COLD WEATHER (U.S. CLS.
6, 18, 44, 46, 51 AND 52).

DEBRA LEE, EXAMINING ATTORNEY

CLASS 5—(Continued).

SN 85-512,187. BE-WARM LLC, TROY, MI. FILED 1-9-2012.



THE COLOR(S) ORANGE, YELLOW, WHITE AND GRAY IS/ARE CLAIMED AS A FEATURE OF THE MARK.

THE MARK CONSISTS OF A SNOWFLAKE THAT TURNS INTO A TWO PIECE FLAME IN ITS UPPER HALF; THE SNOWFLAKE AND FLAME ARE ORANGE WITH A YELLOW OUTLINE ON A GRAY SHADOWED BACKGROUND AND INCLUDE SIX WHITE DIAMONDS REGULARLY POSITIONED IN THE CENTER OF THE SNOWFLAKE.

FOR DIETARY SUPPLEMENTS FOR INCREASING HUMAN TOLERANCE TO COLD WEATHER (U.S. CLS. 6, 18, 44, 46, 51 AND 52).

DEBRA LEE, EXAMINING ATTORNEY

SN 85-512,362. JARROW FORMULAS, INC., LOS ANGELES, CA. FILED 1-9-2012.

MAGMIND

THE MARK CONSISTS OF STANDARD CHARACTERS WITHOUT CLAIM TO ANY PARTICULAR FONT, STYLE, SIZE, OR COLOR.

FOR DIETARY AND NUTRITIONAL SUPPLEMENTS (U.S. CLS. 6, 18, 44, 46, 51 AND 52).

TOBY BULLOFF, EXAMINING ATTORNEY

SN 85-512,470. BROWN, ANDREA, PALM HARBOR, FL. FILED 1-10-2012.

Best In Coat

THE MARK CONSISTS OF STANDARD CHARACTERS WITHOUT CLAIM TO ANY PARTICULAR FONT, STYLE, SIZE, OR COLOR.

FOR DIETARY SUPPLEMENTS FOR PETS; VITAMINS FOR PETS (U.S. CLS. 6, 18, 44, 46, 51 AND 52).

FIRST USE 9-16-2011; IN COMMERCE 10-1-2011.

KIMBERLY FRYE, EXAMINING ATTORNEY

CLASS 5—(Continued).

SN 85-512,612. NOURISHLIFE, LAKE FOREST, IL. FILED 1-10-2012.

speak Smooth

THE MARK CONSISTS OF STANDARD CHARACTERS WITHOUT CLAIM TO ANY PARTICULAR FONT, STYLE, SIZE, OR COLOR.

FOR DIETARY AND NUTRITIONAL SUPPLEMENTS CONTAINING OMEGA-3 AND VITAMIN E; DIETARY SUPPLEMENTS FOR VERBAL APRAXIA (U.S. CLS. 6, 18, 44, 46, 51 AND 52).

FIRST USE 10-10-2011; IN COMMERCE 12-1-2011.

TEJBIR SINGH, EXAMINING ATTORNEY

SN 85-512,898. PFIZER INC., NEW YORK, NY. FILED 1-10-2012.

FASCILIREN

THE MARK CONSISTS OF STANDARD CHARACTERS WITHOUT CLAIM TO ANY PARTICULAR FONT, STYLE, SIZE, OR COLOR.

FOR PHARMACEUTICAL PREPARATIONS FOR THE TREATMENT OF CARDIOVASCULAR, CENTRAL NERVOUS SYSTEM, ENDOCRINE, GASTROINTESTINAL, GENETIC IMMUNOLOGICAL, INFECTIOUS, INFLAMMATORY, MENOPAUSAL, METABOLIC, AUTOIMMUNE, MUSCULOSKELETAL, NEUROLOGICAL, OPHTHALMOLOGICAL, PSYCHIATRIC, RESPIRATORY, UROGENITAL, UROLOGICAL AND VIRAL DISEASES AND DISORDERS; PHARMACEUTICAL PREPARATIONS FOR THE TREATMENT OF ERECTILE DYSFUNCTION, SEXUAL DYSFUNCTION, CANCER, PAIN AND DIABETES; PHARMACEUTICAL PREPARATIONS FOR USE IN HEMATOLOGY; PHARMACEUTICAL PREPARATIONS, NAMELY, ANTIFUNGAL PREPARATIONS, DERMATOLOGICAL PREPARATIONS, SMOKING CESSATION PREPARATIONS, AND TISSUE REPAIR PREPARATIONS; VACCINES FOR HUMAN USE (U.S. CLS. 6, 18, 44, 46, 51 AND 52).

GEORGE LORENZO, EXAMINING ATTORNEY

SN 85-513,057. SYNGENTA PARTICIPATIONS AG, BASEL, SWITZERLAND, FILED 1-10-2012.

Appear

THE MARK CONSISTS OF STANDARD CHARACTERS WITHOUT CLAIM TO ANY PARTICULAR FONT, STYLE, SIZE, OR COLOR.

FOR FUNGICIDES FOR COMMERCIAL, DOMESTIC OR AGRICULTURAL USE (U.S. CLS. 6, 18, 44, 46, 51 AND 52).

JAMES STEIN, EXAMINING ATTORNEY

CLASS 5—(Continued).

SN 85-513,182. ABATTIS BIOLOGIX CORPORATION, VANCOUVER BC, CANADA, FILED 1-10-2012.

DEFENZALL

THE MARK CONSISTS OF STANDARD CHARACTERS WITHOUT CLAIM TO ANY PARTICULAR FONT, STYLE, SIZE, OR COLOR.

FOR DIETARY AND NUTRITIONAL SUPPLEMENTS FOR TREATMENT OF COLD AND FLU SYMPTOMS (U.S. CLS. 6, 18, 44, 46, 51 AND 52).

FRANK LATTUCA, EXAMINING ATTORNEY

CLASS 5—(Continued).

SN 85-513,837. NEU INDUSTRIES, INC., NEW YORK, NY. FILED 1-11-2012.



THE MARK CONSISTS OF IMAGE OF A SEATED FEMALE ANGEL FIGURE.

FOR DIETARY SUPPLEMENTAL DRINKS; LIQUID VITAMIN SUPPLEMENTS; MEDICINAL DRINKS; NUTRITIONALLY FORTIFIED BEVERAGES; VITAMIN AND MINERAL SUPPLEMENTS (U.S. CLS. 6, 18, 44, 46, 51 AND 52).

FIRST USE 1-1-2008; IN COMMERCE 1-1-2008.
BARBARA BROWN, EXAMINING ATTORNEY

SN 85-513,184. SYNGENTA PARTICIPATIONS AG, BASEL, SWITZERLAND, FILED 1-10-2012.

Ariel

THE MARK CONSISTS OF STANDARD CHARACTERS WITHOUT CLAIM TO ANY PARTICULAR FONT, STYLE, SIZE, OR COLOR.

FOR FUNGICIDES FOR COMMERCIAL, DOMESTIC OR AGRICULTURAL USE, NAMELY, FUNGICIDES FOR TURF AND ORNAMENTAL USE (U.S. CLS. 6, 18, 44, 46, 51 AND 52).

JAMES STEIN, EXAMINING ATTORNEY

SN 85-513,879. VELCERA, INC., YARDLEY, PA. FILED 1-11-2012.



THE MARK CONSISTS OF THE WORD "PETTRUST" AND THE WORD "PLUS" CONTAINED WITHIN A STYLIZED IMAGE OF A HEART.

FOR ANTIPARASITIC PREPARATIONS (U.S. CLS. 6, 18, 44, 46, 51 AND 52).

JUSTINE D. PARKER, EXAMINING ATTORNEY

SN 85-513,310. JARROW FORMULAS, INC., LOS ANGELES, CA. FILED 1-10-2012.

CARBAME

THE MARK CONSISTS OF STANDARD CHARACTERS WITHOUT CLAIM TO ANY PARTICULAR FONT, STYLE, SIZE, OR COLOR.

OWNER OF U.S. REG. NOS. 2,582,460, 3,038,312 AND OTHERS.

FOR DIETARY AND NUTRITIONAL SUPPLEMENTS (U.S. CLS. 6, 18, 44, 46, 51 AND 52).

TOBY BULLOFF, EXAMINING ATTORNEY

SN 85-513,932. ELITE SPORTS PRODUCTS INC, MIAMI BEACH, FL. FILED 1-11-2012.

NEUROSURGE

THE MARK CONSISTS OF STANDARD CHARACTERS WITHOUT CLAIM TO ANY PARTICULAR FONT, STYLE, SIZE, OR COLOR.

FOR NUTRITIONAL SUPPLEMENTS (U.S. CLS. 6, 18, 44, 46, 51 AND 52).

FIRST USE 1-11-2011; IN COMMERCE 1-11-2011.

SAMUEL E. SHARPER JR., EXAMINING ATTORNEY

CLASS 5—(Continued).

SN 85-513,933. PENTRON CLINICAL TECHNOLOGIES, LLC, ORANGE, CA. FILED 1-11-2012.



NO CLAIM IS MADE TO THE EXCLUSIVE RIGHT TO USE "ADHESIVE", APART FROM THE MARK AS SHOWN.

THE MARK CONSISTS OF A DESIGN OF A HORIZONTAL PLUS SYMBOL WITH THE WORD "ADHESIVE" BELOW IT AND THE LETTERS/NUMBER "B1P" WITH THE "P" HAVING A VERTICAL PLUS SYMBOL SUPERIMPOSED OVER THE LETTER "P".

FOR BONDING AND PRIMER MATERIALS FOR DENTAL PURPOSES (U.S. CLS. 6, 18, 44, 46, 51 AND 52).
TINA MAI, EXAMINING ATTORNEY

SN 85-513,937. T.W. PELTON & CO., INC., PINE BLUFF, AR. FILED 1-11-2012.

STINKINATOR

THE MARK CONSISTS OF STANDARD CHARACTERS WITHOUT CLAIM TO ANY PARTICULAR FONT, STYLE, SIZE, OR COLOR.

FOR ODOR NEUTRALIZING PREPARATIONS FOR GENERAL USE ON VARIOUS SURFACES (U.S. CLS. 6, 18, 44, 46, 51 AND 52).

FIRST USE 1-4-2012; IN COMMERCE 1-4-2012.
SAMUEL E. SHARPER JR., EXAMINING ATTORNEY

SN 85-514,012. PENTRON CLINICAL TECHNOLOGIES, LLC, ORANGE, CA. FILED 1-11-2012.

SIMILE

THE MARK CONSISTS OF STANDARD CHARACTERS WITHOUT CLAIM TO ANY PARTICULAR FONT, STYLE, SIZE, OR COLOR.

FOR COMPOSITE MATERIAL FOR DENTAL RESTORATIVE USE (U.S. CLS. 6, 18, 44, 46, 51 AND 52).

FIRST USE 10-11-2002; IN COMMERCE 10-11-2002.
TINA MAI, EXAMINING ATTORNEY

CLASS 5—(Continued).

SN 85-514,153. VALENT USA CORPORATION, WALNUT CREEK, CA. FILED 1-11-2012.

FLUMI

THE MARK CONSISTS OF STANDARD CHARACTERS WITHOUT CLAIM TO ANY PARTICULAR FONT, STYLE, SIZE, OR COLOR.

FOR HERBICIDES (U.S. CLS. 6, 18, 44, 46, 51 AND 52).
RICHARD WHITE, EXAMINING ATTORNEY

SN 85-514,522. MOWTOWN LANDSCAPING, LLC, DALLAS, TX. FILED 1-11-2012.

KILL MY ODOR

THE MARK CONSISTS OF STANDARD CHARACTERS WITHOUT CLAIM TO ANY PARTICULAR FONT, STYLE, SIZE, OR COLOR.

FOR ODOR NEUTRALIZING PREPARATIONS FOR GENERAL USE ON VARIOUS SURFACES (U.S. CLS. 6, 18, 44, 46, 51 AND 52).

JUSTINE D. PARKER, EXAMINING ATTORNEY

SN 85-514,536. CARDIOKINE, INC., CARY, NC. FILED 1-11-2012.

LIXIPRES

THE MARK CONSISTS OF STANDARD CHARACTERS WITHOUT CLAIM TO ANY PARTICULAR FONT, STYLE, SIZE, OR COLOR.

FOR PHARMACEUTICAL PREPARATIONS FOR THE TREATMENT OF DISEASE STATES ASSOCIATED WITH CARDIOVASCULAR DISEASES (U.S. CLS. 6, 18, 44, 46, 51 AND 52).

JOSETTE BEVERLY, EXAMINING ATTORNEY

CLASS 5—(Continued).

SN 85-514,538. CARDIOKINE, INC., CARY, NC. FILED 1-11-2012.

LIXIVA

THE MARK CONSISTS OF STANDARD CHARACTERS WITHOUT CLAIM TO ANY PARTICULAR FONT, STYLE, SIZE, OR COLOR.

FOR PHARMACEUTICAL PREPARATIONS FOR THE TREATMENT OF DISEASE STATES ASSOCIATED WITH CARDIOVASCULAR DISEASE (U.S. CLS. 6, 18, 44, 46, 51 AND 52).

JOSETTE BEVERLY, EXAMINING ATTORNEY

CLASS 5—(Continued).

SN 85-514,624. MEDLINE INDUSTRIES, INC., MUNDELEIN, IL. FILED 1-12-2012.

PROTECTION PLUS BLISS

THE MARK CONSISTS OF STANDARD CHARACTERS WITHOUT CLAIM TO ANY PARTICULAR FONT, STYLE, SIZE, OR COLOR.

OWNER OF U.S. REG. NOS. 1,471,161, 1,762,357 AND 2,925,125.

FOR INCONTINENCE GARMENTS (U.S. CLS. 6, 18, 44, 46, 51 AND 52).

ROBERT STRUCK, EXAMINING ATTORNEY

SN 85-514,541. CARDIOKINE, INC., CARY, NC. FILED 1-11-2012.

BRIVOL

THE MARK CONSISTS OF STANDARD CHARACTERS WITHOUT CLAIM TO ANY PARTICULAR FONT, STYLE, SIZE, OR COLOR.

FOR PHARMACEUTICAL PREPARATIONS FOR THE TREATMENT OF DISEASE STATES ASSOCIATED WITH CARDIOVASCULAR DISEASES (U.S. CLS. 6, 18, 44, 46, 51 AND 52).

JOSETTE BEVERLY, EXAMINING ATTORNEY

SN 85-514,756. PREFERRED CHOICE LABS, INC., ALISO VIEJO, CA. FILED 1-12-2012.

CALCIPLEX

THE MARK CONSISTS OF STANDARD CHARACTERS WITHOUT CLAIM TO ANY PARTICULAR FONT, STYLE, SIZE, OR COLOR.

FOR DIETARY AND NUTRITIONAL SUPPLEMENTS (U.S. CLS. 6, 18, 44, 46, 51 AND 52).

MICHAEL TANNER, EXAMINING ATTORNEY

SN 85-514,543. CARDIOKINE, INC., CARY, NC. FILED 1-11-2012.

SOLIZERA

THE MARK CONSISTS OF STANDARD CHARACTERS WITHOUT CLAIM TO ANY PARTICULAR FONT, STYLE, SIZE, OR COLOR.

FOR PHARMACEUTICAL PREPARATIONS FOR THE TREATMENT OF DISEASE STATES ASSOCIATED WITH CARDIOVASCULAR DISEASES (U.S. CLS. 6, 18, 44, 46, 51 AND 52).

JOSETTE BEVERLY, EXAMINING ATTORNEY

SN 85-514,801. ALMIRALL, S.A., BARCELONA, SPAIN, FILED 1-12-2012.

DYNLARIZ

THE MARK CONSISTS OF STANDARD CHARACTERS WITHOUT CLAIM TO ANY PARTICULAR FONT, STYLE, SIZE, OR COLOR.

OWNER OF U.S. REG. NOS. 3,272,679 AND 4,038,019.

FOR PHARMACEUTICAL PREPARATIONS FOR TREATING RESPIRATORY DISEASES, SUPPLIED IN PRE-FILLED INHALERS (U.S. CLS. 6, 18, 44, 46, 51 AND 52).

SALLY SHIH, EXAMINING ATTORNEY

CLASS 5—(Continued).

SN 85-514,808. VILLARREAL, JORGE, ARLINGTON, TX.
FILED 1-12-2012.

Pure Envy

THE MARK CONSISTS OF STANDARD CHARACTERS WITHOUT CLAIM TO ANY PARTICULAR FONT, STYLE, SIZE, OR COLOR.

FOR DIETARY AND NUTRITIONAL SUPPLEMENTS (U.S. CLS. 6, 18, 44, 46, 51 AND 52).

SALLY SHIH, EXAMINING ATTORNEY

SN 85-514,813. LIFEHEALTH SCIENCE LLC, CLEVELAND, OH. FILED 1-12-2012.

NUTRA THERA

THE MARK CONSISTS OF STANDARD CHARACTERS WITHOUT CLAIM TO ANY PARTICULAR FONT, STYLE, SIZE, OR COLOR.

OWNER OF U.S. REG. NOS. 4,025,587 AND 4,061,314. FOR DIETARY AND NUTRITIONAL SUPPLEMENTS (U.S. CLS. 6, 18, 44, 46, 51 AND 52).

FIRST USE 3-1-2011; IN COMMERCE 3-1-2011.
SALLY SHIH, EXAMINING ATTORNEY

SN 85-514,820. INTELLIGENT NUTRIENTS, LLC, MINNEAPOLIS, MN. FILED 1-12-2012.

Intelligent Nutrients

THE MARK CONSISTS OF STANDARD CHARACTERS WITHOUT CLAIM TO ANY PARTICULAR FONT, STYLE, SIZE, OR COLOR.

OWNER OF U.S. REG. NOS. 3,161,714, 4,097,242 AND OTHERS.

NO CLAIM IS MADE TO THE EXCLUSIVE RIGHT TO USE "NUTRIENTS", APART FROM THE MARK AS SHOWN.

FOR MEDICATED AND NON-MEDICATED BODY CREAM, LOTION AND OINTMENT TO AID IN THE PREVENTION OF PREMATURE EJACULATION; PERSONAL LUBRICANTS; CHOLESTEROL REDUCERS; COUGH LOZENGES; DECONGESTANTS; LAXATIVES; MEDICATED LIP BALM (U.S. CLS. 6, 18, 44, 46, 51 AND 52).

AHSEN KHAN, EXAMINING ATTORNEY

CLASS 5—(Continued).

SN 85-514,828. FOREST LABORATORIES, INC., NEW YORK, NY. FILED 1-12-2012.

ENYDRA

THE MARK CONSISTS OF STANDARD CHARACTERS WITHOUT CLAIM TO ANY PARTICULAR FONT, STYLE, SIZE, OR COLOR.

THE NAME(S), PORTRAIT(S), AND/OR SIGNATURE(S) SHOWN IN THE MARK DOES NOT IDENTIFY A PARTICULAR LIVING INDIVIDUAL.

THE WORDING "ENYDRA" HAS NO MEANING IN A FOREIGN LANGUAGE.

FOR PHARMACEUTICAL PREPARATIONS FOR THE TREATMENT OF BACTERIAL INFECTIONS, DIABETES, PAIN, NEUROPATHIC PAIN, DIABETIC NEUROPATHY, CARDIOVASCULAR SYSTEM DISEASES AND DISORDERS, RESPIRATORY SYSTEM DISEASES AND DISORDERS, NEUROLOGICAL DISEASES AND DISORDERS, CENTRAL NERVOUS SYSTEM DISEASES AND DISORDERS, GASTROINTESTINAL DISEASES AND DISORDERS; ANTIDEPRESSANTS; ANTIPSYCHOTICS; CORONARY VASODILATING AGENTS; INHALERS FILLED WITH PHARMACEUTICAL PREPARATIONS FOR THE TREATMENT AND ALLEVIATION OF RESPIRATORY SYSTEM DISEASES AND DISORDERS (U.S. CLS. 6, 18, 44, 46, 51 AND 52).

MIDGE BUTLER, EXAMINING ATTORNEY

SN 85-514,861. FOREST LABORATORIES, INC., NEW YORK, NY. FILED 1-12-2012.

ERGINTO

THE MARK CONSISTS OF STANDARD CHARACTERS WITHOUT CLAIM TO ANY PARTICULAR FONT, STYLE, SIZE, OR COLOR.

THE NAME(S), PORTRAIT(S), AND/OR SIGNATURE(S) SHOWN IN THE MARK DOES NOT IDENTIFY A PARTICULAR LIVING INDIVIDUAL.

THE WORDING "ERGINTO" HAS NO MEANING IN A FOREIGN LANGUAGE.

FOR PHARMACEUTICAL PREPARATIONS FOR THE TREATMENT OF BACTERIAL INFECTIONS, DIABETES, PAIN, NEUROPATHIC PAIN, DIABETIC NEUROPATHY, CARDIOVASCULAR SYSTEM DISEASES AND DISORDERS, RESPIRATORY SYSTEM DISEASES AND DISORDERS, NEUROLOGICAL DISEASES AND DISORDERS, CENTRAL NERVOUS SYSTEM DISEASES AND DISORDERS, GASTROINTESTINAL DISEASES AND DISORDERS; ANTIDEPRESSANTS; ANTIPSYCHOTICS; CORONARY VASODILATING AGENTS; INHALERS FILLED WITH PHARMACEUTICAL PREPARATIONS FOR THE TREATMENT AND ALLEVIATION OF RESPIRATORY SYSTEM DISEASES AND DISORDERS (U.S. CLS. 6, 18, 44, 46, 51 AND 52).

MIDGE BUTLER, EXAMINING ATTORNEY

CLASS 5—(Continued).

SN 85-514,870. FOREST LABORATORIES, INC., NEW YORK, NY. FILED 1-12-2012.

ERNOVIA

THE MARK CONSISTS OF STANDARD CHARACTERS WITHOUT CLAIM TO ANY PARTICULAR FONT, STYLE, SIZE, OR COLOR.

THE NAME(S), PORTRAIT(S), AND/OR SIGNATURE(S) SHOWN IN THE MARK DOES NOT IDENTIFY A PARTICULAR LIVING INDIVIDUAL.

THE WORDING "ERNOVIA" HAS NO MEANING IN A FOREIGN LANGUAGE.

FOR PHARMACEUTICAL PREPARATIONS FOR THE TREATMENT OF BACTERIAL INFECTIONS, DIABETES, PAIN, NEUROPATHIC PAIN, DIABETIC NEUROPATHY, CARDIOVASCULAR SYSTEM DISEASES AND DISORDERS, RESPIRATORY SYSTEM DISEASES AND DISORDERS, NEUROLOGICAL DISEASES AND DISORDERS, CENTRAL NERVOUS SYSTEM DISEASES AND DISORDERS, GASTROINTESTINAL DISEASES AND DISORDERS; ANTIDEPRESSANTS; ANTIPSYCHOTICS; CORONARY VASODILATING AGENTS; INHALERS FILLED WITH PHARMACEUTICAL PREPARATIONS FOR THE TREATMENT AND ALLEVIATION OF RESPIRATORY SYSTEM DISEASES AND DISORDERS (U.S. CLS. 6, 18, 44, 46, 51 AND 52).

MIDGE BUTLER, EXAMINING ATTORNEY

SN 85-514,883. FOREST LABORATORIES, INC., NEW YORK, NY. FILED 1-12-2012.

VECTARGY

THE MARK CONSISTS OF STANDARD CHARACTERS WITHOUT CLAIM TO ANY PARTICULAR FONT, STYLE, SIZE, OR COLOR.

THE NAME(S), PORTRAIT(S), AND/OR SIGNATURE(S) SHOWN IN THE MARK DOES NOT IDENTIFY A PARTICULAR LIVING INDIVIDUAL.

THE WORDING "VECTARGY" HAS NO MEANING IN A FOREIGN LANGUAGE.

FOR PHARMACEUTICAL PREPARATIONS FOR THE TREATMENT OF BACTERIAL INFECTIONS, DIABETES, PAIN, NEUROPATHIC PAIN, DIABETIC NEUROPATHY, CARDIOVASCULAR SYSTEM DISEASES AND DISORDERS, RESPIRATORY SYSTEM DISEASES AND DISORDERS, NEUROLOGICAL DISEASES AND DISORDERS, CENTRAL NERVOUS SYSTEM DISEASES AND DISORDERS, GASTROINTESTINAL DISEASES AND DISORDERS; ANTIDEPRESSANTS; ANTIPSYCHOTICS; CORONARY VASODILATING AGENTS; INHALERS FILLED WITH PHARMACEUTICAL PREPARATIONS FOR THE TREATMENT AND ALLEVIATION OF RESPIRATORY SYSTEM DISEASES AND DISORDERS (U.S. CLS. 6, 18, 44, 46, 51 AND 52).

MIDGE BUTLER, EXAMINING ATTORNEY

CLASS 5—(Continued).

SN 85-514,961. NUSPECIES CORPORATION, STORMVILLE, NY. FILED 1-12-2012.

Exodus

THE MARK CONSISTS OF STANDARD CHARACTERS WITHOUT CLAIM TO ANY PARTICULAR FONT, STYLE, SIZE, OR COLOR.

FOR DIETARY AND NUTRITIONAL SUPPLEMENTS; DIETARY SUPPLEMENTS; HERBAL SUPPLEMENTS; HERBS FOR MEDICINAL PURPOSES; LIQUID NUTRITIONAL SUPPLEMENT; LIQUID VITAMIN SUPPLEMENTS; MEDICINAL HERB EXTRACTS; MEDICINAL HERBS; MINERAL NUTRITIONAL SUPPLEMENTS; MINERAL SUPPLEMENTS; NATURAL HERBAL SUPPLEMENTS; NUTRITIONAL SUPPLEMENTS; NUTRITIONAL SUPPLEMENTS IN THE FORM OF LIQUID, VEGGIE CAPSULES, AND POWDER; VITAMIN AND MINERAL SUPPLEMENTS; VITAMIN SUPPLEMENTS (U.S. CLS. 6, 18, 44, 46, 51 AND 52).

FIRST USE 1-10-2012; IN COMMERCE 1-10-2012.

MATTHEW EINSTEIN, EXAMINING ATTORNEY

SN 85-514,971. TIKKUN LLC, SAN DIEGO, CA. FILED 1-12-2012.

FEBRAX

THE MARK CONSISTS OF STANDARD CHARACTERS WITHOUT CLAIM TO ANY PARTICULAR FONT, STYLE, SIZE, OR COLOR.

FOR ANALGESICS, FEVER RELIEVERS AND PAIN RELIEVERS (U.S. CLS. 6, 18, 44, 46, 51 AND 52).

DANNEAN HETZEL, EXAMINING ATTORNEY

SN 85-515,018. MATTHEWS, JOHN D, DBA SELF, BATON ROUGE, LA. FILED 1-12-2012.

VitaSlim

THE MARK CONSISTS OF STANDARD CHARACTERS WITHOUT CLAIM TO ANY PARTICULAR FONT, STYLE, SIZE, OR COLOR.

FOR VITAMINS (U.S. CLS. 6, 18, 44, 46, 51 AND 52).

ROBERT STRUCK, EXAMINING ATTORNEY

CLASS 5—(Continued).

SN 85-515,034. NUFARM AMERICAS INC., BURR RIDGE, IL. FILED 1-12-2012.

NUFARM EXTREME

THE MARK CONSISTS OF STANDARD CHARACTERS WITHOUT CLAIM TO ANY PARTICULAR FONT, STYLE, SIZE, OR COLOR.

OWNER OF U.S. REG. NO. 2,669,585.
FOR FUNGICIDES; HERBICIDES; INSECTICIDES; PESTICIDES; RODENTICIDES (U.S. CLS. 6, 18, 44, 46, 51 AND 52).

KATHERINE M. DUBRAY, EXAMINING ATTORNEY

SN 85-515,040. SMITHKLINE BEECHAM LIMITED, BRENTFORD, MIDDLESEX, UNITED KINGDOM, FILED 1-12-2012.

NYZAR

THE MARK CONSISTS OF STANDARD CHARACTERS WITHOUT CLAIM TO ANY PARTICULAR FONT, STYLE, SIZE, OR COLOR.

FOR PHARMACEUTICAL PREPARATIONS AND SUBSTANCES FOR THE TREATMENT OF INFECTIOUS DISEASES, BLOOD DISORDERS, PAIN, INFLAMMATION, SEPSIS, ALOPECIA, OBESITY AND COGNITIVE DISORDERS; PHARMACEUTICAL PREPARATIONS AND SUBSTANCES FOR THE TREATMENT OF VIRAL, METABOLIC, ENDOCRINE, MUSCULOSKELETAL, PULMONARY, GENITOURINARY, SEXUAL DYSFUNCTION, ONCOLOGICAL, HEPATOLOGICAL, OPHTHALMOLOGICAL, RESPIRATORY, NEUROLOGICAL, GASTROINTESTINAL, HORMONAL, DERMATOLOGICAL, PSYCHIATRIC AND IMMUNE SYSTEM RELATED DISEASES AND DISORDERS; PHARMACEUTICAL PREPARATIONS AND SUBSTANCES FOR THE TREATMENT OF DAMAGED SKIN AND TISSUE; VACCINES (U.S. CLS. 6, 18, 44, 46, 51 AND 52).

THOMAS MANOR, EXAMINING ATTORNEY

SN 85-515,113. GREEN WAVE, INC., SHANGHAI, CHINA, FILED 1-12-2012.

**BETTER INGREDIENTS, BETTER
LIFE**

THE MARK CONSISTS OF STANDARD CHARACTERS WITHOUT CLAIM TO ANY PARTICULAR FONT, STYLE, SIZE, OR COLOR.

FOR DIETARY AND NUTRITIONAL SUPPLEMENTS (U.S. CLS. 6, 18, 44, 46, 51 AND 52).

FIRST USE 11-1-2011; IN COMMERCE 11-23-2011.

AMY KERTGATE, EXAMINING ATTORNEY

CLASS 5—(Continued).

SN 85-515,329. CLARIANT, INC., ALISO VIEJO, CA. FILED 1-12-2012.

CLARIANT

THE MARK CONSISTS OF STANDARD CHARACTERS WITHOUT CLAIM TO ANY PARTICULAR FONT, STYLE, SIZE, OR COLOR.

OWNER OF U.S. REG. NOS. 3,357,168, 3,419,091 AND OTHERS.

FOR DIAGNOSTIC AND PROGNOSTIC ASSAYS CONSISTING OF ANTIBODIES AND NUCLEIC ACIDS FOR CLINICAL OR MEDICAL ANALYSIS (U.S. CLS. 6, 18, 44, 46, 51 AND 52).

HELENE LIWINSKI, EXAMINING ATTORNEY

SN 85-515,474. USPLABS, LLC, DALLAS, TX. FILED 1-12-2012.

USPlabs MuscleCarb

THE MARK CONSISTS OF STANDARD CHARACTERS WITHOUT CLAIM TO ANY PARTICULAR FONT, STYLE, SIZE, OR COLOR.

OWNER OF U.S. REG. NOS. 3,954,592, 3,955,070 AND OTHERS.

FOR DIETARY SUPPLEMENTS (U.S. CLS. 6, 18, 44, 46, 51 AND 52).

FRANK LATTUCA, EXAMINING ATTORNEY

SN 85-515,652. TRUE BALANCE ATHLETICS, LLC, ROGERS, AR. FILED 1-13-2012.

SLATHER

THE MARK CONSISTS OF STANDARD CHARACTERS WITHOUT CLAIM TO ANY PARTICULAR FONT, STYLE, SIZE, OR COLOR.

FOR SKIN LUBRICANTS FOR ATHLETES TO PREVENT SKIN CHAFING (U.S. CLS. 6, 18, 44, 46, 51 AND 52).

FIRST USE 3-8-2010; IN COMMERCE 3-8-2010.

JACLYN KIDWELL WALKER, EXAMINING ATTORNEY

CLASS 5—(Continued).

SN 85-515,659. TRUE BALANCE ATHLETICS, LLC, ROGERS, AR. FILED 1-13-2012.

SLIK DUST

THE MARK CONSISTS OF STANDARD CHARACTERS WITHOUT CLAIM TO ANY PARTICULAR FONT, STYLE, SIZE, OR COLOR.

FOR POWDERS FOR ATHLETES TO PREVENT SKIN CHAFING (U.S. CLS. 6, 18, 44, 46, 51 AND 52).
FIRST USE 3-8-2010; IN COMMERCE 3-8-2010.
JACLYN KIDWELL WALKER, EXAMINING ATTORNEY

CLASS 5—(Continued).

SN 85-515,806. VIVA LABS INC, TORONTO ON, CANADA, FILED 1-13-2012.

NOVAFLEX

THE MARK CONSISTS OF STANDARD CHARACTERS WITHOUT CLAIM TO ANY PARTICULAR FONT, STYLE, SIZE, OR COLOR.

FOR HERBAL SUPPLEMENTS (U.S. CLS. 6, 18, 44, 46, 51 AND 52).
BARBARA A. GOLD, EXAMINING ATTORNEY

SN 85-515,708. NOVARTIS AG, BASEL, SWITZERLAND, FILED 1-13-2012.

REJENA

THE MARK CONSISTS OF STANDARD CHARACTERS WITHOUT CLAIM TO ANY PARTICULAR FONT, STYLE, SIZE, OR COLOR.

FOR PHARMACEUTICAL OPHTHALMIC PREPARATIONS FOR THE TREATMENT OF DRY EYE (U.S. CLS. 6, 18, 44, 46, 51 AND 52).
LINDA LAVACHE, EXAMINING ATTORNEY

SN 85-515,858. APPLIED LIFESCIENCE RESEARCH INDUSTRIES, INC., LAS VEGAS, NV. FILED 1-13-2012.

XXX Rush

THE MARK CONSISTS OF STANDARD CHARACTERS WITHOUT CLAIM TO ANY PARTICULAR FONT, STYLE, SIZE, OR COLOR.

FOR DIETARY AND NUTRITIONAL SUPPLEMENTS; DIETARY SUPPLEMENTAL DRINKS (U.S. CLS. 6, 18, 44, 46, 51 AND 52).
FIRST USE 1-1-2002; IN COMMERCE 1-1-2002.
JOHN DWYER, EXAMINING ATTORNEY

SN 85-515,795. ATLAS THERAPEUTICS CORPORATION, MARINA DEL REY, CA. FILED 1-13-2012.

MYO-TRIM

THE MARK CONSISTS OF STANDARD CHARACTERS WITHOUT CLAIM TO ANY PARTICULAR FONT, STYLE, SIZE, OR COLOR.

OWNER OF U.S. REG. NO. 3,917,650.
FOR DIETARY AND NUTRITIONAL SUPPLEMENTS (U.S. CLS. 6, 18, 44, 46, 51 AND 52).
BRIDGETT SMITH, EXAMINING ATTORNEY

SN 85-515,859. CLARUS THERAPEUTICS, INC., NORTH-BROOK, IL. FILED 1-13-2012.

TUCLAR

THE MARK CONSISTS OF STANDARD CHARACTERS WITHOUT CLAIM TO ANY PARTICULAR FONT, STYLE, SIZE, OR COLOR.

FOR PHARMACEUTICAL PREPARATIONS FOR THE TREATMENT OF TESTOSTERONE DEFICIENCY (U.S. CLS. 6, 18, 44, 46, 51 AND 52).
DEBORAH LOBO, EXAMINING ATTORNEY

CLASS 5—(Continued).

SN 85-515,990. NATURE'S SUNSHINE PRODUCTS, INC.,
PROVO, UT. FILED 1-13-2012.

MIND-MAX

THE MARK CONSISTS OF STANDARD CHARACTERS
WITHOUT CLAIM TO ANY PARTICULAR FONT, STYLE,
SIZE, OR COLOR.

FOR DIETARY AND NUTRITIONAL SUPPLEMENTS
(U.S. CLS. 6, 18, 44, 46, 51 AND 52).

LINDSEY RUBIN, EXAMINING ATTORNEY

CLASS 5—(Continued).

SN 85-516,107. ORGANOGENESIS INC., CANTON, MA.
FILED 1-13-2012.

CELLORA

THE MARK CONSISTS OF STANDARD CHARACTERS
WITHOUT CLAIM TO ANY PARTICULAR FONT, STYLE,
SIZE, OR COLOR.

FOR LIVING TISSUE CONSTRUCTS FOR TISSUE
AUGMENTATION AND REPAIR IN THE ORAL CAV-
ITY; BIOENGINEERED BIOLOGICAL TISSUES FOR
SURGICAL IMPLANTATION (U.S. CLS. 6, 18, 44, 46, 51
AND 52).

LIEF MARTIN, EXAMINING ATTORNEY

SN 85-516,098. ORGANOGENESIS INC., CANTON, MA.
FILED 1-13-2012.

REVECEL

THE MARK CONSISTS OF STANDARD CHARACTERS
WITHOUT CLAIM TO ANY PARTICULAR FONT, STYLE,
SIZE, OR COLOR.

FOR LIVING TISSUE CONSTRUCTS FOR TISSUE
AUGMENTATION AND REPAIR IN THE ORAL CAV-
ITY; BIOENGINEERED BIOLOGICAL TISSUES FOR
SURGICAL IMPLANTATION (U.S. CLS. 6, 18, 44, 46, 51
AND 52).

LIEF MARTIN, EXAMINING ATTORNEY

SN 85-516,114. ORGANOGENESIS INC., CANTON, MA.
FILED 1-13-2012.

REGINIVA

THE MARK CONSISTS OF STANDARD CHARACTERS
WITHOUT CLAIM TO ANY PARTICULAR FONT, STYLE,
SIZE, OR COLOR.

FOR LIVING TISSUE CONSTRUCTS FOR TISSUE
AUGMENTATION AND REPAIR IN THE ORAL CAV-
ITY; BIOENGINEERED BIOLOGICAL TISSUES FOR
SURGICAL IMPLANTATION (U.S. CLS. 6, 18, 44, 46, 51
AND 52).

LIEF MARTIN, EXAMINING ATTORNEY

SN 85-516,105. ORGANOGENESIS INC., CANTON, MA.
FILED 1-13-2012.

REGENIVA

THE MARK CONSISTS OF STANDARD CHARACTERS
WITHOUT CLAIM TO ANY PARTICULAR FONT, STYLE,
SIZE, OR COLOR.

FOR LIVING TISSUE CONSTRUCTS FOR TISSUE
AUGMENTATION AND REPAIR IN THE ORAL CAV-
ITY; BIOENGINEERED BIOLOGICAL TISSUES FOR
SURGICAL IMPLANTATION (U.S. CLS. 6, 18, 44, 46, 51
AND 52).

LIEF MARTIN, EXAMINING ATTORNEY

SN 85-516,120. ORGANOGENESIS INC., CANTON, MA.
FILED 1-13-2012.

CELORAN

THE MARK CONSISTS OF STANDARD CHARACTERS
WITHOUT CLAIM TO ANY PARTICULAR FONT, STYLE,
SIZE, OR COLOR.

FOR LIVING TISSUE CONSTRUCTS FOR TISSUE
AUGMENTATION AND REPAIR IN THE ORAL CAV-
ITY; BIOENGINEERED BIOLOGICAL TISSUES FOR
SURGICAL IMPLANTATION (U.S. CLS. 6, 18, 44, 46, 51
AND 52).

LIEF MARTIN, EXAMINING ATTORNEY

CLASS 5—(Continued).

SN 85-516,122. ORGANOGENESIS INC., CANTON, MA.
FILED 1-13-2012.

CELORA

THE MARK CONSISTS OF STANDARD CHARACTERS WITHOUT CLAIM TO ANY PARTICULAR FONT, STYLE, SIZE, OR COLOR.

FOR LIVING TISSUE CONSTRUCTS FOR TISSUE AUGMENTATION AND REPAIR IN THE ORAL CAVITY; BIOENGINEERED BIOLOGICAL TISSUES FOR SURGICAL IMPLANTATION (U.S. CLS. 6, 18, 44, 46, 51 AND 52).

LIEF MARTIN, EXAMINING ATTORNEY

SN 85-517,164. MEDLINE INDUSTRIES, INC., MUNDELEIN, IL. FILED 1-16-2012.

ULTRA-SOFT PLUS

THE MARK CONSISTS OF STANDARD CHARACTERS WITHOUT CLAIM TO ANY PARTICULAR FONT, STYLE, SIZE, OR COLOR.

OWNER OF U.S. REG. NO. 3,489,426.
FOR DISPOSABLE INCONTINENCE LINERS AND BRIEFS (U.S. CLS. 6, 18, 44, 46, 51 AND 52).

ROBERT STRUCK, EXAMINING ATTORNEY

SN 85-517,171. MEDLINE INDUSTRIES, INC., MUNDELEIN, IL. FILED 1-16-2012.

PROTECTION PLUS SECRET

THE MARK CONSISTS OF STANDARD CHARACTERS WITHOUT CLAIM TO ANY PARTICULAR FONT, STYLE, SIZE, OR COLOR.

OWNER OF U.S. REG. NOS. 1,471,161, 1,762,357 AND 2,925,125.

FOR INCONTINENCE GARMENTS (U.S. CLS. 6, 18, 44, 46, 51 AND 52).

ROBERT STRUCK, EXAMINING ATTORNEY

CLASS 5—(Continued).

SN 85-517,177. MEDLINE INDUSTRIES, INC., MUNDELEIN, IL. FILED 1-16-2012.

PROTECTION PLUS LIVING

THE MARK CONSISTS OF STANDARD CHARACTERS WITHOUT CLAIM TO ANY PARTICULAR FONT, STYLE, SIZE, OR COLOR.

OWNER OF U.S. REG. NOS. 1,471,161, 1,762,357 AND 2,925,125.

FOR INCONTINENCE GARMENTS (U.S. CLS. 6, 18, 44, 46, 51 AND 52).

ROBERT STRUCK, EXAMINING ATTORNEY

SN 85-517,435. VITATHLETE, VITAMAN LLC, ALVA, FL. FILED 1-16-2012.



THE COLOR(S) RED, WHITE, BLUE, GREEN AND BLACK IS/ARE CLAIMED AS A FEATURE OF THE MARK.

THE MARK CONSISTS OF THE STYLIZED TEXT "VITAMAN" IN BLUE WITH RED DOTS IN THE LETTERS "V" AND "A" ALL UNDER A CARTOON DESIGN OF A BLUE PILL SHAPED ATHLETE PLAYING SOCCER AND SCORING A GOAL. THE ATHLETE IS IN A BLUE AND WHITE SHIRT, RED SHORTS, WHITE AND RED SOCKS, BLACK SHOES WITH WHITE SOLE AND BLUE LACES, AND WITH BLACK AND WHITE FACIAL FEATURES, PLAYING ON A GREEN FIELD WITH WHITE FIELD MARKINGS AND A WHITE NET. A BLACK AND WHITE SOCCER BALL WITH GREEN GRASS STAINS BREAKS THE NET.

FOR VITAMIN SUPPLEMENTS (U.S. CLS. 6, 18, 44, 46, 51 AND 52).

LINDA POWELL, EXAMINING ATTORNEY

CLASS 5—(Continued).

SN 85-517,776. NOVARTIS AG, BASEL, SWITZERLAND,
FILED 1-17-2012.

CLASS 5—(Continued).

SN 85-517,778. NOVARTIS AG, BASEL, SWITZERLAND,
FILED 1-17-2012.

ZEYОВI

LUNTAIN

THE MARK CONSISTS OF STANDARD CHARACTERS WITHOUT CLAIM TO ANY PARTICULAR FONT, STYLE, SIZE, OR COLOR.

THE WORDING "ZEYОВI" HAS NO MEANING IN A FOREIGN LANGUAGE.

FOR ANTI-INFLAMMATORIES; ANTIBACTERIAL PHARMACEUTICALS; ANTIBIOTICS; ANTIFUNGAL PREPARATIONS; ANTIVIRALS; CARDIOVASCULAR PHARMACEUTICALS; PHARMACEUTICAL PREPARATIONS ACTING ON THE CENTRAL NERVOUS SYSTEM; PHARMACEUTICAL PREPARATIONS AND SUBSTANCES FOR THE TREATMENT OF GASTRO-INTESTINAL DISEASES; PHARMACEUTICAL PREPARATIONS FOR THE TREATMENT AND PREVENTION OF DISEASES AND DISORDERS OF THE AUTOIMMUNE SYSTEM, THE METABOLIC SYSTEM, THE MUSCULO-SKELETAL SYSTEM AND THE GENITOURINARY SYSTEM; PHARMACEUTICAL PREPARATIONS FOR USE IN HEMATOLOGY AND IN TISSUE AND ORGAN TRANSPLANTATION; PHARMACEUTICAL PREPARATIONS FOR THE TREATMENT OF EYE DISEASES AND CONDITIONS; PHARMACEUTICAL PREPARATIONS FOR THE TREATMENT OF HEART RHYTHM DISORDERS; PHARMACEUTICAL PREPARATIONS FOR THE TREATMENT OF IMMUNE SYSTEM RELATED DISEASES AND DISORDERS; PHARMACEUTICAL PREPARATIONS FOR THE TREATMENT OF KIDNEY DISEASES; PHARMACEUTICAL PREPARATIONS FOR TREATING DIABETES; PHARMACEUTICAL PREPARATIONS FOR USE IN DERMATOLOGY; PHARMACEUTICAL PRODUCTS FOR OPHTHALMOLOGICAL USE; PHARMACEUTICAL PRODUCTS FOR THE PREVENTION AND TREATMENT OF CANCER; PHARMACEUTICAL PRODUCTS FOR THE TREATMENT OF BONE DISEASES; PHARMACEUTICAL PRODUCTS FOR TREATING RESPIRATORY DISEASES; PHARMACEUTICAL PRODUCTS FOR TREATING RESPIRATORY DISEASES AND ASTHMA; PHARMACEUTICALS, NAMELY, ANTI-INFECTIVES (U.S. CLS. 6, 18, 44, 46, 51 AND 52).

LINDA LAVACHE, EXAMINING ATTORNEY

THE MARK CONSISTS OF STANDARD CHARACTERS WITHOUT CLAIM TO ANY PARTICULAR FONT, STYLE, SIZE, OR COLOR.

THE WORDING "LUNTAIN" HAS NO MEANING IN A FOREIGN LANGUAGE.

FOR ANTI-INFLAMMATORIES; ANTIBACTERIAL PHARMACEUTICALS; ANTIBIOTICS; ANTIFUNGAL PREPARATIONS; ANTIVIRALS; CARDIOVASCULAR PHARMACEUTICALS; PHARMACEUTICAL PREPARATIONS ACTING ON THE CENTRAL NERVOUS SYSTEM; PHARMACEUTICAL PREPARATIONS AND SUBSTANCES FOR THE TREATMENT OF GASTRO-INTESTINAL DISEASES; PHARMACEUTICAL PREPARATIONS FOR THE TREATMENT AND PREVENTION OF DISEASES AND DISORDERS OF THE AUTOIMMUNE SYSTEM, THE METABOLIC SYSTEM, THE MUSCULO-SKELETAL SYSTEM AND THE GENITOURINARY SYSTEM; PHARMACEUTICAL PREPARATIONS FOR USE IN HEMATOLOGY AND IN TISSUE AND ORGAN TRANSPLANTATION; PHARMACEUTICAL PREPARATIONS FOR THE TREATMENT OF EYE DISEASES AND CONDITIONS; PHARMACEUTICAL PREPARATIONS FOR THE TREATMENT OF HEART RHYTHM DISORDERS; PHARMACEUTICAL PREPARATIONS FOR THE TREATMENT OF IMMUNE SYSTEM RELATED DISEASES AND DISORDERS; PHARMACEUTICAL PREPARATIONS FOR THE TREATMENT OF KIDNEY DISEASES; PHARMACEUTICAL PREPARATIONS FOR TREATING DIABETES; PHARMACEUTICAL PREPARATIONS FOR USE IN DERMATOLOGY; PHARMACEUTICAL PRODUCTS FOR OPHTHALMOLOGICAL USE; PHARMACEUTICAL PRODUCTS FOR THE PREVENTION AND TREATMENT OF CANCER; PHARMACEUTICAL PRODUCTS FOR THE TREATMENT OF BONE DISEASES; PHARMACEUTICAL PRODUCTS FOR TREATING RESPIRATORY DISEASES; PHARMACEUTICAL PRODUCTS FOR TREATING RESPIRATORY DISEASES AND ASTHMA; PHARMACEUTICALS, NAMELY, ANTI-INFECTIVES (U.S. CLS. 6, 18, 44, 46, 51 AND 52).

LINDA LAVACHE, EXAMINING ATTORNEY

CLASS 5—(Continued).

SN 85-517,779. NOVARTIS AG, BASEL, SWITZERLAND,
FILED 1-17-2012.

CLASS 5—(Continued).

SN 85-517,782. NOVARTIS AG, BASEL, SWITZERLAND,
FILED 1-17-2012.

VINDRIS

ZONTWIN

THE MARK CONSISTS OF STANDARD CHARACTERS WITHOUT CLAIM TO ANY PARTICULAR FONT, STYLE, SIZE, OR COLOR.

THE WORDING "VINDRIS" HAS NO MEANING IN A FOREIGN LANGUAGE.

FOR ANTI-INFLAMMATORIES; ANTIBACTERIAL PHARMACEUTICALS; ANTIBIOTICS; ANTIFUNGAL PREPARATIONS; ANTIVIRALS; CARDIOVASCULAR PHARMACEUTICALS; PHARMACEUTICAL PREPARATIONS ACTING ON THE CENTRAL NERVOUS SYSTEM; PHARMACEUTICAL PREPARATIONS AND SUBSTANCES FOR THE TREATMENT OF GASTRO-INTESTINAL DISEASES; PHARMACEUTICAL PREPARATIONS FOR THE TREATMENT AND PREVENTION OF DISEASES AND DISORDERS OF THE AUTOIMMUNE SYSTEM, THE METABOLIC SYSTEM, THE MUSCULO-SKELETAL SYSTEM AND THE GENITOURINARY SYSTEM; PHARMACEUTICAL PREPARATIONS FOR USE IN HEMATOLOGY AND IN TISSUE AND ORGAN TRANSPLANTATION; PHARMACEUTICAL PREPARATIONS FOR THE TREATMENT OF EYE DISEASES AND CONDITIONS; PHARMACEUTICAL PREPARATIONS FOR THE TREATMENT OF HEART RHYTHM DISORDERS; PHARMACEUTICAL PREPARATIONS FOR THE TREATMENT OF IMMUNE SYSTEM RELATED DISEASES AND DISORDERS; PHARMACEUTICAL PREPARATIONS FOR THE TREATMENT OF KIDNEY DISEASES; PHARMACEUTICAL PREPARATIONS FOR TREATING DIABETES; PHARMACEUTICAL PREPARATIONS FOR USE IN DERMATOLOGY; PHARMACEUTICAL PRODUCTS FOR OPHTHALMOLOGICAL USE; PHARMACEUTICAL PRODUCTS FOR THE PREVENTION AND TREATMENT OF CANCER; PHARMACEUTICAL PRODUCTS FOR THE TREATMENT OF BONE DISEASES; PHARMACEUTICAL PRODUCTS FOR TREATING RESPIRATORY DISEASES; PHARMACEUTICAL PRODUCTS FOR TREATING RESPIRATORY DISEASES AND ASTHMA; PHARMACEUTICALS, NAMELY, ANTI-INFECTIVES (U.S. CLS. 6, 18, 44, 46, 51 AND 52).

LINDA LAVACHE, EXAMINING ATTORNEY

THE MARK CONSISTS OF STANDARD CHARACTERS WITHOUT CLAIM TO ANY PARTICULAR FONT, STYLE, SIZE, OR COLOR.

THE WORDING "ZONTWIN" HAS NO MEANING IN A FOREIGN LANGUAGE.

FOR ANTI-INFLAMMATORIES; ANTIBACTERIAL PHARMACEUTICALS; ANTIBIOTICS; ANTIFUNGAL PREPARATIONS; ANTIVIRALS; CARDIOVASCULAR PHARMACEUTICALS; PHARMACEUTICAL PREPARATIONS AND SUBSTANCES FOR THE TREATMENT OF GASTRO-INTESTINAL DISEASES; PHARMACEUTICAL PREPARATIONS FOR THE TREATMENT AND PREVENTION OF DISEASES AND DISORDERS OF THE AUTOIMMUNE SYSTEM, THE METABOLIC SYSTEM, THE MUSCULO-SKELETAL SYSTEM AND THE GENITOURINARY SYSTEM; PHARMACEUTICAL PREPARATIONS FOR USE IN HEMATOLOGY AND IN TISSUE AND ORGAN TRANSPLANTATION; PHARMACEUTICAL PREPARATIONS FOR THE TREATMENT OF EYE DISEASES AND CONDITIONS; PHARMACEUTICAL PREPARATIONS FOR THE TREATMENT OF HEART RHYTHM DISORDERS; PHARMACEUTICAL PREPARATIONS FOR THE TREATMENT OF IMMUNE SYSTEM RELATED DISEASES AND DISORDERS; PHARMACEUTICAL PREPARATIONS FOR THE TREATMENT OF KIDNEY DISEASES; PHARMACEUTICAL PREPARATIONS FOR TREATING DIABETES; PHARMACEUTICAL PREPARATIONS FOR USE IN DERMATOLOGY; PHARMACEUTICAL PRODUCTS FOR OPHTHALMOLOGICAL USE; PHARMACEUTICAL PRODUCTS FOR THE PREVENTION AND TREATMENT OF CANCER; PHARMACEUTICAL PRODUCTS FOR THE TREATMENT OF BONE DISEASES; PHARMACEUTICAL PRODUCTS FOR TREATING RESPIRATORY DISEASES; PHARMACEUTICAL PRODUCTS FOR TREATING RESPIRATORY DISEASES AND ASTHMA; PHARMACEUTICALS, NAMELY, ANTI-INFECTIVES (U.S. CLS. 6, 18, 44, 46, 51 AND 52).

LINDA LAVACHE, EXAMINING ATTORNEY

CLASS 5—(Continued).

SN 85-517,783. NOVARTIS AG, BASEL, SWITZERLAND,
FILED 1-17-2012.

CLASS 5—(Continued).

SN 85-517,788. NOVARTIS AG, BASEL, SWITZERLAND,
FILED 1-17-2012.

DIBRIZO

BREZERIS

THE MARK CONSISTS OF STANDARD CHARACTERS WITHOUT CLAIM TO ANY PARTICULAR FONT, STYLE, SIZE, OR COLOR.

FOR ANTI-INFLAMMATORIES; ANTIBACTERIAL PHARMACEUTICALS; ANTIBIOTICS; ANTIFUNGAL PREPARATIONS; ANTIVIRALS; CARDIOVASCULAR PHARMACEUTICALS; PHARMACEUTICAL PREPARATIONS ACTING ON THE CENTRAL NERVOUS SYSTEM; PHARMACEUTICAL PREPARATIONS AND SUBSTANCES FOR THE TREATMENT OF GASTRO-INTESTINAL DISEASES; PHARMACEUTICAL PREPARATIONS FOR THE TREATMENT AND PREVENTION OF DISEASES AND DISORDERS OF THE AUTOIMMUNE SYSTEM, THE METABOLIC SYSTEM, THE MUSCULO-SKELETAL SYSTEM AND THE GENITOURINARY SYSTEM; PHARMACEUTICAL PREPARATIONS FOR USE IN HEMATOLOGY AND IN TISSUE AND ORGAN TRANSPLANTATION; PHARMACEUTICAL PREPARATIONS FOR THE TREATMENT OF EYE DISEASES AND CONDITIONS; PHARMACEUTICAL PREPARATIONS FOR THE TREATMENT OF HEART RHYTHM DISORDERS; PHARMACEUTICAL PREPARATIONS FOR THE TREATMENT OF IMMUNE SYSTEM RELATED DISEASES AND DISORDERS; PHARMACEUTICAL PREPARATIONS FOR THE TREATMENT OF KIDNEY DISEASES; PHARMACEUTICAL PREPARATIONS FOR TREATING DIABETES; PHARMACEUTICAL PREPARATIONS FOR USE IN DERMATOLOGY; PHARMACEUTICAL PRODUCTS FOR OPHTHALMOLOGICAL USE; PHARMACEUTICAL PRODUCTS FOR THE PREVENTION AND TREATMENT OF CANCER; PHARMACEUTICAL PRODUCTS FOR THE TREATMENT OF BONE DISEASES; PHARMACEUTICAL PRODUCTS FOR TREATING RESPIRATORY DISEASES; PHARMACEUTICAL PRODUCTS FOR TREATING RESPIRATORY DISEASES AND ASTHMA; PHARMACEUTICALS, NAMELY, ANTI-INFECTIVES (U.S. CLS. 6, 18, 44, 46, 51 AND 52).

CHRISTINE MARTIN, EXAMINING ATTORNEY

THE MARK CONSISTS OF STANDARD CHARACTERS WITHOUT CLAIM TO ANY PARTICULAR FONT, STYLE, SIZE, OR COLOR.

FOR ANTI-INFLAMMATORIES; ANTIBACTERIAL PHARMACEUTICALS; ANTIBIOTICS; ANTIFUNGAL PREPARATIONS; ANTIVIRALS; CARDIOVASCULAR PHARMACEUTICALS; PHARMACEUTICAL PREPARATIONS ACTING ON THE CENTRAL NERVOUS SYSTEM; PHARMACEUTICAL PREPARATIONS AND SUBSTANCES FOR THE TREATMENT OF GASTRO-INTESTINAL DISEASES; PHARMACEUTICAL PREPARATIONS FOR THE TREATMENT AND PREVENTION OF DISEASES AND DISORDERS OF THE AUTOIMMUNE SYSTEM, THE METABOLIC SYSTEM, THE MUSCULO-SKELETAL SYSTEM AND THE GENITOURINARY SYSTEM; PHARMACEUTICAL PREPARATIONS FOR USE IN HEMATOLOGY AND IN TISSUE AND ORGAN TRANSPLANTATION; PHARMACEUTICAL PREPARATIONS FOR THE TREATMENT OF EYE DISEASES AND CONDITIONS; PHARMACEUTICAL PREPARATIONS FOR THE TREATMENT OF HEART RHYTHM DISORDERS; PHARMACEUTICAL PREPARATIONS FOR THE TREATMENT OF IMMUNE SYSTEM RELATED DISEASES AND DISORDERS; PHARMACEUTICAL PREPARATIONS FOR THE TREATMENT OF KIDNEY DISEASES; PHARMACEUTICAL PREPARATIONS FOR TREATING DIABETES; PHARMACEUTICAL PREPARATIONS FOR USE IN DERMATOLOGY; PHARMACEUTICAL PRODUCTS FOR OPHTHALMOLOGICAL USE; PHARMACEUTICAL PRODUCTS FOR THE PREVENTION AND TREATMENT OF CANCER; PHARMACEUTICAL PRODUCTS FOR THE TREATMENT OF BONE DISEASES; PHARMACEUTICAL PRODUCTS FOR TREATING RESPIRATORY DISEASES; PHARMACEUTICAL PRODUCTS FOR TREATING RESPIRATORY DISEASES AND ASTHMA; PHARMACEUTICALS, NAMELY, ANTI-INFECTIVES (U.S. CLS. 6, 18, 44, 46, 51 AND 52).

CHRISTINE MARTIN, EXAMINING ATTORNEY

CLASS 5—(Continued).

SN 85-517,790. NOVARTIS AG, BASEL, SWITZERLAND,
FILED 1-17-2012.

CLASS 5—(Continued).

SN 85-517,792. NOVARTIS AG, BASEL, SWITZERLAND,
FILED 1-17-2012.

BIONBRI

ALTONBRI

THE MARK CONSISTS OF STANDARD CHARACTERS WITHOUT CLAIM TO ANY PARTICULAR FONT, STYLE, SIZE, OR COLOR.

FOR ANTI-INFLAMMATORIES; ANTIBACTERIAL PHARMACEUTICALS; ANTIBIOTICS; ANTIFUNGAL PREPARATIONS; ANTIVIRALS; CARDIOVASCULAR PHARMACEUTICALS; PHARMACEUTICAL PREPARATIONS ACTING ON THE CENTRAL NERVOUS SYSTEM; PHARMACEUTICAL PREPARATIONS AND SUBSTANCES FOR THE TREATMENT OF GASTRO-INTESTINAL DISEASES; PHARMACEUTICAL PREPARATIONS FOR THE TREATMENT AND PREVENTION OF DISEASES AND DISORDERS OF THE AUTOIMMUNE SYSTEM, THE METABOLIC SYSTEM, THE MUSCULO-SKELETAL SYSTEM AND THE GENITOURINARY SYSTEM; PHARMACEUTICAL PREPARATIONS FOR USE IN HEMATOLOGY AND IN TISSUE AND ORGAN TRANSPLANTATION; PHARMACEUTICAL PREPARATIONS FOR THE TREATMENT OF EYE DISEASES AND CONDITIONS; PHARMACEUTICAL PREPARATIONS FOR THE TREATMENT OF HEART RHYTHM DISORDERS; PHARMACEUTICAL PREPARATIONS FOR THE TREATMENT OF IMMUNE SYSTEM RELATED DISEASES AND DISORDERS; PHARMACEUTICAL PREPARATIONS FOR THE TREATMENT OF KIDNEY DISEASES; PHARMACEUTICAL PREPARATIONS FOR TREATING DIABETES; PHARMACEUTICAL PREPARATIONS FOR USE IN DERMATOLOGY; PHARMACEUTICAL PRODUCTS FOR OPHTHALMOLOGICAL USE; PHARMACEUTICAL PRODUCTS FOR THE PREVENTION AND TREATMENT OF CANCER; PHARMACEUTICAL PRODUCTS FOR THE TREATMENT OF BONE DISEASES; PHARMACEUTICAL PRODUCTS FOR TREATING RESPIRATORY DISEASES; PHARMACEUTICAL PRODUCTS FOR TREATING RESPIRATORY DISEASES AND ASTHMA; PHARMACEUTICALS, NAMELY, ANTI-INFECTIVES (U.S. CLS. 6, 18, 44, 46, 51 AND 52).

CHRISTINE MARTIN, EXAMINING ATTORNEY

THE MARK CONSISTS OF STANDARD CHARACTERS WITHOUT CLAIM TO ANY PARTICULAR FONT, STYLE, SIZE, OR COLOR.

FOR ANTI-INFLAMMATORIES; ANTIBACTERIAL PHARMACEUTICALS; ANTIBIOTICS; ANTIFUNGAL PREPARATIONS; ANTIVIRALS; CARDIOVASCULAR PHARMACEUTICALS; PHARMACEUTICAL PREPARATIONS ACTING ON THE CENTRAL NERVOUS SYSTEM; PHARMACEUTICAL PREPARATIONS AND SUBSTANCES FOR THE TREATMENT OF GASTRO-INTESTINAL DISEASES; PHARMACEUTICAL PREPARATIONS FOR THE TREATMENT AND PREVENTION OF DISEASES AND DISORDERS OF THE AUTOIMMUNE SYSTEM, THE METABOLIC SYSTEM, THE MUSCULO-SKELETAL SYSTEM AND THE GENITOURINARY SYSTEM; PHARMACEUTICAL PREPARATIONS FOR USE IN HEMATOLOGY AND IN TISSUE AND ORGAN TRANSPLANTATION; PHARMACEUTICAL PREPARATIONS FOR THE TREATMENT OF EYE DISEASES AND CONDITIONS; PHARMACEUTICAL PREPARATIONS FOR THE TREATMENT OF HEART RHYTHM DISORDERS; PHARMACEUTICAL PREPARATIONS FOR THE TREATMENT OF IMMUNE SYSTEM RELATED DISEASES AND DISORDERS; PHARMACEUTICAL PREPARATIONS FOR THE TREATMENT OF KIDNEY DISEASES; PHARMACEUTICAL PREPARATIONS FOR TREATING DIABETES; PHARMACEUTICAL PREPARATIONS FOR USE IN DERMATOLOGY; PHARMACEUTICAL PRODUCTS FOR OPHTHALMOLOGICAL USE; PHARMACEUTICAL PRODUCTS FOR THE PREVENTION AND TREATMENT OF CANCER; PHARMACEUTICAL PRODUCTS FOR THE TREATMENT OF BONE DISEASES; PHARMACEUTICAL PRODUCTS FOR TREATING RESPIRATORY DISEASES; PHARMACEUTICAL PRODUCTS FOR TREATING RESPIRATORY DISEASES AND ASTHMA; PHARMACEUTICALS, NAMELY, ANTI-INFECTIVES (U.S. CLS. 6, 18, 44, 46, 51 AND 52).

CHRISTINE MARTIN, EXAMINING ATTORNEY

CLASS 5—(Continued).

SN 85-517,796. NOVARTIS AG, BASEL, SWITZERLAND,
FILED 1-17-2012.

CLASS 5—(Continued).

SN 85-519,105. NUTRADE, LLC, PHOENIX, AZ. FILED 1-18-
2012.

ULTIBRO



THE MARK CONSISTS OF STANDARD CHARACTERS WITHOUT CLAIM TO ANY PARTICULAR FONT, STYLE, SIZE, OR COLOR.

FOR ANTI-INFLAMMATORIES; ANTIBACTERIAL PHARMACEUTICALS; ANTIBIOTICS; ANTIFUNGAL PREPARATIONS; ANTIVIRALS; CARDIOVASCULAR PHARMACEUTICALS; PHARMACEUTICAL PREPARATIONS ACTING ON THE CENTRAL NERVOUS SYSTEM; PHARMACEUTICAL PREPARATIONS AND SUBSTANCES FOR THE TREATMENT OF GASTRO-INTESTINAL DISEASES; PHARMACEUTICAL PREPARATIONS FOR THE TREATMENT AND PREVENTION OF DISEASES AND DISORDERS OF THE AUTOIMMUNE SYSTEM, THE METABOLIC SYSTEM, THE MUSCULOSKELETAL SYSTEM AND THE GENITOURINARY SYSTEM; PHARMACEUTICAL PREPARATIONS FOR USE IN HEMATOLOGY AND IN TISSUE AND ORGAN TRANSPLANTATION; PHARMACEUTICAL PREPARATIONS FOR THE TREATMENT OF EYE DISEASES AND CONDITIONS; PHARMACEUTICAL PREPARATIONS FOR THE TREATMENT OF HEART RHYTHM DISORDERS; PHARMACEUTICAL PREPARATIONS FOR THE TREATMENT OF IMMUNE SYSTEM RELATED DISEASES AND DISORDERS; PHARMACEUTICAL PREPARATIONS FOR THE TREATMENT OF KIDNEY DISEASES; PHARMACEUTICAL PREPARATIONS FOR TREATING DIABETES; PHARMACEUTICAL PREPARATIONS FOR USE IN DERMATOLOGY; PHARMACEUTICAL PRODUCTS FOR OPHTHALMOLOGICAL USE; PHARMACEUTICAL PRODUCTS FOR THE PREVENTION AND TREATMENT OF CANCER; PHARMACEUTICAL PRODUCTS FOR THE TREATMENT OF BONE DISEASES; PHARMACEUTICAL PRODUCTS FOR TREATING RESPIRATORY DISEASES; PHARMACEUTICAL PRODUCTS FOR TREATING RESPIRATORY DISEASES AND ASTHMA; PHARMACEUTICALS, NAMELY, ANTI-INFECTIVES (U.S. CLS. 6, 18, 44, 46, 51 AND 52).

CHRISTINE MARTIN, EXAMINING ATTORNEY

THE COLOR(S) RED AND BLACK IS/ARE CLAIMED AS A FEATURE OF THE MARK.

THE MARK CONSISTS OF A HUMAN STICK FIGURE IN A SEATED POSITION, WITH ONE ARM POSITIONED OVER HIS BACK, AND WITH THREE TRIANGLES AND TWO STARS NEAR HIS BACK, ALL IN BLACK. THIS FIGURE IS SUPERIMPOSED OVER THE INTERNATIONAL SIGN FOR NO, OR STOP OR PROHIBITED IN RED.

FOR DIETARY AND NUTRITIONAL SUPPLEMENTS; AND HERBS AND BOTANICALS FOR USE AS DIETARY SUPPLEMENTS (U.S. CLS. 6, 18, 44, 46, 51 AND 52).

Laurie Mayes, Examining Attorney

CLASS 5—(Continued).

SN 85-519,908. NOVARTIS AG, BASEL, SWITZERLAND,
FILED 1-19-2012.

CLASS 5—(Continued).

SN 85-519,909. NOVARTIS AG, BASEL, SWITZERLAND,
FILED 1-19-2012.

OZYBRI

ULUNAR

THE MARK CONSISTS OF STANDARD CHARACTERS WITHOUT CLAIM TO ANY PARTICULAR FONT, STYLE, SIZE, OR COLOR.

FOR ANTI-INFLAMMATORIES; ANTIBACTERIAL PHARMACEUTICALS; ANTIBIOTICS; ANTIFUNGAL PREPARATIONS; ANTIVIRALS; CARDIOVASCULAR PHARMACEUTICALS; PHARMACEUTICAL PREPARATIONS ACTING ON THE CENTRAL NERVOUS SYSTEM; PHARMACEUTICAL PREPARATIONS AND SUBSTANCES FOR THE TREATMENT OF GASTRO-INTESTINAL DISEASES; PHARMACEUTICAL PREPARATIONS FOR THE TREATMENT AND PREVENTION OF DISEASES AND DISORDERS OF THE AUTOIMMUNE SYSTEM, THE METABOLIC SYSTEM, THE MUSCULOSKELETAL SYSTEM AND THE GENITOURINARY SYSTEM; PHARMACEUTICAL PREPARATIONS FOR USE IN HEMATOLOGY AND IN TISSUE AND ORGAN TRANSPLANTATION; PHARMACEUTICAL PREPARATIONS FOR THE TREATMENT OF EYE DISEASES AND CONDITIONS; PHARMACEUTICAL PREPARATIONS FOR THE TREATMENT OF HEART RHYTHM DISORDERS; PHARMACEUTICAL PREPARATIONS FOR THE TREATMENT OF IMMUNE SYSTEM RELATED DISEASES AND DISORDERS; PHARMACEUTICAL PREPARATIONS FOR THE TREATMENT OF KIDNEY DISEASES; PHARMACEUTICAL PREPARATIONS FOR TREATING DIABETES; PHARMACEUTICAL PREPARATIONS FOR USE IN DERMATOLOGY; PHARMACEUTICAL PRODUCTS FOR OPHTHALMOLOGICAL USE; PHARMACEUTICAL PRODUCTS FOR THE PREVENTION AND TREATMENT OF CANCER; PHARMACEUTICAL PRODUCTS FOR THE TREATMENT OF BONE DISEASES; PHARMACEUTICAL PRODUCTS FOR TREATING RESPIRATORY DISEASES; PHARMACEUTICAL PRODUCTS FOR TREATING RESPIRATORY DISEASES AND ASTHMA; PHARMACEUTICALS, NAMELY, ANTI-INFECTIVES (U.S. CLS. 6, 18, 44, 46, 51 AND 52).

CHRISTINE MARTIN, EXAMINING ATTORNEY

THE MARK CONSISTS OF STANDARD CHARACTERS WITHOUT CLAIM TO ANY PARTICULAR FONT, STYLE, SIZE, OR COLOR.

FOR ANTI-INFLAMMATORIES; ANTIBACTERIAL PHARMACEUTICALS; ANTIBIOTICS; ANTIFUNGAL PREPARATIONS; ANTIVIRALS; CARDIOVASCULAR PHARMACEUTICALS; PHARMACEUTICAL PREPARATIONS ACTING ON THE CENTRAL NERVOUS SYSTEM; PHARMACEUTICAL PREPARATIONS AND SUBSTANCES FOR THE TREATMENT OF GASTRO-INTESTINAL DISEASES; PHARMACEUTICAL PREPARATIONS FOR THE TREATMENT AND PREVENTION OF DISEASES AND DISORDERS OF THE AUTOIMMUNE SYSTEM, THE METABOLIC SYSTEM, THE MUSCULOSKELETAL SYSTEM AND THE GENITOURINARY SYSTEM; PHARMACEUTICAL PREPARATIONS FOR USE IN HEMATOLOGY AND IN TISSUE AND ORGAN TRANSPLANTATION; PHARMACEUTICAL PREPARATIONS FOR THE TREATMENT OF EYE DISEASES AND CONDITIONS; PHARMACEUTICAL PREPARATIONS FOR THE TREATMENT OF HEART RHYTHM DISORDERS; PHARMACEUTICAL PREPARATIONS FOR THE TREATMENT OF IMMUNE SYSTEM RELATED DISEASES AND DISORDERS; PHARMACEUTICAL PREPARATIONS FOR THE TREATMENT OF KIDNEY DISEASES; PHARMACEUTICAL PREPARATIONS FOR TREATING DIABETES; PHARMACEUTICAL PREPARATIONS FOR USE IN DERMATOLOGY; PHARMACEUTICAL PRODUCTS FOR OPHTHALMOLOGICAL USE; PHARMACEUTICAL PRODUCTS FOR THE PREVENTION AND TREATMENT OF CANCER; PHARMACEUTICAL PRODUCTS FOR THE TREATMENT OF BONE DISEASES; PHARMACEUTICAL PRODUCTS FOR TREATING RESPIRATORY DISEASES; PHARMACEUTICAL PRODUCTS FOR TREATING RESPIRATORY DISEASES AND ASTHMA; PHARMACEUTICALS, NAMELY, ANTI-INFECTIVES (U.S. CLS. 6, 18, 44, 46, 51 AND 52).

CHRISTINE MARTIN, EXAMINING ATTORNEY

CLASS 5—(Continued).

SN 85-519,912. NOVARTIS AG, BASEL, SWITZERLAND, FILED 1-19-2012.

FORTONBRI

THE MARK CONSISTS OF STANDARD CHARACTERS WITHOUT CLAIM TO ANY PARTICULAR FONT, STYLE, SIZE, OR COLOR.

FOR ANTI-INFLAMMATORIES; ANTIBACTERIAL PHARMACEUTICALS; ANTIBIOTICS; ANTIFUNGAL PREPARATIONS; ANTIVIRALS; CARDIOVASCULAR PHARMACEUTICALS; PHARMACEUTICAL PREPARATIONS ACTING ON THE CENTRAL NERVOUS SYSTEM; PHARMACEUTICAL PREPARATIONS AND SUBSTANCES FOR THE TREATMENT OF GASTRO-INTESTINAL DISEASES; PHARMACEUTICAL PREPARATIONS FOR THE TREATMENT AND PREVENTION OF DISEASES AND DISORDERS OF THE AUTOIMMUNE SYSTEM, THE METABOLIC SYSTEM, THE MUSCULO-SKELETAL SYSTEM AND THE GENITOURINARY SYSTEM; PHARMACEUTICAL PREPARATIONS FOR USE IN HEMATOLOGY AND IN TISSUE AND ORGAN TRANSPLANTATION; PHARMACEUTICAL PREPARATIONS FOR THE TREATMENT OF EYE DISEASES AND CONDITIONS; PHARMACEUTICAL PREPARATIONS FOR THE TREATMENT OF HEART RHYTHM DISORDERS; PHARMACEUTICAL PREPARATIONS FOR THE TREATMENT OF IMMUNE SYSTEM RELATED DISEASES AND DISORDERS; PHARMACEUTICAL PREPARATIONS FOR THE TREATMENT OF KIDNEY DISEASES; PHARMACEUTICAL PREPARATIONS FOR TREATING DIABETES; PHARMACEUTICAL PREPARATIONS FOR USE IN DERMATOLOGY; PHARMACEUTICAL PRODUCTS FOR OPHTHALMOLOGICAL USE; PHARMACEUTICAL PRODUCTS FOR THE PREVENTION AND TREATMENT OF CANCER; PHARMACEUTICAL PRODUCTS FOR THE TREATMENT OF BONE DISEASES; PHARMACEUTICAL PRODUCTS FOR TREATING RESPIRATORY DISEASES; PHARMACEUTICAL PRODUCTS FOR TREATING RESPIRATORY DISEASES AND ASTHMA; PHARMACEUTICALS, NAMELY, ANTI-INFECTIVES (U.S. CLS. 6, 18, 44, 46, 51 AND 52).

CHRISTINE MARTIN, EXAMINING ATTORNEY

SN 85-520,574. PBM NUTRITIONALS, LLC, GORDONSVILLE, VA. FILED 1-19-2012.

TENDER BALANCE

THE MARK CONSISTS OF STANDARD CHARACTERS WITHOUT CLAIM TO ANY PARTICULAR FONT, STYLE, SIZE, OR COLOR.

FOR INFANT FORMULA (U.S. CLS. 6, 18, 44, 46, 51 AND 52).

GRETTA YAO, EXAMINING ATTORNEY

CLASS 5—(Continued).

SN 85-522,686. BAYER AKTIENGESELLSCHAFT, LEVERKUSEN, FED REP GERMANY, FILED 1-23-2012.



THE COLOR(S) PLUM, SILVER AND GOLD IS/ARE CLAIMED AS A FEATURE OF THE MARK.

THE MARK CONSISTS OF THE LOWERCASE GREEK LETTER "ALPHA" WHERE THE COLOR SILVER APPEARS WITHIN THE SPHERE TO THE LEFT OF THE "ALPHA," THE COLOR GOLD APPEARS WITHIN THE SPHERE TO THE RIGHT OF THE "ALPHA" AND THE COLOR PLUM APPEARS AT THE TOP, MIDDLE AND BOTTOM OF THE SPHERE.

FOR PHARMACEUTICAL PREPARATIONS FOR THE TREATMENT OF CANCER (U.S. CLS. 6, 18, 44, 46, 51 AND 52).

RONALD AIKENS, EXAMINING ATTORNEY

SN 85-523,174. GLAXO GROUP LIMITED, GREENFORD, MIDDLESEX, UNITED KINGDOM, FILED 1-23-2012.

EPERZAN

THE MARK CONSISTS OF STANDARD CHARACTERS WITHOUT CLAIM TO ANY PARTICULAR FONT, STYLE, SIZE, OR COLOR.

FOR PHARMACEUTICAL PREPARATIONS FOR TREATING DIABETES (U.S. CLS. 6, 18, 44, 46, 51 AND 52).

ELISSA GARBER KON, EXAMINING ATTORNEY

SN 85-523,430. ABBOTT LABORATORIES, ABBOTT PARK, IL. FILED 1-24-2012.

ALUVIA

THE MARK CONSISTS OF STANDARD CHARACTERS WITHOUT CLAIM TO ANY PARTICULAR FONT, STYLE, SIZE, OR COLOR.

FOR PRESCRIPTION ONLY ANTI-VIRAL PHARMACEUTICAL PREPARATIONS FOR THE TREATMENT OF HIV (U.S. CLS. 6, 18, 44, 46, 51 AND 52).

YAT SYE, LEE, EXAMINING ATTORNEY

CLASS 5—(Continued).

SN 85-524,413. GIANT SPORTS PRODUCTS LLC, BRICK, NJ. FILED 1-24-2012.

**GIANT SPORTS DELICIOUS
PROTEIN**

THE MARK CONSISTS OF STANDARD CHARACTERS WITHOUT CLAIM TO ANY PARTICULAR FONT, STYLE, SIZE, OR COLOR.

NO CLAIM IS MADE TO THE EXCLUSIVE RIGHT TO USE "SPORTS" OR "PROTEIN", APART FROM THE MARK AS SHOWN.

FOR NUTRITIONAL SUPPLEMENT IN THE NATURE OF A NUTRIENT-DENSE, PROTEIN-BASED DRINK MIX; PROTEIN DIETARY SUPPLEMENTS; PROTEIN SUPPLEMENTS; WHEY PROTEIN SUPPLEMENTS (U.S. CLS. 6, 18, 44, 46, 51 AND 52).

IRA J. GOODSAD, EXAMINING ATTORNEY

SN 85-524,844. CHERRY CAPITAL SERVICES, INC., TRAVERSE CITY, MI. FILED 1-25-2012.

**DELIVERING THE POWER OF
FRUIT**

THE MARK CONSISTS OF STANDARD CHARACTERS WITHOUT CLAIM TO ANY PARTICULAR FONT, STYLE, SIZE, OR COLOR.

NO CLAIM IS MADE TO THE EXCLUSIVE RIGHT TO USE "FRUIT", APART FROM THE MARK AS SHOWN.

FOR DIETARY SUPPLEMENTS (U.S. CLS. 6, 18, 44, 46, 51 AND 52).

FIRST USE 3-31-2006; IN COMMERCE 3-31-2006.
ELISSA GARBER KON, EXAMINING ATTORNEY

SN 85-524,860. CHERRY CAPITAL SERVICES, INC., TRAVERSE CITY, MI. FILED 1-25-2012.

POWERED BY CHERRIES

THE MARK CONSISTS OF STANDARD CHARACTERS WITHOUT CLAIM TO ANY PARTICULAR FONT, STYLE, SIZE, OR COLOR.

NO CLAIM IS MADE TO THE EXCLUSIVE RIGHT TO USE "CHERRIES", APART FROM THE MARK AS SHOWN. FOR DIETARY SUPPLEMENTS CONTAINING CHERRIES (U.S. CLS. 6, 18, 44, 46, 51 AND 52).

FIRST USE 9-30-2011; IN COMMERCE 11-30-2011.
ELISSA GARBER KON, EXAMINING ATTORNEY

CLASS 5—(Continued).

SN 85-525,780. SIX DIMENSIONS, INC., MAYFIELD, KY. FILED 1-26-2012.



NO CLAIM IS MADE TO THE EXCLUSIVE RIGHT TO USE "COFFEE ANTI-AGING BLENDS", APART FROM THE MARK AS SHOWN.

THE MARK CONSISTS OF THE STYLIZED WORDING "M.D. COFFEE ANTI-AGING BLENDS" STACKED ON TOP OF EACH OTHER WITH THE LETTER "M" IN "M.D." FORMING A STYLIZED MUG WITH A HANDLE ON THE LEFT AND STEAM EMANATING FROM THE TOP.

FOR DIETARY BEVERAGE SUPPLEMENTS FOR HUMAN CONSUMPTION IN LIQUID AND DRY MIX FORM FOR THERAPEUTIC PURPOSES, ALL OF THE FOREGOING CONTAINING COFFEE OR COFFEE EXTRACTS (U.S. CLS. 6, 18, 44, 46, 51 AND 52).

AMY KERTGATE, EXAMINING ATTORNEY

SN 85-525,963. TUONG NGUYEN, WESTMINSTER, CA. FILED 1-26-2012.



NO CLAIM IS MADE TO THE EXCLUSIVE RIGHT TO USE "PREMIUM NUTRITION", APART FROM THE MARK AS SHOWN.

THE COLOR(S) BLUE, RED, WHITE, YELLOW AND BLACK IS/ARE CLAIMED AS A FEATURE OF THE MARK.

THE MARK CONSISTS OF A DESIGN OF A WHITE EAGLE HEAD WITH A YELLOW EYE AND YELLOW BEAK, ALL OUTLINED IN BLACK, ABOVE THE WORDING "MAXX" IN WHITE, WHICH IS ABOVE THE WORDING "PREMIUM NUTRITION" IN WHITE. THE EAGLE HEAD AND WORDING ARE ALL SUPERIMPOSED OVER A RED RECTANGLE WITH RED SEMICIRCLE ON TOP, AND ABOVE THE SEMICIRCLE IS A BLUE ARCH CONTAINING FIVE WHITE STARS. ALL THE ELEMENTS ARE OUTLINED IN BLUE.

FOR DIETARY AND NUTRITIONAL SUPPLEMENTS; DIETARY FOOD SUPPLEMENTS; DIETARY SUPPLEMENTS FOR HUMAN CONSUMPTION (U.S. CLS. 6, 18, 44, 46, 51 AND 52).

FIRST USE 1-6-2011; IN COMMERCE 1-6-2011.
JANET LEE, EXAMINING ATTORNEY

CLASS 5—(Continued).

SN 85-530,765. MANZEN, LLC, LAS VEGAS, NV. FILED 2-1-2012.

XENPRO

THE MARK CONSISTS OF STANDARD CHARACTERS WITHOUT CLAIM TO ANY PARTICULAR FONT, STYLE, SIZE, OR COLOR.

FOR PROTEIN SHAKES FOR USE AS A DIETARY AND NUTRITIONAL SUPPLEMENT; DIETARY SUPPLEMENTAL DRINKS; NUTRITIONAL SUPPLEMENT SHAKES; LIQUID PROTEIN SUPPLEMENTS; NUTRITIONALLY FORTIFIED BEVERAGES (U.S. CLS. 6, 18, 44, 46, 51 AND 52).

ROSELLE HERRERA, EXAMINING ATTORNEY

SN 85-537,259. SYNGENTA PARTICIPATIONS AG, BASEL, SWITZERLAND, FILED 2-8-2012.

Briskway

THE MARK CONSISTS OF STANDARD CHARACTERS WITHOUT CLAIM TO ANY PARTICULAR FONT, STYLE, SIZE, OR COLOR.

FOR FUNGICIDES FOR TURF AND HORTICULTURAL USE (U.S. CLS. 6, 18, 44, 46, 51 AND 52).

JAMES STEIN, EXAMINING ATTORNEY

SN 85-538,437. ABBOTT LABORATORIES, ABBOTT PARK, IL. FILED 2-9-2012.

HYDRACARE

THE MARK CONSISTS OF STANDARD CHARACTERS WITHOUT CLAIM TO ANY PARTICULAR FONT, STYLE, SIZE, OR COLOR.

FOR ELECTROLYTE DRINKS FOR MEDICAL PURPOSES; ELECTROLYTE REPLACEMENT SOLUTIONS (U.S. CLS. 6, 18, 44, 46, 51 AND 52).

YAT SYE, LEE, EXAMINING ATTORNEY

CLASS 5—(Continued).

SN 85-538,469. JARROW FORMULAS, INC., LOS ANGELES, CA. FILED 2-9-2012.

ESTRO OPTIMIZER

THE MARK CONSISTS OF STANDARD CHARACTERS WITHOUT CLAIM TO ANY PARTICULAR FONT, STYLE, SIZE, OR COLOR.

OWNER OF U.S. REG. NOS. 2,866,879, 3,754,725 AND OTHERS.

FOR DIETARY AND NUTRITIONAL SUPPLEMENTS (U.S. CLS. 6, 18, 44, 46, 51 AND 52).

TOBY BULLOFF, EXAMINING ATTORNEY

SN 85-539,940. GASPARI NUTRITION, INC., LAKEWOOD, NJ. FILED 2-10-2012.

AMINOLAST

THE MARK CONSISTS OF STANDARD CHARACTERS WITHOUT CLAIM TO ANY PARTICULAR FONT, STYLE, SIZE, OR COLOR.

FOR DIETARY AND NUTRITIONAL SUPPLEMENTS CONTAINING AMINO ACIDS (U.S. CLS. 6, 18, 44, 46, 51 AND 52).

SANI KHOURI, EXAMINING ATTORNEY

SN 85-544,224. GLAXO GROUP LIMITED, GREENFORD, MIDDLESEX, UNITED KINGDOM, FILED 2-16-2012.

BREAIR

THE MARK CONSISTS OF STANDARD CHARACTERS WITHOUT CLAIM TO ANY PARTICULAR FONT, STYLE, SIZE, OR COLOR.

FOR PHARMACEUTICAL PREPARATIONS AND SUBSTANCES FOR THE PREVENTION, TREATMENT, AND/OR ALLEVIATION OF RESPIRATORY DISEASES AND DISORDERS (U.S. CLS. 6, 18, 44, 46, 51 AND 52).

ELISSA GARBER KON, EXAMINING ATTORNEY

CLASS 5—(Continued).

SN 85-544,334. NUTRITION & FITNESS, INC., FAYETTEVILLE, NC. FILED 2-16-2012.

CHIA TO GO

THE MARK CONSISTS OF STANDARD CHARACTERS WITHOUT CLAIM TO ANY PARTICULAR FONT, STYLE, SIZE, OR COLOR.

NO CLAIM IS MADE TO THE EXCLUSIVE RIGHT TO USE "CHIA", APART FROM THE MARK AS SHOWN.

FOR DIETARY SUPPLEMENTS CONTAINING CHIA SEEDS (U.S. CLS. 6, 18, 44, 46, 51 AND 52).

MICHAEL WIENER, EXAMINING ATTORNEY

CLASS 5—(Continued).

SN 85-561,829. WINFIELD SOLUTIONS, LLC, SHOREVIEW, MN. FILED 3-6-2012.

FLARE

THE MARK CONSISTS OF STANDARD CHARACTERS WITHOUT CLAIM TO ANY PARTICULAR FONT, STYLE, SIZE, OR COLOR.

FOR FUNGICIDES AND HERBICIDES; INSECTICIDES (U.S. CLS. 6, 18, 44, 46, 51 AND 52).

JIM RINGLE, EXAMINING ATTORNEY

SN 85-544,341. NUTRITION & FITNESS, INC., FAYETTEVILLE, NC. FILED 2-16-2012.

CHIA ON THE GO

THE MARK CONSISTS OF STANDARD CHARACTERS WITHOUT CLAIM TO ANY PARTICULAR FONT, STYLE, SIZE, OR COLOR.

NO CLAIM IS MADE TO THE EXCLUSIVE RIGHT TO USE "CHIA", APART FROM THE MARK AS SHOWN.

FOR DIETARY SUPPLEMENTS CONTAINING CHIA SEEDS (U.S. CLS. 6, 18, 44, 46, 51 AND 52).

MICHAEL WIENER, EXAMINING ATTORNEY

SN 85-562,368. WINFIELD SOLUTIONS, LLC, SHOREVIEW, MN. FILED 3-7-2012.

WARLOCK

THE MARK CONSISTS OF STANDARD CHARACTERS WITHOUT CLAIM TO ANY PARTICULAR FONT, STYLE, SIZE, OR COLOR.

FOR FUNGICIDES AND HERBICIDES; INSECTICIDES (U.S. CLS. 6, 18, 44, 46, 51 AND 52).

JIM RINGLE, EXAMINING ATTORNEY

SN 85-547,818. CLINICAL THERAPEUTIC SOLUTIONS, WALL, NJ. FILED 2-21-2012.

NEURX-TF

THE MARK CONSISTS OF STANDARD CHARACTERS WITHOUT CLAIM TO ANY PARTICULAR FONT, STYLE, SIZE, OR COLOR.

FOR VITAMIN SUPPLEMENTS DESIGNED TO SUPPORT HEALTHY NERVE FUNCTION (U.S. CLS. 6, 18, 44, 46, 51 AND 52).

LINDA E. BLOHM, EXAMINING ATTORNEY

SN 85-572,952. SHOE BOND SYSTEMS, INC., DBA SBS EQUINE PRODUCTS, NAPLES, FL. FILED 3-19-2012.

THRUSH STOP

THE MARK CONSISTS OF STANDARD CHARACTERS WITHOUT CLAIM TO ANY PARTICULAR FONT, STYLE, SIZE, OR COLOR.

NO CLAIM IS MADE TO THE EXCLUSIVE RIGHT TO USE "THRUSH", APART FROM THE MARK AS SHOWN.

FOR MEDICINAL PREPARATIONS FOR THE TREATMENT OF THRUSH IN THE EQUINE HOOF (U.S. CLS. 6, 18, 44, 46, 51 AND 52).

FIRST USE 1-31-1985; IN COMMERCE 1-31-1985.

MARLENE BELL, EXAMINING ATTORNEY

CLASS 5—(Continued).

SN 85-588,897. WINFIELD SOLUTIONS, LLC, SHOREVIEW, MN. FILED 4-4-2012.

SINGE

THE MARK CONSISTS OF STANDARD CHARACTERS WITHOUT CLAIM TO ANY PARTICULAR FONT, STYLE, SIZE, OR COLOR.

FOR FUNGICIDES AND HERBICIDES; INSECTICIDES (U.S. CLS. 6, 18, 44, 46, 51 AND 52).
JIM RINGLE, EXAMINING ATTORNEY

SN 85-588,898. WINFIELD SOLUTIONS, LLC, SHOREVIEW, MN. FILED 4-4-2012.

INCINERATE

THE MARK CONSISTS OF STANDARD CHARACTERS WITHOUT CLAIM TO ANY PARTICULAR FONT, STYLE, SIZE, OR COLOR.

FOR FUNGICIDES AND HERBICIDES; INSECTICIDES (U.S. CLS. 6, 18, 44, 46, 51 AND 52).
JIM RINGLE, EXAMINING ATTORNEY

CLASS 6—METAL GOODS

SN 79-103,922. CLENERGY (XIAMEN) TECHNOLOGY CO., LTD, XIAMEN 361006, CHINA, FILED 8-11-2011.

EZRACK

THE MARK CONSISTS OF STANDARD CHARACTERS WITHOUT CLAIM TO ANY PARTICULAR FONT, STYLE, SIZE, OR COLOR.

PRIORITY DATE OF 2-11-2011 IS CLAIMED.
OWNER OF INTERNATIONAL REGISTRATION 1094244 DATED 8-11-2011, EXPIRES 8-11-2021.

FOR METAL MOUNTS FOR SOLAR CELLS, SOLAR COLLECTORS, SOLAR PANELS, AND PHOTOVOLTAIC CELLS (U.S. CLS. 2, 12, 13, 14, 23, 25 AND 50).

KELLY TRUSILO, EXAMINING ATTORNEY

CLASS 6—(Continued).

SN 85-182,625. EKSTROM INDUSTRIES, INC., DBA BROOKS UTILITY GROUP, FARMINGTON HILLS, MI. FILED 11-22-2010.

BROOKS KP

THE MARK CONSISTS OF STANDARD CHARACTERS WITHOUT CLAIM TO ANY PARTICULAR FONT, STYLE, SIZE, OR COLOR.

FOR SECURITY LOCKS, NAMELY, METAL LOCKS PROVIDING TAMPER EVIDENCE (U.S. CLS. 2, 12, 13, 14, 23, 25 AND 50).

MAYUR VAGHANI, EXAMINING ATTORNEY

SN 85-255,919. ANCHORS UNLIMITED INCORPORATED, VERONA, PA. FILED 3-2-2011.



NO CLAIM IS MADE TO THE EXCLUSIVE RIGHT TO USE "ANCHORS", "INC." AND "WIRE ANCHOR SPECIALISTS", APART FROM THE MARK AS SHOWN.

THE MARK CONSISTS OF A STYLIZED WIRE ANCHOR IN THE SHAPE OF THE INITIAL LETTERS "A" AND "U" IN THE NAME "ANCHORS UNLIMITED". THE INITIAL LETTERS "A" AND "U" ARE INTERCONNECTED WITH THE FIRST WORD IN THE MARK ABOVE AND SET TO THE LEFT OF THE SECOND WORD IN THE MARK. THE WORDS "WIRE ANCHOR SPECIALISTS" APPEAR BELOW.

FOR ANCHORS; FASTENERS, NAMELY, METAL BARS AND CHAINS (U.S. CLS. 2, 12, 13, 14, 23, 25 AND 50).

FIRST USE 5-16-1977; IN COMMERCE 5-16-1977.
ANDREA BUTLER, EXAMINING ATTORNEY

SN 85-288,520. ECMD, INC., NORTH WILKESBORO, NC. FILED 4-7-2011.

The Transformer System

THE MARK CONSISTS OF STANDARD CHARACTERS WITHOUT CLAIM TO ANY PARTICULAR FONT, STYLE, SIZE, OR COLOR.

NO CLAIM IS MADE TO THE EXCLUSIVE RIGHT TO USE "SYSTEM", APART FROM THE MARK AS SHOWN.

FOR METAL HARDWARE, NAMELY, SHOES AND SOCKETS MADE OF METAL FOR REPLACING WOOD OR METAL BALUSTERS (U.S. CLS. 2, 12, 13, 14, 23, 25 AND 50).

FIRST USE 4-0-2010; IN COMMERCE 4-0-2010.
MICHELE SWAIN, EXAMINING ATTORNEY

CLASS 6—(Continued).

SN 85-297,476. WEST, SUSAN, LAKEVILLE, MN. FILED 4-18-2011.

Pre-Vent Roof Curb

THE MARK CONSISTS OF STANDARD CHARACTERS WITHOUT CLAIM TO ANY PARTICULAR FONT, STYLE, SIZE, OR COLOR.

NO CLAIM IS MADE TO THE EXCLUSIVE RIGHT TO USE "ROOF CURB", APART FROM THE MARK AS SHOWN.

FOR METAL ROOF CURB TO PREVENT LEAKS AT ROOF VENTS (U.S. CLS. 2, 12, 13, 14, 23, 25 AND 50).
KIMBERLY PERRY, EXAMINING ATTORNEY

CLASS 6—(Continued).

SN 85-346,768. CONSOLIDATED SYSTEMS, INC., COLUMBIA, SC. FILED 6-15-2011.

VERSA-FLOOR

THE MARK CONSISTS OF STANDARD CHARACTERS WITHOUT CLAIM TO ANY PARTICULAR FONT, STYLE, SIZE, OR COLOR.

OWNER OF U.S. REG. NOS. 2,629,819, 3,419,876 AND OTHERS.

FOR ENGINEERED FLOOR SYSTEM CONSISTING PRIMARILY OF STRUCTURAL STEEL BEARING COMPONENTS AND LONG-SPAN METAL DECKS AND FLOOR PANELS THAT PROVIDE COMPOSITE ACTION WITH CONCRETE TOPPING (U.S. CLS. 2, 12, 13, 14, 23, 25 AND 50).
TRICIA SONNEBORN, EXAMINING ATTORNEY

SN 85-317,456. PND ENGINEERS INCORPORATED, ANCHORAGE, AK. FILED 5-10-2011.

Strand Bridge

THE MARK CONSISTS OF STANDARD CHARACTERS WITHOUT CLAIM TO ANY PARTICULAR FONT, STYLE, SIZE, OR COLOR.

NO CLAIM IS MADE TO THE EXCLUSIVE RIGHT TO USE "BRIDGE", APART FROM THE MARK AS SHOWN.

FOR PREFABRICATED CABLE SUPPORTED BRIDGES MADE PRIMARILY OF METAL MATERIALS (U.S. CLS. 2, 12, 13, 14, 23, 25 AND 50).
DEBRA LEE, EXAMINING ATTORNEY

SN 85-347,269. SHS INTERNATIONAL, INC., INDIANAPOLIS, IN. FILED 6-15-2011.

HEAD HANGER

THE MARK CONSISTS OF STANDARD CHARACTERS WITHOUT CLAIM TO ANY PARTICULAR FONT, STYLE, SIZE, OR COLOR.

NO CLAIM IS MADE TO THE EXCLUSIVE RIGHT TO USE "HANGER", APART FROM THE MARK AS SHOWN.

SEC. 2(F).
FOR METAL HANGERS AND HOOKS FOR DISPLAYING, SUPPORTING, AND MOUNTING MUSICAL INSTRUMENTS (U.S. CLS. 2, 12, 13, 14, 23, 25 AND 50).
FIRST USE 11-0-2005; IN COMMERCE 11-0-2005.
DOUGLAS LEE, EXAMINING ATTORNEY

SN 85-325,988. ÉCHAFAUDS PLUS (LAVAL) INC., LAVAL (QUÉBEC), CANADA, FILED 5-20-2011.

TUFSTUD

THE MARK CONSISTS OF STANDARD CHARACTERS WITHOUT CLAIM TO ANY PARTICULAR FONT, STYLE, SIZE, OR COLOR.

FOR STRUCTURAL STEEL BEAMS (U.S. CLS. 2, 12, 13, 14, 23, 25 AND 50).
FIRST USE 2-1-2011; IN COMMERCE 2-1-2011.
SUSAN LESLIE DUBOIS, EXAMINING ATTORNEY

SN 85-353,853. T&M INVENTIONS, LLC, GREEN BAY, WI. FILED 6-23-2011.

StripLight

THE MARK CONSISTS OF STANDARD CHARACTERS WITHOUT CLAIM TO ANY PARTICULAR FONT, STYLE, SIZE, OR COLOR.

FOR SKYLIGHTS, WITH METAL SUPPORTING STRUCTURES, FOR USE ON ROOFS OF BUILDINGS (U.S. CLS. 2, 12, 13, 14, 23, 25 AND 50).
LESLEY LAMOTHE, EXAMINING ATTORNEY

CLASS 6—(Continued).

SN 85-353,997. PERMA-PIPE, INC., NILES, IL. FILED 6-23-2011.

CRYO-GARD

THE MARK CONSISTS OF STANDARD CHARACTERS WITHOUT CLAIM TO ANY PARTICULAR FONT, STYLE, SIZE, OR COLOR.

OWNER OF U.S. REG. NOS. 871,600, 900,031 AND 3,405,832.

FOR METAL INSULATED PIPES AND FITTINGS THEREFOR (U.S. CLS. 2, 12, 13, 14, 23, 25 AND 50).

KAPIL BHANOT, EXAMINING ATTORNEY

SN 85-372,551. FERGUSON ENTERPRISES, INC., NEWPORT NEWS, VA. FILED 7-15-2011.

Lincoln Products

THE MARK CONSISTS OF STANDARD CHARACTERS WITHOUT CLAIM TO ANY PARTICULAR FONT, STYLE, SIZE, OR COLOR.

NO CLAIM IS MADE TO THE EXCLUSIVE RIGHT TO USE "PRODUCTS", APART FROM THE MARK AS SHOWN.

FOR PLUMBING FIXTURES, NAMELY, BRASS DRAIN PIPES, WATER SUPPLY METAL NUTS AND METAL WASHERS, WASHING MACHINE METAL HOSES, GALVANIZED AND BRASS PIPE FITTINGS, BRASS FLARE METAL PIPE FITTINGS, METAL JOINERY COMPRESSION FITTINGS, METAL BARBED PIPE FITTINGS, BRASS VALVES NOT BEING PARTS OF MACHINES, METAL FLANGES, BALL COCK METAL WASHERS, SUPPLY METAL NUTS, METAL WASHERS, METAL GASKET RINGS, DRAIN REPAIR METAL WASHERS, TOILET BOLT SETS COMPRISED OF BOLTS, NAILS, AND SCREWS, BLACK STEEL NIPPLES, BRASS NIPPLES, BRASS PIPE FITTINGS, AND GATE METAL VALVES NOT BEING PART OF MACHINES (U.S. CLS. 2, 12, 13, 14, 23, 25 AND 50).

FIRST USE 12-31-2009; IN COMMERCE 12-31-2009.
TASNEEM HUSSAIN, EXAMINING ATTORNEY

SN 85-384,922. CLEARWATER INDUSTRIES LLC, EUGENE, OR. FILED 7-29-2011.

MAN-TOY LASSO

THE MARK CONSISTS OF STANDARD CHARACTERS WITHOUT CLAIM TO ANY PARTICULAR FONT, STYLE, SIZE, OR COLOR.

FOR NON-ELECTRIC SECURITY CABLES OF METAL WRAPPED IN PLASTIC (U.S. CLS. 2, 12, 13, 14, 23, 25 AND 50).

ALAIN LAPTER, EXAMINING ATTORNEY

CLASS 6—(Continued).

SN 85-389,849. CBS BROADCASTING INC., NEW YORK, NY. FILED 8-4-2011.

GUNSMOKE

THE MARK CONSISTS OF STANDARD CHARACTERS WITHOUT CLAIM TO ANY PARTICULAR FONT, STYLE, SIZE, OR COLOR.

OWNER OF U.S. REG. NOS. 2,235,346 AND 3,679,728.

FOR METAL BEVERAGE CANS, METAL BOTTLE STOPPERS, DECORATIVE BOXES MADE OF NON-PRECIOUS METAL, METAL DOG TAGS, METAL COIN BANKS, METAL DOORKNOCKERS, METAL GARDEN STAKES, METAL NOVELTY LICENSE PLATES, METAL MAILBOXES, METAL STEP STOOLS, METAL TOOL BOXES, PEWTER FIGURINES, SCULPTURES OF METAL, WROUGHT IRON DECORATIVE ART WORK, METAL KEY CHAINS (U.S. CLS. 2, 12, 13, 14, 23, 25 AND 50).

TRACY CROSS, EXAMINING ATTORNEY

SN 85-415,336. SECURITY LOCKNUT LLC, MUNDELEIN, IL. FILED 9-6-2011.

SECURITY LOCKNUT

THE MARK CONSISTS OF STANDARD CHARACTERS WITHOUT CLAIM TO ANY PARTICULAR FONT, STYLE, SIZE, OR COLOR.

OWNER OF U.S. REG. NO. 2,502,847.

NO CLAIM IS MADE TO THE EXCLUSIVE RIGHT TO USE "LOCKNUT", APART FROM THE MARK AS SHOWN. SEC. 2(F).

FOR METAL HARDWARE, NAMELY, NUTS AND LOCKNUTS (U.S. CLS. 2, 12, 13, 14, 23, 25 AND 50).

FIRST USE 0-0-1960; IN COMMERCE 0-0-1960.
AHSEN KHAN, EXAMINING ATTORNEY

SN 85-423,361. JIF CORP., WHEELING, IL. FILED 9-15-2011.

JIF•FOIL

THE MARK CONSISTS OF THE TERMS "JIF" AND "FOIL" SEPARATED BY A PERIOD, ALL BEING IN SHADOWED OUTLINED LETTERS.

FOR ALUMINUM FOIL AND ALUMINUM FOIL PAPER (U.S. CLS. 2, 12, 13, 14, 23, 25 AND 50).

FIRST USE 10-15-2011; IN COMMERCE 10-15-2011.

KAPIL BHANOT, EXAMINING ATTORNEY

CLASS 6—(Continued).

SN 85-474,382. WASHIO, GREG, BOCA RATON, FL. FILED 11-16-2011.

CHATT

THE MARK CONSISTS OF STANDARD CHARACTERS WITHOUT CLAIM TO ANY PARTICULAR FONT, STYLE, SIZE, OR COLOR.

FOR METAL BOTTLE STOPPERS; HANGERS IN THE NATURE OF METAL HOOKS USED TO HANG A PURSE, HANDBAG, BRIEFCASE OR COMPUTER BAG FROM A TABLE FOR CONVENIENCE AND SECURITY PURPOSES (U.S. CLS. 2, 12, 13, 14, 23, 25 AND 50).

FIRST USE 3-1-2006; IN COMMERCE 3-1-2006.
MARLENE BELL, EXAMINING ATTORNEY

CLASS 6—(Continued).

SN 85-493,444. MAHAFFEY FABRIC STRUCTURES, MEMPHIS, TN. FILED 12-12-2011.

Boomerang Building

THE MARK CONSISTS OF STANDARD CHARACTERS WITHOUT CLAIM TO ANY PARTICULAR FONT, STYLE, SIZE, OR COLOR.

NO CLAIM IS MADE TO THE EXCLUSIVE RIGHT TO USE "BUILDING", APART FROM THE MARK AS SHOWN. FOR PORTABLE METAL STRUCTURES WITH FLEXIBLE COVERS FOR AGRICULTURAL, COMMERCIAL OR INDUSTRIAL STORAGE (U.S. CLS. 2, 12, 13, 14, 23, 25 AND 50).

FIRST USE 10-0-2011; IN COMMERCE 10-0-2011.
ALYSSA STEEL, EXAMINING ATTORNEY

SN 85-495,433. HAYS, TIM, MATTHEWS, NC. FILED 12-14-2011.

Quick-Lok

THE MARK CONSISTS OF STANDARD CHARACTERS WITHOUT CLAIM TO ANY PARTICULAR FONT, STYLE, SIZE, OR COLOR.

FOR METAL FASTENERS, NAMELY, HARDENED STEEL INSERTS FOR LAND VEHICLE CLUTCHES (U.S. CLS. 2, 12, 13, 14, 23, 25 AND 50).

FIRST USE 10-1-2011; IN COMMERCE 10-1-2011.
EUGENIA MARTIN, EXAMINING ATTORNEY

SN 85-481,284. MICHAEL J. WALSH & ASSOCIATES, INC., CHILOQUIN, OR. FILED 11-28-2011.



OWNER OF U.S. REG. NO. 4,005,173.
THE COLOR(S) RED, GRAY, WHITE, GOLD, TAN, BROWN AND BLACK IS/ARE CLAIMED AS A FEATURE OF THE MARK.

THE MARK CONSISTS OF A CARTOON CHARACTER WHICH IS A RED CARTOON LOCK WITH A GOLD AND WHITE CENTER WHO IS GIVING A THUMBS UP SIGN WITH ITS TAN LEFT HAND AND HAS ITS TAN RIGHT HAND ON ITS HIP. IT HAS WHITE ARMS AND WHITE LEGS WITH RED SOCKS AND BROWN SHOES THAT HAVE GRAY SOLES. THE WORDING "BIG RED" IS FEATURED IN BLACK LETTERS ON THE LOWER PORTION OF THE LOCK.

FOR METAL LOCKS FOR SAFES; METAL SAFES (U.S. CLS. 2, 12, 13, 14, 23, 25 AND 50).
FIRST USE 7-1-2010; IN COMMERCE 7-1-2010.
JULIE VEPPUMTHARA, EXAMINING ATTORNEY

SN 85-507,440. NATIONAL NAIL CORP., GRAND RAPIDS, MI. FILED 1-3-2012.

PROFIT

OWNER OF U.S. REG. NO. 2,987,135.
THE COLOR(S) BLACK AND GOLD IS/ARE CLAIMED AS A FEATURE OF THE MARK.

THE MARK CONSISTS OF THE STYLIZED LETTERS "PRO" IN BLACK AND THE STYLIZED LETTERS "FIT" IN GOLD INSIDE A BLACK RECTANGLE.

FOR METAL FASTENERS, NAMELY, NAILS, SCREWS, STAPLES FOR CONSTRUCTION OR INDUSTRIAL USE (U.S. CLS. 2, 12, 13, 14, 23, 25 AND 50).

FIRST USE 1-0-2010, THE MARK WAS FIRST USED ANYWHERE IN A DIFFERENT FORM OTHER THAN THAT SOUGHT TO BE REGISTERED AT LEAST AS EARLY AS 05/26/1992.; IN COMMERCE 1-0-2010, THE MARK WAS FIRST USED IN COMMERCE IN A DIFFERENT FORM OTHER THAN THAT SOUGHT TO BE REGISTERED AT LEAST AS EARLY AS 05/26/1992..

TINA MAI, EXAMINING ATTORNEY

CLASS 6—(Continued).

SN 85-507,455. NATIONAL NAIL CORP., GRAND RAPIDS, MI. FILED 1-3-2012.

SIMPLY THE BEST FIT

THE MARK CONSISTS OF STANDARD CHARACTERS WITHOUT CLAIM TO ANY PARTICULAR FONT, STYLE, SIZE, OR COLOR.

NO CLAIM IS MADE TO THE EXCLUSIVE RIGHT TO USE "THE BEST FIT", APART FROM THE MARK AS SHOWN.

FOR METAL FASTENERS, NAMELY, NAILS, SCREWS, STAPLES FOR CONSTRUCTION OR INDUSTRIAL USE (U.S. CLS. 2, 12, 13, 14, 23, 25 AND 50).

FIRST USE 1-0-2010; IN COMMERCE 1-0-2010.

TINA MAI, EXAMINING ATTORNEY

CLASS 6—(Continued).

SN 85-511,272. IVAN QUERVALU, DBA IVAN QUERVALU, NEW YORK, NY. FILED 1-8-2012.

Ivan Quervalu

THE MARK CONSISTS OF STANDARD CHARACTERS WITHOUT CLAIM TO ANY PARTICULAR FONT, STYLE, SIZE, OR COLOR.

THE NAME "IVAN QUERVALU" IDENTIFIES A LIVING INDIVIDUAL WHOSE CONSENT IS OF RECORD.

FOR WORKS OF ART OF COMMON METAL; WROUGHT IRON DECORATIVE ARTWORK (U.S. CLS. 2, 12, 13, 14, 23, 25 AND 50).

MIDGE BUTLER, EXAMINING ATTORNEY

SN 85-507,640. NATIONAL NAIL CORP., GRAND RAPIDS, MI. FILED 1-3-2012.

STAPLEPAC

THE MARK CONSISTS OF STANDARD CHARACTERS WITHOUT CLAIM TO ANY PARTICULAR FONT, STYLE, SIZE, OR COLOR.

FOR METAL FASTENERS, NAMELY, STAPLES FOR CONSTRUCTION OR INDUSTRIAL USE (U.S. CLS. 2, 12, 13, 14, 23, 25 AND 50).

FIRST USE 6-0-2003; IN COMMERCE 6-0-2003.

TINA MAI, EXAMINING ATTORNEY

SN 85-515,234. SUGAR POST, INC., SALT LAKE CITY, UT. FILED 1-12-2012.

LITTLE BUGGERS

THE MARK CONSISTS OF STANDARD CHARACTERS WITHOUT CLAIM TO ANY PARTICULAR FONT, STYLE, SIZE, OR COLOR.

FOR METAL SCULPTURES (U.S. CLS. 2, 12, 13, 14, 23, 25 AND 50).

ADA HAN, EXAMINING ATTORNEY

SN 85-508,000. MARVIN, MARK, LAS CRUCES, NM. FILED 1-3-2012.

Acc-U-Cage

THE MARK CONSISTS OF STANDARD CHARACTERS WITHOUT CLAIM TO ANY PARTICULAR FONT, STYLE, SIZE, OR COLOR.

FOR METAL REINFORCEMENT MATERIALS FOR BUILDING (U.S. CLS. 2, 12, 13, 14, 23, 25 AND 50).

MATTHEW EINSTEIN, EXAMINING ATTORNEY

SN 85-515,781. TERRY STEVAHN, BISMARCK, ND. AND ZACHARY HEDSTROM, UNDERWOOD, ND. FILED 1-13-2012.

DKX

THE MARK CONSISTS OF STANDARD CHARACTERS WITHOUT CLAIM TO ANY PARTICULAR FONT, STYLE, SIZE, OR COLOR.

FOR ARMOUR PLATE AND ARMOUR PLATING (U.S. CLS. 2, 12, 13, 14, 23, 25 AND 50).

SALLY SHIH, EXAMINING ATTORNEY

CLASS 6—(Continued).

SN 85-584,475. VALMONT INDUSTRIES, INC., OMAHA, NE. FILED 3-30-2012.

SteelCor

THE MARK CONSISTS OF STANDARD CHARACTERS WITHOUT CLAIM TO ANY PARTICULAR FONT, STYLE, SIZE, OR COLOR.
FOR METAL FORGED RINGS FOR USE WITH METAL POLES (U.S. CLS. 2, 12, 13, 14, 23, 25 AND 50).
EDWARD FENNESSY, EXAMINING ATTORNEY

CLASS 7—(Continued).

SN 76-708,045. MR. MICHAEL N. SCHWARTZ, WEBSTER GROVES, MO. FILED 6-20-2011.



VacuCat

THE MARK CONSISTS OF A GRAPHIC OF THE TOP HALF OF A CAT WITH A CYCLONE GRAPHIC EXTENDING DOWN FROM THE CATS CLAWS. THE WORDING "VACUCAT" APPEARS BELOW THE GRAPHIC.
FOR VACUUM CLEANER ACCESSORY, NAMELY, AN ACCESSORY WITH THE VACUUM CLEANER HOSE THAT ALLOWS FOR CLEANING UNDERNEATH CONFINED AREAS, SUCH AS UNDER REFRIGERATORS CONDENSING COILS (U.S. CLS. 13, 19, 21, 23, 31, 34 AND 35).
ALYSSA STEEL, EXAMINING ATTORNEY

SN 79-101,980. CONTITECH TRANSPORTBANDSYSTEME GMBH, FED REP GERMANY, FILED 10-13-2010.

CLASS 7—MACHINERY

SN 76-706,558. SUZLON WIND ENERGY CORPORATION, CHICAGO, IL. FILED 2-25-2011.



OWNER OF U.S. REG. NOS. 2,811,396 AND 3,497,578.
FOR WIND TURBINES AND THEIR COMPONENTS, NAMELY, NACELLE, GEARBOX, GENERATOR, CONTROL SYSTEM, HUB, TOWER, AND BLADES (U.S. CLS. 13, 19, 21, 23, 31, 34 AND 35).
FIRST USE 5-1-2003; IN COMMERCE 5-1-2003.
ZACHARY BELLO, EXAMINING ATTORNEY

STAHLCORD

OWNER OF INTERNATIONAL REGISTRATION 0200144 DATED 4-29-1957, EXPIRES 4-29-2017.
THE MARK CONSISTS OF THE STYLIZED WORDING "STAHLCORD".
FOR CONVEYOR BELTS (U.S. CLS. 13, 19, 21, 23, 31, 34 AND 35).
BRIAN PINO, EXAMINING ATTORNEY

SN 79-103,025. MEGADYNE S.P.A., ITALY, FILED 5-10-2011.

MEGALINEAR

THE MARK CONSISTS OF STANDARD CHARACTERS WITHOUT CLAIM TO ANY PARTICULAR FONT, STYLE, SIZE, OR COLOR.
PRIORITY DATE OF 4-21-2011 IS CLAIMED.
OWNER OF INTERNATIONAL REGISTRATION 1091979 DATED 5-10-2011, EXPIRES 5-10-2021.
FOR TRANSMISSION BELTS, NOT FOR LAND VEHICLES; CONVEYOR BELTS; PULLEYS BEING PARTS OF MACHINES (U.S. CLS. 13, 19, 21, 23, 31, 34 AND 35).
KRISTINA MORRIS, EXAMINING ATTORNEY

CLASS 7—(Continued).

SN 79-106,407. MIRAIE CORPORATION, MATSUE-CITY, SHIMANE-PREFECTURE 690-0021, JAPAN, FILED 10-31-2011.



PRIORITY DATE OF 10-19-2011 IS CLAIMED.
OWNER OF INTERNATIONAL REGISTRATION 1099708 DATED 10-31-2011, EXPIRES 10-31-2021.

NO CLAIM IS MADE TO THE EXCLUSIVE RIGHT TO USE "CORPORATION", APART FROM THE MARK AS SHOWN.

THE COLOR(S) LIGHT BLUE IS/ARE CLAIMED AS A FEATURE OF THE MARK.

THE COLOR LIGHT BLUE APPEARS IN THE STYLIZED LETTER "M" AND IN THE STYLIZED WORDING "MIRAIE CORPORATION"

THE WORDING "MIRAIE" HAS NO MEANING IN A FOREIGN LANGUAGE.

FOR ORGANIC WASTE PROCESSING EQUIPMENT, NAMELY, COMPOSTING MACHINES IN THE NATURE OF MACHINES THAT AGITATE ORGANIC MATTER TO SUPPLY AIR IN ORDER TO FACILITATE DECOMPOSITION (U.S. CLS. 13, 19, 21, 23, 31, 34 AND 35).
EVELYN BRADLEY, EXAMINING ATTORNEY

SN 79-111,497. BOSCH LAWN AND GARDEN LIMITED, UNITED KINGDOM, FILED 1-20-2012.

Indego

THE MARK CONSISTS OF STANDARD CHARACTERS WITHOUT CLAIM TO ANY PARTICULAR FONT, STYLE, SIZE, OR COLOR.

PRIORITY DATE OF 9-30-2011 IS CLAIMED.
OWNER OF INTERNATIONAL REGISTRATION 1112483 DATED 1-20-2012, EXPIRES 1-20-2022.

FOR ELECTRIC LAWNMOWERS (U.S. CLS. 13, 19, 21, 23, 31, 34 AND 35).

JOHN WILKE, EXAMINING ATTORNEY

CLASS 7—(Continued).

SN 85-253,795. KING KUTTER, INC., WINFIELD, AL. FILED 2-28-2011.

TAYLOR-WAY

THE MARK CONSISTS OF STANDARD CHARACTERS WITHOUT CLAIM TO ANY PARTICULAR FONT, STYLE, SIZE, OR COLOR.

OWNER OF U.S. REG. NO. 3,041,600.
FOR TRACTOR-TOWED GROUND-ENGAGING IMPLEMENTS, NAMELY, DISC PLOWS, DISC HARROWS, DISC TILLER PLOWS, ROTARY TILLERS, SUBSOILER PLOWS, REAR BLADES AND BOX BLADES; GRASS CUTTERS (U.S. CLS. 13, 19, 21, 23, 31, 34 AND 35).

FIRST USE 12-31-1947; IN COMMERCE 12-31-1947.
CAROLYN CATALDO, EXAMINING ATTORNEY

SN 85-253,797. KING KUTTER, INC., WINFIELD, AL. FILED 2-28-2011.

TAYLOR PITTSBURGH

THE MARK CONSISTS OF STANDARD CHARACTERS WITHOUT CLAIM TO ANY PARTICULAR FONT, STYLE, SIZE, OR COLOR.

OWNER OF U.S. REG. NO. 3,041,600.
NO CLAIM IS MADE TO THE EXCLUSIVE RIGHT TO USE "PITTSBURGH", APART FROM THE MARK AS SHOWN.

FOR TRACTOR-TOWED GROUND-ENGAGING IMPLEMENTS, NAMELY, DISC PLOWS, DISC HARROWS, DISC TILLER PLOWS, ROTARY TILLERS, SUBSOILER PLOWS, REAR BLADES AND BOX BLADES; GRASS CUTTERS (U.S. CLS. 13, 19, 21, 23, 31, 34 AND 35).

FIRST USE 12-31-1978; IN COMMERCE 12-31-1978.
CAROLYN CATALDO, EXAMINING ATTORNEY

CLASS 7—(Continued).

SN 85-321,585. BRIGHTSOURCE ENERGY, INC., OAKLAND, CA. FILED 5-16-2011.



THE MARK CONSISTS OF A SIXTEEN-RAYED STAR ON BACKGROUND OF FOUR ADJACENT RECTANGLES.

FOR SOLAR POWERED STEAM TURBINES, GAS TURBINES, GENERATION SETS COMPOSED OF STEAM TURBINE GENERATORS FOR USE IN GENERATING ELECTRICITY; HEAT EXCHANGERS BEING PART OF MACHINES, SOLAR-POWERED ELECTRICITY GENERATORS; DRIVE SYSTEMS FOR HELIOSTATS AND COMPONENTS THEREFOR CONSISTING OF DIRECT CURRENT MOTORS, ALTERNATING CURRENT SERVO MOTORS, GEARS, PLANETARY GEARS, GEAR BOXES FOR ORIENTING REFLECTIVE MIRRORS OR SOLAR PANELS; MOTORS, GEARS AND DRIVES FOR ORIENTATING SOLAR PANELS; MOTORS, GEARS AND DRIVES FOR ORIENTATING REFLECTIVE MIRRORS; ACTUATORS, NAMELY, MULTITURN ACTUATORS, PART-TURN ACTUATORS, AND LINEAR ACTUATORS; APPARATUS AND EQUIPMENT FOR ASSEMBLY AND INSTALLATION OF HELIOSTATS, NAMELY, POWER OPERATED ASSEMBLY JIGS, GLUING JIGS, WELDING JIGS, VIBRATORY PILE DRIVERS, AND HYDRAULIC PILE DRIVERS (U.S. CLS. 13, 19, 21, 23, 31, 34 AND 35).

VIVIAN MICZNIK FIRST, EXAMINING ATTORNEY

SN 85-330,781. TIGERCAT INTERNATIONAL INC., BRANTFORD, CANADA, FILED 5-26-2011.

TURNaround

THE MARK CONSISTS OF THE WORDS "TURN" AND "AROUND" WITH THE "N" IN "TURN" BEING BACKWARDS IN ORIENTATION.

FOR CLEARING MACHINE CAB HAVING A SWIVEL DRIVER'S SEAT THAT LOCKS IN FORWARD OR REAR FACING POSITION ALLOWING OPERATOR FULL CONTROL OF ALL MACHINE CLEARING FUNCTIONS AND DRIVE CONTROLS (U.S. CLS. 13, 19, 21, 23, 31, 34 AND 35).

LINDA LAVACHE, EXAMINING ATTORNEY

CLASS 7—(Continued).

SN 85-333,892. HEAT SEAL, LLC, CLEVELAND, OH. FILED 5-31-2011.

ENERGY SMART

THE MARK CONSISTS OF STANDARD CHARACTERS WITHOUT CLAIM TO ANY PARTICULAR FONT, STYLE, SIZE, OR COLOR.

FOR PACKAGING EQUIPMENT, NAMELY, PACKAGING MACHINES THAT UTILIZE HEAT TO SEAL A PACKAGE (U.S. CLS. 13, 19, 21, 23, 31, 34 AND 35).

LINDA M. KING, EXAMINING ATTORNEY

SN 85-337,910. EPILOG CORPORATION, GOLDEN, CO. FILED 6-3-2011.

HELIX

THE MARK CONSISTS OF STANDARD CHARACTERS WITHOUT CLAIM TO ANY PARTICULAR FONT, STYLE, SIZE, OR COLOR.

FOR LASER ENGRAVING, CUTTING AND MARKING MACHINES (U.S. CLS. 13, 19, 21, 23, 31, 34 AND 35).

FIRST USE 3-31-2005; IN COMMERCE 3-31-2005.

SHAILA SETTLES, EXAMINING ATTORNEY

SN 85-337,972. TECHNOCAST, S.A. DE C.V., COAHUILA, MEXICO, FILED 6-3-2011.



THE MARK CONSISTS OF A TEE, HAVING AT ITS TOP FOUR CIRCLES.

FOR ENGINE BLOCKS, MECHANICAL ENGINE PARTS FOR LAND VEHICLES, VEHICLE PARTS, NAMELY, ENGINE CASES, CYLINDER HEADS FOR ENGINES, INTERNAL COMBUSTION ENGINE PARTS, NAMELY, HEADS (U.S. CLS. 13, 19, 21, 23, 31, 34 AND 35).

FIRST USE 3-17-2007; IN COMMERCE 3-17-2007.

LESLEY LAMOTHE, EXAMINING ATTORNEY

CLASS 7—(Continued).

SN 85-340,527. APPLIED MATERIALS INC., SANTA CLARA, CA. FILED 6-7-2011.

ALLURE

THE MARK CONSISTS OF STANDARD CHARACTERS WITHOUT CLAIM TO ANY PARTICULAR FONT, STYLE, SIZE, OR COLOR.

FOR EQUIPMENT AND MACHINES FOR THE PROCESSING AND PRODUCTION OF SEMICONDUCTOR SUBSTRATES, THIN FILMS, SILICON DISCS AND WAFERS, INCLUDING POLISHING, CLEANING, PROCESS MONITORING, AND SEMICONDUCTOR MEASURING EQUIPMENT (U.S. CLS. 13, 19, 21, 23, 31, 34 AND 35).

STEVEN R. FINE, EXAMINING ATTORNEY

SN 85-341,023. CHRISTOPHER J. FISCHER CORPORATION, COSTA MESA, CA. FILED 6-8-2011.

FORMULA 62

THE MARK CONSISTS OF STANDARD CHARACTERS WITHOUT CLAIM TO ANY PARTICULAR FONT, STYLE, SIZE, OR COLOR.

FOR STRESS RELIEVING AND METAL STABILIZATION MACHINES, NAMELY, UNITS FOR APPLYING VIBRATIONAL ENERGY TO WORKPIECES TO BE STRESS RELIEVED AND STABILIZED (U.S. CLS. 13, 19, 21, 23, 31, 34 AND 35).

FIRST USE 10-1-1963; IN COMMERCE 10-1-1963.
CHERYL CLAYTON, EXAMINING ATTORNEY

SN 85-341,268. MARTIN ENGINEERING COMPANY, NEPONSET, IL. FILED 6-8-2011.

PROBLEM SOLVED

THE MARK CONSISTS OF STANDARD CHARACTERS WITHOUT CLAIM TO ANY PARTICULAR FONT, STYLE, SIZE, OR COLOR.

FOR DUST SUPPRESSION SYSTEMS, COMPRISED OF POWER OPERATED PRESSURIZED FLUID SPRAYERS, INDUSTRIAL VACUUM CLEANERS AND BAGS AND FILTERS THEREFOR, VENTILATING EXHAUST FANS, DUST CURTAINS, AND VENTILATING HOODS, ALL FOR BULK MATERIAL CONVEYOR BELT ASSEMBLIES AND BULK MATERIAL TRANSFER ASSEMBLIES (U.S. CLS. 13, 19, 21, 23, 31, 34 AND 35).

ELLEN PERKINS, EXAMINING ATTORNEY

CLASS 7—(Continued).

SN 85-341,818. REDUCTION ENGINEERING, INC., KENT, OH. FILED 6-9-2011.

REDUCTION ENGINEERING

THE MARK CONSISTS OF STANDARD CHARACTERS WITHOUT CLAIM TO ANY PARTICULAR FONT, STYLE, SIZE, OR COLOR.

NO CLAIM IS MADE TO THE EXCLUSIVE RIGHT TO USE "ENGINEERING", APART FROM THE MARK AS SHOWN.

FOR MACHINES FOR PLASTIC WORKING AND PLASTICS PROCESSING EQUIPMENT, NAMELY, PELLETIZERS, PULVERIZERS, AND ROTATIONAL MOLDING MACHINES (U.S. CLS. 13, 19, 21, 23, 31, 34 AND 35).
FIRST USE 12-31-1993; IN COMMERCE 12-31-1993.
DAVID ELTON, EXAMINING ATTORNEY

SN 85-345,129. WILLETT, MICHAEL, DACULA, GA. FILED 6-13-2011.

Foam Monster

THE MARK CONSISTS OF STANDARD CHARACTERS WITHOUT CLAIM TO ANY PARTICULAR FONT, STYLE, SIZE, OR COLOR.

NO CLAIM IS MADE TO THE EXCLUSIVE RIGHT TO USE "FOAM", APART FROM THE MARK AS SHOWN.

FOR FOAM GENERATING MACHINE FOR PRODUCING FOAM FOR PARTIES AND ENTERTAINMENT PURPOSES (U.S. CLS. 13, 19, 21, 23, 31, 34 AND 35).
LEIGH LOWRY, EXAMINING ATTORNEY

SN 85-349,359. RANDALL INDUSTRIES, INC., DBA DETROIT RADIATOR CORPORATION, ROMULUS, MI. FILED 6-17-2011.

POWERMAX

THE MARK CONSISTS OF STANDARD CHARACTERS WITHOUT CLAIM TO ANY PARTICULAR FONT, STYLE, SIZE, OR COLOR.

FOR RADIATORS FOR VEHICLES (U.S. CLS. 13, 19, 21, 23, 31, 34 AND 35).

AMY KERTGATE, EXAMINING ATTORNEY

CLASS 7—(Continued).

SN 85-349,590. KEY ENERGY SERVICES, LLC, HOUSTON, TX. FILED 6-17-2011.



NO CLAIM IS MADE TO THE EXCLUSIVE RIGHT TO USE "ENHANCED OILFIELD TECHNOLOGIES", APART FROM THE MARK AS SHOWN.

THE MARK CONSISTS OF THE WORDS "ENHANCED OILFIELD TECHNOLOGIES" IN CONJUNCTION WITH A DIAMOND DESIGN. THE DIAMOND DESIGN INCLUDES NINE SMALLER, CLOSELY SPACED SOLID DIAMONDS WHICH DEFINE THE OVERALL DIAMOND SHAPE OF THE DESIGN. THE INTERIOR SMALLER DIAMOND IS SPLIT INTO TWO TRIANGLES.

FOR POWER-OPERATED DOWNHOLE AND SURFACE TOOLS AND EQUIPMENT USED IN THE DRILLING, COMPLETION, AND WORKOVER OF OIL AND GAS WELLS, NAMELY, PRESSURE ISOLATION PACKERS, ANCHORING TOOLS FOR THE PERMANENT OR TEMPORARY INSTALLATION OF TUBULARS AND CASINGS, SURFACE AND SUBSURFACE FLUID CONTROL DIVERTERS, AND DEPLOYMENT TOOLS FOR THE DEPLOYMENT AND SUBSEQUENT PERMANENT OR TEMPORARY INSTALLATION OF TUBULARS, CASINGS, AND PRESSURE ISOLATION PACKERS IN WELLBORES (U.S. CLS. 13, 19, 21, 23, 31, 34 AND 35).

STEVEN JACKSON, EXAMINING ATTORNEY

SN 85-356,321. ULTRA-TOOL INCORPORATED, INC., HUNTINGTON BEACH, CA. FILED 6-25-2011.

SmoothCoat

THE MARK CONSISTS OF STANDARD CHARACTERS WITHOUT CLAIM TO ANY PARTICULAR FONT, STYLE, SIZE, OR COLOR.

OWNER OF U.S. REG. NOS. 2,071,513, 3,088,180 AND 3,539,196.

FOR MACHINES HARDENED POWER-OPERATED, ROTARY METAL CUTTING TOOLS, NAMELY, BORERS, BURRS, COUNTERSINKS, DIESINKERS, DISC CUTTERS, DRILLS, END MILLS, LAPS, KEYSEAT CUTTERS, RADIUS CUTTERS, REAMERS, ROTARY FILES, ROUTERS, AND SAWS (U.S. CLS. 13, 19, 21, 23, 31, 34 AND 35).

FIRST USE 12-5-2003; IN COMMERCE 12-5-2003.
DAVID MURRAY, EXAMINING ATTORNEY

CLASS 7—(Continued).

SN 85-368,890. ENVIPCO HOLDING N.V., DE AMSTERDAM, NETHERLANDS, FILED 7-12-2011.

BestFlat

THE MARK CONSISTS OF STANDARD CHARACTERS WITHOUT CLAIM TO ANY PARTICULAR FONT, STYLE, SIZE, OR COLOR.

FOR MACHINES, IN PARTICULAR MACHINES FOR COUNTING, SORTING, COMPACTING, SEPARATING AND TRANSPORTING CONTAINERS; AUTOMATIC MACHINES FOR RECYCLING EMPTY FOOD OR BEVERAGE CONTAINERS (U.S. CLS. 13, 19, 21, 23, 31, 34 AND 35).

CIMMERIAN COLEMAN, EXAMINING ATTORNEY

SN 85-377,416. THE PREMIERE POLISH COMPANY LIMITED, GLOUCESTERSHIRE, UNITED KINGDOM, FILED 7-21-2011.

ECOFORCE

THE MARK CONSISTS OF STANDARD CHARACTERS WITHOUT CLAIM TO ANY PARTICULAR FONT, STYLE, SIZE, OR COLOR.

OWNER OF EUROPEAN UNION REG. NO. 009400011, DATED 3-6-2011, EXPIRES 9-24-2020.

FOR CLEANING, POLISHING, DRYING AND WRINGING MACHINES, EQUIPMENT AND APPARATUS FOR FLOORS, TEXTILE AND UPHOLSTERY; VACUUM CLEANERS; ROTARY CLEANING AND POLISHING MACHINES, TOOLS AND APPARATUS FOR FLOORS; PAPER BAGS FOR VACUUM CLEANERS (U.S. CLS. 13, 19, 21, 23, 31, 34 AND 35).

TINA MAI, EXAMINING ATTORNEY

SN 85-377,434. THE PREMIERE POLISH COMPANY LIMITED, GLOUCESTERSHIRE, UNITED KINGDOM, FILED 7-21-2011.



OWNER OF EUROPEAN UNION REG. NO. 009420944, DATED 3-11-2011, EXPIRES 10-4-2020.

THE MARK CONSISTS OF THE WORDING "ECOFORCE" WITH AN IMAGE OF A DROP OF WATER CONTAINING A CURVED BAR IN PLACE OF THE SECOND LETTER "O".

FOR CLEANING, POLISHING, DRYING AND WRINGING MACHINES, EQUIPMENT AND APPARATUS FOR FLOORS, TEXTILE AND UPHOLSTERY; VACUUM CLEANERS; ROTARY CLEANING AND POLISHING MACHINES, TOOLS AND APPARATUS FOR FLOORS; PAPER BAGS FOR VACUUM CLEANERS (U.S. CLS. 13, 19, 21, 23, 31, 34 AND 35).

TINA MAI, EXAMINING ATTORNEY

CLASS 7—(Continued).

SN 85-400,838. AUTOMOTIVE & TRACTOR SPARES ENGLAND, MIDDLESEX, UNITED KINGDOM, FILED 8-18-2011.



OWNER OF UNITED KINGDOM REG. NO. 2424297, DATED 6-13-2006, EXPIRES 6-13-2016.

THE MARK CONSISTS OF A SLIGHTLY CONCAVED TRIANGLE SUBDIVIDED INTO THREE DIAMONDS, ONE IN EACH CORNER OF THE TRIANGLE JOINING IN THE MIDDLE, WITH SMALL TRIANGLES IN BETWEEN THE DIAMONDS WITH THE LETTER "A" IN THE CENTRE OF THE TOP DIAMOND, THE LETTER "T" IN THE CENTRE OF THE BOTTOM LEFT DIAMOND AND THE LETTER "S" IN THE CENTRE OF THE BOTTOM RIGHT DIAMOND.

FOR AUTOMOTIVE ENGINE BLOCKS; AXLES FOR MACHINES; BALL BEARINGS FOR USE IN MACHINES, NAMELY, DIESEL ENGINES AND TRACTORS; BEARINGS FOR TRANSMISSION SHAFTS, BEING PARTS OF MACHINES; BEARINGS, AS PARTS OF MACHINES; BELTS FOR ENGINES; BRAKES FOR MACHINES; BRUSHES BEING PARTS OF MOTORS, GENERATORS AND DYNAMOS; COMBUSTION ENGINE FUEL NOZZLES; CONNECTING RODS FOR MACHINES, MOTORS AND ENGINES; CRANK SHAFTS FOR DIESEL ENGINES AND TRACTORS; CRANKCASES FOR MACHINES, MOTORS AND ENGINES; CYLINDER HEADS FOR ENGINES; CYLINDERS FOR MOTORS AND ENGINES; DIESEL ENGINES FOR MACHINES; DISC BRAKES FOR MACHINES; ELECTRIC STARTER MOTORS; ENGINE BEARINGS; ENGINE CYLINDERS FOR LAND VEHICLES; ENGINE CYLINDERS FOR VEHICLES; ENGINE INJECTORS; ENGINE PARTS, NAMELY, ELECTRONIC FUEL INJECTION MODULES; FAN BELTS FOR MOTORS AND ENGINES; FUEL INJECTOR PARTS FOR LAND AND WATER VEHICLE ENGINES; FUEL INJECTORS; FUEL PUMPS FOR LAND VEHICLES; GASKETS FOR INTERNAL COMBUSTION ENGINES; HYDRAULIC PUMPS; INTERNAL COMBUSTION ENGINE PARTS, NAMELY, HEADS; INTERNAL COMBUSTION ENGINE PARTS, NAMELY, PISTON RINGS; INTERNAL COMBUSTION ENGINE PARTS, NAMELY, PISTONS; INTERNAL COMBUSTION ENGINES FOR MACHINE OPERATION AND REPLACEMENT PARTS THEREFOR; INTERNAL COMBUSTION LAND VEHICLE ENGINE PARTS, NAMELY, CONNECTING RODS; LAND VEHICLE PARTS, NAMELY, SPARK PLUG WIRES; MACHINE PARTS, NAMELY, BEARINGS AND BUSHINGS; MACHINE PARTS, NAMELY, CYLINDERS; METAL ENGINE GASKETS FOR VEHICLES; NON-METAL ENGINE GASKET FOR VEHICLES; OIL FILTERS FOR MOTORS AND ENGINES; OIL PUMPS FOR LAND VEHICLES; OIL PUMPS FOR USE IN MOTORS AND ENGINES; PISTON RINGS; PISTONS FOR DIESEL ENGINES AND TRACTORS; POWER TRANSMISSION BELTS FOR MACHINES; PUMP CONTROL VALVES; PUMPS AND COMPRESSORS AS PARTS OF MACHINES, MOTORS AND ENGINES; PUMPS AS PARTS OF MACHINES, MOTORS AND ENGINES; ROLLER BEARINGS FOR MACHINES; SELF-LUBRICATING MECHANICAL FRICTION PARTS, ESPE-

CLASS 7—(Continued).

CIALY OF COMPOSITE MATERIALS, NAMELY, WEAR RINGS, WASHERS, BUSHINGS, SPHERICAL BEARINGS, BEARING PADS, SLIDING BLOCKS AND MACHINE TRANSMISSION GEARS ALL FOR LOAD BEARING MACHINES, CONVEYORS, HANDLING TRUCKS AND MACHINES, LIFTING MACHINES, AGRICULTURAL MACHINERY, CONSTRUCTION EQUIPMENT MACHINES AND HYDRAULIC TURBINES; SHAFT COUPLINGS AS PARTS OF MACHINES; SHAFT COUPLINGS FOR MACHINES; SHAFTS FOR PUMPS; SPARK PLUGS; STARTER MOTORS; STARTERS FOR MOTORS AND ENGINES; TRANSMISSION GEARS FOR MACHINES; VALVES BEING ENGINE PARTS FOR INTRODUCING FUEL-AIR MIXTURES INTO THE COMBUSTION CHAMBERS OF INTERNAL COMBUSTION ENGINES; VALVES FOR PUMPS; WATER PUMPS FOR LAND VEHICLES; WATER PUMPS FOR USE IN MOTORS AND ENGINES; ALL OF THE FOREGOING FOR AGRICULTURAL TRACTORS, AUTOMOTIVE APPLICATIONS AND DIESEL ENGINES (U.S. CLS. 13, 19, 21, 23, 31, 34 AND 35).

Laurie Mayes, Examining Attorney

SN 85-407,556. MINERS, ALLAN, KIAMA, AUSTRALIA, FILED 8-25-2011.

ROTALIN

THE MARK CONSISTS OF STANDARD CHARACTERS WITHOUT CLAIM TO ANY PARTICULAR FONT, STYLE, SIZE, OR COLOR.

FOR MACHINE PARTS, NAMELY, PNEUMATIC AND HYDRAULIC CYLINDERS USED FOR CONTROLLING VALVES, DAMPERS, AND ANY GENERAL PROCESS CONTROL APPLICATIONS (U.S. CLS. 13, 19, 21, 23, 31, 34 AND 35).

FIRST USE 1-6-2009; IN COMMERCE 5-3-2011.

Jenny Park, Examining Attorney

SN 85-417,019. TAM INTERNATIONAL, INC., HOUSTON, TX, FILED 9-7-2011.

POSIFRAC

THE MARK CONSISTS OF STANDARD CHARACTERS WITHOUT CLAIM TO ANY PARTICULAR FONT, STYLE, SIZE, OR COLOR.

FOR OIL AND GAS WELL FRACTURING POWER TOOLS, NAMELY, PACKERS FOR CONTROLLING PRESSURE OR FLUIDS DOWNHOLE FOR ZONE ISOLATION AND ONE OR MORE FLUID CONTROL VALVES (U.S. CLS. 13, 19, 21, 23, 31, 34 AND 35).

Karanendra S. Chhina, Examining Attorney

CLASS 7—(Continued).

SN 85-439,343. DALIAN E.P.Z. NANOTEC INT'L INDUSTRY & TRADE CO., LTD, DALIAN,LIAONING, CHINA, FILED 10-5-2011.

somos

THE MARK CONSISTS OF FIVE LETTERS WHICH ARE "S", "O", "M", "O", "S" LISTED FROM THE LEFT END TO THE RIGHT END. EACH LETTER IS DRAWN BOLD AND WITH LINE.

THE ENGLISH TRANSLATION OF "SOMOS" IN THE MARK IS WE ARE.

FOR GRINDING AND POLISHING MACHINES; GRINDING MACHINES FOR THE TREATMENT OF CERAMICS AND METAL; GRINDING TOOLS FOR GRINDING MACHINES; LAPPING MACHINES; POLISHING MACHINES FOR USE IN GRINDING AND POLISHING METAL, WOOD, CERAMICS AND PLASTICS (U.S. CLS. 13, 19, 21, 23, 31, 34 AND 35).

FIRST USE 0-0-1998; IN COMMERCE 10-29-2001.
GRETTA YAO, EXAMINING ATTORNEY

CLASS 7—(Continued).

SN 85-476,453. MEGTEC SYSTEMS INC., DEPERE, WI. FILED 11-18-2011.

MP

THE MARK CONSISTS OF STANDARD CHARACTERS WITHOUT CLAIM TO ANY PARTICULAR FONT, STYLE, SIZE, OR COLOR.

FOR MACHINE OPERATED WEB SPLICERS (U.S. CLS. 13, 19, 21, 23, 31, 34 AND 35).

LINDA ORNDORFF, EXAMINING ATTORNEY

SN 85-467,385. BAILEIGH INDUSTRIAL, INC., MANITOWOC, WI. FILED 11-8-2011.

BAILEIGH INDUSTRIAL

THE MARK CONSISTS OF STANDARD CHARACTERS WITHOUT CLAIM TO ANY PARTICULAR FONT, STYLE, SIZE, OR COLOR.

OWNER OF U.S. REG. NO. 3,429,714.

NO CLAIM IS MADE TO THE EXCLUSIVE RIGHT TO USE "INDUSTRIAL", APART FROM THE MARK AS SHOWN.

FOR MACHINERY FOR CUTTING, PLANING, SANDING, AND JOINING WOOD AND WOOD BYPRODUCTS, NAMELY, TABLE SAWS, BAND SAWS, RADIAL ARM SAWS, JOINTERS, SPINDLE SHAPERS, BISCUIT JOINERS, POWER-OPERATED SANDERS, POWER-OPERATED OSCILLATING SANDERS, POWER-OPERATED DRUM SANDERS, POWER-OPERATED BELT SANDERS, POWER-OPERATED HAND ROUTERS, POWER-OPERATED CNC ROUTERS, CARVING MACHINES, POWER-OPERATED PLANERS, EDGE BANDING MACHINES, EDGE GLUING MACHINES, HYDRAULIC PRESS FORMERS, POWER-OPERATED DRILL PRESSES, POWER-OPERATED HAND HELD DRILLS, POWER DRILL BITS, ROUTER BITS, MACHINE TOOLS, NAMELY, CLAMPS FOR USE IN THE PRECISION CLAMPING OF WORK PIECES, POWER OPERATED DUST COLLECTION AND DUST EXTRACTION DEVICES, ROUTER TABLES, VENEERING MACHINE, WOOD LATHERING MACHINE, WOOD MILLING MACHINES, POWER-OPERATED NAILING GUNS, POWER TOOLS, NAMELY, SCROLL SAWS, AIR COMPRESSORS, TABLE SAW BLADES, BAND SAW BLADES (U.S. CLS. 13, 19, 21, 23, 31, 34 AND 35).

JENNY PARK, EXAMINING ATTORNEY



NO CLAIM IS MADE TO THE EXCLUSIVE RIGHT TO USE "DRY LUBE", APART FROM THE MARK AS SHOWN.

THE MARK CONSISTS OF THE STYLIZED WORDING "DRY LUBE" APPEARING SURROUNDED BY THE DEPICTION OF A RECTANGULAR A SAW BLADE AND HAVING THE DEPICTION OF A CIRCULAR SAW BLADE APPEARING BETWEEN THE WORDS "DRY" AND "LUBE".

FOR LUBRICATING MACHINES FOR APPLYING LUBRICANT TO ALUMINUM SAW BLADES (U.S. CLS. 13, 19, 21, 23, 31, 34 AND 35).

FIRST USE 5-0-2011; IN COMMERCE 5-0-2011.

MICHAEL TANNER, EXAMINING ATTORNEY

SN 85-490,713. STANLEY FASTENING SYSTEMS, L.P., NEW BRITAIN, CT. FILED 12-8-2011.

STRAPSHOT

THE MARK CONSISTS OF STANDARD CHARACTERS WITHOUT CLAIM TO ANY PARTICULAR FONT, STYLE, SIZE, OR COLOR.

FOR NAILING MACHINES (U.S. CLS. 13, 19, 21, 23, 31, 34 AND 35).

FIRST USE 11-1-2005; IN COMMERCE 11-1-2005.

SANJEEV VOHRA, EXAMINING ATTORNEY

CLASS 7—(Continued).

SN 85-492,896. PRODUCT DEVELOPMENT SYSTEMS, LLC,
SAN DIEGO, CA. FILED 12-12-2011.

SEALNFRESH

THE MARK CONSISTS OF STANDARD CHARACTERS
WITHOUT CLAIM TO ANY PARTICULAR FONT, STYLE,
SIZE, OR COLOR.

FOR HAND-HELD VACUUM PACKAGING MA-
CHINES FOR SEALING FOOD IN STORAGE BAGS
(U.S. CLS. 13, 19, 21, 23, 31, 34 AND 35).

FIRST USE 6-22-2011; IN COMMERCE 6-22-2011.
BILL DAWE, EXAMINING ATTORNEY

SN 85-506,222. WILL HOPPER, CORPUS CHRISTI, TX.
FILED 12-30-2011.

Cosmic Tanner

THE MARK CONSISTS OF STANDARD CHARACTERS
WITHOUT CLAIM TO ANY PARTICULAR FONT, STYLE,
SIZE, OR COLOR.

NO CLAIM IS MADE TO THE EXCLUSIVE RIGHT TO
USE "TANNER", APART FROM THE MARK AS SHOWN.

FOR POWER-OPERATED SPRAYERS (U.S. CLS. 13, 19,
21, 23, 31, 34 AND 35).
STEVEN JACKSON, EXAMINING ATTORNEY

SN 85-506,464. SONNY'S ENTERPRISES, INC., TAMARAC,
FL. FILED 12-30-2011.



OWNER OF U.S. REG. NOS. 2,596,912, 3,167,686 AND
3,395,375.

NO CLAIM IS MADE TO THE EXCLUSIVE RIGHT TO
USE "IN-BAYS", APART FROM THE MARK AS SHOWN.

THE MARK CONSISTS OF A RECTANGULAR BOX
CONTAINING A WATER DROP ON THE LEFT-SIDE AND
A CARWASH BAY ON THE RIGHT-SIDE. THE UNDER-
LINED WORD "SONNY'S" APPEARS BENEATH THE REC-
TANGULAR BOX. THE WORDS "BAYWASH IN-BAYS"
APPEAR BELOW THE HORIZONTAL LINE.

SEC. 2(F) AS TO "BAYWASH".

FOR AUTOMATIC CAR WASHING MACHINES FOR
USE BY COMMERCIAL CAR WASH SERVICES (U.S.
CLS. 13, 19, 21, 23, 31, 34 AND 35).

MICHAEL GAAFAR, EXAMINING ATTORNEY

CLASS 7—(Continued).

SN 85-508,286. PLASMATREAT GMBH, 33803 STEINHAGEN,
FED REP GERMANY, FILED 1-4-2012.

PLASMATREAT

THE MARK CONSISTS OF STANDARD CHARACTERS
WITHOUT CLAIM TO ANY PARTICULAR FONT, STYLE,
SIZE, OR COLOR.

OWNER OF U.S. REG. NOS. 3,099,466 AND 3,389,180.

SEC. 2(F).

FOR MACHINES FOR SURFACE TREATMENT OF
WORK PIECES BY MEANS OF ELECTRICAL DIS-
CHARGE AND/OR REACTIVE MEDIA FOR THE PUR-
POSE OF CLEANING THE SURFACE AND/OR
PROMOTING ADHESION (U.S. CLS. 13, 19, 21, 23, 31,
34 AND 35).

FIRST USE 1-29-2003; IN COMMERCE 1-29-2003.

CHRISTOPHER BUONGIORNO, EXAMINING ATTOR-
NEY

SN 85-508,354. BENTLEY, ROY EARLDEAN, SURREY, BC,
CANADA, FILED 1-4-2012.



THE MARK CONSISTS OF A STYLIZED CHARACTER
DESIGN HAVING HUMAN ELEMENTS CONSISTING OF
HANDS, LEGS, EYES AND NOSE.

FOR A MICRO-HYDRO ELECTRIC GENERATOR FOR
USE BY EDUCATORS AS A DEMONSTRATION TOOL,
DESIGNED TO OPERATE ON RESIDENTIAL / PUBLIC
WATER PRESSURE (U.S. CLS. 13, 19, 21, 23, 31, 34 AND
35).

FIRST USE 10-7-2011; IN COMMERCE 10-7-2011.

KAPIL BHANOT, EXAMINING ATTORNEY

CLASS 7—(Continued).

SN 85-509,987. LAERA, VITO, FORT LAUDERDALE, FL. FILED 1-5-2012.

VLANCO

THE MARK CONSISTS OF STANDARD CHARACTERS WITHOUT CLAIM TO ANY PARTICULAR FONT, STYLE, SIZE, OR COLOR.

THE WORDING "VLANCO" HAS NO MEANING IN A FOREIGN LANGUAGE.

FOR FOOD WASTE DISPOSALS; FOOD WASTE DISPOSERS; GARBAGE DISPOSALS; PRESSURE SWITCHES AS PARTS OF MACHINES (U.S. CLS. 13, 19, 21, 23, 31, 34 AND 35).

FIRST USE 1-1-2006; IN COMMERCE 1-1-2006.
WON TEAK OH, EXAMINING ATTORNEY

CLASS 7—(Continued).

SN 85-513,366. TECHTRONIC OUTDOOR PRODUCTS TECHNOLOGY LIMITED, HAMILTON, BERMUDA, FILED 1-10-2012.

GREEN MACHINE

THE MARK CONSISTS OF STANDARD CHARACTERS WITHOUT CLAIM TO ANY PARTICULAR FONT, STYLE, SIZE, OR COLOR.

OWNER OF U.S. REG. NOS. 1,066,616 AND 3,357,002. NO CLAIM IS MADE TO THE EXCLUSIVE RIGHT TO USE "MACHINE", APART FROM THE MARK AS SHOWN.

FOR POWER-OPERATED WEED AND BRUSH TRIMMERS; RECHARGEABLE HEDGE CUTTERS (U.S. CLS. 13, 19, 21, 23, 31, 34 AND 35).

TEJBIR SINGH, EXAMINING ATTORNEY

SN 85-511,133. NGUYEN-HO, BACH-MAI THI, MISSISSAUGA, CANADA, FILED 1-7-2012.

SANISOL

THE MARK CONSISTS OF STANDARD CHARACTERS WITHOUT CLAIM TO ANY PARTICULAR FONT, STYLE, SIZE, OR COLOR.

FOR WATER PUMPS FOR SPA, BATHS, WHIRLPOOLS, SWIMMING POOLS, WATER FILTERING UNITS; WATER TREATMENT EQUIPMENT, NAMELY, PUMPS FOR USE IN IRRIGATION SYSTEMS (U.S. CLS. 13, 19, 21, 23, 31, 34 AND 35).

SUNG IN, EXAMINING ATTORNEY

SN 85-514,404. INGENIOUS MARKETING, LLC, CENTENNIAL, CO. FILED 1-11-2012.

ECOTONIX

THE MARK CONSISTS OF STANDARD CHARACTERS WITHOUT CLAIM TO ANY PARTICULAR FONT, STYLE, SIZE, OR COLOR.

FOR PRE-COMPOSTING GRINDERS (U.S. CLS. 13, 19, 21, 23, 31, 34 AND 35).

COURTNEY ALVAREZ, EXAMINING ATTORNEY

SN 85-511,387. KINGTEC INDUSTRIAL CO., LTD., NINGBO, ZHEJIANG, CHINA, FILED 1-9-2012.

KINGTEC

THE MARK CONSISTS OF THE LETTERS "KINGTEC" IN A STYLIZED FONT.

FOR CHAIN SAWS; COMPRESSED AIR MACHINES; CUTTING MACHINES; ELECTRIC HAND-HELD DRILLS; ELECTRIC KNIVES; ELECTRIC WELDING MACHINES; ENGRAVING MACHINES; GRINDERS; HAIR SHEARING MACHINES FOR ANIMALS; SPRAY GUNS FOR PAINT (U.S. CLS. 13, 19, 21, 23, 31, 34 AND 35).

GINA HAYES, EXAMINING ATTORNEY

SN 85-516,183. G.A. BRAUN, INC., N. SYRACUSE, NY. FILED 1-13-2012.



NO CLAIM IS MADE TO THE EXCLUSIVE RIGHT TO USE "SERIES", APART FROM THE MARK AS SHOWN.

THE MARK CONSISTS OF THE LITERAL ELEMENT "PRECISION" IN CAPITAL LETTERS OVER THE LITERAL ELEMENT "SERIES" IN CAPITAL LETTERS OF SMALLER TEXT SIZE AND OFFSET TOWARD THE RIGHT END OF THE "PRECISION" ELEMENT IN CONJUNCTION WITH A DESIGN ELEMENT CONSISTING OF A STYLIZED STAR BURST WITH FOUR RAYS EMANATING FROM ITS CENTER WHICH OVERLAYS A CONCENTRIC CIRCLE WHICH ENCLOSES THE LETTER "P" OF THE "PRECISION" ELEMENT.

FOR COMMERCIAL BULK LAUNDRY HANDLING EQUIPMENT, NAMELY, MECHANICAL SPREADER-FEEDERS AND REPLACEMENT PARTS THEREFOR, FLATWORK IRONING MACHINES, SMALL PIECE GOWN/TOWEL FOLDING MACHINES, TEXTILE FLATWARE FOLDING MACHINES (U.S. CLS. 13, 19, 21, 23, 31, 34 AND 35).

GEOFFREY FOSDICK, EXAMINING ATTORNEY

CLASS 7—(Continued).

SN 85-523,674. DERRICK CORPORATION, BUFFALO, NY.
FILED 1-24-2012.



THE MARK CONSISTS OF THE WORD "HYPERPOOL" IN STYLIZED SAN-SERIF LETTERING SUPERIMPOSED ON A RECTANGULAR BLOCK WITH RECTANGULAR PROTRUSIONS BELOW AND IRREGULARLY SHAPED PROTRUSIONS ABOVE.

FOR VIBRATORY INDUSTRIAL SCREENING APPARATUS FOR SEPARATING MATERIALS AND PARTS THEREFOR; REPLACEMENT SCREEN CLOTHS FOR VIBRATORY SCREENING MACHINES; DRILL MUD SCREENING MACHINES; SOLIDS SEPARATION EQUIPMENT, NAMELY, MATERIAL DRYER MACHINES; ELECTRIC VIBRATORY MOTORS FOR MACHINES AND PARTS THEREOF (U.S. CLS. 13, 19, 21, 23, 31, 34 AND 35).

KELLY BOULTON, EXAMINING ATTORNEY

SN 85-533,482. FERRARI IMPORTING COMPANY, PITTSBURGH, PA. FILED 2-3-2012.



OWNER OF U.S. REG. NOS. 3,285,229, 3,285,230 AND 3,285,431.

THE MARK CONSISTS OF THE WORD "GAMMA" IN A STYLIZED FONT.

FOR RACQUET STRINGING MACHINES (U.S. CLS. 13, 19, 21, 23, 31, 34 AND 35).

TINA MAI, EXAMINING ATTORNEY

SN 85-533,505. FERRARI IMPORTING COMPANY, PITTSBURGH, PA. FILED 2-3-2012.



THE MARK CONSISTS OF A CIRCLE WITH A STYLIZED LETTER "G" EMERGING FROM THE INNER LEFT SIDE. FOR RACQUET STRINGING MACHINES (U.S. CLS. 13, 19, 21, 23, 31, 34 AND 35).

TINA MAI, EXAMINING ATTORNEY

CLASS 7—(Continued).

SN 85-536,212. FIBERIO TECHNOLOGY CORPORATION, MCALLEN, TX. FILED 2-7-2012.

FIBERCIDE

THE MARK CONSISTS OF STANDARD CHARACTERS WITHOUT CLAIM TO ANY PARTICULAR FONT, STYLE, SIZE, OR COLOR.

FOR CENTRIFUGAL FIBER MANUFACTURING MACHINES AND STRUCTURAL PARTS THEREFORE, NAMELY, CENTRIFUGAL FIBER PROCESSING CHAMBERS, FIBER COLLECTORS, NOZZLES USED WITH EQUIPMENT TO MAKE FIBERS, NEEDLES USED WITH EQUIPMENT TO MAKE FIBERS, SPINNERETS USED WITH EQUIPMENT TO MAKE FIBERS, NEEDLE HOLDERS USED WITH EQUIPMENT TO MAKE FIBERS, NOZZLE AND NEEDLE HOLDER SETS USED WITH EQUIPMENT TO MAKE FIBERS, AND HEATING ELEMENTS BEING MACHINE PARTS USED WITH EQUIPMENT TO MAKE FIBERS (U.S. CLS. 13, 19, 21, 23, 31, 34 AND 35).

MARK SPARACINO, EXAMINING ATTORNEY

CLASS 8—HAND TOOLS

SN 77-741,407. BACK TO NEW LLC, MAYFIELD HEIGHTS, OH. FILED 5-20-2009.

FURNACE FOÖLER

NO CLAIM IS MADE TO THE EXCLUSIVE RIGHT TO USE "FURNACE", APART FROM THE MARK AS SHOWN.

THE MARK CONSISTS OF THE WORD "FURNACE" ABOVE THE WORD "FOÖLER" WHEREIN THE "O"'S ARE MADE TO LOOK LIKE EYEBALLS WITH INWARDLY SLANTED EYEBROWS ABOVE THE "O"'S.

FOR HAND TOOL, NAMELY, TOOL CONSISTING OF A METAL PLATE AND MAGNET FOR DEPRESSING DOOR SWITCHES (U.S. CLS. 23, 28 AND 44).

FIRST USE 3-3-2008; IN COMMERCE 3-3-2008.

KAPIL BHANOT, EXAMINING ATTORNEY

CLASS 8—(Continued).

SN 79-095,909. CZECH BLADES S.R.O., CZECH REPUBLIC, FILED 2-4-2011.



OWNER OF INTERNATIONAL REGISTRATION 1073421 DATED 2-4-2011, EXPIRES 2-4-2021.

THE MARK CONSISTS OF A HEAD OF A TIGER HOLDING A SHAVING BLADE WITH THE WORDING "TIGER".

FOR SHAVING BLADES (U.S. CLS. 23, 28 AND 44). ALICE BENMAMAN, EXAMINING ATTORNEY

CLASS 8—(Continued).

SN 85-378,627. FROST CUTLERY COMPANY LLC, OOLTEWAH, TN. FILED 7-22-2011.

E.C. SIMMONS

THE MARK CONSISTS OF STANDARD CHARACTERS WITHOUT CLAIM TO ANY PARTICULAR FONT, STYLE, SIZE, OR COLOR.

THE NAME(S), PORTRAIT(S), AND/OR SIGNATURE(S) SHOWN IN THE MARK DOES NOT IDENTIFY A PARTICULAR LIVING INDIVIDUAL.

FOR CUTLERY, NAMELY, POCKET KNIVES, BOOT KNIVES, HUNTING KNIVES AND COLLECTOR'S KNIVES (U.S. CLS. 23, 28 AND 44). CHRISTOPHER LAW, EXAMINING ATTORNEY

SN 85-345,047. CRAFT SUPPLIES USA, PROVO, UT. FILED 6-13-2011.

CRAFT SUPPLIES USA

THE MARK CONSISTS OF STANDARD CHARACTERS WITHOUT CLAIM TO ANY PARTICULAR FONT, STYLE, SIZE, OR COLOR.

OWNER OF U.S. REG. NO. 4,098,621.

NO CLAIM IS MADE TO THE EXCLUSIVE RIGHT TO USE "CRAFT SUPPLIES", APART FROM THE MARK AS SHOWN.

SEC. 2(F).

FOR WOODTURNING TOOLS, NAMELY, LATHE CHISELS AND LATHE CHUCKS (U.S. CLS. 23, 28 AND 44).

FIRST USE 10-21-1982; IN COMMERCE 1-1-1983. PRISCILLA MILTON, EXAMINING ATTORNEY

SN 85-378,643. FROST CUTLERY COMPANY LLC, OOLTEWAH, TN. FILED 7-22-2011.

CARL SPITZER

SN 85-372,525. FERGUSON ENTERPRISES, INC., NEWPORT NEWS, VA. FILED 7-15-2011.

Lincoln Products

THE MARK CONSISTS OF STANDARD CHARACTERS WITHOUT CLAIM TO ANY PARTICULAR FONT, STYLE, SIZE, OR COLOR.

NO CLAIM IS MADE TO THE EXCLUSIVE RIGHT TO USE "PRODUCTS", APART FROM THE MARK AS SHOWN.

FOR HAND OPERATED PLUMBING TOOLS, NAMELY, PVC RATCHET CUTTERS, DRAIN SNAKES, DRAIN AUGERS, AND CABLE SAWS FOR PIPE CUTTING (U.S. CLS. 23, 28 AND 44).

FIRST USE 12-31-1974; IN COMMERCE 12-31-1974. TASNEEM HUSSAIN, EXAMINING ATTORNEY

THE MARK CONSISTS OF STANDARD CHARACTERS WITHOUT CLAIM TO ANY PARTICULAR FONT, STYLE, SIZE, OR COLOR.

THE NAME(S), PORTRAIT(S), AND/OR SIGNATURE(S) SHOWN IN THE MARK DOES NOT IDENTIFY A PARTICULAR LIVING INDIVIDUAL.

FOR CUTLERY, NAMELY, POCKET KNIVES, BOOT KNIVES, HUNTING KNIVES AND COLLECTOR'S KNIVES (U.S. CLS. 23, 28 AND 44).

CHRISTOPHER LAW, EXAMINING ATTORNEY

CLASS 8—(Continued).

SN 85-485,496. ROYALTON OVERSEAS LIMITED, ROAD TOWN, TORTOLA, BR.VIRGIN ISLANDS, FILED 12-2-2011.



THE COLOR(S) BLACK, RED AND WHITE IS/ARE CLAIMED AS A FEATURE OF THE MARK.

THE MARK CONSISTS OF THE STYLIZED WORD "BERGNER" IN BLACK BELOW AN INCOMPLETE SQUARE DESIGN IN RED WITH A VERTICAL WHITE RECTANGLE AND A PERPENDICULAR WHITE QUADRILATERAL.

THE WORDING "BERGNER" HAS NO MEANING IN A FOREIGN LANGUAGE.

FOR ABRADING TOOLS; BUTCHER KNIVES; CAN OPENERS; FIRE IRONS; HAND-OPERATED CHOPPERS; HOUSEHOLD KNIVES; KNIVES; LAWN AND GARDEN TOOLS, NAMELY, CULTIVATORS; MANUALLY OPERATED CONTAINER OPENER FOR HOUSEHOLD OR DOMESTIC USE; MANUALLY OPERATED HAND TOOLS, NAMELY, SCREWDRIVERS, SHOVELS, WRENCHES, HAMMERS; OYSTER OPENERS; SICKLES; TABLEWARE, NAMELY, KNIVES, FORKS AND SPOONS; VEGETABLE KNIVES (U.S. CLS. 23, 28 AND 44).

EDWARD FENNESSY, EXAMINING ATTORNEY

SN 85-486,395. XCELLENT MFG. ASSO. CO., TAIPEI, TAIWAN, FILED 12-2-2011.

Green Seasons

THE MARK CONSISTS OF STANDARD CHARACTERS WITHOUT CLAIM TO ANY PARTICULAR FONT, STYLE, SIZE, OR COLOR.

FOR HAND-OPERATED HORTICULTURE TOOLS, NAMELY, TROWELS, WEEDING FORKS, SPADES, HOES, HEDGE SHEARS, LOPPING SHEARS, PRUNING SHEARS, LEAK RAKES, GARDEN SHOVELS (U.S. CLS. 23, 28 AND 44).

FIRST USE 1-1-1998; IN COMMERCE 1-1-1998.

PAUL MORENO, EXAMINING ATTORNEY

CLASS 8—(Continued).

SN 85-486,881. 2 J-A 1476, S.L., ASPE, SPAIN, FILED 12-5-2011.

ON FLASH

THE MARK CONSISTS OF STANDARD CHARACTERS WITHOUT CLAIM TO ANY PARTICULAR FONT, STYLE, SIZE, OR COLOR.

FOR ELECTRICAL EQUIPMENT FOR HAIR REMOVAL THAT USES INTENSE PULSE LIGHT TECHNOLOGY ON LIGHT BODY HAIR AND/OR TANNED SKIN (U.S. CLS. 23, 28 AND 44).

FIRST USE 10-20-2011; IN COMMERCE 10-20-2011.

JASON BLAIR, EXAMINING ATTORNEY

SN 85-486,896. 2 J-A 1476, S.L., ASPE, SPAIN, FILED 12-5-2011.

*On
flash*

THE MARK CONSISTS OF THE WORDING "ON FLASH" IN STYLIZED FONT.

FOR ELECTRICAL EQUIPMENT FOR HAIR REMOVAL THAT USES INTENSE PULSE LIGHT TECHNOLOGY ON LIGHT BODY HAIR AND/OR TANNED SKIN (U.S. CLS. 23, 28 AND 44).

FIRST USE 10-20-2011; IN COMMERCE 10-20-2011.

JASON BLAIR, EXAMINING ATTORNEY

CLASS 8—(Continued).

SN 85-502,224. HOLLOWPOINT LLC, DBA WICKED EDGE, SANTA FE, NM. FILED 12-22-2011.

Wicked Edge

THE MARK CONSISTS OF STANDARD CHARACTERS WITHOUT CLAIM TO ANY PARTICULAR FONT, STYLE, SIZE, OR COLOR.

NO CLAIM IS MADE TO THE EXCLUSIVE RIGHT TO USE "EDGE", APART FROM THE MARK AS SHOWN.

FOR (BASED ON INTENT-TO-USE) BUTCHER KNIVES; CARVING KNIVES; CHEF KNIVES; CUTLERY, NAMELY, FORKS, SPOONS, KNIVES; DIVING KNIVES; FISH SLICING KITCHEN KNIVES; FISHING KNIVES; FIXED BLADE KNIVES; FLATWARE, NAMELY, FORKS, KNIVES, AND SPOONS; FOLDING KNIVES; HUNTING KNIVES; JACK KNIVES; JAPANESE CHOPPING KITCHEN KNIVES; KNIVES; KNIVES FOR HOBBY USE; KNIVES NAMELY, HUNTING, FOLDING, CHEF, KITCHEN, BUTCHER, PARING, FISHING, SPORT; LEATHER SHEATHS FOR KNIVES; PARING KNIVES; POCKET KNIVES; SIDE ARMS, NOT INCLUDING FIREARMS, NAMELY, HUNTING KNIVES; SPORT KNIVES; UTILITY KNIVES; (BASED ON USE) HAND TOOLS, NAMELY, KNIFE SHARPENERS; HAND TOOLS, NAMELY, MANUALLY-OPERATED SHARPENING WHEELS; HAND-OPERATED SHARPENING TOOLS AND INSTRUMENTS; KNIFE SHARPENERS; MANUALLY OPERATED SHARPENERS; MANUALLY-OPERATED RAZOR BLADE SHARPENERS; SHARPENING RODS; SHARPENING STEELS; SHARPENING STONES (U.S. CLS. 23, 28 AND 44).

FIRST USE 6-26-2007; IN COMMERCE 2-12-2008.
ANDREA BUTLER, EXAMINING ATTORNEY

SN 85-506,194. ALLSTAR MARKETING GROUP, LLC, HAWTHORNE, NY. FILED 12-30-2011.

PERFECT BARBER

THE MARK CONSISTS OF STANDARD CHARACTERS WITHOUT CLAIM TO ANY PARTICULAR FONT, STYLE, SIZE, OR COLOR.

NO CLAIM IS MADE TO THE EXCLUSIVE RIGHT TO USE "BARBER", APART FROM THE MARK AS SHOWN.

FOR HAIR TRIMMERS (U.S. CLS. 23, 28 AND 44).
DOUGLAS LEE, EXAMINING ATTORNEY

CLASS 8—(Continued).

SN 85-509,511. UNITED CUTLERY CORPORATION, MOUNTAINEER, GA. FILED 1-5-2012.

WARPATH

THE MARK CONSISTS OF STANDARD CHARACTERS WITHOUT CLAIM TO ANY PARTICULAR FONT, STYLE, SIZE, OR COLOR.

FOR KNIVES (U.S. CLS. 23, 28 AND 44).
MARK RADEMACHER, EXAMINING ATTORNEY

SN 85-509,745. ABSOLUTELYNEW, INC., SAN FRANCISCO, CA. FILED 1-5-2012.

McKinley Tools

THE MARK CONSISTS OF STANDARD CHARACTERS WITHOUT CLAIM TO ANY PARTICULAR FONT, STYLE, SIZE, OR COLOR.

NO CLAIM IS MADE TO THE EXCLUSIVE RIGHT TO USE "TOOLS", APART FROM THE MARK AS SHOWN.

FOR ABRADING TOOLS; ADJUSTABLE SPANNERS; AXES; BITS FOR HAND DRILLS; CARPENTER'S CLAMPS; CARPENTERS' PINCERS; CARPET KNIVES; CAULKING GUNS; CENTER PUNCHES; CHISELS; CROSSCUT SAW BLADES; CROWBARS; CUTTING PLIERS; DIGGING FORKS; DRAW TAPE REELS; DRILL BITS FOR HAND DRILLS; EMERY FILES; EXTENSION BARS FOR HAND TOOLS; EXTENSIONS FOR HAND TOOLS; FILES; FIXED BLADE KNIVES; FLEXIBLE HEAD SPANNERS; FOLDING KNIVES; FRAMES FOR HANDSAWS; GARDENING SHEARS AND SCISSORS; GARDENING TROWELS; GIMLETS; GLASS CUTTERS; GRINDING TIPS FOR HAND-OPERATED GRINDING WHEELS; HAMMERS; HAND OPERATED ATOMIZERS, VAPORIZERS, AND SPRAYERS FOR USE WITH INDUSTRIAL LIQUIDS; HAND OPERATED LIFTING JACKS; HAND OPERATED PLUMBING SNAKES; HAND SAWS, NAMELY, HACK SAWS; HAND SAWS, NAMELY, MITER SAWS; HAND SAWS, NAMELY, WOOD SAWS; HAND TOOL, NAMELY, RIGID AND ROD HAND BENDERS FOR USE ON PIPES AND CONDUITS; HAND TOOLS FOR PUTTING A FINISH ON CONCRETE, NAMELY, CONCRETE BRUSHES AND COMBS; HAND TOOLS, NAMELY, AUGERS; HAND TOOLS, NAMELY, AWLS; HAND TOOLS, NAMELY, BAR CUTTERS; HAND TOOLS, NAMELY, BOLT CUTTERS; HAND TOOLS, NAMELY, BUSHING DRIVERS; HAND TOOLS, NAMELY, CHALK LINE REELS; HAND TOOLS, NAMELY, CLAMPS; HAND TOOLS, NAMELY, CRIMP WRENCH SETS; HAND TOOLS, NAMELY, CRIMP WRENCHES; HAND TOOLS, NAMELY, CRIMPING IRONS; HAND TOOLS, NAMELY, CUTTER BARS; HAND TOOLS, NAMELY, DIE CHASERS; HAND TOOLS, NAMELY, DIE WRENCHES; HAND TOOLS, NAMELY, DIES; HAND TOOLS, NAMELY, DRILLS; HAND TOOLS, NAMELY, EDGERS FOR GROUT, MORTAR OR CEMENT; HAND TOOLS, NAMELY, FARRIERS' KNIVES; HAND TOOLS, NAMELY, FILES; HAND TOOLS, NAMELY, FULLERS; HAND TOOLS, NAMELY, GOUGES; HAND TOOLS, NAMELY, GRASS WHIPS; HAND TOOLS, NAMELY, GROOVERS FOR GROUT, MORTAR OR CEMENT; HAND TOOLS, NAMELY, HAMMERS; HAND TOOLS, NAMELY, HAND BENDERS FOR USE ON PIPES AND CONDUITS; HAND TOOLS, NAMELY, HAND JACKS; HAND TOOLS, NAMELY, HAND SEAMERS; HAND TOOLS, NAMELY, HAND

CLASS 8—(Continued).

TOOLS FOR SKIMMING WALL REPAIRS IN SMALL OR TIGHT AREAS WITH JOINT COMPOUND, PUTTY, OR SMOOTHING VINYL LETTERING; HAND TOOLS, NAMELY, HATCHETS; HAND TOOLS, NAMELY, HEX KEYS WRENCHES; HAND TOOLS, NAMELY, ICE PICKS; HAND TOOLS, NAMELY, KNEE KICKERS; HAND TOOLS, NAMELY, KNIFE SHARPENERS; HAND TOOLS, NAMELY, LEVERS; HAND TOOLS, NAMELY, MANUALLY-OPERATED GRINDING WHEELS; HAND TOOLS, NAMELY, MANUALLY-OPERATED GRIND-STONES; HAND TOOLS, NAMELY, MANUALLY-OPERATED GUIDES FOR KNIVES AND/OR SAWS; HAND TOOLS, NAMELY, MANUALLY-OPERATED SHARPENING WHEELS; HAND TOOLS, NAMELY, MAULS; HAND TOOLS, NAMELY, MILLING CUTTERS; HAND TOOLS, NAMELY, MITER BOXES; HAND TOOLS, NAMELY, MITRE BOXES; HAND TOOLS, NAMELY, NAIL SETS; HAND TOOLS, NAMELY, NIPPERS; HAND TOOLS, NAMELY, NUT DRIVERS; HAND TOOLS, NAMELY, PAINT SCRAPERS; HAND TOOLS, NAMELY, PAINT TRIM GUIDES; HAND TOOLS, NAMELY, PICKS; HAND TOOLS, NAMELY, PIKES; HAND TOOLS, NAMELY, PINCERS; HAND TOOLS, NAMELY, PLANERS; HAND TOOLS, NAMELY, PLANES; HAND TOOLS, NAMELY, PLIERS SETS; HAND TOOLS, NAMELY, POST HOLE DIGGERS; HAND TOOLS, NAMELY, PRIMING IRONS; HAND TOOLS, NAMELY, PRUNERS; HAND TOOLS, NAMELY, PRUNING SAWS; HAND TOOLS, NAMELY, PULLERS AND SPLITTERS; HAND TOOLS, NAMELY, PUNCHES; HAND TOOLS, NAMELY, PUTTY KNIVES; HAND TOOLS, NAMELY, RAMMERS; HAND TOOLS, NAMELY, RASPS; HAND TOOLS, NAMELY, RATCHET WRENCHES; HAND TOOLS, NAMELY, REAMERS; HAND TOOLS, NAMELY, RIPPING BARS; HAND TOOLS, NAMELY, RIVETERS; HAND TOOLS, NAMELY, ROLLERS AND BRUSHES FOR APPLYING ADHESIVES; HAND TOOLS, NAMELY, RUBBING BRICKS FOR SANDING; HAND TOOLS, NAMELY, SANDERS; HAND TOOLS, NAMELY, SANDING SPONGES; HAND TOOLS, NAMELY, SAWS; HAND TOOLS, NAMELY, SCRAPERS; HAND TOOLS, NAMELY, SCREW EXTRACTORS; HAND TOOLS, NAMELY, SCREWDRIVERS; HAND TOOLS, NAMELY, SCYTHE RINGS; HAND TOOLS, NAMELY, SCYTHE STONES; HAND TOOLS, NAMELY, SHEET METAL SHRINKING AND STRETCHING DEVICE; HAND TOOLS, NAMELY, SOCKET SETS; HAND TOOLS, NAMELY, SOCKET WRENCHES; HAND TOOLS, NAMELY, SOD LIFTERS; HAND TOOLS, NAMELY, SPATULAS; HAND TOOLS, NAMELY, SPOKESHAVES; HAND TOOLS, NAMELY, SQUARES; HAND TOOLS, NAMELY, STAMPING-OUT TOOLS; HAND TOOLS, NAMELY, STAMPS; HAND TOOLS, NAMELY, TAMPERS; HAND TOOLS, NAMELY, TAP AND DIE SETS; HAND TOOLS, NAMELY, TAPS; HAND TOOLS, NAMELY, TILE CUTTERS; HAND TOOLS, NAMELY, TONGS; HAND TOOLS, NAMELY, TORQUE MULTIPLIERS; HAND TOOLS, NAMELY, VICES; HAND TOOLS, NAMELY, WEDGES; HAND TOOLS, NAMELY, WEED CUTTERS; HAND TOOLS, NAMELY, WIRE CUTTERS; HAND TOOLS, NAMELY, WIRE NIPPERS; HAND TOOLS, NAMELY, WIRE STRIPPERS; HAND TOOLS, NAMELY, WRECKING BARS, STRIPPING BARS, SMALL BARS AND NAIL PULLERS, SAN ANGELO BARS, TAMPER BARS, WEDGE POINT BARS, PITCH POINT BARS; HAND TOOLS, NAMELY, WRENCHES; HAND-OPERATED AUTOMOTIVE REPAIR TOOLS, NAMELY, MAGNETIC PICK-UP TOOLS; HAND-OPERATED CHOPPERS; HAND-OPERATED CUTTING TOOLS, NAMELY, BOX CUTTERS; HAND-OPERATED CUTTING TOOLS, NAMELY, SAFETY CUTTERS; HAND-OPERATED DOG WASTE COLLECTION APPARATUS COMPRISING A ROD WITH A CLAMP AT ITS END FOR HOLDING A DISPOSABLE BAG THAT MAY BE POSITIONED BENEATH A DOG TO COLLECT FECES; HAND-OPERATED JIGSAWS; HAND-OPERATED LAWN EDGERS; HAND-OPERATED PIPE CUTTERS; HAND-OPERATED RIVETING TOOLS; HAND-OPERATED SHARPENING TOOLS AND INSTRUMENTS; HAND-OPERATED SHEARS; HAND-OPERATED SLICERS; HAND-OPERATED TELESCOPIC ARM FOR FIXING PANELS OF PLASTER ON WOOD OR WALLS AND CEILINGS; HAND-OPERATED TIN SNIPS; HAND-OPERATED TOOLS, NAMELY, CHISELS; HAND-POWERED STAPLE GUNS; HAND-TOOLS, NAMELY, WIRE CRIMPERS; HATCHETS; HOES; HOES; HOUSEHOLD KNIVES; HOUSEHOLD SHEARS; ICE AXES; ICE

CLASS 8—(Continued).

HAMMERS; ICE PICKS; ICE TONGS; JACK KNIVES; KNIFE SHARPENERS; KNIFE SHEATHS; KNIFE SHEATHS OF LEATHER; KNIVES FOR HOBBY USE; KNIVES MADE OF PRECIOUS METAL; LAWN RAKES; MACHETES; MALLETS; MANUAL CLIPPERS; MANUAL DRILLS; MANUALLY OPERATED HAND TOOL FOR CRUSHING PIPES; MANUALLY OPERATED SHARPENERS; MANUALLY OPERATED TREE PRUNERS; MANUALLY-OPERATED DIBBERS; MANUALLY-OPERATED GREASE GUNS; MANUALLY-OPERATED JACKS; MANUALLY-OPERATED RAZOR BLADE SHARPENERS; MASONS' TROWELS; METAL CUTTING SAWS; METAL VICE JAWS; METAL VISES; METAL-CUTTING SCISSORS; MONKEY WRENCHES; MULTI-PURPOSE SHEARS; NIPPERS; NUT WRENCHES; PALETTE KNIVES; PERCUSSION HAMMERS; PICKAXES; PICKAXES AND MATTOCKS; PIPE WRENCHES; PIT SAWS; PITCH-FORKS; PLANES; PLANING BLADES; PLIERS; POCKET KNIVES; POCKET SHEARS; PRUNING KNIVES; PRUNING SCISSORS; PRUNING SHEARS; PUNCHING DIES; PUTTY KNIVES; RAKES; RATCHET HAND TOOL FOR THE INSTALLATION AND REMOVAL OF ALPINE SKI AND SNOWBOARD RACING GATES; RATCHET HANDLES; RAZOR BLADES; RAZOR CASES; RAZOR KNIVES; RAZORS; RAZORS AND RAZOR BLADES; REAMERS; REPLACEMENT PARTS FOR HAND-OPERATED PLANES, NAMELY, BLADES, HANDLES AND KNOBS; SANDING BLOCKS; SANDING PADS FOR NON-ELECTRIC, HAND-OPERATED SANDERS; SAWS; SAWS FOR CUTTING BRANCHES; SCALPELS FOR HOBBY USE; SCISSOR BLADES; SCISSORS; SCISSORS FOR HOUSEHOLD USE; SCORING KNIFE FOR VENEER SHEETS; SCREW WRENCHES; SCREWDRIVERS; SCYTHES; SHARPENING RODS; SHARPENING STEELS; SHARPENING STONES; SHARPENING WHEELS FOR KNIVES AND BLADES; SHEARS; SHOVELS; SICKLES; SICKLES AND SCYTHES; SLEDGEHAMMERS; SNIPS; SNOW SHOVELS; SOCKET SPANNER; SOCKET SPANNERS; SPADES; SPANNERS; SPARK WRENCHES; SPATULAS FOR SPREADING HOT WAX; SPEARS; STRAIGHT RAZORS; TOOL APRONS; TOOL BELTS; TOOL HOLDERS; TOOL POUCHES FOR ATTACHMENT TO TOOL BELTS; TORQUE WRENCHES; TROWELS; TWEEZERS; UTILITY KNIVES; VICE WORKPIECE STOPS; VICES; WHET STEELS; WHETSTONES; WHETSTONES; WIRE CUTTERS; WIRE STRIPPERS; WORKING KNIVES; WRENCHES; ZESTERS (U.S. CLS. 23, 28 AND 44).

LINDA E. BLOHM, EXAMINING ATTORNEY

SN 85-510,383. HORVATH, DWAYNE A., PITTSTOWN, NJ.
FILED 1-6-2012.

AKU STRIKE

THE MARK CONSISTS OF STANDARD CHARACTERS WITHOUT CLAIM TO ANY PARTICULAR FONT, STYLE, SIZE, OR COLOR.

NO CLAIM IS MADE TO THE EXCLUSIVE RIGHT TO USE "STRIKE", APART FROM THE MARK AS SHOWN.

FOR SIDE ARMS, NOT INCLUDING FIREARMS, NAMELY, HUNTING KNIVES (U.S. CLS. 23, 28 AND 44).
ELI HELLMAN, EXAMINING ATTORNEY

CLASS 8—(Continued).

SN 85-512,349. FENG, BINTAO, ORANGE, CT. FILED 1-9-2012.

FRANK HAND TOOLS

THE MARK CONSISTS OF STANDARD CHARACTERS WITHOUT CLAIM TO ANY PARTICULAR FONT, STYLE, SIZE, OR COLOR.

NO CLAIM IS MADE TO THE EXCLUSIVE RIGHT TO USE "HAND TOOLS", APART FROM THE MARK AS SHOWN.

FOR HAMMERS; HAND TOOLS, NAMELY, HAMMERS (U.S. CLS. 23, 28 AND 44).

RICHARD WHITE, EXAMINING ATTORNEY

SN 85-512,634. KINDLE HILL, LLC, GWYNEDD VALLEY, PA. FILED 1-10-2012.

BE CLEAN, GREEN, AND SEEN

THE MARK CONSISTS OF STANDARD CHARACTERS WITHOUT CLAIM TO ANY PARTICULAR FONT, STYLE, SIZE, OR COLOR.

FOR REUSABLE FOLDING FOOD UTENSIL COMBINING FEATURES OF A FORK, SPOON AND KNIFE; REUSABLE FOLDING FOOD UTENSIL COMBINING FEATURES OF A FORK, SPOON AND KNIFE AND CARRYING CASE FOR REUSABLE FOLDING FOOD UTENSIL SOLD TOGETHER AS A UNIT; REUSABLE FOOD UTENSIL COMBINING FEATURES OF A FORK, SPOON AND KNIFE THAT CAN BE TRANSPORTED IN WASHABLE CARRYING CASE (U.S. CLS. 23, 28 AND 44).

JULIE GUTTADAURO, EXAMINING ATTORNEY

SN 85-512,675. KINDLE HILL, LLC, GWYNEDD VALLEY, PA. FILED 1-10-2012.

**BECAUSE IT'S YOUR WORLD,
AND YOU CARE**

THE MARK CONSISTS OF STANDARD CHARACTERS WITHOUT CLAIM TO ANY PARTICULAR FONT, STYLE, SIZE, OR COLOR.

FOR REUSABLE FOLDING FOOD UTENSIL COMBINING FEATURES OF A FORK, SPOON AND KNIFE; REUSABLE FOLDING FOOD UTENSIL COMBINING FEATURES OF A FORK, SPOON AND KNIFE AND CARRYING CASE FOR REUSABLE FOLDING FOOD UTENSIL SOLD TOGETHER AS A UNIT; REUSABLE FOOD UTENSIL COMBINING FEATURES OF A FORK, SPOON AND KNIFE THAT CAN BE TRANSPORTED IN WASHABLE CARRYING CASE (U.S. CLS. 23, 28 AND 44).

JULIE GUTTADAURO, EXAMINING ATTORNEY

CLASS 8—(Continued).

SN 85-512,695. KINDLE HILL, LLC, GWYNEDD VALLEY, PA. FILED 1-10-2012.

**BECAUSE THE SUSTAINABILITY
OF THE WORLD RESTS IN THE
PALM OF YOUR HAND**

THE MARK CONSISTS OF STANDARD CHARACTERS WITHOUT CLAIM TO ANY PARTICULAR FONT, STYLE, SIZE, OR COLOR.

FOR REUSABLE FOLDING FOOD UTENSIL COMBINING FEATURES OF A FORK, SPOON AND KNIFE, REUSABLE FOLDING FOOD UTENSIL COMBINING FEATURES OF A FORK, SPOON AND KNIFE AND CARRYING CASE FOR REUSABLE FOLDING FOOD UTENSIL SOLD TOGETHER AS A UNIT; REUSABLE FOOD UTENSIL COMBINING FEATURES OF A FORK, SPOON AND KNIFE THAT CAN BE TRANSPORTED IN WASHABLE CARRYING CASE (U.S. CLS. 23, 28 AND 44).

JULIE GUTTADAURO, EXAMINING ATTORNEY

SN 85-513,909. HASHI LINK CORP., IRVINE, CA. FILED 1-11-2012.

Vampire Professional Tools

THE MARK CONSISTS OF STANDARD CHARACTERS WITHOUT CLAIM TO ANY PARTICULAR FONT, STYLE, SIZE, OR COLOR.

NO CLAIM IS MADE TO THE EXCLUSIVE RIGHT TO USE "PROFESSIONAL TOOLS", APART FROM THE MARK AS SHOWN.

FOR HAND TOOLS FOR REPAIR AND MAINTENANCE OF BICYCLES; HAND TOOLS, NAMELY, BAR CUTTERS; HAND TOOLS, NAMELY, BOLT CUTTERS; HAND TOOLS, NAMELY, CLAMPS; HAND TOOLS, NAMELY, CRIMP WRENCH SETS; HAND TOOLS, NAMELY, CRIMP WRENCHES; HAND TOOLS, NAMELY, CRIMPING IRONS; HAND TOOLS, NAMELY, ENGRAVERS; HAND TOOLS, NAMELY, FILES; HAND TOOLS, NAMELY, LEVERS; HAND TOOLS, NAMELY, PINCERS; HAND TOOLS, NAMELY, PLIERS SETS; HAND TOOLS, NAMELY, PULLERS AND SPLITTERS; HAND TOOLS, NAMELY, SCREW EXTRACTORS; HAND TOOLS, NAMELY, SOCKET SETS; HAND TOOLS, NAMELY, TORQUE MULTIPLIERS; HAND TOOLS, NAMELY, VICES; HAND TOOLS, NAMELY, WIRE CUTTERS; HAND TOOLS, NAMELY, WIRE NIPPERS; HAND TOOLS, NAMELY, WIRE STRIPPERS; HAND TOOLS, NAMELY, WRENCHES; HAND TOOLS, NAMELY, PLIERS AND CHANNEL LOCKS; HAND-OPERATED CUTTING TOOLS, NAMELY, SAFETY CUTTERS; HAND-OPERATED DISARMING TOOLS FOR IMPROVISED EXPLOSIVE DEVICES (IED); HAND-TOOLS, NAMELY, WIRE CRIMPERS; MANUALLY OPERATED HAND TOOLS, NAMELY, PLIERS AND CHANNEL LOCKS; MANUALLY OPERATED SHOP TOOLS FOR WORK ON MOTORCYCLES, NAMELY, CHAIN BREAKER TOOL, CHAIN RIVETING TOOL, CHAIN PRESS TOOL, CHAIN ALIGNMENT TOOL, CARBURETOR TUNING TOOL, CARBURETOR TUNING GAUGE SET, TIRE IRONS, TAPPET ADJUSTMENT TOOLS, VALVE SHIM TOOLS, TAPPET FEELER GAUGE, CARBURETOR JET WRENCHES, CLUTCH HOLDING TOOL, PISTON PIN REMOVING TOOL, SPRING REMOVING TOOL, TIMING COVER WRENCH, OIL FILTER WRENCH, SHOCK ABSORBER WRENCH, AXLE WRENCH, FLY WHEEL PULLER TOOL, CLUTCH

CLASS 8—(Continued).

PULLER TOOL AND MAGNETO FLYWHEEL PULLER TOOL; MULTI-FUNCTION HAND TOOLS COMPRISED OF PLIERS, WRENCHES, CHANNEL LOCKS, WIRE CUTTERS, WIRE CRIMPERS; EXTENSIONS FOR HAND TOOLS; HAND TOOL FOR REMOVING HEARING AID BATTERIES; HAND TOOLS, NAMELY, AUGERS; HAND TOOLS, NAMELY, AWLS; HAND TOOLS, NAMELY, CUTTER BARS; HAND TOOLS, NAMELY, DIE WRENCHES; HAND TOOLS, NAMELY, DIES; HAND TOOLS, NAMELY, EXPANDERS; HAND TOOLS, NAMELY, GROOVING TOOLS; HAND TOOLS, NAMELY, HAMMERS; HAND TOOLS, NAMELY, HAND BENDERS FOR USE ON PIPES AND CONDUITS; HAND TOOLS, NAMELY, HAND TOOLS FOR SKIMMING WALL REPAIRS IN SMALL OR TIGHT AREAS WITH JOINT COMPOUND, PUTTY, OR SMOOTHING VINYL LETTERING; HAND TOOLS, NAMELY, RATCHET WRENCHES; HAND TOOLS, NAMELY, RIVETERS; HAND TOOLS, NAMELY, SCREWDRIVERS; HAND TOOLS, NAMELY, SOCKET WRENCHES; HAND TOOLS, NAMELY, STRETCHERS FOR WIRE AND METAL BANDS; HAND TOOLS, NAMELY, TOOLS FOR PLACING A ROPE OR OTHER FLEXIBLE MEMBER THROUGH AN EYE OR AROUND A TARGET OBJECT; HAND TOOLS, NAMELY, WRECKING BARS, STRIPPING BARS, SMALL BARS AND NAIL PULLERS, SAN ANGELO BARS, TAMPER BARS, WEDGE POINT BARS, PITCH POINT BARS; HAND-OPERATED AUTOMOTIVE REPAIR TOOLS, NAMELY, MAGNETIC PICK-UP TOOLS; HAND-OPERATED AUTOMOTIVE REPAIR TOOLS, NAMELY, VALVE HOLDERS; HAND-OPERATED AUTOMOTIVE REPAIR TOOLS, NAMELY, VALVE SPRING COMPRESSORS; HAND-OPERATED AUTOMOTIVE REPAIR TOOLS, NAMELY, VALVE SPRING DEPRESSORS; HAND-OPERATED RIVETING TOOLS; HAND-OPERATED SHARPENING TOOLS AND INSTRUMENTS; HAND-OPERATED TOOLS, NAMELY, CHISELS (U.S. CLS. 23, 28 AND 44).

FIRST USE 1-7-2012; IN COMMERCE 1-7-2012.
BRIDGETT SMITH, EXAMINING ATTORNEY

SN 85-514,545. DIORA PROFESSIONNEL LLC, HALLANDALE BEACH, FL. FILED 1-11-2012.

KERATHERAPY

THE MARK CONSISTS OF STANDARD CHARACTERS WITHOUT CLAIM TO ANY PARTICULAR FONT, STYLE, SIZE, OR COLOR.

FOR BAGS AND CASES SPECIALLY ADAPTED FOR HOLDING OR CARRYING ELECTRIC HAIR CURLING IRONS; ELECTRIC FLAT IRONS; ELECTRIC HAIR CURLING IRONS; ELECTRIC HAIR STRAIGHTENER; ELECTRIC HAIR STRAIGHTENING IRONS; ELECTRIC HAND-HELD HAIR STYLING IRONS; ELECTRIC IRONS; ELECTRIC IRONS FOR STYLING HAIR (U.S. CLS. 23, 28 AND 44).

FIRST USE 1-12-2011; IN COMMERCE 1-12-2011.
JOHN DALIER, EXAMINING ATTORNEY

CLASS 8—(Continued).

SN 85-514,551. DIORA PROFESSIONNEL LLC, HALLANDALE BEACH, FL. FILED 1-11-2012.

DIORA

THE MARK CONSISTS OF STANDARD CHARACTERS WITHOUT CLAIM TO ANY PARTICULAR FONT, STYLE, SIZE, OR COLOR.

FOR BAGS AND CASES SPECIALLY ADAPTED FOR HOLDING OR CARRYING ELECTRIC HAIR CURLING IRONS; ELECTRIC FLAT IRONS; ELECTRIC HAIR CRIMPER; ELECTRIC HAIR CURLING IRONS; ELECTRIC HAIR STRAIGHTENER; ELECTRIC HAIR STRAIGHTENING IRONS; ELECTRIC HAND-HELD HAIR STYLING IRONS; ELECTRIC IRONS; ELECTRIC IRONS FOR STYLING HAIR (U.S. CLS. 23, 28 AND 44).

FIRST USE 1-12-2011; IN COMMERCE 1-12-2011.
JOHN DALIER, EXAMINING ATTORNEY

SN 85-515,351. BROWNING, MORGAN, UT. FILED 1-12-2012.

STONE COLD

THE MARK CONSISTS OF STANDARD CHARACTERS WITHOUT CLAIM TO ANY PARTICULAR FONT, STYLE, SIZE, OR COLOR.

FOR FIXED BLADE KNIVES; HUNTING KNIVES; SPORT KNIVES (U.S. CLS. 23, 28 AND 44).

FIRST USE 7-5-2011; IN COMMERCE 12-14-2011.
CHARISMA HAMPTON, EXAMINING ATTORNEY

SN 85-515,375. BROWNING., MORGAN, UT. FILED 1-12-2012.

SHADOWFAX

THE MARK CONSISTS OF STANDARD CHARACTERS WITHOUT CLAIM TO ANY PARTICULAR FONT, STYLE, SIZE, OR COLOR.

FOR FIXED BLADE KNIVES; HUNTING KNIVES; SPORT KNIVES (U.S. CLS. 23, 28 AND 44).

FIRST USE 6-6-2011; IN COMMERCE 12-14-2011.
BRIAN NEVILLE, EXAMINING ATTORNEY

CLASS 8—(Continued).

SN 85-515,428. BROWNING, MORGAN, UT. FILED 1-12-2012.

PANDEMONIUM

THE MARK CONSISTS OF STANDARD CHARACTERS WITHOUT CLAIM TO ANY PARTICULAR FONT, STYLE, SIZE, OR COLOR.

FOR FIXED BLADE KNIVES; FOLDING KNIVES; HUNTING KNIVES; SHARPENING WHEELS FOR KNIVES AND BLADES; SPORT KNIVES (U.S. CLS. 23, 28 AND 44).

FIRST USE 7-5-2011; IN COMMERCE 12-14-2011.
CHARISMA HAMPTON, EXAMINING ATTORNEY

CLASS 8—(Continued).

SN 85-515,483. BROWNING, MORGAN, UT. FILED 1-12-2012.

DETERRENT

THE MARK CONSISTS OF STANDARD CHARACTERS WITHOUT CLAIM TO ANY PARTICULAR FONT, STYLE, SIZE, OR COLOR.

FOR FIXED BLADE KNIVES; HUNTING KNIVES; SPORT KNIVES (U.S. CLS. 23, 28 AND 44).

FIRST USE 4-7-2011; IN COMMERCE 12-10-2011.
CHARISMA HAMPTON, EXAMINING ATTORNEY

SN 85-515,448. BROWNING, MORGAN, UT. FILED 1-12-2012.

ARBITRATOR

THE MARK CONSISTS OF STANDARD CHARACTERS WITHOUT CLAIM TO ANY PARTICULAR FONT, STYLE, SIZE, OR COLOR.

FOR FIXED BLADE KNIVES; HUNTING KNIVES; SPORT KNIVES (U.S. CLS. 23, 28 AND 44).

FIRST USE 4-7-2011; IN COMMERCE 12-10-2011.
CHARISMA HAMPTON, EXAMINING ATTORNEY

SN 85-515,496. BROWNING, MORGAN, UT. FILED 1-12-2012.

VOLATILE

THE MARK CONSISTS OF STANDARD CHARACTERS WITHOUT CLAIM TO ANY PARTICULAR FONT, STYLE, SIZE, OR COLOR.

FOR FIXED BLADE KNIVES; HUNTING KNIVES; SPORT KNIVES (U.S. CLS. 23, 28 AND 44).

FIRST USE 4-7-2011; IN COMMERCE 12-10-2011.
CHARISMA HAMPTON, EXAMINING ATTORNEY

SN 85-515,473. BROWNING, MORGAN, UT. FILED 1-12-2012.

SHOCK N' AWE

THE MARK CONSISTS OF STANDARD CHARACTERS WITHOUT CLAIM TO ANY PARTICULAR FONT, STYLE, SIZE, OR COLOR.

FOR AXES; FIXED BLADE KNIVES; HUNTING KNIVES; SPORT KNIVES (U.S. CLS. 23, 28 AND 44).

FIRST USE 6-6-2011; IN COMMERCE 12-14-2011.
CHARISMA HAMPTON, EXAMINING ATTORNEY

SN 85-515,774. BROWNING, MORGAN, UT. FILED 1-13-2012.

PERFECT STORM

THE MARK CONSISTS OF STANDARD CHARACTERS WITHOUT CLAIM TO ANY PARTICULAR FONT, STYLE, SIZE, OR COLOR.

FOR FOLDING KNIVES; POCKET KNIVES; SPORT KNIVES (U.S. CLS. 23, 28 AND 44).

FIRST USE 4-7-2011; IN COMMERCE 12-10-2011.
CHARISMA HAMPTON, EXAMINING ATTORNEY

CLASS 8—(Continued).

SN 85-515,876. BROWNING, MORGAN, UT. FILED 1-13-2012.

HELL FIRE

THE MARK CONSISTS OF STANDARD CHARACTERS WITHOUT CLAIM TO ANY PARTICULAR FONT, STYLE, SIZE, OR COLOR.

FOR FOLDING KNIVES; HUNTING KNIVES; POCKET KNIVES; SPORT KNIVES (U.S. CLS. 23, 28 AND 44).

FIRST USE 4-7-2011; IN COMMERCE 12-10-2011.
CHARISMA HAMPTON, EXAMINING ATTORNEY

SN 85-515,887. BROWNING, OGDEN, UT. FILED 1-13-2012.

UNDISPUTED

THE MARK CONSISTS OF STANDARD CHARACTERS WITHOUT CLAIM TO ANY PARTICULAR FONT, STYLE, SIZE, OR COLOR.

FOR FOLDING KNIVES; HUNTING KNIVES; POCKET KNIVES; SPORT KNIVES (U.S. CLS. 23, 28 AND 44).

FIRST USE 4-7-2011; IN COMMERCE 12-10-2011.
CHARISMA HAMPTON, EXAMINING ATTORNEY

SN 85-516,550. ABSOLUTELYNEW, INC., SAN FRANCISCO, CA. FILED 1-13-2012.



NO CLAIM IS MADE TO THE EXCLUSIVE RIGHT TO USE "TOOLS", APART FROM THE MARK AS SHOWN.

THE MARK CONSISTS OF THE WORD "TRADECRAFT" IN STYLIZED LETTERS, WITH THE TOPS OF THE TWO "T"'S JOINED TO CREATE THE LIKENESS OF A STYLIZED HOUSE ROOF; THE WORD "TOOLS" IS LOCATED ABOVE THE SECOND "T" IN "TRADECRAFT".

FOR ABRADING TOOLS; ADJUSTABLE SPANNERS; AXES; BITS FOR HAND DRILLS; CARPENTER'S CLAMPS; CARPENTERS' PINNERS; CARPET KNIVES; CAULKING GUNS; CENTER PUNCHES; CHISELS; CROSSCUT SAW BLADES; CROWBARS; CUTTING PLIERS; DIGGING FORKS; DRAW TAPE REELS; DRILL BITS FOR HAND DRILLS; EMERY FILES; EXTENSION BARS FOR HAND TOOLS; EXTENSIONS FOR HAND TOOLS; FILES; FIXED BLADE KNIVES; FLEXIBLE HEAD SPANNERS; FOLDING KNIVES; FRAMES FOR HANDSAWS; GARDENING SHEARS AND SCISSORS; GARDENING TROWELS; GIMLETS; GLASS CUTTERS; GRINDING TIPS FOR HAND-OPERATED GRINDING WHEELS; HAMMERS; HAND OPERATED ATOMIZERS, VAPORIZERS, AND SPRAYERS FOR USE WITH INDUSTRIAL LIQUIDS; HAND OPERATED LIFTING JACKS; HAND OPERATED PLUMBING SNAKES; HAND SAWS, NAMELY, HACK SAWS; HAND SAWS, NAMELY, MITER SAWS; HAND SAWS, NAMELY, WOOD SAWS; HAND TOOL, NAMELY, RIGID AND ROD HAND

CLASS 8—(Continued).

BENDERS FOR USE ON PIPES AND CONDUITS; HAND TOOLS FOR PUTTING A FINISH ON CONCRETE, NAMELY, CONCRETE BRUSHES AND COMBS; HAND TOOLS, NAMELY, AUGERS; HAND TOOLS, NAMELY, AWLS; HAND TOOLS, NAMELY, BAR CUTTERS; HAND TOOLS, NAMELY, BOLT CUTTERS; HAND TOOLS, NAMELY, BUSHING DRIVERS; HAND TOOLS, NAMELY, CHALK LINE REELS; HAND TOOLS, NAMELY, CLAMPS; HAND TOOLS, NAMELY, CRIMP WRENCH SETS; HAND TOOLS, NAMELY, CRIMP WRENCHES; HAND TOOLS, NAMELY, CRIMPING IRONS; HAND TOOLS, NAMELY, CUTTER BARS; HAND TOOLS, NAMELY, DIE CHASERS; HAND TOOLS, NAMELY, DIE WRENCHES; HAND TOOLS, NAMELY, DIES; HAND TOOLS, NAMELY, DRILLS; HAND TOOLS, NAMELY, EDGERS FOR GROUT, MORTAR OR CEMENT; HAND TOOLS, NAMELY, FARRIERS' KNIVES; HAND TOOLS, NAMELY, FILES; HAND TOOLS, NAMELY, FULLERS; HAND TOOLS, NAMELY, GOUGES; HAND TOOLS, NAMELY, GRASS WHIPS; HAND TOOLS, NAMELY, GROOVERS FOR GROUT, MORTAR OR CEMENT; HAND TOOLS, NAMELY, HAMMERS; HAND TOOLS, NAMELY, HAND BENDERS FOR USE ON PIPES AND CONDUITS; HAND TOOLS, NAMELY, HAND JACKS; HAND TOOLS, NAMELY, HAND SEAMERS; HAND TOOLS, NAMELY, HAND TOOLS FOR SKIMMING WALL REPAIRS IN SMALL OR TIGHT AREAS WITH JOINT COMPOUND, PUTTY, OR SMOOTHING VINYL LETTERING; HAND TOOLS, NAMELY, HATCHETS; HAND TOOLS, NAMELY, HEX KEYS WRENCHES; HAND TOOLS, NAMELY, ICE PICKS; HAND TOOLS, NAMELY, KNEE KICKERS; HAND TOOLS, NAMELY, KNIFE SHARPENERS; HAND TOOLS, NAMELY, LEVERS; HAND TOOLS, NAMELY, MANUALLY-OPERATED GRINDING WHEELS; HAND TOOLS, NAMELY, MANUALLY-OPERATED GRIND-STONES; HAND TOOLS, NAMELY, MANUALLY-OPERATED GUIDES FOR KNIVES AND/OR SAWS; HAND TOOLS, NAMELY, MANUALLY-OPERATED SHARPENING WHEELS; HAND TOOLS, NAMELY, MAULS; HAND TOOLS, NAMELY, MILLING CUTTERS; HAND TOOLS, NAMELY, MITER BOXES; HAND TOOLS, NAMELY, MITRE BOXES; HAND TOOLS, NAMELY, NAIL SETS; HAND TOOLS, NAMELY, NIPPERS; HAND TOOLS, NAMELY, NUT DRIVERS; HAND TOOLS, NAMELY, PAINT SCRAPERS; HAND TOOLS, NAMELY, PAINT TRIM GUIDES; HAND TOOLS, NAMELY, PICKS; HAND TOOLS, NAMELY, PIKES; HAND TOOLS, NAMELY, PINNERS; HAND TOOLS, NAMELY, PLANERS; HAND TOOLS, NAMELY, PLANES; HAND TOOLS, NAMELY, PLIERS SETS; HAND TOOLS, NAMELY, POST HOLE DIGGERS; HAND TOOLS, NAMELY, PRIMING IRONS; HAND TOOLS, NAMELY, PRUNERS; HAND TOOLS, NAMELY, PRUNING SAWS; HAND TOOLS, NAMELY, PULLERS AND SPLITTERS; HAND TOOLS, NAMELY, PUNCHES; HAND TOOLS, NAMELY, PUTTY KNIVES; HAND TOOLS, NAMELY, RAMMERS; HAND TOOLS, NAMELY, RASPS; HAND TOOLS, NAMELY, RATCHET WRENCHES; HAND TOOLS, NAMELY, REAMERS; HAND TOOLS, NAMELY, RIPPING BARS; HAND TOOLS, NAMELY, RIVETERS; HAND TOOLS, NAMELY, ROLLERS AND BRUSHES FOR APPLYING ADHESIVES; HAND TOOLS, NAMELY, RUBBING BRICKS FOR SANDING; HAND TOOLS, NAMELY, SANDERS; HAND TOOLS, NAMELY, SANDING SPONGES; HAND TOOLS, NAMELY, SAWS; HAND TOOLS, NAMELY, SCRAPERS; HAND TOOLS, NAMELY, SCREW EXTRACTORS; HAND TOOLS, NAMELY, SCREWDRIVERS; HAND TOOLS, NAMELY, SCYTHE RINGS; HAND TOOLS, NAMELY, SCYTHE STONES; HAND TOOLS, NAMELY, SHEET METAL SHRINKING AND STRETCHING DEVICE; HAND TOOLS, NAMELY, SOCKET SETS; HAND TOOLS, NAMELY, SOCKET WRENCHES; HAND TOOLS, NAMELY, SOD LIFTERS; HAND TOOLS, NAMELY, SPATULAS; HAND TOOLS, NAMELY, SPOKESHAVES; HAND TOOLS, NAMELY, SQUARES; HAND TOOLS, NAMELY, STAMPING-OUT TOOLS; HAND TOOLS, NAMELY, STAMPS; HAND TOOLS, NAMELY, TAMPERS; HAND TOOLS, NAMELY, TAP AND DIE SETS; HAND TOOLS, NAMELY, TAPS; HAND TOOLS, NAMELY, TILE CUTTERS; HAND TOOLS, NAMELY, TONGS; HAND TOOLS, NAMELY, TORQUE MULTIPLIERS; HAND TOOLS, NAMELY, VICES; HAND TOOLS, NAMELY, WEDGES; HAND TOOLS, NAMELY, WEED CUTTERS; HAND TOOLS, NAMELY, WIRE CUTTERS; HAND TOOLS, NAMELY, WIRE NIPPERS;

CLASS 8—(Continued).

HAND TOOLS, NAMELY, WIRE STRIPPERS; HAND TOOLS, NAMELY, WRECKING BARS, STRIPPING BARS, SMALL BARS AND NAIL PULLERS, SAN ANGELO BARS, TAMPER BARS, WEDGE POINT BARS, PITCH POINT BARS; HAND TOOLS, NAMELY, WRENCHES; HAND-OPERATED AUTOMOTIVE REPAIR TOOLS, NAMELY, MAGNETIC PICK-UP TOOLS; HAND-OPERATED CHOPPERS; HAND-OPERATED CUTTING TOOLS, NAMELY, BOX CUTTERS; HAND-OPERATED CUTTING TOOLS, NAMELY, SAFETY CUTTERS; HAND-OPERATED DOG WASTE COLLECTION APPARATUS COMPRISING A ROD WITH A CLAMP AT ITS END FOR HOLDING A DISPOSABLE BAG THAT MAY BE POSITIONED BENEATH A DOG TO COLLECT FECES; HAND-OPERATED JIGSAWS; HAND-OPERATED LAWN EDGERS; HAND-OPERATED PIPE CUTTERS; HAND-OPERATED RIVETING TOOLS; HAND-OPERATED SHARPENING TOOLS AND INSTRUMENTS; HAND-OPERATED SHEARS; HAND-OPERATED SLICERS; HAND-OPERATED TELESCOPIC ARM FOR FIXING PANELS OF PLASTER ON WOOD OR WALLS AND CEILINGS; HAND-OPERATED TIN SNIPS; HAND-OPERATED TOOLS, NAMELY, CHISELS; HAND-POWERED STAPLE GUNS; HAND-TOOLS, NAMELY, WIRE CRIMPERS; HATCHETS; HOES; HOES; HOUSEHOLD KNIVES; HOUSEHOLD SHEARS; ICE AXES; ICE HAMMERS; ICE PICKS; ICE TONGS; JACK KNIVES; KNIFE SHARPENERS; KNIFE SHEATHS; KNIFE SHEATHS OF LEATHER; KNIVES FOR HOBBY USE; KNIVES MADE OF PRECIOUS METAL; LAWN RAKES; MACHETES; MALLET; MANUAL CLIPPERS; MANUAL DRILLS; MANUALLY OPERATED HAND TOOL FOR CRUSHING PIPES; MANUALLY OPERATED SHARPENERS; MANUALLY OPERATED TREE PRUNERS; MANUALLY-OPERATED DIBBERS; MANUALLY-OPERATED GREASE GUNS; MANUALLY-OPERATED JACKS; MANUALLY-OPERATED RAZOR BLADE SHARPENERS; MASONS' TROWELS; METAL CUTTING SAWS; METAL VICE JAWS; METAL VISES; METAL-CUTTING SCISSORS; MONKEY WRENCHES; MULTI-PURPOSE SHEARS; NIPPERS; NUT WRENCHES; PALETTE KNIVES; PERCUSSION HAMMERS; PICKAXES; PICKAXES AND MATTOCKS; PIPE WRENCHES; PIT SAWS; PITCH-FORKS; PLANES; PLANING BLADES; PLIERS; POCKET KNIVES; POCKET SHEARS; PRUNING KNIVES; PRUNING SCISSORS; PRUNING SHEARS; PUNCHING DIES; PUTTY KNIVES; RAKES; RATCHET HAND TOOL FOR THE INSTALLATION AND REMOVAL OF ALPINE SKI AND SNOWBOARD RACING GATES; RATCHET HANDLES; RAZOR BLADES; RAZOR CASES; RAZOR KNIVES; RAZORS; RAZORS AND RAZOR BLADES; REAMERS; REPLACEMENT PARTS FOR HAND-OPERATED PLANES, NAMELY, BLADES, HANDLES AND KNOBS; SANDING BLOCKS; SANDING PADS FOR NON-ELECTRIC, HAND-OPERATED SANDERS; SAWS; SAWS FOR CUTTING BRANCHES; SCALPELS FOR HOBBY USE; SCISSOR BLADES; SCISSORS; SCISSORS FOR HOUSEHOLD USE; SCORING KNIFE FOR VENEER SHEETS; SCREW WRENCHES; SCREWDRIVERS; SCYTHES; SHARPENING RODS; SHARPENING STEELS; SHARPENING STONES; SHARPENING WHEELS FOR KNIVES AND BLADES; SHEARS; SHOVELS; SICKLES; SICKLES AND SCYTHES; SLEDGEHAMMERS; SNIPS; SNOW SHOVELS; SOCKET SPANNER; SOCKET SPANNERS; SPADES; SPANNERS; SPARK WRENCHES; SPATULAS FOR SPREADING HOT WAX; SPEARS; STRAIGHT RAZORS; TOOL APRONS; TOOL BELTS; TOOL HOLDERS; TOOL POUCHES FOR ATTACHMENT TO TOOL BELTS; TORQUE WRENCHES; TROWELS; TWEEZERS; UTILITY KNIVES; VICE WORKPIECE STOPS; VICES; WHET STEELS; WHETSTONES; WHETSTONES; WIRE CUTTERS; WIRE STRIPPERS; WORKING KNIVES; WRENCHES; ZESTERS (U.S. CLS. 23, 28 AND 44).

LINDA E. BLOHM, EXAMINING ATTORNEY

CLASS 8—(Continued).

SN 85-554,467. D 'N A MARKETING SERVICES, LLC, SANTA ROSA BEACH, FL. FILED 2-28-2012.

THE GAL PAL

THE MARK CONSISTS OF STANDARD CHARACTERS WITHOUT CLAIM TO ANY PARTICULAR FONT, STYLE, SIZE, OR COLOR.

FOR MULTI-FUNCTION HAND TOOLS COMPRISED OF FLASHLIGHT, KEYCHAIN, CAN TAB OPENER, TWEEZERS, NAIL FILE, MIRRORS (U.S. CLS. 23, 28 AND 44).

HAI-LY LAM, EXAMINING ATTORNEY

SN 85-588,035. NEPTUNE TRADING INC., ONTARIO, CA. FILED 4-3-2012.

ONIKIRI

THE MARK CONSISTS OF STANDARD CHARACTERS WITHOUT CLAIM TO ANY PARTICULAR FONT, STYLE, SIZE, OR COLOR.

THE ENGLISH TRANSLATION OF "ONIKIRI" IN THE MARK IS "DEMON CUTTER".

FOR JAPANESE SWORDS; SWORDS (U.S. CLS. 23, 28 AND 44).

FIRST USE 8-14-2010; IN COMMERCE 10-1-2011.

ADA HAN, EXAMINING ATTORNEY

CLASS 9—ELECTRICAL AND SCIENTIFIC APPARATUS

SN 76-708,349. ESSILOR OF AMERICA, INC., DALLAS, TX. FILED 7-15-2011.

IMMIX

THE MARK CONSISTS OF STANDARD CHARACTERS WITHOUT CLAIM TO ANY PARTICULAR FONT, STYLE, SIZE, OR COLOR.

FOR OPHTHALMIC LENSES; OPTICAL LENSES (U.S. CLS. 21, 23, 26, 36 AND 38).

ALICIA COLLINS, EXAMINING ATTORNEY

CLASS 9—(Continued).

SN 76-708,611. WIKA INSTRUMENT CORPORATION, LAWRENCEVILLE, GA. FILED 8-5-2011.

TRUSTED MEASUREMENT

THE MARK CONSISTS OF STANDARD CHARACTERS WITHOUT CLAIM TO ANY PARTICULAR FONT, STYLE, SIZE, OR COLOR.

NO CLAIM IS MADE TO THE EXCLUSIVE RIGHT TO USE "MEASUREMENT", APART FROM THE MARK AS SHOWN.

FOR SCIENTIFIC APPARATUS, NAMELY, PRESSURE GAUGES AND ELECTRONIC PRESSURE TRANSMITTERS, TRANSDUCERS, AND METERS (U.S. CLS. 21, 23, 26, 36 AND 38).

ANDREW LEASER, EXAMINING ATTORNEY

SN 76-708,692. STACK, STEVE, GOSHEN, KY. FILED 8-11-2011.

TCCC MAN

THE MARK CONSISTS OF STANDARD CHARACTERS WITHOUT CLAIM TO ANY PARTICULAR FONT, STYLE, SIZE, OR COLOR.

NO CLAIM IS MADE TO THE EXCLUSIVE RIGHT TO USE "MAN", APART FROM THE MARK AS SHOWN.

FOR MEDICAL APPARATUS, NAMELY, A MANIKIN DESIGNED WITH HUMAN PHYSIOLOGICAL PROPERTIES FOR MEDICAL PRACTICE DURING HARSH TACTICAL MILITARY TRAINING (U.S. CLS. 21, 23, 26, 36 AND 38).

YAT SYE, LEE, EXAMINING ATTORNEY

SN 76-710,102. MURPHY, KATHLEEN, MCLEAN, VA. AND SUDOW, WILLIAM E., MCLEAN, VA. FILED 12-27-2011.

QB2

THE MARK CONSISTS OF STANDARD CHARACTERS WITHOUT CLAIM TO ANY PARTICULAR FONT, STYLE, SIZE, OR COLOR.

FOR FOOTBALL THEMED ELECTRONIC GAME PROGRAMS FOR USE WITH HAND-HELD ELECTRONIC DEVICES (U.S. CLS. 21, 23, 26, 36 AND 38).

MATTHEW MCDOWELL, EXAMINING ATTORNEY

CLASS 9—(Continued).

SN 76-710,103. MURPHY, KATHLEEN, MCLEAN, VA. AND SUDOW, WILLIAM E., MCLEAN, VA. FILED 12-27-2011.

UBQB

THE MARK CONSISTS OF STANDARD CHARACTERS WITHOUT CLAIM TO ANY PARTICULAR FONT, STYLE, SIZE, OR COLOR.

FOR FOOTBALL THEMED ELECTRONIC GAME PROGRAMS FOR USE WITH HAND-HELD ELECTRONIC DEVICES (U.S. CLS. 21, 23, 26, 36 AND 38).

MATTHEW MCDOWELL, EXAMINING ATTORNEY

SN 76-710,165. ESCUE, ERIKA G., HOLLAND, OH. FILED 1-3-2012.

GODOTZ

THE MARK CONSISTS OF STANDARD CHARACTERS WITHOUT CLAIM TO ANY PARTICULAR FONT, STYLE, SIZE, OR COLOR.

FOR REMOVABLY ATTACHABLE CAPACITIVE INTERFACE DEVICE COMPRISING A METALLIC ELEMENT, WEARABLE ON THE PRINT-PORTION OF FINGERS AND/OR THUMBS OF A PERSON, TO ACTIVATE ICONS ON A TOUCH SCREEN (U.S. CLS. 21, 23, 26, 36 AND 38).

LINDA POWELL, EXAMINING ATTORNEY

CLASS 9—(Continued).

SN 77-372,489. DC COMICS, NEW YORK, NY. FILED 1-15-2008.



THE MARK CONSISTS OF SHOOTING STARS SURROUNDING THE STYLIZED WORDS "SUPER POWERS".

FOR MOTION PICTURE FILMS FEATURING COMEDY, DRAMA, ACTION, ADVENTURE AND/OR ANIMATION; AND MOTION PICTURE FILMS FOR BROADCAST ON TELEVISION FEATURING COMEDY, DRAMA, ACTION, ADVENTURE AND/OR ANIMATION; AUDIO TAPES, AUDIO-VIDEO TAPES, AUDIO VIDEO CASSETTES, AUDIO VIDEO DISCS, AND DIGITAL VERSATILE DISCS FEATURING MUSIC, COMEDY, DRAMA, ACTION, ADVENTURE, AND/OR ANIMATION; STEREO HEADPHONES; CORDLESS TELEPHONES; AUDIO CASSETTE AND CD PLAYERS; CD ROM COMPUTER GAME DISCS; TELEPHONE AND/OR RADIO PAGERS; SHORT MOTION PICTURE FILM CASSETTES FEATURING COMEDY, DRAMA, ACTION, ADVENTURE AND/OR ANIMATION TO BE USED WITH HAND-HELD VIEWERS OR PROJECTORS; VIDEO CASSETTE RECORDERS AND PLAYERS, COMPACT DISC PLAYERS, DIGITAL AUDIO TAPE RECORDERS AND PLAYERS; RADIOS; MOUSE PADS; EYEGASSES, SUNGLASSES AND CASES THEREFORE; GAME EQUIPMENT SOLD AS A UNIT FOR PLAYING A PARLOR-TYPE COMPUTER GAME; VIDEO AND COMPUTER GAME PROGRAMS; VIDEO GAME CARTRIDGES AND CASSETTES; CELLULAR TELEPHONE ACCESSORIES, NAMELY, HANDS-FREE ACCESSORIES, CELLULAR TELEPHONE COVERS AND CELLULAR TELEPHONE FACE COVERS; ENCODED MAGNETIC CARDS, NAMELY, PHONE CARDS, CREDIT CARDS, CASH CARDS, DEBIT CARDS AND MAGNETIC KEY CARDS; AND DECORATIVE MAGNETS (U.S. CLS. 21, 23, 26, 36 AND 38).

MARY ROSSMAN, EXAMINING ATTORNEY

CLASS 9—(Continued).

SN 77-677,377. MARVEL CHARACTERS, INC., MANHATTAN BEACH, CA. FILED 2-24-2009.

THOR

THE MARK CONSISTS OF STANDARD CHARACTERS WITHOUT CLAIM TO ANY PARTICULAR FONT, STYLE, SIZE, OR COLOR.

OWNER OF U.S. REG. NOS. 890,918, 958,186 AND 2,933,886.

FOR MOTION PICTURE FILMS FEATURING COMIC BOOK CHARACTERS IN LIVE ACTION AND ANIMATED ADVENTURE; PRE-RECORDED CDS, VIDEO TAPES AND DVDS FEATURING LIVE ACTION ADVENTURE PROGRAMS, MOTION PICTURES FEATURING COMIC BOOK CHARACTERS IN LIVE ACTION AND ANIMATED ADVENTURE, AND ANIMATED CARTOONS IN THE FIELD OF ACTION ADVENTURE BASED ON COMIC BOOK CHARACTERS; COMPUTER GAME CARTRIDGES; COMPUTER GAME DISCS; COMPUTER GAME PROGRAMS; COMPUTER GAME SOFTWARE; INTERACTIVE MULTIMEDIA COMPUTER GAME PROGRAM; INTERACTIVE VIDEO GAME PROGRAMS; VIDEO GAME CARTRIDGES; VIDEO GAME DISCS; VIDEO GAME SOFTWARE (U.S. CLS. 21, 23, 26, 36 AND 38).

FIRST USE 5-3-2011; IN COMMERCE 5-3-2011.

CARYN GLASSER, EXAMINING ATTORNEY

SN 77-798,996. ADT SERVICES AG, SCHAFFHAUSEN, SWITZERLAND, FILED 8-6-2009.

PULSE

THE MARK CONSISTS OF STANDARD CHARACTERS WITHOUT CLAIM TO ANY PARTICULAR FONT, STYLE, SIZE, OR COLOR.

OWNER OF SWITZERLAND REG. NO. 599586, DATED 12-18-2009, EXPIRES 12-18-2019.

FOR FIRE ALARMS, ALARM CENTRAL UNITS, ANTI-INTRUSION ALARMS, BURGLAR ALARMS, PERSONAL SECURITY ALARMS, SMOKE ALARMS, AND GAS ALARMS; SPRINKLER SYSTEMS FOR FIRE PROTECTION; RADIO, VIDEO AND DIGITAL SIGNAL TRANSMITTERS, RECEIVERS AND SWITCHES, ANTENNAS, INTERCOMS, LASERS NOT FOR MEDICAL USE, ELECTRONIC LOCKS, TELEPHONE COMMUNICATION BASE STATIONS, TELEPHONES, AND VOICE AND VIDEO COMMUNICATION HUBS; COMPUTER HARDWARE AND COMPUTER PERIPHERALS; ENVIRONMENTAL SENSORS AND DETECTORS FOR DETECTING HEAT, TEMPERATURE, WATER, SMOKE, GAS, PRESSURE AND MOVEMENT; REMOTE CONTROL UNITS, KEYPADS AND CONTROL PANELS FOR SECURITY SYSTEMS, FIRE ALARMS, ALARM CENTRAL UNITS, ANTI-INTRUSION ALARMS, BURGLAR ALARMS, PERSONAL HEALTH AND SECURITY ALARMS, SMOKE AND GAS ALARMS, HOME SURVEILLANCE SYSTEMS, LIGHTING CONTROLS, HOME AUTOMATION DEVICES AND SPRINKLER SYSTEMS FOR FIRE PROTECTION; COMPUTER SOFTWARE USED TO OPERATE, MANAGE AND MONITOR SECURITY SYSTEMS, FIRE ALARMS, ALARM CENTRAL UNITS, ANTI-INTRUSION ALARMS, BURGLAR ALARMS, PERSONAL HEALTH AND SECURITY ALARMS, SMOKE AND GAS ALARMS, HOME SURVEILLANCE SYSTEMS, LIGHTING CONTROLS AND

CLASS 9—(Continued).

HOME AUTOMATION DEVICES; COMPUTER SOFTWARE USED TO MONITOR AND TRACK MOVEMENT ACTIVITY, HEALTH CONDITIONS AND ENVIRONMENTAL CONDITIONS, AND USED TO TRANSMIT ELECTRONIC MESSAGES AND DATA VIA COMMUNICATIONS NETWORKS; HOME AND OFFICE AUTOMATION SYSTEMS COMPRISING WIRELESS AND WIRED CONTROLLERS, CONTROLLED DEVICES, AND SOFTWARE FOR LIGHTING, HVAC, SECURITY, SAFETY AND OTHER HOME AND OFFICE MONITORING AND CONTROL APPLICATIONS; ELECTRICAL CONTROLLERS AND SWITCHES FOR USE WITH WATER FLOW AND SPRINKLER SYSTEMS, HOME AUTOMATION AND LIGHTING; LIGHTING CONTROL PANELS; MOTION SENSITIVE SECURITY LIGHTS; ELECTRIC AND ELECTRONIC VIDEO SURVEILLANCE INSTALLATIONS; CAMERAS, INCLUDING VIDEO, TELEVISION AND SURVEILLANCE CAMERAS; VIDEO AND TELEVISION MONITORS; MOUNTING DEVICES FOR CAMERAS AND MONITORS; LOCATOR SYSTEMS, NAMELY, SATELLITE AND RADIO TRANSMITTERS AND RECEIVERS, TRANSPONDERS, AND ANTENNAS; VEHICLE, PET AND PERSONNEL LOCATOR AND RECOVERY DEVICE PROGRAMMED TO USE GLOBAL POSITIONING SYSTEMS (GPS) AND CELLULAR TELECOMMUNICATIONS; AND USER MANUALS SOLD AS A UNIT THEREWITH, ALL OF THE AFOREMENTIONED FOR RESIDENTIAL USE (U.S. CLS. 21, 23, 26, 36 AND 38).

ALEX KEAM, EXAMINING ATTORNEY

SN 77-885,060. LG ELECTRONICS INC., SEOUL, REPUBLIC OF KOREA, FILED 12-3-2009.



PRIORITY CLAIMED UNDER SEC. 44(D) ON REPUBLIC OF KOREA APPLICATION NO. 40-2009-0049, FILED 10-9-2009, REG. NO. 0864193, DATED 5-21-2011, EXPIRES 5-21-2021.

NO CLAIM IS MADE TO THE EXCLUSIVE RIGHT TO USE "TOUCH BUTTON", APART FROM THE MARK AS SHOWN.

THE MARK CONSISTS OF A RECTANGLE WITH ROUNDED CORNERS WITH THREE CONCENTRIC CIRCLES IN THE CENTER WITH A FINGERPRINT TOUCHING THE CIRCLES AND THE WORDS "TOUCH BUTTON" BELOW THE CIRCLES.

FOR COMPUTERS; MOBILE PHONES; COMPUTER APPLICATION SOFTWARE FOR MOBILE PHONES FOR IMPROVEMENT OF IMAGE QUALITY (U.S. CLS. 21, 23, 26, 36 AND 38).

ESTHER A. BORSUK, EXAMINING ATTORNEY

CLASS 9—(Continued).

SN 78-579,196. PERKINELMER HEALTH SCIENCES, INC., WALTHAM, MA. FILED 3-3-2005.

LABWORKS

THE MARK CONSISTS OF STANDARD CHARACTERS WITHOUT CLAIM TO ANY PARTICULAR FONT, STYLE, SIZE, OR COLOR.

FOR COMPUTER SOFTWARE FOR LABORATORY INFORMATION MANAGEMENT, NAMELY, SOFTWARE FOR MAINTAINING AND MANAGING A DATABASE OF INFORMATION PERTAINING TO LABORATORY PROCEDURES, FOR PLANNING, SCHEDULING, TRACKING AND EVALUATING LABORATORY EVENTS AND PROCEDURES, FOR MAINTAINING RECORDS OF LABORATORY PROCEDURE DATA, FOR REPORTING INFORMATION ABOUT THE STATUS AND RESULTS OF LABORATORY PROCEDURES, AND FOR THE TRANSFER OF DATA TO AND FROM LABORATORY INSTRUMENTS, IN THE FIELDS OF THE ENVIRONMENT, WATER AND WASTE WATER, UTILITIES, PROCESS CONTROL, FORENSICS, FOODS AND BEVERAGES, AND AGRICULTURE (U.S. CLS. 21, 23, 26, 36 AND 38).

FIRST USE 0-0-1985; IN COMMERCE 0-0-1985.

DAWN HAN, EXAMINING ATTORNEY

SN 79-095,030. ACCELINK TECHNOLOGIES CO., LTD., HONGSHAN DISTRICT, 430074 WUHAN, CHINA, FILED 3-10-2011.

OWNER OF INTERNATIONAL REGISTRATION 1070905 DATED 3-10-2011, EXPIRES 3-10-2021.

THE MARK CONSISTS OF THE WORDING "ACCELINK" IN STYLIZED FORMAT. AN EYE APPEARS WITHIN THE LETTER "A".

FOR COUPLERS FOR COMMUNICATION EQUIPMENT, NAMELY, ACOUSTIC COUPLERS, FIBER OPTICAL COUPLER, SPECIAL WAVELENGTH COUPLER, SINGLE MODE BROADBAND FIBER COUPLER, SINGLE MODE BROADBAND TREE FIBER COUPLER; OPTICAL COMMUNICATION DEVICES FOR USE WITH COMPUTER HARDWARE, NAMELY, INTERNET VIDEO CAMERAS, OPTICAL TRANSMITTERS, OPTICAL RECEIVERS, OPTICAL DATA LINKS, OPTICAL TRANSCIEVERS, CABLE TELEVISION TRANSMITTERS, DIGITAL TRANSMITTERS, COMMUNICATION LINK TESTERS FOR TESTING COMMUNICATION LINKS; DETECTORS, NAMELY, RADAR DETECTORS, LASER SPEED DETECTORS, INFRARED DETECTORS FOR USE IN MILITARY, LAW ENFORCEMENT, CIVIL, SCIENTIFIC AND INDUSTRIAL APPLICATIONS, RADIATION DETECTORS, SMOKE DETECTORS, METAL DETECTORS; METERS, NAMELY, ELECTRIC METERS, GAS METERS, PHOTOGRAPHIC EXPOSURE METERS, VIBRATION METERS, SOUND LEVEL METERS, ACOUSTIC METERS, OPTICAL POWER METER, PORTABLE PON OPTICAL POWER METER, PORTABLE OPTICAL MULTI-METER; DYNAMOMETERS; AMPLIFIERS; CELL SWITCHES, NAMELY, ELECTRIC CUR-

CLASS 9—(Continued).

RENT SWITCHES, POWER SWITCHES, OPTICAL SWITCH, ATTENUATOR, OPTICAL ATTENUATOR, CHANGE-OVER SWITCHES FOR TELECOMMUNICATION APPARATUS; SEMI-CONDUCTORS; OPTICAL GOODS, NAMELY, CAMERAS, BINOCULARS, DEMODULATOR, OPTICAL SEMICONDUCTOR AMPLIFIERS, PHOTOVOLTAIC CELLS AND MODULES, SIGNAL SPLITTERS FOR ELECTRONIC APPARATUS; OPTICAL MIRRORS FOR SCIENTIFIC USE; OPTICAL APPARATUS AND INSTRUMENTS, NAMELY, CAMERAS, BINOCULARS, PROTECTIVE SHEATHS FOR FIBER OPTICAL CABLES; OPTICAL SEMICONDUCTOR AMPLIFIERS, OPTICAL SENSORS, OPTICAL FREQUENCY METROLOGY DEVICES, OPTICAL FIBER CABLES, OPTICAL FRAMES; OPTICAL GLASSES; LIGHT CONDUCTING FILAMENTS; ELECTRIC LIGHT DIMMERS; SEMICONDUCTOR DEVICE; MAGNETIC MATERIALS AND DEVICES, NAMELY, MAGNETIC COMPASSES, MAGNETIC TAPE RECORDERS, MAGNETIC PENS, MAGNETIC OBJECT DETECTORS (U.S. CLS. 21, 23, 26, 36 AND 38).

DAVID HOFFMAN, EXAMINING ATTORNEY

CLASS 9—(Continued).

SN 79-100,828. GO21GO AG, CH-8008 ZÜRICH, SWITZERLAND, FILED 6-8-2011.

go21go

SN 79-100,285. XLNT ADVANCED TECHNOLOGIES B.V., NETHERLANDS, FILED 5-18-2011.

C-DRIVE

THE MARK CONSISTS OF STANDARD CHARACTERS WITHOUT CLAIM TO ANY PARTICULAR FONT, STYLE, SIZE, OR COLOR.

PRIORITY DATE OF 2-11-2011 IS CLAIMED. OWNER OF INTERNATIONAL REGISTRATION 1084859 DATED 5-18-2011, EXPIRES 5-18-2021.

FOR REGULATING AND CONTROLLING APPARATUS, NAMELY, ELECTRONIC CONTROLLERS USED TO REGULATE AND CONTROL POWER SUPPLY AND AUTOMATED OPERATIONAL FUNCTIONS OF CHAIN HOISTS, WIRE WINCHES, STAGE PLATFORMS, TURNABLES, AND TROLLEY/TRACK SYSTEMS (U.S. CLS. 21, 23, 26, 36 AND 38).

TEJBIR SINGH, EXAMINING ATTORNEY

THE MARK CONSISTS OF STANDARD CHARACTERS WITHOUT CLAIM TO ANY PARTICULAR FONT, STYLE, SIZE, OR COLOR.

OWNER OF INTERNATIONAL REGISTRATION 1086160 DATED 6-8-2011, EXPIRES 6-8-2021.

FOR COMPUTER HARDWARE AND SOFTWARE FOR ORGANIZING, BACKING UP AND ACCESSING DATA IN DATABASES; ELECTRONIC MONITORING INSTALLATIONS, NAMELY, INSTALLATIONS WITH ARITHMETIC UNITS IN THE NATURE OF ENERGY METERS FOR TRACKING AND MONITORING ENERGY USAGE, COMPUTERS, COMPUTER SERVERS, VISUAL DISPLAY DEVICES IN THE NATURE OF LIQUID CRYSTAL DISPLAYS, AND COMPUTER SOFTWARE FOR USE IN DATABASE MANAGEMENT, MANAGING CORPORATE PROJECTS, MANAGING PERSONAL AND CORPORATE ACTIVITIES RELATED TO HEALTH, ENERGY USAGE, PROFESSIONAL SKILLS DEVELOPMENT, ENVIRONMENTALLY RELATED ACTIVITIES, PRODUCT MARKETING, AND CHANGES IN CORPORATE POLICIES AND PROCEDURES; COMPUTER SOFTWARE PLATFORMS FOR MANAGING AND TRACKING DATABASES, FOR CORPORATE PROJECT MANAGEMENT, AND FOR MANAGING AND TRACKING PERSONAL AND CORPORATE ACTIVITIES RELATED TO HEALTH, ENERGY USAGE, PROFESSIONAL SKILLS DEVELOPMENT, ENVIRONMENTALLY RELATED ACTIVITIES, PRODUCT MARKETING, AND CHANGES IN CORPORATE POLICIES AND PROCEDURES; RECORDED COMPUTER SOFTWARE FOR MANAGING AND TRACKING DATABASES, FOR CORPORATE PROJECT MANAGEMENT, AND FOR MANAGING AND TRACKING PERSONAL AND CORPORATE ACTIVITIES RELATED TO HEALTH, ENERGY USAGE, PROFESSIONAL SKILLS DEVELOPMENT, ENVIRONMENTALLY RELATED ACTIVITIES, PRODUCT MARKETING, AND CHANGES IN CORPORATE POLICIES AND PROCEDURES; COMPUTER SOFTWARE FOR MANAGING AND TRACKING DATABASES, FOR CORPORATE PROJECT MANAGEMENT, AND FOR MANAGING AND TRACKING PERSONAL AND CORPORATE ACTIVITIES RELATED TO HEALTH, ENERGY USAGE, PROFESSIONAL SKILLS DEVELOPMENT, ENVIRONMENTALLY RELATED ACTIVITIES, PRODUCT MARKETING, AND CHANGES IN CORPORATE POLICIES AND PROCEDURES; DATA LOGGERS, NAMELY, COMPUTER HARDWARE AND SOFTWARE FOR DATA COLLECTION AND MAINTENANCE; COMPUTER GAME SOFTWARE; GAME PROGRAMS FOR MOBILE TELEPHONE SETS; COMPUTER GAME SOFTWARE; GAME PROGRAMS FOR MOBILE TELEPHONES (U.S. CLS. 21, 23, 26, 36 AND 38).

KRISTINA MORRIS, EXAMINING ATTORNEY

CLASS 9—(Continued).

SN 79-101,827. RADIALL, FRANCE, FILED 7-13-2011.

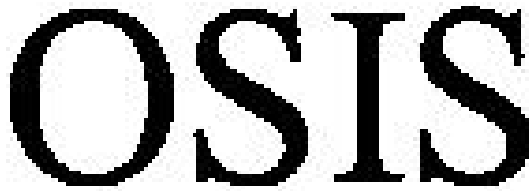

THE MARK CONSISTS OF STANDARD CHARACTERS WITHOUT CLAIM TO ANY PARTICULAR FONT, STYLE, SIZE, OR COLOR.

PRIORITY DATE OF 1-21-2011 IS CLAIMED.

OWNER OF INTERNATIONAL REGISTRATION 1088727 DATED 7-13-2011, EXPIRES 7-13-2021.

FOR ELECTRICAL AND OPTICAL CONNECTION DEVICES AND CONNECTORS, NAMELY, ELECTRICAL CONNECTORS, CONNECTIONS AND CONNECTOR HOUSINGS, OPTICAL CABLES, OPTICAL APPARATUS AND INSTRUMENTS, NAMELY, TRANSMITTERS, RECEIVERS, TRANSCIEVERS, FIBERS, ELECTRICAL CONNECTOR HOUSINGS, ELECTRICAL SOCKETS AND ELECTRICAL PLUGS; ELECTRICAL AND OPTICAL CORDS FITTED WITH END CONNECTORS (U.S. CLS. 21, 23, 26, 36 AND 38).

ERNEST SHOSHO, EXAMINING ATTORNEY

CLASS 9—(Continued).

SN 79-101,856. CHARTERFIELD PTY LTD, AUSTRALIA, FILED 7-5-2011.

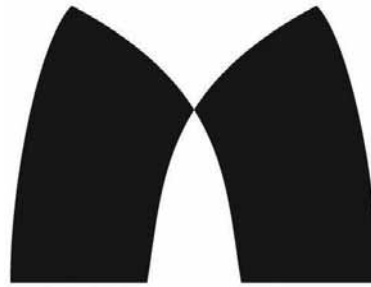

PRIORITY DATE OF 1-5-2011 IS CLAIMED.
OWNER OF INTERNATIONAL REGISTRATION 1088815 DATED 7-5-2011, EXPIRES 7-5-2021.

THE MARK CONSISTS OF A DESIGN OF TWO STYLIZED CURVED QUADRILATERAL SHAPES WHOSE CENTRAL POINTS TOUCH.

FOR COMPUTER HARDWARE; COMPUTER SOFTWARE FOR OPERATION OF CELL PHONES AND HAND HELD ELECTRONIC COMMUNICATION DEVICES AND APPLICATIONS THEREFOR AND FOR ORGANISING FILES AND DATA THEREON; COMPUTERS; MANAGEMENT SOFTWARE FOR TELEPHONES, NAMELY, MOBILE TELEPHONE SOFTWARE FOR USE IN DATABASE MANAGEMENT; ELECTRONIC MAIL AND MESSAGING SOFTWARE; PAGING SOFTWARE; MOBILE TELEPHONE SOFTWARE FOR USE IN ELECTRONIC STORAGE OF DATA; SOFTWARE FOR OPERATION OF AND ORGANISING FILES AND DATA ON HAND HELD DIGITAL ELECTRONIC DEVICES; ELECTRONIC USER MANUALS RECORDED ON COMPUTER MEDIA FEATURING INFORMATION ON THE OPERATION OF APPLICATIONS FOR CELL PHONES AND HAND HELD DIGITAL ELECTRONIC COMMUNICATION DEVICES AND INFORMATION ON THE ORGANISATION AND SHARING OF FILES AND DATA THEREON; HAND HELD AND MOBILE DIGITAL ELECTRONIC DEVICES IN THE NATURE OF PERSONAL DIGITAL ASSISTANTS (PDA) AND SMARTPHONES FOR SENDING AND RECEIVING TELEPHONE CALLS, FAXES, ELECTRONIC MAIL, AND OTHER DIGITAL DATA, NAMELY, USER CREATED RECORDS, FILES AND INFORMATION (U.S. CLS. 21, 23, 26, 36 AND 38).

NATALIE POLZER, EXAMINING ATTORNEY

CLASS 9—(Continued).

SN 79-105,484. DATA MER OPTIK ELEKTRIK ELEKTRO-
NIK; SAN. TIC. LTD. STI., ACIBADEM / ISTANBUL,
TURKEY, FILED 8-24-2011.



OWNER OF INTERNATIONAL REGISTRATION 1097559
DATED 8-24-2011, EXPIRES 8-24-2021.

NO CLAIM IS MADE TO THE EXCLUSIVE RIGHT TO
USE "INTERACTIVE PROJECTOR", APART FROM THE
MARK AS SHOWN.

THE COLOR(S) BLUE, WHITE, GRAY, BROWN, RED
AND BLACK IS/ARE CLAIMED AS A FEATURE OF THE
MARK.

THE MARK CONSISTS OF THE FOLLOWING: WHITE
PROJECTOR WITH BLACK EYEBROWS, BROWN, WHITE
AND BLUE EYES, A WHITE MOUTH, BROWN ARMS AND
HANDS, A GRAY, BLUE, AND WHITE LENS, A BLACK
STRIP, RED LIGHT AND BROWN LEGS AND FEET, ALL
OUTLINED IN BLACK, HOLDING A BLACK AND WHITE
PEN WITH WHITE STARS AROUND THE END, AND THE
WORDING "WALL-MARKER INTERACTIVE PROJECTOR"
IN WHITE, ALL ON A BLUE RECTANGULAR BACK-
GROUND.

FOR SCIENTIFIC, NAUTICAL, SURVEYING, PHOTO-
GRAPHIC, CINEMATOGRAPHIC, OPTICAL, WEIGH-
ING, MEASURING, SIGNALING, CHECKING FOR
SUPERVISION, LIFE-SAVING AND TEACHING APPA-
RATUS AND INSTRUMENTS, NAMELY, CINEMATO-
GRAPHIC PROJECTORS; APPARATUS AND
INSTRUMENTS FOR CONDUCTING, SWITCHING,
TRANSFORMING, ACCUMULATING, REGULATING
OR CONTROLLING ELECTRICITY, NAMELY, ELEC-
TRICAL TRANSFORMERS; APPARATUS FOR REC-
ORDING, TRANSMISSION AND REPRODUCTION OF
SOUND AND IMAGES; CAMERAS; INTERACTIVE PRO-
JECTOR IN THE NATURE OF VIDEO PROJECTORS;
ELECTRONIC PEN; MAGNETIC DATA CARRIERS,
NAMELY, BLANK MAGNETIC DATA CARRIERS; REC-
ORDING DISCS, NAMELY, BLANK OPTICAL DISKS
(U.S. CLS. 21, 23, 26, 36 AND 38).

APRIL ROACH, EXAMINING ATTORNEY

CLASS 9—(Continued).

SN 79-107,401. SUN WEN JIE, TAIWAN, CHINA, FILED 9-5-
2011.



OWNER OF INTERNATIONAL REGISTRATION 1102260
DATED 9-5-2011, EXPIRES 9-5-2021.

THE MARK CONSISTS OF THE WORDING "DUNU"
EMBEDDED IN THE LETTER "D", ALL OF WHICH IS
ENCLOSED IN A SQUARE DESIGN. TO THE RIGHT OF
THE SQUARE IS ANOTHER LARGE LETTER "D" WITH
THE TERM "DUNU" EMBEDDED IN THE LETTER "D".

FOR MEGAPHONES; MICROPHONES; HEAD-
PHONES; HORNS FOR LOUDSPEAKERS; AUDIO RE-
CORDERS; EARPLUGS NOT FOR MEDICAL
PURPOSES; CABINETS FOR LOUDSPEAKERS; SOUND
RECORDING APPARATUS; RADIOS; SOUND TRANSMIT-
TING APPARATUS (U.S. CLS. 21, 23, 26, 36 AND 38).

SANJEEV VOHRA, EXAMINING ATTORNEY

SN 79-110,450. A6 EUROPE SPRL, BELGIUM, FILED 12-13-
2011.



OWNER OF INTERNATIONAL REGISTRATION 1110195
DATED 12-13-2011, EXPIRES 12-13-2021.

THE COLOR(S) BLACK IS/ARE CLAIMED AS A FEAT-
URE OF THE MARK.

THE MARK CONSISTS OF THE STYLIZED WORDING
"ON.EARZ" IN BLACK; THE COLOR WHITE REPRESENTS
BACKGROUND AND IS NOT PART OF THE MARK.

FOR HEADPHONES; ELECTRONIC SENSING APPA-
RATUS, NAMELY, FLOOR MATS THAT SENSE THE
PRESENCE OF A BODY THEREON, ACCESSORIES FOR
COMPUTERS, NAMELY, AUDIO SPEAKERS (U.S. CLS.
21, 23, 26, 36 AND 38).

TASNEEM HUSSAIN, EXAMINING ATTORNEY

CLASS 9—(Continued).

SN 85-027,439. LIFETIME ENTERTAINMENT SERVICES, LLC, NEW YORK, NY. FILED 4-30-2010.

LIFETIME

THE MARK CONSISTS OF STANDARD CHARACTERS WITHOUT CLAIM TO ANY PARTICULAR FONT, STYLE, SIZE, OR COLOR.

OWNER OF U.S. REG. NOS. 2,266,954 AND 3,180,878.

FOR DOWNLOADABLE AUDIO AND VIDEO FILES IN THE FIELDS OF DOCUMENTARY, BIOGRAPHIES, COMEDY, DRAMA, ANIMATION, MYSTERY, HEALTH, NOT INCLUDING ORAL HEALTH AND DENTISTRY, COOKING, ROMANCE, BEAUTY, FASHION, WEDDINGS, INTERIOR DESIGN AND DECORATING, AND/OR ACTION-ADVENTURE; DOWNLOADABLE WEBCASTS IN THE FIELDS OF DOCUMENTARY, BIOGRAPHIES, COMEDY, DRAMA, ANIMATION, MYSTERY, HEALTH, NOT INCLUDING ORAL HEALTH AND DENTISTRY, COOKING, ROMANCE, BEAUTY, FASHION, WEDDINGS, INTERIOR DESIGN AND DECORATING, AND/OR ACTION-ADVENTURE; DOWNLOADABLE ON-LINE DISCUSSION BOARDS IN THE FIELDS OF DOCUMENTARY, BIOGRAPHIES, COMEDY, DRAMA, ANIMATION, MYSTERY, HEALTH, NOT INCLUDING ORAL HEALTH AND DENTISTRY, COOKING, ROMANCE, BEAUTY, FASHION, WEDDINGS, INTERIOR DESIGN AND DECORATING, AND/OR ACTION-ADVENTURE (U.S. CLS. 21, 23, 26, 36 AND 38).

FIRST USE 5-0-2002; IN COMMERCE 5-0-2002.
MARTHA FROMM, EXAMINING ATTORNEY

SN 85-038,359. ROMANENKO, ALEKSANDR, PARK RIDGE, IL. FILED 5-13-2010.

Aleks Di Roma

THE MARK CONSISTS OF STANDARD CHARACTERS WITHOUT CLAIM TO ANY PARTICULAR FONT, STYLE, SIZE, OR COLOR.

THE NAME SHOWN IN THE MARK IDENTIFIES "ALEKSANDR ROMANENKO" WHOSE CONSENT IS MADE OF RECORD.

FOR RECORDED AUDIO AND VIDEO MEDIA, NAMELY, PRE-RECORDED CDS AND DVDS FEATURING MUSIC AND ARTISTIC PERFORMANCES (U.S. CLS. 21, 23, 26, 36 AND 38).

FIRST USE 10-31-2009; IN COMMERCE 10-31-2009.
ANDREW RHIM, EXAMINING ATTORNEY

CLASS 9—(Continued).

SN 85-048,427. NET WORTH MEDIA, LLC, JUPITER, FL. FILED 5-26-2010.

VOLTZ

THE MARK CONSISTS OF STANDARD CHARACTERS WITHOUT CLAIM TO ANY PARTICULAR FONT, STYLE, SIZE, OR COLOR.

FOR BATTERIES (U.S. CLS. 21, 23, 26, 36 AND 38).
DAVID ELTON, EXAMINING ATTORNEY

SN 85-073,420. MOBILE NETWORK MARKETING CORPORATION PTY. LTD., BUNDABERG, QUEENSLAND, AUSTRALIA, FILED 6-29-2010.

ZERO

THE MARK CONSISTS OF STANDARD CHARACTERS WITHOUT CLAIM TO ANY PARTICULAR FONT, STYLE, SIZE, OR COLOR.

FOR APPARATUS FOR TRANSMISSION OF COMMUNICATION, NAMELY, A DEVICE WHICH TRANSMITS ADVERTISEMENTS TO MOBILE PHONES AND COMPUTERS UTILIZING WIRELESS TECHNOLOGY (U.S. CLS. 21, 23, 26, 36 AND 38).

FIRST USE 1-0-2010; IN COMMERCE 1-0-2010.
SANI KHOURI, EXAMINING ATTORNEY

SN 85-145,158. OPENMFG LLC, DBA XTUPLE, NORFOLK, VA. FILED 10-5-2010.

Grow your world.

THE MARK CONSISTS OF STANDARD CHARACTERS WITHOUT CLAIM TO ANY PARTICULAR FONT, STYLE, SIZE, OR COLOR.

FOR DOWNLOADABLE COMPUTER SOFTWARE FOR BUSINESS MANAGEMENT AND GROWTH WORLDWIDE, CONSISTING OF ACCOUNTING, ENTERPRISE RESOURCE PLANNING, SALES, AND CUSTOMER RELATIONSHIP MANAGEMENT FUNCTIONALITY (U.S. CLS. 21, 23, 26, 36 AND 38).

FIRST USE 10-5-2010; IN COMMERCE 10-5-2010.
JAMES MACFARLANE, EXAMINING ATTORNEY

CLASS 9—(Continued).

SN 85-156,207. INNOVATIVE PET SOLUTIONS LLC, ALEXANDRIA, VA. FILED 10-19-2010.

CLASS 9—(Continued).

SN 85-175,536. SCOTT TECHNOLOGIES, INC., BOCA RATON, FL. FILED 11-12-2010.

PET SPA



THE MARK CONSISTS OF STANDARD CHARACTERS WITHOUT CLAIM TO ANY PARTICULAR FONT, STYLE, SIZE, OR COLOR.

NO CLAIM IS MADE TO THE EXCLUSIVE RIGHT TO USE "PET", APART FROM THE MARK AS SHOWN.

FOR PORTABLE, SELF-CONTAINED, AUTOMATIC FLUSHING PET WASTE MANAGEMENT SYSTEM CONSISTING OF A PROXIMITY SENSOR, ELECTRONICALLY CONTROLLED PUMP, LITHIUM ION BATTERY PACK, REMOVABLE PET WASTE RECEPTACLE AND WATER TANK (U.S. CLS. 21, 23, 26, 36 AND 38).

DAWN HAN, EXAMINING ATTORNEY

OWNER OF U.S. REG. NOS. 757,831 AND 2,848,272. NO CLAIM IS MADE TO THE EXCLUSIVE RIGHT TO USE "SAFETY", APART FROM THE MARK AS SHOWN.

THE MARK CONSISTS OF STYLIZED LETTERS "SS" NEXT TO THE STYLIZED WORDS "SCOTT SAFETY".

FOR SELF-RESCUE APPARATUS, NAMELY, SELF-CONTAINED OXYGEN BREATHING UNITS; MEASURING AND CONTROL DEVICES FOR OXYGEN BREATHING UNITS; PRESSURIZING RESPIRATORY BREATHING AIR CYLINDERS USED BY EMERGENCY PERSONNEL, COMPRISING AN AIR COMPRESSOR ASSEMBLY, DRIVE MOTOR, AIR PURIFIERS, AIR STORAGE CYLINDERS, AND AUTOMATIC CONTROLS; THERMAL IMAGING CAMERAS; FACE MASK FOR BREATHING FOR NON-MEDICAL PURPOSES; APPARATUS FOR TRANSMISSION OF COMMUNICATION; SAFETY GARMENTS FOR USE BY FIREFIGHTERS, INDUSTRIAL WORKERS, FIRST RESPONDERS, AND MILITARY PERSONNEL; NON-MEDICAL RESPIRATOR EQUIPMENT, NAMELY, STATIONARY AND MOBILE AIR CHARGING STATION; NON-MEDICAL RESPIRATOR EQUIPMENT, NAMELY, AIR CYLINDER STORAGE RACKS; PERSONNEL LOCATOR AND RECOVERY DEVICE PROGRAMMED TO USE GLOBAL POSITIONING SYSTEM (GPS) AND CELLULAR TELECOMMUNICATIONS; ELECTRONIC DEVICES FOR ASSISTING EMERGENCY PERSONNEL FOR PEOPLE NEEDING ASSISTANCE COMPRISED OF SENSORS FOR DETERMINING STATUS OF PERSON AND APPARATUS FOR SENDING ELECTRONIC ALERTS TO EMERGENCY PERSONNEL; RESPIRATORS OTHER THAN FOR ARTIFICIAL RESPIRATION; FILTERS FOR RESPIRATORY MASKS; GAS MASKS; PORTABLE AND FIXED GAS DETECTORS; PORTABLE AND FIXED FLAME DETECTORS; SELF-RESCUE APPARATUS, NAMELY, OXYGEN BREATHING UNITS USED IN THE AIRLINE INDUSTRY; AIR PURIFYING BREATHING EQUIPMENT FOR NON-MEDICAL PURPOSES; HEARING PROTECTION HEADSETS, NOT FOR MEDICAL USE; INDUSTRIAL SAFETY EYE PROTECTION; TELECOMMUNICATIONS AND DATA NETWORKING HARDWARE, NAMELY, DEVICES FOR TRANSPORTING AND AGGREGATING VOICE, DATA, AND VIDEO COMMUNICATIONS ACROSS MULTIPLE NETWORK INFRASTRUCTURES AND COMMUNICATIONS PROTOCOLS; COMPUTER HARDWARE AND SOFTWARE SYSTEM FOR TRACKING EQUIPMENT AND ASSETS USING GPS DATA ON A DEVICE ON THE TRACKED EQUIPMENT AND ASSETS; SOFTWARE FOR GAS AND FILTER SELECTION MANAGEMENT; AND NON-MEDICAL RESPIRATORY EQUIPMENT, NAMELY, BOTTLED AIR CART; NONE OF THE AFORESAID GOODS FOR SPORTS OR SPORTING ACTIVITIES (U.S. CLS. 21, 23, 26, 36 AND 38).

MARIA-VICTORIA SUAREZ, EXAMINING ATTORNEY

SN 85-170,081. FRONT PORCH DIGITAL, INC., LOUISVILLE, CO. FILED 11-5-2010.

DIVAPUBLISH

THE MARK CONSISTS OF STANDARD CHARACTERS WITHOUT CLAIM TO ANY PARTICULAR FONT, STYLE, SIZE, OR COLOR.

OWNER OF U.S. REG. NOS. 2,864,097, 3,626,187 AND 3,865,183.

FOR COMPUTER SOFTWARE FOR USE IN THE FIELD OF DIGITAL MEDIA FOR THE SCHEDULED PUBLISHING, DISTRIBUTION, DELIVERING, AND METRICS OF DIGITAL ARCHIVE BASED VIDEO CONTENT AND ASSOCIATED METADATA, RIGHTS MANAGEMENT, AND ANALYTICS (U.S. CLS. 21, 23, 26, 36 AND 38).

FIRST USE 10-9-2010; IN COMMERCE 10-9-2010.
ANN E. SAPPENFIELD, EXAMINING ATTORNEY

CLASS 9—(Continued).

SN 85-187,126. WIDEALAB INC., GYEONGGI-DO, REPUBLIC OF KOREA, FILED 11-30-2010.

aurender

THE MARK CONSISTS OF STANDARD CHARACTERS WITHOUT CLAIM TO ANY PARTICULAR FONT, STYLE, SIZE, OR COLOR.

PRIORITY CLAIMED UNDER SEC. 44(D) ON REPUBLIC OF KOREA APPLICATION NO. 40-2010-0043, FILED 8-24-2010, REG. NO. 40-0909756, DATED 3-13-2012, EXPIRES 3-13-2022.

FOR DIGITAL AUDIO PLAYER; DIGITAL VIDEO PLAYER; AUDIO AND VIDEO RECEIVER; SOUND RECORDING AND PLAYBACK APPARATUS; SOFTWARE AUDIO PLAYER, NAMELY, APPARATUS FOR WIRELESS TRANSMISSION OF DIGITAL AUDIO AND DIGITAL VIDEO TO TABLET COMPUTERS (U.S. CLS. 21, 23, 26, 36 AND 38).

SUNG IN, EXAMINING ATTORNEY

SN 85-187,200. EH EUROPE GMBH, ZURICH, SWITZERLAND, FILED 11-30-2010.



The logo for 'Express' features the word in a bold, italicized, sans-serif font. The letter 'X' is highlighted in green, while the remaining letters are black.

THE COLOR(S) BLACK AND GREEN IS/ARE CLAIMED AS A FEATURE OF THE MARK.

THE MARK CONSISTS OF THE WORD "EXPRESS" IN ITALICIZED FORM WITH THE LETTER "X" IN GREEN AND THE REMAINING LETTERS IN BLACK.

FOR INDUSTRIAL MOTIVE POWER BATTERIES USED IN INDUSTRIAL VEHICLES AND EQUIPMENT, NAMELY, FORK LIFTS AND LIFT TRUCKS AND BATTERY CHARGERS USED IN CONNECTION THEREWITH (U.S. CLS. 21, 23, 26, 36 AND 38).

FIRST USE 1-1-2004; IN COMMERCE 1-1-2004.

NAKIA HENRY, EXAMINING ATTORNEY

SN 85-192,451. VIOLIN MEMORY, INC., MOUNTAIN VIEW, CA. FILED 12-7-2010.

VCACHE

THE MARK CONSISTS OF STANDARD CHARACTERS WITHOUT CLAIM TO ANY PARTICULAR FONT, STYLE, SIZE, OR COLOR.

FOR SOLID STATE MEMORY COMPUTER ACCELERATION DEVICE (U.S. CLS. 21, 23, 26, 36 AND 38).

CARYN GLASSER, EXAMINING ATTORNEY

CLASS 9—(Continued).

SN 85-194,216. DIGITOGO, INC., LA JOLLA, CA. FILED 12-9-2010.

DIGITOGO

THE MARK CONSISTS OF STANDARD CHARACTERS WITHOUT CLAIM TO ANY PARTICULAR FONT, STYLE, SIZE, OR COLOR.

FOR AUDIO/VISUAL HARDWARE, NAMELY, AUDIO AND SIGNAL SPLITTERS, AUDIO AND SIGNAL SWITCHES, AUDIO AND SIGNAL EXTENDERS, AUDIO AND SIGNAL CONVERSION BOXES, SCALER BOXES (U.S. CLS. 21, 23, 26, 36 AND 38).

FIRST USE 11-1-2009; IN COMMERCE 11-1-2009.

LINDA E. BLOHM, EXAMINING ATTORNEY

SN 85-195,021. GEM HOLDING CORP., SHIGA 520-0047, JAPAN, FILED 12-10-2010.



The logo for 'Cleanlite EDENEX' features the word 'Cleanlite' in a small, blue, sans-serif font above the word 'EDENEX' in a large, bold, sans-serif font. The letters 'ED' are blue, 'EN' are red, and 'EX' are blue. Below the main text is a tagline: 'Environmental Defense by Enhancing Natural Energy'.

THE COLOR(S) BLUE, RED AND GRAY IS/ARE CLAIMED AS A FEATURE OF THE MARK.

THE MARK CONSISTS OF THE WORDING "CLEANLITE", WITH "CLEAN" IN BLUE AND "LITE" IN RED. BENEATH "CLEANLITE" IS THE WORDING "EDENEX" WITH THE LETTERS "ED" IN BLUE, "EN" IN RED AND "EX" IN BLUE. BENEATH THIS WORDING IS "ENVIRONMENTAL DEFENSE BY ENHANCING NATURAL ENERGY" IN GRAY.

FOR BATTERIES; POWER BATTERY DEVICES, NAMELY, SOLAR CELL PANELS, POWER BATTERY CHARGERS AND CHARGER SYSTEMS COMPRISING BATTERY CHARGERS AND STEADY ELECTRICAL CONTROLLING DEVICES, POWER STORAGE BATTERIES AND STORAGE BATTERY CONTROLLERS, POWER BATTERY DISCHARGER AND DISCHARGER SYSTEM COMPRISING BATTERY DISCHARGER AND ELECTRICAL CONTROLLING DEVICE, AND POWER BATTERY CABLES, MONITORS AND CASES; DC-AC INVERTOR AND INVERTOR SYSTEMS COMPRISING DC-AC INVERTORS AND ELECTRICAL CONTROLLING DEVICES; AC-DC CONVERTORS; IC CIRCUIT BOARDS, CABLES AND CONNECTORS; NATURAL ENERGY GENERATOR-BATTERY SYSTEM DEVICES, NAMELY, SOLAR, WIND POWER, AND FUEL CELL (U.S. CLS. 21, 23, 26, 36 AND 38).

ESTHER A. BORSUK, EXAMINING ATTORNEY

CLASS 9—(Continued).

SN 85-198,908. VIVINT, INC., PROVO, UT. FILED 12-15-2010.

LIVE INTELLIGENT

THE MARK CONSISTS OF STANDARD CHARACTERS WITHOUT CLAIM TO ANY PARTICULAR FONT, STYLE, SIZE, OR COLOR.

FOR COMPUTER PROGRAMS FOR CONTROLLING AND MONITORING BUILDING CONTROL, ALARM AND INTERACTION SYSTEMS; BAGS AND BACKPACKS SPECIFICALLY DESIGNED FOR HOLDING LAPTOP COMPUTERS; ELECTRICAL AND ELECTRONIC BUILDING CONTROL HUMAN INPUT/OUTPUT INTERFACES, NAMELY, ELECTRONIC DISPLAY INTERFACES AND CONTROL PANELS; FIRE AND BURGLAR ALARMS FOR RESIDENTIAL AND COMMERCIAL BUILDINGS; GAS ALARMS, NAMELY, CARBON MONOXIDE DETECTORS; EMERGENCY ALARMS, NAMELY, EMERGENCY EVACUATION DEVICES, NAMELY, FIRE ALARM CONTROL PANELS, SMOKE DETECTORS, HEAT DETECTORS, ALARM PULL STATIONS, AUDIBLE AND VISIBLE NOTIFICATION APPLIANCES, STROBES, SIRENS, HORNS, AND SPEAKERS; TROUBLE ALARMS FOR RESIDENTIAL AND COMMERCIAL BUILDINGS, NAMELY, SOUND ALARMS, MOTION DETECTORS FOR PERIMETERS, DOORS AND WINDOWS, AND ELECTRONIC SIGNALING MECHANISM FOR DETECTING CONNECTION OR POWER FAILURE; LIGHTING SYSTEMS, NAMELY, LIGHTING CONTROLS; ENERGY MANAGEMENT SYSTEMS, NAMELY, ELECTRIC CONTROLS FOR MONITORING AND ADJUSTING ENERGY USAGE; VIDEO CAMERAS; VIDEO SYSTEMS CONSISTING OF VIDEO CAMERAS, MONITORS, RECORDERS AND VIDEO TRANSMISSION APPARATUS; AUTOMATION LOCK SYSTEMS COMPRISING ELECTRONIC CONTROLS FOR MONITORING AND CONTROLLING ELECTRONIC LOCKING MECHANISMS; HOME AND OFFICE HVAC AUTOMATION SYSTEMS COMPRISING WIRELESS AND WIRED CONTROLLERS, CONTROLLED DEVICES, SOFTWARE AND ELECTRONIC CONTROL DEVICES FOR MONITORING AND CONTROLLING HOME AND OFFICE HEATING AND COOLING OPERATIONS (U.S. CLS. 21, 23, 26, 36 AND 38).

ANN E. SAPPENFIELD, EXAMINING ATTORNEY

SN 85-198,912. VIVINT, INC., PROVO, UT. FILED 12-15-2010.

LIVE INTELLIGENT

THE MARK CONSISTS OF STANDARD CHARACTERS WITHOUT CLAIM TO ANY PARTICULAR FONT, STYLE, SIZE, OR COLOR.

FOR ENERGY MANAGEMENT SYSTEMS COMPRISING ENERGY METERS FOR TRACKING AND MONITORING ENERGY USAGE AND CONTROLS FOR LIMITING ENERGY USAGE FOR SMALL APPLIANCES; CLIMATE CONTROL SYSTEMS COMPRISING DIGITAL THERMOSTATS; LIGHTING SYSTEMS COMPRISING LIGHTING CONTROLS FOR LIMITING ENERGY USAGE OF LIGHTS; BUILDING CONTROL SYSTEMS COMPRISING REMOTE CONTROLLED DEVICES FOR MANAGING ENERGY USAGE FOR HEATING, COOLING, LIGHTS AND SMALL APPLIANCES (U.S. CLS. 21, 23, 26, 36 AND 38).

ANN E. SAPPENFIELD, EXAMINING ATTORNEY

CLASS 9—(Continued).

SN 85-199,008. VIVINT, INC., PROVO, UT. FILED 12-15-2010.

SIMPLY SMARTER

THE MARK CONSISTS OF STANDARD CHARACTERS WITHOUT CLAIM TO ANY PARTICULAR FONT, STYLE, SIZE, OR COLOR.

FOR ENERGY MANAGEMENT SYSTEMS COMPRISING ENERGY METERS FOR TRACKING AND MONITORING ENERGY USAGE AND CONTROLS FOR LIMITING ENERGY USAGE FOR SMALL APPLIANCES; CLIMATE CONTROL SYSTEMS COMPRISING DIGITAL THERMOSTATS; LIGHTING SYSTEMS COMPRISING LIGHTING CONTROLS FOR LIMITING ENERGY USAGE OF LIGHTS; BUILDING CONTROL SYSTEMS COMPRISING REMOTE CONTROLLED DEVICES FOR MANAGING ENERGY USAGE FOR HEATING, COOLING, LIGHTS AND SMALL APPLIANCES (U.S. CLS. 21, 23, 26, 36 AND 38).

KEVIN CORWIN, EXAMINING ATTORNEY

SN 85-200,554. DOLI ELEKTRONIK GMBH, MUNCHEN, FED REP GERMANY, FILED 12-17-2010.

DOLI

THE MARK CONSISTS OF STANDARD CHARACTERS WITHOUT CLAIM TO ANY PARTICULAR FONT, STYLE, SIZE, OR COLOR.

PRIORITY CLAIMED UNDER SEC. 44(D) ON ERPN CMNTY TM OFC APPLICATION NO. 009517831, FILED 11-12-2010, REG. NO. 009517831, DATED 3-16-2012, EXPIRES 11-12-2020.

FOR ELECTRONIC APPARATUS FOR TESTING COMPRESSION, STRENGTH, HARDNESS AND TENSILE CHARACTERISTICS OF INDUSTRIAL MATERIALS; CEMENT TESTING MACHINES; ELECTRONIC DEVICES AND INSTRUMENTS FOR MATERIAL TESTING MACHINES, NAMELY, STRENGTH TESTING MACHINES, HARDNESS TESTING MACHINES, COMPRESSION TESTING MACHINES, TENSILE TESTING MACHINES; ELECTRIC MEASURING, SIGNALING, REGULATING, COUNTING, REGISTRATING, MONITORING, STEERING, CONTROLLING, AND SWITCHING APPARATUS AND INSTRUMENTS, NAMELY, STRENGTH TESTING MACHINES, HARDNESS TESTING MACHINES, COMPRESSION TESTING MACHINES, TENSILE TESTING MACHINES; ELECTRONIC CONTROLS FOR MATERIAL TESTING INSTRUMENTS AND MACHINES; AUTOMATED DIGITAL CONTROLS FOR MATERIAL TESTING INSTRUMENTS AND MACHINES; CIRCUIT BOARDS, ELECTRIC PLUGS AND CONNECTORS; ELECTRIC AND ELECTRONIC APPARATUS AND INSTRUMENTS, NAMELY, KEYBOARDS FOR ENTRY ENTERING, STORAGE, PROCESSING AND TRANSMISSION OF DATA; ELECTRIC DATA OUTPUT DEVICES, NAMELY, MONITORS; COMPUTER SOFTWARE FOR PROCESSING MATERIAL TESTING DATA (U.S. CLS. 21, 23, 26, 36 AND 38).

DANNEAN HETZEL, EXAMINING ATTORNEY

CLASS 9—(Continued).

SN 85-205,262. GLOBAL CONTENT PROTECTION ALLIANCE LTD., LAS VEGAS, NV. FILED 12-23-2010.



THE MARK CONSISTS OF STYLIZED LETTERS "CP".
FOR BIOS (BASIC INPUT OUTPUT SYSTEM) COMPUTER PROGRAMS; CELL PHONES/ CELLULAR PHONES/ MOBILE PHONES; COMPUTER GAME DISCS; COMPUTER HARDWARE; COMPUTER OPERATING PROGRAMS, RECORDED; COMPUTER SOFTWARE FOR USE IN THE SAFEGUARDING OF DIGITAL FILES, INCLUDING AUDIO, VIDEO, TEXT, BINARY, STILL IMAGES, GRAPHICS AND MULTIMEDIA FILES; DIGITAL MEDIA, NAMELY, PRE-RECORDED VIDEO CASSETTES, DIGITAL VIDEO DISCS, DIGITAL VERSATILE DISCS, DOWNLOADABLE AUDIO AND VIDEO RECORDINGS, DVDS, AND HIGH DEFINITION DIGITAL DISCS FEATURING MUSIC, KARAOKE, MOVIES FEATURING ACTION, ADVENTURE, DRAMA, SUSPENSE, HORROR, THRILLER, SCIENCE FICTION, ROMANCE, FAMILY AND COMEDY, ANIMATION, COMPUTER GAME PROGRAMS, ELECTRONIC BOOKS AND MAGAZINES FEATURING NEWS, COMPUTERS, ART, LITERATURE, HUMANITY, ENTERTAINMENT, TRAVEL, MUSIC, MOVIES, FASHION, HEALTH, BEAUTY, SPORTS AND BUSINESS; ENCODED INTEGRATED CIRCUIT CARDS CONTAINING PROGRAMMING USED FOR IDENTIFICATION PURPOSES; INTERNET PHONES; MAGNETICALLY ENCODED CREDIT CARDS; MAGNETICALLY ENCODED DEBIT CARDS; MAGNETICALLY ENCODED IDENTITY CARDS; OPTICAL DISCS FEATURING COMPUTER GAME PROGRAMS; PRE-PAID TELEPHONE CALLING CARDS, MAGNETICALLY ENCODED; VIDEO PHONES (U.S. CLS. 21, 23, 26, 36 AND 38).

FIRST USE 1-1-2007; IN COMMERCE 1-1-2007.
RONALD MCMORROW, EXAMINING ATTORNEY

CLASS 9—(Continued).

SN 85-206,781. WILKINSON, WILLIAM T., DBA INNOVATION INDUSTRIES, MEDIA, PA. FILED 12-28-2010.

The Plank

THE MARK CONSISTS OF STANDARD CHARACTERS WITHOUT CLAIM TO ANY PARTICULAR FONT, STYLE, SIZE, OR COLOR.

FOR AUDIO AND VIDEO RECORDINGS FEATURING EXERCISE WORKOUTS; AUDIO DIGITAL TAPES FEATURING EXERCISE WORKOUTS; AUDIO RECORDINGS FEATURING EXERCISE WORKOUT; AUDIO TAPES FEATURING SPOKEN WORD IN THE FIELD OF EXERCISE WORKOUTS; AUDIO TAPES FEATURING EXERCISE WORKOUTS; DIGITAL MEDIA, NAMELY, PRE-RECORDED DVDS, DOWNLOADABLE AUDIO AND VIDEO RECORDINGS, AND CDS FEATURING AND PROMOTING EXERCISE WORKOUTS; DIGITAL MEDIA, NAMELY, PRE-RECORDED VIDEO CASSETTES, DIGITAL VIDEO DISCS, DIGITAL VERSATILE DISCS, DOWNLOADABLE AUDIO AND VIDEO RECORDINGS, DVDS, AND HIGH DEFINITION DIGITAL DISCS FEATURING EXERCISE WORKOUTS; DOWNLOADABLE MP3 FILES, MP3 RECORDINGS, ON-LINE DISCUSSION BOARDS, WEBCASTS, WEBINARS AND PODCASTS FEATURING MUSIC, AUDIO BOOKS IN THE FIELD OF EXERCISE WORKOUTS, AND NEWS BROADCASTS; PRE-RECORDED CDS, VIDEO TAPES, LASER DISKS AND DVDS FEATURING EXERCISE WORKOUTS; PRE-RECORDED DIGITAL VIDEO DISCS FEATURING EXERCISE WORKOUTS; PRE-RECORDED VIDEO CASSETTES FEATURING EXERCISE WORKOUTS; PRERECORDED VIDEO TAPES FEATURING EXERCISE WORKOUTS; VIDEO DISCS FEATURING EXERCISE WORKOUTS; VIDEO TAPES FEATURING EXERCISE WORKOUTS (U.S. CLS. 21, 23, 26, 36 AND 38).

TINA MAI, EXAMINING ATTORNEY

SN 85-219,319. YAPMO, CHICAGO, IL. FILED 1-17-2011.

YAPMO

THE MARK CONSISTS OF STANDARD CHARACTERS WITHOUT CLAIM TO ANY PARTICULAR FONT, STYLE, SIZE, OR COLOR.

FOR COMPUTER APPLICATION SOFTWARE FOR COMPUTERS, MOBILE PHONES AND OTHER MOBILE DEVICES, NAMELY, SOFTWARE FOR SOCIAL MEDIA AND SOCIAL MEDIA MANAGEMENT; COMPUTER SOFTWARE FOR COMPUTERS, MOBILE PHONES AND OTHER MOBILE DEVICES, NAMELY, SOFTWARE FOR SOCIAL MEDIA AND SOCIAL MEDIA MANAGEMENT (U.S. CLS. 21, 23, 26, 36 AND 38).

JAY FLOWERS, EXAMINING ATTORNEY

CLASS 9—(Continued).

SN 85-220,684. M & M MERCHANDISERS, INC., FORT WORTH, TX. FILED 1-19-2011.

Fat Boy

THE MARK CONSISTS OF THE WORDS "FAT BOY" IN PINCHED FAT FONT.
FOR GUITAR AMPLIFIERS (U.S. CLS. 21, 23, 26, 36 AND 38).

RONALD MCMORROW, EXAMINING ATTORNEY

SN 85-220,809. M & M MERCHANDISERS, INC., FORT WORTH, TX. FILED 1-19-2011.



NO CLAIM IS MADE TO THE EXCLUSIVE RIGHT TO USE "ACCESSORIES", APART FROM THE MARK AS SHOWN.

THE MARK CONSISTS OF A RECTANGULAR BOX WITH CURVED CORNERS WITH A BREAK IN THE MIDDLE OF THE BOTTOM HORIZONTAL LINE WITH THE WORD "ACCESSORIES" IN NEWS GOTHIC MT FONT THAT IS CENTERED ALONG THE HORIZONTAL LINE AND IN THE MIDDLE OF THE RECTANGULAR BOX THE WORDS "FAT BOY" IN PINCHED FAT FONT IS CENTERED WITHIN THE BOX.

FOR GUITAR CABLES (U.S. CLS. 21, 23, 26, 36 AND 38).

FIRST USE 9-7-2008; IN COMMERCE 9-7-2008.
RONALD MCMORROW, EXAMINING ATTORNEY

SN 85-226,723. SZECHENYI, MONIQUE, SANDWICH, MA. FILED 1-26-2011.

MR. MCGREGOR'S FENCE

THE MARK CONSISTS OF STANDARD CHARACTERS WITHOUT CLAIM TO ANY PARTICULAR FONT, STYLE, SIZE, OR COLOR.

NO CLAIM IS MADE TO THE EXCLUSIVE RIGHT TO USE "FENCE", APART FROM THE MARK AS SHOWN.
SEC. 2(F).

FOR ELECTRIC FENCES (U.S. CLS. 21, 23, 26, 36 AND 38).

FIRST USE 12-1-2001; IN COMMERCE 1-31-2002.
KRISTINA MORRIS, EXAMINING ATTORNEY

CLASS 9—(Continued).

SN 85-228,235. MAXXUS MARKETING, LLC, CASTRO VALLEY, CA. FILED 1-27-2011.

YOU CAN COOK

THE MARK CONSISTS OF STANDARD CHARACTERS WITHOUT CLAIM TO ANY PARTICULAR FONT, STYLE, SIZE, OR COLOR.

FOR DOWNLOADABLE VIDEO RECORDING FEATURING COOKING COURSES; DVDS FEATURING COOKING COURSES (U.S. CLS. 21, 23, 26, 36 AND 38).

SALLY SHIH, EXAMINING ATTORNEY

SN 85-229,181. VISIBLE VOTE LLC, CHICAGO, IL. FILED 1-28-2011.

MOBILE APPTIVISM

THE MARK CONSISTS OF STANDARD CHARACTERS WITHOUT CLAIM TO ANY PARTICULAR FONT, STYLE, SIZE, OR COLOR.

NO CLAIM IS MADE TO THE EXCLUSIVE RIGHT TO USE "MOBILE", APART FROM THE MARK AS SHOWN.

FOR COMPUTER APPLICATION SOFTWARE FOR COMPUTERS, MOBILE PHONES AND OTHER MOBILE DEVICES, NAMELY, SOFTWARE FOR COMMUNICATIONS; COMPUTER SOFTWARE FOR COMPUTERS, MOBILE PHONES AND OTHER MOBILE DEVICES, NAMELY, SOFTWARE FOR COMMUNICATIONS (U.S. CLS. 21, 23, 26, 36 AND 38).

JAY FLOWERS, EXAMINING ATTORNEY

SN 85-232,027. HEARST COMMUNICATIONS, INC., NEW YORK, NY. FILED 2-2-2011.

7 YEARS YOUNGER

THE MARK CONSISTS OF STANDARD CHARACTERS WITHOUT CLAIM TO ANY PARTICULAR FONT, STYLE, SIZE, OR COLOR.

FOR COMPUTER APPLICATION SOFTWARE FOR MOBILE PHONES, PDA DEVICES, TABLET COMPUTERS, AND PORTABLE HANDHELD DIGITAL ELECTRONIC DEVICES, NAMELY, SOFTWARE FOR ACCESSING, VIEWING, INTERACTING WITH AND DOWNLOADING CONTENT AND INFORMATION FROM WEBSITES IN THE FIELDS OF HEALTH, FITNESS, BEAUTY AND COSMETICS (U.S. CLS. 21, 23, 26, 36 AND 38).

KIMBERLY FRYE, EXAMINING ATTORNEY

CLASS 9—(Continued).

SN 85-232,029. HEARST COMMUNICATIONS, INC., NEW YORK, NY. FILED 2-2-2011.

SEVEN YEARS YOUNGER

THE MARK CONSISTS OF STANDARD CHARACTERS WITHOUT CLAIM TO ANY PARTICULAR FONT, STYLE, SIZE, OR COLOR.

FOR COMPUTER APPLICATION SOFTWARE FOR MOBILE PHONES, PDA DEVICES, TABLET COMPUTERS, AND PORTABLE HANDHELD DIGITAL ELECTRONIC DEVICES, NAMELY, SOFTWARE FOR ACCESSING, VIEWING, INTERACTING WITH AND DOWNLOADING CONTENT AND INFORMATION FROM WEBSITES IN THE FIELDS OF HEALTH, FITNESS, BEAUTY AND COSMETICS (U.S. CLS. 21, 23, 26, 36 AND 38).

KIMBERLY FRYE, EXAMINING ATTORNEY

CLASS 9—(Continued).

SN 85-244,505. MAKE A DIFFERENCE, INC., WEST WINDSOR, VT. FILED 2-17-2011.

iPact

THE MARK CONSISTS OF STANDARD CHARACTERS WITHOUT CLAIM TO ANY PARTICULAR FONT, STYLE, SIZE, OR COLOR.

FOR COMPUTER HARDWARE AND COMPUTER SOFTWARE SYSTEMS ALL FOR USE WITH SPECIAL EDUCATION, PRIMARY AND SECONDARY EDUCATION FROM GRADES K THROUGH 12, AND VOCATIONAL REHABILITATION (U.S. CLS. 21, 23, 26, 36 AND 38).

BERYL GARDNER, EXAMINING ATTORNEY

SN 85-243,227. XELOC INTERNATIONAL INC., CH-9606 BUTSCHWIL, SWITZERLAND, FILED 2-15-2011.



NO CLAIM IS MADE TO THE EXCLUSIVE RIGHT TO USE "SECURITY", APART FROM THE MARK AS SHOWN. THE COLOR(S) BLACK, SILVER, DARK GRAY AND RED IS/ARE CLAIMED AS A FEATURE OF THE MARK.

THE MARK CONSISTS OF A DESIGN OF A DESKTOP COMPUTER IN THE COLORS BLACK, SILVER, AND DARK GRAY WITH A DESIGN OF A SAFE OR VAULT DOOR IN PLACE OF THE COMPUTER MONITOR IN THE COLOR SILVER, WITH THE WORDING "STEEL FORTRESS" TO THE RIGHT OF THE DESIGN IN THE COLOR DARK GRAY AND THE WORDING "XELOC SECURITY" BENEATH THE DESIGN IN THE COLOR RED.

FOR COMPUTER SOFTWARE AND HARDWARE FOR PROVIDING ENHANCED DIGITAL SECURITY, INCLUDING ANTI-SPY FEATURES, SOFTWARE AND HARDWARE ENCRYPTION, FIREWALL PROTECTION, AND ANTI-VIRUS PROTECTION (U.S. CLS. 21, 23, 26, 36 AND 38).

JOHN GARTNER, EXAMINING ATTORNEY

SN 85-253,529. HYDRONALIX, INC., SAHUARITA, AZ. FILED 2-28-2011.

EMILY

THE MARK CONSISTS OF STANDARD CHARACTERS WITHOUT CLAIM TO ANY PARTICULAR FONT, STYLE, SIZE, OR COLOR.

FOR ROBOTIC DEVICE, NAMELY, AN UNATTENDED REMOTE-CONTROLLED MARITIME DEVICE IN THE NATURE OF A MOTORIZED NON-METAL RESCUE BUOY USED IN CONNECTION WITH RESCUING PERSONS IN DISTRESS IN LITTORAL AND BROWN WATER OPERATIONS (U.S. CLS. 21, 23, 26, 36 AND 38).

FIRST USE 4-9-2010; IN COMMERCE 4-9-2010.
ANDREW LEASER, EXAMINING ATTORNEY

CLASS 9—(Continued).

SN 85-271,450. COOPER, DONALD, BOULDER, CO. FILED 3-19-2011.



THE COLOR(S) PURPLE, YELLOW, GREEN, RED, BLACK AND BLUE IS/ARE CLAIMED AS A FEATURE OF THE MARK.

THE MARK CONSISTS OF THE FOLLOWING: A BLACK BUFFALO OUTLINE WITH A BRAIN INSIDE IN PURPLE, YELLOW, GREEN, RED AND BLUE COLORS.

FOR COMPUTER SOFTWARE DESIGNED TO IMPROVE LEARNING AND MEMORY FORMATION BOTH IN AND OUT OF EDUCATIONAL SETTINGS BY ALLOWING USERS TO LISTEN AND WATCH LECTURES AND TAKE SELF ASSESSMENT TESTS; COMPUTER APPLICATION SOFTWARE FOR MOBILE PHONES, NAMELY, SOFTWARE DESIGNED TO IMPROVE LEARNING AND MEMORY FORMATION BOTH IN AND OUT OF EDUCATIONAL SETTINGS BY ALLOWING USERS TO LISTEN AND WATCH LECTURES AND TAKE SELF ASSESSMENT TESTS (U.S. CLS. 21, 23, 26, 36 AND 38).

KATINA MISTER, EXAMINING ATTORNEY

SN 85-272,697. ELITE SEMICONDUCTOR MEMORY TECHNOLOGY INC., HSINCHU, TAIWAN, FILED 3-21-2011.



THE MARK CONSISTS OF THE WORD "USBOOM" WITH LINES IN THE BACKGROUND AND MUSIC NOTES ABOVE THE "OO".

FOR SILICON AND STRUCTURED SEMI-CONDUCTOR WAFERS, MASK, NAMELY, PHOTOLITHOGRAPHY MASK, CIRCUIT BOARD, SEMICONDUCTOR, INTEGRATED CIRCUIT, ELECTRONIC CIRCUIT, PRINTED CIRCUIT BOARD, SEMICONDUCTOR WAFER, SEMICONDUCTOR DEVICE, VERY LARGE SCALE INTEGRATION CIRCUITS, SILICON WAFER, LARGE SCALE INTEGRATION CIRCUITS, POWER MANAGEMENT INTEGRATED CIRCUIT, POWER DEVICES, NAMELY, ELECTRONIC POWER DEVICES IN THE NATURE OF MULTIMEDIA OUTLETS, TAPS, ELECTRONIC CIRCUIT BOARD, HYBRID CIRCUIT BOARD, LOUDSPEAKER, SOUND BOX, NAMELY, SPEAKER BOX, COMPUTER LOUDSPEAKER, STEREO SET STEREO SET CONSISTING OF A PAIR OF SPEAKERS (U.S. CLS. 21, 23, 26, 36 AND 38).

LESLIE RICHARDS, EXAMINING ATTORNEY

CLASS 9—(Continued).

SN 85-273,705. TECHNICOLOR, ISSY LES MOULINEAUX, FRANCE, FILED 3-22-2011.

CONTENT ARMOR

THE MARK CONSISTS OF STANDARD CHARACTERS WITHOUT CLAIM TO ANY PARTICULAR FONT, STYLE, SIZE, OR COLOR.

OWNER OF FRANCE REG. NO. 103762252, DATED 1-14-2011, EXPIRES 8-25-2020.

NO CLAIM IS MADE TO THE EXCLUSIVE RIGHT TO USE "CONTENT", APART FROM THE MARK AS SHOWN.

FOR SOFTWARE AND ENCODED SMART CARDS CONTAINING PROGRAMMING USED FOR THE DETECTION AND PREVENTION OF ILLEGAL DUPLICATION OF AUDIOVISUAL CONTENTS, NAMELY, SOUNDS, IMAGES, TEXTS AND DATA (U.S. CLS. 21, 23, 26, 36 AND 38).

SALLY SHIH, EXAMINING ATTORNEY

SN 85-283,766. VETRONIX RESEARCH CORPORATION, HILTON HEAD ISLAND, SC. FILED 4-1-2011.

VETRONIX

THE MARK CONSISTS OF STANDARD CHARACTERS WITHOUT CLAIM TO ANY PARTICULAR FONT, STYLE, SIZE, OR COLOR.

SEC. 2(F).

FOR POWER AND DATA DISTRIBUTION SYSTEMS FOR MILITARY VEHICLES AND MILITARY AIRCRAFT, NAMELY, BUS CONTROLLERS, SERIAL DATA BUS INTERFACES, MIC BUS INTERFACES, CAN BUS INTERFACES, MIL-STD-1553 BUS INTERFACES, UTILITY BUS INTERFACE MODULES; DIGITAL AUDIO PROCESSORS AND DIAGNOSTIC EQUIPMENT, NAMELY, EMBEDDED VETRONICS MONITORS (EVMS) AND MIC BUS DEVELOPMENT SYSTEMS (MBDSS) COMPRISING CARDS THAT PLUG INTO PERSONAL COMPUTERS AND COMPUTER SOFTWARE FOR USE IN TESTING AND MONITORING HARDWARE; COMPONENT LEVEL AND COMPLETE SYSTEMS THAT INCORPORATE DATA BUSES AND MIC BUSES, REMOTE DIGITAL AND ANALOG SIGNAL ACQUISITION CIRCUIT CARD ASSEMBLIES, HIGH-POWER LOAD CONTROL MODULES (HPLCMS), LOW CURRENT PROGRAMMABLE LOAD CONTROL MODULES (PLCMS); SOLID STATE POWER CONTROLLERS (SSPCS) FOR USE WITH CIRCUIT BREAKER FUNCTIONS FOR LOADS IN GROUND VEHICLES AND AIRCRAFT, INTELLIGENT POWER CONTROLLERS (IPCS), INTELLIGENT POWER CONTROL MODULES (IPCMS), HIGH-ENERGY VOLTAGE TRANSIENT CLAMPS FOR PROTECTING ELECTRICAL CIRCUITS FROM TRANSIENTS IN VEHICLES AND AIRCRAFT; INTEGRATED POWER SUPPLIES AND DC POWER SUPPLIES, NAMELY, DC TO DC CONVERTERS, POWER SEQUENCING ELECTRONICS, NAMELY, MASTER POWER CONTROL MODULES (MPCMS) AND PRIMARY POWER CONTROLLERS (PPCS), FIRE CONTROL CIRCUITS, HIGH-POWER BACKPLANES, BUSBARS AND COMPLETE LINE-REPLACEABLE UNITS (LRUS) (U.S. CLS. 21, 23, 26, 36 AND 38).

FIRST USE 11-22-1989; IN COMMERCE 11-22-1989.
REGINA DRUMMOND, EXAMINING ATTORNEY

CLASS 9—(Continued).

SN 85-288,332. AMUSEMENT ART LLC, LOS ANGELES, CA. FILED 4-6-2011.

MR BRAINWASH

THE MARK CONSISTS OF STANDARD CHARACTERS WITHOUT CLAIM TO ANY PARTICULAR FONT, STYLE, SIZE, OR COLOR.

FOR BLANK USB FLASH DRIVES; DECORATIVE MAGNETS; DOWNLOADABLE IMAGES IN THE FIELD OF ARTWORKS FOR MOBILE PHONES; DOWNLOADABLE SOFTWARE IN THE NATURE OF A MOBILE APPLICATION FOR USE IN DIGITAL TABLETS, CELL PHONES, AND SMARTPHONES; EYEGLOSS CASES; EYEGLOSS FRAMES; EYEGASSES; GOGGLES FOR SPORTS; BLANK HARD DRIVES FOR COMPUTERS; HEADPHONES; MOTORCYCLE HELMETS; MOUSE PADS; MOUSEPADS; SKI GOGGLES; SUNGLASSES; FACEPLATES AND COVERS FOR CELL PHONES; PERSONAL DIGITAL ASSISTANTS AND LAPTOPS; PROTECTIVE MOTORCYCLE RIDING GEAR, NAMELY, HELMETS; VIDEO AND COMPUTER GAME SOFTWARE FOR PERSONAL COMPUTER AND HOME VIDEO GAME CONSOLE; COMPUTER AND VIDEO GAMES, WHICH ARE DESIGNED FOR HARDWARE PLATFORMS, NAMELY, GAME CONSOLES AND PERSONAL COMPUTERS; CELLULAR TELEPHONE ACCESSORIES, NAMELY, HANDS-FREE DEVICES, CELLULAR TELEPHONE COVERS AND CELLULAR TELEPHONE FACE COVERS; ENCODED MAGNETIC CARDS, NAMELY, PHONE CARDS, CREDIT CARDS, CASH CARDS, DEBIT CARDS AND MAGNETIC KEY CARDS; DOWNLOADABLE SCREENSAVER IN THE NATURE OF A MOBILE APPLICATION FOR USE IN SMART PHONES, CELL PHONES, OR DIGITAL TABLETS; CARRYING CASE, BAGS AND LUGGAGE DESIGNED FOR STORAGE AND TRANSPORTATION OF CONSUMER ELECTRONICS, NAMELY, PORTABLE COMPUTERS, MP3 PLAYERS, CELLULAR TELEPHONE, DIGITAL CAMERA, DIGITAL TABLETS, SMART PHONES AND PERSONAL DIGITAL ASSISTANT; DOWNLOADABLE IMAGES IN THE FIELD OF ARTWORKS FOR TABLETS (U.S. CLS. 21, 23, 26, 36 AND 38).

CAROLINE WOOD, EXAMINING ATTORNEY

SN 85-292,990. CINCOM SYSTEMS, INC., CINCINNATI, OH. FILED 4-12-2011.

CINCOM ESP

THE MARK CONSISTS OF STANDARD CHARACTERS WITHOUT CLAIM TO ANY PARTICULAR FONT, STYLE, SIZE, OR COLOR.

OWNER OF U.S. REG. NOS. 1,051,726, 1,062,487 AND OTHERS.

FOR COMPUTER SOFTWARE THAT AUTOMATES THE SELLING OF COMPLEX PRODUCTS AND SERVICES BY PROVIDING A KNOWLEDGE-BASED SELLING SOLUTION IN THE FIELD OF CONTRACT LIFECYCLE MANAGEMENT OF COMPLEX PRODUCTS AND SERVICES (U.S. CLS. 21, 23, 26, 36 AND 38).

FIRST USE 12-20-2010; IN COMMERCE 12-20-2010.

ANDREW RHIM, EXAMINING ATTORNEY

CLASS 9—(Continued).

SN 85-298,724. MARKET TECHNOLOGIES, INC., CHARLEVOIX, MI. FILED 4-19-2011.



OWNER OF U.S. REG. NOS. 2,984,356 AND 3,212,701.

THE MARK CONSISTS OF THE WORDS "VISUAL IN STORE TRACKING ASSISTANT" AND "V.I.S.T.A."

SEC. 2(F) AS TO "VISUAL IN STORE TRACKING ASSISTANT".

FOR COMPUTER SOFTWARE PROGRAM PROVIDING MERCHANDISING LAYOUT WHICH VISUALLY DISPLAYS THE LOCATIONS OF PRODUCTS SELECTED FOR SALE TO CONSUMERS AND WHICH GENERATES A DIGITAL IMAGE, STORED IN ELECTRONIC FORMAT, THE PRODUCTS TO BE DISPLAYED IN SPECIFIC CUSTOMER-DEFINED RETAIL ENVIRONMENTS, WITH OR WITHOUT BRAND DETAILED ADDED (U.S. CLS. 21, 23, 26, 36 AND 38).

ALLISON HOLTZ, EXAMINING ATTORNEY

SN 85-304,033. MLR LICENSING, LLC, LOS ANGELES, CA. FILED 4-25-2011.

ASS CAM

THE MARK CONSISTS OF STANDARD CHARACTERS WITHOUT CLAIM TO ANY PARTICULAR FONT, STYLE, SIZE, OR COLOR.

NO CLAIM IS MADE TO THE EXCLUSIVE RIGHT TO USE "CAM", APART FROM THE MARK AS SHOWN.

FOR COMPUTER CAMERAS; DIGITAL CAMERA ACCESSORY IN THE NATURE OF A DIGITAL PHOTO VIEWER; DIGITAL CAMERAS; MULTIPLE PURPOSE CAMERAS; SELF-TIMERS; TILTING HEADS (U.S. CLS. 21, 23, 26, 36 AND 38).

AISHA CLARKE, EXAMINING ATTORNEY

CLASS 9—(Continued).

SN 85-312,471. M4M VENTURES CORP, SOUTH DAYTONA, FL. FILED 5-4-2011.

BABY JOCK

THE MARK CONSISTS OF STANDARD CHARACTERS WITHOUT CLAIM TO ANY PARTICULAR FONT, STYLE, SIZE, OR COLOR.

NO CLAIM IS MADE TO THE EXCLUSIVE RIGHT TO USE "BABY", APART FROM THE MARK AS SHOWN.

FOR PRERECORDED DIGITAL VIDEO DISKS FEATURING ATHLETIC MATERIAL FOR INFANTS AND TODDLERS (U.S. CLS. 21, 23, 26, 36 AND 38).

ANNE E. GUSTASON, EXAMINING ATTORNEY

CLASS 9—(Continued).

SN 85-314,639. COSMOSID, INC., COLLEGE PARK, MD. FILED 5-6-2011.

GENEBOOK

THE MARK CONSISTS OF STANDARD CHARACTERS WITHOUT CLAIM TO ANY PARTICULAR FONT, STYLE, SIZE, OR COLOR.

FOR ELECTRONIC SEARCHABLE DATABASE IN THE FIELD OF ASSEMBLED WHOLE GENOMES RECORDED ON COMPUTER MEDIA; DOWNLOADABLE SEARCHABLE DATABASE IN THE FIELD OF ASSEMBLED WHOLE GENOMES VIA THE INTERNET AND WIRELESS DEVICES (U.S. CLS. 21, 23, 26, 36 AND 38).

JULIE VEPPUMTHARA, EXAMINING ATTORNEY

SN 85-314,643. COSMOSID, INC., COLLEGE PARK, MD. FILED 5-6-2011.

SN 85-314,466. RED 5 STUDIOS, INC., LAGUNA HILLS, CA. FILED 5-6-2011.

RED 5 STUDIOS

THE MARK CONSISTS OF STANDARD CHARACTERS WITHOUT CLAIM TO ANY PARTICULAR FONT, STYLE, SIZE, OR COLOR.

NO CLAIM IS MADE TO THE EXCLUSIVE RIGHT TO USE "STUDIOS", APART FROM THE MARK AS SHOWN.

FOR DOWNLOADABLE ELECTRONIC PUBLICATIONS, NAMELY, NOVELS, GRAPHIC NOVELS, AND DEVELOPMENT DIARIES IN THE FIELD OF COMPUTER GAMES, AND ART BOOKS; DOWNLOADABLE ELECTRONIC PUBLICATIONS, NAMELY, NEWSLETTERS ON TOPICS RELATED TO COMPUTER GAMES, AND GAME CHARACTERS, PLOTS, AND SETTINGS; ELECTRONIC PUBLICATIONS RECORDED ON COMPUTER MEDIA, NAMELY, NOVELS, GRAPHIC NOVELS, AND DEVELOPMENT DIARIES IN THE FIELD OF COMPUTER GAMES, ART BOOKS; ELECTRONIC PUBLICATIONS RECORDED ON COMPUTER MEDIA, NAMELY, NEWSLETTERS ON TOPICS RELATED TO COMPUTER GAMES, AND GAME CHARACTERS, PLOTS, AND SETTINGS (U.S. CLS. 21, 23, 26, 36 AND 38).

THEODORE MCBRIDE, EXAMINING ATTORNEY

PATHOGENEBOOK

THE MARK CONSISTS OF STANDARD CHARACTERS WITHOUT CLAIM TO ANY PARTICULAR FONT, STYLE, SIZE, OR COLOR.

FOR ELECTRONIC SEARCHABLE DATABASE IN THE FIELD OF ASSEMBLED WHOLE GENOMES RECORDED ON COMPUTER MEDIA; DOWNLOADABLE SEARCHABLE DATABASE IN THE FIELD OF ASSEMBLED WHOLE GENOMES VIA THE INTERNET AND WIRELESS DEVICES (U.S. CLS. 21, 23, 26, 36 AND 38).

JULIE VEPPUMTHARA, EXAMINING ATTORNEY

SN 85-317,365. NEXENTA SYSTEMS, INC., MOUNTAIN VIEW, CA. FILED 5-10-2011.

HYPERVDI

THE MARK CONSISTS OF STANDARD CHARACTERS WITHOUT CLAIM TO ANY PARTICULAR FONT, STYLE, SIZE, OR COLOR.

FOR COMPUTER OPERATING PROGRAMS; COMPUTER SOFTWARE FOR STORAGE OF DATA; COMPUTER SOFTWARE FOR OPERATING SYSTEM PROGRAMS (U.S. CLS. 21, 23, 26, 36 AND 38).

REBECCA SMITH, EXAMINING ATTORNEY

CLASS 9—(Continued).

SN 85-319,175. COBY ELECTRONICS CORPORATION, LAKE SUCCESS, NY. FILED 5-12-2011.

JAMMERZ SPORTS X

THE MARK CONSISTS OF STANDARD CHARACTERS WITHOUT CLAIM TO ANY PARTICULAR FONT, STYLE, SIZE, OR COLOR.

OWNER OF U.S. REG. NOS. 3,905,858, 3,955,563 AND OTHERS.

FOR AUDIO HEADPHONES; EAR BUDS; EAR PHONES; EARPHONES AND HEADPHONES; HEADPHONES; HEADPHONES INCLUDING ATTACHED LANYARD; MUSIC HEADPHONES; PERSONAL HEADPHONES FOR SOUND TRANSMITTING APPARATUSES; PERSONAL HEADPHONES FOR USE WITH SOUND TRANSMITTING SYSTEMS; STEREO HEADPHONES (U.S. CLS. 21, 23, 26, 36 AND 38).

GINA FINK, EXAMINING ATTORNEY

SN 85-319,698. ABSOLUTE IDENTIFICATION, INC., SCOTTS VALLEY, CA. FILED 5-12-2011.



THE MARK CONSISTS OF THE STYLIZED WORDING "ABSOLUTEID" APPEARING TO THE RIGHT OF A DESIGN COMPRISED OF A SHADED CIRCULAR CARRIER CONTAINING AN OUTLINE OF AN ANGULAR SHAPE RESEMBLING A STAR ON TOP OF THE LEGS OF A LETTER "A".

FOR COMPUTER SOFTWARE APPLICATION THAT IS INSTALLED ON ANY MOBILE DEVICE, COMPUTER HARDWARE, OR DIRECT ATTACH HARDWARE SUCH AS A USB HARD DRIVE OR MOBILE PHONE FOR PROVIDING A HIGHLY SECURE COMPUTING ENVIRONMENT TO SECURE USER DATA BOTH LOCALLY ON THE HARDWARE PLATFORM AND IN THE INTERNET CLOUD (U.S. CLS. 21, 23, 26, 36 AND 38).

KAELIE KUNG, EXAMINING ATTORNEY

CLASS 9—(Continued).

SN 85-322,557. MEDIWARE INFORMATION SYSTEMS, INC., LENEXA, KS. FILED 5-17-2011.

MEDIMAR

THE MARK CONSISTS OF STANDARD CHARACTERS WITHOUT CLAIM TO ANY PARTICULAR FONT, STYLE, SIZE, OR COLOR.

OWNER OF U.S. REG. NOS. 2,952,516 AND 3,048,313. FOR COMPUTER SOFTWARE FOR USE IN CONNECTION WITH A NURSING POINT OF CARE SYSTEM IN A HOSPITAL, WHICH COMMUNICATES WITH THE HOSPITAL'S PHARMACY, TRACKS MEDICATION ADMINISTRATION, AND ALERTS NURSES TO POTENTIAL DRUG INTERACTIONS AND DOSAGE PROBLEMS (U.S. CLS. 21, 23, 26, 36 AND 38).

FIRST USE 3-21-2005; IN COMMERCE 3-21-2005.
MARTHA FROMM, EXAMINING ATTORNEY

SN 85-323,772. SONY ELECTRONICS INC., SAN DIEGO, CA. FILED 5-18-2011.

PIXELCAST

THE MARK CONSISTS OF STANDARD CHARACTERS WITHOUT CLAIM TO ANY PARTICULAR FONT, STYLE, SIZE, OR COLOR.

FOR DOWNLOADABLE MULTIMEDIA SOFTWARE APPLICATION THAT ALLOWS USERS TO CREATE AND EDIT COLLABORATIVELY BUILT ON-LINE EXPERIENCES IN VIDEO, MUSIC AND PHOTO FORMAT, TO BE PLAYED BACK ON THE INTERNET THROUGH MULTIPLE COMPUTER DEVICES, MOBILE PHONES, OR POSTED TO VARIOUS SOCIAL NETWORKING SITES (U.S. CLS. 21, 23, 26, 36 AND 38).

ALICE BENMAMAN, EXAMINING ATTORNEY

SN 85-326,849. OPEN SCALABLE FILE SYSTEMS, INC., LIVERMORE, CA. FILED 5-22-2011.



NO CLAIM IS MADE TO THE EXCLUSIVE RIGHT TO USE "OPEN SFS", APART FROM THE MARK AS SHOWN.

THE MARK CONSISTS OF THE WORDING "OPENSFS", WITH THE "O" PARTIALLY OBSTRUCTING A DESIGN ELEMENT CONSISTING OF THREE CONCENTRIC ELLIPSES OPEN AT BOTH THE TOP AND BOTTOM.

FOR DOWNLOADABLE COMPUTER SOFTWARE FOR ACCESSING AND MANAGING OPEN SOURCE FILE SYSTEMS (U.S. CLS. 21, 23, 26, 36 AND 38).

FIRST USE 11-24-2010; IN COMMERCE 11-24-2010.

KAREN SEVERSON, EXAMINING ATTORNEY

CLASS 9—(Continued).

SN 85-326,859. APPS ASSOCIATES, ACTON, MA. FILED 5-22-2011.

ShipConsole

THE MARK CONSISTS OF STANDARD CHARACTERS WITHOUT CLAIM TO ANY PARTICULAR FONT, STYLE, SIZE, OR COLOR.

SEC. 2(F).
FOR COMPUTER SOFTWARE FOR SHIPPING, TRACKING AND LOGISTICS (U.S. CLS. 21, 23, 26, 36 AND 38).

FIRST USE 1-1-2006; IN COMMERCE 1-1-2006.
TAMARA FRAZIER, EXAMINING ATTORNEY

SN 85-329,875. BENTLEY MOTORS LIMITED, CREWE, CHESHIRE, UNITED KINGDOM, FILED 5-25-2011.



OWNER OF ERPN CMNTY TM OFC REG. NO. 8983553, DATED 9-20-2010, EXPIRES 3-25-2020.

OWNER OF U.S. REG. NOS. 344,524, 3,409,583 AND OTHERS.

THE MARK CONSISTS OF THE LETTER "B" WITHIN AN OVAL AND WINGS.

FOR OPTICAL APPARATUS AND INSTRUMENTS, NAMELY, EYEWEAR, SPECTACLES, SUNGLASSES, SPECTACLE LENSES, SPECTACLE FRAMES, PARTS AND ACCESSORIES THEREOF, NAMELY, CASES FOR SPECTACLES AND SUNGLASSES, CHAINS FOR SPECTACLES AND SUNGLASSES; ACCESSORIES FOR MOBILE PHONES, NAMELY, HEADPHONES, SCREEN COVERS, HOLDERS FOR ATTACHING MOBILE PHONES IN VEHICLES, HANDS-FREE APPARATUS FOR USE IN VEHICLES, PHONE COVERS, POUCHES FOR PROTECTION OF PHONES (U.S. CLS. 21, 23, 26, 36 AND 38).

CHARLES L. JENKINS, EXAMINING ATTORNEY

CLASS 9—(Continued).

SN 85-332,012. SAFETY TECHNOLOGY INTERNATIONAL, INC., WATERFORD, MI. FILED 5-27-2011.



OWNER OF U.S. REG. NO. 1,560,550.
THE MARK CONSISTS OF THE THREE-DIMENSIONAL CONFIGURATION OF A SWITCH COVER INCLUDING A FRONT FACE HAVING A CONVEX PORTION AND SLOPED UPPER AND LOWER SURFACES. THE BROKEN LINES DEPICT A PORTION OF A SWITCH MOUNT ON THE INTERIOR OF THE COVER, A RECTANGULAR PERIMETER AND A FLANGE THAT EXTENDS OBLIQUELY FROM THE RECTANGULAR PERIMETER BELOW THE LOWER SURFACE OF THE CONVEX PORTION THAT ARE NOT CLAIMED AS FEATURES OF THE MARK.

SEC. 2(F).
FOR SECURITY AND FIRE ALARMS, NAMELY, COVERS FOR ALARM SWITCHES (U.S. CLS. 21, 23, 26, 36 AND 38).

FIRST USE 12-31-1981; IN COMMERCE 12-31-1981.
CURTIS FRENCH, EXAMINING ATTORNEY

SN 85-332,763. WAMCO, INC., FOUNTAIN VALLEY, CA. FILED 5-27-2011.

NVISABLE

THE MARK CONSISTS OF STANDARD CHARACTERS WITHOUT CLAIM TO ANY PARTICULAR FONT, STYLE, SIZE, OR COLOR.

FOR LIGHT EMITTING DIODES (LEDS), NAMELY, LEDS USED IN THE FIELDS OF AEROSPACE AND GROUND MILITARY APPLICATIONS (U.S. CLS. 21, 23, 26, 36 AND 38).

FIRST USE 2-23-2010; IN COMMERCE 2-23-2010.
LYDIA BELZER, EXAMINING ATTORNEY

CLASS 9—(Continued).

SN 85-333,397. TOPWARE INTERACTIVE INC., LAS VEGAS, NV. FILED 5-30-2011.

Check VS Mate

THE MARK CONSISTS OF STANDARD CHARACTERS WITHOUT CLAIM TO ANY PARTICULAR FONT, STYLE, SIZE, OR COLOR.

FOR APPARATUS FOR BROADCASTING, RECORDING AND TRANSMITTING SOUND AND IMAGES; APPARATUS, NAMELY, COMPUTER PROGRAMS FOR EDITING SOUND AND IMAGES; SCIENTIFIC, PHOTOGRAPHIC, CINEMATOGRAPHIC, OPTICAL, WEIGHING, MEASURING, SIGNALING, AND TEACHING APPARATUS AND INSTRUMENTS, NAMELY, CDS, DVDS, DIGITAL DISKS AND OPTICAL DISKS ALL FEATURING VIDEO GAME SOFTWARE; MAGNETIC, OPTICAL, NUMERICAL COMPUTER STORAGE MEDIA, NAMELY, CDS, DVDS, DIGITAL DISKS AND OPTICAL DISKS ALL FEATURING VIDEO GAME SOFTWARE; COMPUTER PROGRAMS FOR USE AS VIDEO AND AUDIO GAMES, NAMELY, VIDEO GAME SOFTWARE; COMPUTER HARDWARE; AND COMPUTER SOFTWARE FOR USE AS VIDEO AND AUDIO GAMES, NAMELY, VIDEO GAME SOFTWARE; PERSONAL DIGITAL ASSISTANT (PDA); COMPUTER MEMORY; PRINTED CIRCUITS; DESKTOP AND LAPTOP COMPUTERS; COMPUTER PERIPHERALS, NAMELY, MONITORS, KEYBOARDS, MICE, INPUT DEVICES, CD-ROM DRIVES, CONTROL PANELS AND JOYSTICKS, DISK DRIVES FOR MAGNETIC, OPTICAL AND DIGITAL DISKS AND FLOPPY DISKS; STORED COMPUTER PROGRAMS FOR USE AS VIDEO AND AUDIO GAMES, NAMELY, VIDEO GAME SOFTWARE; COMPUTER GAME SOFTWARE; COMPUTER SOFTWARE FOR USE AS VIDEO AND AUDIO GAMES, NAMELY, VIDEO GAME SOFTWARE; COMPUTER GAME AND VIDEO GAME SOFTWARE; COMPUTER GAME PROGRAMS; VIDEO AND AUDIO GAMES, NAMELY, VIDEO GAME SOFTWARE AND PROGRAMS; INTERACTIVE MULTIMEDIA COMPUTER GAME PROGRAMS; COMPUTER SCIENCE SOFTWARE ON MOBILE PHONES FOR USE AS VIDEO AND AUDIO GAMES, NAMELY, VIDEO GAME SOFTWARE; AUDIO-VISUAL GAMES IN THE NATURE OF COMPUTER GAME SOFTWARE FOR COMPUTER HARDWARE PLATFORMS; ELECTRONIC GAMING DEVICES, NAMELY, COMPUTER GAME CONSOLES FOR USE WITH AN EXTERNAL DISPLAY SCREEN OR MONITOR; MAGNETIC, OPTICAL AND DIGITAL MEDIA FOR COMPUTER PROGRAMS, NAMELY, BLANK DIGITAL STORAGE MEDIA, BLANK OPTICAL DISKS, BLANK MAGNETIC DISKS; GAME DEVICES AS ACCESSORIES FOR TVS, NAMELY, VIDEO GAME MACHINES FOR USE WITH TELEVISIONS; COMPUTER SOFTWARE CONTAINING INTEGRATED MUSIC AND INTEGRATED FILM RECORDINGS; CINEMATOGRAPHIC FILMS; VENDING MACHINES AND MECHANISMS FOR COIN OPERATED APPARATUS; DATA PROCESSING EQUIPMENT; ELECTRONIC PUBLICATIONS, NAMELY, OPERATING MANUALS AND USER MANUALS FOR COMPUTERS AND COMPUTER SOFTWARE STORED DIGITALLY, IN PARTICULAR ON FLOPPY DISKS, CD-ROM, DVD-ROM; SUNGLASSES AND GOGGLES; CONSUMER ELECTRONICS, NAMELY, AUDIO CASSETTE AND CD AND VIDEO CASSETTE PLAYERS AND RECORDERS, AUDIO MIXERS, ELECTRONIC CABLES, SATELLITE AND TERRESTRIAL DIGITAL SET-TOP BOXES, CALCULATORS, CAMCORDERS, CAMERAS, CD-ROM DRIVES, CD-ROM WRITERS, CELLULAR TELEPHONES, CELLULAR TELEPHONE ACCESSORIES, NAMELY, HEADPHONES, HEAD SETS, ADAPTERS AND BATTERIES FOR CELLULAR TELEPHONES; ELECTRONIC CHIPS CONTAINING MUSICAL RECORDINGS, CLOCK RADIOS, COMPACT DISC PLAYERS AND RECORDERS, COMPASSES, COMPUTER DISC DRIVES; COMPUTER GAME EQUIPMENT CONTAINING MEMORY DEVICES, NAMELY, VIDEO GAME CARTRIDGES AND DISCS; COMPUTER MODEMS, CORDLESS TELEPHONES, DIC-

CLASS 9—(Continued).

TATION MACHINES, DIGITAL CAMERAS, DIGITAL VIDEO RECORDERS AND PLAYERS, DVD PLAYERS AND RECORDERS, ELECTRONIC PERSONAL ORGANIZERS, HANDHELD COMPUTERS, HEADPHONES, INTERACTIVE VIDEO GAMES OF VIRTUAL REALITY COMPRISED OF COMPUTER HARDWARE AND SOFTWARE, KARAOKE MACHINES, LASER DISC RECORDERS AND PLAYERS, MICROPHONES, MICROSCOPES, MOBILE TELEPHONES, MP3 PLAYERS AND RECORDERS, MULTI MEDIA PLAYERS, MULTI MEDIA RECORDERS, PAGERS, PERSONAL VIDEO PLAYERS, PHOTOGRAPHIC PROJECTORS, PRINTERS, RADAR DETECTORS, RADIO PAGERS, RADIOS, RADON DETECTORS, ROBOTS, SCALES, SPEAKERS, STEREO AMPLIFIERS, STEREO RECEIVERS, STEREO TUNERS, STEREO, TELEPHONE ANSWERING MACHINES, TELEPHONES, TELESCOPES, TELEVISION SET-TOP BOXES, TELEVISIONS, VIDEO CAMERAS, VIDEO CASSETTE RECORDERS AND PLAYERS, VIDEO GAME MACHINES FOR USE WITH TELEVISIONS, VIDEO GAME PLAYERS, NAMELY, GAME CONSOLES FOR USE WITH TELEVISION VIDEO MONITORS, VIDEOPHONES, VIDEO TAPE PLAYERS AND RECORDERS, VOICE MESSAGING SYSTEMS COMPRISING COMPUTER HARDWARE AND SOFTWARE FOR USE IN OPERATING VOICE MAIL AND VOICE MESSAGING, WALKIE-TALKIES, WEB TELEPHONES; HAND-HELD UNITS FOR PLAYING ELECTRONIC GAMES FOR USE WITH AN EXTERNAL DISPLAY SCREEN OR MONITOR; DECORATIVE REFRIGERATOR MAGNETS; SPECTACLE CASES; MOUSE PADS; WRIST AND ARM RESTS FOR USE WITH COMPUTERS; ELECTRONICALLY DOWNLOADABLE SOFTWARE, NAMELY, COMPUTER AND VIDEO GAME SOFTWARE; DVDS CONTAINING VIDEO GAME RELATED TELEVISION AND RADIO PROGRAMS; DVDS AND CDS CONTAINING AUDIO AND VIDEO RECORDINGS IN THE NATURE OF MUSIC AND ARTISTIC PERFORMANCES (U.S. CLS. 21, 23, 26, 36 AND 38).

FIRST USE 2-1-2011; IN COMMERCE 2-2-2011.
ERNEST SHOSHO, EXAMINING ATTORNEY

SN 85-333,410. TOPWARE INTERACTIVE INC., LAS VEGAS, NV. FILED 5-30-2011.

Ravens Cry

THE MARK CONSISTS OF STANDARD CHARACTERS WITHOUT CLAIM TO ANY PARTICULAR FONT, STYLE, SIZE, OR COLOR.

FOR APPARATUS FOR BROADCASTING, RECORDING AND TRANSMITTING SOUND AND IMAGES; APPARATUS, NAMELY, COMPUTER PROGRAMS FOR EDITING SOUND AND IMAGES; SCIENTIFIC, PHOTOGRAPHIC, CINEMATOGRAPHIC, OPTICAL, WEIGHING, MEASURING, SIGNALING, AND TEACHING APPARATUS AND INSTRUMENTS, NAMELY, CDS, DVDS, DIGITAL DISKS AND OPTICAL DISKS ALL FEATURING VIDEO GAME SOFTWARE; MAGNETIC, OPTICAL, NUMERICAL COMPUTER STORAGE MEDIA, NAMELY, CDS, DVDS, DIGITAL DISKS AND OPTICAL DISKS ALL FEATURING VIDEO GAME SOFTWARE; COMPUTER PROGRAMS FOR USE AS VIDEO AND AUDIO GAMES, NAMELY, VIDEO GAME SOFTWARE; COMPUTER HARDWARE; AND COMPUTER SOFTWARE FOR USE AS VIDEO AND AUDIO GAMES, NAMELY, VIDEO GAME SOFTWARE; PERSONAL DIGITAL ASSISTANT (PDA); COMPUTER MEMORY; PRINTED CIRCUITS; DESKTOP AND LAPTOP COMPUTERS; COMPUTER PERIPHERALS, NAMELY, MONITORS, KEYBOARDS, MICE, INPUT DEVICES, CD-ROM DRIVES, CONTROL PANELS AND JOYSTICKS, DISK DRIVES FOR MAGNETIC, OPTICAL AND DIGITAL DISKS AND FLOPPY DISKS; STORED COMPUTER PROGRAMS FOR USE AS VIDEO AND AUDIO GAMES,

CLASS 9—(Continued).

NAMELY, VIDEO GAME SOFTWARE; COMPUTER GAME SOFTWARE; COMPUTER SOFTWARE FOR USE AS VIDEO AND AUDIO GAMES, NAMELY, VIDEO GAME SOFTWARE; COMPUTER GAME AND VIDEO GAME SOFTWARE; COMPUTER GAME PROGRAMS; VIDEO AND AUDIO GAMES, NAMELY, VIDEO GAME SOFTWARE AND PROGRAMS; INTERACTIVE MULTIMEDIA COMPUTER GAME PROGRAMS; COMPUTER SCIENCE SOFTWARE ON MOBILE PHONES FOR USE AS VIDEO AND AUDIO GAMES, NAMELY, VIDEO GAME SOFTWARE; AUDIO-VISUAL GAMES IN THE NATURE OF COMPUTER GAME SOFTWARE FOR COMPUTER HARDWARE PLATFORMS; ELECTRONIC GAMING DEVICES, NAMELY, COMPUTER GAME CONSOLES FOR USE WITH AN EXTERNAL DISPLAY SCREEN OR MONITOR; MAGNETIC, OPTICAL AND DIGITAL MEDIA FOR COMPUTER PROGRAMS, NAMELY, BLANK DIGITAL STORAGE MEDIA, BLANK OPTICAL DISKS, BLANK MAGNETIC DISKS; GAME DEVICES AS ACCESSORIES FOR TVS, NAMELY, VIDEO GAME MACHINES FOR USE WITH TELEVISIONS; COMPUTER SOFTWARE CONTAINING INTEGRATED MUSIC AND INTEGRATED FILM RECORDINGS; CINEMATOGRAPHIC FILMS; VENDING MACHINES AND MECHANISMS FOR COIN OPERATED APPARATUS; DATA PROCESSING EQUIPMENT; ELECTRONIC PUBLICATIONS, NAMELY, OPERATING MANUALS AND USER MANUALS FOR COMPUTERS AND COMPUTER SOFTWARE STORED DIGITALLY, IN PARTICULAR ON FLOPPY DISKS, CD-ROM, DVD-ROM; SUNGLASSES AND GOGGLES; CONSUMER ELECTRONICS, NAMELY, AUDIO CASSETTE AND CD AND VIDEO CASSETTE PLAYERS AND RECORDERS, AUDIO MIXERS, ELECTRONIC CABLES, SATELLITE AND TERRESTRIAL DIGITAL SET-TOP BOXES, CALCULATORS, CAMCORDERS, CAMERAS, CD-ROM DRIVES, CD-ROM WRITERS, CELLULAR TELEPHONES, CELLULAR TELEPHONE ACCESSORIES, NAMELY, HEADPHONES, HEAD SETS, ADAPTERS AND BATTERIES FOR CELLULAR TELEPHONES; ELECTRONIC CHIPS CONTAINING MUSICAL RECORDINGS, CLOCK RADIOS, COMPACT DISC PLAYERS AND RECORDERS, COMPASSES, COMPUTER DISC DRIVES; COMPUTER GAME EQUIPMENT CONTAINING MEMORY DEVICES, NAMELY, VIDEO GAME CARTRIDGES AND DISCS; COMPUTER MODEMS, CORDLESS TELEPHONES, DICTATION MACHINES, DIGITAL CAMERAS, DIGITAL VIDEO RECORDERS AND PLAYERS, DVD PLAYERS AND RECORDERS, ELECTRONIC PERSONAL ORGANIZERS, HANDHELD COMPUTERS, HEADPHONES, INTERACTIVE VIDEO GAMES OF VIRTUAL REALITY COMPRISED OF COMPUTER HARDWARE AND SOFTWARE, KARAOKE MACHINES, LASER DISC RECORDERS AND PLAYERS, MICROPHONES, MICROSCOPES, MOBILE TELEPHONES, MP3 PLAYERS AND RECORDERS, MULTI MEDIA PLAYERS, MULTI MEDIA RECORDERS, PAGERS, PERSONAL VIDEO PLAYERS, PHOTOGRAPHIC PROJECTORS, PRINTERS, RADAR DETECTORS, RADIO PAGERS, RADIOS, RADON DETECTORS, ROBOTS, SCALES, SPEAKERS, STEREO AMPLIFIERS, STEREO RECEIVERS, STEREO TUNERS, STEREOS, TELEPHONE ANSWERING MACHINES, TELEPHONES, TELESCOPES, TELEVISION SET-TOP BOXES, TELEVISIONS, VIDEO CAMERAS, VIDEO CASSETTE RECORDERS AND PLAYERS, VIDEO GAME MACHINES FOR USE WITH TELEVISIONS, VIDEO GAME PLAYERS, NAMELY, GAME CONSOLES FOR USE WITH TELEVISION VIDEO MONITORS, VIDEOPHONES, VIDEO TAPE PLAYERS AND RECORDERS, VOICE MESSAGING SYSTEMS COMPRISING COMPUTER HARDWARE AND SOFTWARE FOR USE IN OPERATING VOICE MAIL AND VOICE MESSAGING, WALKIE-TALKIES, WEB TELEPHONES; HAND-HELD UNITS FOR PLAYING ELECTRONIC GAMES FOR USE WITH AN EXTERNAL DISPLAY SCREEN OR MONITOR; DECORATIVE REFRIGERATOR MAGNETS; SPECTACLE CASES; MOUSE PADS; WRIST AND ARM RESTS FOR USE WITH COMPUTERS; ELECTRONICALLY DOWNLOADABLE SOFTWARE, NAMELY, COMPUTER AND VIDEO GAME SOFTWARE; DVDS CONTAINING VIDEO GAME RELATED TELEVISION AND RADIO PROGRAMS; DVDS AND CDS CONTAINING AUDIO AND VIDEO RECORDINGS IN THE NATURE OF MUSIC AND ARTISTIC PERFORMANCES (U.S. CLS. 21, 23, 26, 36 AND 38).

FIRST USE 1-1-2011; IN COMMERCE 1-1-2011.
ERNEST SHOSHOU, EXAMINING ATTORNEY

CLASS 9—(Continued).

SN 85-333,415. TOPWARE INTERACTIVE INC., LAS VEGAS, NV. FILED 5-30-2011.

Two Worlds

THE MARK CONSISTS OF STANDARD CHARACTERS WITHOUT CLAIM TO ANY PARTICULAR FONT, STYLE, SIZE, OR COLOR.

FOR APPARATUS FOR BROADCASTING, RECORDING AND TRANSMITTING SOUND AND IMAGES; APPARATUS, NAMELY, COMPUTER PROGRAMS FOR EDITING SOUND AND IMAGES; SCIENTIFIC, PHOTOGRAPHIC, CINEMATOGRAPHIC, OPTICAL, WEIGHING, MEASURING, SIGNALING, AND TEACHING APPARATUS AND INSTRUMENTS, NAMELY, CDS, DVDS, DIGITAL DISKS AND OPTICAL DISKS ALL FEATURING VIDEO GAME SOFTWARE; MAGNETIC, OPTICAL, NUMERICAL COMPUTER STORAGE MEDIA, NAMELY, CDS, DVDS, DIGITAL DISKS AND OPTICAL DISKS ALL FEATURING VIDEO GAME SOFTWARE; COMPUTER PROGRAMS FOR USE AS VIDEO AND AUDIO GAMES, NAMELY, VIDEO GAME SOFTWARE; COMPUTER HARDWARE; AND COMPUTER SOFTWARE FOR USE AS VIDEO AND AUDIO GAMES, NAMELY, VIDEO GAME SOFTWARE; PERSONAL DIGITAL ASSISTANT (PDA); COMPUTER MEMORY; PRINTED CIRCUITS; DESKTOP AND LAPTOP COMPUTERS; COMPUTER PERIPHERALS, NAMELY, MONITORS, KEYBOARDS, MICE, INPUT DEVICES, CD-ROM DRIVES, CONTROL PANELS AND JOYSTICKS, DISK DRIVES FOR MAGNETIC, OPTICAL AND DIGITAL DISKS AND FLOPPY DISKS; STORED COMPUTER PROGRAMS FOR USE AS VIDEO AND AUDIO GAMES, NAMELY, VIDEO GAME SOFTWARE; COMPUTER GAME SOFTWARE; COMPUTER SOFTWARE FOR USE AS VIDEO AND AUDIO GAMES, NAMELY, VIDEO GAME SOFTWARE; COMPUTER GAME AND VIDEO GAME SOFTWARE; COMPUTER GAME PROGRAMS; VIDEO AND AUDIO GAMES, NAMELY, VIDEO GAME SOFTWARE AND PROGRAMS; INTERACTIVE MULTIMEDIA COMPUTER GAME PROGRAMS; COMPUTER SCIENCE SOFTWARE ON MOBILE PHONES FOR USE AS VIDEO AND AUDIO GAMES, NAMELY, VIDEO GAME SOFTWARE; AUDIO-VISUAL GAMES IN THE NATURE OF COMPUTER GAME SOFTWARE FOR COMPUTER HARDWARE PLATFORMS; ELECTRONIC GAMING DEVICES, NAMELY, COMPUTER GAME CONSOLES FOR USE WITH AN EXTERNAL DISPLAY SCREEN OR MONITOR; MAGNETIC, OPTICAL AND DIGITAL MEDIA FOR COMPUTER PROGRAMS, NAMELY, BLANK DIGITAL STORAGE MEDIA, BLANK OPTICAL DISKS, BLANK MAGNETIC DISKS; GAME DEVICES AS ACCESSORIES FOR TVS, NAMELY, VIDEO GAME MACHINES FOR USE WITH TELEVISIONS; COMPUTER SOFTWARE CONTAINING INTEGRATED MUSIC AND INTEGRATED FILM RECORDINGS; CINEMATOGRAPHIC FILMS; VENDING MACHINES AND MECHANISMS FOR COIN OPERATED APPARATUS; DATA PROCESSING EQUIPMENT; ELECTRONIC PUBLICATIONS, NAMELY, OPERATING MANUALS AND USER MANUALS FOR COMPUTERS AND COMPUTER SOFTWARE STORED DIGITALLY, IN PARTICULAR ON FLOPPY DISKS, CD-ROM, DVD-ROM; SUNGLASSES AND GOGGLES; CONSUMER ELECTRONICS, NAMELY, AUDIO CASSETTE AND CD AND VIDEO CASSETTE PLAYERS AND RECORDERS, AUDIO MIXERS, ELECTRONIC CABLES, SATELLITE AND TERRESTRIAL DIGITAL SET-TOP BOXES, CALCULATORS, CAMCORDERS, CAMERAS, CD-ROM DRIVES, CD-ROM WRITERS, CELLULAR TELEPHONES, CELLULAR TELEPHONE ACCESSORIES, NAMELY, HEADPHONES, HEAD SETS, ADAPTERS AND BATTERIES FOR CELLULAR TELEPHONES; ELECTRONIC CHIPS CONTAINING MUSICAL RECORDINGS, CLOCK RADIOS, COMPACT DISC PLAYERS AND RECORDERS, COMPASSES, COMPUTER DISC DRIVES; COMPUTER GAME EQUIPMENT CONTAINING MEMORY DEVICES, NAMELY, VIDEO GAME CARTRIDGES AND DISCS; COMPUTER MODEMS, CORDLESS TELEPHONES, DIC-

CLASS 9—(Continued).

TATION MACHINES, DIGITAL CAMERAS, DIGITAL VIDEO RECORDERS AND PLAYERS, DVD PLAYERS AND RECORDERS, ELECTRONIC PERSONAL ORGANIZERS, HANDHELD COMPUTERS, HEADPHONES, INTERACTIVE VIDEO GAMES OF VIRTUAL REALITY COMPRISED OF COMPUTER HARDWARE AND SOFTWARE, KARAOKE MACHINES, LASER DISC RECORDERS AND PLAYERS, MICROPHONES, MICROSCOPES, MOBILE TELEPHONES, MP3 PLAYERS AND RECORDERS, MULTI MEDIA PLAYERS, MULTI MEDIA RECORDERS, PAGERS, PERSONAL VIDEO PLAYERS, PHOTOGRAPHIC PROJECTORS, PRINTERS, RADAR DETECTORS, RADIO PAGERS, RADIOS, RADON DETECTORS, ROBOTS, SCALES, SPEAKERS, STEREO AMPLIFIERS, STEREO RECEIVERS, STEREO TUNERS, STEREO, TELEPHONE ANSWERING MACHINES, TELEPHONES, TELESCOPES, TELEVISION SET-TOP BOXES, TELEVISIONS, VIDEO CAMERAS, VIDEO CASSETTE RECORDERS AND PLAYERS, VIDEO GAME MACHINES FOR USE WITH TELEVISIONS, VIDEO GAME PLAYERS, NAMELY, GAME CONSOLES FOR USE WITH TELEVISION VIDEO MONITORS, VIDEOPHONES, VIDEO TAPE PLAYERS AND RECORDERS, VOICE MESSAGING SYSTEMS COMPRISING COMPUTER HARDWARE AND SOFTWARE FOR USE IN OPERATING VOICE MAIL AND VOICE MESSAGING, WALKIE-TALKIES, WEB TELEPHONES; HAND-HELD UNITS FOR PLAYING ELECTRONIC GAMES FOR USE WITH AN EXTERNAL DISPLAY SCREEN OR MONITOR; DECORATIVE REFRIGERATOR MAGNETS; SPECTACLE CASES; MOUSE PADS; WRIST AND ARM RESTS FOR USE WITH COMPUTERS; ELECTRONICALLY DOWNLOADABLE SOFTWARE, NAMELY, COMPUTER AND VIDEO GAME SOFTWARE; DVDS CONTAINING VIDEO GAME RELATED TELEVISION AND RADIO PROGRAMS; DVDS AND CDS CONTAINING AUDIO AND VIDEO RECORDINGS IN THE NATURE OF MUSIC AND ARTISTIC PERFORMANCES (U.S. CLS. 21, 23, 26, 36 AND 38).

FIRST USE 1-1-2003; IN COMMERCE 1-1-2003.
ERNEST SHOSHO, EXAMINING ATTORNEY

SN 85-333,419. TOPWARE INTERACTIVE INC., LAS VEGAS, NV. FILED 5-30-2011.

Gorky 21

THE MARK CONSISTS OF STANDARD CHARACTERS WITHOUT CLAIM TO ANY PARTICULAR FONT, STYLE, SIZE, OR COLOR.

FOR APPARATUS FOR BROADCASTING, RECORDING AND TRANSMITTING SOUND AND IMAGES; APPARATUS, NAMELY, COMPUTER PROGRAMS FOR EDITING SOUND AND IMAGES; SCIENTIFIC, PHOTOGRAPHIC, CINEMATOGRAPHIC, OPTICAL, WEIGHING, MEASURING, SIGNALING, AND TEACHING APPARATUS AND INSTRUMENTS, NAMELY, CDS, DVDS, DIGITAL DISKS AND OPTICAL DISKS ALL FEATURING VIDEO GAME SOFTWARE; MAGNETIC, OPTICAL, NUMERICAL COMPUTER STORAGE MEDIA, NAMELY, CDS, DVDS, DIGITAL DISKS AND OPTICAL DISKS ALL FEATURING VIDEO GAME SOFTWARE; COMPUTER PROGRAMS FOR USE AS VIDEO AND AUDIO GAMES, NAMELY, VIDEO GAME SOFTWARE; COMPUTER HARDWARE; AND COMPUTER SOFTWARE FOR USE AS VIDEO AND AUDIO GAMES, NAMELY, VIDEO GAME SOFTWARE; PERSONAL DIGITAL ASSISTANT (PDA); COMPUTER MEMORY; PRINTED CIRCUITS; DESKTOP AND LAPTOP COMPUTERS; COMPUTER PERIPHERALS, NAMELY, MONITORS, KEYBOARDS, MICE, INPUT DEVICES, CD-ROM DRIVES, CONTROL PANELS AND JOYSTICKS, DISK DRIVES FOR MAGNETIC, OPTICAL AND DIGITAL DISKS AND FLOPPY DISKS; STORED COMPUTER PROGRAMS FOR USE AS VIDEO AND AUDIO GAMES,

CLASS 9—(Continued).

NAMELY, VIDEO GAME SOFTWARE; COMPUTER GAME SOFTWARE; COMPUTER SOFTWARE FOR USE AS VIDEO AND AUDIO GAMES, NAMELY, VIDEO GAME SOFTWARE; COMPUTER GAME AND VIDEO GAME SOFTWARE; COMPUTER GAME PROGRAMS; VIDEO AND AUDIO GAMES, NAMELY, VIDEO GAME SOFTWARE AND PROGRAMS; INTERACTIVE MULTIMEDIA COMPUTER GAME PROGRAMS; COMPUTER SCIENCE SOFTWARE ON MOBILE PHONES FOR USE AS VIDEO AND AUDIO GAMES, NAMELY, VIDEO GAME SOFTWARE; AUDIO-VISUAL GAMES IN THE NATURE OF COMPUTER GAME SOFTWARE FOR COMPUTER HARDWARE PLATFORMS; ELECTRONIC GAMING DEVICES, NAMELY, COMPUTER GAME CONSOLES FOR USE WITH AN EXTERNAL DISPLAY SCREEN OR MONITOR; MAGNETIC, OPTICAL AND DIGITAL MEDIA FOR COMPUTER PROGRAMS, NAMELY, BLANK DIGITAL STORAGE MEDIA, BLANK OPTICAL DISKS, BLANK MAGNETIC DISKS; GAME DEVICES AS ACCESSORIES FOR TVS, NAMELY, VIDEO GAME MACHINES FOR USE WITH TELEVISIONS; COMPUTER SOFTWARE CONTAINING INTEGRATED MUSIC AND INTEGRATED FILM RECORDINGS; CINEMATOGRAPHIC FILMS; VENDING MACHINES AND MECHANISMS FOR COIN OPERATED APPARATUS; DATA PROCESSING EQUIPMENT; ELECTRONIC PUBLICATIONS, NAMELY, OPERATING MANUALS AND USER MANUALS FOR COMPUTERS AND COMPUTER SOFTWARE STORED DIGITALLY, IN PARTICULAR ON FLOPPY DISKS, CD-ROM, DVD-ROM; SUNGLASSES AND GOGGLES; CONSUMER ELECTRONICS, NAMELY, AUDIO CASSETTE AND CD AND VIDEO CASSETTE PLAYERS AND RECORDERS, AUDIO MIXERS, ELECTRONIC CABLES, SATELLITE AND TERRESTRIAL DIGITAL SET-TOP BOXES, CALCULATORS, CAMCORDERS, CAMERAS, CD-ROM DRIVES, CD-ROM WRITERS, CELLULAR TELEPHONES, CELLULAR TELEPHONE ACCESSORIES, NAMELY, HEADPHONES, HEAD SETS, ADAPTERS AND BATTERIES FOR CELLULAR TELEPHONES; ELECTRONIC CHIPS CONTAINING MUSICAL RECORDINGS, CLOCK RADIOS, COMPACT DISC PLAYERS AND RECORDERS, COMPASSES, COMPUTER DISC DRIVES; COMPUTER GAME EQUIPMENT CONTAINING MEMORY DEVICES, NAMELY, VIDEO GAME CARTRIDGES AND DISCS; COMPUTER MODEMS, CORDLESS TELEPHONES, DICTATION MACHINES, DIGITAL CAMERAS, DIGITAL VIDEO RECORDERS AND PLAYERS, DVD PLAYERS AND RECORDERS, ELECTRONIC PERSONAL ORGANIZERS, HANDHELD COMPUTERS, HEADPHONES, INTERACTIVE VIDEO GAMES OF VIRTUAL REALITY COMPRISED OF COMPUTER HARDWARE AND SOFTWARE, KARAOKE MACHINES, LASER DISC RECORDERS AND PLAYERS, MICROPHONES, MICROSCOPES, MOBILE TELEPHONES, MP3 PLAYERS AND RECORDERS, MULTI MEDIA PLAYERS, MULTI MEDIA RECORDERS, PAGERS, PERSONAL VIDEO PLAYERS, PHOTOGRAPHIC PROJECTORS, PRINTERS, RADAR DETECTORS, RADIO PAGERS, RADIOS, RADON DETECTORS, ROBOTS, SCALES, SPEAKERS, STEREO AMPLIFIERS, STEREO RECEIVERS, STEREO TUNERS, STEREO, TELEPHONE ANSWERING MACHINES, TELEPHONES, TELESCOPES, TELEVISION SET-TOP BOXES, TELEVISIONS, VIDEO CAMERAS, VIDEO CASSETTE RECORDERS AND PLAYERS, VIDEO GAME MACHINES FOR USE WITH TELEVISIONS, VIDEO GAME PLAYERS, NAMELY, GAME CONSOLES FOR USE WITH TELEVISION VIDEO MONITORS, VIDEOPHONES, VIDEO TAPE PLAYERS AND RECORDERS, VOICE MESSAGING SYSTEMS COMPRISING COMPUTER HARDWARE AND SOFTWARE FOR USE IN OPERATING VOICE MAIL AND VOICE MESSAGING, WALKIE-TALKIES, WEB TELEPHONES; HAND-HELD UNITS FOR PLAYING ELECTRONIC GAMES FOR USE WITH AN EXTERNAL DISPLAY SCREEN OR MONITOR; DECORATIVE REFRIGERATOR MAGNETS; SPECTACLE CASES; MOUSE PADS; WRIST AND ARM RESTS FOR USE WITH COMPUTERS; ELECTRONICALLY DOWNLOADABLE SOFTWARE, NAMELY, COMPUTER AND VIDEO GAME SOFTWARE; DVDS CONTAINING VIDEO GAME RELATED TELEVISION AND RADIO PROGRAMS; DVDS AND CDS CONTAINING AUDIO AND VIDEO RECORDINGS IN THE NATURE OF MUSIC AND ARTISTIC PERFORMANCES (U.S. CLS. 21, 23, 26, 36 AND 38).

FIRST USE 1-1-2010; IN COMMERCE 1-1-2010.
ERNEST SHOSHO, EXAMINING ATTORNEY

CLASS 9—(Continued).

SN 85-334,905. MICO, INC., NORTH MANKATO, MN. FILED 6-1-2011.

QUADRIGAGE

THE MARK CONSISTS OF STANDARD CHARACTERS WITHOUT CLAIM TO ANY PARTICULAR FONT, STYLE, SIZE, OR COLOR.

SEC. 2(F).
FOR PRESSURE GAUGES (U.S. CLS. 21, 23, 26, 36 AND 38).

FIRST USE 0-0-1964; IN COMMERCE 0-0-1964.
BARBARA A. GOLD, EXAMINING ATTORNEY

SN 85-335,836. SHANGHAI AI GUAN DIGITAL TECHNOLOGY CO., LTD., SHANGHAI, CHINA, FILED 6-1-2011.

GEVEY

THE WORDING "GEVEY" HAS NO MEANING IN A FOREIGN LANGUAGE.

FOR CABLES; ELECTRIC; CAMERAS; COMPUTER PERIPHERAL DEVICES; COMPUTERS; DESKTOP COMPUTERS; DRY CELLS; ELECTRIC SWITCHES; PERSONAL STEREOS; PHOTOELECTRIC CELLS; SOLAR CELLS; TELEPHONE APPARATUS; WET CELLS; WINDING WIRES (U.S. CLS. 21, 23, 26, 36 AND 38).

MARGARET POWER, EXAMINING ATTORNEY

SN 85-335,936. ATARI INTERACTIVE, INC., NEW YORK, NY. FILED 6-2-2011.

WARLORDS

THE MARK CONSISTS OF STANDARD CHARACTERS WITHOUT CLAIM TO ANY PARTICULAR FONT, STYLE, SIZE, OR COLOR.

OWNER OF U.S. REG. NO. 1,218,227.
FOR ELECTRONIC, VIDEO AND MULTIMEDIA GAME SOFTWARE FOR USE ON PERSONAL COMPUTERS AND ELECTRONIC GAME PLAYING MACHINES; RECORDED COMPUTER GAME SOFTWARE PROGRAMS; GAME SOFTWARE FOR COMPUTERS, DOWNLOADABLE VIDEO GAME SOFTWARE (U.S. CLS. 21, 23, 26, 36 AND 38).

FIRST USE 11-11-2003; IN COMMERCE 11-11-2003.
DAVID I, EXAMINING ATTORNEY

CLASS 9—(Continued).

SN 85-336,430. CARNEGIE LEARNING, INC., PITTSBURGH, PA. FILED 6-2-2011.

Skillometer

THE MARK CONSISTS OF STANDARD CHARACTERS WITHOUT CLAIM TO ANY PARTICULAR FONT, STYLE, SIZE, OR COLOR.

FOR COMPUTER SOFTWARE FOR MATHEMATICS INSTRUCTION; COMPUTER SOFTWARE FOR MATHEMATICS INSTRUCTION THAT MAY BE DOWNLOADED FROM A GLOBAL COMPUTER NETWORK; DOWNLOADABLE COMPUTER SOFTWARE FOR MATHEMATICS INSTRUCTION (U.S. CLS. 21, 23, 26, 36 AND 38).

FIRST USE 1-1-2005; IN COMMERCE 1-1-2005.
JENNIFER MARTIN, EXAMINING ATTORNEY

SN 85-336,846. TRUSTEE OF THE WILLIAM CASTLE TESTAMENTARY TRUST, BELVEDERE, CA. FILED 6-2-2011.

LIVING SCREENPLAY

THE MARK CONSISTS OF STANDARD CHARACTERS WITHOUT CLAIM TO ANY PARTICULAR FONT, STYLE, SIZE, OR COLOR.

NO CLAIM IS MADE TO THE EXCLUSIVE RIGHT TO USE "SCREENPLAY", APART FROM THE MARK AS SHOWN.

FOR DOWNLOADABLE BOOKS FEATURING DRAMATIC AND COMEDIC SCREENPLAYS VIA THE INTERNET AND WIRELESS DEVICES (U.S. CLS. 21, 23, 26, 36 AND 38).

ZHALEH DELANEY, EXAMINING ATTORNEY

CLASS 9—(Continued).

SN 85-337,392. GLOBAL THINK TECHNOLOGY, S.A., CORDOBA, ARGENTINA, FILED 6-3-2011.

DENWA

THE MARK CONSISTS OF STANDARD CHARACTERS WITHOUT CLAIM TO ANY PARTICULAR FONT, STYLE, SIZE, OR COLOR.

FOR COMPUTER HARDWARE AND SOFTWARE, NAMELY, CENTRAL TELEPHONY HARDWARE AND SOFTWARE FOR TELEPHONY COMMUNICATIONS MANAGEMENT AND CONTROL IN AN ENTERPRISE; COMPUTER SOFTWARE, NAMELY, SOFTSWICH SOFTWARE FOR TELEPHONY COMMUNICATIONS MANAGEMENT AMONG TELEPHONY OPERATORS; COMPUTER SOFTWARE, NAMELY, SOFTPHONE SOFTWARE FOR THE COMMUNICATIONS MANAGEMENT TO BE PERFORMED THROUGH A PERSONAL COMPUTER OR A MOBILE PHONE; TELECOMMUNICATION UNITS AND DEVICES, NAMELY, COMPUTER NETWORK SWITCHES, INTERNET PHONES, COMPUTER HARDWARE FOR TELECOMMUNICATIONS DESTINATED TO TELEPHONY COMMUNICATIONS (U.S. CLS. 21, 23, 26, 36 AND 38).

FIRST USE 3-0-2008; IN COMMERCE 3-0-2008.
PAUL MORENO, EXAMINING ATTORNEY

CLASS 9—(Continued).

SN 85-338,976. MYCOSKIE, LLC, SANTA MONICA, CA, FILED 6-6-2011.

TOMS

THE MARK CONSISTS OF STANDARD CHARACTERS WITHOUT CLAIM TO ANY PARTICULAR FONT, STYLE, SIZE, OR COLOR.

OWNER OF U.S. REG. NOS. 3,353,902, 3,662,112 AND OTHERS.

FOR SUNGLASSES AND CASES FOR SUNGLASSES (U.S. CLS. 21, 23, 26, 36 AND 38).

FIRST USE 6-7-2011; IN COMMERCE 6-7-2011.

MEGHAN REINHART, EXAMINING ATTORNEY

SN 85-337,420. HOOTOO.COM INC., SANTA CLARA, CA, FILED 6-3-2011.

TAOTRONICS

THE MARK CONSISTS OF STANDARD CHARACTERS WITHOUT CLAIM TO ANY PARTICULAR FONT, STYLE, SIZE, OR COLOR.

FOR AUDIO AND VIDEO CABLES AND ADAPTERS, NAMELY, HDMI CABLES, MHL CABLES, DISPLAY-PORT CABLES, DVI CABLES, VGA CABLES, S-VIDEO CABLES, SPEAKER WIRES, COAXIAL CABLES; AUDIO VIDEO ACCESSORIES, NAMELY, AUDIO AMPLIFIERS, AUDIO SPEAKERS, AUDIO RECEIVERS, VIDEO DECODERS, AUDIO VIDEO CONVERTERS/SWITCHES/SPLITTERS; COMPUTER PERIPHERALS, NAMELY, KEYBOARDS, MICE, USB HUBS, CARD READERS, HEADSETS AND HEADPHONES, WEBCAMS; COMPUTER NETWORKING DEVICES, NAMELY, WIRELESS ROUTERS, WIRELESS ADAPTERS, MODEMS; NOTEBOOK ACCESSORIES, NAMELY, BATTERIES, AC ADAPTERS, BAGS, COOLING PADS, SCREEN PROTECTORS; TABLET PCS; TABLET PC ACCESSORIES, NAMELY, SLEEVES AND BAGS, SUPPORTING STANDS, POWER ADAPTERS, SCREEN PROTECTORS; MP3/MP4/MP5 PLAYERS; VIDEO AND VOICE RECORDERS; CELL PHONE ACCESSORIES, NAMELY, CASES, SCREEN PROTECTORS, BATTERIES AND CHARGERS; CAR ELECTRONICS, NAMELY, CAR REARVIEW CAMERAS, GPS NAVIGATION, CAR DVD PLAYERS, CAR LIGHTER CHARGERS, CAR STEREO CABLES; SURVEILLANCE CAMERAS (U.S. CLS. 21, 23, 26, 36 AND 38).

HEATHER BIDDULPH, EXAMINING ATTORNEY

SN 85-339,544. LIEBERT CORPORATION, COLUMBUS, OH, FILED 6-7-2011.

OPTIMIZEIT

THE MARK CONSISTS OF STANDARD CHARACTERS WITHOUT CLAIM TO ANY PARTICULAR FONT, STYLE, SIZE, OR COLOR.

FOR SOFTWARE FOR USE IN CONFIGURING DATA CENTER AND COMPUTER ROOM EQUIPMENT; DATA CENTER INFRASTRUCTURE MANAGEMENT SOFTWARE FOR ASSESSING, TESTING, OPERATING, CONTROLLING, MONITORING AND COORDINATING ENVIRONMENTAL EQUIPMENT, ELECTRICAL, BATTERY AND BACK-UP POWER SYSTEMS, POWER DISTRIBUTION SYSTEMS, FIRE SUPPRESSION, SURGE SUPPRESSION, AIR CONDITIONING, COOLING AND PERSONNEL ACCESS CONTROL; VISUAL MODELING SOFTWARE FOR CREATING SPATIAL IMAGES OF BUILDING LAYOUTS AND COMPUTER ROOM AND DATA CENTER EQUIPMENT LAYOUTS (U.S. CLS. 21, 23, 26, 36 AND 38).

GRETCHEN ULRICH, EXAMINING ATTORNEY

CLASS 9—(Continued).

SN 85-340,048. GRANDCARE SYSTEMS, WEST BEND, WI. FILED 6-7-2011.

GrandCare Systems

THE MARK CONSISTS OF STANDARD CHARACTERS WITHOUT CLAIM TO ANY PARTICULAR FONT, STYLE, SIZE, OR COLOR.

NO CLAIM IS MADE TO THE EXCLUSIVE RIGHT TO USE "SYSTEMS", APART FROM THE MARK AS SHOWN. SEC. 2(F).

FOR COMPUTER SYSTEM COMPRISED OF HARDWARE AND SOFTWARE PLACED IN A CLIENT'S RESIDENCE THAT RECEIVES HEALTH DATA AND ACTIVITY DATA FROM WIRELESS DEVICES IN THE RESIDENCE, PROCESSES AND DISPLAYS THE DATA, SENDS ALERTS, AND COMMUNICATES WITH HOME AUTOMATION DEVICES AND INCLUDES A WEB-BASED INTERFACE FOR REMOTE CAREGIVERS TO VIEW THE INFORMATION, AND SET RULES FOR NOTIFICATION AND INCLUDES SOCIAL AND COMMUNICATION FEATURES IN THE NATURE OF VIDEO CHAT, GAMES AND COGNITIVE ASSISTS (U.S. CLS. 21, 23, 26, 36 AND 38).

FIRST USE 12-11-2005; IN COMMERCE 2-1-2006.
ROBERT C. CLARK JR., EXAMINING ATTORNEY

CLASS 9—(Continued).

SN 85-341,355. GUNTHER BLASEIO, DBA QUICK CEPH SYSTEMS, INC., RANCHO SANTA FE, CA. FILED 6-8-2011.



NO CLAIM IS MADE TO THE EXCLUSIVE RIGHT TO USE "QUICK CEPH SYSTEMS", APART FROM THE MARK AS SHOWN.

THE COLOR(S) BLUE, GREEN AND WHITE IS/ARE CLAIMED AS A FEATURE OF THE MARK.

THE MARK CONSISTS OF THE STYLIZED TERM "QUICK" ABOVE THE STYLIZED TERM "CEPH" WHEREIN THE LETTER "C" IN "CEPH" IS COMPRISED OF THE DEPICTION OF THE HEADS OF A MAN AND A CHILD IN PROFILE FACING LEFT ABOVE THE STYLIZED TERM "SYSTEMS", WHICH APPEARS UNDER THE LETTERS "PH" IN "CEPH"; THE COLOR BLUE APPEARS IN THE STYLIZED TERM "CEPH" AND IN THE HEAD OF THE MAN CREATING THE LETTER "C" IN "CEPH"; THE COLOR GREEN APPEARS IN THE STYLIZED TERMS "QUICK" AND "SYSTEMS"; THE COLOR WHITE APPEARS IN THE STYLIZED HEAD OF THE CHILD CREATING THE LETTER "C" IN "CEPH" AND IN THE BACKGROUND OF THE MARK.

FOR DATABASE MANAGEMENT SOFTWARE FOR ORTHODONTISTS AND MAXILLO FACIAL SURGEONS (U.S. CLS. 21, 23, 26, 36 AND 38).

FIRST USE 12-0-1985; IN COMMERCE 1-0-1986.
MYRIAH HABEEB, EXAMINING ATTORNEY

SN 85-340,882. ARIE, ALEXANDER, COSTA MESA, CA. FILED 6-8-2011.

spin type

THE MARK CONSISTS OF STANDARD CHARACTERS WITHOUT CLAIM TO ANY PARTICULAR FONT, STYLE, SIZE, OR COLOR.

NO CLAIM IS MADE TO THE EXCLUSIVE RIGHT TO USE "TYPE", APART FROM THE MARK AS SHOWN.

FOR COMPUTER APPLICATION SOFTWARE FOR MOBILE PHONES, PORTABLE MEDIA PLAYERS, HANDHELD COMPUTERS, COMPUTER, TABLET COMPUTER, NAMELY, SOFTWARE FOR TEXT INPUT (U.S. CLS. 21, 23, 26, 36 AND 38).

LINDA ORNDORFF, EXAMINING ATTORNEY

SN 85-342,024. PASCAL CORTES JAVIER ALEJANDRO, WAUKEGAN, IL. FILED 6-9-2011.



THE COLOR(S) GREY, RED AND WHITE IS/ARE CLAIMED AS A FEATURE OF THE MARK.

THE MARK CONSISTS OF THE STYLIZED CAPITAL LETTER "A" IN GRAY COLOR AND "ADUASIS" WORD IN THE CENTER OF THE IMAGE IN CAPITAL LETTERS IN WHITE, AND THE RED DOT UP ON THE "I". THERE IS ALSO GRAY SHADING AROUND THE "A".

FOR COMPUTER APPLICATION SOFTWARE FOR LOGISTICS, NAMELY, SOFTWARE FOR LOGISTICS AND FOREIGN TRADE (U.S. CLS. 21, 23, 26, 36 AND 38).

FIRST USE 4-1-1989; IN COMMERCE 4-1-1989.
KARANENDRA S. CHHINA, EXAMINING ATTORNEY

CLASS 9—(Continued).

SN 85-342,459. MLR LICENSING, LLC, LOS ANGELES, CA. FILED 6-9-2011.

BOOTY CAM

THE MARK CONSISTS OF STANDARD CHARACTERS WITHOUT CLAIM TO ANY PARTICULAR FONT, STYLE, SIZE, OR COLOR.

NO CLAIM IS MADE TO THE EXCLUSIVE RIGHT TO USE "CAM", APART FROM THE MARK AS SHOWN.

FOR COMPUTER CAMERAS; DIGITAL CAMERA ACCESSORY IN THE NATURE OF A DIGITAL PHOTO VIEWER; DIGITAL CAMERAS; DIGITAL CAMERAS FOR INDUSTRIAL USE; MULTIPLE PURPOSE CAMERAS; SELF-TIMERS; TILTING HEADS (U.S. CLS. 21, 23, 26, 36 AND 38).

AISHA CLARKE, EXAMINING ATTORNEY

SN 85-344,696. MEDQUIST IP LLC, FRANKLIN, TN. FILED 6-13-2011.

QTINUUM

THE MARK CONSISTS OF STANDARD CHARACTERS WITHOUT CLAIM TO ANY PARTICULAR FONT, STYLE, SIZE, OR COLOR.

OWNER OF U.S. REG. NO. 3,491,051.

FOR COMPUTER SOFTWARE IN THE HEALTHCARE FIELD FOR DICTATION, TRANSCRIPTION, EDITING, DATA INTAKE, CODING, MANAGING RECORDS, WORKFLOW MANAGEMENT AND DATA DELIVERY; SPEECH RECOGNITION SOFTWARE FOR USE IN WORKFLOW MANAGEMENT, DICTATION, TRANSCRIPTION AND DATA MANAGEMENT OF MEDICAL AND HEALTH RELATED REPORTS (U.S. CLS. 21, 23, 26, 36 AND 38).

KATHERINE STOIDES, EXAMINING ATTORNEY

CLASS 9—(Continued).

SN 85-346,093. 3E TECHNOLOGIES INTERNATIONAL, INC., ROCKVILLE, MD. FILED 6-14-2011.

SensorEverywhere

THE MARK CONSISTS OF STANDARD CHARACTERS WITHOUT CLAIM TO ANY PARTICULAR FONT, STYLE, SIZE, OR COLOR.

FOR AN ECOSYSTEM OF NETWORKED SENSORS FOR DATA ENABLED BY MESH NODES THAT DELIVER SENSOR DATA OVER A SERVICES ORIENTED ARCHITECTURE (SOA) FRAMEWORK USING MESH-ENABLED MULTI-SENSOR NODES TO FORM A NETWORK SYSTEM COMPRISED OF HARDWARE, SOFTWARE, FIRMWARE AND EQUIPMENT FOR COMMUNICATIONS INFRASTRUCTURE, NAMELY, COMMUNICATIONS SERVERS, DATA ARCHIVES, MULTIPOINT CONTROL UNITS, SWITCHES, MIXERS, GATEWAYS, NAMELY, NETWORK NODES EQUIPPED FOR INTERFACING WITH EACH OTHER (U.S. CLS. 21, 23, 26, 36 AND 38).

MARK RADEMÄCHER, EXAMINING ATTORNEY

SN 85-347,429. PROPHOTOSYNTHETICS INC., GRAND FORKS, ND. FILED 6-15-2011.

PROPHOTOSYNTHETICS

THE MARK CONSISTS OF STANDARD CHARACTERS WITHOUT CLAIM TO ANY PARTICULAR FONT, STYLE, SIZE, OR COLOR.

FOR ALGAE PROPAGATORS, NAMELY, BIOREACTORS FOR CELL CULTURING FOR GROWING ALGAE (U.S. CLS. 21, 23, 26, 36 AND 38).

HAI-LY LAM, EXAMINING ATTORNEY

SN 85-347,547. SOURCE TECHNOLOGIES, LLC, CHARLOTTE, NC. FILED 6-16-2011.

IPEMC2

THE MARK CONSISTS OF STANDARD CHARACTERS WITHOUT CLAIM TO ANY PARTICULAR FONT, STYLE, SIZE, OR COLOR.

FOR BAR CODE LABEL PRINTERS; BAR CODE THERMAL PRINTERS AND PRINT HEADS FOR PRINTERS (U.S. CLS. 21, 23, 26, 36 AND 38).

MEGHAN REINHART, EXAMINING ATTORNEY

CLASS 9—(Continued).

SN 85-347,551. SOURCE TECHNOLOGIES, LLC, CHARLOTTE, NC. FILED 6-16-2011.

ipEMC²

THE MARK CONSISTS OF THE STYLIZED LETTERING "IPEMC" WITH A SUPERSCRIPIT NUMBER "2" APPEARING IMMEDIATELY AFTER THE "C".

FOR BAR CODE LABEL PRINTERS; BAR CODE THERMAL PRINTERS AND PRINT HEADS FOR PRINTERS (U.S. CLS. 21, 23, 26, 36 AND 38).

MEGHAN REINHART, EXAMINING ATTORNEY

SN 85-349,767. MORBITOR CORPORATION, SAN RAMON, CA. FILED 6-17-2011.

MOBITOR

THE MARK CONSISTS OF STANDARD CHARACTERS WITHOUT CLAIM TO ANY PARTICULAR FONT, STYLE, SIZE, OR COLOR.

FOR SOFTWARE FOR FACILITATING REMOTE ACCESS BY BUSINESS PROFESSIONALS TO GLOBAL COMPUTER NETWORKS AND PRIVATE NETWORKS, WITH APPLICATIONS FOR SALES, MARKETING, FINANCIAL, HUMAN RESOURCES, WORK FLOW, AND MANAGEMENT FUNCTIONS (U.S. CLS. 21, 23, 26, 36 AND 38).

FIRST USE 7-1-2001; IN COMMERCE 7-1-2001.
ALEXANDER L. POWERS, EXAMINING ATTORNEY

CLASS 9—(Continued).

SN 85-350,637. LI SHIH CHAO, KAOHSIUNG CITY 802, TAIWAN, FILED 6-20-2011.



THE MARK CONSISTS OF THE STYLIZED WORDS "LEE TELECRANE" WITH THE WORD "LEE" INSIDE A GEOMETRIC SHAPE.

FOR REMOTE CONTROL SYSTEMS FOR USE WITH CRANES, ELECTRONIC CONTROL SYSTEMS FOR CRANES, RADIO TRANSMITTERS AND RECEIVERS FOR REMOTE CONTROLS, RADIO CONTROLS, RADIO ANTENNAS, ELECTRONIC TEST EQUIPMENT, NAMELY, PRECISION TESTING EQUIPMENT FOR ELECTRONICS; ACCESSORIES IN THE NATURE OF ADD-ONS, NAMELY, THERMOCOUPLES, ELECTRONIC WIRE CABLES, ELECTRONIC WIRE PROBES, 10 CHANNEL AND 20 CHANNEL SCANNER ENCODED CARDS CONTAINING PROGRAMMING USED TO ENCODE DATA AND FOR LIFTING EQUIPMENT, PRECISION INJECTION TRANSFORMERS, SOLID STATE SIGNAL INJECTORS BEING ELECTRICITY ADAPTERS, PSRR SIGNAL INJECTORS BEING ELECTRICITY ADAPTERS, DC BIAS INJECTORS BEING ELECTRICITY ADAPTERS, PREAMPLIFIERS AND PROBE REAMPLIFIERS, ACTIVE FILTERS FOR ELECTRONIC DEVICES, ATTENUATORS, SIGNAL SPLITTERS FOR ELECTRONIC APPARATUS, DISTRIBUTION AMPLIFIERS, POWER AMPLIFIERS; COMPUTER HARDWARE, NAMELY, ELECTRONIC LOADS FOR LOADING AN ELECTRONIC CIRCUIT; REPLACEMENT PARTS FOR THE FOREGOING GOODS (U.S. CLS. 21, 23, 26, 36 AND 38).

FIRST USE 3-1-1987; IN COMMERCE 9-16-2008.
KHANH LE, EXAMINING ATTORNEY

SN 85-351,603. CRU ACQUISITION GROUP, LLC, DBA CRU-DATAPORT, VANCOUVER, WA. FILED 6-21-2011.

ECHO

THE MARK CONSISTS OF STANDARD CHARACTERS WITHOUT CLAIM TO ANY PARTICULAR FONT, STYLE, SIZE, OR COLOR.

FOR COMPUTER HARDWARE; COMPUTER PERIPHERAL DEVICES; COMPUTER HARDWARE, NAMELY, A DISTRIBUTED SYSTEM OF HARDWARE CONTROLLERS WHICH PERFORM DIAGNOSTICS AND WHICH ERASE, DUPLICATE AND VERIFY DATA ON MULTIPLE COMPUTER HARD DISK DRIVES AND SOLID STATE DRIVES AT ONE TIME (U.S. CLS. 21, 23, 26, 36 AND 38).

ANNE E. GUSTASON, EXAMINING ATTORNEY

CLASS 9—(Continued).

SN 85-351,956. WGI INNOVATIONS, LTD., GRAND PRAIRIE, TX. FILED 6-21-2011.

MHUNTER

THE MARK CONSISTS OF STANDARD CHARACTERS WITHOUT CLAIM TO ANY PARTICULAR FONT, STYLE, SIZE, OR COLOR.

FOR COMPUTER APPLICATION SOFTWARE FOR PORTABLE AND HANDHELD DIGITAL ELECTRONIC DEVICES, NAMELY, SOFTWARE FOR MAPPING LOCATIONS, RECORDING INFORMATION, TRACKING WEATHER, FINDING LOCATIONS USING A COMPASS AND SENDING MESSAGES (U.S. CLS. 21, 23, 26, 36 AND 38).

JENNY PARK, EXAMINING ATTORNEY

SN 85-351,969. WGI INNOVATIONS, LTD., GRAND PRAIRIE, TX. FILED 6-21-2011.

MBABY

THE MARK CONSISTS OF STANDARD CHARACTERS WITHOUT CLAIM TO ANY PARTICULAR FONT, STYLE, SIZE, OR COLOR.

FOR COMPUTER APPLICATION SOFTWARE FOR PORTABLE AND HANDHELD DIGITAL ELECTRONIC DEVICES, NAMELY, SOFTWARE FOR VIEWING AND RECORDING ACTIVITY AT A REMOTE LOCATION OVER A COMPUTER NETWORK (U.S. CLS. 21, 23, 26, 36 AND 38).

JENNY PARK, EXAMINING ATTORNEY

SN 85-351,974. WGI INNOVATIONS, LTD., GRAND PRAIRIE, TX. FILED 6-21-2011.

MSECURELINK

THE MARK CONSISTS OF STANDARD CHARACTERS WITHOUT CLAIM TO ANY PARTICULAR FONT, STYLE, SIZE, OR COLOR.

FOR COMPUTER APPLICATION SOFTWARE FOR PORTABLE AND HANDHELD DIGITAL ELECTRONIC DEVICES, NAMELY, SOFTWARE FOR VIEWING AND RECORDING ACTIVITY AT A REMOTE LOCATION OVER A COMPUTER NETWORK (U.S. CLS. 21, 23, 26, 36 AND 38).

JENNY PARK, EXAMINING ATTORNEY

CLASS 9—(Continued).

SN 85-352,389. MPURA, INC., FREMONT, CA. FILED 6-22-2011.

mLottery

THE MARK CONSISTS OF STANDARD CHARACTERS WITHOUT CLAIM TO ANY PARTICULAR FONT, STYLE, SIZE, OR COLOR.

FOR COMPUTER SOFTWARE AND FIRMWARE FOR GAMES OF CHANCE ON ANY COMPUTERIZED PLATFORM, INCLUDING DEDICATED GAMING CONSOLES, VIDEO BASED SLOT MACHINES, REEL BASED SLOT MACHINES, AND VIDEO LOTTERY TERMINALS (U.S. CLS. 21, 23, 26, 36 AND 38).

FIRST USE 2-0-2009; IN COMMERCE 2-0-2009.

ALYSSA STEEL, EXAMINING ATTORNEY

SN 85-353,222. GNJ MANUFACTURING INC., HALLANDALE BEACH, FL. FILED 6-22-2011.

CELLALLURE

THE MARK CONSISTS OF STANDARD CHARACTERS WITHOUT CLAIM TO ANY PARTICULAR FONT, STYLE, SIZE, OR COLOR.

OWNER OF U.S. REG. NO. 3,663,701.

FOR CELL PHONE ACCESSORIES, NAMELY, CHARMS, HAND STRAPS, NECK STRAPS, PROTECTIVE CASES, FITTED PLASTIC FILMS KNOWN AS SKINS FOR COVERING AND PROTECTING CELL PHONES, FACE PLATES, RETRACTABLE CLIPS, EAR BUDS, HEAD PHONES, BATTERY CHARGERS, CRYSTAL CLINGING CASES, HOLDERS, ARM BANDS STRAPS, SOCK-LIKE PROTECTIVE CASES, EARPHONES, POUCHES, LAPTOP CASES, MOUSE PADS, COMPUTER MICE, COMPUTER KEYBOARDS, CD CASES, GPS CASES, AND DIGITAL MUSIC PLAYER CASES (U.S. CLS. 21, 23, 26, 36 AND 38).

FIRST USE 11-14-2008; IN COMMERCE 11-14-2008.

REBECCA GILBERT, EXAMINING ATTORNEY

CLASS 9—(Continued).

SN 85-353,586. TRACER TAGS, INC., WOODLAND HILLS, CA. FILED 6-22-2011.



NO CLAIM IS MADE TO THE EXCLUSIVE RIGHT TO USE "TAGS", APART FROM THE MARK AS SHOWN.

THE MARK CONSISTS OF A CIRCULAR DESIGN WITH A POINTED ARROW FOLLOWED BY THE WORDS "TRACER TAGS" FOLLOWED BY THE WORDS "TAG IT", A CIRCULAR DESIGN WITH A POINTED ARROW FOLLOWED BY THE WORDS "GET IT BACK".

SEC. 2(F).
FOR ASSET RETRIEVAL SYSTEM COMPRISED OF TAGS FOR GOODS AND PRODUCTS (U.S. CLS. 21, 23, 26, 36 AND 38).

FIRST USE 3-15-2001; IN COMMERCE 7-30-2001.
SAMUEL E. SHARPER JR., EXAMINING ATTORNEY

CLASS 9—(Continued).

SN 85-354,923. PARATEK MICROWAVE, INC., NASHUA, NH. FILED 6-24-2011.



THE MARK CONSISTS OF STANDARD CHARACTERS WITHOUT CLAIM TO ANY PARTICULAR FONT, STYLE, SIZE, OR COLOR.

FOR ADAPTIVE COMPUTER PROGRAMS USED FOR CONTROLLING AND MANAGING TUNING OF ANTENNAS IN MOBILE COMMUNICATION DEVICES; ADAPTIVE SYSTEM COMPUTER SOFTWARE USED FOR CONTROLLING AND MANAGING RADIO FREQUENCY TUNING OF ANTENNAS IN A CELLULAR PHONE (U.S. CLS. 21, 23, 26, 36 AND 38).
DAVID YONTEF, EXAMINING ATTORNEY

SN 85-353,890. ZEAL OPTICS, INC., BOULDER, CO. FILED 6-23-2011.



OWNER OF U.S. REG. NO. 3,361,977.
THE MARK CONSISTS OF THE STYLIZED LETTER "Z". FOR SUNGLASSES AND SPORTS EYEWEAR (U.S. CLS. 21, 23, 26, 36 AND 38).
JAMES STEIN, EXAMINING ATTORNEY

SN 85-355,434. WAGNER, STEPHEN D., BAKERSFIELD, CA. FILED 6-24-2011.



THE MARK CONSISTS OF STANDARD CHARACTERS WITHOUT CLAIM TO ANY PARTICULAR FONT, STYLE, SIZE, OR COLOR.

FOR COMPUTER SOFTWARE FOR THE COLLECTION, EDITING, ORGANIZING, MODIFYING, BOOK MARKING, TRANSMISSION, STORAGE AND SHARING OF DATA AND INFORMATION (U.S. CLS. 21, 23, 26, 36 AND 38).

FIRST USE 10-20-1999; IN COMMERCE 10-20-1999.
MICHAEL WIENER, EXAMINING ATTORNEY

SN 85-355,675. INTELLIBOT ROBOTICS LLC, PORTLAND, OR. FILED 6-24-2011.

SN 85-354,850. COPPER BEECH VENTURES LLC, NEW CANAAN, CT. FILED 6-23-2011.



THE MARK CONSISTS OF STANDARD CHARACTERS WITHOUT CLAIM TO ANY PARTICULAR FONT, STYLE, SIZE, OR COLOR.

FOR STANDALONE HANDHELD PERSONAL COMPUTERS FOR STORING PERSONAL INFORMATION (U.S. CLS. 21, 23, 26, 36 AND 38).

TEJBIR SINGH, EXAMINING ATTORNEY



THE MARK CONSISTS OF STANDARD CHARACTERS WITHOUT CLAIM TO ANY PARTICULAR FONT, STYLE, SIZE, OR COLOR.

NO CLAIM IS MADE TO THE EXCLUSIVE RIGHT TO USE "TECHNOLOGY", APART FROM THE MARK AS SHOWN.

FOR COMPUTER SOFTWARE FOR THE CONTROL AND OPERATION OF AUTOMATIC MACHINES, NAMELY, AUTOMATIC FLOOR SCRUBBERS, VACUUM CLEANERS, AND INDUSTRIAL ROBOTS IN THE FIELD OF INTERIOR MAINTENANCE OF INDUSTRIAL AND COMMERCIAL BUILDINGS (U.S. CLS. 21, 23, 26, 36 AND 38).

FIRST USE 5-26-2011; IN COMMERCE 5-26-2011.
SHANNON TWOHIG, EXAMINING ATTORNEY

CLASS 9—(Continued).

SN 85-355,749. PREPIT PTY LTD AS TRUSTEE FOR PREPIT UNIT TRUST, BUDERIM, QUEENSLAND, AUSTRALIA, FILED 6-24-2011.

COMWRITER

THE MARK CONSISTS OF STANDARD CHARACTERS WITHOUT CLAIM TO ANY PARTICULAR FONT, STYLE, SIZE, OR COLOR.

PRIORITY CLAIMED UNDER SEC. 44(D) ON AUSTRALIA APPLICATION NO. 1431208, FILED 6-16-2011, REG. NO. 1431208, DATED 3-1-2012, EXPIRES 6-16-2021.

FOR COMPUTER SOFTWARE AND PROGRAMS FOR WORD PROCESSING; COMPUTER SOFTWARE AND PROGRAMS FOR ELECTRONICALLY CREATING, WRITING AND EDITING TEXT AND IMAGE COMPOSITIONS; COMPUTER SOFTWARE AND PROGRAMS FOR DOCUMENT FORMATTING; COMPUTER SOFTWARE AND PROGRAMS FOR CREATING DOCUMENT TEMPLATES; AND INSTRUCTION MANUALS FOR COMPUTER PROGRAMS AND SOFTWARE SOLD AS A UNIT WITH THE AFORESAID COMPUTER SOFTWARE AND PROGRAMS (U.S. CLS. 21, 23, 26, 36 AND 38).

JULIE WATSON, EXAMINING ATTORNEY

SN 85-355,894. GEOTAB INC., OAKVILLE, ONTARIO, CANADA, FILED 6-24-2011.

CHECKMATE

THE MARK CONSISTS OF STANDARD CHARACTERS WITHOUT CLAIM TO ANY PARTICULAR FONT, STYLE, SIZE, OR COLOR.

PRIORITY CLAIMED UNDER SEC. 44(D) ON CANADA APPLICATION NO. 1517689, FILED 3-4-2011, REG. NO. TMA819,299, DATED 3-7-2012, EXPIRES 3-7-2027.

FOR GPS FLEET MANAGEMENT SOFTWARE FOR VEHICLE TRACKING AND MONITORING (U.S. CLS. 21, 23, 26, 36 AND 38).

FIRST USE 0-0-2002; IN COMMERCE 0-0-2002.
SUSAN RICHARDS, EXAMINING ATTORNEY

CLASS 9—(Continued).

SN 85-357,293. SONY CORPORATION, TOKYO, JAPAN, FILED 6-27-2011.

wonderfully simple.

THE MARK CONSISTS OF STANDARD CHARACTERS WITHOUT CLAIM TO ANY PARTICULAR FONT, STYLE, SIZE, OR COLOR.

PRIORITY CLAIMED UNDER SEC. 44(D) ON JAPAN APPLICATION NO. 2010101368, FILED 12-28-2010, REG. NO. 5422001, DATED 7-1-2011, EXPIRES 7-1-2021.

FOR HIGH DEFINITION CAMERAS; VIDEO CAMERAS; DIGITAL STILL CAMERAS (U.S. CLS. 21, 23, 26, 36 AND 38).

BRIAN PINO, EXAMINING ATTORNEY

SN 85-358,202. MEDQUIST IP LLC, FRANKLIN, TN. FILED 6-28-2011.

MEDQUIST DOCQMANAGE

THE MARK CONSISTS OF STANDARD CHARACTERS WITHOUT CLAIM TO ANY PARTICULAR FONT, STYLE, SIZE, OR COLOR.

OWNER OF U.S. REG. NOS. 2,371,334 AND 2,915,575.

FOR DOWNLOADABLE COMPUTER SOFTWARE FOR USE IN WORKFLOW MANAGEMENT AND DATA MANAGEMENT, INTEGRATING DICTATION, TRANSCRIPTION, SPEECH RECOGNITION, AND DELIVERY AND RETRIEVAL OF HEALTH RELATED RECORDS AND REPORTS FOR USE IN THE HEALTH CARE FIELD (U.S. CLS. 21, 23, 26, 36 AND 38).

KATHERINE STOIDES, EXAMINING ATTORNEY

SN 85-358,220. MEDQUIST IP LLC, FRANKLIN, TN. FILED 6-28-2011.

DOCQDIRECT

THE MARK CONSISTS OF STANDARD CHARACTERS WITHOUT CLAIM TO ANY PARTICULAR FONT, STYLE, SIZE, OR COLOR.

FOR DOWNLOADABLE COMPUTER SOFTWARE FOR USE IN WORKFLOW MANAGEMENT AND DATA MANAGEMENT, INTEGRATING DICTATION, TRANSCRIPTION, SPEECH RECOGNITION, AND DELIVERY AND RETRIEVAL OF HEALTH RELATED RECORDS AND REPORTS FOR USE IN THE HEALTH CARE FIELD (U.S. CLS. 21, 23, 26, 36 AND 38).

KATHERINE STOIDES, EXAMINING ATTORNEY

CLASS 9—(Continued).

SN 85-358,228. MEDQUIST IP LLC, FRANKLIN, TN. FILED 6-28-2011.

DOCQLYTICS

THE MARK CONSISTS OF STANDARD CHARACTERS WITHOUT CLAIM TO ANY PARTICULAR FONT, STYLE, SIZE, OR COLOR.

FOR DOWNLOADABLE COMPUTER SOFTWARE FOR USE IN WORKFLOW MANAGEMENT AND DATA MANAGEMENT, INTEGRATING DICTATION, TRANSCRIPTION, SPEECH RECOGNITION, AND DELIVERY AND RETRIEVAL OF HEALTH RELATED RECORDS AND REPORTS FOR USE IN THE HEALTH CARE FIELD (U.S. CLS. 21, 23, 26, 36 AND 38).

KATHERINE STOIDES, EXAMINING ATTORNEY

SN 85-358,238. MEDQUIST IP LLC, FRANKLIN, TN. FILED 6-28-2011.

MEDQUIST DOCQCODE

THE MARK CONSISTS OF STANDARD CHARACTERS WITHOUT CLAIM TO ANY PARTICULAR FONT, STYLE, SIZE, OR COLOR.

OWNER OF U.S. REG. NOS. 2,371,334 AND 2,915,575.
FOR DOWNLOADABLE COMPUTER SOFTWARE FOR USE IN WORKFLOW MANAGEMENT AND DATA MANAGEMENT, INTEGRATING DICTATION, TRANSCRIPTION, SPEECH RECOGNITION, AND DELIVERY AND RETRIEVAL OF HEALTH RELATED RECORDS AND REPORTS FOR USE IN THE HEALTH CARE FIELD (U.S. CLS. 21, 23, 26, 36 AND 38).

KATHERINE STOIDES, EXAMINING ATTORNEY

SN 85-359,343. FAUSTIN BROS S.A., (1638) BUENOS AIRES, ARGENTINA, FILED 6-29-2011.

THE DARK SIDE OF CARTOONS

THE MARK CONSISTS OF STANDARD CHARACTERS WITHOUT CLAIM TO ANY PARTICULAR FONT, STYLE, SIZE, OR COLOR.

NO CLAIM IS MADE TO THE EXCLUSIVE RIGHT TO USE "CARTOONS", APART FROM THE MARK AS SHOWN.

FOR ELECTRONICS, NAMELY, COMPUTER GAME CONSOLES FOR USE WITH AN EXTERNAL DISPLAY SCREEN, COMPUTER GAME CARTRIDGES, COMPUTER GAME HARDWARE, NAMELY, COMPUTER HARDWARE FOR USE WITH COMPUTER GAMES, GAME CONTROLLERS FOR COMPUTER GAMES, COMPUTER GAME SOFTWARE (U.S. CLS. 21, 23, 26, 36 AND 38).

EVELYN BRADLEY, EXAMINING ATTORNEY

CLASS 9—(Continued).

SN 85-359,592. SUVOLTA, INC., LOS GATOS, CA. FILED 6-29-2011.

THE MARK CONSISTS OF THE TERM "SUVOLTA" IN A STYLIZED FONT, WITH AN ARC APPEARING OVER THE MARK.

FOR SEMICONDUCTOR COMPONENTS, NAMELY, SEMICONDUCTOR CHIPS, INTEGRATED CIRCUITS, AND TRANSISTORS THAT ENABLE REDUCED POWER CONSUMPTION (U.S. CLS. 21, 23, 26, 36 AND 38).

DEIRDRE ROBERTSON, EXAMINING ATTORNEY

SN 85-360,319. JUNIPER NETWORKS, INC., SUNNYVALE, CA. FILED 6-30-2011.

CONVERGED SUPERCORE

THE MARK CONSISTS OF STANDARD CHARACTERS WITHOUT CLAIM TO ANY PARTICULAR FONT, STYLE, SIZE, OR COLOR.

FOR COMPUTER HARDWARE AND SOFTWARE, USED ALONE OR IN COMBINATION, FOR INTERCONNECTING, ESTABLISHING, MANAGING, SECURING, MONITORING, CONTROLLING, OPERATING, AND ACCESSING LOCAL, WIDE, AND GLOBAL AREA NETWORKS; COMPUTER HARDWARE AND SOFTWARE, USED ALONE OR IN COMBINATION, FOR ROUTING, SWITCHING, TRANSMITTING, TRANSPORTING, PROCESSING, FILTERING, ANALYZING, SECURING, AND STORING DATA, VIDEO OR VOICE TRAFFIC, PACKETS, OR OTHER FORMS OF COMMUNICATIONS (U.S. CLS. 21, 23, 26, 36 AND 38).

ELLEN B. AWRICH, EXAMINING ATTORNEY

CLASS 9—(Continued).

SN 85-360,448. ONELOUDER APPS, INC., KANSAS CITY, MO. FILED 6-30-2011.

SPORTCASTER

THE MARK CONSISTS OF STANDARD CHARACTERS WITHOUT CLAIM TO ANY PARTICULAR FONT, STYLE, SIZE, OR COLOR.

FOR SOFTWARE AND DOWNLOADABLE SOFTWARE IN THE NATURE OF MOBILE APPLICATIONS FOR USE WITH SMART PHONES, PDA DEVICES, TABLET COMPUTERS AND OTHER PORTABLE HANDHELD DIGITAL ELECTRONIC DEVICES, FEATURING THE ACCESS, DELIVERY AND UTILIZATION OF INFORMATION IN THE FIELD OF ATHLETIC EVENTS, INCLUDING REAL-TIME DELIVERY OF ATHLETIC EVENT INFORMATION THROUGH ONLINE AND MOBILE DISTRIBUTION CHANNELS, INCLUDING INFORMATION ON ATHLETES, SPORTING EVENTS, SCORES AND OTHER DATA RELATED THERETO; SOFTWARE AND DOWNLOADABLE SOFTWARE FOR WIRELESS AGGREGATION AND CONTENT DELIVERY; COMPUTER APPLICATION SOFTWARE FOR USE WITH SMART PHONES, PDA DEVICES, TABLET COMPUTERS AND OTHER PORTABLE HANDHELD DIGITAL ELECTRONIC COMMUNICATION DEVICES, NAMELY, SOFTWARE FOR ACCESSING, VIEWING, INTERACTING WITH AND DOWNLOADING ATHLETIC EVENT INFORMATION AND RELATED CONTENT FROM WEBSITES, SMART PHONES, PDA DEVICES, TABLET COMPUTERS AND OTHER PORTABLE HANDHELD DIGITAL ELECTRONIC COMMUNICATION DEVICES RELATED TO REAL-TIME DELIVERY OF DATA, MESSAGES, IMAGES, PHOTOGRAPHS, DOCUMENTS, TEXT AND OTHER DATA RELATED THERETO, INCLUDING TRANSMISSION OF ELECTRONIC CONTENT IN THE NATURE OF MESSAGES IMAGES, PHOTOGRAPHS, DOCUMENTS, TEXT AND OTHER DATA (U.S. CLS. 21, 23, 26, 36 AND 38).

STEVEN JACKSON, EXAMINING ATTORNEY

SN 85-360,958. NEXANT, INC., SAN FRANCISCO, CA. FILED 6-30-2011.

TradeAlly

THE MARK CONSISTS OF THE WORD "TRADEALLY" WITH A CAPITAL LETTER "T" AND CAPITAL LETTER "A".

FOR COMPUTER SOFTWARE TO ENABLE ENERGY USERS TO IDENTIFY AND SELECT ENERGY EFFICIENCY CONTRACTORS (U.S. CLS. 21, 23, 26, 36 AND 38).

TINA MAI, EXAMINING ATTORNEY

CLASS 9—(Continued).

SN 85-361,150. YAMASA TOKEI CO., LTD., TOKYO, JAPAN, FILED 6-30-2011.

YAMAX

THE MARK CONSISTS OF STANDARD CHARACTERS WITHOUT CLAIM TO ANY PARTICULAR FONT, STYLE, SIZE, OR COLOR.

FOR Pedometers; Pedometers with multiple functions; Calorie consumption activity meters (U.S. CLS. 21, 23, 26, 36 AND 38).

FIRST USE 12-31-1987; IN COMMERCE 12-31-1992.
THEODORE MCBRIDE, EXAMINING ATTORNEY

SN 85-361,905. ISPRING SOLUTIONS, INC., ALEXANDRIA, VA. FILED 7-1-2011.

CodeDrive

THE MARK CONSISTS OF STANDARD CHARACTERS WITHOUT CLAIM TO ANY PARTICULAR FONT, STYLE, SIZE, OR COLOR.

FOR COMPUTER SOFTWARE FOR USE IN SOFTWARE CODE DEVELOPMENT, DOWNLOADABLE COMPUTER SOFTWARE FOR USE IN SOFTWARE CODE DEVELOPMENT AND DOWNLOADABLE COMPUTER SOFTWARE DEVELOPER TOOLS FOR USE IN SOFTWARE CODE DEVELOPMENT AND FOR CREATION OF RICH INTERNET APPLICATIONS (RIA) (U.S. CLS. 21, 23, 26, 36 AND 38).

FIRST USE 4-12-2011; IN COMMERCE 4-12-2011.
CARYN GLASSER, EXAMINING ATTORNEY

SN 85-361,961. BENSUSSEN DEUTSCH & ASSOCIATES, INC., WOODINVILLE, WA. FILED 7-1-2011.

SILICONEHOLLOWPOINTS

THE MARK CONSISTS OF STANDARD CHARACTERS WITHOUT CLAIM TO ANY PARTICULAR FONT, STYLE, SIZE, OR COLOR.

FOR EAR PLUGS NOT FOR MEDICAL PURPOSES; EARPHONE ACCESSORIES, NAMELY, EARPHONE CUSHIONS, EARPHONE PADS, CORD MANAGEMENT SYSTEMS, EARPHONE CASES, AND EARPHONE EXTENSION CORDS; EARPHONES; HEADPHONES; HEARING PROTECTION HEADSETS, NOT FOR MEDICAL USE; PROTECTIVE EAR COVERINGS (U.S. CLS. 21, 23, 26, 36 AND 38).

DAVID ELTON, EXAMINING ATTORNEY

CLASS 9—(Continued).

SN 85-362,675. D&M HOLDINGS, INC., KANAGAWA, JAPAN, FILED 7-4-2011.



THE MARK CONSISTS OF A HEADSET HAVING THREE VERTICAL LINES THEREIN, WHERE A FIRST VERTICAL LINE AND A SECOND VERTICAL LINE ARE EQUALLY SIZED AND PARALLEL, WITH THE THIRD VERTICAL LINE BEING LOCATED BETWEEN THE FIRST AND SECOND EQUALLY SIZED AND PARALLEL LINES, AND WHEREIN THE THIRD LINE IS POSITIONED SLIGHTLY HIGHER THAN THE FIRST LINE AND THE SECOND LINE.

FOR HEADPHONES; EARPHONES; APPARATUS FOR RECORDING, TRANSMISSION OR REPRODUCTION OF SOUND OR IMAGES; DATA PROCESSING EQUIPMENT AND COMPUTERS; AMPLIFIERS; AUDIO RECEIVERS; AUDIO DISC PLAYERS; AUDIO DISC RECORDERS; AUDIO TAPE PLAYERS; AUDIO TAPE RECORDERS; VIDEO DISC PLAYERS; VIDEO DISC RECORDERS; VIDEO TAPE PLAYERS; VIDEO TAPE RECORDERS; LOUDSPEAKERS; HIGH DENSITY DISC (HDD) PLAYERS; HIGH DENSITY DISC (HDD) RECORDERS; INTEGRATED CIRCUIT (IC) MEMORY PLAYERS; INTEGRATED CIRCUIT (IC) MEMORY RECORDERS; SOLID STATE AND FLASH MEMORY PLAYERS AND RECORDERS; CD PLAYERS; CD RECORDERS; DVD PLAYERS; DVD RECORDERS; TELEVISION RECEIVERS; RADIO RECEIVERS; RADIO TRANSMITTERS; ACCESSORIES FOR AUDIO APPARATUS AND VIDEO APPARATUS, NAMELY, STRAPS AND CARRYING CASES; COMPUTERS; ACCESSORIES FOR COMPUTERS, NAMELY, CARRYING CASES; COMPUTER SOFTWARE PROGRAMS FOR OPERATING MOBILE PHONES AND PORTABLE DATA ASSISTANTS; COMPUTER SOFTWARE PROGRAMS FOR OPERATING AUDIO APPARATUS AND VIDEO APPARATUS (U.S. CLS. 21, 23, 26, 36 AND 38).

JAMES GRIFFIN, EXAMINING ATTORNEY

SN 85-363,415. NEWINTENTIONS, LLC, NASHVILLE, TN. FILED 7-5-2011.

NewIntentions

THE MARK CONSISTS OF STANDARD CHARACTERS WITHOUT CLAIM TO ANY PARTICULAR FONT, STYLE, SIZE, OR COLOR.

FOR COMPACT DISCS FEATURING MUSIC; DOWNLOADABLE MUSICAL SOUND RECORDINGS; MUSICAL SOUND RECORDINGS (U.S. CLS. 21, 23, 26, 36 AND 38).

JACLYN KIDWELL WALKER, EXAMINING ATTORNEY

CLASS 9—(Continued).

SN 85-363,430. MONSTER CABLE PRODUCTS, INC., BRISBANE, CA. FILED 7-5-2011.

AXIS

THE MARK CONSISTS OF STANDARD CHARACTERS WITHOUT CLAIM TO ANY PARTICULAR FONT, STYLE, SIZE, OR COLOR.

FOR AUDIO SPEAKERS; HEADPHONES (U.S. CLS. 21, 23, 26, 36 AND 38).

SAMUEL E. SHARPER JR., EXAMINING ATTORNEY

SN 85-363,445. MONSTER CABLE PRODUCTS, INC., BRISBANE, CA. FILED 7-5-2011.

SPECTRUM

THE MARK CONSISTS OF STANDARD CHARACTERS WITHOUT CLAIM TO ANY PARTICULAR FONT, STYLE, SIZE, OR COLOR.

FOR AUDIO SPEAKERS; HEADPHONES (U.S. CLS. 21, 23, 26, 36 AND 38).

SAMUEL E. SHARPER JR., EXAMINING ATTORNEY

SN 85-364,408. WILSON, BRIAN, DBA VISUAL HORIZONS SOFTWARE, LLC, MIAMI BEACH, FL. FILED 7-6-2011.

ConsignPro

THE MARK CONSISTS OF STANDARD CHARACTERS WITHOUT CLAIM TO ANY PARTICULAR FONT, STYLE, SIZE, OR COLOR.

FOR COMPUTER APPLICATION SOFTWARE FOR COMPUTERS, NAMELY, SOFTWARE FOR INVENTORY MANAGEMENT OF RESALE AND CONSIGNMENT SHOPS (U.S. CLS. 21, 23, 26, 36 AND 38).

FIRST USE 1-1-1996; IN COMMERCE 1-1-1997.

TEJBIR SINGH, EXAMINING ATTORNEY

CLASS 9—(Continued).

SN 85-364,409. THE SINGING MACHINE COMPANY, INC., COCONUT CREEK, FL. FILED 7-6-2011.



OWNER OF U.S. REG. NO. 2,478,193.

NO CLAIM IS MADE TO THE EXCLUSIVE RIGHT TO USE "SINGING MACHINE", APART FROM THE MARK AS SHOWN.

THE COLOR(S) BLUE, WHITE AND GREY IS/ARE CLAIMED AS A FEATURE OF THE MARK.

THE MARK CONSISTS OF A RECTANGLE DEFINED BY AN OUTER GREY BORDER WITH AN INNER WHITE BORDER. THE LITERAL ELEMENTS ARE POSITIONED IN A STACKED CONFIGURATION WHERE "THE" IS ON TOP AND IN GREY, THE "SINGING MACHINE" ARE IN WHITE WHERE THE LEG OF THE "H" IN "MACHINE" AND IS ALSO THE "I" IN "SINGING" IS MADE UP OF A MICROPHONE ON A STAND.

FOR KARAOKE PLAYERS FOR HOME AND COMMERCIAL USE; KARAOKE SYSTEMS FOR HOME AND COMMERCIAL USE AND PROFESSIONAL AND SEMI-PROFESSIONAL KARAOKE SYSTEMS COMPRISING DISPLAY MONITORS, BUILT IN SPEAKERS, EXTERNAL SPEAKERS, DISC AND/OR CASSETTE PLAYERS HAVING AMPLIFIERS WITH SPEAKER VOLUME CONTROL AND MICROPHONE VOLUME CONTROL AND RADIOS; AND EXTERNAL VIDEO CAMERAS; ACCESSORIES FOR KARAOKE SYSTEMS, NAMELY WIRED AND WIRELESS MICROPHONES; WIRED AND WIRELESS HEAD SET MICROPHONES; POWER CORDS; REMOTE CONTROLS FOR KARAOKE PLAYERS AND RCA CONNECTION CORDS; MUSIC FOR USE WITH KARAOKE SYSTEMS AND PLAYERS RECORDED ON CASSETTE, COMPACT DISC (CD), COMPACT DISC WITH GRAPHIC (CD+G), DIGITAL VERSATILE DISC (DVD), HIGH DEFINITION DIGITAL VERSATILE DISC, HIGH CAPACITY MAGNETO-OPTICAL DISCS, USB MEMORY KEYS, AND OTHER SIMILAR RECORDABLE MEDIA, SPECIFICALLY, PRE-RECORDED DIGITAL AND ELECTRONIC MEDIA; SOFTWARE FOR PLAYING KARAOKE MUSIC AND ENABLING KARAOKE SERVICES, NAMELY SCROLLING LYRICS AND MICROPHONES FOR SINGING ALONG TO THE MUSIC PROVIDED VIA SMART PHONE APPLICATIONS; SOFTWARE ENABLING DIGITAL DOWNLOADS OF KARAOKE MUSIC (U.S. CLS. 21, 23, 26, 36 AND 38).

FIRST USE 9-1-2009; IN COMMERCE 9-1-2009.

MARK SHINER, EXAMINING ATTORNEY

CLASS 9—(Continued).

SN 85-366,048. DESTINEER STUDIOS, INC., MINNETONKA, MN. FILED 7-7-2011.

SIX DAYS IN FALLUJAH

THE MARK CONSISTS OF STANDARD CHARACTERS WITHOUT CLAIM TO ANY PARTICULAR FONT, STYLE, SIZE, OR COLOR.

FOR COMPUTER GAME SOFTWARE FOR USE WITH PERSONAL COMPUTERS AND VIDEO GAME CONSOLES; DOWNLOADABLE COMPUTER GAME SOFTWARE FOR USE WITH CABLE AND SATELLITE ACCESSIBLE VIDEO CONTROLLERS AND PORTABLE VIDEO DISPLAYS (U.S. CLS. 21, 23, 26, 36 AND 38).

ANDREA HACK, EXAMINING ATTORNEY

SN 85-366,522. WAVECOR LTD., GUANGZHOU, GUANGDONG, CHINA, FILED 7-8-2011.



THE COLOR(S) BLUE IS/ARE CLAIMED AS A FEATURE OF THE MARK.

THE MARK CONSISTS OF "WAVECOR" IN STYLIZED TEXT WITH A STYLIZED WAVE DESIGN OVER THE LETTER "V", ALL IN BLUE.

FOR LOUDSPEAKER COMPONENTS FOR USE BY ORIGINAL EQUIPMENT MANUFACTURERS, NAMELY, LOUDSPEAKER DRIVE UNITS, LOUDSPEAKER CROSSOVERS, LOUDSPEAKER ENCLOSURES, LOUDSPEAKER CONNECTORS, LOUDSPEAKER BASS REFLEX PORT TUBES; LOUDSPEAKER CABINETS FOR USE BY ORIGINAL EQUIPMENT MANUFACTURERS (U.S. CLS. 21, 23, 26, 36 AND 38).

WILLIAM JACKSON, EXAMINING ATTORNEY

CLASS 9—(Continued).

SN 85-368,051. NOHMI BOSAI LTD., CHIYODA-KU, TOKYO, JAPAN, AND KOATSU CO., LTD., HYOGO PREF., JAPAN, FILED 7-11-2011.

NN100

THE MARK CONSISTS OF STANDARD CHARACTERS WITHOUT CLAIM TO ANY PARTICULAR FONT, STYLE, SIZE, OR COLOR.

FOR FIRE-EXTINGUISHING SYSTEMS; GAS FIRE SUPPRESSION SYSTEMS AND COMPONENT PARTS THEREOF, FOR USE IN BUILDINGS, HOMES, MUSEUMS, COMPUTER ROOMS, OCCUPIED SIGNAL TRANSITION MACHINE ROOMS, FIRE PROTECTION CENTERS, CONTROL ROOMS OR OTHER ROOMS CONTAINING ELECTRONICS, MACHINERY OR OTHER SENSITIVE ITEMS, MATERIALS OR EQUIPMENT, RACING VEHICLES, ARMORED VEHICLES, MILITARY VEHICLES, COMMERCIAL VEHICLES, MARINE VEHICLES, AND AVIATION VEHICLES, COMPRISED OF CHARGED BOTTLES, CHARGE GAGES, MOUNTING BASES AND STRAPS, PULL CABLES, NOZZLES, FITTINGS, TUBING, LOCK-OUT VALVES AND SWITCHES, MANUAL CONTROL PANELS, RELEASE VALVES AND SWITCHES, AND STICKERS; FIRE EXTINGUISHERS; FIRE HYDRANTS; FIRE HOSE NOZZLES; SPRINKLER SYSTEMS FOR FIRE PROTECTION; FIRE ALARMS; GAS ALARMS; AUTOMATIC ELECTRIC CONTROL PANELS AND MANUAL CONTROL PANELS FOR USE IN WATER, BUBBLE, POWDER, GAS, CARBON DIOXIDE, NITROGEN GAS, ARGON GAS AND FLUORINE GAS FIRE EXTINGUISHING AND SUPPRESSION SYSTEMS (U.S. CLS. 21, 23, 26, 36 AND 38).

FIRST USE 12-27-2001; IN COMMERCE 5-1-2010.
TARAH HARDY, EXAMINING ATTORNEY

SN 85-370,513. SEARS BRANDS, LLC, HOFFMAN ESTATES, IL. FILED 7-13-2011.

HALOGEN

THE MARK CONSISTS OF STANDARD CHARACTERS WITHOUT CLAIM TO ANY PARTICULAR FONT, STYLE, SIZE, OR COLOR.

FOR MAGNETICALLY-ENCODED RELOADABLE STORED VALUE DEBIT CARD (U.S. CLS. 21, 23, 26, 36 AND 38).

FIRST USE 3-1-2012; IN COMMERCE 3-1-2012.
WON TEAK OH, EXAMINING ATTORNEY

CLASS 9—(Continued).

SN 85-372,374. VILLAGEVINES, DBA SAVORED, NEW YORK, NY. FILED 7-15-2011.



NO CLAIM IS MADE TO THE EXCLUSIVE RIGHT TO USE "DINING", APART FROM THE MARK AS SHOWN.

THE COLOR(S) BLACK, WHITE AND GRAY IS/ARE CLAIMED AS A FEATURE OF THE MARK.

THE MARK CONSISTS OF A WHITE BACKGROUND WITH THE WORD "SAVORED" IN BLACK TEXT ABOVE THE WORDS "UNFORGETTABLE DINING" IN GRAY.

FOR COMPUTER SOFTWARE FOR USE IN THE FIELD OF MEMBER RELATIONSHIP MANAGEMENT, MARKETING, PRODUCTIVITY MANAGEMENT AND ON-LINE DISCOUNTED RESTAURANT RESERVATIONS IN THE FOOD SERVICE INDUSTRY (U.S. CLS. 21, 23, 26, 36 AND 38).

FIRST USE 6-18-2011; IN COMMERCE 6-18-2011.
BARBARA RUTLAND, EXAMINING ATTORNEY

SN 85-374,015. EVRSafe TECHNOLOGIES PTY LTD, HACKNEY, S AUSTRALIA, AUSTRALIA, FILED 7-18-2011.



THE MARK CONSISTS OF THE WORD "EVRSafe" IN STYLIZED FORM ABOVE A WIDE BROKEN CIRCULAR DESIGN.

FOR ALARMS FOR THE DETECTION OF GASES; GAS DETECTORS FOR DETECTING THE PRESENCE OF GAS; GAS SENSORS FOR MEASURING GAS CONCENTRATION; GLOBAL POSITIONING SYSTEM (GPS); VEHICLE LOCATING AND TRACKING SYSTEM COMPRISED OF AN ANTENNA AND RADIO TRANSMITTER TO BE PLACED IN A VEHICLE; COMPUTERS AND DATA PROCESSORS FOR NAVIGATIONAL, DETECTION AND LOCATION PURPOSES; GLOBAL POSITIONING SYSTEM (GPS) BASED NAVIGATION AND LOCATION RECEIVERS; COMPUTER PROGRAMS AND SOFTWARE FOR TRACKING PEOPLE, OBJECTS AND PETS USING GPS DATA ON A DEVICE ON THE TRACKED PEOPLE, OBJECTS AND PETS (U.S. CLS. 21, 23, 26, 36 AND 38).

TEJBIR SINGH, EXAMINING ATTORNEY

CLASS 9—(Continued).

SN 85-375,208. HUAWEI TECHNOLOGIES CO., LTD., SHENZHEN, CHINA, FILED 7-19-2011.

IMPULSE 4G

THE MARK CONSISTS OF STANDARD CHARACTERS WITHOUT CLAIM TO ANY PARTICULAR FONT, STYLE, SIZE, OR COLOR.

NO CLAIM IS MADE TO THE EXCLUSIVE RIGHT TO USE "4G", APART FROM THE MARK AS SHOWN.

FOR MOBILE TELEPHONES (U.S. CLS. 21, 23, 26, 36 AND 38).

FIRST USE 9-18-2011; IN COMMERCE 9-18-2011.
ALEX KEAM, EXAMINING ATTORNEY

CLASS 9—(Continued).

SN 85-376,744. APPLE INC., CUPERTINO, CA. FILED 7-20-2011.

AIRDROP

THE MARK CONSISTS OF STANDARD CHARACTERS WITHOUT CLAIM TO ANY PARTICULAR FONT, STYLE, SIZE, OR COLOR.

PRIORITY CLAIMED UNDER SEC. 44(D) ON JAMAICA APPLICATION NO. 57316, FILED 1-24-2011.

FOR COMPUTER SOFTWARE FOR THE TRANSMISSION AND SHARING OF DATA AND INFORMATION; FILE SHARING SOFTWARE (U.S. CLS. 21, 23, 26, 36 AND 38).

KAPIL BHANOT, EXAMINING ATTORNEY

SN 85-375,893. GOLDBERG, ELLIOTT, SCARSDALE, NY. FILED 7-20-2011.

SIT N' REACH

THE MARK CONSISTS OF STANDARD CHARACTERS WITHOUT CLAIM TO ANY PARTICULAR FONT, STYLE, SIZE, OR COLOR.

SEC. 2(F).

FOR FITNESS DEVICE CONSISTING OF RECTANGULAR BOX WITH MEASURING SCALE ON TOP USED TO TEST FOR FLEXIBILITY (U.S. CLS. 21, 23, 26, 36 AND 38).

FIRST USE 1-1-2005; IN COMMERCE 1-1-2005.
JAY FLOWERS, EXAMINING ATTORNEY

SN 85-377,906. WILLARD SMITH, AS PARENT AND GUARDIAN OF WILLOW SMITH, BEVERLY HILLS, CA. FILED 7-21-2011.

WILLOW

THE NAME "WILLOW" IDENTIFIES THE STAGE NAME OF WILLOW SMITH, A LIVING INDIVIDUAL WHOSE CONSENT IS OF RECORD.

THE MARK CONSISTS OF THE SHADED, STYLIZED CAPITAL LETTERS "WILLOW".

FOR MUSICAL SOUND RECORDINGS; MUSICAL VIDEO/AUDIO RECORDINGS; DIGITAL MUSIC DOWNLOADABLE FROM THE INTERNET; PRE-RECORDED DVD'S FEATURING MUSICAL PERFORMANCES (U.S. CLS. 21, 23, 26, 36 AND 38).

FIRST USE 10-26-2010; IN COMMERCE 10-26-2010.
HOWARD B. LEVINE, EXAMINING ATTORNEY

SN 85-376,381. BYRNE ELECTRICAL SPECIALIST, INC., ROCKFORD, MI. FILED 7-20-2011.

FOOTBRIDGE

THE MARK CONSISTS OF STANDARD CHARACTERS WITHOUT CLAIM TO ANY PARTICULAR FONT, STYLE, SIZE, OR COLOR.

FOR WIRING SYSTEMS FOR OVER-FLOOR POWER AND DATA DISTRIBUTION COMPOSED OF ELECTRICAL WIRING IN PROTECTIVE COVERING; POWER AND DATA DISTRIBUTION SYSTEMS COMPOSED OF ELECTRICAL WIRING IN A PROTECTIVE COVERING (U.S. CLS. 21, 23, 26, 36 AND 38).

FIRST USE 12-1-2011; IN COMMERCE 12-1-2011.
MARK T. MULLEN, EXAMINING ATTORNEY

SN 85-377,911. SADDLEBACK EDUCATIONAL, INC., COSTA MESA, CA. FILED 7-21-2011.

THE HEIGHTS

THE MARK CONSISTS OF STANDARD CHARACTERS WITHOUT CLAIM TO ANY PARTICULAR FONT, STYLE, SIZE, OR COLOR.

FOR DOWNLOADABLE ELECTRONIC PUBLICATIONS, IN THE NATURE OF ELECTRONIC BOOKS IN THE FIELD OF REMEDIAL EDUCATION FOR SECONDARY AND ADULT EDUCATION (U.S. CLS. 21, 23, 26, 36 AND 38).

JULIE GUTTADAURO, EXAMINING ATTORNEY

CLASS 9—(Continued).

SN 85-378,773. DIVERSIFIED CLINICAL SERVICES, INC., JACKSONVILLE, FL. FILED 7-22-2011.

WoundStar

THE MARK CONSISTS OF STANDARD CHARACTERS WITHOUT CLAIM TO ANY PARTICULAR FONT, STYLE, SIZE, OR COLOR.

FOR AN INTEGRATED SUITE OF TECHNOLOGY SOLUTIONS, NAMELY SOFTWARE IN THE FIELD OF WOUND CARE AND HYPERBARIC MEDICINE FOR THE PURPOSES OF REFERRAL MANAGEMENT, IMPROVING CLINICAL PRODUCTIVITY, EDUCATING AND TRAINING PHYSICIANS AND NURSES, AND COLLECTING, ANALYZING, AND GENERATING CLINICAL, FINANCIAL, AND STATISTICAL DATA (U.S. CLS. 21, 23, 26, 36 AND 38).

FIRST USE 9-11-2002; IN COMMERCE 9-11-2002.
JAMES A. RAUEN, EXAMINING ATTORNEY

CLASS 9—(Continued).

SN 85-380,410. DYL, LLC, AKA DIAL YOUR LEADS, TM, MARINA DEL REY, CA. FILED 7-25-2011.

DYL

THE MARK CONSISTS OF STANDARD CHARACTERS WITHOUT CLAIM TO ANY PARTICULAR FONT, STYLE, SIZE, OR COLOR.

FOR SOFTWARE FOR PROVIDING ON-LINE TELEPHONE TRANSFERS FOR CONNECTING THE USER TO POTENTIAL CLIENTS, FOR HOSTING VOIP PHONE SYSTEMS FOR CONNECTING USER TO POTENTIAL CLIENTS, AND FOR MANAGING ON-LINE SALES LEADS (U.S. CLS. 21, 23, 26, 36 AND 38).

FIRST USE 5-31-2009; IN COMMERCE 5-31-2009.
REBECCA SMITH, EXAMINING ATTORNEY

SN 85-380,509. FERGUSON ENTERPRISES, INC., NEWPORT NEWS, VA. FILED 7-25-2011.

LINCOLN PRODUCTS

THE MARK CONSISTS OF STANDARD CHARACTERS WITHOUT CLAIM TO ANY PARTICULAR FONT, STYLE, SIZE, OR COLOR.

NO CLAIM IS MADE TO THE EXCLUSIVE RIGHT TO USE "PRODUCTS", APART FROM THE MARK AS SHOWN.

FOR PLUMBING SUPPLIES, NAMELY, APPLIANCE HEATING CONTROLS, EVAPORATIVE COOLER PARTS, NAMELY, COOLANT-TEMPERATURE SENSORS, AND SPRINKLER TIMERS (U.S. CLS. 21, 23, 26, 36 AND 38).

FIRST USE 12-31-1999; IN COMMERCE 12-31-1999.
TASNEEM HUSSAIN, EXAMINING ATTORNEY

SN 85-380,152. UNIBOO TECHNOLOGY LTD., TAI-NAN CITY, TAIWAN, FILED 7-25-2011.

uniboo

THE MARK CONSISTS OF THE HIGHLY STYLIZED LETTERS "UNIBOO".

FOR SAFETY HELMET FOR SPORT; FOOTBALL HELMET; ELECTRONIC BLACKBOARD FOR DISPLAY GRAPHICS; COMPUTER MOUSE; COMPUTER JOYSTICK; CAMERA; CARRYING CASES FOR PHOTOGRAPHIC EQUIPMENT, NAMELY, CAMERAS, CAMERA FLASHES, CAMERA LENS, CAMERA SHUTTERS AND CAMERA FILTERS; CAMERA BRACE; VIDEO CASSETTE RECORDER (VCR); VIDEO RECORDER; DIGITAL VIDEO CAMERAS; MOTION PICTURE CAMERAS AND APPARATUS, NAMELY, CAMERA TRIPODS; SLIDE PROJECTOR; FLUORESCENT LAMP STARTER; FIRE EXTINGUISHER; FOAM FIRE EXTINGUISHER; GPS NAVIGATION DEVICE; TABLET COMPUTER COVER; CELL-PHONE COVER (U.S. CLS. 21, 23, 26, 36 AND 38).

ODESSA BIBBINS, EXAMINING ATTORNEY

SN 85-384,923. WGI INNOVATIONS, LTD., GRAND PRAIRIE, TX. FILED 7-29-2011.

FLEXTIME

THE MARK CONSISTS OF STANDARD CHARACTERS WITHOUT CLAIM TO ANY PARTICULAR FONT, STYLE, SIZE, OR COLOR.

FOR CAMERAS; CAMERA SHUTTERS (U.S. CLS. 21, 23, 26, 36 AND 38).

JENNY PARK, EXAMINING ATTORNEY

CLASS 9—(Continued).

SN 85-385,980. THE GOVERNMENT OF THE UNITED STATES OF AMERICA AS REPRESENTED BY THE SECRETARY OF THE NAVY, WASHINGTON, DC. FILED 8-1-2011.

ATCF

THE MARK CONSISTS OF STANDARD CHARACTERS WITHOUT CLAIM TO ANY PARTICULAR FONT, STYLE, SIZE, OR COLOR.

FOR COMPUTER SOFTWARE FOR MANAGING TROPICAL CYCLONE DATA AND GENERATING TROPICAL CYCLONE FORECASTS (U.S. CLS. 21, 23, 26, 36 AND 38).

FIRST USE 6-1-1989; IN COMMERCE 6-1-1989.
MICHAEL TANNER, EXAMINING ATTORNEY

SN 85-388,601. RANA, AJ, SANTA CLARA, CA. FILED 8-3-2011.

FAZDEALERS

THE MARK CONSISTS OF STANDARD CHARACTERS WITHOUT CLAIM TO ANY PARTICULAR FONT, STYLE, SIZE, OR COLOR.

FOR COMPUTER APPLICATION SOFTWARE FOR DESKTOP AND PORTABLE COMPUTERS, NAMELY, SOFTWARE FOR MANAGING AND MARKETING AUTOMOBILE DEALER'S INVENTORY (U.S. CLS. 21, 23, 26, 36 AND 38).

JOHN GARTNER, EXAMINING ATTORNEY

SN 85-388,642. MILLS, THOMAS A., DBA TAG-ME CONTACT MANAGER, DOUSMAN, WI. FILED 8-3-2011.

Tag-Me Contact Manager

THE MARK CONSISTS OF STANDARD CHARACTERS WITHOUT CLAIM TO ANY PARTICULAR FONT, STYLE, SIZE, OR COLOR.

NO CLAIM IS MADE TO THE EXCLUSIVE RIGHT TO USE "CONTACT MANAGER", APART FROM THE MARK AS SHOWN.

FOR COMPUTER SOFTWARE FOR THE COLLECTION, EDITING, ORGANIZING, MODIFYING, BOOK MARKING, TRANSMISSION, STORAGE AND SHARING OF DATA AND INFORMATION (U.S. CLS. 21, 23, 26, 36 AND 38).

FIRST USE 8-2-2011; IN COMMERCE 8-2-2011.
SCOTT BIBB, EXAMINING ATTORNEY

CLASS 9—(Continued).

SN 85-388,892. AUTOMOTIVE INDUSTRIAL MARKETING CORPORATION, DBA AIMCO, PORTLAND, OR. FILED 8-3-2011.



THE MARK CONSISTS OF THE WORD "AUDITOR" WITH A WRENCH ABOVE THE LETTERS "ITOR".

FOR MEASURING EQUIPMENT, NAMELY, DIGITAL TORQUE GAUGES (U.S. CLS. 21, 23, 26, 36 AND 38).

KAPIL BHANOT, EXAMINING ATTORNEY

SN 85-390,139. GLOBALENGLISH CORPORATION, BRISBANE, CA. FILED 8-4-2011.

GLOBALENGLISH LINGO

THE MARK CONSISTS OF STANDARD CHARACTERS WITHOUT CLAIM TO ANY PARTICULAR FONT, STYLE, SIZE, OR COLOR.

OWNER OF U.S. REG. NOS. 2,456,280, 2,823,678 AND OTHERS.

NO CLAIM IS MADE TO THE EXCLUSIVE RIGHT TO USE "LINGO", APART FROM THE MARK AS SHOWN.

FOR DOWNLOADABLE COMPUTER APPLICATION SOFTWARE FOR BROWSERS, MOBILE PHONES AND HANDHELD COMPUTERS FOR USE IN APPLYING BUSINESS ENGLISH TO WORK-RELATED TASKS TO OPTIMIZE GLOBAL BUSINESS COMMUNICATION (U.S. CLS. 21, 23, 26, 36 AND 38).

ROBERT STRUCK, EXAMINING ATTORNEY

SN 85-393,124. INNOVATIVE SOLUTIONS & SUPPORT, INC., EXTON, PA. FILED 8-9-2011.

IFMS

THE MARK CONSISTS OF STANDARD CHARACTERS WITHOUT CLAIM TO ANY PARTICULAR FONT, STYLE, SIZE, OR COLOR.

FOR FLIGHT MANAGEMENT SYSTEMS COMPRISING AN ON-AIRCRAFT FLIGHT MANAGEMENT COMPUTER, A NAVIGATION DATA BASE, FLIGHT CONTROL/GUIDANCE FUNCTIONALITY, MULTITUDE OF NAVIGATION SENSORS AND AN ELECTRONIC FLIGHT INSTRUMENT DISPLAY SUITE THAT INTEGRATES THE USER INTERFACE OF THE FLIGHT MANAGEMENT SYSTEM WITH OTHER PRIMARY AND ANCILLARY FLIGHT DATA (U.S. CLS. 21, 23, 26, 36 AND 38).

RONALD AIKENS, EXAMINING ATTORNEY

CLASS 9—(Continued).

SN 85-393,566. SYNAPTICS INCORPORATED, SANTA CLARA, CA. FILED 8-9-2011.

ClickSmart

THE MARK CONSISTS OF STANDARD CHARACTERS WITHOUT CLAIM TO ANY PARTICULAR FONT, STYLE, SIZE, OR COLOR.

FOR ELECTRONIC CIRCUITRY, INTEGRATED CIRCUITS AND CIRCUIT BOARDS; TOUCH-SENSITIVE INPUT DEVICES FOR CONSUMER ELECTRONIC PRODUCTS THAT ALLOW THE USER TO INTERFACE WITH OR CONTROL THE PRODUCTS; CAPACITIVE SENSORS TO INTERFACE WITH OR CONTROL A CONSUMER ELECTRONIC DEVICE (U.S. CLS. 21, 23, 26, 36 AND 38).

HOWARD B. LEVINE, EXAMINING ATTORNEY

CLASS 9—(Continued).

EXTEND FROM THE TOP OF THE LETTER "H" IN THE WORD "HORNY". A FIRST GREEN-COLORED SWIRLY LINE OUTLINED IN ORANGE EXTENDS TO THE LEFT AND DOWNWARD FROM THE TOP OF THE LETTER "R" IN THE WORD "HORNY". A BLACK-COLORED HORN WITH ORANGE OUTLINING EXTENDS FROM THE END OF THE SWIRLY LINE. A SECOND GREEN-COLORED SWIRLY LINE OUTLINED IN ORANGE EXTENDS DOWNWARD AND LEFT FROM THE BOTTOM OF THE LETTER "Y" IN THE WORD "HORNY". A BLACK-COLORED HORN WITH ORANGE OUTLINING EXTENDS FROM THE END OF THE SWIRLY LINE. THE TEXT AND HORNS ALL HAVE THREE-DIMENSIONAL BLACK-COLORED SHADING. THE TEXT HAS SPORADICALLY POSITIONED WHITE-COLORED HIGHLIGHTING.

FOR MOTORCYCLE HELMET ACCESSORIES, NAMELY, FITTED DECORATIVE HORNS FOR ATTACHMENT TO MOTORCYCLE HELMETS (U.S. CLS. 21, 23, 26, 36 AND 38).

FIRST USE 1-0-2011; IN COMMERCE 3-0-2011.

ZHALEH DELANEY, EXAMINING ATTORNEY

SN 85-393,595. HEWLETT-PACKARD DEVELOPMENT COMPANY, L.P., HOUSTON, TX. FILED 8-9-2011.

HP STOREOPEN

THE MARK CONSISTS OF STANDARD CHARACTERS WITHOUT CLAIM TO ANY PARTICULAR FONT, STYLE, SIZE, OR COLOR.

OWNER OF U.S. REG. NOS. 1,840,215, 2,940,854 AND OTHERS.

FOR COMPUTER SOFTWARE FOR ACCESSING, UPDATING AND SHARING DATA STORED ON TAPE; COMPUTER HARDWARE; COMPUTER PERIPHERALS (U.S. CLS. 21, 23, 26, 36 AND 38).

LAURIE MAYES, EXAMINING ATTORNEY

SN 85-395,950. LEAPFROG ENTERPRISES, INC., EMERYVILLE, CA. FILED 8-11-2011.

EDU SNACKS

THE MARK CONSISTS OF STANDARD CHARACTERS WITHOUT CLAIM TO ANY PARTICULAR FONT, STYLE, SIZE, OR COLOR.

NO CLAIM IS MADE TO THE EXCLUSIVE RIGHT TO USE "EDU", APART FROM THE MARK AS SHOWN.

FOR EDUCATIONAL COMPUTER GAME SOFTWARE; DOWNLOADABLE EDUCATIONAL COMPUTER GAME SOFTWARE (U.S. CLS. 21, 23, 26, 36 AND 38).

ANDREA HACK, EXAMINING ATTORNEY

SN 85-394,183. HENRY, MICHAEL L., LAS VEGAS, NV. FILED 8-10-2011.



NO CLAIM IS MADE TO THE EXCLUSIVE RIGHT TO USE "HELMET ACCESSORIES", APART FROM THE MARK AS SHOWN.

THE COLOR(S) GREEN, ORANGE, BLACK AND WHITE IS/ARE CLAIMED AS A FEATURE OF THE MARK.

THE MARK CONSISTS OF STYLIZED WORDS "HORNY HELMET ACCESSORIES". EACH LETTER OF THE WORD "HORNY" IS GREEN OUTLINED IN ORANGE. A PAIR OF BLACK-COLORED HORNS WITH ORANGE OUTLINING

SN 85-396,084. VISION CONCEPTS INTERNATIONAL, LLC, BOCA RATON, FL. FILED 8-12-2011.



THE COLOR(S) RED, WHITE, ORANGE, BLACK IS/ARE CLAIMED AS A FEATURE OF THE MARK.

THE MARK CONSISTS OF TWO BLOODSHOT WHITE EYES HAVING ORANGE AND RED BLOOD VESSELS WITH THE ORANGE AND RED WORDS "STOP FRYING" PARTIALLY OUTLINED IN BLACK ABOVE THE EYES AND THE ORANGE AND RED WORDS "YOUR EYES"

CLASS 9—(Continued).

PARTIALLY OUTLINE IN BLACK APPEAR UNDERNEATH THE EYES; THE PUPILS OF THE EYES ARE BLACK WITH A WHITE CIRCLE IN UPPER RIGHT PORTION OF THE PUPIL IN BOTH EYES; THE PUPIL IS SURROUNDED BY ORANGE AND RED CORNEAS; THE COLOR WHITE ALSO APPEARS IN THREE OPEN AREAS IN THE MIDDLE OF THE WORDING AND DESIGN ELEMENTS; AND THE WORDING AND DESIGN ELEMENTS APPEAR ON AND ORANGE AND RED BACKGROUND.

FOR EYEGLASSES (U.S. CLS. 21, 23, 26, 36 AND 38).
BILL DAWE, EXAMINING ATTORNEY

CLASS 9—(Continued).

SN 85-398,930. CONNECTICUT ELECTRIC, INC., ANDERSON, IN. FILED 8-16-2011.

WADSWORTH

SN 85-398,447. APPLE INC., CUPERTINO, CA. FILED 8-15-2011.



THE MARK CONSISTS OF STANDARD CHARACTERS WITHOUT CLAIM TO ANY PARTICULAR FONT, STYLE, SIZE, OR COLOR.

SEC. 2(F).
FOR CIRCUIT BREAKERS (U.S. CLS. 21, 23, 26, 36 AND 38).

FIRST USE 12-31-1962; IN COMMERCE 12-31-1962.
HOWARD B. LEVINE, EXAMINING ATTORNEY

SN 85-400,961. JANE LABS, LLC, ALAMEDA, CA. FILED 8-18-2011.

OWNER OF U.S. REG. NOS. 1,114,431, 2,753,069 AND OTHERS.

NO CLAIM IS MADE TO THE EXCLUSIVE RIGHT TO USE "CUPERTINO, CA", APART FROM THE MARK AS SHOWN.

THE COLOR(S) BLUE, WHITE, GRAY, BROWN, AND BLACK IS/ARE CLAIMED AS A FEATURE OF THE MARK.

THE MARK CONSISTS OF THE IMAGE OF A STAMP DESIGN WITH THE BORDER AREA APPEARING IN THE COLORS WHITE AND GRAY; IN THE CENTER AREA OF THE STAMP APPEARS A HAWK IN THE COLORS BROWN, WHITE, AND BLACK, WITH SAID HAWK DESIGN APPEARING IN A BLUE SKY BACKGROUND; SUPERIMPOSED ON THE AFOREMENTIONED STAMP DESIGN APPEARS A POSTMARK DESIGN COMPRISED OF FOUR GRAY AND BLUE CONCENTRIC CIRCLES AND ELEVEN GRAY AND BLUE WAVY LINES EXTENDING FROM THE RIGHT EDGE OF THE OUTER CIRCLE; THE STYLIZED WORDING "HELLO FROM CUPERTINO, CA" APPEARS BETWEEN THE INNER TWO AND OUTER TWO CONCENTRIC CIRCLES COMPRISING THE POSTMARK, WITH "HELLO FROM" APPEARING IN THE UPPER AREA OF THE POSTMARK IN THE COLORS GRAY AND BLUE AND WITH "CUPERTINO, CA" APPEARING IN THE LOWER AREA OF THE POSTMARK IN THE COLOR GRAY; AT THE CENTER OF THE INNERMOST CIRCLE APPEARS A STYLIZED GRAY AND BLUE APPLE DESIGN, WITH A BITE REMOVED FROM THE RIGHT EDGE OF THE APPLE.

FOR ELECTRONIC MAIL AND MESSAGING SOFTWARE (U.S. CLS. 21, 23, 26, 36 AND 38).

FIRST USE 1-5-2000; IN COMMERCE 3-24-2001.
KEVIN CORWIN, EXAMINING ATTORNEY

ElectroALERT

THE MARK CONSISTS OF STANDARD CHARACTERS WITHOUT CLAIM TO ANY PARTICULAR FONT, STYLE, SIZE, OR COLOR.

FOR A DISTRIBUTED SYSTEM COMPRISED OF ELECTRONICALLY CONTROLLED AND MONITORED CONTAINMENT SYSTEMS, WHICH ARE COMPRISED OF ELECTRIC SENSORS AND ELECTRONICALLY ENABLED CONTAINERS, FOR THE MANAGEMENT AND HANDLING OF SOLID AND LIQUID MATERIAL (U.S. CLS. 21, 23, 26, 36 AND 38).

MEGHAN REINHART, EXAMINING ATTORNEY

CLASS 9—(Continued).

SN 85-400,978. GENERAC POWER SYSTEMS, INC., WAUKESHA, WI. FILED 8-18-2011.

SILENT GENERATOR

THE MARK CONSISTS OF STANDARD CHARACTERS WITHOUT CLAIM TO ANY PARTICULAR FONT, STYLE, SIZE, OR COLOR.

NO CLAIM IS MADE TO THE EXCLUSIVE RIGHT TO USE "GENERATOR", APART FROM THE MARK AS SHOWN.

FOR UNINTERRUPTIBLE ELECTRICAL POWER SUPPLIES; RENEWABLE BATTERY SYSTEM TO PROVIDE BACKUP POWER; ELECTRICAL POWER DISTRIBUTION PANELS; ELECTRICAL COMBINER FUSE BOXES; ELECTRICAL POWER INVERTERS; POWER CORD SETS, NAMELY, ELECTRICAL POWER EXTENSION CORDS; MANUAL TRANSFER SWITCHES; AUTOMATIC TRANSFER SWITCHES USED WITH ELECTRIC POWER GENERATORS; ELECTRICAL POWER INLET BOXES; ELECTRICAL RELAY BOXES; EMERGENCY LIGHTING SYSTEMS AND COMPONENTS THEREFOR, NAMELY, EMERGENCY WARNING LIGHTS, EMERGENCY SIGNAL TRANSMITTERS AND EMERGENCY FLARES (U.S. CLS. 21, 23, 26, 36 AND 38).

SAMUEL E. SHARPER JR., EXAMINING ATTORNEY

SN 85-400,985. JANE LABS, LLC, ALAMEDA, CA. FILED 8-18-2011.



THE MARK CONSISTS OF THE TEXT "ELECTROALERT" AT THE CENTER OF A HORIZONTAL OVAL SHAPED OUTLINE; A SMALLER ENCLOSED SEMICIRCLE OUTLINE IS FEATURED ON THE RIGHT OF THE OVAL OUTLINE AND A SMALLER ENCLOSED SEMICIRCLE OUTLINE IS FEATURED ON THE LEFT OF THE CENTER OVAL SHAPED OUTLINE.

FOR A DISTRIBUTED SYSTEM COMPRISED OF ELECTRONICALLY CONTROLLED AND MONITORED CONTAINMENT SYSTEMS, WHICH ARE COMPRISED OF ELECTRIC SENSORS AND ELECTRONICALLY ENABLED CONTAINERS, FOR THE MANAGEMENT AND HANDLING OF SOLID AND LIQUID MATERIAL (U.S. CLS. 21, 23, 26, 36 AND 38).

MEGHAN REINHART, EXAMINING ATTORNEY

CLASS 9—(Continued).

SN 85-401,643. SPY OPTIC INC., CARLSBAD, CA. FILED 8-18-2011.

SPECTRA

THE MARK CONSISTS OF STANDARD CHARACTERS WITHOUT CLAIM TO ANY PARTICULAR FONT, STYLE, SIZE, OR COLOR.

FOR LENSES FOR SUNGLASSES AND SPORTS GOGGLES (U.S. CLS. 21, 23, 26, 36 AND 38).

DAVID TAYLOR, EXAMINING ATTORNEY

SN 85-402,348. SONULTRA CORPORATION, ENCINO, CA. FILED 8-19-2011.

SonoReport

THE MARK CONSISTS OF STANDARD CHARACTERS WITHOUT CLAIM TO ANY PARTICULAR FONT, STYLE, SIZE, OR COLOR.

FOR MEDICAL SOFTWARE, ACCESSIBLE VIA AN ULTRASOUND SCANNER, WHICH ACCEPTS DATA FROM THE ULTRASOUND SCANNER AND DISPLAYS IT IN A REPORT (U.S. CLS. 21, 23, 26, 36 AND 38).

FIRST USE 1-5-2008; IN COMMERCE 1-5-2008.

WENDY JUN, EXAMINING ATTORNEY

SN 85-403,827. EMERSON POWER TRANSMISSION CORPORATION, FLORENCE, KY. FILED 8-22-2011.

TOOLBOX TECHNICIAN

THE MARK CONSISTS OF STANDARD CHARACTERS WITHOUT CLAIM TO ANY PARTICULAR FONT, STYLE, SIZE, OR COLOR.

FOR COMPUTER APPLICATION SOFTWARE FOR MOBILE SMART PHONES, NAMELY, SOFTWARE FOR PROVIDING ACCESS TO SEARCHABLE DATABASES OF INFORMATION ABOUT INDUSTRIAL AND COMMERCIAL POWER TRANSMISSION DEVICES (U.S. CLS. 21, 23, 26, 36 AND 38).

SHAILA SETTLES, EXAMINING ATTORNEY

CLASS 9—(Continued).

SN 85-405,642. ROBERTS, BRAD, MARION, IL. FILED 8-24-2011.

S.N.A.P. START NOW AND PREPARE

THE MARK CONSISTS OF STANDARD CHARACTERS WITHOUT CLAIM TO ANY PARTICULAR FONT, STYLE, SIZE, OR COLOR.

FOR EMERGENCY SURVIVAL KITS AND EMERGENCY SUPPLY KITS SOLD AS A UNIT COMPOSED PRIMARILY OF A RADIO, A WHISTLE, DUST MASKS, AND ALSO A NON-ELECTRIC CAN OPENER, PLIERS, TRASH BAGS, A FLASHLIGHT, DUCT TAPE, A FIRST-AID KIT, UNFITTED PLASTIC SHEETING IN THE NATURE OF A DROP CLOTH, PRE-MOISTENED ANTI-BACTERIAL TOWELETTES, AND A STEP-BY-STEP PRINTED GUIDE USED TO FURTHER CUSTOMIZE AND COMPLETE THE KIT (U.S. CLS. 21, 23, 26, 36 AND 38).

ALICIA COLLINS, EXAMINING ATTORNEY

SN 85-406,050. ALSTOM GRID SAS, PARIS LA DEFENSE CEDEX, FRANCE, FILED 8-24-2011.

S1 AGILE

THE MARK CONSISTS OF STANDARD CHARACTERS WITHOUT CLAIM TO ANY PARTICULAR FONT, STYLE, SIZE, OR COLOR.

PRIORITY CLAIMED UNDER SEC. 44(D) ON FRANCE APPLICATION NO. 113853232, FILED 8-17-2011.

FOR CONFIGURATION SOFTWARE USED TO SET PROTECTION RELAYS IN HIGH VOLTAGE UTILITY SYSTEMS (U.S. CLS. 21, 23, 26, 36 AND 38).

JOSETTE BEVERLY, EXAMINING ATTORNEY

SN 85-406,056. ALSTOM GRID SAS, PARIS LA DEFENSE CEDEX, FRANCE, FILED 8-24-2011.

P40 AGILE

THE MARK CONSISTS OF STANDARD CHARACTERS WITHOUT CLAIM TO ANY PARTICULAR FONT, STYLE, SIZE, OR COLOR.

PRIORITY CLAIMED UNDER SEC. 44(D) ON FRANCE APPLICATION NO. 113853163, FILED 8-17-2011.

FOR ELECTRONIC AND NUMERICAL RELAYS USED FOR THE PROTECTION AND CONTROL OF HIGH VOLTAGE POWER SYSTEMS AND ASSOCIATED SOFTWARE (U.S. CLS. 21, 23, 26, 36 AND 38).

JOSETTE BEVERLY, EXAMINING ATTORNEY

CLASS 9—(Continued).

SN 85-406,094. ARISTOCRAT TECHNOLOGIES AUSTRALIA PTY LTD., NORTH RYDE, AUSTRALIA, FILED 8-24-2011.

RING OF THE WHALES

THE MARK CONSISTS OF STANDARD CHARACTERS WITHOUT CLAIM TO ANY PARTICULAR FONT, STYLE, SIZE, OR COLOR.

PRIORITY CLAIMED UNDER SEC. 44(D) ON AUSTRALIA APPLICATION NO. 1442711, FILED 8-18-2011, REG. NO. 1442711, DATED 8-18-2011, EXPIRES 8-18-2021.

FOR ELECTRONIC GAMING MACHINES, NAMELY, DEVICES WHICH ACCEPT A WAGER (U.S. CLS. 21, 23, 26, 36 AND 38).

SUNG IN, EXAMINING ATTORNEY

SN 85-406,812. ARISTOCRAT TECHNOLOGIES AUSTRALIA PTY LTD., NORTH RYDE, NSW, AUSTRALIA, FILED 8-25-2011.

MYSTICAL BUTTERFLY

THE MARK CONSISTS OF STANDARD CHARACTERS WITHOUT CLAIM TO ANY PARTICULAR FONT, STYLE, SIZE, OR COLOR.

PRIORITY CLAIMED UNDER SEC. 44(D) ON AUSTRALIA APPLICATION NO. 1443916, FILED 8-24-2011, REG. NO. 1443916, DATED 8-24-2011, EXPIRES 8-24-2021.

FOR ELECTRONIC GAMING MACHINES, NAMELY, DEVICES WHICH ACCEPT A WAGER (U.S. CLS. 21, 23, 26, 36 AND 38).

LINDA M. KING, EXAMINING ATTORNEY

SN 85-408,544. SUPER DUPER INC., DBA SUPER DUPER PUBLICATIONS, GREENVILLE, SC. FILED 8-26-2011.

SUPER DUPER

THE MARK CONSISTS OF STANDARD CHARACTERS WITHOUT CLAIM TO ANY PARTICULAR FONT, STYLE, SIZE, OR COLOR.

FOR COMPUTER APPLICATION SOFTWARE FOR MOBILE PHONES, PORTABLE MEDIA PLAYERS, HANDHELD COMPUTERS, AND DESKTOP COMPUTERS, NAMELY, EDUCATION SOFTWARE FOR USE IN DATABASE MANAGEMENT OF SCORES AND TEACHING LANGUAGE CONCEPTS (U.S. CLS. 21, 23, 26, 36 AND 38).

FIRST USE 3-29-2011; IN COMMERCE 3-29-2011.

SAMUEL E. SHARPER JR., EXAMINING ATTORNEY

CLASS 9—(Continued).

SN 85-409,380. VXI CORPORATION, DOVER, NH. FILED 8-29-2011.

VXI UC PROSET

THE MARK CONSISTS OF STANDARD CHARACTERS WITHOUT CLAIM TO ANY PARTICULAR FONT, STYLE, SIZE, OR COLOR.

OWNER OF U.S. REG. NOS. 2,398,354, 4,082,222 AND OTHERS.

NO CLAIM IS MADE TO THE EXCLUSIVE RIGHT TO USE "UC", APART FROM THE MARK AS SHOWN.

FOR WIRED HEADSETS FOR USE WITH TELEPHONES AND COMPUTERS; WIRED AND WIRELESS ADAPTERS THAT PERMIT CONNECTIONS BETWEEN COMPUTER, TELEPHONY AND AUDIO VISUAL APPLICATIONS (U.S. CLS. 21, 23, 26, 36 AND 38).

PAUL MORENO, EXAMINING ATTORNEY

CLASS 9—(Continued).

SN 85-412,500. MATTHEW D. LIVINGSTONE, SUDBURY, ONTARIO, CANADA, FILED 8-31-2011.



SN 85-410,649. WGI INNOVATIONS, LTD., GRAND PRAIRIE, TX. FILED 8-30-2011.

FLEXTIME+

THE MARK CONSISTS OF STANDARD CHARACTERS WITHOUT CLAIM TO ANY PARTICULAR FONT, STYLE, SIZE, OR COLOR.

FOR CAMERAS; CAMERA SHUTTERS (U.S. CLS. 21, 23, 26, 36 AND 38).

JENNY PARK, EXAMINING ATTORNEY

SN 85-410,763. ZENCOLOR CORPORATION, WILMINGTON, DE. FILED 8-30-2011.

Navi-tar

THE MARK CONSISTS OF STANDARD CHARACTERS WITHOUT CLAIM TO ANY PARTICULAR FONT, STYLE, SIZE, OR COLOR.

FOR COMPUTER SOFTWARE FOR GENERATING SEASONAL FORECASTS REGARDING COLORS USERS WOULD BE INTERESTED IN; COMPUTER SOFTWARE FOR OPERATING SOCIAL NETWORKING WEBSITES AND PROGRAMS; COMPUTER SOFTWARE FOR OPERATING CHAT WEBSITES AND PROGRAMS; COMPUTER SOFTWARE FOR ANALYZING AND MATCHING USER COLOR PREFERENCES AND HOROSCOPES AS WELL AS MATCHING THEM WITH OTHER USERS; COMPUTER SOFTWARE FOR ANALYZING USER INFORMATION AND INPUT TO GENERATE ASSESSMENTS OF WHAT PRODUCTS WOULD INTEREST THEM (U.S. CLS. 21, 23, 26, 36 AND 38).

CORY BOONE, EXAMINING ATTORNEY

OWNER OF CANADA REG. NO. 1531518, DATED 6-16-2011, EXPIRES 6-16-2026.

THE COLOR(S) GREEN AND WHITE IS/ARE CLAIMED AS A FEATURE OF THE MARK.

THE MARK CONSISTS OF THE LETTER "C" INSIDE A GREEN CIRCLE SURROUNDED BY A WHITE OUTLINE SURROUNDED BY A GREEN OUTLINE. THE WORDING "CITYAPP" IS IN GREEN AND IS LOCATED DIRECTLY BELOW THE "C" IN A CIRCLE DESIGN.

FOR COMPUTER APPLICATION SOFTWARE FOR MOBILE PHONES, NAMELY, SOFTWARE FOR MESSAGE RETRIEVAL FROM PORTALS; COMPUTER SOFTWARE FOR MOBILE PHONES THAT PROVIDES WEB-BASED ACCESS TO APPLICATIONS AND SERVICES THROUGH A WEB OPERATING SYSTEM OR PORTAL INTERFACE (U.S. CLS. 21, 23, 26, 36 AND 38).

NANCY CLARKE, EXAMINING ATTORNEY

CLASS 9—(Continued).

SN 85-415,798. GLOBAL MAGIC FUTURES LIMITED, BERKSWELL, UNITED KINGDOM, FILED 9-6-2011.

take control • achieve more • love life!

PRIORITY CLAIMED UNDER SEC. 44(D) ON ERPN CMNTY TM OFC APPLICATION NO. 10228591, FILED 8-30-2011, REG. NO. 10228591, DATED 2-17-2012, EXPIRES 8-30-2021.

THE MARK CONSISTS OF THE WORDING "TAKE CONTROL", "ACHIEVE MORE", AND "LOVE LIFE!" A DOT SEPARATES EACH PHRASE.

FOR APPARATUS FOR RECORDING, TRANSMISSION OR REPRODUCTION OF SOUND AND IMAGES; COMPUTER STORAGE DEVICES, NAMELY, BLANK FLASH DRIVES; PRERECORDED DIGITAL VIDEO DISCS AND COMPACT DISCS FEATURING PROGRAMS IN THE FIELDS OF FINANCIAL PLANNING, LIFESTYLE MANAGEMENT, AND PERSONAL DEVELOPMENT, NAMELY, SELF-IMPROVEMENT AND SELF-FULFILLMENT; FLASH MEMORY CARDS; COMPUTER SOFTWARE FOR FINANCIAL PLANNING, LIFESTYLE MANAGEMENT, AND PERSONAL DEVELOPMENT, NAMELY, SELF-IMPROVEMENT AND SELF-FULFILLMENT; COMPUTER SOFTWARE FOR CREATING AND DISPLAYING PERSONALIZED COMPUTER DESKTOP BACKGROUNDS; DOWNLOADABLE ELECTRONIC PUBLICATIONS IN THE NATURE OF BOOKS, WORKBOOKS, JOURNALS, BROCHURES, REPORTS, MANUALS, NEWSLETTERS, MAGAZINES, AND PERIODICALS IN THE FIELDS OF FINANCIAL PLANNING, LIFESTYLE MANAGEMENT, AND PERSONAL DEVELOPMENT, NAMELY, SELF-IMPROVEMENT AND SELF-FULFILLMENT (U.S. CLS. 21, 23, 26, 36 AND 38).
WENDY JUN, EXAMINING ATTORNEY

SN 85-416,789. LAMPO LICENSING, LLC, BRENTWOOD, TN. FILED 9-7-2011.

DAVE RAMSEY'S INSIGHTS

THE MARK CONSISTS OF STANDARD CHARACTERS WITHOUT CLAIM TO ANY PARTICULAR FONT, STYLE, SIZE, OR COLOR.

THE NAME(S), PORTRAIT(S), AND/OR SIGNATURE(S) SHOWN IN THE MARK IDENTIFIES "DAVE RAMSEY", WHOSE CONSENT(S) TO REGISTER IS MADE OF RECORD.

FOR DOWNLOADABLE SOFTWARE USED TO ASSESS AN INDIVIDUAL'S COMMUNICATION SKILLS AND COMMUNICATION STYLE WITHIN A COMPANY OR ORGANIZATION (U.S. CLS. 21, 23, 26, 36 AND 38).

FIRST USE 8-2-2011; IN COMMERCE 8-2-2011.

ALYSSA STEEL, EXAMINING ATTORNEY

CLASS 9—(Continued).

SN 85-424,597. TECMO KOEI GAMES CO., LTD., KANAGAWA 223-8503, JAPAN, FILED 9-16-2011.

DEAD OR ALIVE

THE MARK CONSISTS OF STANDARD CHARACTERS WITHOUT CLAIM TO ANY PARTICULAR FONT, STYLE, SIZE, OR COLOR.

OWNER OF U.S. REG. NOS. 2,935,579, 2,974,420 AND 2,976,952.

FOR COMPUTER GAME DISCS, CARTRIDGE, COMPUTER GAME PROGRAMS, COMPUTER GAME SOFTWARE; VIDEO GAME DISCS, VIDEO GAME PROGRAMS, VIDEO GAME SOFTWARE; DOWNLOADABLE COMPUTER GAME SOFTWARE, DOWNLOADABLE VIDEO GAME SOFTWARE (U.S. CLS. 21, 23, 26, 36 AND 38).

FIRST USE 8-1-1996; IN COMMERCE 8-1-1996.

SALLY SHIH, EXAMINING ATTORNEY

SN 85-427,077. SAMSUNG ELECTRONICS CO., LTD., SUWON-SI, GYEONGGI-DO, REPUBLIC OF KOREA, FILED 9-20-2011.

SAMSUNG COLOR PLUS

THE MARK CONSISTS OF STANDARD CHARACTERS WITHOUT CLAIM TO ANY PARTICULAR FONT, STYLE, SIZE, OR COLOR.

OWNER OF U.S. REG. NOS. 2,929,519, 3,503,660 AND OTHERS.

NO CLAIM IS MADE TO THE EXCLUSIVE RIGHT TO USE "COLOR", APART FROM THE MARK AS SHOWN.

THE ENGLISH TRANSLATION OF "SAMSUNG" IN THE MARK IS "THREE STARS".

FOR MOBILE PHONES; SMARTPHONES; TABLET COMPUTER (U.S. CLS. 21, 23, 26, 36 AND 38).

JOHN HWANG, EXAMINING ATTORNEY

SN 85-427,770. THE AQUABATS LLC, SANTA ANA, CA, FILED 9-21-2011.



THE COLOR(S) BLACK, BLUE, PINK, WHITE AND YELLOW IS/ARE CLAIMED AS A FEATURE OF THE MARK.

THE MARK CONSISTS OF THE WORDS "THE AQUABATS! SUPER SHOW!" AND A STYLIZED DESIGN OF A

CLASS 9—(Continued).

BAT WITHIN A CIRCLE. THE WORDING "THE AQUA-BATS!" IS IN THE COLOR WHITE OUTLINED IN BLUE, PINK, AND BLACK WITH PINK, BLUE AND YELLOW DOTS AND STARS SURROUNDING. DIRECTLY BELOW ARE THE WORDS "SUPER" AND "SHOW" IN YELLOW OUTLINED IN BLACK. THE WORDS "SUPER" AND "SHOW" ARE DIVIDED BY A STYLIZED BAT WITH AN "A" ON ITS CHEST AND A POINTY CAPE. THE BAT IS IN THE COLOR BLACK AND WHITE, AND IS WITHIN A BLUE, WHITE, PINK AND BLACK OUTLINED CIRCLE.

FOR PRERECORDED AUDIO AND VIDEO CASSETTES, COMPACT DISCS, VIDEO DISCS, RECORDS, AND CD-ROMS, ALL OF THE FOREGOING FEATURING MUSIC, ANIMATED CARTOONS, LIVE ACTION PERFORMANCES AND LIVE ACTION PERFORMANCES BY COSTUMED CHARACTERS ALL IN THE FIELDS OF SCIENCE FICTION, MYSTERY, FAIRY TALES, COMEDY AND DRAMA; CAMERA CASES; CAMERAS; CASES FOR ELECTRONIC DIARIES; CASES FOR MOBILE PHONES; CASES FOR POCKET CALCULATORS; CD CASES; CD PLAYERS; CELLULAR PHONE ACCESSORY CHARMS; COMPUTER GAME SOFTWARE; DECORATIVE MAGNETS; DOWNLOADABLE COMPUTER GAME PROGRAMS; DOWNLOADABLE COMPUTER GRAPHICS; DOWNLOADABLE IMAGE FILE CONTAINING ARTWORK, TEXT, AUDIO, VIDEO, GAMES AND INTERNET WEB LINKS RELATING TO A COMEDY SERIES; ELECTRONIC DIARIES; ELECTRONIC DAY PLANNERS; ELECTRONIC GAME SOFTWARE AND SOFTWARE GAME APPLICATIONS FOR MOBILE DEVICES AND TELEPHONES; EYEGLASSES; FITTED PLASTIC FILMS KNOWN AS SKINS FOR COVERING AND PROVIDING A SCRATCH PROOF BARRIER OR PROTECTION FOR ELECTRONIC DEVICES, NAMELY, MP3 PLAYERS, MOBILE TELEPHONES, SMART TELEPHONES, DIGITAL CAMERAS, GLOBAL POSITIONING SYSTEMS AND PERSONAL DIGITAL ASSISTANTS; HOLDERS FOR MAGNETICALLY ENCODED GIFT CARDS; MAGNETICALLY ENCODED DEBIT CARDS; INTERACTIVE VIDEO GAME PROGRAMS; MAGNETIC CODED GIFT CARDS; MOBILE TELEPHONES; MP3 PLAYERS; PERSONAL DIGITAL ASSISTANTS (PDA); POCKET CALCULATORS; PRE-PAID TELEPHONE CALLING CARDS, MAGNETICALLY ENCODED; PRE-RECORDED ELECTRONIC AND DIGITAL MEDIA FEATURING A COMEDY SERIES; RADIOS; SUNGLASSES; VIDEO GAME SOFTWARE; INTERACTIVE EDUCATIONAL SOFTWARE FEATURING INSTRUCTION IN MUSIC; ELECTRIC HAIR APPLIANCES, NAMELY, BRAIDERS, WRAPPERS, IRONS, CRIMPERS, CURLERS, CURLING IRONS, ROLLERS, STRAIGHTENERS; BATTERY-OPERATED HAIR APPLIANCES, NAMELY, BRAIDERS, WRAPPERS, IRONS, CRIMPERS, CURLERS, CURLING IRONS, ROLLERS, STRAIGHTENERS. COMPUTER SOFTWARE FOR CREATING, RECORDING, EDITING AND TRANSMITTING AUDIOVISUAL MATERIAL; PRINTERS; PICTURE PROJECTORS; DIGITAL PHOTO FRAMES FOR DISPLAYING DIGITAL PHOTOS; ELECTRONIC AUDIO TAPE RECORDER; DIGITAL AUDIO TAPE PLAYER AND RECORDER; PRE-RECORDED AUDIO AND VIDEO MEDIA, NAMELY, PRE-RECORDED DVDS, DOWNLOADABLE AUDIO AND VIDEO RECORDINGS, AND CDS FEATURING MUSIC; KARAOKE PLAYER AND RECORDER; DOWNLOADABLE ELECTRONIC NEWSLETTERS IN THE FIELD OF ENTERTAINMENT; DOWNLOADABLE ELECTRONIC PUBLICATIONS IN THE NATURE OF MAGAZINES OR BOOKS IN THE FIELD OF ENTERTAINMENT; MAGNETICALLY ENCODED GIFT CARD HOLDERS (U.S. CLS. 21, 23, 26, 36 AND 38).

PAUL MORENO, EXAMINING ATTORNEY

CLASS 9—(Continued).

SN 85-429,311. AICOMP CONSULTING, INC., MEMPHIS, TN. FILED 9-22-2011.



NO CLAIM IS MADE TO THE EXCLUSIVE RIGHT TO USE "POWERPACK", APART FROM THE MARK AS SHOWN.

THE COLOR(S) GREY AND ORANGE IS/ARE CLAIMED AS A FEATURE OF THE MARK.

THE MARK CONSISTS OF THE WORDING "VCPOWERPACK" WITH THE LETTERS "VC" IN UPPER CASE AND COLOR GREY (C0 M0 Y0 K60) AND THE REMAINING PART "POWERPACK" IN ORANGE (C0 M55 Y100 K0) WITH BOTH "P"'S IN UPPER CASE AND THE REMAINING LETTERS IN LOWER CASE. THE LETTER "C" ALSO CONTAINS A SMALL ORANGE COLORED FLAG-LIKE EXTENSION IN THE TOP.

FOR AUTOMATED SYSTEMS, NAMELY, SOFTWARE, HARDWARE AND COMMUNICATIONS DEVICES FOR PLANNING, SCHEDULING, CONTROLLING, MONITORING AND PROVIDING INFORMATION ON TRANSPORTATION ASSETS AND PARTS THEREOF; COMPUTER SOFTWARE AND FIRMWARE FOR OPERATING SYSTEM PROGRAMS; COMPUTER SOFTWARE FOR APPLICATION AND DATABASE INTEGRATION; COMPUTER SOFTWARE FOR COMPUTER SYSTEM AND APPLICATION DEVELOPMENT, DEPLOYMENT AND MANAGEMENT; COMPUTER SOFTWARE THAT PROVIDES REAL-TIME, INTEGRATED BUSINESS MANAGEMENT INTELLIGENCE BY COMBINING INFORMATION FROM VARIOUS DATABASES AND PRESENTING IT IN AN EASY-TO-UNDERSTAND USER INTERFACE; COMPUTER SOFTWARE THAT PROVIDES WEB-BASED ACCESS TO APPLICATIONS AND SERVICES THROUGH A WEB OPERATING SYSTEM OR PORTAL INTERFACE; DATABASE MANAGEMENT SOFTWARE FOR ENTERPRISE RESOURCE PLANNING SYSTEMS; ENTERPRISE SOFTWARE IN THE NATURE OF A DATABASE FOR NON-TRANSACTIONAL DATA AND A SEARCH ENGINE FOR DATABASE CONTENT; SOFTWARE FOR CONFIGURING, QUOTING AND ORDERING ELECTRICAL DISTRIBUTION PRODUCTS (U.S. CLS. 21, 23, 26, 36 AND 38).

FIRST USE 5-1-2008; IN COMMERCE 5-1-2008.

DEBORAH LOBO, EXAMINING ATTORNEY

CLASS 9—(Continued).

SN 85-430,709. A LA MODE, INC., OKLAHOMA CITY, OK. FILED 9-23-2011.

TOTAL 2011

THE MARK CONSISTS OF STANDARD CHARACTERS WITHOUT CLAIM TO ANY PARTICULAR FONT, STYLE, SIZE, OR COLOR.

NO CLAIM IS MADE TO THE EXCLUSIVE RIGHT TO USE "2011", APART FROM THE MARK AS SHOWN.

FOR COMPUTER SOFTWARE FOR USE IN DATABASE MANAGEMENT AND DOCUMENT PRODUCTION FOR REAL ESTATE PROFESSIONALS (U.S. CLS. 21, 23, 26, 36 AND 38).

FIRST USE 9-4-2008; IN COMMERCE 9-4-2008.
JACLYN KIDWELL WALKER, EXAMINING ATTORNEY

CLASS 9—(Continued).

SN 85-430,973. JOHNSON CONTROLS HYBRID AND RECYCLING GMBH, HANNOVER, FED REP GERMANY, FILED 9-23-2011.



OWNER OF U.S. REG. NO. 3,728,589.
THE COLOR(S) BLUE, YELLOW IS/ARE CLAIMED AS A FEATURE OF THE MARK.

THE MARK CONSISTS OF A STYLIZED "V" IN YELLOW AND A BLUE SHIELD.

FOR AUTOMOTIVE BATTERIES (U.S. CLS. 21, 23, 26, 36 AND 38).
JORDAN BAKER, EXAMINING ATTORNEY

SN 85-430,936. IMATION CORP., OAKDALE, MN. FILED 9-23-2011.

IV

THE MARK CONSISTS OF STANDARD CHARACTERS WITHOUT CLAIM TO ANY PARTICULAR FONT, STYLE, SIZE, OR COLOR.

FOR COMPUTER HARDWARE AND COMPUTER DATA STORAGE DEVICES, NAMELY, NETWORK ATTACHED STORAGE, DATA ARCHIVE SYSTEMS WHERE DATA IS MOVED TO A SEPARATE DATA STORAGE DEVICE FOR INDEXING AND LONG TERM RETENTION SO IT CAN BE SEARCHED AND RETRIEVED WHEN NEEDED; CARTRIDGE LIBRARIES, AND BLANK COMPUTER DISK CARTRIDGES; AND COMPUTER SOFTWARE FOR INFORMATION STORAGE, DATA RETRIEVAL AND NETWORK COMMUNICATION, DATA COMPRESSION SOFTWARE (U.S. CLS. 21, 23, 26, 36 AND 38).
DEZMONA MIZELLE, EXAMINING ATTORNEY

SN 85-434,171. IMATION CORP., OAKDALE, MN. FILED 9-28-2011.

IIV

THE MARK CONSISTS OF STANDARD CHARACTERS WITHOUT CLAIM TO ANY PARTICULAR FONT, STYLE, SIZE, OR COLOR.

FOR COMPUTER HARDWARE AND COMPUTER DATA STORAGE DEVICES, NAMELY, NETWORK ATTACHED STORAGE, DATA ARCHIVE SYSTEMS WHERE DATA IS MOVED TO A SEPARATE DATA STORAGE DEVICE FOR INDEXING AND LONG TERM RETENTION SO IT CAN BE SEARCHED AND RETRIEVED WHEN NEEDED, CARTRIDGE LIBRARIES, AND BLANK COMPUTER DISK CARTRIDGES; AND COMPUTER SOFTWARE FOR INFORMATION STORAGE, DATA RETRIEVAL AND NETWORK COMMUNICATION, DATA COMPRESSION SOFTWARE (U.S. CLS. 21, 23, 26, 36 AND 38).
DEZMONA MIZELLE, EXAMINING ATTORNEY

CLASS 9—(Continued).

SN 85-435,878. KIM, KWAN GIL, DBA SYNCULSE SYSTEMS, FAIRFIELD, CA. FILED 9-29-2011.



FOR DATABASE MANAGEMENT SOFTWARE FOR CONSUMER ELECTRONICS AND APPLIANCES (U.S. CLS. 21, 23, 26, 36 AND 38).
 FIRST USE 3-15-1991; IN COMMERCE 4-12-1991.
 DAVID HOFFMAN, EXAMINING ATTORNEY

CLASS 9—(Continued).

SN 85-437,508. EWC CONTROLS, INC., ENGLISHTOWN, NJ. FILED 10-3-2011.



THE MARK CONSISTS OF "ULTRA-TALK" IN STYLIZED FONT.
 FOR CLIMATE CONTROL SYSTEMS CONSISTING OF DIGITAL THERMOSTATS, AIR CONDITIONING, HEATING, VENTILATION AND DRYING CONTROL DEVICES (U.S. CLS. 21, 23, 26, 36 AND 38).
 FIRST USE 8-15-2011; IN COMMERCE 8-15-2011.
 TEJBIR SINGH, EXAMINING ATTORNEY

SN 85-436,830. COMBUSTION RESEARCH AND FLOW TECHNOLOGY, INC., DUBLIN, PA. FILED 9-30-2011.



THE MARK CONSISTS OF STANDARD CHARACTERS WITHOUT CLAIM TO ANY PARTICULAR FONT, STYLE, SIZE, OR COLOR.
 OWNER OF U.S. REG. NO. 2,621,075.
 NO CLAIM IS MADE TO THE EXCLUSIVE RIGHT TO USE "CFD", APART FROM THE MARK AS SHOWN.
 FOR COMPUTER SOFTWARE FOR SIMULATING AND TESTING AERODYNAMIC AND FLUID DYNAMIC PRINCIPLES (U.S. CLS. 21, 23, 26, 36 AND 38).
 FIRST USE 8-16-2001; IN COMMERCE 8-16-2001.
 FRED CARL, EXAMINING ATTORNEY

SN 85-438,095. CHRISTOPHER BRUBECK, DBA BLUE FOREST RECORDS, WILTON, CT. FILED 10-3-2011.



SN 85-436,842. RIVER VALLEY CREDIT UNION, INC., MIAMISBURG, OH. FILED 9-30-2011.



THE MARK CONSISTS OF STANDARD CHARACTERS WITHOUT CLAIM TO ANY PARTICULAR FONT, STYLE, SIZE, OR COLOR.
 NO CLAIM IS MADE TO THE EXCLUSIVE RIGHT TO USE "CARD", APART FROM THE MARK AS SHOWN.
 FOR MAGNETICALLY AND OPTICALLY ENCODED DEBIT CARDS FOR PERSONALIZED USE IN CONNECTION WITH BANKING TRANSACTIONS, IDENTIFICATION AND DATA TRACKING (U.S. CLS. 21, 23, 26, 36 AND 38).
 DEZMONA MIZELLE, EXAMINING ATTORNEY

THE MARK CONSISTS OF STANDARD CHARACTERS WITHOUT CLAIM TO ANY PARTICULAR FONT, STYLE, SIZE, OR COLOR.
 NO CLAIM IS MADE TO THE EXCLUSIVE RIGHT TO USE "RECORDS", APART FROM THE MARK AS SHOWN.
 FOR AUDIO AND VIDEO RECORDINGS FEATURING MUSIC AND ARTISTIC PERFORMANCES; AUDIO TAPES FEATURING MUSIC; COMPACT DISCS FEATURING MUSIC; COMPACT DISCS FEATURING MUSIC AND SPOKEN WORD IN THE FORM OF POETRY; DOWNLOADABLE MUSICAL SOUND RECORDINGS; DOWNLOADABLE RING TONES, GRAPHICS AND MUSIC VIA A GLOBAL COMPUTER NETWORK AND WIRELESS DEVICES; DOWNLOADABLE VIDEO RECORDINGS FEATURING MUSIC (U.S. CLS. 21, 23, 26, 36 AND 38).
 FIRST USE 1-1-2000; IN COMMERCE 1-1-2000.
 PAUL MORENO, EXAMINING ATTORNEY

CLASS 9—(Continued).

SN 85-438,444. HONEYWELL INTERNATIONAL INC., MORRISTOWN, NJ. FILED 10-4-2011.

HONEYWELL

THE MARK CONSISTS OF STANDARD CHARACTERS WITHOUT CLAIM TO ANY PARTICULAR FONT, STYLE, SIZE, OR COLOR.

OWNER OF U.S. REG. NOS. 520,350, 3,256,975 AND OTHERS.

FOR ELECTRICAL WIRE AND CABLE FOR SECURITY, FIRE, SOUND, VOICE AND DATA INDUSTRIES, NAMELY, AUDIO CABLES, CABLES AND FIBERS FOR THE TRANSMISSION OF SOUNDS AND IMAGES, CABLES FOR ELECTRICAL AND OPTICAL SIGNAL TRANSMISSION SYSTEMS, COAXIAL CABLES, COMPONENT VIDEO CABLES, COMPUTER CABLES, ELECTRONIC CABLES, ETHERNET CABLES, HIGH-DEFINITION MULTIMEDIA INTERFACE CABLES, MICROPHONE CABLES, SPEAKER CABLES, STEREO CABLES, TELECOMMUNICATION CABLES, VIDEO CABLES; CABLES USED IN CONNECTION WITH COMPUTERS, COMPUTER PERIPHERAL DEVICES, TELEVISIONS, AUDIO-VIDEO EQUIPMENT, CLOSED-CIRCUIT TV EQUIPMENT, THERMOSTAT AND ENVIRONMENTAL CONTROL EQUIPMENT AND TELECOMMUNICATION EQUIPMENT; CABLE JACKETING MATERIAL SOLD AS AN INTEGRAL FEATURE OF AUDIO CABLES, CABLES AND FIBERS FOR THE TRANSMISSION OF SOUNDS AND IMAGES, CABLES FOR ELECTRICAL AND OPTICAL SIGNAL TRANSMISSION SYSTEMS, COAXIAL CABLES, COMPONENT VIDEO CABLES; CABLE CONNECTORS; ELECTRICAL POWER CORDS (U.S. CLS. 21, 23, 26, 36 AND 38).

FIRST USE 8-31-2010; IN COMMERCE 8-31-2010.
JENNIFER MARTIN, EXAMINING ATTORNEY

CLASS 9—(Continued).

SN 85-448,016. STREAK PRODUCTS INC., PORT WASHINGTON, NY. FILED 10-14-2011.

EASTWEAR

THE MARK CONSISTS OF STANDARD CHARACTERS WITHOUT CLAIM TO ANY PARTICULAR FONT, STYLE, SIZE, OR COLOR.

FOR CASES AND BAGS ADAPTED FOR HOLDING OR CARRYING PORTABLE DEVICES IN THE NATURE OF COMPUTERS, CELLULAR TELEPHONES, LAPTOPS AND NOTEBOOKS; COMPUTER ACCESSORIES, NAMELY, MOUNTING DEVICES FOR MONITORS, BATTERY CHARGERS, BATTERIES, OPTICAL CD-ROM AND DVD DRIVES, DOCKING STATIONS, COMPUTER STANDS SPECIALLY DESIGNED FOR HOLDING A COMPUTER, PRINTER AND ACCESSORIES, KEYBOARDS, MOUSE, STYLUSES, RUBBER PROTECTIVE BUMPERS, CABLES, POWER SUPPLY ADAPTORS FOR CARS FOR USE WITH PORTABLE ELECTRONIC DEVICES, POWER SUPPLIES, COMPUTER MICE, COMPUTER AUDIO SPEAKERS, MOTHERBOARDS, DATA PROCESSORS, HEAT SINKS, INTERNAL COOLING FANS, COMPUTER MEMORY, VIDEO DISPLAY AND CAPTURE CARDS, MODEMS, COMPUTER NETWORKING HARDWARE IN THE NATURE OF NETWORK CARDS, SOUND CARDS, OPTICAL DISC DRIVES, HARD DISC DRIVES, MONITORS, COMPUTER SOFTWARE IN THE NATURE OF OPERATING SYSTEMS AND DEVICE DRIVERS FOR USE IN CONNECTION WITH COMPUTER HARDWARE AND COMPUTER PERIPHERALS (U.S. CLS. 21, 23, 26, 36 AND 38).

KAREN SEVERSON, EXAMINING ATTORNEY

SN 85-448,492. VOLIN, DEE, FAIRVIEW, OR. FILED 10-17-2011.

WACKY CHAN

THE MARK CONSISTS OF STANDARD CHARACTERS WITHOUT CLAIM TO ANY PARTICULAR FONT, STYLE, SIZE, OR COLOR.

THE NAME "WACKY CHAN" DOES NOT IDENTIFY A LIVING INDIVIDUAL.

FOR CHILDREN'S EDUCATIONAL SOFTWARE; COMPUTER GAME SOFTWARE; COMPUTER GAME SOFTWARE DOWNLOADABLE FROM A GLOBAL COMPUTER NETWORK; COMPUTER GAME SOFTWARE FOCUSING ON ACHIEVING A SET OF GOALS, POSITIONS, OWNERSHIP, AND CREDENTIALS, AND PROFESSIONAL AND SOCIAL STATUS, AND GOOD FORTUNE NECESSARY TO SUCCEED PROFESSIONALLY AND PERSONALLY, AND NOT REFERRING EITHER TO A GROUP OF SOFTWARE FOR USE IN COMMERCE OR TO A GROUP OF OFFICES; COMPUTER GAME SOFTWARE FOR PERSONAL COMPUTERS AND HOME VIDEO GAME CONSOLES; COMPUTER GAME SOFTWARE FOR USE ON MOBILE AND CELLULAR PHONES; COMPUTER GAME SOFTWARE FOR USE WITH PERSONAL COMPUTERS, HOME VIDEO GAME CONSOLES USED WITH TELEVISIONS AND ARCADE-BASED VIDEO GAME CONSOLES; COMPUTER GAME SOFTWARE, NAMELY, A COMPUTER CRAPS GAME; COMPUTER GRAPHICS SOFTWARE; COMPUTER HARDWARE AND COMPUTER SOFTWARE PROGRAMS FOR THE INTEGRATION OF TEXT, AUDIO, GRAPHICS, STILL IMAGES AND MOVING

SN 85-446,584. MYCOSKIE, LLC, SANTA MONICA, CA. FILED 10-13-2011.

TOMS

THE MARK CONSISTS OF STANDARD CHARACTERS WITHOUT CLAIM TO ANY PARTICULAR FONT, STYLE, SIZE, OR COLOR.

OWNER OF U.S. REG. NOS. 3,353,902, 3,662,112 AND OTHERS.

FOR EYEWEAR, NAMELY, SUNGLASSES, EYEGLASSES AND OPHTHALMIC FRAMES AND CASES THEREFORE (U.S. CLS. 21, 23, 26, 36 AND 38).

BILL DAWE, EXAMINING ATTORNEY

CLASS 9—(Continued).

PICTURES INTO AN INTERACTIVE DELIVERY FOR MULTIMEDIA APPLICATIONS; COMPUTER SOFTWARE AND FIRMWARE FOR GAMES OF CHANCE ON ANY COMPUTERIZED PLATFORM, INCLUDING DEDICATED GAMING CONSOLES, VIDEO BASED SLOT MACHINES, REEL BASED SLOT MACHINES, AND VIDEO LOTTERY TERMINALS; COMPUTER SOFTWARE FEATURING MUSICAL SOUND RECORDINGS AND MUSICAL VIDEO RECORDINGS; COMPUTER SOFTWARE TO ENHANCE THE AUDIO-VISUAL CAPABILITIES OF MULTIMEDIA APPLICATIONS, NAMELY, FOR THE INTEGRATION OF TEXT, AUDIO, GRAPHICS, STILL IMAGES AND MOVING PICTURES; COMPUTER SOFTWARE, NAMELY, GAME ENGINE SOFTWARE FOR VIDEO GAME DEVELOPMENT AND OPERATION; COMPUTER-GAMING SOFTWARE; DOWNLOADABLE COMPUTER GAME SOFTWARE VIA A GLOBAL COMPUTER NETWORK AND WIRELESS DEVICES; EDUCATIONAL SOFTWARE FEATURING INSTRUCTION IN NATURE, SCIENCE, MAN-MADE THINGS; ELECTRONIC GAME SOFTWARE; ELECTRONIC GAME SOFTWARE FOR CELLULAR TELEPHONES; ELECTRONIC GAME SOFTWARE FOR HANDHELD ELECTRONIC DEVICES; ELECTRONIC GAME SOFTWARE FOR WIRELESS DEVICES; ELECTRONIC GAME SOFTWARE, NAMELY, AN ELECTRONIC CRAPS GAME; ELECTRONIC GAME SOFTWARE, NAMELY, AN ELECTRONIC VIDEO CRAPS GAME; GAME SOFTWARE; INTERACTIVE GAME SOFTWARE; INTERACTIVE VIDEO GAMES OF VIRTUAL REALITY COMPRISED OF COMPUTER HARDWARE FOR USE WITH AN EXTERNAL MONITOR AND SOFTWARE; VIDEO GAME SOFTWARE; VIDEO GAME SOFTWARE, NAMELY, A VIDEO CRAPS GAME; VIRTUAL REALITY GAME SOFTWARE (U.S. CLS. 21, 23, 26, 36 AND 38).

FONG HSU, EXAMINING ATTORNEY

CLASS 9—(Continued).

SN 85-449,262. BARAN, DAYA, SAN JOSE, CA. FILED 10-17-2011.

iSocial

THE MARK CONSISTS OF STANDARD CHARACTERS WITHOUT CLAIM TO ANY PARTICULAR FONT, STYLE, SIZE, OR COLOR.

FOR COMPUTER APPLICATION SOFTWARE FOR MOBILE PHONES, NAMELY, CONNECTING SOCIAL NETWORK USERS WITH BUSINESSES; COMPUTER APPLICATION SOFTWARE FOR CUSTOMER RELATIONSHIP MANAGEMENT, NAMELY, SOFTWARE FOR SOCIAL NETWORKING SERVICES; PROMOTING GOODS AND SERVICES VIA MOBILE AND NON MOBILE APPLICATION FEATURING COUPONS, REBATES, DISCOUNTS, INCENTIVES OR SPECIAL OFFERINGS ON GOODS AND SERVICE PROVIDED BY OTHERS; CONTESTS AND INCENTIVE PROGRAMS TO PROMOTE THE SALE OF PRODUCTS AND SERVICES OF OTHERS (U.S. CLS. 21, 23, 26, 36 AND 38).

FIRST USE 6-1-2011; IN COMMERCE 6-1-2011.

CAROLYN CATALDO, EXAMINING ATTORNEY

SN 85-450,391. XPEC ENTERTAINMENT INC., TAIPEI, TAIWAN, FILED 10-18-2011.



THE COLOR(S) YELLOW, BLACK, WHITE, BROWN, AND GRAY IS/ARE CLAIMED AS A FEATURE OF THE MARK.

THE MARK CONSISTS OF THE STYLIZED WORDING "WEAPONS OF MYTHOLOGY" IN GRAY AND WHITE, OUTLINED IN BLACK, WITHIN A YELLOW, BROWN, AND WHITE FLOWER DESIGN, OUTLINED IN BLACK.

FOR VIDEO GAME SOFTWARE; COMPUTER GAME SOFTWARE; COMPUTER SOFTWARE FOR USE IN DATABASE MANAGEMENT; PRERECORDED DIGITAL VIDEO DISKS FEATURING COMPUTER GAMES SOFTWARE; ELECTRONIC PUBLICATIONS, NAMELY, BOOKS FEATURING STORIES AND EPISODES IN COMPUTER GAMES AND VIDEO GAMES RECORDED ON COMPUTER MEDIA; PERSONAL DIGITAL ASSISTANTS (PDA); DIGITAL CAMERAS; DIGITAL VIDEO DISC DRIVES; LIQUID CRYSTAL DISPLAY (LCD) TELEVISIONS; BATTERIES; POWER CABLES; CABLES FOR ELECTRICAL OR OPTICAL SIGNAL TRANSMISSION; DIGITAL VIDEO OPTICAL DISC FEATURING GAME SOFTWARE; TELEPHONES; GRAPHICS CARDS; ELECTRIC CONNECTORS; MAGNETICALLY ENCODED PRE-PAID CREDIT CARDS FOR ONLINE GAMES (U.S. CLS. 21, 23, 26, 36 AND 38).

STEVEN JACKSON, EXAMINING ATTORNEY

SN 85-449,177. FARMCLOUD, SAMMAMISH, WA. FILED 10-17-2011.

FarmCloud

THE MARK CONSISTS OF STANDARD CHARACTERS WITHOUT CLAIM TO ANY PARTICULAR FONT, STYLE, SIZE, OR COLOR.

FOR COMPUTER SOFTWARE PLATFORMS WHICH PROVIDES AGRICULTURAL INFORMATION TO FARMERS AND THEIR ADVISORS TO MAKE FARMING DECISIONS (U.S. CLS. 21, 23, 26, 36 AND 38).

SANI KHOURI, EXAMINING ATTORNEY

CLASS 9—(Continued).

SN 85-450,922. EYE & EYEWARE, LLC, MILLWOOD, NY. FILED 10-19-2011.

EYE & I

THE MARK CONSISTS OF STANDARD CHARACTERS WITHOUT CLAIM TO ANY PARTICULAR FONT, STYLE, SIZE, OR COLOR.

FOR EYE GLASSES; EYEGLASS FRAMES (U.S. CLS. 21, 23, 26, 36 AND 38).

FIRST USE 9-9-2009; IN COMMERCE 11-3-2010.

JAMES MACFARLANE, EXAMINING ATTORNEY

SN 85-451,674. SPARKPAD LLC, STERLING, VA. FILED 10-20-2011.

SPARKPAD

THE MARK CONSISTS OF STANDARD CHARACTERS WITHOUT CLAIM TO ANY PARTICULAR FONT, STYLE, SIZE, OR COLOR.

FOR ELECTRONIC LCD DISPLAY UNITS FOR INTERACTIVE TOUCH PANELS AND DIGITAL SIGNAGE; TABLET DEVICES AND DIGITAL DISPLAYS FOR INTERACTIVE COMMERCIAL SOLUTIONS, NAMELY, TOUCH PANELS AND DIGITAL SIGNAGE (U.S. CLS. 21, 23, 26, 36 AND 38).

FIRST USE 12-0-2010; IN COMMERCE 12-0-2010.

BERYL GARDNER, EXAMINING ATTORNEY

SN 85-452,658. 8 WEEKS TO WELLNESS, INC, NEWTOWN, PA. FILED 10-20-2011.

THE WELLNESS SCORE

THE MARK CONSISTS OF STANDARD CHARACTERS WITHOUT CLAIM TO ANY PARTICULAR FONT, STYLE, SIZE, OR COLOR.

NO CLAIM IS MADE TO THE EXCLUSIVE RIGHT TO USE "WELLNESS", APART FROM THE MARK AS SHOWN.

FOR COMPUTER SOFTWARE FOR DOCTORS TO MEASURE AND ACCESS THE PHYSIOLOGY OF THEIR PATIENTS AND REPORT THEIR OVERALL WELL-BEING BY LOOKING AT SPECIFIC BIOMETRIC DATA (U.S. CLS. 21, 23, 26, 36 AND 38).

KAREN K. BUSH, EXAMINING ATTORNEY

CLASS 9—(Continued).

SN 85-453,048. REJUVENATIONS INCORPORATED, NAPLES, FL. FILED 10-21-2011.

iSpineHealth

THE MARK CONSISTS OF STANDARD CHARACTERS WITHOUT CLAIM TO ANY PARTICULAR FONT, STYLE, SIZE, OR COLOR.

FOR COMPUTER APPLICATION SOFTWARE FOR MOBILE PHONES, PORTABLE MEDIA PLAYERS, HANDHELD COMPUTERS, TABLET COMPUTERS, AND DESKTOP COMPUTERS, NAMELY, SOFTWARE FOR EXAMINATION AND FOR PROVIDING EDUCATIONAL HEALTH INFORMATION IN THE FIELD OF THE HUMAN BODY, INCLUDING THE SPINE AND MUSCULOSKELETAL SYSTEM (U.S. CLS. 21, 23, 26, 36 AND 38).

ROBIN MITTLER, EXAMINING ATTORNEY

SN 85-453,199. OBEROI, SURINDER, BILBAO, SPAIN, FILED 10-21-2011.

FONEHUT

THE MARK CONSISTS OF STANDARD CHARACTERS WITHOUT CLAIM TO ANY PARTICULAR FONT, STYLE, SIZE, OR COLOR.

OWNER OF ERPN CMNTY TM OFC REG. NO. 002409167, DATED 2-28-2003, EXPIRES 10-10-2021.

FOR MOBILE PHONES, PUBLIC SWITCHED TELECOMMUNICATIONS NETWORK (PSTN) PHONES COMPRISED OF COMPUTER HARDWARE, OPERATING SOFTWARE, AND ELECTRICAL WIRING; ACCESSORIES FOR MOBILE PHONES, NAMELY, SAVER BATTERY CHARGERS, TRAVEL BATTERY CHARGERS, DESKTOP BATTERY CHARGERS, CAR KITS CONSISTING PRIMARILY OF HEADSETS, MICROPHONES, CAR BATTERY CHARGERS, EAR PHONES, EAR PIECES, SPEAKERS, EXTERNAL ANTENNAS, AND ELECTRICAL WIRES FOR USING A MOBILE PHONE IN A CAR; PORTABLE HANDS-FREE HEADSETS FOR MOBILE PHONES, BATTERIES, PHONE CASES, FACE PLATES FOR MOBILE PHONES, SLIDING FACES AND CASINGS FOR MOBILE PHONES, ANTENNAS AND PHONE HOLDERS (U.S. CLS. 21, 23, 26, 36 AND 38).

MARY CRAWFORD, EXAMINING ATTORNEY

CLASS 9—(Continued).

SN 85-454,998. NEST LABS, INC., PALO ALTO, CA. FILED 10-24-2011.



THE MARK CONSISTS OF ARCH DESIGN WITH WORD "NEST" IN LOWER CASE LETTERS INSIDE ARCH ON THE CENTER RIGHT.

FOR CLIMATE CONTROL SYSTEM CONSISTING OF A DIGITAL THERMOSTAT THAT AUTOMATICALLY SETS CLIMATE CONDITIONS BASED ON PRIOR AND HISTORICAL PATTERNS OF CLIMATE SETTINGS SELECTED BY USERS; CLIMATE CONTROL SYSTEM CONSISTING OF A DIGITAL THERMOSTAT THAT CAN BE CONTROLLED WIRELESSLY FROM A REMOTE LOCATION; SOFTWARE APPLICATION FOR USE ON COMPUTERS AND HAND-HELD DEVICES TO CONTROL CLIMATE AND ENERGY USAGE IN HOMES AND BUSINESSES FROM A REMOTE LOCATION (U.S. CLS. 21, 23, 26, 36 AND 38).

SUSAN LESLIE DUBOIS, EXAMINING ATTORNEY

SN 85-456,215. PUTRELLO, ANDREW C., JR., UTICA, NY. FILED 10-26-2011.

ION FLASHLIGHT FIRESTARTER

THE MARK CONSISTS OF STANDARD CHARACTERS WITHOUT CLAIM TO ANY PARTICULAR FONT, STYLE, SIZE, OR COLOR.

NO CLAIM IS MADE TO THE EXCLUSIVE RIGHT TO USE "FLASHLIGHT FIRESTARTER", APART FROM THE MARK AS SHOWN.

FOR MULTI-FUNCTION PORTABLE TOOL, NAMELY, A LED FLASHLIGHT COMBINING AN ILLUMINATING LED LAMP AND ELECTRICALLY-HEATED FIRE STARTING ELEMENT (U.S. CLS. 21, 23, 26, 36 AND 38).

EDWARD NELSON, EXAMINING ATTORNEY

CLASS 9—(Continued).

SN 85-456,633. APPLE INC., CUPERTINO, CA. FILED 10-26-2011.



OWNER OF U.S. REG. NO. 1,855,095.
THE MARK CONSISTS OF AN OPEN RECTANGLE INTERSECTED BY A SOLID TRIANGLE WITH THE WORD "AIRPLAY" WITHIN A SQUARE BORDER.

FOR COMPUTERS; COMPUTER HARDWARE; COMPUTER NETWORKING HARDWARE; COMPUTER PERIPHERAL DEVICES; HANDHELD COMPUTERS; TABLET COMPUTERS; HANDHELD MOBILE DIGITAL ELECTRONIC DEVICES FOR RECORDING, ORGANIZING, TRANSMITTING, MANIPULATING, AND REVIEWING TEXT, DATA, IMAGES, AUDIO AND AUDIOVISUAL FILES, FOR THE SENDING AND RECEIVING OF TELEPHONE CALLS, ELECTRONIC MAIL, AND OTHER DIGITAL DATA, FOR USE AS A DIGITAL FORMAT AUDIO PLAYER, HANDHELD COMPUTER, PERSONAL DIGITAL ASSISTANT, ELECTRONIC ORGANIZER, ELECTRONIC NOTEPAD, CAMERA, AND GLOBAL POSITIONING SYSTEMS (GPS) ELECTRONIC NAVIGATION DEVICE, AND SOFTWARE RELATED THERETO; TELEPHONES; CAMERAS; REMOTE CONTROLS; COMPUTER HARDWARE AND COMPUTER SOFTWARE FOR THE REPRODUCTION, PROCESSING AND STREAMING OF AUDIO, VIDEO AND MULTIMEDIA CONTENT; COMPUTER HARDWARE AND SOFTWARE FOR CONTROLLING THE OPERATION OF AUDIO AND VIDEO DEVICES AND FOR VIEWING, SEARCHING AND/OR PLAYING AUDIO, VIDEO, IMAGES, AND OTHER MULTIMEDIA CONTENT; COMPUTER SOFTWARE FOR AUTHORING, RECORDING, DOWNLOADING, TRANSMITTING, RECEIVING, EDITING, EXTRACTING, ENCODING, DECODING, DISPLAYING, PLAYING, STORING, MANIPULATING, REVIEWING, AND ORGANIZING TEXT, DATA, IMAGES, AUDIO FILES, VIDEO FILES, ELECTRONIC GAMES, AND DIGITAL MEDIA; COMPUTER SOFTWARE TO ENABLE USERS TO PROGRAM, DISTRIBUTE, TRANSMIT AND RECEIVE AUDIO, VIDEO, IMAGES, TEXT AND OTHER MULTIMEDIA CONTENT VIA COMMUNICATIONS NETWORKS; COMPUTER SOFTWARE FOR IDENTIFYING, LOCATING, GROUPING, DISTRIBUTING, AND MANAGING DATA AND LINKS BETWEEN COMPUTERS AND ELECTRONIC

CLASS 9—(Continued).

DEVICES CONNECTED TO ELECTRONIC COMMUNICATIONS NETWORKS; AUDIO RECORDING, REPRODUCING, AND TRANSMITTING APPARATUS; HOME THEATER SYSTEMS COMPRISING AUDIO STEREO SPEAKERS, AUDIO AND VIDEO RECEIVERS, AND AUDIO AND VIDEO MEDIA PLAYERS; STEREO AMPLIFIER AND AUDIO SPEAKER BASE STATIONS; HEADPHONES AND EARPHONES; MICROPHONES; AUDIO SPEAKERS; AUDIO, VIDEO AND DIGITAL MEDIA RECEIVERS; AUDIO AND VIDEO TRANSMITTERS; AUDIO, VIDEO, AND DIGITAL AUDIO AND VIDEO MIXERS; AMPLIFIERS; MP3 AND OTHER DIGITAL FORMAT AUDIO PLAYERS; DIGITAL AUDIO RECORDERS AND PLAYERS; DIGITAL VIDEO RECORDERS AND PLAYERS; RADIOS; TELEVISIONS; TELEVISION MONITORS; VIDEO MONITORS; VIDEO VIEWERS, NAMELY, VIDEO MONITORS FOR MOBILE PHONES, HANDHELD COMPUTERS, AND PORTABLE AND HANDHELD DIGITAL ELECTRONIC DEVICES. TELEVISION SET TOP BOXES; AUTOMOBILE STEREO ADAPTERS (U.S. CLS. 21, 23, 26, 36 AND 38).

KEVIN CORWIN, EXAMINING ATTORNEY

CLASS 9—(Continued).

INSTRUMENTS; DOWNLOADABLE COMPUTER SOFTWARE FOR MOBILE DEVICES THAT ENABLES USERS TO TRANSFORM AND ENHANCE THE VIDEO AND AUDIO CAPABILITIES OF THEIR MOBILE DEVICES; DOWNLOADABLE COMPUTER SOFTWARE EXECUTABLE TO COMMUNICATE AMONGST MOBILE DEVICES USING AUDIO ENCODINGS OF INFORMATION; DOWNLOADABLE COMPUTER SOFTWARE EXECUTABLE TO PROVIDE MOBILE DEVICES WITH SIGNAL PROCESSING CAPABILITIES; DOWNLOADABLE COMPUTER SOFTWARE FOR MOBILE DEVICES THAT ENABLES USERS TO INTERACTIVELY PERFORM INDIVIDUALIZED AUDIO AND VIDEO APPLICATIONS; DOWNLOADABLE COMPUTER SOFTWARE FOR MOBILE DEVICES THAT ENABLES USERS TO SEND MUSIC, TEXT, AUDIO, VIDEO, AND GRAPHICS INFORMATION TO OTHER USERS OF MOBILE DEVICES; DOWNLOADABLE COMPUTER SOFTWARE FOR MOBILE DEVICES FOR ENABLING USERS TO DOWNLOAD AND SHARE INTERACTIVE AUDIO AND MUSIC RECORDINGS (U.S. CLS. 21, 23, 26, 36 AND 38).

FIRST USE 9-8-2011; IN COMMERCE 9-8-2011.

AMY C. KEAN, EXAMINING ATTORNEY

SN 85-462,610. SMULE, INC., PALO ALTO, CA. FILED 11-2-2011.

REMIX YOUR LIFE

THE MARK CONSISTS OF STANDARD CHARACTERS WITHOUT CLAIM TO ANY PARTICULAR FONT, STYLE, SIZE, OR COLOR.

FOR GAME SOFTWARE; DOWNLOADABLE COMPUTER SOFTWARE FOR MOBILE DEVICES FOR PERSONALIZING VIDEO PERFORMANCES ON A MOBILE DEVICE BASED ON USER INTERACTION; COMPUTER APPLICATION SOFTWARE FOR MOBILE COMPUTERS, NAMELY, SOFTWARE THAT ALLOWS A MOBILE DEVICE TO BE USED AS A MUSICAL INSTRUMENT AND ALLOWS USERS TO PLAY MUSIC ALONE OR VIRTUALLY WITH OTHERS; COMPUTER SOFTWARE PROGRAMS FOR THE INTEGRATION OF TEXT, AUDIO, GRAPHICS, STILL IMAGES AND MOVING PICTURES INTO AN INTERACTIVE DELIVERY FOR MULTIMEDIA APPLICATIONS; SOFTWARE FOR PROCESSING DIGITAL MUSIC FILES; COMPUTER SOFTWARE FEATURING MUSICAL SOUND RECORDINGS AND MUSICAL VIDEO RECORDINGS; COMPUTER SOFTWARE FOR COMMUNICATING WITH USERS OF HAND-HELD COMPUTERS; COMPUTER SOFTWARE FOR MANIPULATING DIGITAL AUDIO INFORMATION FOR USE IN AUDIO MEDIA APPLICATIONS; COMPUTER SOFTWARE FOR PROCESSING DIGITAL MUSIC FILES; COMPUTER SOFTWARE PLATFORMS FOR DEVELOPMENT OF INTERACTIVE AUDIO APPLICATIONS FOR USE WITH MOBILE AUDIO PLATFORMS; COMPUTER SOFTWARE EXECUTABLE TO CAUSE MOBILE DEVICES TO FUNCTION AS MUSICAL

SN 85-463,515. SECURE PLANET, INC., ARLINGTON, VA. FILED 11-3-2011.

ABL

THE MARK CONSISTS OF STANDARD CHARACTERS WITHOUT CLAIM TO ANY PARTICULAR FONT, STYLE, SIZE, OR COLOR.

FOR BALLISTIC AND BLAST PROTECTION GARMENTS AND UNDERGARMENTS (U.S. CLS. 21, 23, 26, 36 AND 38).

ALEX KEAM, EXAMINING ATTORNEY

SN 85-464,363. NATIONAL INSTRUMENTS CORPORATION, AUSTIN, TX. FILED 11-4-2011.

NI CompactDAQ

OWNER OF U.S. REG. NOS. 1,715,314, 2,939,331 AND OTHERS.

NO CLAIM IS MADE TO THE EXCLUSIVE RIGHT TO USE "COMPACTDAQ", APART FROM THE MARK AS SHOWN.

THE MARK CONSISTS OF THE UPPERCASE LETTERS "NI" AND THE UNITARY WORD "COMPACTDAQ" WITH THE FIRST "C" AND THE FINAL "DAQ" IN UPPERCASE, AND THE LETTERS "OMPACT" IN LOWERCASE.

FOR COMPUTER HARDWARE AND FIRMWARE FOR USE IN THE COLLECTION AND MEASUREMENT OF ENGINEERING, SCIENTIFIC, AND INDUSTRIAL AUTOMATION INPUT/OUTPUT SIGNALS (U.S. CLS. 21, 23, 26, 36 AND 38).

FIRST USE 5-31-2006; IN COMMERCE 5-31-2006.

STEVEN JACKSON, EXAMINING ATTORNEY

CLASS 9—(Continued).

SN 85-464,373. NATIONAL INSTRUMENTS CORPORATION, AUSTIN, TX. FILED 11-4-2011.

NI COMPACTDAQ

THE MARK CONSISTS OF STANDARD CHARACTERS WITHOUT CLAIM TO ANY PARTICULAR FONT, STYLE, SIZE, OR COLOR.

OWNER OF U.S. REG. NOS. 1,715,314, 2,939,331 AND OTHERS.

NO CLAIM IS MADE TO THE EXCLUSIVE RIGHT TO USE "COMPACTDAQ", APART FROM THE MARK AS SHOWN.

FOR COMPUTER HARDWARE AND FIRMWARE FOR USE IN THE COLLECTION AND MEASUREMENT OF ENGINEERING, SCIENTIFIC, AND INDUSTRIAL AUTOMATION INPUT/OUTPUT SIGNALS (U.S. CLS. 21, 23, 26, 36 AND 38).

FIRST USE 5-31-2006; IN COMMERCE 5-31-2006.
STEVEN JACKSON, EXAMINING ATTORNEY

CLASS 9—(Continued).

SN 85-469,149. EW-ESMT GROUP LLC, DALLAS, TX. FILED 11-10-2011.

The Real You

THE MARK CONSISTS OF STANDARD CHARACTERS WITHOUT CLAIM TO ANY PARTICULAR FONT, STYLE, SIZE, OR COLOR.

FOR COMPUTER SOFTWARE PLATFORM FOR SOCIAL NETWORKING; INTERACTIVE VIDEO GAME PROGRAMS; DOWNLOADABLE COMPUTER SOFTWARE PLATFORM FOR REGISTERED USERS TO ENGAGE IN SOCIAL NETWORKING AND ELECTRONIC GAMING; COMPUTER SOFTWARE TO ENABLE UPLOADING, POSTING, DISPLAYING, TAGGING, BLOGGING, AND SHARING ELECTRONIC PERSONAL PROFILES AND OTHER INFORMATION, NAMELY, THREE-DIMENSIONAL (3-D) DIGITIZED LIFETIME ACHIEVEMENTS, VIA THE INTERNET (U.S. CLS. 21, 23, 26, 36 AND 38).

COLLEEN DOMBROW, EXAMINING ATTORNEY

SN 85-465,054. MARKETRON INTERNATIONAL, LLC, HALEY, ID. FILED 11-4-2011.



OWNER OF U.S. REG. NOS. 2,855,145, 3,964,219 AND 4,078,805.

THE MARK CONSISTS OF FOUR ADJOINED LETTER "M"'S FORMING A CIRCLE AND CONTAINED INSIDE A GRAPHIC OF A CIRCLE.

FOR SOFTWARE FOR USE IN WORD PROCESSING, IN DATABASE MANAGEMENT AND AS A SPREADSHEET FOR RESEARCHING, NEGOTIATING AND SCHEDULING ADVERTISING SPOTS; AND FOR MANAGING STATION AD SCHEDULING, INVENTORY MANAGEMENT AND BILLING; AND FOR MANAGING MOBILE BUSINESS, NETWORK BUSINESS, ADVERTISER RELATIONSHIPS AND PAYMENTS, ELECTRONIC ORDERS AND INVOICES, PAYMENT PROCESSING, MEDIA RELATIONSHIP MANAGEMENT, DIGITAL, EXCHANGE, DATA MANAGEMENT AND REPORTING AND ANALYTICS, ALL IN THE FIELD OF MEDIA (U.S. CLS. 21, 23, 26, 36 AND 38).

FIRST USE 9-7-2010; IN COMMERCE 9-7-2010.
ALYSSA STEEL, EXAMINING ATTORNEY

SN 85-469,675. SISTEMES DE GESTIÓ INFORMÀTICA GIRONA, S.L., GIRONA, SPAIN, FILED 11-10-2011.



THE COLOR(S) GOLD, BROWN, BEIGE AND WHITE IS/ ARE CLAIMED AS A FEATURE OF THE MARK.

THE MARK CONSISTS OF THE TERM "CHALLENGEBALL" IN GOLD APPEARING IN A STYLIZED FORM ABOVE THE PHRASE "CHALLENGE YOUR MIND" IN GOLD ON A GOLD, BROWN AND BEIGE COLORED BACKGROUND. THE COLOR WHITE REPRESENTS A REFLECTION ON THE "C" AND "H" IN "CHALLENGE".

FOR VIDEO GAME SOFTWARE FOR MOBILE DEVICES, PERSONAL COMPUTERS, CONSOLES, TABLETS; ELECTRONIC GAME PROGRAMS; DOWNLOADABLE ELECTRONIC GAME PROGRAMS; ELECTRONIC GAME SOFTWARE; COMPUTER GAME PROGRAMS; DOWNLOADABLE COMPUTER GAME PROGRAMS; INTERACTIVE GAME PROGRAMS; INTERACTIVE GAME SOFTWARE; APPARATUS FOR GAMES ADAPTED FOR USE WITH TELEVISION RECEIVERS; CINEMATOGRAPHIC APPARATUS; PROTECTIVE CARRYING CASES SPECIALLY ADAPTED FOR PHONES AND HANDHELD COMPUTERS (U.S. CLS. 21, 23, 26, 36 AND 38).

KELLY BOULTON, EXAMINING ATTORNEY

CLASS 9—(Continued).

SN 85-470,695. ADESTO TECHNOLOGIES CORPORATION, SUNNYVALE, CA. FILED 11-11-2011.

Adesto

THE MARK CONSISTS OF STANDARD CHARACTERS WITHOUT CLAIM TO ANY PARTICULAR FONT, STYLE, SIZE, OR COLOR.

FOR SEMICONDUCTOR CHIPS; SEMICONDUCTOR DEVICES; SEMICONDUCTORS (U.S. CLS. 21, 23, 26, 36 AND 38).

FIRST USE 3-1-2007; IN COMMERCE 10-5-2011.

ARETHA SOMERVILLE, EXAMINING ATTORNEY

SN 85-470,757. THUNDER SCIENTIFIC CORPORATION, ALBUQUERQUE, NM. FILED 11-11-2011.

THUNDER SCIENTIFIC

THE MARK CONSISTS OF STANDARD CHARACTERS WITHOUT CLAIM TO ANY PARTICULAR FONT, STYLE, SIZE, OR COLOR.

NO CLAIM IS MADE TO THE EXCLUSIVE RIGHT TO USE "SCIENTIFIC", APART FROM THE MARK AS SHOWN.

FOR HUMIDITY GENERATORS FOR CALIBRATION PURPOSES; DATA COLLECTION INSTRUMENTATION FOR USE WITH SUCH HUMIDITY GENERATORS; PSYCHROMETERS; SOFTWARE FOR AUTOMATIC CONTROL OF HUMIDITY CALIBRATION EQUIPMENT, HUMIDITY CONVERSION AND CALCULATION OF UNCERTAINTIES; AND REPAIR KITS AND REPLACEMENT PARTS FOR HUMIDITY GENERATORS FOR CALIBRATION PURPOSES, DATA COLLECTION INSTRUMENTATION FOR SUCH HUMIDITY GENERATORS, AND PSYCHROMETERS (U.S. CLS. 21, 23, 26, 36 AND 38).

FIRST USE 5-31-1966; IN COMMERCE 6-30-1966.

THOMAS MANOR, EXAMINING ATTORNEY

CLASS 9—(Continued).

SN 85-470,990. MIAMI MARLINS, L.P., MIAMI, FL. FILED 11-11-2011.



THE COLOR(S) ORANGE, YELLOW, WHITE, BLUE AND SILVER IS/ARE CLAIMED AS A FEATURE OF THE MARK.

THE MARK CONSISTS OF A STYLIZED LETTER "M" ALTERNATELY LINED IN SILVER, ORANGE, YELLOW, WHITE AND BLUE WITH A STYLIZED FISH DESIGN ALTERNATELY LINED IN SILVER, ORANGE, WHITE AND BLUE CURLING AROUND THE UPPER LEFT SIDE OF THE "M".

FOR ELECTRICAL AND SCIENTIFIC APPARATUS, NAMELY, HEADPHONES, RADIOS, PRE-RECORDED CDS, VIDEO TAPES, LASER DISKS AND DVDS RELATING TO BASEBALL, MAGNETICALLY ENCODED CREDIT CARDS, COMPACT DISC CASES, CARRYING CASES FOR HAND-HELD COMPUTERS, PROTECTIVE CARRYING CASES FOR PORTABLE MUSIC PLAYERS, NAMELY, MP3 PLAYERS, TELEPHONES, EYEGLASS CASES, CASES SPECIALLY ADAPTED FOR PERSONAL DIGITAL ASSISTANTS, CELL PHONES, CELL PHONE ACCESSORIES, NAMELY, CASES AND FACE PLATE COVERS, DECORATIVE CHARMS FOR CELL PHONES, BINOCULARS, PORTABLE LISTENING DEVICES, NAMELY, MP3 PLAYERS, COMPUTER MONITORS, TELEVISIONS AND TELEVISION MONITORS, MOBILE PHONE STRAPS, CALCULATORS, PHOTOGRAPHIC CAMERAS, DECORATIVE SWITCH PLATE COVERS, LUMINOUS SIGNS, NEON SIGNS, FITTED PLASTIC FILMS KNOWN AS SKINS FOR COVERING AND PROVIDING A SCRATCH PROOF BARRIER OR PROTECTION FOR ELECTRONIC DEVICES, NAMELY, MP3 PLAYERS, MOBILE TELEPHONES, SMART TELEPHONES, DIGITAL CAMERAS, GLOBAL POSITIONING SYSTEMS AND PERSONAL DIGITAL ASSISTANTS, PROTECTIVE SLEEVES FOR LAPTOP COMPUTERS, BLANK USB FLASH DRIVES, CUSHIONED SUPPORT BASE SPECIALLY ADAPTED TO PROP UP LAPTOP COMPUTERS, SUNGLASSES, DECORATIVE MAGNETS, PROTECTIVE HELMETS, PROTECTIVE WORK GLOVES, SPORTS HELMETS, GRADUATED RULERS, VIDEO AND COMPUTER GAME CARTRIDGES, VIDEO AND COMPUTER GAME DISCS, VIDEO AND COMPUTER GAME CASSETTES AND VIDEO GAME CONTROLLERS, COMPUTER ACCESSORIES, NAMELY, COMPUTER MOUSE, MOUSE PADS AND KEYBOARD WRIST PADS, COMPUTER SOFTWARE, NAMELY, SCREEN SAVERS FOR PERSONAL COMPUTERS AND CELL PHONES, DOWNLOADABLE RING TONES AND GRAPHICS FOR MOBILE PHONES, COMPUTER GAME PROGRAMS, AND COMPUTER APPLICATION PROGRAMS DOWNLOADABLE FROM A GLOBAL COMPUTER NETWORK FEATURING SCREENSAVERS, PHOTOGRAPHS, DIGITAL IMAGES, TELEVISION SHOWS, RADIO PROGRAMS, MAPS, DRIVING DIRECTIONS, SOCIAL MEDIA ACCESSING CAPABILITIES, TICKETING CAPABILITIES, GAMES, FOOD AND BEVERAGE ORDERING CAPABILITIES, NEWS, AND STATISTICAL INFORMATION IN THE FIELD OF BASEBALL (U.S. CLS. 21, 23, 26, 36 AND 38).

KATHY DE JONGE, EXAMINING ATTORNEY

CLASS 9—(Continued).

SN 85-471,095. CALIN TECHNOLOGY CO., LTD., TAI-CHUNG CITY 427, TAIWAN, FILED 11-12-2011.

CALIN

THE MARK CONSISTS OF STANDARD CHARACTERS WITHOUT CLAIM TO ANY PARTICULAR FONT, STYLE, SIZE, OR COLOR.

FOR BINOCULARS; CAMCORDERS; CAMERAS FOR USE IN PHOTOGRAPHY; COLOR FILTERS FOR USE IN PHOTOGRAPHY; CAMERA PARTS, NAMELY, DIAPHRAGMS; DIGITAL CAMERAS; DRIVING RECORDER IN THE NATURE OF VIDEO RECORDER, AND LENS; CAMERA PARTS, NAMELY, EYEPIECES; FILTERS FOR CAMERAS; LENS HOODS; LENSES FOR ASTROPHOTOGRAPHY; OPTICAL LENSES; COVERS FOR CAMERA LENSES; CASES FOR CAMERA LENSES; PARTS FOR OPTICAL LENSES, NAMELY, OBJECTIVES; OPTICAL INSPECTION APPARATUS AND INSTRUMENTS; OPTICAL GLASSES; OPTICAL GOODS, NAMELY, OPTICAL CHARACTER RECOGNITION APPARATUS; OPTICAL LENSES; PEEPHOLES IN THE NATURE OF MAGNIFYING LENSES FOR DOORS; OPTICAL LENSES FOR USE IN PORTABLE PHONES; OPTICAL PRISMS; PHOTOGRAPHIC PROJECTOR LENS; AUDIO-VISUAL RECEIVERS; LCD AND LED DISPLAY SCREENS FOR USE IN CAMERAS; SHUTTERS FOR USE IN CAMERAS; SPECTROSCOPES; STEREOSCOPES; TELESCOPES; THEFT PREVENTION INSTALLATION IN THE NATURE OF VIDEO RECORDERS; VIDEO RECORDERS; VIDEO SCREENS; OPTICAL REFRACTORS (U.S. CLS. 21, 23, 26, 36 AND 38).

EMILY CARLSEN, EXAMINING ATTORNEY

SN 85-473,475. LUXI ELECTRONICS CORP., IRVINE, CA. FILED 11-15-2011.

PRESENTER

THE MARK CONSISTS OF STANDARD CHARACTERS WITHOUT CLAIM TO ANY PARTICULAR FONT, STYLE, SIZE, OR COLOR.

FOR ELECTRONIC COMPONENTS FOR RECEIVING, SWITCHING, DISTRIBUTING AND TRANSMITTING DIGITAL VIDEO, AUDIO SIGNALS, NAMELY, APPARATUS FOR TRANSMITTING AND REPRODUCING SOUND OR IMAGES THAT CAN BE DAISY-CHAINED TOGETHER IN SERIES; AUDIOVISUAL RECEIVERS THAT CAN BE DAISY-CHAINED TOGETHER IN SERIES; COMPONENT EXTENDED RANGE TRANSMITTERS AND RECEIVERS IN THE NATURE OF DISTRIBUTION AMPLIFIERS FOR AUDIO AND VIDEO SIGNALS THAT CAN BE DAISY-CHAINED TOGETHER IN SERIES (U.S. CLS. 21, 23, 26, 36 AND 38).

FIRST USE 3-25-2010; IN COMMERCE 10-29-2010.
MICHAEL TANNER, EXAMINING ATTORNEY

CLASS 9—(Continued).

SN 85-473,638. INSIGHT SOFTWARE, LLC, WESTON, FL. FILED 11-16-2011.



OWNER OF U.S. REG. NO. 3,338,754.
THE COLOR(S) BLUE, GREEN, WHITE AND GRAY IS/ARE CLAIMED AS A FEATURE OF THE MARK.

THE MARK CONSISTS OF THE LITERAL ELEMENTS "MY VISION EXPRESS" WHEREIN THE WORDS "MY" AND "EXPRESS" ARE WRITTEN IN BLUE COLOR AND THE LETTERS "V","I","S","N" IN THE WORD "VISION" IS WRITTEN IN GREEN COLOR AND LETTER "O" IS DEPICTING A HUMAN EYE COLORED IN SHADES OF BLUE, GRAY AND WHITE AND ABOVE AND BELOW IT IS PLACED BIG AND SMALL CURVED LINES IN BLUE COLORS DEPICTING EYELIDS AS SHOWN IN THE MARK.

FOR COMPUTER SOFTWARE FOR PRACTICE MANAGEMENT AND ELECTRONIC HEALTH RECORDS MANAGEMENT FOR EYE CARE PROFESSIONALS (U.S. CLS. 21, 23, 26, 36 AND 38).

FIRST USE 5-18-2011; IN COMMERCE 7-6-2011.
LINDA ORNDORFF, EXAMINING ATTORNEY

SN 85-474,367. EXQUISITE MULTIMEDIA, INC., CHATSWORTH, CA. FILED 11-16-2011.

EXTREME COMIXXX

THE MARK CONSISTS OF STANDARD CHARACTERS WITHOUT CLAIM TO ANY PARTICULAR FONT, STYLE, SIZE, OR COLOR.

NO CLAIM IS MADE TO THE EXCLUSIVE RIGHT TO USE "COMICS", APART FROM THE MARK AS SHOWN. FOR PRE-RECORDED DVDS FEATURING ADULT ENTERTAINMENT (U.S. CLS. 21, 23, 26, 36 AND 38).

FIRST USE 10-31-2010; IN COMMERCE 10-31-2010.
MARLENE BELL, EXAMINING ATTORNEY

SN 85-476,788. THE NOCO COMPANY, CLEVELAND, OH. FILED 11-18-2011.

NOCO XGRID

THE MARK CONSISTS OF STANDARD CHARACTERS WITHOUT CLAIM TO ANY PARTICULAR FONT, STYLE, SIZE, OR COLOR.

OWNER OF U.S. REG. NOS. 1,165,271, 1,448,179 AND OTHERS.

FOR BATTERY CHARGERS, POWER INVERTERS, ELECTRIC POWER CONVERTERS, ELECTRIC CHARGE CONTROLLERS, AND ELECTRICAL POWER SUPPLIES (U.S. CLS. 21, 23, 26, 36 AND 38).

MARGERY A. TIERNEY, EXAMINING ATTORNEY

CLASS 9—(Continued).

SN 85-477,139. BATTERY MARVEL LLC, ATLANTA, GA. FILED 11-19-2011.

Battery Marvel

THE MARK CONSISTS OF STANDARD CHARACTERS WITHOUT CLAIM TO ANY PARTICULAR FONT, STYLE, SIZE, OR COLOR.

NO CLAIM IS MADE TO THE EXCLUSIVE RIGHT TO USE "BATTERY", APART FROM THE MARK AS SHOWN.

FOR BATTERY MONITORING DEVICES THAT MAY BE ATTACHED TO A BATTERY TO MONITOR THE PERFORMANCE OF THE BATTERY AND OPERATING SOFTWARE FOR USE THEREWITH, SOLD AS A UNIT (U.S. CLS. 21, 23, 26, 36 AND 38).

FIRST USE 2-1-2011; IN COMMERCE 10-1-2011.
JOHN DWYER, EXAMINING ATTORNEY

CLASS 9—(Continued).

SN 85-478,168. ONALLO LLC, LEVITTOWN, PA. FILED 11-21-2011.

önálló

THE MARK CONSISTS OF STANDARD CHARACTERS WITHOUT CLAIM TO ANY PARTICULAR FONT, STYLE, SIZE, OR COLOR.

THE ENGLISH TRANSLATION OF THE HUNGARIAN WORD "ÖNÁLLO" IN THE MARK IS "INDEPENDENT".

FOR SUNGLASSES AND SPECTACLES (U.S. CLS. 21, 23, 26, 36 AND 38).

FIRST USE 11-1-2011; IN COMMERCE 11-1-2011.
MICHAEL TANNER, EXAMINING ATTORNEY

SN 85-478,300. SUN WANG GROUP, INC., SOUTH EL MONTE, CA. FILED 11-21-2011.

SN 85-478,021. SKY TECH WORLDWIDE, INC., CHINO, CA. FILED 11-21-2011.



THE MARK CONSISTS OF THE LETTERS "QUBY" WITH A VEHICLE CHARGER FORMING THE DOWNSTROKE OF THE "Q" AND EARPHONES WITH A CORD FORMING THE "Y". TO THE RIGHT OF THE "Y" IS A MISCELLANEOUS RECTANGULAR DESIGN.

FOR CELL PHONE BATTERY CHARGERS; CHARGERS FOR BATTERIES; CELL PHONE BATTERY CHARGERS FOR USE IN VEHICLES; BATTERY PACKS; EARPHONES; HEADSETS FOR CELLULAR OR MOBILE PHONES; APPARATUS FOR RECORDING, TRANSMISSION, PROCESSING AND REPRODUCTION OF SOUND, IMAGES OR DATA; APPARATUS FOR TRANSMISSION OF COMMUNICATION; ELECTRONIC COMMUNICATIONS SYSTEMS COMPRISED OF COMPUTER HARDWARE AND SOFTWARE FOR THE TRANSMISSION OF DATA BETWEEN TWO POINTS (U.S. CLS. 21, 23, 26, 36 AND 38).

LINDA MICKLEBURGH, EXAMINING ATTORNEY



THE COLOR(S) SILVER, GRAY, BEIGE, BROWN, WHITE AND BLACK IS/ARE CLAIMED AS A FEATURE OF THE MARK.

THE MARK CONSISTS OF THE WORDS, "MOUNTAIN LION" IN WHITE, STYLIZED FORM, BELOW THE DESIGN OF AN ATTACKING MOUNTAIN LION IN SILVER, BEIGE, BROWN, WHITE AND BLACK, ALL INSIDE A SHADED BLACK RECTANGLE.

FOR CASES FOR EYEGLASSES AND SUNGLASSES; CASES FOR SPECTACLES AND SUNGLASSES; FRAMES FOR SPECTACLES AND SUNGLASSES; LENSES FOR SUNGLASSES; NOSE GUARDS WHICH CAN BE WORN BY ATTACHMENT TO EYEWEAR SUCH AS SUNGLASSES AND SKI GOGGLES; SUNGLASS LENSES (U.S. CLS. 21, 23, 26, 36 AND 38).

FIRST USE 10-21-2011; IN COMMERCE 10-21-2011.
BARBARA A. GOLD, EXAMINING ATTORNEY

CLASS 9—(Continued).

SN 85-478,884. ZAGG INTELLECTUAL PROPERTY HOLDING CO., INC., SALT LAKE CITY, UT. FILED 11-22-2011.

ZAGGKEYS

THE MARK CONSISTS OF STANDARD CHARACTERS WITHOUT CLAIM TO ANY PARTICULAR FONT, STYLE, SIZE, OR COLOR.

OWNER OF U.S. REG. NO. 3,838,237.

FOR COMPUTER KEYBOARDS AND CASES THEREFOR THAT CONVERT INTO STANDS FOR TABLET COMPUTERS AND SMART PHONES ALL OF THE FOREGOING SOLD TOGETHER AS A UNIT; COMPUTER KEYBOARDS FOR TABLET COMPUTERS AND SMART PHONES; ACCESSORIES FOR TABLET COMPUTERS AND SMART PHONES, NAMELY, A COMBINED COMPUTER KEYBOARD AND STAND FOR HOLDING A PERSONAL DIGITAL ELECTRONIC DEVICE (U.S. CLS. 21, 23, 26, 36 AND 38).

FIRST USE 7-20-2011; IN COMMERCE 7-20-2011.
MICHAEL TANNER, EXAMINING ATTORNEY

CLASS 9—(Continued).

SN 85-479,649. CPD HEALTH CONSULTANTS, LLC, SAN ANTONIO, TX. FILED 11-23-2011.



THE COLOR(S) WHITE AND RED IS/ARE CLAIMED AS A FEATURE OF THE MARK.

THE MARK CONSISTS OF A LETTER "P" IN LOWERCASE IN WHITE COLOR JOINED WITH A LETTER "D" IN LOWERCASE IN WHITE COLOR WITH SPACE BETWEEN THE COJOINED "P" AND "D". THE SPACE MAKES A VIRTUAL LETTER "C" THESE LETTERS ARE ENCLOSED IN THE IMAGE OF PLUS SIGN IN WHITE COLOR ON A RED COLOR BACKGROUND AS SHOWN IN THE MARK.

FOR USB FLASH DRIVES THAT ARE PREPROGRAMMED TO PROVIDE USERS WITH AN EASY, PORTABLE AND PASSWORD ENCRYPTED WAY TO KEEP THEIR MEDICAL DOCUMENTS UP TO DATE (U.S. CLS. 21, 23, 26, 36 AND 38).

FIRST USE 10-30-2011; IN COMMERCE 11-8-2011.
DAVID MURRAY, EXAMINING ATTORNEY

SN 85-479,078. ERIC BEARE ASSOCIATES LIMITED, KOWLOON, HONG KONG, FILED 11-22-2011.

iCanister

THE MARK CONSISTS OF STANDARD CHARACTERS WITHOUT CLAIM TO ANY PARTICULAR FONT, STYLE, SIZE, OR COLOR.

FOR WATERPROOF LOUDSPEAKERS (U.S. CLS. 21, 23, 26, 36 AND 38).

MICHAEL TANNER, EXAMINING ATTORNEY

SN 85-480,072. ZAGG INTELLECTUAL PROPERTY HOLDING CO., INC., SALT LAKE CITY, UT. FILED 11-23-2011.

FLEX

THE MARK CONSISTS OF STANDARD CHARACTERS WITHOUT CLAIM TO ANY PARTICULAR FONT, STYLE, SIZE, OR COLOR.

FOR COMPUTER KEYBOARDS AND CASES THEREFOR THAT CONVERT INTO STANDS FOR TABLET COMPUTERS AND SMART PHONES ALL OF THE FOREGOING SOLD TOGETHER AS A UNIT; COMPUTERS KEYBOARDS FOR TABLET COMPUTERS AND SMART PHONES (U.S. CLS. 21, 23, 26, 36 AND 38).

FIRST USE 11-8-2011; IN COMMERCE 11-8-2011.
MICHAEL TANNER, EXAMINING ATTORNEY

CLASS 9—(Continued).

SN 85-480,247. ZAGG INTELLECTUAL PROPERTY HOLDING CO., INC., SALT LAKE CITY, UT. FILED 11-23-2011.

ZAGGKEYS FLEX

THE MARK CONSISTS OF STANDARD CHARACTERS WITHOUT CLAIM TO ANY PARTICULAR FONT, STYLE, SIZE, OR COLOR.

OWNER OF U.S. REG. NO. 3,838,237.
FOR COMPUTER KEYBOARDS AND CASES THEREFOR THAT CONVERT INTO STANDS FOR TABLET COMPUTERS AND SMART PHONES ALL OF THE FOREGOING SOLD TOGETHER AS A UNIT; COMPUTERS KEYBOARDS FOR TABLET COMPUTERS AND SMART PHONES (U.S. CLS. 21, 23, 26, 36 AND 38).

FIRST USE 11-8-2011; IN COMMERCE 11-8-2011.
MICHAEL TANNER, EXAMINING ATTORNEY

SN 85-481,932. G4S TECHNOLOGY LIMITED, GLOUCESTERSHIRE, UNITED KINGDOM, FILED 11-28-2011.

OneFacility 

OWNER OF U.S. REG. NO. 3,800,082.

THE MARK CONSISTS OF THE LETTERS "ONEFACILITY" IN BLACK WITH "TF" IN WHITE ON A BLACK SQUARE WITH TWO ROUNDED CORNERS AND TWO POINTED ENDS.

FOR FACILITIES MANAGEMENT SOFTWARE, NAMELY, SOFTWARE TO CONTROL BUILDING ENVIRONMENT, ACCESS AND SECURITY SYSTEMS; ELECTRONIC CONTROL APPARATUS AND ALARM APPARATUS INCORPORATING COMPUTER HARDWARE, CLOSED CIRCUIT TELEVISIONS, ENCODED AND ENCRYPTED MAGNETIC CARDS, KEYPADS AND CARD READERS; ELECTRICAL AND ELECTRONIC CONTROLLERS FOR LIGHTING AND HEATING; ALL SOLD AS A UNIT; ELECTRICAL AND ELECTRONIC APPARATUS AND INSTRUMENTS FOR SECURITY AND CONTROL ACCESS SYSTEMS, NAMELY, ELECTRIC LOCKS AND ELECTRONIC LOCKS; INTRUDER DETECTORS; FIRE SENSORS; CONTROLLERS FOR FIRE SENSORS, INTRUDER SENSORS, EXTERNAL LIGHTING, PARKING BARRIERS AND HEATING SYSTEMS; CLOSED CIRCUIT TELEVISION CAMERAS; CLOSED CIRCUIT TELEVISION MONITORS; CLOSED CIRCUIT TELEVISION CONTROLLERS; CLOSED CIRCUIT TELEVISION SWITCHERS AND MULTIPLEXERS; ANTI-INTRUSION ALARMS; FIRE ALARMS; ALARM SENSORS; ALARM CONTROLLERS AND ALARM CONTROL PANELS; ACCESS MONITORS; DOOR MONITORS; ACCESS CONTROLLERS; TELEPHONE APPARATUS, NAMELY, INTERCOMS; INTERCOM CONTROLLERS; INTERCOM CONTROL SCREENS,

CLASS 9—(Continued).

MAGNETICALLY ENCODED IDENTIFICATION BADGES; DIGITAL VIDEO RECORDERS; ENCODED SMART CARDS CONTAINING PROGRAMMING USED TO CONTROL ACCESS TO SECURE FACILITIES; SMART CARD ENCODERS; SMART CARD READERS; MAGNETIC ENCODED ACCESS CARDS, MAGNETIC STRIPE CARD ENCODERS, MAGNETIC STRIPE CARD READERS; PROXIMITY READERS FOR MAGNETIC CODED CARDS; CONTACT CARD READERS; MUSTER READERS; WALL SWITCH READERS; COMPUTER KEYPADS; ICD DISPLAYS; LED DISPLAYS; ELECTRICAL CABLES; MODEMS; FINGERPRINT SENSORS; FINGERPRINT READERS AND OTHER BIOMETRIC READERS, NAMELY, HAND, IRIS, AND FACE RECOGNITION READERS; MAGNETIC PULSE-ENCODED CARD READERS; REMOTE CONTROLS FOR DOORS; REMOTE CONTROLS FOR ALARMS; CONTROL PANELS FOR ELECTRONIC SECURITY SYSTEMS; ALL THE AFORESAID GOODS RELATING TO SECURITY AND CONTROL ACCESS SYSTEMS (U.S. CLS. 21, 23, 26, 36 AND 38).

MARTHA SANTOMARTINO, EXAMINING ATTORNEY

SN 85-482,826. CLASSIC INSTRUMENTS, INC., BOYNE CITY, MI. FILED 11-29-2011.

ALL AMERICAN SERIES

THE MARK CONSISTS OF STANDARD CHARACTERS WITHOUT CLAIM TO ANY PARTICULAR FONT, STYLE, SIZE, OR COLOR.

NO CLAIM IS MADE TO THE EXCLUSIVE RIGHT TO USE "SERIES", APART FROM THE MARK AS SHOWN.

FOR AUTOMOTIVE MEASURING INSTRUMENTS, NAMELY, SPEEDOMETERS, DISTANCE MEASURING APPARATUS, FUEL GAUGES, PRESSURE GAUGES, WATER TEMPERATURE GAUGES, EXHAUST GAS TEMPERATURE GAUGES, AND FLUID LEVEL GAUGES (U.S. CLS. 21, 23, 26, 36 AND 38).

FIRST USE 8-1-2002; IN COMMERCE 8-1-2002.
MELISSA VALLILLO, EXAMINING ATTORNEY

SN 85-484,573. BYTEMARK, INC., NEW YORK, NY. FILED 12-1-2011.

Bytemark

THE MARK CONSISTS OF STANDARD CHARACTERS WITHOUT CLAIM TO ANY PARTICULAR FONT, STYLE, SIZE, OR COLOR.

FOR COMPUTER APPLICATION SOFTWARE FOR MOBILE PHONES, NAMELY, SOFTWARE FOR PROCESSING FINANCIAL TRANSACTIONS, ELECTRONIC WALLET SERVICES, COUPON STORAGE, AND LOYALTY CARD SYSTEMS; COMPUTER APPLICATION SOFTWARE FOR WEB BROWSERS, NAMELY, SOFTWARE FOR PROCESSING FINANCIAL TRANSACTIONS, ELECTRONIC WALLET SERVICES, COUPON STORAGE, AND LOYALTY CARD SYSTEMS; COMPUTER E-COMMERCE SOFTWARE TO ALLOW USERS TO PERFORM ELECTRONIC BUSINESS TRANSACTIONS VIA A GLOBAL COMPUTER NETWORK; COMPUTER SOFTWARE DEVELOPMENT TOOLS; COMPUTER SOFTWARE FOR ACCESSING INFORMATION DIREC-

CLASS 9—(Continued).

TORIES THAT MAY BE DOWNLOADED FROM THE GLOBAL COMPUTER NETWORK; COMPUTER SOFTWARE FOR COMMUNICATING WITH USERS OF HAND-HELD COMPUTERS; COMPUTER SOFTWARE FOR ENCRYPTION; COMPUTER SOFTWARE FOR PROVIDING AN ON-LINE DATABASE IN THE FIELD OF TRANSACTION PROCESSING TO UPLOAD TRANSACTIONAL DATA, PROVIDE STATISTICAL ANALYSIS, AND PRODUCE NOTIFICATIONS AND REPORTS; COMPUTER SOFTWARE FOR THE COLLECTION, EDITING, ORGANIZING, MODIFYING, BOOK MARKING, TRANSMISSION, STORAGE AND SHARING OF DATA AND INFORMATION; COMPUTER SOFTWARE FOR THE DATABASING, VISUALIZATION, MANIPULATION, VIRTUAL REALITY IMMERSION AND INTEGRATION OF GEOGRAPHIC INFORMATION WITH ON-LINE MEMBER COMMUNITIES; COMPUTER SOFTWARE FOR THE FIELD OF WAREHOUSING AND DISTRIBUTION, TO MANAGE TRANSACTIONAL DATA, PROVIDE STATISTICAL ANALYSIS, AND PRODUCE NOTIFICATIONS AND REPORTS; COMPUTER SOFTWARE FOR USE IN CUSTOMER RELATIONSHIP MANAGEMENT (CRM); COMPUTER SOFTWARE FOR USE IN THE ENCRYPTION AND DECRYPTION OF DIGITAL FILES, INCLUDING AUDIO, VIDEO, TEXT, BINARY, STILL IMAGES, GRAPHICS AND MULTIMEDIA FILES; COMPUTER SOFTWARE FOR USE IN THE SAFEGUARDING OF DIGITAL FILES, INCLUDING AUDIO, VIDEO, TEXT, BINARY, STILL IMAGES, GRAPHICS AND MULTIMEDIA FILES; COMPUTER SOFTWARE FOR WIRELESS CONTENT DELIVERY; COMPUTER SOFTWARE PLATFORMS FOR THE MANAGEMENT OF FINANCIAL AND LOYALTY TRANSACTIONS; COMPUTER SOFTWARE THAT PROVIDES REAL-TIME, INTEGRATED BUSINESS MANAGEMENT INTELLIGENCE BY COMBINING INFORMATION FROM VARIOUS DATABASES AND PRESENTING IT IN AN EASY-TO-UNDERSTAND USER INTERFACE; COMPUTER SOFTWARE THAT PROVIDES WEB-BASED ACCESS TO APPLICATIONS AND SERVICES THROUGH A WEB OPERATING SYSTEM OR PORTAL INTERFACE; COMPUTER SOFTWARE TO AUTOMATE DATA WAREHOUSING; COMPUTER SOFTWARE TO ENABLE THE TRANSMISSION OF PHOTOGRAPHS TO MOBILE TELEPHONES; COMPUTER SOFTWARE, NAMELY, AN APPLICATION ALLOWING SALES AND FIELD SERVICE EMPLOYEES TO UPDATE AND RECEIVE DATA STORED IN AN ENTERPRISE'S COMPUTER DATABASES IN REAL TIME, USING A MOBILE DEVICE, WITH FULL TELEPHONY INTEGRATION WITH THE TELEPHONE AND/OR SOFTWARE FEATURES OF THE MOBILE DEVICE; COMPUTER SOFTWARE, NAMELY, ELECTRONIC FINANCIAL PLATFORM THAT ACCOMMODATES MULTIPLE TYPES OF PAYMENT AND DEBT TRANSACTIONS IN AN INTEGRATED MOBILE PHONE, PDA, AND WEB BASED ENVIRONMENT; COMPUTER SOFTWARE, NAMELY, SOFTWARE DEVELOPMENT TOOLS FOR THE CREATION OF MOBILE INTERNET APPLICATIONS AND CLIENT INTERFACES; DOWNLOADABLE SOFTWARE IN THE NATURE OF A MOBILE APPLICATION FOR FINANCIAL AND LOYALTY TRANSACTIONS AND COUPON MANAGEMENT; SOFTWARE FOR PROCESSING IMAGES, GRAPHICS AND TEXT (U.S. CLS. 21, 23, 26, 36 AND 38).
 FIRST USE 11-1-2010; IN COMMERCE 2-28-2011.
 WENDY JUN, EXAMINING ATTORNEY

CLASS 9—(Continued).

SN 85-484,629. IQUEST ANALYTICS, INC., BARRINGTON, RI. FILED 12-1-2011.



OWNER OF U.S. REG. NO. 3,051,677.
 THE COLOR(S) LIGHT BLUE AND BLACK IS/ARE CLAIMED AS A FEATURE OF THE MARK.
 THE MARK CONSISTS OF A STYLIZED LOWERCASE LETTER "I" INSIDE A CAPITAL LETTER "Q". THESE APPEAR IN BLACK COLOR EXCEPT THE TITLE OF THE LOWERCASE LETTER "I", WHICH APPEARS IN LIGHT BLUE COLOR.
 FOR COMPUTER SOFTWARE FOR CREATING SEARCHABLE DATABASES OF INFORMATION AND DATA; COMPUTER SOFTWARE AND HARDWARE FOR SEMANTIC SEARCHING, RESEARCHING AND ANALYSIS OF DOCUMENTS (U.S. CLS. 21, 23, 26, 36 AND 38).
 FIRST USE 1-1-2011; IN COMMERCE 1-1-2011.
 DAWN HAN, EXAMINING ATTORNEY

SN 85-485,234. TOUCHSTONE MERCHANDISE GROUP, LLC., MASON, OH. FILED 12-1-2011.

FACTORI

THE MARK CONSISTS OF STANDARD CHARACTERS WITHOUT CLAIM TO ANY PARTICULAR FONT, STYLE, SIZE, OR COLOR.
 FOR COMPUTER SOFTWARE PLATFORMS FOR ECOMMERCE TO ALLOW USERS TO PERFORM ELECTRONIC BUSINESS TRANSACTIONS VIA A GLOBAL COMPUTER NETWORK (U.S. CLS. 21, 23, 26, 36 AND 38).
 MARY CRAWFORD, EXAMINING ATTORNEY

CLASS 9—(Continued).

SN 85-485,776. RAYTHEON ANSCHÜTZ GMBH, KIEL, FED REP GERMANY, FILED 12-2-2011.



The logo for "smartblue" features the word "smart" in a lowercase, sans-serif font, followed by "blue" in a larger, bold, lowercase, sans-serif font. To the right of "blue" are three curved lines of increasing size, suggesting motion or a signal.

PRIORITY CLAIMED UNDER SEC. 44(D) ON FED REP GERMANY APPLICATION NO. 302011047388, FILED 8-30-2011, REG. NO. 302011047388, DATED 10-13-2011, EXPIRES 8-31-2021.

THE COLOR(S) GRAY AND BLUE IS/ARE CLAIMED AS A FEATURE OF THE MARK.

THE MARK CONSISTS OF THE LETTERS "SMARTBLUE" ALL IN SMALL CASE IN A STYLIZED FORMAT, WITH THE LETTERS "SMART" IN THE COLOR GRAY, AND THE LETTERS "BLUE" IN THE COLOR BLUE, WITH THREE CURVED LINES APPEARING TO THE ABOVE RIGHT OF THE LAST LETTER "E" IN "SMARTBLUE" APPEARING IN THE COLOR BLUE.

FOR NAUTICAL, MONITORING AND CHECKING (SUPERVISION) APPARATUS, NAMELY, COMMAND STATIONS AND CHECKING STATIONS IN THE NATURE OF ELECTRONIC NAVIGATIONAL AND POSITIONING APPARATUS AND INSTRUMENTS; RADAR EQUIPMENT IN THE NATURE OF RADAR APPARATUS; ELECTRONIC SEA CHARTS AND POSITION CHARTS IN THE NATURE OF ELECTRONIC NAVIGATIONAL AND POSITIONING APPARATUS AND INSTRUMENTS, DATA PROCESSORS, PRERECORDED MAGNETIC DATA CARRIERS FEATURING MARITIME SOFTWARE AND NAVIGATIONAL INFORMATION AND VIDEO MONITORS (U.S. CLS. 21, 23, 26, 36 AND 38).

TRACY FLETCHER, EXAMINING ATTORNEY

SN 85-486,193. ADVANCED NUTRIENTS LTD., ABBOTSFORD, CANADA, FILED 12-2-2011.

INTELLISTRIKE

THE MARK CONSISTS OF STANDARD CHARACTERS WITHOUT CLAIM TO ANY PARTICULAR FONT, STYLE, SIZE, OR COLOR.

PRIORITY CLAIMED UNDER SEC. 44(D) ON CANADA APPLICATION NO. 1554379, FILED 11-30-2011.

FOR SELF-CORRECTING BALLAST CONTROL SYSTEM FOR HIGH INTENSITY LIGHTS, WITH SAID SYSTEM BEING COMPRISED PRIMARILY OF LIGHTING BALLASTS, CAPACITORS, ELECTROMAGNETS, ELECTRIC COILS, ELECTROMAGNETIC COILS AND HEAT SINKS (U.S. CLS. 21, 23, 26, 36 AND 38).

KEVIN CORWIN, EXAMINING ATTORNEY

CLASS 9—(Continued).

SN 85-486,425. CISCO TECHNOLOGY, INC., SAN JOSE, CA, FILED 12-2-2011.

ANYCONNECT

THE MARK CONSISTS OF STANDARD CHARACTERS WITHOUT CLAIM TO ANY PARTICULAR FONT, STYLE, SIZE, OR COLOR.

PRIORITY CLAIMED UNDER SEC. 44(D) ON KUWAIT APPLICATION NO. 123819, FILED 9-20-2011.

OWNER OF U.S. REG. NO. 4,069,423.

FOR VPN (VIRTUAL PRIVATE NETWORK) OPERATING SOFTWARE; SOFTWARE FOR COMPUTERS AND MOBILE DEVICES TO SECURE REMOTE ACCESS VIA THE INTERNET TO PRIVATE COMPUTER NETWORKS (U.S. CLS. 21, 23, 26, 36 AND 38).

FIRST USE 6-0-2007; IN COMMERCE 6-0-2007.

GINA FINK, EXAMINING ATTORNEY

SN 85-486,918. DEI HEADQUARTERS, INC., VISTA, CA, FILED 12-5-2011.

SOUND INSPIRES

THE MARK CONSISTS OF STANDARD CHARACTERS WITHOUT CLAIM TO ANY PARTICULAR FONT, STYLE, SIZE, OR COLOR.

NO CLAIM IS MADE TO THE EXCLUSIVE RIGHT TO USE "SOUND", APART FROM THE MARK AS SHOWN.

FOR AUDIO HEADPHONES; EARPHONES AND HEADPHONES; HEADPHONES; HEADPHONES INCLUDING ATTACHED LANYARD; MUSIC HEADPHONES; STEREO HEADPHONES (U.S. CLS. 21, 23, 26, 36 AND 38).

EDWARD FENNESSY, EXAMINING ATTORNEY

SN 85-487,320. THE TIFFEN COMPANY, LLC, HAUPPAUGE, NY, FILED 12-5-2011.

STEADICAM GRIP

THE MARK CONSISTS OF STANDARD CHARACTERS WITHOUT CLAIM TO ANY PARTICULAR FONT, STYLE, SIZE, OR COLOR.

OWNER OF U.S. REG. NOS. 1,557,750, 1,992,950 AND OTHERS.

NO CLAIM IS MADE TO THE EXCLUSIVE RIGHT TO USE "GRIP", APART FROM THE MARK AS SHOWN.

FOR HAND-HELD STABILIZERS FOR USE WITH CAMERAS AND ELECTRONIC DEVICES WHICH HAVE PHOTOGRAPHIC AND VIDEO-TAKING CAPABILITIES (U.S. CLS. 21, 23, 26, 36 AND 38).

PAUL MORENO, EXAMINING ATTORNEY

CLASS 9—(Continued).

SN 85-487,333. THE TIFFEN COMPANY,LLC, HAUPPAUGE, NY. FILED 12-5-2011.

CLASS 9—(Continued).

SN 85-488,389. POCRASS, ALAN L., SIMI VALLEY, CA. FILED 12-6-2011.

STEADICAM NANO

PLEXCOM

THE MARK CONSISTS OF STANDARD CHARACTERS WITHOUT CLAIM TO ANY PARTICULAR FONT, STYLE, SIZE, OR COLOR.

OWNER OF U.S. REG. NOS. 1,557,750, 1,992,950 AND OTHERS.

NO CLAIM IS MADE TO THE EXCLUSIVE RIGHT TO USE "NANO", APART FROM THE MARK AS SHOWN.

FOR HAND-HELD STABILIZERS FOR USE WITH CAMERAS AND ELECTRONIC DEVICES WHICH HAVE PHOTOGRAPHIC AND VIDEO-TAKING CAPABILITIES (U.S. CLS. 21, 23, 26, 36 AND 38).

PAUL MORENO, EXAMINING ATTORNEY

THE MARK CONSISTS OF STANDARD CHARACTERS WITHOUT CLAIM TO ANY PARTICULAR FONT, STYLE, SIZE, OR COLOR.

FOR FIBER OPTIC TELECOMMUNICATIONS APPARATUS, NAMELY, MULTIPLEXOR, TRANSCEIVERS, COMPUTER SOFTWARE FEATURING DATA SETS FOR USE IN MANAGING TELECOMMUNICATIONS EQUIPMENT, AND FIBER OPTIC WIRES; TELECOMMUNICATIONS APPARATUS IN THE NATURE OF ALARMS USED IN MONITORING CONNECTIVITY; LOCAL AREA NETWORK APPARATUS, NAMELY, TRANSCEIVERS, COMMUNICATION HUBS, ELECTRICAL WIRES, AND COMPUTER NETWORK INTERFACE CARDS (U.S. CLS. 21, 23, 26, 36 AND 38).

MARTHA FROMM, EXAMINING ATTORNEY

SN 85-487,598. MY WORLD MOBILE LLC, WILMINGTON, DE. FILED 12-5-2011.

SN 85-489,280. BUSINESS COMPASS LLC, DBA BUSINESS COMPASS LLC, RANDOLPH, NJ. FILED 12-7-2011.



MBA Sidekick

NO CLAIM IS MADE TO THE EXCLUSIVE RIGHT TO USE "MOBILE", APART FROM THE MARK AS SHOWN.

THE MARK CONSISTS OF THE STYLIZED WORDING "MY WORLD MOBILE", WITH A SPHERE DESIGN APPEARING INSIDE THE LETTER "O" OF THE WORD "WORLD" THEREIN.

FOR COMPUTER APPLICATION SOFTWARE FOR MOBILE PHONES, NAMELY, SOFTWARE FOR FACILITATING DIRECT AUDIO AND VISUAL COMMUNICATIONS BETWEEN MOBILE PHONE USERS; DOWNLOADABLE SOFTWARE IN THE NATURE OF A MOBILE APPLICATION FOR FACILITATING DIRECT AUDIO AND VISUAL COMMUNICATIONS BETWEEN MOBILE PHONE USERS (U.S. CLS. 21, 23, 26, 36 AND 38).

FIRST USE 8-14-2010; IN COMMERCE 8-14-2010. DAWN HAN, EXAMINING ATTORNEY

THE MARK CONSISTS OF STANDARD CHARACTERS WITHOUT CLAIM TO ANY PARTICULAR FONT, STYLE, SIZE, OR COLOR.

NO CLAIM IS MADE TO THE EXCLUSIVE RIGHT TO USE "MBA", APART FROM THE MARK AS SHOWN.

FOR COMPUTER APPLICATION SOFTWARE FOR MOBILE PHONES, NAMELY, SOFTWARE FOR FINANCIAL ANALYSIS TO BE USED BY MBA STUDENTS, EDUCATORS, BANKERS, TRADERS, ANALYSTS, ADVISORS AND ENTHUSIASTS (U.S. CLS. 21, 23, 26, 36 AND 38).

FIRST USE 8-26-2011; IN COMMERCE 8-26-2011. DOMINIC J. FERRAIUOLO, EXAMINING ATTORNEY

CLASS 9—(Continued).

SN 85-489,712. NCH SOFTWARE INC., GREENWOOD VIL-
LAGE, CO. FILED 12-7-2011.

Do more with software

THE MARK CONSISTS OF STANDARD CHARACTERS WITHOUT CLAIM TO ANY PARTICULAR FONT, STYLE, SIZE, OR COLOR.

FOR COMPUTER SOFTWARE AND HARDWARE FOR AUDIO, VIDEO, AND BUSINESS SOLUTIONS, NAMELY, COMPUTER SOFTWARE AND HARDWARE FOR RECORDING, EDITING, MIXING AND FORMATTING AUDIO AND VIDEO RECORDINGS, FOR CONVERTING VINYL RECORDS AND CASSETTES TO CD OR MP3 FORMAT AND FOR CREATING AND MANAGING INVOICES AND BILLING INFORMATION (U.S. CLS. 21, 23, 26, 36 AND 38).

FIRST USE 1-1-2010; IN COMMERCE 1-1-2010.
LINDA LAVACHE, EXAMINING ATTORNEY

SN 85-490,486. JOHN D. CAMPBELL, BOZEMAN, MT. FILED
12-8-2011.

Synergy Surgicalists

THE MARK CONSISTS OF STANDARD CHARACTERS WITHOUT CLAIM TO ANY PARTICULAR FONT, STYLE, SIZE, OR COLOR.

NO CLAIM IS MADE TO THE EXCLUSIVE RIGHT TO USE "SURGICALISTS", APART FROM THE MARK AS SHOWN.

FOR PROTECTIVE CLOTHING WITH AIR-CONDITIONING FUNCTION BY THE INTEGRATION OF PHASE CHANGE COOLING DEVICES FOR COOLING PEOPLE, NAMELY, VESTS FOR COOLING SURGEONS, NURSES AND MEDICAL PERSONNEL (U.S. CLS. 21, 23, 26, 36 AND 38).

LINDA ORNDORFF, EXAMINING ATTORNEY

CLASS 9—(Continued).

SN 85-491,128. NAMO INTERACTIVE, INC., SEOUL, RE-
PUBLIC OF KOREA, FILED 12-8-2011.

CrossEditor

THE MARK CONSISTS OF STANDARD CHARACTERS WITHOUT CLAIM TO ANY PARTICULAR FONT, STYLE, SIZE, OR COLOR.

FOR ENTERPRISE EMBEDDABLE SOFTWARE USED FOR CREATING DOCUMENTS IN THE FIELD OF GENERAL INTEREST; MULTI-PLATFORM SOFTWARE FOR CREATING DOCUMENTS IN THE FIELD OF GENERAL INTEREST; COMPUTER SOFTWARE FOR CREATING DOCUMENTS IN THE FIELD OF GENERAL INTEREST; COMPUTER SOFTWARE FOR USE IN DEVELOPING INTERNAL AND EXTERNAL WEB DOCUMENTS (U.S. CLS. 21, 23, 26, 36 AND 38).

KEVON CHISOLM, EXAMINING ATTORNEY

SN 85-492,457. D&M HOLDINGS, INC., KANAGAWA, JA-
PAN, FILED 12-11-2011.

Globe Cruiser

THE MARK CONSISTS OF STANDARD CHARACTERS WITHOUT CLAIM TO ANY PARTICULAR FONT, STYLE, SIZE, OR COLOR.

FOR HEADPHONES, EARPHONES, APPARATUS FOR RECORDING, TRANSMISSION OR REPRODUCTION OF SOUND OR IMAGES, DATA PROCESSING EQUIPMENT AND COMPUTERS, AMPLIFIERS, AUDIO RECEIVERS, AUDIO DISC PLAYERS, AUDIO DISC RECORDERS, VIDEO DISC PLAYERS, VIDEO DISC RECORDERS, LOUDSPEAKERS, HIGH DENSITY DISC (HDD) PLAYERS, HIGH DENSITY DISC (HDD) RECORDERS, INTEGRATED CIRCUIT (IC) MEMORY PLAYERS, INTEGRATED CIRCUIT (IC) MEMORY RECORDERS, SOLID STATE AND FLASH MEMORY PLAYERS AND RECORDERS, CD PLAYERS, CD RECORDERS, DVD PLAYERS, DVD RECORDERS, TELEVISION RECEIVERS, RADIO RECEIVERS, RADIO TRANSMITTERS, ACCESSORIES FOR HEADPHONES AND EARPHONES, NAMELY, STRAPS AND CARRYING CASES; COMPUTERS; ACCESSORIES FOR COMPUTERS, NAMELY, CARRYING CASES; COMPUTER SOFTWARE PROGRAM FOR MOBILE PHONE OR PORTABLE DATA ASSISTANT FOR USE IN MEASURING BIOMETRIC PARAMETER, PLAYING GAMES, CHECKING STOCKS; COMPUTER SOFTWARE PROGRAM FOR OPERATING AUDIO APPARATUS AND VIDEO APPARATUS (U.S. CLS. 21, 23, 26, 36 AND 38).

LINDA LAVACHE, EXAMINING ATTORNEY

CLASS 9—(Continued).

SN 85-493,419. DOSEMINDER LLC, ARLINGTON, TX. FILED 12-12-2011.

MoneyDiet

THE MARK CONSISTS OF STANDARD CHARACTERS WITHOUT CLAIM TO ANY PARTICULAR FONT, STYLE, SIZE, OR COLOR.

FOR DOWNLOADABLE FINANCIAL COMPUTER SOFTWARE PROGRAM FOR HOME BASED COMPUTERS AND SMART PHONE APPLICATIONS FOR THE PURPOSE OF MONITORING AND ASSISTING THE CUSTOMER WITH THEIR FINANCIAL MATTERS, INCLUDING BUDGETING, CREDIT/DEBIT CARD TRANSACTIONS, SAVINGS, FUNDS SPENT, INVESTMENT PORTFOLIOS AND TAXES, AND FOR TRACKING ALL EXPENDITURES AND INCOME ALLOWING THE USER TO MODIFY SPENDING HABITS (U.S. CLS. 21, 23, 26, 36 AND 38).

ALAIN LAPTER, EXAMINING ATTORNEY

SN 85-493,814. COCHRANE, GRAHAM, WESLEY CHAPEL, FL. FILED 12-13-2011.

The Recording Revolution

THE MARK CONSISTS OF STANDARD CHARACTERS WITHOUT CLAIM TO ANY PARTICULAR FONT, STYLE, SIZE, OR COLOR.

NO CLAIM IS MADE TO THE EXCLUSIVE RIGHT TO USE "RECORDING", APART FROM THE MARK AS SHOWN.

FOR DIGITAL MATERIALS, NAMELY, DOWNLOADABLE VIDEO FILES FEATURING TRAINING IN AUDIO RECORDING AND MIXING (U.S. CLS. 21, 23, 26, 36 AND 38).

FIRST USE 1-1-2010; IN COMMERCE 4-1-2010.
ALAIN LAPTER, EXAMINING ATTORNEY

CLASS 9—(Continued).

SN 85-494,341. ABDUL, PAULA, NEW YORK, NY. FILED 12-13-2011.

MC SKAT KAT

THE MARK CONSISTS OF STANDARD CHARACTERS WITHOUT CLAIM TO ANY PARTICULAR FONT, STYLE, SIZE, OR COLOR.

FOR MUSICAL SOUND RECORDINGS; AUDIO-VISUAL RECORDINGS, NAMELY, COMPACT DISCS, TAPE CASSETTES, AUDIO CASSETTES, AUDIO TAPES, AUDIO DISCS, PHONOGRAPH RECORDS, CD-ROMS, VIDEO TAPES, VIDEO CASSETTES, VIDEO DISCS, DVDS, DIGITAL AUDIO TAPES, MP3S, AND LASER DISCS, ALL FEATURING MUSIC, ANIMATION, DANCE, THEATRICAL PERFORMANCES, MUSICAL AND MOTION PICTURE SOUND TRACKS, AND TELEVISION PROGRAMS AND MOTION PICTURE FILMS FEATURING DANCE, MUSIC, ANIMATION, COMEDY, DRAMA AND SUSPENSE; DOWNLOADABLE MUSICAL SOUND RECORDINGS; DOWNLOADABLE VIDEO RECORDINGS FEATURING MUSIC, THEATRICAL PERFORMANCES, DANCE AND ANIMATION; DOWNLOADABLE ELECTRONIC PUBLICATIONS IN THE NATURE OF BOOKS, BOOKLETS, MAGAZINES, JOURNALS, MANUALS, BROCHURES, LEAFLETS, PAMPHLETS AND NEWSLETTERS, ALL IN THE FIELD OF MUSIC, ENTERTAINMENT, THE ARTS, DANCE, ANIMATION, THEATRE, AND MUSICAL THEATRE; VIDEO MAGAZINE RECORDED ON ELECTRONIC MEDIA FEATURING MUSIC, ENTERTAINMENT, THE ARTS, DANCE, ANIMATION, THEATRE, MUSICAL THEATRE, AND COMPUTER GAMES; ELECTRONIC PUBLICATIONS, NAMELY, BOOKS, BOOKLETS, MAGAZINES, JOURNALS, MANUALS, BROCHURES, LEAFLETS, PAMPHLETS AND NEWSLETTERS, ALL IN THE FIELD OF MUSIC, ENTERTAINMENT, THE ARTS, DANCE, THEATRE, AND MUSICAL THEATRE, RECORDED ON CD-ROMS, DISKETTES, FLOPPY DISKS, VIDEO CASSETTES, AND MAGNETIC TAPES; MAGNETS; DECORATIVE MAGNETS; REFRIGERATOR MAGNETS; NOVELTY MAGNETS; MOUSE PADS; CELL PHONES; FACE PLATES FOR CELL PHONES; CELL PHONE COVERS AND CELL PHONE CASES; COMPACT DISC CASES; PROTECTIVE EYEWEAR; SUNGLASSES AND EYEGLASSES; FRAMES AND LENSES FOR SUNGLASSES, EYEGLASSES AND SPECTACLES; CASES FOR SUNGLASSES, EYEGLASSES AND SPECTACLES; STRAPS AND CHAINS FOR EYEGLASSES, SUNGLASSES AND SPECTACLES; DOWNLOADABLE MUSIC, RING TONES, GRAPHICS, AND ELECTRONIC GAMES VIA THE INTERNET AND WIRELESS DEVICES; DOWNLOADABLE WIRELESS GAME SOFTWARE; DOWNLOADABLE WIRELESS ENTERTAINMENT, NAMELY, RING TONES, SCREEN SAVERS AND IMAGES, AND WALLPAPER VIA A GLOBAL COMPUTER NETWORK AND WIRELESS DEVICES; JACKETS FOR VIDEO CASSETTES, TAPES, AND DISCS; COMPUTER GAME CARTRIDGES, DISCS, CASSETTES, TAPES, JOYSTICKS, PROGRAMS AND SOFTWARE; VIDEO GAME CARTRIDGES, VIDEO GAME DISCS, VIDEO GAME TAPE CASSETTES, VIDEO GAME SOFTWARE, AND VIDEO GAME PROGRAMS; INTERACTIVE MULTIMEDIA COMPUTER GAME PROGRAM; INTERACTIVE VIDEO GAME PROGRAMS; INTERACTIVE AUDIO GAME DISCS CONTAINING ACTION GAMES AND ROLE PLAYING GAMES; INTERACTIVE VIDEO GAMES OF VIRTUAL REALITY COMPRISED OF COMPUTER HARDWARE AND SOFTWARE; VIRTUAL REALITY GAME SOFTWARE; VIDEO TAPES AND VIDEO DISKS PRERECORDED WITH ANIMATION; MULTIMEDIA SOFTWARE RECORDED ON CD-ROM FEATURING MUSIC, ENTERTAINMENT, AND GAMES (U.S. CLS. 21, 23, 26, 36 AND 38).

H. M. FISHER, EXAMINING ATTORNEY

CLASS 9—(Continued).

SN 85-494,774. ATMEL CORPORATION, SAN JOSE, CA. FILED 12-14-2011.

maXCharger

THE MARK CONSISTS OF STANDARD CHARACTERS WITHOUT CLAIM TO ANY PARTICULAR FONT, STYLE, SIZE, OR COLOR.

FOR A FEATURE OF INTEGRATED CIRCUITS FOR ENHANCING THE FUNCTIONALITY OF TOUCH SENSOR CIRCUITS AND FOR COUNTERING DISPLAY OUTPUT AND DISPLAY NOISE SOLD AS AN INTEGRAL COMPONENT OF INTEGRATED CIRCUITS; COMPUTER SOFTWARE FOR ENHANCING THE FUNCTIONALITY OF TOUCH SENSOR CIRCUITS USED IN AN INTEGRATED CIRCUIT AND SOLD AS AN INTEGRAL COMPONENT OF INTEGRATED CIRCUITS; SEMICONDUCTOR DEVICES, INTEGRATED CIRCUITS AND MICROPROCESSORS; AND TOUCH SENSOR CONTROLLERS, ELECTRONIC TOUCH AND PROXIMITY SENSORS, TOUCH PANELS, AND ELECTRONIC TOUCH SENSITIVE SWITCHES (U.S. CLS. 21, 23, 26, 36 AND 38).

HOWARD B. LEVINE, EXAMINING ATTORNEY

SN 85-495,538. GLENN SMITH, CYPRESS, CA. AND KELLY SMITH, CYPRESS, CA. FILED 12-14-2011.



THE MARK CONSISTS OF A STYLIZED LETTER "B" IN A CIRCLE TO THE LEFT OF THE WORD "BERNELLI" IN STYLIZED FONT.

FOR MULTIMEDIA PROJECTORS (U.S. CLS. 21, 23, 26, 36 AND 38).

FIRST USE 12-14-2011; IN COMMERCE 12-14-2011.

TINA BROWN, EXAMINING ATTORNEY

CLASS 9—(Continued).

SN 85-496,815. JIBJAB MEDIA INC., VENICE, CA. FILED 12-15-2011.

STORYBOTS

THE MARK CONSISTS OF STANDARD CHARACTERS WITHOUT CLAIM TO ANY PARTICULAR FONT, STYLE, SIZE, OR COLOR.

FOR DIGITAL MATERIALS, NAMELY, DOWNLOADABLE MULTIMEDIA FILES FEATURING PHOTO-PERSONALIZED CHILDREN'S STORIES; DOWNLOADABLE VIDEOS FEATURING CHILDREN'S ENTERTAINMENT AND ELECTRONIC GAMES VIA THE INTERNET AND WIRELESS DEVICES; PRE-RECORDED ELECTRONIC AND DIGITAL MEDIA FEATURING CHILDREN'S ENTERTAINMENT (U.S. CLS. 21, 23, 26, 36 AND 38).

BRIAN PINO, EXAMINING ATTORNEY

SN 85-496,846. KINESIO CAPTURE LLC., BETHESDA, MD. FILED 12-15-2011.



THE COLOR(S) RED, BLACK, AND YELLOW IS/ARE CLAIMED AS A FEATURE OF THE MARK.

THE MARK CONSISTS OF THE TERM "KINESIO" IN STYLIZED RED LETTERS ABOVE THE WORD "CAPTURE" IN STYLIZED BLACK LETTERS WITH YELLOW SHADING BEHIND THEM, AND A DRAWING OF A RED STREAKING OBJECT WITH YELLOW SHADING AT THE TOP AND BOTTOM THAT HAS A BLACK CAMERA SHUTTER BEHIND IT.

FOR COMPUTER APPLICATION SOFTWARE FOR MOBILE PHONES, PORTABLE MEDIA PLAYERS, AND HANDHELD COMPUTERS, NAMELY, SOFTWARE FOR SPORTS AND MEDICINE FOR THE ANALYZING OF BODY ANGLES AND POSITIONING (U.S. CLS. 21, 23, 26, 36 AND 38).

FIRST USE 5-20-2011; IN COMMERCE 5-20-2011.

PATRICIA EVANKO, EXAMINING ATTORNEY

CLASS 9—(Continued).

SN 85-497,287. SHOULET BLUNT LLC, CLOVIS, CA. FILED 12-16-2011.



NO CLAIM IS MADE TO THE EXCLUSIVE RIGHT TO USE "CAREER" AND "JOB SEEKERS", APART FROM THE MARK AS SHOWN.

THE MARK CONSISTS OF THE STYLIZED TEXT "CAREER PILLAR" WITH A PILLAR IN THE MIDDLE. BELOW THERE IS A LINE. BELOW THE LINE THERE IS THE STYLIZED TEXT "EMPOWERING JOB SEEKERS".

FOR DOWNLOADABLE MULTIMEDIA FILE CONTAINING ARTWORK, TEXT, AUDIO, VIDEO, GAMES, AND INTERNET WEB LINKS RELATING TO TUTORIALS FOR PERFORMING A JOB SEARCH, IMPRESSING FUTURE EMPLOYERS AND PROPERLY INTERVIEWING; DOWNLOADABLE SOFTWARE FOR TEACHING USERS HOW TO PROPERLY PERFORM A JOB SEARCH, IMPRESS FUTURE EMPLOYERS AND PROPERLY INTERVIEW (U.S. CLS. 21, 23, 26, 36 AND 38).

FIRST USE 11-1-2010; IN COMMERCE 5-1-2011.
JENNIFER MARTIN, EXAMINING ATTORNEY

CLASS 9—(Continued).

SN 85-499,021. SR HOLDINGS, LLC, LEXINGTON, MA. FILED 12-19-2011.

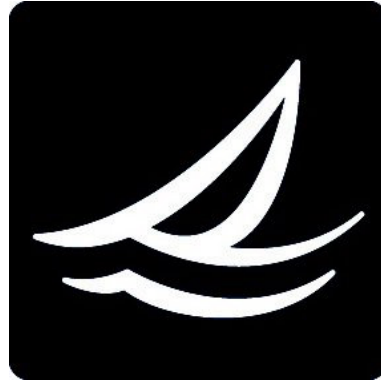

OWNER OF U.S. REG. NOS. 1,810,853 AND 1,860,428.
THE MARK CONSISTS OF A STYLIZED IMAGE OF A SAILBOAT WITH TWO SETS OF WAVES, SURROUNDED BY A SQUARE DESIGN.

FOR EYEWEAR, NAMELY, SUNGLASSES, EYEGLASSES, AND OPHTHALMIC FRAMES AND CASES THEREFOR; CELL PHONE CASES; LIFE JACKETS; PROTECTION AND SAFETY APPARATUS, NAMELY, INFLATABLE FLOTATION DEVICES (U.S. CLS. 21, 23, 26, 36 AND 38).

CURTIS FRENCH, EXAMINING ATTORNEY

SN 85-498,929. SR HOLDINGS, LLC, LEXINGTON, MA. FILED 12-19-2011.

SPERRY TOP-SIDER

THE MARK CONSISTS OF STANDARD CHARACTERS WITHOUT CLAIM TO ANY PARTICULAR FONT, STYLE, SIZE, OR COLOR.

OWNER OF U.S. REG. NOS. 732,519, 3,835,580 AND OTHERS.

FOR EYEWEAR, NAMELY EYEGLASSES AND OPHTHALMIC FRAMES; CASES FOR EYEGLASSES AND SUNGLASSES; CELL PHONE CASES; LIFE JACKETS; PROTECTION AND SAFETY APPARATUS, NAMELY, INFLATABLE FLOTATION DEVICES (U.S. CLS. 21, 23, 26, 36 AND 38).

CURTIS FRENCH, EXAMINING ATTORNEY

SN 85-500,386. SLOAN, SUSIE, SAN FRANCISCO, CA. AND HARKINS, FRANCESCA VASS, SAN FRANCISCO, CA. FILED 12-20-2011.

glogoodz

THE MARK CONSISTS OF STANDARD CHARACTERS WITHOUT CLAIM TO ANY PARTICULAR FONT, STYLE, SIZE, OR COLOR.

FOR REFLECTIVE SAFETY VESTS (U.S. CLS. 21, 23, 26, 36 AND 38).

FIRST USE 12-17-2010; IN COMMERCE 6-3-2011.
SAIMA MAKHDOOM, EXAMINING ATTORNEY

CLASS 9—(Continued).

SN 85-501,816. MERCK KGAA, 64293 DARMSTADT, FED REP GERMANY, FILED 12-22-2011.

MUSE

THE MARK CONSISTS OF STANDARD CHARACTERS WITHOUT CLAIM TO ANY PARTICULAR FONT, STYLE, SIZE, OR COLOR.

PRIORITY CLAIMED UNDER SEC. 44(D) ON ERP N CMNTY TM OFC APPLICATION NO. 010183151, FILED 8-8-2011, REG. NO. 010183151, DATED 8-8-2011, EXPIRES 8-8-2021.

FOR CELL ANALYZER WHICH PROVIDES QUANTITATIVE CELL ANALYSIS FOR SCIENTIFIC, LABORATORY AND GENERAL RESEARCH USES (U.S. CLS. 21, 23, 26, 36 AND 38).

SALLY SHIH, EXAMINING ATTORNEY

SN 85-501,898. WILLIAMS, ROBERT PAUL, AKA TAD WILLIAMS, SOQUEL, CA. FILED 12-22-2011.

OTHERLAND

THE MARK CONSISTS OF STANDARD CHARACTERS WITHOUT CLAIM TO ANY PARTICULAR FONT, STYLE, SIZE, OR COLOR.

OWNER OF U.S. REG. NO. 3,767,469.
FOR COMPUTER GAME PROGRAMS; COMPUTER GAME SOFTWARE (U.S. CLS. 21, 23, 26, 36 AND 38).
BARBARA BROWN, EXAMINING ATTORNEY

SN 85-502,488. VELOCITY MICRO, INC., RICHMOND, VA. FILED 12-22-2011.

VELOCITY MICRO SHINE

THE MARK CONSISTS OF STANDARD CHARACTERS WITHOUT CLAIM TO ANY PARTICULAR FONT, STYLE, SIZE, OR COLOR.

OWNER OF U.S. REG. NO. 3,185,459.
NO CLAIM IS MADE TO THE EXCLUSIVE RIGHT TO USE "MICRO SHINE", APART FROM THE MARK AS SHOWN.

FOR MULTIMEDIA PROJECTORS (U.S. CLS. 21, 23, 26, 36 AND 38).

KRISTIN DAHLING, EXAMINING ATTORNEY

CLASS 9—(Continued).

SN 85-502,665. CYMBRIO, LLC, EAGLE, ID. FILED 12-22-2011.

PLUG2KNOW

THE MARK CONSISTS OF STANDARD CHARACTERS WITHOUT CLAIM TO ANY PARTICULAR FONT, STYLE, SIZE, OR COLOR.

FOR ELECTRONIC DEVICES, NAMELY, METERS FOR TRACKING AND MONITORING ENERGY USAGE (U.S. CLS. 21, 23, 26, 36 AND 38).

SOPHIA S. KIM, EXAMINING ATTORNEY

SN 85-503,031. BO-JIANG TECH CO., LTD., TAINAN CITY, TAIWAN, FILED 12-23-2011.



THE MARK CONSISTS OF AN ELLIPSE DESIGN WITH TWO PARALLEL BARS INTERSECTING THE ELLIPSE FROM LEFT TO RIGHT FORMING THE OUTLINE OF A STYLIZED LETTER "B".

THE LETTERING "BO-JIANG" REPRESENTS A TRANSLITERATION OF NON-LATIN CHARACTERS WHICH HAVE NO MEANING IN ANY LANGUAGE.

FOR DISH ANTENNAS; FIBRE-OPTIC CABLES; OPTICAL FIBRES; RECEIVERS OF ELECTRONIC SIGNALS; TRANSMITTERS AND RECEIVERS FOR AUDIO AND VIDEO SIGNALS FOR TRANSMISSION OVER TWISTED PAIR CABLES; RADIO TRANSMITTERS AND RECEIVERS; APPARATUS FOR TRANSMITTING RADIO PROGRAMMES AND RADIO RELAY MESSAGES; RELAYS FOR RADIO AND TV STATIONS; SATELLITE TRANSMITTERS AND RECEIVERS; GLOBAL POSITIONING SYSTEM (GPS) CONSISTING OF COMPUTERS, COMPUTER SOFTWARE, TRANSMITTERS, RECEIVERS, AND NETWORK INTERFACE DEVICES; SATELLITE NAVIGATIONAL SYSTEM, NAMELY, A GLOBAL POSITIONING SYSTEM (GPS); SIGNAL SPLITTERS FOR ELECTRONIC APPARATUS; MULTIPLEXERS; ELECTRIC COUPLINGS; FIBRE OPTIC COUPLINGS; COMPUTER HARDWARE, NAMELY, WIRELESS NETWORK REPEATERS; COMPUTER NETWORK ADAPTERS; ETHERNET REPEATERS; REPEATERS FOR RADIO AND TELEVISION STATIONS; COMPUTER HARDWARE, NAMELY, COMMUNICATIONS SERVERS; MONITOR SIGNAL AMPLIFIERS; WIRELESS ADAPTERS FOR COMPUTERS; NETWORK ROUTERS; COMPUTER NETWORK BRIDGES; COMPUTER NETWORK HUBS; MONITOR SIGNAL AMPLIFIERS; AMPLIFIERS FOR WIRELESS COMMUNICATIONS; BROADBAND WIRELESS EQUIPMENT, NAMELY, TELECOMMUNICATIONS BASE STATION EQUIPMENT FOR CELLULAR AND FIXED NETWORKING AND

CLASS 9—(Continued).

COMMUNICATIONS APPLICATIONS; ETHERNET ADAPTERS; POWER ADAPTERS FOR COMPUTERS; GATEWAY ROUTERS IN THE NATURE OF COMPUTER CONTROL HARDWARE; MOBILE COMPUTING AND OPERATING PLATFORMS CONSISTING OF DATA TRANSCEIVERS, WIRELESS NETWORKS AND GATEWAYS FOR COLLECTION AND MANAGEMENT OF DATA; AUDIO PROCESSING EQUIPMENT, NAMELY, LIMITERS AND COMPRESSORS; ELECTRICITY LIMITERS; TELECOMMUNICATIONS EQUIPMENT, NAMELY, FIBER-OPTIC TRANSCEIVERS, FIBER OPTIC REPEATERS, CONVERTERS AND OPTIMIZERS, WAVE DIVISION MULTIPLEXERS, FREE-SPACE OPTICS TRANSMISSION SYSTEMS, SWITCHES INCLUDING ETHERNET SWITCHES AND ROUTERS, FIBER-TO-THE-HOME AND ETHERNET-OVER-VDSL ACCESS AGGREGATORS, TERMINATORS AND REPEATERS, AND REMOTE PRESENCE MANAGEMENT PRODUCTS, NAMELY, SWITCHES, AND CONSOLE, ALARM, SENSOR AND POWER MANAGEMENT DEVICES (U.S. CLS. 21, 23, 26, 36 AND 38).

FIRST USE 3-1-2010; IN COMMERCE 3-1-2010.
ZHALEH DELANEY, EXAMINING ATTORNEY

SN 85-503,176. LAKEWOOD MEDIA GROUP, LLC, SHOREWOOD, MN. FILED 12-23-2011.

TRAINING TECH TALK

THE MARK CONSISTS OF STANDARD CHARACTERS WITHOUT CLAIM TO ANY PARTICULAR FONT, STYLE, SIZE, OR COLOR.

OWNER OF U.S. REG. NOS. 1,507,093 AND 1,600,765.
SEC. 2(F) AS TO "TRAINING".

FOR DOWNLOADABLE ELECTRONIC NEWSLETTERS DELIVERED BY EMAIL FEATURING E-LEARNING PRACTICES, PROCESSES AND PRODUCTS IN THE FIELDS OF EXECUTIVE AND LEADERSHIP DEVELOPMENT, EMPLOYEE DEVELOPMENT, AND EMPLOYEE TRAINING (U.S. CLS. 21, 23, 26, 36 AND 38).

FIRST USE 0-0-2006; IN COMMERCE 0-0-2006.
KATHERINE E. HALMEN, EXAMINING ATTORNEY

SN 85-503,190. LAKEWOOD MEDIA GROUP, LLC, SHOREWOOD, MN. FILED 12-23-2011.

TRAINING TOP 125

THE MARK CONSISTS OF STANDARD CHARACTERS WITHOUT CLAIM TO ANY PARTICULAR FONT, STYLE, SIZE, OR COLOR.

OWNER OF U.S. REG. NOS. 1,507,093 AND 1,600,765.
SEC. 2(F) AS TO "TRAINING".

FOR DOWNLOADABLE ELECTRONIC NEWSLETTERS DELIVERED BY EMAIL IN THE FIELDS OF EXECUTIVE AND LEADERSHIP DEVELOPMENT, EMPLOYEE DEVELOPMENT, AND EMPLOYEE TRAINING (U.S. CLS. 21, 23, 26, 36 AND 38).

FIRST USE 0-0-2006; IN COMMERCE 0-0-2006.
KATHERINE E. HALMEN, EXAMINING ATTORNEY

CLASS 9—(Continued).

SN 85-503,211. LAKEWOOD MEDIA GROUP, LLC, SHOREWOOD, MN. FILED 12-23-2011.

INSIDE TRAINING

THE MARK CONSISTS OF STANDARD CHARACTERS WITHOUT CLAIM TO ANY PARTICULAR FONT, STYLE, SIZE, OR COLOR.

OWNER OF U.S. REG. NOS. 1,507,093 AND 1,600,765.
SEC. 2(F) AS TO "TRAINING".

FOR DOWNLOADABLE ELECTRONIC NEWSLETTERS DELIVERED BY E-MAIL FEATURING NEWS, TECHNOLOGY, STRATEGIES, BEST PRACTICES, TRENDS AND RESEARCH IN THE FIELDS OF EXECUTIVE AND LEADERSHIP DEVELOPMENT, EMPLOYEE DEVELOPMENT, AND EMPLOYEE TRAINING (U.S. CLS. 21, 23, 26, 36 AND 38).

FIRST USE 0-0-2007; IN COMMERCE 0-0-2007.
KATHERINE E. HALMEN, EXAMINING ATTORNEY

SN 85-503,563. ALLEYNE, CELESTE, LOS ANGELES, CA. FILED 12-24-2011.

CUPTAIL PARTIES

THE MARK CONSISTS OF STANDARD CHARACTERS WITHOUT CLAIM TO ANY PARTICULAR FONT, STYLE, SIZE, OR COLOR.

NO CLAIM IS MADE TO THE EXCLUSIVE RIGHT TO USE "PARTIES", APART FROM THE MARK AS SHOWN.

FOR ELECTRONIC PUBLICATIONS, NAMELY, BOOKS, MAGAZINES, AND ARTICLES FEATURING PARTY AND EVENT PLANNING IDEAS RECORDED ON COMPUTER MEDIA; AND DIGITAL MEDIA, NAMELY, DVDS AND DOWNLOADABLE AUDIO FILES FEATURING EVENT AND PARTY PLANNING IDEAS (U.S. CLS. 21, 23, 26, 36 AND 38).

MICHAEL KEATING, EXAMINING ATTORNEY

CLASS 9—(Continued).

SN 85-504,143. MYDIGITALFAMILY, LTD., WILMETTE, IL. FILED 12-28-2011.



THE COLOR(S) PURPLE, ORANGE, AND GOLD IS/ARE CLAIMED AS A FEATURE OF THE MARK.

THE MARK CONSISTS OF A PURPLE SPHERE FEATURING A DESIGN RESEMBLING A CHILD COMPRISING A GOLD FOUR POINT STAR WITH A CIRCLE OVER AN ORANGE CURVE DESIGN AND THE WORDING "ZILLY DILLY" IN ORANGE.

FOR CHILDREN'S EDUCATIONAL SOFTWARE; COMMUNICATION SOFTWARE FOR PROVIDING ACCESS TO THE INTERNET (U.S. CLS. 21, 23, 26, 36 AND 38).

FIRST USE 8-11-2011; IN COMMERCE 8-11-2011.
JULIE VEPPUMTHARA, EXAMINING ATTORNEY

SN 85-505,005. JL AUDIO, INC., MIRAMAR, FL. FILED 12-28-2011.

MEDIAMASTER

THE MARK CONSISTS OF STANDARD CHARACTERS WITHOUT CLAIM TO ANY PARTICULAR FONT, STYLE, SIZE, OR COLOR.

FOR DEVICE FOR INTERCONNECTING AN AUDIO AND/OR MULTI-MEDIA SYSTEM TO VARIOUS SOURCES OF AUDIO AND/OR VIDEO CONTENT, NAMELY, DIGITAL ELECTRONIC DEVICES FOR TRANSMITTING AND RECEIVING AUDIO AND VIDEO FILES; RADIO RECEIVERS AND RADIO SIGNAL TUNERS; PRE-AMPLIFIERS (U.S. CLS. 21, 23, 26, 36 AND 38).

MATTHEW MCDOWELL, EXAMINING ATTORNEY

CLASS 9—(Continued).

SN 85-505,973. STAHLNECKER, MICHAEL, J, HENRIETTA, NY. FILED 12-29-2011.

ILLTEST

THE MARK CONSISTS OF STANDARD CHARACTERS WITHOUT CLAIM TO ANY PARTICULAR FONT, STYLE, SIZE, OR COLOR.

FOR PRERECORDING CD'S FEATURING MUSIC (U.S. CLS. 21, 23, 26, 36 AND 38).
AMY C. KEAN, EXAMINING ATTORNEY

SN 85-506,571. SENTER, RANDALL, WEST HOLLYWOOD, CA. FILED 12-30-2011.

SENSITONE

THE MARK CONSISTS OF STANDARD CHARACTERS WITHOUT CLAIM TO ANY PARTICULAR FONT, STYLE, SIZE, OR COLOR.

FOR DIGITAL SIGNAL PROCESSORS (U.S. CLS. 21, 23, 26, 36 AND 38).
CHRISTOPHER BUONGIORNO, EXAMINING ATTORNEY

SN 85-506,617. ID MODELING, INC., ARCADIA, CA. FILED 12-30-2011.

Sedarū

THE MARK CONSISTS OF STANDARD CHARACTERS WITHOUT CLAIM TO ANY PARTICULAR FONT, STYLE, SIZE, OR COLOR.

THE WORDING "SEDARU" HAS NO MEANING IN A FOREIGN LANGUAGE.

FOR COMPUTER SOFTWARE FOR ANALYZING, VISUALIZING, AND IDENTIFYING DEFICIENCIES IN WATER RESOURCE NEEDS AND WATER SYSTEM PERFORMANCE, FOR USE BY INFRASTRUCTURE PROVIDERS, IN THE NATURE OF WATER, SEWER, STORM DRAIN, POWER, AND GAS UTILITY PROVIDERS, THAT OWN, MANAGE, AND MAINTAIN INFRASTRUCTURE, AND ENGINEERS, INDIVIDUAL CONSUMERS, AND WATER USE PROFESSIONALS (U.S. CLS. 21, 23, 26, 36 AND 38).

MICHAEL GAAFAR, EXAMINING ATTORNEY

CLASS 9—(Continued).

SN 85-506,639. GINGGER SHANKAR, SHERMAN OAKS, CA. FILED 12-30-2011.

Little Indian Girl

THE MARK CONSISTS OF STANDARD CHARACTERS WITHOUT CLAIM TO ANY PARTICULAR FONT, STYLE, SIZE, OR COLOR.

FOR DIGITAL MUSIC DOWNLOADABLE FROM THE INTERNET; DOWNLOADABLE MUSICAL SOUND RECORDINGS; MUSICAL SOUND RECORDINGS; MUSICAL VIDEO RECORDINGS; PRE-RECORDED CDS, VIDEO TAPES, LASER DISKS AND DVDS FEATURING MUSIC; SERIES OF MUSICAL SOUND RECORDINGS (U.S. CLS. 21, 23, 26, 36 AND 38).

LINDA LAVACHE, EXAMINING ATTORNEY

SN 85-506,826. WUYANG LONGTIAN PRECISION INSTRUMENTS CO., LTD, HENAN, CHINA, FILED 12-31-2011.



OWNER OF U.S. REG. NO. 4,064,742.

THE MARK CONSISTS OF THE STYLIZED WORDING "SNIPER" AND A DEVICE CONSISTS OF TWO CIRCLES WITH A CROSS.

FOR BATTERIES FOR LIGHTING; BATTERIES FOR POCKETLAMPS; FIBER OPTICS; LASER POINTING DEVICE FOR USE WITH FIREARMS; LASER RANGE-FINDERS; LASER SPEED DETECTORS; LASER TRACERS FOR APPLICATION OF CONDUCTION PATTERNS TO INSULATION MEDIA; LASER-BEAM-EMITTING DEVICE WHICH PROJECTS RIGHT ANGLES FOR CONSTRUCTION PURPOSES; LASERS FOR NON-MEDICAL PURPOSES; LASERS NOT FOR MEDICAL USE; RIFLE SCOPES; RIFLESCOPES; SPOTTING SCOPES; TACTICAL LASER SIGHTS; TELESCOPES; TELESCOPIC GUN SIGHTS (U.S. CLS. 21, 23, 26, 36 AND 38).

FIRST USE 12-1-2010; IN COMMERCE 8-1-2011.

MIDGE BUTLER, EXAMINING ATTORNEY

SN 85-506,859. MONSTER, INC., BRISBANE, CA. FILED 12-31-2011.

ROCKETS

THE MARK CONSISTS OF STANDARD CHARACTERS WITHOUT CLAIM TO ANY PARTICULAR FONT, STYLE, SIZE, OR COLOR.

FOR HEADPHONES (U.S. CLS. 21, 23, 26, 36 AND 38).

IRA J. GOODSAD, EXAMINING ATTORNEY

CLASS 9—(Continued).

SN 85-507,015. JONES, GARY C., DBA LAVATONE, HOUSTON, TX. FILED 1-1-2012.

LAVATONE

OWNER OF U.S. REG. NO. 3,131,138.

THE MARK CONSISTS OF THE WORD "LAVATONE" IN ALL CAPITAL LETTERS. THE "L" IS THE TALLEST LETTER. THE "V" IS SHORTER THAN THE "L", BUT TALLER THAN THE OTHER LETTERS WITH A FLAME CENTERED OVER IT. THIS RESULTS IN THE "V" AND TWO LETTERS "A" TAKING ON THE FORM OF A VOLCANO.

FOR AMPLIFIERS (U.S. CLS. 21, 23, 26, 36 AND 38).

FIRST USE 10-19-2004; IN COMMERCE 10-19-2004.

GISELLE AGOSTO, EXAMINING ATTORNEY

SN 85-507,149. QUEST ANALYTICS LLC, PITTSBURGH, PA. FILED 1-2-2012.

IQLEADS

THE MARK CONSISTS OF STANDARD CHARACTERS WITHOUT CLAIM TO ANY PARTICULAR FONT, STYLE, SIZE, OR COLOR.

FOR COMPUTER SOFTWARE FOR TRACKING SALES LEADS IN THE BANKING INDUSTRY; COMPUTER SOFTWARE FOR TRACKING SALES LEADS IN THE BANKING INDUSTRY THAT MAY BE DOWNLOADED FROM A GLOBAL COMPUTER NETWORK (U.S. CLS. 21, 23, 26, 36 AND 38).

FIRST USE 11-1-2011; IN COMMERCE 11-1-2011.

ALYSSA STEEL, EXAMINING ATTORNEY

CLASS 9—(Continued).

SN 85-507,222. SANTORINI LLC, SEATTLE, WA. FILED 1-2-2012.

Pixie

THE MARK CONSISTS OF STANDARD CHARACTERS WITHOUT CLAIM TO ANY PARTICULAR FONT, STYLE, SIZE, OR COLOR.

FOR ELECTRICAL PLUG DEVICE ENABLING CONNECTION AND DISCONNECTION OF POWER AND/OR CONTROL CABLES (U.S. CLS. 21, 23, 26, 36 AND 38).

GIANCARLO CASTRO, EXAMINING ATTORNEY

SN 85-507,229. TRY-IT DIET, LLC, CENTENNIAL, CO. FILED 1-2-2012.

TRY-IT DIET

THE MARK CONSISTS OF STANDARD CHARACTERS WITHOUT CLAIM TO ANY PARTICULAR FONT, STYLE, SIZE, OR COLOR.

NO CLAIM IS MADE TO THE EXCLUSIVE RIGHT TO USE "DIET", APART FROM THE MARK AS SHOWN.

FOR DOWNLOADABLE ELECTRONIC PUBLICATIONS, NAMELY, BOOKS FEATURING INFORMATION AND INSTRUCTIONS ON DIETS (U.S. CLS. 21, 23, 26, 36 AND 38).

GIANCARLO CASTRO, EXAMINING ATTORNEY

SN 85-507,234. FREEHAND GRAPHICS, INC., SHOREHAM, NY. FILED 1-2-2012.

SPOT PROCESS

THE MARK CONSISTS OF STANDARD CHARACTERS WITHOUT CLAIM TO ANY PARTICULAR FONT, STYLE, SIZE, OR COLOR.

NO CLAIM IS MADE TO THE EXCLUSIVE RIGHT TO USE "PROCESS", APART FROM THE MARK AS SHOWN.

FOR COMPUTER SOFTWARE FOR SEPARATING IMAGES FOR REPRODUCTION ON GARMENT, TEXTILE, AND SCREEN PRINT PRODUCTION EQUIPMENT; COMPUTER SOFTWARE FOR EDITING, CAPTURING AND MANIPULATING IMAGES AND PHOTOS (U.S. CLS. 21, 23, 26, 36 AND 38).

FIRST USE 1-10-1993; IN COMMERCE 2-1-1995.

AMY KELLY, EXAMINING ATTORNEY

CLASS 9—(Continued).

SN 85-507,239. KINIVO LLC, BELLEVUE, WA. FILED 1-2-2012.

KINIVO

THE MARK CONSISTS OF STANDARD CHARACTERS WITHOUT CLAIM TO ANY PARTICULAR FONT, STYLE, SIZE, OR COLOR.

THE WORDING "KINIVO" HAS NO MEANING IN A FOREIGN LANGUAGE.

FOR AUDIO SPEAKERS; BATTERY PACKS; CARRYING CASES, HOLDERS, PROTECTIVE CASES AND STANDS FEATURING POWER SUPPLY CONNECTORS, ADAPTORS, SPEAKERS AND BATTERY CHARGING DEVICES, SPECIALLY ADAPTED FOR USE WITH HANDHELD DIGITAL ELECTRONIC DEVICES; CELL PHONE BATTERY CHARGERS; CELL PHONE BATTERY CHARGERS FOR USE IN VEHICLES; EARPHONES AND HEADPHONES; ELECTRONIC SWITCHERS FOR AUDIO AND VIDEO SIGNALS; MATRIX SWITCHERS FOR AUDIO AND VIDEO SIGNALS; MUSIC HEADPHONES; USB (UNIVERSAL SERIAL BUS) HARDWARE; USB HUBS; WIRELESS ADAPTERS FOR COMPUTERS; WIRELESS COMPUTER PERIPHERALS; WIRELESS INDOOR AND OUTDOOR SPEAKERS; WIRELESS RECEIVERS AND TRANSMITTERS FOR PORTABLE MEDIA PLAYERS (U.S. CLS. 21, 23, 26, 36 AND 38).

FIRST USE 4-1-2011; IN COMMERCE 5-1-2011.

AMY KELLY, EXAMINING ATTORNEY

SN 85-507,293. AINSWORTH GAME TECHNOLOGY LIMITED, NEWINGTON, AUSTRALIA, FILED 1-2-2012.

GOLDEN GLORY

THE MARK CONSISTS OF STANDARD CHARACTERS WITHOUT CLAIM TO ANY PARTICULAR FONT, STYLE, SIZE, OR COLOR.

FOR COMPUTER SOFTWARE AND FIRMWARE FOR GAMES OF CHANCE ON ANY COMPUTERIZED PLATFORM, INCLUDING DEDICATED GAMING CONSOLES, VIDEO BASED SLOT MACHINES, REEL BASED SLOT MACHINES, AND VIDEO LOTTERY TERMINALS (U.S. CLS. 21, 23, 26, 36 AND 38).

MATTHEW PAPPAS, EXAMINING ATTORNEY

CLASS 9—(Continued).

SN 85-507,294. AINSWORTH GAME TECHNOLOGY LIMITED, NEWINGTON, AUSTRALIA, FILED 1-2-2012.

DOUBLE IMPACT

THE MARK CONSISTS OF STANDARD CHARACTERS WITHOUT CLAIM TO ANY PARTICULAR FONT, STYLE, SIZE, OR COLOR.

FOR COMPUTER SOFTWARE AND FIRMWARE FOR GAMES OF CHANCE ON ANY COMPUTERIZED PLATFORM, INCLUDING DEDICATED GAMING CONSOLES, VIDEO BASED SLOT MACHINES, REEL BASED SLOT MACHINES, AND VIDEO LOTTERY TERMINALS (U.S. CLS. 21, 23, 26, 36 AND 38).
MATTHEW PAPPAS, EXAMINING ATTORNEY

SN 85-507,297. AINSWORTH GAME TECHNOLOGY LIMITED, NEWINGTON, AUSTRALIA, FILED 1-2-2012.

FORTUNE OX

THE MARK CONSISTS OF STANDARD CHARACTERS WITHOUT CLAIM TO ANY PARTICULAR FONT, STYLE, SIZE, OR COLOR.

FOR COMPUTER SOFTWARE AND FIRMWARE FOR GAMES OF CHANCE ON ANY COMPUTERIZED PLATFORM, INCLUDING DEDICATED GAMING CONSOLES, VIDEO BASED SLOT MACHINES, REEL BASED SLOT MACHINES, AND VIDEO LOTTERY TERMINALS (U.S. CLS. 21, 23, 26, 36 AND 38).
MATTHEW PAPPAS, EXAMINING ATTORNEY

CLASS 9—(Continued).

SN 85-507,366. ENERGY DYNAMICS, LLC, BALTIMORE, MD. FILED 1-3-2012.



NO CLAIM IS MADE TO THE EXCLUSIVE RIGHT TO USE "ENERGY SAVER", APART FROM THE MARK AS SHOWN.

THE MARK CONSISTS OF A STYLIZED LEAF, WITH THE WORDS "ECO BUSTER" APPEARING ABOVE THE LEAF, AND THE WORDS "ENERGY SAVER" APPEARING BELOW THE LEAF.

FOR CAPACITORS (U.S. CLS. 21, 23, 26, 36 AND 38).
FIRST USE 2-1-2012; IN COMMERCE 2-1-2012.
LINDA LAVACHE, EXAMINING ATTORNEY

SN 85-507,384. NEIGHBORS, LARRY SHANE, TALKING ROCK, GA. AND SHARMA, RAHUL, TALKING ROCK, GA. FILED 1-3-2012.



THE MARK CONSISTS OF THE STYLIZED TEXT "IHELP+".

FOR COMPUTER APPLICATION SOFTWARE FOR MOBILE PHONES, PORTABLE MEDIA PLAYERS, HANDHELD COMPUTERS OR OTHER HANDHELD DEVICES, NAMELY, SOFTWARE FOR ALERTING EMERGENCY CONTACTS NOT FOR USE BY MEDICAL PERSONNEL (U.S. CLS. 21, 23, 26, 36 AND 38).
DAVID MURRAY, EXAMINING ATTORNEY

CLASS 9—(Continued).

SN 85-507,707. DDD GAME CO., LTD., SEOUL, REPUBLIC OF KOREA, FILED 1-3-2012.



THE COLOR(S) GREY, BLACK, ORANGE, YELLOW AND GREEN IS/ARE CLAIMED AS A FEATURE OF THE MARK. THE MARK CONSISTS OF THE STYLIZED WORDING "THREE KINGDOMS" IN GREY AND THE WORDING "DEFENSE" IN GREY WITH YELLOW HIGHLIGHTS, ALL OF THE WORDING WITH A BLACK BORDER AND IN FRONT OF A FIRE DESIGN IN ORANGE, YELLOW AND GREY OVER THE SILHOUETTE OF A BUILDING IN BLACK, ALL OF WHICH IS SUPERIMPOSED OVER STYLIZED REPRESENTATIONS OF MOUNTAINS IN GREEN, GREY AND BLACK AND CONTAINING STYLIZED BIRDS IN BLACK.

FOR DOWNLOADABLE COMPUTER SOFTWARE FOR GAMES; DOWNLOADABLE COMPUTER GAME PROGRAMS; RECORDED COMPUTER GAME PROGRAMS; COMPUTER APPLICATION SOFTWARE FOR MOBILE PHONES, SMART PHONES, TABLET COMPUTERS, NAMELY, SOFTWARE FOR GAMES; VIDEO GAME CARTRIDGES; MOBILE PHONES; SMART PHONES; PERSONAL DIGITAL ASSISTANTS (PDA); TABLET COMPUTERS; NOTEBOOK COMPUTERS; COMPUTERS; COMPUTER GAME PROGRAMS; VIRTUAL REALITY GAME SOFTWARE (U.S. CLS. 21, 23, 26, 36 AND 38).

JOHN HWANG, EXAMINING ATTORNEY

SN 85-507,765. QUEST ANALYTICS LLC, PITTSBURGH, PA. FILED 1-3-2012.

IQFINANCIALS

THE MARK CONSISTS OF STANDARD CHARACTERS WITHOUT CLAIM TO ANY PARTICULAR FONT, STYLE, SIZE, OR COLOR.

FOR COMPUTER SOFTWARE FOR AUTOMATING FINANCIAL REPORTING REQUIREMENTS FOR BANKS AND FINANCIAL INSTITUTIONS; COMPUTER SOFTWARE FOR AUTOMATING FINANCIAL REPORTING REQUIREMENTS FOR BANKS AND FINANCIAL INSTITUTIONS THAT MAY BE DOWNLOADED FROM A GLOBAL COMPUTER NETWORK (U.S. CLS. 21, 23, 26, 36 AND 38).

FIRST USE 11-1-2011; IN COMMERCE 11-1-2011.

ALYSSA STEEL, EXAMINING ATTORNEY

CLASS 9—(Continued).

SN 85-507,815. HIMS INTERNATIONAL CORPORATION, YUSEONG-GU DAEJEON, REPUBLIC OF KOREA, FILED 1-3-2012.

Braille Sense U2

OWNER OF U.S. REG. NO. 3,999,627.

NO CLAIM IS MADE TO THE EXCLUSIVE RIGHT TO USE "BRAILLE", APART FROM THE MARK AS SHOWN.

THE MARK CONSISTS OF THE WORDS "BRAILLE SENSE U2".

FOR NOTEBOOK COMPUTERS FOR USE BY BLIND USERS AS A MEANS TO TAKE NOTE IN BRAILLE (U.S. CLS. 21, 23, 26, 36 AND 38).

CARYN GLASSER, EXAMINING ATTORNEY

SN 85-507,835. REDLINE DESIGN LLC, BIRMINGHAM, AL. FILED 1-3-2012.

FileShark

THE MARK CONSISTS OF STANDARD CHARACTERS WITHOUT CLAIM TO ANY PARTICULAR FONT, STYLE, SIZE, OR COLOR.

FOR COMPUTER SOFTWARE FOR REMOVAL OF BACK UP FILE (U.S. CLS. 21, 23, 26, 36 AND 38).

JOHN HWANG, EXAMINING ATTORNEY

SN 85-507,937. ZEPPIERI, PETER, MALVERNE, NY. AND ZEPPIERI, CHRISTOPHER, MALVERNE, NY. FILED 1-3-2012.

Spot Saver

THE MARK CONSISTS OF STANDARD CHARACTERS WITHOUT CLAIM TO ANY PARTICULAR FONT, STYLE, SIZE, OR COLOR.

FOR COMPUTER APPLICATION SOFTWARE FOR MOBILE PHONES, TABLET COMPUTERS, AND HAND-HELD COMPUTING DEVICES, NAMELY, SOFTWARE FOR USERS TO SAVE LOCATIONS WITH GEOGRAPHICALLY-CODED PHOTOS, TAGS, AND NAME DESCRIPTIONS, SO THAT THEY CAN BE SHARED AMONGST OTHER USERS OF THE APPLICATION, ON VARIOUS SOCIAL NETWORKING WEBSITES (U.S. CLS. 21, 23, 26, 36 AND 38).

FRED CARL, EXAMINING ATTORNEY

CLASS 9—(Continued).

SN 85-508,031. GRANT CAMERON BURKE, DBA MUSIC-ESQUE, MIAMI, FL. FILED 1-3-2012.

Musiquesque

THE MARK CONSISTS OF STANDARD CHARACTERS WITHOUT CLAIM TO ANY PARTICULAR FONT, STYLE, SIZE, OR COLOR.

FOR AUDIO AND VIDEO RECORDINGS FEATURING MUSIC AND ARTISTIC PERFORMANCES; AUDIO TAPES FEATURING MUSIC; COMPACT DISCS FEATURING MUSIC; COMPACT DISCS FEATURING MUSIC AND SPOKEN WORD IN THE FORM OF POETRY; DIGITAL MUSIC DOWNLOADABLE FROM THE INTERNET; PHONOGRAPH RECORDS FEATURING MUSIC; SERIES OF MUSICAL SOUND RECORDINGS (U.S. CLS. 21, 23, 26, 36 AND 38).

FIRST USE 1-1-1996; IN COMMERCE 1-1-1996.

MICHAEL WEBSTER, EXAMINING ATTORNEY

SN 85-508,151. KMW GROUP, INC. DBA SKYTRON, GRAND RAPIDS, MI. FILED 1-4-2012.

SKYTRON

THE MARK CONSISTS OF STANDARD CHARACTERS WITHOUT CLAIM TO ANY PARTICULAR FONT, STYLE, SIZE, OR COLOR.

OWNER OF U.S. REG. NO. 3,071,030.

FOR COMPUTER HARDWARE AND SOFTWARE AND TOUCH PANELS FOR USE IN INTERFACING, DISTRIBUTING, COORDINATING, ROUTING, CONTROLLING, TRANSMITTING, MANIPULATING, STORING AND RETRIEVING DIGITAL DATA, IMAGES, VIDEO AND AUDIO FROM MEDICAL OPERATING ROOMS TO OUTSIDE LOCATIONS; ELECTRONIC REAL TIME LOCATION TRACKING SYSTEMS FOR HEALTHCARE FACILITIES, NAMELY, ELECTRONIC TAGS AND SENSORS AND COMPUTER SOFTWARE FOR RECEIVING AND PROCESSING SIGNALS FROM THE TAGS AND SENSORS FOR MONITORING PURPOSES (U.S. CLS. 21, 23, 26, 36 AND 38).

FIRST USE 0-0-2008; IN COMMERCE 0-0-2008.

AMY KELLY, EXAMINING ATTORNEY

CLASS 9—(Continued).

SN 85-508,259. BELL, LONNIE B, AKA BRANDON BELL, WEST MONROE, LA. AND SEARCY, KERRY S, WEST MONROE, LA. FILED S.R. 1-4-2012; AM. P.R. 4-12-2012.



NO CLAIM IS MADE TO THE EXCLUSIVE RIGHT TO USE "OUTFITTERS", APART FROM THE MARK AS SHOWN.

THE COLOR(S) BLACK, WHITE, GREEN, GOLD IS/ARE CLAIMED AS A FEATURE OF THE MARK.

THE MARK CONSISTS OF THE WORDS "BELL OUTFITTERS" IN BLACK LETTERS OUTLINED IN WHITE OVER A TRIBAL HUNTING AND FISHING DESIGN WITH THE OUTER SECTIONS IN GREEN AND INNER SECTIONS IN GOLD.

FOR MARKER BUOY RETRIEVAL SYSTEM, NAMELY, A DEVICE WHICH RELEASES A BUOYANT FLOAT ATTACHED BY A LINE TO AN OBJECT SUBMERSED IN WATER (U.S. CLS. 21, 23, 26, 36 AND 38).

FIRST USE 6-6-2011; IN COMMERCE 12-21-2011.

JOHN WILKE, EXAMINING ATTORNEY

SN 85-508,277. NEC DISPLAY SOLUTIONS, LTD., MINATOKU, TOKYO, JAPAN, FILED 1-4-2012.

NAVISET

THE MARK CONSISTS OF STANDARD CHARACTERS WITHOUT CLAIM TO ANY PARTICULAR FONT, STYLE, SIZE, OR COLOR.

FOR COMPUTER SOFTWARE FOR COMPUTER MONITORS, NAMELY, COMPUTER SOFTWARE FOR ADJUSTING COMPUTER DISPLAY MONITOR SETTINGS; COMPUTER SOFTWARE FOR PROVIDING ACCESS TO AND REMOTE DIAGNOSIS OF COMPUTER DISPLAY MONITOR SETTING CONTROLS; COMPUTER SOFTWARE FOR PROVIDING ACCESS TO COMPUTER DISPLAY MONITOR ADJUSTMENT CONTROLS; COMPUTER SOFTWARE FOR NETWORK-BASED MANAGEMENT OF COMPUTER DISPLAY MONITORS (U.S. CLS. 21, 23, 26, 36 AND 38).

FIRST USE 4-18-2002; IN COMMERCE 4-18-2002.

JIM RINGLE, EXAMINING ATTORNEY

CLASS 9—(Continued).

SN 85-508,550. ORBIT IRRIGATION PRODUCTS, INC., NORTH SALT LAKE, UT. FILED 1-4-2012.

ORBIT

THE MARK CONSISTS OF STANDARD CHARACTERS WITHOUT CLAIM TO ANY PARTICULAR FONT, STYLE, SIZE, OR COLOR.

OWNER OF U.S. REG. NOS. 2,568,783, 3,565,064 AND OTHERS.

FOR MEASURING APPARATUS, NAMELY, RAIN GAUGES (U.S. CLS. 21, 23, 26, 36 AND 38).

VERNA BETH RIRIE, EXAMINING ATTORNEY

CLASS 9—(Continued).

SN 85-509,194. ASSIMILATE, INC., SANTA CLARA, CA. FILED 1-5-2012.

Scratch Lab

THE MARK CONSISTS OF STANDARD CHARACTERS WITHOUT CLAIM TO ANY PARTICULAR FONT, STYLE, SIZE, OR COLOR.

OWNER OF U.S. REG. NO. 3,163,630.

NO CLAIM IS MADE TO THE EXCLUSIVE RIGHT TO USE "LAB", APART FROM THE MARK AS SHOWN.

FOR COMPUTER SOFTWARE FOR USE IN EDITING FILM AND VIDEO RECORDINGS (U.S. CLS. 21, 23, 26, 36 AND 38).

FIRST USE 4-9-2011; IN COMMERCE 4-9-2011.

NAKIA HENRY, EXAMINING ATTORNEY

SN 85-508,657. BE AEROSPACE, INC., WELLINGTON, FL. FILED 1-4-2012.

PRO-VISION

THE MARK CONSISTS OF STANDARD CHARACTERS WITHOUT CLAIM TO ANY PARTICULAR FONT, STYLE, SIZE, OR COLOR.

FOR OXYGEN MASKS FOR USE ON AIRCRAFT, NOT FOR MEDICAL PURPOSES (U.S. CLS. 21, 23, 26, 36 AND 38).

JAY FLOWERS, EXAMINING ATTORNEY

SN 85-509,483. AZAVEA, INC., PHILADELPHIA, PA. FILED 1-5-2012.

HUNCHLAB

THE MARK CONSISTS OF STANDARD CHARACTERS WITHOUT CLAIM TO ANY PARTICULAR FONT, STYLE, SIZE, OR COLOR.

FOR COMPUTER SOFTWARE FOR GEOGRAPHIC DATA ANALYSIS AND VISUALIZATION (U.S. CLS. 21, 23, 26, 36 AND 38).

FIRST USE 5-16-2006; IN COMMERCE 6-13-2006.

KIMBERLY PERRY, EXAMINING ATTORNEY

SN 85-509,153. LITSENTRY CORPORATION, DUNDAS, MN. FILED 1-5-2012.

Hawk

THE MARK CONSISTS OF STANDARD CHARACTERS WITHOUT CLAIM TO ANY PARTICULAR FONT, STYLE, SIZE, OR COLOR.

OWNER OF U.S. REG. NO. 3,296,248.

FOR OPTICAL INSPECTION APPARATUS FOR INDUSTRIAL USE (U.S. CLS. 21, 23, 26, 36 AND 38).

FIRST USE 8-5-2011; IN COMMERCE 8-5-2011.

TINA MAI, EXAMINING ATTORNEY

SN 85-509,559. HEIS LOGIC LLC, FLORAL CITY, FL. FILED 1-5-2012.

Hierarchy

THE MARK CONSISTS OF STANDARD CHARACTERS WITHOUT CLAIM TO ANY PARTICULAR FONT, STYLE, SIZE, OR COLOR.

FOR COMPUTER PROGRAMS FOR CREATING, EDITING, PRINTING AND ORGANIZING INTO AN HIERARCHY DOCUMENTS CONSISTING OF TEXT AND GRAPHICS; UTILITY PROGRAMS FOR USE THEREWITH; USER MANUALS DISTRIBUTED THEREWITH (U.S. CLS. 21, 23, 26, 36 AND 38).

JESSICA A. POWERS, EXAMINING ATTORNEY

CLASS 9—(Continued).

SN 85-509,584. CLEAR-COM LLC, DBA CLEAR-COM COMMUNICATIONS, ALAMEDA, CA. FILED 1-5-2012.

I.V. CORE

THE MARK CONSISTS OF STANDARD CHARACTERS WITHOUT CLAIM TO ANY PARTICULAR FONT, STYLE, SIZE, OR COLOR.

FOR COMPUTER HARDWARE AND SOFTWARE USED FOR THE CONTROL OF VOICE CONTROLLED INFORMATION AND COMMUNICATION DEVICES (U.S. CLS. 21, 23, 26, 36 AND 38).

ODESSA BIBBINS, EXAMINING ATTORNEY

CLASS 9—(Continued).

SN 85-509,716. GLAD TO HAVE YOU, LLC, DBA GLAD TO HAVE YOU, LYNN HAVEN, FL. FILED 1-5-2012.



THE MARK CONSISTS OF THE NAME OF OUR COMPANY "GLAD TO HAVE YOU" AND THE LAYOUT AND FORMAT OF THE GRAPHIC INCLUDED.

FOR COMPUTER APPLICATION SOFTWARE FOR MOBILE PHONES, NAMELY, SOFTWARE FOR SUPPORTING THE HOSPITALITY INDUSTRY (U.S. CLS. 21, 23, 26, 36 AND 38).

FIRST USE 12-1-2011; IN COMMERCE 12-1-2011.
GINA HAYES, EXAMINING ATTORNEY

SN 85-509,671. SYNTHETIC, LLC, SAUSALITO, CA. FILED 1-5-2012.

D-Series

THE MARK CONSISTS OF STANDARD CHARACTERS WITHOUT CLAIM TO ANY PARTICULAR FONT, STYLE, SIZE, OR COLOR.

FOR DOWNLOADABLE SOFTWARE IN THE NATURE OF A MOBILE APPLICATION FOR PHOTOGRAPHY SIMULATING TOY CAMERA-LIKE EFFECTS WITH MULTIPLE LENS, FLASH AND FILM COMBINATIONS WITH THE ABILITY FOR MULTIPLE USERS TO SHARE AND UPLOAD PHOTOS (U.S. CLS. 21, 23, 26, 36 AND 38).

FIRST USE 12-15-2011; IN COMMERCE 12-15-2011.
DAWN FELDMAN, EXAMINING ATTORNEY

SN 85-509,756. ABRIAMED INC., SAN MARCOS, CA. FILED 1-5-2012.

**My Health Record Putting
You in Charge of Your
Health**

THE MARK CONSISTS OF STANDARD CHARACTERS WITHOUT CLAIM TO ANY PARTICULAR FONT, STYLE, SIZE, OR COLOR.

FOR COMPUTER APPLICATION SOFTWARE FOR MOBILE PHONES, PORTABLE MEDIA PLAYERS, HANDHELD COMPUTERS, AND DESKTOP COMPUTERS, NAMELY, SOFTWARE FOR USE IN DATABASE MANAGEMENT, ELECTRONIC STORAGE OF DATA, AND ELECTRONIC SHARING OF DATA (U.S. CLS. 21, 23, 26, 36 AND 38).

TEJBIR SINGH, EXAMINING ATTORNEY

SN 85-509,677. PCT INTERNATIONAL, INC., MESA, AZ. FILED 1-5-2012.

MOGO

THE MARK CONSISTS OF STANDARD CHARACTERS WITHOUT CLAIM TO ANY PARTICULAR FONT, STYLE, SIZE, OR COLOR.

FOR BAGS SPECIALLY ADAPTED FOR HOLDING, CARRYING AND DISPENSING CABLE FOR USE IN THE TELECOMMUNICATIONS INDUSTRY (U.S. CLS. 21, 23, 26, 36 AND 38).

FIRST USE 10-20-2010; IN COMMERCE 9-28-2011.
GINA HAYES, EXAMINING ATTORNEY

SN 85-509,780. LNZ LABS, LLC, FRISCO, TX. FILED 1-5-2012.

Movio

THE MARK CONSISTS OF STANDARD CHARACTERS WITHOUT CLAIM TO ANY PARTICULAR FONT, STYLE, SIZE, OR COLOR.

FOR COMPUTER APPLICATION SOFTWARE FOR MOBILE PHONES AND TABLET COMPUTERS, NAMELY, SOFTWARE FOR MOBILE VIDEO RECORDING, EDITING, AND SHARING (U.S. CLS. 21, 23, 26, 36 AND 38).

ANGELA DUONG, EXAMINING ATTORNEY

CLASS 9—(Continued).

SN 85-509,792. EDIRECTPHOTO INC, SCOTTSDALE, AZ. FILED 1-5-2012.

LUMACE

THE MARK CONSISTS OF STANDARD CHARACTERS WITHOUT CLAIM TO ANY PARTICULAR FONT, STYLE, SIZE, OR COLOR.

FOR CAMERA FILTERS; LENS FILTERS (U.S. CLS. 21, 23, 26, 36 AND 38).

REBECCA GILBERT, EXAMINING ATTORNEY

SN 85-509,806. MOBILE DATA TECHNOLOGIES, HAMPDEN, ME. FILED 1-5-2012.

doForms

THE MARK CONSISTS OF STANDARD CHARACTERS WITHOUT CLAIM TO ANY PARTICULAR FONT, STYLE, SIZE, OR COLOR.

FOR COMPUTER APPLICATION SOFTWARE FOR MOBILE DEVICES, NAMELY, SOFTWARE FOR MOBILE DISPATCHING, DATA COLLECTION, FORM CREATION, AND DATA MANAGEMENT AND MAPPING (U.S. CLS. 21, 23, 26, 36 AND 38).

FIRST USE 4-26-2010; IN COMMERCE 4-5-2011.

NATALIE POLZER, EXAMINING ATTORNEY

SN 85-509,809. NFLUENCE MEDIA, INC., SEATTLE, WA. FILED 1-5-2012.

DEALBOARD

THE MARK CONSISTS OF STANDARD CHARACTERS WITHOUT CLAIM TO ANY PARTICULAR FONT, STYLE, SIZE, OR COLOR.

FOR COMPUTER AND MOBILE SOFTWARE APPLICATIONS FOR ENABLING USERS TO SELF-DEFINE ONLINE PROFILES AND ACCOUNTS FOR PURPOSES OF FACILITATING THE RECEIPT OF RELEVANT ONLINE AND MOBILE ADVERTISING AND PROMOTIONAL CONTENT AND INFORMATION AND FOR CREATING AN ON-LINE COMMUNITY FOR CONSUMERS FOR THE PURPOSE OF BRAND ADVERTISING, REVIEWS, CRITICISM AND COMMENTARY (U.S. CLS. 21, 23, 26, 36 AND 38).

THOMAS MANOR, EXAMINING ATTORNEY

CLASS 9—(Continued).

SN 85-509,842. CURRENCE, RIKK, WHEATON, IL. FILED 1-5-2012.

JoyFocus

THE MARK CONSISTS OF STANDARD CHARACTERS WITHOUT CLAIM TO ANY PARTICULAR FONT, STYLE, SIZE, OR COLOR.

FOR COMPACT DISCS FEATURING MUSIC/MUSICAL RECORDINGS (U.S. CLS. 21, 23, 26, 36 AND 38).

FIRST USE 1-1-1998; IN COMMERCE 8-17-2001.

LINDA E. BLOHM, EXAMINING ATTORNEY

SN 85-509,856. WILD BRAIN ENTERTAINMENT, INC., SHERMAN OAKS, CA. FILED 1-5-2012.

BIT

THE MARK CONSISTS OF STANDARD CHARACTERS WITHOUT CLAIM TO ANY PARTICULAR FONT, STYLE, SIZE, OR COLOR.

FOR ELECTRICAL AND SCIENTIFIC APPARATUS, NAMELY, ELECTRONIC GAME SOFTWARE; COMPUTER GAME SOFTWARE; DOWNLOADABLE COMPUTER GAMES; COMPUTER AND VIDEO-GAME CASSETTES, CARTRIDGES, DISCS AND PROGRAMS; DOWNLOADABLE GAME SOFTWARE; MOTION PICTURE FILMS FEATURING MUSIC, ANIMATED CARTOONS, LIVE-ACTION PERFORMANCES AND LIVE ACTION PERFORMANCES BY COSTUMED CHARACTERS ALL IN THE FIELD OF CHILDREN'S EDUCATION; PRE-RECORDED VIDEO AND AUDIO CASSETTES, VIDEO AND AUDIO TAPES, VIDEO AND AUDIO DISCS, CD ROMS, COMPACT DISCS, DIGITAL VERSATILE DISCS, MUSICAL VIDEO RECORDINGS, MUSICAL SOUND RECORDINGS AND PHONOGRAPH RECORDS FEATURING MUSIC, ANIMATED CARTOONS, LIVE-ACTION PERFORMANCES AND LIVE ACTION PERFORMANCES BY COSTUMED CHARACTERS ALL IN THE FIELD OF CHILDREN'S EDUCATION; SOFTWARE AND MANUALS SOLD AS A UNIT IN THE FIELD OF CHILDREN'S EDUCATION, NAMELY, FOR USE IN CREATING, UPDATING AND MAINTAINING CALENDARS, FOR INFORMATION MANAGEMENT AND FOR USE AS COMPUTER SCREEN SAVERS; DECORATIVE REFRIGERATOR MAGNETS; HAND HELD UNITS FOR PLAYING ELECTRONIC GAMES FOR USE WITH EXTERNAL DISPLAY SCREEN OR MONITOR (U.S. CLS. 21, 23, 26, 36 AND 38).

EMILY CHUO, EXAMINING ATTORNEY

CLASS 9—(Continued).

SN 85-509,929. WILD BRAIN ENTERTAINMENT, INC., SHERMAN OAKS, CA. FILED 1-5-2012.

DIZZY

THE MARK CONSISTS OF STANDARD CHARACTERS WITHOUT CLAIM TO ANY PARTICULAR FONT, STYLE, SIZE, OR COLOR.

FOR ELECTRICAL AND SCIENTIFIC APPARATUS, NAMELY, ELECTRONIC GAME SOFTWARE; COMPUTER GAME SOFTWARE; DOWNLOADABLE COMPUTER GAMES; COMPUTER AND VIDEO-GAME CASSETTES, CARTRIDGES, DISCS AND PROGRAMS; DOWNLOADABLE GAME SOFTWARE; MOTION PICTURE FILMS FEATURING MUSIC, ANIMATED CARTOONS, LIVE-ACTION PERFORMANCES AND LIVE ACTION PERFORMANCES BY COSTUMED CHARACTERS ALL IN THE FIELD OF CHILDREN'S EDUCATION; PRE-RECORDED VIDEO AND AUDIO CASSETTES, VIDEO AND AUDIO TAPES, VIDEO AND AUDIO DISCS, CD ROMS, COMPACT DISCS, DIGITAL VERSATILE DISCS, MUSICAL VIDEO RECORDINGS, MUSICAL SOUND RECORDINGS AND PHONOGRAPH RECORDS FEATURING MUSIC, ANIMATED CARTOONS, LIVE-ACTION PERFORMANCES AND LIVE ACTION PERFORMANCES BY COSTUMED CHARACTERS ALL IN THE FIELD OF CHILDREN'S EDUCATION; SOFTWARE AND MANUALS SOLD AS A UNIT IN THE FIELD OF CHILDREN'S EDUCATION, NAMELY, FOR USE IN CREATING, UPDATING AND MAINTAINING CALENDARS, FOR INFORMATION MANAGEMENT AND FOR USE AS COMPUTER SCREEN SAVERS; DECORATIVE REFRIGERATOR MAGNETS; HAND HELD UNITS FOR PLAYING ELECTRONIC GAMES FOR USE WITH EXTERNAL DISPLAY SCREEN OR MONITOR (U.S. CLS. 21, 23, 26, 36 AND 38).
EMILY CHUO, EXAMINING ATTORNEY

SN 85-509,937. VENDMORE SYSTEMS, LLC, STAMFORD, CT. FILED 1-5-2012.

SNACK BUDDIES

THE MARK CONSISTS OF STANDARD CHARACTERS WITHOUT CLAIM TO ANY PARTICULAR FONT, STYLE, SIZE, OR COLOR.

FOR COMPUTER APPLICATION SOFTWARE FOR MOBILE DEVICES, NAMELY, SOFTWARE FOR ALLOWING USERS TO PLAY GAMES WITH OTHER USERS, ENGAGE IN SOCIAL NETWORKING, AND SEND GIFTS TO OTHER USERS (U.S. CLS. 21, 23, 26, 36 AND 38).
ANNE E. GUSTASON, EXAMINING ATTORNEY

CLASS 9—(Continued).

SN 85-509,978. OVERSTOCK.COM SERVICES, INC., SALT LAKE CITY, UT. FILED 1-5-2012.

MYCURRENT

THE MARK CONSISTS OF STANDARD CHARACTERS WITHOUT CLAIM TO ANY PARTICULAR FONT, STYLE, SIZE, OR COLOR.

FOR COMPUTER SOFTWARE FOR AGGREGATING SOCIAL MEDIA CONTENT (U.S. CLS. 21, 23, 26, 36 AND 38).

FIRST USE 12-6-2011; IN COMMERCE 12-6-2011.
JOHN GARTNER, EXAMINING ATTORNEY

SN 85-510,027. KENNEDY, RICHARD S., MURRIETA, CA. FILED 1-6-2012.

uFab

THE MARK CONSISTS OF STANDARD CHARACTERS WITHOUT CLAIM TO ANY PARTICULAR FONT, STYLE, SIZE, OR COLOR.

FOR PRINTERS FOR COMPUTERS; PRINTERS FOR USE WITH COMPUTERS; THERMAL PRINTERS (U.S. CLS. 21, 23, 26, 36 AND 38).

LINDA MICKLEBURGH, EXAMINING ATTORNEY

SN 85-510,058. KUDOM ELECTRONICS TECHNOLOGY (SHANGHAI) CO., LTD., SHANGHAI CITY, CHINA, FILED 1-6-2012.

THE MARK CONSISTS OF THE STYLIZED WORD KUDOM, WITH PART OF THE LETTER K BEING A LONG CURVING BAND AND A SMALL DOT AT THE RIGHT END OF THE BAND.

THE WORDING KUDOM HAS NO MEANING IN A FOREIGN LANGUAGE.

FOR APPARATUS AND INSTRUMENTS FOR CONVEYING, DISTRIBUTING, TRANSFORMING, STORING, REGULATING OR CONTROLLING ELECTRIC CURRENT; ELECTRIC CONTROL PANELS; ELECTRIC LIGHT DIMMERS; ELECTRIC RELAYS; ELECTRIC SWITCHES; LIGHT SWITCHES; SEMI-CONDUCTORS; SEMICONDUCTOR DEVICES; STARTERS FOR FLUORESCENT LIGHTS; VOLTAGE REGULATORS (U.S. CLS. 21, 23, 26, 36 AND 38).
LINDA MICKLEBURGH, EXAMINING ATTORNEY

CLASS 9—(Continued).

SN 85-510,201. CHANA, KURT E., ALTAMONTE SPRINGS, FL, FL. FILED 1-6-2012.

I choose to be positive.
Be positive, its easy

THE MARK CONSISTS OF STANDARD CHARACTERS WITHOUT CLAIM TO ANY PARTICULAR FONT, STYLE, SIZE, OR COLOR.

FOR COMPUTER PROGRAMS FOR CONNECTING REMOTELY TO COMPUTERS OR COMPUTER NETWORKS (U.S. CLS. 21, 23, 26, 36 AND 38).
ALEX KEAM, EXAMINING ATTORNEY

CLASS 9—(Continued).

SN 85-510,379. NRD LLC, GRAND ISLAND, NY. FILED 1-6-2012.

IONMASTER

THE MARK CONSISTS OF STANDARD CHARACTERS WITHOUT CLAIM TO ANY PARTICULAR FONT, STYLE, SIZE, OR COLOR.

FOR STATIC ELIMINATORS; STATIC CONTROL IONIZERS (U.S. CLS. 21, 23, 26, 36 AND 38).
FIRST USE 0-0-1980; IN COMMERCE 0-0-1980.
JOHN WILKE, EXAMINING ATTORNEY

SN 85-510,248. OAKLEY, INC., FOOTHILL RANCH, CA. FILED 1-6-2012.

FROGSKINS

THE MARK CONSISTS OF STANDARD CHARACTERS WITHOUT CLAIM TO ANY PARTICULAR FONT, STYLE, SIZE, OR COLOR.

FOR EYEWEAR, NAMELY SUNGLASSES AND ACCESSORIES FOR SUNGLASSES, NAMELY, REPLACEMENT LENSES, EAR STEMS AND NOSE PIECES (U.S. CLS. 21, 23, 26, 36 AND 38).

FIRST USE 4-30-1985; IN COMMERCE 4-30-1985.
AMY KERTGATE, EXAMINING ATTORNEY

SN 85-510,405. NRD LLC, GRAND ISLAND, NY. FILED 1-6-2012.

NUCLECEL

THE MARK CONSISTS OF STANDARD CHARACTERS WITHOUT CLAIM TO ANY PARTICULAR FONT, STYLE, SIZE, OR COLOR.

FOR STATIC ELIMINATORS; STATIC CONTROL IONIZERS (U.S. CLS. 21, 23, 26, 36 AND 38).

FIRST USE 0-0-1980; IN COMMERCE 0-0-1980.
JOHN WILKE, EXAMINING ATTORNEY

SN 85-510,347. ONE HAND CLAPPING LTD., AKA PADLETTE.COM, HONG KONG, HONG KONG, FILED 1-6-2012.

YINYANG

THE MARK CONSISTS OF STANDARD CHARACTERS WITHOUT CLAIM TO ANY PARTICULAR FONT, STYLE, SIZE, OR COLOR.

FOR SUPPORT DEVICES FOR TABLET COMPUTERS AND E-READERS IN THE NATURE OF AN ELASTOMERIC ATTACHMENT THAT SERVES AS A HANDLE OR GRIP (U.S. CLS. 21, 23, 26, 36 AND 38).

FRED CARL, EXAMINING ATTORNEY

SN 85-510,455. TRON 2 INTERNATIONAL CORPORATION, TAIPEI CITY, TAIWAN, FILED 1-6-2012.

MyFin

THE MARK CONSISTS OF STANDARD CHARACTERS WITHOUT CLAIM TO ANY PARTICULAR FONT, STYLE, SIZE, OR COLOR.

FOR CELL PHONE CASES; CELL PHONE COVERS; PROTECTIVE COVERS AND CASES FOR CELL PHONES, LAPTOPS AND PORTABLE MEDIA PLAYERS; PROTECTIVE COVERS FOR ELECTRONIC READING DEVICES; ELECTRONIC BOOK READER COVERS; NOTEBOOK AND LAPTOP COMPUTERS; CAMERA CASES; BULLHORNS; EARPHONE CASES; EYEWEAR CASES (U.S. CLS. 21, 23, 26, 36 AND 38).

MYRIAH HABEEB, EXAMINING ATTORNEY

CLASS 9—(Continued).

SN 85-510,488. CELLCO PARTNERSHIP, DBA VERIZON WIRELESS, BASKING RIDGE, NJ. FILED 1-6-2012.

UNTAMED

THE MARK CONSISTS OF STANDARD CHARACTERS WITHOUT CLAIM TO ANY PARTICULAR FONT, STYLE, SIZE, OR COLOR.

FOR WIRELESS TELECOMMUNICATIONS DEVICE FEATURING TRANSMISSION OF VOICE, DATA, IMAGE AND VIDEO, INCLUDING VOICE, TEXT, PICTURE AND VIDEO MESSAGING, INTERNET ACCESS, ACCESS TO NAVIGATION AND DIRECTIONAL SERVICE OVER THE AIR, THE ABILITY TO DOWNLOAD MUSIC, VIDEOS AND APPLICATIONS OVER THE AIR, AND WHICH HAS A MUSIC PLAYER AND A STILL IMAGE AND VIDEO CAMERA (U.S. CLS. 21, 23, 26, 36 AND 38).

MARK RADEMACHER, EXAMINING ATTORNEY

CLASS 9—(Continued).

SN 85-510,528. INDIGO BIOSYSTEMS, INC., INDIANAPOLIS, IN. FILED 1-6-2012.

INDIGO COMPASS

THE MARK CONSISTS OF STANDARD CHARACTERS WITHOUT CLAIM TO ANY PARTICULAR FONT, STYLE, SIZE, OR COLOR.

OWNER OF U.S. REG. NO. 3,258,713.
FOR COMPUTER SOFTWARE FOR THE MANAGEMENT, ACQUISITION, ORGANIZATION AND RETRIEVAL AND ANALYSIS OF DATA AND INFORMATION, AND DELIVERY OF SUCH DATA AND INFORMATION THROUGH A REAL TIME DASHBOARD (U.S. CLS. 21, 23, 26, 36 AND 38).

MARK SHINER, EXAMINING ATTORNEY

SN 85-510,621. THE LEE COMPANY, WESTBROOK, CT. FILED 1-6-2012.

HYDAMP

THE MARK CONSISTS OF STANDARD CHARACTERS WITHOUT CLAIM TO ANY PARTICULAR FONT, STYLE, SIZE, OR COLOR.

FOR FLUID SYSTEM INSERTS TO PERMIT SELECTIVE MEASUREMENT OF MAXIMUM, AVERAGE OR MINIMUM FLUID PRESSURES (U.S. CLS. 21, 23, 26, 36 AND 38).

FIRST USE 2-22-1973; IN COMMERCE 2-22-1973.
ANDREW LEASER, EXAMINING ATTORNEY

SN 85-510,627. DISNEY ENTERPRISES, INC., BURBANK, CA. FILED 1-6-2012.

DISNEY PERFORMANCE
ALIGNMENT

THE MARK CONSISTS OF STANDARD CHARACTERS WITHOUT CLAIM TO ANY PARTICULAR FONT, STYLE, SIZE, OR COLOR.

FOR COMPUTER HARDWARE AND SOFTWARE FOR USE IN TRACKING AND ASSESSING SAFETY COMPLIANCE; COMPUTER HARDWARE AND SOFTWARE FOR USE IN PROVIDING ASSISTANCE AND ENHANCED ACCESSIBILITY TO INDIVIDUALS WITH DISABILITIES (U.S. CLS. 21, 23, 26, 36 AND 38).

PAUL MORENO, EXAMINING ATTORNEY

SN 85-510,509. BBY SOLUTIONS, INC., RICHFIELD, MN. FILED 1-6-2012.



THE MARK CONSISTS OF THE LETTERS PT WITHIN A SQUARE.

FOR MOBILE PHONE ACCESSORIES, NAMELY, CASES, VEHICLE DASH/WINDSHIELD MOUNTS, BATTERIES AND CHARGERS (U.S. CLS. 21, 23, 26, 36 AND 38).

FIRST USE 10-0-2009; IN COMMERCE 10-0-2009.
FRANK LATTUCA, EXAMINING ATTORNEY

CLASS 9—(Continued).

SN 85-510,648. DISNEY ENTERPRISES, INC., BURBANK, CA. FILED 1-6-2012.

DISNEY ASSIST

THE MARK CONSISTS OF STANDARD CHARACTERS WITHOUT CLAIM TO ANY PARTICULAR FONT, STYLE, SIZE, OR COLOR.

FOR COMPUTER HARDWARE AND SOFTWARE FOR USE IN TRACKING AND ASSESSING SAFETY COMPLIANCE; COMPUTER HARDWARE AND SOFTWARE FOR USE IN PROVIDING ASSISTANCE AND ENHANCED ACCESSIBILITY TO INDIVIDUALS WITH DISABILITIES (U.S. CLS. 21, 23, 26, 36 AND 38).

PAUL MORENO, EXAMINING ATTORNEY

SN 85-510,692. RED DOT SECURITY INC., SANDY, UT. FILED 1-6-2012.

RITEFLASH

THE MARK CONSISTS OF STANDARD CHARACTERS WITHOUT CLAIM TO ANY PARTICULAR FONT, STYLE, SIZE, OR COLOR.

FOR SECURITY ALARM SYSTEM COMPONENTS, NAMELY, CONTROL PANELS, KEYPADS, MOTION SENSORS, DOOR AND WINDOW SENSORS, SIRENS, GLASS-BREAK SENSORS, TEMPERATURE/FREEZE AND HEAT SENSORS, FLOOD DETECTORS AND SMOKE DETECTORS (U.S. CLS. 21, 23, 26, 36 AND 38).

WILLIAM ROSSMAN, EXAMINING ATTORNEY

SN 85-510,793. GLUE TOOLS, LLC, SANTA BARBARA, CA. FILED 1-6-2012.

SÉANCE

THE MARK CONSISTS OF STANDARD CHARACTERS WITHOUT CLAIM TO ANY PARTICULAR FONT, STYLE, SIZE, OR COLOR.

FOR COMMUNICATIONS SOFTWARE FOR CONNECTING CAMERAS TO COMPUTER HARDWARE; COMPUTER APPLICATION SOFTWARE FOR MOBILE PHONES, CAMERAS, AND COMPUTERS, NAMELY, SOFTWARE FOR USE IN CONTROLLING CAMERAS AND DIGITAL STORAGE DEVICES; COMPUTER GRAPHICS SOFTWARE; COMPUTER SOFTWARE PROGRAMS FOR THE DELIVERY OF STILL IMAGES AND MOVING PICTURES INTO HARDWARE STORAGE DEVICES; COMPUTER HARDWARE AND SOFTWARE FOR PROCESSING DIGITAL VIDEO FILES; COMPUTER HARDWARE AND SOFTWARE SYSTEMS FOR CONTROLLING VIDEO DEVICES; COMPUTER SOFTWARE AND FIRMWARE FOR CONTROLLING VIDEO SOURCES ON ANY COMPUTERIZED PLATFORM, INCLUDING CAMERAS, MOTION PICTURE CAMERAS,

CLASS 9—(Continued).

MOBILE PHONES, TABLET COMPUTERS, TABLET PC, AND COMPUTERS; COMPUTER SOFTWARE FOR USE WITH MOTION PICTURE DEVICES; COMPUTER SOFTWARE FOR COMMUNICATING WITH USERS OF HAND-HELD COMPUTERS; COMPUTER SOFTWARE FOR PROCESSING DIGITAL VIDEO FILES; COMPUTER SOFTWARE FOR ORGANIZING AND VIEWING DIGITAL IMAGES AND PHOTOGRAPHS; COMPUTER SOFTWARE FOR MANIPULATING DIGITAL VIDEO INFORMATION FOR USE IN VIDEO MEDIA APPLICATIONS; COMPUTER SOFTWARE FOR PROCESSING DIGITAL IMAGES; COMPUTER SOFTWARE FOR CONTROLLING THE OPERATION OF VIDEO DEVICES; DOWNLOADABLE COMPUTER SOFTWARE FOR USE AS A CONTROLLER OF MOTION PICTURE DEVICES AND CAMERAS; OPTICAL COMMUNICATIONS SYSTEMS COMPRISED OF OPTICAL AND ELECTRONIC HARDWARE AND COMPUTER SOFTWARE FOR THE TRANSMISSION OF DATA BETWEEN TWO POINTS; MOTION PICTURE CAMERA SOFTWARE; COMPUTER SOFTWARE TO ENHANCE THE VISUAL CAPABILITIES OF MOTION PICTURE CAMERAS (U.S. CLS. 21, 23, 26, 36 AND 38).

ANDREW LEASER, EXAMINING ATTORNEY

SN 85-510,800. POINT GREY RESEARCH, INC., RICHMOND, CANADA, FILED 1-6-2012.

GRASSHOPPER EXPRESS

THE MARK CONSISTS OF STANDARD CHARACTERS WITHOUT CLAIM TO ANY PARTICULAR FONT, STYLE, SIZE, OR COLOR.

FOR DIGITAL CAMERAS AND INSTRUCTION MANUALS SOLD AS UNIT THEREWITH (U.S. CLS. 21, 23, 26, 36 AND 38).

FIRST USE 8-25-2011; IN COMMERCE 8-25-2011.

DAVID COLLIER, EXAMINING ATTORNEY

SN 85-510,808. PALMETTO ENGINEERING AND CONSULTING, LLC, PIEDMONT, SC. FILED 1-6-2012.

CrescentLink

THE MARK CONSISTS OF STANDARD CHARACTERS WITHOUT CLAIM TO ANY PARTICULAR FONT, STYLE, SIZE, OR COLOR.

FOR COMPUTER SYSTEMS, NAMELY, UTILITY NETWORK MAPPING SOFTWARE (U.S. CLS. 21, 23, 26, 36 AND 38).

FIRST USE 6-13-2011; IN COMMERCE 6-13-2011.

JULIE WATSON, EXAMINING ATTORNEY

CLASS 9—(Continued).

SN 85-510,846. PARAMETRIC SOUND CORPORATION, HENDERSON, NV. FILED 1-6-2012.

HYPERSONIC

THE MARK CONSISTS OF STANDARD CHARACTERS WITHOUT CLAIM TO ANY PARTICULAR FONT, STYLE, SIZE, OR COLOR.

FOR SOUND REPRODUCTION EQUIPMENT, NAMELY, SPEAKERS, ULTRASONIC SOUND EMITTERS FOR INDIRECTLY GENERATING AUDIBLE SOUND, AND CONTROL CIRCUITRY FOR MIXING FREQUENCIES (U.S. CLS. 21, 23, 26, 36 AND 38).

FIRST USE 8-14-2000; IN COMMERCE 8-14-2000.
HANNO RITTNER, EXAMINING ATTORNEY

SN 85-510,946. ACCESS CONSULTING GROUP, INC., DBA ACG TECHNOLOGIES, RANCHO SANTA MARGARITA, CA. FILED 1-6-2012.



THE MARK CONSISTS OF THE STYLIZED TEXT "PROSTART" ABOVE THE STYLIZED TEXT "MOVING IN THE RIGHT DIRECTION". TO THE LEFT OF THE TEXT IS A CIRCLE WITH A STYLIZED CURVE INSIDE IT THAT RESEMBLES A BACKWARDS S.

FOR DATABASE MANAGEMENT SOFTWARE FOR SALES AND PROJECT MANAGEMENT (U.S. CLS. 21, 23, 26, 36 AND 38).

FIRST USE 9-0-2010; IN COMMERCE 9-0-2010.
SHAUNIA CARLYLE, EXAMINING ATTORNEY

SN 85-510,947. GLOBAL PHOENIX COMPUTER TECHNOLOGIES SOLUTIONS, INC., ITHACA, NY. FILED 1-6-2012.

MIDPAD

THE MARK CONSISTS OF STYLIZED LETTERS IN CAPITAL "M", "D", "P", "A", AND "D" AND A LOWER CASE "I".

FOR PC TABLET; TABLET COMPUTER (U.S. CLS. 21, 23, 26, 36 AND 38).

DORITT L. CARROLL, EXAMINING ATTORNEY

CLASS 9—(Continued).

SN 85-511,000. DISNEY ENTERPRISES, INC., BURBANK, CA. FILED 1-6-2012.

DISNEY SYNCLINK

THE MARK CONSISTS OF STANDARD CHARACTERS WITHOUT CLAIM TO ANY PARTICULAR FONT, STYLE, SIZE, OR COLOR.

FOR COMPUTER HARDWARE AND SOFTWARE FOR USE IN TRACKING AND ASSESSING SAFETY COMPLIANCE; COMPUTER HARDWARE AND SOFTWARE FOR USE IN PROVIDING ASSISTANCE AND ENHANCED ACCESSIBILITY TO INDIVIDUALS WITH DISABILITIES (U.S. CLS. 21, 23, 26, 36 AND 38).

PAUL MORENO, EXAMINING ATTORNEY

SN 85-511,016. DISNEY ENTERPRISES, INC., BURBANK, CA. FILED 1-6-2012.

DISNEY ACS

THE MARK CONSISTS OF STANDARD CHARACTERS WITHOUT CLAIM TO ANY PARTICULAR FONT, STYLE, SIZE, OR COLOR.

FOR COMPUTER HARDWARE AND SOFTWARE FOR USE IN TRACKING AND ASSESSING SAFETY COMPLIANCE; COMPUTER HARDWARE AND SOFTWARE FOR USE IN PROVIDING ASSISTANCE AND ENHANCED ACCESSIBILITY TO INDIVIDUALS WITH DISABILITIES (U.S. CLS. 21, 23, 26, 36 AND 38).

PAUL MORENO, EXAMINING ATTORNEY

SN 85-511,079. SHENZHEN GEEYA TECHNOLOGY CO., LTD., SHENZHEN, CHINA, FILED 1-7-2012.

Speedcom

THE MARK CONSISTS OF STYLIZED WORDS "SPEEDCOM".

THE WORDING "SPEEDCOM" HAS NO MEANING IN A FOREIGN LANGUAGE.

FOR BROADBAND POWER LINE COMMUNICATION SYSTEMS FOR TRANSFERRING BROADBAND DATA OVER ELECTRICAL POWER LINES, COMPRISED OF COMPUTER HARDWARE, SOFTWARE AND MODEMS; COMPUTER HARDWARE, NAMELY, WIRELESS ACCESS POINT (WAP) DEVICES; COMPUTER NETWORK ADAPTERS, SWITCHES, ROUTERS AND HUBS; COMPUTER NETWORKING HARDWARE; ETHERNET ADAPTER; ETHERNET SWITCHES; MODEMS; NETWORK ROUTERS; RECEIVERS FOR RECEIVING CABLE TELEVISION; SET-TOP BOXES (U.S. CLS. 21, 23, 26, 36 AND 38).

ALYSSA STEEL, EXAMINING ATTORNEY

CLASS 9—(Continued).

SN 85-511,201. CARSTENS STUDIOS INC., ITASCA, IL.
FILED 1-7-2012.

MATH ARENA

THE MARK CONSISTS OF STANDARD CHARACTERS
WITHOUT CLAIM TO ANY PARTICULAR FONT, STYLE,
SIZE, OR COLOR.

OWNER OF U.S. REG. NO. 2,948,188.

SEC. 2(F).

FOR CHILDREN'S EDUCATIONAL SOFTWARE (U.S.
CLS. 21, 23, 26, 36 AND 38).

FIRST USE 10-1-1999; IN COMMERCE 10-1-1999.

SALLY SHIH, EXAMINING ATTORNEY

SN 85-511,224. MONEY CHASIN MOVEMENT, LLC, DBA
YG STUNNA, NEW CARROLLTON, MD. FILED 1-7-2012.

MCM Money Chasin Movement

THE MARK CONSISTS OF STANDARD CHARACTERS
WITHOUT CLAIM TO ANY PARTICULAR FONT, STYLE,
SIZE, OR COLOR.

FOR PRE-RECORDED MUSICAL PRODUCTS,
NAMELY, COMPACT DISCS, CASSETTES, VINYL RE-
CORDS, DVD'S; DOWNLOADABLE MUSICAL SOUND
RECORDINGS, DOWNLOADABLE MUSIC VIDEOS;
AUDIO AND VIDEO RECORDINGS FEATURING MU-
SIC AND ARTISTIC PERFORMANCES; DIGITAL MUSIC
DOWNLOADABLE FROM THE INTERNET (U.S. CLS. 21,
23, 26, 36 AND 38).

JENNY PARK, EXAMINING ATTORNEY

SN 85-511,313. POLYLINGUA CORPORATION, INDIANA-
POLIS, IN. FILED 1-8-2012.

PolyLingua

THE MARK CONSISTS OF STANDARD CHARACTERS
WITHOUT CLAIM TO ANY PARTICULAR FONT, STYLE,
SIZE, OR COLOR.

FOR DOWNLOADABLE VIDEO RECORDINGS FEATURING
LANGUAGE TEACHING; PRE-RECORDED
VIDEO DISCS, VIDEO RECORDING AND VIDEO TAPES
FEATURING LANGUAGE TEACHING (U.S. CLS. 21, 23,
26, 36 AND 38).

ANDREA HACK, EXAMINING ATTORNEY

CLASS 9—(Continued).

SN 85-511,334. RIBBEDTEE DESIGNS LLC, SAN JOSE, CA.
FILED 1-8-2012.

HandEband

THE MARK CONSISTS OF STANDARD CHARACTERS
WITHOUT CLAIM TO ANY PARTICULAR FONT, STYLE,
SIZE, OR COLOR.

FOR STRAPS FOR MOBILE PHONES (U.S. CLS. 21, 23,
26, 36 AND 38).

GIANCARLO CASTRO, EXAMINING ATTORNEY

SN 85-511,336. DIEBOLD, INCORPORATED, NORTH CAN-
TON, OH. FILED 1-8-2012.

OWNER OF U.S. REG. NOS. 1,701,403, 3,875,502 AND
OTHERS.

THE MARK CONSISTS OF THE WORD "DIEBOLD"
WITH A PARTIAL ORBIT RING THROUGH THE "DI" OF
"DIEBOLD".

FOR AUTOMATED TRANSACTION MACHINES;
AUTOMATED BANKING MACHINES; AUTOMATED
TELLER MACHINES; COMPUTER SOFTWARE FOR
AUTOMATED TRANSACTION MACHINES, AUTO-
MATED BANKING MACHINES, AND AUTOMATED
TELLER MACHINES (U.S. CLS. 21, 23, 26, 36 AND 38).

FIRST USE 5-5-1998; IN COMMERCE 5-5-1998.

DAVID C. REIHNER, EXAMINING ATTORNEY

CLASS 9—(Continued).

SN 85-511,338. PUBLIC FLIPPER LIMITED, LLC, POWAY, CA. FILED 1-8-2012.

FLIPPER

THE MARK CONSISTS OF STANDARD CHARACTERS WITHOUT CLAIM TO ANY PARTICULAR FONT, STYLE, SIZE, OR COLOR.

FOR PRE-RECORDED VIDEO DISCS, VIDEO RECORDING AND VIDEO TAPES FEATURING PERFORMANCES OF A MUSICAL ARTIST OR GROUP; SOUND RECORDINGS FEATURING PERFORMANCES OF A MUSICAL ARTIST OR GROUP (U.S. CLS. 21, 23, 26, 36 AND 38).

FIRST USE 11-17-1979; IN COMMERCE 11-17-1979.
LESLEY LAMOTHE, EXAMINING ATTORNEY

SN 85-511,344. DIGITAL STORM, FREMONT, CA. FILED 1-8-2012.

Aventum

THE MARK CONSISTS OF STANDARD CHARACTERS WITHOUT CLAIM TO ANY PARTICULAR FONT, STYLE, SIZE, OR COLOR.

FOR COMPUTER CHASSIS (U.S. CLS. 21, 23, 26, 36 AND 38).

FIRST USE 1-7-2012; IN COMMERCE 1-7-2012.
CHRISTOPHER BUONGIORNO, EXAMINING ATTORNEY

SN 85-511,381. XIAMEN LANXI TECHNOLOGY CO., LTD., XIAMEN, FUJIAN, CHINA, FILED 1-9-2012.

enpo

THE MARK CONSISTS OF STANDARD CHARACTERS WITHOUT CLAIM TO ANY PARTICULAR FONT, STYLE, SIZE, OR COLOR.

THE WORDING "ENPO" HAS NO MEANING IN A FOREIGN LANGUAGE.

FOR BATTERY CHARGERS; INVERTERS (U.S. CLS. 21, 23, 26, 36 AND 38).

LOURDES AYALA, EXAMINING ATTORNEY

CLASS 9—(Continued).

SN 85-511,396. ENSIGN, JACOB B, LIBERTY, MO. FILED 1-9-2012.



THE COLOR(S) RED AND BLACK IS/ARE CLAIMED AS A FEATURE OF THE MARK.

THE MARK CONSISTS OF THE WORDS DEADLY DUNGEONS WITH THE WORD DEADLY PLACED ABOVE THE WORD DUNGEONS. A HAND DRAWN CUSTOM FONT HAS BEEN USED FOR THE MARK. THE MARK HAS A BLACK OUTLINE AND IS FILLED WITH VARIOUS HUES OF RED TO MAKE IT APPEAR AS IF IT WERE CUT FROM RED STONE.

FOR COMPUTER GAME SOFTWARE; GAME SOFTWARE; INTERACTIVE GAME PROGRAMS; INTERACTIVE GAME SOFTWARE; INTERACTIVE MULTIMEDIA COMPUTER GAME PROGRAM; INTERACTIVE VIDEO GAME PROGRAMS; VIDEO GAME SOFTWARE (U.S. CLS. 21, 23, 26, 36 AND 38).

FIRST USE 6-17-2010; IN COMMERCE 4-19-2011.
GINA HAYES, EXAMINING ATTORNEY

SN 85-511,436. RETRO64, INC., GLEN ELLYN, IL. FILED 1-9-2012.

Rune Raiders

THE MARK CONSISTS OF STANDARD CHARACTERS WITHOUT CLAIM TO ANY PARTICULAR FONT, STYLE, SIZE, OR COLOR.

FOR COMPUTER GAME PROGRAMMES; COMPUTER GAME PROGRAMMES DOWNLOADABLE VIA THE INTERNET; COMPUTER GAME SOFTWARE FOR PERSONAL COMPUTERS AND HOME VIDEO GAME CONSOLES; COMPUTER GAME SOFTWARE FOR USE ON MOBILE AND CELLULAR PHONES; COMPUTER GAME SOFTWARE FOR USE WITH PERSONAL COMPUTERS, HOME VIDEO GAME CONSOLES USED WITH TELEVISIONS AND ARCADE-BASED VIDEO GAME CONSOLES (U.S. CLS. 21, 23, 26, 36 AND 38).

FIRST USE 1-6-2012; IN COMMERCE 1-6-2012.
WILLIAM VERHOSEK, EXAMINING ATTORNEY

CLASS 9—(Continued).

SN 85-511,442. BRIDGEPOINT INTERNATIONAL, LLC, NAPERVILLE, IL. FILED 1-9-2012.



THE MARK CONSISTS OF A CIRCLE CONTAINING TWO RECTANGLES ABOVE THE WORD "PAUSE", SURROUNDED BY A SECOND CIRCLE.

FOR COMPUTER APPLICATION SOFTWARE FOR MOBILE PHONES, PORTABLE MEDIA PLAYERS, AND HANDHELD COMPUTERS, NAMELY, SOFTWARE FOR USE IN EMPLOYEE TRAINING, EMPLOYEE DEVELOPMENT AND EMPLOYEE EDUCATION PROGRAMS (U.S. CLS. 21, 23, 26, 36 AND 38).

REBECCA GILBERT, EXAMINING ATTORNEY

CLASS 9—(Continued).

SN 85-511,488. CBS STUDIOS INC., STUDIO CITY, CA. FILED 1-9-2012.

ELEMENTARY

THE MARK CONSISTS OF STANDARD CHARACTERS WITHOUT CLAIM TO ANY PARTICULAR FONT, STYLE, SIZE, OR COLOR.

FOR LASER DISCS, AND DIGITAL VIDEO DISCS/DIGITAL VERSATILE DISCS DVD, FEATURING PRE-RECORDED ENTERTAINMENT IN THE NATURE OF A DRAMATIC TELEVISION SERIES EPISODES (U.S. CLS. 21, 23, 26, 36 AND 38).

DOUGLAS LEE, EXAMINING ATTORNEY

SN 85-511,541. APCON, INC., WILSONVILLE, OR. FILED 1-9-2012.

INTELLATAP

THE MARK CONSISTS OF STANDARD CHARACTERS WITHOUT CLAIM TO ANY PARTICULAR FONT, STYLE, SIZE, OR COLOR.

FOR COMPUTER SWITCHES AND ROUTERS THAT ENABLE USERS TO MONITOR ETHERNET IN-LINE OR SPAN NETWORK LINKS (U.S. CLS. 21, 23, 26, 36 AND 38).

KIMBERLY PERRY, EXAMINING ATTORNEY

SN 85-511,477. CERTEFI, INC., PALO ALTO, CA. FILED 1-9-2012.

ReadyPay

THE MARK CONSISTS OF STANDARD CHARACTERS WITHOUT CLAIM TO ANY PARTICULAR FONT, STYLE, SIZE, OR COLOR.

FOR CUSTOMER SELF SERVICE ELECTRONIC CHECKOUT STATION FOR POINT OF SALE; ELECTRONIC EQUIPMENT FOR POINT-OF-SALES (POS) SYSTEMS, NAMELY, POINT-OF-SALE TERMINALS, BAR CODE READERS, OPTICAL READERS, ADVERTISEMENT DISPLAY MONITORS, KEYBOARDS, PRINTERS, SCANNERS, RADIO TRANSMITTERS, RADIO RECEIVERS, COMPUTER HARDWARE, AND COMPUTER OPERATING SOFTWARE; POINT-OF-SALE TERMINALS (U.S. CLS. 21, 23, 26, 36 AND 38).

FIRST USE 3-25-2009; IN COMMERCE 3-25-2009.

KELLY BOULTON, EXAMINING ATTORNEY

SN 85-511,601. MEDIA SCORE, INC. RICHARDSON, TX. FILED 1-9-2012.

uengageit

THE MARK CONSISTS OF STANDARD CHARACTERS WITHOUT CLAIM TO ANY PARTICULAR FONT, STYLE, SIZE, OR COLOR.

FOR COMPUTER SOFTWARE, NAMELY, SOFTWARE DEVELOPMENT TOOLS FOR THE CREATION OF MOBILE INTERNET APPLICATIONS AND CLIENT INTERFACES (U.S. CLS. 21, 23, 26, 36 AND 38).

WILLIAM JACKSON, EXAMINING ATTORNEY

CLASS 9—(Continued).

SN 85-511,619. MAID BRIGADE, INC., ATLANTA, GA. FILED 1-9-2012.

MAID SIMPLE

THE MARK CONSISTS OF STANDARD CHARACTERS WITHOUT CLAIM TO ANY PARTICULAR FONT, STYLE, SIZE, OR COLOR.

FOR COMPUTER SOFTWARE FOR USE IN CUSTOMER RELATIONSHIP MANAGEMENT (CRM); COMPUTER SOFTWARE FOR USE IN DATABASE MANAGEMENT (U.S. CLS. 21, 23, 26, 36 AND 38).

JOHN DALIER, EXAMINING ATTORNEY

CLASS 9—(Continued).

SN 85-511,808. US PLUS YOU, LLC, CHATTANOOGA, TN. FILED 1-9-2012.

ACCESSORIES THAT PERFORM

THE MARK CONSISTS OF STANDARD CHARACTERS WITHOUT CLAIM TO ANY PARTICULAR FONT, STYLE, SIZE, OR COLOR.

FOR CARRYING CASES FOR MOBILE COMPUTERS; COMPUTER CARRYING CASES (U.S. CLS. 21, 23, 26, 36 AND 38).

ROBIN MITTLER, EXAMINING ATTORNEY

SN 85-511,675. R.J. HANLON COMPANY, INC., WESTFIELD, IN. FILED 1-9-2012.

WASHTRACK

THE MARK CONSISTS OF STANDARD CHARACTERS WITHOUT CLAIM TO ANY PARTICULAR FONT, STYLE, SIZE, OR COLOR.

FOR COMPUTER HARDWARE AND SOFTWARE SYSTEMS FOR RECORDING IDENTIFICATION DATA (U.S. CLS. 21, 23, 26, 36 AND 38).

THOMAS MANOR, EXAMINING ATTORNEY

SN 85-511,848. MONSTER, INC., BRISBANE, CA. FILED 1-9-2012.

SN 85-511,797. COMODO SECURITY SOLUTIONS, JERSEY CITY, NJ. FILED 1-9-2012.



THE COLOR(S) RED, GREY AND BLACK IS/ARE CLAIMED AS A FEATURE OF THE MARK.

THE MARK CONSISTS OF A GREY CIRCULAR ELEMENT SURROUNDING A REPRESENTATION OF A RED DRAGON'S EYE WITH A BLACK PUPIL.

FOR COMMUNICATION SOFTWARE FOR PROVIDING ACCESS TO THE INTERNET; COMPUTER PROGRAMS FOR USING THE INTERNET AND THE WORLD WIDE WEB; COMPUTER PROGRAMS FOR USING THE INTERNET AND THE WORLDWIDE WEB (U.S. CLS. 21, 23, 26, 36 AND 38).

FIRST USE 11-20-2009; IN COMMERCE 11-20-2009.
WILLIAM JACKSON, EXAMINING ATTORNEY



THE MARK CONSISTS OF A STYLIZED TRIANGLE DESIGN.

FOR AUDIO SPEAKERS; ELECTRONIC DOCKING STATIONS; HEADPHONES (U.S. CLS. 21, 23, 26, 36 AND 38).

KAREN BRACEY, EXAMINING ATTORNEY

CLASS 9—(Continued).

SN 85-511,879. AVEDIS AUDIO ELECTRONICS, TUJUNGA, CA. FILED 1-9-2012.



THE MARK CONSISTS OF A STYLIZED TRIANGLE SYMBOL POINTING UPWARDS; WHEREIN, THE LEFT AND RIGHT SIDES ARE STRAIGHT AND THE BOTTOM SIDE CURVES UPWARDS TO CONNECT WITH THE LEFT AND RIGHT SIDES.

FOR AUDIO PROCESSING EQUIPMENT, NAMELY, OP AMPS, EQUALIZERS, PRE AMPS, LIMITERS AND COMPRESSORS (U.S. CLS. 21, 23, 26, 36 AND 38).

FIRST USE 8-15-2003; IN COMMERCE 9-1-2003.
LINDA POWELL, EXAMINING ATTORNEY

SN 85-511,884. SHENZHEN RIITEK TECHNOLOGY CO., LTD., SHENZHEN, CHINA, FILED 1-9-2012.

THE MARK CONSISTS OF THE STYLIZED WORDING REIIE.

FOR BAR CODE READERS; BLANK INTEGRATED CIRCUIT CARDS; BLANK SMART CARDS; COMPUTER KEYBOARDS; COMPUTER MEMORIES; COMPUTER MOUSE; COMPUTER PERIPHERAL DEVICES; COMPUTERS; ELECTRONIC PENS; POCKET CALCULATORS; SCANNERS (U.S. CLS. 21, 23, 26, 36 AND 38).

FIRST USE 12-30-2011; IN COMMERCE 12-30-2011.
LINDA POWELL, EXAMINING ATTORNEY

CLASS 9—(Continued).

SN 85-512,066. CIRQUE CORPORATION, SALT LAKE CITY, UT. FILED 1-9-2012.

TOUCHGUARD

THE MARK CONSISTS OF STANDARD CHARACTERS WITHOUT CLAIM TO ANY PARTICULAR FONT, STYLE, SIZE, OR COLOR.

FOR A CAPACITANCE-SENSITIVE COMPUTER TOUCHPAD THAT PREVENTS UNINTENTIONAL CONTACT WITH THE TOUCHPAD FROM BEING INTERPRETED AS INPUT (U.S. CLS. 21, 23, 26, 36 AND 38).

FIRST USE 6-30-2010; IN COMMERCE 6-30-2010.
JOHN WILKE, EXAMINING ATTORNEY

SN 85-512,082. HOYT, JORDAN, FAIRPORT, NY. FILED 1-9-2012.

HEADTRIP

THE MARK CONSISTS OF STANDARD CHARACTERS WITHOUT CLAIM TO ANY PARTICULAR FONT, STYLE, SIZE, OR COLOR.

FOR DIGITAL MEDIA, NAMELY, DOWNLOADABLE AUDIO FILES AND CDS FEATURING MUSIC (U.S. CLS. 21, 23, 26, 36 AND 38).

FIRST USE 2-0-2007; IN COMMERCE 2-0-2007.
DAVID COLLIER, EXAMINING ATTORNEY

SN 85-512,094. VISUALON, INC., SANTA CLARA, CA. FILED 1-9-2012.

ONSTREAM

THE MARK CONSISTS OF STANDARD CHARACTERS WITHOUT CLAIM TO ANY PARTICULAR FONT, STYLE, SIZE, OR COLOR.

FOR COMPUTER SOFTWARE TO FACILITATE THE DEVELOPMENT OF MEDIA PLAYERS BY OTHERS (U.S. CLS. 21, 23, 26, 36 AND 38).

JAMES GRIFFIN, EXAMINING ATTORNEY

CLASS 9—(Continued).

SN 85-512,117. FLYBUY TECHNOLOGIES, INC., SEATTLE, WA. FILED 1-9-2012.

FLYBUY

THE MARK CONSISTS OF STANDARD CHARACTERS WITHOUT CLAIM TO ANY PARTICULAR FONT, STYLE, SIZE, OR COLOR.

FOR COMPUTER SOFTWARE FOR LOGISTICS, COMMUNICATIONS, AND COMMERCE; COMPUTER APPLICATION SOFTWARE FOR MOBILE PHONES AND HANDHELD COMPUTERS, FOR LOGISTICS, COMMUNICATIONS, AND COMMERCE (U.S. CLS. 21, 23, 26, 36 AND 38).

SUSAN LESLIE DUBOIS, EXAMINING ATTORNEY

CLASS 9—(Continued).

SN 85-512,644. PYRAMEX SAFETY PRODUCTS, LLC, COLLIERVILLE, TN. FILED 1-10-2012.

Rotator

THE MARK CONSISTS OF STANDARD CHARACTERS WITHOUT CLAIM TO ANY PARTICULAR FONT, STYLE, SIZE, OR COLOR.

FOR PROTECTIVE EYEWEAR (U.S. CLS. 21, 23, 26, 36 AND 38).

NAAKWAMA ANKRAH, EXAMINING ATTORNEY

SN 85-512,309. MONSTER, INC., BRISBANE, CA. FILED 1-9-2012.

KATANA

THE MARK CONSISTS OF STANDARD CHARACTERS WITHOUT CLAIM TO ANY PARTICULAR FONT, STYLE, SIZE, OR COLOR.

FOR AUDIO SPEAKERS; ELECTRONIC DOCKING STATIONS; HEADPHONES (U.S. CLS. 21, 23, 26, 36 AND 38).

KAREN BRACEY, EXAMINING ATTORNEY

SN 85-512,651. ANCILLARY ADVANTAGE, INC., PLANO, TX. FILED 1-10-2012.

MyAncillary

THE MARK CONSISTS OF STANDARD CHARACTERS WITHOUT CLAIM TO ANY PARTICULAR FONT, STYLE, SIZE, OR COLOR.

FOR COMPUTER SOFTWARE FOR THE FIELD OF HEALTHCARE, TO MANAGE PATIENT TRANSACTIONS, TRANSACTIONAL DATA, PROVIDE STATISTICAL ANALYSIS AND FINANCIAL CONTROLS, AND PRODUCE NOTIFICATIONS AND REPORTS (U.S. CLS. 21, 23, 26, 36 AND 38).

FIRST USE 3-1-2011; IN COMMERCE 9-1-2011.

PATRICIA EVANKO, EXAMINING ATTORNEY

SN 85-512,589. WIGSCO LLC, CULVER CITY, CA. FILED 1-10-2012.

WIGS

THE MARK CONSISTS OF STANDARD CHARACTERS WITHOUT CLAIM TO ANY PARTICULAR FONT, STYLE, SIZE, OR COLOR.

FOR PRERECORDED AUDIOVISUAL RECORDINGS, VIDEO DISCS, COMPACT DISCS, DVDS AND MULTIMEDIA SOFTWARE RECORDED ON CD-ROM, ALL FEATURING SUBJECTS OF GENERAL HUMAN INTEREST; DIGITAL MEDIA, NAMELY, DOWNLOADABLE PRERECORDED VIDEO CLIPS, PRERECORDED AUDIO CLIPS, TEXT AND GRAPHICS HELD IN ELECTRONIC PERSONAL COMPUTERS AND HANDHELD WIRELESS DEVICES, ALL FEATURING SUBJECTS OF GENERAL HUMAN INTEREST (U.S. CLS. 21, 23, 26, 36 AND 38).

TARAH HARDY, EXAMINING ATTORNEY

SN 85-512,750. DPI, INC., ST. LOUIS, MO. FILED 1-10-2012.

SPROUTS

THE MARK CONSISTS OF STANDARD CHARACTERS WITHOUT CLAIM TO ANY PARTICULAR FONT, STYLE, SIZE, OR COLOR.

FOR EAR BUDS; HEADPHONES (U.S. CLS. 21, 23, 26, 36 AND 38).

WANDA KAY PRICE, EXAMINING ATTORNEY

CLASS 9—(Continued).

SN 85-512,775. NOKIA CORPORATION, ESPOO, FINLAND,
FILED 1-10-2012.

LUMIA

THE MARK CONSISTS OF STANDARD CHARACTERS
WITHOUT CLAIM TO ANY PARTICULAR FONT, STYLE,
SIZE, OR COLOR.

PRIORITY CLAIMED UNDER SEC. 44(D) ON ERPN
CMNTY TM OFC APPLICATION NO. 010210599, FILED 8-
22-2011.

FOR MOBILE PHONES, SMART PHONES; ACCES-
SORIES FOR MOBILE PHONES, NAMELY, CASES AND
HEADSETS; AND REPLACEMENT PARTS FOR MOBILE
PHONES (U.S. CLS. 21, 23, 26, 36 AND 38).

TARAH HARDY, EXAMINING ATTORNEY

SN 85-512,825. CUREATR INC., NEW YORK, NY. FILED 1-
10-2012.

Cureatr

THE MARK CONSISTS OF STANDARD CHARACTERS
WITHOUT CLAIM TO ANY PARTICULAR FONT, STYLE,
SIZE, OR COLOR.

FOR COMPUTER SOFTWARE FOR CONTROLLING
AND MANAGING PATIENT MEDICAL INFORMATION
(U.S. CLS. 21, 23, 26, 36 AND 38).

FIRST USE 4-1-2011; IN COMMERCE 7-1-2011.
JOHN DALIER, EXAMINING ATTORNEY

CLASS 9—(Continued).

SN 85-512,922. VSIG.COM, INC., REDWOOD CITY, CA.
FILED 1-10-2012.

VSIG

THE MARK CONSISTS OF STANDARD CHARACTERS
WITHOUT CLAIM TO ANY PARTICULAR FONT, STYLE,
SIZE, OR COLOR.

FOR COMPUTER SOFTWARE TO FACILITATE AS-
SIGNMENT OF A LEGALLY BINDING ELECTRONIC
SIGNATURE TO A DOCUMENT OR FILE AND TO
CREATE, VIEW, CAPTURE, ASSIGN, AND STORE
ELECTRONIC SIGNATURES RELATED TO ELECTRO-
NIC DATA; COMPUTER SOFTWARE FOR ELECTRO-
NIC SIGNATURE VERIFICATION SERVICES AND FOR
AUTHENTICATION OF PERSONAL IDENTIFICATION
INFORMATION; COMPUTER APPLICATION SOFT-
WARE FOR MOBILE PHONES, PORTABLE MEDIA
PLAYERS, TABLET COMPUTERS, AND HANDHELD
COMPUTERS, NAMELY, SOFTWARE TO FACILITATE
ASSIGNMENT OF A LEGALLY BINDING ELECTRONIC
SIGNATURE TO A DOCUMENT OR FILE AND TO
CREATE, VIEW, CAPTURE, ASSIGN AND STORE ELEC-
TRONIC SIGNATURES RELATED TO ELECTRONIC
DATA; COMPUTER APPLICATION SOFTWARE FOR
MOBILE PHONES, PORTABLE MEDIA PLAYERS, TA-
BLET COMPUTERS, AND HANDHELD COMPUTERS,
NAMELY, SOFTWARE FOR ELECTRONIC SIGNATURE
VERIFICATION SERVICES AND AUTHENTICATION OF
PERSONAL IDENTIFICATION INFORMATION; COM-
PUTER SOFTWARE AND COMPUTER APPLICATION
SOFTWARE FOR MOBILE PHONES, PORTABLE MEDIA
PLAYERS, TABLET COMPUTERS, AND HANDHELD
COMPUTERS, NAMELY, SOFTWARE TO UPLOAD,
CREATE, POPULATE, AND TRANSMIT ELECTRONI-
CALLY SIGNED DOCUMENTS VIA REGISTERED MO-
BILE DEVICES AND VIA THE INTERNET (U.S. CLS. 21,
23, 26, 36 AND 38).

KAREN K. BUSH, EXAMINING ATTORNEY

SN 85-512,944. NRG SYSTEMS, INC., HINESBURG, VT.
FILED 1-10-2012.

Echomet

THE MARK CONSISTS OF STANDARD CHARACTERS
WITHOUT CLAIM TO ANY PARTICULAR FONT, STYLE,
SIZE, OR COLOR.

FOR WIND MEASURING APPARATUS CONSISTING
PRIMARILY OF A TOWER AND A SOUND DETECTION
AND RANGING INSTRUMENT, FOR USE IN DETECT-
ING, MEASURING AND RECORDING THE QUANTITY
AND QUALITY OF WIND FOR ENERGY GENERATION
PURPOSES (U.S. CLS. 21, 23, 26, 36 AND 38).

WILLIAM VERHOSEK, EXAMINING ATTORNEY

CLASS 9—(Continued).

SN 85-513,112. DAKOTA FLUID POWER, INC., SIOUX FALLS, SD. FILED 1-10-2012.

FEEDLOK

THE MARK CONSISTS OF STANDARD CHARACTERS WITHOUT CLAIM TO ANY PARTICULAR FONT, STYLE, SIZE, OR COLOR.

FOR COMPUTER HARDWARE AND SOFTWARE FOR READING RADIO FREQUENCY IDENTIFICATION DEVICE TAGS TO CORRECTLY PLACE ANIMAL FEED IN THE CORRECT FEED BINS WITHOUT CROSS BLENDING FEEDS AND IF THE RADIO FREQUENCY IDENTIFICATION DEVICE TAGS DO NOT MATCH, THE MACHINERY WILL NOT DISPENSE (U.S. CLS. 21, 23, 26, 36 AND 38).

CHRISTOPHER SIDOTI, EXAMINING ATTORNEY

CLASS 9—(Continued).

SN 85-513,527. OCZ TECHNOLOGY GROUP, INC., SAN JOSE, CA. FILED 1-11-2012.

INDILINX INFUSED

THE MARK CONSISTS OF STANDARD CHARACTERS WITHOUT CLAIM TO ANY PARTICULAR FONT, STYLE, SIZE, OR COLOR.

FOR NON-VOLATILE MASS STORAGE DEVICE FOR USE WITH COMPUTERS IN THE NATURE OF A NON-VOLATILE STORAGE MEDIUM THAT EMPLOYS INTEGRATED CIRCUITS (U.S. CLS. 21, 23, 26, 36 AND 38).

FIRST USE 10-20-2011; IN COMMERCE 10-20-2011.

ALEX KEAM, EXAMINING ATTORNEY

SN 85-513,123. MONSTER, INC., BRISBANE, CA. FILED 1-10-2012.

M1

THE MARK CONSISTS OF STANDARD CHARACTERS WITHOUT CLAIM TO ANY PARTICULAR FONT, STYLE, SIZE, OR COLOR.

FOR AUDIO SPEAKERS; ELECTRONIC DOCKING STATIONS; HEADPHONES (U.S. CLS. 21, 23, 26, 36 AND 38).

KRISTINA MORRIS, EXAMINING ATTORNEY

SN 85-513,530. OCZ TECHNOLOGY GROUP, INC., SAN JOSE, CA. FILED 1-11-2012.



THE MARK CONSISTS OF "INDILINX" IN STYLIZED BLOCK FONT, "INDI" OF A BOLDER FONT THAN "LINX"; "INFUSED" IN STYLIZED ITALICIZED FONT; "INDILINX" PLACED HORIZONTALLY ABOVE "INFUSED".

FOR NON-VOLATILE MASS STORAGE DEVICE FOR USE WITH COMPUTERS IN THE NATURE OF A NON-VOLATILE STORAGE MEDIUM THAT EMPLOYS INTEGRATED CIRCUITS (U.S. CLS. 21, 23, 26, 36 AND 38).

FIRST USE 10-20-2011; IN COMMERCE 10-20-2011.

ALEX KEAM, EXAMINING ATTORNEY

SN 85-513,418. MAGUINO, CESAR, MAYS LANDING, NJ. AND DONATO, RYAN, MAYS LANDING, NJ. FILED 1-10-2012.



THE COLOR(S) BLACK, YELLOW, AND RED IS/ARE CLAIMED AS A FEATURE OF THE MARK.

THE MARK CONSISTS OF THE STYLIZED TEXT "CONDITION CRITICAL" IN YELLOW AND RED. THE STYLIZED TEXT IS INSIDE A BLACK BACKGROUND.

FOR DIGITAL MATERIALS, NAMELY, CDS FEATURING MUSIC (U.S. CLS. 21, 23, 26, 36 AND 38).

BENJAMIN OKEKE, EXAMINING ATTORNEY

SN 85-513,691. COTA, DANIEL, SAN JUAN CAPISTRANO, CA. FILED 1-11-2012.

DrawCast

THE MARK CONSISTS OF STANDARD CHARACTERS WITHOUT CLAIM TO ANY PARTICULAR FONT, STYLE, SIZE, OR COLOR.

FOR COMPUTER SOFTWARE FOR IMAGE CREATION AND IMAGE SHARING (U.S. CLS. 21, 23, 26, 36 AND 38).

FIRST USE 7-17-2010; IN COMMERCE 7-17-2010.

KRISTIN DAHLING, EXAMINING ATTORNEY

CLASS 9—(Continued).

SN 85-513,916. WIRELESS NRG, LLC, MIAMI, FL. FILED 1-11-2012.

SUNDIAL

THE MARK CONSISTS OF STANDARD CHARACTERS WITHOUT CLAIM TO ANY PARTICULAR FONT, STYLE, SIZE, OR COLOR.

FOR ELECTRONIC DEVICE TO CHARGE AND SECURE CELL PHONES (U.S. CLS. 21, 23, 26, 36 AND 38).
ROBERT C. CLARK JR., EXAMINING ATTORNEY

SN 85-513,972. ZIONEYEZ LLC, SEATTLE, WA. FILED 1-11-2012.

ZEYEZ

THE MARK CONSISTS OF STANDARD CHARACTERS WITHOUT CLAIM TO ANY PARTICULAR FONT, STYLE, SIZE, OR COLOR.

FOR EYE GLASSES EQUIPPED WITH VIDEO CAMERAS; SUN GLASSES EQUIPPED WITH VIDEO CAMERAS; VIDEO CAMERAS; WIRELESS COMMUNICATION DEVICES FOR TRANSMITTING SOUND AND IMAGES TAKEN BY A VIDEO CAMERA; SOFTWARE FOR TRANSMITTING SOUND AND IMAGES TAKEN BY A VIDEO CAMERA; SOFTWARE APPLICATION FOR USE WITH MOBILE TELEPHONES, SMARTPHONES, PDAS, HANDHELD DIGITAL ELECTRONIC DEVICES, WIRELESS INFORMATION DEVICES, COMPUTERS, LAPTOPS, COMPUTER TABLETS AND NETBOOKS FOR TRANSMITTING SOUND AND IMAGES TAKEN BY A VIDEO CAMERA (U.S. CLS. 21, 23, 26, 36 AND 38).
JOHN GARTNER, EXAMINING ATTORNEY

SN 85-514,082. BENÉT, ELEANORA, ALEXANDRIA, VA. FILED 1-11-2012.

GIRLS UNITED

THE MARK CONSISTS OF STANDARD CHARACTERS WITHOUT CLAIM TO ANY PARTICULAR FONT, STYLE, SIZE, OR COLOR.

FOR COMPUTER SOFTWARE FOR IDENTIFYING TO SUBSCRIBERS THE MAKE AND SOURCE OF GOODS BEING WORN BY OTHER SUBSCRIBERS (U.S. CLS. 21, 23, 26, 36 AND 38).
MARTHA FROMM, EXAMINING ATTORNEY

CLASS 9—(Continued).

SN 85-514,234. DIRECTV, LLC, EL SEGUNDO, CA. FILED 1-11-2012.

MÁS QUE VER TV. DIRECTV

THE MARK CONSISTS OF STANDARD CHARACTERS WITHOUT CLAIM TO ANY PARTICULAR FONT, STYLE, SIZE, OR COLOR.

OWNER OF U.S. REG. NOS. 2,698,197, 2,939,061 AND 3,051,285.

THE ENGLISH TRANSLATION OF "MÁS QUE VER TV" IN THE MARK IS "MORE THAN WATCHING TV".

FOR TELECOMMUNICATIONS PRODUCTS, NAMELY, SET-TOP BOXES PRIMARILY COMPRISED OF A RECEIVER AND CIRCUITRY; TELECOMMUNICATIONS PRODUCTS, NAMELY, DIGITAL VIDEO RECORDERS; COMPUTER SOFTWARE FOR USE WITH TELECOMMUNICATIONS PRODUCTS, NAMELY, SET-TOP BOXES PRIMARILY COMPRISED OF A RECEIVER AND CIRCUITRY; COMPUTER SOFTWARE FOR USE WITH TELECOMMUNICATIONS PRODUCTS, NAMELY, DIGITAL VIDEO RECORDERS; COMPUTER SOFTWARE FOR USE IN ACCESSING AND VIEWING INTERACTIVE TELEVISION PROGRAM GUIDES VIA GLOBAL COMPUTER NETWORKS, WIRELESS NETWORKS AND ELECTRONIC COMMUNICATION NETWORKS; COMPUTER SOFTWARE FOR THE REMOTE PROGRAMMING OF AUDIO AND VIDEO DEVICES VIA GLOBAL COMPUTER NETWORKS, WIRELESS NETWORKS AND ELECTRONIC COMMUNICATION NETWORKS; COMPUTER SOFTWARE FOR THE REPRODUCTION, PROCESSING AND STREAMING OF AUDIO, VIDEO AND MULTIMEDIA CONTENT (U.S. CLS. 21, 23, 26, 36 AND 38).

ELIZABETH KAJUBI, EXAMINING ATTORNEY

SN 85-514,286. INTELLIGENCE ENGINE DESIGN SYSTEMS LLC, HILTON HEAD ISLAND, SC. FILED 1-11-2012.

CITY CONQUEST

THE MARK CONSISTS OF STANDARD CHARACTERS WITHOUT CLAIM TO ANY PARTICULAR FONT, STYLE, SIZE, OR COLOR.

FOR VIDEO GAME SOFTWARE (U.S. CLS. 21, 23, 26, 36 AND 38).
LAURA KOVALSKY, EXAMINING ATTORNEY

CLASS 9—(Continued).

SN 85-514,346. ARANZ GEO LIMITED, CHRISTCHURCH, NEW ZEALAND, FILED 1-11-2012.

LEAPFROG

THE MARK CONSISTS OF STANDARD CHARACTERS WITHOUT CLAIM TO ANY PARTICULAR FONT, STYLE, SIZE, OR COLOR.

FOR GEOLOGICAL MODELING SOFTWARE FOR USE IN THE MINING, GEOTHERMAL ENERGY AND GROUNDWATER INDUSTRIES (U.S. CLS. 21, 23, 26, 36 AND 38).

FIRST USE 8-2-2005; IN COMMERCE 8-2-2005.
COLLEEN DOMBROW, EXAMINING ATTORNEY

CLASS 9—(Continued).

SN 85-514,431. AINSWORTH GAME TECHNOLOGY LIMITED, NEWINGTON, AUSTRALIA, FILED 1-11-2012.

WILD DREAMS

THE MARK CONSISTS OF STANDARD CHARACTERS WITHOUT CLAIM TO ANY PARTICULAR FONT, STYLE, SIZE, OR COLOR.

FOR COMPUTER SOFTWARE AND FIRMWARE FOR GAMES OF CHANCE ON ANY COMPUTERIZED PLATFORM, INCLUDING DEDICATED GAMING CONSOLES, VIDEO BASED SLOT MACHINES, REEL BASED SLOT MACHINES, AND VIDEO LOTTERY TERMINALS (U.S. CLS. 21, 23, 26, 36 AND 38).

MATTHEW PAPPAS, EXAMINING ATTORNEY

SN 85-514,407. SUREFIRE, LLC, FOUNTAIN VALLEY, CA. FILED 1-11-2012.



OWNER OF U.S. REG. NOS. 2,657,142, 3,820,152 AND OTHERS.

THE MARK CONSISTS OF THE WORD SUREFIRE WITH PARENTHESES ABOVE AND BELOW THE WORD SPANNING BETWEEN THE FIRST "R" AND THE "I".

FOR BATTERIES (U.S. CLS. 21, 23, 26, 36 AND 38).
JUSTINE D. PARKER, EXAMINING ATTORNEY

SN 85-514,436. AINSWORTH GAME TECHNOLOGY LIMITED, NEWINGTON, AUSTRALIA, FILED 1-11-2012.

WILD SECRETS

THE MARK CONSISTS OF STANDARD CHARACTERS WITHOUT CLAIM TO ANY PARTICULAR FONT, STYLE, SIZE, OR COLOR.

FOR COMPUTER SOFTWARE AND FIRMWARE FOR GAMES OF CHANCE ON ANY COMPUTERIZED PLATFORM, INCLUDING DEDICATED GAMING CONSOLES, VIDEO BASED SLOT MACHINES, REEL BASED SLOT MACHINES, AND VIDEO LOTTERY TERMINALS (U.S. CLS. 21, 23, 26, 36 AND 38).

MATTHEW PAPPAS, EXAMINING ATTORNEY

SN 85-514,425. AINSWORTH GAME TECHNOLOGY LIMITED, NEWINGTON, AUSTRALIA, FILED 1-11-2012.

REELS OF WHEELS

THE MARK CONSISTS OF STANDARD CHARACTERS WITHOUT CLAIM TO ANY PARTICULAR FONT, STYLE, SIZE, OR COLOR.

FOR COMPUTER SOFTWARE AND FIRMWARE FOR GAMES OF CHANCE ON ANY COMPUTERIZED PLATFORM, INCLUDING DEDICATED GAMING CONSOLES, VIDEO BASED SLOT MACHINES, REEL BASED SLOT MACHINES, AND VIDEO LOTTERY TERMINALS (U.S. CLS. 21, 23, 26, 36 AND 38).

MATTHEW PAPPAS, EXAMINING ATTORNEY

SN 85-514,452. AINSWORTH GAME TECHNOLOGY LIMITED, NEWINGTON, AUSTRALIA, FILED 1-11-2012.

JADE TIGER

THE MARK CONSISTS OF STANDARD CHARACTERS WITHOUT CLAIM TO ANY PARTICULAR FONT, STYLE, SIZE, OR COLOR.

FOR COMPUTER SOFTWARE AND FIRMWARE FOR GAMES OF CHANCE ON ANY COMPUTERIZED PLATFORM, INCLUDING DEDICATED GAMING CONSOLES, VIDEO BASED SLOT MACHINES, REEL BASED SLOT MACHINES, AND VIDEO LOTTERY TERMINALS (U.S. CLS. 21, 23, 26, 36 AND 38).

MATTHEW PAPPAS, EXAMINING ATTORNEY

CLASS 9—(Continued).

SN 85-514,547. NELSON, CHRISTOPHER A, YUCAIPA, CA.
FILED 1-11-2012.

Keep your head in the cloud

THE MARK CONSISTS OF STANDARD CHARACTERS WITHOUT CLAIM TO ANY PARTICULAR FONT, STYLE, SIZE, OR COLOR.
FOR CELL PHONES (U.S. CLS. 21, 23, 26, 36 AND 38).
JOSETTE BEVERLY, EXAMINING ATTORNEY

SN 85-514,664. SRRN GAMES LLC, RICHMOND, VA. FILED 1-12-2012.

LOST STAR LEGACY

THE MARK CONSISTS OF STANDARD CHARACTERS WITHOUT CLAIM TO ANY PARTICULAR FONT, STYLE, SIZE, OR COLOR.
FOR COMPUTER GAME SOFTWARE; VIDEO GAME SOFTWARE; DOWNLOADABLE COMPUTER GAME APPLICATION SOFTWARE FOR MULTI-MEDIA SMART PHONES, WIRELESS MOBILE DEVICES, AND PORTABLE MEDIA PLAYERS (U.S. CLS. 21, 23, 26, 36 AND 38).
MARK RADEMACHER, EXAMINING ATTORNEY

SN 85-514,674. XEROX CORPORATION, NORWALK, CT.
FILED 1-12-2012.

DocToMe

THE MARK CONSISTS OF STANDARD CHARACTERS WITHOUT CLAIM TO ANY PARTICULAR FONT, STYLE, SIZE, OR COLOR.
FOR MOBILE DEVICE APPLICATION SOFTWARE FOR WIRELESSLY RECEIVING COPIES OF DOCUMENTS OR OTHER SCANNED IMAGES FROM A MOBILE SCANNER (U.S. CLS. 21, 23, 26, 36 AND 38).
DAWN FELDMAN, EXAMINING ATTORNEY

CLASS 9—(Continued).

SN 85-514,733. TRS QUALITY, INC., FORT WORTH, TX.
FILED 1-12-2012.



OWNER OF U.S. REG. NOS. 2,895,432, 3,254,686 AND OTHERS.
THE COLOR(S) GREEN IS/ARE CLAIMED AS A FEATURE OF THE MARK.
THE MARK CONSISTS OF THE WORDING "LIFE" IN LIGHT GREEN AND "WISE" IN DARK GREEN.
FOR PEDOMETERS (U.S. CLS. 21, 23, 26, 36 AND 38).
FIRST USE 10-17-2011; IN COMMERCE 10-17-2011.
KEVIN DINALLO, EXAMINING ATTORNEY

SN 85-514,807. IQUMULUS, LLC, AUSTIN, TX. FILED 1-12-2012.

IQUMULUS

THE MARK CONSISTS OF STANDARD CHARACTERS WITHOUT CLAIM TO ANY PARTICULAR FONT, STYLE, SIZE, OR COLOR.
FOR COMPUTER SOFTWARE, NAMELY, SOFTWARE DEVELOPMENT TOOLS FOR THE AUTOMATED CREATION OF SOFTWARE APPLICATIONS (U.S. CLS. 21, 23, 26, 36 AND 38).
MICHAEL TANNER, EXAMINING ATTORNEY

SN 85-514,874. KIEFFER BROS., LLC, APPLETON, WI.
FILED 1-12-2012.

BLOCKWICK

THE MARK CONSISTS OF STANDARD CHARACTERS WITHOUT CLAIM TO ANY PARTICULAR FONT, STYLE, SIZE, OR COLOR.
FOR COMPUTER GAME SOFTWARE FOR USE ON MOBILE AND CELLULAR PHONES (U.S. CLS. 21, 23, 26, 36 AND 38).
FIRST USE 11-17-2011; IN COMMERCE 12-14-2011.
MARK SPARACINO, EXAMINING ATTORNEY

CLASS 9—(Continued).

SN 85-514,967. VENDSCREEN, INC., PORTLAND, OR. FILED 1-12-2012.

VendScreen

THE MARK CONSISTS OF STANDARD CHARACTERS WITHOUT CLAIM TO ANY PARTICULAR FONT, STYLE, SIZE, OR COLOR.

FOR COMPUTER APPLICATION SOFTWARE FOR VENDING MACHINE USER INTERFACE HARDWARE, NAMELY, SOFTWARE FOR USE IN ELECTRONIC STORAGE AND SHARING OF DATA AND INFORMATION; COMPUTER SOFTWARE AND TOUCH-SCREEN HARDWARE FOR ELECTRONIC PAYMENT PROCESSING, DISSEMINATING ADVERTISING FOR OTHERS, AND MONITORING AND MANAGING RETAIL VENDING MACHINE PRODUCT INFORMATION AND INVENTORY DATA, SOLD AS A UNIT (U.S. CLS. 21, 23, 26, 36 AND 38).

JULIE VEPPUMTHARA, EXAMINING ATTORNEY



SN 85-515,048. KRG2 LLC, COLUMBUS, OH. FILED 1-12-2012.



THE MARK CONSISTS OF A SHIELD DESIGN CONTAINING AN EXCLAMATION POINT FOLLOWED BY THE WORDS "CAMPUSKNIGHT".

FOR SOFTWARE, NAMELY, SOFTWARE FOR PROVIDING A CENTRAL DISPATCH OF SECURITY, MEDICAL AND OTHER EMERGENCY SERVICES AND RESPONDERS VIA MOBILE DEVICES, SMARTPHONES, CELL PHONES, LAPTOPS, TABLETS AND OTHER COMPUTING AND COMMUNICATION DEVICES (U.S. CLS. 21, 23, 26, 36 AND 38).

JAMES STEIN, EXAMINING ATTORNEY



SN 85-515,054. MARLOW INDUSTRIES, INC., DALLAS, TX. FILED 1-12-2012.

TRITON ICE

THE MARK CONSISTS OF STANDARD CHARACTERS WITHOUT CLAIM TO ANY PARTICULAR FONT, STYLE, SIZE, OR COLOR.

FOR APPARATUS FOR CONVERTING ELECTRICAL ENERGY FOR COOLING ELECTRONICS, NAMELY, THERMOELECTRIC COOLERS; ELECTRONIC COMPONENT COOLERS, NAMELY, THERMOELECTRIC-BASED COOLING MODULES (U.S. CLS. 21, 23, 26, 36 AND 38).

CHRIS WELLS, EXAMINING ATTORNEY

CLASS 9—(Continued).

SN 85-515,201. PYRAMEX SAFETY PRODUCTS, LLC, COLLIERVILLE, TN. FILED 1-12-2012.

ONIX

THE MARK CONSISTS OF STANDARD CHARACTERS WITHOUT CLAIM TO ANY PARTICULAR FONT, STYLE, SIZE, OR COLOR.

FOR SAFETY EYEWEAR (U.S. CLS. 21, 23, 26, 36 AND 38).

FIRST USE 8-15-2007; IN COMMERCE 8-15-2007. NAAKWAMA ANKRAH, EXAMINING ATTORNEY



SN 85-515,202. NOVUS GAMES LLC, MIAMI, FL. FILED 1-12-2012.

FantasyMe

THE MARK CONSISTS OF STANDARD CHARACTERS WITHOUT CLAIM TO ANY PARTICULAR FONT, STYLE, SIZE, OR COLOR.

FOR COMPUTER SOFTWARE APPLICATION FOR GAMES ON SOCIAL NETWORKS, TABLETS, SMARTPHONES AND OTHER MOBILE DEVICES (U.S. CLS. 21, 23, 26, 36 AND 38).

RONALD MCMORROW, EXAMINING ATTORNEY



SN 85-515,253. PYRAMEX SAFETY PRODUCTS, LLC, COLLIERVILLE, TN. FILED 1-12-2012.

PROVOQ

THE MARK CONSISTS OF STANDARD CHARACTERS WITHOUT CLAIM TO ANY PARTICULAR FONT, STYLE, SIZE, OR COLOR.

FOR SAFETY EYEGLASSES (U.S. CLS. 21, 23, 26, 36 AND 38).

NAAKWAMA ANKRAH, EXAMINING ATTORNEY

CLASS 9—(Continued).

SN 85-515,260. PURDUE PHARMA L.P., STAMFORD, CT. FILED 1-12-2012.

RE-CHARGE

THE MARK CONSISTS OF STANDARD CHARACTERS WITHOUT CLAIM TO ANY PARTICULAR FONT, STYLE, SIZE, OR COLOR.

FOR DOWNLOADABLE ELECTRONIC NEWSLETTERS IN THE FIELD OF CAREGIVING (U.S. CLS. 21, 23, 26, 36 AND 38).

FIRST USE 1-9-2012; IN COMMERCE 1-9-2012.
NAKIA HENRY, EXAMINING ATTORNEY

CLASS 9—(Continued).

SN 85-515,389. WILLIAM SCHNAPP, DBA WILLIAM SCHNAPP, MIAMI BEACH, FL. FILED 1-12-2012.

Migraine Free

THE MARK CONSISTS OF STANDARD CHARACTERS WITHOUT CLAIM TO ANY PARTICULAR FONT, STYLE, SIZE, OR COLOR.

FOR COMPUTER APPLICATION SOFTWARE FOR MOBILE PHONES, NAMELY, SOFTWARE FOR HEADACHE MANAGEMENT (U.S. CLS. 21, 23, 26, 36 AND 38).
MIDGE BUTLER, EXAMINING ATTORNEY

SN 85-515,367. GRACE MICROELECTRONICS, INC., MIAMI, FL. FILED 1-12-2012.



NO CLAIM IS MADE TO THE EXCLUSIVE RIGHT TO USE "MICROELECTRONICS", APART FROM THE MARK AS SHOWN.

THE MARK CONSISTS OF THE WORD "GRACE" WITH A BLUE "G" AND "RACE" IN GREY WITH THE WORD "MICROELECTRONICS", IN TWO COLORS, "MICROEL" IN PURPLE AND "ECTRONICS" IN WHITE IN FRONT OF A BLUE GLASS STONE.

FOR CELLULAR PHONES; HANDHELD COMPUTERS; HANDHELD PERSONAL COMPUTERS; SMARTPHONES (U.S. CLS. 21, 23, 26, 36 AND 38).

FIRST USE 2-3-2007; IN COMMERCE 2-3-2007.
BRIAN NEVILLE, EXAMINING ATTORNEY

SN 85-515,431. THE MEYER RESOURCE GROUP, INC., WACO, TX. FILED 1-12-2012.

BECOMING A TOTAL PERSON

THE MARK CONSISTS OF STANDARD CHARACTERS WITHOUT CLAIM TO ANY PARTICULAR FONT, STYLE, SIZE, OR COLOR.

OWNER OF U.S. REG. NOS. 3,879,181 AND 3,967,577.
FOR PRERECORDED AUDIO AND VIDEO RECORDINGS RELATING TO PERSONAL AND PROFESSIONAL DEVELOPMENT, SELF MOTIVATION AND IMPROVEMENT, GOAL SETTING, PLANNING, LEADERSHIP AND MANAGEMENT (U.S. CLS. 21, 23, 26, 36 AND 38).

FIRST USE 1-1-1968; IN COMMERCE 1-1-1968.
CHRISTOPHER SIDOTI, EXAMINING ATTORNEY

SN 85-515,386. BURKLEY, VAL J., LAS VEGAS, NV. FILED 1-12-2012.

Techne

THE MARK CONSISTS OF STANDARD CHARACTERS WITHOUT CLAIM TO ANY PARTICULAR FONT, STYLE, SIZE, OR COLOR.

FOR CAD/CAM SOFTWARE FOR GENERAL USE (U.S. CLS. 21, 23, 26, 36 AND 38).

FIRST USE 2-1-2011; IN COMMERCE 12-2-2011.
BRIAN NEVILLE, EXAMINING ATTORNEY

SN 85-515,450. ISLAND RESOURCES, INC., DBA WWW.ULTIMATEISLANDGUIDE.COM, FORT MYERS BEACH, FL. FILED 1-12-2012.

islandIQ

THE MARK CONSISTS OF STANDARD CHARACTERS WITHOUT CLAIM TO ANY PARTICULAR FONT, STYLE, SIZE, OR COLOR.

FOR COMPUTER APPLICATION SOFTWARE FOR MOBILE PHONES, NAMELY, SOFTWARE FOR DATABASE MANAGEMENT; COMPUTER APPLICATION SOFTWARE FOR MOBILE PHONES, PORTABLE MEDIA PLAYERS, HANDHELD COMPUTERS, DESK TOP AND LAPTOP COMPUTERS, NAMELY, SOFTWARE FOR LOCATING, CREATING, SORTING AND PLANNING ALL ISLAND VACATION RELATED ACTIVITIES (U.S. CLS. 21, 23, 26, 36 AND 38).

HENRY S. ZAK, EXAMINING ATTORNEY

CLASS 9—(Continued).

SN 85-515,514. SUREFIRE, LLC, FOUNTAIN VALLEY, CA. FILED 1-12-2012.



OWNER OF U.S. REG. NOS. 2,657,142, 3,820,152 AND OTHERS.

THE MARK CONSISTS OF THE WORD SUREFIRE IN ITALICIZED BLOCK LETTERS, WITH HORIZONTAL ORIENTED PARENTHESES ABOVE AND BELOW THE WORD, SPANNING FROM THE FIRST "R" TO THE "F".

FOR BATTERIES (U.S. CLS. 21, 23, 26, 36 AND 38).
FIRST USE 5-21-2001; IN COMMERCE 5-21-2001.
JUSTINE D. PARKER, EXAMINING ATTORNEY

CLASS 9—(Continued).

SN 85-515,791. THOMAS, JAMES, HOUSTON, TX. FILED 1-13-2012.

introduce 'em

THE MARK CONSISTS OF STANDARD CHARACTERS WITHOUT CLAIM TO ANY PARTICULAR FONT, STYLE, SIZE, OR COLOR.

FOR COMPUTER APPLICATION SOFTWARE FOR MOBILE PHONES, NAMELY, SOFTWARE FOR THE PURPOSE OF ACCESSING, CREATING, EDITING, MODIFYING, TRANSMITTING, SHARING AND STORING DATING-RELATED INTRODUCTIONS, SOCIAL-NETWORKING INTRODUCTIONS, BUSINESS INTRODUCTIONS, CAREERS AND EMPLOYMENT INTRODUCTIONS, DATING INTRODUCTIONS, FRIENDSHIP INTRODUCTIONS, INTRODUCTIONS CONTACT MANAGEMENT, AND INTRODUCTION IDENTITY MANAGEMENT; COMPUTER APPLICATION SOFTWARE FOR MOBILE PHONES, PORTABLE MEDIA AND HANDHELD COMPUTERS, NAMELY, SOFTWARE FOR THE PURPOSE OF ACCESSING, CREATING, EDITING, MODIFYING, TRANSMITTING, SHARING AND STORING DATING-RELATED INTRODUCTIONS, SOCIAL-NETWORKING INTRODUCTIONS, BUSINESS INTRODUCTIONS, CAREERS AND EMPLOYMENT INTRODUCTIONS, DATING INTRODUCTIONS, FRIENDSHIP INTRODUCTIONS, INTRODUCTIONS CONTACT MANAGEMENT, AND INTRODUCTION IDENTITY MANAGEMENT (U.S. CLS. 21, 23, 26, 36 AND 38).

FIRST USE 11-28-2010; IN COMMERCE 6-16-2011.
DOUGLAS LEE, EXAMINING ATTORNEY

SN 85-515,585. CRAIG MUTH, SAN FRANCISCO, CA. FILED 1-12-2012.

xiki

THE MARK CONSISTS OF STANDARD CHARACTERS WITHOUT CLAIM TO ANY PARTICULAR FONT, STYLE, SIZE, OR COLOR.

FOR COMPUTER SOFTWARE DEVELOPMENT TOOLS; DOWNLOADABLE COMPUTER SOFTWARE FOR CREATING MENU BASED USER INTERFACES (U.S. CLS. 21, 23, 26, 36 AND 38).

FIRST USE 11-22-2008; IN COMMERCE 11-22-2008.
TASHIA BUNCH, EXAMINING ATTORNEY

SN 85-515,836. CHAO, TOM SHIH WEI, BEIJING, CHINA, AND SUN, BEN TONG, BEIJING, CHINA, AND GU, CHEN, BEIJING, CHINA, FILED 1-13-2012.



SN 85-515,727. GOWAN BRAE HOLDINGS LTD., VANCOUVER, CANADA, FILED 1-13-2012.

Viboti

THE MARK CONSISTS OF STANDARD CHARACTERS WITHOUT CLAIM TO ANY PARTICULAR FONT, STYLE, SIZE, OR COLOR.

FOR PORTABLE VIBRATION SPEAKERS (U.S. CLS. 21, 23, 26, 36 AND 38).
CHRISTINE MARTIN, EXAMINING ATTORNEY

THE MARK CONSISTS OF THE STYLIZED TEXT "WOO" WHERE EACH LETTER "O" RESEMBLES A WHEEL WITH COGS.

FOR COMPUTER SOFTWARE AND HARDWARE FOR REMOTELY CONTROLLING LIGHTING AND POWER SWITCHES OF HOME APPLIANCE VIA WIRELESS CONNECTIVITY (U.S. CLS. 21, 23, 26, 36 AND 38).

FIRST USE 3-1-2011; IN COMMERCE 6-1-2011.
BRIDGETT SMITH, EXAMINING ATTORNEY

CLASS 9—(Continued).

SN 85-515,874. KEENAN, BRIAN, BROOKLYN, NY. AND BROWNING, JENNIFER, BROOKLYN, NY. FILED 1-13-2012.

YAK

THE MARK CONSISTS OF STANDARD CHARACTERS WITHOUT CLAIM TO ANY PARTICULAR FONT, STYLE, SIZE, OR COLOR.

FOR COMPUTER SOFTWARE PLATFORMS FOR THE ONLINE CREATION OF CONTENT FOR CHILDREN'S BOOKS, GAMES AND NETWORKS (U.S. CLS. 21, 23, 26, 36 AND 38).

JOHN DWYER, EXAMINING ATTORNEY

SN 85-515,969. NEXGRID LLC, LOCUST GROVE, VA. FILED 1-13-2012.



THE MARK CONSISTS OF THE WORD "NEXGRID" IN LOWER CASE, WITH THE LETTER "E" REPRESENTED A POWER ICON AND IN THE WORD "GRID", ABOVE THE LETTER "I" A PARTIALLY SHADED CIRCLE, WITH TWO INVERTED CURVED LINES, WITH THE LONGER CURVED LINE ON TOP.

FOR COMPUTER HARDWARE AND SOFTWARE SYSTEMS INCORPORATING ADVANCED METERING INFRASTRUCTURE, INCLUDING METERING, MONITORING AND CONTROL DEVICES WITH INTEGRATED COMMUNICATIONS TECHNOLOGY; COMPUTER SOFTWARE AND SOFTWARE PLATFORM ACCESSED VIA GLOBAL COMMUNICATION NETWORKS FOR MANAGING WATER AND ENERGY COSTS AND USES AND FOR OPTIMIZING WATER AND ENERGY PROCUREMENT PROCEDURES BY COLLECTING, MANAGING, ANALYZING, MINING, INTEGRATING, REPORTING, BENCHMARKING, VALIDATING, MANAGING LOAD-REDUCTION PROGRAMS, FORECASTING, BILLING, MANAGING, ANALYZING, AND REPORTING WATER, ENERGY AND ENERGY-RELATED DATA; COMPUTER SOFTWARE PLATFORMS FOR COMPUTER DATABASE MANAGEMENT SOFTWARE USED FOR RECEIVING AND MONITORING ENERGY USAGE INFORMATION FROM MULTIPLE REMOTE COMMODITY METERS IN

CLASS 9—(Continued).

THE PUBLIC UTILITIES, GAS UTILITIES, ELECTRIC UTILITIES AND WATER UTILITIES INDUSTRIES; ELECTRIC UTILITY METERS, NAMELY, GAS METERS, ELECTRIC METERS, AND WATER METERS; COMPUTER SOFTWARE FOR USE IN DISTRIBUTED INFORMATION ACCESS AND COLLECTION AND BUILDING DEVICE INTEGRATION, CONTROL AND MANAGEMENT FOR USE IN WATER AND ENERGY MANAGEMENT, NAMELY, USE, ANALYSIS AND PURCHASING OF THE SAME; FOR TRANSMISSION AND DISTRIBUTION LINE DESIGN AND OPTIMIZATION; ELECTRONIC INTERFACE MODULES; ELECTRONIC INTERFACE MODULES FOR RECEIVING AND TRANSMITTING ENERGY-RELATED INFORMATION AND REQUESTS BETWEEN A COMMODITY METER AND A HOST COMPUTER OVER A WIDE AREA NETWORK AND A LOCAL AREA NETWORK TO INPUT OR OUTPUT CNC COMPUTER NUMERICAL CONTROL DATA; ELECTRIC UTILITY METERS, NAMELY, GAS METERS, ELECTRIC METERS, AND WATER METERS (U.S. CLS. 21, 23, 26, 36 AND 38).

FIRST USE 3-22-2011; IN COMMERCE 3-22-2011.
JOHN WILKE, EXAMINING ATTORNEY

SN 85-516,027. VIDEACE TECHNOLOGY CO., TAIPEI CITY 114, TAIWAN, FILED 1-13-2012.

UltraControl

THE MARK CONSISTS OF STANDARD CHARACTERS WITHOUT CLAIM TO ANY PARTICULAR FONT, STYLE, SIZE, OR COLOR.

FOR ALL-IN-ONE PCS; COMPUTER HARDWARE AND COMPUTER SOFTWARE PROGRAMS FOR THE INTEGRATION OF TEXT, AUDIO, GRAPHICS, STILL IMAGES AND MOVING PICTURES INTO AN INTERACTIVE DELIVERY FOR MULTIMEDIA APPLICATIONS; COMPUTER HARDWARE AND SOFTWARE FOR PROCESSING DIGITAL MUSIC FILES; COMPUTER OPERATING PROGRAMS; COMPUTER OPERATING PROGRAMS AND COMPUTER OPERATING SYSTEMS; COMPUTER OPERATING PROGRAMS, RECORDED; COMPUTER OPERATING RECORDED PROGRAMS; COMPUTER OPERATING SYSTEMS; COMPUTER PROGRAMS FOR SEARCHING THE CONTENTS OF COMPUTERS AND COMPUTER NETWORKS BY REMOTE CONTROL; COMPUTER PROGRAMS FOR USING THE INTERNET AND THE WORLDWIDE WEB; COMPUTER SOFTWARE FOR COMMUNICATING WITH USERS OF HAND-HELD COMPUTERS; COMPUTER SOFTWARE FOR ORGANIZING AND VIEWING DIGITAL IMAGES AND PHOTOGRAPHS; COMPUTER SOFTWARE FOR REMOTE CONTROL OF COMPUTERS AND TELEPHONIC DEVICES, FOR VIEWING AND USING MULTIMEDIA APPLICATIONS IN THE FIELD OF REMOTE CONTROLLED COMPUTERS AND TELEPHONIC DEVICES, AND FOR CONTENT SHARING AND GAME PLAYING; COMPUTER TELEPHONIC SOFTWARE; COMPUTERS; DESKTOP COMPUTERS; DOWNLOADABLE COMPUTER SOFTWARE FOR REMOTE CONTROL OF COMPUTERS AND TELEPHONIC DEVICES, FOR VIEWING AND USING MULTIMEDIA APPLICATIONS IN THE FIELD OF REMOTE CONTROLLED COMPUTERS AND TELEPHONIC DEVICES, AND FOR CONTENT SHARING AND GAME PLAYING; HANDHELD COMPUTERS; HANDHELD PERSONAL COMPUTERS; INTERFACES FOR COMPUTERS; MOBILE COMPUTERS; NOTEBOOK AND LAPTOP COMPUTERS; NOTEBOOK COMPUTERS; SET-TOP BOXES; SMARTPHONES; TABLET COMPUTER (U.S. CLS. 21, 23, 26, 36 AND 38).

BRIAN CALLAGHAN, EXAMINING ATTORNEY

CLASS 9—(Continued).

SN 85-516,053. VOICEME, LLC, LAS VEGAS, NV. FILED 1-13-2012.

VoiceCoupon

THE MARK CONSISTS OF STANDARD CHARACTERS WITHOUT CLAIM TO ANY PARTICULAR FONT, STYLE, SIZE, OR COLOR.

FOR DOWNLOADABLE SOFTWARE IN THE NATURE OF A MOBILE APPLICATION FOR A VOICE OPERATED SEARCH ENGINE (U.S. CLS. 21, 23, 26, 36 AND 38).

JOHN WILKE, EXAMINING ATTORNEY

CLASS 9—(Continued).

SN 85-516,220. YOUR DOLLAR MATTERS, INC., OLYMPIA, WA. FILED 1-13-2012.

WORD WARRIOR

THE MARK CONSISTS OF STANDARD CHARACTERS WITHOUT CLAIM TO ANY PARTICULAR FONT, STYLE, SIZE, OR COLOR.

FOR COMPUTER SOFTWARE FOR AUTOMATING DOCUMENTS AND CREATING FORMS; COMPUTER SOFTWARE THAT CREATES FORMS AUTOMATICALLY WITH INFORMATION GENERATED BY ANSWERS FROM THE USER (U.S. CLS. 21, 23, 26, 36 AND 38).

TINA L. SNAPP, EXAMINING ATTORNEY

SN 85-516,124. CRISAFULLI, KELLEE J, NEWCASTLE, WA. FILED 1-13-2012.



THE MARK CONSISTS OF STYLIZED CROSS-SECTION REPRESENTATION OF AN INDUSTRY STANDARD RJ45 CONNECTOR WITH THE LITERAL TRADEMARK NAME "SNAPBUS" OVER-LAYED.

FOR HOME AND OFFICE AUTOMATION SYSTEMS COMPRISING WIRELESS AND WIRED CONTROLLERS, CONTROLLED DEVICES, AND SOFTWARE FOR LIGHTING, HVAC, SECURITY, SAFETY AND OTHER HOME AND OFFICE MONITORING AND CONTROL APPLICATIONS (U.S. CLS. 21, 23, 26, 36 AND 38).

FIRST USE 11-27-2011; IN COMMERCE 1-13-2012.
MARK SHINER, EXAMINING ATTORNEY

SN 85-516,239. YOUR DOLLAR MATTERS, INC., OLYMPIA, WA. FILED 1-13-2012.

THE POWER TO BE SIMPLE

THE MARK CONSISTS OF STANDARD CHARACTERS WITHOUT CLAIM TO ANY PARTICULAR FONT, STYLE, SIZE, OR COLOR.

FOR COMPUTER SOFTWARE FOR AUTOMATING DOCUMENTS AND CREATING FORMS; COMPUTER SOFTWARE THAT CREATES FORMS AUTOMATICALLY WITH INFORMATION GENERATED BY ANSWERS FROM THE USER (U.S. CLS. 21, 23, 26, 36 AND 38).

TINA L. SNAPP, EXAMINING ATTORNEY

SN 85-516,213. CURBSIDE LLC, DUBOIS, PA. FILED 1-13-2012.

CURBSIDE DOC

THE MARK CONSISTS OF STANDARD CHARACTERS WITHOUT CLAIM TO ANY PARTICULAR FONT, STYLE, SIZE, OR COLOR.

FOR COMPUTER APPLICATION SOFTWARE FOR MOBILE PHONES, NAMELY, SOFTWARE FOR ACCESSING MEDICAL INFORMATION (U.S. CLS. 21, 23, 26, 36 AND 38).

ANDREW LEASER, EXAMINING ATTORNEY

SN 85-516,244. POWERS TREVOR, DBA YOUTH LAGOON, BOISE, ID. FILED 1-13-2012.

YOUTH LAGOON

THE MARK CONSISTS OF STANDARD CHARACTERS WITHOUT CLAIM TO ANY PARTICULAR FONT, STYLE, SIZE, OR COLOR.

FOR AUDIO AND VIDEO RECORDINGS FEATURING MUSIC AND ARTISTIC PERFORMANCES (U.S. CLS. 21, 23, 26, 36 AND 38).

FIRST USE 3-1-2011; IN COMMERCE 9-27-2011.
TINA L. SNAPP, EXAMINING ATTORNEY

CLASS 9—(Continued).

SN 85-516,305. MARLOW INDUSTRIES, INC., DALLAS, TX.
FILED 1-13-2012.

EVERGEN

THE MARK CONSISTS OF STANDARD CHARACTERS WITHOUT CLAIM TO ANY PARTICULAR FONT, STYLE, SIZE, OR COLOR.

FOR APPARATUS FOR CONVERTING THERMAL ENERGY TO ELECTRICAL ENERGY, NAMELY, THERMOELECTRIC CONVERTERS; POWER GENERATORS, NAMELY, THERMOELECTRIC-BASED ENERGY HARVESTING MODULES (U.S. CLS. 21, 23, 26, 36 AND 38).
CHRIS WELLS, EXAMINING ATTORNEY

SN 85-516,327. CADWELL INDUSTRIES, INC., KENNEWICK, WA. FILED 1-13-2012.

DUAL VIEW

THE MARK CONSISTS OF STANDARD CHARACTERS WITHOUT CLAIM TO ANY PARTICULAR FONT, STYLE, SIZE, OR COLOR.

FOR INTRA-OPERATIVE NEUROMONITORING INSTRUMENTATION SOFTWARE FOR MEDICAL USE (U.S. CLS. 21, 23, 26, 36 AND 38).
KYLE PEETE, EXAMINING ATTORNEY

SN 85-516,898. GLADNEY, MARLON, INDIANAPOLIS, IN. AND LEE GILDON SR, QUINTIN, INDIANAPOLIS, IN. FILED 1-15-2012.

Q&M Records

THE MARK CONSISTS OF STANDARD CHARACTERS WITHOUT CLAIM TO ANY PARTICULAR FONT, STYLE, SIZE, OR COLOR.

NO CLAIM IS MADE TO THE EXCLUSIVE RIGHT TO USE "RECORDS", APART FROM THE MARK AS SHOWN.
FOR APPARATUS FOR RECORDING AND REPRODUCTION OF SOUND, IMAGES OR DATA (U.S. CLS. 21, 23, 26, 36 AND 38).
JAMES GRIFFIN, EXAMINING ATTORNEY

CLASS 9—(Continued).

SN 85-517,100. SR HOLDINGS, LLC, LEXINGTON, MA.
FILED 1-16-2012.

STS 35

THE MARK CONSISTS OF STANDARD CHARACTERS WITHOUT CLAIM TO ANY PARTICULAR FONT, STYLE, SIZE, OR COLOR.

FOR EYEWEAR, NAMELY, SUNGLASSES, EYEGLASSES, AND OPHTHALMIC FRAMES AND CASES THEREFOR; CELL PHONE CASES; LIFE JACKETS; PROTECTION AND SAFETY APPARATUS, NAMELY, INFLATABLE FLOTATION DEVICES (U.S. CLS. 21, 23, 26, 36 AND 38).
STEVEN JACKSON, EXAMINING ATTORNEY

SN 85-517,153. HIMS INTERNATIONAL CORPORATION, YUSEONG-GU DAEJEON, REPUBLIC OF KOREA, FILED 1-16-2012.

Braille EDGE

THE MARK CONSISTS OF STANDARD CHARACTERS WITHOUT CLAIM TO ANY PARTICULAR FONT, STYLE, SIZE, OR COLOR.

NO CLAIM IS MADE TO THE EXCLUSIVE RIGHT TO USE "BRAILLE", APART FROM THE MARK AS SHOWN.

FOR BRAILLE DISPLAY DEVICES IN THE NATURE OF AN ELECTRONIC DISPLAY BOX INCORPORATING A TACTILE KEYBOARD FOR USE CONNECTING TO COMPUTERS, NOTEBOOK COMPUTERS, AND SMARTPHONES (U.S. CLS. 21, 23, 26, 36 AND 38).
CARYN GLASSER, EXAMINING ATTORNEY

SN 85-517,374. SR HOLDINGS, LLC, LEXINGTON, MA.
FILED 1-16-2012.

TEAM SPERRY TOP-SIDER

THE MARK CONSISTS OF STANDARD CHARACTERS WITHOUT CLAIM TO ANY PARTICULAR FONT, STYLE, SIZE, OR COLOR.

OWNER OF U.S. REG. NOS. 132,519, 3,835,580 AND OTHERS.

NO CLAIM IS MADE TO THE EXCLUSIVE RIGHT TO USE "TEAM", APART FROM THE MARK AS SHOWN.

FOR EYEWEAR, NAMELY, SUNGLASSES, EYEGLASSES, AND OPHTHALMIC FRAMES AND CASES THEREFOR; CELL PHONE CASES; LIFE JACKETS; PROTECTION AND SAFETY APPARATUS, NAMELY, INFLATABLE FLOTATION DEVICES (U.S. CLS. 21, 23, 26, 36 AND 38).
CURTIS FRENCH, EXAMINING ATTORNEY

CLASS 9—(Continued).

SN 85-518,750. UNIVERSAL INSTRUMENTS CORPORATION, CONKLIN, NY. FILED 1-18-2012.

Fusion

THE MARK CONSISTS OF STANDARD CHARACTERS WITHOUT CLAIM TO ANY PARTICULAR FONT, STYLE, SIZE, OR COLOR.

FOR ELECTRICAL MACHINES, NAMELY, MACHINES USED IN ELECTRONIC CIRCUIT BOARD ASSEMBLY, NAMELY, MACHINES FOR MOUNTING AND BONDING ELECTRONIC COMPONENTS IN THE ASSEMBLY OF ELECTRONIC CIRCUIT BOARDS (U.S. CLS. 21, 23, 26, 36 AND 38).

INGA ERVIN, EXAMINING ATTORNEY

CLASS 9—(Continued).

SN 85-525,315. PARAMETRIC SOUND CORPORATION, HENDERSON, NV. FILED 1-25-2012.

HYPERSOUND

THE MARK CONSISTS OF STANDARD CHARACTERS WITHOUT CLAIM TO ANY PARTICULAR FONT, STYLE, SIZE, OR COLOR.

FOR SOUND REPRODUCTION EQUIPMENT, NAMELY, SPEAKERS, ULTRASONIC SOUND EMITTERS FOR INDIRECTLY GENERATING AUDIBLE SOUND, AND CONTROL CIRCUITRY FOR MIXING FREQUENCIES (U.S. CLS. 21, 23, 26, 36 AND 38).

HANNO RITTNER, EXAMINING ATTORNEY

SN 85-520,173. FUSION-IO, INC., SALT LAKE CITY, UT. FILED 1-19-2012.

IOSCALE

THE MARK CONSISTS OF STANDARD CHARACTERS WITHOUT CLAIM TO ANY PARTICULAR FONT, STYLE, SIZE, OR COLOR.

FOR COMPUTER ACCELERATOR BOARD; COMPUTER CARD ADAPTER; COMPUTER EXPANSION BOARDS; COMPUTER MEMORY HARDWARE; COMPUTER STORAGE DEVICES, NAMELY, FLASH DRIVES (U.S. CLS. 21, 23, 26, 36 AND 38).

KATHERINE CHANG, EXAMINING ATTORNEY

SN 85-525,347. GLUE TOOLS, LLC, SANTA BARBARA, CA. FILED 1-25-2012.

OUIJA

THE MARK CONSISTS OF STANDARD CHARACTERS WITHOUT CLAIM TO ANY PARTICULAR FONT, STYLE, SIZE, OR COLOR.

FOR COMMUNICATIONS SOFTWARE FOR CONNECTING CAMERAS TO COMPUTER HARDWARE; COMPUTER APPLICATION SOFTWARE FOR CAMERAS AND COMPUTERS, NAMELY, SOFTWARE FOR USE IN CONTROLLING CAMERAS AND DIGITAL STORAGE DEVICES; COMPUTER GRAPHIC IMAGE SOFTWARE; COMPUTER SOFTWARE PROGRAMS FOR THE DELIVERY OF STILL IMAGES AND MOVING PICTURES INTO HARDWARE STORAGE DEVICES; COMPUTER HARDWARE AND SOFTWARE FOR PROCESSING DIGITAL FILES; COMPUTER HARDWARE AND SOFTWARE SYSTEMS FOR CONTROLLING HARDWARE DEVICES; COMPUTER SOFTWARE AND FIRMWARE FOR CONTROLLING IMAGING SOURCES ON ANY COMPUTERIZED PLATFORM, INCLUDING CAMERAS, MOTION PICTURE CAMERAS, TABLET COMPUTERS, AND COMPUTERS; COMPUTER SOFTWARE FOR USE WITH MOTION PICTURE DEVICES; COMPUTER SOFTWARE FOR COMMUNICATING WITH USERS OF HAND-HELD COMPUTERS; COMPUTER SOFTWARE FOR PROCESSING DIGITAL FILES; COMPUTER SOFTWARE FOR ORGANIZING AND VIEWING DIGITAL IMAGES AND PHOTOGRAPHS; COMPUTER SOFTWARE FOR MANIPULATING DIGITAL INFORMATION FOR USE IN MEDIA APPLICATIONS; COMPUTER SOFTWARE FOR PROCESSING DIGITAL IMAGES; DOWNLOADABLE COMPUTER SOFTWARE FOR USE AS A CONTROLLER OF MOTION PICTURE DEVICES AND CAMERAS; OPTICAL COMMUNICATIONS SYSTEMS COMPRISED OF OPTICAL AND ELECTRONIC HARDWARE AND COMPUTER SOFTWARE FOR THE TRANSMISSION OF DATA BETWEEN TWO POINTS; MOTION PICTURE CAMERA SOFTWARE; COMPUTER SOFTWARE TO ENHANCE THE VISUAL CAPABILITIES OF MOTION PICTURE CAMERAS (U.S. CLS. 21, 23, 26, 36 AND 38).

ANDREW LEASER, EXAMINING ATTORNEY

SN 85-524,310. THE KETCHUM GROUP, INC., DBA OUTDOOR TECHNOLOGY, INGLEWOOD, CA. FILED 1-24-2012.

TURTLE SHELL

THE MARK CONSISTS OF STANDARD CHARACTERS WITHOUT CLAIM TO ANY PARTICULAR FONT, STYLE, SIZE, OR COLOR.

FOR AUDIO SPEAKERS (U.S. CLS. 21, 23, 26, 36 AND 38).

FIRST USE 1-10-2012; IN COMMERCE 1-10-2012.

ALAIN LAPTER, EXAMINING ATTORNEY

CLASS 9—(Continued).

SN 85-526,744. STANLEY LOGISTICS, L.L.C., NEW BRITAIN, CT. FILED 1-27-2012.

MaxPack

THE MARK CONSISTS OF STANDARD CHARACTERS WITHOUT CLAIM TO ANY PARTICULAR FONT, STYLE, SIZE, OR COLOR.

FOR BATTERY PACKS (U.S. CLS. 21, 23, 26, 36 AND 38).

ALAIN LAPTER, EXAMINING ATTORNEY

SN 85-530,053. ABLE PLANET, INCORPORATED, WHEAT RIDGE, CO. FILED 1-31-2012.

True Fidelity

THE MARK CONSISTS OF STANDARD CHARACTERS WITHOUT CLAIM TO ANY PARTICULAR FONT, STYLE, SIZE, OR COLOR.

OWNER OF U.S. REG. NO. 3,673,029.

FOR ASSISTIVE LISTENING DEVICE NOT FOR MEDICAL PURPOSES; AUDIO AND VISUAL HEADSETS FOR USE IN PLAYING VIDEO GAMES; AUDIO HEADPHONES; COMMUNICATIONS HEADSETS FOR USE WITH COMMUNICATION RADIOS, INTERCOM SYSTEMS, OR OTHER COMMUNICATIONS NETWORK TRANSCIEVERS; EARPHONES AND HEADPHONES; GAMING HEADSETS FOR USE IN PLAYING VIDEO GAMES; HEADPHONES; HEADPHONES INCLUDING ATTACHED LANYARD; HEADSETS FOR CELLULAR OR MOBILE PHONES; HEADSETS FOR MOBILE TELEPHONES; HEADSETS FOR TELEPHONES; HEADSETS FOR USE WITH COMPUTERS; HEARING PROTECTION HEADSETS, NOT FOR MEDICAL USE; LOUDSPEAKERS, HEADPHONES, MICROPHONES AND CD PLAYERS; MUSIC HEADPHONES; PERSONAL HEADPHONES FOR SOUND TRANSMITTING APPARATUSES; PERSONAL HEADPHONES FOR USE WITH SOUND TRANSMITTING SYSTEMS; PORTABLE LISTENING DEVICES, NAMELY, MP3 PLAYERS; STEREO HEADPHONES; TELEPHONE HEADSETS; VIRTUAL REALITY HEADSETS AND HELMETS FOR USE IN PLAYING VIDEO GAMES; WIRELESS CELLULAR PHONE HEADSETS (U.S. CLS. 21, 23, 26, 36 AND 38).

FIRST USE 3-1-2007; IN COMMERCE 3-1-2007.

ALYSSA STEEL, EXAMINING ATTORNEY

CLASS 9—(Continued).

SN 85-532,588. CELLCO PARTNERSHIP, DBA VERIZON WIRELESS, BASKING RIDGE, NJ. FILED 2-2-2012.

THEATRIX

THE MARK CONSISTS OF STANDARD CHARACTERS WITHOUT CLAIM TO ANY PARTICULAR FONT, STYLE, SIZE, OR COLOR.

FOR WIRELESS TELECOMMUNICATIONS PRODUCTS, NAMELY, A SOFTWARE APPLICATION FOR WIRELESS DEVICES THAT CREATES A PORTAL TO SEARCH FOR MOVIES, TELEVISION SHOWS AND OTHER MEDIA AVAILABLE OVER THE INTERNET, THAT PROVIDES INFORMATION ABOUT SUCH MEDIA CONTENT, AND THAT ENABLES USERS TO RATE THE MEDIA CONTENT AS WELL AS TO SHARE THEIR COMMENTS VIA EMAIL AND SOCIAL NETWORKING SITES (U.S. CLS. 21, 23, 26, 36 AND 38).

MARK RADEMACHER, EXAMINING ATTORNEY

SN 85-532,590. CELLCO PARTNERSHIP, DBA VERIZON WIRELESS, BASKING RIDGE, NJ. FILED 2-2-2012.

ROCKADE

THE MARK CONSISTS OF STANDARD CHARACTERS WITHOUT CLAIM TO ANY PARTICULAR FONT, STYLE, SIZE, OR COLOR.

FOR WIRELESS TELECOMMUNICATIONS DEVICE FEATURING TRANSMISSION OF VOICE, DATA, IMAGE AND VIDEO, INCLUDING VOICE, TEXT, PICTURE AND VIDEO MESSAGING, INTERNET ACCESS, ACCESS TO NAVIGATION AND DIRECTIONAL SERVICE OVER THE AIR, THE ABILITY TO DOWNLOAD MUSIC, VIDEOS AND APPLICATIONS OVER THE AIR, AND WHICH HAS A MUSIC PLAYER AND A STILL IMAGE AND VIDEO CAMERA (U.S. CLS. 21, 23, 26, 36 AND 38).

MARK RADEMACHER, EXAMINING ATTORNEY

CLASS 9—(Continued).

SN 85-534,387. CELLCO PARTNERSHIP, DBA VERIZON WIRELESS, BASKING RIDGE, NJ. FILED 2-6-2012.

LIGHTBURST

THE MARK CONSISTS OF STANDARD CHARACTERS WITHOUT CLAIM TO ANY PARTICULAR FONT, STYLE, SIZE, OR COLOR.

FOR WIRELESS TELECOMMUNICATIONS DEVICE FEATURING TRANSMISSION OF VOICE, DATA, IMAGE AND VIDEO, INCLUDING VOICE, TEXT, PICTURE AND VIDEO MESSAGING, INTERNET ACCESS, ACCESS TO NAVIGATION AND DIRECTIONAL SERVICE OVER THE AIR, THE ABILITY TO DOWNLOAD MUSIC, VIDEOS AND APPLICATIONS OVER THE AIR, AND WHICH HAS A MUSIC PLAYER AND A STILL IMAGE AND VIDEO CAMERA (U.S. CLS. 21, 23, 26, 36 AND 38).

MARK RADEMACHER, EXAMINING ATTORNEY



SN 85-535,627. CELLCO PARTNERSHIP, DBA VERIZON WIRELESS, BASKING RIDGE, NJ. FILED 2-7-2012.

EXUDE

THE MARK CONSISTS OF STANDARD CHARACTERS WITHOUT CLAIM TO ANY PARTICULAR FONT, STYLE, SIZE, OR COLOR.

FOR WIRELESS TELECOMMUNICATIONS DEVICE FEATURING TRANSMISSION OF VOICE, DATA, IMAGE AND VIDEO, INCLUDING VOICE, TEXT, PICTURE AND VIDEO MESSAGING, INTERNET ACCESS, ACCESS TO NAVIGATION AND DIRECTIONAL SERVICE OVER THE AIR, THE ABILITY TO DOWNLOAD MUSIC, VIDEOS AND APPLICATIONS OVER THE AIR, AND WHICH HAS A MUSIC PLAYER AND A STILL IMAGE AND VIDEO CAMERA (U.S. CLS. 21, 23, 26, 36 AND 38).

MARK RADEMACHER, EXAMINING ATTORNEY



SN 85-536,193. ROCKY BRANDS, INC., NELSONVILLE, OH. FILED 2-7-2012.



THE MARK CONSISTS OF THE WORD "ROCKY" PRECEDED BY THE ILLUSTRATION OF A RAM IN FRONT OF A MOUNTAIN.

FOR CASES FOR ELECTRONIC EQUIPMENT, NAMELY, CASES FOR MOBILE PHONES, HAND-HELD COMPUTING DEVICES, AND PORTABLE MEDIA PLAYERS; CAMERAS (U.S. CLS. 21, 23, 26, 36 AND 38).

JAMES LOVELACE, EXAMINING ATTORNEY

CLASS 9—(Continued).

SN 85-537,239. CELLCO PARTNERSHIP, DBA VERIZON WIRELESS, BASKING RIDGE, NJ. FILED 2-8-2012.

VIEWDINI

THE MARK CONSISTS OF STANDARD CHARACTERS WITHOUT CLAIM TO ANY PARTICULAR FONT, STYLE, SIZE, OR COLOR.

FOR WIRELESS TELECOMMUNICATIONS PRODUCTS, NAMELY, A SOFTWARE APPLICATION FOR WIRELESS DEVICES THAT CREATES A PORTAL TO SEARCH FOR MOVIES, TELEVISION SHOWS AND OTHER MEDIA AVAILABLE OVER THE INTERNET, THAT PROVIDES INFORMATION ABOUT SUCH MEDIA CONTENT, AND THAT ENABLES USERS TO RATE THE MEDIA CONTENT AS WELL AS TO SHARE THEIR COMMENTS VIA EMAIL AND SOCIAL NETWORKING SITES (U.S. CLS. 21, 23, 26, 36 AND 38).

MARK RADEMACHER, EXAMINING ATTORNEY



SN 85-537,939. CELLCO PARTNERSHIP, DBA VERIZON WIRELESS, BASKING RIDGE, NJ. FILED 2-9-2012.

POISE

THE MARK CONSISTS OF STANDARD CHARACTERS WITHOUT CLAIM TO ANY PARTICULAR FONT, STYLE, SIZE, OR COLOR.

FOR WIRELESS TELECOMMUNICATIONS DEVICE FEATURING TRANSMISSION OF VOICE, DATA, IMAGE AND VIDEO, INCLUDING VOICE, TEXT, PICTURE AND VIDEO MESSAGING, INTERNET ACCESS, ACCESS TO NAVIGATION AND DIRECTIONAL SERVICE OVER THE AIR, THE ABILITY TO DOWNLOAD MUSIC, VIDEOS AND APPLICATIONS OVER THE AIR, AND WHICH HAS A MUSIC PLAYER AND A STILL IMAGE AND VIDEO CAMERA (U.S. CLS. 21, 23, 26, 36 AND 38).

MARK RADEMACHER, EXAMINING ATTORNEY

CLASS 9—(Continued).

SN 85-540,128. V-MODA, LLC, HOLLYWOOD, CA. FILED 2-10-2012.

EAR ARMOR

THE MARK CONSISTS OF STANDARD CHARACTERS WITHOUT CLAIM TO ANY PARTICULAR FONT, STYLE, SIZE, OR COLOR.

NO CLAIM IS MADE TO THE EXCLUSIVE RIGHT TO USE "EAR", APART FROM THE MARK AS SHOWN.

FOR AUDIO HEADPHONES; EARPHONES; EARPHONES AND HEADPHONES; HEADPHONES; MUSIC HEADPHONES; PERSONAL HEADPHONES FOR SOUND TRANSMITTING APPARATUSES; PERSONAL HEADPHONES FOR USE WITH SOUND TRANSMITTING SYSTEMS; STEREO HEADPHONES (U.S. CLS. 21, 23, 26, 36 AND 38).

CHRISTINA SOBRAL, EXAMINING ATTORNEY

SN 85-541,247. ENERGY DYNAMICS, LLC, BALTIMORE, MD. FILED 2-13-2012.

ECO BUSTER ENERGY SAVER

THE MARK CONSISTS OF STANDARD CHARACTERS WITHOUT CLAIM TO ANY PARTICULAR FONT, STYLE, SIZE, OR COLOR.

NO CLAIM IS MADE TO THE EXCLUSIVE RIGHT TO USE "ENERGY SAVER", APART FROM THE MARK AS SHOWN.

FOR CAPACITORS (U.S. CLS. 21, 23, 26, 36 AND 38).

FIRST USE 2-1-2012; IN COMMERCE 2-1-2012.
LINDA LAVACHE, EXAMINING ATTORNEY

SN 85-541,680. POINT GREY RESEARCH, INC., RICHMOND, CANADA, FILED 2-14-2012.

TRICLOPS

THE MARK CONSISTS OF STANDARD CHARACTERS WITHOUT CLAIM TO ANY PARTICULAR FONT, STYLE, SIZE, OR COLOR.

FOR SOFTWARE, NAMELY, IMAGE RECTIFICATION AND STEREO PROCESSING SOFTWARE FOR DIGITAL CAMERAS AND INSTRUCTION MANUALS SOLD AS A UNIT THEREWITH (U.S. CLS. 21, 23, 26, 36 AND 38).

FIRST USE 0-0-1998; IN COMMERCE 0-0-1998.

DAVID COLLIER, EXAMINING ATTORNEY

CLASS 9—(Continued).

SN 85-543,928. JLAB LLC, TUCSON, AZ. FILED 2-15-2012.

Black Ops

THE MARK CONSISTS OF STANDARD CHARACTERS WITHOUT CLAIM TO ANY PARTICULAR FONT, STYLE, SIZE, OR COLOR.

FOR AUDIO HEADPHONES; EAR BUDS; EARPHONES AND HEADPHONES; HEADPHONES; HEADPHONES INCLUDING ATTACHED LANYARD; LOUDSPEAKERS, HEADPHONES, MICROPHONES AND CD PLAYERS; MUSIC HEADPHONES; PERSONAL HEADPHONES FOR SOUND TRANSMITTING APPARATUSES; PERSONAL HEADPHONES FOR USE WITH SOUND TRANSMITTING SYSTEMS; STEREO HEADPHONES (U.S. CLS. 21, 23, 26, 36 AND 38).

MATTHEW EINSTEIN, EXAMINING ATTORNEY

SN 85-545,857. BROOKSTONE PURCHASING, INC., MERRIMACK, NH. FILED 2-17-2012.

SILIPHONES

THE MARK CONSISTS OF STANDARD CHARACTERS WITHOUT CLAIM TO ANY PARTICULAR FONT, STYLE, SIZE, OR COLOR.

FOR HEADPHONES (U.S. CLS. 21, 23, 26, 36 AND 38).

CHRISTOPHER BUONGIORNO, EXAMINING ATTORNEY

SN 85-546,524. ASSA ABLOY AB, STOCKHOLM, SWEDEN, FILED 2-17-2012.



OWNER OF U.S. REG. NO. 3,820,165.

THE COLOR(S) BLACK, WHITE AND YELLOW IS/ARE CLAIMED AS A FEATURE OF THE MARK.

THE MARK CONSISTS OF THE WORD "EASYLOBBY" IN STYLIZED FORM IN THE COLOR BLACK WITH A DESIGN OF WORLD GLOBE FORMING THE LETTER "O" IN THE COLOR BLACK AND YELLOW WITH THE CONTINENTS IN BLACK AND THE OCEAN IN YELLOW AND WHITE SHOWN TO DISPLAY SHADING AS CURVATURE OF THE GLOBE; WITH GRAY CURVED LINE OUTLINED IN WHITE.

FOR ELECTRONIC ACCESS CONTROL SYSTEM COMPRISING COMPUTER SOFTWARE AND MAGNETICALLY ENCODED IDENTIFICATION BADGES FOR TRACKING VISITORS AND EVENT MANAGEMENT (U.S. CLS. 21, 23, 26, 36 AND 38).

JOSETTE BEVERLY, EXAMINING ATTORNEY

CLASS 9—(Continued).

SN 85-547,159. SMITH & NEPHEW, INC., MEMPHIS, TN. FILED 2-20-2012.

ACUFEX

THE MARK CONSISTS OF STANDARD CHARACTERS WITHOUT CLAIM TO ANY PARTICULAR FONT, STYLE, SIZE, OR COLOR.

OWNER OF U.S. REG. NOS. 1,565,731, 1,684,351 AND 3,146,779.

FOR COMPUTER SOFTWARE FOR USE IN PLANNING AND MANAGING SURGERY (U.S. CLS. 21, 23, 26, 36 AND 38).

MIDGE BUTLER, EXAMINING ATTORNEY

SN 85-548,912. ORBIT IRRIGATION PRODUCTS, INC., NORTH SALT LAKE, UT. FILED 2-21-2012.

ORBIT

THE MARK CONSISTS OF STANDARD CHARACTERS WITHOUT CLAIM TO ANY PARTICULAR FONT, STYLE, SIZE, OR COLOR.

OWNER OF U.S. REG. NOS. 2,568,783, 3,565,064 AND OTHERS.

FOR ELECTRONIC APPARATUS, NAMELY, MOTION DETECTORS (U.S. CLS. 21, 23, 26, 36 AND 38).

VERNA BETH RIRIE, EXAMINING ATTORNEY

SN 85-554,098. QUALCOMM INCORPORATED, SAN DIEGO, CA. FILED 2-27-2012.



THE MARK CONSISTS OF A CIRCLE WITH A SWIRL IN IT.

FOR COMPUTER CHIPS; COMPUTER HARDWARE; COMPUTER PERIPHERALS; AND, COMPUTER SOFTWARE AND COMPUTER FIRMWARE THAT FUNCTIONS TO CONTROL, IMPLEMENT AND OPTIMIZE THE COMMUNICATIONS LINK IN NETWORKING, WIRELESS AND COMPUTER COMMUNICATIONS; MODEMS (U.S. CLS. 21, 23, 26, 36 AND 38).

MICHAEL ENGEL, EXAMINING ATTORNEY

CLASS 9—(Continued).

SN 85-554,798. THE CARTOON NETWORK, INC., ATLANTA, GA. FILED 2-28-2012.

BOOMERANG GO

THE MARK CONSISTS OF STANDARD CHARACTERS WITHOUT CLAIM TO ANY PARTICULAR FONT, STYLE, SIZE, OR COLOR.

OWNER OF U.S. REG. NOS. 2,029,598, 3,138,895 AND OTHERS.

FOR COMPUTER SOFTWARE FOR USE IN PROCESSING, TRANSMITTING, RECEIVING, ORGANIZING, MANIPULATING, PLAYING, REVIEWING, REPRODUCING AND STREAMING AUDIO, VIDEO AND MULTIMEDIA CONTENT INCLUDING TEXT, DATA, IMAGE, AUDIO, VIDEO AND AUDIOVISUAL FILES; COMPUTER SOFTWARE FOR CONTROLLING THE OPERATION OF AUDIO AND VIDEO DEVICES AND FOR VIEWING, SEARCHING AND/OR PLAYING AUDIO, VIDEO, TELEVISION, MOVIES, OTHER DIGITAL IMAGES, AND OTHER MULTIMEDIA CONTENT; COMPUTER SOFTWARE FOR INTERACTIVE ENTERTAINMENT, WHICH ALLOWS USERS TO CUSTOMIZE THE VIEWING, LISTENING, AND PLAYING EXPERIENCE BY SELECTING AND ARRANGING THE DISPLAY AND PERFORMANCE OF AUDIO, VIDEO AND AUDIOVISUAL ELEMENTS; DOWNLOADABLE AUDIO, VISUAL, AND AUDIOVISUAL FILES AND RECORDINGS, FEATURING MULTIMEDIA ENTERTAINMENT PROGRAMS AND CONTENT (U.S. CLS. 21, 23, 26, 36 AND 38).

MARK SPARACINO, EXAMINING ATTORNEY

SN 85-555,056. THE CARTOON NETWORK, INC., ATLANTA, GA. FILED 2-28-2012.

ADULT SWIM GO

THE MARK CONSISTS OF STANDARD CHARACTERS WITHOUT CLAIM TO ANY PARTICULAR FONT, STYLE, SIZE, OR COLOR.

OWNER OF U.S. REG. NOS. 3,193,789, 3,683,152 AND OTHERS.

FOR COMPUTER SOFTWARE FOR USE IN PROCESSING, TRANSMITTING, RECEIVING, ORGANIZING, MANIPULATING, PLAYING, REVIEWING, REPRODUCING AND STREAMING AUDIO, VIDEO AND MULTIMEDIA CONTENT INCLUDING TEXT, DATA, IMAGE, AUDIO, VIDEO AND AUDIOVISUAL FILES; COMPUTER SOFTWARE FOR CONTROLLING THE OPERATION OF AUDIO AND VIDEO DEVICES AND FOR VIEWING, SEARCHING AND/OR PLAYING AUDIO, VIDEO, TELEVISION, MOVIES, OTHER DIGITAL IMAGES, AND OTHER MULTIMEDIA CONTENT; COMPUTER SOFTWARE FOR INTERACTIVE ENTERTAINMENT, WHICH ALLOWS USERS TO CUSTOMIZE THE VIEWING, LISTENING, AND PLAYING EXPERIENCE BY SELECTING AND ARRANGING THE DISPLAY AND PERFORMANCE OF AUDIO, VIDEO AND AUDIOVISUAL ELEMENTS; DOWNLOADABLE AUDIO, VISUAL, AND AUDIOVISUAL FILES AND RECORDINGS, FEATURING MULTIMEDIA ENTERTAINMENT PROGRAMS AND CONTENT (U.S. CLS. 21, 23, 26, 36 AND 38).

MARK SPARACINO, EXAMINING ATTORNEY

CLASS 9—(Continued).

SN 85-556,249. THE LEE COMPANY, WESTBROOK, CT. FILED 2-29-2012.



THE MARK CONSISTS OF "LIF" BETWEEN LATERAL BRACKET SHAPES AND BETWEEN UPPER AND LOWER RECTANGULAR SHAPES CONTAINING TWO SHADED TRIANGLES.

FOR SOLENOID VALVES (U.S. CLS. 21, 23, 26, 36 AND 38).

FIRST USE 0-0-1975; IN COMMERCE 0-0-1975.
ANDREW LEASER, EXAMINING ATTORNEY

SN 85-558,775. TRANSITIONS OPTICAL, INC., PINELLAS PARK, FL. FILED 3-2-2012.

QUALICHROME

THE MARK CONSISTS OF STANDARD CHARACTERS WITHOUT CLAIM TO ANY PARTICULAR FONT, STYLE, SIZE, OR COLOR.

FOR EYEGLASS LENSES AND LENS BLANKS (U.S. CLS. 21, 23, 26, 36 AND 38).

BRIDGETT SMITH, EXAMINING ATTORNEY

SN 85-558,946. SUSSMAN-AUTOMATIC CORPORATION, LONG ISLAND CITY, NY. FILED 3-2-2012.

SteamStart

THE MARK CONSISTS OF STANDARD CHARACTERS WITHOUT CLAIM TO ANY PARTICULAR FONT, STYLE, SIZE, OR COLOR.

FOR CONTROLS FOR STEAMBATHS AND STEAMBATH GENERATORS (U.S. CLS. 21, 23, 26, 36 AND 38).

CAROLINE WOOD, EXAMINING ATTORNEY

CLASS 9—(Continued).

SN 85-572,222. LINUX FOUNDATION, THE, SAN FRANCISCO, CA. FILED 3-16-2012.

Certified For Linux

THE MARK CONSISTS OF STANDARD CHARACTERS WITHOUT CLAIM TO ANY PARTICULAR FONT, STYLE, SIZE, OR COLOR.

OWNER OF U.S. REG. NO. 3,699,993.

NO CLAIM IS MADE TO THE EXCLUSIVE RIGHT TO USE "CERTIFIED", APART FROM THE MARK AS SHOWN.

FOR COMPUTER SOFTWARE, NAMELY, TESTING SOFTWARE FOR ESTABLISHING CONFORMANCE TO SPECIFIC TECHNICAL SPECIFICATIONS IN THE FIELD OF INTEROPERABILITY FOR COMPUTER APPLICATIONS AND COMPUTER OPERATING SYSTEMS; COMPUTER SOFTWARE PROGRAMS FEATURING EDUCATIONAL, INSTRUCTIONAL, AND TRAINING MATERIALS, NAMELY, INFORMATION AND TECHNICAL SPECIFICATIONS FOR USE IN THE DEVELOPING OF COMPUTER APPLICATIONS AND OPERATING SYSTEMS; COMPUTER SOFTWARE DEVELOPMENT TOOLS, NAMELY, PROGRAMS FOR DEVELOPING SOFTWARE THAT CONFORMS WITH TECHNICAL SPECIFICATIONS IN THE FIELD OF COMPUTER APPLICATIONS AND COMPUTER OPERATING SYSTEMS AND USER MANUALS SOLD AS UNIT THEREWITH; COMPUTER HARDWARE AND PERIPHERALS (U.S. CLS. 21, 23, 26, 36 AND 38).

LINDA POWELL, EXAMINING ATTORNEY

SN 85-573,753. ORBIT IRRIGATION PRODUCTS, INC., NORTH SALT LAKE, UT. FILED 3-19-2012.

ORBIT

THE MARK CONSISTS OF STANDARD CHARACTERS WITHOUT CLAIM TO ANY PARTICULAR FONT, STYLE, SIZE, OR COLOR.

OWNER OF U.S. REG. NOS. 2,568,783, 2,819,521 AND 3,565,064.

FOR ELECTRIC OR ELECTRONIC SENSORS FOR MEASURING MOISTURE LEVELS IN SOIL (U.S. CLS. 21, 23, 26, 36 AND 38).

VERNA BETH RIRIE, EXAMINING ATTORNEY

CLASS 9—(Continued).

SN 85-580,876. ILLUMINA, INC., SAN DIEGO, CA. FILED 3-27-2012.

BASECAMP

THE MARK CONSISTS OF STANDARD CHARACTERS WITHOUT CLAIM TO ANY PARTICULAR FONT, STYLE, SIZE, OR COLOR.

FOR COMPUTER SOFTWARE FOR PROCESSING AND ANALYZING GENOMIC AND OTHER BIOINFORMATIC DATA FROM SEQUENCING INSTRUMENTS, FOR SEQUENCE ALIGNMENT, VARIANT CALLING, GENOME ASSEMBLY, DEEP SEQUENCING, AND METAGENOMICS (U.S. CLS. 21, 23, 26, 36 AND 38).
CURTIS FRENCH, EXAMINING ATTORNEY

CLASS 9—(Continued).

SN 85-584,108. SUPER MICRO COMPUTER, INC., SAN JOSE, CA. FILED 3-29-2012.

BBP

THE MARK CONSISTS OF STANDARD CHARACTERS WITHOUT CLAIM TO ANY PARTICULAR FONT, STYLE, SIZE, OR COLOR.

FOR HOT SWAPPABLE BATTERY FOR A COMPUTER SERVER THAT MOUNTS THROUGH AN EXTERNAL PORT OF A COMPUTER SERVER HOUSING (U.S. CLS. 21, 23, 26, 36 AND 38).
EDWARD NELSON, EXAMINING ATTORNEY

SN 85-580,892. ILLUMINA, INC., SAN DIEGO, CA. FILED 3-27-2012.

HOMEBASE

THE MARK CONSISTS OF STANDARD CHARACTERS WITHOUT CLAIM TO ANY PARTICULAR FONT, STYLE, SIZE, OR COLOR.

FOR COMPUTER SOFTWARE FOR PROCESSING AND ANALYZING GENOMIC AND OTHER BIOINFORMATIC DATA FROM SEQUENCING INSTRUMENTS, FOR SEQUENCE ALIGNMENT, VARIANT CALLING, GENOME ASSEMBLY, DEEP SEQUENCING, AND METAGENOMICS (U.S. CLS. 21, 23, 26, 36 AND 38).
CURTIS FRENCH, EXAMINING ATTORNEY

SN 85-584,119. SUPER MICRO COMPUTER, INC., SAN JOSE, CA. FILED 3-29-2012.

SUPERBOOK

THE MARK CONSISTS OF STANDARD CHARACTERS WITHOUT CLAIM TO ANY PARTICULAR FONT, STYLE, SIZE, OR COLOR.

OWNER OF U.S. REG. NOS. 2,891,872, 3,902,574 AND OTHERS.
FOR PORTABLE PERSONAL COMPUTER (U.S. CLS. 21, 23, 26, 36 AND 38).
EDWARD NELSON, EXAMINING ATTORNEY

SN 85-583,398. RADIATION DETECTION COMPANY, INC., GILROY, CA. FILED 3-29-2012.

RDCFLASH

THE MARK CONSISTS OF STANDARD CHARACTERS WITHOUT CLAIM TO ANY PARTICULAR FONT, STYLE, SIZE, OR COLOR.

FOR WEARABLE, ELECTRONIC USB DOSIMETER FOR REAL TIME ASSESSMENT OF EXPOSURE TO RADIATION (U.S. CLS. 21, 23, 26, 36 AND 38).
JORDAN BAKER, EXAMINING ATTORNEY

SN 85-584,642. NIPPON DENKI KABUSHIKI KAISHA, DBA NEC CORPORATION, MINATO-KU, TOKYO, JAPAN, FILED 3-30-2012.

InfoFrame

THE MARK CONSISTS OF STANDARD CHARACTERS WITHOUT CLAIM TO ANY PARTICULAR FONT, STYLE, SIZE, OR COLOR.

FOR COMPUTER SOFTWARE FOR USE IN INFORMATION MANAGEMENT, INFORMATION ANALYSIS AND DATABASE MANAGEMENT (U.S. CLS. 21, 23, 26, 36 AND 38).
DAVID I, EXAMINING ATTORNEY

CLASS 9—(Continued).

SN 85-584,931. PONG RESEARCH CORPORATION, LEESBURG, VA. FILED 3-30-2012.

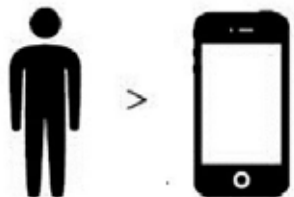

THE MARK CONSISTS OF A STYLIZED HUMAN FIGURE, THE GREATER THAN SYMBOL AND A STYLIZED IMAGE OF A MOBILE COMMUNICATION DEVICE.

FOR CASES FOR MOBILE PHONES, CELL PHONES, LAPTOP COMPUTERS, TABLET COMPUTERS, NOTEBOOK COMPUTERS, AND OTHER WIRELESS COMMUNICATION DEVICES (U.S. CLS. 21, 23, 26, 36 AND 38).
INGA ERVIN, EXAMINING ATTORNEY

SN 85-588,268. DPIX, LLC, COLORADO SPRINGS, CO. FILED 4-3-2012.

MAXFILL

THE MARK CONSISTS OF STANDARD CHARACTERS WITHOUT CLAIM TO ANY PARTICULAR FONT, STYLE, SIZE, OR COLOR.

FOR ELECTRONIC SENSOR ARRAYS FOR USE IN MEDICAL, NON-DESTRUCTIVE TESTING, AND SECURITY TYPE X-RAY SYSTEMS (U.S. CLS. 21, 23, 26, 36 AND 38).

FIRST USE 11-16-2004; IN COMMERCE 11-16-2004.
DANNEAN HETZEL, EXAMINING ATTORNEY

SN 85-590,359. BARON SERVICES, INC., HUNTSVILLE, AL. FILED 4-5-2012.

THREAT MATRIX

THE MARK CONSISTS OF STANDARD CHARACTERS WITHOUT CLAIM TO ANY PARTICULAR FONT, STYLE, SIZE, OR COLOR.

FOR COMPUTER HARDWARE AND SOFTWARE SYSTEM FOR GATHERING REAL-TIME, SITE-SPECIFIC RADAR, LIGHTNING, THUNDERSTORM, STORM INTENSITY AND STORM TRAVEL DIRECTION, AND OTHER WEATHER DATA AND INFORMATION, AND FOR DISTRIBUTING AND PROVIDING THE SAME, TO REMOTE USERS FOR WARNINGS, GRAPHICAL DISPLAY, AND OTHER USES (U.S. CLS. 21, 23, 26, 36 AND 38).

RENEE MCCRAY, EXAMINING ATTORNEY

CLASS 10—MEDICAL APPARATUS

SN 77-928,544. ONESTOP INC., TERRYVILLE, CT. FILED 2-4-2010.

DR. SKINCARE ROLLER

THE MARK CONSISTS OF STANDARD CHARACTERS WITHOUT CLAIM TO ANY PARTICULAR FONT, STYLE, SIZE, OR COLOR.

NO CLAIM IS MADE TO THE EXCLUSIVE RIGHT TO USE "SKINCARE ROLLER", APART FROM THE MARK AS SHOWN.

FOR ACUPUNCTURE EQUIPMENT; ACUPUNCTURE INSTRUMENTS; APPARATUS FOR ACUPUNCTURE THERAPY; DRUG DELIVERY SYSTEMS; MASSAGE APPARATUS; MASSAGE APPARATUS AND INSTRUMENTS; MASSAGING APPARATUS FOR PERSONAL USE; MEDICAL APPARATUS FOR INTRODUCING PHARMACEUTICAL PREPARATIONS INTO THE HUMAN BODY (U.S. CLS. 26, 39 AND 44).

BARBARA GAYNOR, EXAMINING ATTORNEY

SN 79-099,207. SOPRO, FRANCE, FILED 6-9-2011.

UBICAM

THE MARK CONSISTS OF STANDARD CHARACTERS WITHOUT CLAIM TO ANY PARTICULAR FONT, STYLE, SIZE, OR COLOR.

PRIORITY DATE OF 12-24-2010 IS CLAIMED.

OWNER OF INTERNATIONAL REGISTRATION 1082246 DATED 6-9-2011, EXPIRES 6-9-2021.

FOR DIAGNOSTIC APPARATUS FOR SURGICAL, MEDICAL, DENTAL AND VETERINARY PURPOSES, NAMELY, DIGITAL VIDEO CAMERA CONNECTED TO A PROBE FOR VIEWING CAVITIES OF ANIMALS AND HUMAN BEINGS FOR DIAGNOSTIC PURPOSES; PROBES FOR SURGICAL, MEDICAL, DENTAL AND VETERINARY PURPOSES; ENDOSCOPES; DIAGNOSTIC ENDOSCOPES FOR DIGITAL IMAGING; ENDOSCOPIC CAMERAS FOR MEDICAL OR VETERINARY PURPOSES (U.S. CLS. 26, 39 AND 44).

JOSETTE BEVERLY, EXAMINING ATTORNEY

CLASS 10—(Continued).

SN 79-101,192. TOMHEY CORPORATION, AICHI-KEN 451-0051, JAPAN, FILED 4-28-2011.

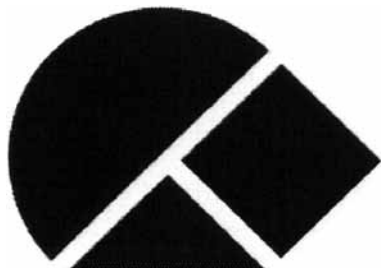

OWNER OF INTERNATIONAL REGISTRATION 1087089 DATED 4-28-2011, EXPIRES 4-28-2021.

OWNER OF U.S. REG. NOS. 1,834,513, 3,088,116 AND OTHERS.

THE MARK CONSISTS OF AN ABSTRACT SHAPE COMBINING A SEMI-CIRCLE, TRIANGLE, AND DIAMOND, EACH OF THE ELEMENTS MEANS ONE PERSONALITY, WITH THE WHOLE MARK MEANING AN ASSEMBLY OF VARIOUS PERSONALITIES. THE SPACES BETWEEN THE ELEMENTS EXPRESS THE SHAPE OF THE LETTER T, AND ALSO MEAN AN IMAGE OF HUMAN BEINGS.

FOR MEDICAL APPARATUS AND EQUIPMENTS FOR USE IN OPHTHALMIC TREATMENT AND EXAMINATION, NAMELY, OPHTHALMOMETERS, OPHTHALMOSCOPES; VISUAL ACUITY CHARTS FOR MEDICAL USE; REFRACTOMETERS FOR MEDICAL USE; KERATOMETERS FOR MEDICAL USE; CORNEAL TOPOGRAPHERS FOR MEDICAL USE; TONOMETERS FOR MEDICAL USE; SPECULAR MICROSCOPES FOR MEDICAL USE; OPTICAL COHERENCE TOMOGRAPHY (OCT) IMAGING SYSTEMS FOR MEDICAL USE COMPRISED OF COMPUTER HARDWARE AND SOFTWARE, LIGHT SOURCE AND CAMERA; OPTICAL MEASURING SYSTEMS FOR OCULAR DIMENSION FOR MEDICAL USE COMPRISED OF COMPUTER HARDWARE AND SOFTWARE, LIGHT SOURCE AND CAMERA; SCHEIMPFLUG CAMERAS FOR MEDICAL USE; ELECTRORETINOGRAPHS FOR MEDICAL USE; AXIAL LENGTH BIOMETERS FOR MEDICAL USE; PACHYMETERS FOR MEDICAL USE; ULTRASONIC DIAGNOSTIC IMAGING EQUIPMENTS FOR MEDICAL USE; THERMOGRAPHS FOR MEDICAL USE; LENS-METERS FOR MEDICAL USE (U.S. CLS. 26, 39 AND 44).

STEVEN PEREZ, EXAMINING ATTORNEY

SN 79-105,025. SUDIMPLANT, FRANCE, FILED 10-4-2011.

PERIOSAVE

OWNER OF INTERNATIONAL REGISTRATION 1096757 DATED 10-4-2011, EXPIRES 10-4-2021.

FOR MEDICAL AND DENTAL INSTRUMENTS FOR BONE AND GINGIVAL HEALING, PRESERVATION OF THE PERIODONTIUM, AND BACTERIAL AND PERI-IMPLANT DISEASE REDUCTION; ARTIFICIAL TEETH, DENTAL IMPLANTS (U.S. CLS. 26, 39 AND 44).

ALLISON HOLTZ, EXAMINING ATTORNEY

CLASS 10—(Continued).

SN 79-106,952. ULRICH GMBH & CO KG, FED REP GERMANY, FILED 11-3-2011.

Microbolus

THE MARK CONSISTS OF STANDARD CHARACTERS WITHOUT CLAIM TO ANY PARTICULAR FONT, STYLE, SIZE, OR COLOR.

PRIORITY DATE OF 8-15-2011 IS CLAIMED.

OWNER OF INTERNATIONAL REGISTRATION 1101040 DATED 11-3-2011, EXPIRES 11-3-2021.

FOR MEDICAL APPARATUS AND INSTRUMENTS FOR USE IN ORTHOPEDIC SURGERY; MEDICAL APPARATUS AND INSTRUMENTS, NAMELY, X-RAY APPARATUS, BLOOD-DRAWING APPARATUS, DROPPERS FOR ADMINISTERING MEDICATION SOLD EMPTY, HYPODERMIC NEEDLES, HYPODERMIC SYRINGES, INTRAVENOUS FEEDING BOTTLES, INTRAVENOUS FEEDING TUBES, MEDICAL SYRINGES, LANCETS, STETHOSCOPES, SUTURES, THERMOMETERS FOR MEDICAL PURPOSES, TONGUE DEPRESSORS, TOURNIQUETS, ORTHOPEDIC SUPPORTS, BRACES AND BELTS, SUPPORT BANDAGES, BLOOD PRESSURE MEASURING APPARATUS, HEARING AIDS, ELECTRIC HEATING PADS FOR MEDICAL PURPOSES, APPARATUS FOR ARTIFICIAL RESPIRATION, DIALYSIS MACHINES; CANISTERS FOR PHARMACEUTICALS, NAMELY, CONTAINERS SPECIFICALLY DESIGNED FOR TRANSPORTING AND HOLDING RADIO PHARMACEUTICALS; SYRINGES FOR MEDICAL USE; MEDICAL FLUID INJECTORS FOR DIAGNOSTIC IMAGING USING COMPUTERIZED TOMOGRAPHY AND MAGNETIC RESONANCE IMAGING; MEDICAL FLUID INJECTORS FOR INJECTING CONTRAST AGENTS AND ISOTONIC SALINE SOLUTION DURING MEDICAL IMAGING PROCEDURES; CONTRAST AGENT MEDICAL FLUID INJECTORS FOR COMPUTER TOMOGRAPHY AND NUCLEAR SPIN TOMOGRAPHY; INFUSION APPARATUS FOR ADMINISTERING CONTRAST AGENTS AND ISOTONIC SALINE SOLUTION FOR DIAGNOSTIC IMAGING USING COMPUTER TOMOGRAPHY AND MAGNETIC RESONANCE IMAGING; PUMPS FOR MEDICAL PURPOSES, NAMELY, CONTRAST AGENT PUMPS FOR APPLICATION OF CONTRAST AGENTS AND ISOTONIC SALINE SOLUTION DURING MEDICAL IMAGING PROCEDURES; MR/CT INJECTION PUMPS FOR THE APPLICATION OF FLUIDS FOR MAGNETIC RESONANCE IMAGING AND COMPUTER TOMOGRAPHY; PUMP HOSES, PATIENT TUBES, NAMELY, INTRAVENOUS INJECTION TUBES FOR MEDICAL PURPOSES; CANNULAE; INJECTION NEEDLES; SUTURE NEEDLES; RESERVOIRS FOR DECANTING CONTRAST AGENTS FOR USE IN MAGNETIC RESONANCE IMAGING AND COMPUTER TOMOGRAPHY; ANALYSIS APPARATUS FOR MEDICAL PURPOSES FOR INJECTING CONTRAST AGENT AND SALINE SOLUTION TO IMPROVE IMAGE QUALITY OF DIAGNOSTIC IMAGING USING COMPUTER TOMOGRAPHY AND MAGNETIC RESONANCE IMAGING; DIAGNOSIS APPARATUS FOR MEDICAL PURPOSES FOR INJECTING CONTRAST AGENT AND SALINE SOLUTION TO IMPROVE IMAGE QUALITY OF DIAGNOSTIC IMAGING USING COMPUTER TOMOGRAPHY AND MAGNETIC RESONANCE IMAGING; CONTAINERS FOR MEDICAL WASTE (U.S. CLS. 26, 39 AND 44).

WILLIAM ROSSMAN, EXAMINING ATTORNEY

CLASS 10—(Continued).

SN 79-107,192. NOVALUNG GMBH, FED REP GERMANY, FILED 11-18-2011.

NOVAPORT

THE MARK CONSISTS OF STANDARD CHARACTERS WITHOUT CLAIM TO ANY PARTICULAR FONT, STYLE, SIZE, OR COLOR.

OWNER OF INTERNATIONAL REGISTRATION 0897807 DATED 7-26-2006, EXPIRES 7-26-2016.

OWNER OF U.S. REG. NOS. 3,330,446 AND 3,485,152. FOR MEDICAL APPARATUS AND INSTRUMENTS FOR SUPPORTING LUNG FUNCTION OF A HUMAN BEING, NAMELY, ARTIFICIAL LUNGS; MEDICAL MEASURING INSTRUMENTS, NAMELY, DEVICES FOR MEASURING BLOOD FLOW IN THE NATURE OF BLOOD FLOW METERS; DILATORS, NAMELY, DILATORS TO WIDEN AN OPENING OF A HOLLOW ORGAN; TUBES, FILTERS, MEMBRANES, CLAMPS, NEEDLES, CANNULAS AND CLOSURES FOR AFOREMENTIONED GOODS; SCALPELS (U.S. CLS. 26, 39 AND 44).

ANDREA K. NADELMAN, EXAMINING ATTORNEY

SN 85-070,874. J. BRASCH CO., LINCOLN, NE. FILED 6-24-2010.



THE COLOR(S) GREEN AND PURPLE IS/ARE CLAIMED AS A FEATURE OF THE MARK.

THE MARK CONSISTS OF THE DESIGN OF AN INCOMPLETE OVAL WITH A HAND IN THE LOWER LEFT OF THE OVAL IN THE COLOR GREEN WITH THE STYLIZED WORDING "SAFEPRESENCE" IN PURPLE LETTERING INSIDE OF THE OVAL.

FOR PATIENT MONITORING SENSORS AND ALARMS (U.S. CLS. 26, 39 AND 44).

AMY C. KEAN, EXAMINING ATTORNEY

CLASS 10—(Continued).

SN 85-079,845. ASCENSION ORTHOPEDICS, INC., AUSTIN, TX. FILED 7-7-2010.

ATLAS

THE MARK CONSISTS OF STANDARD CHARACTERS WITHOUT CLAIM TO ANY PARTICULAR FONT, STYLE, SIZE, OR COLOR.

FOR ORTHOPEDIC IMPLANTS COMPOSED OF ARTIFICIAL MATERIALS FOR THE REGION OF THE UPPER ARM AND SHOULDER (U.S. CLS. 26, 39 AND 44).

SETH A. RAPPAPORT, EXAMINING ATTORNEY

SN 85-268,366. SCHERING-PLOUGH HEALTHCARE PRODUCTS, INC., MEMPHIS, TN. FILED 3-16-2011.

SHOCK GUARD

THE MARK CONSISTS OF STANDARD CHARACTERS WITHOUT CLAIM TO ANY PARTICULAR FONT, STYLE, SIZE, OR COLOR.

OWNER OF U.S. REG. NO. 3,655,969.

NO CLAIM IS MADE TO THE EXCLUSIVE RIGHT TO USE "SHOCK", APART FROM THE MARK AS SHOWN.

FOR BALL OF FOOT AND ARCH SUPPORTS FOR PLACEMENT AS ORTHOTIC INSERTS TO ALLEVIATE PAIN (U.S. CLS. 26, 39 AND 44).

AISHA CLARKE, EXAMINING ATTORNEY

SN 85-328,422. YUKON MEDICAL, LLC, RESEARCH TRIANGLE PARK, NC. FILED 5-24-2011.

ARISURE

THE MARK CONSISTS OF STANDARD CHARACTERS WITHOUT CLAIM TO ANY PARTICULAR FONT, STYLE, SIZE, OR COLOR.

FOR NEEDLE-FREE ACCESS, PREPARATION, AND DELIVERY SYSTEM FOR MEDICATIONS, COMPRISED OF A VIAL ACCESS DEVICE, INFUSION ACCESS DEVICE, AND A CLOSED MALE LUER FOR NEEDLE-FREE DRUG ADMINISTRATION (U.S. CLS. 26, 39 AND 44).

FLORENTINA BLANDU, EXAMINING ATTORNEY

CLASS 10—(Continued).

SN 85-331,451. WORLD HEART CORPORATION, SALT LAKE CITY, UT. FILED 5-26-2011.

MIFLOW

THE MARK CONSISTS OF STANDARD CHARACTERS WITHOUT CLAIM TO ANY PARTICULAR FONT, STYLE, SIZE, OR COLOR.

FOR MEDICAL APPARATUS, NAMELY, IMPLANTED HEART ASSIST DEVICE IN THE NATURE OF VENTRICULAR ASSIST DEVICE AND PARTS THEREFOR (U.S. CLS. 26, 39 AND 44).

CHRISTINA SOBRAL, EXAMINING ATTORNEY

CLASS 10—(Continued).

SN 85-340,398. THE STOCKROOM, INC., LOS ANGELES, CA. FILED 6-7-2011.

Neon Wand

THE MARK CONSISTS OF STANDARD CHARACTERS WITHOUT CLAIM TO ANY PARTICULAR FONT, STYLE, SIZE, OR COLOR.

NO CLAIM IS MADE TO THE EXCLUSIVE RIGHT TO USE "WAND", APART FROM THE MARK AS SHOWN, FOR ADULT SEXUAL STIMULATION AIDS, NAMELY, ELECTRIC SKIN AND GENITAL STIMULATORS (U.S. CLS. 26, 39 AND 44).

FIRST USE 6-7-2011; IN COMMERCE 6-7-2011.

FONG HSU, EXAMINING ATTORNEY

SN 85-334,995. AIR FEET LLC, AVON, IN. FILED 6-1-2011.

Air Feet

THE MARK CONSISTS OF STANDARD CHARACTERS WITHOUT CLAIM TO ANY PARTICULAR FONT, STYLE, SIZE, OR COLOR.

NO CLAIM IS MADE TO THE EXCLUSIVE RIGHT TO USE "FEET", APART FROM THE MARK AS SHOWN.

FOR ORTHOPEDIC SOLES, NAMELY, CUSHIONED INSOLES FOR THERAPEUTIC USE (U.S. CLS. 26, 39 AND 44).

KRISTIN CARLSON, EXAMINING ATTORNEY

SN 85-344,977. MASIMO CORPORATION, IRVINE, CA. FILED 6-13-2011.

E1

SN 85-335,707. PURTHREAD TECHNOLOGIES, INC., SAN FRANCISCO, CA. FILED 6-1-2011.

PURTHREAD

THE MARK CONSISTS OF STANDARD CHARACTERS WITHOUT CLAIM TO ANY PARTICULAR FONT, STYLE, SIZE, OR COLOR.

FOR COMPRESSION BANDAGES; MEDICAL APPAREL NAMELY, SURGICAL SHOE COVERS, SLIPPERS, BOOTIES, PATIENTS' GOWNS, SURGICAL GOWNS, MEDICAL SCRUB TOPS AND PANTS AND COMPRESSION SOCKS; SUTURES; DRAW-SHEETS FOR SICK BEDS; ALL EXCLUDING SURGICAL GLOVES (U.S. CLS. 26, 39 AND 44).

MARTHA FROMM, EXAMINING ATTORNEY

THE MARK CONSISTS OF STANDARD CHARACTERS WITHOUT CLAIM TO ANY PARTICULAR FONT, STYLE, SIZE, OR COLOR.

FOR MEDICAL DEVICES, NAMELY, PATIENT SENSORS DESIGNED FOR USE ON OR IN THE EAR FOR MEASURING AND MONITORING BLOOD PROPERTIES OR RESPIRATORY EVENTS (U.S. CLS. 26, 39 AND 44).

CURTIS FRENCH, EXAMINING ATTORNEY

CLASS 10—(Continued).

SN 85-353,638. GBT HOLDING LIMITED, KL, HONG KONG, FILED 6-22-2011.

PAPAYA Toys

Rediscover Passion

NO CLAIM IS MADE TO THE EXCLUSIVE RIGHT TO USE "TOYS", APART FROM THE MARK AS SHOWN.

THE MARK CONSISTS OF THE STYLIZED WORDS "PAPAYA TOYS" POSITIONED ABOVE THE WORDING "REDISCOVER PASSION". THE WORDING "PAPAYA TOYS" IS UNDERLINED IN THREE SEGMENTS WITH THE MIDDLE SEGMENT CURVING UP AT THE LEFT AND CURVING DOWN AT THE RIGHT.

FOR ADULT SEXUAL STIMULATION AIDS, NAMELY, ARTIFICIAL PENISES, PENIS ENLARGERS, VIBRATORS, BENWA BALLS, ARTIFICIAL VAGINAS; MASSAGE APPARATUS AND INSTRUMENTS (U.S. CLS. 26, 39 AND 44).

FIRST USE 8-17-2009; IN COMMERCE 8-17-2009.
 RUSS HERMAN, EXAMINING ATTORNEY

SN 85-354,366. T-ZONE HEALTH INC., DBA T-ZONE VIBRATION TECHNOLOGY, 726929 ONTARIO LTD., TORONTO, CANADA, FILED 6-23-2011.



NO CLAIM IS MADE TO THE EXCLUSIVE RIGHT TO USE "MEDICAL VIBRATION TECHNOLOGY", APART FROM THE MARK AS SHOWN.

THE COLOR(S) BLUE, RED, GRAY, BLACK, AND WHITE IS/ARE CLAIMED AS A FEATURE OF THE MARK.

THE MARK CONSISTS OF THE WORDING "T-ZONE VIBRATION MEDICAL TECHNOLOGY" WHERE "T-ZONE" APPEARS IN DARK BLUE, AND "VIBRATION" APPEARS IN RED WITH BLACK, GRAY AND BLUE SHADOWING. THE TERM "MEDICAL" IS IN WHITE AND INSIDE A RED RECTANGLE, AND THE TERM "TECHNOLOGY" IS IN WHITE AND INSIDE A DARK BLUE RECTANGLE. THE ENTIRE MARK IS ENCLOSED IN A RED CURVED RECTANGULAR OUTLINE. THE AREA INSIDE THE RED OUTLINE IS TRANSPARENT.

FOR VIBRATING APPARATUS USED TO STIMULATE MUSCLES, AND INCREASE STRENGTH AND PHYSICAL PERFORMANCE FOR HEALTH AND MEDICAL PURPOSES, IN PARTICULAR, ORTHOPEDIC AND CHIROPRACTIC THERAPY AND MASSAGE (U.S. CLS. 26, 39 AND 44).

FIRST USE 1-3-2011; IN COMMERCE 1-3-2011.
 ALYSSA STEEL, EXAMINING ATTORNEY

CLASS 10—(Continued).

SN 85-355,216. SPECTRA MEDICAL DEVICES, INC., WILMINGTON, MA. FILED 6-24-2011.

GUIDE GLIDE

THE MARK CONSISTS OF STANDARD CHARACTERS WITHOUT CLAIM TO ANY PARTICULAR FONT, STYLE, SIZE, OR COLOR.

FOR MEDICAL NEEDLES AND INTRODUCERS (U.S. CLS. 26, 39 AND 44).

DAVID C. REIHNER, EXAMINING ATTORNEY

SN 85-358,131. AUDIOLOGY DISTRIBUTION, LLC, WEST PALM BEACH, FL. FILED 6-28-2011.

PRESTIGE

THE MARK CONSISTS OF STANDARD CHARACTERS WITHOUT CLAIM TO ANY PARTICULAR FONT, STYLE, SIZE, OR COLOR.

FOR HEARING AIDS (U.S. CLS. 26, 39 AND 44).
 MARK PILARO, EXAMINING ATTORNEY

SN 85-362,750. PAUL F. BECKER, STUART, FL. FILED 7-5-2011.

SleepEasy

THE MARK CONSISTS OF STANDARD CHARACTERS WITHOUT CLAIM TO ANY PARTICULAR FONT, STYLE, SIZE, OR COLOR.

FOR LOW FREQUENCY ELECTROMAGNETIC THERAPY APPARATUS (U.S. CLS. 26, 39 AND 44).

FIRST USE 3-1-2011; IN COMMERCE 4-1-2011.
 FRANK LATTUCA, EXAMINING ATTORNEY

CLASS 10—(Continued).

SN 85-366,651. GLOBUS MEDICAL, INC, DBA GLOBUS MEDICAL, INC, AUDUBON, PA. FILED 7-8-2011.

LATIS

THE MARK CONSISTS OF STANDARD CHARACTERS WITHOUT CLAIM TO ANY PARTICULAR FONT, STYLE, SIZE, OR COLOR.
FOR SPINAL IMPLANTS FOR USE IN SPINE SURGERY CONSISTING OF ARTIFICIAL MATERIALS (U.S. CLS. 26, 39 AND 44).
ANDREA HACK, EXAMINING ATTORNEY

SN 85-368,264. ELIZUR CORPORATION, PITTSBURGH, PA. FILED 7-11-2011.

eSling

THE MARK CONSISTS OF STANDARD CHARACTERS WITHOUT CLAIM TO ANY PARTICULAR FONT, STYLE, SIZE, OR COLOR.
FOR ORTHOPEDIC APPARATUS AND INSTRUMENTS FOR DIAGNOSTIC AND THERAPEUTIC USE; SLINGS FOR MEDICAL USE (U.S. CLS. 26, 39 AND 44).
SAIMA MAKHDOOM, EXAMINING ATTORNEY

SN 85-420,967. SYNTHES USA, LLC, WEST CHESTER, PA. FILED 9-13-2011.

FACETSAVER

THE MARK CONSISTS OF STANDARD CHARACTERS WITHOUT CLAIM TO ANY PARTICULAR FONT, STYLE, SIZE, OR COLOR.
FOR SURGICAL IMPLANTS, NAMELY, BONE ANCHOR SUPPORTS, CONNECTORS AND RODS, ALL OF METAL (U.S. CLS. 26, 39 AND 44).
APRIL ROACH, EXAMINING ATTORNEY

CLASS 10—(Continued).

SN 85-427,915. PANDA, JASON K, NEW YORK, NY. FILED 9-21-2011.

Platinum

THE MARK CONSISTS OF STANDARD CHARACTERS WITHOUT CLAIM TO ANY PARTICULAR FONT, STYLE, SIZE, OR COLOR.
FOR CONDOMS (U.S. CLS. 26, 39 AND 44).
FIRST USE 9-21-2011; IN COMMERCE 9-21-2011.
MAYUR VAGHANI, EXAMINING ATTORNEY

SN 85-437,617. SUPRAMED AMERICA, INC., CORAL GABLES, FL. FILED 10-3-2011.

teksurge

THE MARK CONSISTS OF BLACK LETTERS ON A WHITE BACKGROUND, SPELLING THE WORD "TEKSURGE" IN LOWERCASE LETTERS, WITH THE EXCEPTION OF THE "K" IN "TEKSURGE", WHICH IS CAPITALIZED AND BACKWARDS. ALSO, THE MARK INCLUDES A LINE EXTENDING FROM THE LETTER "G" UNDER ALL THE PREVIOUS LETTERS IN THE WORD, THROUGH THE FIRST LETTER, "K".
FOR SURGICAL DEVICES AND INSTRUMENTS NOT FOR USE IN THE FIELD OF UROLOGY NOR RELATED TO UROLOGICAL PRODUCTS; SURGICAL INSTRUMENTS AND APPARATUS NOT FOR USE IN THE FIELD OF UROLOGY NOR RELATED TO UROLOGICAL PRODUCTS (U.S. CLS. 26, 39 AND 44).
FIRST USE 10-10-2011; IN COMMERCE 10-10-2011.
THOMAS MANOR, EXAMINING ATTORNEY

SN 85-442,403. SONENDO, INC., LAGUNA HILLS, CA. FILED 10-7-2011.

SONENDO

THE MARK CONSISTS OF STANDARD CHARACTERS WITHOUT CLAIM TO ANY PARTICULAR FONT, STYLE, SIZE, OR COLOR.
THE WORDING "SONENDO" HAS NO MEANING IN A FOREIGN LANGUAGE.
FOR DENTAL INSTRUMENTS FOR USE IN ENDODONTIC THERAPY (U.S. CLS. 26, 39 AND 44).
FIRST USE 10-13-2011; IN COMMERCE 10-13-2011.
MICHAEL KEATING, EXAMINING ATTORNEY

CLASS 10—(Continued).

SN 85-445,813. VIRTUAL IMAGING, INC., DEERFIELD BEACH, FL. FILED 10-12-2011.

D2-50RF

THE MARK CONSISTS OF STANDARD CHARACTERS WITHOUT CLAIM TO ANY PARTICULAR FONT, STYLE, SIZE, OR COLOR.

FOR MEDICAL IMAGING APPARATUS FOR MEDICAL ANALYSIS AND DIAGNOSIS AND PERIPHERAL DEVICES THERETO, NAMELY, HIGH FREQUENCY GENERATORS, MEDICAL TABLES, TUBE STANDS, TUBE CRANES AND WALL STANDS, AND COMPONENTS OF ALL THE AFORESAID GOODS (U.S. CLS. 26, 39 AND 44).

DOUGLAS LEE, EXAMINING ATTORNEY

SN 85-455,986. WESCOR INC., LOGAN, UT. FILED 10-25-2011.

CHLOROCHek

THE MARK CONSISTS OF STANDARD CHARACTERS WITHOUT CLAIM TO ANY PARTICULAR FONT, STYLE, SIZE, OR COLOR.

FOR ELECTRONIC SWEAT CHLORIDE ANALYZERS FOR MEDICAL TESTING PURPOSES (U.S. CLS. 26, 39 AND 44).

DAVID HOFFMAN, EXAMINING ATTORNEY

SN 85-462,181. NEOS TECHNOLOGY LLC., TORRINGTON, CT. FILED 11-2-2011.

PURRFECT MASSAGER

THE MARK CONSISTS OF STANDARD CHARACTERS WITHOUT CLAIM TO ANY PARTICULAR FONT, STYLE, SIZE, OR COLOR.

NO CLAIM IS MADE TO THE EXCLUSIVE RIGHT TO USE "MASSAGER", APART FROM THE MARK AS SHOWN.

FOR ADULT SEXUAL STIMULATION AIDS, NAMELY, BATTERY-OPERATED VIBRATING MASSAGER, RECHARGEABLE MASSAGER, PLUGIN MASSAGER, VIBRATORS, GLASS DILDOS, SEX TOYS, ANAL BALLS, ANAL TOYS, BUTT PLUGS, STIMULATING BEADS, WEIGHTED PLEASURE BALLS, DILDOS, DONGS, NIPPLE CLAMPS, NIPPLE SUCTION CUPS, PENIS EXTENDERS, PENIS RINGS, EROGENOUS ZONE PUMPS, SIMULATED PENISES AND VAGINAS, VIBRATING EGGS (U.S. CLS. 26, 39 AND 44).

FRANK LATTUCA, EXAMINING ATTORNEY

CLASS 10—(Continued).

SN 85-463,390. CELADON, INC., ARLINGTON, VA. FILED 11-3-2011.

Celadon

THE MARK CONSISTS OF STANDARD CHARACTERS WITHOUT CLAIM TO ANY PARTICULAR FONT, STYLE, SIZE, OR COLOR.

FOR MEDICAL DIAGNOSTIC APPARATUS, NAMELY, NON-IONIZING RADIATION APPARATUS WITH INTEGRATED SOFTWARE FOR MEDICAL DIAGNOSTIC IMAGING SOLD AS A UNIT (U.S. CLS. 26, 39 AND 44).

SALLY SHIH, EXAMINING ATTORNEY

SN 85-473,080. ANIMAL INNOVATIONS, INC., AMARILLO, TX. FILED 11-15-2011.

PERFECTDOSE

THE MARK CONSISTS OF STANDARD CHARACTERS WITHOUT CLAIM TO ANY PARTICULAR FONT, STYLE, SIZE, OR COLOR.

FOR AUTOMATED MEDICAL SYRINGE INJECTION SYSTEM CONSISTING OF A PORTABLE MEDICAL SYRINGE, AND A PUMP, BOTH USED IN CONJUNCTION WITH A VIAL TO AUTOMATICALLY FILL THE SYRINGE WITH MATERIALS STORED IN THE VIAL (U.S. CLS. 26, 39 AND 44).

GIANCARLO CASTRO, EXAMINING ATTORNEY

CLASS 10—(Continued).

SN 85-478,758. LENOX MACLAREN SURGICAL CORPORATION, LOUISVILLE, CO. FILED 11-22-2011.

BOACHIE SHARPS

THE MARK CONSISTS OF STANDARD CHARACTERS WITHOUT CLAIM TO ANY PARTICULAR FONT, STYLE, SIZE, OR COLOR.

NO CLAIM IS MADE TO THE EXCLUSIVE RIGHT TO USE "SHARPS", APART FROM THE MARK AS SHOWN.

FOR MEDICAL INSTRUMENTS, SURGICAL INSTRUMENTS AND APPARATUS, NAMELY, CURETTES, ELEVATORS, IMPACTORS, TROCARS, AWLS, BONE TOOLS, BONE GRINDERS, BONE GRAFT HOLDERS, BONE TAPS, BONE MILLS, CHISELS, CUTTERS, SURGICAL CUTTERS, ROD CUTTERS, SCREWCUTTERS, PIN CUTTERS, DISSECTORS, SURGICAL KNIVES, OSTEOTOMES, PEDICAL MARKER SETS, SACRAL SOUNDERS, SURGICAL INSTRUMENT HANDLES, SPINAL ROD POSITIONERS, GOUGES, MALLET, PROBES, PEDICAL PROBES, WIRE PROBES, RETRACTORS, BLADES, STERILIZATION TRAYS; SERRATED INSTRUMENTS, NAMELY, SERRATED CURETTES (U.S. CLS. 26, 39 AND 44).

FIRST USE 12-0-2009; IN COMMERCE 12-0-2009.
EMILY CARLSEN, EXAMINING ATTORNEY

SN 85-486,955. BEAVER-VISITEC INTERNATIONAL (US), INC., LAKE FOREST, IL. FILED 12-5-2011.

ATOMIC EDGE

THE MARK CONSISTS OF STANDARD CHARACTERS WITHOUT CLAIM TO ANY PARTICULAR FONT, STYLE, SIZE, OR COLOR.

FOR MEDICAL INSTRUMENTS, NAMELY, OPHTHALMIC BLADES AND KNIVES (U.S. CLS. 26, 39 AND 44).

FIRST USE 3-31-2011; IN COMMERCE 3-31-2011.
DEBORAH LOBO, EXAMINING ATTORNEY

SN 85-490,497. MICROLINE SURGICAL, INC., BEVERLY, MA. FILED 12-8-2011.

MiPower

THE MARK CONSISTS OF STANDARD CHARACTERS WITHOUT CLAIM TO ANY PARTICULAR FONT, STYLE, SIZE, OR COLOR.

FOR SURGICAL APPARATUS AND INSTRUMENTS (U.S. CLS. 26, 39 AND 44).

SAMUEL E. SHARPER JR., EXAMINING ATTORNEY

CLASS 10—(Continued).

SN 85-490,902. KIM NEWLEN, RICHMOND, VA. FILED 12-8-2011.

LYMPHEDOGGIE

THE MARK CONSISTS OF STANDARD CHARACTERS WITHOUT CLAIM TO ANY PARTICULAR FONT, STYLE, SIZE, OR COLOR.

FOR MEDICAL ELEVATION DEVICE FOR TREATING LYMPHEDEMA, NAMELY, A LIGHTWEIGHT, PORTABLE, DOG-SHAPED FOAM DEVICE FOR PHYSICAL AND LYMPHEDEMA THERAPY (U.S. CLS. 26, 39 AND 44).

FIRST USE 6-1-2011; IN COMMERCE 6-1-2011.
SANI KHOURI, EXAMINING ATTORNEY

SN 85-495,690. MAYA MEDICAL, INC., SARATOGA, CA. FILED 12-14-2011.

ONESHOT

THE MARK CONSISTS OF STANDARD CHARACTERS WITHOUT CLAIM TO ANY PARTICULAR FONT, STYLE, SIZE, OR COLOR.

FOR MEDICAL DEVICE COMPRISED OF A CATHETER AND RADIO FREQUENCY (RF) GENERATOR FOR THE TREATMENT OF RESISTANT HYPERTENSION (U.S. CLS. 26, 39 AND 44).

SKYE YOUNG, EXAMINING ATTORNEY

SN 85-495,693. MAYA MEDICAL, INC., SARATOGA, CA. FILED 12-14-2011.

ONESHOT RENAL DENERVATION SYSTEM

THE MARK CONSISTS OF STANDARD CHARACTERS WITHOUT CLAIM TO ANY PARTICULAR FONT, STYLE, SIZE, OR COLOR.

NO CLAIM IS MADE TO THE EXCLUSIVE RIGHT TO USE "RENAL DENERVATION SYSTEM", APART FROM THE MARK AS SHOWN.

FOR MEDICAL DEVICE COMPRISED OF A CATHETER AND RADIO FREQUENCY (RF) GENERATOR FOR THE TREATMENT OF RESISTANT HYPERTENSION (U.S. CLS. 26, 39 AND 44).

SKYE YOUNG, EXAMINING ATTORNEY

CLASS 10—(Continued).

SN 85-498,874. BOSTON SCIENTIFIC SCIMED, INC., MAPLE GROVE, MN. FILED 12-19-2011.

VICTORY

THE MARK CONSISTS OF STANDARD CHARACTERS WITHOUT CLAIM TO ANY PARTICULAR FONT, STYLE, SIZE, OR COLOR.

FOR MEDICAL PERIPHERAL GUIDE WIRES TO TRACK CATHETERS (U.S. CLS. 26, 39 AND 44).
CHRISTINA SOBRAL, EXAMINING ATTORNEY

SN 85-499,661. PHYSICAL CORRECTIVE SOLUTIONS, PHILADELPHIA, PA. FILED 12-20-2011.

Posture Angel

THE MARK CONSISTS OF STANDARD CHARACTERS WITHOUT CLAIM TO ANY PARTICULAR FONT, STYLE, SIZE, OR COLOR.

NO CLAIM IS MADE TO THE EXCLUSIVE RIGHT TO USE "POSTURE", APART FROM THE MARK AS SHOWN.
FOR MANUALLY-OPERATED EXERCISE EQUIPMENT FOR PHYSICAL THERAPY PURPOSES (U.S. CLS. 26, 39 AND 44).

NAAKWAMA ANKRAH, EXAMINING ATTORNEY

SN 85-505,830. WOUND ZOOM, INC., LONGMONT, CO. FILED 12-29-2011.

WOUND ZOOM

THE MARK CONSISTS OF STANDARD CHARACTERS WITHOUT CLAIM TO ANY PARTICULAR FONT, STYLE, SIZE, OR COLOR.

NO CLAIM IS MADE TO THE EXCLUSIVE RIGHT TO USE "WOUND", APART FROM THE MARK AS SHOWN.
FOR MEDICAL DEVICES, NAMELY, DEVICES FOR MEASURING WOUNDS (U.S. CLS. 26, 39 AND 44).

HEATHER THOMPSON, EXAMINING ATTORNEY

CLASS 10—(Continued).

SN 85-508,847. VISIONGATE, INC., PHEONIX, AZ. FILED 1-4-2012.

SURVEYOR

THE MARK CONSISTS OF STANDARD CHARACTERS WITHOUT CLAIM TO ANY PARTICULAR FONT, STYLE, SIZE, OR COLOR.

FOR INSTRUMENT AND APPARATUS SYSTEMS FOR MEDICAL DIAGNOSTIC USES CONSISTING OF AN INSTRUMENT AND APPARATUS THAT ALLOWS EVALUATION AND ANNOTATION OF 2D AND 3D CELL IMAGE DATA, INCLUDING CELLS FROM SPUTUM SPECIMENS, IDENTIFIED AS SUSPICIOUS FOR DYSPLASIA OR CANCER; AND MEDICAL APPARATUS AND INSTRUMENT FOR DIAGNOSTIC USE, NAMELY, APPARATUS FOR MEDICAL DIAGNOSTIC EVALUATION OF 2D AND 3D CELL IMAGE DATA IN THE FIELDS OF CANCER OR OTHER TISSUE-BASED DIAGNOSTIC TESTING, CYTOLOGY AND CELL-BASED TESTING (U.S. CLS. 26, 39 AND 44).

AMY KELLY, EXAMINING ATTORNEY

SN 85-509,565. PARI PHARMA GMBH, STARNBERG, FED REP GERMANY, FILED 1-5-2012.

EBASE

THE MARK CONSISTS OF STANDARD CHARACTERS WITHOUT CLAIM TO ANY PARTICULAR FONT, STYLE, SIZE, OR COLOR.

OWNER OF U.S. REG. NO. 2,782,244.
FOR MEDICAL DEVICES FOR APPLICATION OF SUBSTANCES INTO THE LUNGS, NAMELY NEBULIZERS, INHALERS, COMPRESSORS USED IN THE TREATMENT OF RESPIRATORY DISEASES (U.S. CLS. 26, 39 AND 44).

MICHAEL SOUDERS, EXAMINING ATTORNEY

SN 85-509,632. NEW YORK CHIROPRACTIC COLLEGE, SENECA FALLS, NY. FILED 1-5-2012.

CONNECTX

THE MARK CONSISTS OF STANDARD CHARACTERS WITHOUT CLAIM TO ANY PARTICULAR FONT, STYLE, SIZE, OR COLOR.

FOR MEDICAL DEVICE USED IN THE DIAGNOSIS AND TREATMENT OF SOFT TISSUE DISORDERS AND INJURIES (U.S. CLS. 26, 39 AND 44).

HENRY S. ZAK, EXAMINING ATTORNEY

CLASS 10—(Continued).

SN 85-509,668. KCI LICENSING, INC., SAN ANTONIO, TX. FILED 1-5-2012.



THE MARK CONSISTS OF A SHADED PROFILE OF A HORSE WITH AN OUTLINE OF A DOG SUPERIMPOSED THEREON, WITH THE DOGS EAR FORMING THE LETTER V.

FOR NEGATIVE PRESSURE WOUND THERAPY VETERINARY DEVICE IN THE NATURE OF A SUBATMOSPHERIC PRESSURE SOURCE AND RELATED TUBING, ALL FOR USE WITH WOUND INTERFACE DRAINAGE RECEPTACLES, AND ALL FOR PROMOTING WOUND HEALING (U.S. CLS. 26, 39 AND 44).

FIRST USE 5-0-2010; IN COMMERCE 5-0-2010.
DAWN FELDMAN, EXAMINING ATTORNEY

SN 85-510,085. S.S. WHITE TECHNOLOGIES INC., PISCATAWAY, NJ. FILED 1-6-2012.

SHUKLA MEDICAL

THE MARK CONSISTS OF STANDARD CHARACTERS WITHOUT CLAIM TO ANY PARTICULAR FONT, STYLE, SIZE, OR COLOR.

OWNER OF U.S. REG. NO. 3,684,653.
NO CLAIM IS MADE TO THE EXCLUSIVE RIGHT TO USE "MEDICAL", APART FROM THE MARK AS SHOWN. THE NAME(S), PORTRAIT(S), AND/OR SIGNATURE(S) SHOWN IN THE MARK IDENTIFIES RAHUL B. SHUKLA, WHOSE CONSENT(S) TO REGISTER IS MADE OF RECORD.

SEC. 2(F).
FOR HAND OPERATED MEDICAL INSTRUMENT SYSTEMS USED IN ORTHOPEDICS, NAMELY: BROKEN, STRIPPED AND SEIZED SCREW EXTRACTOR SYSTEMS COMPRISED OF EXTRACTORS, EXTENSIONS AND RATCHETING T HANDLES; RATCHETING SCREWDRIVER SYSTEMS COMPRISED OF FLEXIBLE AND STRAIGHT DRIVER SHAFTS AND RATCHETING HANDLES; INTRAMEDULLARY NAIL EXTRACTOR SYSTEMS COMPRISED OF EXTRACTORS, EXTRACTION FRAMES AND MALLETS; SPINE HARDWARE EXTRACTION SYSTEMS COMPRISED OF EXTRACTORS, PRY BARS, EXTENSIONS AND RATCHETING HANDLES; COMPRESSION HIP HARDWARE EXTRACTION SYSTEMS COMPRISED OF EXTRACTORS, RATCHETING HANDLES AND SLAP HANDLES; CORE DECOMPRESSION SYSTEMS COMPRISED OF TREPHINES, GUIDE WIRES AND T HANDLES; HIP SYSTEMS COMPRISED OF STEM CLAMPS AND EXTRACTORS; AND MULTI-SYSTEM DEMONSTRATION KITS COMPRISED OF VARIOUS COMPONENTS SELECTED FROM THE AFOREMENTIONED SYSTEMS (U.S. CLS. 26, 39 AND 44).

FIRST USE 1-1-2007; IN COMMERCE 1-1-2007.
ELIZABETH KAJUBI, EXAMINING ATTORNEY

CLASS 10—(Continued).

SN 85-510,413. JOHNSON & JOHNSON, NEW BRUNSWICK, NJ. FILED 1-6-2012.

CERTIGARD

THE MARK CONSISTS OF STANDARD CHARACTERS WITHOUT CLAIM TO ANY PARTICULAR FONT, STYLE, SIZE, OR COLOR.

FOR INJECTION APPARATUS FOR MEDICAL PURPOSES, NAMELY, DRUG DELIVERY SYSTEMS SOLD EMPTY AND INTENDED FOR USE WITH PRE-FILLED SYRINGES CONTAINING A PHARMACEUTICAL PREPARATION DESIGNED TO PROMOTE THE PRODUCTION OF RED BLOOD CELLS IN THE BODY (U.S. CLS. 26, 39 AND 44).

CARYN GLASSER, EXAMINING ATTORNEY

SN 85-510,477. ANGELA MALONE, CINCINNATI, OH. FILED 1-6-2012.

DR. SCRIBBLES

THE MARK CONSISTS OF STANDARD CHARACTERS WITHOUT CLAIM TO ANY PARTICULAR FONT, STYLE, SIZE, OR COLOR.

FOR COVERINGS FOR MEDICAL EXAM TABLES (U.S. CLS. 26, 39 AND 44).

MATTHEW PAPPAS, EXAMINING ATTORNEY

SN 85-510,572. LFP IP, LLC, BEVERLY HILLS, CA. FILED 1-6-2012.

GET YOUR HEART ON

THE MARK CONSISTS OF STANDARD CHARACTERS WITHOUT CLAIM TO ANY PARTICULAR FONT, STYLE, SIZE, OR COLOR.

FOR ADULT SEXUAL STIMULATION AIDS, NAMELY, VIBRATORS AND MASSAGE DEVICES (U.S. CLS. 26, 39 AND 44).

AMY KELLY, EXAMINING ATTORNEY

CLASS 10—(Continued).

SN 85-510,649. XR. LLC, HUNTINGTON BEACH, CA. FILED 1-6-2012.

PRISMS

THE MARK CONSISTS OF STANDARD CHARACTERS WITHOUT CLAIM TO ANY PARTICULAR FONT, STYLE, SIZE, OR COLOR.

FOR ADULT SEXUAL STIMULATION AIDS, NAMELY, DILDOS AND ANAL PLUGS (U.S. CLS. 26, 39 AND 44).

FIRST USE 11-5-2011; IN COMMERCE 11-5-2011.
KEVIN DINALLO, EXAMINING ATTORNEY

SN 85-510,690. MYO PARTNERSHIP, SEALY, TX. FILED 1-6-2012.

TEMPERIUM

THE MARK CONSISTS OF STANDARD CHARACTERS WITHOUT CLAIM TO ANY PARTICULAR FONT, STYLE, SIZE, OR COLOR.

FOR MASSAGE APPARATUS (U.S. CLS. 26, 39 AND 44).

GEORGE LORENZO, EXAMINING ATTORNEY

SN 85-510,776. REMI SCIENCES INC, SOUTHLAKE, TX. FILED 1-6-2012.

RHEOLASTIC

THE MARK CONSISTS OF STANDARD CHARACTERS WITHOUT CLAIM TO ANY PARTICULAR FONT, STYLE, SIZE, OR COLOR.

FOR MEDICAL, SURGICAL AND ORTHOPAEDIC IMPLANTS MADE OF ARTIFICIAL MATERIALS; ORTHOPEDIC JOINT IMPLANTS (U.S. CLS. 26, 39 AND 44).

ANDREW LEASER, EXAMINING ATTORNEY

CLASS 10—(Continued).

SN 85-511,362. GOLDBERG, ELLIOTT, SCARSDALE, NY. FILED 1-8-2012.



THE COLOR(S) YELLOW AND BLACK IS/ARE CLAIMED AS A FEATURE OF THE MARK.

THE MARK CONSISTS OF THE WORD "FABSTIM" IN BLACK STYLIZED LETTERS WHICH ARE SLIGHTLY SLANTED TO THE RIGHT WITH THE VERTICAL PORTION OF THE LETTER "I" CONSISTING OF A VERTICAL YELLOW ZIG-ZAG LINE OUTLINED IN BLACK ENDING BELOW THE OTHER LETTERS.

FOR ELECTRODES FOR ELECTROTHERAPY (U.S. CLS. 26, 39 AND 44).
JEFF DEFORD, EXAMINING ATTORNEY

SN 85-511,742. MOTHER KNOWS BEST, LLC, WATER VALLEY, MS. FILED 1-9-2012.

Gum-Ease

THE MARK CONSISTS OF STANDARD CHARACTERS WITHOUT CLAIM TO ANY PARTICULAR FONT, STYLE, SIZE, OR COLOR.

FOR TEETHER (U.S. CLS. 26, 39 AND 44).
MEGHAN REINHART, EXAMINING ATTORNEY

SN 85-512,392. BAYSHORE DENTAL STUDIO LLC, TAMPA, FL. FILED 1-10-2012.

ZMAX

THE MARK CONSISTS OF STANDARD CHARACTERS WITHOUT CLAIM TO ANY PARTICULAR FONT, STYLE, SIZE, OR COLOR.

FOR DENTAL CROWNS (U.S. CLS. 26, 39 AND 44).
ELIZABETH HUGHITT, EXAMINING ATTORNEY

CLASS 10—(Continued).

SN 85-512,562. GREAT CHINA ACUPUNCTURE SUPPLIES, INC., CLACKAMAS, OR. FILED 1-10-2012.

TEMPO

THE MARK CONSISTS OF STANDARD CHARACTERS WITHOUT CLAIM TO ANY PARTICULAR FONT, STYLE, SIZE, OR COLOR.

FOR MEDICAL APPARATUS AND INSTRUMENTS, NAMELY, ACUPUNCTURE NEEDLES (U.S. CLS. 26, 39 AND 44).
ERIN FALK, EXAMINING ATTORNEY

CLASS 10—(Continued).

SN 85-513,558. MEDLINE INDUSTRIES, INC., MUNDELEIN, IL. FILED 1-11-2012.

HEMO-FORCE

THE MARK CONSISTS OF STANDARD CHARACTERS WITHOUT CLAIM TO ANY PARTICULAR FONT, STYLE, SIZE, OR COLOR.

FOR PNEUMATIC COMPRESSION PUMPS, SLEEVES, AND TUBING SETS USED TO HELP REDUCE INCIDENCE OF DEEP VEIN THROMBOSIS (U.S. CLS. 26, 39 AND 44).

ROBERT STRUCK, EXAMINING ATTORNEY

SN 85-512,630. NANO VALLEY CO., LTD., SOEUL, REPUBLIC OF KOREA, FILED 1-10-2012.

NANO VALLEY

THE MARK CONSISTS OF STANDARD CHARACTERS WITHOUT CLAIM TO ANY PARTICULAR FONT, STYLE, SIZE, OR COLOR.

FOR DENTAL PROSTHESES (U.S. CLS. 26, 39 AND 44). FIRST USE 1-15-2011; IN COMMERCE 1-15-2011.
KIMBERLY PERRY, EXAMINING ATTORNEY

SN 85-513,657. AD-TECH MEDICAL INSTRUMENT CORPORATION, RACINE, WI. FILED 1-11-2012.



THE MARK CONSISTS OF THE LITERAL ELEMENT "CTAC" WITH A STYLIZED ELECTRICAL CONNECTOR COMING OUT OF THE LETTER "C".

FOR MEDICAL INSTRUMENTS, NAMELY, ELECTRICAL CONNECTORS USED FOR MAPPING AND MONITORING BRAIN ACTIVITY (U.S. CLS. 26, 39 AND 44).
CHRISTINE MARTIN, EXAMINING ATTORNEY

SN 85-512,661. MITAKA KOHKI CO., LTD., TOKYO, JAPAN, FILED 1-10-2012.

UniARM

THE MARK CONSISTS OF STANDARD CHARACTERS WITHOUT CLAIM TO ANY PARTICULAR FONT, STYLE, SIZE, OR COLOR.

FOR SUPPORTING ARMS FOR HOLDING SURGICAL INSTRUMENTS; SUPPORTING ARMS FOR HOLDING MEDICAL ENDOSCOPES (U.S. CLS. 26, 39 AND 44).
KAPIL BHANOT, EXAMINING ATTORNEY

SN 85-513,659. SUPRAMED AMERICA, INC., CORAL GABLES, FL. FILED 1-11-2012.

SECUTEK

THE MARK CONSISTS OF STANDARD CHARACTERS WITHOUT CLAIM TO ANY PARTICULAR FONT, STYLE, SIZE, OR COLOR.

FOR DENTAL GLOVES; GLOVES FOR MEDICAL PURPOSES; GLOVES FOR MEDICAL USE; GLOVES FOR USE IN HOSPITALS; LATEX MEDICAL GLOVES; MEDICAL EXAMINATION GLOVES; MEDICAL GLOVES; NITRILE GLOVES FOR MEDICAL USE; PROTECTIVE GLOVES FOR MEDICAL USE; SURGICAL GLOVES (U.S. CLS. 26, 39 AND 44).

BRENDAN MCCAULEY, EXAMINING ATTORNEY

CLASS 10—(Continued).

SN 85-513,690. AD-TECH MEDICAL INSTRUMENT CORPORATION, RACINE, WI. FILED 1-11-2012.

CTAC

THE MARK CONSISTS OF STANDARD CHARACTERS WITHOUT CLAIM TO ANY PARTICULAR FONT, STYLE, SIZE, OR COLOR.

FOR MEDICAL INSTRUMENTS, NAMELY, ELECTRICAL CONNECTORS USED FOR MAPPING AND MONITORING BRAIN ACTIVITY (U.S. CLS. 26, 39 AND 44).
CHRISTINE MARTIN, EXAMINING ATTORNEY

SN 85-513,834. PINOOK USA, LLC, ORLANDO, FL. FILED 1-11-2012.

PINOOK

THE MARK CONSISTS OF STANDARD CHARACTERS WITHOUT CLAIM TO ANY PARTICULAR FONT, STYLE, SIZE, OR COLOR.

OWNER OF U.S. REG. NOS. 3,831,015 AND 4,003,920.
THE ENGLISH TRANSLATION OF "PINOOK" IN THE MARK IS "TO SPOIL".
FOR MASSAGE APPARATUS (U.S. CLS. 26, 39 AND 44).
FIRST USE 10-1-2009; IN COMMERCE 10-1-2009.
ANDREA BUTLER, EXAMINING ATTORNEY

SN 85-513,999. SPECTRA MEDICAL DEVICES, INC., WILMINGTON, MA. FILED 1-11-2012.

RED SNAPPER

THE MARK CONSISTS OF STANDARD CHARACTERS WITHOUT CLAIM TO ANY PARTICULAR FONT, STYLE, SIZE, OR COLOR.

FOR DISPOSABLE OPENERS FOR DRUG AMPOULES (U.S. CLS. 26, 39 AND 44).
DARRYL SPRUILL, EXAMINING ATTORNEY

CLASS 10—(Continued).

SN 85-514,416. ERCHONIA CORPORATION, MCKINNEY, TX. FILED 1-11-2012.



THE MARK CONSISTS OF THE IMAGE OF TWO INTERLOCKING CRESCENT SHAPED DESIGN ELEMENTS ABOVE THE WORDS "LUNULALASER".

FOR LASERS FOR MEDICAL USE (U.S. CLS. 26, 39 AND 44).
REBECCA GILBERT, EXAMINING ATTORNEY

SN 85-514,516. ENDOLOGIX, INC., IRVINE, CA. FILED 1-11-2012.

INNOVATION THAT EMPOWERS

THE MARK CONSISTS OF STANDARD CHARACTERS WITHOUT CLAIM TO ANY PARTICULAR FONT, STYLE, SIZE, OR COLOR.

FOR MEDICAL DEVICES FOR TREATING VASCULAR AND CARDIOVASCULAR DISEASE; MEDICAL DEVICES FOR TREATING VASCULAR ANEURYSMS; MEDICAL APPARATUS AND INSTRUMENTS FOR TREATING VASCULAR AND CARDIOVASCULAR DISEASE; STENT DELIVERY SYSTEMS; STENTS; SYNTHETIC STENT GRAFTS; ARTIFICIAL VASCULAR GRAFTS; CATHETERS AND PARTS AND FITTINGS THEREFOR; MEDICAL DEVICES, NAMELY, MINIMALLY INVASIVE DEVICES FOR AORTIC DISEASE REPAIR; MEDICAL INTRODUCERS; MEDICAL DEVICES FOR USE IN VASCULAR AND CARDIOVASCULAR PROCEDURES, NAMELY, CATHETERS, WIRES, SYRINGES, INJECTION DEVICES (U.S. CLS. 26, 39 AND 44).
JUSTINE D. PARKER, EXAMINING ATTORNEY

SN 85-514,729. GLOBUS MEDICAL, INC, AUDUBON, PA. FILED 1-12-2012.

INTERVENTIONS FOR LIFE

THE MARK CONSISTS OF STANDARD CHARACTERS WITHOUT CLAIM TO ANY PARTICULAR FONT, STYLE, SIZE, OR COLOR.

FOR MEDICAL INSTRUMENTS FOR TREATING SPINAL PATHOLOGIES AND CONDITIONS FOR USE IN SPINAL SURGERY; SPINAL IMPLANTS COMPOSED OF METAL AND/OR ARTIFICIAL MATERIALS; AND SURGICAL INSTRUMENTS FOR USE IN SPINAL SURGICAL PROCEDURES (U.S. CLS. 26, 39 AND 44).
KATHERINE CHANG, EXAMINING ATTORNEY

CLASS 10—(Continued).

SN 85-515,247. HEALTH BODY WORLD SUPPLY INC.,
HEMET, CA. FILED 1-12-2012.

WABBO

THE MARK CONSISTS OF STANDARD CHARACTERS WITHOUT CLAIM TO ANY PARTICULAR FONT, STYLE, SIZE, OR COLOR.

FOR ACUPUNCTURE EQUIPMENT; ACUPUNCTURE INSTRUMENTS; ACUPUNCTURE NEEDLES; APPARATUS FOR ACUPUNCTURE THERAPY (U.S. CLS. 26, 39 AND 44).

FIRST USE 8-24-2008; IN COMMERCE 8-24-2008.
DOUGLAS LEE, EXAMINING ATTORNEY

CLASS 10—(Continued).

SN 85-516,063. DENTEK ORAL CARE, INC., MARYVILLE,
TN. FILED 1-13-2012.

SLEEP EASY

THE MARK CONSISTS OF STANDARD CHARACTERS WITHOUT CLAIM TO ANY PARTICULAR FONT, STYLE, SIZE, OR COLOR.

FOR MOUTH GUARDS SOLD OVER THE COUNTER TO CONSUMERS FOR TREATING BRUXISM AND TEETH GRINDING (U.S. CLS. 26, 39 AND 44).

COLLEEN KEARNEY, EXAMINING ATTORNEY

SN 85-515,493. OREGON AESTHETIC TECHNOLOGIES,
INC., PORTLAND, OR. FILED 1-12-2012.

HALO

THE MARK CONSISTS OF STANDARD CHARACTERS WITHOUT CLAIM TO ANY PARTICULAR FONT, STYLE, SIZE, OR COLOR.

FOR ELECTRONIC INSTRUMENTS, NAMELY, LAMPS AND LED DEVICES FOR TREATMENT OF A VARIETY OF SKIN CONDITIONS AND FOR ANTI-AGING THERAPY (U.S. CLS. 26, 39 AND 44).

FIRST USE 8-30-2011; IN COMMERCE 8-30-2011.
ROBIN MITTLER, EXAMINING ATTORNEY

SN 85-517,695. DENTSPLY INTERNATIONAL INC., YORK,
PA. FILED 1-17-2012.

TEKFIT

THE MARK CONSISTS OF STANDARD CHARACTERS WITHOUT CLAIM TO ANY PARTICULAR FONT, STYLE, SIZE, OR COLOR.

FOR DENTAL APPARATUS, NAMELY, INTERORAL DENTAL DEVICES CONSTRUCTED OF SPECIALIZED PLASTIC FOR TOOTH REPOSITIONING, ADJUSTING OR CONDITIONING (U.S. CLS. 26, 39 AND 44).

LUCY ARANT, EXAMINING ATTORNEY

SN 85-515,651. CHART SEQUAL TECHNOLOGIES INC.,
GARFIELD HEIGHTS, OH. FILED 1-13-2012.

OPTIMIZER

THE MARK CONSISTS OF STANDARD CHARACTERS WITHOUT CLAIM TO ANY PARTICULAR FONT, STYLE, SIZE, OR COLOR.

FOR OXYGEN CONCENTRATORS AND OXYGEN TANKS FOR MEDICAL APPLICATIONS (U.S. CLS. 26, 39 AND 44).

ALAIN LAPTER, EXAMINING ATTORNEY

SN 85-517,715. ORMCO CORPORATION, DBA SYBRONEN-
DO DIVISION, ORANGE, CA. FILED 1-17-2012.

REALSEAL

THE MARK CONSISTS OF STANDARD CHARACTERS WITHOUT CLAIM TO ANY PARTICULAR FONT, STYLE, SIZE, OR COLOR.

FOR ENDODONTIC PRODUCTS, NAMELY, ENDO-DONTIC OBTURATION SYSTEMS, ROOT CANAL SEALERS, ROOT CANAL FILLING MATERIALS, AND OBTURATION MATERIALS (U.S. CLS. 26, 39 AND 44).

FIRST USE 6-6-2005; IN COMMERCE 6-6-2005.
INGA ERVIN, EXAMINING ATTORNEY

CLASS 10—(Continued).

SN 85-518,605. NIKE, INC., BEAVERTON, OR. FILED 1-17-2012.

NIKE+ FUELBAND

THE MARK CONSISTS OF STANDARD CHARACTERS WITHOUT CLAIM TO ANY PARTICULAR FONT, STYLE, SIZE, OR COLOR.

FOR HEALTH MONITORING DEVICES, NAMELY, BLOOD PRESSURE MONITORS, THERMOMETERS, PEDOMETERS, METABOLIC MONITORS, AND CALORIE MONITORS; BODY FAT MONITORS; HEART RATE MONITORS; HEART MONITORS TO BE WORN DURING EXERCISE; PULSE RATE MONITORS; RESPIRATION MONITORS; RESPIRATORY MONITORS FOR SPORTS ACTIVITIES (U.S. CLS. 26, 39 AND 44).
JAY FLOWERS, EXAMINING ATTORNEY

SN 85-518,785. ORMCO CORPORATION, DBA SYBRONENDO DIVISION, ORANGE, CA. FILED 1-18-2012.

K3XF

THE MARK CONSISTS OF STANDARD CHARACTERS WITHOUT CLAIM TO ANY PARTICULAR FONT, STYLE, SIZE, OR COLOR.

FOR ENDODONTIC INSTRUMENTS, NAMELY, ROOT CANAL FILES (U.S. CLS. 26, 39 AND 44).
FIRST USE 9-0-2011; IN COMMERCE 9-0-2011.
INGA ERVIN, EXAMINING ATTORNEY

SN 85-519,121. ORMCO CORPORATION, ORANGE, CA. FILED 1-18-2012.

INSPIRE ICE

THE MARK CONSISTS OF STANDARD CHARACTERS WITHOUT CLAIM TO ANY PARTICULAR FONT, STYLE, SIZE, OR COLOR.

FOR ORTHODONTIC BRACKETS (U.S. CLS. 26, 39 AND 44).
FIRST USE 11-3-2003; IN COMMERCE 11-3-2003.
INGA ERVIN, EXAMINING ATTORNEY

CLASS 10—(Continued).

SN 85-522,726. BOSTON SCIENTIFIC SCIMED, INC., MAPLE GROVE, MN. FILED 1-23-2012.

ZURPAZ

THE MARK CONSISTS OF STANDARD CHARACTERS WITHOUT CLAIM TO ANY PARTICULAR FONT, STYLE, SIZE, OR COLOR.

OWNER OF U.S. REG. NO. 2,341,593.
FOR ELECTROPHYSIOLOGY CATHETER INTRODUCER SHEATHS (U.S. CLS. 26, 39 AND 44).
CHRISTINA SOBRAL, EXAMINING ATTORNEY

SN 85-529,424. BROOKSTONE PURCHASING, INC., MERRIMACK, NH. FILED 1-31-2012.

BACK-IN-10

THE MARK CONSISTS OF STANDARD CHARACTERS WITHOUT CLAIM TO ANY PARTICULAR FONT, STYLE, SIZE, OR COLOR.

FOR ELECTRIC MASSAGE APPARATUS FOR HOUSEHOLD USE; ELECTRIC MASSAGE APPLIANCES, NAMELY, ELECTRIC VIBRATING MASSAGER; MASSAGE APPARATUS; MASSAGING APPARATUS FOR PERSONAL USE (U.S. CLS. 26, 39 AND 44).
CHRISTOPHER BUONGIORNO, EXAMINING ATTORNEY

SN 85-533,058. IDEXX LABORATORIES, INC., WESTBROOK, ME. FILED 2-3-2012.

CATALYST ONE

THE MARK CONSISTS OF STANDARD CHARACTERS WITHOUT CLAIM TO ANY PARTICULAR FONT, STYLE, SIZE, OR COLOR.

OWNER OF U.S. REG. NOS. 3,612,894 AND 3,648,006.
FOR VETERINARY BLOOD ANALYSIS APPARATUS (U.S. CLS. 26, 39 AND 44).
MICHAEL TANNER, EXAMINING ATTORNEY

CLASS 10—(Continued).

SN 85-533,132. BOSTON SCIENTIFIC SCIMED, INC., MAPLE GROVE., MN. FILED 2-3-2012.

METRIQ

THE MARK CONSISTS OF STANDARD CHARACTERS WITHOUT CLAIM TO ANY PARTICULAR FONT, STYLE, SIZE, OR COLOR.

FOR IRRIGATION PUMP FOR USE WITH ELECTROPHYSIOLOGY CATHETERS FOR MEDICAL USE (U.S. CLS. 26, 39 AND 44).

CHRISTINA SOBRAL, EXAMINING ATTORNEY



SN 85-547,971. MICROAIRE SURGICAL INSTRUMENTS, LLC, AKA MICROAIRE, CHARLOTTESVILLE, VA. FILED 2-21-2012.

Cascade

THE MARK CONSISTS OF STANDARD CHARACTERS WITHOUT CLAIM TO ANY PARTICULAR FONT, STYLE, SIZE, OR COLOR.

FOR SURGICAL INSTRUMENTS AND APPARATUS FOR EXTRACTION AND/OR COLLECTION OF ADIPOSE TISSUE AND/OR FLUIDS, FILTERING AND/OR WASHING OF ADIPOSE TISSUE AND/OR FLUIDS, MECHANICAL CELL SEPARATION FROM EXTRACTED TISSUE AND/OR FLUIDS, AND THERAPEUTIC USES OF EXTRACTED TISSUE, FLUIDS AND/OR CELLS (U.S. CLS. 26, 39 AND 44).

PAUL MORENO, EXAMINING ATTORNEY



SN 85-556,505. PRO BREATH MD LLC, DBA DENTIST SELECT, SAYREVILLE, NJ. FILED 2-29-2012.

HALICURE

THE MARK CONSISTS OF STANDARD CHARACTERS WITHOUT CLAIM TO ANY PARTICULAR FONT, STYLE, SIZE, OR COLOR.

FOR TONGUE SCRAPERS (U.S. CLS. 26, 39 AND 44).

STEVEN JACKSON, EXAMINING ATTORNEY

CLASS 10—(Continued).

SN 85-571,263. SMITH & NEPHEW, INC., MEMPHIS, TN. FILED 3-16-2012.

REDAPT

THE MARK CONSISTS OF STANDARD CHARACTERS WITHOUT CLAIM TO ANY PARTICULAR FONT, STYLE, SIZE, OR COLOR.

PRIORITY CLAIMED UNDER SEC. 44(D) ON ERPN CMNTY TM OFC APPLICATION NO. 10677631, FILED 2-27-2012.

FOR ORTHOPAEDIC MEDICAL DEVICES; ORTHOPAEDIC IMPLANTS; ORTHOPAEDIC SURGICAL INSTRUMENTS (U.S. CLS. 26, 39 AND 44).

MIDGE BUTLER, EXAMINING ATTORNEY



CLASS 11—ENVIRONMENTAL CONTROL APPARATUS

SN 76-709,894. ZUMTOBEL LIGHTING, INC., HIGHLAND, NY. FILED 12-6-2011.

KAVEROS

THE MARK CONSISTS OF STANDARD CHARACTERS WITHOUT CLAIM TO ANY PARTICULAR FONT, STYLE, SIZE, OR COLOR.

THE NAME(S), PORTRAIT(S), AND/OR SIGNATURE(S) SHOWN IN THE MARK DOES NOT IDENTIFY A PARTICULAR LIVING INDIVIDUAL.

FOR ELECTRIC LIGHTING FIXTURES; LED LIGHTING FIXTURES; ELECTRICAL TRACK LIGHTING UNITS; ELECTRICAL TRACK LIGHTING FOR LIGHTING FIXTURES AND LED LIGHTING FIXTURES (U.S. CLS. 13, 21, 23, 31 AND 34).

FIRST USE 11-14-2011; IN COMMERCE 11-14-2011.

ZACHARY BELLO, EXAMINING ATTORNEY

CLASS 11—(Continued).

SN 77-089,933. LG ELECTRONICS INC., SEOUL, REPUBLIC OF KOREA, FILED 1-24-2007.

Ubiquitous Infotainment System

OWNER OF REPUBLIC OF KOREA REG. NO. 0021868, DATED 12-19-2007, EXPIRES 12-27-2017.

NO CLAIM IS MADE TO THE EXCLUSIVE RIGHT TO USE "INFOTAINMENT SYSTEM", APART FROM THE MARK AS SHOWN.

FOR ROOM COOLERS FOR HOUSEHOLD PURPOSES, NAMELY, WINDOW AIR CONDITIONING UNITS; AIR CONDITIONERS; WATER PURIFIERS FOR HOUSEHOLD PURPOSES; GAS RANGES; KITCHEN RANGES, NAMELY, ELECTRIC COOKING OVENS; GAS STOVES; RADIATORS, NAMELY, ELECTRICAL BOILERS FOR HOUSEHOLD PURPOSES; HEATING BOILERS FOR HOUSEHOLD PURPOSES; GAS REFRIGERATORS; GAS LAMPS; INCANDESCENT LAMPS; HOUSEHOLD AIR CLEANERS (U.S. CLS. 13, 21, 23, 31 AND 34).

JENNY PARK, EXAMINING ATTORNEY

CLASS 11—(Continued).

SN 79-108,782. OSRAM AG, AKA OSRAM AKTIENGESELLSCHAFT, D-81543 MUENCHEN, FED REP GERMANY, FILED 10-13-2011.

Airabesc

THE MARK CONSISTS OF STANDARD CHARACTERS WITHOUT CLAIM TO ANY PARTICULAR FONT, STYLE, SIZE, OR COLOR.

OWNER OF INTERNATIONAL REGISTRATION 1105753 DATED 10-13-2011, EXPIRES 10-13-2021.

THE WORDING "AIRABESC" HAS NO MEANING IN A FOREIGN LANGUAGE.

FOR APPARATUS FOR LIGHTING, NAMELY, ELECTRIC LAMPS AND LUMINAIRES; LED LAMPS AND LED LUMINAIRES; LED-MODULES, NAMELY, LIGHTING MODULES CONSTRUCTED OF LEDS OR ORGANIC LEDS; AND COMPONENT PARTS OF THE AFORESAID GOODS (U.S. CLS. 13, 21, 23, 31 AND 34).

HAI-LY LAM, EXAMINING ATTORNEY

SN 79-101,765. FOSHAN AMSTRONG IMPORT & EXPORT CO., LTD., GUANGDONG, CHINA, FILED 5-30-2011.

 cones
LIGHTPOINTS

PRIORITY DATE OF 4-8-2011 IS CLAIMED.
OWNER OF INTERNATIONAL REGISTRATION 1088583 DATED 5-30-2011, EXPIRES 5-30-2021.

NO CLAIM IS MADE TO THE EXCLUSIVE RIGHT TO USE "CONES", APART FROM THE MARK AS SHOWN.

THE MARK CONSISTS OF THE WORDING "CONES" ABOVE THE WORDING "LIGHTPOINTS", WITH A DESIGN TO THE LEFT THAT FEATURES AN INCOMPLETE CIRCLE THAT INCLUDES A SHINING LIGHT EMANATING FROM LEFT TO RIGHT INSIDE THE CIRCLE, MAKING THE CIRCLE INCOMPLETE.

FOR LIGHT BULBS; LAMPS; LANTERNS FOR LIGHTING; PROJECTOR LAMPS; CHANDELIERS; CEILING LIGHTS; CHINESE LANTERNS; STREET LAMPS; AQUARIUM LIGHTS; FLUORESCENT LAMP TUBES; LIGHTS FOR VEHICLES (U.S. CLS. 13, 21, 23, 31 AND 34).

SHAILA SETTLES, EXAMINING ATTORNEY

SN 79-109,118. THE HOSHO CORPORATION, JAPAN, FILED 10-19-2011.

HEAT♥OASIS

PRIORITY DATE OF 7-26-2011 IS CLAIMED.
OWNER OF INTERNATIONAL REGISTRATION 1106744 DATED 10-19-2011, EXPIRES 10-19-2021.

NO CLAIM IS MADE TO THE EXCLUSIVE RIGHT TO USE "HEAT", APART FROM THE MARK AS SHOWN.

FOR POCKET WARMERS, NAMELY, CHEMICALLY-ACTIVATED HEATING PACKETS FOR WARMING HANDS; PORTABLE BODY WARMERS, NAMELY, CHEMICALLY-ACTIVATED HEATING PACKETS FOR WARMING THE BODY; PORTABLE HAND WARMERS, NAMELY, CHEMICALLY-ACTIVATED HEATING PACKETS FOR WARMING HANDS; HEATING AND COOLING PACKS FILLED WITH CHEMICAL SUBSTANCES THAT REACT WHEN REQUIRED TO WARM OR COOL THE BODY NOT FOR MEDICAL PURPOSES; POCKET WARMERS WITH ADHESIVE TAPE, NAMELY, CHEMICALLY-ACTIVATED HEATING PACKETS FOR WARMING HANDS; PORTABLE BODY WARMERS WITH ADHESIVE TAPE, NAMELY, CHEMICALLY-ACTIVATED HEATING PACKETS FOR WARMING THE BODY; POCKET WARMERS ATTACHABLE TO SOCKS, NAMELY, CHEMICALLY-ACTIVATED HEATING PACKETS FOR WARMING FEET; POCKET WARMERS ATTACHABLE TO INSOLES FOR FOOTWEAR, NAMELY, CHEMICALLY-ACTIVATED HEATING PACKETS FOR WARMING FEET; ALL OF THE AFORESAID WARMERS BEING NON ELECTRIC (U.S. CLS. 13, 21, 23, 31 AND 34).

DOMINIC FATHY, EXAMINING ATTORNEY

CLASS 11—(Continued).

SN 79-109,312. OSRAM AG, MÜNCHEN, FED REP GERMANY, FILED 11-24-2011.

BRIGTEZ

THE MARK CONSISTS OF STANDARD CHARACTERS WITHOUT CLAIM TO ANY PARTICULAR FONT, STYLE, SIZE, OR COLOR.

PRIORITY DATE OF 8-26-2011 IS CLAIMED.

OWNER OF INTERNATIONAL REGISTRATION 1107270 DATED 11-24-2011, EXPIRES 11-24-2021.

FOR APPARATUS FOR LIGHTING, NAMELY, ELECTRIC LAMPS AND LUMINAIRES; ELECTRIC LAMPS COMPOSED OF ORGANIC LIGHT EMITTING DIODES; LUMINAIRES, USING LIGHT EMITTING DIODES AS A LIGHT SOURCE, FOR STREET OR ROADWAY LIGHTING, AND COMPONENT PARTS OF THE FOREGOING GOODS, NAMELY, SOLID-STATE SEMICONDUCTOR CHIPS, REFLECTORS, LENSES, AND ELECTRICAL TERMINALS AND WIRING (U.S. CLS. 13, 21, 23, 31 AND 34).

CHRISTINE MARTIN, EXAMINING ATTORNEY

SN 85-127,852. LG ELECTRONICS INC., SEOUL, REPUBLIC OF KOREA, FILED 9-13-2010.

ARTCOOL Mirror

THE MARK CONSISTS OF STANDARD CHARACTERS WITHOUT CLAIM TO ANY PARTICULAR FONT, STYLE, SIZE, OR COLOR.

PRIORITY CLAIMED UNDER SEC. 44(D) ON REPUBLIC OF KOREA APPLICATION NO. 40-2010-0039, FILED 7-30-2010, REG. NO. 0884989, DATED 10-13-2011, EXPIRES 10-13-2021.

OWNER OF U.S. REG. NO. 3,169,359.

FOR ELECTRIC REFRIGERATORS; ELECTRIC REFRIGERATORS FOR PRESERVING KIMCHI; LIGHT WAVE OVENS; WINE COOLERS, NAMELY, REFRIGERATED CABINETS CONTAINING RACKS FOR WINE BOTTLES AND STORAGE SHELVES; ELECTRIC COOKING OVENS; ELECTRIC FREEZERS; ELECTRIC CLOTHES DRYERS; GAS RANGES; MICROWAVE RANGES; GAS COOKTOPS; ELECTRIC RANGES FOR HOUSEHOLD PURPOSE; AIR PURIFYING APPARATUS; AIR CONDITIONERS; HOT AIR BLOWERS; HUMIDIFIERS; ELECTRIC DEHUMIDIFIERS; GAS GRILLS; DISH DISINFECTANT APPARATUS FOR INDUSTRIAL PURPOSES; WATER PURIFIERS FOR HOUSEHOLD PURPOSES; ELECTRIC WATER PURIFIERS FOR HOUSEHOLD PURPOSES; WATER IONIZERS; NON-ELECTRIC WATER PURIFIERS FOR HOUSEHOLD PURPOSES; WATER PURIFYING APPARATUS; ELECTRIC FOOT WARMERS; WATER PURIFICATION INSTALLATIONS AND APPARATUS; WATER FILTERS (U.S. CLS. 13, 21, 23, 31 AND 34).

GRETCHEN ULRICH, EXAMINING ATTORNEY

CLASS 11—(Continued).

SN 85-127,878. LG ELECTRONICS INC., SEOUL, REPUBLIC OF KOREA, FILED 9-13-2010.

ARTCOOL Gallery

THE MARK CONSISTS OF STANDARD CHARACTERS WITHOUT CLAIM TO ANY PARTICULAR FONT, STYLE, SIZE, OR COLOR.

PRIORITY CLAIMED UNDER SEC. 44(D) ON REPUBLIC OF KOREA APPLICATION NO. 40-2010-0039, FILED 7-30-2010, REG. NO. 0886513, DATED 10-24-2011, EXPIRES 10-24-2021.

OWNER OF U.S. REG. NO. 3,169,359.

FOR ELECTRIC REFRIGERATORS; ELECTRIC REFRIGERATORS FOR PRESERVING KIMCHI; LIGHT WAVE OVENS; WINE COOLERS, NAMELY, REFRIGERATED CABINETS CONTAINING RACKS FOR WINE BOTTLES AND STORAGE SHELVES; ELECTRIC COOKING OVENS; ELECTRIC FREEZERS; ELECTRIC CLOTHES DRYERS; GAS RANGES; MICROWAVE RANGES; GAS COOKTOPS; ELECTRIC RANGES FOR HOUSEHOLD PURPOSE; AIR PURIFYING APPARATUS; AIR CONDITIONERS; HOT AIR BLOWERS; HUMIDIFIERS; ELECTRIC DEHUMIDIFIERS; GAS GRILLS; DISH DISINFECTANT APPARATUS FOR INDUSTRIAL PURPOSES; WATER PURIFIERS FOR HOUSEHOLD PURPOSES; ELECTRIC WATER PURIFIERS FOR HOUSEHOLD PURPOSES; WATER IONIZERS; NON-ELECTRIC WATER PURIFIERS FOR HOUSEHOLD PURPOSES; WATER PURIFYING APPARATUS; ELECTRIC FOOT WARMERS; WATER PURIFICATION INSTALLATIONS AND APPARATUS; WATER FILTERS (U.S. CLS. 13, 21, 23, 31 AND 34).

GRETCHEN ULRICH, EXAMINING ATTORNEY

SN 85-133,367. HOMER TLC, INC., WILMINGTON, DE. FILED 9-20-2010.

Perfect Home Essentials

THE MARK CONSISTS OF STANDARD CHARACTERS WITHOUT CLAIM TO ANY PARTICULAR FONT, STYLE, SIZE, OR COLOR.

OWNER OF U.S. REG. NO. 3,090,873.

NO CLAIM IS MADE TO THE EXCLUSIVE RIGHT TO USE "HOME ESSENTIALS", APART FROM THE MARK AS SHOWN.

FOR CEILING FANS; ELECTRIC HOLIDAY LIGHTS; FAUCETS; LIGHTING FIXTURES (U.S. CLS. 13, 21, 23, 31 AND 34).

LAURA HAMMEL, EXAMINING ATTORNEY

CLASS 11—(Continued).

SN 85-136,071. GROHE AG, D-58675 HEMER, FED REP GERMANY, FILED 9-22-2010.

GROHE Home Spa Collection

THE MARK CONSISTS OF STANDARD CHARACTERS WITHOUT CLAIM TO ANY PARTICULAR FONT, STYLE, SIZE, OR COLOR.

OWNER OF ERPN CMNTY TM OFC REG. NO. 009393497, DATED 3-1-2011, EXPIRES 9-22-2020.

OWNER OF U.S. REG. NOS. 1,151,616, 3,476,852 AND OTHERS.

NO CLAIM IS MADE TO THE EXCLUSIVE RIGHT TO USE "HOME SPA COLLECTION", APART FROM THE MARK AS SHOWN.

FOR SHOWERS; SHOWER HEADS AND COMPONENTS THEREOF; SHOWER PARTS AND PLUMBING FITTINGS, NAMELY, SHOWER CONTROL VALVES; HAND SHOWERS; OVER-HEAD SHOWERS; SHOWER HEADS; SIDE SHOWERS; HAND SHOWER HOLDERS; SHOWER HEAD HOLDERS; SHOWER SETS PRIMARILY CONSISTING OF HAND SHOWERS, HAND SHOWER HOLDERS, AND SHOWER HEAD HOLDERS; SHOWER SYSTEMS PRIMARILY COMPOSED OF HAND SHOWERS, OVER-HEAD SHOWERS, SHOWER HEADS, SIDE SHOWERS, CONTROL VALVES, HAND SHOWER HOLDERS, AND SHOWER HEAD HOLDERS (U.S. CLS. 13, 21, 23, 31 AND 34).

BERYL GARDNER, EXAMINING ATTORNEY

SN 85-146,960. THE WALK IN BATHTUB COMPANY INC, FARMINGDALE, NY. FILED 10-7-2010.

THE SAFER BATHING EXPERIENCE

THE MARK CONSISTS OF STANDARD CHARACTERS WITHOUT CLAIM TO ANY PARTICULAR FONT, STYLE, SIZE, OR COLOR.

NO CLAIM IS MADE TO THE EXCLUSIVE RIGHT TO USE "BATHING", APART FROM THE MARK AS SHOWN.

FOR BATH TUBS AND BATHTUB ENCLOSURES (U.S. CLS. 13, 21, 23, 31 AND 34).

FIRST USE 1-1-2006; IN COMMERCE 1-1-2006.
CURTIS FRENCH, EXAMINING ATTORNEY

CLASS 11—(Continued).

SN 85-200,851. TRIFLOW CONCEPTS LIMITED, ESSEX, UNITED KINGDOM, FILED 12-17-2010.

TRIFLOW QUADRO

THE MARK CONSISTS OF STANDARD CHARACTERS WITHOUT CLAIM TO ANY PARTICULAR FONT, STYLE, SIZE, OR COLOR.

PRIORITY CLAIMED UNDER SEC. 44(D) ON ERPN CMNTY TM OFC APPLICATION NO. 009498511, FILED 11-4-2010, REG. NO. 009498511, DATED 4-19-2011, EXPIRES 11-4-2020.

OWNER OF U.S. REG. NOS. 1,973,896 AND 3,841,530.

FOR APPARATUS FOR LIGHTING PURPOSES, NAMELY, LIGHTING FIXTURES, LIGHTING TRACKS, LIGHTING TUBES, HOUSEHOLD LIGHTING FIXTURES, LAMPS, LAMPS FOR OUTDOOR USE, LIGHTS FOR OUTDOOR USE, NAMELY, PAVER, PORCH, GARDEN, AND PATIO LIGHTS; SUPPORTS BEING STRUCTURAL PARTS OF LIGHTING FIXTURES FOR OUTDOOR USE, NAMELY, SUPPORTS FOR PAVER, PORCH, GARDEN, AND PATIO LIGHTS; LAMP SHADES, LAMP SHADE HOLDERS, LAMP BASES, LANDSCAPE LIGHTING INSTALLATIONS; APPARATUS FOR HEATING PURPOSES, NAMELY, HOT WATER DISPENSER HEATING INSTALLATIONS, HEATING PANELS FOR INDOOR HEATING PURPOSES, HEATING SYSTEMS FOR RESIDENTIAL AND COMMERCIAL BUILDINGS, NAMELY, INDOOR RADIANT HEATING SYSTEMS AND RADIATORS FOR HEATING, HOT AIR SPACE HEATING APPARATUS, HOT WATER SPACE HEATING APPARATUS; APPARATUS FOR REFRIGERATING PURPOSES, NAMELY, REFRIGERATORS, REFRIGERATING MACHINES, REFRIGERATING CABINETS, REFRIGERATING DISPLAY CABINETS; REFRIGERATION EQUIPMENT, NAMELY, FOOD AND BEVERAGE CHILLING UNITS, REFRIGERATION EQUIPMENT, NAMELY, RAPID FOOD CHILLING UNITS, REFRIGERATOR SHELVING, DRAWERS, BINS AND TRAYS; APPARATUS FOR WATER SUPPLY AND SANITARY PURPOSES, NAMELY, TOILETS, SINKS, BATHTUBS AND PIPES BEING PARTS OF SANITARY FACILITIES; LIGHTING FIXTURES FOR INSTALLATION AS AN INTEGRAL PART OF KITCHEN FURNITURE, NAMELY, KITCHEN CABINETS, KITCHEN UNITS, KITCHEN CUPBOARDS; LIGHTING FIXTURES FOR INSTALLATION AS AN INTEGRAL PART OF BATHROOM FURNITURE, NAMELY, BATHROOM CABINETS, BATHROOM UNITS, BATHROOM CUPBOARDS; SANITARY WARE, NAMELY, PIPES BEING PARTS OF SANITARY FACILITIES, TOILETS, TOILET BOWLS, SINKS; WATER TAPS, NAMELY, TAP WATER FAUCETS; FILTERED WATER DISPENSERS, NAMELY, WATER COOLING TOWERS, WATER COOLERS, WATER FOUNTAINS, WATER PURIFIERS; CARTRIDGES FOR WATER TREATMENT, NAMELY, FILTERS FOR DRINKING WATER; STRUCTURAL PARTS FOR ALL THE AFORESAID GOODS (U.S. CLS. 13, 21, 23, 31 AND 34).

BARBARA BROWN, EXAMINING ATTORNEY

CLASS 11—(Continued).

SN 85-210,687. INAX CORPORATION, TOKONAME-SHI, AICHI, JAPAN, FILED 1-5-2011.

Rainer

THE MARK CONSISTS OF STANDARD CHARACTERS WITHOUT CLAIM TO ANY PARTICULAR FONT, STYLE, SIZE, OR COLOR.

FOR SHOWER TOILETS AND STRUCTURAL PARTS THEREFOR; TOILET SEATS, INCLUDING TOILET SEATS WITH WASHING WATER SQUIRTER; TOILET BOWLS, INCLUDING TOILET BOWLS EQUIPPED WITH WASHING WATER SQUIRTER; TOILET SEATS FOR HEATING, WASHING AND DRYING BODY PARTS; BIDETS AND REMOTE CONTROLS FOR USE WITH BIDETS, SOLD TOGETHER AS A UNIT; WATER CLOSETS AND REMOTE CONTROLS FOR USE WITH WATER CLOSETS, SOLD TOGETHER AS A UNIT; TOILET TANKS AND STRUCTURAL PARTS THEREFOR; TOILET TANK ASSEMBLIES COMPRISED OF TOILET TANK BOWLS FOR FLUSHING TOILET TANKS; TOILETS AND REMOTE CONTROLS FOR USE WITH TOILETS, SOLD TOGETHER AS A UNIT; TANKS, NAMELY, CISTERN TANKS FOR TOILETS; TOILET TANK BALLS; TAP WATER FAUCETS; FIXED SPOUTS USED DIRECTLY IN BIDETS AND TOILETS; PLUMBING FIXTURES, NAMELY, SHOWER SPRAYERS FOR USE WITH TOILETS AND BIDETS; BIDET NOZZLES; ELECTRIC HAND DRYING APPARATUS FOR WASH-ROOMS, NAMELY, ELECTRIC HAND DRYERS; ELECTRIC WATER WARMER; HOT WATER HEATER USING GAS AND STRUCTURAL PARTS THEREFOR; HOT WATER HEATER USING OIL AND STRUCTURAL PARTS THEREFOR; BASINS AND WASH-HAND BOWLS BEING PARTS OF SANITARY INSTALLATIONS; HANDLES FOR FLUSHING TOILET WATER OPERATED BY REMOTE CONTROL; CONTROL VALVES FOR TOILET FLUSHING WATER; SINKS; BATH FITTINGS, NAMELY, BATH TUBS WITH WASHING PLACE; BATH TUBS WITH BUBBLE GENERATION APPARATUS; SHOWERS; BATH TUBS; BATH UNITS, NAMELY, PREFABRICATED BATH ROOMS CONTAINING A FAUCET, BATH TUB, FLOOR, WALLS, CEILING BOARD AND SHOWER (U.S. CLS. 13, 21, 23, 31 AND 34).

TOBY BULLOFF, EXAMINING ATTORNEY

CLASS 11—(Continued).

SN 85-219,516. IONIZED PTY LTD, UNLEY, AUSTRALIA, FILED 1-18-2011.

Hydrosmart

THE MARK CONSISTS OF STANDARD CHARACTERS WITHOUT CLAIM TO ANY PARTICULAR FONT, STYLE, SIZE, OR COLOR.

FOR WATER CONDITIONING UNITS; WATER PURIFICATION UNITS; WATER SOFTENING UNITS; WATER SCALE PREVENTION UNITS; EQUIPMENT FOR TREATING CHEMICALS AND MINERALS IN WATER, NAMELY, DEVICES SUBJECTING WATER FLOW TO RESONANT FREQUENCIES; SPECIALIZED WATER TREATMENT TECHNOLOGY, NAMELY, DEVICES UTILIZING COMPUTER GENERATED RESONANCE FREQUENCIES TO DISRUPT BONDING BETWEEN MINERALS AND CHARGED COMPOUNDS FOR AGRICULTURE, INDUSTRIAL PROCESSES, MINING, RESIDENTIAL AND MUNICIPAL DRINKING WATER SUPPLIES, AND SWIMMING POOLS; WATER TREATMENT DEVICES TREATING WATER FLOW BY USING RESONANT FREQUENCIES (U.S. CLS. 13, 21, 23, 31 AND 34).

JAY FLOWERS, EXAMINING ATTORNEY

SN 85-251,219. CAO GROUP, INC., WEST JORDAN, UT, FILED 2-24-2011.

FLARE

THE MARK CONSISTS OF STANDARD CHARACTERS WITHOUT CLAIM TO ANY PARTICULAR FONT, STYLE, SIZE, OR COLOR.

FOR LED LIGHTING MODULES FOR STREET LIGHTS, SIGNS, COMMERCIAL LIGHTING, BUILDINGS, AND OTHER ARCHITECTURAL USES (U.S. CLS. 13, 21, 23, 31 AND 34).

FIRST USE 2-23-2011; IN COMMERCE 2-23-2011.
KIM MONINGHOFF, EXAMINING ATTORNEY

CLASS 11—(Continued).

SN 85-301,931. DELTA T CORPORATION, LEXINGTON, KY.
FILED 4-22-2011.



OWNER OF U.S. REG. NO. 3,947,106.
NO CLAIM IS MADE TO THE EXCLUSIVE RIGHT TO
USE "180", APART FROM THE MARK AS SHOWN.

THE MARK CONSISTS OF THE WORD "PIVOT" WITH A
REPRESENTATION OF A FAN IN THE "O", AND CON-
NECTED TO A DOUBLE HEADED ARCUATE ARROW
AND A SUBSCRIPT "180".

SEC. 2(F) AS TO "PIVOT".

FOR VENTILATING FANS FOR COMMERCIAL AND
INDUSTRIAL USE AND PARTS THEREFOR; ELECTRIC
FANS AND PARTS THEREFOR (U.S. CLS. 13, 21, 23, 31
AND 34).

FIRST USE 6-0-2010; IN COMMERCE 6-0-2010.
BRIDGETT SMITH, EXAMINING ATTORNEY

CLASS 11—(Continued).

SN 85-343,726. FEDERAL-MOGUL PRODUCTS, INC.,
SOUTHFIELD, MI. FILED 6-10-2011.

BRITELITE

THE MARK CONSISTS OF STANDARD CHARACTERS
WITHOUT CLAIM TO ANY PARTICULAR FONT, STYLE,
SIZE, OR COLOR.

SEC. 2(F).

FOR AUTOMOTIVE HEADLAMPS; VEHICLE HEAD-
LIGHTS (U.S. CLS. 13, 21, 23, 31 AND 34).

FIRST USE 12-31-1996; IN COMMERCE 12-31-1996.

JESSICA A. POWERS, EXAMINING ATTORNEY

SN 85-308,350. SMOKY MOUNTAIN EMPORIUM, LTD,
CANDLER, NC. FILED S.R. 4-29-2011; AM. P.R. 8-19-2011.

DYNAVENT

THE MARK CONSISTS OF STANDARD CHARACTERS
WITHOUT CLAIM TO ANY PARTICULAR FONT, STYLE,
SIZE, OR COLOR.

OWNER OF U.S. REG. NO. 1,721,726.

FOR GAS GENERATING FURNACES; GAS STOVES
(U.S. CLS. 13, 21, 23, 31 AND 34).

FIRST USE 4-1-2011; IN COMMERCE 4-1-2011.

JASON TURNER, EXAMINING ATTORNEY

SN 85-330,425. LATINA MEDIA VENTURES LLC, NEW
YORK, NY. FILED 5-25-2011.

GOOD LIVING BY LATINA

THE MARK CONSISTS OF STANDARD CHARACTERS
WITHOUT CLAIM TO ANY PARTICULAR FONT, STYLE,
SIZE, OR COLOR.

THE ENGLISH TRANSLATION OF "LATINA" IN THE
MARK IS "LATIN OR LATIN WOMAN".

FOR LAMPS (U.S. CLS. 13, 21, 23, 31 AND 34).

STEPHANIE ALI, EXAMINING ATTORNEY

SN 85-348,070. AMP PLUS, INC., DBA ELCO LIGHTING,
VERNON, CA. FILED 6-16-2011.

OWNER OF U.S. REG. NO. 3,882,112.

NO CLAIM IS MADE TO THE EXCLUSIVE RIGHT TO
USE "COMMERCIAL LIGHTING", APART FROM THE
MARK AS SHOWN.

THE COLOR(S) BLACK, PURPLE, GREEN, BLUE AND
RED IS/ARE CLAIMED AS A FEATURE OF THE MARK.

THE MARK CONSISTS OF THE COINED WORD "ELCO-
LUME" IN THE COLOR BLACK ABOVE THE WORDS
"COMMERCIAL LIGHTING" IN THE COLOR BLACK
NEXT TO FOUR OVERLAPPING DOTS OF THE COLORS
PURPLE, GREEN, BLUE AND RED.

FOR LIGHTING PRODUCTS, NAMELY, RECESSED
LIGHTING FIXTURES, LED LIGHTING FIXTURES FOR
ARCHITECTURAL PURPOSES, ELECTRIC TRACK
LIGHTING UNITS, ELECTRIC OUTDOOR LIGHTING
FIXTURES AND LANDSCAPE LIGHTING INSTALLA-
TIONS, WALL LIGHTING, NAMELY, SCONCE LIGHT-
ING FIXTURES, PENDANT LIGHTING FIXTURES,
LAMPS, LIGHTING ACCESSORIES, NAMELY, BULBS,
LIGHT FIXTURE LENSES, SOCKET EXTENDERS FOR
ELECTRIC LIGHTS, SOCKET ADAPTERS FOR ELEC-
TRIC LIGHTS, LAMP AND LIGHTING FIXTURE
SHADES, AND MOUNTING PARTS FOR INSTALLA-
TION OF LIGHT FIXTURES SOLD AS A UNIT THERE-
OF (U.S. CLS. 13, 21, 23, 31 AND 34).

COLLEEN DOMBROW, EXAMINING ATTORNEY

CLASS 11—(Continued).

SN 85-351,997. RAB LIGHTING INC., NORTHVALE, NJ. FILED 6-21-2011.

ELED

THE MARK CONSISTS OF STANDARD CHARACTERS WITHOUT CLAIM TO ANY PARTICULAR FONT, STYLE, SIZE, OR COLOR.

OWNER OF U.S. REG. NOS. 3,821,419 AND 3,843,323.
FOR ELECTRIC LIGHTING FIXTURES; LED (LIGHT EMITTING DIODE) LIGHTING FIXTURES; LIGHTING FIXTURES (U.S. CLS. 13, 21, 23, 31 AND 34).
JANET LEE, EXAMINING ATTORNEY

SN 85-362,250. MAAX SPAS INDUSTRIES CORP., CHANDLER, AZ. FILED 7-1-2011.

URBAN SERIES

THE MARK CONSISTS OF STANDARD CHARACTERS WITHOUT CLAIM TO ANY PARTICULAR FONT, STYLE, SIZE, OR COLOR.

NO CLAIM IS MADE TO THE EXCLUSIVE RIGHT TO USE "SERIES", APART FROM THE MARK AS SHOWN.
FOR HOT TUBS; SPAS IN THE NATURE OF HEATED POOLS (U.S. CLS. 13, 21, 23, 31 AND 34).
JACLYN KIDWELL WALKER, EXAMINING ATTORNEY

SN 85-363,441. KONICA MINOLTA HOLDINGS, INC., TOKYO, JAPAN, FILED 7-5-2011.

SYMFOS

THE MARK CONSISTS OF STANDARD CHARACTERS WITHOUT CLAIM TO ANY PARTICULAR FONT, STYLE, SIZE, OR COLOR.

FOR ELECTRIC LAMPS; LAMPS; LIGHTS FOR ILLUMINATING STAIRS, DOORS AND OTHER PORTIONS OF BUILDINGS; LIGHTS FOR USE IN ILLUMINATING SIGNS AND DISPLAYS; LIGHTS FOR VEHICLES; LIGHTING APPARATUS, NAMELY, LIGHTING INSTALLATIONS, LIGHTING APPARATUS FOR VEHICLES; SAFETY LAMPS; STANDARD LAMPS; STREET LAMPS; CEILING LIGHTS (U.S. CLS. 13, 21, 23, 31 AND 34).

LINDA ORNDORFF, EXAMINING ATTORNEY

CLASS 11—(Continued).

SN 85-372,496. FERGUSON ENTERPRISES, INC., NEWPORT NEWS, VA. FILED 7-15-2011.

Lincoln Products

THE MARK CONSISTS OF STANDARD CHARACTERS WITHOUT CLAIM TO ANY PARTICULAR FONT, STYLE, SIZE, OR COLOR.

NO CLAIM IS MADE TO THE EXCLUSIVE RIGHT TO USE "PRODUCTS", APART FROM THE MARK AS SHOWN.

FOR PLUMBING FIXTURES, NAMELY, SHOWER HEADS, PERSONAL SHOWERS, SHOWER DRAINS, WATER SUPPLY STOPS AND LINES, GAS CONNECTORS, NAMELY, GAS REGULATORS; TOILET FLUSH LEVERS, TOILET TANK FLAPPERS, TOILET FLUSH VALVES, TOILET TANK REPAIR KITS COMPRISED OF REPLACEMENT PLUMBING FITTINGS, NAMELY, BIBBS, COCKS, TRAPS AND VALVES; TOILET SEAT REPAIR KITS COMPRISED OF REPLACEMENT TOILET SEAT HANDLES AND SEATS; TOILET TANK AND BOWL REPAIR KITS COMPRISED OF REPLACEMENT PLUMBING FITTINGS, NAMELY, BIBBS, COCKS, TRAPS AND VALVES; BALL COCKS, BALL COCK REPAIR KITS COMPRISED OF REPLACEMENT BALL COCKS; TWO-WAY AND THREE-WAY STANDARD SUPPLY VALVES, FAUCET HANDLES, NYLON BARBED FITTINGS, NAMELY, PLUMBING COUPLERS; PVC FITTINGS, NAMELY, PLUMBING COUPLERS; VALVES BEING PARTS OF SPRINKLER SYSTEMS; ICE MAKER KITS COMPRISED OF ICE MAKING MACHINES; WATER HEATER PLUMBING COUPLERS (U.S. CLS. 13, 21, 23, 31 AND 34).

FIRST USE 12-31-2009; IN COMMERCE 12-31-2009.
TASNEEM HUSSAIN, EXAMINING ATTORNEY

SN 85-381,017. GENERAL ELECTRIC COMPANY, SCHENECTADY, NY. FILED 7-26-2011.

CUSTOM SELECT

THE MARK CONSISTS OF STANDARD CHARACTERS WITHOUT CLAIM TO ANY PARTICULAR FONT, STYLE, SIZE, OR COLOR.

FOR COMPONENT FEATURE OF WATER SOFTENERS FOR ADJUSTING WATER HARDNESS (U.S. CLS. 13, 21, 23, 31 AND 34).

REBECCA SMITH, EXAMINING ATTORNEY

CLASS 11—(Continued).

SN 85-382,449. AS IP HOLDCO, LLC, PISCATAWAY, NJ. FILED 7-27-2011.

OCEAN GROVE

THE MARK CONSISTS OF STANDARD CHARACTERS WITHOUT CLAIM TO ANY PARTICULAR FONT, STYLE, SIZE, OR COLOR.

OWNER OF U.S. REG. NO. 4,026,571.
FOR FAUCETS (U.S. CLS. 13, 21, 23, 31 AND 34).
KHANH LE, EXAMINING ATTORNEY

SN 85-390,620. PACIFIC TRENDS LAMP & LIGHTING PRODUCTS, INC., IRVINE, CA. FILED 8-5-2011.

PACIFIC TRENDS

THE MARK CONSISTS OF STANDARD CHARACTERS WITHOUT CLAIM TO ANY PARTICULAR FONT, STYLE, SIZE, OR COLOR.

FOR LAMPS (U.S. CLS. 13, 21, 23, 31 AND 34).
FIRST USE 9-3-1992; IN COMMERCE 9-3-1992.
JORDAN BAKER, EXAMINING ATTORNEY

SN 85-404,507. KENNEDY, WILLIAM S., FALLON, NV. FILED 8-23-2011.

THE MARK CONSISTS OF THE LETTERS "SFR" IN BLACK, STYLIZED SCRIPT.

FOR COFFEE ROASTERS (U.S. CLS. 13, 21, 23, 31 AND 34).
FIRST USE 1-1-2009; IN COMMERCE 1-1-2009.
DAVID C. REIHNER, EXAMINING ATTORNEY

CLASS 11—(Continued).

SN 85-411,871. KONICA MINOLTA HOLDINGS, INC., TOKYO, JAPAN, FILED 8-31-2011.

THE MARK CONSISTS OF THE WORDING "SYMFOS" WITH A STYLIZED LETTER "S".

FOR ELECTRIC LAMPS; LAMPS; LIGHTS FOR ILLUMINATING STAIRS, DOORS AND OTHER PORTIONS OF BUILDINGS; LIGHTS FOR USE IN ILLUMINATING SIGNS AND DISPLAYS; LIGHTS FOR VEHICLES; LIGHTING APPARATUS, NAMELY, LIGHTING INSTALLATIONS; LIGHTING APPARATUS FOR VEHICLES; SAFETY LAMPS; STANDARD LAMPS; STREET LAMPS; CEILING LIGHTS (U.S. CLS. 13, 21, 23, 31 AND 34).

LINDA ORNDORFF, EXAMINING ATTORNEY

SN 85-436,040. MUELLER INTERNATIONAL, LLC, ATLANTA, GA. FILED 9-30-2011.



OWNER OF U.S. REG. NO. 2,455,833.
NO CLAIM IS MADE TO THE EXCLUSIVE RIGHT TO USE "HYDRO", APART FROM THE MARK AS SHOWN.

THE MARK CONSISTS OF A STYLIZED DEPICTION OF A STALLION HEAD ABOVE THE WORD "HYDRO" WHICH IS STACKED ON TOP OF THE WORD "GUARD" IN STYLIZED SHADOWED FONT.

FOR AUTOMATIC WATER MAIN FLUSHING UNITS, NAMELY, AN AUTOMATED PROGRAMMABLE VALVE FOR PURGING UNDERGROUND DRINKING WATER DISTRIBUTION SYSTEMS (U.S. CLS. 13, 21, 23, 31 AND 34).

FIRST USE 0-0-2005; IN COMMERCE 0-0-2005.
MICHAEL LITZAU, EXAMINING ATTORNEY

CLASS 11—(Continued).

SN 85-438,765. HOUSTON TECHNICAL SALES, INC., STAFFORD, TX. FILED 10-4-2011.

DUO-TAPE

THE MARK CONSISTS OF STANDARD CHARACTERS WITHOUT CLAIM TO ANY PARTICULAR FONT, STYLE, SIZE, OR COLOR.

FOR ELECTRICAL HEATING TAPES (U.S. CLS. 13, 21, 23, 31 AND 34).

FIRST USE 1-1-1980; IN COMMERCE 1-1-1980.
DANIEL CAPSHAW, EXAMINING ATTORNEY

CLASS 11—(Continued).

SN 85-466,923. DIVERSIFIED PRODUCTS, LLC, OMAHA, NE. FILED 11-8-2011.

TOW PRO HEATER

THE MARK CONSISTS OF STANDARD CHARACTERS WITHOUT CLAIM TO ANY PARTICULAR FONT, STYLE, SIZE, OR COLOR.

NO CLAIM IS MADE TO THE EXCLUSIVE RIGHT TO USE "HEATER", APART FROM THE MARK AS SHOWN.

FOR DIESEL FUELED HEATER FOR USE IN THE CONSTRUCTION INDUSTRY (U.S. CLS. 13, 21, 23, 31 AND 34).

ASMAT KHAN, EXAMINING ATTORNEY

SN 85-457,204. MURPHREE, BRIAN, COOKEVILLE, TN. FILED 10-26-2011.

The Sauna Place

THE MARK CONSISTS OF STANDARD CHARACTERS WITHOUT CLAIM TO ANY PARTICULAR FONT, STYLE, SIZE, OR COLOR.

NO CLAIM IS MADE TO THE EXCLUSIVE RIGHT TO USE "SAUNA", APART FROM THE MARK AS SHOWN.

FOR SAUNAS; STEAM BATHS FOR RECREATIONAL USE; PREFABRICATED SAUNA KITS COMPRISED PRIMARILY OF PRE-CUT CEDAR FOR SAUNA STRUCTURES, CEDAR BENCHES FOR SAUNAS, SAUNA DOORS, MOLDINGS AND TRIM FOR SAUNA STRUCTURES, SAUNA HEATERS, AND SAUNA CONTROLS ALL SOLD AS A UNIT; STEAM BATH GENERATORS, NAMELY, GENERATORS FOR PRODUCING STEAM FROM WATER FOR USE IN A SHOWER, STEAM ROOM, OR OTHERS ENCLOSED ROOMS (U.S. CLS. 13, 21, 23, 31 AND 34).

FIRST USE 4-20-2004; IN COMMERCE 4-20-2004.
DAVID C. REIHNER, EXAMINING ATTORNEY

SN 85-471,682. UNMACK PAUL NEILSON, BUTTE, MT. FILED 11-14-2011.



THE COLOR(S) RED, WHITE, BLUE AND BLACK IS/ARE CLAIMED AS A FEATURE OF THE MARK.

THE MARK CONSISTS OF RED CAPITAL "A", LEFT LEG SLANTED LOWER LEFT TO UPPER RIGHT, RIGHT LEG VERTICAL WITH RED AND WHITE VERTICAL STRIPES AND TOPPED WITH WHITE STARS ON BLUE FIELD, HORIZONTAL RED BAR TO COMPLETE THE "A", WHITE CAPITAL VERTICAL "R", BLUE CAPITAL VERTICAL "P", WITH THE OUTLINE OF THE LETTERS "ARP" IN THE COLOR BLACK.

FOR TRANSPORT REFRIGERATION UNITS FOR TRUCKS, TRAILERS AND SHIPPING CONTAINERS (U.S. CLS. 13, 21, 23, 31 AND 34).

FIRST USE 7-15-2010; IN COMMERCE 10-15-2011.
ANNE E. GUSTASON, EXAMINING ATTORNEY

SN 85-465,461. KNUCKLE LIGHTS LLC, WEST LINN, OR. FILED 11-5-2011.

Knuckle Lights

THE MARK CONSISTS OF STANDARD CHARACTERS WITHOUT CLAIM TO ANY PARTICULAR FONT, STYLE, SIZE, OR COLOR.

NO CLAIM IS MADE TO THE EXCLUSIVE RIGHT TO USE "LIGHTS", APART FROM THE MARK AS SHOWN.

FOR FLASHLIGHTS (U.S. CLS. 13, 21, 23, 31 AND 34).

FIRST USE 6-1-2010; IN COMMERCE 6-1-2010.
ROBERT C. CLARK JR., EXAMINING ATTORNEY

SN 85-475,803. LOUISIANA LED, LAFAYETTE, LA. FILED 11-17-2011.



NO CLAIM IS MADE TO THE EXCLUSIVE RIGHT TO USE "LA LED", APART FROM THE MARK AS SHOWN.

THE MARK CONSISTS OF THE WORDING "LALED" WITH THE LETTER "A" COMPRISED OF A STYLIZED REPRESENTATION OF A PRISM.

FOR LED (LIGHT EMITTING DIODE) LIGHTING FIXTURES; LED LIGHT BULBS; LED LUMINAIRES (U.S. CLS. 13, 21, 23, 31 AND 34).

FIRST USE 11-16-2009; IN COMMERCE 11-17-2009.
JULIE WATSON, EXAMINING ATTORNEY

CLASS 11—(Continued).

SN 85-476,474. THERMODYNAMIQUE SOLUTIONS INC., LAC-BEAUPORT, CANADA, FILED 11-18-2011.

AISX

THE MARK CONSISTS OF STANDARD CHARACTERS WITHOUT CLAIM TO ANY PARTICULAR FONT, STYLE, SIZE, OR COLOR.

FOR GEOTHERMAL-BASED HVAC UNITS (U.S. CLS. 13, 21, 23, 31 AND 34).
LINDA ORNDORFF, EXAMINING ATTORNEY

SN 85-478,470. WATTS, MARTIN JAMES, SALEM, MO. FILED 11-22-2011.

Ozark River Portable Sinks

THE MARK CONSISTS OF STANDARD CHARACTERS WITHOUT CLAIM TO ANY PARTICULAR FONT, STYLE, SIZE, OR COLOR.

NO CLAIM IS MADE TO THE EXCLUSIVE RIGHT TO USE "PORTABLE SINKS", APART FROM THE MARK AS SHOWN.

FOR SINKS (U.S. CLS. 13, 21, 23, 31 AND 34).
FIRST USE 5-1-2007; IN COMMERCE 5-1-2007.
PAM WILLIS, EXAMINING ATTORNEY

SN 85-480,365. M.K. PLASTICS CORPORATION, MONTREAL, QUEBEC, CANADA, FILED 11-23-2011.

K-KORE

THE MARK CONSISTS OF STANDARD CHARACTERS WITHOUT CLAIM TO ANY PARTICULAR FONT, STYLE, SIZE, OR COLOR.

FOR PLENUM CHAMBERS FOR USE IN HVAC SYSTEMS (U.S. CLS. 13, 21, 23, 31 AND 34).
FIRST USE 12-31-2011; IN COMMERCE 12-31-2011.
NICHOLAS ALTREE, EXAMINING ATTORNEY

CLASS 11—(Continued).

SN 85-502,244. PARK ENVIRONMENTAL EQUIPMENT, LTD., HOUSTON, TX. FILED 12-22-2011.

HYDRORECYCLE

THE MARK CONSISTS OF STANDARD CHARACTERS WITHOUT CLAIM TO ANY PARTICULAR FONT, STYLE, SIZE, OR COLOR.

FOR WATER RECYCLING IRRIGATION SYSTEM COMPRISED PRIMARILY OF WASTE WATER TREATMENT TANKS, WATER PUMPS AND WATER FILTRATION UNITS FOR WATER REUSE; WATER RECYCLING SYSTEM COMPRISED PRIMARILY OF WASTE WATER TREATMENT TANKS, WATER PUMPS, AND WATER FILTRATION UNITS FOR WATER RECLAMATION; WATER RECYCLING SYSTEM COMPRISED PRIMARILY OF WASTE WATER TREATMENT TANKS, WATER PUMPS, AND WATER FILTRATION UNITS FOR RAINWATER HARVESTING; WATER RECYCLING GRAY WATER SYSTEM COMPRISED PRIMARILY OF WASTE WATER TREATMENT TANKS, WATER PUMPS, AND WATER FILTRATION UNITS FOR WATER REUSE; WATER RECYCLING SYSTEM COMPRISED PRIMARILY OF WASTE WATER TREATMENT TANKS, WATER PUMPS, AND WATER FILTRATION UNITS FOR CAR WASH WATER RECLAMATION; RECYCLED WATER HOLDING TANKS, NAMELY, WATER FILTRATION TANKS (U.S. CLS. 13, 21, 23, 31 AND 34).

HAI-LY LAM, EXAMINING ATTORNEY

SN 85-504,573. QUEST WATER SOLUTIONS, INC., VANCOUVER, B.C., CANADA, FILED 12-28-2011.



NO CLAIM IS MADE TO THE EXCLUSIVE RIGHT TO USE "WATER PURIFICATION AND DISTRIBUTION SYSTEM", APART FROM THE MARK AS SHOWN.

THE COLOR(S) BLUE, GREEN, BLACK AND WHITE IS/ARE CLAIMED AS A FEATURE OF THE MARK.

THE MARK CONSISTS OF THE WORD "AQUA" IN BLACK CAPITAL LETTERS AGAINST A WHITE BACKGROUND, WITH A BLUE WATER DROP OVER THE FIRST LETTER "A". THE WORD "VEND" IN WHITE LOWER-CASE LETTERS AGAINST A BLUE BACKGROUND FORMING THE WORD "AQUAVEND". UNDERNEATH THE WORD "AQUAVEND", THERE APPEARS IN WHITE CAPITAL LETTERS ON A GREEN BACKGROUND THE WORDING "QUEST AQUAVEND - WATER PURIFICATION & DISTRIBUTION SYSTEM".

FOR WATER FILTRATION AND PURIFICATION UNITS AND REPLACEMENT CARTRIDGES AND FILTERS THEREFOR; WATER PURIFICATION AND FILTRATION APPARATUS; WATER PURIFICATION INSTALLATIONS; WATER PURIFICATION MACHINES; WATER PURIFICATION TANKS; WATER PURIFICATION UNITS; WATER PURIFIERS; WATER PURIFYING APPARATUS; WATER PURIFYING UNITS, FOR POTABLE WATER FOR DOMESTIC USE (U.S. CLS. 13, 21, 23, 31 AND 34).

JULIE VEPPUMTHARA, EXAMINING ATTORNEY

CLASS 11—(Continued).

SN 85-504,983. SAFEHOUSE HABITATS (SCOTLAND) LIMITED, DUNDEE, UNITED KINGDOM, FILED 12-28-2011.

SAFECOOL

THE MARK CONSISTS OF STANDARD CHARACTERS WITHOUT CLAIM TO ANY PARTICULAR FONT, STYLE, SIZE, OR COLOR.

PRIORITY CLAIMED UNDER SEC. 44(D) ON UNITED KINGDOM APPLICATION NO. 2586039, FILED 6-28-2011, REG. NO. 2586039, DATED 9-30-2011, EXPIRES 6-28-2021.

FOR AIR CONDITIONING APPARATUS FOR USE WITH HOT WORK WELDING ENCLOSURES AND HABITATS (U.S. CLS. 13, 21, 23, 31 AND 34).

ANDREA HACK, EXAMINING ATTORNEY

SN 85-506,748. OMNI ENVIRO, LLC, OAKLAND, CA. FILED 12-31-2011.

MORE PLANT FOR LESS WATER

THE MARK CONSISTS OF STANDARD CHARACTERS WITHOUT CLAIM TO ANY PARTICULAR FONT, STYLE, SIZE, OR COLOR.

FOR WATER TREATMENT APPARATUS, NAMELY, MAGNETIC TREATMENT UNITS FOR MOLECULAR MANIPULATION OF WATER MOLECULES; WATER CONDITIONING UNITS; WATER FILTERING UNITS FOR DOMESTIC, COMMERCIAL, AGRICULTURAL AND INDUSTRIAL USE; WATER FILTERS; WATER SOFTENING APPARATUS AND INSTALLATIONS; WATER SOFTENING UNITS; WATER TREATMENT EQUIPMENT, NAMELY, CARTRIDGE FILTRATION UNITS (U.S. CLS. 13, 21, 23, 31 AND 34).

FIRST USE 4-0-2010; IN COMMERCE 4-0-2010.

KAPIL BHANOT, EXAMINING ATTORNEY

SN 85-507,696. ROHL, LLC, IRVINE, CA. FILED 1-3-2012.

AVANTI

THE MARK CONSISTS OF STANDARD CHARACTERS WITHOUT CLAIM TO ANY PARTICULAR FONT, STYLE, SIZE, OR COLOR.

THE ENGLISH TRANSLATION OF "AVANTI" IS "FORWARD".

FOR PLUMBING AND SHOWER FIXTURES, NAMELY, FAUCETS, SHOWER HEADS, RESTS FOR SHOWER HEADS, HAND SHOWERS, THERMOSTATIC CONTROL FOR SHOWERS, AND SHOWER MIXERS (U.S. CLS. 13, 21, 23, 31 AND 34).

JOHN HWANG, EXAMINING ATTORNEY

CLASS 11—(Continued).

SN 85-507,757. FULTON MANAGEMENT SERVICES, INC., PULASKI, NY. FILED 1-3-2012.

CALIBER

THE MARK CONSISTS OF STANDARD CHARACTERS WITHOUT CLAIM TO ANY PARTICULAR FONT, STYLE, SIZE, OR COLOR.

FOR BOILERS, NAMELY, STEAM HEATING BOILERS, HOT WATER BOILERS, AND HYDRONIC BOILERS; WATER HEATERS; COMPONENTS FOR HEATING BOILERS AND WATER HEATERS, NAMELY, HEAT EXCHANGERS, VALVES IN THE NATURE OF PLUMBING FITTINGS AND PRESSURE VESSELS (U.S. CLS. 13, 21, 23, 31 AND 34).

HANNO RITTNER, EXAMINING ATTORNEY

SN 85-507,775. FULTON MANAGEMENT SERVICES, INC., PULASKI, NY. FILED 1-3-2012.

CADENCE

THE MARK CONSISTS OF STANDARD CHARACTERS WITHOUT CLAIM TO ANY PARTICULAR FONT, STYLE, SIZE, OR COLOR.

FOR BOILERS, NAMELY, STEAM HEATING BOILERS, HOT WATER BOILERS, AND HYDRONIC BOILERS; WATER HEATERS; COMPONENTS FOR HEATING BOILERS AND WATER HEATERS, NAMELY, HEAT EXCHANGERS, VALVES IN THE NATURE OF PLUMBING FITTINGS AND PRESSURE VESSELS (U.S. CLS. 13, 21, 23, 31 AND 34).

HANNO RITTNER, EXAMINING ATTORNEY

SN 85-507,786. FLEXCON INDUSTRIES, INC., RANDOLPH, MA. FILED 1-3-2012.

FLEXWAVE

THE MARK CONSISTS OF STANDARD CHARACTERS WITHOUT CLAIM TO ANY PARTICULAR FONT, STYLE, SIZE, OR COLOR.

OWNER OF U.S. REG. NOS. 3,031,000, 3,380,641 AND 3,971,762.

FOR WATER WELL TANKS (U.S. CLS. 13, 21, 23, 31 AND 34).

HANNO RITTNER, EXAMINING ATTORNEY

CLASS 11—(Continued).

SN 85-508,449. WRIGHT MATERIALS RESEARCH CO., BEAVERCREEK, OH. FILED 1-4-2012.

Puritrate

THE MARK CONSISTS OF STANDARD CHARACTERS WITHOUT CLAIM TO ANY PARTICULAR FONT, STYLE, SIZE, OR COLOR.

FOR AIR FILTERS FOR DOMESTIC USE; AIR FILTERS FOR INDUSTRIAL INSTALLATIONS; FIBROUS FILTERING MEDIA FOR GENERAL INDUSTRIAL USE IN THE PURIFICATION OF AIR AND INDUSTRIAL FLUIDS; FILTERS FOR FLUIDS, NAMELY, FOR WATER AND AREA-WATER SOLUTIONS; MEMBRANE FILTER CARTRIDGES FOR THE SEPARATION OF BIOMOLECULES IN BIOPHARMACEUTICAL PRODUCTION; WATER FILTERS (U.S. CLS. 13, 21, 23, 31 AND 34).

FIRST USE 12-22-2011; IN COMMERCE 1-3-2012.
SANJEEV VOHRA, EXAMINING ATTORNEY

SN 85-509,092. LASKO HOLDINGS, INC., WILMINGTON, DE. FILED 1-5-2012.

PURE-AIR BY LASKO

THE MARK CONSISTS OF STANDARD CHARACTERS WITHOUT CLAIM TO ANY PARTICULAR FONT, STYLE, SIZE, OR COLOR.

OWNER OF U.S. REG. NOS. 1,794,855, 3,402,479 AND OTHERS.

SEC. 2(F) AS TO "PURE-AIR".
FOR PORTABLE ELECTRIC FANS, PORTABLE ELECTRIC NON-INDUSTRIAL AIR CLEANERS, PORTABLE ELECTRIC AIR PURIFIERS, PORTABLE ELECTRIC HEATERS (U.S. CLS. 13, 21, 23, 31 AND 34).
TINA MAI, EXAMINING ATTORNEY

SN 85-509,198. ORBIT IRRIGATION PRODUCTS, INC., NORTH SALT LAKE, UT. FILED 1-5-2012.

HYDRO-RAIN

THE MARK CONSISTS OF STANDARD CHARACTERS WITHOUT CLAIM TO ANY PARTICULAR FONT, STYLE, SIZE, OR COLOR.

OWNER OF U.S. REG. NOS. 2,921,760, 2,921,761 AND OTHERS.

FOR ELECTRIC LIGHTING FIXTURES (U.S. CLS. 13, 21, 23, 31 AND 34).
VERNA BETH RIRIE, EXAMINING ATTORNEY

CLASS 11—(Continued).

SN 85-509,488. MSB INCORPORATED, WEST CHESTER, PA. FILED 1-5-2012.

B LIT

THE MARK CONSISTS OF STANDARD CHARACTERS WITHOUT CLAIM TO ANY PARTICULAR FONT, STYLE, SIZE, OR COLOR.

FOR FLASHLIGHT HOLDERS (U.S. CLS. 13, 21, 23, 31 AND 34).

KIMBERLY PERRY, EXAMINING ATTORNEY

SN 85-509,693. A.P.T. 1505, LLC, HOUSTON, TX. FILED 1-5-2012.

KulFlo

THE MARK CONSISTS OF STANDARD CHARACTERS WITHOUT CLAIM TO ANY PARTICULAR FONT, STYLE, SIZE, OR COLOR.

FOR PORTABLE AIR VENTILATION SYSTEM FOR PURIFYING AND COOLING AIR (U.S. CLS. 13, 21, 23, 31 AND 34).

GINA HAYES, EXAMINING ATTORNEY

SN 85-510,584. INDUSTRIAL REVOLUTION, INC., REDMOND, WA. FILED 1-6-2012.



THE MARK CONSISTS OF THE TERM YAYLABS! SITUATED BENEATH THE DESIGN OF A FACTORY OR LABORATORY, WITH SIX STAR DESIGNS SITUATED ABOVE COLUMNS OR STACKS OF THE FACTORY OR LABORATORY.

FOR ICE CREAM MAKERS (U.S. CLS. 13, 21, 23, 31 AND 34).
HANNO RITTNER, EXAMINING ATTORNEY

CLASS 11—(Continued).

SN 85-510,771. LASKO HOLDINGS, INC., WILMINGTON, DE. FILED 1-6-2012.

ZERO3

THE MARK CONSISTS OF STANDARD CHARACTERS WITHOUT CLAIM TO ANY PARTICULAR FONT, STYLE, SIZE, OR COLOR.
FOR PORTABLE ELECTRIC FANS, PORTABLE ELECTRIC NON-INDUSTRIAL AIR CLEANERS, PORTABLE ELECTRIC AIR PURIFIERS, PORTABLE ELECTRIC HEATERS (U.S. CLS. 13, 21, 23, 31 AND 34).
TINA MAI, EXAMINING ATTORNEY

SN 85-512,345. ENVIRO WATER SOLUTIONS, INC., DBA PELICAN WATER TECHNOLOGIES, DELAND, FL. FILED 1-9-2012.

PEOPLE WHO CHOOSE PREMIUM,
CHOOSE PELICAN

THE MARK CONSISTS OF STANDARD CHARACTERS WITHOUT CLAIM TO ANY PARTICULAR FONT, STYLE, SIZE, OR COLOR.
FOR FILTERS FOR DRINKING WATER; WATER FILTERING UNITS FOR DOMESTIC USE; WATER FILTERS; WATER FILTRATION AND PURIFICATION UNITS AND REPLACEMENT CARTRIDGES AND FILTERS THEREFOR; WATER SOFTENING UNITS (U.S. CLS. 13, 21, 23, 31 AND 34).
FIRST USE 1-1-2012; IN COMMERCE 1-1-2012.
MARK SHINER, EXAMINING ATTORNEY

SN 85-512,603. CYCLOPTICS TECHNOLOGIES, LLC, DAYTON, OH. FILED 1-10-2012.

BULBSTICK

THE MARK CONSISTS OF STANDARD CHARACTERS WITHOUT CLAIM TO ANY PARTICULAR FONT, STYLE, SIZE, OR COLOR.
FOR ELECTRIC LAMPS; ELECTRIC LUMINAIRES; LAMPS; LED (LIGHT EMITTING DIODE) LIGHTING FIXTURES; LED LUMINAIRES; LIGHTING FIXTURES (U.S. CLS. 13, 21, 23, 31 AND 34).
MICHAEL SOUDERS, EXAMINING ATTORNEY

CLASS 11—(Continued).

SN 85-512,851. WHIRLPOOL PROPERTIES, INC., ST. JOSEPH, MI. FILED 1-10-2012.

WHIRLPOOL

THE MARK CONSISTS OF STANDARD CHARACTERS WITHOUT CLAIM TO ANY PARTICULAR FONT, STYLE, SIZE, OR COLOR.
OWNER OF U.S. REG. NOS. 660,780, 2,079,116 AND OTHERS.
FOR HUMIDIFIERS (U.S. CLS. 13, 21, 23, 31 AND 34).
GEORGE LORENZO, EXAMINING ATTORNEY

SN 85-512,865. WHIRLPOOL PROPERTIES, INC., ST. JOSEPH, MI. FILED 1-10-2012.



OWNER OF U.S. REG. NOS. 1,251,511, 1,832,111 AND OTHERS.
THE MARK CONSISTS OF THE WORD WHIRLPOOL WITH A SWIRL AND RING.
FOR HUMIDIFIERS (U.S. CLS. 13, 21, 23, 31 AND 34).
GEORGE LORENZO, EXAMINING ATTORNEY

SN 85-512,980. D3BANDS, LLC, NASHUA, NH. FILED 1-10-2012.

She's Got Light

THE MARK CONSISTS OF STANDARD CHARACTERS WITHOUT CLAIM TO ANY PARTICULAR FONT, STYLE, SIZE, OR COLOR.
FOR FLASHLIGHTS, FLASHLIGHT POINTERS, FLASHLIGHT HOLDERS, RED LED FLASHLIGHTS FOR ILLUMINATION PURPOSES, TACTICAL FLASHLIGHTS, BOOK LIGHTS, ELECTRICAL MAGNIFYING LIGHT FIXTURES, LASER LIGHT PROJECTORS, READING LIGHTS, PEN LIGHTS (U.S. CLS. 13, 21, 31 AND 34).
JUDITH HELFMAN, EXAMINING ATTORNEY

CLASS 11—(Continued).

SN 85-513,913. BEHMOR INC., INCLINE VILLAGE, NV.
FILED 1-11-2012.

Brazen

THE MARK CONSISTS OF STANDARD CHARACTERS
WITHOUT CLAIM TO ANY PARTICULAR FONT, STYLE,
SIZE, OR COLOR.

FOR ELECTRIC COFFEE MAKERS (U.S. CLS. 13, 21,
23, 31 AND 34).

JOHN GARTNER, EXAMINING ATTORNEY

SN 85-513,936. AFC-HOLCROFT, L.L.C., WIXOM, MI. FILED
1-11-2012.

PIFCO

THE MARK CONSISTS OF STANDARD CHARACTERS
WITHOUT CLAIM TO ANY PARTICULAR FONT, STYLE,
SIZE, OR COLOR.

FOR INDUSTRIAL FURNACES (U.S. CLS. 13, 21, 23, 31
AND 34).

SAMUEL E. SHARPER JR., EXAMINING ATTORNEY

SN 85-513,971. BEHMOR INC., INCLINE VILLAGE, NV.
FILED 1-11-2012.

Behmor

THE MARK CONSISTS OF STANDARD CHARACTERS
WITHOUT CLAIM TO ANY PARTICULAR FONT, STYLE,
SIZE, OR COLOR.

OWNER OF U.S. REG. NO. 3,718,188.

FOR ELECTRIC COFFEE MAKERS (U.S. CLS. 13, 21,
23, 31 AND 34).

JOHN GARTNER, EXAMINING ATTORNEY

CLASS 11—(Continued).

SN 85-514,468. SUREFIRE, LLC, FOUNTAIN VALLEY, CA.
FILED 1-11-2012.

OWNER OF U.S. REG. NOS. 2,657,142, 3,820,152 AND
OTHERS.

THE MARK CONSISTS OF THE WORD SUREFIRE WITH
PARENTHESES LOCATED ABOVE AND BELOW THE
WORD, SPANNING BETWEEN THE FIRST "R" AND THE
"I".

FOR FLASHLIGHTS (U.S. CLS. 13, 21, 23, 31 AND 34).

FIRST USE 9-27-2010; IN COMMERCE 9-27-2010.

JUSTINE D. PARKER, EXAMINING ATTORNEY

SN 85-516,007. KISS NAIL PRODUCTS, INC., PORT WA-
SHINGTON, NY. FILED 1-13-2012.

CPO

THE MARK CONSISTS OF STANDARD CHARACTERS
WITHOUT CLAIM TO ANY PARTICULAR FONT, STYLE,
SIZE, OR COLOR.

FOR HAIR DRYERS (U.S. CLS. 13, 21, 23, 31 AND 34).

ELIZABETH KAJUBI, EXAMINING ATTORNEY

SN 85-518,330. GREENTECH ENVIRONMENTAL, LLC,
GRAY, TN. FILED 1-17-2012.

GT3000

THE MARK CONSISTS OF STANDARD CHARACTERS
WITHOUT CLAIM TO ANY PARTICULAR FONT, STYLE,
SIZE, OR COLOR.

NO CLAIM IS MADE TO THE EXCLUSIVE RIGHT TO
USE "3000", APART FROM THE MARK AS SHOWN.

FOR AIR PURIFIERS (U.S. CLS. 13, 21, 23, 31 AND 34).

FIRST USE 1-29-2010; IN COMMERCE 3-8-2010.

GRETTA YAO, EXAMINING ATTORNEY

CLASS 11—(Continued).

SN 85-518,358. GREENTECH ENVIRONMENTAL, LLC, GRAY, TN. FILED 1-17-2012.

GT1500

THE MARK CONSISTS OF STANDARD CHARACTERS WITHOUT CLAIM TO ANY PARTICULAR FONT, STYLE, SIZE, OR COLOR.

NO CLAIM IS MADE TO THE EXCLUSIVE RIGHT TO USE "1500", APART FROM THE MARK AS SHOWN.

FOR AIR PURIFIERS (U.S. CLS. 13, 21, 23, 31 AND 34). FIRST USE 3-31-2011; IN COMMERCE 5-3-2011. GRETTA YAO, EXAMINING ATTORNEY

SN 85-521,130. TAIYO NIPPON SANSO CORPORATION, TOKYO, JAPAN, FILED 1-20-2012.

Innova-Jet

THE MARK CONSISTS OF STANDARD CHARACTERS WITHOUT CLAIM TO ANY PARTICULAR FONT, STYLE, SIZE, OR COLOR.

PRIORITY CLAIMED UNDER SEC. 44(D) ON JAPAN APPLICATION NO. 2011-057298, FILED 8-10-2011, REG. NO. 5465945, DATED 1-27-2012, EXPIRES 1-27-2022.

FOR BURNERS FOR INDUSTRIAL FURNACES (U.S. CLS. 13, 21, 23, 31 AND 34). BARBARA GAYNOR, EXAMINING ATTORNEY

SN 85-530,847. LAERA, VITO, FORT LAUDERDALE, FL. FILED 2-1-2012.

VLANCO

THE MARK CONSISTS OF STANDARD CHARACTERS WITHOUT CLAIM TO ANY PARTICULAR FONT, STYLE, SIZE, OR COLOR.

OWNER OF U.S. REG. NO. 3,588,180.

THE WORDING "VLANCO" HAS NO MEANING IN A FOREIGN LANGUAGE.

FOR AIR CLEANING UNITS; AIR CLEANING UNITS CONTAINING AN AIR FILTER, ULTRAVIOLET LIGHTS AND A PHOTOCATALYTIC FILTER; AIR CONDITIONERS; AIR CONDITIONING APPARATUS; AIR CONDITIONING APPARATUS AND INSTALLATIONS; AIR CONDITIONING INSTALLATIONS; AIR CONDITIONING UNITS; AIR COOLING APPARATUS; AIR FILTERING INSTALLATIONS; AIR FILTERS FOR AIR CONDITIONERS IN VEHICLE PASSENGER COMPARTMENTS; AIR FILTERS FOR AIR CONDITIONING UNITS; AIR FILTERS FOR DOMESTIC USE; AIR FILTERS FOR INDUSTRIAL INSTALLATIONS; AIR HANDLERS; AIR PURIFICATION UNITS; AIR PURIFIERS; AIR PURIFIERS; AIR PURIFYING APPARATUS; AIR PURIFYING APPARATUS AND MACHINES; AIR STERILISERS; AIR-CONDITIONING APPARATUS; AIR-

CLASS 11—(Continued).

CONDITIONING APPARATUS; AIR-CONDITIONING APPARATUS AND INSTALLATIONS; AIR-CONDITIONING INSTALLATIONS; AIR-CONDITIONING, AIR COOLING AND VENTILATION APPARATUS AND INSTRUMENTS; ANTI-SPLASH TAP NOZZLES; ARM RESTS FOR USE WITH TOILET SEATS; BATH TUB JETS; BATH TUBS; BATH TUBS AND SHOWER TRAYS; BATHROOM EXHAUST FANS; BATHS, BATHTUBS, WHIRLPOOL BATHS AND BATH INSTALLATIONS; BATTERY-OPERATED TAP LIGHTS; CEILING LIGHTS; COILS AS PARTS OF DISTILLING, HEATING OR COOLING INSTALLATIONS; COMMERCIAL REFRIGERATORS AND FREEZERS AND PARTS AND FITTINGS THEREFOR; COMPONENT PARTS OF WATER COOLING TOWERS IN THE NATURE OF WIRE MESH HANGERS FOR SECURING SLAT FILL; DECORATIVE TABLE-TOP WATER FOUNTAINS; DECORATIVE WATER FOUNTAINS; DRAIN STRUCTURES FOR USE IN SPAS, STEAM ROOMS AND BATHS; ELECTRIC BATH-WATER PURIFYING APPARATUS FOR HOUSEHOLD PURPOSES; ELECTRIC LIGHTING FIXTURES; EXHAUST HOODS FOR KITCHENS; EXTRACTOR HOODS FOR KITCHENS; FABRIC AIR DISPERSION DUCTS FOR DISTRIBUTING AND DISPENSING AIR AS PART OF A HVAC SYSTEM; FILTERS FOR AIR CONDITIONING; FILTERS FOR AIR EXTRACTOR HOODS; FILTERS FOR DRINKING WATER; FILTERS, HEATERS AND PUMPS SOLD IN COMBINATION FOR USE IN HOT TUBS; FITTED LINERS FOR HOT TUBS OR SPAS; FITTED SPA COVERS; FLEXIBLE PIPES BEING PARTS OF BASIN PLUMBING INSTALLATIONS; FLEXIBLE PIPES BEING PARTS OF BATH PLUMBING INSTALLATIONS; FLEXIBLE PIPES BEING PARTS OF SHOWER PLUMBING INSTALLATIONS; FLEXIBLE PIPES BEING PARTS OF SINK PLUMBING INSTALLATIONS; HAND HELD SHOWER HEADS; HAND SHOWERS; HAND-HELD SHOWERS; HEAT SINKS FOR USE IN HEATING, COOLING AND VENTILATING APPARATUS; HOT TUB JETS; HOT TUBS; HOT WATER HEATERS; HOT WATER TANKS; HOUSEHOLD AIR CLEANERS; HYDROMASSAGE BATH APPARATUS; INDUSTRIAL AIR FILTER MACHINES; INDUSTRIAL AIR PURIFIERS; KITCHEN SINK SPRAYERS; KITCHEN SINKS; LAVATORIES; LAVATORY BOWLS; LAVATORY SEATS; LIGHTING APPARATUS, NAMELY, LIGHTING INSTALLATIONS; LIGHTING FIXTURES; MANUALLY-OPERATED PLUMBING VALVES; MIXER FAUCETS FOR WATER PIPES; MULTIPLE POSITION BATH SEATS; PAVEMENT HEATING APPARATUS; PIPES BEING PARTS OF SANITARY FACILITIES; PLUMBING FITTINGS, NAMELY, AERATORS FOR FAUCETS; PLUMBING FITTINGS, NAMELY, BAFFLES; PLUMBING FITTINGS, NAMELY, BIBBS; PLUMBING FITTINGS, NAMELY, COCKS; PLUMBING FITTINGS, NAMELY, COUPLERS; PLUMBING FITTINGS, NAMELY, DRAINS; PLUMBING FITTINGS, NAMELY, FAUCET FILTERS; PLUMBING FITTINGS, NAMELY, FRESH WATER FILLS FOR RECREATIONAL VEHICLES; PLUMBING FITTINGS, NAMELY, SHOWER CONTROL VALVES; PLUMBING FITTINGS, NAMELY, SINK STRAINERS; PLUMBING FITTINGS, NAMELY, SPOUTS; PLUMBING FITTINGS, NAMELY, TRAPS; PLUMBING FITTINGS, NAMELY, TUB CONTROL VALVES; PLUMBING FITTINGS, NAMELY, VALVES; PLUMBING FIXTURES, NAMELY, SHOWER MIXERS; PLUMBING FIXTURES, NAMELY, SHOWER SPRAYERS; PLUMBING FIXTURES, NAMELY, SINK SPRAYERS; PLUMBING FIXTURES, NAMELY, SINK TRAPS; PLUMBING SUPPLIES, NAMELY, SINK STRAINERS; PORTABLE SHOWERS; PRESSURE REGULATORS FOR SANITARY INSTALLATIONS; PRESSURE REGULATORS FOR WATER INSTALLATIONS; SANITARY INSTALLATIONS IN THE NATURE OF STEAM ROOMS; SAUNA BATH INSTALLATIONS; SEPARATORS FOR THE CLEANING AND PURIFICATION OF LIQUIDS; SHOWER AND BATH CUBICLES; SHOWER BASES; SHOWER CONTROL FITTINGS, NAMELY, ESCUTCHEONS; SHOWER DOORS; SHOWER ENCLOSURES; SHOWER FAUCET EXTENSIONS; SHOWER HEAD SPRAYERS; SHOWER HEADS; SHOWER PANELS; SHOWER PLATFORMS; SHOWER STANDS; SHOWER SURROUNDS; SHOWER TRAYS; SHOWER TUBS; SHOWERS; SHOWERS AND SHOWER CUBICLES; SIDE-ENTRY BATHS FOR USE BY THE PHYSICALLY HANDICAPPED; SINGLE LEVER FIXTURES FOR LAVATORIES AND SINKS; SINK DRAINER SYSTEM COMPRISED OF A DRAIN TRAY, SINK MOUNT, KICK

CLASS 11—(Continued).

STAND AND ROD; SINK PEDESTALS; SINKS INTEGRATED INTO COUNTERTOPS OR COUNTERTOPS; SPOUTS FOR AFFIXING ON WALLS FOR BATHS, BASINS, BIDETS; STAINLESS STEEL BOTTOM GRIDS SPECIALLY ADAPTED AND SHAPED FOR USE IN SINKS; STRAINERS FOR PLUMBING DRAINS; STRAINERS FOR WATER LINES; TANKLESS WATER HEATERS; TAP WATER FAUCETS; TAP-WATER PURIFYING APPARATUS; TAPS FOR WASHSTANDS; TOILET ACCESSORIES, NAMELY, HANDLES THAT ARE AFFIXED TO TOILET SEATS; TOILET ACCESSORIES, NAMELY, PLASTIC HANDLES THAT ARE AFFIXED TO TOILET SEATS; TOILET BOWLS; TOILET CONVERSION KITS FOR CONVERTING A SINGLE-FLUSH TOILET INTO A DUAL-FLUSH TOILET; TOILET SEAT ADAPTORS FOR CHILDREN IN THE NATURE OF A PLASTIC DEVICE THAT IS SPECIALLY ADAPTED TO REST ON A TOILET SEAT; TOILET SEATS; TOILET STOOL UNITS WITH A WASHING WATER SQUIRTER; TOILET TANK BALLS; TOILET TANKS; TOILET TRAINER SEATS, NAMELY, SMALLER TRAINING SEATS FOR ATTACHMENT TO FULL-SIZE TOILETS AND TOILET SEATS FOR TRAINING PURPOSES; TOILETS; TUB PARTS, NAMELY, TUB OVERFLOWS; TUB PARTS, NAMELY, TUB WASTES; TUB SPOUTS; VALVES FOR AIR CONDITIONERS; WALL WATER FOUNTAINS; WATER CLOSETS; WATER COOLERS; WATER DISTILLING UNITS; WATER FAUCET SPOUT; WATER FILTERING APPARATUS; WATER FILTERS; WATER FILTRATION AND PURIFICATION UNITS AND REPLACEMENT CARTRIDGES AND FILTERS THEREFOR; WATER FILTRATION APPARATUS FOR THE DEIONIZATION OF WATER; WATER FOUNTAINS; WATER HEATERS; WATER PURIFICATION AND FILTRATION APPARATUS; WATER PURIFICATION MACHINES; WATER PURIFICATION TANKS; WATER PURIFICATION UNITS; WATER PURIFYING APPARATUS; WATER SOFTENING APPARATUS AND INSTALLATIONS; WATER SOFTENING UNITS; WATER TREATMENT EQUIPMENT, NAMELY, CARTRIDGE FILTRATION UNITS; WATER TREATMENT EQUIPMENT, NAMELY, CHEMICAL STERILIZATION UNITS; WATER TREATMENT EQUIPMENT, NAMELY, REVERSE OSMOSIS FILTRATION UNITS; WATER TREATMENT EQUIPMENT, NAMELY, REVERSE OSMOSIS UNITS; WATER TREATMENT EQUIPMENT, NAMELY, ULTRAVIOLET STERILIZATION UNITS; WATER TREATMENT EQUIPMENT, NAMELY, WATER FILTRATION UNITS; WHIRLPOOL BATHS (U.S. CLS. 13, 21, 23, 31 AND 34).

FIRST USE 1-1-2006; IN COMMERCE 3-1-2006.
WON TEAK OH, EXAMINING ATTORNEY

PRO STYLER

THE MARK CONSISTS OF STANDARD CHARACTERS WITHOUT CLAIM TO ANY PARTICULAR FONT, STYLE, SIZE, OR COLOR.

OWNER OF U.S. REG. NOS. 3,058,111 AND 4,024,110.
NO CLAIM IS MADE TO THE EXCLUSIVE RIGHT TO USE "STYLER", APART FROM THE MARK AS SHOWN.

FOR HAND-HELD ELECTRIC HAIR DRYERS (U.S. CLS. 13, 21, 23, 31 AND 34).

WILLIAM JACKSON, EXAMINING ATTORNEY

CLASS 11—(Continued).

SN 85-538,480. THE TIFFEN COMPANY,LLC, HAUPPAUGE, NY. FILED 2-9-2012.

LOWEL GL-1

THE MARK CONSISTS OF STANDARD CHARACTERS WITHOUT CLAIM TO ANY PARTICULAR FONT, STYLE, SIZE, OR COLOR.

OWNER OF U.S. REG. NOS. 1,097,964 AND 3,054,120.
FOR LIGHTING EQUIPMENT FOR STILL PHOTOGRAPHY, MOTION PICTURE PHOTOGRAPHY, VIDEOGRAPHY AND TELEVISION, NAMELY, ELECTRIC LIGHTS AND FIXTURES; FLOODLIGHTS; SOFT LIGHTS; SPOTLIGHTS; PORTABLE ELECTRICAL PHOTOGRAPHIC MULTI-PURPOSE LIGHTS, LAMP SUPPORTS, STANDS AND MOUNTS; LIGHT FILTERS; AND LIGHT REFLECTORS (U.S. CLS. 13, 21, 23, 31 AND 34).

PAUL MORENO, EXAMINING ATTORNEY

SN 85-539,388. LAERA, VITO, FORT LAUDERDALE, FL. FILED 2-10-2012.

ATTALIA

THE MARK CONSISTS OF STANDARD CHARACTERS WITHOUT CLAIM TO ANY PARTICULAR FONT, STYLE, SIZE, OR COLOR.

THE WORDING "ATTALIA" HAS NO MEANING IN A FOREIGN LANGUAGE.

FOR AUTOMATIC FAUCETS; FAUCET AERATORS; FAUCET HANDLES; FAUCET SPRAYERS; FAUCETS; KITCHEN SINK SPRAYERS; KITCHEN SINKS; MIXER FAUCETS FOR WATER PIPES; PLUMBING FITTINGS, NAMELY, AERATORS FOR FAUCETS; PLUMBING FITTINGS, NAMELY, FAUCET FILTERS; PLUMBING FITTINGS, NAMELY, SINK STRAINERS; PLUMBING FIXTURES, NAMELY, SINK SPRAYERS; PLUMBING FIXTURES, NAMELY, SINK TRAPS; PLUMBING SUPPLIES, NAMELY, SINK STRAINERS; SHOWER FAUCET EXTENSIONS; SINGLE LEVER FIXTURES FOR LAVATORIES AND SINKS; SINK DRAINER SYSTEM COMPRISED OF A DRAIN TRAY, SINK MOUNT, KICK STAND AND ROD; SINK PEDESTALS; SINKS INTEGRATED INTO COUNTERTOPS OR COUNTERTOPS; STAINLESS STEEL BOTTOM GRIDS SPECIALLY ADAPTED AND SHAPED FOR USE IN SINKS; STRAINERS FOR PLUMBING DRAINS; TAP WATER FAUCETS; TAPS; WATER FAUCET SPOUT (U.S. CLS. 13, 21, 23, 31 AND 34).

FIRST USE 1-1-2007; IN COMMERCE 1-1-2007.

WON TEAK OH, EXAMINING ATTORNEY

CLASS 11—(Continued).

SN 85-545,265. ORBIT IRRIGATION PRODUCTS, INC., NORTH SALT LAKE, UT. FILED 2-16-2012.

LIGHTMASTER

THE MARK CONSISTS OF STANDARD CHARACTERS WITHOUT CLAIM TO ANY PARTICULAR FONT, STYLE, SIZE, OR COLOR.
FOR LIGHTING FIXTURES ATTACHABLE TO A STAKE THAT MAY BE DRIVEN INTO THE GROUND (U.S. CLS. 13, 21, 23, 31 AND 34).
VERNA BETH RIRIE, EXAMINING ATTORNEY

SN 85-550,472. LASKO HOLDINGS, INC., WILMINGTON, DE. FILED 2-23-2012.

LASKO

THE MARK CONSISTS OF STANDARD CHARACTERS WITHOUT CLAIM TO ANY PARTICULAR FONT, STYLE, SIZE, OR COLOR.
OWNER OF U.S. REG. NOS. 1,794,855, 3,402,479 AND OTHERS.
FOR PORTABLE NON-INDUSTRIAL AIR CLEANERS AND PURIFIERS (U.S. CLS. 13, 21, 23, 31 AND 34).
FIRST USE 5-1-2003; IN COMMERCE 5-1-2003.
TINA MAI, EXAMINING ATTORNEY

SN 85-561,928. GREAT EAGLE LIGHTING CORPORATION, OAKLAND GARDENS, NY. FILED 3-6-2012.

THE LIGHT HAS COME

THE MARK CONSISTS OF STANDARD CHARACTERS WITHOUT CLAIM TO ANY PARTICULAR FONT, STYLE, SIZE, OR COLOR.
FOR ELECTRIC BULBS; ELECTRIC LIGHT BULBS; LED LIGHT BULBS; LIGHT BULBS; VEHICLE TURN-SIGNAL LIGHT BULBS (U.S. CLS. 13, 21, 23, 31 AND 34).
THEODORE MCBRIDE, EXAMINING ATTORNEY

CLASS 11—(Continued).

SN 85-588,932. TRANSWORLD IMPORTS INC., SUWANEE, GA. FILED 4-4-2012.

JOIN THE TRIBE

THE MARK CONSISTS OF STANDARD CHARACTERS WITHOUT CLAIM TO ANY PARTICULAR FONT, STYLE, SIZE, OR COLOR.
FOR BARBECUES AND GRILLS (U.S. CLS. 13, 21, 23, 31 AND 34).
MICHAEL LITZAU, EXAMINING ATTORNEY

CLASS 12—VEHICLES

SN 76-710,032. SUTONG CHINA TIRE RESOURCES, INC., HOUSTON, TX. FILED 12-19-2011.

AETHON

THE MARK CONSISTS OF STANDARD CHARACTERS WITHOUT CLAIM TO ANY PARTICULAR FONT, STYLE, SIZE, OR COLOR.
FOR VEHICLE TIRES, INCLUSIVE OF PASSENGER, TRUCK, INDUSTRIAL AND OFF-THE ROAD-TIRES, AND TUBES THEREFOR (U.S. CLS. 19, 21, 23, 31, 35 AND 44).
ALICIA COLLINS, EXAMINING ATTORNEY

SN 76-710,035. SUTONG CHINA TIRE RESOURCES, INC., HOUSTON, TX. FILED 12-19-2011.

BOREAS

THE MARK CONSISTS OF STANDARD CHARACTERS WITHOUT CLAIM TO ANY PARTICULAR FONT, STYLE, SIZE, OR COLOR.
FOR VEHICLE TIRES, INCLUSIVE OF PASSENGER, TRUCK, INDUSTRIAL AND OFF-THE ROAD-TIRES, AND TUBES THEREFOR (U.S. CLS. 19, 21, 23, 31, 35 AND 44).
ALICIA COLLINS, EXAMINING ATTORNEY

CLASS 12—(Continued).

SN 79-092,853. BAYERISCHE MOTOREN WERKE AKTIENGESELLSCHAFT, FED REP GERMANY, FILED 12-21-2010.

MINI Crossover

THE MARK CONSISTS OF STANDARD CHARACTERS WITHOUT CLAIM TO ANY PARTICULAR FONT, STYLE, SIZE, OR COLOR.

PRIORITY DATE OF 8-17-2010 IS CLAIMED.

OWNER OF INTERNATIONAL REGISTRATION 1065887 DATED 12-21-2010, EXPIRES 12-21-2020.

NO CLAIM IS MADE TO THE EXCLUSIVE RIGHT TO USE "CROSSOVER", APART FROM THE MARK AS SHOWN.

FOR PASSENGER CARS AND STRUCTURAL PARTS THEREFOR (U.S. CLS. 19, 21, 23, 31, 35 AND 44).

MELISSA VALLILLO, EXAMINING ATTORNEY

SN 79-095,071. PIRELLI TYRE S.P.A., ITALY, FILED 2-3-2011.

CYBER

THE MARK CONSISTS OF STANDARD CHARACTERS WITHOUT CLAIM TO ANY PARTICULAR FONT, STYLE, SIZE, OR COLOR.

PRIORITY DATE OF 1-28-2011 IS CLAIMED.

OWNER OF INTERNATIONAL REGISTRATION 1070969 DATED 2-3-2011, EXPIRES 2-3-2021.

FOR TYRES; PNEUMATIC, SEMI-PNEUMATIC AND SOLID TYRES FOR VEHICLE WHEELS; WHEELS FOR VEHICLES, WHEEL RIMS (U.S. CLS. 19, 21, 23, 31, 35 AND 44).

DEBRA LEE, EXAMINING ATTORNEY

SN 79-100,344. HANGZHOU GENERAL RUBBER FACTORY, HANGZHOU CITY, ZHEJIANG, CHINA, FILED 6-29-2011.

ORNATE

OWNER OF INTERNATIONAL REGISTRATION 1084917 DATED 6-29-2011, EXPIRES 6-29-2021.

THE MARK CONSISTS OF THE TERM "ORNATE" IN STYLIZED LETTERS.

FOR TIRES FOR VEHICLES; TIRES OF BICYCLES; TIRES OF CYCLES; CASINGS FOR PNEUMATIC TIRES; AUTOMOBILE TIRES; INNER TUBES FOR BICYCLES, CYCLES (U.S. CLS. 19, 21, 23, 31, 35 AND 44).

MARK T. MULLEN, EXAMINING ATTORNEY

CLASS 12—(Continued).

SN 79-103,958. DAHON TECHNOLOGIES, LTD., CHINA, FILED 9-26-2011.

BICECO

THE MARK CONSISTS OF STANDARD CHARACTERS WITHOUT CLAIM TO ANY PARTICULAR FONT, STYLE, SIZE, OR COLOR.

OWNER OF INTERNATIONAL REGISTRATION 1094340 DATED 9-26-2011, EXPIRES 9-26-2021.

THE WORDING "BICECO" HAS NO MEANING IN A FOREIGN LANGUAGE.

FOR BICYCLES; CYCLE CARS; TRICYCLES; MOPEDS; FRAMES FOR BICYCLES AND CYCLES; SCOOTERS IN THE NATURE OF VEHICLES; ELECTRICAL BICYCLES; ELECTRICAL TRICYCLES; ELECTRICALLY POWER ASSISTED CYCLES; HANDLE BARS FOR BICYCLES AND CYCLES (U.S. CLS. 19, 21, 23, 31, 35 AND 44).

SEAN CROWLEY, EXAMINING ATTORNEY

SN 79-107,720. DRETTMANN YACHTS GMBH, FED REP GERMANY, FILED 7-25-2011.



OWNER OF INTERNATIONAL REGISTRATION 1103059 DATED 7-25-2011, EXPIRES 7-25-2021.

THE COLOR(S) BLACK, BEIGE, WHITE, GREY IS/ARE CLAIMED AS A FEATURE OF THE MARK.

THE MARK CONSISTS OF THE STYLIZED LETTERS "DY" ABOVE THE WORDING "DRETTMAN" IN BLACK. THE LEFT PORTION OF THE DESIGN IS IN VARYING SHADES OF THE COLORS BEIGE AND WHITE, AND THE RIGHT SIDE OF THE DESIGN IN THE COLORS BLACK, GREY, AND WHITE.

FOR VEHICLES, NAMELY, BOATS; APPARATUS FOR LOCOMOTION BY WATER, NAMELY, BOATS (U.S. CLS. 19, 21, 23, 31, 35 AND 44).

DAVID HOFFMAN, EXAMINING ATTORNEY

CLASS 12—(Continued).

SN 79-108,485. AUGUSTA BENELUX B.V., NETHERLANDS, FILED 10-4-2011.



PRIORITY DATE OF 5-18-2011 IS CLAIMED.
OWNER OF INTERNATIONAL REGISTRATION 1105082 DATED 10-4-2011, EXPIRES 10-4-2021.
THE MARK CONSISTS OF A WIDE CURVED BAND EXTENDING WITH A FINER LINE TO THE RIGHT.
FOR PARTS AND ACCESSORIES OF BICYCLES, NAMELY, BICYCLE TYRES, BICYCLE BELLS, BICYCLE PUMPS, BICYCLE PEDALS, BICYCLE HANDLEBARS, BICYCLE HANDLEBAR TAPES, BICYCLE HANDLEBAR GRIPS, BICYCLE HANDLEBAR STEMS, BICYCLE SADDLES, BICYCLE SEAT POSTS, BICYCLE BRAKES, BICYCLE BRAKESHOES, BICYCLE BAR ENDS, BICYCLE STANDS, BICYCLE HEADSETS, BICYCLE BOTTLE CAGES, BICYCLE SPOKES, BICYCLE CHAINRINGS, BICYCLE MUDGUARDS, BICYCLE BAGS, BICYCLE SADDLEBAGS; BICYCLE CHAINS, BICYCLE BASKETS, BICYCLE CHILD SEATS, BICYCLE LUGGAGE CARRIERS, BICYCLE WHEELSETS, BICYCLE CRANKSETS; BICYCLE HUBS; BICYCLE TRANSMISSION PARTS (U.S. CLS. 19, 21, 23, 31, 35 AND 44).
GISELLE AGOSTO, EXAMINING ATTORNEY

SN 79-110,132. GUSTAV MAGENWIRTH GMBH & CO. KG, FED REP GERMANY, FILED 1-20-2012.

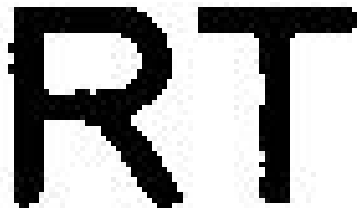

THE MARK CONSISTS OF STANDARD CHARACTERS WITHOUT CLAIM TO ANY PARTICULAR FONT, STYLE, SIZE, OR COLOR.
PRIORITY DATE OF 7-22-2011 IS CLAIMED.
OWNER OF INTERNATIONAL REGISTRATION 1109805 DATED 1-20-2012, EXPIRES 1-20-2022.
FOR BICYCLE BRAKES, NAMELY HYDRAULIC RIM AND DISK BRAKES AND PARTS THEREOF (U.S. CLS. 19, 21, 23, 31, 35 AND 44).
SCOTT BIBB, EXAMINING ATTORNEY

CLASS 12—(Continued).

SN 79-111,456. GUSTAV MAGENWIRTH GMBH & CO. KG, FED REP GERMANY, FILED 1-23-2012.

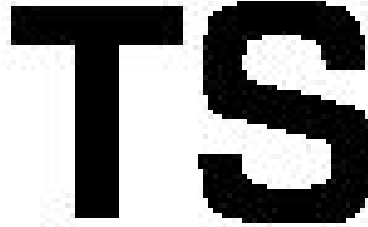

THE MARK CONSISTS OF STANDARD CHARACTERS WITHOUT CLAIM TO ANY PARTICULAR FONT, STYLE, SIZE, OR COLOR.
OWNER OF INTERNATIONAL REGISTRATION 1112393 DATED 1-23-2012, EXPIRES 1-23-2022.
FOR BICYCLE PARTS, NAMELY SUSPENSION FORKS AND SHOCK AND VIBRATION ABSORBERS AND PARTS THEREOF (U.S. CLS. 19, 21, 23, 31, 35 AND 44).
SCOTT BIBB, EXAMINING ATTORNEY

SN 85-230,400. SAPIENT AUTOMATION, LLC, DOYLES-TOWN, PA. FILED 1-31-2011.



THE MARK CONSISTS OF STANDARD CHARACTERS WITHOUT CLAIM TO ANY PARTICULAR FONT, STYLE, SIZE, OR COLOR.
NO CLAIM IS MADE TO THE EXCLUSIVE RIGHT TO USE "PICK CART", APART FROM THE MARK AS SHOWN.
FOR CARTS, NAMELY, ORDER PICKING AND MATERIAL HANDLING EQUIPMENT (U.S. CLS. 19, 21, 23, 31, 35 AND 44).
FIRST USE 8-23-2010; IN COMMERCE 8-23-2010.
DAWN FELDMAN, EXAMINING ATTORNEY

SN 85-289,824. DANSK TEKNOLOGI PRODUKTIONS-AKTIESELSKAB, AKA DANSK TEKNOLOGI A/S, ALLEROED, DENMARK, FILED 4-8-2011.



PRIORITY CLAIMED UNDER SEC. 44(D) ON DENMARK APPLICATION NO. 009879446, FILED 4-8-2011, REG. NO. 009879446, DATED 8-23-2011, EXPIRES 4-8-2021.
NO CLAIM IS MADE TO THE EXCLUSIVE RIGHT TO USE "NOX REDUCTION", APART FROM THE MARK AS SHOWN.
THE MARK CONSISTS OF THE STYLIZED AND UNDERLINED WORD "BLUNOX" WITH THE "X" INTERRUPTING THE UNDERLINE, ALL OVER THE WORDING "NEXT GENERATION NOX REDUCTION".
FOR MARINE VEHICLES, NAMELY, RUN-ABOUTS (U.S. CLS. 19, 21, 23, 31, 35 AND 44).
JASON TURNER, EXAMINING ATTORNEY

CLASS 12—(Continued).

SN 85-331,720. ECOSPAN, LLC, GREENBRAE, CA. FILED 5-26-2011.



THE MARK CONSISTS OF THE WORD "ECOSPAN" IN A STYLIZED FORMAT PLUS PARTIAL CONCENTRIC OVAL SHAPES.

FOR ACCESSORIES AND COMPONENTS FOR AUTOMOBILE INTERIORS CONSTRUCTED FROM BIOPOLYMER-BASED RESIN AND PLASTIC SHAPES, NAMELY, CUP HOLDERS, HANDBRAKE KNOBS, AUTOMOTIVE INTERIOR PLASTIC EXTRUDED DECORATIVE AND PROTECTIVE TRIM, AUTOMOTIVE INTERIOR PANELING, DOOR HANDLES, DRINK HOLDERS, SEAT COVERS FOR VEHICLES, WINDSHIELD VISORS, SUN SHIELDS AND VISORS, AIR VENTS BEING STRUCTURAL COMPONENTS OF AIR PUMPS OF AUTOMOBILES FOR FEEDING AIR INTO VEHICLE INTERIORS, AIR DUCTS BEING STRUCTURAL COMPONENTS OF AIR PUMPS OF AUTOMOBILES FOR FEEDING AIR INTO VEHICLE INTERIORS, GLOVE BOXES, CENTER CONSOLES, AIRBAG MOLDINGS, CARGO HOLD MOLDINGS (U.S. CLS. 19, 21, 23, 31, 35 AND 44).

ALLISON SCHRODY, EXAMINING ATTORNEY

SN 85-333,890. SCHAEFER, JEANNA, CHARLOTTE, NC. FILED 5-31-2011.

CONTEGO

THE MARK CONSISTS OF STANDARD CHARACTERS WITHOUT CLAIM TO ANY PARTICULAR FONT, STYLE, SIZE, OR COLOR.

FOR BICYCLE COVERS (U.S. CLS. 19, 21, 23, 31, 35 AND 44).

LINDA M. KING, EXAMINING ATTORNEY

CLASS 12—(Continued).

SN 85-342,666. INDIAN HEAD INDUSTRIES, INC., CHARLOTTE, NC. FILED 6-9-2011.



NO CLAIM IS MADE TO THE EXCLUSIVE RIGHT TO USE "CORROSION", APART FROM THE MARK AS SHOWN.

THE MARK CONSISTS OF THE WORD "CORROSION" IN A STYLIZED FONT MADE TO LOOK AS IF THE BOTTOM PORTION OF EACH LETTER IS IN BROKEN PIECES ABOVE THE WORD "FIGHTER" WITH TWO HORIZONTAL LINES IN FRONT OF AND AFTER THE TERM "FIGHTER".

FOR BRAKE HARDWARE FOR VEHICLES; PRESSURE FLUID MOTORS, VALVES AND PARTS THEREFOR, FOR ACTUATING VEHICULAR BRAKES (U.S. CLS. 19, 21, 23, 31, 35 AND 44).

FIRST USE 12-0-2010; IN COMMERCE 12-0-2010.

FLORENTINA BLANDU, EXAMINING ATTORNEY

SN 85-342,820. WIDERGREN, DOUGLAS, OAKLAND, CA. FILED 6-10-2011.

FREEDOMRIDERS M/C CALIFORNIA

THE MARK CONSISTS OF STANDARD CHARACTERS WITHOUT CLAIM TO ANY PARTICULAR FONT, STYLE, SIZE, OR COLOR.

NO CLAIM IS MADE TO THE EXCLUSIVE RIGHT TO USE "M/C" AND "CALIFORNIA", APART FROM THE MARK AS SHOWN.

FOR VEHICLES, NAMELY, MOTORCYCLES (U.S. CLS. 19, 21, 23, 31, 35 AND 44).

MARILYN IZZI, EXAMINING ATTORNEY

SN 85-346,849. HOTCHKIS PERFORMANCE, SANTA FE SPRINGS, CA. FILED 6-15-2011.



NO CLAIM IS MADE TO THE EXCLUSIVE RIGHT TO USE "SPORT SUSPENSION", APART FROM THE MARK AS SHOWN.

THE MARK CONSISTS OF THE NAME "HOTCHKIS" WITH A LINE GOING THROUGH THE CENTER OF IT, THE WORDS "SPORT" AND "SUSPENSION" DIRECTLY UNDER THE NAME "HOTCHKIS".

FOR SUSPENSION SYSTEMS FOR LAND VEHICLES (U.S. CLS. 19, 21, 23, 31, 35 AND 44).

FIRST USE 10-1-2005; IN COMMERCE 10-1-2005.

SUE LAWRENCE, EXAMINING ATTORNEY

CLASS 12—(Continued).

SN 85-349,619. L & P PROPERTY MANAGEMENT COMPANY, SOUTH GATE, CA. FILED 6-17-2011.

SLIDE-DOWN

THE MARK CONSISTS OF STANDARD CHARACTERS WITHOUT CLAIM TO ANY PARTICULAR FONT, STYLE, SIZE, OR COLOR.

SEC. 2(F).
FOR VEHICLE RACKS FOR USE IN STORING AND CARRYING LADDERS, FEATURING MOTION CONTROL ASSISTS FOR LOWERING LADDERS (U.S. CLS. 19, 21, 23, 31, 35 AND 44).

FIRST USE 0-0-1992; IN COMMERCE 0-0-1992.
GRETTA YAO, EXAMINING ATTORNEY

CLASS 12—(Continued).

SN 85-357,321. REDLINE AVIATION, RANCHO SANTA FE, CA. FILED 6-27-2011.

SIDEWINDER

THE MARK CONSISTS OF STANDARD CHARACTERS WITHOUT CLAIM TO ANY PARTICULAR FONT, STYLE, SIZE, OR COLOR.

FOR POWERED DEVICE FOR MOVING AIRCRAFT ON THE GROUND, NAMELY, AIRCRAFT TUGS (U.S. CLS. 19, 21, 23, 31, 35 AND 44).

FIRST USE 7-15-2008; IN COMMERCE 7-15-2008.
KATHERINE CONNOLLY, EXAMINING ATTORNEY

SN 85-354,059. PRIDE MOBILITY PRODUCTS CORPORATION, EXETER, PA. FILED 6-23-2011.

KIDS UP

THE MARK CONSISTS OF STANDARD CHARACTERS WITHOUT CLAIM TO ANY PARTICULAR FONT, STYLE, SIZE, OR COLOR.

NO CLAIM IS MADE TO THE EXCLUSIVE RIGHT TO USE "KIDS", APART FROM THE MARK AS SHOWN.

FOR PEDIATRIC WHEELCHAIRS, BOTH MANUAL AND POWERED; PEDIATRIC WHEELCHAIRS, BOTH MANUAL AND POWERED, INCLUDING REPAIR AND REPLACEMENT PARTS THEREFOR, SOLD AS A UNIT; PEDIATRIC WHEELCHAIRS, BOTH MANUAL AND POWERED, INCLUDING REPAIR AND REPLACEMENT PARTS THEREFOR (U.S. CLS. 19, 21, 23, 31, 35 AND 44).

DAVID I, EXAMINING ATTORNEY

SN 85-370,911. GREENMAN MACHINERY COMPANY, SHUNYI DIST., BEIJING, CHINA, FILED 7-13-2011.

GREENMAN

THE MARK CONSISTS OF "GREENMAN".

FOR BODIES FOR VEHICLES; CABLE CARS; ELECTRIC CARS; ELECTRIC DRIVES FOR VEHICLES; ELECTRIC GOLF CADDIES; ELECTRIC MOTORCYCLES; ELECTRIC VEHICLES, NAMELY, ELECTRIC GOLF VEHICLES; FITTED COVERS FOR MOTORIZED GOLF CARTS; FOUR-WHEELED MOTOR VEHICLES; LAND VEHICLES; LAND VEHICLES AND STRUCTURAL PARTS THEREFOR; LAND VEHICLES, NAMELY, LOW-SPEED ELECTRIC VEHICLES; LUGGAGE CARRIERS FOR VEHICLES; LUGGAGE RACKS FOR MOTOR CARS; MOTOR VEHICLES, NAMELY, AUTOMOBILES, TRUCKS, VANS, SPORT UTILITY VEHICLES AND STRUCTURAL PARTS THEREFOR; MOTOR VEHICLES, NAMELY, PASSENGER AUTOMOBILES, THEIR STRUCTURAL PARTS, TRIM AND BADGES; MOTORIZED AND COMPUTERIZED GOLF CARTS; MOTORIZED GOLF CARTS; MOTORIZED GOLF TROLLEYS; MOTORIZED LUGGAGE CARTS; MOTORIZED, ELECTRIC-POWERED, SELF-PROPELLED, SELF-BALANCING, WHEELED PERSONAL MOBILITY, TRANSPORTATION DEVICE; SELF-PROPELLED ELECTRIC VEHICLE; SPORTS UTILITY VEHICLES; TRICYCLES (U.S. CLS. 19, 21, 23, 31, 35 AND 44).

PATRICIA EVANKO, EXAMINING ATTORNEY

SN 85-354,125. PRIDE MOBILITY PRODUCTS CORPORATION, EXETER, PA. FILED 6-23-2011.

KIDS ROCK

THE MARK CONSISTS OF STANDARD CHARACTERS WITHOUT CLAIM TO ANY PARTICULAR FONT, STYLE, SIZE, OR COLOR.

NO CLAIM IS MADE TO THE EXCLUSIVE RIGHT TO USE "KIDS", APART FROM THE MARK AS SHOWN.

FOR PEDIATRIC WHEELCHAIRS; PEDIATRIC WHEELCHAIRS INCLUDING REPAIR AND REPLACEMENT PARTS SOLD AS A UNIT; PEDIATRIC WHEELCHAIRS INCLUDING REPAIR AND REPLACEMENT PARTS THEREFOR (U.S. CLS. 19, 21, 23, 31, 35 AND 44).

DAVID I, EXAMINING ATTORNEY

CLASS 12—(Continued).

SN 85-380,063. THOR TECH, INC., JACKSON CENTER, OH.
FILED 7-25-2011.

MISSION

THE MARK CONSISTS OF STANDARD CHARACTERS WITHOUT CLAIM TO ANY PARTICULAR FONT, STYLE, SIZE, OR COLOR.

FOR VANS MODIFIED FOR HANDICAPPED USE (U.S. CLS. 19, 21, 23, 31, 35 AND 44).

FIRST USE 1-0-2011; IN COMMERCE 1-0-2011.

JIM RINGLE, EXAMINING ATTORNEY

SN 85-393,863. SHIMANO INC., SAKAI CITY, OSAKA,
JAPAN, FILED 8-9-2011.

ZEE

THE MARK CONSISTS OF STANDARD CHARACTERS WITHOUT CLAIM TO ANY PARTICULAR FONT, STYLE, SIZE, OR COLOR.

FOR BICYCLES, AND THEIR PARTS AND FITTINGS, NAMELY, WHEEL HUBS, INTERNAL GEAR HUBS, BICYCLE DYNAMO HUBS, HUB QUICK RELEASE LEVERS, HUB QUICK RELEASE DEVICES, GEAR RELEASE LEVERS, GEAR SHIFT LEVERS, FRONT DERAILLEURS, REAR DERAILLEURS, CHAIN GUIDES, FREEWHEELS, SPROCKETS, PULLEYS ADAPTED FOR USE WITH BICYCLES, CHAINS FOR BICYCLES, SHIFT CABLES, CRANKS, CRANK SETS, FRONT CHAIN WHEELS, PEDALS, TOE CLIPS, BRAKE LEVERS, FRONT BRAKES, REAR BRAKES, BRAKE CABLES, BRAKE SHOES, RIMS, WHEELS, SPOKES, SPOKE CLIPS, BOTTOM BRACKETS, SEAT PILLARS, SEAT PILLAR QUICK RELEASES, HEAD PARTS FOR FRAME-FORK ASSEMBLY, SUSPENSIONS, HANDLEBARS, HANDLEBAR STEMS, GRIPS FOR HANDLE BARS, BAR ENDS, SEAT POSTS, SADDLES, DERAILLEURS CONTROLLED BY COMPUTER, WHEEL BAGS FOR BICYCLES, GEAR POSITION INDICATORS FOR BICYCLES (U.S. CLS. 19, 21, 23, 31, 35 AND 44).

ALEX KEAM, EXAMINING ATTORNEY

CLASS 12—(Continued).

SN 85-405,630. SHIMANO INC., SAKAI CITY, OSAKA,
JAPAN, FILED 8-24-2011.

MEGAPULLEY

THE MARK CONSISTS OF STANDARD CHARACTERS WITHOUT CLAIM TO ANY PARTICULAR FONT, STYLE, SIZE, OR COLOR.

OWNER OF U.S. REG. NOS. 2,344,046, 2,490,350 AND OTHERS.

FOR ELECTRIC BICYCLES, BICYCLES, AND THEIR PARTS AND FITTINGS, NAMELY, WHEEL HUBS, INTERNAL GEAR HUBS, BICYCLE DYNAMO HUBS, HUB QUICK RELEASE LEVERS, GEAR RELEASE LEVERS, GEAR SHIFT LEVERS, FRONT DERAILLEURS, REAR DERAILLEURS, CHAIN GUIDES, FREEWHEELS, SPROCKETS, PULLEYS ADAPTED FOR USE WITH BICYCLES, CHAINS FOR BICYCLES, SHIFT CABLES, CRANKS, CRANK SETS, FRONT CHAIN WHEELS, PEDALS, TOE CLIPS, BRAKE LEVERS, FRONT BRAKES, REAR BRAKES, BRAKE CABLES, BRAKE SHOES, RIMS, WHEELS, SPOKES, SPOKE CLIPS, BOTTOM BRACKETS, SEAT PILLARS, SEAT PILLAR QUICK RELEASES, HEAD PARTS FOR FRAME-FORK ASSEMBLY, SUSPENSIONS, HANDLEBARS, HANDLEBAR STEMS, GRIPS FOR HANDLE BARS, BAR ENDS, SEAT POSTS, SADDLES, DERAILLEURS CONTROLLED BY COMPUTER, WHEEL BAGS FOR BICYCLES, GEAR POSITION INDICATORS FOR BICYCLES (U.S. CLS. 19, 21, 23, 31, 35 AND 44).

ALEX KEAM, EXAMINING ATTORNEY

SN 85-412,507. SHIMANO INC., SAKAI CITY, OSAKA,
JAPAN, FILED 8-31-2011.



THE MARK CONSISTS OF THE WORDING "ZEE".

FOR BICYCLES, AND THEIR PARTS AND FITTINGS, NAMELY, WHEEL HUBS, INTERNAL GEAR HUBS, BICYCLE DYNAMO HUBS, HUB QUICK RELEASE LEVERS, HUB QUICK RELEASE DEVICES, GEAR RELEASE LEVERS, GEAR SHIFT LEVERS, FRONT DERAILLEURS, REAR DERAILLEURS, CHAIN GUIDES, FREEWHEELS, SPROCKETS, PULLEYS ADAPTED FOR USE WITH BICYCLES, CHAINS FOR BICYCLES, SHIFT CABLES, CRANKS, CRANK SETS, FRONT CHAIN WHEELS, PEDALS, TOE CLIPS, BRAKE LEVERS, FRONT BRAKES, REAR BRAKES, BRAKE CABLES, BRAKE SHOES, RIMS, WHEELS, SPOKES, SPOKE CLIPS, BOTTOM BRACKETS, SEAT PILLARS, SEAT PILLAR QUICK RELEASES, HEAD PARTS FOR FRAME-FORK ASSEMBLY, SUSPENSIONS, HANDLEBARS, HANDLEBAR STEMS, GRIPS FOR HANDLE BARS, BAR ENDS, SEAT POSTS, SADDLES, DERAILLEURS CONTROLLED BY COMPUTER, WHEEL BAGS FOR BICYCLES, GEAR POSITION INDICATORS FOR BICYCLES (U.S. CLS. 19, 21, 23, 31, 35 AND 44).

ALEX KEAM, EXAMINING ATTORNEY

CLASS 12—(Continued).

SN 85-421,321. KAKIMOTO RACING CO., LTD., SAKAI-SHI, OSAKA, JAPAN, FILED 9-13-2011.

KAKIMOTO RACING

THE MARK CONSISTS OF STANDARD CHARACTERS WITHOUT CLAIM TO ANY PARTICULAR FONT, STYLE, SIZE, OR COLOR.

OWNER OF U.S. REG. NO. 3,077,288.

NO CLAIM IS MADE TO THE EXCLUSIVE RIGHT TO USE "RACING", APART FROM THE MARK AS SHOWN. SEC. 2(F).

FOR CARS AND STRUCTURAL PARTS THEREFOR; MOTORCYCLES AND STRUCTURAL PARTS THEREFOR; BICYCLES AND STRUCTURAL PARTS THEREFOR; AIR TURBINES FOR LAND VEHICLES, HYDRAULIC TURBINES FOR LAND VEHICLES AND GAS TURBINES FOR LAND VEHICLES; MOTORS FOR LAND VEHICLES; JET ENGINES FOR LAND VEHICLES; ENGINES FOR LAND VEHICLES; AXLES FOR LAND VEHICLES; COUPLINGS FOR MUFFLERS; JOINTS FOR MUFFLERS, WHEEL BEARINGS FOR LAND VEHICLES; DRIVE GEARS FOR LAND VEHICLES; SHOCK ABSORBERS FOR LAND VEHICLES; LAND VEHICLES SUSPENSION PARTS, NAMELY, COIL SPRINGS AND LEAF SPRINGS; BRAKES FOR LAND VEHICLES; ELECTRIC MOTORS FOR LAND VEHICLES; ADHESIVE RUBBER PATCHES FOR REPAIRING TIRE TUBES; AND ANTI-THEFT ALARMS FOR VEHICLES (U.S. CLS. 19, 21, 23, 31, 35 AND 44).

FIRST USE 5-1-1975; IN COMMERCE 3-16-2001.

HOWARD B. LEVINE, EXAMINING ATTORNEY

CLASS 12—(Continued).

SN 85-445,424. SLIPNOT TRACTION SYSTEM, BAYFIELD, CO. FILED 10-12-2011.

SLIPNOT
BICYCLE TRACTION SYSTEM

NO CLAIM IS MADE TO THE EXCLUSIVE RIGHT TO USE "SLIP NOT BICYCLE TRACTION SYSTEM", APART FROM THE MARK AS SHOWN.

THE MARK CONSISTS OF THE STYLIZED TEXT "SLIPNOT" WITH A STYLIZED DESIGN OF BICYCLE TIRE SNOW CHAINS FORMING THE LETTER "O", THE STYLIZED TEXT "BICYCLE TRACTION SYSTEM" APPEARS BELOW.

FOR BICYCLE PARTS, NAMELY, TIRE SNOW CHAINS (U.S. CLS. 19, 21, 23, 31, 35 AND 44).

FIRST USE 9-12-2011; IN COMMERCE 9-12-2011.

NATALIE POLZER, EXAMINING ATTORNEY

SN 85-433,617. TEKTRO TECHNOLOGY CORPORATION, CHANGHUA, TAIWAN, FILED 9-28-2011.

TEKTRO
Gemini

OWNER OF U.S. REG. NOS. 2,739,515, 3,031,686 AND OTHERS.

THE MARK CONSISTS OF A STENCILED STYLIZED WORDING "GEMINI" CONTAINED IN A RECTANGULAR DESIGN ON A LOWER PORTION AND A STYLIZED WORDING "TEKTRO" ON AN UPPER, CENTERED PORTION.

THE WORDING "TEKTRO" HAS NO MEANING IN A FOREIGN LANGUAGE.

FOR BICYCLE BRAKES; BICYCLE PARTS, NAMELY, BRAKE LEVERS; HYDRAULIC DISC BRAKES; HYDRAULIC RIM BRAKES (U.S. CLS. 19, 21, 23, 31, 35 AND 44).

FIRST USE 5-9-2000; IN COMMERCE 8-10-2000.

GEORGE LORENZO, EXAMINING ATTORNEY

SN 85-456,735. CANTIERI DI SARNICO S.P.A., 20121 MILANO, ITALY, FILED 10-26-2011.

Cantieri di Sarnico

NO CLAIM IS MADE TO THE EXCLUSIVE RIGHT TO USE "CANTIERI", APART FROM THE MARK AS SHOWN.

THE MARK CONSISTS OF THE WORDS "CANTIERI DI SARNICO", ABOVE WHICH ARE TWO CROSSED NAUTICAL FLAGS, THE FLAG POINTING TO THE LEFT BEING A DARK FLAG WITH THREE LIGHT HORIZONTAL STRIPES, THE FLAG POINTING TO THE RIGHT BEING A LIGHT FLAG WITH A DARK HORIZONTAL BAR IN THE CENTRAL PORTION.

THE ENGLISH TRANSLATION OF "CANTIERI DI SARNICO" IN THE MARK IS "SARNICO'S YARD".

FOR BOATS AND STRUCTURAL PARTS THEREFOR (U.S. CLS. 19, 21, 23, 31, 35 AND 44).

DAVID H. STINE, EXAMINING ATTORNEY

CLASS 12—(Continued).

SN 85-456,747. CANTIERI DI SARNICO S.P.A., 20121 MILANO, ITALY, FILED 10-26-2011.



NO CLAIM IS MADE TO THE EXCLUSIVE RIGHT TO USE "YACHTS", APART FROM THE MARK AS SHOWN.

THE MARK CONSISTS OF THE WORDS "SARNICO YACHTS", ABOVE WHICH ARE TWO CROSSED FLAGS, THE FLAG POINTING RIGHT BEING LIGHT WITH A DARK HORIZONTAL BAR IN THE CENTRAL PORTION, AND THE FLAG POINTING LEFT BEING A DARK FLAG WITH THREE LIGHT HORIZONTAL STRIPES.

FOR BOATS AND STRUCTURAL PARTS THEREFOR (U.S. CLS. 19, 21, 23, 31, 35 AND 44).

DAVID H. STINE, EXAMINING ATTORNEY

SN 85-477,766. PIHSIANG ELECTRIC VEHICLE MFG. CO., LTD., HSINCHU COUNTY, TAIWAN, FILED 11-21-2011.

ACHENSA

THE MARK CONSISTS OF STYLIZED DESIGN OF WORDING "ACHENSA".

THE WORDING "ACHENSA" HAS NO MEANING IN A FOREIGN LANGUAGE.

FOR AUTOMOBILE BODIES; AUTOMOBILES; BICYCLES; CARS; CARRIER TRICYCLES; ELECTRIC VEHICLES, NAMELY, AUTOMOBILES, ELECTRIC CARS; MOTOR CARS; MOTOR BUSES; MOTORCYCLES; OMNIBUSES; TRUCKS; ELECTRIC MOTORS FOR LAND VEHICLES; MOTORIZED GOLF CARTS; ELECTRICALLY OPERATED WHEELCHAIR (U.S. CLS. 19, 21, 23, 31, 35 AND 44).

DEBORAH LOBO, EXAMINING ATTORNEY

SN 85-489,454. THOR TECH, INC., JACKSON CENTER, OH. FILED 12-7-2011.

BOUNDARY WATERS

THE MARK CONSISTS OF STANDARD CHARACTERS WITHOUT CLAIM TO ANY PARTICULAR FONT, STYLE, SIZE, OR COLOR.

FOR RECREATIONAL VEHICLES, NAMELY, TOWABLE TRAILERS (U.S. CLS. 19, 21, 23, 31, 35 AND 44).

FIRST USE 2-0-2012; IN COMMERCE 2-0-2012.

DEZMONA MIZELLE, EXAMINING ATTORNEY

CLASS 12—(Continued).

SN 85-492,746. ZF FRIEDRICHSHAFEN AG, 88046 FRIEDRICHSHAFEN, FED REP GERMANY, FILED 12-12-2011.

ROTATRONIC

THE MARK CONSISTS OF STANDARD CHARACTERS WITHOUT CLAIM TO ANY PARTICULAR FONT, STYLE, SIZE, OR COLOR.

FOR GEARSHIFT SYSTEMS FOR TRANSMISSIONS FOR LAND VEHICLES (U.S. CLS. 19, 21, 23, 31, 35 AND 44).

JESSICA A. POWERS, EXAMINING ATTORNEY

SN 85-501,927. QUINN, WILLIAM, WESTERN SPRINGS, IL. FILED 12-22-2011.

BUCKLE BITERS

THE MARK CONSISTS OF STANDARD CHARACTERS WITHOUT CLAIM TO ANY PARTICULAR FONT, STYLE, SIZE, OR COLOR.

NO CLAIM IS MADE TO THE EXCLUSIVE RIGHT TO USE "BUCKLE", APART FROM THE MARK AS SHOWN.

FOR FITTED FABRIC COVERS FOR SEATBELTS IN VEHICLES AND VEHICLE CHILD SAFETY SEATS (U.S. CLS. 19, 21, 23, 31, 35 AND 44).

FIRST USE 3-1-2010; IN COMMERCE 10-1-2011.

KRISTIN DAHLING, EXAMINING ATTORNEY

SN 85-502,223. SKIDZ MARX & STAYNS, INC., LANDIS, NC. FILED 12-22-2011.

GRAN ROYALE

THE MARK CONSISTS OF STANDARD CHARACTERS WITHOUT CLAIM TO ANY PARTICULAR FONT, STYLE, SIZE, OR COLOR.

FOR BICYCLES AND BICYCLE PARTS, NAMELY, FRAMES, SEATS, SEAT POSTS, CRANKS, FORKS, HANDLEBARS, AXLE PEGS, WHEELS, HANDLEBAR STEMS, CHAIN SPROCKETS AND CHAIN GUARDS, HANDLEBAR GRIPS, PEDALS, CHAINS AND WHEEL HUBS (U.S. CLS. 19, 21, 23, 31, 35 AND 44).

C. DIONNE CLYBURN, EXAMINING ATTORNEY

CLASS 12—(Continued).

SN 85-502,366. COUNTRYWIDE TIRE AND RUBBER, INC., PLYMOUTH, MN. FILED 12-22-2011.

STEEL MASTER

THE MARK CONSISTS OF STANDARD CHARACTERS WITHOUT CLAIM TO ANY PARTICULAR FONT, STYLE, SIZE, OR COLOR.

OWNER OF U.S. REG. NO. 1,183,665.

NO CLAIM IS MADE TO THE EXCLUSIVE RIGHT TO USE "STEEL", APART FROM THE MARK AS SHOWN.

FOR LAND VEHICLE PARTS, NAMELY, STEEL WHEELS; VEHICLE WHEEL RIMS MADE OF STEEL; VEHICLE WHEELS MADE OF STEEL (U.S. CLS. 19, 21, 23, 31, 35 AND 44).

MAYUR VAGHANI, EXAMINING ATTORNEY

CLASS 12—(Continued).

SN 85-509,268. LASKIN, BARBARA, NEW YORK, NY. FILED 1-5-2012.

PORTAPOOCH

THE MARK CONSISTS OF STANDARD CHARACTERS WITHOUT CLAIM TO ANY PARTICULAR FONT, STYLE, SIZE, OR COLOR.

FOR CARGO CARRIERS FOR BICYCLES, NAMELY, SECURE BICYCLE-MOUNTED PET HOUSINGS FOR SMALL DOGS UP TO TWELVE POUNDS (U.S. CLS. 19, 21, 23, 31, 35 AND 44).

JAY BESCH, EXAMINING ATTORNEY

SN 85-506,653. A.N.DESIGN WORKS, INC., TORRANCE, CA. FILED 12-30-2011.



THE MARK CONSISTS OF THE STYLIZED TEXT "TO-KYO" IN THE SHAPE OF A BICYCLE. FOR BICYCLES (U.S. CLS. 19, 21, 23, 31, 35 AND 44). FIRST USE 9-1-2010; IN COMMERCE 9-1-2010. SHANNON TWOHIG, EXAMINING ATTORNEY

SN 85-508,070. ROAM OFFROAD INC, HALF MOON BAY, CA. FILED 1-3-2012.

ROAM OFFROAD

THE MARK CONSISTS OF STANDARD CHARACTERS WITHOUT CLAIM TO ANY PARTICULAR FONT, STYLE, SIZE, OR COLOR.

NO CLAIM IS MADE TO THE EXCLUSIVE RIGHT TO USE "OFFROAD", APART FROM THE MARK AS SHOWN. FOR STEERING KNUCKLES; WHEEL HUBS FOR AUTOMOBILES (U.S. CLS. 19, 21, 23, 31, 35 AND 44).

FIRST USE 7-1-2011; IN COMMERCE 9-28-2011. LAURIE KAUFMAN, EXAMINING ATTORNEY

SN 85-511,097. CHECKWATER LLC, DBA CHECKWATER HYDRATION TECHNOLOGY, CAMPBELL, CA. FILED 1-7-2012.

CageLink

THE MARK CONSISTS OF STANDARD CHARACTERS WITHOUT CLAIM TO ANY PARTICULAR FONT, STYLE, SIZE, OR COLOR.

FOR BICYCLE WATER BOTTLE CAGES; WATER BOTTLE CAGES FOR BICYCLES; WATER BOTTLE HOLDERS FOR BICYCLES (U.S. CLS. 19, 21, 23, 31, 35 AND 44).

KATHERINE M. DUBRAY, EXAMINING ATTORNEY

SN 85-511,098. CHECKWATER LLC, DBA CHECKWATER HYDRATION TECHNOLOGY, CAMPBELL, CA. FILED 1-7-2012.

SnugCage

THE MARK CONSISTS OF STANDARD CHARACTERS WITHOUT CLAIM TO ANY PARTICULAR FONT, STYLE, SIZE, OR COLOR.

FOR BICYCLE WATER BOTTLE CAGES; WATER BOTTLE CAGES FOR BICYCLES; WATER BOTTLE HOLDERS FOR BICYCLES (U.S. CLS. 19, 21, 23, 31, 35 AND 44).

KATHERINE M. DUBRAY, EXAMINING ATTORNEY

CLASS 12—(Continued).

SN 85-511,506. SOGAARD INTERNATIONAL LLC, MIAMI, FL. FILED 1-9-2012.

Velocette

THE MARK CONSISTS OF STANDARD CHARACTERS WITHOUT CLAIM TO ANY PARTICULAR FONT, STYLE, SIZE, OR COLOR.

FOR ADHESIVE FOAM PADS SPECIALLY ADAPTED FOR MOTORCYCLE GAS TANKS FOR RIDER PROTECTION; BELLS FOR MOTORCYCLES; BRAKE DISCS FOR MOTORCYCLES; ELASTOMERIC APPLIQUES FOR PLACEMENT ONTO MOTORCYCLES, ALL-TERRAIN VEHICLES, AND BICYCLES TO PREVENT RIDERS FROM SLIPPING; ELECTRIC MOTORCYCLES; FITTED MOTORCYCLE COVERS; FITTED PLASTIC LINER AND SUPPORT PANELS FOR MOTORCYCLE SADDLEBAGS; HOLDER USED TO MOUNT A SURFBOARD TO A MOTORCYCLE; HUBS FOR VEHICLE WHEELS (MOTORCYCLES); LUGGAGE SPECIALLY ADAPTED FOR USE ON MOTORCYCLES; MECHANICAL SOUND-MAKING DEVICES THAT ARE MOUNTED ON THE FORKS OF A BICYCLE TO PRODUCE MOTORCYCLE-LIKE SOUNDS AS THE BICYCLE MOVES; METAL STANDS FOR HOLDING STATIONARY MOTORCYCLES IN AN UPRIGHT POSITION; MOTORCYCLE ACCESSORIES, NAMELY, FRONT AND SIDE PLATES; MOTORCYCLE ACCESSORIES, NAMELY, GAS TANK AND RADIATOR SHROUDS; MOTORCYCLE AND AUTOMOBILE STRUCTURAL PARTS, NAMELY, SUMP GUARDS; MOTORCYCLE BAGS, NAMELY, TANK BAGS, SADDLE BAGS, SISSY BAR BAGS AND TAIL BAGS; MOTORCYCLE DRIVE CHAINS ; MOTORCYCLE ENGINES; MOTORCYCLE GRIP TAPE; MOTORCYCLE KICKSTANDS; MOTORCYCLE PARTS, NAMELY, BRACKETS FOR MOUNTING MOTORCYCLE SADDLEBAGS TO MOTORCYCLES; MOTORCYCLE PARTS, NAMELY, CHROMED SAFETY PADS; MOTORCYCLE PARTS, NAMELY, HEEL GUARDS; MOTORCYCLE SADDLEBAGS; MOTORCYCLE SIDECARS; MOTORCYCLE SPROCKETS; MOTORCYCLE TRIKE CONVERSION KITS FOR CONVERTING A TWO-WHEELED MOTORCYCLE INTO A THREE-WHEELED MOTORCYCLE; MOTORCYCLES; MOTORCYCLES AND STRUCTURAL PARTS THEREFOR; MOTORCYCLES FOR MOTOCROSS; PANNIER BAGS FOR MOTORCYCLES; PARTS OF MOTORCYCLES, NAMELY, BRAKE CABLES; PARTS OF MOTORCYCLES, NAMELY, BRAKE CALIPERS; PARTS OF MOTORCYCLES, NAMELY, BRAKE LEVERS; PARTS OF MOTORCYCLES, NAMELY, BRAKE MASTER CYLINDER ASSEMBLIES; PARTS OF MOTORCYCLES, NAMELY, BRAKE PEDALS; PARTS OF MOTORCYCLES, NAMELY, BRAKE ROTORS; PARTS OF MOTORCYCLES, NAMELY, CLUTCH CABLES; PARTS OF MOTORCYCLES, NAMELY, CLUTCH MASTER CYLINDER ASSEMBLIES; PARTS OF MOTORCYCLES, NAMELY, FORK BEARINGS AND RACES; PARTS OF MOTORCYCLES, NAMELY, FORK DUST BOOTS; PARTS OF MOTORCYCLES, NAMELY, FORK SEALS; PARTS OF MOTORCYCLES, NAMELY, FRONT DASH PANELS; PARTS OF MOTORCYCLES, NAMELY, FRONT SPACERS; PARTS OF MOTORCYCLES, NAMELY, HANDLE BAR CONTROL LEVERS; PARTS OF MOTORCYCLES, NAMELY, HANDLE BAR DAMPERS; PARTS OF MOTORCYCLES, NAMELY, HANDLE BAR GRIPS; PARTS OF MOTORCYCLES, NAMELY, HANDLE BAR THROTTLES; PARTS OF MOTORCYCLES, NAMELY, HANDLE BARS; PARTS OF MOTORCYCLES, NAMELY, HEADLIGHT MOUNTS; PARTS OF MOTORCYCLES, NAMELY, MASTER CYLINDERS; PARTS OF MOTORCYCLES, NAMELY, SHIFT LEVERS; PNEUMATIC TYRES AND INNER TUBES FOR MOTORCYCLES; SHOCK ABSORBERS FOR MOTORCYCLES; STRUCTURAL PARTS FOR MOTORCYCLES (U.S. CLS. 19, 21, 23, 31, 35 AND 44).

JOHN GARTNER, EXAMINING ATTORNEY

CLASS 12—(Continued).

SN 85-512,086. SHOWA CORPORATION, GYODA CITY, SAITAMA, JAPAN, FILED 1-9-2012.

BRA-EPS

THE MARK CONSISTS OF STANDARD CHARACTERS WITHOUT CLAIM TO ANY PARTICULAR FONT, STYLE, SIZE, OR COLOR.

FOR LAND VEHICLE PARTS, NAMELY, ELECTRIC POWER STEERING DEVICES; STEERING GEAR BOXES, SOLD AS AN INTEGRAL COMPONENT OF ELECTRIC POWER STEERING; MOTOR ASSEMBLY, SOLD AS AN INTEGRAL COMPONENT OF ELECTRIC POWER STEERING; SENSOR ASSEMBLY, SOLD AS AN INTEGRAL COMPONENT OF ELECTRIC POWER STEERING (U.S. CLS. 19, 21, 23, 31, 35 AND 44).

JAMES GRIFFIN, EXAMINING ATTORNEY

SN 85-512,089. SHOWA CORPORATION, GYODA CITY, SAITAMA, JAPAN, FILED 1-9-2012.

SBWS

THE MARK CONSISTS OF STANDARD CHARACTERS WITHOUT CLAIM TO ANY PARTICULAR FONT, STYLE, SIZE, OR COLOR.

FOR LAND VEHICLE PARTS, NAMELY, ELECTRIC POWER STEERING DEVICES; STEERING GEAR BOXES, SOLD AS AN INTEGRAL COMPONENT OF ELECTRIC POWER STEERING; MOTOR ASSEMBLY, SOLD AS AN INTEGRAL COMPONENT OF ELECTRIC POWER STEERING; SENSOR ASSEMBLY, SOLD AS AN INTEGRAL COMPONENT OF ELECTRIC POWER STEERING (U.S. CLS. 19, 21, 23, 31, 35 AND 44).

JAMES GRIFFIN, EXAMINING ATTORNEY

SN 85-512,093. SHOWA CORPORATION, GYODA CITY, SAITAMA, JAPAN, FILED 1-9-2012.

BW-EPS

THE MARK CONSISTS OF STANDARD CHARACTERS WITHOUT CLAIM TO ANY PARTICULAR FONT, STYLE, SIZE, OR COLOR.

FOR LAND VEHICLE PARTS, NAMELY, ELECTRIC POWER STEERING DEVICES; STEERING GEAR BOXES, SOLD AS AN INTEGRAL COMPONENT OF ELECTRIC POWER STEERING; MOTOR ASSEMBLY, SOLD AS AN INTEGRAL COMPONENT OF ELECTRIC POWER STEERING; SENSOR ASSEMBLY, SOLD AS AN INTEGRAL COMPONENT OF ELECTRIC POWER STEERING (U.S. CLS. 19, 21, 23, 31, 35 AND 44).

JAMES GRIFFIN, EXAMINING ATTORNEY

CLASS 12—(Continued).

SN 85-512,232. GREAT DANE LIMITED PARTNERSHIP, CHICAGO, IL. FILED 1-9-2012.

CLASS 12—(Continued).

SN 85-513,983. KATIECARTS, LLC, CEDAR RAPIDS, IA. FILED 1-11-2012.

ENDUROGUARD

You Are What You Drive

THE MARK CONSISTS OF STANDARD CHARACTERS WITHOUT CLAIM TO ANY PARTICULAR FONT, STYLE, SIZE, OR COLOR.
FOR STEEL FRAMES SOLD AS AN INTEGRAL PART OF SEMI-TRAILERS (U.S. CLS. 19, 21, 23, 31, 35 AND 44).
CHARISMA HAMPTON, EXAMINING ATTORNEY

THE MARK CONSISTS OF STANDARD CHARACTERS WITHOUT CLAIM TO ANY PARTICULAR FONT, STYLE, SIZE, OR COLOR.
FOR GROCERY CARTS (U.S. CLS. 19, 21, 23, 31, 35 AND 44).
JANICE KIM, EXAMINING ATTORNEY

SN 85-513,413. DIMORA, ALFRED J., PALM SPRINGS, CA. FILED 1-10-2012.

SN 85-515,005. POLARIS INDUSTRIES INC., MEDINA, MN. FILED 1-12-2012.

VICCI

OCTANE

THE MARK CONSISTS OF STANDARD CHARACTERS WITHOUT CLAIM TO ANY PARTICULAR FONT, STYLE, SIZE, OR COLOR.
THE WORDING VICCI HAS NO MEANING IN A FOREIGN LANGUAGE.
FOR AUTOMOBILES (U.S. CLS. 19, 21, 23, 31, 35 AND 44).
BENJAMIN OKEKE, EXAMINING ATTORNEY

THE MARK CONSISTS OF STANDARD CHARACTERS WITHOUT CLAIM TO ANY PARTICULAR FONT, STYLE, SIZE, OR COLOR.
FOR RECREATIONAL VEHICLES, NAMELY, THREE-WHEELED MOTOR VEHICLES AND MOTORCYCLES FOR ON-ROAD USE AND STRUCTURAL PARTS THEREFOR (U.S. CLS. 19, 21, 23, 31, 35 AND 44).
MARK SPARACINO, EXAMINING ATTORNEY

SN 85-513,420. DIMORA, ALFRED J., PALM SPRINGS, CA. FILED 1-10-2012.

SN 85-515,472. MILLER, BRANDON, ENCINITAS, CA. FILED 1-12-2012.

ADINA

V-ROLL

THE MARK CONSISTS OF STANDARD CHARACTERS WITHOUT CLAIM TO ANY PARTICULAR FONT, STYLE, SIZE, OR COLOR.
THE WORDING ADINA HAS NO MEANING IN A FOREIGN LANGUAGE.
FOR AUTOMOBILES (U.S. CLS. 19, 21, 23, 31, 35 AND 44).
BENJAMIN OKEKE, EXAMINING ATTORNEY

THE MARK CONSISTS OF THE WORD V-ROLL IN A STYLIZED FONT.
FOR WHEELS AND TIRES FOR VEHICLES, SPECIFICALLY ALL TERRAIN VEHICLES (ATVS) AND UTILITY TERRAIN VEHICLES (UTVS) (U.S. CLS. 19, 21, 23, 31, 35 AND 44).
FIRST USE 9-13-2011; IN COMMERCE 9-13-2011.
AMY HELLA, EXAMINING ATTORNEY

CLASS 12—(Continued).

SN 85-522,758. INDIAN MOTORCYCLE INTERNATIONAL, LLC, MEDINA, MN. FILED 1-23-2012.

INDIAN

THE MARK CONSISTS OF STANDARD CHARACTERS WITHOUT CLAIM TO ANY PARTICULAR FONT, STYLE, SIZE, OR COLOR.

OWNER OF U.S. REG. NOS. 2,486,405, 2,511,305 AND 2,594,450.

FOR CARGO TRAILERS, NAMELY, TRAILERS FOR THE TRANSPORT OF MOTORCYCLES (U.S. CLS. 19, 21, 23, 31, 35 AND 44).

KATHLEEN M. VANSTON, EXAMINING ATTORNEY

CLASS 12—(Continued).

SN 85-523,608. SHOWA CORPORATION, GYODA CITY, SAITAMA, JAPAN, FILED 1-24-2012.

BFRC

THE MARK CONSISTS OF STANDARD CHARACTERS WITHOUT CLAIM TO ANY PARTICULAR FONT, STYLE, SIZE, OR COLOR.

OWNER OF U.S. REG. NO. 4,024,523.

FOR HYDRAULIC SHOCK ABSORBERS FOR TWO-WHEELED MOTOR VEHICLES, BICYCLES, AUTOMOBILES (U.S. CLS. 19, 21, 23, 31, 35 AND 44).

JAMES GRIFFIN, EXAMINING ATTORNEY

SN 85-523,556. SHOWA CORPORATION, GYODA CITY, SAITAMA, JAPAN, FILED 1-24-2012.

BPF-F

THE MARK CONSISTS OF STANDARD CHARACTERS WITHOUT CLAIM TO ANY PARTICULAR FONT, STYLE, SIZE, OR COLOR.

FOR HYDRAULIC SHOCK ABSORBERS FOR TWO-WHEELED MOTOR VEHICLES, BICYCLES (U.S. CLS. 19, 21, 23, 31, 35 AND 44).

JAMES GRIFFIN, EXAMINING ATTORNEY

SN 85-547,890. RADIO FLYER, INC., CHICAGO, IL. FILED 2-21-2012.

GROOVE GLIDER

THE MARK CONSISTS OF STANDARD CHARACTERS WITHOUT CLAIM TO ANY PARTICULAR FONT, STYLE, SIZE, OR COLOR.

FOR KICK SCOOTERS (U.S. CLS. 19, 21, 23, 31, 35 AND 44).

DAVID COLLIER, EXAMINING ATTORNEY

SN 85-523,562. SHOWA CORPORATION, GYODA CITY, SAITAMA, JAPAN, FILED 1-24-2012.

BPF

THE MARK CONSISTS OF STANDARD CHARACTERS WITHOUT CLAIM TO ANY PARTICULAR FONT, STYLE, SIZE, OR COLOR.

FOR HYDRAULIC SHOCK ABSORBERS FOR TWO-WHEELED MOTOR VEHICLES, BICYCLES, AUTOMOBILES (U.S. CLS. 19, 21, 23, 31, 35 AND 44).

JAMES GRIFFIN, EXAMINING ATTORNEY

SN 85-553,394. CORONA CLIPPER, INC., CORONA, CA. FILED 2-27-2012.

EASY LIFTER BY CORONA

THE MARK CONSISTS OF STANDARD CHARACTERS WITHOUT CLAIM TO ANY PARTICULAR FONT, STYLE, SIZE, OR COLOR.

OWNER OF U.S. REG. NOS. 527,173, 3,676,978 AND OTHERS.

NO CLAIM IS MADE TO THE EXCLUSIVE RIGHT TO USE "LIFTER", APART FROM THE MARK AS SHOWN.

FOR WHEELBARROWS (U.S. CLS. 19, 21, 23, 31, 35 AND 44).

FIRST USE 9-30-2011; IN COMMERCE 9-30-2011.

HEATHER THOMPSON, EXAMINING ATTORNEY

CLASS 13—FIREARMS

SN 77-631,698. IMPERIAL MANUFACTURING GROUP INC., RICHIBUCTO, CANADA, FILED 12-11-2008.



The logo for TimberLite features the word "TimberLite" in a stylized, outlined font. The letters are white with a black outline, and the "i" in "Lite" has a small flame-like shape above it.

PRIORITY CLAIMED UNDER SEC. 44(D) ON CANADA APPLICATION NO. 1,399,080, FILED 6-11-2008, REG. NO. TMA813999, DATED 12-14-2011, EXPIRES 12-14-2026.

THE MARK CONSISTS OF STYLIZED "TIMBERLITE" WITH FLAMES.

FOR FIRE IGNITERS (U.S. CLS. 2 AND 9).

ANNE E. GUSTASON, EXAMINING ATTORNEY

SN 79-103,252. DIEHL BGT DEFENCE GMBH & CO. KG, FED REP GERMANY, FILED 3-25-2011.



The logo for RASMO consists of the word "RASMO" in a bold, black, sans-serif font.

THE MARK CONSISTS OF STANDARD CHARACTERS WITHOUT CLAIM TO ANY PARTICULAR FONT, STYLE, SIZE, OR COLOR.

PRIORITY DATE OF 10-15-2010 IS CLAIMED.

OWNER OF INTERNATIONAL REGISTRATION 1092551 DATED 3-25-2011, EXPIRES 3-25-2021.

THE WORDING "RASMO" HAS NO MEANING IN A FOREIGN LANGUAGE.

FOR AMMUNITION; SMOKE BUILDING AMMUNITION, NAMELY, SMOKE AMMUNITION; SMOKE OBSCURATION AMMUNITION, NAMELY, SMOKE GENERATOR IN THE NATURE PYROTECHNIC GAS GENERATORS; SMOKE BUILDING THROWING DEVICES, NAMELY, SMOKE PROJECTILES; HAND GRENADES; SMOKE BUILDING HAND GRENADES, NAMELY, SMOKE GRENADES (U.S. CLS. 2 AND 9).

ALICE BENMAMAN, EXAMINING ATTORNEY

SN 85-417,681. B.J. ALAN COMPANY, YOUNGSTOWN, OH, FILED 9-8-2011.

PHANTOM FIREWORKS EXPRESS

THE MARK CONSISTS OF STANDARD CHARACTERS WITHOUT CLAIM TO ANY PARTICULAR FONT, STYLE, SIZE, OR COLOR.

OWNER OF U.S. REG. NOS. 1,923,559, 4,013,383 AND OTHERS.

NO CLAIM IS MADE TO THE EXCLUSIVE RIGHT TO USE "FIREWORKS", APART FROM THE MARK AS SHOWN.

FOR FIREWORKS (U.S. CLS. 2 AND 9).

FIRST USE 6-25-2011; IN COMMERCE 6-25-2011.

JESSICA A. POWERS, EXAMINING ATTORNEY

CLASS 13—(Continued).

SN 85-506,791. DEFENDER INNOVATIONS, INC., AKA BEAMLOKR, BEAMLOKR, OTHER VARIATIONS THEREOF, ACTIONTEXASTACTICAL.COM, AND/OR PATRIOT MANUFACTURING LLC, ROUND ROCK, TX, FILED 12-31-2011.



The logo for BEAMLOKR consists of the word "BEAMLOKR" in a bold, black, sans-serif font.

THE MARK CONSISTS OF STANDARD CHARACTERS WITHOUT CLAIM TO ANY PARTICULAR FONT, STYLE, SIZE, OR COLOR.

FOR ATTACHMENTS FOR WEAPONRY, NAMELY, MOUNTS FOR ATTACHING LIGHTS TO A WEAPON (U.S. CLS. 2 AND 9).

FIRST USE 3-6-2010; IN COMMERCE 3-6-2010.

JAMES GRIFFIN, EXAMINING ATTORNEY

SN 85-506,834. WUYANG LONGTIAN PRECISION INSTRUMENTS CO., LTD, HENAN, CHINA, FILED 12-31-2011.



The logo for SNIPER features the word "SNIPER" in a bold, italicized, sans-serif font, followed by a target symbol consisting of two concentric circles with a crosshair in the center.

OWNER OF U.S. REG. NO. 4,064,742.

THE MARK CONSISTS OF THE STYLIZED WORDING "SNIPER" AND A DEVICE CONSISTS OF TWO CIRCLES WITH A CROSS.

FOR ADJUSTING KNOBS FOR GUN SIGHTS; CLEANING RODS FOR FIREARMS; COMPONENT PARTS FOR PISTOLS; COMPONENT PARTS FOR RIFLES; COMPONENT PARTS FOR SHOTGUNS; FIREARM HAND GUARDS; FIREARM SIGHTS; FORESIGHTS FOR FIREARMS; GUN MOUNTS; GUN PARTS; GUNSTOCKS; RIFLE COVERS; RIFLE HAND GUARDS; RIFLE MOUNTS; RIFLE RAILS; RIFLE RINGS; RIFLE SCOPE RINGS; RIFLE SLINGS; RIFLE STOCKS; SIGHT PROTECTORS FOR FIREARMS (U.S. CLS. 2 AND 9).

FIRST USE 12-1-2010; IN COMMERCE 8-1-2011.

MIDGE BUTLER, EXAMINING ATTORNEY

SN 85-508,339. ENSIGN-BICKFORD AEROSPACE & DEFENSE COMPANY, SIMSBURY, CT. FILED 1-4-2012.



The logo for MPLC consists of the letters "MPLC" in a bold, black, serif font.

THE MARK CONSISTS OF STANDARD CHARACTERS WITHOUT CLAIM TO ANY PARTICULAR FONT, STYLE, SIZE, OR COLOR.

FOR AN EXPLOSIVE LINE CHARGE DEPLOYED BY A ROCKET MOTOR AND CARRIED BY A SINGLE PERSON (U.S. CLS. 2 AND 9).

MARK SHINER, EXAMINING ATTORNEY

CLASS 13—(Continued).

SN 85-509,056. PERSONALSAVERS, SUWANEE, GA. FILED 1-5-2012.



OWNER OF U.S. REG. NO. 4,037,460.
NO CLAIM IS MADE TO THE EXCLUSIVE RIGHT TO USE "WRIST", APART FROM THE MARK AS SHOWN.
THE COLOR(S) SILVER AND ORANGE IS/ARE CLAIMED AS A FEATURE OF THE MARK.

THE MARK CONSISTS OF AN ORANGE SHIELD OUTLINED IN SILVER WITH SILVER RIVETS AROUND THE EDGES, THE WORD "WRIST" DISPLAYED HORIZONTALLY IN A RIVETED DESIGN ACROSS THE SHIELD AND THE WORD "SAVER" BELOW IT ALSO WITH THE LETTERS BEING DISPLAYED HORIZONTALLY ACROSS THE SHIELD IN A RIVETED DESIGN ALL DEPICTED IN THE COLOR ORANGE.

FOR WRIST POUCH WITH PEPPER SPRAY, LED LIGHT AND ID CARD HOLDER (U.S. CLS. 2 AND 9).
FIRST USE 11-11-2009; IN COMMERCE 11-20-2010.
BRIDGETT SMITH, EXAMINING ATTORNEY

SN 85-510,119. BLACK RAIN ORDNANCE, INC., NEOSHO, MO. FILED 1-6-2012.

LET IT RAIN!

THE MARK CONSISTS OF STANDARD CHARACTERS WITHOUT CLAIM TO ANY PARTICULAR FONT, STYLE, SIZE, OR COLOR.

FOR FIREARMS; GUN PARTS (U.S. CLS. 2 AND 9).
FIRST USE 6-14-2009; IN COMMERCE 6-14-2009.
MELISSA VALLILLO, EXAMINING ATTORNEY

SN 85-514,200. LHR SPORTING ARMS, LLC, ROCHESTER, NH. FILED 1-11-2012.

REDEMPTION

THE MARK CONSISTS OF STANDARD CHARACTERS WITHOUT CLAIM TO ANY PARTICULAR FONT, STYLE, SIZE, OR COLOR.

FOR MUZZLE-LOADING RIFLES (U.S. CLS. 2 AND 9).
KATINA MISTER, EXAMINING ATTORNEY

CLASS 13—(Continued).

SN 85-514,668. UNITED STATES MARKETING CORPORATION, HUNTINGTON STATION, NY. FILED 1-12-2012.

BENCH BEAST

THE MARK CONSISTS OF STANDARD CHARACTERS WITHOUT CLAIM TO ANY PARTICULAR FONT, STYLE, SIZE, OR COLOR.

FOR RIFLE RESTS, HANDGUN RESTS, FIREARM RECOIL ABSORBERS, FIREARM RECOIL ABSORBING SYSTEMS, HANDGUN STORAGE CASES, LONG GUN STORAGE CASES AND SUPPORTS FOR SHOOTING FIREARMS (U.S. CLS. 2 AND 9).
JOHN WILKE, EXAMINING ATTORNEY

SN 85-520,139. SMITH & WESSON CORP., SPRINGFIELD, MA. FILED 1-19-2012.

M&P

THE MARK CONSISTS OF STANDARD CHARACTERS WITHOUT CLAIM TO ANY PARTICULAR FONT, STYLE, SIZE, OR COLOR.

OWNER OF U.S. REG. NOS. 3,336,344, 3,392,903 AND 3,697,138.
FOR FIREARMS (U.S. CLS. 2 AND 9).
FIRST USE 1-24-2005; IN COMMERCE 1-24-2005.
DAWN HAN, EXAMINING ATTORNEY

SN 85-524,233. ALLIANT TECHSYSTEMS INC., MINNEAPOLIS, MN. FILED 1-24-2012.

GOLD DOT G2

THE MARK CONSISTS OF STANDARD CHARACTERS WITHOUT CLAIM TO ANY PARTICULAR FONT, STYLE, SIZE, OR COLOR.

OWNER OF U.S. REG. NOS. 1,898,839 AND 2,512,419.
FOR AMMUNITION (U.S. CLS. 2 AND 9).
MARK T. MULLEN, EXAMINING ATTORNEY

CLASS 13—(Continued).

SN 85-525,200. HENRY RAC HOLDING CORP., DBA HENRY REPEATING ARMS COMPANY, BAYONNE, NJ. FILED 1-25-2012.

HENRY AMERICAN BEAUTY

THE MARK CONSISTS OF STANDARD CHARACTERS WITHOUT CLAIM TO ANY PARTICULAR FONT, STYLE, SIZE, OR COLOR.

FOR GUNS, RIFLES AND FIREARMS (U.S. CLS. 2 AND 9).

KARANENDRA S. CHHINA, EXAMINING ATTORNEY

CLASS 14—JEWELRY

SN 78-471,023. JHANE BARNES (DEL.) INC., WILMINGTON, DE. FILED 8-20-2004.

BARNES STORM

THE MARK CONSISTS OF STANDARD CHARACTERS WITHOUT CLAIM TO ANY PARTICULAR FONT, STYLE, SIZE, OR COLOR.

FOR WATCHES, CLOCKS, JEWELRY (U.S. CLS. 2, 27, 28 AND 50).

REBECCA POVARCHUK, EXAMINING ATTORNEY

SN 79-069,919. LONDON CLOCK CO. LTD. AYLESFORD, KENT ME20 6SE, UNITED KINGDOM, FILED 4-18-2009.

LC DESIGNS

THE MARK CONSISTS OF STANDARD CHARACTERS WITHOUT CLAIM TO ANY PARTICULAR FONT, STYLE, SIZE, OR COLOR.

OWNER OF INTERNATIONAL REGISTRATION 1005339 DATED 4-18-2009, EXPIRES 4-18-2019.

NO CLAIM IS MADE TO THE EXCLUSIVE RIGHT TO USE "DESIGNS", APART FROM THE MARK AS SHOWN.

FOR CLOCKS; APPARATUS FOR SPORTS TIMING; SUNDIALS (U.S. CLS. 2, 27, 28 AND 50).

MICHAEL WEBSTER, EXAMINING ATTORNEY

CLASS 14—(Continued).

SN 79-103,675. GERNER GMBH, 84032 ALTDORF, FED REP GERMANY, FILED 8-4-2011.

André Belfort

THE MARK CONSISTS OF STANDARD CHARACTERS WITHOUT CLAIM TO ANY PARTICULAR FONT, STYLE, SIZE, OR COLOR.

OWNER OF INTERNATIONAL REGISTRATION 1093606 DATED 8-4-2011, EXPIRES 8-4-2021.

THE NAME(S), PORTRAIT(S), AND/OR SIGNATURE(S) SHOWN IN THE MARK DOES NOT IDENTIFY A PARTICULAR LIVING INDIVIDUAL.

FOR HOROLOGICAL AND CHRONOMETRIC INSTRUMENTS (U.S. CLS. 2, 27, 28 AND 50).

CHRISTOPHER SIDOTI, EXAMINING ATTORNEY

SN 85-212,317. THE KEEP A BREAST FOUNDATION, CARLSBAD, CA. FILED 1-6-2011.

I LOVE BOOBIES

THE MARK CONSISTS OF STANDARD CHARACTERS WITHOUT CLAIM TO ANY PARTICULAR FONT, STYLE, SIZE, OR COLOR.

FOR BRACELETS (U.S. CLS. 2, 27, 28 AND 50).

FIRST USE 9-1-2010, THE MARK WAS FIRST USED ANYWHERE IN A DIFFERENT FORM OTHER THAN THAT SOUGHT TO BE REGISTERED AT LEAST AS EARLY AS 02/01/2007.; IN COMMERCE 9-1-2010, THE MARK WAS FIRST USED IN COMMERCE IN A DIFFERENT FORM OTHER THAN THAT SOUGHT TO BE REGISTERED AT LEAST AS EARLY AS 05/15/2009..

TIMOTHY FINNEGAN, EXAMINING ATTORNEY

SN 85-220,498. MAX POWER UNLIMITED, RANCHO CUCAMONGA, CA. FILED 1-18-2011.



THE MARK CONSISTS OF THE WORDINGS "MAX POWER UNLIMITED" DISPOSED ON THE DESIGN COMPRISES OF A CROWNED SHIELD, TWO WINGS EXTENDING THEREFROM, AND A RIBBON DESIGN.

FOR JEWELRY AND WATCHES EMBEDDED WITH HEALTH THERAPEUTIC DEVICE; KEY CHAINS OF PRECIOUS METAL EMBEDDED WITH HEALTH THERAPEUTIC (U.S. CLS. 2, 27, 28 AND 50).

DEIRDRE ROBERTSON, EXAMINING ATTORNEY

CLASS 14—(Continued).

SN 85-268,533. MARTIN FLYER JEWELRY, LLC, NEW YORK, NY. FILED S.R. 3-16-2011; AM. P.R. 4-5-2012.



OWNER OF U.S. REG. NO. 3,299,437.
THE MARK CONSISTS OF A DESIGN FEATURING DIAMOND-GEM SHAPED PENTAGON WITH TWO WINGS ON THE BOTTOM LEFT AND RIGHT SIDES OF THE DIAMOND SHAPED PENTAGON.

FOR JEWELRY (U.S. CLS. 2, 27, 28 AND 50).
FIRST USE 2-1-2008; IN COMMERCE 2-1-2008.
TRACY WHITTAKER-BROWN, EXAMINING ATTORNEY

SN 85-281,818. MAGASIN CHÂTEAU D'IVOIRE INC./CHATEAU D'IVOIRE STORES INC., MONTREAL, QUEBEC, CANADA, FILED 3-30-2011.

MIDNIGHT LIGHT

THE MARK CONSISTS OF STANDARD CHARACTERS WITHOUT CLAIM TO ANY PARTICULAR FONT, STYLE, SIZE, OR COLOR.

OWNER OF CANADA REG. NO. TMA761,587, DATED 3-12-2010, EXPIRES 3-12-2025.

FOR JEWELRY COLLECTION, NAMELY, NECKLACES, CHOKERS, RINGS, PENDANTS, BRACELETS, EARRINGS, CUFFLINKS, BROOCHES, PINS AND KEYCHAINS MADE WITH 18KT WHITE GOLD, 18KT YELLOW GOLD, 18KT ROSE GOLD, PLATINUM, STAINLESS STEEL, RUBBER, TITANIUM AND COMBINATIONS THEREOF; JEWELRY COLLECTION, NAMELY, NECKLACES, CHOKERS, RINGS, PENDANTS, BRACELETS, EARRINGS, CUFFLINKS, BROOCHES, PINS AND KEYCHAINS MADE WITH DIAMONDS, FANCY COLORED DIAMONDS, PRECIOUS/SEMI-PRECIOUS COLORED STONES AND COMBINATIONS THEREOF (U.S. CLS. 2, 27, 28 AND 50).

SKYE YOUNG, EXAMINING ATTORNEY

CLASS 14—(Continued).

SN 85-304,067. RADIUM ENTERPRISE, INC, HOUSTON, TX. FILED 4-25-2011.

DIAMOND MATRIX

THE MARK CONSISTS OF STANDARD CHARACTERS WITHOUT CLAIM TO ANY PARTICULAR FONT, STYLE, SIZE, OR COLOR.

NO CLAIM IS MADE TO THE EXCLUSIVE RIGHT TO USE "DIAMOND", APART FROM THE MARK AS SHOWN, FOR DIAMOND WATCHES AND DIAMOND JEWELRY (U.S. CLS. 2, 27, 28 AND 50).

FIRST USE 3-21-2011; IN COMMERCE 3-21-2011.
GINA HAYES, EXAMINING ATTORNEY

SN 85-316,144. EDDIE DEMIRDJIAN, GLENDALE, CA. AND SHANT MOUGHALIAN, GLENDALE, CA. FILED 5-9-2011.

OROMARC

THE MARK CONSISTS OF STANDARD CHARACTERS WITHOUT CLAIM TO ANY PARTICULAR FONT, STYLE, SIZE, OR COLOR.

FOR JEWELRY (U.S. CLS. 2, 27, 28 AND 50).
MARILYN IZZI, EXAMINING ATTORNEY

SN 85-327,160. NADEAU, LISA, PARENT OF NADEAU, ALYSA, WEST SAYVILLE, NY. FILED 5-23-2011.



THE NAME(S), PORTRAIT(S), AND/OR SIGNATURE(S) SHOWN IN THE MARK IDENTIFIES "ALYSA NADEAU", WHOSE CONSENT(S) TO REGISTER IS MADE OF RECORD.

THE MARK CONSISTS OF TWO CONCENTRIC CIRCLES, THE OUTER CONCENTRIC CIRCLE HAVING A THICKER BORDER THAN THE INNER CONCENTRIC CIRCLE, AND THE INNER CONCENTRIC CIRCLE INCLUDING A DE-

CLASS 14—(Continued).

SIGN OF THE EIFFEL TOWER, AND INCLUDING BETWEEN THE TWO CONCENTRIC CIRCLES, THE WORD "ALYSA" FOLLOWING THE CURVATURE OF THE CIRCLES AROUND A TOP PORTION OF THE DESIGN, THE WORD "NADEAU" FOLLOWING THE CURVATURE OF THE CIRCLES AROUND A BOTTOM PORTION OF THE DESIGN, AND A SOLID CIRCLE FORMED WITHIN A LARGER CIRCLE POSITIONED BETWEEN THE TWO CONCENTRIC CIRCLES ON LEFT AND RIGHT SIDES OF THE DESIGN.

FOR JEWELRY (U.S. CLS. 2, 27, 28 AND 50).
LINDA ESTRADA, EXAMINING ATTORNEY

SN 85-329,512. JOHN HARDY LIMITED, NORTH POINT, HONG KONG, FILED 5-25-2011.

ANGELA BY JOHN HARDY

THE MARK CONSISTS OF STANDARD CHARACTERS WITHOUT CLAIM TO ANY PARTICULAR FONT, STYLE, SIZE, OR COLOR.

OWNER OF U.S. REG. NOS. 770,861, 3,362,554 AND OTHERS.

THE NAME(S), PORTRAIT(S), AND/OR SIGNATURE(S) SHOWN IN THE MARK IDENTIFIES "JOHN HARDY", WHOSE CONSENT(S) TO REGISTER IS MADE OF RECORD.

FOR JEWELRY (U.S. CLS. 2, 27, 28 AND 50).
CIMMERIAN COLEMAN, EXAMINING ATTORNEY

SN 85-330,436. LATINA MEDIA VENTURES LLC, NEW YORK, NY. FILED 5-25-2011.

GOOD LIVING BY LATINA

THE MARK CONSISTS OF STANDARD CHARACTERS WITHOUT CLAIM TO ANY PARTICULAR FONT, STYLE, SIZE, OR COLOR.

THE ENGLISH TRANSLATION OF "LATINA" IN THE MARK IS "LATIN OR LATIN WOMAN".

FOR JEWELRY (U.S. CLS. 2, 27, 28 AND 50).
STEPHANIE ALI, EXAMINING ATTORNEY

CLASS 14—(Continued).

SN 85-333,101. CHAPMAN, KEITH D., DBA KEITH CHAPMAN JEWELER, ATHENS, OH. FILED 5-28-2011.

KEITH

THE MARK CONSISTS OF STANDARD CHARACTERS WITHOUT CLAIM TO ANY PARTICULAR FONT, STYLE, SIZE, OR COLOR.

FOR CHARMS; GEMSTONE JEWELRY; JEWELRY; JEWELRY CHAINS; RINGS BEING JEWELRY (U.S. CLS. 2, 27, 28 AND 50).

FIRST USE 11-10-1998; IN COMMERCE 2-26-1999.
JACQUELINE A. LAVINE, EXAMINING ATTORNEY

SN 85-343,723. MUÑOZ WATANABE, ENRIQUE GUILLERMO, CHULA VISTA, CA. FILED 6-10-2011.

CKLASS

THE MARK CONSISTS OF STANDARD CHARACTERS WITHOUT CLAIM TO ANY PARTICULAR FONT, STYLE, SIZE, OR COLOR.

OWNER OF U.S. REG. NO. 2,926,989.
FOR WATCHES, CLOCKS, JEWELRY AND IMITATION JEWELRY (U.S. CLS. 2, 27, 28 AND 50).
BARBARA BROWN, EXAMINING ATTORNEY

SN 85-346,625. VEEJOU - JEWELRY LOUNGE, LAS VEGAS, NV. FILED 6-15-2011.

Veejou
JEWELRY LOUNGE

NO CLAIM IS MADE TO THE EXCLUSIVE RIGHT TO USE "JEWELRY", APART FROM THE MARK AS SHOWN.

THE MARK CONSISTS OF THE STYLIZED WORDS "VEEJOU JEWELRY LOUNGE" WITH A "O" IN "VEEJOU" THE DESIGN OF A RING.

FOR JEWELRY; WATCHES (U.S. CLS. 2, 27, 28 AND 50).

HOWARD B. LEVINE, EXAMINING ATTORNEY

CLASS 14—(Continued).

SN 85-349,283. MONTANA SILVERSMITHS, INC., COLUMBUS, MT. FILED 6-17-2011.

ELMER

THE MARK CONSISTS OF STANDARD CHARACTERS WITHOUT CLAIM TO ANY PARTICULAR FONT, STYLE, SIZE, OR COLOR.

FOR JEWELRY; BOLO TIES WITH PRECIOUS METAL TIPS (U.S. CLS. 2, 27, 28 AND 50).
FIRST USE 1-0-2001; IN COMMERCE 1-0-2001.
LAURIE MAYES, EXAMINING ATTORNEY

CLASS 14—(Continued).

SN 85-355,378. Z LUXE GROUP, INC., DBA DELATORI, SAN DIEGO, CA. FILED 6-24-2011.

Where To Wear

THE MARK CONSISTS OF STANDARD CHARACTERS WITHOUT CLAIM TO ANY PARTICULAR FONT, STYLE, SIZE, OR COLOR.

FOR JEWELRY; JEWELRY WATCHES (U.S. CLS. 2, 27, 28 AND 50).
FIRST USE 5-1-2011; IN COMMERCE 5-1-2011.
BRENDAN REGAN, EXAMINING ATTORNEY

SN 85-350,008. WILCOX, KELLY K, SANTA BARBARA, CA. FILED 6-19-2011.

Kelebek Travers

THE MARK CONSISTS OF STANDARD CHARACTERS WITHOUT CLAIM TO ANY PARTICULAR FONT, STYLE, SIZE, OR COLOR.

OWNER OF U.S. REG. NO. 3,802,994.
FOR JEWELRY (U.S. CLS. 2, 27, 28 AND 50).
FIRST USE 5-24-2011; IN COMMERCE 5-24-2011.
RAMONA ORTIGA, EXAMINING ATTORNEY

SN 85-360,681. LAMESHA LUXE, INC., WESTFIELD, IN. FILED 6-30-2011.



MISHA MILES

THE NAME(S), PORTRAIT(S), AND/OR SIGNATURE(S) SHOWN IN THE MARK DOES NOT IDENTIFY A PARTICULAR LIVING INDIVIDUAL.

THE MARK CONSISTS OF A STYLIZED LETTER "M" APPROXIMATING A HEAD OVER THE WORDS "MISHA MILES".
FOR JEWELRY (U.S. CLS. 2, 27, 28 AND 50).
HENRY S. ZAK, EXAMINING ATTORNEY

SN 85-354,066. LAMESHA LUXE, INC., WESTFIELD, IN. FILED 6-23-2011.

MISHA MILES

THE MARK CONSISTS OF STANDARD CHARACTERS WITHOUT CLAIM TO ANY PARTICULAR FONT, STYLE, SIZE, OR COLOR.

THE NAME(S), PORTRAIT(S), AND/OR SIGNATURE(S) SHOWN IN THE MARK DOES NOT IDENTIFY A PARTICULAR LIVING INDIVIDUAL.
FOR JEWELRY (U.S. CLS. 2, 27, 28 AND 50).
HENRY S. ZAK, EXAMINING ATTORNEY

SN 85-365,571. CHOWDHARY, JAMAL, GLENDALE, CA. FILED 7-7-2011.

XTREME ENERGY

THE MARK CONSISTS OF STANDARD CHARACTERS WITHOUT CLAIM TO ANY PARTICULAR FONT, STYLE, SIZE, OR COLOR.

NO CLAIM IS MADE TO THE EXCLUSIVE RIGHT TO USE "ENERGY", APART FROM THE MARK AS SHOWN.
FOR SILICONE NECKLACES AND WRISTBANDS IN THE NATURE OF BRACELETS (U.S. CLS. 2, 27, 28 AND 50).
KIM MONINGHOFF, EXAMINING ATTORNEY

CLASS 14—(Continued).

SN 85-384,487. CHARLOTTE RONSON LLC, NEW YORK, NY. FILED 7-29-2011.

CHARLOTTE RONSON

THE MARK CONSISTS OF STANDARD CHARACTERS WITHOUT CLAIM TO ANY PARTICULAR FONT, STYLE, SIZE, OR COLOR.

OWNER OF U.S. REG. NOS. 3,614,032, 3,620,635 AND 3,620,843.

THE NAME(S), PORTRAIT(S), AND/OR SIGNATURE(S) SHOWN IN THE MARK IDENTIFIES A PARTICULAR LIVING INDIVIDUAL, WHOSE CONSENT(S) TO REGISTER IS MADE OF RECORD.

FOR JEWELRY, WATCHES, NECKLACES, BRACELETS, EARRINGS, RINGS, BANGLES, BROOCHES, JEWELRY CHAINS, CHARMS, CUFFLINKS, JEWELRY CASES, KEY RINGS OF PRECIOUS METAL, KEY CHAINS OF PRECIOUS METAL, LOCKETS, MEDALLIONS, PENDANTS, FINE JEWELRY, IMITATION JEWELRY AND COSTUME JEWELRY (U.S. CLS. 2, 27, 28 AND 50).

TEJBIR SINGH, EXAMINING ATTORNEY

SN 85-437,808. HARRIS ORIGINALS OF NEW YORK, INC., HAUPPAUGE, NY. FILED 10-3-2011.



NO CLAIM IS MADE TO THE EXCLUSIVE RIGHT TO USE "MEDAL" AND "ORIGINALS", APART FROM THE MARK AS SHOWN.

THE MARK CONSISTS OF A STAR DESIGN SURROUNDED BY HEART DESIGNS WITH THE WORDS "MEDAL OF HONOR" UNDERLINED NEXT TO THE DESIGN WITH THE WORDS "BY HARRIS ORIGINALS" UNDER THE LETTERS "NOR".

FOR JEWELRY (U.S. CLS. 2, 27, 28 AND 50).

ALEXANDER L. POWERS, EXAMINING ATTORNEY

SN 85-447,066. FINE, JAMES M., NORTH HAVEN, CT. FILED 10-13-2011.

BaciBaci

THE MARK CONSISTS OF STANDARD CHARACTERS WITHOUT CLAIM TO ANY PARTICULAR FONT, STYLE, SIZE, OR COLOR.

THE ENGLISH TRANSLATION OF "BACIBACI" IN THE MARK IS "KISSESKISSES".

FOR JEWELRY (U.S. CLS. 2, 27, 28 AND 50).

GEOFFREY FOSDICK, EXAMINING ATTORNEY

CLASS 14—(Continued).

SN 85-456,278. GREENWOOD, INC., DBA GREENWOOD PLASTICS CO., DANVILLE, IL. FILED 10-26-2011.

MEMORY RING

THE MARK CONSISTS OF STANDARD CHARACTERS WITHOUT CLAIM TO ANY PARTICULAR FONT, STYLE, SIZE, OR COLOR.

FOR BURIAL MEMORIAL MEDALLION (U.S. CLS. 2, 27, 28 AND 50).

FIRST USE 11-1-2010; IN COMMERCE 11-1-2010.

ESTHER A. BORSUK, EXAMINING ATTORNEY

SN 85-458,119. BONATO OLIVIERO GIOIELLI S.R.L., MILANO, ITALY, FILED 10-27-2011.



NO CLAIM IS MADE TO THE EXCLUSIVE RIGHT TO USE "GIOIELLI", APART FROM THE MARK AS SHOWN.

THE MARK CONSISTS OF THE EXPRESSION "BONATO GIOIELLI" WRITTEN IN STYLIZED CHARACTERS, WITH THE LETTERS "B" AND "G" IN BIGGER CHARACTERS COMBINED WITH TWO IRREGULAR FIGURES REPRESENTING STYLIZED BIRDS AND WITH THE STYLIZED REPRESENTATION OF A STAR AND OF A PARTIAL MOON.

THE ENGLISH TRANSLATION OF "GIOIELLI" IN THE MARK IS "JEWELRY".

FOR JEWELRY; IMITATION JEWELRY FOR MEN, LADIES AND CHILDREN, NAMELY, RINGS, NECKLACES, BRACELETS, PENDANTS, EARRINGS, BROOCHES, TIE PINS; JEWELRY OF PRECIOUS METAL MADE OF GOLD, PLATINUM, SILVER AND PRECIOUS STONES FOR MEN, LADIES AND CHILDREN, NAMELY, RINGS, NECKLACES, BRACELETS, PENDANTS, EARRINGS, BROOCHES, TIE PINS (U.S. CLS. 2, 27, 28 AND 50).

FIRST USE 5-25-2000; IN COMMERCE 5-25-2000.

MARK SPACINO, EXAMINING ATTORNEY

CLASS 14—(Continued).

SN 85-462,303. COUSIN CORPORATION OF AMERICA, LARGO, FL. FILED 11-2-2011.

Fun Pack

THE MARK CONSISTS OF STANDARD CHARACTERS WITHOUT CLAIM TO ANY PARTICULAR FONT, STYLE, SIZE, OR COLOR.

NO CLAIM IS MADE TO THE EXCLUSIVE RIGHT TO USE "PACK", APART FROM THE MARK AS SHOWN.

FOR JEWELRY MAKING KITS FOR MAKING COSTUME JEWELRY (U.S. CLS. 2, 27, 28 AND 50).

FIRST USE 10-18-2011; IN COMMERCE 10-18-2011.

ELLEN B. AWRICH, EXAMINING ATTORNEY

SN 85-466,637. JAMES AND SONS, LTD., ORLAND PARK, IL. FILED 11-7-2011.

J&S

THE MARK CONSISTS OF STANDARD CHARACTERS WITHOUT CLAIM TO ANY PARTICULAR FONT, STYLE, SIZE, OR COLOR.

OWNER OF U.S. REG. NO. 3,232,154.

FOR CUSTOM DESIGNED JEWELRY MADE OF PRECIOUS METALS AND/OR PRECIOUS AND SEMI-PRECIOUS GEMSTONES (U.S. CLS. 2, 27, 28 AND 50).

FIRST USE 11-1-2011; IN COMMERCE 11-1-2011.

ANDREA BUTLER, EXAMINING ATTORNEY

CLASS 14—(Continued).

SN 85-470,991. MIAMI MARLINS, L.P., MIAMI, FL. FILED 11-11-2011.



THE COLOR(S) ORANGE, YELLOW, WHITE, BLUE AND SILVER IS/ARE CLAIMED AS A FEATURE OF THE MARK.

THE MARK CONSISTS OF A STYLIZED LETTER "M" ALTERNATELY LINED IN SILVER, ORANGE, YELLOW, WHITE AND BLUE WITH A STYLIZED FISH DESIGN ALTERNATELY LINED IN SILVER, ORANGE, WHITE AND BLUE CURLING AROUND THE UPPER LEFT SIDE OF THE "M".

FOR JEWELRY, NAMELY, BRACELETS, CHARMS, EARRINGS, RINGS, BELLY RINGS, NECKLACES, PENDANTS, WATCHES, WATCH FOBS, WATCH BANDS, WATCH STRAPS, POCKET WATCHES, COSTUME JEWELRY, RUBBER OR SILICONE BRACELETS, MEDALLIONS, ORNAMENTAL PINS, LAPEL PINS, TIE CLIPS, TIE FASTENERS, CUFF LINKS, TIE TACKS, TIE PINS, KEY CHAINS OF PRECIOUS METAL, KEY RINGS OF PRECIOUS METAL, CLOCKS, WALL CLOCKS, ALARM CLOCKS, CLOCKS INCORPORATED INTO KEY CHAINS AND NON-MONETARY COINS OF PRECIOUS METAL (U.S. CLS. 2, 27, 28 AND 50).

KATHY DE JONGE, EXAMINING ATTORNEY

SN 85-473,094. ROSY BLUE JEWELRY, INC., NEW YORK, NY. FILED 11-15-2011.

HEARTS·ARROWS·TOGETHER

THE MARK CONSISTS OF STANDARD CHARACTERS WITHOUT CLAIM TO ANY PARTICULAR FONT, STYLE, SIZE, OR COLOR.

FOR DIAMONDS; PRECIOUS AND SEMI-PRECIOUS STONES; JEWELRY (U.S. CLS. 2, 27, 28 AND 50).

SUNG IN, EXAMINING ATTORNEY

CLASS 14—(Continued).

SN 85-475,805. MAYAN OBSESSIONS, NEW ORLEANS, LA.
FILED 11-17-2011.

Sterling Silvia

THE MARK CONSISTS OF STANDARD CHARACTERS WITHOUT CLAIM TO ANY PARTICULAR FONT, STYLE, SIZE, OR COLOR.

NO CLAIM IS MADE TO THE EXCLUSIVE RIGHT TO USE "STERLING", APART FROM THE MARK AS SHOWN. FOR JEWELRY; RINGS; BRACELETS; PENDANTS; JEWELRY CHAINS; NECKLACES; BANGLES; CUFF-LINKS; EARRINGS; JEWELRY, NAMELY, ANKLETS; CHARMS; ALL OF THE FOREGOING MADE IN WHOLE OR SIGNIFICANT PART OF STERLING SILVER (U.S. CLS. 2, 27, 28 AND 50).

FIRST USE 5-0-2000; IN COMMERCE 5-0-2000.
TASNEEM HUSSAIN, EXAMINING ATTORNEY

CLASS 14—(Continued).

SN 85-486,272. SENO JEWELRY, LLC, NEW YORK, NY.
FILED 12-2-2011.

IPPOLITA ROMA LINKS

THE MARK CONSISTS OF STANDARD CHARACTERS WITHOUT CLAIM TO ANY PARTICULAR FONT, STYLE, SIZE, OR COLOR.

OWNER OF U.S. REG. NOS. 2,829,602, 3,857,388 AND OTHERS.

NO CLAIM IS MADE TO THE EXCLUSIVE RIGHT TO USE "LINKS", APART FROM THE MARK AS SHOWN.

THE NAME(S), PORTRAIT(S), AND/OR SIGNATURE(S) SHOWN IN THE MARK IDENTIFIES "IPPOLITA ROSTAGNO", WHOSE CONSENT(S) TO REGISTER IS MADE OF RECORD.

THE ENGLISH TRANSLATION OF THE WORD "ROMA" IN THE MARK IS "ROME".

FOR JEWELRY (U.S. CLS. 2, 27, 28 AND 50).
CURTIS FRENCH, EXAMINING ATTORNEY

SN 85-484,098. LIMO LANE, DBA LIMO LANE, GUN
BARREL CITY, TX. FILED 11-30-2011.



THE MARK CONSISTS OF THE STYLIZED WORDING "LIMO" FOLLOWED BY A PERIOD.

FOR JEWELRY (U.S. CLS. 2, 27, 28 AND 50).
MICHAEL GAAFAR, EXAMINING ATTORNEY

SN 85-486,366. PILPEL INC, LOS ANGELES, CA. FILED 12-2-2011.

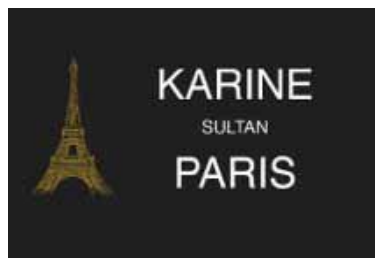

NO CLAIM IS MADE TO THE EXCLUSIVE RIGHT TO USE "PARIS", APART FROM THE MARK AS SHOWN.

THE NAME(S), PORTRAIT(S), AND/OR SIGNATURE(S) SHOWN IN THE MARK IDENTIFIES "KARINE SULTAN", WHOSE CONSENT(S) TO REGISTER IS MADE OF RECORD.

THE COLOR(S) WHITE, BLACK, BROWN IS/ARE CLAIMED AS A FEATURE OF THE MARK.

THE MARK CONSISTS OF THE EIFFEL TOWER IN A BROWN COLOR, NEXT TO THE WORDS "KARINE, SULTAN", AND "PARIS" ALL IN WHITE. THE "SULTAN" APPEARS IN A MUCH SMALLER FONT THAT "KARINE" AND "PARIS" DO. THIS ALL SET AGAINST A BLACK BACKGROUND.

FOR COSTUME JEWELRY, NAMELY, NECKLACES, EARRINGS, BROACHES, WATCHES AND BRACELETS NOT INCLUDING CHARMS; IMITATION FASHION JEWELRY, NAMELY, NECKLACES, EARRINGS, BROACHES, WATCHES AND BRACELETS NOT INCLUDING CHARMS (U.S. CLS. 2, 27, 28 AND 50).

FIRST USE 12-1-2011; IN COMMERCE 12-1-2011.
AISHA CLARKE, EXAMINING ATTORNEY

SN 85-484,425. CLARKS FORK ENTERPRISES, INC., MAR-
IETTA, GA. FILED 11-30-2011.

GLU-N-GO

THE MARK CONSISTS OF STANDARD CHARACTERS WITHOUT CLAIM TO ANY PARTICULAR FONT, STYLE, SIZE, OR COLOR.

FOR JEWELRY END CAPS AND FINDINGS (U.S. CLS. 2, 27, 28 AND 50).

FIRST USE 1-31-2010; IN COMMERCE 1-31-2010.
STEVEN JACKSON, EXAMINING ATTORNEY

CLASS 14—(Continued).

SN 85-492,107. ROBERT WILLIAMS, INDIO, CA. FILED 12-9-2011.

ION D

THE MARK CONSISTS OF STANDARD CHARACTERS WITHOUT CLAIM TO ANY PARTICULAR FONT, STYLE, SIZE, OR COLOR.

NO CLAIM IS MADE TO THE EXCLUSIVE RIGHT TO USE "ION", APART FROM THE MARK AS SHOWN. FOR JEWELRY (U.S. CLS. 2, 27, 28 AND 50). FIRST USE 7-11-2011; IN COMMERCE 8-20-2011. SUSAN STIGLITZ, EXAMINING ATTORNEY

SN 85-494,173. ANAYA GEMS, INC., DBA OTC INTERNATIONAL, LTD., LONG ISLAND CITY, NY. FILED 12-13-2011.

Forever Color

THE MARK CONSISTS OF STANDARD CHARACTERS WITHOUT CLAIM TO ANY PARTICULAR FONT, STYLE, SIZE, OR COLOR.

NO CLAIM IS MADE TO THE EXCLUSIVE RIGHT TO USE "COLOR", APART FROM THE MARK AS SHOWN. FOR JEWELRY (U.S. CLS. 2, 27, 28 AND 50). GINA HAYES, EXAMINING ATTORNEY

SN 85-498,493. ERMENEGILDO ZEGNA CORPORATION, ENGLEWOOD, NJ. FILED 12-19-2011.

ERMENEGILDO ZEGNA HIGH PERFORMANCE

THE MARK CONSISTS OF STANDARD CHARACTERS WITHOUT CLAIM TO ANY PARTICULAR FONT, STYLE, SIZE, OR COLOR.

OWNER OF U.S. REG. NOS. 1,273,447, 3,857,681 AND OTHERS.

NO CLAIM IS MADE TO THE EXCLUSIVE RIGHT TO USE "HIGH PERFORMANCE", APART FROM THE MARK AS SHOWN.

THE NAME(S), PORTRAIT(S), AND/OR SIGNATURE(S) SHOWN IN THE MARK DOES NOT IDENTIFY A PARTICULAR LIVING INDIVIDUAL.

FOR WATCHES (U.S. CLS. 2, 27, 28 AND 50). NAAKWAMA ANKRAH, EXAMINING ATTORNEY

CLASS 14—(Continued).

SN 85-498,925. SR HOLDINGS, LLC, LEXINGTON, MA. FILED 12-19-2011.

SPERRY TOP-SIDER

THE MARK CONSISTS OF STANDARD CHARACTERS WITHOUT CLAIM TO ANY PARTICULAR FONT, STYLE, SIZE, OR COLOR.

OWNER OF U.S. REG. NOS. 732,519, 3,835,580 AND OTHERS.

FOR JEWELRY, CLOCKS AND WATCHES; WATCH STRAPS; WATCH CASES; WATCH CHAINS; WATCH BANDS; WATCH BOXES; WATCH FOBS; KEY RINGS OF PRECIOUS METAL (U.S. CLS. 2, 27, 28 AND 50). CURTIS FRENCH, EXAMINING ATTORNEY

SN 85-499,046. SR HOLDINGS, LLC, LEXINGTON, MA. FILED 12-19-2011.



OWNER OF U.S. REG. NOS. 1,810,853 AND 1,860,428. THE MARK CONSISTS OF A STYLIZED IMAGE OF A SAILBOAT WITH TWO SETS OF WAVES, SURROUNDED BY A SQUARE DESIGN.

FOR JEWELRY, CLOCKS AND WATCHES; WATCH STRAPS; WATCH CASES; WATCH CHAINS; WATCH BANDS; WATCH BOXES; WATCH FOBS; KEY RINGS OF PRECIOUS METAL (U.S. CLS. 2, 27, 28 AND 50).

CURTIS FRENCH, EXAMINING ATTORNEY

CLASS 14—(Continued).

SN 85-500,016. FVCPI, LLC, MIAMI, FL. FILED 12-20-2011.

POOKIE CHARMZ

THE MARK CONSISTS OF STANDARD CHARACTERS WITHOUT CLAIM TO ANY PARTICULAR FONT, STYLE, SIZE, OR COLOR.

NO CLAIM IS MADE TO THE EXCLUSIVE RIGHT TO USE "CHARMS", APART FROM THE MARK AS SHOWN.

FOR BRACELETS; BRACELETS MADE OF RUBBER SILICON; CHARMS; RUBBER OR SILICON WRIST-BANDS IN THE NATURE OF A BRACELET (U.S. CLS. 2, 27, 28 AND 50).

FIRST USE 12-15-2011; IN COMMERCE 12-15-2011.
FRED CARL, EXAMINING ATTORNEY

CLASS 14—(Continued).

SN 85-505,169. MATTA, NEW YORK, LTD., NEW YORK, NY. FILED 12-28-2011.

MATAH

THE MARK CONSISTS OF STANDARD CHARACTERS WITHOUT CLAIM TO ANY PARTICULAR FONT, STYLE, SIZE, OR COLOR.

FOR JEWELRY, NAMELY, NECKLACES, BRACELETS, RINGS, EARRINGS, ANKLETS AND TOE RINGS (U.S. CLS. 2, 27, 28 AND 50).

MATTHEW MCDOWELL, EXAMINING ATTORNEY

SN 85-506,740. MAMANI FLORES, MARTIN NAZARIO, AKA MARTIN MAMANI, LIMA, PERU, FILED 12-30-2011.

SN 85-501,731. BLOOM, MARK, NEW YORK, NY. FILED 12-22-2011.

THE BIRTH DIAMOND

THE MARK CONSISTS OF STANDARD CHARACTERS WITHOUT CLAIM TO ANY PARTICULAR FONT, STYLE, SIZE, OR COLOR.

NO CLAIM IS MADE TO THE EXCLUSIVE RIGHT TO USE "DIAMOND", APART FROM THE MARK AS SHOWN.

FOR JEWELRY PRIMARILY COMPRISED IN WHOLE OR IN PART OF DIAMONDS (U.S. CLS. 2, 27, 28 AND 50).

AMY C. KEAN, EXAMINING ATTORNEY



THE MARK CONSISTS OF A STYLIZED FISH DESIGN AND THE WORD "CORNAVIN" IN STYLIZED FONT.

FOR CLOCKS; JEWELLERY; STRAPS FOR WRIST-WATCHES; TIMEPIECES (U.S. CLS. 2, 27, 28 AND 50).

ERNEST SHOSHO, EXAMINING ATTORNEY

SN 85-502,162. BLOOM, MARK, NEW YORK, NY. FILED 12-22-2011.

THE BIRTH DIAMOND

THE MARK CONSISTS OF STANDARD CHARACTERS WITHOUT CLAIM TO ANY PARTICULAR FONT, STYLE, SIZE, OR COLOR.

NO CLAIM IS MADE TO THE EXCLUSIVE RIGHT TO USE "DIAMOND", APART FROM THE MARK AS SHOWN.

FIRST USE 12-4-2003; IN COMMERCE 12-4-2003.
AMY C. KEAN, EXAMINING ATTORNEY

SN 85-506,822. MARS, INCORPORATED, MCLEAN, VA. FILED 12-31-2011.

M&M'S

THE MARK CONSISTS OF STANDARD CHARACTERS WITHOUT CLAIM TO ANY PARTICULAR FONT, STYLE, SIZE, OR COLOR.

OWNER OF U.S. REG. NOS. 1,774,366, 2,316,573 AND 2,406,181.

FOR CLOCKS; JEWELRY; JEWELRY BOXES; LAPEL PINS; PINS BEING JEWELRY; WATCHES (U.S. CLS. 2, 27, 28 AND 50).

FIRST USE 1-31-2009; IN COMMERCE 1-31-2009.
GILBERT SWIFT, EXAMINING ATTORNEY

CLASS 14—(Continued).

SN 85-507,372. YURMAN STUDIO, INC., NEW YORK, NY.
FILED 1-3-2012.

MEANDRO

THE MARK CONSISTS OF STANDARD CHARACTERS WITHOUT CLAIM TO ANY PARTICULAR FONT, STYLE, SIZE, OR COLOR.

THE ENGLISH TRANSLATION OF "MEANDRO" IS "MEANDER".

FOR JEWELRY (U.S. CLS. 2, 27, 28 AND 50).
DOMINIC FATHY, EXAMINING ATTORNEY

SN 85-507,763. COHEN, SAUL, ENGLEWOOD, NJ. FILED 1-3-2012.

HEFFET

THE MARK CONSISTS OF STANDARD CHARACTERS WITHOUT CLAIM TO ANY PARTICULAR FONT, STYLE, SIZE, OR COLOR.

FOR JEWELRY (U.S. CLS. 2, 27, 28 AND 50).
FIRST USE 1-0-2010; IN COMMERCE 1-0-2010.
JOHN HWANG, EXAMINING ATTORNEY

SN 85-509,660. AMANDA STERETT DESIGN, LLC, DALLAS, TX. FILED 1-5-2012.



THE NAME(S), PORTRAIT(S), AND/OR SIGNATURE(S) SHOWN IN THE MARK IDENTIFIES AMANDA STERETT, WHOSE CONSENT(S) TO REGISTER IS MADE OF RECORD.

THE MARK CONSISTS OF A SQUARE WITH ROUNDED CORNERS FEATURING THE WORD "OLIVIA" ABOVE THE WORD BY ABOVE THE WORDS "AMANDA STERETT" IN THE CENTER OF THE SQUARE AND SURROUNDED BY A PARTIAL CIRCLE AND LEAVES.

FOR JEWELRY, NAMELY, EARRINGS, NECKLACES, BRACELETS, CHARMS, PENDANTS, RINGS (U.S. CLS. 2, 27, 28 AND 50).

JEFF DEFORD, EXAMINING ATTORNEY

CLASS 14—(Continued).

SN 85-509,704. AMANDA STERETT DESIGN, LLC, DALLAS, TX. FILED 1-5-2012.

OLIVIA BY AMANDA STERETT

THE MARK CONSISTS OF STANDARD CHARACTERS WITHOUT CLAIM TO ANY PARTICULAR FONT, STYLE, SIZE, OR COLOR.

THE NAME(S), PORTRAIT(S), AND/OR SIGNATURE(S) SHOWN IN THE MARK IDENTIFIES AMANDA STERETT, WHOSE CONSENT(S) TO REGISTER IS MADE OF RECORD.

FOR JEWELRY, NAMELY, EARRINGS, NECKLACES, BRACELETS, CHARMS, PENDANTS, RINGS (U.S. CLS. 2, 27, 28 AND 50).

JEFF DEFORD, EXAMINING ATTORNEY

SN 85-510,078. THE CARTOON NETWORK, INC., ATLANTA, GA. FILED 1-6-2012.



OWNER OF U.S. REG. NOS. 1,798,899, 2,131,857 AND OTHERS.

THE COLOR(S) BLACK AND WHITE IS/ARE CLAIMED AS A FEATURE OF THE MARK.

THE MARK CONSISTS OF THE WORD CARTOON NETWORK STACKED WITH EACH LETTER IN ALTERNATING BLACK AND WHITE BOXES.

FOR CLOCKS, WATCHES, COSTUME JEWELRY AND DECORATIVE BOXES MADE OF PRECIOUS METAL (U.S. CLS. 2, 27, 28 AND 50).

MARK SPARACINO, EXAMINING ATTORNEY

CLASS 14—(Continued).

SN 85-510,579. LAKE COUNTRY JEWELERS LTD., PEWAU-
KEE, WI. FILED 1-6-2012.



THE MARK CONSISTS OF A CIRCULAR RING WITH A
STYLIZED CROSS IN THE CENTER. ALONG THE TOP OF
THE RING IS THE STYLIZED TEXT "BLACK" AND
ALONG THE BOTTOM OF THE RING IS THE STYLIZED
TEXT "DELTA".

FOR HOROLOGICAL AND CHRONOMETRIC IN-
STRUMENTS AND CASES THEREFOR; HOROLOGICAL
AND CHRONOMETRIC INSTRUMENTS AND PARTS
THEREOF; WATCH CASES; WATCHES (U.S. CLS. 2, 27,
28 AND 50).

FIRST USE 11-20-2010; IN COMMERCE 11-20-2010.
SUSAN LESLIE DUBOIS, EXAMINING ATTORNEY

CLASS 14—(Continued).

SN 85-510,843. SINLESS LIFE, LLC, NEW YORK, NY. FILED
1-6-2012.

LIFE IS A PUZZLE AND WE
ARE THE PIECES

THE MARK CONSISTS OF STANDARD CHARACTERS
WITHOUT CLAIM TO ANY PARTICULAR FONT, STYLE,
SIZE, OR COLOR.

FOR JEWELRY, JEWELRY BOXES, EARRINGS,
NECKLACES, RINGS, BRACELETS, ANKLETS (U.S.
CLS. 2, 27, 28 AND 50).

DAVID COLLIER, EXAMINING ATTORNEY

SN 85-510,884. BARRETT, LESLIE, SIMI VALLEY, CA.
FILED 1-6-2012.

SN 85-510,623. MCCARTHY, TRICIA, ANN, DBA NALUKAI,
SAN FRANCISCO, CA. FILED 1-6-2012.



NALUKAI

THE MARK CONSISTS OF THE WORD "NALUKAI" AND
ALSO A CIRCLE WITH A STYLIZED "N" INSIDE IT.

THE ENGLISH TRANSLATION OF THE WORD "NALU-
KAI" IN THE MARK IS "WEATHERWORN; PEOPLE WHO
HAVE WEATHERED THE STORMS OF LIFE".

FOR JEWELRY (U.S. CLS. 2, 27, 28 AND 50).
MIDGE BUTLER, EXAMINING ATTORNEY

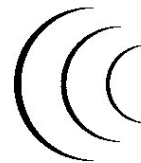

THE MARK CONSISTS OF THREE CURVED BANDS IN A
ROW. THE ONE ON THE LEFT IS LARGEST AND THE
FIGURES GET SMALLER FROM LEFT TO RIGHT.

FOR BRACELETS; EARRINGS; JEWELRY; NECK-
LACES (U.S. CLS. 2, 27, 28 AND 50).

FIRST USE 8-27-2009; IN COMMERCE 12-9-2009.
DAVID COLLIER, EXAMINING ATTORNEY

CLASS 14—(Continued).

SN 85-511,428. FAN FAN, BEIJING, CHINA, FILED 1-9-2012.

Sislenia

THE MARK CONSISTS OF THE WORDING "SISLENIA" IN STYLIZED FORM.

FOR BEADS FOR MAKING JEWELRY; BEADS FOR USE IN THE MANUFACTURE OF JEWELRY; BODY JEWELRY; BRACELETS; BROACHES; BRONZE JEWELRY; BROOCHES; CAMEOS; CHARMS FOR COLLAR JEWELRY AND BRACELET; COSTUME JEWELRY; DIAMOND JEWELRY; EARRINGS; GEMS; GEMSTONE JEWELRY; GOLD THREAD JEWELRY; HAIR JEWELRY IN THE NATURE OF JEWELRY FOR USE IN THE HAIR; IDENTIFICATION BRACELETS; INEXPENSIVE NON-JEWELRY WATCHES; IVORY JEWELRY; JEWELRY; JEWELRY AND IMITATION JEWELRY; JEWELRY ARMOIRES; JEWELRY BOXES; JEWELRY BOXES OF PRECIOUS METAL; JEWELRY BROOCHES; JEWELRY CASES; JEWELRY CASES OF PRECIOUS METAL; JEWELRY CASKETS; JEWELRY CASKETS OF PRECIOUS METAL; JEWELRY CHAINS; JEWELRY DISHES; JEWELRY FINDINGS; JEWELRY FOR ATTACHMENT TO CLOTHING; JEWELRY FOR THE HEAD; JEWELRY IN THE NATURE OF ARMBANDS; JEWELRY INCORPORATING A COMPUTER STORAGE DEVICE CONTAINING MEDICAL INFORMATION FOR MEDICAL ALERT PURPOSES; JEWELRY MAKING KITS; JEWELRY ORGANIZERS; JEWELRY PINS FOR USE ON HATS; JEWELRY RING HOLDERS; JEWELRY STICKPINS; JEWELRY THAT FITS OVER THE FRONT TEETH; JEWELRY THAT INCORPORATES TECHNOLOGY FOR REBALANCING THE HUMAN ENERGY FIELD; JEWELRY TO BE AFFIXED TO BIKINIS; JEWELRY WATCHES; JEWELRY, NAMELY, AMULETS; JEWELRY, NAMELY, ANKLETS; JEWELRY, NAMELY, ARM CUFFS; JEWELRY, NAMELY, BRACELETS, WRISTBANDS AND NECKLACES THAT ALSO PROVIDES NOTIFICATION TO THE WEARER OF A PENDING MEDICAL RELATED TASK; JEWELRY, NAMELY, CROSSES; JEWELRY, NAMELY, DOG TAGS FOR WEAR BY HUMANS FOR DECORATIVE PURPOSES; JEWELRY, NAMELY, MAGNETIC NECKLACES; JEWELRY, NAMELY, MAGNETIC PENDANTS; JEWELRY, NAMELY, PRECIOUS METAL PLATED REAL LEAVES AND FLOWERS; JEWELRY, NAMELY, STONE PENDANTS; LAPEL PINS; METAL WIRE FOR USE IN THE MAKING OF JEWELRY, NAMELY, JEWELRY CABLE; MUSICAL JEWELRY BOXES; PET JEWELRY; PINS BEING JEWELRY; PLASTIC BRACELETS IN THE NATURE OF JEWELRY; PRECIOUS AND SEMI-PRECIOUS CRYSTAL STONES AND BEADS FOR USE IN JEWELRY; RINGS; RINGS BEING JEWELRY; SOUVENIR PRESSED COINS; STAINLESS STEEL JEWELRY BRACELETS; WATCHES AND JEWELRY; WATCHES, CLOCKS, JEWELRY AND IMITATION JEWELRY; WOMEN'S JEWELRY (U.S. CLS. 2, 27, 28 AND 50).

FIRST USE 5-28-2011; IN COMMERCE 10-22-2011.
PATRICIA EVANKO, EXAMINING ATTORNEY

CLASS 14—(Continued).

SN 85-512,320. 21ST CENTURY SURVIVAL LLC, NEW YORK, NY. FILED 1-9-2012.

TRADEMARK

THE MARK CONSISTS OF STANDARD CHARACTERS WITHOUT CLAIM TO ANY PARTICULAR FONT, STYLE, SIZE, OR COLOR.

FOR JEWELRY, NAMELY EARRINGS, NECKLACES, BRACELETS, AND WATCHES; DECORATIVE BOXES MADE OF PRECIOUS METAL (U.S. CLS. 2, 27, 28 AND 50).

DANNEAN HETZEL, EXAMINING ATTORNEY

SN 85-513,168. CEDAR BAY ENTERTAINMENT LLC, BRANSON, MO. FILED 1-10-2012.

NELLIE

THE MARK CONSISTS OF STANDARD CHARACTERS WITHOUT CLAIM TO ANY PARTICULAR FONT, STYLE, SIZE, OR COLOR.

THE NAME(S), PORTRAIT(S), AND/OR SIGNATURE(S) SHOWN IN THE MARK DOES NOT IDENTIFY A PARTICULAR LIVING INDIVIDUAL.

FOR BRACELETS; BROOCHES; CAMEOS; EARRINGS; JEWELRY; NECKLACES; PENDANTS; PINS BEING JEWELRY; RINGS (U.S. CLS. 2, 27, 28 AND 50).

RICHARD WHITE, EXAMINING ATTORNEY

SN 85-513,406. MAMANI FLORES, MARTIN NAZARIO, AKA MARTIN MAMANI, LIMA, PERU, FILED 1-10-2012.

**CORNAVIN
DATOCOR**

THE MARK CONSISTS OF THE WORDS "CORNAVIN DATOCOR" IN STYLIZED FONT.

FOR CLOCKS; JEWELLERY; STRAPS FOR WRISTWATCHES; TIMEPIECES (U.S. CLS. 2, 27, 28 AND 50).

ERNEST SHOSHO, EXAMINING ATTORNEY

CLASS 14—(Continued).

SN 85-513,655. YURMAN STUDIO, INC., NEW YORK, NY. FILED 1-11-2012.

MEANDER

THE MARK CONSISTS OF STANDARD CHARACTERS WITHOUT CLAIM TO ANY PARTICULAR FONT, STYLE, SIZE, OR COLOR.

FOR JEWELRY (U.S. CLS. 2, 27, 28 AND 50).
DOMINIC FATHY, EXAMINING ATTORNEY



SN 85-513,762. CEDAR BAY ENTERTAINMENT LLC, BRANSON, MO. FILED 1-11-2012.

IRENE

THE MARK CONSISTS OF STANDARD CHARACTERS WITHOUT CLAIM TO ANY PARTICULAR FONT, STYLE, SIZE, OR COLOR.

THE NAME(S), PORTRAIT(S), AND/OR SIGNATURE(S) SHOWN IN THE MARK DOES NOT IDENTIFY A PARTICULAR LIVING INDIVIDUAL.

FOR BRACELETS; BROOCHES; CAMEOS; EARRINGS; JEWELRY; NECKLACES; PENDANTS; PINS BEING JEWELRY; RINGS (U.S. CLS. 2, 27, 28 AND 50).
RICHARD WHITE, EXAMINING ATTORNEY



SN 85-513,980. HOLLY, L.L.C., MT. PLEASANT, IA. FILED 1-11-2012.

GlamourGrid.com

THE MARK CONSISTS OF THE WORD "GLAMOUR-GRID.COM" IN A STYLIZED MANNER.

FOR JEWELRY ORGANIZER (U.S. CLS. 2, 27, 28 AND 50).
FIRST USE 12-21-2011; IN COMMERCE 12-21-2011.
BRENDAN REGAN, EXAMINING ATTORNEY

CLASS 14—(Continued).

SN 85-514,005. SHY CREATION, LOS ANGELES, CA. FILED 1-11-2012.

SHY CREATION

THE MARK CONSISTS OF STANDARD CHARACTERS WITHOUT CLAIM TO ANY PARTICULAR FONT, STYLE, SIZE, OR COLOR.

FOR BRACELETS; BROACHES; BROOCHES; CHARMS; CHARMS FOR COLLAR JEWELRY AND BRACELET; DIAMOND JEWELRY; GEMSTONE JEWELRY; GOLD; GOLD, UNWORKED OR SEMI-WORKED; JEWELRY; JEWELRY AND IMITATION JEWELRY; JEWELRY BROOCHES; JEWELRY CHAINS; JEWELRY FOR ATTACHMENT TO CLOTHING; JEWELRY FOR THE HEAD; JEWELRY, NAMELY, CROSSES; JEWELRY, NAMELY, STONE PENDANTS; PINS BEING JEWELRY; PLATINUM; PRECIOUS AND SEMI-PRECIOUS CRYSTAL STONES AND BEADS FOR USE IN JEWELRY; RINGS; RINGS BEING JEWELRY; SILVER; STAINLESS STEEL JEWELRY BRACELETS; WATCHES AND JEWELRY; WOMEN'S JEWELRY (U.S. CLS. 2, 27, 28 AND 50).
FIRST USE 2-20-2001; IN COMMERCE 2-20-2001.
LEIGH CAROLINE CASE, EXAMINING ATTORNEY



SN 85-514,198. DBYS INTERNATIONAL, INC., EDGEWATER, NJ. FILED 1-11-2012.

THE COLOR(S) BLACK AND PURPLE IS/ARE CLAIMED AS A FEATURE OF THE MARK.

THE MARK CONSISTS OF THE WORD "EPIC" IN BLACK EDWARDIAN SCRIPT WITH AN UPPER CASE "E" AND REMAINING LETTERS IN LOWER CASE. A SPECIAL MARK RESEMBLING A STARBURST IS USED AS A DOT OVER THE LOWER CASE "I" IN PURPLE TONE.

FOR BRACELETS; BROACHES; BROOCHES; CAMEOS; CHARMS; COSTUME JEWELRY EXCLUDING WATCHES; GOLD THREAD JEWELRY EXCLUDING WATCHES; ALL FOR SALE TO REGISTERED WHOLESALEERS ONLY (U.S. CLS. 2, 27, 28 AND 50).
LUCY ARANT, EXAMINING ATTORNEY

CLASS 14—(Continued).

SN 85-514,374. GINDI NISIM, AKA NEMO, BROOKLYN, NY.
FILED 1-11-2012.



THE MARK CONSISTS OF STYLIZED FONT OF VIA NOVA IN CAPITAL LETTERS WITH A DOUBLE WAVE DESIGN SEPARATING THE WORDS "VIA" AND "NOVA".
FOR WRISTWATCHES (U.S. CLS. 2, 27, 28 AND 50).
FIRST USE 3-29-2010; IN COMMERCE 12-24-2010.
RAUL CORDOVA, EXAMINING ATTORNEY

SN 85-515,213. BRENTON J. BYRD, ELBERON, VA. FILED 1-12-2012.

WE MUST PRAY

THE MARK CONSISTS OF STANDARD CHARACTERS WITHOUT CLAIM TO ANY PARTICULAR FONT, STYLE, SIZE, OR COLOR.
FOR RUBBER OR SILICON WRISTBANDS IN THE NATURE OF A BRACELET (U.S. CLS. 2, 27, 28 AND 50).
AMY KELLY, EXAMINING ATTORNEY

SN 85-515,417. KENNETH O ELDIB, INDIANAPOLIS, IN.
FILED 1-12-2012.



THE MARK CONSISTS OF AN ANKH WITH AN UPWARD POINTING ARROW IN THE CIRCULAR PART OF THE ANKH.
FOR JEWELRY (U.S. CLS. 2, 27, 28 AND 50).
FIRST USE 1-12-2012; IN COMMERCE 1-12-2012.
LOURDES AYALA, EXAMINING ATTORNEY

CLASS 14—(Continued).

SN 85-517,376. SR HOLDINGS, LLC, LEXINGTON, MA.
FILED 1-16-2012.

TEAM SPERRY TOP-SIDER

THE MARK CONSISTS OF STANDARD CHARACTERS WITHOUT CLAIM TO ANY PARTICULAR FONT, STYLE, SIZE, OR COLOR.

OWNER OF U.S. REG. NOS. 732,519, 3,835,580 AND OTHERS.

NO CLAIM IS MADE TO THE EXCLUSIVE RIGHT TO USE "TEAM", APART FROM THE MARK AS SHOWN.

FOR JEWELRY, CLOCKS AND WATCHES; WATCH STRAPS; WATCH CASES; WATCH CHAINS; WATCH BANDS; WATCH BOXES; WATCH FOBS; KEY RINGS OF PRECIOUS METAL (U.S. CLS. 2, 27, 28 AND 50).

CURTIS FRENCH, EXAMINING ATTORNEY

SN 85-527,666. NIKE, INC., BEAVERTON, OR. FILED 1-27-2012.

NIKE+ FUEL BAND

THE MARK CONSISTS OF STANDARD CHARACTERS WITHOUT CLAIM TO ANY PARTICULAR FONT, STYLE, SIZE, OR COLOR.

OWNER OF U.S. REG. NOS. 2,196,735, 3,618,440 AND OTHERS.

FOR WATCHES; BRACELETS; WATCHES AND BRACELETS INCORPORATING FUNCTIONS FOR MONITORING AND REPORTING FITNESS, TRAINING, AND ACTIVITY DATA, NAMELY, TIME, DISTANCE, PACE, BODY RATE, WEIGHT MANAGEMENT, CALORIES BURNED, AND CUMULATIVE ACTIVITY LEVEL; WATCHES AND BRACELETS THAT COMMUNICATE DATA TO PERSONAL DIGITAL ASSISTANTS, SMART PHONES, AND PERSONAL COMPUTERS THROUGH INTERNET WEBSITES AND OTHER COMPUTER AND ELECTRONIC COMMUNICATION NETWORKS (U.S. CLS. 2, 27, 28 AND 50).

JAY FLOWERS, EXAMINING ATTORNEY

CLASS 14—(Continued).

SN 85-527,706. NIKE, INC., BEAVERTON, OR. FILED 1-27-2012.



THE MARK CONSISTS OF A PLUS SIGN WITHIN AN OPEN CIRCLE.

FOR WATCHES; BRACELETS; WATCHES AND BRACELETS INCORPORATING FUNCTIONS FOR MONITORING AND REPORTING FITNESS, TRAINING, AND ACTIVITY DATA, NAMELY, TIME, DISTANCE, PACE, BODY RATE, WEIGHT MANAGEMENT, CALORIES BURNED, AND CUMULATIVE ACTIVITY LEVEL; WATCHES AND BRACELETS THAT COMMUNICATE DATA TO PERSONAL DIGITAL ASSISTANTS, SMART PHONES, AND PERSONAL COMPUTERS THROUGH INTERNET WEBSITES AND OTHER COMPUTER AND ELECTRONIC COMMUNICATION NETWORKS (U.S. CLS. 2, 27, 28 AND 50).

JAY FLOWERS, EXAMINING ATTORNEY

CLASS 14—(Continued).

SN 85-564,415. OZ'S JEWELERS, HICKORY, NC. FILED 3-8-2012.

SHH!

THE MARK CONSISTS OF STANDARD CHARACTERS WITHOUT CLAIM TO ANY PARTICULAR FONT, STYLE, SIZE, OR COLOR.

FOR JEWELRY (U.S. CLS. 2, 27, 28 AND 50).
DAVID TOOLEY, EXAMINING ATTORNEY

SN 85-531,494. INTERNATIONAL DIAMOND DISTRIBUTORS, INC., NEW YORK, NY. FILED 2-1-2012.



NO CLAIM IS MADE TO THE EXCLUSIVE RIGHT TO USE "BRIDAL", APART FROM THE MARK AS SHOWN.

THE MARK CONSISTS OF HEART SHAPED DESIGN CROWNED BY A JEWEL ADJACENT TO THE TERMS "IDDEAL BRIDAL" IN A SCRIPT FONT.

FOR JEWELRY; PRECIOUS GEMSTONES; PRECIOUS METALS AND THEIR ALLOYS; PRECIOUS STONES (U.S. CLS. 2, 27, 28 AND 50).

DARRYL SPRUILL, EXAMINING ATTORNEY



OWNER OF U.S. REG. NO. 3,469,381.
THE MARK CONSISTS OF THE STYLIZED WORDING "REVER" HAVING A LEAF OVER THE LETTER "V". THE TERMS "DISCOVER UNIQUENESS" ARE BELOW THE WORDING "REVER".

THE ENGLISH TRANSLATION OF "REVER" IN THE MARK IS "TO DREAM".

FOR JEWELRY, NAMELY, NECKLACES, PENDANTS, BRACELETS, RINGS, EARRINGS, CHAINS, LAPEL PINS, BROACHES AND OTHER JEWELLED PINS, JEWELLED ACCESSORIES, NAMELY, WATCHES, WATCH STRAPS, CLOCKS, CLOCK PARTS, GIFT PENDANTS (U.S. CLS. 2, 27, 28 AND 50).

MELISSA VALLILLO, EXAMINING ATTORNEY

CLASS 15—MUSICAL INSTRUMENTS

SN 85-221,424. M & M MERCHANDISERS, INC., FORT WORTH, TX. FILED 1-19-2011.



NO CLAIM IS MADE TO THE EXCLUSIVE RIGHT TO USE "ACCESSORIES", APART FROM THE MARK AS SHOWN.

THE MARK CONSISTS OF A RECTANGULAR BOX WITH CURVED CORNERS WITH A BREAK IN THE MIDDLE OF THE BOTTOM HORIZONTAL LINE WITH THE WORD "ACCESSORIES" IN NEWS GOTHIC MT FONT THAT IS CENTERED ALONG THE HORIZONTAL LINE AND IN THE MIDDLE OF THE RECTANGULAR BOX THE WORDS "FAT BOY" IN PINCHED FAT FONT IS CENTERED WITHIN THE BOX.

FOR GUITAR BRIDGES; GUITAR PEDALS; GUITAR PICKS; TUNERS FOR MUSICAL INSTRUMENTS (U.S. CLS. 2, 21 AND 36).

FIRST USE 9-7-2008; IN COMMERCE 9-7-2008.

RONALD MCMORROW, EXAMINING ATTORNEY

CLASS 15—(Continued).

SN 85-410,198. JOHN HORNBY SKEWES & CO LTD, LEEDS. LS25 2HR, UNITED KINGDOM, FILED 8-30-2011.

DRUM TECH

THE MARK CONSISTS OF STANDARD CHARACTERS WITHOUT CLAIM TO ANY PARTICULAR FONT, STYLE, SIZE, OR COLOR.

OWNER OF UNITED KINGDOM REG. NO. 2414874, DATED 2-24-2006, EXPIRES 2-24-2016.

NO CLAIM IS MADE TO THE EXCLUSIVE RIGHT TO USE "DRUM", APART FROM THE MARK AS SHOWN.

FOR PERCUSSION MUSICAL INSTRUMENTS, PARTS THEREOF, AND ACCESSORIES THEREFOR, NAMELY, DRUM OUTFITS, DRUMS, CYMBALS, HI-HATS, COWBELLS, DRUM STICKS AND MALLETS AND WIRE BRUSHES, CYMBAL AND DRUM BEATERS, DRUM AND CYMBAL PEDALS, PRACTICE PADS, DRUM THRONES; BAGS AND CASES FOR ALL THE ABOVE INSTRUMENTS; STANDS, L-ARMS, MULTI CLAMPS AND CLUTCHES, X-HATS, DRUM HEADS, DRUM SPURS, FELT WASHERS, DRUM HOOPS, DRUM TENSION RODS, SNARE SWITCHES, SNARE STRANDS AND STRAINERS, DRUM PEDAL TENSION SPRINGS, DRUM SPURS, DRUM KEYS, FOR ALL THE ABOVE INSTRUMENTS (U.S. CLS. 2, 21 AND 36).

KAELIE KUNG, EXAMINING ATTORNEY

SN 85-429,226. LOUIS J. FEMENELLA, BROOKLYN, NY. FILED 9-22-2011.

Femenella Custom Bellrest**PUJE**

THE MARK CONSISTS OF STANDARD CHARACTERS WITHOUT CLAIM TO ANY PARTICULAR FONT, STYLE, SIZE, OR COLOR.

FOR TRUMPETS (U.S. CLS. 2, 21 AND 36).

GEOFFREY FOSDICK, EXAMINING ATTORNEY

THE MARK CONSISTS OF STANDARD CHARACTERS WITHOUT CLAIM TO ANY PARTICULAR FONT, STYLE, SIZE, OR COLOR.

NO CLAIM IS MADE TO THE EXCLUSIVE RIGHT TO USE "CUSTOM BELLREST", APART FROM THE MARK AS SHOWN.

FOR ATTACHMENT FOR THE BELL OF A MUSICAL INSTRUMENT TO ALLOW THE PLAYER TO HOLD THE HORN IN A MORE COMFORTABLE AND NATURAL PLAYING POSITION (U.S. CLS. 2, 21 AND 36).

FIRST USE 8-1-2011; IN COMMERCE 8-1-2011.

JEFF DEFORD, EXAMINING ATTORNEY

SN 85-352,458. JOSEPH C. BODIFORD, TAMPA, FL. FILED 6-22-2011.

CLASS 15—(Continued).

SN 85-499,554. KIMBLE, JOHN H, ALLEN, TX. FILED 12-20-2011.

social entropy

THE MARK CONSISTS OF STANDARD CHARACTERS WITHOUT CLAIM TO ANY PARTICULAR FONT, STYLE, SIZE, OR COLOR.
 FOR ELECTRONIC MUSICAL INSTRUMENTS (U.S. CLS. 2, 21 AND 36).
 FIRST USE 12-12-1999; IN COMMERCE 7-11-2008.
 KAREN K. BUSH, EXAMINING ATTORNEY

CLASS 15—(Continued).

SN 85-508,861. DUNLOP MANUFACTURING, INC., BENICIA, CA. FILED 1-4-2012.

ROAD PRO

THE MARK CONSISTS OF STANDARD CHARACTERS WITHOUT CLAIM TO ANY PARTICULAR FONT, STYLE, SIZE, OR COLOR.
 FOR MUSICAL INSTRUMENT ACCESSORIES, NAMELY, STRINGWINDERS (U.S. CLS. 2, 21 AND 36).
 FIRST USE 1-14-2010; IN COMMERCE 1-14-2010.
 LOURDES AYALA, EXAMINING ATTORNEY

SN 85-500,529. REACTORZ PTY LTD, AKA REACTORZ, MELBOURNE, VIC, AUSTRALIA, FILED 12-21-2011.

R E A C T O R Z

THE MARK CONSISTS OF THE "REACTORZ" LOGO IS REPRESENTED BY A UNIQUE AGGRESSIVE LOOKING TYPEFACE THAT HAS RAZOR EDGES TO GIVE IT A LOOK ALL OF ITS OWN. THE DOUBLE SPACING IS AN ELEMENT THAT PROVIDES A MORE SOLID BALD LOOK.
 FOR DRUM PARTS, NAMELY, DRUM AND PERCUSSION PRODUCTS AND ACCESSORIES, NAMELY, HARDWARE AND ILLUMINATING TRIGGERED AND SOLID LIT DIE-CAST RESONANT RINGS FOR THE BASS DRUM WHICH IMPROVE THE AESTHETICS OF A DRUM KIT (U.S. CLS. 2, 21 AND 36).
 FIRST USE 11-12-2011; IN COMMERCE 11-12-2011.
 DAVID HOFFMAN, EXAMINING ATTORNEY

SN 85-511,380. PRO MUSIC DEVELOPMENTS LTD., TEL AVIV, ISRAEL, FILED 1-9-2012.

PYKMAX

THE MARK CONSISTS OF STANDARD CHARACTERS WITHOUT CLAIM TO ANY PARTICULAR FONT, STYLE, SIZE, OR COLOR.
 FOR GUITAR PICKS (U.S. CLS. 2, 21 AND 36).
 LOURDES AYALA, EXAMINING ATTORNEY

SN 85-506,814. MARS, INCORPORATED, MCLEAN, VA. FILED 12-31-2011.

M&M'S

THE MARK CONSISTS OF STANDARD CHARACTERS WITHOUT CLAIM TO ANY PARTICULAR FONT, STYLE, SIZE, OR COLOR.
 OWNER OF U.S. REG. NOS. 1,774,366, 2,406,181 AND OTHERS.
 FOR MUSIC BOXES (U.S. CLS. 2, 21 AND 36).
 FIRST USE 1-31-2004; IN COMMERCE 1-31-2004.
 GILBERT SWIFT, EXAMINING ATTORNEY

SN 85-564,942. LFP IP, LLC, BEVERLY HILLS, CA. FILED 3-9-2012.

HUSTLER

THE MARK CONSISTS OF STANDARD CHARACTERS WITHOUT CLAIM TO ANY PARTICULAR FONT, STYLE, SIZE, OR COLOR.
 OWNER OF U.S. REG. NOS. 1,011,001, 3,918,404 AND OTHERS.
 FOR ELECTRIC GUITARS; GUITAR PEDALS; GUITAR PICKS; GUITAR STRAPS (U.S. CLS. 2, 21 AND 36).
 AMY KELLY, EXAMINING ATTORNEY

CLASS 16—PAPER GOODS AND PRINTED MATTER

SN 76-705,694. VISUAL INTELLIGENCE LP, HOUSTON, TX. FILED 12-15-2010.

DIGITALFILM

THE MARK CONSISTS OF STANDARD CHARACTERS WITHOUT CLAIM TO ANY PARTICULAR FONT, STYLE, SIZE, OR COLOR.

SEC. 2(F).
FOR MAPS, DIGITAL PHOTOGRAPHS (U.S. CLS. 2, 5, 22, 23, 29, 37, 38 AND 50).
FIRST USE 12-0-2006; IN COMMERCE 12-0-2006.
NANCY CLARKE, EXAMINING ATTORNEY

SN 76-709,370. FEINBERG, ALIXANDRA, DBA SPEAK WITH STRENGTH, A SPEECH THERAPY AGENCY, SACRAMENTO, CA. FILED 10-12-2011.

SPEAK IN STEPS

THE MARK CONSISTS OF STANDARD CHARACTERS WITHOUT CLAIM TO ANY PARTICULAR FONT, STYLE, SIZE, OR COLOR.

OWNER OF U.S. REG. NO. 3,643,942.
FOR PRINTED INSTRUCTIONAL, TEACHING AND EDUCATIONAL MATERIALS, AND FLASH CARDS, IN THE FIELD OF SPEECH AND LANGUAGE INSTRUCTION AND COUNSELING USED IN THE DELIVERY OF SPEECH LANGUAGE PATHOLOGY SERVICES AND IN THE DELIVERY OF COUNSELING SERVICES RELATED TO SPEECH PATHOLOGY (U.S. CLS. 2, 5, 22, 23, 29, 37, 38 AND 50).
FIRST USE 9-20-2010; IN COMMERCE 8-10-2011.
ELISSA GARBER KON, EXAMINING ATTORNEY

SN 77-962,251. NICKLAUS COMPANIES, LLC, NORTH PALM BEACH, FL. FILED 3-18-2010.

Golf My Way

THE MARK CONSISTS OF STANDARD CHARACTERS WITHOUT CLAIM TO ANY PARTICULAR FONT, STYLE, SIZE, OR COLOR.

NO CLAIM IS MADE TO THE EXCLUSIVE RIGHT TO USE "GOLF", APART FROM THE MARK AS SHOWN.
FOR BOOKS IN THE FIELD OF GOLF (U.S. CLS. 2, 5, 22, 23, 29, 37, 38 AND 50).
FIRST USE 12-31-2002; IN COMMERCE 12-31-2002.
JULIE WATSON, EXAMINING ATTORNEY

CLASS 16—(Continued).

SN 79-102,132. SATO HOLDINGS KABUSHIKI KAISHA, JAPAN, FILED 8-3-2011.



PRIORITY DATE OF 3-4-2011 IS CLAIMED.
OWNER OF INTERNATIONAL REGISTRATION 1089649 DATED 8-3-2011, EXPIRES 8-3-2021.

NO CLAIM IS MADE TO THE EXCLUSIVE RIGHT TO USE "ECO", APART FROM THE MARK AS SHOWN.
THE COLOR(S) GREEN IS/ARE CLAIMED AS A FEATURE OF THE MARK.

THE MARK CONSISTS OF A LARGE GREEN CIRCLE WHEREIN A STYLIZED WORD "ECO" ABOVE THE STYLIZED WORD "NANO" WHERE THE LETTER "O" OF "ECO" IS COMPRISED OF THE FIRST OF THREE CIRCLES RISING OUT OF THE LARGER CIRCLE; THE SECOND SMALLER CIRCLE IS PARTIALLY GREEN AND THE THIRD OUTSIDE SMALLER CIRCLE IS GREEN; THE WORDS AND DESIGNS SHOWN IN WHITE ARE TRANSPARENT AND ARE NOT PART OF THE MARK.

FOR LABELS, NOT OF TEXTILE, NAMELY, ADHESIVE LABELS, BAR CODE LABELS, PAPER LABELS, PRINTED PAPER LABELS, PAPER LINERLESS LABELS, PRINTED PAPER LINERLESS LABELS; SEALS, BAGGAGE TAGS; TAGS, NAMELY, CARDBOARD HANG TAGS, PAPER TAGS, PRICE TAGS, PAPER IDENTIFICATION TAGS; STATIONERY; PAPER; HAND LABELING APPLIANCES; LABEL DISPENSERS FOR HOUSEHOLD AND STATIONERY USE; INKING RIBBONS (U.S. CLS. 2, 5, 22, 23, 29, 37, 38 AND 50).

WILLIAM VERHOSEK, EXAMINING ATTORNEY

SN 79-102,239. SATO HOLDINGS KABUSHIKI KAISHA, JAPAN, FILED 8-3-2011.

econano

THE MARK CONSISTS OF STANDARD CHARACTERS WITHOUT CLAIM TO ANY PARTICULAR FONT, STYLE, SIZE, OR COLOR.

PRIORITY DATE OF 2-21-2011 IS CLAIMED.
OWNER OF INTERNATIONAL REGISTRATION 1089876 DATED 8-3-2011, EXPIRES 8-3-2021.

FOR LABELS, NOT OF TEXTILE, NAMELY, ADHESIVE LABELS, BAR CODE LABELS, PAPER LABELS, PRINTED PAPER LABELS, PAPER LINERLESS LABELS, PRINTED PAPER LINERLESS LABELS; SEALS, BAGGAGE TAGS; TAGS, NAMELY, CARDBOARD HANG TAGS, PAPER TAGS, PRICE TAGS, PAPER IDENTIFICATION TAGS; STATIONERY; PAPER; HAND LABELING APPLIANCES; LABEL DISPENSERS FOR HOUSEHOLD AND STATIONERY USE; INKING RIBBONS (U.S. CLS. 2, 5, 22, 23, 29, 37, 38 AND 50).

WILLIAM VERHOSEK, EXAMINING ATTORNEY

CLASS 16—(Continued).

SN 85-089,052. DISNEY ENTERPRISES, INC., BURBANK, CA. FILED 7-20-2010.

JUNGLE JUNCTION

THE MARK CONSISTS OF STANDARD CHARACTERS WITHOUT CLAIM TO ANY PARTICULAR FONT, STYLE, SIZE, OR COLOR.

OWNER OF U.S. REG. NO. 3,785,125.

FOR ADDRESS BOOKS; ALMANACS; APPLIQUES IN THE FORM OF DECALS; APPOINTMENT BOOKS; ART PRINTS; ARTS AND CRAFT PAINT KITS; AUTOGRAPH BOOKS; BABY BOOKS; BALL POINT PENS; BASEBALL CARDS; BINDERS; BOOKENDS; BOOKMARKS; A SERIES OF FICTION BOOKS; BOOKS, MAGAZINES, NEWSLETTERS AND PERIODICALS, FEATURING STORIES, GAMES AND ACTIVITIES; BUMPER STICKERS; CALENDARS; CARTOON STRIPS; CHRISTMAS CARDS; CHALK; CHILDREN'S ACTIVITY BOOKS; COASTERS MADE OF PAPER; COIN ALBUMS; COLORING BOOKS; COLOR PENCILS; COMIC BOOKS; COMIC STRIPS; COUPON BOOKS; DECALS; DECORATIVE PAPER CENTERPIECES; DIARIES; DISPOSABLE DIAPERS FOR BABIES MADE OF PAPER; DRAWING RULERS; ENVELOPES; ERASERS; FELT PENS; FLASH CARDS; PAPER GIFT CARDS; GIFT WRAPPING PAPER; GLOBES; GREETING CARDS; GUEST BOOKS; MAPS; MEMO PADS; MODELING CLAY; NEWSPAPERS; NOTE PAPER; NOTEBOOKS; NOTEBOOK PAPER; PAINTINGS; PAPER FLAGS; PAPER PARTY FAVORS; PAPER CAKE DECORATIONS; PAPER PARTY DECORATIONS; PAPER NAPKINS; PAPER PARTY BAGS; PAPERWEIGHTS; PAPER GIFT WRAP BOWS; PAPER PENNANTS; PAPER PLACE MATS; PAPER TABLE CLOTHS; PEN AND PENCIL HOLDERS; PENCILS; PENCIL SHARPENERS; PEN AND PENCIL CASES AND BOXES; PENS; PHOTOGRAPH ALBUMS; PHOTOGRAPHS; PHOTO-ENGRAVINGS; PICTORIAL PRINTS; PICTURE BOOKS; PORTRAITS; POSTCARDS; POSTERS; PRINTED AWARDS; PRINTED CERTIFICATES; PRINTED INVITATIONS; PRINTED MENUS; RECIPE BOOKS; RUBBER STAMPS; SCORE CARDS; STAMP ALBUMS; STATIONERY; STAPLERS; STICKERS; TRADING CARDS; UNGRADUATED RULERS; WRITING PAPER; WRITING IMPLEMENTS (U.S. CLS. 2, 5, 22, 23, 29, 37, 38 AND 50).
SANI KHOURI, EXAMINING ATTORNEY

CLASS 16—(Continued).

SN 85-214,236. OH, SEJONG, SEOUL, REPUBLIC OF KOREA, FILED 1-10-2011.



OWNER OF REPUBLIC OF KOREA REG. NO. 28400, DATED 12-4-2007, EXPIRES 3-24-2024.

THE MARK CONSISTS OF THE WORDS "PONY BROWN" WITH AN ILLUSTRATION OF A PONY APPEARING ABOVE THE WORDS.

FOR CHART POINTERS, NON-ELECTRONIC; DRAWER LINERS OF PAPER, PERFUMED AND NOT PERFUMED; FORMS, PRINTED; ACCOUNT BOOKS; OFFICE REQUISITES, EXCEPT FURNITURE, NAMELY, ADHESIVE TAPE DISPENSERS AND ADHESIVE NOTE PADS; PENCIL SHARPENERS, ELECTRIC AND NON-ELECTRIC; ACCOUNT SLIP PADS; PENCIL SHARPENING MACHINES, ELECTRIC AND NON-ELECTRIC; ADDRESS BOOKS; ADHESIVE FOILS STATIONERY; ALBUMS FOR PHOTOGRAPHS; ADHESIVE FOR STATIONERY PURPOSES; ADHESIVE NOTE PADS; ADHESIVE NOTE PAPER; ALBUMS FOR STICKERS; ADHESIVE TAPES FOR STATIONERY; ADVERTISING PAMPHLETS; ALMANACS; PRINTED ARITHMETICAL TABLES; ANNOUNCEMENT CARDS; PAINT TRAYS, NAMELY, ARTISTS' WATERCOLOR SAUCERS; ATLASES; BALL PENS; BOOKS IN THE FIELD OF STORIES FOR CHILDREN; BALLS FOR BALL-POINT PENS; BINDERS; OFFICE SUPPLIES, NAMELY, BINDERS; BOOKENDS; BOOKLETS IN THE FIELD OF STORIES FOR CHILDREN; BLOTTER; BLACKBOARD ERASERS; BLACKBOARDS; BOOKBINDING CORDS; BOOKMARKERS; BOOKS FOR USE IN THE TEACHING OF MUSIC; PAPER BOWS FOR GIFT WRAP; BOXES FOR PENS; BULLDOG CLIPS; BUSINESS CARD PAPER; BUSINESS CARDS; DESKTOP CABINETS FOR STATIONERY; CALENDARS; CARTOON STRIPS; CANVAS FOR PAINTING; CARBON PAPER; CARDS, NAMELY, INDEX CARDS AND GREETING CARDS; CHALK ERASERS; CASES FOR STAMPS; CASES FOR STATIONERY; CHALK; CHALK FOR LITHOGRAPHY; CHALK HOLDERS FOR BLACKBOARD CHALK; CHALK STICKS; CHARCOAL PENCILS; CHECKBOOKS; BANK CHECKS; CLIPBOARDS; CLIPS FOR LETTERS; CLIPS FOR OFFICES, NAMELY, PAPER CLIPS; COLOR PENCILS; COLOR PENS; COMIC BOOKS; CRAYONS; COMPASSES FOR DRAWING; COMPOSITION BOOKS; COPY BOOKS; CORRECTING FLUIDS; CORRECTING PENCILS; CORRECTION FLUIDS FOR DOCUMENTS; CORRESPONDENCE RACKS; COVERS, NAMELY, DOCUMENT COVERS; CREDIT CARDS WITHOUT MAGNETIC CODING; DECORATIONS FOR PENCILS; PAPER CUTTERS; DAILY NEWSPAPER; DIARIES; DIRECTORY PAPER; DOCUMENT HOLDERS; DOCUMENT FILES FOR STATIONERY; DOCUMENT FOLDERS IN THE FORM OF WALLETS; DOCUMENT MARKERS; DRAWING PADS; DOCUMENT PORTFOLIOS; DRAFTING PAPER; DRAWING MATERIALS, NAMELY, TABLETS, PAPER, PENS, NOTEPADS, PENCILS, AND RULERS; DRAWING MATERIALS FOR BLACKBOARDS; DRAWING PENS; DRAWING PINS, NAMELY, PUSH PINS; DRAWING SETS COMPRISING PAPER, PENS, PENCILS AND RULERS; DRAWING SQUARES; DRAWING T-SQUARES; EASELS; ENVELOPE PAPERS; ELASTIC BANDS FOR OFFICES; ENCYCLOPEDIAS; ENGRAVING PLATES; ENTRY TICKETS; ENVELOPES; EVENT ALBUMS; ERASERS; DRAWING MATERIALS, NAMELY, ERASING SHIELDS; ETCHING NEEDLES; FELT MARKING PENS; FILE FOLDERS; FINGER-STALLS; FOLDERS; FOLDERS FOR PAPERS; PENCILS; FOUNTAIN PENS; FRENCH CURVES; GEL ROLLER PENS; GEOGRAPHICAL MAPS; GLOBES; HANDBOOKS IN THE FIELD OF CHILDREN'S EDUCATION AND ENTERTAINMENT; GLUE FOR STATIONERY; GLUE FOR THE OFFICE; GRAPHIC PRINTS; GREETING CARDS; GUMS FOR STATIONERY, NAMELY, GUMMED TAPE AND PAPER; GUMMED

CLASS 16—(Continued).

TAPE; HIGHLIGHTER PENS; INDIA INK PENS; HANDRESTS FOR PAINTERS; PRINTED TEACHING MATERIALS IN THE FIELD OF HANDWRITING IN THE NATURE OF HANDWRITING SAMPLES FOR COPYING; HOLDERS FOR NOTEPADS; HOLDERS FOR STAMPS, NAMELY, STAMP CASES; ILLUSTRATED NOTEPADS; INDEX CARDS; INDIAN INKS; MAGAZINES IN THE FIELD OF STORIES FOR CHILDREN; INK FOR WRITING INSTRUMENTS; INK STICKS; INK STONES; INKING PADS; LETTER TRAYS; INVITATION CARDS; ADHESIVES FOR STATIONERY PURPOSES; PAPER FILE JACKETS; PERFORATED CARDS FOR JACQUARD LOOMS; PAPER KNIVES; LEDGER BOOKS; LETTER PAPER; LETTERHEAD PAPER; LETTER-OPENERS; LITHOGRAPHIC STONES; LOOSE-LEAF PAPER; MAGAZINE PAPER; PEN NIBS; MAGNETIC BOARDS; MANIFOLD PAPER; MANUALS IN THE FIELD OF CHILDREN'S EDUCATION; MARKERS; MARKING PENS; MEMO BLOCKS; MEMO PADS; MEMO PAPER; MOISTENERS IN THE NATURE OF HAND HELD DEVICES FOR GUMMED PAPER SURFACES; NOTEBOARDS; MUSICAL GREETING CARDS; NEWSPAPERS; NOTE BOOKS; PADS; PAMPHLETS IN THE FIELD OF CHILDREN'S EDUCATION AND STORIES FOR CHILDREN; WRITING PADS, NAMELY, NOTE PADS, AND MEMO PADS; PAINT BOXES; PAINTBRUSHES; PALETTES FOR PAINTERS; PEN RESTS; PAPER CLIPS; PAPER FILING TOOLS, NAMELY, FILING FOLDERS; PAPER KNIVES; PAPER PICTURE MOUNTS; PAPER RIBBONS; PAPER SHEETS FOR NOTETAKING; PAPER-CLIPS; PAPERWEIGHTS; PEN CLIPS; PASSENGER TICKETS; PASTELS; PRINTED PATTERNS; PENCIL HOLDERS; PATTERNS FOR MAKING CLOTHES; PEN CASES; PENCIL LEAD HOLDERS; PENCIL LEADS; PENHOLDERS; PENCIL OR PEN BOXES; PENCIL ORNAMENTS; PENCIL POINT PROTECTORS; PICTURE BOOKS; PENCILS FOR PAINTING AND DRAWING; PENS; PHOTOGRAPH CORNERS; PHOTOGRAPH STANDS; PHOTOGRAPHIC ALBUMS; PICTURE POSTCARDS; PINS, NAMELY, PUSH PINS; PRINTED PLANS; PLOTTING PAPERS; POCKET MEMORANDUM BOOKS; POCKET NOTEBOOKS; POSTAGE STAMPS; POSTCARDS; POSTERS; POSTERS MADE OF PAPER; PRINTED CALENDARS; POUCHES FOR WRITING INSTRUMENTS; PRINTED MATTER, NAMELY, PAMPHLETS CONTAINING STORIES FOR CHILDREN IN THE FIELD OF CHILDREN'S EDUCATION AND ENTERTAINMENT; PRINTED PUBLICATIONS IN THE NATURE OF STORIES FOR CHILDREN IN THE FIELD OF CHILDREN'S EDUCATION AND ENTERTAINMENT; PRINTED TIMETABLES; PROTRACTORS; PUNCHES; RECORD CARDS; RED INK PASTE USED FOR SEALS; REFILLS FOR BALLPOINT PENS; RETRACTABLE PENCILS; SCRAPBOOKS; RUBBER ERASERS; RUBBER STAMPS; RULED PAPER; RULERS; SCHOOL SUPPLIES, NAMELY, PENS, PENCILS, RUBBER ERASERS, STAMPS, RULERS, WRITING BOOKS, AND NOTE PADS; SCHOOL WRITING BOOKS; SCORE-BOOKS; SEALING STAMPS; SEALING COMPOUNDS FOR STATIONERY PURPOSES, NAMELY, SEALING STAMPS; SEALS; SEALS FOR OFFICES; SELF-ADHESIVE TAPES FOR STATIONERY PURPOSES; SHARP PENCILS; STATIONERY; SHEETS OF PLASTICS PLACED UNDER A SHEET OF PAPER WHEN WRITING; SKETCHBOOKS; SLATE PENCILS; STAMP STANDS; SMALL BLACKBOARDS; SONG BOOKS; SPIRAL-BOUND NOTEBOOKS; STAMP PADS; STEEL PENS; STAMPS, NAMELY, RUBBER STAMPS AND INK STAMPS; STAMPS MATERIALS, NAMELY, STAMP PADS AND STAMP INKS; STANDS FOR PENS; STANDS FOR PENS AND PENCILS; STANDS FOR WRITING IMPLEMENTS; STAPLER HOLDERS; STAPLERS; STAPLES FOR OFFICES; STAPLING PRESSES; STARCH FOR STATIONERY; STEEL PENS; STENCIL CASES; STENCIL PLATES; STENCILS; STICKERS; STUDY BOOKS OR PAPERS IN THE FIELD OF CHILDREN'S EDUCATION; PRINTED SUBWAY TICKETS; TAGS FOR INDEX CARDS; PAPER TEACHING MATERIALS IN THE FIELD OF CHILDREN'S EDUCATION; TEAR-OFF CALENDARS; TELEPHONE DIRECTORIES; THUMB TACKS; THUMB TACKS FOR DRAWING; DAY PLANNERS; DESKTOP PLANNERS; TIPS FOR BALLPOINT PENS; TOOLS FOR WORDS MEMORIZATION, NAMELY, FLASHCARDS; TRACING NEEDLES FOR DRAWING PURPOSES; TRACING PAPER; TRACING PATTERNS OF PAPER; TRADING CARDS; PAPER TRANSPARENCIES; PLASTIC TRANSPARENCIES; TRAYS FOR SORTING AND COUNTING

CLASS 16—(Continued).

MONEY, NOT INCLUDING MACHINES THEREFOR; WRITING BOARDS ERASERS; WRITING BOARDS, NAMELY, SLATE BOARDS, DRY ERASE BOARDS; WRISTBANDS FOR THE RETENTION OF WRITING INSTRUMENTS; WRITING BRUSHES; WRITING CASES, NAMELY, STATIONERY CASES, AND PEN AND PENCIL CASES; WRITING CHALK; WRITING INSTRUMENTS; WRITING OR DRAWING BOOKS, NAMELY, SCHOOL WRITING BOOKS AND MEMO PADS; WRITING PAPER HOLDERS; WRITING PAPER PADS; AND WRITING SLATES (U.S. CLS. 2, 5, 22, 23, 29, 37, 38 AND 50).

HELENE LIWINSKI, EXAMINING ATTORNEY

SN 85-237,412. AZCO CORPORATION, FAIRFIELD, NJ. FILED 2-9-2011.

SUR-STAK

THE MARK CONSISTS OF STANDARD CHARACTERS WITHOUT CLAIM TO ANY PARTICULAR FONT, STYLE, SIZE, OR COLOR.

FOR LAMINATED PAPER SOLD IN ROLLS OR SHEETS FOR COMMERCIAL USE TO BE AFFIXED TO BOXES AND BAGS TO PREVENT SLIPPAGE WHEN PLACED ON SKIDS OR STACKED (U.S. CLS. 2, 5, 22, 23, 29, 37, 38 AND 50).

FIRST USE 1-11-2010; IN COMMERCE 1-11-2010.
LESLEY LAMOTHE, EXAMINING ATTORNEY

SN 85-273,883. FLUENCY FOUNDATION, LAKE FOREST PARK, WA. FILED 3-22-2011.

THE GAME OF YES

THE MARK CONSISTS OF STANDARD CHARACTERS WITHOUT CLAIM TO ANY PARTICULAR FONT, STYLE, SIZE, OR COLOR.

NO CLAIM IS MADE TO THE EXCLUSIVE RIGHT TO USE "GAME", APART FROM THE MARK AS SHOWN.

FOR EDUCATIONAL PUBLICATIONS, NAMELY, EDUCATIONAL LEARNING CARDS, FLASH CARDS, ACTIVITY CARDS, WORKBOOKS, TEXTBOOKS, ACTIVITY BOOKS, STORY BOOKS, PUZZLE BOOKS, PRINTED PUZZLES, TEACHER GUIDES, MANUALS, POSTERS AND EDUCATIONAL BOOKLETS IN THE FIELD OF PERSONAL GROWTH (U.S. CLS. 2, 5, 22, 23, 29, 37, 38 AND 50).

FIRST USE 2-10-2011; IN COMMERCE 2-10-2011.
MELISSA VALLILLO, EXAMINING ATTORNEY

CLASS 16—(Continued).

SN 85-288,952. THE TRUSTEES OF INDIANA UNIVERSITY, BLOOMINGTON, IN. FILED 4-7-2011.

THE FUND RAISING SCHOOL

THE MARK CONSISTS OF STANDARD CHARACTERS WITHOUT CLAIM TO ANY PARTICULAR FONT, STYLE, SIZE, OR COLOR.

SEC. 2(F).

FOR PRINTED EDUCATIONAL, INSTRUCTIONAL AND TEACHING MATERIALS PROVIDING INFORMATION FOR CONDUCTING CAPITAL AND MAJOR GIFT CAMPAIGNS, PREPARING GRANT PROPOSALS, SUSTAINING ANNUAL GIVING, USING SOCIAL MEDIA IN ACQUIRING FINANCIAL GIFTS, USING INTERPERSONAL COMMUNICATIONS IN RAISING DONATIONS, AND IDENTIFYING TRENDS IN PHILANTHROPY (U.S. CLS. 2, 5, 22, 23, 29, 37, 38 AND 50).

FIRST USE 10-1-1987; IN COMMERCE 10-1-1987. DANIEL CAPSHAW, EXAMINING ATTORNEY

SN 85-291,970. MARION LAURSEN & LINDA SHAW, VANCOUVER, B.C., CANADA, FILED 4-11-2011.

AMIGOS DEL MUNDO
Friends of the World



PRIORITY CLAIMED UNDER SEC. 44(D) ON CANADA APPLICATION NO. TMA821069, FILED 10-29-2010, REG. NO. 821069, DATED 3-30-2012, EXPIRES 3-30-2027.

THE MARK CONSISTS OF THE WORDS "AMIGOS DEL MUNDO" AT THE TOP, BENEATH WHICH ARE THE WORDS "FRIENDS OF THE WORLD" BENEATH WHICH IS A CRESCENT SHAPE IN THE MIDDLE OF WHICH IS THE SIDE VIEW OF A FACE WITH CURLY HAIR FLOWING ABOVE AND BEHIND THE FACE AND TO BEHIND THE CRESCENT SHAPE.

THE ENGLISH TRANSLATION OF "AMIGOS DEL MUNDO" IS "FRIENDS OF THE WORLD".

FOR HAND-MADE GIFT BAGS MADE FROM HAND-WOVEN NATURAL FIBERS WITH A POCKET CONTAINING A SMALL NOTEBOOK (U.S. CLS. 2, 5, 22, 23, 29, 37, 38 AND 50).

EMILY CARLSEN, EXAMINING ATTORNEY

CLASS 16—(Continued).

SN 85-315,436. JORDAN IP, LLC, STEVENSVILLE, MD. FILED 5-9-2011.



NO CLAIM IS MADE TO THE EXCLUSIVE RIGHT TO USE "PUBLISHING, INC.", APART FROM THE MARK AS SHOWN.

THE COLOR(S) GOLD IS/ARE CLAIMED AS A FEATURE OF THE MARK.

THE MARK CONSISTS OF THE STYLIZED WORDING "JORDAN PUBLISHING, INC." ALL IN GOLD WITH THE LETTER "J" CAPITALIZED AND IN A MUCH LARGER STYLIZED FONT THAN THE REMAINING LETTERS.

FOR MAGAZINES FEATURING PREMIERE COMMUNITY BUSINESSES (U.S. CLS. 2, 5, 22, 23, 29, 37, 38 AND 50).

FIRST USE 2-1-2006; IN COMMERCE 2-1-2006. MICHAEL WEBSTER, EXAMINING ATTORNEY

SN 85-319,457. PAINTING THE DREAM, INC., SAFETY HARBOR, FL. FILED 5-12-2011.

CURT A. BARKER

THE MARK CONSISTS OF STANDARD CHARACTERS WITHOUT CLAIM TO ANY PARTICULAR FONT, STYLE, SIZE, OR COLOR.

THE NAME(S), PORTRAIT(S), AND/OR SIGNATURE(S) SHOWN IN THE MARK IDENTIFIES "CURT A. BARKER", WHOSE CONSENT(S) TO REGISTER IS MADE OF RECORD.

FOR PAINTINGS AND DRAWINGS AND THEIR REPRODUCTIONS; ART PRINTS AND GICLEE PRINTS; STATIONERY; CALENDARS; STICKERS; DESK PADS (U.S. CLS. 2, 5, 22, 23, 29, 37, 38 AND 50).

DAVID ELTON, EXAMINING ATTORNEY

CLASS 16—(Continued).

SN 85-325,021. WOHL PUBLISHING, INC., MORRISTOWN, NJ. FILED 5-19-2011.

THE WELL ORGANIZED WEB FOR
TEACHING

THE MARK CONSISTS OF STANDARD CHARACTERS WITHOUT CLAIM TO ANY PARTICULAR FONT, STYLE, SIZE, OR COLOR.

FOR EDUCATIONAL PUBLICATIONS, NAMELY, STUDENT WORKBOOKS AND TEACHER INSTRUCTIONAL GUIDES IN THE FIELDS OF PERSONAL FINANCE, U.S. HISTORY, ECONOMICS, AMERICAN GOVERNMENT AND WORLD HISTORY; PRINTED TEACHER INSTRUCTIONAL GUIDES THAT PROVIDE AN INDEX OF EDUCATIONAL WEBSITES THAT HAVE BEEN RESEARCHED, EVALUATED, RATED, ORGANIZED AND IDENTIFIED TO REFLECT THE TOPIC OR SUBJECT, TYPE OF TEACHING STRATEGY, PRIMARY LEARNING MODALITY, DIFFICULTY LEVEL, AND NATIONAL AND STATE CONTENT STANDARD AS WELL AS PROVIDING INSTRUCTIONS FOR TEACHERS ON HOW TO UTILIZE THIS MATERIAL IN THE CLASSROOM (U.S. CLS. 2, 5, 22, 23, 29, 37, 38 AND 50).
MICHAEL TANNER, EXAMINING ATTORNEY

SN 85-325,068. WOHL PUBLISHING, INC., MORRISTOWN, NJ. FILED 5-19-2011.

WOW FOR TEACHING

THE MARK CONSISTS OF STANDARD CHARACTERS WITHOUT CLAIM TO ANY PARTICULAR FONT, STYLE, SIZE, OR COLOR.

FOR EDUCATIONAL PUBLICATIONS, NAMELY, STUDENT WORKBOOKS AND TEACHER INSTRUCTIONAL GUIDES IN THE FIELDS OF PERSONAL FINANCE, U.S. HISTORY, ECONOMICS, AMERICAN GOVERNMENT AND WORLD HISTORY; PRINTED TEACHER INSTRUCTIONAL GUIDES THAT PROVIDE AN INDEX OF EDUCATIONAL WEBSITES THAT HAVE BEEN RESEARCHED, EVALUATED, RATED, ORGANIZED AND IDENTIFIED TO REFLECT THE TOPIC OR SUBJECT, TYPE OF TEACHING STRATEGY, PRIMARY LEARNING MODALITY, DIFFICULTY LEVEL, AND NATIONAL AND STATE CONTENT STANDARD AS WELL AS PROVIDING INSTRUCTIONS FOR TEACHERS ON HOW TO UTILIZE THIS MATERIAL IN THE CLASSROOM (U.S. CLS. 2, 5, 22, 23, 29, 37, 38 AND 50).
MICHAEL TANNER, EXAMINING ATTORNEY

CLASS 16—(Continued).

SN 85-342,939. ARCHAEOLOGY ASTRONAUTICS AND SETI RESEARCH ASSOCIATION, OCEANSIDE, CA. FILED 6-10-2011.

LEGENDARY TIMES

THE MARK CONSISTS OF STANDARD CHARACTERS WITHOUT CLAIM TO ANY PARTICULAR FONT, STYLE, SIZE, OR COLOR.

NO CLAIM IS MADE TO THE EXCLUSIVE RIGHT TO USE "TIMES", APART FROM THE MARK AS SHOWN.

FOR MAGAZINES, NEWSLETTERS, JOURNALS, AND PAMPHLETS ON THE SUBJECT OF ARCHAEOLOGY, ASTRONAUTICS, AND THE SEARCH FOR EXTRATERRESTRIAL INTELLIGENCE (U.S. CLS. 2, 5, 22, 23, 29, 37, 38 AND 50).

FIRST USE 6-18-1998; IN COMMERCE 6-18-1998.

KIM SAITO, EXAMINING ATTORNEY

SN 85-343,460. CRAFT SUPPLIES USA, PROVO, UT. FILED 6-10-2011.

THE WOODTURNERS CATALOG

THE MARK CONSISTS OF STANDARD CHARACTERS WITHOUT CLAIM TO ANY PARTICULAR FONT, STYLE, SIZE, OR COLOR.

NO CLAIM IS MADE TO THE EXCLUSIVE RIGHT TO USE "CATALOG", APART FROM THE MARK AS SHOWN. SEC. 2(F).

FOR CATALOGS IN THE FIELD OF WOODTURNING SUPPLIES AND TOOLS (U.S. CLS. 2, 5, 22, 23, 29, 37, 38 AND 50).

FIRST USE 9-1-1988; IN COMMERCE 9-1-1988.

PRISCILLA MILTON, EXAMINING ATTORNEY

SN 85-347,977. CITY CASH NASHVILLE, LLC, FRANKLIN, TN. FILED 6-16-2011.

CITY CASH

THE MARK CONSISTS OF STANDARD CHARACTERS WITHOUT CLAIM TO ANY PARTICULAR FONT, STYLE, SIZE, OR COLOR.

NO CLAIM IS MADE TO THE EXCLUSIVE RIGHT TO USE "CASH", APART FROM THE MARK AS SHOWN.

FOR NEWSPAPERS IN THE FIELD OF GENERAL FEATURES, LOCAL EVENTS, LOCAL BUSINESS LISTINGS AND DISCOUNT COUPONS FOR LOCAL BUSINESSES (U.S. CLS. 2, 5, 22, 23, 29, 37, 38 AND 50).

FIRST USE 11-1-2011; IN COMMERCE 11-1-2011.

LINDA M. KING, EXAMINING ATTORNEY

CLASS 16—(Continued).

SN 85-354,401. COPELAND, MARY ELLEN, TA MARY ELLEN COPELAND, WEST DUMMERSTON, VT. FILED 6-23-2011.

Plan de Acción para la Recuperación del Bienestar

THE MARK CONSISTS OF STANDARD CHARACTERS WITHOUT CLAIM TO ANY PARTICULAR FONT, STYLE, SIZE, OR COLOR.

OWNER OF U.S. REG. NO. 3,161,756.

THE ENGLISH TRANSLATION OF "PLAN DE ACCIÓN PARA LA RECUPERACIÓN DEL BIENESTAR" IN THE MARK IS "WELLNESS RECOVERY ACTION PLAN".

FOR PRINTED EDUCATIONAL MATERIALS IN THE NATURE OF A BOOK IN THE FIELD OF MENTAL HEALTH RECOVERY (U.S. CLS. 2, 5, 22, 23, 29, 37, 38 AND 50).

FIRST USE 1-1-2000; IN COMMERCE 1-1-2001.

C. DIONNE CLYBURN, EXAMINING ATTORNEY

SN 85-354,956. VOSS, KATHERINE LYNN, CARY, NC. FILED 6-24-2011.

BEHIND EVERY CLOUD THE SUN IS ALWAYS SHINING!

THE MARK CONSISTS OF STANDARD CHARACTERS WITHOUT CLAIM TO ANY PARTICULAR FONT, STYLE, SIZE, OR COLOR.

FOR PAPER AND GOODS MADE FROM PAPER, NAMELY, MEMO PADS, ADHESIVE NOTE PADS, GREETING CARDS, STATIONERY, ENVELOPES, POSTAGE STAMPS, BUMPER STICKERS, STICKERS, CALENDARS, NAPKINS, BINDERS, FOLDERS, PAPER CLIPS, DECALS, LABELS, BOOKMARKS (U.S. CLS. 2, 5, 22, 23, 29, 37, 38 AND 50).

ANDREW LEASER, EXAMINING ATTORNEY

SN 85-355,972. THE GERONTOLOGICAL SOCIETY OF AMERICA, WASHINGTON, DC. FILED 6-24-2011.

PUBLIC POLICY & AGING REPORT

THE MARK CONSISTS OF STANDARD CHARACTERS WITHOUT CLAIM TO ANY PARTICULAR FONT, STYLE, SIZE, OR COLOR.

NO CLAIM IS MADE TO THE EXCLUSIVE RIGHT TO USE "REPORT", APART FROM THE MARK AS SHOWN. SEC. 2(F).

FOR PUBLICATIONS, NAMELY, JOURNAL IN THE FIELD OF POLICY RELATING TO GERONTOLOGY AND AGING (U.S. CLS. 2, 5, 22, 23, 29, 37, 38 AND 50).

FIRST USE 1-1-2000; IN COMMERCE 1-1-2000.

MARY CRAWFORD, EXAMINING ATTORNEY

CLASS 16—(Continued).

SN 85-356,460. DENTAL IMPLANT & PERIODONTAL SURGEONS PC, LIMA, PA. FILED 6-26-2011.

Implant Periodontics Alert

THE MARK CONSISTS OF STANDARD CHARACTERS WITHOUT CLAIM TO ANY PARTICULAR FONT, STYLE, SIZE, OR COLOR.

NO CLAIM IS MADE TO THE EXCLUSIVE RIGHT TO USE "IMPLANT PERIODONTICS", APART FROM THE MARK AS SHOWN.

FOR PRINTED PAMPHLETS, BROCHURES, MANUALS, BOOKS, BOOKLETS, INFORMATIONAL LEAFLETS, FLYERS, SHEETS AND NEWSLETTERS ALL IN THE FIELD OF DENTISTRY; ADHESIVE BACKED STICKERS; AND KITS COMPRISING ONE OR MORE OF THE FOREGOING MATERIALS (U.S. CLS. 2, 5, 22, 29, 37, 38 AND 50).

FIRST USE 2-27-2011; IN COMMERCE 2-27-2011.

KIMBERLY PERRY, EXAMINING ATTORNEY

SN 85-357,094. PETITE ALMA, LLC, NEW YORK, NY. FILED 6-27-2011.

CLOVER

THE MARK CONSISTS OF STANDARD CHARACTERS WITHOUT CLAIM TO ANY PARTICULAR FONT, STYLE, SIZE, OR COLOR.

FOR PAPER STATIONERY (U.S. CLS. 2, 5, 22, 23, 29, 37, 38 AND 50).

ANDREA HACK, EXAMINING ATTORNEY

SN 85-357,357. SHEBOYGAN PAPER BOX CO., SHEBOYGAN, WI. FILED 6-27-2011.

SPBCo

THE MARK CONSISTS OF STANDARD CHARACTERS WITHOUT CLAIM TO ANY PARTICULAR FONT, STYLE, SIZE, OR COLOR.

FOR PAPER GOODS, NAMELY, PAPER BOXES, CORRUGATED PAPER AND PAPER BOARD CONTAINERS, AND PAPER CONTAINERS AND WRAPS (U.S. CLS. 2, 5, 22, 23, 29, 37, 38 AND 50).

FIRST USE 2-0-2011; IN COMMERCE 2-0-2011.

CHRISTINE COOPER, EXAMINING ATTORNEY

CLASS 16—(Continued).

SN 85-359,094. MCNABB, DAVID G., OXNARD, CA. FILED 6-29-2011.

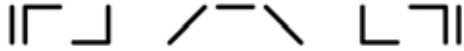

THE MARK CONSISTS OF A LINEAR STRING OF NINE MARKS, DESCRIBED LEFT TO RIGHT AS A VERTICAL LINE; AN UPSIDE DOWN "L"; AN INVERTED "L"; A FORWARD SLASH; A SHORTENED HORIZONTAL LINE POSITIONED NEAR THE TOP PORTION OF THE FORWARD SLASH AND THE FOLLOWING BACKWARD SLASH; A BACKWARD SLASH; AN "L"; AN INVERTED UPSIDE DOWN "L"; AND, A VERTICAL LINE.

FOR PRINTED LOGIC AND REASONING PUZZLES FOR EDUCATION AND ENTERTAINMENT PURPOSES (U.S. CLS. 2, 5, 22, 23, 29, 37, 38 AND 50).

TOBY BULLOFF, EXAMINING ATTORNEY

SN 85-361,370. S2 RESOURCES, DALLAS, TX. FILED 7-1-2011.

M3 MAGAZINE

THE MARK CONSISTS OF STANDARD CHARACTERS WITHOUT CLAIM TO ANY PARTICULAR FONT, STYLE, SIZE, OR COLOR.

NO CLAIM IS MADE TO THE EXCLUSIVE RIGHT TO USE "MAGAZINE", APART FROM THE MARK AS SHOWN. FOR GENERAL FEATURE MAGAZINE IN THE FIELD OF METALWARE AND METAL ARTISANS (U.S. CLS. 2, 5, 22, 23, 29, 37, 38 AND 50).

FIRST USE 3-15-2011; IN COMMERCE 3-15-2011.

STEVEN PEREZ, EXAMINING ATTORNEY

SN 85-361,664. STAR EDUCATIONAL CONSULTING LLC, NEW YORK, NY. FILED 7-1-2011.

123 ORGANIZE ME

THE MARK CONSISTS OF STANDARD CHARACTERS WITHOUT CLAIM TO ANY PARTICULAR FONT, STYLE, SIZE, OR COLOR.

FOR PERSONAL ORGANIZER COMPRISED OF A COMBINATION BINDER, FOLDER, AND FILER, ALSO INCLUDING TABS, DIVIDERS, LOOSE-LEAF RINGS, PENCIL CASE, HOLE PUNCHER, POCKET FOLDERS, AND HANGING FILE FOLDERS (U.S. CLS. 2, 5, 22, 23, 29, 37, 38 AND 50).

GISELLE AGOSTO, EXAMINING ATTORNEY

CLASS 16—(Continued).

SN 85-368,217. ALLIANCE DATA SYSTEMS CORPORATION, DALLAS, TX. FILED 7-11-2011.

OWNER OF U.S. REG. NOS. 2,919,231 AND 4,029,047. THE MARK CONSISTS OF THE WORD "LOYALTYONE" IN STYLIZED FONT.

FOR NEWSLETTERS IN THE FIELD OF MARKETING (U.S. CLS. 2, 5, 22, 23, 29, 37, 38 AND 50).

FIRST USE 8-0-2009; IN COMMERCE 8-0-2009.

BARBARA GAYNOR, EXAMINING ATTORNEY

SN 85-374,103. BZ MEDIA LLC, HUNTINGTON, NY. FILED 7-18-2011.

BZ MEDIA

THE MARK CONSISTS OF STANDARD CHARACTERS WITHOUT CLAIM TO ANY PARTICULAR FONT, STYLE, SIZE, OR COLOR.

NO CLAIM IS MADE TO THE EXCLUSIVE RIGHT TO USE "MEDIA", APART FROM THE MARK AS SHOWN.

FOR MAGAZINES AND NEWSPAPERS FEATURING SOFTWARE DEVELOPMENT (U.S. CLS. 2, 5, 22, 23, 29, 37, 38 AND 50).

FIRST USE 2-23-2000; IN COMMERCE 2-23-2000.

JORDAN BAKER, EXAMINING ATTORNEY

SN 85-374,446. STEVENS CREATIVE ENTERPRISES INC., DBA OOH LA LA CANDY, SCARSDALE, NY. FILED 7-18-2011.

BREW LA LA COFFEE

THE MARK CONSISTS OF STANDARD CHARACTERS WITHOUT CLAIM TO ANY PARTICULAR FONT, STYLE, SIZE, OR COLOR.

OWNER OF U.S. REG. NOS. 3,993,803 AND 3,994,038. NO CLAIM IS MADE TO THE EXCLUSIVE RIGHT TO USE "COFFEE", APART FROM THE MARK AS SHOWN.

FOR GREETING CARDS; PAPER STATIONERY (U.S. CLS. 2, 5, 22, 23, 29, 37, 38 AND 50).

PAUL MORENO, EXAMINING ATTORNEY

CLASS 16—(Continued).

SN 85-377,667. CHRISTOPHER G. KULP, YONKERS, NY.
FILED 7-21-2011.



THE MARK CONSISTS OF A STYLIZED DEPICTION OF THE CHARACTER MASON VALENTINE FEATURING AN OVERSIZED GEOMETRICAL HEAD WITH A CURVED DOME OVER A BODY WITH ATTACHED ARMS, TORSO, LEGS AND FEET.

FOR COMIC BOOKS; COMIC MAGAZINES; COMIC STRIPS; COMICS (U.S. CLS. 2, 5, 22, 23, 29, 37, 38 AND 50).

FIRST USE 1-21-2011; IN COMMERCE 1-21-2011.
BRENDAN MCCAULEY, EXAMINING ATTORNEY

SN 85-377,902. SADDLEBACK EDUCATIONAL, INC.,
COSTA MESA, CA. FILED 7-21-2011.

THE HEIGHTS

THE MARK CONSISTS OF STANDARD CHARACTERS WITHOUT CLAIM TO ANY PARTICULAR FONT, STYLE, SIZE, OR COLOR.

FOR SERIES OF FICTION BOOKS IN THE FIELD OF REMEDIAL EDUCATION FOR SECONDARY AND ADULT EDUCATION; PRINTED MATTER, NAMELY, BOOKS IN THE FIELD OF REMEDIAL EDUCATION FOR SECONDARY AND ADULT EDUCATION (U.S. CLS. 2, 5, 22, 23, 29, 37, 38 AND 50).

FIRST USE 0-0-2010; IN COMMERCE 0-0-2010.
JULIE GUTTADAURO, EXAMINING ATTORNEY

SN 85-392,341. FRIEDMAN, ROBERT JAY, CAPE CORAL,
FL. FILED 8-8-2011.

Bobby the Bowler

THE MARK CONSISTS OF STANDARD CHARACTERS WITHOUT CLAIM TO ANY PARTICULAR FONT, STYLE, SIZE, OR COLOR.

FOR PICTURE BOOKS (U.S. CLS. 2, 5, 22, 23, 29, 37, 38 AND 50).

ANGELA DUONG, EXAMINING ATTORNEY

CLASS 16—(Continued).

SN 85-397,118. MZ. BEE BOOKS, LLC, WASHINGTON
CROSSING, PA. FILED 8-12-2011.



NO CLAIM IS MADE TO THE EXCLUSIVE RIGHT TO USE "YOUNG READERS", APART FROM THE MARK AS SHOWN.

THE COLOR(S) BLUE, GREEN, PINK, WHITE, LIGHT BLUE, BROWN, BLACK, DARK GREEN, LIGHT GREEN, YELLOW, AND RED IS/ARE CLAIMED AS A FEATURE OF THE MARK.

THE MARK CONSISTS OF A BLUE CIRCLE WITH THE STYLIZED TEXT "ITSY BITSY FRANNY FROG ADVENTURES FOR YOUNG READERS" WITHIN WHICH IS A COLOR IMAGE OF A GREEN FROG WITH HUMAN CHARACTERISTICS, INCLUDING BROWN EYES WITH BLACK PUPILS, WEARING A WHITE DIAPER WITH A PINK-CAPPED SAFETY PIN, SITTING ON A GREEN LILY PAD WITH PINK FLOWERS IN A LIGHT BLUE POND UNDERNEATH BROWN TREE BRANCHES WITH GREEN LEAVES AND YELLOW FLOWERS WITH A RED BERRY AND BROWN NUTS. LIGHT GREEN AND DARK GREEN GRASS SITS IN THE FOREFRONT OF THE IMAGE.

FOR CHILDREN'S ACTIVITY BOOKS; CHILDREN'S BOOKS; SERIES OF FICTION BOOKS; SERIES OF FICTION WORKS, NAMELY, NOVELS AND BOOKS; STORY BOOKS (U.S. CLS. 2, 5, 22, 23, 29, 37, 38 AND 50).

ALLISON HOLTZ, EXAMINING ATTORNEY

CLASS 16—(Continued).

SN 85-401,175. GREEN TOKYO CORPORATION, SEATTLE, WA. FILED 8-18-2011.



NO CLAIM IS MADE TO THE EXCLUSIVE RIGHT TO USE "GREEN TOKYO", APART FROM THE MARK AS SHOWN.

THE COLOR(S) LIGHT GREEN, DARK GREEN AND BLACK IS/ARE CLAIMED AS A FEATURE OF THE MARK. THE MARK CONSISTS OF THE WORDS "GREEN" IN TITLE CASE LETTERING IN BLACK AND "TOKYO" IN UPPER CASE BLACK LETTERING WITH A GREEN LEAF COMPOSING PART OF THE LETTER "Y", BOTH PROCEEDED BY A FIGURE OF A GREEN TREE. LIGHT GREEN APPEARS IN THE LEAF AND THE TOP PORTION OF THE TREE, AND DARK GREEN APPEARS IN THE TREE TRUNK.

FOR PACKAGING, CARTONS, AND CONTAINERS FOR FOOD AND BEVERAGES COMPRISED OF PLANT MATERIALS AND NON-WOOD PAPER MADE OF REED, BUGASSE FIBER, FALBOARD FROM THE FALCATA TREE, AND TAPIOCA, DESIGNED TO LESSEN ADVERSE EFFECTS ON THE ENVIRONMENT (U.S. CLS. 2, 5, 22, 23, 29, 37, 38 AND 50).

FIRST USE 12-1-2008; IN COMMERCE 11-1-2009.
THOMAS MANOR, EXAMINING ATTORNEY

SN 85-404,925. SUN CHEMICAL CORPORATION, PARSIPPANY, NJ. FILED 8-23-2011.

SUNDOT

THE MARK CONSISTS OF STANDARD CHARACTERS WITHOUT CLAIM TO ANY PARTICULAR FONT, STYLE, SIZE, OR COLOR.

FOR PRINTING PRESS BLANKETS (U.S. CLS. 2, 5, 22, 23, 29, 37, 38 AND 50).

FIRST USE 2-28-2009; IN COMMERCE 2-28-2009.
CURTIS FRENCH, EXAMINING ATTORNEY

SN 85-406,580. CANAWIPE DISTRIBUTORS LTD. AND MASS ENVIRONMENTAL SERVICES INC., COQUITLAM, B.C., CANADA, FILED 8-24-2011.

DoCC

THE MARK CONSISTS OF STANDARD CHARACTERS WITHOUT CLAIM TO ANY PARTICULAR FONT, STYLE, SIZE, OR COLOR.

FOR DISPOSABLE WIPES NOT IMPREGNATED WITH CHEMICALS OR COMPOUNDS FOR GENERAL HOUSEHOLD USE (U.S. CLS. 2, 5, 22, 23, 29, 37, 38 AND 50).

YAT SYE, LEE, EXAMINING ATTORNEY

CLASS 16—(Continued).

SN 85-415,661. GLOBAL MAGIC FUTURES LIMITED, BERKSWELL, UNITED KINGDOM, FILED 9-6-2011.

MAGIC NUMBER

THE MARK CONSISTS OF STANDARD CHARACTERS WITHOUT CLAIM TO ANY PARTICULAR FONT, STYLE, SIZE, OR COLOR.

PRIORITY CLAIMED UNDER SEC. 44(D) ON ERPNCMNTY TM OFC APPLICATION NO. 10228351, FILED 8-30-2011, REG. NO. 10228351, DATED 3-13-2012, EXPIRES 8-30-2021.

FOR PRINTED PUBLICATIONS, NAMELY, BOOKS, WORKBOOKS, JOURNALS, BROCHURES, REPORTS, MANUALS, NEWSLETTERS, MAGAZINES, AND PERIODICALS IN THE FIELDS OF FINANCIAL PLANNING, LIFESTYLE MANAGEMENT, AND PERSONAL DEVELOPMENT, NAMELY, SELF-IMPROVEMENT AND SELF-FULFILLMENT; PRINTED INSTRUCTIONAL, EDUCATIONAL, AND TEACHING MATERIALS IN THE FIELDS OF FINANCIAL PLANNING, LIFESTYLE MANAGEMENT, AND PERSONAL DEVELOPMENT, NAMELY, SELF-IMPROVEMENT AND SELF-FULFILLMENT (U.S. CLS. 2, 5, 22, 23, 29, 37, 38 AND 50).

JASON TURNER, EXAMINING ATTORNEY

SN 85-415,804. GLOBAL MAGIC FUTURES LIMITED, BERKSWELL, UNITED KINGDOM, FILED 9-6-2011.

take control • achieve more • love life!

PRIORITY CLAIMED UNDER SEC. 44(D) ON ERPNCMNTY TM OFC APPLICATION NO. 10228591, FILED 8-30-2011, REG. NO. 10228591, DATED 2-17-2012, EXPIRES 8-30-2021.

THE MARK CONSISTS OF THE WORDING "TAKE CONTROL", "ACHIEVE MORE", AND "LOVE LIFE!" A DOT SEPARATES EACH PHRASE.

FOR PRINTED PUBLICATIONS, NAMELY, BOOKS, WORKBOOKS, JOURNALS, BROCHURES, REPORTS, MANUALS, NEWSLETTERS, MAGAZINES, AND PERIODICALS IN THE FIELDS OF FINANCIAL PLANNING, LIFESTYLE MANAGEMENT, AND PERSONAL DEVELOPMENT, NAMELY, SELF-IMPROVEMENT AND SELF-FULFILLMENT; PRINTED INSTRUCTIONAL, EDUCATIONAL, AND TEACHING MATERIALS IN THE FIELDS OF FINANCIAL PLANNING, LIFESTYLE MANAGEMENT, AND PERSONAL DEVELOPMENT, NAMELY, SELF-IMPROVEMENT AND SELF-FULFILLMENT (U.S. CLS. 2, 5, 22, 23, 29, 37, 38 AND 50).

WENDY JUN, EXAMINING ATTORNEY

CLASS 16—(Continued).

SN 85-420,339. HENNESSEY, JACQUELINE, BARRINGTON, RI. FILED 9-12-2011.

VENTING SESSIONS

THE MARK CONSISTS OF STANDARD CHARACTERS WITHOUT CLAIM TO ANY PARTICULAR FONT, STYLE, SIZE, OR COLOR.

NO CLAIM IS MADE TO THE EXCLUSIVE RIGHT TO USE "VENTING", APART FROM THE MARK AS SHOWN.

FOR A SERIES OF BOOKS AND WRITTEN ARTICLES ABOUT MOTHERS VENTING AND SHARING RECIPES (U.S. CLS. 2, 5, 22, 23, 29, 37, 38 AND 50).

WON TEAK OH, EXAMINING ATTORNEY

CLASS 16—(Continued).

SN 85-452,556. TMI ACQUISITION, LLC, TUCSON, AZ. FILED 10-20-2011.



NO CLAIM IS MADE TO THE EXCLUSIVE RIGHT TO USE "SKIN", APART FROM THE MARK AS SHOWN.

THE COLOR(S) BLACK AND PINK IS/ARE CLAIMED AS A FEATURE OF THE MARK.

THE MARK CONSISTS OF THE TEXT "SKIN" IN BLACK LETTERING AND THE TEXT "COUTURE" IN PINK LETTERING WITH BLOTCHES SURROUNDING THE "S" AND "N" IN PINK.

FOR PRINTED MATERIALS, NAMELY, TEMPORARY TATTOOS (U.S. CLS. 2, 5, 22, 23, 29, 37, 38 AND 50).

DAVID H. STINE, EXAMINING ATTORNEY

SN 85-451,597. GOWERY, DAWN M., DBA HEALTHY BEGINNINGS LIFESTYLE MAGAZINE, RENO, NV. FILED 10-19-2011.

Healthy Beginnings Lifestyle Magazine

THE MARK CONSISTS OF STANDARD CHARACTERS WITHOUT CLAIM TO ANY PARTICULAR FONT, STYLE, SIZE, OR COLOR.

NO CLAIM IS MADE TO THE EXCLUSIVE RIGHT TO USE "LIFESTYLE MAGAZINE", APART FROM THE MARK AS SHOWN.

FOR GENERAL FEATURE MAGAZINE IN THE FIELD OF NATURAL, ALTERNATIVE AND HOLISTIC HEALTH (U.S. CLS. 2, 5, 22, 23, 29, 37, 38 AND 50).

FIRST USE 5-1-2006; IN COMMERCE 8-1-2006.

DORITT L. CARROLL, EXAMINING ATTORNEY

SN 85-454,322. CARRA L. RILEY, P.C., DBA CARRA RILEY, INC., WILLIAMS, AZ. FILED 10-24-2011.

Know Your Monkey

SN 85-452,541. TMI ACQUISITION, LLC, TUCSON, AZ. FILED 10-20-2011.

EMBODY ART

THE MARK CONSISTS OF STANDARD CHARACTERS WITHOUT CLAIM TO ANY PARTICULAR FONT, STYLE, SIZE, OR COLOR.

NO CLAIM IS MADE TO THE EXCLUSIVE RIGHT TO USE "ART", APART FROM THE MARK AS SHOWN.

FOR PRINTED MATERIALS, NAMELY, TEMPORARY TATTOOS (U.S. CLS. 2, 5, 22, 23, 29, 37, 38 AND 50).

DAVID H. STINE, EXAMINING ATTORNEY

THE MARK CONSISTS OF STANDARD CHARACTERS WITHOUT CLAIM TO ANY PARTICULAR FONT, STYLE, SIZE, OR COLOR.

FOR A SERIES OF BOOKS, WRITTEN ARTICLES, HANDOUTS AND WORKSHEETS IN THE FIELD OF WORK/LIFE BALANCE AND LIFE MANAGEMENT (U.S. CLS. 2, 5, 22, 23, 29, 37, 38 AND 50).

FIRST USE 5-27-2011; IN COMMERCE 5-27-2011.

LINDA E. BLOHM, EXAMINING ATTORNEY

CLASS 16—(Continued).

SN 85-454,339. CARRA L. RILEY, P.C., DBA CARRA RILEY, INC., WILLIAMS, AZ. FILED 10-24-2011.



THE MARK CONSISTS OF A GRAPHIC OF A MONKEY WAVING WITH ITS RIGHT PAW.

FOR A SERIES OF BOOKS, WRITTEN ARTICLES, HANDOUTS AND WORKSHEETS IN THE FIELD OF WORK/LIFE BALANCE AND LIFE MANAGEMENT (U.S. CLS. 2, 5, 22, 23, 29, 37, 38 AND 50).

FIRST USE 5-27-2011; IN COMMERCE 5-27-2011.

LINDA E. BLOHM, EXAMINING ATTORNEY

CLASS 16—(Continued).

SN 85-460,405. THE WYANOKE GROUP, INC., THOROFARE, NJ. FILED 10-31-2011.

JOURNAL OF CONTINUING EDUCATION IN NURSING

THE MARK CONSISTS OF STANDARD CHARACTERS WITHOUT CLAIM TO ANY PARTICULAR FONT, STYLE, SIZE, OR COLOR.

OWNER OF U.S. REG. NO. 924,504.

NO CLAIM IS MADE TO THE EXCLUSIVE RIGHT TO USE "JOURNAL", APART FROM THE MARK AS SHOWN. SEC. 2(F).

FOR MEDICAL JOURNAL (U.S. CLS. 2, 5, 22, 23, 29, 37, 38 AND 50).

FIRST USE 5-1-1970; IN COMMERCE 5-1-1970.

ELI HELLMAN, EXAMINING ATTORNEY

SN 85-454,350. KAIROS PRISON MINISTRY INTERNATIONAL, INC., WINTER PARK, FL. FILED 10-24-2011.

KAIROS

THE MARK CONSISTS OF STANDARD CHARACTERS WITHOUT CLAIM TO ANY PARTICULAR FONT, STYLE, SIZE, OR COLOR.

OWNER OF U.S. REG. NOS. 1,299,957, 2,973,011 AND OTHERS.

THE ENGLISH TRANSLATION OF "KAIROS" IN THE MARK IS "SPECIAL TIME" OR "GOD'S SPECIAL TIME".

FOR PUBLICATIONS IN THE FIELD OF PRISON MINISTRY, NAMELY, MINISTRY PROGRAM, TRAINING AND OPERATING PROCEDURES MANUALS; GUIDEBOOKS ON PRISON MINISTRY TOPICS; SONGBOOKS, NEWSLETTERS AND BROCHURES IN THE FIELD OF PRISON MINISTRY (U.S. CLS. 2, 5, 22, 23, 29, 37, 38 AND 50).

FIRST USE 3-15-1984; IN COMMERCE 3-15-1984.

JOHN KELLY, EXAMINING ATTORNEY

SN 85-468,740. STORA ENSO OYJ, HELSINKI, FINLAND, FILED 11-9-2011.

LUX CREAM JET

THE MARK CONSISTS OF STANDARD CHARACTERS WITHOUT CLAIM TO ANY PARTICULAR FONT, STYLE, SIZE, OR COLOR.

PRIORITY CLAIMED UNDER SEC. 44(D) ON ERPNTY TM OFC APPLICATION NO. 009960162, FILED 5-11-2011, REG. NO. 009960162, DATED 9-26-2011, EXPIRES 5-11-2021.

NO CLAIM IS MADE TO THE EXCLUSIVE RIGHT TO USE "CREAM JET", APART FROM THE MARK AS SHOWN.

FOR UNPRINTED PAPER (U.S. CLS. 2, 5, 22, 23, 29, 37, 38 AND 50).

HAI-LY LAM, EXAMINING ATTORNEY

CLASS 16—(Continued).

SN 85-470,992. MIAMI MARLINS, L.P., MIAMI, FL. FILED 11-11-2011.



THE COLOR(S) ORANGE, YELLOW, WHITE, BLUE AND SILVER IS/ARE CLAIMED AS A FEATURE OF THE MARK.

THE MARK CONSISTS OF A STYLIZED LETTER "M" ALTERNATELY LINED IN SILVER, ORANGE, YELLOW, WHITE AND BLUE WITH A STYLIZED FISH DESIGN ALTERNATELY LINED IN SILVER, ORANGE, WHITE AND BLUE CURLING AROUND THE UPPER LEFT SIDE OF THE "M".

FOR PAPER GOODS AND PRINTED MATTER, NAMELY, TRADING CARDS, POSTERS, STICKERS, DECALS, TEMPORARY TATTOOS, BUMPER STICKERS, SCORE BOOKS, SCORECARDS, PRINTED BASEBALL GAME PROGRAMS, MAGAZINES AND BOOKS FEATURING BASEBALL, NEWSLETTERS, BROCHURES AND PAMPHLETS FEATURING BASEBALL, WRITING PADS, NOTE PAPER, NOTEBOOKS, BINDERS, STATIONERY-TYPE PORTFOLIOS, STATIONERY FOLDERS, STATIONERY SETS, NAMELY, WRITING PAPER, CARDS, AND ENVELOPES, COMMEMORATIVE ENVELOPES, FLIP BOOKS, PREPRINTED AGENDA ORGANIZERS, MEMORANDUM BOARDS, SCRAPBOOKS, AUTOGRAPH BOOKS, BASEBALL CARD ALBUMS, BOOK COVERS, BOOKMARKS, BOOKENDS, CALENDARS, GREETING CARDS, POSTCARDS, PRINTED BANK CHECKBOOKS, CHECKBOOK COVERS, COLLECTIBLE STAMPS, RUBBER STAMPS, INK STAMPS, COMMEMORATIVE STAMPS, PAPER PENNANTS, GIFT WRAPPING PAPER, PAPER GIFT AND PARTY BAGS, PAPER PARTY GOODS IN THE NATURE OF PAPER PARTY DECORATIONS, PAPER COASTERS, PAPER NAPKINS, FACIAL TISSUE, PAPER TABLECLOTHS, MOUNTED AND UNMOUNTED PHOTOGRAPHS, PHOTOGRAPH ALBUMS, LITHOGRAPHS, PLASTIC BASEBALL CARD HOLDERS, HOLDERS SPECIALLY ADAPTED FOR HOLDING CHRISTMAS CARDS, PAPERWEIGHTS, LETTER OPENERS, PENS, PENCILS, PENCIL TOP ORNAMENTS, CRAYONS, MARKERS, NON-ELECTRIC ERASERS, PENCIL SHARPENERS, PENCIL CASES, UNGRADUATED RULERS, PAPER TICKET HOLDERS AND NON-METAL LANYARDS FOR PAPER TICKET HOLDERS SOLD AS A UNIT, SPECIALLY ADAPTED FOR HOLDING PAPER TICKETS, ART PICTURES, DRY ERASE WRITING BOARDS AND WRITING SURFACES, MONEY CLIPS AND ART PRINTS (U.S. CLS. 2, 5, 22, 23, 29, 37, 38 AND 50).

KATHY DE JONGE, EXAMINING ATTORNEY

CLASS 16—(Continued).

SN 85-475,461. LACY, TIFFANIE, POST FALLS, ID. FILED 11-17-2011.

Korkys Push Pins

THE MARK CONSISTS OF STANDARD CHARACTERS WITHOUT CLAIM TO ANY PARTICULAR FONT, STYLE, SIZE, OR COLOR.

NO CLAIM IS MADE TO THE EXCLUSIVE RIGHT TO USE "PUSH PINS", APART FROM THE MARK AS SHOWN. FOR DECORATIVE PUSH PINS (U.S. CLS. 2, 5, 22, 23, 29, 37, 38 AND 50).

FIRST USE 1-0-2008; IN COMMERCE 2-1-2009.
LUCY ARANT, EXAMINING ATTORNEY

SN 85-475,761. PWXYZ, LLC, NEW YORK, NY. FILED 11-17-2011.

PW Select

THE MARK CONSISTS OF STANDARD CHARACTERS WITHOUT CLAIM TO ANY PARTICULAR FONT, STYLE, SIZE, OR COLOR.

OWNER OF U.S. REG. NOS. 393,903, 3,325,635 AND 3,996,797.

NO CLAIM IS MADE TO THE EXCLUSIVE RIGHT TO USE "SELECT", APART FROM THE MARK AS SHOWN.

FOR PRINTED PERIODICALS IN THE FIELD OF SELF-PUBLISHED BOOKS (U.S. CLS. 2, 5, 22, 23, 29, 37, 38 AND 50).

FIRST USE 8-23-2010; IN COMMERCE 8-23-2010.
ROBIN MITTLER, EXAMINING ATTORNEY

SN 85-475,929. THE WYANOKE GROUP, INC., THOROFARE, NJ. FILED 11-17-2011.

Journal of Refractive Surgery

THE MARK CONSISTS OF STANDARD CHARACTERS WITHOUT CLAIM TO ANY PARTICULAR FONT, STYLE, SIZE, OR COLOR.

NO CLAIM IS MADE TO THE EXCLUSIVE RIGHT TO USE "JOURNAL", APART FROM THE MARK AS SHOWN. SEC. 2(F).

FOR PRINTED PERIODICALS IN THE FIELD OF MEDICINE (U.S. CLS. 2, 5, 22, 23, 29, 37, 38 AND 50).

FIRST USE 2-27-1995; IN COMMERCE 2-27-1995.
ELI HELLMAN, EXAMINING ATTORNEY

CLASS 16—(Continued).

SN 85-479,211. BIG BANG INC., BOONTON, NJ. FILED 11-22-2011.



OWNER OF U.S. REG. NO. 3,693,559.
THE COLOR(S) BLACK, WHITE, RED AND GRAY IS/ARE CLAIMED AS A FEATURE OF THE MARK.

THE MARK CONSISTS OF THE WORDING "THE DRAGONS OF BLIZZARD ISLAND" IN STYLIZED TEXT, WITH THE WORDS "THE", "OF" AND "ISLAND" IN GRAY AND WHITE OUTLINED IN BLACK, AND THE WORDS "DRAGONS" AND "BLIZZARD" IN RED OUTLINED IN BLACK WITH WHITE SNOW/ICE HANGING FROM AND APPEARING ON INDIVIDUAL LETTERS OF THE WORDS.

FOR CHILDREN'S BOOKS; COMIC BOOKS; SERIES OF FICTION BOOKS (U.S. CLS. 2, 5, 22, 23, 29, 37, 38 AND 50).

FIRST USE 11-0-2011; IN COMMERCE 11-0-2011.
DOMINIC J. FERRAIUOLO, EXAMINING ATTORNEY

SN 85-479,656. BIOMET 3I, LLC, PALM BEACH GARDENS, FL. FILED 11-23-2011.

SMILE TODAY

THE MARK CONSISTS OF STANDARD CHARACTERS WITHOUT CLAIM TO ANY PARTICULAR FONT, STYLE, SIZE, OR COLOR.

FOR PRINTED DENTAL EDUCATION MATERIALS FOR INSTRUCTING DENTAL CLINICIANS AND PATIENTS ABOUT DENTAL RESTORATIONS, DENTAL TREATMENT TECHNIQUES, DENTAL IMPLANTS, DENTAL ABUTMENTS, AND DENTAL SURGICAL AND RESTORATIVE INSTRUMENTS (U.S. CLS. 2, 5, 22, 23, 29, 37, 38 AND 50).

JULIE VEPPUMTHARA, EXAMINING ATTORNEY

CLASS 16—(Continued).

SN 85-485,566. AIRBRUSH ACTION, INC., ALLENWOOD, NJ. FILED 12-2-2011.

cheap tricks & special f/x

THE MARK CONSISTS OF STANDARD CHARACTERS WITHOUT CLAIM TO ANY PARTICULAR FONT, STYLE, SIZE, OR COLOR.

NO CLAIM IS MADE TO THE EXCLUSIVE RIGHT TO USE "SPECIAL F/X", APART FROM THE MARK AS SHOWN.

FOR A SERIES OF BOOKS AND WRITTEN ARTICLES IN THE FIELD OF ARTS AND CRAFTS; EDUCATIONAL BOOKS FEATURING ARTS AND CRAFTS; EDUCATIONAL KITS SOLD AS A UNIT IN THE FIELD OF ARTS AND CRAFTS CONSISTING PRIMARILY OF AIRBRUSHES, PAPER, INSTRUCTIONS AND ALSO INCLUDING DVDS (U.S. CLS. 2, 5, 22, 23, 29, 37, 38 AND 50).

FIRST USE 6-1-1994; IN COMMERCE 6-1-1994.
MARLENE BELL, EXAMINING ATTORNEY

SN 85-486,507. WILLIAMS & ASSOCIATES COMMUNICATIONS INC., DBA AMERICAN BANNER BOOKS, PINE BLUFF, AR. FILED 12-3-2011.

AC8RN

THE MARK CONSISTS OF STANDARD CHARACTERS WITHOUT CLAIM TO ANY PARTICULAR FONT, STYLE, SIZE, OR COLOR.

FOR SERIES OF NON-FICTION BOOKS IN THE FIELD OF COMMUNITY ORGANIZING (U.S. CLS. 2, 5, 22, 23, 29, 37, 38 AND 50).

FIRST USE 11-15-2008; IN COMMERCE 11-20-2011.
EMILY CARLSEN, EXAMINING ATTORNEY

SN 85-491,055. BABY BRIEFCASE LLC, MILTON, MA. FILED 12-8-2011.

BABYBRIEFCASE

THE MARK CONSISTS OF STANDARD CHARACTERS WITHOUT CLAIM TO ANY PARTICULAR FONT, STYLE, SIZE, OR COLOR.

FOR PAPERWORK ORGANIZERS, NAMELY, ORGANIZERS FOR PERSONAL PAPERS AND FILE ORGANIZERS (U.S. CLS. 2, 5, 22, 23, 29, 37, 38 AND 50).

FIRST USE 8-16-2003; IN COMMERCE 10-20-2003.
SAIMA MAKHDOOM, EXAMINING ATTORNEY

CLASS 16—(Continued).

SN 85-492,393. HANDELOK BAG COMPANY, INC., LANSDALE, PA. FILED 12-11-2011.

HBCPACKAGING

THE MARK CONSISTS OF STANDARD CHARACTERS WITHOUT CLAIM TO ANY PARTICULAR FONT, STYLE, SIZE, OR COLOR.

FOR PAPER AND PLASTIC BAGS FOR PACKAGING (U.S. CLS. 2, 5, 22, 23, 29, 37, 38 AND 50).

FIRST USE 11-0-2011; IN COMMERCE 11-0-2011.
ALYSSA STEEL, EXAMINING ATTORNEY



SN 85-493,583. MANTELMACHER, ANN, OWINGS MILLS, MD. AND MANTELMACHER H. LEE, OWINGS MILLS, MD. FILED 12-13-2011.

KISS

THE MARK CONSISTS OF STANDARD CHARACTERS WITHOUT CLAIM TO ANY PARTICULAR FONT, STYLE, SIZE, OR COLOR.

FOR ADHESIVES FOR HOUSEHOLD PURPOSES (U.S. CLS. 2, 5, 22, 23, 29, 37, 38 AND 50).

APRIL ROACH, EXAMINING ATTORNEY



SN 85-497,529. GLOBAL EVANGELISM, INC., SAN ANTONIO, TX. FILED 12-16-2011.

WHAT'S BETTER THAN CANDY?

THE MARK CONSISTS OF STANDARD CHARACTERS WITHOUT CLAIM TO ANY PARTICULAR FONT, STYLE, SIZE, OR COLOR.

FOR PRINTED MATERIALS, NAMELY, NEWSLETTERS AND FLYERS IN THE FIELD OF THE BIBLE, RELIGION AND SPIRITUALITY (U.S. CLS. 2, 5, 22, 23, 29, 37, 38 AND 50).

JENNY PARK, EXAMINING ATTORNEY

CLASS 16—(Continued).

SN 85-497,533. GLOBAL EVANGELISM, INC., SAN ANTONIO, TX. FILED 12-16-2011.

THE LIVING WORD BOOK BY BOOK WITH PASTOR JOHN HAGEE

THE MARK CONSISTS OF STANDARD CHARACTERS WITHOUT CLAIM TO ANY PARTICULAR FONT, STYLE, SIZE, OR COLOR.

THE NAME(S), PORTRAIT(S), AND/OR SIGNATURE(S) SHOWN IN THE MARK IDENTIFIES "JOHN HAGEE", WHOSE CONSENT(S) TO REGISTER IS MADE OF RECORD.

FOR A SERIES OF BOOKS IN THE FIELD OF THE BIBLE, RELIGION AND SPIRITUALITY (U.S. CLS. 2, 5, 22, 23, 29, 37, 38 AND 50).

JENNY PARK, EXAMINING ATTORNEY



SN 85-497,535. GLOBAL EVANGELISM, INC., SAN ANTONIO, TX. FILED 12-16-2011.

THE LIVING WORD BOOK BY BOOK

THE MARK CONSISTS OF STANDARD CHARACTERS WITHOUT CLAIM TO ANY PARTICULAR FONT, STYLE, SIZE, OR COLOR.

FOR A SERIES OF BOOKS IN THE FIELD OF THE BIBLE, RELIGION AND SPIRITUALITY (U.S. CLS. 2, 5, 22, 23, 29, 37, 38 AND 50).

JENNY PARK, EXAMINING ATTORNEY



SN 85-497,672. VICERE ASSOCIATES, INC., PETERSBURG, PA. FILED 12-16-2011.

SLCQ

THE MARK CONSISTS OF STANDARD CHARACTERS WITHOUT CLAIM TO ANY PARTICULAR FONT, STYLE, SIZE, OR COLOR.

FOR PRINTED SURVEY ANSWER SHEETS (U.S. CLS. 2, 5, 22, 23, 29, 37, 38 AND 50).

FIRST USE 2-1-2001; IN COMMERCE 2-1-2001.

FLORENTINA BLANDU, EXAMINING ATTORNEY

CLASS 16—(Continued).

SN 85-499,469. AGORA STRATEGIES LTD., LONDON, UNITED KINGDOM, FILED 12-20-2011.

THE SOVEREIGNTY INDEX

THE MARK CONSISTS OF STANDARD CHARACTERS WITHOUT CLAIM TO ANY PARTICULAR FONT, STYLE, SIZE, OR COLOR.

NO CLAIM IS MADE TO THE EXCLUSIVE RIGHT TO USE "INDEX", APART FROM THE MARK AS SHOWN.

FOR PRINTED MATERIALS AND PUBLICATIONS, NAMELY, MANUALS, LEAFLETS, CARDS, REPORTS, BOOKS AND WRITTEN ARTICLES PERTAINING TO GLOBAL POLITICAL AND SOCIOECONOMIC CHANGE (U.S. CLS. 2, 5, 22, 23, 29, 37, 38 AND 50).

SANDRA BUJA, EXAMINING ATTORNEY

SN 85-501,309. ROCCO WHALEN, ROCKY RIVER, OH. FILED 12-21-2011.

CHEF ROCCO WHALEN

THE MARK CONSISTS OF STANDARD CHARACTERS WITHOUT CLAIM TO ANY PARTICULAR FONT, STYLE, SIZE, OR COLOR.

THE NAME(S), PORTRAIT(S), AND/OR SIGNATURE(S) SHOWN IN THE MARK IDENTIFIES "ROCCO WHALEN", WHOSE CONSENT(S) TO REGISTER IS MADE OF RECORD.

FOR COOK BOOKS; COOKBOOK HOLDERS; MAGAZINE COLUMNS ABOUT COOKING, RECIPES, FOOD AND DRINK; MAGAZINES FEATURING INFORMATION AND ARTICLES ABOUT COOKING, RECIPES, FOOD AND DRINK; RECIPE BOOKS (U.S. CLS. 2, 5, 22, 23, 29, 37, 38 AND 50).

KRISTIN DAHLING, EXAMINING ATTORNEY

SN 85-501,325. ROCCO WHALEN, ROCKY RIVER, OH. FILED 12-21-2011.

ROCCO WHALEN'S

THE MARK CONSISTS OF STANDARD CHARACTERS WITHOUT CLAIM TO ANY PARTICULAR FONT, STYLE, SIZE, OR COLOR.

THE NAME(S), PORTRAIT(S), AND/OR SIGNATURE(S) SHOWN IN THE MARK IDENTIFIES "ROCCO WHALEN", WHOSE CONSENT(S) TO REGISTER IS MADE OF RECORD.

FOR COOK BOOKS; COOKBOOK HOLDERS; MAGAZINE COLUMNS ABOUT COOKING, RECIPES, FOOD AND DRINK; MAGAZINES FEATURING INFORMATION AND ARTICLES ABOUT COOKING, RECIPES, FOOD AND DRINK; RECIPE BOOKS (U.S. CLS. 2, 5, 22, 23, 29, 37, 38 AND 50).

KRISTIN DAHLING, EXAMINING ATTORNEY

CLASS 16—(Continued).

SN 85-501,787. M.C. WEASEL LLC, LONG VALLEY, NJ. FILED 12-22-2011.

M.C. WEASEL

THE MARK CONSISTS OF STANDARD CHARACTERS WITHOUT CLAIM TO ANY PARTICULAR FONT, STYLE, SIZE, OR COLOR.

THE NAME(S), PORTRAIT(S), AND/OR SIGNATURE(S) SHOWN IN THE MARK IDENTIFIES MARY E. COLLINS, WHOSE CONSENT(S) TO REGISTER IS MADE OF RECORD.

FOR SERIES OF FICTION WORKS, NAMELY, NOVELS, BOOKS AND E-BOOKS (U.S. CLS. 2, 5, 22, 23, 29, 37, 38 AND 50).

GRETTA YAO, EXAMINING ATTORNEY

SN 85-504,409. MONTEFIORE MEDICAL CENTER, BRONX, NY. FILED 12-27-2011.

INSPIRED MEDICINE

THE MARK CONSISTS OF STANDARD CHARACTERS WITHOUT CLAIM TO ANY PARTICULAR FONT, STYLE, SIZE, OR COLOR.

OWNER OF U.S. REG. NO. 4,096,668.

NO CLAIM IS MADE TO THE EXCLUSIVE RIGHT TO USE "MEDICINE", APART FROM THE MARK AS SHOWN.

FOR PRINT PUBLICATIONS, NAMELY, BOOKLETS, PAMPHLETS, GUIDES, MAGAZINES, NEWSLETTERS, BROCHURES, BULLETINS AND CIRCULARS IN THE FIELDS OF HEALTH AND MEDICINE (U.S. CLS. 2, 5, 22, 23, 29, 37, 38 AND 50).

FIRST USE 9-1-2009; IN COMMERCE 8-15-2011.

KATHERINE STOIDES, EXAMINING ATTORNEY

CLASS 16—(Continued).

SN 85-504,520. AMUSEMENT ART LLC, LOS ANGELES, CA. FILED 12-27-2011.



THE MARK CONSISTS OF THE WORDING "FOLLOW YOUR DREAMS" BESIDE AN APE OR CHIMP HOLDING A SPRAY PAINT CAN AND SITTING ON A CHEST.

FOR BLACKBOARDS AND SCRAP BOOKS; BLANK JOURNAL BOOKS; BLANK OR PARTIALLY PRINTED POSTCARDS; BOOK COVERS; BOOK MARKS; BUMPER STICKERS; CALENDAR DESK PADS; CALENDARS; COLORING BOOKS; DECALS; FITTED FABRIC NOTEBOOK COVERS; GRAPHIC FINE ART PRINTS; HEAT TRANSFER PAPER; LITHOGRAPHIC PRINTS; LITHOGRAPHIC WORKS OF ART; LITHOGRAPHS; MAGAZINES FEATURING ART; MOUNTED AND UNMOUNTED PHOTOGRAPHS; NAPKIN PAPER; NOTE BOOKS; NOTEBOOKS; OIL PASTELS; PAINT BRUSHES; PAINT PADDLES; PAINT ROLLERS; PAINT TRAYS; PAINTINGS; PAINTINGS IN MIXED MEDIA; PAPER BAGS; PAPER TABLECLOTHS; PASTELS; PHOTOGRAPHIC PRINTS; PHOTOGRAPHS; PICTURE POSTCARDS; POSTCARD PAPER; POSTCARDS; POSTCARDS AND GREETING CARDS; POSTCARDS AND PICTURE POSTCARDS; POSTERS; POSTERS MADE OF PAPER; PRINTED CALENDARS; RUBBER STAMP; SCHOOL SUPPLY KITS CONTAINING VARIOUS COMBINATIONS OF SELECTED SCHOOL SUPPLIES, NAMELY, WRITING INSTRUMENTS, PENS, PENCILS, MECHANICAL PENCILS, ERASERS, MARKERS, CRAYONS, HIGHLIGHTER PENS, FOLDERS, NOTEBOOKS, PAPER, PROTRACTORS, PAPER CLIPS, PENCIL SHARPENERS, WRITING GRIPS, GLUE AND BOOK MARKS; STICKERS; STICKERS AND TRANSFERS; TEAR-OFF CALENDARS; WALL CALENDARS (U.S. CLS. 2, 5, 22, 23, 29, 37, 38 AND 50).

HANNO RITTNER, EXAMINING ATTORNEY

SN 85-504,543. GUERRA, MIGUEL, NEW YORK, NY. AND GUERRA, SUZY D, NEW YORK, NY. FILED 12-27-2011.

Super Corporate Heroes

THE MARK CONSISTS OF STANDARD CHARACTERS WITHOUT CLAIM TO ANY PARTICULAR FONT, STYLE, SIZE, OR COLOR.

FOR COMIC BOOKS; COMIC MAGAZINES; COMIC STRIPS; COMIC STRIPS' COMIC FEATURES; COMICS; POSTERS; PRINTED MATERIALS, NAMELY, NOVELS AND SERIES OF FICTION BOOKS AND SHORT STORIES FEATURING SCENES AND CHARACTERS BASED ON VIDEO GAMES (U.S. CLS. 2, 5, 22, 23, 29, 37, 38 AND 50).

FIRST USE 12-1-2011; IN COMMERCE 12-1-2011.

JACLYN KIDWELL WALKER, EXAMINING ATTORNEY

CLASS 16—(Continued).

SN 85-504,745. HOYT, DAVID L, CHICAGO, IL. FILED 12-28-2011.

SUDOKU EXPRESS

THE MARK CONSISTS OF STANDARD CHARACTERS WITHOUT CLAIM TO ANY PARTICULAR FONT, STYLE, SIZE, OR COLOR.

NO CLAIM IS MADE TO THE EXCLUSIVE RIGHT TO USE "SUDOKU", APART FROM THE MARK AS SHOWN.

FOR WORD PUZZLE BOOKS, MAGAZINES IN THE FIELD OF PUZZLES, PRINTED PUZZLES FEATURED IN BOOKS, MAGAZINES AND NEWSPAPERS (U.S. CLS. 2, 5, 22, 23, 29, 37, 38 AND 50).

EUGENIA MARTIN, EXAMINING ATTORNEY

SN 85-505,429. ALL BRIGHT IDEAS, ALLENTOWN, PA. FILED 12-29-2011.

Work Piles Made Easy

THE MARK CONSISTS OF STANDARD CHARACTERS WITHOUT CLAIM TO ANY PARTICULAR FONT, STYLE, SIZE, OR COLOR.

OWNER OF U.S. REG. NO. 3,917,255.

FOR PAPER ORGANIZING KIT COMPRISED OF FILE FOLDERS, FILE BOXES FOR STORAGE OF BUSINESS AND PERSONAL RECORDS, TAB INSERTS IN THE NATURE OF LABELS, ADHESIVE OR PAPER LABELS, PERSONAL ORGANIZERS IN THE NATURE OF RECEIPT ORGANIZERS, PERSONAL ORGANIZERS IN THE NATURE OF COUPON ORGANIZERS, BINDERS, ENVELOPES AND INSTRUCTIONS, INCLUDING PRINTED INSTRUCTIONS AND PRE-RECORDED ELECTRONIC AND DIGITAL MEDIA FEATURING INSTRUCTIONS (U.S. CLS. 2, 5, 22, 23, 29, 37, 38 AND 50).

SUSAN RICHARDS, EXAMINING ATTORNEY

SN 85-506,674. SANTOSO, ALEX, SANTA CLARITA, CA. FILED 12-30-2011.

NEATOSHOP

THE MARK CONSISTS OF STANDARD CHARACTERS WITHOUT CLAIM TO ANY PARTICULAR FONT, STYLE, SIZE, OR COLOR.

FOR REMOVABLE TATTOOS; DECORATIVE PAPER AND PLASTIC STICKERS, DECORATIVE ADHESIVE STICKERS (U.S. CLS. 2, 5, 22, 23, 29, 37, 38 AND 50).

FIRST USE 4-1-2010; IN COMMERCE 9-26-2011.

KATHLEEN M. VANSTON, EXAMINING ATTORNEY

CLASS 16—(Continued).

SN 85-506,678. MAIL'S HERE, SIGNAL HILL, CA. FILED 12-30-2011.

MAIL'S HERE

THE MARK CONSISTS OF STANDARD CHARACTERS WITHOUT CLAIM TO ANY PARTICULAR FONT, STYLE, SIZE, OR COLOR.

FOR SERIES OF CHILDREN'S STORIES DELIVERED IN THE FORM OF LETTERS COMPRISING PORTIONS OF EACH STORY (U.S. CLS. 2, 5, 22, 23, 29, 37, 38 AND 50).

FIRST USE 9-6-2011; IN COMMERCE 10-21-2011.
ANDREA HACK, EXAMINING ATTORNEY

CLASS 16—(Continued).

SN 85-507,912. MARK L. LAYTON PRODUCTIONS, DBA LAYTON PRODUCTIONS, OREM, UT. FILED 1-3-2012.



NO CLAIM IS MADE TO THE EXCLUSIVE RIGHT TO USE "BEST" AND "PROMOTIONS", APART FROM THE MARK AS SHOWN.

THE MARK CONSISTS OF THE LETTERS "BOS" IN STYLIZED FONT ON A SQUARE BACKGROUND FOLLOWED BY "BEST OF STATE" IN LARGE CAPS AND "PROMOTIONS" IN SMALL CAPS.

FOR PUBLICATIONS, NAMELY, MAGAZINES, GUIDES, BOOKS, BOOKLETS, MANUALS, NEWSLETTERS AND PERIODICALS, ALL IN THE NATURE OF PROVIDING RECOGNITION AND INCENTIVES THROUGH AWARDS FOR EXCELLENCE IN THE FIELDS OF ARTS, TECHNOLOGIES, ACADEMIA, TRADE, BUSINESS AND INDUSTRY (U.S. CLS. 2, 5, 22, 23, 29, 37, 38 AND 50).

FIRST USE 6-1-2011; IN COMMERCE 6-1-2011.
MAYUR VAGHANI, EXAMINING ATTORNEY

SN 85-507,201. RALPH BENDER, TEMECULA, CA. FILED 1-2-2012.

Running Money

THE MARK CONSISTS OF STANDARD CHARACTERS WITHOUT CLAIM TO ANY PARTICULAR FONT, STYLE, SIZE, OR COLOR.

FOR NEWSLETTERS IN THE FIELD OF FINANCIAL SERVICES (U.S. CLS. 2, 5, 22, 23, 29, 37, 38 AND 50).

FIRST USE 4-7-2009; IN COMMERCE 4-7-2009.
PAUL E. FAHRENKOPF, EXAMINING ATTORNEY

SN 85-508,892. MAYNARD, CLAUDE, JACKSONVILLE, FL. FILED 1-4-2012.

Slow To Move Quick To Do Nothing

SN 85-507,881. MEULINK, JACOB C, SPOKANE, WA. AND MEULINK, WILLIAM F, SPOKANE, WA. FILED 1-3-2012.

My Toys

THE MARK CONSISTS OF STANDARD CHARACTERS WITHOUT CLAIM TO ANY PARTICULAR FONT, STYLE, SIZE, OR COLOR.

FOR BUMPER STICKERS; MAGNETIC BUMPER STICKERS (U.S. CLS. 2, 5, 22, 23, 29, 37, 38 AND 50).

GRETTA YAO, EXAMINING ATTORNEY

THE MARK CONSISTS OF STANDARD CHARACTERS WITHOUT CLAIM TO ANY PARTICULAR FONT, STYLE, SIZE, OR COLOR.

FOR STICKERS (U.S. CLS. 2, 5, 22, 23, 29, 37, 38 AND 50).

LOURDES AYALA, EXAMINING ATTORNEY

CLASS 16—(Continued).

SN 85-508,989. FRANKLIN COVEY CO., SALT LAKE CITY, UT. FILED 1-5-2012.

THE LEADER IN ME

THE MARK CONSISTS OF STANDARD CHARACTERS WITHOUT CLAIM TO ANY PARTICULAR FONT, STYLE, SIZE, OR COLOR.

OWNER OF U.S. REG. NO. 4,080,353.

FOR PRINTED MATERIALS, NAMELY, MANUALS, REFERENCE GUIDES, PARTICIPANT GUIDES, NOTEBOOKS, AND PAMPHLETS IN THE FIELDS OF TIME MANAGEMENT, LEADERSHIP, COMMUNICATION AND PERSONAL DEVELOPMENT; PROJECT PLANNERS, DAY PLANNERS FOR USE IN PROJECT PLANNING AND TIME MANAGEMENT, CALENDARS, PERSONAL ORGANIZERS, BINDERS, NOTEBOOKS AND POUCHES FOR PRINTED MATERIALS (U.S. CLS. 2, 5, 22, 23, 29, 37, 38 AND 50).

FIRST USE 9-2-2008; IN COMMERCE 9-2-2008.

JOHN GARTNER, EXAMINING ATTORNEY

SN 85-509,826. ZACHRY PUBLICATIONS LP, ABILENE, TX. FILED 1-5-2012.

PB Oil & Gas

THE MARK CONSISTS OF STANDARD CHARACTERS WITHOUT CLAIM TO ANY PARTICULAR FONT, STYLE, SIZE, OR COLOR.

NO CLAIM IS MADE TO THE EXCLUSIVE RIGHT TO USE "OIL & GAS", APART FROM THE MARK AS SHOWN.

FOR MAGAZINES IN THE FIELD OF THE OIL AND GAS INDUSTRY (U.S. CLS. 2, 5, 22, 23, 29, 37, 38 AND 50).

FIRST USE 9-0-2006; IN COMMERCE 9-0-2006.

REBECCA SMITH, EXAMINING ATTORNEY

CLASS 16—(Continued).

SN 85-509,926. WILD BRAIN ENTERTAINMENT, INC., SHERMAN OAKS, CA. FILED 1-5-2012.

DIZZY

THE MARK CONSISTS OF STANDARD CHARACTERS WITHOUT CLAIM TO ANY PARTICULAR FONT, STYLE, SIZE, OR COLOR.

FOR PAPER GOODS AND PRINTED MATTER, NAMELY, A SERIES OF FICTION BOOKS FEATURING STORIES IN THE FIELD OF CHILDREN'S EDUCATION; TRADING CARDS; COLLECTORS CARDS; COMIC BOOKS AND MAGAZINES IN THE FIELD OF CHILDREN'S EDUCATION; GRAPHIC NOVELS; NOVELS; PRINTED POSTCARDS; PICTURE POSTCARDS; COMIC POSTCARDS; POSTCARDS; NOTEBOOKS; BINDERS; DECALS; STICKERS; POSTERS; PHOTOGRAPH AND SCRAPBOOK ALBUMS; CALENDARS; GREETING CARDS; FOLDERS; DESK PADS; WRITING PADS; STATIONERY FOLDERS AND STATIONERY; PENS; PENCILS; ERASERS; VIDEO GAME STRATEGY MANUALS AND BOOKS; COMPUTER GAME INSTRUCTION MANUALS; PAPER TOWELS; PAPER STORAGE CONTAINERS; CHALK BOARDS; DRY ERASE WRITING BOARDS AND WRITING SURFACES; PAPER FLAGS; PAPER PENNANTS (U.S. CLS. 2, 5, 22, 23, 29, 37, 38 AND 50).

EMILY CHUO, EXAMINING ATTORNEY

SN 85-510,081. HALEY BIRK-LYNCH, WEST SAYVILLE, NY. FILED 1-6-2012.

DOG AT HOME

THE MARK CONSISTS OF STANDARD CHARACTERS WITHOUT CLAIM TO ANY PARTICULAR FONT, STYLE, SIZE, OR COLOR.

FOR DISPOSABLE HOUSEBREAKING PADS FOR PETS (U.S. CLS. 2, 5, 22, 23, 29, 37, 38 AND 50).

MARK SPARACINO, EXAMINING ATTORNEY

SN 85-510,204. TRANS WESTERN POLYMERS, INC., LIVERMORE, CA. FILED 1-6-2012.

Rip Block

THE MARK CONSISTS OF STANDARD CHARACTERS WITHOUT CLAIM TO ANY PARTICULAR FONT, STYLE, SIZE, OR COLOR.

FOR TRASH BAGS (U.S. CLS. 2, 5, 22, 23, 29, 37, 38 AND 50).

GEORGE LORENZO, EXAMINING ATTORNEY

CLASS 16—(Continued).

SN 85-510,369. HOMINY NAMES, LLC, KEY WEST, FL. FILED 1-6-2012.

WHITE TRASH

THE MARK CONSISTS OF STANDARD CHARACTERS WITHOUT CLAIM TO ANY PARTICULAR FONT, STYLE, SIZE, OR COLOR.

FOR TRASH BAGS (U.S. CLS. 2, 5, 22, 23, 29, 37, 38 AND 50).

MAYUR VAGHANI, EXAMINING ATTORNEY

SN 85-510,694. TRUSTEE OF THE CLARE CHESTER STONE MARITAL TRUST, PURCHASE, NY. FILED 1-6-2012.

ALLAN STONE COLLECTION

THE MARK CONSISTS OF STANDARD CHARACTERS WITHOUT CLAIM TO ANY PARTICULAR FONT, STYLE, SIZE, OR COLOR.

NO CLAIM IS MADE TO THE EXCLUSIVE RIGHT TO USE "COLLECTION", APART FROM THE MARK AS SHOWN.

THE NAME "ALLAN STONE" DOES NOT IDENTIFY A LIVING INDIVIDUAL.

FOR CALENDARS; DATE BOOKS; PAPER; SKETCH PADS; GIFT WRAP PAPER; TISSUE PAPER; POSTERS; NOTEBOOKS; PAPER NOTE TABLETS, PAPER DRAWING TABLETS, PAPER WRITING TABLETS AND PAPER PAINTING TABLETS; NOTE CARDS; GREETING CARDS; STATIONERY; PICTURES, LITHOGRAPHS, ART PRINTS AND THEIR REPRODUCTIONS; DIARIES; BOOKS IN THE FIELD OF ART; BROCHURES IN THE FIELD OF ART (U.S. CLS. 2, 5, 22, 23, 29, 37, 38 AND 50).

DAVID COLLIER, EXAMINING ATTORNEY

SN 85-510,779. DAVID VELASQUEZ, INGLEWOOD, CA. FILED 1-6-2012.

Letters To Live By

THE MARK CONSISTS OF STANDARD CHARACTERS WITHOUT CLAIM TO ANY PARTICULAR FONT, STYLE, SIZE, OR COLOR.

FOR BOOKS IN THE FIELD OF ART AND TATTOO ART (U.S. CLS. 2, 5, 22, 23, 29, 37, 38 AND 50).

FIRST USE 6-1-2010; IN COMMERCE 6-1-2010.

ANDREW LEASER, EXAMINING ATTORNEY

CLASS 16—(Continued).

SN 85-510,994. DALLAS DIGITAL COLOR, LLC, RICHARDSON, TX. FILED 1-6-2012.



THE MARK CONSISTS OF A FLAG BANNER TIED WITH A BOW ON EITHER SIDE. BELOW THERE IS THE STYLIZED TEXT "WOWENDARS" INSIDE A RECTANGLE.

FOR CALENDARS (U.S. CLS. 2, 5, 22, 23, 29, 37, 38 AND 50).

LINDA M. KING, EXAMINING ATTORNEY

SN 85-511,001. ROMA, URSULA, CINCINNATI, OH. FILED 1-6-2012.

Ursula Roma

THE MARK CONSISTS OF STANDARD CHARACTERS WITHOUT CLAIM TO ANY PARTICULAR FONT, STYLE, SIZE, OR COLOR.

THE NAME URSULA ROMA IDENTIFIES A LIVING INDIVIDUAL WHOSE CONSENT IS OF RECORD.

FOR ART ETCHINGS; ART PICTURES; ART PRINTS; ART PRINTS ON CANVAS; GRAPHIC ART PRINTS; GRAPHIC FINE ART PRINTS (U.S. CLS. 2, 5, 22, 23, 29, 37, 38 AND 50).

FIRST USE 5-1-1986; IN COMMERCE 5-1-1986.

LINDA M. KING, EXAMINING ATTORNEY

SN 85-511,031. ARIA ASSETS, LLC, LOS ANGELES, CA. FILED 1-6-2012.

EVERYTHING GUYS KNOW ABOUT GIRLS

THE MARK CONSISTS OF STANDARD CHARACTERS WITHOUT CLAIM TO ANY PARTICULAR FONT, STYLE, SIZE, OR COLOR.

FOR SERIES OF BOOKS; PAPER NOTEBOOKS; NOTEBOOKS (U.S. CLS. 2, 5, 22, 23, 29, 37, 38 AND 50).

JAY FLOWERS, EXAMINING ATTORNEY

CLASS 16—(Continued).

SN 85-511,439. BRIDGEPOINT INTERNATIONAL, LLC, NAPERVILLE, IL. FILED 1-9-2012.



THE MARK CONSISTS OF A CIRCLE CONTAINING TWO RECTANGLES ABOVE THE WORD "PAUSE", SURROUNDED BY A SECOND CIRCLE.

FOR EDUCATIONAL PUBLICATIONS, NAMELY, BOOKS AND TRAINING MANUALS IN THE FIELDS OF EMPLOYEE TRAINING, EMPLOYEE DEVELOPMENT AND EMPLOYEE EDUCATION; PRINTED TRAINING MATERIALS IN THE FIELDS OF EMPLOYEE TRAINING, EMPLOYEE DEVELOPMENT AND EMPLOYEE EDUCATION (U.S. CLS. 2, 5, 22, 23, 29, 37, 38 AND 50).

FIRST USE 10-1-2011; IN COMMERCE 10-1-2011, REBECCA GILBERT, EXAMINING ATTORNEY

SN 85-511,503. KAINOCO INC, LOS ANGELES, CA. FILED 1-9-2012.

Misprint

THE MARK CONSISTS OF STANDARD CHARACTERS WITHOUT CLAIM TO ANY PARTICULAR FONT, STYLE, SIZE, OR COLOR.

FOR BOOKS IN THE FIELD OF ART (U.S. CLS. 2, 5, 22, 23, 29, 37, 38 AND 50).

JOHN GARTNER, EXAMINING ATTORNEY

CLASS 16—(Continued).

SN 85-511,622. ASTUTE HOOT, LLC, MESA, AZ. FILED 1-9-2012.



FOR PRINTED EDUCATIONAL MATERIALS IN THE FIELD OF READING FLUENCY AND COMPREHENSION (U.S. CLS. 2, 5, 22, 23, 29, 37, 38 AND 50).

FIRST USE 10-1-2010; IN COMMERCE 11-1-2010. CHRISTINE MARTIN, EXAMINING ATTORNEY

SN 85-511,671. HAYS, JULIA, LAKEWOOD RANCH, FL. FILED 1-9-2012.

**Sending Sunflowers,
Butterflies and Rainbows...**

THE MARK CONSISTS OF STANDARD CHARACTERS WITHOUT CLAIM TO ANY PARTICULAR FONT, STYLE, SIZE, OR COLOR.

FOR BLANK CARDS; STATIONERY (U.S. CLS. 2, 5, 22, 23, 29, 37, 38 AND 50).

WILLIAM JACKSON, EXAMINING ATTORNEY

SN 85-512,096. BANKS PATRICIA, BURNHAM, IL. FILED 1-9-2012.

**Want to meet God up close
and personal: TEXT while
DRIVING**

THE MARK CONSISTS OF STANDARD CHARACTERS WITHOUT CLAIM TO ANY PARTICULAR FONT, STYLE, SIZE, OR COLOR.

FOR BUMPER STICKERS (U.S. CLS. 2, 5, 22, 23, 29, 37, 38 AND 50).

JAMES GRIFFIN, EXAMINING ATTORNEY

CLASS 16—(Continued).

SN 85-512,271. ON AIR PRODUCTIONS, CORTLAND, NY.
FILED 1-9-2012.

The Sweet Taste of Life...

THE MARK CONSISTS OF STANDARD CHARACTERS WITHOUT CLAIM TO ANY PARTICULAR FONT, STYLE, SIZE, OR COLOR.

FOR PRINTED RECIPE CARDS (U.S. CLS. 2, 5, 22, 23, 29, 37, 38 AND 50).

RONALD MCMORROW, EXAMINING ATTORNEY

SN 85-512,343. JOHNSON, STEVEN W, DBA HNK CONCEPTS, PEARLAND, TX. FILED 1-9-2012.

Power Up!

THE MARK CONSISTS OF STANDARD CHARACTERS WITHOUT CLAIM TO ANY PARTICULAR FONT, STYLE, SIZE, OR COLOR.

FOR CARTOON PRINTS; CARTOON STRIPS; COMIC BOOKS; COMIC STRIPS; COMICS (U.S. CLS. 2, 5, 22, 23, 29, 37, 38 AND 50).

FIRST USE 7-21-2010; IN COMMERCE 11-2-2011.
JOHN WILKE, EXAMINING ATTORNEY

SN 85-512,421. STAPLES THE OFFICE SUPERSTORE, LLC, FRAMINGHAM, MA. FILED 1-10-2012.

TASK COMPLETE

THE MARK CONSISTS OF STANDARD CHARACTERS WITHOUT CLAIM TO ANY PARTICULAR FONT, STYLE, SIZE, OR COLOR.

FOR OFFICE SUPPLIES, NAMELY, INDEX CARDS, NOTEBOOKS, NOTEPADS, ADHESIVE NOTE PADS, PAPER (U.S. CLS. 2, 5, 22, 23, 29, 37, 38 AND 50).

JASON BLAIR, EXAMINING ATTORNEY

CLASS 16—(Continued).

SN 85-512,433. RAYMOND GEDDES AND COMPANY INC, BALTIMORE, MD. FILED 1-10-2012.

Snack Attack

THE MARK CONSISTS OF STANDARD CHARACTERS WITHOUT CLAIM TO ANY PARTICULAR FONT, STYLE, SIZE, OR COLOR.

FOR (BASED ON USE IN COMMERCE) BALL POINT PENS; BALL-POINT PENS; BALLPOINT PENS; BOOKMARKS; DRAWING PENCILS; ERASERS; GEL ROLLER PENS; HIGHLIGHTER PENS; HIGHLIGHTING MARKERS; INK PENS; INK STAMPS; MARKING STAMPS; MECHANICAL PENCIL SHARPENERS; PAPER CLIPS; PENCIL SHARPENERS; PENCILS; PENS; RUBBER ERASERS; WRITING IMPLEMENTS; WRITING IMPLEMENTS; WRITING INSTRUMENTS; WRITING UTENSILS(BASED ON INTENT TO USE) MECHANICAL PENCILS; RETRACTABLE PENCILS; WRITING GRIPS (U.S. CLS. 2, 5, 22, 23, 29, 37, 38 AND 50).

FIRST USE 12-23-2009; IN COMMERCE 7-26-2010.
TEJBIR SINGH, EXAMINING ATTORNEY

SN 85-512,636. WIGSCO LLC, CULVER CITY, CA. FILED 1-10-2012.

WIGS

THE MARK CONSISTS OF STANDARD CHARACTERS WITHOUT CLAIM TO ANY PARTICULAR FONT, STYLE, SIZE, OR COLOR.

FOR BOOKS, MAGAZINES, NEWSLETTERS, INSTRUCTIONAL MANUALS AND PRINTED INSTRUCTIONAL TEACHING MATERIALS, ALL FEATURING SUBJECTS OF GENERAL HUMAN INTEREST; PHOTOGRAPHS; STATIONERY; ADHESIVES FOR STATIONERY OR HOUSEHOLD USES; ARTISTS' MATERIALS, NAMELY, ARTISTS' BRUSHES AND ARTISTS' PASTELS; PAINT BRUSHES; PLASTIC MATERIAL FOR PACKAGING, NAMELY, PLASTIC BAGS; PRINTERS' TYPE; PRINTING BLOCKS; POSTERS; POSTCARDS; NOTE CARDS; DESK TOP ORGANIZERS; DESK SETS; DESK PADS; BLOTTERS; PERSONAL ORGANIZERS; DIARIES; AGENDAS; PENS; PENCILS; PENCIL CASES; PEN CASES; DRAWING RULERS; BOOKMARKS; BOOK PLATES; BOOK COVERS; PAPER STATIONERY PORTFOLIOS; BINDERS; NOTEBOOKS; COLORING BOOKS; NOTE PADS; NON-ELECTRIC ERASERS; NON-ELECTRIC PENCIL SHARPENERS; STENCILS; STATIONERY LETTER AND WRITING PAPER HOLDERS; FILE FOLDERS; RUBBER STAMPS; BLACKBOARDS; PAPER BAGS; PLASTIC BAGS FOR GENERAL USE; WRAPPING PAPER; TRADING CARDS; CHILDREN'S ACTIVITY BOOKS; EDUCATIONAL ACTIVITY BOOKS IN FIELDS OF GENERAL HUMAN INTEREST; COMPOSITION BOOKS; STICKERS; DECALS; PAPER NAPKINS; PAPER TABLECLOTHS; PLACE MATS OF PAPER; CALENDARS; PAPER, INCLUDING WRITING PAPER, ART PAPER, CONSTRUCTION PAPER; ART AND CRAFTS PAINT KITS; ART PRINTS; COLOR PRINTS; LITHOGRAPHIC PRINTS; PHOTOGRAPHIC PRINTS; COMIC STRIPS; PAPER PARTY FAVORS; PAPER PARTY DECORATIONS; PAPER PARTY BAGS; MAPS (U.S. CLS. 2, 5, 22, 23, 29, 37, 38 AND 50).

TARAH HARDY, EXAMINING ATTORNEY

CLASS 16—(Continued).

SN 85-512,657. VIACOM INTERNATIONAL INC., NEW YORK, NY. FILED 1-10-2012.

POWER OF 12

THE MARK CONSISTS OF STANDARD CHARACTERS WITHOUT CLAIM TO ANY PARTICULAR FONT, STYLE, SIZE, OR COLOR.

FOR POSTERS AND INFORMATIONAL PAMPHLETS AND BROCHURES DISTRIBUTED PERIODICALLY ON ELECTION AND POLITICAL ISSUES (U.S. CLS. 2, 5, 22, 23, 29, 37, 38 AND 50).

DAVID C. REIHNER, EXAMINING ATTORNEY

CLASS 16—(Continued).

SN 85-512,917. AMERICAN ACADEMY OF PEDIATRICS, ELK GROVE VILLAGE, IL. FILED 1-10-2012.

NRP

THE MARK CONSISTS OF STANDARD CHARACTERS WITHOUT CLAIM TO ANY PARTICULAR FONT, STYLE, SIZE, OR COLOR.

FOR PRINTED PUBLICATIONS, NAMELY INSTRUCTIONAL MATERIALS IN THE FIELD OF NEONATAL RESUSCITATION (U.S. CLS. 2, 5, 22, 23, 29, 37, 38 AND 50).

FIRST USE 12-31-1987; IN COMMERCE 12-31-1987.
KAREN K. BUSH, EXAMINING ATTORNEY

SN 85-512,708. JBP BUSINESS, LLC, PALM BEACH, FL. FILED 1-10-2012.

WOMEN'S MURDER CLUB

THE MARK CONSISTS OF STANDARD CHARACTERS WITHOUT CLAIM TO ANY PARTICULAR FONT, STYLE, SIZE, OR COLOR.

FOR NOVELS; SERIES OF FICTION WORKS, NAMELY, NOVELS AND BOOKS (U.S. CLS. 2, 5, 22, 23, 29, 37, 38 AND 50).

FIRST USE 3-5-2001; IN COMMERCE 3-5-2001.
STEVEN JACKSON, EXAMINING ATTORNEY

SN 85-513,133. MOORECO, INC., TEMPLE, TX. FILED 1-10-2012.

VISIONARY

THE MARK CONSISTS OF STANDARD CHARACTERS WITHOUT CLAIM TO ANY PARTICULAR FONT, STYLE, SIZE, OR COLOR.

FOR DRY ERASE WRITING BOARDS AND WRITING SURFACES; MAGNETIC BOARDS (U.S. CLS. 2, 5, 22, 23, 29, 37, 38 AND 50).

FIRST USE 8-31-2011; IN COMMERCE 8-31-2011.
TASHIA BUNCH, EXAMINING ATTORNEY

SN 85-512,717. JBP BUSINESS, LLC, PALM BEACH, FL. FILED 1-10-2012.

MAXIMUM RIDE

THE MARK CONSISTS OF STANDARD CHARACTERS WITHOUT CLAIM TO ANY PARTICULAR FONT, STYLE, SIZE, OR COLOR.

FOR NOVELS; SERIES OF FICTION WORKS, NAMELY, NOVELS AND BOOKS (U.S. CLS. 2, 5, 22, 23, 29, 37, 38 AND 50).

FIRST USE 4-1-2005; IN COMMERCE 4-1-2005.
STEVEN JACKSON, EXAMINING ATTORNEY

SN 85-513,161. MCKITTRICK, LAURA, GREENWICH, CT. FILED 1-10-2012.

GREENWICH GIRL

THE MARK CONSISTS OF STANDARD CHARACTERS WITHOUT CLAIM TO ANY PARTICULAR FONT, STYLE, SIZE, OR COLOR.

NO CLAIM IS MADE TO THE EXCLUSIVE RIGHT TO USE "GREENWICH", APART FROM THE MARK AS SHOWN.

FOR SERIES OF FICTION BOOKS (U.S. CLS. 2, 5, 22, 23, 29, 37, 38 AND 50).
RONALD AIKENS, EXAMINING ATTORNEY

CLASS 16—(Continued).

SN 85-513,566. TOYBRIDGE, INC., MONSEY, NY. FILED 1-11-2012.

MARVELAT

THE MARK CONSISTS OF STANDARD CHARACTERS WITHOUT CLAIM TO ANY PARTICULAR FONT, STYLE, SIZE, OR COLOR.

FOR FOAM ART KITS, CONSISTING OF FOAM STICKERS, CARDBOARD BACKGROUND, FOAM FRAME AND BACK (U.S. CLS. 2, 5, 22, 23, 29, 37, 38 AND 50).

JULIE WATSON, EXAMINING ATTORNEY

SN 85-513,567. PAN AMERICAN WORLD AIRWAYS, INC., DOVER, NH. FILED 1-11-2012.



OWNER OF U.S. REG. NOS. 3,171,135, 3,804,943 AND OTHERS.

THE MARK CONSISTS OF A GLOBE WITH THE WORDS "PAN AM" ACROSS IT.

FOR CALENDARS; POSTERS; PRINTED ART REPRODUCTIONS; WALL CALENDARS (U.S. CLS. 2, 5, 22, 23, 29, 37, 38 AND 50).

MARILYN IZZI, EXAMINING ATTORNEY

SN 85-513,713. THERM O WEB, INC., WHEELING, IL. FILED 1-11-2012.

ICRAFT

THE MARK CONSISTS OF STANDARD CHARACTERS WITHOUT CLAIM TO ANY PARTICULAR FONT, STYLE, SIZE, OR COLOR.

FOR ADHESIVES FOR PAPER, FABRIC AND OTHER HOUSEHOLD PURPOSES (U.S. CLS. 2, 5, 22, 23, 29, 37, 38 AND 50).

KATHRYN COWARD, EXAMINING ATTORNEY

CLASS 16—(Continued).

SN 85-513,773. SKRYPEK, THEODORE, WESTWOOD, MA. FILED 1-11-2012.

UPPER CLASS AMERICAN

THE MARK CONSISTS OF STANDARD CHARACTERS WITHOUT CLAIM TO ANY PARTICULAR FONT, STYLE, SIZE, OR COLOR.

FOR NEWSLETTERS IN THE FIELD OF PERSONAL AND GENERAL BUSINESS PLANNING, DEVELOPMENT, AND SUCCESS (U.S. CLS. 2, 5, 22, 23, 29, 37, 38 AND 50).

RONALD DELGIZZI, EXAMINING ATTORNEY

SN 85-514,032. DIMENSIONS CRAFTS LLC, WYOMISSING, PA. FILED 1-11-2012.

DIMENSIONS

THE MARK CONSISTS OF STANDARD CHARACTERS WITHOUT CLAIM TO ANY PARTICULAR FONT, STYLE, SIZE, OR COLOR.

OWNER OF U.S. REG. NO. 1,214,121.

FOR ARTS AND CRAFT PAINT KITS; BOOKLETS IN THE FIELD OF NEEDLECRAFT AND ARTS AND CRAFTS (U.S. CLS. 2, 5, 22, 23, 29, 37, 38 AND 50).

FIRST USE 6-1-1998; IN COMMERCE 6-1-1998.

NAAKWAMA ANKRAH, EXAMINING ATTORNEY

SN 85-514,051. HIXSON-BURRIS PUBLISHING, LLC, LUBBOCK, TX. FILED 1-11-2012.

ProDentist

THE MARK CONSISTS OF STANDARD CHARACTERS WITHOUT CLAIM TO ANY PARTICULAR FONT, STYLE, SIZE, OR COLOR.

FOR MAGAZINES AND NEWSLETTERS IN THE FIELD OF DENTISTRY (U.S. CLS. 2, 5, 22, 23, 29, 37, 38 AND 50).

DEBORAH LOBO, EXAMINING ATTORNEY

CLASS 16—(Continued).

SN 85-514,307. CPP INTERNATIONAL, LLC, DBA CAROLINA PAD, CHARLOTTE, NC. FILED 1-11-2012.

VIEW-IT

THE MARK CONSISTS OF STANDARD CHARACTERS WITHOUT CLAIM TO ANY PARTICULAR FONT, STYLE, SIZE, OR COLOR.

FOR BINDERS; BINDERS FOR OFFICE USE; BLANK PAPER NOTEBOOKS; COMPOSITION BOOKS; FOLDERS; LOOSE LEAF BINDERS; NOTEBOOKS; OFFICE BINDERS; PAPER FOLDERS; PAPER NOTEBOOKS; POUCHES FOR WRITING INSTRUMENTS; PRESENTATION FOLDERS; THREE-RING BINDERS (U.S. CLS. 2, 5, 22, 23, 29, 37, 38 AND 50).

FIRST USE 12-22-2011; IN COMMERCE 12-22-2011.
ODESSA BIBBINS, EXAMINING ATTORNEY

SN 85-514,357. CPP INTERNATIONAL, LLC, DBA CAROLINA PAD, CHARLOTTE, NC. FILED 1-11-2012.

ZIP-IT

THE MARK CONSISTS OF STANDARD CHARACTERS WITHOUT CLAIM TO ANY PARTICULAR FONT, STYLE, SIZE, OR COLOR.

FOR BINDERS; BINDERS FOR OFFICE USE; BLANK PAPER NOTEBOOKS; COMPOSITION BOOKS; FILE FOLDERS; FOLDERS; LOOSE LEAF BINDERS; NOTEBOOKS; OFFICE BINDERS; PAPER EXPANDING FILES; PAPER FOLDERS; PAPER NOTEBOOKS; POUCHES FOR WRITING INSTRUMENTS; PRESENTATION FOLDERS; SPIRAL-BOUND NOTEBOOKS; THREE-RING BINDERS; WIRE-BOUND NOTEBOOKS (U.S. CLS. 2, 5, 22, 23, 29, 37, 38 AND 50).

FIRST USE 12-21-2011; IN COMMERCE 12-21-2011.
ODESSA BIBBINS, EXAMINING ATTORNEY

SN 85-515,038. BRIEFINGS MEDIA GROUP, LLC, CHANTILLY, VA. FILED 1-12-2012.

APC

THE MARK CONSISTS OF STANDARD CHARACTERS WITHOUT CLAIM TO ANY PARTICULAR FONT, STYLE, SIZE, OR COLOR.

FOR MONTHLY PUBLICATIONS, NAMELY, MAGAZINES DEVOTED TO THE INTEREST OF THE PAINTING CONTRACTOR (U.S. CLS. 2, 5, 22, 23, 29, 37, 38 AND 50).

ALLISON HOLTZ, EXAMINING ATTORNEY

CLASS 16—(Continued).

SN 85-515,228. MARCAL PAPER MILLS, LLC, ELMWOOD PARK, NJ. FILED 1-12-2012.



OWNER OF U.S. REG. NOS. 573,133, 949,162 AND OTHERS.

THE COLOR(S) BLUE, BLACK, WHITE, AND RED IS/ARE CLAIMED AS A FEATURE OF THE MARK.

THE MARK CONSISTS OF THE WORD "MARCAL" IN WHITE WITH BLACK, BLUE, AND WHITE SHADOWING FOR DEPTH IN FRONT OF A BLUE BACKGROUND. BENEATH "MARCAL" IS RED AND WHITE STRIPES WITH THE WORD "PRIDE" ON A RED RIBBON IN THE FOREGROUND OF THE STRIPING.

FOR BATHROOM TISSUE; FACIAL TISSUE; PAPER BAGS; PAPER NAPKINS; PAPER TOWELS (U.S. CLS. 2, 5, 22, 23, 29, 37, 38 AND 50).

FIRST USE 11-18-2011; IN COMMERCE 11-18-2011.
WILLIAM BRECKENFELD, EXAMINING ATTORNEY

SN 85-515,334. PRODUCE FOR KIDS INC., REIDSVILLE, GA. FILED 1-12-2012.



THE COLOR(S) YELLOW, RED, AND WHITE IS/ARE CLAIMED AS A FEATURE OF THE MARK.

THE MARK CONSISTS OF A RECTANGLE WITH ROUNDED CORNERS OUTLINED WITH A RED LINE AND FILLED WITH YELLOW THAT GRADUALLY BECOMES LIGHTER TOWARD THE CENTER, AND THE WORD "IDEALMEALS" INSIDE THE RECTANGLE IN RED LETTERS WITH A WHITE OUTLINE, WITH THE LETTER "D" IN THE SHAPE OF A SPOON, THE FIRST LETTER "L" IN THE SHAPE OF A FORK, AND THE SECOND LETTER "L" IN THE SHAPE OF A KNIFE.

FOR PRINTED RECIPE CARDS (U.S. CLS. 2, 5, 22, 23, 29, 37, 38 AND 50).

FIRST USE 5-0-2010; IN COMMERCE 5-0-2010.
HELENE LIWINSKI, EXAMINING ATTORNEY

CLASS 16—(Continued).

SN 85-515,828. THE LIFE IS GOOD COMPANY, BOSTON, MA. FILED 1-13-2012.



OWNER OF U.S. REG. NO. 2,055,452.
THE MARK CONSISTS OF A FANCIFUL HUMAN FACE WITH BERET.

FOR ADHESIVE NOTE PADS; ADHESIVE NOTE PAPER; ANNOUNCEMENT CARDS; BLANK CARDS; BLANK NOTE CARDS; CALENDARS; CARDS BEARING UNIVERSAL GREETINGS; CHRISTMAS CARDS; CORRESPONDENCE CARDS; DAILY PLANNERS; DAY PLANNERS; DECORATIVE PAPER BOWS FOR WRAPPING; DESKTOP PLANNERS; FABRIC GIFT BAGS; GIFT BAGS; GIFT BOXES; GIFT BOXES CONTAINING NOTE CARDS; GIFT BOXES MADE OF CARDBOARD; GIFT WRAP PAPER; GREETING CARDS; GREETINGS CARDS AND POSTCARDS; HOLIDAY CARDS; INVITATION CARDS; METALLIC GIFT WRAP; MOTIVATIONAL CARDS; MUSICAL GREETING CARDS; NOTE BOOKS; NOTE CARDS; NOTE PAD HOLDERS; NOTE PADS; NOTE PAPER; NOTE PAPERS; NOTEBOOKS; NOVELTY IDENTIFICATION CARDS; OCCASION CARDS; ORGANIZERS FOR STATIONERY USE; PAPER BOWS FOR GIFT WRAP; PAPER FOR WRAPPING AND PACKAGING; PAPER GIFT BAGS; PAPER GIFT CARDS; PAPER GIFT TAGS; PAPER GIFT WRAP; PAPER GIFT WRAP BOWS; PAPER GIFT WRAPPING RIBBONS; PAPER NOTE TABLETS; PAPER SHEETS FOR NOTE TAKING; PERSONAL ORGANIZERS; PLASTIC GIFT WRAP; POST CARDS; POSTCARDS AND GREETING CARDS; SOCIAL NOTE CARDS; STATIONERY; STICKERS; WRAPPING PAPER (U.S. CLS. 2, 5, 22, 23, 29, 37, 38 AND 50).

WILLIAM JACKSON, EXAMINING ATTORNEY

SN 85-515,871. MATHNASIUM, LLC, LOS ANGELES, CA. FILED 1-13-2012.

TriMathlon

THE MARK CONSISTS OF STANDARD CHARACTERS WITHOUT CLAIM TO ANY PARTICULAR FONT, STYLE, SIZE, OR COLOR.

FOR PRINTED MATTER, NAMELY, PAMPHLETS, BROCHURES, MANUALS, BOOKLETS, LEAFLETS, FLYERS, INFORMATIONAL SHEETS, NEWSLETTERS, CURRICULUM, STATIONERY WRITING PAPER AND ENVELOPES, PLASTIC OR PAPER BAGS FOR MERCHANDISE PACKAGING, AWARD CERTIFICATES AND ADHESIVE BACKED STICKERS IN THE FIELD OF MATHEMATICS (U.S. CLS. 2, 5, 22, 23, 29, 37, 38 AND 50).

FIRST USE 1-1-2011; IN COMMERCE 1-1-2011.
DEBORAH LOBO, EXAMINING ATTORNEY

CLASS 16—(Continued).

SN 85-515,880. SPC RESOURCES, INC., HARTSVILLE, SC. FILED 1-13-2012.

VERTEX

THE MARK CONSISTS OF STANDARD CHARACTERS WITHOUT CLAIM TO ANY PARTICULAR FONT, STYLE, SIZE, OR COLOR.

FOR PAPERBOARD LAMINATED OR COATED WITH FOIL OR METALLIZED FILM (U.S. CLS. 2, 5, 22, 23, 29, 37, 38 AND 50).

FIRST USE 10-18-2011; IN COMMERCE 10-18-2011.
JAMES LOVELACE, EXAMINING ATTORNEY

SN 85-516,328. LAKEWOOD CHURCH, HOUSTON, TX. FILED 1-13-2012.

Today's Word

THE MARK CONSISTS OF STANDARD CHARACTERS WITHOUT CLAIM TO ANY PARTICULAR FONT, STYLE, SIZE, OR COLOR.

NO CLAIM IS MADE TO THE EXCLUSIVE RIGHT TO USE "WORD", APART FROM THE MARK AS SHOWN.

FOR EDUCATIONAL PUBLICATIONS, NAMELY, BOOKS, MAGAZINES, PAMPHLETS, NEWSLETTERS IN THE FIELDS OF RELIGIOUS TOPICS (U.S. CLS. 2, 5, 22, 23, 29, 37, 38 AND 50).

FIRST USE 12-1-2006; IN COMMERCE 12-1-2006.
TASNEEM HUSSAIN, EXAMINING ATTORNEY

SN 85-521,067. WESTERN RETAIL SERVICE CORPORATION, ROSEVILLE, CA. FILED 1-20-2012.

Retailer NOW

THE MARK CONSISTS OF STANDARD CHARACTERS WITHOUT CLAIM TO ANY PARTICULAR FONT, STYLE, SIZE, OR COLOR.

NO CLAIM IS MADE TO THE EXCLUSIVE RIGHT TO USE "RETAILER", APART FROM THE MARK AS SHOWN. FOR MAGAZINES IN THE FIELD OF HOME FURNISHINGS RETAILING (U.S. CLS. 2, 5, 22, 23, 29, 37, 38 AND 50).

WENDY JUN, EXAMINING ATTORNEY

CLASS 16—(Continued).

SN 85-523,159. GLAXO GROUP LIMITED, GREENFORD, MIDDLESEX, UNITED KINGDOM, FILED 1-23-2012.



Respiratory Care Connection

NO CLAIM IS MADE TO THE EXCLUSIVE RIGHT TO USE "RESPIRATORY CARE", APART FROM THE MARK AS SHOWN.

THE MARK CONSISTS OF THE WORDS "RESPIRATORY CARE" AND UNDERNEATH OF THESE WORDS IS THE WORD "CONNECTION". TO THE LEFT OF THE WORDS "RESPIRATORY CARE CONNECTION" IS A CIRCLE WITH TWO CURVED TRIANGLES WITH BRANCH-LIKE FIGURES IN THE MIDDLE FORMING AN IMAGE OF TWO LUNGS.

FOR PRINTED MATERIALS, NAMELY, BROCHURES, PAMPHLETS, LEAFLETS AND BOOKLETS FEATURING HEALTH INFORMATION ABOUT RESPIRATORY DISEASE (U.S. CLS. 2, 5, 22, 23, 29, 37, 38 AND 50).

ELISSA GARBER KON, EXAMINING ATTORNEY

CLASS 16—(Continued).

SN 85-535,864. AGC, LLC, CLEVELAND, OH. FILED 2-7-2012.



NO CLAIM IS MADE TO THE EXCLUSIVE RIGHT TO USE "CARTOON", APART FROM THE MARK AS SHOWN.

THE MARK CONSISTS OF THE WORDS "CARTOON FACTORY" IN A CLOUD OF SMOKE EMANATING FROM TWO CHIMNEYS CONNECTED TO A FACTORY BUILDING RESEMBLING A CARTOON CHARACTER WITH HUMAN FACIAL FEATURES AND SMALL SHRUBBERY ON EACH SIDE OF THE BUILDING.

FOR GREETING CARDS (U.S. CLS. 2, 5, 22, 23, 29, 37, 38 AND 50).

DAVID YONTEF, EXAMINING ATTORNEY

SN 85-525,569. VANGALIS, ANGELA J. COPPELL, TX. FILED S.R. 1-26-2012; AM. P.R. 1-26-2012.

It's only the beginning

THE MARK CONSISTS OF STANDARD CHARACTERS WITHOUT CLAIM TO ANY PARTICULAR FONT, STYLE, SIZE, OR COLOR.

FOR DRAWING TEMPLATES AND ACCESSORIES FOR CREATIVE DRAWING AND ART THERAPY, NAMELY, RUBBER STAMPS, DIGITAL STAMPS, INK PADS, ACRYLIC BLOCKS AND NEWSLETTERS FEATURING ART, TIPS ON DRAWING, AND INFORMATION ON TRAINING CLASSES (U.S. CLS. 2, 5, 22, 23, 29, 37, 38 AND 50).

FIRST USE 1-7-2012; IN COMMERCE 1-7-2012. JENNY PARK, EXAMINING ATTORNEY

SN 85-538,682. AGC, LLC, CLEVELAND, OH. FILED 2-9-2012.



OWNER OF U.S. REG. NO. 3,945,166. NO CLAIM IS MADE TO THE EXCLUSIVE RIGHT TO USE "PREMIER", APART FROM THE MARK AS SHOWN.

THE MARK CONSISTS OF THE WORDS "TODAY AND ALWAYS" AND "PREMIER" ALL SHOWN IN STYLIZED FONT AND A HEART DESIGN IN-BETWEEN A BROKEN HORIZONTAL LINE.

FOR GREETING CARDS (U.S. CLS. 2, 5, 22, 23, 29, 37, 38 AND 50).

DAVID YONTEF, EXAMINING ATTORNEY

CLASS 16—(Continued).

SN 85-542,500. AGC, LLC, CLEVELAND, OH. FILED 2-14-2012.



OWNER OF U.S. REG. NO. 3,009,356.
 NO CLAIM IS MADE TO THE EXCLUSIVE RIGHT TO USE "MESSAGE", APART FROM THE MARK AS SHOWN.
 THE MARK CONSISTS OF THE WORDS "MESSAGE" AND "MAKERS" IN STYLIZED FONT WITHIN TWO CONNECTED SPEECH CLOUD DESIGNS.
 FOR GREETING CARDS (U.S. CLS. 2, 5, 22, 23, 29, 37, 38 AND 50).
 DAVID YONTEF, EXAMINING ATTORNEY

SN 85-542,541. AGC, LLC, CLEVELAND, OH. FILED 2-14-2012.



THE MARK CONSISTS OF THE WORDS "YOU'VE GOT GAME" IN STYLIZED FONT AND A CIRCLE AROUND THE WORD "GOT" WITH THREE LINES EMANATING THEREFROM.
 FOR GREETING CARDS (U.S. CLS. 2, 5, 22, 23, 29, 37, 38 AND 50).
 DAVID YONTEF, EXAMINING ATTORNEY

CLASS 16—(Continued).

SN 85-546,454. AGC, LLC, CLEVELAND, OH. FILED 2-17-2012.

YOU WANT FUNNY WITH THAT

THE MARK CONSISTS OF STANDARD CHARACTERS WITHOUT CLAIM TO ANY PARTICULAR FONT, STYLE, SIZE, OR COLOR.
 FOR GREETING CARDS (U.S. CLS. 2, 5, 22, 23, 29, 37, 38 AND 50).
 DAVID YONTEF, EXAMINING ATTORNEY

SN 85-571,654. AGC, LLC, CLEVELAND, OH. FILED 3-16-2012.



OWNER OF U.S. REG. NOS. 773,675, 1,243,365 AND OTHERS.
 NO CLAIM IS MADE TO THE EXCLUSIVE RIGHT TO USE "GREETINGS" AND "PREMIER", APART FROM THE MARK AS SHOWN.
 THE MARK CONSISTS OF THE WORDS "AMERICAN GREETINGS" AND "PREMIER" ALL SHOWN IN STYLIZED FONT AND A ROSE DESIGN
 FOR GREETING CARDS (U.S. CLS. 2, 5, 22, 23, 29, 37, 38 AND 50).
 DAVID YONTEF, EXAMINING ATTORNEY

SN 85-589,442. DMB MESA PROVING GROUNDS LLC, SCOTTSDALE, AZ. FILED 4-4-2012.



THE MARK CONSISTS OF THE WORD "EASTMARK" BELOW A DESIGN OF A SQUARE BORDERED ON EACH SIDE BY A TRIANGLE.
 FOR PAPER; STATIONERY; PRINTED INVITATIONS AND ANNOUNCEMENTS; PENCILS; PENS; PRINTED PUBLICATIONS, NAMELY, LIFESTYLE AND REAL ESTATE MAGAZINES AND NEWSLETTERS, INSTRUCTIONAL, TEACHING AND ENTERTAINMENT MATERIAL, GUIDES, CATALOGUES AND BROCHURES, ALL IN THE FIELD OF LIFESTYLE AND REAL ESTATE (U.S. CLS. 2, 5, 22, 23, 29, 37, 38 AND 50).
 APRIL HESIK, EXAMINING ATTORNEY

CLASS 17—RUBBER GOODS

SN 79-095,903. SEKISUI KAGAKU KOGYO KABUSHIKI KAISHA (DOING BUSINESS AS SEKISUI CHEMICAL CO., LTD.), JAPAN, FILED 9-24-2010.

SEKISUI

OWNER OF INTERNATIONAL REGISTRATION 1073401 DATED 9-24-2010, EXPIRES 9-24-2020.

OWNER OF U.S. REG. NOS. 1,441,669, 2,422,458 AND 3,572,787.

FOR CARBON FIBERS, OTHER THAN FOR TEXTILE USE; PLASTIC FIBERS FOR USE IN THE MANUFACTURE OF PIPES, NOT FOR USE IN TEXTILES; SEMI-PROCESSED PLASTIC IN THE FORM OF FILMS, SHEETS, TUBES, BARS, OR RODS; PLASTIC FILM FOR COMMERCIAL AND INDUSTRIAL USE; ANTI-DAZZLE FILMS FOR WINDOWS; SEMI-PROCESSED FOAMS AND FILMS OF PLASTIC; FOIL OF REGENERATED CELLULOSE, OTHER THAN FOR PACKING; FOILS OF METAL FOR BUILDING INSULATION; INSULATING TAPE FOR USE ON PIPES AND OTHER AIR CONDITIONING, REFRIGERATION, HEATING, AND VENTILATION EQUIPMENT; PLASTIC PIPE JACKETS, NOT OF METAL FOR USE WITH WATER PIPES AND SEWAGE PIPES; PLASTIC PIPE MUFFS, NOT OF METAL, FOR USE WITH WATER PIPES AND SEWAGE PIPES; JOINT PACKINGS FOR WATER PIPES AND SEWAGE PIPES; PLASTIC SHEETING FOR AGRICULTURAL PURPOSES; PLASTIC SHEETS FOR GENERAL INDUSTRIAL USE (U.S. CLS. 1, 5, 12, 13, 35 AND 50).

CHRISTOPHER BUONGIORNO, EXAMINING ATTORNEY



SN 85-354,004. PERMA-PIPE, INC., NILES, IL. FILED 6-23-2011.

CRYO-GARD

THE MARK CONSISTS OF STANDARD CHARACTERS WITHOUT CLAIM TO ANY PARTICULAR FONT, STYLE, SIZE, OR COLOR.

OWNER OF U.S. REG. NOS. 871,600, 900,031 AND 3,405,832.

FOR NON-METALLIC INSULATED PIPES, PIPE FITTINGS, COUPLINGS, AND JOINTS (U.S. CLS. 1, 5, 12, 13, 35 AND 50).

KAPIL BHANOT, EXAMINING ATTORNEY

CLASS 17—(Continued).

SN 85-354,045. FLINT TRADING, INC., THOMASVILLE, NC. FILED 6-23-2011.

TRAFFICSCAPES

THE MARK CONSISTS OF STANDARD CHARACTERS WITHOUT CLAIM TO ANY PARTICULAR FONT, STYLE, SIZE, OR COLOR.

FOR PREFORMED THERMOPLASTIC SHEETS FOR USE AS PAVEMENT MARKINGS (U.S. CLS. 1, 5, 12, 13, 35 AND 50).

HENRY S. ZAK, EXAMINING ATTORNEY



SN 85-354,057. FLINT TRADING, INC., THOMASVILLE, NC. FILED 6-23-2011.

TRAFFICPATTERNSXD

THE MARK CONSISTS OF STANDARD CHARACTERS WITHOUT CLAIM TO ANY PARTICULAR FONT, STYLE, SIZE, OR COLOR.

OWNER OF U.S. REG. NO. 3,761,909.

FOR PREFORMED THERMOPLASTIC SHEETS FOR USE AS PAVEMENT MARKINGS (U.S. CLS. 1, 5, 12, 13, 35 AND 50).

HENRY S. ZAK, EXAMINING ATTORNEY



SN 85-354,068. FLINT TRADING, INC., THOMASVILLE, NC. FILED 6-23-2011.

TRAFFICPATTERNSLT

THE MARK CONSISTS OF STANDARD CHARACTERS WITHOUT CLAIM TO ANY PARTICULAR FONT, STYLE, SIZE, OR COLOR.

OWNER OF U.S. REG. NO. 3,761,909.

FOR PREFORMED THERMOPLASTIC SHEETS FOR USE AS PAVEMENT MARKINGS (U.S. CLS. 1, 5, 12, 13, 35 AND 50).

HENRY S. ZAK, EXAMINING ATTORNEY

CLASS 17—(Continued).

SN 85-365,119. TBL THERMOPLASTIC BIOLOGIC, SPARTA, NJ. FILED 7-7-2011.

DAIRYFLOW

THE MARK CONSISTS OF STANDARD CHARACTERS WITHOUT CLAIM TO ANY PARTICULAR FONT, STYLE, SIZE, OR COLOR.

FOR PLASTIC TUBING FOR THE TRANSPORT OF MILK (U.S. CLS. 1, 5, 12, 13, 35 AND 50).

FIRST USE 4-11-2011; IN COMMERCE 4-11-2011.
FRANK LATTUCA, EXAMINING ATTORNEY

SN 85-386,248. STAR THERMOPLASTICS ALLOYS AND RUBBERS, INC., BROADVIEW, IL. FILED 8-1-2011.

STARBOND

THE MARK CONSISTS OF STANDARD CHARACTERS WITHOUT CLAIM TO ANY PARTICULAR FONT, STYLE, SIZE, OR COLOR.

FOR THERMOPLASTIC ELASTOMERS IN PELLET FORM USED IN THE INJECTION MOLDING AND EXTRUSION APPLICATIONS (U.S. CLS. 1, 5, 12, 13, 35 AND 50).

NATALIE POLZER, EXAMINING ATTORNEY

SN 85-394,315. KONICA MINOLTA HOLDINGS, INC., TOKYO, JAPAN, FILED 8-10-2011.

FLEXENT

THE MARK CONSISTS OF STANDARD CHARACTERS WITHOUT CLAIM TO ANY PARTICULAR FONT, STYLE, SIZE, OR COLOR.

FOR INSULATING MATERIALS; PLASTIC FILM OTHER THAN FOR WRAPPING, NAMELY, PLASTIC FILM COATED WITH A TRANSPARENT CONDUCTIVE COATING FOR COMMERCIAL AND INDUSTRIAL USE, USE IN THE MANUFACTURE OF SOLAR BATTERIES OR USE IN THE MANUFACTURE OF DISPLAYS, PLASTIC FILM CONTAINING ANTIREFLECTIVE AGENTS FOR COMMERCIAL AND INDUSTRIAL USE, USE IN THE MANUFACTURE OF SOLAR BATTERIES OR USE IN THE MANUFACTURE OF DISPLAYS (U.S. CLS. 1, 5, 12, 13, 35 AND 50).

LINDA ORNDORFF, EXAMINING ATTORNEY

CLASS 17—(Continued).

SN 85-435,544. WADSWORTH, ROBERT L., LOWELL, IN. FILED 9-29-2011.



NO CLAIM IS MADE TO THE EXCLUSIVE RIGHT TO USE "PEARL", APART FROM THE MARK AS SHOWN.

THE COLOR(S) GREY, BLUE, BLACK, YELLOW, PINK, AND WHITE IS/ARE CLAIMED AS A FEATURE OF THE MARK.

THE MARK CONSISTS OF THE WORDS "ASTRO" AND "PEARL" APPEARING IN GREY OVER THE IMAGE OF AN BLUE, YELLOW, PINK AND BLACK OYSTER CONTAINING A WHITE PEARL WITH THE WORDS "THE GEM OF REFLECTIVE INSULATION" APPEARING IN BLACK BENEATH THE OYSTER.

FOR LAMINATED VAPOR BARRIER (U.S. CLS. 1, 5, 12, 13, 35 AND 50).

FIRST USE 9-26-2011; IN COMMERCE 9-26-2011.
CHRISTINE MARTIN, EXAMINING ATTORNEY

SN 85-507,925. PROTECTO WRAP COMPANY, DENVER, CO. FILED 1-3-2012.

Audiopad

THE MARK CONSISTS OF STANDARD CHARACTERS WITHOUT CLAIM TO ANY PARTICULAR FONT, STYLE, SIZE, OR COLOR.

FOR ACOUSTIC AND THERMAL INSULATION FOR USE IN THE AUTOMOTIVE, HVAC, APPLIANCE AND COMMERCIAL INTERIOR INDUSTRIES (U.S. CLS. 1, 5, 12, 13, 35 AND 50).

DAVID H. STINE, EXAMINING ATTORNEY

SN 85-509,845. HOWELL, EDWARD B., SISTERSVILLE, WV. FILED 1-5-2012.

critter patch

THE MARK CONSISTS OF STANDARD CHARACTERS WITHOUT CLAIM TO ANY PARTICULAR FONT, STYLE, SIZE, OR COLOR.

NO CLAIM IS MADE TO THE EXCLUSIVE RIGHT TO USE "PATCH", APART FROM THE MARK AS SHOWN.

FOR PLASTIC FLEXIBLE TUBING FITTING FOR USE IN MAPLE SYRUP PRODUCTION COMPRISING A PLASTIC PATCH AFFIXED WITH WIRE TIES (U.S. CLS. 1, 5, 12, 13, 35 AND 50).

GENE MACIOL, EXAMINING ATTORNEY

CLASS 17—(Continued).

SN 85-510,183. INSULATION SOLUTIONS, INC., EAST PEORIA, IL. FILED 1-6-2012.

REDI-FOAM

THE MARK CONSISTS OF STANDARD CHARACTERS WITHOUT CLAIM TO ANY PARTICULAR FONT, STYLE, SIZE, OR COLOR.

OWNER OF U.S. REG. NO. 3,777,072.
FOR SPRAY FOAM FOR BUILDING INSULATION; FOAM SHEETING FOR USE AS A BUILDING INSULATION (U.S. CLS. 1, 5, 12, 13, 35 AND 50).
ALEX KEAM, EXAMINING ATTORNEY

SN 85-511,530. POLYON BARKAI INDUSTRIES (1993) LTD., KIBUTZ BARKAI, ISRAEL, FILED 1-9-2012.

POLYNUM

THE MARK CONSISTS OF STANDARD CHARACTERS WITHOUT CLAIM TO ANY PARTICULAR FONT, STYLE, SIZE, OR COLOR.

FOR REFLECTIVE INSULATION FOR BUILDINGS; THERMAL INSULATION FOR BUILDINGS; ACOUSTIC INSULATION FOR BUILDINGS; MOISTURE INSULATION FOR BUILDINGS; INSULATING MATERIALS; PACKING AND INSULATING MATERIALS (U.S. CLS. 1, 5, 12, 13, 35 AND 50).
JULIE GUTTADAURO, EXAMINING ATTORNEY

SN 85-512,249. SHERRILL, DAN, LEWISVILLE, TX. FILED 1-9-2012.

FreezePro

THE MARK CONSISTS OF STANDARD CHARACTERS WITHOUT CLAIM TO ANY PARTICULAR FONT, STYLE, SIZE, OR COLOR.

FOR THERMAL INSULATION COVERS FOR STORAGE OR TRANSPORTATION OF GOODS, NAMELY, THERMAL INSULATING BLANKETS, THERMAL INSULATING JACKETS, THERMAL INSULATING TEXTILE COVERS, THERMAL INSULATING PALLET COVERS (U.S. CLS. 1, 5, 12, 13, 35 AND 50).
FIRST USE 8-12-2011; IN COMMERCE 8-12-2011.
BRENDAN REGAN, EXAMINING ATTORNEY

CLASS 17—(Continued).

SN 85-514,297. INHON INTERNATIONAL CO. LTD., TAIPEI CITY, TAIWAN, FILED 1-11-2012.

Inhon

THE MARK CONSISTS OF STANDARD CHARACTERS WITHOUT CLAIM TO ANY PARTICULAR FONT, STYLE, SIZE, OR COLOR.

FOR SEMI-PROCESSED ARTIFICIAL RESINS; SEMI-PROCESSED SYNTHETIC RESINS; CARBON FIBERS NOT FOR TEXTILE USE; SEMI-PROCESSED PLASTIC SUBSTANCES; PLASTIC FIBERS NOT FOR TEXTILE USE; FIBERGLASS FOR INSULATION (U.S. CLS. 1, 5, 12, 13, 35 AND 50).
TOBY BULLOFF, EXAMINING ATTORNEY

CLASS 18—LEATHER GOODS

SN 77-636,719. JAMES AND CATHY HOLDINGS CORP., OAKVILLE, ONTARIO, CANADA, FILED 12-19-2008.

HOCKOOL

THE MARK CONSISTS OF STANDARD CHARACTERS WITHOUT CLAIM TO ANY PARTICULAR FONT, STYLE, SIZE, OR COLOR.

PRIORITY CLAIMED UNDER SEC. 44(D) ON CANADA APPLICATION NO. 1401580, FILED 6-19-2008, REG. NO. TMA795,692, DATED 4-15-2011, EXPIRES 4-15-2026.
FOR ALL-PURPOSE SPORT BAGS AND ALL-PURPOSE ATHLETIC BAGS (U.S. CLS. 1, 2, 3, 22 AND 41).
ESTHER BELENKER, EXAMINING ATTORNEY

CLASS 18—(Continued).

SN 85-244,266. JOIN EQUAL CO., LTD., NEW TAIPEI CITY 22151, TAIWAN, FILED 2-16-2011.



THE NAME(S), PORTRAIT(S), AND/OR SIGNATURE(S) SHOWN IN THE MARK DOES NOT IDENTIFY A PARTICULAR LIVING INDIVIDUAL.

THE MARK CONSISTS OF A CENTRAL CIRCLE DESIGN UPON WHICH APPEARS A CHINESE CHARACTER, WITH THE AFOREMENTIONED SURROUNDED BY A CIRCLE BORDER; THE WORDING "LIAN LI" APPEARS ON A UNDERNEATH THE CIRCLE DESIGN, UPON A RECTANGULAR BACKGROUND DESIGN HAVING ROUNDED CORNERS.

THE ENGLISH TRANSLATION OF "LI" IN THE MARK IS STRENGTH AND THE ENGLISH TRANSLATION OF THE WORD "LIAN" IN THE MARK IS UNITED.

THE NON-LATIN CHARACTERS IN THE MARK TRANSLITERATE TO "LI" AND THIS MEANS "STRENGTH" IN ENGLISH.

FOR NOTECASES, NAMELY, BRIEFCASES; PURSES; WALLETS; CHAIN MESH PURSES; BACKPACKS; SCHOOLBAGS; WAIST BAGS; LEATHER SUITCASES; SHOE BAGS FOR TRAVEL; SUITCASES; TRAVELLING CASES; TRAVEL GARMENT BAGS; HANDHELD TRAVELLING CASES; HANDBAGS; SHOPPING BAGS, NAMELY, REUSABLE SHOPPING BAGS, SHOPPING BAGS MADE OF SKIN; MESH SHOPPING BAGS; BRIEFCASES; TRAVEL BAGS; MOUNTAINEERING BAGS, NAMELY, RUCKSACKS FOR MOUNTAINEERS; CAMPING BAGS, NAMELY, BACKPACKS; KEY WALLETS; COSMETIC BAGS SOLD EMPTY; HAND CASES, NAMELY, VANITY CASES SOLD EMPTY; TRAVELLING BAGS; COSMETIC CASES SOLD EMPTY; PURSE STRAPS; LEATHER STRAPS; SHOPPING BAGS WITH WHEELS; HANDBAG FRAMES; SPORTS BACKPACKS; SPORTS BAGS; BEACH BAGS; DIAPER BAGS; BUSINESS CARD WALLETS; CREDIT CARD WALLETS; PASSPORT WALLETS; ID WALLETS; SUITCASE HANDLES; CANVAS BACKPACKS; TRAVEL LEATHER BAG SETS COMPRISED OF LEATHER TRAVEL BAGS; MUSIC SCORE BAGS, NAMELY, SHOULDER BAGS, SLING BAGS; LEATHER TOOL BAGS SOLD EMPTY; LEATHER HAT CASES IN THE NATURE OF HAT BOXES OF LEATHER; LEATHER BAGS FOR PACKAGING; LEATHER WRAPPERS FOR PACKAGING; LEATHER POUCHES FOR PACKAGING; BAGS FOR PET SUPPLIES, NAMELY, CANVAS, VINYL, AND LEATHER POUCHES FOR HOLDING DISPOSABLE BAGS TO PLACE PET WASTE IN; LEATHER CASES; VULCANIZED FIBER CASES, NAMELY, CARRYING CASES, BUSINESS CASES; HUNTING BAGS; YOGA BACKPACKS; BUSINESS CARD CASES; CANVAS SHOPPING BAGS; AUTOMATIC UMBRELLAS; ANIMAL HIDES, NAMELY, COWHIDE; ARTIFICIAL LEATHER; PET CARRIER BAGS; BABY CARRIER BAGS; LEATHER LUGGAGE TAGS (U.S. CLS. 1, 2, 3, 22 AND 41).

KEVIN CORWIN, EXAMINING ATTORNEY

CLASS 18—(Continued).

SN 85-261,464. HURLEY INTERNATIONAL LLC, COSTA MESA, CA. FILED 3-8-2011.

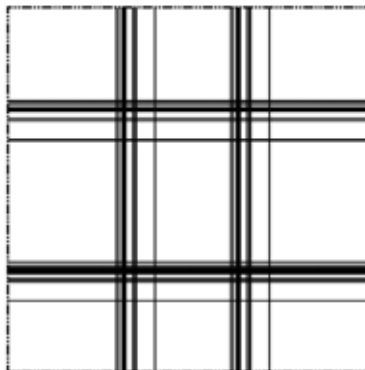

THE MARK CONSISTS OF VERTICAL AND HORIZONTAL LINES, AND SQUARES AND RECTANGLES, FORMING A PLAID PATTERN. THE PLAID PATTERN IS A REPEATING DESIGN APPLIED IN WHOLE OR IN PART ON OR CONNECTION WITH THE GOODS. THE BROKEN LINES IN THE DRAWING SIGNIFY THAT THE MARK IS NOT LIMITED TO POSITION OR PLACEMENT. THE LINING IS A FEATURE OF THE MARK AND IS NOT INTENDED TO INDICATE COLOR.

SEC. 2(F).

FOR BAGS, NAMELY, BACKPACKS, ALL PURPOSE SPORTS BAGS, MESSENGER BAGS, WALLETS, PURSES, AND LUGGAGE (U.S. CLS. 1, 2, 3, 22 AND 41). FIRST USE 4-1-2007; IN COMMERCE 4-1-2007.

TEJBIR SINGH, EXAMINING ATTORNEY

SN 85-337,914. REED KRAKOFF, LLC, NEW YORK, NY. FILED 6-3-2011.

BOXER

THE MARK CONSISTS OF STANDARD CHARACTERS WITHOUT CLAIM TO ANY PARTICULAR FONT, STYLE, SIZE, OR COLOR.

FOR HANDBAGS (U.S. CLS. 1, 2, 3, 22 AND 41).

FIRST USE 9-7-2009; IN COMMERCE 9-7-2009.

STEVEN PEREZ, EXAMINING ATTORNEY

CLASS 18—(Continued).

SN 85-354,072. LAMESHA LUXE, INC., WESTFIELD, IN. FILED 6-23-2011.

MISHA MILES

THE MARK CONSISTS OF STANDARD CHARACTERS WITHOUT CLAIM TO ANY PARTICULAR FONT, STYLE, SIZE, OR COLOR.

THE NAME(S), PORTRAIT(S), AND/OR SIGNATURE(S) SHOWN IN THE MARK DOES NOT IDENTIFY A PARTICULAR LIVING INDIVIDUAL.

FOR LEATHER GOODS, NAMELY, HANDBAGS (U.S. CLS. 1, 2, 3, 22 AND 41).

HENRY S. ZAK, EXAMINING ATTORNEY

SN 85-356,374. HABIGHORST, RITA, PHOENIX, AZ. AND HABIGHORST, VERNON, PHOENIX, AZ. FILED 6-26-2011.

BLUE RIBBON

THE MARK CONSISTS OF STANDARD CHARACTERS WITHOUT CLAIM TO ANY PARTICULAR FONT, STYLE, SIZE, OR COLOR.

OWNER OF U.S. REG. NOS. 2,437,748 AND 2,437,749.

FOR HARNESS FOR HORSES; HORSE TACK, NAMELY, SADDLES, TAIL SETS, BRIDLES, STIRRUP LEATHERS, HALTERS, HALTER LEADS, BITS, GIRTHS, BREAST COLLARS, POMMEL PADS, BIBS, SOAKING SWABS, ANKLE RINGS, HEAD BUMPERS, BELTS AND STRAPS, SPUR STRAPS, CHAPS, AND REINS (U.S. CLS. 1, 2, 3, 22 AND 41).

FIRST USE 6-21-1982; IN COMMERCE 12-19-1983.

JAMES LOVELACE, EXAMINING ATTORNEY

SN 85-356,830. JK SOUTH CO LLC, WYNCOTE, PA. FILED 6-27-2011.

Baseball's Original Seed Sack

THE MARK CONSISTS OF STANDARD CHARACTERS WITHOUT CLAIM TO ANY PARTICULAR FONT, STYLE, SIZE, OR COLOR.

NO CLAIM IS MADE TO THE EXCLUSIVE RIGHT TO USE "ORIGINAL SEED SACK", APART FROM THE MARK AS SHOWN.

FOR SQUEEZE FRAME POUCH MADE OF LEATHER, CANVAS, VINYL, OR NYLON, USED FOR STORING EDIBLE SEEDS, NUTS OR CANDIES (U.S. CLS. 1, 2, 3, 22 AND 41).

FIRST USE 5-1-2011; IN COMMERCE 5-18-2011.

ESTHER BELENKER, EXAMINING ATTORNEY

CLASS 18—(Continued).

SN 85-360,701. LAMESHA LUXE, INC., WESTFIELD, IN. FILED 6-30-2011.



MISHA MILES

THE NAME(S), PORTRAIT(S), AND/OR SIGNATURE(S) SHOWN IN THE MARK DOES NOT IDENTIFY A PARTICULAR LIVING INDIVIDUAL.

THE MARK CONSISTS OF STYLIZED LETTER "M" APPROXIMATING A HEAD OVER THE WORDS "MISHA MILES".

FOR LEATHER GOODS, NAMELY, HANDBAGS (U.S. CLS. 1, 2, 3, 22 AND 41).

HENRY S. ZAK, EXAMINING ATTORNEY

SN 85-364,411. COUNTRY ROAD CLOTHING PTY LTD, RICHMOND, VICTORIA, AUSTRALIA, FILED 7-6-2011.

COUNTRY ROAD

THE MARK CONSISTS OF STANDARD CHARACTERS WITHOUT CLAIM TO ANY PARTICULAR FONT, STYLE, SIZE, OR COLOR.

OWNER OF U.S. REG. NOS. 1,213,557, 1,573,457 AND 1,862,951.

FOR BAGS NAMELY, ATTACHÉ CASES, BRIEF-CASES, TRUNKS, TRAVEL BAGGAGE, VALISES, BEACH BAGS, BACKPACKS, SUITCASES, SUITCASE HANDLES, SATCHELS, TRAVELLING BAGS AND TRUNKS, WALLETS, LEATHER WALLETS, COIN WALLETS, POCKET WALLETS, PURSES AND HANDBAGS; UMBRELLAS, PARASOLS AND WALKING STICKS; WHIPS, HARNESS AND SADDLERY; LUGGAGE TAGS, LUGGAGE LABELS OF LEATHER OR IMITATION LEATHER (U.S. CLS. 1, 2, 3, 22 AND 41).

WILLIAM P. SHANAHAN, EXAMINING ATTORNEY

CLASS 18—(Continued).

SN 85-364,453. COUNTRY ROAD CLOTHING PTY LTD, RICHMOND, VICTORIA, AUSTRALIA, FILED 7-6-2011.

TRENER Y

THE MARK CONSISTS OF STANDARD CHARACTERS WITHOUT CLAIM TO ANY PARTICULAR FONT, STYLE, SIZE, OR COLOR.

FOR BAGS, NAMELY, ATTACHÉ CASES, BRIEF-CASES, TRUNKS, TRAVEL BAGGAGE, VALISES, BEACH BAGS, BACKPACKS, SUITCASES, SUITCASE HANDLES, SACHELS, TRAVELLING BAGS AND TRUNKS, WALLETS, LEATHER WALLETS, COIN WALLETS, POCKET WALLETS, PURSES AND HANDBAGS; UMBRELLAS, PARASOLS AND WALKING STICKS; WHIPS, HARNESS AND SADDLERY; LUGGAGE TAGS, LUGGAGE LABELS OF LEATHER OR IMITATION LEATHER (U.S. CLS. 1, 2, 3, 22 AND 41).

WILLIAM P. SHANAHAN, EXAMINING ATTORNEY

CLASS 18—(Continued).

SN 85-369,159. AMERICAN LEGACY FOUNDATION, WASHINGTON, DC. FILED 7-12-2011.

TRUTH 1585

THE MARK CONSISTS OF STANDARD CHARACTERS WITHOUT CLAIM TO ANY PARTICULAR FONT, STYLE, SIZE, OR COLOR.

OWNER OF U.S. REG. NOS. 2,656,118, 2,675,974 AND 3,891,733.

FOR BAGS, NAMELY, ALL-PURPOSE CARRYING BAGS, ATHLETIC BAGS, BOOK BAGS, SPORTS BAGS, TRAVEL BAGS, DUFFEL BAGS, AND BACKPACKS; WALLETS (U.S. CLS. 1, 2, 3, 22 AND 41).

TINA L. SNAPP, EXAMINING ATTORNEY

SN 85-382,088. CORE DISTRIBUTION, INC., MINNEAPOLIS, MN. FILED 7-27-2011.

ACTIVE ORGANIZATION SYSTEM

THE MARK CONSISTS OF STANDARD CHARACTERS WITHOUT CLAIM TO ANY PARTICULAR FONT, STYLE, SIZE, OR COLOR.

NO CLAIM IS MADE TO THE EXCLUSIVE RIGHT TO USE "ORGANIZATION SYSTEM", APART FROM THE MARK AS SHOWN.

FOR SOFT-SIDED TOOL BAGS SOLD EMPTY; TOOL BAGS SOLD EMPTY; TOOL POUCHES SOLD EMPTY; FASTENER BAGS SOLD EMPTY (U.S. CLS. 1, 2, 3, 22 AND 41).

BRENDAN REGAN, EXAMINING ATTORNEY

SN 85-368,077. MASSIF MOUNTAIN GEAR COMPANY, LLC, ASHLAND, OR. FILED 7-11-2011.

OWNER OF U.S. REG. NOS. 3,381,129, 3,977,854 AND OTHERS.

THE MARK CONSISTS OF THE BLOCK LETTERS "MAS" ON TOP OF THE BLOCK LETTERS "SIF".

FOR ATTACHÉ CASES, ALL-PURPOSE CARRYING BAGS, BACKPACKS, BAGS, NAMELY, HANDBAGS, MESSENGER BAGS, PURSES, MEN'S PURSES AND SMALL BAGS FOR MEN, BILLFOLDS, BRIEF CASES, BRIEFCASE-TYPE PORTFOLIOS, CARRYALLS, LUGGAGE, MEN'S CLUTCH BAGS, TRAVEL GARMENT BAGS, WALLETS, SUITCASES, TRAVELING CASES/BAGS, TOTE BAGS, SHOULDER BAGS, VANITY CASES SOLD EMPTY, SLING BAGS, SUIT CARRIERS, BUSINESS CARD CASES, CALLING CARD CASES (U.S. CLS. 1, 2, 3, 22 AND 41).

B. PARADEWELAI, EXAMINING ATTORNEY

SN 85-438,262. GILT GROUPE, INC., NEW YORK, NY. FILED 10-3-2011.

KNK

THE MARK CONSISTS OF STANDARD CHARACTERS WITHOUT CLAIM TO ANY PARTICULAR FONT, STYLE, SIZE, OR COLOR.

FOR WALLETS, COIN PURSES, BUSINESS CARD CASES, KEY CHAIN KEY FOBS, HANDBAGS, CLUTCH BAGS, LEATHER KEY CHAINS, COSMETIC BAGS SOLD EMPTY, AND UMBRELLAS (U.S. CLS. 1, 2, 3, 22 AND 41).

ERNEST SHOSHO, EXAMINING ATTORNEY

CLASS 18—(Continued).

SN 85-445,109. COPLAY CULTURAL & CREATIVE CORPORATION, NEW TAIPEI CITY 100, TAIWAN, FILED 10-12-2011.



PRIORITY CLAIMED UNDER SEC. 44(D) ON TAIWAN APPLICATION NO. 100026354, FILED 5-26-2011. OWNER OF CHINA REG. NO. 01446615, DATED 3-1-2012, EXPIRES 2-28-2022.

THE MARK CONSISTS OF THE STYLIZED TERM "COPLAY" AND SIX PARTIALLY-SHADED, CONNECTED CIRCLES, WITH EACH LETTER PLACED INSIDE A SEPARATE CIRCLE.

FOR PURSE; BACKPACK; SCHOOL BAGS; HANDBAG; SHOE BAG FOR TRAVEL; LUGGAGE BAG; LUGGAGE CASE; KNAPSACK; REUSABLE SHOPPING BAGS; KEY CASE; COSMETIC CASE SOLD EMPTY; BRIEFCASE; TRAVELLING BAG; ALL-PURPOSE CARRYING BAGS; ALL-PURPOSE SPORT BAGS; BEACH BAGS; BAGS FOR CARRYING BABIES ACCESSORIES IN THE NATURE OF DIAPER, MILK BOTTLE AND CLOTHES; CANVAS RUCKSACK; MUSIC CASES; BAGS FOR CARRYING PET ACCESSORIES IN THE NATURE OF SPECIALLY DESIGNED CANVAS, VINYL OR LEATHER BAGS ATTACHED TO ANIMAL LEASHES FOR HOLDING SMALL ITEMS, NAMELY, KEYS, CREDIT CARDS, MONEY OR DISPOSABLE BAGS FOR DISPOSING OF PET WASTE (U.S. CLS. 1, 2, 3, 22 AND 41).

FIRST USE 4-15-2011; IN COMMERCE 4-15-2011. ANDREA K. NADELMAN, EXAMINING ATTORNEY

CLASS 18—(Continued).

SN 85-448,986. BATTLE FOAM, LLC, GILBERT, AZ. FILED 10-17-2011.

BATTLE FOAM DESIGNS

THE MARK CONSISTS OF STANDARD CHARACTERS WITHOUT CLAIM TO ANY PARTICULAR FONT, STYLE, SIZE, OR COLOR.

OWNER OF U.S. REG. NOS. 3,784,117 AND 3,805,467. NO CLAIM IS MADE TO THE EXCLUSIVE RIGHT TO USE "FOAM DESIGNS", APART FROM THE MARK AS SHOWN.

FOR CARRYING CASES (U.S. CLS. 1, 2, 3, 22 AND 41). SAIMA MAKHDOOM, EXAMINING ATTORNEY

SN 85-448,946. BATTLE FOAM, LLC, GILBERT, AZ. FILED 10-17-2011.



OWNER OF U.S. REG. NOS. 3,784,117 AND 3,805,467. NO CLAIM IS MADE TO THE EXCLUSIVE RIGHT TO USE "FOAM DESIGNS", APART FROM THE MARK AS SHOWN.

THE MARK CONSISTS OF A CUBE WITH A PORTION CUT OUT AND POSITIONED LOWER THAN THE CUBE SURFACE AND A ROD WITH ROUNDED END EXTENDING THROUGH THE CUBE AND THE WORDS "BATTLE FOAM DESIGNS".

FOR CARRYING CASES (U.S. CLS. 1, 2, 3, 22 AND 41). SAIMA MAKHDOOM, EXAMINING ATTORNEY



CHARLES JOURDAN

OWNER OF U.S. REG. NOS. 987,611, 3,207,023 AND OTHERS.

THE NAME(S), PORTRAIT(S), AND/OR SIGNATURE(S) SHOWN IN THE MARK DOES NOT IDENTIFY A PARTICULAR LIVING INDIVIDUAL.

THE MARK CONSISTS OF THE LETTERS "CJ" IN STYLIZED FORMAT AND THE WORDS "CHARLES JOURDAN".

FOR HANDBAGS, SMALL LEATHER GOODS, NAMELY, KEY CASES, CHANGE PURSES, COIN CASES, BUSINESS CARD HOLDERS IN THE NATURE OF CARD CASES, CREDIT CARD HOLDERS, BILLFOLDS, FRENCH PURSES, WALLETS, PASSPORT CASES, LUGGAGE (U.S. CLS. 1, 2, 3, 22 AND 41).

JUSTINE D. PARKER, EXAMINING ATTORNEY

CLASS 18—(Continued).

SN 85-480,257. OURZ FASHION, INC., NEW YORK, NY. FILED 11-23-2011.



THE MARK CONSISTS OF A CIRCLE SURROUNDING A LION'S HEAD WITH A CROWN.
FOR HANDBAGS (U.S. CLS. 1, 2, 3, 22 AND 41).
FIRST USE 9-30-2011; IN COMMERCE 9-30-2011.
KATINA MISTER, EXAMINING ATTORNEY

SN 85-481,296. DOGMATIC (UK) LTD, BROUGHTON, UNITED KINGDOM, FILED 11-28-2011.



OWNER OF UNITED KINGDOM REG. NO. 2230717, DATED 12-29-2000, EXPIRES 4-27-2020.
THE MARK CONSISTS OF A DOG'S HEAD WITH HEAD COLLAR ATTACHED FEATURES WITHIN THE LETTER "O" IN THE WORD "DOGMATIC", STRAPLINE "AUTOMATICALLY LEADING THE WAY" FEATURES BELOW THE WORD "DOGMATIC".
FOR DOG COLLARS; DOG COLLARS AND LEADS; DOG LEASHES (U.S. CLS. 1, 2, 3, 22 AND 41).
JANICE KIM, EXAMINING ATTORNEY

SN 85-488,371. SHARP HILL DESIGNS LLC, WILTON, CT. FILED 12-6-2011.

sharp hill designs elegant
accessories for women

THE MARK CONSISTS OF STANDARD CHARACTERS WITHOUT CLAIM TO ANY PARTICULAR FONT, STYLE, SIZE, OR COLOR.
NO CLAIM IS MADE TO THE EXCLUSIVE RIGHT TO USE "DESIGNS" AND "ACCESSORIES FOR WOMEN", APART FROM THE MARK AS SHOWN.
FOR HANDBAGS; TOTE BAGS (U.S. CLS. 1, 2, 3, 22 AND 41).
FIRST USE 5-1-2007; IN COMMERCE 5-1-2007.
BERNICE MIDDLETON, EXAMINING ATTORNEY

CLASS 18—(Continued).

SN 85-499,063. SR HOLDINGS, LLC, LEXINGTON, MA. FILED 12-19-2011.



OWNER OF U.S. REG. NOS. 1,810,853 AND 1,860,428.
THE MARK CONSISTS OF A STYLIZED IMAGE OF A SAILBOAT WITH TWO SETS OF WAVES, SURROUNDED BY A SQUARE DESIGN.
FOR LUGGAGE AND TRUNKS; TRAVELING BAGS; BRIEFCASES; SPORT BAGS; MESSENGER BAGS; PULLMANS; LUGGAGE TAGS; GARMENT BAGS FOR TRAVEL; COIN PURSES; PARASOLS; PET ACCESSORIES, NAMELY, SPECIALLY DESIGNED CANVAS, VINYL OR LEATHER BAGS ATTACHED TO ANIMAL LEASHES FOR HOLDING SMALL ITEMS SUCH AS KEYS, CREDIT CARDS, MONEY OR DISPOSABLE BAGS FOR DISPOSING OF PET WASTE; COLLARS FOR PETS; ANIMAL LEASHES (U.S. CLS. 1, 2, 3, 22 AND 41).
CURTIS FRENCH, EXAMINING ATTORNEY

SN 85-499,600. ULTRA LIFT, MANAWA, WI. FILED 12-20-2011.

PETSITTER

THE MARK CONSISTS OF STANDARD CHARACTERS WITHOUT CLAIM TO ANY PARTICULAR FONT, STYLE, SIZE, OR COLOR.
FOR A PET RESTRAINING DEVICE FEATURING A VERTICALLY ADJUSTABLE HORIZONTAL BAR FOR PREVENTING ANIMALS FROM SITTING OR LAYING DURING GROOMING (U.S. CLS. 1, 2, 3, 22 AND 41).
FIRST USE 11-28-2011; IN COMMERCE 11-28-2011.
ELLEN PERKINS, EXAMINING ATTORNEY

CLASS 18—(Continued).

SN 85-504,211. PINKERMAN, RHONDA L. DBA POODOO PRODUCTIONS, NASHVILLE, TN. FILED 12-27-2011.

PooDoo Leash

THE MARK CONSISTS OF STANDARD CHARACTERS WITHOUT CLAIM TO ANY PARTICULAR FONT, STYLE, SIZE, OR COLOR.

NO CLAIM IS MADE TO THE EXCLUSIVE RIGHT TO USE "LEASH", APART FROM THE MARK AS SHOWN.

FOR ANIMAL LEASHES; DOG LEASHES; LEASHES FOR ANIMALS; PET ACCESSORIES, NAMELY, SPECIALLY DESIGNED CANVAS, VINYL OR LEATHER BAGS ATTACHED TO ANIMAL LEASHES FOR HOLDING SMALL ITEMS SUCH AS KEYS, CREDIT CARDS, MONEY OR DISPOSABLE BAGS FOR DISPOSING OF PET WASTE; PET PRODUCTS, NAMELY, PET RESTRAINING DEVICES CONSISTING OF LEASHES, COLLARS, HARNESSES, RESTRAINING STRAPS, AND LEASHES WITH LOCKING DEVICES (U.S. CLS. 1, 2, 3, 22 AND 41).

SKYE YOUNG, EXAMINING ATTORNEY

SN 85-505,188. MATTA, NEW YORK, LTD., NEW YORK, NY. FILED 12-28-2011.

MATAH

THE MARK CONSISTS OF STANDARD CHARACTERS WITHOUT CLAIM TO ANY PARTICULAR FONT, STYLE, SIZE, OR COLOR.

FOR PURSES, HANDBAGS, TOTE BAGS AND TRAVEL BAGS (U.S. CLS. 1, 2, 3, 22 AND 41).

MATTHEW MCDOWELL, EXAMINING ATTORNEY

SN 85-506,909. HARRIS, JCARLYA, DBA FLAIRLINE, FORT LAUDERDALE, FL. FILED 12-31-2011.

Flairline

THE MARK CONSISTS OF STANDARD CHARACTERS WITHOUT CLAIM TO ANY PARTICULAR FONT, STYLE, SIZE, OR COLOR.

FOR LUGGAGE TAGS (U.S. CLS. 1, 2, 3, 22 AND 41). FIRST USE 7-0-2009; IN COMMERCE 7-0-2009.

IRA J. GOODSaid, EXAMINING ATTORNEY

CLASS 18—(Continued).

SN 85-507,121. FCT INC., NAPERVILLE, IL. FILED 1-2-2012.

Vicel

THE MARK CONSISTS OF STANDARD CHARACTERS WITHOUT CLAIM TO ANY PARTICULAR FONT, STYLE, SIZE, OR COLOR.

FOR CELLULOSE FOOD CASINGS; PAPER-REINFORCED CELLULOSE FOOD CASINGS (U.S. CLS. 1, 2, 3, 22 AND 41).

JEFFREY LOOK, EXAMINING ATTORNEY

SN 85-508,987. LINKE DYRDAHL, SEATTLE, WA. FILED 1-5-2012.

RFA Ready For Action

THE MARK CONSISTS OF STANDARD CHARACTERS WITHOUT CLAIM TO ANY PARTICULAR FONT, STYLE, SIZE, OR COLOR.

FOR BACKPACKS, BOOK BAGS, SPORTS BAGS, BUM BAGS, WALLETS AND HANDBAGS; MILITARY DUFFLE BAGS; GARMENT BAGS FOR TRAVEL; TOTE BAGS; SHOULDER BAGS AND BACKPACKS; SMALL BACKPACKS (U.S. CLS. 1, 2, 3, 22 AND 41).

JOHN GARTNER, EXAMINING ATTORNEY

SN 85-509,801. STERN, RENA, SAN MATEO, CA. AND KAUFER, DAPHNE, REDWOOD CITY, CA. FILED 1-5-2012.



THE MARK CONSISTS OF THE STYLIZED TEXT "SUPERME" WITH A CAPE CENTERED ON TOP OF TEXT. THERE IS A CARTOON HEAD WITH EYE MASK PEAKING OVER.

FOR BACKPACKS; MESSENGER BAGS (U.S. CLS. 1, 2, 3, 22 AND 41).

GENE MACIOL, EXAMINING ATTORNEY

CLASS 18—(Continued).

SN 85-509,927. EMBERSKYE LP, DENVER, CO. FILED 1-5-2012.

EMBER SKYE

THE MARK CONSISTS OF STANDARD CHARACTERS WITHOUT CLAIM TO ANY PARTICULAR FONT, STYLE, SIZE, OR COLOR.

FOR CARRY-ALL BAGS; CLUTCH BAGS; CLUTCH PURSES; EVENING BAGS; EVENING HANDBAGS; FASHION HANDBAGS; HANDBAGS; HOBO BAGS; LEATHER AND IMITATION LEATHER BAGS; LEATHER HANDBAGS; LEATHER PURSES; PURSES; SHOULDER BAGS; TOTE BAGS (U.S. CLS. 1, 2, 3, 22 AND 41).

FIRST USE 2-0-2010; IN COMMERCE 4-0-2011.
BRENDAN REGAN, EXAMINING ATTORNEY

CLASS 18—(Continued).

SN 85-511,015. FAIR TRADE ENTERPRISE CO., LTD., TAIPEI, TAIWAN, FILED 1-6-2012.



THE MARK CONSISTS OF A STYLIZED PENGUIN. FOR ALL PURPOSE SPORT BAGS; BACKPACKS; BOOK BAGS; BRIEFCASES; CANES; COIN PURSES; FUR PELTS; GARMENT BAGS FOR TRAVEL; HANDBAGS; IMITATION LEATHER; LEATHER FOR FURNITURE; LEATHER POUCHES; LUGGAGE; LUGGAGE AND TRUNKS; OVERNIGHT CASES; PARASOLS; POCKET WALLETS; SCHOOL BAGS; SHOPPING BAGS WITH WHEELS ATTACHED; SHOULDER BAGS; SLING BAGS FOR CARRYING INFANTS; SUITCASES; TEXTILE SHOPPING BAGS; TOTE BAGS; TRAVELING BAGS; UMBRELLA COVERS; UMBRELLAS; VALISES (U.S. CLS. 1, 2, 3, 22 AND 41).

FIRST USE 8-14-2007; IN COMMERCE 8-26-2011.
GEORGE LORENZO, EXAMINING ATTORNEY

SN 85-511,364. SHANGHAI NEWEST LUGGAGE CO., LTD., SHANGHI, CHINA, FILED 1-8-2012.

SN 85-510,433. WILKINSON, WILLIAM T., DBA INNOVATION INDUSTRIES, MEDIA, PA. FILED 1-6-2012.

TRAVELFIT

THE MARK CONSISTS OF STANDARD CHARACTERS WITHOUT CLAIM TO ANY PARTICULAR FONT, STYLE, SIZE, OR COLOR.

FOR LUGGAGE (U.S. CLS. 1, 2, 3, 22 AND 41).
GINA HAYES, EXAMINING ATTORNEY

LIGHT IS GREEN

OWNER OF U.S. REG. NO. 4,048,118.

THE MARK CONSISTS OF STYLIZED CAPITAL WORDING "LIGHT IS GREEN".

FOR ANIMAL SKINS; ATTACHE CASES; BACKPACKS; BAGS FOR SPORTS; BRIEFCASES; CANVAS SHOPPING BAGS; HANDBAGS; HAVERSACKS; IMITATION LEATHER; LEATHER OR LEATHER-BOARD BOXES; LEATHER SHOPPING BAGS; LEATHER STRAPS; MESH SHOPPING BAGS; PARASOLS; REUSABLE SHOPPING BAGS; SCHOOL BAGS; SUITCASES; TEXTILE SHOPPING BAGS; TRAVELING BAGS; TRAVELLING TRUNKS; UMBRELLAS; VALISES; VANITY CASES SOLD EMPTY; WHEELED SHOPPING BAGS (U.S. CLS. 1, 2, 3, 22 AND 41).

FIRST USE 11-25-2010; IN COMMERCE 11-25-2010.
JEFF DEFORD, EXAMINING ATTORNEY

CLASS 18—(Continued).

SN 85-511,474. TOWA UMBRELLA INDUSTRY COMPANY, HSN CHU, TAIWAN, FILED 1-9-2012.

towa

THE MARK CONSISTS OF THE WORD "TOWA" IN LOWER CASE LETTERS IN WHICH THE "CROSS" FOR THE LETTER "T" EXTENDS TO THE LEFT.

THE WORDING TOWA HAS NO MEANING IN A FOREIGN LANGUAGE.

FOR UMBRELLAS, PARASOLS; PARTS FOR UMBRELLAS AND PARASOLS, NAMELY UMBRELLA RIBS AND PARASOL RIBS; UMBRELLA STICKS, UMBRELLA HANDLES, UMBRELLA COVERS; KEY CASES MADE OF LEATHER, WALLETS, HANDBAGS, TRAVELING BAGS, BACKPACKS, BRIEFCASES; WALKING STICKS (U.S. CLS. 1, 2, 3, 22 AND 41).

LINDA E. BLOHM, EXAMINING ATTORNEY

CLASS 18—(Continued).

SN 85-512,236. MONSTER, INC., BRISBANE, CA. FILED 1-9-2012.

ATTAIN

THE MARK CONSISTS OF STANDARD CHARACTERS WITHOUT CLAIM TO ANY PARTICULAR FONT, STYLE, SIZE, OR COLOR.

FOR ATHLETIC BAGS; BACKPACKS; CARRY-ON BAGS; CASES FOR KEYS; DUFFLE BAGS; FANNY PACKS; HANDBAGS; LUGGAGE; MESSENGER BAGS; OVERNIGHT BAGS; PURSES; TOILETRY CASES SOLD EMPTY; WALLETS (U.S. CLS. 1, 2, 3, 22 AND 41).

KAREN BRACEY, EXAMINING ATTORNEY

SN 85-511,806. COGLEY, THOMAS P, DBA VETERINARIAN, PINELLAS PARK, FL. FILED 1-9-2012.

c-muzzle

THE MARK CONSISTS OF STANDARD CHARACTERS WITHOUT CLAIM TO ANY PARTICULAR FONT, STYLE, SIZE, OR COLOR.

FOR MUZZLES (U.S. CLS. 1, 2, 3, 22 AND 41).

ROBIN MITTLER, EXAMINING ATTORNEY

SN 85-512,240. MONSTER, INC., BRISBANE, CA. FILED 1-9-2012.

DRIVE

THE MARK CONSISTS OF STANDARD CHARACTERS WITHOUT CLAIM TO ANY PARTICULAR FONT, STYLE, SIZE, OR COLOR.

FOR ATHLETIC BAGS; BACKPACKS; CARRY-ON BAGS; CASES FOR KEYS; DUFFLE BAGS; FANNY PACKS; HANDBAGS; LUGGAGE; MESSENGER BAGS; OVERNIGHT BAGS; PURSES; TOILETRY CASES SOLD EMPTY; WALLETS (U.S. CLS. 1, 2, 3, 22 AND 41).

KAREN BRACEY, EXAMINING ATTORNEY

SN 85-512,175. JEOWIND LLC, ST. AUGUSTINE, FL. FILED 1-9-2012.

Power of Dog

THE MARK CONSISTS OF STANDARD CHARACTERS WITHOUT CLAIM TO ANY PARTICULAR FONT, STYLE, SIZE, OR COLOR.

NO CLAIM IS MADE TO THE EXCLUSIVE RIGHT TO USE "DOG", APART FROM THE MARK AS SHOWN.

FOR COLLARS FOR PETS; LEASHES FOR ANIMALS; PET CLOTHING; PET TAGS SPECIALLY ADAPTED FOR ATTACHING TO PET LEASHES OR COLLARS (U.S. CLS. 1, 2, 3, 22 AND 41).

MICHAEL WEBSTER, EXAMINING ATTORNEY

SN 85-514,278. RIVERA, LES, PASADENA, CA. FILED 1-11-2012.

THE RAVE

THE MARK CONSISTS OF STANDARD CHARACTERS WITHOUT CLAIM TO ANY PARTICULAR FONT, STYLE, SIZE, OR COLOR.

FOR WALLETS; PURSES; LEATHER BAGS (U.S. CLS. 1, 2, 3, 22 AND 41).

FIRST USE 1-22-2000; IN COMMERCE 2-10-2000.

KAREN K. BUSH, EXAMINING ATTORNEY

CLASS 18—(Continued).

SN 85-514,344. CLCM ASSOCIATES LLC, DBA VPI, LYNDHURST, NJ. FILED 1-11-2012.

TRANQUILITY MOUNTAIN

THE MARK CONSISTS OF STANDARD CHARACTERS WITHOUT CLAIM TO ANY PARTICULAR FONT, STYLE, SIZE, OR COLOR.

FOR BACKPACKS (U.S. CLS. 1, 2, 3, 22 AND 41).
COLLEEN DOMBROW, EXAMINING ATTORNEY

CLASS 18—(Continued).

SN 85-515,135. RONALD J. LOURO, WARREN, RI. FILED 1-12-2012.

Easy Leader

THE MARK CONSISTS OF STANDARD CHARACTERS WITHOUT CLAIM TO ANY PARTICULAR FONT, STYLE, SIZE, OR COLOR.

FOR DOG COLLARS; DOG LEASHES; PET RESTRAINING DEVICES CONSISTING OF HARNESSES AND/OR RESTRAINING STRAPS FOR USE IN PET CARE (U.S. CLS. 1, 2, 3, 22 AND 41).

JORDAN BAKER, EXAMINING ATTORNEY

SN 85-514,785. WHETHER BAGS LLC, CHICAGO, IL. FILED 1-12-2012.

whether

THE MARK CONSISTS OF THE STYLIZED WORD "WHETHER" WITH THE LETTER "T" AS A DESIGN OF AN UMBRELLA.

FOR HANDBAGS (U.S. CLS. 1, 2, 3, 22 AND 41).
FIRST USE 10-1-2010; IN COMMERCE 5-1-2011.
JUDITH HELFMAN, EXAMINING ATTORNEY

SN 85-517,145. SR HOLDINGS, LLC, LEXINGTON, MA. FILED 1-16-2012.

STS 35

THE MARK CONSISTS OF A STYLIZED DRAWING OF A SHARK.

FOR LUGGAGE; ALL-PURPOSE CARRYING BAGS; BOOK BAGS; BACKPACKS; ALL-PURPOSE SPORTING BAGS; BRIEFCASES; DUFFLE BAGS; CARRY-ON BAGS; TOILETRY BAGS SOLD EMPTY; ROLLING LUGGAGE; ROLLING BRIEFCASES (U.S. CLS. 1, 2, 3, 22 AND 41).
ALYSSA STEEL, EXAMINING ATTORNEY

THE MARK CONSISTS OF STANDARD CHARACTERS WITHOUT CLAIM TO ANY PARTICULAR FONT, STYLE, SIZE, OR COLOR.

FOR HANDBAGS; SHOULDER BAGS; PURSES; WALLETS; TOTE BAGS; DUFFEL BAGS; BACKPACKS; LUGGAGE AND TRUNKS; TRAVELING BAGS; BRIEFCASES; SPORT BAGS; MESSENGER BAGS; PULLMANS; LUGGAGE TAGS; GARMENT BAGS FOR TRAVEL; COIN PURSES; UMBRELLAS; PARASOLS; LEATHER KEY CHAINS; PET ACCESSORIES, NAMELY, SPECIALLY DESIGNED CANVAS, VINYL OR LEATHER BAGS ATTACHED TO ANIMAL LEASHES FOR HOLDING SMALL ITEMS SUCH AS KEYS, CREDIT CARDS, MONEY OR DISPOSABLE BAGS FOR DISPOSING OF PET WASTE; COLLARS FOR PETS; ANIMAL LEASHES (U.S. CLS. 1, 2, 3, 22 AND 41).
STEVEN JACKSON, EXAMINING ATTORNEY

CLASS 18—(Continued).

SN 85-517,378. SR HOLDINGS, LLC, LEXINGTON, MA. FILED 1-16-2012.

TEAM SPERRY TOP-SIDER

THE MARK CONSISTS OF STANDARD CHARACTERS WITHOUT CLAIM TO ANY PARTICULAR FONT, STYLE, SIZE, OR COLOR.

OWNER OF U.S. REG. NOS. 732,519, 3,835,580 AND OTHERS.

NO CLAIM IS MADE TO THE EXCLUSIVE RIGHT TO USE "TEAM", APART FROM THE MARK AS SHOWN.

FOR HANDBAGS; SHOULDER BAGS; PURSES; WALLET; TOTE BAGS; DUFFEL BAGS; BACKPACKS; LUGGAGE AND TRUNKS; TRAVELING BAGS; BRIEF-CASES; SPORT BAGS; MESSENGER BAGS; PULLMANS; LUGGAGE TAGS; GARMENT BAGS FOR TRAVEL; COIN PURSES; UMBRELLAS; PARASOLS; LEATHER KEY CHAINS; PET ACCESSORIES, NAMELY, SPECIALLY DESIGNED CANVAS, VINYL OR LEATHER BAGS ATTACHED TO ANIMAL LEASHES FOR HOLDING SMALL ITEMS SUCH AS KEYS, CREDIT CARDS, MONEY OR DISPOSABLE BAGS FOR DISPOSING OF PET WASTE; COLLARS FOR PETS; ANIMAL LEASHES (U.S. CLS. 1, 2, 3, 22 AND 41).

CURTIS FRENCH, EXAMINING ATTORNEY

SN 85-527,409. LANDSCAPE FORMS, INC., KALAMAZOO, MI. FILED 1-27-2012.



OWNER OF U.S. REG. NOS. 3,444,427, 3,444,431 AND OTHERS.

NO CLAIM IS MADE TO THE EXCLUSIVE RIGHT TO USE "STUDIO", APART FROM THE MARK AS SHOWN.

THE MARK CONSISTS OF THE WORD, "STUDIO" TO THE LEFT OF A CIRCLE HAVING THE NUMBERS "431" INSIDE THE CIRCLE.

FOR UMBRELLAS (U.S. CLS. 1, 2, 3, 22 AND 41).

FIRST USE 11-22-2011; IN COMMERCE 11-22-2011.

CURTIS FRENCH, EXAMINING ATTORNEY

CLASS 19—NON-METALLIC BUILDING MATERIALS

SN 76-702,986. CONCRETE ACCESSORIES INC., LAS VEGAS, NV. FILED 5-17-2010.



NO CLAIM IS MADE TO THE EXCLUSIVE RIGHT TO USE "CONSTRUCTION PRODUCTS", APART FROM THE MARK AS SHOWN.

THE MARK CONSISTS OF THE WORD "CALICO" IN WITH THE LETTERS "C" AND "O" ENLARGED. UNDERNEATH THE WORD "CALICO" IS THE WORDING "CONSTRUCTION PRODUCTS". ALL THREE WORDS ARE IMPOSED OVER AN OVAL WITH TWO STYLIZED BULLET-HOLE DESIGNS ON EITHER SIDE OF THE WORDING. ABOVE THE WORD "CALICO" IS A STYLIZED CIRCLE WHICH CONTAINS TWO CROSSED PISTOLS. UNDERNEATH THE PISTOLS IS A STYLIZED BULLET-HOLE.

FOR CONSTRUCTION PRODUCTS, NAMELY, CONCRETE; CONCRETE PATCHING COMPOUNDS MADE OF A TAR BASE; CONCRETE RESURFACING COMPOUNDS MADE OF A TAR BASE; DECORATIVE CONCRETE STAMPING PAVERS; FLOOR PATCHING MATERIALS, NAMELY, CONCRETE SEALERS; ASPHALT; ASPHALT PATCHING COMPOUNDS MADE OF A TAR BASE; ASPHALT RESURFACING COMPOUNDS MADE OF A TAR BASE; DECORATIVE ASPHALT STAMPING PAVERS; BITUMEN AND TAR-BASED SEALANTS FOR ASPHALT (U.S. CLS. 1, 12, 33 AND 50).

FIRST USE 1-1-2003; IN COMMERCE 1-1-2003.

TARAH HARDY, EXAMINING ATTORNEY

SN 77-183,644. LINGEN INC., FORT PIERCE, FL. FILED 5-17-2007.

SimStone

THE MARK CONSISTS OF STANDARD CHARACTERS WITHOUT CLAIM TO ANY PARTICULAR FONT, STYLE, SIZE, OR COLOR.

FOR NON-METAL DECORATIVE MOLDINGS AND DECORATIVE TRIM FOR USE IN BUILDING CONSTRUCTION (U.S. CLS. 1, 12, 33 AND 50).

FIRST USE 5-1-2007; IN COMMERCE 5-1-2007.

STEPHANIE ALI, EXAMINING ATTORNEY

CLASS 19—(Continued).

SN 77-902,227. RESINART EAST, INC., FLETCHER, NC.
FILED 12-29-2009.

DURAFLEX

THE MARK CONSISTS OF STANDARD CHARACTERS WITHOUT CLAIM TO ANY PARTICULAR FONT, STYLE, SIZE, OR COLOR.

FOR RESIN- AND URETHANE-BASED BUILDING MATERIALS, NAMELY, FLEXIBLE TRIM MOULDINGS, DECORATIVE TRIM ORNAMENTAL MOULDINGS; RESIN- AND URETHANE-BASED BUILDING MATERIALS, NAMELY, DECORATIVE TRIM ACCESSORIES IN THE NATURE OF KEYSTONES, ROSETTES, AND BULL-NOSED BASE CORNERS (U.S. CLS. 1, 12, 33 AND 50).

FIRST USE 5-0-1992; IN COMMERCE 5-0-1992.
CYNTHIA TRIPI, EXAMINING ATTORNEY

CLASS 19—(Continued).

SN 85-203,732. CREATIVE LIVING DESIGNS, LLC, BISHOPVILLE, SC. FILED 12-22-2010.

House In A Box

THE MARK CONSISTS OF STANDARD CHARACTERS WITHOUT CLAIM TO ANY PARTICULAR FONT, STYLE, SIZE, OR COLOR.

NO CLAIM IS MADE TO THE EXCLUSIVE RIGHT TO USE "HOUSE", APART FROM THE MARK AS SHOWN.

FOR MANUFACTURED HOUSING, NAMELY, MOBILE HOMES; MANUFACTURED HOUSING, NAMELY, TRANSPORTABLE HOMES; PRE-FABRICATED HOMES (U.S. CLS. 1, 12, 33 AND 50).

FIRST USE 6-1-2010; IN COMMERCE 6-1-2010.
JAMES A. RAUEN, EXAMINING ATTORNEY

SN 85-272,303. NICHIIHA CORPORATION, NAGOYA-SHI, AICHI, JAPAN, FILED 3-21-2011.

NichiStaggered

THE MARK CONSISTS OF STANDARD CHARACTERS WITHOUT CLAIM TO ANY PARTICULAR FONT, STYLE, SIZE, OR COLOR.

FOR NON-METAL BUILDING MATERIALS, NAMELY, CEMENT EXTERIOR WALLS (U.S. CLS. 1, 12, 33 AND 50).

FIRST USE 2-1-2011; IN COMMERCE 2-1-2011.
RENEE MCCRAY, EXAMINING ATTORNEY

SN 77-902,236. RESINART EAST, INC., FLETCHER, NC.
FILED 12-29-2009.

DURAFLEX THE ORIGINAL FLEXIBLE MOULDING

THE MARK CONSISTS OF STANDARD CHARACTERS WITHOUT CLAIM TO ANY PARTICULAR FONT, STYLE, SIZE, OR COLOR.

NO CLAIM IS MADE TO THE EXCLUSIVE RIGHT TO USE "THE ORIGINAL FLEXIBLE MOULDING", APART FROM THE MARK AS SHOWN.

FOR RESIN- AND URETHANE-BASED BUILDING MATERIALS, NAMELY, FLEXIBLE TRIM MOULDINGS, DECORATIVE TRIM ORNAMENTAL MOULDINGS; RESIN- AND URETHANE-BASED BUILDING MATERIALS, NAMELY, DECORATIVE TRIM ACCESSORIES IN THE NATURE OF KEYSTONES, ROSETTES, AND BULL-NOSED BASE CORNERS (U.S. CLS. 1, 12, 33 AND 50).

FIRST USE 5-0-1992; IN COMMERCE 5-0-1992.
CYNTHIA TRIPI, EXAMINING ATTORNEY

SN 85-272,306. NICHIIHA CORPORATION, NAGOYA-SHI, AICHI, JAPAN, FILED 3-21-2011.

NichiStraight

THE MARK CONSISTS OF STANDARD CHARACTERS WITHOUT CLAIM TO ANY PARTICULAR FONT, STYLE, SIZE, OR COLOR.

FOR NON-METAL BUILDING MATERIALS, NAMELY, CEMENT EXTERIOR WALLS (U.S. CLS. 1, 12, 33 AND 50).

FIRST USE 2-1-2011; IN COMMERCE 2-1-2011.
RENEE MCCRAY, EXAMINING ATTORNEY

CLASS 19—(Continued).

SN 85-339,656. ROBERT B. ARCHIE, RENO, NV. FILED 6-7-2011.

Perfect Pitch

THE MARK CONSISTS OF STANDARD CHARACTERS WITHOUT CLAIM TO ANY PARTICULAR FONT, STYLE, SIZE, OR COLOR.

FOR TAR-BASED ASPHALT SEALANTS (U.S. CLS. 1, 12, 33 AND 50).

TINA BROWN, EXAMINING ATTORNEY

CLASS 19—(Continued).

SN 85-359,055. MARBLE OF THE WORLD, INC., FORT LAUDERDALE, FL. FILED 6-29-2011.

SHELLS REEF

THE MARK CONSISTS OF STANDARD CHARACTERS WITHOUT CLAIM TO ANY PARTICULAR FONT, STYLE, SIZE, OR COLOR.

NO CLAIM IS MADE TO THE EXCLUSIVE RIGHT TO USE "SHELLS", APART FROM THE MARK AS SHOWN.

FOR CORAL AND SHELL STONE TILE AND FLOORING (U.S. CLS. 1, 12, 33 AND 50).

FIRST USE 5-0-2008; IN COMMERCE 5-0-2008.

JANICE L. MCMORROW, EXAMINING ATTORNEY

SN 85-353,640. GARDNER ASPHALT CORPORATION, TAMPA, FL. FILED 6-22-2011.

BITUCRYLIC

THE MARK CONSISTS OF STANDARD CHARACTERS WITHOUT CLAIM TO ANY PARTICULAR FONT, STYLE, SIZE, OR COLOR.

FOR FLUID-APPLIED ASPHALT MODIFIED COATINGS FOR USE ON ROOFS, WALLS AND FOUNDATIONS (U.S. CLS. 1, 12, 33 AND 50).

RONALD MCMORROW, EXAMINING ATTORNEY

SN 85-361,165. POLYGLASS S.P.A, TREVISO, ITALY, FILED 6-30-2011.

ELASTOKOOL

SN 85-353,642. GARDNER ASPHALT CORPORATION, TAMPA, FL. FILED 6-22-2011.

BITUCRYL

THE MARK CONSISTS OF STANDARD CHARACTERS WITHOUT CLAIM TO ANY PARTICULAR FONT, STYLE, SIZE, OR COLOR.

FOR FLUID-APPLIED ASPHALT MODIFIED COATINGS FOR USE ON ROOFS, WALLS AND FOUNDATIONS (U.S. CLS. 1, 12, 33 AND 50).

RONALD MCMORROW, EXAMINING ATTORNEY

THE MARK CONSISTS OF STANDARD CHARACTERS WITHOUT CLAIM TO ANY PARTICULAR FONT, STYLE, SIZE, OR COLOR.

FOR WHITE, REFLECTIVE ROOFING MEMBRANE FOR COMMERCIAL AND RESIDENTIAL APPLICATIONS (U.S. CLS. 1, 12, 33 AND 50).

EMILY CARLSEN, EXAMINING ATTORNEY

CLASS 19—(Continued).

SN 85-417,306. ZHEJIANG TIANZHEN BAMBOO & WOOD DEVELOPMENT CO., LTD., HUZHOU CITY, ZHEJIANG, CHINA, FILED 9-8-2011.



OWNER OF CHINA REG. NO. 5243886, DATED 7-14-2009, EXPIRES 7-13-2019.

NO CLAIM IS MADE TO THE EXCLUSIVE RIGHT TO USE "BAMBOO", APART FROM THE MARK AS SHOWN.

THE MARK CONSISTS OF A STYLIZED DESIGN OF TWO IRREGULAR POLYGONS FORMING A "T", THE WORDS "TIANZHEN BAMBOO", AND TWO CHINESE CHARACTERS.

THE NON-LATIN CHARACTERS IN THE MARK TRANSLITERATE TO "TIAN"; "ZHEN" AND THIS MEANS "SHAKE" IN ENGLISH.

FOR FLOOR BOARDS; PLYWOOD; BUILDING TIMBER; WOOD VENEERS; BAMBOO VENEERS; PARQUET FLOOR BOARDS; REFRACTORY CONSTRUCTION MATERIALS, NOT OF METAL; CEMENT (U.S. CLS. 1, 12, 33 AND 50).

PAUL MORENO, EXAMINING ATTORNEY

SN 85-459,953. LATICRETE SUPERCAP LLC, BETHANY, CT. FILED 10-31-2011.

THE NEXT GENERATION SLAB

THE MARK CONSISTS OF STANDARD CHARACTERS WITHOUT CLAIM TO ANY PARTICULAR FONT, STYLE, SIZE, OR COLOR.

NO CLAIM IS MADE TO THE EXCLUSIVE RIGHT TO USE "SLAB", APART FROM THE MARK AS SHOWN.

FOR A CEMENT-BASED PRODUCT, NAMELY, HYDRAULIC CEMENT, FOR CAPPING CONCRETE SURFACES (U.S. CLS. 1, 12, 33 AND 50).

RAMONA ORTIGA, EXAMINING ATTORNEY

CLASS 19—(Continued).

SN 85-500,265. BUILDING MATERIALS INVESTMENT CORPORATION, DALLAS, TX. FILED 12-20-2011.



NO CLAIM IS MADE TO THE EXCLUSIVE RIGHT TO USE "METAL-LOOK TPO ROOFING", APART FROM THE MARK AS SHOWN.

THE MARK CONSISTS OF THE WORD "PROFILES" WITH A STYLIZED "P" ON TOP OF THE WORDS "METAL-LOOK TPO ROOFING", WITH THE PHRASE "TPO" IN BOLD.

FOR NON-METAL THERMOPLASTIC POLYOLEFIN ROOFING SYSTEM COMPRISING ROOF COVERINGS (U.S. CLS. 1, 12, 33 AND 50).

JULIE VEPPUMTHARA, EXAMINING ATTORNEY

SN 85-510,073. FORTIFIBER CORPORATION, FERNLEY, NV. FILED 1-6-2012.

FORTIFLEX

THE MARK CONSISTS OF STANDARD CHARACTERS WITHOUT CLAIM TO ANY PARTICULAR FONT, STYLE, SIZE, OR COLOR.

FOR NON-METAL BUILDING MATERIALS FOR WEATHERPROOFING WINDOW FRAMES, NAMELY, SELF-ADHESIVE WINDOW FLASHING (U.S. CLS. 1, 12, 33 AND 50).

FIRST USE 12-20-2011; IN COMMERCE 12-20-2011.

MATTHEW KLINE, EXAMINING ATTORNEY

SN 85-510,494. ORCHARD, BRIAN KEITH, LONDON, CANADA, FILED 1-6-2012.

COYOTE CLIP

THE MARK CONSISTS OF STANDARD CHARACTERS WITHOUT CLAIM TO ANY PARTICULAR FONT, STYLE, SIZE, OR COLOR.

NO CLAIM IS MADE TO THE EXCLUSIVE RIGHT TO USE "CLIP", APART FROM THE MARK AS SHOWN.

FOR PLASTIC BRACKETS, FASTENERS AND CLIPS FOR USE IN THE CONSTRUCTION AND ASSEMBLY OF DECKING (U.S. CLS. 1, 12, 33 AND 50).

MICHAEL ENGEL, EXAMINING ATTORNEY

CLASS 19—(Continued).

SN 85-511,976. OLDCASTLE BUILDING PRODUCTS, INC., ATLANTA, GA. FILED 1-9-2012.

ENDURAMAX

THE MARK CONSISTS OF STANDARD CHARACTERS WITHOUT CLAIM TO ANY PARTICULAR FONT, STYLE, SIZE, OR COLOR.

FOR MASONRY VENEER SYSTEM, NAMELY, NON-METALLIC INSULATING PANELS FOR HOLDING MASONRY VENEER AND MASONRY UNITS COMPRISED OF BRICK, CONCRETE BRICK OR STONE (U.S. CLS. 1, 12, 33 AND 50).

LAKEISHA LEWIS, EXAMINING ATTORNEY

SN 85-512,074. HEARTLAND CEMENT SALES COMPANY, BETHLEHEM, PA. FILED 1-9-2012.

ULTI-PAVE3

THE MARK CONSISTS OF STANDARD CHARACTERS WITHOUT CLAIM TO ANY PARTICULAR FONT, STYLE, SIZE, OR COLOR.

FOR FAST-SETTING CEMENTITIOUS MATERIAL WITH RAPID STRENGTH GAINS FOR PAVEMENT REPAIR (U.S. CLS. 1, 12, 33 AND 50).

FIRST USE 8-13-2007; IN COMMERCE 8-13-2007.
MARK SHINER, EXAMINING ATTORNEY

SN 85-515,793. BORAL STONE PRODUCTS LLC, ROSWELL, GA. FILED 1-13-2012.

DARK RIDGE

THE MARK CONSISTS OF STANDARD CHARACTERS WITHOUT CLAIM TO ANY PARTICULAR FONT, STYLE, SIZE, OR COLOR.

FOR MANUFACTURED STONE; MANUFACTURED STONE VENEER (U.S. CLS. 1, 12, 33 AND 50).
BRIDGETT SMITH, EXAMINING ATTORNEY

CLASS 19—(Continued).

SN 85-519,315. VALCON INDUSTRIES INC., BARRIE, ONTARIO, CANADA, FILED 1-18-2012.



NO CLAIM IS MADE TO THE EXCLUSIVE RIGHT TO USE "COAT", APART FROM THE MARK AS SHOWN.

THE MARK CONSISTS OF THE WORDING "RHINO" ABOVE THE WORDING "COAT", WITH ALL THE AFOREMENTIONED APPEARING BELOW A STYLIZED RHINOCEROS.

FOR CEMENTITIOUS MIX OF PORTLAND CEMENT AND MARBLE FOR APPLICATION TO SWIMMING POOLS (U.S. CLS. 1, 12, 33 AND 50).

KAREN SEVERSON, EXAMINING ATTORNEY

SN 85-520,255. UNILIN FLOORING NC, LLC, CHATSWORTH, GA. FILED 1-19-2012.

RECLAIME

THE MARK CONSISTS OF STANDARD CHARACTERS WITHOUT CLAIM TO ANY PARTICULAR FONT, STYLE, SIZE, OR COLOR.

FOR LAMINATE FLOORING (U.S. CLS. 1, 12, 33 AND 50).

MICHAEL ENGEL, EXAMINING ATTORNEY

SN 85-549,771. LAFARGE NORTH AMERICA INC., RESTON, VA. FILED 2-22-2012.



THE MARK CONSISTS OF A CIRCLE WITH A CUT OUT OF AN OIL DERRICK.

FOR CEMENT (U.S. CLS. 1, 12, 33 AND 50).
TEJBIR SINGH, EXAMINING ATTORNEY

CLASS 19—(Continued).

SN 85-558,953. ALLSTAR MARKETING GROUP, LLC, HAWTHORNE, NY. FILED 3-2-2012.

INSTAPATCH

THE MARK CONSISTS OF STANDARD CHARACTERS WITHOUT CLAIM TO ANY PARTICULAR FONT, STYLE, SIZE, OR COLOR.

FOR COMPOUND MADE OF A TAR BASE USED TO PATCH HOLES IN DRYWALL, PLASTER AND WOOD SOLD IN STICK FORM (U.S. CLS. 1, 12, 33 AND 50).
DOUGLAS LEE, EXAMINING ATTORNEY

CLASS 20—(Continued).

SN 77-916,958. EVR TECHNOLOGY, LLC, BEVERLY HILLS, CA. FILED 1-21-2010.

SIT4EVR

THE MARK CONSISTS OF STANDARD CHARACTERS WITHOUT CLAIM TO ANY PARTICULAR FONT, STYLE, SIZE, OR COLOR.

FOR PORTABLE BACK SUPPORT FOR USE WITH CHAIRS (U.S. CLS. 2, 13, 22, 25, 32 AND 50).
ALEX KEAM, EXAMINING ATTORNEY

CLASS 20—FURNITURE AND ARTICLES NOT OTHERWISE CLASSIFIED

SN 76-709,034. CABER SURE FIT INC., MARKHAM, ONTARIO, CANADA, FILED 9-9-2011.

FABRIC SENSE

THE MARK CONSISTS OF STANDARD CHARACTERS WITHOUT CLAIM TO ANY PARTICULAR FONT, STYLE, SIZE, OR COLOR.

NO CLAIM IS MADE TO THE EXCLUSIVE RIGHT TO USE "FABRIC", APART FROM THE MARK AS SHOWN.

FOR PROTECTIVE COVERS FOR BEDDING, NAMELY, PILLOW COVERS, DUVET COVERS MADE OF TREATED FABRIC; PROTECTIVE COVERS FOR MATTRESSES, MADE OF TREATED FABRIC, UNFITTED PROTECTIVE FABRIC FURNITURE COVERS MADE OF TREATED FABRIC, PROTECTIVE COVERS FOR CUSHIONS MADE OF TREATED FABRIC (U.S. CLS. 2, 13, 22, 25, 32 AND 50).
LAURA HAMMEL, EXAMINING ATTORNEY

SN 79-100,387. VITRA PATENTE AG, SWITZERLAND, FILED 5-27-2011.

GRAND REPOS

THE MARK CONSISTS OF STANDARD CHARACTERS WITHOUT CLAIM TO ANY PARTICULAR FONT, STYLE, SIZE, OR COLOR.

PRIORITY DATE OF 4-5-2011 IS CLAIMED.
OWNER OF INTERNATIONAL REGISTRATION 1085023 DATED 5-27-2011, EXPIRES 5-27-2021.

THE ENGLISH TRANSLATION OF THE FOREIGN WORD(S) IN THE MARK IS: "LARGE QUIETNESS".

FOR HOME FURNITURE, CHAIRS (U.S. CLS. 2, 13, 22, 25, 32 AND 50).
MARLENE BELL, EXAMINING ATTORNEY

SN 77-660,146. BAMBOO-ABBOTT INC., EDISON, NJ. FILED 1-30-2009.

FLORENTINE

THE MARK CONSISTS OF STANDARD CHARACTERS WITHOUT CLAIM TO ANY PARTICULAR FONT, STYLE, SIZE, OR COLOR.

SEC. 2(F).
FOR FABRIC WINDOW BLINDS; WINDOW SHADES (U.S. CLS. 2, 13, 22, 25, 32 AND 50).
FIRST USE 7-1-1998; IN COMMERCE 7-1-1998.
ELLEN B. AWRICH, EXAMINING ATTORNEY

SN 79-101,975. SATO OFFICE GMBH, FED REP GERMANY, FILED 6-14-2011.



PRIORITY DATE OF 12-15-2010 IS CLAIMED.
OWNER OF INTERNATIONAL REGISTRATION 1089172 DATED 6-14-2011, EXPIRES 6-14-2021.

NO CLAIM IS MADE TO THE EXCLUSIVE RIGHT TO USE "OFFICE", APART FROM THE MARK AS SHOWN.
THE COLOR(S) RED AND BLACK IS/ARE CLAIMED AS A FEATURE OF THE MARK.

THE MARK CONSISTS OF THE STYLIZED WORDING "GRAMMER OFFICE" IN BLACK. TO THE LEFT OF THE WORDING, A DESIGN OF TWO CURVED, VERTICAL LINES APPEARS IN RED.

FOR SEATING FURNITURE, NAMELY, OFFICE CHAIRS (U.S. CLS. 2, 13, 22, 25, 32 AND 50).
MARILYN IZZI, EXAMINING ATTORNEY

CLASS 20—(Continued).

SN 79-104,574. DONGGUAN COOMO FURNITURE CO.,LTD, GUANGDONG PROVINCE, CHINA, FILED 9-5-2011.

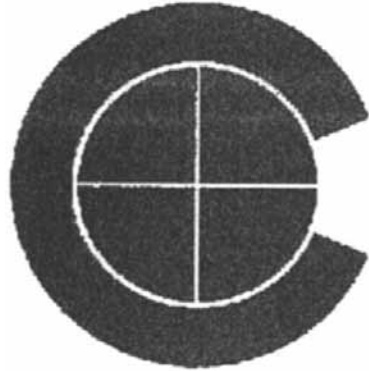

OWNER OF INTERNATIONAL REGISTRATION 1095814 DATED 9-5-2011, EXPIRES 9-5-2021.

THE MARK CONSISTS OF A STYLIZED LETTER "C" SURROUNDING A SOLID CIRCLE DIVIDED INTO FOUR QUARTERS INTENDED TO REPRESENT A SCREW VIEWED FROM ABOVE.

FOR FURNITURE; CHAIRS; MATTRESSES; BEDS; SOFAS; FURNITURE SHELVES; MIRRORS BEING FURNITURE; WORKS OF ART OF WOOD, WAX, PLASTER OR PLASTIC; DOORS FOR FURNITURE; BOLSTERS (U.S. CLS. 2, 13, 22, 25, 32 AND 50).

STEVEN PEREZ, EXAMINING ATTORNEY

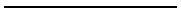

SN 79-105,790. CHEN MIN, CHINA, FILED 11-2-2011.



OWNER OF INTERNATIONAL REGISTRATION 1098485 DATED 11-2-2011, EXPIRES 11-2-2021.

THE MARK CONSISTS OF STYLIZED WORD "ASIS", WITH THE LEFT SLASH OF THE LETTER "A" AND THE BOTTOM PORTION OF BOTH LETTER "S" ERASED.

FOR FURNITURE; SLATTED INDOOR BLINDS; WORKBENCH; FURNITURE, NAMELY, TRESTLES; DOORS FOR FURNITURE; FURNITURE, NAMELY, SHOWCASES; FURNITURE, NAMELY, FLOWER-STANDS; BEDS; PICTURE FRAMES; END TABLE (U.S. CLS. 2, 13, 22, 25, 32 AND 50).

MICHAEL ENGEL, EXAMINING ATTORNEY

CLASS 20—(Continued).

SN 79-106,036. ZHEJIANG SUNBOW ARTS CO.,LTD., ZHEJIANG, CHINA, FILED 8-8-2011.



OWNER OF INTERNATIONAL REGISTRATION 1098887 DATED 8-8-2011, EXPIRES 8-8-2021.

THE MARK CONSISTS OF A STYLIZED DESIGN OF A LETTER "G" AND THE CHINESE CHARACTER FOR THE NUMBER 9.

THE NON-LATIN CHARACTERS IN THE MARK TRANSLITERATE TO "JIU" AND THIS MEANS THE NUMBER "9" IN ENGLISH.

FOR BAMBOO BASKETS FOR TRANSPORTING GOODS FOR COMMERCIAL PURPOSES; BAMBOO TABLES; NON-METAL BOTTLE STOPPERS (U.S. CLS. 2, 13, 22, 25, 32 AND 50).

LINDA M. KING, EXAMINING ATTORNEY

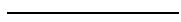

SN 85-093,142. LUBECORE INTERNATIONAL INC., CAMPBELLVILLE, CANADA, FILED 7-26-2010.



OWNER OF U.S. REG. NO. 3,855,380.

THE COLOR(S) BLACK IS/ARE CLAIMED AS A FEATURE OF THE MARK.

THE MARK CONSISTS OF A DESIGN OF THREE INCOMPLETE BLACK MAPLE LEAVES WITH A DROP OF BLACK OIL IN THE CENTER OF THE LEAVES AND THE STYLIZED BLACK WORD "LUBECORE" TO THE RIGHT OF THE LEAVES AND THE BLACK COLOR OF THE CYLINDRICAL GREASE CONTAINER. THE BROKEN LINES DEPICTING THE THREE-DIMENSIONAL SHAPE OF THE GREASE CONTAINER INDICATE PLACEMENT OF THE AFOREMENTIONED MARK ELEMENTS ON THE GOODS AND ARE NOT PART OF THE MARK. THE COLOR GRAY REPRESENTS OUTLINING AND IS NOT PART OF THE MARK.

FOR PLASTIC CONTAINERS, NAMELY, DISPOSABLE AND REFILLABLE, NON-ELECTRIC, INDUSTRIAL RIDGED PLASTIC CONTAINERS FOR DISPENSING CHASSIS GREASE TO INDUSTRIAL APPLICATIONS (U.S. CLS. 2, 13, 22, 25, 32 AND 50).

KRISTIN CARLSON, EXAMINING ATTORNEY

CLASS 20—(Continued).

SN 85-093,172. LUBECORE INTERNATIONAL INC., CAMP-BELLVILLE, CANADA, FILED 7-26-2010.



OWNER OF U.S. REG. NO. 3,855,380.
THE COLOR(S) BLACK, GRAY, RED AND WHITE IS/
ARE CLAIMED AS A FEATURE OF THE MARK.

THE MARK CONSISTS OF A WHITE CAP WITH THREE INCOMPLETE RED MAPLE LEAVES ON THE CAP'S TOP WITH A DROP OF GRAY OIL IN THE CENTER OF THE LEAVES AND THE BLACK COLOR OF THE CYLINDRICAL GREASE CONTAINER. THE BROKEN LINES DEPICTING THE THREE-DIMENSIONAL SHAPE OF THE CAP AND THE THREE-DIMENSIONAL SHAPE OF THE GREASE CONTAINER INDICATE PLACEMENT OF THE AFOREMENTIONED MARK ELEMENTS ON THE GOODS AND ARE NOT PART OF THE MARK. THE COLOR GRAY REPRESENTED IN THE OUTLINING IS NOT PART OF THE MARK.

FOR PLASTIC CONTAINERS, NAMELY, DISPOSABLE AND REFILLABLE, NON-ELECTRIC, INDUSTRIAL RIDGED PLASTIC CONTAINERS FOR DISPENSING CHASSIS GREASE TO INDUSTRIAL APPLICATIONS (U.S. CLS. 2, 13, 22, 25, 32 AND 50).

KRISTIN CARLSON, EXAMINING ATTORNEY

SN 85-119,943. GREEN HARBOUR PTY LTD ITF THE GREEN FAMILY TRUST, TA KIT BAG, MIDVALE, PERTH, AUSTRALIA, FILED 8-31-2010.

RECON

THE MARK CONSISTS OF STANDARD CHARACTERS WITHOUT CLAIM TO ANY PARTICULAR FONT, STYLE, SIZE, OR COLOR.

FOR SLEEPING BAGS (U.S. CLS. 2, 13, 22, 25, 32 AND 50).

FIRST USE 1-0-2000; IN COMMERCE 1-0-2004.
DANIEL CAPSHAW, EXAMINING ATTORNEY

CLASS 20—(Continued).

SN 85-133,381. HOMER TLC, INC., WILMINGTON, DE. FILED 9-20-2010.

Perfect Home Essentials

THE MARK CONSISTS OF STANDARD CHARACTERS WITHOUT CLAIM TO ANY PARTICULAR FONT, STYLE, SIZE, OR COLOR.

OWNER OF U.S. REG. NO. 3,090,873.

NO CLAIM IS MADE TO THE EXCLUSIVE RIGHT TO USE "HOME ESSENTIALS", APART FROM THE MARK AS SHOWN.

FOR CHAIRS; NON-METAL FABRIC STORAGE BIN ORGANIZER; PATIO FURNITURE; SHELVES FOR STORAGE; TABLES (U.S. CLS. 2, 13, 22, 25, 32 AND 50).

LAURA HAMMEL, EXAMINING ATTORNEY

SN 85-220,367. GUARD MASTER INC., FARMINGDALE, NY. FILED 1-18-2011.

GUARD MASTER SLEEP SYSTEM

THE MARK CONSISTS OF STANDARD CHARACTERS WITHOUT CLAIM TO ANY PARTICULAR FONT, STYLE, SIZE, OR COLOR.

NO CLAIM IS MADE TO THE EXCLUSIVE RIGHT TO USE "SLEEP SYSTEM", APART FROM THE MARK AS SHOWN.

FOR LABELED PILLOWS FOR USE BY POTENTIAL CUSTOMERS IN SAMPLING MATTRESSES SOLD BY THIRD PARTIES (U.S. CLS. 2, 13, 22, 25, 32 AND 50).

FIRST USE 10-10-2010; IN COMMERCE 10-10-2010.

TEJBIR SINGH, EXAMINING ATTORNEY

SN 85-330,446. LATINA MEDIA VENTURES LLC, NEW YORK, NY. FILED 5-25-2011.

GOOD LIVING BY LATINA

THE MARK CONSISTS OF STANDARD CHARACTERS WITHOUT CLAIM TO ANY PARTICULAR FONT, STYLE, SIZE, OR COLOR.

THE ENGLISH TRANSLATION OF "LATINA" IN THE MARK IS "LATIN OR LATIN WOMAN".

FOR ACCENT PILLOWS; PICTURE FRAMES; PILLOWS (U.S. CLS. 2, 13, 22, 25, 32 AND 50).

STEPHANIE ALI, EXAMINING ATTORNEY

CLASS 20—(Continued).

SN 85-350,265. SELECT COMFORT CORPORATION, PLYMOUTH, MN. FILED 6-20-2011.

AIRFIT

THE MARK CONSISTS OF STANDARD CHARACTERS WITHOUT CLAIM TO ANY PARTICULAR FONT, STYLE, SIZE, OR COLOR.

FOR BED PILLOWS, BEDS, MATTRESSES, AND MATTRESS TOPPERS (U.S. CLS. 2, 13, 22, 25, 32 AND 50).
DAVID HOFFMAN, EXAMINING ATTORNEY

CLASS 20—(Continued).

SN 85-359,831. HOSLER, ERIC, TACOMA, WA. FILED 6-29-2011.

PURRCH

THE MARK CONSISTS OF STANDARD CHARACTERS WITHOUT CLAIM TO ANY PARTICULAR FONT, STYLE, SIZE, OR COLOR.

FOR MONOPOD SEATS (U.S. CLS. 2, 13, 22, 25, 32 AND 50).
PATRICIA EVANKO, EXAMINING ATTORNEY

SN 85-351,545. ARTSTARKRAFT, INC., SARASOTA, FL. FILED 6-21-2011.

DOCTOR DOOR STOP

THE MARK CONSISTS OF STANDARD CHARACTERS WITHOUT CLAIM TO ANY PARTICULAR FONT, STYLE, SIZE, OR COLOR.

NO CLAIM IS MADE TO THE EXCLUSIVE RIGHT TO USE "DOOR STOP", APART FROM THE MARK AS SHOWN.
FOR DOOR STOPS OF PLASTIC (U.S. CLS. 2, 13, 22, 25, 32 AND 50).

HENRY S. ZAK, EXAMINING ATTORNEY

SN 85-360,335. H.I.S. JUVENILES, DEAL, NJ. FILED 6-30-2011.

PILLOW PAL

THE MARK CONSISTS OF STANDARD CHARACTERS WITHOUT CLAIM TO ANY PARTICULAR FONT, STYLE, SIZE, OR COLOR.

NO CLAIM IS MADE TO THE EXCLUSIVE RIGHT TO USE "PILLOW", APART FROM THE MARK AS SHOWN.

FOR PILLOWS WITH BLANKET STORED WITHIN, SOLD TOGETHER AS A UNIT; PILLOWS DESIGNED FOR STORAGE OF A BLANKET WITHIN (U.S. CLS. 2, 13, 22, 25, 32 AND 50).

FIRST USE 5-1-2011; IN COMMERCE 5-1-2011.

RUDY R. SINGLETON, EXAMINING ATTORNEY

SN 85-351,678. FUN-TIME INTERNATIONAL INC., MALVERN, PA. FILED 6-21-2011.



THE MARK CONSISTS OF THE WORD "FLAV-O-STRAWS" IN STRIPED FONT WITH A HYPHEN BETWEEN "FLAV" AND "O" AND A HYPHEN BETWEEN "O" AND "STRAWS" AND FIVE DROPS POSITIONED OUTWARD FROM THE TOP OF THE "O".

FOR DRINKING STRAWS WITH ADDED SCENT AND/OR FLAVOR (U.S. CLS. 2, 13, 22, 25, 32 AND 50).

JULIE VEPPUMTHARA, EXAMINING ATTORNEY

SN 85-363,351. S2 RESOURCES, DALLAS, TX. FILED 7-5-2011.

VINTAGE FINDS

THE MARK CONSISTS OF STANDARD CHARACTERS WITHOUT CLAIM TO ANY PARTICULAR FONT, STYLE, SIZE, OR COLOR.

NO CLAIM IS MADE TO THE EXCLUSIVE RIGHT TO USE "VINTAGE", APART FROM THE MARK AS SHOWN.

FOR FURNITURE, NAMELY, PICTURE FRAMES, CUPBOARDS, BOOKCASES, WOOD BOXES, WORKS OF ART MADE OF WOOD, ORIENTAL FOLDING PARTITION SCREENS (U.S. CLS. 2, 13, 22, 25, 32 AND 50).

STEVEN PEREZ, EXAMINING ATTORNEY

CLASS 20—(Continued).

SN 85-378,135. BUNKIE CRIBS LLC, NOKOMIS, FL. FILED 7-22-2011.



NO CLAIM IS MADE TO THE EXCLUSIVE RIGHT TO USE "CRIBS" AND "FURNITURE", APART FROM THE MARK AS SHOWN.

THE MARK CONSISTS OF THE WORD "BUNKIE" THEN A PICTURE OF A CRIB WITH A BEAR INSIDE OF IT, THEN THE WORD "CRIBS," UNDER THE WORD "CRIBS" IS THE WORD "FURNITURE".

FOR ROCKING CHAIRS AND INFANT'S FURNITURE (U.S. CLS. 2, 13, 22, 25, 32 AND 50).

FIRST USE 12-10-2008; IN COMMERCE 12-10-2008.
KAREN BRACEY, EXAMINING ATTORNEY

SN 85-386,909. BOYD SPECIALTY SLEEP, MARYLAND HEIGHTS, MO. FILED 8-2-2011.

Planet Sleep

THE MARK CONSISTS OF STANDARD CHARACTERS WITHOUT CLAIM TO ANY PARTICULAR FONT, STYLE, SIZE, OR COLOR.

NO CLAIM IS MADE TO THE EXCLUSIVE RIGHT TO USE "SLEEP", APART FROM THE MARK AS SHOWN.

FOR AIR MATTRESSES FOR USE WHEN CAMPING; BEDS, MATTRESSES, PILLOWS AND BOLSTERS; INFLATABLE MATTRESSES FOR USE WHEN CAMPING; MATTRESS FOUNDATIONS; MATTRESS TOPPERS; MATTRESSES; MATTRESSES AND PILLOWS; SLEEP PRODUCTS, NAMELY, MATTRESSES, SPRING MATTRESSES, BOX SPRINGS AND MATTRESS FOUNDATIONS (U.S. CLS. 2, 13, 22, 25, 32 AND 50).

FIRST USE 2-1-2010; IN COMMERCE 2-1-2010.
SKYE YOUNG, EXAMINING ATTORNEY

SN 85-389,310. HENRY G. COLE, RIO RANCHO, NM. FILED 8-4-2011.



NO CLAIM IS MADE TO THE EXCLUSIVE RIGHT TO USE "DESIGNS", APART FROM THE MARK AS SHOWN.

THE MARK CONSISTS OF THE WORD COMPONENTS "IN" AND "VIEW" AND "DESIGNS" WITH A DARKENED CIRCLE BENEATH THE "V" IN THE WORD COMPONENT "VIEW".

FOR GLASS-FRONTED WOOD FRAMED DISPLAY CASES (U.S. CLS. 2, 13, 22, 25, 32 AND 50).

KAREN BRACEY, EXAMINING ATTORNEY

CLASS 20—(Continued).

SN 85-396,504. TAI-PAN TRADING INTERNATIONAL, INC., SANDY, UT. FILED 8-12-2011.



OWNER OF U.S. REG. NO. 3,347,663.
NO CLAIM IS MADE TO THE EXCLUSIVE RIGHT TO USE "HOME", APART FROM THE MARK AS SHOWN.

THE MARK CONSISTS OF THE STYLIZED WORDING "T P T HOME" WITH THE DESIGN OF GENERALLY HORIZONTAL ART DECO SCROLLS ABOVE AND BELOW THE WORDING.

FOR BATHROOM FURNITURE; BEDROOM FURNITURE; CUSHIONS; CUSTOM FURNITURE; DECORATIONS OF PLASTIC FOR FOODSTUFFS; DECORATIVE BOXES MADE OF WOOD; DECORATIVE WINDOW FINIALS; DECORATIVE WOODEN WALL LETTERS FOR SPELLING NAMES AND WORDS; ENTERTAINMENT CENTERS; FURNITURE; FURNITURE CHESTS; FURNITURE FOR DISPLAYING GOODS; FURNITURE FOR HOUSE, OFFICE AND GARDEN; FURNITURE MADE FROM WOOD OR SUBSTITUTES FOR WOOD; FURNITURE OF METAL; FURNITURE, MIRRORS, PICTURE FRAMES; FURNITURE, NAMELY, DRESSERS; FURNITURE, NAMELY, WARDROBES; HOLIDAY ORNAMENTS OF PLASTIC; LAWN FURNITURE; LIVING ROOM FURNITURE; METAL FURNITURE; MIRRORS; OUTDOOR FURNITURE; PATIO FURNITURE; PICTURE AND PHOTOGRAPH FRAMES; PICTURE FRAMES; PLASTIC FURNITURE FOR GARDENS; POT RACKS; SEATS; TABLES (U.S. CLS. 2, 13, 22, 25, 32 AND 50).

FIRST USE 10-1-2010; IN COMMERCE 10-1-2010.
JAY BESCH, EXAMINING ATTORNEY

SN 85-422,079. LUNDH, JORAN, KOWLOON, HONG KONG, FILED 9-14-2011.

KIDDYGUARD

THE MARK CONSISTS OF STANDARD CHARACTERS WITHOUT CLAIM TO ANY PARTICULAR FONT, STYLE, SIZE, OR COLOR.

PRIORITY CLAIMED UNDER SEC. 44(D) ON ERPNTY TM OFC APPLICATION NO. 009811423, FILED 3-15-2011, REG. NO. 009811423, DATED 10-27-2011, EXPIRES 3-15-2021.

FOR NON-METAL SAFETY GATES AND BARRIERS FOR PREVENTING BABIES, CHILDREN OR PETS FROM PASSING THROUGH DOORWAYS OR STAIRCASES (U.S. CLS. 2, 13, 22, 25, 32 AND 50).

NICHOLAS ALTREE, EXAMINING ATTORNEY

CLASS 20—(Continued).

SN 85-441,889. MARK E. HISLE, EVANSVILLE, IN. FILED 10-7-2011.

SLEEP NATURAL

THE MARK CONSISTS OF STANDARD CHARACTERS WITHOUT CLAIM TO ANY PARTICULAR FONT, STYLE, SIZE, OR COLOR.
FOR MATTRESSES AND PILLOWS MADE OF NATURAL MATERIALS (U.S. CLS. 2, 13, 22, 25, 32 AND 50).
DAVID I, EXAMINING ATTORNEY

SN 85-450,119. FUTURE FOAM, INC., COUNCIL BLUFF, IA. FILED 10-18-2011.

BODYFLEX

THE MARK CONSISTS OF STANDARD CHARACTERS WITHOUT CLAIM TO ANY PARTICULAR FONT, STYLE, SIZE, OR COLOR.
FOR MATTRESSES, MATTRESS TOPPERS AND PILLOWS (U.S. CLS. 2, 13, 22, 25, 32 AND 50).
KYLE PEETE, EXAMINING ATTORNEY

SN 85-463,505. SOCIÉTÉ PARTITION MANUFACTURIERS ASSOCIES (PMA) INC., SAGUENAY (QUEBEC), CANADA, FILED 11-3-2011.



OWNER OF U.S. REG. NO. 3,913,431.
THE MARK CONSISTS OF THE WORD "STARWALL", A SHOOTING STAR CROSSING THE LETTER "S", AND THREE (3) RECTANGLES BELOW THE LETTERS "WALL".
FOR MOVABLE OFFICE PARTITIONS (U.S. CLS. 2, 13, 22, 25, 32 AND 50).
FIRST USE 1-30-2000; IN COMMERCE 1-30-2000.
BARBARA GAYNOR, EXAMINING ATTORNEY

CLASS 20—(Continued).

SN 85-468,272. STYLEX, INC., DELANCO, NJ. FILED 11-9-2011.

GENIUS AT WORK

THE MARK CONSISTS OF STANDARD CHARACTERS WITHOUT CLAIM TO ANY PARTICULAR FONT, STYLE, SIZE, OR COLOR.
FOR FURNITURE, NAMELY, CHAIRS (U.S. CLS. 2, 13, 22, 25, 32 AND 50).
CORY BOONE, EXAMINING ATTORNEY

SN 85-484,703. ZINUS INC., HAYWARD, CA. FILED 12-1-2011.



THE COLOR(S) BLUE IS/ARE CLAIMED AS A FEATURE OF THE MARK.
THE MARK CONSISTS OF BLUE CAPITAL "R" FOLLOWED BY A BLUE SUBSCRIPT "3".
FOR MATTRESSES (U.S. CLS. 2, 13, 22, 25, 32 AND 50).
BRENDAN MCCAULEY, EXAMINING ATTORNEY

SN 85-488,053. ARDEN CORPORATION, BINGHAM FARMS, MI. FILED 12-6-2011.

SNAP DRY

THE MARK CONSISTS OF STANDARD CHARACTERS WITHOUT CLAIM TO ANY PARTICULAR FONT, STYLE, SIZE, OR COLOR.
NO CLAIM IS MADE TO THE EXCLUSIVE RIGHT TO USE "DRY", APART FROM THE MARK AS SHOWN.
FOR CUSHIONS (U.S. CLS. 2, 13, 22, 25, 32 AND 50).
JOHN SCHUYLER YARD, EXAMINING ATTORNEY

CLASS 20—(Continued).

SN 85-503,695. DAVIS, RICHARD W, DBA RICHARD DAVIS INC., LEANDER, TX. FILED 12-26-2011.



THE COLOR(S) DARK PINK AND BLACK IS/ARE CLAIMED AS A FEATURE OF THE MARK.

THE MARK CONSISTS OF A DARK PINK HEART OUTLINED IN BLACK WITH THE WORDS "HEART SAVER 79" INSIDE THE HEART.

FOR COMMERCIAL DISPENSERS FOR PILLS OR CAPSULES SOLD EMPTY (U.S. CLS. 2, 13, 22, 25, 32 AND 50).

HELENE LIWINSKI, EXAMINING ATTORNEY

SN 85-507,240. TREEHANGERS LLC, CHICAGO, IL. FILED 1-2-2012.



NO CLAIM IS MADE TO THE EXCLUSIVE RIGHT TO USE "HANGERS", APART FROM THE MARK AS SHOWN. THE COLOR(S) GREEN IS/ARE CLAIMED AS A FEATURE OF THE MARK.

THE MARK CONSISTS OF A STYLIZED IMAGE OF A GREEN TREE CONSISTING OF A TRUNK AND FOUR LEAVES OUTLINED IN GREEN WITH GREEN STIPPLING, AND THE TRUNK SERVES AS THE FIRST LETTER IN "TREE" IN GREEN TEXT WHICH IS CENTERED AND STACKED ABOVE THE WORD "HANGERS" IN GREEN TEXT. THE COLOR WHITE SERVES AS A BACKGROUND AND IS NOT A PART OF THE MARK. THE STIPPLING IS A FEATURE OF THE MARK.

FOR COAT HANGERS; HANGERS FOR CLOTHES (U.S. CLS. 2, 13, 22, 25, 32 AND 50).

AMY KELLY, EXAMINING ATTORNEY

CLASS 20—(Continued).

SN 85-510,087. MIFORMA, INC., ITASCA, IL. FILED 1-6-2012.

REST BY DESIGN

THE MARK CONSISTS OF STANDARD CHARACTERS WITHOUT CLAIM TO ANY PARTICULAR FONT, STYLE, SIZE, OR COLOR.

FOR MATTRESSES AND PILLOWS (U.S. CLS. 2, 13, 22, 25, 32 AND 50).

ELIZABETH KAJUBI, EXAMINING ATTORNEY

SN 85-510,335. MGM RESORTS INTERNATIONAL, LAS VEGAS, NV. FILED 1-6-2012.

MGM GRAND

THE MARK CONSISTS OF STANDARD CHARACTERS WITHOUT CLAIM TO ANY PARTICULAR FONT, STYLE, SIZE, OR COLOR.

OWNER OF U.S. REG. NOS. 2,540,402, 3,908,061 AND OTHERS.

FOR PILLOWS; MATTRESSES (U.S. CLS. 2, 13, 22, 25, 32 AND 50).

KIMBERLY PERRY, EXAMINING ATTORNEY

SN 85-510,536. BEXCO ENTERPRISES, INC., MONTEBELLO, CA. FILED 1-6-2012.

SOFA SO GOOD

THE MARK CONSISTS OF STANDARD CHARACTERS WITHOUT CLAIM TO ANY PARTICULAR FONT, STYLE, SIZE, OR COLOR.

FOR FURNITURE (U.S. CLS. 2, 13, 22, 25, 32 AND 50).

CHRISTOPHER SIDOTI, EXAMINING ATTORNEY

CLASS 20—(Continued).

SN 85-510,942. OMNIA ITALIAN DESIGN, INC., CHINO, CA. FILED 1-6-2012.

PERSONALIZING COMFORT

THE MARK CONSISTS OF STANDARD CHARACTERS WITHOUT CLAIM TO ANY PARTICULAR FONT, STYLE, SIZE, OR COLOR.

FOR FURNITURE, NAMELY, FINE LEATHER COVERED SOFAS, COUCHES, SECTIONALS, CURVED SOFAS, LOVESEATS, CHAISES, CHAIRS AND OTTOMANS (U.S. CLS. 2, 13, 22, 25, 32 AND 50).

JANICE L. MCMORROW, EXAMINING ATTORNEY

CLASS 20—(Continued).

SN 85-512,519. AMERICAN SIGNATURE, INC., COLUMBUS, OH. FILED 1-10-2012.

MIRACLE FOAM GEL

THE MARK CONSISTS OF STANDARD CHARACTERS WITHOUT CLAIM TO ANY PARTICULAR FONT, STYLE, SIZE, OR COLOR.

OWNER OF U.S. REG. NOS. 2,642,684, 3,069,956 AND 3,550,179.

NO CLAIM IS MADE TO THE EXCLUSIVE RIGHT TO USE "FOAM GEL", APART FROM THE MARK AS SHOWN. FOR BOX SPRINGS; MATTRESSES (U.S. CLS. 2, 13, 22, 25, 32 AND 50).

HENRY S. ZAK, EXAMINING ATTORNEY

SN 85-511,096. BROTHER MAX LIMITED, LONDON, UNITED KINGDOM, FILED 1-7-2012.

SKETCH

THE MARK CONSISTS OF STANDARD CHARACTERS WITHOUT CLAIM TO ANY PARTICULAR FONT, STYLE, SIZE, OR COLOR.

OWNER OF ERPN CMNTY TM OFC REG. NO. 010166544, DATED 12-9-2011, EXPIRES 8-1-2021.

FOR HIGH CHAIRS; HIGH CHAIRS FOR BABIES AND INFANTS; CUSHIONS FOR HIGH CHAIRS; TRAYS, NOT OF METAL, FOR HIGH CHAIRS; NURSERY COTS; TRAVEL COTS; SAFETY COTS; COTS FOR USE BY INFANTS AND CHILDREN (U.S. CLS. 2, 13, 22, 25, 32 AND 50).

JENNIFER WILLISTON, EXAMINING ATTORNEY

SN 85-512,523. AMERICAN SIGNATURE, INC., COLUMBUS, OH. FILED 1-10-2012.

GEL-INFUSED MIRACLE FOAM

THE MARK CONSISTS OF STANDARD CHARACTERS WITHOUT CLAIM TO ANY PARTICULAR FONT, STYLE, SIZE, OR COLOR.

OWNER OF U.S. REG. NOS. 2,642,684, 3,069,956 AND 3,550,179.

NO CLAIM IS MADE TO THE EXCLUSIVE RIGHT TO USE "GEL-INFUSED" AND "FOAM", APART FROM THE MARK AS SHOWN.

FOR BOX SPRINGS; MATTRESSES (U.S. CLS. 2, 13, 22, 25, 32 AND 50).

HENRY S. ZAK, EXAMINING ATTORNEY

SN 85-511,595. STONEBROOKE EQUIPMENT INC., DBA ACROTECH OF MINNESOTA, BURNSVILLE, MN. FILED 1-9-2012.

UltraBench

THE MARK CONSISTS OF STANDARD CHARACTERS WITHOUT CLAIM TO ANY PARTICULAR FONT, STYLE, SIZE, OR COLOR.

FOR WORKBENCHES (U.S. CLS. 2, 13, 22, 25, 32 AND 50).

FIRST USE 2-1-2000; IN COMMERCE 2-1-2000.

JOHN WILKE, EXAMINING ATTORNEY

SN 85-513,296. IDEA NUOVA, INC., NEW YORK, NY. FILED 1-10-2012.

Glam Star

THE MARK CONSISTS OF STANDARD CHARACTERS WITHOUT CLAIM TO ANY PARTICULAR FONT, STYLE, SIZE, OR COLOR.

FOR CHAIRS; CHILDREN'S MATS USED FOR SLEEPING; NAP MATS; SLEEPING MATS (U.S. CLS. 2, 13, 22, 25, 32 AND 50).

FIRST USE 11-20-2011; IN COMMERCE 12-23-2011.

THEODORE MCBRIDE, EXAMINING ATTORNEY

CLASS 20—(Continued).

SN 85-514,350. PACIFIC COAST FEATHER COMPANY,
SEATTLE, WA. FILED 1-11-2012.

EXTREMECLEAN

THE MARK CONSISTS OF STANDARD CHARACTERS
WITHOUT CLAIM TO ANY PARTICULAR FONT, STYLE,
SIZE, OR COLOR.

FOR NATURAL FEATHERS AND DOWN SOLD AS A
COMPONENT OF PILLOWS (U.S. CLS. 2, 13, 22, 25, 32
AND 50).

FIRST USE 8-31-2003; IN COMMERCE 8-31-2003.
TEJBIR SINGH, EXAMINING ATTORNEY

SN 85-514,616. HAYNES, KAITELYN, DBA CUTELY
CRAFTED, WASHINGTON, DC. AND HAYNES, REBECCA,
WASHINGTON, DC. FILED 1-12-2012.

Cutely Crafted

THE MARK CONSISTS OF STANDARD CHARACTERS
WITHOUT CLAIM TO ANY PARTICULAR FONT, STYLE,
SIZE, OR COLOR.

FOR WORKS OF ART OF POLYMER CLAY AND
DUCT TAPE (U.S. CLS. 2, 13, 22, 25, 32 AND 50).

MICHAEL KEATING, EXAMINING ATTORNEY

SN 85-515,036. LAIBE, ERIK, DOWNEY, CA. FILED 1-12-
2012.

Hang Rite

THE MARK CONSISTS OF STANDARD CHARACTERS
WITHOUT CLAIM TO ANY PARTICULAR FONT, STYLE,
SIZE, OR COLOR.

FOR CLOTHES HANGERS (U.S. CLS. 2, 13, 22, 25, 32
AND 50).

KATHERINE M. DUBRAY, EXAMINING ATTORNEY

CLASS 20—(Continued).

SN 85-515,602. SCHULTZ, KATIE, CENTERPORT, NY.
FILED 1-13-2012.

COUCHIE

THE MARK CONSISTS OF STANDARD CHARACTERS
WITHOUT CLAIM TO ANY PARTICULAR FONT, STYLE,
SIZE, OR COLOR.

FOR PILLOWS; PILLOWS, NAMELY, BODY PILLOWS
(U.S. CLS. 2, 13, 22, 25, 32 AND 50).

TRACY WHITTAKER-BROWN, EXAMINING ATTORNEY

SN 85-517,362. SPC RESOURCES, INC., HARTSVILLE, SC.
FILED 1-16-2012.

TWIST-LOK

THE MARK CONSISTS OF STANDARD CHARACTERS
WITHOUT CLAIM TO ANY PARTICULAR FONT, STYLE,
SIZE, OR COLOR.

FOR NON-METAL, NON-MECHANICAL FLANGED
SPOOLS AND REELS FOR SHIPPING AND STORAGE
OF STRAND MATERIAL AND STRAND-LIKE PRO-
DUCTS (U.S. CLS. 2, 13, 22, 25, 32 AND 50).

JAMES LOVELACE, EXAMINING ATTORNEY

CLASS 20—(Continued).

SN 85-520,792. BRECKINRIDGE TAYLOR LLC, DALLAS, TX. FILED 1-19-2012.



THE MARK CONSISTS OF THE SHAPE OF A SOLID COLOR CAPITAL LETTER "B" CONTAINING THE SHAPE OF A CAPITAL LETTER "T" ANGLED AT APPROXIMATELY 45 DEGREES TO THE LEFT IN THE UPPER PORTION OF THE SOLID LETTER "B", WITH THE "T" SHOWN IN A LIGHT SHADED CONTRASTING COLOR OR SHOWN IN THE NEGATIVE AS THE ABSENCE OF THE DARK COLOR USED FOR THE "B" (IF USED ON A COLORED BACKGROUND).

FOR ACCENT PILLOWS; ARMOIRES; BED FRAMES; BED HEADBOARDS; BEDS, MATTRESSES, PILLOWS AND BOLSTERS; BENCHES; BOOKCASES; BOOKSHELVES; BUFFETS; CABINETS; CABINETS FOR DISPLAY PURPOSES; CHAIR CUSHIONS; CHAIRS; CHAISE LOUNGES; CHEVAL FLOOR MIRRORS; CREDENZAS; CUSHIONS; CUSHIONS; DECORATIVE 3D PILLOWS AND CUSHIONS; DESKS; DINING CHAIRS; DINING TABLES; DRESSERS; END TABLES; FITTED FABRIC SLIPCOVERS FOR FURNITURE; FOLDING FLOOR SCREENS; FURNITURE, MIRRORS, PICTURE FRAMES; LOUNGE CHAIRS; MIRROR FRAMES; MIRRORS; NIGHT TABLES; NIGHTSTANDS; OCCASIONAL TABLES; OFFICE CHAIRS; OFFICE DESKS; OFFICE TABLES; OTTOMANS; PATIO FURNITURE; ROOM DIVIDERS; SCULPTURES OF WOOD, PLASTIC, RESIN OR TEXTILES; SEAT CUSHIONS; SHELVES; SHELVES FOR BOOKS; SHELVES FOR STORAGE; SHELVING; SHELVING AND COMPONENT PARTS THEREOF, NAMELY, SHELVES AND BRACKETS SOLD AS A UNIT; SOFAS; SOFT SCULPTURE WALL DECORATIONS; STOOLS; TABLES; WOOD CARVINGS; WRITING DESKS (U.S. CLS. 2, 13, 22, 25, 32 AND 50).

FIRST USE 12-0-2010; IN COMMERCE 12-0-2010.
JOHN DALIER, EXAMINING ATTORNEY

SN 85-542,592. KING KOIL LICENSING COMPANY, INC., CHICAGO, IL. FILED 2-14-2012.

SLEEP COUTURE FROM KING
KOIL

THE MARK CONSISTS OF STANDARD CHARACTERS WITHOUT CLAIM TO ANY PARTICULAR FONT, STYLE, SIZE, OR COLOR.

OWNER OF U.S. REG. NOS. 2,519,613, 3,041,279 AND OTHERS.

NO CLAIM IS MADE TO THE EXCLUSIVE RIGHT TO USE "SLEEP", APART FROM THE MARK AS SHOWN.

FOR BEDS; BOX SPRINGS; MATTRESSES (U.S. CLS. 2, 13, 22, 25, 32 AND 50).

ANNE E. GUSTASON, EXAMINING ATTORNEY

CLASS 20—(Continued).

SN 85-549,097. THE STOW COMPANY, FORMERLY WIND-QUEST COMPANIES, INC, HOLLAND, MI. FILED 2-22-2012.

Live Life, Organized

THE MARK CONSISTS OF STANDARD CHARACTERS WITHOUT CLAIM TO ANY PARTICULAR FONT, STYLE, SIZE, OR COLOR.

FOR FURNITURE FOR HOUSE, OFFICE AND GARDEN; STORAGE AND ORGANIZATION SYSTEMS COMPRISING SHELVES, DRAWERS, CUPBOARDS, BASKETS AND CLOTHES RODS, SOLD AS A UNIT (U.S. CLS. 2, 13, 22, 25, 32 AND 50).

FIRST USE 2-10-2012; IN COMMERCE 2-10-2012.
KELLY TRUSILO, EXAMINING ATTORNEY

SN 85-576,723. MUSIDOR B.V., AMSTERDAM, NETHERLANDS, FILED 3-22-2012.

THE STONES

THE MARK CONSISTS OF STANDARD CHARACTERS WITHOUT CLAIM TO ANY PARTICULAR FONT, STYLE, SIZE, OR COLOR.

OWNER OF U.S. REG. NOS. 3,035,916 AND 4,109,006.
FOR BULLETIN BOARDS (U.S. CLS. 2, 13, 22, 25, 32 AND 50).

GENE MACIOL, EXAMINING ATTORNEY

CLASS 21—HOUSEWARES AND GLASS

SN 76-674,818. JOHNSON & JOHNSON, NEW BRUNSWICK, NJ. FILED 3-29-2007.



THE MARK CONSISTS OF THE STYLIZED WORDING "ONE".

FOR TOOTHBRUSHES (U.S. CLS. 2, 13, 23, 29, 30, 33, 40 AND 50).

FIRST USE 1-17-2007; IN COMMERCE 1-17-2007.
SANI KHOURI, EXAMINING ATTORNEY

CLASS 21—(Continued).

SN 76-698,423. ALL SEASONS FEEDERS, INC., SAN ANTONIO, TX. FILED 7-15-2009.

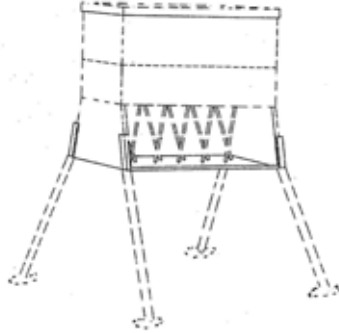

OWNER OF U.S. REG. NOS. 3,010,110, 3,486,761 AND 3,574,360.

THE MARK CONSISTS OF A THREE-DIMENSIONAL CONFIGURATION OF A HAY FEEDER DESIGN WHICH CONSISTS OF RECTANGULAR FOUR-WALL UPPER HOUSING HAVING A LID ENGAGED TO FIT THEREUPON, THE OPENING BELOW THE UPPER HOUSING WITH TWO SIDE WALLS AND A FLOOR, IT HAS NINE SLANTED VERTICAL BARS, AND FOUR LEGS WITH CIRCULAR FEET ANGLED OUTWARD AND ENGAGING THE CORNERS OF THE LOWER OPENING. THE MATTER SHOWN IN DOTTED OR BROKEN LINES IS NOT PART OF THE MARK. THE MATTER SHOWN IN THE DRAWING THAT IS DOTTED OR BROKEN LINES IS NOT PART OF THE MARK.

SEC. 2(F).

FOR ANIMAL AND WILDLIFE FEEDERS, NAMELY, ANIMAL ACTIVATED ANIMAL AND WILDLIFE FEEDERS; NON-MECHANIZED ANIMAL AND WILDLIFE FEEDERS (U.S. CLS. 2, 13, 23, 29, 30, 33, 40 AND 50).

FIRST USE 1-1-2000; IN COMMERCE 1-1-2000.

MARLENE BELL, EXAMINING ATTORNEY

CLASS 21—(Continued).

FEEDER. THE FLAT BOTTOM WALL OF BOTH HOUSINGS JOINED TOGETHER AND BOTH HOUSINGS BEING INTEGRAL WITH THE LOWER END OF THE RECTANGULAR UPPER COMPARTMENT. THE DOTTED LINES SHOW THE POSITION OF THE LIDS, THE OPEN SECTION THAT HOLDS THE FEED, THE VERTICAL BARS WHERE THE CONTAINER OPENS AND THE FOUR ANGLES LEGS WITH CIRCULAR FEET. THE MATTER SHOWN IN DOTTED OR BROKEN LINES IS NOT PART OF THE MARK.

SEC. 2(F).

FOR ANIMAL AND WILDLIFE FEEDERS, NAMELY, ANIMAL ACTIVATED ANIMAL AND WILDLIFE FEEDERS; NON-MECHANIZED ANIMAL AND WILDLIFE FEEDERS (U.S. CLS. 2, 13, 23, 29, 30, 33, 40 AND 50).

FIRST USE 1-1-2000; IN COMMERCE 1-1-2000.

MARLENE BELL, EXAMINING ATTORNEY

SN 79-102,663. KONINKLIJKE PHILIPS ELECTRONICS N.V., NETHERLANDS, FILED 5-30-2011.

SN 76-698,424. ALL SEASONS FEEDERS, INC., SAN ANTONIO, TX. FILED 7-15-2009.

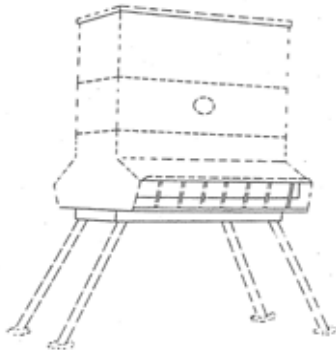

OWNER OF U.S. REG. NOS. 3,486,761 AND 3,574,360.

THE MARK CONSISTS OF A THREE-DIMENSIONAL CONFIGURATION OF A RECTANGULAR ANIMAL FEEDER WITH A LID AT THE TOP THEREOF AND, AT THE BOTTOM THEREOF, A PAIR OF OPPOSED HOUSINGS, EACH HOUSING HAS A DOWNWARD SLOPED TOP WALL, TWO SIDE WALLS, AND A FLAT BOTTOM WALL. THE OPENING HAS SEVEN VERTICAL BARS. THE FEEDER HAS FOUR LEGS WITH CIRCULAR FEET ANGLED OUTWARD THAT EXTEND FROM THE BASE OF THE

DIAMOND CLEAN

THE MARK CONSISTS OF STANDARD CHARACTERS WITHOUT CLAIM TO ANY PARTICULAR FONT, STYLE, SIZE, OR COLOR.

PRIORITY DATE OF 12-7-2010 IS CLAIMED.

OWNER OF INTERNATIONAL REGISTRATION 1090964 DATED 5-30-2011, EXPIRES 5-30-2021.

NO CLAIM IS MADE TO THE EXCLUSIVE RIGHT TO USE "CLEAN", APART FROM THE MARK AS SHOWN.

FOR TOOTHBRUSHES AND ELECTRIC TOOTHBRUSHES; APPARATUS FOR CLEANING TEETH AND GUMS USING HIGH PRESSURE WATER FOR HOME USE; DENTAL FLOSSING AIDS SOLD AS A UNIT WITH DENTAL FLOSS; APPARATUS WHICH USE WATER AND AIR FOR DENTAL CARE FOR HOME USE (U.S. CLS. 2, 13, 23, 29, 30, 33, 40 AND 50).

JESSICA A. POWERS, EXAMINING ATTORNEY

CLASS 21—(Continued).

SN 79-102,848. ZWIESEL KRISTALLGLAS AG, FED REP GERMANY, FILED 1-25-2011.



OWNER OF INTERNATIONAL REGISTRATION 0786814 DATED 8-13-2002, EXPIRES 8-13-2012.

THE MARK CONSISTS OF THE STYLIZED LETTER "Z" FORMED BY THREE ZIG-ZAG SHAPED BANDS.

FOR HOUSEHOLD BEVERAGE GLASSWARE AND TABLE BEVERAGE GLASSWARE; STEMWARE; DRINKING GLASSES, NAMELY, TUMBLERS AND FANCY GLASSES; ORNAMENTAL AND FANCY ARTICLES AND GLASSWARE, NAMELY, VASES, CANDLESTICKS, FIGURINES, DECORATIVE GLASS, WORKS OF ART, DRINKING GLASSES, BEVERAGeware, BOWLS, DISHES, CUPS, PLATES, MUGS, JUGS, PANS, POTS, BOTTLES SOLD EMPTY, CARAFES, DECANTERS, CONTAINERS FOR STORING OR COOKING FOOD OR LIQUIDS FOR KITCHEN PURPOSES, ALL OF THE AFOREMENTIONED MADE FROM GLASS, CRYSTAL GLASS AND LEAD-BASED CRYSTAL (U.S. CLS. 2, 13, 23, 29, 30, 33, 40 AND 50).

JAY BESCH, EXAMINING ATTORNEY

CLASS 21—(Continued).

SN 79-105,040. GÉRARD LEHMANN, FRANCE, FILED 10-26-2011.



PRIORITY DATE OF 5-23-2011 IS CLAIMED.
OWNER OF INTERNATIONAL REGISTRATION 1096803 DATED 10-26-2011, EXPIRES 10-26-2021.

NO CLAIM IS MADE TO THE EXCLUSIVE RIGHT TO USE "DESIGN", APART FROM THE MARK AS SHOWN.

THE COLOR(S) GRAY AND ORANGE IS/ARE CLAIMED AS A FEATURE OF THE MARK.

THE MARK CONSISTS OF THE STYLIZED GRAY WORDING "LEHMANN DESIGN" APPEARING UNDERNEATH A GRAPHIC OF A GRAY LETTER "L" AND ORANGE SQUARE.

FOR HOUSEHOLD OR KITCHEN UTENSILS, NAMELY, POT AND PAN SCRAPERS, ROLLING PINS, SPATULAS, TURNERS AND WHISKS; HOUSEHOLD CONTAINERS, NAMELY, WINE AND CHAMPAGNE BUCKETS; KITCHEN CONTAINERS; COMBS; SPONGES FOR HOUSEHOLD CLEANING; METAL SPONGES FOR HOUSEHOLD USE; CLEANING BRUSHES FOR HOUSEHOLD USE; CLEANING BRUSHES FOR BOTTLES AND CARAFES, POT CLEANING BRUSHES; MATERIAL FOR BRUSH-MAKING; STEEL WOOL; UNWORKED OR SEMI- WORKED GLASS; BEVERAGE GLASSWARE, NAMELY, TASTING GLASSES, CARAFES, CHAMPAGNE FLUTES, FLASKS, DECANTERS, WINE GLASSES; CUPS, PLATES, BOWLS, SERVING TRAYS, KNIFE RESTS AND MUGS OF PORCELAIN AND EARTHENWARE (U.S. CLS. 2, 13, 23, 29, 30, 33, 40 AND 50).

ALYSSA STEEL, EXAMINING ATTORNEY

CLASS 21—(Continued).

SN 79-105,041. GÉRARD LEHMANN, FRANCE, FILED 10-26-2011.



PRIORITY DATE OF 5-23-2011 IS CLAIMED.
OWNER OF INTERNATIONAL REGISTRATION 1096804 DATED 10-26-2011, EXPIRES 10-26-2021.

NO CLAIM IS MADE TO THE EXCLUSIVE RIGHT TO USE "GLASS", APART FROM THE MARK AS SHOWN.

THE COLOR(S) GRAY AND ORANGE IS/ARE CLAIMED AS A FEATURE OF THE MARK.

THE MARK CONSISTS OF THE STYLIZED GRAY WORDING "LEHMANN GLASS" APPEARING UNDERNEATH A GRAPHIC OF A GRAY LETTER "L" AND ORANGE SQUARE.

FOR HOUSEHOLD OR KITCHEN UTENSILS, NAMELY, POT AND PAN SCRAPERS, ROLLING PINS, SPATULAS, TURNERS AND WHISKS; HOUSEHOLD CONTAINERS, NAMELY, WINE AND CHAMPAGNE BUCKETS; KITCHEN CONTAINERS; COMBS; SPONGES FOR HOUSEHOLD CLEANING; METAL SPONGES FOR HOUSEHOLD USE; CLEANING BRUSHES FOR HOUSEHOLD USE, CLEANING BRUSHES FOR BOTTLES AND CARAFES, POT CLEANING BRUSHES; MATERIAL FOR BRUSH-MAKING; STEEL WOOL; UNWORKED OR SEMI- WORKED GLASS; BEVERAGE GLASSWARE, NAMELY, TASTING GLASSES, CARAFES, CHAMPAGNE FLUTES, FLASKS, DECANTERS, WINE GLASSES; CUPS, PLATES, BOWLS, SERVING TRAYS, KNIFE RESTS AND MUGS OF PORCELAIN AND EARTHENWARE (U.S. CLS. 2, 13, 23, 29, 30, 33, 40 AND 50).

ALYSSA STEEL, EXAMINING ATTORNEY

SN 85-048,708. PARIS PRESENTS INCORPORATED, GURNEE, IL. FILED 5-26-2010.



THE COLOR(S) GREEN AND BROWN IS/ARE CLAIMED AS A FEATURE OF THE MARK.

THE MARK CONSISTS OF THE TRADE DRESS CHARACTERIZING PACKAGING FOR THE GOODS. THE PACKAGE COMPRISES A VERTICALLY ORIENTED RECTANGLE WITH A HORIZONTAL BROWN RECTANGLE IN THE CENTER WITH LIGHT BROWN PERIMETER STITCHING, WITH THE TOP PORTION OF THE PACKAGE COMPRISING A CLOSURE FEATURE AND AN OPENING FOR HANGING THE PACKAGING AND LIGHT BROWN STITCHING ALONG THE ENTIRE PERIMETER OF THE VERTICALLY ORIENTED RECTANGLE AND A GREEN

CLASS 21—(Continued).

FLORAL DESIGN ON THE LEFT THAT EXTENDS FROM A LEVEL ROUGHLY THE MIDDLE OF THE HORIZONTAL RECTANGLE UP THE CLOSURE FEATURE OF THE PACKAGING, ANOTHER GREEN FLORAL DESIGN IN THE UPPER RIGHT CORNER THAT BEGINS AT THE CLOSURE FEATURE AND ENDS AT THE BROWN STITCHING AND A THIRD GREEN FLORAL DESIGN AT THE BOTTOM RIGHT OF THE PACKAGE THAT BEGINS SLIGHTLY ABOVE THE UPPER-MOST LEVEL OF THE CENTERED RECTANGLE AND EXTENDS DOWN TO THE BOTTOM EDGE OF THE PACKAGING IN AN APPROXIMATION OF A RIGHT TRIANGLE. THE COLOR WHITE IN THE MARK REPRESENTS TRANSPARENT AREAS AND IS NOT CLAIMED AS A FEATURE OF THE MARK. THE BLACK DOTTED LINES SURROUNDING THE ENTIRE PACKAGE IDENTIFYING THE OVERALL SHAPE OF THE PACKAGE, THE BLACK DOTTED LINES OUTLINING THE OPENING FOR HANGING THE PACKAGING AND THE THREE HORIZONTAL BLACK DOTTED LINES IN THE TOP PORTION OF THE PACKAGE REPRESENTING THE CLOSURE FEATURE REPRESENT FEATURES OF THE MARK THAT SHOW PLACEMENT OF THE MARK AND ARE NOT CLAIMED FEATURES OF THE MARK.

SEC. 2(F).

FOR COSMETIC BRUSHES (U.S. CLS. 2, 13, 23, 29, 30, 33, 40 AND 50).

FIRST USE 12-31-2007; IN COMMERCE 12-31-2007.

RONALD AIKENS, EXAMINING ATTORNEY

SN 85-125,111. ST. JACQUES, STEFAN, OTTAWA, ONTARIO, CANADA, FILED 9-8-2010.

STAYBOWLIZER

THE MARK CONSISTS OF STANDARD CHARACTERS WITHOUT CLAIM TO ANY PARTICULAR FONT, STYLE, SIZE, OR COLOR.

PRIORITY CLAIMED UNDER SEC. 44(D) ON CANADA APPLICATION NO. 1479453, FILED 5-3-2010, REG. NO. TMA821991, DATED 4-11-2012, EXPIRES 4-22-2027.

FOR COOKWARE, NAMELY, BOWL STANDS (U.S. CLS. 2, 13, 23, 29, 30, 33, 40 AND 50).

SCOTT BIBB, EXAMINING ATTORNEY

SN 85-133,388. HOMER TLC, INC., WILMINGTON, DE. FILED 9-20-2010.

Perfect Home Essentials

THE MARK CONSISTS OF STANDARD CHARACTERS WITHOUT CLAIM TO ANY PARTICULAR FONT, STYLE, SIZE, OR COLOR.

OWNER OF U.S. REG. NO. 3,090,873.

NO CLAIM IS MADE TO THE EXCLUSIVE RIGHT TO USE "HOME ESSENTIALS", APART FROM THE MARK AS SHOWN.

FOR GENERAL PURPOSE STORAGE BINS FOR HOUSEHOLD USE; TRASH CANS (U.S. CLS. 2, 13, 23, 29, 30, 33, 40 AND 50).

LAURA HAMMEL, EXAMINING ATTORNEY

CLASS 21—(Continued).

SN 85-185,666. PAPAVERO, ANTHONY T, REDLANDS, CA. AND PAPAVERO, EMILY A., REDLANDS, CA. FILED 11-27-2010.

Butter Up

THE MARK CONSISTS OF STANDARD CHARACTERS WITHOUT CLAIM TO ANY PARTICULAR FONT, STYLE, SIZE, OR COLOR.

FOR HOUSEHOLD UTENSILS, NAMELY, BUTTER APPLICATOR FOR FOODS (U.S. CLS. 2, 13, 23, 29, 30, 33, 40 AND 50).

ANN E. SAPPENFIELD, EXAMINING ATTORNEY

CLASS 21—(Continued).

SN 85-320,608. JOHLES, AARON, SANTA MONICA, CA. FILED 5-13-2011.



NO CLAIM IS MADE TO THE EXCLUSIVE RIGHT TO USE "IBIZA" AND "HAIR", APART FROM THE MARK AS SHOWN.

THE MARK CONSISTS OF A RECTANGLE WITH A VERTICAL LINE RUNNING FROM JUST INSIDE THE TOP OF THE RECTANGLE OUT THE BOTTOM, A HORIZONTAL LINE EXTENDS FROM THE CENTER OF THE VERTICAL LINE AND RUNS OUT THE OF THE RECTANGLE TO THE RIGHT, THE WORD ELEMENTS "IBIZA" AND "HAIR" APPEAR STACKED IN STYLIZED FONT TO THE RIGHT OF THE DESIGN AND ARE SEPARATED BY A HORIZONTAL LINE.

THE WORDING "IBIZA" HAS NO MEANING IN A FOREIGN LANGUAGE.

FOR COMBS; COSMETIC BRUSHES; HAIR BRUSHES (U.S. CLS. 2, 13, 23, 29, 30, 33, 40 AND 50).

FIRST USE 9-0-2000; IN COMMERCE 9-0-2000.

JEFF DEFORD, EXAMINING ATTORNEY

SN 85-251,698. BKD ACQUISITION, INC., OAKBROOK, IL. FILED 2-25-2011.

BUG POD

THE MARK CONSISTS OF STANDARD CHARACTERS WITHOUT CLAIM TO ANY PARTICULAR FONT, STYLE, SIZE, OR COLOR.

NO CLAIM IS MADE TO THE EXCLUSIVE RIGHT TO USE "BUG", APART FROM THE MARK AS SHOWN.

FOR COMBINATION SCOOP FOR GATHERING BATH TOYS AND PLASTIC STORAGE CONTAINER FOR BATH PRODUCTS AND ACCESSORIES, NAMELY, BATH SOAP, SHAMPOO, CONDITIONER, WASH-CLOTHS, BATH POUFS (U.S. CLS. 2, 13, 23, 29, 30, 33, 40 AND 50).

FIRST USE 12-8-2008; IN COMMERCE 12-8-2008.

AMY KELLY, EXAMINING ATTORNEY

SN 85-351,312. STEWART C. GAERDNER, NORTH ATTLEBORO, MA. FILED 6-21-2011.



NO CLAIM IS MADE TO THE EXCLUSIVE RIGHT TO USE THE PICTORIAL REPRESENTATION OF A HUMMINGBIRD AND "NO CLEANING NO MESS", APART FROM THE MARK AS SHOWN.

THE COLOR(S) WHITE, BLACK, RED, BROWN, BURNT ORANGE, AND GREY IS/ARE CLAIMED AS A FEATURE OF THE MARK.

THE MARK CONSISTS OF THE WORDS "THE HUMM" IN RED, THE WORDS "NO CLEANING NO MESS" IN BLACK, A HUMMINGBIRD WITH A BLACK BEAK, BLACK EYE AND BLACK FEET, A BROWN, WHITE AND BURNT ORANGE HEAD AND BODY, A RED THROAT, AND GREY WINGS.

FOR BIRD FEEDERS (U.S. CLS. 2, 13, 23, 29, 30, 33, 40 AND 50).

FIRST USE 10-1-2008; IN COMMERCE 10-1-2008.

ANTHONY RINKER, EXAMINING ATTORNEY

CLASS 21—(Continued).

SN 85-353,981. WILDGAME INNOVATIONS, LLC, BROUSSARD, LA. FILED 6-23-2011.

**NATURE SHOPPE SWINGING
BLOCK**

THE MARK CONSISTS OF STANDARD CHARACTERS WITHOUT CLAIM TO ANY PARTICULAR FONT, STYLE, SIZE, OR COLOR.

NO CLAIM IS MADE TO THE EXCLUSIVE RIGHT TO USE "SHOPPE SWINGING BLOCK", APART FROM THE MARK AS SHOWN.

FOR COMBINATION FEED BLOCK, TREAT BLOCK, AND SWING TOY FOR SQUIRRELS (U.S. CLS. 2, 13, 23, 29, 30, 33, 40 AND 50).

BRIAN CALLAGHAN, EXAMINING ATTORNEY

CLASS 21—(Continued).

SN 85-406,973. SCHROEDER & TREMAYNE, INC., ST. LOUIS, MO. FILED 8-25-2011.



OWNER OF U.S. REG. NO. 4,020,390.
NO CLAIM IS MADE TO THE EXCLUSIVE RIGHT TO USE "KITCHEN", APART FROM THE MARK AS SHOWN.

THE MARK CONSISTS OF A RECTANGLE DESIGN WITH THE STYLIZED WORDING "KITCHEN BASICS" INSIDE THE RECTANGLE AND WITH A FORK AND KNIFE DESIGN REPRESENTING THE "I" IN "KITCHEN" AND "BASICS". THE OUTER RECTANGLE IS INTENDED TO DELINEATE THE LIMIT OF THE MARK, AND IS NOT CLAIMED AS A FEATURE OF THE MARK.

FOR CLEANING CLOTHS MADE OF MICROFIBER FABRIC (U.S. CLS. 2, 13, 23, 29, 30, 33, 40 AND 50).

LESLIE RICHARDS, EXAMINING ATTORNEY

SN 85-356,063. PLANT PIE, LLC, POMPTON PLAINS, NJ. FILED 6-24-2011.

Plant Pie

THE MARK CONSISTS OF STANDARD CHARACTERS WITHOUT CLAIM TO ANY PARTICULAR FONT, STYLE, SIZE, OR COLOR.

NO CLAIM IS MADE TO THE EXCLUSIVE RIGHT TO USE "PLANT", APART FROM THE MARK AS SHOWN.

FOR PLANTERS FOR FLOWERS AND PLANTS (U.S. CLS. 2, 13, 23, 29, 30, 33, 40 AND 50).

FIRST USE 3-1-2006; IN COMMERCE 5-1-2006.

MATTHEW EINSTEIN, EXAMINING ATTORNEY

SN 85-411,671. COOPER & COMPANY, INC., CINCINNATI, OH. FILED 8-31-2011.

SUPP STUFF

SN 85-399,640. YEDI, INC., LOS ANGELES, CA. FILED 8-16-2011.



NO CLAIM IS MADE TO THE EXCLUSIVE RIGHT TO USE "HOME", APART FROM THE MARK AS SHOWN.

THE COLOR(S) BEIGE AND GRAY IS/ARE CLAIMED AS A FEATURE OF THE MARK.

THE MARK CONSISTS OF THE WORD "BOTERO" IN BEIGE WITH THE WORD "HOME" IN GRAY BELOW AND IN SMALLER FONT WITH A BEIGE CURVED LINE UNDERNEATH THE WORD "HOME".

FOR COFFEE CUPS, TEA CUPS, NON-ELECTRIC TEAPOTS, MUGS, PLATES, BOWLS, DRINKING GLASSES, TEA SETS, SUGAR AND CREAMER SETS (U.S. CLS. 2, 13, 23, 29, 30, 33, 40 AND 50).

FIRST USE 8-15-2011; IN COMMERCE 8-15-2011.

DAVID MURRAY, EXAMINING ATTORNEY

THE MARK CONSISTS OF STANDARD CHARACTERS WITHOUT CLAIM TO ANY PARTICULAR FONT, STYLE, SIZE, OR COLOR.

FOR PLASTIC CONTAINERS FOR HOUSEHOLD STORAGE OF FOOD PRODUCTS AND DIETARY SUPPLEMENTS; PERSONAL PLASTIC DISPENSERS FOR NUTRITIONAL SUPPLEMENTS FOR DOMESTIC USE; PLASTIC CONTAINERS FOR STORAGE OF FOOD PRODUCTS AND DIETARY SUPPLEMENTS FOR PERSONAL USE (U.S. CLS. 2, 13, 23, 29, 30, 33, 40 AND 50).

HANNO RITTNER, EXAMINING ATTORNEY

CLASS 21—(Continued).

SN 85-423,366. JIF CORP., WHEELING, IL. FILED 9-15-2011.

JIF·FOIL

THE MARK CONSISTS OF THE TERMS "JIF" AND "FOIL" SEPARATED BY A PERIOD, ALL BEING IN SHADOWED OUTLINED LETTERS.

FOR NON-ELECTRIC ALUMINUM AND ROASTING PANS WITH PLASTIC LIDS, CONTAINERS FORMED OF ALUMINUM FOIL WITH PLASTIC LIDS FOR HOUSEHOLD USE, PANS FORMED OF ALUMINUM FOIL WITH WIRE HANDLES AND PLASTIC LIDS, AND PANS FORMED OF ALUMINUM FOIL WITH PLASTIC LIDS (U.S. CLS. 2, 13, 23, 29, 30, 33, 40 AND 50).

FIRST USE 9-30-2011; IN COMMERCE 9-30-2011.
KAPIL BHANOT, EXAMINING ATTORNEY

SN 85-446,320. OOPSA DAISY LLC, HAWTHORNE, NJ. FILED 10-13-2011.



NO CLAIM IS MADE TO THE EXCLUSIVE RIGHT TO USE "GARDEN FLOWER FRAMES", APART FROM THE MARK AS SHOWN.

THE MARK CONSISTS OF WHITE LETTERING ON A BLACK BACKGROUND. THE FIRST LINE CONSISTS OF THE WORD "POTTY". THE WORD TO THE RIGHT OF "POTTY" IS "MOUTH" WITH A PLANT TAKING THE PLACE OF THE "O" IN "MOUTH". ON THE LINE BELOW STARTING UNDER THE MIDDLE OF THE "M" IN "MOUTH" IS THE WORD "GARDEN". ON THE SAME LINE TO THE RIGHT OF THE WORD "GARDEN" ARE THE WORDS "FLOWER FRAMES".

FOR FLOWER POTS, FLOWER AND PLANT PLANTERS (U.S. CLS. 2, 13, 23, 29, 30, 33, 40 AND 50).
JENNIFER VASQUEZ, EXAMINING ATTORNEY

SN 85-462,243. GRACE MANUFACTURING INC., RUSSELLVILLE, AR. FILED 11-2-2011.

MICROPLANE

THE MARK CONSISTS OF STANDARD CHARACTERS WITHOUT CLAIM TO ANY PARTICULAR FONT, STYLE, SIZE, OR COLOR.

FOR HOUSEHOLD UTENSILS, NAMELY, HAND OPERATED SPICE AND CHEESE GRATERS AND FRUIT PEEL GRATER USED AS A ZESTER (U.S. CLS. 2, 13, 23, 29, 30, 33, 40 AND 50).

FIRST USE 12-14-2000; IN COMMERCE 12-14-2000.
LINDA M. KING, EXAMINING ATTORNEY

CLASS 21—(Continued).

SN 85-463,087. SEB, SELONGEY, FRANCE, FILED 11-2-2011.

ULTRACRISP

THE MARK CONSISTS OF STANDARD CHARACTERS WITHOUT CLAIM TO ANY PARTICULAR FONT, STYLE, SIZE, OR COLOR.

PRIORITY CLAIMED UNDER SEC. 44(D) ON FRANCE APPLICATION NO. 113833855, FILED 5-23-2011, REG. NO. 113833855, DATED 5-23-2011, EXPIRES 5-22-2021.

FOR NON-ELECTRIC COOKING UTENSILS, NAMELY, BASKETS FOR FRENCH FRIES (U.S. CLS. 2, 13, 23, 29, 30, 33, 40 AND 50).

TINA L. SNAPP, EXAMINING ATTORNEY

SN 85-470,639. JONES, ANA, KATY, TX. FILED 11-11-2011.



NO CLAIM IS MADE TO THE EXCLUSIVE RIGHT TO USE "SILICONE BAKEWARE", APART FROM THE MARK AS SHOWN.

THE MARK CONSISTS OF A SQUARE FILLED WITH THIN VERTICAL LINES ALONG THE LEFT AND RIGHT. IN THE CENTER IS A WIDE VERTICAL RECTANGLE COVERED IN SMALL DOTS. IN THE CENTER OF THE SQUARE, OVERLAPPING THE VERTICAL RECTANGLE IS A FLOWER-SHAPED OUTLINE WITH A BORDER AROUND IT. INSIDE THE OUTLINE IS AN IMAGE OF A CUPCAKE WITH A SWIRL ON TOP AND VARIOUS TRIANGULAR CONFETTI FLAKES ON IT. AROUND THE BASE OF THE CUPCAKE IS AN OVAL. BELOW THE OVAL IS THE STYLIZED TEXT "POLYMEROSE" ABOVE THE STYLIZED TEXT "SILICONE BAKEWARE".

FOR SILICONE BAKEWARE (U.S. CLS. 2, 13, 23, 29, 30, 33, 40 AND 50).
ROBIN CHOSID, EXAMINING ATTORNEY

CLASS 21—(Continued).

SN 85-485,501. ROYALTON OVERSEAS LIMITED, ROAD TOWN, TORTOLA, BR.VIRGIN ISLANDS, FILED 12-2-2011.



THE COLOR(S) BLACK, RED AND WHITE IS/ARE CLAIMED AS A FEATURE OF THE MARK.

THE MARK CONSISTS OF THE STYLIZED WORD "BERGNER" IN BLACK BELOW AN INCOMPLETE SQUARE DESIGN IN RED WITH A VERTICAL WHITE RECTANGLE AND A PERPENDICULAR WHITE QUADRILATERAL.

THE WORDING "BERGNER" HAS NO MEANING IN A FOREIGN LANGUAGE.

FOR ALL PURPOSE PORTABLE HOUSEHOLD CONTAINERS; BOTTLE OPENERS; CERAMIC SCULPTURES, VASES, VESSELS, BOWLS, PLATES AND POTS; COFFEE SERVICES; CONTAINERS FOR HOUSEHOLD OR KITCHEN USE NOT OF PRECIOUS METAL; COOKING POT SETS; COOKING POTS AND PANS; COOKING STEAMERS; COOKING UTENSILS, NAMELY, GRILLS; COOKWARE, NAMELY, STEAMERS; CUPS; DRINKING VESSELS; FLASKS; FRYING PANS; GRIDDLES; HOUSEHOLD UTENSILS, NAMELY, SIEVES, POT AND PAN SCRAPERS, ROLLING PINS, SPATULAS, TURNERS, WHISKS; NON-ELECTRIC FOOD BLENDERS; NON-ELECTRIC KETTLES; PANS; PIZZA PEELS; SERVING FORKS; SERVING SPOONS; SERVING TRAYS; TEA SERVICES; TRAYS FOR DOMESTIC PURPOSES; VACUUM BOTTLES; VACUUM FLASKS (U.S. CLS. 2, 13, 23, 29, 30, 33, 40 AND 50).

EDWARD FENNESSY, EXAMINING ATTORNEY

SN 85-487,745. TWO LITTLE FISHIES, INC., MIAMI GARDENS, FL. FILED 12-6-2011.

BETTAMAG

THE MARK CONSISTS OF STANDARD CHARACTERS WITHOUT CLAIM TO ANY PARTICULAR FONT, STYLE, SIZE, OR COLOR.

FOR SCRAPERS FOR HOUSEHOLD PURPOSES, NAMELY, SCRAPERS INCORPORATING CLEANING PADS AND MAGNETS FOR CLEANING AQUARIUMS (U.S. CLS. 2, 13, 23, 29, 30, 33, 40 AND 50).

GINA FINK, EXAMINING ATTORNEY

CLASS 21—(Continued).

SN 85-491,344. SEA PEST, INC., PLANTATION, FL. FILED 12-9-2011.

Sea Pest

THE MARK CONSISTS OF STANDARD CHARACTERS WITHOUT CLAIM TO ANY PARTICULAR FONT, STYLE, SIZE, OR COLOR.

NO CLAIM IS MADE TO THE EXCLUSIVE RIGHT TO USE "PEST", APART FROM THE MARK AS SHOWN.

FOR PEST CONTROL KITS COMPRISING RODENT TRAPS, RODENTICIDES AND PESTICIDES IN THE NATURE OF PEST CONTROL SPRAYS AND POWDERS, AND PEST CONTROL CANDLES AND CITRONELLA IN THE NATURE OF CANDLES AND CITRONELLA CONTAINING INSECT REPELLENTS, SOLD AS A UNIT (U.S. CLS. 2, 13, 23, 29, 30, 33, 40 AND 50).

TASHIA BUNCH, EXAMINING ATTORNEY

SN 85-492,576. JACOB BROMWELL, INC., TEMPE, AZ. FILED 12-12-2011.

JACOB BROMWELL

THE MARK CONSISTS OF STANDARD CHARACTERS WITHOUT CLAIM TO ANY PARTICULAR FONT, STYLE, SIZE, OR COLOR.

THE NAME(S), PORTRAIT(S), AND/OR SIGNATURE(S) SHOWN IN THE MARK DOES NOT IDENTIFY A PARTICULAR LIVING INDIVIDUAL.

FOR BAKEWARE; CAKE PANS; CHEESE GRATERS; COLANDERS; COOKIE SHEETS; COOLING RACKS FOR BAKED GOODS; DRINKING CUPS; FLOUR SIFTERS; FUNNELS; MIXING BOWLS; POTATO RICERS; ROLLING PINS (U.S. CLS. 2, 13, 23, 29, 30, 33, 40 AND 50).

FIRST USE 1-1-2011; IN COMMERCE 1-1-2011.

DAWN HAN, EXAMINING ATTORNEY

SN 85-501,600. SCS COLLECTIBLES INC, STRATFORD, CT. FILED 12-21-2011.

Sipping Stones

THE MARK CONSISTS OF STANDARD CHARACTERS WITHOUT CLAIM TO ANY PARTICULAR FONT, STYLE, SIZE, OR COLOR.

NO CLAIM IS MADE TO THE EXCLUSIVE RIGHT TO USE "STONES", APART FROM THE MARK AS SHOWN.

FOR MILLED SOAPSTONE, GRANITE, MARBLE AND OTHER STONE USED TO CHILL BEVERAGES (U.S. CLS. 2, 13, 23, 29, 30, 33, 40 AND 50).

FIRST USE 6-1-2011; IN COMMERCE 6-1-2011.

JORDAN BAKER, EXAMINING ATTORNEY

CLASS 21—(Continued).

SN 85-506,202. ALLSTAR MARKETING GROUP, LLC,
HAWTHORNE, NY. FILED 12-30-2011.

SPRAYTASTIC

THE MARK CONSISTS OF STANDARD CHARACTERS
WITHOUT CLAIM TO ANY PARTICULAR FONT, STYLE,
SIZE, OR COLOR.

FOR GARDEN HOSE SPRAYERS (U.S. CLS. 2, 13, 23,
29, 30, 33, 40 AND 50).

DOUGLAS LEE, EXAMINING ATTORNEY

SN 85-506,367. KOCH, HANS G., RENTON, WA. AND
NESBITT, JOHN, RENTON, WA. FILED 12-30-2011.

MOSQUITO REAPER

THE MARK CONSISTS OF STANDARD CHARACTERS
WITHOUT CLAIM TO ANY PARTICULAR FONT, STYLE,
SIZE, OR COLOR.

NO CLAIM IS MADE TO THE EXCLUSIVE RIGHT TO
USE "MOSQUITO", APART FROM THE MARK AS SHOWN.

FOR INSECT TRAPS (U.S. CLS. 2, 13, 23, 29, 30, 33, 40
AND 50).

MIDGE BUTLER, EXAMINING ATTORNEY

SN 85-507,850. SCHIMEL, WENDY, ARMONK, NY. FILED 1-
3-2012.

PUKEE PAIL

THE MARK CONSISTS OF STANDARD CHARACTERS
WITHOUT CLAIM TO ANY PARTICULAR FONT, STYLE,
SIZE, OR COLOR.

NO CLAIM IS MADE TO THE EXCLUSIVE RIGHT TO
USE "PAIL", APART FROM THE MARK AS SHOWN.

FOR PLASTIC CONTAINERS, NAMELY, BUCKETS
AND PAILS FOR THE RECEIPT OF VOMIT (U.S. CLS.
2, 13, 23, 29, 30, 33, 40 AND 50).

JENNIFER VASQUEZ, EXAMINING ATTORNEY

CLASS 21—(Continued).

SN 85-507,859. GURALLAR YAPI MALZEMELERI VE KI-
MYA SANAYI ANONIM SIRKETI, KUTAHYA, TURKEY,
FILED 1-3-2012.

The logo for GURALLAR ARTCRAFT features the word "GURALLAR" in a bold, blue, sans-serif font. Below it, the words "ARTCRAFT" are written in a smaller, light blue, sans-serif font, with a thin blue horizontal line separating the two words.

THE COLOR(S) BLUE AND LIGHT BLUE IS/ARE
CLAIMED AS A FEATURE OF THE MARK.

THE MARK CONSISTS OF THE TERM "GURALLAR"
WRITTEN IN STYLIZED, BLUE LETTERING AND UNDER-
LINED IN BLUE ALL SITUATED DIRECTLY ABOVE THE
PHRASE "ART CRAFT" IN STYLIZED, LIGHT BLUE
LETTERING.

FOR DRINKING GLASSES, NON-METALLIC TRAYS,
PITCHERS, CONTAINERS FOR HOUSEHOLD OR
KITCHEN USE, GLASS JARS, GLASS STORAGE JARS,
BOTTLES SOLD EMPTY, SUGAR BOWLS, JARS FOR
JAMS AND JELLIES OF GLASS, DISHES AND PLATES
NOT OF PRECIOUS METAL (U.S. CLS. 2, 13, 23, 29, 30,
33, 40 AND 50).

B. PARADEWELAI, EXAMINING ATTORNEY

SN 85-507,899. GURALLAR YAPI MALZEMELERI VE KI-
MYA SANAYI ANONIM SIRKETI, KUTAHYA, TURKEY,
FILED 1-3-2012.

The logo for Art (A) Craft features the word "Art" in a serif font, followed by a stylized letter "A" enclosed in a square with rounded corners, and then the word "Craft" in a serif font.

THE MARK CONSISTS OF THE PHRASE "ART CRAFT"
IN STYLIZED LETTERING AND HAVING A SQUARE
WITH ROUNDED EDGES BETWEEN THE WORDS "ART"
AND "CRAFT" THAT CONTAINS AN ABSTRACT DESIGN
THAT IS CURVED UPWARDS.

FOR DRINKING GLASSES, NON-METALLIC TRAYS,
PITCHERS, CONTAINERS FOR HOUSEHOLD OR
KITCHEN USE, GLASS JARS, GLASS STORAGE JARS,
BOTTLES SOLD EMPTY, SUGAR BOWLS, JARS FOR
JAMS AND JELLIES OF GLASS, DISHES AND PLATES
NOT OF PRECIOUS METAL (U.S. CLS. 2, 13, 23, 29, 30,
33, 40 AND 50).

B. PARADEWELAI, EXAMINING ATTORNEY

CLASS 21—(Continued).

SN 85-507,927. MARK L. LAYTON PRODUCTIONS, DBA LAYTON PRODUCTIONS, OREM, UT. FILED 1-3-2012.



NO CLAIM IS MADE TO THE EXCLUSIVE RIGHT TO USE "BEST" AND "PROMOTIONS", APART FROM THE MARK AS SHOWN.

THE MARK CONSISTS OF THE LETTERS "BOS" IN STYLIZED FONT ON A SQUARE BACKGROUND FOLLOWED BY "BEST OF STATE" IN LARGE CAPS AND "PROMOTIONS" IN SMALL CAPS.

FOR COMMEMORATIVE PLATES, MUGS, DINNERWARE AND DISHWARE; PLAQUES OF CHINA AND PORCELAIN; WORKS OF ART OF CHINA AND PORCELAIN (U.S. CLS. 2, 13, 23, 29, 30, 33, 40 AND 50).

FIRST USE 12-1-2011; IN COMMERCE 12-1-2011.
MAYUR VAGHANI, EXAMINING ATTORNEY

SN 85-508,279. YOUCOPIA PRODUCTS, INC., ARLINGTON HEIGHTS, IL. FILED 1-4-2012.

YOUCOPIA PRODUCTS

THE MARK CONSISTS OF STANDARD CHARACTERS WITHOUT CLAIM TO ANY PARTICULAR FONT, STYLE, SIZE, OR COLOR.

NO CLAIM IS MADE TO THE EXCLUSIVE RIGHT TO USE "PRODUCTS", APART FROM THE MARK AS SHOWN.

FOR CONTAINERS FOR HOUSEHOLD OR KITCHEN USE NOT OF PRECIOUS METAL; PORTABLE CONTAINERS FOR STORING HOUSEHOLD AND KITCHEN GOODS, NAMELY, COFFEE, TEA, AND HOT CHOCOLATE, BAKING TOOLS AND ACCESSORIES, AND PLASTIC BOTTLES; PLASTIC RACKS WITH STORAGE COMPARTMENTS FOR STORING SINGLE SERVINGS OF COFFEE, TEA AND HOT CHOCOLATE IN PLASTIC POD SHAPE, BAKING ACCESSORIES, NAMELY, CAKE TIPS, COOKIE CUTTERS, DECORATING MATERIALS, AND VARIOUS KITCHEN TOOLS, AND SPICES, MEDICINES, VITAMINS, SPRINKLES, BAKING EXTRACTS IN ROUND PLASTIC SHAPE (U.S. CLS. 2, 13, 23, 29, 30, 33, 40 AND 50).

DEBORAH LOBO, EXAMINING ATTORNEY

CLASS 21—(Continued).

SN 85-508,355. ARAMCO IMPORTS, INC., COMMERCE, CA. FILED 1-4-2012.

COFFEE ME

THE MARK CONSISTS OF STANDARD CHARACTERS WITHOUT CLAIM TO ANY PARTICULAR FONT, STYLE, SIZE, OR COLOR.

NO CLAIM IS MADE TO THE EXCLUSIVE RIGHT TO USE "COFFEE", APART FROM THE MARK AS SHOWN.

FOR BEVERAGE GLASSWARE, CUPS AND MUGS, INSULATED COFFEE AND BEVERAGE CUPS, NON-ELECTRIC COFFEE PRESSES (U.S. CLS. 2, 13, 23, 29, 30, 33, 40 AND 50).

DORITT L. CARROLL, EXAMINING ATTORNEY

SN 85-508,656. THE EVERCARE COMPANY, SUITE 650, GA. FILED 1-4-2012.

FUR ERASE

THE MARK CONSISTS OF STANDARD CHARACTERS WITHOUT CLAIM TO ANY PARTICULAR FONT, STYLE, SIZE, OR COLOR.

NO CLAIM IS MADE TO THE EXCLUSIVE RIGHT TO USE "FUR", APART FROM THE MARK AS SHOWN.

FOR LINT ROLLERS (U.S. CLS. 2, 13, 23, 29, 30, 33, 40 AND 50).

JAY FLOWERS, EXAMINING ATTORNEY

SN 85-509,593. MEDLINE INDUSTRIES, INC., MUNDELEIN, IL. FILED 1-5-2012.

MICROMAX

THE MARK CONSISTS OF STANDARD CHARACTERS WITHOUT CLAIM TO ANY PARTICULAR FONT, STYLE, SIZE, OR COLOR.

FOR CLEANING CLOTHS; CLEANING RAGS; MOPS (U.S. CLS. 2, 13, 23, 29, 30, 33, 40 AND 50).

ROBERT STRUCK, EXAMINING ATTORNEY

CLASS 21—(Continued).

SN 85-509,948. FUSIONBRANDS, INC., NAPLES, NY. FILED 1-5-2012.

coverblubber

THE MARK CONSISTS OF STANDARD CHARACTERS WITHOUT CLAIM TO ANY PARTICULAR FONT, STYLE, SIZE, OR COLOR.

FOR BUTTER-DISH AND CHEESE-DISH COVERS; CHEESE COVERS; DISH COVERS; HOUSEHOLD CONTAINERS FOR FOODS; HOUSEHOLD STORAGE CONTAINERS FOR PET FOOD; INSULATED BAGS FOR FOOD OR BEVERAGE FOR DOMESTIC USE; INSULATED CONTAINERS FOR FOOD OR BEVERAGE FOR DOMESTIC USE; KITCHEN UTENSIL, NAMELY, NON-METAL FLEXIBLE LID DESIGNED FOR DRAINING OR PRESSING LIQUIDS FROM A FOOD CAN; LOCKABLE NON-METAL HOUSEHOLD CONTAINERS FOR FOOD; REUSABLE SELF-SEALING LIDS FOR HOUSEHOLD USE FOR BOWLS, CUPS, CONTAINERS AND THE STORAGE OF FOOD; THERMAL INSULATED CONTAINERS FOR FOOD OR BEVERAGES (U.S. CLS. 2, 13, 23, 29, 30, 33, 40 AND 50).

EMILY CHUO, EXAMINING ATTORNEY

CLASS 21—(Continued).

SN 85-510,355. WALLIS H. WALLIS, SAN JUAN CAPISTRANO, CA. FILED 1-6-2012.

THE COOLEST BEVERAGE COOLER ON THE PLANET

THE MARK CONSISTS OF STANDARD CHARACTERS WITHOUT CLAIM TO ANY PARTICULAR FONT, STYLE, SIZE, OR COLOR.

FOR PORTABLE BEVERAGE COOLER, NAMELY FOR INDIVIDUAL BEVERAGE CONTAINERS (U.S. CLS. 2, 13, 23, 29, 30, 33, 40 AND 50).

ELI HELLMAN, EXAMINING ATTORNEY

SN 85-510,737. FREUDENBERG HOUSEHOLD PRODUCTS LP, AURORA, IL. FILED 1-6-2012.

SN 85-510,334. WALLIS H. WALLIS, SAN JUAN CAPISTRANO, CA. FILED 1-6-2012.



THE MARK CONSISTS OF A FIGURE OF A ONE-EYED, SMILING MONSTER. THE MONSTER IS STANDING UPRIGHT WITH ITS LEFT FOOT SLIGHTLY RAISED OFF THE GROUND. THE MONSTER HAS TWO EARS AND ONE EYE IN THE MIDDLE OF ITS FACE. HE'S SMILING AND SHOWING SIX TEETH WHICH ARE ALL ON THE TOP ROW OF HIS MOUTH. IN ITS LEFT HAND IT'S HOLDING A SOFT DRINK CAN AND IN ITS RIGHT HAND IT'S HOLDING A BOTTLE, BOTH OF WHICH ARE INSIDE OF AN INDIVIDUAL CAN/BOTTLE COOLER.

FOR PORTABLE BEVERAGE COOLER, NAMELY FOR INDIVIDUAL BEVERAGE CONTAINERS (U.S. CLS. 2, 13, 23, 29, 30, 33, 40 AND 50).

ELI HELLMAN, EXAMINING ATTORNEY

PROSPIN

THE MARK CONSISTS OF STANDARD CHARACTERS WITHOUT CLAIM TO ANY PARTICULAR FONT, STYLE, SIZE, OR COLOR.

FOR GLASS AND BOTTLE BRUSHES FOR HOUSEHOLD USE (U.S. CLS. 2, 13, 23, 29, 30, 33, 40 AND 50).

MICHAEL SOUDERS, EXAMINING ATTORNEY

SN 85-510,889. BRING IT ON THE MUSICAL LLC, UNIVERSAL CITY, CA. FILED 1-6-2012.

BRING IT ON THE MUSICAL

THE MARK CONSISTS OF STANDARD CHARACTERS WITHOUT CLAIM TO ANY PARTICULAR FONT, STYLE, SIZE, OR COLOR.

FOR REUSABLE STAINLESS STEEL WATER BOTTLES SOLD EMPTY (U.S. CLS. 2, 13, 23, 29, 30, 33, 40 AND 50).

FIRST USE 10-30-2011; IN COMMERCE 10-30-2011.

KELLY TRUSILO, EXAMINING ATTORNEY

CLASS 21—(Continued).

SN 85-511,805. WINESTRAWS, LLC, LADERA RANCH, CA. FILED 1-9-2012.

DRINK RED SMILE WHITE

THE MARK CONSISTS OF STANDARD CHARACTERS WITHOUT CLAIM TO ANY PARTICULAR FONT, STYLE, SIZE, OR COLOR.

FOR DRINKING STRAWS (U.S. CLS. 2, 13, 23, 29, 30, 33, 40 AND 50).

FIRST USE 10-19-2010; IN COMMERCE 12-1-2010.
ROBIN MITTLER, EXAMINING ATTORNEY

CLASS 21—(Continued).

SN 85-512,615. PATRICIA WILMOTH, WEST PALM BEACH, FL. FILED 1-10-2012.

THE ANATOME BRUSH

THE MARK CONSISTS OF STANDARD CHARACTERS WITHOUT CLAIM TO ANY PARTICULAR FONT, STYLE, SIZE, OR COLOR.

NO CLAIM IS MADE TO THE EXCLUSIVE RIGHT TO USE "BRUSH", APART FROM THE MARK AS SHOWN.

FOR BODY BRUSHES, NAMELY, BRUSHES APPLIED TO THE SKIN FOR EXFOLIATION AND TO INCREASE BLOOD FLOW TO THE SURFACE OF THE SKIN (U.S. CLS. 2, 13, 23, 29, 30, 33, 40 AND 50).

CHARISMA HAMPTON, EXAMINING ATTORNEY

SN 85-512,016. THE CUP-IT! CORPORATION, LUTES MOUNTAIN, NEW BR, CANADA, FILED 1-9-2012.

CUP-IT!

THE MARK CONSISTS OF STANDARD CHARACTERS WITHOUT CLAIM TO ANY PARTICULAR FONT, STYLE, SIZE, OR COLOR.

FOR NON-METAL, TIP-RESISTANT, HOLDERS AND SLEEVES FOR HOUSEHOLD PRODUCT CONTAINERS (U.S. CLS. 2, 13, 23, 29, 30, 33, 40 AND 50).

JAY BESCH, EXAMINING ATTORNEY

SN 85-513,333. GOODMAN, SARAH, LUBBOCK, TX. FILED 1-10-2012.

Haute Oven

THE MARK CONSISTS OF STANDARD CHARACTERS WITHOUT CLAIM TO ANY PARTICULAR FONT, STYLE, SIZE, OR COLOR.

FOR RECIPE BOXES (U.S. CLS. 2, 13, 23, 29, 30, 33, 40 AND 50).

PAM WILLIS, EXAMINING ATTORNEY

SN 85-512,177. WENDY LOVATO, LAS VEGAS, NV. AND PATRICK TAYLOR, LAS VEGAS, NV. FILED 1-9-2012.

CALENDAR SPONGE

THE MARK CONSISTS OF STANDARD CHARACTERS WITHOUT CLAIM TO ANY PARTICULAR FONT, STYLE, SIZE, OR COLOR.

NO CLAIM IS MADE TO THE EXCLUSIVE RIGHT TO USE "SPONGE", APART FROM THE MARK AS SHOWN.

FOR BATH SPONGES; CLEANING SPONGES; SPONGES FOR HOUSEHOLD PURPOSES (U.S. CLS. 2, 13, 23, 29, 30, 33, 40 AND 50).

RUSS HERMAN, EXAMINING ATTORNEY

SN 85-513,517. LOUIE, LINDA, HACIENDA HEIGHTS, CA. FILED 1-11-2012.

BANA

THE MARK CONSISTS OF STANDARD CHARACTERS WITHOUT CLAIM TO ANY PARTICULAR FONT, STYLE, SIZE, OR COLOR.

OWNER OF U.S. REG. NO. 3,861,368.

FOR CUPS; DRINKING CUPS; DRINKING CUPS SOLD WITH LIDS THEREFOR; TEA CANISTERS; TEA INFUSERS; TEA POTS; TEA POTS NOT OF PRECIOUS METAL; TEA SETS; TEA STRAINERS (U.S. CLS. 2, 13, 23, 29, 30, 33, 40 AND 50).

FIRST USE 6-1-2011; IN COMMERCE 6-1-2011.

ALEX KEAM, EXAMINING ATTORNEY

CLASS 21—(Continued).

SN 85-513,939. THE ERWYN GROUP, MORGANVILLE, NJ. FILED 1-11-2012.

MY EARTH

THE MARK CONSISTS OF STANDARD CHARACTERS WITHOUT CLAIM TO ANY PARTICULAR FONT, STYLE, SIZE, OR COLOR.

OWNER OF U.S. REG. NO. 3,808,157.

FOR BATHROOM AMENITIES, NAMELY, TISSUE BOXES, TOILET TISSUE HOLDERS, FACIAL TISSUE HOLDERS, SOAP DISHES, TRAYS FOR DOMESTIC PURPOSES AND BATHROOM AMENITIES, WASTE BASKETS, AND ICE BUCKETS (U.S. CLS. 2, 13, 23, 29, 30, 33, 40 AND 50).

SAMUEL E. SHARPER JR., EXAMINING ATTORNEY

SN 85-514,496. OUR NEIGHBORHOOD PLACE, LLC, SAN FRANCISCO, CA. FILED 1-11-2012.

THE TIPSYPIG

THE MARK CONSISTS OF STANDARD CHARACTERS WITHOUT CLAIM TO ANY PARTICULAR FONT, STYLE, SIZE, OR COLOR.

FOR GLASS JARS (U.S. CLS. 2, 13, 23, 29, 30, 33, 40 AND 50).

FIRST USE 12-23-2011; IN COMMERCE 12-23-2011.

JOHN DALIER, EXAMINING ATTORNEY

SN 85-514,531. GIRAFFICS L.C., LINDON, UT. FILED 1-11-2012.



NO CLAIM IS MADE TO THE EXCLUSIVE RIGHT TO USE "BOWLS", APART FROM THE MARK AS SHOWN.

THE MARK CONSISTS OF THE WORD STADIUM IN ITALIC CAPITAL LETTERS ABOVE THE WORD BOWLS ALSO IN ITALIC CAPITAL LETTERS, BOTH WORDS BEING SURROUNDED BY AN ELLIPSE THAT IS OPEN ON THE LOWER LEFT.

FOR BOWLS; DINNERWARE, NAMELY, BOWLS MADE OF POLYMERIC PLASTIC RESINS; DISPOSABLE DINNERWARE, NAMELY, BOWLS MADE OF POLYMERIC PLASTIC RESINS; FINGER BOWLS (U.S. CLS. 2, 13, 23, 29, 30, 33, 40 AND 50).

KRISTIN DAHLING, EXAMINING ATTORNEY

CLASS 21—(Continued).

SN 85-515,009. CREATIVE EDGE DESIGN GROUP, LTD., CANTON, OH. FILED 1-12-2012.



THE MARK CONSISTS OF TWO TRIANGLES AND THE WORDING "CREATIVE EDGE".

FOR BOTTLES, SOLD EMPTY (U.S. CLS. 2, 13, 23, 29, 30, 33, 40 AND 50).

FIRST USE 1-13-1999; IN COMMERCE 5-0-2002.

ANNE E. GUSTASON, EXAMINING ATTORNEY

SN 85-515,231. ANHEUSER-BUSCH, LLC, ST. LOUIS, MO. FILED 1-12-2012.

YOUR BEER. YOUR TAP. YOU'RE HOME.

THE MARK CONSISTS OF STANDARD CHARACTERS WITHOUT CLAIM TO ANY PARTICULAR FONT, STYLE, SIZE, OR COLOR.

FOR PORTABLE BEVERAGE DISPENSERS (U.S. CLS. 2, 13, 23, 29, 30, 33, 40 AND 50).

FIRST USE 12-13-2011; IN COMMERCE 12-13-2011.

TASHIA BUNCH, EXAMINING ATTORNEY

SN 85-515,275. ANHEUSER-BUSCH, LLC, ST. LOUIS, MO. FILED 1-12-2012.

GO OUT AT HOME

THE MARK CONSISTS OF STANDARD CHARACTERS WITHOUT CLAIM TO ANY PARTICULAR FONT, STYLE, SIZE, OR COLOR.

FOR PORTABLE BEVERAGE DISPENSERS (U.S. CLS. 2, 13, 23, 29, 30, 33, 40 AND 50).

FIRST USE 12-13-2011; IN COMMERCE 12-13-2011.

TASHIA BUNCH, EXAMINING ATTORNEY

CLASS 21—(Continued).

SN 85-516,108. BOW DESIGN GROUP, LLC, EAST SYRACUSE, NY. FILED 1-13-2012.

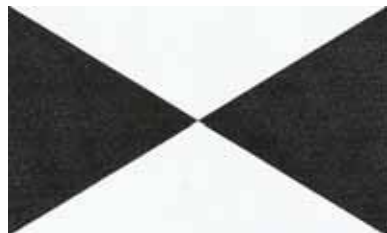

THE MARK CONSISTS OF TWO TRIANGLES WITH THE POINTS TOUCHING TO FORM THE LIKENESS OF A BOWTIE.

FOR BATHROOM ACCESSORIES, NAMELY, CUP HOLDERS, BATHROOM TRASH PAILS, DISPENSERS FOR FACIAL TISSUES, GOBLETS, SOAP BRACKETS, SOAP CONTAINERS, SOAP DISHES, SOAP DISPENSERS, SOAP HOLDERS, TOOTHBRUSH HOLDERS, WALL SOAP HOLDERS (U.S. CLS. 2, 13, 23, 29, 30, 33, 40 AND 50).

JOHN WILKE, EXAMINING ATTORNEY

SN 85-520,523. ALLSTAR MARKETING GROUP, LLC, HAWTHORNE, NY. FILED 1-19-2012.

PERFECT STUFF

THE MARK CONSISTS OF STANDARD CHARACTERS WITHOUT CLAIM TO ANY PARTICULAR FONT, STYLE, SIZE, OR COLOR.

OWNER OF U.S. REG. NOS. 2,733,418, 3,938,548 AND OTHERS.

FOR BAKEDWARE (U.S. CLS. 2, 13, 23, 29, 30, 33, 40 AND 50).

DOUGLAS LEE, EXAMINING ATTORNEY

SN 85-520,590. ALLSTAR MARKETING GROUP, LLC, HAWTHORNE, NY. FILED 1-19-2012.

PERFECT TORTILLA

THE MARK CONSISTS OF STANDARD CHARACTERS WITHOUT CLAIM TO ANY PARTICULAR FONT, STYLE, SIZE, OR COLOR.

OWNER OF U.S. REG. NOS. 2,733,418, 3,938,548 AND OTHERS.

NO CLAIM IS MADE TO THE EXCLUSIVE RIGHT TO USE "TORTILLA", APART FROM THE MARK AS SHOWN.

FOR BAKEDWARE (U.S. CLS. 2, 13, 23, 29, 30, 33, 40 AND 50).

DOUGLAS LEE, EXAMINING ATTORNEY

CLASS 21—(Continued).

SN 85-538,916. LIM, SANG MAN, KIMPO-SI, GYEONGGI-DO., REPUBLIC OF KOREA, FILED 2-9-2012.



OWNER OF REPUBLIC OF KOREA REG. NO. 0838308, DATED 10-5-2010, EXPIRES 10-5-2020.

THE MARK CONSISTS OF THE STYLIZED TEXT "LOCK" ABOVE THE STYLIZED TEXT "STAR", AND FOUR STARS ARRANGED IN AN IMAGINARY CURVE THAT LINKS THE LETTER "K" AND THE LETTER "R", WHEREIN THE ORIFICE IN THE LETTER "R" IS IN THE SHAPE OF A FIVE POINT STAR.

FOR NON-METAL CONTAINERS FOR USE WITH FOOD; NON-METAL CRUETS; COOKING STEAMERS FOR RICE; SPICE RACK; PORTABLE COLDBOXES NON-ELECTRIC; RICE CHESTS; BUCKETS FOR USE WITH DISHWASHING (U.S. CLS. 2, 13, 23, 29, 30, 33, 40 AND 50).

JACQUELINE A. LAVINE, EXAMINING ATTORNEY

SN 85-547,431. SCENTSY, INC., MERIDIAN, ID. FILED 2-20-2012.

VELATA

THE MARK CONSISTS OF STANDARD CHARACTERS WITHOUT CLAIM TO ANY PARTICULAR FONT, STYLE, SIZE, OR COLOR.

THE ENGLISH TRANSLATION OF THE WORD "VELATA" IN THE MARK IS "VEILED".

FOR HAND-OPERATED KITCHEN UTENSILS, NAMELY, FONDUE POTS WITHOUT HEAT SOURCE (U.S. CLS. 2, 13, 23, 29, 30, 33, 40 AND 50).

MARY CRAWFORD, EXAMINING ATTORNEY

CLASS 21—(Continued).

SN 85-560,033. WILTON INDUSTRIES, INC., WOODRIDGE, IL. FILED 3-5-2012.

TO DRIVE

THE MARK CONSISTS OF STANDARD CHARACTERS WITHOUT CLAIM TO ANY PARTICULAR FONT, STYLE, SIZE, OR COLOR.
FOR REUSABLE PLASTIC WATER BOTTLES SOLD EMPTY (U.S. CLS. 2, 13, 23, 29, 30, 33, 40 AND 50).
MARK SHINER, EXAMINING ATTORNEY

SN 85-560,035. WILTON INDUSTRIES, INC., WOODRIDGE, IL. FILED 3-5-2012.

TO MOVE

THE MARK CONSISTS OF STANDARD CHARACTERS WITHOUT CLAIM TO ANY PARTICULAR FONT, STYLE, SIZE, OR COLOR.
FOR REUSABLE PLASTIC WATER BOTTLES SOLD EMPTY (U.S. CLS. 2, 13, 23, 29, 30, 33, 40 AND 50).
MARK SHINER, EXAMINING ATTORNEY

SN 85-560,038. WILTON INDUSTRIES, INC., WOODRIDGE, IL. FILED 3-5-2012.

TO SHARE

THE MARK CONSISTS OF STANDARD CHARACTERS WITHOUT CLAIM TO ANY PARTICULAR FONT, STYLE, SIZE, OR COLOR.
FOR REUSABLE PLASTIC WATER BOTTLES SOLD EMPTY (U.S. CLS. 2, 13, 23, 29, 30, 33, 40 AND 50).
MARK SHINER, EXAMINING ATTORNEY

CLASS 21—(Continued).

SN 85-570,908. HUHTAMAKI, INC., DESOTO, KS. FILED 3-15-2012.

STRONGHOLDER

THE MARK CONSISTS OF STANDARD CHARACTERS WITHOUT CLAIM TO ANY PARTICULAR FONT, STYLE, SIZE, OR COLOR.
OWNER OF U.S. REG. NOS. 3,508,305, 3,511,677 AND 3,644,543.
FOR PLASTIC AND PAPERBOARD PLATES (U.S. CLS. 2, 13, 23, 29, 30, 33, 40 AND 50).
JULIE WATSON, EXAMINING ATTORNEY

CLASS 22—CORDAGE AND FIBERS

SN 85-261,182. INTERNATIONAL MERCHANDISING SERVICE, INC., AKA ULTIMATE SOLUTION TOOLS, FULLERTON, CA. FILED 3-8-2011.



NO CLAIM IS MADE TO THE EXCLUSIVE RIGHT TO USE "TARPS" AND THE PICTORIAL REPRESENTATION OF THE UNITED STATES, APART FROM THE MARK AS SHOWN.

THE COLOR(S) RED, BLUE, WHITE, AND BLACK IS/ARE CLAIMED AS A FEATURE OF THE MARK.

THE MARK CONSISTS OF THE OUTLINE OF THE CONTINENTAL UNITED STATES IN BLACK; THE LETTERS "US" ARE BLUE, WITH BLACK OUTLINING AND WHITE SHADOW/EMBOSSING EFFECT; THE LETTER "T" IS RED WITH BLACK OUTLINING AND WHITE SHADOW/EMBOSSING EFFECT; AND THE WORDING "ULTIMATE SOLUTION TARPS" IS BLACK, WITH WHITE OUTLINING.
FOR TARPULINS (U.S. CLS. 1, 2, 7, 19, 22, 42 AND 50).

FIRST USE 2-1-2011; IN COMMERCE 2-1-2011.
NAAKWAMA ANKRAH, EXAMINING ATTORNEY

CLASS 22—(Continued).

SN 85-506,821. MARS, INCORPORATED, MCLEAN, VA.
FILED 12-31-2011.

M&M'S

THE MARK CONSISTS OF STANDARD CHARACTERS WITHOUT CLAIM TO ANY PARTICULAR FONT, STYLE, SIZE, OR COLOR.

OWNER OF U.S. REG. NOS. 1,774,366, 2,406,181 AND OTHERS.

FOR LANYARDS FOR HOLDING BADGES (U.S. CLS. 1, 2, 7, 19, 22, 42 AND 50).

FIRST USE 4-30-2009; IN COMMERCE 4-30-2009.
GILBERT SWIFT, EXAMINING ATTORNEY

SN 85-511,970. DOWNHOME, INC., DBA DOWN DECOR,
CINCINNATI, OH. FILED 1-9-2012.

D DOWNTEK

THE MARK CONSISTS OF THE LETTER "D" IN A STYLIZED FORMAT FOLLOWED BY THE WORD "DOWNTEK".

FOR DOWN FILL (U.S. CLS. 1, 2, 7, 19, 22, 42 AND 50).
STEVEN PEREZ, EXAMINING ATTORNEY

SN 85-515,796. CAMPVALLEY (XIAMEN) CO., LTD., XIAMEN, FUJIAN 361022, CHINA, FILED 1-13-2012.

CAMPVALLEY

THE MARK CONSISTS OF STANDARD CHARACTERS WITHOUT CLAIM TO ANY PARTICULAR FONT, STYLE, SIZE, OR COLOR.

FOR TENTS; TENTS FOR MOUNTAINEERING OR CAMPING (U.S. CLS. 1, 2, 7, 19, 22, 42 AND 50).

FIRST USE 10-30-2011; IN COMMERCE 10-30-2011.
GEORGE LORENZO, EXAMINING ATTORNEY

CLASS 22—(Continued).

SN 85-516,040. CAMPVALLEY (XIAMEN) CO., LTD., XIAMEN, FUJIAN 361022, CHINA, FILED 1-13-2012.

CAMPVALLEY

THE MARK CONSISTS OF THE WORD "CAMPVALLEY" IN STYLIZED LETTERS AND A SILHOUETTE OF A MOUNTAIN RANGE AND A PARTIAL REFLECTION OF THE MOUNTAIN RANGE WITHIN AND ABOVE THE LETTER "V".

FOR TENTS; TENTS FOR MOUNTAINEERING OR CAMPING (U.S. CLS. 1, 2, 7, 19, 22, 42 AND 50).

FIRST USE 10-30-2011; IN COMMERCE 10-30-2011.
GEORGE LORENZO, EXAMINING ATTORNEY

SN 85-528,717. SCRIPPS NETWORKS, LLC, KNOXVILLE, TN. FILED 1-30-2012.

ROOM BY ROOM

THE MARK CONSISTS OF STANDARD CHARACTERS WITHOUT CLAIM TO ANY PARTICULAR FONT, STYLE, SIZE, OR COLOR.

FOR TEXTILE DROPCLOTHS (U.S. CLS. 1, 2, 7, 19, 22, 42 AND 50).

SUZANNE BLANE, EXAMINING ATTORNEY

CLASS 23—YARNS AND THREADS

SN 85-332,703. LORO PIANA S.P.A., QUARONA (VC), ITALY, FILED 5-27-2011.

THE CASH^one

PRIORITY CLAIMED UNDER SEC. 44(D) ON ITALY APPLICATION NO. TO2011C00187, FILED 5-26-2011, REG. NO. 0001473021, DATED 12-15-2011, EXPIRES 5-26-2021.

NO CLAIM IS MADE TO THE EXCLUSIVE RIGHT TO USE "CASH", APART FROM THE MARK AS SHOWN.

THE MARK CONSISTS OF THE STYLIZED WORDS "THE CASH ONE" WITH THE "O" IN "ONE" BEING A BROKEN CIRCLE SURROUNDING THE "H" IN "CASH", AND WITH "ONE" UNDERLINED.

FOR YARNS AND THREADS COMPRISED AT LEAST IN PART OF NATURAL CASHMERE FIBERS (U.S. CL. 43).

KAELIE KUNG, EXAMINING ATTORNEY

CLASS 24—FABRICS

SN 85-229,134. EXCLUSIVE FABRICS & FURNISHINGS, LLC, PLEASANTON, CA. FILED 1-28-2011.



NO CLAIM IS MADE TO THE EXCLUSIVE RIGHT TO USE "HALF PRICE DRAPES", APART FROM THE MARK AS SHOWN.

THE MARK CONSISTS OF STYLIZED VINES ABOVE THE STYLIZED LETTERS "HPD" AND THE WORDS "HALF" AND "PRICE", AND "DRAPES" BELOW THE LETTERS, ALL APPEARING ON A SHADED RECTANGULAR BACKGROUND.

FOR TEXTILE GOODS, NAMELY, INTERIOR FABRIC WINDOW COVERINGS IN THE NATURE OF DRAPES AND CURTAINS (U.S. CLS. 42 AND 50).

KATHERINE CONNOLLY, EXAMINING ATTORNEY

SN 85-334,318. PAK-A-ROO, LLC, LOS ANGELES, CA. FILED 5-31-2011.

PakaRoo

THE MARK CONSISTS OF STANDARD CHARACTERS WITHOUT CLAIM TO ANY PARTICULAR FONT, STYLE, SIZE, OR COLOR.

FOR DUAL PURPOSE TOWEL AND BLANKET THAT IS CAPABLE OF FOLDING UP INTO ITS OWN BAG (U.S. CLS. 42 AND 50).

ANGELA M. MICHELI, EXAMINING ATTORNEY

CLASS 24—(Continued).

SN 85-364,423. COUNTRY ROAD CLOTHING PTY LTD, RICHMOND, VICTORIA, AUSTRALIA, FILED 7-6-2011.

COUNTRY ROAD

THE MARK CONSISTS OF STANDARD CHARACTERS WITHOUT CLAIM TO ANY PARTICULAR FONT, STYLE, SIZE, OR COLOR.

OWNER OF U.S. REG. NOS. 1,213,557, 1,573,457 AND 1,862,951.

FOR BED AND TABLE COVERS NAMELY BED LINEN, BEDSPREADS, BED CLOTHES IN THE NATURE OF SHEETS, COVERS, QUILTS AND PILLOWCASES; BATH LINEN; PRINTED CALICO CLOTH ; CURTAINS OF TEXTILE OR PLASTIC; DOOR CURTAINS; EIDER-DOWNS; HOUSEHOLD LINEN; MATTRESS COVERS; MOSQUITO NETS; TABLE LINEN; TEA TOWELS; FABRIC TABLE RUNNERS; SILK CLOTH; TAPESTRY OF TEXTILES; TABLE CLOTHS NOT OF PAPER; TABLE MATS NOT OF PAPER; PLACE MATS MADE OF CORK; PLACE MATS MADE OF PLASTIC MATERIAL; TOWELS OF TEXTILE; UPHOLSTERY FABRICS; VELVET; WALL HANGINGS OF TEXTILE (U.S. CLS. 42 AND 50).

WILLIAM P. SHANAHAN, EXAMINING ATTORNEY

SN 85-441,897. MARK E. HISLE, EVANSVILLE, IN. FILED 10-7-2011.

SLEEP NATURAL

THE MARK CONSISTS OF STANDARD CHARACTERS WITHOUT CLAIM TO ANY PARTICULAR FONT, STYLE, SIZE, OR COLOR.

FOR BED SHEETS, MATTRESS COVERS, PILLOW COVERS, ALL MADE FROM NATURAL MATERIALS (U.S. CLS. 42 AND 50).

DAVID I, EXAMINING ATTORNEY

SN 85-460,287. MAQKAY ENTERPRISES, LLC, CARMEL, IN. FILED 10-31-2011.



THE MARK CONSISTS OF THE STYLIZED WORDING "PETALPATT" BELOW A DESIGN OF A LOTUS FLOWER.

FOR WOVEN SYNTHETIC TEXTILE COSMETIC WIPES; WOVEN SYNTHETIC TEXTILE COSMETIC WIPES SOLD IN A COSMETIC CASE (U.S. CLS. 42 AND 50).

KRISTINA MORRIS, EXAMINING ATTORNEY

CLASS 24—(Continued).

SN 85-474,059. DANIELS, SARAH E, VAN NUYS, CA. FILED 11-16-2011.

Lovers Covers

THE MARK CONSISTS OF STANDARD CHARACTERS WITHOUT CLAIM TO ANY PARTICULAR FONT, STYLE, SIZE, OR COLOR.

NO CLAIM IS MADE TO THE EXCLUSIVE RIGHT TO USE "COVERS", APART FROM THE MARK AS SHOWN.

FOR BED BLANKETS (U.S. CLS. 42 AND 50).
RUSS HERMAN, EXAMINING ATTORNEY

SN 85-489,096. GOODMAN, WENLEI, FOXBOROUGH, MA. FILED 12-7-2011.

LovaSilk

THE MARK CONSISTS OF STANDARD CHARACTERS WITHOUT CLAIM TO ANY PARTICULAR FONT, STYLE, SIZE, OR COLOR.

FOR BED SHEETS, COMFORTERS, PILLOW CASES, ALL MADE PRIMARILY OF SILK (U.S. CLS. 42 AND 50).
FIRST USE 9-14-2010; IN COMMERCE 9-14-2010.
JENNIFER DIXON, EXAMINING ATTORNEY

SN 85-508,771. JENNICK ASSOCIATES, LLC, RINGWOOD, NJ. FILED 1-4-2012.

JENNICK

THE MARK CONSISTS OF STANDARD CHARACTERS WITHOUT CLAIM TO ANY PARTICULAR FONT, STYLE, SIZE, OR COLOR.

THE WORDING "JENNICK" HAS NO MEANING IN A FOREIGN LANGUAGE.

FOR LAP BLANKETS (U.S. CLS. 42 AND 50).
FIRST USE 10-1-2009; IN COMMERCE 10-1-2009.
ELISSA GARBER KON, EXAMINING ATTORNEY

CLASS 24—(Continued).

SN 85-510,324. MGM RESORTS INTERNATIONAL, LAS VEGAS, NV. FILED 1-6-2012.

MGM GRAND

THE MARK CONSISTS OF STANDARD CHARACTERS WITHOUT CLAIM TO ANY PARTICULAR FONT, STYLE, SIZE, OR COLOR.

OWNER OF U.S. REG. NOS. 2,540,402, 3,908,061 AND OTHERS.

FOR BED SHEETS; BED BLANKETS; DUVETS; TOWELS AND WASHCLOTHS (U.S. CLS. 42 AND 50).
KIMBERLY PERRY, EXAMINING ATTORNEY

SN 85-511,191. ROGER LEE (AUST) P/L - ACN 065394818, MORTLAKE NSW 2137, AUSTRALIA, FILED 1-7-2012.

LOLLI LIVING

THE MARK CONSISTS OF STANDARD CHARACTERS WITHOUT CLAIM TO ANY PARTICULAR FONT, STYLE, SIZE, OR COLOR.

FOR BABY BEDDING, NAMELY, BUNDLE BAGS, SWADDLING BLANKETS, CRIB BUMPERS, FITTED CRIB SHEETS, CRIB SKIRTS, CRIB BLANKETS, AND DIAPER CHANGING PAD COVERS NOT OF PAPER; BED AND TABLE LINEN; BED AND TABLE LINEN; WALL HANGINGS OF TEXTILE; BED BLANKETS; BED CANOPIES; BED COVERS; BED LINEN; BED LINEN AND TABLE LINEN; BED PADS; BED SHEETS; BED SHEETS OF PAPER; BED SKIRTS; BED SPREADS; BED THROWS; FITTED BED SHEETS; FITTED BED SHEETS FOR PETS; FLAT BED SHEETS; PILLOW-TOP, LOW-PROFILE BED SKIRTS; SILK BED BLANKETS; TABLE AND BED LINEN (U.S. CLS. 42 AND 50).

SALLY SHIH, EXAMINING ATTORNEY

CLASS 24—(Continued).

SN 85-511,288. GARY M LESLEY, BURNSVILLE, MN. FILED 1-8-2012.

SpiderLite

THE MARK CONSISTS OF STANDARD CHARACTERS WITHOUT CLAIM TO ANY PARTICULAR FONT, STYLE, SIZE, OR COLOR.

FOR BALLISTIC RESISTANT FABRICS FOR USE IN THE PRODUCTION OF BULLETPROOF AND BLAST PROOF CLOTHING, SHOES AND BULLET PROOF AND BLAST PROOF GARMENTS AND SHIELDS; FABRIC CURTAINS FOR MINING AND INDUSTRIAL USES; FABRICS FOR TEXTILE USE; FABRICS FOR THE MANUFACTURE OF PROTECTIVE CLOTHING, PERSONAL PROTECTIVE EQUIPMENT AND BALLIST ARMOR PROTECTION; KNITTED FABRICS OF SILK YARN; SEMI-FINISHED PLASTIC PRODUCTS, NAMELY, WOVEN ARAMID FABRICS FOR USE IN THE MANUFACTURE OF PROTECTIVE CLOTHING AND HELMETS AND IN HARD ARMOR; SEMI-SYNTHETIC FIBER FABRICS; SILK BASE MIXED FABRICS; SILK CLOTH; SILK FABRICS; SILK-COTTON MIXED FABRICS; SILK-WOOL MIXED FABRICS; SPUN SILK FABRICS; TEXTILE FABRICS FOR USE IN THE MANUFACTURE OF GARMENTS, BAGS, JACKETS, GLOVES, AND APPAREL (U.S. CLS. 42 AND 50).

DEBORAH LOBO, EXAMINING ATTORNEY

CLASS 24—(Continued).

SN 85-514,613. ZHEJIANG ASUKA HOME TEXTILE CO., LTD., ZHEJIANG PROVINCE., CHINA, FILED 1-12-2012.



THE MARK CONSISTS OF THE NUMERIC 32 AND THE SYMBOL OF THE DEGREE CELSIUS CHARACTER "C" WITHIN A CIRCULAR CARRIER, AND THE STYLIZED WORDS DEGREES CELSIUS BELOW THE CIRCULAR CARRIER.

FOR BED BLANKETS; BED COVERS; BED LINEN; EIDERDOWN COVERS; FUTON TICKS, NAMELY, UNSTUFFED FUTON COVERS NOT OF PAPER; MOSQUITO NETS; QUILT COVERS; QUILTS; TOWEL SHEET; TOWELS (U.S. CLS. 42 AND 50).

SUSAN RICHARDS, EXAMINING ATTORNEY

SN 85-512,335. KASSIA MEADOR, ENCINITAS, CA. FILED 1-9-2012.



THE NAME(S), PORTRAIT(S), AND/OR SIGNATURE(S) SHOWN IN THE MARK IDENTIFIES KASSIA "MEADOR", WHOSE CONSENT(S) TO REGISTER IS MADE OF RECORD.

THE MARK CONSISTS OF THE LETTER "K" FOLLOWED BY AN ASTERISK, FOLLOWED BY THE WORD "MEADOR", ALL IN VINTAGE TYPEWRITER FONT.

FOR SHEETS, PILLOW CASES, COMFORTERS, PILLOW SHAMS, BEDSPREADS, DUST RUFFLES, TOWELS, WASHCLOTHS, FABRIC WINDOW VALANCES, DRAPERIES, DUVET COVERS, SHOWER CURTAINS (U.S. CLS. 42 AND 50).

LESLEY LAMOTHE, EXAMINING ATTORNEY

SN 85-515,285. GARY BENZ, BRENTWOOD, TN. FILED 1-12-2012.

EASYFOLD

THE MARK CONSISTS OF STANDARD CHARACTERS WITHOUT CLAIM TO ANY PARTICULAR FONT, STYLE, SIZE, OR COLOR.

FOR BLANKETS FOR OUTDOOR USE; LAP BLANKETS (U.S. CLS. 42 AND 50).

THOMAS MANOR, EXAMINING ATTORNEY

CLASS 24—(Continued).

SN 85-515,371. MATTHEWS, BRINSLEY, WEST PALM BEACH, FL. FILED 1-12-2012.



THE NAME(S), PORTRAIT(S), AND/OR SIGNATURE(S) SHOWN IN THE MARK IDENTIFIES BRINSLEY, WHOSE CONSENT(S) TO REGISTER IS MADE OF RECORD.

THE MARK CONSISTS OF A MIRROR-IMAGE OF THE LETTER B TO THE LEFT OF A NORMAL LETTER B, BOTH LETTERS ABOVE THE WORD BRINSLEY, AND ALL CONTAINED WITHIN A PENTAGONAL DESIGN.

FOR BED AND TABLE LINEN, WALL HANGINGS OF TEXTILE; BED COVERS; BED SKIRTS; BED SPREADS; BED THROWS; CURTAINS MADE OF TEXTILE FABRICS; FABRIC TABLE RUNNERS; FABRIC WINDOW COVERINGS AND TREATMENTS, NAMELY, CURTAINS, DRAPERIES, SHEERS, SWAGS AND VALANCES; FITTED BED SHEETS; FLAT BED SHEETS; FURNISHING AND UPHOLSTERY FABRICS; HAND-TOWELS MADE OF TEXTILE FABRICS; INTERIOR DECORATION FABRICS; TEXTILE FABRICS FOR THE MANUFACTURE OF CLOTHING; UPHOLSTERY FABRICS (U.S. CLS. 42 AND 50).

BRIAN NEVILLE, EXAMINING ATTORNEY

CLASS 24—(Continued).

SN 85-515,596. MYTEX, L.L.C., HONOLULU, HI. FILED 1-12-2012.



NO CLAIM IS MADE TO THE EXCLUSIVE RIGHT TO USE "LUXURY LINENS AND BEDDING", APART FROM THE MARK AS SHOWN.

THE MARK CONSISTS OF "HR" IN LARGE BACKGROUND LETTERS WITH THE WORDS "HOME RESORT" ABOVE AND THE WORDS "LUXURY LINENS AND BEDDING" BELOW BOTH SUPERIMPOSED OVER THE LETTERS "HR".

FOR BATH SHEETS; BATH TOWELS; BED AND TABLE LINEN; BED BLANKETS; BED LINEN; BED LINEN AND TABLE LINEN; BED SHEETS; BED SKIRTS; BED SPREADS; BED THROWS; COMFORTERS; COVERLETS; DRAPERIES; DUVET COVERS; DUVETS; FITTED BED SHEETS; FLAT BED SHEETS; HAND TOWELS; PILLOW CASES; PILLOW COVERS; PILLOW SHAMS; PILLOWCASES; QUILT COVERS; QUILTS; SHAMS; SHEET SETS; SHOWER CURTAINS; TABLE AND BED LINEN; TOWELS (U.S. CLS. 42 AND 50).

FIRST USE 3-5-2012; IN COMMERCE 3-5-2012.

MIDGE BUTLER, EXAMINING ATTORNEY

SN 85-515,595. MYTEX, L.L.C., HONOLULU, HI. FILED 1-12-2012.



THE MARK CONSISTS OF CAPITAL LETTERS "HR" IN LARGE FONT.

FOR BATH SHEETS; BATH TOWELS; BED AND TABLE LINEN; BED BLANKETS; BED LINEN; BED LINEN AND TABLE LINEN; BED SHEETS; BED SKIRTS; BED SPREADS; BED THROWS; COMFORTERS; COVERLETS; DRAPERIES; DUVET COVERS; DUVETS; FITTED BED SHEETS; FLAT BED SHEETS; HAND TOWELS; PILLOW CASES; PILLOW COVERS; PILLOW SHAMS; PILLOWCASES; QUILT COVERS; QUILTS; SHAMS; SHEET SETS; SHOWER CURTAINS; TABLE AND BED LINEN; TOWELS (U.S. CLS. 42 AND 50).

FIRST USE 3-5-2012; IN COMMERCE 3-5-2012.

MIDGE BUTLER, EXAMINING ATTORNEY

SN 85-520,876. ROGER LEE (AUST) P/L - ACN065394818, MORTLAKE NSW 2137, AUSTRALIA, FILED 1-20-2012.

ALLURA LIVING

THE MARK CONSISTS OF STANDARD CHARACTERS WITHOUT CLAIM TO ANY PARTICULAR FONT, STYLE, SIZE, OR COLOR.

FOR BABY BEDDING, NAMELY, BUNDLE BAGS, SWADDLING BLANKETS, CRIB BUMPERS, FITTED CRIB SHEETS, CRIB SKIRTS, CRIB BLANKETS, AND DIAPER CHANGING PAD COVERS NOT OF PAPER; BEAVER SKIN BED BLANKETS; BED AND TABLE LINEN; BED AND TABLE LINEN, WALL HANGINGS OF TEXTILE; BED BLANKETS; BED CANOPIES; BED COVERS; BED LINEN; BED LINEN AND TABLE LINEN; BED SHEETS; BED SHEETS, FITTED BED SHEET COVERS, BED FLAT SHEETS, AND PILLOW CASES USED IN THE BEDDING, HEALTH CARE, HOME-HEALTH CARE AND NURSING HOME INDUSTRIES MADE OF BIODEGRADABLE FILM CREATED FROM RENEWABLE BIO-POLYMER RESOURCES; BED SKIRTS; BED SPREADS; BED THROWS; FITTED BED SHEETS; FITTED BED SHEETS FOR PETS; FLAT BED SHEETS; PILLOW-TOP, LOW-PROFILE BED SKIRTS; TABLE AND BED LINEN; WINDOW CURTAINS (U.S. CLS. 42 AND 50).

SALLY SHIH, EXAMINING ATTORNEY

CLASS 25—CLOTHING

SN 76-005,983. BLACKICE BY DESIGN INC., TORONTO, CANADA, AND PRIMUS, JOEL, ABBOTSFORD, CANADA, FILED 3-23-2000.

PLANET NAKED

FOR INFANT, TODDLER, JUNIOR, MISSES, WOMEN'S, MEN'S AND MATERNITY CLOTHING, NAMELY, SLEEPWEAR, SHIRTS, BLAZERS, RAINCOATS, CAPES, JUMPERS, BERMUDA SHORTS, ATHLETIC SWEAT SUITS, SKIRTS, SANDALS, JACKETS, JEANS, JERSEYS, JOGGING SUITS, KNITTED AND WOVEN TOPS AND BOTTOMS, LEGGINGS, LEOTARDS, LINGERIE, LOUNGE WEAR, MITTENS, NIGHT SHIRTS, NIGHTGOWNS, OVERCOATS, PAJAMAS, PANTS, PANTSUITS, PANTY GIRDLES, PANTY HOSE, PARKAS, PEIGNOIR SETS, POLO SHIRTS, PULLOVERS, ROBES, SCARVES, SHAWLS, SHORTS, SLIPPERS, SOCKS, SPORTS BRAS, SPORTS COATS, SUITS, SWEATERS, SWEATPANTS, SWEATSHIRTS, SWIMWEAR, TANK TOPS, TEDDIES, TENNIS SHOES, THERMAL UNDERWEAR, TIES, TOPS, TROUSERS, T-SHIRTS, TURTLENECKS, UNDERGARMENT THONGS, UNDERGARMENTS, UNDERGARMENT SUPPORTS SUCH AS GIRDLES, BODYSHAPERS, UNDERSHIRTS, UNITARDS, VESTS, WARM-UP SUITS, BOOTS, DRESS SHOES, BANDANNAS, BATHING SUITS, BATHING TRUNKS, BATHROBES, BEACH THONGS, BED JACKETS, BELTS, BIKE SHIRTS AND SHORTS, BLOUSES, BODY BRIEFS, BOLEROS, BOXER SHORTS, BRAS, BUSTIER, CAMISOLES, CAMP SHIRTS, CARDIGANS, CASUAL AND ATHLETIC FOOTWEAR, CHEMISES, COATS, CORSETS, CROP TOPS, DRESSES, DRESSING GOWNS, FOOTWEAR, HEADBANDS, HEADWEAR, NAMELY, HATS, CAPS AND VISORS, HOSIERY (U.S. CLS. 22 AND 39).

CHARLOTTE CORWIN, EXAMINING ATTORNEY

SN 76-304,207. TREVCO, INC., TROY, MI. FILED 8-23-2001.

ISLAND EDGE GIRL

NO CLAIM IS MADE TO THE EXCLUSIVE RIGHT TO USE "GIRL", APART FROM THE MARK AS SHOWN.

FOR CLOTHING, NAMELY, T-SHIRTS, SWEATSHIRTS, NIGHTSHIRTS, JACKETS, SHORTS, BOARD SHORTS, VOLLEY SHORTS, WOVEN AND SILK SHIRTS, SWIMWEAR, ALOHA WRAPS, AND HEADWEAR (U.S. CLS. 22 AND 39).

RUDY R. SINGLETON, EXAMINING ATTORNEY

SN 76-414,826. LONESTAR, NASHVILLE, TN. FILED 5-30-2002.

LONESTAR

FOR CLOTHING MERCHANDISE, NAMELY, T-SHIRTS, SWEATSHIRTS, JACKETS AND HEADWEAR, SOLD IN CONNECTION WITH THE ENTERTAINMENT SERVICES OF A LIVE MUSIC GROUP (U.S. CLS. 22 AND 39).

FIRST USE 1-1-1995; IN COMMERCE 1-1-1995.
CHRISIE B. KING, EXAMINING ATTORNEY

CLASS 25—(Continued).

SN 76-708,022. Z'S TERMITE INSPECTION, INC., GLENDALE, CA. FILED 6-17-2011.

TANTUM LOS ANGELES

THE MARK CONSISTS OF STANDARD CHARACTERS WITHOUT CLAIM TO ANY PARTICULAR FONT, STYLE, SIZE, OR COLOR.

NO CLAIM IS MADE TO THE EXCLUSIVE RIGHT TO USE "LOS ANGELES", APART FROM THE MARK AS SHOWN.

FOR CLOTHING, NAMELY, T-SHIRTS FOR MEN; SHIRTS FOR MEN; JACKETS FOR MEN; HATS FOR MEN (U.S. CLS. 22 AND 39).

FIRST USE 3-21-2011; IN COMMERCE 3-21-2011.

SCOTT BIBB, EXAMINING ATTORNEY

SN 76-708,072. AS IP HOLDINGS, INC., SECAUCUS, NJ. FILED 6-21-2011.

BELLA BY ASHLEY STEWART

THE MARK CONSISTS OF STANDARD CHARACTERS WITHOUT CLAIM TO ANY PARTICULAR FONT, STYLE, SIZE, OR COLOR.

OWNER OF U.S. REG. NOS. 2,046,868, 3,939,361 AND OTHERS.

THE NAME "ASHLEY STEEWART" DOES NOT IDENTIFY A LIVING INDIVIDUAL, AND THIS STATEMENT HAS BEEN PREVIOUSLY MADE OF RECORD.

FOR CLOTHING, NAMELY, LINGERIE, BRAS, SUITS, DRESSES, BLAZERS, PANTY HOSE, PANTS, SHIRTS, BLOUSES, SWEATERS, JACKETS, SOCKS, HATS; ACTIVE WEAR, NAMELY, SWEAT PANTS, SWEAT SHIRTS, YOGA PANTS, SPORT SHIRTS, SPORT SHORTS, SPORTS PANTS, TIGHTS, SPORTS BRAS (U.S. CLS. 22 AND 39).

RENEE MCCRAY, EXAMINING ATTORNEY

SN 76-708,111. EQUI IN STYLE, LLC, GENEVA, FL. FILED 6-23-2011.

COOL SHIRT

THE MARK CONSISTS OF STANDARD CHARACTERS WITHOUT CLAIM TO ANY PARTICULAR FONT, STYLE, SIZE, OR COLOR.

NO CLAIM IS MADE TO THE EXCLUSIVE RIGHT TO USE "SHIRT", APART FROM THE MARK AS SHOWN.

FOR CLOTHING, NAMELY, SHIRTS, JACKETS, PANTS AND HATS (U.S. CLS. 22 AND 39).

WARREN L. OLANDRIA, EXAMINING ATTORNEY

CLASS 25—(Continued).

SN 76-709,297. COLLINS, KERRY N., FORT PIERCE, FL. 3, FL. FILED 10-4-2011.



THE MARK CONSISTS OF THE LETTERS "HJH" WITH THE LETTER "J" APPEARING IN STYLIZED FORM IN THE COLOR BLUE AND FEATURING AN ARC EXTENDING ABOVE THE SECOND LETTER "H". THE LETTER "H" IS IN THE COLOR BLACK AND APPEARS ON EACH SIDE OF THE LETTER "J".

FOR MEN'S UNDERWEAR AND SOCKS (U.S. CLS. 22 AND 39).

DAVID TAYLOR, EXAMINING ATTORNEY

SN 76-709,774. MAYS TFJ REALTY, LLC., NEW YORK, NY. FILED 11-18-2011.

VIVA ZAPALLA

THE MARK CONSISTS OF STANDARD CHARACTERS WITHOUT CLAIM TO ANY PARTICULAR FONT, STYLE, SIZE, OR COLOR.

THE ENGLISH TRANSLATION OF THE WORDS "VIVA ZAPALLA" IN THE MARK IS LIVE FOREVER LLAMA.

FOR TOPS, DRESSES, COATS, PANTS, SHIRTS, SKIRTS, BLOUSES, JEANS, UNDERWEAR, HOSIERY, HATS, SCARVES, GLOVES, JACKETS, SWEATERS, SUITS, NECKTIES AND FOOTWEAR (U.S. CLS. 22 AND 39).

DAVID TAYLOR, EXAMINING ATTORNEY

SN 76-710,104. DAVID D. BENBOW JR., PASSAIC, NJ. FILED 12-27-2011.

David Barassi

THE MARK CONSISTS OF STANDARD CHARACTERS WITHOUT CLAIM TO ANY PARTICULAR FONT, STYLE, SIZE, OR COLOR.

THE NAME "DAVID BARASSI" DOES NOT IDENTIFY A LIVING INDIVIDUAL.

FOR SHIRTS, PANTS, JACKETS, SHOES (U.S. CLS. 22 AND 39).

MATTHEW MCDOWELL, EXAMINING ATTORNEY

CLASS 25—(Continued).

SN 76-710,335. GRANT, HASAN, FREEHOLD, NJ. FILED 1-23-2012.

DAMN YANKS

THE MARK CONSISTS OF STANDARD CHARACTERS WITHOUT CLAIM TO ANY PARTICULAR FONT, STYLE, SIZE, OR COLOR.

FOR MEN'S, WOMEN'S AND CHILDREN'S APPAREL AND CLOTHING OF ALL TYPES, NAMELY, JERSEYS, SWEAT BANDS, JUMP SUITS, UNIFORMS, SPORTS PANTS, KNIT SHIRTS, SHIRTS, T-SHIRTS, POLO SHIRTS, TANK-TOPS, BLOUSES, SLACKS, JEANS, SHORTS, BELTS, UNDERWEAR, STOCKINGS, SOCKS, SWIMWEAR, NIGHTWEAR, LEOTARDS, LEGGINGS, COATS, TUXEDOS, JACKETS, PARKAS, OVERCOATS, PULLOVERS, SWEATSHIRTS, SWEATERS, HEADWEAR AND FOOTWEAR (U.S. CLS. 22 AND 39).

WILLIAM ROSSMAN, EXAMINING ATTORNEY

SN 77-071,625. WHITE, CARL FREDERICK, VENICE, FL. FILED 12-27-2006.

DODADS

THE MARK CONSISTS OF STANDARD CHARACTERS WITHOUT CLAIM TO ANY PARTICULAR FONT, STYLE, SIZE, OR COLOR.

SEC. 2(F).

FOR SHORT AND LONG SLEEVE T-SHIRTS, HATS, POLO SHIRTS, KNIT SHIRTS, DRESS SHIRTS, SWEAT SHIRTS AND PANTS, SCARVES, SOCKS, SLIPPERS (U.S. CLS. 22 AND 39).

FIRST USE 5-31-2005; IN COMMERCE 5-31-2005.

TIMOTHY FINNEGAN, EXAMINING ATTORNEY

SN 77-199,773. GOMEZ, LOUIS, F., LOS ANGELES, CA. FILED 6-6-2007.

KUSTOM LYFE STYL

THE MARK CONSISTS OF STANDARD CHARACTERS WITHOUT CLAIM TO ANY PARTICULAR FONT, STYLE, SIZE, OR COLOR.

NO CLAIM IS MADE TO THE EXCLUSIVE RIGHT TO USE "CUSTOM", APART FROM THE MARK AS SHOWN.

FOR SHORT-SLEEVED OR LONG-SLEEVED T-SHIRTS; T-SHIRTS; BRIEFS; LADIES' UNDERWEAR; THONGS; UNDERWEAR; UNDERWEAR, NAMELY, BOY SHORTS; SWEATSHIRTS, JACKETS; HATS CAPS, BEANIES (U.S. CLS. 22 AND 39).

KEVIN CORWIN, EXAMINING ATTORNEY

CLASS 25—(Continued).

SN 77-905,755. BEY, KHALID, QUANTU, DBA QUAYAAA-
NI ENTERPRISES INTERNATIONAL LLC/Q.U.E INTER-
NATIONAL, YONKERS, NY. FILED 1-6-2010.



THE MARK CONSISTS OF LADY WEARING A ONE
PIECE GARMENT, WITH GLASSES, A SCARF AND HAIR
EXTENDED OUT THE END OF SCARF SITTING ON A
STOOL, WITH THIGH HIGH, HIGH HEEL BOOTS, READ-
ING A BOOK.

FOR ATHLETIC APPAREL, NAMELY, SHIRTS,
PANTS, JACKETS, FOOTWEAR, HATS AND CAPS,
ATHLETIC UNIFORMS (U.S. CLS. 22 AND 39).

FIRST USE 5-28-2007; IN COMMERCE 5-28-2008.
KIM MONINGHOFF, EXAMINING ATTORNEY

CLASS 25—(Continued).

SN 79-094,784. ERCAN ILHAN, TURKEY, FILED 11-12-2010.



OWNER OF INTERNATIONAL REGISTRATION 0891276
DATED 2-9-2006, EXPIRES 2-9-2016.

NO CLAIM IS MADE TO THE EXCLUSIVE RIGHT TO
USE "SPORTSWEAR COMPANY", APART FROM THE
MARK AS SHOWN.

THE COLOR(S) BROWN, BLACK, WHITE AND GOLD IS/
ARE CLAIMED AS A FEATURE OF THE MARK.

THE MARK CONSISTS OF THE BROWN STYLIZED
WORDING "SPORTS WEAR COMPANY" OVER THE
WORDING "BIG SAM" IN WHITE LETTERS THAT ARE
OUTLINED IN BLACK. UNDER THE WORDING IS A
WHITE BULLDOG HOLDING A WHITE BARBELL IN ITS
MOUTH WITH BOTH THE DOG AND BARBELL BEING
OUTLINED IN BLACK. THE MARK HAS A WHITE AND
GOLD STRIPPED BACKGROUND.

FOR KNITWEAR, NAMELY, KNITTED SWEATERS,
DRESSES, SKIRTS, HATS, AND PANTS; JEANS IN THE
NATURE OF CLOTHING; CLOTHING OF LEATHER,
NAMELY, LEATHER JACKETS AND PANTS; CLOTH-
ING OF IMITATIONS OF LEATHER, NAMELY, COATS;
TRACK SUITS; SHIRTS, JACKETS; DENIM JACKETS;
TROUSERS; SKIRTS; BLOUSES; BATHING SUITS AND
BEACH CLOTHES, NAMELY, BEACHWEAR; UNDER-
WEAR, GLOVES; SOCKS; SHOES, BOOTS, SLIPPERS,
BABIES' SHOES, SPORTS SHOES, IRON FITTINGS FOR
SHOES, NAMELY, CLEATS FOR ATTACHING TO
SPORTS SHOES; SOLES FOR FOOTWEAR; HEEL PIECES
FOR BOOTS AND SHOES; STOCKINGS, SHOE UPPERS;
HEADWEAR; HATS, BERETS AND CAPS; BABIES'
DIAPERS OF TEXTILE, BABIES' JACKETS, BIBS NOT
OF PAPER; NECKTIES, BOWTIES; SHAWLS; SCARVES;
COLLARS, MUFFS; BANDANAS IN THE NATURE OF
NECKERCHIEFS, WRISTBANDS; BELTS, SUSPENDERS
IN THE NATURE OF BRACES FOR CLOTHING; GAR-
TERS (U.S. CLS. 22 AND 39).

TRACY WHITTAKER-BROWN, EXAMINING ATTOR-
NEY

CLASS 25—(Continued).

SN 79-102,081. RAMSEYGATE PTY LTD AS TRUSTEE FOR THE LEVI RAMSEY FAMILY TRUST, AUSTRALIA, AND RAMSEYCORP PTY LTD AS TRUSTEE FOR THE HEATH RAMSEY FAMILY TRUST, CAPALABA QLD 4157, AUSTRALIA, FILED 8-16-2011.

IRONLAK

THE MARK CONSISTS OF STANDARD CHARACTERS WITHOUT CLAIM TO ANY PARTICULAR FONT, STYLE, SIZE, OR COLOR.

PRIORITY DATE OF 8-4-2011 IS CLAIMED.
OWNER OF INTERNATIONAL REGISTRATION 1089510 DATED 8-16-2011, EXPIRES 8-16-2021.

FOR CLOTHING, NAMELY, SHIRTS, T-SHIRTS, SWEATERS, SWEATSHIRTS, HOODED SWEATSHIRTS, JACKETS, SPRAY JACKETS, AND PUFFER JACKETS; FOOTWEAR; HEADGEAR, NAMELY, HATS, CAPS, BUCKET CAPS AND BEANIES (U.S. CLS. 22 AND 39).
LEIGH CAROLINE CASE, EXAMINING ATTORNEY

CLASS 25—(Continued).

SN 79-102,416. HENRY CANTON, FED REP GERMANY, FILED 6-29-2011.



PRIORITY DATE OF 12-30-2010 IS CLAIMED.
OWNER OF INTERNATIONAL REGISTRATION 1090345 DATED 6-29-2011, EXPIRES 6-29-2021.

THE MARK CONSISTS OF A SIX POINTED STAR ON A SHADED TRIANGLE SUPERIMPOSED ON AND TO THE LEFT OF DIAGONAL STRIPES AT DIFFERING ANGLES.

FOR CLOTHING, NAMELY, SWEATERS, DRESS SHIRTS, RUGBY SHIRTS, KNIT SHIRTS, JEANS, FUR JACKETS, LEATHER JACKETS, WIND RESISTANT JACKETS, FUR COATS, LAB COATS, LEATHER COATS, OVERCOATS, RAIN COATS, SPORT COATS, SUIT COATS, TOP COATS, SLACKS, GYM PANTS, GYM SUITS, PLAY SUITS, SKI SUITS, SNOW SUITS, SWEAT SUITS, VESTED SUITS, LEISURE SUITS, TRAINING SUITS, JOGGING SUITS, WARM-UP SUITS, VISORS, BLOUSES, DRESSES, CARDIGANS, JERSEYS, SHORTS, BERMUDA SHORTS, GYM SHORTS, BANDANAS, HEADBANDS, WRISTBANDS, SWEATBANDS, OVERALLS, ROBES, TOPS, TANK TOPS, SINGLET, ATHLETIC UNIFORMS, SWIMWEAR, BRIEFS, KNEE HIGHS, MITTENS, MUFFS, EAR MUFFS, SLEEPWEAR, SNEAKERS, BOOTIES AND SANDALS; FOOTWEAR; SUITS; LAYETTES; BABIES' DIAPERS OF TEXTILE; BATHING SUITS, BATHING TRUNKS, BATH ROBES, BATHING CAPS, BATH SLIPPERS; BIKINIS; POCKET SQUARES; MASQUERADE COSTUMES; FOOTBALL SHOES; BELTS FOR CLOTHING; CLOTHING FOR GYMNASTICS, NAMELY, MOISTURE-WICKING SPORTS SHIRTS, MOISTURE-WICKING SPORTS PANTS, MOISTURE-WICKING SPORTS BRAS AND SPORTS OVERUNIFORMS, GYMNASTIC SHOES, SCARVES, GLOVES, SHIRTS AND/OR JUMPERS, TROUSERS, INCLUDED IN THIS CLASS, HATS, JACKETS, HOODS, NECKTIES, ASCOTS, BIBS, NOT OF PAPER, COATS, CAPS, HEADWEAR, PULLOVERS, CYCLISTS' CLOTHING, NAMELY, CYCLISTS' JERSEYS, WATER-PROOF JACKETS, PANTS, RAIN CAPES, RAIN PONCHOS, SKIRTS, PAJAMAS, SHOES, INCLUDED IN THIS CLASS, APRONS, SOCKS, SPORTS SHOES, INCLUDED IN THIS CLASS, BEACH WEAR, STOCKINGS, TIGHTS, KNITWEAR, NAMELY, KNITTED SHIRTS, T-SHIRTS, UNDERWEAR (U.S. CLS. 22 AND 39).
COLLEEN DOMBROW, EXAMINING ATTORNEY

SN 79-102,298. DAVID BENJAMEN IRAMIA, GREENFIELD PARK NSW 2176, AUSTRALIA, FILED 8-6-2011.



PRIORITY DATE OF 2-14-2011 IS CLAIMED.
OWNER OF INTERNATIONAL REGISTRATION 1090016 DATED 8-6-2011, EXPIRES 8-6-2021.

THE MARK CONSISTS OF THE STYLIZED LOWERCASE LETTERS "DF", WHICH ARE JOINED TOGETHER TO FORM A GEOMETRIC DESIGN.

FOR APPAREL AND CLOTHING, NAMELY, PRINTED T SHIRTS, T SHIRTS, PANTS, COATS, DRESSES, WRAPS, JUMPERS, POLO SWEATERS, SPORTS SWEATERS, TANK TOPS, SHORTS, ATHLETICS SHORTS, BOXERS SHORTS, GYM SHORTS AND ATHLETICS WEAR IN THE NATURE OF ATHLETIC SHIRTS, ATHLETIC SHORTS, ATHLETIC UNIFORMS, SPORTS JERSEYS; FOOTWEAR; HEADGEAR, NAMELY, CAPS, HATS, BERETS (U.S. CLS. 22 AND 39).
KRISTIN CARLSON, EXAMINING ATTORNEY

CLASS 25—(Continued).

SN 79-102,508. CARS JEANS & CASUALS B.V., NETHERLANDS, FILED 7-28-2011.



PRIORITY DATE OF 3-31-2011 IS CLAIMED.
OWNER OF INTERNATIONAL REGISTRATION 1090663 DATED 7-28-2011, EXPIRES 7-28-2021.
NO CLAIM IS MADE TO THE EXCLUSIVE RIGHT TO USE "JEANS & CASUALS", APART FROM THE MARK AS SHOWN.

THE COLOR(S) BLUE AND WHITE IS/ARE CLAIMED AS A FEATURE OF THE MARK.

THE MARK CONSISTS OF THE WORD "CARS" IN WHITE STYLIZED FONT ON A BLUE OVAL SHAPE WITH THE PHRASE "JEANS & CASUALS" UNDERNEATH IN BLUE STYLIZED FONT, ALL ON A WHITE BACKGROUND.

FOR CLOTHING, NAMELY, TROUSERS, SHORTS, PANTS, SKIRTS, DRESSES, SHIRTS, JACKETS, TEE-SHIRTS, TANK TOPS, SWEATERS; FOOTGEAR, NAMELY, SHOES, BOOTS, SANDALS, SLIPPERS, RUNNING SHOES; HEADGEAR, NAMELY, CAPS, HATS, BERETS (U.S. CLS. 22 AND 39).

ERNEST SHOSHO, EXAMINING ATTORNEY

SN 79-102,608. PINGYANG WENSEN LEATHER PRODUCTS CO., LTD., ZHEJIANG PROVINCE, CHINA, FILED 8-26-2011.



OWNER OF INTERNATIONAL REGISTRATION 1090848 DATED 8-26-2011, EXPIRES 8-26-2021.

THE MARK CONSISTS OF A STYLIZED LETTER "B", AN INVENTED WORD "KALEWENSEN" AND FOUR CHINESE CHARACTERS.

THE ENGLISH TRANSLATION OF THE FOREIGN WORD(S) IN THE MARK IS: THE FIRST CHINESE CHARACTER IN THE TRADEMARK MEANS "CARD", THE SECOND CHINESE CHARACTER MEANS "HAPPY", THE THIRD CHINESE CHARACTER MEANS "LITERARY", THE LAST CHINESE CHARACTER IN THE MARK MEANS "FOREST".

THE TRANSLITERATION OF THE NON-LATIN CHARACTERS IN THE MARK IS: THE FOUR CHINESE CHARACTERS IN THE MARK ARE TRANSLITERATED AS "KA LE WEN SEN".

FOR SHAPEWEAR, NAMELY, GIRDLES; BELTS BEING CLOTHING; SUSPENDERS; BRACES, SUSPENDERS FOR CLOTHING; NECKTIES; SCARVES; SHAWLS (U.S. CLS. 22 AND 39).

MELISSA VALLILLO, EXAMINING ATTORNEY

CLASS 25—(Continued).

SN 79-104,501. ZHEJIANG TONGDA CLOTHING CO., LTD., CHINA, FILED 9-27-2011.



OWNER OF INTERNATIONAL REGISTRATION 1095621 DATED 9-27-2011, EXPIRES 9-27-2021.

THE MARK CONSISTS OF THE WORD "BIPAI" WITH ASIAN CHARACTERS WRITTEN BELOW IT. ABOVE THE WORDING IS A STYLIZED BANNER COMPOSED OF TWO CURVED LINES CONNECTED BY A VERTICAL LINE.

THE WORDING "BIPAI" HAS NO MEANING IN A FOREIGN LANGUAGE.

THE NON-LATIN CHARACTERS IN THE MARK TRANSLITERATE TO "BI PAI".

FOR CLOTHING, NAMELY, SHIRTS, PANTS, SKIRTS, UNDERWEAR; SHOES; HATS; HOSIERY; GLOVES, FOR CLOTHING; BELTS, FOR CLOTHING; SCARVES; LAYETTES OF CLOTHING; SWIMSUITS (U.S. CLS. 22 AND 39).

FRANK LATTUCA, EXAMINING ATTORNEY

SN 79-106,124. WIGES AB, SWEDEN, FILED 11-2-2011.



PRIORITY DATE OF 5-31-2011 IS CLAIMED.
OWNER OF INTERNATIONAL REGISTRATION 1099171 DATED 11-2-2011, EXPIRES 11-2-2021.

THE COLOR(S) BLACK AND WHITE IS/ARE CLAIMED AS A FEATURE OF THE MARK.

THE MARK CONSISTS OF THE TERM "DR+" IN WHITE SUPERIMPOSED ON A BLACK RECTANGLE.

FOR CLOTHING, NAMELY, SHIRTS, PANTS, UNDERWEAR; HOSIERY, SOCKS, STRETCH TIGHTS (U.S. CLS. 22 AND 39).

HAI-LY LAM, EXAMINING ATTORNEY

CLASS 25—(Continued).

SN 79-106,190. WIGES AB, SWEDEN, FILED 11-1-2011.



PRIORITY DATE OF 6-14-2011 IS CLAIMED.
OWNER OF INTERNATIONAL REGISTRATION 1099362
DATED 11-1-2011, EXPIRES 11-1-2021.

THE COLOR(S) BLACK, WHITE AND GRAY IS/ARE
CLAIMED AS A FEATURE OF THE MARK.

THE MARK CONSISTS OF THE WORDING "THE DOCTOR
RECOMMENDS" IN WHITE TO THE LEFT OF A
DESIGN OF A GRAY AND WHITE CADUCEUS AND ALL
OF WHICH ARE SUPERIMPOSED ON A BLACK RECTAN-
GLE.

FOR CLOTHING, NAMELY, SHIRTS, PANTS, UN-
DERWEAR; HOSIERY, SOCKS, STRETCH TIGHTS (U.S.
CLS. 22 AND 39).

HAI-LY LAM, EXAMINING ATTORNEY

SN 79-107,511. ZHEJIANG TONGDA CLOTHING CO., LTD.,
CHINA, FILED 11-8-2011.



OWNER OF INTERNATIONAL REGISTRATION 1102474
DATED 11-8-2011, EXPIRES 11-8-2021.

THE MARK CONSISTS OF TWO CURVED BANDS CON-
NECTED BY A VERTICAL LINE.

FOR CLOTHING, NAMELY, SHIRTS, PANTS, SKIRTS,
UNDERWEAR; GLOVES FOR CLOTHING; HEADWEAR,
NAMELY, CAPS; HOSIERY; FOOTWEAR; BELTS, FOR
CLOTHING; SCARVES; NECKTIES; SWIMSUITS;
CLOTHING, NAMELY, LAYETTES (U.S. CLS. 22 AND
39).

FRANK LATTUCA, EXAMINING ATTORNEY

SN 79-109,338. SIE (AUST) PTY LTD., AUSTRALIA, FILED 1-
23-2012.

SOUL PRINCESS

THE MARK CONSISTS OF STANDARD CHARACTERS
WITHOUT CLAIM TO ANY PARTICULAR FONT, STYLE,
SIZE, OR COLOR.

PRIORITY DATE OF 9-6-2011 IS CLAIMED.
OWNER OF INTERNATIONAL REGISTRATION 1107341
DATED 1-23-2012, EXPIRES 1-23-2022.

FOR FOOTWEAR (U.S. CLS. 22 AND 39).

JACLYN KIDWELL WALKER, EXAMINING ATTORNEY

CLASS 25—(Continued).

SN 85-065,557. COLE, JOHN WALKER, FAYETTEVILLE, AR.
FILED 6-17-2010.

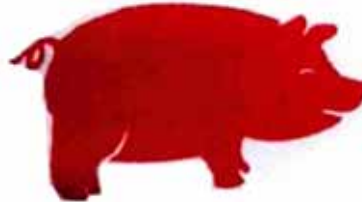

THE MARK CONSISTS OF A RED CURLY TAIL PIG,
FOR MEN'S, WOMEN'S AND CHILDREN'S APPAREL,
NAMELY, DRESS SHIRTS, T-SHIRTS, GOLF SHIRTS,
BLOUSES, PANTS, UNDERWEAR, HATS AND CAPS
(U.S. CLS. 22 AND 39).

FIRST USE 1-1-2010; IN COMMERCE 1-1-2010.

MICHAEL LITZAU, EXAMINING ATTORNEY

SN 85-066,291. THE OHIO STATE UNIVERSITY, COLUM-
BUS, OH. FILED 6-18-2010.



THE COLOR(S) GRAY, WHITE, AND BLACK IS/ARE
CLAIMED AS A FEATURE OF THE MARK.

THE MARK CONSISTS OF ELEVEN HORIZONTAL
STRIPES STACKED ON TOP OF ONE ANOTHER IN THE
FOLLOWING ORDER FROM TOP TO BOTTOM: BLACK,
GRAY, BLACK, WHITE, BLACK, GRAY, BLACK, WHITE,
BLACK, GRAY, BLACK. THE MATTER SHOWN IN BRO-
KEN LINES IS NOT PART OF THE MARK AND SERVES
ONLY TO SHOW POSITION OR PLACEMENT OF THE
MARK.

SEC. 2(F).

FOR FOOTBALL JERSEYS (U.S. CLS. 22 AND 39).

FIRST USE 9-0-1975; IN COMMERCE 9-0-1975.

MARY I. SPARROW, EXAMINING ATTORNEY

CLASS 25—(Continued).

SN 85-080,380. LUCKY STAR LICENSING LLC, NEW YORK, NY. FILED 7-8-2010.

MIAMI THRICE

THE MARK CONSISTS OF STANDARD CHARACTERS WITHOUT CLAIM TO ANY PARTICULAR FONT, STYLE, SIZE, OR COLOR.

FOR CLOTHING, NAMELY, SHIRTS, T-SHIRTS, LONG-SLEEVED SHIRTS, UNDER SHIRTS, POLO SHIRTS, RUGBY SHIRTS, JERSEYS, SCRUBS NOT FOR MEDICAL PURPOSES, SMOCKS, DRESS SHIRTS, STRETCH PANTS, OVERALLS, COVERALLS, DENIM JEANS, JUMPERS, JUMP SUITS, STRETCH TOPS, TUBE TOPS, CROP TOPS, TANKINIS, HALTER TOPS, HOODED SWEAT SHIRTS, WRAPS, WARM-UP SUITS, JOGGING SUITS, TRACK SUITS, PARKAS, CAPES, PONCHOS, CARDIGANS, PANTS, JEAN JACKETS, CARGO PANTS, SHORTS, BOXER SHORTS, TOPS, TANK TOPS, SWEAT SHIRTS, SWEAT JACKETS, SWEAT SHORTS, SWEAT PANTS, BLOUSES, DRESSES, SWEATERS, VESTS, FLEECE VESTS, PULLOVERS, JACKETS, COATS, SUITS, TURTLENECKS, REVERSIBLE JACKETS, WIND-RESISTANT JACKETS, SHELL JACKETS, SPORTS JACKETS, GOLF AND SKI JACKETS, HEAVY COATS, OVER COATS, TOP COATS, SWIMWEAR, BEACHWEAR, TENNIS WEAR, SURF WEAR, SKI WEAR, INFANTWEAR, SWIM CAPS, VISORS, HEADBANDS, THERMAL UNDERWEAR, LONG UNDERWEAR, BRIEFS, BRAS, PANTIES, THONGS, G-STRINGS, SINGLETS, UNDERCLOTHES, NIGHT GOWNS, NIGHTIES, LINGERIE, SLIPS, SARONGS, LEGGINGS, TIGHTS, LEOTARDS, CAPS, HATS, HEADWEAR, SCARVES, BANDANAS, BELTS, NECKWEAR, TIES, UNDERWEAR, SOCKS, LOUNGEWEAR, ROBES, PAJAMAS, SLEEPWEAR, HOSIERY, GLOVES, RAIN SLICKERS, RAINWEAR, FOOTWEAR, SHOES AND SNEAKERS, SANDALS, FLIP-FLOPS, AND SLIPPERS (U.S. CLS. 22 AND 39).

JIM RINGLE, EXAMINING ATTORNEY

CLASS 25—(Continued).

SN 85-099,783. CHAINSON FOOTWEAR INC., OXNARD, CA. FILED 8-4-2010.

miss robertson

THE MARK CONSISTS OF STYLIZED WORDS "MISS ROBERTSON" FOR FOOTWEAR (U.S. CLS. 22 AND 39). FIRST USE 11-17-2009; IN COMMERCE 3-2-2010. DOMINIC J. FERRAIUOLO, EXAMINING ATTORNEY

SN 85-099,823. CHAINSON FOOTWEAR INC., OXNARD, CA. FILED 8-4-2010.

MISS ROBERTSON

THE MARK CONSISTS OF STANDARD CHARACTERS WITHOUT CLAIM TO ANY PARTICULAR FONT, STYLE, SIZE, OR COLOR.

FOR FOOTWEAR (U.S. CLS. 22 AND 39). FIRST USE 11-17-2009; IN COMMERCE 3-2-2010. DOMINIC J. FERRAIUOLO, EXAMINING ATTORNEY

SN 85-113,136. L.V. INDUSTRIA DE CONFECÇÕES LTDA E.P.P., ALDEOTA - FORTALEZA, BRAZIL, FILED 8-23-2010.

LINO VILLAVENTURA

SN 85-080,588. JUAN CARLOS LOPEZ CASTANO, DBA PONTEBELLA, VALLEY STREAM, NY. FILED 7-8-2010.

Ponte Bella
Piensa en tu Figura

THE MARK CONSISTS OF THE MARK "PONTEBELLA" IS WRITTEN IN FRENCH SCRIPT MT FONT STYLE THE LETTER "P" AND "B" ARE IN CAPITAL LETTERS.

THE ENGLISH TRANSLATION OF "PONTE BELLA" IN THE MARK IS "BE BEAUTIFUL". THE ENGLISH TRANSLATION OF THE WORDING "PIENSA EN TU FIGURA" IN THE MARK IS "THINK ABOUT YOUR FIGURE".

FOR SHAPEWEAR, NAMELY, BODY SHAPERS, BODY SUITS, CAPRIS, CORSETS, PANTIES, SHORTS (U.S. CLS. 22 AND 39).

FIRST USE 5-1-2001; IN COMMERCE 6-6-2003. JAY FLOWERS, EXAMINING ATTORNEY

OWNER OF BRAZIL REG. NO. 810908174, DATED 7-17-1984, EXPIRES 7-17-2014.

THE NAME(S), PORTRAIT(S), AND/OR SIGNATURE(S) SHOWN IN THE MARK IDENTIFIES "LINO VILLAVENTURA", WHOSE CONSENT(S) TO REGISTER IS MADE OF RECORD.

THE MARK CONSISTS OF THE WORDS "LINO VILLAVENTURA" IN STYLIZED LETTERS.

FOR BELTS; BERMUDA SHORTS; COATS; DRESSES; GLOVES; HATS; JERSEYS; JUMPERS; LEGGINGS; LEOTARDS; NECKERCHIEFS; PANTS; SANDALS; SCARFS; SHIRTS; SHOES; SLEEVED OR SLEEVELESS JACKETS; SOCKS; SUITS; SWEATERS; SWIMSUITS; T-SHIRTS; TIGHTS; WARM-UP SUITS (U.S. CLS. 22 AND 39).

JENNIFER DIXON, EXAMINING ATTORNEY

CLASS 25—(Continued).

SN 85-159,616. RANGERS BASEBALL LLC, ARLINGTON, TX. FILED 10-22-2010.



THE MARK CONSISTS OF A HUMAN HAND SHAPED LIKE A CLAW.
 SEC. 2(F).
 FOR SHIRTS (U.S. CLS. 22 AND 39).
 FIRST USE 9-8-2010; IN COMMERCE 9-8-2010.
 WENDY GOODMAN, EXAMINING ATTORNEY

SN 85-193,457. FRANCIS, DAN ROY, WOODSIDE, CA. FILED 12-8-2010.

LET OUT SOME STRING

THE MARK CONSISTS OF STANDARD CHARACTERS WITHOUT CLAIM TO ANY PARTICULAR FONT, STYLE, SIZE, OR COLOR.
 FOR SHIRTS; PANTS; HATS; T-SHIRTS; CAPS; APPAREL AND CLOTHING, NAMELY, SWEATSHIRTS (U.S. CLS. 22 AND 39).
 LAURIE MAYES, EXAMINING ATTORNEY

SN 85-195,972. DINAH BROTHERS BRANDS, INC., LIBERTY HILL, TX. FILED 12-12-2010.

**Hot Iron
 Get Branded**

THE MARK CONSISTS OF STANDARD CHARACTERS WITHOUT CLAIM TO ANY PARTICULAR FONT, STYLE, SIZE, OR COLOR.
 FOR WEARABLE GARMENTS AND CLOTHING, NAMELY, SHIRTS (U.S. CLS. 22 AND 39).
 FIRST USE 8-15-2011; IN COMMERCE 8-15-2011.
 DAVID C. REIHNER, EXAMINING ATTORNEY

CLASS 25—(Continued).

SN 85-226,170. KNOTT, REBECCA J, DBA MEDUSA FIGHTER, LOUISVILLE, CO. FILED 1-26-2011.



THE COLOR(S) BLUE, GOLD, PURPLE, MAUVE, OLIVE GREEN, RED, PEACH, GOLDEN PEACH, NION GREEN AND SILVER IS/ARE CLAIMED AS A FEATURE OF THE MARK.

THE MARK CONSISTS OF A MEDUSA HEAD WITH A PEACH AND GOLD FACE, WITH 1 BLUE SNAKE, 1 GOLD SNAKE, 1 GREEN SNAKE, 1 PURPLE SNAKE, 2 RED SNAKES, GREEN EYES AND THE TEXT "MEDUSA FIGHTER" IN THE COLOR SILVER.

FOR ATHLETIC APPAREL, NAMELY, SHIRTS, PANTS, JACKETS, FOOTWEAR, HATS AND CAPS, ATHLETIC UNIFORMS (U.S. CLS. 22 AND 39).
 GINA HAYES, EXAMINING ATTORNEY

SN 85-253,877. MICHAEL NWOKOLO, AKA FLY BOY CITY, WEEHAWKEN, NJ. FILED 2-28-2011.



THE MARK CONSISTS OF THE STYLIZED WORDING "FLY" ABOVE THE STYLIZED WORDING "BOY" ABOVE THE STYLIZED WORDING "CITY", AND THE DESIGN OF WINGS EXTENDING FROM THE WORDING "FLY".

FOR CLOTHING, NAMELY, TOPS, BOTTOMS, UNDERWEAR, HEADWEAR, FOOTWEAR, T-SHIRTS, BELTS, SUSPENDERS, SWIMWEAR, JEANS, DRESSES, TIES, SCARVES, GLOVES, NECKERCHIEFS, NIGHTWEAR, SUITS, COATS, AND JACKETS (U.S. CLS. 22 AND 39).

FIRST USE 6-22-2008; IN COMMERCE 6-22-2008.
 JAY BESCH, EXAMINING ATTORNEY

CLASS 25—(Continued).

SN 85-254,681. SOPER, NANCY, DBA ON TARGET FOR YOU, SAN FRANCISCO, CA. FILED 3-1-2011.

ON TARGET FOR YOU

THE MARK CONSISTS OF STANDARD CHARACTERS WITHOUT CLAIM TO ANY PARTICULAR FONT, STYLE, SIZE, OR COLOR.
 FOR WOMEN'S DRESSES; COATS; JACKETS; PANTS; BLOUSES (U.S. CLS. 22 AND 39).
 FIRST USE 7-15-2011; IN COMMERCE 7-15-2011.
 MAYUR VAGHANI, EXAMINING ATTORNEY

SN 85-262,480. GOUSSON - CONSULTADORIA E MARKETING S.A.R.L, L-1746, LUXEMBOURG, FILED 3-9-2011.

ROGER VIVIER

THE MARK CONSISTS OF STANDARD CHARACTERS WITHOUT CLAIM TO ANY PARTICULAR FONT, STYLE, SIZE, OR COLOR.
 OWNER OF BENELUX REG. NO. 590402, DATED 8-5-1992, RENEWED AS REG. NO. 590402, DATED 8-5-2002, EXPIRES 8-5-2012.
 OWNER OF ERPNTM CMNTY TM OFC REG. NO. 6349138, DATED 10-17-2008, EXPIRES 10-10-2017.
 OWNER OF U.S. REG. NOS. 2,947,572 AND 2,954,090.
 THE NAME(S), PORTRAIT(S), AND/OR SIGNATURE(S) SHOWN IN THE MARK DOES NOT IDENTIFY A PARTICULAR LIVING INDIVIDUAL.
 FOR GLOVES; SHOES (U.S. CLS. 22 AND 39).
 CHARLOTTE CORWIN, EXAMINING ATTORNEY

SN 85-311,412. GILI RITZ, BEVERLY HILLS, CA. FILED 5-3-2011.

SMOOSH

THE MARK CONSISTS OF STANDARD CHARACTERS WITHOUT CLAIM TO ANY PARTICULAR FONT, STYLE, SIZE, OR COLOR.
 OWNER OF U.S. REG. NOS. 3,591,042, 3,608,764 AND 3,675,551.
 FOR CAPRI PANTS; CARGO PANTS; CROP PANTS; GYM PANTS; JOGGING PANTS; LOUNGE PANTS; PANTS; SLEEP PANTS; SPORTS PANTS; SWEAT PANTS (U.S. CLS. 22 AND 39).
 FIRST USE 5-3-2007; IN COMMERCE 5-3-2007.
 STEVEN R. FINE, EXAMINING ATTORNEY

CLASS 25—(Continued).

SN 85-314,683. SIRIUS ATHLETIC WEAR, INC, SAHUARITA, AZ. FILED 5-6-2011.

SIRIUS ATHLETIC WEAR

THE MARK CONSISTS OF STANDARD CHARACTERS WITHOUT CLAIM TO ANY PARTICULAR FONT, STYLE, SIZE, OR COLOR.
 NO CLAIM IS MADE TO THE EXCLUSIVE RIGHT TO USE "ATHLETIC WEAR", APART FROM THE MARK AS SHOWN.
 FOR MARTIAL ARTS UNIFORMS (U.S. CLS. 22 AND 39).
 FIRST USE 10-23-2003; IN COMMERCE 12-20-2003.
 MARK T. MULLEN, EXAMINING ATTORNEY

SN 85-317,105. D & S PROJECTS LLC, POMONA, CA. FILED 5-10-2011.

GOLD BAR

THE MARK CONSISTS OF THE STYLIZED WORDS "GOLD BAR".
 FOR JEANS, JACKETS, SKIRTS, DRESSES, SHIRTS, VESTS, PANTS, SHORTS, OVERALLS, HEADWEAR, SHOES, FOOTWEAR (U.S. CLS. 22 AND 39).
 ALYSSA STEEL, EXAMINING ATTORNEY

SN 85-317,628. MACCARTHY, WEIHUA, NEWINGTON, CT. FILED 5-11-2011.



THE COLOR(S) BLACK, RED, BLUE AND GREEN IS/ARE CLAIMED AS A FEATURE OF THE MARK.
 THE MARK CONSISTS OF AN IMAGE OF A BIRD IN BLACK COLOR WITH THE SHAMROCK WHICH IS MADE UP OF 3 HEART SHAPES AND EACH SHAPE IS MADE UP OF RED, BLUE AND GREEN COLOR. THE WORD "MCCARTHY" WRITTEN IN BLACK COLOR TO THE RIGHT HAND SIDE OF THE IMAGE; WHITE IS NOT A FEATURE OF THE MARK AND REPRESENTS TRANSPARENT AREAS.
 FOR CLOTHING, NAMELY, DRESSES, DANCE COSTUMES, CHILDREN'S OUTWEAR IN THE NATURE OF COATS, JACKETS, TOPS, BOTTOMS, T-SHIRTS, PANTS, JACKETS, SHORTS, DRESS SHIRTS, AND KNIT TOPS, KNIT SHIRTS, KNIT BOTTOMS, KNIT JACKETS, SWIMWEAR, TOPS, BOTTOMS, BEACHWEAR, SOCKS, SHOES, HATS (U.S. CLS. 22 AND 39).
 HEATHER BIDDULPH, EXAMINING ATTORNEY

CLASS 25—(Continued).

SN 85-317,929. BENDIGO CONSULTANTS, LLC, SANTA BARBARA, CA. FILED 5-11-2011.

JOBB

THE MARK CONSISTS OF STANDARD CHARACTERS WITHOUT CLAIM TO ANY PARTICULAR FONT, STYLE, SIZE, OR COLOR.

THE ENGLISH TRANSLATION OF THE WORD "JOBB" IN THE MARK IS "JOB".

FOR CLOTHING, NAMELY, SHIRTS, BLOUSES, SWEATERS, VESTS, JACKETS, SUITS, COATS, T-SHIRTS, TANK TOPS, CAMISOLES, SWEATSHIRTS, SHORTS, PANTS, TROUSERS, SKIRTS, DRESSES (U.S. CLS. 22 AND 39).

DAVID COLLIER, EXAMINING ATTORNEY

SN 85-329,105. TAIL CHASERS, INC., NEW SMYRNA BEACH, FL. FILED 5-24-2011.

GAME CHASERS

THE MARK CONSISTS OF STANDARD CHARACTERS WITHOUT CLAIM TO ANY PARTICULAR FONT, STYLE, SIZE, OR COLOR.

FOR APPAREL, NAMELY, T-SHIRTS, POLO SHIRTS, JACKETS, PANTS, SHORTS, HATS, AND CAPS (U.S. CLS. 22 AND 39).

FIRST USE 5-1-2011; IN COMMERCE 5-1-2011.
KAREN BRACEY, EXAMINING ATTORNEY

SN 85-330,449. ATELIER STP INC, BRONXVILLE, NY. FILED 5-25-2011.

GOOD GENES

THE MARK CONSISTS OF STANDARD CHARACTERS WITHOUT CLAIM TO ANY PARTICULAR FONT, STYLE, SIZE, OR COLOR.

FOR JEANS AND SHOES FOR MEN, WOMEN AND KIDS (U.S. CLS. 22 AND 39).

KATHERINE STOIDES, EXAMINING ATTORNEY

CLASS 25—(Continued).

SN 85-330,951. RCRV, INC., LOS ANGELES, CA. FILED 5-26-2011.

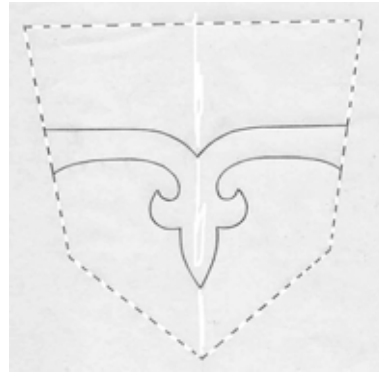

THE MARK CONSISTS OF A THREE-DIMENSIONAL DESIGN FEATURE CONSISTING OF A STYLIZED INVERTED FLEUR DE LIS DESIGN STITCHED ON THE BACK POCKET OF A JEANS PRODUCT. DEPICTED IN THE DRAWING AS A SOLID BLACK LINE. THE DOTTED OUTLINE OF THE GOODS IS INTENDED TO SHOW THE POSITION OF THE MARK AND IS NOT PART OF THE MARK AS SHOWN.

SEC. 2(F).

FOR APPAREL, NAMELY, JEANS, SHORTS AND SKIRTS (U.S. CLS. 22 AND 39).

FIRST USE 11-23-2005; IN COMMERCE 3-17-2006.
MARK SPARACINO, EXAMINING ATTORNEY

SN 85-332,644. MARISA PEREIRA CONSULTING LLC, ROSWELL, GA. FILED 5-27-2011.

Michaela Noel

THE MARK CONSISTS OF STANDARD CHARACTERS WITHOUT CLAIM TO ANY PARTICULAR FONT, STYLE, SIZE, OR COLOR.

THE NAME(S), PORTRAIT(S), AND/OR SIGNATURE(S) SHOWN IN THE MARK IDENTIFIES "MICHAELA NOEL POCOCK", WHOSE CONSENT(S) TO REGISTER IS MADE OF RECORD.

FOR WOMEN'S CLOTHING, NAMELY, SHIRTS, DRESSES, SKIRTS, BLOUSES (U.S. CLS. 22 AND 39).

FIRST USE 3-1-2011; IN COMMERCE 5-2-2011.

MATTHEW EINSTEIN, EXAMINING ATTORNEY

CLASS 25—(Continued).

SN 85-333,134. LEE, PRISCILLA, LOS ANGELES, CA. FILED 5-28-2011.

CLASS 25—(Continued).

SN 85-333,416. PBS FASHION COMPANY LIMITED, BANGKOK, THAILAND, FILED 5-30-2011.



THE MARK CONSISTS OF TWO STACKED OLIVES WITH A PICK HOLDING THEM TOGETHER, TOP OLIVE SYMBOLIZING THE LETTER "O" AND BOTTOM OLIVE SYMBOLIZING THE LETTER "P".

FOR CAPRIS; CAPS; CLOTHING, NAMELY, ARM WARMERS; DRESSES; EAR MUFFS; GLOVES; HATS; HEADBANDS; HOODED SWEATSHIRTS; JACKETS; LONG SLEEVE PULLOVERS; MITTENS; PANTS; SCARVES; SHIRTS; SHORTS; T-SHIRTS; TANK TOPS (U.S. CLS. 22 AND 39).

FIRST USE 4-1-2011; IN COMMERCE 4-1-2011.

NORA BUCHANAN WILL, EXAMINING ATTORNEY

OWNER OF THAILAND REG. NO. KOR7970-01/1, DATED 2-5-2007, EXPIRES 2-5-2017.

OWNER OF THAILAND REG. NO. KOR273062, DATED 2-5-2007, EXPIRES 2-5-2017.

NO CLAIM IS MADE TO THE EXCLUSIVE RIGHT TO USE "INTERNATIONAL", APART FROM THE MARK AS SHOWN.

THE MARK CONSISTS OF TWO RECTANGLES, SEPARATED BY A SPACE WITH THE WORD "POLICE" APPEARING BETWEEN THE RECTANGLES; THE UPPER RECTANGLE CONTAINING THE HEADS AND UPPER BODIES OF PEOPLE AND THE LOWER RECTANGLE CONTAINING THE LEGS AND FEET OF THE SAME PEOPLE AND CONTAINING THE WORD "INTERNATIONAL".

FOR SHIRTS, SHORT-SLEEVED BUTTON-FRONT SHIRTS, JACKETS, T-SHIRTS, TROUSERS, SHORTS, JEANS, SUITS, NECKTIES, MEN-UNDERWEARS, UNDERPANTS, UNDERSHIRTS, ROUND-NECKLINE UNDERSHIRTS, NIGHTGOWNS, SOCKS, HATS, BELTS, SHOES NOT BEING SPORTS SHOES, SPORTS SHOES, SLIPPERS, INNER UPPER GARMENTS FOR WOMEN, UNDER PANTS FOR WOMEN, CAPS, SPORT UPPER GARMENTS, SPORTS PANTS (U.S. CLS. 22 AND 39).

SHANNON TWOHIG, EXAMINING ATTORNEY

CLASS 25—(Continued).

SN 85-334,778. STRIKERDANGER, ALEXANDRIA, VA. FILED 6-1-2011.



NO CLAIM IS MADE TO THE EXCLUSIVE RIGHT TO USE "STRIKER", APART FROM THE MARK AS SHOWN.

THE MARK CONSISTS OF THE STYLIZED TERMS "STRIKER DANGER." THE STYLIZED TERM "STRIKER" IS ABOVE A SET OF CLINCHED TEETH. FROM THE SIDES OF THE TEETH THERE IS ONE LIGHTNING BOLT ON EACH SIDE OF THE MOUTH. THE STYLIZED TERM "DANGER" IS BELOW THE SET OF TEETH.

FOR ATHLETIC APPAREL, NAMELY, SHIRTS, PANTS, JACKETS, FOOTWEAR, HATS AND CAPS, ATHLETIC UNIFORMS; COMPRESSION GARMENTS FOR ATHLETIC OR OTHER NON-MEDICAL USE, NAMELY, SHORTS AND SHIRTS; HATS; HOODED SWEATSHIRTS; SOCKS; SWEATPANTS; SWEATSHIRTS (U.S. CLS. 22 AND 39).

FIRST USE 8-0-2009; IN COMMERCE 8-0-2009.
TINA BROWN, EXAMINING ATTORNEY

SN 85-336,084. BIKA LLC, DBA BIKA, JUPITER, FL. FILED 6-2-2011.



NO CLAIM IS MADE TO THE EXCLUSIVE RIGHT TO USE "LOS ANGELES, MIAMI, MUMBAI", APART FROM THE MARK AS SHOWN.

THE NAME(S), PORTRAIT(S), AND/OR SIGNATURE(S) SHOWN IN THE MARK IDENTIFIES AMBIKA SANJANA, WHOSE CONSENT(S) TO REGISTER IS MADE OF RECORD.

THE COLOR(S) PURPLE AND BLACK IS/ARE CLAIMED AS A FEATURE OF THE MARK.

THE MARK CONSISTS OF ON THE TOP, TWO DIAGONAL S-TYPE AND PAISLEY-TYPE DESIGNS THAT ARE PURPLE IN COLOR, THE FIRST ONE LEANING TO THE LEFT AND THE SECOND ONE LEANING TO THE RIGHT. UNDERNEATH THESE S-TYPE DESIGNS, THE WORD "BIKA" IS WRITTEN IN FUTURE FONT WITH SPACES IN BETWEEN EACH LETTER OF THE WORD. THE LETTERS

CLASS 25—(Continued).

"B", "I", AND "A" ARE IN LOWERCASE FORM AND ARE BLACK IN COLOR. THE LETTER "K" IS IN UPPERCASE FORM AND IS PURPLE IN COLOR. UNDERNEATH THE WORD "BIKA", ARE THE WORDS "LOS ANGELES", "MIAMI" AND "MUMBAI" WHICH ARE SEPARATED BY A PURPLE COLORED DOT IN BETWEEN THEM. ALL 3 OF THESE WORDS ARE IN UPPERCASE FORM AND ARE BLACK IN COLOR AND ARE WRITTEN IN FUTURA FONT. THESE 3 WORDS ARE SMALLER IN FONT THAN THE WORD "BIKA".

FOR BATHING SUITS; BIKINIS; CLOTHING, NAMELY, WRAP-AROUNDS; HOODS; JACKETS; SWIM SUITS; TOPS; WEARABLE GARMENTS AND CLOTHING, NAMELY, SHIRTS; WOMEN'S CLOTHING, NAMELY, SHIRTS, DRESSES, SKIRTS, BLOUSES; WRAPS (U.S. CLS. 22 AND 39).

PAUL E. FAHRENKOPF, EXAMINING ATTORNEY

SN 85-337,703. LUCKY DOG ENTERTAINMENT, INC., LOS ANGELES, CA. FILED 6-3-2011.

PEEK INSIDE

THE MARK CONSISTS OF STANDARD CHARACTERS WITHOUT CLAIM TO ANY PARTICULAR FONT, STYLE, SIZE, OR COLOR.

FOR CHILDREN'S APPAREL AND CLOTHING, NAMELY, SHIRTS, T-SHIRTS, SWEATSHIRTS, TOPS, BLOUSES, PANTS, TROUSERS, SHORTS, DRESSES, SKIRTS, JACKETS, COATS, VESTS, PAJAMAS, ROBES, NIGHTGOWNS, SLEEPWEAR, FOOTWEAR, HATS, AND CAPS (U.S. CLS. 22 AND 39).

ANN E. SAPPENFIELD, EXAMINING ATTORNEY

SN 85-340,462. FRED HASSON, NEW YORK, NY. AND SIBEL ISIK, NEW YORK, NY. FILED 6-7-2011.

fred AND sibel

THE NAMES "FRED" AND "SIBEL" IDENTIFY LIVING INDIVIDUALS WHOSE CONSENT IS OF RECORD.

THE MARK CONSISTS OF THE WORDS "FRED AND SIBEL". THE WORD "AND" IS IN VERTICAL PRESENTATION.

FOR CLOTHING, NAMELY, SWEATERS; SWEATER TOPS; KNITS, NAMELY, KNIT DRESSES, KNIT JACKETS, KNIT SHIRTS, KNIT SKIRTS, KNIT TOPS, KNIT SWEATERS, KNIT PANTS; JUMPERS; JUMPSUITS; DRESSES; MINI SKIRTS; SASHES; SCARVES; SHAWLS; SHIRTS; SKIRTS; SWEAT SHIRTS; TURTLENECK SWEATERS; TURTLENECKS; V-NECK SWEATERS; SWEATER DRESSES; SWEATER SKIRTS; SWEATER PANTS; BOTTOMS; SKIRTS; PANTS; JACKETS; CARDIGANS; WOVEN TOPS; WOVEN SHIRTS; WOVEN DRESSES; WOVEN SKIRTS; WOVEN PANTS (U.S. CLS. 22 AND 39).

LINDA ESTRADA, EXAMINING ATTORNEY

CLASS 25—(Continued).

SN 85-343,135. UDECHUKWU CHIDOZIE CHUKWUNEKE, JOS, PLATEAU STATE, NIGERIA, FILED 6-10-2011.



THE NAME(S), PORTRAIT(S), AND/OR SIGNATURE(S) SHOWN IN THE MARK IDENTIFIES "UDECHUKWU CHIDOZIE CHUKWUNEKE", WHOSE CONSENT(S) TO REGISTER IS MADE OF RECORD.

THE COLOR(S) BLACK, BROWN, GOLD, AND WHITE IS/ ARE CLAIMED AS A FEATURE OF THE MARK.

THE MARK CONSISTS OF THE PROMINENT, STYLIZED GOLD COLOR WORDING "VINCENT DOZ", WITH WHITE COLOR LIGHT REFLECTIONS DEPICTED ON THE UPPER PART OF IT; THE STYLIZED BROWN COLOR ACRONYM "VD" DEPICTED BEHIND THE SAID WORDING "VINCENT DOZ", AND THE STYLIZED GOLD COLOR WORDING "MARK YOUR SIZE" DEPICTED BELOW THE ABOVE DESCRIBED ELEMENTS. ALL THE ABOVE-DESCRIBED DESIGN ELEMENTS ARE DEPICTED OVER A BLACK BACKGROUND.

FOR CAPS; DENIMS; HOODED PULLOVERS; HOODED SWEAT SHIRTS; HOODS; JEANS; POLO SHIRTS; T-SHIRTS (U.S. CLS. 22 AND 39), JENNY PARK, EXAMINING ATTORNEY

SN 85-345,354. AMAZONAS PRODUTOS PARA CALCADOS LTDA., SAO PAULO, BRAZIL, FILED 6-14-2011.



OWNER OF U.S. REG. NO. 2,260,191. THE MARK CONSISTS OF A SWIRL DESIGN ABOVE THE WORD "AMAZONAS".

SEC. 2(F) AS TO "AMAZONAS". FOR SHOES, SANDALS, FLIP-FLOPS SANDALS, INNER SOLES, SOLES AND STUDS FOR FOOTWEAR (U.S. CLS. 22 AND 39).

YAT SYE, LEE, EXAMINING ATTORNEY

CLASS 25—(Continued).

SN 85-347,859. STREAMLINE DESIGN & SILKSCREEN, INC., VENTURA, CA. FILED 6-16-2011.

Coastal Classics

THE MARK CONSISTS OF STANDARD CHARACTERS WITHOUT CLAIM TO ANY PARTICULAR FONT, STYLE, SIZE, OR COLOR.

NO CLAIM IS MADE TO THE EXCLUSIVE RIGHT TO USE "CLASSICS", APART FROM THE MARK AS SHOWN.

FOR APPAREL, NAMELY, MEN'S AND WOMEN'S T-SHIRTS, TANK-TOPS, CREW SHIRTS, SWEATSHIRTS, AND HEADGEAR, NAMELY, HATS, VISORS, CAPS, BEANIES (U.S. CLS. 22 AND 39).

FIRST USE 11-1-1995; IN COMMERCE 1-1-2000.

WILLIAM P. SHANAHAN, EXAMINING ATTORNEY

SN 85-347,991. FREDERICK JR., RICHARD T., DANBURY, CT. FILED 6-16-2011.

Zombie Hunter

THE MARK CONSISTS OF STANDARD CHARACTERS WITHOUT CLAIM TO ANY PARTICULAR FONT, STYLE, SIZE, OR COLOR.

FOR CLOTHING ITEMS, NAMELY, T-SHIRTS, HOODED SWEATSHIRTS, SWEATSHIRTS, TANK TOPS, UNDERGARMENTS, AND HEADWEAR (U.S. CLS. 22 AND 39).

JAY BESCH, EXAMINING ATTORNEY

SN 85-348,617. ROCCO E GIORDANO, JERSEY CITY, NJ. FILED 6-16-2011.



THE MARK CONSISTS OF A SIX POINTED STAR WITH ALL INNER POINTS MEETING OFF CENTER. THE NORTH POINT'S LEFT SIDE IS LONGER THAN THE NORTH POINT'S RIGHT SIDE. TURNING CLOCKWISE,

CLASS 25—(Continued).

THE TOP SIDE OF THE NEXT POINT IS LONGER THEN THE BOTTOM POINT OF THE SIDE. CONTINUING CLOCKWISE, THE TOP SIDE OF THE NEXT POINT IS LONGER THEN THE BOTTOM. THE RIGHT SIDE OF THE NEXT POINT IS SLIGHTLY HIGHER THEN THE LEFT SIDE. THERE IS A SPACE BETWEEN THIS POINT AND THE NEXT POINT GOING CLOCKWISE. THE NEXT POINT IS THE THINNEST AND SHORTEST. THE BOTTOM PART OF THIS POINT IS LONGER THEN THE TOP SIDE. BOTH SIDES ARE EVEN ON THE NEXT AND FINAL POINT.

FOR BASEBALL CAPS AND HATS; BERMUDA SHORTS; BUTTON DOWN SHIRTS; CREW NECK SWEATERS; DENIM JACKETS; DRESS SHIRTS; HEAVY JACKETS; OUTER JACKETS; POLO SHIRTS; SCARFS; SHORT-SLEEVED SHIRTS; SHORTS; SWEATERS; T-SHIRTS; V-NECK SWEATERS (U.S. CLS. 22 AND 39).

FIRST USE 8-1-2000; IN COMMERCE 8-1-2000.
NELSON SNYDER, EXAMINING ATTORNEY

CLASS 25—(Continued).

SN 85-352,114. ROCKETOWN OF MIDDLE TENNESSEE, INC., NASHVILLE, TN. FILED 6-21-2011.



SN 85-349,952. COOL WATER DESIGNS, LLC, DBA FABBY-GABBY, TEQUESTA, FL. FILED 6-19-2011.

FabbyGabby

THE MARK CONSISTS OF THE WORD "ROCKETOWN" AND CIRCLE WITH A UPWARD POINTING ARROW INSIDE THE CIRCLE LOCATED TO THE RIGHT OF THE WORD.

FOR SHORT-SLEEVED OR LONG-SLEEVED T-SHIRTS (U.S. CLS. 22 AND 39).

FIRST USE 8-1-2010; IN COMMERCE 8-1-2010.
SUE LAWRENCE, EXAMINING ATTORNEY

THE MARK CONSISTS OF STANDARD CHARACTERS WITHOUT CLAIM TO ANY PARTICULAR FONT, STYLE, SIZE, OR COLOR.

FOR BABY AND CHILDRENS CLOTHING AND ACCESSORIES, NAMELY, TUTUS, SKIRTS, DRESSES, SHIRTS, BLOOMERS, HEADBANDS (U.S. CLS. 22 AND 39).

FIRST USE 6-1-2005; IN COMMERCE 6-1-2005.
CIMMERIAN COLEMAN, EXAMINING ATTORNEY

SN 85-352,195. ROCKETOWN OF MIDDLE TENNESSEE, INC., NASHVILLE, TN. FILED 6-21-2011.



SN 85-352,027. SITTING PRETTY BOOKS LLC, GLENDALE, AZ. FILED 6-21-2011.

SITTING PRETTY

THE MARK CONSISTS OF STANDARD CHARACTERS WITHOUT CLAIM TO ANY PARTICULAR FONT, STYLE, SIZE, OR COLOR.

FOR CLOTHING, NAMELY, HATS, T-SHIRTS, SWEATSHIRTS; FOOTWEAR; HEADWEAR (U.S. CLS. 22 AND 39).

JENNY PARK, EXAMINING ATTORNEY

NO CLAIM IS MADE TO THE EXCLUSIVE RIGHT TO USE "NASHVILLE", APART FROM THE MARK AS SHOWN.

THE MARK CONSISTS OF "SIXTHAVENUE" IN LOWER CASE TEXT WITHOUT SPACES AND, "SKATEPARK NASHVILLE" LOCATED BELOW "SIXTHAVENUE" IN SMALLER, ALL CAPITALIZED, TEXT WITH "SKATEPARK" AND "NASHVILLE" SEPARATED BY A VERTICAL LINE.

FOR SHORT-SLEEVED OR LONG-SLEEVED T-SHIRTS (U.S. CLS. 22 AND 39).

FIRST USE 1-6-2003; IN COMMERCE 1-6-2003.
SUE LAWRENCE, EXAMINING ATTORNEY

CLASS 25—(Continued).

SN 85-352,318. ROGUE MARBLE PRODUCTIONS, INC., WOODLAND HILLS, CA. FILED 6-21-2011.

STALLONE

THE MARK CONSISTS OF STANDARD CHARACTERS WITHOUT CLAIM TO ANY PARTICULAR FONT, STYLE, SIZE, OR COLOR.

OWNER OF U.S. REG. NO. 2,981,266.

THE NAME(S), PORTRAIT(S), AND/OR SIGNATURE(S) SHOWN IN THE MARK IDENTIFIES "SYLVESTER STALLONE", WHOSE CONSENT(S) TO REGISTER IS MADE OF RECORD.

THE ENGLISH TRANSLATION OF "STALLONE" IN THE MARK IS "STALLION".

FOR EXERCISE AND FITNESS SPECIFIC APPAREL AND ACCESSORIES, NAMELY, SWEAT BANDS, JOGGING SUITS, WARM-UP SUITS, SWEAT SHIRTS, SWEAT PANTS, LOUNGEWEAR, AND GLOVES; UNDERGARMENTS; JEAN PANTS; BOTTOMS; FOOTWEAR; TOPS; SUITS; JACKETS; COATS; CARDIGANS; SWEATERS; HEADWEAR; AND BELTS (U.S. CLS. 22 AND 39).

CHARLES L. JENKINS, EXAMINING ATTORNEY

SN 85-354,822. DISNEY ENTERPRISES, INC., BURBANK, CA. FILED 6-23-2011.

ACTIVI T'S

THE MARK CONSISTS OF STANDARD CHARACTERS WITHOUT CLAIM TO ANY PARTICULAR FONT, STYLE, SIZE, OR COLOR.

FOR CLOTHING, NAMELY, APRONS, BEACHWEAR, BELTS, BOTTOMS, CHAPS, CLOAKS, CLOTH BIBS, COATS, COSTUMES FOR USE IN ROLE-PLAYING GAMES, BEACH COVER-UPS, CUMMERBUNDS, DRESSES, EAR MUFFS, GOWNS, GLOVES, HALLOWEEN COSTUMES, HOSIERY, INFANTWEAR, JACKETS, LEOTARDS, LINGERIE, LOUNGEWEAR, MITTENS, OVERALLS, PANTS, PONCHOS, RAINWEAR, SCARVES, SHIRTS, SHORTS, SKIRTS, SLEEPWEAR, SOCKS, SUITS, SWEATERS, SWEATSHIRTS, SWIMWEAR, TIES, TOPS, UNDERWEAR, WRIST BANDS; FOOTWEAR AND HEADWEAR (U.S. CLS. 22 AND 39).

KIMBERLY FRYE, EXAMINING ATTORNEY

CLASS 25—(Continued).

SN 85-355,651. PLATINUM DAD INC., DALLAS, TX. FILED 6-24-2011.



THE COLOR(S) BLUE, BLACK AND WHITE IS/ARE CLAIMED AS A FEATURE OF THE MARK.

THE MARK CONSISTS OF THE LITERAL ELEMENTS "PLATINUM DAD F P M W JOHN 3:16 LUKE 15:11 "A FATHER'S PROMISE.... A MAN'S WORD" "BENEFITING YOUTH SPORTS...NUTRITION AND FITNESS" WHEREIN THE IMAGE CONSISTS OF A CREST WITH WINGS IN BLUE, BLACK AND WHITE COLOR COMBINATION ABOVE WHICH THE WORDS "PLATINUM DAD" ARE WRITTEN IN BLACK COLOR, INSIDE THE CREST THERE ARE FOUR PARTS OF WHICH TWO IN WHITE COLOR AND TWO IN BLACK COLOR AND IN EACH PARTS THE LETTERS "F" "P" "M" "W" ARE PLACED IN BLUE COLOR AS SHOWN IN THE MARK, IN THE PART "F" WHICH IS IN WHITE COLOR THE WORDS "JOHN 3:16" IS WRITTEN AT THE BOTTOM RIGHT CORNER AND IN THE PART "W" WHICH IS IN WHITE COLOR THE WORDS "LUKE 15:11" ARE WRITTEN AT THE TOP LEFT CORNER, BELOW THE IMAGE THE WORDS "A FATHER'S PROMISE.... A MAN'S WORD" "BENEFITING YOUTH SPORTS...NUTRITION AND FITNESS" ARE PLACED IN BLACK COLOR AS SHOWN IN THE MARK.

THE NON-LATIN CHARACTERS IN THE MARK TRANSLITERATE TO "FU" AND THIS MEANS "FATHER" IN ENGLISH.

FOR CLOTHING, NAMELY, TOPS, BOTTOMS, T-SHIRTS, HATS, CAPS (U.S. CLS. 22 AND 39).

EMILY CHUO, EXAMINING ATTORNEY

SN 85-356,327. BIZEX, INC, ASTORIA, NY. FILED 6-25-2011.

RUCKER PARK

THE MARK CONSISTS OF STANDARD CHARACTERS WITHOUT CLAIM TO ANY PARTICULAR FONT, STYLE, SIZE, OR COLOR.

FOR HEADWEAR: ATHLETIC APPAREL, NAMELY, SHIRTS, PANTS, JACKETS, FOOTWEAR, HATS AND CAPS, ATHLETIC UNIFORMS; FOOTWEAR (U.S. CLS. 22 AND 39).

CHRIS WELLS, EXAMINING ATTORNEY

CLASS 25—(Continued).

SN 85-356,821. ROWAN, CHRIS, CANTON, MA. FILED 6-27-2011.



NO CLAIM IS MADE TO THE EXCLUSIVE RIGHT TO USE "AMERICAN", APART FROM THE MARK AS SHOWN. THE MARK CONSISTS OF A CROWN WITH A CROSS AND STARS INSIDE. BELOW THERE IS THE STYLIZED TEXT "AMERICAN KINGS".

FOR BELTS; HATS; JACKETS; PANTS; SHIRTS; SHOES (U.S. CLS. 22 AND 39).
SUE LAWRENCE, EXAMINING ATTORNEY

CLASS 25—(Continued).

SN 85-360,248. S & G FOOTWEAR LLC, KEY BISCAYNE, FL. FILED 6-30-2011.

DOGEN

THE MARK CONSISTS OF STANDARD CHARACTERS WITHOUT CLAIM TO ANY PARTICULAR FONT, STYLE, SIZE, OR COLOR.

FOR FOOTWEAR (U.S. CLS. 22 AND 39).
FIRST USE 6-15-2011; IN COMMERCE 6-15-2011.
MICHAEL WEBSTER, EXAMINING ATTORNEY

SN 85-357,498. DOWN TO EARTH DESIGNS, INC., PORTLAND, OR. FILED 6-27-2011.

TINY GPANTS

THE MARK CONSISTS OF STANDARD CHARACTERS WITHOUT CLAIM TO ANY PARTICULAR FONT, STYLE, SIZE, OR COLOR.

FOR CLOTH DIAPERS CONSISTING OF A REUSABLE OUTER COVER AND A DETACHABLE INNER POUCH FOR HOLDING A REUSABLE ABSORBENT CLOTH PAD OR A FLUSHABLE BIODEGRADABLE PAD (U.S. CLS. 22 AND 39).
JUDITH HELFMAN, EXAMINING ATTORNEY

SN 85-361,710. OPERATION WELCOME YOU HOME, NFP, NAPERVILLE, IL. FILED 7-1-2011.



SN 85-357,764. GOOD OL' BOYZ, LLC, FORT MYERS, FL. FILED 6-28-2011.

GOOD OL' BOYZ

THE MARK CONSISTS OF STANDARD CHARACTERS WITHOUT CLAIM TO ANY PARTICULAR FONT, STYLE, SIZE, OR COLOR.

FOR ATHLETIC APPAREL, NAMELY, SHIRTS, PANTS, JACKETS, FOOTWEAR, HATS AND CAPS, ATHLETIC UNIFORMS; SHORT-SLEEVED OR LONG-SLEEVED T-SHIRTS; SHORT-SLEEVED SHIRTS; SHORTS; T-SHIRTS (U.S. CLS. 22 AND 39).
KRISTINA MORRIS, EXAMINING ATTORNEY

THE COLOR(S) BLACK, ORANGE, RED, WHITE, BLUE IS/ARE CLAIMED AS A FEATURE OF THE MARK.

THE MARK CONSISTS OF A CIRCULAR DESIGN. A SALUTING SOLDIER IN FATIGUES IS PICTURED IN A BLACK SILHOUETTE IN THE CENTER, WITH A PORTION OF AN ANGLED WAVING RED, WHITE AND BLUE STYLIZED AMERICAN FLAG DESIGN IMMEDIATELY BEHIND HIM, THIS FORMS AN "INNER" CIRCLE. THE SOLDIER IS SALUTING WITH HIS RIGHT HAND, THE LEFT HAND AT HIS SIDE. THE CENTER INNER CIRCLE IS SEPARATED FROM THE OUTER RING BY A THIN ORANGE CIRCLE. THE OUTER RING IS BLACK WITH THE WORDS "OPERATION WELCOME YOU HOME" IN WHITE. "OPERATION" IS AT THE TOP OF THE OUTER RING IN ALL CAPITAL LETTERS. "WELCOME YOU HOME" IS EVENLY SPACED AROUND THE BOTTOM HALF OF THE OUTER RING IN ALL CAPITAL LETTERS. THE OUTER RING IS SURROUNDED BY A THIN ORANGE CIRCLE.

FOR T-SHIRTS, SWEATSHIRTS, HATS AND JACKETS (U.S. CLS. 22 AND 39).
FIRST USE 5-21-2010; IN COMMERCE 5-21-2010.
KATHERINE CONNOLLY, EXAMINING ATTORNEY

CLASS 25—(Continued).

SN 85-362,559. BESLER, JENNIFER J., ROBBINSVILLE, NJ. FILED 7-3-2011.

It's Goal Time!

THE MARK CONSISTS OF STANDARD CHARACTERS WITHOUT CLAIM TO ANY PARTICULAR FONT, STYLE, SIZE, OR COLOR.

FOR ATHLETIC APPAREL, NAMELY, SHIRTS, PANTS, JACKETS, FOOTWEAR, HATS AND CAPS, ATHLETIC UNIFORMS (U.S. CLS. 22 AND 39).

FIRST USE 6-1-2011; IN COMMERCE 6-1-2011.

Laurie Mayes, Examining Attorney

SN 85-363,423. MERCURY RETAIL SERVICES LLC, SAN ANTONIO, TX. FILED 7-5-2011.

RIKA TIKA

THE MARK CONSISTS OF STANDARD CHARACTERS WITHOUT CLAIM TO ANY PARTICULAR FONT, STYLE, SIZE, OR COLOR.

FOR APRONS; ATHLETIC FOOTWEAR; ATHLETIC SHOES; ATHLETIC UNIFORMS; BABY BIBS NOT OF PAPER; BABY DOLL PYJAMAS; BATH SLIPPERS; BATHING CAPS; BATHING COSTUMES; BATHING COSTUMES FOR WOMEN; BATHING SUITS; BATHING SUITS FOR MEN; BATHING TRUNKS; BATHROBES; BEACH FOOTWEAR; BEACH SHOES; BEACHWEAR; BEANIES; BELTS; BELTS MADE OF LEATHER; BELTS OF TEXTILE; BERETS; BERMUDA SHORTS; BIKINIS; CLOGS; COATS; COATS FOR MEN AND WOMEN; COATS MADE OF COTTON; COVERUPS; CROP TOPS; DANCE COSTUMES; EAR MUFFS; FABRIC BELTS; FLEECE PULLOVERS; FLIP FLOPS; FOOTWEAR; FOOTWEAR FOR MEN AND WOMEN; FOOTWEAR FOR WOMEN; GLOVES; HATS; HEAD SCARVES; HEAD SWEATBANDS; HEAD WEAR; HEADBANDS; HEADWEAR; JAPANESE FOOTWEAR OF RICE STRAW (WARAJI); JAPANESE SLEEPING ROBES (NEMAKI); JAPANESE SPLIT-TOED WORK FOOTWEAR (JIKATABI); JAPANESE STYLE CLOGS AND SANDALS; JAPANESE STYLE SANDALS (ZORI); JAPANESE STYLE SANDALS OF FELT; JAPANESE STYLE SANDALS OF LEATHER; JAPANESE STYLE SOCKS (TABI COVERS); JAPANESE STYLE SOCKS (TABI); JAPANESE STYLE WOODEN CLOGS (GETA); JAPANESE TOE-STRAP SANDALS (ASAURA-ZORI); JEANS; KIMONOS; LACE BOOTS; LADIES' BOOTS; LADIES' SUITS; LADIES' UNDERWEAR; LEATHER BELTS; LEATHER SHOES; LEATHER SLIPPERS; LINGERIE; LONG JACKETS; MATERNITY SLEEPWEAR; MINISKIRTS; MUSCLE TOPS; MUU MUUS; NECK BANDS; NECKERCHIEFS; NIGHT GOWNS; NIGHT SHIRTS; NIGHTDRESSES; NIGHTIES; NIGHTWEAR; ONE PIECE GARMENT FOR INFANTS AND TODDLERS; OPEN-NECKED SHIRTS; PAJAMAS; PANTIES; PANTIES, SHORTS AND BRIEFS; PANTS; PLASTIC BABY BIBS; POLO SHIRTS; PONCHOS; RAIN BOOTS; RAIN COATS; RAIN JACKETS; ROBES; ROMPERS; SANDAL-CLOGS; SANDALS; SARIS; SASHES; SCARVES; SHAWLS AND HEADSCARVES; SHIRT FRONTS; SHOES; SHORTS; SKI AND SNOWBOARD SHOES AND PARTS THEREOF; SKI BOOT BAGS; SKI BOOTS; SKI JACKETS; SKI WEAR; SKIRTS; SKIRTS AND DRESSES; SKORTS; SKULL CAPS; SKULLIES;

CLASS 25—(Continued).

SLEEPWEAR; SLIPPERS; SMALL HATS; SNEAKERS; SNOW BOARDING SUITS; SNOW PANTS; SNOW SUITS; SNOWBOARD BOOTS; SNOWBOARD PANTS; SOCKS; SPORTS JACKETS; STRAPLESS BRAS; SUN VISORS; SUNSUITS; SURF WEAR; SUSPENDERS; SWEAT PANTS; SWEAT SHIRTS; SWEAT SHORTS; SWEAT SUITS; SWEATBANDS; SWEATERS; SWIM CAPS; SWIM SUITS; SWIM TRUNKS; SWIM WEAR; SWIM WEAR FOR GENTLEMEN AND LADIES; SWIMMING COSTUMES; SWIMMING TRUNKS; SWIMSUITS; T-SHIRTS; TANK-TOPS; TANKINIS; TENNIS SHOES; TENNIS WEAR; THERMAL UNDERWEAR; THONGS; THONGS; TRACK PANTS; TRACK SUITS; TRUNKS; TURTLE-NECK SWEATERS; TURTLENECKS; UNDER GARMENTS; UNDERGARMENTS; UNDERSHIRTS; V-NECK SWEATERS; VISORS; WAISTBANDS; WALKING SHORTS; WARM UP SUITS; WET SUIT GLOVES; WET SUITS; WET SUITS FOR WATER-SKIING AND SUB-AQUA; WINTER BOOTS; WOMEN'S SHOES; WOMEN'S UNDERWEAR; WORK SHOES AND BOOTS; WRAPS; WRIST BANDS; WRISTBANDS (U.S. CLS. 22 AND 39).

Florentina Blandu, Examining Attorney

SN 85-364,572. WEST, DENNIS, KELLER, TX. FILED 7-6-2011.

NUTZN'NANNERS

THE MARK CONSISTS OF STANDARD CHARACTERS WITHOUT CLAIM TO ANY PARTICULAR FONT, STYLE, SIZE, OR COLOR.

FOR WEARABLE GARMENTS AND CLOTHING, NAMELY, SHIRTS (U.S. CLS. 22 AND 39).

FIRST USE 5-20-2010; IN COMMERCE 5-20-2010.

JENNIFER WILLISTON, EXAMINING ATTORNEY

SN 85-364,815. DOWN TO FISH, LLC, OSTEEEN, FL. FILED 7-7-2011.

Down To Fish

THE MARK CONSISTS OF STANDARD CHARACTERS WITHOUT CLAIM TO ANY PARTICULAR FONT, STYLE, SIZE, OR COLOR.

NO CLAIM IS MADE TO THE EXCLUSIVE RIGHT TO USE "FISH", APART FROM THE MARK AS SHOWN.

FOR ATHLETIC APPAREL, NAMELY, SHIRTS, PANTS, JACKETS, FOOTWEAR, HATS AND CAPS, ATHLETIC UNIFORMS; COLLARED SHIRTS; FISHING SHIRTS; HATS; HOODED SWEAT SHIRTS; LONG-SLEEVED SHIRTS; POLO SHIRTS; SHIRTS; SHIRTS AND SHORT-SLEEVED SHIRTS; SHORT-SLEEVED OR LONG-SLEEVED T-SHIRTS; SHORT-SLEEVED SHIRTS; SWEAT SHIRTS; T-SHIRTS; TEE SHIRTS (U.S. CLS. 22 AND 39).

Thomas Manor, Examining Attorney

CLASS 25—(Continued).

SN 85-367,058. BORN FILTHY LLC, PALM COAST, FL. FILED 7-8-2011.



THE STIPPLING IS A FEATURE OF THE MARK AND DOES NOT INDICATE COLOR.

THE MARK CONSISTS OF THE STYLIZED TEXT "BORN FILTHY".

FOR CLOTHING, NAMELY, SHIRTS, SHORTS, MIXED MARTIAL ARTS (MMA) FIGHTING SHORTS, AND MIXED MARTIAL ARTS (MMA) FIGHTING SHIRTS (U.S. CLS. 22 AND 39).

WANDA KAY PRICE, EXAMINING ATTORNEY

SN 85-369,167. AMERICAN LEGACY FOUNDATION, WASHINGTON, DC. FILED 7-12-2011.

TRUTH 1585

THE MARK CONSISTS OF STANDARD CHARACTERS WITHOUT CLAIM TO ANY PARTICULAR FONT, STYLE, SIZE, OR COLOR.

OWNER OF U.S. REG. NOS. 2,656,118, 2,675,974 AND 3,891,733.

FOR CLOTHING, NAMELY, PANTS, SHIRTS, JACKETS, KHAKIS, SHORTS, COATS, SOCKS, BELTS, FOOTWEAR, AND HEADWEAR (U.S. CLS. 22 AND 39).

TINA L. SNAPP, EXAMINING ATTORNEY

SN 85-375,377. NAVIE, INC., DBA BEULAH SYTLE, LOS ANGELES, CA. FILED 7-19-2011.



NO CLAIM IS MADE TO THE EXCLUSIVE RIGHT TO USE "STYLE", APART FROM THE MARK AS SHOWN.

THE MARK CONSISTS OF THE STYLIZED WORDING "BEULAH STYLE" ON A BLACK BACKGROUND WHICH IS NOT A FEATURE OF THE MARK.

FOR WOMEN'S CLOTHING, NAMELY, SHIRTS, DRESSES, SKIRTS, BLOUSES (U.S. CLS. 22 AND 39).

FIRST USE 1-1-2011; IN COMMERCE 1-1-2011.

HOWARD B. LEVINE, EXAMINING ATTORNEY

CLASS 25—(Continued).

SN 85-380,496. OMAR MENESES WALLACE, DBA OMAR MENESES WALLACE, BROOKLYN, NY. FILED S.R. 7-25-2011; AM. P.R. 4-13-2012.



MENESES

THE MARK CONSISTS OF THE STYLIZED LETTERS "AP", TOGETHER ARE FASHIONED SO AS TO CREATE OR DISPLAY A FIVE POINT STAR, ACCOMPANIED BY THE WORD "MENESES" BELOW.

FOR ATHLETIC APPAREL, NAMELY, SHIRTS, PANTS, JACKETS, FOOTWEAR, HATS AND CAPS, ATHLETIC UNIFORMS (U.S. CLS. 22 AND 39).

THEODORE MCBRIDE, EXAMINING ATTORNEY

SN 85-382,114. JONATHAN B. HASKETT, SAN DIEGO, CA. AND BENJAMIN P. STURGELL, PHOENIX, AZ. FILED 7-27-2011.

CORNFRONTATION

THE MARK CONSISTS OF STANDARD CHARACTERS WITHOUT CLAIM TO ANY PARTICULAR FONT, STYLE, SIZE, OR COLOR.

FOR A-SHIRTS; APPAREL FOR DANCERS, NAMELY, TEE SHIRTS, SWEATSHIRTS, PANTS, LEGGINGS, SHORTS AND JACKETS; ATHLETIC APPAREL, NAMELY, SHIRTS, PANTS, JACKETS, FOOTWEAR, HATS AND CAPS, ATHLETIC UNIFORMS; BODY SHIRTS; BUTTON DOWN SHIRTS; BUTTON-FRONT ALOHA SHIRTS; CAMOUFLAGE SHIRTS; CAMP SHIRTS; CLOTHING FOR ATHLETIC USE, NAMELY, PADDED SHIRTS; CLOTHING FOR BABIES, TODDLERS AND CHILDREN, TREATED WITH FIRE AND HEAT RETARDANTS, NAMELY, PAJAMAS, JACKETS, SHIRTS, PANTS, JUMPERS; CLOTHING SHIELDS, NAMELY, PADS APPLIED TO THE UNDERARMS OF SHIRTS; BLOUSES AND SWEATERS; COLLARED SHIRTS; DRESS SHIRTS; FISHING SHIRTS; GOLF PANTS, SHIRTS AND SKIRTS; GOLF SHIRTS; HOODED SWEAT SHIRTS; HUNTING SHIRTS; KNIT SHIRTS; LEATHER SHIRTS; LONG-SLEEVED SHIRTS; MATERNITY CLOTHING, NAMELY, SHIRT, HATS; MOISTURE-WICKING SPORTS SHIRTS; NIGHT SHIRTS; OPEN-NECKED SHIRTS; OVER SHIRTS; PIQUE SHIRTS; POLO SHIRTS; RUGBY SHIRTS; SCIENTIFIC AND TECHNOLOGICAL APPAREL, NAMELY, SHIRTS,

CLASS 25—(Continued).

PANTS, JACKETS, FOOTWEAR, HATS AND CAPS, UNIFORMS; SHIRT FRONTS; SHIRT INSERTS, NAMELY, DICKIES; SHIRT YOKES; SHIRTS; SHIRTS AND SHORT-SLEEVED SHIRTS; SHIRTS AND SLIPS; SHIRTS FOR INFANTS, BABIES, TODDLERS AND CHILDREN; SHIRTS FOR SUITS; SHORT-SLEEVED OR LONG-SLEEVED T-SHIRTS; SHORT-SLEEVED SHIRTS; SLEEP SHIRTS; SLEEVES WORN SEPARATE AND APART FROM BLOUSES, SHIRTS AND OTHER TOPS; SNAP CROTCH SHIRTS FOR INFANTS AND TODDLERS; SPORT SHIRTS; SPORTS SHIRTS; SPORTS SHIRTS WITH SHORT SLEEVES; SUN PROTECTIVE CLOTHING, NAMELY, SHIRTS, HATS, VISORS; SWEAT SHIRTS; T-SHIRTS; TEE SHIRTS; TRIATHLON CLOTHING, NAMELY, TRIATHLON TIGHTS, TRIATHLON SHORTS, TRIATHLON SINGLET, TRIATHLON SHIRTS, TRIATHLON SUITS; TURTLE NECK SHIRTS; WEARABLE GARMENTS AND CLOTHING, NAMELY, SHIRTS; WIND SHIRTS; WOMEN'S CLOTHING, NAMELY, SHIRTS, DRESSES, SKIRTS, BLOUSES; YOGA SHIRTS (U.S. CLS. 22 AND 39).

MARGERY A. TIERNEY, EXAMINING ATTORNEY

CLASS 25—(Continued).

SN 85-387,020. OLIVET INTERNATIONAL INC, MIRA LOMA, CA. FILED 8-2-2011.

DEARFLEECE

THE MARK CONSISTS OF STANDARD CHARACTERS WITHOUT CLAIM TO ANY PARTICULAR FONT, STYLE, SIZE, OR COLOR.

FOR GLOVES, MITTENS, SCARVES, SCARF-HOODS, EAR MUFFS, HATS, SHAWLS, ANKLE WARMERS, ARM WARMERS, SOCKS, BALACLAVA, AND WIND-RESISTANT HEADWEAR (U.S. CLS. 22 AND 39).
STEVEN PEREZ, EXAMINING ATTORNEY

SN 85-382,473. SCHMAYBE, LLC, SYRACUSE, NY. FILED 7-27-2011.

SCHMAYBE

THE MARK CONSISTS OF STANDARD CHARACTERS WITHOUT CLAIM TO ANY PARTICULAR FONT, STYLE, SIZE, OR COLOR.

FOR MEN'S, WOMEN'S AND CHILDREN'S CLOTHING, NAMELY, SHIRTS, T-SHIRTS, SWEATSHIRTS, JACKETS, CAPS, SHORTS AND PANTS (U.S. CLS. 22 AND 39).

FIRST USE 7-14-2011; IN COMMERCE 7-26-2011.
DAVID H. STINE, EXAMINING ATTORNEY

SN 85-389,784. ROEHRICK, NICHOLAS, ORLANDO, FL. FILED 8-4-2011.

BLACK HARDT

THE MARK CONSISTS OF STANDARD CHARACTERS WITHOUT CLAIM TO ANY PARTICULAR FONT, STYLE, SIZE, OR COLOR.

FOR CLOTHING, NAMELY, TOPS, BOTTOMS, T-SHIRTS, HATS (U.S. CLS. 22 AND 39).

FIRST USE 5-25-2010; IN COMMERCE 6-22-2010.
JAMES MACFARLANE, EXAMINING ATTORNEY

SN 85-383,660. ANITA MEI YAN FU, DOUGLSTON, NY. FILED 7-28-2011.

209 WST 38

THE MARK CONSISTS OF STANDARD CHARACTERS WITHOUT CLAIM TO ANY PARTICULAR FONT, STYLE, SIZE, OR COLOR.

FOR CLOTHING, NAMELY, JACKETS, PANTS, BLOUSES, SHIRTS, SKIRTS, DRESSES, JUMP SUITS, SUITS, COATS AND FULLY FASHION KNITS (U.S. CLS. 22 AND 39).

JAMES MACFARLANE, EXAMINING ATTORNEY

SN 85-392,125. FLAT-OUT EVENTS, LLC, NEWPORT NEWS, VA. FILED 8-8-2011.

Personal Best is Temporary

THE MARK CONSISTS OF STANDARD CHARACTERS WITHOUT CLAIM TO ANY PARTICULAR FONT, STYLE, SIZE, OR COLOR.

FOR BOTTOMS; CAPS; FOOTWEAR; HATS; JACKETS; SHIRTS; SHORTS; SWEATBANDS; SWIMWEAR; TOPS (U.S. CLS. 22 AND 39).

FIRST USE 12-8-2008; IN COMMERCE 9-3-2010.
JASON TURNER, EXAMINING ATTORNEY

CLASS 25—(Continued).

SN 85-394,372. Q. T FASHION, INC., LOS ANGELES, CA.
FILED 8-10-2011.



OWNER OF U.S. REG. NOS. 3,692,624 AND 3,734,312.
NO CLAIM IS MADE TO THE EXCLUSIVE RIGHT TO
USE "MATERNITY U.S.A.", APART FROM THE MARK AS
SHOWN.

THE LINING SHOWN IN THE GREY FIELDS OF THE
DRAWING IS A FEATURE OF THE MARK.

THE COLOR(S) GRAY, LIGHT-GRAY, BLACK, AND
PINK IS/ARE CLAIMED AS A FEATURE OF THE MARK.

THE MARK CONSISTS OF THREE HEARTS AND THE
WORDS "MATERNITY U.S.A.". THE BIGGER HEART IS
OUTLINED IN PINK WITH "Q-T" IN BLACK INSIDE THE
HEART AND TWO SMALLER HEARTS IN PINK ABOVE
THE BIGGER HEART. THE COLOR GRAY APPEARS IN
THE DESIGN OF THE SQUARE ENCOMPASSING THE
HEARTS, THE COLOR PINK APPEARS IN THE DESIGN OF
THE HEARTS, AND THE COLOR BLACK APPEARS IN THE
WORDING "MATERNITY U.S.A." WHICH APPEARS BE-
LOW THE FIRST GRAY SQUARE AND WITHIN A SECOND
LIGHTER GRAY SQUARE WHICH ENCOMPASSES ALL OF
THE ELEMENTS OF THE MARK.

FOR CLOTHING IN GENERAL FOR INFANTS, CHIL-
DREN, JUNIORS, AND PLUS SIZE WOMEN AND
MATERNITY CLOTHING, NAMELY, PANTS, DRESSES,
SHORTS, TWIN SETS, SHORT SETS, DENIMS, SKIRTS,
TOPS, JACKETS, HOSIERY, TRACKSUITS, SWIMWEAR,
SLEEP WEAR, UNDERGARMENTS, LINGERIE, KNIT-
WEAR, NAMELY, KNIT SHIRTS, KNITTED VESTS,
PULLOVERS, SWEATERS, KNITTED PONCHOS,
SCARVES, SHAWLS, WRAPS, TIES, BOW TIES, COL-
LARS, TENNIS SUITS, MUFFLERS, JEANS, EXERCISE
WEAR, NAMELY, SOCKS, TIGHTS, LEG WARMERS,
SWEAT PANTS, KNITTED CAPS, GLOVES, MITTENS,
BLOUSES, T-SHIRTS, BLAZERS, PAJAMAS, COATS,
TANK TOPS, NURSING BRAS, SPORTS BRAS, BRAS,
WARM-UP SUITS, SWEATBANDS, JOGGING SUITS,
BODY SUITS, NURSING APPAREL, NAMELY, SHOES,
PANTS, SHORTS, TOPS, DRESSES, LAB COATS, TU-
NICS, JUMPERS, HATS, AND NIGHTGOWNS (U.S. CLS.
22 AND 39).

FIRST USE 6-13-2006; IN COMMERCE 6-13-2006.
THOMAS MANOR, EXAMINING ATTORNEY

CLASS 25—(Continued).

SN 85-399,175. EDELMAN SHOE, INC., NEW YORK, NY.
FILED 8-16-2011.

SAM EDELMAN

THE MARK CONSISTS OF STANDARD CHARACTERS
WITHOUT CLAIM TO ANY PARTICULAR FONT, STYLE,
SIZE, OR COLOR.

OWNER OF U.S. REG. NOS. 3,271,895, 3,978,944 AND
OTHERS.

THE NAME(S), PORTRAIT(S), AND/OR SIGNATURE(S)
SHOWN IN THE MARK IDENTIFIES "SAM EDELMAN",
WHOSE CONSENT(S) TO REGISTER IS MADE OF RE-
CORD.

FOR CLOTHING, NAMELY, JACKETS, COATS,
PANTS, SHIRTS, SHORTS, SKIRTS, DRESSES; CLOTH-
ING ACCESSORIES, NAMELY, SCARVES, SOCKS, HOSI-
ERY AND LEGGINGS (U.S. CLS. 22 AND 39).

ALYSSA STEEL, EXAMINING ATTORNEY

SN 85-400,380. SHAKUHACHI PTY. LTD., PADDINGTON,
NSW, AUSTRALIA, FILED 8-17-2011.

SHAKUHACHI

THE MARK CONSISTS OF STANDARD CHARACTERS
WITHOUT CLAIM TO ANY PARTICULAR FONT, STYLE,
SIZE, OR COLOR.

FOR WOMEN'S CLOTHING ITEMS AND ACCES-
SORIES, NAMELY, SHIRTS, BLOUSES, PANTS, SKIRTS,
JACKETS, AND FOOTWEAR (U.S. CLS. 22 AND 39).

FIRST USE 2-0-2010; IN COMMERCE 2-0-2010.

KRISTIN DAHLING, EXAMINING ATTORNEY

SN 85-401,750. NEW ERA CAP CO., INC., BUFFALO, NY.
FILED 8-18-2011.

9FORTY

THE MARK CONSISTS OF STANDARD CHARACTERS
WITHOUT CLAIM TO ANY PARTICULAR FONT, STYLE,
SIZE, OR COLOR.

OWNER OF U.S. REG. NO. 3,733,476.

FOR HEADWEAR (U.S. CLS. 22 AND 39).

MICHAEL WIENER, EXAMINING ATTORNEY

CLASS 25—(Continued).

SN 85-404,134. NGUYEN, QUANG, NEW ORLEANS, LA. FILED 8-22-2011.

PADAUX

THE MARK CONSISTS OF STANDARD CHARACTERS WITHOUT CLAIM TO ANY PARTICULAR FONT, STYLE, SIZE, OR COLOR.

THE WORDING "PADAUX" HAS NO MEANING IN A FOREIGN LANGUAGE.

FOR CLOTHING, NAMELY, SHIRTS, PANTS, SHORTS, SHOES, SOCKS, BELTS, VESTS, CAPS, HATS, BANDANNAS, JACKETS, SCARVES, SLEEPWEAR, SWIMWEAR, BLOUSES, DRESSES, FOOTWEAR, GLOVES AND SWEATERS (U.S. CLS. 22 AND 39).
NICHOLAS ALTREE, EXAMINING ATTORNEY

CLASS 25—(Continued).

SN 85-405,044. AMUSEMENT ART LLC, LOS ANGELES, CA. FILED 8-23-2011.

LIFE IS BEAUTIFUL

THE MARK CONSISTS OF STANDARD CHARACTERS WITHOUT CLAIM TO ANY PARTICULAR FONT, STYLE, SIZE, OR COLOR.

FOR T-SHIRTS (U.S. CLS. 22 AND 39).
FIRST USE 6-26-2008; IN COMMERCE 6-26-2008.
SHAILA SETTLES, EXAMINING ATTORNEY

SN 85-407,045. ABERCROMBIE & FITCH TRADING CO., NEW ALBANY, OH. FILED 8-25-2011.

SN 85-404,690. NYC FIVE, INC., WEST PARK, FL. FILED 8-23-2011.



NO CLAIM IS MADE TO THE EXCLUSIVE RIGHT TO USE "BRONX", "BROOKLYN", "QUEENS", "MANHATTAN", "STATEN ISLAND", AND "NYC", APART FROM THE MARK AS SHOWN.

THE MARK CONSISTS OF THREE CIRCLES WITH THE STYLIZED LETTERING "NYC" APPEARING INSIDE THE INNER-MOST CIRCLE. IN THE OUTER-MOST CIRCLE APPEARS THE STYLIZED WORDS "BROOKLYN QUEENS MANHATTAN STATEN ISLAND BRONX" SEPARATED BY STARS.

FOR HATS; JACKETS; SHIRTS; T-SHIRTS (U.S. CLS. 22 AND 39).
CHERYL CLAYTON, EXAMINING ATTORNEY

BONDI BEACH CLUB

THE MARK CONSISTS OF STANDARD CHARACTERS WITHOUT CLAIM TO ANY PARTICULAR FONT, STYLE, SIZE, OR COLOR.

FOR BELTS; BOTTOMS; COATS; DRESSES; FOOTWEAR; GLOVES; HEADWEAR; JACKETS; LEGGINGS; LINGERIE; SCARVES; SLEEPWEAR; SWIMWEAR; TOPS; UNDERGARMENTS (U.S. CLS. 22 AND 39).
NORA BUCHANAN WILL, EXAMINING ATTORNEY

SN 85-412,272. TINAJERO, KATHLEEN D. KENDRICK, PEORIA, IL. FILED 8-31-2011.

TINFISH

THE MARK CONSISTS OF STANDARD CHARACTERS WITHOUT CLAIM TO ANY PARTICULAR FONT, STYLE, SIZE, OR COLOR.

FOR ATHLETIC APPAREL, NAMELY, SHIRTS, PANTS, JACKETS, FOOTWEAR, HATS AND CAPS, ATHLETIC UNIFORMS (U.S. CLS. 22 AND 39).
FIRST USE 8-19-2011; IN COMMERCE 8-19-2011.
ANDREA BUTLER, EXAMINING ATTORNEY

CLASS 25—(Continued).

SN 85-414,568. NYC FIVE, INC., WEST PARK, FL. FILED 9-2-2011.



NO CLAIM IS MADE TO THE EXCLUSIVE RIGHT TO USE "NYC", APART FROM THE MARK AS SHOWN.

THE MARK CONSISTS OF THE STYLIZED WORDS "NYC FIVE" SEPARATED BY A SLASH. THE WORDS AND SLASH APPEAR INSIDE A SQUARE WITH ROUND EDGES. FOR HATS; JACKETS; SHIRTS; T-SHIRTS (U.S. CLS. 22 AND 39).

CHERYL CLAYTON, EXAMINING ATTORNEY

SN 85-416,667. MAVERICK J LLC, CULVER CITY, CA. FILED 9-7-2011.

JAMES CAMPBELL

THE MARK CONSISTS OF STANDARD CHARACTERS WITHOUT CLAIM TO ANY PARTICULAR FONT, STYLE, SIZE, OR COLOR.

THE NAME(S), PORTRAIT(S), AND/OR SIGNATURE(S) SHOWN IN THE MARK IDENTIFIES JAMES "CAMPBELL", WHOSE CONSENT(S) TO REGISTER IS MADE OF RECORD.

FOR CLOTHING, NAMELY, DRESS SHIRTS, SPORTS-HIRTS, PANTS, SWEATERS, KNITWEAR IN THE NATURE OF T-SHIRTS, POLO SHIRTS, CARDIGANS, KNIT BLAZERS, PANTS, TIES, SCARVES AND POLO SHIRTS, TIES, SUITS, AND BELTS (U.S. CLS. 22 AND 39).

FIRST USE 5-24-2007; IN COMMERCE 5-24-2007.
MELISSA VALLILLO, EXAMINING ATTORNEY

SN 85-416,677. MAVERICK J LLC, CULVER CITY, CA. FILED 9-7-2011.

J. CAMPBELL

THE MARK CONSISTS OF STANDARD CHARACTERS WITHOUT CLAIM TO ANY PARTICULAR FONT, STYLE, SIZE, OR COLOR.

THE NAME(S), PORTRAIT(S), AND/OR SIGNATURE(S) SHOWN IN THE MARK IDENTIFIES JAMES "CAMPBELL", WHOSE CONSENT(S) TO REGISTER IS MADE OF RECORD.

FOR CLOTHING, NAMELY, DRESS SHIRTS, SPORTS-HIRTS, PANTS, SWEATERS, KNITWEAR IN THE NATURE OF T-SHIRTS, POLO SHIRTS, CARDIGANS, KNIT BLAZERS, PANTS, TIES, SCARVES AND POLO SHIRTS, TIES, SUITS, AND BELTS (U.S. CLS. 22 AND 39).

FIRST USE 5-24-2007; IN COMMERCE 5-24-2007.
MELISSA VALLILLO, EXAMINING ATTORNEY

CLASS 25—(Continued).

SN 85-416,879. NASSIRI FRED, DBA NASSIRI MUSIC LLC, LAS VEGAS, NV. FILED 9-7-2011.



THE COLOR(S) RED, BLUE AND WHITE IS/ARE CLAIMED AS A FEATURE OF THE MARK.

THE MARK CONSISTS OF THE WORD "NASSIRI" IN CURSIVE, IN THE COLOR RED WITH WHITE BORDER. THERE ARE TWO FIVE-POINTED STARS IN THE COLOR BLUE, THAT SERVE AS THE PERIOD ON THE LETTER I. FOR ATHLETIC APPAREL, NAMELY, SHIRTS, PANTS, JACKETS, FOOTWEAR, HATS AND CAPS, ATHLETIC UNIFORMS (U.S. CLS. 22 AND 39).

FIRST USE 1-1-2011; IN COMMERCE 3-1-2011.
WANDA KAY PRICE, EXAMINING ATTORNEY

SN 85-421,600. KYLE KORVER, NEW YORK, NY. FILED 9-13-2011.



THE MARK CONSISTS OF SILHOUETTE OF A CHILD'S HEAD WITH A CROWN.

FOR CLOTHING, NAMELY, SHIRTS, T-SHIRTS AND SWEATSHIRTS (U.S. CLS. 22 AND 39).

FIRST USE 8-23-2010; IN COMMERCE 8-23-2010.
RAMONA ORTIGA, EXAMINING ATTORNEY

CLASS 25—(Continued).

SN 85-431,975. THE ASTRONOMY KLUB, JONESBORO, GA. FILED 9-26-2011.

THE ASTRONOMY KLUB

THE MARK CONSISTS OF THE TEXT "THE ASTRONOMY KLUB" IN THE FOO FONT.
 FOR BEANIES; HATS; JACKETS; PANTS; POLO SHIRTS; SCARVES; SHORTS; SWEATSHIRTS; T-SHIRTS (U.S. CLS. 22 AND 39).
 ROBIN MITTLER, EXAMINING ATTORNEY

SN 85-432,044. CHICO'S BRANDS INVESTMENTS, INC., FORT MYERS, FL. FILED 9-26-2011.

SENSUOUS SIDES

THE MARK CONSISTS OF STANDARD CHARACTERS WITHOUT CLAIM TO ANY PARTICULAR FONT, STYLE, SIZE, OR COLOR.
 FOR FOUNDATION GARMENTS, BRAS, CAMISOLES, TOPS, DRESSES, SWIMWEAR, SHAPEWEAR, NAMELY, CAMIS, TORSETS, BODY SHAPERS, BODY SUITS (U.S. CLS. 22 AND 39).
 ANTHONY RINKER, EXAMINING ATTORNEY

SN 85-432,045. CHICO'S BRANDS INVESTMENTS, INC., FORT MYERS, FL. FILED 9-26-2011.

RAVISHING

THE MARK CONSISTS OF STANDARD CHARACTERS WITHOUT CLAIM TO ANY PARTICULAR FONT, STYLE, SIZE, OR COLOR.
 FOR FOUNDATION GARMENTS, BRAS AND PANTIES, SLEEPWEAR, NIGHTGOWNS, SLEEPSHIRTS, CHEMISES, PAJAMA TOPS, PAJAMA BOTTOMS, CAMISOLES, ROBES, WRAPS, KIMONOS, SLIPPERS (U.S. CLS. 22 AND 39).
 ANTHONY RINKER, EXAMINING ATTORNEY

CLASS 25—(Continued).

SN 85-432,053. CHICO'S BRANDS INVESTMENTS, INC., FORT MYERS, FL. FILED 9-26-2011.

BREATHTAKING

THE MARK CONSISTS OF STANDARD CHARACTERS WITHOUT CLAIM TO ANY PARTICULAR FONT, STYLE, SIZE, OR COLOR.
 FOR FOUNDATION GARMENTS, BRAS AND PANTIES, SLEEPWEAR, NIGHTGOWNS, SLEEPSHIRTS, CHEMISES, PAJAMA TOPS, PAJAMA BOTTOMS, CAMISOLES, ROBES, WRAPS, KIMONOS, SLIPPERS (U.S. CLS. 22 AND 39).
 ANTHONY RINKER, EXAMINING ATTORNEY

SN 85-435,009. ZAMORA, MARIA ANGELES BOTELLA, ELDA (ALICANTE), SPAIN, FILED 9-29-2011.

Capuaria IV

PRIORITY CLAIMED UNDER SEC. 44(D) ON ERP N CMNTY TM OFC APPLICATION NO. 010290583, FILED 9-26-2011, REG. NO. 010290583, DATED 2-6-2012, EXPIRES 9-26-2021.
 THE COLOR(S) GOLD IS/ARE CLAIMED AS A FEATURE OF THE MARK.
 THE MARK CONSISTS OF THE WORD "CAPUARIA IV" IN STYLIZED FORM IN GOLD.
 THE WORD(S) "CAPUARIA" HAS NO MEANING IN A FOREIGN LANGUAGE.
 FOR CLOTHING, NAMELY, BELTS, COATS, RAINCOATS, OVERCOATS, WAISTCOATS, BLOUSES AND PULLOVERS, JACKETS, PANTS, GOWNS, DRESSES, SUITS, SHIRTS AND CHEMISES, T-SHIRTS, SWEATERS, UNDERWEAR, SOCKS, STOCKINGS, GLOVES, TIES, SCARVES, FOOTWEAR, HEADGEAR, NAMELY, HATS AND CAPS (U.S. CLS. 22 AND 39).
 YAT SYE, LEE, EXAMINING ATTORNEY

CLASS 25—(Continued).

SN 85-435,872. HOOLIGAN BEAR, INC., VENICE, CA. FILED 9-29-2011.

HOOLIGAN BEAR

THE MARK CONSISTS OF STANDARD CHARACTERS WITHOUT CLAIM TO ANY PARTICULAR FONT, STYLE, SIZE, OR COLOR.

OWNER OF U.S. REG. NO. 4,067,403.

FOR CLOTHING, NAMELY, T-SHIRTS, GOLF SHIRTS, SHIRTS, TANK TOPS, SWEATERS, SWEATSHIRTS, SWEAT PANTS, TROUSERS, SHORTS, SKIRTS, BATHING SUITS, SWIM TRUNKS, COATS, RAINWEAR, JACKETS, RAINCOATS, VESTS, MITTENS, GLOVES, HEADWEAR, HATS, CAPS, VISORS, HEAD BANDS, SHOES, SOCKS, SLIPPERS, ROBES, UNDERWEAR, SLEEPWEAR, PAJAMAS, TIES, BELTS, CLOTH BIBS; AND HALLOWEEN COSTUMES (U.S. CLS. 22 AND 39).
BILL DAWE, EXAMINING ATTORNEY

SN 85-437,231. HOUSE OF PEEKABOO CORP., PASADENA, CA. FILED 10-1-2011.

House of Peekaboo

THE MARK IS A MOTION MARK. THE MARK CONSISTS OF A STYLIZED BEAR WHERE THE HANDS COVERING THE EYES AND PART OF THE FACE MOVE AWAY FROM THE FACE IN AN OUTWARD MOTION, REVEALING THE EYES AND PART OF THE FACE, WHICH WERE HIDDEN. THE WORDING "HOUSE OF PEEKABOO" APPEARS ABOVE THE IMAGE, AND A HORIZONTAL LINE IS BELOW THE BEAR.

FOR MEN'S, WOMEN'S, AND CHILDREN'S APPAREL, FASHION ACCESSORIES, AND CLOTHING OF ALL TYPES, NAMELY, PANTS, SHIRTS, VESTS, ROMPERS, SHORTS, ROBES, SOCKS, JACKETS, UNDERWEAR, PAJAMAS, SLEEPWEAR, SKIRTS, BIBS NOT OF PAPER, DRESSES, TIGHTS, SUITS, FOOTWEAR, TIES, SCARVES, SWIMWEAR, BELTS, GLOVES, SWEATERS, ONE-PIECE GARMENTS FOR CHILDREN, COATS, HATS, LAYETTES, COVER-UPS, HEADWEAR, RAINWEAR, OVERALLS, MITTENS, SWEATSHIRTS AND SWEAT-SUITS, BOOTIES, BODYSUITS, BATHING SUITS, AND APRONS (U.S. CLS. 22 AND 39).
JASON BLAIR, EXAMINING ATTORNEY

CLASS 25—(Continued).

SN 85-439,935. WILD INTUITIONS, LLC, SUDBURY, MA. FILED 10-5-2011.

WILD INTUITIONS

THE MARK CONSISTS OF STANDARD CHARACTERS WITHOUT CLAIM TO ANY PARTICULAR FONT, STYLE, SIZE, OR COLOR.

FOR WOMEN'S APPAREL, NAMELY, SHIRTS, PANTS, DRESSES, SKIRTS, COATS, JACKETS, BLOUSES, PAJAMAS, NIGHTGOWNS, LINGERIE, CAMISOLES (U.S. CLS. 22 AND 39).

VERNA BETH RIRIE, EXAMINING ATTORNEY

SN 85-441,924. MNK GLOBAL VENTURES LLC, NEW YORK, NY. FILED 10-7-2011.

OPPORTUNO

THE MARK CONSISTS OF STANDARD CHARACTERS WITHOUT CLAIM TO ANY PARTICULAR FONT, STYLE, SIZE, OR COLOR.

THE ENGLISH TRANSLATION OF "OPPORTUNO" IN THE MARK IS "APPROPRIATE".

FOR CAPES; CARDIGANS; COATS; DRESSES; GLOVES; HATS; PONCHOS; SCARVES; SWEATERS; TURTLENECKS; WRAPS (U.S. CLS. 22 AND 39).

DAVID C. REIHNER, EXAMINING ATTORNEY

SN 85-444,213. LIZARD LICK TOWING & RECOVERY, LLC, LIZARD LICK, NC. FILED 10-11-2011.

LIZARD LICK TOWING & RECOVERY

THE MARK CONSISTS OF STANDARD CHARACTERS WITHOUT CLAIM TO ANY PARTICULAR FONT, STYLE, SIZE, OR COLOR.

NO CLAIM IS MADE TO THE EXCLUSIVE RIGHT TO USE "TOWING & RECOVERY", APART FROM THE MARK AS SHOWN.

SEC. 2(F).

FOR APPAREL AND CLOTHING OF ALL TYPES FOR MEN, WOMEN AND CHILDREN, NAMELY, T-SHIRTS, PANTS, SHORTS, WOVEN SHIRTS, JACKETS, HOODED SWEATSHIRTS, SWEATSHIRTS, JEANS, COATS, SWEATERS, CAPS, AND HATS (U.S. CLS. 22 AND 39).

FIRST USE 12-31-2000; IN COMMERCE 12-31-2000.
DOMINICK J. SALEMI, EXAMINING ATTORNEY

CLASS 25—(Continued).

SN 85-444,847. ROBLAS INTERNATIONAL LIMITED, INC. TAMPA, FL. FILED 10-11-2011.

MAINER MOOSE

THE MARK CONSISTS OF STANDARD CHARACTERS WITHOUT CLAIM TO ANY PARTICULAR FONT, STYLE, SIZE, OR COLOR.

FOR CLOTHING, NAMELY, T-SHIRTS, SWEAT-SHIRTS; HEADGEAR, NAMELY, HATS, CAPS (U.S. CLS. 22 AND 39).

ERNEST SHOSHO, EXAMINING ATTORNEY

SN 85-445,059. GILT GROUPE, INC., NEW YORK, NY. FILED 10-12-2011.

ZOE & SAM

THE MARK CONSISTS OF STANDARD CHARACTERS WITHOUT CLAIM TO ANY PARTICULAR FONT, STYLE, SIZE, OR COLOR.

FOR CLOTHING, NAMELY, DRESSES, SUITS, SWEATERS, TOPS, PANTS, SHORTS, SKIRTS, JACKETS, OUTERWEAR IN THE NATURE OF JACKETS AND HATS, HEADWEAR, SCARVES, GLOVES, SOCKS, SLEEPWEAR, LINGERIE, FOOTWEAR (U.S. CLS. 22 AND 39).

ERNEST SHOSHO, EXAMINING ATTORNEY

SN 85-446,104. ALGEBROTHERS LLC, LOS ANGELES, CA. FILED 10-12-2011.

algeBeauties

THE MARK CONSISTS OF STANDARD CHARACTERS WITHOUT CLAIM TO ANY PARTICULAR FONT, STYLE, SIZE, OR COLOR.

FOR ATHLETIC APPAREL, NAMELY, SHIRTS, PANTS, JACKETS, FOOTWEAR, HATS AND CAPS, ATHLETIC UNIFORMS; SHIRTS; SHORT-SLEEVED OR LONG-SLEEVED T-SHIRTS; SHORT-SLEEVED SHIRTS; SLEEP SHIRTS; T-SHIRTS; WEARABLE GARMENTS AND CLOTHING, NAMELY, SHIRTS (U.S. CLS. 22 AND 39).

FIRST USE 1-1-2009; IN COMMERCE 1-1-2010.
HANNO RITTNER, EXAMINING ATTORNEY

CLASS 25—(Continued).

SN 85-447,286. ONYEJEKWE, CHUKWUEMEKA, N, AKA MEKKA DON, JERSEY CITY, NJ. FILED 10-13-2011.

PILOT BOYS

THE MARK CONSISTS OF THE WORDS "PILOT BOYS" WITH THREE LINES ON EACH SIDES OF THE WORDS WITH THE LINES APPEARING TO LOOK SIMILAR TO WINGS FLANKING THE WORDS "PILOT BOYS".

FOR HOODED SWEAT SHIRTS; T-SHIRTS (U.S. CLS. 22 AND 39).

FIRST USE 9-1-2011; IN COMMERCE 9-1-2011.
JOHN HWANG, EXAMINING ATTORNEY

SN 85-449,121. GILLZ, LLC, LAKELAND, FL. FILED 10-17-2011.

BREATHE LIKE A BASS

THE MARK CONSISTS OF STANDARD CHARACTERS WITHOUT CLAIM TO ANY PARTICULAR FONT, STYLE, SIZE, OR COLOR.

FOR CLOTHING, NAMELY, SHIRTS, T-SHIRTS, LONG SLEEVE SHIRTS, TURTLE NECKS, MOCK TURTLE NECKS, SUN MASKS, SHIRTS WITH ATTACHED SUN MASK, HATS, CAPS, HEADWEAR, TANK TOPS, SWEAT SHIRTS, PULLOVERS, MOISTURE WICKING SHIRTS (U.S. CLS. 22 AND 39).

SUNG IN, EXAMINING ATTORNEY

SN 85-450,103. CHARLOTTE RONSON LLC, NEW YORK, NY. FILED 10-18-2011.

I ♥ RONSON

OWNER OF U.S. REG. NOS. 3,614,032, 3,620,843 AND OTHERS.

THE NAME(S), PORTRAIT(S), AND/OR SIGNATURE(S) SHOWN IN THE MARK IDENTIFIES CHARLOTTE "RONSON", WHOSE CONSENT(S) TO REGISTER IS MADE OF RECORD.

THE MARK CONSISTS OF "I" AND "RONSON" SEPARATED BY A HEART SHAPE.

FOR CLOTHING, NAMELY, HATS, CAPS, HEADWEAR, UNDERWEAR, SLEEPWEAR, AND FOOTWEAR (U.S. CLS. 22 AND 39).

TEJBIR SINGH, EXAMINING ATTORNEY

CLASS 25—(Continued).

SN 85-452,059. BREMEN CASTINGS, INC., BREMEN, IN. FILED 10-20-2011.

STATUS QUO SUCKS!

THE MARK CONSISTS OF STANDARD CHARACTERS WITHOUT CLAIM TO ANY PARTICULAR FONT, STYLE, SIZE, OR COLOR.

OWNER OF U.S. REG. NO. 3,688,765.

FOR CLOTHING, NAMELY, HATS, T-SHIRTS, GOLF SHIRTS, POLO SHIRTS, LONG SLEEVE BUTTON DOWN SHIRTS, SHORT SLEEVE BUTTON DOWN SHIRTS, WIND SHIRTS, TANK TOPS, SWEAT SHIRTS, VESTS, JACKETS, COATS AND BANDANAS (U.S. CLS. 22 AND 39).

FIRST USE 9-30-2008; IN COMMERCE 9-30-2008.
ASMAT KHAN, EXAMINING ATTORNEY

CLASS 25—(Continued).

SN 85-452,730. THOMPSON, TONY, PULLMAN, WA. FILED 10-21-2011.



NO CLAIM IS MADE TO THE EXCLUSIVE RIGHT TO USE "APPAREL CO.", APART FROM THE MARK AS SHOWN.

THE MARK CONSISTS OF THE LITERAL ELEMENT "TORTIS APPAREL CO." WHEREIN AN IMAGE OF TORTOISE IS PLACED TO THE LEFT OF THE WORDS "TORTIS APPAREL CO." AS SHOWN IN THE MARK.

FOR CLOTHING, NAMELY, BEANIES AND T-SHIRTS (U.S. CLS. 22 AND 39).

MATTHEW MCDOWELL, EXAMINING ATTORNEY

SN 85-455,199. SEIZE IT. LIVE IT. LIFESTYLE APPAREL COMPANY, INC., DBA SEIZE IT. LIVE IT., JACKSONVILLE, FL. FILED 10-25-2011.

Seize it.  Live it.

THE MARK CONSISTS OF STYLIZED LETTERS: "SEIZE IT. LIVE IT." WITH INFINITY KNOT CIRCULAR EMBLEM/ LOGO IN THE CENTER ALL IN BLACK.

FOR ATHLETIC APPAREL, NAMELY, SHIRTS, PANTS, JACKETS, FOOTWEAR, HATS AND CAPS, ATHLETIC UNIFORMS (U.S. CLS. 22 AND 39).

FIRST USE 8-1-2011; IN COMMERCE 10-1-2011.
DOUGLAS LEE, EXAMINING ATTORNEY

SN 85-452,653. STOLZ, ALEXANDER, GLEN MILLS, PA. FILED 10-20-2011.



THE COLOR(S) PURPLE, WHITE AND BLACK IS/ARE CLAIMED AS A FEATURE OF THE MARK.

THE MARK CONSISTS OF TWO PARALLEL VERTICAL BARS IN WHITE WITH BLACK COLOR OUTLINE WHICH IS PLACED OVER PURPLE CROSS SIGN WITH BLACK OUTLINE.

FOR CLOTHING, NAMELY, TOPS, BOTTOMS, LONG AND SHORT SLEEVED SHIRTS, HOODED SWEATSHIRTS, CREW NECK SWEAT SHIRTS, HATS, ADJUSTABLE BASEBALL STYLE HATS, PANTS, JEANS, DENIM PANTS, SHORTS, UNDERGARMENTS, SHOES (U.S. CLS. 22 AND 39).

KAREN K. BUSH, EXAMINING ATTORNEY

SN 85-459,413. UNTAMED VINTAGE, INC, PUNTA GORDA, FL. FILED 10-28-2011.

SHE LIKES IT

THE MARK CONSISTS OF STANDARD CHARACTERS WITHOUT CLAIM TO ANY PARTICULAR FONT, STYLE, SIZE, OR COLOR.

FOR CLOTHING, NAMELY, T-SHIRTS, TANK TOPS, V-NECK SHIRTS, BASEBALL CAPS, JEANS, SHORTS, BIKINIS, SKIRTS, BLOUSES, SWEAT SUITS, SWEATSHIRTS, VISORS, UNDERWEAR, AND LINGERIE (U.S. CLS. 22 AND 39).

DEBORAH LOBO, EXAMINING ATTORNEY

CLASS 25—(Continued).

SN 85-461,923. CLARK PIPELINE SERVICES, TAFT, TX.
FILED 11-1-2011.

Paydirt

THE MARK CONSISTS OF STANDARD CHARACTERS WITHOUT CLAIM TO ANY PARTICULAR FONT, STYLE, SIZE, OR COLOR.

FOR CLOTHING, NAMELY, T-SHIRTS, CAPS, PULL-OVERS, SWEATSHIRTS, SHORTS, BEANIES (U.S. CLS. 22 AND 39).

FIRST USE 1-1-2011; IN COMMERCE 6-1-2011.
DAVID COLLIER, EXAMINING ATTORNEY

CLASS 25—(Continued).

SN 85-465,957. FRAULEIN KINK, WEST BLOOMFIELD, MI.
FILED 11-7-2011.

FRAULEIN KINK

SN 85-463,958. W.R 9000 CORP, NEW YORK, NY. FILED 11-3-2011.

Allyson Cara

THE MARK CONSISTS OF STANDARD CHARACTERS WITHOUT CLAIM TO ANY PARTICULAR FONT, STYLE, SIZE, OR COLOR.

THE NAME "ALLYSON CARA" DOES NOT IDENTIFY A LIVING INDIVIDUAL.

THE ENGLISH TRANSLATION OF THE WORD "CARA" IN THE MARK IS "DEAR" IN ITALIAN.

FOR CLOTHING, NAMELY, SHIRTS, T-SHIRTS, PANTS, TROUSERS, JACKETS, DRESSES, PAJAMAS, SWEATERS, JUMPERS, SKIRTS, UNDERWEAR, OVERCOATS, SUITS AND SHOES (U.S. CLS. 22 AND 39).

FIRST USE 9-15-2006; IN COMMERCE 9-15-2006.
JILL C. ALT, EXAMINING ATTORNEY

SN 85-465,224. KIDROBOT, INC., BOULDER, CO. FILED 11-4-2011.

KIDROBOT

THE MARK CONSISTS OF STANDARD CHARACTERS WITHOUT CLAIM TO ANY PARTICULAR FONT, STYLE, SIZE, OR COLOR.

OWNER OF U.S. REG. NOS. 2,926,356, 3,196,546 AND 3,444,478.

FOR CLOTHING, NAMELY, SWEATSHIRTS, PULL-OVERS, CREW NECKS, HOODED SWEATSHIRTS, SWEATERS, WOVEN TOPS, SHIRTS, POLO SHIRTS, T-SHIRTS, GOLF SHIRTS, TANK TOPS, BLOUSES, VESTS, DRESSES, SKIRTS, JACKETS, TRACK JACKETS, SPORTS JACKETS, COATS, RAINWEAR, PANTS, SHORTS, SOCKS, PAJAMAS, NIGHTSHIRTS, GLOVES, SCARVES, AND BELTS FOR CLOTHING, AND SKI-WEAR; HEADGEAR, NAMELY, HATS, CAPS, BASEBALL CAPS, AND BEANIES; FOOTWEAR; INSOLES (U.S. CLS. 22 AND 39).

GENE MACIOL, EXAMINING ATTORNEY

THE MARK CONSISTS OF STANDARD CHARACTERS WITHOUT CLAIM TO ANY PARTICULAR FONT, STYLE, SIZE, OR COLOR.

NO CLAIM IS MADE TO THE EXCLUSIVE RIGHT TO USE "FRAULEIN", APART FROM THE MARK AS SHOWN. THE ENGLISH TRANSLATION OF "FRAULEIN" IN THE MARK IS "YOUNG LADY OR MISS".

FOR WOMEN'S LINGERIE AND LINGERIE ACCESSORIES, NAMELY, GARTER BELTS, CUFFS, SLEEP MASKS AND BLINDFOLDS FOR EYES (U.S. CLS. 22 AND 39).

FIRST USE 5-0-2011; IN COMMERCE 5-0-2011.
MICHAEL WEBSTER, EXAMINING ATTORNEY

CLASS 25—(Continued).

SN 85-466,319. SHEERMAX, LLC, FORMERLY PINKBERRY UNDERWEAR, LLC, NEW YORK, NY. FILED 11-7-2011.



THE COLOR(S) BLACK AND ROSE IS/ARE CLAIMED AS A FEATURE OF THE MARK.

THE MARK CONSISTS OF THE WORD "FLAUNT" COLORED IN ROSE IN A LARGE STYLISTIC PRINT IN BETWEEN TWO ORNAMENTAL DESIGNS COLORED IN ROSE WITH THE WORDS "FLAUNT IT IF YA GO IT!" COLORED IN ROSE IN A FANCY TYPE OF SCRIPT THAT IS BOTH A COMBINATION OF PRINT AND SCRIPT SET BELOW THE WORD "FLAUNT" SET AGAINST A BLACK RECTANGULAR BACKGROUND.

FOR APPAREL FOR DANCERS, NAMELY, TEE SHIRTS, SWEATSHIRTS, PANTS, LEGGINGS, SHORTS AND JACKETS; BABY DOLL PAJAMAS; BIKINIS; BOXER SHORTS; BRAS; BRIEFS; BUSTIERS; CAMISOLES; CAPRI PANTS; CAPRIS; CHEMISES; CORSETS; DRESSING GOWNS AND BATH ROBES; G-STRINGS; GARTER BELTS; GARTERS; LEGGINGS, NAMELY, PANTS THAT ARE PARTIALLY JEANS AND PARTIALLY LEGGINGS; LADIES' UNDERWEAR; LEG SHAPERS; LEGGINGS; LEOTARDS; LINGERIE; NEGLIGEEES; NIGHT GOWNS; NIGHT SHIRTS; NIGHTGOWNS; NIGHTIES; NIGHTSHIRTS; NIGHTWEAR; PAJAMA BOTTOMS; PAJAMAS; PANTIES; PANTIES, SHORTS AND BRIEFS; ROBES; SHAPEWEAR, NAMELY, CONTROL GARMENTS GIRDLE, WOMEN'S BRIEFS, BODY SUIT, SHORTS, LEGGINS, BUSTIER, CAMISOLE.; SHORTS; SLEEP PANTS; SLEEP SHIRTS; SLEEPING GARMENTS; SLEEPWEAR; SPORTS BRA; SPORTS BRAS; STRAPLESS BRAS; STRAPS FOR BRAS; TANK TOPS; TANK-TOPS; TEE SHIRTS; THONGS; TIGHTS; UNDERPANTS; UNDERSHIRTS; UNDERWEAR; UNDERWEAR, NAMELY, BOY SHORTS; WOMEN'S TOPS, NAMELY, CAMIS; WOMEN'S UNDERWEAR; YOGA PANTS; YOGA SHIRTS (U.S. CLS. 22 AND 39).

FIRST USE 10-1-2011; IN COMMERCE 10-7-2011.
TIMOTHY FINNEGAN, EXAMINING ATTORNEY

CLASS 25—(Continued).

SN 85-466,640. HAKA CO., LTD., TAICHUNG CITY, TAIWAN, FILED 11-7-2011.

USTINI

THE MARK CONSISTS OF STANDARD CHARACTERS WITHOUT CLAIM TO ANY PARTICULAR FONT, STYLE, SIZE, OR COLOR.

THE WORDING "USTINI" HAS NO MEANING IN A FOREIGN LANGUAGE.

FOR SANDALS; BATH SLIPPERS; BEACH SHOES; BELTS; SHOE UPPERS; BOOTS FOR SPORTS; WELTS FOR BOOTS; CLOTHING FOR GYMNASTICS, NAMELY, GYM SHORTS, GYM SUITS, LEOTARDS, TIGHTS; LEATHER; COATS; TOP COATS; COLLARS; COMBINATIONS; SPORT SHIRTS; SPORT PANTS; CLOTHING FOR ATHLETIC USE, NAMELY, PADDED PANTS; CLOTHING FOR ATHLETIC USE, NAMELY, PADDED SHIRTS; FISHING VESTS; FOOTBALL BOOTS; STUDS FOR FOOTBALL BOOTS; FOOTBALL SHOES; FOOTWEAR; TIPS FOR FOOTWEAR; GAITERS; GALOSHES; GLOVES; GYMNASTIC SHOES; HATS; HEADBANDS; HEELS; HOSIERY; INNER SOLES; LACE BOOTS; MITTENS; OVERALLS; SHOES; WELTS FOR SHOES; SHOULDER WRAPS; SINGLET; SKI BOOTS; SLIPPERS; SMOCKS; SOLES FOR FOOTWEAR; SPATS; SPORTS JERSEYS; SPORTS SHOES; SUITS; T-SHIRTS; TROUSERS; TURBANS; WOODEN SHOES; INSOLE; SHOE-PADS IN THE NATURE OF INSOLES (U.S. CLS. 22 AND 39).

ANDREA BUTLER, EXAMINING ATTORNEY

SN 85-467,586. ADRIANNA NUNEZ, DBA STREET TIGER, ENCINITAS, CA. FILED 11-8-2011.



NO CLAIM IS MADE TO THE EXCLUSIVE RIGHT TO USE "HANDCRAFTED IN U.S.A" AND "VINTAGE INSPIRED", APART FROM THE MARK AS SHOWN.

THE MARK CONSISTS OF THE STYLIZED WORDS "STREET TIGER" INSIDE A CIRCULAR CARRIER FORMED BY TWO CONCENTRIC CIRCLES. WRITTEN AROUND THE TOP OF THE CARRIER, BETWEEN THE CONCENTRIC CIRCLES, ARE THE STYLIZED WORDS "HANDCRAFTED IN U.S.A" AND AROUND THE BOTTOM BETWEEN THE CONCENTRIC CIRCLES, THE STYLIZED WORDS "VINTAGE INSPIRED".

FOR CAPS; HEADWEAR; HOODED SWEATSHIRTS; SHIRTS; SWEATSHIRTS; T-SHIRTS; TANK-TOPS; THERMAL UNDERWEAR; TOPS (U.S. CLS. 22 AND 39).
FIRST USE 10-1-2011; IN COMMERCE 10-1-2011.

FLORENTINA BLANDU, EXAMINING ATTORNEY

CLASS 25—(Continued).

SN 85-472,257. HONG, JUSTIN JUN PYO, FULLERTON, CA. FILED 11-14-2011.

PRO DA YA

THE MARK CONSISTS OF STANDARD CHARACTERS WITHOUT CLAIM TO ANY PARTICULAR FONT, STYLE, SIZE, OR COLOR.

THE WORDING "PRO DA YA" HAS NO MEANING IN A FOREIGN LANGUAGE.

FOR CAPS; GLOVES; JACKETS; SHOES; SOCKS; T-SHIRTS (U.S. CLS. 22 AND 39).

FIRST USE 11-14-2011; IN COMMERCE 11-14-2011.
TINA BROWN, EXAMINING ATTORNEY

SN 85-474,970. GILT GROUPE, INC., NEW YORK, NY. FILED 11-17-2011.

GILT MAN

THE MARK CONSISTS OF STANDARD CHARACTERS WITHOUT CLAIM TO ANY PARTICULAR FONT, STYLE, SIZE, OR COLOR.

OWNER OF U.S. REG. NOS. 3,920,768, 4,073,370 AND OTHERS.

NO CLAIM IS MADE TO THE EXCLUSIVE RIGHT TO USE "MAN", APART FROM THE MARK AS SHOWN.

FOR SUITS, BLAZERS, PANTS, SHIRTS, T-SHIRTS, POLO SHIRTS, SWEATSHIRTS, SWEATERS, OUTERWEAR IN THE NATURE OF JACKETS AND COATS, SHORTS, SWIMWEAR, SCARVES, HEADWEAR, BELTS, TIES, SOCKS, GLOVES, FOOTWEAR, UNDERWEAR, AND SLEEPWEAR (U.S. CLS. 22 AND 39).

SKYE YOUNG, EXAMINING ATTORNEY

CLASS 25—(Continued).

SN 85-475,014. GIFTED ATHLETE MAXIMUM EFFORT LLC, CINCINNATI, OH. FILED 11-17-2011.



Gifted. Athlete. Maximum. Effort.

THE MARK CONSISTS OF A STYLIZED "G" AT AN ANGLE WITH THE WORDS "GIFTED.ATHLETE.MAXIMUM.EFFORT." BELOW. THE "G", "A", "M", AND "E" ARE ALL BOLDED LETTERS (THE FIRST LETTERS OF EACH WORD).

FOR ATHLETIC APPAREL, NAMELY, SHIRTS, PANTS, JACKETS, FOOTWEAR, HATS, CAPS, ATHLETIC UNIFORMS, T-SHIRTS, TANK TOPS, FLEECE PULLOVERS, FLEECE BOTTOMS, FLEECE SHORTS, FLEECE TOPS, HOODED PULLOVERS, HOODED SWEAT SHIRTS, KNIT SHIRTS, LONG-SLEEVED SHIRTS, MOISTURE-WICKING SHIRTS, POLO KNIT SHIRTS, SHORT-SLEEVED SHIRTS, SLEEVELESS JERSEYS, SPORTS JERSEYS, SWEAT PANTS, LEGGINGS, SHORTS, BOTTOMS, MOISTURE-WICKING SPORTS PANTS, WIND PANTS, JOGGING PANTS, UNDERWEAR, BRAS, SPORTS BRAS, BOXER SHORTS, MOISTURE WICKING SPORTS BRAS, HEAD WEAR, VISORS, BANDANNAS, SCARVES, BEANIES, WRISTBANDS, HEAD SWEATBANDS, HEADBANDS AGAINST SWEATING, JACKETS, WIND RESISTANT JACKETS, SPORTS VESTS, COATS, SOCKS, FOOTIES, ANKLE SOCKS, MEN'S SOCKS, GLOVES, MITTENS, AND HAND-WARMERS; CLOTHING FOR ATHLETIC USE, NAMELY, PADDED SHIRTS, PADDED PANTS, PADDED SHORTS, AND PADDED ELBOW COMPRESSION SLEEVES BEING PART OF AN ATHLETIC GARMENT; ATHLETIC FOOTWEAR, RUNNING SHOES, FLIP FLOPS, ATHLETIC SLIDES, TRAINING SHOES, CLEATS, CLEATS FOR ATTACHMENT TO SPORTS SHOES, SANDALS, BASEBALL CAPS, SOCCER APPAREL, NAMELY, SOCCER JERSEYS, SOCCER SHOES, SOCCER SHORTS, AND SOCCER SOCKS; TENNIS WEAR, VOLLEYBALL JERSEYS, SNEAKERS, MARTIAL ARTS UNIFORMS, NAMELY, GIS, MARTIAL ARTS UNIFORMS, MIXED MARTIAL ARTS SUITS, SWIMWEAR, YOGA PANTS, YOGA SHIRTS, SPORTS JERSEYS AND BREECHES FOR SPORTS, SPORTS SHIRTS, SPORTS SHORTS, SPORTS PANTS, SPORTS VESTS, SKULLWRAPS, SKULL CAPS, HEADWEAR FOR WINTER AND SUMMER, MOCK TURTLE NECK SWEATERS, ATHLETIC TIGHTS, BATHING SUITS, BEACH COVERUPS, BEACHWEAR, BERMUDA SHORTS, CANVAS SHOES, EAR BANDS, DO RAGS, FOOTWEAR FOR TRACK AND FIELD ATHLETICS, JOGGING SUITS, LOUNGEWEAR, MUSCLE SHIRTS, RUGBY SHIRTS, RUGBY SHORTS, RUNNING SUITS, SKULL CAPS, TRACK SUITS, TRACK JACKETS, TRACK PANTS, WARM UP SUITS, WAIST BANDS, A-SHIRTS, ATHLETIC SHOES, BOWLING SHOES, BOXER BRIEFS, BOXING SHORTS, CYCLING SHOES, FOOTBALL SHOES, FOOTWEAR FOR MEN AND WOMEN, GYM PANTS, GYM SHORTS, INFANT WEAR, KNITTED CAPS, RUNNING SHOES, SHOES, SOLES FOR FOOTWEAR AND BOXING SHOES (U.S. CLS. 22 AND 39).

CURTIS FRENCH, EXAMINING ATTORNEY

CLASS 25—(Continued).

SN 85-476,569. CJ CHARLES JOURDAN FASHION GROUP LLC, BOCA RATON, FL. FILED 11-18-2011.



CHARLES JOURDAN

OWNER OF U.S. REG. NOS. 1,342,788, 3,207,023 AND OTHERS.

THE NAME(S), PORTRAIT(S), AND/OR SIGNATURE(S) SHOWN IN THE MARK DOES NOT IDENTIFY A PARTICULAR LIVING INDIVIDUAL.

THE MARK CONSISTS OF THE LETTERS "CJ" IN STYLIZED FORMAT AND THE WORDS "CHARLES JOURDAN".

FOR FOOTWEAR; CLOTHING, NAMELY, JACKETS, VESTS AND PANTS FOR MEN, JACKETS, VESTS, SKIRTS AND PANTS FOR WOMEN, SCARVES AND BELTS (U.S. CLS. 22 AND 39).

JUSTINE D. PARKER, EXAMINING ATTORNEY

CLASS 25—(Continued).

SN 85-477,243. INSHORE ANGLER CHARTERS, INC., DBA INSHORE ANGLER, FORT WALTON BEACH, FL. FILED 11-20-2011.

Little Fish'n Guides

THE MARK CONSISTS OF STANDARD CHARACTERS WITHOUT CLAIM TO ANY PARTICULAR FONT, STYLE, SIZE, OR COLOR.

OWNER OF U.S. REG. NOS. 3,444,596, 4,015,284 AND OTHERS.

NO CLAIM IS MADE TO THE EXCLUSIVE RIGHT TO USE "GUIDES", APART FROM THE MARK AS SHOWN.

FOR CLOTHING FOR BABIES, TODDLERS AND CHILDREN, TREATED WITH FIRE AND HEAT RETARDANTS, NAMELY, PAJAMAS, JACKETS, SHIRTS, PANTS, JUMPERS; HATS FOR INFANTS, BABIES, TODDLERS AND CHILDREN; T-SHIRTS FOR INFANTS, BABIES, TODDLERS, CHILDREN (U.S. CLS. 22 AND 39).

NAAKWAMA ANKRAH, EXAMINING ATTORNEY

SN 85-477,573. CARTER, RUSSELL, SAN JOSE, CA. FILED 11-21-2011.

SN 85-477,013. TNB STORE, CORPUS CHRISTI, TX. FILED 11-18-2011.

Trust No Bitch



THE MARK CONSISTS OF STANDARD CHARACTERS WITHOUT CLAIM TO ANY PARTICULAR FONT, STYLE, SIZE, OR COLOR.

OWNER OF U.S. REG. NO. 4,100,406.

FOR BANDANAS; BASEBALL CAPS; BOARD SHORTS; HATS; HOODED SWEAT SHIRTS; HOODED SWEATSHIRTS; SHORT-SLEEVED OR LONG-SLEEVED T-SHIRTS; SHORTS; SOCKS; SWEAT SHIRTS; SWEATSHIRTS; SWIMWEAR; T-SHIRTS; TANK TOPS; TANK-TOPS; UNDERGARMENTS; YOGA PANTS (U.S. CLS. 22 AND 39).

FIRST USE 9-1-2009; IN COMMERCE 9-1-2009.
ELLEN PERKINS, EXAMINING ATTORNEY

THE MARKS CONSISTS OF THE STYLIZED TERM "S1R" WHEREIN THE NUMERAL "1" AND THE LEFT HAND SIDE OF THE LETTER "R" SHARE A COMMON VERTICAL LINE.

FOR HATS; SHORTS; T-SHIRTS; WARM UP OUTFITS (U.S. CLS. 22 AND 39).

FIRST USE 12-31-2009; IN COMMERCE 12-31-2009.
MICHAEL TANNER, EXAMINING ATTORNEY

CLASS 25—(Continued).

SN 85-478,744. DIMAIO, RICHARD, STATEN ISLAND, NY. FILED 11-22-2011.

Brooklyn Tough

THE MARK CONSISTS OF STANDARD CHARACTERS WITHOUT CLAIM TO ANY PARTICULAR FONT, STYLE, SIZE, OR COLOR.

NO CLAIM IS MADE TO THE EXCLUSIVE RIGHT TO USE "BROOKLYN", APART FROM THE MARK AS SHOWN.

FOR ASCOTS; BRAS; HATS; JACKETS; LEG WARMERS; PANTS; SCARVES; SHIRTS; SHOES; SHORTS; SOCKS; UNDERWEAR; WRISTBANDS (U.S. CLS. 22 AND 39).

BRENDAN MCCAULEY, EXAMINING ATTORNEY

CLASS 25—(Continued).

SN 85-483,303. CARTER, NEISHA, PLANTATION, FL. FILED 11-30-2011.

THE MARK CONSISTS OF THE WORDING "ZAFFU TO" IN STYLIZED FONT WHEREIN THE LETTER "Z" IS PARTIALLY ENCIRCLED BY AN ELLIPTICAL DESIGN.

THE WORDING "ZAFFU" OR "ZAFFU TO" HAS NO MEANING IN A FOREIGN LANGUAGE.

FOR FOOTWEAR FOR WOMEN (U.S. CLS. 22 AND 39). AMY KELLY, EXAMINING ATTORNEY

SN 85-484,811. VOPAT, EUGENE O., HAYS, KS. FILED 12-1-2011.

Spread'n Stupid

THE MARK CONSISTS OF STANDARD CHARACTERS WITHOUT CLAIM TO ANY PARTICULAR FONT, STYLE, SIZE, OR COLOR.

FOR ATHLETIC APPAREL, NAMELY, SHIRTS, PANTS, JACKETS, FOOTWEAR, HATS AND CAPS, ATHLETIC UNIFORMS; BASEBALL CAPS AND HATS; BEANIES; BOXER BRIEFS; BOXER SHORTS; HOODED SWEATSHIRTS; SPORTS CAPS AND HATS; SWEATSHIRTS; T-SHIRTS (U.S. CLS. 22 AND 39).

KATHERINE E. HALMEN, EXAMINING ATTORNEY

SN 85-482,190. ARTIFICER LIFE CORP., TAIPEI CITY, TAIWAN, FILED 11-29-2011.

THE MARK CONSISTS OF THE WORD "ARTIFICER". A CIRCULAR DESIGN WITH A DOT IN THE MIDDLE OF THE CIRCLE, TO THE LEFT OF THE WORD.

FOR KNIT TOPS; T-SHIRTS; SUITS; PANTS; SKIRTS; LEISURE CLOTHING, NAMELY, SHIRTS, PANTS, JACKETS; COATS; VESTS; SHOES; SOCKS; GLOVES; TIES; HATS; WAIST BELTS; SCARVES; BELTS FOR CLOTHING; CHILDREN'S AND INFANT'S APPAREL, NAMELY, JUMPERS, OVERALL SLEEPWEAR, PAJAMAS, ROMPERS AND ONE-PIECE GARMENTS (U.S. CLS. 22 AND 39).

FIRST USE 6-10-2011; IN COMMERCE 11-15-2011.

ELI HELLMAN, EXAMINING ATTORNEY

SN 85-486,709. YU, JAMES C., DBA AMERICAN PRINTING CORPORATION, TAMUNING, GUAM, FILED 12-5-2011.

Guam Rocks

THE MARK CONSISTS OF STANDARD CHARACTERS WITHOUT CLAIM TO ANY PARTICULAR FONT, STYLE, SIZE, OR COLOR.

NO CLAIM IS MADE TO THE EXCLUSIVE RIGHT TO USE "GUAM", APART FROM THE MARK AS SHOWN.

FOR A-SHIRTS (U.S. CLS. 22 AND 39).

FIRST USE 12-4-2011; IN COMMERCE 12-4-2011.

SANDRA BUJA, EXAMINING ATTORNEY

CLASS 25—(Continued).

SN 85-487,365. SR HOLDINGS, LLC, LEXINGTON, MA.
FILED 12-5-2011.

HAPPY SINCE 1916

THE MARK CONSISTS OF STANDARD CHARACTERS WITHOUT CLAIM TO ANY PARTICULAR FONT, STYLE, SIZE, OR COLOR.

NO CLAIM IS MADE TO THE EXCLUSIVE RIGHT TO USE "SINCE 1916", APART FROM THE MARK AS SHOWN.

FOR FOOTWEAR; CLOTHING, NAMELY, TOPS, BOTTOMS, SHIRTS, T-SHIRTS, KNIT POLO SHIRTS, TANK TOPS, SWEATERS, SWEATSHIRTS, JERSEYS, BLAZERS, JACKETS, COATS, VESTS, DRESSES, ROBES, SLEEPWEAR, INFANT SLEEPERS, INFANTWEAR, FOUL WEATHER GEAR, BODY SUITS, SWEATSUITS, WARM-UP SUITS, JOGGING SUITS, BRASSIERES, SPORT BRAS, UNDERWEAR, BRIEFS, BOXER SHORTS, SHORTS, JEANS, PANTS, LEGWARMERS, TIGHTS, SWIMWEAR, SKIRTS, SCARVES, BELTS, HOSIERY, SOCKS, SUSPENDERS, WRIST BANDS, GLOVES, MITTENS, HEADWEAR, NAMELY, HATS, CAPS, HEADBANDS, BANDANAS, BEANIES, VISORS AND SWIMCAPS (U.S. CLS. 22 AND 39).

CURTIS FRENCH, EXAMINING ATTORNEY

SN 85-488,253. MISS KINSMAN, LLC, WINDHAM, ME.
FILED 12-6-2011.

MISS KINSMAN

THE MARK CONSISTS OF STANDARD CHARACTERS WITHOUT CLAIM TO ANY PARTICULAR FONT, STYLE, SIZE, OR COLOR.

THE NAME(S), PORTRAIT(S), AND/OR SIGNATURE(S) SHOWN IN THE MARK IDENTIFIES JOANNA KINSMAN, WHOSE CONSENT(S) TO REGISTER IS MADE OF RECORD.

FOR SWIMWEAR (U.S. CLS. 22 AND 39).

FIRST USE 6-25-2011; IN COMMERCE 6-25-2011.

CHARLOTTE CORWIN, EXAMINING ATTORNEY

CLASS 25—(Continued).

SN 85-488,409. MISS KINSMAN, LLC, WINDHAM, ME.
FILED 12-6-2011.



THE NAME(S), PORTRAIT(S), AND/OR SIGNATURE(S) SHOWN IN THE MARK IDENTIFIES JOANNA KINSMAN, WHOSE CONSENT(S) TO REGISTER IS MADE OF RECORD.

THE MARK CONSISTS OF A SEAL COMPRISED OF A CROSS AND CONCENTRIC CIRCLES WITH A WIDE NOTCHED RING IN THE CENTER OF TWO CIRCLES; THREE CUTS APPEAR ACROSS THE VERTICAL SECTIONS OF THE CROSS AND THE FOUR ENDS ARE CUT INTO AN ARROW POINT; IN THE WIDE RING FORMED BY THE CONCENTRIC CIRCLES THE WORDS "MISS KINSMAN" APPEARS WITH LEAF DESIGNS BETWEEN THE WORDS; IN THE CENTER OF THE SEAL IS A LETTER "K".

FOR SWIMWEAR (U.S. CLS. 22 AND 39).

FIRST USE 6-25-2011; IN COMMERCE 6-25-2011.

CHARLOTTE CORWIN, EXAMINING ATTORNEY

SN 85-488,822. MERINGCARSON, SACRAMENTO, CA.
FILED 12-6-2011.



THE MARK CONSISTS OF THE NUMBER "6" WITH A STAR CENTERED IN THE LOWER ROUNDED PORTION OF THE "6".

FOR APPAREL AND CLOTHING, NAMELY, T-SHIRTS, SWEATSHIRTS, JACKETS, BASEBALL CAPS, BEANIES, HATS, AND WRISTBANDS; ATHLETIC AND WORKOUT CLOTHING, NAMELY, SWEATPANTS, SWEATSHIRTS, GYM SHORTS, T-SHIRTS AND WORKOUT SHIRTS (U.S. CLS. 22 AND 39).

TRACY WHITTAKER-BROWN, EXAMINING ATTORNEY

CLASS 25—(Continued).

SN 85-489,073. CIVILIZED NATIONS UNITED, LLC, MIAMI, FL. FILED 12-7-2011.



NO CLAIM IS MADE TO THE EXCLUSIVE RIGHT TO USE "EST 2008", APART FROM THE MARK AS SHOWN.

THE MARK CONSISTS OF THE WORD "CIVILIZED" IN A STYLIZED FONT AT THE TOP OF A STYLIZED 5 LAYER CIRCLE, THE FIRST LAYER IS BRAIDED, THE SECOND LAYER CONSISTS OF AN OVAL DESIGN, THE THIRD LAYER IS A PLAIN LINE, THE FOURTH LAYER CONSISTS OF STARS, THE FIFTH LAYER IS A PLAIN DOUBLE LINE. THE CENTER OF THE CIRCLE, CONSISTS OF TWO STYLIZED "C"'S BACK TO BACK AND OVERLAPPING WITH A STYLIZED "V" OVERLAPPING THE "C"'S. BENEATH THE CIRCLE, THE WORD "NATIONS" APPEARS IN A STYLIZED FONT. ON EITHER SIDE OF THE CIRCLE, AN OUTWARD LOOKING HEAD IN PROFILE APPEARS. ON THE LEFT, UNDERNEATH THE OUTWARD LOOKING HEAD IN PROFILE, THE WORD "EST" APPEARS IN A STYLIZED FONT. ON THE RIGHT, UNDERNEATH THE OUTWARD LOOKING HEAD IN PROFILE APPEARS THE YEAR "2008" IN A STYLIZED FONT.

FOR APPAREL FOR DANCERS, NAMELY, TEE SHIRTS, SWEATSHIRTS, PANTS, LEGGINGS, SHORTS AND JACKETS; ATHLETIC APPAREL, NAMELY, SHIRTS, PANTS, JACKETS, FOOTWEAR, HATS AND CAPS, ATHLETIC UNIFORMS; BASEBALL CAPS AND HATS; COLLARED SHIRTS; DENIMS; FLEECE PULL-OVERS; GOLF CAPS; HATS; HOODED PULLOVERS; HOODED SWEAT SHIRTS; HOODED SWEATSHIRTS; HOODED SWEATSHIRTS FOR ADULTS AND CHILDREN; JEANS; KNIT SHIRTS; LONG SLEEVE PULL-OVERS; LONG-SLEEVED SHIRTS; OUTER JACKETS; PIQUE SHIRTS; POLO KNIT TOPS; POLO SHIRTS; PULLOVERS; SHIRTS; SHORT TROUSERS; SHORTS; SKULL CAPS; SPORT SHIRTS; SPORTS CAPS AND HATS; SWEAT PANTS; SWEAT SHIRTS; SWEATSHIRTS FOR ADULTS AND CHILDREN; T-SHIRTS; T-SHIRTS FOR ADULTS AND CHILDREN; TANK TOPS; WOMEN'S HATS AND HOODS (U.S. CLS. 22 AND 39).

FIRST USE 1-1-2008; IN COMMERCE 1-1-2011.
BARNEY CHARLON, EXAMINING ATTORNEY

SN 85-489,105. MACKR LLC, CHESTERTOWN, MD. FILED 12-7-2011.

Mackr

THE MARK CONSISTS OF STANDARD CHARACTERS WITHOUT CLAIM TO ANY PARTICULAR FONT, STYLE, SIZE, OR COLOR.

FOR CLOTHING GEARED TO EXTREME SPORTS, NAMELY, SHORTS, PANTS, T-SHIRTS, SWEATSHIRTS, AND HATS (U.S. CLS. 22 AND 39).

FIRST USE 10-15-2011; IN COMMERCE 10-15-2011.
JENNIFER WILLISTON, EXAMINING ATTORNEY

CLASS 25—(Continued).

SN 85-489,300. HORSELOVERSGUIDE LLC, SAXONBURG, PA. FILED 12-7-2011.



NO CLAIM IS MADE TO THE EXCLUSIVE RIGHT TO USE "GEAR", APART FROM THE MARK AS SHOWN.

THE MARK CONSISTS OF A DESIGN OF THREE HORSES RUNNING LEFT WITH THEIR MANES BEING A STRIPED FLAG WITH THREE STARS WITH THE STYLIZED TEXT "HORSE LOVERS GEAR" UNDER.

FOR JACKETS; PANTS; SHIRTS; SHOES (U.S. CLS. 22 AND 39).

FIRST USE 12-1-2009; IN COMMERCE 12-1-2009.
DOMINIC J. FERRAIUOLO, EXAMINING ATTORNEY

SN 85-489,718. MERINGCARSON, SACRAMENTO, CA. FILED 12-7-2011.

WE'VE GOT YOUR SIX

THE MARK CONSISTS OF STANDARD CHARACTERS WITHOUT CLAIM TO ANY PARTICULAR FONT, STYLE, SIZE, OR COLOR.

FOR APPAREL AND CLOTHING, NAMELY, T-SHIRTS, SWEATSHIRTS, JACKETS, BASEBALL CAPS, BEANIES, HATS, AND WRISTBANDS; ATHLETIC AND WORKOUT CLOTHING, NAMELY, SWEATPANTS, SWEATSHIRTS, GYM SHORTS, T-SHIRTS AND WORK-OUT SHIRTS (U.S. CLS. 22 AND 39).

TRACY WHITTAKER-BROWN, EXAMINING ATTORNEY

CLASS 25—(Continued).

SN 85-489,875. UNCLE SCRAPPY SPORTS DESIGNS, MELBOURNE, FL. FILED 12-7-2011.



NO CLAIM IS MADE TO THE EXCLUSIVE RIGHT TO USE "SPORTS DESIGNS", APART FROM THE MARK AS SHOWN.

THE NAME "UNCLE SCRAPPY" DOES NOT IDENTIFY A LIVING INDIVIDUAL.

THE MARK CONSISTS OF THE WORDING "UNCLE SCRAPPY SPORTS DESIGNS" IN STYLIZED FONT; BETWEEN THE WORDING "UNCLE" AND "SCRAPPY" IS A DESIGN OF A MAN WITH A MUSTACHE WEARING A HAT, T-SHIRT, AND SUNGLASSES POINTING HIS FINGER FORWARD, WITH TWO BANDS ABOVE THE WORDING AND DESIGN AND ONE BAND BELOW, AND THE WORDING "SPORTS DESIGNS" DIRECTLY BELOW THE LOWER BAND, ON A SHADED RECTANGULAR BACKGROUND.

FOR BASEBALL CAPS; COMBATIVE SPORTS UNIFORMS; GYM PANTS; GYM SHORTS; HATS; HOODED SWEATSHIRTS; PANTS; PINNIES IN THE NATURE OF SCRIMMAGE VESTS FOR USE IN SPORTS; SHIRTS; SHORT-SLEEVED SHIRTS; SHORTS; SPORT COATS; SPORT SHIRTS; SPORT STOCKINGS; SPORTS BRA; SPORTS BRAS; SPORTS CAPS AND HATS; SPORTS JACKETS; SPORTS JERSEYS; SPORTS JERSEYS AND BREECHES FOR SPORTS; SPORTS OVER UNIFORMS; SPORTS OVERUNIFORMS; SPORTS PANTS; SPORTS SHIRTS; SPORTS SHIRTS WITH SHORT SLEEVES; SPORTS VESTS; SWEAT PANTS; SWEATERS; SWEATSHIRTS; T-SHIRTS; TRACK PANTS; UNIFORMS (U.S. CLS. 22 AND 39).

NICHOLAS COLEMAN, EXAMINING ATTORNEY

SN 85-490,709. INTEGRATIVE NUTRITION, INC., NEW YORK, NY. FILED 12-8-2011.



OWNER OF U.S. REG. NOS. 2,956,412, 3,354,697 AND 3,362,440.

NO CLAIM IS MADE TO THE EXCLUSIVE RIGHT TO USE "INSTITUTE AND NUTRITION", APART FROM THE MARK AS SHOWN.

THE COLOR(S) RED AND BLACK IS/ARE CLAIMED AS A FEATURE OF THE MARK.

THE MARK CONSISTS OF A RED SPIRAL TO THE LEFT OF THE WORDS "INSTITUTE FOR INTEGRATIVE NUTRITION" IN BLACK; THE COLOR WHITE IN THE MARK REPRESENTS BACKGROUND AND IS NOT PART OF THE MARK.

FOR CLOTHING, NAMELY, SHIRTS; AND HEADGEAR, NAMELY, HATS AND CAPS (U.S. CLS. 22 AND 39).

VIVIAN MICZNIK FIRST, EXAMINING ATTORNEY

CLASS 25—(Continued).

SN 85-491,107. WALKER, AUSTIN, GREENSBORO, NC. FILED 12-8-2011.



NO CLAIM IS MADE TO THE EXCLUSIVE RIGHT TO USE "MMIX", APART FROM THE MARK AS SHOWN.

THE STIPPLING IS FOR SHADING PURPOSES ONLY.

THE MARK CONSISTS OF THE TEXT "F.I.T.E FAILURE IS THE ENEMY MMIX" ON A STYLIZED SHIELD-LIKE BACKGROUND.

FOR JACKETS; PANTS; SHIRTS; SHOES (U.S. CLS. 22 AND 39).

ELLEN BURNS, EXAMINING ATTORNEY

SN 85-491,170. VALENZUELA, DON A., LOS ANGELES, CA. FILED 12-9-2011.

D. Anthony

THE MARK CONSISTS OF STANDARD CHARACTERS WITHOUT CLAIM TO ANY PARTICULAR FONT, STYLE, SIZE, OR COLOR.

THE NAME(S), PORTRAIT(S), AND/OR SIGNATURE(S) SHOWN IN THE MARK IDENTIFIES DON ANTHONY VALENZUELA, WHOSE CONSENT(S) TO REGISTER IS MADE OF RECORD.

FOR BUTTON DOWN SHIRTS; COLLARED SHIRTS; DENIMS; DRESS SHIRTS; HOODED SWEATSHIRTS FOR MEN AND WOMEN; JEANS; JEGGINGS, NAMELY, PANTS THAT ARE PARTIALLY JEANS AND PARTIALLY LEGGINGS; MEN'S AND WOMEN'S JACKETS, COATS, TROUSERS, VESTS; T-SHIRTS FOR MEN AND WOMEN (U.S. CLS. 22 AND 39).

FIRST USE 12-15-2010; IN COMMERCE 1-1-2011.

WARREN L. OLANDRIA, EXAMINING ATTORNEY

CLASS 25—(Continued).

SN 85-493,542. NL APPAREL USA LLC, WHITE PLAINS, NY. FILED 12-13-2011.



NO CLAIM IS MADE TO THE EXCLUSIVE RIGHT TO USE "NEW YORK", APART FROM THE MARK AS SHOWN. THE COLOR(S) RED, BLUE, BLACK IS/ARE CLAIMED AS A FEATURE OF THE MARK.

THE MARK CONSISTS OF THE LETTERS "NL" IN RED NEXT TO A BLUE STAR WITH FIVE POINTS AND UNDERNEATH APPEARS THE WORDS "N&L NEW YORK" IN BLACK.

FOR A FULL LINE OF CLOTHING, NAMELY, SHIRTS, PANTS, SWEAT PANTS, SWEAT SHIRTS, T-SHIRTS, SCARVES, CAPS AND CLOTH BIBS (U.S. CLS. 22 AND 39).

ANGELA M. MICHELI, EXAMINING ATTORNEY

CLASS 25—(Continued).

SN 85-494,900. OWCZAREK, JAKUB, ENCINO, CA. FILED 12-14-2011.



THE COLOR(S) RED, BLACK AND GRAY IS/ARE CLAIMED AS A FEATURE OF THE MARK.

THE MARK CONSISTS OF THE WORDS "ROYAL TRASH" APPEARING IN RED BELOW A BLACK CROWN DESIGN IN WHICH THE CROWN IS SPLIT IN HALF AND RED BLOOD IS DRIPPING FROM THE BOTTOM OF THE RIGHT HALF OF THE CROWN, ALL APPEARING ON A GRAY BACKGROUND.

FOR T-SHIRTS (U.S. CLS. 22 AND 39).

FIRST USE 12-12-2011; IN COMMERCE 12-12-2011.

KELLY TRUSILO, EXAMINING ATTORNEY

SN 85-494,339. YALE SPORTSWEAR CORPORATION, FEDERALSBURG, MD. FILED 12-13-2011.



OWNER OF U.S. REG. NOS. 1,356,758, 2,313,239 AND 2,562,113.

NO CLAIM IS MADE TO THE EXCLUSIVE RIGHT TO USE "SPORTSWEAR", APART FROM THE MARK AS SHOWN.

THE MARK CONSISTS OF STYLIZED SPLIT "Y" SUPERPOSED OVER A OFFSET OVAL ALL OVERLYING THE WORDS "YALE SPORTSWEAR".

FOR ATHLETIC APPAREL, NAMELY, SHIRTS, PANTS, JACKETS, FOOTWEAR, HATS AND CAPS, ATHLETIC UNIFORMS; ATHLETIC UNIFORMS (U.S. CLS. 22 AND 39).

FIRST USE 11-1-2011; IN COMMERCE 11-1-2011.

H. M. FISHER, EXAMINING ATTORNEY

SN 85-496,050. SEIBOLD, PAMELA DEE, OSHKOSH, WI. FILED 12-15-2011.



THE MARK CONSISTS OF THE WORDING "PAIRS" WITH THE LETTER "I" REPLACED BY A STYLIZED UPSIDE DOWN QUESTION MARK UNDER TWO LINES FOLLOWED BY A STYLIZED QUESTION MARK OVER TWO LINES AND BENEATH THE STYLIZED REPRESENTATIONS OF TWO QUESTION MARKS APPEARING IN AN OVAL.

FOR CLOTHING, NAMELY, SHOES, SHIRTS, PANTS, SOCKS, MITTENS, GLOVES, BELTS, FOOTWEAR, AND HEADWEAR (U.S. CLS. 22 AND 39).

DOMINIC J. FERRAIUOLO, EXAMINING ATTORNEY

CLASS 25—(Continued).

SN 85-499,104. SR HOLDINGS, LLC, LEXINGTON, MA. FILED 12-19-2011.



OWNER OF U.S. REG. NOS. 1,810,853 AND 1,860,428. THE MARK CONSISTS OF A STYLIZED IMAGE OF A SAILBOAT WITH TWO SETS OF WAVES, SURROUNDED BY A SQUARE DESIGN.

FOR GLOVES; SUSPENDERS; THERMAL UNDERWEAR; SWIMWEAR; COVERUPS; HOODED SWEATSHIRTS; HOODED PULLOVERS; HOSIERY; LEGGINGS; SCARVES (U.S. CLS. 22 AND 39).

CURTIS FRENCH, EXAMINING ATTORNEY

CLASS 25—(Continued).

SN 85-501,463. FABKA FABRICS LLC, VERNON, CA. FILED 12-21-2011.



SN 85-500,062. MELCHOR, GISELLE, EAST LOS ANGELES, CA. AND MELCHOR, NIEVES SUZANA, EAST LOS ANGELES, CA. FILED 12-20-2011.



THE MARK CONSISTS OF AN ANGRY MARSHMALLOW WITH ROUND EYES AND WEARING A BOW TIE, ALL OF WHICH ARE DISPLAYED BETWEEN THE STYLIZED WORDS "KILLING" AND "MARSHMALLOW".

FOR BOOTS; BOTTOMS; FOOTWEAR; JACKETS; LINGERIE; SHIRTS (U.S. CLS. 22 AND 39).

YAT SYE, LEE, EXAMINING ATTORNEY

NO CLAIM IS MADE TO THE EXCLUSIVE RIGHT TO USE "BABY", APART FROM THE MARK AS SHOWN.

THE COLOR(S) BROWN, WHITE, GREEN AND YELLOW IS/ARE CLAIMED AS A FEATURE OF THE MARK.

THE MARK CONSISTS OF THE FOLLOWING: THE WORDING "Geffen" IN BROWN, WITH THE END OF THE "N" EXTENDING TO THE PART OF THE FOOT OF A YELLOW GIRAFFE OUTLINED IN BROWN, WITH BROWN LEGS AND FEET, BROWN SPOTS, AND BROWN EYES AND EARS AND A PARTIALLY WHITE FACE, AND THE WORDING "BABY" IN GREEN.

FOR CLOTH DIAPERS; INFANT CLOTH DIAPERS; INSERTS SPECIALLY ADAPTED FOR CLOTH DIAPERS MADE OF HEMP; TEXTILE DIAPERS (U.S. CLS. 22 AND 39).

FIRST USE 6-8-2011; IN COMMERCE 6-8-2011.

APRIL ROACH, EXAMINING ATTORNEY

CLASS 25—(Continued).

SN 85-501,524. PRATT, DOROTHY JEAN, DBA A TOUCH OF RENAISSANCE, SCOTTSDALE, AZ. FILED 12-21-2011.



NO CLAIM IS MADE TO THE EXCLUSIVE RIGHT TO USE "DESIGNS", APART FROM THE MARK AS SHOWN.

THE COLOR(S) DARK GOLD, PURPLE, LAVENDER, ROYAL BLUE AND BLACK IS/ARE CLAIMED AS A FEATURE OF THE MARK.

THE MARK CONSISTS OF A SQUARE WITH THE BACKGROUND COLOR IN DARK GOLD WITH A CIRCLE IN THE MIDDLE DEPICTING A ROSE IN VARIOUS SHADES OF PURPLE. THE LETTERING OF "TUDOR ROSE DESIGNS" IS DONE IN A SPECIAL FONT WITH THE LETTERS DONE WITH A BLACK OUTLINE AND LAVENDER AND ROYAL BLUE SHADING WITHIN THE LETTERS. THE WORD "TUDOR" APPEARS IN THE UPPER LEFT, THE WORD "ROSE" IN THE UPPER RIGHT, THE WORD "DESIGNS" IN THE LOWER LEFT.

FOR HATS; SHAWLS AND HEADSCARVES (U.S. CLS. 22 AND 39).

FIRST USE 12-1-2011; IN COMMERCE 12-1-2011.
JAMES LOVELACE, EXAMINING ATTORNEY

SN 85-501,525. BISHOP, KEITH, NEW YORK, NY. FILED 12-21-2011.

GoLLy NYC

THE MARK CONSISTS OF STANDARD CHARACTERS WITHOUT CLAIM TO ANY PARTICULAR FONT, STYLE, SIZE, OR COLOR.

NO CLAIM IS MADE TO THE EXCLUSIVE RIGHT TO USE "NYC", APART FROM THE MARK AS SHOWN.

FOR T-SHIRTS (U.S. CLS. 22 AND 39).
HAI-LY LAM, EXAMINING ATTORNEY

CLASS 25—(Continued).

SN 85-501,669. GOLDSTEIN, ALISHA, WEST HOLLYWOOD, CA. FILED 12-22-2011.

JANE SMITH

THE MARK CONSISTS OF STANDARD CHARACTERS WITHOUT CLAIM TO ANY PARTICULAR FONT, STYLE, SIZE, OR COLOR.

THE NAME "JANE SMITH" DOES NOT IDENTIFY A LIVING INDIVIDUAL.

FOR CLOTHING, NAMELY, TOPS, BOTTOMS, SHIRTS, T-SHIRTS, TANK TOPS, PANTS, BLOUSES, SWEATSHIRTS, HOODED SWEATSHIRTS, SWEAT-PANTS, CAPS, HATS, JACKETS, COATS, SKIRTS, DRESSES, SOCKS, JERSEYS, KNIT TOPS, KNIT BOTTOMS, KNIT DRESSES, KNIT SKIRTS, KNIT JACKETS, LEATHER SHIRTS, LEATHER PANTS, LEATHER SKIRTS, LEATHER JACKETS, STOCKINGS, LINGERIE, UNDERWEAR, SHOES AND BELTS (U.S. CLS. 22 AND 39).

TINA MAI, EXAMINING ATTORNEY

SN 85-502,317. SUN SOUTH PRODUCTS, LLC, NORCROSS, GA. FILED 12-22-2011.

COOL-CAT

THE MARK CONSISTS OF STANDARD CHARACTERS WITHOUT CLAIM TO ANY PARTICULAR FONT, STYLE, SIZE, OR COLOR.

FOR SUN PROTECTIVE CLOTHING, NAMELY, TUBE SHAPED NECK SCARVES FOR OUTDOOR WORKERS SOLD THROUGH SPECIALTY RETAIL CHANNELS FOR THE CONSTRUCTION AND AGRICULTURAL INDUSTRIES (U.S. CLS. 22 AND 39).

COLLEEN KEARNEY, EXAMINING ATTORNEY

CLASS 25—(Continued).

SN 85-502,776. MILES VELLANDI, DBA BAD ASS GENTLEMAN, MISSION VIEJO, CA. FILED 12-22-2011.

BAD ASS GENTLEMAN

THE MARK CONSISTS OF STANDARD CHARACTERS WITHOUT CLAIM TO ANY PARTICULAR FONT, STYLE, SIZE, OR COLOR.

NO CLAIM IS MADE TO THE EXCLUSIVE RIGHT TO USE "GENTLEMAN", APART FROM THE MARK AS SHOWN.

FOR CLOTHING EXTENSION USED TO EXTEND THE NORMAL SIZE RANGE OF CLOTHING ITEMS TO ACCOMMODATE PREGNANCY SIZE CHANGES; CLOTHING FOR WEAR IN JUDO PRACTICES; CLOTHING FOR WEAR IN WRESTLING GAMES; COMBINATIONS; FABRIC SOLD AS AN INTEGRAL COMPONENT OF FINISHED CLOTHING ITEMS, NAMELY, SHIRTS; GLOVES AS CLOTHING; HEADBANDS FOR CLOTHING; HOODS; JACKETS; JERSEYS; LEATHER BELTS; SUN PROTECTIVE CLOTHING, NAMELY, SHIRTS; TOPS; TRAVEL CLOTHING CONTAINED IN A PACKAGE COMPRISING REVERSIBLE JACKETS, PANTS, SKIRTS, TOPS AND A BELT OR SCARF; WEARABLE GARMENTS AND CLOTHING, NAMELY, SHIRTS; WOMEN'S CLOTHING, NAMELY, SHIRTS, DRESSES, SKIRTS, BLOUSES; WRIST BANDS (U.S. CLS. 22 AND 39).

FRANK LATTUCA, EXAMINING ATTORNEY

SN 85-503,120. IBEPALINO, CAROL, DBA MY ROADDOG CORP (M.R.D.), SEVIERVILLE, TN. FILED 12-23-2011.

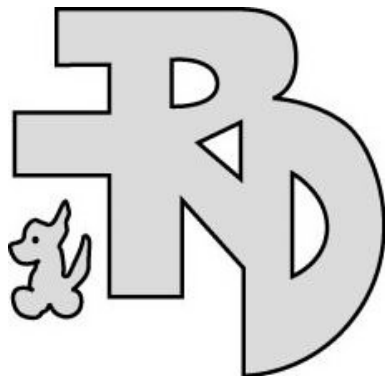

THE MARK CONSISTS OF SMALL DOG WITH TAIL POINT UP WALKING WITH THE LETTER "RD" .
FOR A-SHIRTS (U.S. CLS. 22 AND 39).
FIRST USE 7-7-2005; IN COMMERCE 9-13-2005.
CURTIS FRENCH, EXAMINING ATTORNEY

CLASS 25—(Continued).

SN 85-503,265. THE SOUTHEASTERN CONFERENCE, BIRMINGHAM, AL. FILED 12-23-2011.

SEC

THE MARK CONSISTS OF STANDARD CHARACTERS WITHOUT CLAIM TO ANY PARTICULAR FONT, STYLE, SIZE, OR COLOR.

OWNER OF U.S. REG. NO. 1,633,675.
FOR HATS; JACKETS; T-SHIRTS (U.S. CLS. 22 AND 39).

FIRST USE 9-0-2000; IN COMMERCE 9-0-2000.
TARAH HARDY, EXAMINING ATTORNEY

SN 85-504,051. TREMBLAY, MICHELLE, CONIFER, CO. FILED 12-27-2011.

Hard Core Colorado

THE MARK CONSISTS OF STANDARD CHARACTERS WITHOUT CLAIM TO ANY PARTICULAR FONT, STYLE, SIZE, OR COLOR.

NO CLAIM IS MADE TO THE EXCLUSIVE RIGHT TO USE "COLORADO", APART FROM THE MARK AS SHOWN.

FOR HATS; HOODED SWEATSHIRTS; LONG-SLEEVED SHIRTS; SWEATSHIRTS; T-SHIRTS (U.S. CLS. 22 AND 39).

ANNE FARRELL, EXAMINING ATTORNEY

SN 85-504,171. CLASSIC ALASKA TRADING COMPANY / BIG RAY'S ALASKA, INC., FAIRBANKS, AK. FILED 12-27-2011.



NO CLAIM IS MADE TO THE EXCLUSIVE RIGHT TO USE "ALASKA WEAR", APART FROM THE MARK AS SHOWN.

THE MARK CONSISTS OF THE WORDING KAVIK IN LARGE LOWER CASE LETTERING ABOVE THE WORDING "ALASKA WEAR" IN SMALLER ALL CAPS LETTERING. THE FIRST "K" IN THE WORD "KAVIK" HAS A PORTION THAT EXTENDS WELL BELOW THE REMAINDER OF THE MARK AND COMES TO A POINT RESEMBLING A CLAW. TO THE RIGHT OF THE SECOND "K" IS A THREE POINTED CLAW DESIGN.

FOR CLOTHING, NAMELY, PARKAS, JACKETS, HATS AND GLOVES (U.S. CLS. 22 AND 39).
SHARON MEIER, EXAMINING ATTORNEY

CLASS 25—(Continued).

SN 85-504,426. AMUSEMENT ART LLC, LOS ANGELES, CA. FILED 12-27-2011.



THE MARK CONSISTS OF THE WORDING "FOLLOW YOUR DREAMS" BESIDE AN APE OR CHIMP HOLDING A SPRAY PAINT CAN AND SITTING ON A CHEST.

FOR BEANIES; COATS; COATS FOR MEN AND WOMEN; COATS MADE OF COTTON; COATS OF DENIM; FABRIC BELTS; HATS; HEADGEAR, NAMELY, CAPS; JACKETS; JEANS; LEATHER BELTS; LEATHER JACKETS; PANTS; POLO SHIRTS; SCARVES; SHIRTS; SHIRTS FOR SUITS; SHOES; SHORT SETS; SHORT TROUSERS; SHORT-SLEEVED OR LONG-SLEEVED T-SHIRTS; SHORTS; SNEAKERS; SOCKS; SOCKS AND STOCKINGS; SWEAT SHORTS; SWEATERS; T-SHIRTS; TURTLENECK SWEATERS; UNDERWEAR; V-NECK SWEATERS; WAIST BELTS; WOMEN'S UNDERWEAR (U.S. CLS. 22 AND 39).

HANNO RITTNER, EXAMINING ATTORNEY

SN 85-504,893. CATTYWOMPUS RECORDS LLC, FORT WAYNE, IN. FILED 12-28-2011.

**THE
GOOD
ONES**

THE MARK CONSISTS OF "THE GOOD ONES" IN LARGE, BLOCK LETTERING.

FOR CHILDREN'S AND INFANT'S APPAREL, NAMELY, JUMPERS, OVERALL SLEEPWEAR, PAJAMAS, ROMPERS AND ONE-PIECE GARMENTS (U.S. CLS. 22 AND 39).

EUGENIA MARTIN, EXAMINING ATTORNEY

CLASS 25—(Continued).

SN 85-505,198. MATTA, NEW YORK, LTD., NEW YORK, NY. FILED 12-28-2011.

MATAH

THE MARK CONSISTS OF STANDARD CHARACTERS WITHOUT CLAIM TO ANY PARTICULAR FONT, STYLE, SIZE, OR COLOR.

FOR CLOTHING, NAMELY, TOPS, T-SHIRTS, TANK TOPS, SHIRTS, BLOUSES, TUNICS, DRESSES, SKIRTS, PANTS, VESTS, JACKETS, SUITS, COATS, SWEATERS, SCARVES, SHAWLS, STOLE, MUFFLERS, WRAPS, SARONGS AND BELTS (U.S. CLS. 22 AND 39).

MATTHEW MCDOWELL, EXAMINING ATTORNEY

SN 85-505,518. KNOT STANDARD LIMITED, COMPANY NO. 091476, VICTORIA, MAHE, SEYCHELLES, FILED 12-29-2011.

KK

THE MARK CONSISTS OF THE LETTER "K". FOR CLOTHING, NAMELY, CUSTOM MADE SUITS, SHIRTS, BLAZERS AND SLACKS; AND CLOTHING ACCESSORIES, NAMELY, TIES (U.S. CLS. 22 AND 39).

FIRST USE 6-15-2011; IN COMMERCE 6-15-2011. ZHALEH DELANEY, EXAMINING ATTORNEY

SN 85-506,700. RIPLAY, INC., CITY OF INDUSTRY, CA. FILED 12-30-2011.

FRH

THE MARK CONSISTS OF "FRH" IN STYLIZED LETTERING.

FOR FOOTWEAR FOR MEN AND WOMEN (U.S. CLS. 22 AND 39).

FIRST USE 10-10-2011; IN COMMERCE 10-10-2011. FRANK LATTUCA, EXAMINING ATTORNEY

CLASS 25—(Continued).

SN 85-506,702. RIPLAY, INC., CITY OF INDUSTRY, CA.
FILED 12-30-2011.

FRH

THE MARK CONSISTS OF STANDARD CHARACTERS WITHOUT CLAIM TO ANY PARTICULAR FONT, STYLE, SIZE, OR COLOR.

FOR FOOTWEAR FOR MEN AND WOMEN (U.S. CLS. 22 AND 39).

FIRST USE 10-10-2011; IN COMMERCE 10-10-2011.

FRANK LATTUCA, EXAMINING ATTORNEY

SN 85-506,708. 4Q2 FIGHTWEAR INTERNATIONAL, LLC,
EAST MEADOW, NY. FILED 12-30-2011.

YOGA SKINS

THE MARK CONSISTS OF STANDARD CHARACTERS WITHOUT CLAIM TO ANY PARTICULAR FONT, STYLE, SIZE, OR COLOR.

NO CLAIM IS MADE TO THE EXCLUSIVE RIGHT TO USE "YOGA", APART FROM THE MARK AS SHOWN.

FOR ATHLETIC FOOTWEAR; BOOTIES; FOOTWEAR (U.S. CLS. 22 AND 39).

FRANK LATTUCA, EXAMINING ATTORNEY

SN 85-506,900. GENTLEMEN INK, LLC, NEW ROCHELLE,
NY. FILED 12-31-2011.

GENTLEMEN INK

THE MARK CONSISTS OF STANDARD CHARACTERS WITHOUT CLAIM TO ANY PARTICULAR FONT, STYLE, SIZE, OR COLOR.

FOR HATS; SHIRTS; SHORTS; SWEATPANTS; SWEATSHIRTS (U.S. CLS. 22 AND 39).

FIRST USE 6-1-2007; IN COMMERCE 6-1-2007.

TEJBIR SINGH, EXAMINING ATTORNEY

CLASS 25—(Continued).

SN 85-507,051. DURDEN, DWIGHT C., GREENSBORO, NC.
FILED 1-1-2012.



NO CLAIM IS MADE TO THE EXCLUSIVE RIGHT TO USE "PROVERBS 18:21 "DEATH AND LIFE ARE IN THE POWER OF THE TONGUE; AND THEY THAT LOVE IT SHALL EAT THE FRUIT THEREOF."", APART FROM THE MARK AS SHOWN.

THE COLOR(S) YELLOW, RED, CYAN, GREEN, DEEP YELLOW, AND ORANGE IS/ARE CLAIMED AS A FEATURE OF THE MARK.

THE MARK CONSISTS OF THE WORDS "LOVE YOU TO LIFE" TO THE RIGHT OF A GREEN, YELLOW, RED, AND ORANGE TREE. THE LETTERS "L" AND "V" IN "LOVE" ARE RED AND OUTLINED IN YELLOW AND THE LETTERS "O" AND "E" ARE CYAN AND OUTLINED IN YELLOW. THE WORDS "YOU TO" ARE WRITTEN IN RED AND OUTLINED IN YELLOW. THE LETTERS "L" AND "F" ARE RED AND OUTLINED IN YELLOW AND THE LETTERS "I" AND "E" ARE CYAN AND OUTLINED IN YELLOW. THERE IS A CYAN AND YELLOW RIVER BETWEEN THE "L" IN "LOVE" AND THE "L" IN "LIFE". UNDERNEATH THE RIVER IN RED IS "PROVERBS 18:21" AND "DEATH AND LIFE ARE IN THE POWER OF THE TONGUE; AND THEY THAT LOVE IT SHALL EAT THE FRUIT THEREOF".

FOR BASEBALL CAPS AND HATS, POLO SHIRTS, SHORT-SLEEVED AND LONG-SLEEVED T-SHIRTS, SWEATSHIRTS, TIES, WRISTBANDS (U.S. CLS. 22 AND 39).

SHAUNIA CARLYLE, EXAMINING ATTORNEY

SN 85-507,221. SCOT G. CAMERON, IRVINE, CA. FILED 1-2-2012.

ROCKY POINT

THE MARK CONSISTS OF STANDARD CHARACTERS WITHOUT CLAIM TO ANY PARTICULAR FONT, STYLE, SIZE, OR COLOR.

FOR ATHLETIC APPAREL, NAMELY, SHIRTS, PANTS, JACKETS, FOOTWEAR, HATS AND CAPS, ATHLETIC UNIFORMS (U.S. CLS. 22 AND 39).

GIANCARLO CASTRO, EXAMINING ATTORNEY

CLASS 25—(Continued).

SN 85-507,228. ENKIDU VENTURES LLC, NEW YORK, NY. FILED 1-2-2012.

RIGHTEOUS SHIKSA

THE MARK CONSISTS OF STANDARD CHARACTERS WITHOUT CLAIM TO ANY PARTICULAR FONT, STYLE, SIZE, OR COLOR.

THE ENGLISH TRANSLATION OF "SHIKSA" IN THE MARK IS NON-JEWISH WOMAN.

FOR CLOTHING, APPAREL, AND CASUALWEAR, NAMELY, HATS AND CAPS, T-SHIRTS, AND SWEATSHIRTS (U.S. CLS. 22 AND 39).

AMY KELLY, EXAMINING ATTORNEY

SN 85-507,275. ALEXANDER SANDOVAL, CHICAGO, IL. FILED 1-2-2012.

COFFER

THE MARK CONSISTS OF STANDARD CHARACTERS WITHOUT CLAIM TO ANY PARTICULAR FONT, STYLE, SIZE, OR COLOR.

FOR COATS; HATS; JACKETS; JEANS; PANTS; SHORT-SLEEVED OR LONG-SLEEVED T-SHIRTS; SWEAT PANTS; SWEAT SHIRTS; T-SHIRTS (U.S. CLS. 22 AND 39).

FIRST USE 12-1-2011; IN COMMERCE 12-1-2011.

CURTIS FRENCH, EXAMINING ATTORNEY

SN 85-507,432. MARLIN JR., BARRY LEE, ARLINGTON, VA. FILED 1-3-2012.



THE COLOR(S) RED, WHITE, BLUE AND BLACK IS/ARE CLAIMED AS A FEATURE OF THE MARK.

THE MARK CONSISTS OF THE STYLIZED WORD "SWIM" ON A BLACK BACKGROUND. THE "S", THE DOT OF THE "I" AND HALF OF THE "M" ARE IN BLUE AND CONTAIN WHITE STARS. THE "W", "I" AND OTHER HALF OF THE "M" ARE IN RED. THE ENTIRE WORD "SWIM" HAS A WHITE OUTLINE.

FOR SHIRTS; T-SHIRTS (U.S. CLS. 22 AND 39).

FIRST USE 1-1-2012; IN COMMERCE 1-1-2012.

DAVID MURRAY, EXAMINING ATTORNEY

CLASS 25—(Continued).

SN 85-507,478. COOK, DUSTIN, WEST COVINA, CA. FILED 1-3-2012.

SPEC-5

THE MARK CONSISTS OF STANDARD CHARACTERS WITHOUT CLAIM TO ANY PARTICULAR FONT, STYLE, SIZE, OR COLOR.

FOR GLOVES; HATS; HOODED SWEATSHIRTS; JACKETS; PANTS; SHORTS; SOCKS; T-SHIRTS (U.S. CLS. 22 AND 39).

JULIE WATSON, EXAMINING ATTORNEY

SN 85-507,506. LEEANI, EDISON, NJ. FILED 1-3-2012.



THE STIPPLING IS FOR SHADING PURPOSES.

THE MARK CONSISTS OF THE STYLIZED TEXT "MUST B KARMA".

FOR JACKETS; LEGGINGS; PANTS; SHIRTS; SHORTS; SPORTS BRAS; SWEAT SHIRTS; SWEAT-PANTS; T-SHIRTS (U.S. CLS. 22 AND 39).

LINDA POWELL, EXAMINING ATTORNEY

SN 85-507,756. BONILLA,CHRIS D, LONG BEACH, NY. FILED 1-3-2012.

You Drink No BEERS

THE MARK CONSISTS OF STANDARD CHARACTERS WITHOUT CLAIM TO ANY PARTICULAR FONT, STYLE, SIZE, OR COLOR.

FOR T-SHIRTS (U.S. CLS. 22 AND 39).

DANIEL CAPSHAW, EXAMINING ATTORNEY

CLASS 25—(Continued).

SN 85-507,781. YAN, XIANG, DULUTH, GA. FILED 1-3-2012.



THE MARK CONSISTS OF THE WORD "WHS" IN STYLIZED CAPITAL LETTERS WITH A UNDERLINE BELOW THE LETTER "W".

FOR (BASED ON USE IN COMMERCE) ATHLETIC APPAREL, NAMELY, SHIRTS, PANTS, JACKETS, FOOTWEAR, HATS AND CAPS, ATHLETIC UNIFORMS; COATS; COATS FOR MEN AND WOMEN; COATS MADE OF COTTON; FUR COATS AND JACKETS; LEATHER COATS; MEN'S AND WOMEN'S JACKETS, COATS, TROUSERS, VESTS; OVER COATS; RAIN COATS; RIDING COATS; SKI JACKETS; SKI PANTS; SPORT COATS; WATERPROOF JACKETS AND PANTS; WIND COATS(BASED ON INTENT TO USE) BELTS; BELTS FOR CLOTHING; BELTS MADE FROM IMITATION LEATHER; BELTS MADE OF LEATHER; BELTS MADE OUT OF CLOTH; BELTS OF TEXTILE; PARKAS; SKI BOOTS; SKI GLOVES; SKIING SHOES; SNOW BOOTS; SNOWBOARD BOOTS; SOCKS; WATER PROOF BOOTS; WATER SOCKS; WATERPROOF FOOTWEAR; WATERPROOF LEATHER BOOTS; WATERPROOF LEATHER SHOES; WATERPROOF LEATHER SHOES AND BOOTS; WOOLLEN SOCKS (U.S. CLS. 22 AND 39).
FIRST USE 0-0-2003; IN COMMERCE 10-0-2011.
COURTNEY ALVAREZ, EXAMINING ATTORNEY

SN 85-507,935. MARK L. LAYTON PRODUCTIONS, DBA LAYTON PRODUCTIONS, OREM, UT. FILED 1-3-2012.



NO CLAIM IS MADE TO THE EXCLUSIVE RIGHT TO USE "BEST" AND "PROMOTIONS", APART FROM THE MARK AS SHOWN.

THE MARK CONSISTS OF THE LETTERS "BOS" IN STYLIZED FONT ON A SQUARE BACKGROUND FOLLOWED BY "BEST OF STATE" IN LARGE CAPS AND "PROMOTIONS" IN SMALL CAPS.

FOR CLOTHING, NAMELY, CAPS, HATS, JACKETS, COATS, SHIRTS, T-SHIRTS, PANTS, BLOUSES AND SKIRTS (U.S. CLS. 22 AND 39).

FIRST USE 12-1-2011; IN COMMERCE 12-1-2011.
MAYUR VAGHANI, EXAMINING ATTORNEY

CLASS 25—(Continued).

SN 85-507,951. PHILLIPS, BARRY, CLINTON, TN. FILED 1-3-2012.



NO CLAIM IS MADE TO THE EXCLUSIVE RIGHT TO USE "BRAND", APART FROM THE MARK AS SHOWN.

THE MARK CONSISTS OF AN OVAL SHAPE WITH THE TEXT "DAMN IT BOY!" AT THE CENTER WITH THE A SMILEY FACE IN THE PLACE OF THE "O" IN "BOY" WITH A MOUTH AND EYES, "BRAND" BELOW THE EXCLAMATION SYMBOL, AND "WWW.DAMNITBOYBRAND.COM" UNDERNEATH.

FOR HATS; JACKETS; PANTS; SHIRTS; SHOES; SHORTS; SOCKS; UNDERWEAR (U.S. CLS. 22 AND 39).

FIRST USE 6-1-2011; IN COMMERCE 7-1-2011.
MATTHEW KLINE, EXAMINING ATTORNEY

SN 85-507,971. DEAN, GARY, TUCSON, AZ. FILED 1-3-2012.

SCAMFACTORY

THE MARK CONSISTS OF STANDARD CHARACTERS WITHOUT CLAIM TO ANY PARTICULAR FONT, STYLE, SIZE, OR COLOR.

FOR FOOTWEAR; HEADWEAR; T-SHIRTS (U.S. CLS. 22 AND 39).

JUDITH HELFMAN, EXAMINING ATTORNEY

SN 85-508,002. NOVAS, STEVE, SOUTH OZONE PARK, NY. FILED 1-3-2012.

(S.I.M.C)

THE MARK CONSISTS OF STANDARD CHARACTERS WITHOUT CLAIM TO ANY PARTICULAR FONT, STYLE, SIZE, OR COLOR.

FOR HATS; JACKETS; LONG-SLEEVED SHIRTS; SHIRTS; SHORTS; SWEAT PANTS; SWEAT SHIRTS; SWEATERS; UNDERGARMENTS (U.S. CLS. 22 AND 39).

MATTHEW EINSTEIN, EXAMINING ATTORNEY

CLASS 25—(Continued).

SN 85-508,374. LI-WEI CHIH, SILVER SPRING, MD. FILED 1-4-2012.



OWNER OF U.S. REG. NO. 3,321,091.

THE MARK CONSISTS OF A STYLIZED LETTER "M" WITH THE TWO UPPER CORNERS OF "M" RESEMBLING TWO HORNS AND THE BOTTOM CORNER RESEMBLING AN ARROW-SHAPED TAIL PROTRUDING AND POINTING SLIGHTLY TOWARDS BOTTOM LEFT.

FOR BASEBALL CAPS AND HATS; GOLF CAPS; HATS; HOODED SWEAT SHIRTS; KNITTED CAPS; SPORTS CAPS AND HATS; SWEATERS; T-SHIRTS; WEARABLE GARMENTS AND CLOTHING, NAMELY, SHIRTS (U.S. CLS. 22 AND 39).

FIRST USE 5-15-2005; IN COMMERCE 5-15-2005.
GEOFFREY FOSDICK, EXAMINING ATTORNEY

SN 85-509,052. G P M, INC., ARCANUM, OH. FILED 1-5-2012.

Arcanum Jeans Co.

THE MARK CONSISTS OF STANDARD CHARACTERS WITHOUT CLAIM TO ANY PARTICULAR FONT, STYLE, SIZE, OR COLOR.

NO CLAIM IS MADE TO THE EXCLUSIVE RIGHT TO USE "JEANS CO.", APART FROM THE MARK AS SHOWN.

FOR CLOTHING, NAMELY, SHIRTS, PANTS, SWEATERS, JACKETS, SOCKS, JACKETS, SKIRTS, SHORTS, HATS, AND DRESSES (U.S. CLS. 22 AND 39).

BRIDGETT SMITH, EXAMINING ATTORNEY

CLASS 25—(Continued).

SN 85-509,504. DESTANIE INC., BROOKLYN, NY. FILED 1-5-2012.

princejames

THE MARK CONSISTS OF STANDARD CHARACTERS WITHOUT CLAIM TO ANY PARTICULAR FONT, STYLE, SIZE, OR COLOR.

THE NAME(S), PORTRAIT(S), AND/OR SIGNATURE(S) SHOWN IN THE MARK DOES NOT IDENTIFY A PARTICULAR LIVING INDIVIDUAL.

FOR HATS; HOODED SWEATSHIRTS; JACKETS; PANTS; SHIRTS; SHOES; SHORT-SLEEVED OR LONG-SLEEVED T-SHIRTS; SHORTS; SWEATERS; SWEATSHIRTS; T-SHIRTS (U.S. CLS. 22 AND 39).

SCOTT BIBB, EXAMINING ATTORNEY

SN 85-509,619. TULLE, INC., NEW YORK, NY. FILED 1-5-2012.

TULLE BY NcNAIRY & GUAL

THE MARK CONSISTS OF STANDARD CHARACTERS WITHOUT CLAIM TO ANY PARTICULAR FONT, STYLE, SIZE, OR COLOR.

NO CLAIM IS MADE TO THE EXCLUSIVE RIGHT TO USE "TULLE", APART FROM THE MARK AS SHOWN.

FOR DRESSES; GLOVES; GOWNS; HATS; LINGERIE; SHOES (U.S. CLS. 22 AND 39).

MICHAEL WEBSTER, EXAMINING ATTORNEY

SN 85-509,680. JULIANO, ANTHONY, FRANKFORT, NY. FILED 1-5-2012.

QUESTION AUTHORITY

THE MARK CONSISTS OF STANDARD CHARACTERS WITHOUT CLAIM TO ANY PARTICULAR FONT, STYLE, SIZE, OR COLOR.

FOR T-SHIRTS FOR BABIES, ADULTS, CHILDREN, WOMEN, MEN AND APPAREL, NAMELY, SHIRTS, PANTS, JACKETS, FOOTWEAR, HATS, CAPS, AND UNIFORMS (U.S. CLS. 22 AND 39).

GINA HAYES, EXAMINING ATTORNEY

CLASS 25—(Continued).

SN 85-509,720. STRONG LOLA, INC., MANSFIELD, TX. FILED 1-5-2012.

STRONG LOLA

THE MARK CONSISTS OF STANDARD CHARACTERS WITHOUT CLAIM TO ANY PARTICULAR FONT, STYLE, SIZE, OR COLOR.

THE NAME(S), PORTRAIT(S), AND/OR SIGNATURE(S) SHOWN IN THE MARK DOES NOT IDENTIFY A PARTICULAR LIVING INDIVIDUAL.

FOR PANTS; SWEAT SHIRTS; T-SHIRTS; TANK TOPS; TOPS; WRISTBANDS (U.S. CLS. 22 AND 39).

FIRST USE 12-17-2011; IN COMMERCE 12-17-2011.
GINA HAYES, EXAMINING ATTORNEY

CLASS 25—(Continued).

SN 85-509,803. KIDD, PORSCHLA, DALLAS, TX. FILED 1-5-2012.

CHANGE KIDD

THE MARK CONSISTS OF THE WORDS "CHANGE KIDD" IN A STYLIZED FONT.

FOR CHILDREN'S AND INFANT'S APPAREL, NAMELY, JUMPERS, OVERALL SLEEPWEAR, PAJAMAS, ROMPERS AND ONE-PIECE GARMENTS; HATS; JACKETS; PANTS; SHIRTS; SHOES; SOCKS (U.S. CLS. 22 AND 39).

GENE MACIOL, EXAMINING ATTORNEY

SN 85-509,772. KIDD, PORSCHLA, DALLAS, TX. FILED 1-5-2012.



THE COLOR(S) MEDIUM BLUE, LIGHT BLUE, LIGHT BROWN AND BLACK IS/ARE CLAIMED AS A FEATURE OF THE MARK.

THE MARK CONSISTS OF A STYLIZED MONKEY BETWEEN THE WORDS "CHANGE" AND "KIDD", BOTH WORDS IN MEDIUM BLUE; SAID MONKEY BEING MEDIUM BLUE HAVING LIGHT BLUE PAWS, CHEST AND FACE AND WEARING A LIGHT BROWN HAT WITH FEATURES OUTLINED IN BLACK.

FOR CHILDREN'S AND INFANT'S APPAREL, NAMELY, JUMPERS, OVERALL SLEEPWEAR, PAJAMAS, ROMPERS AND ONE-PIECE GARMENTS; HATS; JACKETS; PANTS; SHIRTS; SHOES; SOCKS (U.S. CLS. 22 AND 39).

GENE MACIOL, EXAMINING ATTORNEY

SN 85-509,831. FAHRENBACH-WRUBEL, MICHELLE, HOUSTON, TX. FILED 1-5-2012.

Anna Irion

THE MARK CONSISTS OF STANDARD CHARACTERS WITHOUT CLAIM TO ANY PARTICULAR FONT, STYLE, SIZE, OR COLOR.

THE NAME(S), PORTRAIT(S), AND/OR SIGNATURE(S) SHOWN IN THE MARK IDENTIFIES MICHELLE ANNA IRION FAHRENBACH-WRUBEL, WHOSE CONSENT(S) TO REGISTER IS MADE OF RECORD.

FOR PONCHOS; SCARVES; SHAWLS (U.S. CLS. 22 AND 39).

FIRST USE 2-7-2011; IN COMMERCE 1-5-2012.

COLLEEN DOMBROW, EXAMINING ATTORNEY

SN 85-509,785. BADDOGGYPOLITICS.COM INC., PORTSMOUTH, VA. FILED 1-5-2012.

BADDOGGYPOLITICS.COM

THE MARK CONSISTS OF STANDARD CHARACTERS WITHOUT CLAIM TO ANY PARTICULAR FONT, STYLE, SIZE, OR COLOR.

FOR HOODED SWEATSHIRTS; SHIRTS (U.S. CLS. 22 AND 39).

FIRST USE 7-14-2010; IN COMMERCE 9-10-2011.

DAWN HAN, EXAMINING ATTORNEY

SN 85-509,832. RAMIREZ, SETH, FRESNO, CA. FILED 1-5-2012.

Dirty Business

THE MARK CONSISTS OF STANDARD CHARACTERS WITHOUT CLAIM TO ANY PARTICULAR FONT, STYLE, SIZE, OR COLOR.

FOR BANDANAS; BLOUSES; GLOVES; HATS; JACKETS; JERSEYS; SCARVES; SHIRTS; SHOES; SHORTS; SOCKS; SWEAT SHIRTS; SWEATPANTS; T-SHIRTS; TANK TOPS (U.S. CLS. 22 AND 39).

COLLEEN DOMBROW, EXAMINING ATTORNEY

CLASS 25—(Continued).

SN 85-509,859. WILD BRAIN ENTERTAINMENT, INC., SHERMAN OAKS, CA. FILED 1-5-2012.

BIT

THE MARK CONSISTS OF STANDARD CHARACTERS WITHOUT CLAIM TO ANY PARTICULAR FONT, STYLE, SIZE, OR COLOR.

FOR CLOTHING, NAMELY, SHIRTS, T-SHIRTS, SWEATSHIRTS, SWEATERS, VESTS, JACKETS, WARM-UP SUITS, ROBES, PANTS, SHORTS, CLOTHING BELTS, DRESSES, OVERALLS, INFANTWEAR, PLAYSUITS, CLOTH BIBS, HEADWEAR, FOOTWEAR, BOOTS, SOCKS, TIGHTS, BEACHWEAR, SWIMSUITS, SWIMWEAR, BATHING CAPS, TENNIS WEAR, RAINWEAR, COATS, GLOVES, MUFFLERS, HATS, SUN VISORS, NECKWEAR, CUMMERBUNDS, BANDANAS, SCARVES, PAJAMAS, NIGHTSHIRTS, NIGHTGOWNS, UNDERGARMENTS, APRONS, MASQUERADE COSTUMES, MASQUERADE COSTUMES WITH MASKS SOLD IN CONNECTION THEREWITH, TANK TOPS, UNDERWEAR, AND WRISTBANDS (U.S. CLS. 22 AND 39).

EMILY CHUO, EXAMINING ATTORNEY

CLASS 25—(Continued).

SN 85-509,930. WILD BRAIN ENTERTAINMENT, INC., SHERMAN OAKS, CA. FILED 1-5-2012.

DIZZY

THE MARK CONSISTS OF STANDARD CHARACTERS WITHOUT CLAIM TO ANY PARTICULAR FONT, STYLE, SIZE, OR COLOR.

FOR CLOTHING, NAMELY, SHIRTS, T-SHIRTS, SWEATSHIRTS, SWEATERS, VESTS, JACKETS, WARM-UP SUITS, ROBES, PANTS, SHORTS, CLOTHING BELTS, DRESSES, OVERALLS, INFANTWEAR, PLAYSUITS, CLOTH BIBS, HEADWEAR, FOOTWEAR, BOOTS, SOCKS, TIGHTS, BEACHWEAR, SWIMSUITS, SWIMWEAR, BATHING CAPS, TENNIS WEAR, RAINWEAR, COATS, GLOVES, MUFFLERS, HATS, SUN VISORS, NECKWEAR, CUMMERBUNDS, BANDANAS, SCARVES, PAJAMAS, NIGHTSHIRTS, NIGHTGOWNS, UNDERGARMENTS, APRONS, MASQUERADE COSTUMES, MASQUERADE COSTUMES WITH MASKS SOLD IN CONNECTION THEREWITH, TANK TOPS, UNDERWEAR, AND WRISTBANDS (U.S. CLS. 22 AND 39).

EMILY CHUO, EXAMINING ATTORNEY

SN 85-509,957. THE SC GROUP LLC, DBA ALL THINGS BLING, PARKER, CO. FILED 1-5-2012.

All Things Bling

SN 85-509,890. VOLLSTEDT, CHARLES SHEA, SUISUN CITY, CA. FILED 1-5-2012.

ishness

THE MARK CONSISTS OF STANDARD CHARACTERS WITHOUT CLAIM TO ANY PARTICULAR FONT, STYLE, SIZE, OR COLOR.

FOR BEANIES; BOTTOMS; HATS; HOODED SWEATSHIRTS; JACKETS; LONG-SLEEVED SHIRTS; SHIRTS; SWEATPANTS; SWEATSHIRTS; T-SHIRTS; TANK-TOPS; TOPS (U.S. CLS. 22 AND 39).

FIRST USE 10-13-2011; IN COMMERCE 10-13-2011. JAMES A. RAUEN, EXAMINING ATTORNEY

THE MARK CONSISTS OF STANDARD CHARACTERS WITHOUT CLAIM TO ANY PARTICULAR FONT, STYLE, SIZE, OR COLOR.

FOR APPAREL FOR DANCERS, NAMELY, TEE SHIRTS, SWEATSHIRTS, PANTS, LEGGINGS, SHORTS AND JACKETS; ATHLETIC APPAREL, NAMELY, SHIRTS, PANTS, JACKETS, FOOTWEAR, HATS AND CAPS, ATHLETIC UNIFORMS; BASEBALL CAPS AND HATS; COLLARED SHIRTS; DENIMS; DRESS PANTS; DRESS SHIRTS; GLOVES FOR APPAREL; GOLF PANTS, SHIRTS AND SKIRTS; GOLF SHIRTS; HAT BANDS; HATS; HATS FOR INFANTS, BABIES, TODDLERS AND CHILDREN; HOODED SWEAT SHIRTS; JEGGINGS, NAMELY, PANTS THAT ARE PARTIALLY JEANS AND PARTIALLY LEGGINGS; KNIT SHIRTS; LONG-SLEEVED SHIRTS; LOUNGE PANTS; OPEN-NECKED SHIRTS; PANTS; POLO SHIRTS; RUGBY SHIRTS; SHIRTS; SHIRTS AND SHORT-SLEEVED SHIRTS; SHIRTS FOR INFANTS, BABIES, TODDLERS AND CHILDREN; SHORT-SLEEVED OR LONG-SLEEVED T-SHIRTS; SHORT-SLEEVED SHIRTS; SPORT SHIRTS; SPORTS CAPS AND HATS; SPORTS SHIRTS; SPORTS SHIRTS WITH SHORT SLEEVES; SWEAT PANTS; SWEAT SHIRTS; T-SHIRTS; TEE SHIRTS; TURTLE NECK SHIRTS; WOMEN'S CLOTHING, NAMELY, SHIRTS, DRESSES, SKIRTS, BLOUSES; WOMEN'S HATS AND HOODS (U.S. CLS. 22 AND 39).

FIRST USE 10-1-2011; IN COMMERCE 10-1-2011. EMILY CHUO, EXAMINING ATTORNEY

CLASS 25—(Continued).

SN 85-509,974. RADIANT ACTIVEWEAR, INC, CARLSBAD, CA. FILED 1-5-2012.

COZY ORANGE

THE MARK CONSISTS OF STANDARD CHARACTERS WITHOUT CLAIM TO ANY PARTICULAR FONT, STYLE, SIZE, OR COLOR.

NO CLAIM IS MADE TO THE EXCLUSIVE RIGHT TO USE "ORANGE", APART FROM THE MARK AS SHOWN.

FOR BODY SUITS; BRAS; DRESSES; HEADBANDS; JACKETS; LEGGINGS; LEOTARDS; PANTS; SCARVES; SHORTS; SKIRTS; SOCKS; SPORTS BRAS; T-SHIRTS; TANK TOPS; TIGHTS; TOPS; UNDERWEAR; UNITARDS; VESTS; WARM UP SUITS; WOMEN'S ATHLETIC TOPS WITH BUILT-IN BRAS; WRIST BANDS (U.S. CLS. 22 AND 39).

ALYSSA STEEL, EXAMINING ATTORNEY

SN 85-509,988. GUANGDONG HESHAN PITANCO SHOES LEATHER CO., LTD, HESHAN CITY, GUANGDONG, CHINA, FILED 1-5-2012.

PITANCO

THE MARK CONSISTS OF THE WORD "PITANCO" IN STYLIZED LETTERS, WITH THE LETTERS A AND THE N CONNECTED BY AN INTERSECTING LINE.

THE WORDING PITANCO HAS NO MEANING IN A FOREIGN LANGUAGE.

FOR ATHLETIC APPAREL, NAMELY, SHIRTS, PANTS, JACKETS, FOOTWEAR, HATS AND CAPS, ATHLETIC UNIFORMS; BELTS FOR CLOTHING; BOOTS; FOOTWEAR; HEADWEAR; INSOLES FOR FOOTWEAR; JACKETS; NECKTIES; PANTS; SHIRTS; SHOES; SKIRTS; SOLES FOR FOOTWEAR (U.S. CLS. 22 AND 39).

WON TEAK OH, EXAMINING ATTORNEY

SN 85-510,022. RADIANT ACTIVEWEAR, INC, CARLSBAD, CA. FILED 1-6-2012.

COZY VALENI

THE MARK CONSISTS OF STANDARD CHARACTERS WITHOUT CLAIM TO ANY PARTICULAR FONT, STYLE, SIZE, OR COLOR.

THE WORDING "VALENI" HAS NO MEANING IN A FOREIGN LANGUAGE.

FOR BODY SUITS; BRAS; DRESSES; HEADBANDS; JACKETS; LEGGINGS; LEOTARDS; PANTS; SCARVES; SHORTS; SKIRTS; SOCKS; SPORTS BRAS; T-SHIRTS; TANK TOPS; TIGHTS; TOPS; UNDERWEAR; UNITARDS; VESTS; WARM UP SUITS; WOMEN'S ATHLETIC TOPS WITH BUILT-IN BRAS; WRIST BANDS (U.S. CLS. 22 AND 39).

ALYSSA STEEL, EXAMINING ATTORNEY

CLASS 25—(Continued).

SN 85-510,133. MUNOZ, DIANA, RESEDA, CA. FILED 1-6-2012.

azygous

THE MARK CONSISTS OF STANDARD CHARACTERS WITHOUT CLAIM TO ANY PARTICULAR FONT, STYLE, SIZE, OR COLOR.

FOR FOOTWEAR; HEADWEAR; WETSUITS; SWIMWEAR; T-SHIRTS; SHIRTS AND CASUAL TOPS WITH LONG AND SHORT SLEEVES; SLEEVELESS SHIRTS; SLEEVELESS TOPS; SWEAT TOPS; MEN'S SUITS; JACKETS; COATS; SHORTS; BOARD SHORTS; WALK SHORTS; LONG PANTS; TROUSERS; JEANS; DRESSES; SKIRTS; SKI WEAR AND SNOWBOARD WEAR, NAMELY, SKI PANTS, SKI JACKETS, SNOWBOARD PANTS, AND SNOWBOARD JACKETS; UNDERWEAR; SOCKS; BELTS; GLOVES; BEANIES; HATS; VISORS; CAPS; SURF HOODS; BOOTS; SHOES; THONGED AND STRAPPED SANDALS (U.S. CLS. 22 AND 39).

KATHLEEN LORENZO, EXAMINING ATTORNEY

SN 85-510,162. DIXIT, ANUJ, RIVERSIDE, CA. FILED 1-6-2012.

Zygote Clothing Company

THE MARK CONSISTS OF STANDARD CHARACTERS WITHOUT CLAIM TO ANY PARTICULAR FONT, STYLE, SIZE, OR COLOR.

NO CLAIM IS MADE TO THE EXCLUSIVE RIGHT TO USE "CLOTHING COMPANY", APART FROM THE MARK AS SHOWN.

FOR BELTS; BOTTOMS; FOOTWEAR; HATS; HEADWEAR; TOPS (U.S. CLS. 22 AND 39).

ALEX KEAM, EXAMINING ATTORNEY

SN 85-510,173. BOOT ROYALTY COMPANY, L.P., FORT WORTH, TX. FILED 1-6-2012.

JOURNEY ONE BY CHIPPEWA

THE MARK CONSISTS OF STANDARD CHARACTERS WITHOUT CLAIM TO ANY PARTICULAR FONT, STYLE, SIZE, OR COLOR.

OWNER OF U.S. REG. NOS. 773,714 AND 2,198,056.

FOR FOOTWEAR (U.S. CLS. 22 AND 39).

GEORGE LORENZO, EXAMINING ATTORNEY

CLASS 25—(Continued).

SN 85-510,271. OAKLEY, INC., Foothill Ranch, CA.
FILED 1-6-2012.

RED CODE

THE MARK CONSISTS OF STANDARD CHARACTERS WITHOUT CLAIM TO ANY PARTICULAR FONT, STYLE, SIZE, OR COLOR.
FOR FOOTWEAR AND FOOTWEAR COMPONENTS, NAMELY MIDSOLES (U.S. CLS. 22 AND 39).
FIRST USE 9-11-2002; IN COMMERCE 9-11-2002.
AMY KERTGATE, EXAMINING ATTORNEY

SN 85-510,346. MGM RESORTS INTERNATIONAL, LAS VEGAS, NV. FILED 1-6-2012.

MGM GRAND

THE MARK CONSISTS OF STANDARD CHARACTERS WITHOUT CLAIM TO ANY PARTICULAR FONT, STYLE, SIZE, OR COLOR.
OWNER OF U.S. REG. NOS. 2,540,402, 3,908,061 AND OTHERS.
FOR ROBES (U.S. CLS. 22 AND 39).
KIMBERLY PERRY, EXAMINING ATTORNEY

SN 85-510,372. BUSTOUT POKER, LLC, COLUMBIA, SC. FILED 1-6-2012.

**FOR THOSE ABOUT TO GRIND,
WE SALUTE YOU**

THE MARK CONSISTS OF STANDARD CHARACTERS WITHOUT CLAIM TO ANY PARTICULAR FONT, STYLE, SIZE, OR COLOR.
FOR HATS; HOODED SWEATSHIRTS; T-SHIRTS (U.S. CLS. 22 AND 39).
FRANK LATTUCA, EXAMINING ATTORNEY

CLASS 25—(Continued).

SN 85-510,487. TAYLOR KRAENZEL, DICKINSON, ND. FILED 1-6-2012.

swelaye

THE MARK CONSISTS OF STANDARD CHARACTERS WITHOUT CLAIM TO ANY PARTICULAR FONT, STYLE, SIZE, OR COLOR.
FOR BEANIES; CAPRIS; DRESSES; HATS; HOODED SWEATSHIRTS; JACKETS; PANTS; SHIRTS; SHORT-SLEEVED OR LONG-SLEEVED T-SHIRTS; SHORTS; SKIRTS; SOCKS; SWEATERS; SWEATSHIRTS; T-SHIRTS; TANK TOPS (U.S. CLS. 22 AND 39).
MATTHEW PAPPAS, EXAMINING ATTORNEY

SN 85-510,550. VERASTY CLOTHING LLC, MURRIETA, CA. FILED 1-6-2012.



THE MARK CONSISTS OF A STYLIZED LETTER V WITH 2 GEOMETRIC CURVED OBJECTS ON EACH SIDE OF THE LETTER V. EACH GEOMETRIC OBJECT CURVES ALONG THE LETTER V AND HAS POINTED TIPS AT BOTH ENDS.
FOR ATHLETIC APPAREL, NAMELY, SHIRTS, PANTS, JACKETS, FOOTWEAR, HATS AND CAPS, ATHLETIC UNIFORMS; CREW NECKS; HOODED SWEAT SHIRTS; JACKETS; MEN'S AND WOMEN'S JACKETS, COATS, TROUSERS, VESTS; SHIRTS AND SHORT-SLEEVED SHIRTS; SPORT SHIRTS; SPORTS CAPS AND HATS; SWEAT SHIRTS; T-SHIRTS; WOMEN'S CLOTHING, NAMELY, SHIRTS, DRESSES, SKIRTS, BLOUSES (U.S. CLS. 22 AND 39).
FIRST USE 9-1-2011; IN COMMERCE 12-17-2011.
SUNG IN, EXAMINING ATTORNEY

CLASS 25—(Continued).

SN 85-510,568. VERASTY CLOTHING LLC, MURRIETA, CA.
FILED 1-6-2012.

Verasty

THE MARK CONSISTS OF STANDARD CHARACTERS WITHOUT CLAIM TO ANY PARTICULAR FONT, STYLE, SIZE, OR COLOR.

FOR ATHLETIC APPAREL, NAMELY, SHIRTS, PANTS, JACKETS, FOOTWEAR, HATS AND CAPS, ATHLETIC UNIFORMS; CREW NECKS; HOODED SWEAT SHIRTS; JACKETS; MEN'S AND WOMEN'S JACKETS, COATS, TROUSERS, VESTS; SHIRTS AND SHORT-SLEEVED SHIRTS; SPORT SHIRTS; SPORTS CAPS AND HATS; SWEAT SHIRTS; T-SHIRTS; WOMEN'S CLOTHING, NAMELY, SHIRTS, DRESSES, SKIRTS, BLOUSES (U.S. CLS. 22 AND 39).

FIRST USE 9-1-2011; IN COMMERCE 12-17-2011.
SUNG IN, EXAMINING ATTORNEY

SN 85-510,585. BARRY, HOWARD, ISLIP, NY. FILED 1-6-2012.

SKANKYYANKEES

THE MARK CONSISTS OF STANDARD CHARACTERS WITHOUT CLAIM TO ANY PARTICULAR FONT, STYLE, SIZE, OR COLOR.

FOR CLOTHING, NAMELY, BEANIES, BRIEFS, CAMISOLES, CAPS, FLEECE PULLOVERS, FLEECE SHORTS, FLEECE TOPS, GYM PANTS, GYM SHORTS, HOODED PULLOVERS, HOODED SWEATSHIRTS, JOGGING PANTS, JOGGING SUITS, MEN'S UNDERWEAR, NEGLIGEEES, NIGHTSHIRTS, NIGHTWEAR, PANTIES, SHORTS, BRIEFS, PULLOVERS, SHORT-SLEEVED OR LONG-SLEEVED T-SHIRT, SKULLIES, SPORTS BRAS, STRAPLESS BRAS, SWEATPANTS, SWEATSHIRTS, TANK TOPS, TEDDIES (U.S. CLS. 22 AND 39).

KATHERINE E. HALMEN, EXAMINING ATTORNEY

SN 85-510,632. WASH PARK ENTERPRISES, DENVER, CO.
FILED 1-6-2012.

TULAVAYA

THE MARK CONSISTS OF STANDARD CHARACTERS WITHOUT CLAIM TO ANY PARTICULAR FONT, STYLE, SIZE, OR COLOR.

FOR CLOTHING, NAMELY SHIRTS, T-SHIRTS, PANTS, SHORTS, JACKETS, COATS, HEADBANDS, UNDERGARMENTS, SOCKS (U.S. CLS. 22 AND 39).

TEJBIR SINGH, EXAMINING ATTORNEY

CLASS 25—(Continued).

SN 85-510,866. MELENDEZ, LUIS, BONITA SPRINGS, FL.
AND SANCHEZ, EMMANUEL, BONITA SPRINGS, FL.
FILED 1-6-2012.

THE MARK CONSISTS OF THE TEXT "FLY" ON TOP, AN AIRPLANE FLYING UNDERNEATH "FLY", AND THE TEXT "LATINOS" UNDERNEATH THE FLYING AIRPLANE.

FOR PANTS; SWEATERS; T-SHIRTS; TANK TOPS (U.S. CLS. 22 AND 39).

FIRST USE 9-1-2011; IN COMMERCE 9-1-2011.
DAWN HAN, EXAMINING ATTORNEY

SN 85-510,887. KNIGHTS CODE INT'L TRADING, INC., LOS ANGELES, CA. FILED 1-6-2012.

KNIGHTS CLUB

THE MARK CONSISTS OF STANDARD CHARACTERS WITHOUT CLAIM TO ANY PARTICULAR FONT, STYLE, SIZE, OR COLOR.

FOR COATS; HATS; JACKETS; JOGGING SUITS; PAJAMAS; PANTS; POLO SHIRTS; SHIRTS; SHOES; SHORTS; SOCKS; SWEATERS; UNDERWEAR (U.S. CLS. 22 AND 39).

FIRST USE 12-0-1999; IN COMMERCE 12-0-1999.
DAVID MURRAY, EXAMINING ATTORNEY

SN 85-510,891. SCHAUMAN, NICHOLAS M., BALTIMORE, MD. FILED 1-6-2012.

CHU-PER BOWL

THE MARK CONSISTS OF STANDARD CHARACTERS WITHOUT CLAIM TO ANY PARTICULAR FONT, STYLE, SIZE, OR COLOR.

FOR HATS; SHIRTS; SWEAT SHIRTS (U.S. CLS. 22 AND 39).

DAVID COLLIER, EXAMINING ATTORNEY

CLASS 25—(Continued).

SN 85-510,906. MEDRANO, JUAN GABRIEL, AMARILLO, TX. FILED 1-6-2012.

Full grown fighter

THE MARK CONSISTS OF STANDARD CHARACTERS WITHOUT CLAIM TO ANY PARTICULAR FONT, STYLE, SIZE, OR COLOR.

FOR CLOTHING, NAMELY, SHIRTS, SWEATSHIRTS, SWEATPANTS, JACKETS, JEANS, PANTS, CASUAL SHORTS, AND ATHLETIC SHORTS (U.S. CLS. 22 AND 39).
MICHAEL LITZAU, EXAMINING ATTORNEY

SN 85-510,960. LE PETIT CIRQUE LA LLC, CULVER CITY, CA. FILED 1-6-2012.

LE PETIT CIRQUE

THE MARK CONSISTS OF STANDARD CHARACTERS WITHOUT CLAIM TO ANY PARTICULAR FONT, STYLE, SIZE, OR COLOR.

THE ENGLISH TRANSLATION OF "LE PETIT CIRQUE" IN THE MARK IS "THE LITTLE CIRCUS".
FOR ATHLETIC APPAREL, NAMELY, SHIRTS, PANTS, JACKETS, FOOTWEAR, HATS AND CAPS, ATHLETIC UNIFORMS; SWEATSHIRTS; PANTS; SHIRTS; JACKETS; HEADWEAR; CHILDREN'S SHIRTS, PANTS, JACKETS, HATS, FOOTWEAR, HEADWEAR (U.S. CLS. 22 AND 39).
SOPHIA S. KIM, EXAMINING ATTORNEY

SN 85-511,105. AUSTIN M. PARK, DALLAS, TX. FILED 1-7-2012.

Bodhisattva Fascination

THE MARK CONSISTS OF STANDARD CHARACTERS WITHOUT CLAIM TO ANY PARTICULAR FONT, STYLE, SIZE, OR COLOR.

FOR DRESSES; JEANS; KNIT DRESSES; KNIT SHIRTS; SHIRTS; SHORT-SLEEVED OR LONG-SLEEVED T-SHIRTS; SKIRTS AND DRESSES; SPORT SHIRTS; SWEAT SHIRTS; T-SHIRTS (U.S. CLS. 22 AND 39).
MEGHAN REINHART, EXAMINING ATTORNEY

CLASS 25—(Continued).

SN 85-511,187. MICHAEL ANTHONY COLLECTION, LLC, NEW YORK, NY. FILED 1-7-2012.

PIECES OF A MAN

THE MARK CONSISTS OF STANDARD CHARACTERS WITHOUT CLAIM TO ANY PARTICULAR FONT, STYLE, SIZE, OR COLOR.

FOR NIGHT GOWNS; NIGHT SHIRTS; UNDER GARMENTS; UNDERWEAR (U.S. CLS. 22 AND 39).
BRIAN NEVILLE, EXAMINING ATTORNEY

SN 85-511,188. CARDOSO, CARLOS M., DBA BEYOND NORM DESIGN, BOSTON, MA. FILED 1-7-2012.



THE MARK CONSISTS OF SCRIPTED FONT FOR THE WORD "ILLUSORY" IN LOWER CASE LETTERS AND GREEK FONT FOR THE WORD "GEEK" IN UPPER CASE LETTERS. EACH WORD IS IN THE COLOR BLACK. THE WORD "ILLUSORY" IS ALWAYS STACKED ON TOP OF THE WORD "GEEK".

FOR HOODED SWEATSHIRTS; SHORT-SLEEVED OR LONG-SLEEVED T-SHIRTS; SWEATSHIRTS (U.S. CLS. 22 AND 39).
KATHERINE M. DUBRAY, EXAMINING ATTORNEY

SN 85-511,241. FLOWERS, CHRISTOPHER NATHANIEL, RANCHO CUCAMONGA, CA. FILED 1-7-2012.



THE MARK CONSISTS OF THE WORDING ALL BREAD GOOD... AND A SINGLE SLICE OF BREAD WITH A BITE ON THE CORNER.

FOR BASEBALL CAPS AND HATS; BEANIES; HOODED SWEAT SHIRTS; SHIRTS; SWEAT SHIRTS; T-SHIRTS (U.S. CLS. 22 AND 39).
CHARISMA HAMPTON, EXAMINING ATTORNEY

CLASS 25—(Continued).

SN 85-511,250. THE LITTLE GIPPER COMPANY, LLC, SPOKANE, WA. FILED 1-8-2012.

The Baby Gipper

THE MARK CONSISTS OF STANDARD CHARACTERS WITHOUT CLAIM TO ANY PARTICULAR FONT, STYLE, SIZE, OR COLOR.

FOR CHILDREN'S AND INFANT'S APPAREL, NAMELY, JUMPERS, OVERALL SLEEPWEAR, PAJAMAS, ROMPERS AND ONE-PIECE GARMENTS; CHILDREN'S AND INFANTS' CLOTH BIBS; CHILDREN'S HEADWEAR; GLOVES FOR APPAREL; HATS FOR INFANTS, BABIES, TODDLERS AND CHILDREN; HOODED SWEATSHIRTS FOR YOUTH (U.S. CLS. 22 AND 39).

DOMINICK J. SALEMI, EXAMINING ATTORNEY

CLASS 25—(Continued).

SN 85-511,326. RICKY NOU, NORWALK, CA. FILED 1-8-2012.

hnd

THE MARK CONSISTS OF STANDARD CHARACTERS WITHOUT CLAIM TO ANY PARTICULAR FONT, STYLE, SIZE, OR COLOR.

FOR T-SHIRTS (U.S. CLS. 22 AND 39).
FIRST USE 12-21-2011; IN COMMERCE 12-21-2011.
GIANCARLO CASTRO, EXAMINING ATTORNEY

SN 85-511,255. MC CONCEPTS, LLC, FREEHOLD, NJ. FILED 1-8-2012.

Swagger By

THE MARK CONSISTS OF STANDARD CHARACTERS WITHOUT CLAIM TO ANY PARTICULAR FONT, STYLE, SIZE, OR COLOR.

FOR FOOTWEAR (U.S. CLS. 22 AND 39).
DOMINICK J. SALEMI, EXAMINING ATTORNEY

SN 85-511,358. BEL-BORN MANAGEMENT CORPORATION, SAN DIEGO, CA. FILED 1-8-2012.

JAXON

THE MARK CONSISTS OF STANDARD CHARACTERS WITHOUT CLAIM TO ANY PARTICULAR FONT, STYLE, SIZE, OR COLOR.

OWNER OF U.S. REG. NOS. 3,065,840 AND 3,065,841.
FOR (BASED ON USE IN COMMERCE) ATHLETIC APPAREL, NAMELY, SHIRTS, PANTS, JACKETS, FOOTWEAR, HATS AND CAPS, ATHLETIC UNIFORMS; BASEBALL CAPS AND HATS; FUR HATS; HAT BANDS; HATS; HEADGEAR, NAMELY, HATS AND CAPS; LEATHER HATS; PAPER HATS FOR USE AS CLOTHING ITEMS; PARTY HATS; PERSPIRATION ABSORBENT STRAP TO BE USED IN THE BILL OF A HAT; RAIN HATS; SCIENTIFIC AND TECHNOLOGICAL APPAREL, NAMELY, SHIRTS, PANTS, JACKETS, FOOTWEAR, HATS AND CAPS, UNIFORMS; SEDGE HATS (SUGE-GASA); SMALL HATS; SPORTS CAPS AND HATS; TOBOGGAN HATS, PANTS AND CAPS; WOMEN'S HATS AND HOODS; WOOLLY HATS; (BASED ON INTENT TO USE) CHEF'S HATS; HATS FOR INFANTS, BABIES, TODDLERS AND CHILDREN (U.S. CLS. 22 AND 39).

FIRST USE 5-31-2004; IN COMMERCE 5-31-2004.
ELIZABETH KAJUBI, EXAMINING ATTORNEY

SN 85-511,290. DOOBALLO FOOTWEAR, INC., NORCROSS, GA. FILED 1-8-2012.

VIEW BY DOOBALLO

THE MARK CONSISTS OF STANDARD CHARACTERS WITHOUT CLAIM TO ANY PARTICULAR FONT, STYLE, SIZE, OR COLOR.

FOR FOOTWEAR (U.S. CLS. 22 AND 39).
LESLEY LAMOTHE, EXAMINING ATTORNEY

CLASS 25—(Continued).

SN 85-511,366. BEL-BORN MANAGEMENT CORPORATION, SAN DIEGO, CA. FILED 1-8-2012.



THE MARK CONSISTS OF TWO DOGS DISPLAYED IN SILHOUETTES, BETWEEN THE DOGS APPEARS THE LETTER "J" AND ABOVE THE DOGS APPEARS A CROWN. BELOW THE DESIGN OF THE DOGS APPEARS A DESIGN OF A VINE AND THE WORD "JAXON."

FOR (BASED ON USE IN COMMERCE) ATHLETIC APPAREL, NAMELY, SHIRTS, PANTS, JACKETS, FOOTWEAR, HATS AND CAPS, ATHLETIC UNIFORMS; BASEBALL CAPS AND HATS; FUR HATS; HAT BANDS; HATS; HEADGEAR, NAMELY, HATS AND CAPS; LEATHER HATS; PAPER HATS FOR USE AS CLOTHING ITEMS; PARTY HATS; PERSPIRATION ABSORBENT STRAP TO BE USED IN THE BILL OF A HAT; RAIN HATS; SCIENTIFIC AND TECHNOLOGICAL APPAREL, NAMELY, SHIRTS, PANTS, JACKETS, FOOTWEAR, HATS AND CAPS, UNIFORMS; SEDGE HATS (SUGE-GASA); SMALL HATS; SPORTS CAPS AND HATS; TOBOGGAN HATS, PANTS AND CAPS; WOMEN'S HATS AND HOODS; WOOLLY HATS; (BASED ON INTENT TO USE) CHEF'S HATS; HATS FOR INFANTS, BABIES, TODDLERS AND CHILDREN (U.S. CLS. 22 AND 39).

FIRST USE 5-31-2004; IN COMMERCE 5-31-2004.
ELIZABETH KAJUBI, EXAMINING ATTORNEY

SN 85-511,415. DAVID & GOLIATH, INC., CLEARWATER, FL. FILED 1-9-2012.

VEGGIES WITH WEDGIES

THE MARK CONSISTS OF STANDARD CHARACTERS WITHOUT CLAIM TO ANY PARTICULAR FONT, STYLE, SIZE, OR COLOR.

FOR CLOTHING, NAMELY, UNDERWEAR, PAJAMAS, T-SHIRTS, SHIRTS, UNDERSHIRTS AND SOCKS (U.S. CLS. 22 AND 39).

CHRISTINE MARTIN, EXAMINING ATTORNEY

CLASS 25—(Continued).

SN 85-511,416. DAVID & GOLIATH, INC., CLEARWATER, FL. FILED 1-9-2012.

ANIMALS IN UNDIES

THE MARK CONSISTS OF STANDARD CHARACTERS WITHOUT CLAIM TO ANY PARTICULAR FONT, STYLE, SIZE, OR COLOR.

FOR CLOTHING, NAMELY, UNDERWEAR, PAJAMAS, T-SHIRTS, SHIRTS, UNDERSHIRTS AND SOCKS (U.S. CLS. 22 AND 39).

CHRISTINE MARTIN, EXAMINING ATTORNEY

SN 85-511,482. TOWA UMBRELLA INDUSTRY COMPANY, HSIN CHU, TAIWAN, FILED 1-9-2012.



THE MARK CONSISTS OF THE WORD "TOWA" IN LOWER CASE LETTERS IN WHICH THE "CROSS" FOR THE LETTER "T" EXTENDS TO THE LEFT.

THE WORDING TOWA HAS NO MEANING IN A FOREIGN LANGUAGE.

FOR READY-MADE CLOTHING, NAMELY, PANTS, SKIRTS; DUST COATS; WATERPROOF CLOTHING, NAMELY, RAIN JACKETS; RAIN COATS; FOOTWEAR; SHOES; RAIN BOOTS; HOODS; HATS; HEADWEAR, NAMELY, CAPS; HOSIERY; MITTENS; MUFFS; GLOVES; NECKTIES; COLLARS; SCARVES; TURBANS; BELTS (U.S. CLS. 22 AND 39).

LINDA E. BLOHM, EXAMINING ATTORNEY

SN 85-511,528. JACOBS, CHRISTOPHER T., PIERMONT, NH. FILED 1-9-2012.

It's All About The Endorphins

THE MARK CONSISTS OF STANDARD CHARACTERS WITHOUT CLAIM TO ANY PARTICULAR FONT, STYLE, SIZE, OR COLOR.

FOR ATHLETIC APPAREL, NAMELY, SHIRTS, PANTS, JACKETS, FOOTWEAR, HATS AND CAPS, ATHLETIC UNIFORMS (U.S. CLS. 22 AND 39).

CHRISTINE MARTIN, EXAMINING ATTORNEY

CLASS 25—(Continued).

SN 85-511,567. ANDERSON, PENNY MARIE, OKEECHOBEE, FL. FILED 1-9-2012.

HILLBETTY

THE MARK CONSISTS OF STANDARD CHARACTERS WITHOUT CLAIM TO ANY PARTICULAR FONT, STYLE, SIZE, OR COLOR.

SEC. 2(F).

FOR ADULT NOVELTY GAG CLOTHING ITEM, NAMELY, SOCKS; BABIES' PANTS; BELTS; BELTS FOR CLOTHING; BELTS MADE OUT OF CLOTH; BOTTOMS; CHILDREN'S AND INFANTS' CLOTH BIBS; CLOTH BIBS; CLOTH BIBS FOR ADULT DINERS; CLOTHING FOR BABIES, TODDLERS AND CHILDREN, TREATED WITH FIRE AND HEAT RETARDANTS, NAMELY, PAJAMAS, JACKETS, SHIRTS, PANTS, JUMPERS; CLOTHING, NAMELY, ATHLETIC SLEEVES; CLOTHING, NAMELY, KHAKIS; HEADBANDS FOR CLOTHING; HOODS; INFANT AND TODDLER ONE PIECE CLOTHING; JACKETS; JERSEYS; LEATHER BELTS; MUFFLERS; POCKET SQUARES; SHIRTS; SHORT SETS; SHOULDER WRAPS; SHOULDER WRAPS FOR CLOTHING; SWADDLING CLOTHES; TIES; TOPS; TRAVEL CLOTHING CONTAINED IN A PACKAGE COMPRISING REVERSIBLE JACKETS, PANTS, SKIRTS, TOPS AND A BELT OR SCARF; TRIATHLON CLOTHING, NAMELY, TRIATHLON TIGHTS, TRIATHLON SHORTS, TRIATHLON SINGLET, TRIATHLON SHIRTS, TRIATHLON SUITS; WEARABLE GARMENTS AND CLOTHING, NAMELY, SHIRTS; WOMEN'S CLOTHING, NAMELY, SHIRTS, DRESSES, SKIRTS, BLOUSES; WRAPS; WRIST BANDS; WRISTBANDS (U.S. CLS. 22 AND 39).

FIRST USE 10-3-2011; IN COMMERCE 10-3-2011.

SAMUEL E. SHARPER JR., EXAMINING ATTORNEY

SN 85-511,650. HASHTAGSWAG LLC, PFLUGERVILLE, TX. FILED 1-9-2012.

hashtagswag

THE MARK CONSISTS OF STANDARD CHARACTERS WITHOUT CLAIM TO ANY PARTICULAR FONT, STYLE, SIZE, OR COLOR.

FOR BIKINIS; BLOUSES; BOOTS; BOTTOMS; BOXER SHORTS; BRIEFS; DRESSES; FLIP FLOPS; FOOTWEAR; HATS; HEADBANDS; HEELS; PANTIES; PANTS; PONCHOS; SANDALS; SCARVES; SHIRTS; SHOES; SHORTS; SOCKS; SUITS; SWEAT SHIRTS; SWEATERS; SWEATSHIRTS; SWIM TRUNKS; T-SHIRTS; TANK TOPS; TIES; UNDERSHIRTS; UNDERWEAR (U.S. CLS. 22 AND 39).

FIRST USE 11-13-2011; IN COMMERCE 11-13-2011.

JOSETTE BEVERLY, EXAMINING ATTORNEY

CLASS 25—(Continued).

SN 85-511,819. PANTELIODIS, AGLAIA, CHARLOTTE, NC. FILED 1-9-2012.



THE MARK CONSISTS OF "MODERN" WRITTEN IN STYLIZED FONT, A BIRD DESIGN POSITIONED BELOW "MODERN", AND "GYPSY" WRITTEN IN STYLIZED FONT BELOW THE BIRD DESIGN.

FOR TOPS; WEARABLE GARMENTS AND CLOTHING, NAMELY, SHIRTS (U.S. CLS. 22 AND 39).

FIRST USE 10-1-2010; IN COMMERCE 10-1-2010.

ELI HELLMAN, EXAMINING ATTORNEY

SN 85-512,031. UPSTART TV LLC, HOUSTON, TX. FILED 1-9-2012.

No kisses

THE MARK CONSISTS OF STANDARD CHARACTERS WITHOUT CLAIM TO ANY PARTICULAR FONT, STYLE, SIZE, OR COLOR.

FOR BABY BIBS NOT OF PAPER; BIBS NOT OF PAPER; BABY BODYSUITS; BEANIES; BODY SHIRTS; CHILDREN'S AND INFANTS' CLOTH BIBS; CHILDREN'S CLOTH EATING BIBS; CLOTH BIBS; HATS FOR INFANTS, BABIES, TODDLERS AND CHILDREN; PLASTIC BABY BIBS; SHIRTS FOR INFANTS, BABIES, TODDLERS AND CHILDREN; SNAP CROTCH SHIRTS FOR INFANTS AND TODDLERS; T-SHIRTS (U.S. CLS. 22 AND 39).

DAVID YONTEF, EXAMINING ATTORNEY

CLASS 25—(Continued).

SN 85-512,106. J&R ADVENTURES, LLC, BOCA RATON, FL.
FILED 1-9-2012.

TRIBUT

THE MARK CONSISTS OF STANDARD CHARACTERS WITHOUT CLAIM TO ANY PARTICULAR FONT, STYLE, SIZE, OR COLOR.

FOR MEN'S AND WOMEN'S CLOTHING, NAMELY, PANTS, JEANS, SHORTS, OVERALLS, SHIRTS, T-SHIRTS, BLOUSES, VESTS, SKIRTS, JACKETS, COATS, SPORTCOATS, SWEATERS, SWEATSHIRTS, SWEAT-PANTS, HATS, TIES, BELTS, SOCKS AND UNDERWEAR, AND CHILDREN'S AND INFANTS' CLOTHING, NAMELY, SHORTS, SHORT SETS CONSISTING OF TOP AND BOTTOM; SHIRTS, PANTS, DRESSES, COVERALLS, ROMPERS, CREEPERS, OVERALLS, OVERALL SETS COMPRISED OF OVERALL AND TOP; INFANTS' AND CHILDREN'S UNDERWEAR, SHORTALLS, SHORTALL SETS COMPRISED OF SHORTALL AND TOP; T-SHIRTS, THREE-PIECE SETS CONSISTING OF DIAPER SHIRTS, TOPS AND BOTTOMS; COORDINATING SETS CONSISTING OF TOPS AND BOTTOMS; LAYETTE SETS COMPRISED OF GOWN AND CAP, TOP AND PANT, CARDIGAN, TOP AND PANT, SHORTALL AND TOP, OVERALL AND TOP, CARDIGAN AND PANT, CREEPER AND PANT, CREEPER AND SHORTS OR COVERALLS AND BLANKET; SLEEPWEAR; JACKETS; ZIPPERED PULL-OVER JACKETS, WINDSUITS, BABY BUNTINGS, SNOWSUITS, RAINCOATS, PONCHOS, RAIN JACKETS, RAIN SUITS, SWIM SUITS, SWIM COVER-UPS; SWIMWEAR SETS CONSISTING OF SWIMSUIT OR SWIM TRUNKS AND COVER-UP; SHORT SETS CONSISTING OF SHORTS AND TOPS (U.S. CLS. 22 AND 39).

JENNY PARK, EXAMINING ATTORNEY

SN 85-512,190. FLORES, WILBERTO, NORTH LAUDERDALE, FL. FILED 1-9-2012.

EVOQUEST

THE MARK CONSISTS OF STANDARD CHARACTERS WITHOUT CLAIM TO ANY PARTICULAR FONT, STYLE, SIZE, OR COLOR.

FOR LADIES' APPAREL, NAMELY, T-SHIRTS, SHIRTS, BLOUSES, SWEATERS, PANTS; MEN'S APPAREL, NAMELY, PANTS SWEATERS, SHIRTS, SWEATSHIRTS, T-SHIRTS; CHILDREN'S APPAREL, NAMELY, T-SHIRTS, SHIRTS, BLOUSES, SWEATERS, PANTS, AND SWEATSHIRTS; CLOTHING, NAMELY, FOOTWEAR, HEADWEAR, TOPS, BOTTOMS, SHIRTS, AND PANTS (U.S. CLS. 22 AND 39).

DOMINIC FATHY, EXAMINING ATTORNEY

CLASS 25—(Continued).

SN 85-512,238. MILES, DAVID L., OKLAHOMA CITY, OK.
FILED 1-9-2012.

USE 2 SPORTS

THE MARK CONSISTS OF STANDARD CHARACTERS WITHOUT CLAIM TO ANY PARTICULAR FONT, STYLE, SIZE, OR COLOR.

NO CLAIM IS MADE TO THE EXCLUSIVE RIGHT TO USE "SPORTS", APART FROM THE MARK AS SHOWN.

FOR SHORT-SLEEVED OR LONG-SLEEVED T-SHIRTS; T-SHIRTS (U.S. CLS. 22 AND 39).

FIRST USE 12-19-2011; IN COMMERCE 12-19-2011.

BRENDAN REGAN, EXAMINING ATTORNEY

SN 85-512,322. 21ST CENTURY SURVIVAL LLC, NEW YORK, NY. FILED 1-9-2012.

TRADEMARK

THE MARK CONSISTS OF STANDARD CHARACTERS WITHOUT CLAIM TO ANY PARTICULAR FONT, STYLE, SIZE, OR COLOR.

FOR CLOTHING, NAMELY SHIRTS, PANTS, SWEATERS, JACKETS, COATS, HATS, SHOES, FLIP-FLOPS, BOOTS, SANDALS, SNEAKERS, SKIRTS, DRESSES, BLOUSES, BELTS, SCARVES, AND BATHING SUITS (U.S. CLS. 22 AND 39).

DANNEAN HETZEL, EXAMINING ATTORNEY

SN 85-512,368. MONTES, DATHAN, HILLSBORO, OR. AND MONTES, MOANA K., HILLSBORO, OR. FILED 1-10-2012.

claptrap

THE MARK CONSISTS OF STANDARD CHARACTERS WITHOUT CLAIM TO ANY PARTICULAR FONT, STYLE, SIZE, OR COLOR.

FOR ATHLETIC APPAREL, NAMELY, SHIRTS, PANTS, JACKETS, FOOTWEAR, HATS AND CAPS, ATHLETIC UNIFORMS (U.S. CLS. 22 AND 39).

MARK SPARACINO, EXAMINING ATTORNEY

CLASS 25—(Continued).

SN 85-512,384. QUEEN, JOSEPH, POWAY, CA. AND HICOK, KEVIN, SAN DIEGO, CA. FILED 1-10-2012.

Geeky Guys for GOD

THE MARK CONSISTS OF STANDARD CHARACTERS WITHOUT CLAIM TO ANY PARTICULAR FONT, STYLE, SIZE, OR COLOR.

FOR T-SHIRTS (U.S. CLS. 22 AND 39).
JUSTINE D. PARKER, EXAMINING ATTORNEY

CLASS 25—(Continued).

SN 85-512,505. DANJER A PERIL, LLC, KAILUA-KONA, HI. FILED 1-10-2012.

DANJER A PERIL

THE MARK CONSISTS OF STANDARD CHARACTERS WITHOUT CLAIM TO ANY PARTICULAR FONT, STYLE, SIZE, OR COLOR.

THE WORDING DANJER A PERIL HAS NO MEANING IN A FOREIGN LANGUAGE.

FOR BOARD SHORTS; HATS; T-SHIRTS FOR MEN AND WOMEN (U.S. CLS. 22 AND 39).

B. PARADEWELAI, EXAMINING ATTORNEY

SN 85-512,431. THE LITTLEST GOLFER, INC., ASHEVILLE, NC. FILED 1-10-2012.



THE MARK CONSISTS OF THE LETTERS "TLG" WITH A LINE UNDERNEATH AND A GOLF FLAG EXTENDING UPWARDLY FROM THE LINE TO THE RIGHT OF THE "G." THE INSIDE CURVE OF THE G IS LINED WITH GOLF BALL DIMPLES.

FOR GOLF SHIRTS, HATS, T-SHIRTS, SHORTS, SKIRTS, DRESSES, WIND SHIRTS, SHIRTS, AND CAPS (U.S. CLS. 22 AND 39).

MIDGE BUTLER, EXAMINING ATTORNEY

SN 85-512,507. DANJER A PERIL, LLC, KAILUA-KONA, HI. FILED 1-10-2012.



THE MARK CONSISTS OF AN IMAGE OF A STICK FIGURINE PRESENTED AT A SLIGHT ANGLE TO THE RIGHT, WHOSE BODY COMPRISES AN OPEN-ENDED TRIANGLE, THE RIGHT ARM IS SHAPED LIKE A CLOSED TRIANGLE, THE LEFT ARM IS SHAPED LIKE A PARALLELOGRAM, AND THE HEAD IS SHAPED LIKE A BACKWARDS OPEN-ENDED LETTER "D".

FOR BOARD SHORTS; HATS; T-SHIRTS FOR MEN AND WOMEN (U.S. CLS. 22 AND 39).

B. PARADEWELAI, EXAMINING ATTORNEY

SN 85-512,481. CROSS, TY, NORTH MIAMI, FL. FILED 1-10-2012.

Mamasota

THE MARK CONSISTS OF STANDARD CHARACTERS WITHOUT CLAIM TO ANY PARTICULAR FONT, STYLE, SIZE, OR COLOR.

FOR BLOUSES; HATS; JEANS; JEGGINGS, NAMELY, PANTS THAT ARE PARTIALLY JEANS AND PARTIALLY LEGGINGS; LEGGINGS; LINGERIE; SHOES; SKIRTS; T-SHIRTS; TOPS; UNDERGARMENTS (U.S. CLS. 22 AND 39).

KAREN SEVERSON, EXAMINING ATTORNEY

SN 85-512,565. CAT GEAR, LLC, PHOENIX, AZ. FILED 1-10-2012.

GO WILD, CATS

THE MARK CONSISTS OF STANDARD CHARACTERS WITHOUT CLAIM TO ANY PARTICULAR FONT, STYLE, SIZE, OR COLOR.

FOR CLOTHING, NAMELY, T-SHIRTS, SWEATSHIRTS, CAPS, BOXER SHORTS, GYM SHORTS AND SWEATPANTS (U.S. CLS. 22 AND 39).

ERIN FALK, EXAMINING ATTORNEY

CLASS 25—(Continued).

SN 85-512,578. NWABUEZE, URSULA-PEARL, BROOKLYN, NY. FILED 1-10-2012.

Simon Elias

THE MARK CONSISTS OF STANDARD CHARACTERS WITHOUT CLAIM TO ANY PARTICULAR FONT, STYLE, SIZE, OR COLOR.

THE NAME(S), PORTRAIT(S), AND/OR SIGNATURE(S) SHOWN IN THE MARK DOES NOT IDENTIFY A PARTICULAR LIVING INDIVIDUAL.

FOR SHOES (U.S. CLS. 22 AND 39).

AISHA SALEM, EXAMINING ATTORNEY

CLASS 25—(Continued).

SN 85-512,633. WIDE SIDE RIGHT SIDE LTD., NEW YORK, NY. FILED 1-10-2012.

DUETS

THE MARK CONSISTS OF STANDARD CHARACTERS WITHOUT CLAIM TO ANY PARTICULAR FONT, STYLE, SIZE, OR COLOR.

FOR TIES (U.S. CLS. 22 AND 39).

KIMBERLY PERRY, EXAMINING ATTORNEY

SN 85-512,645. WIGSCO LLC, CULVER CITY, CA. FILED 1-10-2012.

WIGS

THE MARK CONSISTS OF STANDARD CHARACTERS WITHOUT CLAIM TO ANY PARTICULAR FONT, STYLE, SIZE, OR COLOR.

FOR CLOTHING, NAMELY, SHIRTS, PANTS, SHORTS, SKIRTS, SKORTS, DRESSES, TOPS, BOTTOMS, OVERALLS, FOUL WEATHER GEAR, RAINWEAR, JACKETS, COATS, PONCHOS, SWEATERS, SWEAT SHIRTS, SWEAT PANTS, SWEAT JACKETS, SWEAT SUITS, TRACKSUITS, T-SHIRTS, JERSEYS, PULL-OVERS, LOUNGEWEAR, SOCKS, HOSIERY, UNDERGARMENTS, PAJAMAS, ROBES, NIGHTWEAR, SLEEPWEAR, SLEEP MASKS, GLOVES, MITTENS, SCARVES, BEACHWEAR, SWIMWEAR, BABY TOPS, BABY BOTTOMS, BABY BIBS NOT OF PAPER, BATH-ROBES, BELTS, NECKWEAR AND SUSPENDERS; HEADWEAR; FOOTWEAR (U.S. CLS. 22 AND 39).

TARAH HARDY, EXAMINING ATTORNEY

SN 85-512,609. HODGES, ROBERT M, RICHMOND, VA. FILED 1-10-2012.

uSwag

THE MARK CONSISTS OF STANDARD CHARACTERS WITHOUT CLAIM TO ANY PARTICULAR FONT, STYLE, SIZE, OR COLOR.

FOR WRIST BANDS (U.S. CLS. 22 AND 39).

JOHN E. MICHOS, EXAMINING ATTORNEY

SN 85-512,621. ASHBURY SKIES, INC., SAN FRANCISCO, CA. FILED 1-10-2012.

ASHBURY SKIES

THE MARK CONSISTS OF STANDARD CHARACTERS WITHOUT CLAIM TO ANY PARTICULAR FONT, STYLE, SIZE, OR COLOR.

FOR FOOTWEAR; SHOES (U.S. CLS. 22 AND 39).

JEAN IM, EXAMINING ATTORNEY

SN 85-512,678. PARRIS, WAYNE, STUART, FL. FILED 1-10-2012.

Deck Candy

THE MARK CONSISTS OF STANDARD CHARACTERS WITHOUT CLAIM TO ANY PARTICULAR FONT, STYLE, SIZE, OR COLOR.

FOR BATHING SUITS; DRESS SHIRTS; HATS; SHOES; SHORTS; T-SHIRTS (U.S. CLS. 22 AND 39).

JULIE VEPPUMTHARA, EXAMINING ATTORNEY

CLASS 25—(Continued).

SN 85-512,706. JBP BUSINESS, LLC, PALM BEACH, FL. FILED 1-10-2012.

MIDDLE SCHOOL: THE WORST
YEARS OF MY LIFE

THE MARK CONSISTS OF STANDARD CHARACTERS WITHOUT CLAIM TO ANY PARTICULAR FONT, STYLE, SIZE, OR COLOR.

FOR COATS; HATS; HEADWEAR; PANTS; RAINWEAR; SHIRTS; SHORTS; SLEEPWEAR; SWEATERS; T-SHIRTS; VESTS (U.S. CLS. 22 AND 39).

STEVEN JACKSON, EXAMINING ATTORNEY

SN 85-512,731. GYMFDS, BRANDON, FL. FILED 1-10-2012.

GYMFDS

THE MARK CONSISTS OF STANDARD CHARACTERS WITHOUT CLAIM TO ANY PARTICULAR FONT, STYLE, SIZE, OR COLOR.

FOR BASEBALL CAPS; LONG-SLEEVED SHIRTS; SHIRTS; SHORT-SLEEVED OR LONG-SLEEVED T-SHIRTS; T-SHIRTS (U.S. CLS. 22 AND 39).

KATHLEEN LORENZO, EXAMINING ATTORNEY

SN 85-512,739. CAHEE, GERALD W, LAFAYETTE, LA. FILED 1-10-2012.

Fitzgerald XCXG

THE MARK CONSISTS OF STANDARD CHARACTERS WITHOUT CLAIM TO ANY PARTICULAR FONT, STYLE, SIZE, OR COLOR.

FOR APPAREL FOR DANCERS, NAMELY, TEE SHIRTS, SWEATSHIRTS, PANTS, LEGGINGS, SHORTS AND JACKETS; ATHLETIC APPAREL, NAMELY, SHIRTS, PANTS, JACKETS, FOOTWEAR, HATS AND CAPS, ATHLETIC UNIFORMS (U.S. CLS. 22 AND 39).

TINA MAI, EXAMINING ATTORNEY

CLASS 25—(Continued).

SN 85-512,761. NUCHI, NATAN, NEW YORK, NY. FILED 1-10-2012.



THE MARK CONSISTS OF AN IMAGE THAT REPRESENTS A FINGER AND FINGERNAIL.

FOR ATHLETIC APPAREL, NAMELY, SHIRTS, PANTS, JACKETS, FOOTWEAR, HATS AND CAPS, ATHLETIC UNIFORMS (U.S. CLS. 22 AND 39).

FIRST USE 1-20-2012; IN COMMERCE 1-20-2012.

AMY KELLY, EXAMINING ATTORNEY

SN 85-512,834. TOTTON, AUTUMN, BROOKLYN, NY. FILED 1-10-2012.

FRESHU

THE MARK CONSISTS OF STANDARD CHARACTERS WITHOUT CLAIM TO ANY PARTICULAR FONT, STYLE, SIZE, OR COLOR.

FOR INSOLES FOR FOOTWEAR (U.S. CLS. 22 AND 39).

JASON BLAIR, EXAMINING ATTORNEY

SN 85-513,093. NAPUTI, VANESSA, DBA PUREBADASS, TAMPA, FL. AND NAPUTI, VINCE, DBA PUREBADASS, TAMPA, FL. AND SABLAN, SHARONA, DBA PUREBADASS, TAMPA, FL. AND SABLAN, RYAN, DBA PUREBADASS, TAMPA, FL. FILED 1-10-2012.

PUREBADASS

THE MARK CONSISTS OF STANDARD CHARACTERS WITHOUT CLAIM TO ANY PARTICULAR FONT, STYLE, SIZE, OR COLOR.

FOR ATHLETIC APPAREL, NAMELY, SHIRTS, PANTS, JACKETS, FOOTWEAR, HATS AND CAPS, ATHLETIC UNIFORMS (U.S. CLS. 22 AND 39).

ANDREW RHIM, EXAMINING ATTORNEY

CLASS 25—(Continued).

SN 85-513,302. GREENIDGE, JANSEN, DBA VINTAGE J CLOTHING, BROOKLYN, NY. FILED 1-10-2012.

VINTAGE J

THE MARK CONSISTS OF STANDARD CHARACTERS WITHOUT CLAIM TO ANY PARTICULAR FONT, STYLE, SIZE, OR COLOR.

NO CLAIM IS MADE TO THE EXCLUSIVE RIGHT TO USE "VINTAGE", APART FROM THE MARK AS SHOWN.

FOR APPAREL FOR DANCERS, NAMELY, TEE SHIRTS, SWEATSHIRTS, PANTS, LEGGINGS, SHORTS AND JACKETS; ATHLETIC APPAREL, NAMELY, SHIRTS, PANTS, JACKETS, FOOTWEAR, HATS AND CAPS, ATHLETIC UNIFORMS (U.S. CLS. 22 AND 39).

JORDAN BAKER, EXAMINING ATTORNEY

SN 85-513,323. CARTER, NICHOLAS G., NASHVILLE, TN. FILED 1-10-2012.

NC2

THE MARK CONSISTS OF STANDARD CHARACTERS WITHOUT CLAIM TO ANY PARTICULAR FONT, STYLE, SIZE, OR COLOR.

FOR ATHLETIC APPAREL, NAMELY, SHIRTS, PANTS, JACKETS, FOOTWEAR, HATS AND CAPS, ATHLETIC UNIFORMS (U.S. CLS. 22 AND 39).

KAPIL BHANOT, EXAMINING ATTORNEY

SN 85-513,334. CARTER, NICHOLAS G., NASHVILLE, TN. FILED 1-10-2012.

NIBIRU

THE MARK CONSISTS OF STANDARD CHARACTERS WITHOUT CLAIM TO ANY PARTICULAR FONT, STYLE, SIZE, OR COLOR.

FOR ATHLETIC APPAREL, NAMELY, SHIRTS, PANTS, JACKETS, FOOTWEAR, HATS AND CAPS, ATHLETIC UNIFORMS (U.S. CLS. 22 AND 39).

KAPIL BHANOT, EXAMINING ATTORNEY

CLASS 25—(Continued).

SN 85-513,381. AL2B DESIGN LLC, NEW YORK, NY. FILED 1-10-2012.



THE MARK CONSISTS OF THE WORD "NAIS" IN STYLIZED LETTERS.

FOR BOXER BRIEFS; BOXER SHORTS; BRAS; LINGERIE; LOUNGE PANTS; PANTIES, SHORTS AND BRIEFS; PANTS; SLEEP PANTS; T-SHIRTS; TOPS; WOMEN'S CLOTHING, NAMELY, SHIRTS, DRESSES, SKIRTS, BLOUSES (U.S. CLS. 22 AND 39).

FIRST USE 11-1-2011; IN COMMERCE 1-1-2012.

DOMINIC FATHY, EXAMINING ATTORNEY

SN 85-513,389. UPSTART TV LLC, HOUSTON, TX. FILED 1-10-2012.

No kissing my baby

THE MARK CONSISTS OF STANDARD CHARACTERS WITHOUT CLAIM TO ANY PARTICULAR FONT, STYLE, SIZE, OR COLOR.

FOR BABY BIBS NOT OF PAPER; BIBS NOT OF PAPER; CHILDREN'S AND INFANTS' CLOTH BIBS; CHILDREN'S CLOTH EATING BIBS; BEANIES; BODY SHIRTS; HATS; HATS FOR INFANTS, BABIES, TODDLERS AND CHILDREN; SNAP CROTCH SHIRTS FOR INFANTS AND TODDLERS; T-SHIRTS (U.S. CLS. 22 AND 39).

DAVID YONTEF, EXAMINING ATTORNEY

CLASS 25—(Continued).

SN 85-513,618. UDI, TOM, FAYETTEVILLE, GA. AND DODD, ANASTASIA, FAYETTEVILLE, GA. FILED 1-11-2012.



THE MARK CONSISTS OF AN OUTLINE OF A CLOUD WITH THE STYLIZED TEXT "SKHI" INSIDE. ABOVE THE CLOUD IS A GRADUATION CAP WITH A THREAD HANGING FROM THE RIGHT SIDE WITH A STAR AT THE END.

FOR BELTS; CARDIGANS; DRESSES; GLOVES; HATS; JACKETS; PANTS; SHIRTS; SHOES; SHORTS; SOCKS; SUITS; SWEATERS; UNDERGARMENTS; UNDERWEAR (U.S. CLS. 22 AND 39).

ALLISON SCHRODY, EXAMINING ATTORNEY

CLASS 25—(Continued).

SN 85-513,686. QUADROS, RAYMOND DOMINIC PAUL, CAMPBELL, CA. FILED 1-11-2012.

La Vida es Maravillosa

THE MARK CONSISTS OF STANDARD CHARACTERS WITHOUT CLAIM TO ANY PARTICULAR FONT, STYLE, SIZE, OR COLOR.

THE ENGLISH TRANSLATION OF "LA VIDA ES MARAVILLOSA" IN THE MARK IS "LIFE IS MARVELOUS".

FOR BELTS; BLOUSES; CAPS; COATS; COVERALLS; FOOTWEAR; HATS; HEADWEAR; JACKETS; PAJAMAS; ROBES; SHORTS; SWEATERS; SWEATSHIRTS; SWIMWEAR; T-SHIRTS; UNDERWEAR (U.S. CLS. 22 AND 39).
FIRST USE 6-30-2000; IN COMMERCE 9-9-2009.

MARILYN IZZI, EXAMINING ATTORNEY

SN 85-514,030. GLOBAL TRADEMARKS, INC., STOCKERTOWN, PA. FILED 1-11-2012.

GO GREEN GO GORGEOUS

THE MARK CONSISTS OF STANDARD CHARACTERS WITHOUT CLAIM TO ANY PARTICULAR FONT, STYLE, SIZE, OR COLOR.

FOR BLOUSES; DRESSES; JEANS; SHAPEWEAR, NAMELY, BRAS, PANTIES, GIRDLES, CAMISOLES; SWIMWEAR; T-SHIRTS; TOPS (U.S. CLS. 22 AND 39).

JOHN HWANG, EXAMINING ATTORNEY

SN 85-513,662. WILD LEGEND INC., NORTH BELLMORE, NY. FILED 1-11-2012.

THE MARK CONSISTS OF THE STYLIZED TEXT "WILD LEGEND" WITH AN IMAGE OF A STAR BETWEEN THE WORDS.

FOR CLOTHING, NAMELY, T-SHIRTS, HATS, SWEATPANTS, SWEATSHIRTS, JEANS, JERSEYS, SCARVES, BELTS, SOCKS, GLOVES, SLEEP WEAR, SHIRTS, POLO SHIRTS, LOUNGEWEAR, JACKETS, WARM UP OUTFITS, WIND RESISTANT JACKETS, SHORTS, TANK TOPS, TOPS, SHOES, UNDERWEAR, VESTS, SWEATERS, HOODED SWEATSHIRTS, CAPS, ZIPPER HOODED SWEATSHIRTS (U.S. CLS. 22 AND 39).

MICHAEL TANNER, EXAMINING ATTORNEY

SN 85-514,093. CHANGE THE DEFINITION APPAREL COMPANY, GRESHAM, OR. FILED 1-11-2012.

Change the Definition

THE MARK CONSISTS OF STANDARD CHARACTERS WITHOUT CLAIM TO ANY PARTICULAR FONT, STYLE, SIZE, OR COLOR.

FOR T-SHIRTS (U.S. CLS. 22 AND 39).

FIRST USE 1-10-2012; IN COMMERCE 1-10-2012.

JOHN DWYER, EXAMINING ATTORNEY

CLASS 25—(Continued).

SN 85-514,192. PAWTUCKET RED SOX BASEBALL CLUB, INC., PAWTUCKET, RI. FILED 1-11-2012.

PROVIDENCE GRAYS

THE MARK CONSISTS OF STANDARD CHARACTERS WITHOUT CLAIM TO ANY PARTICULAR FONT, STYLE, SIZE, OR COLOR.

NO CLAIM IS MADE TO THE EXCLUSIVE RIGHT TO USE "PROVIDENCE", APART FROM THE MARK AS SHOWN.

FOR CLOTHING, NAMELY, HATS, CAPS, T-SHIRTS, AND JERSEYS (U.S. CLS. 22 AND 39).

WILLIAM VERHOSEK, EXAMINING ATTORNEY

CLASS 25—(Continued).

SN 85-514,303. MARIANNE TRUDEL, NEW YORK, NY. FILED 1-11-2012.

MARIDEL

THE MARK CONSISTS OF STANDARD CHARACTERS WITHOUT CLAIM TO ANY PARTICULAR FONT, STYLE, SIZE, OR COLOR.

FOR CLOTHING, NAMELY, COWLS AND SMOKE RING SCARVES; HEAD SCARVES; SCARVES; SHOULDER SCARVES; SILK SCARVES (U.S. CLS. 22 AND 39).

KRISTIN DAHLING, EXAMINING ATTORNEY

SN 85-514,207. PAWTUCKET RED SOX BASEBALL CLUB, INC., PAWTUCKET, RI. FILED 1-11-2012.

PAWTUCKET SLATERS

THE MARK CONSISTS OF STANDARD CHARACTERS WITHOUT CLAIM TO ANY PARTICULAR FONT, STYLE, SIZE, OR COLOR.

NO CLAIM IS MADE TO THE EXCLUSIVE RIGHT TO USE "PAWTUCKET", APART FROM THE MARK AS SHOWN.

FOR CLOTHING, NAMELY, HATS, CAPS, T-SHIRTS, AND JERSEYS (U.S. CLS. 22 AND 39).

WILLIAM VERHOSEK, EXAMINING ATTORNEY

SN 85-514,321. OLVERA, GREG, DBA GO SOFTWARE, LOS ANGELES, CA. FILED 1-11-2012.

JOCK ICON

THE MARK CONSISTS OF STANDARD CHARACTERS WITHOUT CLAIM TO ANY PARTICULAR FONT, STYLE, SIZE, OR COLOR.

FOR HATS; JACKETS; PANTS; SHIRTS; SHOES; SHORTS; SWEATSHIRTS; UNDERWEAR (U.S. CLS. 22 AND 39).

LESLEY LAMOTHE, EXAMINING ATTORNEY

SN 85-514,262. HOSKINS, KIMBERLY A, ORANGE, CA. FILED 1-11-2012.

LamboGirl

THE MARK CONSISTS OF STANDARD CHARACTERS WITHOUT CLAIM TO ANY PARTICULAR FONT, STYLE, SIZE, OR COLOR.

FOR WEARABLE GARMENTS AND CLOTHING, NAMELY, SHIRTS (U.S. CLS. 22 AND 39).

DAVID H. STINE, EXAMINING ATTORNEY

SN 85-514,380. VIACOM INTERNATIONAL INC., NEW YORK, NY. FILED 1-11-2012.

SLIME

THE MARK CONSISTS OF STANDARD CHARACTERS WITHOUT CLAIM TO ANY PARTICULAR FONT, STYLE, SIZE, OR COLOR.

FOR CLOTHING, NAMELY, COATS, SOCKS, FOOTWEAR, DRESSES, GLOVES, SHORTS, NECKWEAR, JACKETS, PAJAMAS, PANTS, SHIRTS, SWEATERS, UNDERCLOTHES, HEADWEAR, BATH ROBES, BEACHWEAR (U.S. CLS. 22 AND 39).

DAVID C. REIHNER, EXAMINING ATTORNEY

CLASS 25—(Continued).

SN 85-514,446. GLOVEABLES, INC., LOS ANGELES, CA. FILED 1-11-2012.

WE'VE GOT YOUR FRONT

THE MARK CONSISTS OF STANDARD CHARACTERS WITHOUT CLAIM TO ANY PARTICULAR FONT, STYLE, SIZE, OR COLOR.
FOR APRONS; BRAS; SHIRTS (U.S. CLS. 22 AND 39).
SHARON MEIER, EXAMINING ATTORNEY

SN 85-514,498. THE NEW NORMAL, LLC, SOLVANG, CA. FILED 1-11-2012.

PURE POP HITS

THE MARK CONSISTS OF STANDARD CHARACTERS WITHOUT CLAIM TO ANY PARTICULAR FONT, STYLE, SIZE, OR COLOR.
FOR CLOTHING, NAMELY BANDANAS, CULOTTES, DO RAGS, INFANTWEAR, JACKETS, JEANS, JERSEYS, LOUNGEWEAR, NECKWEAR, PANTS, PONCHOS, ROBES, SHIRTS, SHORTS, SLEEPWEAR, SWEATERS, SWEATPANTS, SWEATSHIRTS, TANK TOPS AND T-SHIRTS, VEST, BELTS; FOOTWEAR; AND HEADWEAR (U.S. CLS. 22 AND 39).
FIRST USE 5-20-2011; IN COMMERCE 5-20-2011.
PAM WILLIS, EXAMINING ATTORNEY

SN 85-514,511. OUR NEIGHBORHOOD PLACE, LLC, SAN FRANCISCO, CA. FILED 1-11-2012.

THE TIPSYPIG

THE MARK CONSISTS OF STANDARD CHARACTERS WITHOUT CLAIM TO ANY PARTICULAR FONT, STYLE, SIZE, OR COLOR.
FOR SWEAT SHIRTS; T-SHIRTS (U.S. CLS. 22 AND 39).
FIRST USE 12-15-2008; IN COMMERCE 12-15-2008.
JOHN DALIER, EXAMINING ATTORNEY

CLASS 25—(Continued).

SN 85-514,519. SOMB LLC, LOS ANGELES, CA. FILED 1-11-2012.

FROM CALI WITH LOVE

THE MARK CONSISTS OF STANDARD CHARACTERS WITHOUT CLAIM TO ANY PARTICULAR FONT, STYLE, SIZE, OR COLOR.
FOR BASEBALL CAPS AND HATS; HOODED SWEATSHIRTS; HOODED SWEATSHIRTS FOR ADULTS; LEISURE SHOES; SWEATSHIRTS; T-SHIRTS; T-SHIRTS FOR ADULTS; TEE SHIRTS (U.S. CLS. 22 AND 39).
BILL DAWE, EXAMINING ATTORNEY

SN 85-514,549. MARCY BUTLER DESIGNS, LLC, WASHINGTON, DC. FILED 1-11-2012.

MARCY BUTLER DESIGNS

THE MARK CONSISTS OF STANDARD CHARACTERS WITHOUT CLAIM TO ANY PARTICULAR FONT, STYLE, SIZE, OR COLOR.
NO CLAIM IS MADE TO THE EXCLUSIVE RIGHT TO USE "DESIGNS", APART FROM THE MARK AS SHOWN.
THE NAME "MARCY BUTLER" IDENTIFIES A LIVING INDIVIDUAL WHOSE CONSENT IS OF RECORD.
FOR APRONS; BABY BIBS NOT OF PAPER; BABY BODYSUITS; BABY BOTTOMS; BABY BUNTING; BABY TOPS; BOTTOMS; BUTTON DOWN SHIRTS; CHEF'S COATS; CHILDREN'S AND INFANT'S APPAREL, NAMELY, JUMPERS, OVERALL SLEEPWEAR, PAJAMAS, ROMPERS AND ONE-PIECE GARMENTS; CHILDREN'S AND INFANTS' CLOTH BIBS; COVERUPS; FABRIC BELTS; LOUNGEWEAR; NECKTIES; NIGHTWEAR; OBIS; PLASTIC APRONS; POLO SHIRTS; SARONGS; SCARVES; SCRUBS NOT FOR MEDICAL PURPOSES; SLEEPWEAR; WOMEN'S CLOTHING, NAMELY, SHIRTS, DRESSES, SKIRTS, BLOUSES (U.S. CLS. 22 AND 39).
KIM MONINGHOFF, EXAMINING ATTORNEY

CLASS 25—(Continued).

SN 85-514,608. CHOCOLATE DIAMOND LLC, BEVERLY HILLS, CA. FILED 1-12-2012.

Marecrae

THE MARK CONSISTS OF STANDARD CHARACTERS WITHOUT CLAIM TO ANY PARTICULAR FONT, STYLE, SIZE, OR COLOR.

FOR BELTS; BODY SHIRTS; BUTTON DOWN SHIRTS; CAPRI PANTS; CARGO PANTS; COLLARED SHIRTS; DENIMS; DRESS PANTS; GOLF PANTS, SHIRTS AND SKIRTS; GOLF SHIRTS; HEADBANDS FOR CLOTHING; HOODED SWEAT SHIRTS; HOODS; JACKETS; JEANS; JUMPSUITS; LEATHER BELTS; LEATHER BOOTS; LEATHER COATS; LEATHER HATS; LEATHER HEADWEAR; LEATHER JACKETS; LEATHER PANTS; LEATHER SHIRTS; LEATHER SHOES; LEATHER SKIRTS; LEATHER SLIPPERS; LEATHER VESTS; LINGERIE; MEN'S SUITS, WOMEN'S SUITS; PANTS; SHIRTS; SHOES; SLEEPWEAR; SLEEPWEAR TREATED WITH FIRE AND HEAT RETARDANTS; SWEATPANTS; SWIMWEAR; TRACKSUITS; WEARABLE GARMENTS AND CLOTHING, NAMELY, SHIRTS; WOMEN'S CLOTHING, NAMELY, SHIRTS, DRESSES, SKIRTS, BLOUSES (U.S. CLS. 22 AND 39).

GRETTA YAO, EXAMINING ATTORNEY

CLASS 25—(Continued).

SN 85-514,684. NINE WEST DEVELOPMENT CORPORATION, WILMINGTON, DE. FILED 1-12-2012.

9 BY NINE WEST

THE MARK CONSISTS OF STANDARD CHARACTERS WITHOUT CLAIM TO ANY PARTICULAR FONT, STYLE, SIZE, OR COLOR.

OWNER OF U.S. REG. NOS. 1,170,312, 3,827,781 AND OTHERS.

FOR FOOTWEAR (U.S. CLS. 22 AND 39).

KATHLEEN LORENZO, EXAMINING ATTORNEY

SN 85-514,695. LARRY TIMMONS, SOUTH CHARLESTON, OH. FILED 1-12-2012.

Gotta Go Gotta Go I'm a BTO

THE MARK CONSISTS OF STANDARD CHARACTERS WITHOUT CLAIM TO ANY PARTICULAR FONT, STYLE, SIZE, OR COLOR.

FOR HATS; SWEATSHIRTS; T-SHIRTS (U.S. CLS. 22 AND 39).

KATHERINE CHANG, EXAMINING ATTORNEY

SN 85-514,640. BROOKLYN HOLDINGS INC., CHARLOTTE, NC. FILED 1-12-2012.

JEWNITY

THE MARK CONSISTS OF STANDARD CHARACTERS WITHOUT CLAIM TO ANY PARTICULAR FONT, STYLE, SIZE, OR COLOR.

FOR CLOTHING FOR MEN AND WOMEN, NAMELY, T-SHIRTS, SHORT SLEEVE SHIRTS, LONG SLEEVE SHIRTS, TANK TOPS, SWEATSHIRTS, SWEATPANTS, HOODED SHIRTS, HOODED SWEATSHIRTS, SWEATERS, JACKETS, PANTS, SHORTS, DRESSES, SKIRTS, BLOUSES, PAJAMAS, SWIMSUITS, UNDERWEAR, NIGHTSHIRTS, NIGHTGOWNS, PAJAMAS, SHOWER CAPS, BATHROBES, SOCKS, SHOES, FOOTWEAR, SCARVES, HATS, BASEBALL CAPS, STOCKING CAPS, BEANIES, HEADBANDS, GLOVES, MITTENS, AND BELTS; CLOTHING FOR INFANTS, BABIES, TODDLERS AND CHILDREN, NAMELY, TOPS, BOTTOMS, SHIRTS, SHORTS, PANTS, JUMPERS, OVERALLS, SLEEPWEAR, PAJAMAS, ROMPERS, ONE-PIECE GARMENTS, HATS, SOCKS, SHOES (U.S. CLS. 22 AND 39).

ANDREA HACK, EXAMINING ATTORNEY

SN 85-514,816. LAUREN E. MUTTY, ORLANDO, FL. FILED 1-12-2012.

SpiritKix

THE MARK CONSISTS OF STANDARD CHARACTERS WITHOUT CLAIM TO ANY PARTICULAR FONT, STYLE, SIZE, OR COLOR.

FOR FLIP FLOPS; FOOTWEAR FOR MEN AND WOMEN (U.S. CLS. 22 AND 39).

FIRST USE 9-15-2010; IN COMMERCE 10-3-2010.

MATTHEW KLINE, EXAMINING ATTORNEY

CLASS 25—(Continued).

SN 85-514,914. CHAZ ORTIZ, LLC, CARPENTERSVILLE, IL. FILED 1-12-2012.

CHAZ ORTIZ

THE MARK CONSISTS OF STANDARD CHARACTERS WITHOUT CLAIM TO ANY PARTICULAR FONT, STYLE, SIZE, OR COLOR.

THE NAME(S), PORTRAIT(S), AND/OR SIGNATURE(S) SHOWN IN THE MARK IDENTIFIES CHAZ ORTIZ, WHOSE CONSENT(S) TO REGISTER IS MADE OF RECORD.

FOR CLOTHING AND ATHLETIC WEAR, NAMELY, SHIRTS, T-SHIRTS, TANK TOPS, PANTS, SHORTS, SOCKS, JEANS, SWEATERS, SWEATSHIRTS, SWEATPANTS, HOODED SWEATSHIRTS, JACKETS; FOOTWEAR; HEADWEAR, NAMELY, HATS, CAPS, AND BEANIES (U.S. CLS. 22 AND 39).

DEBRA LEE, EXAMINING ATTORNEY

SN 85-514,919. RUBIN, HOWARD J., BOCA RATON, FL. FILED 1-12-2012.

DRYPEL

THE MARK CONSISTS OF STANDARD CHARACTERS WITHOUT CLAIM TO ANY PARTICULAR FONT, STYLE, SIZE, OR COLOR.

OWNER OF U.S. REG. NO. 2,679,805.

FOR APPAREL AND ACTIVEWEAR, NAMELY, PANTS, SWEATPANTS, SHORTS, T-SHIRTS, UNDERWEAR, SHIRTS, SWEATSHIRTS, SWEATERS, JACKETS, COATS, HATS, CAPS, SOCKS, FOOTWEAR, BOOTS, GLOVES AND WARM-UP SUITS (U.S. CLS. 22 AND 39).

ELIZABETH HUGHITT, EXAMINING ATTORNEY

SN 85-514,940. EVERYDAY NOBLE CLOTHING, LLC, LEE'S SUMMIT, MO. FILED 1-12-2012.



NO CLAIM IS MADE TO THE EXCLUSIVE RIGHT TO USE "CLOTHING", APART FROM THE MARK AS SHOWN.

THE MARK CONSISTS OF THE TEXT "EVERYDAY" IN BLOCK LETTERS ON THE LEFT SIDE OF THE MARK; "NOBLE" IN ITALICIZED TEXT ON THE RIGHT SIDE OF THE MARK, UNDER WHICH THE TEXT "CLOTHING" IS FEATURED IN BLOCK LETTERS; THE CENTER OF THE MARK FEATURES A FRAMED SILHOUETTE OF A GORILLA WEARING A CROWN, ON TOP OF WHICH A LARGER CROWN IS FEATURED; THE SILHOUETTE IS FEATURED WITH DRIPPING INK BELOW IT PRESENTED IN THE FORM OF FOUR LINES OF VARYING LENGTHS.

FOR HOODED SWEATSHIRTS; SWEATSHIRTS; T-SHIRTS (U.S. CLS. 22 AND 39).

FIRST USE 9-7-2011; IN COMMERCE 9-7-2011.

FRANK LATTUCA, EXAMINING ATTORNEY

CLASS 25—(Continued).

SN 85-514,963. FOREIGN EXCHANGE, INC., LOS ANGELES, CA. FILED 1-12-2012.

UNITY REQUIRED

THE MARK CONSISTS OF STANDARD CHARACTERS WITHOUT CLAIM TO ANY PARTICULAR FONT, STYLE, SIZE, OR COLOR.

FOR CLOTHING, NAMELY PANTS, JEANS, SHORTS, OVERALLS, TOPS, SHIRTS, T-SHIRTS, BLOUSES, VESTS, SKIRTS, JACKETS, COATS, SWEATSHIRTS, SWEATPANTS (U.S. CLS. 22 AND 39).

FIRST USE 9-17-2007; IN COMMERCE 9-17-2007.

JANICE KIM, EXAMINING ATTORNEY

SN 85-515,027. BELLAVANCE, JESSE, CHARLOTTESVILLE, VA. FILED 1-12-2012.

KILLER BEE

THE MARK CONSISTS OF STANDARD CHARACTERS WITHOUT CLAIM TO ANY PARTICULAR FONT, STYLE, SIZE, OR COLOR.

FOR BELTS MADE OUT OF CLOTH; MARTIAL ARTS UNIFORMS, NAMELY, GIS; SHORT-SLEEVED OR LONG-SLEEVED T-SHIRTS (U.S. CLS. 22 AND 39).

FIRST USE 1-1-2010; IN COMMERCE 1-1-2010.

JORDAN BAKER, EXAMINING ATTORNEY

CLASS 25—(Continued).

SN 85-515,042. GARY MYERS, FISHERS, IN. FILED 1-12-2012.

Iron Bear

THE MARK CONSISTS OF STANDARD CHARACTERS WITHOUT CLAIM TO ANY PARTICULAR FONT, STYLE, SIZE, OR COLOR.

FOR ATHLETIC APPAREL, NAMELY, SHIRTS, PANTS, JACKETS, FOOTWEAR, HATS AND CAPS, ATHLETIC UNIFORMS; ATHLETIC FOOTWEAR; ATHLETIC SHOES; ATHLETIC UNIFORMS; BODY SHIRTS; CLOTHING FOR ATHLETIC USE, NAMELY, PADDED ELBOW COMPRESSION SLEEVES BEING PART OF AN ATHLETIC GARMENT; CLOTHING FOR ATHLETIC USE, NAMELY, PADDED PANTS; CLOTHING FOR ATHLETIC USE, NAMELY, PADDED SHIRTS; CLOTHING FOR ATHLETIC USE, NAMELY, PADDED SHORTS; CLOTHING FOR WEAR IN JUDO PRACTICES; CLOTHING FOR WEAR IN WRESTLING GAMES; CLOTHING ITEMS, NAMELY, ADHESIVE POCKETS THAT MAY BE AFFIXED DIRECTLY TO THE BODY AS A DECORATIVE PIECE OF CLOTHING WITH UTILITY; CLOTHING, NAMELY, ATHLETIC SLEEVES; FOOTWEAR NOT FOR SPORTS; HEADBANDS FOR CLOTHING; HOODED SWEAT SHIRTS; JACKETS; JERSEYS; LONG-SLEEVED SHIRTS; MOISTURE-WICKING SPORTS BRAS; MOISTURE-WICKING SPORTS PANTS; MOISTURE-WICKING SPORTS SHIRTS; POLO SHIRTS; RUGBY SHIRTS; SHIRTS; SHIRTS AND SHORT-SLEEVED SHIRTS; SHORT SETS; SHORT-SLEEVED OR LONG-SLEEVED T-SHIRTS; SHORT-SLEEVED SHIRTS; SPORT COATS; SPORT SHIRTS; SPORT STOCKINGS; SPORTS BRA; SPORTS BRAS; SPORTS CAPS AND HATS; SPORTS JACKETS; SPORTS JERSEYS; SPORTS JERSEYS AND BRECHES FOR SPORTS; SPORTS PANTS; SPORTS SHIRTS; SPORTS SHIRTS WITH SHORT SLEEVES; SWEAT BANDS; SWEAT JACKETS; SWEAT PANTS; SWEAT SHIRTS; SWEAT SHORTS; SWEAT SUITS; T-SHIRTS; TOPS; WEARABLE GARMENTS AND CLOTHING, NAMELY, SHIRTS; WRIST BANDS (U.S. CLS. 22 AND 39).

LINDA LAVACHE, EXAMINING ATTORNEY

SN 85-515,118. JINCHAO, PAN, LOS ANGELES, CA. FILED 1-12-2012.

LANUVIO

THE MARK CONSISTS OF STANDARD CHARACTERS WITHOUT CLAIM TO ANY PARTICULAR FONT, STYLE, SIZE, OR COLOR.

FOR BLOUSES; DRESS PANTS; GYM SHORTS; JACKETS; MEN'S SUITS, WOMEN'S SUITS; PANTS; SHIRTS; SHORTS; TOPS; UNDERWEAR (U.S. CLS. 22 AND 39).
FIRST USE 3-0-2010; IN COMMERCE 3-0-2010.
JAY BESCH, EXAMINING ATTORNEY

CLASS 25—(Continued).

SN 85-515,208. BRENTON J. BYRD, ELBERON, VA. FILED 1-12-2012.

WE MUST PRAY

THE MARK CONSISTS OF STANDARD CHARACTERS WITHOUT CLAIM TO ANY PARTICULAR FONT, STYLE, SIZE, OR COLOR.

FOR HATS; SHORT-SLEEVED OR LONG-SLEEVED T-SHIRTS (U.S. CLS. 22 AND 39).
AMY KELLY, EXAMINING ATTORNEY

SN 85-515,271. GARDNER, MICAH, ISLAMORADA, FL. FILED 1-12-2012.

SUNSHINE BILLIONAIRE

THE MARK CONSISTS OF STANDARD CHARACTERS WITHOUT CLAIM TO ANY PARTICULAR FONT, STYLE, SIZE, OR COLOR.

FOR HEADWEAR; SHIRTS (U.S. CLS. 22 AND 39).
NAKIA HENRY, EXAMINING ATTORNEY

SN 85-515,315. SOMB, LOS ANGELES, CA. FILED 1-12-2012.

FCWL

THE MARK CONSISTS OF STANDARD CHARACTERS WITHOUT CLAIM TO ANY PARTICULAR FONT, STYLE, SIZE, OR COLOR.

FOR HOODED SWEATSHIRTS; HOODED SWEATSHIRTS FOR ADULTS; SHORT-SLEEVED OR LONG-SLEEVED T-SHIRTS; SPORTS CAPS AND HATS; SWEATSHIRTS; T-SHIRTS; T-SHIRTS FOR ADULTS (U.S. CLS. 22 AND 39).
JANICE KIM, EXAMINING ATTORNEY

CLASS 25—(Continued).

SN 85-515,399. THE RANCH APPAREL GROUP, INC., LOS ANGELES, CA. FILED 1-12-2012.



THE MARK CONSISTS OF THE STYLIZED LETTERS "RIDER'S UNION".
FOR BELTS; HATS; JACKETS; PANTS; SHIRTS; SHOES (U.S. CLS. 22 AND 39).
ROBERT STRUCK, EXAMINING ATTORNEY

CLASS 25—(Continued).

SN 85-515,452. BLACKFORD, DAVID, TORRANCE, CA. FILED 1-12-2012.



THE MARK CONSISTS OF A RECTANGLE WITH ROUNDED CORNERS. IN THE MIDDLE OF THE RECTANGLE IS THE SHAFT AND BLADE OF A CARBON FIBER PADDLE. IN THE MIDDLE OF THE BLADE ARE THE LETTERS "PD".
FOR HATS; PANTS; RASH GUARDS; SHIRTS (U.S. CLS. 22 AND 39).
HENRY S. ZAK, EXAMINING ATTORNEY

SN 85-515,501. KOESTER, PAUL, GRAND ISLAND, NE. FILED 1-12-2012.



THE MARK CONSISTS OF UNEVEN ARROW HAVING SUBSTANTIALLY OPEN ARROWHEAD AND TWO SHORT LINES CROSSING THE TAIL OF THE ARROW IN A PERPENDICULAR FASHION.
FOR SHORT-SLEEVED OR LONG-SLEEVED T-SHIRTS (U.S. CLS. 22 AND 39).
KIMBERLY PERRY, EXAMINING ATTORNEY

SN 85-515,427. FAQIRZADEH, SAID, DISCOVERY BAY, CA. FILED 1-12-2012.



THE MARK CONSISTS OF A DESIGN OF TWO HANDS COMING TOGETHER TO FORM A HEART WITH THE HEADS OF TWO EAGLES BREAKING AWAY FROM THE KNUCKLES OF EACH HAND.
FOR BELTS; BOTTOMS; BRAS; DRESS SHIRTS; HATS; JACKETS; JEANS; PANTS; SCARVES; SHOES; SOCKS; TIES; TOPS; UNDERWEAR (U.S. CLS. 22 AND 39).
CHRISTOPHER SIDOTI, EXAMINING ATTORNEY

SN 85-515,748. MICHAEL MALLERY ENTERPRISE L.L.C., LAFAYETTE, LA. FILED 1-13-2012.



THE COLOR(S) RED, DARK BLUE, LIGHT BLUE, BROWN, GOLD AND WHITE IS/ARE CLAIMED AS A FEATURE OF THE MARK.
THE MARK CONSISTS OF THE LETTERING "ISE" AND

CLASS 25—(Continued).

THE CORRESPONDING WORDING "I'M SO EDUCATED" WITH THE LETTER "E" IN "ISE" FORMING THE WORD "EDUCATED". THE LETTERING "ISE" APPEARS IN RED BORDERED BY A RED HORIZONTAL BAR AT THE TOP AND BOTTOM SUPERIMPOSED UPON A SILHOUETTE OF A BUST OF A MAN IN A CAP AND GOWN IN THE COLOR DARK BLUE. THE WORDING "I'M SO" APPEARS IN RED WITH A DARK BLUE OUTLINE TO THE TOP LEFT OF THE LETTERING "ISE" IN LINE WITH THE TOP RED HORIZONTAL BAR. TO THE RIGHT OF THE LETTERING "ISE" APPEARS A RED RECTANGLE VERTICALLY PLACED FEATURING DARK BLUE AND BROWN CLASPED HANDS OVER AN OPEN BOOK IN LIGHT BLUE OUTLINED IN DARK BLUE WITH THE LETTERS "DUCATED" IN RED OUTLINED IN WHITE SUPERIMPOSED THEREON FORMING THE WORD "EDUCATED" WHEN COMBINED WITH THE RED LETTER "E" OF "ISE". A GOLD STAR APPEARS ON EITHER SIDE OF THE CLASPED HANDS, AND 5 GOLD STARS APPEAR BELOW THE OPEN BOOK IN A TRIANGULAR FORMAT. THE MARK AS A WHOLE FORMS A MISCELLANEOUS INCOMPLETE RECTANGLE.

FOR SHORT-SLEEVED OR LONG-SLEEVED T-SHIRTS; T-SHIRTS (U.S. CLS. 22 AND 39).

ZHALEH DELANEY, EXAMINING ATTORNEY

CLASS 25—(Continued).

SN 85-515,809. RAMIREZ, SETH, FRESNO, CA. FILED 1-13-2012.



THE MARK CONSISTS OF THE STYLIZED LOWERCASE LETTERS "DB" BACK TO BACK.

FOR CLOTHING, NAMELY, T-SHIRTS, SWEATSHIRTS, SWEATPANTS, HATS, LONG-SLEEVED T-SHIRTS, SOCKS, SHOES, JACKETS, GLOVES, JERSEYS, BANDANAS, ATHLETIC SHORTS, PLAID SHORTS, DENIM SHORTS, CARGO SHORTS, AND TANK TOPS (U.S. CLS. 22 AND 39).

COLLEEN DOMBROW, EXAMINING ATTORNEY

SN 85-515,758. GEORGEANN HUSZAR, ROYAL OAK, MI. FILED 1-13-2012.

SN 85-515,857. FLIRTYLICIOUS BRANDS, LLC, CORPUS CHRISTI, TX. FILED 1-13-2012.

A LITTLE KICK IN THE PANTS

THE MARK CONSISTS OF STANDARD CHARACTERS WITHOUT CLAIM TO ANY PARTICULAR FONT, STYLE, SIZE, OR COLOR.

FOR CLOTHING, NAMELY SHIRTS, JACKETS, TANK TOPS, PANTS, SHORTS, BRAS, ROBES, EXERCISE WEAR, NAMELY LEOTARDS, TIGHTS, T-SHIRTS, SWEATSHIRTS, SWEAT PANTS, WARM-UP SUITS, JOGGING SUITS, BODY SUITS, LEG WARMERS AND LEGGINGS; PAJAMAS, UNDERWEAR, FOOTWEAR, SOCKS, SCARVES, HATS, GLOVES, SWEATERS AND HEADBANDS (U.S. CLS. 22 AND 39).

MARTHA FROMM, EXAMINING ATTORNEY

THE MARK CONSISTS OF THE STYLIZED TEXT "CUPCAKE CHEEKS" WHERE THE LETTER "U" IN "CUPCAKE" IS REPRESENTED BY A SMALL CUPCAKE.

FOR CLOTHING FOR CHILDREN OF ALL AGES, NAMELY, SHIRTS, PANTS, HEADWEAR, JACKETS, SHOES, SOCKS, AND UNDERWEAR (U.S. CLS. 22 AND 39).

JOHN DWYER, EXAMINING ATTORNEY

CLASS 25—(Continued).

SN 85-515,861. THE VAT APPAREL LLC, LONG BEACH, CA. FILED 1-13-2012.



THE MARK CONSISTS OF THE STYLIZED TEXT "THE" ENCLOSED IN A SQUARE, AS IF STAMPED, BELOW AND TO THE LEFT IS THE STYLIZED TEXT "VAT" IN LARGER TYPE.

FOR CLOTH BIBS; HATS; ONE PIECE GARMENT FOR INFANTS AND TODDLERS; PANTS; T-SHIRTS; TANK TOPS; UNDERWEAR (U.S. CLS. 22 AND 39).

KAREN SEVERSON, EXAMINING ATTORNEY

SN 85-515,904. FAIRHURST, LYNTON, NEW PORT RICHEY, FL. FILED 1-13-2012.



THE MARK CONSISTS OF A SICKLE MOON WITH TWO STARS TO THE RIGHT OF THE STYLIZED TEXT "LIFE...". FOR T-SHIRTS (U.S. CLS. 22 AND 39).

APRIL HESIK, EXAMINING ATTORNEY

SN 85-515,955. SHAW, TAYLOR, SYLMAR, CA. FILED 1-13-2012.



THE MARK CONSISTS OF A LIME WEDGE, WITH 2 LIME JUICE SQUIRTS COMING FROM THE TOP OF THE WEDGE. INSIDE THERE IS THE STYLIZED TEXT "LYM". FOR BEANIES; HATS; T-SHIRTS (U.S. CLS. 22 AND 39).

FIRST USE 6-1-2011; IN COMMERCE 8-1-2011. JAMES LOVELACE, EXAMINING ATTORNEY

CLASS 25—(Continued).

SN 85-515,995. PEERLESS TYRE CO., A COLORADO CORPORATION, DENVER, CO. FILED 1-13-2012.

PEERLESS TIRES 4 LESS

THE MARK CONSISTS OF STANDARD CHARACTERS WITHOUT CLAIM TO ANY PARTICULAR FONT, STYLE, SIZE, OR COLOR.

FOR UNIFORMS; CLOTHING, NAMELY, HATS, CAPS, SHIRTS, JACKETS, AND SWEATERS (U.S. CLS. 22 AND 39).

FIRST USE 10-30-2004; IN COMMERCE 10-30-2004. ANTHONY RINKER, EXAMINING ATTORNEY

SN 85-516,039. DENTEH, OMAR K., DOLTON, IL. AND OLADEINDE, OLABODE A, DOLTON, IL. FILED 1-13-2012.

Urban Elegance

THE MARK CONSISTS OF STANDARD CHARACTERS WITHOUT CLAIM TO ANY PARTICULAR FONT, STYLE, SIZE, OR COLOR.

FOR A-SHIRTS; ANKLE SOCKS; ANTI-PERSPIRANT SOCKS; APPAREL FOR DANCERS, NAMELY, TEE SHIRTS, SWEATSHIRTS, PANTS, LEGGINGS, SHORTS AND JACKETS; ATHLETIC APPAREL, NAMELY, SHIRTS, PANTS, JACKETS, FOOTWEAR, HATS AND CAPS, ATHLETIC UNIFORMS; BODY SHIRTS; BRIEFS; BUTTON DOWN SHIRTS; CAMOUFLAGE PANTS; CAPRI PANTS; CARGO PANTS; CLOTHING FOR ATHLETIC USE, NAMELY, PADDED PANTS; CLOTHING FOR ATHLETIC USE, NAMELY, PADDED SHIRTS; CLOTHING FOR BABIES, TODDLERS AND CHILDREN, TREATED WITH FIRE AND HEAT RETARDANTS, NAMELY, PAJAMAS, JACKETS, SHIRTS, PANTS, JUMPERS; CLOTHING SHIELDS, NAMELY, PADS APPLIED TO THE UNDERARMS OF SHIRTS, BLOUSES AND SWEATERS; COLLARED SHIRTS; CREW NECK SWEATERS; DENIMS; DISPOSABLE UNDERWEAR; DRESS PANTS; DRESS SHIRTS; GOLF PANTS, SHIRTS AND SKIRTS; GYM PANTS; HOODED SWEAT SHIRTS; HUNTING PANTS; HUNTING SHIRTS; JACKETS AND SOCKS; JEANS; JOGGING PANTS; KNIT SHIRTS; KNITTED UNDERWEAR; LADIES' UNDERWEAR; LEATHER PANTS; LEG SHIELDING DEVICE, ATTACHABLE TO AND DETACHABLE FROM A PERSON'S PANTS, COMPRISED OF PADDING TO SHIELD THE LEGS FROM FLYING DEBRIS WHEN MOWING WITH A STRING TRIMMER; LONG UNDERWEAR; LONG-SLEEVED SHIRTS; LOUNGE PANTS; MEN'S DRESS SOCKS; MEN'S SOCKS; MEN'S UNDERWEAR; MOCK TURTLE-NECK SWEATERS; MOISTURE-WICKING SPORTS PANTS; MOISTURE-WICKING SPORTS SHIRTS; NIGHT SHIRTS; NON-DISPOSABLE CLOTH TRAINING PANTS; NON-SLIP SOCKS; NURSE PANTS; OPEN-NECKED SHIRTS; PANTS; PAPER SHOES USED WHEN GOING THROUGH METAL DETECTORS TO KEEP FEET AND SOCKS CLEAN; PERSPIRATION ABSORBENT UNDERWEAR CLOTHING; PETTI-PANTS; POLO KNIT TOPS; POLO SHIRTS; RUGBY SHIRTS; SCIENTIFIC AND TECHNOLOGICAL APPAREL, NAMELY, SHIRTS, PANTS, JACKETS, FOOTWEAR, HATS AND CAPS, UNIFORMS; SHIRT FRONTS; SHIRT INSERTS, NAMELY, DICKIES; SHIRTS; SHIRTS AND SHORT-SLEEVED SHIRTS; SHIRTS FOR INFANTS, BABIES, TODDLERS AND CHILDREN; SHIRTS FOR

CLASS 25—(Continued).

SUITS; SHORT-SLEEVED OR LONG-SLEEVED T-SHIRTS; SHORT-SLEEVED SHIRTS; SKI PANTS; SLEEP PANTS; SLEEP SHIRTS; SLEEVES WORN SEPARATE AND APART FROM BLOUSES, SHIRTS AND OTHER TOPS; SLIPPER SOCKS; SNAP CROTCH SHIRTS FOR INFANTS AND TODDLERS; SNOW PANTS; SNOWBOARD PANTS; SOCKS; SOCKS AND STOCKINGS; SPORT SHIRTS; SPORTS PANTS; SPORTS SHIRTS; SPORTS SHIRTS WITH SHORT SLEEVES; SWEAT SHIRTS; SWEATERS; T-SHIRTS; T-SHIRTS FOR FASHION; TEE SHIRTS; THERMAL SOCKS; THERMAL UNDERWEAR; THONGS; TRIATHLON CLOTHING, NAMELY, TRIATHLON TIGHTS, TRIATHLON SHORTS, TRIATHLON SINGLETS, TRIATHLON SHIRTS, TRIATHLON SUITS; TURTLE NECK SHIRTS; TURTLE-NECK SWEATERS; UNDERWEAR; V-NECK SWEATERS; WATER SOCKS; WEARABLE GARMENTS AND CLOTHING, NAMELY, SHIRTS; WIND SHIRTS; WOMEN'S CLOTHING, NAMELY, SHIRTS, DRESSES, SKIRTS, BLOUSES; WOMEN'S UNDERWEAR; WOOLLEN SOCKS; WOVEN OR KNITTED UNDERWEAR; YOGA SHIRTS (U.S. CLS. 22 AND 39).

SUZANNE BLANE, EXAMINING ATTORNEY

SN 85-516,117. FINTASTIC SPORTS LLC, TAMPA, FL. FILED 1-13-2012.

I HUNT SCALLOPS

THE MARK CONSISTS OF STANDARD CHARACTERS WITHOUT CLAIM TO ANY PARTICULAR FONT, STYLE, SIZE, OR COLOR.

FOR HATS; T-SHIRTS (U.S. CLS. 22 AND 39).
FIRST USE 9-12-2011; IN COMMERCE 9-12-2011.
ELISSA GARBER KON, EXAMINING ATTORNEY

SN 85-516,129. INVERSIONES TALON S.A., MEDELLIN - ANTIOQUIA, COLOMBIA, FILED 1-13-2012.



NO CLAIM IS MADE TO THE EXCLUSIVE RIGHT TO USE "SOCKS", APART FROM THE MARK AS SHOWN.

THE COLOR(S) BLACK, LIGHT YELLOW, YELLOW, DARK YELLOW, LIGHT BLUE, BLUE, DARK BLUE, LIGHT VIOLET, VIOLET, DARK VIOLET, LIGHT GREEN, GREEN, DARK GREEN, LIGHT PINK, PINK, DARK PINK, LIGHT ORANGE, ORANGE, DARK ORANGE AND WHITE. IS/ARE CLAIMED AS A FEATURE OF THE MARK.

THE MARK CONSISTS OF A CIRCULAR FIGURE INSIDE OF WHICH APPEARS THE WORDING "LUCCI SOCKS" IN STYLIZED LETTERS. THE BACKGROUND

CLASS 25—(Continued).

AREA INSIDE THE CIRCULAR FIGURE CONSISTS OF SMALL SQUARES IN VARIOUS COLORS. THE COLOR WHITE APPEARS IN THE WORDS "LUCCI SOCKS". THE COLOR BLACK APPEARS IN THE OUTER BORDER OF THE CIRCLE. THE COLORS LIGHT YELLOW, YELLOW, DARK YELLOW, LIGHT BLUE, BLUE, DARK BLUE, LIGHT VIOLET, VIOLET, DARK VIOLET, LIGHT GREEN, GREEN, DARK GREEN, LIGHT PINK, PINK, DARK PINK, LIGHT ORANGE, ORANGE, DARK ORANGE AND WHITE APPEAR IN THE SMALL SQUARES.

FOR SOCKS (U.S. CLS. 22 AND 39).
FIRST USE 4-9-2011; IN COMMERCE 4-9-2011.
DORITT L. CARROLL, EXAMINING ATTORNEY

SN 85-516,159. RAJ MANUFACTURING LLC, TUSTIN, CA. FILED 1-13-2012.

N BY NEXT

THE MARK CONSISTS OF STANDARD CHARACTERS WITHOUT CLAIM TO ANY PARTICULAR FONT, STYLE, SIZE, OR COLOR.

FOR APPAREL, NAMELY, SWIMWEAR AND ACTIVE WEAR, NAMELY, PANTS AND JACKETS USED FOR STAND UP PADDLE BOARDING, YOGA, PILATES AND OTHER ACTIVITIES (U.S. CLS. 22 AND 39).

ANDREW LEASER, EXAMINING ATTORNEY

SN 85-516,200. RAJ MANUFACTURING LLC, TUSTIN, CA. FILED 1-13-2012.

MY SUPPORT GROUP

THE MARK CONSISTS OF STANDARD CHARACTERS WITHOUT CLAIM TO ANY PARTICULAR FONT, STYLE, SIZE, OR COLOR.

FOR APPAREL, NAMELY, SWIMWEAR (U.S. CLS. 22 AND 39).
ANDREW LEASER, EXAMINING ATTORNEY

CLASS 25—(Continued).

SN 85-516,246. CASCIA, LLC, EASTLAKE, OH. FILED 1-13-2012.



THE MARK CONSISTS OF A STYLIZED "C" WITH A LIGHTHOUSE.

FOR CLOTHING, NAMELY, APRONS, ATHLETIC UNIFORMS, BANDANAS, BOXER SHORTS, CAPS, CLOTH BABY BIBS, COATS, GOLF SHIRTS, GYM SHORTS, GYM SUITS, HATS, JACKETS, JERSEYS, JOGGING SUITS, KNIT SHIRTS, PAJAMAS, POLO SHIRTS, PONCHOS, PULLOVERS, RAIN COATS, RAINWEAR, SWEATERS, SWEAT PANTS, SWEAT SHIRTS, SWEAT SUITS, SOCKS, SPORT SHIRTS, T- SHIRTS, TANK TOPS, TIES, VISORS, WIND RESISTANT JACKETS AND WRISTBANDS (U.S. CLS. 22 AND 39).

FIRST USE 10-15-2011; IN COMMERCE 10-15-2011.
JAY BESCH, EXAMINING ATTORNEY

CLASS 25—(Continued).

SN 85-516,326. SALT OPTICS, INC., COSTA MESA, CA. FILED 1-13-2012.

STORMY MONDAY

THE MARK CONSISTS OF STANDARD CHARACTERS WITHOUT CLAIM TO ANY PARTICULAR FONT, STYLE, SIZE, OR COLOR.

FOR BOARD SHORTS; CAPS; HATS; HOODED SWEAT SHIRTS; LONG-SLEEVED SHIRTS; PANTS; SHIRTS; SHOES; SHORTS; SOCKS; SWIMSUITS (U.S. CLS. 22 AND 39).

LAURA KOVALSKY, EXAMINING ATTORNEY

SN 85-516,272. KRISTI YAMAGUCHI, LLC, FREMONT, CA. FILED 1-13-2012.

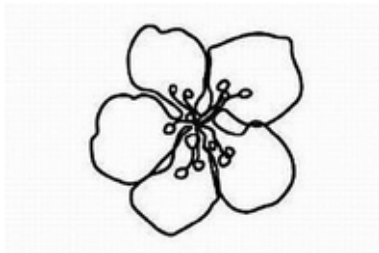

THE MARK CONSISTS OF A FLOWER DESIGN.

FOR CLOTHING, NAMELY, T-SHIRTS, SHIRTS, JACKETS, COATS, SWEATSHIRTS, WALKING SHORTS, BOARDSHORTS, SHORTS, SWEATPANTS, PANTS, PULLOVERS, SOCKS, POLO SHIRTS, GLOVES, SCARVES, SWIMWEAR, BATHING SUITS, BELTS, JEANS, SLACKS, WOVEN SHIRTS, KNIT SHIRTS, HALTER TOPS, BLOUSES, TANK TOPS, SKIRTS, DRESSES, SWEATERS, CARDIGANS, BEACH COVER UPS, SLEEPWEAR, UNDERWEAR, BRAS, CAMISOLES, PAJAMAS, ROBES, JUMP SUITS, ROMPERS, WARM UP SUITS, OVERALLS; HEADWEAR; FOOTWEAR (U.S. CLS. 22 AND 39).

JOHN E. MICHOS, EXAMINING ATTORNEY

SN 85-516,337. SEARS BRANDS, LLC, HOFFMAN ESTATES, IL. FILED 1-13-2012.



THE MARK CONSISTS OF THREE SILHOUETTES OF FLYING DUCKS.

FOR APPAREL, NAMELY, PANTS, JEANS, SHORTS, SHIRTS, T-SHIRTS, TANK TOPS, KNIT TOPS, SWEATERS, JACKETS, COATS, VESTS, FLEECE TOPS, FLEECE BOTTOMS, SWEATSHIRTS, SWEATPANTS, LOUNGEWEAR, PAJAMAS, SKIRTS, DRESSES, CAPRIS, SWIMWEAR, FOOTWEAR; ACCESSORIES, NAMELY, SCARVES, BELTS, HEAD WEAR, HATS, GLOVES, MITTENS, HEADBANDS (U.S. CLS. 22 AND 39).

BERYL GARDNER, EXAMINING ATTORNEY

CLASS 25—(Continued).

SN 85-517,096. UPSTART TV LLC, HOUSTON, TX. FILED 1-16-2012.



THE MARK CONSISTS OF THE WORDS "DON'T KISS THE BABY" IN STYLIZED FONT BELOW A DESIGN OF A BABY'S FACE FEATURING BULGING EYES, A NOSE AND FROWN AND A DESIGN OF HUMAN LIPS ON THE LEFT CHEEK.

FOR BABY BODYSUITS; BEANIES; BABY BIBS NOT OF PAPER; BIBS NOT OF PAPER; CHILDREN'S AND INFANTS' CLOTH BIBS; CHILDREN'S CLOTH EATING BIBS; HATS FOR INFANTS, BABIES, TODDLERS AND CHILDREN; T-SHIRTS FOR INFANTS AND TODDLERS (U.S. CLS. 22 AND 39).

DAVID YONTEF, EXAMINING ATTORNEY

CLASS 25—(Continued).

SN 85-517,382. SR HOLDINGS, LLC, LEXINGTON, MA. FILED 1-16-2012.

TEAM SPERRY TOP-SIDER

THE MARK CONSISTS OF STANDARD CHARACTERS WITHOUT CLAIM TO ANY PARTICULAR FONT, STYLE, SIZE, OR COLOR.

OWNER OF U.S. REG. NOS. 732,519, 3,835,580 AND OTHERS.

NO CLAIM IS MADE TO THE EXCLUSIVE RIGHT TO USE "TEAM", APART FROM THE MARK AS SHOWN.

FOR FOOTWEAR; APPAREL, NAMELY, FOUL WEATHER GEAR; OUTER JACKETS; JACKETS; COATS; PULLOVERS; VESTS; TOPS; SHIRTS; T-SHIRTS, POLO SHIRTS; DRESS SHIRTS; SHORT-SLEEVED OR LONG-SLEEVED T-SHIRTS; SWEATERS; SWEATSHIRTS; THERMAL UNDERWEAR; SWIMWEAR; BEACH COVERUPS; COVERUPS; HOODED SWEATSHIRTS; HOODED PULLOVERS; SHORTS; PANTS; SWEAT-PANTS; JEANS; BOTTOMS; HEADWEAR; HATS; CAPS; BELTS; GLOVES; SUSPENDERS; SOCKS; HOSIERY; LEGGINGS; SCARVES (U.S. CLS. 22 AND 39).

CURTIS FRENCH, EXAMINING ATTORNEY

SN 85-517,160. PUBLIC FLIPPER LIMITED, LLC, POWAY, CA. FILED 1-16-2012.

FLIPPER

THE MARK CONSISTS OF STANDARD CHARACTERS WITHOUT CLAIM TO ANY PARTICULAR FONT, STYLE, SIZE, OR COLOR.

FOR CAPS; HOODED SWEAT SHIRTS; SHORT-SLEEVED OR LONG-SLEEVED T-SHIRTS; T-SHIRTS FOR BABIES AND CHILDREN (U.S. CLS. 22 AND 39).

FIRST USE 3-14-1980; IN COMMERCE 8-21-1980.
LESLEY LAMOTHE, EXAMINING ATTORNEY

SN 85-518,033. CHIH, LI-WEI, SILVER SPRING, MD. FILED 1-17-2012.

MonsterFishKeepers

THE MARK CONSISTS OF STANDARD CHARACTERS WITHOUT CLAIM TO ANY PARTICULAR FONT, STYLE, SIZE, OR COLOR.

OWNER OF U.S. REG. NO. 3,321,085.

FOR BASEBALL CAPS AND HATS; GOLF CAPS; HATS; HOODED SWEAT SHIRTS; KNITTED CAPS; LONG-SLEEVED SHIRTS; SPORTS CAPS AND HATS; SWEATERS; T-SHIRTS (U.S. CLS. 22 AND 39).

FIRST USE 5-15-2005; IN COMMERCE 5-15-2005.
GEOFFREY FOSDICK, EXAMINING ATTORNEY

CLASS 25—(Continued).

SN 85-518,777. UPSTART TV LLC, HOUSTON, TX. FILED 1-18-2012.



THE MARK CONSISTS OF THE WORDS "NO KISSES" IN STYLIZED FONT BELOW A DESIGN OF HUMAN LIPS WITHIN A PROHIBITION SYMBOL.

FOR BABY BIBS NOT OF PAPER; BEANIES; HATS FOR INFANTS, BABIES, TODDLERS AND CHILDREN; SNAP CROTCH SHIRTS FOR INFANTS AND TODDLERS; T-SHIRTS (U.S. CLS. 22 AND 39).

DAVID YONTEF, EXAMINING ATTORNEY

CLASS 25—(Continued).

SN 85-523,033. SUN SOUTH PRODUCTS, LLC, NORCROSS, GA. FILED 1-23-2012.



THE MARK CONSISTS OF THE FRONT-FACING HEAD OF A CAT WITH UPWARD POINTED EARS WEARING STYLIZED SUNGLASSES AND HAVING 3 SETS OF WHISKERS WITH THE OUTWARD THIRD OF THE WHISKERS PROJECTING OUTSIDE THE OUTLINE OF THE CAT'S FACE AND THE WORDS "COOL-CAT" IN STYLIZED MODIFIED CURSIVE SCRIPT UNDERNEATH.

FOR SUN PROTECTIVE CLOTHING, NAMELY, TUBE SHAPED NECK SCARVES FOR OUTDOOR WORKERS SOLD THROUGH SPECIALTY RETAIL CHANNELS FOR THE CONSTRUCTION AND AGRICULTURAL INDUSTRIES (U.S. CLS. 22 AND 39).

COLLEEN KEARNEY, EXAMINING ATTORNEY

SN 85-522,757. KAHANOFF, ALEJANDRO JAVIER, BUENOS AIRES, ARGENTINA, FILED 1-23-2012.

ATTACK VS DEFENCE MATCH

THE MARK CONSISTS OF STANDARD CHARACTERS WITHOUT CLAIM TO ANY PARTICULAR FONT, STYLE, SIZE, OR COLOR.

OWNER OF ARGENTINA REG. NO. 2354787, DATED 3-26-2010, EXPIRES 3-26-2020.

FOR FOOTWEAR; HEADGEAR, NAMELY, HEADWEAR, SWEATBANDS, HEADBANDS, PEAKED CAPS, KNITTED CAPS, BONNETS, CAPS, HATS; SHIRTS; KNITWEAR, NAMELY, KNIT SHIRTS, KNIT PANTS, KNITTED UNDERWEAR, KNITTED CAPS; JERSEYS, PULLOVERS, TANK TOPS; T-SHIRTS; SINGLET; SLEEVELESS T-SHIRTS; UNDERWEAR; SWIMWEAR, SHORTS; PANTS; SWEATERS; BONNETS; CAPS; HATS; SCARVES; HEADSCARVES, SHAWLS; CAPS WITH VISORS; WARM-UP SUITS; SWEATSHIRTS; JACKETS; SPORTS JACKETS; STADIUM JACKETS; BLAZERS; RAINWEAR; COATS; UNIFORMS; TIES; WRISTBANDS; HEADBANDS; GLOVES; APRONS; BIBS NOT OF PAPER; PAJAMAS; TODDLER AND INFANT PLAYWEAR, NAMELY, INFANTWEAR AND ONE PIECE GARMENTS FOR INFANTS AND TODDLERS; SOCKS AND HOSIERY; SUSPENDERS; BELTS; BRACES (U.S. CLS. 22 AND 39).

PRISCILLA MILTON, EXAMINING ATTORNEY

SN 85-523,288. BOGLE, NATHAN, NEW YORK, NY. FILED 1-23-2012.

BOGLE

THE MARK CONSISTS OF STANDARD CHARACTERS WITHOUT CLAIM TO ANY PARTICULAR FONT, STYLE, SIZE, OR COLOR.

FOR CLOTHING FOR MEN, WOMEN AND CHILDREN, NAMELY, PANTS, JEANS, TROUSERS, SHORTS, BELTS, TOPS, SHIRTS, JERSEYS, TURTLE-NECKS, GOLF SHIRTS, T-SHIRTS, SWEATSHIRTS, SWEATPANTS, WARM-UP SUITS, TANK TOPS, DRESSES, SKIRTS, BLOUSES, SUITS, TUXEDOS, BLAZERS, SPORT COATS, SWEATERS, KNITWEAR IN THE NATURE OF KNIT BOTTOMS AND TOPS, KNIT DRESSES, KNITTED CAPS AND KNITTED UNDERWEAR, OUTERWEAR IN THE NATURE OF OUTER JACKETS, OVERALLS, JUMPERS, VESTS, HATS, SCARVES, COATS, JACKETS, OVERCOATS, PARKAS, SOCKS, FOOTWEAR, SHOES, BOOTS, SNEAKERS, BEACH SHOES, SANDALS, SLIPPERS, TIES, SUSPENDERS, UNDERWEAR, HEADWEAR, BEANIES, GLOVES, MITTENS, PONCHOS, RAINCOATS, WIND-RESISTANT JACKETS, SLEEPWEAR, ROBES, BATHROBES, PAJAMAS, LINGERIE, HOSIERY, BOXER SHORTS, CAPS, WOOL HATS, VISORS, HEADBANDS, EAR MUFFS, WRISTBANDS AND CLOTH BIBS (U.S. CLS. 22 AND 39).

DAVID YONTEF, EXAMINING ATTORNEY

CLASS 25—(Continued).

SN 85-524,818. TOTES ISOTONER CORPORATION, CINCINNATI, OH. FILED 1-25-2012.

JUST SHEEPSKIN

THE MARK CONSISTS OF STANDARD CHARACTERS WITHOUT CLAIM TO ANY PARTICULAR FONT, STYLE, SIZE, OR COLOR.

NO CLAIM IS MADE TO THE EXCLUSIVE RIGHT TO USE "SHEEPSKIN", APART FROM THE MARK AS SHOWN. FOR CLOTHING, NAMELY, FOOTWEAR, GLOVES, HATS AND SCARVES MADE IN SIGNIFICANT PART OF SHEEPSKIN (U.S. CLS. 22 AND 39).

KEVON CHISOLM, EXAMINING ATTORNEY

CLASS 25—(Continued).

SN 85-526,499. CYRUS DA ZINE LLC, HAMILTON, MA. FILED 1-26-2012.



THE MARK CONSISTS OF A STYLIZED LETTER "C" WRAPPING AROUND A WRITING TOOL OR IMPLEMENT. FOR HATS (U.S. CLS. 22 AND 39).

FIRST USE 9-1-2010; IN COMMERCE 10-1-2010.

KAREN BRACEY, EXAMINING ATTORNEY

SN 85-532,998. UPSTART TV LLC, HOUSTON, TX. FILED 2-3-2012.

Don't Kiss Me

SN 85-525,176. SR HOLDINGS, LLC, LEXINGTON, MA. FILED 1-25-2012.



THE MARK CONSISTS OF STANDARD CHARACTERS WITHOUT CLAIM TO ANY PARTICULAR FONT, STYLE, SIZE, OR COLOR.

FOR BABY BIBS NOT OF PAPER; BASEBALL CAPS AND HATS; BEANIES; BIBS NOT OF PAPER; BODY SHIRTS; CHILDREN'S AND INFANTS' CLOTH BIBS; CHILDREN'S CLOTH EATING BIBS; CLOTH BIBS; HATS; HATS FOR INFANTS, BABIES, TODDLERS AND CHILDREN; INFANT SLEEPERS; MITTENS; NIGHT GOWNS; PLASTIC BABY BIBS; SHIRTS; SHIRTS FOR INFANTS, BABIES, TODDLERS AND CHILDREN; SNAP CROTCH SHIRTS FOR INFANTS AND TODDLERS; T-SHIRTS (U.S. CLS. 22 AND 39).

DAVID YONTEF, EXAMINING ATTORNEY

SN 85-535,546. DOOBALLO FOOTWEAR, INC., NORCROSS, GA. FILED 2-7-2012.

RUNHILL

OWNER OF U.S. REG. NOS. 1,810,853 AND 1,860,428. THE MARK CONSISTS OF A STYLIZED IMAGE OF A SAILBOAT WITH TWO SETS OF WAVES, SURROUNDED BY A SQUARE DESIGN.

FOR INNER SOLES (U.S. CLS. 22 AND 39).

CURTIS FRENCH, EXAMINING ATTORNEY

THE MARK CONSISTS OF STANDARD CHARACTERS WITHOUT CLAIM TO ANY PARTICULAR FONT, STYLE, SIZE, OR COLOR.

FOR FOOTWEAR (U.S. CLS. 22 AND 39).

LESLEY LAMOTHE, EXAMINING ATTORNEY

CLASS 25—(Continued).

SN 85-535,727. THE CARTOON NETWORK, INC., ATLANTA, GA. FILED 2-7-2012.

SQUIDBILLIES

THE MARK CONSISTS OF STANDARD CHARACTERS WITHOUT CLAIM TO ANY PARTICULAR FONT, STYLE, SIZE, OR COLOR.

OWNER OF U.S. REG. NOS. 3,086,231, 3,522,426 AND 3,579,611.

FOR CLOTHING FOR MEN, WOMEN AND CHILDREN, NAMELY, T-SHIRTS, SWEATSHIRTS, JOGGING SUITS, TANK TOPS, TIES, HATS, CAPS, SUNVISORS, SNEAKERS, MASQUERADE AND HALLOWEEN COSTUMES AND MASKS SOLD IN CONNECTION THEREWITH (U.S. CLS. 22 AND 39).

MARK SPARACINO, EXAMINING ATTORNEY

SN 85-539,923. STRATEGIC PARTNERS, INC., CHATSWORTH, CA. FILED 2-10-2012.

Code Happy

THE MARK CONSISTS OF STANDARD CHARACTERS WITHOUT CLAIM TO ANY PARTICULAR FONT, STYLE, SIZE, OR COLOR.

FOR BOTTOMS; DRESSES; FOOTWEAR; HEADWEAR; JACKETS; PANTS; SCRUBS NOT FOR MEDICAL PURPOSES; SHIRTS; SWEATERS; T-SHIRTS; TOPS; TUNICS; UNIFORMS (U.S. CLS. 22 AND 39).

NAAKWAMA ANKRAH, EXAMINING ATTORNEY

SN 85-540,392. GHADIR GHUZLAN LLC, BROOKLYN, NY. FILED 2-11-2012.

FullXLovers

THE MARK CONSISTS OF STANDARD CHARACTERS WITHOUT CLAIM TO ANY PARTICULAR FONT, STYLE, SIZE, OR COLOR.

FOR HALLOWEEN COSTUMES; LINGERIE (U.S. CLS. 22 AND 39).

TIMOTHY FINNEGAN, EXAMINING ATTORNEY

CLASS 25—(Continued).

SN 85-543,034. MACKR LLC, CHESTERTOWN, MD. FILED 2-15-2012.



THE MARK CONSISTS OF THE SILHOUETTE OF AN OWL WEARING A CROWN AND DEPICTING ONE SET OF TALONS.

FOR HATS; PANTS; SHORTS; SWEATSHIRTS; T-SHIRTS (U.S. CLS. 22 AND 39).

FIRST USE 10-15-2011; IN COMMERCE 10-15-2011.

JENNIFER WILLISTON, EXAMINING ATTORNEY

SN 85-545,515. BROOKSTONE PURCHASING, INC., MERRIMACK, NH. FILED 2-17-2012.

BIOSENSE

THE MARK CONSISTS OF STANDARD CHARACTERS WITHOUT CLAIM TO ANY PARTICULAR FONT, STYLE, SIZE, OR COLOR.

FOR SLIPPERS (U.S. CLS. 22 AND 39).

CHRISTOPHER BUONGIORNO, EXAMINING ATTORNEY

SN 85-546,274. GHADIR GHUZLAN LLC, BROOKLYN, NY. FILED 2-17-2012.

Devote Yourself to Self Improvement

THE MARK CONSISTS OF STANDARD CHARACTERS WITHOUT CLAIM TO ANY PARTICULAR FONT, STYLE, SIZE, OR COLOR.

FOR ATHLETIC APPAREL, NAMELY, SHIRTS, PANTS, JACKETS, FOOTWEAR, HATS AND CAPS, ATHLETIC UNIFORMS; SPORTS BRA (U.S. CLS. 22 AND 39).

TIMOTHY FINNEGAN, EXAMINING ATTORNEY

CLASS 25—(Continued).

SN 85-552,197. BARRY, HOWARD, ISLP, NY. FILED 2-24-2012.

I LOVE
 it when
MY WIFE
 lets me go fishing

THE MARK CONSISTS OF THE UPPER CASE WORDING "I LOVE", THE LOWER CASE WORDING "IT WHEN", THE UPPER CASE WORDING "MY WIFE", AND THE LOWER CASE WORDING "LETS ME GO FISHING".

FOR HOODED SWEAT SHIRTS; SHORT-SLEEVED OR LONG-SLEEVED T-SHIRTS; SWEAT SHIRTS (U.S. CLS. 22 AND 39).

KATHERINE E. HALMEN, EXAMINING ATTORNEY

CLASS 25—(Continued).

SN 85-563,048. RESTORATION SOFTWARE, LTD, DBA LEUCADIA SURF WEAR, ST. LOUIS, MO. FILED 3-7-2012.

LEUCADIA

THE MARK CONSISTS OF STANDARD CHARACTERS WITHOUT CLAIM TO ANY PARTICULAR FONT, STYLE, SIZE, OR COLOR.

FOR BUTTON DOWN SHIRTS; COLLARED SHIRTS; DRESS SHIRTS; GOLF SHIRTS; HOODED SWEAT SHIRTS; LONG-SLEEVED SHIRTS; POLO SHIRTS; RUGBY SHIRTS; SHIRTS; SHIRTS AND SHORT-SLEEVED SHIRTS; SHORT-SLEEVED OR LONG-SLEEVED T-SHIRTS; SHORT-SLEEVED SHIRTS; SPORT SHIRTS; SPORTS SHIRTS; SPORTS SHIRTS WITH SHORT SLEEVES; SUN PROTECTIVE CLOTHING, NAMELY, RASH GUARDS; SWEAT SHIRTS; T-SHIRTS; T-SHIRTS FOR SURFING; TEE SHIRTS; YOGA SHIRTS (U.S. CLS. 22 AND 39).

ADA HAN, EXAMINING ATTORNEY

SN 85-562,234. GREAT EAGLE LIGHTING CORPORATION, OAKLAND GARDENS, NY. FILED 3-6-2012.

THE LIGHT HAS COME

THE MARK CONSISTS OF STANDARD CHARACTERS WITHOUT CLAIM TO ANY PARTICULAR FONT, STYLE, SIZE, OR COLOR.

FOR SHORT-SLEEVED OR LONG-SLEEVED T-SHIRTS; SWEAT SHIRTS; T-SHIRTS; WEARABLE GARMENTS AND CLOTHING, NAMELY, SHIRTS (U.S. CLS. 22 AND 39).

THEODORE MCBRIDE, EXAMINING ATTORNEY

SN 85-589,127. BROOKLYN HOLDINGS INC., CHARLOTTE, NC. FILED 4-4-2012.



THE MARK CONSISTS OF THE STAR OF DAVID SUPERIMPOSED ON A CROSS WITH AN ENCIRCLING HOOP.

FOR CLOTHING FOR MEN AND WOMEN, NAMELY, T-SHIRTS, SHORT SLEEVE SHIRTS, LONG SLEEVE SHIRTS, TANK TOPS, SWEATSHIRTS, SWEATPANTS, HOODED SHIRTS, HOODED SWEATSHIRTS, SWEATERS, JACKETS, PANTS, SHORTS, DRESSES, SKIRTS, BLOUSES, PAJAMAS, SWIMSUITS, UNDERWEAR, NIGHTSHIRTS, NIGHTGOWNS, PAJAMAS, SHOWER CAPS, BATHROBES, SOCKS, SHOES, FOOTWEAR, SCARVES, HATS, BASEBALL CAPS, STOCKING CAPS, BEANIES, HEADBANDS, GLOVES, MITTENS, AND BELTS; CLOTHING FOR INFANTS, BABIES, TODDLERS AND CHILDREN, NAMELY, TOPS, BOTTOMS, SHIRTS, SHORTS, PANTS, JUMPERS, OVERALLS, SLEEPWEAR, PAJAMAS, ROMPERS, ONE-PIECE GARMENTS, HATS, SOCKS, SHOES (U.S. CLS. 22 AND 39).

ANDREA HACK, EXAMINING ATTORNEY

CLASS 25—(Continued).

SN 85-589,452. DMB MESA PROVING GROUNDS LLC, SCOTTSDALE, AZ. FILED 4-4-2012.



THE MARK CONSISTS OF THE WORD "EASTMARK" BELOW A DESIGN OF A SQUARE BORDERED ON EACH SIDE BY A TRIANGLE.

FOR CLOTHING, NAMELY, T-SHIRTS, SPORT SHIRTS, JACKETS, SWEATERS, SHORTS, PANTS, WARM-UP SUITS, SWEATSHIRTS, SWEATPANTS, HEADBANDS, WRIST BANDS, DRESS SHIRTS, POLO SHIRTS, HATS, CAPS, AND VISORS; FOOTWEAR (U.S. CLS. 22 AND 39).

APRIL HESIK, EXAMINING ATTORNEY

SN 85-592,133. GLOBAL TRADEMARKS, INC., STOCKERTOWN, PA. FILED 4-9-2012.

"ONCE"

THE MARK CONSISTS OF STANDARD CHARACTERS WITHOUT CLAIM TO ANY PARTICULAR FONT, STYLE, SIZE, OR COLOR.

FOR SHAPEWEAR, NAMELY, PANTIES, BRAS, GIRDLES, CAMISOLES; SWIMWEAR (U.S. CLS. 22 AND 39).

JOHN HWANG, EXAMINING ATTORNEY

SN 85-592,404. GLOBAL TRADEMARKS, INC., STOCKERTOWN, PA. FILED 4-9-2012.

ELONG

THE MARK CONSISTS OF STANDARD CHARACTERS WITHOUT CLAIM TO ANY PARTICULAR FONT, STYLE, SIZE, OR COLOR.

FOR SWIMWEAR (U.S. CLS. 22 AND 39).

JOHN HWANG, EXAMINING ATTORNEY

CLASS 26—FANCY GOODS

SN 85-439,397. CONAIR CORPORATION, STAMFORD, CT. FILED 10-5-2011.

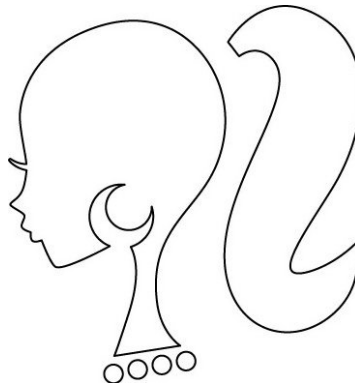

THE MARK CONSISTS OF A SILHOUETTE OF A GIRL WITH A PONYTAIL WEARING AN EARRING AND A NECKLACE.

FOR HAIR ACCESSORIES, NAMELY, HAIR TIES, HAIR SCRUNCHIES, HAIR ELASTICS, HAIR BARRIETTES, HAIR CLIPS, HAIR PINS, HAIR BANDS (U.S. CLS. 37, 39, 40, 42 AND 50).

CHARLES L. JENKINS, EXAMINING ATTORNEY

SN 85-470,548. SAMANTHA MONIQUE SCOTT, TA STAR STRICKEN HAIR EXTENSION, SMYRNA, GA. FILED 11-11-2011.

STAR STRICKEN HAIR EXT.

THE MARK CONSISTS OF STANDARD CHARACTERS WITHOUT CLAIM TO ANY PARTICULAR FONT, STYLE, SIZE, OR COLOR.

NO CLAIM IS MADE TO THE EXCLUSIVE RIGHT TO USE "HAIR EXT.", APART FROM THE MARK AS SHOWN. FOR HAIR EXTENSIONS (U.S. CLS. 37, 39, 40, 42 AND 50).

FIRST USE 11-2-2011; IN COMMERCE 11-2-2011.

LINDA E. BLOHM, EXAMINING ATTORNEY

SN 85-493,634. A&E GROUP, LLC, MARYLAND HEIGHTS, MO. FILED 12-13-2011.



THE COLOR(S) BLUE, PURPLE AND WHITE IS/ARE CLAIMED AS A FEATURE OF THE MARK.

THE MARK CONSISTS OF THE STYLIZED WORDS "POP" AND "EYES" APPEARING IN WHITE AND OUTLINED IN BLUE AND PURPLE; THE TERMS ARE SEPARATED BY A PAIR OF WHITE AND BLUE EYES OUTLINED IN PURPLE WITH BLUE EYEBROWS.

FOR FASTENERS FOR AFFIXING BADGES, INSIGNIA AND NAMETAGS TO CLOTHING (U.S. CLS. 37, 39, 40, 42 AND 50).

FIRST USE 12-1-2011; IN COMMERCE 12-1-2011.

ANTHONY RINKER, EXAMINING ATTORNEY

CLASS 26—(Continued).

SN 85-510,896. U-LACE, LLC, BUFFALO, NY. FILED 1-6-2012.

BREAK THE TIES

THE MARK CONSISTS OF STANDARD CHARACTERS WITHOUT CLAIM TO ANY PARTICULAR FONT, STYLE, SIZE, OR COLOR.

FOR LACES FOR FOOTWEAR (U.S. CLS. 37, 39, 40, 42 AND 50).

JASON BLAIR, EXAMINING ATTORNEY

CLASS 26—(Continued).

SN 85-512,077. COMMONWEALTH OF CHRMZ LLC, PORTLAND, OR. FILED 1-9-2012.



NO CLAIM IS MADE TO THE EXCLUSIVE RIGHT TO USE "CHARMS", APART FROM THE MARK AS SHOWN.

THE MARK CONSISTS OF THE STYLIZED WORDS "COMMONWEALTH OF" LOCATED IN CURVED MANNER ABOVE A CROWN DESIGN; LOCATED UNDERNEATH THE CROWN DESIGN IS THE STYLIZED WORD "CHRMZ" IN A LARGER SIZED FONT.

FOR CHARMS FOR FLIP FLOPS AND SANDALS (U.S. CLS. 37, 39, 40, 42 AND 50).

FIRST USE 12-21-2011; IN COMMERCE 12-21-2011.
ANNE E. GUSTASON, EXAMINING ATTORNEY

SN 85-511,227. U-LACE, LLC, BUFFALO, NY. FILED 1-7-2012.

BREAK ALL TIES

THE MARK CONSISTS OF STANDARD CHARACTERS WITHOUT CLAIM TO ANY PARTICULAR FONT, STYLE, SIZE, OR COLOR.

FOR SHOE LACES (U.S. CLS. 37, 39, 40, 42 AND 50).
JASON BLAIR, EXAMINING ATTORNEY

SN 85-515,616. ZHANG, QING, IRVINE, CA. FILED 1-13-2012.

SUSHO

GenieTabs

THE MARK CONSISTS OF STANDARD CHARACTERS WITHOUT CLAIM TO ANY PARTICULAR FONT, STYLE, SIZE, OR COLOR.

FOR ZIPPER FASTENERS; ZIPPER PULLS; ZIPPERS (U.S. CLS. 37, 39, 40, 42 AND 50).

GIANCARLO CASTRO, EXAMINING ATTORNEY

THE MARK CONSISTS OF STANDARD CHARACTERS WITHOUT CLAIM TO ANY PARTICULAR FONT, STYLE, SIZE, OR COLOR.

FOR SILK EMBROIDERY WALL ART; DOUBLE SIDED SILK EMBROIDERY ART (U.S. CLS. 37, 39, 40, 42 AND 50).

FIRST USE 4-4-2011; IN COMMERCE 5-2-2011.
KRISTIN DAHLING, EXAMINING ATTORNEY

CLASS 26—(Continued).

SN 85-515,624. FOREVER YOUNG INTERNATIONAL HOLDINGS LIMITED, CHAI WAN, HONG KONG, FILED 1-13-2012.

foryang

THE MARK CONSISTS OF THE STYLIZED WORD FORYANG.

THE WORDING FORYANG HAS NO MEANING IN A FOREIGN LANGUAGE.

FOR FALSE BEARDS; FALSE HAIR; FALSE MOUSTACHES; HAIR EXTENSIONS; HAIR NETS; HAIR ORNAMENTS; HAIR PIECES; HAIR SLIDES; TOUPEES; WIGS (U.S. CLS. 37, 39, 40, 42 AND 50).

FIRST USE 10-1-2000; IN COMMERCE 2-1-2006.
GISELLE AGOSTO, EXAMINING ATTORNEY

SN 85-520,379. ALLSTAR MARKETING GROUP, LLC, HAWTHORNE, NY. FILED 1-19-2012.

TAILOR'S SECRET

THE MARK CONSISTS OF STANDARD CHARACTERS WITHOUT CLAIM TO ANY PARTICULAR FONT, STYLE, SIZE, OR COLOR.

FOR CLOTHING ACCESSORIES, NAMELY, EXTRA BUTTONS AND HOOKS ATTACHED TO THE WAISTBAND OF PANTS TO EXTEND WAIST SIZE (U.S. CLS. 37, 39, 40, 42 AND 50).

DOUGLAS LEE, EXAMINING ATTORNEY

CLASS 26—(Continued).

SN 85-525,185. SR HOLDINGS, LLC, LEXINGTON, MA. FILED 1-25-2012.



OWNER OF U.S. REG. NOS. 1,810,853 AND 1,860,428.
THE MARK CONSISTS OF A STYLIZED IMAGE OF A SAILBOAT WITH TWO SETS OF WAVES, SURROUNDED BY A SQUARE DESIGN.

FOR SHOE LACES (U.S. CLS. 37, 39, 40, 42 AND 50).
CURTIS FRENCH, EXAMINING ATTORNEY

SN 85-539,577. MOSAIC INTERNATIONAL LLC, SAN ROMAN, CA. FILED 2-10-2012.

TONY PONY

THE MARK CONSISTS OF STANDARD CHARACTERS WITHOUT CLAIM TO ANY PARTICULAR FONT, STYLE, SIZE, OR COLOR.

FOR HAIR ACCESSORIES, NAMELY, HAIR TIES AND HAIR WRAPS; HAIR ELASTICS; PONYTAIL HOLDERS (U.S. CLS. 37, 39, 40, 42 AND 50).

FIRST USE 1-1-2001; IN COMMERCE 1-1-2001.
MARC LEIPZIG, EXAMINING ATTORNEY

SN 85-541,137. MOSAIC INTERNATIONAL LLC, SAN ROMAN, CA. FILED 2-13-2012.

CLIP-N-PONY

THE MARK CONSISTS OF STANDARD CHARACTERS WITHOUT CLAIM TO ANY PARTICULAR FONT, STYLE, SIZE, OR COLOR.

FOR HAIR BARRETTES; HAIR EXTENSIONS; PONYTAIL HOLDERS; WIGS, HAIRPIECES, AND ADD-IN AND ADD-ON HAIR ACCESSORIES CONSTRUCTED PRIMARILY OF SYNTHETIC AND/OR HUMAN HAIR (U.S. CLS. 37, 39, 40, 42 AND 50).

FIRST USE 1-1-2012; IN COMMERCE 1-1-2012.
MARC LEIPZIG, EXAMINING ATTORNEY

CLASS 27—FLOOR COVERINGS

SN 77-953,421. RCR INTERNATIONAL INC., BOUCHERVILLE, CANADA, FILED 3-8-2010.



PRIORITY CLAIMED UNDER SEC. 44(D) ON CANADA APPLICATION NO. 1468414, FILED 2-4-2010, REG. NO. TMA789242, DATED 2-1-2011, EXPIRES 2-1-2026.

THE MARK CONSISTS OF THE WORDING "ITILE" IN STYLIZED FONT; THE CAPITAL LETTER "T" IS FORMED BY FIVE SQUARES.

FOR SELF-ADHESIVE MULTIPURPOSE CARPET TILES FOR FLOOR COVERING; DOUBLE-FACE ADHESIVE TAPE SOLD AS AN INTEGRAL COMPONENT OF CARPET TILES FOR FLOOR COVERING (U.S. CLS. 19, 20, 37, 42 AND 50).

DAVID HOFFMAN, EXAMINING ATTORNEY

SN 85-510,321. MGM RESORTS INTERNATIONAL, LAS VEGAS, NV. FILED 1-6-2012.

MGM GRAND

THE MARK CONSISTS OF STANDARD CHARACTERS WITHOUT CLAIM TO ANY PARTICULAR FONT, STYLE, SIZE, OR COLOR.

OWNER OF U.S. REG. NOS. 2,540,402, 3,908,061 AND OTHERS.

FOR BATH MATS (U.S. CLS. 19, 20, 37, 42 AND 50).
KIMBERLY PERRY, EXAMINING ATTORNEY

SN 85-511,276. JOY CARPETS & CO., FT. OGLETHORPE, GA. FILED 1-8-2012.

THE FIRST AND STILL THE BEST!

THE MARK CONSISTS OF STANDARD CHARACTERS WITHOUT CLAIM TO ANY PARTICULAR FONT, STYLE, SIZE, OR COLOR.

FOR RUGS (U.S. CLS. 19, 20, 37, 42 AND 50).
MARY CRAWFORD, EXAMINING ATTORNEY

CLASS 27—(Continued).

SN 85-511,279. JOY CARPETS & CO., FT. OGLETHORPE, GA. FILED 1-8-2012.

A TUFT ABOVE THE REST!

THE MARK CONSISTS OF STANDARD CHARACTERS WITHOUT CLAIM TO ANY PARTICULAR FONT, STYLE, SIZE, OR COLOR.

FOR RUGS (U.S. CLS. 19, 20, 37, 42 AND 50).
MARY CRAWFORD, EXAMINING ATTORNEY

SN 85-511,285. JOY CARPETS & CO., FT. OGLETHORPE, GA. FILED 1-8-2012.

THE FIRST AND STILL THE BEST AND A TUFT ABOVE THE REST!

THE MARK CONSISTS OF STANDARD CHARACTERS WITHOUT CLAIM TO ANY PARTICULAR FONT, STYLE, SIZE, OR COLOR.

FOR RUGS (U.S. CLS. 19, 20, 37, 42 AND 50).
MARY CRAWFORD, EXAMINING ATTORNEY

SN 85-511,575. STONEBROOKE EQUIPMENT INC., DBA ACROTECH OF MINNESOTA, BURNSVILLE, MN. FILED 1-9-2012.

AcroMat

THE MARK CONSISTS OF STANDARD CHARACTERS WITHOUT CLAIM TO ANY PARTICULAR FONT, STYLE, SIZE, OR COLOR.

FOR ANTI-FATIGUE FLOOR MAT (U.S. CLS. 19, 20, 37, 42 AND 50).
FIRST USE 4-1-2007; IN COMMERCE 4-1-2007.
JOHN WILKE, EXAMINING ATTORNEY

CLASS 28—TOYS AND SPORTING GOODS

SN 76-636,347. HOMIESHOP PROPERTIES, L.L.C., FAIRFIELD, CA. FILED 4-18-2005.

COUNTY DOGPOUND

THE MARK CONSISTS OF STANDARD CHARACTERS WITHOUT CLAIM TO ANY PARTICULAR FONT, STYLE, SIZE, OR COLOR.

FOR TOY ACTION FIGURES AND ACCESSORIES THEREFOR; TOY ANIMALS AND ACCESSORIES THEREFOR; PLASTIC CHARACTER TOYS, DOLLS, STUFFED TOYS; PLUSH TOYS AND PET TOYS (U.S. CLS. 22, 23, 38 AND 50).

CHRISTINE COOPER, EXAMINING ATTORNEY

SN 77-372,576. DC COMICS, NEW YORK, NY. FILED 1-15-2008.



THE MARK CONSISTS OF SHOOTING STARS SURROUNDING THE STYLIZED WORDS "SUPER POWERS".

FOR TOYS AND SPORTING GOODS, INCLUDING GAMES AND PLAYTHINGS, NAMELY, ACTION FIGURES AND ACCESSORIES THEREFOR; PLUSH TOYS; BALLOONS; BATHTUB TOYS; RIDE-ON TOYS; EQUIPMENT SOLD AS A UNIT FOR PLAYING CARD GAMES; TOY VEHICLES; DOLLS; FLYING DISCS; ELECTRONIC HAND-HELD GAME UNIT OTHER THAN THOSE ADAPTED FOR USE WITH AN EXTERNAL DISPLAY SCREEN OR MONITOR; GAME EQUIPMENT SOLD AS A UNIT FOR PLAYING A BOARD GAME, A CARD GAME, A MANIPULATIVE GAME, A PARLOR GAME AND AN ACTION TYPE TARGET GAME; STAND ALONE VIDEO OUTPUT GAME MACHINES; JIGSAW AND MANIPULATIVE PUZZLES; PAPER PARTY FAVORS AND PAPER PARTY DECORATIONS, NAMELY, PAPER HATS; PAPER FACE MASKS; SKATEBOARDS; ICE SKATES; WATER SQUIRTING TOYS; BALLS, NAMELY, PLAYGROUND BALLS, SOCCER BALLS, BASEBALLS, BASKETBALLS; BASEBALL GLOVES; SWIMMING FLOATS FOR RECREATIONAL USE; KICKBOARD FLOTATION DEVICES FOR RECREATIONAL USE; SURFBOARDS; SWIM BOARDS FOR RECREATIONAL USE; SWIM FINS; TOY BAKEWARE AND TOY COOKWARE; TOY BANKS; TOY SNOW GLOBES; AND CHRISTMAS TREE ORNAMENTS (U.S. CLS. 22, 23, 38 AND 50).

MARY ROSSMAN, EXAMINING ATTORNEY

CLASS 28—(Continued).

SN 77-677,787. LAI ON PRODUCTS (INDUSTRIAL) LIMITED, KWAI CHUNG, HONG KONG, FILED 2-25-2009.



THE MARK CONSISTS OF WORDS AND SHAPES. FOR TOY MODEL HOBBY CRAFT KITS; TOY MODELING DOUGH; HOBBY CRAFT KITS COMPRISING MODELING DOUGH, MOLDS AND CUTTERS; DRAWING TOYS; TOY STAMPS; ARTIFICIAL CHRISTMAS GARLANDS; ARTIFICIAL CHRISTMAS TREES; CHRISTMAS STOCKINGS; CHRISTMAS TREE DECORATIONS, EXCEPT CONFECTIONERY OR ILLUMINATION ARTICLES; CHRISTMAS TREE SKIRTS; CHRISTMAS TREE STANDS; RING GAMES, NAMELY, QUILTS; CHESS SETS; PLAYGROUND BALLS; TARGET GAMES; SLING SHOTS; PLAY SWIMMING POOLS; BODY BOARDS; FISHING CREELS (U.S. CLS. 22, 23, 38 AND 50).

MIDGE BUTLER, EXAMINING ATTORNEY

SN 77-905,324. FORMATION MARKETING CANADA LTD., BURLINGTON, CANADA, FILED 1-5-2010.

ROLLABALL

THE MARK CONSISTS OF STANDARD CHARACTERS WITHOUT CLAIM TO ANY PARTICULAR FONT, STYLE, SIZE, OR COLOR.

FOR AMUSEMENT PRODUCTS, NAMELY, INFLATABLE BALLS (U.S. CLS. 22, 23, 38 AND 50).

MARIA-VICTORIA SUAREZ, EXAMINING ATTORNEY

SN 77-908,202. ROOM8CLUB, CHICAGO, IL. FILED 1-8-2010.

ROOM8CLUB

THE MARK CONSISTS OF STANDARD CHARACTERS WITHOUT CLAIM TO ANY PARTICULAR FONT, STYLE, SIZE, OR COLOR.

FOR DOLL HOUSES; DOLLS; DOLLS AND ACCESSORIES THEREFOR (U.S. CLS. 22, 23, 38 AND 50).

KEVON CHISOLM, EXAMINING ATTORNEY

CLASS 28—(Continued).

SN 79-098,294. ROZETTA CORPORATION, TOKYO 150-0022, JAPAN, FILED 4-1-2011.

POSIT

PRIORITY DATE OF 10-22-2010 IS CLAIMED.
OWNER OF INTERNATIONAL REGISTRATION 1079736
DATED 4-1-2011, EXPIRES 4-1-2021.
FOR BOARD GAMES (U.S. CLS. 22, 23, 38 AND 50).
KIMBERLY PERRY, EXAMINING ATTORNEY

SN 79-107,973. TECHTRON ELECTRONICS PTY LTD, AUSTRALIA, FILED 11-28-2011.

TENNISMATIC

THE MARK CONSISTS OF STANDARD CHARACTERS WITHOUT CLAIM TO ANY PARTICULAR FONT, STYLE, SIZE, OR COLOR.

OWNER OF INTERNATIONAL REGISTRATION 1103812
DATED 11-28-2011, EXPIRES 11-28-2021.

FOR SPORTING ARTICLES, NAMELY, TENNIS BALL MACHINES, TENNIS BALL MACHINE SERVE STANDS, TENNIS BALLS, TENNIS RACQUETS, TENNIS RACQUET GRIPS, TENNIS STRINGS, TENNIS NETS, REBOUND NETS, MINI TENNIS NETS, WINDBREAK NETS, TENNIS NET WINDERS, BALL PICK UP BASKETS, RINGS AND CONES (U.S. CLS. 22, 23, 38 AND 50).
JENNIFER VASQUEZ, EXAMINING ATTORNEY

SN 85-133,412. HOMER TLC, INC., WILMINGTON, DE. FILED 9-20-2010.

Perfect Home Essentials

THE MARK CONSISTS OF STANDARD CHARACTERS WITHOUT CLAIM TO ANY PARTICULAR FONT, STYLE, SIZE, OR COLOR.

OWNER OF U.S. REG. NO. 3,090,873.

NO CLAIM IS MADE TO THE EXCLUSIVE RIGHT TO USE "HOME ESSENTIALS", APART FROM THE MARK AS SHOWN.

FOR ARTIFICIAL CHRISTMAS TREES; CHRISTMAS TREE ORNAMENTS AND DECORATIONS (U.S. CLS. 22, 23, 38 AND 50).

LAURA HAMMEL, EXAMINING ATTORNEY

CLASS 28—(Continued).

SN 85-171,985. GINN, LARRY, LONG BEACH, CT. FILED 11-8-2010.



NO CLAIM IS MADE TO THE EXCLUSIVE RIGHT TO USE "THE ROMANCE GAME", APART FROM THE MARK AS SHOWN.

THE COLOR(S) RED, GOLD, PURPLE AND WHITE IS/ARE CLAIMED AS A FEATURE OF THE MARK.

THE MARK CONSISTS OF THE WORDING "THE ROMANCE GAME" IN STYLIZED FONT AND IN GOLD LETTERS ON TOP OF A HEART THAT IS OUTLINED IN GOLD AND HAS A LIGHT RED AND RED MIXED BACKGROUND. INSIDE THE HEART ARE THE LETTERS "R" AND "G" IN STYLIZED FONT AND IN PURPLE. THERE IS AN ARROW GOING THROUGH THE HEART WHICH IS IN GOLD AND THE HEAD OF THE ARROW IS A HEART THAT IS IN RED. BELOW THE HEART ON EACH SIDE ARE THE WORDS "HE SAID IT" AND "SHE SAID IT" IN PURPLE. DIRECTLY BENEATH THE HEART IS THE WORDING "CAN YOU GUESS WHO SAID IT?", "SHE SAYS" AND "THEN HE SAYS" ALL IN WHITE, AND ALSO THE WORDING "I LOVE IT WHEN HE GENTLY HOLDS THE BACK OF MY HEAD WITH HIS LEFT HAND AND FIRMLY GRIPS MY WAIST WITH HIS RIGHT" AND "IN MY EYES YOUR BEAUTY IS INTOXICATING. IT LEAVES ME BREATHLESS AND.." IN GOLD. ALL OF WHICH IS ON A RED BACKGROUND.

FOR BOARD GAMES (U.S. CLS. 22, 23, 38 AND 50).

FIRST USE 9-7-2010; IN COMMERCE 9-7-2010.

LAKEISHA LEWIS, EXAMINING ATTORNEY

CLASS 28—(Continued).

SN 85-214,524. ELITE SPORTS LIMITED, GIBRALTAR, GIBRALTAR, FILED 1-10-2011.



OWNER OF U.S. REG. NO. 3,923,241.

NO CLAIM IS MADE TO THE EXCLUSIVE RIGHT TO USE "BABYTV", APART FROM THE MARK AS SHOWN.

THE MARK CONSISTS OF THE STYLIZED WORD "BABYTV" ABOVE WHICH THE DESIGN OF A BUTTERFLY.

FOR CHRISTMAS TREE DECORATIONS; CHRISTMAS TREE ORNAMENTS; HAND HELD UNITS FOR PLAYING ELECTRONIC GAMES OTHER THAN THOSE ADAPTED FOR USE WITH AN EXTERNAL DISPLAY SCREEN OR MONITOR; DOLLS AND DOLL CLOTHING; TOY FIGURES; PLUSH TOYS; BATHTUB TOYS; RUBBER CHARACTER TOYS; BENDABLE TOYS; WIND-UP TOYS; TOY BUILDING BLOCKS; JIGSAW AND MANIPULATIVE PUZZLES; TOY ACTION FIGURES AND ACCESSORIES THEREFOR; ACTION FIGURE PLAY ENVIRONMENTS; PARTY GAMES; PARLOR GAMES; ROLE PLAYING GAMES; BOARD GAMES; ACTION SKILL GAMES; CARD GAMES; PLAYING CARDS; FLYING DISCS; TOY JEWELRY; TOY WATCHES; DART BOARDS; TOY VEHICLES AND ACCESSORIES THEREFOR; SIT-IN AND RIDE-ON TOY VEHICLES; INDOOR PLAY TENTS; HAND HELD PUPPETS; TOY BANKS; WATER SQUIRTING TOYS; TOY PISTOLS; PINBALL AND ARCADE GAME MACHINES; BALLS FOR GAMES; BALLS FOR SPORTS; TENNIS RACKETS; SKATEBOARDS; BALLOONS; HOBBY CRAFT KITS COMPRISED OF TOY FIGURE PLASTIC MOLDS, FASTENERS FOR ATTACHING TOY FIGURE MOLDS, AND DECORATIVE ACCESSORIES FOR MOLDED TOY FIGURES; FLOTATION DEVICES FOR RECREATIONAL USE, NAMELY, INFLATABLE BALLS AND WATER WINGS SWIM AIDS FOR RECREATIONAL USE; COSTUME MASKS (U.S. CLS. 22, 23, 38 AND 50).

SUSAN RICHARDS, EXAMINING ATTORNEY

SN 85-219,786. READY AMONGST WILLING LLC, SOMERVILLE, MA. FILED 1-18-2011.

RAW

THE MARK CONSISTS OF STANDARD CHARACTERS WITHOUT CLAIM TO ANY PARTICULAR FONT, STYLE, SIZE, OR COLOR.

FOR BAGS FOR SKATEBOARDS; NUTS AND BOLTS FOR SKATEBOARDS; SKATEBOARD WHEELS; SKATEBOARDS (U.S. CLS. 22, 23, 38 AND 50).

FIRST USE 6-6-2006; IN COMMERCE 6-6-2006.

ANDREA HACK, EXAMINING ATTORNEY

CLASS 28—(Continued).

SN 85-311,749. KENDALL BUCHTER, CAROLYN, SOUTHAMPTON, NY. FILED 5-4-2011.

TEDDY BEAR FAIR

THE MARK CONSISTS OF STANDARD CHARACTERS WITHOUT CLAIM TO ANY PARTICULAR FONT, STYLE, SIZE, OR COLOR.

NO CLAIM IS MADE TO THE EXCLUSIVE RIGHT TO USE "TEDDY BEAR", APART FROM THE MARK AS SHOWN.

FOR RUBBER ACTION BALLS; ACTION FIGURES AND ACCESSORIES THEREFOR; ACTION SKILL GAMES; MECHANICAL ACTION TOYS; ELECTRIC ACTION TOYS; ACTION-TYPE TARGET GAMES; AMUSEMENT PARK RIDES; CARNIVAL AMUSEMENT RIDES; STUFFED TOYS; STUFFED TOY ANIMALS; BABY MULTIPLE ACTIVITY TOYS; BALLOONS; TOY BANKS; BASEBALL GLOVES; BASEBALL MITTS; BASEBALLS; BATH TOYS; BEAN BAGS; TOY BUILDING BLOCKS; BOARD GAMES; ROLE PLAYING EQUIPMENT IN THE NATURE OF A GAME AND MANUALS SOLD THEREWITH; BODY BOARDS; VENTRILOQUIST'S DUMMIES; DOLLS AND DOLL ACCESSORIES THEREFOR; PAPER FACE MASKS; PARTY FAVORS IN THE NATURE OF SMALL TOYS; MUSICAL BOX TOYS; MUSICAL TOYS; TOY BOXES; CARD GAMES; CASES FOR ACTION FIGURES, PLAY ACCESSORIES, TOY STRUCTURES, TOY VEHICLES; TOY CONSTRUCTION BLOCKS; CLOTHING FOR TOY FIGURES, NAMELY, ACTION FIGURE AND PLAY FIGURE CLOTHING; ELECTRONIC GAME EQUIPMENT WITH A WATCH FUNCTION; HAND HELD UNITS FOR PLAYING ELECTRONIC GAMES OTHER THAN THOSE ADAPTED FOR USE WITH AN EXTERNAL DISPLAY SCREEN OR MONITOR; HAND HELD UNITS FOR PLAYING VIDEO GAMES OTHER THAN THOSE ADAPTED FOR USE WITH AN EXTERNAL DISPLAY SCREEN OR MONITOR; FLYING DISCS; FOOTBALLS; CHESS AND CHECKER SETS; JIGSAW PUZZLES; KICK BOARD FLOTATION DEVICES FOR RECREATIONAL USE; KITES; TOY MOBILES; TOY AND RADIO CONTROLLED MODEL VEHICLES AND RELATED ACCESSORIES SOLD AS A UNIT; ELECTRONICALLY OPERATED TOY MOTOR VEHICLES; COIN AND NON-COIN OPERATED PINBALL MACHINES; PLAYGROUND BALLS; PORCELAIN DOLLS; PUPPETS; PUZZLES; THREE DIMENSIONAL PUZZLES; RAG DOLLS; RIDE-ON TOYS; TOY SCOOTERS; SKATEBOARDS; SNOW SLEDS FOR RECREATIONAL USE; SOCCER BALLS; PLUSH TOYS; SOFTBALL MITTS AND GLOVES; SPORT BALLS; SURFBOARDS; SURF FINS; SURFBOARD FINS; SURFBOARD LEASHES; SURFBOARD WAX; SWIM FINS; SWIM FLOATS FOR RECREATIONAL USE; SWIMMING AIDS, NAMELY, POOL RINGS AND ARM FLOATS FOR RECREATIONAL USE; INFLATABLE SWIMMING POOLS; PLAY SWIMMING POOLS; PLAYGROUND EQUIPMENT, NAMELY, CLIMBING UNITS, SAND BOXES, SWING SETS, AND SLIDES; GAME TABLES; BILLIARD TABLES; TENNIS RACKETS, BALLS, AND RACKET COVERS; TABLE TENNIS PADDLES, BALLS, AND PADDLE COVERS; TETHER BALLS; TOY VEHICLES; SOFT SCULPTURE TOYS; WATER SQUIRTING TOYS; WIND-UP TOYS; TOY MODEL TRAIN SETS; MAGIC TRICKS; WATER SKIS; SKIS; YO-YOS; CHRISTMAS TREE DECORATIONS AND ORNAMENTS; ARTIFICIAL CHRISTMAS GARLANDS (U.S. CLS. 22, 23, 38 AND 50).

KAREN BRACEY, EXAMINING ATTORNEY

CLASS 28—(Continued).

SN 85-342,869. CHILKOOT TRAIL VENTURES LLC, DENVER, CO. FILED 6-10-2011.

SLINGER

THE MARK CONSISTS OF STANDARD CHARACTERS WITHOUT CLAIM TO ANY PARTICULAR FONT, STYLE, SIZE, OR COLOR.

FOR TOYS, NAMELY, AN APPARATUS FOR THROWING BALLS AND DISKS; DOG TOYS, NAMELY, AN OBJECT THROWING APPARATUS FOR PLAYING FETCH WITH A DOG (U.S. CLS. 22, 23, 38 AND 50).

FIRST USE 5-7-2011; IN COMMERCE 5-29-2011.
CHRISIE B. KING, EXAMINING ATTORNEY

CLASS 28—(Continued).

SN 85-354,801. DISNEY ENTERPRISES, INC., BURBANK, CA. FILED 6-23-2011.

LITTLE KINGDOM

THE MARK CONSISTS OF STANDARD CHARACTERS WITHOUT CLAIM TO ANY PARTICULAR FONT, STYLE, SIZE, OR COLOR.

FOR ACTION SKILL GAMES; ACTION FIGURES AND ACCESSORIES THEREFOR; BOARD GAMES; CARD GAMES; CHILDREN'S MULTIPLE ACTIVITY TOYS; BALLOONS; BATH TOYS; BEACH BALLS; BEAN BAG DOLLS; CHILDREN'S PLAY COSMETICS; CHRISTMAS STOCKINGS; CHRISTMAS TREE ORNAMENTS AND DECORATIONS; COLLECTABLE TOY FIGURES; DOLLS; DOLL CLOTHING; DOLL ACCESSORIES; DOLL PLAYSETS; HAND-HELD UNITS FOR PLAYING ELECTRONIC GAMES OTHER THAN THOSE ADAPTED FOR USE WITH AN EXTERNAL DISPLAY SCREEN OR MONITOR; INFANT TOYS; INFLATABLE TOYS; JIGSAW PUZZLES; JUMP ROPES; KITES; MANIPULATIVE GAMES; MECHANICAL TOYS; MUSIC BOX TOYS; PARLOR GAMES; PARTY FAVORS IN THE NATURE OF SMALL TOYS; PAPER PARTY HATS; PARTY GAMES; PLAYING CARDS; PLUSH TOYS; PUPPETS; RUBBER BALLS; TALKING TOYS; TOY ACTION FIGURES AND ACCESSORIES THEREFOR; TOY BUCKET AND SHOVEL SETS; TOY MOBILES; TOY FIGURES; TOY BANKS (U.S. CLS. 22, 23, 38 AND 50).

KIMBERLY FRYE, EXAMINING ATTORNEY

SN 85-346,135. TURNER ENTERTAINMENT CO., BURBANK, CA. FILED 6-14-2011.

DOROTHY

THE MARK CONSISTS OF STANDARD CHARACTERS WITHOUT CLAIM TO ANY PARTICULAR FONT, STYLE, SIZE, OR COLOR.

OWNER OF U.S. REG. NOS. 2,423,711, 2,597,928 AND OTHERS.

THE NAME "DOROTHY" DOES NOT IDENTIFY A LIVING INDIVIDUAL.

FOR SNOW GLOBES (U.S. CLS. 22, 23, 38 AND 50).
FIRST USE 1-20-2006; IN COMMERCE 1-20-2006.
MICHAEL WIENER, EXAMINING ATTORNEY

SN 85-355,268. KOSAMA HOLDINGS, LLC, CHANHASSEN, MN. FILED 6-24-2011.

KOSAMA

THE MARK CONSISTS OF STANDARD CHARACTERS WITHOUT CLAIM TO ANY PARTICULAR FONT, STYLE, SIZE, OR COLOR.

OWNER OF U.S. REG. NOS. 3,919,465 AND 3,919,466.

FOR EXERCISE EQUIPMENT, NAMELY, TENSION BANDS AND HANDHELD WEIGHTS; PHYSICAL FITNESS EQUIPMENT, NAMELY, INDIVIDUAL EXERCISE MATS AND WORKOUT GLOVES (U.S. CLS. 22, 23, 38 AND 50).

KATHERINE CHANG, EXAMINING ATTORNEY

CLASS 28—(Continued).

SN 85-355,553. FLIP SKATEBOARDS, INC., LAGUNA NI-
GUEL, CA. FILED 6-24-2011.

SKATE CITY

THE MARK CONSISTS OF STANDARD CHARACTERS WITHOUT CLAIM TO ANY PARTICULAR FONT, STYLE, SIZE, OR COLOR.

NO CLAIM IS MADE TO THE EXCLUSIVE RIGHT TO USE "SKATE". APART FROM THE MARK AS SHOWN.

FOR SPORTING GOODS, NAMELY, TRUCKS FOR SKATEBOARDS (U.S. CLS. 22, 23, 38 AND 50).

SETH A. RAPPAPORT, EXAMINING ATTORNEY

CLASS 28—(Continued).

SN 85-360,406. INTERNET SHOPS INC. COM, CANTON, GA.
FILED 6-30-2011.

Dura-Pro Golf Mats



"The NO BOUNCE
Hit Down & Through Golf Mats"

NO CLAIM IS MADE TO THE EXCLUSIVE RIGHT TO USE "GOLF MATS; NO BOUNCE" AND "HIT DOWN AND THROUGH". APART FROM THE MARK AS SHOWN.

THE MARK CONSISTS OF THE STYLIZED WORDS "DURA-PRO GOLF MATS NO BOUNCE "THE NO BOUNCE HIT DOWN & THROUGH GOLF MATS"". AN IMAGE OF A CIRCLE WITH A LINE GOING THROUGH IT IN THE BACKGROUND OF THE WORDS "NO BOUNCE".

FOR GOLF HITTING MATS (U.S. CLS. 22, 23, 38 AND 50).

FIRST USE 11-0-2004; IN COMMERCE 11-0-2004.

CHRIS WELLS, EXAMINING ATTORNEY

SN 85-360,400. INTERNET SHOPS INC. COM, CANTON, GA.
FILED 6-30-2011.



NO CLAIM IS MADE TO THE EXCLUSIVE RIGHT TO USE "GOLF MATS NO SHOCK" AND "WORLD'S #1", APART FROM THE MARK AS SHOWN.

THE MARK CONSISTS OF THE STYLIZED WORDS AND NUMBER "DURA-PRO GOLF MATS NO SHOCK WORLD'S #1 GOLF MAT". AN IMAGE OF A CIRCLE WITH A LINE GOING THROUGH IT IN THE BACKGROUND OF THE WORDS "NO SHOCK".

FOR GOLF HITTING MATS (U.S. CLS. 22, 23, 38 AND 50).

FIRST USE 11-0-2004; IN COMMERCE 11-0-2004.

CHRIS WELLS, EXAMINING ATTORNEY

SN 85-380,408. PYI PYI FAMILY GIFTS CO., LTD.,
TAOYUAN COUNTY, TAIWAN, FILED 7-25-2011.



NO CLAIM IS MADE TO THE EXCLUSIVE RIGHT TO USE "FAMILY GIFTS CO. LTD." AND "WANPIKAZOKU" THE TRANSLITERATION OF THE JAPANESE CHARACTERS, APART FROM THE MARK AS SHOWN.

THE MARK CONSISTS OF CHINESE WORDING APPEARING ABOVE CARTOON CHARACTERS IN THE SHAPES OF ANIMALS AND FOOD WITH JAPANESE WORDING APPEARING ON SOME OF THE CARTOON CHARACTERS AND ALSO APPEARING BELOW IT; SPECIFICALLY THERE IS JAPANESE WRITING ON THE TWO SQUASH CHARACTERS IN THE BACK RIGHT OF THE GROUPING OF CHARACTERS. THERE ARE TWO CHARACTERS TO THE LEFT OF THE SQUASH CHARACTERS THAT EACH HAVE A "P" ON THEIR CHESTS ONE CHARACTER IS LARGER THAN THE OTHER. TO THE LEFT OF THE CHARACTERS WITH THE "P" ON THEIR CHESTS ARE TWO SLICES OF BREAD CHARACTERS WITH THE LARGER OF THE TWO HAVING A BIRD ON TOP OF IT. TO THE LEFT OF THE BREAD CHARACTERS ARE TWO CARROT CHARACTERS. THE FRONT ROW OF CHARACTERS BEGINS WITH THREE SMALL CHARACTERS STACKED ON TOP OF EACH OTHER. TO THE

CLASS 28—(Continued).

RIGHT OF THE STACKED CHARACTERS ARE THE IMAGES OF A BEAR, TWO CHARACTERS WITH HEADS THAT APPEAR TO BE ROUGHLY RECTANGULAR IN SHAPE, ONE OF WHICH IS PULLING A WAGON WITH A DOG IN IT. THE FINAL CHARACTERS SEEM TO BE CHARACTERS OF A BEAR WEARING A LIFE PRESERVER AND TWO RABBIT CHARACTERS. UNDER THE CHARACTER GROUPING IS JAPANESE WORDING. TO THE RIGHT OF THE JAPANESE WORDING AT THE BOTTOM OF THE PICTURE IS A WHITE SYMBOL ROUGHLY RECTANGULAR IN SHAPE INSIDE OF A BLACK SQUARE WITH ROUNDED CORNERS WITH A DIALOG BALLOON TO THE RIGHT OF THE SYMBOL WITH MORE JAPANESE WRITING; BELOW THE JAPANESE WORDING AND WHITE AND BLACK SYMBOL AT THE BOTTOM OF THE PICTURE ARE THE ENGLISH WORDS "PYI PYI FAMILY GIFTS CO., LTD.", FOLLOWED BY JAPANESE WORDING AND THE NUMBER "5688"

THE CHINESE CHARACTERS AT THE TOP OF THE MARK TRANSLATE TO "STEAMED BUN FAMILY" AND TRANSLITERATE TO "MANTOUJIATZU." THE JAPANESE CHARACTERS ON THE BELLY OF THE FIRST CHARACTER THAT APPEARS TO BE A SQUASH TRANSLATES TO "MR. LOOFAH" AND TRANSLITERATES TO "HECHIMASAN." THE JAPANESE CHARACTERS ON THE BELLY OF THE SECOND CHARACTER THAT APPEARS TO BE A SQUASH TRANSLATES TO "MS. LOOFAH" AND TRANSLITERATES TO "HECHICAN." THE JAPANESE CHARACTERS IN THE DIALOG BUBBLE AT THE BOTTOM OF THE MARK HAVE NO TRANSLATION BUT TRANSLITERATE TO "PAN." THE JAPANESE CHARACTERS UNDER THE GROUP OF CHARACTERS TRANSLATES TO "MR. STEAMED BUN" AND TRANSLITERATES TO "MANJUSAN." THE JAPANESE CHARACTERS AT THE BOTTOM OF THE PROPOSED MARK TRANSLATES TO "PYI PYI FAMILY GIFTS CO.LTD." AND TRANSLITERATES TO "WANPIKAZOKU".

FOR ACTION FIGURE TOYS; ACTION FIGURES; MULTIPLE ACTIVITY TOYS FOR BABIES; BATH TOYS; BATTERY-OPERATED ACTION TOYS; BENDABLE TOYS; DOMINOES; ACTION SKILL GAMES; ARCADE GAMES; CASES FOR PLAY ACCESSORIES; ORDINARY PLAYING CARDS; TOY PIANOS (U.S. CLS. 22, 23, 38 AND 50).

DAWN FELDMAN, EXAMINING ATTORNEY

SN 85-389,494. BEACH TENNIS USA, LLC, FRANKLIN SQUARE, NY. FILED 8-4-2011.

ALL-VOLLEY TENNIS

THE MARK CONSISTS OF STANDARD CHARACTERS WITHOUT CLAIM TO ANY PARTICULAR FONT, STYLE, SIZE, OR COLOR.

NO CLAIM IS MADE TO THE EXCLUSIVE RIGHT TO USE "TENNIS", APART FROM THE MARK AS SHOWN.

FOR SPORTS EQUIPMENT, NAMELY, BEACH TENNIS PADDLES; NETS FOR SPORTS (U.S. CLS. 22, 23, 38 AND 50).

FIRST USE 2-0-2011; IN COMMERCE 2-0-2011.

ALEXANDER L. POWERS, EXAMINING ATTORNEY

CLASS 28—(Continued).

SN 85-391,449. ANGLER INNOVATIONS, LLC, BORING, OR. FILED 8-6-2011.

ANGLER INNOVATIONS

THE MARK CONSISTS OF STANDARD CHARACTERS WITHOUT CLAIM TO ANY PARTICULAR FONT, STYLE, SIZE, OR COLOR.

NO CLAIM IS MADE TO THE EXCLUSIVE RIGHT TO USE "ANGLER", APART FROM THE MARK AS SHOWN.

FOR FISHING TACKLE (U.S. CLS. 22, 23, 38 AND 50).

FIRST USE 11-16-2007; IN COMMERCE 8-30-2009.

MARIA-VICTORIA SUAREZ, EXAMINING ATTORNEY

SN 85-394,578. WORLD WRESTLING ENTERTAINMENT, INC., STAMFORD, CT. FILED 8-10-2011.

EXTREME CHAMPIONSHIP WRESTLING

THE MARK CONSISTS OF STANDARD CHARACTERS WITHOUT CLAIM TO ANY PARTICULAR FONT, STYLE, SIZE, OR COLOR.

NO CLAIM IS MADE TO THE EXCLUSIVE RIGHT TO USE "WRESTLING", APART FROM THE MARK AS SHOWN.

FOR TOYS, NAMELY, ACTION FIGURES AND ACCESSORIES THEREFOR; CASES FOR ACTION FIGURES; TOY WRESTLING RINGS; TOY VEHICLES; BOARD GAMES; PLAYING CARDS; PUZZLES; STUFFED TOYS; PLUSH TOYS; TOY BELTS; KNEE AND ELBOW PADS FOR ATHLETIC USE; TOY FOAM HANDS; COSTUME MASKS; DOLLS (U.S. CLS. 22, 23, 38 AND 50).

JOHN DALIER, EXAMINING ATTORNEY

SN 85-397,385. SHIMANO INC., SAKAI CITY, OSAKA, JAPAN, FILED 8-13-2011.

TALICA 20BFC

THE MARK CONSISTS OF STANDARD CHARACTERS WITHOUT CLAIM TO ANY PARTICULAR FONT, STYLE, SIZE, OR COLOR.

OWNER OF U.S. REG. NO. 3,719,889.

THE WORDING "TALICA" HAS NO MEANING IN A FOREIGN LANGUAGE.

FOR FISHING REELS; FISHING TACKLE (U.S. CLS. 22, 23, 38 AND 50).

ALEX KEAM, EXAMINING ATTORNEY

CLASS 28—(Continued).

SN 85-397,609. ACUSHNET COMPANY, FAIRHAVEN, MA.
FILED 8-15-2011.

SUREFIT

THE MARK CONSISTS OF STANDARD CHARACTERS WITHOUT CLAIM TO ANY PARTICULAR FONT, STYLE, SIZE, OR COLOR.

FOR GOLF CLUBS; GOLF CLUB COMPONENTS, NAMELY, SLEEVE AND RING WHICH ROTATES TO PROVIDE ADJUSTMENT (U.S. CLS. 22, 23, 38 AND 50).
FIRST USE 2-0-2008; IN COMMERCE 2-0-2008.

VIVIAN MICZNIK FIRST, EXAMINING ATTORNEY

SN 85-400,303. O2TRAINER, INC., WESTLAKE VILLAGE, CA. FILED 8-17-2011.

O2 TRAINER

THE MARK CONSISTS OF STANDARD CHARACTERS WITHOUT CLAIM TO ANY PARTICULAR FONT, STYLE, SIZE, OR COLOR.

NO CLAIM IS MADE TO THE EXCLUSIVE RIGHT TO USE "TRAINER", APART FROM THE MARK AS SHOWN.

FOR EXERCISE EQUIPMENT, NAMELY, BREATHING APPARATUS FOR STRENGTHENING THE LUNGS (U.S. CLS. 22, 23, 38 AND 50).

FIRST USE 5-5-2009; IN COMMERCE 2-23-2011.
RONALD AIKENS, EXAMINING ATTORNEY

CLASS 28—(Continued).

SN 85-409,482. PINE FOREST CAMO, LLC, PALM BAY, FL.
FILED 8-29-2011.



THE MARK CONSISTS OF THE LETTERS "P", "F", AND "C" DISPOSED IN A TRADITIONAL CATTLE BRAND STYLE CONFIGURATION WITH THE LETTER "P" BEING LOCATED AT THE TOP CENTER OF THE DESIGN, THE LETTER "F" BEING LOCATED AT THE BOTTOM LEFT OF THE DESIGN, AND THE LETTER "C" BEING LOCATED AT THE BOTTOM RIGHT OF THE DESIGN.

FOR VINYL URETHANE FILMS FEATURING CAMOUFLAGE PATTERNS FOR HUNTING PURPOSES (U.S. CLS. 22, 23, 38 AND 50).

WARREN L. OLANDRIA, EXAMINING ATTORNEY

SN 85-409,667. Q-NINER, LLC, MUSCATINE, IA. FILED 8-29-2011.

Q-NINER

THE MARK CONSISTS OF STANDARD CHARACTERS WITHOUT CLAIM TO ANY PARTICULAR FONT, STYLE, SIZE, OR COLOR.

FOR HUNTING ACCESSORIES, NAMELY, WATERFOWL HUNTING DECOY SUPPORT FRAMES AND FLOATING WATERFOWL HUNTING DECOY FRAMES (U.S. CLS. 22, 23, 38 AND 50).

RONALD DELGIZZI, EXAMINING ATTORNEY

SN 85-435,839. FERENC KUNCZ, MIAMI, FL. FILED 9-29-2011.

X-45

THE MARK CONSISTS OF STANDARD CHARACTERS WITHOUT CLAIM TO ANY PARTICULAR FONT, STYLE, SIZE, OR COLOR.

FOR RACKETS FOR TENNIS, RACQUETBALL AND SQUASH (U.S. CLS. 22, 23, 38 AND 50).

FIRST USE 8-19-2001; IN COMMERCE 8-19-2001.
BARBARA GAYNOR, EXAMINING ATTORNEY

CLASS 28—(Continued).

SN 85-446,459. J. LLOYD INTERNATIONAL, INC, CEDAR RAPIDS, IA. FILED 10-13-2011.

CLASS 28—(Continued).

SN 85-469,809. KDE DIRECT, WASHOUGAL, WA. FILED 11-10-2011.

SUZY HOMEMAKER

THE MARK CONSISTS OF STANDARD CHARACTERS WITHOUT CLAIM TO ANY PARTICULAR FONT, STYLE, SIZE, OR COLOR.

FOR CHILDREN'S TOYS, NAMELY, HOUSEKEEPING TOYS, NAMELY, BROOMS, MOPS, DUST PANS, AND TEA SETS; DOLL CARE SETS COMPOSED OF BABY BOTTLES, BIBS, AND PLAY PACIFIERS (U.S. CLS. 22, 23, 38 AND 50).

FIRST USE 5-31-2000; IN COMMERCE 5-31-2000.
FRANK LATTUCA, EXAMINING ATTORNEY



SN 85-456,142. CLOUD B, INC., GARDENA, CA. FILED 10-25-2011.

SLEEP SHEEP ON THE GO

THE MARK CONSISTS OF STANDARD CHARACTERS WITHOUT CLAIM TO ANY PARTICULAR FONT, STYLE, SIZE, OR COLOR.

OWNER OF U.S. REG. NO. 2,973,422.

NO CLAIM IS MADE TO THE EXCLUSIVE RIGHT TO USE "SHEEP", APART FROM THE MARK AS SHOWN.

FOR STUFFED TOY ANIMAL (U.S. CLS. 22, 23, 38 AND 50).

ZACHARY BELLO, EXAMINING ATTORNEY

THE MARK CONSISTS OF A SQUARE WITH AN OVAL SHAPE ON THE INNER LEFT SIDE OF THE SQUARE AND THE LETTERS "KDE" AND THE WORD "DIRECT" ALONG THE UPPER SECTION.

FOR REMOTE CONTROL TOY GLIDER, AIRPLANE, SAILPLANE, AND HELICOPTER EQUIPMENT AND PARTS, NAMELY, ROTOR HEAD MECHANICS, TAIL PITCH CONTROL ASSEMBLIES, BRUSHLESS MOTORS AND MOUNTS, BATTERY SUPPORTS, MAIN ROTOR BEARING BLOCKS, FRAME BRACES, AND TRANSMISSION COMPONENTS (U.S. CLS. 22, 23, 38 AND 50).

FIRST USE 5-1-2008; IN COMMERCE 5-1-2008.

GIANCARLO CASTRO, EXAMINING ATTORNEY

CLASS 28—(Continued).

SN 85-470,997. MIAMI MARLINS, L.P., MIAMI, FL. FILED 11-11-2011.



THE COLOR(S) ORANGE, YELLOW, WHITE, BLUE AND SILVER IS/ARE CLAIMED AS A FEATURE OF THE MARK.

THE MARK CONSISTS OF A STYLIZED LETTER "M" ALTERNATELY LINED IN SILVER, ORANGE, YELLOW, WHITE AND BLUE WITH A STYLIZED FISH DESIGN ALTERNATELY LINED IN SILVER, ORANGE, WHITE AND BLUE CURLING AROUND THE UPPER LEFT SIDE OF THE "M".

FOR TOYS AND SPORTING GOODS, NAMELY, STUFFED TOYS, PLUSH TOYS, SOFT SCULPTURE FOAM TOYS, FOAM NOVELTY ITEMS, NAMELY, FOAM FINGERS, PUPPETS, BALLOONS, CHECKER SETS, CHESS SETS, DOMINOES, BOARD GAMES, CARD GAMES, DICE GAMES, TRIVIA GAME PLAYED WITH CARDS AND GAME COMPONENTS, PARLOR GAMES, PLAYING CARDS, DART BOARDS AND DART BOARD ACCESSORIES, NAMELY, DARTS, DART SHAFTS AND DART FLIGHTS, TOY CARS AND TRUCKS, TOY TRAINS, TOY MOBILES, PUZZLES, YO-YO'S, TOY BANKS, TOY FIGURES, TOY VEHICLES, DOLLS AND DOLL ACCESSORIES, BOBBING HEAD DOLLS, DECORATIVE WIND SOCKS, MINIATURE BASEBALL BATS, MINI BATTING HELMET REPLICAS, TOY NECKLACES, MINIATURE TOY BASEBALLS, BASEBALLS, HOLDERS FOR BASEBALLS, AUTOGRAPHED BASEBALLS, PLAYGROUND BALLS, BEACH BALLS, GOLF BALLS, GOLF CLUB HEAD COVERS, GOLF CLUB BAGS, GOLF PUTTERS, GAME TABLES, CORNHOLE SETS, NAMELY, BEAN BAG GAMES, BILLIARD ACCESSORIES, NAMELY, CUES, BILLIARD BALLS AND CUE CASES, BASEBALL BASES, BASEBALL BATS, BATTING GLOVES, PET TOYS, INFLATABLE TOYS, SNOW SLEDS FOR RECREATIONAL USE, SNOW GLOBES, COSTUME MASKS, CHRISTMAS TREE ORNAMENTS AND DECORATIONS, FLYING DISKS, ACTION FIGURES, BALLS FOR GAMES, GAMING EQUIPMENT, NAMELY, POKER CHIPS, INFLATABLE TOYS AND LOTTERY TICKETS (U.S. CLS. 22, 23, 38 AND 50).

KATHY DE JONGE, EXAMINING ATTORNEY

CLASS 28—(Continued).

SN 85-475,208. WILSON SPORTING GOODS CO., CHICAGO, IL. FILED 11-17-2011.



OWNER OF U.S. REG. NO. 1,902,873.

THE MARK CONSISTS OF THE TERM "ATEC" SURROUNDED BY A PLURALITY OF OVALS AND INCLUDING A TAPERED LINE EXTENDING OVER THE TERM.

FOR BASEBALL AND SOFTBALL EQUIPMENT, NAMELY, BALL TOSsing MACHINES, BALL PITCHING MACHINES, NETS, BALL TEES, BALL BASKETS, BALL BAGS, BAT BAGS, PROTECTIVE BASEBALL AND SOFTBALL PITCHING SCREENS, PRACTICE NETS, BALL FEEDERS IN THE NATURE OF BASEBALL AND SOFTBALL TRAINING APPARATUS USED FOR PITCHING AND BATTING, BALL BACK STOPS, BATTING CAGES, AND BASES (U.S. CLS. 22, 23, 38 AND 50).

FIRST USE 1-1-2004; IN COMMERCE 1-1-2004.

FONG HSU, EXAMINING ATTORNEY

SN 85-477,687. CWA CARLIN WEST AGENCY LCC, NEW YORK, NY. FILED 11-21-2011.

Militeddy Bears

THE MARK CONSISTS OF STANDARD CHARACTERS WITHOUT CLAIM TO ANY PARTICULAR FONT, STYLE, SIZE, OR COLOR.

NO CLAIM IS MADE TO THE EXCLUSIVE RIGHT TO USE "BEARS", APART FROM THE MARK AS SHOWN.

FOR STUFFED TOY BEARS (U.S. CLS. 22, 23, 38 AND 50).

MICHAEL TANNER, EXAMINING ATTORNEY

CLASS 28—(Continued).

SN 85-479,230. BIG BANG INC., BOONTON, NJ. FILED 11-22-2011.



OWNER OF U.S. REG. NO. 3,693,559.
THE COLOR(S) BLACK, WHITE, RED AND GRAY IS/ARE CLAIMED AS A FEATURE OF THE MARK.

THE MARK CONSISTS OF THE WORDING "THE DRAGONS OF BLIZZARD ISLAND" IN STYLIZED TEXT, WITH THE WORDS "THE", "OF" AND "ISLAND" IN GRAY AND WHITE OUTLINED IN BLACK, AND THE WORDS "DRAGONS" AND "BLIZZARD" IN RED OUTLINED IN BLACK WITH WHITE SNOW/ICE HANGING FROM AND APPEARING ON INDIVIDUAL LETTERS OF THE WORDS.

FOR ACTION FIGURES; MOLDED TOY FIGURES; PLUSH TOYS (U.S. CLS. 22, 23, 38 AND 50).

FIRST USE 6-23-2009; IN COMMERCE 6-23-2009.

DOMINIC J. FERRAIUOLO, EXAMINING ATTORNEY

SN 85-479,754. SLICK STUFF, LLC, GLEN MILLS, PA. FILED 11-23-2011.

PARTY RATTLZ

THE MARK CONSISTS OF STANDARD CHARACTERS WITHOUT CLAIM TO ANY PARTICULAR FONT, STYLE, SIZE, OR COLOR.

NO CLAIM IS MADE TO THE EXCLUSIVE RIGHT TO USE "RATTLES", APART FROM THE MARK AS SHOWN.

FOR HAND-MOUNTABLE NOISEMAKERS FOR USE AT SPORTING AND CELEBRATORY EVENTS (U.S. CLS. 22, 23, 38 AND 50).

MARILYN IZZI, EXAMINING ATTORNEY

SN 85-484,592. ROSS ARCHERY INC., OLATHE, KS. FILED 12-1-2011.



THE COLOR(S) WHITE, GOLD AND BLACK IS/ARE CLAIMED AS A FEATURE OF THE MARK.

THE MARK CONSISTS OF THE CAPITAL LETTERS "XD" IN BLACK BORDERED WITH GOLD, WITH THE "X" APPEARING AS A WHITE SILHOUETTE FORMED BY A LARGE TRIANGLE ON THE LEFT SIDE AND THE RIGHT

CLASS 28—(Continued).

SIDE, A SMALL TRIANGLE ON THE TOP AND THE BOTTOM; THE RIGHT SIDE OF THE LETTER "D" SHOWING GOLD AND BLACK SHARDS OF THE LETTER BLOWN AWAY; THE WORDS "XTREME DEVASTATION" APPEAR BELOW THE "XD" LETTERS. THE WORD "XTREME" IS IN GOLD AND "DEVASTATION" IS IN BLACK; STARTING WITH THE "D" FROM DEVASTATION THE LETTERS ARE PROGRESSIVELY SHOWN WITH MORE SHARDS UNTIL THE LETTER "N" IS MOSTLY BLOWN AWAY.

FOR ARCHERY EQUIPMENT, NAMELY, ARCHERY BOWS (U.S. CLS. 22, 23, 38 AND 50).

CAROLYN CATALDO, EXAMINING ATTORNEY

SN 85-488,873. BAZOO GLOBAL, LLC, HUBBARD, OH. FILED 12-6-2011.



OWNER OF U.S. REG. NO. 3,198,653.

THE MARK CONSISTS OF THE WORDS "BAZOO GLOBAL" WITHIN A RECTANGLE.

FOR GAMES AND PLAYTHINGS, NAMELY, BATTERY-POWERED COMPUTER GAME WITH LCD SCREEN, CARD GAMES, BOARD GAMES, BUILDING GAMES, DICE GAMES, ELECTRONIC EDUCATIONAL GAME MACHINES FOR CHILDREN, ELECTRONIC GAMES FOR THE TEACHING OF CHILDREN, TOY BOXES AND CHESTS, ELECTRONIC GAMES OTHER THAN THOSE ADAPTED FOR USE WITH TELEVISION RECEIVERS, BATH TOYS, EQUIPMENT SOLD AS A UNIT FOR PLAYING BOARD GAMES, EQUIPMENT SOLD AS A UNIT FOR PLAYING CARD GAMES, BATHTUB TOYS, HAND HELD UNITS FOR PLAYING ELECTRONIC GAMES OTHER THAN THOSE ADAPTED FOR USE WITH AN EXTERNAL DISPLAY SCREEN OR MONITOR, HAND HELD UNITS FOR PLAYING VIDEO GAMES OTHER THAN THOSE ADAPTED FOR USE WITH AN EXTERNAL DISPLAY SCREEN OR MONITOR, MANIPULATIVE GAMES, MEMORY GAMES, PARLOR GAMES, PARTY GAMES, PINBALL-TYPE GAMES, PUZZLE GAMES, TARGET GAMES, TOY, BATTERY-POWERED COMPUTER GAME WITH LCD SCREEN WHICH FEATURES ANIMATION AND SOUND EFFECTS, BATTERY OPERATED ACTION TOYS, BENDABLE TOYS, CAPS FOR TOY PISTOLS, CASES FOR TOY VEHICLES, CLOCKWORK TOYS OF METAL, CLOCKWORK TOYS OF PLASTIC, COLLECTABLE TOY FIGURES, DISC TOSS TOYS, DOG TOYS, ELECTRONIC LEARNING TOYS, ELECTRONICALLY OPERATED TOY MOTOR VEHICLES, FANTASY CHARACTER TOYS, FLYING SAUCER TOYS, INFANT ACTION CRIB TOYS, INFANT DEVELOPMENT TOYS, INFANT TOYS, INFLATABLE BATH TOYS, INFLATABLE TOYS, LEVER ACTION TOYS, MECHANICAL ACTION TOYS, MECHANICAL TOYS, MODELED PLASTIC TOY FIGURINES, MOLDED TOY FIGURES, MUSIC BOX TOYS, MUSICAL TOYS, NON-RIDING TRANSPORTATION TOYS, PARTY FAVORS IN THE NATURE OF SMALL TOYS, PLASTIC CHARACTER TOYS, PRINTING TOYS, PULL TOYS, PUNCHING TOYS, PUSH TOYS, REMOTE CONTROL TOYS, NAMELY, ROBOTS AND KITES, RIDE-ON TOYS, RUBBER CHARACTER TOYS, SAND TOYS, SANDBOX TOYS, SQUEEZABLE SQUEAKING TOYS, SQUEEZE TOYS, STACKING TOYS, TALKING TOYS, TOSsing DISC TOYS, TOY AIRPLANES, TOY ANIMALS AND ACCESSORIES THEREFORE, TOY ARMOR, TOY BAKEWARE AND COOKWARE, TOY BANKS, TOY BOWS AND ARROWS, TOY BOXES, TOY BUILDING BLOCKS, TOY BUILDING BLOCKS CAPABLE OF INTERCONNECTION, TOY BUTTERFLY NETS, TOY CAP PISTOLS, TOY CLOCKS AND

CLASS 28—(Continued).

WATCHES, TOY CONSTRUCTION BLOCKS, TOY CONSTRUCTION SETS, TOY FIGURES, TOY FURNITURE, TOY GLIDERS, TOY GUNS, TOY HARMONICAS, TOY HOOP SETS, TOY MAIL BOXES, TOY MASKS, TOY CARS, TOY MODEL TRAIN SETS, TOY MODELING DOUGH, TOY MUSIC BOXES, TOY NOISEMAKERS, TOY PIANOS, TOY PISTOLS, TOY PRISM GLASSES, TOY PUTTY, TOY ROBOTS, TOY ROCKETS, TOY SAFES, TOY SCOOTERS, TOY SETS OF CARPENTERS' TOOLS, TOY SNOW GLOBES, TOY SWORDS, TOY TRAINS, TOY VEHICLES, TOY WATER GLOBES, TOY WEAPONS, TOY XYLOPHONES, TOY POP GUNS, DISK TOSS GAME WHEREIN OTHER DISKS ARE FLIPPED AND COLLECTED, WATER SQUIRTING TOYS, WIND-UP WALKING TOYS, JACK - IN - THE - BOXES, TOY DISH SETS; NONE OF THE AFOREMENTIONED GOODS BEING RELATED TO JEWELRY OR CRAFT KITS (U.S. CLS. 22, 23, 38 AND 50).

FIRST USE 1-15-2009; IN COMMERCE 1-15-2009.
TRACY WHITTAKER-BROWN, EXAMINING ATTORNEY

SN 85-489,025. PLAYCORE IP SUB, INC., CHATTANOOGA, TN. FILED 12-7-2011.



THE MARK CONSISTS OF "G2" WITH TWO SWIRLS AROUND THE "G" AND THE "2".

FOR PLAYGROUND EQUIPMENT, NAMELY, SPINNING UNITS IN THE NATURE OF A ROTATING BASKET ON A POLE MOUNT (U.S. CLS. 22, 23, 38 AND 50).

MATTHEW PAPPAS, EXAMINING ATTORNEY

SN 85-489,984. SHEETS, TODD R, MISSION VIEJO, CA. FILED 12-7-2011.

ABLITERATOR

THE MARK CONSISTS OF STANDARD CHARACTERS WITHOUT CLAIM TO ANY PARTICULAR FONT, STYLE, SIZE, OR COLOR.

FOR EXERCISE EQUIPMENT, NAMELY, ABDOMINAL EXERCISE DEVICE (U.S. CLS. 22, 23, 38 AND 50).
ANGELA DUONG, EXAMINING ATTORNEY

CLASS 28—(Continued).

SN 85-491,235. INNOVATIVE DESIGN & SOURCING, LLC, MILFORD, CT. FILED 12-9-2011.

WET DOG

THE MARK CONSISTS OF STANDARD CHARACTERS WITHOUT CLAIM TO ANY PARTICULAR FONT, STYLE, SIZE, OR COLOR.

NO CLAIM IS MADE TO THE EXCLUSIVE RIGHT TO USE "DOG", APART FROM THE MARK AS SHOWN.
FOR PET TOYS (U.S. CLS. 22, 23, 38 AND 50).
GEOFFREY FOSDICK, EXAMINING ATTORNEY

SN 85-492,914. HEARTLAND CONSUMER PRODUCTS, LLC, LAKEWOOD, OH. FILED 12-12-2011.

RODEO RUMMY

THE MARK CONSISTS OF STANDARD CHARACTERS WITHOUT CLAIM TO ANY PARTICULAR FONT, STYLE, SIZE, OR COLOR.

NO CLAIM IS MADE TO THE EXCLUSIVE RIGHT TO USE "RUMMY", APART FROM THE MARK AS SHOWN.
FOR DICE AND DICE GAMES (U.S. CLS. 22, 23, 38 AND 50).

KEVON CHISOLM, EXAMINING ATTORNEY

SN 85-493,024. RUBIE'S COSTUME CO., INC., RICHMOND HILL, NY. FILED 12-12-2011.

FLUTTERY LASHES

THE MARK CONSISTS OF STANDARD CHARACTERS WITHOUT CLAIM TO ANY PARTICULAR FONT, STYLE, SIZE, OR COLOR.

NO CLAIM IS MADE TO THE EXCLUSIVE RIGHT TO USE "LASHES", APART FROM THE MARK AS SHOWN.
FOR TOY NOVELTY ITEMS IN THE NATURE OF NOVELTY EYELASHES AND USED PRIMARILY BY CHILDREN IN DISGUISES (U.S. CLS. 22, 23, 38 AND 50).

FIRST USE 6-1-1974; IN COMMERCE 6-1-1974.
SUSAN BILLHEIMER, EXAMINING ATTORNEY

CLASS 28—(Continued).

SN 85-493,259. WARNER BROS. ENTERTAINMENT INC., BURBANK, CA. FILED 12-12-2011.

GREYFOUNDRY

THE MARK CONSISTS OF STANDARD CHARACTERS WITHOUT CLAIM TO ANY PARTICULAR FONT, STYLE, SIZE, OR COLOR.

FOR TOYS AND SPORTING GOODS, INCLUDING GAMES AND PLAYTHINGS, NAMELY, ACTION FIGURES AND ACCESSORIES THEREFOR; PLUSH TOYS; BALLOONS; EQUIPMENT SOLD AS A UNIT FOR PLAYING CARD GAMES; TOY VEHICLES; DOLLS; FLYING DISCS; HAND HELD UNITS FOR PLAYING ELECTRONIC GAMES OTHER THAN THOSE ADAPTED FOR USE WITH AN EXTERNAL DISPLAY SCREEN OR MONITOR; GAME EQUIPMENT SOLD AS A UNIT FOR PLAYING A BOARD GAME, A CARD GAME, A MANIPULATIVE GAME, A PARLOR GAME AND AN ACTION TYPE TARGET GAME; STAND ALONE VIDEO OUTPUT GAME MACHINES; JIGSAW AND MANIPULATIVE PUZZLES; PAPER FACE MASKS; SKATEBOARDS; ICE SKATES; WATER SQUIRTING TOYS; AND CHRISTMAS TREE ORNAMENTS (U.S. CLS. 22, 23, 38 AND 50).

THEODORE MCBRIDE, EXAMINING ATTORNEY

SN 85-498,059. DUSTIN BERK, IRVINE, CA. FILED 12-17-2011.

NINJA CARDS

THE MARK CONSISTS OF STANDARD CHARACTERS WITHOUT CLAIM TO ANY PARTICULAR FONT, STYLE, SIZE, OR COLOR.

NO CLAIM IS MADE TO THE EXCLUSIVE RIGHT TO USE "CARDS", APART FROM THE MARK AS SHOWN.

FOR ACTION SKILL GAME; ACTION TARGET GAME (U.S. CLS. 22, 23, 38 AND 50).

BRIDGETT SMITH, EXAMINING ATTORNEY

SN 85-498,536. PRACTICAL STRATEGIES, INC., WEST BEND, WI. FILED 12-19-2011.

SPEAK DC

THE MARK CONSISTS OF STANDARD CHARACTERS WITHOUT CLAIM TO ANY PARTICULAR FONT, STYLE, SIZE, OR COLOR.

NO CLAIM IS MADE TO THE EXCLUSIVE RIGHT TO USE "DC", APART FROM THE MARK AS SHOWN.

FOR CARD GAMES FEATURING GOVERNMENT ACRONYMS (U.S. CLS. 22, 23, 38 AND 50).

FIRST USE 12-19-2011; IN COMMERCE 12-19-2011.

JENNIFER MARTIN, EXAMINING ATTORNEY

CLASS 28—(Continued).

SN 85-500,294. THE TRUSTEE OF THE SMITH TRUST, THE TRUSTEE COMPRISING REBA MCENTIRE BLACKSTOCK, A U.S. CITIZEN, NASHVILLE, TN. FILED 12-20-2011.

REBA

THE MARK CONSISTS OF STANDARD CHARACTERS WITHOUT CLAIM TO ANY PARTICULAR FONT, STYLE, SIZE, OR COLOR.

OWNER OF U.S. REG. NOS. 2,090,414, 3,838,774 AND 3,932,509.

THE NAME(S), PORTRAIT(S), AND/OR SIGNATURE(S) SHOWN IN THE MARK IDENTIFIES REBA MCENTIRE BLACKSTOCK, WHOSE CONSENT(S) TO REGISTER IS MADE OF RECORD.

FOR CHRISTMAS TREE ORNAMENTS AND DECORATIONS (U.S. CLS. 22, 23, 38 AND 50).

FIRST USE 9-30-2011; IN COMMERCE 9-30-2011.

ANNE FARRELL, EXAMINING ATTORNEY

SN 85-500,515. SPORTSMEN'S OUTDOOR STRATEGIES, LLC., FORKSVILLE, PA. FILED 12-21-2011.

SLAYER CROSSBOWS

THE MARK CONSISTS OF STANDARD CHARACTERS WITHOUT CLAIM TO ANY PARTICULAR FONT, STYLE, SIZE, OR COLOR.

NO CLAIM IS MADE TO THE EXCLUSIVE RIGHT TO USE "CROSSBOWS", APART FROM THE MARK AS SHOWN.

FOR CROSSBOWS; ARCHERY BOWS; ARCHERY EQUIPMENT, NAMELY, ARM GUARDS, ARROW FLETCHING DEVICES, BOW CASES, NON-TELESCOPIC BOW SIGHTS, QUIVERS; ARCHERY BOW STRINGS; ARCHERY BOW STRING CHANGERS; ARCHERY ARROWS; ARCHERY SETS; ARCHERY TARGETS (U.S. CLS. 22, 23, 38 AND 50).

FIRST USE 11-9-2009; IN COMMERCE 9-1-2011.

WILLIAM BRECKENFELD, EXAMINING ATTORNEY

CLASS 28—(Continued).

SN 85-500,775. RAW TOYS LLC, ST. PAUL, MN. FILED 12-21-2011.

RAW CREATIVITY

THE MARK CONSISTS OF STANDARD CHARACTERS WITHOUT CLAIM TO ANY PARTICULAR FONT, STYLE, SIZE, OR COLOR.

FOR CHILDREN'S EDUCATIONAL TOYS AND GAMES FOR COGNITIVE AND MOTOR SKILLS DEVELOPMENT; BOARD AND CARD GAMES; HOBBY CRAFT KITS COMPRISING RECYCLABLE CRAFT PAPER, CRAFT CARDBOARD, ADHESIVE TAPE, ADHESIVE STICKERS, CRAFT GLUE, STRING, YARN, THREAD, RIBBONS, FABRIC, PAPER AND CARDBOARD TUBES, PAPER AND CARDBOARD BOXES, ELASTIC BANDS, FUNNELS AND TONGUE DEPRESSORS (U.S. CLS. 22, 23, 38 AND 50).

LINDA ORNDORFF, EXAMINING ATTORNEY

SN 85-501,607. TAGLIAVIA, JOSEPH, STATEN ISLAND, NY. FILED 12-21-2011.



NO CLAIM IS MADE TO THE EXCLUSIVE RIGHT TO USE "ROCK", APART FROM THE MARK AS SHOWN.

THE MARK CONSISTS OF TWO CIRCLES WITH THE STYLIZED TEXT "RETALIATION ROCK" ON THE OUTER CIRCLE. IN THE MIDDLE THERE IS THE LETTER "RR" BACK TO BACK.

FOR TOYS OF FOAM, NAMELY, NOVELTY FOAM ROCKS (U.S. CLS. 22, 23, 38 AND 50).

LINDA ORNDORFF, EXAMINING ATTORNEY

CLASS 28—(Continued).

SN 85-502,895. JOSE LINARES, FEEDING HILLS, MA. FILED 12-23-2011.

FlexTerrain

THE MARK CONSISTS OF STANDARD CHARACTERS WITHOUT CLAIM TO ANY PARTICULAR FONT, STYLE, SIZE, OR COLOR.

FOR GAME EQUIPMENT, NAMELY, THREE-DIMENSIONAL ASSEMBLIES TO SIMULATE TOPOGRAPHY, NAMELY, RIVERS, BRIDGES, STONE WALLS, ROADS, BLUFFS, MOUNTAINS AND VALLEYS (U.S. CLS. 22, 23, 38 AND 50).

EDWARD NELSON, EXAMINING ATTORNEY

SN 85-506,293. DOMESTIC ACTIVITIES INC., NEWARK, NJ. FILED 12-30-2011.

Domestic Activities Inc.

THE MARK CONSISTS OF STANDARD CHARACTERS WITHOUT CLAIM TO ANY PARTICULAR FONT, STYLE, SIZE, OR COLOR.

NO CLAIM IS MADE TO THE EXCLUSIVE RIGHT TO USE "INC.", APART FROM THE MARK AS SHOWN.

FOR BOARD GAMES; PUZZLES (U.S. CLS. 22, 23, 38 AND 50).

ANDREW RHIM, EXAMINING ATTORNEY

SN 85-506,304. PARK, JONG CHOO, MARIETTA, GA. FILED 12-30-2011.



THE MARK CONSISTS OF A BABY SEAL IMAGE AND THE STYLIZED WORDING "S O S SAVE OUR SPACE" UNDERNEATH THE BABY SEAL IMAGE.

FOR PLUSH TOYS; STUFFED AND PLUSH TOYS; STUFFED TOY ANIMALS (U.S. CLS. 22, 23, 38 AND 50). FIRST USE 11-3-2003; IN COMMERCE 11-3-2003.

BRENDAN MCCAULEY, EXAMINING ATTORNEY

CLASS 28—(Continued).

SN 85-506,358. NOMAD LACROSSE DISTRIBUTORS, LLC, FREEHOLD, NJ. FILED 12-30-2011.

PREDATOR

THE MARK CONSISTS OF STANDARD CHARACTERS WITHOUT CLAIM TO ANY PARTICULAR FONT, STYLE, SIZE, OR COLOR.

FOR LACROSSE EQUIPMENT, NAMELY, LACROSSE GOALS, LACROSSE NETS, LACROSSE BALL AND STICK BAGS, LACROSSE PRACTICE TARGETS (U.S. CLS. 22, 23, 38 AND 50).

FIRST USE 7-2-2010; IN COMMERCE 7-2-2010.
SANDRA BUJA, EXAMINING ATTORNEY

SN 85-506,543. BREB, LLC, WEST MONROE, LA. FILED 12-30-2011.



THE MARK CONSISTS OF THE IMAGE OF TWO PEOPLE PLAYING SOCCER WITH A SOCCER BALL AT THE LOWER LEFT HAND CORNER, ALL IMAGES BEING INSIDE A CIRCULAR DESIGN.

FOR SOCCER GOAL NETS (U.S. CLS. 22, 23, 38 AND 50).
SANJEEV VOHRA, EXAMINING ATTORNEY

SN 85-506,545. BREB, LLC, WEST MONROE, LA. FILED 12-30-2011.

MIDDLE DEFENDER

THE MARK CONSISTS OF STANDARD CHARACTERS WITHOUT CLAIM TO ANY PARTICULAR FONT, STYLE, SIZE, OR COLOR.

FOR SOCCER GOAL NETS (U.S. CLS. 22, 23, 38 AND 50).
SANJEEV VOHRA, EXAMINING ATTORNEY

CLASS 28—(Continued).

SN 85-506,554. NOELLE ENTERPRISES, INC., WILMINGTON, NC. FILED 12-30-2011.

The Little Tree of Big Wishes

THE MARK CONSISTS OF STANDARD CHARACTERS WITHOUT CLAIM TO ANY PARTICULAR FONT, STYLE, SIZE, OR COLOR.

FOR HOLIDAY ORNAMENTS, NAMELY, DECORATIVE ITEMS IN THE SHAPE OF CHRISTMAS TREES WITH ACRYLIC STAR ORNAMENTS (U.S. CLS. 22, 23, 38 AND 50).

FIRST USE 12-27-2011; IN COMMERCE 12-27-2011.
DAVID MURRAY, EXAMINING ATTORNEY

SN 85-506,568. FP CONCEPTS, LLC, DBA GAME SIGNS, DAVIS, CA. FILED 12-30-2011.

GAME SIGNS

THE MARK CONSISTS OF STANDARD CHARACTERS WITHOUT CLAIM TO ANY PARTICULAR FONT, STYLE, SIZE, OR COLOR.

NO CLAIM IS MADE TO THE EXCLUSIVE RIGHT TO USE "GAME", APART FROM THE MARK AS SHOWN.

FOR OUTDOOR ACTIVITY GAME EQUIPMENT IN THE NATURE OF ATHLETIC SIGNAL ENHANCEMENT EQUIPMENT, NAMELY, STICKERS USED ON THE HANDS OF BASEBALL AND SOFTBALL CATCHERS AND OTHER ATHLETES WHO USE HAND SIGNALS (U.S. CLS. 22, 23, 38 AND 50).

ELISSA GARBER KON, EXAMINING ATTORNEY

CLASS 28—(Continued).

SN 85-506,573. FP CONCEPTS, LLC, DBA GAME SIGNS, DAVIS, CA. FILED 12-30-2011.



NO CLAIM IS MADE TO THE EXCLUSIVE RIGHT TO USE "GAME", APART FROM THE MARK AS SHOWN.

THE MARK CONSISTS OF THE WORDS "GAME SIGNS" UNDER A STYLIZED BASEBALL WITH A SMILING FACE. THERE ARE TWO OVAL SHAPES INSIDE THE UPPER CASE "G" AND FIRST "S" IN "SIGNS".

FOR OUTDOOR ACTIVITY GAME EQUIPMENT IN THE NATURE OF ATHLETIC SIGNAL ENHANCEMENT EQUIPMENT, NAMELY, STICKERS USED ON THE HANDS OF BASEBALL AND SOFTBALL CATCHERS AND OTHER ATHLETES WHO USE HAND SIGNALS (U.S. CLS. 22, 23, 38 AND 50).

ELISSA GARBER KON, EXAMINING ATTORNEY

SN 85-506,581. FP CONCEPTS, LLC, DBA GAME SIGNS, DAVIS, CA. FILED 12-30-2011.

DON'T GET CROSSED UP

THE MARK CONSISTS OF STANDARD CHARACTERS WITHOUT CLAIM TO ANY PARTICULAR FONT, STYLE, SIZE, OR COLOR.

FOR OUTDOOR ACTIVITY GAME EQUIPMENT IN THE NATURE OF ATHLETIC SIGNAL ENHANCEMENT EQUIPMENT, NAMELY, STICKERS USED ON THE HANDS OF BASEBALL AND SOFTBALL CATCHERS AND OTHER ATHLETES WHO USE HAND SIGNALS (U.S. CLS. 22, 23, 38 AND 50).

ELISSA GARBER KON, EXAMINING ATTORNEY

SN 85-506,796. LARRY BUTCH MCLEOD, SUMTER, SC. FILED 12-31-2011.

CHOKE-UP CHUCK

THE MARK CONSISTS OF STANDARD CHARACTERS WITHOUT CLAIM TO ANY PARTICULAR FONT, STYLE, SIZE, OR COLOR.

NO CLAIM IS MADE TO THE EXCLUSIVE RIGHT TO USE "CHOKE-UP", APART FROM THE MARK AS SHOWN.

FOR STRAP FOR ATTACHING TO A BASEBALL OR SOFTBALL BAT TO ASSIST CHILDREN WITH CHOKING UP THE BAT (U.S. CLS. 22, 23, 38 AND 50).

JAMES GRIFFIN, EXAMINING ATTORNEY

CLASS 28—(Continued).

SN 85-506,887. FERRARI IMPORTING COMPANY, PITTSBURGH, PA. FILED 12-31-2011.



NO CLAIM IS MADE TO THE EXCLUSIVE RIGHT TO USE "RACQUET", APART FROM THE MARK AS SHOWN.

THE MARK CONSISTS OF A TRIANGLE WITH CONCAVE EDGES IS CENTERED AND POSITIONED BENEATH THE WORDS "BLACK RACQUET".

FOR TENNIS RACQUETS (U.S. CLS. 22, 23, 38 AND 50).

FIRST USE 8-24-2011; IN COMMERCE 11-1-2011.

TINA MAI, EXAMINING ATTORNEY

SN 85-506,891. FERRARI IMPORTING COMPANY, PITTSBURGH, PA. FILED 12-31-2011.

BLACK RACQUET

THE MARK CONSISTS OF STANDARD CHARACTERS WITHOUT CLAIM TO ANY PARTICULAR FONT, STYLE, SIZE, OR COLOR.

NO CLAIM IS MADE TO THE EXCLUSIVE RIGHT TO USE "RACQUET", APART FROM THE MARK AS SHOWN.

FOR TENNIS RACQUETS (U.S. CLS. 22, 23, 38 AND 50).

FIRST USE 8-24-2011; IN COMMERCE 11-1-2011.

TINA MAI, EXAMINING ATTORNEY

CLASS 28—(Continued).

SN 85-507,292. LANARD TOYS LIMITED, TSIMSHATSUI, HONG KONG, FILED 1-2-2012.

PARTY PONIES

THE MARK CONSISTS OF STANDARD CHARACTERS WITHOUT CLAIM TO ANY PARTICULAR FONT, STYLE, SIZE, OR COLOR.

NO CLAIM IS MADE TO THE EXCLUSIVE RIGHT TO USE "PONIES", APART FROM THE MARK AS SHOWN.

FOR TOYS, NAMELY TOY PONIES AND ACCESSORIES THEREFOR; TOY SETS COMPRISING TOY PONIES, DOLLS, DOLL CLOTHING AND ACCESSORIES, TOY VEHICLES, PLAY HOUSES AND MINIATURE TOY ANIMALS; BATH TOYS; TOYS IN THE NATURE OF IMITATION FOODSTUFFS (U.S. CLS. 22, 23, 38 AND 50).

FIRST USE 6-6-1994; IN COMMERCE 6-6-1994.
DAVID MURRAY, EXAMINING ATTORNEY

SN 85-507,477. FALCON OUTDOORS, LLC, SECAUCUS, NJ, FILED 1-3-2012.

MINX

THE MARK CONSISTS OF STANDARD CHARACTERS WITHOUT CLAIM TO ANY PARTICULAR FONT, STYLE, SIZE, OR COLOR.

FOR BOWS FOR ARCHERY (U.S. CLS. 22, 23, 38 AND 50).

ESTHER A. BORSUK, EXAMINING ATTORNEY

SN 85-507,982. BRUNNER, MICHAEL, DBA ROPE STRENGTH, COOPERSBURG, PA. FILED 1-3-2012.



NO CLAIM IS MADE TO THE EXCLUSIVE RIGHT TO USE "ROPE" AND DESIGN OF A ROPE, APART FROM THE MARK AS SHOWN.

THE COLOR(S) ORANGE, WHITE AND BLACK IS/ARE CLAIMED AS A FEATURE OF THE MARK.

THE MARK CONSISTS OF AN ORANGE HEXAGON CONTAINING THE WHITE OUTLINE OF AN INDIVIDUAL INTERTWINED WITH A BLACK ROPE WITH ORANGE TIPS AND THE WORDS "ROPE" AND "STRENGTH" IN BLACK.

FOR EXERCISE EQUIPMENT, NAMELY, TRAINING ROPES (U.S. CLS. 22, 23, 38 AND 50).

DAVID C. REIHNER, EXAMINING ATTORNEY

CLASS 28—(Continued).

SN 85-507,985. BRUNNER, MICHAEL, DBA ROPE STRENGTH, COOPERSBURG, PA. FILED 1-3-2012.

CRACK THE WHIP

THE MARK CONSISTS OF STANDARD CHARACTERS WITHOUT CLAIM TO ANY PARTICULAR FONT, STYLE, SIZE, OR COLOR.

FOR EXERCISE EQUIPMENT, NAMELY, TRAINING ROPES (U.S. CLS. 22, 23, 38 AND 50).

DAVID C. REIHNER, EXAMINING ATTORNEY

SN 85-508,525. THE ANDY VAN TUSK COLLECTION, SODDY DAISY, TN. FILED 1-4-2012.

**THE ANDY VAN TUSK
COLLECTION**

THE MARK CONSISTS OF STANDARD CHARACTERS WITHOUT CLAIM TO ANY PARTICULAR FONT, STYLE, SIZE, OR COLOR.

NO CLAIM IS MADE TO THE EXCLUSIVE RIGHT TO USE "COLLECTION", APART FROM THE MARK AS SHOWN.

THE NAME "ANDY VAN TUSK" DOES NOT IDENTIFY A LIVING INDIVIDUAL.

FOR STUFFED TOY ANIMALS (U.S. CLS. 22, 23, 38 AND 50).

FIRST USE 8-17-2011; IN COMMERCE 8-17-2011.
JORDAN BAKER, EXAMINING ATTORNEY

SN 85-508,940. BIRCHWOOD LABORATORIES, INC., EDEN PRAIRIE, MN. FILED 1-4-2012.

CRAWL SPACE

THE MARK CONSISTS OF STANDARD CHARACTERS WITHOUT CLAIM TO ANY PARTICULAR FONT, STYLE, SIZE, OR COLOR.

FOR FIREARM TARGETS (U.S. CLS. 22, 23, 38 AND 50).

FIRST USE 11-21-2011; IN COMMERCE 11-21-2011.
MATTHEW PAPPAS, EXAMINING ATTORNEY

CLASS 28—(Continued).

SN 85-508,941. BIRCHWOOD LABORATORIES, INC., EDEN PRAIRIE, MN. FILED 1-4-2012.

HOUSE GUEST

THE MARK CONSISTS OF STANDARD CHARACTERS WITHOUT CLAIM TO ANY PARTICULAR FONT, STYLE, SIZE, OR COLOR.
FOR FIREARM TARGETS (U.S. CLS. 22, 23, 38 AND 50).
FIRST USE 11-21-2011; IN COMMERCE 11-21-2011.
MATTHEW PAPPAS, EXAMINING ATTORNEY

SN 85-508,942. BIRCHWOOD LABORATORIES, INC., EDEN PRAIRIE, MN. FILED 1-4-2012.

BUZZ KILL

THE MARK CONSISTS OF STANDARD CHARACTERS WITHOUT CLAIM TO ANY PARTICULAR FONT, STYLE, SIZE, OR COLOR.
FOR FIREARM TARGETS (U.S. CLS. 22, 23, 38 AND 50).
FIRST USE 11-21-2011; IN COMMERCE 11-21-2011.
MATTHEW PAPPAS, EXAMINING ATTORNEY

SN 85-509,708. SPIRAFLEX, INC., KANSAS CITY, MO. FILED 1-5-2012.

OYO

THE MARK CONSISTS OF STANDARD CHARACTERS WITHOUT CLAIM TO ANY PARTICULAR FONT, STYLE, SIZE, OR COLOR.
FOR MANUALLY-OPERATED EXERCISE EQUIPMENT (U.S. CLS. 22, 23, 38 AND 50).
JEFF DEFORD, EXAMINING ATTORNEY

CLASS 28—(Continued).

SN 85-509,743. JAY AT PLAY INTERNATIONAL HONG KONG LIMITED, HONG KONG, HONG KONG, FILED 1-5-2012.

CUPKIDS

THE MARK CONSISTS OF STANDARD CHARACTERS WITHOUT CLAIM TO ANY PARTICULAR FONT, STYLE, SIZE, OR COLOR.
FOR STUFFED AND PLUSH TOYS (U.S. CLS. 22, 23, 38 AND 50).
FIRST USE 11-21-2011; IN COMMERCE 11-21-2011.
BERNICE MIDDLETON, EXAMINING ATTORNEY

SN 85-509,866. WILD BRAIN ENTERTAINMENT, INC., SHERMAN OAKS, CA. FILED 1-5-2012.

BIT

THE MARK CONSISTS OF STANDARD CHARACTERS WITHOUT CLAIM TO ANY PARTICULAR FONT, STYLE, SIZE, OR COLOR.
FOR TOYS, GAMES AND SPORTING GOODS, NAMELY, BOARD GAMES, CARD GAMES, PLAY FIGURES AND ACCESSORIES THEREFOR, ACTION FIGURES AND ACCESSORIES THEREFOR, TOY FIGURES, ELECTRIC ACTION TOYS, MECHANICAL ACTION TOYS, DOLLS AND ACCESSORIES THEREFOR, DOLL PLAYSETS, PLUSH TOYS, STUFFED TOYS, PUPPETS, WINDUP TOYS, DOMINOES, JIGSAW PUZZLES, MANIPULATIVE GAMES, MARBLES, PADDLE BALL GAMES, YO-YO'S, BALLOONS, JUMP ROPES, KITES AND ACCESSORIES THEREFOR, NAMELY, KITE BOARDS, KITE HANDLES, KITE STRING, KITE TAILS AND KITE REELS, BUBBLE MAKING WANDS AND SOLUTION SETS, MAGIC TRICKS, BATH TOYS, PLAY SWIMMING POOLS, TOY VEHICLES AND ACCESSORIES THEREFOR, TOY MODEL HOBBY CRAFT KITS, TOY BANKS, TOY BOXES, TOY GUNS, TOY HOLSTERS, TOY ARCHERY BOWS AND ARROWS, TOY ROCKETTS, TOY BUCKET AND SHOVEL SETS, CHILDREN'S PLAY COSMETICS, BABY RATTLES, BABY MULTIPLE ACTIVITY TOYS, TOY CONSTRUCTION BLOCKS, MUSICAL TOYS, TARGET GAMES, ACTION SKILL GAMES, BALLS, NAMELY, BASEBALLS, BASKETBALLS, FOOTBALLS, GOLF BALLS, TENNIS BALLS, PLAYGROUND BALLS, SPORT BALLS, SOCCER BALLS, VOLLEYBALLS, RUBBER BALLS, FOAM RUBBER BALLS, BASEBALL BATS, BASEBALL GLOVES, FLYING DISKS, DISC TYPE TOSS TOYS, BODY BOARDS, BADMINTON SETS, DART FLIGHTS, GOLF CLUB HEAD COVERS, ROLLER SKATES, SKATEBOARDS, TOY SCOOTERS, SWIM FINS, SWIM FLOATS FOR RECREATIONAL USE, FACE MASKS, PINBALL-TYPE GAMES, CHRISTMAS TREE DECORATIONS, EGG DECORATING KITS, HAND HELD UNITS FOR PLAYING ELECTRONIC GAMES OTHER THAN THOSE ADAPTED FOR USE WITH AN EXTERNAL DISPLAY SCREEN OR MONITOR, ARCADE GAME MACHINES, ARCADE-TYPE ELECTRONIC VIDEO GAME MACHINES, PINBALL MACHINES, PINBALL-TYPE GAME MACHINES, STAND-ALONE VIDEO GAME MACHINES, LCD GAME MACHINES, BEACH BALLS, IN-LINE SKATES, RIDE-ON TOYS, TOY SWORDS, AND PLAYING CARDS (U.S. CLS. 22, 23, 38 AND 50).
EMILY CHUO, EXAMINING ATTORNEY

CLASS 28—(Continued).

SN 85-509,933. WILD BRAIN ENTERTAINMENT, INC., SHERMAN OAKS, CA. FILED 1-5-2012.

DIZZY

THE MARK CONSISTS OF STANDARD CHARACTERS WITHOUT CLAIM TO ANY PARTICULAR FONT, STYLE, SIZE, OR COLOR.

FOR TOYS, GAMES AND SPORTING GOODS, NAMELY, BOARD GAMES, CARD GAMES, PLAY FIGURES AND ACCESSORIES THEREFOR, ACTION FIGURES AND ACCESSORIES THEREFOR, TOY FIGURES, ELECTRIC ACTION TOYS, MECHANICAL ACTION TOYS, DOLLS AND ACCESSORIES THEREFOR, DOLL PLAYSETS, PLUSH TOYS, STUFFED TOYS, PUPPETS, WINDUP TOYS, DOMINOES, JIGSAW PUZZLES, MANIPULATIVE GAMES, MARBLES, PADDLE BALL GAMES, YO-YO'S, BALLOONS, JUMP ROPES, KITES AND ACCESSORIES THEREFOR, NAMELY, KITE BOARDS, KITE HANDLES, KITE STRING, KITE TAILS AND KITE REELS, BUBBLE MAKING WANDS AND SOLUTION SETS, MAGIC TRICKS, BATH TOYS, PLAY SWIMMING POOLS, TOY VEHICLES AND ACCESSORIES THEREFOR, TOY MODEL HOBBY CRAFT KITS, TOY BANKS, TOY BOXES, TOY GUNS, TOY HOLSTERS, TOY ARCHERY BOWS AND ARROWS, TOY ROCKETS, TOY BUCKET AND SHOVEL SETS, CHILDREN'S PLAY COSMETICS, BABY RATTLES, BABY MULTIPLE ACTIVITY TOYS, TOY CONSTRUCTION BLOCKS, MUSICAL TOYS, TARGET GAMES, ACTION SKILL GAMES, BALLS, NAMELY, BASEBALLS, BASKETBALLS, FOOTBALLS, GOLF BALLS, TENNIS BALLS, PLAYGROUND BALLS, SPORT BALLS, SOCCER BALLS, VOLLEYBALLS, RUBBER BALLS, FOAM RUBBER BALLS, BASEBALL BATS, BASEBALL GLOVES, FLYING DISKS, DISC TYPE TOSS TOYS, BODY BOARDS, BADMINTON SETS, DART FLIGHTS, GOLF CLUB HEAD COVERS, ROLLER SKATES, SKATEBOARDS, TOY SCOOTERS, SWIM FINS, SWIM FLOATS FOR RECREATIONAL USE, FACE MASKS, PINBALL-TYPE GAMES, CHRISTMAS TREE DECORATIONS, EGG DECORATING KITS, HAND HELD UNITS FOR PLAYING ELECTRONIC GAMES OTHER THAN THOSE ADAPTED FOR USE WITH AN EXTERNAL DISPLAY SCREEN OR MONITOR, ARCADE GAME MACHINES, ARCADE-TYPE ELECTRONIC VIDEO GAME MACHINES, PINBALL MACHINES, PINBALL-TYPE GAME MACHINES, STAND-ALONE VIDEO GAME MACHINES, LCD GAME MACHINES, BEACH BALLS, IN-LINE SKATES, RIDE-ON TOYS, TOY SWORDS, AND PLAYING CARDS (U.S. CLS. 22, 23, 38 AND 50).

EMILY CHUO, EXAMINING ATTORNEY

SN 85-510,013. BAUMAN, MIKE, NEW ALBANY, OH. FILED 1-5-2012.

THE DISTANCE SOLUTION A
PERFECT COMBINATION OF
SWING MECHANICS AND
EFFORTLESS POWER

THE MARK CONSISTS OF STANDARD CHARACTERS WITHOUT CLAIM TO ANY PARTICULAR FONT, STYLE, SIZE, OR COLOR.

FOR GOLF TRAINING AID, NAMELY, A MOTORIZED GOLF CHIPPING PRACTICE AID (U.S. CLS. 22, 23, 38 AND 50).

MATTHEW KLINE, EXAMINING ATTORNEY

CLASS 28—(Continued).

SN 85-510,029. PROCOPIOU, ANDREW, AKA ANDREAS PROCOPIOU, KENSINGTON, CA. FILED 1-6-2012.



The logo for ChubbyBot features the word "ChubbyBot" in a stylized, rounded font. The letters "C", "H", "U", "Y", "B", and "T" are dark gray, while the letter "O" is orange and contains a white star. The letter "B" is light blue.

THE COLOR(S) BLACK, DARK GRAY, LIGHT BLUE AND ORANGE IS/ARE CLAIMED AS A FEATURE OF THE MARK.

THE MARK CONSISTS OF THE WORD "CHUBBYBOT" WITH A BLACK OUTLINE. THE LETTERS "C", "H", "U", "Y", "B", "T", ARE DARK GRAY. THE TWO SMALL LETTER "B'S ARE LIGHT BLUE. THE LETTER "O" IS ORANGE AND REPRESENTS A STYLIZED VERSION OF THE TOP VIEW OF A SCREW HEAD.

FOR COLLECTABLE TOY FIGURES; MODELED PLASTIC TOY FIGURINES; PLASTIC CHARACTER TOYS; POSITIONABLE TOY FIGURES; TOY FIGURES; TOY ROBOTS (U.S. CLS. 22, 23, 38 AND 50).

KATHLEEN LORENZO, EXAMINING ATTORNEY

SN 85-510,238. HAYABUSA FIGHTWEAR INC., KINGSTON, ONTARIO, CANADA, FILED 1-6-2012.

IKUSA

THE MARK CONSISTS OF STANDARD CHARACTERS WITHOUT CLAIM TO ANY PARTICULAR FONT, STYLE, SIZE, OR COLOR.

FOR SPORTS EQUIPMENT FOR BOXING AND MARTIAL ARTS, NAMELY, SPARRING GLOVES, TRAINING GLOVES FOR KARATE, SHOOTO STYLE GLOVES IN THE NATURE OF KARATE GLOVES, BOXING GLOVES, PUNCHING BAG GLOVES, STRIKING PADS, ATHLETIC TRAINING PADS FOR SPORT FIGHTING, ATHLETIC FOCUS PADS FOR SPORTS FIGHTING, KICK MITTS IN THE NATURE OF ATHLETIC PADS FOR THE HANDS, SHIN GUARDS FOR ATHLETIC USE, BOXING AND MARTIAL ARTS HEAD GUARDS, ATHLETIC EAR PROTECTORS, ANKLE SUPPORTS FOR ATHLETIC USE, BAGS SPECIALLY ADAPTED FOR SPORTS EQUIPMENT (U.S. CLS. 22, 23, 38 AND 50).

GEORGE LORENZO, EXAMINING ATTORNEY

CLASS 28—(Continued).

SN 85-510,243. HAYABUSA FIGHTWEAR INC., KINGSTON, ONTARIO, CANADA, FILED 1-6-2012.

KANPEKI ELITE

THE MARK CONSISTS OF STANDARD CHARACTERS WITHOUT CLAIM TO ANY PARTICULAR FONT, STYLE, SIZE, OR COLOR.

FOR SPORTS EQUIPMENT FOR BOXING AND MARTIAL ARTS, NAMELY, SPARRING GLOVES, TRAINING GLOVES FOR KARATE, SHOOTO STYLE GLOVES IN THE NATURE OF KARATE GLOVES, BOXING GLOVES, PUNCHING BAG GLOVES, STRIKING PADS, ATHLETIC TRAINING PADS FOR SPORT FIGHTING, ATHLETIC FOCUS PADS FOR SPORTS FIGHTING, KICK MITTS IN THE NATURE OF ATHLETIC PADS FOR THE HANDS, SHIN GUARDS FOR ATHLETIC USE, BOXING AND MARTIAL ARTS HEAD GUARDS, ATHLETIC EAR PROTECTORS, ANKLE SUPPORTS FOR ATHLETIC USE, BAGS SPECIALLY ADAPTED FOR SPORTS EQUIPMENT (U.S. CLS. 22, 23, 38 AND 50).

GEORGE LORENZO, EXAMINING ATTORNEY

SN 85-510,245. HAYABUSA FIGHTWEAR INC., KINGSTON, ONTARIO, CANADA, FILED 1-6-2012.

TOKUSHU

THE MARK CONSISTS OF STANDARD CHARACTERS WITHOUT CLAIM TO ANY PARTICULAR FONT, STYLE, SIZE, OR COLOR.

FOR SPORTS EQUIPMENT FOR BOXING AND MARTIAL ARTS, NAMELY, SPARRING GLOVES, TRAINING GLOVES FOR KARATE, SHOOTO STYLE GLOVES IN THE NATURE OF KARATE GLOVES, BOXING GLOVES, PUNCHING BAG GLOVES, STRIKING PADS, ATHLETIC TRAINING PADS FOR SPORT FIGHTING, ATHLETIC FOCUS PADS FOR SPORTS FIGHTING, KICK MITTS IN THE NATURE OF ATHLETIC PADS FOR THE HANDS, SHIN GUARDS FOR ATHLETIC USE, BOXING AND MARTIAL ARTS HEAD GUARDS, ATHLETIC EAR PROTECTORS, ANKLE SUPPORTS FOR ATHLETIC USE, BAGS SPECIALLY ADAPTED FOR SPORTS EQUIPMENT (U.S. CLS. 22, 23, 38 AND 50).

GEORGE LORENZO, EXAMINING ATTORNEY

CLASS 28—(Continued).

SN 85-510,249. HAYABUSA FIGHTWEAR INC., KINGSTON, ONTARIO, CANADA, FILED 1-6-2012.

DELTRA EG

THE MARK CONSISTS OF STANDARD CHARACTERS WITHOUT CLAIM TO ANY PARTICULAR FONT, STYLE, SIZE, OR COLOR.

FOR SAFETY PADDING FOR IMPACT SPORTS (U.S. CLS. 22, 23, 38 AND 50).

GEORGE LORENZO, EXAMINING ATTORNEY

SN 85-510,404. CBS STUDIOS INC., STUDIO CITY, NY, FILED 1-6-2012.

TRICORDER

THE MARK CONSISTS OF STANDARD CHARACTERS WITHOUT CLAIM TO ANY PARTICULAR FONT, STYLE, SIZE, OR COLOR.

FOR MODEL TOY MULTIFUNCTIONAL HANDHELD DEVICE USED FOR SENSOR SCANNING, DATA ANALYSIS, AND RECORDING DATA (U.S. CLS. 22, 23, 38 AND 50).

FIRST USE 12-31-1994; IN COMMERCE 12-31-1994.

DOUGLAS LEE, EXAMINING ATTORNEY

SN 85-510,475. RANDALL HALL SENTER, WEST HOLLYWOOD, CA, FILED 1-6-2012.

FORKITE

THE MARK CONSISTS OF STANDARD CHARACTERS WITHOUT CLAIM TO ANY PARTICULAR FONT, STYLE, SIZE, OR COLOR.

FOR BATHTUB TOYS; CRIB TOYS; SQUEEZABLE SQUEAKING TOYS; SQUEEZE TOYS; STUFFED AND PLUSH TOYS; STUFFED TOYS; TOY ACTION FIGURES AND ACCESSORIES THEREFOR; TOY BALLOONS; TOY MUSIC BOXES; TOY NOISEMAKERS (U.S. CLS. 22, 23, 38 AND 50).

JULIE WATSON, EXAMINING ATTORNEY

CLASS 28—(Continued).

SN 85-510,522. RANDALL HALL SENTER, WEST HOLLYWOOD, CA. FILED 1-6-2012.

Forkitron

THE MARK CONSISTS OF STANDARD CHARACTERS WITHOUT CLAIM TO ANY PARTICULAR FONT, STYLE, SIZE, OR COLOR.

FOR ACTION FIGURE TOYS; BATHTUB TOYS; BATTERY OPERATED ACTION TOYS; TOY ACTION FIGURES AND ACCESSORIES THEREFOR; TOY CAP PISTOLS; TOY GUNS; TOY HOLSTERS; TOY PISTOLS; TOY ROCKETTS; TOY SWORDS; TOY VEHICLES; TOY WEAPONS; WATER SQUIRTING TOYS (U.S. CLS. 22, 23, 38 AND 50).

JULIE WATSON, EXAMINING ATTORNEY

CLASS 28—(Continued).

SN 85-511,254. EYERMAN, EDMUND A, RIDGEFIELD, NJ. FILED 1-8-2012.

CHOOKIE CHUM

THE MARK CONSISTS OF STANDARD CHARACTERS WITHOUT CLAIM TO ANY PARTICULAR FONT, STYLE, SIZE, OR COLOR.

FOR ACTION FIGURE TOYS; BABY MULTIPLE ACTIVITY TOYS; CHILDREN'S MULTIPLE ACTIVITY TOYS; CHILDREN'S MULTIPLE ACTIVITY TOYS SOLD AS A UNIT WITH PRINTED BOOKS (U.S. CLS. 22, 23, 38 AND 50).

DOMINICK J. SALEMI, EXAMINING ATTORNEY

SN 85-510,868. LAWYERS WITHOUT BORDERS, INC., HARTFORD, CT. FILED 1-6-2012.

RECORD !T

THE MARK CONSISTS OF STANDARD CHARACTERS WITHOUT CLAIM TO ANY PARTICULAR FONT, STYLE, SIZE, OR COLOR.

FOR BOARD GAME (U.S. CLS. 22, 23, 38 AND 50).

TINA MAI, EXAMINING ATTORNEY

SN 85-511,271. HALASZ, STEVEN JON, MONTCLAIR, NJ. FILED 1-8-2012.

Story Time Squares

THE MARK CONSISTS OF STANDARD CHARACTERS WITHOUT CLAIM TO ANY PARTICULAR FONT, STYLE, SIZE, OR COLOR.

NO CLAIM IS MADE TO THE EXCLUSIVE RIGHT TO USE "SQUARES", APART FROM THE MARK AS SHOWN.

FOR BOARD GAMES (U.S. CLS. 22, 23, 38 AND 50).

RICHARD WHITE, EXAMINING ATTORNEY

SN 85-511,056. WAX RESEARCH, INC., CARLSBAD, CA. FILED 1-6-2012.

PUNT

THE MARK CONSISTS OF STANDARD CHARACTERS WITHOUT CLAIM TO ANY PARTICULAR FONT, STYLE, SIZE, OR COLOR.

FOR WAX PRODUCTS; NAMELY, SURFBOARD, SNOWBOARD AND SKI WAX (U.S. CLS. 22, 23, 38 AND 50).

GEORGE LORENZO, EXAMINING ATTORNEY

SN 85-511,766. MOTHER KNOWS BEST, LLC, WATER VALLEY, MS. FILED 1-9-2012.

Sweet Sights

THE MARK CONSISTS OF STANDARD CHARACTERS WITHOUT CLAIM TO ANY PARTICULAR FONT, STYLE, SIZE, OR COLOR.

FOR MOBILE FOR CRIB OR CHANGING TABLE (U.S. CLS. 22, 23, 38 AND 50).

MEGHAN REINHART, EXAMINING ATTORNEY

CLASS 28—(Continued).

SN 85-512,100. SAGE MANUFACTURING CORPORATION,
BAINBRIDGE ISLAND, WA. FILED 1-9-2012.

CIRCA

THE MARK CONSISTS OF STANDARD CHARACTERS
WITHOUT CLAIM TO ANY PARTICULAR FONT, STYLE,
SIZE, OR COLOR.

FOR FISHING RODS (U.S. CLS. 22, 23, 38 AND 50).
JOHN DALIER, EXAMINING ATTORNEY

SN 85-512,112. SAGE MANUFACTURING CORPORATION,
BAINBRIDGE ISLAND, WA. FILED 1-9-2012.

APPROACH

THE MARK CONSISTS OF STANDARD CHARACTERS
WITHOUT CLAIM TO ANY PARTICULAR FONT, STYLE,
SIZE, OR COLOR.

FOR FISHING RODS (U.S. CLS. 22, 23, 38 AND 50).
JOHN DALIER, EXAMINING ATTORNEY

SN 85-512,139. SAGE MANUFACTURING CORPORATION,
BAINBRIDGE ISLAND, WA. FILED 1-9-2012.

RESPONSE

THE MARK CONSISTS OF STANDARD CHARACTERS
WITHOUT CLAIM TO ANY PARTICULAR FONT, STYLE,
SIZE, OR COLOR.

FOR FISHING RODS (U.S. CLS. 22, 23, 38 AND 50).
JOHN DALIER, EXAMINING ATTORNEY

CLASS 28—(Continued).

SN 85-512,365. PAWABUNGA! LLC, MINNEAPOLIS, MN.
FILED 1-9-2012.



THE COLOR(S) GOLD AND WHITE IS/ARE CLAIMED AS
A FEATURE OF THE MARK.

THE MARK CONSISTS OF A SILHOUETTE OF VARIOUS
DOGS IN THE COLOR GOLD WITH THE WORD "PAWA-
BUNGA!" IN WHITE STYLIZED BLOCK LETTERS IN THE
CENTER OF THE SILHOUETTE WITH TWO WHITE
STRIPES UNDERLINING THE WORD.

FOR DOG TOYS IN THE NATURE OF NON-DIGES-
TIBLE CHEW BONES (U.S. CLS. 22, 23, 38 AND 50).
DOMINICK J. SALEMI, EXAMINING ATTORNEY

SN 85-512,556. ELITE OUTDOORS LLC, HENRIETTA, NY.
FILED 1-10-2012.



THE MARK CONSISTS OF THE LETTER E.
FOR ARCHERY EQUIPMENT, NAMELY, BOWS, BOW
BAGS, BOW CASES, QUIVERS, AND STABILIZERS (U.S.
CLS. 22, 23, 38 AND 50).

FIRST USE 9-26-2011; IN COMMERCE 9-26-2011.
REBECCA SMITH, EXAMINING ATTORNEY

SN 85-512,686. ENCHANTED ELF, ALPHARETTA, GA.
FILED 1-10-2012.

Enchanted Elf

THE MARK CONSISTS OF STANDARD CHARACTERS
WITHOUT CLAIM TO ANY PARTICULAR FONT, STYLE,
SIZE, OR COLOR.

NO CLAIM IS MADE TO THE EXCLUSIVE RIGHT TO
USE "ELF", APART FROM THE MARK AS SHOWN.

FOR DOLL ACCESSORIES; DOLLS AND DOLLS'
CLOTHING; PLUSH DOLLS (U.S. CLS. 22, 23, 38 AND
50).

YAT SYE, LEE, EXAMINING ATTORNEY

CLASS 28—(Continued).

SN 85-512,691. LIQUID IRON INCORPORATED, PEMBROKE PINES, FL. FILED 1-10-2012.

ISOMAX

THE MARK CONSISTS OF STANDARD CHARACTERS WITHOUT CLAIM TO ANY PARTICULAR FONT, STYLE, SIZE, OR COLOR.

FOR SPORTING GOODS, NAMELY, A SPORTS TRAINING DEVICE TO IMPROVE STRENGTH, TONING, CONDITIONING, BALANCE, AND PROPRIOCEPTION (U.S. CLS. 22, 23, 38 AND 50).
YAT SYE, LEE, EXAMINING ATTORNEY

CLASS 28—(Continued).

SN 85-512,833. SENARIO LLC, WOODSTOCK, IL. FILED 1-10-2012.

Revoltoids

THE MARK CONSISTS OF STANDARD CHARACTERS WITHOUT CLAIM TO ANY PARTICULAR FONT, STYLE, SIZE, OR COLOR.

FOR REMOTE CONTROL TOYS, NAMELY, IN THE NATURE OF MONSTER FIGURES (U.S. CLS. 22, 23, 38 AND 50).
EDWARD NELSON, EXAMINING ATTORNEY

SN 85-512,701. SCHATZMAN, ROBERT, ROCKLEDGE, FL. FILED 1-10-2012.

Gold Grapple

THE MARK CONSISTS OF STANDARD CHARACTERS WITHOUT CLAIM TO ANY PARTICULAR FONT, STYLE, SIZE, OR COLOR.

FOR CARD GAMES (U.S. CLS. 22, 23, 38 AND 50).
BRENDAN REGAN, EXAMINING ATTORNEY

SN 85-512,887. SENARIO LLC, WOODSTOCK, IL. FILED 1-10-2012.

Aux

THE MARK CONSISTS OF STANDARD CHARACTERS WITHOUT CLAIM TO ANY PARTICULAR FONT, STYLE, SIZE, OR COLOR.

FOR REMOTE CONTROL TOYS, NAMELY, ROBOTS (U.S. CLS. 22, 23, 38 AND 50).
EDWARD NELSON, EXAMINING ATTORNEY

SN 85-512,813. SENARIO LLC, WOODSTOCK, IL. FILED 1-10-2012.

Zoobits

THE MARK CONSISTS OF STANDARD CHARACTERS WITHOUT CLAIM TO ANY PARTICULAR FONT, STYLE, SIZE, OR COLOR.

FOR REMOTE CONTROL TOYS, NAMELY, TOY ANIMALS (U.S. CLS. 22, 23, 38 AND 50).
EDWARD NELSON, EXAMINING ATTORNEY

SN 85-512,908. SENARIO LLC, WOODSTOCK, IL. FILED 1-10-2012.

Sync

THE MARK CONSISTS OF STANDARD CHARACTERS WITHOUT CLAIM TO ANY PARTICULAR FONT, STYLE, SIZE, OR COLOR.

FOR REMOTE CONTROL TOYS, NAMELY, ROBOTS (U.S. CLS. 22, 23, 38 AND 50).
EDWARD NELSON, EXAMINING ATTORNEY

CLASS 28—(Continued).

SN 85-512,947. SENARIO LLC, WOODSTOCK, IL. FILED 1-10-2012.

ARC

THE MARK CONSISTS OF STANDARD CHARACTERS WITHOUT CLAIM TO ANY PARTICULAR FONT, STYLE, SIZE, OR COLOR.
FOR REMOTE CONTROL TOYS, NAMELY, ROBOTS (U.S. CLS. 22, 23, 38 AND 50).
EDWARD NELSON, EXAMINING ATTORNEY

CLASS 28—(Continued).

SN 85-512,982. SENARIO LLC, WOODSTOCK, IL. FILED 1-10-2012.

Skit

THE MARK CONSISTS OF STANDARD CHARACTERS WITHOUT CLAIM TO ANY PARTICULAR FONT, STYLE, SIZE, OR COLOR.
FOR REMOTE CONTROL TOYS, NAMELY, ROBOTS (U.S. CLS. 22, 23, 38 AND 50).
JUDITH HELFMAN, EXAMINING ATTORNEY

SN 85-512,953. SENARIO LLC, WOODSTOCK, IL. FILED 1-10-2012.

Tactik

THE MARK CONSISTS OF STANDARD CHARACTERS WITHOUT CLAIM TO ANY PARTICULAR FONT, STYLE, SIZE, OR COLOR.
FOR REMOTE CONTROL TOYS, NAMELY, ROBOTS (U.S. CLS. 22, 23, 38 AND 50).
EDWARD NELSON, EXAMINING ATTORNEY

SN 85-512,985. SENARIO LLC, WOODSTOCK, IL. FILED 1-10-2012.

Qore

THE MARK CONSISTS OF STANDARD CHARACTERS WITHOUT CLAIM TO ANY PARTICULAR FONT, STYLE, SIZE, OR COLOR.
FOR REMOTE CONTROL TOYS, NAMELY, ROBOTS (U.S. CLS. 22, 23, 38 AND 50).
JUDITH HELFMAN, EXAMINING ATTORNEY

SN 85-512,964. SENARIO LLC, WOODSTOCK, IL. FILED 1-10-2012.

BIZ

THE MARK CONSISTS OF STANDARD CHARACTERS WITHOUT CLAIM TO ANY PARTICULAR FONT, STYLE, SIZE, OR COLOR.
FOR REMOTE CONTROL TOYS, NAMELY, ROBOTS (U.S. CLS. 22, 23, 38 AND 50).
EDWARD NELSON, EXAMINING ATTORNEY

SN 85-512,993. SENARIO LLC, WOODSTOCK, IL. FILED 1-10-2012.

Radius

THE MARK CONSISTS OF STANDARD CHARACTERS WITHOUT CLAIM TO ANY PARTICULAR FONT, STYLE, SIZE, OR COLOR.
FOR REMOTE CONTROL TOYS, NAMELY, ROBOTS (U.S. CLS. 22, 23, 38 AND 50).
JUDITH HELFMAN, EXAMINING ATTORNEY

CLASS 28—(Continued).

SN 85-512,998. SENARIO LLC, WOODSTOCK, IL. FILED 1-10-2012.

Dek

THE MARK CONSISTS OF STANDARD CHARACTERS WITHOUT CLAIM TO ANY PARTICULAR FONT, STYLE, SIZE, OR COLOR.

FOR REMOTE CONTROL TOYS, NAMELY, ROBOTS (U.S. CLS. 22, 23, 38 AND 50).

JUDITH HELFMAN, EXAMINING ATTORNEY

CLASS 28—(Continued).

SN 85-513,283. SPRO CORP., KENNESAW, GA. FILED 1-10-2012.

FAT PAPA

THE MARK CONSISTS OF STANDARD CHARACTERS WITHOUT CLAIM TO ANY PARTICULAR FONT, STYLE, SIZE, OR COLOR.

FOR FISHING LURES (U.S. CLS. 22, 23, 38 AND 50).

FIRST USE 2-29-2012; IN COMMERCE 2-29-2012.

SUSAN LESLIE DUBOIS, EXAMINING ATTORNEY

SN 85-513,003. SENARIO LLC, WOODSTOCK, IL. FILED 1-10-2012.

Mek

THE MARK CONSISTS OF STANDARD CHARACTERS WITHOUT CLAIM TO ANY PARTICULAR FONT, STYLE, SIZE, OR COLOR.

FOR REMOTE CONTROL TOYS, NAMELY, ROBOTS (U.S. CLS. 22, 23, 38 AND 50).

JUDITH HELFMAN, EXAMINING ATTORNEY

SN 85-513,309. CALLAWAY GOLF COMPANY, CARLSBAD, CA. FILED 1-10-2012.

Stacks

THE MARK CONSISTS OF STANDARD CHARACTERS WITHOUT CLAIM TO ANY PARTICULAR FONT, STYLE, SIZE, OR COLOR.

FOR GOLF BAGS; GOLF CLUBS; HEAD COVERS FOR GOLF CLUBS (U.S. CLS. 22, 23, 38 AND 50).

DAWN HAN, EXAMINING ATTORNEY

SN 85-513,151. ADAM MARTIN BUSINESS VENTURES, LLC, BEND, OR. FILED 1-10-2012.

ALIGN MATE

THE MARK CONSISTS OF STANDARD CHARACTERS WITHOUT CLAIM TO ANY PARTICULAR FONT, STYLE, SIZE, OR COLOR.

FOR DRIVING PRACTICE MATS (U.S. CLS. 22, 23, 38 AND 50).

RONALD AIKENS, EXAMINING ATTORNEY

SN 85-513,324. ARUZE GAMING AMERICA, INC., LAS VEGAS, NV. FILED 1-10-2012.

G-ENEX 22

THE MARK CONSISTS OF STANDARD CHARACTERS WITHOUT CLAIM TO ANY PARTICULAR FONT, STYLE, SIZE, OR COLOR.

OWNER OF U.S. REG. NO. 3,554,313.

FOR ELECTRONIC AND ELECTRO-MECHANICAL GAMING TABLES WITH VIDEO OUTPUT; ELECTRONIC GAMING MACHINES, NAMELY, DEVICES WHICH ACCEPT A WAGER; GAMING MACHINES; GAMING MACHINES INCLUDING SLOT MACHINES OR VIDEO LOTTERY TERMINALS; GAMING MACHINES THAT GENERATE OR DISPLAY WAGER OUTCOMES; MACHINES FOR PLAYING GAMES OF CHANCE; SLOT MACHINES (U.S. CLS. 22, 23, 38 AND 50).

MICHAEL TANNER, EXAMINING ATTORNEY

CLASS 28—(Continued).

SN 85-513,339. BRYCE, TRACY, HAIKU, CANADA, FILED 1-10-2012.

GAIA TREE

THE MARK CONSISTS OF STANDARD CHARACTERS WITHOUT CLAIM TO ANY PARTICULAR FONT, STYLE, SIZE, OR COLOR.

FOR TOYS, NAMELY, DOLLS, STROLLERS FOR DOLLS, TOY ANIMALS, TOY BUILDING BLOCKS, TOY CARS, AND TOY DINOSAURS (U.S. CLS. 22, 23, 38 AND 50).

JOHN WILKE, EXAMINING ATTORNEY

SN 85-513,447. BLACK, ERIC, ASTORIA, NY. AND BLACK, ERIN, ASTORIA, NY. FILED 1-10-2012.

Lyla Tov Monsters

THE MARK CONSISTS OF STANDARD CHARACTERS WITHOUT CLAIM TO ANY PARTICULAR FONT, STYLE, SIZE, OR COLOR.

THE ENGLISH TRANSLATION OF "LYLA TOV" IN THE MARK IS "GOOD NIGHT".

FOR STUFFED AND PLUSH TOYS (U.S. CLS. 22, 23, 38 AND 50).

FIRST USE 10-9-2010; IN COMMERCE 10-9-2010.
KIMBERLY PERRY, EXAMINING ATTORNEY

SN 85-513,524. LOGUE, JONATHAN W, SANTA ROSA, CA. FILED 1-11-2012.

Spitfire

THE MARK CONSISTS OF STANDARD CHARACTERS WITHOUT CLAIM TO ANY PARTICULAR FONT, STYLE, SIZE, OR COLOR.

FOR BASEBALLS; GAME APPARATUS, NAMELY, BASES, BATS, AND BALLS FOR PLAYING BASEBALL-LIKE INDOOR AND OUTDOOR GAMES (U.S. CLS. 22, 23, 38 AND 50).

ALEX KEAM, EXAMINING ATTORNEY

CLASS 28—(Continued).

SN 85-513,561. MASTRANGELO, LAURA, STATEN ISLAND, NY. FILED 1-11-2012.



THE NAME(S), PORTRAIT(S), AND/OR SIGNATURE(S) SHOWN IN THE MARK IDENTIFIES LAURA MASTRANGELO, WHOSE CONSENT(S) TO REGISTER IS MADE OF RECORD.

THE COLOR(S) BLUE IS/ARE CLAIMED AS A FEATURE OF THE MARK.

THE MARK CONSISTS OF SCRIPT LETTERS IN THE COLOR BLUE FORMING TWO WORDS, SPECIFICALLY THE NAME "LAURA MASTRANGELO".

FOR CHRISTMAS TREE ORNAMENTS AND DECORATIONS (U.S. CLS. 22, 23, 38 AND 50).

FIRST USE 5-13-1985; IN COMMERCE 1-30-1993.
COURTNEY ALVAREZ, EXAMINING ATTORNEY

SN 85-513,562. TOYBRIDGE, INC., MONSEY, NY. FILED 1-11-2012.

OOPSY MAZEY

THE MARK CONSISTS OF STANDARD CHARACTERS WITHOUT CLAIM TO ANY PARTICULAR FONT, STYLE, SIZE, OR COLOR.

FOR THREE DIMENSIONAL MAZE GAME CONTAINED WITHIN A TRANSPARENT ELLIPSOID (U.S. CLS. 22, 23, 38 AND 50).

JULIE WATSON, EXAMINING ATTORNEY

SN 85-513,591. DENOVAL, THIERRY, SAN FRANCISCO, CA. FILED 1-11-2012.

SHRIMP COCKTAIL

THE MARK CONSISTS OF STANDARD CHARACTERS WITHOUT CLAIM TO ANY PARTICULAR FONT, STYLE, SIZE, OR COLOR.

FOR BOARD GAMES; CARD GAMES; EDUCATIONAL CARD GAMES; GAME CARDS; PARLOUR GAMES; PLAYING CARDS AND CARD GAMES; PROMOTIONAL GAME CARDS (U.S. CLS. 22, 23, 38 AND 50).

FIRST USE 10-15-2011; IN COMMERCE 10-15-2011.
KAREN SEVERSON, EXAMINING ATTORNEY

CLASS 28—(Continued).

SN 85-513,615. DENOUIL, THIERRY, SAN FRANCISCO, CA. FILED 1-11-2012.

FLAPZ

THE MARK CONSISTS OF STANDARD CHARACTERS WITHOUT CLAIM TO ANY PARTICULAR FONT, STYLE, SIZE, OR COLOR.

FOR BOARD GAMES; CARD GAMES; GAME CARDS; PARLOR GAMES; PARTY GAMES; PLAYING CARDS AND CARD GAMES; TRIVIA GAME PLAYED WITH CARDS AND GAME COMPONENTS (U.S. CLS. 22, 23, 38 AND 50).

FIRST USE 10-15-2011; IN COMMERCE 10-15-2011.
KAREN SEVERSON, EXAMINING ATTORNEY

SN 85-513,624. DENOUIL, THIERRY, SAN FRANCISCO, CA. FILED 1-11-2012.

SPEEDEEBEE

THE MARK CONSISTS OF STANDARD CHARACTERS WITHOUT CLAIM TO ANY PARTICULAR FONT, STYLE, SIZE, OR COLOR.

FOR BOARD GAMES; CARD GAMES; DICE GAMES; GAME CARDS; PARLOR GAMES; PARTY GAMES (U.S. CLS. 22, 23, 38 AND 50).

FIRST USE 10-15-2011; IN COMMERCE 10-15-2011.
KAREN SEVERSON, EXAMINING ATTORNEY

SN 85-513,839. CAMPOS, LUIS, NORTH HOLLYWOOD, CA. FILED 1-11-2012.

FILL'ERUP!

THE MARK CONSISTS OF STANDARD CHARACTERS WITHOUT CLAIM TO ANY PARTICULAR FONT, STYLE, SIZE, OR COLOR.

FOR BOARD GAMES; PUZZLE GAMES (U.S. CLS. 22, 23, 38 AND 50).

ANDREA BUTLER, EXAMINING ATTORNEY

CLASS 28—(Continued).

SN 85-513,970. THE PROPHET CORPORATION, OWATONA, MN. FILED 1-11-2012.

STEPPERFECT

THE MARK CONSISTS OF STANDARD CHARACTERS WITHOUT CLAIM TO ANY PARTICULAR FONT, STYLE, SIZE, OR COLOR.

FOR AEROBIC STEPS (U.S. CLS. 22, 23, 38 AND 50).
JOHN GARTNER, EXAMINING ATTORNEY

SN 85-514,024. SCOTT DOWNING, FRANKLIN, IN. FILED 1-11-2012.

myPutt

THE MARK CONSISTS OF STANDARD CHARACTERS WITHOUT CLAIM TO ANY PARTICULAR FONT, STYLE, SIZE, OR COLOR.

FOR GOLF PUTTING AIDS, NAMELY, A PORTABLE PUTTING TARGET (U.S. CLS. 22, 23, 38 AND 50).

JAY BESCH, EXAMINING ATTORNEY

SN 85-514,298. DOUG JALLAS, CHANDLERVILLE, IL. FILED 1-11-2012.

BAND COLLECTOR

THE MARK CONSISTS OF STANDARD CHARACTERS WITHOUT CLAIM TO ANY PARTICULAR FONT, STYLE, SIZE, OR COLOR.

FOR HUNTING GAME CALLS (U.S. CLS. 22, 23, 38 AND 50).

FIRST USE 8-1-2006; IN COMMERCE 8-1-2006.
SHAUNIA CARLYLE, EXAMINING ATTORNEY

CLASS 28—(Continued).

SN 85-514,337. CHRISTOPHER R. MILES, SPRINGVILLE, UT. FILED 1-11-2012.

HUNGA MUNGA

THE MARK CONSISTS OF STANDARD CHARACTERS WITHOUT CLAIM TO ANY PARTICULAR FONT, STYLE, SIZE, OR COLOR.

FOR ARCHERY ARROW POINTS; ARCHERY ARROWS; ARROWS (U.S. CLS. 22, 23, 38 AND 50).
MIDGE BUTLER, EXAMINING ATTORNEY

SN 85-514,340. PARRIS MANUFACTURING COMPANY, SAVANNAH, TN. FILED 1-11-2012.

PLAINSMAN

THE MARK CONSISTS OF STANDARD CHARACTERS WITHOUT CLAIM TO ANY PARTICULAR FONT, STYLE, SIZE, OR COLOR.

FOR TOY GUNS (U.S. CLS. 22, 23, 38 AND 50).
LESLEY LAMOTHE, EXAMINING ATTORNEY

SN 85-514,447. COTE, CHRISTOPHER, SANTEE, CA. FILED 1-11-2012.

Smanimals

THE MARK CONSISTS OF STANDARD CHARACTERS WITHOUT CLAIM TO ANY PARTICULAR FONT, STYLE, SIZE, OR COLOR.

FOR STUFFED AND PLUSH TOYS (U.S. CLS. 22, 23, 38 AND 50).
SEAN CROWLEY, EXAMINING ATTORNEY

SN 85-514,456. SCHATZMAN, ROBERT, ROCKLEDGE, FL. FILED 1-11-2012.

**Escape Pod Race
Extraordinaire**

THE MARK CONSISTS OF STANDARD CHARACTERS WITHOUT CLAIM TO ANY PARTICULAR FONT, STYLE, SIZE, OR COLOR.

FOR BOARD GAMES (U.S. CLS. 22, 23, 38 AND 50).
BRENDAN REGAN, EXAMINING ATTORNEY

CLASS 28—(Continued).

SN 85-515,343. GRAND VISION GAMING, LLC, BILLINGS, MT. FILED 1-12-2012.

ANCIENT THUNDER

THE MARK CONSISTS OF STANDARD CHARACTERS WITHOUT CLAIM TO ANY PARTICULAR FONT, STYLE, SIZE, OR COLOR.

FOR GAMING MACHINES (U.S. CLS. 22, 23, 38 AND 50).
MIDGE BUTLER, EXAMINING ATTORNEY

SN 85-515,405. CENTRAL CAROLINA SPECIALTIES, INC., STATESVILLE, NC. FILED 1-12-2012.

Ther-e-is

THE MARK CONSISTS OF STANDARD CHARACTERS WITHOUT CLAIM TO ANY PARTICULAR FONT, STYLE, SIZE, OR COLOR.

FOR SALTWATER ARTIFICIAL FISHING LURES (U.S. CLS. 22, 23, 38 AND 50).
MARIA-VICTORIA SUAREZ, EXAMINING ATTORNEY

SN 85-515,408. SIMPLYFUN, LLC, BELLEVUE, WA. FILED 1-12-2012.

SPELL TREK

THE MARK CONSISTS OF STANDARD CHARACTERS WITHOUT CLAIM TO ANY PARTICULAR FONT, STYLE, SIZE, OR COLOR.

NO CLAIM IS MADE TO THE EXCLUSIVE RIGHT TO USE "SPELL", APART FROM THE MARK AS SHOWN.

FOR BOARD GAMES; EDUCATIONAL GAMES USING PRIMARILY A BOARD, DICE, AND PAWNS TO PROMOTE SPELLING SKILLS AND UNDERSTANDING OF VOWELS (U.S. CLS. 22, 23, 38 AND 50).
NICHOLAS ALTREE, EXAMINING ATTORNEY

CLASS 28—(Continued).

SN 85-515,445. COMSTOCK STUDIOS, INC., GLENDALE, CA. FILED 1-12-2012.

FEETBALL

THE MARK CONSISTS OF STANDARD CHARACTERS WITHOUT CLAIM TO ANY PARTICULAR FONT, STYLE, SIZE, OR COLOR.
FOR RUBBER ACTION BALLS (U.S. CLS. 22, 23, 38 AND 50).
MIDGE BUTLER, EXAMINING ATTORNEY

CLASS 28—(Continued).

SN 85-515,751. BARSKI, KAREN, TRUMBULL, CT. FILED 1-13-2012.

MommyTime

THE MARK CONSISTS OF STANDARD CHARACTERS WITHOUT CLAIM TO ANY PARTICULAR FONT, STYLE, SIZE, OR COLOR.
FOR DOLLS ; SOFT DOLLS (U.S. CLS. 22, 23, 38 AND 50).
FIRST USE 4-1-2011; IN COMMERCE 11-30-2011.
KRISTINA MORRIS, EXAMINING ATTORNEY

SN 85-515,502. WACH, CHRISTIAN SEBASTIAN, SANTA BARBARA, CA. FILED 1-12-2012.

SEAFOAM

THE MARK CONSISTS OF THE WORD SEAFOAM WITH A DESIGN OF A SURFBOARD AS PART OF THE LETTER O.
FOR SURFBOARDS (U.S. CLS. 22, 23, 38 AND 50).
KIMBERLY PERRY, EXAMINING ATTORNEY

SN 85-515,754. BARSKI, KAREN, TRUMBULL, CT. FILED 1-13-2012.

DaddyTime

THE MARK CONSISTS OF STANDARD CHARACTERS WITHOUT CLAIM TO ANY PARTICULAR FONT, STYLE, SIZE, OR COLOR.
FOR DOLLS : SOFT DOLLS FEATURING A SMALL TIMER TO TEACH THE CHILD A SENSE OF TIME (U.S. CLS. 22, 23, 38 AND 50).
FIRST USE 11-4-2011; IN COMMERCE 11-30-2011.
KRISTINA MORRIS, EXAMINING ATTORNEY

SN 85-515,597. NOMAD LACROSSE DISTRIBUTORS, LLC, FREEHOLD, NJ. FILED 1-12-2012.

LAX R.A.T.

THE MARK CONSISTS OF STANDARD CHARACTERS WITHOUT CLAIM TO ANY PARTICULAR FONT, STYLE, SIZE, OR COLOR.
NO CLAIM IS MADE TO THE EXCLUSIVE RIGHT TO USE "LAX", APART FROM THE MARK AS SHOWN.
FOR LACROSSE PRACTICE TARGETS (U.S. CLS. 22, 23, 38 AND 50).
SANDRA BUJA, EXAMINING ATTORNEY

SN 85-515,785. HOME BOX OFFICE, INC., NEW YORK, NY. FILED 1-13-2012.

ENTOURAGE AND DESIGN

THE MARK CONSISTS OF STANDARD CHARACTERS WITHOUT CLAIM TO ANY PARTICULAR FONT, STYLE, SIZE, OR COLOR.
OWNER OF U.S. REG. NOS. 3,293,874 AND 3,645,096.
FOR PLAYING CARDS AND POKER CHIPS (U.S. CLS. 22, 23, 38 AND 50).
RUSS HERMAN, EXAMINING ATTORNEY

CLASS 28—(Continued).

SN 85-515,938. MATTEL, INC., EL SEGUNDO, CA. FILED 1-13-2012.

DINNER DATE NIGHT

THE MARK CONSISTS OF STANDARD CHARACTERS WITHOUT CLAIM TO ANY PARTICULAR FONT, STYLE, SIZE, OR COLOR.

FOR DOLLS, DOLL CLOTHING AND DOLL ACCESSORIES; DOLL PLAYSETS AND ACCESSORIES THEREFOR; DOLL FURNITURE AND ACCESSORIES THEREFOR (U.S. CLS. 22, 23, 38 AND 50).

JAMES LOVELACE, EXAMINING ATTORNEY

CLASS 28—(Continued).

SN 85-515,951. MATTEL, INC., EL SEGUNDO, CA. FILED 1-13-2012.

THREADARELLA

THE MARK CONSISTS OF STANDARD CHARACTERS WITHOUT CLAIM TO ANY PARTICULAR FONT, STYLE, SIZE, OR COLOR.

FOR DOLLS, DOLL CLOTHING AND DOLL ACCESSORIES (U.S. CLS. 22, 23, 38 AND 50).

JAMES LOVELACE, EXAMINING ATTORNEY

SN 85-515,940. MATTEL, INC., EL SEGUNDO, CA. FILED 1-13-2012.

PUPPY WATER PLAY

THE MARK CONSISTS OF STANDARD CHARACTERS WITHOUT CLAIM TO ANY PARTICULAR FONT, STYLE, SIZE, OR COLOR.

NO CLAIM IS MADE TO THE EXCLUSIVE RIGHT TO USE "PUPPY WATER", APART FROM THE MARK AS SHOWN.

FOR DOLLS, DOLL CLOTHING AND DOLL ACCESSORIES; TOY ANIMAL FIGURES AND ACCESSORIES THEREFOR (U.S. CLS. 22, 23, 38 AND 50).

JAMES LOVELACE, EXAMINING ATTORNEY

SN 85-516,071. D. H. HUTSON ENTERPRISES, INC., WAX-HAW, NC. FILED 1-13-2012.

HIT ME AGAIN

THE MARK CONSISTS OF STANDARD CHARACTERS WITHOUT CLAIM TO ANY PARTICULAR FONT, STYLE, SIZE, OR COLOR.

FOR GOLF BALLS (U.S. CLS. 22, 23, 38 AND 50).

FIRST USE 9-30-1993; IN COMMERCE 9-30-1993.

APRIL HESIK, EXAMINING ATTORNEY

SN 85-515,947. MATTEL, INC., EL SEGUNDO, CA. FILED 1-13-2012.

FLASH FACTORY

THE MARK CONSISTS OF STANDARD CHARACTERS WITHOUT CLAIM TO ANY PARTICULAR FONT, STYLE, SIZE, OR COLOR.

FOR TOY VEHICLES AND ACCESSORIES THEREFOR; TOY VEHICLE PLAYSETS AND ACCESSORIES THEREFOR (U.S. CLS. 22, 23, 38 AND 50).

JAMES LOVELACE, EXAMINING ATTORNEY

SN 85-516,224. THE DREW OLIVER COMPANY, LLC, STAMFORD, CT. FILED 1-13-2012.

HUMERUS

THE MARK CONSISTS OF STANDARD CHARACTERS WITHOUT CLAIM TO ANY PARTICULAR FONT, STYLE, SIZE, OR COLOR.

FOR COLLECTABLE TOY FIGURES; PLUSH TOYS; SOFT SCULPTURE TOYS; SQUEEZABLE SPEAKING TOYS; SQUEEZE TOYS; TOY FIGURES; DOLLS (U.S. CLS. 22, 23, 38 AND 50).

TINA L. SNAPP, EXAMINING ATTORNEY

CLASS 28—(Continued).

SN 85-516,358. SALT OPTICS, INC., COSTA MESA, CA. FILED 1-13-2012.

STORMY MONDAY

THE MARK CONSISTS OF STANDARD CHARACTERS WITHOUT CLAIM TO ANY PARTICULAR FONT, STYLE, SIZE, OR COLOR.

FOR PADDLE SURFBOARDS; SKATEBOARD DECKS; SKATEBOARD RAILS; SKATEBOARD TRUCKS; SKATEBOARD WAX; SKATEBOARDS; SURFBOARD LEASHES; SURFBOARD WAX; SURFBOARDS (U.S. CLS. 22, 23, 38 AND 50).

LAURA KOVALSKY, EXAMINING ATTORNEY



SN 85-517,019. JAY AT PLAY INTERNATIONAL HONG KONG LIMITED, HONG KONG, HONG KONG, FILED 1-16-2012.

POP 'N PLAY VILLAGE

THE MARK CONSISTS OF STANDARD CHARACTERS WITHOUT CLAIM TO ANY PARTICULAR FONT, STYLE, SIZE, OR COLOR.

FOR STUFFED AND PLUSH TOYS; STUFFED DOLLS AND ANIMALS (U.S. CLS. 22, 23, 38 AND 50).

BERNICE MIDDLETON, EXAMINING ATTORNEY



SN 85-518,030. KARL BEITZEL, CANTON, OH. FILED 1-17-2012.

JACK HOOKS

THE MARK CONSISTS OF STANDARD CHARACTERS WITHOUT CLAIM TO ANY PARTICULAR FONT, STYLE, SIZE, OR COLOR.

NO CLAIM IS MADE TO THE EXCLUSIVE RIGHT TO USE "HOOKS", APART FROM THE MARK AS SHOWN.

FOR FISHING TACKLE CAPABLE OF KNOTLESS CONNECTION TO A FISHING LINE (U.S. CLS. 22, 23, 38 AND 50).

FIRST USE 12-22-2010; IN COMMERCE 7-15-2011.
SUSAN LESLIE DUBOIS, EXAMINING ATTORNEY

CLASS 28—(Continued).

SN 85-525,831. JAY AT PLAY INTERNATIONAL HONG KONG LIMITED, HONG KONG, HONG KONG, FILED 1-26-2012.

TOTALLY KOO KOO

THE MARK CONSISTS OF STANDARD CHARACTERS WITHOUT CLAIM TO ANY PARTICULAR FONT, STYLE, SIZE, OR COLOR.

FOR PLUSH DOLLS; PLUSH TOYS; STUFFED AND PLUSH TOYS (U.S. CLS. 22, 23, 38 AND 50).

BERNICE MIDDLETON, EXAMINING ATTORNEY



SN 85-533,396. FERRARI IMPORTING COMPANY, PITTSBURGH, PA. FILED 2-3-2012.



THE MARK CONSISTS OF A CIRCLE WITH A STYLIZED LETTER "G" EMERGING FROM THE INNER LEFT SIDE.

FOR BADMINTON RACKET STRINGS; GRIP TAPES FOR RACKETS; PROTECTIVE COVERS FOR RACKETS; RACQUET BALL RACKET STRINGS; SQUASH RACKET STRINGS; TENNIS BALLS; TENNIS RACKET COVERS; TENNIS RACKET STRINGS; TENNIS RACKETS; BAGS SPECIALLY ADAPTED FOR SPORTS EQUIPMENT; TENNIS BALL RETRIEVERS (U.S. CLS. 22, 23, 38 AND 50).

FIRST USE 1-25-2012; IN COMMERCE 1-25-2012.
TINA MAI, EXAMINING ATTORNEY

CLASS 28—(Continued).

SN 85-533,411. FERRARI IMPORTING COMPANY, PITTSBURGH, PA. FILED 2-3-2012.

RZR

THE MARK CONSISTS OF STANDARD CHARACTERS WITHOUT CLAIM TO ANY PARTICULAR FONT, STYLE, SIZE, OR COLOR.

FOR BADMINTON RACKET STRINGS; GRIP TAPES FOR RACKETS; PROTECTIVE COVERS FOR RACKETS; RACQUET BALL RACKET STRINGS; SQUASH RACKET STRINGS; TENNIS BALLS; TENNIS RACKET COVERS; TENNIS RACKET STRINGS; TENNIS RACKETS; BAGS SPECIALLY ADAPTED FOR SPORTS EQUIPMENT; TENNIS BALL RETRIEVERS (U.S. CLS. 22, 23, 38 AND 50).

FIRST USE 1-25-2012; IN COMMERCE 1-25-2012.
TINA MAI, EXAMINING ATTORNEY

SN 85-533,516. AGC, LLC, CLEVELAND, OH. FILED 2-3-2012.

BOOFLE

THE MARK CONSISTS OF STANDARD CHARACTERS WITHOUT CLAIM TO ANY PARTICULAR FONT, STYLE, SIZE, OR COLOR.

OWNER OF U.S. REG. NO. 3,987,305.
FOR PLUSH TOYS (U.S. CLS. 22, 23, 38 AND 50).
FIRST USE 1-31-2012; IN COMMERCE 1-31-2012.
DAVID YONTEF, EXAMINING ATTORNEY

SN 85-533,527. FERRARI IMPORTING COMPANY, PITTSBURGH, PA. FILED 2-3-2012.



OWNER OF U.S. REG. NOS. 3,285,229, 3,285,230 AND 3,285,431.

THE MARK CONSISTS OF THE WORD "GAMMA" IN STYLIZED FONT.

FOR BADMINTON RACKET STRINGS; GRIP TAPES FOR RACKETS; PROTECTIVE COVERS FOR RACKETS; RACQUET BALL RACKET STRINGS; SQUASH RACKET STRINGS; TENNIS BALLS; TENNIS RACKET COVERS; TENNIS RACKET STRINGS; TENNIS RACKETS; BAGS SPECIALLY ADAPTED FOR SPORTS EQUIPMENT; TENNIS BALL RETRIEVERS (U.S. CLS. 22, 23, 38 AND 50).

FIRST USE 1-25-2012; IN COMMERCE 1-25-2012.
TINA MAI, EXAMINING ATTORNEY

CLASS 28—(Continued).

SN 85-548,683. AGC, LLC, CLEVELAND, OH. FILED 2-21-2012.



OWNER OF U.S. REG. NO. 3,987,305.
THE MARK CONSISTS OF THE WORD "BOOFLE" IN A STYLIZED FONT.

FOR PLUSH TOYS (U.S. CLS. 22, 23, 38 AND 50).
FIRST USE 1-31-2012; IN COMMERCE 1-31-2012.
DAVID YONTEF, EXAMINING ATTORNEY

SN 85-550,676. JAY AT PLAY INTERNATIONAL HONG KONG LIMITED, HONG KONG, HONG KONG, FILED 2-23-2012.

BEST FLOWER BUDS

THE MARK CONSISTS OF STANDARD CHARACTERS WITHOUT CLAIM TO ANY PARTICULAR FONT, STYLE, SIZE, OR COLOR.

FOR DOLL ACCESSORIES; DOLL CLOTHING; DOLLS; TOY FIGURES (U.S. CLS. 22, 23, 38 AND 50).
BERNICE MIDDLETON, EXAMINING ATTORNEY

SN 85-558,493. PRACTICAL STRATEGIES, INC., WEST BEND, WI. FILED 3-2-2012.

SPEAK IT

THE MARK CONSISTS OF STANDARD CHARACTERS WITHOUT CLAIM TO ANY PARTICULAR FONT, STYLE, SIZE, OR COLOR.

NO CLAIM IS MADE TO THE EXCLUSIVE RIGHT TO USE "IT", APART FROM THE MARK AS SHOWN.

FOR CARD GAMES FEATURING INTERNET TECHNOLOGY SPECIFIC ACRONYMS (U.S. CLS. 22, 23, 38 AND 50).

JENNIFER MARTIN, EXAMINING ATTORNEY

CLASS 28—(Continued).

SN 85-560,418. SPIN MASTER LTD., TORONTO, ONTARIO, CANADA, FILED 3-5-2012.

STRIKER

THE MARK CONSISTS OF STANDARD CHARACTERS WITHOUT CLAIM TO ANY PARTICULAR FONT, STYLE, SIZE, OR COLOR.
OWNER OF CANADA REG. NO. TMA629241, DATED 1-4-2005, EXPIRES 1-4-2020.
FOR TOY AIRPLANES (U.S. CLS. 22, 23, 38 AND 50).
KATHERINE M. DUBRAY, EXAMINING ATTORNEY

CLASS 28—(Continued).

SN 85-592,717. MIAMI TRIBE OF OKLAHOMA BUSINESS DEVELOPMENT AUTHORITY, A TRIBAL ENTERPRISE OF THE MIAMI TRIBE OF OKLAHOMA, MIAMI, OK. FILED 4-9-2012.

5 OF A KIND BLITZ

THE MARK CONSISTS OF STANDARD CHARACTERS WITHOUT CLAIM TO ANY PARTICULAR FONT, STYLE, SIZE, OR COLOR.
NO CLAIM IS MADE TO THE EXCLUSIVE RIGHT TO USE "5 OF A KIND", APART FROM THE MARK AS SHOWN.
FOR GAMING MACHINES, NAMELY, BINGO-RELATED GAMES AND SLOT MACHINES (U.S. CLS. 22, 23, 38 AND 50).
KATHY DE JONGE, EXAMINING ATTORNEY

SN 85-565,008. LFP IP, LLC, BEVERLY HILLS, CA. FILED 3-9-2012.

HUSTLER

THE MARK CONSISTS OF STANDARD CHARACTERS WITHOUT CLAIM TO ANY PARTICULAR FONT, STYLE, SIZE, OR COLOR.
OWNER OF U.S. REG. NOS. 1,011,001, 3,918,404 AND OTHERS.
FOR SKATEBOARDS; SKIM BOARDS; SKIS; SNOW BOARDS; SURF BOARDS; WAKE BOARDS (U.S. CLS. 22, 23, 38 AND 50).
AMY KELLY, EXAMINING ATTORNEY

CLASS 29—MEATS AND PROCESSED FOODS

SN 79-100,299. VORTELLA-LEBENSMITTELWERK W. VORTMEYER GMBH, FED REP GERMANY, FILED 6-28-2011.

Vortella

OWNER OF INTERNATIONAL REGISTRATION 0244663 DATED 6-24-1961, EXPIRES 6-24-2021.
THE WORDING "VORTELLA" HAS NO MEANING IN A FOREIGN LANGUAGE.
FOR MARGARINE AND EDIBLE VEGETABLE FATS (U.S. CL. 46).
LYDIA BELZER, EXAMINING ATTORNEY

SN 85-584,104. SCHATZMAN, ROBERT, ROCKLEDGE, FL. FILED 3-29-2012.

Nose Pick

THE MARK CONSISTS OF STANDARD CHARACTERS WITHOUT CLAIM TO ANY PARTICULAR FONT, STYLE, SIZE, OR COLOR.
FOR CARD GAMES (U.S. CLS. 22, 23, 38 AND 50).
BRENDAN REGAN, EXAMINING ATTORNEY

SN 79-103,735. SVENSK MJÖLK AB, SWEDEN, FILED 9-20-2011.

PRÄST

THE MARK CONSISTS OF STANDARD CHARACTERS WITHOUT CLAIM TO ANY PARTICULAR FONT, STYLE, SIZE, OR COLOR.
OWNER OF INTERNATIONAL REGISTRATION 1093767 DATED 9-20-2011, EXPIRES 9-20-2021.
THE ENGLISH TRANSLATION OF THE WORD "PRÄST" IN THE MARK IS "PRIEST".
FOR MILK AND MILK PRODUCTS, NAMELY, CHEESE AND OTHER DAIRY PRODUCTS, EXCLUDING ICE CREAM, ICE MILK AND FROZEN YOGURT (U.S. CL. 46).
WILLIAM ROSSMAN, EXAMINING ATTORNEY

CLASS 29—(Continued).

SN 85-030,968. REBORNNE NEW ZEALAND LIMITED, AUCKLAND, NEW ZEALAND, FILED 5-5-2010.

REBORNNE

THE MARK CONSISTS OF STANDARD CHARACTERS WITHOUT CLAIM TO ANY PARTICULAR FONT, STYLE, SIZE, OR COLOR.

FOR MILK; MILK POWDER; COLOSTRUM MILK POWDER FOR NUTRITIONAL PURPOSES (U.S. CL. 46).
KELLY BOULTON, EXAMINING ATTORNEY

SN 85-173,629. LAKONIA GREEK PRODUCTS LLC, SACO, ME. FILED 11-10-2010.

DÁFNI

THE MARK CONSISTS OF STANDARD CHARACTERS WITHOUT CLAIM TO ANY PARTICULAR FONT, STYLE, SIZE, OR COLOR.

THE ENGLISH TRANSLATION OF "DÁFNI" IN THE MARK IS "LAUREL" OR "DAPHNE".

FOR OIL, NAMELY, EDIBLE OIL, COOKING OIL, OLIVE OIL, SALAD OIL; AND PROCESSED, AND PRESERVED OLIVES (U.S. CL. 46).

FIRST USE 2-28-2009; IN COMMERCE 2-28-2009.
NAPOLEON SHARMA, EXAMINING ATTORNEY

SN 85-215,151. HOMESTYLE DINING LLC, DBA PONDEROSA STEAKHOUSE, PLANO, TX. FILED 1-11-2011.

PONDEROSA

THE MARK CONSISTS OF STANDARD CHARACTERS WITHOUT CLAIM TO ANY PARTICULAR FONT, STYLE, SIZE, OR COLOR.

OWNER OF U.S. REG. NOS. 903,604, 1,254,681 AND 2,418,851.

FOR MEAT; POULTRY; PROCESSED VEGETABLES; SEAFOOD; PREPARED ENTREES CONSISTING PRIMARILY OF MEAT, FISH, POULTRY OR VEGETABLES (U.S. CL. 46).

LESLEY LAMOTHE, EXAMINING ATTORNEY

CLASS 29—(Continued).

SN 85-328,286. BELCAMPO GROUP, INC., OAKLAND, CA. FILED 5-24-2011.

BELCAMPO

THE MARK CONSISTS OF STANDARD CHARACTERS WITHOUT CLAIM TO ANY PARTICULAR FONT, STYLE, SIZE, OR COLOR.

THE ENGLISH TRANSLATION OF THE WORD "BELCAMPO" IN THE MARK IS "BEAUTIFUL LAND OR BEAUTIFUL FIELD".

FOR MEAT, POULTRY, CHICKEN, GAME, VEAL, PROCESSED LAMB AND PORK; PROCESSED MEATS, NAMELY, SAUSAGE, FRANKFURTERS, AND SMOKED MEATS; CURED MEATS, NAMELY, BEEF, PORK, POULTRY, VEAL, LAMB AND GAME; DRIED MEAT; MEAT PRESERVES; HAMBURGER; MEAT PATTIES, NAMELY, PATTIES OF BEEF, PORK, POULTRY, VEAL, LAMB AND GAME; MARINATED MEAT; MEATBALLS, NAMELY, BEEF, PORK, POULTRY, VEAL, LAMB AND GAME; MEAT-BASED MOUSSE; MEAT-BASED SNACK FOODS; MEAT-BASED SPREADS; PREPARED MEAT, NAMELY, SHREDDED MEATS AND MEAT PIECES; BROTH; MATZO BALL SOUP; PREPARATIONS FOR MAKING SOUPS; SOUP MIXES; SOUP PASTES; SOUPS; SOUPS AND PREPARATIONS FOR MAKING SOUPS; PORK CUTLETS; SAUSAGES; HAM; PORK RINDS, HOT DOGS, LUNCHEON MEATS, FRANKFURTERS AND FISH; PICKLES, CHILI, JERKY, MEAT JELLIES, MEAT PASTE, MEAT EXTRACT, MEAT-BASED SPREADS, MEAT JUICES, MEAT SUBSTITUTES AND MINCE-MEAT; PREPARED OR PACKAGED ENTREES CONSISTING PRIMARILY OF MEAT, FISH, POULTRY OR VEGETABLES; SALADS, NAMELY, PRE-CUT VEGETABLE, FRUIT, GARDEN AND SEAFOOD SALADS; POTATO CHIPS, POTATO-BASED SNACK FOODS, PROCESSED NUTS, PROCESSED EDIBLE SEEDS, FRUIT-BASED SNACK FOODS; FRUIT ROLLS; CANDIED NUTS, CANDIED FRUIT, CANDIED FRUIT SNACKS; FRUIT CHIPS, FRUIT LEATHERS, FRUIT PASTE, FRUIT PEELS, FRUIT CONSERVES AND PRESERVES, FRUIT PULPS AND RINDS, BANANA CHIPS AND YUCCA CHIPS, VEGETABLE PASTE; FRUIT SAUCES, NAMELY, CRANBERRY SAUCE AND FRUIT TOPPING; PROTEIN-BASED, NUTRIENT-DENSE SNACK BARS; DAIRY PRODUCTS EXCLUDING ICE CREAM, ICE MILK AND FROZEN YOGURT; CHEESE, CHEESE FOOD, COTTAGE CHEESE, HALF AND HALF, CREAM, SOUR CREAM AND SOUR CREAM SUBSTITUTES, WHIPPED TOPPING AND NON-DAIRY CREAMER; CHEESE SPREADS; BUTTER, MARGARINE, COCOA BUTTER; FRUIT-BASED FOOD BEVERAGE; DAIRY-BASED FOOD BEVERAGE; VEGETABLE-BASED FOOD BEVERAGE; MILK-BASED BEVERAGE CONTAINING COFFEE; EGG NOG AND EGG NOG MIXES, EGG PRODUCT, EGGS AND EGG SUBSTITUTE; DAIRY-BASED, FRUIT-BASED AND VEGETABLE-BASED SPREADS; HAZELNUT SPREAD, SNACK DIPS AND SNACK FOOD DIPS; VEGETABLE, SALAD, COOKING AND EDIBLE OILS; EDIBLE FATS, FOOD PACKAGE COMBINATIONS CONSISTING PRIMARILY OF CHEESE, MEAT AND/OR PROCESSED FRUIT; SNACK MIX CONSISTING PRIMARILY OF FRUITS, PROCESSED NUTS AND/OR RAISINS; AND CHEESE AND CRACKER COMBINATIONS; APPLESAUCE; PROCESSED ALMONDS; DAIRY AND VEGETABLE BASED CHOCOLATE FOOD BEVERAGES, CHOCOLATE MILK, COMBINED PEANUT BUTTER AND CHOCOLATE SANDWICH SPREADS (U.S. CL. 46).

ROBIN CHOSID, EXAMINING ATTORNEY

CLASS 29—(Continued).

SN 85-332,312. MILLERCOORS LLC, CHICAGO, IL. FILED 5-27-2011.

CLASS 29—(Continued).

SN 85-344,938. PARSONS, JOSEPH, LAUDERDALE-BY-THE-SEA, FL. FILED 6-13-2011.

COLORADO NATIVE

WE ROCK THE GUAC

THE MARK CONSISTS OF STANDARD CHARACTERS WITHOUT CLAIM TO ANY PARTICULAR FONT, STYLE, SIZE, OR COLOR.

NO CLAIM IS MADE TO THE EXCLUSIVE RIGHT TO USE "COLORADO", APART FROM THE MARK AS SHOWN.

FOR COLORADO MEATS (U.S. CL. 46).
SUSAN RICHARDS, EXAMINING ATTORNEY

THE MARK CONSISTS OF STANDARD CHARACTERS WITHOUT CLAIM TO ANY PARTICULAR FONT, STYLE, SIZE, OR COLOR.

FOR GUACAMOLE (U.S. CL. 46).
ELLEN BURNS, EXAMINING ATTORNEY

SN 85-332,383. ANHING CORPORATION, LOS ANGELES, CA. FILED 5-27-2011.

SN 85-346,013. EME IMPORTS, SAN DIEGO, CA. FILED 6-14-2011.

SARAP

PureFish

THE MARK CONSISTS OF STANDARD CHARACTERS WITHOUT CLAIM TO ANY PARTICULAR FONT, STYLE, SIZE, OR COLOR.

OWNER OF U.S. REG. NOS. 1,871,459, 2,736,843 AND OTHERS.

THE ENGLISH TRANSLATION OF "SARAP" IN THE MARK IS "FAR FROM BEING CAUGHT UP" OR "INCOMPARABLE".

FOR SAUSAGES (U.S. CL. 46).
FIRST USE 5-24-2011; IN COMMERCE 5-24-2011.
HELENE LIWINSKI, EXAMINING ATTORNEY

THE MARK CONSISTS OF STANDARD CHARACTERS WITHOUT CLAIM TO ANY PARTICULAR FONT, STYLE, SIZE, OR COLOR.

FOR SEAFOOD (U.S. CL. 46).
FIRST USE 4-1-2006; IN COMMERCE 4-1-2006.
CHRIS WELLS, EXAMINING ATTORNEY

SN 85-336,296. THE YOFARM COMPANY, NAUGATUCK, CT. FILED 6-2-2011.

SN 85-346,676. KEMPER FOODS INTERNATIONAL, LLC, NEW ALBANY, IN. FILED 6-15-2011.

YOCRUNCH GREEK PARFAIT

SPUDTACULARS

THE MARK CONSISTS OF STANDARD CHARACTERS WITHOUT CLAIM TO ANY PARTICULAR FONT, STYLE, SIZE, OR COLOR.

OWNER OF U.S. REG. NO. 1,660,980.
NO CLAIM IS MADE TO THE EXCLUSIVE RIGHT TO USE "GREEK PARFAIT", APART FROM THE MARK AS SHOWN.

FOR YOGURT (U.S. CL. 46).
FRED CARL, EXAMINING ATTORNEY

THE MARK CONSISTS OF STANDARD CHARACTERS WITHOUT CLAIM TO ANY PARTICULAR FONT, STYLE, SIZE, OR COLOR.

FOR PREPARED FOODS MADE FROM POTATOES (U.S. CL. 46).
SHAILA SETTLES, EXAMINING ATTORNEY

CLASS 29—(Continued).

SN 85-347,421. DISNEY ENTERPRISES, INC., BURBANK, CA. FILED 6-15-2011.

PHINEAS AND FERB

THE MARK CONSISTS OF STANDARD CHARACTERS WITHOUT CLAIM TO ANY PARTICULAR FONT, STYLE, SIZE, OR COLOR.

OWNER OF U.S. REG. NOS. 3,610,415, 4,006,413 AND OTHERS.

FOR CANDIED FRUIT; CHOCOLATE MILK; FRUIT-BASED SNACKS; DAIRY PRODUCTS EXCLUDING ICE CREAM, ICE MILK AND FROZEN YOGURT; DRIED FRUITS; FRUIT PRESERVES; FRUIT-BASED SNACK FOODS; JAMS; JELLIES; MARMALADES; MEATS; POULTRY; POTATO CHIPS; PREPARED OR PACKAGED MEALS CONSISTING PRIMARILY OF MEAT, FISH, POULTRY OR VEGETABLES; PROCESSED, CANNED, BOTTLED, DRIED, FROZEN, COOKED, OR PRESERVED FRUITS AND VEGETABLES; PROCESSED FRUITS AND VEGETABLES; POWDERED MILK; SNACK MIX CONSISTING PRIMARILY OF PROCESSED FRUITS, PROCESSED NUTS; YOGURTS (U.S. CL. 46).

KIMBERLY FRYE, EXAMINING ATTORNEY

SN 85-352,857. D'S SPECIALTY FOODS, LLC, MELVILLE, NY. FILED 6-22-2011.

**NANA'S
B&B
PICKLES**

NO CLAIM IS MADE TO THE EXCLUSIVE RIGHT TO USE "B&B PICKLES", APART FROM THE MARK AS SHOWN.

THE MARK CONSISTS OF THE TERM "NANA'S" ABOVE "B&B" WHICH IS SURROUNDED ON ITS LEFT AND RIGHT SIDE WITH THREE HORIZONTAL LINES AND IS ABOVE THE TERM "PICKLES".

FOR PICKLES (U.S. CL. 46).

BRIAN PINO, EXAMINING ATTORNEY

SN 85-355,078. HEB GROCERY COMPANY LP, SAN ANTONIO, TX. FILED 6-24-2011.

ENERGY CRUNCH

THE MARK CONSISTS OF STANDARD CHARACTERS WITHOUT CLAIM TO ANY PARTICULAR FONT, STYLE, SIZE, OR COLOR.

FOR TRAIL MIX CONSISTING PRIMARILY OF PROCESSED NUTS, SEEDS, DRIED FRUIT, AND ALSO INCLUDING SOYBEANS (U.S. CL. 46).

SCOTT BIBB, EXAMINING ATTORNEY

CLASS 29—(Continued).

SN 85-366,648. THE TRUSTEES OF THE ROSEANNE LIVING TRUST, A CALIFORNIA TRUST, THE TRUSTEE COMPRISING OF ROSEANNE BARR, A U.S. CITIZEN, SHERMAN OAKS, CA. FILED 7-8-2011.

ROSEANNE'S NUTS

THE MARK CONSISTS OF STANDARD CHARACTERS WITHOUT CLAIM TO ANY PARTICULAR FONT, STYLE, SIZE, OR COLOR.

NO CLAIM IS MADE TO THE EXCLUSIVE RIGHT TO USE "NUTS", APART FROM THE MARK AS SHOWN.

THE NAME(S), PORTRAIT(S), AND/OR SIGNATURE(S) SHOWN IN THE MARK IDENTIFIES "ROSEANNE" BARR, WHOSE CONSENT(S) TO REGISTER IS MADE OF RECORD.

FOR PROCESSED AND ROASTED NUTS, NAMELY, PROCESSED AND ROASTED MACADAMIA NUTS (U.S. CL. 46).

BARBARA GAYNOR, EXAMINING ATTORNEY

SN 85-372,451. ROBINSON, MELISSA, MISHAWAKA, IN. FILED 7-15-2011.

Chiptos

THE MARK CONSISTS OF STANDARD CHARACTERS WITHOUT CLAIM TO ANY PARTICULAR FONT, STYLE, SIZE, OR COLOR.

THE WORDING "CHIPTOS" HAS NO MEANING IN A FOREIGN LANGUAGE.

FOR POTATO CRISPS AND CHIPS (U.S. CL. 46).

FIRST USE 6-12-2011; IN COMMERCE 6-12-2011.

JESSICA FATHY, EXAMINING ATTORNEY

SN 85-372,804. ZIPS ENERGY, LLC, GILBERT, AZ. FILED 7-15-2011.

ZIPS ENERGY SEEDS

THE MARK CONSISTS OF STANDARD CHARACTERS WITHOUT CLAIM TO ANY PARTICULAR FONT, STYLE, SIZE, OR COLOR.

NO CLAIM IS MADE TO THE EXCLUSIVE RIGHT TO USE "ENERGY SEEDS", APART FROM THE MARK AS SHOWN.

FOR PROCESSED SUNFLOWER SEEDS (U.S. CL. 46).

FIRST USE 5-24-2011; IN COMMERCE 5-24-2011.

AMY KELLY, EXAMINING ATTORNEY

CLASS 29—(Continued).

SN 85-376,053. EDIBLE CORP, BROOKLYN, NY. FILED 7-20-2011.



NO CLAIM IS MADE TO THE EXCLUSIVE RIGHT TO USE THE NON-LATIN CHARACTERS THAT TRANSLITERATE TO KIMCHI, APART FROM THE MARK AS SHOWN.
THE COLOR(S) RED IS/ARE CLAIMED AS A FEATURE OF THE MARK.

THE MARK CONSISTS OF A RED SQUARE LOGO SLANTED SLIGHTLY COUNTER-CLOCKWISE WITH KOREAN CHARACTERS PUNCHED OUT THAT SAY ARIRANG KIMCHI IN KOREAN. THE COLORS BLACK, WHITE AND/OR GRAY REPRESENT BACKGROUND, OUTLINING, SHADING, AND/OR TRANSPARENT AREAS AND ARE NOT PART OF THE MARK.

THE NON-LATIN CHARACTERS IN THE MARK TRANSLITERATE TO "ARIRANG KIMCHI", AND THIS HAS NO MEANING IN A FOREIGN LANGUAGE.

FOR FERMENTED VEGETABLES; RADISH CUBED KIMCHI; WATERY RADISH KIMCHI (U.S. CL. 46).

FIRST USE 6-25-1991; IN COMMERCE 6-25-1992.
STEVEN JACKSON, EXAMINING ATTORNEY

SN 85-399,941. KONOPKA, ZENON, ONTARIO, CANADA, AND SMITH, PATRICK, ONTARIO, CANADA, FILED 8-17-2011.

ZEN ESSENTIALS

THE MARK CONSISTS OF STANDARD CHARACTERS WITHOUT CLAIM TO ANY PARTICULAR FONT, STYLE, SIZE, OR COLOR.

FOR COLD PRESSED GRAPE SEED OIL FOR COOKING AND FLAVORING (U.S. CL. 46).

KATHERINE CHANG, EXAMINING ATTORNEY

CLASS 29—(Continued).

SN 85-402,291. GLOBAL SMOKED FOODS LIMITED FOUNDATION, CHARLESTOWN, ST.KITTS-NEVIS, FILED 8-19-2011.



NO CLAIM IS MADE TO THE EXCLUSIVE RIGHT TO USE "SALMON", APART FROM THE MARK AS SHOWN.

THE MARK CONSISTS OF THE WORDING "SIMPLE SALMON" ABOVE TWO FLOATING HEARTS AND A FISH. FOR SMOKED FISH; SALMON (U.S. CL. 46).
MARY CRAWFORD, EXAMINING ATTORNEY

SN 85-402,708. LAWRENCE FOODS, INC., ELK GROVE VILLAGE, IL. FILED 8-19-2011.

FIL-N-TOP

THE MARK CONSISTS OF STANDARD CHARACTERS WITHOUT CLAIM TO ANY PARTICULAR FONT, STYLE, SIZE, OR COLOR.

FOR MULTI-USE FOOD INGREDIENTS FOR FOOD SERVICE OPERATORS AND IN-STORE BAKERIES, NAMELY, FRUIT FILLINGS (U.S. CL. 46).

FIRST USE 1-1-1975; IN COMMERCE 1-1-1975.
ELIZABETH KAJUBI, EXAMINING ATTORNEY

SN 85-403,807. NUTRI/SYSTEM IPHC, INC., WILMINGTON, DE. FILED 8-22-2011.

REAL BALANCED NUTRITION

THE MARK CONSISTS OF STANDARD CHARACTERS WITHOUT CLAIM TO ANY PARTICULAR FONT, STYLE, SIZE, OR COLOR.

NO CLAIM IS MADE TO THE EXCLUSIVE RIGHT TO USE "BALANCED NUTRITION", APART FROM THE MARK AS SHOWN.

FOR BREAKFAST, LUNCH AND DINNER ENTREES, AND SNACKS CONSISTING PRIMARILY OF MEAT, FISH AND POULTRY; EGGS; MILK AND MILK PRODUCTS, NAMELY, CREAM CHEESE SPREAD, CHEESE SPREAD, COTTAGE CHEESE, SOUR CREAM; DRIED AND COOKED FRUITS AND VEGETABLES; JELLIES; SAUCES, NAMELY, APPLESAUCE; SNACK DIPS AND SOUPS; PROTEIN BASED NUTRIENT DENSE SNACK BARS; YOGURTS (U.S. CL. 46).

CHARLOTTE CORWIN, EXAMINING ATTORNEY

CLASS 29—(Continued).

SN 85-414,144. GLOBAL SMOKED FOODS LIMITED FOUNDATION, CHARLESTOWN, ST.KITTS-NEVIS, FILED 9-2-2011.

SCOTTISH DAWN

THE MARK CONSISTS OF STANDARD CHARACTERS WITHOUT CLAIM TO ANY PARTICULAR FONT, STYLE, SIZE, OR COLOR.

NO CLAIM IS MADE TO THE EXCLUSIVE RIGHT TO USE "SCOTTISH", APART FROM THE MARK AS SHOWN. FOR SMOKED FISH, NAMELY, SALMON ORIGINATING FROM SCOTLAND (U.S. CL. 46).

FIRST USE 9-11-2003; IN COMMERCE 9-11-2003.
MARY CRAWFORD, EXAMINING ATTORNEY

SN 85-423,655. RITCHIE ENTERPRISES INC, WOODLAKE, CA. FILED 9-15-2011.



NO CLAIM IS MADE TO THE EXCLUSIVE RIGHT TO USE "OLIVA" AND "OLIVE OIL", APART FROM THE MARK AS SHOWN.

THE MARK CONSISTS OF TWO OLIVE BRANCHES ORIGINATING FROM THE BOTTOM AND CROSSING AT THE TOP, AND THE TEXT "OLIVA DI VITA OLIVE OIL" STACKED BELOW THE OLIVE BRANCHES, ALL ON A RECTANGULAR BACKGROUND WITH FLORAL CORNER DESIGNS.

THE ENGLISH TRANSLATION OF "OLIVA DI VITA" IN THE MARK IS "OLIVE OF LIFE".

FOR OLIVE OIL (U.S. CL. 46).
TINA MAI, EXAMINING ATTORNEY

CLASS 29—(Continued).

SN 85-427,868. CAVEMAN CUISINE, AUSTIN, TX. FILED 9-21-2011.



NO CLAIM IS MADE TO THE EXCLUSIVE RIGHT TO USE "CUISINE FOOD", APART FROM THE MARK AS SHOWN.

THE MARK CONSISTS OF A STYLIZED DESIGN OF A CAVE DRAWING. THE DRAWING CONSISTS OF A PERSON WEARING A CHEF HAT POINTING A BOW AND AN ARROW AT A DEER-LIKE ANIMAL TO THE RIGHT. ON THE OTHER SIDE ANOTHER FIGURE IS POINTING A BOW AND ARROW AT THE ANIMAL. UNDER THE DRAWING IS THE STYLIZED TEXT "CAVEMAN CUISINE FOOD FOR THE MODERN DAY CAVEMAN" WHERE THE PHRASE "CAVEMAN CUISINE" APPEARS ABOVE THE PHRASE "FOOD FOR THE MODERN DAY CAVEMAN".

FOR FROZEN AND FRESHLY PREPARED BREAKFAST, LUNCH AND DINNER ENTREES, SNACKS AND DESSERTS CONTAINING MEAT, FISH AND POULTRY, EGGS, MILK AND MILK PRODUCTS, FRESH, DRIED AND COOKED FRUITS AND VEGETABLES, JELLIES, SAUCES, SOUPS, FOR USE BASED ON GLUTEN FREE AND PALEOLITHIC DIET (U.S. CL. 46).

VIVIAN MICZNIK FIRST, EXAMINING ATTORNEY

SN 85-429,494. GLOBAL VISION, LLC, TUCSON, AZ. FILED 9-22-2011.

ANCIENT RECIPE AMAZING FLAVOR

THE MARK CONSISTS OF STANDARD CHARACTERS WITHOUT CLAIM TO ANY PARTICULAR FONT, STYLE, SIZE, OR COLOR.

NO CLAIM IS MADE TO THE EXCLUSIVE RIGHT TO USE "RECIPE" AND "FLAVOR", APART FROM THE MARK AS SHOWN.

FOR PROCESSED AND FROZEN FOODS, NAMELY, VEGETABLES, BEANS, AND LENTILS (U.S. CL. 46).

FIRST USE 5-1-2011; IN COMMERCE 5-1-2011.
EMILY CHUO, EXAMINING ATTORNEY

CLASS 29—(Continued).

SN 85-439,849. GUTTENBERG, JAMIE L., DBA GUTTENBERG FARMS, TAYLOR, WI. FILED 10-5-2011.



NO CLAIM IS MADE TO THE EXCLUSIVE RIGHT TO USE "FARMS" AND "QUALITY CONTROLLED", APART FROM THE MARK AS SHOWN.

THE STIPPLING IS FOR SHADING PURPOSES ONLY. THE COLOR(S) GOLD, BROWN, GREY, WHITE, AND MAROON IS/ARE CLAIMED AS A FEATURE OF THE MARK.

THE MARK CONSISTS OF A GOLD SHADED OVAL WITH BROWN OUTLINES, BROWN LETTERING, WITH WHITE OUTLINE FOR "GUTTENBERG FARMS" AND "QUALITY CONTROLLED", AND BROWN LETTERING FOR "THE WAY NATURE INTENDED", MAROON AND GREY CLOUDS, GREY WINDMILL, MAROON BARN, GREY AND MAROON BIRDS, GREY BUSHES, MAROON FENCE, MAROON AND GREY CROP ROWS.

FOR CHICKEN; TURKEY (U.S. CL. 46).
DAVID TAYLOR, EXAMINING ATTORNEY

CLASS 29—(Continued).

SN 85-459,148. WESTERN PACIFIC OILS LLC, LOS ANGELES, CA. FILED 10-28-2011.



NO CLAIM IS MADE TO THE EXCLUSIVE RIGHT TO USE "PALM", APART FROM THE MARK AS SHOWN.

THE MARK CONSISTS OF THE WORDS "GOLDEN PALM" BENEATH FIVE STARS WITHIN AN OVAL.

FOR OIL, NAMELY, PALM OIL (U.S. CL. 46).
FIRST USE 8-30-2010; IN COMMERCE 8-30-2010.
ANGELA DUONG, EXAMINING ATTORNEY

SN 85-471,861. DELI HALAL LLC, OLATHE, KS. FILED 11-14-2011.



NO CLAIM IS MADE TO THE EXCLUSIVE RIGHT TO USE "DELI HALAL", APART FROM THE MARK AS SHOWN.

THE MARK CONSISTS OF THE WORDING "DELI HALAL" PARTIALLY SURROUNDED BY A CRESCENT MOON, WITH A STAR ABOVE THE "I" IN THE WORD "DELI".

FOR HALAL DELI FOOD PRODUCTS, NAMELY, SLICED MEATS, SLICED CHEESES, SHREDDED CHEESES, PROCESSED MEAT PRODUCTS; HALAL MEATS AND MEAT-BASED PRODUCTS, NAMELY, BEEF BOLOGNA, ROAST BEEF, BEEF MORTADELLA, BEEF HOT DOGS, BEEF WIENERS; HALAL POULTRY AND POULTRY-BASED PRODUCTS, NAMELY, TURKEY BREAST, TURKEY THIGH MEAT, PROCESSED CHICKEN; HALAL DAIRY PRODUCTS, NAMELY, AMERICAN CHEESE, PEPPER JACK CHEESE, YELLOW CHEDDAR CHEESE, WHITE CHEDDAR CHEESE, SWISS CHEESE; HALAL FOOD PRODUCTS, NAMELY, HALAL MEAT AND HALAL PROCESSED MEAT, NONE OF WHICH CONTAIN PORK OR PORK BY-PRODUCTS, LIQUOR, POPPY SEED OR NUTMEG (U.S. CL. 46).

FIRST USE 9-9-2011; IN COMMERCE 9-10-2011.
RONALD MCMORROW, EXAMINING ATTORNEY

BOLERO

THE MARK CONSISTS OF STANDARD CHARACTERS WITHOUT CLAIM TO ANY PARTICULAR FONT, STYLE, SIZE, OR COLOR.

THE ENGLISH TRANSLATION OF "BOLERO" IN THE MARK IS "DANCE OR A SLEEVELESS JACKET".

FOR EDIBLE OIL; COOKING OIL; SALAD OIL; OLIVE OIL (U.S. CL. 46).

ANNE E. GUSTASON, EXAMINING ATTORNEY

SN 85-446,812. CORTOPASSI PARTNERS, MODESTO, CA. FILED 10-13-2011.

CLASS 29—(Continued).

SN 85-481,272. BRETON ENTERPRISES, INC., HUNTINGTON, NY. FILED 11-28-2011.

NECTAR SQUEEZE

THE MARK CONSISTS OF STANDARD CHARACTERS WITHOUT CLAIM TO ANY PARTICULAR FONT, STYLE, SIZE, OR COLOR.

NO CLAIM IS MADE TO THE EXCLUSIVE RIGHT TO USE "NECTAR", APART FROM THE MARK AS SHOWN.

FOR APPLESAUCE; FRUIT-BASED SNACK FOOD (U.S. CL. 46).

ASMAT KHAN, EXAMINING ATTORNEY

SN 85-483,548. FRONT PORCH FARM LLC, MILL VALLEY, CA. FILED 11-30-2011.

CINTA SONOMA

THE MARK CONSISTS OF STANDARD CHARACTERS WITHOUT CLAIM TO ANY PARTICULAR FONT, STYLE, SIZE, OR COLOR.

NO CLAIM IS MADE TO THE EXCLUSIVE RIGHT TO USE "SONOMA", APART FROM THE MARK AS SHOWN.

THE ENGLISH TRANSLATION OF "CINTA" IN THE MARK IS "RIBBON".

FOR PROCESSED MEAT, NAMELY, PROSCIUTTO (U.S. CL. 46).

RUSS HERMAN, EXAMINING ATTORNEY

SN 85-485,737. SALM PARTNERS, LLC, DENMARK, WI. FILED 12-2-2011.

PASTEURPACK

THE MARK CONSISTS OF STANDARD CHARACTERS WITHOUT CLAIM TO ANY PARTICULAR FONT, STYLE, SIZE, OR COLOR.

FOR FULLY COOKED READY TO EAT MEAT PRODUCTS, NAMELY, BEEF, PORK, CHICKEN, TURKEY, SEAFOOD, FISH, LAMB, FRANKFURTERS, SAUSAGES, AND BRATWURST (U.S. CL. 46).

LESLEY LAMOTHE, EXAMINING ATTORNEY

CLASS 29—(Continued).

SN 85-486,140. NATURAL SELECTION FOODS, LLC, SAN JUAN BAUTISTA, CA. FILED 12-2-2011.

QIIQ

THE MARK CONSISTS OF STANDARD CHARACTERS WITHOUT CLAIM TO ANY PARTICULAR FONT, STYLE, SIZE, OR COLOR.

FOR CONDENSED NUTRIENT-DENSE VEGETABLE-AND FRUIT-BASED FOOD BEVERAGE (U.S. CL. 46).

TINA MAI, EXAMINING ATTORNEY

SN 85-494,595. INTERNATIONAL MARINE PRODUCTS, INC., LOS ANGELES, CA. FILED 12-13-2011.

ROYAL MAGURO

THE MARK CONSISTS OF STANDARD CHARACTERS WITHOUT CLAIM TO ANY PARTICULAR FONT, STYLE, SIZE, OR COLOR.

NO CLAIM IS MADE TO THE EXCLUSIVE RIGHT TO USE "MAGURO", APART FROM THE MARK AS SHOWN.

FOR FISH (U.S. CL. 46).

MICHELLE DUBOIS, EXAMINING ATTORNEY

SN 85-495,558. LA DOLCE VITA ANIMAL RESCUE FOUNDATION, AKA LA DOLCE VITA GOURMET, TOPANGA, CA. FILED 12-14-2011.

La Dolce Vita Gourmet

THE MARK CONSISTS OF STANDARD CHARACTERS WITHOUT CLAIM TO ANY PARTICULAR FONT, STYLE, SIZE, OR COLOR.

NO CLAIM IS MADE TO THE EXCLUSIVE RIGHT TO USE "GOURMET", APART FROM THE MARK AS SHOWN.

THE ENGLISH TRANSLATION OF "DOLCE VITA" IS "SWEET LIFE".

FOR CRUELTY FREE VEGAN FOOD GOODS WHOSE PROCEEDS BENEFIT ANIMAL WELFARE CHARITIES, NAMELY, CASHEW BUTTER AND HUMMUS (U.S. CL. 46).

FIRST USE 1-2-2011; IN COMMERCE 2-2-2011.

REBECCA POVARCHUK, EXAMINING ATTORNEY

CLASS 29—(Continued).

SN 85-497,165. PACIFIC FREEZE DRIED, INC., LOS ANGELES, CA. FILED 12-16-2011.

NATURE'S ALL FOODS

THE MARK CONSISTS OF STANDARD CHARACTERS WITHOUT CLAIM TO ANY PARTICULAR FONT, STYLE, SIZE, OR COLOR.

OWNER OF U.S. REG. NO. 3,971,041.

NO CLAIM IS MADE TO THE EXCLUSIVE RIGHT TO USE "FOODS", APART FROM THE MARK AS SHOWN.

FOR DRIED FRUITS, PACKAGED DEHYDRATED FRUITS, PACKAGED DEHYDRATED VEGETABLES, FREEZE-DRIED YOGURT SNACKS, FREEZE-DRIED FRUIT SNACK FOODS, FRUIT-BASED SNACK FOODS, AND SNACKS CONSISTING OF FREEZE-DRIED PIECES OF SMOOTHIES (U.S. CL. 46).

CHRISTOPHER BUONGIORNO, EXAMINING ATTORNEY



SN 85-497,755. KAIA FOODS, INC., OAKLAND, CA. FILED 12-16-2011.

Hempisphere

THE MARK CONSISTS OF STANDARD CHARACTERS WITHOUT CLAIM TO ANY PARTICULAR FONT, STYLE, SIZE, OR COLOR.

FOR NUT AND SEED-BASED SNACK BARS MADE IN WHOLE OR SUBSTANTIAL PART OF HEMP (U.S. CL. 46).

ANDREW LAWRENCE, EXAMINING ATTORNEY



SN 85-499,614. AMERICAN FOODS GROUP, LLC, FAIRMONT, MN. FILED 12-20-2011.



OWNER OF U.S. REG. NO. 3,273,057.

NO CLAIM IS MADE TO THE EXCLUSIVE RIGHT TO USE "LAHAM", APART FROM THE MARK AS SHOWN.

THE MARK CONSISTS OF THE STYLIZED WORDS "LAHAM LAZIZ".

THE ENGLISH TRANSLATION OF "LAHAM LAZIZ" IN THE MARK IS "MEAT DELICIOUS".

SEC. 2(F).

FOR MEAT (U.S. CL. 46).

FIRST USE 11-10-2006; IN COMMERCE 11-10-2006.

KATHERINE E. HALMEN, EXAMINING ATTORNEY

CLASS 29—(Continued).

SN 85-501,071. ATK FOODS, INC., CHICAGO, IL. FILED 12-21-2011.

MEATLOAF BY AMYLU

THE MARK CONSISTS OF STANDARD CHARACTERS WITHOUT CLAIM TO ANY PARTICULAR FONT, STYLE, SIZE, OR COLOR.

OWNER OF U.S. REG. NOS. 3,667,321, 3,722,199 AND 3,733,787.

NO CLAIM IS MADE TO THE EXCLUSIVE RIGHT TO USE "MEATLOAF", APART FROM THE MARK AS SHOWN.

THE NAME "AMYLU" IDENTIFIES A LIVING INDIVIDUAL WHOSE CONSENT IS OF RECORD.

FOR MEAT PRODUCTS, NAMELY, MEATLOAF (U.S. CL. 46).

FIRST USE 12-16-2011; IN COMMERCE 12-16-2011.

SAMUEL E. SHARPER JR., EXAMINING ATTORNEY



SN 85-501,099. AQUAMAR, INC., RANCHO CUCAMONGA, CA. FILED 12-21-2011.

AQUAMAR NATURALLY

THE MARK CONSISTS OF STANDARD CHARACTERS WITHOUT CLAIM TO ANY PARTICULAR FONT, STYLE, SIZE, OR COLOR.

OWNER OF U.S. REG. NO. 3,016,681.

FOR FISH AND SEAFOOD PRODUCTS, NAMELY, FROZEN AND FRESH PROCESSED FISH AND SEAFOOD, AND IMITATION CRAB MEAT (U.S. CL. 46).

LEIGH CAROLINE CASE, EXAMINING ATTORNEY

CLASS 29—(Continued).

SN 85-505,203. LOLLIPOP LANE LIMITED, MANCHESTER, UNITED KINGDOM, FILED 12-28-2011.



PRIORITY CLAIMED UNDER SEC. 44(D) ON UNITED KINGDOM APPLICATION NO. 2603066, FILED 11-30-2011.

THE MARK CONSISTS OF A BLACK COLORED SILHOUETTE OF TWO PEOPLE IN A HOWDAH, FASTENED TO THE TOP (BACK) OF A STYLIZED BLACK ELEPHANT WITH SWIRLS OF GRAY AND WHITE, AND A WHITE EYE OVER THE WORD "HOWDAH" IN FANCY FONT.

FOR (BASED ON INTENT TO USE) COOKED FRUITS AND VEGETABLES; DRIED BEANS; DRIED FRUITS; DRIED LENTILS; FISH; MEAT; MEAT, FISH, FRUIT AND VEGETABLE PRESERVES; MEAT-BASED SNACK FOODS; NUT-BASED SNACK FOODS; PICKLES; POTATO CRISPS AND CHIPS; POTATO-BASED SNACK FOODS; PREPARED MEAT; PREPARED NUTS; PRESERVED FISH; PRESERVED PEAS; PROCESSED BEANS; PROCESSED FISH; PROCESSED MEAT; PROCESSED NUTS; PULSES; SNACK FOOD DIPS; SNACK MIX CONSISTING PRIMARILY OF PROCESSED FRUITS, PROCESSED NUTS AND/OR RAISINS; VEGETABLE-BASED SNACK FOODS; PREPARED MEALS CONSISTING PRIMARILY OF MEAT, FISH, POULTRY OR VEGETABLES(BASED ON 44(D) PRIORITY APPLICATION) COOKED FRUITS AND VEGETABLES; DRIED BEANS; DRIED FRUITS; DRIED LENTILS; FISH; MEAT; NUT-BASED SNACK FOODS; PICKLES; POTATO CRISPS AND CHIPS; POTATO-BASED SNACK FOODS; PREPARED MEAT; PREPARED NUTS; PRESERVED FISH; PRESERVED PEAS; PROCESSED BEANS; PROCESSED FISH; PROCESSED MEAT; PROCESSED NUTS; PULSES; SNACK FOOD DIPS; SNACK MIX CONSISTING PRIMARILY OF PROCESSED FRUITS, PROCESSED NUTS AND/OR RAISINS; VEGETABLE-BASED SNACK FOODS; PREPARED MEALS CONSISTING PRIMARILY OF MEAT, FISH, POULTRY OR VEGETABLES (U.S. CL. 46).

APRIL HESIK, EXAMINING ATTORNEY

CLASS 29—(Continued).

SN 85-506,511. RIKEN VITAMIN CO., LTD., TOKYO, JAPAN, FILED 12-30-2011.



OWNER OF U.S. REG. NOS. 3,042,455, 3,042,456 AND OTHERS.

NO CLAIM IS MADE TO THE EXCLUSIVE RIGHT TO USE "WAKAME SOUP SCALLOP UMAMI PLUS ROASTED SESAME FLAVORS". THE NON-LATIN CHARACTERS THAT TRANSLITERATE TO "MIYOK" AND "CHUINTAZAITAN", AND THE DESIGN OF MEAT, GREENS, AND SESAME SEEDS, APART FROM THE MARK AS SHOWN.

THE COLOR(S) GREEN, RED, BLACK, WHITE, BEIGE, BROWN, BLUE IS/ARE CLAIMED AS A FEATURE OF THE MARK.

THE MARK CONSISTS OF A LABEL ON WHICH APPEARS A DESIGN COMPOSED OF BROWN MEAT AND A BROWN AND BLACK NET AND THICK WAVY LINES OF GREEN AND BROWN; THE CONTENTS OF A SOUP CUP CONTAINING GREEN LEAVES, SESAME SEEDS IN BEIGE, A SPOON IN WHITE; A RED AND WHITE SQUARE CONTAINING THE WORD "RIKEN" AND A STYLIZED "R" IN WHITE, JAPANESE LANGUAGE CHARACTERS IN BLACK, BLUE AND RED; THE WORDS "WAKAME SOUP" IN BLACK WITH WHITE FRAMING, THE WORDS "SCALLOP UMAMI PLUS ROASTED SESAME FLAVORS" IN RED.

THE NON-LATIN CHARACTERS IN THE MARK TRANSLITERATE TO "MIYOK" AND "CHUINTAZAITAN" AND THIS MEANS "WAKAME SOUP" IN ENGLISH.

FOR PREPARATIONS FOR MAKING SOUP, INSTANT OR PRE-COOKED SOUP (U.S. CL. 46).

KRISTIN DAHLING, EXAMINING ATTORNEY

SN 85-507,391. OLISON, TIMOTHY, PORTLAND, OR. FILED 1-3-2012.

KingTot

THE MARK CONSISTS OF STANDARD CHARACTERS WITHOUT CLAIM TO ANY PARTICULAR FONT, STYLE, SIZE, OR COLOR.

FOR PROCESSED POTATOES (U.S. CL. 46).

LINDA ESTRADA, EXAMINING ATTORNEY

CLASS 29—(Continued).

SN 85-508,377. GOTHBERG FARMS L.L.C., BOW, WA. FILED 1-4-2012.



NO CLAIM IS MADE TO THE EXCLUSIVE RIGHT TO USE "FARMS", APART FROM THE MARK AS SHOWN.

THE COLOR(S) WHITE, LIGHT BLUE, AND DARK BLUE IS/ARE CLAIMED AS A FEATURE OF THE MARK.

THE MARK CONSISTS OF THE WORDING "GOTHBERG FARMS" IN DARK BLUE BENEATH A STYLIZED DEPICTION OF A GOAT IN WHITE AND OUTLINED IN DARK BLUE HOLDING A DARK BLUE AND WHITE HERB BRANCH IN ITS MOUTH. THE GOAT IS SET AGAINST A BACKGROUND OVAL IN DARK BLUE AND IT INCLUDES A STYLIZED DEPICTION OF MOUNTAINS IN WHITE AND LIGHT BLUE. THE HERB BRANCH FORMS A PORTION OF THE LETTER "H" IN THE WORD "GOTHBERG".

FOR DAIRY PRODUCTS EXCLUDING ICE CREAM, ICE MILK AND FROZEN YOGURT (U.S. CL. 46).

FIRST USE 8-1-2004; IN COMMERCE 8-1-2004.

JIM RINGLE, EXAMINING ATTORNEY

SN 85-508,513. MAR-LEES HOLDING, LLC, DBA MAR-LEES SEAFOODS, LLC, NEW BEDFORD, MA. FILED 1-4-2012.



NO CLAIM IS MADE TO THE EXCLUSIVE RIGHT TO USE "DEEP SEA HARVEST", APART FROM THE MARK AS SHOWN.

THE COLOR(S) DARK BLUE, GOLD, WHITE AND BLUE IS/ARE CLAIMED AS A FEATURE OF THE MARK.

THE MARK CONSISTS OF A FISHING VESSEL ILLUSTRATION OUTLINED IN DARK BLUE ABOVE A BLUE OVAL SHAPE WITH A GOLD OUTLINE CONTAINING THE TEXT "DEEP SEA HARVEST" IN WHITE HAND-DRAWN LETTERING STYLE WITH GOLD OUTLINING, WITH "DEEP SEA" APPEARING INSIDE A DARK BLUE BANNER WITH A GOLD OUTLINE. A WHEAT DESIGN APPEARS IN GOLD AT THE BOTTOM OF THE OVAL CONTAINER. THE MARK APPEARS ON A TRANSPARENT BACKGROUND.

FOR PROCESSED SEAFOOD; PROCESSED SEAFOOD, NAMELY, FISH; SEAFOOD; SEAFOOD, NAMELY, SCALLOPS (U.S. CL. 46).

APRIL HESIK, EXAMINING ATTORNEY

CLASS 29—(Continued).

SN 85-509,390. SAMPCO, INC., CHICAGO, IL. FILED 1-5-2012.

SAMPCO

THE MARK CONSISTS OF STANDARD CHARACTERS WITHOUT CLAIM TO ANY PARTICULAR FONT, STYLE, SIZE, OR COLOR.

OWNER OF U.S. REG. NO. 1,456,700.

FOR ROAST BEEF (U.S. CL. 46).

FIRST USE 10-0-2009; IN COMMERCE 10-0-2009.

BRIAN CALLAGHAN, EXAMINING ATTORNEY

SN 85-509,571. LITTLE DUCK ORGANICS, INC., NEW-BURYPORT, MA. FILED 1-5-2012.

LITTLE DUCK ORGANICS

THE MARK CONSISTS OF STANDARD CHARACTERS WITHOUT CLAIM TO ANY PARTICULAR FONT, STYLE, SIZE, OR COLOR.

NO CLAIM IS MADE TO THE EXCLUSIVE RIGHT TO USE "ORGANICS", APART FROM THE MARK AS SHOWN.

FOR FRUIT-BASED ORGANIC SNACK FOODS FOR BABIES AND CHILDREN (U.S. CL. 46).

FIRST USE 4-29-2009; IN COMMERCE 4-29-2009.

GENE MACIOL, EXAMINING ATTORNEY

SN 85-509,793. HAGGERTY, DAVID, HARPSWELL, ME. FILED 1-5-2012.

HARMONY HADDOCK

THE MARK CONSISTS OF STANDARD CHARACTERS WITHOUT CLAIM TO ANY PARTICULAR FONT, STYLE, SIZE, OR COLOR.

NO CLAIM IS MADE TO THE EXCLUSIVE RIGHT TO USE "HADDOCK", APART FROM THE MARK AS SHOWN.

FOR FISH, NAMELY, HADDOCK (U.S. CL. 46).

MICHAEL SOUDERS, EXAMINING ATTORNEY

CLASS 29—(Continued).

SN 85-510,170. WALKER, MARVIN W., LADSON, SC. FILED 1-6-2012.



THE MARK CONSISTS OF THE WORD "SONLITE" IN STYLIZED LETTERING.
FOR FRUIT PRESERVES (U.S. CL. 46).
FIRST USE 11-4-2011; IN COMMERCE 11-21-2011.
ALEX KEAM, EXAMINING ATTORNEY

SN 85-510,411. SHRIL PATEL, ROUND ROCK, TX. FILED 1-6-2012.



FASAL

THE MARK CONSISTS OF STANDARD CHARACTERS WITHOUT CLAIM TO ANY PARTICULAR FONT, STYLE, SIZE, OR COLOR.

THE ENGLISH TRANSLATION OF "FASAL" IN THE MARK IS "CROP".
FOR COOKING OIL; DRIED LENTILS; EDIBLE OILS; PRESERVED PEAS; PROCESSED BEANS (U.S. CL. 46).
FIRST USE 12-1-2009; IN COMMERCE 12-1-2009.
MATTHEW PAPPAS, EXAMINING ATTORNEY

CLASS 29—(Continued).

SN 85-511,467. DALIAN HAIYANGDAO FISHERIES GROUP CO.,LTD., CHANGHAI COUNTY, CHINA, FILED 1-9-2012.



THE MARK CONSISTS OF THREE STYLIZED CHINESE CHARACTERS REPRESENTING THE WORDS "HAI YANG DAO" IN THE PINYIN CHINESE ROMANIZATION SYSTEM.

THE NON-LATIN CHARACTERS IN THE MARK TRANSLITERATE TO HAI YANG DAO AND THIS MEANS OCEANIC ISLAND IN ENGLISH.

FOR CANNED FISH; CHEESE; CRUSTACEANS; DRIED VEGETABLES; FISH; FISH AND CHIPS; FISH AND MEAT PRESERVES; FISH BURGER PATTIES; FISH MOUSSE; FISH PRESERVES; FISH SAUSAGES; FISH STOCK; MEAT, FISH, FRUIT AND VEGETABLE JELLIES; MEAT, FISH, FRUIT AND VEGETABLE PRESERVES; MEAT, FISH, POULTRY AND GAME; MEAT, FISH, POULTRY AND GAME PRESERVES; MEAT, FRUIT AND VEGETABLE JELLIES, JAMS; MEAT, FRUIT AND VEGETABLE JELLIES, JAMS, EGGS; PICKLED CUCUMBERS; PRESERVED FISH; PROCESSED FISH; PROCESSED FISH ROE; PROCESSED NUTS; PROCESSED PUMPKIN SEEDS; PROCESSED VEGETABLES, NAMELY, COOKED CUCUMBER, DAIKON, MUSHROOMS, BELLFLOWER ROOT, SPINACH, SOYBEAN SPROUTS AND BRACKEN FERN STEMS USED IN BIBIMBAP DISHES; PUMPKIN SEED OIL; SALCHIPAPAS, NAMELY, A MIXTURE OF COCKTAIL FRANKFURTERS, YELLOW POTATOES, FRENCH FRIED POTATOES AND QUAIL EGGS; SEA BASSES; SEA BREAMS; SEA CUCUMBERS; SEA SALMON OR TROUT ROE; SEA URCHINS; SEA-CUCUMBERS, NOT LIVE; SHELLFISH FOR HUMAN CONSUMPTION; SHELLFISH, NOT LIVE; SHRIMPS, NOT LIVE; TUNA FISH (U.S. CL. 46).

FIRST USE 5-8-2008; IN COMMERCE 12-9-2008.
KELLY BOULTON, EXAMINING ATTORNEY

SN 85-511,955. MARTINEZ, FELIX, MIAMI, FL. FILED 1-9-2012.



NO CLAIM IS MADE TO THE EXCLUSIVE RIGHT TO USE "BOAR", APART FROM THE MARK AS SHOWN.

THE MARK CONSISTS OF AN IMAGE OF A BOAR IN A MIRROR WITH A DECORATIVE FLORAL FRAME, AND BELOW, A LINE, AND UNDERNEATH THE LINE, THE WORDING "GOLDEN BOAR".

FOR CANNED COOKED MEAT; PRESERVED MEATS AND SAUSAGES; PROCESSED MEAT (U.S. CL. 46).
SUZANNE BLANE, EXAMINING ATTORNEY

CLASS 29—(Continued).

SN 85-513,368. COLEMAN NATURAL PRODUCTS, LLC, GOLDEN, CO. FILED 1-10-2012.

SUPPORT YOUR LOCAL CHICKEN

THE MARK CONSISTS OF STANDARD CHARACTERS WITHOUT CLAIM TO ANY PARTICULAR FONT, STYLE, SIZE, OR COLOR.
FOR POULTRY (U.S. CL. 46).
KAPIL BHANOT, EXAMINING ATTORNEY

SN 85-513,519. LAMEX AGRIFOODS, INC., MIAMI, FL. FILED 1-11-2012.

NATURE REVEALED

THE MARK CONSISTS OF STANDARD CHARACTERS WITHOUT CLAIM TO ANY PARTICULAR FONT, STYLE, SIZE, OR COLOR.
FOR FROZEN FRUITS; FROZEN VEGETABLES (U.S. CL. 46).
ALEX KEAM, EXAMINING ATTORNEY

SN 85-514,081. RICELAND FOODS, INC., STUTTGART, AR. FILED 1-11-2012.

CHEF-WAY

THE MARK CONSISTS OF STANDARD CHARACTERS WITHOUT CLAIM TO ANY PARTICULAR FONT, STYLE, SIZE, OR COLOR.
OWNER OF U.S. REG. NOS. 963,760, 3,114,164 AND OTHERS.
FOR DRIED BEANS (U.S. CL. 46).
MARTHA FROMM, EXAMINING ATTORNEY

CLASS 29—(Continued).

SN 85-514,622. 425CHEESES, INC., DBA BEER BITES, STRATHAM, NH. FILED 1-12-2012.

Beer Bites

THE MARK CONSISTS OF STANDARD CHARACTERS WITHOUT CLAIM TO ANY PARTICULAR FONT, STYLE, SIZE, OR COLOR.
NO CLAIM IS MADE TO THE EXCLUSIVE RIGHT TO USE "BITES", APART FROM THE MARK AS SHOWN.
FOR DAIRY-BASED SNACK FOODS EXCLUDING ICE CREAM, ICE MILK AND FROZEN YOGURT; MEAT-BASED SNACK FOODS; NUT-BASED SNACK FOODS; NUT-BASED SNACK FOODS, NAMELY, NUT CLUSTERS; NUT-BASED SNACK FOODS, NAMELY, NUT CRISPS; POTATO-BASED SNACK FOODS; SOY-BASED SNACK FOODS; VEGETABLE-BASED SNACK FOODS (U.S. CL. 46).
LUCY ARANT, EXAMINING ATTORNEY

SN 85-514,669. VARIETY FRANKS, LLC, WINSTON-SALEM, NC. FILED 1-12-2012.

SLITTERS

THE MARK CONSISTS OF STANDARD CHARACTERS WITHOUT CLAIM TO ANY PARTICULAR FONT, STYLE, SIZE, OR COLOR.
FOR MEAT PRODUCTS, NAMELY, HOT DOGS (U.S. CL. 46).
DAWN FELDMAN, EXAMINING ATTORNEY

SN 85-515,047. NATURALSHRIMP HOLDINGS, INC., WACO, TX. FILED 1-12-2012.

NATURALSHRIMP

THE MARK CONSISTS OF STANDARD CHARACTERS WITHOUT CLAIM TO ANY PARTICULAR FONT, STYLE, SIZE, OR COLOR.
SEC. 2(F).
FOR RAW SHRIMP FEATURING NO PESTICIDES, NO ANTIBIOTICS AND NO CHEMICAL ADDITIVES, GROWN IN SELF-CONTAINED RECIRCULATING BIO-SECURE SALTWATER ENVIRONMENT (U.S. CL. 46).
FIRST USE 12-31-2004; IN COMMERCE 12-31-2004.
KELLY TRUSILO, EXAMINING ATTORNEY

CLASS 29—(Continued).

SN 85-515,311. ORGANIC PLUS PTE. LTD., SINGAPORE, SINGAPORE, FILED 1-12-2012.

THE COLOR(S) BLUE IS/ARE CLAIMED AS A FEATURE OF THE MARK.

THE MARK CONSISTS OF THE TERM "KAIS" RENDERED IN A STYLIZED MANNER, ALL IN CAPS. THE COLOR BLUE APPEARS IN THE WORD "KAIS".

THE WORDING KAIS HAS NO MEANING IN A FOREIGN LANGUAGE.

FOR COOKING OIL; EDIBLE OILS; PALM OIL FOR FOOD (U.S. CL. 46).

JANICE KIM, EXAMINING ATTORNEY

SN 85-515,345. MCT MANUFACTURING LLC, MILLBURN, NJ, FILED 1-12-2012.

MAC YOURSELF

THE MARK CONSISTS OF STANDARD CHARACTERS WITHOUT CLAIM TO ANY PARTICULAR FONT, STYLE, SIZE, OR COLOR.

FOR CHEESE POWDER FOR MAKING CHEESE SAUCE (U.S. CL. 46).

MIDGE BUTLER, EXAMINING ATTORNEY

SN 85-515,777. CHATAM INTERNATIONAL INCORPORATED, WILMINGTON, DE, FILED 1-13-2012.

CHARLES JACQUIN

THE MARK CONSISTS OF STANDARD CHARACTERS WITHOUT CLAIM TO ANY PARTICULAR FONT, STYLE, SIZE, OR COLOR.

THE NAME(S), PORTRAIT(S), AND/OR SIGNATURE(S) SHOWN IN THE MARK DOES NOT IDENTIFY A PARTICULAR LIVING INDIVIDUAL.

FOR DRIED FRUITS; FRUIT CONSERVES; FRUIT PRESERVES; FRUIT SALADS; FRUIT SPREADS; FRUIT TOPPING; JELLIES, JAMS; PRESERVED FRUITS (U.S. CL. 46).

DAVID COLLIER, EXAMINING ATTORNEY

CLASS 29—(Continued).

SN 85-515,889. EUREKA SAUSAGE INC., NORTH HOLLYWOOD, CA, FILED 1-13-2012.

AL MUNA

THE MARK CONSISTS OF STANDARD CHARACTERS WITHOUT CLAIM TO ANY PARTICULAR FONT, STYLE, SIZE, OR COLOR.

THE ENGLISH TRANSLATION OF "AL MUNA" IN THE MARK IS "TO WISH WELL".

FOR BOLOGNA; HOT DOGS; MORTADELLA; PASTRAMI; SALAMI; SAUSAGES; SAUSAGES, NAMELY, SUJUK (U.S. CL. 46).

FIRST USE 1-9-2012; IN COMMERCE 1-9-2012.

KRISTINA MORRIS, EXAMINING ATTORNEY

SN 85-516,332. ILIOS BRANDS, LLC, MINERVA, OH, FILED 1-13-2012.



THE COLOR(S) BLACK, WHITE, BLUE, LIGHT BLUE, GREEN, LIGHT GREEN, LIGHT BROWN, BROWN, AND GOLD IS/ARE CLAIMED AS A FEATURE OF THE MARK.

THE MARK CONSISTS OF A RECTANGULAR BACKGROUND DEPICTING A GREEK VILLAGE, WITH BUILDINGS HAVING COLUMNS, DOMES AND TOWERS, THE BUILDINGS OUTLINED IN LIGHT BROWN AND COLORED GREEN, LIGHT GREEN, BLUE AND LIGHT BLUE. SUPERIMPOSED AND CENTERED ON THE BACKGROUND IS A DESIGN COMPRISING CONCENTRIC OVALS WITH THEIR LONG AXES HORIZONTAL, COLORED (RESPECTIVELY FROM LARGEST TO SMALLEST) BLUE, WHITE, GOLD, AND VARIEGATED BLACK AND BLUE. Ilios IS IN BLOCK CAPITAL LETTERS ON THE UPPER HALF OF THE INNERMOST OVAL. THE LETTERS OF Ilios ARE OUTLINED IN LIGHT BROWN AND ARE SHADED FROM WHITE AT THE TOP TO LIGHT BROWN AT THE BOTTOM. BLACK SHADOWS OF THE LETTERS OF Ilios APPEAR BELOW AND TO THE RIGHT OF THE LETTERS. A FINE GOLD LINE, FORMING AN OVAL INTERRUPTED AT THE BOTTOM, SURROUNDS Ilios. A DEPICTION OF A BROWN RIBBON, LINED IN WHITE, FORMS A HORIZONTAL ARC SUPERIMPOSED UPON THE OVALS BELOW Ilios AND EXTENDING BEYOND THE LEFT AND RIGHT EDGES OF THE OUTER OVAL.

FOR DAIRY PRODUCTS EXCLUDING ICE CREAM, ICE MILK AND FROZEN YOGURT (U.S. CL. 46).

FIRST USE 12-21-2011; IN COMMERCE 12-21-2011.

KATHRYN COWARD, EXAMINING ATTORNEY

CLASS 29—(Continued).

SN 85-516,342. MCCRAY, STEPHEN, SOUTH HADLEY, MA. FILED 1-13-2012.

HOME TOWN COW

THE MARK CONSISTS OF STANDARD CHARACTERS WITHOUT CLAIM TO ANY PARTICULAR FONT, STYLE, SIZE, OR COLOR.
FOR MILK (U.S. CL. 46).
CHRISTINE MARTIN, EXAMINING ATTORNEY

SN 85-525,255. MAR-LEES HOLDING, LLC, DBA MAR-LEES SEAFOODS, LLC, NEW BEDFORD, MA. FILED 1-25-2012.

Naked Lobster

THE MARK CONSISTS OF STANDARD CHARACTERS WITHOUT CLAIM TO ANY PARTICULAR FONT, STYLE, SIZE, OR COLOR.
NO CLAIM IS MADE TO THE EXCLUSIVE RIGHT TO USE "LOBSTER", APART FROM THE MARK AS SHOWN.
FOR LOBSTERS; SHELLFISH; SHRIMPS, PRAWNS AND LOBSTERS; SPINY LOBSTERS, NOT LIVE (U.S. CL. 46).
APRIL HESIK, EXAMINING ATTORNEY

SN 85-531,787. SAMPCO, INC., CHICAGO, IL. FILED 2-2-2012.



THE MARK CONSISTS OF A STYLIZED DESIGN OF TWO STEERS STANDING SIDE BY SIDE.
FOR ROAST BEEF; FROZEN COOKED BEEF; CUBED BEEF; SHREDDED BEEF; CORNED BEEF; GROUND BEEF; BEEF EXTRACT (U.S. CL. 46).
FIRST USE 10-0-2009; IN COMMERCE 10-0-2009.
BRIAN CALLAGHAN, EXAMINING ATTORNEY

CLASS 29—(Continued).

SN 85-532,099. BBI, INC., WILMINGTON, DE. FILED 2-2-2012.

COCINA LATINA DE BUSH

THE MARK CONSISTS OF STANDARD CHARACTERS WITHOUT CLAIM TO ANY PARTICULAR FONT, STYLE, SIZE, OR COLOR.
OWNER OF U.S. REG. NOS. 520,028, 1,616,897 AND OTHERS.
NO CLAIM IS MADE TO THE EXCLUSIVE RIGHT TO USE "LATINA", APART FROM THE MARK AS SHOWN.
THE ENGLISH TRANSLATION OF THE MARK "COCINA LATINA DE BUSH" IS "BUSH'S LATIN KITCHEN".
FOR CANNED BEANS; CANNED BEANS AND VEGETABLES (U.S. CL. 46).
ANDREW LEASER, EXAMINING ATTORNEY

SN 85-539,551. THE LAURA SCUDDER'S COMPANY, LLC, NEWPORT BEACH, CA. FILED 2-10-2012.

LAURA SCUDDER'S POTATA'S

THE MARK CONSISTS OF STANDARD CHARACTERS WITHOUT CLAIM TO ANY PARTICULAR FONT, STYLE, SIZE, OR COLOR.
OWNER OF U.S. REG. NOS. 2,334,272, 2,965,379 AND OTHERS.
NO CLAIM IS MADE TO THE EXCLUSIVE RIGHT TO USE "POTATOES", APART FROM THE MARK AS SHOWN.
THE NAME(S), PORTRAIT(S), AND/OR SIGNATURE(S) SHOWN IN THE MARK DOES NOT IDENTIFY A PARTICULAR LIVING INDIVIDUAL.
FOR POTATO CHIPS (U.S. CL. 46).
JOHN DWYER, EXAMINING ATTORNEY

SN 85-539,590. BBI, INC., WILMINGTON, DE. FILED 2-10-2012.

COCINA LATINA FRIJOLES CHARROS MACHACADOS

THE MARK CONSISTS OF STANDARD CHARACTERS WITHOUT CLAIM TO ANY PARTICULAR FONT, STYLE, SIZE, OR COLOR.
NO CLAIM IS MADE TO THE EXCLUSIVE RIGHT TO USE "LATINA FRIJOLES CHARROS MACHACADOS", APART FROM THE MARK AS SHOWN.
THE ENGLISH TRANSLATION OF THE MARK IS "LATIN KITCHEN MASHED COWBOY-STYLE BEANS".
FOR CANNED BEANS; CANNED BEANS AND VEGETABLES (U.S. CL. 46).
ANDREW LEASER, EXAMINING ATTORNEY

CLASS 29—(Continued).

SN 85-575,280. MCCAIN FOODS USA, INC., LISLE, IL. FILED 3-21-2012.

PUB CITY

THE MARK CONSISTS OF STANDARD CHARACTERS WITHOUT CLAIM TO ANY PARTICULAR FONT, STYLE, SIZE, OR COLOR.

FOR APPETIZERS CONSISTING PRIMARILY OF MEAT, SEAFOOD, POULTRY, VEGETABLES AND/OR CHEESE (U.S. CL. 46).

LINDA POWELL, EXAMINING ATTORNEY

SN 85-579,692. SLADE GORTON & COMPANY, INC., BOSTON, MA. AND GRAY AQUA GROUP LTD., NORTHAMPTON NB, CANADA, FILED 3-26-2012.

WELL RAISED

THE MARK CONSISTS OF STANDARD CHARACTERS WITHOUT CLAIM TO ANY PARTICULAR FONT, STYLE, SIZE, OR COLOR.

FOR FISH, NAMELY, SALMON (U.S. CL. 46). FIRST USE 12-16-2011; IN COMMERCE 12-16-2011.

ALAIN LAPTEP, EXAMINING ATTORNEY

SN 85-590,609. LOVEJOY GOURMET LLC, BALTIMORE, MD. FILED 4-5-2012.

LOVEJOY GOURMET

THE MARK CONSISTS OF STANDARD CHARACTERS WITHOUT CLAIM TO ANY PARTICULAR FONT, STYLE, SIZE, OR COLOR.

NO CLAIM IS MADE TO THE EXCLUSIVE RIGHT TO USE "GOURMET", APART FROM THE MARK AS SHOWN.

FOR FROZEN, PREPARED OR PACKAGED ENTREES CONSISTING PRIMARILY OF MEAT, FISH, POULTRY OR VEGETABLES; AND FOOD PACKAGE COMBINATIONS CONSISTING PRIMARILY OF CHEESE, MEAT AND/OR PROCESSED FRUITS AND VEGETABLES; COOKED MEALS TO BE SOLD IN DELI SECTIONS, WHICH CONSIST MAINLY OF COOKED MEATS AND VEGETABLES (U.S. CL. 46).

FIRST USE 10-11-2011; IN COMMERCE 10-11-2011.

ELLEN B. AWRICH, EXAMINING ATTORNEY

CLASS 30—STAPLE FOODS

SN 77-292,235. CIDRE, MANUEL, SAN JUAN, PUERTO RICO, FILED 9-29-2007.

LOS CIDRINES

THE MARK CONSISTS OF STANDARD CHARACTERS WITHOUT CLAIM TO ANY PARTICULAR FONT, STYLE, SIZE, OR COLOR.

THE WORDING "LOS CIDRINES" HAS NO MEANING IN A FOREIGN LANGUAGE.

FOR BAKERY PRODUCTS; FROZEN DOUGH FOR USE AS BREAD OR OTHER BREAD-TYPE PRODUCTS; PASTRY; BREADS; PUFF PASTRY (U.S. CL. 46).

FIRST USE 12-16-1978; IN COMMERCE 12-16-1978.

JENNY PARK, EXAMINING ATTORNEY

SN 77-873,944. NEHAD BAKER, JAMESTOWN, NC. FILED 11-17-2009.

SAVOY CANDY DELIGHT

THE MARK CONSISTS OF STANDARD CHARACTERS WITHOUT CLAIM TO ANY PARTICULAR FONT, STYLE, SIZE, OR COLOR.

NO CLAIM IS MADE TO THE EXCLUSIVE RIGHT TO USE "CANDY", APART FROM THE MARK AS SHOWN.

FOR CANDY AND SWEETS (U.S. CL. 46).

BERYL GARDNER, EXAMINING ATTORNEY

SN 79-090,631. GEBRÜDER NEEB GMBH & CO. KG, FED REP GERMANY, FILED 11-16-2010.

Bukross

THE MARK CONSISTS OF STANDARD CHARACTERS WITHOUT CLAIM TO ANY PARTICULAR FONT, STYLE, SIZE, OR COLOR.

OWNER OF INTERNATIONAL REGISTRATION 1060172 DATED 11-16-2010, EXPIRES 11-16-2020.

FOR SPICED MIXES IN THE NATURE OF SEASONING MIX THAT CAN BE ADDED TO DIPS, SAUCES, SOUPS, SALADS, FOODS, BAKED GOODS, DESSERTS, MIXED BEVERAGES, CEREALS AND CEREAL MIXTURES, AND CEREAL BASED FOOD ADDITIVES FOR NON-NUTRITIONAL PURPOSES FOR USE AS A FLAVORING, EXCLUSIVELY WITH A BASE OF BUCKWHEAT (U.S. CL. 46).

RAMONA ORTIGA, EXAMINING ATTORNEY

CLASS 30—(Continued).

SN 79-096,585. YASAR DONDURMA VE GIDA MADDELERI ANONIM SIRKETI, TURKEY, FILED 3-4-2011.



PRIORITY DATE OF 12-1-2010 IS CLAIMED.
OWNER OF INTERNATIONAL REGISTRATION 1074920 DATED 3-4-2011, EXPIRES 3-4-2021.

THE COLOR(S) BLUE, SKY BLUE AND WHITE IS/ARE CLAIMED AS A FEATURE OF THE MARK.

THE MARK CONSISTS OF THE WORDING "MARDO" IN A STYLIZED WHITE FONT ON A BLUE BACKGROUND AND IN A SHAPED FRAME OF WHITE AND DARK BLUE LINES, UNDER THE LETTERS "DO" THERE ARE TWO FIGURES OF DROPS IN THE COLOR SKY BLUE.

THE WORDING "MARDO" HAS NO MEANING IN A FOREIGN LANGUAGE.

FOR COFFEE, COCOA, ARTIFICIAL COFFEE, MOCHA COFFEE, VEGETAL PREPARATIONS FOR USE AS COFFEE SUBSTITUTES, COCOA-BASED BEVERAGES, COFFEE-BASED BEVERAGES; TAPIOCA, SAGO; NOODLES, MACARONI, RAVIOLI; BAKERY PRODUCTS, NAMELY, SWEET BAKERY GOODS; PASTRIES; FLOUR-BASED PRODUCTS, NAMELY, CHIPS, PASTA, DOUGH PRODUCTS, NAMELY, BISCUITS, WAFFLES, CRACKERS, DESSERTS MADE OF FLOUR, NAMELY, BAKERY DESSERTS; ICE CREAM CAKES, TARTS, READY CAKE MIXES, PIZZA DOUGH, CAKE DOUGH, BREAD DOUGH, BREAD, PIZZAS, SANDWICHES; DOUGH DESSERTS MADE WITH MILK, NAMELY, DOUGH-ENROBED FOODS CONSISTING OF A DOUGH-BASED WRAPPER WITH FILLINGS CONSISTING PRIMARILY OF ICE CREAM AND OTHER DAIRY-BASED DESSERTS; PUDDINGS, NAMELY, CREME CARAMEL, CUSTARDS, ASURE, NAMELY, A KIND OF TURKISH-STYLE FRUIT AND NUT DESSERT PUD- DING; HONEY, ROYAL JELLY FOR HUMAN CON- SUMPTION, NOT FOR MEDICAL PURPOSES, PROPOLIS FOR HUMAN CONSUMPTION; MOLASSES SYRUP FOR FOOD; FLOUR FOR FOOD, PROCESSED SEMOLINA, FOOD STARCHES; TEAS, ICE TEAS, HER- BAL TEA, OTHER THAN FOR MEDICINAL USE; CANDIES, TURKISH DELIGHT, HALVAH, PISMANIYE, NAMELY, A KIND OF TURKISH-STYLE COTTON CANDY, FROZEN YOGURT CONFECTIONERY, CHO- COLATES, CHOCOLATE PRODUCTS, NAMELY, CHO- COLATE CHIPS, CHOCOLATE AND SUGAR COVERED PRODUCTS, NAMELY, SUGAR-COATED ALMONDS, CHOCOLATE AND CONFECTIONERY FOR DECORAT- ING CHRISTMAS TREES, CHOCOLATE BASED BEV- ERAGES WITH MILK; CHEWING GUMS NOT FOR MEDICAL PURPOSES; ICE, ICE CREAMS, EDIBLE FRUIT ICES; SALT; RICE, BULGUR, NAMELY, A KIND OF TURKISH-STYLE BOILED AND POUNDED WHEAT; CEREALS AND CEREAL PRODUCTS, NAMELY, BREAKFAST CEREALS; CEREAL BASED SNACK FOODS MADE FROM CORN FLAKES, CEREAL BASED SNACK FOODS MADE FROM OATMEAL; GRANU- LATED SUGAR, CUBE SUGAR, POWDERED SUGAR (U.S. CL. 46).

BARBARA RUTLAND, EXAMINING ATTORNEY

CLASS 30—(Continued).

SN 79-107,547. JOINT-STOCK COMPANY; "KRASNYJ OC- TYABR", RUSSIAN FED., FILED 11-3-2011.



OWNER OF INTERNATIONAL REGISTRATION 1102599 DATED 11-3-2011, EXPIRES 11-3-2021.

OWNER OF U.S. REG. NOS. 2,303,686, 2,454,393 AND 3,225,325.

NO CLAIM IS MADE TO THE EXCLUSIVE RIGHT TO USE "KARAMELY KOND F-KA MOSKVA", APART FROM THE MARK AS SHOWN.

THE COLOR(S) RED, WHITE, BLACK IS/ARE CLAIMED AS A FEATURE OF THE MARK.

THE MARK CONSISTS OF THE STYLIZED IMAGE OF THE CRAWFISH, THE WORDS IN THE CYRILLIC ALPH- ABET TRANSLITERATED AS RAKOVYIE SHEYKI, KARAMELY, KOND; F-KA "KRASNYI OCTYABR", MOSKVA AND THE LOGO WITH THE GLOBE AND THE WORDS KRASNYI OCTYABR. THE IMAGE OF THE CRAWFISH APPEARS IN RED, WHITE AND BLACK COLORS, THE WORDS APPEAR IN BLACK COLOR, THE IMAGE OF THE LOGO WITH THE GLOBE APPEAR IN BLACK COLOR.

THE NON-LATIN CHARACTERS IN THE MARK TRANS- LITERATE TO "RAKOVYIE SHEYKI KARAMELY KOND F- KA KRASNYI OCTYABR MOSKVA" AND THIS MEANS "CRAYFISH NECKS CARAMEL RED OCTOBER CONFE- CTIONERY PLANT MOSCOW" IN ENGLISH.

FOR SWEETMEATS (U.S. CL. 46).
ROBERT STRUCK, EXAMINING ATTORNEY

SN 79-109,558. BRAND ASSOCIATES LIMITED, UNITED KINGDOM, FILED 1-23-2012.



THE MARK CONSISTS OF STANDARD CHARACTERS WITHOUT CLAIM TO ANY PARTICULAR FONT, STYLE, SIZE, OR COLOR.

OWNER OF INTERNATIONAL REGISTRATION 1107839 DATED 1-23-2012, EXPIRES 1-23-2022.

FOR RICE (U.S. CL. 46).
JACLYN KIDWELL WALKER, EXAMINING ATTORNEY

CLASS 30—(Continued).

SN 85-186,251. PERFETTI VAN MELLE S.P.A., LAINATE, ITALY, FILED 11-29-2010.



OWNER OF TURKEY REG. NO. 201070879, DATED 3-5-2012, EXPIRES 11-5-2020.

THE COLOR(S) RED, GREEN, YELLOW AND WHITE IS/ARE CLAIMED AS A FEATURE OF THE MARK.

THE MARK CONSISTS OF A RED BACKGROUND WITH AN EXPLODING RED AND WHITE STRAWBERRY WITH A GREEN LEAF TOP AND YELLOW SEEDS.

FOR CONFECTIONERY, NAMELY, CHOCOLATE, CRYSTAL SUGAR PIECES; BUBBLE GUM, CHEWING GUM, CHEW CANDIES, CANDIES, CANDY DROPS, GUMDROPS, FRUIT JELLIES BEING CONFECTIONERY, LOLLIPOPS, PASTRY, SWEETS, TOFFEE, PASTILLES (U.S. CL. 46).

JORDAN BAKER, EXAMINING ATTORNEY

SN 85-193,580. GEORGIA NUT COMPANY, SKOKIE, IL. FILED 12-8-2010.



THE MARK CONSISTS OF THE WORDING "WHOLE CHOCOLATES" WITH A STYLIZED DESIGN OF THREE LEAVES BEHIND THE WORDING.

FOR CANDY COATINGS MADE OF CHOCOLATE FOR CANDY, BAKED GOODS AND DAIRY PRODUCTS (U.S. CL. 46).

NANCY CLARKE, EXAMINING ATTORNEY

CLASS 30—(Continued).

SN 85-204,451. GO FAST SPORTS & BEVERAGE COMPANY, DENVER, CO. FILED 12-22-2010.

GO FUNCTIONAL

THE MARK CONSISTS OF STANDARD CHARACTERS WITHOUT CLAIM TO ANY PARTICULAR FONT, STYLE, SIZE, OR COLOR.

OWNER OF U.S. REG. NOS. 2,929,528, 3,640,651 AND OTHERS.

NO CLAIM IS MADE TO THE EXCLUSIVE RIGHT TO USE "FUNCTIONAL", APART FROM THE MARK AS SHOWN.

FOR CHEWING GUM (U.S. CL. 46).

LINDA ORNDORFF, EXAMINING ATTORNEY

SN 85-215,160. HOMESTYLE DINING LLC, DBA PONDEROSA STEAKHOUSE, PLANO, TX. FILED 1-11-2011.

PONDEROSA

THE MARK CONSISTS OF STANDARD CHARACTERS WITHOUT CLAIM TO ANY PARTICULAR FONT, STYLE, SIZE, OR COLOR.

OWNER OF U.S. REG. NOS. 903,604, 1,254,681 AND 2,418,851.

FOR BREAD AND PASTRY; FLAVOURINGS AND SEASONINGS; SAUCES; SUGAR AND SUGAR SUBSTITUTES (U.S. CL. 46).

LESLEY LAMOTHE, EXAMINING ATTORNEY

SN 85-256,316. MUSEUM X OF CONTEMPORARY ART, LLC, POMONA, CA. FILED 3-2-2011.



NO CLAIM IS MADE TO THE EXCLUSIVE RIGHT TO USE "VEGAN TIRAMISU", APART FROM THE MARK AS SHOWN.

THE COLOR(S) RED, ORANGE AND GREEN IS/ARE CLAIMED AS A FEATURE OF THE MARK.

THE MARK CONSISTS OF THE WORDS "VEGAN TIRAMISU" IN A STYLIZED FONT WITH THE TERM "VEGAN" IN GREEN AND THE TERM "TIRAMISU" IN RED. AN ORANGE TRIANGLE APPEARS IN THE LETTER "V" AND AN ORANGE CIRCLE WITH A TRIANGLE CUT OUT FROM IT APPEARS BEHIND THE WORDING.

FOR VEGAN DESSERTS, NAMELY, TIRAMISU (U.S. CL. 46).

FIRST USE 1-1-2009; IN COMMERCE 1-9-2010.

GIANCARLO CASTRO, EXAMINING ATTORNEY

CLASS 30—(Continued).

SN 85-298,353. TEA & TOBACCO PRODUCTS, INC., THE WOODLANDS, TX. FILED 4-19-2011.

LA CARABELA

THE MARK CONSISTS OF STANDARD CHARACTERS WITHOUT CLAIM TO ANY PARTICULAR FONT, STYLE, SIZE, OR COLOR.

THE ENGLISH TRANSLATION OF THE WORD "LA CARABELA" IN THE MARK IS "CARAVEL".

FOR TEA (U.S. CL. 46).
ANGELA DUONG, EXAMINING ATTORNEY

SN 85-327,273. SOPHAST SALES & MARKETING, LLC, COLUMBIA, MD. FILED 5-23-2011.



NO CLAIM IS MADE TO THE EXCLUSIVE RIGHT TO USE "SENZA GLUTINE" AND "GLUTEN FREE", APART FROM THE MARK AS SHOWN.

THE MARK CONSISTS OF THE WORLD IN THE SHAPE OF A HEART WITH A RIBBON AROUND IT AND A RIBBON TRAILING BENEATH ABOVE THE WORDS "SENZA GLUTINE" WITH THE WORDS "GLUTEN FREE" CENTERED BELOW THE LETTERS "LUTIN" IN THE WORD "GLUTINE".

THE ENGLISH TRANSLATION OF "SENZA GLUTINE" IN THE MARK IS "WITHOUT GLUTEN".

FOR PIZZA, PAR BAKED PIZZA CRUST, RAW PIZZA CRUST, PRE-TOPPED PIZZA, PIZZA DOUGH, PIZZA IN A BAG, RAVIOLI, STUFFED PASTA SHELLS, TOMATO SAUCE, MEAT SAUCE, LASAGNA, RIGATONI, SPIRAL PASTA, MANICOTTI, LINGUINE, COOKIES, CAKES, DESSERTS, NAMELY, BAKERY DESSERTS, ALL OF THE AFOREMENTIONED FOODS BEING GLUTEN FREE (U.S. CL. 46).

TINA BROWN, EXAMINING ATTORNEY

SN 85-331,326. S-L SNACKS NATIONAL, LLC, CHARLOTTE, NC. FILED 5-26-2011.



OWNER OF U.S. REG. NOS. 2,180,713 AND 3,092,963. NO CLAIM IS MADE TO THE EXCLUSIVE RIGHT TO USE "COFFEE", APART FROM THE MARK AS SHOWN.

THE MARK CONSISTS OF AN OUTLINED BANNER WITH THE WORDS "STELLA D'ORO AND COFFEE" SEPARATED BY A COFFEE CUP SURROUNDED BY A STARBURST-LIKE IMAGE INSIDE AN OVAL.

THE ENGLISH TRANSLATION OF "STELLA D'ORO" IN THE MARK IS "STAR OF GOLD".

FOR COOKIES (U.S. CL. 46).
FIRST USE 11-30-2008; IN COMMERCE 11-30-2008.
YAT SYE, LEE, EXAMINING ATTORNEY

CLASS 30—(Continued).

SN 85-337,863. PROCESADORA DE CACAO REAL, C.A., GUARENAS, CARACAS, VENEZUELA, FILED 6-3-2011.



OWNER OF VENEZUELA REG. NO. P-304769, DATED 7-23-2010, EXPIRES 7-23-2025.

THE COLOR(S) RED, GRAY AND WHITE IS/ARE CLAIMED AS A FEATURE OF THE MARK.

THE MARK CONSISTS OF A RED RECTANGLE WITH THE STYLIZED LETTERS "KKO" APPEARING IN WHITE WITHIN IT, THE STYLIZED WORD "REAL" APPEARING IN GRAY WITHIN THE RED RECTANGLE AND BELOW THE LETTERS "KKO", THE STYLIZED WORD "PREMIER" APPEARING IN GRAY BELOW THE RED RECTANGLE, AND THE STYLIZED WORD "RESERVA" APPEARING IN GRAY BELOW THE WORD "PREMIER". THE COLOR WHITE APPEARING IN THE BACKGROUND OF THE MARK REPRESENTS TRANSPARENT AREAS AND THEREFORE IS NOT PART OF THE MARK.

THE ENGLISH TRANSLATION OF "RESERVA" IN THE MARK IS "RESERVE".

FOR CHOCOLATE (U.S. CL. 46).
BRENDAN MCCAULEY, EXAMINING ATTORNEY

SN 85-343,386. ALLERGYFREE, INC., ATLANTA, GA. FILED 6-10-2011.



NO CLAIM IS MADE TO THE EXCLUSIVE RIGHT TO USE "BEST, BAKED GOODS", AND "NO GLUTEN NO WHEAT NO DAIRY NO EGGS NO PEANUTS NO TREE NUTS", APART FROM THE MARK AS SHOWN.

THE NAME(S), PORTRAIT(S), AND/OR SIGNATURE(S) SHOWN IN THE MARK IDENTIFIES "ISABELLA" GREEN, WHOSE CONSENT(S) TO REGISTER IS MADE OF RECORD.

THE MARK CONSISTS OF THE WORDS "ISABELLA'S BEST BAKED GOODS" BELOW A DRAWING OF A YOUNG GIRL'S HEAD AND SHOULDERS OVER A POLKA-DOT BACKGROUND.

FOR SPECIALTY COOKIES, NAMELY, COOKIES CONTAINING NO EGGS, DAIRY, PEANUTS, WHEAT, OR GLUTEN (U.S. CL. 46).

FIRST USE 9-1-2009; IN COMMERCE 9-14-2009.
DANNEAN HETZEL, EXAMINING ATTORNEY

CLASS 30—(Continued).

SN 85-352,621. SEOUL SHIK POOM, INC. DBA SEOUL TRADING USA CO., ENGLEWOOD, NJ. FILED 6-22-2011.

BAEKSEAMI

THE MARK CONSISTS OF STANDARD CHARACTERS WITHOUT CLAIM TO ANY PARTICULAR FONT, STYLE, SIZE, OR COLOR.

THE ENGLISH TRANSLATION OF "BAEKSEAMI" IN THE MARK IS "LONG AND HEALTHY LIFE".

FOR RICE (U.S. CL. 46).
ELI HELLMAN, EXAMINING ATTORNEY

SN 85-353,558. KATJES FASSIN GMBH & CO. KG, EMMER-ICH AM RHEIN, FED REP GERMANY, FILED 6-22-2011.

TAPPSY

THE MARK CONSISTS OF STANDARD CHARACTERS WITHOUT CLAIM TO ANY PARTICULAR FONT, STYLE, SIZE, OR COLOR.

FOR CONFECTIONARY, NAMELY, CANDY (U.S. CL. 46).

KIMBERLY PERRY, EXAMINING ATTORNEY

SN 85-356,941. LAZY DAZY II, LLC, WINNETKA, IL. FILED 6-27-2011.

HEINEMANN'S

THE MARK CONSISTS OF STANDARD CHARACTERS WITHOUT CLAIM TO ANY PARTICULAR FONT, STYLE, SIZE, OR COLOR.

OWNER OF U.S. REG. NOS. 1,890,030 AND 2,978,639. SEC. 2(F).

FOR BAKERY GOODS (U.S. CL. 46).
FIRST USE 12-30-1929; IN COMMERCE 8-5-1935.
MARLENE BELL, EXAMINING ATTORNEY

CLASS 30—(Continued).

SN 85-357,086. REINHARDT, LISA, PHOENIX, AZ. FILED 6-27-2011.

WEI OF CHOCOLATE

THE MARK CONSISTS OF STANDARD CHARACTERS WITHOUT CLAIM TO ANY PARTICULAR FONT, STYLE, SIZE, OR COLOR.

NO CLAIM IS MADE TO THE EXCLUSIVE RIGHT TO USE "CHOCOLATE", APART FROM THE MARK AS SHOWN.

THE ENGLISH TRANSLATION OF "WEI" IN THE MARK IS "TRANSFORMATIVE ACTION."

FOR BEVERAGES WITH A CHOCOLATE BASE; CHOCOLATE SAUCE; CHOCOLATES AND CHOCOLATE BASED READY TO EAT CANDIES AND SNACKS; HOT CHOCOLATE (U.S. CL. 46).

FIRST USE 2-10-2007; IN COMMERCE 2-10-2007.
COURTNEY ALVAREZ, EXAMINING ATTORNEY

SN 85-357,330. THE COCA-COLA COMPANY, ATLANTA, GA. FILED 6-27-2011.

THE GEORGIA COFFEE COMPANY

THE MARK CONSISTS OF STANDARD CHARACTERS WITHOUT CLAIM TO ANY PARTICULAR FONT, STYLE, SIZE, OR COLOR.

OWNER OF U.S. REG. NO. 3,752,337.

NO CLAIM IS MADE TO THE EXCLUSIVE RIGHT TO USE "COFFEE COMPANY", APART FROM THE MARK AS SHOWN.

SEC. 2(F) AS TO "GEORGIA".
FOR COFFEE; COFFEE BASED BEVERAGES (U.S. CL. 46).

GEOFFREY FOSDICK, EXAMINING ATTORNEY

SN 85-357,956. NATIONAL IMPORTERS INC., RICHMOND, BC, CANADA, FILED 6-28-2011.

SESAME CRUNCH

THE MARK CONSISTS OF STANDARD CHARACTERS WITHOUT CLAIM TO ANY PARTICULAR FONT, STYLE, SIZE, OR COLOR.

OWNER OF CANADA REG. NO. TMA384438, DATED 5-17-1991, RENEWED AS REG. NO. TMA384438, DATED 5-17-2006, EXPIRES 5-17-2021.

NO CLAIM IS MADE TO THE EXCLUSIVE RIGHT TO USE "SESAME", APART FROM THE MARK AS SHOWN.

FOR SESAME WAFERS; SESAME BISCUITS; SESAME CANDY; SESAME-BASED SNACK BARS; AND SESAME SANDWICHES (U.S. CL. 46).

ANGELA M. MICHELI, EXAMINING ATTORNEY

CLASS 30—(Continued).

SN 85-358,342. NISSIN FOODS HOLDINGS CO., LTD., OSAKA, JAPAN, FILED 6-28-2011.

Donbei

THE MARK CONSISTS OF STANDARD CHARACTERS WITHOUT CLAIM TO ANY PARTICULAR FONT, STYLE, SIZE, OR COLOR.

OWNER OF U.S. REG. NO. 2,087,260.
 THE WORDING "DONBEI" HAS NO MEANING IN A FOREIGN LANGUAGE.
 FOR NOODLES, INSTANT NOODLES (U.S. CL. 46).
 FIRST USE 0-0-2000; IN COMMERCE 0-0-2000.
 RON FAIRBANKS, EXAMINING ATTORNEY

SN 85-361,361. TABORA, BURT, FRANKLIN, WI. FILED 7-1-2011.

GRAND'OLA

THE MARK CONSISTS OF STANDARD CHARACTERS WITHOUT CLAIM TO ANY PARTICULAR FONT, STYLE, SIZE, OR COLOR.

FOR GRANOLA; OAT-BASED SNACK FOODS; CHOCOLATE (U.S. CL. 46).
 HANNO RITTNER, EXAMINING ATTORNEY

SN 85-380,560. VANCE, HENRY M, DBA ROJO TEJAS, DALLAS, TX. FILED 7-26-2011.



NO CLAIM IS MADE TO THE EXCLUSIVE RIGHT TO USE "HOT", APART FROM THE MARK AS SHOWN.

THE COLOR(S) DARKER AND LIGHTER YELLOW, RED, BLACK, GREY, WHITE IS/ARE CLAIMED AS A FEATURE OF THE MARK.

THE MARK CONSISTS OF DARKER YELLOW STATE OF TEXAS TRIMMED IN BLACK ON TOP OF IT THE WORDS "ROJO TEJAS" IN RED TRIMMED IN BLACK, THE WORD HOT, IN BLACK, TO THE BOTTOM RIGHT OF THE STATE OF TEXAS, THE PHRASE "SALSA FOR THE SOUL", IN BLACK, TO THE BOTTOM LEFT OF THE STATE OF TEXAS, THE LETTER "J" IN THE WORD "ROJO" IS IN A

CLASS 30—(Continued).

FORM OF A RED PEPPER WITH A GREEN STEM AND WITH A YELLOW TRIMMED IN RED FLAME COMING FROM THE TOP OF IT. THE RED PEPPER ALSO REPLACES THE "X" IN THE WORDING TEXAS, WHICH IS STANDING ON TOP OF THE LEFT OR WEST OF TEXAS IS A BULL FIGHTER DRESSED IN GREY SUIT WITH A RED CUMMERBUND, BLACK SHOES, AND RED TIE, WHITE SHIRT, BLACK HAT WAVING HIS HAND OVER HIS HEAD WITH HANDS AND FACE THE SAME COLOR AS TEXAS IN THIS DESIGN; ALL ON A LIGHTER YELLOW BACKGROUND AND BLACK SPECS.

THE ENGLISH TRANSLATION OF THE WORD "ROJO TEJAS" IN THE MARK IS "RED TEXAS".
 FOR CHUTNEYS (U.S. CL. 46).
 FIRST USE 1-1-2000; IN COMMERCE 2-1-2000.
 NAKIA HENRY, EXAMINING ATTORNEY

SN 85-393,601. BOBA STATION INC, MIAMI, FL. FILED 8-9-2011.



NO CLAIM IS MADE TO THE EXCLUSIVE RIGHT TO USE "BOBA", APART FROM THE MARK AS SHOWN.

THE COLOR(S) GREEN, BLACK, AND WHITE IS/ARE CLAIMED AS A FEATURE OF THE MARK.

THE MARK CONSISTS OF THE FOLLOWING LITERAL ELEMENTS IN WHITE LOWER CASE LETTERS IN THE CENTER OF THE GREEN CIRCLE: "BOBA", THE FOLLOWING LITERAL ELEMENTS IN WHITE UPPER CASE LETTERS UNDERNEATH THE WORD "BOBA" IN THE GREEN CIRCLE, "STATION"; A WHITE OUTLINE DIRECTLY AROUND THE GREEN CIRCLE, A GREEN OUTLINE DIRECTLY AROUND THE WHITE OUTLINE, AND A BLACK OUTLINE DIRECTLY AROUND THE GREEN OUTLINE.

FOR ARTIFICIAL COFFEE AND TEA; BEVERAGES MADE OF TEA; BEVERAGES WITH A TEA BASE; BLACK TEA; CHAI TEA; COFFEE AND TEA; FLAVOURINGS OF TEA; FRUIT TEAS; GINSENG TEA; GREEN TEA; HERB TEA; HERBAL TEA; ICED TEA; INSTANT TEA; JAPANESE GREEN TEA; LIME TEA; MIXES IN THE NATURE OF CONCENTRATES, SYRUPS OR POWDERS USED IN THE PREPARATION OF TEA BASED BEVERAGES; OOLONG TEA; SAGE TEA; SYRUPS FOR MAKING TEA; TEA; TEA BAGS; TEA EXTRACTS; TEA FOR INFUSIONS; TEA-BASED BEVERAGES; TEA-BASED BEVERAGES WITH FRUIT FLAVORING (U.S. CL. 46).

KAPIL BHANOT, EXAMINING ATTORNEY

CLASS 30—(Continued).

SN 85-394,950. TIPU'S CHAI, INC., POLSON, MT. FILED 8-10-2011.

TIPU'S CHAI NOW

THE MARK CONSISTS OF STANDARD CHARACTERS WITHOUT CLAIM TO ANY PARTICULAR FONT, STYLE, SIZE, OR COLOR.

NO CLAIM IS MADE TO THE EXCLUSIVE RIGHT TO USE "CHAI", APART FROM THE MARK AS SHOWN.

FOR INSTANT CHAI TEA IN POWDER FORM (U.S. CL. 46).

ROBIN MITTLER, EXAMINING ATTORNEY

SN 85-399,658. B CANDY INC., CORONA DEL MAR, CA. FILED 8-16-2011.



NO CLAIM IS MADE TO THE EXCLUSIVE RIGHT TO USE "CANDY", APART FROM THE MARK AS SHOWN.

THE COLOR(S) CYAN, GREEN, MAGENTA, ORANGE, PURPLE, RED, ROSE, WHITE AND YELLOW IS/ARE CLAIMED AS A FEATURE OF THE MARK.

THE MARK CONSISTS OF A STRIPED SQUARE FEATURING A WHITE CIRCLE WITH BORDERS IN THE COLORS YELLOW, ORANGE, ROSE AND WHITE. IN THE CENTER OF THE CIRCLE APPEARS THE LETTER "B" IN ROSE AND MAGENTA FOLLOWED BY A CANDY WITH A ROSE AND ORANGE WRAPPER WITH A RED BORDER. BENEATH THE "B" IS THE WORD "CANDY" IN ROSE WITH ORANGE DOTS ON THE LETTER "C", YELLOW DOTS ON THE LETTER "A", GREEN DOTS ON THE LETTER "N", CYAN DOTS ON THE LETTER "D" AND MAGENTA DOTS ON THE LETTER "Y". THE STRIPES ON THE SQUARE BACKGROUND APPEAR IN THE FOLLOWING COLORS, FROM LEFT TO RIGHT: YELLOW, ROSE, WHITE, CYAN, MAGENTA, GREEN, WHITE, YELLOW, ROSE, GREEN, CYAN, WHITE, ORANGE, WHITE, YELLOW, GREEN, WHITE, PURPLE, CYAN, WHITE, YELLOW, GREEN, WHITE AND ROSE.

FOR SWEETS AND CANDY (U.S. CL. 46).

FIRST USE 4-19-2006; IN COMMERCE 11-15-2010.

MARTHA FROMM, EXAMINING ATTORNEY

CLASS 30—(Continued).

SN 85-409,355. J H WHITTAKER & SONS LIMITED, WELLINGTON, NEW ZEALAND, FILED 8-29-2011.

SANTE

THE MARK CONSISTS OF STANDARD CHARACTERS WITHOUT CLAIM TO ANY PARTICULAR FONT, STYLE, SIZE, OR COLOR.

OWNER OF NEW ZEALAND REG. NO. 669721, DATED 6-5-2003, EXPIRES 12-4-2019.

THE ENGLISH TRANSLATION OF "SANTE" IS "HEALTH" OR "HOLY".

FOR CONFECTIONERY, NAMELY, CHOCOLATE CONFECTIONERY (U.S. CL. 46).

REGINA DRUMMOND, EXAMINING ATTORNEY

SN 85-410,479. DOROTHY COX'S CANDIES, INC., DBA DOROTHY COX'S CHOCOLATES, FAIRHAVEN, MA. FILED 8-30-2011.

Dorothy Cox's Chocolates

THE MARK CONSISTS OF STANDARD CHARACTERS WITHOUT CLAIM TO ANY PARTICULAR FONT, STYLE, SIZE, OR COLOR.

NO CLAIM IS MADE TO THE EXCLUSIVE RIGHT TO USE "CHOCOLATES", APART FROM THE MARK AS SHOWN.

THE NAME(S), PORTRAIT(S), AND/OR SIGNATURE(S) SHOWN IN THE MARK DOES NOT IDENTIFY A PARTICULAR LIVING INDIVIDUAL.

FOR CHOCOLATES AND CHOCOLATE BASED READY TO EAT CANDIES AND SNACKS (U.S. CL. 46).

FIRST USE 12-31-1928; IN COMMERCE 12-31-1928.

WARREN L. OLANDRIA, EXAMINING ATTORNEY

CLASS 30—(Continued).

SN 85-410,702. KUNMING KAWAGEBO ADVERTISING CO.,LTD., YUNNAN, CHINA, FILED 8-30-2011.



NO CLAIM IS MADE TO THE EXCLUSIVE RIGHT TO USE "TEA" AND THE NON-LATIN CHARACTERS THAT TRANSLITERATE TO "PIN", APART FROM THE MARK AS SHOWN.

THE MARK CONSISTS OF AN ELEPHANT WITH A TREE SPROUTING FROM ITS BACK, FOLLOWED BY TWO CHINESE CHARACTERS, UNDERNEATH OF WHICH IS THE WORDING "ANCIENT TEA & ELEPHANT".

THE NON-LATIN CHARACTERS IN THE MARK TRANSLITERATE TO "PIN" WHICH MEANS "PRODUCT OR GOODS" AND "XIANG" WHICH MEANS "ELEPHANT".

FOR CEREAL BASED SNACK FOOD; COFFEE; HONEY; ICE CREAM; NOODLES; RICE; SEASONINGS; SUGAR; TEA; TEA-BASED BEVERAGES (U.S. CL. 46).

RAMONA ORTIGA, EXAMINING ATTORNEY

CLASS 30—(Continued).

SN 85-426,094. EDIBLE ARRANGEMENTS, WALLINGFORD, CT. FILED 9-19-2011.

HEELS FOR HEALING

THE MARK CONSISTS OF STANDARD CHARACTERS WITHOUT CLAIM TO ANY PARTICULAR FONT, STYLE, SIZE, OR COLOR.

FOR FRUITS CUT INTO SHAPES AND ARRANGED IN CONTAINERS AS FLORAL DESIGNS; ARRANGEMENTS OF FRESH FRUIT CUT INTO SHAPES AND AT LEAST PARTIALLY COATED WITH AN EDIBLE TOPPING, NAMELY, COCONUT, PROCESSED NUTS, CINNAMON, CHOCOLATE AND COMBINATIONS THEREOF; FRUITS CUT INTO SHAPES AND AT LEAST PARTIALLY COATED WITH AN EDIBLE TOPPING, NAMELY, COCONUT, PROCESSED NUTS, CINNAMON, CHOCOLATE AND COMBINATIONS THEREOF AND ARRANGED IN CONTAINERS A FLORAL DESIGNS; FRESH FRUIT CUT INTO SHAPES, SKEWERED, AND AT LEAST PARTIALLY COATED WITH AN EDIBLE TOPPING, NAMELY, CHOCOLATE; ARRANGEMENTS MADE OF PROCESSED FRUIT AT LEAST PARTIALLY COATED WITH AN EDIBLE TOPPING, NAMELY, CHOCOLATE, CINNAMON AND COMBINATIONS THEREOF (U.S. CL. 46).

FIRST USE 10-1-2010; IN COMMERCE 10-1-2010.
LUCY ARANT, EXAMINING ATTORNEY

SN 85-429,709. LIZ LOVELY, INCORPORATED, WAITSFIELD, VT. FILED 9-22-2011.

BAKING A DIFFERENCE

THE MARK CONSISTS OF STANDARD CHARACTERS WITHOUT CLAIM TO ANY PARTICULAR FONT, STYLE, SIZE, OR COLOR.

FOR COOKIES (U.S. CL. 46).
FIRST USE 3-1-2005; IN COMMERCE 3-1-2005.
TARAH HARDY, EXAMINING ATTORNEY

SN 85-436,431. ACH FOOD COMPANIES, INC., CORDOVA, TN. FILED 9-30-2011.

V&O TO GO

THE MARK CONSISTS OF STANDARD CHARACTERS WITHOUT CLAIM TO ANY PARTICULAR FONT, STYLE, SIZE, OR COLOR.

NO CLAIM IS MADE TO THE EXCLUSIVE RIGHT TO USE "V&O", APART FROM THE MARK AS SHOWN.
FOR SALAD DRESSINGS (U.S. CL. 46).

WILLIAM P. SHANAHAN, EXAMINING ATTORNEY

BUZZ 'N HONEY

THE MARK CONSISTS OF STANDARD CHARACTERS WITHOUT CLAIM TO ANY PARTICULAR FONT, STYLE, SIZE, OR COLOR.

NO CLAIM IS MADE TO THE EXCLUSIVE RIGHT TO USE "HONEY", APART FROM THE MARK AS SHOWN.
FOR SAUCES FOR FLAVORING FOODS (U.S. CL. 46).

EMILY CHUO, EXAMINING ATTORNEY

CLASS 30—(Continued).

SN 85-440,490. DRAYTON FOODS LLC, FARGO, ND. FILED 10-6-2011.

Smart Crust

THE MARK CONSISTS OF STANDARD CHARACTERS WITHOUT CLAIM TO ANY PARTICULAR FONT, STYLE, SIZE, OR COLOR.

NO CLAIM IS MADE TO THE EXCLUSIVE RIGHT TO USE "CRUST", APART FROM THE MARK AS SHOWN.

FOR FROZEN DOUGH FOR USE AS PIZZA, BREAD OR OTHER BREAD-TYPE PRODUCTS (U.S. CL. 46).

MAUREEN DALL, EXAMINING ATTORNEY

SN 85-441,435. ADAM TEA, BAKERSFIELD, CA. FILED 10-6-2011.

Adam

THE MARK CONSISTS OF STANDARD CHARACTERS WITHOUT CLAIM TO ANY PARTICULAR FONT, STYLE, SIZE, OR COLOR.

THE NAME(S), PORTRAIT(S), AND/OR SIGNATURE(S) SHOWN IN THE MARK DOES NOT IDENTIFY A PARTICULAR LIVING INDIVIDUAL.

FOR LOOSE LEAF TEA AND TEA BAGS; FLAVORED TEA (U.S. CL. 46).

NAAKWAMA ANKRAH, EXAMINING ATTORNEY

SN 85-455,636. FOOD NEW MEDIA GROUP, INC., NEW YORK, NY. FILED 10-25-2011.



OWNER OF U.S. REG. NOS. 3,970,288 AND 3,970,407.
THE MARK CONSISTS OF THE TERM "ARTISTRE" IN A STYLIZED SCRIPT WITH FOUR PAINT STROKES TO THE UPPER RIGHT OF THE LETTER "E".

FOR FLAVORING ADDITIVES FOR NON-NUTRITIONAL PURPOSES; FOOD ADDITIVES FOR NON-NUTRITIONAL PURPOSES FOR USE AS A FLAVORING; FOOD FLAVOURINGS; FOOD SEASONINGS; SEASONINGS (U.S. CL. 46).

KATINA MISTER, EXAMINING ATTORNEY

CLASS 30—(Continued).

SN 85-464,782. SEGAFREDO-ZANETTI S.P.A., (PROVINCE OF BOLOGNA), ITALY, FILED 11-4-2011.



OWNER OF U.S. REG. NO. 1,527,004.
THE COLOR(S) RED IS/ARE CLAIMED AS A FEATURE OF THE MARK.

THE MARK CONSISTS OF A STYLIZED LETTER "S" IN RED.

FOR COFFEE (U.S. CL. 46).

FIRST USE 1-0-2011; IN COMMERCE 1-0-2011.

JENNIFER WILLISTON, EXAMINING ATTORNEY

SN 85-476,574. ARNOLD PRODUCTS, INC., HORSHAM, PA. FILED 11-18-2011.

FROM GRAINS TO GLORY

THE MARK CONSISTS OF STANDARD CHARACTERS WITHOUT CLAIM TO ANY PARTICULAR FONT, STYLE, SIZE, OR COLOR.

FOR BAKERY PRODUCTS (U.S. CL. 46).
GENE MACIOL, EXAMINING ATTORNEY

SN 85-481,005. VERMANA HERBALS, LLC, HYDE PARK, VT. FILED 11-26-2011.

Vermana Herbals

THE MARK CONSISTS OF STANDARD CHARACTERS WITHOUT CLAIM TO ANY PARTICULAR FONT, STYLE, SIZE, OR COLOR.

NO CLAIM IS MADE TO THE EXCLUSIVE RIGHT TO USE "HERBALS", APART FROM THE MARK AS SHOWN.
THE WORDING "VERMANA" HAS NO MEANING IN A FOREIGN LANGUAGE.

FOR HERBAL TEA; TEA EXTRACTS (U.S. CL. 46).

FIRST USE 11-26-2011; IN COMMERCE 11-26-2011.

GRETTA YAO, EXAMINING ATTORNEY

CLASS 30—(Continued).

SN 85-483,701. CHARLOTTE NEUVILLE DESIGN LLC, NEW YORK, NY. FILED 11-30-2011.

THE FASHION CHEF

THE MARK CONSISTS OF STANDARD CHARACTERS WITHOUT CLAIM TO ANY PARTICULAR FONT, STYLE, SIZE, OR COLOR.

NO CLAIM IS MADE TO THE EXCLUSIVE RIGHT TO USE "CHEF", APART FROM THE MARK AS SHOWN.

FOR PASTRIES, CAKES AND COOKIES (U.S. CL. 46). FIRST USE 11-18-2011; IN COMMERCE 11-18-2011.

TRACY WHITTAKER-BROWN, EXAMINING ATTORNEY

CLASS 30—(Continued).

SN 85-485,710. STELLA'S FAMOUS SAUCE, LLC, SCOTTSDALE, AZ. FILED 12-2-2011.



NO CLAIM IS MADE TO THE EXCLUSIVE RIGHT TO USE "FAMOUS SAUCES, LLC", APART FROM THE MARK AS SHOWN.

THE STIPPLING IS FOR SHADING PURPOSES ONLY. THE LIKENESS (OR, "PORTRAIT") IN THE MARK AND THE NAME "STELLA'S" DO NOT IDENTIFY A LIVING INDIVIDUAL.

THE MARK CONSISTS OF A STYLIZED DRAWING OF A WOMAN IN A CAMEO WITH A RIBBON THAT CONTAINS THE STYLIZED WORDING "STELLA'S". BELOW THE DRAWING IS A STYLIZED DESIGN OF THREE TOMATOES BETWEEN TWO LEAVES AND THE STYLIZED WORDING "FAMOUS SAUCES, LLC" BELOW.

FOR PASTA SAUCE (U.S. CL. 46). AMEEN IMAM, EXAMINING ATTORNEY

SN 85-484,609. STURM FOODS, INC., MANAWA, WI. FILED 12-1-2011.

CAZA TRAIL

THE MARK CONSISTS OF STANDARD CHARACTERS WITHOUT CLAIM TO ANY PARTICULAR FONT, STYLE, SIZE, OR COLOR.

THE ENGLISH TRANSLATION OF THE WORD "CAZA" IN THE MARK IS "HUNTING".

FOR COFFEE (U.S. CL. 46). CAROLYN CATALDO, EXAMINING ATTORNEY

SN 85-485,880. FOODS AMERICA INC, FORMERLY CEARS AMERICA INC, SPARKS, MD. FILED 12-2-2011.



NO CLAIM IS MADE TO THE EXCLUSIVE RIGHT TO USE "CHOICE", APART FROM THE MARK AS SHOWN.

THE MARK CONSISTS OF THE STYLIZED WORDS "MAHARANI'S CHOICE". THE GREY BACKGROUND IS NOT PART OF THE MARK.

FOR FROZEN VEGETARIAN POROTTA IN THE NATURE OF FLATBREAD; FROZEN VEGETARIAN IDLI IN THE NATURE OF SOUTH INDIAN CAKE (U.S. CL. 46).

FIRST USE 8-19-1997; IN COMMERCE 8-19-1997. SIMON TENG, EXAMINING ATTORNEY

CLASS 30—(Continued).

SN 85-486,634. FROSAE, LLC, DBA FROSAE, LLC, BELL-PORT, NY. FILED 12-4-2011.



NO CLAIM IS MADE TO THE EXCLUSIVE RIGHT TO USE "WINE SORBET", APART FROM THE MARK AS SHOWN.

THE COLOR(S) PURPLE, RED AND GREEN IS/ARE CLAIMED AS A FEATURE OF THE MARK.

THE MARK CONSISTS OF THE WORDS "FROSAE WINE SORBAE" IN PURPLE WITH THE WORDS "WINE SORBAE" IN SMALLER LETTERING UNDERNEATH THE TERM "FROSAE". OVER THE LETTER "E" IN "FROSAE" IS A SINGLE RED ROSE WITH A GREEN STEM AND LEAVES.

FOR SORBET MADE WITH WINE, CONTAINING THE FLAVOR AND ALCOHOL CONTENT OF THE WINE USED (U.S. CL. 46).

LUCY ARANT, EXAMINING ATTORNEY

SN 85-489,376. HAN LION GROUP LIMITED, ROAD TOWN, TORTOLA, BR. VIRGIN ISLANDS, FILED 12-7-2011.



漢獅
HAN LION

THE MARK CONSISTS OF A STYLIZED LION'S FACE WITHIN A SQUARE; THE WORDS "HAN LION" TO THE RIGHT OF THE SQUARE, AND CHINESE CHARACTERS ABOVE THE WORDS "HAN LION".

THE ENGLISH TRANSLATION OF "HAN LION" IN THE MARK IS "CHINESE LION".

THE NON-LATIN CHARACTERS IN THE MARK TRANSLITERATE TO "HAN LION" AND THIS MEANS "CHINESE LION" IN ENGLISH.

FOR TEA; NON-MEDICATED TEA PRODUCTS; NON-MEDICATED TEA BEVERAGES AND EXTRACTS; AROMATIC TEAS OTHER THAN FOR MEDICINAL USE; BEVERAGES MADE OF TEA; HERBAL BEVERAGES, EXTRACTS, INFUSIONS AND TEA OTHER THAN FOR MEDICINAL USE; ARTIFICIAL TEA OTHER THAN FOR MEDICINAL USE; AROMATIC BEVERAGES MADE OF TEA; FRUIT FLAVORED TEA OTHER THAN FOR MEDICINAL USE; FRUIT TEA OTHER THAN FOR MEDICAL USE; HERBAL TEA OTHER THAN FOR MEDICINAL USE (U.S. CL. 46).

FIRST USE 7-22-2010; IN COMMERCE 9-3-2010.

GINA HAYES, EXAMINING ATTORNEY

CLASS 30—(Continued).

SN 85-489,916. KELLY, PETER J., PROVIDENCE, RI. FILED 12-7-2011.



NO CLAIM IS MADE TO THE EXCLUSIVE RIGHT TO USE "LITTLE FALLS CHOCOLATE MILL" OR "CLASSIC AMERICAN CONFECTIONS", APART FROM THE MARK AS SHOWN.

THE STIPPLING IS FOR SHADING PURPOSES ONLY.

THE NAME(S), PORTRAIT(S), AND/OR SIGNATURE(S) SHOWN IN THE MARK DOES NOT IDENTIFY A PARTICULAR LIVING INDIVIDUAL.

THE MARK CONSISTS OF AN OVAL CONTAINING A PHOTOGRAPH OF A MAN IN A SUIT AND TIE, WITH A DISTINCTIVE MUSTACHE. THE WORDS "UNCLE TRUSCOTT'S" APPEAR IN AN ARCH OVER HIS HEAD, "LITTLE FALLS CHOCOLATE MILL" APPEARS BELOW HIS PHOTO AND BETWEEN TWO HORIZONTAL LINES/BARS, AND "CLASSIC AMERICAN CONFECTIONS" APPEARS IN SCRIPT BELOW THAT.

FOR CANDY; CARAMELS; CHOCOLATE TOPPING; CHOCOLATE TRUFFLES; PEANUT BRITTLE; TOFFEE (U.S. CL. 46).

LINDA LAVACHE, EXAMINING ATTORNEY

SN 85-491,849. CRUDESSSENCE KOMBUCHA INC., MONTRÉAL, CANADA, FILED 12-9-2011.

RISE KOMBUCHA

THE MARK CONSISTS OF STANDARD CHARACTERS WITHOUT CLAIM TO ANY PARTICULAR FONT, STYLE, SIZE, OR COLOR.

NO CLAIM IS MADE TO THE EXCLUSIVE RIGHT TO USE "KOMBUCHA", APART FROM THE MARK AS SHOWN.

FOR BEVERAGES MADE FROM TEA CONTAINING KOMBUCHA (U.S. CL. 46).

ALEXANDER L. POWERS, EXAMINING ATTORNEY

CLASS 30—(Continued).

SN 85-495,215. HEALTHY FROZEN FOOD, INC., PHOENIX, AZ. FILED 12-14-2011.

**EMILY'S NATURALLY
DELICIOUS WAFFLES**

THE MARK CONSISTS OF STANDARD CHARACTERS WITHOUT CLAIM TO ANY PARTICULAR FONT, STYLE, SIZE, OR COLOR.

NO CLAIM IS MADE TO THE EXCLUSIVE RIGHT TO USE "WAFFLES", APART FROM THE MARK AS SHOWN, FOR PANCAKES, FRENCH TOAST AND WAFFLES (U.S. CL. 46).

SKYE YOUNG, EXAMINING ATTORNEY

SN 85-497,487. LUHSE TEA, DBA LUHSE TEA, KISSIMMEE, FL. FILED 12-16-2011.



THE MARK CONSISTS OF A SEMI-CIRCLE REPRESENTING A TEACUP ON THE BOTTOM AND THE WORDING "LUHSE TEA" WRITTEN ABOVE, AND TOGETHER THEY FORM WHAT LOOKS LIKE A CIRCLE.

FOR BAKING SPICES; BLACK TEA; CHAI TEA; COFFEE AND TEA; GREEN TEA; ICED TEA; OOLONG TEA; SPICE BLENDS; SPICES; TEA; TEA BAGS (U.S. CL. 46).

FIRST USE 9-22-2011; IN COMMERCE 11-28-2011.
DOUGLAS LEE, EXAMINING ATTORNEY

CLASS 30—(Continued).

SN 85-498,913. ROMERO, MARIO NUÑEZ, PUEBLA, MEXICO, FILED 12-19-2011.

MACHA

THE MARK CONSISTS OF STANDARD CHARACTERS WITHOUT CLAIM TO ANY PARTICULAR FONT, STYLE, SIZE, OR COLOR.

THE ENGLISH TRANSLATION OF "MACHA" IN THE MARK IS "MALE".

FOR HOT SAUCE, PACKAGED TACO SHELLS, TOSTADA SHELLS AND TORTILLAS, SOFT CORN TORTILLA, SOFT FLOUR TORTILLA, DRY TACO SEASONING, ENCHILADA SAUCE, KITS FOR TACO DINNERS CONTAINING TACO SHELLS, KITS FOR ENCHILADAS COMPRISING SALSA AND TORTILLAS, KITS FOR CHILAQUILES COMPRISING SALSA AND CHIPS, KITS FOR BURRITOS COMPRISING SALSA AND TORTILLAS, KITS FOR GORDITAS COMPRISING SALSA AND TORTILLAS, KITS FOR FAJITAS COMPRISING SALSA AND TORTILLAS, TACO SAUCE AND DRY TACO SEASONING MIX, FROZEN MEXICAN ENTREES, COMPRISING TORTILLAS, TORTILLAS, RICE AND SAUCE; FROZEN MEXICAN FOODS, NAMELY, BURRITOS, TAQUITOS, TACOS, ENCHILADAS, QUESADILLAS, CHIMICHANGAS, TAMALES AND TORTILLAS FILLED WITH MEATS, CHEESES, VEGETABLES, RICE, BEANS AND SAUCE (U.S. CL. 46).

MELISSA VALLILLO, EXAMINING ATTORNEY

SN 85-499,837. LEKAI, NICCOLO', DBA LEO LEO GELATO, PASO ROBLES, CA. FILED 12-20-2011.



NO CLAIM IS MADE TO THE EXCLUSIVE RIGHT TO USE "GELATO" AND "MASTER GELATIERIS", APART FROM THE MARK AS SHOWN.

THE COLOR(S) ORANGE, GOLD AND GREY IS/ARE CLAIMED AS A FEATURE OF THE MARK.

THE MARK CONSISTS OF AN IMAGE OF WINGED SAINT MARK'S LION FACING LEFT OVER DECORATIVE CURVED LINES OVER COMPANY NAME "LEO LEO GELATO", ALL CAPS, OVER STATEMENT "MASTER GELATIERIS".

FOR GELATO; SHERBETS (U.S. CL. 46).
FIRST USE 6-1-2011; IN COMMERCE 9-1-2011.
PRISCILLA MILTON, EXAMINING ATTORNEY

CLASS 30—(Continued).

SN 85-500,371. WILD WIFE GOURMET FOODS, INC., DANVILLE, CA. FILED 12-20-2011.

Wild Wife!



THE MARK CONSISTS OF THE WORDS "WILD WIFE!" IN STYLIZED SCRIPT FONT CENTERED ABOVE A DRAWING OF A LIPSTICK MARK.

FOR SAUCES; SEASONINGS (U.S. CL. 46).
FIRST USE 2-1-1997; IN COMMERCE 2-1-1997.
SANJEEV VOHRA, EXAMINING ATTORNEY

CLASS 30—(Continued).

SN 85-501,377. ROCCO WHALEN, ROCKY RIVER, OH. FILED 12-21-2011.

ROCCO WHALEN'S

THE MARK CONSISTS OF STANDARD CHARACTERS WITHOUT CLAIM TO ANY PARTICULAR FONT, STYLE, SIZE, OR COLOR.

THE NAME(S), PORTRAIT(S), AND/OR SIGNATURE(S) SHOWN IN THE MARK IDENTIFIES "ROCCO WHALEN", WHOSE CONSENT(S) TO REGISTER IS MADE OF RECORD.

FOR NACHOS; TACO CHIPS; TACO SEASONING; TACO SHELLS; TACOS (U.S. CL. 46).

KRISTIN DAHLING, EXAMINING ATTORNEY

SN 85-502,333. BAMBRICK, DEAN, TEMECULA, CA. FILED 12-22-2011.

Katani Tea

THE MARK CONSISTS OF STANDARD CHARACTERS WITHOUT CLAIM TO ANY PARTICULAR FONT, STYLE, SIZE, OR COLOR.

NO CLAIM IS MADE TO THE EXCLUSIVE RIGHT TO USE "TEA", APART FROM THE MARK AS SHOWN.

THE WORDING "KATANI" HAS NO MEANING IN A FOREIGN LANGUAGE.

FOR BEVERAGES WITH A TEA BASE (U.S. CL. 46).

ELLEN PERKINS, EXAMINING ATTORNEY

SN 85-500,699. D&D AR FOODS LIMITED LIABILITY COMPANY, WELLINGTON, FL. FILED 12-21-2011.



NO CLAIM IS MADE TO THE EXCLUSIVE RIGHT TO USE "MUFFIN", APART FROM THE MARK AS SHOWN.

THE COLOR(S) GREEN, BROWN, YELLOW, WHITE, BLACK AND BLUE IS/ARE CLAIMED AS A FEATURE OF THE MARK.

THE MARK CONSISTS OF A FANCIFUL DESIGN OF A 'MUSCLED MUFFIN' IN THE COLOR BROWN WITH WHITE EYES AND TEETH AND YELLOW, BLACK AND GREEN HIGHLIGHTS, SURROUNDED BY A STYLIZED LETTER "P" AND A STYLIZED LETTER "M" BELOW THE DESIGN IN THE COLORS GREEN, YELLOW AND BLACK, WITH THE WORD "HIGH" ABOVE THE DESIGN AND THE WORDS "PERFORMANCE MUFFIN" BELOW THE DESIGN IN THE COLOR GREEN WITH BLUE, YELLOW AND BLACK HIGHLIGHTS.

FOR FLOUR-FREE FOODS, NAMELY, PROTEIN-ENRICHED MUFFINS (U.S. CL. 46).

FIRST USE 11-15-2011; IN COMMERCE 11-15-2011.
LINDA ORNDORFF, EXAMINING ATTORNEY

SN 85-503,099. WARP FOODS, INC., LOS GATOS, CA. FILED 12-23-2011.

FLAVOR WORLD

THE MARK CONSISTS OF STANDARD CHARACTERS WITHOUT CLAIM TO ANY PARTICULAR FONT, STYLE, SIZE, OR COLOR.

NO CLAIM IS MADE TO THE EXCLUSIVE RIGHT TO USE "FLAVOR", APART FROM THE MARK AS SHOWN.

FOR SAUCES (U.S. CL. 46).

EUGENIA MARTIN, EXAMINING ATTORNEY

CLASS 30—(Continued).

SN 85-504,175. AMERICAN ITALIAN PASTA COMPANY, KANSAS CITY, MO. FILED 12-27-2011.

CLASS 30—(Continued).

SN 85-506,346. RIKEN VITAMIN CO., LTD., TOKYO, JAPAN, FILED 12-30-2011.

GOLDEN VEGGIE

THE MARK CONSISTS OF STANDARD CHARACTERS WITHOUT CLAIM TO ANY PARTICULAR FONT, STYLE, SIZE, OR COLOR.

NO CLAIM IS MADE TO THE EXCLUSIVE RIGHT TO USE "VEGGIE", APART FROM THE MARK AS SHOWN. FOR PASTA (U.S. CL. 46).
BARBARA BROWN, EXAMINING ATTORNEY



SN 85-505,197. LOLLIPOP LANE LIMITED, MANCHESTER, UNITED KINGDOM, FILED 12-28-2011.



PRIORITY CLAIMED UNDER SEC. 44(D) ON ERPN CMNTY TM OFC APPLICATION NO. 010422558, FILED 11-16-2011.

THE MARK CONSISTS OF A BLACK COLORED SILHOUETTE OF TWO PEOPLE IN A HOWDAH, FASTENED TO THE TOP (BACK) OF A STYLIZED BLACK ELEPHANT WITH SWIRLS OF GRAY AND WHITE, AND A WHITE EYE OVER THE WORD "HOWDAH" IN FANCY FONT.

FOR (BASED ON INTENT TO USE) BREAD; CHUTNEY; CONFECTIONERIES, NAMELY, SNACK FOODS, NAMELY, CHOCOLATE; COOKING SAUCES; CURRY PASTES; FLAT BREAD; FLAVORINGS; FLOUR FOR FOOD; PASTRY; RICE; RICE-BASED PUDDING DESSERT; RICE-BASED SNACK FOODS; ROLLS; SPICES(-BASED ON 44(D) PRIORITY APPLICATION) BREAD; CHUTNEY; CONFECTIONERIES, NAMELY, SNACK FOODS, NAMELY, CHOCOLATE; COOKING SAUCES; CURRY PASTES; FLAT BREAD; FLAVORINGS; FLOUR FOR FOOD; PASTRY; RICE; RICE-BASED PUDDING DESSERT; RICE-BASED SNACK FOODS; ROLLS; SPICES (U.S. CL. 46).

APRIL HESIK, EXAMINING ATTORNEY



OWNER OF U.S. REG. NOS. 3,042,455, 3,042,456 AND OTHERS.

NO CLAIM IS MADE TO THE EXCLUSIVE RIGHT TO USE "JAPANESE STYLE DRESSING AOJISO", THE NON-LATIN CHARACTERS THAT TRANSLITERATE TO "NON-OIL" AND "AOJISO", AND THE DESIGN OF AOJISO LEAVES, APART FROM THE MARK AS SHOWN.

THE COLOR(S) GREEN, RED, WHITE, BLACK IS/ARE CLAIMED AS A FEATURE OF THE MARK.

THE MARK CONSISTS OF A LABEL IN SHADES OF GREEN ENCLOSING LEAF DESIGN IN GREEN WITH JAPANESE LANGUAGE CHARACTERS IN WHITE WITH BLACK SHADING CENTERED ON THE LEAF; ON THE TOP OF THE LEAF A HORIZONTAL LINE IN RED WITH A VARYING WIDTH AND WITH CURVED ENDS; ON TOP OF WHICH APPEARS JAPANESE CHARACTERS IN BLACK; UNDERNEATH THE LEAF APPEARS THE WORDS "JAPANESE STYLE DRESSING" IN BLACK, THE WORD "AOJISO" IN BLACK AND WHITE; AND A RED SQUARE CONTAINING THE WORD "RIKEN" AND STYLIZED "R" IN WHITE.

THE NON-LATIN CHARACTERS IN THE MARK TRANSLITERATE TO "RIKEN NO NON-OIL" AND "AOJISO" AND THIS MEANS "RIKEN OF NON-OILY" AND "AOJISO" IN ENGLISH.

FOR SALAD DRESSINGS, SEASONINGS (U.S. CL. 46).
KRISTIN DAHLING, EXAMINING ATTORNEY

CLASS 30—(Continued).

SN 85-506,368. RIKEN VITAMIN CO., LTD., TOKYO, JAPAN,
FILED 12-30-2011.

**CLASS 30—(Continued).**

SN 85-506,402. RIKEN VITAMIN CO., LTD., TOKYO, JAPAN,
FILED 12-30-2011.



OWNER OF U.S. REG. NOS. 3,042,455, 3,042,546 AND OTHERS.

NO CLAIM IS MADE TO THE EXCLUSIVE RIGHT TO USE "ITALIAN DRESSING WITH BASIL", THE NON-LATIN CHARACTERS THAT TRANSLITERATE TO "BASIL" AND "ITALIAN", AND THE DESIGN OF BASIL LEAVES, APART FROM THE MARK AS SHOWN.

THE COLOR(S) ORANGE, RED, GREEN, BLACK, WHITE IS/ARE CLAIMED AS A FEATURE OF THE MARK.

THE MARK CONSISTS OF A LABEL IN ORANGE SHADING ENCLOSING A LEAF DESIGN IN GREEN;

JAPANESE LANGUAGE CHARACTERS ARE ON THE LEAF IN WHITE WITH BLACK SHADING AND IN RED AND GREEN WITH WHITE SHADING; ON THE TOP OF THE LEAF A HORIZONTAL LINE IN RED WITH A VARYING WIDTH AND WITH CURVED ENDS; ON THE TOP OF WHICH APPEARS JAPANESE CHARACTERS IN BLACK; UNDERNEATH THE LEAF ARE THE WORDS "ITALIAN DRESSING WITH" IN BLACK AND THE WORD "BASIL" IN BLACK AND WHITE; AND A RED SQUARE CONTAINING THE WORD "RIKEN" AND A STYLIZED "R" IN WHITE.

THE NON-LATIN CHARACTERS IN THE MARK TRANSLITERATE TO "RIKEN NO NON-OIL" AND "BASIL ITALIAN" AND THIS MEANS "RIKEN OF NON-OILY" AND "BASIL ITALIAN" IN ENGLISH.

FOR SALAD DRESSINGS, SEASONINGS (U.S. CL. 46).
KRISTIN DAHLING, EXAMINING ATTORNEY

OWNER OF U.S. REG. NOS. 3,042,455, 3,042,456 AND OTHERS.

NO CLAIM IS MADE TO THE EXCLUSIVE RIGHT TO USE "ASIAN STYLE DRESSING SESAME", THE NON-LATIN CHARACTERS THAT TRANSLITERATE TO "NON-OIL" AND "SESAME CHUKA", AND THE DESIGN OF SESAME SEEDS, APART FROM THE MARK AS SHOWN.

THE COLOR(S) BEIGE, RED, BLACK, WHITE IS/ARE CLAIMED AS A FEATURE OF THE MARK.

THE MARK CONSISTS OF A LABEL IN SHADES OF BEIGE ENCLOSING A DESIGN IN BEIGE COMPRISED OF NUMEROUS SESAME SEEDS IN THE CENTER; ON THE TOP OF THE DESIGN IS A HORIZONTAL LINE IN RED WITH A VARYING WIDTH AND WITH CURVED ENDS; ON THE TOP OF WHICH APPEARS JAPANESE CHARACTERS IN BLACK; UNDERNEATH THE DESIGN APPEARS THE WORDS "ASIAN STYLE DRESSING" IN BLACK AND THE WORD "SESAME" IN BLACK AND WHITE AND A RED SQUARE CONTAINING THE WORD "RIKEN" IN WHITE AND A STYLIZED "R" IN WHITE.

THE NON-LATIN CHARACTERS IN THE MARK TRANSLITERATE TO "RIKEN NO NON-OIL SESAME CHUKA" AND THIS MEANS "RIKEN OF NON-OILY SESAME CHINESE" IN ENGLISH.

FOR SALAD DRESSINGS, SEASONINGS (U.S. CL. 46).
KRISTIN DAHLING, EXAMINING ATTORNEY

CLASS 30—(Continued).

SN 85-506,437. RIKEN VITAMIN CO., LTD., TOKYO, JAPAN, FILED 12-30-2011.



OWNER OF U.S. REG. NOS. 3,042,455, 3,042,456 AND OTHERS.

NO CLAIM IS MADE TO THE EXCLUSIVE RIGHT TO USE "JAPANESE STYLE DRESSING SAVORY SESAME", THE NON-LATIN CHARACTERS THAT TRANSLITERATE TO "NON-OIL" AND "SESAME MAROYAKA", AND THE DESIGN OF SESAME SEEDS, APART FROM THE MARK AS SHOWN.

THE COLOR(S) PINK, BEIGE, RED, BLACK, WHITE IS/ ARE CLAIMED AS A FEATURE OF THE MARK.

THE MARK CONSISTS OF A LABEL IN PINK ENCLOSING A DESIGN COMPRISED OF SESAME SEEDS IN BEIGE, ON WHICH THERE ARE JAPANESE CHARACTERS IN BLACK WITH WHITE SHADING; ABOVE THE DESIGN IS A HORIZONTAL LINE IN RED WITH VARYING WIDTH WITH CURVED ENDS, ON TOP OF WHICH APPEARS JAPANESE CHARACTERS IN BLACK; ON THE BOTTOM OF THE LABEL THE WORDS "JAPANESE STYLE DRESSING" IN BLACK AND THE WORDS "SAVORY SESAME" IN BLACK, AND A RED SQUARE CONTAINING THE WORD "RIKEN" AND A STYLIZED "R" IN WHITE.

THE NON-LATIN CHARACTERS IN THE MARK TRANSLITERATE TO "RIKEN NO NON-OIL SESAME MAROYAKA" AND THIS MEANS "RIKEN OF NON-OILY SESAME SAVORY" IN ENGLISH.

FOR SALAD DRESSINGS, SEASONINGS (U.S. CL. 46). KRISTIN DAHLING, EXAMINING ATTORNEY

CLASS 30—(Continued).

SN 85-507,673. TEXAR A-1, TA HYBCO, U.S.A., LOS ANGELES, CA. FILED 1-3-2012.

TEXAR A-1

THE MARK CONSISTS OF STANDARD CHARACTERS WITHOUT CLAIM TO ANY PARTICULAR FONT, STYLE, SIZE, OR COLOR.

FOR ENRICHED RICE; RICE (U.S. CL. 46). FIRST USE 1-2-1984; IN COMMERCE 1-2-1984. TINA MAI, EXAMINING ATTORNEY

SN 85-507,860. LUGER PARTNERS, LLC, SAN ANTONIO, TX. FILED 1-3-2012.

SmartDENT

THE MARK CONSISTS OF STANDARD CHARACTERS WITHOUT CLAIM TO ANY PARTICULAR FONT, STYLE, SIZE, OR COLOR.

FOR SUGAR-FREE CHEWING GUM; SUGARFREE CHEWING GUM (U.S. CL. 46). FIRST USE 11-29-2011; IN COMMERCE 11-29-2011. JENNIFER VASQUEZ, EXAMINING ATTORNEY

SN 85-506,444. MOORE, KAREN E., ALPHARETTA, GA. FILED 12-30-2011.

“Desserts That Put Love on Your Lips ... Without the Fat on Your Hips”

THE MARK CONSISTS OF STANDARD CHARACTERS WITHOUT CLAIM TO ANY PARTICULAR FONT, STYLE, SIZE, OR COLOR.

FOR VEGAN AND VEGETARIAN DESSERTS, NAMELY, CAKES, PIES, COOKIES, TARTS, AND CANDY (U.S. CL. 46).

JOHN WILKE, EXAMINING ATTORNEY

SN 85-508,166. NUTS ABOUT GRANOLA, LLC, YORK, PA. FILED 1-4-2012.

Granola Basics

THE MARK CONSISTS OF STANDARD CHARACTERS WITHOUT CLAIM TO ANY PARTICULAR FONT, STYLE, SIZE, OR COLOR.

NO CLAIM IS MADE TO THE EXCLUSIVE RIGHT TO USE "GRANOLA", APART FROM THE MARK AS SHOWN. FOR GRANOLA (U.S. CL. 46).

ANTHONY RINKER, EXAMINING ATTORNEY

CLASS 30—(Continued).

SN 85-509,242. WESTERN RICE MILLS LTD., RICHMOND, BC, CANADA, FILED 1-5-2012.

TEXANA

THE MARK CONSISTS OF STANDARD CHARACTERS WITHOUT CLAIM TO ANY PARTICULAR FONT, STYLE, SIZE, OR COLOR.

PRIORITY CLAIMED UNDER SEC. 44(D) ON CANADA APPLICATION NO. 1,534,479, FILED 7-6-2011.

FOR (BASED ON USE AND FOREIGN APPLICATION) RICE; (BASED ON INTENT TO USE AND FOREIGN APPLICATION) PROCESSED WHOLE WHEAT GRAINS BEING UNCOOKED (U.S. CL. 46).

FIRST USE 12-31-1966; IN COMMERCE 2-28-2002.

TINA MAI, EXAMINING ATTORNEY

SN 85-509,493. MARS, INCORPORATED, MCLEAN, VA. FILED 1-5-2012.

DOVE NOT ONLY TASTES GOOD,
IT DOES GOOD

THE MARK CONSISTS OF STANDARD CHARACTERS WITHOUT CLAIM TO ANY PARTICULAR FONT, STYLE, SIZE, OR COLOR.

OWNER OF U.S. REG. NOS. 1,415,202, 3,664,207 AND OTHERS.

FOR CANDY (U.S. CL. 46).

MICHAEL ENGEL, EXAMINING ATTORNEY

SN 85-509,534. ACTIUM LLC, UPPER MONTCLAIR, NJ. FILED 1-5-2012.

THUMB BREAD

THE MARK CONSISTS OF STANDARD CHARACTERS WITHOUT CLAIM TO ANY PARTICULAR FONT, STYLE, SIZE, OR COLOR.

NO CLAIM IS MADE TO THE EXCLUSIVE RIGHT TO USE "BREAD", APART FROM THE MARK AS SHOWN.

FOR BREAD (U.S. CL. 46).

FIRST USE 2-1-2007; IN COMMERCE 2-1-2007.

MARK SPARACINO, EXAMINING ATTORNEY

CLASS 30—(Continued).

SN 85-509,576. ACTIUM LLC, UPPER MONTCLAIR, NJ. FILED 1-5-2012.

PITA-STACKERS

THE MARK CONSISTS OF STANDARD CHARACTERS WITHOUT CLAIM TO ANY PARTICULAR FONT, STYLE, SIZE, OR COLOR.

FOR SANDWICHES (U.S. CL. 46).

FIRST USE 2-1-2007; IN COMMERCE 2-1-2007.

MARK SPARACINO, EXAMINING ATTORNEY

SN 85-510,253. LAFAYETTE CAFE INC., SHELBY, NC. FILED 1-6-2012.



THE MARK CONSISTS OF A CHEF TO THE LEFT OF THE WORDS "SHELBY CAFE". WITH THE LETTERS "HELBY" IN "SHELBY" UNDERLINED AND "CAFE" BELOW THE UNDERLINE.

FOR MARINADES; SAUCES (U.S. CL. 46).

CHRIS WELLS, EXAMINING ATTORNEY

SN 85-510,292. PICO PLATA AVV, LIMITED, CORAL GABLES, FL. FILED 1-6-2012.

GR-5

THE MARK CONSISTS OF STANDARD CHARACTERS WITHOUT CLAIM TO ANY PARTICULAR FONT, STYLE, SIZE, OR COLOR.

FOR GRANOLA (U.S. CL. 46).

AMY KERTGATE, EXAMINING ATTORNEY

CLASS 30—(Continued).

SN 85-510,370. KITTY'S KUBANO, LLC, CHARLESTON, SC.
FILED 1-6-2012.

Lucky #1 Sub

THE MARK CONSISTS OF STANDARD CHARACTERS WITHOUT CLAIM TO ANY PARTICULAR FONT, STYLE, SIZE, OR COLOR.
NO CLAIM IS MADE TO THE EXCLUSIVE RIGHT TO USE "#1 SUB", APART FROM THE MARK AS SHOWN.
FOR SANDWICHES (U.S. CL. 46).
FIRST USE 6-5-2010; IN COMMERCE 6-5-2010.
JENNIFER WILLISTON, EXAMINING ATTORNEY

CLASS 30—(Continued).

SN 85-510,715. DOUMAK INC., ELK GROVE VILLAGE, IL.
FILED 1-6-2012.

ROCKY MOUNTAIN

THE MARK CONSISTS OF STANDARD CHARACTERS WITHOUT CLAIM TO ANY PARTICULAR FONT, STYLE, SIZE, OR COLOR.
FOR MARSHMALLOWS (U.S. CL. 46).
FIRST USE 7-2-1997; IN COMMERCE 7-2-1997.
MARK SPARACINO, EXAMINING ATTORNEY

SN 85-510,409. SHRIL PATEL, ROUND ROCK, TX. FILED 1-6-2012.

FASAL

THE MARK CONSISTS OF STANDARD CHARACTERS WITHOUT CLAIM TO ANY PARTICULAR FONT, STYLE, SIZE, OR COLOR.
THE ENGLISH TRANSLATION OF "FASAL" IN THE MARK IS "CROP".
FOR FLOUR; FOOD FLAVOURINGS; PROCESSED HERBS; PROCESSED WHEAT; SPICES (U.S. CL. 46).
FIRST USE 12-1-2009; IN COMMERCE 12-1-2009.
MATTHEW PAPPAS, EXAMINING ATTORNEY

SN 85-511,003. BMTB, LLC, DBA BLACKSMITH COFFEE ROASTERY, LINDSBORG, KS. FILED 1-6-2012.

Blacksmith Coffee

THE MARK CONSISTS OF STANDARD CHARACTERS WITHOUT CLAIM TO ANY PARTICULAR FONT, STYLE, SIZE, OR COLOR.
NO CLAIM IS MADE TO THE EXCLUSIVE RIGHT TO USE "COFFEE", APART FROM THE MARK AS SHOWN.
FOR PREMIUM ROASTED COFFEES (U.S. CL. 46).
FIRST USE 11-1-2008; IN COMMERCE 12-1-2008.
LINDA M. KING, EXAMINING ATTORNEY

SN 85-510,607. KEVIN VICKERY, KENNARD, IN. FILED 1-6-2012.

VICKERY

THE MARK CONSISTS OF STANDARD CHARACTERS WITHOUT CLAIM TO ANY PARTICULAR FONT, STYLE, SIZE, OR COLOR.
OWNER OF U.S. REG. NO. 3,161,204.
SEC. 2(F).
FOR CANDY (U.S. CL. 46).
FIRST USE 6-13-2006; IN COMMERCE 6-13-2006.
DANIEL CAPSHAW, EXAMINING ATTORNEY

SN 85-511,176. BRYAN EHRENHOLM, RIVERBANK, CA.
FILED 1-7-2012.

PURE JOY

THE MARK CONSISTS OF STANDARD CHARACTERS WITHOUT CLAIM TO ANY PARTICULAR FONT, STYLE, SIZE, OR COLOR.
FOR BAKERY DESSERTS; BAKERY GOODS; BAKERY PRODUCTS (U.S. CL. 46).
BRIAN NEVILLE, EXAMINING ATTORNEY

CLASS 30—(Continued).

SN 85-511,311. JONES BAKERY, DAVIS, CA. FILED 1-8-2012.

Good Cookie, Good Time

THE MARK CONSISTS OF STANDARD CHARACTERS WITHOUT CLAIM TO ANY PARTICULAR FONT, STYLE, SIZE, OR COLOR.

FOR COOKIES AND CRACKERS (U.S. CL. 46).
FIRST USE 12-9-2007; IN COMMERCE 12-9-2007.
JUDITH HELFMAN, EXAMINING ATTORNEY

CLASS 30—(Continued).

SN 85-512,204. CREATA MACAO COMMERCIAL OFFSHORE LIMITED, MACAU, MACAO, FILED 1-9-2012.

PURE BLAST

THE MARK CONSISTS OF STANDARD CHARACTERS WITHOUT CLAIM TO ANY PARTICULAR FONT, STYLE, SIZE, OR COLOR.

FOR CONFECTIONERY, NAMELY, CANDY AND GUMMY CANDY (U.S. CL. 46).
LESLEY LAMOTHE, EXAMINING ATTORNEY

SN 85-511,431. FOSTER POULTRY FARMS, DBA FOSTER FARMS, LIVINGSTON, CA. FILED 1-9-2012.

GRAB WRAPS

THE MARK CONSISTS OF STANDARD CHARACTERS WITHOUT CLAIM TO ANY PARTICULAR FONT, STYLE, SIZE, OR COLOR.

NO CLAIM IS MADE TO THE EXCLUSIVE RIGHT TO USE "WRAPS", APART FROM THE MARK AS SHOWN.
FOR SANDWICHES; SANDWICH WRAPS (U.S. CL. 46).
PATRICIA EVANKO, EXAMINING ATTORNEY

SN 85-512,225. JIMMY JOHN'S ENTERPRISES, LLC, CHAMPAIGN, IL. FILED 1-9-2012.

SKINNY JIMMY

THE MARK CONSISTS OF STANDARD CHARACTERS WITHOUT CLAIM TO ANY PARTICULAR FONT, STYLE, SIZE, OR COLOR.

OWNER OF U.S. REG. NO. 2,959,439.
FOR SANDWICHES (U.S. CL. 46).
JORDAN BAKER, EXAMINING ATTORNEY

SN 85-511,838. CHOCO BANANA LLC, HOUSTON, TX. FILED 1-9-2012.

CHOCOBANANA

THE MARK CONSISTS OF STANDARD CHARACTERS WITHOUT CLAIM TO ANY PARTICULAR FONT, STYLE, SIZE, OR COLOR.

FOR CHOCOLATE COVERED FRUIT (U.S. CL. 46).
CHRISTOPHER BUONGIORNO, EXAMINING ATTORNEY

SN 85-512,230. JIMMY JOHN'S ENTERPRISES, LLC, CHAMPAIGN, IL. FILED 1-9-2012.

SKINNY MINI JIMMY

THE MARK CONSISTS OF STANDARD CHARACTERS WITHOUT CLAIM TO ANY PARTICULAR FONT, STYLE, SIZE, OR COLOR.

OWNER OF U.S. REG. NOS. 2,555,213 AND 2,661,985.
FOR SANDWICHES (U.S. CL. 46).
JORDAN BAKER, EXAMINING ATTORNEY

CLASS 30—(Continued).

SN 85-512,312. PWN HOLDINGS PTY LTD, MELBOURNE, AUSTRALIA, FILED 1-9-2012.

PWN

THE MARK CONSISTS OF STANDARD CHARACTERS WITHOUT CLAIM TO ANY PARTICULAR FONT, STYLE, SIZE, OR COLOR.
 FOR CHEWING GUM (U.S. CL. 46).
 FIRST USE 1-5-2012; IN COMMERCE 1-5-2012.
 RUSS HERMAN, EXAMINING ATTORNEY



SN 85-512,326. SARTORE, KRISTIN, DBA THE CONFECTION OVEN, POWAY, CA. FILED 1-9-2012.

the CONFECTION OVEN

THE MARK CONSISTS OF STANDARD CHARACTERS WITHOUT CLAIM TO ANY PARTICULAR FONT, STYLE, SIZE, OR COLOR.
 FOR BAKED GOODS, NAMELY, CRUMBLES; CARAMELS; MACARONS (U.S. CL. 46).
 FIRST USE 12-5-2011; IN COMMERCE 12-15-2011.
 TASHIA BUNCH, EXAMINING ATTORNEY

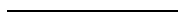

SN 85-512,766. FREEMAN, ERIC D., NAPA, CA. FILED 1-10-2012.

STEEMIN' FREEMAN

THE MARK CONSISTS OF STANDARD CHARACTERS WITHOUT CLAIM TO ANY PARTICULAR FONT, STYLE, SIZE, OR COLOR.
 FOR SAUCES (U.S. CL. 46).
 FIRST USE 11-25-2011; IN COMMERCE 11-25-2011.
 GISELLE AGOSTO, EXAMINING ATTORNEY

CLASS 30—(Continued).

SN 85-513,288. GRATIA LLC, MORRISTOWN, NJ. FILED 1-10-2012.

GRATIA SPICE CO.

THE MARK CONSISTS OF STANDARD CHARACTERS WITHOUT CLAIM TO ANY PARTICULAR FONT, STYLE, SIZE, OR COLOR.
 NO CLAIM IS MADE TO THE EXCLUSIVE RIGHT TO USE "SPICE CO.", APART FROM THE MARK AS SHOWN. THE ENGLISH TRANSLATION OF "GRATIA" IN THE MARK IS "GRACE".
 FOR DRIED SPICES AND HERBS (U.S. CL. 46).
 DEBORAH LOBO, EXAMINING ATTORNEY



SN 85-513,291. GRATIA LLC, MORRISTOWN, NJ. FILED 1-10-2012.



NO CLAIM IS MADE TO THE EXCLUSIVE RIGHT TO USE "SPICE CO.", APART FROM THE MARK AS SHOWN.
 THE COLOR(S) LIGHT GREEN, WHITE, BROWN, LIGHT BROWN AND DARK BROWN IS/ARE CLAIMED AS A FEATURE OF THE MARK.
 THE MARK CONSISTS OF THE WORD "GRATIA" IN STYLIZED UPPER CASE LETTERS COLORED WHITE WITH DARK BROWN SHADOWS AND LIGHT BROWN CONTOUR LINES; UNDERNEATH THE WORD "GRATIA" IS THE WORD "SPICE" IN STYLIZED UPPER CASE LETTERS COLORED WHITE WITH DARK BROWN SHADOWS; UNDERNEATH THE WORD "SPICE" IS THE WORD "CO" HAVING THE LETTER "C" IN STYLIZED UPPER CASE AND THE LETTER "O" IN STYLIZED LOWER CASE AND UNDERLINED, WITH THE LETTERS COLORED WHITE WITH DARK BROWN SHADOWS; ABOVE THE WORDS ARE THREE LIGHT GREEN LEAVES WITH DARK BROWN VEINS HAVING LIGHT BROWN SHADOWS; THE WORDS AND LEAVES ARE ENTIRELY ENCLOSED WITHIN A FOUR LEAF CLOVER SHAPE WITH A STRIPED BROWN BACKGROUND AND A TRI-COLOR BORDER HAVING A DARK BROWN OUTERMOST EDGE, A LIGHT BROWN MIDDLE AND A WHITE INNERMOST EDGE.
 THE ENGLISH TRANSLATION OF "GRATIA" IN THE MARK IS "GRACE".
 FOR DRIED SPICES AND HERBS (U.S. CL. 46).
 DEBORAH LOBO, EXAMINING ATTORNEY

CLASS 30—(Continued).

SN 85-513,987. KONA ICE, INC., FLORENCE, KY. FILED 1-11-2012.



THE COLOR(S) YELLOW, BLUE, GRAY, WHITE AND BROWN IS/ARE CLAIMED AS A FEATURE OF THE MARK.

THE MARK CONSISTS OF A YELLOW SUN ENCIRCLED IN A BROWN RING WITH BROWN EYEBROWS UNDER SHADED IN YELLOW WITH YELLOW AND WHITE EYES OUTLINED IN GRAY WEARING BLUE SQUARED SPECTACLES FRAMED IN BROWN WITH A BROWN SMILE.

FOR FLAVORED ICES (U.S. CL. 46).
FIRST USE 3-1-2009; IN COMMERCE 3-1-2009.
CAROLYN CATALDO, EXAMINING ATTORNEY

SN 85-514,045. SWEETPUZZLES, LLC, DORAL, FL. FILED 1-11-2012.

SWEETPUZZLES

THE MARK CONSISTS OF STANDARD CHARACTERS WITHOUT CLAIM TO ANY PARTICULAR FONT, STYLE, SIZE, OR COLOR.

FOR CHOCOLATE; CHOCOLATE BARS; CHOCOLATE CANDIES; CHOCOLATE CONFECTIONS; CHOCOLATE COVERED COOKIES; COOKIES (U.S. CL. 46).

MICHAEL WIENER, EXAMINING ATTORNEY

CLASS 30—(Continued).

SN 85-514,636. GENERAL MILLS IP HOLDINGS I, LLC, MINNEAPOLIS, MN. FILED 1-12-2012.

CHEERIOS MEDLEY CRUNCH

THE MARK CONSISTS OF STANDARD CHARACTERS WITHOUT CLAIM TO ANY PARTICULAR FONT, STYLE, SIZE, OR COLOR.

OWNER OF U.S. REG. NOS. 414,338, 1,734,860 AND OTHERS.

NO CLAIM IS MADE TO THE EXCLUSIVE RIGHT TO USE "MEDLEY", APART FROM THE MARK AS SHOWN.

FOR PROCESSED CEREAL-BASED FOOD TO BE USED AS A BREAKFAST FOOD, SNACK FOOD OR INGREDIENT FOR MAKING OTHER FOODS (U.S. CL. 46).

RAUL CORDOVA, EXAMINING ATTORNEY

SN 85-515,382. FAIRYTALE BROWNIES, INC., PHOENIX, AZ. FILED 1-12-2012.

FAIRYTALE BAKERY

THE MARK CONSISTS OF STANDARD CHARACTERS WITHOUT CLAIM TO ANY PARTICULAR FONT, STYLE, SIZE, OR COLOR.

OWNER OF U.S. REG. NOS. 2,555,642, 3,212,350 AND OTHERS.

NO CLAIM IS MADE TO THE EXCLUSIVE RIGHT TO USE "BAKERY", APART FROM THE MARK AS SHOWN.

FOR BAKERY GOODS, NAMELY BAKED DESSERT CONFECTIONS IN THE NATURE OF BROWNIES, CHOCOLATE-COATED BROWNIES, COOKIES, BLONDIES, CAKES, CUPCAKES, MUFFINS, DESSERT BREADS, COOKIE SANDWICHES, COOKIE BARS, CAKE BARS, FRUIT BARS, AND NUT BARS; GIFT PACKAGES AND CUSTOM GIFT PACKAGES CONSISTING PRIMARILY OF DESSERT CONFECTIONS AND/OR OTHER SPECIALTY FOOD AND BEVERAGE ITEMS (U.S. CL. 46).

BRIAN NEVILLE, EXAMINING ATTORNEY

SN 85-515,628. OTERO, MARIA, DBA FLANTASTIC DESERTS, WHITTIER, CA. FILED 1-13-2012.

Flantastic

THE MARK CONSISTS OF STANDARD CHARACTERS WITHOUT CLAIM TO ANY PARTICULAR FONT, STYLE, SIZE, OR COLOR.

FOR FLAN (U.S. CL. 46).

FIRST USE 1-9-2009; IN COMMERCE 5-30-2010.

DAVID MURRAY, EXAMINING ATTORNEY

CLASS 30—(Continued).

SN 85-515,671. CINNABON, INC., ATLANTA, GA. FILED 1-13-2012.

CINNAPACK

THE MARK CONSISTS OF STANDARD CHARACTERS WITHOUT CLAIM TO ANY PARTICULAR FONT, STYLE, SIZE, OR COLOR.

OWNER OF U.S. REG. NOS. 1,424,169 AND 2,304,346. FOR BAKERY GOODS (U.S. CL. 46). JULIE GUTTADAURO, EXAMINING ATTORNEY

SN 85-515,801. SUN COUNTRY FOODS, INC., NORWOOD, MA. FILED 1-13-2012.

SUN COUNTRY

THE MARK CONSISTS OF STANDARD CHARACTERS WITHOUT CLAIM TO ANY PARTICULAR FONT, STYLE, SIZE, OR COLOR.

OWNER OF U.S. REG. NO. 3,223,132. FOR WHEAT GERM FOR HUMAN CONSUMPTION; PROCESSED BRAN (U.S. CL. 46). BRIDGETT SMITH, EXAMINING ATTORNEY

SN 85-515,827. E. BRUCE WEISS, DENVER, CO. FILED 1-13-2012.

H2O

THE MARK CONSISTS OF STANDARD CHARACTERS WITHOUT CLAIM TO ANY PARTICULAR FONT, STYLE, SIZE, OR COLOR.

FOR BREAKFAST CEREALS (U.S. CL. 46). JENNY PARK, EXAMINING ATTORNEY

CLASS 30—(Continued).

SN 85-515,899. PEPSICO, INC., PURCHASE, NY. FILED 1-13-2012.

PALETIUX

THE MARK CONSISTS OF STANDARD CHARACTERS WITHOUT CLAIM TO ANY PARTICULAR FONT, STYLE, SIZE, OR COLOR.

FOR CANDY (U.S. CL. 46). JENNIFER VASQUEZ, EXAMINING ATTORNEY

SN 85-515,906. E. BRUCE WEISS, DENVER, CO. FILED 1-13-2012.

H2.0

THE MARK CONSISTS OF STANDARD CHARACTERS WITHOUT CLAIM TO ANY PARTICULAR FONT, STYLE, SIZE, OR COLOR.

FOR BREAKFAST CEREALS (U.S. CL. 46). JENNY PARK, EXAMINING ATTORNEY

SN 85-516,103. ALQUIROS, LEO, MONROE, NJ. FILED 1-13-2012.

ISLAND MELT

THE MARK CONSISTS OF STANDARD CHARACTERS WITHOUT CLAIM TO ANY PARTICULAR FONT, STYLE, SIZE, OR COLOR.

FOR BAKERY PRODUCTS (U.S. CL. 46). MARK SHINER, EXAMINING ATTORNEY

SN 85-522,775. MARS, INCORPORATED, MCLEAN, VA. FILED 1-23-2012.

MAGIC IN THE DARK

THE MARK CONSISTS OF STANDARD CHARACTERS WITHOUT CLAIM TO ANY PARTICULAR FONT, STYLE, SIZE, OR COLOR.

FOR CANDY (U.S. CL. 46). MICHAEL ENGEL, EXAMINING ATTORNEY

CLASS 30—(Continued).

SN 85-526,500. WESTERN RICE MILLS LTD., RICHMOND, BC, CANADA, FILED 1-26-2012.



NO CLAIM IS MADE TO THE EXCLUSIVE RIGHT TO USE "FOODS", APART FROM THE MARK AS SHOWN.

THE MARK CONSISTS OF A IMAGE OF THE GLOBE WITH THE WORD "PLANET" OVER THE MIDDLE OF THE GLOBE AND THE WORD "THIRD" AROUND THE OUTER TOP HALF AND THE WORD "FOODS" AROUND THE BOTTOM HALF.

FOR RICE (U.S. CL. 46).

FIRST USE 12-31-1996; IN COMMERCE 12-31-1997.

TINA MAI, EXAMINING ATTORNEY

SN 85-561,668. AMERICAN ITALIAN PASTA COMPANY, KANSAS CITY, MO. FILED 3-6-2012.

RONCO

THE MARK CONSISTS OF STANDARD CHARACTERS WITHOUT CLAIM TO ANY PARTICULAR FONT, STYLE, SIZE, OR COLOR.

OWNER OF U.S. REG. NO. 1,063,465.

THE WORDING "RONCO" HAS NO MEANING IN A FOREIGN LANGUAGE.

FOR PASTA (U.S. CL. 46).

FIRST USE 1-1-1935; IN COMMERCE 1-1-1935.

BARBARA BROWN, EXAMINING ATTORNEY

SN 85-578,488. HEB GROCERY COMPANY LP, SAN ANTONIO, TX. FILED 3-23-2012.

H-E-B WHOPIE OF A COOKIE

THE MARK CONSISTS OF STANDARD CHARACTERS WITHOUT CLAIM TO ANY PARTICULAR FONT, STYLE, SIZE, OR COLOR.

FOR COOKIES (U.S. CL. 46).

JUDITH HELFMAN, EXAMINING ATTORNEY

CLASS 30—(Continued).

SN 85-584,092. JJ'S SWEETS, BOULDER, CO. FILED 3-29-2012.

Cocomels

THE MARK CONSISTS OF STANDARD CHARACTERS WITHOUT CLAIM TO ANY PARTICULAR FONT, STYLE, SIZE, OR COLOR.

FOR CARAMELS (U.S. CL. 46).

FIRST USE 3-1-2010; IN COMMERCE 4-3-2010.

MARK SPARACINO, EXAMINING ATTORNEY

SN 85-588,565. COSTA RICAN GOLD COFFEE COMPANY, DBA GOLD COFFEE COMPANY, JUPITER, FL. FILED 4-4-2012.



NO CLAIM IS MADE TO THE EXCLUSIVE RIGHT TO USE "RAINFOREST", APART FROM THE MARK AS SHOWN.

THE MARK CONSISTS OF THE STYLIZED WORDING "RAINFOREST GOLD" WITHIN AN OVAL BACKGROUND, WITH A SINGLE LEAF APPEARING ABOVE THE WORD "RAINFOREST".

FOR COFFEE; COFFEE BEANS; GROUND COFFEE BEANS (U.S. CL. 46).

FIRST USE 12-1-2011; IN COMMERCE 12-1-2011.

ANDREW LEASER, EXAMINING ATTORNEY

CLASS 31—NATURAL AGRICULTURAL PRODUCTS

SN 77-854,013. UNI-CHARM CORPORATION, EHIME-KEN, JAPAN, FILED 10-21-2009.

UNICHARM

THE MARK CONSISTS OF STANDARD CHARACTERS WITHOUT CLAIM TO ANY PARTICULAR FONT, STYLE, SIZE, OR COLOR.

OWNER OF JAPAN REG. NO. 5456324, DATED 12-9-2011, EXPIRES 12-9-2021.

OWNER OF U.S. REG. NO. 2,790,177.

FOR PET FOOD; ANIMAL LITTER (U.S. CLS. 1 AND 46).

LINDA ESTRADA, EXAMINING ATTORNEY

CLASS 31—(Continued).

SN 79-102,161. DOGGY KITCHEN AG, CH-6403 KÜSS-
NACHT AM RIGI, SWITZERLAND, FILED 7-13-2011.



PRIORITY DATE OF 2-10-2011 IS CLAIMED.
OWNER OF INTERNATIONAL REGISTRATION 1089735
DATED 7-13-2011, EXPIRES 7-13-2021.

THE MARK CONSISTS OF THE WORDING "DOGGY-
KITCHEN NUR DAS BESTE FÜR IHREN HUND" REPRE-
SENTED IN STYLIZED FONT WITH A SILHOUETTE OF A
DOG TO THE LEFT OF THE WORDING.

THE ENGLISH TRANSLATION OF "NUR DAS BESTE
FÜR IHREN HUND" IN THE MARK IS "ONLY THE BEST
FOR YOUR DOG".

FOR PET FOOD, NAMELY, DOG SNACKS BASED ON
DRIED BEEF, CALF AND PIG MEAT (U.S. CLS. 1 AND
46).

WARREN L. OLANDRIA, EXAMINING ATTORNEY

CLASS 31—(Continued).

SN 85-353,173. MIDWESTERN PET FOODS, INC., EVANS-
VILLE, IN. FILED 6-22-2011.

ADULT VANTAGE

THE MARK CONSISTS OF STANDARD CHARACTERS
WITHOUT CLAIM TO ANY PARTICULAR FONT, STYLE,
SIZE, OR COLOR.

OWNER OF U.S. REG. NO. 3,975,782.

NO CLAIM IS MADE TO THE EXCLUSIVE RIGHT TO
USE "ADULT", APART FROM THE MARK AS SHOWN.

FOR DOG FOOD (U.S. CLS. 1 AND 46).

FIRST USE 5-6-2009; IN COMMERCE 5-6-2009.

ROBIN MITTLER, EXAMINING ATTORNEY

SN 85-261,337. SAGE FRUIT COMPANY, LLC, YAKIMA,
WA. FILED 3-8-2011.



THE COLOR(S) RED, BLUE AND WHITE. IS/ARE
CLAIMED AS A FEATURE OF THE MARK.

THE MARK CONSISTS OF THE WORDS "SUPER TREAT"
IN THE COLOR WHITE, LOCATED INSIDE A BLUE
RECTANGLE WITH A WHITE LINE AROUND THE
BORDER OF THE RECTANGLE; A RED "VF", OUTLINED IN
BLUE IS LOCATED IN THE CENTER OF THE TOP
BORDER OF THE RECTANGLE.

FOR FRESH FRUIT (U.S. CLS. 1 AND 46).

FIRST USE 8-0-1982; IN COMMERCE 8-0-1982.

CARRIE GENOVESE, EXAMINING ATTORNEY

SN 85-360,045. FRANK J. KIEFER III, INDIANAPOLIS, IN.
FILED 6-29-2011.

POO-CHI SUSHI

THE MARK CONSISTS OF STANDARD CHARACTERS
WITHOUT CLAIM TO ANY PARTICULAR FONT, STYLE,
SIZE, OR COLOR.

FOR PET FOOD AND TREATS (U.S. CLS. 1 AND 46).

BRENDAN REGAN, EXAMINING ATTORNEY

SN 85-323,185. SUNBURST FARMS, INC., MIAMI, FL. FILED
5-17-2011.

SUNBURST FARMS

THE MARK CONSISTS OF STANDARD CHARACTERS
WITHOUT CLAIM TO ANY PARTICULAR FONT, STYLE,
SIZE, OR COLOR.

NO CLAIM IS MADE TO THE EXCLUSIVE RIGHT TO
USE "FARMS", APART FROM THE MARK AS SHOWN.

FOR CUT FLOWERS (U.S. CLS. 1 AND 46).

VERNA BETH RIRIE, EXAMINING ATTORNEY

SN 85-370,378. KLAMATH ALGAE PRODUCTS, INC., KLA-
MATH FALLS, OR. FILED 7-13-2011.

E3LIVE FOR HORSES

THE MARK CONSISTS OF STANDARD CHARACTERS
WITHOUT CLAIM TO ANY PARTICULAR FONT, STYLE,
SIZE, OR COLOR.

OWNER OF U.S. REG. NOS. 2,516,939 AND 3,549,801.

NO CLAIM IS MADE TO THE EXCLUSIVE RIGHT TO
USE "FOR HORSES", APART FROM THE MARK AS
SHOWN.

FOR HORSE FEED (U.S. CLS. 1 AND 46).

FIRST USE 9-1-1998; IN COMMERCE 9-1-1998.

ALEX KEAM, EXAMINING ATTORNEY

CLASS 31—(Continued).

SN 85-398,554. FRANK J. KIEFER III, INDIANAPOLIS, IN. FILED 8-15-2011.



THE MARK CONSISTS OF A SQUARE FIGURE CONTAINING A CIRCULAR FIGURE SHOWING A PAW PRINT WITH THE TERMS "POO-CHI SUSHI A LITTLE BLISS IN EVERY BITE".

FOR PET FOOD AND TREATS (U.S. CLS. 1 AND 46).
BRENDAN REGAN, EXAMINING ATTORNEY

SN 85-408,267. PENNINGTON SEED, INC. OF NEBRASKA, MADISON, GA. FILED 8-26-2011.



THE MARK CONSISTS OF THE STYLIZED LETTERS AND NUMBER "QUIKGROW2X." THE STEM OF THE LETTER "Q" EXTENDS AND CURVES UNDER THE LETTER "U". THE UPPER STEM OF THE LETTER "K" EXTENDS OVER THE LETTER "G" AND THE "2X" IS SLIGHTLY LOWERED FROM THE PRECEDING STYLIZED CHARACTERS.

FOR GRASS SEED ADDITIVE SOLD ONLY AS APPLIED TO AND AS AN INTEGRAL COMPONENT OF THE SEED (U.S. CLS. 1 AND 46).

MARLENE BELL, EXAMINING ATTORNEY

SN 85-476,507. ROME POINT LLC, WARWICK, RI. FILED 11-18-2011.

GOOSENECK

THE MARK CONSISTS OF STANDARD CHARACTERS WITHOUT CLAIM TO ANY PARTICULAR FONT, STYLE, SIZE, OR COLOR.

FOR LIVE OYSTERS (U.S. CLS. 1 AND 46).
FIRST USE 6-7-2008; IN COMMERCE 6-7-2008.
ANDREA K. NADELMAN, EXAMINING ATTORNEY

CLASS 31—(Continued).

SN 85-476,516. ROME POINT LLC, WARWICK, RI. FILED 11-18-2011.

WILD GOOSE

THE MARK CONSISTS OF STANDARD CHARACTERS WITHOUT CLAIM TO ANY PARTICULAR FONT, STYLE, SIZE, OR COLOR.

FOR LIVE OYSTERS (U.S. CLS. 1 AND 46).
FIRST USE 2-2-2008; IN COMMERCE 2-2-2008.
ANDREA K. NADELMAN, EXAMINING ATTORNEY

SN 85-476,526. ROME POINT LLC, WARWICK, RI. FILED 11-18-2011.

ROME POINT

THE MARK CONSISTS OF STANDARD CHARACTERS WITHOUT CLAIM TO ANY PARTICULAR FONT, STYLE, SIZE, OR COLOR.

FOR LIVE OYSTERS (U.S. CLS. 1 AND 46).
FIRST USE 5-5-2003; IN COMMERCE 5-5-2003.
ANDREA K. NADELMAN, EXAMINING ATTORNEY

CLASS 31—(Continued).

SN 85-482,933. KANG LONG GROUP CORP., POMONA, CA.
FILED 11-29-2011.



叶氏康松

OWNER OF U.S. REG. NO. 2,268,856.

THE MARK CONSISTS OF THE LETTER "K" AND THE DESIGN AS SHOWN IN THE DRAWING. THERE IS A GLOBE AND WITHIN THE GLOBE IS THE LETTER "K". THE TOP LEFT PORTION OF THE "K" IS COMPRISED OF STARS AND THE REMAINDER OF THE "K" IS COMPRISED OF STRIPES. THE NON-ENGLISH CHARACTERS DEPICTED AT THE BOTTOM OF THE GLOBE DESIGN ARE YE SHI KANG SONG WHICH TRANSLATES AS FOLLOWS: YE SHI MEANS THE FAMILY NAME, KANG MEANS HEALTHY, AND SONG MEANS PINE.

THE NON-LATIN CHARACTERS TRANSLITERATE TO "YE SHI KANG SONG" WHICH TRANSLATES AS FOLLOWS "YE SHI" MEANS "THE FAMILY NAME", "KANG" MEANS "HEALTHY", AND "SONG" MEANS "PINE".

FOR UNPROCESSED HERBS, NAMELY, CULTIVATED AND WILD GINSENG ROOTS; CULTIVATED AND WILD GINSENG SEEDS (U.S. CLS. 1 AND 46).

FIRST USE 5-0-2005; IN COMMERCE 5-0-2005.

BRENDAN MCCAULEY, EXAMINING ATTORNEY

SN 85-483,552. FRONT PORCH FARM LLC, MILL VALLEY, CA. FILED 11-30-2011.

CINTA SONOMA

THE MARK CONSISTS OF STANDARD CHARACTERS WITHOUT CLAIM TO ANY PARTICULAR FONT, STYLE, SIZE, OR COLOR.

NO CLAIM IS MADE TO THE EXCLUSIVE RIGHT TO USE "SONOMA", APART FROM THE MARK AS SHOWN.

THE ENGLISH TRANSLATION OF "CINTA" IN THE MARK IS "RIBBON".

FOR LIVESTOCK, NAMELY, PIGS (U.S. CLS. 1 AND 46).

RUSS HERMAN, EXAMINING ATTORNEY

CLASS 31—(Continued).

SN 85-487,274. OMS INVESTMENTS, INC., LOS ANGELES, CA. FILED 12-5-2011.

NATURE'S CARE

THE MARK CONSISTS OF STANDARD CHARACTERS WITHOUT CLAIM TO ANY PARTICULAR FONT, STYLE, SIZE, OR COLOR.

OWNER OF U.S. REG. NOS. 3,250,568 AND 3,375,928.

FOR SEEDS FOR PLANTING, NAMELY, GRASS SEED, LAWN SEED, FLOWER SEEDS, VEGETABLE SEEDS, PLANT SEEDS; GRASS PRODUCTS, NAMELY, GRASS SOD AND GRASS PLUGS; LIVE PLANTS; TOP SOIL; PEAT MOSS; RAW BARK, NAMELY, PINE BARK AND PINE NUGGETS; MULCH; WILD BIRD FOOD (U.S. CLS. 1 AND 46).

ROBIN MITTLER, EXAMINING ATTORNEY

SN 85-494,995. QUALITY FRESH TROPICALS, CORP, MIAMI, FL. FILED 12-14-2011.



NO CLAIM IS MADE TO THE EXCLUSIVE RIGHT TO USE "QUALITY FRESH TROPICALS", APART FROM THE MARK AS SHOWN.

THE COLOR(S) GREEN, YELLOW, BROWN, RED, ORANGE, PURPLE AND WHITE IS/ARE CLAIMED AS A FEATURE OF THE MARK.

THE MARK CONSISTS OF THE WORDS "QUALITY FRESH TROPICALS" IN GREEN BELOW A GREEN OVAL WITH A YELLOW BACKGROUND CONTAINING PICTURES OF VARIOUS FRUITS AND VEGETABLES INCLUDING A PINEAPPLE IN BROWN, YELLOW AND GREEN, A TOMATO IN RED AND GREEN, GREEN LIMES, A GREEN AND YELLOW SQUASH, GREENISH YELLOW BANANAS, BROWN AND WHITE POTATOES, AN ONION IN WHITE AND PURPLE, AN ORANGE IN THE COLOR ORANGE, AND PURPLE GRAPES.

FOR RAW FRUITS; RAW VEGETABLES; UNPROCESSED FRUITS; UNPROCESSED VEGETABLES (U.S. CLS. 1 AND 46).

CARRIE GENOVESE, EXAMINING ATTORNEY

CLASS 31—(Continued).

SN 85-496,024. MATTOON RURAL KING SUPPLY, INC.,
MATTOON, IL. FILED 12-15-2011.

MIDWEST ADVANTAGE

THE MARK CONSISTS OF STANDARD CHARACTERS
WITHOUT CLAIM TO ANY PARTICULAR FONT, STYLE,
SIZE, OR COLOR.

NO CLAIM IS MADE TO THE EXCLUSIVE RIGHT TO
USE "MIDWEST", APART FROM THE MARK AS SHOWN.
FOR FEED FOR LIVESTOCK AND POULTRY (U.S.
CLS. 1 AND 46).

DOMINIC J. FERRAIUOLO, EXAMINING ATTORNEY

SN 85-497,798. RUSH DIRECT, INC, WOOD DALE, IL. FILED
12-16-2011.

Ferrera Farms Naturals

THE MARK CONSISTS OF STANDARD CHARACTERS
WITHOUT CLAIM TO ANY PARTICULAR FONT, STYLE,
SIZE, OR COLOR.

NO CLAIM IS MADE TO THE EXCLUSIVE RIGHT TO
USE "FARMS NATURALS", APART FROM THE MARK AS
SHOWN.

FOR DOG TREATS; EDIBLE CHEWS FOR DOGS (U.S.
CLS. 1 AND 46).
FIRST USE 2-1-2008; IN COMMERCE 2-1-2008.

KATHERINE E. HALMEN, EXAMINING ATTORNEY

SN 85-502,693. MARS, INCORPORATED, MCLEAN, VA.
FILED 12-22-2011.

FIN-tastic!

THE MARK CONSISTS OF STANDARD CHARACTERS
WITHOUT CLAIM TO ANY PARTICULAR FONT, STYLE,
SIZE, OR COLOR.

FOR CAT TREATS (U.S. CLS. 1 AND 46).
GILBERT SWIFT, EXAMINING ATTORNEY

CLASS 31—(Continued).

SN 85-503,482. KRISTJONSSON, JOHANN, DENVER, CO.
FILED 12-23-2011.

Bella Bones

THE MARK CONSISTS OF STANDARD CHARACTERS
WITHOUT CLAIM TO ANY PARTICULAR FONT, STYLE,
SIZE, OR COLOR.

NO CLAIM IS MADE TO THE EXCLUSIVE RIGHT TO
USE "BONES", APART FROM THE MARK AS SHOWN.
FOR DIGESTIBLE CHEWING BONES FOR DOGS;
DOG TREATS (U.S. CLS. 1 AND 46).

ANTHONY RINKER, EXAMINING ATTORNEY

SN 85-507,032. DOBRANSKI, AMY, DBA RED HILL RANCH
LLC, EDGEFIELD, SC. FILED 1-1-2012.

Keep Pace

THE MARK CONSISTS OF STANDARD CHARACTERS
WITHOUT CLAIM TO ANY PARTICULAR FONT, STYLE,
SIZE, OR COLOR.

FOR ANIMAL FEED (U.S. CLS. 1 AND 46).
FIRST USE 4-25-2008; IN COMMERCE 5-26-2008.

AMEEN IMAM, EXAMINING ATTORNEY

SN 85-509,465. GOEDE HOOP VRUGTE (PROPRIETARY)
LIMITED, CERES, SOUTH AFRICA, FILED 1-5-2012.



THE MARK CONSISTS OF A DIAMOND SHAPE WITH
THE LETTERS "GH" ENCIRCLED BY A STYLIZED DRAW-
ING OF A PIECE OF FRUIT.

FOR FRESH FRUIT (U.S. CLS. 1 AND 46).
FIRST USE 6-13-2001; IN COMMERCE 6-13-2001.
GINA FINK, EXAMINING ATTORNEY

CLASS 31—(Continued).

SN 85-509,648. 888 EXPORTS, INC., CRYSTAL LAKE, IL. FILED 1-5-2012.

Lucky Horse

THE MARK CONSISTS OF STANDARD CHARACTERS WITHOUT CLAIM TO ANY PARTICULAR FONT, STYLE, SIZE, OR COLOR.

NO CLAIM IS MADE TO THE EXCLUSIVE RIGHT TO USE "HORSE", APART FROM THE MARK AS SHOWN.

FOR EDIBLE HORSE TREATS; HORSE FEED (U.S. CLS. 1 AND 46).

CHRISTINA SOBRAL, EXAMINING ATTORNEY



SN 85-511,163. GARDENS IN THE KOOP, INC., HILLSBOROUGH, NC. FILED 1-7-2012.

PLANT A SEED, CHANGE A LIFE

THE MARK CONSISTS OF STANDARD CHARACTERS WITHOUT CLAIM TO ANY PARTICULAR FONT, STYLE, SIZE, OR COLOR.

FOR SEEDS FOR FLOWERS; SEEDS FOR FRUIT AND VEGETABLES (U.S. CLS. 1 AND 46).

LUCY ARANT, EXAMINING ATTORNEY



SN 85-513,640. SOCIETE DES PRODUITS NESTLE SA, VEVEY, SWITZERLAND, FILED 1-11-2012.

LOVE, RESPECT, NOURISH

THE MARK CONSISTS OF STANDARD CHARACTERS WITHOUT CLAIM TO ANY PARTICULAR FONT, STYLE, SIZE, OR COLOR.

FOR PET FOOD (U.S. CLS. 1 AND 46).

MICHAEL GAAFAR, EXAMINING ATTORNEY

CLASS 31—(Continued).

SN 85-513,642. SOCIETE DES PRODUITS NESTLE SA, VEVEY, SWITZERLAND, FILED 1-11-2012.

MUSE

THE MARK CONSISTS OF STANDARD CHARACTERS WITHOUT CLAIM TO ANY PARTICULAR FONT, STYLE, SIZE, OR COLOR.

FOR PET FOOD (U.S. CLS. 1 AND 46).

MICHAEL GAAFAR, EXAMINING ATTORNEY



SN 85-514,977. SOSIO'S FRUIT AND PRODUCE, INC., SEATTLE, WA. FILED 1-12-2012.

OH MY GOD

THE MARK CONSISTS OF STANDARD CHARACTERS WITHOUT CLAIM TO ANY PARTICULAR FONT, STYLE, SIZE, OR COLOR.

FOR FRESH FRUITS (U.S. CLS. 1 AND 46).

FIRST USE 12-31-1990; IN COMMERCE 12-31-1990.

DEBRA LEE, EXAMINING ATTORNEY



SN 85-525,234. MARS, INCORPORATED, MCLEAN, VA. FILED 1-25-2012.



NO CLAIM IS MADE TO THE EXCLUSIVE RIGHT TO USE "RESPONSIBLY SOURCED FISH", APART FROM THE MARK AS SHOWN.

THE MARK CONSISTS OF A FISH DESIGN WITH A CURVED LINE AND THE WORDS "RESPONSIBLY" APPEARING ABOVE THE FISH AND THE WORDS "SOURCED FISH" AND ANOTHER CURVED LINE APPEARING BELOW.

FOR PET FOOD (U.S. CLS. 1 AND 46).

MICHAEL ENGEL, EXAMINING ATTORNEY

CLASS 31—(Continued).

SN 85-541,953. MARS, INCORPORATED, MCLEAN, VA.
FILED 2-14-2012.

SURFERS' DELIGHT

THE MARK CONSISTS OF STANDARD CHARACTERS
WITHOUT CLAIM TO ANY PARTICULAR FONT, STYLE,
SIZE, OR COLOR.

FOR PET FOOD (U.S. CLS. 1 AND 46).
FIRST USE 1-3-2011; IN COMMERCE 1-3-2011.
MICHAEL ENGEL, EXAMINING ATTORNEY

SN 85-568,895. SYNGENTA PARTICIPATIONS AG, BASEL,
SWITZERLAND, FILED 3-14-2012.

Reunion

THE MARK CONSISTS OF STANDARD CHARACTERS
WITHOUT CLAIM TO ANY PARTICULAR FONT, STYLE,
SIZE, OR COLOR.

FOR AGRICULTURAL SEEDS (U.S. CLS. 1 AND 46).
JAMES STEIN, EXAMINING ATTORNEY

CLASS 32—LIGHT BEVERAGES

SN 76-709,848. PEPTEA LLC, KANEOHE, HI. FILED 11-29-
2011.



THE COLOR(S) YELLOW, WHITE, BLUE AND GREEN IS/
ARE CLAIMED AS A FEATURE OF THE MARK.

THE MARK CONSISTS OF THE WORD "PEPTEA" IN
BLUE OUTLINED IN WHITE IN FRONT OF AN IRREGU-
LAR SWIRL DESIGN IN YELLOW ALL ON A GREEN
BACKGROUND.

FOR NON ALCOHOLIC BEVERAGES WITH TEA
FLAVOR (U.S. CLS. 45, 46 AND 48).

FIRST USE 9-9-2009; IN COMMERCE 9-9-2009.
WANDA KAY PRICE, EXAMINING ATTORNEY

CLASS 32—(Continued).

SN 76-710,328. S & D COAL COMPANY, WILLIS, TX. FILED
1-23-2012.

SHAGGY DOG

THE MARK CONSISTS OF STANDARD CHARACTERS
WITHOUT CLAIM TO ANY PARTICULAR FONT, STYLE,
SIZE, OR COLOR.

FOR NON-ALCOHOLIC COCKTAIL MIX, NAMELY,
BLOODY MARY MIX (U.S. CLS. 45, 46 AND 48).
JACLYN KIDWELL WALKER, EXAMINING ATTORNEY

SN 77-109,228. BOTTICELLI FOODS CORP., COMMACK,
NY. FILED 2-16-2007.

SIMPLY NATURAL JUICES

THE MARK CONSISTS OF STANDARD CHARACTERS
WITHOUT CLAIM TO ANY PARTICULAR FONT, STYLE,
SIZE, OR COLOR.

NO CLAIM IS MADE TO THE EXCLUSIVE RIGHT TO
USE "NATURAL JUICES", APART FROM THE MARK AS
SHOWN.

FOR FRUIT JUICES (U.S. CLS. 45, 46 AND 48).
STEVEN R. FINE, EXAMINING ATTORNEY

SN 77-680,935. GURU BEVERAGE INC., MONTREAL, QUE-
BEC, CANADA, FILED 3-1-2009.

**CLEAN ENERGY FOR DIRTY
MINDS**

THE MARK CONSISTS OF STANDARD CHARACTERS
WITHOUT CLAIM TO ANY PARTICULAR FONT, STYLE,
SIZE, OR COLOR.

FOR NON-ALCOHOLIC CARBONATED AND NON-
CARBONATED BEVERAGES, NAMELY, FRUIT
DRINKS AND ENERGY DRINKS (U.S. CLS. 45, 46
AND 48).

REBECCA SMITH, EXAMINING ATTORNEY

CLASS 32—(Continued).

SN 77-930,950. CERVECERIA HONDURENA, S.A. DE C.V., SAN PEDRO SULA, HONDURAS, FILED 2-8-2010.



NO CLAIM IS MADE TO THE EXCLUSIVE RIGHT TO USE "LA CERVEZA NACIONAL", "DESDE 1916", "EXPOSITION INDUSTRIAL HONDURAS 1921", "LA COMPANIA INDUSTRIAL CEIBENA", AND "MONDE SELECTION BRUXELLES 1983", APART FROM THE MARK AS SHOWN.

THE MARK CONSISTS OF A BORDERED SQUARE WITH A CURVED TOP AND BOTTOM AND ROUNDED EDGES. BETWEEN THE OUTERMOST BORDER AND THE INNER BORDER IS THE WORDING "LA CERVEZA NACIONAL" NEAR THE TOP OF THE MARK, A WHEAT STALK ON EACH SIDE OF THE MARK, AND THE WORDING "DESDE 1916" ON THE BOTTOM OF THE MARK. THE INNERMOST SECTION OF THE MARK CONTAINS THE WORDING "SALVA VIDA" BELOW THE LETTERS "SV" WHICH ARE ENCIRCLED BY A LIFE PRESERVER RING WHICH IS FLANKED BY TWO FLAGS OF THREE HORIZONTAL STRIPES EACH. UNDER THE WORDING "SALVA VIDA" ARE THREE SHADED CIRCLES, THE FIRST CONTAINING THE WORDING "EXPOSITION INDUSTRIAL HONDURAS 1921", THE SECOND CONTAINING FIVE STARS IN THE CENTER AND THE WORDING "LA COMPANIA INDUSTRIAL CEIBENA", AND THE THIRD CONTAINING A FLOWER, "1983" AND THE WORDING "MONDE SELECTION BRUXELLES".

THE ENGLISH TRANSLATION OF THE WORDS "SALVA VIDA" IN THE MARK IS "LIFE SAVER". THE ENGLISH TRANSLATION OF THE WORDS "LA CERVEZA NACIONAL" IN THE MARK IS THE "NATIONAL BEER". THE ENGLISH TRANSLATION OF THE WORD "DESDE 1916" IN THE MARK IS "SINCE 1916". THE ENGLISH TRANSLATION OF THE WORDS "EXPOSITION INDUSTRIAL" IN THE MARK IS "INDUSTRIAL EXPOSITION". THE ENGLISH TRANSLATION OF THE WORDS "LA COMPANIA INDUSTRIAL CEIBENA" IN THE MARK IS "THE INDUSTRIAL COMPANY ORIGINALLY FROM LA CEIBA". THE ENGLISH TRANSLATION OF THE WORDS "MONDE SELECTION BRUXELLES" IN THE MARK IS "WORLD SELECTION BRUSSELS".

FOR BEER (U.S. CLS. 45, 46 AND 48).
FIRST USE 9-19-1988; IN COMMERCE 9-19-1988.
ELLEN B. AWRICH, EXAMINING ATTORNEY

CLASS 32—(Continued).

SN 79-106,552. GREENLAND SPRINGWATER AG, SWITZERLAND, FILED 11-21-2011.



PRIORITY DATE OF 6-22-2011 IS CLAIMED.
OWNER OF INTERNATIONAL REGISTRATION 1100145 DATED 11-21-2011, EXPIRES 11-21-2021.

THE MARK CONSISTS OF THE WORD "GRON" WITH A SLASH THROUGH THE LETTER "O" AND A DESIGN OF A STYLIZED ICEBERG TO THE RIGHT.

THE ENGLISH TRANSLATION OF THE WORD "GRON" IN THE MARK IS "GREEN".

FOR BEER; MINERAL AND AERATED WATERS AND LEMONADES; SODA WATER; TABLE WATERS; FRUIT DRINKS AND FRUIT JUICES; SYRUPS AND OTHER PREPARATIONS FOR MAKING FRUIT DRINKS AND LEMONADES (U.S. CLS. 45, 46 AND 48).

JAMES A. RAUEN, EXAMINING ATTORNEY

SN 79-107,673. GREENLAND SPRINGWATER AG, SWITZERLAND, FILED 11-21-2011.



PRIORITY DATE OF 6-22-2011 IS CLAIMED.
OWNER OF INTERNATIONAL REGISTRATION 1102942 DATED 11-21-2011, EXPIRES 11-21-2021.

THE MARK CONSISTS OF A DESIGN OF A BEAR AND THE WORD "NANUK" BENEATH.

THE ENGLISH TRANSLATION OF THE WORD "NANUK" IN THE MARK IS "POLAR BEAR".

FOR BEER; MINERAL AND AERATED WATERS AND LEMONADES; SODA WATER; TABLE WATERS; FRUIT DRINKS AND FRUIT JUICES; SYRUPS AND OTHER PREPARATIONS FOR MAKING FRUIT DRINKS AND LEMONADES (U.S. CLS. 45, 46 AND 48).

JAMES A. RAUEN, EXAMINING ATTORNEY

CLASS 32—(Continued).

SN 85-304,551. LUVV ENERGY PRODUCTS, NAPLES, FL. FILED 4-26-2011.

Feel Great Naturally

THE MARK CONSISTS OF STANDARD CHARACTERS WITHOUT CLAIM TO ANY PARTICULAR FONT, STYLE, SIZE, OR COLOR.

FOR SPORTS DRINKS, NAMELY, ENERGY DRINKS (U.S. CLS. 45, 46 AND 48).

KIMBERLY PERRY, EXAMINING ATTORNEY

SN 85-324,270. THE DUPUIS GROUP, LLC, WESTLAKE VILLAGE, NV. FILED 5-18-2011.

PLANET SODA

THE MARK CONSISTS OF STANDARD CHARACTERS WITHOUT CLAIM TO ANY PARTICULAR FONT, STYLE, SIZE, OR COLOR.

NO CLAIM IS MADE TO THE EXCLUSIVE RIGHT TO USE "SODA", APART FROM THE MARK AS SHOWN.

FOR BEVERAGES, NAMELY, SOFT DRINKS; NON-CARBONATED BEVERAGES, NAMELY, FRUIT JUICES AND FRUIT DRINKS; FUNCTIONAL DRINKS, NAMELY, ENERGY AND SPORTS DRINKS WITH NUTRITIONAL ADDITIVES; SYRUPS, POWDERS AND CONCENTRATES FOR MAKING BEVERAGES, NAMELY, SOFT DRINKS; SPORTS DRINKS; ENERGY DRINKS; MINERAL AND AERATED WATERS (U.S. CLS. 45, 46 AND 48).

TINA L. SNAPP, EXAMINING ATTORNEY

SN 85-324,289. THE DUPUIS GROUP, LLC, WESTLAKE VILLAGE, NV. FILED 5-18-2011.

PLANET COLA

THE MARK CONSISTS OF STANDARD CHARACTERS WITHOUT CLAIM TO ANY PARTICULAR FONT, STYLE, SIZE, OR COLOR.

NO CLAIM IS MADE TO THE EXCLUSIVE RIGHT TO USE "COLA", APART FROM THE MARK AS SHOWN.

FOR BEVERAGES, NAMELY, SOFT DRINKS; NON-CARBONATED BEVERAGES, NAMELY, FRUIT JUICES AND FRUIT DRINKS; FUNCTIONAL DRINKS, NAMELY, ENERGY AND SPORTS DRINKS WITH NUTRITIONAL ADDITIVES; SYRUPS, POWDERS AND CONCENTRATES FOR MAKING BEVERAGES, NAMELY, SOFT DRINKS; SPORTS DRINKS; ENERGY DRINKS; MINERAL AND AERATED WATERS (U.S. CLS. 45, 46 AND 48).

TINA L. SNAPP, EXAMINING ATTORNEY

CLASS 32—(Continued).

SN 85-333,531. INTELLECTUAL PROPERTY DEVELOPMENT CORPORATION PTY LTD, MELBOURNE, AUSTRALIA, FILED 5-31-2011.

ACTION BEER

THE MARK CONSISTS OF STANDARD CHARACTERS WITHOUT CLAIM TO ANY PARTICULAR FONT, STYLE, SIZE, OR COLOR.

OWNER OF AUSTRALIA REG. NO. 1138358, DATED 9-29-2006, EXPIRES 9-29-2016.

NO CLAIM IS MADE TO THE EXCLUSIVE RIGHT TO USE "BEER", APART FROM THE MARK AS SHOWN.

FOR (BASED ON INTENT TO USE) BEER MAKING KIT; BEERS (BASED ON 44(E)) BEERS (U.S. CLS. 45, 46 AND 48).

LYDIA BELZER, EXAMINING ATTORNEY

SN 85-333,534. INTELLECTUAL PROPERTY DEVELOPMENT CORPORATION PTY LTD, MELBOURNE, AUSTRALIA, FILED 5-31-2011.

SCREAM TIME

THE MARK CONSISTS OF STANDARD CHARACTERS WITHOUT CLAIM TO ANY PARTICULAR FONT, STYLE, SIZE, OR COLOR.

OWNER OF AUSTRALIA REG. NO. 1138357, DATED 9-29-2006, EXPIRES 9-29-2016.

FOR BEERS (U.S. CLS. 45, 46 AND 48).

LYDIA BELZER, EXAMINING ATTORNEY

SN 85-334,501. PRET A MANGER (EUROPE) LIMITED, LONDON, ENGLAND, FILED 5-31-2011.

PRET

THE MARK CONSISTS OF STANDARD CHARACTERS WITHOUT CLAIM TO ANY PARTICULAR FONT, STYLE, SIZE, OR COLOR.

OWNER OF UNITED KINGDOM REG. NO. 2022695, DATED 6-2-1995, EXPIRES 6-2-2015.

OWNER OF U.S. REG. NOS. 2,071,984, 3,938,206 AND OTHERS.

THE ENGLISH TRANSLATION OF THE WORD "PRET" IN THE MARK IS "READY".

FOR MINERAL AND AERATED WATERS; BOTTLED WATER (U.S. CLS. 45, 46 AND 48).

FIRST USE 0-0-1994; IN COMMERCE 7-0-2000.

WON TEAK OH, EXAMINING ATTORNEY

CLASS 32—(Continued).

SN 85-351,355. RUSHMORE SUPERFOODS, LLC, DANA POINT, CA. FILED 6-21-2011.



OWNER OF U.S. REG. NO. 3,979,265.
NO CLAIM IS MADE TO THE EXCLUSIVE RIGHT TO USE "SUPER FOOD", APART FROM THE MARK AS SHOWN.

THE MARK CONSISTS OF THE STYLIZED WORDS "RUSHMORE SUPERFOOD" WITH A GRAPHIC DEPICTION OF MOUNTAINS ABOVE THE WORDS.

FOR ENERGY DRINKS; FRUIT BEVERAGES (U.S. CLS. 45, 46 AND 48).

FIRST USE 3-1-2011; IN COMMERCE 3-1-2011.

ALICE BENMAMAN, EXAMINING ATTORNEY

SN 85-351,538. DS WATERS OF AMERICA, INC., ATLANTA, GA. FILED 6-21-2011.



OWNER OF U.S. REG. NO. 2,310,943.
NO CLAIM IS MADE TO THE EXCLUSIVE RIGHT TO USE "SINCE 1898", APART FROM THE MARK AS SHOWN.

THE MARK CONSISTS OF THE WORDING "MOUNT OLYMPUS" IMPOSED ON A SNOW-CAPPED MOUNTAIN. THE WORDING "SINCE 1898" APPEARS BELOW THE MOUNTAIN.

FOR BOTTLED WATER (U.S. CLS. 45, 46 AND 48).

ALYSSA STEEL, EXAMINING ATTORNEY

CLASS 32—(Continued).

SN 85-352,023. KIM, JOHN JUNGMIN, REDONDO BEACH, CA. FILED 6-21-2011.

QI (CHI) WATER

THE MARK CONSISTS OF STANDARD CHARACTERS WITHOUT CLAIM TO ANY PARTICULAR FONT, STYLE, SIZE, OR COLOR.

NO CLAIM IS MADE TO THE EXCLUSIVE RIGHT TO USE "WATER", APART FROM THE MARK AS SHOWN.

FOR DRINKING WATER; MINERAL AND AERATED WATER; PURIFIED BOTTLED DRINKING WATER; SPRING WATER (U.S. CLS. 45, 46 AND 48).

JENNY PARK, EXAMINING ATTORNEY

SN 85-353,188. HYDRO RESEARCH AND TECHNOLOGY, LLC, KEEGO HARBOR, MI. FILED 6-22-2011.

PH+ BALANCED HYDRATION

THE MARK CONSISTS OF STANDARD CHARACTERS WITHOUT CLAIM TO ANY PARTICULAR FONT, STYLE, SIZE, OR COLOR.

NO CLAIM IS MADE TO THE EXCLUSIVE RIGHT TO USE "HYDRATION", APART FROM THE MARK AS SHOWN.

FOR NON-ALCOHOLIC BEVERAGES, NAMELY, ENERGY DRINKS, SPORT DRINKS, AND IONIZED WATER (U.S. CLS. 45, 46 AND 48).

KIMBERLY FRYE, EXAMINING ATTORNEY

SN 85-354,265. LAGUNITAS BREWING COMPANY, PETALUMA, CA. FILED 6-23-2011.

WILCO TANGO FOXTROT

THE MARK CONSISTS OF STANDARD CHARACTERS WITHOUT CLAIM TO ANY PARTICULAR FONT, STYLE, SIZE, OR COLOR.

FOR ALE (U.S. CLS. 45, 46 AND 48).

FIRST USE 2-26-2010; IN COMMERCE 2-26-2010.

CAROLINE WOOD, EXAMINING ATTORNEY

CLASS 32—(Continued).

SN 85-355,336. HYDRO RESEARCH AND TECHNOLOGY, LLC, KEEGO HARBOR, MI. FILED 6-24-2011.



NO CLAIM IS MADE TO THE EXCLUSIVE RIGHT TO USE "HYDRATION", APART FROM THE MARK AS SHOWN.

THE COLOR(S) BLUE, GREEN, AND DARK GREEN IS/ ARE CLAIMED AS A FEATURE OF THE MARK.

THE MARK CONSISTS OF AN IMAGE OF VARIOUS STANDARD CHARACTERS FORMING THE IMAGE "BALANCED HYDRATION" AND STYLIZED CHARACTERS FORMING THE IMAGE "PH+". THE IMAGE "BALANCED" IS BLUE AND LOCATED BELOW THE IMAGE "PH+". THE IMAGE "HYDRATION" IS BLUE AND LOCATED BELOW THE IMAGE "BALANCED". THE STYLIZED IMAGE "PH+" HAS A STYLIZED IMAGE "P" THAT IS BLUE AND PARTLY OVERLAPS THE IMAGE "H" OF "PH+", WHEREIN THE OVERLAPPING PORTION IS DARK GREEN. THE STYLIZED IMAGE "PH+" HAS A STYLIZED IMAGE "+" THAT IS BLUE AND PARTLY OVERLAPS THE UPPERWARD RIGHT SIDE OF THE IMAGE "H" OF "PH+", WHEREIN THE OVERLAPPING PORTION IS DARK GREEN. THE NON-OVERLAPPED PORTION OF THE IMAGE "H" OF "PH+" IS GREEN.

FOR NON-ALCOHOLIC BEVERAGES, NAMELY, ENERGY DRINKS, SPORT DRINKS, AND IONIZED WATER (U.S. CLS. 45, 46 AND 48).

KIMBERLY FRYE, EXAMINING ATTORNEY

CLASS 32—(Continued).

SN 85-359,815. HACHETTE FILIPACCHI PRESSE, LEVAL-LOIS-PERRET, FRANCE. FILED 6-29-2011.

ELLE

OWNER OF FRANCE REG. NO. 1.538.354, DATED 6-27-1989, EXPIRES 6-27-2019.

OWNER OF U.S. REG. NOS. 758,137, 3,745,516 AND OTHERS.

THE ENGLISH TRANSLATION OF "ELLE" IN THE MARK IS "SHE".

FOR BEERS; MINERAL WATER, STILL WATER, SPRING WATER, AERATED AND CARBONATED WATERS, DRINKING WATER WITH VITAMINS, MINERAL OR HERB BASE; ENERGY DRINKS ENHANCED WITH VITAMINS, MINERAL OR HERB BASE; NON-ALCOHOLIC WATER-BASED BEVERAGES WITH TEA EXTRACTS; FLAVORED WATER, TREATED DRINKING WATER, NON-ALCOHOLIC BEVERAGES MADE WITH FRUIT AND/OR FRUIT FLAVOURED; FRUIT JUICES AND VEGETABLE JUICES, FRUIT NECTARS, LEMONADES, SODA WATER, SYRUPS AND OTHER NON-ALCOHOLIC PREPARATIONS FOR MAKING NON-ALCOHOLIC BEVERAGES AND AERATED WATER; ISOTONIC BEVERAGES; NON-ALCOHOLIC ENERGY DRINK, NON-ALCOHOLIC APERITIFS, NON-ALCOHOLIC COCKTAILS, PASTILLES AND POWDERS USED IN MAKING NON ALCOHOLIC EFFERVESCENT BEVERAGES (U.S. CLS. 45, 46 AND 48).

JUDITH HELFMAN, EXAMINING ATTORNEY

SN 85-376,765. PRIVATE SPRING WATER, LLC, SAN MARTIN, CA. FILED 7-20-2011.

RAVE

THE MARK CONSISTS OF STANDARD CHARACTERS WITHOUT CLAIM TO ANY PARTICULAR FONT, STYLE, SIZE, OR COLOR.

FOR BOTTLED WATER AND WATER BEVERAGES SOLD DIRECTLY TO THE CONSUMING PUBLIC (U.S. CLS. 45, 46 AND 48).

CHRIS WELLS, EXAMINING ATTORNEY

CLASS 32—(Continued).

SN 85-385,827. TOPCO HOLDINGS, INC., SKOKIE, IL. FILED 8-1-2011.

**+H2O LIQUID BEVERAGE
ENHANCER**

THE MARK CONSISTS OF STANDARD CHARACTERS WITHOUT CLAIM TO ANY PARTICULAR FONT, STYLE, SIZE, OR COLOR.

NO CLAIM IS MADE TO THE EXCLUSIVE RIGHT TO USE "LIQUID BEVERAGE ENHANCER", APART FROM THE MARK AS SHOWN.

FOR PRE-PACKAGED PREPARATIONS FOR MAKING BEVERAGES (U.S. CLS. 45, 46 AND 48).

LESLEY LAMOTHE, EXAMINING ATTORNEY



SN 85-400,824. BOJI BEER COMPANY, SPENCER, IA. FILED 8-18-2011.

BOJI GIRL

THE MARK CONSISTS OF STANDARD CHARACTERS WITHOUT CLAIM TO ANY PARTICULAR FONT, STYLE, SIZE, OR COLOR.

NO CLAIM IS MADE TO THE EXCLUSIVE RIGHT TO USE "BOJI", APART FROM THE MARK AS SHOWN.

THE WORD(S) "BOJI" HAS NO MEANING IN A FOREIGN LANGUAGE.

FOR BEER; PALE ALE (U.S. CLS. 45, 46 AND 48).

NELSON SNYDER, EXAMINING ATTORNEY



SN 85-403,851. NUTRI/SYSTEM IPHC, INC., WILMINGTON, DE. FILED 8-22-2011.

REAL BALANCED NUTRITION

THE MARK CONSISTS OF STANDARD CHARACTERS WITHOUT CLAIM TO ANY PARTICULAR FONT, STYLE, SIZE, OR COLOR.

NO CLAIM IS MADE TO THE EXCLUSIVE RIGHT TO USE "BALANCED NUTRITION", APART FROM THE MARK AS SHOWN.

FOR FRUIT DRINKS; FRUIT JUICES; SYRUPS AND POWDER MIXES FOR MAKING BEVERAGES, NAMELY, FOR MAKING SOFT DRINKS, ENERGY DRINKS AND FRUIT DRINKS; PREPARATIONS FOR MAKING FRUIT DRINKS; SOFT DRINKS (U.S. CLS. 45, 46 AND 48).

CHARLOTTE CORWIN, EXAMINING ATTORNEY

CLASS 32—(Continued).

SN 85-403,899. NUTRI/SYSTEM IPHC, INC., WILMINGTON, DE. FILED 8-22-2011.

NUTRISYSTEM EVERYDAY

THE MARK CONSISTS OF STANDARD CHARACTERS WITHOUT CLAIM TO ANY PARTICULAR FONT, STYLE, SIZE, OR COLOR.

OWNER OF U.S. REG. NOS. 1,297,847, 1,956,649 AND OTHERS.

FOR FRUIT DRINKS; FRUIT JUICES; SYRUPS AND POWDER MIXES FOR MAKING BEVERAGES, NAMELY, FOR MAKING SOFT DRINKS, ENERGY DRINKS AND FRUIT DRINKS; PREPARATIONS FOR MAKING FRUIT DRINKS; SOFT DRINKS (U.S. CLS. 45, 46 AND 48).

CHARLOTTE CORWIN, EXAMINING ATTORNEY



SN 85-456,355. INTERNATIONAL HARVEST, INC., MOUNT VERNON, NY. FILED 10-26-2011.



OWNER OF U.S. REG. NOS. 3,343,533 AND 3,738,183. NO CLAIM IS MADE TO THE EXCLUSIVE RIGHT TO USE "INTERNATIONAL" AND "ORGANIC & VEGAN", APART FROM THE MARK AS SHOWN.

THE MARK CONSISTS OF THE WORDS "INTERNATIONAL HARVEST'S" SURROUNDING A GLOBE WITH THE WORDS "ORGANIC & VEGAN" IN A RIBBON ACROSS THE GLOBE.

FOR ORGANIC AND VEGAN FRUIT DRINKS, FRUIT JUICES, COCONUT WATER (U.S. CLS. 45, 46 AND 48).

FIRST USE 10-25-2011; IN COMMERCE 10-25-2011.

CARYN GLASSER, EXAMINING ATTORNEY

CLASS 32—(Continued).

SN 85-463,593. OCEANIC BEVERAGES CO., LTD., NEW TAIPEI CITY, TAIWAN, FILED 11-3-2011.



NO CLAIM IS MADE TO THE EXCLUSIVE RIGHT TO USE "APPLE SIDRA", APART FROM THE MARK AS SHOWN.

THE COLOR(S) RED, GREEN AND YELLOW IS/ARE CLAIMED AS A FEATURE OF THE MARK.

THE MARK CONSISTS OF A RED APPLE WITH GREEN LEAVES AGAINST A YELLOW BACKGROUND, WITH GREEN LETTERS "APPLE SIDRA" ON A YELLOW BANNER ACROSS THE APPLE.

THE ENGLISH TRANSLATION OF "SIDRA" IN THE MARK IS "CIDER".

FOR MINERAL AND AERATED WATERS; BOTTLED DISTILLED DRINKING WATER; NON-ALCOHOLIC BEVERAGES, NAMELY, SOFT-DRINKS, NON-ALCOHOLIC FRUIT DRINKS AND FRUIT JUICES, SYRUPS FOR BEVERAGES, PREPARATIONS FOR MAKING AERATED WATER (U.S. CLS. 45, 46 AND 48).

FIRST USE 7-31-1981; IN COMMERCE 5-31-2000.

JULIE VEPPUMTHARA, EXAMINING ATTORNEY

SN 85-481,114. ACCOLADE WINES LIMITED, GUILDFORD, SURREY, UNITED KINGDOM, FILED 11-27-2011.

STONE'S ALCOHOLIC GINGER BEER

THE MARK CONSISTS OF STANDARD CHARACTERS WITHOUT CLAIM TO ANY PARTICULAR FONT, STYLE, SIZE, OR COLOR.

OWNER OF U.S. REG. NOS. 311,853, 785,331 AND 969,760. NO CLAIM IS MADE TO THE EXCLUSIVE RIGHT TO USE "ALCOHOLIC GINGER BEER", APART FROM THE MARK AS SHOWN.

THE NAME(S), PORTRAIT(S), AND/OR SIGNATURE(S) SHOWN IN THE MARK DOES NOT IDENTIFY A PARTICULAR LIVING INDIVIDUAL.

FOR BEERS; GINGER BEER (U.S. CLS. 45, 46 AND 48).

NORA BUCHANAN WILL, EXAMINING ATTORNEY

CLASS 32—(Continued).

SN 85-495,343. SPRINGER, AL, DRIPPING SPRINGS, TX. AND WELCH, TIM, DRIPPING SPRINGS, TX. FILED 12-14-2011.



NO CLAIM IS MADE TO THE EXCLUSIVE RIGHT TO USE "COMPLETE BREAKFAST DRINK", APART FROM THE MARK AS SHOWN.

THE COLOR(S) ORANGE IS/ARE CLAIMED AS A FEATURE OF THE MARK.

THE MARK CONSISTS OF THE ORANGE WORDS "REV COMPLETE BREAKFAST DRINK" WITH FOUR LINES UPWARDLY CROWNING THE LOWERCASE "E".

FOR SOY-BASED BEVERAGES NOT BEING MILK SUBSTITUTES (U.S. CLS. 45, 46 AND 48).

FIRST USE 5-1-2011; IN COMMERCE 8-1-2011.

RAMONA ORTIGA, EXAMINING ATTORNEY

SN 85-500,976. ANDERSON VALLEY ACQUISITION COMPANY, LLC, DBA ANDERSON VALLEY BREWING COMPANY, BOONVILLE, CA. FILED 12-21-2011.



THE COLOR(S) BROWN, TAN, BLACK, WHITE, AND GREEN IS/ARE CLAIMED AS A FEATURE OF THE MARK.

THE MARK CONSISTS OF A BROWN BEAR WITH A TAN MUZZLE WITH A BLACK NOSE AND BROWN AND BLACK EARS BEARING ANTLERS THAT ARE WHITE, OUTLINED IN BLACK AND HAS SOME GREEN.

FOR BEER, ALE, PORTER, AND STOUT (U.S. CLS. 45, 46 AND 48).

RAMONA ORTIGA, EXAMINING ATTORNEY

CLASS 32—(Continued).

SN 85-507,306. COHEN, NATHAN CHONG, BROOMFIELD, CA. FILED 1-2-2012.

PATRIOT ENERGY DRINK

THE MARK CONSISTS OF STANDARD CHARACTERS WITHOUT CLAIM TO ANY PARTICULAR FONT, STYLE, SIZE, OR COLOR.

NO CLAIM IS MADE TO THE EXCLUSIVE RIGHT TO USE "ENERGY DRINK", APART FROM THE MARK AS SHOWN.

FOR ENERGY DRINKS (U.S. CLS. 45, 46 AND 48).
GISELLE AGOSTO, EXAMINING ATTORNEY

SN 85-507,783. THIRSTY DOG BREWING COMPANY, AKRON, OH. FILED 1-3-2012.

ROSEWOOD RED ALE

THE MARK CONSISTS OF STANDARD CHARACTERS WITHOUT CLAIM TO ANY PARTICULAR FONT, STYLE, SIZE, OR COLOR.

NO CLAIM IS MADE TO THE EXCLUSIVE RIGHT TO USE "RED ALE", APART FROM THE MARK AS SHOWN.

FOR MALT LIQUOR (U.S. CLS. 45, 46 AND 48).
HANNO RITTRER, EXAMINING ATTORNEY

SN 85-508,422. EXKLUSIVE, LLC., MIAMI, FL. FILED 1-4-2012.



NO CLAIM IS MADE TO THE EXCLUSIVE RIGHT TO USE "KING SIZE WATER", "FLORIDIAN SPRING WATER", AND "SINCE 1852", APART FROM THE MARK AS SHOWN.

THE COLOR(S) BLACK, GOLD, AND GRAY IS/ARE CLAIMED AS A FEATURE OF THE MARK.

THE MARK CONSISTS OF A SHIELD OUTLINED IN GOLD, THEN BLACK AND THEN GOLD AGAIN. THE SHIELD IS FILLED IN WITH ALTERNATING BLACK AND GRAY STRIPES. THERE ARE TWO GOLD NAILS NEAR

CLASS 32—(Continued).

THE TOP OF THE SHIELD AND ONE NEAR THE BOTTOM. THERE IS A GOLD AND BLACK BALD EAGLE HEAD NEAR THE TOP OF THE SHIELD. BELOW THAT THE WORDING "KSW" IN BLACK AND OUTLINED IN GOLD AND BLACK. BELOW THAT ARE THE WORDS "KING SIZE WATER" IN GOLD OUTLINED IN BLACK, WITH A GOLD CROWN OUTLINED IN BLACK BELOW THAT AND THE WORDING "LEGENDARY FLORIDIAN SPRING WATER SINCE 1852" IN GOLD LETTERING OUTLINED IN BLACK BELOW THE CROWN.

FOR BOTTLED DRINKING WATER (U.S. CLS. 45, 46 AND 48).

FIRST USE 11-1-2011; IN COMMERCE 11-1-2011.
TASHIA BUNCH, EXAMINING ATTORNEY

SN 85-509,574. YOGA WELLNESS, LLC, BOCA RATON, FL. FILED 1-5-2012.

BIKRAM BALANCE

THE MARK CONSISTS OF STANDARD CHARACTERS WITHOUT CLAIM TO ANY PARTICULAR FONT, STYLE, SIZE, OR COLOR.

FOR NONALCOHOLIC BEVERAGE, NAMELY A FRUIT AND VEGETABLE VITALITY DRINK (U.S. CLS. 45, 46 AND 48).

FIRST USE 12-0-2011; IN COMMERCE 12-0-2011.
GENE MACIOL, EXAMINING ATTORNEY

SN 85-509,614. ARI BLUMOFE, BOCA RATON, FL. FILED 1-5-2012.

MED₂O

THE MARK CONSISTS OF THE LETTERS "M", "E", "D", THEN THE SUBSCRIPT "2" FOLLOWED BY THE LETTER "O".

FOR DRINKING WATER WITH VITAMINS (U.S. CLS. 45, 46 AND 48).

MICHAEL WEBSTER, EXAMINING ATTORNEY

CLASS 32—(Continued).

SN 85-509,627. FULTON STREET BREWERY, LLC, CHICAGO, IL. FILED 1-5-2012.

KING HENRY

THE MARK CONSISTS OF STANDARD CHARACTERS WITHOUT CLAIM TO ANY PARTICULAR FONT, STYLE, SIZE, OR COLOR.

THE NAME(S), PORTRAIT(S), AND/OR SIGNATURE(S) SHOWN IN THE MARK DOES NOT IDENTIFY A PARTICULAR LIVING INDIVIDUAL.

FOR BEER (U.S. CLS. 45, 46 AND 48).
FIRST USE 11-26-2011; IN COMMERCE 11-26-2011.
HENRY S. ZAK, EXAMINING ATTORNEY

CLASS 32—(Continued).

SN 85-510,221. LIFESTYLE BRANDS INTERNATIONAL LLC, EAST SYRACUSE, NY. FILED 1-6-2012.

UVĒ

THE MARK CONSISTS OF STANDARD CHARACTERS WITHOUT CLAIM TO ANY PARTICULAR FONT, STYLE, SIZE, OR COLOR.

FOR FRUIT FLAVORED DRINKS; NON-ALCOHOLIC BEVERAGES CONTAINING FRUIT JUICES; NON-ALCOHOLIC BEVERAGES, NAMELY, CARBONATED BEVERAGES (U.S. CLS. 45, 46 AND 48).

RAUL CORDOVA, EXAMINING ATTORNEY

SN 85-509,786. SCOTT WIZWELL, DUCHESNE, UT. FILED 1-5-2012.

T-WATER

THE MARK CONSISTS OF STANDARD CHARACTERS WITHOUT CLAIM TO ANY PARTICULAR FONT, STYLE, SIZE, OR COLOR.

FOR AERATED MINERAL WATERS; AERATED WATER; BOTTLED ARTESIAN WATER; BOTTLED DRINKING WATER; BOTTLED WATER; DISTILLED DRINKING WATER; DRINKING WATERS; GLACIAL WATER; MINERAL AND AERATED WATER; MINERAL WATER; PURIFIED BOTTLED DRINKING WATER; SELTZER WATER; SPARKLING WATER; WATER BEVERAGES (U.S. CLS. 45, 46 AND 48).

DAWN HAN, EXAMINING ATTORNEY

SN 85-510,363. ROYAL WINE CORPORATION, BAYONNE, NJ. FILED 1-6-2012.

KEDEM QUENCHERS

THE MARK CONSISTS OF STANDARD CHARACTERS WITHOUT CLAIM TO ANY PARTICULAR FONT, STYLE, SIZE, OR COLOR.

OWNER OF U.S. REG. NOS. 547,548, 1,990,795 AND 2,864,511.

NO CLAIM IS MADE TO THE EXCLUSIVE RIGHT TO USE "QUENCHERS", APART FROM THE MARK AS SHOWN.

THE ENGLISH TRANSLATION OF "KEDEM" IN THE MARK IS "EASTWARD".

FOR FRUIT JUICES (U.S. CLS. 45, 46 AND 48).
JOHN GARTNER, EXAMINING ATTORNEY

SN 85-509,848. JAMES C. BURGE, SAN MARINO, CA. FILED 1-5-2012.

Pure Order Beer

THE MARK CONSISTS OF STANDARD CHARACTERS WITHOUT CLAIM TO ANY PARTICULAR FONT, STYLE, SIZE, OR COLOR.

NO CLAIM IS MADE TO THE EXCLUSIVE RIGHT TO USE "PURE" AND "BEER", APART FROM THE MARK AS SHOWN.

FOR BEER; BEER, ALE AND LAGER (U.S. CLS. 45, 46 AND 48).

EDWARD NELSON, EXAMINING ATTORNEY

SN 85-510,399. PEPSICO, INC., PURCHASE, NY. FILED 1-6-2012.

CLÁSICO DE CALLE

THE MARK CONSISTS OF STANDARD CHARACTERS WITHOUT CLAIM TO ANY PARTICULAR FONT, STYLE, SIZE, OR COLOR.

THE ENGLISH TRANSLATION OF "CLÁSICO DE CALLE" IN THE MARK IS "STREET CLASSIC" OR "CLASSIC OF THE STREET".

FOR SOFT DRINKS (U.S. CLS. 45, 46 AND 48).
JENNIFER VASQUEZ, EXAMINING ATTORNEY

CLASS 32—(Continued).

SN 85-510,457. PEPSICO, INC., PURCHASE, NY. FILED 1-6-2012.



The logo for WIN2WAYS features the word "WIN" in a bold, sans-serif font, followed by a stylized number "2" that is larger and more decorative, and then the word "WAYS" in the same bold, sans-serif font.

THE MARK CONSISTS OF "WIN2WAYS" IN STYLIZED FORM.

FOR SOFT DRINKS; NON-ALCOHOLIC, NON-CARBONATED FRUIT-FLAVORED DRINKS; ENERGY DRINKS; SPORTS DRINKS; DRINKING WATER AND WATER ENHANCED WITH VITAMINS, MINERALS OR ANTIOXIDANTS (U.S. CLS. 45, 46 AND 48).

JENNIFER VASQUEZ, EXAMINING ATTORNEY

SN 85-510,473. PEPSICO, INC., PURCHASE, NY. FILED 1-6-2012.

PEPSI MAX CALLE ALL STARS

THE MARK CONSISTS OF STANDARD CHARACTERS WITHOUT CLAIM TO ANY PARTICULAR FONT, STYLE, SIZE, OR COLOR.

OWNER OF U.S. REG. NOS. 3,607,615, 3,911,249 AND OTHERS.

THE ENGLISH TRANSLATION OF "CALLE" IN THE MARK IS "STREET".

FOR SOFT DRINKS (U.S. CLS. 45, 46 AND 48).

JENNIFER VASQUEZ, EXAMINING ATTORNEY

SN 85-510,565. THE CONCENTRATE MANUFACTURING COMPANY OF IRELAND, HAMILTON, BERMUDA, FILED 1-6-2012.

NO TODO ES BLANCO Y NEGRO

THE MARK CONSISTS OF STANDARD CHARACTERS WITHOUT CLAIM TO ANY PARTICULAR FONT, STYLE, SIZE, OR COLOR.

THE ENGLISH TRANSLATION OF "NO TODO ES BLANCO Y NEGRO" IN THE MARK IS "NOT EVERYTHING IS BLACK AND WHITE".

FOR SOFT DRINKS (U.S. CLS. 45, 46 AND 48).

SUNG IN, EXAMINING ATTORNEY

CLASS 32—(Continued).

SN 85-510,763. ORCA BEVERAGE, INC., MUKILTEO, WA. FILED 1-6-2012.



The logo for Spiffy features the word "Spiffy" in a stylized, cursive font with a slight shadow effect.

THE MARK CONSISTS OF STANDARD CHARACTERS WITHOUT CLAIM TO ANY PARTICULAR FONT, STYLE, SIZE, OR COLOR.

FOR CONCENTRATES, SYRUPS OR POWDERS FOR MAKING SOFT DRINKS OR TEA-FLAVORED BEVERAGES; SOFT DRINKS, NAMELY, SODAS (U.S. CLS. 45, 46 AND 48).

KATHERINE E. HALMEN, EXAMINING ATTORNEY

SN 85-510,770. THE BERK GROUP, WYNNWOOD, PA. FILED 1-6-2012.

CONFUCIUS SNACKS AND DRINKS

THE MARK CONSISTS OF STANDARD CHARACTERS WITHOUT CLAIM TO ANY PARTICULAR FONT, STYLE, SIZE, OR COLOR.

NO CLAIM IS MADE TO THE EXCLUSIVE RIGHT TO USE "SNACKS AND DRINKS", APART FROM THE MARK AS SHOWN.

FOR FRUIT JUICES (U.S. CLS. 45, 46 AND 48).

ANDREW LEASER, EXAMINING ATTORNEY

SN 85-510,795. ORCA BEVERAGE, INC., MUKILTEO, WA. FILED 1-6-2012.



The logo for Triple Cola features the words "Triple Cola" in a large, bold, serif font.

THE MARK CONSISTS OF STANDARD CHARACTERS WITHOUT CLAIM TO ANY PARTICULAR FONT, STYLE, SIZE, OR COLOR.

NO CLAIM IS MADE TO THE EXCLUSIVE RIGHT TO USE "COLA", APART FROM THE MARK AS SHOWN.

FOR CONCENTRATES, SYRUPS OR POWDERS FOR MAKING SOFT DRINKS OR TEA-FLAVORED BEVERAGES; SOFT DRINKS, NAMELY, SODAS (U.S. CLS. 45, 46 AND 48).

KATHERINE E. HALMEN, EXAMINING ATTORNEY

CLASS 32—(Continued).

SN 85-510,819. ORCA BEVERAGE, INC., MUKILTEO, WA. FILED 1-6-2012.

Old Red Eye

THE MARK CONSISTS OF STANDARD CHARACTERS WITHOUT CLAIM TO ANY PARTICULAR FONT, STYLE, SIZE, OR COLOR.

FOR CONCENTRATES, SYRUPS OR POWDERS FOR MAKING SOFT DRINKS OR TEA-FLAVORED BEVERAGES; SOFT DRINKS, NAMELY, SODAS (U.S. CLS. 45, 46 AND 48).

KATHERINE E. HALMEN, EXAMINING ATTORNEY

SN 85-510,836. ORCA BEVERAGE, INC., MUKILTEO, WA. FILED 1-6-2012.

Brownie

THE MARK CONSISTS OF STANDARD CHARACTERS WITHOUT CLAIM TO ANY PARTICULAR FONT, STYLE, SIZE, OR COLOR.

FOR CONCENTRATES, SYRUPS OR POWDERS FOR MAKING SOFT DRINKS OR TEA-FLAVORED BEVERAGES; SOFT DRINKS, NAMELY, SODAS (U.S. CLS. 45, 46 AND 48).

KATHERINE E. HALMEN, EXAMINING ATTORNEY

SN 85-511,189. CHECKWATER LLC, DBA CHECKWATER HYDRATION TECHNOLOGY, CAMPBELL, CA. FILED 1-7-2012.

Hydridia

THE MARK CONSISTS OF STANDARD CHARACTERS WITHOUT CLAIM TO ANY PARTICULAR FONT, STYLE, SIZE, OR COLOR.

FOR BOTTLED ARTESIAN WATER; BOTTLED DRINKING WATER; BOTTLED WATER; DRINKING WATER; DRINKING WATERS; FLAVORED BOTTLED WATER; FLAVORED ENHANCED WATER; FLAVORED MINERAL WATER; FLAVOURED WATERS; MINERAL WATER; PURIFIED BOTTLED DRINKING WATER; SPORTS DRINKS; SPORTS DRINKS CONTAINING ELECTROLYTES; SPORTS DRINKS, NAMELY, PERFORMANCE DRINKS; SPRING WATER; WATER BEVERAGES (U.S. CLS. 45, 46 AND 48).

KATHERINE M. DUBRAY, EXAMINING ATTORNEY

CLASS 32—(Continued).

SN 85-511,483. CARIBBEAN DISTILLERS LLC, LAKE ALFRED, FL. FILED 1-9-2012.

Skully

THE MARK CONSISTS OF STANDARD CHARACTERS WITHOUT CLAIM TO ANY PARTICULAR FONT, STYLE, SIZE, OR COLOR.

FOR FRUIT JUICE (U.S. CLS. 45, 46 AND 48).
PATRICIA EVANKO, EXAMINING ATTORNEY

SN 85-511,537. SPYRU INC., PROVIDENCIALES, TURKS/CAICOS IS., FILED 1-9-2012.

SPYRU

THE MARK CONSISTS OF STANDARD CHARACTERS WITHOUT CLAIM TO ANY PARTICULAR FONT, STYLE, SIZE, OR COLOR.

FOR ENERGY DRINKS; ENERGY DRINKS ENHANCED WITH SPIRULINA (U.S. CLS. 45, 46 AND 48).
KIMBERLY PERRY, EXAMINING ATTORNEY

SN 85-511,922. INDEED BREWING COMPANY, LLC, ST. PAUL, MN. FILED 1-9-2012.

MIDNIGHT RYDER

THE MARK CONSISTS OF STANDARD CHARACTERS WITHOUT CLAIM TO ANY PARTICULAR FONT, STYLE, SIZE, OR COLOR.

FOR BEER (U.S. CLS. 45, 46 AND 48).
GISELLE AGOSTO, EXAMINING ATTORNEY

SN 85-511,942. INDEED BREWING COMPANY, LLC, ST. PAUL, MN. FILED 1-9-2012.

DAY TRIPPER

THE MARK CONSISTS OF STANDARD CHARACTERS WITHOUT CLAIM TO ANY PARTICULAR FONT, STYLE, SIZE, OR COLOR.

FOR BEER (U.S. CLS. 45, 46 AND 48).
GISELLE AGOSTO, EXAMINING ATTORNEY

CLASS 32—(Continued).

SN 85-511,956. INDEED BREWING COMPANY, LLC, ST. PAUL, MN. FILED 1-9-2012.

STIR CRAZY

THE MARK CONSISTS OF STANDARD CHARACTERS WITHOUT CLAIM TO ANY PARTICULAR FONT, STYLE, SIZE, OR COLOR.
 FOR BEER (U.S. CLS. 45, 46 AND 48).
 GISELLE AGOSTO, EXAMINING ATTORNEY

CLASS 32—(Continued).

SN 85-513,230. OTTER CREEK BREWING COMPANY LLC, BRIDGEWATER CORNERS, VT. FILED 1-10-2012.

THE SHED

THE MARK CONSISTS OF STANDARD CHARACTERS WITHOUT CLAIM TO ANY PARTICULAR FONT, STYLE, SIZE, OR COLOR.
 FOR ALE; BEER (U.S. CLS. 45, 46 AND 48).
 FIRST USE 0-0-1995; IN COMMERCE 0-0-1995.
 FRANK LATTUCA, EXAMINING ATTORNEY

SN 85-512,549. RUCKUS LIFE LLC, NEW HARTFORD, NY. FILED 1-10-2012.

RUCKUS PUNCH

THE MARK CONSISTS OF STANDARD CHARACTERS WITHOUT CLAIM TO ANY PARTICULAR FONT, STYLE, SIZE, OR COLOR.
 NO CLAIM IS MADE TO THE EXCLUSIVE RIGHT TO USE "PUNCH", APART FROM THE MARK AS SHOWN.
 FOR FRUIT-FLAVORED NON-ALCOHOLIC BEVERAGE, NAMELY A NON-ALCOHOLIC MIX SOLD IN A CONTAINER TO WHICH THE PURCHASER MAY ADD A LIQUOR (U.S. CLS. 45, 46 AND 48).
 GENE MACIOL, EXAMINING ATTORNEY

SN 85-513,363. CORONADO BREWING COMPANY, INC., CORONADO, CA. FILED 1-10-2012.

Tusk and Grain

THE MARK CONSISTS OF STANDARD CHARACTERS WITHOUT CLAIM TO ANY PARTICULAR FONT, STYLE, SIZE, OR COLOR.
 FOR BEER; BEER, ALE AND LAGER; BEER, ALE AND PORTER; BEER, ALE, LAGER, STOUT AND PORTER; BEER, ALE, LAGER, STOUT, PORTER, SHANDY; BEER-BASED COOLERS; BEERS; BLACK BEER; BREWED MALT-BASED ALCOHOLIC BEVERAGE IN THE NATURE OF A BEER; COFFEE-FLAVORED BEER; FLAVORED BEERS; GINGER BEER; MALT BEER; MALT LIQUOR; NON-ALCOHOLIC BEER; PALE BEER; PORTER (U.S. CLS. 45, 46 AND 48).
 JEFFREY LOOK, EXAMINING ATTORNEY

SN 85-512,970. SLY FOX BREWING COMPANY, INC., PHOENIXVILLE, PA. FILED 1-10-2012.

SLY FOX O'REILLY'S STOUT

THE MARK CONSISTS OF STANDARD CHARACTERS WITHOUT CLAIM TO ANY PARTICULAR FONT, STYLE, SIZE, OR COLOR.
 OWNER OF U.S. REG. NO. 3,727,900.
 NO CLAIM IS MADE TO THE EXCLUSIVE RIGHT TO USE "STOUT", APART FROM THE MARK AS SHOWN.
 FOR BEER (U.S. CLS. 45, 46 AND 48).
 FIRST USE 2-22-2006; IN COMMERCE 2-22-2006.
 APRIL ROACH, EXAMINING ATTORNEY

SN 85-513,518. LAMEX AGRIFOODS, INC., MIAMI, FL. FILED 1-11-2012.

MIRAGE

THE MARK CONSISTS OF STANDARD CHARACTERS WITHOUT CLAIM TO ANY PARTICULAR FONT, STYLE, SIZE, OR COLOR.
 FOR FRUIT NECTARS (U.S. CLS. 45, 46 AND 48).
 ALEX KEAM, EXAMINING ATTORNEY

CLASS 32—(Continued).

SN 85-513,564. PEPSICO, INC., PURCHASE, NY. FILED 1-11-2012.



OWNER OF U.S. REG. NOS. 1,917,411, 3,677,636 AND OTHERS.

NO CLAIM IS MADE TO THE EXCLUSIVE RIGHT TO USE "BOTTLE", "BOTELLA", "50% LESS PLASTIC" OR "50% MENOS PLÁSTICO", APART FROM THE MARK AS SHOWN.

THE COLOR(S) BLUE, WHITE AND GREEN IS/ARE CLAIMED AS A FEATURE OF THE MARK.

THE MARK CONSISTS OF THE WORDS "BOTTLE ECO-FINA BOTELLA" IN WHITE LETTERS WITH BLUE OUTLINES. THE WORDS ARE SUPERIMPOSED OVER NORTH AND SOUTH AMERICAN CONTINENT DESIGNS. THE CONTINENT DESIGNS ARE BLUE ON A LIGHT BLUE BACKGROUND. A GREEN RECYCLING LOGO OUTLINED IN BLUE SURROUNDS "BOTTLE ECO-FINA BOTELLA" AND THE CONTINENT DESIGNS. THE WORDS "50% LESS PLASTIC*" AND "50% MENOS PLÁSTICO*" IN BLUE LETTERING SURROUND THE OVERALL DESIGN.

THE ENGLISH TRANSLATION OF "BOTELLA" AND "MENOS PLÁSTICO" IN THE MARK IS "BOTTLE" AND "LESS PLASTIC".

FOR DRINKING WATER (U.S. CLS. 45, 46 AND 48).
JENNIFER VASQUEZ, EXAMINING ATTORNEY

SN 85-513,782. LAKEFRONT BREWERY, INC., MILWAUKEE, WI. FILED 1-11-2012.

WISCONSINITE

THE MARK CONSISTS OF STANDARD CHARACTERS WITHOUT CLAIM TO ANY PARTICULAR FONT, STYLE, SIZE, OR COLOR.

FOR BEER (U.S. CLS. 45, 46 AND 48).
ELLEN BURNS, EXAMINING ATTORNEY

CLASS 32—(Continued).

SN 85-513,872. NEU INDUSTRIES, INC., NEW YORK, NY. FILED 1-11-2012.



THE MARK CONSISTS OF IMAGE OF A SEATED FEMALE ANGEL FIGURE.

FOR ENERGY DRINKS; NON-ALCOHOLIC BEVERAGES, NAMELY, CARBONATED BEVERAGES; SOFT DRINKS (U.S. CLS. 45, 46 AND 48).

FIRST USE 1-1-2008; IN COMMERCE 1-1-2008.
BARBARA BROWN, EXAMINING ATTORNEY

SN 85-514,034. WATSON JR., JAMES H., ENGLEWOOD, CO. FILED 1-11-2012.

WICKED LIQUID

THE MARK CONSISTS OF STANDARD CHARACTERS WITHOUT CLAIM TO ANY PARTICULAR FONT, STYLE, SIZE, OR COLOR.

NO CLAIM IS MADE TO THE EXCLUSIVE RIGHT TO USE "LIQUID", APART FROM THE MARK AS SHOWN.

FOR CONCENTRATES AND POWDERS USED IN THE PREPARATION OF ENERGY DRINKS AND FRUIT-FLAVORED BEVERAGES; CONCENTRATES, SYRUPS OR POWDERS USED IN THE PREPARATION OF SPORTS AND ENERGY DRINKS; ENERGY DRINKS; ENERGY DRINKS ENHANCED WITH CAFFEINE; SPORTS DRINKS; SPORTS DRINKS CONTAINING ELECTROLYTES; SPORTS DRINKS ENHANCED WITH CAFFEINE; SPORTS DRINKS, NAMELY, ENERGY DRINKS; SPORTS DRINKS, NAMELY, PERFORMANCE DRINKS; SPORTS DRINKS, NAMELY, RECOVERY DRINKS (U.S. CLS. 45, 46 AND 48).

NAKWAMA ANKRAH, EXAMINING ATTORNEY

CLASS 32—(Continued).

SN 85-514,222. AQUAMANTRA, INC., DANA POINT, CA. FILED 1-11-2012.

I AM PEACE

THE MARK CONSISTS OF STANDARD CHARACTERS WITHOUT CLAIM TO ANY PARTICULAR FONT, STYLE, SIZE, OR COLOR.
FOR DRINKING WATER (U.S. CLS. 45, 46 AND 48).
WILLIAM VERHOSEK, EXAMINING ATTORNEY

SN 85-514,699. TOPCO HOLDINGS, INC., SKOKIE, IL. FILED 1-12-2012.

**ELEVATE YOUR ENERGY.
ELEVATE YOURSELF.**

THE MARK CONSISTS OF STANDARD CHARACTERS WITHOUT CLAIM TO ANY PARTICULAR FONT, STYLE, SIZE, OR COLOR.
FOR SPORTS DRINKS, ENERGY DRINKS AND SOFT DRINKS (U.S. CLS. 45, 46 AND 48).
GENE MACIOL, EXAMINING ATTORNEY

SN 85-514,985. FOUR CORNERS BREWING CO. LLC, DALLAS, TX. FILED 1-12-2012.

**Where local flavor meets
craft brewing**

THE MARK CONSISTS OF STANDARD CHARACTERS WITHOUT CLAIM TO ANY PARTICULAR FONT, STYLE, SIZE, OR COLOR.
FOR FLAVORED BEERS; GINGER BEER; MALT BEER; MALT LIQUOR; PALE BEER; PORTER (U.S. CLS. 45, 46 AND 48).
KAREN K. BUSH, EXAMINING ATTORNEY

CLASS 32—(Continued).

SN 85-515,051. A&S BREWING COLLABORATIVE LLC, BURLINGTON, VT. FILED 1-12-2012.

HOUSE OF SHANDY JOURNEY

THE MARK CONSISTS OF STANDARD CHARACTERS WITHOUT CLAIM TO ANY PARTICULAR FONT, STYLE, SIZE, OR COLOR.
NO CLAIM IS MADE TO THE EXCLUSIVE RIGHT TO USE "SHANDY", APART FROM THE MARK AS SHOWN.
THE NAME(S), PORTRAIT(S), AND/OR SIGNATURE(S) SHOWN IN THE MARK DOES NOT IDENTIFY A PARTICULAR LIVING INDIVIDUAL.
FOR BEER AND ALE (U.S. CLS. 45, 46 AND 48).
ROSELLE HERRERA, EXAMINING ATTORNEY

SN 85-515,083. ANHEUSER-BUSCH, LLC, ST. LOUIS, MO. FILED 1-12-2012.

**YOUR BEER. YOUR TAP.
YOU'RE HOME.**

THE MARK CONSISTS OF STANDARD CHARACTERS WITHOUT CLAIM TO ANY PARTICULAR FONT, STYLE, SIZE, OR COLOR.
NO CLAIM IS MADE TO THE EXCLUSIVE RIGHT TO USE "BEER", APART FROM THE MARK AS SHOWN.
FOR BEER (U.S. CLS. 45, 46 AND 48).
FIRST USE 12-13-2011; IN COMMERCE 12-13-2011.
TASHIA BUNCH, EXAMINING ATTORNEY

SN 85-515,331. GO OUT AT HOME, ST. LOUIS, MO. FILED 1-12-2012.

GO OUT AT HOME

THE MARK CONSISTS OF STANDARD CHARACTERS WITHOUT CLAIM TO ANY PARTICULAR FONT, STYLE, SIZE, OR COLOR.
FOR BEER (U.S. CLS. 45, 46 AND 48).
FIRST USE 12-13-2011; IN COMMERCE 12-13-2011.
HELENE LIWINSKI, EXAMINING ATTORNEY

CLASS 32—(Continued).

SN 85-515,396. ANNAMARIA RIEDINGER, TURLOCK, CA. FILED 1-12-2012.

Hey Honey!

THE MARK CONSISTS OF STANDARD CHARACTERS WITHOUT CLAIM TO ANY PARTICULAR FONT, STYLE, SIZE, OR COLOR.

FOR LEMONADES (U.S. CLS. 45, 46 AND 48).
BRENDAN MCCAULEY, EXAMINING ATTORNEY

SN 85-515,436. C2O PURE COCONUT WATER, LLC, LONG BEACH, CA. FILED 1-12-2012.

Live Rejuvenated!

THE MARK CONSISTS OF STANDARD CHARACTERS WITHOUT CLAIM TO ANY PARTICULAR FONT, STYLE, SIZE, OR COLOR.

FOR COCONUT WATER (U.S. CLS. 45, 46 AND 48).
FIRST USE 4-1-2010; IN COMMERCE 4-1-2010.
TOBY BULLOFF, EXAMINING ATTORNEY

SN 85-515,515. CASEY GLOBAL, LLC, BOSTON, MA. FILED 1-12-2012.

THE SMOOTHEST BEER IN SPORT

THE MARK CONSISTS OF STANDARD CHARACTERS WITHOUT CLAIM TO ANY PARTICULAR FONT, STYLE, SIZE, OR COLOR.

FOR BEER (U.S. CLS. 45, 46 AND 48).
KIMBERLY PERRY, EXAMINING ATTORNEY

SN 85-515,518. BELLA VODA USA INC., DEL MAR, CA. FILED 1-12-2012.

ZORG

THE MARK CONSISTS OF STANDARD CHARACTERS WITHOUT CLAIM TO ANY PARTICULAR FONT, STYLE, SIZE, OR COLOR.

FOR BEERS (U.S. CLS. 45, 46 AND 48).
FIRST USE 12-0-2010; IN COMMERCE 12-0-2010.
LINDA POWELL, EXAMINING ATTORNEY

CLASS 32—(Continued).

SN 85-515,823. MILLERCOORS LLC, CHICAGO, IL. FILED 1-13-2012.

BAND OF BREWERS

THE MARK CONSISTS OF STANDARD CHARACTERS WITHOUT CLAIM TO ANY PARTICULAR FONT, STYLE, SIZE, OR COLOR.

FOR BEER (U.S. CLS. 45, 46 AND 48).
ELISSA GARBER KON, EXAMINING ATTORNEY

SN 85-515,851. BOSTON BEER CORPORATION, BOSTON, MA. FILED 1-13-2012.

PORCH ROCKER

THE MARK CONSISTS OF STANDARD CHARACTERS WITHOUT CLAIM TO ANY PARTICULAR FONT, STYLE, SIZE, OR COLOR.

FOR ALE; BEER (U.S. CLS. 45, 46 AND 48).
AMY KELLY, EXAMINING ATTORNEY

SN 85-516,146. OFFBEAT BREWING COMPANY, ESCONDIDO, CA. FILED 1-13-2012.

OFFBEAT BREWING COMPANY

THE MARK CONSISTS OF STANDARD CHARACTERS WITHOUT CLAIM TO ANY PARTICULAR FONT, STYLE, SIZE, OR COLOR.

NO CLAIM IS MADE TO THE EXCLUSIVE RIGHT TO USE "BREWING COMPANY", APART FROM THE MARK AS SHOWN.

FOR BEER (U.S. CLS. 45, 46 AND 48).
TASNEEM HUSSAIN, EXAMINING ATTORNEY

CLASS 32—(Continued).

SN 85-516,298. MODERN TIMES, LLC, SAN DIEGO, CA. FILED 1-13-2012.

MODERN TIMES

THE MARK CONSISTS OF STANDARD CHARACTERS WITHOUT CLAIM TO ANY PARTICULAR FONT, STYLE, SIZE, OR COLOR.

FOR ALCOHOLIC BEVERAGES NAMELY BEER AND ALE (U.S. CLS. 45, 46 AND 48).

JAMES A. RAUEN, EXAMINING ATTORNEY

SN 85-517,676. ANDERSON VALLEY ACQUISITION COMPANY, LLC, DBA ANDERSON VALLEY BREWING COMPANY, BOONVILLE, CA. FILED 1-17-2012.

**ANDERSON VALLEY BREWING
COMPANY**

THE MARK CONSISTS OF STANDARD CHARACTERS WITHOUT CLAIM TO ANY PARTICULAR FONT, STYLE, SIZE, OR COLOR.

NO CLAIM IS MADE TO THE EXCLUSIVE RIGHT TO USE "BREWING COMPANY", APART FROM THE MARK AS SHOWN.

SEC. 2(F).
FOR BEER, ALE, PORTER, AND STOUT (U.S. CLS. 45, 46 AND 48).

FIRST USE 12-31-1987; IN COMMERCE 12-31-1989.
RAMONA ORTIGA, EXAMINING ATTORNEY

SN 85-519,819. KÖNIG LUDWIG INTERNATIONAL GMBH & CO. KG, GELTENDORF, FED REP GERMANY, FILED 1-19-2012.

**ROYAL BAVARIAN FESTIVAL
BREW**

THE MARK CONSISTS OF STANDARD CHARACTERS WITHOUT CLAIM TO ANY PARTICULAR FONT, STYLE, SIZE, OR COLOR.

OWNER OF U.S. REG. NOS. 1,247,266, 2,597,118 AND 2,676,257.

NO CLAIM IS MADE TO THE EXCLUSIVE RIGHT TO USE "BAVARIAN" AND "BREW", APART FROM THE MARK AS SHOWN.

FOR BEER (U.S. CLS. 45, 46 AND 48).
FRANK LATTUCA, EXAMINING ATTORNEY

CLASS 32—(Continued).

SN 85-521,571. A&S BREWING COLLABORATIVE LLC, BURLINGTON, VT. FILED 1-20-2012.

HOUSE OF SHANDY

THE MARK CONSISTS OF STANDARD CHARACTERS WITHOUT CLAIM TO ANY PARTICULAR FONT, STYLE, SIZE, OR COLOR.

NO CLAIM IS MADE TO THE EXCLUSIVE RIGHT TO USE "SHANDY", APART FROM THE MARK AS SHOWN.

FOR BEER AND ALE (U.S. CLS. 45, 46 AND 48).
ROSELLE HERRERA, EXAMINING ATTORNEY

SN 85-521,636. SOUL CIRCUS, INC., ATLANTA, GA. FILED 1-20-2012.

UNIVERSOUL

THE MARK CONSISTS OF STANDARD CHARACTERS WITHOUT CLAIM TO ANY PARTICULAR FONT, STYLE, SIZE, OR COLOR.

OWNER OF U.S. REG. NOS. 2,724,091, 3,828,729 AND OTHERS.

FOR NON-ALCOHOLIC BEVERAGES, NAMELY, FRUIT DRINKS, FRUIT JUICES, FRUIT FLAVORED DRINKS, LIMEADE, LEMONADE, PUNCHES, SPORTS DRINKS AND SMOOTHIES; BOTTLED DRINKING WATER (U.S. CLS. 45, 46 AND 48).

TEJBIR SINGH, EXAMINING ATTORNEY

SN 85-522,505. PEPSICO, INC., PURCHASE, NY. FILED 1-23-2012.

LOTTA TASTE LITTLE CAN

THE MARK CONSISTS OF STANDARD CHARACTERS WITHOUT CLAIM TO ANY PARTICULAR FONT, STYLE, SIZE, OR COLOR.

FOR SOFT DRINKS (U.S. CLS. 45, 46 AND 48).
JENNIFER VASQUEZ, EXAMINING ATTORNEY

CLASS 32—(Continued).

SN 85-522,525. PEPSICO, INC., PURCHASE, NY. FILED 1-23-2012.

OPEN A LITTLE AWESOMENESS

THE MARK CONSISTS OF STANDARD CHARACTERS WITHOUT CLAIM TO ANY PARTICULAR FONT, STYLE, SIZE, OR COLOR.

FOR SOFT DRINKS (U.S. CLS. 45, 46 AND 48).
JENNIFER VASQUEZ, EXAMINING ATTORNEY

SN 85-522,530. PEPSICO, INC., PURCHASE, NY. FILED 1-23-2012.

A LITTLE REFRESHMENT GOES
A LONG WAY

THE MARK CONSISTS OF STANDARD CHARACTERS WITHOUT CLAIM TO ANY PARTICULAR FONT, STYLE, SIZE, OR COLOR.

FOR SOFT DRINKS (U.S. CLS. 45, 46 AND 48).
JENNIFER VASQUEZ, EXAMINING ATTORNEY

SN 85-526,134. CORONADO BREWING COMPANY, INC., CORONADO, CA. FILED 1-26-2012.

Frog's Breath

THE MARK CONSISTS OF STANDARD CHARACTERS WITHOUT CLAIM TO ANY PARTICULAR FONT, STYLE, SIZE, OR COLOR.

FOR BEER; BEER, ALE AND LAGER; BEER, ALE AND PORTER; BEER, ALE, LAGER, STOUT AND PORTER; BEER, ALE, LAGER, STOUT, PORTER, SHANDY; BEERS; BLACK BEER; BREWED MALT-BASED ALCOHOLIC BEVERAGE IN THE NATURE OF A BEER; COFFEE-FLAVORED BEER; MALT BEER; MALT LIQUOR; PALE BEER; PORTER (U.S. CLS. 45, 46 AND 48).
JEFFREY LOOK, EXAMINING ATTORNEY

CLASS 32—(Continued).

SN 85-529,496. KING JUICE COMPANY, INC., MILWAUKEE, WI. FILED 1-31-2012.

LEMINZZ

THE MARK CONSISTS OF STANDARD CHARACTERS WITHOUT CLAIM TO ANY PARTICULAR FONT, STYLE, SIZE, OR COLOR.

NO CLAIM IS MADE TO THE EXCLUSIVE RIGHT TO USE "LEMONS" APART FROM THE MARK AS SHOWN. FOR NON-ALCOHOLIC BEVERAGES CONTAINING FRUIT JUICES (U.S. CLS. 45, 46 AND 48).
ELISSA GARBER KON, EXAMINING ATTORNEY

SN 85-530,334. WINERY EXCHANGE, INC., NOVATO, CA. FILED 1-31-2012.

FURO

THE MARK CONSISTS OF STANDARD CHARACTERS WITHOUT CLAIM TO ANY PARTICULAR FONT, STYLE, SIZE, OR COLOR.

FOR BEER (U.S. CLS. 45, 46 AND 48).
BILL DAWE, EXAMINING ATTORNEY

SN 85-530,770. MANZEN, LLC, LAS VEGAS, NV. FILED 2-1-2012.

XENPRO

THE MARK CONSISTS OF STANDARD CHARACTERS WITHOUT CLAIM TO ANY PARTICULAR FONT, STYLE, SIZE, OR COLOR.

FOR ENERGY DRINKS; ENERGY DRINKS ENHANCED WITH PROTEIN AND NUTRIENTS; SOFT DRINKS; SOFT DRINKS, NAMELY, ENERGY PROTEIN DRINKS; WHEY BEVERAGES (U.S. CLS. 45, 46 AND 48).
ROSELLE HERRERA, EXAMINING ATTORNEY

CLASS 32—(Continued).

SN 85-531,099. CHIQUITA BRANDS L.L.C., CINCINNATI, OH. FILED 2-1-2012.



OWNER OF U.S. REG. NOS. 670,320, 2,424,101 AND OTHERS.

THE COLOR(S) YELLOW, WHITE AND BLUE IS/ARE CLAIMED AS A FEATURE OF THE MARK.

THE MARK CONSISTS OF A DESIGN OF A LADY WITH FRUITED HAT ABOVE THE WORDING "CHIQUITA" ALL WITHIN AN OVAL, WHERE THE DESIGN OF THE LADY AND THE INSIDE BORDER OF THE OVAL IS IN THE COLOR YELLOW, THE WORDING "CHIQUITA" IS IN THE COLOR WHITE, AND THE BACKGROUND OF THE OVAL IS IN THE COLOR BLUE.

THE ENGLISH TRANSLATION OF "CHIQUITA" IN THE MARK IS "LITTLE GIRL".

FOR FRUIT JUICES AND FRUIT DRINKS (U.S. CLS. 45, 46 AND 48).

TASNEEM HUSSAIN, EXAMINING ATTORNEY

SN 85-544,842. 23 BOTTLES OF BEER LLC, SANTA ROSA, CA. FILED 2-16-2012.



OWNER OF U.S. REG. NO. 3,380,766.

NO CLAIM IS MADE TO THE EXCLUSIVE RIGHT TO USE "MICROBREWED", "SONOMA COUNTY" AND "BREWING COMPANY", APART FROM THE MARK AS SHOWN.

THE MARK CONSISTS OF SEVERAL PINE TREES WITH

CLASS 32—(Continued).

A RIVER RUNNING THERETHROUGH ENCIRCLED BY TWO CONCENTRIC CIRCLES WITHIN WHICH THE WORDS "MICROBREWED SONOMA COUNTY" ARE DEPICTED. THE WORDS "RUSSIAN RIVER BREWING COMPANY" APPEAR CENTERED WITHIN AND BELOW THE CIRCLE. ON EITHER SIDE OF THE WORDS "RUSSIAN RIVER BREWING COMPANY" APPEARS A SMALLER CIRCLE WITH HORIZONTAL LINES AND A PINECONE IN THE CENTER. A FLOWING DESIGN EMANATES FROM EACH OF THE SMALLER CIRCLES.

SEC. 2(F) AS TO "RUSSIAN RIVER BREWING COMPANY".

FOR BEER (U.S. CLS. 45, 46 AND 48).

JORDAN BAKER, EXAMINING ATTORNEY

SN 85-564,390. BOSTON BEER CORPORATION, BOSTON, MA. FILED 3-8-2012.

SAMUEL ADAMS IPA HOPOLOGY

THE MARK CONSISTS OF STANDARD CHARACTERS WITHOUT CLAIM TO ANY PARTICULAR FONT, STYLE, SIZE, OR COLOR.

OWNER OF U.S. REG. NOS. 1,987,062, 2,597,646 AND OTHERS.

NO CLAIM IS MADE TO THE EXCLUSIVE RIGHT TO USE "IPA", APART FROM THE MARK AS SHOWN.

THE NAME(S), PORTRAIT(S), AND/OR SIGNATURE(S) SHOWN IN THE MARK DOES NOT IDENTIFY A PARTICULAR LIVING INDIVIDUAL.

FOR ALE; BEER (U.S. CLS. 45, 46 AND 48).

AMY KELLY, EXAMINING ATTORNEY

SN 85-566,579. LBI BRANDS, INC., VANCOUVER, CANADA, FILED 3-12-2012.

LIQUID POTENTIAL

THE MARK CONSISTS OF STANDARD CHARACTERS WITHOUT CLAIM TO ANY PARTICULAR FONT, STYLE, SIZE, OR COLOR.

NO CLAIM IS MADE TO THE EXCLUSIVE RIGHT TO USE "LIQUID", APART FROM THE MARK AS SHOWN.

FOR BOTTLED DRINKING WATER; FLAVORED BOTTLED WATER; FRUIT FLAVORED DRINKS; NON-ALCOHOLIC BEVERAGES, NAMELY, CARBONATED BEVERAGES; SOFT DRINKS; SPRING WATER; WATER BEVERAGES (U.S. CLS. 45, 46 AND 48).

ANDREW LEASER, EXAMINING ATTORNEY

CLASS 32—(Continued).

SN 85-584,426. CARIBBEAN DISTILLERS LLC, LAKE ALFRED, FL. FILED 3-30-2012.

PE

THE MARK CONSISTS OF STANDARD CHARACTERS WITHOUT CLAIM TO ANY PARTICULAR FONT, STYLE, SIZE, OR COLOR.

FOR SPORTS DRINKS, NAMELY, ENERGY DRINKS (U.S. CLS. 45, 46 AND 48).

PATRICIA EVANKO, EXAMINING ATTORNEY

CLASS 33—WINES AND SPIRITS

SN 77-671,785. CANOPY MANAGEMENT, LLC, NAPA, CA. FILED 2-17-2009.

CROOKED LEGS

THE MARK CONSISTS OF STANDARD CHARACTERS WITHOUT CLAIM TO ANY PARTICULAR FONT, STYLE, SIZE, OR COLOR.

FOR DISTILLED SPIRITS (U.S. CLS. 47 AND 49).
KATHLEEN LORENZO, EXAMINING ATTORNEY

SN 79-058,072. LA SOCIÉTÉ À RESPONSABILITÉ LIMITÉE; "FANTASTIC BRAND", RUSSIAN FED., FILED 6-11-2008.

IMPERATIVE

PRIORITY DATE OF 12-19-2007 IS CLAIMED.
OWNER OF INTERNATIONAL REGISTRATION 0975266 DATED 6-11-2008, EXPIRES 6-11-2018.

THE MARK CONSISTS OF THE STYLIZED WORDING "IMPERATIVE".

FOR VODKA (U.S. CLS. 47 AND 49).
PAUL MORENO, EXAMINING ATTORNEY

CLASS 33—(Continued).

SN 79-097,297. QINGDAO LANGYATAI GROUP CO., LTD., CHINA, FILED 4-27-2011.

PRIORITY DATE OF 1-6-2011 IS CLAIMED.
OWNER OF INTERNATIONAL REGISTRATION 1076872 DATED 4-27-2011, EXPIRES 4-27-2021.

THE MARK CONSISTS OF THREE CHINESE CHARACTERS.

THE ENGLISH TRANSLATION OF THE FOREIGN WORD(S) IN THE MARK IS "SMALL", "TINKLE" AND "TALL" RESPECTIVELY; BUT THE THREE CHINESE CHARACTERS AS A WHOLE HAVE NO MEANING.

THE TRANSLITERATION OF THE NON-LATIN CHARACTERS IN THE MARK IS "XIAO LANG GAO".

FOR FRUIT EXTRACTS, ALCOHOLIC; ARAK; WINE; BRANDY; ALCOHOLIC BEVERAGES, EXCEPT BEER; LIGHT SPARKLING WINE (U.S. CLS. 47 AND 49).
BERNICE MIDDLETON, EXAMINING ATTORNEY

SN 79-099,164. AROMATIQUE GMBH SPIRITUOSENFABRIK, FED REP GERMANY, FILED 5-26-2011.



OWNER OF INTERNATIONAL REGISTRATION 1082106 DATED 5-26-2011, EXPIRES 5-26-2021.

NO CLAIM IS MADE TO THE EXCLUSIVE RIGHT TO USE NO CLAIM IS MADE TO THE EXCLUSIVE RIGHT TO USE "LIKÖR SEMI-BITTER LIQUEUR FROM THÜRINGER 30% VOL 70CL" AND "DEUTSCHES ERZEUGNIS" "THE DESIGN OF A BARCODE WITH THE NUMERALS 4 013092 000557" THE RECYCLE SYMBOL "NACH EINER TRADITIONELLEN REZEPTUR SORGSAM AUFBEREITETE KRÄUTER UND FRUCHTSÄFTE PRÄGEN DEN GESCH-

CLASS 33—(Continued).

MACK DIESES HALBBITTER-LIKÖRS, GENTEBEN SIE IHN LEICHT GEKÜHIT, VOR ODER NACH DEM ESSEN" "CAREFULLY PREPARED ACCORDING TO A TRADITIONAL RECIPE, HERBS AND FRUIT JUICES DETERMINE THE FLAVOUR OF THE SEMI-BITTER LIQUEUR. ENJOY IT SLIGHTLY CHILLED BEFORE AFTER YOU MEAL" AND "SPIRITUOSENFABRIK AROMATIQUE GMBH 99192 NEUDIETENDORF/THURINGEN GERMANY" APART FROM THE MARK AS SHOWN, APART FROM THE MARK AS SHOWN.

THE COLOR(S) WHITE, BROWN, GOLD, GREEN, LIGHT GREEN, GRAY, YELLOW, RED AND BLACK IS/ARE CLAIMED AS A FEATURE OF THE MARK.

THE MARK CONSISTS OF A DEPICTION OF THE HEAD OF A DOG IN THE COLORS BROWN, WHITE AND GOLD, WITH THE WORDS "JAGD WÄCHTER" UNDERNEATH, SHOWN IN THE COLOR GREEN WITH A GRAY SHADOW ALL CONTAINED ON A WHITE COLORED SHIELD DESIGN OUTLINED IN THE COLORS RED AND GREEN, SET ON TOP OF LARGER SHIELD-LIKE DESIGN IN THE COLOR YELLOW AND OUTLINED IN THE COLORS RED AND GREEN. BELOW THE WHITE SHIELD DESIGN IS THE WORDING "THÜRINGER HALBBITTER-LIKÖR" IN THE COLOR GREEN, WITH A STYLIZED BANNER BELOW IN THE COLOR GREEN AND LIGHT GREEN WITH THE WORDING "SEMI-BITTER LIQUEUR FROM THÜRINGER" CONTAINED THEREIN SHOWN IN THE COLOR WHITE. TO LOWER LEFT OF THE BANNER IS "30% VOL" SHOWN IN THE COLOR BLACK AND TO THE LOWER RIGHT OF THE BANNER IS "70CL" SHOWN IN THE COLOR BLACK. BELOW THOSE TWO ELEMENTS IS A RED RECTANGULAR CARRIER OUTLINED IN THE COLOR BLACK WITH THE WORDING "AROMATIQUE" THEREIN SHOWN IN THE COLOR WHITE, WITH A DESIGN OF GOBLET IN THE COLOR WHITE. BELOW THE RED RECTANGULAR CARRIER IS THE WORDING "DEUTSCHES ERZEUGNIS" SHOWN IN THE COLOR BLACK. A NEXT ELEMENT IS A CURVED RECTANGLE-LIKE CARRIER IN THE COLOR GREEN WITH A YELLOW INTERIOR CARRIER OUTLINED IN THE COLOR RED WITH ANOTHER SHOWING OF RED RECTANGULAR CARRIER OUTLINED IN THE COLOR BLACK WITH THE WORDING "AROMATIQUE" THEREIN SHOWN IN THE COLOR WHITE, WITH A DESIGN OF GOBLET IN THE COLOR WHITE. THE NEXT ELEMENT IS AN ELONGATED RECTANGLE IN THE COLOR YELLOW OUTLINED WITH THE COLORS RED AND GREEN, CONTAINING A GREEN AND LIGHT GREEN BANNER OUTLINED IN THE COLOR BLACK WITH THE WORDING "JAGDWÄCHTER" THEREIN IN THE COLOR BLACK. BELOW THAT IS "NACH EINER TRADITIONELLEN REZEPTUR SORGSAM AUFBEREITETE KRÄUTER UND FRUCHTSÄFTE PRÄGEN DEN GESCHMACK DIESES HALBBITTER-LIKÖRS, GENIEßEN SIE IHN LEICHT GEKÜHIT, VOR ODER NACH DEM ESSEN." SHOWN IN THE COLOR GREEN. BELOW THE GERMAN WORDING IS "CAREFULLY PREPARED ACCORDING TO A TRADITIONAL RECIPE, HERBS AND FRUIT JUICES DETERMINE THE FLAVOUR OF THIS SEMI-BITTER LIQUEUR. ENJOY IT SLIGHTLY CHILLED BEFORE OR AFTER YOUR MEAL.", SHOWN IN THE COLOR BLACK. BELOW THAT, IS THE WORDING "AROMATIQUE GMBH SPIRITUOSENFABRIK 99192 NEUDIETENDORF/THURINGEN GERMANY" AND "INTERNET: WWW.AROMATIQUE.DE" SHOWN IN THE COLOR BLACK AND "30% VOL 70CL" SHOWN IN THE COLOR BLACK. WITH A BARCODE SHOWN IN THE COLOR BLACK AND WHITE AND THE NUMERALS "4 013092 000557" SHOWN IN THE COLOR BLACK.

THE ENGLISH TRANSLATION OF THE WORDS "JAGD" IN THE MARK IS "HUNT"; THE ENGLISH TRANSLATION OF THE WORD "DEUTSCHES" IN THE MARK IS "GERMAN"; THE ENGLISH TRANSLATION OF THE WORD "ERZEUGNIS" IN THE MARK IS "PRODUCT". THE ENGLISH TRANSLATION OF THE WORDS "NACH EINER TRADITIONELLEN REZEPTUR SORGSAM AUFBEREITETE KRÄUTER UND FRUCHTSÄFTE PRÄGEN DEN GESCHMACK DIESES HALBBITTER-LIKÖRS, GENIEßEN SIE IHN LEICHT GEKÜHIT, VOR ODER NACH DEM ESSEN" IS "CAREFULLY PREPARED ACCORDING TO A TRADITIONAL RECIPE, HERBS AND FRUIT JUICES DETERMINE THE FLAVOUR OF THIS SEMI-BITTER LIQUEUR. ENJOY IT SLIGHTLY CHILLED BEFORE OR AFTER YOUR MEAL".

FOR SEMI-BITTER LIQUEUR (U.S. CLS. 47 AND 49).
LINDA E. BLOHM, EXAMINING ATTORNEY

CLASS 33—(Continued).

SN 79-099,464. LUIS CABALLERO, S.A., CÁDIZ, SPAIN,
FILED 5-13-2011.



PRIORITY DATE OF 1-14-2011 IS CLAIMED.
OWNER OF INTERNATIONAL REGISTRATION 1082864
DATED 5-13-2011, EXPIRES 5-13-2021.

OWNER OF U.S. REG. NO. 3,323,997.

NO CLAIM IS MADE TO THE EXCLUSIVE RIGHT TO USE "SPAIN" AND "FUNDADA EN 1830", APART FROM THE MARK AS SHOWN.

THE NAME "LUIS CABALLERO" DOES NOT IDENTIFY A LIVING INDIVIDUAL.

THE COLOR(S) RED, WHITE, NAVY BLUE, DARK YELLOW, LIGHT YELLOW AND ORANGE IS/ARE CLAIMED AS A FEATURE OF THE MARK.

THE MARK CONSISTS OF THE WORDING "CABALLERO" IN RED WITH WHITE OUTLINING, ABOVE THE WORDING "THE SPIRIT OF SPAIN" IN ORANGE. THE WORDING IS SUPERIMPOSED OVER AN INVERTED PENTAGON DESIGN WITH A COAT OF ARMS AT THE TOP AND A SEAL AT THE BOTTOM. THE PENTAGON DESIGN CONSISTS OF 7 CONSECUTIVE BORDERS OF VARYING COLOR. STARTING FROM THE OUTSIDE, THE BORDER COLORS ARE NAVY BLUE, GREY, WHITE, DARK YELLOW, BLUE, DARK YELLOW, DARK YELLOW AND THE CENTER IS LIGHT YELLOW. THE COAT OF ARMS CONSISTS OF A RED AND YELLOW SHIELD SURROUNDED BY NAVY BLUE AND WHITE LEAVES. THE SEAL IS ORANGE AND YELLOW AND CONSISTS OF THE WORDING "CABALLERO" IN THE MIDDLE OF THE SEAL, AND THE WORDING "LUIS CABALLERO CASA FUNDADA EN 1830" ON THE PERIMETER OF THE SEAL, ALL IN YELLOW.

THE ENGLISH TRANSLATION OF "LUIS CABALLERO" AND "CASA FUNDADA EN" IN THE MARK IS "DISHEVELED GENTLEMAN" AND "HOUSE FOUNDED IN", RESPECTIVELY.

FOR LIQUEURS (U.S. CLS. 47 AND 49).

DAVID HOFFMAN, EXAMINING ATTORNEY

CLASS 33—(Continued).

SN 79-099,777. GIANNI GAGLIARDO VILLA MONTISEL S.R.L., ITALY, FILED 5-31-2011.



PRIORITY DATE OF 5-30-2011 IS CLAIMED.
OWNER OF INTERNATIONAL REGISTRATION 1083525 DATED 5-31-2011, EXPIRES 5-31-2021.
NO CLAIM IS MADE TO THE EXCLUSIVE RIGHT TO USE "DOLCE 3", APART FROM THE MARK AS SHOWN.
THE MARK CONSISTS OF THE WORDING "DOLCE 3", ORIGINALLY WRITTEN ON HALF EMPTY COLORED HORIZONTAL THICK LINES.
THE ENGLISH TRANSLATION OF THE WORD "DOLCE" IN THE MARK IS "SWEET".
FOR WINES (U.S. CLS. 47 AND 49).
SEAN CROWLEY, EXAMINING ATTORNEY

SN 79-101,865. TACCONI BERNADETTA ANGELA, I-53100 SIENA, ITALY, FILED 7-26-2011.

AMANTIS

THE MARK CONSISTS OF STANDARD CHARACTERS WITHOUT CLAIM TO ANY PARTICULAR FONT, STYLE, SIZE, OR COLOR.
OWNER OF INTERNATIONAL REGISTRATION 1088853 DATED 7-26-2011, EXPIRES 7-26-2021.
THE WORDING "AMANTIS" HAS NO MEANING IN A FOREIGN LANGUAGE.
FOR WINES (U.S. CLS. 47 AND 49).
NATALIE POLZER, EXAMINING ATTORNEY

SN 79-101,925. GUARDIGLI GUIDO, I-06035 GUALDO CATTANEO (PG), ITALY, FILED 7-20-2011.

PERTICAIA

OWNER OF INTERNATIONAL REGISTRATION 1089023 DATED 7-20-2011, EXPIRES 7-20-2021.
THE MARK CONSISTS OF TWO CROSSED LETTERS "P" ABOVE THE WORDING "PERTICAIA".
THE ENGLISH TRANSLATION OF "PERTICAIA" IN THE MARK IS "PLOW".
FOR WINES, GRAPPA (U.S. CLS. 47 AND 49).
TRACY FLETCHER, EXAMINING ATTORNEY

CLASS 33—(Continued).

SN 79-101,944. MHCS, EPERNAY, FRANCE, FILED 7-25-2011.

PRIORITY DATE OF 1-26-2011 IS CLAIMED.
OWNER OF INTERNATIONAL REGISTRATION 1089075 DATED 7-25-2011, EXPIRES 7-25-2021.
OWNER OF U.S. REG. NOS. 1,228,687, 3,608,119 AND OTHERS.
THE MARK CONSISTS OF THE STYLIZED TERM "KRUG" WHEREIN EACH OF THE LETTERS HAS A HORIZONTAL STRIPED BACKGROUND AND THE LETTERS "KRU" HAVE A SINGLE DIAMOND IN THE CENTER OF THE LEFT DOWNWARD STROKE OF THE LETTER AND THE LETTER "G" HAS A DIAMOND IN THE CENTER OF THE LEFT DOWNWARD STROKE OF THE LETTER AND A DIAMOND ON THE RIGHT DOWNWARD STROKE OF THE LETTER.
THE ENGLISH TRANSLATION OF "KRUG" IN THE MARK IS "PITCHER" OR "JUG".
FOR CHAMPAGNE WINES; SPARKLING WINES (U.S. CLS. 47 AND 49).
MYRIAH HABEEB, EXAMINING ATTORNEY

SN 79-101,987. UNICOGNAC S.A., SAINT-GERMAIN-DE-LUSIGNAN, FRANCE, FILED 7-13-2011.

QUEST OF VENTURE

THE MARK CONSISTS OF STANDARD CHARACTERS WITHOUT CLAIM TO ANY PARTICULAR FONT, STYLE, SIZE, OR COLOR.
OWNER OF INTERNATIONAL REGISTRATION 0815331 DATED 11-21-2003, EXPIRES 11-21-2013.
FOR ALCOHOLIC BEVERAGES, NAMELY, WINES, SPIRITS, COGNAC (U.S. CLS. 47 AND 49).
WARREN L. OLANDRIA, EXAMINING ATTORNEY

SN 79-103,796. UNITED DRINKS A/S, DENMARK, FILED 5-9-2011.

COOL FIESTA

THE MARK CONSISTS OF STANDARD CHARACTERS WITHOUT CLAIM TO ANY PARTICULAR FONT, STYLE, SIZE, OR COLOR.
OWNER OF INTERNATIONAL REGISTRATION 1058603 DATED 11-4-2010, EXPIRES 11-4-2020.
FOR LIQUEURS; PREPARED ALCOHOLIC COCKTAILS (U.S. CLS. 47 AND 49).
SUE LAWRENCE, EXAMINING ATTORNEY

CLASS 33—(Continued).

SN 79-105,038. SCANDINAVIAN WINE & SPIRIT OY, FI-00170 HELSINKI, FINLAND, FILED 10-12-2011.

Old Fockers Scotch Whisky

THE MARK CONSISTS OF STANDARD CHARACTERS WITHOUT CLAIM TO ANY PARTICULAR FONT, STYLE, SIZE, OR COLOR.

OWNER OF INTERNATIONAL REGISTRATION 1096788 DATED 10-12-2011, EXPIRES 10-12-2021.

NO CLAIM IS MADE TO THE EXCLUSIVE RIGHT TO USE "SCOTCH WHISKY", APART FROM THE MARK AS SHOWN.

FOR ALCOHOLIC BEVERAGES EXCEPT BEERS (U.S. CLS. 47 AND 49).

ROBERT STRUCK, EXAMINING ATTORNEY

CLASS 33—(Continued).

SN 79-108,474. BACKAFALLSBYN AB, SWEDEN, FILED 12-9-2011.



OWNER OF INTERNATIONAL REGISTRATION 1105057 DATED 12-9-2011, EXPIRES 12-9-2021.

NO CLAIM IS MADE TO THE EXCLUSIVE RIGHT TO USE "BACKAFALLSBYN", APART FROM THE MARK AS SHOWN.

THE MARK CONSISTS OF THE WORDING "SPIRIT OF HVEN BACKAFALLSBYN" IN STYLIZED FONT WHEREIN A STYLIZED BOTTLE DESIGN IS FEATURED IN THE CENTER.

FOR ALCOHOLIC BEVERAGES, NAMELY, DISTILLED SPIRITS (U.S. CLS. 47 AND 49).

AMY KELLY, EXAMINING ATTORNEY

SN 79-105,039. SCANDINAVIAN WINE & SPIRIT OY, FINLAND, FILED 10-12-2011.

Scandinavian Wolf Shot

THE MARK CONSISTS OF STANDARD CHARACTERS WITHOUT CLAIM TO ANY PARTICULAR FONT, STYLE, SIZE, OR COLOR.

OWNER OF INTERNATIONAL REGISTRATION 1096789 DATED 10-12-2011, EXPIRES 10-12-2021.

NO CLAIM IS MADE TO THE EXCLUSIVE RIGHT TO USE "SCANDINAVIAN" AND "SHOT", APART FROM THE MARK AS SHOWN.

FOR ALCOHOLIC BEVERAGES EXCEPT BEERS (U.S. CLS. 47 AND 49).

ROBERT STRUCK, EXAMINING ATTORNEY

SN 79-110,192. GRUPPO ITALIANO VINI S.P.A., ITALY, FILED 1-19-2012.

FREE HUGS

SN 79-108,277. LA REMEDIADORA, SDAD. COOP. DE C.L.M, SPAIN, FILED 11-17-2011.

TÓPICO

THE MARK CONSISTS OF STANDARD CHARACTERS WITHOUT CLAIM TO ANY PARTICULAR FONT, STYLE, SIZE, OR COLOR.

OWNER OF INTERNATIONAL REGISTRATION 1104519 DATED 11-17-2011, EXPIRES 11-17-2021.

THE ENGLISH TRANSLATION OF "TÓPICO" IN THE MARK IS "TOPIC".

FOR WINES AND OTHER ALCOHOLIC BEVERAGES (EXCEPT BEER) (U.S. CLS. 47 AND 49).

Laurie Mayes, Examining Attorney

THE MARK CONSISTS OF STANDARD CHARACTERS WITHOUT CLAIM TO ANY PARTICULAR FONT, STYLE, SIZE, OR COLOR.

PRIORITY DATE OF 12-30-2011 IS CLAIMED. OWNER OF INTERNATIONAL REGISTRATION 1109825 DATED 1-19-2012, EXPIRES 1-19-2022.

FOR WINES (U.S. CLS. 47 AND 49).

Patricia Evanko, Examining Attorney

CLASS 33—(Continued).

SN 79-110,754. SANTONI DI G. & S. SANTONI SNC, ITALY,
FILED 1-18-2012.



PRIORITY DATE OF 12-14-2011 IS CLAIMED.
OWNER OF INTERNATIONAL REGISTRATION 1110954
DATED 1-18-2012, EXPIRES 1-18-2022.

THE TRADEMARK IS COMPOSED OF A CIRCULAR
STAMP CONTAINING THE FANCY DRAGON DEVICE
AND THE WORDS "KNIGHT GABRIELLO".

FOR ALCOHOLIC BEVERAGES CONTAINING FRUIT,
NAMESLY LIMONCELLO, ALCOHOLIC FRUIT EX-
TRACTS, ALCOHOLIC EXTRACTS, NAMESLY HERB
LIQUEURS, ALCOHOLIC BEVERAGES, NAMESLY, DI-
GESTIFS, SPIRIT AND LIQUEURS, NAMESLY AQUAVIT,
GRAPE WINE, GRAPPA AND VODKA, CREAM LI-
QUEURS (U.S. CLS. 47 AND 49).

SANI KHOURI, EXAMINING ATTORNEY

SN 85-023,188. MARSHALL S. RUBEN, HARTFORD, CT.
FILED 4-26-2010.

BLUE STATE WHISKY

THE MARK CONSISTS OF STANDARD CHARACTERS
WITHOUT CLAIM TO ANY PARTICULAR FONT, STYLE,
SIZE, OR COLOR.

OWNER OF U.S. REG. NOS. 3,230,366, 3,680,083 AND
OTHERS.

NO CLAIM IS MADE TO THE EXCLUSIVE RIGHT TO
USE "WHISKY", APART FROM THE MARK AS SHOWN.

FOR ALCOHOLIC BEVERAGES, NAMESLY, FLAVOR-
INFUSED WHISKEY; WHISKY (U.S. CLS. 47 AND 49).

WANDA KAY PRICE, EXAMINING ATTORNEY

CLASS 33—(Continued).

SN 85-023,217. MARSHALL S. RUBEN, HARTFORD, CT.
FILED 4-26-2010.

RED STATE WHISKY

THE MARK CONSISTS OF STANDARD CHARACTERS
WITHOUT CLAIM TO ANY PARTICULAR FONT, STYLE,
SIZE, OR COLOR.

OWNER OF U.S. REG. NOS. 3,230,366, 3,680,083 AND
OTHERS.

NO CLAIM IS MADE TO THE EXCLUSIVE RIGHT TO
USE "WHISKY", APART FROM THE MARK AS SHOWN.

FOR ALCOHOLIC BEVERAGES, NAMESLY, FLAVOR-
INFUSED WHISKY; WHISKY (U.S. CLS. 47 AND 49).

WANDA KAY PRICE, EXAMINING ATTORNEY

SN 85-212,918. INTERCONTINENTAL PACKAGING CO., ST.
PAUL, MN. FILED 1-7-2011.

KINKY

THE MARK CONSISTS OF STANDARD CHARACTERS
WITHOUT CLAIM TO ANY PARTICULAR FONT, STYLE,
SIZE, OR COLOR.

FOR DISTILLED SPIRITS; LIQUEURS (U.S. CLS. 47
AND 49).

FIRST USE 8-1-2011; IN COMMERCE 8-2-2011.

BRENDAN MCCAULEY, EXAMINING ATTORNEY

SN 85-258,571. MCEBREN, LLC, COMANCHE, TX. FILED 3-
4-2011.

4.0 CELLARS

THE MARK CONSISTS OF STANDARD CHARACTERS
WITHOUT CLAIM TO ANY PARTICULAR FONT, STYLE,
SIZE, OR COLOR.

NO CLAIM IS MADE TO THE EXCLUSIVE RIGHT TO
USE "CELLARS", APART FROM THE MARK AS SHOWN.

FOR WINE (U.S. CLS. 47 AND 49).

SANDRA BUJA, EXAMINING ATTORNEY

CLASS 33—(Continued).

SN 85-263,536. KENDALL FARMS, SUNNYSIDE, WA. FILED 3-10-2011.

Trade Up To WASHINGTON

THE MARK CONSISTS OF STANDARD CHARACTERS WITHOUT CLAIM TO ANY PARTICULAR FONT, STYLE, SIZE, OR COLOR.
NO CLAIM IS MADE TO THE EXCLUSIVE RIGHT TO USE "WASHINGTON", APART FROM THE MARK AS SHOWN.
FOR GRAPE WINE (U.S. CLS. 47 AND 49).
ALLISON SCHRODY, EXAMINING ATTORNEY

SN 85-306,999. SAN ANTONIO LIVESTOCK EXPOSITION, INC., SAN ANTONIO, TX. FILED 4-28-2011.



THE MARK CONSISTS OF THE LETTER "S" DESIGNED TO FORM A COWBOY HAT.
FOR SPIRITS (U.S. CLS. 47 AND 49).
ESTHER BELENKER, EXAMINING ATTORNEY

CLASS 33—(Continued).

SN 85-326,787. AMBITION BEV II, INC., NEW YORK, NY. FILED 5-21-2011.



VISION
VODKA

OWNER OF U.S. REG. NOS. 3,784,183 AND 3,970,105.
NO CLAIM IS MADE TO THE EXCLUSIVE RIGHT TO USE "VODKA", APART FROM THE MARK AS SHOWN.
THE MARK CONSISTS OF THE WORD "VISION" OVER THE WORD "VODKA" ALL BELOW A DESIGN CONSISTING OF A TRIANGLE WITH CURVED EDGES AND TWO "V'S" INSIDE.
FOR VODKA (U.S. CLS. 47 AND 49).
FIRST USE 9-15-2009; IN COMMERCE 9-15-2009.
MAYUR VAGHANI, EXAMINING ATTORNEY

SN 85-336,235. CULLOM, APRIL, NEW YORK, NY. FILED 6-2-2011.

CASA ABRIL

THE MARK CONSISTS OF STANDARD CHARACTERS WITHOUT CLAIM TO ANY PARTICULAR FONT, STYLE, SIZE, OR COLOR.
THE ENGLISH TRANSLATION OF "CASA ABRIL" IN THE MARK IS "APRIL HOUSE".
FOR WINES (U.S. CLS. 47 AND 49).
DAVID YONTEF, EXAMINING ATTORNEY

CLASS 33—(Continued).

SN 85-341,753. ESPIRITU DE CHILE LIMITED, LONDON, UNITED KINGDOM, FILED 6-9-2011.

ESPIRITU OF NEW ZEALAND

THE MARK CONSISTS OF STANDARD CHARACTERS WITHOUT CLAIM TO ANY PARTICULAR FONT, STYLE, SIZE, OR COLOR.

NO CLAIM IS MADE TO THE EXCLUSIVE RIGHT TO USE "NEW ZEALAND", APART FROM THE MARK AS SHOWN.

THE ENGLISH TRANSLATION OF "ESPIRITU" IN THE MARK IS "SPIRIT".

FOR SPARKLING WINES; WINES (U.S. CLS. 47 AND 49).

RAMONA ORTIGA, EXAMINING ATTORNEY

CLASS 33—(Continued).

SN 85-341,779. ESPIRITU DE CHILE LIMITED, LONDON, UNITED KINGDOM, FILED 6-9-2011.

ESPIRITU OF USA

THE MARK CONSISTS OF STANDARD CHARACTERS WITHOUT CLAIM TO ANY PARTICULAR FONT, STYLE, SIZE, OR COLOR.

NO CLAIM IS MADE TO THE EXCLUSIVE RIGHT TO USE "USA", APART FROM THE MARK AS SHOWN.

THE ENGLISH TRANSLATION OF "ESPIRITU" IN THE MARK IS "SPIRIT".

FOR SPARKLING WINES; WINES (U.S. CLS. 47 AND 49).

RAMONA ORTIGA, EXAMINING ATTORNEY

SN 85-341,754. ESPIRITU DE CHILE LIMITED, LONDON, UNITED KINGDOM, FILED 6-9-2011.

ESPIRITU OF AUSTRALIA

THE MARK CONSISTS OF STANDARD CHARACTERS WITHOUT CLAIM TO ANY PARTICULAR FONT, STYLE, SIZE, OR COLOR.

NO CLAIM IS MADE TO THE EXCLUSIVE RIGHT TO USE "AUSTRALIA", APART FROM THE MARK AS SHOWN.

THE ENGLISH TRANSLATION OF "ESPIRITU" IN THE MARK IS "SPIRIT".

FOR SPARKLING WINES; WINES (U.S. CLS. 47 AND 49).

RAMONA ORTIGA, EXAMINING ATTORNEY

SN 85-341,778. ESPIRITU DE CHILE LIMITED, LONDON, UNITED KINGDOM, FILED 6-9-2011.

ESPIRITU OF CALIFORNIA

THE MARK CONSISTS OF STANDARD CHARACTERS WITHOUT CLAIM TO ANY PARTICULAR FONT, STYLE, SIZE, OR COLOR.

NO CLAIM IS MADE TO THE EXCLUSIVE RIGHT TO USE "CALIFORNIA", APART FROM THE MARK AS SHOWN.

THE ENGLISH TRANSLATION OF "ESPIRITU" IN THE MARK IS "SPIRIT".

FOR SPARKLING WINES; WINES (U.S. CLS. 47 AND 49).

RAMONA ORTIGA, EXAMINING ATTORNEY

SN 85-341,837. BODEGAS AGNUSDEI, S.L., MEAÑO (PONTEVEDRA), SPAIN, FILED 6-9-2011.



NO CLAIM IS MADE TO THE EXCLUSIVE RIGHT TO USE "WHITE", APART FROM THE MARK AS SHOWN.

THE COLOR(S) PINK, WHITE, BLACK, GREY, GREEN, LIME GREEN, AND PURPLE IS/ARE CLAIMED AS A FEATURE OF THE MARK.

THE MARK CONSISTS OF A FLAG LIKE BACKGROUND WHICH COLORS ARE PURPLE, LIME GREEN AND WHITE WITH GREEN SPLOTCHES; THE COLORS OF THE FLAG ARE SORT OF FADING OR APPEAR WITH A WASH-OFF EFFECT AND THE SHAPE OF THE FLAG SEEMS TO BE AS AN ENGLAND ONE. TO THE LEFT SIDE, ON THE BOTTOM PART OF THE FLAG APPEAR VARIOUS ELEMENTS SUCH AS A SPINNING PHONOGRAPHIC RECORD IN BLACK WITH A PURPLE CIRCLE IN THE MIDDLE, WHITE HOLE, AND WHITE ILLUMINATION IN SOME OF ITS PARTS. TO THE RIGHT SIDE OF THE RECORD, APPEARS IN BLACK AND VARIOUS SHADES OF GREEN COLOR A VINEYARD TYPE OF GROUNDS WITH THE SILHOUETTE OF SOME SPANISH LIKE BUILDINGS ON TOP; ALSO ON THE BOTTOM TO THE RIGHT SIDE APPEARS A SLANTED ENGLAND TYPE TELEPHONE BOOTH IN BLACK, GRAY, AND WHITE COLOR WITH A WHITE STRIPE ON TOP WHICH READS TELEPHONE IN BLACK AND A WHITE CROWN ON TOP. ON TOP OF ALL THE AFOREMENTIONED ELEMENTS APPEAR SOME ASYMMETRIC RECTANGLES AND SQUARES IN THE COLORS PINK AND WHITE WITH BLACK OUTLINES, WITH ONE LETTER INSIDE EACH AND ALL PUT TOGETHER THE WORDS READ "YOU & ME". THE LETTER "Y" IS IN BLACK COLOR INSIDE A PINK RECTANGLE,

CLASS 33—(Continued).

THE LETTER "O" IS IN BLACK COLOR INSIDE A WHITE RECTANGLE, THE LETTER "U" IS IN PINK COLOR INSIDE A WHITE SQUARE, THE SYMBOL "&" IS IN WHITE COLOR INSIDE A PINK SQUARE, THE LETTER "M" IS IN BLACK COLOR INSIDE A WHITE SQUARE AND THE LETTER "E" IS IN WHITE COLOR INSIDE A PINK RECTANGLE. ON THE BOTTOM RIGHT SIDE UNDER THE TELEPHONE BOOTH APPEAR THE WORDS "WHITE EXPERIENCE" IN WHITE COLOR WITH A BLACK THICK SHADOW.

FOR WHITE WINE (U.S. CLS. 47 AND 49).
ROBIN MITTLER, EXAMINING ATTORNEY

SN 85-345,754. OH IL ENTERPRISE CO., LTD., SEOUL, REPUBLIC OF KOREA, FILED 6-14-2011.

JANGSOO

THE MARK CONSISTS OF STANDARD CHARACTERS WITHOUT CLAIM TO ANY PARTICULAR FONT, STYLE, SIZE, OR COLOR.

THE ENGLISH TRANSLATION OF "JANGSOO" IN THE MARK IS "LONG LIFE".

FOR TAG-JU (UNSTRAINED RICE WINE) (U.S. CLS. 47 AND 49).
MARGERY A. TIERNEY, EXAMINING ATTORNEY

SN 85-346,096. TEAZ PRODUCTIONS, LLC, PHOENIX, AZ. FILED 6-14-2011.



The logo for Teaz Vodka features the word "Teaz" in a stylized, cursive script font, with "VODKA" in a smaller, bold, sans-serif font below it.

NO CLAIM IS MADE TO THE EXCLUSIVE RIGHT TO USE "VODKA", APART FROM THE MARK AS SHOWN.

THE MARK CONSISTS OF THE STYLIZED WORDING "TEAZ VODKA". THE WORDING "TEAZ" APPEARS IN A LARGER FONT AND IS IN THE UPPER LEFT PORTION OF THE MARK.

FOR ALCOHOLIC BEVERAGES, NAMELY, DISTILLED SPIRITS, NOT INCLUDING TEA VODKA, TEA-FLAVORED VODKA, OR TEA INFUSED VODKA (U.S. CLS. 47 AND 49).

JORDAN BAKER, EXAMINING ATTORNEY

CLASS 33—(Continued).

SN 85-352,672. TRADER JOE'S COMPANY, MONROVIA, CA. FILED 6-22-2011.

TRADER JOSÉ'S

THE MARK CONSISTS OF STANDARD CHARACTERS WITHOUT CLAIM TO ANY PARTICULAR FONT, STYLE, SIZE, OR COLOR.

OWNER OF U.S. REG. NOS. 1,421,383, 2,158,990 AND 3,515,993.

FOR TEQUILA (U.S. CLS. 47 AND 49).
DEBORAH LOBO, EXAMINING ATTORNEY

SN 85-354,391. LUCAS, DAVID, LODI, CA. FILED 6-23-2011.

A ZINFANDEL IS NEVER TRULY
HAPPY UNLESS IT'S SHARED
AMONG FRIENDS

THE MARK CONSISTS OF STANDARD CHARACTERS WITHOUT CLAIM TO ANY PARTICULAR FONT, STYLE, SIZE, OR COLOR.

FOR WINES (U.S. CLS. 47 AND 49).

FIRST USE 1-1-1996; IN COMMERCE 1-1-1996.

MICHAEL KEATING, EXAMINING ATTORNEY

SN 85-355,508. PERNOD RICARD NEW ZEALAND LIMITED, AUCKLAND 1010, NEW ZEALAND, FILED 6-24-2011.



PRIORITY CLAIMED UNDER SEC. 44(D) ON NEW ZEALAND APPLICATION NO. 844424, FILED 6-22-2011, REG. NO. 1432721, DATED 1-23-2012, EXPIRES 6-23-2021.

OWNER OF U.S. REG. NOS. 2,554,683 AND 3,453,998.

NO CLAIM IS MADE TO THE EXCLUSIVE RIGHT TO USE "VINEYARDS", APART FROM THE MARK AS SHOWN.

THE COLOR(S) GOLD, BROWN, BLACK, SILVER AND WHITE IS/ARE CLAIMED AS A FEATURE OF THE MARK.

THE MARK CONSISTS OF A STYLIZED DEPICTION OF A TREE WITH GOLD AND SILVER LEAVES, SILVER TRUNK, AND WHITE HIGHLIGHTS; BENEATH THE TREE APPEARS A STYLIZED DEPICTION OF ROCKS IN GOLD AND BROWN WITH WHITE HIGHLIGHTS; THE TERM "STONELEIGH" IN BLACK APPEARS TO THE LEFT SIDE OF THE TREE; THE TERM "VINEYARDS" IN BLACK APPEARS ON THE RIGHT SIDE OF THE TREE; THE MARK IS SURROUNDED BY A GOLD AND BROWN OVAL WITH WHITE HIGHLIGHTS; THE BACKGROUND OF THE ENTIRE MARK IS WHITE.

FOR WINE (U.S. CLS. 47 AND 49).

JIM RINGLE, EXAMINING ATTORNEY

CLASS 33—(Continued).

SN 85-355,755. EAGLEVIEW HILL, LLC, DBA VINA SALIDA, RAINIER, WA. FILED 6-24-2011.

Viña Salida

THE MARK CONSISTS OF STANDARD CHARACTERS WITHOUT CLAIM TO ANY PARTICULAR FONT, STYLE, SIZE, OR COLOR.

NO CLAIM IS MADE TO THE EXCLUSIVE RIGHT TO USE "VIÑA", APART FROM THE MARK AS SHOWN.

THE ENGLISH TRANSLATION OF "VIÑA SALIDA" IN THE MARK IS "PROJECTED VINEYARD".

FOR GRAPE WINE (U.S. CLS. 47 AND 49).

FIRST USE 9-1-2008; IN COMMERCE 5-1-2009.

ANDREA K. NADELMAN, EXAMINING ATTORNEY

SN 85-363,096. BEREZAN MANAGEMENT (TEQUILA) LTD., LANGLEY, B.C., CANADA, FILED 7-5-2011.

DE LA TIERRE

THE MARK CONSISTS OF STANDARD CHARACTERS WITHOUT CLAIM TO ANY PARTICULAR FONT, STYLE, SIZE, OR COLOR.

THE ENGLISH TRANSLATION OF "DE LA TIERRE" IN THE MARK IS "FROM THE EARTH".

FOR ALCOHOLIC BEVERAGES, NAMELY, TEQUILA (U.S. CLS. 47 AND 49).

RUSS HERMAN, EXAMINING ATTORNEY

SN 85-364,789. 619 SPIRITS, SAN DIEGO, CA. FILED 7-6-2011.

SIX ONE NINE VODKA

THE MARK CONSISTS OF STANDARD CHARACTERS WITHOUT CLAIM TO ANY PARTICULAR FONT, STYLE, SIZE, OR COLOR.

NO CLAIM IS MADE TO THE EXCLUSIVE RIGHT TO USE "VODKA", APART FROM THE MARK AS SHOWN.

FOR DISTILLED SPIRITS (U.S. CLS. 47 AND 49).

FIRST USE 9-2-2011; IN COMMERCE 9-2-2011.

KELLY BOULTON, EXAMINING ATTORNEY

CLASS 33—(Continued).

SN 85-365,992. SMITH & HOOK WINERY, INC., SOLEDAD, CA. FILED 7-7-2011.

CICLI FIAT

THE MARK CONSISTS OF STANDARD CHARACTERS WITHOUT CLAIM TO ANY PARTICULAR FONT, STYLE, SIZE, OR COLOR.

OWNER OF U.S. REG. NOS. 3,115,294 AND 3,175,141.

THE ENGLISH TRANSLATION OF "CICLI FIAT" IN THE MARK IS "LET THERE BE CYCLES".

FOR WINE (U.S. CLS. 47 AND 49).

JAMES LOVELACE, EXAMINING ATTORNEY

SN 85-367,296. AGAVERA CAMICHINES, S.A. DE C.V., JALISCO, MEXICO, FILED 7-9-2011.

DOS SIGLOS

THE MARK CONSISTS OF STANDARD CHARACTERS WITHOUT CLAIM TO ANY PARTICULAR FONT, STYLE, SIZE, OR COLOR.

THE ENGLISH TRANSLATION OF "DOS SIGLOS" IN THE MARK IS "TWO CENTURIES".

FOR ALCOHOLIC BEVERAGES, NAMELY, TEQUILA, TEQUILA LIQUEURS, ALCOHOLIC COCKTAILS CONTAINING TEQUILA (U.S. CLS. 47 AND 49).

REBECCA SMITH, EXAMINING ATTORNEY

SN 85-370,082. CHATEAU KEFRAYA S.A.L., BEKAA OUEST, LEBANON, FILED 7-13-2011.

LES BRETECHES

THE MARK CONSISTS OF STANDARD CHARACTERS WITHOUT CLAIM TO ANY PARTICULAR FONT, STYLE, SIZE, OR COLOR.

PRIORITY CLAIMED UNDER SEC. 44(D) ON ERP CMNTY TM OFC APPLICATION NO. 009963729, FILED 5-12-2011, REG. NO. 009963729, DATED 9-22-2011, EXPIRES 5-12-2021.

THE ENGLISH TRANSLATION OF "LES BRETECHE" IN THE MARK IS A FORTIFIED PORTION OF A FACADE PECULIAR TO MEDIEVAL CASTLE ARCHITECTURE IN THE BRITANNY REGION OF FRANCE.

FOR ALCOHOLIC BEVERAGES, EXCEPT BEERS (U.S. CLS. 47 AND 49).

KATHLEEN M. VANSTON, EXAMINING ATTORNEY

CLASS 33—(Continued).

SN 85-373,870. ALMA - THE SOUL OF ITALIAN WINE, BAL HARBOUR, FL. FILED 7-18-2011.

SUPRENO

THE MARK CONSISTS OF STANDARD CHARACTERS WITHOUT CLAIM TO ANY PARTICULAR FONT, STYLE, SIZE, OR COLOR.

PRIORITY CLAIMED UNDER SEC. 44(D) ON ERPN CMNTY TM OFC APPLICATION NO. 009670472, FILED 1-19-2011.

THE WORDING "SUPRENO" HAS NO MEANING IN A FOREIGN LANGUAGE.

FOR WINE (U.S. CLS. 47 AND 49).

RICHARD WHITE, EXAMINING ATTORNEY

CLASS 33—(Continued).

SN 85-391,460. HEARTLAND WINE AND SPIRITS GROUP, INC, DAYTON, OH. FILED 8-6-2011.

Soul Noir

THE MARK CONSISTS OF STANDARD CHARACTERS WITHOUT CLAIM TO ANY PARTICULAR FONT, STYLE, SIZE, OR COLOR.

THE ENGLISH TRANSLATION OF "NOIR" IN THE MARK IS "BLACK".

FOR ALCOHOLIC BEVERAGES EXCEPT BEERS (U.S. CLS. 47 AND 49).

MARK SPARACINO, EXAMINING ATTORNEY

SN 85-374,584. BANSHEE SPIRITS IRELAND LIMITED, DUBLIN, IRELAND, FILED 7-19-2011.

BANSHEE LEGEND

THE MARK CONSISTS OF STANDARD CHARACTERS WITHOUT CLAIM TO ANY PARTICULAR FONT, STYLE, SIZE, OR COLOR.

FOR IRISH WHISKEY (U.S. CLS. 47 AND 49).

MARY CRAWFORD, EXAMINING ATTORNEY

SN 85-403,118. AVROKO HOSPITALITY GROUP, INC., NEW YORK, NY. FILED 8-21-2011.

PAROLE

THE MARK CONSISTS OF STANDARD CHARACTERS WITHOUT CLAIM TO ANY PARTICULAR FONT, STYLE, SIZE, OR COLOR.

FOR ALCOHOLIC BEVERAGES, NAMELY, WHISKEY (U.S. CLS. 47 AND 49).

FRANK LATTUCA, EXAMINING ATTORNEY

SN 85-382,706. AGAVERA CAMICHINES, S.A. DE C.V., JALISCO, MEXICO, FILED 7-27-2011.

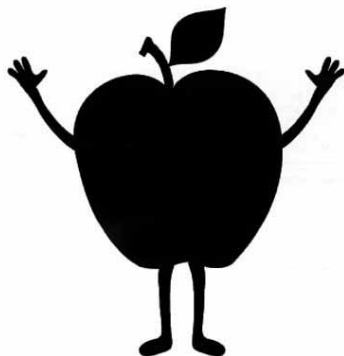

THE MARK CONSISTS OF A REPRESENTATION OF AN APPLE WITH A STEM, LEAF AND TWO ARMS AND TWO LEGS.

FOR ALCOHOLIC BEVERAGES, EXCEPT BEERS (U.S. CLS. 47 AND 49).

REBECCA SMITH, EXAMINING ATTORNEY

SN 85-403,645. SHANNON VINEYARDS & WINES CC, ELGIN, WESTERN CAPE, SOUTH AFRICA, FILED 8-22-2011.

DOWNES

THE MARK CONSISTS OF STANDARD CHARACTERS WITHOUT CLAIM TO ANY PARTICULAR FONT, STYLE, SIZE, OR COLOR.

FOR WINES (U.S. CLS. 47 AND 49).

ALEXANDER L. POWERS, EXAMINING ATTORNEY

CLASS 33—(Continued).

SN 85-418,952. 750 ML, LLC, MILFORD, DE. FILED 9-9-2011.



NO CLAIM IS MADE TO THE EXCLUSIVE RIGHT TO USE "MADE WITH ALL NATURAL FLAVORS MADE SLOW 77 PROOF LIQUEUR WILD STRAWBERRY "SOUR MASH" PROUDLY MADE IN THE USA USING ONLY THE FINEST NATURAL FLAVORS, LIKE WILD STRAWBERRY AND TANGY CITRUS, TO PRODUCE A COMBINATION OF BOLD FLAVORS YOUR TASTE BUDS HAVE ONLY DREAMED ABOUT DON'T BE FOOLED BY ITS ROSY COLORED ATTITUDE - IT'S RAW, BOLD AND SINFULLY DELICIOUS SERVE AS A SHOT OR ON THE ROCKS 750ML" AND "38.5%/ALC/VOL (77 PROOF)", APART FROM THE MARK AS SHOWN.

THE COLOR(S) PINK, BLACK, GRAY AND WHITE IS/ ARE CLAIMED AS A FEATURE OF THE MARK.

THE MARK CONSISTS OF WORDS AND DESIGNS ON A PINK RECTANGULAR BACKGROUND OUTLINED IN PINK. THE BLACK AND GRAY WORDING CONSISTS OF "MADE WITH ALL NATURAL FLAVORS MADE SLOW 77 PROOF SWEET REVENGE LIQUEUR WILD STRAWBERRY "SOUR MASH" PROUDLY MADE IN THE USA USING ONLY THE FINEST NATURAL FLAVORS, LIKE WILD STRAWBERRY AND TANGY CITRUS, TO PRODUCE A COMBINATION OF BOLD FLAVORS YOUR TASTE BUDS HAVE ONLY DREAMED ABOUT. DON'T BE FOOLED BY IT'S ROSY COLORED ATTITUDE - IT'S RAW, BOLD AND SINFULLY DELICIOUS. SERVE AS A SHOT OR ON THE ROCKS 750ML 38.5%/ALC/VOL (77 PROOF)". THE DESIGNS CONSIST OF SCROLL TYPE BANNERS IN WHITE AND GRAY AND PINK, WITH THE BANNER CONTAINING THE WORDING "SWEET REVENGE" HAVING GRAY AND PINK ENDS, VINES WITH LEAVES AND STRAWBERRIES, IN GRAY AND PINK, AND A STYLIZED SHIELD WITH BORDER, WORDS, NUMBERS, BANNERS AND DAGGERS, IN PINK, BLACK, GRAY AND WHITE.

FOR ALCOHOLIC BEVERAGES EXCEPT BEERS (U.S. CLS. 47 AND 49).

PAUL MORENO, EXAMINING ATTORNEY

SN 85-430,920. SAN ANTONIO WINERY, INC., LOS ANGELES, CA. FILED 9-23-2011.

IL CONTE 1917

THE MARK CONSISTS OF STANDARD CHARACTERS WITHOUT CLAIM TO ANY PARTICULAR FONT, STYLE, SIZE, OR COLOR.

NO CLAIM IS MADE TO THE EXCLUSIVE RIGHT TO USE "1917", APART FROM THE MARK AS SHOWN.

THE ENGLISH TRANSLATION OF "IL CONTE" IN THE MARK IS "THE COUNT".

FOR WINE (U.S. CLS. 47 AND 49).

JILL C. ALT, EXAMINING ATTORNEY

CLASS 33—(Continued).

SN 85-431,472. BAKSHI, DEEPAK, ATLANTA, GA. FILED 9-26-2011.

MODA

THE MARK CONSISTS OF STANDARD CHARACTERS WITHOUT CLAIM TO ANY PARTICULAR FONT, STYLE, SIZE, OR COLOR.

THE ENGLISH TRANSLATION OF "MODA" IN THE MARK IS "FASHION".

FOR SPIRITS; TEQUILA (U.S. CLS. 47 AND 49).
RONALD MCMORROW, EXAMINING ATTORNEY

SN 85-432,830. BODEGAS BILBAINAS, S.A., BILBAO, VIZCAYA, SPAIN, FILED 9-27-2011.

EDERRA

THE MARK CONSISTS OF STANDARD CHARACTERS WITHOUT CLAIM TO ANY PARTICULAR FONT, STYLE, SIZE, OR COLOR.

OWNER OF U.S. REG. NO. 1,186,069.
THE ENGLISH TRANSLATION OF "EDERRA" IN THE MARK IS "BEAUTIFUL".

FOR WINES (U.S. CLS. 47 AND 49).
TARAH HARDY, EXAMINING ATTORNEY

SN 85-447,258. TERRAVANT WINE COMPANY, LLC, DBA CURRENTS WINES, SANTA BARBARA, CA. FILED 10-13-2011.

CURRENTS

THE MARK CONSISTS OF STANDARD CHARACTERS WITHOUT CLAIM TO ANY PARTICULAR FONT, STYLE, SIZE, OR COLOR.

FOR WINE; WINES (U.S. CLS. 47 AND 49).
FIRST USE 12-9-2011; IN COMMERCE 12-9-2011.

AMY KELLY, EXAMINING ATTORNEY

CLASS 33—(Continued).

SN 85-460,698. JACK DANIEL'S PROPERTIES, INC., SAN RAFAEL, CA. FILED 10-31-2011.

JACK HONEY

THE MARK CONSISTS OF STANDARD CHARACTERS WITHOUT CLAIM TO ANY PARTICULAR FONT, STYLE, SIZE, OR COLOR.

OWNER OF U.S. REG. NO. 2,815,221.
NO CLAIM IS MADE TO THE EXCLUSIVE RIGHT TO USE "HONEY", APART FROM THE MARK AS SHOWN.
FOR DISTILLED SPIRITS (U.S. CLS. 47 AND 49).
ROBERT STRUCK, EXAMINING ATTORNEY

SN 85-462,840. QUENCH, LLC, VENICE, CA. FILED 11-2-2011.

LIQUID MISTLETOE

THE MARK CONSISTS OF STANDARD CHARACTERS WITHOUT CLAIM TO ANY PARTICULAR FONT, STYLE, SIZE, OR COLOR.

FOR ALCOHOLIC BEVERAGES, NAMELY, TEQUILA (U.S. CLS. 47 AND 49).
DARRYL SPRUILL, EXAMINING ATTORNEY

SN 85-466,273. CASAS DEL TOQUI S.A., REQUINOA, CHILE, FILED 11-7-2011.

Pequen

THE MARK CONSISTS OF STANDARD CHARACTERS WITHOUT CLAIM TO ANY PARTICULAR FONT, STYLE, SIZE, OR COLOR.

THE WORDING "PEQUEN" HAS NO MEANING IN A FOREIGN LANGUAGE.

FOR WINES; ALCOHOLIC BEVERAGES EXCLUDING BEER (U.S. CLS. 47 AND 49).

JASON TURNER, EXAMINING ATTORNEY

CLASS 33—(Continued).

SN 85-490,309. GOLDEN RIDGE CELLARS WALLA WALLA, LLC, WALLA WALLA, WA. FILED 12-8-2011.

GOLDEN RIDGE

THE MARK CONSISTS OF STANDARD CHARACTERS WITHOUT CLAIM TO ANY PARTICULAR FONT, STYLE, SIZE, OR COLOR.

FOR WINES (U.S. CLS. 47 AND 49).
FIRST USE 7-14-2011; IN COMMERCE 7-14-2011.
WILLIAM ROSSMAN, EXAMINING ATTORNEY

SN 85-491,296. WOLF VALLEY IMPORTS, SUITE 108, PA. FILED 12-9-2011.

AN ELIOT THOMAS SELECTION

THE MARK CONSISTS OF STANDARD CHARACTERS WITHOUT CLAIM TO ANY PARTICULAR FONT, STYLE, SIZE, OR COLOR.

NO CLAIM IS MADE TO THE EXCLUSIVE RIGHT TO USE "SELECTION", APART FROM THE MARK AS SHOWN.

THE NAME(S), PORTRAIT(S), AND/OR SIGNATURE(S) SHOWN IN THE MARK DOES NOT IDENTIFY A PARTICULAR LIVING INDIVIDUAL.

FOR WINES (U.S. CLS. 47 AND 49).
JASON TURNER, EXAMINING ATTORNEY

SN 85-493,417. QUADY WINERY INCORPORATED, MADERA, CA. FILED 12-12-2011.

FLORE DE MOSCATO FIZZANTE

THE MARK CONSISTS OF STANDARD CHARACTERS WITHOUT CLAIM TO ANY PARTICULAR FONT, STYLE, SIZE, OR COLOR.

OWNER OF U.S. REG. NO. 3,694,060.

NO CLAIM IS MADE TO THE EXCLUSIVE RIGHT TO USE "MOSCATO", APART FROM THE MARK AS SHOWN.

THE ENGLISH TRANSLATION OF "FLORE" IN THE MARK IS FLORA. THE WORD(S) "FIZZANTE" HAS NO MEANING IN A FOREIGN LANGUAGE.

FOR WINE (U.S. CLS. 47 AND 49).

JUSTINE D. PARKER, EXAMINING ATTORNEY

CLASS 33—(Continued).

SN 85-496,125. MARQUIS DE CAUSSADE SAS, EAUZE, FRANCE, FILED 12-15-2011.

MARQUIS DE CAUSSADE

THE MARK CONSISTS OF STANDARD CHARACTERS WITHOUT CLAIM TO ANY PARTICULAR FONT, STYLE, SIZE, OR COLOR.

THE NAME "MARQUIS DE CAUSSADE" DOES NOT IDENTIFY A LIVING INDIVIDUAL.

FOR ALCOHOLIC BEVERAGES, NAMELY, BRANDIES, ARMAGNAC (U.S. CLS. 47 AND 49).

FIRST USE 0-0-1935; IN COMMERCE 0-0-1980.
PAULA MAHONEY, EXAMINING ATTORNEY

CLASS 33—(Continued).

SN 85-499,961. STILL 630, LLC, ST. LOUIS, MO. FILED 12-20-2011.



SN 85-496,538. BARON PHILIPPE DE ROTHSCHILD MAIPO CHILE S.A., BUIN, SANTIAGO, CHILE, FILED 12-15-2011.

MAS ANDES

THE MARK CONSISTS OF STANDARD CHARACTERS WITHOUT CLAIM TO ANY PARTICULAR FONT, STYLE, SIZE, OR COLOR.

NO CLAIM IS MADE TO THE EXCLUSIVE RIGHT TO USE "ANDES", APART FROM THE MARK AS SHOWN.

THE ENGLISH TRANSLATION OF "MAS" IN THE MARK IS "MORE".

FOR WINES (U.S. CLS. 47 AND 49).
JAMES A. RAUEN, EXAMINING ATTORNEY

NO CLAIM IS MADE TO THE EXCLUSIVE RIGHT TO USE "STILL", APART FROM THE MARK AS SHOWN.

THE MARK CONSISTS OF A RECTANGULAR BOX, WIDER THAN IT IS TALL, INSIDE WHICH IS A SECOND RECTANGULAR BOX, TALLER THAN IT IS WIDE, INSIDE WHICH AT THE BOTTOM ARE TWO HORIZONTALLY STACKED RECTANGULAR BOXES WITH THE TOP BOX CONTAINING THE WORD "STILL" AND THE BOTTOM BOX CONTAINING THE NUMBERS "630" AND STACKED ON THE TOP BOX IS A PORTION OF AN ARCH WHICH APPEARS TO EXTEND FROM ITS BASE TO DISAPPEAR OUT OF THE TOP OF THE LOGO.

FOR DISTILLED SPIRITS (U.S. CLS. 47 AND 49).
C. DIONNE CLYBURN, EXAMINING ATTORNEY

SN 85-497,454. SPARKLING OREGON, LLC, DBA R. STUART & CO., MCMINNVILLE, OR. FILED S.R. 12-16-2011; AM. P.R. 4-16-2012.

stanza

THE MARK CONSISTS OF STANDARD CHARACTERS WITHOUT CLAIM TO ANY PARTICULAR FONT, STYLE, SIZE, OR COLOR.

FOR GRAPE WINE; RED WINE; RED WINES; STILL WINES; WINE; WINES (U.S. CLS. 47 AND 49).

FIRST USE 12-1-2011; IN COMMERCE 12-1-2011.
BARBARA A. GOLD, EXAMINING ATTORNEY

SN 85-501,588. HK VINEYARD HOLDINGS, LLC, SAN FRANCISCO, CA. FILED 12-21-2011.

SONOMA VIEW

THE MARK CONSISTS OF STANDARD CHARACTERS WITHOUT CLAIM TO ANY PARTICULAR FONT, STYLE, SIZE, OR COLOR.

NO CLAIM IS MADE TO THE EXCLUSIVE RIGHT TO USE "SONOMA", APART FROM THE MARK AS SHOWN.

FOR WINES MADE FROM GRAPES GROWN IN THE SONOMA COUNTY REGION IN CALIFORNIA (U.S. CLS. 47 AND 49).

TINA MAI, EXAMINING ATTORNEY

CLASS 33—(Continued).

SN 85-506,645. UPSTART TV LLC, HOUSTON, TX. FILED 12-30-2011.

Sexy Vine

THE MARK CONSISTS OF STANDARD CHARACTERS WITHOUT CLAIM TO ANY PARTICULAR FONT, STYLE, SIZE, OR COLOR.

FOR APERITIF WINES; APERITIFS WITH A WINE BASE; COOKING WINE; FORTIFIED WINES; FRUIT WINE; GRAPE WINE; HONEY WINE; NATURAL SPARKLING WINES; PORT WINES; PREPARED WINE COCKTAILS; RED WINE; RED WINES; ROSE WINE; SPARKLING FRUIT WINE; SPARKLING GRAPE WINE; SPARKLING WINES; STILL WINES; STRAWBERRY WINE; SWEET WINES; TABLE WINES; WHITE WINE; WINE; WINE COOLERS; WINE PUNCH; WINE PUNCHES; WINE-BASED BEVERAGE, NAMELY, PIQUETTE; WINE-BASED DRINKS; WINES; WINES AND FORTIFIED WINES; WINES AND LIQUEURS; WINES AND SPARKLING WINES (U.S. CLS. 47 AND 49).

DAVID YONTEF, EXAMINING ATTORNEY

CLASS 33—(Continued).

SN 85-506,880. REGER, JOHN, HOUSTON, TX. FILED 12-31-2011.

Syn Wines

THE MARK CONSISTS OF STANDARD CHARACTERS WITHOUT CLAIM TO ANY PARTICULAR FONT, STYLE, SIZE, OR COLOR.

NO CLAIM IS MADE TO THE EXCLUSIVE RIGHT TO USE "WINES", APART FROM THE MARK AS SHOWN.

FOR APERITIF WINES; APERITIFS WITH A WINE BASE; COOKING WINE; FORTIFIED WINES; FRUIT WINE; GRAPE WINE; HONEY WINE; NATURAL SPARKLING WINES; PORT WINES; PREPARED WINE COCKTAILS; RED WINE; RED WINES; ROSE WINE; SPARKLING FRUIT WINE; SPARKLING GRAPE WINE; SPARKLING WINES; STILL WINES; STRAWBERRY WINE; SWEET WINES; TABLE WINES; TONIC SWEET GRAPE WINE CONTAINING EXTRACTS FROM GINSENG AND CONCHONA BARK (NINJIN-KINATETSU WINE); WHITE WINE; WINE; WINE COOLERS; WINE PUNCH; WINE PUNCHES; WINE-BASED BEVERAGE, NAMELY, PIQUETTE; WINE-BASED DRINKS; WINES; WINES AND FORTIFIED WINES; WINES AND LIQUEURS; WINES AND SPARKLING WINES (U.S. CLS. 47 AND 49).

MIDGE BUTLER, EXAMINING ATTORNEY

SN 85-506,680. GOTLIBOVSKY, FRANK, BROOKLYN, NY. FILED 12-30-2011.

Sweet Seduction Moscato

THE MARK CONSISTS OF STANDARD CHARACTERS WITHOUT CLAIM TO ANY PARTICULAR FONT, STYLE, SIZE, OR COLOR.

NO CLAIM IS MADE TO THE EXCLUSIVE RIGHT TO USE "MOSCATO", APART FROM THE MARK AS SHOWN. FOR WINES (U.S. CLS. 47 AND 49).

JENNIFER MARTIN, EXAMINING ATTORNEY

SN 85-507,444. LA COMMANDERIE, SAINT EMILION, FRANCE, FILED 1-3-2012.

CHATEAU LA COMMANDERIE

THE MARK CONSISTS OF STANDARD CHARACTERS WITHOUT CLAIM TO ANY PARTICULAR FONT, STYLE, SIZE, OR COLOR.

NO CLAIM IS MADE TO THE EXCLUSIVE RIGHT TO USE "CHATEAU", APART FROM THE MARK AS SHOWN.

THE ENGLISH TRANSLATION OF "CHATEAU LA COMMANDERIE" IS "CASTLE COMMANDERY".

FOR WINES (U.S. CLS. 47 AND 49). FIRST USE 0-0-1988; IN COMMERCE 0-0-1990. JAMES LOVELACE, EXAMINING ATTORNEY

CLASS 33—(Continued).

SN 85-507,668. DIEGO ZAMORA, S.A., CARTEGENA 30205 MURCIA, SPAIN, FILED 1-3-2012.

CUARENTA Y TRES

THE MARK CONSISTS OF STANDARD CHARACTERS WITHOUT CLAIM TO ANY PARTICULAR FONT, STYLE, SIZE, OR COLOR.

OWNER OF SPAIN REG. NO. 2.107.813, DATED 5-5-1998, EXPIRES 7-31-2017.

OWNER OF U.S. REG. NO. 1,429,472.

THE ENGLISH TRANSLATION OF "CUARENTA Y TRES" IN THE MARK IS "FORTY-THREE".

FOR WINE, LIQUORS AND SPIRITS (U.S. CLS. 47 AND 49).

FIRST USE 10-11-1978; IN COMMERCE 10-18-1978.

JOHN HWANG, EXAMINING ATTORNEY

SN 85-507,755. DIEGO ZAMORA, S.A., CARTEGENA 30205 MURCIA, SPAIN, FILED 1-3-2012.



OWNER OF U.S. REG. NO. 1,429,472.

NO CLAIM IS MADE TO THE EXCLUSIVE RIGHT TO USE "LICOR", APART FROM THE MARK AS SHOWN.

THE COLOR(S) RED, GOLD, BLACK AND LIGHT BROWN IS/ARE CLAIMED AS A FEATURE OF THE MARK.

THE MARK CONSISTS OF THE NUMBER "43" IN STYLIZED FONT IN GOLD WITH THE APPEARANCE OF A LIGHT BROWN SHADOW ALONG THE EDGES PLACED WITHIN A CIRCLE COMPRISED OF A BLACK BACKGROUND. THE BLACK BACKGROUND OF THE CIRCLE IS THEN OVERLAID FIRST WITH AN INNER CIRCLE IN LIGHT BROWN AND THEN WITH A GOLD CIRCULAR LINING WHICH COMES TOGETHER AT THE TOP WITH THE WORD "LICOR". THIS WORD ALSO OVERLAYS A FINAL OUTER RING IN RED THAT SURROUNDS THE BLACK CIRCLE.

THE ENGLISH TRANSLATION OF "LICOR" IN THE MARK IS "LIQUEUR".

FOR WINE, LIQUORS AND SPIRITS (U.S. CLS. 47 AND 49).

FIRST USE 6-0-2006; IN COMMERCE 6-0-2006.

JOHN HWANG, EXAMINING ATTORNEY

CLASS 33—(Continued).

SN 85-508,074. AVO UVEZIAN WORLD CORPORATION, ORLANDO, FL. FILED 1-3-2012.

AVO UVEZIAN

THE MARK CONSISTS OF STANDARD CHARACTERS WITHOUT CLAIM TO ANY PARTICULAR FONT, STYLE, SIZE, OR COLOR.

THE NAME(S), PORTRAIT(S), AND/OR SIGNATURE(S) SHOWN IN THE MARK IDENTIFIES AVEDIS "UVEZIAN", WHOSE CONSENT(S) TO REGISTER IS MADE OF RECORD.

FOR ALCOHOLIC BEVERAGES EXCEPT BEERS; LIQUOR; WINE (U.S. CLS. 47 AND 49).

TIMOTHY FINNEGAN, EXAMINING ATTORNEY

SN 85-508,096. NOBLESSE BEVERAGES, INC., NEW YORK, NY. FILED 1-3-2012.

NOBLESSE

THE MARK CONSISTS OF STANDARD CHARACTERS WITHOUT CLAIM TO ANY PARTICULAR FONT, STYLE, SIZE, OR COLOR.

FOR ALCOHOLIC BEVERAGES, NAMELY, CHAMPAGNE AND SPARKLING WINE (U.S. CLS. 47 AND 49).

DANIEL CAPSHAW, EXAMINING ATTORNEY

SN 85-509,404. RWWINES LLC, SAN MATEO, CA. FILED 1-5-2012.

UNIVERSITY CELLARS

THE MARK CONSISTS OF STANDARD CHARACTERS WITHOUT CLAIM TO ANY PARTICULAR FONT, STYLE, SIZE, OR COLOR.

NO CLAIM IS MADE TO THE EXCLUSIVE RIGHT TO USE "CELLARS", APART FROM THE MARK AS SHOWN.

FOR WINE (U.S. CLS. 47 AND 49).

MARK SHINER, EXAMINING ATTORNEY

CLASS 33—(Continued).

SN 85-509,626. WINERY EXCHANGE, INC., NOVATO, CA. FILED 1-5-2012.

FRATELLI ALLIANO

THE MARK CONSISTS OF STANDARD CHARACTERS WITHOUT CLAIM TO ANY PARTICULAR FONT, STYLE, SIZE, OR COLOR.
THE ENGLISH TRANSLATION OF "FRATELLI" IN THE MARK IS "BROTHERS". THE WORD(S) "ALLIANO" HAS NO MEANING IN A FOREIGN LANGUAGE.
FOR ALCOHOLIC BEVERAGES EXCEPT BEERS (U.S. CLS. 47 AND 49).
BILL DAWE, EXAMINING ATTORNEY

SN 85-509,672. B&G WINES USA LLC, OLD BROOKVILLE, NY. FILED 1-5-2012.

CRESO

THE MARK CONSISTS OF STANDARD CHARACTERS WITHOUT CLAIM TO ANY PARTICULAR FONT, STYLE, SIZE, OR COLOR.
FOR WINES (U.S. CLS. 47 AND 49).
DAWN FELDMAN, EXAMINING ATTORNEY

SN 85-509,730. HORACIO O. PEIRO, DORAL, FL. FILED 1-5-2012.

7 Treasures

THE MARK CONSISTS OF THE LITERAL ELEMENT "7 TREASURES" IN STYLIZED LETTERING, AS SHOWN.
FOR WINE (U.S. CLS. 47 AND 49).
JORDAN BAKER, EXAMINING ATTORNEY

CLASS 33—(Continued).

SN 85-509,862. LEW SEMONES, DALLAS, TX. FILED 1-5-2012.

2H Dos Hermanos

THE MARK CONSISTS OF STANDARD CHARACTERS WITHOUT CLAIM TO ANY PARTICULAR FONT, STYLE, SIZE, OR COLOR.
THE ENGLISH TRANSLATION OF "DOS HERMANOS" IN THE MARK IS "TWO BROTHERS".
FOR RED WINE (U.S. CLS. 47 AND 49).
REBECCA SMITH, EXAMINING ATTORNEY

SN 85-510,165. HOYT FAMILY VINEYARDS, MALIBU, CA. FILED 1-6-2012.

Spin Art

THE MARK CONSISTS OF STANDARD CHARACTERS WITHOUT CLAIM TO ANY PARTICULAR FONT, STYLE, SIZE, OR COLOR.
FOR WHITE WINE (U.S. CLS. 47 AND 49).
GEORGE LORENZO, EXAMINING ATTORNEY

SN 85-510,567. LONE STAR DISTILLERY, LLC, AUSTIN, TX. FILED 1-6-2012.

TEXAS BORN FROM TEXAS CORN

THE MARK CONSISTS OF STANDARD CHARACTERS WITHOUT CLAIM TO ANY PARTICULAR FONT, STYLE, SIZE, OR COLOR.
FOR BOURBON WHISKY (U.S. CLS. 47 AND 49).
FIRST USE 1-8-2008; IN COMMERCE 1-8-2008.
KATINA MISTER, EXAMINING ATTORNEY

CLASS 33—(Continued).

SN 85-510,582. ARIDUS WINE COMPANY LLC, CAVE CREEK, AZ. FILED 1-6-2012.

Aridus

THE MARK CONSISTS OF STANDARD CHARACTERS WITHOUT CLAIM TO ANY PARTICULAR FONT, STYLE, SIZE, OR COLOR.

THE ENGLISH TRANSLATION OF "ARIDUS" IN THE MARK IS "PARCHED" OR "ARID".
FOR ALCOHOLIC BEVERAGES EXCEPT BEERS;
WINES (U.S. CLS. 47 AND 49).
SUNG IN, EXAMINING ATTORNEY

SN 85-510,691. CHATAM INTERNATIONAL INCORPORATED, WILMINGTON, DE. FILED 1-6-2012.

OLD COUNTRY

THE MARK CONSISTS OF STANDARD CHARACTERS WITHOUT CLAIM TO ANY PARTICULAR FONT, STYLE, SIZE, OR COLOR.

FOR ALCOHOLIC BEVERAGES EXCEPT BEERS (U.S. CLS. 47 AND 49).
DAVID COLLIER, EXAMINING ATTORNEY

SN 85-510,948. STRANGER & STRANGER, NEW YORK, NY. FILED 1-6-2012.

KINGBIRD

THE MARK CONSISTS OF STANDARD CHARACTERS WITHOUT CLAIM TO ANY PARTICULAR FONT, STYLE, SIZE, OR COLOR.

FOR WINE (U.S. CLS. 47 AND 49).
SOPHIA S. KIM, EXAMINING ATTORNEY

CLASS 33—(Continued).

SN 85-510,965. STRANGER & STRANGER, NEW YORK, NY. FILED 1-6-2012.

SHINING MOON

THE MARK CONSISTS OF STANDARD CHARACTERS WITHOUT CLAIM TO ANY PARTICULAR FONT, STYLE, SIZE, OR COLOR.

FOR SPIRIT (U.S. CLS. 47 AND 49).
SOPHIA S. KIM, EXAMINING ATTORNEY

SN 85-510,992. SCOPUS HOLDINGS, ORINDA, CA. FILED 1-6-2012.

SCOPUS

THE MARK CONSISTS OF STANDARD CHARACTERS WITHOUT CLAIM TO ANY PARTICULAR FONT, STYLE, SIZE, OR COLOR.

FOR ALCOHOLIC BEVERAGES, NAMELY, WINE (U.S. CLS. 47 AND 49).
LINDA M. KING, EXAMINING ATTORNEY

SN 85-511,005. MCGEOUGH, HOLLY, FALL CITY, WA. FILED 1-6-2012.

HAPPILY EVER ASPEN

THE MARK CONSISTS OF STANDARD CHARACTERS WITHOUT CLAIM TO ANY PARTICULAR FONT, STYLE, SIZE, OR COLOR.

FOR DISTILLED SPIRITS (U.S. CLS. 47 AND 49).
LINDA M. KING, EXAMINING ATTORNEY

SN 85-511,089. MENTE, ORION, SUNNYVALE, CA. FILED 1-7-2012.

SLIMTINI

THE MARK CONSISTS OF STANDARD CHARACTERS WITHOUT CLAIM TO ANY PARTICULAR FONT, STYLE, SIZE, OR COLOR.

FOR LOW CALORIE ALCOHOLIC BEVERAGES, EXCEPT BEER (U.S. CLS. 47 AND 49).
ALYSSA STEEL, EXAMINING ATTORNEY

CLASS 33—(Continued).

SN 85-511,337. SCOTT CURTIS, CENTENNIAL, CO. FILED 1-8-2012.

AVIATRIX

THE MARK CONSISTS OF STANDARD CHARACTERS WITHOUT CLAIM TO ANY PARTICULAR FONT, STYLE, SIZE, OR COLOR.

FOR GRAPE WINE; PORT WINES; RED WINE; RED WINES; ROSE WINE; SPARKLING WINES; SWEET WINES; TABLE WINES; WHITE WINE; WINE; WINES; WINES AND FORTIFIED WINES; WINES AND LIQUEURS; WINES AND SPARKLING WINES (U.S. CLS. 47 AND 49).

ELISSA GARBER KON, EXAMINING ATTORNEY

CLASS 33—(Continued).

SN 85-511,513. BANTAM CIDER COMPANY, CAMBRIDGE, MA. FILED 1-9-2012.

BANTAM

THE MARK CONSISTS OF STANDARD CHARACTERS WITHOUT CLAIM TO ANY PARTICULAR FONT, STYLE, SIZE, OR COLOR.

FOR ALCOHOLIC BEVERAGES, NAMELY, HARD CIDER (U.S. CLS. 47 AND 49).

FIRST USE 12-5-2011; IN COMMERCE 12-5-2011.

JOHN GARTNER, EXAMINING ATTORNEY

SN 85-511,683. POWER IP, LLC, MIAMI BEACH, FL. FILED 1-9-2012.

SN 85-511,404. VINTAGE ROCKEFELLER CHAMPAGNE GROUP CORPORATION, OAKDALE, NY. FILED 1-9-2012.

Empire Rockefeller

THE MARK CONSISTS OF STANDARD CHARACTERS WITHOUT CLAIM TO ANY PARTICULAR FONT, STYLE, SIZE, OR COLOR.

FOR DISTILLED SPIRITS (U.S. CLS. 47 AND 49).
ALLISON SCHRODY, EXAMINING ATTORNEY

TRÜU SWAG

THE MARK CONSISTS OF STANDARD CHARACTERS WITHOUT CLAIM TO ANY PARTICULAR FONT, STYLE, SIZE, OR COLOR.

FOR ALCOHOLIC TEA-BASED BEVERAGES; ALCOHOLIC COFFEE-BASED BEVERAGES; ALCOHOLIC BEVERAGES OF FRUIT; ALCOHOLIC BEVERAGES CONTAINING FRUIT; ALCOHOLIC BEVERAGES EXCEPT BEERS; ALCOHOLIC BEVERAGES, NAMELY, FLAVOR-INFUSED WHISKEY; ALCOHOLIC CARBONATED BEVERAGES, EXCEPT BEER; ALCOHOLIC COCKTAIL MIXES; ALCOHOLIC ENERGY DRINKS; ALCOHOLIC FRUIT COCKTAIL DRINKS; ALCOHOLIC FRUIT EXTRACTS; ALCOHOLIC MIXED BEVERAGES EXCEPT BEERS; ALCOHOLIC PUNCHES; APERITIFS WITH A DISTILLED ALCOHOLIC LIQUOR BASE; PREPARED ALCOHOLIC COCKTAILS; RUMS (U.S. CLS. 47 AND 49).

BENJAMIN OKEKE, EXAMINING ATTORNEY

SN 85-511,406. VINTAGE ROCKEFELLER CHAMPAGNE GROUP CORPORATION, OAKDALE, NY. FILED 1-9-2012.

Grande Rockefeller

THE MARK CONSISTS OF STANDARD CHARACTERS WITHOUT CLAIM TO ANY PARTICULAR FONT, STYLE, SIZE, OR COLOR.

FOR WINE (U.S. CLS. 47 AND 49).
ALLISON SCHRODY, EXAMINING ATTORNEY

SN 85-512,144. BARBA, DANIEL, TEMECULA, CA. FILED 1-9-2012.

Provocame

THE MARK CONSISTS OF STANDARD CHARACTERS WITHOUT CLAIM TO ANY PARTICULAR FONT, STYLE, SIZE, OR COLOR.

FOR DISTILLED SPIRITS (U.S. CLS. 47 AND 49).
JOHN DALIER, EXAMINING ATTORNEY

CLASS 33—(Continued).

SN 85-512,146. SUTTER HOME WINERY, INC., ST. HELENA, CA. FILED 1-9-2012.

SQUARE PEG

THE MARK CONSISTS OF STANDARD CHARACTERS WITHOUT CLAIM TO ANY PARTICULAR FONT, STYLE, SIZE, OR COLOR.
FOR ALCOHOLIC BEVERAGES EXCEPT BEERS (U.S. CLS. 47 AND 49).
NATALIE POLZER, EXAMINING ATTORNEY

SN 85-512,183. TASSINARI, STEPHEN, PEABODY, MA. AND TASSINARI, MAX, EAST BOSTON, MA. AND KEEGAN, LAWRENCE, EAST BOSTON, MA. FILED 1-9-2012.

Brahmin

THE MARK CONSISTS OF STANDARD CHARACTERS WITHOUT CLAIM TO ANY PARTICULAR FONT, STYLE, SIZE, OR COLOR.
FOR DISTILLED SPIRITS (U.S. CLS. 47 AND 49).
SUSAN LESLIE DUBOIS, EXAMINING ATTORNEY

SN 85-512,551. SUNTORY HOLDINGS LIMITED, OSAKA-SHI, OSAKA, JAPAN. FILED 1-10-2012.

PAVAN

THE MARK CONSISTS OF STANDARD CHARACTERS WITHOUT CLAIM TO ANY PARTICULAR FONT, STYLE, SIZE, OR COLOR.
FOR LIQUEURS (U.S. CLS. 47 AND 49).
GENE MACIOL, EXAMINING ATTORNEY

CLASS 33—(Continued).

SN 85-512,620. NOVITSKY, MAXIM, DIX HILLS, NY. FILED 1-10-2012.

MAXX

THE MARK CONSISTS OF STANDARD CHARACTERS WITHOUT CLAIM TO ANY PARTICULAR FONT, STYLE, SIZE, OR COLOR.
FOR LIQUEURS; VODKA; WHISKEY (U.S. CLS. 47 AND 49).
TEJBIR SINGH, EXAMINING ATTORNEY

SN 85-512,696. EASTWOOD, SCOTT C., LOS ANGELES, CA. FILED 1-10-2012.

The Good, the Bad and the Ugly

THE MARK CONSISTS OF STANDARD CHARACTERS WITHOUT CLAIM TO ANY PARTICULAR FONT, STYLE, SIZE, OR COLOR.
FOR WHISKY (U.S. CLS. 47 AND 49).
KAREN SEVERSON, EXAMINING ATTORNEY

SN 85-512,757. ONE TRUE VINE, LLC, ST. HELENA, CA. FILED 1-10-2012.

SEE YOU NEXT TUESDAY

THE MARK CONSISTS OF STANDARD CHARACTERS WITHOUT CLAIM TO ANY PARTICULAR FONT, STYLE, SIZE, OR COLOR.
FOR WINES (U.S. CLS. 47 AND 49).
GISELLE AGOSTO, EXAMINING ATTORNEY

SN 85-512,772. ONE TRUE VINE, LLC, ST. HELENA, CA. FILED 1-10-2012.

NEW'D

THE MARK CONSISTS OF STANDARD CHARACTERS WITHOUT CLAIM TO ANY PARTICULAR FONT, STYLE, SIZE, OR COLOR.
FOR WINES (U.S. CLS. 47 AND 49).
GISELLE AGOSTO, EXAMINING ATTORNEY

CLASS 33—(Continued).

SN 85-512,785. INTERVINE INC., NAPA, CA. FILED 1-10-2012.

CONSONANCE BRIDGE

THE MARK CONSISTS OF STANDARD CHARACTERS WITHOUT CLAIM TO ANY PARTICULAR FONT, STYLE, SIZE, OR COLOR.

FOR ALCOHOLIC BEVERAGES EXCEPT BEERS (U.S. CLS. 47 AND 49).

GIANCARLO CASTRO, EXAMINING ATTORNEY

CLASS 33—(Continued).

SN 85-513,705. THE MORLET SELECTION, INCORPORATED, ST. HELENA, CA. FILED 1-11-2012.

ENTR'ACTE

THE MARK CONSISTS OF STANDARD CHARACTERS WITHOUT CLAIM TO ANY PARTICULAR FONT, STYLE, SIZE, OR COLOR.

THE ENGLISH TRANSLATION OF "ENTR'ACTE" IN THE MARK IS "BETWEEN ACTS".

FOR ALCOHOLIC BEVERAGES EXCEPT BEERS (U.S. CLS. 47 AND 49).

CORY BOONE, EXAMINING ATTORNEY

SN 85-512,810. INTERVINE INC., NAPA, CA. FILED 1-10-2012.

LEYLAND CREEK

THE MARK CONSISTS OF STANDARD CHARACTERS WITHOUT CLAIM TO ANY PARTICULAR FONT, STYLE, SIZE, OR COLOR.

FOR ALCOHOLIC BEVERAGES EXCEPT BEERS (U.S. CLS. 47 AND 49).

GIANCARLO CASTRO, EXAMINING ATTORNEY

SN 85-513,995. RONBOW INTERNATIONAL, GEORGETOWN, GRND CAYMAN, CAYMAN ISLANDS, FILED 1-11-2012.

Noble Woods

THE MARK CONSISTS OF STANDARD CHARACTERS WITHOUT CLAIM TO ANY PARTICULAR FONT, STYLE, SIZE, OR COLOR.

FOR WINE (U.S. CLS. 47 AND 49).

FIRST USE 12-6-2011; IN COMMERCE 12-18-2011.

JENNIFER VASQUEZ, EXAMINING ATTORNEY

SN 85-513,698. CLEARY & SWEENEY WINES LLC, DBA SPANKING BOTTOM WINE, FOXBORO, MA. FILED 1-11-2012.

Spanking Bottom

THE MARK CONSISTS OF STANDARD CHARACTERS WITHOUT CLAIM TO ANY PARTICULAR FONT, STYLE, SIZE, OR COLOR.

FOR WINES (U.S. CLS. 47 AND 49).

CHRISTINE MARTIN, EXAMINING ATTORNEY

SN 85-514,365. INTERVINE INC., NAPA, CA. FILED 1-11-2012.

LANDEN RANCH

THE MARK CONSISTS OF STANDARD CHARACTERS WITHOUT CLAIM TO ANY PARTICULAR FONT, STYLE, SIZE, OR COLOR.

THE ENGLISH TRANSLATION OF "LANDEN" IN THE MARK IS "LAND".

FOR ALCOHOLIC BEVERAGES EXCEPT BEERS (U.S. CLS. 47 AND 49).

GIANCARLO CASTRO, EXAMINING ATTORNEY

CLASS 33—(Continued).

SN 85-514,406. PETITO, THOMAS, NORTH BERGEN, NJ.
FILED 1-11-2012.

2727

THE MARK CONSISTS OF STANDARD CHARACTERS
WITHOUT CLAIM TO ANY PARTICULAR FONT, STYLE,
SIZE, OR COLOR.
FOR WINE (U.S. CLS. 47 AND 49).
JENNIFER VASQUEZ, EXAMINING ATTORNEY

SN 85-514,670. FINCAS Y BODEGAS MONTECHEZ S.A.,
BUENOS AIRES, ARGENTINA, FILED 1-12-2012.

MONTECHEZ

THE MARK CONSISTS OF STANDARD CHARACTERS
WITHOUT CLAIM TO ANY PARTICULAR FONT, STYLE,
SIZE, OR COLOR.
OWNER OF ARGENTINA REG. NO. 2.383.429, DATED 9-
14-2010, EXPIRES 9-9-2020.
FOR WINES (U.S. CLS. 47 AND 49).
DAWN FELDMAN, EXAMINING ATTORNEY

SN 85-515,650. STE. MICHELLE WINE ESTATES LTD.,
WOODINVILLE, WA. FILED 1-13-2012.

TWO VINES

THE MARK CONSISTS OF STANDARD CHARACTERS
WITHOUT CLAIM TO ANY PARTICULAR FONT, STYLE,
SIZE, OR COLOR.
NO CLAIM IS MADE TO THE EXCLUSIVE RIGHT TO
USE "VINES", APART FROM THE MARK AS SHOWN.
FOR ALCOHOLIC BEVERAGES, EXCEPT BEER (U.S.
CLS. 47 AND 49).
FIRST USE 11-13-2002; IN COMMERCE 1-14-2003.
ROBERT C. CLARK JR., EXAMINING ATTORNEY

CLASS 33—(Continued).

SN 85-515,737. 585 WINE PARTNERS, LLC, NAPA, CA.
FILED 1-13-2012.

MANOS UNIDOS

THE MARK CONSISTS OF STANDARD CHARACTERS
WITHOUT CLAIM TO ANY PARTICULAR FONT, STYLE,
SIZE, OR COLOR.
THE ENGLISH TRANSLATION OF "MANOS UNIDOS" IN
THE MARK IS "UNITED HANDS".
FOR WINE (U.S. CLS. 47 AND 49).
MARTHA FROMM, EXAMINING ATTORNEY

SN 85-515,763. 585 WINE PARTNERS, LLC, NAPA, CA.
FILED 1-13-2012.

PAPER LANTERN

THE MARK CONSISTS OF STANDARD CHARACTERS
WITHOUT CLAIM TO ANY PARTICULAR FONT, STYLE,
SIZE, OR COLOR.
FOR WINE (U.S. CLS. 47 AND 49).
MARTHA FROMM, EXAMINING ATTORNEY

SN 85-515,892. ONE PLUS TWO INC., CONCORD, CA. FILED
1-13-2012.

4X4

THE MARK CONSISTS OF STANDARD CHARACTERS
WITHOUT CLAIM TO ANY PARTICULAR FONT, STYLE,
SIZE, OR COLOR.
FOR ALCOHOLIC BEVERAGES EXCEPT BEERS (U.S.
CLS. 47 AND 49).
KRISTIN DAHLING, EXAMINING ATTORNEY

CLASS 33—(Continued).

SN 85-515,894. ONE PLUS TWO INC., CONCORD, CA. FILED 1-13-2012.

INTERMINGLING

THE MARK CONSISTS OF STANDARD CHARACTERS WITHOUT CLAIM TO ANY PARTICULAR FONT, STYLE, SIZE, OR COLOR.
FOR ALCOHOLIC BEVERAGES EXCEPT BEERS (U.S. CLS. 47 AND 49).
KRISTIN DAHLING, EXAMINING ATTORNEY

SN 85-516,348. EVANS, D. JACQUES, CLEVELAND, OH. FILED 1-13-2012.

Champagne Of Vodka

THE MARK CONSISTS OF STANDARD CHARACTERS WITHOUT CLAIM TO ANY PARTICULAR FONT, STYLE, SIZE, OR COLOR.
NO CLAIM IS MADE TO THE EXCLUSIVE RIGHT TO USE "VODKA", APART FROM THE MARK AS SHOWN.
FOR DISTILLED SPIRITS, NAMELY, VODKA (U.S. CLS. 47 AND 49).
CARYN GLASSER, EXAMINING ATTORNEY

SN 85-516,378. SNOVA, LLC, LITTLETON, CO. FILED 1-13-2012.



THE MARK CONSISTS OF A THREE-DIMENSIONAL PEBBLED DESIGN EMBEDDED IN A GLASS BOTTLE. THE OUTLINE OF THE BOTTLE SHOWN IN BROKEN LINES SERVES TO SHOW THE POSITION OF THE MARK AND FORMS NO PART OF THE MARK.
FOR VODKA (U.S. CLS. 47 AND 49).
TASNEEM HUSSAIN, EXAMINING ATTORNEY

CLASS 33—(Continued).

SN 85-521,869. TASTY COCKTAILS LLC, HENDERSON, NV. FILED 1-20-2012.

Numb

THE MARK CONSISTS OF STANDARD CHARACTERS WITHOUT CLAIM TO ANY PARTICULAR FONT, STYLE, SIZE, OR COLOR.
OWNER OF U.S. REG. NOS. 3,845,672 AND 3,874,408.
FOR PREPARED ALCOHOLIC COCKTAIL (U.S. CLS. 47 AND 49).
FIRST USE 7-10-2010; IN COMMERCE 7-10-2010.
JANICE KIM, EXAMINING ATTORNEY

SN 85-521,959. STRANGER & STRANGER INC, NEW YORK, NY. FILED 1-21-2012.

BELIEVE IT OR NOT

THE MARK CONSISTS OF STANDARD CHARACTERS WITHOUT CLAIM TO ANY PARTICULAR FONT, STYLE, SIZE, OR COLOR.
FOR WINE (U.S. CLS. 47 AND 49).
SOPHIA S. KIM, EXAMINING ATTORNEY

SN 85-524,380. INTERVINE INC., NAPA, CA. FILED 1-24-2012.

NERISSA'S NOTE

THE MARK CONSISTS OF STANDARD CHARACTERS WITHOUT CLAIM TO ANY PARTICULAR FONT, STYLE, SIZE, OR COLOR.
FOR ALCOHOLIC BEVERAGES EXCEPT BEERS (U.S. CLS. 47 AND 49).
GIANCARLO CASTRO, EXAMINING ATTORNEY

CLASS 33—(Continued).

SN 85-525,661. SARINA II, LLC, WILMINGTON, DE. FILED
1-26-2012.

ANGRY INCH

THE MARK CONSISTS OF STANDARD CHARACTERS
WITHOUT CLAIM TO ANY PARTICULAR FONT, STYLE,
SIZE, OR COLOR.
FOR ALCOHOLIC BEVERAGES EXCEPT BEERS (U.S.
CLS. 47 AND 49).
CURTIS FRENCH, EXAMINING ATTORNEY

CLASS 33—(Continued).

SN 85-529,958. SUTTER HOME WINERY, INC., ST. HELENA,
CA. FILED 1-31-2012.

90 MILE BEACH

THE MARK CONSISTS OF STANDARD CHARACTERS
WITHOUT CLAIM TO ANY PARTICULAR FONT, STYLE,
SIZE, OR COLOR.
FOR ALCOHOLIC BEVERAGES EXCEPT BEERS (U.S.
CLS. 47 AND 49).
NATALIE POLZER, EXAMINING ATTORNEY

SN 85-525,676. SARINA II, LLC, WILMINGTON, DE. FILED
1-26-2012.

PRETTY IN PINK

THE MARK CONSISTS OF STANDARD CHARACTERS
WITHOUT CLAIM TO ANY PARTICULAR FONT, STYLE,
SIZE, OR COLOR.
FOR ALCOHOLIC BEVERAGES EXCEPT BEERS (U.S.
CLS. 47 AND 49).
CURTIS FRENCH, EXAMINING ATTORNEY

SN 85-530,310. SUTTER HOME WINERY, INC., ST. HELENA,
CA. FILED 1-31-2012.

ECHO BAY

THE MARK CONSISTS OF STANDARD CHARACTERS
WITHOUT CLAIM TO ANY PARTICULAR FONT, STYLE,
SIZE, OR COLOR.
FOR ALCOHOLIC BEVERAGES EXCEPT BEERS (U.S.
CLS. 47 AND 49).
NATALIE POLZER, EXAMINING ATTORNEY

SN 85-529,951. SUTTER HOME WINERY, INC., ST. HELENA,
CA. FILED 1-31-2012.

BUSY BEE

THE MARK CONSISTS OF STANDARD CHARACTERS
WITHOUT CLAIM TO ANY PARTICULAR FONT, STYLE,
SIZE, OR COLOR.
FOR ALCOHOLIC BEVERAGES EXCEPT BEERS (U.S.
CLS. 47 AND 49).
NATALIE POLZER, EXAMINING ATTORNEY

SN 85-530,316. SUTTER HOME WINERY, INC., ST. HELENA,
CA. FILED 1-31-2012.

TEAR DROP

THE MARK CONSISTS OF STANDARD CHARACTERS
WITHOUT CLAIM TO ANY PARTICULAR FONT, STYLE,
SIZE, OR COLOR.
FOR ALCOHOLIC BEVERAGES EXCEPT BEERS (U.S.
CLS. 47 AND 49).
NATALIE POLZER, EXAMINING ATTORNEY

CLASS 33—(Continued).

SN 85-532,634. AGAVERA CAMICHINES, S.A. DE C.V., JALISCO, MEXICO, FILED 2-2-2012.

KRUDO

THE MARK CONSISTS OF STANDARD CHARACTERS WITHOUT CLAIM TO ANY PARTICULAR FONT, STYLE, SIZE, OR COLOR.
FOR ALCOHOLIC BEVERAGES EXCEPT BEERS (U.S. CLS. 47 AND 49).
KATHERINE CONNOLLY, EXAMINING ATTORNEY

SN 85-533,227. WINE BY JOE, LLC, DUNDEE, OR. FILED 2-3-2012.

JOE DOBBES WINES

THE MARK CONSISTS OF STANDARD CHARACTERS WITHOUT CLAIM TO ANY PARTICULAR FONT, STYLE, SIZE, OR COLOR.
OWNER OF U.S. REG. NO. 2,924,180.
NO CLAIM IS MADE TO THE EXCLUSIVE RIGHT TO USE "WINES", APART FROM THE MARK AS SHOWN.
THE NAME "JOE DOBBES" IDENTIFIES A LIVING INDIVIDUAL WHOSE CONSENT IS OF RECORD.
FOR WINE (U.S. CLS. 47 AND 49).
DAWN HAN, EXAMINING ATTORNEY

SN 85-535,177. BOSTON BEER CORPORATION, BOSTON, MA. FILED 2-6-2012.



THE MARK CONSISTS OF A STYLIZED TREE DESIGN FEATURING A FACE IN THE TRUNK WITH TWO BITTEN APPLES HANGING OFF BRANCHES.
FOR HARD CIDER (U.S. CLS. 47 AND 49).
FIRST USE 9-12-2011; IN COMMERCE 9-12-2011.
AMY KELLY, EXAMINING ATTORNEY

CLASS 33—(Continued).

SN 85-535,193. BOSTON BEER CORPORATION, BOSTON, MA. FILED 2-6-2012.



THE MARK CONSISTS OF A STYLIZED TREE DESIGN FEATURING A FACE IN THE TRUNK WITH TWO BITTEN APPLES HANGING OFF BRANCHES.
FOR HARD CIDER (U.S. CLS. 47 AND 49).
FIRST USE 9-12-2011; IN COMMERCE 9-12-2011.
AMY KELLY, EXAMINING ATTORNEY

SN 85-535,199. BOSTON BEER CORPORATION, BOSTON, MA. FILED 2-6-2012.



THE MARK CONSISTS OF A STYLIZED TREE DESIGN FEATURING A FACE IN THE TRUNK WITH TWO BITTEN APPLES HANGING OFF BRANCHES.
FOR HARD CIDER (U.S. CLS. 47 AND 49).
FIRST USE 9-12-2011; IN COMMERCE 9-12-2011.
AMY KELLY, EXAMINING ATTORNEY

SN 85-535,353. STRANGER & STRANGER INC, NEW YORK, NY. FILED 2-6-2012.

PAPER LANE

THE MARK CONSISTS OF STANDARD CHARACTERS WITHOUT CLAIM TO ANY PARTICULAR FONT, STYLE, SIZE, OR COLOR.
FOR ALCOHOLIC BEVERAGES EXCEPT BEERS (U.S. CLS. 47 AND 49).
SOPHIA S. KIM, EXAMINING ATTORNEY

CLASS 33—(Continued).

SN 85-539,926. SUTTER HOME WINERY, INC., ST. HELENA, CA. FILED 2-10-2012.

THE GOLDSMITH

THE MARK CONSISTS OF STANDARD CHARACTERS WITHOUT CLAIM TO ANY PARTICULAR FONT, STYLE, SIZE, OR COLOR.
FOR ALCOHOLIC BEVERAGES EXCEPT BEERS (U.S. CLS. 47 AND 49).
NATALIE POLZER, EXAMINING ATTORNEY

SN 85-540,186. WINERY EXCHANGE, INC., NOVATO, CA. FILED 2-10-2012.

COX & ROW

THE MARK CONSISTS OF STANDARD CHARACTERS WITHOUT CLAIM TO ANY PARTICULAR FONT, STYLE, SIZE, OR COLOR.
FOR ALCOHOLIC BEVERAGES EXCEPT BEERS (U.S. CLS. 47 AND 49).
BILL DAWE, EXAMINING ATTORNEY

SN 85-540,188. WINERY EXCHANGE, INC., NOVATO, CA. FILED 2-10-2012.

SOUTHSHOT

THE MARK CONSISTS OF STANDARD CHARACTERS WITHOUT CLAIM TO ANY PARTICULAR FONT, STYLE, SIZE, OR COLOR.
FOR ALCOHOLIC BEVERAGES EXCEPT BEERS (U.S. CLS. 47 AND 49).
BILL DAWE, EXAMINING ATTORNEY

CLASS 33—(Continued).

SN 85-542,520. SUTTER HOME WINERY, INC., ST. HELENA, CA. FILED 2-14-2012.

NIGHTSKY

THE MARK CONSISTS OF STANDARD CHARACTERS WITHOUT CLAIM TO ANY PARTICULAR FONT, STYLE, SIZE, OR COLOR.
FOR ALCOHOLIC BEVERAGES EXCEPT BEERS (U.S. CLS. 47 AND 49).
NATALIE POLZER, EXAMINING ATTORNEY

SN 85-548,087. REAL, JOSELITO G, WOODLAND, CA. FILED 2-21-2012.

Extraordinary Wines and Beyond

THE MARK CONSISTS OF STANDARD CHARACTERS WITHOUT CLAIM TO ANY PARTICULAR FONT, STYLE, SIZE, OR COLOR.

FOR APERITIF WINES; APERITIFS WITH A WINE BASE; COOKING WINE; FORTIFIED WINES; FRUIT WINE; GRAPE WINE; HONEY WINE; KITS FOR MAKING WINE; NATURAL SPARKLING WINES; PORT WINES; PREPARED WINE COCKTAILS; RED WINE; RED WINES; ROSE WINE; SPARKLING FRUIT WINE; SPARKLING GRAPE WINE; SPARKLING WINES; STILL WINES; STRAWBERRY WINE; SWEET WINES; TABLE WINES; TONIC SWEET GRAPE WINE CONTAINING EXTRACTS FROM GINSENG AND CONCHONA BARK (NINJIN-KINATETSU WINE); WHITE WINE; WINE; WINE COOLERS; WINE PUNCH; WINE PUNCHES; WINE-BASED BEVERAGE, NAMELY, PIQUETTE; WINE-BASED DRINKS; WINES; WINES AND FORTIFIED WINES; WINES AND LIQUEURS; WINES AND SPARKLING WINES; WINES DERIVED FROM GRAPES GROWN IN CALIFORNIA, LABELED AND ADVERTISED IN COMPLIANCE WITH ABC AND TTB LAWS FOR COLA (U.S. CLS. 47 AND 49).
JENNIFER VASQUEZ, EXAMINING ATTORNEY

CLASS 33—(Continued).

SN 85-555,730. ISLAND DISTILLERS INC., HONOLULU, HI. FILED 2-29-2012.

HUMUHUMUNUKUNUKUAPUA'A

THE MARK CONSISTS OF STANDARD CHARACTERS WITHOUT CLAIM TO ANY PARTICULAR FONT, STYLE, SIZE, OR COLOR.

THE NAME(S), PORTRAIT(S), AND/OR SIGNATURE(S) SHOWN IN THE MARK DOES NOT IDENTIFY A PARTICULAR LIVING INDIVIDUAL.

THE ENGLISH TRANSLATION OF "HUMUHUMUNUKUNUKUAPUA'A" IN THE MARK IS "REEF TRIGGER-FISH".

FOR ALCOHOLIC BEVERAGES, NAMELY, SPIRITS (U.S. CLS. 47 AND 49).

TIMOTHY FINNEGAN, EXAMINING ATTORNEY

CLASS 33—(Continued).

SN 85-579,473. CARIBBEAN DISTILLERS LLC, LAKE ALFRED, FL. FILED 3-26-2012.

Nakisha

THE MARK CONSISTS OF STANDARD CHARACTERS WITHOUT CLAIM TO ANY PARTICULAR FONT, STYLE, SIZE, OR COLOR.

FOR VODKA (U.S. CLS. 47 AND 49).

PATRICIA EVANKO, EXAMINING ATTORNEY

SN 85-557,018. WINERY EXCHANGE, INC., NOVATO, CA. FILED 2-29-2012.

ACRONYM

THE MARK CONSISTS OF STANDARD CHARACTERS WITHOUT CLAIM TO ANY PARTICULAR FONT, STYLE, SIZE, OR COLOR.

FOR ALCOHOLIC BEVERAGES EXCEPT BEERS (U.S. CLS. 47 AND 49).

BILL DAWE, EXAMINING ATTORNEY

CLASS 34—SMOKERS' ARTICLES

SN 77-621,550. ITC LIMITED, KOLKATA, INDIA. FILED 11-25-2008.



SN 85-562,278. WINERY EXCHANGE, INC., NOVATO, CA. FILED 3-6-2012.

KICKSTAND

THE MARK CONSISTS OF STANDARD CHARACTERS WITHOUT CLAIM TO ANY PARTICULAR FONT, STYLE, SIZE, OR COLOR.

FOR ALCOHOLIC BEVERAGES EXCEPT BEERS (U.S. CLS. 47 AND 49).

BILL DAWE, EXAMINING ATTORNEY

OWNER OF INDIA REG. NO. 886969, DATED 11-17-1999, RENEWED AS REG. NO. 886969, DATED 11-12-2009, EXPIRES 11-17-2019.

NO CLAIM IS MADE TO THE EXCLUSIVE RIGHT TO USE "NAVY CUT", APART FROM THE MARK AS SHOWN.

THE NAME(S), PORTRAIT(S), AND/OR SIGNATURE(S) SHOWN IN THE MARK DOES NOT IDENTIFY A PARTICULAR LIVING INDIVIDUAL.

THE MARK CONSISTS OF A DEPICTION OF A SHIELD CONTAINING THE LETTERS "WD", "HO" AND THE WORD "WILLS". THE SHIELD IS HELD BY A LION AND HORSE, AND A CROWN IS SET ABOVE THE SHIELD, AND A BANNER WITH THE TERM "W.D. & H.O. WILLS" APPEARS BELOW THE SHIELD. BENEATH THE BANNER, IN A DOUBLE LINED RECTANGLE APPEARS THE TERM "WILLS NAVY CUT".

FOR CIGARETTES (U.S. CLS. 2, 8, 9 AND 17).

BERYL GARDNER, EXAMINING ATTORNEY

CLASS 34—(Continued).

SN 79-036,379. KONINKLIJKE FABRIEK VAN TABAKSPIJ-PEN ELBERT GUBBELS EN ZONEN B.V., NL-6045 GG ROERMOND, NETHERLANDS, FILED 10-19-2006.

BIG BEN

OWNER OF INTERNATIONAL REGISTRATION 0427957 DATED 10-18-1976, EXPIRES 10-18-2016.

FOR SMOKING PIPES; SACHETS IN THE NATURE OF PIPE POUCHES AND CARRYING CASES FOR SMOKING PIPES; TOBACCO POUCHES AND TOBACCO POUCHES FOR ROLLING CIGARETTES; TOBACCO JARS; SMOKING PIPE HOLDERS; SMOKING PIPE CLEANERS; SMOKING PIPE CLEANERS IN THE NATURE OF PIPE SCRAPERS AND PIPE BRUSHES; LIGHTERS FOR SMOKERS; CIGAR AND CIGARETTE HOLDERS; CIGAR AND CIGARETTE CASES; ASH-TRAYS; CIGAR AND CIGARETTE EXTINGUISHERS; TOBACCO FILTERS FOR TOBACCO PIPES, FOR CIGAR HOLDERS AND FOR CIGARETTE HOLDERS; CIGAR CUTTERS; TOBACCO, CIGAR AND CIGARETTE BOXES; SNUFF BOXES; GAS CONTAINERS BEING STRUCTURAL PARTS OF LIGHTERS FOR SMOKERS (U.S. CLS. 2, 8, 9 AND 17).

KATHERINE E. HALMEN, EXAMINING ATTORNEY

SN 79-104,327. GIZEH RAUCHERBEDARF GMBH, 51647 GUMMERSBACH, FED REP GERMANY, FILED 9-30-2011.

GIZEH BLACK

THE MARK CONSISTS OF STANDARD CHARACTERS WITHOUT CLAIM TO ANY PARTICULAR FONT, STYLE, SIZE, OR COLOR.

PRIORITY DATE OF 4-5-2011 IS CLAIMED.

OWNER OF INTERNATIONAL REGISTRATION 1095242 DATED 9-30-2011, EXPIRES 9-30-2021.

OWNER OF U.S. REG. NOS. 1,877,884, 3,136,077 AND OTHERS.

NO CLAIM IS MADE TO THE EXCLUSIVE RIGHT TO USE "BLACK", APART FROM THE MARK AS SHOWN.

THE ENGLISH TRANSLATION OF "GIZEH" IN THE MARK IS "GIZA".

FOR CIGARETTE PAPER; CIGARETTE PAPER SHEETS; CIGARETTE PAPER, NAMELY, BOOKS OF CIGARETTE PAPER; CIGARETTE TUBES, IN PARTICULAR FILTER CIGARETTE TUBES; SMOKERS' ARTICLES, NAMELY, APPARATUS FOR MAKING CIGARETTES, IN PARTICULAR FOR ROLLING AND FILLING CIGARETTES; TOBACCO SMOKE FILTERS; ABSORBENT PAPER FOR TOBACCO PIPES; PAPER TOBACCO FILTERS; TOBACCO PIPES; SMOKING PIPE CLEANERS; TOBACCO PIPE CLEANERS; TOOLS FOR SMOKING PIPES, NAMELY, PIPE TAMPERS; TOBACCO TINS, CIGARETTE HOLDERS, TOBACCO POUCHES, CIGARETTE CASES, CIGARETTE HOLDERS, CIGAR CUTTERS, LIGHTERS FOR SMOKERS, ALL THE AFORESAID GOODS NOT MADE OF PRECIOUS METALS AND THEIR ALLOYS, OR COATED THEREWITH; TOBACCO, IN PARTICULAR SMOKING TOBACCO; CIGARETTES; FILTER CIGARETTES; CIGARETTES CONTAINING TOBACCO SUBSTITUTES, NOT FOR MEDICAL PURPOSES; CIGARILLOS; CIGARS (U.S. CLS. 2, 8, 9 AND 17).

AISHA SALEM, EXAMINING ATTORNEY

CLASS 34—(Continued).

SN 85-306,272. ERNESTO CASILLA, MIAMI, FL. FILED 4-27-2011.



THE MARK CONSISTS OF GLOBE WITH OUTLINES OF CONTINENTS WITH A MAN WEARING A BUSINESS SUIT AND A HAT SMOKING A CIGAR WITH SMOKE RISING FROM THE CIGAR WALKING ON TOP OF THE GLOBE.

FOR CIGAR AND CIGARETTE BOXES; CIGARS (U.S. CLS. 2, 8, 9 AND 17).

FIRST USE 10-0-1973; IN COMMERCE 10-0-1973.

LINDA POWELL, EXAMINING ATTORNEY

SN 85-328,158. ECX LLC, CUSTER, WA. FILED 5-24-2011.

ecigexpress

THE MARK CONSISTS OF THE WORDING "ECIGEXPRESS" IN STYLIZED FONT WHERE THE LETTER "I" IS FORMED BY A UNIVERSAL SERIAL BUS CABLE.

FOR ELECTRIC CIGARETTES; ELECTRONIC CIGARETTES; ELECTRONIC CIGARETTES FOR USE AS AN ALTERNATIVE TO TRADITIONAL CIGARETTES; SMOKELESS CIGARETTE VAPORIZER PIPE (U.S. CLS. 2, 8, 9 AND 17).

FIRST USE 6-24-2009; IN COMMERCE 6-24-2009.

TINA BROWN, EXAMINING ATTORNEY

CLASS 34—(Continued).

SN 85-397,728. AGAPI, INC., HOUSTON, TX. FILED 8-15-2011.

SPACECADET

THE MARK CONSISTS OF STANDARD CHARACTERS WITHOUT CLAIM TO ANY PARTICULAR FONT, STYLE, SIZE, OR COLOR.

FOR TOBACCO, SHISHA TOBACCO, CIGARETTES, CIGARS AND SMOKING ACCESSORIES, NAMELY, LIGHTERS, ELECTRONIC CIGARETTES, PIPES; HOOKAHS, GRINDERS, TOBACCO PRESSES, LIGHTER COALS, NAMELY, WATER PIPE CHARCOALS, LIGHTER ROPES, NAMELY, LIGHTER WICKS, TOBACCO STORAGE BOXES, TOBACCO ROLLING PAPERS, LEAFS AND WRAPS (U.S. CLS. 2, 8, 9 AND 17).
SANI KHOURI, EXAMINING ATTORNEY

SN 85-425,132. SMOKE MONEY PAPERS, SAINT PETERSBURG, FL. FILED 9-16-2011.

Smoke Money Papers

THE MARK CONSISTS OF STANDARD CHARACTERS WITHOUT CLAIM TO ANY PARTICULAR FONT, STYLE, SIZE, OR COLOR.

NO CLAIM IS MADE TO THE EXCLUSIVE RIGHT TO USE "SMOKE" AND "PAPERS", APART FROM THE MARK AS SHOWN.

FOR TOBACCO ROLLING PAPER (U.S. CLS. 2, 8, 9 AND 17).
STEVEN R. FINE, EXAMINING ATTORNEY

CLASS 34—(Continued).

SN 85-464,279. LEGEND FOR TOBACCO MANUFACTURING, LTD., AMMAN, JORDAN, FILED 11-4-2011.



Argelini

THE MARK CONSISTS OF THE WORDING "ARGELINI" IN A STYLIZED FONT BENEATH A DESIGN THAT CONSISTS OF A SCEPTER INSIDE A SHIELD, TWO EAGLES ARE ON THE LEFT AND RIGHT SIDE OF THE SHIELD FACING EACH OTHER, WHEREIN THE EAGLES HAVE CURVED TAILS WITH A LEAF AT THE END OF THE TAIL. A BANDEROLE IS BELOW THE SHIELD AND TWO EAGLES, WHEREIN THE ARABIC CHARACTERS ARE IN THE BANDEROLE.

THE WORDING "ARGELINI" HAS NO MEANING IN A FOREIGN LANGUAGE.

THE NON-LATIN CHARACTERS IN THE MARK TRANSLITERATE TO "ARGELINI" AND THIS HAS NO MEANING IN A FOREIGN LANGUAGE.

FOR CIGAR CUTTERS; CIGARETTE CASES; HOOKAH PARTS, NAMELY, HOSES, BOWLS, MOUTHPIECES, BASES; HOOKAH TOBACCO; LIGHTERS NOT OF PRECIOUS METAL; MOLASSES TOBACCO; SMOKER'S ARTICLES, NAMELY, FILTER TUBES; SMOKERS' ARTICLES, NAMELY, CIGAR GLUE; SMOKERS' ARTICLES, NAMELY, CIGAR RELIGHTING LIQUID SOLUTION; SMOKERS' ARTICLES, NAMELY, HOOKAH CHARCOAL; SMOKERS' ARTICLES, NAMELY, KEYSTONES FOR PIPES; SMOKERS' ARTICLES, NAMELY, OUTDOOR RECEPTACLES FOR CIGAR AND CIGARETTE ASH AND WASTE; SMOKERS' ARTICLES, NAMELY, REHYDRATION TUBES; SMOKER'S ARTICLES, NAMELY, METAL POCKET-SIZED RECEPTACLES WITH LIDS FOR CIGARETTE BUTTS; SMOKING PIPE CLEANERS; SMOKING PIPES; TOBACCO; TOBACCO POUCHES; TOBACCO, CIGARS AND CIGARETTES (U.S. CLS. 2, 8, 9 AND 17).

FIRST USE 12-6-2007; IN COMMERCE 10-1-2010.
RENEE MCCRAY, EXAMINING ATTORNEY

SN 85-486,080. HAZE TOBACCO, LLC, STAFFORD, TX. FILED 12-2-2011.

COCO ROAST

THE MARK CONSISTS OF STANDARD CHARACTERS WITHOUT CLAIM TO ANY PARTICULAR FONT, STYLE, SIZE, OR COLOR.

NO CLAIM IS MADE TO THE EXCLUSIVE RIGHT TO USE "COCO", APART FROM THE MARK AS SHOWN.

FOR HOOKAH TOBACCO; SMOKING TOBACCO; TOBACCO (U.S. CLS. 2, 8, 9 AND 17).
FIRST USE 11-17-2011; IN COMMERCE 11-17-2011.
CHERYL CLAYTON, EXAMINING ATTORNEY

CLASS 34—(Continued).

SN 85-490,445. SHEFFIELD EXCHANGE, LLC, SAN MARCOS, TX. FILED 12-8-2011.

SHEFFIELD EXCHANGE

THE MARK CONSISTS OF STANDARD CHARACTERS WITHOUT CLAIM TO ANY PARTICULAR FONT, STYLE, SIZE, OR COLOR.

FOR SNUFFS, SMOKING TOBACCOS, SMOKING PIPES; AND SMOKER'S ACCESSORIES, NAMELY, SNUFF POUCHES AND SNUFF CASES, NOT OF PRECIOUS METAL, CIGAR CUTTERS, CIGAR HOLDERS, CIGAR POUCHES, AND CIGAR CASES, ALL NOT OF PRECIOUS METAL, HUMIDORS, PIPE TAMPERS, PIPE PICKS AND PIPE RESTS, LIGHTERS NOT OF PRECIOUS METAL, AND ASH TRAYS NOT OF PRECIOUS METAL (U.S. CLS. 2, 8, 9 AND 17).

FIRST USE 3-11-1998; IN COMMERCE 3-11-1998.
ALYSSA STEEL, EXAMINING ATTORNEY

SN 85-491,480. GALAXY TOBACCO, INC., DORAL, FL. FILED 12-9-2011.

GT PIPE TOBACCO

THE MARK CONSISTS OF STANDARD CHARACTERS WITHOUT CLAIM TO ANY PARTICULAR FONT, STYLE, SIZE, OR COLOR.

NO CLAIM IS MADE TO THE EXCLUSIVE RIGHT TO USE "PIPE TOBACCO", APART FROM THE MARK AS SHOWN.

FOR PIPE TOBACCO (U.S. CLS. 2, 8, 9 AND 17).
DAWN FELDMAN, EXAMINING ATTORNEY

SN 85-507,352. REMBERTO ESTRELLA, SANTIAGO, DOMINICAN REP, FILED 1-3-2012.

SALSA CIGARS

THE MARK CONSISTS OF STANDARD CHARACTERS WITHOUT CLAIM TO ANY PARTICULAR FONT, STYLE, SIZE, OR COLOR.

NO CLAIM IS MADE TO THE EXCLUSIVE RIGHT TO USE "CIGARS", APART FROM THE MARK AS SHOWN.

FOR CIGAR WRAPS; CIGARILLOS; CIGARS; MOLASSES TOBACCO; PIPE TOBACCO; TOBACCO (U.S. CLS. 2, 8, 9 AND 17).

COLLEEN MULCRONE, EXAMINING ATTORNEY

CLASS 34—(Continued).

SN 85-510,928. GALLAHER LIMITED, WEYBRIDGE, SURREY KT13, UNITED KINGDOM, FILED 1-6-2012.

Glamour

THE MARK CONSISTS OF STANDARD CHARACTERS WITHOUT CLAIM TO ANY PARTICULAR FONT, STYLE, SIZE, OR COLOR.

OWNER OF U.S. REG. NO. 3,623,222.

FOR TOBACCO, WHETHER MANUFACTURED OR UNMANUFACTURED; SMOKING TOBACCO; PIPE TOBACCO; HAND ROLLING TOBACCO; CHEWING TOBACCO; SNUS TOBACCO; CIGARETTES; CIGARS; CIGARILLOS; CIGARETTES CONTAINING TOBACCO SUBSTITUTES NOT FOR MEDICINAL OR CURATIVE PURPOSES; TOBACCO SUBSTITUTES NOT FOR MEDICAL OR CURATIVE PURPOSES; SNUFF; CIGARETTE PAPERS; CIGARETTE TUBES AND MATCHES (U.S. CLS. 2, 8, 9 AND 17).

ELLEN PERKINS, EXAMINING ATTORNEY

SN 85-511,148. MARTIN-MCKENNA IMPORTS LLC, CINCINNATI, OH. FILED 1-7-2012.

LA ABEJA

THE MARK CONSISTS OF STANDARD CHARACTERS WITHOUT CLAIM TO ANY PARTICULAR FONT, STYLE, SIZE, OR COLOR.

THE ENGLISH TRANSLATION OF "LA ABEJA" IN THE MARK IS "THE BEE".

FOR CIGARS (U.S. CLS. 2, 8, 9 AND 17).

LINDA M. KING, EXAMINING ATTORNEY

SN 85-511,633. HIGHER INHALATION TECHNOLOGY LLC, TUCSON, AZ. FILED 1-9-2012.

HIT

THE MARK CONSISTS OF STANDARD CHARACTERS WITHOUT CLAIM TO ANY PARTICULAR FONT, STYLE, SIZE, OR COLOR.

FOR TOBACCO WATER PIPES (U.S. CLS. 2, 8, 9 AND 17).

FIRST USE 2-0-2011; IN COMMERCE 6-0-2011.

RENEE MCCRAY, EXAMINING ATTORNEY

CLASS 34—(Continued).

SN 85-512,164. MONIKA B. JONES, SAINT PETERSBURG, FL. FILED 1-9-2012.

TarX

THE MARK CONSISTS OF STANDARD CHARACTERS WITHOUT CLAIM TO ANY PARTICULAR FONT, STYLE, SIZE, OR COLOR.
FOR CIGARETTE FILTERS (U.S. CLS. 2, 8, 9 AND 17).
FIRST USE 12-23-2011; IN COMMERCE 12-23-2011.
DOMINIC FATHY, EXAMINING ATTORNEY

CLASS 34—(Continued).

SN 85-516,046. CIGARS & TOBACCO BUREAU CORP., CIUDAD DE PANAMA, PANAMA, FILED 1-13-2012.

BALTIMORE

THE MARK CONSISTS OF STANDARD CHARACTERS WITHOUT CLAIM TO ANY PARTICULAR FONT, STYLE, SIZE, OR COLOR.
FOR CIGARETTES AND LITTLE CIGARS (U.S. CLS. 2, 8, 9 AND 17).
MICHAEL SOUDERS, EXAMINING ATTORNEY

SN 85-546,704. TABLE 36, LLC, ST. LOUIS, MO. FILED 2-18-2012.

SN 85-513,619. PLAYING THE LIGHT, LLC, ANN ARBOR, MI. FILED 1-11-2012.

Inspiration meets its match

THE MARK CONSISTS OF STANDARD CHARACTERS WITHOUT CLAIM TO ANY PARTICULAR FONT, STYLE, SIZE, OR COLOR.
FOR DECORATIVE MATCHBOOKS (U.S. CLS. 2, 8, 9 AND 17).
JORDAN BAKER, EXAMINING ATTORNEY

Fellowship

THE MARK CONSISTS OF STANDARD CHARACTERS WITHOUT CLAIM TO ANY PARTICULAR FONT, STYLE, SIZE, OR COLOR.
FOR CIGAR BOXES; CIGAR TUBES; CIGARS (U.S. CLS. 2, 8, 9 AND 17).
FRED CARL, EXAMINING ATTORNEY

SN 85-584,865. SANTA FE NATURAL TOBACCO COMPANY, INC., SANTA FE, NM. FILED 3-30-2012.

SN 85-513,761. PLAYING THE LIGHT, LLC, ANN ARBOR, MI. FILED 1-11-2012.

Playing the Light

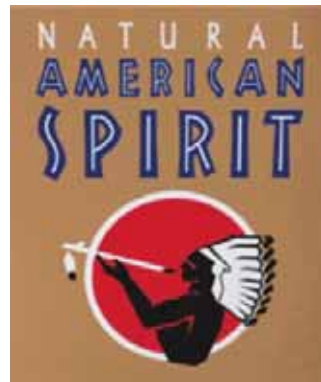

THE MARK CONSISTS OF STANDARD CHARACTERS WITHOUT CLAIM TO ANY PARTICULAR FONT, STYLE, SIZE, OR COLOR.
FOR DECORATIVE MATCHBOOKS (U.S. CLS. 2, 8, 9 AND 17).
JORDAN BAKER, EXAMINING ATTORNEY

OWNER OF U.S. REG. NOS. 1,718,559, 2,692,958 AND OTHERS.
THE COLOR(S) RED, WHITE, BLUE, BLACK, AND TAN IS/ARE CLAIMED AS A FEATURE OF THE MARK.
THE MARK CONSISTS OF THE STYLIZED WORDING "NATURAL AMERICAN SPIRIT" STACKED ABOVE A

CLASS 34—(Continued).

DESIGN COMPRISING THE ENCIRCLED PROFILE OF A NATIVE AMERICAN CHIEFTAIN WEARING A FEATHERED WAR BONNET AND SMOKING A PEACE PIPE. THE WORD "NATURAL" APPEARS IN WHITE LETTERING. THE WORDS "AMERICAN SPIRIT" ARE IN WHITE LETTERING OUTLINED IN BLUE. THE SILHOUETTE OF THE CHIEFTAIN IS BLACK. THE PEACE PIPE AND HEAD- DRESS ARE WHITE WITH BLACK ACCENTS. THE INTER- IOR OF THE CIRCLE IS RED WITH A WHITE BORDER. THE ENTIRE DESIGN IS ON A TAN BACKGROUND.

SEC. 2(F) AS TO "NATURAL".
FOR CIGARETTES (U.S. CLS. 2, 8, 9 AND 17).
FIRST USE 7-31-2010; IN COMMERCE 7-31-2010.
KATHY DE JONGE, EXAMINING ATTORNEY

CLASS 34—(Continued).

SN 85-584,882. SANTA FE NATURAL TOBACCO COMPANY, INC., SANTA FE, NM. FILED 3-30-2012.

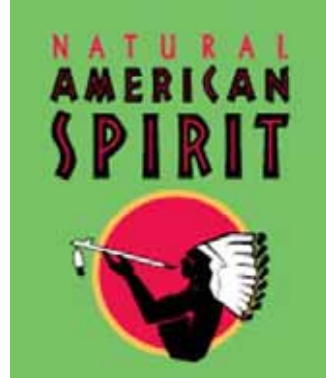

OWNER OF U.S. REG. NOS. 1,718,559, 2,692,958 AND OTHERS.

THE COLOR(S) WHITE, BLACK, RED, GOLD AND GREEN IS/ARE CLAIMED AS A FEATURE OF THE MARK.

THE MARK CONSISTS OF THE STYLIZED WORDING "NATURAL AMERICAN SPIRIT" STACKED ABOVE A DESIGN COMPRISING THE ENCIRCLED PROFILE OF A NATIVE AMERICAN CHIEFTAIN WEARING A FEATHERED WAR BONNET AND SMOKING A PEACE PIPE. THE WORD "NATURAL" APPEARS IN RED LETTERING. THE WORDS "AMERICAN SPIRIT" ARE IN RED LETTERING OUTLINED IN BLACK. THE SILHOUETTE OF THE CHIEFTAIN IS BLACK. THE PEACE PIPE AND HEAD- DRESS ARE WHITE WITH BLACK ACCENTS. THE INTERIOR OF THE CIRCLE IS RED WITH A GOLD BORDER. THE ENTIRE DESIGN IS ON A BRIGHT GREEN BACKGROUND.

SEC. 2(F) AS TO "NATURAL".
FOR CIGARETTES (U.S. CLS. 2, 8, 9 AND 17).
FIRST USE 6-30-2010; IN COMMERCE 6-30-2010.
KATHLEEN M. VANSTON, EXAMINING ATTORNEY

SN 85-584,875. SANTA FE NATURAL TOBACCO COMPANY, INC., SANTA FE, NM. FILED 3-30-2012.



OWNER OF U.S. REG. NOS. 1,718,559, 2,692,958 AND OTHERS.

THE COLOR(S) WHITE, BLACK, GOLD AND DARK GOLD IS/ARE CLAIMED AS A FEATURE OF THE MARK.

THE MARK CONSISTS OF THE STYLIZED WORDING "NATURAL AMERICAN SPIRIT" STACKED ABOVE A DESIGN COMPRISING THE ENCIRCLED PROFILE OF A NATIVE AMERICAN CHIEFTAIN WEARING A FEATHERED WAR BONNET AND SMOKING A PEACE PIPE. THE WORD "NATURAL" APPEARS IN BLACK LETTERING. THE WORDS "AMERICAN SPIRIT" ARE IN GOLD LETTERING OUTLINED IN BLACK. THE SILHOUETTE OF THE CHIEFTAIN IS BLACK. THE PEACE PIPE AND HEAD- DRESS ARE WHITE WITH BLACK ACCENTS. THE INTERIOR OF THE CIRCLE IS DARK GOLD WITH A BLACK BORDER. THE ENTIRE DESIGN IS ON A GOLD BACKGROUND WITH A DARK GOLD BORDER ON THE LEFT AND RIGHT.

SEC. 2(F) AS TO "NATURAL".
FOR CIGARETTES (U.S. CLS. 2, 8, 9 AND 17).
FIRST USE 11-30-2000; IN COMMERCE 11-30-2000.
KATHY DE JONGE, EXAMINING ATTORNEY

SN 85-584,889. SANTA FE NATURAL TOBACCO COMPANY, INC., SANTA FE, NM. FILED 3-30-2012.



OWNER OF U.S. REG. NOS. 1,718,559, 2,692,958 AND OTHERS.

THE COLOR(S) WHITE, BLACK, RED, GOLD AND LIGHT BLUE IS/ARE CLAIMED AS A FEATURE OF THE MARK.

THE MARK CONSISTS OF THE STYLIZED WORDING "NATURAL AMERICAN SPIRIT" STACKED ABOVE A

CLASS 34—(Continued).

DESIGN COMPRISING THE ENCIRCLED PROFILE OF A NATIVE AMERICAN CHIEFTAIN WEARING A FEATHERED WAR BONNET AND SMOKING A PEACE PIPE. THE WORD "NATURAL" APPEARS IN RED LETTERING. THE WORDS "AMERICAN SPIRIT" ARE IN RED LETTERING OUTLINED IN BLACK. THE SILHOUETTE OF THE CHIEFTAIN IS BLACK. THE PEACE PIPE AND HEADDRESS ARE WHITE WITH BLACK ACCENTS. THE INTERIOR OF THE CIRCLE IS RED WITH A GOLD BORDER. THE ENTIRE DESIGN IS ON A LIGHT BLUE BACKGROUND.

SEC. 2(F) AS TO "NATURAL".
FOR CIGARETTES; ROLLING TOBACCO (U.S. CLS. 2, 8, 9 AND 17).
FIRST USE 12-31-1993; IN COMMERCE 12-31-1993.
KATHY DE JONGE, EXAMINING ATTORNEY

CLASS 34—(Continued).

SN 85-584,901. SANTA FE NATURAL TOBACCO COMPANY, INC., SANTA FE, NM. FILED 3-30-2012.

SN 85-584,896. SANTA FE NATURAL TOBACCO COMPANY, INC., SANTA FE, NM. FILED 3-30-2012.



OWNER OF U.S. REG. NOS. 1,718,559, 2,692,958 AND OTHERS.

THE COLOR(S) WHITE, BLACK, RED, AND GOLD IS/ARE CLAIMED AS A FEATURE OF THE MARK.

THE MARK CONSISTS OF THE STYLIZED WORDING "NATURAL AMERICAN SPIRIT" STACKED ABOVE A DESIGN COMPRISING THE ENCIRCLED PROFILE OF A NATIVE AMERICAN CHIEFTAIN WEARING A FEATHERED WAR BONNET AND SMOKING A PEACE PIPE. THE WORD "NATURAL" APPEARS IN RED LETTERING. THE WORDS "AMERICAN SPIRIT" ARE IN RED LETTERING OUTLINED IN GOLD. THE SILHOUETTE OF THE CHIEFTAIN IS BLACK. THE PEACE PIPE AND HEADDRESS ARE WHITE WITH BLACK ACCENTS. THE INTERIOR OF THE CIRCLE IS RED WITH A GOLD BORDER. THE ENTIRE DESIGN IS ON A BLACK BACKGROUND.

SEC. 2(F) AS TO "NATURAL".
FOR CIGARETTES; ROLLING TOBACCO (U.S. CLS. 2, 8, 9 AND 17).
FIRST USE 11-30-2000; IN COMMERCE 11-30-2000.
KATHLEEN M. VANSTON, EXAMINING ATTORNEY

OWNER OF U.S. REG. NOS. 1,718,559, 2,692,958 AND OTHERS.

THE COLOR(S) WHITE, BLACK, MAROON, GREEN, AND GOLD IS/ARE CLAIMED AS A FEATURE OF THE MARK.

THE MARK CONSISTS OF THE STYLIZED WORDING "NATURAL AMERICAN SPIRIT" STACKED ABOVE A DESIGN COMPRISING THE ENCIRCLED PROFILE OF A NATIVE AMERICAN CHIEFTAIN WEARING A FEATHERED WAR BONNET AND SMOKING A PEACE PIPE. THE WORD "NATURAL" APPEARS IN GOLD LETTERING. THE WORDS "AMERICAN SPIRIT" ARE IN GOLD LETTERING OUTLINED IN GREEN. THE SILHOUETTE OF THE CHIEFTAIN IS BLACK. THE PEACE PIPE AND HEADDRESS ARE WHITE WITH BLACK ACCENTS. THE INTERIOR OF THE CIRCLE IS GOLD WITH A GREEN BORDER. THE ENTIRE DESIGN IS ON A MAROON BACKGROUND.

SEC. 2(F) AS TO "NATURAL".
FOR ROLLING TOBACCO (U.S. CLS. 2, 8, 9 AND 17).
FIRST USE 2-28-1999; IN COMMERCE 2-28-1999.
KATHY DE JONGE, EXAMINING ATTORNEY

CLASS 35—(Continued).**SERVICE MARKS****CLASS 35—ADVERTISING AND BUSINESS**

SN 76-704,883. O.C. SEACRETS, INC, OCEAN CITY, MD.
FILED 10-13-2010.



OWNER OF U.S. REG. NOS. 2,102,604, 3,767,755 AND OTHERS.

THE COLOR(S) RED, ORANGE, YELLOW AND BLACK IS/ARE CLAIMED AS A FEATURE OF THE MARK.

THE MARK CONSISTS OF THE WORD "SEACRETS" APPEARING IN ORANGE WITH A YELLOW BORDER AND A REFLECTION OF THE WORD "SEACRETS" APPEARING IN YELLOW, ALL ON A CIRCULAR DESIGN COMPRISED OF A RED AND ORANGE SKY, AN ORANGE SUN, BLACK WATER, AND YELLOW BIRDS ALL SURROUNDED BY A YELLOW BORDER.

FOR FRANCHISING, NAMELY, OFFERING BUSINESS MANAGEMENT ASSISTANCE IN THE ESTABLISHMENT AND/OR OPERATION OF HOTELS, MOTELS, BARS, RESTAURANTS AND NIGHT CLUBS; FRANCHISING, NAMELY, OFFERING BUSINESS MANAGEMENT ASSISTANCE IN THE ESTABLISHMENT AND/OR OPERATION OF CATERING SERVICES; FRANCHISING, NAMELY, OFFERING BUSINESS MANAGEMENT ASSISTANCE IN THE ESTABLISHMENT AND/OR OPERATION OF ENTERTAINMENT FACILITIES FOR BAND, COMEDY, SPORTS, AND SHOW PERFORMANCES (U.S. CLS. 100, 101 AND 102).

CHRISTINE MARTIN, EXAMINING ATTORNEY

CLASS 35—(Continued).

SN 76-704,885. O.C. SEACRETS, INC, OCEAN CITY, MD.
FILED 10-13-2010.

SEACRETS

THE MARK CONSISTS OF STANDARD CHARACTERS WITHOUT CLAIM TO ANY PARTICULAR FONT, STYLE, SIZE, OR COLOR.

OWNER OF U.S. REG. NOS. 2,102,604, 3,767,755 AND OTHERS.

FOR FRANCHISING, NAMELY, OFFERING BUSINESS MANAGEMENT ASSISTANCE IN THE ESTABLISHMENT AND/OR OPERATION OF HOTELS, MOTELS, BARS, RESTAURANTS AND NIGHT CLUBS; FRANCHISING, NAMELY, OFFERING BUSINESS MANAGEMENT ASSISTANCE IN THE ESTABLISHMENT AND/OR OPERATION OF CATERING SERVICES; FRANCHISING, NAMELY, OFFERING BUSINESS MANAGEMENT ASSISTANCE IN THE ESTABLISHMENT AND/OR OPERATION OF ENTERTAINMENT FACILITIES FOR BAND, COMEDY, SPORTS, AND SHOW PERFORMANCES (U.S. CLS. 100, 101 AND 102).

CHRISTINE MARTIN, EXAMINING ATTORNEY

SN 76-704,886. O.C. SEACRETS, INC, OCEAN CITY, MD.
FILED 10-13-2010.

Seacrets

OWNER OF U.S. REG. NOS. 2,102,604, 3,767,755 AND OTHERS.

THE MARK CONSISTS OF THE STYLIZED WORD "SEACRETS".

FOR FRANCHISING, NAMELY, OFFERING BUSINESS MANAGEMENT ASSISTANCE IN THE ESTABLISHMENT AND/OR OPERATION OF HOTELS, MOTELS, BARS, RESTAURANTS AND NIGHT CLUBS; FRANCHISING, NAMELY, OFFERING BUSINESS MANAGEMENT ASSISTANCE IN THE ESTABLISHMENT AND/OR OPERATION OF CATERING SERVICES; FRANCHISING, NAMELY, OFFERING BUSINESS MANAGEMENT ASSISTANCE IN THE ESTABLISHMENT AND/OR OPERATION OF ENTERTAINMENT FACILITIES FOR BAND, COMEDY, SPORTS AND SHOW PERFORMANCES (U.S. CLS. 100, 101 AND 102).

CHRISTINE MARTIN, EXAMINING ATTORNEY

CLASS 35—(Continued).

SN 76-708,193. FRITZ TERFLOTH STIFTUNG, D-48149 MÜNSTER, FED REP GERMANY, FILED 6-29-2011.



The Green Pantry

THE MARK CONSISTS OF THE WORDING "THE GREEN PANTRY" IN STYLIZED FONT WITHIN A DESIGN OF 3 CONCENTRIC CIRCLES FILLED WITH SMALLER CIRCLES AND A TREE DESIGN IN THE CENTER

FOR ADVERTISING; BUSINESS MANAGEMENT; BUSINESS ADMINISTRATION; OFFICE FUNCTIONS; ALL IN RELATION TO FOOD BENEFITS AND ACTIVITIES IN THE FIELD OF PREVENTING ILLNESSES AND PROMOTION OF WELLBEING (U.S. CLS. 100, 101 AND 102).

WILLIAM ROSSMAN, EXAMINING ATTORNEY

CLASS 35—(Continued).

SN 76-708,645. TELEMUNDO NETWORK GROUP LLC, HIALEAH, FL. FILED 8-8-2011.

ALERTA VERDE

THE MARK CONSISTS OF STANDARD CHARACTERS WITHOUT CLAIM TO ANY PARTICULAR FONT, STYLE, SIZE, OR COLOR.

NO CLAIM IS MADE TO THE EXCLUSIVE RIGHT TO USE "VERDE", APART FROM THE MARK AS SHOWN. THE ENGLISH TRANSLATION OF "ALERTA VERDE" IS "GREEN ALERT".

FOR PROMOTING PUBLIC AWARENESS OF ENVIRONMENTAL MATTERS (U.S. CLS. 100, 101 AND 102).

FIRST USE 4-0-2008; IN COMMERCE 4-0-2008.
KELLY BOULTON, EXAMINING ATTORNEY

SN 76-708,339. HOPE FOR THE HEART, PLANO, TX. FILED 7-14-2011.



NO CLAIM IS MADE TO THE EXCLUSIVE RIGHT TO USE "INTERNATIONAL MEDIA", APART FROM THE MARK AS SHOWN.

THE COLOR(S) BLUE, GREEN, RED, WHITE, BLACK, YELLOW AND PINK IS/ARE CLAIMED AS A FEATURE OF THE MARK.

THE MARK CONSISTS OF A DESIGN OF A STAINED GLASS WINDOW OUTLINED IN PINK AND BLACK DEPICTING A PARTIAL WORLD GLOBE IN THE LOWER RIGHT CORNER IN GREEN WITH MERIDIAN LINES IN BLACK, A RED CROSS OUTLINED IN BLACK IN THE CENTER, THREE CURVED SHAPES IN THE UPPER PORTION ABOVE THE CROSS IN WHITE AND YELLOW, LINES DELINEATING STYLIZED PANES OF STAINED GLASS IN BLACK AND THE WORDS "HOPE INTERNATIONAL MEDIA" IN STACKED FORM AT THE RIGHT SIDE OF THE DESIGN IN BLACK. THE COLOR BLUE APPEARS IN THE BACKGROUND AS SKY ABOVE THE GLOBE AND CROSS.

FOR ADVERTISING SERVICES, NAMELY, PROMOTION SERVICES, PREPARING AND PLACING ADVERTISEMENTS, PRODUCTION AND DISTRIBUTION OF RADIO COMMERCIALS, BUSINESS MANAGEMENT CONSULTING IN THE FIELD OF PROGRAMMING (U.S. CLS. 100, 101 AND 102).

DEIRDRE ROBERTSON, EXAMINING ATTORNEY

SN 77-599,349. RED ANTLER, INC, BROOKLYN, NY. FILED 10-23-2008.

RED ANTLER

FOR ADVERTISING AND PUBLICITY SERVICES, NAMELY, PROMOTING THE GOODS, SERVICES, BRAND IDENTITY AND COMMERCIAL INFORMATION AND NEWS OF THIRD PARTIES THROUGH PRINT, AUDIO, VIDEO, DIGITAL AND ON-LINE MEDIUM; ADVERTISING CONSULTATION; ADVERTISING SERVICES, NAMELY, CREATING CORPORATE AND BRAND IDENTITY FOR OTHERS; ADVERTISING, MARKETING AND PROMOTION SERVICES; BRAND CONCEPT AND BRAND DEVELOPMENT SERVICES FOR CORPORATE CLIENTS; BRAND IMAGERY CONSULTING SERVICES; BUSINESS ADVICE AND ANALYSIS OF MARKETS; BUSINESS CONSULTATION AND MANAGEMENT REGARDING MARKETING ACTIVITIES AND LAUNCHING OF NEW PRODUCTS; BUSINESS CONSULTING SERVICES, NAMELY, PROVIDING ASSISTANCE IN DEVELOPMENT OF BUSINESS STRATEGIES AND CREATIVE IDEATION; CONSUMER RESEARCH; CREATIVE MARKETING DESIGN SERVICES; DESIGN OF INTERNET ADVERTISING; DEVELOPMENT OF MARKETING STRATEGIES AND CONCEPTS; MARKET RESEARCH; MARKET RESEARCH CONSULTATION; MARKETING AND BRANDING SERVICES, NAMELY, PERFORMING CONSUMER INSIGHT AND BRAND STRATEGY OF COMPANY LOGOS; MARKETING SERVICES, NAMELY, CONSUMER MARKETING RESEARCH; PROVIDING BUSINESS MANAGEMENT INFORMATION IN CONNECTION WITH CONSULTING AND ADVISORY SERVICES IN THE FIELD OF STRATEGIC PLANNING (U.S. CLS. 100, 101 AND 102).

FIRST USE 8-16-2007; IN COMMERCE 8-16-2007.
MARK SHINER, EXAMINING ATTORNEY

CLASS 35—(Continued).

SN 77-645,228. BENGE, MELISSA, ROWLETT, TX. FILED 1-7-2009.



NO CLAIM IS MADE TO THE EXCLUSIVE RIGHT TO USE "BANDERA, TEXAS", APART FROM THE MARK AS SHOWN.

THE MARK CONSISTS OF WESTERN-STYLED LETTERS RUNNING STRAIGHT ACROSS THE TOP SPELLING OUT "GUNSLINGER" IN ALL CAPITAL LETTERS, WITH FOUR LINES BULL-WHIPPING THROUGH THE "GUNSLINGER" LETTERS; AND SMALLER, ALL CAPITAL BOLD-FACED LETTERS RUNNING UNDERNEATH AND ALONG THE BOTTOM WHICH SPELL OUT "BANDERA, TEXAS".

FOR RETAIL STORES FEATURING "RANCH LIFE-STYLE" COUTURE, NAMELY, FURNITURE, PHOTOGRAPHY, ART, AND MUSIC (U.S. CLS. 100, 101 AND 102).

FIRST USE 1-1-2008; IN COMMERCE 11-1-2008.
KRISTIN DAHLING, EXAMINING ATTORNEY

SN 77-645,302. BENGE, MELISSA, ROWLETT, TX. FILED 1-7-2009.



NO CLAIM IS MADE TO THE EXCLUSIVE RIGHT TO USE "BANDERA", APART FROM THE MARK AS SHOWN. THE STIPPLING IS FOR SHADING PURPOSES.

THE MARK CONSISTS OF "GUNSLINGER" RUNS PROMINENT IN BOLD WESTERN-STYLE, ALL CAPITAL LETTERS, WITH FOUR LINES BULL-WHIPPING THROUGH THE "GUNSLINGER" LETTERS; BARBED WIRE CURVES AROUND EACH SIDE OF THE "GUNSLINGER" LETTERS AND JOINS AT THE TOP WITH TWO COWBOY-STYLED SIX-SHOOTING PISTOLS WHICH CROSS EACH OTHER'S BARREL; A ROSE LAYS AT THE BOTTOM UNDERNEATH THE "GUNSLINGER" LETTERS AND TO THE RIGHT OF A SMALL, ALL-CAPS PRINT OF THE WORD "BANDERA"; A FIVE-POINT STAR IS CENTERED UNDER THE CROSSING BARRELS OF THE TWO PISTOLS, CENTERED IN CIRCLES OF WESTERN MOTIF; A BOLD-FACED, DOUBLE-LINED BORDER RUNS AROUND THE ENTIRE CONTENTS OF THE MARK.

FOR RETAIL STORES FEATURING "RANCH LIFE-STYLE" COUTURE, NAMELY, FURNITURE, PHOTOGRAPHY, ART, AND MUSIC (U.S. CLS. 100, 101 AND 102).

FIRST USE 1-1-2008; IN COMMERCE 11-1-2008.
KRISTIN DAHLING, EXAMINING ATTORNEY

CLASS 35—(Continued).

SN 79-100,284. TREND-ON-LINE SÀRL, SWITZERLAND, FILED 6-15-2011.



PRIORITY DATE OF 5-3-2011 IS CLAIMED.
OWNER OF INTERNATIONAL REGISTRATION 1084858 DATED 6-15-2011, EXPIRES 6-15-2021.

THE COLOR(S) BLACK AND BROWN IS/ARE CLAIMED AS A FEATURE OF THE MARK.

THE MARK CONSISTS OF THE WORDING "T ON L", WITH THE LETTERS "T" AND "L" IN BLACK AND THE WORD "ON" IN WHITE ON A BROWN CIRCLE; UNDERNEATH IS THE WORDING "TREND ON LINE", WITH THE WORDS "TREND" AND "LINE" IN BLACK AND THE WORD "ON" IN BLACK ON A BROWN CIRCLE. THE COLOR WHITE IS NOT CLAIMED AS A FEATURE OF THE MARK AND MERELY REPRESENTS BACKGROUND.

FOR ON-LINE RETAIL STORE SERVICES FEATURING DECORATIVE HOUSEHOLD LANDSCAPE ITEMS (U.S. CLS. 100, 101 AND 102).

SHAILA SETTLES, EXAMINING ATTORNEY

CLASS 35—(Continued).

SN 79-100,475. MAMBO GRAPHICS PTY LIMITED, AUSTRALIA, FILED 4-21-2011.

MAMBO

THE MARK CONSISTS OF STANDARD CHARACTERS WITHOUT CLAIM TO ANY PARTICULAR FONT, STYLE, SIZE, OR COLOR.

OWNER OF INTERNATIONAL REGISTRATION 1085266 DATED 4-21-2011, EXPIRES 4-21-2021.

OWNER OF U.S. REG. NOS. 2,074,995, 2,112,750 AND OTHERS.

FOR RETAIL STORE AND WHOLESALE STORE SERVICES FEATURING CLOTHING, FOOTWEAR, HEADGEAR, BOOKS, SUNGLASSES, WATCHES, BAGS, BOOKS, STATIONERY, TOWELS, SPORTING EQUIPMENT; BRINGING TOGETHER, FOR THE BENEFIT OF OTHERS, OF A VARIETY OF GOODS ENABLING CUSTOMERS TO CONVENIENTLY VIEW AND PURCHASE THOSE GOODS IN THE FIELD OF; CLOTHING, FOOTWEAR, HEADGEAR, BOOKS, SUNGLASSES, WATCHES, BAGS, BOOKS, STATIONERY, TOWELS, SPORTING EQUIPMENT; CUSTOMER LOYALTY PROGRAMS, NAMELY, PROMOTING THE GOODS AND SERVICES OF OTHERS BY MEANS OF THE ISSUANCE OF LOYALTY REWARD CARDS, A DISTRIBUTION OF DISCOUNT CARDS AND INCENTIVE SCHEMES, NAMELY, THE ISSUANCE AND PROCESSING OF LOYALTY POINT FOR ONLINE PURCHASE OF A COMPANIES GOODS AND/OR SERVICES; PROVIDING INFORMATION REGARDING DISCOUNT SHOPPING SERVICES FOR SHOPPERS, TRAVELERS AND BUSINESSES; MARKETING OF ENTERTAINMENT, SPORTING AND CULTURAL EVENTS; PUBLICATION AND DISSEMINATION OF PUBLICITY MATERIAL; ORGANIZATION OF EXHIBITIONS FOR COMMERCIAL OR ADVERTISING PURPOSES; COMMERCIAL ADMINISTRATION FOR LICENSING OF THE GOODS AND SERVICES OF OTHERS; PRESENTATION OF GOODS ON COMMUNICATION MEDIA, FOR RETAIL PURPOSES; SALES PROMOTION FOR OTHERS; DISTRIBUTION OF SAMPLES (U.S. CLS. 100, 101 AND 102).

ELLEN PERKINS, EXAMINING ATTORNEY

SN 79-100,624. TREND-ON-LINE SÀRL, SWITZERLAND, FILED 6-15-2011.

TREND on LINE

PRIORITY DATE OF 5-3-2011 IS CLAIMED.

OWNER OF INTERNATIONAL REGISTRATION 1085628 DATED 6-15-2011, EXPIRES 6-15-2021.

THE COLOR(S) BLACK AND BROWN IS/ARE CLAIMED AS A FEATURE OF THE MARK.

THE MARK CONSISTS OF THE WORDING "TREND ON LINE", WITH THE WORDS "TREND" AND "LINE" IN BLACK AND THE WORD "ON" IN BLACK ON A BROWN CIRCLE. THE COLOR WHITE IS NOT CLAIMED AS A FEATURE OF THE MARK AND MERELY REPRESENTS BACKGROUND.

FOR ON-LINE RETAIL STORE SERVICES FEATURING DECORATIVE HOUSEHOLD LANDSCAPE ITEMS (U.S. CLS. 100, 101 AND 102).

SHAILA SETTLES, EXAMINING ATTORNEY

CLASS 35—(Continued).

SN 85-025,067. WELLNESS & PREVENTION, INC., ANN ARBOR, MI. FILED 4-28-2010.

HEALTHMEDIA ACCELERATE

THE MARK CONSISTS OF STANDARD CHARACTERS WITHOUT CLAIM TO ANY PARTICULAR FONT, STYLE, SIZE, OR COLOR.

OWNER OF U.S. REG. NOS. 2,276,506, 2,971,969 AND OTHERS.

SEC. 2(F) AS TO "HEALTHMEDIA".

FOR BUSINESS CUSTOMER SUPPORT SERVICES, NAMELY, PROVIDING BUSINESS CONSULTING TO CUSTOMERS FEATURING MARKETING SUPPORT, BUSINESS PLANNING, AND BUSINESS ACCOUNT MANAGEMENT SERVICES IN THE FIELD OF HEALTHCARE, WELLNESS, DISEASE MANAGEMENT, HEALTH RISK MANAGEMENT, HEALTH PROMOTION AND BEHAVIORAL CHANGE (U.S. CLS. 100, 101 AND 102).

BERYL GARDNER, EXAMINING ATTORNEY

SN 85-036,986. APPLE INC., CUPERTINO, CA. FILED 5-12-2010.



THE COLOR(S) STEEL GRAY, LIGHT BROWN AND BLACK IS/ARE CLAIMED AS A FEATURE OF THE MARK.

THE MARK CONSISTS OF THE DESIGN AND LAYOUT OF A RETAIL STORE. THE STORE FEATURES A CLEAR GLASS STOREFRONT SURROUNDED BY A paneled, STEEL GRAY FACADE CONSISTING OF LARGE, RECTANGULAR HORIZONTAL PANELS OVER THE TOP OF THE GLASS FRONT, AND TWO NARROWER PANELS STACKED ON EITHER SIDE OF THE STOREFRONT. WITHIN THE STORE, RECTANGULAR RECESSED LIGHTING UNITS TRAVERSE THE LENGTH OF THE STORE'S CEILING. THERE ARE LIGHT BROWN CANTILEVERED SHELVES BELOW RECESSED DISPLAY SPACES ALONG THE SIDE WALLS, AND LIGHT BROWN RECTANGULAR TABLES ARRANGED IN A LINE IN THE MIDDLE OF THE STORE PARALLEL TO THE WALLS AND EXTENDING FROM THE STOREFRONT TO THE BACK OF THE STORE. THERE IS MULTI-TIERED SHELVING ALONG THE SIDE WALLS, AND A LIGHT BROWN OBLONG TABLE WITH BLACK STOOLS LOCATED AT THE BACK OF THE STORE, SET BELOW VIDEO SCREENS FLUSH MOUNTED ON THE BACK WALL. THE WALLS, FLOORS, LIGHTING, AND OTHER FIXTURES APPEAR IN DOTTED LINES AND ARE NOT CLAIMED AS INDIVIDUAL FEATURES OF THE MARK; HOWEVER, THE COLORS AND PLACEMENT OF THE VARIOUS ITEMS ARE CONSIDERED TO BE PART OF THE OVERALL MARK. SIMILARLY, THE WHITE IN THE DRAWING REPRESENTS BACKGROUND AREAS AND IS NOT PART OF THE MARK.

SEC. 2(F).

FOR RETAIL STORE SERVICES FEATURING COMPUTERS, COMPUTER SOFTWARE, COMPUTER PERIPHERALS, MOBILE PHONES, CONSUMER ELECTRONICS AND RELATED ACCESSORIES, AND DEMONSTRATION OF PRODUCTS RELATING THERE (U.S. CLS. 100, 101 AND 102).

FIRST USE 9-0-2006; IN COMMERCE 9-0-2006.

MICHAEL W. BAIRD, EXAMINING ATTORNEY

CLASS 35—(Continued).

SN 85-036,990. APPLE INC., CUPERTINO, CA. FILED 5-12-2010.

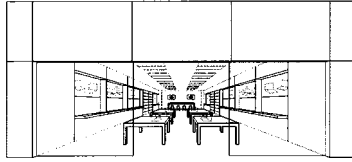

THE MARK CONSISTS OF THE DESIGN AND LAYOUT OF A RETAIL STORE. THE STORE FEATURES A CLEAR GLASS STOREFRONT SURROUNDED BY A paneled facade consisting of large, rectangular horizontal panels over the top of the glass front, and two narrower panels stacked on either side of the storefront. Within the store, rectangular recessed lighting units traverse the length of the store's ceiling. There are cantilevered shelves below recessed display spaces along the side walls, and rectangular tables arranged in a line in the middle of the store parallel to the walls and extending from the storefront to the back of the store. There is multi-tiered shelving along the side walls, and a oblong table with stools located at the back of the store, set below video screens flush mounted on the back wall. The walls, floors, lighting, and other fixtures appear in dotted lines and are not claimed as individual features of the mark; however, the placement of the various items are considered to be part of the overall mark.

SEC. 2(F).

FOR RETAIL STORE SERVICES FEATURING COMPUTERS, COMPUTER SOFTWARE, COMPUTER PERIPHERALS, MOBILE PHONES, CONSUMER ELECTRONICS AND RELATED ACCESSORIES, AND DEMONSTRATION OF PRODUCTS RELATING THERE-TO (U.S. CLS. 100, 101 AND 102).

FIRST USE 9-0-2006; IN COMMERCE 9-0-2006.
MICHAEL W. BAIRD, EXAMINING ATTORNEY

SN 85-052,429. SUSTENTATOR S.A., BUENOS AIRES, ARGENTINA, FILED 6-2-2010.

SUSTENTATOR

THE MARK CONSISTS OF STANDARD CHARACTERS WITHOUT CLAIM TO ANY PARTICULAR FONT, STYLE, SIZE, OR COLOR.

PRIORITY CLAIMED UNDER SEC. 44(D) ON ARGENTINA APPLICATION NO. 2996286, FILED 4-19-2010, REG. NO. 2,423,991, DATED 2-21-2011, EXPIRES 2-21-2021.

FOR ADVERTISING SERVICES, PRODUCT MERCHANDISING, AND BUSINESS DEVELOPMENT CONSULTING IN THE AREA OF ENVIRONMENTAL PROTECTION RELEVANT TO IMPROVING SUSTAINABLE DEVELOPMENT (U.S. CLS. 100, 101 AND 102).

ESTHER BELENKER, EXAMINING ATTORNEY

CLASS 35—(Continued).

SN 85-103,890. THE MI GROUP LTD., MISSISSAUGA, ONTARIO, CANADA, FILED 8-10-2010.



THE MARK CONSISTS OF STANDARD CHARACTERS WITHOUT CLAIM TO ANY PARTICULAR FONT, STYLE, SIZE, OR COLOR.

PRIORITY CLAIMED UNDER SEC. 44(D) ON CANADA APPLICATION NO. 1188404, FILED 7-13-2010, REG. NO. TMA812794, DATED 11-28-2011, EXPIRES 11-28-2026.

OWNER OF U.S. REG. NOS. 1,969,984, 3,048,466 AND OTHERS.

NO CLAIM IS MADE TO THE EXCLUSIVE RIGHT TO USE "WORLDWIDE PARTNER NETWORK", APART FROM THE MARK AS SHOWN.

FOR MOVING AND RELOCATION SERVICES, NAMELY, PLANNING AND IMPLEMENTING MOVES OF HOMES AND OFFICES; TRANSPORTATION LOGISTICS SERVICES, NAMELY, ARRANGING FOR THE TRANSPORTATION OF GOODS FOR OTHERS; PERSONNEL REPATRIATION RELOCATION CONSULTING SERVICES IN THE FIELD OF PERSONNEL RELOCATION TO THEIR PLACE OF ORIGIN OR CITIZENSHIP (U.S. CLS. 100, 101 AND 102).

SIMON TENG, EXAMINING ATTORNEY

SN 85-128,258. VB ENTERPRISES, LLC, DBA VELVET BOX, FORT WORTH, TX. FILED 9-13-2010.



THE MARK CONSISTS OF A SQUARE TURNED TO THE SIDE LIKE A DIAMOND WITH THE WORDS "VELVET-BOX" WRITTEN ACROSS THE MIDDLE, BREAKING THE LINES AND RIGHT AND LEFT CORNERS OF THE BOX/DIAMOND. THE WORDS "INSPIRE PASSION" IN BLOCK LETTERS ARE WRITTEN BELOW "VELVETBOX" AND ARE INSIDE A RECTANGULAR LINE/BOX THAT IS THE SAME WIDTH AS "VELVETBOX" LETTERING ABOVE IT. THE "V" OF "VELVET" IS IN A STYLIZED DESIGN, WITH THE "V" ALSO FORMING THE SHAPE OF A HEART.

FOR RETAIL STORE FEATURING ADULT INTIMACY PRODUCTS (U.S. CLS. 100, 101 AND 102).

FIRST USE 12-23-2009; IN COMMERCE 12-23-2009.
DOMINICK J. SALEMI, EXAMINING ATTORNEY

CLASS 35—(Continued).

SN 85-182,510. PALMER, AMY, ALTAMONTE SPRINGS, FL. FILED 11-22-2010.



NO CLAIM IS MADE TO THE EXCLUSIVE RIGHT TO USE "BOOKS", APART FROM THE MARK AS SHOWN.

THE COLOR(S) BLACK, GREEN, RED, AND WHITE IS/ ARE CLAIMED AS A FEATURE OF THE MARK.

THE MARK CONSISTS OF A GREEN WORM WITH A RED TONGUE WEARING GLASSES. THE WORM IS CRAWLING THROUGH THE "O"S IN THE WORD "BOOKS". THE WORDING "WACKA DOODLE BOOKS" APPEARS IN THE COLOR BLACK. THE COLOR BLACK IS USED TO OUTLINE AND HIGHLIGHT THE FEATURES OF THE WORM AND THE COLOR WHITE APPEARS IN THE INTERIOR OF THE GLASSES.

FOR ON-LINE RETAIL STORE SERVICES FEATURING CHILDREN'S BOOKS (U.S. CLS. 100, 101 AND 102).
JEAN IM, EXAMINING ATTORNEY

SN 85-184,958. PLANNING PERSPECTIVES, INC., BIRMINGHAM, MI. FILED 11-24-2010.

WORKING RELATIONS INDEX

THE MARK CONSISTS OF STANDARD CHARACTERS WITHOUT CLAIM TO ANY PARTICULAR FONT, STYLE, SIZE, OR COLOR.

SEC. 2(F).

FOR BUSINESS CONSULTING SERVICES IN THE FIELD OF IMPROVING CUSTOMER RELATIONS (U.S. CLS. 100, 101 AND 102).

FIRST USE 4-28-2003; IN COMMERCE 5-16-2003.
GRETCHEN ULRICH, EXAMINING ATTORNEY

SN 85-188,032. ZWIG, ADAM, PORTLAND, OR. FILED 12-1-2010.

Conscious Records Music

THE MARK CONSISTS OF STANDARD CHARACTERS WITHOUT CLAIM TO ANY PARTICULAR FONT, STYLE, SIZE, OR COLOR.

NO CLAIM IS MADE TO THE EXCLUSIVE RIGHT TO USE "RECORDS" AND "MUSIC", APART FROM THE MARK AS SHOWN.

FOR ENTERTAINMENT MARKETING SERVICES, NAMELY, MARKETING, PROMOTION AND ADVERTISING FOR INDEPENDENT RECORDING ARTISTS (U.S. CLS. 100, 101 AND 102).

FIRST USE 2-1-2000; IN COMMERCE 2-1-2000.
KEVIN DINALLO, EXAMINING ATTORNEY

CLASS 35—(Continued).

SN 85-195,362. STOCKUP INVENTORY LLC, NEW YORK, NY. FILED 12-10-2010.

STOCKUP INVENTORY

THE MARK CONSISTS OF STANDARD CHARACTERS WITHOUT CLAIM TO ANY PARTICULAR FONT, STYLE, SIZE, OR COLOR.

NO CLAIM IS MADE TO THE EXCLUSIVE RIGHT TO USE "INVENTORY", APART FROM THE MARK AS SHOWN.

FOR INVENTORY PROCUREMENT, NAMELY, PURCHASING INVENTORY IN THE NATURE OF A WIDE VARIETY OF GOODS FOR OTHERS (U.S. CLS. 100, 101 AND 102).

FIRST USE 9-7-2010; IN COMMERCE 9-7-2010.
CYNTHIA TRIPI, EXAMINING ATTORNEY

SN 85-195,394. STOCKUP INVENTORY LLC, NEW YORK, NY. FILED 12-10-2010.



NO CLAIM IS MADE TO THE EXCLUSIVE RIGHT TO USE "INVENTORY", APART FROM THE MARK AS SHOWN.

THE MARK CONSISTS OF THE STYLIZED WORDING "STOCKUP INVENTORY" AND A DESIGN COMPRISED OF SIX SHADED SQUARES IN A STAIRSTEP ARRANGEMENT, WITH THREE SQUARES ON THE BOTTOM, TWO SQUARES IN THE MIDDLE, AND ONE SQUARE ON TOP.

FOR INVENTORY PROCUREMENT, NAMELY, PURCHASING INVENTORY IN THE NATURE OF A WIDE VARIETY OF GOODS FOR OTHERS (U.S. CLS. 100, 101 AND 102).

FIRST USE 9-7-2010; IN COMMERCE 9-7-2010.
CYNTHIA TRIPI, EXAMINING ATTORNEY

SN 85-226,484. NEVINS, SEAN M., BRYN MAWR, PA. FILED 1-26-2011.

beerjobber

THE MARK CONSISTS OF STANDARD CHARACTERS WITHOUT CLAIM TO ANY PARTICULAR FONT, STYLE, SIZE, OR COLOR.

FOR PROVIDING A WEBSITE FOR THE MARKETING AND PROMOTION OF GOODS OF OTHERS, NAMELY, CRAFT BEER; PROVIDING A WEBSITE FOR INFORMATION, REVIEWS AND PERSONALIZED RECOMMENDATIONS IN THE FIELD OF CRAFT BEER FOR COMMERCIAL PURPOSES (U.S. CLS. 100, 101 AND 102).
ELLEN PERKINS, EXAMINING ATTORNEY

CLASS 35—(Continued).

SN 85-230,673. CLCV INC., NEW YORK, NY. FILED 1-31-2011.



THE MARK CONSISTS OF A STYLIZED LETTER "A". FOR ON-LINE RETAIL STORE SERVICES FEATURING ART AND ART FRAMES (U.S. CLS. 100, 101 AND 102).

WON TEAK OH, EXAMINING ATTORNEY

SN 85-235,093. PIERRE, RAVIN R, DBA WHAT WOULD SCIENCE DO?, SEATTLE, WA. FILED 2-5-2011.

What Would Science Do?

THE MARK CONSISTS OF STANDARD CHARACTERS WITHOUT CLAIM TO ANY PARTICULAR FONT, STYLE, SIZE, OR COLOR.

FOR PROMOTING, ADVERTISING AND MARKETING OF THE BRANDS, PRODUCTS, SERVICES OR ONLINE WEBSITES OF INDIVIDUALS, BUSINESSES AND NONPROFIT ORGANIZATIONS (U.S. CLS. 100, 101 AND 102).

FIRST USE 12-15-2010; IN COMMERCE 1-27-2011.
C. DIONNE CLYBURN, EXAMINING ATTORNEY

CLASS 35—(Continued).

SN 85-238,317. MEDIA SPACE, INC., NORWALK, CT. FILED S.R. 2-9-2011; AM. P.R. 4-6-2012.



OWNER OF U.S. REG. NO. 2,617,460.

NO CLAIM IS MADE TO THE EXCLUSIVE RIGHT TO USE "MEDIA SPACE SOLUTIONS", APART FROM THE MARK AS SHOWN.

THE MARK CONSISTS OF A STYLIZED LETTER "M" ON THE LEFT SIDE WITH A VERTICAL LINE SEPARATING THE LITERAL WORDING ON THE RIGHT IN SMALLER FONT, STYLIZED TERMS "MEDIASPACE" ON TOP AND "SOLUTIONS" BELOW IT.

FOR ADVERTISING SERVICES, NAMELY, NEGOTIATING AND PLACING ADVERTISEMENTS FOR OTHERS IN PRINT MEDIA; BUSINESS CONSULTING SERVICES IN THE FIELD OF ADVERTISING AND MARKETING (U.S. CLS. 100, 101 AND 102).

FIRST USE 2-8-2011; IN COMMERCE 2-8-2011.

NAKWAMA ANKRAH, EXAMINING ATTORNEY

SN 85-257,858. ENERGY EARTH, LLC, CHATTANOOGA, TN. FILED 3-4-2011.

USE LESS. GET MORE.

THE MARK CONSISTS OF STANDARD CHARACTERS WITHOUT CLAIM TO ANY PARTICULAR FONT, STYLE, SIZE, OR COLOR.

FOR RETAIL STORE SERVICES PROVIDED FROM A CONVENTIONAL STOREFRONT AND FROM AN ON-LINE, WEB-BASED VIRTUAL STOREFRONT, BOTH FEATURING A VARIETY OF ENERGY EFFICIENT, ENVIRONMENTALLY FRIENDLY, AND RENEWABLE ENERGY-RELATED CONSUMER AND HOUSEHOLD PRODUCTS AND APPLIANCES (U.S. CLS. 100, 101 AND 102).

JOHN E. MICHOS, EXAMINING ATTORNEY

SN 85-261,711. CHINNI, CHRIS, DEERFIELD BEACH, FL. FILED 3-9-2011.

SAY HELLO TO GOOD BUYS

THE MARK CONSISTS OF STANDARD CHARACTERS WITHOUT CLAIM TO ANY PARTICULAR FONT, STYLE, SIZE, OR COLOR.

FOR OPERATION OF TELEPHONE CALL CENTERS FOR OTHERS; ORDER-TAKING SERVICES FOR OTHERS VIA TELEPHONE CALL CENTERS (U.S. CLS. 100, 101 AND 102).

FIRST USE 1-31-2011; IN COMMERCE 2-10-2011.
STEVEN R. FINE, EXAMINING ATTORNEY

CLASS 35—(Continued).

SN 85-270,177. STRONG KNIGHT ENTERPRISES, COPPELL, TX. FILED 3-17-2011.

sunshine  avenue

Doing good for those who are doing good.

THE MARK CONSISTS OF THE WORD "SUNSHINE" APPEARING ON THE LEFT, A GRAPHIC IMAGE OF A SUN IN THE MIDDLE, THE WORD "AVENUE" APPEARING ON THE RIGHT OF THE SUN GRAPHIC IMAGE, AND THE WORDS "DOING GOOD FOR THOSE WHO ARE DOING GOOD." BELOW.

FOR CONSULTING IN THE AREAS OF INTERNET MARKETING, SOCIAL MEDIA MARKETING AND PUBLIC RELATIONS (U.S. CLS. 100, 101 AND 102).

KATINA MISTER, EXAMINING ATTORNEY

SN 85-271,722. STRAIN SOURCE, LLC, DENVER, CO. FILED 3-20-2011.

STRAIN SOURCE

THE MARK CONSISTS OF STANDARD CHARACTERS WITHOUT CLAIM TO ANY PARTICULAR FONT, STYLE, SIZE, OR COLOR.

NO CLAIM IS MADE TO THE EXCLUSIVE RIGHT TO USE "STRAIN", APART FROM THE MARK AS SHOWN.

FOR PROVIDING A SEARCHABLE WEBSITE FEATURING THE GOODS AND SERVICES OF OTHER VENDORS (U.S. CLS. 100, 101 AND 102).

FIRST USE 12-11-2010; IN COMMERCE 12-11-2010.

ROBERT STRUCK, EXAMINING ATTORNEY

SN 85-278,551. ALETHEA CAPITAL MANAGEMENT, LLC, SAN DIEGO, CA. FILED 3-28-2011.

ALETHEA

THE MARK CONSISTS OF STANDARD CHARACTERS WITHOUT CLAIM TO ANY PARTICULAR FONT, STYLE, SIZE, OR COLOR.

FOR CONSULTANCY IN THE FIELD OF BUSINESS SUCCESSION PLANNING; TAX AND TAXATION PLANNING (U.S. CLS. 100, 101 AND 102).

FIRST USE 11-18-2009; IN COMMERCE 11-18-2009.

JUSTINE D. PARKER, EXAMINING ATTORNEY

CLASS 35—(Continued).

SN 85-305,291. ADIUVO GROUP LTD., TORONTO, ONTARIO, CANADA, FILED 4-26-2011.

ADIUVO

THE MARK CONSISTS OF STANDARD CHARACTERS WITHOUT CLAIM TO ANY PARTICULAR FONT, STYLE, SIZE, OR COLOR.

PRIORITY CLAIMED UNDER SEC. 44(D) ON CANADA APPLICATION NO. 1502005, FILED 11-1-2010, REG. NO. TMA818952, DATED 3-2-2012, EXPIRES 3-2-2027.

THE ENGLISH TRANSLATION OF "ADIUVO" IN THE MARK IS "ASSIST".

FOR RECRUITMENT AND PLACEMENT OF PERSONNEL IN THE FIELD OF INFORMATION TECHNOLOGY; BUSINESS MANAGEMENT; BUSINESS ADMINISTRATION (U.S. CLS. 100, 101 AND 102).

SALLY SHIH, EXAMINING ATTORNEY

SN 85-308,352. GLOBAL INFOMERCIAL SERVICES, INC., RENO, NV. FILED 4-29-2011.



OWNER OF U.S. REG. NOS. 3,376,493, 3,566,240 AND 3,626,990.

NO CLAIM IS MADE TO THE EXCLUSIVE RIGHT TO USE "INFOMERCIAL SERVICES", APART FROM THE MARK AS SHOWN.

THE MARK CONSISTS OF THE IMAGE OF A GLOBE, TRANSPARENT WHERE WATER IS LOCATED, IMPOSED OVER THE LETTERS "GIS", ALL ABOVE THE WORDS "GLOBAL INFOMERCIAL SERVICES".

SEC. 2(F) AS TO "GLOBAL INFOMERCIAL SERVICES".

FOR GENERAL BUSINESS MERCHANDISING SERVICES, NAMELY, MARKETING; MARKETING SERVICES, NAMELY, PROMOTING OR ADVERTISING THE GOODS AND SERVICES OF OTHERS; PRODUCT MERCHANDISING (U.S. CLS. 100, 101 AND 102).

FIRST USE 9-13-2009; IN COMMERCE 9-13-2009.

TARA PATE, EXAMINING ATTORNEY

CLASS 35—(Continued).

SN 85-310,933. DOREEN PATRICK, DBA VIRTUAL BUSINESS PARTNERS, WOODRIDGE, IL. FILED 5-3-2011.

VIRTUAL
BUSINESS
PARTNERS

THE MARK CONSISTS OF STANDARD CHARACTERS WITHOUT CLAIM TO ANY PARTICULAR FONT, STYLE, SIZE, OR COLOR.

SEC. 2(F).

FOR PROVIDING VIRTUAL ON-LINE OFFICE SUPPORT STAFF SERVICES FOR BUSINESSES AND INDIVIDUALS; VIRTUAL ON-LINE ADVERTISING AND MARKETING SERVICES FOR BUSINESSES AND INDIVIDUALS (U.S. CLS. 100, 101 AND 102).

FIRST USE 2-17-2006; IN COMMERCE 2-20-2006.
MICHAEL SOUDERS, EXAMINING ATTORNEY

SN 85-319,309. CH INTERNATIONAL CORP., STATEN ISLAND, NY. FILED 5-12-2011.

新創意電器

NO CLAIM IS MADE TO THE EXCLUSIVE RIGHT TO USE THE NON-LATIN CHARACTERS THAT TRANSLITERATE TO "DIAN QI" AND TRANSLATE INTO ENGLISH AS "ELECTRIC APPLIANCES", APART FROM THE MARK AS SHOWN.

THE COLOR(S) RED IS/ARE CLAIMED AS A FEATURE OF THE MARK.

THE MARK CONSISTS OF CHINESE CHARACTERS, WHICH TRANSLATE TO "NEW CREATIVE IDEA APPLIANCES", APPEARING IN RED.

THE NON-LATIN CHARACTERS IN THE MARK TRANSLITERATE TO "XIN CHUANG YI DIAN QI" AND THIS MEANS "NEW CREATIVE IDEA ELECTRIC APPLIANCE" IN ENGLISH.

FOR WHOLESALE AND RETAIL STORE SERVICES FEATURING APPLIANCES (U.S. CLS. 100, 101 AND 102).
KAREN K. BUSH, EXAMINING ATTORNEY

CLASS 35—(Continued).

SN 85-319,516. XCEL ENERGY INC., MINNEAPOLIS, MN. FILED 5-12-2011.

THE BIG SAVE

THE MARK CONSISTS OF STANDARD CHARACTERS WITHOUT CLAIM TO ANY PARTICULAR FONT, STYLE, SIZE, OR COLOR.

FOR PUBLIC GAS AND ELECTRIC UTILITY ENERGY MANAGEMENT CONSULTATION FOR COMMERCIAL AND INDUSTRIAL CUSTOMERS, NAMELY, CONSULTATION CONCERNING ALTERNATIVE FUEL AND ENERGY BACK-UP PROGRAMS, LOAD BALANCING PROGRAMS, ENERGY SUPPLY MANAGEMENT AND ENERGY CONSERVATION PROGRAMS; PROMOTING THE GOODS AND SERVICES OF OTHERS THROUGH THE ADMINISTRATION OF AIR CONDITIONING REBATE PROGRAMS AND ENERGY SAVING REBATE PROGRAMS; ELECTRIC UTILITY SERVICES IN THE NATURE OF OFFERING INCENTIVE PRICING FOR CONTROLLED USE OF ELECTRICITY DURING SPECIFIC HOURS; ENERGY CONSERVATION CONSULTATION, CONSULTATION IN THE FIELD OF ENERGY USE AND REGARDING ENERGY EFFICIENT APPLIANCES SUCH AS AIR CONDITIONING AND FURNACES; PROMOTING PUBLIC AWARENESS OF THE NEED FOR ENERGY CONSERVATION AND EFFICIENT ELECTRICITY UTILIZATION BY CONSUMERS THROUGH ENERGY AUDITS AND CONSULTATION IN THE EFFECTS OF ENERGY EFFICIENT LIGHTING, ENERGY EFFICIENT AIR CONDITIONING, ENERGY EFFICIENT REFRIGERATION, WINDOW GLAZING, AND ENERGY CONSERVATION AND HOME ENERGY AUDITS; PROMOTING PUBLIC AWARENESS OF THE NEED FOR APPLIANCE REBATES, ENERGY EFFICIENT LIGHTING FOR HOMES, AIR CONDITIONING LOAD CONTROL, APPLIANCE RECYCLING, AND SPECIAL TIME-OF-DAY RATES; CONSULTATION AND ANALYSIS REGARDING ENERGY EFFICIENCY AND CUSTOMER'S USAGE MANAGEMENT OF ELECTRIC AND GAS UTILITY SERVICES, NAMELY, ENERGY USE ANALYSIS, ENERGY PROFILING AND MONITORING, CONTROLLING ENERGY COSTS AND USAGE; ADMINISTERING ENERGY EFFICIENCY AND ENERGY USAGE MANAGEMENT PROGRAMS, NAMELY, ENERGY LOAD CONTROL PROGRAMS, ENERGY SCHEDULING PROGRAMS, AND ENERGY RATE ANALYSIS SERVICES; PROVISION OF INFORMATION IN THE FIELD OF ENERGY USAGE MANAGEMENT, DISTRIBUTED THROUGH THE INTERNET (U.S. CLS. 100, 101 AND 102).

DAVID ELTON, EXAMINING ATTORNEY

CLASS 35—(Continued).

SN 85-319,526. XCEL ENERGY INC., MINNEAPOLIS, MN.
FILED 5-12-2011.

CLASS 35—(Continued).

SN 85-325,091. AMERICAN CONSOLIDATED MEDIA, LLC,
IRVING, TX. FILED 5-19-2011.

BRANDBASICS

THE MARK CONSISTS OF STANDARD CHARACTERS WITHOUT CLAIM TO ANY PARTICULAR FONT, STYLE, SIZE, OR COLOR.

FOR PREPARING ADVERTISEMENTS FOR OTHERS; AND BUSINESS CONSULTATION SERVICES, NAMELY, NEW PRODUCT BRAND-NAME DEVELOPMENT, MARKET RESEARCH, AND PUBLIC RELATIONS RELATED TO BRAND-NAME DEVELOPMENT (U.S. CLS. 100, 101 AND 102).

DAVID TAYLOR, EXAMINING ATTORNEY

THE MARK CONSISTS OF AN ELECTRICAL CORD AND PLUG WITHIN A CIRCLE FOLLOWED BY THE WORDING "THE" WRITTEN FROM BOTTOM TO TOP ALONG THE LETTER "B" OF THE WORDING "BIG" WRITTEN OVER THE WORDING "SAVE".

FOR PUBLIC GAS AND ELECTRIC UTILITY ENERGY MANAGEMENT CONSULTATION FOR COMMERCIAL AND INDUSTRIAL CUSTOMERS, NAMELY, CONSULTATION CONCERNING ALTERNATIVE FUEL AND ENERGY BACK-UP PROGRAMS, LOAD BALANCING PROGRAMS, ENERGY SUPPLY MANAGEMENT AND ENERGY CONSERVATION PROGRAMS; PROMOTING THE GOODS AND SERVICES OF OTHERS THROUGH THE ADMINISTRATION OF AIR CONDITIONING REBATE PROGRAMS AND ENERGY SAVING REBATE PROGRAMS; ELECTRIC UTILITY SERVICES IN THE NATURE OF OFFERING INCENTIVE PRICING FOR CONTROLLED USE OF ELECTRICITY DURING SPECIFIC HOURS; ENERGY CONSERVATION CONSULTATION, CONSULTATION IN THE FIELD OF ENERGY USE AND REGARDING ENERGY EFFICIENT APPLIANCES SUCH AS AIR CONDITIONING AND FURNACES; PROMOTING PUBLIC AWARENESS OF THE NEED FOR ENERGY CONSERVATION AND EFFICIENT ELECTRICITY UTILIZATION BY CONSUMERS THROUGH ENERGY AUDITS AND CONSULTATION IN THE EFFECTS OF ENERGY EFFICIENT LIGHTING, ENERGY EFFICIENT AIR CONDITIONING, ENERGY EFFICIENT REFRIGERATION, WINDOW GLAZING, AND ENERGY CONSERVATION AND HOME ENERGY AUDITS; PROMOTING PUBLIC AWARENESS OF THE NEED FOR APPLIANCE REBATES, ENERGY EFFICIENT LIGHTING FOR HOMES, AIR CONDITIONING LOAD CONTROL, APPLIANCE RECYCLING, AND SPECIAL TIME-OF-DAY RATES; CONSULTATION AND ANALYSIS REGARDING ENERGY EFFICIENCY AND CUSTOMER'S USAGE MANAGEMENT OF ELECTRIC AND GAS UTILITY SERVICES, NAMELY, ENERGY USE ANALYSIS, ENERGY PROFILING AND MONITORING, CONTROLLING ENERGY COSTS AND USAGE; ADMINISTERING ENERGY EFFICIENCY AND ENERGY USAGE MANAGEMENT PROGRAMS, NAMELY, ENERGY LOAD CONTROL PROGRAMS, ENERGY SCHEDULING PROGRAMS, AND ENERGY RATE ANALYSIS SERVICES; PROVISION OF INFORMATION IN THE FIELD OF ENERGY USAGE MANAGEMENT, DISTRIBUTED THROUGH THE INTERNET (U.S. CLS. 100, 101 AND 102).

DAVID ELTON, EXAMINING ATTORNEY

SN 85-328,369. BELCAMPO GROUP, INC., OAKLAND, CA.
FILED 5-24-2011.

BELCAMPO

THE MARK CONSISTS OF STANDARD CHARACTERS WITHOUT CLAIM TO ANY PARTICULAR FONT, STYLE, SIZE, OR COLOR.

THE ENGLISH TRANSLATION OF THE WORD "BELCAMPO" IN THE MARK IS "BEAUTIFUL LAND" OR "BEAUTIFUL FIELD".

FOR BUTCHER SHOPS; WHOLESALE AND RETAIL STORE SERVICES FEATURING FOODS AND BEVERAGES; ONLINE WHOLESALE AND RETAIL STORES SERVICES, ONLINE ORDERING SERVICES AND MAIL ORDER SERVICES AVAILABLE THROUGH COMPUTER COMMUNICATIONS AND INTERACTIVE TELEVISION, FEATURING FOODS AND BEVERAGES; FOOD AND BEVERAGE DISTRIBUTORSHIP SERVICES; CATALOG ORDERING SERVICES, MAIL ORDER CATALOG SERVICES, AND RETAIL SERVICES BY DIRECT SOLICITATION BY SALES AGENTS IN THE FIELD OF FOOD AND BEVERAGES; FREIGHT LOGISTICS MANAGEMENT; BUSINESS ADMINISTRATION AND MANAGEMENT; PROVIDING OFFICE FUNCTIONS; RETAIL BAKERY SHOPS; PROVIDING ONLINE DIRECTORY INFORMATION SERVICE FEATURING INFORMATION ON THE SUBJECTS OF FOOD, HEALTH, ENVIRONMENT, CLIMATE, NATURE, WILDLIFE AND SEA LIFE VIA THE INTERNET; ONLINE RETAIL STORE SERVICES FEATURING DOWNLOADABLE AUDIO AND VIDEO RECORDINGS ON THE SUBJECTS OF FOOD, HEALTH, ENVIRONMENT, CLIMATE, NATURE, WILDLIFE AND SEA LIFE; ONLINE RETAIL STORE SERVICES FEATURING DOWNLOADABLE SCIENTIFIC

CLASS 35—(Continued).

AND NON-SCIENTIFIC DATA ON THE SUBJECTS OF FOOD, HEALTH, ENVIRONMENT, CLIMATE, NATURE, WILDLIFE AND SEA LIFE; ONLINE RETAIL STORE SERVICES FEATURING FOOD PRODUCTS; ADVISORY AND CONSULTING SERVICES, NAMELY, BUSINESS MANAGEMENT IN THE FIELDS OF RESTAURANT INDUSTRY, FOOD INDUSTRY, BEVERAGE INDUSTRY, AND HOSPITALITY INDUSTRY; FRANCHISING, NAMELY, OFFERING BUSINESS MANAGEMENT ASSISTANCE IN THE ESTABLISHMENT AND/OR OPERATION OF FOOD AND HOSPITALITY ESTABLISHMENTS; OFFERING BUSINESS MANAGEMENT ASSISTANCE IN THE ESTABLISHMENT AND/OR OPERATION OF FOOD AND HOSPITALITY ESTABLISHMENTS; ON-LINE BUSINESS DIRECTORIES FEATURING RESTAURANTS, BARS, CAFES AND HOTELS; RESTAURANT MANAGEMENT FOR OTHERS; CONCESSION STANDS, RETAIL KIOSKS AND ROVING VENDOR SERVICES FEATURING FOOD AND BEVERAGES; VENDING MACHINE SERVICES (U.S. CLS. 100, 101 AND 102).

ROBIN CHOSID, EXAMINING ATTORNEY

SN 85-328,516. CAPITALIST, INC., CHICAGO, IL. FILED 5-24-2011.

NO FLUFF BRANDING

THE MARK CONSISTS OF STANDARD CHARACTERS WITHOUT CLAIM TO ANY PARTICULAR FONT, STYLE, SIZE, OR COLOR.

NO CLAIM IS MADE TO THE EXCLUSIVE RIGHT TO USE "BRANDING", APART FROM THE MARK AS SHOWN.

FOR ADVERTISING AND PUBLICITY SERVICES, FOR BRANDING, NAMELY, PROMOTING THE GOODS, SERVICES, BRAND IDENTITY AND COMMERCIAL INFORMATION AND NEWS OF THIRD PARTIES THROUGH PRINT, AUDIO, VIDEO, DIGITAL AND ON-LINE MEDIUM; ADVERTISING SERVICES, NAMELY, CREATING CORPORATE AND BRAND IDENTITY FOR OTHERS; ADVERTISING SERVICES, NAMELY, PROMOTING THE BRANDS, GOODS AND SERVICES OF OTHERS; BRAND CONCEPT AND BRAND DEVELOPMENT SERVICES FOR CORPORATE AND INDIVIDUAL CLIENTS; BRAND POSITIONING SERVICES; BRANDING SERVICES, NAMELY, CONSULTING, DEVELOPMENT, MANAGEMENT AND MARKETING OF BRANDS FOR BUSINESSES (U.S. CLS. 100, 101 AND 102).

FIRST USE 11-1-2010; IN COMMERCE 11-1-2010.
CHERYL CLAYTON, EXAMINING ATTORNEY

CLASS 35—(Continued).

SN 85-328,962. COTTERWEB ENTERPRISES, INC., MENDOTA HEIGHTS, MN. FILED 5-24-2011.



OWNER OF U.S. REG. NO. 3,382,015.

THE MARK CONSISTS OF STYLIZED IMAGE OF AN ENVELOPE CONTAINING A DOLLAR SIGN WITH THE PHRASE "SENDEARNINGS" TO THE RIGHT.

FOR ONLINE CONSUMER LOYALTY SERVICES, NAMELY, ADMINISTRATION OF INCENTIVE REWARD PROGRAMS TO PROMOTE READING E-MAILED ADVERTISING MESSAGES, COMPLETING ONLINE SHOPPING, ONLINE MARKET RESEARCH SURVEYS AND PLAYING ONLINE GAMES (U.S. CLS. 100, 101 AND 102).

MARTHA FROMM, EXAMINING ATTORNEY

SN 85-330,087. ALPHAQUEST TAX SERVICE, INC., SUMMERFIELD, SC. FILED 5-25-2011.

alphaquest

THE MARK CONSISTS OF STANDARD CHARACTERS WITHOUT CLAIM TO ANY PARTICULAR FONT, STYLE, SIZE, OR COLOR.

FOR PROVIDING TAX PLANNING, INCOME TAX PREPARATION FOR BUSINESSES AND INDIVIDUALS, INCOME TAX PLANNING (U.S. CLS. 100, 101 AND 102).
FIRST USE 5-16-2011; IN COMMERCE 5-16-2011.

C. DIONNE CLYBURN, EXAMINING ATTORNEY

SN 85-331,327. LINGUALINX LANGUAGE SOLUTIONS, INC., COHOES, NY. FILED 5-26-2011.

WORLD-READY CONTENT INTELLIGENCE

THE MARK CONSISTS OF STANDARD CHARACTERS WITHOUT CLAIM TO ANY PARTICULAR FONT, STYLE, SIZE, OR COLOR.

NO CLAIM IS MADE TO THE EXCLUSIVE RIGHT TO USE "CONTENT INTELLIGENCE", APART FROM THE MARK AS SHOWN.

FOR SERVICES FOR MANAGEMENT, PLANNING AND DEVELOPMENT OF CONTENT, NAMELY, COLLECTION, COMPILATION, AND SYSTEMATIZATION OF DOCUMENTS, IMAGES, COMMUNICATIONS MEDIA, AND INFORMATION INTO COMPUTER DATABASES; AUTHORING SERVICES, NAMELY, TRANSCRIPTION OF WRITTEN AND RECORDED CONTENT; AND PROVISION OF CONSULTANCY SERVICES RELATED TO THE AFORESAID (U.S. CLS. 100, 101 AND 102).

CAROLINE WOOD, EXAMINING ATTORNEY

CLASS 35—(Continued).

SN 85-335,826. INDIVIDUAL DIGITAL, INC., NEW YORK, NY. FILED 6-1-2011.

REVJAM

THE MARK CONSISTS OF STANDARD CHARACTERS WITHOUT CLAIM TO ANY PARTICULAR FONT, STYLE, SIZE, OR COLOR.

FOR ADVERTISING AND ADVERTISING CONSULTING SERVICES; DATA MANAGEMENT SERVICES FOR OTHERS FOR USE IN ADVERTISING; PROVIDING A WEB-BASED SYSTEM AND ONLINE PORTAL IN THE FIELD OF CONSUMER-TO-BUSINESS, BUSINESS-TO-CONSUMER, AND BUSINESS-TO-BUSINESS COMMERCE WHICH PROVIDE CUSTOMERS WITH PRECISE DATA TO FACILITATE ADVERTISING; PROVIDING A WEB-BASED SYSTEM AND ONLINE PORTAL IN THE FIELD OF CONSUMER-TO-BUSINESS, BUSINESS-TO-CONSUMER, AND BUSINESS-TO-BUSINESS COMMERCE WHICH PROVIDE CUSTOMERS WITH PRECISE DATA TO FACILITATE COMMERCE RELATED ACTIVITIES (U.S. CLS. 100, 101 AND 102).

MARGARET POWER, EXAMINING ATTORNEY

SN 85-337,027. SUMMIT ENTERTAINMENT, LLC, SANTA MONICA, CA. FILED 6-3-2011.

TWILIGHT BRIDAL

THE MARK CONSISTS OF STANDARD CHARACTERS WITHOUT CLAIM TO ANY PARTICULAR FONT, STYLE, SIZE, OR COLOR.

OWNER OF U.S. REG. NOS. 3,867,985, 3,944,718 AND OTHERS.

NO CLAIM IS MADE TO THE EXCLUSIVE RIGHT TO USE "BRIDAL", APART FROM THE MARK AS SHOWN.

FOR ORGANIZATION OF BUSINESS CONVENTIONS, EXHIBITIONS AND EVENTS IN THE FIELDS OF WEDDINGS, VACATION, AND TRAVEL (U.S. CLS. 100, 101 AND 102).

ASMAT KHAN, EXAMINING ATTORNEY

CLASS 35—(Continued).

SN 85-338,159. ROBERT SEARFOSS, ATLANTA, GA. FILED 6-4-2011.

TIMES MEDIA

THE MARK CONSISTS OF STANDARD CHARACTERS WITHOUT CLAIM TO ANY PARTICULAR FONT, STYLE, SIZE, OR COLOR.

NO CLAIM IS MADE TO THE EXCLUSIVE RIGHT TO USE MEDIA, APART FROM THE MARK AS SHOWN.

FOR PROVIDING INFORMATION IN THE FIELD OF POLITICS BY MEANS OF A GLOBAL COMPUTER INFORMATION NETWORK (U.S. CLS. 100, 101 AND 102).

FIRST USE 4-10-1998; IN COMMERCE 4-10-1998.

FRED CARL, EXAMINING ATTORNEY

SN 85-339,599. EASE-E MEDICAL, INC., PENROSE, CO. FILED 6-7-2011.

THE MARK CONSISTS OF THE STYLIZED WORD "EASE", A FOUR SQUARE BLOCK DESIGN, FOLLOWED BY A STYLIZED LETTER "E".

FOR ON-LINE RETAIL STORE SERVICES FEATURING HOME MEDICAL EQUIPMENT AND SUPPLIES (U.S. CLS. 100, 101 AND 102).

SHAUNIA CARLYLE, EXAMINING ATTORNEY

SN 85-340,033. MICHIGAN POWERSPORTS, INC., GRAND HAVEN, MI. FILED 6-7-2011.

PARTS GIANT

THE MARK CONSISTS OF STANDARD CHARACTERS WITHOUT CLAIM TO ANY PARTICULAR FONT, STYLE, SIZE, OR COLOR.

NO CLAIM IS MADE TO THE EXCLUSIVE RIGHT TO USE "PARTS", APART FROM THE MARK AS SHOWN.

FOR ON-LINE RETAIL STORE SERVICES FEATURING MOTORCYCLE PARTS AND ACCESSORIES (U.S. CLS. 100, 101 AND 102).

LURIE MAYES, EXAMINING ATTORNEY

CLASS 35—(Continued).

SN 85-341,101. AFFILIATED FOODS MIDWEST COOPERATIVE, INC., NORFOLK, NE. FILED 6-8-2011.



NO CLAIM IS MADE TO THE EXCLUSIVE RIGHT TO USE "MEDIA SOLUTIONS CORP", APART FROM THE MARK AS SHOWN.

THE MARK CONSISTS OF THE WORDING "MEDIA SOLUTIONS CORP" IN STYLIZED LETTERING APPEARING PARTIALLY INSIDE OF A DESIGN OF AN INCOMPLETE CIRCLE FORMED BY A SERIES OF CONCENTRIC SEMICIRCULAR ARCS.

FOR ADVERTISING, MARKETING, PROMOTION AND SOCIAL MEDIA MARKETING STRATEGY SERVICES; ADVERTISING, MARKETING, AND PROMOTION OF SALES COOPERATIVES AND OF WHOLESALE AND DISTRIBUTORS OF GOODS, PROVIDED VIA THE INTERNET, SOCIAL MEDIA, AND PRINT ADVERTISING (U.S. CLS. 100, 101 AND 102).

DEBRA LEE, EXAMINING ATTORNEY

SN 85-341,386. BLOPN S.A.C., CALLAO, LIMA, PERU, FILED 6-8-2011.

BRANDS LOOP NETWORK

THE MARK CONSISTS OF STANDARD CHARACTERS WITHOUT CLAIM TO ANY PARTICULAR FONT, STYLE, SIZE, OR COLOR.

PRIORITY CLAIMED UNDER SEC. 44(D) ON PERU APPLICATION NO. 454975, FILED 5-10-2011, REG. NO. 00005275, DATED 10-28-2011, EXPIRES 10-28-2021.

NO CLAIM IS MADE TO THE EXCLUSIVE RIGHT TO USE "BRANDS" AND "NETWORK", APART FROM THE MARK AS SHOWN.

FOR ON-LINE WHOLESALE AND RETAIL STORE SERVICES FEATURING ELECTRIC APPLIANCES, CLOTHING, GENERAL CONSUMER MERCHANDISE, FOOD (U.S. CLS. 100, 101 AND 102).

WARREN L. OLANDRIA, EXAMINING ATTORNEY

CLASS 35—(Continued).

SN 85-342,389. GYPSUM MANAGEMENT AND SUPPLY, INC., TUCKER, GA. FILED 6-9-2011.



TRIANGLE MATERIALS, INC.

NO CLAIM IS MADE TO THE EXCLUSIVE RIGHT TO USE "MATERIALS, INC.", APART FROM THE MARK AS SHOWN.

THE MARK CONSISTS OF THE LETTERS "T", "M", "I" IN STYLIZED LETTERS TO THE LEFT OF THE WORDS "TRIANGLE MATERIALS, INC." IN BLOCK LETTERS.

FOR DISTRIBUTORSHIPS IN THE FIELD OF COMMERCIAL BUILDING MATERIALS; WHOLESALE DISTRIBUTORSHIPS IN THE FIELD OF COMMERCIAL BUILDING MATERIALS (U.S. CLS. 100, 101 AND 102).

FIRST USE 9-10-1985; IN COMMERCE 9-10-1985.

LINDSEY RUBIN, EXAMINING ATTORNEY

SN 85-345,419. APPLIED TECHNOLOGY PUBLICATIONS, INC., BARRINGTON, IL. FILED 6-14-2011.

**MAINTENANCE AND
RELIABILITY TECHNOLOGY
SUMMIT**

THE MARK CONSISTS OF STANDARD CHARACTERS WITHOUT CLAIM TO ANY PARTICULAR FONT, STYLE, SIZE, OR COLOR.

OWNER OF U.S. REG. NO. 3,102,491.

NO CLAIM IS MADE TO THE EXCLUSIVE RIGHT TO USE "SUMMIT", APART FROM THE MARK AS SHOWN.

SEC. 2(F).

FOR ARRANGING AND CONDUCTING TRADE SHOWS IN THE FIELD OF TECHNOLOGY, RELATING TO EQUIPMENT RELIABILITY, MAINTENANCE OF EQUIPMENT, AND MANAGEMENT OF BUSINESS ASSETS, NAMELY, BUSINESS RECORDS AND EQUIPMENT (U.S. CLS. 100, 101 AND 102).

FIRST USE 10-0-2003; IN COMMERCE 10-0-2003.

DAWN HAN, EXAMINING ATTORNEY

CLASS 35—(Continued).

SN 85-345,462. TSUNAMI CAPITAL GROUP, INC., TORRANCE, CA. FILED 6-14-2011.

F.a.m.e.
FASHION • ART • MUSIC • ENTERTAINMENT

OWNER OF U.S. REG. NOS. 3,463,150 AND 3,709,763.
NO CLAIM IS MADE TO THE EXCLUSIVE RIGHT TO USE "FASHION, ART, MUSIC, ENTERTAINMENT", APART FROM THE MARK AS SHOWN.

THE MARK CONSISTS OF TWO COMPONENTS THAT ARE ALIGNED VERTICALLY. THE FIRST COMPONENT OF THE MARK IS COMPRISED OF THE WORDS "FASHION" "ART" "MUSIC" "ENTERTAINMENT", THE SECOND COMPONENT OF THE MARK IS COMPRISED OF THE LETTERS "F" "A" "M" "E", WHICH IS AN ACRONYM FORMED BY THE INITIAL LETTERS OF THE FIRST COMPONENT OF THE MARK, NAMELY THE WORDS "FASHION" "ART" "MUSIC" "ENTERTAINMENT".

FOR RETAIL STORE SERVICES FOR CLOTHING, ART, MUSIC, AND LIFESTYLE RELATED PRODUCTS AND ACCESSORIES; BUSINESS MANAGEMENT FOR CELEBRITIES, PERFORMING ARTISTS, MODELS, PROFESSIONAL ATHLETES, AUTHORS AND DESIGNERS; ASSISTANCE WITH BUSINESS MANAGEMENT OF BUSINESS ACTIVITIES AND EVENTS; PROMOTING THE GOODS AND SERVICES OF OTHERS VIA ELECTRONIC MEDIA; PROVIDING COMMERCIAL INFORMATION, VIA PRINT AND ELECTRONIC MEDIA, IN THE FIELDS OF FASHION, SPORTS, ART, MUSIC, CONSUMER PRODUCTS, LICENSING AND ENDORSEMENTS; ADVERTISING AND PUBLICITY SERVICES, NAMELY, PROMOTING THE GOODS, SERVICES AND BRAND IDENTITY OF THIRD PARTIES THROUGH PRINT, AUDIO, VIDEO, DIGITAL AND ON-LINE MEDIA; ADVERTISING, INCLUDING PROMOTION OF PRODUCTS AND SERVICES OF THIRD PARTIES THROUGH SPONSORING ARRANGEMENTS AND LICENSE AGREEMENTS; COMMERCIAL CONSULTANCY; MARKETING CONSULTING; SALES PROMOTION AND PUBLIC RELATIONS CONSULTING SERVICES; MODELING AGENCIES; PLANNING AND CONDUCTING OF TRADE SHOWS, EVENTS, EXHIBITIONS AND PRESENTATIONS FOR PROMOTING THE GOODS AND SERVICES OF OTHERS, IN THE FIELDS OF FASHION, SPORTS, ART, MUSIC, CONSUMER PRODUCTS, LICENSING AND ENDORSEMENTS (U.S. CLS. 100, 101 AND 102).

FIRST USE 6-14-2011; IN COMMERCE 6-14-2011.
PAUL MORENO, EXAMINING ATTORNEY

SN 85-346,658. INNOVID, NEW YORK, NY. FILED 6-15-2011.

iRoll Engage

THE MARK CONSISTS OF STANDARD CHARACTERS WITHOUT CLAIM TO ANY PARTICULAR FONT, STYLE, SIZE, OR COLOR.

OWNER OF U.S. REG. NO. 3,827,429.
FOR PROVIDING ADVERTISING SERVICES, NAMELY, DEVELOPMENT OF DYNAMIC VIDEO ADVERTISING CAMPAIGNS FOR PERSONAL COMPUTERS, MOBILE TELEPHONES AND TELEVISION (U.S. CLS. 100, 101 AND 102).

Laura Hammel, EXAMINING ATTORNEY

CLASS 35—(Continued).

SN 85-348,329. SHAREDISE GROUP LIMITED, NICOSIA, CYPRUS, FILED 6-16-2011.

SHAREDISE

THE MARK CONSISTS OF STANDARD CHARACTERS WITHOUT CLAIM TO ANY PARTICULAR FONT, STYLE, SIZE, OR COLOR.

FOR ON-LINE INTERACTIVE SHOPPING SITE FEATURING A WIDE VARIETY OF CONSUMER GOODS AND SERVICES OF OTHERS; PROMOTING AND SHOWCASING A WIDE VARIETY OF CONSUMER GOODS OF OTHERS BY PROVIDING A WEB SITE WHERE USERS CAN UPLOAD AN IMAGE, PHOTOGRAPH, OR OTHER MEDIA OF AN ITEM THAT WHEN CLICKED ON EITHER LINKS TO THE WEBSITES OF OTHERS WHERE A PRODUCT THAT IS IDENTICAL OR SIMILAR TO THE ITEM SHOWN IN THE IMAGE, PHOTOGRAPH, OR OTHER MEDIA CAN BE PURCHASED OR ALLOWS USERS TO VIEW AND DIRECTLY PURCHASE A PRODUCT IDENTICAL OR SIMILAR TO THE ITEM SHOWN IN THE IMAGE WITHOUT BEING REDIRECTED TO THE WEBSITES OF OTHERS (U.S. CLS. 100, 101 AND 102).

JOHN GARTNER, EXAMINING ATTORNEY

SN 85-349,797. RAPHAEL KHALFANI, DBA UBN CONSULTING, PASADENA, CA. FILED 6-18-2011.

VenueScout

THE MARK CONSISTS OF STANDARD CHARACTERS WITHOUT CLAIM TO ANY PARTICULAR FONT, STYLE, SIZE, OR COLOR.

FOR ADVERTISING SERVICES, NAMELY, PROMOTING AND MARKETING THE GOODS AND SERVICES OF OTHERS IN THE FIELDS OF EVENT PLANNING, EVENT MANAGEMENT, EVENT PROMOTION, EVENT VENUE MARKETING, EVENT VENUE MANAGEMENT, EVENT VENUE SEARCHING, EVENT VENUE SELECTION, EVENT VENUE PROMOTION, EVENT VENUE SCHEDULING, AND EVENT VENUE RATINGS, ALL VIA PRINT AND ELECTRONIC MEDIA; PROVIDING INFORMATION ABOUT AND MAKING REFERRALS IN THE FIELD OF CONSUMER PRODUCTS AND SERVICES FOR RETAIL SERVICES CONCERNING PRODUCTS, SERVICES, EVENTS, ACTIVITIES, ATTRACTIONS AND FACILITIES IN PARTICULAR GEOGRAPHIC LOCATIONS (U.S. CLS. 100, 101 AND 102).

FIRST USE 6-17-2011; IN COMMERCE 6-17-2011.
JAY BESCH, EXAMINING ATTORNEY

CLASS 35—(Continued).

SN 85-351,600. SAYHIRED, INC., SAN FRANCISCO, CA.
FILED 6-21-2011.

SAYGENT

THE MARK CONSISTS OF STANDARD CHARACTERS WITHOUT CLAIM TO ANY PARTICULAR FONT, STYLE, SIZE, OR COLOR.

FOR CONDUCTING BUSINESS SURVEYS PROVIDED THROUGH ANALYSIS, VALIDATION, DATA GATHERING OF VOICE AND HUMAN AUDIO INPUT THROUGH DESKTOP, WEB, AND PHONE APPLICATIONS (U.S. CLS. 100, 101 AND 102).

BRIDGETT SMITH, EXAMINING ATTORNEY

SN 85-351,629. SAYHIRED, INC., SAN FRANCISCO, CA.
FILED 6-21-2011.

SAYHIRED

THE MARK CONSISTS OF STANDARD CHARACTERS WITHOUT CLAIM TO ANY PARTICULAR FONT, STYLE, SIZE, OR COLOR.

FOR PROVIDING INFORMATION IN THE FIELDS OF EMPLOYMENT, PERSONNEL PLACEMENT AND RECRUITMENT, CAREERS, AND PERSONNEL MANAGEMENT RELATED TO CAREERS AND WORK LIFE, JOB RESOURCES, JOB LISTINGS, RESUMES, AND PHONE SCREENS PROVIDED THROUGH ANALYSIS, VALIDATION, DATA GATHERING OF VOICE AND HUMAN AUDIO INPUT THROUGH DESKTOP, WEB, AND PHONE APPLICATIONS (U.S. CLS. 100, 101 AND 102).

FIRST USE 11-1-2009; IN COMMERCE 11-1-2009.

BRIDGETT SMITH, EXAMINING ATTORNEY

SN 85-353,796. CONTRACTPOWER, LLC, PALM BEACH GARDENS, FL. FILED 6-23-2011.

CONTRACTPOWER

THE MARK CONSISTS OF STANDARD CHARACTERS WITHOUT CLAIM TO ANY PARTICULAR FONT, STYLE, SIZE, OR COLOR.

FOR WEB BASED SINGLE AND MULTI-STAGE SERVICE AUCTION BIDDING FOR CONSTRUCTION PROJECTS WITH A VARIETY OF PARTICIPANTS; COST MANAGEMENT SERVICES FOR THE CONSTRUCTION INDUSTRY; BID SERVICES, NAMELY, PROVIDING AN ONLINE NETWORK FOR CONTRACTORS TO RECEIVE LEADS AND BIDDING OPPORTUNITIES BY MEANS OF AN ONLINE MARKETPLACE FOR THE PURPOSE OF DEVELOPING BUSINESS IN THE CONSTRUCTION INDUSTRY (U.S. CLS. 100, 101 AND 102).

FIRST USE 7-19-2002; IN COMMERCE 11-10-2002.

JULIE WATSON, EXAMINING ATTORNEY

CLASS 35—(Continued).

SN 85-354,109. ADRIENNE WILBURN, MATTESON, IL.
FILED 6-23-2011.

LadyBella

THE MARK CONSISTS OF STANDARD CHARACTERS WITHOUT CLAIM TO ANY PARTICULAR FONT, STYLE, SIZE, OR COLOR.

THE ENGLISH TRANSLATION OF THE WORD "BELLA" IN THE MARK IS "BEAUTIFUL".

FOR ON-LINE RETAIL STORE SERVICES FEATURING WOMEN'S SHOES; RETAIL STORE AND ON-LINE RETAIL STORE SERVICES FEATURING WOMEN'S SHOES (U.S. CLS. 100, 101 AND 102).

DANNEAN HETZEL, EXAMINING ATTORNEY

SN 85-355,846. AMERICAN ESCROW & CLOSING COMPANY, MOUNT PROSPECT, IL. FILED 6-24-2011.

EXPENSEPORT

THE MARK CONSISTS OF STANDARD CHARACTERS WITHOUT CLAIM TO ANY PARTICULAR FONT, STYLE, SIZE, OR COLOR.

FOR BUSINESS SERVICES, NAMELY, MANAGING AND ADMINISTERING SOME NON-CORE FUNCTIONS, NAMELY, PAYROLL, ACCOUNTING, AND SPECIALIZED EXPENSE MANAGEMENT; BUSINESS EMPLOYEE RELOCATION SERVICES, NAMELY, EXPENSE MANAGEMENT; BUSINESS EMPLOYEE RECRUITING SERVICES, NAMELY, EXPENSE MANAGEMENT (U.S. CLS. 100, 101 AND 102).

FIRST USE 5-14-2011; IN COMMERCE 5-14-2011.

KATHY DE JONGE, EXAMINING ATTORNEY

CLASS 35—(Continued).

SN 85-355,950. THE GERONTOLOGICAL SOCIETY OF AMERICA, WASHINGTON, DC. FILED 6-24-2011.

ASSOCIATION FOR
GERONTOLOGY IN HIGHER
EDUCATION

THE MARK CONSISTS OF STANDARD CHARACTERS WITHOUT CLAIM TO ANY PARTICULAR FONT, STYLE, SIZE, OR COLOR.

OWNER OF U.S. REG. NOS. 2,522,123 AND 2,546,495.

NO CLAIM IS MADE TO THE EXCLUSIVE RIGHT TO USE "ASSOCIATION", APART FROM THE MARK AS SHOWN.

SEC. 2(F).

FOR ASSOCIATION SERVICES, NAMELY, PROMOTING INTEREST IN THE FIELDS OF GERONTOLOGY AND GERIATRICS EDUCATION IN ACADEMIC INSTITUTIONS; EDUCATION LEADERSHIP DEVELOPMENT IN THE FIELDS OF GERONTOLOGY AND GERIATRICS EDUCATION; PUBLIC ADVOCACY TO PROMOTE AWARENESS OF THE NEED FOR PUBLIC AND PRIVATE FINANCIAL SUPPORT FOR GERONTOLOGY AND GERIATRICS EDUCATION AT EDUCATIONAL INSTITUTIONS (U.S. CLS. 100, 101 AND 102).

FIRST USE 1-1-1976; IN COMMERCE 1-1-1976.

MARY CRAWFORD, EXAMINING ATTORNEY

CLASS 35—(Continued).

SN 85-361,227. CREATIVE AMERICA CAMPAIGN, INC., TOLUCA LAKE, CA. FILED 6-30-2011.

©creativeamerica

THE MARK CONSISTS OF THE UNITARY WORD "CREATIVEAMERICA" WITH THE LETTER "C" OF THE WORD "CREATIVE" HOUSED IN A CIRCLE.

FOR PROMOTING THE PROTECTION OF INTELLECTUAL PROPERTY RIGHTS AND SOLUTIONS TO THE PROBLEM OF CONTENT THEFT ON THE INTERNET; PUBLIC ADVOCACY TO PROMOTE AWARENESS OF THE PROTECTION OF INTELLECTUAL PROPERTY RIGHTS AND SOLUTIONS TO THE PROBLEM OF CONTENT THEFT ON THE INTERNET (U.S. CLS. 100, 101 AND 102).

DAVID MURRAY, EXAMINING ATTORNEY

SN 85-361,224. CREATIVE AMERICA CAMPAIGN, INC., TOLUCA LAKE, CA. FILED 6-30-2011.

SN 85-361,229. CREATIVE AMERICA CAMPAIGN, TOLUCA LAKE, CA. FILED 6-30-2011.



THE COLOR(S) RED AND BLUE IS/ARE CLAIMED AS A FEATURE OF THE MARK.

THE MARK CONSISTS OF THE LETTERS "CA" WITH THE LETTER "C" IN RED AND HOUSED IN A RED CIRCLE, AND THE LETTER "A" IN BLUE. BENEATH THE LETTERS "CA" IS THE UNITARY WORD "CREATIVEAMERICA" WITH THE WORD "CREATIVE" IN RED AND WITH THE LETTER "C" HOUSED IN A RED CIRCLE. THE WORD "AMERICA" IS IN BLUE.

FOR PROMOTING THE PROTECTION OF INTELLECTUAL PROPERTY RIGHTS AND SOLUTIONS TO THE PROBLEM OF CONTENT THEFT ON THE INTERNET; PUBLIC ADVOCACY TO PROMOTE AWARENESS OF THE PROTECTION OF INTELLECTUAL PROPERTY RIGHTS AND SOLUTIONS TO THE PROBLEM OF CONTENT THEFT ON THE INTERNET (U.S. CLS. 100, 101 AND 102).

DAVID MURRAY, EXAMINING ATTORNEY

©creativeamerica

THE COLOR(S) RED AND BLUE IS/ARE CLAIMED AS A FEATURE OF THE MARK.

THE MARK CONSISTS OF THE UNITARY WORD "CREATIVEAMERICA" WITH THE WORD "CREATIVE" IN RED AND WITH THE LETTER "C" HOUSED IN A RED CIRCLE. THE WORD "AMERICA" IS IN BLUE.

FOR PROMOTING THE PROTECTION OF INTELLECTUAL PROPERTY RIGHTS AND SOLUTIONS TO THE PROBLEM OF CONTENT THEFT ON THE INTERNET; PUBLIC ADVOCACY TO PROMOTE AWARENESS OF THE PROTECTION OF INTELLECTUAL PROPERTY RIGHTS AND SOLUTIONS TO THE PROBLEM OF CONTENT THEFT ON THE INTERNET (U.S. CLS. 100, 101 AND 102).

DAVID MURRAY, EXAMINING ATTORNEY

CLASS 35—(Continued).

SN 85-362,733. STREET TEAM PROMOTION.COM LLC, STATEN ISLAND, NY. FILED 7-5-2011.

STREET TEAM

THE MARK CONSISTS OF STANDARD CHARACTERS WITHOUT CLAIM TO ANY PARTICULAR FONT, STYLE, SIZE, OR COLOR.

SEC. 2(F).

FOR EMPLOYMENT AGENCY SERVICES, NAMELY, FILLING THE TEMPORARY STAFFING NEEDS OF BUSINESSES (U.S. CLS. 100, 101 AND 102).

FIRST USE 7-14-2003; THE MARK WAS FIRST USED ANYWHERE IN A DIFFERENT FORM OTHER THAN THAT SOUGHT TO BE REGISTERED AT LEAST AS EARLY AS 02/17/1998 ; IN COMMERCE 7-14-2003. THE MARK WAS FIRST USED IN COMMERCE IN A DIFFERENT FORM OTHER THAN THAT SOUGHT TO BE REGISTERED AT LEAST AS EARLY AS 06/25/1997.

ALYSSA STEEL, EXAMINING ATTORNEY

SN 85-362,922. MIDDLE EAST INVESTMENT INITIATIVE (MEII), WASHINGTON, DC. FILED 7-5-2011.

MEII

THE MARK CONSISTS OF STANDARD CHARACTERS WITHOUT CLAIM TO ANY PARTICULAR FONT, STYLE, SIZE, OR COLOR.

FOR PROMOTING ECONOMIC DEVELOPMENT IN THE MIDDLE EAST (U.S. CLS. 100, 101 AND 102).

FIRST USE 1-15-2007; IN COMMERCE 1-15-2007.

DOUGLAS LEE, EXAMINING ATTORNEY

SN 85-364,443. COUNTRY ROAD CLOTHING PTY LTD, RICHMOND, VICTORIA, AUSTRALIA, FILED 7-6-2011.

COUNTRY ROAD

THE MARK CONSISTS OF STANDARD CHARACTERS WITHOUT CLAIM TO ANY PARTICULAR FONT, STYLE, SIZE, OR COLOR.

OWNER OF U.S. REG. NOS. 1,213,557, 1,573,457 AND 1,862,951.

FOR ONLINE RETAIL STORE SERVICES FEATURING BAGS, HOUSEWARES, TEXTILES AND TEXTILE GOODS, CLOTHING, FOOTWEAR AND HEADGEAR (U.S. CLS. 100, 101 AND 102).

WILLIAM P. SHANAHAN, EXAMINING ATTORNEY

CLASS 35—(Continued).

SN 85-364,462. COUNTRY ROAD CLOTHING PTY LTD, RICHMOND, VICTORIA, AUSTRALIA, FILED 7-6-2011.

TRENERY

THE MARK CONSISTS OF STANDARD CHARACTERS WITHOUT CLAIM TO ANY PARTICULAR FONT, STYLE, SIZE, OR COLOR.

FOR ONLINE RETAIL STORE SERVICES, FEATURING BAGS, HOUSEWARES, TEXTILES AND TEXTILE GOODS, CLOTHING, FOOTWEAR AND HEADGEAR (U.S. CLS. 100, 101 AND 102).

WILLIAM P. SHANAHAN, EXAMINING ATTORNEY

SN 85-364,486. KEY WEST YOGURT, INC., VIRGINIA BEACH, VA. FILED 7-6-2011.



NO CLAIM IS MADE TO THE EXCLUSIVE RIGHT TO USE "YOGURT", APART FROM THE MARK AS SHOWN.

THE MARK CONSISTS OF A SLICE OF LIME ABOVE THE WORDS "KEY WEST" AND THE WORDS "CHILLIN' YOGURT" BELOW THE WORDS "KEY WEST".

FOR FRANCHISE SERVICES, NAMELY, OFFERING BUSINESS MANAGEMENT ASSISTANCE IN THE ESTABLISHMENT AND OPERATION OF FROZEN YOGURT SHOPS; FRANCHISING, NAMELY, CONSULTATION AND ASSISTANCE IN BUSINESS MANAGEMENT, ORGANIZATION AND PROMOTION; RESTAURANT FRANCHISING, NAMELY, OFFERING BUSINESS MANAGEMENT ASSISTANCE IN THE ESTABLISHMENT AND/OR OPERATION OF RESTAURANTS (U.S. CLS. 100, 101 AND 102).

FIRST USE 11-22-2010; IN COMMERCE 12-15-2010.

KRISTIN DAHLING, EXAMINING ATTORNEY

CLASS 35—(Continued).

SN 85-366,238. MARBLE, LYRA, DBA MR. GREENTREES, BEVERLY HILLS, CA. FILED 7-8-2011.

MR. GREENTREES

THE MARK CONSISTS OF STANDARD CHARACTERS WITHOUT CLAIM TO ANY PARTICULAR FONT, STYLE, SIZE, OR COLOR.

THE NAME(S), PORTRAIT(S), AND/OR SIGNATURE(S) SHOWN IN THE MARK DOES NOT IDENTIFY A PARTICULAR LIVING INDIVIDUAL.

FOR RETAIL STORE AND ON-LINE RETAIL STORE SERVICES FEATURING CHRISTMAS TREES, ORNAMENTS, WREATHS, CHRISTMAS GREENS AND DECORATIONS; WHOLESALE AND RETAIL STORE SERVICES AND ON-LINE RETAIL AND WHOLESALE STORE SERVICES FEATURING CHRISTMAS TREES, ORNAMENTS, WREATHS, CHRISTMAS GREENS AND DECORATIONS (U.S. CLS. 100, 101 AND 102).

FIRST USE 11-0-1986; IN COMMERCE 11-0-1986.
BILL DAWE, EXAMINING ATTORNEY

CLASS 35—(Continued).

SN 85-366,336. TEXAS HIGHER EDUCATION COORDINATING BOARD, AUSTIN, TX. FILED 7-8-2011.

GRAD TX

Finish Your College Degree

NO CLAIM IS MADE TO THE EXCLUSIVE RIGHT TO USE "TX" AND "FINISH YOUR COLLEGE DEGREE", APART FROM THE MARK AS SHOWN.

THE MARK CONSISTS OF THE STYLIZED WORDING "GRAD TX FINISH YOUR COLLEGE DEGREE" WITH A SQUARE DESIGN SURROUNDING THE TERM "TX".

FOR ADVERTISING, PROMOTION, AND MARKETING SERVICES IN THE NATURE OF A PUBLIC AWARENESS CAMPAIGN THROUGHOUT TEXAS OF BACCALAUREATE DEGREE COMPLETION PROGRAMS FOR RETURNING ADULT STUDENTS (U.S. CLS. 100, 101 AND 102).

FIRST USE 4-29-2011; IN COMMERCE 6-24-2011.
NATALIE POLZER, EXAMINING ATTORNEY

SN 85-366,246. MARBLE, LYRA, DBA MR. BONES PUMPKIN PATCH, BEVERLY HILLS, CA. FILED 7-8-2011.

MR. BONES PUMPKIN PATCH

THE MARK CONSISTS OF STANDARD CHARACTERS WITHOUT CLAIM TO ANY PARTICULAR FONT, STYLE, SIZE, OR COLOR.

NO CLAIM IS MADE TO THE EXCLUSIVE RIGHT TO USE "PUMPKIN PATCH", APART FROM THE MARK AS SHOWN.

THE NAME(S), PORTRAIT(S), AND/OR SIGNATURE(S) SHOWN IN THE MARK DOES NOT IDENTIFY A PARTICULAR LIVING INDIVIDUAL.

FOR RETAIL STORE AND ON-LINE RETAIL STORE SERVICES FEATURING PUMPKINS, HARVEST MERCHANDISE AND HALLOWEEN MERCHANDISE; WHOLESALE AND RETAIL STORE SERVICES AND ON-LINE RETAIL AND WHOLESALE STORE SERVICES FEATURING PUMPKINS, HARVEST MERCHANDISE AND HALLOWEEN MERCHANDISE (U.S. CLS. 100, 101 AND 102).

FIRST USE 10-0-1989; IN COMMERCE 10-0-1989.
BILL DAWE, EXAMINING ATTORNEY

SN 85-368,362. SMARTREVENUE.COM, INC., DBA SMARTREVENUE, RIDGEFIELD, CT. FILED 7-11-2011.

Shopper Circuitry

THE MARK CONSISTS OF STANDARD CHARACTERS WITHOUT CLAIM TO ANY PARTICULAR FONT, STYLE, SIZE, OR COLOR.

NO CLAIM IS MADE TO THE EXCLUSIVE RIGHT TO USE "SHOPPER", APART FROM THE MARK AS SHOWN.

FOR ANALYSIS OF PURCHASER HABIT STATES IN CONNECTION WITH CUSTOMERS IN A VARIETY OF INDUSTRIES, PRIMARILY CONSUMER PACKAGE GOODS AND RETAIL (U.S. CLS. 100, 101 AND 102).

FIRST USE 7-11-2011; IN COMMERCE 7-11-2011.
SHAUNIA CARLYLE, EXAMINING ATTORNEY

CLASS 35—(Continued).

SN 85-369,098. MEDSOURCE INTERNATIONAL, LLC, MOUND, MN. FILED 7-12-2011.

MedSource International, LLC

THE MARK CONSISTS OF STANDARD CHARACTERS WITHOUT CLAIM TO ANY PARTICULAR FONT, STYLE, SIZE, OR COLOR.

NO CLAIM IS MADE TO THE EXCLUSIVE RIGHT TO USE "INTERNATIONAL, LLC", APART FROM THE MARK AS SHOWN.

FOR WHOLESALE DISTRIBUTORSHIPS FEATURING MEDICAL EQUIPMENT AND SUPPLIES (U.S. CLS. 100, 101 AND 102).

FIRST USE 1-23-2006; IN COMMERCE 1-23-2007.
TRACY FLETCHER, EXAMINING ATTORNEY

SN 85-369,531. COMPETITOR GROUP, INC., SAN DIEGO, CA. FILED 7-12-2011.

ROCK 'N' ROLL

THE MARK CONSISTS OF STANDARD CHARACTERS WITHOUT CLAIM TO ANY PARTICULAR FONT, STYLE, SIZE, OR COLOR.

OWNER OF U.S. REG. NOS. 2,131,333, 3,422,420 AND OTHERS.

FOR ORGANIZING, PROMOTING AND CONDUCTING EXHIBITIONS AND TRADESHOWS FOR BUSINESS PURPOSES FEATURING BOOTHS AND DISPLAYS RELATING TO COMPETITIVE ENDURANCE SPORTS EVENTS (U.S. CLS. 100, 101 AND 102).

KAREN SEVERSON, EXAMINING ATTORNEY

SN 85-370,815. ERLY, INC., MENLO PARK, CA. FILED 7-13-2011.

ERLY

THE MARK CONSISTS OF STANDARD CHARACTERS WITHOUT CLAIM TO ANY PARTICULAR FONT, STYLE, SIZE, OR COLOR.

FOR PROMOTING THE GOODS AND SERVICES OF OTHERS, NAMELY, ADMINISTRATION OF A PROGRAM ENABLING PARTICIPANTS TO OBTAIN DISCOUNTS ON PRODUCTS AND SERVICES OF OTHERS, AND PROVIDING ONLINE COUPONS, REBATES, VOUCHERS AND INFORMATION REGARDING SPECIAL OFFERS FOR THE GOODS AND SERVICES OF OTHERS (U.S. CLS. 100, 101 AND 102).

JOHN DWYER, EXAMINING ATTORNEY

CLASS 35—(Continued).

SN 85-371,049. STUBY, JESSICA E, AKA BABES FOR BULLIES (B4B), ARNOLD, MD. FILED 7-14-2011.

BABES 4 BULLIES

THE MARK CONSISTS OF STANDARD CHARACTERS WITHOUT CLAIM TO ANY PARTICULAR FONT, STYLE, SIZE, OR COLOR.

FOR PUBLIC ADVOCACY TO PROMOTE AWARENESS OF THE PIT BULL BREED (U.S. CLS. 100, 101 AND 102).

FIRST USE 2-1-2011; IN COMMERCE 2-1-2011.
MARK SHINER, EXAMINING ATTORNEY

SN 85-373,747. LOREX TECHNOLOGY INC., MARKHAM, ONTARIO, CANADA, FILED 7-18-2011.

VIEW YOUR WORLD

THE MARK CONSISTS OF STANDARD CHARACTERS WITHOUT CLAIM TO ANY PARTICULAR FONT, STYLE, SIZE, OR COLOR.

PRIORITY CLAIMED UNDER SEC. 44(D) ON CANADA APPLICATION NO. 1526320, FILED 5-4-2011.

FOR RETAIL STORE SERVICES FEATURING WIRELESS CONSUMER ELECTRONICS; MAIL ORDER SERVICES FEATURING WIRELESS CONSUMER ELECTRONICS; ON-LINE RETAIL STORE SERVICES FEATURING WIRELESS CONSUMER ELECTRONICS (U.S. CLS. 100, 101 AND 102).

FIRST USE 2-7-2011; IN COMMERCE 2-7-2011.
COLLEEN DOMBROW, EXAMINING ATTORNEY

SN 85-374,286. WONDER MARKETING, INC., SANTA BARBARA, CA. FILED 7-18-2011.

BEAUTY BRUNCH

THE MARK CONSISTS OF STANDARD CHARACTERS WITHOUT CLAIM TO ANY PARTICULAR FONT, STYLE, SIZE, OR COLOR.

FOR RETAIL SHOP-AT-HOME PARTY SERVICES IN THE FIELDS OF COSMETICS, BEAUTY CARE PRODUCTS, SKIN CARE PRODUCTS, MULTIPURPOSE CLEANING AND RECONDITIONING PREPARATIONS; SHOP AT HOME PARTIES FEATURING COSMETICS AND SKIN CARE PRODUCTS; PROVIDING AN ON-LINE COMPUTER WEB SITE FEATURING BUSINESS INFORMATION AND BUSINESS ARTICLES, PROMOTIONAL AND MARKETING INFORMATION AND MATERIALS, ALL IN THE FIELDS OF COSMETICS AND BEAUTY CARE PRODUCTS, DIRECT SALES OF COSMETICS, BEAUTY CARE PRODUCTS, ALL-PURPOSE HOUSEHOLD, AUTO, AND INDUSTRIAL CLEANING PREPARATIONS, PREPARATIONS FOR CLEANING, PROTECTING, RESTORING, TREATING, AND CONDITIONING LEATHER, FURNITURE, CAR SEATS, JACKETS, PURSES, SHOES, SADDLES, BOOTS, VINYL, LEATHER CLEANER AND CONDITIONER FOR SPORTING GOODS, AND MULTIPURPOSE CLEANING AND RECONDITIONING PREPARATIONS; PROMOTING

CLASS 35—(Continued).

THE SALE OF GOODS AND SERVICES OF OTHERS BY PROVIDING DISCOUNTS ON THOSE GOODS AND SERVICES TO INDEPENDENT SALES PERSONS ENGAGED IN THE SALE OF COSMETICS, SKIN CARE, BEAUTY AND OTHER PERSONAL CARE PRODUCTS; RETAIL STORE SERVICES, MAIL ORDER CATALOG SALES SERVICES, AND INTERACTIVE RETAIL STORE SERVICES RENDERED BY MEANS OF A GLOBAL COMPUTER INFORMATION NETWORK, IN THE FIELDS OF COSMETICS AND BEAUTY CARE, PERSONAL CARE PRODUCTS, TOILETRIES, GIFTS, AND HOUSE CLEANING PRODUCTS; DISTRIBUTORSHIP SERVICES, RETAIL STORE SERVICES, RETAIL SERVICES BY DIRECT SOLICITATION BY INDEPENDENT SALES REPRESENTATIVES, INTERACTIVE RETAIL STORE SERVICES RENDERED BY MEANS OF A GLOBAL COMPUTER INFORMATION NETWORK IN THE FIELDS OF BEAUTY CARE, SKIN CARE, HOUSEWARES, COSMETICS, PERSONAL CARE PRODUCTS, PREPARATIONS FOR CLEANING, PROTECTING, RESTORING, TREATING, AND CONDITIONING LEATHER, FURNITURE, CAR SEATS, JACKETS, PURSES, SHOES, SADDLES, BOOTS, VINYL, LEATHER CLEANER AND CONDITIONER FOR SPORTING GOODS, MULTIPURPOSE CLEANING AND RECONDITIONING PREPARATIONS (U.S. CLS. 100, 101 AND 102).
PAUL MORENO, EXAMINING ATTORNEY

SN 85-376,144. SNAP-ON INCORPORATED, KENOSHA, WI. FILED 7-20-2011.

SNAP-ON NO COMPROMISE TOUR

THE MARK CONSISTS OF STANDARD CHARACTERS WITHOUT CLAIM TO ANY PARTICULAR FONT, STYLE, SIZE, OR COLOR.

OWNER OF U.S. REG. NOS. 964,404, 2,966,535 AND OTHERS.

FOR PRODUCT DEMONSTRATION, NAMELY, FOR TOOLS; CONDUCTING TOOL EXHIBITIONS FOR BUSINESS PURPOSES (U.S. CLS. 100, 101 AND 102).

FIRST USE 9-25-2008; IN COMMERCE 9-25-2008.

NAKIA HENRY, EXAMINING ATTORNEY

SN 85-379,547. CANADIAN JEWELLERY GROUP, HUNTSVILLE, ONTARIO, CANADA, FILED 7-25-2011.

BRING THE SPARKLE HOME

THE MARK CONSISTS OF STANDARD CHARACTERS WITHOUT CLAIM TO ANY PARTICULAR FONT, STYLE, SIZE, OR COLOR.

PRIORITY CLAIMED UNDER SEC. 44(D) ON CANADA APPLICATION NO. 1524606, FILED 4-21-2011.

FOR ASSOCIATION SERVICES, NAMELY, PROMOTING THE INTERESTS OF JEWELLERY RETAILERS; BUSINESS ADMINISTRATION ASSISTANCE; BUYING CLUB SERVICES IN THE FIELD OF JEWELLERY; COOPERATIVE ADVERTISING AND MARKETING; PURCHASING AGENTS (U.S. CLS. 100, 101 AND 102).

FIRST USE 9-1-2008; IN COMMERCE 9-1-2008.

LINDSEY RUBIN, EXAMINING ATTORNEY

CLASS 35—(Continued).

SN 85-382,138. RETAIL SERVICES & SYSTEMS, INC., POTOMAC, MD. FILED S.R. 7-27-2011; AM. P.R. 4-13-2012.

THE SELECTION IS RIDICULOUS

THE MARK CONSISTS OF STANDARD CHARACTERS WITHOUT CLAIM TO ANY PARTICULAR FONT, STYLE, SIZE, OR COLOR.

FOR RETAIL STORE SERVICES FEATURING ALCOHOLIC BEVERAGES, SNACK FOODS AND PAPER PRODUCTS IN THE NATURE OF PAPER NAPKINS AND PAPER CUPS (U.S. CLS. 100, 101 AND 102).

FIRST USE 6-0-2011; IN COMMERCE 6-0-2011.

SHAILA SETTLES, EXAMINING ATTORNEY

SN 85-383,263. ORGANIC FOOD SUPPLY COMPANY, COVINA, CA. FILED 7-28-2011.

OFSC

THE MARK CONSISTS OF STANDARD CHARACTERS WITHOUT CLAIM TO ANY PARTICULAR FONT, STYLE, SIZE, OR COLOR.

FOR WHOLESALE AND RETAIL STORE SERVICES FEATURING ORGANIC FOODS AND FOOD BARS (U.S. CLS. 100, 101 AND 102).

LESLIE RICHARDS, EXAMINING ATTORNEY

SN 85-383,454. BAYRU, LLC, SKOKIE, IL. FILED 7-28-2011.

DOSTAMI

THE MARK CONSISTS OF STANDARD CHARACTERS WITHOUT CLAIM TO ANY PARTICULAR FONT, STYLE, SIZE, OR COLOR.

THE WORDING "DOSTAMI" HAS NO MEANING IN A FOREIGN LANGUAGE.

FOR BRINGING TOGETHER, FOR THE BENEFIT OF OTHERS, OF A VARIETY OF GOODS AND SERVICES, ENABLING CUSTOMERS TO CONVENIENTLY VIEW AND PURCHASE THOSE GOODS AND SERVICES FROM AN INTERNET WEB SITE PARTICULARLY SPECIALIZING IN THE MARKETING OF THE SALE OF GOODS AND SERVICES OF OTHERS; ON-LINE AUCTION BIDDING FOR OTHERS; ONLINE AUCTION MANAGEMENT PROVIDED TO OTHERS OVER A WEB SITE ACCESSED THROUGH A GLOBAL COMPUTER NETWORK; PROMOTING THE GOODS AND SERVICES OF OTHERS; PROVIDING A WEB SITE WHEREBY BUYERS OF GOODS OR SERVICES LOCATE AND RECEIVE QUOTATIONS FROM MULTIPLE COMPETITIVE SOURCES AND SELLERS OF GOODS OR SERVICES; ON-LINE TRADING SERVICES TO FACILITATE THE SALE OF GOODS AND SERVICES BY OTHERS VIA A COMPUTER NETWORK FEATURING COMPUTERIZED ON-LINE ORDERING WHICH ALLOWS CONSU-

CLASS 35—(Continued).

MERS TO SEARCH AND ORDER A WIDE VARIETY OF CONSUMER GOODS AND SERVICES; PROVIDING AN ONLINE COMMERCIAL INFORMATION DIRECTORY FOR BUYERS ON THE INTERNET; BUSINESS SERVICES, NAMELY, PROVIDING SEARCHABLE COMPUTER DATABASES REGARDING THE PURCHASE AND SALE OF A WIDE VARIETY OF PRODUCTS AND SERVICES OF OTHERS, AS WELL AS THE PRODUCERS AND SELLERS OF THOSE PRODUCTS; PROVIDING INFORMATION ABOUT THE GOODS AND SERVICES OF OTHERS VIA THE GLOBAL COMPUTER NETWORK; ADVERTISING AND ADVERTISEMENT SERVICES; DISSEMINATION OF ADVERTISING FOR OTHERS VIA A GLOBAL COMPUTER NETWORK; ONLINE ADVERTISING SERVICES FOR OTHERS, NAMELY, PROVIDING ADVERTISING SPACE ON WEB PAGES ON A GLOBAL COMPUTER NETWORK; AUCTION MANAGEMENT SERVICES PROVIDED TO OTHERS OVER AN ON-LINE WEB SITE ACCESSED THROUGH A GLOBAL COMPUTER NETWORK; OPERATING ONLINE MARKETPLACES FOR SELLERS AND BUYERS OF GOODS AND SERVICES; PROVIDING A SEARCHABLE ONLINE ADVERTISING GUIDE FEATURING THE GOODS AND SERVICES OF OTHERS; PROVIDING EVALUATIVE FEEDBACK AND RATINGS OF SELLERS' GOODS AND SERVICES AND THE VALUE AND PRICES OF SELLERS' GOODS (U.S. CLS. 100, 101 AND 102).

COURTNEY ALVAREZ, EXAMINING ATTORNEY

CLASS 35—(Continued).

SERVICES OF OTHERS, AS WELL AS THE PRODUCERS AND SELLERS OF THOSE PRODUCTS; PROVIDING INFORMATION ABOUT THE GOODS AND SERVICES OF OTHERS VIA THE GLOBAL COMPUTER NETWORK; ADVERTISING AND ADVERTISEMENT SERVICES; DISSEMINATION OF ADVERTISING FOR OTHERS VIA A GLOBAL COMPUTER NETWORK; ONLINE ADVERTISING SERVICES FOR OTHERS, NAMELY, PROVIDING ADVERTISING SPACE ON WEB PAGES ON A GLOBAL COMPUTER NETWORK; AUCTION MANAGEMENT SERVICES PROVIDED TO OTHERS OVER AN ON-LINE WEB SITE ACCESSED THROUGH A GLOBAL COMPUTER NETWORK; OPERATING ONLINE MARKETPLACES FOR SELLERS AND BUYERS OF GOODS AND SERVICES; PROVIDING A SEARCHABLE ONLINE ADVERTISING GUIDE FEATURING THE GOODS AND SERVICES OF OTHERS; PROVIDING EVALUATIVE FEEDBACK AND RATINGS OF SELLERS' GOODS AND SERVICES AND THE VALUE AND PRICES OF SELLERS' GOODS (U.S. CLS. 100, 101 AND 102).

COURTNEY ALVAREZ, EXAMINING ATTORNEY

SN 85-383,468. BAYRU, LLC, SKOKIE, IL. FILED 7-28-2011.

SN 85-384,254. THE SULPHUR INSTITUTE, INC., WASHINGTON, DC. FILED 7-29-2011.

ZAMOSTOM

THE MARK CONSISTS OF STANDARD CHARACTERS WITHOUT CLAIM TO ANY PARTICULAR FONT, STYLE, SIZE, OR COLOR.

THE ENGLISH TRANSLATION OF "ZAMOSTOM" IN THE MARK IS "BEHIND THE BRIDGE".

FOR BRINGING TOGETHER, FOR THE BENEFIT OF OTHERS, OF A VARIETY OF GOODS AND SERVICES, ENABLING CUSTOMERS TO CONVENIENTLY VIEW AND PURCHASE THOSE GOODS AND SERVICES FROM AN INTERNET WEB SITE PARTICULARLY SPECIALIZING IN THE MARKETING OF THE SALE OF GOODS AND SERVICES OF OTHERS; ON-LINE AUCTION BIDDING FOR OTHERS; ONLINE AUCTION MANAGEMENT PROVIDED TO OTHERS OVER A WEB SITE ACCESSED THROUGH A GLOBAL COMPUTER NETWORK; PROMOTING THE GOODS AND SERVICES OF OTHERS; PROVIDING A WEB SITE WHEREBY BUYERS OF GOODS OR SERVICES LOCATE AND RECEIVE QUOTATIONS FROM MULTIPLE COMPETITIVE SOURCES AND SELLERS OF GOODS OR SERVICES; ON-LINE TRADING SERVICES TO FACILITATE THE SALE OF GOODS AND SERVICES BY OTHERS VIA A COMPUTER NETWORK FEATURING COMPUTERIZED ON-LINE ORDERING WHICH ALLOWS CONSUMERS TO SEARCH AND ORDER A WIDE VARIETY OF CONSUMER GOODS AND SERVICES; PROVIDING AN ONLINE COMMERCIAL INFORMATION DIRECTORY FOR BUYERS ON THE INTERNET; BUSINESS SERVICES, NAMELY, PROVIDING SEARCHABLE COMPUTER DATABASES REGARDING THE PURCHASE AND SALE OF A WIDE VARIETY OF PRODUCTS AND



NO CLAIM IS MADE TO THE EXCLUSIVE RIGHT TO USE "INSTITUTE", APART FROM THE MARK AS SHOWN. THE MARK CONSISTS OF THE STYLIZED WORD "TSI" WITH THE WORDS "THE SULPHUR INSTITUTE" TO THE RIGHT AND AN ARCH DESIGN AT THE TOP.

SEC. 2(F) AS TO "THE SULPHUR INSTITUTE". FOR TRADE ASSOCIATION SERVICES, NAMELY, PROMOTING THE INTERESTS OF THE SULPHUR INDUSTRY (U.S. CLS. 100, 101 AND 102).

FIRST USE 5-1-2005; IN COMMERCE 5-1-2005. MARY CRAWFORD, EXAMINING ATTORNEY

CLASS 35—(Continued).

SN 85-384,983. DOBES, JERROLD, BROOKFIELD, IL. FILED 7-29-2011.



NO CLAIM IS MADE TO THE EXCLUSIVE RIGHT TO USE "BROOKFIELD CHAMBER OF COMMERCE", APART FROM THE MARK AS SHOWN.

THE MARK CONSISTS OF A GIRAFFE ON THE LEFT SIDE WITH THE STYLIZED TEXT "BROOKFIELD CHAMBER OF COMMERCE". THERE IS A LINE BELOW.

FOR CHAMBER OF COMMERCE SERVICES, NAMELY, PROMOTING BUSINESS AND TOURISM IN THE BROOKFIELD, ILLINOIS AREA (U.S. CLS. 100, 101 AND 102).

NAAKWAMA ANKRAH, EXAMINING ATTORNEY

CLASS 35—(Continued).

SN 85-387,563. MYDOWNTIME, LLC, NEW YORK, NY. FILED 8-2-2011.



SN 85-385,835. PALLADIAN HEALTH, LLC, WEST SENECA, NY. FILED 8-1-2011.



OWNER OF U.S. REG. NOS. 3,848,293, 3,944,698 AND OTHERS.

NO CLAIM IS MADE TO THE EXCLUSIVE RIGHT TO USE "FIT" AND "WELLNESS PROGRAMS", APART FROM THE MARK AS SHOWN.

THE COLOR(S) BLUE, WHITE AND YELLOW IS/ARE CLAIMED AS A FEATURE OF THE MARK.

THE MARK CONSISTS OF A SOLID BLUE BOX WITH THE WORD "PALLADIAN" IN WHITE LETTERS AT THE TOP CENTER, SITUATED ABOVE A WHITE LINE. BELOW THE WHITE LINE IS THE CAPITAL LETTERS "FIT" IN YELLOW IN THE MIDDLE CENTER OF THE BOX, SITUATED ABOVE A SECOND WHITE LINE. BELOW THE SECOND WHITE LINE IS THE WORDS "WELLNESS PROGRAMS" IN ALL CAPITAL LETTERS IN WHITE AT THE BOTTOM CENTER OF THE BLUE BOX.

FOR PROMOTING THE BENEFITS OF A HEALTHY LIFESTYLE TO MEMBERS OF A HEALTH PLAN BY PROVIDING A VALUE ADDED BENEFIT PROGRAM REGARDING FITNESS AND WELLNESS THAT PROVIDES DISCOUNTS FOR USING COMMERCIAL FITNESS CENTERS, HOLISTIC HEALTH AND WELLNESS STUDIOS, HEALTH FOOD STORES, COMMUNITY EDUCATION CLASS AND PUBLIC AND PRIVATE INDOOR AND OUTDOOR RECREATION FACILITIES (U.S. CLS. 100, 101 AND 102).

CHRISTOPHER LAW, EXAMINING ATTORNEY

THE MARK CONSISTS OF A STYLIZED IMAGE AND WORDS COMPRISING OF (I) TWO UNEQUAL SEMI CIRCLES THAT JOIN TOGETHER TO PORTRAY THE IMAGE OF A CLOCK WITH THE HANDS OF THE CLOCK INDICATING THE TIME OF 5:15, (II) THE WORD "DOWNTIME" APPEARING BELOW THE IMAGE OF THE CLOCK, AND (III) THE WORDS "TIME FOR A CHANGE" APPEARING BELOW THE WORD "DOWNTIME".

FOR PROMOTIONAL SERVICES, NAMELY, PROMOTING THE CHARITIES OF OTHERS AND DEVELOPING AND MANAGING THE CHARITABLE GIVING PROGRAMS OF OTHERS ALL TO ENABLE AND/OR FACILITATE ARTISTS, ATHLETES, CELEBRITIES AND OTHER PERSONS TO GET INVOLVED IN THEIR CHOSEN CHARITABLE CAUSES OR PROJECTS (U.S. CLS. 100, 101 AND 102).

FIRST USE 6-15-2011; IN COMMERCE 6-15-2011.

ROBERT STRUCK, EXAMINING ATTORNEY

CLASS 35—(Continued).

SN 85-387,730. KEARSARGE HEALTHCARE CONSULTING, INC., DBA REPORTINGMD, GEORGES MILLS, NH. FILED 8-2-2011.



NO CLAIM IS MADE TO THE EXCLUSIVE RIGHT TO USE "REPORTING MD", APART FROM THE MARK AS SHOWN.

THE COLOR(S) BLACK, WHITE, GRAY, BLUE, AND ORANGE IS/ARE CLAIMED AS A FEATURE OF THE MARK.

THE MARK CONSISTS OF THE WORDING "REPORTINGMD" WITH THE TERM "REPORTING" IN BLUE AND THE TERM "MD" IN ORANGE. TO THE LEFT APPEARS A STYLIZED DEPICTION OF A CLIPBOARD IN BLUE WITH A GRAY, WHITE, AND BLACK CLIP ATTACHING A WHITE PIECE OF PAPER CONTAINING AN ORANGE JAGGED LINE WITH THE LOWER RIGHT CORNER FLIPPED BACK WITH GRAY OUTLINING AND HIGHLIGHTS. THE CLIPBOARD CASTS A GRAY SHADOW. THE BACKGROUND OF THE ENTIRE MARK IS WHITE.

FOR BUSINESS INFORMATION REPORTING SERVICES FOR HOSPITALS, NAMELY, PROVIDING HOSPITAL SPECIFIC REPORTS FOR THE PURPOSE OF ANALYZING GOVERNMENT REIMBURSEMENT DATA AND DRIVE BUSINESS DECISION MAKING; BUSINESS SERVICES PROVIDED TO THE HEALTHCARE INDUSTRY, NAMELY, THE COLLECTION, REPORTING, AND ANALYSIS OF HEALTHCARE QUALITY DATA FOR BUSINESS PURPOSES; MARKET REPORTS AND STUDIES; PROVIDING AN INTERNET-BASED DATABASE OF PATIENT MEDICAL INFORMATION DESIGNED TO FACILITATE PATIENT-AUTHORIZED, HIPAA-COMPLIANT SHARING AND MAINTENANCE OF PATIENT MEDICAL INFORMATION AMONGST A PATIENT'S DOCTORS SUCH THAT THIS INFORMATION CAN BE DIRECTLY INSERTED INTO THE DOCTOR'S MEDICAL REPORTS AS A MEANS OF INCREASING MEDICAL RECORD GENERATION EFFICIENCY AND ACCURACY (U.S. CLS. 100, 101 AND 102).

FIRST USE 7-15-2011; IN COMMERCE 8-2-2011.

JIM RINGLE, EXAMINING ATTORNEY

SN 85-387,872. WESTERN AEROSOL INFORMATION BUREAU, FULLERTON, CA. FILED 8-3-2011.



NO CLAIM IS MADE TO THE EXCLUSIVE RIGHT TO USE "RECYCLING SYMBOL" AND "AEROSOL CAN", APART FROM THE MARK AS SHOWN.

THE COLOR(S) GREEN, WHITE AND BLACK IS/ARE CLAIMED AS A FEATURE OF THE MARK.

THE MARK CONSISTS OF THE BLACK WORDS "USE IT. RECYCLE IT." AND A DESIGN OF A BLACK AND WHITE AEROSOL CAN WITH A GREEN LABEL WITH THE BLACK RECYCLING SYMBOL ON IT.

FOR PROMOTING PUBLIC AWARENESS FOR THE NEED TO RECYCLE AEROSOL PRODUCTS (U.S. CLS. 100, 101 AND 102).

CHRISTOPHER BUONGIORNO, EXAMINING ATTORNEY

CLASS 35—(Continued).

SN 85-388,625. STUDENSE LLC., WILMINGTON, DE. FILED 8-3-2011.

STOUPONS

THE MARK CONSISTS OF STANDARD CHARACTERS WITHOUT CLAIM TO ANY PARTICULAR FONT, STYLE, SIZE, OR COLOR.

FOR PROMOTIONAL SERVICES, NAMELY, PROMOTING THE GOODS AND SERVICES OF OTHERS BY MEANS OF PROVIDING ONLINE COUPONS, COUPON CODES AND DEALS; ADVERTISING AND PROMOTIONAL SERVICES, NAMELY, PROMOTING THE GOODS AND SERVICES OF OTHERS BY PROVIDING ONLINE GIFT CARDS, GIFT CERTIFICATES, COUPONS AND RESTAURANT MENUS; ONLINE ADVERTISING AND PROMOTIONAL SERVICES NAMELY, PROMOTING THE GOODS AND SERVICES OF OTHERS BY PROVIDING ONLINE GIFT CARDS, GIFT CERTIFICATES, COUPONS AND RESTAURANT MENUS; PROMOTIONAL SERVICES FOR OTHERS, NAMELY, PROVIDING DAILY DEALS FEATURED ON A WEBSITE FOR STUDENTS (U.S. CLS. 100, 101 AND 102).

PAUL MORENO, EXAMINING ATTORNEY

SN 85-388,737. WILMINGTON CONSULTING GROUP, LLC, WILMINGTON, NC. FILED 8-3-2011.



NO CLAIM IS MADE TO THE EXCLUSIVE RIGHT TO USE "WILMINGTON CONSULTING GROUP" AND "THE CAROLINAS PREMIER BRAND DEVELOPMENT AGENCY", APART FROM THE MARK AS SHOWN.

THE MARK CONSISTS OF STYLIZED W WITH STYLIZED C DIRECTLY ABOVE STYLIZED G ALONG THE RIGHT SIDE OF THE STYLIZED W. UNDER STYLIZED LETTERS IS THE PHRASE "WILMINGTON CONSULTING GROUP" SPLIT INTO TWO PARTS. THE WORD "WILMINGTON" IN ALL CAPS WITH STRAIGHT LINE ABOVE AND BELOW THE WORD. UNDER "WILMINGTON" IS "CONSULTING GROUP" IN ALL CAPS. UNDER "CONSULTING GROUP" IS THE PHRASE "THE CAROLINAS PREMIER BRAND DEVELOPMENT AGENCY" SPLIT INTO TWO LINES. FIRST LINE HAS "THE CAROLINAS" IN ALL CAPS AND LAST LINE HAS "PREMIER BRAND DEVELOPMENT AGENCY" IN ALL CAPS.

FOR BRANDING SERVICES, NAMELY, CONSULTING, DEVELOPMENT, MANAGEMENT AND MARKETING OF BRANDS FOR BUSINESSES (U.S. CLS. 100, 101 AND 102).

FIRST USE 8-1-2009; IN COMMERCE 8-1-2009.

CHARLES L. JENKINS, EXAMINING ATTORNEY

CLASS 35—(Continued).

SN 85-389,676. CALDWELL, ANNIKA VJ, DBA INSIDE SCANDINAVIA, OAKTON, VA. FILED 8-4-2011.

CLASS 35—(Continued).

SN 85-392,384. PARTNERSHIP FOR ECONOMIC DEVELOPMENT OF YORK COUNTY, YORK, PA. FILED 8-8-2011.



NO CLAIM IS MADE TO THE EXCLUSIVE RIGHT TO USE "YORK PENNSYLVANIA", APART FROM THE MARK AS SHOWN.

THE COLOR(S) ORANGE, BLACK, AND GRAY IS/ARE CLAIMED AS A FEATURE OF THE MARK.

THE MARK CONSISTS OF THE WORDS "YORK" IN BLACK, "PENNSYLVANIA" IN GRAY, AND "CREATIVITY UNLEASHED" IN ORANGE. FOUR CIRCLES IN GRAY AND FIVE CIRCLES IN ORANGE.

SEC. 2(F).

FOR PROMOTING THE ECONOMIC DEVELOPMENT IN THE COUNTY OF YORK PENNSYLVANIA (U.S. CLS. 100, 101 AND 102).

FIRST USE 0-0-2010; IN COMMERCE 0-0-2010.

TINA L. SNAPP, EXAMINING ATTORNEY

SN 85-403,058. ERLY, INC., MENLO PARK, CA. FILED 8-20-2011.

NO CLAIM IS MADE TO THE EXCLUSIVE RIGHT TO USE "SCANDINAVIA", APART FROM THE MARK AS SHOWN.

THE MARK CONSISTS OF A DESIGN OF A SYMBOL FROM THE FINNISH EPIC KALEVALA CONSISTING OF AN UNBROKEN LINE DESIGN WITH CIRCLE POINTS ON FOUR SIDES AND A SQUARE IN THE CENTER WITH A CIRCULAR POINT INSIDE OF THE SQUARE. TO THE RIGHT OF THE DESIGN IS A VERTICAL LINE AND THE TERM "INSIDE" ABOVE THE TERM "SCANDINAVIA". THE PHRASE- "INSIDE SCANDINAVIA-WHERE ART AND TECHNOLOGY INSPIRE DESIGN" IS BELOW THE TERM "SCANDINAVIA".

FOR GOODS IMPORT-EXPORT AGENCIES; ON-LINE WHOLESALE AND RETAIL STORE SERVICES FEATURING GLASSWARE, KITCHEN UTENSILS, TABLEWARE, DINNERWARE, COOKWARE, CUTLERY, KITCHEN KNIVES AND SIMILAR GOODS; TEXTILES; JEWELRY; PACKAGED GOURMET FOOD ITEMS; FURNITURE; BOOKS; OPERATING, ASSISTING AND OUTSOURCING THE OPERATION OF A DISTRIBUTION CENTER OR WAREHOUSE FACILITY CONTAINING MAIL ORDER OR DISTRIBUTION INVENTORY; RETAIL JEWELRY STORES; RETAIL STORE AND ON-LINE RETAIL STORE SERVICES FEATURING GLASSWARE, KITCHEN UTENSILS, TABLEWARE, DINNERWARE, COOKWARE, CUTLERY, KITCHEN KNIVES AND SIMILAR GOODS; TEXTILES; JEWELRY; PACKAGED GOURMET FOOD ITEMS; FURNITURE; BOOKS (U.S. CLS. 100, 101 AND 102).

SALLY SHIH, EXAMINING ATTORNEY

EXPERIENCE GRAPH

THE MARK CONSISTS OF STANDARD CHARACTERS WITHOUT CLAIM TO ANY PARTICULAR FONT, STYLE, SIZE, OR COLOR.

FOR PROMOTING THE GOODS AND SERVICES OF OTHERS, NAMELY, ADMINISTRATION OF A PROGRAM ENABLING PARTICIPANTS TO OBTAIN DISCOUNTS ON PRODUCTS AND SERVICES OF OTHERS, AND PROVIDING ONLINE COUPONS, REBATES, VOUCHERS AND INFORMATION REGARDING SPECIAL OFFERS FOR THE GOODS AND SERVICES OF OTHERS (U.S. CLS. 100, 101 AND 102).

JOHN DWYER, EXAMINING ATTORNEY

CLASS 35—(Continued).

SN 85-403,216. WORKFORCE CAPITAL, LLC, MARTINEZ, GA. FILED 8-21-2011.



NO CLAIM IS MADE TO THE EXCLUSIVE RIGHT TO USE "CERTIFIED WORKFORCE READY", "PROVIDED BY WORKFORCE CAPITAL" AND "LLC", APART FROM THE MARK AS SHOWN.

THE COLOR(S) RED, TEAL AND BLACK IS/ARE CLAIMED AS A FEATURE OF THE MARK.

THE MARK CONSISTS OF "CERTIFIED" IN RED, "WORKFORCE READY" AND "BY WORKFORCE CAPITAL, LLC" IN BLACK, A TEAL ELEMENT REPRESENTING A PERSON WITH A RED DOT BETWEEN THE ELEMENT REPRESENTING THE ARMS. "CERTIFIED" IS STACKED ON TOP OF "WORKFORCE READY" AND "BY WORKFORCE CAPITAL, LLC" IS REPRESENTED LIKE A TAGLINE UNDER "BY WORKFORCE CAPITAL, LLC". THE DESIGN ELEMENT IS IN THE UPPER RIGHT HAND SIDE OF THE TOTAL LOGO.

FOR TESTING TO DETERMINE EMPLOYMENT SKILLS (U.S. CLS. 100, 101 AND 102).

FIRST USE 6-1-2007; IN COMMERCE 6-1-2007.
BARNEY CHARLON, EXAMINING ATTORNEY

SN 85-408,026. LOZANO, JOEL, PALM DESERT, CA. FILED 8-26-2011.



NO CLAIM IS MADE TO THE EXCLUSIVE RIGHT TO USE "RIDERS", APART FROM THE MARK AS SHOWN.

THE MARK CONSISTS OF A DIAMOND SHAPE CONTAINING A BICYCLE DRAWING ABOVE THE STYLIZED TEXT "BNG" WHICH APPEARS ABOVE "RIDERS". A THIN BORDER SURROUNDS THE DIAMOND.

FOR CLUB SERVICES, NAMELY, PROMOTING THE INTERESTS OF MOUNTAIN BIKERS (U.S. CLS. 100, 101 AND 102).

MICHELE SWAIN, EXAMINING ATTORNEY

CLASS 35—(Continued).

SN 85-408,853. STIQRD, INC, MEMPHIS, TN. FILED 8-26-2011.

stiqrđ

THE MARK CONSISTS OF STANDARD CHARACTERS WITHOUT CLAIM TO ANY PARTICULAR FONT, STYLE, SIZE, OR COLOR.

FOR ADMINISTRATION OF A CUSTOMER LOYALTY PROGRAM WHICH PROVIDES CUSTOMER ANALYTICS TO BUSINESSES, REWARDS TO REPEAT CUSTOMERS AND COUPONS TO ANY CUSTOMER; PROMOTION OF GOODS AND SERVICES OF OTHERS THROUGH DIGITAL AND MOBILE LOYALTY CARDS AND COUPONS; PROVIDING ADVERTISING, PROMOTIONAL AND MARKETING SERVICES VIA INDIRECT METHODS OF MARKETING COMMUNICATIONS, NAMELY, SOCIAL MEDIA, SEARCH ENGINE MARKETING, INTERNET MARKETING, MOBILE MARKETING, BLOGGING, AND GEO-LOCATION MARKETING (U.S. CLS. 100, 101 AND 102).

FIRST USE 2-21-2011; IN COMMERCE 3-4-2011.
SOPHIA S. KIM, EXAMINING ATTORNEY

SN 85-410,778. ONEMAIN FINANCIAL HOLDINGS, INC., WILMINGTON, DE. FILED 8-30-2011.

ONEMAIN CERTIFIED GOLD

THE MARK CONSISTS OF STANDARD CHARACTERS WITHOUT CLAIM TO ANY PARTICULAR FONT, STYLE, SIZE, OR COLOR.

NO CLAIM IS MADE TO THE EXCLUSIVE RIGHT TO USE "CERTIFIED", APART FROM THE MARK AS SHOWN.

FOR ARRANGING AND CONDUCTING OF VEHICLE AUCTION SALES (U.S. CLS. 100, 101 AND 102).

JAY BESCH, EXAMINING ATTORNEY

SN 85-410,794. ONEMAIN FINANCIAL HOLDINGS, INC., WILMINGTON, DE. FILED 8-30-2011.

ONEMAIN CERTIFIED SILVER

THE MARK CONSISTS OF STANDARD CHARACTERS WITHOUT CLAIM TO ANY PARTICULAR FONT, STYLE, SIZE, OR COLOR.

NO CLAIM IS MADE TO THE EXCLUSIVE RIGHT TO USE "CERTIFIED", APART FROM THE MARK AS SHOWN.

FOR ARRANGING AND CONDUCTING OF VEHICLE AUCTION SALES (U.S. CLS. 100, 101 AND 102).

JAY BESCH, EXAMINING ATTORNEY

CLASS 35—(Continued).

SN 85-414,153. TIC GUMS, INC., WHITE MARSH, MD. FILED 9-2-2011.

SMART WORKERS = SMART COMPANIES

THE MARK CONSISTS OF STANDARD CHARACTERS WITHOUT CLAIM TO ANY PARTICULAR FONT, STYLE, SIZE, OR COLOR.

FOR PROVIDING INFORMATION IN THE FIELDS OF EMPLOYMENT, RECRUITMENT, AND JOB AND INTERNSHIP LISTINGS; PROVIDING ONLINE INTERACTIVE JOB AND INTERNSHIP PLACEMENT SERVICES; PROVIDING ONLINE INTERACTIVE EMPLOYMENT COUNSELING; PROVIDING COMPANY PROFILES FEATURING BUSINESS INFORMATION (U.S. CLS. 100, 101 AND 102).

FIRST USE 5-31-2010; IN COMMERCE 5-31-2010.
MARK SHINER, EXAMINING ATTORNEY

SN 85-414,809. ILLLOVEUFOREVER.COM INC., DBA UNIONVERSE, FREEPORT, NY. FILED 9-3-2011.

UNIONVERSE

THE COLOR(S) GOLD, PURPLE AND WHITE IS/ARE CLAIMED AS A FEATURE OF THE MARK.

THE MARK CONSISTS OF THE WORDING "UNIONVERSE" IN GOLD AND WHITE AND OUTLINED IN PURPLE.

FOR ONLINE ADVERTISEMENTS (U.S. CLS. 100, 101 AND 102).

SHAUNIA CARLYLE, EXAMINING ATTORNEY

SN 85-415,519. NATIONAL RESTAURANT ASSOCIATION, WASHINGTON, DC. FILED 9-6-2011.



OWNER OF U.S. REG. NOS. 1,240,672, 2,966,011 AND OTHERS.

NO CLAIM IS MADE TO THE EXCLUSIVE RIGHT TO USE "EMPLOYEE", APART FROM THE MARK AS SHOWN.

THE MARK CONSISTS OF A PARTIAL STAR WITH THE WORDS "EMPLOYEE EDGE" TO THE RIGHT OF THE PARTIAL STAR AND THE WORDS "FROM THE NATIONAL RESTAURANT ASSOCIATION" UNDERNEATH.

SEC. 2(F) AS TO "NATIONAL RESTAURANT ASSOCIATION".

FOR ARRANGING AND CONDUCTING INCENTIVE REWARDS PROGRAMS FOR MEMBER-EMPLOYEES OF THE APPLICANT TO PROMOTE EMPLOYEE PRODUCTIVITY, PERFORMANCE, LOYALTY, RECOGNITION AND MORALE (U.S. CLS. 100, 101 AND 102).

DAWN FELDMAN, EXAMINING ATTORNEY

CLASS 35—(Continued).

SN 85-418,054. ATH POWER CONSULTING CORP., AND-OVER, MA. FILED 9-8-2011.

ATH POWER

THE MARK CONSISTS OF STANDARD CHARACTERS WITHOUT CLAIM TO ANY PARTICULAR FONT, STYLE, SIZE, OR COLOR.

FOR BUSINESS CONSULTING SERVICES FOR OTHERS IN THE FINANCIAL SERVICES FIELD, NAMELY, PROVIDING CONSUMER RESEARCH, MARKET RESEARCH, CONDUCTING BUSINESS AND MARKET SURVEYS, PROVIDING BENCHMARKING INFORMATION, PROVIDING CONSULTATION IN THE FIELD OF EMPLOYEE DEVELOPMENT, PROVIDING CONSUMER INSIGHT AND ANALYSIS OF MARKETING OF BRANDS; CONDUCTING BUSINESS AND MARKET RESEARCH SURVEYS IN THE FINANCIAL SERVICES INDUSTRY (U.S. CLS. 100, 101 AND 102).

FIRST USE 1-7-1997; IN COMMERCE 1-7-1997.
JASON TURNER, EXAMINING ATTORNEY

SN 85-418,124. ATH POWER CONSULTING CORP., AND-OVER, MA. FILED 9-8-2011.

ASSESS, ALIGN, ACHIEVE

THE MARK CONSISTS OF STANDARD CHARACTERS WITHOUT CLAIM TO ANY PARTICULAR FONT, STYLE, SIZE, OR COLOR.

FOR BUSINESS CONSULTING SERVICES FOR OTHERS IN THE FINANCIAL SERVICES FIELD, NAMELY, PROVIDING CONSUMER RESEARCH, MARKET RESEARCH, CONDUCTING BUSINESS AND MARKET SURVEYS, PROVIDING BENCHMARKING INFORMATION, PROVIDING CONSULTATION IN THE FIELD OF EMPLOYEE DEVELOPMENT, PROVIDING CONSUMER INSIGHT AND ANALYSIS OF MARKETING OF BRANDS; CONDUCTING BUSINESS AND MARKET RESEARCH SURVEYS IN THE FINANCIAL SERVICES INDUSTRY (U.S. CLS. 100, 101 AND 102).

FIRST USE 1-7-1997; IN COMMERCE 1-7-1997.
JASON TURNER, EXAMINING ATTORNEY

CLASS 35—(Continued).

SN 85-418,569. TRUSTWORKZ, INC., WOODSTOCK, GA. FILED 9-9-2011.

WebOp

THE MARK CONSISTS OF STANDARD CHARACTERS WITHOUT CLAIM TO ANY PARTICULAR FONT, STYLE, SIZE, OR COLOR.

FOR ADVERTISING AND MARKETING SERVICES PROVIDED BY MEANS OF INDIRECT METHODS OF MARKETING COMMUNICATIONS, NAMELY, SOCIAL MEDIA, SEARCH ENGINE MARKETING, INQUIRY MARKETING, INTERNET MARKETING, MOBILE MARKETING, BLOGGING AND OTHER FORMS OF PASSIVE, SHARABLE OR VIRAL COMMUNICATIONS CHANNELS (U.S. CLS. 100, 101 AND 102).

FIRST USE 9-2-2011; IN COMMERCE 9-2-2011.
AMY KELLY, EXAMINING ATTORNEY

CLASS 35—(Continued).

SN 85-420,990. LIBERTY COUNSEL, INC., AKA LIBERTY COUNCIL, ORLANDO, FL. FILED 9-13-2011.

Liberty Ambassador Counsel

THE MARK CONSISTS OF STANDARD CHARACTERS WITHOUT CLAIM TO ANY PARTICULAR FONT, STYLE, SIZE, OR COLOR.

OWNER OF U.S. REG. NOS. 2,287,617, 3,831,070 AND OTHERS.

NO CLAIM IS MADE TO THE EXCLUSIVE RIGHT TO USE "COUNSEL", APART FROM THE MARK AS SHOWN.

FOR PROMOTING PUBLIC AWARENESS OF THE NEED FOR THE RULE OF LAW AND SOUND INTERNATIONAL POLICIES THAT ADVANCE LIFE, LIBERTY, FAMILY AND FAITH THROUGH EDUCATION, ADVOCACY AND ONSITE INSTRUCTION (U.S. CLS. 100, 101 AND 102).

FIRST USE 9-12-2011; IN COMMERCE 9-13-2011.
SHAILA SETTLES, EXAMINING ATTORNEY

SN 85-420,901. NEW YORK INKJET, LLC, BALDWIN, NY. FILED 9-12-2011.

NEWYORKINKJET

THE MARK CONSISTS OF STANDARD CHARACTERS WITHOUT CLAIM TO ANY PARTICULAR FONT, STYLE, SIZE, OR COLOR.

SEC. 2(F).

FOR ADVERTISING SERVICES, NAMELY, PROMOTING AND MARKETING THE GOODS AND SERVICES OF OTHERS IN THE FIELD OF OFFICE SUPPLIES, FURNITURE AND ELECTRONICS VIA PRINT AND ELECTRONIC MEDIA; ON-LINE RETAIL STORE SERVICES FEATURING A WIDE VARIETY OF CONSUMER GOODS OF OTHERS; ON-LINE WHOLESALE AND RETAIL STORE SERVICES FEATURING OFFICE SUPPLIES, FURNITURE AND ELECTRONIC PRODUCTS (U.S. CLS. 100, 101 AND 102).

FIRST USE 4-1-2005; IN COMMERCE 4-1-2005.
STEVEN R. FINE, EXAMINING ATTORNEY

SN 85-421,656. GREAT LITTLE SPOTS, LLC, BLOOMFIELD HILLS, MI. FILED 9-13-2011.

GREAT LITTLE SPOTS

THE MARK CONSISTS OF STANDARD CHARACTERS WITHOUT CLAIM TO ANY PARTICULAR FONT, STYLE, SIZE, OR COLOR.

FOR ADVERTISING SERVICES, NAMELY, PROMOTING AND MARKETING THE GOODS AND SERVICES OF OTHERS THROUGH PUBLIC COMMUNICATION MEANS; ONLINE ADVERTISING SERVICES FOR OTHERS; PROMOTIONAL SERVICES, NAMELY, PROMOTING THE GOODS AND SERVICES OF OTHERS BY PROVIDING GIFT CARDS (U.S. CLS. 100, 101 AND 102).

FIRST USE 5-0-2011; IN COMMERCE 5-0-2011.
CHRISTOPHER BUONGIORNO, EXAMINING ATTORNEY

CLASS 35—(Continued).

SN 85-424,866. IMPACT COMPUTERS AND ELECTRONICS, INC., HOLLYWOOD, FL. FILED 9-16-2011.



NO CLAIM IS MADE TO THE EXCLUSIVE RIGHT TO USE "COMPUTERS & ELECTRONICS", APART FROM THE MARK AS SHOWN.

THE MARK CONSISTS OF THE WORD "IMPACT" FOLLOWED BY THE WORDS "COMPUTERS & ELECTRONICS" UNDERNEATH INSIDE A RECTANGULAR BACKGROUND.

FOR WHOLESALE DISTRIBUTORSHIP AND RETAIL STORE SERVICES FEATURING COMPUTERS, PRINTERS, HAND HELD ELECTRONIC DEVICES, AND COMPUTER PARTS; ON-LINE WHOLESALE DISTRIBUTORSHIP AND RETAIL STORE SERVICES FEATURING COMPUTERS, PRINTERS, HAND HELD ELECTRONIC DEVICES, AND COMPUTER PARTS; COMPUTER REPAIR SERVICES (U.S. CLS. 100, 101 AND 102).

FIRST USE 11-7-1995; IN COMMERCE 2-2-1996.

NAKWAMA ANKRAH, EXAMINING ATTORNEY

CLASS 35—(Continued).

SN 85-427,721. B2B PROSPECTING, LLC, DBA THE B2B PROSPECTING SOURCE, KERRVILLE, TX. FILED 9-20-2011.



NO CLAIM IS MADE TO THE EXCLUSIVE RIGHT TO USE "THE B2B PROSPECTING SOURCE", APART FROM THE MARK AS SHOWN.

THE COLOR(S) WHITE, BLUE, ORANGE AND TAN IS/ARE CLAIMED AS A FEATURE OF THE MARK.

THE MARK CONSISTS OF THE COLOR(S) WHITE, BLUE, ORANGE AND TAN IS/ARE CLAIMED AS A FEATURE OF THE MARK. THE MARK CONSISTS OF THE WORDING "THE B2B PROSPECTING SOURCE." WITH THE WORD "THE" IN ORANGE IN AN ITALICIZED FONT ARE IN THE UPPER LEFT HAND CORNER OF THE RECTANGULAR LOGO. THE WORDING "B2B PROSPECTING" IN WHITE LETTERING AND OUTLINED IN BLUE IN ALL UPPER CASE LETTERING CENTERED IN THE RECTANGULAR LOGO, AND IN THE BOTTOM RIGHT CORNER THE WORD "SOURCE" IN ALL UPPERCASE LETTERS ARE SOLID BLUE AND ARE JUSTIFIED RIGHT. IN FRONT OF THE WORD SOURCE IS AN ORANGE BAR THE SAME HEIGHT AS THE LETTERS IN SOURCE THAT STARTS ON THE LEFT WITH A ORANGE COLOR SLOWING FADING TO TAN AND THEN TO WHITE. BEGINNING ON THE LEFT SIDE OF THE RECTANGULAR LOGO, 3 LINE ARCH AND SWIRL IN THE BACKGROUND. THE BOTTOM LINE IS THE THICKEST AND STARTS BLUNT AT THE LETTERS PROS IN PROSPECTING AND ARCHES UPWARDS AND THEN SWOOPS AROUND TO A FINE POINT POINTING DOWN AT THE END OF THE WORD SOURCE. THE SECOND LINE STARTS AT A FINE POINT ABOVE THE P IN PROSPECTING AND FOLLOWS THE SWOOP OF LINE ONE UNTIL IT MEETS THE FAR RIGHT EDGE OF THE MARK AND ENDS IN A FINE POINT. THE THIRD LINE STARTS BLUNT ON THE LEFT EDGE TOWARDS THE TOP OF THE MARK AND SWOOPS DOWNWARDS SLIGHTLY AND THEN FOLLOWS LINE TWO UNTIL ABOUT HALF WAY ACROSS THE MARK AND ENDS IN A FINE POINT. ALL THREE LINES ARE IN A SOFT ORANGE COLOR AND FADE TO WHITE AT THE BORDER OF THE LOGO.

FOR APPOINTMENT SCHEDULING SERVICES (U.S. CLS. 100, 101 AND 102).

FIRST USE 2-1-2011; IN COMMERCE 2-1-2011.

LINDA M. KING, EXAMINING ATTORNEY

SN 85-426,496. BIZWIRE LLC, BUFORD, GA. FILED 9-19-2011.



THE COLOR(S) BLUE, GREEN AND BLACK IS/ARE CLAIMED AS A FEATURE OF THE MARK.

THE MARK CONSISTS OF A TWISTED ARROW DESIGN WITH THE TOP ARROW IN GREEN, THE BOTTOM ARROW IN BLUE ON A BLACK CIRCLE DESIGN TO THE LEFT OF THE STYLIZED WORDING "BIZWIRE" WITH "BIZ" IN BLUE, "WIRE" IN GREEN AND OUTLINED IN BLACK AND "NOW YOU'RE PLUGGED IN!" APPEARING BELOW IN BLACK.

FOR MARKETING CONSULTING (U.S. CLS. 100, 101 AND 102).

FIRST USE 6-1-2011; IN COMMERCE 6-1-2011.

KAREN K. BUSH, EXAMINING ATTORNEY

CLASS 35—(Continued).

SN 85-428,516. WALGREEN CO., DEERFIELD, IL. FILED 9-21-2011.



OWNER OF U.S. REG. NOS. 2,292,545, 3,303,249 AND OTHERS.

THE MARK CONSISTS OF A SEMI-SPHERICAL REPRESENTATION OF THE EARTH POSITIONED ABOVE THE WORD "PURE" IN LOWER CASE FONT, POSITIONED ABOVE THE SCRIPTED WORD "WALGREENS" POSITIONED ABOVE THE PHRASE "FOR THE HEALTH AND WELLNESS OF OUR PLANET".

FOR PROMOTING PUBLIC AWARENESS OF ENVIRONMENTAL MATTERS (U.S. CLS. 100, 101 AND 102).

GEORGE LORENZO, EXAMINING ATTORNEY

SN 85-428,693. ANYSPACE TECHNOLOGIES INC, WEDGEFIELD, SC. FILED 9-21-2011.

h>

THE MARK CONSISTS OF STANDARD CHARACTERS WITHOUT CLAIM TO ANY PARTICULAR FONT, STYLE, SIZE, OR COLOR.

OWNER OF U.S. REG. NO. 3,977,534.

FOR BUSINESS ADVISORY SERVICES, NAMELY, SEARCH FOR AND SELECTION OF THE BEST POTENTIAL SUPPLIERS FOR OTHERS; COMPILATION OF ADVERTISEMENTS FOR USE AS WEB PAGES ON THE INTERNET; MARKETING AND CONSULTING SERVICES IN THE FIELD OF PROMOTING AND TRACKING THE GOODS, SERVICES, AND BRANDS OF OTHERS THROUGH ALL PUBLIC COMMUNICATION MEANS; PROVIDING ADVERTISING, MARKETING AND PROMOTIONAL SERVICES, NAMELY, DEVELOPMENT OF ADVERTISING CAMPAIGNS PROVIDED THROUGH CABLE TELEVISION BROADCAST, WEB CASTS, RADIO BROADCASTS, NEWSPAPERS, MAGAZINES, ONLINE BANNERS, OUTDOOR BILLBOARDS, WILD POSTINGS, BUS AND SUBWAY ADS (U.S. CLS. 100, 101 AND 102).

FIRST USE 1-1-2011; IN COMMERCE 1-1-2011.

ALYSSA STEEL, EXAMINING ATTORNEY

CLASS 35—(Continued).

SN 85-429,789. MICHAEL, VICTOR J., NEW YORK, NY. FILED 9-22-2011.

TEN PEOPLE

THE MARK CONSISTS OF STANDARD CHARACTERS WITHOUT CLAIM TO ANY PARTICULAR FONT, STYLE, SIZE, OR COLOR.

FOR CONSULTING SERVICES RELATED TO THE ADMINISTRATIVE COORDINATION OF ORGANIZATIONS AND INDIVIDUALS PROVIDING HUMANITARIAN ACTIVITIES (U.S. CLS. 100, 101 AND 102).

JULIE GUTTADAURO, EXAMINING ATTORNEY

SN 85-430,469. SOUTHERN BELLE ORIGINALS, INC., CALHOUN CITY, MS. FILED 9-23-2011.

Cowgirl Honey

THE MARK CONSISTS OF STANDARD CHARACTERS WITHOUT CLAIM TO ANY PARTICULAR FONT, STYLE, SIZE, OR COLOR.

FOR RETAIL STORE SERVICES FEATURING TEE SHIRTS (U.S. CLS. 100, 101 AND 102).

FIRST USE 1-1-2009; IN COMMERCE 1-1-2009.

ALAIN LAPTER, EXAMINING ATTORNEY

SN 85-431,827. BRESSLER, STEPHEN R., SAMMAMISH, WA. FILED 9-26-2011.

Thumb Driven Leadership (TDL)

THE MARK CONSISTS OF STANDARD CHARACTERS WITHOUT CLAIM TO ANY PARTICULAR FONT, STYLE, SIZE, OR COLOR.

NO CLAIM IS MADE TO THE EXCLUSIVE RIGHT TO USE "LEADERSHIP", APART FROM THE MARK AS SHOWN.

FOR BUSINESS CONSULTATION IN THE FIELD OF BUSINESS LEADERSHIP DEVELOPMENT; BUSINESS MANAGEMENT CONSULTATION IN THE FIELD OF EXECUTIVE AND LEADERSHIP DEVELOPMENT; CONSULTING SERVICES IN BUSINESS LEADERSHIP DEVELOPMENT AND BUSINESS MANAGEMENT (U.S. CLS. 100, 101 AND 102).

FIRST USE 2-9-2011; IN COMMERCE 9-2-2011.

DAVID HOFFMAN, EXAMINING ATTORNEY

CLASS 35—(Continued).

SN 85-432,581. AREA CODES BEST, DBA JINGLE IT, ROGERSVILLE, MO. FILED 9-27-2011.



NO CLAIM IS MADE TO THE EXCLUSIVE RIGHT TO USE "AREA CODES BEST," "CERTIFIED," OR "TRUSTED PROFESSIONAL RELIABLE", APART FROM THE MARK AS SHOWN.

THE COLOR(S) BLUE, ORANGE, GOLD AND WHITE IS/ ARE CLAIMED AS A FEATURE OF THE MARK.

THE MARK CONSISTS OF GOLD CIRCLE WITH A BORDER CONSISTING OF TWO ORANGE CIRCLES SEPARATED BY A GOLD CIRCLE. BLUE STYLIZED WHEAT APPEARS ON THE LEFT AND RIGHT SIDES OF THE CIRCLE. AN ORANGE BANNER WITH A GOLD BORDER AND THE WORDING "AREA CODES BEST" IN WHITE APPEARS ACROSS THE CENTER OF THE CIRCLE. THE LETTERS "ACB" APPEAR ON THE CIRCLE IN BLUE ABOVE THE BANNER AND THE WORD "CERTIFIED" APPEARS ON THE CIRCLE IN BLUE BELOW THE BANNER. WITH SMALL BLUE CIRCLES ON EITHER SIDE OF "CERTIFIED". BENEATH THE CIRCLE APPEAR THE WORDS "TRUSTED," "PROFESSIONAL" AND "RELIABLE" IN BLUE, SEPARATED BY SMALL BLUE CIRCLES.

FOR ADVERTISING AND PROMOTIONAL SERVICES (U.S. CLS. 100, 101 AND 102).

FIRST USE 8-29-2011; IN COMMERCE 9-22-2011.
WILLIAM JACKSON, EXAMINING ATTORNEY

SN 85-434,588. SRL, LLC, LEXINGTON, MA. FILED 9-28-2011.



THE MARK CONSISTS OF UPPER CASE BOLDED FONT "POGO" FOLLOWED BY A STYLIZED HYPHEN, WHICH IS FOLLOWED BY UPPER CASE BOLDED FONT "TEK" ENDING WITH A BOLDED STYLIZED EXCLAMATION ALL WITH AN OUTLINE AROUND "POGO-TEK!".

FOR RETAIL SHOE AND FASHION ACCESSORIES STORE SERVICES; COMPUTERIZED ON-LINE RETAIL STORE SERVICES IN THE FIELD OF FOOTWEAR, APPAREL, ACCESSORIES AND BAGS, ACCESSIBLE VIA GLOBAL COMPUTER NETWORKS (U.S. CLS. 100, 101 AND 102).

LINDA POWELL, EXAMINING ATTORNEY

CLASS 35—(Continued).

SN 85-437,587. THE WOLF ORGANIZATION, INC., YORK, PA. FILED 10-3-2011.



OWNER OF U.S. REG. NOS. 2,163,439 AND 3,901,472.
THE MARK CONSISTS OF THE WORD "WOLF" WITH THE HEAD OF A WOLF IN THE "O".
FOR DISTRIBUTORSHIP SERVICES IN THE FIELD OF BUILDING SUPPLIES (U.S. CLS. 100, 101 AND 102).
DOUGLAS LEE, EXAMINING ATTORNEY

SN 85-437,600. THE WOLF ORGANIZATION, INC., YORK, PA. FILED 10-3-2011.



OWNER OF U.S. REG. NOS. 2,163,439 AND 3,901,472.
THE COLOR(S) GREEN AND BLACK IS/ARE CLAIMED AS A FEATURE OF THE MARK.
THE MARK CONSISTS OF THE WORD "WOLF" IN GREEN LETTERS WITH THE HEAD OF A WOLF IN BLACK IN THE LETTER "O".
FOR DISTRIBUTORSHIP SERVICES IN THE FIELD OF BUILDING SUPPLIES (U.S. CLS. 100, 101 AND 102).
DOUGLAS LEE, EXAMINING ATTORNEY

SN 85-437,687. AMERICAN EXPRESS MARKETING & DEVELOPMENT CORP., NEW YORK, NY. FILED 10-3-2011.

5 MINUTES FORWARD

THE MARK CONSISTS OF STANDARD CHARACTERS WITHOUT CLAIM TO ANY PARTICULAR FONT, STYLE, SIZE, OR COLOR.

FOR CAREER INFORMATION SERVICES, NAMELY, PROVIDING A WEB SITE FEATURING A SERIES OF VIDEO PRESENTATIONS IN THE FIELD OF CAREER DEVELOPMENT FOR PROFESSIONALS FEATURING INTERVIEWS AND NARRATIVE INFORMATION FROM LEADERS IN VARIOUS INDUSTRIES (U.S. CLS. 100, 101 AND 102).

STEVEN PEREZ, EXAMINING ATTORNEY

CLASS 35—(Continued).

SN 85-439,121. MIRAPATH, INC., CUPERTINO, CA. FILED 10-4-2011.

MIRAPATH

THE MARK CONSISTS OF STANDARD CHARACTERS WITHOUT CLAIM TO ANY PARTICULAR FONT, STYLE, SIZE, OR COLOR.

FOR RESELLER SERVICES, NAMELY, DISTRIBUTORSHIP SERVICES IN THE FIELD OF DATA CENTER AND LAB PRODUCTS (U.S. CLS. 100, 101 AND 102).

FIRST USE 2-17-2003; IN COMMERCE 2-17-2003.
JUDITH HELFMAN, EXAMINING ATTORNEY

SN 85-444,271. THE MOMS ON MAIN, LLC, WINSTON-SALEM, NC. FILED 10-11-2011.

Moms on Main

THE MARK CONSISTS OF STANDARD CHARACTERS WITHOUT CLAIM TO ANY PARTICULAR FONT, STYLE, SIZE, OR COLOR.

FOR PROVIDING A WEBSITE FEATURING BUSINESS ADVERTISING AND PROMOTIONAL SERVICES FOR THE PRODUCTS, SERVICES, BRAND IDENTITY AND COMMERCIAL INFORMATION OF OTHERS; ADVERTISING AND PUBLICITY SERVICES, NAMELY, PROMOTING THE GOODS, SERVICES, BRAND IDENTITY AND COMMERCIAL INFORMATION AND NEWS OF THIRD PARTIES THROUGH PRINT, AUDIO, VIDEO, DIGITAL AND ON-LINE MEDIA (U.S. CLS. 100, 101 AND 102).

FIRST USE 10-8-2010; IN COMMERCE 10-20-2010.
KATHERINE CHANG, EXAMINING ATTORNEY

CLASS 35—(Continued).

SN 85-445,877. U.S. AUTO PARTS NETWORK, INC., CARSON, CA. FILED 10-12-2011.

US AUTO PARTS

THE MARK CONSISTS OF STANDARD CHARACTERS WITHOUT CLAIM TO ANY PARTICULAR FONT, STYLE, SIZE, OR COLOR.

OWNER OF U.S. REG. NO. 3,203,019.

NO CLAIM IS MADE TO THE EXCLUSIVE RIGHT TO USE "AUTO PARTS", APART FROM THE MARK AS SHOWN.

SEC. 2(F).

FOR ONLINE RETAIL STORE SERVICES FEATURING AUTOMOBILE PARTS AND ACCESSORIES; ONLINE RETAIL STORE SERVICES FEATURING AFTERMARKET AUTOMOBILE PARTS AND ACCESSORIES; WHOLESALE ORDERING SERVICES FEATURING AUTOMOBILE PARTS AND ACCESSORIES AND AFTERMARKET AUTOMOBILE PARTS AND ACCESSORIES; WHOLESALE DISTRIBUTORSHIP SERVICES FEATURING AUTOMOBILE PARTS AND ACCESSORIES AND AFTERMARKET AUTOMOBILE PARTS AND ACCESSORIES; WHOLESALE STORE SERVICES FEATURING AUTOMOBILE PARTS AND ACCESSORIES AND AFTERMARKET AUTOMOBILE PARTS AND ACCESSORIES (U.S. CLS. 100, 101 AND 102).

FIRST USE 5-25-2005; IN COMMERCE 5-25-2005.

ALAIN LAPTER, EXAMINING ATTORNEY

SN 85-445,934. SHERILYN HENRY, FAIRFIELD, CA. FILED 10-12-2011.

YIPPIE YOGURT

THE MARK CONSISTS OF STANDARD CHARACTERS WITHOUT CLAIM TO ANY PARTICULAR FONT, STYLE, SIZE, OR COLOR.

NO CLAIM IS MADE TO THE EXCLUSIVE RIGHT TO USE "YOGURT", APART FROM THE MARK AS SHOWN.

FOR DESSERT SHOPS (U.S. CLS. 100, 101 AND 102).

GRETTA YAO, EXAMINING ATTORNEY

CLASS 35—(Continued).

SN 85-446,490. IN-STORE MARKETING INSTITUTE, INC., DBA THE PATH TO PURCHASE INSTITUTE, SKOKIE, IL. FILED 10-13-2011.

Path to Purchase Institute

THE MARK CONSISTS OF STANDARD CHARACTERS WITHOUT CLAIM TO ANY PARTICULAR FONT, STYLE, SIZE, OR COLOR.

NO CLAIM IS MADE TO THE EXCLUSIVE RIGHT TO USE "INSTITUTE", APART FROM THE MARK AS SHOWN.

FOR ASSOCIATION SERVICES, NAMELY, PROMOTING THE INTERESTS OF RETAIL MARKETING PROFESSIONALS (U.S. CLS. 100, 101 AND 102).

FIRST USE 9-9-2011; IN COMMERCE 9-9-2011.
ROBERT STRUCK, EXAMINING ATTORNEY

SN 85-446,497. IN-STORE MARKETING INSTITUTE, INC., DBA THE PATH TO PURCHASE INSTITUTE, SKOKIE, IL. FILED 10-13-2011.

PATH TO PURCHASE
INSTITUTE

NO CLAIM IS MADE TO THE EXCLUSIVE RIGHT TO USE "INSTITUTE", APART FROM THE MARK AS SHOWN. THE MARK CONSISTS OF THE WORDS "PATH TO PURCHASE" ABOVE THE WORD "INSTITUTE" WITH "INSTITUTE" APPEARING IN A BOX.

FOR ASSOCIATION SERVICES, NAMELY, PROMOTING THE INTERESTS OF RETAIL MARKETING PROFESSIONALS (U.S. CLS. 100, 101 AND 102).

FIRST USE 9-9-2011; IN COMMERCE 9-9-2011.
ROBERT STRUCK, EXAMINING ATTORNEY

CLASS 35—(Continued).

SN 85-446,754. DEL MONTE & ASSOCIATES, INC., MINNETONKA, MN. FILED 10-13-2011.



NO CLAIM IS MADE TO THE EXCLUSIVE RIGHT TO USE "AGENCY", APART FROM THE MARK AS SHOWN.

THE COLOR(S) DENIM BLUE AND BURNT ORANGE IS/ARE CLAIMED AS A FEATURE OF THE MARK.

THE MARK CONSISTS OF THE WORDS "DEL MONTE" IN THE COLOR DENIM BLUE ON THE FIRST LINE OF WRITINGS, WITH THE WORD "AGENCY" IN THE COLOR BURNT ORANGE ON THE SECOND LINE OF WRITINGS, AND THE PHRASE "THE NON ADVERTISING AGENCY" IN THE COLOR DENIM BLUE EXCEPT FOR THE LETTERS "NON" WHICH ARE IN THE COLOR BURNT ORANGE ON THE BOTTOM LINE OF WRITINGS. ABOVE THE "M" IN "DEL MONTE" THERE IS A STYLIZED DEPICTION OF THE LETTER "M" WITH A BAR HORIZONTALLY ACROSS THE BOTTOM OF THE LEFT AND RIGHT TRIANGULAR ARCHES OF THE LETTER "M", WITH A DENIM BLUE ARROW FORMING THE TRIANGULAR LEFT SIDE ARCH OF THE LETTER "M" AND PASSING IN FRONT OF THE BOTTOM HORIZONTAL BAR, AND A BURNT ORANGE TRIANGULAR RIGHT SIDE ARCH OF THE LETTER "M" THAT PASSES BEHIND THE HORIZONTAL BOTTOM BAR AND JOINS THE DENIM BLUE ARROW FROM THE LEFT SIDE OF THE "M" TO FORM A DENIM BLUE ARROW POINT THAT POINTS DOWN INTO THE CENTER OF THE LETTER "M" IN "DEL MONTE".

FOR ADVERTISING AGENCIES, NAMELY, PROMOTING THE GOODS AND SERVICES OF OTHERS (U.S. CLS. 100, 101 AND 102).

FIRST USE 9-6-2011; IN COMMERCE 9-6-2011.
KAREN BRACEY, EXAMINING ATTORNEY

SN 85-446,669. JP FUJI GROUP, QUINCY, MA. FILED 10-13-2011.

JP Fuji Group

THE MARK CONSISTS OF STANDARD CHARACTERS WITHOUT CLAIM TO ANY PARTICULAR FONT, STYLE, SIZE, OR COLOR.

NO CLAIM IS MADE TO THE EXCLUSIVE RIGHT TO USE "GROUP", APART FROM THE MARK AS SHOWN.

FOR FRANCHISE SERVICES, NAMELY, OFFERING BUSINESS MANAGEMENT ASSISTANCE, VIA A FRANCHISE RELATIONSHIP AS FRANCHISOR TO CONTROL QUALITY OF SERVICES OFFERED BY FRANCHISEES, IN THE ESTABLISHMENT AND OPERATION OF FOOD SERVICES INCLUDING MOBILE FOOD SERVICES AND FIXED LOCATION FOOD SERVICES (U.S. CLS. 100, 101 AND 102).

INGA ERVIN, EXAMINING ATTORNEY

SN 85-447,010. ALL ABOUT SOCKS CO., LLC, LOGAN, UT. FILED 10-13-2011.

ALL ABOUT SOCKS

THE MARK CONSISTS OF STANDARD CHARACTERS WITHOUT CLAIM TO ANY PARTICULAR FONT, STYLE, SIZE, OR COLOR.

NO CLAIM IS MADE TO THE EXCLUSIVE RIGHT TO USE "SOCKS", APART FROM THE MARK AS SHOWN.

FOR RETAIL STORE SERVICES FEATURING SOCKS AND STOCKINGS (U.S. CLS. 100, 101 AND 102).

FIRST USE 6-1-2009; IN COMMERCE 6-1-2009.
STEVEN JACKSON, EXAMINING ATTORNEY

CLASS 35—(Continued).

SN 85-447,057. JEFFERSON W. DAVIS, LOS ANGELES, CA.
FILED 10-13-2011.

CLASS 35—(Continued).

SN 85-451,178. LOYALTYONE US, INC., WILMINGTON, DE.
FILED 10-19-2011.

Profiles in Management

THE MARK CONSISTS OF STANDARD CHARACTERS WITHOUT CLAIM TO ANY PARTICULAR FONT, STYLE, SIZE, OR COLOR.

FOR ON-LINE BUSINESS NETWORKING SERVICES (U.S. CLS. 100, 101 AND 102).

FIRST USE 10-1-2011; IN COMMERCE 10-1-2011.
GIANCARLO CASTRO, EXAMINING ATTORNEY

SN 85-447,334. DUDLESTON, VICTORIA, SHERMAN, IL.
FILED 10-14-2011.

FEWER BETTER THINGS

THE MARK CONSISTS OF STANDARD CHARACTERS WITHOUT CLAIM TO ANY PARTICULAR FONT, STYLE, SIZE, OR COLOR.

FOR RETAIL STORE SERVICES FEATURING HIGH END PRODUCTS IN THE FIELDS OF CLOTHING, GENERAL CONSUMER MERCHANDISE, JEWELRY, HANDBAGS, LEATHER GOODS, NAMELY, LUGGAGE, BRIEFCASES, PURSES (U.S. CLS. 100, 101 AND 102).
BRIDGETT SMITH, EXAMINING ATTORNEY

SN 85-451,171. LOYALTYONE US, INC., WILMINGTON, DE.
FILED 10-19-2011.

MAXIT

THE MARK CONSISTS OF STANDARD CHARACTERS WITHOUT CLAIM TO ANY PARTICULAR FONT, STYLE, SIZE, OR COLOR.

FOR ORGANIZATION, OPERATION AND SUPERVISION OF CUSTOMER LOYALTY SCHEMES AND INCENTIVE SCHEMES; COOPERATIVE ADVERTISING, MARKETING AND PROMOTION OF GOODS AND SERVICES FOR OTHERS (U.S. CLS. 100, 101 AND 102).

FIRST USE 0-0-1998; IN COMMERCE 0-0-1998.
GIANCARLO CASTRO, EXAMINING ATTORNEY

MAXIT REWARDS

THE MARK CONSISTS OF STANDARD CHARACTERS WITHOUT CLAIM TO ANY PARTICULAR FONT, STYLE, SIZE, OR COLOR.

NO CLAIM IS MADE TO THE EXCLUSIVE RIGHT TO USE "REWARDS", APART FROM THE MARK AS SHOWN.

FOR ORGANIZATION, OPERATION AND SUPERVISION OF CUSTOMER LOYALTY SCHEMES AND INCENTIVE SCHEMES; COOPERATIVE ADVERTISING, MARKETING AND PROMOTION OF GOODS AND SERVICES FOR OTHERS (U.S. CLS. 100, 101 AND 102).

CAROLYN CATALDO, EXAMINING ATTORNEY

SN 85-452,157. JOBWIRE, INC., NEW YORK, NY. FILED 10-20-2011.

INTERNATIONAL BUSINESS SEARCH

THE MARK CONSISTS OF STANDARD CHARACTERS WITHOUT CLAIM TO ANY PARTICULAR FONT, STYLE, SIZE, OR COLOR.

NO CLAIM IS MADE TO THE EXCLUSIVE RIGHT TO USE "INTERNATIONAL" AND "SEARCH", APART FROM THE MARK AS SHOWN.

FOR PROFESSIONAL STAFFING AND RECRUITMENT SERVICES AND HUMAN RESOURCE SERVICES, NAMELY, PERSONNEL SELECTION FOR OTHERS (U.S. CLS. 100, 101 AND 102).

FIRST USE 0-0-1998; IN COMMERCE 0-0-1998.
GIANCARLO CASTRO, EXAMINING ATTORNEY

CLASS 35—(Continued).

SN 85-454,821. CONTAGIOUS CHANGE, LLC, MESA, AZ.
FILED 10-24-2011.

CONTAGIOUS CHANGE

THE MARK CONSISTS OF STANDARD CHARACTERS WITHOUT CLAIM TO ANY PARTICULAR FONT, STYLE, SIZE, OR COLOR.

FOR BUSINESS CONSULTING AND ADVISORY SERVICES IN THE FIELDS OF BUSINESS ORGANIZATIONAL EXCELLENCE; BUSINESS CONSULTING SERVICES RELATING TO THE INTEGRATION OF THE AREA OF BUSINESS ORGANIZATIONAL LEARNING; ORGANIZATIONAL CHANGE MANAGEMENT; BUSINESS ORGANIZATIONAL DEVELOPMENT, BUSINESS CONSULTATION SERVICES, NAMELY, BUSINESS PROCESS IMPROVEMENT AND ENTERPRISE ARCHITECTURE DESIGN; PERFORMANCE IMPROVEMENT, NAMELY, BUSINESS PROCESS IMPROVEMENT; BUSINESS RISK REDUCTION MANAGEMENT STRATEGIES AND EXECUTION; BUSINESS CONSULTING SERVICES IN THE FIELD OF ORGANIZATIONAL CHANGE MANAGEMENT INNOVATION AND GROWTH PROCESSES; CONSULTANCY SERVICES REGARDING BUSINESS STRATEGIES; BUSINESS MANAGEMENT CONSULTING IN THE FIELD OF EXECUTIVE TEAM DEVELOPMENT; MANAGEMENT CONSULTING AND ADVISORY SERVICES IN THE AREAS OF CORPORATE GROWTH STRATEGY, INNOVATION AND GROWTH PROCESSES, ORGANIZATIONAL TRANSFORMATION, AND TALENT MANAGEMENT AND DEVELOPMENT STRATEGIES; TOTAL QUALITY MANAGEMENT SERVICES, NAMELY, BUSINESS MANAGEMENT SERVICES FOR ESTABLISHING BUSINESS QUALITY POLICY AND DETERMINING BUSINESS MEANS FOR IMPLEMENTING THOSE POLICIES TO IMPROVE CUSTOMER SATISFACTION; BUSINESS CONSULTATION SERVICES, NAMELY, BUSINESS PROCESS IMPROVEMENT AND ENTERPRISE ARCHITECTURE DESIGN; BUSINESS DATA ANALYSIS; BUSINESS MANAGEMENT CONSULTING IN THE FIELD OF TEAM DEVELOPMENT (U.S. CLS. 100, 101 AND 102).

FIRST USE 8-0-2010; IN COMMERCE 8-0-2010.
LOURDES AYALA, EXAMINING ATTORNEY

CLASS 35—(Continued).

SN 85-454,835. CONTAGIOUS CHANGE, LLC, MESA, AZ.
FILED 10-24-2011.



THE MARK CONSISTS OF THE WORDING "CONTAGIOUS CHANGE" WITH A TRIANGLE AND INFINITY SYMBOL BEHIND THE TRIANGLE, ALONG SIDE THE STACKED WORDS "CONTAGIOUS" AND "CHANGE".

FOR BUSINESS CONSULTING AND ADVISORY SERVICES IN THE FIELDS OF BUSINESS ORGANIZATIONAL EXCELLENCE; BUSINESS CONSULTING SERVICES RELATING TO THE INTEGRATION OF THE AREA OF BUSINESS ORGANIZATIONAL LEARNING; ORGANIZATIONAL CHANGE MANAGEMENT; BUSINESS ORGANIZATIONAL DEVELOPMENT, BUSINESS CONSULTATION SERVICES, NAMELY, BUSINESS PROCESS IMPROVEMENT AND ENTERPRISE ARCHITECTURE DESIGN; PERFORMANCE IMPROVEMENT, NAMELY, BUSINESS PROCESS IMPROVEMENT; BUSINESS RISK REDUCTION MANAGEMENT STRATEGIES AND EXECUTION; BUSINESS CONSULTING SERVICES IN THE FIELD OF ORGANIZATIONAL CHANGE MANAGEMENT INNOVATION AND GROWTH PROCESSES; CONSULTANCY SERVICES REGARDING BUSINESS STRATEGIES; BUSINESS MANAGEMENT CONSULTING IN THE FIELD OF EXECUTIVE TEAM DEVELOPMENT; MANAGEMENT CONSULTING AND ADVISORY SERVICES IN THE AREAS OF CORPORATE GROWTH STRATEGY, INNOVATION AND GROWTH PROCESSES, ORGANIZATIONAL TRANSFORMATION, AND TALENT MANAGEMENT AND DEVELOPMENT STRATEGIES; TOTAL QUALITY MANAGEMENT SERVICES, NAMELY, BUSINESS MANAGEMENT SERVICES FOR ESTABLISHING BUSINESS QUALITY POLICY AND DETERMINING BUSINESS MEANS FOR IMPLEMENTING THOSE POLICIES TO IMPROVE CUSTOMER SATISFACTION; BUSINESS CONSULTATION SERVICES, NAMELY, BUSINESS PROCESS IMPROVEMENT AND ENTERPRISE ARCHITECTURE DESIGN; BUSINESS DATA ANALYSIS; BUSINESS MANAGEMENT CONSULTING IN THE FIELD OF TEAM DEVELOPMENT (U.S. CLS. 100, 101 AND 102).

FIRST USE 8-0-2010; IN COMMERCE 8-0-2010.
LOURDES AYALA, EXAMINING ATTORNEY

SN 85-456,330. REED ELSEVIER INC., NEWTON, MA. FILED
10-26-2011.

NEW YORK 411

THE MARK CONSISTS OF STANDARD CHARACTERS WITHOUT CLAIM TO ANY PARTICULAR FONT, STYLE, SIZE, OR COLOR.

OWNER OF U.S. REG. NO. 3,363,989.
NO CLAIM IS MADE TO THE EXCLUSIVE RIGHT TO USE "NEW YORK", APART FROM THE MARK AS SHOWN. FOR PROVIDING ONLINE DIRECTORIES OF INFORMATION FOR THE FILM, ENTERTAINMENT, ADVERTISING AND COMMERCIAL PRODUCTION INDUSTRIES (U.S. CLS. 100, 101 AND 102).

FIRST USE 6-15-2004; IN COMMERCE 6-15-2004.
SANI KHOURI, EXAMINING ATTORNEY

CLASS 35—(Continued).

SN 85-456,385. REED ELSEVIER INC., NEWTON, MA. FILED 10-26-2011.

LA 411

THE MARK CONSISTS OF STANDARD CHARACTERS WITHOUT CLAIM TO ANY PARTICULAR FONT, STYLE, SIZE, OR COLOR.

OWNER OF U.S. REG. NO. 1,487,531.

NO CLAIM IS MADE TO THE EXCLUSIVE RIGHT TO USE "LA", APART FROM THE MARK AS SHOWN.

FOR PROVIDING ONLINE DIRECTORIES OF INFORMATION FOR THE FILM, ENTERTAINMENT, ADVERTISING AND COMMERCIAL PRODUCTION INDUSTRIES (U.S. CLS. 100, 101 AND 102).

FIRST USE 6-1-1997; IN COMMERCE 6-7-1997.

SANI KHOURI, EXAMINING ATTORNEY

SN 85-458,253. CLIPPER CORPORATION, CARSON, CA. FILED 10-27-2011.



NO CLAIM IS MADE TO THE EXCLUSIVE RIGHT TO USE "DIRECT", APART FROM THE MARK AS SHOWN.

THE COLOR(S) BLUE, BLACK, WHITE IS/ARE CLAIMED AS A FEATURE OF THE MARK.

THE MARK CONSISTS OF THE WORD "CLIPPER" IN WHITE LETTERING INSIDE A BLUE DIAMOND, BELOW WHICH IS THE WORD "DIRECT" IN WHITE LETTERING INSIDE A BLACK BOX OUTLINED IN BLUE.

FOR (BASED ON USE IN COMMERCE) ONLINE RETAIL STORE FEATURING COOKWARE, BAKE WARE, KITCHEN WARES AND ACCESSORIES, TABLE SERVICE GOODS, BAR SUPPLIES, CLEANING TOOLS, DISPOSABLE UTENSILS, TO GO CONTAINERS, APPAREL, COOKING APPAREL, HOSPITALITY APPAREL; (BASED ON INTENT-TO-USE) ONLINE RETAIL STORE FEATURING SHOES (U.S. CLS. 100, 101 AND 102).

FIRST USE 8-11-2011; IN COMMERCE 10-4-2011.

KATHERINE CONNOLLY, EXAMINING ATTORNEY

CLASS 35—(Continued).

SN 85-458,374. EC VENTURES, INC., VIRGINIA BEACH, VA. FILED 10-27-2011.



OWNER OF U.S. REG. NO. 3,653,882.

THE MARK CONSISTS OF THE LETTERS "DSD" IN STYLIZED BLOCK LETTERING WITH A CIRCLE SWISH AROUND THE "S".

FOR RETAIL STORE SERVICES FEATURING HEALTH FOODS, DIETARY SUPPLEMENTS, NUTRITIONAL SUPPLEMENTS, HERBS, VITAMINS, SPORTS NUTRITION PRODUCTS, FITNESS PRODUCTS AND APPAREL, BODY CARE, OR AROMATHERAPY PRODUCTS (U.S. CLS. 100, 101 AND 102).

FIRST USE 5-31-2011; IN COMMERCE 5-31-2011.

JOHN E. MICHOS, EXAMINING ATTORNEY

SN 85-459,201. ELAINE ALDEN KRAICH, DBA ELAINE ALDEN, LONGWOOD, FL. FILED 10-28-2011.

Elaine Alden

THE MARK CONSISTS OF STANDARD CHARACTERS WITHOUT CLAIM TO ANY PARTICULAR FONT, STYLE, SIZE, OR COLOR.

THE NAME(S), PORTRAIT(S), AND/OR SIGNATURE(S) SHOWN IN THE MARK IDENTIFIES "ELAINE ALDEN" KRAICH, WHOSE CONSENT(S) TO REGISTER IS MADE OF RECORD.

FOR MODELING FOR ADVERTISING OR SALES PROMOTION (U.S. CLS. 100, 101 AND 102).

FIRST USE 5-1-2003; IN COMMERCE 5-1-2003.

ANDREA K. NADELMAN, EXAMINING ATTORNEY

CLASS 35—(Continued).

SN 85-460,218. EVER ENERGY, INC., SPRINGVILLE, UT.
FILED 10-31-2011.



NO CLAIM IS MADE TO THE EXCLUSIVE RIGHT TO USE "SLIDER", APART FROM THE MARK AS SHOWN.

THE MARK CONSISTS OF THE WORD "SLIDER", WITH THE "Y" BEING STYLIZED AS A DOOR ROLLER IN THE SHAPE OF A "Y" WITH A CIRCLE FRAMING THE TOP POINTS OF THE "Y" (DEPICTING WHEELS), SUSPENDED OVER A STRAIGHT LINE THAT BEGINS ABOVE THE "S" AND ENDS ABOVE THE "R" IN THE WORD.

FOR ON-LINE RETAIL STORE SERVICES IN THE FIELD OF DOOR HARDWARE (U.S. CLS. 100, 101 AND 102).

FIRST USE 10-27-2011; IN COMMERCE 10-27-2011.
STEVEN R. FINE, EXAMINING ATTORNEY

SN 85-460,909. CHILTON PROPERTIES, LLC, PHOENIX, AZ.
FILED 10-31-2011.

RIDENOW POWERSPORTS

THE MARK CONSISTS OF STANDARD CHARACTERS WITHOUT CLAIM TO ANY PARTICULAR FONT, STYLE, SIZE, OR COLOR.

NO CLAIM IS MADE TO THE EXCLUSIVE RIGHT TO USE "POWERSPORTS", APART FROM THE MARK AS SHOWN.

FOR RETAIL STORE SERVICES FEATURING ATVS (ALL TERRAIN VEHICLES), WATERCRAFT, MOTORCYCLES, SCOOTERS, UTILITY VEHICLES, BOATS, TRIKES, AND SNOWMOBILES, AND TRAILERS FOR THE FOREGOING; RETAIL STORE SERVICES FEATURING PARTS, ACCESSORIES, APPAREL AND SAFETY EQUIPMENT ALL FOR ATVS (ALL TERRAIN VEHICLES), WATERCRAFT, MOTORCYCLES, SCOOTERS, UTILITY VEHICLES, BOATS, TRIKES AND SNOWMOBILES, AND TRAILERS FOR THE FOREGOING; ON-LINE RETAIL STORE SERVICES FEATURING PARTS, ACCESSORIES, APPAREL AND SAFETY EQUIPMENT ALL FOR ATVS (ALL TERRAIN VEHICLES), WATERCRAFT, MOTORCYCLES, SCOOTERS, UTILITY VEHICLES, BOATS, TRIKES AND SNOWMOBILES, AND TRAILERS FOR THE FOREGOING (U.S. CLS. 100, 101 AND 102).

FIRST USE 6-12-2006; IN COMMERCE 9-22-2007.
LESLEY LAMOTHE, EXAMINING ATTORNEY

CLASS 35—(Continued).

SN 85-460,917. CHILTON PROPERTIES, LLC, PHOENIX, AZ.
FILED 10-31-2011.



NO CLAIM IS MADE TO THE EXCLUSIVE RIGHT TO USE "POWERSPORTS", APART FROM THE MARK AS SHOWN.

THE MARK CONSISTS OF THE STYLIZED WORD "RIDENOW" FEATURING AN ARC DESIGN AROUND THE LETTERS "RID", ABOVE THE WORD "POWERSPORTS". THE WORD "POWERSPORTS" IS CENTERED ON A BLACK BANNER WHICH REPRESENTS BACKGROUND.

FOR RETAIL STORE SERVICES FEATURING ATVS (ALL TERRAIN VEHICLES), WATERCRAFT, MOTORCYCLES, SCOOTERS, UTILITY VEHICLES, BOATS, TRIKES, AND SNOWMOBILES, AND TRAILERS FOR THE FOREGOING; RETAIL STORE SERVICES FEATURING PARTS, ACCESSORIES, APPAREL AND SAFETY EQUIPMENT ALL FOR ATVS (ALL TERRAIN VEHICLES), WATERCRAFT, MOTORCYCLES, SCOOTERS, UTILITY VEHICLES, BOATS, TRIKES AND SNOWMOBILES, AND TRAILERS FOR THE FOREGOING; ON-LINE RETAIL STORE SERVICES FEATURING PARTS, ACCESSORIES, APPAREL AND SAFETY EQUIPMENT ALL FOR ATVS (ALL TERRAIN VEHICLES), WATERCRAFT, MOTORCYCLES, SCOOTERS, UTILITY VEHICLES, BOATS, TRIKES AND SNOWMOBILES, AND TRAILERS FOR THE FOREGOING (U.S. CLS. 100, 101 AND 102).

FIRST USE 6-12-2006; IN COMMERCE 9-22-2007.
LESLEY LAMOTHE, EXAMINING ATTORNEY

SN 85-461,392. SMOKY MOUNTAIN EMPORIUM LTD, DBA
SMOKY MOUNTAIN GENERAL STORE, CANDLER, NC.
FILED S.R. 11-1-2011; AM. P.R. 5-1-2012.



NO CLAIM IS MADE TO THE EXCLUSIVE RIGHT TO USE "SMOKY MOUNTAIN GENERAL STORE", APART FROM THE MARK AS SHOWN.

THE COLOR(S) BLACK, BROWN, WHITE, TAN, LIGHT GRAY, AND DARK GRAY IS/ARE CLAIMED AS A FEATURE OF THE MARK.

THE MARK CONSISTS OF THE WORDING "SMOKY MOUNTAIN" IN BLACK ABOVE AN OVAL OUTLINED IN BROWN WITH A MOUNTAIN LANDSCAPE INSIDE IT IN THE COLORS WHITE, BROWN, LIGHT GRAY, AND TAN. WITHIN THE OVAL ARE THE WORDS "GENERAL STORE" IN DARK GRAY. THE BACKGROUND OF THE MARK IS TRANSPARENT.

FOR ON-LINE RETAIL STORE SERVICES FEATURING A WIDE VARIETY OF CONSUMER GOODS OF OTHER (U.S. CLS. 100, 101 AND 102).

FIRST USE 10-31-2011; IN COMMERCE 10-31-2011.
ANDREA HACK, EXAMINING ATTORNEY

CLASS 35—(Continued).

SN 85-463,181. COVIS PHARMACEUTICALS SARL, LUXEMBOURG, LUXEMBOURG, FILED 11-3-2011.



NO CLAIM IS MADE TO THE EXCLUSIVE RIGHT TO USE "PHARMA", APART FROM THE MARK AS SHOWN. THE COLOR(S) BLUE AND BLACK IS/ARE CLAIMED AS A FEATURE OF THE MARK.

THE MARK CONSISTS OF THE DESIGN OF THREE OVERLAPPING SQUARES IN VARIOUS SHADES OF BLUE NEXT TO THE WORDS "COVIS PHARMA" IN BLACK.

FOR WHOLESALE DISTRIBUTORSHIPS FEATURING PRESCRIPTION DRUGS (U.S. CLS. 100, 101 AND 102).

FIRST USE 11-2-2011; IN COMMERCE 11-2-2011.
AHSEN KHAN, EXAMINING ATTORNEY

CLASS 35—(Continued).

SN 85-463,912. OLAH INC, NEW YORK, NY. FILED 11-3-2011.

Kingpins TV

THE MARK CONSISTS OF STANDARD CHARACTERS WITHOUT CLAIM TO ANY PARTICULAR FONT, STYLE, SIZE, OR COLOR.

OWNER OF U.S. REG. NO. 3,615,347.

NO CLAIM IS MADE TO THE EXCLUSIVE RIGHT TO USE "TV", APART FROM THE MARK AS SHOWN.

FOR PROMOTIONAL SERVICES, NAMELY, PROVIDING A WEBSITE AT WHICH BUSINESS TO BUSINESS COMPANIES IN THE FIELD OF TEXTILE PRODUCTS CAN SHOWCASE ONLINE THEIR LATEST PRODUCTS AND SERVICES AND PROVIDING BUSINESS INFORMATION IN THE FIELD OF TEXTILE PRODUCTS RELATED TO THE LATEST MARKET TRENDS, NEWS AND TEXTILE PRODUCT OPPORTUNITIES (U.S. CLS. 100, 101 AND 102).

BRENDAN MCCAULEY, EXAMINING ATTORNEY

SN 85-463,842. OLAH INC., NEW YORK, NY. FILED 11-3-2011.

Kingpins Media

THE MARK CONSISTS OF STANDARD CHARACTERS WITHOUT CLAIM TO ANY PARTICULAR FONT, STYLE, SIZE, OR COLOR.

OWNER OF U.S. REG. NO. 3,615,347.

NO CLAIM IS MADE TO THE EXCLUSIVE RIGHT TO USE "MEDIA", APART FROM THE MARK AS SHOWN.

FOR PROMOTIONAL SERVICES, NAMELY, PROVIDING A WEBSITE AT WHICH BUSINESS TO BUSINESS COMPANIES IN THE FIELD OF TEXTILE PRODUCTS CAN SHOWCASE ONLINE THEIR LATEST PRODUCTS AND SERVICES AND PROVIDING BUSINESS INFORMATION IN THE FIELD OF TEXTILE PRODUCTS RELATED TO THE LATEST MARKET TRENDS, NEWS AND TEXTILE PRODUCT OPPORTUNITIES (U.S. CLS. 100, 101 AND 102).

BRENDAN MCCAULEY, EXAMINING ATTORNEY

SN 85-463,951. OLAH INC., NEW YORK, NY. FILED 11-3-2011.

Kingpins News

THE MARK CONSISTS OF STANDARD CHARACTERS WITHOUT CLAIM TO ANY PARTICULAR FONT, STYLE, SIZE, OR COLOR.

OWNER OF U.S. REG. NO. 3,615,347.

NO CLAIM IS MADE TO THE EXCLUSIVE RIGHT TO USE "NEWS", APART FROM THE MARK AS SHOWN.

FOR PROMOTIONAL SERVICES, NAMELY, PROVIDING A WEBSITE AT WHICH BUSINESS TO BUSINESS COMPANIES IN THE FIELD OF TEXTILE PRODUCTS CAN SHOWCASE ONLINE THEIR LATEST PRODUCTS AND SERVICES AND PROVIDING BUSINESS INFORMATION IN THE FIELD OF TEXTILE PRODUCTS RELATED TO THE LATEST MARKET TRENDS, RECENT EVENTS AND TEXTILE PRODUCT OPPORTUNITIES (U.S. CLS. 100, 101 AND 102).

BRENDAN MCCAULEY, EXAMINING ATTORNEY

CLASS 35—(Continued).

SN 85-464,181. HOUSTON HEIGHTS ASSOCIATION, HOUSTON, TX. FILED 11-3-2011.



NO CLAIM IS MADE TO THE EXCLUSIVE RIGHT TO USE "ASSOCIATION", APART FROM THE MARK AS SHOWN.

THE MARK CONSISTS OF THE WORDING "HOUSTON HEIGHTS ASSOCIATION" BETWEEN SEVERAL CONCENTRIC CIRCLES, AND IN THE MIDDLE IS A DESIGN OF A HEXAGONAL VICTORIAN CUPOLA VIEWED FROM THE SIDE.

SEC. 2(F).

FOR HOMEOWNER ASSOCIATION SERVICES, NAMELY, PROMOTING THE INTERESTS OF HOMEOWNERS IN A SPECIFIC COMMUNITY AND MARKETING THE COMMUNITY NATIONWIDE TO PROSPECTIVE NEW RESIDENTS AND PROPERTY OWNERS (U.S. CLS. 100, 101 AND 102).

FIRST USE 1-1-1995; IN COMMERCE 1-1-1995.
JOHN DWYER, EXAMINING ATTORNEY

CLASS 35—(Continued).

SN 85-466,614. EON EDITIONS, LLC, DBA EONEDITION-S.COM, PASADENA, CA. FILED 11-7-2011.



NO CLAIM IS MADE TO THE EXCLUSIVE RIGHT TO USE "EDITIONS", APART FROM THE MARK AS SHOWN.

THE COLOR(S) BLUE, GREY, AND WHITE IS/ARE CLAIMED AS A FEATURE OF THE MARK.

THE MARK CONSISTS OF THE WORD "EON" IN WHITE, DROPPED-OUT OF A SOLID BLUE CIRCLE, ALONG WITH THE WORDS "EON EDITIONS". FOR THE WORDS "EON EDITIONS", THE FIRST WORD "EON" IS REPRESENTED IN BLUE, AND THE SECOND WORD "EDITIONS" IS REPRESENTED IN GREY.

FOR BUSINESS SERVICES, NAMELY, PROVIDING ON-LINE COMPUTER DATABASES REGARDING THE PURCHASE AND SALE OF A SPECIFIC VARIETY OF PRODUCTS AND SERVICES OF OTHERS, NAMELY, FINE CRAFTS, FINE ART, AND FINE ART PRINTS IN THE FIELD OF VISUAL ARTS; COLLECTION AND COMPILATION OF INFORMATION INTO COMPUTER DATABASES, NAMELY, TRADE AND CONSUMER INFORMATION IN THE FIELD OF VISUAL ART; ON-LINE ART GALLERY; ON-LINE RETAIL STORE SERVICES FEATURING A SPECIFIC VARIETY OF CONSUMER GOODS OF OTHERS, SPECIFICALLY FINE CRAFTS, FINE ART, AND FINE ART PRINTS IN THE FIELD OF VISUAL ARTS (U.S. CLS. 100, 101 AND 102).

FIRST USE 6-15-2002; IN COMMERCE 4-15-2011.
BRIAN PINO, EXAMINING ATTORNEY

SN 85-466,423. MINORBEAT, LLC, NASHVILLE, TN. FILED 11-7-2011.

MINORBEAT

THE MARK CONSISTS OF STANDARD CHARACTERS WITHOUT CLAIM TO ANY PARTICULAR FONT, STYLE, SIZE, OR COLOR.

FOR PROVIDING A WEBSITE FEATURING INFORMATION, LINKS, AND INTERACTIVE PORTALS RELATING TO THE MUSIC INDUSTRY, NAMELY, PROMOTION, MARKETING AND BUSINESS ADVICE TO MUSICIANS, AND CAREER, PROJECT AND VENUE MANAGEMENT, AND PRODUCER/MUSICIAN BUSINESS NETWORKING (U.S. CLS. 100, 101 AND 102).

LEIGH CAROLINE CASE, EXAMINING ATTORNEY

SN 85-466,878. NIGHTTIME ENTERPRISES, INC., DRIPPING SPRINGS, TX. FILED 11-8-2011.

Nightmare Factory

THE MARK CONSISTS OF STANDARD CHARACTERS WITHOUT CLAIM TO ANY PARTICULAR FONT, STYLE, SIZE, OR COLOR.

FOR ONLINE RETAIL STORE SERVICES FEATURING THEATRICAL COSTUMES, MASKS, AND PROPS; RETAIL STORE SERVICES FEATURING THEATRICAL COSTUMES, MASKS, AND PROPS (U.S. CLS. 100, 101 AND 102).

FIRST USE 6-21-1995; IN COMMERCE 6-21-1995.
JOHN DWYER, EXAMINING ATTORNEY

CLASS 35—(Continued).

SN 85-470,831. APPLIED BUSINESS SOLUTIONS, LLC, RENO, NV. FILED 11-11-2011.

APPLIED BUSINESS SOLUTIONS

THE MARK CONSISTS OF STANDARD CHARACTERS WITHOUT CLAIM TO ANY PARTICULAR FONT, STYLE, SIZE, OR COLOR.

NO CLAIM IS MADE TO THE EXCLUSIVE RIGHT TO USE "BUSINESS SOLUTIONS", APART FROM THE MARK AS SHOWN.

FOR PROFESSIONAL EMPLOYER ORGANIZATION SERVICES IN THE NATURE OF EMPLOYEE LEASING (U.S. CLS. 100, 101 AND 102).

FIRST USE 9-1-2005; IN COMMERCE 9-1-2005.

JOHN WILKE, EXAMINING ATTORNEY

SN 85-471,105. TIPPYBOB, LLC, DENVER, CO. FILED 11-12-2011.

tippybob

meet, know, grow your investment

THE MARK CONSISTS OF THE ALL LOWERCASE TEXT "TIPPYBOB" AT THE TOP AND "MEET, KNOW, GROW YOUR INVESTMENT" AT THE BOTTOM, AND THE "O" IN "TIPPYBOB" IS A RIGHT LEANING EGG WITH SHADOW ON BOTTOM RIGHT.

FOR PROVIDING A WEBSITE FEATURING RATINGS AND REVIEWS OF FINANCIAL ADVISORS FOR FINANCIAL ADVISORS AND AS RESEARCH TOOL FOR INVESTORS FOR COMMERCIAL PURPOSES (U.S. CLS. 100, 101 AND 102).

EMILY CARLSEN, EXAMINING ATTORNEY

CLASS 35—(Continued).

SN 85-471,864. SIMPLE SURVEY SOLUTIONS LLC, DELRAY BEACH, FL. FILED 11-14-2011.

Simple Survey Solutions

THE MARK CONSISTS OF STANDARD CHARACTERS WITHOUT CLAIM TO ANY PARTICULAR FONT, STYLE, SIZE, OR COLOR.

NO CLAIM IS MADE TO THE EXCLUSIVE RIGHT TO USE "SURVEY SOLUTIONS", APART FROM THE MARK AS SHOWN.

FOR CONDUCTING BUSINESS RESEARCH AND SURVEYS (U.S. CLS. 100, 101 AND 102).

FIRST USE 1-1-2009; IN COMMERCE 1-1-2009.

RONALD MCMORROW, EXAMINING ATTORNEY

SN 85-472,114. 4SITE, INC., SAN FRANCISCO, CA. FILED 11-14-2011.

4Site

THE MARK CONSISTS OF STANDARD CHARACTERS WITHOUT CLAIM TO ANY PARTICULAR FONT, STYLE, SIZE, OR COLOR.

FOR BRANDING SERVICES, NAMELY, BRAND CONCEPT, DEVELOPMENT, DESIGN, IDENTITY, VISION, NAMELY, STRATEGIC PLANNING, STRATEGY, POSITIONING, EVALUATION AND IMAGERY, BRAND CONSULTING AND MANAGEMENT, ADVERTISING AND MARKETING OF BRANDS (U.S. CLS. 100, 101 AND 102).

FIRST USE 8-15-2011; IN COMMERCE 8-15-2011.

RICHARD WHITE, EXAMINING ATTORNEY

SN 85-472,168. PROGREN AG, LLC, TECUMSEH, KS. FILED 11-14-2011.

PROGREN AG

THE MARK CONSISTS OF STANDARD CHARACTERS WITHOUT CLAIM TO ANY PARTICULAR FONT, STYLE, SIZE, OR COLOR.

NO CLAIM IS MADE TO THE EXCLUSIVE RIGHT TO USE "AG", APART FROM THE MARK AS SHOWN.

FOR RETAIL SERVICES THROUGH DIRECT SOLICITATION BY SALESPERSONS DIRECTED TO END-USERS FEATURING HUMIC ACID; CALCIUM; ADJUVANT FOR USE WITH AGRICULTURAL CHEMICALS; SURFACTANTS FOR USE IN CONNECTION WITH AGRICULTURAL PESTICIDES (U.S. CLS. 100, 101 AND 102).

FIRST USE 12-31-2008; IN COMMERCE 12-31-2008.

ANNE MADDEN, EXAMINING ATTORNEY

CLASS 35—(Continued).

SN 85-473,053. ARBITRON INC., COLUMBIA, MD. FILED 11-15-2011.

ARB-TV

THE MARK CONSISTS OF STANDARD CHARACTERS WITHOUT CLAIM TO ANY PARTICULAR FONT, STYLE, SIZE, OR COLOR.

FOR CONDUCTING MARKET RESEARCH SURVEYS AND ANALYSIS OF MARKET RESEARCH DATA AND STATISTICS IN THE FIELDS OF TELEVISION VIEWING BEHAVIOR, TELEVISION ADVERTISING AND MARKETING REACH AND EFFECTIVENESS; CONDUCTING TELEVISION AUDIENCE PARTICIPATION AUDIENCE MEASUREMENT SURVEYS, MEDIA EXPOSURE MEASUREMENT SURVEYS, AND AUDIENCE EXPOSURE TO COMMERCIAL MEASUREMENT SURVEYS FOR OTHERS; CONDUCTING BUSINESS RESEARCH AND MARKET RESEARCH FOR OTHERS; PUBLIC OPINION RESEARCH; PROVIDING AUDIENCE MEASUREMENT RATINGS, NAMELY, AUDIENCE RATING DETERMINATION FOR TELEVISION, CABLE, INTERNET, AND VIDEO-BASED MEDIA PROGRAMMING AND BROADCASTS; CONDUCTING MARKET RESEARCH REGARDING AUDIENCE MEASUREMENT, MEDIA EXPOSURE MEASUREMENT, AND AUDIENCE EXPOSURE TO COMMERCIAL MEASUREMENT; CONDUCTING DATA MATCHING SERVICES, NAMELY, COLLECTION, COMPILATION, AND ANALYSIS OF MARKETING RESEARCH AND BUSINESS RESEARCH DATA FOR OTHERS WITH RESPECT TO AUDIENCE MEASUREMENT, MEDIA EXPOSURE MEASUREMENT, AND AUDIENCE EXPOSURE TO COMMERCIAL MEASUREMENT; DEMOGRAPHIC AND GEOGRAPHIC RESEARCH FOR BUSINESS AND MARKETING PURPOSES; CONDUCTING CONSUMER BEHAVIOR RESEARCH AND CONSUMER TREND ANALYSIS; COLLECTION, COMPILATION, AND ANALYSIS OF MARKETING RESEARCH AND BUSINESS RESEARCH DATA FOR OTHERS; PROVIDING BUSINESS RESEARCH AND ADVERTISING AND MARKET RESEARCH INFORMATION AND ANALYSIS TO CUSTOMERS; PROVIDING AN ON-LINE SEARCHABLE DATABASE FEATURING MARKET RESEARCH, BUSINESS RESEARCH AND CONSUMER BEHAVIOR DATA AS IT PERTAINS TO AUDIENCE MEASUREMENT, AUDIENCE RATINGS, PUBLIC OPINION, MEDIA EXPOSURE MEASUREMENT, DEMOGRAPHICS, GEOGRAPHICS, AND CONSUMER TRENDS (U.S. CLS. 100, 101 AND 102).

FIRST USE 6-23-2009; IN COMMERCE 6-23-2009.
MICHAEL TANNER, EXAMINING ATTORNEY

SN 85-473,371. APPLIED BUSINESS SOLUTIONS LLC, RENO, NV. FILED 11-15-2011.

APPLIED RECRUITING SOLUTIONS

THE MARK CONSISTS OF STANDARD CHARACTERS WITHOUT CLAIM TO ANY PARTICULAR FONT, STYLE, SIZE, OR COLOR.

NO CLAIM IS MADE TO THE EXCLUSIVE RIGHT TO USE "RECRUITING SOLUTIONS", APART FROM THE MARK AS SHOWN.

FOR PROFESSIONAL STAFFING AND RECRUITING SERVICES (U.S. CLS. 100, 101 AND 102).

FIRST USE 1-1-2009; IN COMMERCE 1-1-2009.
JOHN WILKE, EXAMINING ATTORNEY

CLASS 35—(Continued).

SN 85-474,558. BOEHRINGER INGELHEIM PHARMACEUTICALS, INC., RIDGFIELD, CT. FILED 11-16-2011.

THE STROKE RISK REDUCER

THE MARK CONSISTS OF STANDARD CHARACTERS WITHOUT CLAIM TO ANY PARTICULAR FONT, STYLE, SIZE, OR COLOR.

NO CLAIM IS MADE TO THE EXCLUSIVE RIGHT TO USE "STROKE RISK", APART FROM THE MARK AS SHOWN.

FOR PROMOTING PUBLIC AWARENESS OF STROKE SYMPTOMS, CAUSES AND TREATMENT, AND FACTORS AFFECTING STROKE RISK (U.S. CLS. 100, 101 AND 102).

JULIE VEPPUMTHARA, EXAMINING ATTORNEY

SN 85-474,633. SNYDER, DEBORAH L., ALEXANDRIA, VA. FILED 11-16-2011.

Operation Renewed Hope Foundation

THE MARK CONSISTS OF STANDARD CHARACTERS WITHOUT CLAIM TO ANY PARTICULAR FONT, STYLE, SIZE, OR COLOR.

NO CLAIM IS MADE TO THE EXCLUSIVE RIGHT TO USE "FOUNDATION", APART FROM THE MARK AS SHOWN.

FOR CHARITABLE SERVICES, NAMELY, ORGANIZING AND CONDUCTING VOLUNTEER PROGRAMS AND COMMUNITY SERVICE PROJECTS AIMED AT INCREASING SUPPORT AND MORALE OF FAMILIES OF DECEASED WAR VETERANS, WAR VETERANS, CURRENT MEMBERS AND FUTURE MEMBERS OF THE U.S. MILITARY (U.S. CLS. 100, 101 AND 102).

ELI HELLMAN, EXAMINING ATTORNEY

SN 85-476,650. SELF STORAGE LEGAL NETWORK, L.L.C., DBA SELF STORAGE LEGAL NETWORK, ATLANTA, GA. FILED 11-18-2011.



NO CLAIM IS MADE TO THE EXCLUSIVE RIGHT TO USE "SELF STORAGE LEGAL NETWORK", APART FROM THE MARK AS SHOWN.

THE COLOR(S) PURPLE AND GRAY IS/ARE CLAIMED AS A FEATURE OF THE MARK.

THE MARK CONSISTS OF THE PURPLE WORDING "SELF STORAGE LEGAL NETWORK", A THIN GRAY HORIZONTAL LINE BETWEEN "SELF STORAGE" AND "LEGAL NETWORK", AND TWO PURPLE COLUMNS, ALL SET AGAINST A TRANSPARENT BACKGROUND.

FOR BUSINESS ADVISORY SERVICES, CONSULTANCY AND INFORMATION (U.S. CLS. 100, 101 AND 102).

FIRST USE 7-15-1995; IN COMMERCE 7-15-1995.
TOBY BULLOFF, EXAMINING ATTORNEY

CLASS 35—(Continued).

SN 85-477,195. LEILA MARLENE VON MEYER, STAMFORD, CT. FILED 11-19-2011.

phantomlovely

THE MARK CONSISTS OF STANDARD CHARACTERS WITHOUT CLAIM TO ANY PARTICULAR FONT, STYLE, SIZE, OR COLOR.

FOR ART GALLERIES; ON-LINE ART GALLERIES; RETAIL AND ON-LINE RETAIL STORE SERVICES FEATURING APPAREL, ACCESSORIES, OUTERWEAR, FOOTWEAR, LEATHER GOODS, EYEWEAR, JEWELRY, COSMETICS, FRAGRANCE, HOUSEWARES, PAPER GOODS AND PRINTED MATTER (U.S. CLS. 100, 101 AND 102).

FIRST USE 12-9-1998; IN COMMERCE 12-9-1998.
ANN E. SAPPENFIELD, EXAMINING ATTORNEY

SN 85-477,585. LADIDA LLC, JACKSON, NJ. FILED 11-21-2011.

la-di-da

THE MARK CONSISTS OF STANDARD CHARACTERS WITHOUT CLAIM TO ANY PARTICULAR FONT, STYLE, SIZE, OR COLOR.

FOR ON-LINE RETAIL STORE SERVICES FEATURING CLOTHING FOR INFANTS AND CHILDREN; RETAIL STORE SERVICES FEATURING CLOTHING FOR INFANTS AND CHILDREN (U.S. CLS. 100, 101 AND 102).

FIRST USE 8-3-2008; IN COMMERCE 8-3-2008.
JASON BLAIR, EXAMINING ATTORNEY

CLASS 35—(Continued).

SN 85-479,382. KARNATION INTIMATE APPAREL, INC., POCATELLO, ID. FILED 11-22-2011.



THE MARK CONSISTS OF THE STYLIZED WORDING "KARNATION" APPEARING ABOVE A HORIZONTAL LINE WHICH APPEARS ABOVE THE STYLIZED WORDING "THE ULTIMATE IN INTIMATE". ABOVE THE TERM "KARNATION" APPEARS THE DEPICTION OF A PAIR OF STYLIZED WINGS AND FLEUR-DE-LIS LOCATED BELOW THE DEPICTION OF A HEART.

FOR ON-LINE RETAIL STORE SERVICES FEATURING INTIMATE APPAREL AND INTIMACY PRODUCTS; RETAIL STORE SERVICES FEATURING INTIMATE APPAREL AND INTIMACY PRODUCT (U.S. CLS. 100, 101 AND 102).

FIRST USE 9-1-2011; IN COMMERCE 10-8-2011.
MICHAEL TANNER, EXAMINING ATTORNEY

SN 85-480,149. MEDULLA, LLC, DBA MEDULLA, MIDLOTHIAN, VA. FILED 11-23-2011.



THE COLOR(S) GRAY AND GREEN IS/ARE CLAIMED AS A FEATURE OF THE MARK.

THE MARK CONSISTS OF THE WORDING "MEDULLA" IN GRAY WITH TWO STYLIZED DROP LETTER "L" S IN GREEN, A STYLIZED 3/4 GEAR COG LOCATED TO THE BOTTOM RIGHT OF THE WORDING "MEDULLA", WITH THE WORDING "THE HUB OF CREATION" IN GRAY WRAPPED AROUND THE 3/4 GREEN GEAR COG.

FOR ADVERTISING AND MARKETING (U.S. CLS. 100, 101 AND 102).

FIRST USE 5-13-2011; IN COMMERCE 6-30-2011.
AMY HELLA, EXAMINING ATTORNEY

CLASS 35—(Continued).

SN 85-480,808. LADIDA LLC, JACKSON, NJ. FILED 11-25-2011.

Ladida

THE MARK CONSISTS OF STANDARD CHARACTERS WITHOUT CLAIM TO ANY PARTICULAR FONT, STYLE, SIZE, OR COLOR.

FOR ON-LINE RETAIL STORE SERVICES FEATURING CLOTHING FOR INFANTS AND CHILDREN; RETAIL STORE SERVICES FEATURING CLOTHING FOR INFANTS AND CHILDREN (U.S. CLS. 100, 101 AND 102).

FIRST USE 8-3-2008; IN COMMERCE 8-3-2008.

JASON BLAIR, EXAMINING ATTORNEY

SN 85-482,221. TRUE NORTH CUSTOM PUBLISHING, LLC, CHATTANOOGA, TN. FILED 11-29-2011.

VARI SMART

OWNER OF U.S. REG. NO. 3,176,996.

THE MARK CONSISTS OF THE TERM "VARI" AND THE TERM "SMART" WITH THREE ANGLED TRANSLUCENT PANES DISPOSED THEREBETWEEN.

FOR BUSINESS MARKETING CONSULTING SERVICES; CONSUMER MARKETING RESEARCH AND CONSULTING RELATED THERETO; DEVELOPMENT OF MARKETING STRATEGIES AND CONCEPTS; MARKETING ANALYSIS SERVICES; MARKETING CONSULTATION IN THE FIELD OF HEALTHCARE; MARKETING CONSULTING, NAMELY, DESIGN AND DEVELOPMENT OF MARKETING CAMPAIGNS FOR OTHERS; MARKETING PLAN DEVELOPMENT; MARKETING SERVICES, NAMELY, CONSUMER MARKETING RESEARCH; PROMOTION AND MARKETING SERVICES AND RELATED CONSULTING; PROVIDING MARKETING SOLUTIONS FOR HEALTHCARE PROVIDERS (U.S. CLS. 100, 101 AND 102).

FIRST USE 7-28-2011; IN COMMERCE 7-28-2011.

MEGHAN REINHART, EXAMINING ATTORNEY

SN 85-482,273. LOFTON, STANLEY, MILLERSVILLE, MD. FILED 11-29-2011.

**GAP FITTERS SOLUTIONS
(GFS), LLC**

THE MARK CONSISTS OF STANDARD CHARACTERS WITHOUT CLAIM TO ANY PARTICULAR FONT, STYLE, SIZE, OR COLOR.

NO CLAIM IS MADE TO THE EXCLUSIVE RIGHT TO USE "SOLUTIONS" OR "LLC", APART FROM THE MARK AS SHOWN.

FOR HUMAN RESOURCE ANALYSIS AND CONSULTING SERVICES; HUMAN RESOURCES SERVICES, NAMELY, PERSONNEL SELECTION FOR OTHERS (U.S. CLS. 100, 101 AND 102).

FIRST USE 11-9-2011; IN COMMERCE 11-9-2011.

DAWN HAN, EXAMINING ATTORNEY

CLASS 35—(Continued).

SN 85-482,576. ACE HARDWARE CORPORATION, OAK BROOK, IL. FILED 11-29-2011.

IN-STORE WINGMAN

THE MARK CONSISTS OF STANDARD CHARACTERS WITHOUT CLAIM TO ANY PARTICULAR FONT, STYLE, SIZE, OR COLOR.

NO CLAIM IS MADE TO THE EXCLUSIVE RIGHT TO USE "IN-STORE", APART FROM THE MARK AS SHOWN.

FOR RETAIL STORE SERVICES IN THE FIELD OF HARDWARE AND RELATED GOODS (U.S. CLS. 100, 101 AND 102).

KATHLEEN LORENZO, EXAMINING ATTORNEY

SN 85-484,731. MAVERICK POLES AND STRUCTURE, LLC, FORT WORTH, TX. FILED 12-1-2011.



NO CLAIM IS MADE TO THE EXCLUSIVE RIGHT TO USE "POLES AND STRUCTURE, LLC.", APART FROM THE MARK AS SHOWN.

THE COLOR(S) GREEN, BROWN, AND CREAM IS/ARE CLAIMED AS A FEATURE OF THE MARK.

THE MARK CONSISTS OF A GREEN SEMI CIRCLE WITH A BROWN OUTLINED HORSE IN THE CENTER. THE HORSE IS CREAM IN COLOR. THE BACKGROUND IS CREAM. THE WORD "MAVERICK" APPEARS IN GREEN COLOR AND IS AT THE BASE OF THE SEMI CIRCLE. THE WORDS "POLES AND STRUCTURE LLC" APPEAR UNDERNEATH THE WORD "MAVERICK". THE WORD "POLES" IS IN BROWN. THE WORD "AND" IS IN GREEN. THE WORDS "STRUCTURE LLC." ARE IN BROWN.

FOR DISTRIBUTORSHIP SERVICES IN THE FIELD OF METAL POLES (U.S. CLS. 100, 101 AND 102).

FIRST USE 3-1-2010; IN COMMERCE 3-1-2010.

GRETTA YAO, EXAMINING ATTORNEY

CLASS 35—(Continued).

SN 85-484,786. INLOHER CORP, COCONUT CREEK, FL. FILED 12-1-2011.



NO CLAIM IS MADE TO THE EXCLUSIVE RIGHT TO USE "SALVAGE AUTOS AUCTION", APART FROM THE MARK AS SHOWN.

THE COLOR(S) SILVER, WHITE, RED AND BLACK IS/ ARE CLAIMED AS A FEATURE OF THE MARK.

THE MARK CONSISTS OF THE DEPICTION OF A CAR GRILL WITH A RED QUADRILATERAL OUTLINED IN SILVER. TWO HORIZONTAL SILVER LINES EXTEND FROM THE QUADRILATERAL ON BOTH SIDES. THE WORDING "SALVAGE AUTOS AUCTION" APPEARS IN WHITE BETWEEN THE TWO SILVER LINES. ALL OF THE FOREGOING APPEARS ON A BLACK BACKGROUND.

FOR AUCTION SERVICES; AUTOMOBILE DEALERSHIPS; DEALERSHIPS IN THE FIELD OF USED AUTOMOBILES (U.S. CLS. 100, 101 AND 102).

FIRST USE 7-18-2010; IN COMMERCE 7-18-2010.
KATHERINE CHANG, EXAMINING ATTORNEY

SN 85-485,105. ETHNIFACTS, LLC, FLOWER MOUND, TX. FILED 12-1-2011.

MetaOpinions

THE MARK CONSISTS OF STANDARD CHARACTERS WITHOUT CLAIM TO ANY PARTICULAR FONT, STYLE, SIZE, OR COLOR.

FOR MARKET RESEARCH SERVICES, NAMELY, GATHERING, MANAGING AND ANALYZING DATA CONCERNING CONSUMER PURCHASES, SPENDING AND PREFERENCES; COLLECTION OF DATA RELATING TO HISPANIC CONSUMERS' SPENDING AND PREFERENCES; CONDUCTING CONSUMER TRACKING BEHAVIOR RESEARCH AND TREND ANALYSIS; CONSULTING SERVICES REGARDING MARKETING AND ADVERTISING (U.S. CLS. 100, 101 AND 102).

TINA BROWN, EXAMINING ATTORNEY

CLASS 35—(Continued).

SN 85-485,177. VEREQUEST INCORPORATED, TORONTO, ON, CANADA, FILED 12-1-2011.

HELPING COMPANIES KEEP THE PROMISES THEY MAKE

THE MARK CONSISTS OF STANDARD CHARACTERS WITHOUT CLAIM TO ANY PARTICULAR FONT, STYLE, SIZE, OR COLOR.

FOR BUSINESS CONSULTATION IN THE BUSINESS SALES AND COMMUNICATION FIELDS, SPECIFICALLY, CONSULTING ON BUSINESS-TO-CUSTOMER AND BUSINESS-TO-BUSINESS INTERACTIONS IN AN EFFORT TO IMPROVE THE SALES AND SERVICE EXPERIENCES (U.S. CLS. 100, 101 AND 102).

FIRST USE 9-13-2007; IN COMMERCE 9-13-2007.
JUDITH HELFMAN, EXAMINING ATTORNEY

SN 85-485,765. D. SMITH ENTERPRISES, L.L.C., OKLAHOMA CITY, OK. FILED 12-2-2011.

THE REFEREE'S CALL

THE MARK CONSISTS OF STANDARD CHARACTERS WITHOUT CLAIM TO ANY PARTICULAR FONT, STYLE, SIZE, OR COLOR.

OWNER OF U.S. REG. NO. 2,533,270.

FOR RETAIL STORE SERVICES FEATURING EQUIPMENT, CLOTHING, AND ACCESSORIES FOR SPORTS OFFICIALS (U.S. CLS. 100, 101 AND 102).

FIRST USE 0-0-1992; IN COMMERCE 0-0-1992.

JENNIFER RICHARDSON, EXAMINING ATTORNEY

SN 85-486,911. PENTON MEDIA, INC., NEW YORK, NY. FILED 12-5-2011.

Used Equipment Directory

THE MARK CONSISTS OF STANDARD CHARACTERS WITHOUT CLAIM TO ANY PARTICULAR FONT, STYLE, SIZE, OR COLOR.

OWNER OF U.S. REG. NO. 929,589.

NO CLAIM IS MADE TO THE EXCLUSIVE RIGHT TO USE "DIRECTORY", APART FROM THE MARK AS SHOWN.

SEC. 2(F).

FOR ON-LINE BUSINESS DIRECTORIES FEATURING USED MACHINERY, MACHINE TOOLS, INDUSTRIAL EQUIPMENT, AND ELECTRICAL AND POWER APPARATUS, ON-LINE LISTING, NOT ON-LINE PUBLICATION (U.S. CLS. 100, 101 AND 102).

FIRST USE 0-0-2007; IN COMMERCE 0-0-2007.

TIMOTHY FINNEGAN, EXAMINING ATTORNEY

CLASS 35—(Continued).

SN 85-487,230. S2YD FRANCHISING, LLC, AUSTIN, TX. FILED 12-5-2011.



THE COLOR(S) ORANGE, GREY, LIGHT GREY, DARK GREY, RED, WHITE AND BLACK IS/ARE CLAIMED AS A FEATURE OF THE MARK.

THE MARK CONSISTS OF AN ORANGE THREE DIMENSIONAL DOOR WHICH CONTAINS A DARK GREY DOOR-KNOB AND TWO SQUARE PANELS ADJACENT TO ONE ANOTHER ON THE TOP PORTION OF THE THREE DIMENSIONAL DOOR WITH TWO RECTANGULAR PANELS BELOW SAID TWO SQUARE PANELS ALSO ADJACENT TO ONE ANOTHER, THE BOTTOM HALF OF WHICH ARE PARTIALLY OBSCURED BY A THREE DIMENSIONAL RED ARROW WHICH CONTAINS A THIN BLACK LINE ON THE TOP OF SAID RED ARROW WHICH WRAPS AROUND 180 DEGREES OF THE CENTER OF THE ORANGE THREE DIMENSIONAL DOOR. EACH OF THE PANELS ON THE THREE DIMENSIONAL DOOR HAVE A THIN GREY OUTLINE WITHIN SUCH PANELS AND EACH SUCH PANEL HAS A WHITE OUTLINE OUTSIDE THE THIN GREY RECTANGULAR OUTLINE AND A WHITE CENTER. IN THE BACKGROUND OF THE ORANGE THREE DIMENSIONAL DOOR AND THE RED THREE DIMENSIONAL ARROW ARE A DARK GREY MOUNTAINOUS SHAPE FIGURE AND A LIGHT GREY SKYLINE. ALL OF THE FOREGOING FEATURES OF THE MARK ARE ENCLOSED IN A CIRCLE.

FOR ON-LINE ORDERING SERVICES IN THE FIELD OF RESTAURANT PREPARED FOOD AND TAKE OUT MEALS AND DELIVERY (U.S. CLS. 100, 101 AND 102).

FIRST USE 10-1-2006; IN COMMERCE 5-1-2008. EDWARD NELSON, EXAMINING ATTORNEY

SN 85-487,382. SR HOLDINGS, LLC, LEXINGTON, MA. FILED 12-5-2011.

HAPPY SINCE 1916

THE MARK CONSISTS OF STANDARD CHARACTERS WITHOUT CLAIM TO ANY PARTICULAR FONT, STYLE, SIZE, OR COLOR.

NO CLAIM IS MADE TO THE EXCLUSIVE RIGHT TO USE "SINCE 1916", APART FROM THE MARK AS SHOWN.

FOR RETAIL SHOE AND FASHION ACCESSORIES STORE SERVICES; COMPUTERIZED ON-LINE RETAIL STORE SERVICES IN THE FIELD OF FOOTWEAR, APPAREL, ACCESSORIES AND BAGS, ACCESSIBLE VIA GLOBAL COMPUTER NETWORKS (U.S. CLS. 100, 101 AND 102).

CURTIS FRENCH, EXAMINING ATTORNEY

CLASS 35—(Continued).

SN 85-488,181. INTERSTATE FURNITURE SALES, INC., SMYRNA, GA. FILED 12-6-2011.

SAVE BIG MATTRESS

THE MARK CONSISTS OF STANDARD CHARACTERS WITHOUT CLAIM TO ANY PARTICULAR FONT, STYLE, SIZE, OR COLOR.

NO CLAIM IS MADE TO THE EXCLUSIVE RIGHT TO USE "MATTRESS", APART FROM THE MARK AS SHOWN.

FOR RETAIL STORE SERVICES FEATURING MATTRESSES AND BEDDING (U.S. CLS. 100, 101 AND 102).

FIRST USE 1-1-2004; IN COMMERCE 1-1-2004. KRISTINA MORRIS, EXAMINING ATTORNEY

SN 85-488,306. EFLO AMERICA CORP., LAS VEGAS, NV. FILED 12-6-2011.

eFlo America

THE MARK CONSISTS OF STANDARD CHARACTERS WITHOUT CLAIM TO ANY PARTICULAR FONT, STYLE, SIZE, OR COLOR.

NO CLAIM IS MADE TO THE EXCLUSIVE RIGHT TO USE "AMERICA", APART FROM THE MARK AS SHOWN.

FOR FRANCHISING, NAMELY, OFFERING BUSINESS MANAGEMENT ASSISTANCE IN THE ESTABLISHMENT AND/OR OPERATION OF WHOLESALE STORE SERVICES FEATURING CHEMICALS USED BY COMMERCIAL LAUNDRY ESTABLISHMENTS (U.S. CLS. 100, 101 AND 102).

SAMUEL E. SHARPER JR., EXAMINING ATTORNEY

SN 85-488,595. SYSTEM STREET, INC., NEW YORK, NY. FILED 12-6-2011.

Lawyer Next

THE MARK CONSISTS OF STANDARD CHARACTERS WITHOUT CLAIM TO ANY PARTICULAR FONT, STYLE, SIZE, OR COLOR.

NO CLAIM IS MADE TO THE EXCLUSIVE RIGHT TO USE "LAWYER", APART FROM THE MARK AS SHOWN.

FOR PROVIDING A SEARCHABLE WEBSITE FEATURING THE GOODS AND SERVICES OF OTHER VENDORS (U.S. CLS. 100, 101 AND 102).

FIRST USE 11-25-2011; IN COMMERCE 11-25-2011. EDWARD FENNESSY, EXAMINING ATTORNEY

CLASS 35—(Continued).

SN 85-489,536. SHIELDS, EUGENE, NORWALK, CT. FILED 12-7-2011.

Positioning you for Success



**GLOBAL
RECRUITMENT
SPECIALISTS**

NO CLAIM IS MADE TO THE EXCLUSIVE RIGHT TO USE "GLOBAL RECRUITMENT SPECIALISTS", APART FROM THE MARK AS SHOWN.

THE MARK CONSISTS OF A GLOBE WITH THE STYLIZED TEXT "POSITIONING YOU FOR SUCCESS" ABOVE THE GLOBE AND THE STYLIZED TEXT "GLOBAL RECRUITMENT SPECIALISTS" BELOW THE GLOBE.

FOR BUSINESS SUCCESSION PLANNING; PROFESSIONAL STAFFING AND RECRUITING SERVICES; EXECUTIVE RECRUITING SERVICES; RESUME PREPARATION (U.S. CLS. 100, 101 AND 102).

FIRST USE 10-1-1993; IN COMMERCE 10-1-1993.
JEFFREY LOOK, EXAMINING ATTORNEY

SN 85-489,918. GRANZA, INC., THOUSAND OAKS, CA. FILED 12-7-2011.



OWNER OF U.S. REG. NOS. 3,368,036 AND 3,593,663.
THE MARK CONSISTS OF THE UNDERLINED WORD "GRANZA" WITH A PALM TREE WITH 3 COCONUTS IN FRONT OF THE LETTER "G" IN THE WORDING "GRANZA".

THE ENGLISH TRANSLATION OF THE WORD "GRANZA" IN THE MARK IS "RICE" AS WELL AS "A PLASTIC".
FOR ON-LINE ADVERTISING AND MARKETING SERVICES (U.S. CLS. 100, 101 AND 102).

FIRST USE 9-1-2010; IN COMMERCE 9-1-2010.
SAMUEL E. SHARPER JR., EXAMINING ATTORNEY

CLASS 35—(Continued).

SN 85-490,124. A PARENT COMPANY LLC, SAN FRANCISCO, CA. FILED S.R. 12-8-2011; AM. P.R. 4-25-2012.



NO CLAIM IS MADE TO THE EXCLUSIVE RIGHT TO USE "COMPANY", APART FROM THE MARK AS SHOWN.

THE COLOR(S) YELLOW, BLUE, WHITE, CHARCOAL GRAY AND MEDIUM GRAY IS/ARE CLAIMED AS A FEATURE OF THE MARK.

THE MARK CONSISTS OF A LARGE YELLOW "A", THE WORD "PARENT" IN WHITE, THE WORD "COMPANY" IN CHARCOAL GRAY, A MAN FIGURE IN MEDIUM GRAY, A WOMAN FIGURE IN YELLOW AND A CHILD FIGURE IN CHARCOAL GRAY, WITH A BLUE BACKGROUND.

FOR ON-LINE RETAIL STORE SERVICES FEATURING CHILD SAFETY PRODUCTS (U.S. CLS. 100, 101 AND 102).

FIRST USE 12-7-2011; IN COMMERCE 12-7-2011.
MICHAEL KEATING, EXAMINING ATTORNEY

SN 85-490,310. LUCRATIVE GAMING LLC, SACRAMENTO, CA. FILED 12-8-2011.

FGL

THE MARK CONSISTS OF STANDARD CHARACTERS WITHOUT CLAIM TO ANY PARTICULAR FONT, STYLE, SIZE, OR COLOR.

FOR BUSINESS SERVICES, NAMELY, PROVIDING AN ONLINE MARKETPLACE FOR DEVELOPERS AND BUYERS/LICENSERS OF VIDEO GAMES (U.S. CLS. 100, 101 AND 102).

FIRST USE 10-0-2011; IN COMMERCE 10-0-2011.
ANNE MADDEN, EXAMINING ATTORNEY

SN 85-490,722. AVANTAS, LLC, OMAHA, NE. FILED 12-8-2011.

HEALTHCARE WORKING SMARTER

THE MARK CONSISTS OF STANDARD CHARACTERS WITHOUT CLAIM TO ANY PARTICULAR FONT, STYLE, SIZE, OR COLOR.

FOR CONSULTING IN THE FIELD OF HEALTHCARE LABOR MANAGEMENT (U.S. CLS. 100, 101 AND 102).

FIRST USE 10-4-2011; IN COMMERCE 10-4-2011.
ELI HELLMAN, EXAMINING ATTORNEY

CLASS 35—(Continued).

SN 85-490,953. WAATODOO, INC., SANTA MONICA, CA.
FILED 12-8-2011.

PEPs

THE MARK CONSISTS OF STANDARD CHARACTERS WITHOUT CLAIM TO ANY PARTICULAR FONT, STYLE, SIZE, OR COLOR.

FOR ADVERTISEMENT VIA MOBILE PHONE NETWORKS; ADVERTISING AND BUSINESS SERVICES, NAMELY, SECURING AIRTIME ON ALL FORMS OF MEDIA COMMUNICATIONS STATIONS, SYSTEMS, NETWORKS, AND SERVICES FOR THE PURPOSE OF PROMOTING THE GOODS AND SERVICES OF OTHERS; ADVERTISING AND MARKETING SERVICES PROVIDED BY MEANS OF INDIRECT METHODS OF MARKETING COMMUNICATIONS, NAMELY, SOCIAL MEDIA, SEARCH ENGINE MARKETING, INQUIRY MARKETING, INTERNET MARKETING, MOBILE MARKETING, BLOGGING AND OTHER FORMS OF PASSIVE, SHARABLE OR VIRAL COMMUNICATIONS CHANNELS; ADVERTISING BY TRANSMISSION OF ON-LINE PUBLICITY FOR THIRD PARTIES THROUGH ELECTRONIC COMMUNICATIONS NETWORKS; ADVERTISING, MARKETING AND PROMOTIONAL SERVICES RELATED TO ALL INDUSTRIES FOR THE PURPOSE OF FACILITATING NETWORKING AND SOCIALIZING OPPORTUNITIES FOR BUSINESS PURPOSES; AUCTION MANAGEMENT SERVICES PROVIDED TO OTHERS OVER AN ON-LINE WEB SITE ACCESSED THROUGH A GLOBAL COMPUTER NETWORK; AUCTIONING VIA TELECOMMUNICATION NETWORKS; BARTER EXCHANGE SERVICES, NAMELY, PROVIDING COMMERCIAL BARTER AND TRADE EXCHANGE OF PRODUCTS AND SERVICES VIA A GLOBAL COMPUTER INFORMATION NETWORK; BUSINESS ASSISTANCE SERVICES, NAMELY, ASSISTING HEALTH CARE FACILITIES AND OTHER COMPANIES WITH CUSTOMER FOLLOW-UP TO IMPROVE CUSTOMER OUTCOMES AND SATISFACTION THROUGH THE USE OF TELECOMMUNICATION DEVICES AND COMPUTER NETWORKS WITH AUTOMATED INTERACTION AND DATA FEEDBACK, MONITORING AND COMPILATION CAPACITY; BUSINESS COLLABORATION SERVICES, NAMELY, PROVIDING A NATIONAL COMPUTER-BASED NETWORKING WEB SITE FOR HEALTH CARE EDUCATORS AND MEDICAL EDUCATORS TO COLLABORATE ACROSS DISCIPLINES TO HELP IMPROVE HEALTH CARE EDUCATION AND MEDICAL EDUCATION; BUSINESS CONSULTATION SERVICES TO ASSIST NON-PROFIT ORGANIZATIONS IN PLANNING, MANAGING, AND CONDUCTING FUNDRAISING ACTIVITIES VIA A GLOBAL COMPUTER NETWORK; BUSINESS CONSULTING SERVICE THAT PROVIDES TRANSFORMATIONAL STRATEGIES TO COMPANIES WISHING TO MOVE TOWARDS SUSTAINABILITY AND SOCIALLY RESPONSIBLE BUSINESS PRACTICES, PROVIDED MAINLY TO THE CONSUMER PRODUCTS INDUSTRY; BUSINESS NETWORKING; BUSINESS NETWORKING OF PEER TO PEER LEARNING GROUPS OF HIGH NET WORTH INDIVIDUALS; BUSINESS SERVICES, NAMELY, A NETWORK OF SOLAR CONTRACTORS RECEIVING LEADS AND BIDDING OPPORTUNITIES BY MEANS OF AN ONLINE MARKETPLACE FOR THE PURPOSE OF DEVELOPING INFORMATION TO EVALUATE THE INVESTMENT VALUE OF SOLAR ENERGY FOR A WEB-BASED CONSUMER; BUSINESS SERVICES, NAMELY, FREIGHT INFORMATION MANAGEMENT SERVICES, SHIPMENT PROCESSING, PREPARING SHIPPING DOCUMENTS AND INVOICES, TRACKING DOCUMENTS, PACKAGES AND FREIGHT OVER COMPUTER NETWORKS, INTRANETS AND INTERNETS; BUSINESS SERVICES, NAMELY, PROVIDING AN ONLINE NETWORK FOR CONTRACTORS TO RECEIVE BIDDING OPPORTUNITIES BY MEANS OF AN ONLINE MARKETPLACE FOR THE PURPOSE OF DEVELOPING BUSINESS FOR SUSTAINABLE RELATED BUILDING

CLASS 35—(Continued).

PRODUCTS AND SERVICES; BUSINESS SERVICES, NAMELY, PROVIDING AN ONLINE NETWORK FOR CONTRACTORS TO RECEIVE LEADS AND BIDDING OPPORTUNITIES BY MEANS OF AN ONLINE MARKETPLACE FOR THE PURPOSE OF DEVELOPING BUSINESS; BUSINESS SERVICES, NAMELY, PROVIDING AN ONLINE NETWORK FOR CONTRACTORS TO RECEIVE LEADS AND BIDDING OPPORTUNITIES BY MEANS OF AN ONLINE MARKETPLACE FOR THE PURPOSE OF DEVELOPING BUSINESS FOR ENERGY RELATED PRODUCTS AND SERVICES; BUSINESS SERVICES, NAMELY, PROVIDING AN ONLINE NETWORK FOR CONTRACTORS TO RECEIVE LEADS AND BIDDING OPPORTUNITIES BY MEANS OF AN ONLINE MARKETPLACE FOR THE PURPOSE OF DEVELOPING BUSINESS IN THE RESTAURANT, ENTERTAINMENT AND RECREATION INDUSTRY; COOPERATIVE ADVERTISING AND MARKETING SERVICES BY WAY OF SOLICITATION, CUSTOMER SERVICE AND PROVIDING MARKETING INFORMATION VIA WEB SITES ON A GLOBAL COMPUTER NETWORK; DEVELOPMENT, OPERATION AND ADMINISTRATION OF DIGITAL SIGNAGE SYSTEMS AND DIGITAL ADVERTISING SYSTEMS FOR OTHERS, NAMELY, PROVIDING ADVERTISING SPACE BY ELECTRONIC MEANS AND GLOBAL COMPUTER INFORMATION NETWORKS; DISSEMINATION OF ADVERTISING FOR OTHERS VIA PUBLIC AND PRIVATE WIRELESS NETWORKS FOR DISPLAY ON MOBILE DEVICES; DISSEMINATION OF ADVERTISING, SCHEDULING AND MANAGING OF TRAINING COURSES AND PROGRAMS FOR OTHERS VIA A GLOBAL COMPUTER NETWORK; ELECTRONIC COMMERCE SERVICES, NAMELY, PROVIDING INFORMATION ABOUT PRODUCTS VIA TELECOMMUNICATION NETWORKS FOR ADVERTISING AND SALES PURPOSES; EMPLOYMENT HIRING, RECRUITING, PLACEMENT, STAFFING AND CAREER NETWORKING SERVICES; GENERAL BUSINESS NETWORKING REFERRAL SERVICES, NAMELY, PROMOTING THE GOODS AND SERVICES OF OTHERS BY PASSING BUSINESS LEADS AND REFERRALS AMONG GROUP MEMBERS; INFORMATION MANAGEMENT SERVICES, NAMELY, SHIPMENT PROCESSING, PREPARING SHIPPING DOCUMENTS AND INVOICES, TRACKING DOCUMENTS, PACKAGES AND FREIGHT OVER COMPUTER NETWORKS, INTRANETS AND INTERNETS; INTEGRATED TRACKING AND MANAGEMENT OF COMMERCIAL TRANSACTIONS ON A GLOBAL COMPUTER NETWORK; MANAGING TELECOMMUNICATIONS NETWORKS FOR OTHERS, NAMELY, MANAGING TELEPHONE SERVICE FOR OTHER CARRIERS; MATCHING CONSUMERS WITH PROFESSIONALS IN THE FIELD OF RESIDENTIAL AND COMMERCIAL SERVICES VIA COMPUTER NETWORK; MATCHING CONSUMERS WITH REAL ESTATE PROFESSIONALS IN THE FIELD OF REAL ESTATE SERVICES VIA COMPUTER NETWORK; MEDICAL CLAIMS MANAGEMENT SERVICES, NAMELY, ELECTRONIC RE-PRICING OF PHYSICIAN, HOSPITAL, AND ANCILLARY MEDICAL CARE PROVIDER TRANSACTIONS VIA THE GLOBAL INFORMATION NETWORK; ON-LINE ADVERTISING ON COMPUTER COMMUNICATION NETWORKS; ON-LINE ADVERTISING ON COMPUTER NETWORKS; ON-LINE BUSINESS NETWORKING SERVICES; ON-LINE PROFESSIONAL NETWORKING SERVICES; ON-LINE PROMOTION OF COMPUTER NETWORKS AND WEBSITES; ONLINE ADVERTISING VIA A COMPUTER COMMUNICATIONS NETWORK; ONLINE SERVICE FOR CONNECTING SOCIAL NETWORK USERS WITH RETAILERS FOR THE PURPOSE OF FACILITATING DISCOUNTED PURCHASES; OPERATION AND ADMINISTRATION OF TELECOMMUNICATION SYSTEMS AND NETWORKS FOR OTHERS; PROMOTING PUBLIC AWARENESS IN THE FIELD OF SOCIAL WELFARE; PROMOTING THE GOODS AND SERVICES OF OTHERS BY PREPARING AND PLACING ADVERTISEMENTS IN AN ELECTRONIC MAGAZINE ACCESSED THROUGH A GLOBAL COMPUTER NETWORK; PROMOTING THE GOODS AND SERVICES OF OTHERS VIA A GLOBAL COMPUTER NETWORK; PROVIDING A WEB SITE WHICH FEATURES ADVERTISEMENTS FOR THE GOODS AND SERVICES OF OTHERS ON A GLOBAL COMPUTER NETWORK; PROVIDING A WEBSITE FOR USERS WITH SPECIFIC INFORMED RECOMMENDATIONS OF SPECIFIC CONSUMER PRODUCTS AND SERVICES VALIDATED BY THE USERS' INPUTTED PREFER-

CLASS 35—(Continued).

ENCES AND SOCIAL NETWORK; PROVIDING AN ON-LINE MARKETING COLLABORATION NETWORK FOR SOCIAL MEDIA AND ONLINE MARKETING PROFESSIONALS FOR THE PURPOSE OF SYNDICATING CONTENT THROUGH THE NETWORK TO BE SHARED BY OTHERS; PROVIDING BUSINESS INFORMATION, ALSO VIA INTERNET, THE CABLE NETWORK OR OTHER FORMS OF DATA TRANSFER; PROVIDING COMMERCIAL INFORMATION UPDATES ONLINE AND OVER A GLOBAL COMPUTER NETWORK IN THE FIELDS OF BUSINESS, COMMERCE, AND INDUSTRY; PROVIDING INFORMATION ABOUT COMMERCIAL BUSINESS AND COMMERCIAL INFORMATION VIA THE GLOBAL COMPUTER NETWORK; PROVIDING INFORMATION ABOUT THE GOODS AND SERVICES OF OTHERS VIA THE GLOBAL COMPUTER NETWORK; PROVIDING INFORMATION ON THE TOPIC OF PROMOTING PATIENT, PHYSICIAN AND EMPLOYEE SATISFACTION VIA A GLOBAL COMPUTER NETWORK; PROVIDING INFORMATION PERTAINING TO PROCUREMENT, BUYING, SELLING AND TENDERING INFORMATION AND OPPORTUNITIES RELATING TO GOODS, SERVICES, AND CONSTRUCTION VIA COMPUTER, COMPUTER NETWORKS, TELEPHONE, THE INTERNET OR ELECTRONIC MAIL; PROVIDING NETWORKING OPPORTUNITIES FOR INDIVIDUALS SEEKING EMPLOYMENT; PROVIDING ON-LINE EMPLOYMENT PLACEMENT SERVICES, NAMELY, MATCHING RESUMES AND POTENTIAL EMPLOYERS VIA A GLOBAL COMPUTER NETWORK; PROVIDING RATINGS VIA A GLOBAL COMPUTER NETWORK FOR HOME PRODUCTS AND SERVICES RECOMMENDED BY CONSUMERS; PROVISION OF ADVERTISING SPACE BY ELECTRONIC MEANS AND GLOBAL INFORMATION NETWORKS; PROVISION OF BUSINESS INFORMATION VIA GLOBAL COMPUTER NETWORKS; SOCIAL MEDIA STRATEGY AND MARKETING CONSULTANCY FOCUSING ON HELPING CLIENTS CREATE AND EXTEND THEIR PRODUCT AND BRAND STRATEGIES BY BUILDING VIRALLY ENGAGING MARKETING SOLUTIONS; TELECOMMUNICATIONS NETWORK MANAGEMENT SERVICES, NAMELY, THE OPERATION AND ADMINISTRATION OF TELECOMMUNICATION SYSTEMS AND NETWORKS FOR OTHERS (U.S. CLS. 100, 101 AND 102).

FIRST USE 12-1-2011; IN COMMERCE 12-1-2011.
LINDA POWELL, EXAMINING ATTORNEY

SN 85-491,716. WILD BIRD WAY INC., PARKER, CO. FILED 12-9-2011.

Wild Bird Way

THE MARK CONSISTS OF STANDARD CHARACTERS WITHOUT CLAIM TO ANY PARTICULAR FONT, STYLE, SIZE, OR COLOR.

NO CLAIM IS MADE TO THE EXCLUSIVE RIGHT TO USE "WILD BIRD", APART FROM THE MARK AS SHOWN. FOR RETAIL STORE SERVICES FEATURING BIRD SEED, BIRD FEEDERS, OPTICS, BIRD BATHS, NATURE GIFTS AND OTHER PRODUCTS RELATED TO WILD BIRDS (U.S. CLS. 100, 101 AND 102).

FIRST USE 7-1-2011; IN COMMERCE 7-1-2011.
DARRYL SPRUILL, EXAMINING ATTORNEY

CLASS 35—(Continued).

SN 85-492,367. HAFENBRACK MARKETING & COMMUNICATIONS, INC., DAYTON, OH. FILED 12-11-2011.

Genessa Health Marketing

THE MARK CONSISTS OF STANDARD CHARACTERS WITHOUT CLAIM TO ANY PARTICULAR FONT, STYLE, SIZE, OR COLOR.

NO CLAIM IS MADE TO THE EXCLUSIVE RIGHT TO USE "HEALTH MARKETING", APART FROM THE MARK AS SHOWN.

FOR PROVIDING MARKETING SOLUTIONS FOR HEALTHCARE INDUSTRY PARTICIPANTS (U.S. CLS. 100, 101 AND 102).

FIRST USE 6-30-2010; IN COMMERCE 5-1-2011.
BILL DAWE, EXAMINING ATTORNEY

SN 85-493,948. PLANET, INC., WALTHAM, MA. FILED 12-13-2011.

SHOEHUB.COM

THE MARK CONSISTS OF STANDARD CHARACTERS WITHOUT CLAIM TO ANY PARTICULAR FONT, STYLE, SIZE, OR COLOR.

FOR ON-LINE RETAIL STORE SERVICES FEATURING SHOES (U.S. CLS. 100, 101 AND 102).

FIRST USE 10-25-2011; IN COMMERCE 10-26-2011.
TINA BROWN, EXAMINING ATTORNEY

SN 85-494,153. AMERICAN ASSOCIATION FOR LABORATORY ANIMAL SCIENCE, MEMPHIS, TN. FILED 12-13-2011.



THE MARK CONSISTS OF THE LETTERS "AALAS" IN A PYRAMID-TYPE DESIGN.

FOR ASSOCIATION SERVICES, NAMELY, PROMOTING PUBLIC INTEREST AND AWARENESS ABOUT THE RESPONSIBLE CARE AND USE OF LABORATORY ANIMALS FOR THE BENEFIT OF HUMAN AND ANIMAL HEALTH (U.S. CLS. 100, 101 AND 102).

FIRST USE 4-30-1967; IN COMMERCE 4-30-1967.
CHRISIE B. KING, EXAMINING ATTORNEY

CLASS 35—(Continued).

SN 85-494,453. FLYING NANNY INC., HALEIWA, HI. FILED 12-13-2011.

Flying Nanny

THE MARK CONSISTS OF STANDARD CHARACTERS WITHOUT CLAIM TO ANY PARTICULAR FONT, STYLE, SIZE, OR COLOR.

FOR PROVIDING AN ON-LINE SEARCHABLE DATABASE FEATURING CLASSIFIED AD LISTINGS AND EMPLOYMENT OPPORTUNITIES (U.S. CLS. 100, 101 AND 102).

MIAH ROSENBERG, EXAMINING ATTORNEY

CLASS 35—(Continued).

SN 85-495,428. FULTON, STANLEY M, DBA GOODINFO-COM, SARASOTA, FL. FILED 12-14-2011.

Commerce for Good

THE MARK CONSISTS OF STANDARD CHARACTERS WITHOUT CLAIM TO ANY PARTICULAR FONT, STYLE, SIZE, OR COLOR.

NO CLAIM IS MADE TO THE EXCLUSIVE RIGHT TO USE "COMMERCE", APART FROM THE MARK AS SHOWN.

FOR COOPERATIVE ADVERTISING AND MARKETING (U.S. CLS. 100, 101 AND 102).

JOHN SCHUYLER YARD, EXAMINING ATTORNEY

SN 85-495,832. SMART SAMANTHA L.L.C., ALPHARETTA, GA. FILED 12-15-2011.

SN 85-494,950. INTERNATIONAL CONCRETE POLISHING & STAINING CONFERENCE, LLC., MARIETTA, GA. FILED 12-14-2011.



NO CLAIM IS MADE TO THE EXCLUSIVE RIGHT TO USE "CONCRETE ALLIANCES", APART FROM THE MARK AS SHOWN.

THE MARK CONSISTS OF A DESIGN OF THE COLOSSEUM IN THE CENTER OF A CIRCLE WITH THE STYLIZED WORDING "CONCRETE ALLIANCES" AND "CLEARLY POLISHED" AROUND THE OUTSIDE OF THE CIRCLE SEPARATED BY TWO SMALL CIRCLES.

FOR ADVERTISING, MARKETING AND PROMOTION SERVICES; ADVERTISING, MARKETING AND PROMOTION SERVICES IN THE FIELD OF CONCRETE FLOOR SERVICE INDUSTRY; ADVERTISING, PROMOTION, AND MARKETING SERVICES IN THE NATURE OF MARKETING STRATEGIES TO PROMOTE BUSINESS IN THE CONCRETE FLOOR SERVICE INDUSTRY FOR SERVICES OF THE PROCESS OF GRINDING, HONING, AND POLISHING OF CONCRETE FLOORS (U.S. CLS. 100, 101 AND 102).

FIRST USE 9-26-2011; IN COMMERCE 9-26-2011.

KRISTINA MORRIS, EXAMINING ATTORNEY

ECO SAMMY

THE MARK CONSISTS OF STANDARD CHARACTERS WITHOUT CLAIM TO ANY PARTICULAR FONT, STYLE, SIZE, OR COLOR.

NO CLAIM IS MADE TO THE EXCLUSIVE RIGHT TO USE "ECO", APART FROM THE MARK AS SHOWN.

THE NAME(S), PORTRAIT(S), AND/OR SIGNATURE(S) SHOWN IN THE MARK DOES NOT IDENTIFY A PARTICULAR LIVING INDIVIDUAL.

FOR ON-LINE RETAIL STORE SERVICES FEATURING A WIDE VARIETY OF CONSUMER GOODS OF OTHERS; PROVIDING CONSUMER INFORMATION IN THE FIELD OF ECO-FRIENDLY TOPICS (U.S. CLS. 100, 101 AND 102).

NELSON SNYDER, EXAMINING ATTORNEY

SN 85-496,047. TOUCH OF BRASS FURNITURE GALLERY, INC., EDGEWOOD, KY. FILED 12-15-2011.

DESIGN WITH US FURNITURE

THE MARK CONSISTS OF STANDARD CHARACTERS WITHOUT CLAIM TO ANY PARTICULAR FONT, STYLE, SIZE, OR COLOR.

NO CLAIM IS MADE TO THE EXCLUSIVE RIGHT TO USE "FURNITURE", APART FROM THE MARK AS SHOWN.

FOR COMPUTERIZED ON-LINE RETAIL STORE SERVICES IN THE FIELD OF FURNITURE AND HOME FURNISHINGS (U.S. CLS. 100, 101 AND 102).

FIRST USE 11-1-2011; IN COMMERCE 11-1-2011.

DOMINIC J. FERRAIUOLO, EXAMINING ATTORNEY

CLASS 35—(Continued).

SN 85-497,178. SHORT LEASH, LLC, DENVER, CO. FILED 12-16-2011.



THE NAME(S), PORTRAIT(S), AND/OR SIGNATURE(S) SHOWN IN THE MARK IDENTIFIES "DAVE LOGAN", WHOSE CONSENT(S) TO REGISTER IS MADE OF RECORD.

THE MARK CONSISTS OF THE STYLIZED TERM "TEAM" PLACED VERTICALLY NEXT TO THE HORIZONTAL PLACEMENT OF THE NAME "DAVE" ABOVE THE NAME "LOGAN.COM".

FOR ON-LINE ADVERTISING SERVICES FOR OTHERS; REFERRALS IN THE FIELD OF HOME IMPROVEMENT SERVICES, HOME DECOR AND FURNITURE PRODUCTS, REAL ESTATE AND FINANCIAL SERVICES (U.S. CLS. 100, 101 AND 102).

FIRST USE 11-2-2008; IN COMMERCE 6-2-2009.
CHRISTOPHER BUONGIORNO, EXAMINING ATTORNEY

SN 85-497,584. VIOLETA RADENOVICH, M.D., P.A., DBA THE CHILDREN'S EYE CENTER OF EL PASO, EL PASO, TX. FILED 12-16-2011.



NO CLAIM IS MADE TO THE EXCLUSIVE RIGHT TO USE "CHILDREN'S OPTICAL", APART FROM THE MARK AS SHOWN.

THE COLOR(S) BLUE AND BLACK IS/ARE CLAIMED AS A FEATURE OF THE MARK.

THE MARK CONSISTS OF THE WORDING "THE CHILDREN'S OPTICAL" IN BLUE WITH A CHILD IN BLACK GRABBING THE LETTER "C" OF "CHILDREN'S" AND A CHILD IN BLACK GRABBING THE LETTER "S" OF "CHILDREN'S". THERE IS A PAIR OF GLASSES IN BLACK TO THE LEFT OF THE WORD "OPTICAL".

FOR RETAIL OPTICAL STORE SERVICES (U.S. CLS. 100, 101 AND 102).

FIRST USE 10-15-2009; IN COMMERCE 10-15-2009.
DAVID ELTON, EXAMINING ATTORNEY

CLASS 35—(Continued).

SN 85-497,642. VICERE ASSOCIATES, INC., PETERSBURG, PA. FILED 12-16-2011.

DIRECTION AND ALIGNMENT ASSESSMENT (DNA)

THE MARK CONSISTS OF STANDARD CHARACTERS WITHOUT CLAIM TO ANY PARTICULAR FONT, STYLE, SIZE, OR COLOR.

NO CLAIM IS MADE TO THE EXCLUSIVE RIGHT TO USE "ASSESSMENT", APART FROM THE MARK AS SHOWN.

FOR BUSINESS MANAGEMENT CONSULTING AND ADVISORY SERVICES (U.S. CLS. 100, 101 AND 102).

FIRST USE 2-1-2001; IN COMMERCE 2-1-2001.
FLORENTINA BLANDU, EXAMINING ATTORNEY

SN 85-497,714. VICERE ASSOCIATES, INC., PETERSBURG, PA. FILED 12-16-2011.

LIFECYCLE-CULTURE MATRIX

THE MARK CONSISTS OF STANDARD CHARACTERS WITHOUT CLAIM TO ANY PARTICULAR FONT, STYLE, SIZE, OR COLOR.

NO CLAIM IS MADE TO THE EXCLUSIVE RIGHT TO USE "MATRIX", APART FROM THE MARK AS SHOWN.

FOR BUSINESS MANAGEMENT CONSULTING AND ADVISORY SERVICES (U.S. CLS. 100, 101 AND 102).

FIRST USE 8-31-2002; IN COMMERCE 8-31-2002.
FLORENTINA BLANDU, EXAMINING ATTORNEY

SN 85-497,750. VICERE ASSOCIATES, INC., PETERSBURG, PA. FILED 12-16-2011.

SHADOW PYRAMID

THE MARK CONSISTS OF STANDARD CHARACTERS WITHOUT CLAIM TO ANY PARTICULAR FONT, STYLE, SIZE, OR COLOR.

FOR BUSINESS MANAGEMENT ASSESSMENT AND CONSULTATION SERVICES RELATIVE TO THE SELECTION AND IMPLEMENTATION OF BUSINESS OPERATIONAL STRUCTURAL FORMS (U.S. CLS. 100, 101 AND 102).

FIRST USE 1-1-1992; IN COMMERCE 1-1-1992.
FLORENTINA BLANDU, EXAMINING ATTORNEY

CLASS 35—(Continued).

SN 85-498,111. BISOGNO, JOSEPH J., DE SOTO, KY. FILED 12-17-2011.

SOS Solutions Group

THE MARK CONSISTS OF STANDARD CHARACTERS WITHOUT CLAIM TO ANY PARTICULAR FONT, STYLE, SIZE, OR COLOR.

NO CLAIM IS MADE TO THE EXCLUSIVE RIGHT TO USE "SOLUTIONS GROUP", APART FROM THE MARK AS SHOWN.

FOR BUSINESS CONSULTATION AND MANAGEMENT REGARDING MARKETING ACTIVITIES AND LAUNCHING OF NEW PRODUCTS; BUSINESS CONSULTATION IN THE FIELD OF TELECOMMUNICATIONS EXPENSE MANAGEMENT; BUSINESS CONSULTATION SERVICES; BUSINESS CONSULTING AND BUSINESS INFORMATION FOR ENTERPRISES; BUSINESS CONSULTING AND INFORMATION SERVICES; BUSINESS CONSULTING SERVICES RELATED TO MONITORING, CONTROLLING, AND MANAGING TELEPRESENCE ENVIRONMENTS OF OTHERS; BUSINESS CONSULTING SERVICES RELATING TO THE INTEGRATION OF THE AREAS OF BUSINESS PROCESS TECHNOLOGY, ORGANIZATIONAL LEARNING, CHANGE MANAGEMENT, AND OPERATIONAL SUSTAINABILITY; BUSINESS CONSULTING SERVICES, NAMELY, PROVIDING ASSISTANCE IN DEVELOPMENT OF BUSINESS STRATEGIES AND CREATIVE IDEATION; BUSINESS CONSULTING, INQUIRIES OR INFORMATION; PROFESSIONAL BUSINESS CONSULTATION (U.S. CLS. 100, 101 AND 102).

FIRST USE 11-22-2011; IN COMMERCE 11-22-2011.
BRIDGETT SMITH, EXAMINING ATTORNEY

SN 85-498,245. ALO GROUP, LLC, RIDGEWOOD, NJ. FILED 12-18-2011.



THE COLOR(S) GRAY, BLUE, BLACK IS/ARE CLAIMED AS A FEATURE OF THE MARK.

THE MARK CONSISTS OF THE WORDING "PROVIEW", WITH "PRO" IN GRAY AND "VIEW" IN BLUE. UNDERNEATH THE TERM "PROVIEW" IS THE WORDING "MEASURINGEFFECTIVENESS" WITH "MEASURING" IN BLUE AND "EFFECTIVENESS" IN BLACK. THE LETTER "O" IN "PROVIEW" APPEARS AS A GRAPHIC OF A GRAY AND BLUE COMPASS.

FOR CONDUCTING BUSINESS AND MARKET RESEARCH SURVEYS (U.S. CLS. 100, 101 AND 102).

ALYSSA STEEL, EXAMINING ATTORNEY

CLASS 35—(Continued).

SN 85-498,331. YEUNG, TAK SHING, PORTLAND, OR. FILED 12-19-2011.

COMP AND SAVE

THE MARK CONSISTS OF STANDARD CHARACTERS WITHOUT CLAIM TO ANY PARTICULAR FONT, STYLE, SIZE, OR COLOR.

FOR ONLINE RETAIL STORE SERVICES FEATURING INKJETS, LASER TONERS, PRINTER AND COMPUTER RELATED ACCESSORIES, INCLUDING PHOTO PAPER AND SIGN SUPPLY (U.S. CLS. 100, 101 AND 102).

FIRST USE 10-15-2004; IN COMMERCE 10-15-2004.

MYRIAH HABEEB, EXAMINING ATTORNEY

SN 85-498,544. PROFESSIONAL SURVIVAL GROUP, WARREN, NJ. FILED 12-19-2011.

Professional Survival Group

THE MARK CONSISTS OF STANDARD CHARACTERS WITHOUT CLAIM TO ANY PARTICULAR FONT, STYLE, SIZE, OR COLOR.

NO CLAIM IS MADE TO THE EXCLUSIVE RIGHT TO USE "PROFESSIONAL" OR "GROUP", APART FROM THE MARK AS SHOWN.

FOR BUSINESS TO BUSINESS EXCHANGE SERVICES, NAMELY, MATCHING SMALL BUSINESS CONSUMERS WITH PROFESSIONALS IN THE FIELD OF COMMERCIAL SERVICES VIA COMPUTER NETWORK (U.S. CLS. 100, 101 AND 102).

ALYSSA STEEL, EXAMINING ATTORNEY

SN 85-499,471. AGORA STRATEGIES LTD., LONDON, UNITED KINGDOM, FILED 12-20-2011.

THE SOVEREIGNTY INDEX

THE MARK CONSISTS OF STANDARD CHARACTERS WITHOUT CLAIM TO ANY PARTICULAR FONT, STYLE, SIZE, OR COLOR.

NO CLAIM IS MADE TO THE EXCLUSIVE RIGHT TO USE "INDEX", APART FROM THE MARK AS SHOWN.

FOR PROVIDING CONSULTING, RESEARCH, ANALYSIS, AND ADVISORY SERVICES TO ASSIST AND EDUCATE GOVERNMENTS, BUSINESS ENTITIES, COUNTRIES, AND NATIONS, IN THE FIELDS OF GLOBAL ECONOMIC FORECASTING, POLITICAL, AND SOCIOECONOMIC CHANGE; COMPILING, ANALYZING AND PROVIDING DATA PERTAINING TO GLOBAL ECONOMIC FORECASTING, POLITICAL, AND SOCIOECONOMIC CHANGE (U.S. CLS. 100, 101 AND 102).

SANDRA BUJA, EXAMINING ATTORNEY

CLASS 35—(Continued).

SN 85-499,932. LEAD GENERATION TECHNOLOGIES, INC., TEMECULA, CA. FILED 12-20-2011.

**CARITAS SENIOR HOUSING
NETWORK**

THE MARK CONSISTS OF STANDARD CHARACTERS WITHOUT CLAIM TO ANY PARTICULAR FONT, STYLE, SIZE, OR COLOR.

NO CLAIM IS MADE TO THE EXCLUSIVE RIGHT TO USE "SENIOR HOUSING NETWORK", APART FROM THE MARK AS SHOWN.

THE ENGLISH TRANSLATION OF "CARITAS" IS "LOVE FOR ALL".

FOR PROVIDING REFERRALS IN THE FIELD OF ELDERLY CARE (U.S. CLS. 100, 101 AND 102).

FIRST USE 9-1-2011; IN COMMERCE 9-1-2011.

BRIAN PINO, EXAMINING ATTORNEY

SN 85-500,277. STAIRWAY ENTERTAINMENT, LLC, MARINA DEL RAY, CA. FILED 12-20-2011.

STAIRWAY ENTERTAINMENT

THE MARK CONSISTS OF STANDARD CHARACTERS WITHOUT CLAIM TO ANY PARTICULAR FONT, STYLE, SIZE, OR COLOR.

NO CLAIM IS MADE TO THE EXCLUSIVE RIGHT TO USE "ENTERTAINMENT", APART FROM THE MARK AS SHOWN.

FOR MANAGEMENT OF PERFORMING AND RECORDING ARTISTS; PERSONAL MANAGEMENT SERVICES FOR ENTERTAINERS; PERSONAL MANAGEMENT SERVICES FOR MUSICAL PERFORMERS; TALENT AGENCIES; TALENT AGENCIES FOR MUSICAL ARTISTS (U.S. CLS. 100, 101 AND 102).

FIRST USE 6-10-2011; IN COMMERCE 6-10-2011.

BRETT J. GOLDEN, EXAMINING ATTORNEY

CLASS 35—(Continued).

SN 85-500,430. TYREUS, PER, LANDENBERG, PA. FILED 12-20-2011.



THE MARK CONSISTS OF A DARK CIRCLE AROUND A LIGHT DOTTED CONCENTRIC CIRCLE WITH ANOTHER DARK CIRCLE WITH THE STYLIZED LETTERS "FZ" CENTERED INSIDE AND THE LETTERS "FRIENDZ" PROJECTED TO THE RIGHT.

FOR ADVERTISING AND MARKETING SERVICES PROVIDED BY MEANS OF INDIRECT METHODS OF MARKETING COMMUNICATIONS, NAMELY, SOCIAL MEDIA, SEARCH ENGINE MARKETING, INQUIRY MARKETING, INTERNET MARKETING, MOBILE MARKETING, BLOGGING AND OTHER FORMS OF PASSIVE, SHARABLE OR VIRAL COMMUNICATIONS CHANNELS; ADVERTISING, MARKETING AND PROMOTIONAL SERVICES RELATED TO ALL INDUSTRIES FOR THE PURPOSE OF FACILITATING NETWORKING AND SOCIALIZING OPPORTUNITIES FOR BUSINESS PURPOSES; ONLINE SERVICE FOR CONNECTING SOCIAL NETWORK USERS WITH RETAILERS FOR THE PURPOSE OF FACILITATING DISCOUNTED PURCHASES; PROVIDING A WEBSITE FOR USERS WITH SPECIFIC INFORMED RECOMMENDATIONS OF SPECIFIC CONSUMER PRODUCTS AND SERVICES VALIDATED BY THE USERS' INPUTTED PREFERENCES AND SOCIAL NETWORK; PROVIDING AN ONLINE MARKETING COLLABORATION NETWORK FOR SOCIAL MEDIA AND ONLINE MARKETING PROFESSIONALS FOR THE PURPOSE OF SYNDICATING CONTENT THROUGH THE NETWORK TO BE SHARED BY OTHERS; SOCIAL MEDIA STRATEGY AND MARKETING CONSULTANCY FOCUSING ON HELPING CLIENTS CREATE AND EXTEND THEIR PRODUCT AND BRAND STRATEGIES BY BUILDING VIRALLY ENGAGING MARKETING SOLUTIONS (U.S. CLS. 100, 101 AND 102).

FIRST USE 3-7-2011; IN COMMERCE 3-7-2011.

KARANENDRA S. CHHINA, EXAMINING ATTORNEY

SN 85-500,487. ENVIROPACK LLC, DBA ENVIROPACK, LONGWOOD, FL. FILED 12-21-2011.

**Making it Easier to be
Green**

THE MARK CONSISTS OF STANDARD CHARACTERS WITHOUT CLAIM TO ANY PARTICULAR FONT, STYLE, SIZE, OR COLOR.

FOR FRANCHISING, NAMELY, OFFERING BUSINESS MANAGEMENT ASSISTANCE IN THE ESTABLISHMENT AND/OR OPERATION OF BUSINESSES FOR GREEN CONSULTING IN THE FIELDS OF SOLAR ENERGY FOR HOMES AND BUSINESSES, WIND ENERGY, RAINWATER AND STORMWATER HARVESTING AND RECYCLING OF COMMERCIAL PLASTIC FILM (U.S. CLS. 100, 101 AND 102).

FIRST USE 7-12-2011; IN COMMERCE 7-12-2011.

MARGERY A. TIERNEY, EXAMINING ATTORNEY

CLASS 35—(Continued).

SN 85-500,531. MPAC CARD, LLC, GULF SHORES, AL. FILED 12-21-2011.



NO CLAIM IS MADE TO THE EXCLUSIVE RIGHT TO USE "CARD", APART FROM THE MARK AS SHOWN.

THE COLOR(S) BLACK, ORANGE, GRAY IS/ARE CLAIMED AS A FEATURE OF THE MARK.

THE MARK CONSISTS OF THE STYLIZED LETTERS "MPAC CARD" ON A BLACK BACKGROUND, WITH THE LETTER "M" BEING BLACK WITHIN A SOLID ORANGE CIRCLE AND THE LETTERS "PAC" BEING ORANGE ON THE BLACK BACKGROUND, AND THE LETTERS "CARD" BEING GRAY ALL ON THE BLACK BACKGROUND.

FOR PROMOTING THE GOODS AND SERVICES OF OTHERS THROUGH THE DISTRIBUTION OF DISCOUNT CARDS (U.S. CLS. 100, 101 AND 102).

FIRST USE 11-15-2011; IN COMMERCE 11-15-2011.
CHARLOTTE CORWIN, EXAMINING ATTORNEY

CLASS 35—(Continued).

SN 85-500,797. AMERICAN WATER AND ENERGY SAVERS, BOCA RATON, FL. FILED 12-21-2011.



NO CLAIM IS MADE TO THE EXCLUSIVE RIGHT TO USE "TREND ANALYSIS BILLING SYSTEM", APART FROM THE MARK AS SHOWN.

THE STIPPLING IS FOR SHADING PURPOSES ONLY.

THE MARK CONSISTS OF THE LETTERS "T.A.B.S." WITH A CIRCLE FORMING THE HORIZONTAL PORTION OF THE LETTER "A"; INSIDE OF THE CIRCLE ARE THE STYLIZED LETTERS "AW", SUPERIMPOSED OVER ONE ANOTHER; BELOW THE LETTERS "T.A.B.S." THERE IS A HORIZONTAL LINE UNDERNEATH WHICH IS THE STYLIZED TEXT "TREND ANALYSIS BILLING SYSTEM".

FOR BILLING (U.S. CLS. 100, 101 AND 102).

FIRST USE 5-1-2009; IN COMMERCE 5-1-2009.

JOHN GARTNER, EXAMINING ATTORNEY

SN 85-500,669. JONES SR., NYLES KELLEY, LA PORTE, TX. FILED 12-21-2011.

ROADDAWG

THE MARK CONSISTS OF STANDARD CHARACTERS WITHOUT CLAIM TO ANY PARTICULAR FONT, STYLE, SIZE, OR COLOR.

OWNER OF U.S. REG. NOS. 3,152,036, 3,413,405 AND 3,413,406.

FOR ASSOCIATION SERVICES, NAMELY, PROMOTING PUBLIC AWARENESS ABOUT THE DANGERS OF DRINKING AND DRIVING AND THE IMPORTANCE OF DESIGNATED DRIVERS (U.S. CLS. 100, 101 AND 102).

FIRST USE 12-0-2004; IN COMMERCE 12-0-2004.
LINDA ORNDORFF, EXAMINING ATTORNEY

SN 85-500,830. KW SAVINGS CO, CAYCE, SC. FILED 12-21-2011.



THE COLOR(S) RED, YELLOW, BLUE, BLACK, BROWN, AND WHITE IS/ARE CLAIMED AS A FEATURE OF THE MARK.

THE MARK CONSISTS OF THE WORDS "HELP MY HOUSE!" IN RED STYLIZED SHADOW BLOCK TEXT WITH THE WORD "HELP" ABOVE THE WORD "MY" ABOVE THE WORD "HOUSE!" EXTENDING THREE LINES HIGH. THE STYLIZED DESIGN OF A THREE DIMENSIONAL HOUSE IS ADJACENT TO THE RIGHT SIDE OF THE SECOND LINE OF TEXT ABOVE THE WORD "HOUSE!" AND CONSISTS OF A YELLOW FRONT WALL, BROWN DOOR WITH BLACK DOORKNOB, BROWN CHIMNEY, RED ROOF, AND BLUE WALL WITH A CENTRAL WHITE WINDOW, ALL OUTLINED IN BLACK. BELOW THE WORD "HOUSE!" IS THE SLOGAN "SHAPE UP YOUR HOME FOR ENERGY SAVINGS" WHICH APPEARS IN BLACK.

FOR INFORMATION IN THE FIELD OF ENERGY EFFICIENCY; PROMOTING THE ENERGY EFFICIENT PRODUCTS AND SERVICES OF OTHERS; PROVISION OF INFORMATION, ADVICE AND CONSULTANCY IN RELATION TO ENERGY EFFICIENCY; PUBLIC ADVOCACY TO PROMOTE AWARENESS OF ENERGY EFFICIENCY (U.S. CLS. 100, 101 AND 102).

FIRST USE 6-1-2009; IN COMMERCE 6-1-2009.

JENNIFER WILLISTON, EXAMINING ATTORNEY

SN 85-500,698. KULE, LLC, NEW YORK, NY. FILED 12-21-2011.

KULE

THE MARK CONSISTS OF STANDARD CHARACTERS WITHOUT CLAIM TO ANY PARTICULAR FONT, STYLE, SIZE, OR COLOR.

OWNER OF U.S. REG. NOS. 3,350,076 AND 4,076,588. FOR RETAIL APPAREL STORES (U.S. CLS. 100, 101 AND 102).

NELSON SNYDER, EXAMINING ATTORNEY

CLASS 35—(Continued).

SN 85-501,145. TECHATLAS GROUP, LLC, BOSTON, MA. FILED 12-21-2011.

TECHATLAS GROUP

THE MARK CONSISTS OF STANDARD CHARACTERS WITHOUT CLAIM TO ANY PARTICULAR FONT, STYLE, SIZE, OR COLOR.

NO CLAIM IS MADE TO THE EXCLUSIVE RIGHT TO USE "GROUP", APART FROM THE MARK AS SHOWN.

FOR MARKET RESEARCH AND ANALYSIS SERVICES; PROVISION OF MARKET RESEARCH INFORMATION (U.S. CLS. 100, 101 AND 102).

FIRST USE 12-12-2011; IN COMMERCE 12-12-2011.

ROBIN MITTLER, EXAMINING ATTORNEY

CLASS 35—(Continued).

SN 85-501,531. WESTERHOFF, ANGELIKA, GERMANTOWN, NY. FILED 12-21-2011.

A. Westerhoff Antiques

THE MARK CONSISTS OF STANDARD CHARACTERS WITHOUT CLAIM TO ANY PARTICULAR FONT, STYLE, SIZE, OR COLOR.

NO CLAIM IS MADE TO THE EXCLUSIVE RIGHT TO USE "ANTIQUES", APART FROM THE MARK AS SHOWN.

THE NAME "A. WESTERHOFF" IDENTIFIES A LIVING INDIVIDUAL WHOSE CONSENT IS OF RECORD.

FOR RETAIL STORE SERVICES FEATURING ANTIQUES (U.S. CLS. 100, 101 AND 102).

FIRST USE 1-0-1990; IN COMMERCE 1-0-1990.

LINDA M. KING, EXAMINING ATTORNEY

SN 85-501,465. THE NUT BOY INC., TEHACHAPI, CA. FILED 12-21-2011.



NO CLAIM IS MADE TO THE EXCLUSIVE RIGHT TO USE "NUT", APART FROM THE MARK AS SHOWN.

THE MARK CONSISTS OF AN IMAGE OF A YOUNG BOY WITH THICK HEAD OF HAIR LIKE DAGWOOD BUMSTEAD WITH A BIG COWL LICK IN FRONT AND BACK OF HEAD, GOOFY SMILE, AND FRECKLES. THE HEAD IS INSIDE A DOUBLE CIRCLE WITH THE WORDS "THE NUT BOY" IN A SEMI CIRCLE UNDER THE HEAD OF THE BOY. THE WORDS ARE SEPARATED BY SMALL PEANUTS.

FOR WHOLESALE DISTRIBUTORSHIPS FEATURING FRUITS AND NUTS (U.S. CLS. 100, 101 AND 102).

FIRST USE 2-0-1989; IN COMMERCE 2-0-1989.

MARK T. MULLEN, EXAMINING ATTORNEY

SN 85-501,900. QUARLES PETROLEUM, INC., FREDERICKSBURG, VA. FILED 12-22-2011.

QUARLES FLEET FUELING

THE MARK CONSISTS OF STANDARD CHARACTERS WITHOUT CLAIM TO ANY PARTICULAR FONT, STYLE, SIZE, OR COLOR.

OWNER OF U.S. REG. NOS. 3,930,815, 3,943,405 AND OTHERS.

NO CLAIM IS MADE TO THE EXCLUSIVE RIGHT TO USE "FLEET FUELING", APART FROM THE MARK AS SHOWN.

SEC. 2(F) AS TO "QUARLES".

FOR RETAIL GASOLINE SUPPLY SERVICES FOR VEHICLE FLEET OWNERS; VEHICLE FLEET MANAGEMENT SERVICES FOR VEHICLE FLEET OWNERS IN THE NATURE OF TRACKING OF VEHICLES FOR COMMERCIAL PURPOSES; LOGISTICS MANAGEMENT IN THE FIELD OF COMMERCIAL VEHICLE FLEETS; PREPARING BUSINESS REPORTS FOR THE TRANSPORTATION AND VEHICLE FLEET INDUSTRIES; ADMINISTRATION OF A MEMBERSHIP PROGRAM FOR ENABLING PARTICIPANTS TO RECEIVE IMPROVED SERVICES THROUGH USE OF A MEMBERSHIP CARD (U.S. CLS. 100, 101 AND 102).

FIRST USE 10-28-2011; IN COMMERCE 10-28-2011.

HEATHER BIDDULPH, EXAMINING ATTORNEY

CLASS 35—(Continued).

SN 85-502,085. ATTRACTION MARKETING FORMULA, LLC, MONROVIA, CA. FILED 12-22-2011.

SEO Networker

THE MARK CONSISTS OF STANDARD CHARACTERS WITHOUT CLAIM TO ANY PARTICULAR FONT, STYLE, SIZE, OR COLOR.

NO CLAIM IS MADE TO THE EXCLUSIVE RIGHT TO USE "SEO", APART FROM THE MARK AS SHOWN.

FOR BRANDING SERVICES, NAMELY, CONSULTING, DEVELOPMENT, MANAGEMENT AND MARKETING OF BRANDS FOR BUSINESSES (U.S. CLS. 100, 101 AND 102).

FIRST USE 8-1-2008; IN COMMERCE 8-1-2008.
MARIA-VICTORIA SUAREZ, EXAMINING ATTORNEY

CLASS 35—(Continued).

SN 85-502,937. BEDI, SATVINDER S., JACKSON, MS. FILED 12-23-2011.

Fuel Time

THE MARK CONSISTS OF STANDARD CHARACTERS WITHOUT CLAIM TO ANY PARTICULAR FONT, STYLE, SIZE, OR COLOR.

NO CLAIM IS MADE TO THE EXCLUSIVE RIGHT TO USE "FUEL", APART FROM THE MARK AS SHOWN.

FOR RETAIL STORE SERVICES FEATURING CONVENIENCE STORE ITEMS AND GASOLINE (U.S. CLS. 100, 101 AND 102).

FIRST USE 2-0-2005; IN COMMERCE 12-0-2005.
MARILYN IZZI, EXAMINING ATTORNEY

SN 85-503,512. FIGUEROA, ERIC J., AVENTURA, FL. FILED 12-23-2011.

Yeah Baby

THE MARK CONSISTS OF STANDARD CHARACTERS WITHOUT CLAIM TO ANY PARTICULAR FONT, STYLE, SIZE, OR COLOR.

OWNER OF U.S. REG. NO. 4,083,983.

FOR ADVERTISING AGENCIES; ADVERTISING AND MARKETING; ADVERTISING AND PUBLICITY SERVICES, NAMELY, PROMOTING THE GOODS, SERVICES, BRAND IDENTITY AND COMMERCIAL INFORMATION AND NEWS OF THIRD PARTIES THROUGH PRINT, AUDIO, VIDEO, DIGITAL AND ON-LINE MEDIUM (U.S. CLS. 100, 101 AND 102).

FIRST USE 8-22-2010; IN COMMERCE 8-22-2010.
TRACY CROSS, EXAMINING ATTORNEY

SN 85-502,706. ART.COM, INC., EMERYVILLE, CA. FILED 12-22-2011.

LIFE IS HOW YOU FRAME IT. ART.COM

THE MARK CONSISTS OF STANDARD CHARACTERS WITHOUT CLAIM TO ANY PARTICULAR FONT, STYLE, SIZE, OR COLOR.

OWNER OF U.S. REG. NOS. 2,586,749, 3,110,895 AND 3,601,346.

SEC. 2(F) AS TO "ART.COM".

FOR CATALOG ORDERING SERVICE FEATURING ART, FINE ART REPRODUCTIONS, FINE ART PRINTS, LITHOGRAPHS, ETCHINGS, WOOD-CUTS, ART PRINTS, DRAWINGS, GRAPHIC ART IMAGES, POSTERS, WALL DECOR, ART REPRODUCTIONS, FILM CELLS, PHOTOGRAPHS, MURALS, SIGNS, PLAQUES, TAPESTRIES, MAGNETS, MIRRORS, CALENDARS, POSTCARDS, NOTECARDS, NOTEBOOKS, ART FRAMES, AND T-SHIRTS; ON-LINE RETAIL STORE SERVICES FEATURING ART, FINE ART REPRODUCTIONS, FINE ART PRINTS, LITHOGRAPHS, ETCHINGS, WOOD-CUTS, ART PRINTS, DRAWINGS, GRAPHIC ART IMAGES, POSTERS, WALL DECOR, ART REPRODUCTIONS, FILM CELLS, PHOTOGRAPHS, MURALS, SIGNS, PLAQUES, TAPESTRIES, MAGNETS, MIRRORS, CALENDARS, POSTCARDS, NOTECARDS, NOTEBOOKS, ART FRAMES, AND T-SHIRTS (U.S. CLS. 100, 101 AND 102).

GILBERT SWIFT, EXAMINING ATTORNEY

SN 85-503,715. TALISMAN LBS, LLC, HONOLULU, HI. FILED 12-26-2011.

MILAN MARKETPLACE

THE MARK CONSISTS OF STANDARD CHARACTERS WITHOUT CLAIM TO ANY PARTICULAR FONT, STYLE, SIZE, OR COLOR.

FOR BUSINESS MONITORING AND CONSULTING SERVICES, NAMELY, TRACKING WEB SITES AND APPLICATIONS OF OTHERS TO PROVIDE STRATEGY, INSIGHT, OPERATION, PRODUCT DESIGN, PARTICULARLY SPECIALIZING IN THE USE OF ANALYTIC AND STATISTIC MODELS FOR THE UNDERSTANDING AND PREDICTING OF CONSUMERS, BUSINESSES, AND MARKET TRENDS AND ACTIONS (U.S. CLS. 100, 101 AND 102).

FIRST USE 11-15-2010; IN COMMERCE 10-10-2011.
APRIL ROACH, EXAMINING ATTORNEY

CLASS 35—(Continued).

SN 85-503,928. MINISTRY CONSULTANTS, INC., ALLEN, TX. FILED 12-27-2011.

ALL IN FOR ALLEN

THE MARK CONSISTS OF STANDARD CHARACTERS WITHOUT CLAIM TO ANY PARTICULAR FONT, STYLE, SIZE, OR COLOR.

NO CLAIM IS MADE TO THE EXCLUSIVE RIGHT TO USE "ALLEN", APART FROM THE MARK AS SHOWN.

FOR BUSINESS DEVELOPMENT SERVICES; MARKETING SERVICES, NAMELY, PROMOTING OR ADVERTISING THE GOODS AND SERVICES OF OTHERS; POLITICAL PARTY SERVICES, NAMELY, PROMOTING THE INTERESTS OF A POLITICAL ORGANIZATION; PROMOTION AND MARKETING SERVICES AND RELATED CONSULTING (U.S. CLS. 100, 101 AND 102).
PRISCILLA MILTON, EXAMINING ATTORNEY

SN 85-504,287. MONTEREY BAY BOUQUET ACQUISITION PARTNERS, LLC, WATSONVILLE, CA. FILED 12-27-2011.



NO CLAIM IS MADE TO THE EXCLUSIVE RIGHT TO USE "BAY AREA BOUQUET", APART FROM THE MARK AS SHOWN.

THE MARK CONSISTS OF THE STYLIZED DESIGN OF BUILDING ON GRASS WITH THE SHADOW OF THE BUILDING IN FRONT OF IT AND THE SKY IN THE BACKGROUND, WITH CLOUD BEHIND THE BUILDING AND TO THE RIGHT OF THE BUILDING, AND TWO FLOWERS AND A LEAF COMING OUT OF THE TOP OF THE BUILDING, ALL SET WITHIN A RECTANGLE, TO THE LEFT OF THE WORDS "BAY AREA BOUQUET" IN ALL CAPS, UNDERLINED.

FOR MARKETING AND DISTRIBUTORSHIP OF FRESH FLOWERS (U.S. CLS. 100, 101 AND 102).

FIRST USE 5-31-2001; IN COMMERCE 5-31-2001.

HEATHER THOMPSON, EXAMINING ATTORNEY

CLASS 35—(Continued).

SN 85-504,502. LA TRUCHA SERVICES INC, SALINAS, CA. FILED 12-27-2011.

La Trucha Income Tax

THE MARK CONSISTS OF STANDARD CHARACTERS WITHOUT CLAIM TO ANY PARTICULAR FONT, STYLE, SIZE, OR COLOR.

NO CLAIM IS MADE TO THE EXCLUSIVE RIGHT TO USE "INCOME TAX", APART FROM THE MARK AS SHOWN.

THE ENGLISH TRANSLATION OF "LA TRUCHA" IN THE MARK IS "THE TROUT".

FOR INCOME TAX PREPARATION (U.S. CLS. 100, 101 AND 102).

FIRST USE 7-0-2011; IN COMMERCE 7-0-2011.

THOMAS MANOR, EXAMINING ATTORNEY

SN 85-504,638. CORAL HOSPITALITY, LLC, NAPLES, FL. FILED 12-28-2011.

CORAL HOSPITALITY

THE MARK CONSISTS OF STANDARD CHARACTERS WITHOUT CLAIM TO ANY PARTICULAR FONT, STYLE, SIZE, OR COLOR.

NO CLAIM IS MADE TO THE EXCLUSIVE RIGHT TO USE "HOSPITALITY", APART FROM THE MARK AS SHOWN.

FOR MANAGEMENT OF HOTELS AND HOTEL RESORTS FOR OTHERS; BUSINESS MANAGEMENT OF HOMEOWNERS ASSOCIATIONS FOR OTHERS; BUSINESS MANAGEMENT OF GOLF AND COUNTRY CLUBS FOR OTHERS (U.S. CLS. 100, 101 AND 102).

FIRST USE 5-24-2004; IN COMMERCE 5-24-2004.

KELLEY WELLS, EXAMINING ATTORNEY

SN 85-504,643. CORAL HOSPITALITY, LLC, NAPLES, FL. FILED 12-28-2011.

EXPERIENCED IN SUCCESS

THE MARK CONSISTS OF STANDARD CHARACTERS WITHOUT CLAIM TO ANY PARTICULAR FONT, STYLE, SIZE, OR COLOR.

FOR MANAGEMENT OF HOTELS AND HOTEL RESORTS FOR OTHERS; BUSINESS MANAGEMENT OF HOMEOWNERS ASSOCIATIONS FOR OTHERS; BUSINESS MANAGEMENT OF GOLF AND COUNTRY CLUBS FOR OTHERS (U.S. CLS. 100, 101 AND 102).

FIRST USE 12-22-2011; IN COMMERCE 12-22-2011.

KELLEY WELLS, EXAMINING ATTORNEY

CLASS 35—(Continued).

SN 85-504,843. YOUNG, GREGG WHEELER, AUSTIN, TX. FILED 12-28-2011.



THE COLOR(S) LIGHT GREEN, DARK GREEN, AND WHITE IS/ARE CLAIMED AS A FEATURE OF THE MARK. THE MARK CONSISTS OF A GREEN SQUARE WITH CURVED CORNERS WITH THE UPPER PORTION A LIGHTER GREEN AND THE LOWER PORTION A DARKER GREEN CONTAINING A WHITE DOLLAR SIGN "\$" WITH THE WHITE TERM, "QPONS" BELOW.

FOR ADMINISTRATION OF A DISCOUNT PROGRAM FOR ENABLING PARTICIPANTS TO OBTAIN DISCOUNTS ON GOODS AND SERVICES THROUGH USE OF A DISCOUNT MEMBERSHIP CARD; ADMINISTRATION OF A DISCOUNT PROGRAM FOR ENABLING PARTICIPANTS TO OBTAIN DISCOUNTS ON THE COST OF SERVICES OR RECEIVE IMPROVED SERVICES THROUGH USE OF A MEMBERSHIP CARD; ADMINISTRATION OF A PROGRAM FOR ENABLING PARTICIPANTS TO OBTAIN DISCOUNTS ON GOODS AND RECEIVE IMPROVED SERVICES; ADMINISTRATION OF A PROGRAM FOR ENABLING PARTICIPANTS TO OBTAIN DISCOUNTS ON PRODUCTS AND SERVICES; ADMINISTRATION OF A PROGRAM FOR ENABLING PARTICIPANTS TO OBTAIN DISCOUNTS ON THE COST OF SERVICES OR RECEIVE IMPROVED SERVICES; ADVERTISING AGENCIES, NAMELY, PROMOTING THE SERVICES OF RESTAURANTS, BARS, AUTO DEALERS, BANKS, BEAUTY AND SPA CENTERS, SPORTS FACILITIES THROUGH THE DISTRIBUTION OF PRINTED AND AUDIO PROMOTIONAL MATERIALS AND BY RENDERING SALES PROMOTION ADVICE; ADVERTISING SERVICES, NAMELY, PROMOTING PROPERTIES FOR SALE BY OWNER VIA THE INTERNET; AN INTERACTIVE WEB SITE FOR USERS TO REVIEW AND RATE INTERNET CONTENT, PEOPLE, COMPANIES, PRODUCTS AND/OR SERVICES UTILIZING A SOFTWARE APPLICATION TO AWARD POINTS WHEREBY WEB SITE USERS ARE ELIGIBLE TO EXCHANGE POINTS EARNED FOR PROMOTIONAL ITEMS CONSISTING OF COUPONS, REBATES, DISCOUNTS OR SPECIAL OFFERINGS ON GOODS AND/OR SERVICE PROVIDED BY WEB SITE SPONSORS; ARRANGING AND CONDUCTING SALES FOR OTHERS OF LIVESTOCK AND REGISTERED AND COMMERCIAL CATTLE; ARRANGING AND CONDUCTION OF AUCTION SALES; ARRANGING OF AUCTION SALES; CONDUCTING AND ADMINISTERING A PROGRAM FOR PARTICIPATING HEALTH AND FITNESS CLUBS FEATURING DISCOUNTS ON CLUB MEMBERSHIP FOR ACCESS TO THE CLUBS TO PROGRAM MEMBERS; CONDUCTING INCENTIVE AWARD PROGRAMS TO PROMOTE THE SALE OF SCHOOL AND OFFICE PRODUCTS; CONDUCTING OF AUCTION SALES; CONSULTING IN SALES TECHNIQUES AND SALES PROGRAMMES; CONSULTING IN THE FIELD OF SALES METHODS, SALES MANAGEMENT, AND SALES IMPROVEMENT; COOPERATIVE ADVERTISING AND MARKETING SERVICES, NAMELY, OFFERING DISCOUNTS TO CLIENTS THROUGH THE JOINT PARTICIPATION OF MEMBER BEAUTY SALONS; HUMAN RESOURCES SERVICES IN THE FIELD OF EDUCATION, NAMELY, OFFERING OF ASSESSMENTS AND SURVEYS IN THE FIELD OF EDUCATOR TRAINING AND PERFORMANCE FOR THE PURPOSE OF TEACHER PLACEMENT BASED ON SUCCESS IN AN ACA-

CLASS 35—(Continued).

DEMIG PROGRAM; INCENTIVE AWARD PROGRAMS TO PROMOTE THE SALE OF PRODUCTS AND SERVICES OF OTHERS; OFFERING BUSINESS MANAGEMENT ASSISTANCE IN THE ESTABLISHMENT AND/OR OPERATION OF RESTAURANTS; ONLINE SERVICE FOR CONNECTING SOCIAL NETWORK USERS WITH RETAILERS FOR THE PURPOSE OF FACILITATING DISCOUNTED PURCHASES; OUTSOURCING IN THE FIELD OF SALES AND MARKETING OF COMPUTER SOFTWARE; PROCESSING MANUFACTURER'S COUPONS; PROMOTING AND MARKETING THE GOODS AND SERVICES OF OTHERS BY DISTRIBUTING ADVERTISING MATERIAL, COUPONS AND DISCOUNT OFFERS VIA TEXT MESSAGES; PROMOTING THE GOODS AND SERVICES OF OTHERS BY PROVIDING A WEBSITE FEATURING COUPONS, REBATES, PRICE-COMPARISON INFORMATION, PRODUCT REVIEWS, LINKS TO THE RETAIL WEBSITES OF OTHERS, AND DISCOUNT INFORMATION; PROMOTING THE GOODS AND SERVICES OF OTHERS BY PROVIDING AN INTERACTIVE WEBSITE WHERE USERS CAN INCREASE THE CURRENT VALUE OF AN ONLINE DISCOUNT BEING OFFERED BY PURCHASING THE GOODS AND SERVICES ASSOCIATED WITH THAT DISCOUNT IN THE FORM OF AN ONLINE COUPON, VOUCHER OR GIFT CARD; PROMOTING THE GOODS AND SERVICES OF OTHERS THROUGH THE DISTRIBUTION OF DISCOUNT CARDS; PROMOTING THE GOODS OF OTHERS, NAMELY, PROVIDING COUPONS, REBATES AND VOUCHERS FOR THE GOODS OF OTHERS; PROMOTIONAL SERVICES, NAMELY, PROMOTING THE GOODS OF OTHERS BY MEANS OF PROVIDING ONLINE COUPONS; PROVIDING A WEB SITE WHEREBY BUYERS OF GOODS OR SERVICES LOCATE AND RECEIVE QUOTATIONS FROM MULTIPLE COMPETITIVE SOURCES AND SELLERS OF GOODS OR SERVICES IDENTIFY AND BID ON MULTIPLE NEW SALES OPPORTUNITIES; PROVIDING A WEB-BASED SYSTEM AND ONLINE PORTALS IN THE FIELD OF CONSUMER-TO-BUSINESS COMMERCE FOR CONSUMERS TO ENTER, MANAGE AND MODIFY THEIR CONSUMER PREFERENCE INFORMATION FOR USE BY MERCHANTS TO CREATE AND MANAGE OFFERS FOR DELIVERY TO CONSUMERS; PROVIDING INTERNET AUCTION SERVICES VIA MOBILE AND DESKTOP PC APPLICATION; PROVISION OF INFORMATION CONCERNING COMMERCIAL SALES; RESTAURANT FRANCHISING, NAMELY, OFFERING BUSINESS MANAGEMENT ASSISTANCE IN THE ESTABLISHMENT AND/OR OPERATION OF RESTAURANTS; RETAIL DISCOUNT RESTAURANT STORE SERVICES; RETAIL DISCOUNT SPA AND BEAUTY SALON STORE SERVICES; RETAIL DISCOUNT CONSUMER ELECTRONICS STORE SERVICES, RETAIL DISCOUNT CLOTHING STORE SERVICES; RETAIL DISCOUNT GENERAL CONSUMER MERCHANDISE STORE SERVICES; AND RETAIL DISCOUNT FOOD STORE SERVICES (U.S. CLS. 100, 101 AND 102).

ODESSA BIBBINS, EXAMINING ATTORNEY

CLASS 35—(Continued).

SN 85-504,874. AMERICAN MEDICAL ASSOCIATION, CHICAGO, IL. FILED 12-28-2011.

AMERICAN MEDICAL
ASSOCIATION

THE MARK CONSISTS OF STANDARD CHARACTERS WITHOUT CLAIM TO ANY PARTICULAR FONT, STYLE, SIZE, OR COLOR.

OWNER OF U.S. REG. NO. 3,207,140.

NO CLAIM IS MADE TO THE EXCLUSIVE RIGHT TO USE "MEDICAL ASSOCIATION", APART FROM THE MARK AS SHOWN.

SEC. 2(F).

FOR ASSOCIATION SERVICES, NAMELY, PROMOTING THE INTERESTS, GOALS AND OBJECTIVES OF THE MEDICAL COMMUNITY THROUGH PROGRAMS, PUBLICATIONS, AND COMMUNICATIONS IN THE FIELD OF SCIENCE AND MEDICINE (U.S. CLS. 100, 101 AND 102).

FIRST USE 5-31-1847; IN COMMERCE 5-31-1847.

ADA HAN, EXAMINING ATTORNEY

CLASS 35—(Continued).

SN 85-505,051. MILOSCH'S PALACE CHRYSLER DODGE JEEP RAM, DBA MILOSCH'S PALACE CHRYSLER DODGE JEEP RAM, LAKE ORION, MI. FILED 12-28-2011.

HEMIENVY

NO CLAIM IS MADE TO THE EXCLUSIVE RIGHT TO USE "HEMI", APART FROM THE MARK AS SHOWN.

THE COLOR(S) BLACK AND GOLD IS/ARE CLAIMED AS A FEATURE OF THE MARK.

THE MARK CONSISTS OF THE ENGLISH WORDS "HEMIENVY" IN A STYLIZED FORMAT BOWING TO GIVE A 3D APPEARANCE. THE WORD "HEMI" IS BLACK AND THE WORD "ENVY" IS GOLD.

FOR ON-LINE RETAIL STORE SERVICES FEATURING A WIDE VARIETY OF CONSUMER GOODS OF OTHERS (U.S. CLS. 100, 101 AND 102).

EUGENIA MARTIN, EXAMINING ATTORNEY

SN 85-505,756. FORT WAYNE/ALLEN COUNTY CONVENTION & VISITORS BUREAU, INC., FORT WAYNE, IN. FILED 12-29-2011.

SN 85-505,030. KOCH DEVELOPMENT CORPORATION, SANTA CLAUS, IN. FILED 12-28-2011.

VISIT FORT WAYNE

ROCK THE WORLD

THE MARK CONSISTS OF STANDARD CHARACTERS WITHOUT CLAIM TO ANY PARTICULAR FONT, STYLE, SIZE, OR COLOR.

FOR PROMOTING LIVE MUSIC FESTIVALS (U.S. CLS. 100, 101 AND 102).

MICHAEL WIENER, EXAMINING ATTORNEY

THE MARK CONSISTS OF STANDARD CHARACTERS WITHOUT CLAIM TO ANY PARTICULAR FONT, STYLE, SIZE, OR COLOR.

NO CLAIM IS MADE TO THE EXCLUSIVE RIGHT TO USE "FORT WAYNE", APART FROM THE MARK AS SHOWN.

FOR CONVENTION AND VISITORS BUREAU SERVICES, NAMELY, PROMOTING TOURISM, BUSINESS AND CONVENTIONS IN THE FORT WAYNE, INDIANA AND ALLEN COUNTY AREAS (U.S. CLS. 100, 101 AND 102).

FIRST USE 9-1-2010; IN COMMERCE 9-1-2010.

JERI J. FICKES, EXAMINING ATTORNEY

CLASS 35—(Continued).

SN 85-505,805. RE-MARKETING GROUP, INC., COMMERCE, CA. FILED 12-29-2011.

CLASS 35—(Continued).

SN 85-506,080. BOWLING GREEN AREA CONVENTION & VISITORS BUREAU, BOWLING GREEN, KY. FILED 12-29-2011.



THE COLOR(S) BLACK, YELLOW, RED, WHITE, GREEN IS/ARE CLAIMED AS A FEATURE OF THE MARK.

THE MARK CONSISTS OF THE WORDS "TREASURE HUNT" APPEARING IN BLACK ON A YELLOW DIAMOND WITH A WHITE CLIPPER SHIP IN THE MIDDLE. THE WORD "TREASURE" IS ARCHED OVER THE TOP OF THE CLIPPER SHIP AND THE WORD "HUNT" IS FLAT BENEATH THE CLIPPER SHIP. THE YELLOW DIAMOND HAS A PLAIN RED BORDER. A GREEN BANNER ARCHING DOWNWARD, BELOW THE WORD "HUNT", CONTAINS THE WORDS, "AN ADVENTURE IN BARGAIN HUNTING!" IN WHITE LETTERING. POSTAL WAVES/RIPPLES APPEAR IN THE BACKGROUND OF THE ENTIRE IMAGE DESCRIBED PREVIOUSLY.

FOR RETAIL DISCOUNT STORE SERVICES IN THE FIELD OF GENERAL CONSUMER MERCHANDISE (U.S. CLS. 100, 101 AND 102).

ELLEN PERKINS, EXAMINING ATTORNEY



NO CLAIM IS MADE TO THE EXCLUSIVE RIGHT TO USE "BG", APART FROM THE MARK AS SHOWN.

THE MARK CONSISTS OF THE CHARACTERS "I" AND "BG" WITH A DRAWING OF A HEART.

FOR ADVERTISING AGENCIES SPECIALIZING IN PROMOTING BOWLING GREEN, KENTUCKY THROUGH COMMUNICATIONS TO THE PUBLIC OF SERVICES FOR TRAVELERS' ACCOMMODATIONS, SERVICES PROVIDED BY PERSONS WHOSE AIM IS TO PREPARE FOOD AND DRINK FOR CONSUMPTION, AND SERVICES PROVIDED TO OBTAIN BED AND BOARD IN HOTELS OR OTHER ESTABLISHMENTS PROVIDING TEMPORARY ACCOMMODATION; ADVERTISING AND MARKETING; ADVERTISING AND MARKETING SERVICES, NAMELY, PROMOTING THE GOODS AND SERVICES OF OTHERS; ADVERTISING AND PROMOTIONAL SERVICES; ADVERTISING, MARKETING AND PROMOTION SERVICES (U.S. CLS. 100, 101 AND 102).

FIRST USE 9-3-2010; IN COMMERCE 9-3-2010.
DARRYL SPRUILL, EXAMINING ATTORNEY

SN 85-506,197. JTW MEDIA GROUP, LLC, OCALA, FL. FILED 12-30-2011.

ZUNI

THE MARK CONSISTS OF STANDARD CHARACTERS WITHOUT CLAIM TO ANY PARTICULAR FONT, STYLE, SIZE, OR COLOR.

FOR PROVIDING ADVERTISING SERVICES TO OTHERS VIA AN INTERACTIVE WEBSITE; ADMINISTRATION OF A PROGRAM ENABLING PARTICIPANTS TO OBTAIN DISCOUNTS ON PRODUCTS AND SERVICES AND PROVIDING SALES ADVERTISEMENTS TO OTHERS, ALL VIA AN INTERACTIVE WEBSITE AND VIA EMAIL SOLICITATIONS TO SUBSCRIBERS (U.S. CLS. 100, 101 AND 102).

SARA BENJAMIN, EXAMINING ATTORNEY

CLASS 35—(Continued).

SN 85-506,371. VON MAUR, INC., DAVENPORT, IA. FILED 12-30-2011.

Shopping Perfected

THE MARK CONSISTS OF STANDARD CHARACTERS WITHOUT CLAIM TO ANY PARTICULAR FONT, STYLE, SIZE, OR COLOR.

NO CLAIM IS MADE TO THE EXCLUSIVE RIGHT TO USE "SHOPPING", APART FROM THE MARK AS SHOWN. FOR RETAIL AND ON-LINE DEPARTMENT STORE SERVICES (U.S. CLS. 100, 101 AND 102).

FIRST USE 10-7-2011; IN COMMERCE 10-7-2011.
DEBORAH LOBO, EXAMINING ATTORNEY

SN 85-506,507. RIM, CHRISTOPHER, PARAMUS, NJ. FILED 12-30-2011.

IT ENDS TODAY

THE MARK CONSISTS OF STANDARD CHARACTERS WITHOUT CLAIM TO ANY PARTICULAR FONT, STYLE, SIZE, OR COLOR.

FOR ASSOCIATION SERVICES, NAMELY, PROMOTING PUBLIC AWARENESS OF ANTI-BULLYING EFFORTS AND ACTIONS (U.S. CLS. 100, 101 AND 102).

FIRST USE 4-27-2011; IN COMMERCE 4-27-2011.
FONG HSU, EXAMINING ATTORNEY

SN 85-506,533. MILITARY MAIL SOLUTIONS, LLC, QUINCY, MA. FILED 12-30-2011.

MEET YOUR NEW BEST FRIEND

THE MARK CONSISTS OF STANDARD CHARACTERS WITHOUT CLAIM TO ANY PARTICULAR FONT, STYLE, SIZE, OR COLOR.

FOR ARRANGING FOR PARCEL DELIVERY (U.S. CLS. 100, 101 AND 102).

FIRST USE 12-15-2011; IN COMMERCE 12-15-2011.
DEBORAH LOBO, EXAMINING ATTORNEY

CLASS 35—(Continued).

SN 85-506,534. GULF & SOUTH ATLANTIC FISHERIES FOUNDATION, INC., TAMPA, FL. FILED 12-30-2011.



NO CLAIM IS MADE TO THE EXCLUSIVE RIGHT TO USE "GULF COAST SEAFOOD", APART FROM THE MARK AS SHOWN.

THE COLOR(S) SEA GREEN AND LIGHT SEA GREEN IS/ ARE CLAIMED AS A FEATURE OF THE MARK.

THE MARK CONSISTS OF A LARGE CAPITAL LETTER "G" IN SEA GREEN INCORPORATING A SILHOUETTE PROFILE HOLDING A TRIDENT-FORK IN LIGHT SEA GREEN WITH THE WORDS "GULF COAST SEAFOOD" DISPLAYED TO THE RIGHT IN THE SAME SEA GREEN AS THE LARGE CAPITAL LETTER "G".

FOR ASSOCIATION SERVICES, NAMELY, PROMOTING THE INTERESTS OF THE SEAFOOD INDUSTRIES OF MISSISSIPPI, LOUISIANA, FLORIDA, ALABAMA, AND TEXAS (U.S. CLS. 100, 101 AND 102).

FIRST USE 12-26-2011; IN COMMERCE 12-26-2011.
KAREN K. BUSH, EXAMINING ATTORNEY

SN 85-506,538. SOCIETE HOSPITALITY CORPORATION, LAS VEGAS, NV. FILED 12-30-2011.

YOGEARTH

THE MARK CONSISTS OF STANDARD CHARACTERS WITHOUT CLAIM TO ANY PARTICULAR FONT, STYLE, SIZE, OR COLOR.

FOR SELF-SERVE FROZEN YOGURT SHOP SERVICES (U.S. CLS. 100, 101 AND 102).

SANJEEV VOHRA, EXAMINING ATTORNEY

CLASS 35—(Continued).

SN 85-506,548. GULF & SOUTH ATLANTIC FISHERIES FOUNDATION, INC., TAMPA, FL. FILED 12-30-2011.



NO CLAIM IS MADE TO THE EXCLUSIVE RIGHT TO USE "GULF COAST SEAFOOD", APART FROM THE MARK AS SHOWN.

THE COLOR(S) SEA GREEN AND LIGHT SEA GREEN IS/ ARE CLAIMED AS A FEATURE OF THE MARK.

THE MARK CONSISTS OF A LARGE CAPITAL LETTER "G" IN SEA GREEN INCORPORATING A SILHOUETTE PROFILE HOLDING A TRIDENT-FORK IN LIGHT SEA GREEN WITH THE WORDS "GULF COAST SEAFOOD FLAVOR FULL" DISPLAYED TO THE RIGHT IN THE SAME SEA GREEN AS THE LARGE CAPITAL LETTER "G" WITH A SET OF THREE SMALL BUBBLES BETWEEN THE WORDS "FLAVOR" AND "FULL".

FOR ASSOCIATION SERVICES, NAMELY, PROMOTING THE INTERESTS OF THE SEAFOOD INDUSTRIES OF MISSISSIPPI, LOUISIANA, FLORIDA, ALABAMA, AND TEXAS (U.S. CLS. 100, 101 AND 102).

FIRST USE 12-26-2011; IN COMMERCE 12-26-2011.

KAREN K. BUSH, EXAMINING ATTORNEY

SN 85-506,550. TRENDSIDE PR LLC, JOHNSTON, IA. FILED 12-30-2011.

TrendSide PR

THE MARK CONSISTS OF STANDARD CHARACTERS WITHOUT CLAIM TO ANY PARTICULAR FONT, STYLE, SIZE, OR COLOR.

NO CLAIM IS MADE TO THE EXCLUSIVE RIGHT TO USE "PR", APART FROM THE MARK AS SHOWN.

FOR PUBLIC RELATIONS (U.S. CLS. 100, 101 AND 102).

FIRST USE 11-1-2011; IN COMMERCE 12-15-2011.

KAREN K. BUSH, EXAMINING ATTORNEY

CLASS 35—(Continued).

SN 85-506,576. ARCHONIA N.V., DIEPENBEEK, BELGIUM, FILED 12-30-2011.

ARCHONIA.COM

THE MARK CONSISTS OF STANDARD CHARACTERS WITHOUT CLAIM TO ANY PARTICULAR FONT, STYLE, SIZE, OR COLOR.

OWNER OF U.S. REG. NO. 2,539,359.

NO CLAIM IS MADE TO THE EXCLUSIVE RIGHT TO USE ".COM", APART FROM THE MARK AS SHOWN.

FOR ON-LINE RETAIL STORE SERVICES FEATURING COMIC BOOKS, GAMES, DVDS WITH ANIMATED CARTOONS, ANIME DVDS, ACTION FIGURES, PVC FIGURES AND STATUES, POSTERS, WALL SCROLLS, KEY CHAINS, CHARMS, DECORATIVE PINS, PILLOWS, TOTE BAGS, MESSENGER BAGS, AND MERCHANDISE FEATURING FICTIONAL CHARACTERS (U.S. CLS. 100, 101 AND 102).

FIRST USE 11-30-2011; IN COMMERCE 11-30-2011.

JENNIFER WILLISTON, EXAMINING ATTORNEY

SN 85-506,622. HAMEL, JESSICA, M, DBA BIG OCEAN MARKETING, PEABODY, MA. FILED 12-30-2011.

Big Ocean Marketing

THE MARK CONSISTS OF STANDARD CHARACTERS WITHOUT CLAIM TO ANY PARTICULAR FONT, STYLE, SIZE, OR COLOR.

NO CLAIM IS MADE TO THE EXCLUSIVE RIGHT TO USE "MARKETING", APART FROM THE MARK AS SHOWN.

FOR ADVERTISING AND MARKETING CONSULTANCY; ADVERTISING AND MARKETING SERVICES PROVIDED BY MEANS OF INDIRECT METHODS OF MARKETING COMMUNICATIONS, NAMELY, SOCIAL MEDIA, SEARCH ENGINE MARKETING, INQUIRY MARKETING, INTERNET MARKETING, MOBILE MARKETING, BLOGGING AND OTHER FORMS OF PASSIVE, SHARABLE OR VIRAL COMMUNICATIONS CHANNELS; ADVERTISING AND MARKETING SERVICES, NAMELY, PROMOTING THE GOODS AND SERVICES OF OTHERS; BUSINESS TO BUSINESS DIRECT MARKETING SERVICES; CONSULTATION SERVICES, NAMELY, CREATIVE AND STRATEGIC CONSULTATION REGARDING DEVELOPMENT AND PRODUCTION OF MARKETING CAMPAIGNS FOR OTHERS; DEVELOPMENT OF MARKETING STRATEGIES AND CONCEPTS; EVENT PLANNING AND MANAGEMENT FOR MARKETING, BRANDING, PROMOTING OR ADVERTISING THE GOODS AND SERVICES OF OTHERS; MARKETING CONSULTING; MARKETING PLAN DEVELOPMENT; PROVIDING MARKETING AND PROMOTION OF SPECIAL EVENTS; SOCIAL MEDIA STRATEGY AND MARKETING CONSULTANCY FOCUSING ON HELPING CLIENTS CREATE AND EXTEND THEIR PRODUCT AND BRAND STRATEGIES BY BUILDING VIRALLY ENGAGING MARKETING SOLUTIONS (U.S. CLS. 100, 101 AND 102).

FIRST USE 12-1-2008; IN COMMERCE 3-23-2009.

RENEE MCCRAY, EXAMINING ATTORNEY

CLASS 35—(Continued).

SN 85-506,715. JABER, FARHOUD, BROOKLYN, NY. FILED 12-30-2011.

Earth's Basket

THE MARK CONSISTS OF STANDARD CHARACTERS WITHOUT CLAIM TO ANY PARTICULAR FONT, STYLE, SIZE, OR COLOR.

FOR (BASED ON USE IN COMMERCE) SUPERMARKETS (BASED ON INTENT TO USE) RETAIL CONVENIENCE STORES; RETAIL DELICATESSEN SERVICES; RETAIL GROCERY STORES FEATURING PHONE-IN ORDERS; RETAIL STORE SERVICES FEATURING A WIDE VARIETY OF CONSUMER GOODS OF OTHERS (U.S. CLS. 100, 101 AND 102).

FIRST USE 7-1-2009; IN COMMERCE 8-1-2009.
RENEE MCCRAY, EXAMINING ATTORNEY

CLASS 35—(Continued).

SN 85-506,804. GROSS, FREDERICK M, FREEPORT, NY. AND JOSEPH FURINO, FRANKLIN SQUARE, NY. FILED 12-31-2011.



THE COLOR(S) GREEN AND RED IS/ARE CLAIMED AS A FEATURE OF THE MARK.

THE MARK CONSISTS OF A SHIELD DESIGN WITH CROSSED SWORDS BEHIND IT, A KNIGHT'S HELMET ON TOP OF IT, AND THE GREEK LETTERS ALPHA, OMEGA AND THETA ON THE FRONT OF IT. ABOVE THE SHIELD ARE THE WORDS "ALPHA OMEGA THETA". ALL OF THE WORDING AND DESIGNS ARE RED AND APPEAR ON A GREEN BACKGROUND.

FOR ASSOCIATION SERVICES, NAMELY, ORGANIZING CHAPTERS OF A FRATERNITY AND PROMOTING THE INTERESTS OF THE MEMBERS THEREOF (U.S. CLS. 100, 101 AND 102).

FIRST USE 3-25-1948; IN COMMERCE 3-25-1948.
JAMES GRIFFIN, EXAMINING ATTORNEY

SN 85-506,798. STREET QUALITY ENTERTAINMENT LTD., VICTORIA, B.C., CANADA, FILED 12-31-2011.



THE MARK CONSISTS OF A SQUARE WITH 8 RECTANGLES INSIDE OF IT.

FOR MANAGEMENT OF PERFORMING ARTISTS; PERSONAL MANAGEMENT SERVICES FOR ENTERTAINERS (U.S. CLS. 100, 101 AND 102).

FIRST USE 4-30-2011; IN COMMERCE 4-30-2011.
JAMES GRIFFIN, EXAMINING ATTORNEY

SN 85-506,806. SCHNEIDER CONSULTING GROUP, L.L.C., NEWON, IA. FILED 12-31-2011.



Cultural Architects

NO CLAIM IS MADE TO THE EXCLUSIVE RIGHT TO USE "CULTURAL", APART FROM THE MARK AS SHOWN. THE MARK CONSISTS OF THE WORDS "EDGE CULTURAL ARCHITECTS". THE WORD "EDGE" IS ENCLOSED IN A DARK SHADED RECTANGLE. THE FIRST "E" OF THE WORD "EDGE" IS THE GEOMETRIC SYMBOL FOR CONGRUENT. THE WORDS "CULTURAL ARCHITECTS" APPEAR UNDER THE DARK SHADED RECTANGLE.

FOR PROVIDING COMPREHENSIVE AND INTEGRATED BUSINESS ORGANIZATIONAL CONSULTING SERVICES RELATED TO HUMAN AND FINANCIAL RESOURCE DEVELOPMENT AND UTILIZATION (U.S. CLS. 100, 101 AND 102).

FIRST USE 12-31-2011; IN COMMERCE 12-31-2011.
JAMES GRIFFIN, EXAMINING ATTORNEY

CLASS 35—(Continued).

SN 85-506,896. NEVA ENTERPRISES, INC., SALT LAKE CITY, UT. FILED 12-31-2011.

REGINE

THE MARK CONSISTS OF STANDARD CHARACTERS WITHOUT CLAIM TO ANY PARTICULAR FONT, STYLE, SIZE, OR COLOR.

FOR ON-LINE RETAIL STORE SERVICES FEATURING SUN GLASSES AND SKI GOGGLES (U.S. CLS. 100, 101 AND 102).

TEJBIR SINGH, EXAMINING ATTORNEY

SN 85-506,899. NEVA ENTERPRISES, INC., SALT LAKE CITY, UT. FILED 12-31-2011.



THE MARK CONSISTS OF A DEPICTION OF A CAPITAL "R" IN A CIRCLE.

FOR ON-LINE RETAIL STORE SERVICES FEATURING SUN GLASSES AND SKI GOGGLES (U.S. CLS. 100, 101 AND 102).

TEJBIR SINGH, EXAMINING ATTORNEY

SN 85-506,950. MUNDT, MATTHEW A., SEATTLE, WA. FILED 12-31-2011.

VERSIFY LIFE

THE MARK CONSISTS OF STANDARD CHARACTERS WITHOUT CLAIM TO ANY PARTICULAR FONT, STYLE, SIZE, OR COLOR.

FOR COMPUTERIZED ON-LINE RETAIL STORE SERVICES IN THE FIELD OF PERSONALIZED DECORATED APPAREL, PHOTOGRAPHY, ART AND POSTERS (U.S. CLS. 100, 101 AND 102).

B. PARADEWELAI, EXAMINING ATTORNEY

CLASS 35—(Continued).

SN 85-507,158. LETTUCE CARRY, PINEVILLE, NC. FILED 1-2-2012.



NO CLAIM IS MADE TO THE EXCLUSIVE RIGHT TO USE "LETTUCE", APART FROM THE MARK AS SHOWN.

THE COLOR(S) GREEN AND BLACK IS/ARE CLAIMED AS A FEATURE OF THE MARK.

THE COLOR GREEN APPEARS IN A CURVED STYLIZED FIGURE IN RUNNING MOTION, IN THE BAGS, AND THE WORDING "THE STORE AT YOUR DOOR". THE COLOR BLACK APPEARS IN THE WORDING "LETTUCE CARRY".

FOR RETAIL AND ON-LINE GROCERY STORE SERVICES FEATURING HOME DELIVERY SERVICE; RETAIL GROCERY STORES FEATURING PHONE-IN ORDERS (U.S. CLS. 100, 101 AND 102).

FIRST USE 11-29-2011; IN COMMERCE 11-30-2011. DANNEAN HETZEL, EXAMINING ATTORNEY

SN 85-507,163. SEE IT BIGGER LLC, ALEXANDRIA, VA. FILED 1-2-2012.

See It Bigger

THE MARK CONSISTS OF STANDARD CHARACTERS WITHOUT CLAIM TO ANY PARTICULAR FONT, STYLE, SIZE, OR COLOR.

OWNER OF U.S. REG. NO. 3,520,029.

FOR ON-LINE RETAIL STORE SERVICES FEATURING WIDE VARIETY OF PRODUCTS THAT ENABLE ONE TO SEE THINGS BIGGER, NAMELY, MAGNIFIERS, MAGNIFYING GLASSES, MAGNIFYING MIRRORS, READING GLASSES, SPECIALTY GLASSES, BINOCULARS, LOW VISION AIDS, OPERA GLASSES, LARGE DISPLAY CLOCKS, LARGE DISPLAY CALENDARS, MICROSCOPES, AND MONOCULARS; RETAIL STORE SERVICES FEATURING WIDE VARIETY OF PRODUCTS THAT ENABLE ONE TO SEE THINGS BIGGER, NAMELY, MAGNIFIERS, MAGNIFYING GLASSES, MAGNIFYING MIRRORS, READING GLASSES, SPECIALTY GLASSES, BINOCULARS, LOW VISION AIDS, OPERA GLASSES, LARGE DISPLAY CLOCKS, LARGE DISPLAY CALENDARS, MICROSCOPES, AND MONOCULARS, ACCESSIBLE ON-LINE AND BY TELEPHONE, FACSIMILE AND MAIL ORDER (U.S. CLS. 100, 101 AND 102).

FIRST USE 3-6-2008; IN COMMERCE 3-17-2008. DEBORAH LOBO, EXAMINING ATTORNEY

CLASS 35—(Continued).

SN 85-507,224. LA FETRA CONSULTING, SUNNYVALE, CA. FILED 1-2-2012.

Customer Mosaic

THE MARK CONSISTS OF STANDARD CHARACTERS WITHOUT CLAIM TO ANY PARTICULAR FONT, STYLE, SIZE, OR COLOR.

FOR ADVERTISING AND MARKETING CONSULTANCY (U.S. CLS. 100, 101 AND 102).

FIRST USE 1-1-2012; IN COMMERCE 1-1-2012.

GIANCARLO CASTRO, EXAMINING ATTORNEY

SN 85-507,376. THE NATIONAL CENTER FOR RESEARCH IN ADVANCED INFORMATION AND DIGITAL TECHNOLOGIES, WASHINGTON, DC. FILED 1-3-2012.

Digital Promise

THE MARK CONSISTS OF STANDARD CHARACTERS WITHOUT CLAIM TO ANY PARTICULAR FONT, STYLE, SIZE, OR COLOR.

FOR PROMOTING PUBLIC AWARENESS OF THE NEED FOR AND ACCELERATING THE DEVELOPMENT OF TECHNOLOGIES TO IMPROVE EDUCATION AND LEARNING (U.S. CLS. 100, 101 AND 102).

FIRST USE 12-31-1998; IN COMMERCE 4-6-2001.

TOBY BULLOFF, EXAMINING ATTORNEY

CLASS 35—(Continued).

SN 85-507,381. FS MARKETING SOLUTIONS, INC., WESTBOROUGH, MA. FILED 1-3-2012.



NO CLAIM IS MADE TO THE EXCLUSIVE RIGHT TO USE "MARKETING SOLUTIONS", APART FROM THE MARK AS SHOWN.

THE COLOR(S) ORANGE AND BLUE IS/ARE CLAIMED AS A FEATURE OF THE MARK.

THE MARK CONSISTS OF THE WORDING "FS MARKETING SOLUTIONS", WITH "FS MARKETING" SHOWN IN ORANGE, AND "SOLUTIONS" SHOWN IN BLUE, AND WITH A BLUE OVAL SHAPE AROUND THE LETTERS "FS".

FOR CONSULTATION SERVICES, NAMELY, CREATIVE AND STRATEGIC CONSULTATION REGARDING DEVELOPMENT AND PRODUCTION OF MARKETING CAMPAIGNS FOR OTHERS; DESIGN OF ADVERTISING MATERIALS FOR OTHERS; DESIGN OF INTERNET ADVERTISING; DEVELOPMENT OF MARKETING STRATEGIES AND CONCEPTS; MARKETING CONSULTING, NAMELY, DESIGN AND DEVELOPMENT OF MARKETING CAMPAIGNS FOR OTHERS, AND DEVELOPMENT OF MARKETING STRATEGIES FOR BUILDING ONLINE COMMUNITIES AND ENCOURAGING DIGITAL WORD OF MOUTH COMMUNICATIONS; PROMOTION AND MARKETING SERVICES AND RELATED CONSULTING; PUBLIC RELATIONS (U.S. CLS. 100, 101 AND 102).

TOBY BULLOFF, EXAMINING ATTORNEY

SN 85-507,394. PMA MEDIA GROUP, INC., LEHI, UT. FILED 1-3-2012.



NO CLAIM IS MADE TO THE EXCLUSIVE RIGHT TO USE "MEDIA GROUP", APART FROM THE MARK AS SHOWN.

THE MARK CONSISTS OF THREE HEXAGONS IN A LEFT-POINTING ARROWHEAD FORMATION, FOLLOWED BY LARGE-SCRIPT LOWER-CASE "PMA"; BELOW THE LETTERS "PMA" APPEAR IN ALL-CAPS, SMALLER FONT, "MEDIA GROUP".

FOR ADVERTISING, MARKETING, AND PROMOTING THE GOODS AND SERVICES OF OTHERS VIA THE INTERNET, E-MAIL, CALL CENTER, ONLINE AFFILIATE NETWORKS, AND SEARCH ENGINE OPTIMIZATION (U.S. CLS. 100, 101 AND 102).

FIRST USE 6-1-2011; IN COMMERCE 6-1-2011.

WILLIAM JACKSON, EXAMINING ATTORNEY

CLASS 35—(Continued).

SN 85-507,464. PANHANDLE PRESORT SERVICE, LTD., DBA MAIL REVOLUTION, AMARILLO, TX. FILED 1-3-2012.

MAIL REVOLUTION

THE MARK CONSISTS OF STANDARD CHARACTERS WITHOUT CLAIM TO ANY PARTICULAR FONT, STYLE, SIZE, OR COLOR.

NO CLAIM IS MADE TO THE EXCLUSIVE RIGHT TO USE "MAIL", APART FROM THE MARK AS SHOWN.

FOR DIRECT MAIL ADVERTISING SERVICES INCLUDING MAILING LIST PREPARATION BASED ON MARKETING DEMOGRAPHICS (U.S. CLS. 100, 101 AND 102).

TOBY BULLOFF, EXAMINING ATTORNEY

SN 85-507,780. HOSS RODS CORPORATION, COOPERCITY, FL. FILED 1-3-2012.

HOSS RODS

THE MARK CONSISTS OF STANDARD CHARACTERS WITHOUT CLAIM TO ANY PARTICULAR FONT, STYLE, SIZE, OR COLOR.

FOR ON-LINE RETAIL STORE SERVICES FEATURING SHIRTS, T-SHIRTS, TANKTOP SHIRTS, LONG-SLEEVE SHIRTS, COLLARED SHIRTS, DRESS SHIRTS, JERSEYS, SWEATERS, SWEATSHIRTS, HOODED SWEATSHIRTS, PULL-OVER SWEATSHIRTS, JACKETS; ON-LINE RETAIL STORE SERVICES FEATURING ACCESSORIES FOR CLOTHING, NAMELY, BELTS, BELT BUCKLES, PINS AND CHARMS (U.S. CLS. 100, 101 AND 102).

FIRST USE 4-16-2010; IN COMMERCE 4-16-2010.
HANNO RITTNER, EXAMINING ATTORNEY

SN 85-507,792. INFINITY STAFFING SOLUTIONS LLC, DBA LYNEER STAFFING SOLUTIONS, LAWRENCEVILLE, NJ. FILED 1-3-2012.

LYNEER

THE MARK CONSISTS OF STANDARD CHARACTERS WITHOUT CLAIM TO ANY PARTICULAR FONT, STYLE, SIZE, OR COLOR.

FOR EMPLOYMENT AGENCY SERVICES, NAMELY, FILLING THE TEMPORARY AND PERMANENT STAFFING NEEDS OF BUSINESSES (U.S. CLS. 100, 101 AND 102).

JOHN HWANG, EXAMINING ATTORNEY

CLASS 35—(Continued).

SN 85-507,807. INFINITY STAFFING SOLUTIONS LLC, DBA LYNEER STAFFING SOLUTIONS, LAWRENCEVILLE, NJ. FILED 1-3-2012.

LYNEER STAFFING SOLUTIONS

THE MARK CONSISTS OF STANDARD CHARACTERS WITHOUT CLAIM TO ANY PARTICULAR FONT, STYLE, SIZE, OR COLOR.

NO CLAIM IS MADE TO THE EXCLUSIVE RIGHT TO USE "STAFFING SOLUTIONS", APART FROM THE MARK AS SHOWN.

FOR EMPLOYMENT AGENCY SERVICES, NAMELY, FILLING THE TEMPORARY AND PERMANENT STAFFING NEEDS OF BUSINESSES (U.S. CLS. 100, 101 AND 102).

JOHN HWANG, EXAMINING ATTORNEY

SN 85-507,819. SPICEWOOD TRADING COMPANY, LLC, AUSTIN, TX. FILED 1-3-2012.

Keep Austin Local

THE MARK CONSISTS OF STANDARD CHARACTERS WITHOUT CLAIM TO ANY PARTICULAR FONT, STYLE, SIZE, OR COLOR.

NO CLAIM IS MADE TO THE EXCLUSIVE RIGHT TO USE "AUSTIN", APART FROM THE MARK AS SHOWN.

FOR OPERATING ON-LINE MARKETPLACES FOR SELLERS OF GOODS AND/OR SERVICES (U.S. CLS. 100, 101 AND 102).

MAYUR VAGHANI, EXAMINING ATTORNEY

SN 85-507,828. ROBY SMITH, DAVENPORT, IA. AND KARI SMITH, DAVENPORT, IA. FILED 1-3-2012.

Mr. Ice

THE MARK CONSISTS OF STANDARD CHARACTERS WITHOUT CLAIM TO ANY PARTICULAR FONT, STYLE, SIZE, OR COLOR.

FOR MOBILE FOOD KIOSK SERVICES; MOBILE RETAIL STORE SERVICES FEATURING FROZEN CONFECTIONS; MOBILE STREET VENDOR SERVICES FEATURING FOOD AND DRINK (U.S. CLS. 100, 101 AND 102).

DAVID MURRAY, EXAMINING ATTORNEY

CLASS 35—(Continued).

SN 85-507,832. ROBY SMITH, DAVENPORT, IA. AND KARI SMITH, DAVENPORT, IA. FILED 1-3-2012.

Mr. Shaved Ice

THE MARK CONSISTS OF STANDARD CHARACTERS WITHOUT CLAIM TO ANY PARTICULAR FONT, STYLE, SIZE, OR COLOR.

FOR MOBILE FOOD KIOSK SERVICES; MOBILE RETAIL STORE SERVICES FEATURING FROZEN CONFECTIONS; MOBILE STREET VENDOR SERVICES FEATURING FOOD AND DRINK (U.S. CLS. 100, 101 AND 102).

DAVID MURRAY, EXAMINING ATTORNEY

SN 85-507,841. TRADEFIRST.COM, INC., OAK PARK, MI. FILED 1-3-2012.

THE NEW BUSINESS CURRENCY

THE MARK CONSISTS OF STANDARD CHARACTERS WITHOUT CLAIM TO ANY PARTICULAR FONT, STYLE, SIZE, OR COLOR.

FOR BUSINESS EXCHANGE SERVICES, NAMELY, BARTERING OF GOODS AND SERVICES FOR OTHERS (U.S. CLS. 100, 101 AND 102).

FIRST USE 7-30-2011; IN COMMERCE 7-30-2011.

COURTNEY ALVAREZ, EXAMINING ATTORNEY

SN 85-507,852. THE ULTIMATE LIFE, INC., SANTA BARBARA, CA. FILED 1-3-2012.

FASHION WITH COMPASSION

THE MARK CONSISTS OF STANDARD CHARACTERS WITHOUT CLAIM TO ANY PARTICULAR FONT, STYLE, SIZE, OR COLOR.

FOR PROMOTING PUBLIC INTEREST IN VEGAN LIFESTYLES WITH REGARD TO ANIMAL CRUELTY-FREE CLOTHING AND COSMETICS (U.S. CLS. 100, 101 AND 102).

SANDRA BUJA, EXAMINING ATTORNEY

CLASS 35—(Continued).

SN 85-507,874. COCOBOP INC, MENLO PARK, CA. FILED 1-3-2012.

COCOBOP

THE MARK CONSISTS OF STANDARD CHARACTERS WITHOUT CLAIM TO ANY PARTICULAR FONT, STYLE, SIZE, OR COLOR.

FOR COMPUTERIZED ON-LINE RETAIL STORE SERVICES IN THE FIELD OF WOMEN'S ACCESSORIES (U.S. CLS. 100, 101 AND 102).

FIRST USE 11-1-2011; IN COMMERCE 11-1-2011.

JOHN HWANG, EXAMINING ATTORNEY

SN 85-507,915. 360CONNEX, LLC, DBA 360CONNEX, OAK PARK, IL. FILED 1-3-2012.

CXI

THE MARK CONSISTS OF STANDARD CHARACTERS WITHOUT CLAIM TO ANY PARTICULAR FONT, STYLE, SIZE, OR COLOR.

FOR ASSISTANCE, ADVISORY SERVICES AND CONSULTANCY WITH REGARD TO BUSINESS PLANNING, BUSINESS ANALYSIS, BUSINESS MANAGEMENT, BUSINESS ORGANIZATION, MARKETING AND CUSTOMER ANALYSIS; CUSTOMER RELATIONSHIP MANAGEMENT; MARKETING AND BRANDING SERVICES, NAMELY, PROVIDING CUSTOMIZED COMMUNICATION PROGRAMS TO OBTAIN CONSUMER INSIGHTS AND DEVELOP BRANDING STRATEGIES; SHOPPING BY RESEARCHERS WHO POSE AS CUSTOMERS TO EVALUATE THE QUALITY OF SERVICE DELIVERED; TOTAL QUALITY MANAGEMENT SERVICES, NAMELY, BUSINESS MANAGEMENT SERVICES FOR ESTABLISHING BUSINESS QUALITY POLICY AND DETERMINING BUSINESS MEANS FOR IMPLEMENTING THOSE POLICIES TO IMPROVE CUSTOMER SATISFACTION (U.S. CLS. 100, 101 AND 102).

DAVID H. STINE, EXAMINING ATTORNEY

SN 85-507,921. SL GREEN REALTY CORP., NEW YORK, NY. FILED 1-3-2012.

EMERGE212

THE MARK CONSISTS OF STANDARD CHARACTERS WITHOUT CLAIM TO ANY PARTICULAR FONT, STYLE, SIZE, OR COLOR.

OWNER OF U.S. REG. NO. 4,122,665.

FOR PROVIDING VIRTUAL OFFICE SUPPORT STAFF SERVICES FOR BUSINESSES (U.S. CLS. 100, 101 AND 102).

FIRST USE 5-4-2011; IN COMMERCE 5-4-2011.

JOHN HWANG, EXAMINING ATTORNEY

CLASS 35—(Continued).

SN 85-508,006. DJIUSA, INC., GOODRICH, MI. FILED 1-3-2012.

DJIUSA

THE MARK CONSISTS OF STANDARD CHARACTERS WITHOUT CLAIM TO ANY PARTICULAR FONT, STYLE, SIZE, OR COLOR.

FOR ON-LINE RETAIL STORE SERVICES FEATURING AERIAL PHOTOGRAPHY EQUIPMENT (U.S. CLS. 100, 101 AND 102).

FIRST USE 10-1-2010; IN COMMERCE 11-1-2010.
JESSICA A. POWERS, EXAMINING ATTORNEY

CLASS 35—(Continued).

SN 85-508,067. SSC DISABILITY, LLC, SHELTON, CT. FILED 1-3-2012.

FREEDOM CASH REWARDS

THE MARK CONSISTS OF STANDARD CHARACTERS WITHOUT CLAIM TO ANY PARTICULAR FONT, STYLE, SIZE, OR COLOR.

OWNER OF U.S. REG. NOS. 3,751,774 AND 3,757,161.

NO CLAIM IS MADE TO THE EXCLUSIVE RIGHT TO USE "CASH REWARDS", APART FROM THE MARK AS SHOWN.

FOR REFERRALS IN THE FIELD OF SOCIAL SECURITY DISABILITY (SSDI) (U.S. CLS. 100, 101 AND 102).

FIRST USE 12-5-2011; IN COMMERCE 12-5-2011.
LAURIE KAUFMAN, EXAMINING ATTORNEY

SN 85-508,133. ZACHARIAH'S WAY, INC., GAINESVILLE, GA. FILED 1-4-2012.

SN 85-508,050. LOCAL CROP, LLC, DBA LOCALCROP.COM, CLEVELAND, OH. FILED 1-3-2012.



NO CLAIM IS MADE TO THE EXCLUSIVE RIGHT TO USE "LOCAL", APART FROM THE MARK AS SHOWN.

THE COLOR(S) GRAY, BROWN, GREEN, GOLD AND WHITE IS/ARE CLAIMED AS A FEATURE OF THE MARK.

THE MARK CONSISTS OF THE WORDING "LOCAL CROP.COM CULTIVATE. HARVEST. CONNECT." THE WORDING "LOCAL CROP.COM" IS IN GRAY WITH THE "C" IN CROP STYLIZED TO LOOK LIKE A GRAY SICKLE WITH A SLIGHTLY BROWN HANDLE THAT GRADUALLY BECOMES GRAY AND APPEARS TO HAVE A GREEN ROOT GROWING FROM THE BOTTOM OF THE HANDLE, AS WELL AS THE WORDS "CULTIVATE. HARVEST.CONNECT." BELOW IN WHITE, OUTLINED WITH A GOLD RECTANGULAR BOX.

FOR PROVIDING A WEBSITE FEATURING AN ON-LINE MARKETPLACE FOR EXCHANGING GOODS AND SERVICES WITH OTHER USERS (U.S. CLS. 100, 101 AND 102).

FIRST USE 7-5-2008; IN COMMERCE 7-5-2008.
JULIE WATSON, EXAMINING ATTORNEY

PURE MINISTRIES

THE MARK CONSISTS OF STANDARD CHARACTERS WITHOUT CLAIM TO ANY PARTICULAR FONT, STYLE, SIZE, OR COLOR.

NO CLAIM IS MADE TO THE EXCLUSIVE RIGHT TO USE "MINISTRIES", APART FROM THE MARK AS SHOWN.

FOR CHARITABLE SERVICES, NAMELY, ORGANIZING AND CONDUCTING VOLUNTEER PROGRAMS AND COMMUNITY SERVICE PROJECTS THROUGH LOCAL CHURCHES FOR PEOPLE WITH SPECIAL NEEDS AND THEIR FAMILIES (U.S. CLS. 100, 101 AND 102).

FIRST USE 12-1-2011; IN COMMERCE 12-1-2011.
GIANCARLO CASTRO, EXAMINING ATTORNEY

SN 85-508,268. JEVO, INC., DBA PHYSIQUE 57, NEW YORK, NY. FILED 1-4-2012.

PHYSIQUE BOUTIQUE

THE MARK CONSISTS OF STANDARD CHARACTERS WITHOUT CLAIM TO ANY PARTICULAR FONT, STYLE, SIZE, OR COLOR.

NO CLAIM IS MADE TO THE EXCLUSIVE RIGHT TO USE "BOUTIQUE", APART FROM THE MARK AS SHOWN.

FOR ON-LINE RETAIL STORE SERVICES FEATURING PHYSICAL FITNESS APPAREL, EQUIPMENT, ACCESSORIES, AND INSTRUCTIONAL MATERIALS; RETAIL STORE SERVICES FEATURING PHYSICAL FITNESS APPAREL, EQUIPMENT, ACCESSORIES, AND INSTRUCTIONAL MATERIALS (U.S. CLS. 100, 101 AND 102).

DANNEAN HETZEL, EXAMINING ATTORNEY

CLASS 35—(Continued).

SN 85-509,284. NATIONAL AUTO BODY PARTS WAREHOUSE, INC., GRAND PRAIRIE, TX. FILED 1-5-2012.



THE MARK CONSISTS OF THE DESIGN OF A ROUND-EDGED SHADED DIAMOND WITH AN EAGLE'S HEAD INSIDE AND FACING RIGHT, WITH THE BASE OF THE EAGLE'S NECK INTEGRATED WITH THE LEFT TWO SIDES OF THE DIAMOND AND DEPICTED BY WAVY LINES; THE EYE OF THE EAGLE IS SHOWN AS A SHADED DIAMOND.

FOR ON-LINE RETAIL STORE SERVICES FEATURING AUTO PARTS; ON-LINE WHOLESALE STORE SERVICES FEATURING AUTO PARTS; RETAIL STORE SERVICES FEATURING AUTO PARTS; WHOLESALE STORE SERVICES FEATURING AUTO PARTS (U.S. CLS. 100, 101 AND 102).

FIRST USE 9-1-1994; IN COMMERCE 9-1-1994.
BARBARA A. GOLD, EXAMINING ATTORNEY

SN 85-509,475. AVA REESE, ATLANTA, GA. FILED 1-5-2012.

Bella Girly Girl

THE MARK CONSISTS OF STANDARD CHARACTERS WITHOUT CLAIM TO ANY PARTICULAR FONT, STYLE, SIZE, OR COLOR.

FOR ON-LINE RETAIL STORE SERVICES FEATURING A WIDE VARIETY OF CONSUMER GOODS OF OTHERS (U.S. CLS. 100, 101 AND 102).

FIRST USE 11-30-2011; IN COMMERCE 11-30-2011.
MIDGE BUTLER, EXAMINING ATTORNEY

CLASS 35—(Continued).

SN 85-509,494. SCANSOURCE, INC., GREENVILLE, SC. FILED 1-5-2012.

UC MORE

THE MARK CONSISTS OF STANDARD CHARACTERS WITHOUT CLAIM TO ANY PARTICULAR FONT, STYLE, SIZE, OR COLOR.

NO CLAIM IS MADE TO THE EXCLUSIVE RIGHT TO USE "UC", APART FROM THE MARK AS SHOWN.

FOR DISTRIBUTORSHIP SERVICES IN THE FIELD OF UNIFIED COMMUNICATIONS PRODUCTS (U.S. CLS. 100, 101 AND 102).

KATHERINE CHANG, EXAMINING ATTORNEY

SN 85-509,543. OPENMATTERS LLC, DOVER, MA. FILED 1-5-2012.

OpenMatters

THE MARK CONSISTS OF STANDARD CHARACTERS WITHOUT CLAIM TO ANY PARTICULAR FONT, STYLE, SIZE, OR COLOR.

FOR BUSINESS MANAGEMENT CONSULTANCY SERVICES (U.S. CLS. 100, 101 AND 102).

FIRST USE 4-1-2011; IN COMMERCE 4-1-2011.
FRANK LATTUCA, EXAMINING ATTORNEY

SN 85-509,581. KNOWPLICITY, INC., SAN FRANCISCO, CA. FILED 1-5-2012.

WELLO

THE MARK CONSISTS OF STANDARD CHARACTERS WITHOUT CLAIM TO ANY PARTICULAR FONT, STYLE, SIZE, OR COLOR.

FOR PROVIDING A WEBSITE FEATURING AN ON-LINE MARKETPLACE FOR HEALTH AND WELLNESS EDUCATION AND SERVICES AS WELL AS FITNESS TRAINING SESSIONS THAT ARE PERFORMED OVER LIVE VIDEO (U.S. CLS. 100, 101 AND 102).

FIRST USE 7-21-2011; IN COMMERCE 8-18-2011.
ODESSA BIBBINS, EXAMINING ATTORNEY

CLASS 35—(Continued).

SN 85-509,589. SOCIETY OF INDEPENDENT SHOW ORGANIZERS, SANTA MONICA, CA. FILED 1-5-2012.

SISO

THE MARK CONSISTS OF STANDARD CHARACTERS WITHOUT CLAIM TO ANY PARTICULAR FONT, STYLE, SIZE, OR COLOR.

FOR ARRANGING AND CONDUCTING BUSINESS CONFERENCES; ASSOCIATION SERVICES, NAMELY, PROMOTING THE INTERESTS OF BUSINESS EVENT OWNERS, PRODUCERS, AND VENDORS (U.S. CLS. 100, 101 AND 102).

FIRST USE 5-0-1991; IN COMMERCE 5-0-1991.
DAWN FELDMAN, EXAMINING ATTORNEY

CLASS 35—(Continued).

SN 85-509,816. NFLUENCE MEDIA, INC., SEATTLE, WA. FILED 1-5-2012.

DEALBOARD

THE MARK CONSISTS OF STANDARD CHARACTERS WITHOUT CLAIM TO ANY PARTICULAR FONT, STYLE, SIZE, OR COLOR.

FOR ADVERTISING AND MARKETING SERVICES, NAMELY, PROMOTING THE GOODS, SERVICES, AND BRAND IDENTITIES OF OTHERS; ADVERTISING CONSULTING SERVICES; MARKET REPORTS AND STUDIES; PROMOTING THE GOODS, SERVICES AND BRANDS OF OTHERS BY PROVIDING A COMMUNITY-DRIVEN WEB SITE FEATURING USER-SUBMITTED CONTENT IN THE NATURE OF COUPONS, REBATES, PRICE-COMPARISON INFORMATION, PRODUCT REVIEWS, SERVICE REVIEWS, LINKS TO THE RETAIL WEB SITES OF OTHERS, AND DISCOUNT INFORMATION; PROVIDING A WEB SITE WHERE USERS CAN POST RATINGS, REVIEWS, CRITICISM, COMMENTARY AND RECOMMENDATIONS ON PRODUCTS AND SERVICES FOR COMMERCIAL PURPOSES (U.S. CLS. 100, 101 AND 102).

THOMAS MANOR, EXAMINING ATTORNEY

SN 85-509,612. COMPRESSOR WORLD, LLC, BROCKTON, MA. FILED 1-5-2012.

COMPRESSOR WORLD

THE MARK CONSISTS OF STANDARD CHARACTERS WITHOUT CLAIM TO ANY PARTICULAR FONT, STYLE, SIZE, OR COLOR.

NO CLAIM IS MADE TO THE EXCLUSIVE RIGHT TO USE "COMPRESSOR", APART FROM THE MARK AS SHOWN.

FOR COMPUTERIZED ON-LINE ORDERING SERVICES IN THE FIELD OF AIR COMPRESSORS (U.S. CLS. 100, 101 AND 102).

FIRST USE 3-23-2000; IN COMMERCE 3-23-2000.
MICHAEL WEBSTER, EXAMINING ATTORNEY

SN 85-509,892. SIX MONTH SMILES, INC., SCOTTSVILLE, NY. FILED 1-5-2012.

FREQUENT SMILER PROGRAM

THE MARK CONSISTS OF STANDARD CHARACTERS WITHOUT CLAIM TO ANY PARTICULAR FONT, STYLE, SIZE, OR COLOR.

NO CLAIM IS MADE TO THE EXCLUSIVE RIGHT TO USE "PROGRAM", APART FROM THE MARK AS SHOWN.

FOR ARRANGING AND CONDUCTING INCENTIVE REWARD PROGRAMS TO PROMOTE THE SALE OF DENTAL SERVICES (U.S. CLS. 100, 101 AND 102).

FIRST USE 5-30-2011; IN COMMERCE 5-30-2011.
JAMES A. RAUEN, EXAMINING ATTORNEY

CLASS 35—(Continued).

SN 85-510,028. GANTHIER, GINA, HYATTSVILLE, MD. AND GANTHIER, MARVIN, HYATTSVILLE, MD. FILED 1-6-2012.

CAGEM AUTO SALES

THE MARK CONSISTS OF STANDARD CHARACTERS WITHOUT CLAIM TO ANY PARTICULAR FONT, STYLE, SIZE, OR COLOR.

NO CLAIM IS MADE TO THE EXCLUSIVE RIGHT TO USE "AUTO SALES", APART FROM THE MARK AS SHOWN.

FOR AUTOMOBILE DEALERSHIPS (U.S. CLS. 100, 101 AND 102).

LINDA MICKLEBURGH, EXAMINING ATTORNEY

SN 85-510,031. LATINWORKS MARKETING, LLC, AUSTIN, TX. FILED 1-6-2012.

BILENNIALS

THE MARK CONSISTS OF STANDARD CHARACTERS WITHOUT CLAIM TO ANY PARTICULAR FONT, STYLE, SIZE, OR COLOR.

FOR MARKETING SERVICES, NAMELY, CONDUCTING CONSUMER TRACKING BEHAVIOR RESEARCH AND CONSUMER TREND ANALYSIS; MARKETING SERVICES, NAMELY, CONSUMER MARKETING RESEARCH; CONSUMER MARKETING RESEARCH AND CONSULTING RELATED THERETO; BUSINESS CONSULTATION AND MANAGEMENT REGARDING MARKETING ACTIVITIES AND LAUNCHING OF NEW PRODUCTS; BUSINESS MARKETING SERVICES; CONDUCTING MARKETING STUDIES; MARKETING ANALYSIS SERVICES; MARKETING RESEARCH SERVICES (U.S. CLS. 100, 101 AND 102).

JOHN GARTNER, EXAMINING ATTORNEY

SN 85-510,063. LOGUE, LEAH, ATLANTA, GA. FILED 1-6-2012.

COUNTRY UP

THE MARK CONSISTS OF STANDARD CHARACTERS WITHOUT CLAIM TO ANY PARTICULAR FONT, STYLE, SIZE, OR COLOR.

FOR ONLINE RETAIL STORE SERVICES FEATURING CLOTHING AND ACCESSORIES, INSULATED BEVERAGE HOLDERS AND VARIOUS SUNDRIES, BUMPER STICKERS AND DECALS (U.S. CLS. 100, 101 AND 102).

WILLIAM JACKSON, EXAMINING ATTORNEY

CLASS 35—(Continued).

SN 85-510,218. OAKLEY, INC., FOOTHILL RANCH, CA. FILED 1-6-2012.

PERFORM BEAUTIFULLY

THE MARK CONSISTS OF STANDARD CHARACTERS WITHOUT CLAIM TO ANY PARTICULAR FONT, STYLE, SIZE, OR COLOR.

FOR RETAIL STORE SERVICES AND ON-LINE RETAIL STORE SERVICES FEATURING EYEWEAR, REPLACEMENT LENSES, EYEWEAR NOSEPIECE KITS, CLOTHING, HEADWEAR, FOOTWEAR, WATCHES, DECALS, ELECTRONICS DEVICES, POSTERS, ATHLETIC BAGS, HANDBAGS, BACKPACKS AND LUGGAGE (U.S. CLS. 100, 101 AND 102).

FIRST USE 2-28-2010; IN COMMERCE 2-28-2010.

AMY KERTGATE, EXAMINING ATTORNEY

SN 85-510,360. PSP METRICS, INC., PITTSBURGH, PA. FILED 1-6-2012.

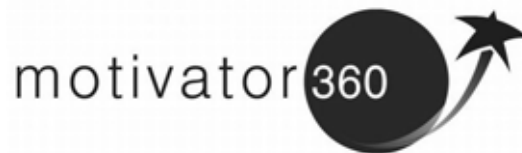

THE MARK CONSISTS OF THE WORD "MOTIVATOR" IN DARK CHARACTERS AND THE NUMBER "360" IN LIGHT CHARACTERS, OVERLAPPING WITH A DARK CIRCLE OUT OF WHICH IS COMING A DARK SHOOTING STAR WITH TAIL.

FOR CONDUCTING RESEARCH SURVEYS IN CONNECTION WITH GAP ANALYSIS, QUALITY MEASUREMENT, JOB TASK ANALYSIS, IDENTIFYING SUCCESS/FAILURE FACTORS, GOAL SETTING, DETERMINING PRIORITIES, EMPLOYEE DEVELOPMENT, PERFORMANCE APPRAISAL, DOWNSIZING, TRAINING NEEDS ANALYSIS AND EMPLOYEE OPINIONS (U.S. CLS. 100, 101 AND 102).

FIRST USE 1-22-2007; IN COMMERCE 1-22-2007.

RONALD MCMORROW, EXAMINING ATTORNEY

CLASS 35—(Continued).

SN 85-510,381. DRAGON ENTERPRISE SOLUTIONS, INC., GLEN RIDGE, NJ. FILED 1-6-2012.



THE COLOR(S) RED AND BLACK IS/ARE CLAIMED AS A FEATURE OF THE MARK.
THE MARK CONSISTS OF A FANCIFUL BLACK DRAGON INSIDE A RED OCTAGON.
FOR IMPORT AND EXPORT AGENCIES (U.S. CLS. 100, 101 AND 102).
FIRST USE 5-15-2010; IN COMMERCE 5-15-2010.
ELI HELLMAN, EXAMINING ATTORNEY

CLASS 35—(Continued).

SN 85-510,598. PLADOOGLE, COEUR D'ALENE, ID. FILED 1-6-2012.

pladoogle

THE MARK CONSISTS OF STANDARD CHARACTERS WITHOUT CLAIM TO ANY PARTICULAR FONT, STYLE, SIZE, OR COLOR.
FOR ADVERTISING AND MARKETING; ADVERTISING AND MARKETING SERVICES PROVIDED BY MEANS OF INDIRECT METHODS OF MARKETING COMMUNICATIONS, NAMELY, SOCIAL MEDIA, SEARCH ENGINE MARKETING, INQUIRY MARKETING, INTERNET MARKETING, MOBILE MARKETING, BLOGGING AND OTHER FORMS OF PASSIVE, SHARABLE OR VIRAL COMMUNICATIONS CHANNELS; DEVELOPMENT OF MARKETING STRATEGIES, CONCEPTS AND TACTICS, NAMELY, AUDIENCE DEVELOPMENT, BRAND AWARENESS, ONLINE COMMUNITY BUILDING AND DIGITAL WORD OF MOUTH COMMUNICATIONS (U.S. CLS. 100, 101 AND 102).
FIRST USE 6-21-2008; IN COMMERCE 4-16-2009.
TOBY BULLOFF, EXAMINING ATTORNEY

SN 85-510,619. ADVENT ADVISORY GROUP LLC, ASTORIA, NY. FILED 1-6-2012.



SN 85-510,573. DENVER TACO BELL RESTAURANT ADVERTISING ASSOCIATION INC., DENVER, CO. FILED 1-6-2012.

Feed Your Manimal

THE MARK CONSISTS OF STANDARD CHARACTERS WITHOUT CLAIM TO ANY PARTICULAR FONT, STYLE, SIZE, OR COLOR.
FOR RETAIL STORE SERVICES FEATURING TACOS (U.S. CLS. 100, 101 AND 102).
AMY KELLY, EXAMINING ATTORNEY

NO CLAIM IS MADE TO THE EXCLUSIVE RIGHT TO USE "ADVISORY GROUP", APART FROM THE MARK AS SHOWN.
THE COLOR(S) RED AND BROWN IS/ARE CLAIMED AS A FEATURE OF THE MARK.
THE MARK CONSISTS OF A RED DATA INSPIRED IMAGE IN THE SHAPE OF A FLOWER SEPARATED FROM THE WORDS "ADVENT ADVISORY GROUP" IN BROWN LETTERING BY A PERPENDICULAR BROWN LINE.
FOR BUSINESS ASSISTANCE, ADVISORY AND CONSULTING SERVICES IN THE FIELD OF HEALTH CARE (U.S. CLS. 100, 101 AND 102).
FIRST USE 7-1-2007; IN COMMERCE 7-1-2007.
KATHERINE CONNOLLY, EXAMINING ATTORNEY

CLASS 35—(Continued).

SN 85-510,646. SOCIETY OF THE PLASTICS INDUSTRY, INC., WASHINGTON, DC. FILED 1-6-2012.

APBA

THE MARK CONSISTS OF STANDARD CHARACTERS WITHOUT CLAIM TO ANY PARTICULAR FONT, STYLE, SIZE, OR COLOR.

FOR PUBLIC ADVOCACY TO PROMOTE RESPONSIBLE USE, REUSE, RECYCLING AND DISPOSAL OF PLASTIC BAGS (U.S. CLS. 100, 101 AND 102).
HANNO RITTNER, EXAMINING ATTORNEY

SN 85-510,706. TRUSTEE OF THE CLARE CHESTER STONE MARITAL TRUST, PURCHASE, NY. FILED 1-6-2012.

ALLAN STONE GALLERY

THE MARK CONSISTS OF STANDARD CHARACTERS WITHOUT CLAIM TO ANY PARTICULAR FONT, STYLE, SIZE, OR COLOR.

NO CLAIM IS MADE TO THE EXCLUSIVE RIGHT TO USE "GALLERY", APART FROM THE MARK AS SHOWN. THE NAME "ALLAN STONE" DOES NOT IDENTIFY A LIVING INDIVIDUAL.

FOR ART GALLERIES; RETAIL STORE SERVICES FEATURING BOOKS (U.S. CLS. 100, 101 AND 102).
FIRST USE 12-7-1960; IN COMMERCE 12-7-1960.
DAVID COLLIER, EXAMINING ATTORNEY

SN 85-510,729. COMMUNITY HEALTH CHARITIES OF AMERICA, ARLINGTON, VA. FILED 1-6-2012.

VOLUNTEER MATTERS 365

THE MARK CONSISTS OF STANDARD CHARACTERS WITHOUT CLAIM TO ANY PARTICULAR FONT, STYLE, SIZE, OR COLOR.

FOR PROMOTING PUBLIC AWARENESS OF HEALTH CHARITIES AND THEIR NEED FOR COMMUNITY AND CHARITABLE SUPPORT (U.S. CLS. 100, 101 AND 102).

FIRST USE 6-1-2011; IN COMMERCE 6-1-2011.
SHANNON TWOHIG, EXAMINING ATTORNEY

CLASS 35—(Continued).

SN 85-510,759. JESSICA LAM, IRVINE, CA. FILED 1-6-2012.

Smitten Soirée

THE MARK CONSISTS OF THE WORDS "SMITTEN SOIRÉE" IN STYLIZED SCRIPT FONT.

FOR ADVERTISING AND DIRECTORY SERVICES, NAMELY, PROMOTING THE SERVICES OF OTHERS BY PROVIDING A WEB PAGE FEATURING LINKS TO THE WEBSITES OF OTHERS; ADVERTISING AND MARKETING SERVICES, NAMELY, PROMOTING THE GOODS AND SERVICES OF OTHERS; GENERAL BUSINESS NETWORKING REFERRAL SERVICES, NAMELY, PROMOTING THE GOODS AND SERVICES OF OTHERS BY PASSING BUSINESS LEADS AND REFERRALS AMONG GROUP MEMBERS; ON-LINE BUSINESS NETWORKING SERVICES; OPERATING ON-LINE MARKETPLACES FOR SELLERS OF GOODS AND/OR SERVICES (U.S. CLS. 100, 101 AND 102).

FIRST USE 12-0-2011; IN COMMERCE 12-0-2011.
ANDREW LEASER, EXAMINING ATTORNEY

SN 85-510,877. SWINGBAGZ, LLC, WOODBRIDGE, NJ. FILED 1-6-2012.

Keep it to your Cellf

THE MARK CONSISTS OF STANDARD CHARACTERS WITHOUT CLAIM TO ANY PARTICULAR FONT, STYLE, SIZE, OR COLOR.

FOR COMPUTERIZED ON-LINE RETAIL STORE SERVICES IN THE FIELD OF CELL PHONE BAGS, NAMELY, BAGS SPECIFICALLY ADAPTED FOR CARRYING CELL PHONES (U.S. CLS. 100, 101 AND 102).

FIRST USE 7-1-2011; IN COMMERCE 7-1-2011.
DAVID YONTEF, EXAMINING ATTORNEY

SN 85-510,879. MARITZ HOLDINGS INC., FENTON, MO. FILED 1-6-2012.

YOUR REWARDING ESCAPES

THE MARK CONSISTS OF STANDARD CHARACTERS WITHOUT CLAIM TO ANY PARTICULAR FONT, STYLE, SIZE, OR COLOR.

OWNER OF U.S. REG. NO. 2,662,582.
FOR PROMOTING, CONDUCTING AND ADMINISTERING BUSINESS PERFORMANCE IMPROVEMENT PROGRAMS AND CONSUMER LOYALTY AWARD PROGRAMS FOR OTHERS FEATURING DO-IT-YOURSELF TRAVEL REWARDS (U.S. CLS. 100, 101 AND 102).
ANNE MADDEN, EXAMINING ATTORNEY

CLASS 35—(Continued).

SN 85-510,883. GET CROCHETED HANDMADE GIFTS WITH A VINTAGE FLAIR LLC, OKLAHOMA CITY, OK. FILED 1-6-2012.

Get Crocheted!

THE MARK CONSISTS OF STANDARD CHARACTERS WITHOUT CLAIM TO ANY PARTICULAR FONT, STYLE, SIZE, OR COLOR.

NO CLAIM IS MADE TO THE EXCLUSIVE RIGHT TO USE "CROCHETED", APART FROM THE MARK AS SHOWN.

FOR MOBILE RETAIL STORE SERVICES FEATURING HANDMADE CLOTHING, HANDMADE HOME DECOR AND ACCESSORIES, AND HANDMADE STUFFED ANIMALS AND DOLLS; ON-LINE RETAIL GIFT SHOPS (U.S. CLS. 100, 101 AND 102).

FIRST USE 8-26-2011; IN COMMERCE 9-24-2011.

KATHLEEN M. VANSTON, EXAMINING ATTORNEY

SN 85-510,890. GURU GURU EXCHANGE, FOREST HILLS, NY. FILED 1-6-2012.

GangIt

THE MARK CONSISTS OF STANDARD CHARACTERS WITHOUT CLAIM TO ANY PARTICULAR FONT, STYLE, SIZE, OR COLOR.

FOR ON-LINE TRADING SERVICES IN WHICH SELLER POSTS PRODUCTS TO BE AUCTIONED AND BIDDING IS DONE VIA THE INTERNET (U.S. CLS. 100, 101 AND 102).

DAVID COLLIER, EXAMINING ATTORNEY

SN 85-510,934. U.S. ENERGY SERVICES, INC., PLYMOUTH, MN. FILED 1-6-2012.

H2Oversight Service

THE MARK CONSISTS OF STANDARD CHARACTERS WITHOUT CLAIM TO ANY PARTICULAR FONT, STYLE, SIZE, OR COLOR.

NO CLAIM IS MADE TO THE EXCLUSIVE RIGHT TO USE "SERVICE", APART FROM THE MARK AS SHOWN.

FOR PROVIDING BUSINESS ADVICE IN THE FIELD OF WATER AND WASTEWATER EFFICIENCY MANAGEMENT, NAMELY, AUDITING AND TRACKING IN-AND-OUTBOUND WATER USAGE FOR THE PURPOSE OF INCREASING EFFICIENCY, REDUCING ADMINISTRATION COST AND RESOLVING BILLING AND METERING INCONSISTENCIES (U.S. CLS. 100, 101 AND 102).

FIRST USE 9-30-2011; IN COMMERCE 9-30-2011.

JANICE L. MCMORROW, EXAMINING ATTORNEY

CLASS 35—(Continued).

SN 85-510,939. FAT PILGRIM LLC, SONOMA, CA. FILED 1-6-2012.



THE MARK CONSISTS OF A RECTANGLE WITH CINCHED SIDES THAT CONTAINS THE STYLIZED TEXT "FAT PILGRIM".

FOR RETAIL STORE SERVICES FEATURING A WIDE VARIETY OF CONSUMER GOODS OF OTHERS (U.S. CLS. 100, 101 AND 102).

FIRST USE 10-10-2011; IN COMMERCE 10-30-2011.

SHAUNIA CARLYLE, EXAMINING ATTORNEY

SN 85-510,970. GOODOOL, INC, PLANTATION, FL. FILED 1-6-2012.

GOODOOL

THE MARK CONSISTS OF STANDARD CHARACTERS WITHOUT CLAIM TO ANY PARTICULAR FONT, STYLE, SIZE, OR COLOR.

FOR PROMOTING DISCOUNTS, DEALS, COUPONS, REBATES, VOUCHERS AND SPECIAL OFFERS FOR THE GOODS AND SERVICES OF OTHERS BY PROVIDING A WEBSITE FEATURING COUPONS, REBATES, PRICE-COMPARISON INFORMATION, PRODUCT REVIEWS, LINKS TO THE RETAIL WEBSITES OF OTHERS, AND DISCOUNT INFORMATION (U.S. CLS. 100, 101 AND 102).

FIRST USE 6-18-2008; IN COMMERCE 1-1-2009.

SOPHIA S. KIM, EXAMINING ATTORNEY

CLASS 35—(Continued).

SN 85-510,988. ROWLAND, HILARY, DBA JUICE ROCKET, NEW YORK, NY. FILED 1-6-2012.

JUICE ROCKET

THE MARK CONSISTS OF STANDARD CHARACTERS WITHOUT CLAIM TO ANY PARTICULAR FONT, STYLE, SIZE, OR COLOR.

FOR ADVERTISING AGENCY SPECIALIZING IN THE DESIGN AND EXECUTION OF WORD OF MOUTH, VIRAL, BUZZ AND EXPERIENTIAL MARKETING PROGRAMS; ADVERTISING AND DIRECTORY SERVICES, NAMELY, PROMOTING THE SERVICES OF OTHERS BY PROVIDING A WEB PAGE FEATURING LINKS TO THE WEBSITES OF OTHERS; ADVERTISING IN PERIODICALS, BROCHURES AND NEWSPAPERS; BUSINESS CARD DESIGN SERVICES; BUSINESS MONITORING AND CONSULTING SERVICES, NAMELY, TRACKING WEB SITES AND APPLICATIONS OF OTHERS TO PROVIDE STRATEGY, INSIGHT, MARKETING, SALES, OPERATION, PRODUCT DESIGN, PARTICULARLY SPECIALIZING IN THE USE OF ANALYTIC AND STATISTIC MODELS FOR THE UNDERSTANDING AND PREDICTING OF CONSUMERS, BUSINESSES, AND MARKET TRENDS AND ACTIONS; CONTESTS AND INCENTIVE AWARD PROGRAMS TO PROMOTE THE SALE OF PRODUCTS AND SERVICES OF OTHERS; CREATIVE MARKETING DESIGN SERVICES; DESIGN OF ADVERTISING BROCHURES FOR OTHERS; DESIGN OF ADVERTISING FLYERS FOR OTHERS; DESIGN OF ADVERTISING MATERIALS FOR OTHERS; DESIGN OF INTERNET ADVERTISING; DISSEMINATION OF ADVERTISEMENTS AND OF ADVERTISING MATERIAL; DISSEMINATION OF ADVERTISING MATERIAL; DISTRIBUTION OF PUBLICITY MATERIALS FLYERS, PROSPECTUSES, BROCHURES, SAMPLES, PARTICULARLY FOR CATALOGUE LONG DISTANCE SALES WHETHER CROSS BORDER OR NOT; DISTRIBUTION OF PUBLICITY MATERIALS, NAMELY, FLYERS, PROSPECTUSES, BROCHURES, SAMPLES, PARTICULARLY FOR CATALOGUE LONG DISTANCE SALES; INCENTIVE AWARD PROGRAMS TO PROMOTE THE SALE OF PRODUCTS AND SERVICES OF OTHERS; ON-LINE PROMOTION OF COMPUTER NETWORKS AND WEBSITES; ONLINE MEDIA MONITORING SERVICES USING COMPUTER SOFTWARE TO AUTOMATICALLY MONITOR INTERNET WEBSITES AND ONLINE PUBLICATIONS FOR CUSTOMER-SPECIFIED TOPICS AND TO CAPTURE RELEVANT CONTENT ON THOSE TOPICS, AND PROVIDING DOCUMENTATION AND ANALYSIS OF THAT ONLINE CONTENT TO OTHERS FOR BUSINESS PURPOSES; PROMOTING THE GOODS AND SERVICES OF OTHERS BY MEANS OF WORD-OF-MOUTH AND NONTRADITIONAL MARKETING PROGRAMS; PROMOTING THE GRAPHIC ARTS DESIGN SERVICES OF OTHERS BY MEANS OF A WEBSITE FEATURING GRAPHIC ARTWORK SUBMITTED BY GRAPHIC ART DESIGNERS; PROMOTING, ADVERTISING AND MARKETING OF THE BRANDS, PRODUCTS, SERVICES AND ONLINE WEBSITES OF INDIVIDUALS, BUSINESSES AND NON-PROFIT ORGANIZATIONS; PROMOTIONAL SERVICES, NAMELY, PROVIDING A WEBSITE AT WHICH ARTISTS CAN SHOWCASE THEIR TALENTS VIA AN ONLINE PORTFOLIO; PROVIDING A SEARCHABLE WEBSITE FEATURING THE GOODS AND SERVICES OF OTHER VENDORS; PROVIDING ADVERTISING SERVICES USING 3D AND ANIMATION DESIGNS; PROVIDING INCENTIVE AWARD PROGRAMS FOR CUSTOMERS THROUGH ISSUANCE AND PROCESSING OF LOYALTY POINTS FOR ON-LINE PURCHASE OF COMPANY'S GOODS AND SERVICES (U.S. CLS. 100, 101 AND 102).

FIRST USE 8-15-2011; IN COMMERCE 8-15-2011.
LINDA M. KING, EXAMINING ATTORNEY

CLASS 35—(Continued).

SN 85-511,024. WAL-MART STORES, INC., BENTONVILLE, AR. FILED 1-6-2012.

UNLIMITED FAMILY PLAN AT A FAMILY PRICE

THE MARK CONSISTS OF STANDARD CHARACTERS WITHOUT CLAIM TO ANY PARTICULAR FONT, STYLE, SIZE, OR COLOR.

FOR RETAIL STORE SERVICES FEATURING A WIDE VARIETY OF CONSUMER GOODS OF OTHERS (U.S. CLS. 100, 101 AND 102).

JUDITH HELFMAN, EXAMINING ATTORNEY

SN 85-511,044. DENOVO GROUP LLC, INDIANAPOLIS, IN. FILED 1-6-2012.

Results Focused Management

THE MARK CONSISTS OF STANDARD CHARACTERS WITHOUT CLAIM TO ANY PARTICULAR FONT, STYLE, SIZE, OR COLOR.

NO CLAIM IS MADE TO THE EXCLUSIVE RIGHT TO USE "MANAGEMENT", APART FROM THE MARK AS SHOWN.

FOR ACQUISITION AND MERGER CONSULTATION; ADVICE AND INFORMATION CONCERNING COMMERCIAL BUSINESS MANAGEMENT; ADVICE IN THE FIELD OF BUSINESS MANAGEMENT AND MARKETING; ADVICE RELATING TO THE ORGANISATION AND MANAGEMENT OF BUSINESS; ADVISORY SERVICE FOR ORGANIZATIONAL ISSUES AND BUSINESS ADMINISTRATION, WITH AND WITHOUT THE HELP OF ELECTRONIC DATA BASES; ADVISORY SERVICES RELATING TO BUSINESS MANAGEMENT AND BUSINESS OPERATIONS; ARRANGING AND CONDUCTING BUSINESS CONFERENCES; ASSISTANCE AND ADVICE REGARDING BUSINESS ORGANIZATION AND MANAGEMENT; ASSISTANCE IN MANAGEMENT OF BUSINESS ACTIVITIES; ASSISTANCE TO INDUSTRIAL OR COMMERCIAL ENTERPRISES IN THE RUNNING OF THEIR BUSINESS; ASSISTANCE WITH BUSINESS MANAGEMENT AND PLANNING; ASSISTANCE, ADVICE AND CONSULTANCY WITH REGARD TO BUSINESS PLANNING, BUSINESS ANALYSIS, BUSINESS MANAGEMENT AND BUSINESS ORGANIZATION RELATING TO PURCHASING FUNCTIONS; ASSISTANCE, ADVISORY SERVICES AND CONSULTANCY WITH REGARD TO BUSINESS PLANNING, BUSINESS ANALYSIS, BUSINESS MANAGEMENT, AND BUSINESS ORGANIZATION; BRANDING SERVICES, NAMELY, CONSULTING, DEVELOPMENT, MANAGEMENT AND MARKETING OF BRANDS FOR BUSINESSES; BUSINESS ACQUISITION AND MERGER CONSULTATION; BUSINESS ADMINISTRATION CONSULTANCY; BUSINESS ADMINISTRATION SERVICES FOR PROCESSING SALES MADE ON THE INTERNET; BUSINESS ADVICE AND COMMERCIAL INFORMATION; BUSINESS ADVICE AND INFORMATION; BUSINESS ADVISORY SERVICES, CONSULTANCY AND INFORMATION; BUSINESS ADVISORY SERVICES, NAMELY, SEARCH FOR AND SELECTION OF THE BEST POTENTIAL SUPPLIERS FOR OTHERS; BUSINESS ANALYSIS AND BUSINESS STRATEGIC PLANNING SERVICES IN THE TECHNOLOGY INDUSTRY; BUSINESS AND MANAGEMENT CONSULTING FOR HEALTHCARE PROVIDERS AND RELATED BUSINESSES; BUSINESS APPRAISALS AND EVALUATIONS IN BUSINESS MATTERS; BUSI-

CLASS 35—(Continued).

NESS ASSISTANCE, MANAGEMENT AND INFORMATION SERVICES; BUSINESS AUDITING; BUSINESS CONSULTANCY; BUSINESS CONSULTATION; BUSINESS CONSULTATION IN THE FIELD OF BUSINESS LEADERSHIP DEVELOPMENT; BUSINESS CONSULTATION SERVICES, NAMELY, BUSINESS PROCESS IMPROVEMENT AND ENTERPRISE ARCHITECTURE DESIGN; BUSINESS CONSULTING SERVICES IN THE FIELD OF ORGANIZATIONAL CHANGE MANAGEMENT; BUSINESS CONSULTING SERVICES RELATING TO THE INTEGRATION OF THE AREAS OF BUSINESS PROCESS TECHNOLOGY, ORGANIZATIONAL LEARNING, CHANGE MANAGEMENT, AND OPERATIONAL SUSTAINABILITY; BUSINESS CONSULTING SERVICES, NAMELY, PROVIDING ASSISTANCE IN DEVELOPMENT OF BUSINESS STRATEGIES AND CREATIVE IDEATION; BUSINESS CONSULTING, MANAGEMENT, PLANNING AND SUPERVISION; BUSINESS EFFICIENCY ADVICE; BUSINESS EFFICIENCY EXPERT SERVICES; BUSINESS MANAGEMENT; BUSINESS MANAGEMENT ADVICE; BUSINESS MANAGEMENT ANALYSIS; BUSINESS MANAGEMENT AND ADVICE; BUSINESS MANAGEMENT AND CONSULTATION; BUSINESS MANAGEMENT AND ENTERPRISE ORGANIZATION CONSULTANCY; BUSINESS MANAGEMENT ASSISTANCE TO INDUSTRIAL OR COMMERCIAL COMPANIES; BUSINESS MANAGEMENT CONSULTANCY AS WELL AS DEVELOPMENT OF PROCESSES FOR THE ANALYSIS AND THE IMPLEMENTATION OF STRATEGY PLANS AND MANAGEMENT PROJECTS; BUSINESS MANAGEMENT CONSULTANCY SERVICES; BUSINESS MANAGEMENT CONSULTANCY, ALSO VIA THE INTERNET; BUSINESS MANAGEMENT CONSULTATION; BUSINESS MANAGEMENT CONSULTATION IN THE FIELD OF EXECUTIVE AND LEADERSHIP DEVELOPMENT; BUSINESS MANAGEMENT CONSULTING; BUSINESS MANAGEMENT CONSULTING AND ADVISORY SERVICES; BUSINESS MANAGEMENT CONSULTING IN THE FIELD OF TEAM DEVELOPMENT; BUSINESS MANAGEMENT CONSULTING WITH RELATION TO STRATEGY, MARKETING, PRODUCTION, PERSONNEL AND RETAIL SALE MATTERS; BUSINESS MANAGEMENT PLANNING; BUSINESS MANAGEMENT SERVICES, NAMELY, MANAGING LOGISTICS, REVERSE LOGISTICS, SUPPLY CHAIN SERVICES, SUPPLY CHAIN VISIBILITY AND SYNCHRONIZATION, SUPPLY AND DEMAND FORECASTING AND PRODUCT DISTRIBUTION PROCESSES FOR OTHERS; BUSINESS MANAGEMENT SERVICES, NAMELY, SUPPLY CHAIN LOGISTICS, REVERSE LOGISTICS AND LIQUIDATION OF GOODS OF OTHERS; BUSINESS MANAGEMENT SUPERVISION; BUSINESS MERGER CONSULTATION; BUSINESS ORGANISATION CONSULTING; BUSINESS ORGANIZATION ADVICE; BUSINESS ORGANIZATION AND MANAGEMENT CONSULTANCY INCLUDING PERSONNEL MANAGEMENT; BUSINESS ORGANIZATION AND MANAGEMENT CONSULTING; BUSINESS ORGANIZATION AND OPERATION CONSULTANCY; BUSINESS ORGANIZATION CONSULTING; BUSINESS ORGANIZATIONAL CONSULTATION; BUSINESS PLANNING; BUSINESS PROCESS RE-ENGINEERING SERVICES; BUSINESS RESEARCH CONSULTATION; BUSINESS RESEARCH USING FOCUS GROUPS; BUSINESS STRATEGIC PLANNING SERVICES; BUSINESS STRATEGY DEVELOPMENT SERVICES; BUSINESS SUCCESSION PLANNING; BUSINESS SUPERVISION; BUSINESS SUPPORT SERVICES, NAMELY, BUSINESS CONSULTING TO FREELANCERS, START-UPS, EXISTING BUSINESSES AND NON-PROFIT ORGANIZATIONS; COMMERCIAL BUSINESS MANAGEMENT; COMMERCIAL CONSULTANCY; CONSULTANCY SERVICES REGARDING BUSINESS STRATEGIES; CONSULTING SERVICES IN THE FIELDS OF BUSINESS MANAGEMENT, HUMAN RESOURCES, AND BUSINESS ORGANIZATIONAL DESIGN (U.S. CLS. 100, 101 AND 102).

FIRST USE 11-14-2011; IN COMMERCE 11-14-2011.
 JORDAN BAKER, EXAMINING ATTORNEY

CLASS 35—(Continued).

SN 85-511,054. DENOVO GROUP LLC, INDIANAPOLIS, IN.
 FILED 1-6-2012.

Pracademic

THE MARK CONSISTS OF STANDARD CHARACTERS WITHOUT CLAIM TO ANY PARTICULAR FONT, STYLE, SIZE, OR COLOR.

FOR ACQUISITION AND MERGER CONSULTATION; ADVICE AND INFORMATION CONCERNING COMMERCIAL BUSINESS MANAGEMENT; ADVICE IN THE FIELD OF BUSINESS MANAGEMENT AND MARKETING; ADVICE RELATING TO THE ORGANISATION AND MANAGEMENT OF BUSINESS; ASSISTANCE AND ADVICE REGARDING BUSINESS ORGANIZATION AND MANAGEMENT; ASSISTANCE IN MANAGEMENT OF BUSINESS ACTIVITIES; ASSISTANCE, ADVICE AND CONSULTANCY WITH REGARD TO BUSINESS PLANNING, BUSINESS ANALYSIS, BUSINESS MANAGEMENT AND BUSINESS ORGANIZATION RELATING TO PURCHASING FUNCTIONS; ASSISTANCE, ADVISORY SERVICES AND CONSULTANCY WITH REGARD TO BUSINESS PLANNING, BUSINESS ANALYSIS, BUSINESS MANAGEMENT, AND BUSINESS ORGANIZATION; ASSISTANCE, ADVISORY SERVICES AND CONSULTANCY WITH REGARD TO BUSINESS PLANNING, BUSINESS ANALYSIS, BUSINESS MANAGEMENT, BUSINESS ORGANIZATION, MARKETING AND CUSTOMER ANALYSIS; BRAND IMAGERY CONSULTING SERVICES; BRANDING SERVICES, NAMELY, CONSULTING, DEVELOPMENT, MANAGEMENT AND MARKETING OF BRANDS FOR BUSINESSES; BUSINESS ACQUISITION AND MERGER CONSULTATION; BUSINESS ADMINISTRATION AND MANAGEMENT; BUSINESS ADMINISTRATION AND OFFICE WORK; BUSINESS ADMINISTRATION ASSISTANCE; BUSINESS ADMINISTRATION CONSULTANCY; BUSINESS ADMINISTRATION SERVICES FOR PROCESSING SALES MADE ON THE INTERNET; BUSINESS ADVICE AND INFORMATION; BUSINESS ADVISORY SERVICES, CONSULTANCY AND INFORMATION; BUSINESS ANALYSIS AND BUSINESS STRATEGIC PLANNING SERVICES IN THE TECHNOLOGY INDUSTRY; BUSINESS ASSISTANCE, MANAGEMENT AND INFORMATION SERVICES; BUSINESS CONSULTANCY; BUSINESS CONSULTATION; BUSINESS CONSULTATION AND MANAGEMENT REGARDING MARKETING ACTIVITIES AND LAUNCHING OF NEW PRODUCTS; BUSINESS CONSULTATION IN THE FIELD OF BUSINESS LEADERSHIP DEVELOPMENT; BUSINESS CONSULTATION SERVICES; BUSINESS CONSULTATION SERVICES, NAMELY, BUSINESS PROCESS IMPROVEMENT AND ENTERPRISE ARCHITECTURE DESIGN; BUSINESS CONSULTING AND INFORMATION SERVICES; BUSINESS CONSULTING SERVICES IN THE FIELD OF ORGANIZATIONAL CHANGE MANAGEMENT; BUSINESS CONSULTING SERVICES RELATING TO THE INTEGRATION OF THE AREAS OF BUSINESS PROCESS TECHNOLOGY, ORGANIZATIONAL LEARNING, CHANGE MANAGEMENT, AND OPERATIONAL SUSTAINABILITY; BUSINESS CONSULTING SERVICES, NAMELY, PROVIDING ASSISTANCE IN DEVELOPMENT OF BUSINESS STRATEGIES AND CREATIVE IDEATION; BUSINESS EFFICIENCY ADVICE; BUSINESS EFFICIENCY EXPERT SERVICES; BUSINESS MANAGEMENT; BUSINESS MANAGEMENT ADVICE; BUSINESS MANAGEMENT ANALYSIS; BUSINESS MANAGEMENT AND ADVICE; BUSINESS MANAGEMENT AND CONSULTATION; BUSINESS MANAGEMENT AND ENTERPRISE ORGANIZATION CONSULTANCY; BUSINESS MANAGEMENT ASSISTANCE TO INDUSTRIAL OR COMMERCIAL COMPANIES; BUSINESS MANAGEMENT CONSULTANCY AND ADVISORY SERVICES; BUSINESS MANAGEMENT CONSULTANCY AS WELL AS DEVELOPMENT OF PROCESSES FOR THE ANALYSIS AND THE IMPLEMENTATION OF STRATEGY PLANS AND MANAGEMENT PROJECTS; BUSINESS MANAGEMENT CONSULTANCY IN THE FIELD OF INSOUR-

CLASS 35—(Continued).

CING, NAMELY, ASSISTING BUSINESSES IN THE DEVELOPMENT OF PROCESSES FOR THE ANALYSIS AND THE IMPLEMENTATION OF THE DELEGATION OF OPERATIONS OR JOBS FROM PRODUCTION WITHIN A BUSINESS TO AN INTERNAL ENTITY THAT SPECIALIZES IN THAT OPERATION; BUSINESS MANAGEMENT CONSULTANCY IN THE FIELD OF PURCHASES, NAMELY, ASSISTING BUSINESSES IN IMPROVEMENT OF PURCHASING FUNCTIONS; BUSINESS MANAGEMENT CONSULTANCY SERVICES; BUSINESS MANAGEMENT CONSULTANCY, ALSO VIA THE INTERNET; BUSINESS MANAGEMENT CONSULTATION; BUSINESS MANAGEMENT CONSULTATION IN THE FIELD OF EXECUTIVE AND LEADERSHIP DEVELOPMENT; BUSINESS MANAGEMENT CONSULTING; BUSINESS MANAGEMENT CONSULTING IN THE FIELD OF TEAM DEVELOPMENT; BUSINESS MANAGEMENT PLANNING; BUSINESS MERGER CONSULTATION; BUSINESS OPERATION, BUSINESS ADMINISTRATION AND OFFICE FUNCTIONS; BUSINESS ORGANISATION AND MANAGEMENT CONSULTING SERVICES; BUSINESS ORGANISATION CONSULTING; BUSINESS ORGANIZATION ADVICE; BUSINESS ORGANIZATION AND MANAGEMENT CONSULTANCY INCLUDING PERSONNEL MANAGEMENT; BUSINESS ORGANIZATION AND MANAGEMENT CONSULTING; BUSINESS ORGANIZATION AND OPERATION CONSULTANCY; BUSINESS ORGANIZATION CONSULTING; BUSINESS ORGANIZATIONAL CONSULTATION; BUSINESS PLANNING; BUSINESS PROCESS RE-ENGINEERING SERVICES; BUSINESS RESEARCH; BUSINESS RESEARCH USING FOCUS GROUPS; BUSINESS STRATEGIC PLANNING SERVICES; BUSINESS STRATEGY DEVELOPMENT SERVICES; BUSINESS SUCCESSION PLANNING; COMMERCIAL BUSINESS MANAGEMENT; COMMERCIAL CONSULTANCY; CONSULTANCY AND ADVISORY SERVICES IN THE FIELD OF BUSINESS STRATEGY; CONSULTANCY SERVICES REGARDING BUSINESS STRATEGIES; CONSULTING SERVICES IN BUSINESS LEADERSHIP DEVELOPMENT AND BUSINESS MANAGEMENT; CONSULTING SERVICES IN BUSINESS ORGANIZATION AND MANAGEMENT; CONSULTING SERVICES IN THE FIELDS OF BUSINESS MANAGEMENT, HUMAN RESOURCES, AND BUSINESS ORGANIZATIONAL DESIGN (U.S. CLS. 100, 101 AND 102).

JORDAN BAKER, EXAMINING ATTORNEY

SN 85-511,086. MEALEO INC., COHOES, NY. FILED 1-7-2012.

A MEAL FOR A MEAL

THE MARK CONSISTS OF STANDARD CHARACTERS WITHOUT CLAIM TO ANY PARTICULAR FONT, STYLE, SIZE, OR COLOR.

FOR ON-LINE ORDERING SERVICES IN THE FIELD OF RESTAURANT TAKE-OUT AND DELIVERY FROM LOCAL RESTAURANTS (U.S. CLS. 100, 101 AND 102).

SUNG IN, EXAMINING ATTORNEY

CLASS 35—(Continued).

SN 85-511,111. ENCUESTA, INC., MIAMI, FL. FILED 1-7-2012.

ESTAMOS UNIDOS

THE MARK CONSISTS OF STANDARD CHARACTERS WITHOUT CLAIM TO ANY PARTICULAR FONT, STYLE, SIZE, OR COLOR.

THE ENGLISH TRANSLATION OF "ESTAMOS UNIDOS" IN THE MARK IS "WE ARE UNITED".

FOR CONDUCTING BUSINESS AND MARKET RESEARCH SURVEYS; CONDUCTING MARKETING STUDIES; CONDUCTING PUBLIC OPINION POLLS; MARKET OPINION POLLING STUDIES; ONLINE BUSINESS RESEARCH SERVICES THAT ALLOW USERS TO SHARE OPINIONS WITH A MARKETING RESEARCH COMPANY RELATED TO EVERYDAY CONSUMER PRODUCTS AND SERVICES; SOCIAL MEDIA STRATEGY AND MARKETING CONSULTANCY FOCUSING ON HELPING CLIENTS CREATE AND EXTEND THEIR PRODUCT AND BRAND STRATEGIES BY BUILDING VIRALLY ENGAGING MARKETING SOLUTIONS (U.S. CLS. 100, 101 AND 102).

SUNG IN, EXAMINING ATTORNEY

SN 85-511,321. EVANS, CHARLES, STOCKBRIDGE, GA. FILED 1-8-2012.

A HOUSE MULTIPLIED

THE MARK CONSISTS OF STANDARD CHARACTERS WITHOUT CLAIM TO ANY PARTICULAR FONT, STYLE, SIZE, OR COLOR.

FOR ASSOCIATION SERVICES, NAMELY, PROMOTING THE INTERESTS OF DIFFERENT COLLEGES AND UNIVERSITIES (U.S. CLS. 100, 101 AND 102).

RICHARD WHITE, EXAMINING ATTORNEY

SN 85-511,458. FGS-WI, LLC, MILTON, WI. FILED 1-9-2012.

ENABLING IMAGINATION

THE MARK CONSISTS OF STANDARD CHARACTERS WITHOUT CLAIM TO ANY PARTICULAR FONT, STYLE, SIZE, OR COLOR.

FOR DIRECT MAIL ADVERTISING SERVICES (U.S. CLS. 100, 101 AND 102).

FIRST USE 8-31-2011; IN COMMERCE 10-0-2011.

KRISTINA MORRIS, EXAMINING ATTORNEY

CLASS 35—(Continued).

SN 85-511,664. URBAN TRI GEAR LLC, WESTMONT, IL. FILED 1-9-2012.



UrbanTriGear
SWIM • BIKE • RUN

NO CLAIM IS MADE TO THE EXCLUSIVE RIGHT TO USE "SWIM BIKE RUN", APART FROM THE MARK AS SHOWN.

THE MARK CONSISTS OF A SQUARE WITH THE LETTER "R" AND A DOT ON THE TOP. TO THE RIGHT THERE IS THE STYLIZED TEXT "URBANTRIGEAR SWIM BIKE RUN". THERE IS A SMALL SQUARE IN BETWEEN "SWIM" AND "BIKE" AND "BIKE" AND "RUN".

FOR ON-LINE RETAIL STORE SERVICES FEATURING SPORTING GOODS; RETAIL STORE SERVICES FEATURING SPORTING GOODS (U.S. CLS. 100, 101 AND 102).

FIRST USE 3-1-2005; IN COMMERCE 3-1-2005.
KATHY DE JONGE, EXAMINING ATTORNEY

SN 85-511,721. LITERA CORP., MCLEANSVILLE, NC. FILED 1-9-2012.

CONTENT CONFIDENCE

THE MARK CONSISTS OF STANDARD CHARACTERS WITHOUT CLAIM TO ANY PARTICULAR FONT, STYLE, SIZE, OR COLOR.

FOR BUSINESS CONSULTING AND MANAGEMENT TO OTHERS IN THE FIELD OF DOCUMENT LIFE-CYCLE MANAGEMENT SOLUTION SOFTWARE (U.S. CLS. 100, 101 AND 102).

FIRST USE 6-1-2011; IN COMMERCE 6-1-2011.
BENJAMIN OKEKE, EXAMINING ATTORNEY

CLASS 35—(Continued).

SN 85-511,751. ROBERTSON, MARK, NEWPORT BEACH, CA. FILED 1-9-2012.

REEL VIDEO

THE MARK CONSISTS OF STANDARD CHARACTERS WITHOUT CLAIM TO ANY PARTICULAR FONT, STYLE, SIZE, OR COLOR.

FOR ADVERTISING AND MARKETING SERVICES PROVIDED BY MEANS OF INDIRECT METHODS OF MARKETING COMMUNICATIONS, NAMELY, SOCIAL MEDIA, SEARCH ENGINE MARKETING, INQUIRY MARKETING, INTERNET MARKETING, MOBILE MARKETING, BLOGGING AND OTHER FORMS OF PASSIVE, SHARABLE OR VIRAL COMMUNICATIONS CHANNELS; ADVERTISING AND MARKETING SERVICES, NAMELY, PROMOTING THE GOODS AND SERVICES OF OTHERS; CONSULTING SERVICES IN THE FIELD OF INTERNET MARKETING; DEVELOPMENT OF MARKETING STRATEGIES, CONCEPTS AND TACTICS, NAMELY, AUDIENCE DEVELOPMENT, BRAND AWARENESS, ONLINE COMMUNITY BUILDING AND DIGITAL WORD OF MOUTH COMMUNICATIONS; PROMOTING THE GOODS AND SERVICES OF OTHERS BY PROVIDING A WEBSITE FEATURING ONLINE VIDEOS; PROVIDING ADVERTISING, MARKETING AND PROMOTIONAL SERVICES, NAMELY, DEVELOPMENT OF ADVERTISING CAMPAIGNS FOR DIGITAL MEDIA; PROVIDING CONSUMER INFORMATION AND RELATED NEWS IN THE FIELD OF SEARCH ENGINE OPTIMIZATION, MOBILE, BUSINESS, WEB DEVELOPMENT, TECHNOLOGY, FILM AND ENTERTAINMENT.; SOCIAL MEDIA STRATEGY AND MARKETING CONSULTANCY FOCUSING ON HELPING CLIENTS CREATE AND EXTEND THEIR PRODUCT AND BRAND STRATEGIES BY BUILDING VIRALLY ENGAGING MARKETING SOLUTIONS (U.S. CLS. 100, 101 AND 102).

MEGHAN REINHART, EXAMINING ATTORNEY

SN 85-511,834. IPAW, INC., MONTGOMERY, AL. FILED 1-9-2012.

Randy's List

THE MARK CONSISTS OF STANDARD CHARACTERS WITHOUT CLAIM TO ANY PARTICULAR FONT, STYLE, SIZE, OR COLOR.

NO CLAIM IS MADE TO THE EXCLUSIVE RIGHT TO USE "LIST", APART FROM THE MARK AS SHOWN.

THE NAME(S), PORTRAIT(S), AND/OR SIGNATURE(S) SHOWN IN THE MARK IDENTIFIES RANDALL TODD SIMONTON, WHOSE CONSENT(S) TO REGISTER IS MADE OF RECORD.

FOR PROVIDING RATINGS OF CONSUMERS VIA A GLOBAL COMPUTER NETWORK FOR SERVICE INDUSTRY PROFESSIONALS (U.S. CLS. 100, 101 AND 102).

FIRST USE 7-1-2011; IN COMMERCE 12-23-2011.
KARANENDRA S. CHHINA, EXAMINING ATTORNEY

CLASS 35—(Continued).

SN 85-511,839. NETBALLISTICS, LLC, LOUISVILLE, KY. FILED 1-9-2012.

IAMMO

THE MARK CONSISTS OF STANDARD CHARACTERS WITHOUT CLAIM TO ANY PARTICULAR FONT, STYLE, SIZE, OR COLOR.

FOR RETAIL STORE SERVICES AND ON-LINE RETAIL STORE SERVICES FEATURING AMMUNITION, FIREARMS, CLIPS AND MAGAZINES, SCOPES, LASER AND NIGHT VISION EQUIPMENT, GUN PARTS AND ACCESSORIES, HAND CUFFS AND LEG IRONS, HOLSTERS AND ACCESSORIES, FIREARM CLEANING AND CARE PRODUCTS, SLINGS, SWIVELS, GUN RESTS, BIPODS AND TRIPODS, EYE AND HEARING PROTECTION, RELOADING EQUIPMENT, MUZZLE LOADING EQUIPMENT, BLACK POWDER, KNIVES, TOOLS AND ACCESSORIES, SAFETY AND STORAGE EQUIPMENT, TARGETS AND TARGET TRAINING EQUIPMENT, CLOTHING AND TACTICAL WEAR, HUNTING SUPPLIES AND GEAR, SURVIVAL GEAR, ATV PARTS AND ACCESSORIES, AIR GUNS, ARCHERY EQUIPMENT AND ACCESSORIES, BOOKS AND VIDEOS ABOUT FIREARMS, SHOOTING SKILLS AND TRAINING, GUN CARE, HUNTING, WILD GAME PROCESSING, HUNTING AND GUN SPORTS, RELOADING, AND GUN SAFETY (U.S. CLS. 100, 101 AND 102).

FIRST USE 1-5-2010; IN COMMERCE 1-5-2010.
RUSS HERMAN, EXAMINING ATTORNEY

SN 85-511,928. POLYONE CORPORATION, AVON LAKE, OH. FILED 1-9-2012.

**COLLABORATION. INNOVATION.
EXCELLENCE.**

THE MARK CONSISTS OF STANDARD CHARACTERS WITHOUT CLAIM TO ANY PARTICULAR FONT, STYLE, SIZE, OR COLOR.

FOR BUSINESS ADVICE AND INFORMATION (U.S. CLS. 100, 101 AND 102).
JENNIFER MARTIN, EXAMINING ATTORNEY

SN 85-512,013. LITTLE COLLECTOR, LLC, LAKE OSWEGO, OR. FILED 1-9-2012.

LITTLECOLLECTOR

THE MARK CONSISTS OF STANDARD CHARACTERS WITHOUT CLAIM TO ANY PARTICULAR FONT, STYLE, SIZE, OR COLOR.

FOR ON-LINE ART GALLERIES (U.S. CLS. 100, 101 AND 102).
FIRST USE 11-2-2009; IN COMMERCE 12-13-2010.
JAY BESCH, EXAMINING ATTORNEY

CLASS 35—(Continued).

SN 85-512,032. PRODUCT INNOVATIONS RESEARCH LLC, DALLAS, TX. FILED 1-9-2012.

TANUARY

THE MARK CONSISTS OF STANDARD CHARACTERS WITHOUT CLAIM TO ANY PARTICULAR FONT, STYLE, SIZE, OR COLOR.

FOR ADVERTISING AND MARKETING SERVICES PROMOTING THE SALE OF INDOOR TANNING PRODUCTS (U.S. CLS. 100, 101 AND 102).

DANIEL CAPSHAW, EXAMINING ATTORNEY

SN 85-512,037. HUHTAMAKI, INC., DESOTO, KS. FILED 1-9-2012.

MORNING ROUTINE

THE MARK CONSISTS OF STANDARD CHARACTERS WITHOUT CLAIM TO ANY PARTICULAR FONT, STYLE, SIZE, OR COLOR.

FOR PROMOTING THE SALE OF PRODUCTS OF OTHERS (U.S. CLS. 100, 101 AND 102).

JULIE WATSON, EXAMINING ATTORNEY

SN 85-512,049. SKILLMASTER SHOOTING RANGE INC., SCOUDOUC NEW BRUNSWICK, CANADA, FILED 1-9-2012.

HOCKEYSHOT.COM

THE MARK CONSISTS OF STANDARD CHARACTERS WITHOUT CLAIM TO ANY PARTICULAR FONT, STYLE, SIZE, OR COLOR.

FOR ON-LINE RETAIL STORE SERVICES FEATURING SPORTING GOODS, SPORTS DVD'S, SPORTS TRAINING AIDS, HOME ICE RINKS AND BOOKS (U.S. CLS. 100, 101 AND 102).

FIRST USE 11-29-1999; IN COMMERCE 11-29-1999.
JOHN WILKE, EXAMINING ATTORNEY

CLASS 35—(Continued).

SN 85-512,075. SHARETIZE INC., PALO ALTO, CA. FILED 1-9-2012.

SHARETIZE

THE MARK CONSISTS OF STANDARD CHARACTERS WITHOUT CLAIM TO ANY PARTICULAR FONT, STYLE, SIZE, OR COLOR.

FOR ADVERTISING AGENCIES, NAMELY, PROMOTING THE GOODS AND SERVICES OF OTHERS (U.S. CLS. 100, 101 AND 102).

FIRST USE 7-13-2011; IN COMMERCE 7-13-2011.
ANNE E. GUSTASON, EXAMINING ATTORNEY

CLASS 35—(Continued).

SN 85-512,228. AML INVESTMENTS, LLC, DBA THOUGHT DIVISION, LAS VEGAS, NV. FILED 1-9-2012.



THE MARK CONSISTS OF A CUBE MADE UP OF SMALLER SPACED APART SEMI-TRANSPARENT CUBES. FOR ADVERTISING SERVICES, NAMELY PRODUCTION OF ADVERTISING MATERIALS FOR AUDIO, VIDEO, DIGITAL, ONLINE, AND PRINT MEDIUM (U.S. CLS. 100, 101 AND 102).

FIRST USE 12-4-2009; IN COMMERCE 12-4-2009.
BRENDAN REGAN, EXAMINING ATTORNEY

SN 85-512,126. RED SKY BRANDS, LLC, RYE, NY. FILED 1-9-2012.



THE MARK CONSISTS OF THE WORDING "PRICE FIGHTER" BELOW A BOXING GLOVE DESIGN SURROUNDED BY A RECTANGULAR BORDER.

FOR MAIL ORDER CATALOG SERVICES FEATURING GENERAL MERCHANDISE, GIFTS AND DRUGS; RETAIL STORE SERVICES FEATURING GENERAL MERCHANDISE, GIFTS AND DRUGS; AND RETAIL STORE SERVICES AVAILABLE THROUGH COMPUTER COMMUNICATIONS FEATURING GENERAL MERCHANDISE, GIFTS AND DRUGS (U.S. CLS. 100, 101 AND 102).

JULIE GUTTADAURO, EXAMINING ATTORNEY

SN 85-512,291. FRONTIER COMMUNICATIONS CORPORATION, STAMFORD, CT. FILED 1-9-2012.

FTR

SN 85-512,160. FEBUS, BRETT, HILLIARD, OH. FILED 1-9-2012.

Knetwork

THE MARK CONSISTS OF STANDARD CHARACTERS WITHOUT CLAIM TO ANY PARTICULAR FONT, STYLE, SIZE, OR COLOR.

FOR BUSINESS PROCESS OUTSOURCING SERVICES IN THE FIELD OF SALES (U.S. CLS. 100, 101 AND 102).
FIRST USE 2-0-2011; IN COMMERCE 11-20-2011.

NATALIE POLZER, EXAMINING ATTORNEY

THE MARK CONSISTS OF STANDARD CHARACTERS WITHOUT CLAIM TO ANY PARTICULAR FONT, STYLE, SIZE, OR COLOR.

FOR CONSULTING SERVICES RELATING TO ADVERTISING, PROMOTION, AND RETURN ON ADVERTISING INVESTMENT; ADVERTISING AND PROMOTIONAL SERVICES; ADVERTISING AND PROMOTING THE GOODS AND SERVICES OF OTHERS; MANAGING ONLINE ADVERTISING CAMPAIGNS FOR OTHERS; PROVIDING ADVERTISING SPACE ON THE INTERNET TO OTHERS; DISSEMINATING ADVERTISING MATERIAL FOR OTHERS; ADVERTISING SERVICES, NAMELY, CREATING ADVERTISING MATERIAL FOR OTHERS; ADVERTISING AND MARKETING SERVICES PROVIDED BY MEANS OF INDIRECT METHODS OF MARKETING COMMUNICATIONS, NAMELY, SOCIAL MEDIA, SEARCH ENGINE MARKETING, INQUIRY MARKETING, INTERNET MARKETING, MOBILE MARKETING, BLOGGING AND OTHER FORMS OF PASSIVE, SHARABLE OR VIRAL COMMUNICATIONS CHANNELS; PROVIDING A WEBSITE FEATURING DOWNLOADABLE AND NON-

CLASS 35—(Continued).

DOWNLOADABLE COMPUTER GAMES FOR THE PURPOSE OF DISSEMINATING ADVERTISING AND PROMOTIONAL MATERIAL FOR OTHERS; MARKETING AND DISTRIBUTING DOWNLOADABLE AND ONLINE, NON-DOWNLOADABLE COMPUTER GAMES FOR OTHERS; PROVIDING RESIDENTIAL AND COMMERCIAL DIRECTORY INFORMATION VIA TELEPHONE AND GLOBAL COMMUNICATIONS NETWORKS; PROVIDING ONLINE DIRECTORY INFORMATION SERVICES FEATURING HYPERLINKS TO THE WEBSITES OF OTHERS; GEOMARKETING SERVICES FOR OTHERS, NAMELY, USING GEOGRAPHIC INFORMATION ABOUT WEBSITE VISITORS IN THE COURSE OF PLANNING AND IMPLEMENTING TARGETED ADVERTISING CAMPAIGNS FOR OTHERS; ONLINE RETAIL STORE SERVICES FEATURING TELECOMMUNICATION PRODUCTS, TELECOMMUNICATION SERVICE PLANS, AND TELECOMMUNICATION SERVICE ACTIVATION; CUSTOMER LOYALTY SERVICES FOR COMMERCIAL, PROMOTIONAL, AND/OR ADVERTISING PURPOSES (U.S. CLS. 100, 101 AND 102).

DAVID I, EXAMINING ATTORNEY

SN 85-512,299. WORKPLACE EMPORIUM, SAN JOSE, CA. FILED 1-9-2012.

NationalCubicles

THE MARK CONSISTS OF STANDARD CHARACTERS WITHOUT CLAIM TO ANY PARTICULAR FONT, STYLE, SIZE, OR COLOR.

FOR ON-LINE RETAIL STORE SERVICES FEATURING FURNITURE; RETAIL STORE SERVICES FEATURING FURNITURE (U.S. CLS. 100, 101 AND 102).

JACQUELINE A. LAVINE, EXAMINING ATTORNEY

SN 85-512,461. COMSCORE, INC., RESTON, VA. FILED 1-10-2012.

vGRP

THE MARK CONSISTS OF STANDARD CHARACTERS WITHOUT CLAIM TO ANY PARTICULAR FONT, STYLE, SIZE, OR COLOR.

FOR BUSINESS CONSULTING AND RESEARCH INFORMATION SERVICES, NAMELY, MONITORING, TRACKING, VALIDATING AND REPORTING OF THE USE OF DIGITAL MEDIA AND DIGITAL ADVERTISEMENTS (U.S. CLS. 100, 101 AND 102).

JIM RINGLE, EXAMINING ATTORNEY

CLASS 35—(Continued).

SN 85-512,490. NEXTCREW CORPORATION, NORTH-BROOK, IL. FILED 1-10-2012.

NEXTCREW

THE MARK CONSISTS OF STANDARD CHARACTERS WITHOUT CLAIM TO ANY PARTICULAR FONT, STYLE, SIZE, OR COLOR.

FOR EMPLOYMENT AGENCY SERVICES, NAMELY, FILLING THE TEMPORARY STAFFING NEEDS OF BUSINESSES AND INDIVIDUALS (U.S. CLS. 100, 101 AND 102).

FIRST USE 1-1-2012; IN COMMERCE 1-1-2012.

GENE MACIOL, EXAMINING ATTORNEY

SN 85-512,567. KNEEDROPS LLC, BEDMINSTER, NJ. FILED 1-10-2012.



THE MARK CONSISTS OF A PERSON CENTERED INSIDE A CIRCLE DROPPING DOWN TO HIS LEFT KNEE, SIMULTANEOUSLY RAISING HIS LEFT HAND STRAIGHT UP INTO THE AIR, AND MOVING HIS RIGHT HAND TO HIS FACE. THE TEXT "KNEEDROPS.COM" THEN APPEARS ON THE RIGHT IN LARGER LETTERS, AND THE PHRASE "TAKE A KNEE...BECOME A LEGEND" BELOW IT.

FOR ADVERTISING, MARKETING AND PROMOTION SERVICES (U.S. CLS. 100, 101 AND 102).

ERIN FALK, EXAMINING ATTORNEY

SN 85-512,590. POWER BY THE PEOPLE, LLC, TARZANA, CA. FILED 1-10-2012.

HESD

THE MARK CONSISTS OF STANDARD CHARACTERS WITHOUT CLAIM TO ANY PARTICULAR FONT, STYLE, SIZE, OR COLOR.

FOR PROMOTING THE GOODS AND SERVICES OF OTHERS BY PROVIDING A WEB SITE AT WHICH USERS CAN LINK TO COMPANIES THAT PROVIDE GOODS AND SERVICES FOR HOMEOWNERS AND THOSE THAT ARE MOVING; PROMOTING THE GOODS AND SERVICES OF OTHERS VIA A GLOBAL COMPUTER NETWORK; THE BRINGING TOGETHER, FOR THE BENEFIT OF OTHERS, OF A VARIETY OF GOODS AND SERVICES, ENABLING CUSTOMERS TO CONVENIENTLY VIEW AND PURCHASE THOSE GOODS AND SERVICES FROM AN INTERNET WEB SITE PARTICULARLY SPECIALIZING IN THE MARKETING OF THE SALE OF GOODS AND SERVICES OF OTHERS (U.S. CLS. 100, 101 AND 102).

PATRICIA EVANKO, EXAMINING ATTORNEY

CLASS 35—(Continued).

SN 85-512,614. ASHBURY SKIES, INC., SAN FRANCISCO, CA. FILED 1-10-2012.

ASHBURY SKIES

THE MARK CONSISTS OF STANDARD CHARACTERS WITHOUT CLAIM TO ANY PARTICULAR FONT, STYLE, SIZE, OR COLOR.

FOR ONLINE RETAIL STORE SERVICES FEATURING FOOTWEAR AND SHOES (U.S. CLS. 100, 101 AND 102).

FIRST USE 9-16-2011; IN COMMERCE 9-16-2011.
JEAN IM, EXAMINING ATTORNEY

SN 85-512,616. POWER BY THE PEOPLE, LLC, TARZANA, CA. FILED 1-10-2012.

TCWRC

THE MARK CONSISTS OF STANDARD CHARACTERS WITHOUT CLAIM TO ANY PARTICULAR FONT, STYLE, SIZE, OR COLOR.

FOR PROMOTING THE GOODS AND SERVICES OF OTHERS BY PROVIDING A WEB SITE AT WHICH USERS CAN LINK TO COMPANIES THAT PROVIDE GOODS AND SERVICES FOR HOMEOWNERS AND THOSE THAT ARE MOVING; PROMOTING THE GOODS AND SERVICES OF OTHERS VIA A GLOBAL COMPUTER NETWORK; THE BRINGING TOGETHER, FOR THE BENEFIT OF OTHERS, OF A VARIETY OF GOODS AND SERVICES, ENABLING CUSTOMERS TO CONVENIENTLY VIEW AND PURCHASE THOSE GOODS AND SERVICES FROM AN INTERNET WEB SITE PARTICULARLY SPECIALIZING IN THE MARKETING OF THE SALE OF GOODS AND SERVICES OF OTHERS (U.S. CLS. 100, 101 AND 102).

PATRICIA EVANKO, EXAMINING ATTORNEY

SN 85-512,619. ASHBURY SKIES, INC., SAN FRANCISCO, CA. FILED 1-10-2012.

EVERY REVOLUTION LEAVES A FOOTPRINT

THE MARK CONSISTS OF STANDARD CHARACTERS WITHOUT CLAIM TO ANY PARTICULAR FONT, STYLE, SIZE, OR COLOR.

FOR ONLINE RETAIL STORE SERVICES FEATURING FOOTWEAR AND SHOES (U.S. CLS. 100, 101 AND 102).

FIRST USE 9-16-2011; IN COMMERCE 9-16-2011.
JEAN IM, EXAMINING ATTORNEY

CLASS 35—(Continued).

SN 85-512,646. ABFW ENTERPRISES, LLC, ST. LOUIS, MO. FILED 1-10-2012.

COUPON FRACKING - EXTRACTING SAVINGS USING COUPONS, DISCOUNTS, DEALS, AND MORE

THE MARK CONSISTS OF STANDARD CHARACTERS WITHOUT CLAIM TO ANY PARTICULAR FONT, STYLE, SIZE, OR COLOR.

NO CLAIM IS MADE TO THE EXCLUSIVE RIGHT TO USE "COUPON", APART FROM THE MARK AS SHOWN.

FOR PROMOTING THE GOODS OF OTHERS, NAMELY, PROVIDING INFORMATION REGARDING DISCOUNTS, COUPONS, REBATES, VOUCHERS AND SPECIAL OFFERS FOR THE GOODS OF OTHERS; PROMOTING THE SALE OF GOODS AND SERVICES OF OTHERS THROUGH ELECTRONIC COUPONING, PROMOTIONS AND DISCOUNTS (U.S. CLS. 100, 101 AND 102).

JORDAN BAKER, EXAMINING ATTORNEY

SN 85-512,832. UPSTREAM TELECOMMUNICATIONS AND SOFTWARE SYSTEMS SOCIETE ANONYME, GERAKAS ATTIKI, GREECE, FILED 1-10-2012.

UPSTREAM

THE MARK CONSISTS OF STANDARD CHARACTERS WITHOUT CLAIM TO ANY PARTICULAR FONT, STYLE, SIZE, OR COLOR.

FOR ADVERTISING AND MARKETING SERVICES PROVIDED BY MEANS OF INDIRECT METHODS OF MARKETING COMMUNICATIONS, NAMELY, SOCIAL MEDIA, SEARCH ENGINE MARKETING, INQUIRY MARKETING, INTERNET MARKETING, MOBILE MARKETING, BLOGGING AND OTHER FORMS OF PASSIVE, SHARABLE OR VIRAL COMMUNICATIONS CHANNELS (U.S. CLS. 100, 101 AND 102).

JASON BLAIR, EXAMINING ATTORNEY

CLASS 35—(Continued).

SN 85-512,837. UPSTREAM TELECOMMUNICATIONS AND SOFTWARE SYSTEMS SOCIETE ANONYME, GERAKAS ATTIKI, GREECE, FILED 1-10-2012.

UPSTREAMIZATION

THE MARK CONSISTS OF STANDARD CHARACTERS WITHOUT CLAIM TO ANY PARTICULAR FONT, STYLE, SIZE, OR COLOR.

FOR ADVERTISING AND MARKETING SERVICES PROVIDED BY MEANS OF INDIRECT METHODS OF MARKETING COMMUNICATIONS, NAMELY, SOCIAL MEDIA, SEARCH ENGINE MARKETING, INQUIRY MARKETING, INTERNET MARKETING, MOBILE MARKETING, BLOGGING AND OTHER FORMS OF PASSIVE, SHARABLE OR VIRAL COMMUNICATIONS CHANNELS (U.S. CLS. 100, 101 AND 102).

JASON BLAIR, EXAMINING ATTORNEY

SN 85-512,912. CHI ENERGY INC., WHITE PLAINS, NY. FILED 1-10-2012.

Less Energy - More Power

THE MARK CONSISTS OF STANDARD CHARACTERS WITHOUT CLAIM TO ANY PARTICULAR FONT, STYLE, SIZE, OR COLOR.

FOR BUSINESS CONSULTING SERVICES IN THE FIELDS OF ENERGY MEASUREMENT TO IMPROVE ENERGY EFFICIENCY WITHIN RESIDENTIAL, COMMERCIAL, INDUSTRIAL AND INSTITUTIONAL FACILITIES; CONDUCTING ENERGY AUDITS OF COMMERCIAL AND INSTITUTIONAL FACILITIES FOR THE PURPOSE OF IMPROVING ENERGY EFFICIENCY; CONSULTATION IN THE FIELD OF ENERGY EFFICIENCY; CONSULTING SERVICES IN THE FIELD OF ENERGY EFFICIENCY FOR COMMERCIAL AND INSTITUTIONAL FACILITIES; CONSULTING SERVICES IN THE FIELD OF ENERGY USAGE MANAGEMENT AND ENERGY EFFICIENCY; CONSULTING SERVICES IN THE FIELDS OF ENERGY CONSUMPTION AND USAGE CONSERVATION TO IMPROVE ENERGY EFFICIENCY; ENERGY AUDITING; ENERGY USAGE MANAGEMENT; ENERGY USAGE MANAGEMENT INFORMATION SERVICES; HOME ENERGY ASSESSMENT SERVICES FOR THE PURPOSE OF DETERMINING ENERGY EFFICIENCY OR USAGE MANAGEMENT; PROMOTING THE ENERGY EFFICIENT PRODUCTS AND SERVICES OF OTHERS; PROVISION OF INFORMATION, ADVICE AND CONSULTANCY IN RELATION TO ENERGY EFFICIENCY (U.S. CLS. 100, 101 AND 102).

FIRST USE 6-1-2011; IN COMMERCE 11-21-2011.

KAREN K. BUSH, EXAMINING ATTORNEY

CLASS 35—(Continued).

SN 85-512,939. EVERYTHING2GO.COM LLC, MILWAUKEE, WI. FILED 1-10-2012.

EVERYTHING2GO.COM

THE MARK CONSISTS OF STANDARD CHARACTERS WITHOUT CLAIM TO ANY PARTICULAR FONT, STYLE, SIZE, OR COLOR.

FOR ON-LINE RETAIL STORE SERVICES FEATURING A WIDE VARIETY OF CONSUMER GOODS OF OTHERS (U.S. CLS. 100, 101 AND 102).

FIRST USE 11-30-2005; IN COMMERCE 7-7-2006.
WILLIAM VERHOSEK, EXAMINING ATTORNEY

SN 85-513,051. DSF ADVANCED STAFFING, INC., DBA ADVANCED STAFFING, BEAUMONT, TX. FILED 1-10-2012.

ADVANCED STAFFING

THE MARK CONSISTS OF STANDARD CHARACTERS WITHOUT CLAIM TO ANY PARTICULAR FONT, STYLE, SIZE, OR COLOR.

NO CLAIM IS MADE TO THE EXCLUSIVE RIGHT TO USE "STAFFING", APART FROM THE MARK AS SHOWN. FOR EMPLOYMENT AGENCY SERVICES, NAMELY EMPLOYEE HIRING, RECRUITMENT, TEMPORARY AND PERMANENT PLACEMENT, STAFFING, AND EMPLOYEE MANAGEMENT AND HUMAN RESOURCES CONSULTATION (U.S. CLS. 100, 101 AND 102).

FIRST USE 1-1-1997; IN COMMERCE 1-1-1997.

VIVIAN MICZNIK FIRST, EXAMINING ATTORNEY

SN 85-513,068. CYBERSETTLE HOLDINGS, INC., OLD GREENWICH, CT. FILED 1-10-2012.

PAYMD

THE MARK CONSISTS OF STANDARD CHARACTERS WITHOUT CLAIM TO ANY PARTICULAR FONT, STYLE, SIZE, OR COLOR.

FOR ACCOUNTING SERVICES; MEDICAL BILLING SUPPORT SERVICES (U.S. CLS. 100, 101 AND 102).

RAUL CORDOVA, EXAMINING ATTORNEY

CLASS 35—(Continued).

SN 85-513,224. JOSEPH ANTHONY MARTINEZ, TEMECULA, CA. FILED 1-10-2012.

Get Loud!

THE MARK CONSISTS OF STANDARD CHARACTERS WITHOUT CLAIM TO ANY PARTICULAR FONT, STYLE, SIZE, OR COLOR.

FOR PROMOTING SPORTS COMPETITIONS AND ENTERTAINMENT EVENTS OF OTHERS USING A PUBLIC ADDRESS SYSTEM, ELECTRONIC MEDIA AND WRITTEN CARDS OR SIGNS (U.S. CLS. 100, 101 AND 102).

FIRST USE 4-1-1996; IN COMMERCE 4-1-1996.
FRANK LATTUCA, EXAMINING ATTORNEY

SN 85-513,391. ISBEL, INC., SAN FRANCISCO, CA. FILED 1-10-2012.

isbel

THE MARK CONSISTS OF STANDARD CHARACTERS WITHOUT CLAIM TO ANY PARTICULAR FONT, STYLE, SIZE, OR COLOR.

FOR PROMOTING THE GOODS AND SERVICES OF OTHERS BY PROVIDING A WEBSITE FEATURING COUPONS, REBATES, PRICE-COMPARISON INFORMATION, PRODUCT REVIEWS, LINKS TO THE RETAIL WEBSITES OF OTHERS, AND DISCOUNT INFORMATION; PROVIDING A SEARCHABLE ON-LINE ADVERTISING WEBSITE AND GUIDE FEATURING THE GOODS AND SERVICES OF OTHER VENDORS VIA THE INTERNET; PROVIDING A WEBSITE FOR USERS WITH SPECIFIC INFORMED RECOMMENDATIONS OF SPECIFIC CONSUMER PRODUCTS AND SERVICES VALIDATED BY THE USERS' INPUTTED PREFERENCES AND SOCIAL NETWORK (U.S. CLS. 100, 101 AND 102).

DOMINIC FATHY, EXAMINING ATTORNEY

SN 85-513,415. HEADWAY MARKETING, LLC, ALPHARETTA, GA. FILED 1-10-2012.

HEADWAY

THE MARK CONSISTS OF STANDARD CHARACTERS WITHOUT CLAIM TO ANY PARTICULAR FONT, STYLE, SIZE, OR COLOR.

FOR ADVERTISING, MARKETING AND PROMOTION SERVICES; CONSULTING SERVICES IN THE FIELDS OF ADVERTISING AND MARKETING (U.S. CLS. 100, 101 AND 102).

BENJAMIN OKEKE, EXAMINING ATTORNEY

CLASS 35—(Continued).

SN 85-513,444. CIRCLE FOODS, LLC, SAN DIEGO, CA. FILED 1-10-2012.

BRINGING GREAT TASTES TO THE TABLE

THE MARK CONSISTS OF STANDARD CHARACTERS WITHOUT CLAIM TO ANY PARTICULAR FONT, STYLE, SIZE, OR COLOR.

FOR WHOLESALE FOOD DISTRIBUTORSHIP SERVICES (U.S. CLS. 100, 101 AND 102).

FIRST USE 1-31-2009; IN COMMERCE 1-31-2009.
JAY FLOWERS, EXAMINING ATTORNEY

SN 85-513,475. QUICKSTOVE, LLC, PLEASANT GROVE, UT. FILED 1-10-2012.

QUICKSTOVE

THE MARK CONSISTS OF STANDARD CHARACTERS WITHOUT CLAIM TO ANY PARTICULAR FONT, STYLE, SIZE, OR COLOR.

FOR ON-LINE RETAIL STORE SERVICES FEATURING SELF CONTAINED STOVES, STOVES, FUEL FOR BURNING IN STOVES, FUEL DISKS, NON-CHEMICAL FUEL CELLS, STOVE AND COOKING ACCESSORIES (U.S. CLS. 100, 101 AND 102).

FIRST USE 6-1-2011; IN COMMERCE 6-1-2011.
CHRIS WELLS, EXAMINING ATTORNEY

SN 85-513,636. MARSHALL COHEN, NEW YORK, NY. FILED 1-11-2012.

URBAN HELP

THE MARK CONSISTS OF STANDARD CHARACTERS WITHOUT CLAIM TO ANY PARTICULAR FONT, STYLE, SIZE, OR COLOR.

NO CLAIM IS MADE TO THE EXCLUSIVE RIGHT TO USE "HELP", APART FROM THE MARK AS SHOWN.

FOR ADVERTISING, MARKETING, AND PROMOTING THE GOODS AND SERVICES OF OTHERS VIA ONLINE JOB BOARD, ONLINE HELP WANTED ADVERTISEMENTS, AND ONLINE PROFILES FOR SERVICE PROVIDERS; PROVIDING AN ON-LINE SEARCHABLE DATABASE FEATURING CLASSIFIED AD LISTINGS AND EMPLOYMENT OPPORTUNITIES (U.S. CLS. 100, 101 AND 102).

FIRST USE 1-1-2010; IN COMMERCE 12-1-2011.
DOMINICK J. SALEMI, EXAMINING ATTORNEY

CLASS 35—(Continued).

SN 85-513,771. SKRYPEK, THEODORE, WESTWOOD, MA. FILED 1-11-2012.

UPPER CLASS AMERICAN

THE MARK CONSISTS OF STANDARD CHARACTERS WITHOUT CLAIM TO ANY PARTICULAR FONT, STYLE, SIZE, OR COLOR.

FOR BUSINESS ASSISTANCE, ADVISORY AND CONSULTING SERVICES IN THE FIELD OF NEW BUSINESS DEVELOPMENT; BUSINESS MANAGEMENT AND CONSULTING AND ADVISORY SERVICES; BUSINESS ORGANIZATION AND MANAGEMENT CONSULTING SERVICES; CONSULTING SERVICES IN BUSINESS LEADERSHIP DEVELOPMENT AND BUSINESS MANAGEMENT; NEW BUSINESS VENTURE DEVELOPMENT AND FORMATION CONSULTING SERVICES; PROVIDING BUSINESS MANAGEMENT INFORMATION IN CONNECTION WITH CONSULTING AND ADVISORY SERVICES IN THE FIELD OF STRATEGIC PLANNING (U.S. CLS. 100, 101 AND 102).

RONALD DELGIZZI, EXAMINING ATTORNEY

SN 85-513,812. MONTGOMERY COUNTY COLLABORATION COUNCIL FOR CHILDREN, YOUTH AND FAMILIES, INC., ROCKVILLE, MD. FILED 1-11-2012.

EXCEL BEYOND THE BELL

THE MARK CONSISTS OF STANDARD CHARACTERS WITHOUT CLAIM TO ANY PARTICULAR FONT, STYLE, SIZE, OR COLOR.

FOR PROMOTING PUBLIC AWARENESS OF THE NEED TO SUPPORT THE HEALTHY DEVELOPMENT OF CHILDREN AND FAMILIES (U.S. CLS. 100, 101 AND 102).

FIRST USE 5-28-2008; IN COMMERCE 5-28-2008.
SUSAN RICHARDS, EXAMINING ATTORNEY

CLASS 35—(Continued).

SN 85-513,877. ABEL/NOSER CORP., NEW YORK, NY. FILED 1-11-2012.

**THE A.N.G.L.E. [THE ABEL
NOSER GAIN/LOSS
EXPECTATION]**

THE MARK CONSISTS OF STANDARD CHARACTERS WITHOUT CLAIM TO ANY PARTICULAR FONT, STYLE, SIZE, OR COLOR.

FOR ASSISTANCE, ADVISORY SERVICES AND CONSULTANCY WITH REGARD TO BUSINESS PLANNING, BUSINESS ANALYSIS, BUSINESS MANAGEMENT, AND BUSINESS ORGANIZATION; BUSINESS ADVICE AND ANALYSIS OF MARKETS; BUSINESS MANAGEMENT CONSULTANCY AS WELL AS DEVELOPMENT OF PROCESSES FOR THE ANALYSIS AND THE IMPLEMENTATION OF STRATEGY PLANS AND MANAGEMENT PROJECTS; MARKET ANALYSIS; TRANSACTION COST ANALYSIS FOR TRADING STOCKS, BONDS AND OTHER FINANCIAL INSTRUMENTS; COST ANALYSES; COST PRICE ANALYSIS (U.S. CLS. 100, 101 AND 102).

KIMBERLY PERRY, EXAMINING ATTORNEY

SN 85-513,890. ACCOUNTS RECEIVABLE MANAGEMENT SYSTEMS, INC., BOISE, ID. FILED 1-11-2012.

QUE
FINANCIAL

OWNER OF U.S. REG. NO. 3,179,734.
NO CLAIM IS MADE TO THE EXCLUSIVE RIGHT TO USE "FINANCIAL", APART FROM THE MARK AS SHOWN.

THE MARK CONSISTS OF THE WORDING "QUE" HAVING A STYLIZED LETTER "Q" AND THE LETTERS "UE" ABOVE THE WORDING "FINANCIAL".

FOR MANAGEMENT OF ACCOUNTS RECEIVABLE BILLINGS FOR HEALTH CARE FACILITIES (U.S. CLS. 100, 101 AND 102).

FIRST USE 3-1-2004; IN COMMERCE 3-1-2004.
HANNO RITTNER, EXAMINING ATTORNEY

SN 85-513,998. JORDAN, GREGORY, VENTURA, CA. FILED 1-11-2012.

HUMANTROPIC

THE MARK CONSISTS OF STANDARD CHARACTERS WITHOUT CLAIM TO ANY PARTICULAR FONT, STYLE, SIZE, OR COLOR.

FOR ADMINISTERING STUDY ABROAD PROGRAMS FOR HIGH SCHOOL STUDENTS (U.S. CLS. 100, 101 AND 102).

FIRST USE 1-0-2012; IN COMMERCE 1-0-2012.
DARRYL SPRUILL, EXAMINING ATTORNEY

CLASS 35—(Continued).

SN 85-514,019. ECHEN INC., SOUTH EL MONTE, CA. FILED 1-11-2012.



THE COLOR(S) GOLD AND BLACK IS/ARE CLAIMED AS A FEATURE OF THE MARK.
 THE MARK CONSISTS OF THE WORDS CELLULARFACTORY IN A STYLIZED FONT. THE WORD "CELLULAR" IS PRESENTED IN GOLD AND THE WORD "FACTORY" IS PRESENTED IN BLACK. THE LETTER "U" IN THE WORD "CELLULAR" REPRESENTS THE IMAGE OF A PHONE WITH VOLUME VIBRATIONS.

SEC. 2(F).
 FOR ON-LINE RETAIL STORE SERVICES FEATURING PHONES, CAMERAS, COMPUTERS, MP3 PLAYERS AND PRINTER ACCESSORIES (U.S. CLS. 100, 101 AND 102).
 FIRST USE 9-0-1999; IN COMMERCE 9-9-1999.
 TINA MAI, EXAMINING ATTORNEY

SN 85-514,022. THE PENNSYLVANIA INDEPENDENT OIL AND GAS ASSOCIATION, WEXFORD, PA. FILED 1-11-2012.

**Pennsylvania: The
 Keystone to America's
 Energy Future**

THE MARK CONSISTS OF STANDARD CHARACTERS WITHOUT CLAIM TO ANY PARTICULAR FONT, STYLE, SIZE, OR COLOR.
 FOR TRADE ASSOCIATION SERVICES, NAMELY, PROMOTING THE INTERESTS OF PENNSYLVANIA INDEPENDENT OIL AND NATURAL GAS PRODUCERS, MARKETERS, SERVICE COMPANIES AND RELATED BUSINESSES (U.S. CLS. 100, 101 AND 102).
 FIRST USE 4-0-2010; IN COMMERCE 4-0-2010.
 DORITT L. CARROLL, EXAMINING ATTORNEY

SN 85-514,050. ELYTICO, LLC, SOLON, OH. FILED 1-11-2012.

FAIRFARE

THE MARK CONSISTS OF STANDARD CHARACTERS WITHOUT CLAIM TO ANY PARTICULAR FONT, STYLE, SIZE, OR COLOR.
 FOR COST AND PROFIT ANALYSIS; COST, PROFIT AND PRICE ANALYSIS FOR AIRFARE PRICES (U.S. CLS. 100, 101 AND 102).
 ELI HELLMAN, EXAMINING ATTORNEY

CLASS 35—(Continued).

SN 85-514,053. LITTLE GENERAL STORE, INC., BECKLEY, WV. FILED 1-11-2012.

LITTLE GENERAL

THE MARK CONSISTS OF STANDARD CHARACTERS WITHOUT CLAIM TO ANY PARTICULAR FONT, STYLE, SIZE, OR COLOR.
 FOR RETAIL STORE SERVICES FEATURING CONVENIENCE STORE ITEMS AND GASOLINE (U.S. CLS. 100, 101 AND 102).
 FIRST USE 6-1-1975; IN COMMERCE 6-1-1975.
 MAYUR VAGHANI, EXAMINING ATTORNEY

SN 85-514,162. STADIUM WRAP AMERICA, LLC, JACKSON, MS. FILED 1-12-2012.



THE MARK CONSISTS OF THE WORD "SOLO" IN LARGE LETTERS, WITH A SILHOUETTE OF A MAN IN PLACE OF THE "L" AND THE WORD "ENDORSE" CONTAINED INSIDE OF THE SECOND "O".
 FOR ADVERTISING, MARKETING AND PROMOTION SERVICES (U.S. CLS. 100, 101 AND 102).
 FIRST USE 12-15-2011; IN COMMERCE 12-15-2011.
 MICHAEL KEATING, EXAMINING ATTORNEY

SN 85-514,249. FULTON, STANLEY, SARASOTA, FL. FILED 1-11-2012.

**GOOD FRIENDS YOU CAN TRUST
 ... HOPEFULLY!**

THE MARK CONSISTS OF STANDARD CHARACTERS WITHOUT CLAIM TO ANY PARTICULAR FONT, STYLE, SIZE, OR COLOR.
 FOR COOPERATIVE ADVERTISING AND MARKETING; PROVIDING A WEB SITE WHERE USERS CAN POST RATINGS, REVIEWS AND RECOMMENDATIONS ON PRODUCTS AND SERVICES FOR COMMERCIAL PURPOSES (U.S. CLS. 100, 101 AND 102).
 HELENE LIWINSKI, EXAMINING ATTORNEY

CLASS 35—(Continued).

SN 85-514,275. ADJECTIVES, INC., WINTER PARK, FL. FILED 1-11-2012.

ADJECTIVES

THE MARK CONSISTS OF STANDARD CHARACTERS WITHOUT CLAIM TO ANY PARTICULAR FONT, STYLE, SIZE, OR COLOR.

FOR MARKETING, ADVERTISING, AND PROMOTING THE RETAIL GOODS AND SERVICES OF OTHERS THROUGH WIRELESS ELECTRONIC DEVICES; ON-LINE RETAIL CONSIGNMENT STORES FEATURING A WIDE VARIETY OF CONSUMER GOODS; ON-LINE RETAIL STORE SERVICES FEATURING A WIDE VARIETY OF CONSUMER GOODS OF OTHERS; ONLINE SERVICE FOR CONNECTING SOCIAL NETWORK USERS WITH RETAILERS FOR THE PURPOSE OF FACILITATING DISCOUNTED PURCHASES; RETAIL APPAREL STORES; RETAIL CLOTHING BOUTIQUES; RETAIL CONSIGNMENT STORES IN THE FIELD OF A WIDE VARIETY OF CONSUMER GOODS; RETAIL FURNITURE STORES; RETAIL GIFT SHOPS; RETAIL JEWELRY STORES; RETAIL MARKETS FEATURING A WIDE VARIETY OF CONSUMER GOODS; RETAIL STORE SERVICES FEATURING A WIDE VARIETY OF CONSUMER GOODS OF OTHERS; RETAIL VARIETY STORES (U.S. CLS. 100, 101 AND 102).

KAREN K. BUSH, EXAMINING ATTORNEY

SN 85-514,443. CENTER FOR ART AND THOUGHT, INC., LOS ANGELES, CA. FILED 1-11-2012.

Center for Art and Thought

THE MARK CONSISTS OF STANDARD CHARACTERS WITHOUT CLAIM TO ANY PARTICULAR FONT, STYLE, SIZE, OR COLOR.

NO CLAIM IS MADE TO THE EXCLUSIVE RIGHT TO USE "CENTER FOR ART", APART FROM THE MARK AS SHOWN.

FOR ART GALLERY SERVICES; COMMISSIONING OF WORKS OF ART; ON-LINE ART GALLERIES; PROMOTING THE GRAPHIC ARTS DESIGN SERVICES OF OTHERS BY MEANS OF A WEBSITE FEATURING GRAPHIC ARTWORK SUBMITTED BY GRAPHIC ART DESIGNERS; PROMOTING VISUAL AND PERFORMING ARTS EVENTS BY MEANS OF PROVIDING AN ONLINE EVENTS CALENDAR, ORIGINAL ARTICLES, INTERVIEWS, AND INFORMATION ABOUT ART, ARTISTS AND ARTS EVENTS VIA AN INTERNET WEB SITE, ALL FOR PROMOTIONAL PURPOSES (U.S. CLS. 100, 101 AND 102).

FIRST USE 12-20-2011; IN COMMERCE 12-20-2011.

SHARON MEIER, EXAMINING ATTORNEY

CLASS 35—(Continued).

SN 85-514,444. VCOUNSEL LLC, DALLAS, TX. FILED 1-11-2012.

VCOUNSEL

THE MARK CONSISTS OF STANDARD CHARACTERS WITHOUT CLAIM TO ANY PARTICULAR FONT, STYLE, SIZE, OR COLOR.

FOR ASSISTANCE, ADVISORY SERVICES AND CONSULTANCY WITH REGARD TO BUSINESS PLANNING, BUSINESS ANALYSIS, BUSINESS MANAGEMENT, AND BUSINESS ORGANIZATION; BUSINESS ADMINISTRATION CONSULTANCY; BUSINESS ADVISORY SERVICES, CONSULTANCY AND INFORMATION; BUSINESS CONSULTANCY; BUSINESS CONSULTATION; BUSINESS CONSULTATION SERVICES; BUSINESS CONSULTATION SERVICES, NAMELY, BUSINESS PROCESS IMPROVEMENT AND ENTERPRISE ARCHITECTURE DESIGN; BUSINESS CONSULTING AND BUSINESS INFORMATION FOR ENTERPRISES; BUSINESS CONSULTING AND INFORMATION SERVICES; BUSINESS CONSULTING IN THE CONSUMER PRODUCTS INDUSTRY; BUSINESS CONSULTING SERVICES, NAMELY, PROVIDING ASSISTANCE IN DEVELOPMENT OF BUSINESS STRATEGIES AND CREATIVE IDEATION; BUSINESS CONSULTING, MANAGEMENT, PLANNING AND SUPERVISION; BUSINESS DEVELOPMENT CONSULTING SERVICES; BUSINESS ORGANISATION CONSULTING; BUSINESS ORGANIZATION AND OPERATION CONSULTANCY; BUSINESS ORGANIZATION CONSULTING; BUSINESS ORGANIZATIONAL CONSULTATION; BUSINESS SERVICES, NAMELY, STRUCTURING, OPTIMIZING AND CHANGE MANAGEMENT CONSULTING RELATED TO CORPORATE IN-HOUSE INTELLECTUAL PROPERTY DEPARTMENTS AND INTELLECTUAL PROPERTY ASSET MANAGEMENT PROGRAMS; CONSULTANCY AND ADVISORY SERVICES IN THE FIELD OF BUSINESS STRATEGY; CONSULTANCY SERVICES REGARDING BUSINESS STRATEGIES; CONSULTING SERVICES IN BUSINESS ORGANIZATION AND MANAGEMENT; CONSULTING SERVICES IN THE AREA OF SUSTAINABLE BUSINESS SOLUTIONS (U.S. CLS. 100, 101 AND 102).

SHARON MEIER, EXAMINING ATTORNEY

SN 85-514,482. WALTER, GREGORY, COPPELL, TX. AND HOPSON, DAN, COPPELL, TX. FILED 1-11-2012.

iPitchPro

THE STIPPLING IS FOR SHADING PURPOSES ONLY. THE MARK CONSISTS OF THE STYLIZED TEXT "IPITCHPRO" WITH A CIRCLE RIGHT POINTING ARROW INSIDE.

FOR ADVERTISING AND MARKETING (U.S. CLS. 100, 101 AND 102).

FIRST USE 9-22-2011; IN COMMERCE 11-30-2011.

SEAN CROWLEY, EXAMINING ATTORNEY

CLASS 35—(Continued).

SN 85-514,603. AMIR-ALIKHANI, SHIRIN, COLFAX, CA. AND HEE, MICHAEL DAVID VAN, COLFAX, CA. FILED 1-12-2012.

SWEET LOLA

THE MARK CONSISTS OF STANDARD CHARACTERS WITHOUT CLAIM TO ANY PARTICULAR FONT, STYLE, SIZE, OR COLOR.

FOR WHOLESALE STORE SERVICES FEATURING JEWELRY AND COSTUME JEWELRY; WHOLESALE ORDERING SERVICES IN THE FIELD OF JEWELRY AND COSTUME JEWELRY; WHOLESALE DISTRIBUTORSHIPS FEATURING JEWELRY AND COSTUME JEWELRY; ON-LINE RETAIL STORE SERVICES AND RETAIL STORE SERVICES FEATURING JEWELRY AND COSTUME JEWELRY (U.S. CLS. 100, 101 AND 102).
FIRST USE 5-1-2010; IN COMMERCE 7-20-2010.
ALAIN LAPTER, EXAMINING ATTORNEY

CLASS 35—(Continued).

SN 85-514,689. LOYALTY LOCK, DBA REPEAT RETURNS, LAS VEGAS, NV. FILED 1-12-2012.

FRIEND FACTORY

THE MARK CONSISTS OF STANDARD CHARACTERS WITHOUT CLAIM TO ANY PARTICULAR FONT, STYLE, SIZE, OR COLOR.

FOR ADVERTISEMENT FOR OTHERS ON THE INTERNET; ON-LINE ADVERTISING AND MARKETING SERVICES; PROVIDING ADVERTISING, MARKETING AND PROMOTIONAL SERVICES, NAMELY, DEVELOPMENT OF ADVERTISING CAMPAIGNS FOR BUILDING ONLINE COMMUNITIES, INCREASING REPEAT CUSTOMER ACTIVITY, AND REWARDING CUSTOMER LOYALTY AND CUSTOMER REFERRALS (U.S. CLS. 100, 101 AND 102).
FIRST USE 1-5-2012; IN COMMERCE 1-5-2012.
DORITT L. CARROLL, EXAMINING ATTORNEY

SN 85-514,606. AMIR-ALIKHANI, SHIRIN, COLFAX, CA. AND HEE, MICHAEL DAVID VAN, COLFAX, CA. FILED 1-12-2012.

SWEET LOLA

THE MARK CONSISTS OF THE LITERAL ELEMENTS "SWEET LOLA" WRITTEN IN STYLIZED FORM, WHEREIN THE ALPHABET "O" IN THE WORD "LOLA" DEPICTS AN IMAGE OF A FLOWER AS SHOWN IN THE MARK.

FOR WHOLESALE STORE SERVICES FEATURING JEWELRY AND COSTUME JEWELRY; WHOLESALE ORDERING SERVICES IN THE FIELD OF JEWELRY AND COSTUME JEWELRY; WHOLESALE DISTRIBUTORSHIPS FEATURING JEWELRY AND COSTUME JEWELRY; ON-LINE RETAIL STORE SERVICES AND RETAIL STORE SERVICES FEATURING JEWELRY AND COSTUME JEWELRY (U.S. CLS. 100, 101 AND 102).
FIRST USE 5-1-2010; IN COMMERCE 7-20-2010.
ALAIN LAPTER, EXAMINING ATTORNEY

SN 85-514,734. EXCENTUS CORPORATION, DALLAS, TX. FILED 1-12-2012.

CENTEGO

THE MARK CONSISTS OF STANDARD CHARACTERS WITHOUT CLAIM TO ANY PARTICULAR FONT, STYLE, SIZE, OR COLOR.

OWNER OF U.S. REG. NO. 3,007,788.
FOR PROMOTION OF THE GOODS AND SERVICES OF OTHERS VIA CONSUMER PROMOTION PROGRAMS THAT PROVIDE REWARDS ON DEFINED PRODUCTS AND SERVICES (U.S. CLS. 100, 101 AND 102).
FIRST USE 7-15-2010, THE MARK WAS FIRST USED ANYWHERE IN A DIFFERENT FORM OTHER THAN THAT SOUGHT TO BE REGISTERED AT LEAST AS EARLY AS 03/10/2003; IN COMMERCE 8-1-2010, THE MARK WAS FIRST USED IN COMMERCE IN A DIFFERENT FORM OTHER THAN THAT SOUGHT TO BE REGISTERED AT LEAST AS EARLY AS 03/10/2003.
ERIN FALK, EXAMINING ATTORNEY

CLASS 35—(Continued).

SN 85-514,793. INTELLECT RESOURCES, INC., GREENSBORO, NC. FILED 1-12-2012.



FOR ARRANGING AND CONDUCTING SPECIAL EVENTS FOR BUSINESS PURPOSES; MANAGEMENT AND BUSINESS CONSULTING SERVICES IN THE FIELD OF TRAINING AND RECRUITMENT (U.S. CLS. 100, 101 AND 102).

FIRST USE 11-16-2011; IN COMMERCE 11-16-2011.
KATHRYN COWARD, EXAMINING ATTORNEY

SN 85-514,886. REQUESTMASTER, LLC, MIAMI, FL. FILED 1-12-2012.

Recommendations from people you trust

THE MARK CONSISTS OF STANDARD CHARACTERS WITHOUT CLAIM TO ANY PARTICULAR FONT, STYLE, SIZE, OR COLOR.

FOR PROVIDING A WEB SITE WHERE USERS CAN POST RATINGS, REVIEWS AND RECOMMENDATIONS ON PRODUCTS AND SERVICES FOR COMMERCIAL PURPOSES (U.S. CLS. 100, 101 AND 102).

FIRST USE 1-12-2012; IN COMMERCE 1-12-2012.
MIDGE BUTLER, EXAMINING ATTORNEY

SN 85-514,921. ENERGY EDUCATION, INC., DALLAS, TX. FILED 1-12-2012.

OPTI-COMMISSIONING

THE MARK CONSISTS OF STANDARD CHARACTERS WITHOUT CLAIM TO ANY PARTICULAR FONT, STYLE, SIZE, OR COLOR.

FOR CONSULTATION IN THE FIELD OF ENERGY EFFICIENCY; ENERGY AUDITING; ENERGY USAGE MANAGEMENT; ENERGY USAGE MANAGEMENT INFORMATION SERVICES; INFORMATION IN THE FIELD OF ENERGY EFFICIENCY (U.S. CLS. 100, 101 AND 102).

ELIZABETH HUGHITT, EXAMINING ATTORNEY

CLASS 35—(Continued).

SN 85-514,986. BACKSTAGE CREATIONS, INC., SANTA MONICA, CA. FILED 1-12-2012.

Giving Suite

THE MARK CONSISTS OF STANDARD CHARACTERS WITHOUT CLAIM TO ANY PARTICULAR FONT, STYLE, SIZE, OR COLOR.

FOR ADVERTISING, MARKETING, AND PROMOTING THE GOODS AND SERVICES OF OTHERS VIA CELEBRITY EVENTS AND GIFT SUITES; ARRANGING AND CONDUCTING MARKETING PROMOTIONAL EVENTS FOR OTHERS; CHARITABLE SERVICES, NAMELY, COORDINATION OF THE PROCUREMENT AND DISTRIBUTION OF GIFT-IN-KIND PRODUCT DONATIONS FROM MANUFACTURERS, WHOLESALERS, RETAILERS, AND GOVERNMENT AGENCIES TO ORGANIZATIONS PROVIDING FREE PRODUCTS TO NEEDY PEOPLE; EVENT PLANNING AND MANAGEMENT FOR MARKETING, BRANDING, PROMOTING OR ADVERTISING THE GOODS AND SERVICES OF OTHERS (U.S. CLS. 100, 101 AND 102).

FIRST USE 8-3-2011; IN COMMERCE 8-3-2011.
KAREN K. BUSH, EXAMINING ATTORNEY

SN 85-515,001. CALLAWAY CONSOLIDATED, INC., TUCKER, GA. FILED 1-12-2012.

THE PARTS BEHIND THE PRETTY...

THE MARK CONSISTS OF STANDARD CHARACTERS WITHOUT CLAIM TO ANY PARTICULAR FONT, STYLE, SIZE, OR COLOR.

FOR RETAIL STORE SERVICES FEATURING JEWELRY AND UNASSEMBLED JEWELRY, NAMELY RINGS, WEDDING BANDS, EARRINGS, NECKLACES, CHAINS, PENDANTS, COIN-FRAMES, SETTINGS, BRACELETS, BROOCHES, BEADS, FINDINGS, SHANKS, MOUNTINGS, SOLITAIRES, DIAMONDS, GEMSTONES, SOLDER AND RAW PRECIOUS METALS FOR THE MANUFACTURE OF JEWELRY; WHOLESALE STORE SERVICES FEATURING JEWELRY AND UNASSEMBLED JEWELRY, NAMELY RINGS, WEDDING BANDS, EARRINGS, NECKLACES, CHAINS, PENDANTS, COIN-FRAMES, SETTINGS, BRACELETS, BROOCHES, BEADS, FINDINGS, SHANKS, MOUNTINGS, SOLITAIRES, DIAMONDS, GEMSTONES, SOLDER AND RAW PRECIOUS METALS FOR THE MANUFACTURE OF JEWELRY (U.S. CLS. 100, 101 AND 102).

FIRST USE 1-6-2012; IN COMMERCE 1-6-2012.
ANNE E. GUSTASON, EXAMINING ATTORNEY

CLASS 35—(Continued).

SN 85-515,064. NUOGEN LLC, RIDGEFIELD, NJ. FILED 1-12-2012.

RAYNOTAX

THE MARK CONSISTS OF STANDARD CHARACTERS WITHOUT CLAIM TO ANY PARTICULAR FONT, STYLE, SIZE, OR COLOR.

NO CLAIM IS MADE TO THE EXCLUSIVE RIGHT TO USE "TAX", APART FROM THE MARK AS SHOWN.

FOR TAX FILING SERVICES; TAX PREPARATION (U.S. CLS. 100, 101 AND 102).

FIRST USE 10-31-2011; IN COMMERCE 10-31-2011.
CHRIS WELLS, EXAMINING ATTORNEY

SN 85-515,109. SPARKBASE, INC., CLEVELAND, OH. FILED 1-12-2012.

SOCIAL WALLET

THE MARK CONSISTS OF STANDARD CHARACTERS WITHOUT CLAIM TO ANY PARTICULAR FONT, STYLE, SIZE, OR COLOR.

FOR PROVIDING INCENTIVE AND LOYALTY AWARDS PROGRAMS FOR CUSTOMERS INVOLVING ISSUANCE, DISTRIBUTION, SHARING AND PROCESSING OF INCENTIVES FOR USE WITH PARTICIPATING BUSINESSES (U.S. CLS. 100, 101 AND 102).

NATALIE POLZER, EXAMINING ATTORNEY

SN 85-515,142. LOGOVISION, LLC, TROY, MI. FILED 1-12-2012.



OWNER OF U.S. REG. NOS. 2,223,679 AND 2,243,483.
THE MARK CONSISTS OF THE WORD "LOGOVISION" WITH A STYLIZED LETTER "V".

FOR PROCUREMENT, NAMELY, PURCHASING GENERAL MERCHANDISE, IN THE NATURE OF PROMOTIONAL GOODS BEARING CUSTOMIZED GRAPHIC DESIGNS AND INSIGNIA FOR OTHERS (U.S. CLS. 100, 101 AND 102).

FIRST USE 11-30-1999; IN COMMERCE 11-30-1999.
JOHN DALIER, EXAMINING ATTORNEY

CLASS 35—(Continued).

SN 85-515,265. FIRST BUSEY CORPORATION, URBANA, IL. FILED 1-12-2012.

BUSEY AG SERVICES

THE MARK CONSISTS OF STANDARD CHARACTERS WITHOUT CLAIM TO ANY PARTICULAR FONT, STYLE, SIZE, OR COLOR.

OWNER OF U.S. REG. NOS. 3,153,643, 3,457,634 AND OTHERS.

NO CLAIM IS MADE TO THE EXCLUSIVE RIGHT TO USE "AG SERVICES", APART FROM THE MARK AS SHOWN.

FOR BUSINESS CONSULTING SERVICES IN THE AGRICULTURAL FIELD (U.S. CLS. 100, 101 AND 102).

FIRST USE 11-10-2011; IN COMMERCE 11-10-2011.
ADA HAN, EXAMINING ATTORNEY

SN 85-515,344. LOYALTY LOCK, DBA REPEAT RETURNS, LAS VEGAS, NV. FILED 1-12-2012.

CHATTERBOX

THE MARK CONSISTS OF STANDARD CHARACTERS WITHOUT CLAIM TO ANY PARTICULAR FONT, STYLE, SIZE, OR COLOR.

FOR ONLINE ADVERTISING SERVICES FOR OTHERS, NAMELY SENDING ADVERTISING AND OFFERS BY EMAIL, THROUGH ONLINE SOCIAL NETWORKS, AND BY ELECTRONIC COMMUNICATION TO MOBILE DEVICES, TO ENCOURAGE CUSTOMER REPEAT BUSINESS AND CUSTOMER REFERRALS (U.S. CLS. 100, 101 AND 102).

FIRST USE 12-1-2011; IN COMMERCE 12-1-2011.
DORITT L. CARROLL, EXAMINING ATTORNEY

SN 85-515,418. ENUMAY CORP, ASTORIA, NY. FILED 1-12-2012.



THE MARK CONSISTS OF STANDARD CHARACTERS WITHOUT CLAIM TO ANY PARTICULAR FONT, STYLE, SIZE, OR COLOR.

FOR ON-LINE ORDERING SERVICES IN THE FIELD OF RESTAURANT TAKE-OUT AND DELIVERY (U.S. CLS. 100, 101 AND 102).

FIRST USE 12-1-2009; IN COMMERCE 12-1-2009.
CARYN GLASSER, EXAMINING ATTORNEY

CLASS 35—(Continued).

SN 85-515,433. ALL THE TASTES OF NEW YORK LLC, NEW YORK, NY. FILED 1-12-2012.

All The Tastes Of New York
- Food Crawling at its Finest

THE MARK CONSISTS OF STANDARD CHARACTERS WITHOUT CLAIM TO ANY PARTICULAR FONT, STYLE, SIZE, OR COLOR.

FOR SPECIAL EVENT PLANNING FOR COMMERCIAL, PROMOTIONAL OR ADVERTISING PURPOSES (U.S. CLS. 100, 101 AND 102).

JORDAN BAKER, EXAMINING ATTORNEY

SN 85-515,519. ID ANALYTICS, INC., SAN DIEGO, CA. FILED 1-12-2012.

RESOLVE360

THE MARK CONSISTS OF STANDARD CHARACTERS WITHOUT CLAIM TO ANY PARTICULAR FONT, STYLE, SIZE, OR COLOR.

FOR BUSINESS CONSULTATION SERVICES IN THE FIELDS OF REGULATION COMPLIANCE, IDENTITY VERIFICATION, IDENTITY FRAUD AND IDENTITY THEFT (U.S. CLS. 100, 101 AND 102).

DAVID TOOLEY, EXAMINING ATTORNEY

SN 85-515,568. DICKINSON, STEVEN, EAST NORTHPORT, NY. AND KALLMAN, DAVID, EAST NORTHPORT, NY. FILED 1-12-2012.

Unisun

THE MARK CONSISTS OF STANDARD CHARACTERS WITHOUT CLAIM TO ANY PARTICULAR FONT, STYLE, SIZE, OR COLOR.

FOR ON-LINE RETAIL STORE SERVICES FEATURING SUNGLASSES AND ACCESSORIES RELATED TO SUNGLASSES, T SHIRTS (U.S. CLS. 100, 101 AND 102).

MARK SPARACINO, EXAMINING ATTORNEY

CLASS 35—(Continued).

SN 85-515,615. HUMAN CAPITAL MANAGEMENT INSTITUTE, LLC, MARINA DEL REY, CA. FILED 1-13-2012.

SOLVE

THE MARK CONSISTS OF STANDARD CHARACTERS WITHOUT CLAIM TO ANY PARTICULAR FONT, STYLE, SIZE, OR COLOR.

FOR HUMAN RESOURCE ANALYSIS AND CONSULTING SERVICES (U.S. CLS. 100, 101 AND 102).

JULIE GUTTADAURO, EXAMINING ATTORNEY

SN 85-515,627. CHARLOTTE ALLIANCE FOR A SAFE AND DRUG FREE COMMUNITY., DBA DRUG FREE CHARLOTTE COUNTY, PORT CHARLOTTE, FL. FILED 1-13-2012.

VERIFY TRUTH

THE MARK CONSISTS OF STANDARD CHARACTERS WITHOUT CLAIM TO ANY PARTICULAR FONT, STYLE, SIZE, OR COLOR.

FOR CHARITABLE SERVICES, NAMELY, PROMOTING PUBLIC AWARENESS OF AN ANTI-DRUG COALITION CAMPAIGN, PROMOTING DRUG-TESTING (U.S. CLS. 100, 101 AND 102).

DAVID MURRAY, EXAMINING ATTORNEY

SN 85-515,710. FAIRFAX COUNTY ECONOMIC DEVELOPMENT AUTHORITY, TYSONS CORNER, VA. FILED 1-13-2012.

ONE OF THE GREAT ECONOMIC
SUCCESS STORIES OF OUR TIME

THE MARK CONSISTS OF STANDARD CHARACTERS WITHOUT CLAIM TO ANY PARTICULAR FONT, STYLE, SIZE, OR COLOR.

FOR PROMOTING THE ECONOMIC DEVELOPMENT OF FAIRFAX COUNTY, VA (U.S. CLS. 100, 101 AND 102).

WILLIAM BRECKENFELD, EXAMINING ATTORNEY

CLASS 35—(Continued).

SN 85-515,715. SPRINGLEAF STRATEGIES LLC, 27624, NC. FILED 1-13-2012.



NO CLAIM IS MADE TO THE EXCLUSIVE RIGHT TO USE "STRATEGIES", APART FROM THE MARK AS SHOWN.

THE COLOR(S) BROWN AND GREEN IS/ARE CLAIMED AS A FEATURE OF THE MARK.

THE MARK CONSISTS OF "SPRINGLEAF" IN BROWN LARGE STYLIZED FONT WITH A GREEN CIRCLE WITH LEAVES WITHIN IT. BELOW "SPRINGLEAF" IS "STRATEGIES" IN SMALLER BROWN STYLIZED FONT. WHITE IS NOT A FEATURE OF THE MARK, BUT BACKGROUND.

FOR BUSINESS CONSULTING SERVICE THAT PROVIDES TRANSFORMATIONAL STRATEGIES TO COMPANIES WISHING TO MOVE TOWARDS SUSTAINABILITY AND SOCIALLY RESPONSIBLE BUSINESS PRACTICES, PROVIDED MAINLY TO THE CONSUMER PRODUCTS INDUSTRY; BUSINESS CONSULTING SERVICES RELATING TO THE INTEGRATION OF THE AREAS OF BUSINESS PROCESS TECHNOLOGY, ORGANIZATIONAL LEARNING, CHANGE MANAGEMENT, AND OPERATIONAL SUSTAINABILITY; MARKETING CONSULTING (U.S. CLS. 100, 101 AND 102).

FIRST USE 4-1-2008; IN COMMERCE 4-1-2008.
BARBARA GAYNOR, EXAMINING ATTORNEY

SN 85-515,756. EXPANSE ENTERPRISES, SNELLVILLE, GA. FILED 1-13-2012.

Do Good Get Rewards

THE MARK CONSISTS OF STANDARD CHARACTERS WITHOUT CLAIM TO ANY PARTICULAR FONT, STYLE, SIZE, OR COLOR.

FOR PROVIDING AN ONLINE VOLUNTEER REWARDS PROGRAM, WHEREIN VOLUNTEERS CAN EARN POINTS FOR HOURS SERVED, AND REDEEM THEM FOR COUPONS AND GIFT CERTIFICATES THAT ARE PROVIDED BY BUSINESSES, FOR CUSTOMER ACQUISITION (U.S. CLS. 100, 101 AND 102).

FIRST USE 1-10-2009; IN COMMERCE 1-10-2009.
APRIL ROACH, EXAMINING ATTORNEY

CLASS 35—(Continued).

SN 85-515,884. BUSINESS WORLD RISING, INC., DBA BUSINESS WOMEN RISING, INC., NEWPORT BEACH, CA. FILED 1-13-2012.

Infinite-Win

THE MARK CONSISTS OF STANDARD CHARACTERS WITHOUT CLAIM TO ANY PARTICULAR FONT, STYLE, SIZE, OR COLOR.

FOR BUSINESS CONSULTATION IN THE FIELD OF BUSINESS LEADERSHIP DEVELOPMENT; BUSINESS MANAGEMENT AND CONSULTATION IN THE FIELD OF EXECUTIVE, PROFESSIONAL AND LEADERSHIP DEVELOPMENT; BUSINESS MANAGEMENT CONSULTATION IN THE FIELD OF EXECUTIVE AND LEADERSHIP DEVELOPMENT; CONSULTING SERVICES IN BUSINESS LEADERSHIP DEVELOPMENT AND BUSINESS MANAGEMENT; MANAGEMENT AND BUSINESS CONSULTING SERVICES IN THE FIELD OF MANAGEMENT AND TRANSFORMATIONAL LEADERSHIP DEVELOPMENT; MANAGEMENT CONSULTING AND ADVISORY SERVICES IN THE AREAS OF CORPORATE GROWTH STRATEGY, INNOVATION AND GROWTH PROCESSES, ORGANIZATIONAL TRANSFORMATION, AND TALENT MANAGEMENT AND DEVELOPMENT STRATEGIES (U.S. CLS. 100, 101 AND 102).

FIRST USE 12-22-2011; IN COMMERCE 1-4-2012.
JAMES LOVELACE, EXAMINING ATTORNEY

SN 85-515,912. ZELLNER, QUANDRA, STONE MOUNTAIN, GA. FILED 1-13-2012.

Blessed Divas

THE MARK CONSISTS OF STANDARD CHARACTERS WITHOUT CLAIM TO ANY PARTICULAR FONT, STYLE, SIZE, OR COLOR.

FOR CHARITABLE SERVICES, NAMELY, ORGANIZING AND CONDUCTING VOLUNTEER PROGRAMS AND COMMUNITY SERVICE PROJECTS (U.S. CLS. 100, 101 AND 102).

FIRST USE 12-30-2010; IN COMMERCE 12-30-2010.
JENNY PARK, EXAMINING ATTORNEY

SN 85-515,928. BIRDS2BLOSSOMS LLC, EAST SANDWICH, MA. FILED 1-13-2012.

Birds2Blossoms

THE MARK CONSISTS OF STANDARD CHARACTERS WITHOUT CLAIM TO ANY PARTICULAR FONT, STYLE, SIZE, OR COLOR.

FOR ON-LINE RETAIL STORE SERVICES FEATURING A WIDE VARIETY OF CONSUMER GOODS OF OTHERS (U.S. CLS. 100, 101 AND 102).

THOMAS MANOR, EXAMINING ATTORNEY

CLASS 35—(Continued).

SN 85-515,932. STAR GROUP COMMUNICATIONS, INC.,
VOORHEES, NJ. FILED 1-13-2012.

Synegrated

THE MARK CONSISTS OF STANDARD CHARACTERS WITHOUT CLAIM TO ANY PARTICULAR FONT, STYLE, SIZE, OR COLOR.

FOR ADVERTISING, PROMOTION, AND MARKETING SERVICES IN THE NATURE OF DEVELOPING COMPREHENSIVE AND FULLY INTEGRATED COMMUNICATIONS PROGRAMS CREATED BY MULTIPLE TEAM MEMBERS FOR BUSINESSES DESIRING COMPLETE ADVERTISING, PUBLIC RELATIONS, AND MARKETING OF THEIR GOODS AND SERVICES (U.S. CLS. 100, 101 AND 102).

FIRST USE 8-1-2010; IN COMMERCE 8-1-2010.
STEVEN R. FINE, EXAMINING ATTORNEY

SN 85-515,943. MCPHILLIPS, EILEEN, M., AKA BRAND
LAB, SALEM TWP, ME. FILED 1-13-2012.



THE COLOR(S) RED AND VARYING SHADES OF RED AND ORANGE IS/ARE CLAIMED AS A FEATURE OF THE MARK.

THE MARK CONSISTS OF "BRAND LAB" LOGOTYPE IS RED; LOGOTYPE IS STYLIZED WITH WHITE HIGHLIGHTS FOR 3D EFFECT. BUBBLES AND CLOUD ARE VARYING SHADES OF RED AND ORANGE; A HIGHLIGHT APPLIED TO BUBBLES AND CLOUD GIVES DIMENSIONALITY.

FOR ADVERTISING AGENCY SPECIALIZING IN THE DESIGN AND EXECUTION OF WORD OF MOUTH, VIRAL, BUZZ AND EXPERIENTIAL MARKETING PROGRAMS; ADVERTISING AND MARKETING; ADVERTISING AND MARKETING CONSULTANCY; ADVERTISING AND MARKETING SERVICES PROVIDED BY MEANS OF INDIRECT METHODS OF MARKETING COMMUNICATIONS, NAMELY, SOCIAL MEDIA, SEARCH ENGINE MARKETING, INQUIRY MARKETING, INTERNET MARKETING, MOBILE MARKETING, BLOGGING AND OTHER FORMS OF PASSIVE, SHARABLE OR VIRAL COMMUNICATIONS CHANNELS; ADVERTISING AND MARKETING SERVICES, NAMELY, PROMOTING THE GOODS AND SERVICES OF OTHERS; ADVERTISING SERVICES, NAMELY, PROMOTING AND MARKETING THE GOODS AND SERVICES OF OTHERS THROUGH ALL PUBLIC COMMUNICATION MEANS; ADVERTISING, MARKETING AND PROMOTING THE GOODS AND SERVICES OF OTHERS USING KIOSKS; ADVERTISING, MARKETING AND PROMOTION SERVICES; ADVERTISING, MARKETING AND PROMOTIONAL SERVICES FOR THE DONATION OF HUMAN BLOOD THAT EXACTLY MATCHES THE BLOOD TYPE OF INDIVIDUALS NEEDING TRANSFUSIONS; ADVERTISING, MARKETING AND PROMOTIONAL SERVICES RE-

CLASS 35—(Continued).

LATED TO ALL INDUSTRIES FOR THE PURPOSE OF FACILITATING NETWORKING AND SOCIALIZING OPPORTUNITIES FOR BUSINESS PURPOSES; ADVERTISING, PROMOTION AND MARKETING SERVICES BASED ON CONSUMER CREDIT REPORTS AND SCORES OF OTHERS; ADVERTISING, PROMOTION AND MARKETING SERVICES IN THE NATURE OF E-MAIL BLAST CAMPAIGNS FOR OTHERS; ADVICE CONCERNING CHEMICAL PRODUCT MARKETING; ADVICE IN THE FIELD OF BUSINESS MANAGEMENT AND MARKETING; ANALYSIS OF MARKET RESEARCH DATA AND STATISTICS; ANALYZING AND COMPILING DATA FOR MEASURING THE PERFORMANCE OF FINANCIAL MARKETS; ARRANGING AND CONDUCTING MARKETING PROMOTIONAL EVENTS FOR OTHERS; ASSISTANCE, ADVISORY SERVICES AND CONSULTANCY WITH REGARD TO BUSINESS PLANNING, BUSINESS ANALYSIS, BUSINESS MANAGEMENT, BUSINESS ORGANIZATION, MARKETING AND CUSTOMER ANALYSIS; BRANDING SERVICES, NAMELY, CONSULTING, DEVELOPMENT, MANAGEMENT AND MARKETING OF BRANDS FOR BUSINESSES; BUSINESS ADVICE AND ANALYSIS OF MARKETS; BUSINESS CONSULTATION AND MANAGEMENT REGARDING MARKETING ACTIVITIES AND LAUNCHING OF NEW PRODUCTS; BUSINESS MANAGEMENT CONSULTING WITH RELATION TO STRATEGY, MARKETING, PRODUCTION, PERSONNEL AND RETAIL SALE MATTERS; BUSINESS MARKETING CONSULTING SERVICES; BUSINESS MARKETING CONSULTING SERVICES TO CHILD-CARE ORGANIZATIONS; BUSINESS MARKETING SERVICES; BUSINESS MONITORING AND CONSULTING SERVICES, NAMELY, TRACKING WEB SITES AND APPLICATIONS OF OTHERS TO PROVIDE STRATEGY, INSIGHT, MARKETING, SALES, OPERATION, PRODUCT DESIGN, PARTICULARLY SPECIALIZING IN THE USE OF ANALYTIC AND STATISTIC MODELS FOR THE UNDERSTANDING AND PREDICTING OF CONSUMERS, BUSINESSES, AND MARKET TRENDS AND ACTIONS; BUSINESS TO BUSINESS DIRECT MARKETING SERVICES; COLLECTION OF MARKET RESEARCH INFORMATION; COMMERCIAL INFORMATION AGENCIES; COMPILING FINANCIAL, SECURITIES, STOCK EXCHANGE, TRADE AND QUOTE, INDEX VALUE AND OTHER FINANCIAL MARKET INFORMATION FOR BUSINESS PURPOSES; COMPUTERIZED MARKET RESEARCH SERVICES; CONDUCTING BUSINESS AND MARKET RESEARCH SURVEYS; CONDUCTING MARKET SURVEYS; CONDUCTING MARKETING STUDIES; CONSULTATION SERVICES, NAMELY, CREATIVE AND STRATEGIC CONSULTATION REGARDING DEVELOPMENT AND PRODUCTION OF MARKETING CAMPAIGNS FOR OTHERS; CONSULTING SERVICES IN THE FIELD OF INTERNET MARKETING; CONSULTING SERVICES IN THE FIELD OF MARKETING OF EDUCATIONAL TRAINING; CONSUMER MARKETING RESEARCH AND CONSULTING RELATED THERETO; COOPERATIVE ADVERTISING AND MARKETING; COOPERATIVE ADVERTISING AND MARKETING SERVICES BY WAY OF SOLICITATION, CUSTOMER SERVICE AND PROVIDING MARKETING INFORMATION VIA WEB SITES ON A GLOBAL COMPUTER NETWORK; COOPERATIVE ADVERTISING AND MARKETING SERVICES, NAMELY, OFFERING DISCOUNTS TO CLIENTS THROUGH THE JOINT PARTICIPATION OF MEMBER BEAUTY SALONS; CREATIVE MARKETING DESIGN SERVICES; CUSTOM WRITING SERVICES COMPRISING PUBLIC RELATIONS AND MARKETING MATERIALS FOR THE AUDIO, VIDEO AND TECHNOLOGY INDUSTRIES; DEVELOPMENT OF MARKETING STRATEGIES AND CONCEPTS; DEVELOPMENT OF MARKETING STRATEGIES, CONCEPTS AND TACTICS, NAMELY, AUDIENCE DEVELOPMENT, BRAND AWARENESS, ONLINE COMMUNITY BUILDING AND DIGITAL WORD OF MOUTH COMMUNICATIONS; DIRECT MARKETING ADVERTISING FOR OTHERS; DIRECT MARKETING CONSULTING SERVICES; DIRECT MARKETING SERVICES; ENTERTAINMENT MARKETING SERVICES, NAMELY, MARKETING, PROMOTION AND ADVERTISING FOR RECORDING AND PERFORMING ARTISTS; EVENT PLANNING AND MANAGEMENT FOR MARKETING, BRANDING, PROMOTING OR ADVERTISING THE GOODS AND SERVICES OF OTHERS; FARMERS' MARKETS; FLEA MARKETS; GRAIN MARKET ANALYSIS; HOMEOWNER ASSOCIATION SER-

CLASS 35—(Continued).

VICES, NAMELY, PROMOTING THE INTERESTS OF HOMEOWNERS IN A SPECIFIC COMMUNITY AND MARKETING THE COMMUNITY NATIONWIDE TO PROSPECTIVE NEW RESIDENTS AND PROPERTY OWNERS; MARKET ANALYSIS; MARKET ANALYSIS AND RESEARCH SERVICES; MARKET ASSESSMENT SERVICES; MARKET MANIPULATION RESEARCH AND ANALYSIS, WHETHER OR NOT VIA THE INTERNET; MARKET OPINION POLLING STUDIES; MARKET REPORTS AND STUDIES; MARKET RESEARCH; MARKET RESEARCH AND BUSINESS ANALYSES; MARKET RESEARCH AND MARKET INTELLIGENCE SERVICES; MARKET RESEARCH BY MEANS OF A COMPUTER DATABASE; MARKET RESEARCH CONSULTATION; MARKET RESEARCH SERVICES; MARKET RESEARCH STUDIES; MARKET SEGMENTATION CONSULTATION; MARKET STUDY AND ANALYSIS OF MARKET STUDIES; MARKETING ANALYSIS SERVICES; MARKETING AND ADVERTISING SERVICES FOR AUTOMOBILE DEALERSHIPS; MARKETING AND BRANDING SERVICES, NAMELY, PROVIDING CUSTOMIZED COMMUNICATION PROGRAMS TO OBTAIN CONSUMER INSIGHTS AND DEVELOP BRANDING STRATEGIES; MARKETING AND CONSULTING SERVICES IN THE FIELD OF PROMOTING AND TRACKING THE GOODS, SERVICES, AND BRANDS OF OTHERS THROUGH ALL PUBLIC COMMUNICATION MEANS; MARKETING CONSULTING; MARKETING CONSULTING SERVICES RELATING TO LONG-TERM BUSINESS STRATEGY DEVELOPMENT FOR NON-PROFIT ORGANIZATIONS; MARKETING PLAN DEVELOPMENT; MARKETING RESEARCH IN THE FIELDS OF COSMETICS, PERFUMERY AND BEAUTY PRODUCTS; MARKETING RESEARCH SERVICES; MARKETING SERVICES; MARKETING SERVICES, NAMELY, CONDUCTING CONSUMER TRACKING BEHAVIOR RESEARCH AND CONSUMER TREND ANALYSIS; MARKETING SERVICES, NAMELY, CONSUMER MARKETING RESEARCH; MARKETING SERVICES, NAMELY, PROMOTING OR ADVERTISING THE GOODS AND SERVICES OF OTHERS; MARKETING SERVICES, NAMELY, PROMOTIONAL SERVICES IN THE FIELD OF PLANNED-GIVING FOR NON-PROFIT AND CHARITABLE ORGANIZATIONS; MARKETING, ADVERTISING, AND PROMOTING THE RETAIL GOODS AND SERVICES OF OTHERS THROUGH WIRELESS ELECTRONIC DEVICES; MARKETING, PROMOTIONAL AND ADVERTISING SERVICES PROVIDED BY MOBILE TELEPHONE CONNECTIONS; MEDIA PLANNING, NAMELY, ADVISING THE CLIENT ON THE CORRECT TIMES AND STATIONS TO ADVERTISE BASED ON MEDIA ANALYSIS OF THE MARKET FOR THAT MEDIA; MEMBERSHIP CLUB SERVICES, NAMELY, PROVIDING ON-LINE INFORMATION TO MEMBERS IN THE FIELDS OF BRANDING, BUSINESS DEVELOPMENT, BUSINESS MARKETING, AND MARKETING; MULTI-LEVEL MARKETING SERVICES; ON-LINE ADVERTISING AND MARKETING SERVICES; ONLINE BUSINESS RESEARCH SERVICES THAT ALLOW USERS TO SHARE OPINIONS WITH A MARKETING RESEARCH COMPANY RELATED TO EVERYDAY CONSUMER PRODUCTS AND SERVICES; OUTSOURCING IN THE FIELD OF SALES AND MARKETING OF COMPUTER SOFTWARE; PLANNING, DESIGN, DEVELOPMENT, MAINTENANCE, TRACKING AND REPORTING OF ONLINE MARKETING ACTIVITIES FOR THIRD PARTIES; PROMOTING AND MARKETING THE DELIVERY OF WATER WITHOUT GREENHOUSE GAS EMISSIONS; PROMOTING AND MARKETING THE GOODS AND SERVICES OF OTHERS BY DISTRIBUTING ADVERTISING MATERIAL, COUPONS AND DISCOUNT OFFERS VIA TEXT MESSAGES; PROMOTING THE GOODS AND SERVICES OF OTHERS BY MEANS OF WORD-OF-MOUTH AND NONTRADITIONAL MARKETING PROGRAMS; PROMOTING, ADVERTISING AND MARKETING OF THE BRANDS, PRODUCTS, SERVICES AND ONLINE WEBSITES OF INDIVIDUALS, BUSINESSES AND NONPROFIT ORGANIZATIONS; PROMOTING, ADVERTISING AND MARKETING ONLINE WEB SITES OF OTHERS; PROMOTING, ADVERTISING AND MARKETING THE ON-LINE DATABASES AND ELECTRONIC PUBLICATIONS OF OTHERS; PROMOTING, MARKETING AND ADVERTISING THE BRANDS AND GOODS OF OTHERS RELATED TO ALL INDUSTRIES, THROUGH ALL PUBLIC AND PRIVATE COMMUNICATION MEANS, NAMELY, PROMOTING THE BRANDS AND GOODS OF OTHERS MADE IN

CLASS 35—(Continued).

THE UNITED STATES; PROMOTION AND MARKETING SERVICES AND RELATED CONSULTING; PROMOTIONAL MARKETING AND REPRESENTATION SERVICES FOR SALES TO THE PUBLIC SECTOR; PROMOTIONAL MARKETING SERVICES USING AUDIOVISUAL MEDIA; PROMOTIONAL SERVICES, NAMELY, GUERRILLA MARKETING SERVICES; PROVIDING A WEB SITE FEATURING A DIRECTORY OF MARKET RESEARCH PANELS FOR CONSUMERS; PROVIDING A WEB SITE THAT FEATURES AN ONLINE MARKET FOR USERS TO LIST OFFERED OR WANTED PERSONAL AND BUSINESS ASSETS AND SKILLS FOR HIRE, RENT, SALE OR AUCTION TRANSACTIONS ON THE BASIS OF PREDEFINED PERFORMANCE AND CLOSING TERMS AND CONDITIONS; PROVIDING ADVERTISING, MARKETING AND PROMOTIONAL SERVICES, NAMELY, DEVELOPMENT OF ADVERTISING CAMPAIGNS PROVIDED THROUGH CABLE TELEVISION BROADCAST, WEB CASTS, RADIO BROADCASTS, NEWSPAPERS, MAGAZINES, ONLINE BANNERS, OUTDOOR BILLBOARDS, WILD POSTINGS, BUS AND SUBWAY ADS; PROVIDING FINANCIAL INDICES OF SELECT BONDS TO ENABLE CONSUMERS TO EVALUATE INVESTMENTS AND MARKET TRENDS IN THE BOND MARKET; PROVIDING FINANCIAL INDICES OF SELECT SECURITIES TO ENABLE CONSUMERS TO EVALUATE INVESTMENTS AND MARKET TRENDS IN THE SECURITIES MARKET; PROVIDING MARKETING AND PROMOTION OF SPECIAL EVENTS; PROVIDING ONLINE BUSINESS MANAGEMENT SERVICES INCLUDING ACCOUNTING, MARKETING, BUSINESS PROJECT MANAGEMENT, AND BUSINESS DEVELOPMENT; PROVIDING PUBLIC SECTOR BUSINESS AND MARKET INTELLIGENCE; PROVIDING PUBLIC SECTOR GO-TO-MARKET ADVICE AND STRATEGIES; PROVIDING REAL ESTATE VIDEO TOURS FOR MARKETING PURPOSES; PROVIDING REIMBURSEMENT BENCHMARKING INFORMATION AND OTHER MARKET INTELLIGENCE TO HEALTHCARE ORGANIZATIONS; PROVISION OF DATABASES FEATURING LISTINGS OF MARKETERS FOR USE BY OTHERS IN IDENTIFYING AND CONTACTING MARKETERS FOR PROMOTIONAL PURPOSES; PROVISION OF MARKET RESEARCH INFORMATION; PROVISION OF MARKETING REPORTS; REAL ESTATE MARKETING ANALYSIS; REAL ESTATE MARKETING SERVICES, NAMELY, ON-LINE SERVICES FEATURING THE PROMOTION OF RESIDENTIAL NEW CONSTRUCTION, WHICH ALSO CONTAINS BACK OFFICE SOLUTIONS FOR BUILDERS; REAL ESTATE MARKETING SERVICES, NAMELY, ON-LINE SERVICES FEATURING TOURS OF RESIDENTIAL AND COMMERCIAL REAL ESTATE; RENTAL OF ALL PUBLICITY AND MARKETING PRESENTATION MATERIALS; SOCIAL MEDIA STRATEGY AND MARKETING CONSULTANCY FOCUSING ON HELPING CLIENTS CREATE AND EXTEND THEIR PRODUCT AND BRAND STRATEGIES BY BUILDING VIRALLY ENGAGING MARKETING SOLUTIONS; STATISTICAL EVALUATIONS OF MARKETING DATA; THE BRINGING TOGETHER, FOR THE BENEFIT OF OTHERS, OF A VARIETY OF GOODS AND SERVICES, ENABLING CUSTOMERS TO CONVENIENTLY VIEW AND PURCHASE THOSE GOODS AND SERVICES FROM AN INTERNET WEB SITE PARTICULARLY SPECIALIZING IN THE MARKETING OF THE SALE OF GOODS AND SERVICES OF OTHERS (U.S. CLS. 100, 101 AND 102).

FIRST USE 3-1-2009; IN COMMERCE 3-1-2009.
JOHN DALIER, EXAMINING ATTORNEY

CLASS 35—(Continued).

SN 85-516,091. BABYBOOMERGOLD.COM, INC., RENO, NV. FILED 1-13-2012.

BabyBoomerGold.com

THE MARK CONSISTS OF STANDARD CHARACTERS WITHOUT CLAIM TO ANY PARTICULAR FONT, STYLE, SIZE, OR COLOR.

FOR ADMINISTRATION OF A CONSUMER LOYALTY PROGRAM TO PROMOTE RESTAURANT SERVICES AND RETAIL SERVICES OF OTHERS; ADMINISTRATION OF A DISCOUNT PROGRAM FOR ENABLING PARTICIPANTS TO OBTAIN DISCOUNTS ON GOODS AND SERVICES THROUGH USE OF A DISCOUNT MEMBERSHIP CARD; ADMINISTRATION OF A DISCOUNT PROGRAM FOR ENABLING PARTICIPANTS TO OBTAIN DISCOUNTS ON THE COST OF SERVICES OR RECEIVE IMPROVED SERVICES THROUGH USE OF A MEMBERSHIP CARD; ADMINISTRATION OF A PROGRAM FOR ENABLING PARTICIPANTS TO OBTAIN DISCOUNTS ON GOODS AND RECEIVE IMPROVED SERVICES; ADMINISTRATION OF A PROGRAM FOR ENABLING PARTICIPANTS TO OBTAIN DISCOUNTS ON PRODUCTS AND SERVICES; ADMINISTRATION OF A PROGRAM FOR ENABLING PARTICIPANTS TO OBTAIN DISCOUNTS ON THE COST OF SERVICES OR RECEIVE IMPROVED SERVICES (U.S. CLS. 100, 101 AND 102).

AMY C. KEAN, EXAMINING ATTORNEY

SN 85-516,127. SOCIETE DES PRODUITS NESTLE SA, VEVEY, SWITZERLAND, FILED 1-13-2012.

TALES FOR THE PET LOVER'S
HEART

THE MARK CONSISTS OF STANDARD CHARACTERS WITHOUT CLAIM TO ANY PARTICULAR FONT, STYLE, SIZE, OR COLOR.

FOR ADVERTISING, MARKETING AND PROMOTION SERVICES IN THE FIELD OF PETS, PET CARE AND PET FOOD (U.S. CLS. 100, 101 AND 102).

MICHAEL GAAFAR, EXAMINING ATTORNEY

CLASS 35—(Continued).

SN 85-516,138. EVENTAGE, SOUTH ORANGE, NJ. FILED 1-13-2012.

Dadcathlon

THE MARK CONSISTS OF STANDARD CHARACTERS WITHOUT CLAIM TO ANY PARTICULAR FONT, STYLE, SIZE, OR COLOR.

FOR ARRANGING AND CONDUCTING SPECIAL EVENTS FOR COMMERCIAL, PROMOTIONAL OR ADVERTISING PURPOSES; CORPORATE EVENT MANAGEMENT SERVICES; EVENT PLANNING AND MANAGEMENT FOR MARKETING, BRANDING, PROMOTING OR ADVERTISING THE GOODS AND SERVICES OF OTHERS (U.S. CLS. 100, 101 AND 102).

LIEF MARTIN, EXAMINING ATTORNEY

SN 85-516,160. JACK'S RENTAL SEARCH LLC, CHESTER, PA. FILED 1-13-2012.



NO CLAIM IS MADE TO THE EXCLUSIVE RIGHT TO USE "RENTAL SEARCH", APART FROM THE MARK AS SHOWN.

THE COLOR(S) BLACK, RED AND WHITE IS/ARE CLAIMED AS A FEATURE OF THE MARK.

THE MARK CONSISTS OF A BLACK AND WHITE PUPPY CENTERED OVER THE WORD "JACK'S" IN RED LETTERS, WHICH IS CENTERED OVER THE WORDS "RENTAL SEARCH" IN BLACK LETTERS.

FOR ADVERTISING OF COMMERCIAL OR RESIDENTIAL REAL ESTATE (U.S. CLS. 100, 101 AND 102).

FIRST USE 2-1-2011; IN COMMERCE 2-1-2011.

IRA J. GOODSaid, EXAMINING ATTORNEY

CLASS 35—(Continued).

SN 85-516,238. PROSOLVE MEDICAL BILLING SERVICES, LLC, OLATHE, KS. FILED 1-13-2012.

PROSOLVE

THE MARK CONSISTS OF STANDARD CHARACTERS WITHOUT CLAIM TO ANY PARTICULAR FONT, STYLE, SIZE, OR COLOR.

FOR MEDICAL BILLING SERVICES (U.S. CLS. 100, 101 AND 102).

ANDREW LEASER, EXAMINING ATTORNEY

SN 85-516,247. MAXCOM TELECOMUNICACIONES S.A.B. DE C.V., MEXICO CITY, MEXICO, FILED 1-13-2012.

MEZCALL

THE MARK CONSISTS OF STANDARD CHARACTERS WITHOUT CLAIM TO ANY PARTICULAR FONT, STYLE, SIZE, OR COLOR.

FOR BUSINESS CONSULTING SERVICES IN THE FIELD OF VOICE OVER INTERNET PROTOCOL AND CELLULAR TELEPHONE SERVICES; RETAIL STORE SERVICES FEATURING VOICE OVER INTERNET PROTOCOL AND CELLULAR TELEPHONE SERVICES (U.S. CLS. 100, 101 AND 102).

TINA L. SNAPP, EXAMINING ATTORNEY

SN 85-516,256. MILITARY MAIL SOLUTIONS, LLC, QUINCY, MA. FILED 1-13-2012.

YOUR GLOBAL LIFELINE

THE MARK CONSISTS OF STANDARD CHARACTERS WITHOUT CLAIM TO ANY PARTICULAR FONT, STYLE, SIZE, OR COLOR.

FOR ARRANGING FOR PARCEL DELIVERY (U.S. CLS. 100, 101 AND 102).

FIRST USE 12-15-2011; IN COMMERCE 12-15-2011.

DEBORAH LOBO, EXAMINING ATTORNEY

CLASS 35—(Continued).

SN 85-516,258. TITAN ENTERTAINMENT GROUP LIMITED, LONDON, UNITED KINGDOM, FILED 1-13-2012.



THE MARK CONSISTS OF A REPRESENTATION OF A ROCKET AND A STARBURST PATTERN OVER AN OVAL CARRIER.

FOR RETAIL STORE SERVICES IN THE FIELD OF BOOKS, COMIC BOOKS, MAGAZINES, MOVIES, TV SHOWS, SOUNDTRACKS, TOYS, DVDS, APPAREL, AND GENERAL MERCHANDISE; ON-LINE RETAIL STORE SERVICES IN THE FIELD OF BOOKS, COMIC BOOKS, MAGAZINES, TOYS, DVDS, APPAREL, AND GENERAL MERCHANDISE; DIGITAL DOWNLOAD RETAIL STORE SERVICES IN THE FIELD OF BOOKS, COMIC BOOKS, MAGAZINES, MOVIES, TV SHOWS, SOUNDTRACKS; AND MAIL ORDER SERVICES IN THE FIELD OF BOOKS, COMIC BOOKS, MAGAZINES, TOYS, DVDS, APPAREL, AND GENERAL MERCHANDISE (U.S. CLS. 100, 101 AND 102).

TINA L. SNAPP, EXAMINING ATTORNEY

SN 85-516,355. KLEVER MARKETING, INC., LAGUNA NIGUEL, CA. FILED 1-13-2012.

KleverKloud

THE MARK CONSISTS OF STANDARD CHARACTERS WITHOUT CLAIM TO ANY PARTICULAR FONT, STYLE, SIZE, OR COLOR.

FOR ADVERTISING AND COMMERCIAL INFORMATION SERVICES, VIA THE INTERNET; ADVICE AND INFORMATION ABOUT CUSTOMER SERVICES AND PRODUCT MANAGEMENT AND PRICES ON INTERNET SITES IN CONNECTION WITH PURCHASES MADE OVER THE INTERNET; DISSEMINATION OF ADVERTISING FOR OTHERS VIA AN ON-LINE COMMUNICATIONS NETWORK ON THE INTERNET; FACILITATING THE EXCHANGE OF NEEDED INFORMATION FOR FINANCIAL COMPENSATION VIA THE INTERNET INCLUDING DISCOUNT AND COUPONING OPPORTUNITIES; PROVIDING INFORMATION PERTAINING TO PROCUREMENT, BUYING, SELLING AND TENDERING INFORMATION AND OPPORTUNITIES RELATING TO GOODS AND SERVICES VIA COMPUTER, COMPUTER NETWORKS, TELEPHONE, THE INTERNET OR ELECTRONIC MAIL (U.S. CLS. 100, 101 AND 102).

JAMES A. RAUEN, EXAMINING ATTORNEY

CLASS 35—(Continued).

SN 85-516,361. KLEVER MARKETING, INC., LAGUNA NIGUEL, CA. FILED 1-13-2012.

KleverDash

THE MARK CONSISTS OF STANDARD CHARACTERS WITHOUT CLAIM TO ANY PARTICULAR FONT, STYLE, SIZE, OR COLOR.

FOR ADVERTISING AND COMMERCIAL INFORMATION SERVICES, VIA THE INTERNET; ADVICE AND INFORMATION ABOUT CUSTOMER SERVICES AND PRODUCT MANAGEMENT AND PRICES ON INTERNET SITES IN CONNECTION WITH PURCHASES MADE OVER THE INTERNET; DISSEMINATION OF ADVERTISING FOR OTHERS VIA AN ON-LINE COMMUNICATIONS NETWORK ON THE INTERNET; FACILITATING THE EXCHANGE OF NEEDED INFORMATION FOR FINANCIAL COMPENSATION VIA THE INTERNET INCLUDING DISCOUNT AND COUPONING OPPORTUNITIES; PROVIDING INFORMATION PERTAINING TO PROCUREMENT, BUYING, SELLING AND TENDERING INFORMATION AND OPPORTUNITIES RELATING TO GOODS AND SERVICES VIA COMPUTER, COMPUTER NETWORKS, TELEPHONE, THE INTERNET OR ELECTRONIC MAIL (U.S. CLS. 100, 101 AND 102).

JAMES A. RAUEN, EXAMINING ATTORNEY

CLASS 35—(Continued).

SN 85-516,485. WEMHANER, SY, SAN MARCOS, CA. FILED 1-13-2012.

Adovio

THE MARK CONSISTS OF STANDARD CHARACTERS WITHOUT CLAIM TO ANY PARTICULAR FONT, STYLE, SIZE, OR COLOR.

THE WORDING "ADOVIO" HAS NO MEANING IN A FOREIGN LANGUAGE.

FOR INTERNET MARKETING SERVICES (U.S. CLS. 100, 101 AND 102).

FIRST USE 11-1-2011; IN COMMERCE 11-1-2011.

AMY KELLY, EXAMINING ATTORNEY

SN 85-518,139. APOTHECARY PRODUCTS, INC., BURNSVILLE, MN. FILED 1-17-2012.

SN 85-516,377. BY RV, INC., DBA B. YOUNG RV, MILWAUKIE, OR. FILED 1-13-2012.

B. YOUNG RV

THE MARK CONSISTS OF STANDARD CHARACTERS WITHOUT CLAIM TO ANY PARTICULAR FONT, STYLE, SIZE, OR COLOR.

NO CLAIM IS MADE TO THE EXCLUSIVE RIGHT TO USE "RV", APART FROM THE MARK AS SHOWN.

FOR RETAIL STORE SERVICES FEATURING NEW AND PRE-OWNED RECREATIONAL VEHICLES IN MULTIPLE RV CLASSES, PLUS AFTER-MARKET SERVICE AND PARTS FOR SAME (U.S. CLS. 100, 101 AND 102).

FIRST USE 1-4-2010; IN COMMERCE 3-22-2010.

DEIRDRE ROBERTSON, EXAMINING ATTORNEY



OWNER OF U.S. REG. NO. 3,195,961.

THE MARK CONSISTS OF A STYLIZED CHARACTER RESEMBLING A MORTAR AND PESTLE.

FOR CATALOG ORDERING SERVICES FEATURING A FULL LINE OF PHARMACY SUPPLIES AND EQUIPMENT (U.S. CLS. 100, 101 AND 102).

LUCY ARANT, EXAMINING ATTORNEY

CLASS 35—(Continued).

SN 85-518,903. WINMARK CONCEPTS, INC., WASHINGTON, DC. FILED 1-18-2012.



THE COLOR(S) BLUE, ORANGE AND PURPLE IS/ARE CLAIMED AS A FEATURE OF THE MARK.

THE MARK CONSISTS OF THE WORDS "DIRECT" AND "MALE" IN BLUE AND TWO ROTATED, OVERLAPPING CARETS. THE TOP CARET IS ORANGE AND BOTTOM CARET IS PURPLE. "DIRECT" APPEARS OVER "MALE" AND "MALE" IS OFFSET. THE CARETS ARE ROTATED CLOCKWISE. THE ORANGE CARET FORMS A STYLIZED "D". TOGETHER, THE ORANGE AND PURPLE CARET FORM A STYLIZED "M".

FOR ADVERTISING AND MARKETING SERVICES, NAMELY, PROMOTING THE GOODS AND SERVICES OF OTHERS (U.S. CLS. 100, 101 AND 102).

FIRST USE 12-5-2011; IN COMMERCE 1-13-2012.
LINDA E. BLOHM, EXAMINING ATTORNEY

CLASS 35—(Continued).

SN 85-520,296. SCHOOLHOUSE OUTFITTERS, LLC, CINCINNATI, OH. FILED 1-19-2012.



OWNER OF U.S. REG. NOS. 2,777,002, 3,077,974 AND 3,630,889.

THE COLOR(S) BLACK AND YELLOW IS/ARE CLAIMED AS A FEATURE OF THE MARK.

THE MARK CONSISTS OF THREE RECTANGULAR OVERLAPPING BLACK BLOCKS SURROUNDED BY A YELLOW CIRCLE, WITH THE WORDS "SCHOOL OUTFITTERS" APPEARING TO THE RIGHT OF THE DESIGN IN BLACK LETTERING.

SEC. 2(F).

FOR MAIL ORDER SERVICES AND ONLINE RETAIL STORE SERVICES FEATURING OFFICE AND SCHOOL FURNITURE, OFFICE AND SCHOOL EQUIPMENT, OFFICE AND SCHOOL SUPPLIES AND TEACHING AIDS (U.S. CLS. 100, 101 AND 102).

FIRST USE 10-30-2005; IN COMMERCE 10-30-2005.

MATTHEW MCDOWELL, EXAMINING ATTORNEY

SN 85-518,983. MASSAMIO, LLC, TUCSON, AZ. FILED 1-18-2012.

MASSAMIO

THE MARK CONSISTS OF STANDARD CHARACTERS WITHOUT CLAIM TO ANY PARTICULAR FONT, STYLE, SIZE, OR COLOR.

FOR PROMOTING THE GOODS AND SERVICES OF OTHERS BY PROVIDING A WEBSITE FOR CONSUMERS FEATURING INFORMATION ABOUT THE SERVICES OFFERED BY MASSAGE THERAPISTS AND OTHER BODY WORKS PROFESSIONALS (U.S. CLS. 100, 101 AND 102).

FIRST USE 3-15-2011; IN COMMERCE 4-1-2011.
CURTIS FRENCH, EXAMINING ATTORNEY

SN 85-522,281. MYPERFECTGIFT.COM, LLC, NAPA, CA. FILED 1-22-2012.

Gifts that Click

THE MARK CONSISTS OF STANDARD CHARACTERS WITHOUT CLAIM TO ANY PARTICULAR FONT, STYLE, SIZE, OR COLOR.

NO CLAIM IS MADE TO THE EXCLUSIVE RIGHT TO USE "GIFTS", APART FROM THE MARK AS SHOWN. FOR GIFT REGISTRY SERVICES (U.S. CLS. 100, 101 AND 102).

FIRST USE 12-1-2011; IN COMMERCE 12-1-2011.
FRANK LATTUCA, EXAMINING ATTORNEY

CLASS 35—(Continued).

SN 85-525,821. YOUNG, GREGG WHEELER, AUSTIN, TX.
FILED 1-26-2012.



THE COLOR(S) LIGHT GREEN, DARK GREEN, AND WHITE IS/ARE CLAIMED AS A FEATURE OF THE MARK. THE MARK CONSISTS OF GREEN SQUARE WITH CURVED CORNERS WITH THE UPPER PORTION A LIGHTER GREEN AND THE LOWER PORTION A DARKER GREEN CONTAINING A WHITE DOLLAR SIGN "\$" WITH THE WHITE TERM, "BIGdeal" BELOW. THE TERM "BIG" IN ALL CAPS AND "deal" IN LOWERCASE.

FOR ADMINISTRATION OF A DISCOUNT PROGRAM FOR ENABLING PARTICIPANTS TO OBTAIN DISCOUNTS ON GOODS AND SERVICES THROUGH USE OF A DISCOUNT MEMBERSHIP CARD; ADMINISTRATION OF A DISCOUNT PROGRAM FOR ENABLING PARTICIPANTS TO OBTAIN DISCOUNTS ON THE COST OF SERVICES OR RECEIVE IMPROVED SERVICES THROUGH USE OF A MEMBERSHIP CARD; ADMINISTRATION OF A PROGRAM FOR ENABLING PARTICIPANTS TO OBTAIN DISCOUNTS ON GOODS AND RECEIVE IMPROVED SERVICES; ADMINISTRATION OF A PROGRAM FOR ENABLING PARTICIPANTS TO OBTAIN DISCOUNTS ON PRODUCTS AND SERVICES; ADMINISTRATION OF A PROGRAM FOR ENABLING PARTICIPANTS TO OBTAIN DISCOUNTS ON THE COST OF SERVICES OR RECEIVE IMPROVED SERVICES; AN INTERACTIVE WEB SITE FOR USERS TO REVIEW AND RATE INTERNET CONTENT, PEOPLE, COMPANIES, PRODUCTS AND/OR SERVICES UTILIZING A SOFTWARE APPLICATION TO AWARD POINTS WHEREBY WEB SITE USERS ARE ELIGIBLE TO EXCHANGE POINTS EARNED FOR PROMOTIONAL ITEMS CONSISTING OF COUPONS, REBATES, DISCOUNTS OR SPECIAL OFFERINGS ON GOODS AND/OR SERVICE PROVIDED BY WEB SITE SPONSORS; ONLINE SERVICE FOR CONNECTING SOCIAL NETWORK USERS WITH RETAILERS FOR THE PURPOSE OF FACILITATING DISCOUNTED PURCHASES; PROCESSING MANUFACTURER'S COUPONS; PROMOTING AND MARKETING THE GOODS AND SERVICES OF OTHERS BY DISTRIBUTING ADVERTISING MATERIAL, COUPONS AND DISCOUNT OFFERS VIA TEXT MESSAGES; PROMOTING THE GOODS AND SERVICES OF OTHERS BY PROVIDING A WEBSITE FEATURING COUPONS, REBATES, PRICE-COMPARISON INFORMATION, PRODUCT REVIEWS, LINKS TO THE RETAIL WEBSITES OF OTHERS, AND DISCOUNT INFORMATION; PROMOTING THE GOODS AND SERVICES OF OTHERS BY PROVIDING A WEBSITE FEATURING COUPONS, REBATES, PRICE-COMPARISON INFORMATION, PRODUCT REVIEWS, LINKS TO THE RETAIL WEBSITES OF OTHERS, AND DISCOUNT INFORMATION; PROMOTING THE GOODS AND SERVICES OF OTHERS BY PROVIDING AN INTERACTIVE WEBSITE WHERE USERS CAN INCREASE THE CURRENT VALUE OF AN ONLINE DISCOUNT BEING OFFERED BY PURCHASING THE GOODS AND SERVICES ASSOCIATED WITH THAT DISCOUNT IN THE FORM OF AN ONLINE COUPON, VOUCHER OR GIFT CARD; PROMOTING THE GOODS AND SERVICES OF OTHERS BY ONLINE UPLOADING DEALS OF THE DAY TO A WEBSITE AND RECEIVING ON A MOBILE APPLICATION ALSO; PROMOTING THE GOODS OF OTHERS, NAMELY, PROVIDING COUPONS, REBATES AND VOUCHERS FOR THE GOODS OF OTHERS; PROMOT-

CLASS 35—(Continued).

ING THE GOODS OF OTHERS, NAMELY, PROVIDING INFORMATION REGARDING DISCOUNTS, COUPONS, REBATES, VOUCHERS AND SPECIAL OFFERS FOR THE GOODS OF OTHERS; PROMOTIONAL SERVICES, NAMELY, DISTRIBUTION OF ADVERTISING FLYERS, COUPONS, CATALOGS AND PROMOTIONAL ITEMS OF OTHERS; PROMOTIONAL SERVICES, NAMELY, PROMOTING THE GOODS OF OTHERS BY MEANS OF PROVIDING ONLINE COUPONS; PROMOTIONAL SERVICES, NAMELY, PROMOTING THE GOODS OF OTHERS BY MEANS OF PROVIDING ONLINE GIFT CARDS; PROMOTIONAL SERVICES, NAMELY, PROMOTING THE GOODS OF OTHERS BY MEANS OF PROVIDING ONLINE GIFT CERTIFICATES; PROMOTIONAL SERVICES, NAMELY, PROMOTING THE GOODS OF OTHERS BY MEANS OF PROVIDING ONLINE RESTAURANT MENUS; PROVIDING AN INCENTIVE AWARD PROGRAM FOR DEALERS AND CONSUMERS THAT PROVIDES FOR DISCOUNTED PRICING FOR AND EXPEDITED SHIPPING OF SPECIFIED PRODUCTS TO THE DEALERS AND CONSUMERS FOR THEIR PURCHASES OF SAID SPECIFIED PRODUCTS; PROVIDING INCENTIVE AWARD PROGRAMS FOR CUSTOMERS THROUGH THE ISSUANCE AND PROCESSING OF LOYALTY COUPONS FOR FREQUENT USE OF PARTICIPATING BUSINESSES; RETAIL DISCOUNT STORE SERVICES IN THE FIELD OF CONSUMER ELECTRONICS, CLOTHING, GENERAL CONSUMER MERCHANDISE, FOOD, BEVERAGES, VEHICLES; RETAIL STORE SERVICES FEATURING VIRTUAL GOODS, NAMELY, CONSUMER ELECTRONICS, CLOTHING, GENERAL CONSUMER MERCHANDISE, FOOD, BEVERAGES, VEHICLES FOR USE IN ONLINE VIRTUAL WORLDS (U.S. CLS. 100, 101 AND 102).

ODESSA BIBBINS, EXAMINING ATTORNEY

SN 85-526,553. THOMAS, DENNIS, NEW BRIGHTON, PA.
FILED 1-26-2012.

Estimateguard

THE MARK CONSISTS OF STANDARD CHARACTERS WITHOUT CLAIM TO ANY PARTICULAR FONT, STYLE, SIZE, OR COLOR.

FOR ON-LINE RETAIL STORE SERVICES FEATURING COMPUTER SOFTWARE (U.S. CLS. 100, 101 AND 102).

FIRST USE 8-0-2011; IN COMMERCE 12-0-2011.

MATTHEW EINSTEIN, EXAMINING ATTORNEY

CLASS 35—(Continued).

SN 85-527,115. THE SOUTHERN COMPANY, ATLANTA, GA. FILED 1-27-2012.



OWNER OF U.S. REG. NO. 3,326,039. THE COLOR(S) GREEN, BLACK, AND WHITE IS/ARE CLAIMED AS A FEATURE OF THE MARK.

THE MARK CONSISTS OF THE COLOR(S) GREEN, BLACK, AND WHITE, WITH THE COLORS GREEN AND WHITE APPEARING IN THE CIRCULAR DESIGN FORMED BY THREE ARROWS, THE COLOR GREEN APPEARING IN THE WORD "TARGET" AND IN THE TARGET DESIGN FORMING THE LETTER "O" IN THE WORD "ZERO", THE COLOR BLACK IN THE WORDING "BELIEVE", "COMMIT", "ACT", "ZERO", WITH THE EXCEPTION OF THE "O", AND "EVERY DAY, EVERY JOB, SAFELY".

FOR CONDUCTING EMPLOYEE INCENTIVE AWARD PROGRAMS TO PROMOTE ON THE JOB SAFETY; PROMOTING PUBLIC AWARENESS OF PUBLIC SAFETY IN CONNECTION WITH ENERGY (U.S. CLS. 100, 101 AND 102).

FIRST USE 1-1-2012; IN COMMERCE 1-1-2012. KRISTIN DAHLING, EXAMINING ATTORNEY

SN 85-527,618. TRU RX LLC, EAGLE, ID. FILED 1-27-2012.

1-2-3 Pets

THE MARK CONSISTS OF STANDARD CHARACTERS WITHOUT CLAIM TO ANY PARTICULAR FONT, STYLE, SIZE, OR COLOR.

NO CLAIM IS MADE TO THE EXCLUSIVE RIGHT TO USE "PETS", APART FROM THE MARK AS SHOWN.

FOR INFORMATIONAL AND INTERACTIVE ON-LINE WHOLESALE STORE SERVICES FEATURING PET FOOD AND TREATS AND PET HEALTH CARE PRODUCTS (U.S. CLS. 100, 101 AND 102).

TASNEEM HUSSAIN, EXAMINING ATTORNEY

CLASS 35—(Continued).

SN 85-528,359. OVERSTOCK.COM, INC., SALT LAKE CITY, UT. FILED 1-30-2012.

UNEXPECTED VALUE

THE MARK CONSISTS OF STANDARD CHARACTERS WITHOUT CLAIM TO ANY PARTICULAR FONT, STYLE, SIZE, OR COLOR.

FOR ON-LINE RETAIL STORE SERVICES FEATURING GENERAL CONSUMER MERCHANDISE (U.S. CLS. 100, 101 AND 102).

AMEEN IMAM, EXAMINING ATTORNEY

SN 85-528,418. OVERSTOCK.COM, INC., SALT LAKE CITY, UT. FILED 1-30-2012.

UNEXPECTED VALUE FOR YOUR LIFE

THE MARK CONSISTS OF STANDARD CHARACTERS WITHOUT CLAIM TO ANY PARTICULAR FONT, STYLE, SIZE, OR COLOR.

FOR ON-LINE RETAIL STORE SERVICES FEATURING GENERAL CONSUMER MERCHANDISE (U.S. CLS. 100, 101 AND 102).

AMEEN IMAM, EXAMINING ATTORNEY

SN 85-528,847. U.S. MARINE CORPS, A COMPONENT OF THE U.S. DEPARTMENT OF THE NAVY, WASHINGTON, DC. FILED 1-30-2012.



THE MARK CONSISTS OF THE LETTERS "MCX" WITH THE WORDS "CORE BRANDS" AND "CORPS VALUES" BENEATH THE "MCX". BENEATH "MCX CORE BRANDS" IS A HORIZONTAL LINE.

FOR ON-LINE RETAIL STORE SERVICES FEATURING A WIDE VARIETY OF CONSUMER GOODS OF OTHERS; RETAIL APPAREL STORES; RETAIL DEPARTMENT STORE SERVICES (U.S. CLS. 100, 101 AND 102).

FIRST USE 9-4-2003; IN COMMERCE 9-4-2003. NELSON SNYDER, EXAMINING ATTORNEY

CLASS 35—(Continued).

SN 85-528,874. U.S. MARINE CORPS, A COMPONENT OF THE U.S. DEPARTMENT OF THE NAVY, WASHINGTON, DC. FILED 1-30-2012.



THE COLOR(S) BLUE AND RED IS/ARE CLAIMED AS A FEATURE OF THE MARK.

THE MARK CONSISTS OF THE LETTERS "MCX" IN BLUE WITH A RED HORIZONTAL BAND APPEARING IN THE MIDDLE OF EACH LETTER. THE WORDING "CORE BRANDS" APPEARS IN BLUE BELOW "MCX", AND THE WORDING "CORPS VALUE" APPEARS IN BLUE BELOW "CORE BRANDS". A RED HORIZONTAL LINE SEPARATES THE WORDING "CORE BRANDS" AND "CORPS VALUE".

FOR ON-LINE RETAIL STORE SERVICES FEATURING A WIDE VARIETY OF CONSUMER GOODS OF OTHERS; RETAIL DEPARTMENT STORE SERVICES; RETAIL GASOLINE SUPPLY SERVICES (U.S. CLS. 100, 101 AND 102).

FIRST USE 9-4-2003; IN COMMERCE 9-4-2003.
NELSON SNYDER, EXAMINING ATTORNEY

SN 85-529,940. FIRST NIAGARA FINANCIAL GROUP, INC., BUFFALO, NY. FILED 1-31-2012.

WE LOVE UPSTATE NY

THE MARK CONSISTS OF STANDARD CHARACTERS WITHOUT CLAIM TO ANY PARTICULAR FONT, STYLE, SIZE, OR COLOR.

FOR CONDUCTING AN ADVERTISING AND PROMOTIONAL CAMPAIGN ON ISSUES RELATING TO COMMUNITY DEVELOPMENT AND OUTREACH (U.S. CLS. 100, 101 AND 102).

FIRST USE 8-21-2011; IN COMMERCE 8-21-2011.
KEVIN DINALLO, EXAMINING ATTORNEY

SN 85-532,105. D.L. RYAN COMPANIES, LLC, WILTON, CT. FILED 2-2-2012.

THE ART OF CONVERSION

THE MARK CONSISTS OF STANDARD CHARACTERS WITHOUT CLAIM TO ANY PARTICULAR FONT, STYLE, SIZE, OR COLOR.

FOR ADVERTISING, MARKETING AND PROMOTION SERVICES (U.S. CLS. 100, 101 AND 102).

MARK SHINER, EXAMINING ATTORNEY

CLASS 35—(Continued).

SN 85-537,579. STRATEGIC PARTNERS, INC., CHATSWORTH, CA. FILED 2-8-2012.

Code Happy Club

THE MARK CONSISTS OF STANDARD CHARACTERS WITHOUT CLAIM TO ANY PARTICULAR FONT, STYLE, SIZE, OR COLOR.

NO CLAIM IS MADE TO THE EXCLUSIVE RIGHT TO USE "CLUB", APART FROM THE MARK AS SHOWN.

FOR ADMINISTRATION OF A PROGRAM FOR ENABLING PARTICIPANTS TO OBTAIN DISCOUNTS ON PRODUCTS AND SERVICES; ON-LINE RETAIL STORE SERVICES FEATURING PRODUCTS AND SERVICES FOR HEALTH CARE PROFESSIONALS (U.S. CLS. 100, 101 AND 102).

NAAKWAMA ANKRAH, EXAMINING ATTORNEY

SN 85-539,625. HUHTAMAKI, INC., DESOTO, KS. FILED 2-10-2012.

BE SEEN AS GREEN

THE MARK CONSISTS OF STANDARD CHARACTERS WITHOUT CLAIM TO ANY PARTICULAR FONT, STYLE, SIZE, OR COLOR.

FOR PROMOTING THE SALE OF GOODS OF OTHERS (U.S. CLS. 100, 101 AND 102).

JULIE WATSON, EXAMINING ATTORNEY

CLASS 35—(Continued).

SN 85-540,942. PROMONTORY INTERFINANCIAL NETWORK, LLC, ARLINGTON, VA. FILED 2-13-2012.



NO CLAIM IS MADE TO THE EXCLUSIVE RIGHT TO USE "MLS", APART FROM THE MARK AS SHOWN.

THE MARK CONSISTS OF THE LETTERS "MLS+", IN A DESIGN WHERE THE "+" SYMBOL IS DISPLAYED IN A CIRCLE THAT APPEARS TO BE ABOVE AND BEHIND THE LETTERS "L" AND "S".

FOR PROVIDING AN ONLINE WEB SITE WHERE PERSONS AND COMPANIES CAN CONNECT AND MAKE KNOWN THEIR INTEREST IN BUYING OR SELLING VARIOUS GOODS, INTANGIBLE ASSETS AND FINANCIAL ASSETS, AND FACILITATING THE BUYING AND SELLING OF THE ASSETS; OPERATING AN ONLINE MARKETPLACE FOR BUYERS AND SELLERS OF VARIOUS GOODS, INTANGIBLE ASSETS AND FINANCIAL ASSETS; PROVIDING A WEBSITE FEATURING AN ONLINE MARKETPLACE FOR ENGAGING IN BUYING AND/OR SELLING TRANSACTIONS WITH OTHER USERS (U.S. CLS. 100, 101 AND 102).
DAWN FELDMAN, EXAMINING ATTORNEY

CLASS 35—(Continued).

SN 85-544,253. CSC BRANDS LP, CAMDEN, NJ. FILED 2-16-2012.

FOCUS FORWARD

THE MARK CONSISTS OF STANDARD CHARACTERS WITHOUT CLAIM TO ANY PARTICULAR FONT, STYLE, SIZE, OR COLOR.

FOR PROVIDING BUSINESS INFORMATION TO THE PUBLIC IN THE FIELDS OF CORPORATE INFORMATION, STRATEGIC INITIATIVES AND NEW PRODUCTS (U.S. CLS. 100, 101 AND 102).

FIRST USE 8-1-2011; IN COMMERCE 8-1-2011.
DORITT L. CARROLL, EXAMINING ATTORNEY

SN 85-544,757. CSC BRANDS LP, CAMDEN, NJ. FILED 2-16-2012.

SN 85-542,608. HOWARD G. BUFFETT FOUNDATION, DECATUR, IL. FILED 2-14-2012.



NO CLAIM IS MADE TO THE EXCLUSIVE RIGHT TO USE "BROWN REVOLUTION", APART FROM THE MARK AS SHOWN.

THE MARK CONSISTS OF THE WORDS "BROWN REVOLUTION" IN A LARGER FONT AND THE WORDS "SAVE OUR SOILS, SAVE OUR FUTURE" BENEATH THEM IN A SMALLER FONT, WITH THE LETTER "V" IN "REVOLUTION" FORMED BY THREE PAIRS OF LEAVES.

FOR CHARITABLE SERVICES, NAMELY, ORGANIZING AND PROMOTING PROJECTS THAT IMPROVE SOIL QUALITY AND AGRICULTURAL PRODUCTIVITY (U.S. CLS. 100, 101 AND 102).
FIRST USE 1-31-2012; IN COMMERCE 1-31-2012.
HANNO RITTNER, EXAMINING ATTORNEY



THE COLOR(S) RED, PINK, ORANGE, YELLOW AND BLACK IS/ARE CLAIMED AS A FEATURE OF THE MARK.

THE MARK CONSISTS OF THE WORD "FOCUS" IN BLACK ABOVE THE WORD "FORWARD" IN RED BESIDE A MULTI-COLORED ARROW OF RED, PINK ORANGE AND YELLOW.

FOR PROVIDING BUSINESS INFORMATION TO THE PUBLIC IN THE FIELDS OF CORPORATE INFORMATION, STRATEGIC INITIATIVES AND NEW PRODUCTS (U.S. CLS. 100, 101 AND 102).
FIRST USE 8-1-2011; IN COMMERCE 8-1-2011.
DORITT L. CARROLL, EXAMINING ATTORNEY

CLASS 35—(Continued).

SN 85-544,775. CSC BRANDS LP, CAMDEN, NJ. FILED 2-16-2012.



THE COLOR(S) RED, PINK, ORANGE AND YELLOW IS/ ARE CLAIMED AS A FEATURE OF THE MARK.
THE MARK CONSISTS OF A MULTI-COLORED ARROW. FOR PROVIDING BUSINESS INFORMATION TO THE PUBLIC IN THE FIELDS OF CORPORATE INFORMATION, STRATEGIC INITIATIVES AND NEW PRODUCTS (U.S. CLS. 100, 101 AND 102).
FIRST USE 8-1-2011; IN COMMERCE 8-1-2011.
DORITT L. CARROLL, EXAMINING ATTORNEY

SN 85-544,860. SCANSOURCE, INC., GREENVILLE, SC. FILED 2-16-2012.

DUE SOUTH

THE MARK CONSISTS OF STANDARD CHARACTERS WITHOUT CLAIM TO ANY PARTICULAR FONT, STYLE, SIZE, OR COLOR.
FOR DISTRIBUTORSHIP SERVICES IN THE FIELD OF VOICE, VIDEO AND DATA EQUIPMENT (U.S. CLS. 100, 101 AND 102).
KATHERINE CHANG, EXAMINING ATTORNEY

SN 85-552,078. HCPRO, INC., DANVERS, MA. FILED 2-24-2012.

Credence

THE MARK CONSISTS OF STANDARD CHARACTERS WITHOUT CLAIM TO ANY PARTICULAR FONT, STYLE, SIZE, OR COLOR.
FOR BUSINESS PROCESS OUTSOURCING SERVICES IN THE FIELD OF MEDICAL STAFF SERVICES (U.S. CLS. 100, 101 AND 102).
KATHERINE M. DUBRAY, EXAMINING ATTORNEY

CLASS 35—(Continued).

SN 85-564,099. MILEMETER, INC., DALLAS, TX. FILED 3-8-2012.

ROUNDUP FOR STARTUPS

THE MARK CONSISTS OF STANDARD CHARACTERS WITHOUT CLAIM TO ANY PARTICULAR FONT, STYLE, SIZE, OR COLOR.
FOR EMPLOYMENT HIRING, RECRUITING, PLACEMENT, STAFFING AND CAREER NETWORKING SERVICES (U.S. CLS. 100, 101 AND 102).
FIRST USE 3-7-2012; IN COMMERCE 3-7-2012.
AMY KELLY, EXAMINING ATTORNEY

SN 85-571,693. VENNGOGH, INC., BOCA RATON, FL. FILED 3-16-2012.

The Art of Giving Back

THE MARK CONSISTS OF STANDARD CHARACTERS WITHOUT CLAIM TO ANY PARTICULAR FONT, STYLE, SIZE, OR COLOR.
FOR ADVERTISING SERVICES, NAMELY, PROMOTING AND MARKETING THE GOODS AND SERVICES OF OTHERS THROUGH ALL PUBLIC COMMUNICATION MEANS (U.S. CLS. 100, 101 AND 102).
FIRST USE 2-15-2012; IN COMMERCE 2-15-2012.
ROBERT C. CLARK JR., EXAMINING ATTORNEY

SN 85-574,396. REITHEL, RYAN, GARY, IN. FILED 3-20-2012.



NO CLAIM IS MADE TO THE EXCLUSIVE RIGHT TO USE DESIGN OF THE QUICK RESPONSE CODE, "REGISTER, CONFIRM, EDUCATE & MOBILIZE", "INDIANA WORKERS VOTE .COM" THE OUTLINE OF THE MAP OF INDIANA AND "WWW.INDIANWORKERSVOTE.COM", APART FROM THE MARK AS SHOWN.

THE MARK CONSISTS OF THE DESIGN OF A QUICK

CLASS 35—(Continued).

RESPONSE CODE, A DOUBLE LINE CIRCLE AROUND THE OUTLINE OF THE STATE OF INDIANA WITH A BANNER HAVING THE WORDING "INDIANA WORKERS VOTE" RUNNING THROUGH IT, THE WORDING ".COM" APPEARS ON THE BOTTOM RIGHT HAND SIDE OF THE IMAGE OF THE STATE. ON THE UPPER RIGHT HAND OUTSIDE SIDE EDGE OF THE CIRCLE IS THE WORDING "REGISTER, CONFIRM, EDUCATE & MOBILIZE", AND ON THE BOTTOM LEFT HAND OUTER EDGE IS THE WORDING "WWW.INDIANAWORKERSVOTE.COM".

FOR PROVIDING A WEBSITE FEATURING INFORMATION ABOUT POLITICAL ISSUES; PROVIDING INFORMATION ABOUT POLITICAL ELECTIONS; PROVIDING INFORMATION REGARDING POLITICAL ISSUES, KNOWING HOW TO VOTE AND KNOWING HOW TO REGISTER TO VOTE (U.S. CLS. 100, 101 AND 102).

FIRST USE 2-20-2012; IN COMMERCE 2-20-2012.
COLLEEN KEARNEY, EXAMINING ATTORNEY

SN 85-576,024. TRINETRA, INC., FRESNO, CA. FILED 3-21-2012.

WINMYTRIP

THE MARK CONSISTS OF STANDARD CHARACTERS WITHOUT CLAIM TO ANY PARTICULAR FONT, STYLE, SIZE, OR COLOR.

FOR AUCTIONING VIA TELECOMMUNICATION NETWORKS; ON-LINE AUCTION SERVICES (U.S. CLS. 100, 101 AND 102).

GIANCARLO CASTRO, EXAMINING ATTORNEY

SN 85-576,054. TRINETRA, INC., FRESNO, CA. FILED 3-21-2012.

WINMYTRIP.COM

THE MARK CONSISTS OF STANDARD CHARACTERS WITHOUT CLAIM TO ANY PARTICULAR FONT, STYLE, SIZE, OR COLOR.

FOR AUCTIONING VIA TELECOMMUNICATION NETWORKS; CARRYING OUT AUCTION SALES; CONDUCTING OF AUCTION SALES; ON-LINE AUCTION SERVICES; ON-LINE AUCTIONEERING SERVICES VIA THE INTERNET; ON-LINE TRADING SERVICES IN WHICH SELLER POSTS PRODUCTS TO BE AUCTIONED AND BIDDING IS DONE VIA THE INTERNET (U.S. CLS. 100, 101 AND 102).

GIANCARLO CASTRO, EXAMINING ATTORNEY

CLASS 35—(Continued).

SN 85-576,087. TRINETRA, INC., FRESNO, CA. FILED 3-21-2012.

WINMYTRIPS.COM

THE MARK CONSISTS OF STANDARD CHARACTERS WITHOUT CLAIM TO ANY PARTICULAR FONT, STYLE, SIZE, OR COLOR.

FOR ARRANGING AND CONDUCTING AUCTIONS; ARRANGING AND CONDUCTION OF AUCTION SALES; ARRANGING OF AUCTION SALES; AUCTION MANAGEMENT SERVICES PROVIDED TO OTHERS OVER AN ON-LINE WEB SITE ACCESSED THROUGH A GLOBAL COMPUTER NETWORK; AUCTION SERVICES; AUCTIONEERING PROVIDED ON THE INTERNET; AUCTIONING VIA TELECOMMUNICATION NETWORKS; CARRYING OUT AUCTION SALES; CONDUCTING OF AUCTION SALES; ON-LINE AUCTION BIDDING FOR OTHERS; ON-LINE AUCTION SERVICES; ON-LINE AUCTION SERVICES IN WHICH BUYERS WHO DONATE TO CHARITY RECEIVE ADDITIONAL BIDDING RIGHTS; ON-LINE AUCTIONEERING SERVICES VIA THE INTERNET; ON-LINE TRADING SERVICES IN WHICH SELLER POSTS PRODUCTS TO BE AUCTIONED AND BIDDING IS DONE VIA THE INTERNET (U.S. CLS. 100, 101 AND 102).

GIANCARLO CASTRO, EXAMINING ATTORNEY

SN 85-578,743. WAL-MART STORES, INC., BENTONVILLE, AR. FILED 3-23-2012.

WALMART TIRES ON DEMAND

THE MARK CONSISTS OF STANDARD CHARACTERS WITHOUT CLAIM TO ANY PARTICULAR FONT, STYLE, SIZE, OR COLOR.

OWNER OF U.S. REG. NOS. 2,891,003, 3,612,345 AND OTHERS.

NO CLAIM IS MADE TO THE EXCLUSIVE RIGHT TO USE "TIRES ON DEMAND", APART FROM THE MARK AS SHOWN.

FOR RETAIL STORE SERVICES FEATURING A WIDE VARIETY OF CONSUMER GOODS OF OTHERS; RETAIL STORE SERVICES FEATURING TIRES (U.S. CLS. 100, 101 AND 102).

JUDITH HELFMAN, EXAMINING ATTORNEY

CLASS 35—(Continued).

SN 85-976,311. LIFESTYLE CAR CLUB LOS ANGELES LLC, RANCHO CUCAMONGA, CA. FILED 5-27-2011.

LIFESTYLE CAR CLUB

THE MARK CONSISTS OF STANDARD CHARACTERS WITHOUT CLAIM TO ANY PARTICULAR FONT, STYLE, SIZE, OR COLOR.

NO CLAIM IS MADE TO THE EXCLUSIVE RIGHT TO USE "CAR CLUB", APART FROM THE MARK AS SHOWN. SEC. 2(F).

FOR CLUB SERVICES, NAMELY, PROMOTING THE INTERESTS OF LOW RIDER CAR ENTHUSIASTS (U.S. CLS. 100, 101 AND 102).

FIRST USE 7-15-1975; IN COMMERCE 7-15-1975.

CAROLINE WOOD, EXAMINING ATTORNEY

CLASS 36—INSURANCE AND FINANCIAL

SN 75-804,210. DIME SAVINGS BANK OF NEW YORK, FSB, THE, NEW YORK, NY. FILED 9-21-1999.

**DIME UNITED BANCORP,
INC.**

NO CLAIM IS MADE TO THE EXCLUSIVE RIGHT TO USE "BANCORP, INC.", APART FROM THE MARK AS SHOWN.

FOR BANKING SERVICES; SAVINGS BANK SERVICES; MORTGAGE BANKING; DEBIT CARD SERVICES; ELECTRONIC FUNDS TRANSFER; PROVIDING BANKING SERVICES AND INFORMATION RELATED TO BANKING AND FINANCE MATTERS THROUGH A GLOBAL COMPUTER NETWORK; LOAN FINANCING; FINANCING SERVICES; HOME EQUITY LOANS; INSTALLMENT LOANS; MORTGAGE LENDING; MONEY ORDER SERVICES; SAFETY DEPOSIT BOX SERVICES; TRAVELER'S CHECK ISSUANCE; AUTOMATED 24-HOUR BRANCH BANKING SERVICES; CREDIT AND FINANCIAL SERVICES, NAMELY, PROVIDING A REVOLVING LINE OF CREDIT TO CONSUMERS; SECURITY BROKERAGE SERVICES (U.S. CLS. 100, 101 AND 102).

KATHLEEN M. VANSTON, EXAMINING ATTORNEY

CLASS 36—(Continued).

SN 76-708,164. AMERICAN INSURANCE ADMINISTRATORS, INC, COLUMBUS, OH. FILED 6-27-2011.

READYMED

THE MARK CONSISTS OF STANDARD CHARACTERS WITHOUT CLAIM TO ANY PARTICULAR FONT, STYLE, SIZE, OR COLOR.

FOR MEDICAL INSURANCE BROKERAGE SERVICES (U.S. CLS. 100, 101 AND 102).

FIRST USE 5-0-1996; IN COMMERCE 5-0-1996.

ELLEN PERKINS, EXAMINING ATTORNEY

SN 76-709,869. AMERICAN INSURANCE ADMINISTRATORS, INC., COLUMBUS, OH. FILED 12-1-2011.

AlumniAD&D

Accidental Death & Dismemberment

OWNER OF U.S. REG. NOS. 2,109,386, 2,355,676 AND OTHERS.

NO CLAIM IS MADE TO THE EXCLUSIVE RIGHT TO USE "AD & D" AND "ACCIDENTAL DEATH & DISMEMBERMENT", APART FROM THE MARK AS SHOWN.

THE MARK CONSISTS OF THE WORD "ALUMNIA&DD" ABOVE THE WORDS "ACCIDENTAL DEATH & DISMEMBERMENT" WITH A LINE POSITIONED THEREBETWEEN.

FOR ACCIDENTAL DEATH AND DISMEMBERMENT INSURANCE BROKERAGE SERVICES (U.S. CLS. 100, 101 AND 102).

FIRST USE 10-17-2011; IN COMMERCE 10-17-2011.

JAMES STEIN, EXAMINING ATTORNEY

SN 76-709,871. AMERICAN INSURANCE ADMINISTRATORS, INC., COLUMBUS, OH. FILED 12-1-2011.

AlumniHIP

Hospital Indemnity PLAN

NO CLAIM IS MADE TO THE EXCLUSIVE RIGHT TO USE "HOSPITAL INDEMNITY PLAN", APART FROM THE MARK AS SHOWN.

THE MARK CONSISTS OF THE WORD "ALUMNIHIP" ABOVE THE WORDS "HOSPITAL INDEMNITY PLAN" WITH A LINE POSITIONED THEREBETWEEN.

FOR HOSPITAL INDEMNITY INSURANCE BROKERAGE SERVICES (U.S. CLS. 100, 101 AND 102).

FIRST USE 10-17-2011; IN COMMERCE 10-17-2011.

JAMES STEIN, EXAMINING ATTORNEY

CLASS 36—(Continued).

SN 76-710,312. PEOPLE FIRST FEDERAL CREDIT UNION, ALLENTOWN, PA. FILED 1-19-2012.



OWNER OF U.S. REG. NOS. 1,872,782 AND 2,904,533. THE MARK CONSISTS OF THE DESIGN OF THE UPPER PORTION OF A STYLIZED HUMAN FIGURE SHOWING HEAD AND UPRAISED ARMS SURROUNDED BY A RECTANGLE WITH ROUNDED CORNERS TO THE LEFT OF THE WORDS "PEOPLE FIRST".
FOR CREDIT UNION SERVICES (U.S. CLS. 100, 101 AND 102).
FIRST USE 10-1-1992; IN COMMERCE 10-1-1992.
LINDSEY RUBIN, EXAMINING ATTORNEY

SN 77-581,855. LIBERTY TRANSFER INTERNATIONAL, CHICAGO, IL. FILED 9-30-2008.



THE MARK CONSISTS OF THE STYLIZED WORD "LIBERTY" UNDERLINED BY A BAND CURVING UPWARDS FROM LEFT TO RIGHT, STARTING WITH THE LETTER "L" AND ENDING NEAR THE LETTER "Y"; BEHIND THE LETTERS "LIB" APPEARS AN OUTLINE OF THE STATUE OF LIBERTY ON TOP OF AN OUTLINE OF NORTH AMERICA.
FOR FINANCIAL SERVICES, NAMELY, ELECTRONIC TRANSFERS OF MONEY (U.S. CLS. 100, 101 AND 102).
FIRST USE 7-31-2006; IN COMMERCE 8-1-2007.
EDWARD FENNESSY, EXAMINING ATTORNEY

SN 77-755,658. FEDERATION OF RENTAL-HOUSING PROVIDERS OF ONTARIO, TORONTO, ONTARIO, CANADA, FILED 6-9-2009.



PRIORITY CLAIMED UNDER SEC. 44(D) ON CANADA APPLICATION NO. 1427788, FILED 2-13-2009, REG. NO. TMA804684, DATED 8-18-2011, EXPIRES 8-18-2026.
NO CLAIM IS MADE TO THE EXCLUSIVE RIGHT TO USE "CERTIFIED RENTAL BUILDING", APART FROM THE MARK AS SHOWN.
FOR RENTAL OF RESIDENTIAL HOUSING (U.S. CLS. 100, 101 AND 102).
SIMON TENG, EXAMINING ATTORNEY

CLASS 36—(Continued).

SN 77-755,671. FEDERATION OF RENTAL-HOUSING PROVIDERS OF ONTARIO, TORONTO, ONTARIO, CANADA, FILED 6-9-2009.



PRIORITY CLAIMED UNDER SEC. 44(D) ON CANADA APPLICATION NO. 1427788, FILED 2-13-2009.
NO CLAIM IS MADE TO THE EXCLUSIVE RIGHT TO USE "CERTIFIED RENTAL BUILDING", APART FROM THE MARK AS SHOWN.
FOR RENTAL OF RESIDENTIAL HOUSING (U.S. CLS. 100, 101 AND 102).
SIMON TENG, EXAMINING ATTORNEY

SN 85-042,686. DAISHIN SECURITIES CO. LTD, SEOUL. 150-884, REPUBLIC OF KOREA, FILED 5-19-2010.



PRIORITY CLAIMED UNDER SEC. 44(D) ON REPUBLIC OF KOREA APPLICATION NO. 41-2010-0002, FILED 1-25-2010, REG. NO. 0217674, DATED 9-23-2011, EXPIRES 9-23-2021.
THE MARK CONSISTS OF THE WORD "DAISHIN" WITH A DESIGN TO THE RIGHT OF THE WORD "DAISHIN".
FOR CONSULTANCY SERVICE RELATING TO DEVELOPMENT FINANCING; FINANCING SERVICES FOR DEVELOPMENT; ARRANGING OF PERSONAL LOANS; MARRIAGE LOAN SERVICES; FINANCING OF PURCHASES; CONSULTANCY SERVICES RELATING TO INTERNATIONAL FINANCE; INTERNATIONAL BANKING; INTERNATIONAL FUND INVESTMENT; MILITARY FINANCE; DEPOSITS OF VALUABLES; SAFE DEPOSIT SERVICES; CONSULTANCY SERVICES RELATING TO FINANCE; BROKERAGE SERVICES RELATING TO FINANCIAL INSTRUMENTS; FINANCIAL ASSET MANAGEMENT; PROVISION OF INFORMATION IN THE FIELD OF FINANCING; FINANCIAL BROKERAGE; ACQUISITION AND TRANSFER OF MONETARY CLAIMS; ARRANGING OF FINANCIAL INVESTMENT; MONEY RECEIVABLES COLLECTION AGENCIES; CORPORATE LENDING; DOMESTIC EXCHANGE TRANSACTIONS; PROVIDING INFORMATION OF DOMESTIC EXCHANGE TRANSACTIONS; FINANCING OF BRIDGING LOANS; ARRANGING OF LOANS AGAINST SECURITY; MORTGAGE LENDING; CURRENT ACCOUNT SERVICES; PAYMENT AND RECEIPT OF MONEY AS AGENTS; LOANS; RENTAL OF SAFE; DEBT COLLECTION; CONSULTANCY SERVICES RELATING LOANS; DEBIT CARD SERVICES; LEASE FINANCING; MORTGAGE LOAN SERVICES; UNSECURED LOANS; STOCK BROKERAGE VIA WIRELESS TERMINALS; PROVISION OF INFORMATION RELATING TO FINANCE VIA WIRELESS COMMUNICATIONS; STOCK BROKERAGE VIA WIRELESS COMMUNICATIONS; STOCK INVESTMENT CONSULTANCY VIA WIRELESS COMMUNICATIONS; TRADE FINANCE SERVICES; PROVISION OF PRICING INFORMATION ABOUT MUTUAL FUNDS; VENTURE CAPITAL FINANCING; LENDING AGAINST SECURITY; SURETY SERVICES; ASSURANCE SER-

CLASS 36—(Continued).

VICES; ISSUING OF LOTTERY; ARRANGING THE PROVISION OF FINANCE FOR REAL ESTATE PURCHASE; INDUSTRIAL FINANCING SERVICES; COMMERCIAL BANKING; MUTUAL FUNDS; MUTUAL CREDIT FUNDS; PROVISION OF PRICING INFORMATION ABOUT FUTURES; BROKERAGE SERVICES RELATING TO FUTURES EXCHANGE; CONSUMER LENDING SERVICES; EXPORT FINANCE SERVICES; CHECK VERIFICATION; ISSUING OF CHECKS; FINANCING SERVICES FOR NEW TECHNOLOGY; CREDIT BUREAU; CREDIT AND CASH CARD SERVICES; ISSUANCE OF CREDIT CARDS; CREDIT CARD SERVICES; INSTALLMENT CREDIT FINANCING; FIDUCIARY; ISSUING OF PROMISSORY NOTES; FINANCIAL CLEARING; LOANS AND DISCOUNT OF BILLS; ISSUING OF CHECKS AND LETTERS OF CREDIT; ISSUING OF TRAVELER'S CHECKS; TRUSTEESHIP OF PENSIONS; ADMINISTRATION OF DEPOSIT TAKING; DEPOSIT-TAKING SERVICES; FOREIGN EXCHANGE TRANSACTIONS; PROVISION OF PRICING INFORMATION ABOUT FOREIGN EXCHANGE; ISSUING OF NEGOTIABLE INSTRUMENTS; SECURITY BROKERAGE; BANKING SERVICES RELATING TO THE TRANSFER OF FUNDS FROM ACCOUNTS; CONSULTATIONS RELATING TO BANKING; BANKING; INTERNET BANKING; RENT COLLECTION; LEASE-PURCHASE FINANCING; MONEY LENDING; PLACEMENT OF FUNDS; MONEY TRANSFER; FUND RAISING; MONEY BROKERAGE; CHECK CASHING; DIRECT DEBIT SERVICES; FINANCIAL SERVICES RELATING TO MOTOR VEHICLES; AUTOMATED TELLER MACHINE SERVICES; CAPITAL INVESTMENT CONSULTATION; CAPITAL INVESTMENTS; FINANCIAL BANKING; FINANCIAL SPONSORSHIP; MORTGAGE BANKING; SAVINGS BANKS; LENDING AGAINST SECURITY; ELECTRONIC FUNDS TRANSFER; STOCK INDEX FUTURES OPTIONS TRADING SERVICES; STOCKS AND BONDS BROKERAGE; PROVIDING STOCK/SECURITIES MARKET INFORMATION; STOCK EXCHANGE QUOTATIONS; VALUATION OF STOCK EXCHANGE QUOTATIONS; HOME EQUITY LOANS; ARRANGING THE FINANCE FOR HOME LOANS; SECURITIES BUSINESS; SECURITIES BROKERAGE; STOCK INVESTMENT CONSULTANCY; BOND PURCHASING; ISSUANCE OF BONDS; BROKERAGE OF BONDS; DEBT COLLECTION AGENCIES; GUARANTEE OF AN OBLIGATION; ISSUE OF TOKENS OF VALUE; ELECTRONIC FUNDS TRANSFER BY TELECOMMUNICATIONS; RETIREMENT PAYMENT SERVICES; FINANCIAL SERVICES RELATING TO INVESTMENT; INVESTMENT TRUSTS; FACTORING; INVESTMENT OF FUNDS FOR OTHERS; PROVISION OF LOANS FOR SCHOOL FEES; INSTALLMENT LOANS; HIRE-PURCHASE FINANCING; RENTAL OF AUTOMATED-TELLER MACHINES; CASH CARD SERVICES; HOME BANKING; EXCHANGING MONEY; HEALTH INSURANCE UNDERWRITING; EDUCATIONAL ENDOWMENT INSURANCE; BUYER'S CREDIT UNDERWRITING; BURGLARY INSURANCE SERVICES; BAILBONDING; GUARANTEE ASSURANCE UNDERWRITING; INSURANCE APPRAISAL; INSURANCE AGENCY; INSURANCE ASSESSMENTS; INSURANCE CONSULTANCY; INSURANCE LOSS ASSESSMENT; INSURANCE SERVICES; INSURANCE ADVISORY SERVICES; INSURANCE INFORMATION; INSURANCE BROKERAGE; ACTUARIAL SERVICES; REAL ESTATE INSURANCE SERVICES; COMPULSORY SOCIAL SECURITY INSURANCE; INDUSTRIAL ACCIDENT INSURANCE UNDERWRITING; INSURANCE OF GOODS WHILE IN TRANSIT; ACCIDENT INSURANCE UNDERWRITING; MUTUAL INSURANCE SERVICES; PLANNING SERVICES RELATING TO LIFE ASSURANCE; LIFE INSURANCE UNDERWRITING; ENDOWMENT INSURANCE SERVICES; ANNUITY UNDERWRITING; SPORTS INSURANCE SERVICES; TRANSIT INSURANCE UNDERWRITING; MEDICAL INSURANCE SERVICES; AUTOMOBILE INSURANCE SERVICES; REINSURANCE SERVICES; PROFESSIONAL INDEMNITY INSURANCE; LIABILITY INSURANCE SERVICES; AVIATION INSURANCE SERVICES; MARINE INSURANCE UNDERWRITING; FIRE INSURANCE UNDERWRITING; FINANCIAL EVALUATION; FINANCIAL MANAGEMENT FOR REAL ESTATE; FINANCIAL ADVICE RELATING TO TAXATION; FINANCIAL ADVICE RELATING TO TRUST; FINANCIAL MANAGEMENT OF PENSIONS; FINANCIAL ADVISORY SERVICES RELATING TO ASSETS MANAGEMENT; FISCAL VALUATIONS AND ASSES-

CLASS 36—(Continued).

MENTS; FINANCIAL MANAGEMENT; FINANCIAL ANALYSIS; FINANCIAL CONSULTANCY; ADVISORY SERVICES RELATING TO FINANCIAL PLANNING; FINANCIAL INFORMATION; FISCAL ASSESSMENTS; REPAIR COSTS EVALUATION; FINANCIAL MANAGEMENT OF STOCKS; FINANCIAL BUSINESS LIQUIDATION SERVICES; PROVISION OF INFORMATION RELATING TO BUILDING OR LAND; BUILDING MANAGEMENT; PURCHASE AND SALE OF BUILDING; BUILDING SALES SERVICES; PROVISION OF INFORMATION RELATING TO BUILDING SALES; BUILDING LEASING; APARTMENT HOUSE MANAGEMENT; HOUSING AGENTS; LEASING OF FACTORIES; LEASING OF FARMS; HYPERMARKET MANAGEMENT; DEPARTMENT STORE MANAGEMENT; REAL ESTATE APPRAISAL; PROVISION OF INFORMATION RELATING TO REAL ESTATE; REAL ESTATE MANAGEMENT; PURCHASE AND SALE OF REAL ESTATE; REAL ESTATE SALES SERVICES; REAL ESTATE CONSULTANCY; REAL ESTATE TRUSTEE SERVICES; LEASING OF REAL ESTATE; BROKERAGE AND LEASING OF REAL PROPERTY; REAL ESTATE AGENCIES; REAL ESTATE ACQUISITION SERVICES FOR OTHERS; RENTAL OF OFFICES; SHOPPING CENTER MANAGEMENT; SHOPPING CENTER SALES SERVICES; LEASING OF SHOPPING CENTERS; SUPER MARKET MANAGEMENT; MARKET MANAGEMENT; APARTMENT HOUSE MANAGEMENT; RENTING OF APARTMENT; HOME APPRAISAL SERVICES; HOUSE MANAGEMENT; ACCOMMODATION BUREAU; HOUSING AGENCIES; LAND LEASING; CONVENIENCE STORES MANAGEMENT; CREDIT INQUIRIES SERVICES RELATING TO FINANCE; CREDIT INQUIRIES OF ENTERPRISES; CREDIT INQUIRIES SERVICES RELATING TO INSURANCE; CREDIT REPORTING AGENCY; CREDIT INQUIRIES; TRADE AGENCY; TRADE CONSULTANCY; TRADE BROKERAGE; OFFER SERVICES; CUSTOMS BROKERAGE; ANTIQUE APPRAISAL; APPRAISAL OF PRECIOUS METALS; PICTURE APPRAISAL SERVICES; COLLECTIONS OF CONTRIBUTION; ORGANIZATION OF COLLECTIONS; APPRAISAL SERVICES FOR WORKS OF ART; ART APPRAISAL; JEWELRY APPRAISAL; NUMISMATIC APPRAISAL; STAMP APPRAISAL; CHARITABLE FUND RAISING (U.S. CLS. 100, 101 AND 102).

JACQUELINE A. LAVINE, EXAMINING ATTORNEY

SN 85-048,621. ROADRUNNER FOOD BANK, INC., ALBUQUERQUE, NM. FILED 5-26-2010.

ROADRUNNER FOOD BANK

THE MARK CONSISTS OF STANDARD CHARACTERS WITHOUT CLAIM TO ANY PARTICULAR FONT, STYLE, SIZE, OR COLOR.

NO CLAIM IS MADE TO THE EXCLUSIVE RIGHT TO USE "FOOD BANK", APART FROM THE MARK AS SHOWN.

FOR CHARITABLE FUNDRAISING SERVICES USING PROCEEDS FROM THE SALE OF APPAREL, PENS, KEY CHAINS, CARDBOARD BOXES, FLATS AND CASES FOR HOLDING FOOD, AND STICKERS, TO PROCURE AND DISTRIBUTE FREE FOOD TO NEEDY PEOPLE AND THE VICTIMS OF REGIONAL DISASTERS (U.S. CLS. 100, 101 AND 102).

FIRST USE 7-1-1995; IN COMMERCE 7-1-1995.

BRIAN CALLAGHAN, EXAMINING ATTORNEY

CLASS 36—(Continued).

SN 85-103,992. THE MI GROUP LTD., MISSISSAUGA, ONTARIO, CANADA, FILED 8-10-2010.



PRIORITY CLAIMED UNDER SEC. 44(D) ON CANADA APPLICATION NO. 1488404, FILED 7-13-2010, REG. NO. TMA812794, DATED 11-28-2011, EXPIRES 11-28-2026.

OWNER OF U.S. REG. NOS. 1,969,984, 3,048,466 AND OTHERS.

NO CLAIM IS MADE TO THE EXCLUSIVE RIGHT TO USE "WORLDWIDE PARTNER NETWORK", APART FROM THE MARK AS SHOWN.

FOR REAL ESTATE CONSULTATION; REAL ESTATE MANAGEMENT SERVICES (U.S. CLS. 100, 101 AND 102). SIMON TENG, EXAMINING ATTORNEY

SN 85-168,520. SCHOEN, JEFFREY, GRAFTON, WI. FILED 11-3-2010.

BEOME

THE MARK CONSISTS OF STANDARD CHARACTERS WITHOUT CLAIM TO ANY PARTICULAR FONT, STYLE, SIZE, OR COLOR.

FOR PROVIDING REAL ESTATE LISTINGS VIA THE INTERNET (U.S. CLS. 100, 101 AND 102).

FIRST USE 10-23-2009; IN COMMERCE 2-1-2010. MEGHAN REINHART, EXAMINING ATTORNEY

SN 85-173,559. BB&T CORPORATION, WINSTON-SALEM, NC. FILED 11-10-2010.

SHARING KNOWLEDGE FOR A BRIGHTER DIRECTION

THE MARK CONSISTS OF STANDARD CHARACTERS WITHOUT CLAIM TO ANY PARTICULAR FONT, STYLE, SIZE, OR COLOR.

FOR BANKING SERVICES AND RELATED FINANCIAL SERVICES, NAMELY, FINANCIAL ANALYSIS, CONSULTATION, PLANNING AND MANAGEMENT, COMMERCIAL AND CONSUMER LENDING SERVICES, MORTGAGE LENDING AND LOAN FINANCING, CREDIT CARD SERVICES, DEBIT CARD SERVICES, FACTORING AGENCY SERVICES, FINANCIAL PLANNING AND ADMINISTRATION OF EMPLOYEE BENEFITS CONCERNING INSURANCE AND FINANCE, BILL PAYMENT SERVICES, AND CONSULTING SERVICES; INVESTMENT SERVICES, NAMELY, PROVIDING AN INVESTMENT ANALYSIS, CONSULTATION, PLANNING, MANAGEMENT, ADVISORY, BROKERAGE AND BANKING AND RESEARCH SERVICES WITH RESPECT TO FINANCIAL PRODUCTS, REAL ESTATE AND OTHER INSTRUMENTS OF INVESTMENT (U.S. CLS. 100, 101 AND 102).

MICHAEL WEBSTER, EXAMINING ATTORNEY

CLASS 36—(Continued).

SN 85-193,644. PROSPECT HILL CAPITAL PARTNERS LLC, WAYNE, PA. FILED 12-8-2010.

PROSPECT HILL CAPITAL PARTNERS

THE MARK CONSISTS OF STANDARD CHARACTERS WITHOUT CLAIM TO ANY PARTICULAR FONT, STYLE, SIZE, OR COLOR.

NO CLAIM IS MADE TO THE EXCLUSIVE RIGHT TO USE "CAPITAL PARTNERS", APART FROM THE MARK AS SHOWN.

FOR ACQUISITION OF INVESTMENTS FOR OTHERS; MANAGING INVESTMENTS IN ASSET MANAGEMENT FIRMS BY STRUCTURING AND HOLDING OF INVESTMENTS FOR OTHERS; FINANCIAL SERVICES, NAMELY, INVESTMENT ADVICE, INVESTMENT MANAGEMENT, INVESTMENT CONSULTATION AND INVESTMENT OF FUNDS FOR OTHERS; MUTUAL FUND INVESTMENT SERVICES (U.S. CLS. 100, 101 AND 102). LAURIE MAYES, EXAMINING ATTORNEY

SN 85-210,322. UNITED SERVICES AUTOMOBILE ASSOCIATION, SAN ANTONIO, TX. FILED 1-4-2011.

COLLEGE START

THE MARK CONSISTS OF STANDARD CHARACTERS WITHOUT CLAIM TO ANY PARTICULAR FONT, STYLE, SIZE, OR COLOR.

NO CLAIM IS MADE TO THE EXCLUSIVE RIGHT TO USE "COLLEGE", APART FROM THE MARK AS SHOWN.

FOR FINANCIAL SERVICES, NAMELY, BANKING, CREDIT AND DEBIT CARD, AND LOAN SERVICES; ESTATE TRUST MANAGEMENT SERVICES; FINANCIAL ASSET MANAGEMENT SERVICES; MORTGAGE BANKING AND LENDING SERVICES; PAYMENT OF THIRD PARTY BILLS SERVICES; FINANCIAL AND INVESTMENT SERVICES, NAMELY, MANAGEMENT AND BROKERAGE IN THE FIELDS OF STOCKS, BONDS, OPTIONS, COMMODITIES, MUTUAL FUNDS, REAL ESTATE, FUTURES AND OTHER SECURITIES, AND THE INVESTMENT OF FUNDS OF OTHERS; FINANCIAL AND INVESTMENT INFORMATION, ADVICE, ANALYSIS, CONSULTATION, RESEARCH, PLANNING AND MANAGEMENT SERVICES; INSURANCE SERVICES, NAMELY, UNDERWRITING, ISSUING AND ADMINISTRATION OF ALL TYPES OF INSURANCES; INSURANCE ADVICE, ANALYSIS, CONSULTATION, RESEARCH, PLANNING AND MANAGEMENT SERVICES; INSURANCE AGENCY AND BROKERAGE SERVICES (U.S. CLS. 100, 101 AND 102).

AISHA SALEM, EXAMINING ATTORNEY

CLASS 36—(Continued).

SN 85-217,123. ASCENSION HEALTH, ST. LOUIS, MO. FILED 1-13-2011.



NO CLAIM IS MADE TO THE EXCLUSIVE RIGHT TO USE "HEALTH", APART FROM THE MARK AS SHOWN.

THE COLOR(S) FUCHSIA AND DARK PURPLE/BLUE IS/ARE CLAIMED AS A FEATURE OF THE MARK.

THE MARK CONSISTS OF A STYLIZED PLUS SIGN IN FUCHSIA TO THE LEFT OF THE WORDING "CERTITUDE BY ASCENSION HEALTH" IN DARK PURPLE/BLUE.

FOR PROFESSIONAL LIABILITY INSURANCE SERVICES, NAMELY, INSURANCE UNDERWRITING IN THE FIELD OF PROFESSIONAL LIABILITY, ADMINISTRATION, CARRIER SELECTION, CLAIMS ADJUSTMENT, CLAIMS MANAGEMENT, NAMELY, INSURANCE CLAIMS ADMINISTRATION, CLAIMS PROCESSING, CONSULTATION SERVICES, RATING SERVICES, AND COLLECTION; INSURANCE UNDERWRITING IN THE FIELD OF PROFESSIONAL LIABILITY; INSURANCE ADMINISTRATION; INSURANCE PLACEMENT, NAMELY, PROVIDING INSURANCE FOR PHYSICIANS AND RELATED MEDICAL PROFESSIONALS, NAMELY, PROVIDING INSURANCE BROKERAGE SERVICES; INSURANCE CLAIMS ADMINISTRATION SERVICES; INSURANCE RISK/LOSS PREVENTION SERVICES, NAMELY, INSURANCE RISK MANAGEMENT SERVICES AND INSURANCE LOSS CONTROL MANAGEMENT SERVICES (U.S. CLS. 100, 101 AND 102).

SANI KHOURI, EXAMINING ATTORNEY

SN 85-220,988. GROUNDHOG ENTERPRISES, INC., ANNAPOLIS, MD. FILED 1-19-2011.

MERCHANT LYNX SERVICES

THE MARK CONSISTS OF STANDARD CHARACTERS WITHOUT CLAIM TO ANY PARTICULAR FONT, STYLE, SIZE, OR COLOR.

NO CLAIM IS MADE TO THE EXCLUSIVE RIGHT TO USE "MERCHANT" OR "SERVICES", APART FROM THE MARK AS SHOWN.

FOR PAYMENT PROCESSING SERVICES, NAMELY, CREDIT CARD AND DEBIT CARD TRANSACTION PROCESSING SERVICES; PROVIDING ELECTRONIC PROCESSING OF CREDIT CARD TRANSACTIONS AND ELECTRONIC PAYMENTS VIA A GLOBAL COMPUTER NETWORK (U.S. CLS. 100, 101 AND 102).

FIRST USE 0-0-1994; IN COMMERCE 0-0-1994.

KRISTINA MORRIS, EXAMINING ATTORNEY

CLASS 36—(Continued).

SN 85-264,919. ADVANCED PATIENT ADVOCACY, LLC, ANNAPOLIS, MD. FILED 3-11-2011.



NO CLAIM IS MADE TO THE EXCLUSIVE RIGHT TO USE "PATIENT ADVOCACY", APART FROM THE MARK AS SHOWN.

THE MARK CONSISTS OF A STYLIZED LETTER "A" WITH THE WORDS "ADVANCED PATIENT ADVOCACY" TO THE RIGHT OF THE STYLIZED "A", AND THE WORDS "HEALTHY RESULTS. GUARANTEED." BENEATH THE WORDS "ADVANCED PATIENT ADVOCACY".

FOR ASSISTANCE TO HOSPITALS, PATIENTS, INSURANCE CARRIERS AND HEALTH CARE PROVIDERS IN THE NATURE OF HEALTH CARE BENEFITS, NAMELY, PROVIDING COUNSELING AND CONSULTING IN THE FIELD OF HEALTH CARE BENEFIT PLANS; ASSISTANCE TO HOSPITALS, PATIENTS AND HEALTH CARE PROVIDERS IN THE NATURE OF INSURANCE ELIGIBILITY REVIEW AND VERIFICATION, AND INSURANCE CONSULTATION IN THE HEALTH INDUSTRY (U.S. CLS. 100, 101 AND 102).

FIRST USE 2-15-2011; IN COMMERCE 2-15-2011.

LAURIE MAYES, EXAMINING ATTORNEY

SN 85-273,268. VISA INTERNATIONAL SERVICE ASSOCIATION, FOSTER CITY, CA. FILED 3-22-2011.

LIFE TAKES VISA

THE MARK CONSISTS OF STANDARD CHARACTERS WITHOUT CLAIM TO ANY PARTICULAR FONT, STYLE, SIZE, OR COLOR.

OWNER OF U.S. REG. NOS. 1,071,114 AND 3,379,438.

FOR BROAD BASED FINANCIAL SERVICES, NAMELY, BANKING SERVICES, CREDIT CARD SERVICES, DEBIT CARD SERVICES, CHARGE CARD SERVICES, PRE-PAID CARD SERVICES OFFERED THROUGH CARDS WITH STORED VALUE, BILL PAYMENT SERVICES, ELECTRONIC CASH TRANSACTIONS; AUTOMATED TELLER MACHINE SERVICES, NAMELY, PROVIDING DEPOSIT ACCESS, WITHDRAWALS AND FINANCIAL INFORMATION; ELECTRONIC FUNDS TRANSFER, ELECTRONIC PAYMENT PROCESSING SERVICES, CREDIT CARD AND DEBIT CARD VERIFICATION; VALUE EXCHANGE SERVICES, NAMELY, SECURE ELECTRONIC CASH TRANSACTIONS OVER COMPUTER NETWORKS TO FACILITATE ELECTRONIC COMMERCE; PROCESSING OF FINANCIAL TRANSACTIONS ONLINE VIA A GLOBAL COMPUTER NETWORK; ELECTRONIC CASH SERVICES, NAMELY, CURRENCY EXCHANGE OVER A GLOBAL ELECTRONIC NETWORK; DISSEMINATION OF FINANCIAL INFORMATION VIA A GLOBAL COMPUTER NETWORK (U.S. CLS. 100, 101 AND 102).

JOHN GARTNER, EXAMINING ATTORNEY

CLASS 36—(Continued).

SN 85-280,282. PROSPERITY BANK, ST. AUGUSTINE, FL. FILED 3-29-2011.

Senior Partners

THE MARK CONSISTS OF STANDARD CHARACTERS WITHOUT CLAIM TO ANY PARTICULAR FONT, STYLE, SIZE, OR COLOR.

NO CLAIM IS MADE TO THE EXCLUSIVE RIGHT TO USE "SENIOR", APART FROM THE MARK AS SHOWN.

FOR BANKING AND FINANCING SERVICES (U.S. CLS. 100, 101 AND 102).

FIRST USE 3-29-2011; IN COMMERCE 3-29-2011.
KAREN SEVERSON, EXAMINING ATTORNEY

SN 85-285,435. PAG IPR HOLDINGS LIMITED, CENTRAL, HONG KONG, FILED 4-4-2011.

PAG

THE MARK CONSISTS OF STANDARD CHARACTERS WITHOUT CLAIM TO ANY PARTICULAR FONT, STYLE, SIZE, OR COLOR.

THE WORDING "PAG" HAS NO MEANING IN A FOREIGN LANGUAGE.

FOR FINANCIAL ANALYSIS; CAPITAL INVESTMENT SERVICES; FINANCIAL CONSULTANCY; PROVISION OF FINANCIAL INFORMATION; FINANCIAL MANAGEMENT; FINANCING OF LOANS; FINANCIAL DEBT COLLECTIONS; FINANCIAL SERVICES, NAMELY, FINANCIAL ADVISORY AND CONSULTANCY SERVICES; FINANCIAL INVESTMENT BROKERAGE; FINANCIAL LOAN SERVICES, NAMELY, LOAN DEFAULT MITIGATION SERVICES; INVESTMENT ADVISORY SERVICES; RAISING OF CAPITAL, NAMELY, VENTURE CAPITAL FINANCING; FINANCIAL SPONSORSHIP OF SPORTS EVENTS; FINANCIAL ASSET MANAGEMENT; MANAGEMENT OF A CAPITAL INVESTMENT FUND; CORPORATE FINANCING, NAMELY, FINANCING OF LOANS FOR CORPORATIONS (U.S. CLS. 100, 101 AND 102).

PAULA MAHONEY, EXAMINING ATTORNEY

SN 85-291,084. CARPENTER, FRANK M., BETHESDA, MD. FILED 4-9-2011.

Vegas Athletic Department

THE MARK CONSISTS OF STANDARD CHARACTERS WITHOUT CLAIM TO ANY PARTICULAR FONT, STYLE, SIZE, OR COLOR.

NO CLAIM IS MADE TO THE EXCLUSIVE RIGHT TO USE "VEGAS ATHLETIC", APART FROM THE MARK AS SHOWN.

FOR CHARITABLE FUNDRAISING SERVICES BY MEANS OF SELLING T-SHIRTS TO RAISE FUNDS FOR YOUTH ATHLETIC LEAGUES (U.S. CLS. 100, 101 AND 102).

FIRST USE 3-21-2011; IN COMMERCE 4-2-2011.
CIMMERIAN COLEMAN, EXAMINING ATTORNEY

CLASS 36—(Continued).

SN 85-307,345. WAPIYAPI, DENVER, CO. FILED 4-28-2011.

WAPIYAPI CLASSIC

THE MARK CONSISTS OF STANDARD CHARACTERS WITHOUT CLAIM TO ANY PARTICULAR FONT, STYLE, SIZE, OR COLOR.

NO CLAIM IS MADE TO THE EXCLUSIVE RIGHT TO USE "CLASSIC", APART FROM THE MARK AS SHOWN.

FOR CHARITABLE FUNDRAISING SERVICES BY MEANS OF A CYCLING EVENT (U.S. CLS. 100, 101 AND 102).

FIRST USE 2-1-2010; IN COMMERCE 5-1-2010.
BENJAMIN OKEKE, EXAMINING ATTORNEY

SN 85-309,928. THE SEIBELS BRUCE GROUP, INC., COLUMBIA, SC. FILED 5-2-2011.

SEIBELS

THE MARK CONSISTS OF STANDARD CHARACTERS WITHOUT CLAIM TO ANY PARTICULAR FONT, STYLE, SIZE, OR COLOR.

OWNER OF U.S. REG. NOS. 2,218,275 AND 3,657,535.
SEC. 2(F).

FOR CLAIMS ADJUSTMENT IN THE FIELD OF INSURANCE; INSURANCE AGENCY AND BROKERAGE; INSURANCE CONSULTANCY SERVICES, NAMELY, PROVIDING ADVICE IN THE FIELD OF PROPERTY AND CASUALTY INSURANCE; INSURANCE SERVICES, NAMELY, UNDERWRITING PROPERTY AND CASUALTY INSURANCE; INSURANCE SERVICES, NAMELY, WRITING PROPERTY AND CASUALTY INSURANCE (U.S. CLS. 100, 101 AND 102).

FIRST USE 12-31-1869; IN COMMERCE 12-31-1869.
EDWARD FENNESSY, EXAMINING ATTORNEY

SN 85-311,116. WARMACK WOODLANDS LP, TEXARKANA, TX. FILED 5-3-2011.



THE COLOR(S) GREEN AND BLUE IS/ARE CLAIMED AS A FEATURE OF THE MARK.

THE MARK CONSISTS OF A STYLISTIC REPRESENTATION OF GREEN COLORED TREES ADJACENT TO THE WORDS "RESEARCH FOREST" ABOVE A STYLISTIC REPRESENTATION OF BLUE COLORED AND REFLECTED TREES NEXT TO THE WORD "LAKESIDE".

FOR REAL ESTATE SERVICES, NAMELY, RENTAL, BROKERAGE, LEASING AND MANAGEMENT OF COMMERCIAL PROPERTY, OFFICES AND OFFICE SPACE (U.S. CLS. 100, 101 AND 102).

CURTIS FRENCH, EXAMINING ATTORNEY

CLASS 36—(Continued).

SN 85-317,311. HALBERT HARGROVE GLOBAL ADVISORS LLC, DBA HALBERT HARGROVE, LONG BEACH, CA. FILED 5-10-2011.

CLASS 36—(Continued).

SN 85-318,128. KING, MATTHEW HASKELL, DBA PROGRESSION PROPERTIES, LLC, BALTIMORE, NJ. FILED S.R. 5-11-2011; AM. P.R. 8-31-2011.

Intelligent Rebalancing

THE MARK CONSISTS OF STANDARD CHARACTERS WITHOUT CLAIM TO ANY PARTICULAR FONT, STYLE, SIZE, OR COLOR.

NO CLAIM IS MADE TO THE EXCLUSIVE RIGHT TO USE "REBALANCING", APART FROM THE MARK AS SHOWN.

FOR FINANCIAL SERVICES, NAMELY, COORDINATION, WITHIN A SINGLE ACCOUNT, OF AN INVESTMENT PORTFOLIO'S MAINTENANCE, TRADING, REBALANCING, AND TAX MANAGEMENT NEEDS (U.S. CLS. 100, 101 AND 102).

FIRST USE 5-1-2011; IN COMMERCE 5-10-2011.

LESLEY LAMOTHE, EXAMINING ATTORNEY

SN 85-317,447. PREPAID CARD HOLDINGS, INC., IRVINE, CA. FILED 5-10-2011.

PREPAYD CENTER

NO CLAIM IS MADE TO THE EXCLUSIVE RIGHT TO USE "PREPAID CENTER", APART FROM THE MARK AS SHOWN.

THE COLOR(S) BLACK, RED, AND BLUE IS/ARE CLAIMED AS A FEATURE OF THE MARK.

THE MARK CONSISTS OF THE LETTERS "PREPAYD CENTER" IN BLACK, WHEREIN THE "Y" IS RED, WITH A STYLIZED BLUE DIAMOND SHAPE INSIDE/ON TOP.

FOR FINANCIAL SERVICES, NAMELY, ISSUING PRE-PAID DEBIT CARDS, PRE-PAID GIFT CARDS, PRE-PAID CREDIT CARDS; PREPAID CARD SERVICES IN THE NATURE OF MAKING PAYMENTS TO PRE-PAID OR PAY-AS-YOU-GO WIRELESS MOBILE PHONE, TELEPHONE AND INTERNET SERVICES; BILL PAYMENT SERVICES; CHECK CASHING, CASH REMITTANCE, NAMELY, ONLINE CASH ACCOUNT SERVICES (U.S. CLS. 100, 101 AND 102).

ELIZABETH KAJUBI, EXAMINING ATTORNEY



SN 85-317,839. SPORTS SHARES MANAGEMENT, LLC, GREENWOOD VILLAGE, CO. FILED 5-11-2011.

SPORTS SHARES

THE MARK CONSISTS OF STANDARD CHARACTERS WITHOUT CLAIM TO ANY PARTICULAR FONT, STYLE, SIZE, OR COLOR.

NO CLAIM IS MADE TO THE EXCLUSIVE RIGHT TO USE "SPORTS", APART FROM THE MARK AS SHOWN.

FOR FRACTIONAL LUXURY ENTERTAINMENT SUITE CLUB, NAMELY, PROVIDING TO CLUB MEMBERS SEATS AND TICKETS FOR SPORTING EVENTS, THEATRICAL PERFORMANCES, MUSICAL CONCERTS AND OTHER ENTERTAINMENT EVENTS (U.S. CLS. 100, 101 AND 102).

FIRST USE 3-15-2006; IN COMMERCE 3-15-2006.

WARREN L. OLANDRIA, EXAMINING ATTORNEY

NO CLAIM IS MADE TO THE EXCLUSIVE RIGHT TO USE "PROPERTIES LLC", APART FROM THE MARK AS SHOWN.

THE COLOR(S) GRAY, TEAL AND BLACK IS/ARE CLAIMED AS A FEATURE OF THE MARK.

THE MARK CONSISTS OF THE WORDING "PROGRESSION PROPERTIES LLC" IN WHICH "PROGRESSION" IS BLACK WITH A BLACK CROWN ON EACH SIDE AND THREE BLACK ROOFTOP IMAGES ABOVE. THE WORDING "PROPERTIES LLC" APPEARS IN GRAY INSIDE A BLACK BAR. THE BACKGROUND APPEARS IN PALE SHADES OF GRAY AND TEAL.

FOR REAL ESTATE SERVICE, NAMELY, RENTAL PROPERTY MANAGEMENT; REAL ESTATE SERVICES IN THE FORM OF PROVIDING PHYSICAL ACCESS TO AVAILABLE PROPERTIES VIA A REMOTE CALL-IN LOCKING DEVICE; REAL ESTATE SERVICES, NAMELY, PROPERTY MANAGEMENT SERVICES FOR CONDOMINIUM ASSOCIATIONS, HOMEOWNER ASSOCIATIONS AND APARTMENT BUILDINGS; REAL ESTATE SERVICES, NAMELY, RENTAL, BROKERAGE, LEASING AND MANAGEMENT OF COMMERCIAL PROPERTY, OFFICES AND OFFICE SPACE (U.S. CLS. 100, 101 AND 102).

TAMARA FRAZIER, EXAMINING ATTORNEY

CLASS 36—(Continued).

SN 85-321,979. REVERSE MORTGAGE SOLUTIONS, INC., SPRING, TX. FILED 5-16-2011.



THE COLOR(S) LIGHT BLUE, BLUE, DARK BLUE, YELLOW AND WHITE IS/ARE CLAIMED AS A FEATURE OF THE MARK.

THE MARK CONSISTS OF THE LETTER "S" IN DARK BLUE, HAVING A SHADOWED LETTER "S" IN BLUE, WHICH IS SHADOWED BY THE LETTER "S" IN LIGHT BLUE, THE DARK BLUE LETTER "S" IS FOLLOWED BY THE NUMBER "3" IN YELLOW TO INDICATE THE TERMINOLOGY OF "S" CUBED; IN THE MIDDLE OF THE DARK BLUE LETTER "S" IS A WHITE STAR.

FOR FINANCING AND LOAN SERVICES, NAMELY, LOAN SERVICING AND ADMINISTRATION; LOAN ESCROW SERVICES, NAMELY, MAINTAINING MORTGAGE ESCROW ACCOUNTS; FINANCIAL SERVICES, NAMELY, LOAN DEFAULT MITIGATION SERVICES; DEFAULT MITIGATION AND LOSS CONTROL SERVICES, NAMELY, LOAN DEFAULT MITIGATION SERVICES AND LOSS CONTROL MANAGEMENT FOR OTHERS FOR PERFORMING AND NON-PERFORMING REAL ESTATE LOANS; FINANCIAL SERVICES, NAMELY, ARRANGING OF MODIFIED MORTGAGE LOAN TERMS DESIGNED TO PREVENT REAL ESTATE FORECLOSURE OR DEFAULT; FINANCIAL ASSET MANAGEMENT SERVICES, NAMELY, MANAGEMENT OF REAL PROPERTY ASSETS AND DISTRESSED ASSETS IN THE FIELD OF REAL ESTATE, MORTGAGES, AND REVERSE MORTGAGES; FINANCIAL RISK MANAGEMENT AND FISCAL ASSESSMENT SERVICES IN THE FIELD OF REAL ESTATE, MORTGAGES, AND REVERSE MORTGAGES; FINANCIAL ASSET MANAGEMENT; FINANCIAL PORTFOLIO ANALYSIS AND FINANCIAL TRACKING SERVICES IN THE FIELD OF REAL ESTATE, MORTGAGES, AND REVERSE MORTGAGES; FINANCIAL DUE DILIGENCE SERVICES IN THE FIELD OF REAL ESTATE, MORTGAGES, AND REVERSE MORTGAGES; FINANCIAL AND ASSET LOSS CONTROL MANAGEMENT FOR OTHERS IN THE FIELD OF REAL ESTATE, MORTGAGES, AND REVERSE MORTGAGES; FINANCIAL SERVICES, NAMELY, LOSS MITIGATION SERVICES FOR UNDER OR NON-PERFORMING MORTGAGE LOANS AND DISTRESSED ASSETS; MORTGAGE FORECLOSURE SERVICES; MORTGAGE FORECLOSURE AND DISTRESSED FINANCIAL ASSET MITIGATION AND LOAN DEFAULT MITIGATION SERVICES, NAMELY, ACQUISITION AND LEASE-BACK OF REAL ESTATE, PREFORECLOSURE SHORT SALES, DEEDS-IN-LIEU FORECLOSURE, INSTALLMENT SALE, LEASE OPTION, AND REAL ESTATE AGENCY, LEASING, AND BROKERAGE SERVICES IN CONNECTION WITH REAL ESTATE SALES, LEASE OPTIONS, AND INSTALLMENT SALES; REAL ESTATE SERVICES, NAMELY, REAL ESTATE INVESTMENT SERVICES INVOLVING DISTRESSED REAL ESTATE AND REAL PROPERTY MANAGEMENT SERVICES; REAL ESTATE CONSULTANCY; REAL ESTATE AND DISTRESSED REAL ESTATE ASSET ASSESSMENT AND APPRAISAL; REAL ESTATE AGENCY SERVICES, LEASING OF REAL ESTATE, REAL ESTATE BROKERAGE SERVICES; MANAGEMENT OF LISTED AND UNLISTED PROPERTY TRUSTS OR SPECIALIZED FUNDS, NAMELY, REAL ESTATE TRUSTEE SERVICES (U.S. CLS. 100, 101 AND 102).

FIRST USE 8-1-2010; IN COMMERCE 8-1-2010.
SHAILA SETTLES, EXAMINING ATTORNEY

CLASS 36—(Continued).

SN 85-322,450. WATKINS, JOE, ROLESVILLE, NC. FILED 5-17-2011.

WALLSTWIZ

THE MARK CONSISTS OF STANDARD CHARACTERS WITHOUT CLAIM TO ANY PARTICULAR FONT, STYLE, SIZE, OR COLOR.

FOR PROVIDING A WEB SITE FEATURING PERSONAL FINANCIAL INFORMATION AND FINANCIAL ADVICE; FINANCIAL ANALYSIS SERVICES (U.S. CLS. 100, 101 AND 102).

FIRST USE 4-11-2008; IN COMMERCE 4-11-2008.
MARLENE BELL, EXAMINING ATTORNEY

SN 85-330,498. GETLOANS.COM, INC., INCLINE VILLAGE, NV. FILED 5-25-2011.

getloans.com

THE MARK CONSISTS OF STANDARD CHARACTERS WITHOUT CLAIM TO ANY PARTICULAR FONT, STYLE, SIZE, OR COLOR.

SEC. 2(F).

FOR MORTGAGE SERVICES, NAMELY, BUYER PRE-QUALIFICATION OF MORTGAGES FOR MORTGAGE BROKERS AND BANKS (U.S. CLS. 100, 101 AND 102).

FIRST USE 6-18-1995; IN COMMERCE 11-8-2001.
REBECCA EISINGER, EXAMINING ATTORNEY

SN 85-331,717. WHOLE FOODS MARKET IP, L.P., AUSTIN, TX. FILED 5-26-2011.



OWNER OF U.S. REG. NOS. 1,557,320, 3,627,793 AND OTHERS.

NO CLAIM IS MADE TO THE EXCLUSIVE RIGHT TO USE "LOCAL PRODUCER LOAN PROGRAM" AND "EST. 2006", APART FROM THE MARK AS SHOWN.

FOR FINANCIAL SERVICES IN THE FIELD OF MONEY LENDING (U.S. CLS. 100, 101 AND 102).

FIRST USE 6-30-2009; IN COMMERCE 6-30-2009.
MARY CRAWFORD, EXAMINING ATTORNEY

CLASS 36—(Continued).

SN 85-333,983. FEARON FINANCIAL, LLC, POWELL, OH. FILED 5-31-2011.

SmarterMortgages

THE MARK CONSISTS OF STANDARD CHARACTERS WITHOUT CLAIM TO ANY PARTICULAR FONT, STYLE, SIZE, OR COLOR.

NO CLAIM IS MADE TO THE EXCLUSIVE RIGHT TO USE "MORTGAGES", APART FROM THE MARK AS SHOWN.

FOR FINANCIAL SERVICES, NAMELY, MORTGAGE PLANNING FOR RESIDENTIAL FIRST MORTGAGES, EXCLUDING MANUFACTURED HOMES AND FARMS; FINANCIAL SERVICES, NAMELY, MORTGAGE REFINANCING FOR RESIDENTIAL FIRST MORTGAGES, EXCLUDING MANUFACTURED HOMES AND FARMS; MORTGAGE BANKING FOR RESIDENTIAL FIRST MORTGAGES, EXCLUDING MANUFACTURED HOMES AND FARMS; MORTGAGE BROKERAGE FOR RESIDENTIAL FIRST MORTGAGES, EXCLUDING MANUFACTURED HOMES AND FARMS; MORTGAGE LENDING FOR RESIDENTIAL FIRST MORTGAGES, EXCLUDING MANUFACTURED HOMES AND FARMS (U.S. CLS. 100, 101 AND 102).

FIRST USE 3-25-2005; IN COMMERCE 3-25-2005.
TINA L. SNAPP, EXAMINING ATTORNEY

SN 85-334,628. FEARON FINANCIAL, LLC, POWELL, OH. FILED 5-31-2011.

Smarter Mortgages

THE MARK CONSISTS OF STANDARD CHARACTERS WITHOUT CLAIM TO ANY PARTICULAR FONT, STYLE, SIZE, OR COLOR.

NO CLAIM IS MADE TO THE EXCLUSIVE RIGHT TO USE "MORTGAGES", APART FROM THE MARK AS SHOWN.

FOR FINANCIAL SERVICES, NAMELY, MORTGAGE PLANNING FOR RESIDENTIAL FIRST MORTGAGES, EXCLUDING MANUFACTURED HOMES AND FARMS; FINANCIAL SERVICES, NAMELY, MORTGAGE REFINANCING FOR RESIDENTIAL FIRST MORTGAGES, EXCLUDING MANUFACTURED HOMES AND FARMS; MORTGAGE BANKING FOR RESIDENTIAL FIRST MORTGAGES, EXCLUDING MANUFACTURED HOMES AND FARMS; MORTGAGE BROKERAGE FOR RESIDENTIAL FIRST MORTGAGES, EXCLUDING MANUFACTURED HOMES AND FARMS; MORTGAGE LENDING FOR RESIDENTIAL FIRST MORTGAGES, EXCLUDING MANUFACTURED HOMES AND FARMS (U.S. CLS. 100, 101 AND 102).

FIRST USE 3-20-2005; IN COMMERCE 3-20-2005.
TINA L. SNAPP, EXAMINING ATTORNEY

CLASS 36—(Continued).

SN 85-335,819. DMCG INC., DBA BAIL HOTLINE BAIL BONDS, RIVERSIDE, CA. FILED 6-1-2011.

BAIL HOTLINE

THE MARK CONSISTS OF STANDARD CHARACTERS WITHOUT CLAIM TO ANY PARTICULAR FONT, STYLE, SIZE, OR COLOR.

NO CLAIM IS MADE TO THE EXCLUSIVE RIGHT TO USE "BAIL", APART FROM THE MARK AS SHOWN. SEC. 2(F).

FOR BAIL BONDING (U.S. CLS. 100, 101 AND 102).
FIRST USE 2-0-2006; IN COMMERCE 1-6-2009.
EVELYN BRADLEY, EXAMINING ATTORNEY

SN 85-335,920. R.W. SCOBIE, INC., CHIPPEWA FALLS, WI. FILED 6-2-2011.



OWNER OF U.S. REG. NOS. 3,273,610 AND 3,273,611.
NO CLAIM IS MADE TO THE EXCLUSIVE RIGHT TO USE "GROUP", APART FROM THE MARK AS SHOWN.

THE MARK CONSISTS OF THE WORD "SCOBIE" WITH A CURVED LINE GOING THROUGH THE BOTTOM; THE WORD "GROUP" UNDER THE WORD "SCOBIE" IN SMALLER LETTERING.

SEC. 2(F) AS TO "SCOBIE".
FOR INSURANCE UNDERWRITING AND BROKERAGE SERVICES IN THE FIELDS OF PROPERTY AND CASUALTY INSURANCE, TRANSPORTATION INSURANCE, AGRIBUSINESS INSURANCE, MARINE INSURANCE, FINANCIAL INSTITUTIONS INSURANCE, AND PERSONAL LINES INSURANCE (U.S. CLS. 100, 101 AND 102).

FIRST USE 1-26-2011; IN COMMERCE 1-26-2011.
MATTHEW EINSTEIN, EXAMINING ATTORNEY

SN 85-336,032. TAYLOR, WILFORD R., ROGERS, AR. FILED 6-2-2011.

SECTOR GRID ADVISORS

THE MARK CONSISTS OF STANDARD CHARACTERS WITHOUT CLAIM TO ANY PARTICULAR FONT, STYLE, SIZE, OR COLOR.

OWNER OF U.S. REG. NO. 2,995,732.
NO CLAIM IS MADE TO THE EXCLUSIVE RIGHT TO USE "ADVISORS", APART FROM THE MARK AS SHOWN.

FOR FINANCIAL CONSULTING SERVICES (U.S. CLS. 100, 101 AND 102).
LINDA ORNDORFF, EXAMINING ATTORNEY

CLASS 36—(Continued).

SN 85-340,693. FLEXIBLE PLAN INVESTMENTS, LTD., BLOOMFIELD HILLS, MI. FILED 6-8-2011.

ONTARGET INVESTING

THE MARK CONSISTS OF STANDARD CHARACTERS WITHOUT CLAIM TO ANY PARTICULAR FONT, STYLE, SIZE, OR COLOR.

NO CLAIM IS MADE TO THE EXCLUSIVE RIGHT TO USE "INVESTING", APART FROM THE MARK AS SHOWN. FOR INVESTMENT ADVISORY SERVICES; INVESTMENT MANAGEMENT SERVICES (U.S. CLS. 100, 101 AND 102).

FIRST USE 7-13-2007; IN COMMERCE 7-13-2007.
BRENDAN MCCAULEY, EXAMINING ATTORNEY

SN 85-341,830. EVERYDAY HERO HOUSING ASSISTANCE FUND, LLC, DENVER, CO. FILED 6-9-2011.

EVERYDAY HERO HOUSING ASSISTANCE FUND

THE MARK CONSISTS OF STANDARD CHARACTERS WITHOUT CLAIM TO ANY PARTICULAR FONT, STYLE, SIZE, OR COLOR.

NO CLAIM IS MADE TO THE EXCLUSIVE RIGHT TO USE "HOUSING ASSISTANCE FUND", APART FROM THE MARK AS SHOWN.

FOR PROVIDING GRANTS FOR TEACHERS, FIREMEN, POLICE OFFICERS AND MEDICAL PROFESSIONALS TO ASSIST THEM WITH CLOSING COSTS ASSOCIATED WITH PURCHASING A HOME; PROVIDING FINANCIAL ASSISTANCE FOR PURCHASING HOMES TO PEOPLE WORKING AS POLICE OFFICERS, FIREFIGHTERS, TEACHERS AND MEDICAL PROFESSIONALS; PROVISION OF FUNDS FOR PURCHASING HOMES; FINANCIAL SERVICES, NAMELY, GRANTING FUNDS TO ASSIST IN PURCHASING HOMES TO PEOPLE WORKING AS POLICE OFFICERS, FIREFIGHTERS, TEACHERS AND MEDICAL PROFESSIONALS; PROVISION OF FUNDS FOR HOME MORTGAGE CLOSING COSTS; FINANCIAL SERVICES TO FACILITATE CHARITABLE GIVING, NAMELY, ADMINISTRATING MONETARY CHARITABLE CONTRIBUTIONS AND ELEMOSYNARY SERVICES IN THE FIELD OF MANAGEMENT, AND DISBURSEMENTS OF MONEY IN CONNECTION WITH PROGRAMS TO ASSIST IN HOME PURCHASING FOR QUALIFIED INDIVIDUALS; PROVIDING MORTGAGE LOAN INFORMATION; REAL ESTATE FINANCING SERVICES; REAL ESTATE SERVICE, NAMELY, PROVISION OF FUNDS TO ASSIST IN HOME PURCHASES; REAL ESTATE CONSULTANCY; PROVIDING INFORMATION IN THE FIELD OF REAL ESTATE VIA THE INTERNET; PROVIDING A DATABASE OF RESIDENTIAL REAL ESTATE LISTINGS WITHIN NEIGHBORHOODS AND COMMUNITIES SPECIFICALLY IDENTIFIED BY USERS; PROVIDING REAL ESTATE LISTINGS AND REAL ESTATE INFORMATION VIA THE INTERNET; PROVIDING INFORMATION IN THE FIELD OF REAL ESTATE VIA THE INTERNET, NAMELY, INFORMATION ON CREDIT REPAIR AND RESTORATION FOR HOME LOAN QUALIFICATION (U.S. CLS. 100, 101 AND 102).

FIRST USE 4-19-2011; IN COMMERCE 4-19-2011.
MICHAEL WIENER, EXAMINING ATTORNEY

CLASS 36—(Continued).

SN 85-344,269. HUDSON FINANCIAL ADVISORS, INC., STREETSBORO, OH. FILED 6-13-2011.

Empowering Smart Choices

THE MARK CONSISTS OF STANDARD CHARACTERS WITHOUT CLAIM TO ANY PARTICULAR FONT, STYLE, SIZE, OR COLOR.

FOR FINANCIAL PLANNING FOR INDIVIDUALS (U.S. CLS. 100, 101 AND 102).

FIRST USE 5-13-2010; IN COMMERCE 5-13-2010.
KIM SAITO, EXAMINING ATTORNEY

SN 85-346,524. BIDPAWN LLC, HOMESTEAD, FL. FILED 6-15-2011.



NO CLAIM IS MADE TO THE EXCLUSIVE RIGHT TO USE "PAWN", APART FROM THE MARK AS SHOWN.

THE COLOR(S) BLACK AND YELLOW IS/ARE CLAIMED AS A FEATURE OF THE MARK.

THE MARK CONSISTS OF THE WORD "BID" IN BLACK IN A VERTICAL DIRECTION WITH THREE YELLOW BUBBLES ON THE LETTER "B" AND THE "PAWN" IN BLACK STYLIZED LETTERS.

FOR PAWNSHOP SERVICES INCLUDING PAWN BROKERAGE WITH ONLINE BUSINESSES (U.S. CLS. 100, 101 AND 102).

FIRST USE 2-19-2010; IN COMMERCE 2-19-2010.
JAMES A. RAUEN, EXAMINING ATTORNEY

CLASS 36—(Continued).

SN 85-347,372. MOZIDO, LLC, DALLAS, TX. FILED 6-15-2011.



OWNER OF U.S. REG. NO. 3,936,545.

THE MARK CONSISTS OF THE WORD "MOZIDO" WITH A CURVED ARC LOCATED ABOVE THE LETTERING.

THE WORDING "MOZIDO" HAS NO MEANING IN A FOREIGN LANGUAGE.

FOR FINANCIAL SERVICES PROVIDED BY MOBILE TELEPHONE CONNECTIONS, INTERACTIVE VOICE RESPONSE OVER TELEPHONE CONNECTIONS, RETAIL POINT-OF-SALE CONNECTIONS AND THE INTERNET, NAMELY, MOBILE BANKING, MOBILE MONEY TRANSFERS, MOBILE PURCHASING, NAMELY, PROVIDING ELECTRONIC PROCESSING OF CREDIT/DEBIT CARD TRANSACTIONS AND ELECTRONIC PAYMENTS VIA MOBILE PHONE FOR ALLOWING CONSUMERS TO PURCHASE GOODS AND SERVICES OF OTHERS, MOBILE MULTICHANNEL PAYMENTS, NAMELY, BILL PAYMENT SERVICES AND LOAN PAYMENT SERVICES; FINANCIAL SERVICES, NAMELY, STORED-VALUE CASH OR DEBIT CARD SERVICES, NAMELY, LOADING, MANAGING, AND PAYMENT PROCESSING, PROVIDED BY MOBILE TELEPHONE CONNECTIONS, INTERACTIVE VOICE RESPONSE OVER TELEPHONE CONNECTIONS, RETAIL POINT-OF-SALE CONNECTIONS AND THE INTERNET (U.S. CLS. 100, 101 AND 102).

BRIAN PINO, EXAMINING ATTORNEY

SN 85-350,328. PVM OIL ASSOCIATES, INC., HOBOKEN, NJ. FILED 6-20-2011.

PVM

THE MARK CONSISTS OF STANDARD CHARACTERS WITHOUT CLAIM TO ANY PARTICULAR FONT, STYLE, SIZE, OR COLOR.

FOR BROKERAGE IN THE FIELD OF COMMODITIES, DERIVATIVES, OPTIONS AND FUTURES; FINANCIAL ADVISORY AND CONSULTANCY SERVICES; FINANCIAL ADVISORY AND CONSULTANCY SERVICES, NAMELY, PROVIDING A WEBSITE FEATURING INFORMATION IN THE FIELD OF FINANCIAL INFORMATION AND FORECASTING IN THE ENERGY MARKETS; FINANCIAL ANALYSIS AND CONSULTATION; FINANCIAL ANALYSIS AND RESEARCH SERVICES; FINANCIAL CONSULTATION IN THE FIELD OF ENERGY, ENERGY DEVELOPMENT, ENERGY EXPLORATION, ENERGY PLANTS AND SYSTEMS, ENERGY PRICES AND ENERGY BROKERAGE; FUTURES EXCHANGE SERVICES; GLOBAL INVESTMENT RESEARCH SERVICES (U.S. CLS. 100, 101 AND 102).

FIRST USE 12-20-1971; IN COMMERCE 12-20-1971.

BARBARA GAYNOR, EXAMINING ATTORNEY

CLASS 36—(Continued).

SN 85-351,854. THE OVARIAN CANCER RESEARCH FUND, INC., NEW YORK, NY. FILED 6-21-2011.

OVARIAN CANCER RESEARCH
FUND

THE MARK CONSISTS OF STANDARD CHARACTERS WITHOUT CLAIM TO ANY PARTICULAR FONT, STYLE, SIZE, OR COLOR.

NO CLAIM IS MADE TO THE EXCLUSIVE RIGHT TO USE "CANCER RESEARCH FUND", APART FROM THE MARK AS SHOWN.

SEC. 2(F).

FOR CHARITABLE FUNDRAISING SERVICES; CHARITABLE FUNDRAISING TO SUPPORT EDUCATION AND MEDICAL RESEARCH CONCERNING CANCER DETECTION, TREATMENT AND CURE; CHARITABLE FUNDRAISING SERVICES BY MEANS OF SELLING CLOTHING, HATS, JEWELRY, CDS, BOOKS, COSMETICS, BAGS, FOOD, FLOWERS, GREETING CARDS, AND NOTE CARDS TO RAISE FUNDS FOR EDUCATION AND MEDICAL RESEARCH CONCERNING CANCER DETECTION, TREATMENT AND CURE; FINANCING MEDICAL RESEARCH OF OTHERS; ACCEPTING AND ADMINISTERING MONETARY CHARITABLE CONTRIBUTIONS TO FUND MEDICAL RESEARCH (U.S. CLS. 100, 101 AND 102).

FIRST USE 12-8-1994; IN COMMERCE 3-31-1996.

EMILY CHUO, EXAMINING ATTORNEY

SN 85-352,797. SOCIETY OF SETTLEMENT PLANNERS, INC., WEST LINN, OR. FILED 6-22-2011.



NO CLAIM IS MADE TO THE EXCLUSIVE RIGHT TO USE "SOCIETY OF SETTLEMENT PLANNERS", APART FROM THE MARK AS SHOWN.

THE COLOR(S) BLUE, WHITE, BLACK AND YELLOW IS/ARE CLAIMED AS A FEATURE OF THE MARK.

THE MARK CONSISTS OF THE COLOR WHITE APPEARS IN THE WORDING "SOCIETY OF SETTLEMENT PLANNERS", IN THE OUTLINE OF A SEMI-CIRCLE AND IN THE LINE AND INVERTED TRIANGLE UNDER THE WORDING "SETTLEMENT PLANNERS". THE COLORS BLACK, WHITE AND YELLOW APPEAR IN THE DIAMOND SHAPED DESIGNS WITHIN THE SEMI-CIRCLE. THE COLOR BLUE APPEARS IN THE RECTANGLE WHICH FORMS THE BACKGROUND OF THE MARK AND INSIDE THE SEMI-CIRCLE.

FOR FINANCIAL PLANNING AND INVESTMENT ADVISORY SERVICES; FINANCIAL PLANNING CONSULTATION; FINANCIAL PLANNING, NAMELY, CREATING PERSONALIZED SETTLEMENT PLANS FOR ACHIEVING FINANCIAL INDEPENDENCE WITHIN THE CONTEXT OF PERSONAL INJURY AND OTHER TYPES OF FINANCIAL SETTLEMENTS; FINANCIAL RISK MANAGEMENT CONSULTATION (U.S. CLS. 100, 101 AND 102).

FIRST USE 3-1-2000; IN COMMERCE 3-1-2000.

EVELYN BRADLEY, EXAMINING ATTORNEY

CLASS 36—(Continued).

SN 85-353,244. BIOMED REALTY TRUST, INC., SAN DIEGO, CA. FILED 6-22-2011.

BIOMED VENTURES

THE MARK CONSISTS OF STANDARD CHARACTERS WITHOUT CLAIM TO ANY PARTICULAR FONT, STYLE, SIZE, OR COLOR.

OWNER OF U.S. REG. NO. 4,097,891.

NO CLAIM IS MADE TO THE EXCLUSIVE RIGHT TO USE "VENTURES", APART FROM THE MARK AS SHOWN. SEC. 2(F) AS TO "BIOMED".

FOR VENTURE CAPITAL FINANCING; VENTURE CAPITAL FUND MANAGEMENT; VENTURE CAPITAL SERVICES, NAMELY, PROVIDING FINANCING TO EMERGING AND START-UP COMPANIES (U.S. CLS. 100, 101 AND 102).

THOMAS MANOR, EXAMINING ATTORNEY

CLASS 36—(Continued).

SN 85-355,766. MATHEW, GEORGE, SAN FRANCISCO, CA. FILED 6-24-2011.

Serelyn

THE MARK CONSISTS OF STANDARD CHARACTERS WITHOUT CLAIM TO ANY PARTICULAR FONT, STYLE, SIZE, OR COLOR.

FOR PROVIDING A WEBSITE FEATURING EDUCATIONAL INFORMATION, ADVICE, AND FINANCIAL MODELS RELATED TO PERSONAL FINANCE MATTERS (U.S. CLS. 100, 101 AND 102).

FIRST USE 9-6-2009; IN COMMERCE 6-15-2011.

LESLEY LAMOTHE, EXAMINING ATTORNEY

SN 85-354,922. SILVER & GOLD, INC., DBA GOLDSILVER.-COM, SANTA MONICA, CA. FILED 6-24-2011.

Saving the world one investor at a time

THE MARK CONSISTS OF STANDARD CHARACTERS WITHOUT CLAIM TO ANY PARTICULAR FONT, STYLE, SIZE, OR COLOR.

FOR COMMODITY BROKERAGE (U.S. CLS. 100, 101 AND 102).

ANDREW LEASER, EXAMINING ATTORNEY

SN 85-357,124. KEYASSETS FINANCIAL, LLC, BUFFALO GROVE, IL. FILED 6-27-2011.

KeyAssets

THE MARK CONSISTS OF STANDARD CHARACTERS WITHOUT CLAIM TO ANY PARTICULAR FONT, STYLE, SIZE, OR COLOR.

FOR BROKERAGE IN THE FIELD OF NEW, USED AND REFURBISHED SEMICONDUCTOR AND OTHER HIGH-TECHNOLOGY MANUFACTURING EQUIPMENT IN THE NATURE OF SEMICONDUCTOR MANUFACTURING EQUIPMENT AND THE ARRANGEMENT OF FINANCING SERVICES, NAMELY, FACILITATING AND ARRANGING FOR THE FINANCING OF NEW, USED, AND REFURBISHED SEMICONDUCTOR AND OTHER HIGH-TECHNOLOGY MANUFACTURING EQUIPMENT IN THE NATURE OF SEMICONDUCTOR MANUFACTURING EQUIPMENT (U.S. CLS. 100, 101 AND 102).

FIRST USE 9-1-1999; IN COMMERCE 5-1-2000.

JAMES STEIN, EXAMINING ATTORNEY

SN 85-355,062. KAREN E. MUMFORD CANCER FOUNDATION, CLEVELAND HEIGHTS, OH. FILED 6-24-2011.

Karen E. Mumford Cancer Foundation

THE MARK CONSISTS OF STANDARD CHARACTERS WITHOUT CLAIM TO ANY PARTICULAR FONT, STYLE, SIZE, OR COLOR.

NO CLAIM IS MADE TO THE EXCLUSIVE RIGHT TO USE "CANCER FOUNDATION", APART FROM THE MARK AS SHOWN.

THE NAME(S), PORTRAIT(S), AND/OR SIGNATURE(S) SHOWN IN THE MARK DOES NOT IDENTIFY A PARTICULAR LIVING INDIVIDUAL.

FOR CHARITABLE FOUNDATION SERVICES, NAMELY, PROVIDING FUNDRAISING ACTIVITIES, FUNDING, AND/OR FINANCIAL ASSISTANCE IN THE FIELD OF HEALTH, NUTRITION AND LIFESTYLE WELLNESS FOR CANCER PATIENTS AND THEIR FAMILIES (U.S. CLS. 100, 101 AND 102).

REBECCA GILBERT, EXAMINING ATTORNEY

SN 85-359,526. ALBARIAN JR., GABRIEL A, WOODLAND HILLS, CA. FILED 6-29-2011.

FINANCIAL SWAGGER

THE MARK CONSISTS OF STANDARD CHARACTERS WITHOUT CLAIM TO ANY PARTICULAR FONT, STYLE, SIZE, OR COLOR.

NO CLAIM IS MADE TO THE EXCLUSIVE RIGHT TO USE "FINANCIAL", APART FROM THE MARK AS SHOWN.

FOR FINANCIAL CONSULTING SERVICES, NAMELY, EXPERT ANALYSIS IN FINANCE (U.S. CLS. 100, 101 AND 102).

ANNE MADDEN, EXAMINING ATTORNEY

CLASS 36—(Continued).

SN 85-360,951. FORD MOTOR COMPANY, DEARBORN, MI. FILED 6-30-2011.

STELLIS

THE MARK CONSISTS OF STANDARD CHARACTERS WITHOUT CLAIM TO ANY PARTICULAR FONT, STYLE, SIZE, OR COLOR.

FOR WRITING AND ADMINISTERING PROPERTY AND CASUALTY INSURANCE; PROVIDING INSURANCE AGENCY SERVICES (U.S. CLS. 100, 101 AND 102).
SHAILA SETTLES, EXAMINING ATTORNEY

SN 85-361,059. THE JIM MORAN FOUNDATION, INC., DEERFIELD BEACH, FL. FILED 6-30-2011.

**THE FUTURE BELONGS TO
THOSE WHO PREPARE FOR IT.**

THE MARK CONSISTS OF STANDARD CHARACTERS WITHOUT CLAIM TO ANY PARTICULAR FONT, STYLE, SIZE, OR COLOR.

FOR PROVIDING GRANTS TO NONPROFIT ORGANIZATIONS; PHILANTHROPIC SERVICES, NAMELY, FUNDING PROGRAMS OF NON-PROFIT ORGANIZATIONS (U.S. CLS. 100, 101 AND 102).

FIRST USE 1-0-2001; IN COMMERCE 1-0-2001.
HANNO RITTRER, EXAMINING ATTORNEY

SN 85-362,970. METROPOLITAN LIFE INSURANCE COMPANY, NEW YORK, NY. FILED 7-5-2011.

LIFELONG INCOME FOR YOU

THE MARK CONSISTS OF STANDARD CHARACTERS WITHOUT CLAIM TO ANY PARTICULAR FONT, STYLE, SIZE, OR COLOR.

OWNER OF U.S. REG. NO. 3,147,674.
SEC. 2(F).
FOR UNDERWRITING, ISSUANCE AND ADMINISTRATION OF ANNUITIES (U.S. CLS. 100, 101 AND 102).
FIRST USE 1-1-2005; IN COMMERCE 1-1-2005.
KATHLEEN LORENZO, EXAMINING ATTORNEY

CLASS 36—(Continued).

SN 85-366,529. ONEMAIN FINANCIAL HOLDINGS, INC., WILMINGTON, DE. FILED 7-8-2011.

PRESTANDO CONFIANZA

THE MARK CONSISTS OF STANDARD CHARACTERS WITHOUT CLAIM TO ANY PARTICULAR FONT, STYLE, SIZE, OR COLOR.

THE ENGLISH TRANSLATION OF "PRESTANDO CONFIANZA" IN THE MARK IS "LENDING CONFIDENCE".

FOR FINANCIAL SERVICES, NAMELY, CONSUMER LENDING SERVICES, CREDIT AND LOAN SERVICES, AND FINANCING SERVICES; CREDIT INSURANCE UNDERWRITING SERVICES (U.S. CLS. 100, 101 AND 102).

JAY BESCH, EXAMINING ATTORNEY

SN 85-372,576. FEDERACIÓN MEXICANA DE FÚTBOL ASOCIACIÓN, A.C., MEXICO, D.F. 06700, MEXICO, FILED 7-15-2011.



OWNER OF MEXICO REG. NO. 1022446, DATED 1-30-2008, EXPIRES 10-12-2017.

OWNER OF U.S. REG. NO. 3,119,262.

NO CLAIM IS MADE TO THE EXCLUSIVE RIGHT TO USE "A.C.", APART FROM THE MARK AS SHOWN.

THE COLOR(S) GREEN, RED, GOLD, BLACK AND WHITE IS/ARE CLAIMED AS A FEATURE OF THE MARK.

THE MARK CONSISTS OF THE FOLLOWING: A GENERALLY CIRCULAR SEAL WHEREIN THE WORDS "FEDERACION MEXICANA DE FUTBOL ASOC., A.C." IN STYLIZED BLACK FONT APPEAR IN ITS OUTER CIRCUMFERENCE, WHICH IS GOLD WITH A BLACK BORDER; HAVING AN EAGLE DESIGN IN BLACK AND WHITE OVER A BLACK AND WHITE SOCCER BALL DESIGN CENTERED VERTICALLY ON THE SEAL, THE FIELD OF THE SEAL HAVING AN INSCRIPTION OF VARIOUS GEOMETRIC DESIGNS AND HIEROGLYPHICS EACH IN BLACK ON A WHITE BACKGROUND; A GREEN ARC ON THE LEFT AND A RED ARC ON THE RIGHT SEPARATING THE OUTER CIRCUMFERENCE FROM THE FIELD.

THE ENGLISH TRANSLATION OF THE FOREIGN WORDING IN THE MARK IS "MEXICAN SOCCER FEDERATION".

FOR INSURANCE AGENCY, BROKERAGE AND CONSULTATION SERVICES; FINANCIAL PLANNING, MANAGEMENT AND CONSULTATION SERVICES; MONETARY MATTERS, NAMELY, FINANCIAL INFORMATION, MANAGEMENT AND ANALYSIS SERVICES; REAL ESTATE AGENCY, BROKERAGE AND MANAGEMENT SERVICES (U.S. CLS. 100, 101 AND 102).

ERNEST SHOSHO, EXAMINING ATTORNEY

CLASS 36—(Continued).

SN 85-376,298. TROOSTWIJK GROEP B.V., AMSTERDAM, NETHERLANDS, FILED 7-20-2011.



OWNER OF ERPN CMNTY TM OFC REG. NO. 9461922, DATED 5-4-2011, EXPIRES 10-20-2020.

THE MARK CONSISTS OF A STYLIZED CURVED PATHWAY UNDERNEATH AND THROUGH AN ARCHED BRIDGE.

FOR REAL ESTATE AFFAIRS, NAMELY, ASSESSMENT AND MANAGEMENT OF REAL ESTATE, FINANCING OF REAL ESTATE DEVELOPMENT PROJECTS; REAL ESTATE AND MACHINERY APPRAISALS; FINANCIAL SERVICES, NAMELY, FINANCIAL CONSULTING AND ADVISING IN THE FIELD OF MERGERS AND ACQUISITIONS; FINANCIAL VALUATIONS, LAND VALUATIONS, REAL ESTATE VALUATIONS, INTELLECTUAL PROPERTY VALUATIONS, FISCAL VALUATIONS, FINANCIAL VALUATIONS FOR INSURANCE PURPOSES FOR MANUFACTURING PLANTS AND MACHINERY AND BUSINESS VALUATIONS; PROVIDING FINANCIAL ASSESSMENTS OF DAMAGES AFTER A DISASTER; FINANCIAL VALUATIONS; INSURANCE AGENCIES; PROVIDING INFORMATION IN INSURANCE MATTERS; FINANCIAL AND MONETARY SERVICES, NAMELY, FINANCIAL EVALUATION, TRACKING, ANALYSES, FORECASTING, CONSULTANCY, ADVISORY AND RESEARCH SERVICES RELATING TO SECURITIES AND OTHER FINANCIAL INSTRUMENTS, FINANCIAL EVALUATION FOR INSURANCE PURPOSES (U.S. CLS. 100, 101 AND 102).

ADA HAN, EXAMINING ATTORNEY

SN 85-378,547. FIRST CONNECTICUT BANCORP, INC., FARMINGTON, CT. FILED 7-22-2011.

FARMINGTON BANK

THE MARK CONSISTS OF STANDARD CHARACTERS WITHOUT CLAIM TO ANY PARTICULAR FONT, STYLE, SIZE, OR COLOR.

NO CLAIM IS MADE TO THE EXCLUSIVE RIGHT TO USE "BANK", APART FROM THE MARK AS SHOWN.

SEC. 2(F) AS TO "FARMINGTON".
FOR BANKING SERVICES (U.S. CLS. 100, 101 AND 102).

FIRST USE 11-16-2009; IN COMMERCE 11-16-2009.
JANICE L. MCMORROW, EXAMINING ATTORNEY

CLASS 36—(Continued).

SN 85-379,540. ROYAL MERCHANT HOLDINGS, INC., MIAMI, FL. FILED 7-25-2011.

Royal Merchant Holdings

THE MARK CONSISTS OF STANDARD CHARACTERS WITHOUT CLAIM TO ANY PARTICULAR FONT, STYLE, SIZE, OR COLOR.

NO CLAIM IS MADE TO THE EXCLUSIVE RIGHT TO USE "MERCHANT HOLDINGS", APART FROM THE MARK AS SHOWN.

FOR PAYMENT PROCESSING SERVICES, NAMELY, CREDIT CARD AND DEBIT CARD TRANSACTION PROCESSING SERVICES (U.S. CLS. 100, 101 AND 102).

H. M. FISHER, EXAMINING ATTORNEY

SN 85-380,780. MORGAN STANLEY SMITH BARNEY HOLDINGS LLC, PURCHASE, NY. FILED 7-26-2011.

XTILES

THE MARK CONSISTS OF STANDARD CHARACTERS WITHOUT CLAIM TO ANY PARTICULAR FONT, STYLE, SIZE, OR COLOR.

FOR FINANCIAL SERVICES, NAMELY, INVESTMENT ADVISORY SERVICES UTILIZING DYNAMIC ANALYTICS MODULES THAT ALLOW USERS TO EVALUATE RELATIVE AND ABSOLUTE VALUE OF VARIOUS CLUSTERS OF SECURITIES AGAINST EACH OTHER (U.S. CLS. 100, 101 AND 102).

ANGELA DUONG, EXAMINING ATTORNEY

SN 85-380,795. MORGAN STANLEY SMITH BARNEY HOLDINGS LLC, PURCHASE, NY. FILED 7-26-2011.

IDEAS CURVE

THE MARK CONSISTS OF STANDARD CHARACTERS WITHOUT CLAIM TO ANY PARTICULAR FONT, STYLE, SIZE, OR COLOR.

FOR FINANCIAL SERVICES, NAMELY, INVESTMENT ADVISORY SERVICES UTILIZING DYNAMIC ANALYTICS MODULES THAT ALLOW USERS TO EVALUATE RELATIVE AND ABSOLUTE VALUE OF VARIOUS CLUSTERS OF SECURITIES AGAINST EACH OTHER (U.S. CLS. 100, 101 AND 102).

ANGELA DUONG, EXAMINING ATTORNEY

CLASS 36—(Continued).

SN 85-390,422. NORTHBROOK BANK & TRUST COMPANY, NORTHBROOK, IL. FILED 8-5-2011.

FIRST CHICAGO BANK & TRUST

THE MARK CONSISTS OF STANDARD CHARACTERS WITHOUT CLAIM TO ANY PARTICULAR FONT, STYLE, SIZE, OR COLOR.

NO CLAIM IS MADE TO THE EXCLUSIVE RIGHT TO USE "FIRST" AND "BANK & TRUST", APART FROM THE MARK AS SHOWN.

SEC. 2(F), FOR BANKING SERVICES (U.S. CLS. 100, 101 AND 102).

FIRST USE 12-8-2006; IN COMMERCE 12-8-2006. ROBERT C. CLARK JR., EXAMINING ATTORNEY

SN 85-391,832. BEAVERS, BRETT, BELLA VISTA, AR. FILED 8-8-2011.

PeopleSurance

THE MARK CONSISTS OF STANDARD CHARACTERS WITHOUT CLAIM TO ANY PARTICULAR FONT, STYLE, SIZE, OR COLOR.

FOR HEALTH INSURANCE AGENCIES, LIFE INSURANCE AGENCIES (U.S. CLS. 100, 101 AND 102). BRENDAN REGAN, EXAMINING ATTORNEY

SN 85-392,972. MHO, LLC, TAMPA, FL. FILED 8-9-2011.

BE CONFIDENT MORTGAGE

THE MARK CONSISTS OF STANDARD CHARACTERS WITHOUT CLAIM TO ANY PARTICULAR FONT, STYLE, SIZE, OR COLOR.

NO CLAIM IS MADE TO THE EXCLUSIVE RIGHT TO USE "MORTGAGE", APART FROM THE MARK AS SHOWN.

FOR MORTGAGE LENDING (U.S. CLS. 100, 101 AND 102). FIRST USE 9-0-2007; IN COMMERCE 9-0-2007. CORY BOONE, EXAMINING ATTORNEY

CLASS 36—(Continued).

SN 85-398,202. SHIFT4 CORPORATION, LAS VEGAS, NV. FILED 8-15-2011.

SECURITY BEYOND COMPLIANCE

THE MARK CONSISTS OF STANDARD CHARACTERS WITHOUT CLAIM TO ANY PARTICULAR FONT, STYLE, SIZE, OR COLOR.

FOR PAYMENT PROCESSING SERVICES, NAMELY, MANAGING ELECTRONIC PAYMENT INFORMATION AND CARDHOLDER PAYMENT DATA DURING PROCESSING; CREDIT CARD, DEBIT CARD AND CARD PAYMENT TRANSACTION PROCESSING SERVICES (U.S. CLS. 100, 101 AND 102).

DAVID H. STINE, EXAMINING ATTORNEY

SN 85-398,301. ENTERPRISE HOLDINGS, INC., ST. LOUIS, MO. FILED 8-15-2011.



NO CLAIM IS MADE TO THE EXCLUSIVE RIGHT TO USE "TOLLPASS", APART FROM THE MARK AS SHOWN.

THE MARK CONSISTS OF THE WORD "TOLLPASS" WITHIN A GENERALLY RECTANGULAR BORDER, AND INCLUDING A DEPICTION OF A CURVED ROAD EXTENDING FROM A CENTRAL PORTION OF THE MARK TOWARD THE LOWER RIGHT CORNER OF THE MARK.

FOR TOLL ROAD FEE COLLECTION SERVICES, NAMELY, AUTOMATED COLLECTION OF FEES USING AN ELECTRONIC SYSTEM TO EXPEDITE PASSAGE OF VEHICLES THROUGH A COLLECTION FACILITY (U.S. CLS. 100, 101 AND 102).

FIRST USE 11-30-2009; IN COMMERCE 11-30-2009. WILLIAM BRECKENFELD, EXAMINING ATTORNEY

SN 85-399,093. ROYAL BANK OF CANADA, MONTREAL, QUEBEC, CANADA, FILED 8-16-2011.

RBC NOW

THE MARK CONSISTS OF STANDARD CHARACTERS WITHOUT CLAIM TO ANY PARTICULAR FONT, STYLE, SIZE, OR COLOR.

OWNER OF U.S. REG. NOS. 3,110,599, 3,186,170 AND OTHERS.

FOR FINANCIAL SERVICES IN THE NATURE OF TRADING SECURITIES FOR OTHERS USING A PROPRIETARY ALGORITHMIC STRATEGY (U.S. CLS. 100, 101 AND 102).

FIRST USE 1-0-2010; IN COMMERCE 1-0-2010. LINDA ESTRADA, EXAMINING ATTORNEY

CLASS 36—(Continued).

SN 85-403,881. FOUNTAINHEAD FINANCIAL, LLC, CHICAGO, IL. FILED 8-22-2011.

FOUNTAINHEAD FINANCIAL, LLC

THE MARK CONSISTS OF STANDARD CHARACTERS WITHOUT CLAIM TO ANY PARTICULAR FONT, STYLE, SIZE, OR COLOR.

NO CLAIM IS MADE TO THE EXCLUSIVE RIGHT TO USE "FINANCIAL, LLC", APART FROM THE MARK AS SHOWN.

FOR INVESTMENT ADVISORY SERVICES, NAMELY, MANAGING SECURITIES, NAMELY, STOCKS, BONDS, MUTUAL FUNDS AND EXCHANGE TRADED FUNDS FOR OTHERS, ALL OF THE AFOREMENTIONED SERVICES SPECIFICALLY EXCLUDING INVESTMENT ADVISORY SERVICES WITH RESPECT TO REAL ESTATE (U.S. CLS. 100, 101 AND 102).

FIRST USE 10-1-2009; IN COMMERCE 10-1-2009.
KAREN SEVERSON, EXAMINING ATTORNEY

CLASS 36—(Continued).

SN 85-415,666. GLOBAL MAGIC FUTURES LIMITED, BERKSWELL, UNITED KINGDOM, FILED 9-6-2011.

MAGIC NUMBER

THE MARK CONSISTS OF STANDARD CHARACTERS WITHOUT CLAIM TO ANY PARTICULAR FONT, STYLE, SIZE, OR COLOR.

PRIORITY CLAIMED UNDER SEC. 44(D) ON ERPN CMNTY TM OFC APPLICATION NO. 10228377, FILED 8-30-2011, REG. NO. 10228377, DATED 2-22-2012, EXPIRES 8-30-2021.

FOR FINANCIAL INFORMATION AND FINANCIAL ADVICE BOTH RELATING TO LIFESTYLE MANAGEMENT AND PERSONAL DEVELOPMENT (U.S. CLS. 100, 101 AND 102).

JASON TURNER, EXAMINING ATTORNEY

SN 85-415,715. GLOBAL MAGIC FUTURES LIMITED, BERKSWELL, UNITED KINGDOM, FILED 9-6-2011.

SN 85-410,908. MONEYHONEY, LLC, PITTSBURGH, PA. FILED 8-30-2011.

giftya

THE MARK CONSISTS OF STANDARD CHARACTERS WITHOUT CLAIM TO ANY PARTICULAR FONT, STYLE, SIZE, OR COLOR.

FOR ELECTRONIC MONETARY GIFT EXCHANGE SERVICES, NAMELY, PROVISION OF A VIRTUAL GIFT CARD SERVICE ENABLING A GIVER OF A VIRTUAL GIFT CARD TO UTILIZE THEIR EXISTING CREDIT OR DEBIT CARD ACCOUNT TO GIVE A VIRTUAL GIFT CARD AND ENABLING THE RECIPIENT OF SUCH VIRTUAL GIFT CARD TO USE THEIR EXISTING CREDIT OR DEBIT CARD ACCOUNT TO REDEEM THE VIRTUAL GIFT CARD (U.S. CLS. 100, 101 AND 102).

SKYE YOUNG, EXAMINING ATTORNEY



magicnumber.com
take control • achieve more • love life!

PRIORITY CLAIMED UNDER SEC. 44(D) ON ERPN CMNTY TM OFC APPLICATION NO. 10228393, FILED 8-30-2011, REG. NO. 10228393, DATED 2-21-2012, EXPIRES 9-30-2021.

THE MARK CONSISTS OF THE TERM "MAGICNUMBER.COM" IN STYLIZED LOWERCASE LETTERS, WITH THE PHRASES "TAKE CONTROL", "ACHIEVE MORE" AND "LOVE LIFE!" APPEARING IMMEDIATELY BELOW IN STYLIZED LOWERCASE LETTERS AND SEPARATED BY DOTS, AND AN ORB AND SHADOW DESIGN APPEARING TO THE IMMEDIATE LEFT.

FOR FINANCIAL INFORMATION AND FINANCIAL ADVICE BOTH RELATING TO LIFESTYLE MANAGEMENT AND PERSONAL DEVELOPMENT (U.S. CLS. 100, 101 AND 102).

JASON TURNER, EXAMINING ATTORNEY

CLASS 36—(Continued).

SN 85-415,766. GLOBAL MAGIC FUTURES LIMITED, BERKSWELL, UNITED KINGDOM, FILED 9-6-2011.



PRIORITY CLAIMED UNDER SEC. 44(D) ON ERPN CMNTY TM OFC APPLICATION NO. 10228476, FILED 8-30-2011, REG. NO. 10228476, DATED 2-2-2012, EXPIRES 8-30-2021.

THE COLOR(S) BLUE, YELLOW, RED, PINK, ORANGE, PURPLE, WHITE AND GREEN IS/ARE CLAIMED AS A FEATURE OF THE MARK.

THE MARK CONSISTS OF AN ORB DESIGN CONTAINING VARIOUS SHADES OF THE COLORS BLUE, YELLOW, RED, PINK, ORANGE, PURPLE, WHITE AND GREEN IN A SWIRL DESIGN, WITH A PURPLE SHADOW DIRECTLY BELOW THE ORB DESIGN.

FOR FINANCIAL INFORMATION AND FINANCIAL ADVICE BOTH RELATING TO LIFESTYLE MANAGEMENT AND PERSONAL DEVELOPMENT (U.S. CLS. 100, 101 AND 102).

WENDY JUN, EXAMINING ATTORNEY

SN 85-419,295. STONEGATE CAPITAL PARTNERS, LLC, ATLANTA, GA. FILED 9-9-2011.

PrimeOne

THE MARK CONSISTS OF STANDARD CHARACTERS WITHOUT CLAIM TO ANY PARTICULAR FONT, STYLE, SIZE, OR COLOR.

FOR BANKING AND FINANCING SERVICES (U.S. CLS. 100, 101 AND 102).

FIRST USE 5-1-2011; IN COMMERCE 9-1-2011.

ALYSSA STEEL, EXAMINING ATTORNEY

CLASS 36—(Continued).

SN 85-423,079. PATRICIA J. BRADY, BURIEN, WA. FILED 9-14-2011.

Resaleware

THE MARK CONSISTS OF STANDARD CHARACTERS WITHOUT CLAIM TO ANY PARTICULAR FONT, STYLE, SIZE, OR COLOR.

FOR BROKERAGE SERVICES FEATURING COMPUTER SOFTWARE AND COMPUTER SOFTWARE FOR USE WITH COMPUTER HARDWARE; ON-LINE BROKERAGE SERVICES FEATURING COMPUTER SOFTWARE AND COMPUTER SOFTWARE FOR USE WITH COMPUTER HARDWARE; BROKERAGE SERVICE FEATURING COMPUTER CONSULTING SERVICES IN THE FIELD OF COMPUTER SOFTWARE; ON-LINE BROKERAGE SERVICES FEATURING COMPUTER CONSULTING SERVICES IN THE FIELD OF COMPUTER SOFTWARE FOR USE WITH COMPUTER HARDWARE (U.S. CLS. 100, 101 AND 102).

FIRST USE 7-19-2011; IN COMMERCE 7-19-2011.

RAMONA ORTIGA, EXAMINING ATTORNEY

SN 85-430,889. THE FARESE GROUP, LLC, RIDGELAND, MS. FILED 9-23-2011.



THE FARESE GROUP

NO CLAIM IS MADE TO THE EXCLUSIVE RIGHT TO USE "GROUP", APART FROM THE MARK AS SHOWN.

THE MARK CONSISTS OF THE TERM "THE FARESE GROUP" WITH A STYLIZED CIRCLE WITH INTERSECTING LINES TO THE LEFT OF THE TERM.

FOR FINANCIAL SERVICES IN THE FIELD OF RETIREMENT PLANNING; PROVIDING FINANCIAL INFORMATION IN THE FIELD OF RETIREMENT PLANNING; MUTUAL FUND INVESTMENT SERVICES; FINANCIAL PLANNING SERVICES, INVESTMENT MANAGEMENT SERVICES; SECURITIES BROKERAGE SERVICES; MONEY MANAGEMENT SERVICES; FINANCIAL ANALYSIS SERVICES; PROVIDING PERSONALIZED INVESTMENT INFORMATION, INVESTMENT ACCOUNT MANAGEMENT AND SECURITIES BROKERAGE SERVICES (U.S. CLS. 100, 101 AND 102).

FIRST USE 6-0-2006; IN COMMERCE 6-0-2006.

SUSAN LESLIE DUBOIS, EXAMINING ATTORNEY

CLASS 36—(Continued).

SN 85-438,718. UMPQUA BANK, EUGENE, OR. FILED 10-4-2011.

**UMPQUA BANK WEALTH
MANAGEMENT**

THE MARK CONSISTS OF STANDARD CHARACTERS WITHOUT CLAIM TO ANY PARTICULAR FONT, STYLE, SIZE, OR COLOR.

OWNER OF U.S. REG. NOS. 2,571,638, 2,991,368 AND 3,078,369.

NO CLAIM IS MADE TO THE EXCLUSIVE RIGHT TO USE "BANK WEALTH MANAGEMENT", APART FROM THE MARK AS SHOWN.

SEC. 2(F) AS TO "UMPQUA".

FOR PERSONAL AND COMMERCIAL BANKING SERVICES, NAMELY, SAVINGS AND CHECKING ACCOUNT SERVICES, CONSUMER AND COMMERCIAL LENDING SERVICES, ONLINE BANKING, MORTGAGE BANKING, FINANCIAL SERVICES, NAMELY, FINANCIAL CONSULTATION, INVESTMENT CONSULTATION, FINANCIAL INVESTMENT SERVICES IN THE FIELD OF SECURITIES, ANNUITIES, BONDS, CERTIFICATES OF DEPOSIT, DEFINED PORTFOLIOS, FUTURES, COMMODITIES, INSURANCE, MUTUAL FUNDS, STOCKS, OPTIONS, AND OTHER SECURITIES, AND FINANCIAL BROKERAGE SERVICES IN THE NATURE OF MUTUAL FUND, SECURITY AND STOCK BROKERAGE SERVICES (U.S. CLS. 100, 101 AND 102).
REBECCA GILBERT, EXAMINING ATTORNEY

CLASS 36—(Continued).

SN 85-458,092. CELLULAR SALES OF TENNESSEE, LLC, KNOXVILLE, TN. FILED 10-27-2011.

TECHPROTECT

THE MARK CONSISTS OF STANDARD CHARACTERS WITHOUT CLAIM TO ANY PARTICULAR FONT, STYLE, SIZE, OR COLOR.

FOR INSURANCE BROKERAGE SERVICES AND PROVIDING EXTENDED WARRANTIES ON WIRELESS COMMUNICATION DEVICES, NAMELY, CELL PHONES, SMART PHONES, AND WIRELESS TABLETS (U.S. CLS. 100, 101 AND 102).

FIRST USE 11-8-2011; IN COMMERCE 11-22-2011.

MICHAEL GAFFAR, EXAMINING ATTORNEY

SN 85-460,160. OUR CHILDREN MAKING CHANGE, A NEW JERSEY NONPROFIT CORPORATION, MARGATE CITY, NJ. FILED 10-31-2011.

SN 85-448,632. KINGSGUARD ADVISORS, LP, NEW YORK, NY. FILED 10-17-2011.

KINGSGUARD ADVISORS

THE MARK CONSISTS OF STANDARD CHARACTERS WITHOUT CLAIM TO ANY PARTICULAR FONT, STYLE, SIZE, OR COLOR.

NO CLAIM IS MADE TO THE EXCLUSIVE RIGHT TO USE "ADVISORS", APART FROM THE MARK AS SHOWN.

FOR FINANCIAL SERVICES, NAMELY, INVESTMENT MANAGEMENT SERVICES, INVESTMENT ADVISORY SERVICES, FUND INVESTMENT AND FUND MANAGEMENT SERVICES (U.S. CLS. 100, 101 AND 102).
INGA ERVIN, EXAMINING ATTORNEY



THE MARK CONSISTS OF FOUR CHILDREN HOLDING HANDS, ALTERNATING FROM LEFT TO RIGHT BOY, GIRL, BOY, GIRL, ALL OF WHICH APPEAR STANDING ON TOP OF A DEPICTION OF THE PLANET EARTH.

FOR CONDUCTING CHARITABLE FUNDRAISING ACTIVITIES FOR CHILDREN FOR THE PURPOSE OF PROMOTING SOCIAL, PHYSICAL AND INTELLECTUAL GROWTH AND DEVELOPMENT (U.S. CLS. 100, 101 AND 102).

FIRST USE 5-1-2009; IN COMMERCE 5-1-2010.

MEGHAN REINHART, EXAMINING ATTORNEY

CLASS 36—(Continued).

SN 85-461,041. CHINAFUTURE GROUP LIMITED, HONG KONG, HONG KONG, FILED 11-1-2011.



THE MARK CONSISTS OF THE WORDING "CFG" TO THE RIGHT OF A STAR IN A STRIPE SQUARE.

FOR AGENCIES OR BROKERAGE FOR TRADING OF SECURITIES, SECURITIES INDEX FUTURES, SECURITIES OPTIONS, AND OVERSEAS MARKET SECURITIES FUTURES; ASSESSMENT AND MANAGEMENT OF REAL ESTATE; BANKING AND FINANCING SERVICES; BANKING CONSULTATION; BILL PAYMENT SERVICES PROVIDED THROUGH A WEBSITE; CAPITAL INVESTMENT CONSULTING; ELECTRONIC COMMERCE PAYMENT SERVICES, NAMELY, ESTABLISHING FUNDED ACCOUNTS USED TO PURCHASE GOODS AND SERVICES ON THE INTERNET; ELECTRONIC FINANCIAL TRADING SERVICES; ELECTRONIC FUNDS TRANSFER; FINANCIAL ADVICE AND CONSULTANCY SERVICES; FINANCIAL ANALYSIS AND CONSULTATION; FINANCIAL AND INVESTMENT SERVICES, NAMELY, MANAGEMENT AND BROKERAGE IN THE FIELDS OF STOCKS, BONDS, OPTIONS, COMMODITIES, FUTURES AND OTHER SECURITIES, AND THE INVESTMENT OF FUNDS OF OTHERS; FINANCIAL CONSULTANCY AND INSURANCE CONSULTANCY; FINANCIAL COUNSELING SERVICES, NAMELY, HELPING OTHERS BUILD A BETTER WORKING RELATIONSHIP WITH THEIR MONEY; FINANCIAL CREDIT SCORING SERVICES; FINANCIAL INFORMATION AND ADVISORY SERVICES; FINANCIAL INVESTMENT IN THE FIELD OF EDUCATION; FINANCIAL SERVICES, NAMELY, INVESTMENT FUND TRANSFER AND TRANSACTION SERVICES; FINANCIAL SERVICES, NAMELY, PROVIDING A VIRTUAL CURRENCY FOR USE BY MEMBERS OF AN ON-LINE COMMUNITY VIA A GLOBAL COMPUTER NETWORK; PROVIDING ELECTRONIC PROCESSING OF ELECTRONIC FUNDS TRANSFER, ACH, CREDIT CARD, DEBIT CARD, ELECTRONIC CHECK AND ELECTRONIC PAYMENTS; PROVIDING MULTIPLE PAYMENT OPTIONS BY MEANS OF CUSTOMER-OPERATED ELECTRONIC TERMINALS AVAILABLE ON-SITE IN RETAIL STORES; PROVISION AND FINANCIAL ADMINISTRATION OF A DEBIT CARD SAVINGS PROGRAM; REAL ESTATE AGENCIES; TRUSTESHIP REPRESENTATIVES (U.S. CLS. 100, 101 AND 102).

ANGELA DUONG, EXAMINING ATTORNEY

CLASS 36—(Continued).

SN 85-462,044. CHINAFUTURE GROUP LIMITED, HONG KONG, HONG KONG, FILED 11-2-2011.



THE MARK CONSISTS OF FIVE PERSONS STANDING IN A CIRCLE.

FOR AGENCIES OR BROKERAGE FOR TRADING OF SECURITIES, SECURITIES INDEX FUTURES, SECURITIES OPTIONS, AND OVERSEAS MARKET SECURITIES FUTURES; ASSESSMENT AND MANAGEMENT OF REAL ESTATE; BANKING AND FINANCING SERVICES; BANKING CONSULTATION; BILL PAYMENT SERVICES PROVIDED THROUGH A WEBSITE; CAPITAL INVESTMENT CONSULTING; ELECTRONIC COMMERCE PAYMENT SERVICES, NAMELY, ESTABLISHING FUNDED ACCOUNTS USED TO PURCHASE GOODS AND SERVICES ON THE INTERNET; ELECTRONIC FINANCIAL TRADING SERVICES; ELECTRONIC FUNDS TRANSFER; FINANCIAL ADVICE AND CONSULTANCY SERVICES; FINANCIAL ANALYSIS AND CONSULTATION; FINANCIAL AND INVESTMENT SERVICES, NAMELY, MANAGEMENT AND BROKERAGE IN THE FIELDS OF STOCKS, BONDS, OPTIONS, COMMODITIES, FUTURES AND OTHER SECURITIES, AND THE INVESTMENT OF FUNDS OF OTHERS; FINANCIAL CONSULTANCY AND INSURANCE CONSULTANCY; FINANCIAL COUNSELING SERVICES, NAMELY, HELPING OTHERS BUILD A BETTER WORKING RELATIONSHIP WITH THEIR MONEY; FINANCIAL CREDIT SCORING SERVICES; FINANCIAL INFORMATION AND ADVISORY SERVICES; FINANCIAL INVESTMENT IN THE FIELD OF EDUCATION; FINANCIAL SERVICES, NAMELY, INVESTMENT FUND TRANSFER AND TRANSACTION SERVICES; FINANCIAL SERVICES, NAMELY, PROVIDING A VIRTUAL CURRENCY FOR USE BY MEMBERS OF AN ON-LINE COMMUNITY VIA A GLOBAL COMPUTER NETWORK; PROVIDING ELECTRONIC PROCESSING OF ELECTRONIC FUNDS TRANSFER, ACH, CREDIT CARD, DEBIT CARD, ELECTRONIC CHECK AND ELECTRONIC PAYMENTS; PROVIDING MULTIPLE PAYMENT OPTIONS BY MEANS OF CUSTOMER-OPERATED ELECTRONIC TERMINALS AVAILABLE ON-SITE IN RETAIL STORES; PROVISION AND FINANCIAL ADMINISTRATION OF A DEBIT CARD SAVINGS PROGRAM; REAL ESTATE AGENCIES; TRUSTESHIP REPRESENTATIVES (U.S. CLS. 100, 101 AND 102).

ANGELA DUONG, EXAMINING ATTORNEY

CLASS 36—(Continued).

SN 85-463,447. RIVER BEND CENTER, LLC, STAMFORD, CT. FILED 11-3-2011.

RIVER BEND CENTER

THE MARK CONSISTS OF STANDARD CHARACTERS WITHOUT CLAIM TO ANY PARTICULAR FONT, STYLE, SIZE, OR COLOR.

NO CLAIM IS MADE TO THE EXCLUSIVE RIGHT TO USE "CENTER", APART FROM THE MARK AS SHOWN.

FOR REAL ESTATE SERVICES, NAMELY, RENTAL, BROKERAGE, LEASING AND MANAGEMENT OF COMMERCIAL PROPERTY, OFFICES AND OFFICE SPACE (U.S. CLS. 100, 101 AND 102).

FIRST USE 12-31-1998; IN COMMERCE 12-31-1998.

JAY BESCH, EXAMINING ATTORNEY

SN 85-470,243. ZIPPIO, LLC, CORAL GABLES, FL. FILED 11-11-2011.

ZIPPIO

THE MARK CONSISTS OF STANDARD CHARACTERS WITHOUT CLAIM TO ANY PARTICULAR FONT, STYLE, SIZE, OR COLOR.

FOR FINANCIAL TRANSACTION SERVICES, NAMELY, PROVIDING SECURE COMMERCIAL TRANSACTIONS AND PAYMENT OPTIONS FEATURING THE TRANSFERS OF ACCOUNT BALANCES AND VIRTUAL CURRENCY BETWEEN AND AMONG INDIVIDUALS AND ENTITIES, USING COMPUTERS AND MOBILE DEVICES (U.S. CLS. 100, 101 AND 102).

FIRST USE 8-30-2010; IN COMMERCE 9-22-2011.

DAWN HAN, EXAMINING ATTORNEY

SN 85-478,566. KENNETH VAUGHAN, NEW YORK, NY. FILED 11-22-2011.



THE MARK CONSISTS OF A HUMAN STICK FIGURE SEATED ON A CHAIR AT A DESK WITH A COMPUTER. MOVEMENT LINES APPEAR TO THE RIGHT SIDE OF THE CHAIR AND THE HEAD OF THE FIGURE.

FOR PROVIDING EDUCATIONAL INFORMATION IN THE FIELD OF FINANCE, INCLUDING TEXT AND INTERACTIVE CHECKLISTS, ALL OVER A GLOBAL COMPUTER NETWORK (U.S. CLS. 100, 101 AND 102).

AMY KERTGATE, EXAMINING ATTORNEY

CLASS 36—(Continued).

SN 85-480,095. TRANSUNION INTERACTIVE, INC., CHICAGO, IL. FILED 11-23-2011.

ASK AUDREY

THE MARK CONSISTS OF STANDARD CHARACTERS WITHOUT CLAIM TO ANY PARTICULAR FONT, STYLE, SIZE, OR COLOR.

THE NAME(S), PORTRAIT(S), AND/OR SIGNATURE(S) SHOWN IN THE MARK DOES NOT IDENTIFY A PARTICULAR LIVING INDIVIDUAL.

FOR PROVIDING FINANCIAL INFORMATION, DATA AND REPORTS, NAMELY, CREDIT SCORES BY MEANS OF THE INTERNET; PROVIDING ONLINE CREDIT SCORING AND EVALUATION SERVICES; CONSULTING SERVICES IN THE FIELD OF CONSUMER CREDIT AND DEBT CONSOLIDATION (U.S. CLS. 100, 101 AND 102).

FIRST USE 6-30-2003; IN COMMERCE 6-30-2003.

CYNTHIA TRIPI, EXAMINING ATTORNEY

SN 85-480,914. WILLIAM E. GUNDELFINGER III, DBA SENIOR BENEFIT ADVISORS, LAKEWOOD, CO. FILED 11-25-2011.

MR. MEDICARE

THE MARK CONSISTS OF STANDARD CHARACTERS WITHOUT CLAIM TO ANY PARTICULAR FONT, STYLE, SIZE, OR COLOR.

FOR INSURANCE BROKERAGE SERVICES (U.S. CLS. 100, 101 AND 102).

FIRST USE 9-15-2011; IN COMMERCE 9-22-2011.

JULIE WATSON, EXAMINING ATTORNEY

SN 85-481,673. PATH 2 BUY, LLC, VERNON HILLS, IL. FILED 11-28-2011.



THE MARK CONSISTS OF THE LITERAL ELEMENT OF THE MARK. THE PHRASE "PATH 2 BUY" WITH AN ACCENT BEGINNING TO THE LEFT OF THE PHRASE, PASSING THROUGH THE LETTER "P" AND WIDENING TO RESEMBLE A ROAD WHICH ENDS AT A DEPICTION OF THE UPPER STORY OF A HOME.

FOR FINANCIAL CONSULTATION IN THE FIELD OF HOME BUYING, MORTGAGE FINANCING AND THE HOUSING MARKET.; FINANCIAL SERVICES, NAMELY, MORTGAGE PLANNING (U.S. CLS. 100, 101 AND 102).

FIRST USE 8-26-2011; IN COMMERCE 8-26-2011.

PAM WILLIS, EXAMINING ATTORNEY

CLASS 36—(Continued).

SN 85-483,488. THE WENTWORTH GROUP, LLC, RESTON, VA. FILED 11-30-2011.

THE PEOPLE'S NETWORK

THE MARK CONSISTS OF STANDARD CHARACTERS WITHOUT CLAIM TO ANY PARTICULAR FONT, STYLE, SIZE, OR COLOR.

NO CLAIM IS MADE TO THE EXCLUSIVE RIGHT TO USE "NETWORK", APART FROM THE MARK AS SHOWN.

FOR PROVIDING AN ONLINE SEARCHABLE DATABASE FEATURING INFORMATION ABOUT CHARITABLE SERVICES IN THE NATURE OF CHARITABLE MONETARY GIVING (U.S. CLS. 100, 101 AND 102).
ANGELA DUONG, EXAMINING ATTORNEY

SN 85-488,975. STALWORTH, COLLEGE STATION, TX. FILED 12-7-2011.

LEGACY POINT

THE MARK CONSISTS OF STANDARD CHARACTERS WITHOUT CLAIM TO ANY PARTICULAR FONT, STYLE, SIZE, OR COLOR.

FOR REAL ESTATE SERVICES, NAMELY, LEASING AND MANAGEMENT OF OFFICE SPACE, RETAIL SPACE AND STUDENT HOUSING; RENTAL PROPERTY MANAGEMENT; REAL ESTATE INVESTMENT SERVICES (U.S. CLS. 100, 101 AND 102).
DAVID C. REIHNER, EXAMINING ATTORNEY

CLASS 36—(Continued).

SN 85-489,186. CLARK & LAVEY BENEFITS SOLUTIONS, INC, MERRIMACK, NH. FILED 12-7-2011.



OWNER OF U.S. REG. NO. 4,110,301.

THE COLOR(S) BLUE AND WHITE IS/ARE CLAIMED AS A FEATURE OF THE MARK.

THE MARK CONSISTS OF A BLUE BOX WITH THE LITERAL ELEMENT OF "H" IN WHITE ABOVE THE WORDING "ZONE" IN WHITE ENCLOSED IN THE BLUE BOX.

FOR ADVISORY SERVICES IN THE FIELD OF EMPLOYEE BENEFITS FOR GROUP HEALTHCARE AND BUSINESS INSURANCE OFFERED TO EMPLOYEES IN ADDITION TO STANDARD BENEFITS SUCH AS MEDICAL, DENTAL, LIFE INSURANCE INCLUDING SHORT TERM DISABILITY, LONG TERM DISABILITY, CANCER INSURANCE, ACCIDENTAL DEATH AND DISMEMBERMENT (U.S. CLS. 100, 101 AND 102).

FIRST USE 3-13-2011; IN COMMERCE 4-5-2011.

JULIE WATSON, EXAMINING ATTORNEY

SN 85-491,673. MICA ENTERTAINMENT, LLC, DEARBORN, MI. FILED 12-9-2011.

MICA ENTERTAINMENT

THE MARK CONSISTS OF STANDARD CHARACTERS WITHOUT CLAIM TO ANY PARTICULAR FONT, STYLE, SIZE, OR COLOR.

NO CLAIM IS MADE TO THE EXCLUSIVE RIGHT TO USE "ENTERTAINMENT", APART FROM THE MARK AS SHOWN.

FOR MOTION PICTURE FILM FINANCING SERVICES (U.S. CLS. 100, 101 AND 102).

FIRST USE 8-10-2011; IN COMMERCE 8-10-2011.

KIMBERLY PERRY, EXAMINING ATTORNEY

CLASS 36—(Continued).

SN 85-492,900. RESOURCE BANK, N.A., DEKALB, IL. FILED 12-12-2011.

Re-Fuel Checking

THE MARK CONSISTS OF STANDARD CHARACTERS WITHOUT CLAIM TO ANY PARTICULAR FONT, STYLE, SIZE, OR COLOR.

NO CLAIM IS MADE TO THE EXCLUSIVE RIGHT TO USE "CHECKING", APART FROM THE MARK AS SHOWN. FOR BANKING (U.S. CLS. 100, 101 AND 102). FIRST USE 12-1-2011; IN COMMERCE 12-1-2011. ROBIN CHOSID, EXAMINING ATTORNEY

CLASS 36—(Continued).

SN 85-496,133. LVPMC, LLC, SAN FRANCISCO, CA. FILED 12-15-2011.

LVP

THE MARK CONSISTS OF STANDARD CHARACTERS WITHOUT CLAIM TO ANY PARTICULAR FONT, STYLE, SIZE, OR COLOR.

FOR VENTURE CAPITAL ADVISORY SERVICES, VENTURE CAPITAL FINANCING, VENTURE CAPITAL FUND MANAGEMENT (U.S. CLS. 100, 101 AND 102). FIRST USE 12-11-2002; IN COMMERCE 12-11-2002. JACLYN KIDWELL WALKER, EXAMINING ATTORNEY

SN 85-493,208. WOODBRIDGE GROUP, LLC, WOODBRIDGE, CT. FILED 12-12-2011.



NO CLAIM IS MADE TO THE EXCLUSIVE RIGHT TO USE "GROUP, LLC", APART FROM THE MARK AS SHOWN.

THE MARK CONSISTS OF THE WORD "WOODBRIDGE" UNDERLINED AND THE WORDS "GROUP, LLC" ITALICIZED UNDERNEATH WITH A FEATHER ON THE RIGHT HAND SIDE.

SEC. 2(F). FOR BUSINESS BROKERAGE SERVICES AND RELATED CONSULTING PERTAINING TO BUSINESS SALES, MERGERS, ACQUISITIONS AND BUSINESS VALUATIONS; FINANCIAL SERVICES, NAMELY, RAISING DEBT AND EQUITY CAPITAL FOR OTHERS (U.S. CLS. 100, 101 AND 102). FIRST USE 4-13-1993; IN COMMERCE 4-13-1993. CHRISTINA SOBRAL, EXAMINING ATTORNEY

SN 85-497,050. DICKS, MORAIS, VALLEY STREAM, NY. FILED 12-16-2011.

autoloanhookup.com

THE MARK CONSISTS OF STANDARD CHARACTERS WITHOUT CLAIM TO ANY PARTICULAR FONT, STYLE, SIZE, OR COLOR.

FOR LENDING CONSULTANT SERVICES, NAMELY, PROVIDING ADVICE AND CONSULTATION IN THE FIELD OF AUTOMOTIVE LOANS (U.S. CLS. 100, 101 AND 102). JENNIFER MARTIN, EXAMINING ATTORNEY

SN 85-494,903. HALIGAS, JENNA FLINT, CUMMING, GA. FILED 12-14-2011.

ANGELS FOR ATHLETICS

THE MARK CONSISTS OF STANDARD CHARACTERS WITHOUT CLAIM TO ANY PARTICULAR FONT, STYLE, SIZE, OR COLOR.

NO CLAIM IS MADE TO THE EXCLUSIVE RIGHT TO USE "ATHLETICS", APART FROM THE MARK AS SHOWN. FOR CHARITABLE FOUNDATION SERVICES, NAMELY, PROVIDING FUNDRAISING ACTIVITIES, FUNDING, SCHOLARSHIPS AND/OR FINANCIAL ASSISTANCE FOR ATHLETES (U.S. CLS. 100, 101 AND 102).

FIRST USE 10-23-2008; IN COMMERCE 10-23-2008. ALYSSA STEEL, EXAMINING ATTORNEY

SN 85-497,293. VIZZDA LLC, SCOTTSDALE, AZ. FILED 12-16-2011.

VIZZDA

THE MARK CONSISTS OF STANDARD CHARACTERS WITHOUT CLAIM TO ANY PARTICULAR FONT, STYLE, SIZE, OR COLOR.

FOR PROVIDING INFORMATION IN THE FIELD OF REAL ESTATE (U.S. CLS. 100, 101 AND 102). FIRST USE 9-28-2011; IN COMMERCE 10-17-2011. JOHN SCHUYLER YARD, EXAMINING ATTORNEY

CLASS 36—(Continued).

SN 85-498,897. PROMONTORY INTERFINANCIAL NETWORK, LLC, ARLINGTON, VA. FILED 12-19-2011.

ICS

THE MARK CONSISTS OF STANDARD CHARACTERS WITHOUT CLAIM TO ANY PARTICULAR FONT, STYLE, SIZE, OR COLOR.

OWNER OF U.S. REG. NO. 4,053,744.

FOR BANKING SERVICES; FINANCIAL SERVICES, NAMELY, ASSISTING FINANCIAL INSTITUTIONS WITH THE MANAGEMENT OF CUSTOMER FUNDS AND FACILITATING THE TRANSFER OF FUNDS BETWEEN FUND SOURCES AND DEPOSIT ACCOUNTS; FINANCIAL SERVICES, NAMELY, THE MANAGEMENT OF DEPOSIT ACCOUNTS AND FACILITATING THE TRANSFER OF FUNDS BETWEEN FUND SOURCES AND DEPOSIT ACCOUNTS; FINANCIAL SERVICES, NAMELY, FUNDS TRANSFER AND TRANSACTION SERVICES; FINANCIAL SERVICES, NAMELY, ALLOCATION OF FUNDS TO AND PLACEMENT OF FUNDS IN DEPOSIT ACCOUNTS; FINANCIAL TRANSACTION SERVICES, NAMELY, MAINTAINING CUSTOMER RECORDS FOR FINANCIAL TRANSACTIONS, CUSTODIAL AND SUB-CUSTODIAL SERVICES, AND SETTLEMENT SERVICES; FDIC INSURANCE CLAIM PROCESSING SERVICES (U.S. CLS. 100, 101 AND 102).

FIRST USE 0-0-2010; IN COMMERCE 0-0-2010.
DAWN FELDMAN, EXAMINING ATTORNEY

CLASS 36—(Continued).

SN 85-501,413. DURLING, JENNIFER, DBA L.A. PROPERTY SOLUTIONS, PASADENA, CA. FILED 12-21-2011.



NO CLAIM IS MADE TO THE EXCLUSIVE RIGHT TO USE "LA PROPERTY SOLUTIONS", APART FROM THE MARK AS SHOWN.

THE COLOR(S) ORANGE, GRAY, BLACK, BEIGE IS/ARE CLAIMED AS A FEATURE OF THE MARK.

THE MARK CONSISTS OF THE STYLIZED, GRAY LETTERS "LA" WITH GRAY ARCHITECTURAL ELEMENTS BEHIND THEM TO THE RIGHT OF A STYLIZED ARCHITECTURAL DRAWING OF ORANGE, GRAY, BLACK, AND BEIGE BUILDINGS ALL ABOVE THE BLACK WORDS "PROPERTY SOLUTIONS".

FOR REAL ESTATE BROKERAGE; REAL ESTATE CONSULTATION; REAL ESTATE PROCUREMENT FOR OTHERS (U.S. CLS. 100, 101 AND 102).

FIRST USE 9-18-2010; IN COMMERCE 9-18-2010.
H. M. FISHER, EXAMINING ATTORNEY

SN 85-499,647. MOSAIK PARTNERS, LLC, NAPA, CA. FILED 12-20-2011.

Mosaik Partners

THE MARK CONSISTS OF STANDARD CHARACTERS WITHOUT CLAIM TO ANY PARTICULAR FONT, STYLE, SIZE, OR COLOR.

NO CLAIM IS MADE TO THE EXCLUSIVE RIGHT TO USE "PARTNERS", APART FROM THE MARK AS SHOWN.

FOR INVESTMENT BANKING SERVICES; FINANCIAL INFORMATION AND ADVISORY SERVICES; FINANCIAL ASSET MANAGEMENT; FINANCIAL INVESTMENT FUND MANAGEMENT SERVICES; PRIVATE EQUITY FUND INVESTMENT SERVICES (U.S. CLS. 100, 101 AND 102).

FIRST USE 10-18-2011; IN COMMERCE 10-18-2011.
WILLIAM P. SHANAHAN, EXAMINING ATTORNEY

SN 85-502,063. SEARS BRANDS, LLC, HOFFMAN ESTATES, IL. FILED 12-22-2011.

LAYAWAY ANGELS

THE MARK CONSISTS OF STANDARD CHARACTERS WITHOUT CLAIM TO ANY PARTICULAR FONT, STYLE, SIZE, OR COLOR.

NO CLAIM IS MADE TO THE EXCLUSIVE RIGHT TO USE "LAYAWAY", APART FROM THE MARK AS SHOWN.

FOR CHARITABLE SERVICES, NAMELY, PROVIDING INDIVIDUAL MEMBERS OF THE PUBLIC WITH THE INFORMATION AND OPPORTUNITY TO MAKE MONETARY DONATIONS TOWARDS LAYAWAY BALANCES (U.S. CLS. 100, 101 AND 102).

JESSICA A. POWERS, EXAMINING ATTORNEY

CLASS 36—(Continued).

SN 85-503,292. STEARNS LENDING, INC., SANTA ANA, CA. FILED 12-23-2011.

WE CAN HELP YOU!

THE MARK CONSISTS OF STANDARD CHARACTERS WITHOUT CLAIM TO ANY PARTICULAR FONT, STYLE, SIZE, OR COLOR.

FOR FINANCIAL SERVICES, NAMELY, MORTGAGE LENDING, MORTGAGE BANKING, AND MORTGAGE BROKERAGE SERVICES IN THE NATURE OF THE PURCHASE OF MORTGAGES ON BEHALF OF OTHERS AND THE ISSUANCE OF MORTGAGE-BACKED SECURITIES; MORTGAGE BROKERAGE FEATURING PRIVATE AND PUBLIC MORTGAGE LOANS AND MORTGAGE LOAN PORTFOLIOS; MORTGAGE BANKING SERVICES, NAMELY, SERVICING OF MORTGAGE LOANS AND BROKERAGE OF MORTGAGE LOANS; REAL ESTATE TITLE INSURANCE UNDERWRITING (U.S. CLS. 100, 101 AND 102).

FIRST USE 10-31-2004; IN COMMERCE 10-31-2004.
TARAH HARDY, EXAMINING ATTORNEY

CLASS 36—(Continued).

SN 85-504,285. CAPITAL COMMUNICATIONS FEDERAL CREDIT UNION, AKA CAPITAL COMMUNICATIONS FCU OR CAP COM FCU, ALBANY, NY. FILED 12-27-2011.



THE MARK CONSISTS OF THE PHRASE "GREAT GRADES" IN STYLIZED UPPER-AND-LOWER-CASE LETTERING WITH A SILHOUETTE OF A YOUNG GIRL FORMING THE LETTER "A" IN "GRADES" AND THE SILHOUETTE OF A YOUNG BOY FORMING THE LETTER "T" IN "GREAT."

FOR BANKING; BANKING AND FINANCING SERVICES (U.S. CLS. 100, 101 AND 102).
JILL C. ALT, EXAMINING ATTORNEY

SN 85-504,132. LOS OJOS DE LA FAMILIA, ALBUQUERQUE, NM. FILED 12-27-2011.

Los Ojos de la Familia

THE MARK CONSISTS OF STANDARD CHARACTERS WITHOUT CLAIM TO ANY PARTICULAR FONT, STYLE, SIZE, OR COLOR.

THE ENGLISH TRANSLATION OF "LOS OJOS DE LA FAMILIA" IN THE MARK IS "THE EYES OF THE FAMILY".

FOR CHARITABLE FOUNDATION SERVICES, NAMELY, PROVIDING FINANCIAL ASSISTANCE FOR PROGRAMS AND SERVICES OF OTHERS; CHARITABLE FOUNDATION SERVICES, NAMELY, PROVIDING FUNDRAISING ACTIVITIES, FUNDING, SCHOLARSHIPS AND/OR FINANCIAL ASSISTANCE FOR THOSE IN NEED; CHARITABLE FOUNDATION SERVICES, NAMELY, PROVIDING FUNDRAISING ACTIVITIES, SUPPLEMENTAL FUNDING, CAPITAL IMPROVEMENT FUNDING, SCHOLARSHIPS AND FINANCIAL ASSISTANCE FOR PROGRAMS AND SERVICES OF OTHERS; CHARITABLE SERVICES, NAMELY, PROVIDING FINANCIAL ASSISTANCE TO DISADVANTAGED PERSONS FOR FOOD, RENT, HEALTH CARE AND OTHER BASIC NEEDS; CHARITABLE SERVICES, NAMELY, PROVIDING FINANCIAL ASSISTANCE TO MEET THE PHYSICAL, PSYCHOLOGICAL, SOCIAL AND OTHER SPECIAL NEEDS OF CHILDREN; CHARITABLE SERVICES, NAMELY, PROVIDING FINANCIAL ASSISTANCE TO MEET THE PHYSICAL, PSYCHOLOGICAL, SOCIAL AND OTHER SPECIAL NEEDS OF DISABLED PERSONS; PROVIDING EMERGENCY FINANCIAL ASSISTANCE FOR INDIVIDUALS AND FAMILIES (U.S. CLS. 100, 101 AND 102).

FIRST USE 12-30-2009; IN COMMERCE 12-30-2009.
RONALD AIKENS, EXAMINING ATTORNEY

SN 85-504,382. MUNICH HEALTH NORTH AMERICA, INC., PRINCETON, NJ. FILED 12-27-2011.

STERLING INSURANCE

THE MARK CONSISTS OF STANDARD CHARACTERS WITHOUT CLAIM TO ANY PARTICULAR FONT, STYLE, SIZE, OR COLOR.

OWNER OF U.S. REG. NOS. 2,815,962, 2,815,964 AND OTHERS.

NO CLAIM IS MADE TO THE EXCLUSIVE RIGHT TO USE "INSURANCE", APART FROM THE MARK AS SHOWN.

FOR INSURANCE SERVICES, NAMELY, UNDERWRITING, ISSUING AND ADMINISTRATION OF HEALTH AND LIFE INSURANCE (U.S. CLS. 100, 101 AND 102).

FIRST USE 10-24-2011; IN COMMERCE 10-24-2011.
SCOTT BIBB, EXAMINING ATTORNEY

CLASS 36—(Continued).

SN 85-504,416. NATIONAL ASSOCIATION OF PROFESSIONAL PET SITTERS, INC., MT. LAUREL, NJ. FILED 12-27-2011.



OWNER OF U.S. REG. NOS. 3,575,458 AND 3,668,946.
NO CLAIM IS MADE TO THE EXCLUSIVE RIGHT TO USE "NATIONAL ASSOCIATION", APART FROM THE MARK AS SHOWN.

THE COLOR(S) BLUE, YELLOW, AND BEIGE IS/ARE CLAIMED AS A FEATURE OF THE MARK.

THE MARK CONSISTS OF A BEIGE HUMAN HAND HOLDING A YELLOW PAW OVER A BLUE BACKGROUND WHICH CONTAINS THE YELLOW WORD "PRESENTS" ABOVE A YELLOW NUMERAL "4" WITH A BLUE AND YELLOW BORDER ABOVE THE YELLOW WORD "PETS" AND IS ENCIRCLED BY YELLOW, ALL OF WHICH IS ENCIRCLED BY THE BLUE WORDS "NATIONAL ASSOCIATION OF PROFESSIONAL PET SITTERS" WITH A YELLOW PAW PRINT APPEARING ON EACH SIDE.

SEC. 2(F) AS TO "NATIONAL ASSOCIATION OF PROFESSIONAL PET SITTERS".

FOR CHARITABLE FUNDRAISING (U.S. CLS. 100, 101 AND 102).

FIRST USE 1-1-2011; IN COMMERCE 1-1-2011.
SUSAN RICHARDS, EXAMINING ATTORNEY

SN 85-505,014. MEDINA CAPITAL PARTNERS, INC., MIAMI, FL. FILED 12-28-2011.



NO CLAIM IS MADE TO THE EXCLUSIVE RIGHT TO USE "CAPITAL PARTNERS", APART FROM THE MARK AS SHOWN.

THE MARK CONSISTS OF THE WORDS "MEDINA

CLASS 36—(Continued).

CAPITAL PARTNERS" WITH "MEDINA" IN A LARGER SIZE RELATIVE TO, AND POSITIONED ABOVE, THE WORDS "CAPITAL PARTNERS", WITH A VERTICAL LINE TO THE LEFT OF THE WORDS AND THREE VERTICAL TRAPEZOID SHAPES POSITIONED ADJACENT TO EACH OTHER TO THE LEFT OF THE WORDS, WITH THE TOP SIDE OF THE CENTRAL AND RIGHT TRAPEZOID SLOPING DOWNWARDLY FROM RIGHT TO LEFT, AND THE TOP SIDE OF THE LEFT TRAPEZOID SLOPING DOWNWARDLY FROM LEFT TO RIGHT.

FOR FINANCIAL SERVICES, NAMELY, INVESTMENT ADVICE, INVESTMENT MANAGEMENT, INVESTMENT CONSULTATION AND INVESTMENT OF FUNDS FOR OTHERS, INCLUDING PRIVATE AND PUBLIC EQUITY AND DEBT INVESTMENT SERVICES (U.S. CLS. 100, 101 AND 102).

FIRST USE 9-1-2011; IN COMMERCE 9-1-2011.
KRISTIN DAHLING, EXAMINING ATTORNEY

SN 85-506,460. SAFETY NATIONAL CASUALTY CORPORATION, ST. LOUIS, MO. FILED 12-30-2011.

MAP CLIENT SERVICES

THE MARK CONSISTS OF STANDARD CHARACTERS WITHOUT CLAIM TO ANY PARTICULAR FONT, STYLE, SIZE, OR COLOR.

NO CLAIM IS MADE TO THE EXCLUSIVE RIGHT TO USE "CLIENT SERVICES", APART FROM THE MARK AS SHOWN.

FOR INSURANCE RISK MANAGEMENT AND LOSS PREVENTION SERVICES IN THE FIELD OF CASUALTY INSURANCE AND EXCESS WORKERS' COMPENSATION INSURANCE (U.S. CLS. 100, 101 AND 102).

FIRST USE 8-1-2009; IN COMMERCE 8-1-2009.
FRANK LATTUCA, EXAMINING ATTORNEY

SN 85-506,474. SAFETY NATIONAL CASUALTY CORPORATION, ST. LOUIS, MO. FILED 12-30-2011.

**MAP CLIENT SERVICES
MANAGEMENT ANALYSIS
PREVENTION**

THE MARK CONSISTS OF STANDARD CHARACTERS WITHOUT CLAIM TO ANY PARTICULAR FONT, STYLE, SIZE, OR COLOR.

NO CLAIM IS MADE TO THE EXCLUSIVE RIGHT TO USE "CLIENT SERVICES MANAGEMENT ANALYSIS PREVENTION", APART FROM THE MARK AS SHOWN.

FOR INSURANCE RISK MANAGEMENT AND LOSS PREVENTION SERVICES IN THE FIELD OF CASUALTY INSURANCE AND EXCESS WORKERS' COMPENSATION INSURANCE (U.S. CLS. 100, 101 AND 102).

FIRST USE 8-1-2009; IN COMMERCE 8-1-2009.
FRANK LATTUCA, EXAMINING ATTORNEY

CLASS 36—(Continued).

SN 85-506,770. CHECKI, JOHN, DALLAS, TX. FILED 12-31-2011.

FROM HERE AND NOW TO WOW

THE MARK CONSISTS OF STANDARD CHARACTERS WITHOUT CLAIM TO ANY PARTICULAR FONT, STYLE, SIZE, OR COLOR.

FOR FINANCIAL ADVISORY AND CONSULTANCY SERVICES; FINANCIAL PLANNING FOR RETIREMENT; ESTATE PLANNING; FINANCIAL PLANNING (U.S. CLS. 100, 101 AND 102).

FIRST USE 9-1-2007; IN COMMERCE 9-1-2008.
DOMINIC FATHY, EXAMINING ATTORNEY

SN 85-507,076. PAFFRATH, KEVIN H, VENTURA, CA. FILED 1-2-2012.

No-Pressure Agent

THE MARK CONSISTS OF STANDARD CHARACTERS WITHOUT CLAIM TO ANY PARTICULAR FONT, STYLE, SIZE, OR COLOR.

NO CLAIM IS MADE TO THE EXCLUSIVE RIGHT TO USE "AGENT", APART FROM THE MARK AS SHOWN.

FOR REAL ESTATE BROKERAGE (U.S. CLS. 100, 101 AND 102).

FIRST USE 8-13-2011; IN COMMERCE 8-13-2011.
MATTHEW KLINE, EXAMINING ATTORNEY

SN 85-507,863. THE BAIL BOND SPECIALISTS AGENCY, LLC, HERMITAGE, TN. FILED 1-3-2012.



NO CLAIM IS MADE TO THE EXCLUSIVE RIGHT TO USE "BAIL BOND SPECIALISTS", APART FROM THE MARK AS SHOWN.

THE COLOR(S) BLUE, GOLD, AND WHITE IS/ARE CLAIMED AS A FEATURE OF THE MARK.

THE MARK CONSISTS OF A BLUE CIRCLE OUTLINED IN GOLD CONTAINING THE IMAGE OF A WHITE HAND HOLDING A GOLD KEY OUTLINED IN BLUE ABOVE THE WORDS "BAIL BOND" IN UPPER CASE BLUE LETTER ABOVE THE WORD "SPECIALISTS" IN UPPER CASE GOLD LETTERS.

FOR BAIL BONDING (U.S. CLS. 100, 101 AND 102).
MARK RADEMACHER, EXAMINING ATTORNEY

CLASS 36—(Continued).

SN 85-507,867. SURETY BAIL SPECIALISTS GENERAL AGENCY LLC, HERMITAGE, TN. FILED 1-3-2012.



NO CLAIM IS MADE TO THE EXCLUSIVE RIGHT TO USE "SURETY BAIL SPECIALISTS", APART FROM THE MARK AS SHOWN.

THE COLOR(S) GREEN, BROWN, TAN, AND OFF-WHITE IS/ARE CLAIMED AS A FEATURE OF THE MARK.

THE MARK CONSISTS OF A TAN CIRCLE CONTAINING THE OUTLINE OF A GREEN CIRCLE AND THE OUTLINE OF A BROWN DOTTED CIRCLE WITH A BROWN SCALE OF JUSTICE IN THE UPPER PORTION OF THE CIRCLE HAVING A GREEN BANNER ACROSS THE MIDDLE OF THE CIRCLE CONTAINING THE WORD "SURETY" IN OFF-WHITE UPPER CASE LETTERS WITH THE WORD "BAIL" BELOW THE BANNER IN GREEN UPPER CASE LETTERS, A BROWN HORIZONTAL LINE INTERSECTED BY TWO BROWN VERTICAL LINES, AND THE WORD "SPECIALISTS" IN BROWN UPPER CASE LETTERS BELOW THE WORD "BAIL".

FOR BAIL BONDING; SURETY SERVICES (U.S. CLS. 100, 101 AND 102).

TINA MAI, EXAMINING ATTORNEY

SN 85-507,975. BOK FINANCIAL CORPORATION, TULSA, OK. FILED 1-3-2012.

Firstland Mortgage Servicing

THE MARK CONSISTS OF STANDARD CHARACTERS WITHOUT CLAIM TO ANY PARTICULAR FONT, STYLE, SIZE, OR COLOR.

NO CLAIM IS MADE TO THE EXCLUSIVE RIGHT TO USE "MORTGAGE SERVICING", APART FROM THE MARK AS SHOWN.

FOR MORTGAGE BANKING SERVICES, NAMELY, ORIGINATION, ACQUISITION, SERVICING, SECURITIZATION AND BROKERAGE OF MORTGAGE LOANS (U.S. CLS. 100, 101 AND 102).

CHRISTOPHER BUONGIORNO, EXAMINING ATTORNEY

CLASS 36—(Continued).

SN 85-508,016. BOK FINANCIAL CORPORATION, TULSA, OK. FILED 1-3-2012.

Firstland Mortgage

THE MARK CONSISTS OF STANDARD CHARACTERS WITHOUT CLAIM TO ANY PARTICULAR FONT, STYLE, SIZE, OR COLOR.

NO CLAIM IS MADE TO THE EXCLUSIVE RIGHT TO USE "MORTGAGE", APART FROM THE MARK AS SHOWN.

FOR MORTGAGE BANKING SERVICES, NAMELY, ORIGINATION, ACQUISITION, SERVICING, SECURITIZATION AND BROKERAGE OF MORTGAGE LOANS (U.S. CLS. 100, 101 AND 102).

CHRISTOPHER BUONGIORNO, EXAMINING ATTORNEY

CLASS 36—(Continued).

SN 85-509,596. HELPHOPELIVE, INC., RADNOR, PA. FILED 1-5-2012.



THE MARK CONSISTS OF THE OUTLINE OF A PERSON WITH FOLDED HANDS MAKING THE SHAPE OF A HEART NEXT, TO THE WORD "HELPHOPELIVE".

FOR CHARITABLE FUNDRAISING SERVICES, NAMELY, ASSISTING AND EMPOWERING INDIVIDUALS AND FAMILIES IN OVERCOMING FINANCIAL OBSTACLES TO MEDICAL CARE THROUGH GRASS-ROOTS FUNDRAISING ACTIVITIES; CONSULTING SERVICES FOR INDIVIDUALS AND FAMILIES FOR RAISING FUNDS TO BRIDGE GAP BETWEEN HEALTH INSURANCE AND FUNDS NEEDED TO HEAL, LIVE AND THRIVE (U.S. CLS. 100, 101 AND 102).

FIRST USE 10-0-2011; IN COMMERCE 10-0-2011. SANDRA BUJA, EXAMINING ATTORNEY

SN 85-508,294. EXP613, LLC, MIAMI, FL. FILED 1-4-2012.

EXP

THE MARK CONSISTS OF STANDARD CHARACTERS WITHOUT CLAIM TO ANY PARTICULAR FONT, STYLE, SIZE, OR COLOR.

OWNER OF U.S. REG. NOS. 3,551,264, 4,053,310 AND OTHERS.

FOR MANAGEMENT OF APARTMENTS (U.S. CLS. 100, 101 AND 102).

CAROLYN CATALDO, EXAMINING ATTORNEY

SN 85-509,736. TD AMERITRADE IP COMPANY, INC., OMAHA, NE. FILED 1-5-2012.

**DOING IT ON YOUR OWN
DOESN'T MEAN DOING IT ALONE**

SN 85-509,569. HELPHOPELIVE, INC., RADNOR, PA. FILED 1-5-2012.

HELPHOPELIVE

THE MARK CONSISTS OF STANDARD CHARACTERS WITHOUT CLAIM TO ANY PARTICULAR FONT, STYLE, SIZE, OR COLOR.

FOR CHARITABLE FUNDRAISING SERVICES, NAMELY, ASSISTING AND EMPOWERING INDIVIDUALS AND FAMILIES IN OVERCOMING FINANCIAL OBSTACLES TO MEDICAL CARE THROUGH GRASS-ROOTS FUNDRAISING ACTIVITIES; CONSULTING SERVICES FOR INDIVIDUALS AND FAMILIES FOR RAISING FUNDS TO BRIDGE GAP BETWEEN HEALTH INSURANCE AND FUNDS NEEDED TO HEAL, LIVE AND THRIVE (U.S. CLS. 100, 101 AND 102).

FIRST USE 10-0-2011; IN COMMERCE 10-0-2011. SANDRA BUJA, EXAMINING ATTORNEY

THE MARK CONSISTS OF STANDARD CHARACTERS WITHOUT CLAIM TO ANY PARTICULAR FONT, STYLE, SIZE, OR COLOR.

FOR FINANCIAL SERVICES, NAMELY, PROVIDING SECURITIES AND INVESTMENT INFORMATION; COMMODITY TRADING FOR OTHERS (U.S. CLS. 100, 101 AND 102).

TARAH HARDY, EXAMINING ATTORNEY

CLASS 36—(Continued).

SN 85-509,755. CU HOME MORTGAGE SOLUTIONS, LLC, PORTLAND, OR. FILED 1-5-2012.

CUHMS

THE MARK CONSISTS OF STANDARD CHARACTERS WITHOUT CLAIM TO ANY PARTICULAR FONT, STYLE, SIZE, OR COLOR.

FOR INSURANCE UNDERWRITING CONSULTATION; LENDING CONSULTANT SERVICES; MORTGAGE BANKING SERVICES, NAMELY, ORIGATION, ACQUISITION, SERVICING, SECURITIZATION AND BROKERAGE OF MORTGAGE LOANS; MORTGAGE COMPLIANCE CONSULTING SERVICES CONCERNING FINANCIAL REQUIREMENTS FOR MORTGAGES FOR MORTGAGE LENDERS AND SERVICERS AND MORTGAGE BROKERS; MORTGAGE PROCUREMENT FOR OTHERS (U.S. CLS. 100, 101 AND 102).

FIRST USE 7-12-2000; IN COMMERCE 7-12-2000. JAMES STEIN, EXAMINING ATTORNEY

CLASS 36—(Continued).

SN 85-510,138. JEANETTE R. WEILAND, SILVER SPRING, MD. FILED 1-6-2012.

Fortegy

THE MARK CONSISTS OF STANDARD CHARACTERS WITHOUT CLAIM TO ANY PARTICULAR FONT, STYLE, SIZE, OR COLOR.

FOR FINANCIAL AND INVESTMENT SERVICES, NAMELY, MANAGEMENT AND BROKERAGE IN THE FIELDS OF STOCKS, BONDS, OPTIONS, COMMODITIES, FUTURES AND OTHER SECURITIES, AND THE INVESTMENT OF FUNDS OF OTHERS (U.S. CLS. 100, 101 AND 102).

FIRST USE 11-1-2011; IN COMMERCE 1-1-2012. CHRISTOPHER BUONGIORNO, EXAMINING ATTORNEY

SN 85-509,841. LISTING REPORT LLC, FALLS CHURCH, VA. FILED 1-5-2012.



THE MARK CONSISTS OF THE TEXT "FIVESTARLISTING.COM" CENTERED WITH THE OUTLINE OF A RESIDENTIAL HOME'S ROOF OVER IT. TO THE LEFT OF THE TEXT IS A SMALL, VERTICAL WALL WHICH ATTACHES TO THE ROOF, AND A CHIMNEY ON THE ROOF WITH FIVE STARS OF VARIOUS SIZES BILLOWING OUT OF IT.

FOR CONSULTATION SERVICES IN THE FIELD OF RESIDENTIAL REAL ESTATE LISTING (U.S. CLS. 100, 101 AND 102).

GENE MACIOL, EXAMINING ATTORNEY

SN 85-510,342. TD AMERITRADE IP COMPANY, INC., OMAHA, NE. FILED 1-6-2012.

INVESTED IN ALL OF US

THE MARK CONSISTS OF STANDARD CHARACTERS WITHOUT CLAIM TO ANY PARTICULAR FONT, STYLE, SIZE, OR COLOR.

FOR FINANCIAL SERVICES, NAMELY, PROVIDING SECURITIES AND INVESTMENT INFORMATION; COMMODITY TRADING FOR OTHERS (U.S. CLS. 100, 101 AND 102).

TARAH HARDY, EXAMINING ATTORNEY

SN 85-510,018. POSITIVE EXPOSURE PRODUCTIONS, INC., NEW YORK, NY. FILED 1-5-2012.

POSITIVE EXPOSURE

THE MARK CONSISTS OF STANDARD CHARACTERS WITHOUT CLAIM TO ANY PARTICULAR FONT, STYLE, SIZE, OR COLOR.

FOR CHARITABLE FUND RAISING SERVICES (U.S. CLS. 100, 101 AND 102).

FIRST USE 4-15-2002; IN COMMERCE 5-6-2002. STEVEN JACKSON, EXAMINING ATTORNEY

SN 85-510,351. CAPSTEAD MORTGAGE CORPORATION, DALLAS, TX. FILED 1-6-2012.

CAPSTEAD

THE MARK CONSISTS OF STANDARD CHARACTERS WITHOUT CLAIM TO ANY PARTICULAR FONT, STYLE, SIZE, OR COLOR.

FOR PROVIDING FINANCIAL SERVICES, NAMELY, INVESTMENT MANAGEMENT (U.S. CLS. 100, 101 AND 102).

FIRST USE 0-0-1989; IN COMMERCE 12-23-1996. JOHN GARTNER, EXAMINING ATTORNEY

CLASS 36—(Continued).

SN 85-510,436. FEDERAL HOME LOAN MORTGAGE CORPORATION, MCLEAN, VA. FILED 1-6-2012.

MLAN

THE MARK CONSISTS OF STANDARD CHARACTERS WITHOUT CLAIM TO ANY PARTICULAR FONT, STYLE, SIZE, OR COLOR.

FOR FINANCIAL AND REAL ESTATE SERVICES IN THE FIELD OF MORTGAGE LOANS AND MORTGAGE-BACKED OR MORTGAGE RELATED SECURITIES (U.S. CLS. 100, 101 AND 102).

AMY KELLY, EXAMINING ATTORNEY

SN 85-510,456. BRATRUD MIDDLETON INSURANCE BROKERS, INC., DBA PROPEL INSURANCE, TACOMA, WA. FILED 1-6-2012.

PROPELONE

THE MARK CONSISTS OF STANDARD CHARACTERS WITHOUT CLAIM TO ANY PARTICULAR FONT, STYLE, SIZE, OR COLOR.

OWNER OF U.S. REG. NO. 3,613,486.
FOR INSURANCE BROKERAGE SERVICES (U.S. CLS. 100, 101 AND 102).

MYRIAH HABEEB, EXAMINING ATTORNEY

SN 85-510,912. U.S. ENERGY SERVICES, INC., PLYMOUTH, MN. FILED 1-6-2012.

Sentinel Service

THE MARK CONSISTS OF STANDARD CHARACTERS WITHOUT CLAIM TO ANY PARTICULAR FONT, STYLE, SIZE, OR COLOR.

NO CLAIM IS MADE TO THE EXCLUSIVE RIGHT TO USE "SERVICE", APART FROM THE MARK AS SHOWN.

FOR FINANCIAL RISK MANAGEMENT SERVICES, NAMELY, MONITORING, MEASURING, AND EVALUATING ENERGY MARKET RISKS AND OPPORTUNITIES AND DELIVERING TO CUSTOMERS A CUSTOMIZED RISK PLAN ALIGNED WITH A CUSTOMER'S OBJECTIVES AND RISK TOLERANCE (U.S. CLS. 100, 101 AND 102).

FIRST USE 8-31-2011; IN COMMERCE 8-31-2011.

JANICE L. MCMORROW, EXAMINING ATTORNEY

CLASS 36—(Continued).

SN 85-510,989. MBT IP LLC, EL SEGUNDO, CA. FILED 1-6-2012.

EXN

THE MARK CONSISTS OF STANDARD CHARACTERS WITHOUT CLAIM TO ANY PARTICULAR FONT, STYLE, SIZE, OR COLOR.

FOR CURRENCY TRADING; ON-LINE REAL-TIME CURRENCY TRADING (U.S. CLS. 100, 101 AND 102).

FIRST USE 12-0-2011; IN COMMERCE 12-0-2011.

LINDA M. KING, EXAMINING ATTORNEY

SN 85-511,028. WINDEN, RYAN, MANHATTAN BEACH, CA. FILED 1-6-2012.

Aerie Specialty Finance

THE MARK CONSISTS OF STANDARD CHARACTERS WITHOUT CLAIM TO ANY PARTICULAR FONT, STYLE, SIZE, OR COLOR.

NO CLAIM IS MADE TO THE EXCLUSIVE RIGHT TO USE "SPECIALTY FINANCE", APART FROM THE MARK AS SHOWN.

FOR ADVISING OTHERS CONCERNING INVESTMENTS IN INTELLECTUAL PROPERTY ASSETS AND INTANGIBLE BUSINESS ASSETS, BOTH DIRECTLY AND INDIRECTLY THROUGH OTHER ENTITIES; CORPORATE FINANCE SERVICES, NAMELY, CONSULTATION IN THE FIELD OF ASSET SALES; FINANCIAL AND INVESTMENT SERVICES, NAMELY, ASSET AND INVESTMENT ACQUISITION, CONSULTATION, ADVISORY AND DEVELOPMENT; FINANCIAL ASSET MANAGEMENT; INVESTMENT SERVICES, NAMELY, ASSET ACQUISITION, CONSULTATION, DEVELOPMENT AND MANAGEMENT SERVICES (U.S. CLS. 100, 101 AND 102).

LINDA E. BLOHM, EXAMINING ATTORNEY

SN 85-511,035. DIEBOLD, INCORPORATED, NORTH CANTON, OH. FILED 1-6-2012.

BOLD CHANGES ALL

THE MARK CONSISTS OF STANDARD CHARACTERS WITHOUT CLAIM TO ANY PARTICULAR FONT, STYLE, SIZE, OR COLOR.

FOR AUTOMATED TELLER MACHINE SERVICES (U.S. CLS. 100, 101 AND 102).

DAVID C. REIHNER, EXAMINING ATTORNEY

CLASS 36—(Continued).

SN 85-511,122. RIZZI, RON, BALL GROUND, GA. FILED 1-7-2012.

Flash Your Headlights

THE MARK CONSISTS OF STANDARD CHARACTERS WITHOUT CLAIM TO ANY PARTICULAR FONT, STYLE, SIZE, OR COLOR.

FOR CHARITABLE FUNDRAISING SERVICES BY MEANS OF ORGANIZING AND CONDUCTING SPECIAL EVENTS TO ELEVATE AND RAISE AWARENESS THROUGH COMMUNICATION FOR CAUSES FOR THE PURPOSE OF RAISING FUNDS FROM PLEDGES AND DONATIONS OF DRIVERS, RIDERS, AND COMMUTERS THAT ARE COMMUTING AND TRAVELLING REGULARLY CERTAIN DISTANCES TO AND FROM DESTINATIONS CONSISTING OF HOME, WORK, AND SCHOOL, BY AUTOMOBILE AND PUBLIC TRANSPORTATION (U.S. CLS. 100, 101 AND 102).

FIRST USE 1-7-2012; IN COMMERCE 1-7-2012.
NAKIA HENRY, EXAMINING ATTORNEY

SN 85-511,496. UNITED SERVICES AUTOMOBILE ASSOCIATION, SAN ANTONIO, TX. FILED 1-9-2012.

MYSHOP

THE MARK CONSISTS OF STANDARD CHARACTERS WITHOUT CLAIM TO ANY PARTICULAR FONT, STYLE, SIZE, OR COLOR.

FOR INSURANCE CLAIMS ADMINISTRATION; INSURANCE CLAIMS PROCESSING (U.S. CLS. 100, 101 AND 102).

TIMOTHY FINNEGAN, EXAMINING ATTORNEY

SN 85-511,525. BOSTON INDEMNITY GROUP, INC., LOUISVILLE, KY. FILED 1-9-2012.



THE MARK CONSISTS OF A SLANTED OVAL SURROUNDING A BLOCK, UPPER CASE LETTER "B" HAVING THE STRAIGHT EDGE OF THE LETTER "B" TAKING THE FORM OF A LOWER CASE LETTER "I".

FOR FINANCIAL GUARANTEE AND SURETY; INSURANCE UNDERWRITING IN THE FIELD OF SURETY SERVICES; SURETY SERVICES (U.S. CLS. 100, 101 AND 102).

JULIE GUTTADAURO, EXAMINING ATTORNEY

CLASS 36—(Continued).

SN 85-511,647. CU HOME MORTGAGE SOLUTIONS, LLC, PORTLAND, OR. FILED 1-9-2012.



NO CLAIM IS MADE TO THE EXCLUSIVE RIGHT TO USE "CREDIT UNION HOME MORTGAGE", APART FROM THE MARK AS SHOWN.

THE MARK CONSISTS OF THE WORDS "CREDIT UNION" PRINTED ABOVE THE WORDS "HOME MORTGAGE", WHICH ARE IN TURN PRINTED ABOVE THE WORD "SOLUTIONS", ALL APPEARING DIRECTLY BELOW A LOGO DESIGN CONSISTING OF THREE PARTIAL ARCS, TWO OF WHICH ENCIRCLE A STRUCTURE CONSISTING OF TWO CONJOINED BUILDINGS, THE SMALLER OF WHICH APPEARS TO EXTEND IN FRONT AND TO THE LEFT OF THE LARGER BUILDING, AND WITH TWO PAISLEY SHAPES ABOVE AND BELOW THE STRUCTURE AND ALSO ENCIRCLED BY THE TWO PARTIAL ARCS, AND WITH THE THIRD PARTIAL ARC APPEARING BELOW THE STRUCTURE AND BELOW ONE OF THE AFOREMENTIONED PARTIAL ARCS ENCIRCLING THE STRUCTURE.

FOR INSURANCE UNDERWRITING CONSULTATION; LENDING CONSULTANT SERVICES; MORTGAGE BANKING SERVICES, NAMELY, ORIGINATION, ACQUISITION, SERVICING, SECURITIZATION AND BROKERAGE OF MORTGAGE LOANS; MORTGAGE COMPLIANCE CONSULTING SERVICES CONCERNING FINANCIAL REQUIREMENTS FOR MORTGAGES FOR MORTGAGE LENDERS AND SERVICERS AND MORTGAGE BROKERS; MORTGAGE PROCUREMENT FOR OTHERS (U.S. CLS. 100, 101 AND 102).

FIRST USE 7-12-2000; IN COMMERCE 7-12-2000.
JAMES STEIN, EXAMINING ATTORNEY

SN 85-511,761. THE RAINIER GROUP, INC., BELLEVUE, WA. FILED 1-9-2012.

Experior

THE MARK CONSISTS OF STANDARD CHARACTERS WITHOUT CLAIM TO ANY PARTICULAR FONT, STYLE, SIZE, OR COLOR.

THE ENGLISH TRANSLATION OF "EXPERIOR" IN THE MARK IS "PUT TO THE TEST"

FOR FINANCIAL ADVICE; FINANCIAL CONSULTING; FINANCIAL FORECASTING; PROVIDING FINANCIAL INFORMATION (U.S. CLS. 100, 101 AND 102).

MEGHAN REINHART, EXAMINING ATTORNEY

CLASS 36—(Continued).

SN 85-512,200. LINDSAY DREYER, LLC, WASHINGTON, DC. FILED 1-9-2012.

City Chic Real Estate

THE MARK CONSISTS OF STANDARD CHARACTERS WITHOUT CLAIM TO ANY PARTICULAR FONT, STYLE, SIZE, OR COLOR.

NO CLAIM IS MADE TO THE EXCLUSIVE RIGHT TO USE "REAL ESTATE", APART FROM THE MARK AS SHOWN.

FOR COMMERCIAL AND RESIDENTIAL REAL ESTATE AGENCY SERVICES (U.S. CLS. 100, 101 AND 102). FIRST USE 1-7-2008; IN COMMERCE 1-7-2008. KATHERINE CONNOLLY, EXAMINING ATTORNEY

SN 85-512,212. NIP GROUP, INC., WOODBRIDGE, NJ. FILED 1-9-2012.

M MedEdge

THE MARK CONSISTS OF STANDARD CHARACTERS WITHOUT CLAIM TO ANY PARTICULAR FONT, STYLE, SIZE, OR COLOR.

OWNER OF U.S. REG. NO. 3,942,189.

FOR INSURANCE ADMINISTRATION IN THE FIELD OF PROFESSIONAL LIABILITY INSURANCE TO HEALTH CARE PRACTITIONERS, INCLUDING PHYSICIAN ASSISTANTS, NURSE PRACTITIONERS, OPTOMETRISTS, AND PODIATRISTS AND NOT INCLUDING HEALTH CARE BENEFITS, HEALTH INSURANCE OR PHARMACY BENEFIT INSURANCE; INSURANCE AGENCIES IN THE FIELD OF PROFESSIONAL LIABILITY INSURANCE TO HEALTH CARE PRACTITIONERS, INCLUDING PHYSICIAN ASSISTANTS, NURSE PRACTITIONERS, OPTOMETRISTS, AND PODIATRISTS AND NOT INCLUDING HEALTH CARE BENEFITS, HEALTH INSURANCE OR PHARMACY BENEFIT INSURANCE; INSURANCE BROKERAGE IN THE FIELD OF PROFESSIONAL LIABILITY INSURANCE TO HEALTH CARE PRACTITIONERS, INCLUDING PHYSICIAN ASSISTANTS, NURSE PRACTITIONERS, OPTOMETRISTS, AND PODIATRISTS AND NOT INCLUDING HEALTH CARE BENEFITS, HEALTH INSURANCE OR PHARMACY BENEFIT INSURANCE (U.S. CLS. 100, 101 AND 102).

FIRST USE 10-14-2010; IN COMMERCE 10-14-2010. JOHN DALIER, EXAMINING ATTORNEY

CLASS 36—(Continued).

SN 85-512,527. MAYER DEVELOPMENT COMPANY, SAN LEANDRO, CA. FILED 1-10-2012.

If You prefer to pay rent and not own a home don't call us

THE MARK CONSISTS OF STANDARD CHARACTERS WITHOUT CLAIM TO ANY PARTICULAR FONT, STYLE, SIZE, OR COLOR.

FOR REAL ESTATE PROCUREMENT FOR OTHERS (U.S. CLS. 100, 101 AND 102).

GENE MACIOL, EXAMINING ATTORNEY

SN 85-512,699. DRAGON GATE INVESTMENT PARTNERS, NEW YORK, NY. FILED 1-10-2012.

CorpOnline

THE MARK CONSISTS OF STANDARD CHARACTERS WITHOUT CLAIM TO ANY PARTICULAR FONT, STYLE, SIZE, OR COLOR.

FOR PROVIDING INFORMATION AND RESEARCH IN THE FIELD OF FINANCE AND FINANCIAL INVESTMENTS; PROVIDING INVESTORS WITH FINANCIAL INFORMATION (U.S. CLS. 100, 101 AND 102).

FIRST USE 8-14-2009; IN COMMERCE 8-14-2009. JULIE GUTTADAURO, EXAMINING ATTORNEY

SN 85-512,780. TIMBERVEST, LLC, ATLANTA, GA. FILED 1-10-2012.

Liquid Timber

THE MARK CONSISTS OF STANDARD CHARACTERS WITHOUT CLAIM TO ANY PARTICULAR FONT, STYLE, SIZE, OR COLOR.

FOR FINANCIAL AND INVESTMENT SERVICES, NAMELY, MANAGEMENT AND BROKERAGE IN THE FIELDS OF STOCKS, BONDS, OPTIONS, COMMODITIES, FUTURES AND OTHER SECURITIES, AND THE INVESTMENT OF FUNDS OF OTHERS (U.S. CLS. 100, 101 AND 102).

COLLEEN KEARNEY, EXAMINING ATTORNEY

CLASS 36—(Continued).

SN 85-512,840. CORNERSTONE MORTGAGE COMPANY, HOUSTON, TX. FILED 1-10-2012.



OWNER OF U.S. REG. NOS. 2,213,863 AND 3,976,505.
NO CLAIM IS MADE TO THE EXCLUSIVE RIGHT TO USE "HOME LENDING", APART FROM THE MARK AS SHOWN.

THE MARK CONSISTS OF "CORNERSTONE HOME LENDING" WITH THE "C" IN "CORNERSTONE" INTERSECTING THE BOTTOM RIGHT HAND CORNER OF THE OUTLINE OF A HOUSE.

FOR MORTGAGE SERVICES, NAMELY, MORTGAGE BANKING, MORTGAGE BROKERAGE, AND MORTGAGE LENDING (U.S. CLS. 100, 101 AND 102).

FIRST USE 12-31-1990; IN COMMERCE 12-31-1990.
JASON BLAIR, EXAMINING ATTORNEY



SN 85-513,150. CHARLESTON AREA FEDERAL CREDIT UNION, CHARLESTON, SC. FILED 1-10-2012.

LATITUDE 32

THE MARK CONSISTS OF STANDARD CHARACTERS WITHOUT CLAIM TO ANY PARTICULAR FONT, STYLE, SIZE, OR COLOR.

FOR CREDIT UNION SERVICES (U.S. CLS. 100, 101 AND 102).
RONALD AIKENS, EXAMINING ATTORNEY



SN 85-513,152. CHARLESTON AREA FEDERAL CREDIT UNION, CHARLESTON, SC. FILED 1-10-2012.

LAT 32

THE MARK CONSISTS OF STANDARD CHARACTERS WITHOUT CLAIM TO ANY PARTICULAR FONT, STYLE, SIZE, OR COLOR.

FOR CREDIT UNION SERVICES (U.S. CLS. 100, 101 AND 102).
RONALD AIKENS, EXAMINING ATTORNEY

CLASS 36—(Continued).

SN 85-513,295. MY DWELLING, LLC, MILWAUKEE, WI. FILED 1-10-2012.

MYDWELLING

THE MARK CONSISTS OF STANDARD CHARACTERS WITHOUT CLAIM TO ANY PARTICULAR FONT, STYLE, SIZE, OR COLOR.

FOR REAL ESTATE BROKERAGE SERVICES; APARTMENT, CONDO AND SINGLE FAMILY HOME LEASING AND MANAGEMENT SERVICES (U.S. CLS. 100, 101 AND 102).

FIRST USE 3-31-2006; IN COMMERCE 3-31-2006.
JENNIFER MARTIN, EXAMINING ATTORNEY



SN 85-513,298. MY DWELLING, LLC, MILWAUKEE, WI. FILED 1-10-2012.



THE COLOR(S) BLUE IS/ARE CLAIMED AS A FEATURE OF THE MARK.

THE MARK CONSISTS OF A BLUE RIBBON DESIGN IN THE SHAPE OF AN "M".

FOR REAL ESTATE BROKERAGE SERVICES; APARTMENT, CONDO AND SINGLE FAMILY HOME LEASING AND MANAGEMENT SERVICES (U.S. CLS. 100, 101 AND 102).

FIRST USE 3-31-2006; IN COMMERCE 3-31-2006.
JENNIFER MARTIN, EXAMINING ATTORNEY



SN 85-513,343. WALSH, PAT, FORT WALTON BEACH, FL. FILED 1-10-2012.

MIDNIGHT ON THE DRAGON

THE MARK CONSISTS OF STANDARD CHARACTERS WITHOUT CLAIM TO ANY PARTICULAR FONT, STYLE, SIZE, OR COLOR.

FOR CHARITABLE FUNDRAISING SERVICES BY MEANS OF ORGANIZING AND CONDUCTING SPECIAL EVENTS; CHARITABLE FUNDRAISING SERVICES (U.S. CLS. 100, 101 AND 102).

DAWN HAN, EXAMINING ATTORNEY

CLASS 36—(Continued).

SN 85-513,696. CAROLINA COLLEGIATE FEDERAL CREDIT UNION, COLUMBIA, SC. FILED 1-11-2012.

Stress Free USC

THE MARK CONSISTS OF STANDARD CHARACTERS WITHOUT CLAIM TO ANY PARTICULAR FONT, STYLE, SIZE, OR COLOR.

FOR CREDIT UNION SERVICES (U.S. CLS. 100, 101 AND 102).

FIRST USE 2-1-2009; IN COMMERCE 2-1-2009.
KELLY TRUSILO, EXAMINING ATTORNEY

SN 85-513,767. LIFE AUDIT PROFESSIONALS, LLC, BOCA RATON, FL. FILED 1-11-2012.

MyLifeGiving

THE MARK CONSISTS OF STANDARD CHARACTERS WITHOUT CLAIM TO ANY PARTICULAR FONT, STYLE, SIZE, OR COLOR.

OWNER OF U.S. REG. NO. 3,711,899.

FOR CHARITABLE FUNDRAISING SERVICES, NAMELY, BY PROVIDING INDIVIDUALS WITH THE INFORMATION AND OPPORTUNITY TO MAKE MONETARY DONATIONS TO THEIR FAVORITE CHARITY; INSURANCE AGENCIES IN THE FIELD OF LIFE; INSURANCE CONSULTING IN THE FIELD OF LIFE INSURANCE (U.S. CLS. 100, 101 AND 102).

ALYSSA STEEL, EXAMINING ATTORNEY

SN 85-513,850. GREENVIEW MANAGEMENT COMPANY, SAN FRANCISCO, CA. FILED 1-11-2012.

GREENVIEW

THE MARK CONSISTS OF STANDARD CHARACTERS WITHOUT CLAIM TO ANY PARTICULAR FONT, STYLE, SIZE, OR COLOR.

FOR AUDITING UTILITY RATES FOR OTHERS; BILLING, NAMELY PROCESSING UTILITY INVOICES FOR THIRD PARTIES; ENERGY USAGE MANAGEMENT; UTILITY-BILL MANAGEMENT SERVICES, NAMELY, TRACKING, REPORTING, ANALYZING, AND DELIVERING ENERGY INFORMATION IN THE FORM OF UTILITY BILLS AND UTILITY METER DATA RATE SCHEDULES; CONSULTING SERVICES IN THE FIELD OF ENERGY MEASUREMENT TO IMPROVE ENERGY EFFICIENCY (U.S. CLS. 100, 101 AND 102).

FIRST USE 5-5-2009; IN COMMERCE 5-5-2009.
RENEE MCCRAY, EXAMINING ATTORNEY

CLASS 36—(Continued).

SN 85-514,118. LENDTRADE, INC., WEST DES MOINES, IA. FILED 1-11-2012.

WHERE SECONDS COME FIRST

THE MARK CONSISTS OF STANDARD CHARACTERS WITHOUT CLAIM TO ANY PARTICULAR FONT, STYLE, SIZE, OR COLOR.

FOR INVESTMENT BANKING SERVICES (U.S. CLS. 100, 101 AND 102).

FIRST USE 12-28-2011; IN COMMERCE 12-28-2011.
LINDSEY RUBIN, EXAMINING ATTORNEY

SN 85-514,131. LENDTRADE, INC., WEST DES MOINES, IA. FILED 1-11-2012.



THE MARK CONSISTS OF TWO INTERCONNECTING SEMICIRCLES; THE SEMICIRCLE ON THE LEFT HAVING AN OUTSIDE BORDER WHICH DECREASES IN THICKNESS FROM THE TOP TO THE BOTTOM (COUNTERCLOCKWISE); THE SEMICIRCLE ON THE RIGHT HAVING AN OUTSIDE BORDER WHICH INCREASES IN THICKNESS FROM THE TOP TO THE BOTTOM (CLOCKWISE).

FOR INVESTMENT BANKING SERVICES (U.S. CLS. 100, 101 AND 102).

FIRST USE 12-28-2011; IN COMMERCE 12-28-2011.
LINDSEY RUBIN, EXAMINING ATTORNEY

SN 85-514,373. MEEMIC INSURANCE COMPANY, AUBURN HILLS, MI. FILED 1-11-2012.

**Meemic**

OWNER OF U.S. REG. NOS. 2,324,798, 2,834,383 AND 3,187,154.

THE MARK CONSISTS OF A TREE CONSISTING OF FOUR BRANCHES, TWO BRANCHES CURVING TO THE LEFT, AND TWO BRANCHES CURVING TO THE RIGHT

CLASS 36—(Continued).

AND EACH BRANCH SPLITS AT THE END TO FORM AN ADDITIONAL BRANCH, WHICH CURVES IN AN OPPOSITE DIRECTION FROM THE INITIAL BRANCH. EACH BRANCH IS SURROUNDED BY OVAL SHAPED LEAVES. BENEATH THE TREE IS A SLIGHTLY CURVING HORIZONTAL LINE THAT BEGINS ON THE LEFT WITH A SMALL POINT THAT INCREASES IN THICKNESS AS IT MOVES TO THE RIGHT AND GRADUALLY DECREASES IN THICKNESS TO END IN A POINT. TO THE RIGHT OF THE TREE DESIGN IS THE WORD "MEEMIC".

FOR CLAIMS ADJUSTMENT IN THE FIELD OF INSURANCE; INSURANCE BROKERAGE SERVICES; INSURANCE CARRIER SERVICES; INSURANCE CLAIMS ADMINISTRATION; INSURANCE CLAIMS PROCESSING; INSURANCE UNDERWRITING IN THE FIELD OF PROPERTY AND CASUALTY INSURANCE, AUTOMOBILE INSURANCE, HOMEOWNERS INSURANCE, TENANT INSURANCE, CONDOMINIUM INSURANCE, WATERCRAFT INSURANCE, AND PERSONAL UMBRELLA INSURANCE; PROVIDING INFORMATION IN INSURANCE MATTERS (U.S. CLS. 100, 101 AND 102).
DOUGLAS LEE, EXAMINING ATTORNEY

CLASS 36—(Continued).

SITE DIRECTION FROM THE INITIAL BRANCH. EACH BRANCH IS SURROUNDED BY OVAL SHAPED LEAVES. BENEATH THE TREE IS A SLIGHTLY CURVING HORIZONTAL LINE THAT BEGINS ON THE LEFT WITH A SMALL POINT THAT INCREASES IN THICKNESS AS IT MOVES TO THE RIGHT AND GRADUALLY DECREASES IN THICKNESS TO END IN A POINT. TO THE RIGHT OF THE TREE DESIGN IS THE WORD "MEEMIC", AND BELOW IT ARE THE WORDS "INSURING OUR EDUCATIONAL COMMUNITY".

FOR CLAIMS ADJUSTMENT IN THE FIELD OF INSURANCE; INSURANCE BROKERAGE SERVICES; INSURANCE CARRIER SERVICES; INSURANCE CLAIMS ADMINISTRATION; INSURANCE CLAIMS PROCESSING; INSURANCE UNDERWRITING IN THE FIELD OF PROPERTY AND CASUALTY INSURANCE, AUTOMOBILE INSURANCE, HOMEOWNERS INSURANCE, TENANT INSURANCE, CONDOMINIUM INSURANCE, WATERCRAFT INSURANCE, AND PERSONAL UMBRELLA INSURANCE; PROVIDING INFORMATION IN INSURANCE MATTERS (U.S. CLS. 100, 101 AND 102).
DOUGLAS LEE, EXAMINING ATTORNEY

SN 85-514,395. MEEMIC INSURANCE COMPANY, AUBURN HILLS, MI. FILED 1-11-2012.

INSURING OUR EDUCATIONAL
COMMUNITY

THE MARK CONSISTS OF STANDARD CHARACTERS WITHOUT CLAIM TO ANY PARTICULAR FONT, STYLE, SIZE, OR COLOR.

FOR CLAIMS ADJUSTMENT IN THE FIELD OF INSURANCE; INSURANCE BROKERAGE SERVICES; INSURANCE CARRIER SERVICES; INSURANCE CLAIMS ADMINISTRATION; INSURANCE CLAIMS PROCESSING; INSURANCE UNDERWRITING IN THE FIELD OF PROPERTY AND CASUALTY INSURANCE, AUTOMOBILE INSURANCE, HOMEOWNERS INSURANCE, TENANT INSURANCE, CONDOMINIUM INSURANCE, WATERCRAFT INSURANCE, AND PERSONAL UMBRELLA INSURANCE; PROVIDING INFORMATION IN INSURANCE MATTERS (U.S. CLS. 100, 101 AND 102).
DOUGLAS LEE, EXAMINING ATTORNEY

SN 85-514,398. MEEMIC INSURANCE COMPANY, AUBURN HILLS, MI. FILED 1-11-2012.



OWNER OF U.S. REG. NOS. 2,324,798, 2,834,383 AND 3,187,154.

THE MARK CONSISTS OF A TREE CONSISTING OF FOUR BRANCHES, TWO BRANCHES CURVING TO THE LEFT, AND TWO BRANCHES CURVING TO THE RIGHT AND EACH BRANCH SPLITS AT THE END TO FORM AN ADDITIONAL BRANCH, WHICH CURVES IN AN OPPO-

SN 85-515,298. AMBICARD LLC, AKA AMBICARD, SPRINGFIELD, MO. FILED 1-12-2012.

Ambicard

FOR CREDIT AND CASH CARD SERVICES (U.S. CLS. 100, 101 AND 102).
FIRST USE 11-1-2008; IN COMMERCE 11-1-2008.
ELLEN BURNS, EXAMINING ATTORNEY

SN 85-515,313. AMBICASH LLC, AKA AMBICASH, SPRINGFIELD, MO. FILED 1-12-2012.

ambicash

THE MARK CONSISTS OF THE NAME "AMBICASH" BEGINNING WITH A LOWER-CASE "A", USING THE ENTER SANSMAN FONT, WITH BOLD AND ITALIC.

FOR BILL PAYMENT SERVICES PROVIDED THROUGH A WEBSITE (U.S. CLS. 100, 101 AND 102).
JANICE KIM, EXAMINING ATTORNEY

CLASS 36—(Continued).

SN 85-515,357. LILLIE BEN, FRANKTOWN, CO. FILED 1-12-2012.

**WHEN YOU CANNOT DO IT
ALONE... WE CAN DO IT
TOGETHER**

THE MARK CONSISTS OF STANDARD CHARACTERS WITHOUT CLAIM TO ANY PARTICULAR FONT, STYLE, SIZE, OR COLOR.
FOR FINANCIAL ADVICE AND CONSULTANCY SERVICES (U.S. CLS. 100, 101 AND 102).
FIRST USE 1-12-2012; IN COMMERCE 1-12-2012.
KATHY DE JONGE, EXAMINING ATTORNEY

SN 85-515,446. ICS INVESTMENT RESEARCH LLC, BALLWIN, MO. FILED 1-12-2012.

plan-Z

THE MARK CONSISTS OF STANDARD CHARACTERS WITHOUT CLAIM TO ANY PARTICULAR FONT, STYLE, SIZE, OR COLOR.
FOR INVESTMENT RESEARCH RELATED TO RETIREMENT INCOME; INVESTMENT RESEARCH RELATED TO STOCK SELECTION; INVESTMENT RESEARCH RELATED TO PORTFOLIO MANAGEMENT OF RETIREMENT PLANS; ASSET ALLOCATIONS FOR RETIREMENT PLANS (U.S. CLS. 100, 101 AND 102).
HENRY S. ZAK, EXAMINING ATTORNEY

SN 85-515,603. ATTORNEYS' TITLE GUARANTY FUND, INC., CHICAGO, IL. FILED 1-13-2012.

ATG PROPERTY SOLUTIONS

THE MARK CONSISTS OF STANDARD CHARACTERS WITHOUT CLAIM TO ANY PARTICULAR FONT, STYLE, SIZE, OR COLOR.
OWNER OF U.S. REG. NOS. 1,611,540, 3,361,907 AND OTHERS.
NO CLAIM IS MADE TO THE EXCLUSIVE RIGHT TO USE "PROPERTY SOLUTIONS", APART FROM THE MARK AS SHOWN.
FOR REAL ESTATE ACQUISITION SERVICES; REAL ESTATE BROKERAGE; REAL ESTATE CONSULTATION; REAL ESTATE INVESTMENT SERVICES; REAL ESTATE VALUATIONS (U.S. CLS. 100, 101 AND 102).
AMY KELLY, EXAMINING ATTORNEY

CLASS 36—(Continued).

SN 85-515,604. ATTORNEYS' TITLE GUARANTY FUND, INC., CHICAGO, IL. FILED 1-13-2012.

SHORT SALES BY ATG

THE MARK CONSISTS OF STANDARD CHARACTERS WITHOUT CLAIM TO ANY PARTICULAR FONT, STYLE, SIZE, OR COLOR.

OWNER OF U.S. REG. NOS. 1,611,540, 3,361,907 AND OTHERS.

NO CLAIM IS MADE TO THE EXCLUSIVE RIGHT TO USE "SHORT SALES", APART FROM THE MARK AS SHOWN.

FOR REAL ESTATE ACQUISITION SERVICES; REAL ESTATE BROKERAGE; REAL ESTATE CONSULTATION; REAL ESTATE INVESTMENT SERVICES; REAL ESTATE VALUATIONS (U.S. CLS. 100, 101 AND 102).
AMY KELLY, EXAMINING ATTORNEY

SN 85-515,976. APPS FINANCIAL GROUP, INC., HOUSTON, TX. FILED 1-13-2012.

180 degree's from Ordinary

THE MARK CONSISTS OF STANDARD CHARACTERS WITHOUT CLAIM TO ANY PARTICULAR FONT, STYLE, SIZE, OR COLOR.

FOR FINANCIAL CONSULTING; FINANCIAL PLANNING FOR RETIREMENT (U.S. CLS. 100, 101 AND 102).
JOHN WILKE, EXAMINING ATTORNEY

SN 85-516,025. RADIAN GROUP INC., PHILADELPHIA, PA. FILED 1-13-2012.

A PASSION FOR YOUR SUCCESS

THE MARK CONSISTS OF STANDARD CHARACTERS WITHOUT CLAIM TO ANY PARTICULAR FONT, STYLE, SIZE, OR COLOR.

FOR REAL ESTATE MORTGAGE INSURANCE UNDERWRITING SERVICES (U.S. CLS. 100, 101 AND 102).
EVELYN BRADLEY, EXAMINING ATTORNEY

CLASS 36—(Continued).

SN 85-518,771. CENTAURI SPECIALTY INSURANCE HOLDINGS, INC., SARASOTA, FL. FILED 1-18-2012.



NO CLAIM IS MADE TO THE EXCLUSIVE RIGHT TO USE INSURANCE, APART FROM THE MARK AS SHOWN. THE MARK CONSISTS OF THE WORD "CENTAURI" OVER THE WORD "INSURANCE" AND A STAR-LIKE DESIGN. THE TOP POINT OF THE STAR-LIKE DESIGN APPEARS BETWEEN THE "R" AND "I" IN THE WORD "CENTAURI".

FOR ACCIDENT INSURANCE UNDERWRITING, APPRAISALS FOR INSURANCE CLAIMS OF PERSONAL PROPERTY, APPRAISALS FOR INSURANCE CLAIMS OF REAL ESTATE, CLAIMS ADJUSTMENT IN THE FIELD OF INSURANCE, INSURANCE ADMINISTRATION, INSURANCE CLAIMS ADMINISTRATION, INSURANCE CLAIMS PROCESSING, INSURANCE CONSULTATION, INSURANCE PREMIUM RATE COMPUTING, INSURANCE SERVICES IN THE NATURE OF LOSS CONTROL MANAGEMENT FOR OTHERS, INSURANCE SERVICES, NAMELY, WRITING PROPERTY AND CASUALTY INSURANCE, INSURANCE SUBROGATION, INSURANCE FOR SUBROGATION AND SALVAGE, INSURANCE UNDERWRITING CONSULTATION, AND INSURANCE UNDERWRITING SERVICES FOR ALL TYPES OF INSURANCE (U.S. CLS. 100, 101 AND 102).

FIRST USE 9-1-2011; IN COMMERCE 9-1-2011. DAVID COLLIER, EXAMINING ATTORNEY

SN 85-519,187. RIZZI, RON, BALL GROUND, GA. FILED 1-18-2012.

**Turn Your Head Lights On -
Accelerate Brain Tumor
Research**

THE MARK CONSISTS OF STANDARD CHARACTERS WITHOUT CLAIM TO ANY PARTICULAR FONT, STYLE, SIZE, OR COLOR.

NO CLAIM IS MADE TO THE EXCLUSIVE RIGHT TO USE "ACCELERATE BRAIN TUMOR RESEARCH", APART FROM THE MARK AS SHOWN.

FOR CHARITABLE FUNDRAISING SERVICES BY MEANS OF ORGANIZING AND CONDUCTING SPECIAL EVENTS TO ELEVATE AND RAISE AWARENESS THROUGH COMMUNICATION FOR CAUSES FOR THE PURPOSE OF RAISING FUNDS FROM PLEDGES AND DONATIONS OF DRIVERS, RIDERS, AND COMMUTERS THAT ARE COMMUTING AND TRAVELLING REGULARLY CERTAIN DISTANCES TO AND FROM DESTINATIONS CONSISTING OF HOME, WORK, AND SCHOOL, BY AUTOMOBILE AND PUBLIC TRANSPORTATION (U.S. CLS. 100, 101 AND 102).

FIRST USE 1-18-2012; IN COMMERCE 1-18-2012. NAKIA HENRY, EXAMINING ATTORNEY

CLASS 36—(Continued).

SN 85-521,085. STATE FARM MUTUAL AUTOMOBILE INSURANCE COMPANY, BLOOMINGTON, IL. FILED 1-20-2012.

Life Illustrated

THE MARK CONSISTS OF STANDARD CHARACTERS WITHOUT CLAIM TO ANY PARTICULAR FONT, STYLE, SIZE, OR COLOR.

NO CLAIM IS MADE TO THE EXCLUSIVE RIGHT TO USE "LIFE", APART FROM THE MARK AS SHOWN.

FOR INSURANCE UNDERWRITING SERVICES IN THE FIELD OF LIFE INSURANCE (U.S. CLS. 100, 101 AND 102).

FIRST USE 10-5-2011; IN COMMERCE 10-5-2011. SANI KHOURI, EXAMINING ATTORNEY

SN 85-521,637. ALLSTATE INSURANCE COMPANY, NORTHBROOK, IL. FILED 1-20-2012.

ALLSTATE SAVINGS PROTECTOR

THE MARK CONSISTS OF STANDARD CHARACTERS WITHOUT CLAIM TO ANY PARTICULAR FONT, STYLE, SIZE, OR COLOR.

OWNER OF U.S. REG. NOS. 717,683 AND 3,620,568. FOR UNDERWRITING, ISSUANCE AND ADMINISTRATION OF ANNUITIES (U.S. CLS. 100, 101 AND 102). TINA L. SNAPP, EXAMINING ATTORNEY

SN 85-522,844. ALLSTATE INSURANCE COMPANY, NORTHBROOK, IL. FILED 1-23-2012.

ALLSTATE INCOME PROTECTOR

THE MARK CONSISTS OF STANDARD CHARACTERS WITHOUT CLAIM TO ANY PARTICULAR FONT, STYLE, SIZE, OR COLOR.

OWNER OF U.S. REG. NOS. 717,683 AND 3,620,568. FOR UNDERWRITING, ISSUANCE AND ADMINISTRATION OF ANNUITIES (U.S. CLS. 100, 101 AND 102). TINA L. SNAPP, EXAMINING ATTORNEY

CLASS 36—(Continued).

SN 85-523,658. AMERICAN INTERNATIONAL GROUP, INC., NEW YORK, NY. FILED 1-24-2012.

WE'RE NOT ONLY DIFFERENT,
WE'RE MAKING A DIFFERENCE

THE MARK CONSISTS OF STANDARD CHARACTERS WITHOUT CLAIM TO ANY PARTICULAR FONT, STYLE, SIZE, OR COLOR.

FOR INSURANCE UNDERWRITING IN THE FIELD OF MORTGAGE GUARANTY INSURANCE (U.S. CLS. 100, 101 AND 102).

FIRST USE 12-14-2011; IN COMMERCE 12-14-2011.
NANCY CLARKE, EXAMINING ATTORNEY

CLASS 36—(Continued).

SN 85-528,194. BELSITO, JOSEPH, NEW WINDSOR, NY. FILED 1-30-2012.

HEROES MORTGAGE PROGRAM

THE MARK CONSISTS OF STANDARD CHARACTERS WITHOUT CLAIM TO ANY PARTICULAR FONT, STYLE, SIZE, OR COLOR.

NO CLAIM IS MADE TO THE EXCLUSIVE RIGHT TO USE "MORTGAGE PROGRAM", APART FROM THE MARK AS SHOWN.

FOR FINANCIAL SERVICES, NAMELY, OFFERING MEMBERS OF THE EMERGENCY SERVICES COMMUNITY AND OF THE MILITARY ORIGINATION, ACQUISITION, SERVICING, SECURITIZATION AND BROKERAGE OF MORTGAGE LOANS FEATURING DISCOUNTED MORTGAGE FEES AND LOW INTEREST RATES (U.S. CLS. 100, 101 AND 102).

FRANK LATTUCA, EXAMINING ATTORNEY

SN 85-530,009. THINK FINANCE, INC., FT. WORTH, TX. FILED 1-31-2012.

FAIR AND SQUARE

THE MARK CONSISTS OF STANDARD CHARACTERS WITHOUT CLAIM TO ANY PARTICULAR FONT, STYLE, SIZE, OR COLOR.

FOR FINANCIAL SERVICES, NAMELY, PROVIDING SHORT TERM LOANS VIA THE INTERNET, PHONE, AND RETAIL LOCATIONS; CONSULTING SERVICES CONCERNING THE PROVISION OF SHORT TERM LENDING PROGRAMS; STORED-VALUE AND CREDIT CARD SERVICES (U.S. CLS. 100, 101 AND 102).

LIEF MARTIN, EXAMINING ATTORNEY

SN 85-524,102. GLAXO GROUP LIMITED, GREENFORD, MIDDLESEX, UNITED KINGDOM, FILED 1-24-2012.



NO CLAIM IS MADE TO THE EXCLUSIVE RIGHT TO USE THE DESIGN OF THE CADUCEUS SYMBOL, APART FROM THE MARK AS SHOWN.

THE MARK CONSISTS OF THREE TOUCHING CIRCLES OF WHICH THE FIRST AND LAST ARE NOT COMPLETELY CLOSED. THE FIRST CIRCLE CONTAINS AN IMAGE OF TWO HANDS SHAKING. THE MIDDLE CIRCLE CONTAINS AN IMAGE OF THE SCALES OF JUSTICE AND CADUCEUS SYMBOL. THE LAST CIRCLE CONTAINS A DIAMOND SHAPE WITH A DOT AND STEM FORMING AN IMAGE OF A PERSON.

FOR FINANCIAL SERVICES, NAMELY, FUNDING INDEPENDENT MEDICAL EDUCATION PROGRAMS FOR HEALTH CARE PROVIDERS (U.S. CLS. 100, 101 AND 102).

FIRST USE 12-16-2011; IN COMMERCE 12-16-2011.
ELISSA GARBER KON, EXAMINING ATTORNEY

SN 85-543,414. FEDERAL HOME LOAN MORTGAGE CORPORATION, MCLEAN, VA. FILED 2-15-2012.

STACR

THE MARK CONSISTS OF STANDARD CHARACTERS WITHOUT CLAIM TO ANY PARTICULAR FONT, STYLE, SIZE, OR COLOR.

FOR FINANCIAL AND REAL ESTATE SERVICES IN THE FIELD OF MORTGAGE LOANS AND MORTGAGE-BACKED OR MORTGAGE RELATED SECURITIES (U.S. CLS. 100, 101 AND 102).

AMY KELLY, EXAMINING ATTORNEY

CLASS 36—(Continued).

SN 85-544,693. PEOPLES BANK, NATIONAL ASSOCIATION, MARIETTA, OH. FILED 2-16-2012.



OWNER OF U.S. REG. NOS. 3,131,519 AND 3,207,036.
 NO CLAIM IS MADE TO THE EXCLUSIVE RIGHT TO USE "BANK", APART FROM THE MARK AS SHOWN.
 THE MARK CONSISTS OF THE WORDS "PEOPLES BANK" AND AN ARCHED THREE-RIBBON LOGO.
 FOR BANKING SERVICES (U.S. CLS. 100, 101 AND 102).
 JENNY PARK, EXAMINING ATTORNEY

SN 85-554,061. EMMIS RADIO, LLC, INDIANAPOLIS, IN. FILED 2-27-2012.

HIP HOP HAS HEART

THE MARK CONSISTS OF STANDARD CHARACTERS WITHOUT CLAIM TO ANY PARTICULAR FONT, STYLE, SIZE, OR COLOR.
 OWNER OF U.S. REG. NOS. 2,611,930 AND 3,123,677.
 FOR CHARITABLE FUNDRAISING SERVICES (U.S. CLS. 100, 101 AND 102).
 FIRST USE 6-8-2004; IN COMMERCE 6-8-2004.
 MATTHEW PAPPAS, EXAMINING ATTORNEY

SN 85-555,319. BOK FINANCIAL CORPORATION, TULSA, OK. FILED 2-28-2012.

SafeSource

THE MARK CONSISTS OF STANDARD CHARACTERS WITHOUT CLAIM TO ANY PARTICULAR FONT, STYLE, SIZE, OR COLOR.
 FOR FINANCIAL SERVICES, NAMELY, ELECTRONIC REMOTE CHECK AND CASH DEPOSIT SERVICES (U.S. CLS. 100, 101 AND 102).
 CHRISTOPHER BUONGIORNO, EXAMINING ATTORNEY

CLASS 36—(Continued).

SN 85-560,880. TRANSAMERICA CORPORATION, CEDAR RAPIDS, IA. FILED 3-5-2012.

TRANSAMERICA DESTINATIONS

THE MARK CONSISTS OF STANDARD CHARACTERS WITHOUT CLAIM TO ANY PARTICULAR FONT, STYLE, SIZE, OR COLOR.
 FOR LIFE INSURANCE UNDERWRITING (U.S. CLS. 100, 101 AND 102).
 KARANENDRA S. CHHINA, EXAMINING ATTORNEY

SN 85-561,259. NIP GROUP, INC., WOODBRIDGE, NJ. FILED 3-6-2012.

LANDPRO

THE MARK CONSISTS OF STANDARD CHARACTERS WITHOUT CLAIM TO ANY PARTICULAR FONT, STYLE, SIZE, OR COLOR.
 OWNER OF U.S. REG. NO. 2,381,237.
 FOR INSURANCE AGENCIES IN THE FIELD OF LANDSCAPE GARDENING, LAWN CARE AND TREE SERVICES INDUSTRIES; INSURANCE SERVICES, NAMELY, UNDERWRITING, ISSUANCE AND ADMINISTRATION OF LANDSCAPE GARDENING, LAWN CARE AND TREE SERVICES INDUSTRIES; INSURANCE SERVICES, NAMELY, WRITING PROPERTY AND CASUALTY INSURANCE (U.S. CLS. 100, 101 AND 102).
 FIRST USE 7-8-1999; IN COMMERCE 7-8-1999.
 JOHN DALIER, EXAMINING ATTORNEY

SN 85-576,486. NIP GROUP, INC., WOODBRIDGE, NJ. FILED 3-22-2012.

LANDPROTREEPRO

THE MARK CONSISTS OF STANDARD CHARACTERS WITHOUT CLAIM TO ANY PARTICULAR FONT, STYLE, SIZE, OR COLOR.
 FOR INSURANCE AGENCIES IN THE FIELD OF LANDSCAPE GARDENING, LAWN CARE AND TREE SERVICES INDUSTRIES; INSURANCE BROKERAGE IN THE FIELD OF LANDSCAPE GARDENING, LAWN CARE AND TREE SERVICES INDUSTRIES; INSURANCE SERVICES, NAMELY, UNDERWRITING, ISSUANCE AND ADMINISTRATION OF LANDSCAPE GARDENING, LAWN CARE AND TREE SERVICES INDUSTRIES; INSURANCE SERVICES, NAMELY, WRITING PROPERTY AND CASUALTY INSURANCE (U.S. CLS. 100, 101 AND 102).
 FIRST USE 7-8-2001; IN COMMERCE 7-8-2001.
 JOHN DALIER, EXAMINING ATTORNEY

CLASS 36—(Continued).

SN 85-590,567. TEJAS SECURITIES GROUP, INC., AUSTIN, TX. FILED 4-5-2012.

INVEST IN KNOWLEDGE

THE MARK CONSISTS OF STANDARD CHARACTERS WITHOUT CLAIM TO ANY PARTICULAR FONT, STYLE, SIZE, OR COLOR.

NO CLAIM IS MADE TO THE EXCLUSIVE RIGHT TO USE "INVEST", APART FROM THE MARK AS SHOWN.

FOR FINANCIAL SERVICES, NAMELY, SECURITIES INVESTMENT AND FINANCIAL PLANNING (U.S. CLS. 100, 101 AND 102).

FIRST USE 4-20-2000; IN COMMERCE 4-20-2000.

MARLENE BELL, EXAMINING ATTORNEY

CLASS 37—CONSTRUCTION AND REPAIR

SN 79-106,881. NEOGARD KOREA CO., LTD, REPUBLIC OF KOREA, FILED 11-16-2011.

EnerTar

THE MARK CONSISTS OF STANDARD CHARACTERS WITHOUT CLAIM TO ANY PARTICULAR FONT, STYLE, SIZE, OR COLOR.

OWNER OF INTERNATIONAL REGISTRATION 1100849 DATED 11-16-2011, EXPIRES 11-16-2021.

FOR REPAIR OF BUILDINGS; GROUTING SERVICES; INSTALLATION OF HEATING AND AIR CONDITIONING APPARATUS; PAPER HANGING; FLOOR SANDING; PLASTERING; BUILDING SEALING; BUILDING FIREPROOFING, NAMELY, INSTALLING FIREPROOFING INSULATION AND PROTECTIVE COATINGS FOR FIREPROOFING PURPOSES; PLUMBING; OFFICE BUILDING CONSTRUCTION; COMMERCIAL BUILDING CONSTRUCTION; MASONRY SERVICES; ARCADE CONSTRUCTION; APARTMENT CONSTRUCTION; CONSTRUCTION OF TENEMENT HOUSES; PAINTING, INTERIOR AND EXTERIOR; CONSTRUCTION OF HOUSES; CONSTRUCTION OF CONDOMINIUMS; PUMICING; MINING EXTRACTION; QUARRYING SERVICES; HEATING EQUIPMENT INSTALLATION; UPHOLSTERING; KITCHEN EQUIPMENT INSTALLATION (U.S. CLS. 100, 103 AND 106).

ANDREA BUTLER, EXAMINING ATTORNEY

CLASS 37—(Continued).

SN 85-172,103. BRIGGS, SCOTT, SUMTER, SC. FILED 11-9-2010.



NO CLAIM IS MADE TO THE EXCLUSIVE RIGHT TO USE "AIR CONDITIONING HEATING & MECHANICAL SERVICES, LLC", APART FROM THE MARK AS SHOWN.

THE NAME(S), PORTRAIT(S), AND/OR SIGNATURE(S) SHOWN IN THE MARK IDENTIFIES "SCOTT BRIGGS", WHOSE CONSENT(S) TO REGISTER IS MADE OF RECORD.

THE COLOR(S) RED, BLUE AND WHITE IS/ARE CLAIMED AS A FEATURE OF THE MARK.

THE MARK CONSISTS OF THE WORDS "SCOTT BRIGGS" WHICH IS WRITTEN IN BLUE COLOR AND THE WORDS "AIR CONDITIONING-HEATING & MECHANICAL SERVICES, LLC" ARE WRITTEN BELOW THE WORDS "SCOTT BRIGGS" IN RED COLOR. BELOW THE WORDS "AIR CONDITIONING-HEATING & MECHANICAL SERVICES, LLC" THERE IS ONE TRIANGLE IN RED COLOR AND IN THE CENTER OF THE TRIANGLE THERE IS A CIRCLE IN BLUE COLOR WITH WHITE STAR AS SHOWN IN THE MARK.

FOR AIR CONDITIONING INSTALLATION AND REPAIR SERVICES (U.S. CLS. 100, 103 AND 106).

FIRST USE 1-22-2002; IN COMMERCE 3-1-2002.

MARK SPARACINO, EXAMINING ATTORNEY

SN 85-200,493. KATCH KAN LIMITED, EDMONTON, CANADA, FILED 12-17-2010.

KATCH KAN

THE MARK CONSISTS OF STANDARD CHARACTERS WITHOUT CLAIM TO ANY PARTICULAR FONT, STYLE, SIZE, OR COLOR.

OWNER OF CANADA REG. NO. TMA461616, DATED 8-23-1996, RENEWED AS REG. NO. TMA461616, DATED 8-23-2011, EXPIRES 8-23-2026.

FOR OIL RIG AND OIL FIELD CONSTRUCTION SERVICES, NAMELY, ASSEMBLY AND ATTACHMENT OF NON-METAL CONTAINERS FOR INDUSTRIAL USE TO AN OIL RIG TO CAPTURE, FILTER AND RECYCLE DRILLING FLUIDS (U.S. CLS. 100, 103 AND 106).

ELLEN PERKINS, EXAMINING ATTORNEY

CLASS 37—(Continued).

SN 85-275,873. LEE, TIMOTHY, DBA THE PEFECTIONIST HOME SERVICES LLC, PHOENIX, AZ. FILED 3-24-2011.



NO CLAIM IS MADE TO THE EXCLUSIVE RIGHT TO USE "HOME SERVICES", APART FROM THE MARK AS SHOWN.

THE COLOR(S) RED, BLUE, AND GOLD IS/ARE CLAIMED AS A FEATURE OF THE MARK.

THE MARK CONSISTS OF A GOLD CROWN, ABOVE THE WORDING "THE PERFECTIONIST" IN RED AND UNDERLINED IN GOLD, WITH THE WORDING "HOME SERVICES" IN BLUE BELOW THE LINE, AND THE WORDING "PAYS ATTENTION TO DETAIL" IN THE COLOR RED BELOW THAT. THE COLOR WHITE REPRESENTS BACKGROUND OR TRANSPARENT AREAS AND IS NOT PART OF THE MARK.

FOR CARPET AND RUG CLEANING; CARPET CLEANING; CLEANING OF BUILDING EXTERIOR SURFACES; CLEANING OF BUILDINGS; CLEANING OF COMMERCIAL PREMISES; CLEANING OF RESIDENTIAL HOUSES; REAL ESTATE PROPERTY CLEANING, REPAIR AND MAINTENANCE SERVICES; RUG CLEANING; WINDOW CLEANING (U.S. CLS. 100, 103 AND 106).

FIRST USE 10-1-2006; IN COMMERCE 10-1-2006.
SANDRA BUJA, EXAMINING ATTORNEY

SN 85-310,718. THE SILVER STREET GROUP, LLC, PORTLAND, ME. FILED 5-3-2011.

SILVER STREET GROUP

THE MARK CONSISTS OF STANDARD CHARACTERS WITHOUT CLAIM TO ANY PARTICULAR FONT, STYLE, SIZE, OR COLOR.

NO CLAIM IS MADE TO THE EXCLUSIVE RIGHT TO USE "GROUP", APART FROM THE MARK AS SHOWN.

FOR REAL ESTATE DEVELOPMENT (U.S. CLS. 100, 103 AND 106).

FIRST USE 12-31-2008; IN COMMERCE 12-31-2008.
JOHN DWYER, EXAMINING ATTORNEY

CLASS 37—(Continued).

SN 85-310,730. SILVER STREET GROUP, LLC, THE, PORTLAND, ME. FILED 5-3-2011.

SILVER STREET

THE MARK CONSISTS OF STANDARD CHARACTERS WITHOUT CLAIM TO ANY PARTICULAR FONT, STYLE, SIZE, OR COLOR.

FOR REAL ESTATE DEVELOPMENT (U.S. CLS. 100, 103 AND 106).

FIRST USE 12-31-1997; IN COMMERCE 12-31-1997.
JOHN DWYER, EXAMINING ATTORNEY

SN 85-323,471. GREEN EARTH OPTIONS BIOFUEL - USA, MEMPHIS, TN. FILED 5-18-2011.

Green Earth Options Biofuel

THE MARK CONSISTS OF STANDARD CHARACTERS WITHOUT CLAIM TO ANY PARTICULAR FONT, STYLE, SIZE, OR COLOR.

NO CLAIM IS MADE TO THE EXCLUSIVE RIGHT TO USE "BIOFUEL", APART FROM THE MARK AS SHOWN.

FOR RECYCLING SERVICES, NAMELY, COLLECTING USED FAT OR VEGETABLE OIL OR COOKING OIL FOR PURPOSES OF CONVERTING IT TO BIOFUEL OR BLENDING IT WITH PETROLEUM DIESEL TO CREATE BIODIESEL FUEL (U.S. CLS. 100, 103 AND 106).

FIRST USE 2-1-2011; IN COMMERCE 2-1-2011.
CHARLES L. JENKINS, EXAMINING ATTORNEY

SN 85-323,949. ENERGY WELDFAB, INC., WHITE OAK, TX. FILED 5-18-2011.

ENERGY WELDFAB

THE MARK CONSISTS OF STANDARD CHARACTERS WITHOUT CLAIM TO ANY PARTICULAR FONT, STYLE, SIZE, OR COLOR.

NO CLAIM IS MADE TO THE EXCLUSIVE RIGHT TO USE "ENERGY", APART FROM THE MARK AS SHOWN.

FOR APPLICATION OF PROTECTIVE COATINGS; APPLYING PROTECTIVE COATINGS TO OIL AND GAS EQUIPMENT (U.S. CLS. 100, 103 AND 106).

FIRST USE 0-0-1990; IN COMMERCE 0-0-1990.
RAUL CORDOVA, EXAMINING ATTORNEY

CLASS 37—(Continued).

SN 85-323,958. ENERGY WELDFAB, INC., WHITE OAK, TX. FILED 5-18-2011.



NO CLAIM IS MADE TO THE EXCLUSIVE RIGHT TO USE "ENERGY", APART FROM THE MARK AS SHOWN.
 THE MARK CONSISTS OF THE WORD "ENERGY" OVER THE WORD "WELDFAB" AND TO THE RIGHT OF THE WORDS, A FANCIFUL IMAGE OF A WELDING ARC.
 FOR APPLICATION OF PROTECTIVE COATINGS; APPLYING PROTECTIVE COATINGS TO OIL AND GAS EQUIPMENT (U.S. CLS. 100, 103 AND 106).
 FIRST USE 3-0-2011; IN COMMERCE 3-0-2011.
 RAUL CORDOVA, EXAMINING ATTORNEY

SN 85-331,069. BRIGHTERGY, LLC, LENEXA, KS. FILED 5-26-2011.

Brightergy

THE MARK CONSISTS OF STANDARD CHARACTERS WITHOUT CLAIM TO ANY PARTICULAR FONT, STYLE, SIZE, OR COLOR.
 FOR CONSULTING SERVICES IN THE FIELD OF CONSTRUCTION OF WIND ENERGY FACILITIES; INSTALLATION AND MAINTENANCE OF PHOTOVOLTAIC INSTALLATIONS; INSTALLATION AND MAINTENANCE OF PHOTOVOLTAIC/SOLAR THERMAL HYBRID INSTALLATIONS; INSTALLATION AND MAINTENANCE OF SOLAR THERMAL INSTALLATIONS; INSTALLATION OF SOLAR ENERGY SYSTEMS AND ALTERNATIVE ENERGY PRODUCTS FOR RESIDENTIAL AND COMMERCIAL USE (U.S. CLS. 100, 103 AND 106).
 FIRST USE 11-1-2010; IN COMMERCE 11-1-2010.
 STEVEN R. FINE, EXAMINING ATTORNEY

CLASS 37—(Continued).

SN 85-334,007. LEDCOR IP HOLDINGS LTD., VANCOUVER, CANADA, FILED 5-31-2011.



OWNER OF U.S. REG. NOS. 2,078,367, 2,978,366 AND 3,002,518.
 THE MARK CONSISTS OF A GLOBE AND DIAGONALLY-PLACED BANDEROLE CONTAINING THE TEXT "LEDCOR".
 FOR CONSTRUCTION AND CONSTRUCTION MANAGEMENT OF INDUSTRIAL BUILDINGS, COMMERCIAL BUILDINGS, OFFICE BUILDINGS, RETAIL BUILDINGS, MIXED OFFICE AND RETAIL BUILDINGS AND RETAIL AND HIGH RISE RESIDENTIAL APARTMENT BUILDINGS; CONSTRUCTION AND CONSTRUCTION MANAGEMENT OF FIBER OPTIC CABLE SYSTEMS, CABLE DATA TRANSMISSION SYSTEMS, INTERNET, HIGH-SPEED INTERNET AND INTERNET PROTOCOL TELEVISION SYSTEMS, TELEPHONY AND VOICE TRANSMISSION SYSTEMS; CONSTRUCTION AND CONSTRUCTION MANAGEMENT OF ROADS, ROAD BUILDING, ROAD PAVING, GRAVEL CRUSHING, EARTH MOVING; MINING EXTRACTION; CONSTRUCTION OF POWER PLANTS AND POWER FACILITIES; CONSTRUCTION AND CONSTRUCTION MANAGEMENT OF PROCESSING PLANTS AND FACILITIES; CONSTRUCTION AND INSTALLATION OF UNDERGROUND PIPING FOR WATER, UTILITIES, HYDROCARBON AND SEWER, PIPING FOR PLANTS; CONSTRUCTION AND ERECTION OF PRE-BUILT STRUCTURES, EQUIPMENT RIGGING AND LIFTING (U.S. CLS. 100, 103 AND 106).
 FIRST USE 6-30-1983; IN COMMERCE 12-31-1986.
 CARYN GLASSER, EXAMINING ATTORNEY

SN 85-336,588. 350GREEN LLC, LOS ANGELES, CA. FILED 6-2-2011.



NO CLAIM IS MADE TO THE EXCLUSIVE RIGHT TO USE "GREEN", APART FROM THE MARK AS SHOWN.
 THE COLOR(S) SILVER, GREEN AND BLACK IS/ARE CLAIMED AS A FEATURE OF THE MARK.
 THE MARK CONSISTS OF THE LITERAL ELEMENTS

CLASS 37—(Continued).

"350GREEN" OF WHICH "350" IS IN BLACK COLOR AND "GREEN" IS IN GREEN COLOR WHEREIN THE IMAGE CONSISTS OF A METALLIC WHEEL IN SILVER COLOR, BLACK IN COLOR FROM INSIDE, IN THE MIDDLE THERE ARE TWO LEAVES AND STEM IN GREEN COLOR AND TO THE CENTER OF THEM THERE IS A SMALL METALLIC CIRCLE IN SILVER COLOR, THE LITERAL ELEMENTS ARE PLACED AT THE BOTTOM RIGHT CORNER OUTSIDE THE CIRCULAR IMAGE AS SHOWN IN THE MARK.

FOR BUILDING CONSTRUCTION SERVICES RELATING TO THE INSTALLATION OF ELECTRIC CAR CHARGING STATIONS; ELECTRIC VEHICLES BATTERY CHARGING SERVICES FOR ELECTRIC VEHICLE OWNERS (U.S. CLS. 100, 103 AND 106).

FIRST USE 1-2-2009; IN COMMERCE 1-5-2009.
CIMMERIAN COLEMAN, EXAMINING ATTORNEY

SN 85-338,869. SOLAR UNIVERSE, INC., LIVERMORE, CA. FILED 6-6-2011.



OWNER OF U.S. REG. NOS. 3,533,649, 3,563,814 AND OTHERS.

NO CLAIM IS MADE TO THE EXCLUSIVE RIGHT TO USE "NETWORK". APART FROM THE MARK AS SHOWN. THE COLOR(S) ORANGE, TEAL, BLACK AND GRAY IS/ARE CLAIMED AS A FEATURE OF THE MARK.

THE MARK CONSISTS OF THE COLOR ORANGE WHICH APPEARS IN THE WORD "SOLAR"; THE COLOR TEAL APPEARS IN THE WORD "UNIVERSE" AND ON THE SOLAR PANEL, THE COLOR GRAY APPEARS IN THE WORD "NETWORK", AND THE COLOR BLACK APPEARS IN THE GRID LINES ON THE SOLAR PANEL AND IN THE SHADOWING ON THE WORDING "SOLARUNIVERSE" AND "NETWORK" AND IN THE WORDING "THE S.U.N. WORKS FOR EVERYONE".

FOR INSTALLATION AND MAINTENANCE OF PHOTOVOLTAIC AND SOLAR THERMAL SYSTEMS (U.S. CLS. 100, 103 AND 106).

KAPIL BHANOT, EXAMINING ATTORNEY

SN 85-338,878. SOLAR UNIVERSE, INC., LIVERMORE, CA. FILED 6-6-2011.



OWNER OF U.S. REG. NOS. 3,533,649, 3,864,893 AND OTHERS.

THE MARK CONSISTS OF THE WORDS "SOLARUNIVERSE" OVERLAYING AN IMAGE OF A SOLAR PANEL.

FOR INSTALLATION AND MAINTENANCE OF PHOTOVOLTAIC AND SOLAR THERMAL SYSTEMS (U.S. CLS. 100, 103 AND 106).

KAPIL BHANOT, EXAMINING ATTORNEY

CLASS 37—(Continued).

SN 85-355,682. FOUR SEASONS HEATING AND AIR CONDITIONING, INC., CHICAGO, IL. FILED 6-24-2011.

FOR ALL THE RIGHT REASONS

THE MARK CONSISTS OF STANDARD CHARACTERS WITHOUT CLAIM TO ANY PARTICULAR FONT, STYLE, SIZE, OR COLOR.

FOR AIR DUCT CLEANING SERVICES; HEATING EQUIPMENT INSTALLATION AND REPAIR; INSTALLATION AND REPAIR OF AIR CONDITIONING APPARATUS; INSTALLATION AND REPAIR OF HEATING, VENTILATING AND AIR CONDITIONING EQUIPMENT; INSTALLATION AND REPLACEMENT SERVICE FOR HEATING, VENTILATING AND AIR CONDITIONING SYSTEMS; INSTALLATION, REPAIR AND MAINTENANCE OF HEATING EQUIPMENT (U.S. CLS. 100, 103 AND 106).

FIRST USE 1-31-1995; IN COMMERCE 1-31-1995.
LINDA ESTRADA, EXAMINING ATTORNEY

SN 85-363,527. YORDANOPOULOS, BYRON, MISSOURI CITY, TX. FILED 7-5-2011.



THE MARK CONSISTS OF THE TEXT "LEAKWRAP" INSIDE A STYLIZED OVAL IMAGE.

FOR SEALING SERVICES OF LEAKING PIPES AND PIPE JOINTS (U.S. CLS. 100, 103 AND 106).

FIRST USE 10-0-2009; IN COMMERCE 1-0-2011.
TOBY BULLOFF, EXAMINING ATTORNEY

SN 85-364,237. PARKWOODS II NC, LLC, FORT MYERS, FL. FILED 7-6-2011.

ASHEVILLE HIGHLANDS

THE MARK CONSISTS OF STANDARD CHARACTERS WITHOUT CLAIM TO ANY PARTICULAR FONT, STYLE, SIZE, OR COLOR.

NO CLAIM IS MADE TO THE EXCLUSIVE RIGHT TO USE "ASHEVILLE", APART FROM THE MARK AS SHOWN.

FOR REAL ESTATE DEVELOPMENT SERVICES (U.S. CLS. 100, 103 AND 106).

JAMES STEIN, EXAMINING ATTORNEY

CLASS 37—(Continued).

SN 85-412,059. SKURKA AEROSPACE INC., CAMARILLO, CA. FILED 8-31-2011.



OWNER OF U.S. REG. NO. 3,047,649.
NO CLAIM IS MADE TO THE EXCLUSIVE RIGHT TO USE "AIRCRAFT PARTS CORPORATION", APART FROM THE MARK AS SHOWN.

THE MARK CONSISTS OF THE STYLIZED LETTERS "A", "P", "C" WITH AN AIRPLANE DESIGN AND THE WORDING "AIRCRAFT PARTS CORPORATION" TO THE RIGHT OF THE DESIGN.

FOR REPAIR, MAINTENANCE, AND MODIFICATION OF AIRCRAFT ENGINE PARTS, NAMELY, AIRCRAFT STARTER GENERATORS, LINEAR ACTUATORS, MOTORS AND BRUSHES, AND GENERATOR CONTROL UNITS (U.S. CLS. 100, 103 AND 106).

FIRST USE 8-30-1970; IN COMMERCE 8-30-1970.
JENNIFER MARTIN, EXAMINING ATTORNEY

SN 85-428,664. MY GREEN BUILDINGS, LLC, DBA MY-GREENBUILDINGS, SARASOTA, FL. FILED 9-21-2011.



THE COLOR(S) LIGHT GREEN, DARK GREEN, BLACK AND WHITE IS/ARE CLAIMED AS A FEATURE OF THE MARK.

THE MARK CONSISTS OF THE WORDING "MY GREEN BUILDINGS" IN A STYLIZED FONT IN THE COLORS BLACK AND LIGHT GREEN AND A DESIGN THAT CONSISTS OF A LIGHT GREEN HOUSE WITH WHITE DOOR AND CHIMNEY ON A DARKER GREEN BACKGROUND CONTAINED WITHIN A CIRCLE.

FOR GENERAL BUILDING CONTRACTOR SERVICES (U.S. CLS. 100, 103 AND 106).

FIRST USE 9-1-2006; IN COMMERCE 9-1-2006.
RENEE MCCRAY, EXAMINING ATTORNEY

CLASS 37—(Continued).

SN 85-429,118. S & S SERVICES, INC., DBA DAMAGE DOCTORS, MUNCIE, IN. FILED 9-22-2011.



NO CLAIM IS MADE TO THE EXCLUSIVE RIGHT TO USE "DAMAGE", APART FROM THE MARK AS SHOWN.

THE COLOR(S) BLUE, ORANGE, WHITE AND BLACK IS/ARE CLAIMED AS A FEATURE OF THE MARK.

THE MARK CONSISTS OF BLUE CAPITALIZED WORD "DAMAGE", POSITIONED BESIDE A WHITE CROSS WITH BLACK SHADING AROUND THE CROSS, THAT ENCLOSES A SPLIT DROPLET WITH THE TOP PORTION BEING AN ORANGE FLAME AND THE BOTTOM A BLUE WATER DROPLET, BESIDE AN ORANGE CAPITALIZED WORD "DOCTORS", ALL ABOVE THE BLACK WORDS "HOW DAMAGE GETS UNDONE."

FOR BUILDING CONSTRUCTION, REMODELING AND REPAIR; BUILDING RESTORATION; CONSTRUCTION AND RENOVATION OF BUILDINGS; CONSTRUCTION AND REPAIR OF BUILDINGS; CONSTRUCTION, MAINTENANCE AND RENOVATION OF PROPERTY; REAL ESTATE PROPERTY CLEANING, REPAIR AND MAINTENANCE SERVICES; RENOVATION AND RESTORATION OF BUILDINGS; RESTORATION SERVICES IN THE FIELD OF WATER, SMOKE AND FIRE DAMAGE (U.S. CLS. 100, 103 AND 106).

FIRST USE 2-27-2008; IN COMMERCE 2-27-2008.
LUCY ARANT, EXAMINING ATTORNEY

SN 85-432,693. EPIC FORCE, INC., DBA THE HOOD BOSS, NORTH RICHLAND HILLS, TX. FILED 9-27-2011.

The Hood Boss

THE MARK CONSISTS OF STANDARD CHARACTERS WITHOUT CLAIM TO ANY PARTICULAR FONT, STYLE, SIZE, OR COLOR.

FOR KITCHEN EXHAUST CLEANING SERVICES (U.S. CLS. 100, 103 AND 106).

JASON BLAIR, EXAMINING ATTORNEY

SN 85-434,068. DORMAN, TERESA M, MIAMI, FL. FILED 9-28-2011.

Pretty Handy

THE MARK CONSISTS OF STANDARD CHARACTERS WITHOUT CLAIM TO ANY PARTICULAR FONT, STYLE, SIZE, OR COLOR.

FOR HANDYMAN SERVICE, NAMELY, BUILDING REPAIR AND MAINTENANCE (U.S. CLS. 100, 103 AND 106).

FIRST USE 9-15-2011; IN COMMERCE 9-25-2011.
RONALD MCMORROW, EXAMINING ATTORNEY

CLASS 37—(Continued).

SN 85-451,389. VWI/VISTOSO DEVELOPMENT, LLC, TUCSON, AZ. FILED 10-19-2011.

INNOVATION PARK

THE MARK CONSISTS OF STANDARD CHARACTERS WITHOUT CLAIM TO ANY PARTICULAR FONT, STYLE, SIZE, OR COLOR.

NO CLAIM IS MADE TO THE EXCLUSIVE RIGHT TO USE "PARK", APART FROM THE MARK AS SHOWN.

FOR BUILDING OF QUALITY BUSINESS COMMUNITIES AND RETAIL CENTERS; BUILDING OFFICES; REAL ESTATE DEVELOPMENT SERVICES; COMMERCIAL BUILDING CONSTRUCTION; CONSTRUCTION MANAGEMENT; REAL ESTATE SITE SELECTION; REAL ESTATE SITE DEVELOPMENT; OFFICE DEVELOPING SERVICES; DEVELOPMENT OF COMMERCIAL AND RETAIL PROPERTIES; DEVELOPMENT OF MEDICAL, INDUSTRIAL AND OFFICE PARKS; PLANNING AND LAYING OUT OF OFFICE, INDUSTRIAL SPACE AND COMMERCIAL COMMUNITIES (U.S. CLS. 100, 103 AND 106).

FIRST USE 4-1-2007; IN COMMERCE 4-1-2007.
BRIDGETT SMITH, EXAMINING ATTORNEY

SN 85-454,566. STRUCTURAL COATINGS HERTFORD, LLC, CLAYTON, NC. FILED 10-24-2011.

PLATE SHIELD

THE MARK CONSISTS OF STANDARD CHARACTERS WITHOUT CLAIM TO ANY PARTICULAR FONT, STYLE, SIZE, OR COLOR.

FOR APPLICATION OF PROTECTIVE COATINGS TO STEEL AFTER ABRASIVE CLEANING (U.S. CLS. 100, 103 AND 106).

JENNIFER MARTIN, EXAMINING ATTORNEY

SN 85-460,913. CHILTON PROPERTIES, LLC, PHOENIX, AZ. FILED 10-31-2011.

RIDENOW POWERSPORTS

THE MARK CONSISTS OF STANDARD CHARACTERS WITHOUT CLAIM TO ANY PARTICULAR FONT, STYLE, SIZE, OR COLOR.

NO CLAIM IS MADE TO THE EXCLUSIVE RIGHT TO USE "POWERSPORTS", APART FROM THE MARK AS SHOWN.

FOR MAINTENANCE AND REPAIR SERVICES FOR ATVS (ALL TERRAIN VEHICLES), WATERCRAFT, MOTORCYCLES, SCOOTERS, UTILITY VEHICLES, BOATS, TRIKES AND SNOWMOBILES, AND TRAILERS FOR THE FOREGOING (U.S. CLS. 100, 103 AND 106).

FIRST USE 7-7-2006; IN COMMERCE 11-2-2007.
LESLEY LAMOTHE, EXAMINING ATTORNEY

CLASS 37—(Continued).

SN 85-460,920. CHILTON PROPERTIES, LLC, PHOENIX, AZ. FILED 10-31-2011.



NO CLAIM IS MADE TO THE EXCLUSIVE RIGHT TO USE "POWERSPORTS", APART FROM THE MARK AS SHOWN.

THE MARK CONSISTS OF THE STYLIZED WORD "RIDENOW" FEATURING AN ARC DESIGN AROUND THE LETTERS "RID", ABOVE THE WORD "POWERSPORTS". THE WORD "POWERSPORTS" IS CENTERED ON A BLACK BANNER WHICH REPRESENTS BACKGROUND.

FOR MAINTENANCE AND REPAIR SERVICES FOR ATVS (ALL TERRAIN VEHICLES), WATERCRAFT, MOTORCYCLES, SCOOTERS, UTILITY VEHICLES, BOATS, TRIKES AND SNOWMOBILES, AND TRAILERS FOR THE FOREGOING (U.S. CLS. 100, 103 AND 106).

FIRST USE 7-7-2006; IN COMMERCE 11-2-2007.
LESLEY LAMOTHE, EXAMINING ATTORNEY

SN 85-460,969. PETRACARBON PTE LTD, SINGAPORE, SINGAPORE, FILED 10-31-2011.



NO CLAIM IS MADE TO THE EXCLUSIVE RIGHT TO USE "SERVICES INTERNATIONAL", APART FROM THE MARK AS SHOWN.

THE COLOR(S) BLACK, RED AND WHITE IS/ARE CLAIMED AS A FEATURE OF THE MARK.

THE MARK CONSISTS OF A BLACK OVAL WITH THE STYLIZED LETTERS "P", "S", "I" IN THE MIDDLE BELOW A RED SEMI-OVAL WITH THE WORD "PETRACARBON" AND ABOVE A RED SEMI-OVAL WITH THE WORDS "SERVICES INTERNATIONAL", ALL OF THE WORDS AND LETTERS BEING WHITE.

FOR OIL AND GAS PIPELINES INSTALLATION, MAINTENANCE, AND REPAIR SERVICES (U.S. CLS. 100, 103 AND 106).

MIDGE BUTLER, EXAMINING ATTORNEY

CLASS 37—(Continued).

SN 85-461,937. ENCORE SPACE SOLUTIONS INC, EAST DUNDEE, IL. FILED 11-1-2011.



THE MARK CONSISTS OF A CIRCULAR SHAPED SYMBOL MADE UP OF THREE PARTS AND WITH THE LETTER "E" INSIDE. TO THE RIGHT THERE IS THE STYLIZED TEXT "ENCOREGARAGE".

FOR HOUSING SERVICES, NAMELY, REPAIR AND IMPROVEMENT OF GARAGE INTERIORS (U.S. CLS. 100, 103 AND 106).

FIRST USE 1-1-2011; IN COMMERCE 2-1-2011.

COLLEEN KEARNEY, EXAMINING ATTORNEY

SN 85-463,455. RIVER BEND CENTER, LLC, STAMFORD, CT. FILED 11-3-2011.

RIVER BEND CENTER

THE MARK CONSISTS OF STANDARD CHARACTERS WITHOUT CLAIM TO ANY PARTICULAR FONT, STYLE, SIZE, OR COLOR.

NO CLAIM IS MADE TO THE EXCLUSIVE RIGHT TO USE "CENTER", APART FROM THE MARK AS SHOWN.

FOR REAL ESTATE DEVELOPMENT AND CONSTRUCTION OF COMMERCIAL PROPERTY, OFFICES AND OFFICE SPACE (U.S. CLS. 100, 103 AND 106).

JAY BESCH, EXAMINING ATTORNEY

SN 85-476,651. ARTHUR PAUL WHITE, LAKELAND, FL. FILED 11-18-2011.



NO CLAIM IS MADE TO THE EXCLUSIVE RIGHT TO USE "HOMES", APART FROM THE MARK AS SHOWN.

THE COLOR(S) GREEN AND GRAY IS/ARE CLAIMED AS A FEATURE OF THE MARK.

THE MARK CONSISTS OF THE WORD "GREENOVATIVE" WITH "GREEN" IN THE COLOR GREEN AND "OVATIVE" IN GRAY, ABOVE THE WORD "HOMES" IN GREEN, ALL UNDER A STYLIZED OUTLINE OF A GRAY ROOF WITH A GREEN LEAF SUPERIMPOSED OVER IT.

FOR CONSTRUCTION AND RENOVATION OF ENERGY-EFFICIENT HOMES FEATURING HIGH LEVELS OF INSULATION (U.S. CLS. 100, 103 AND 106).

FIRST USE 9-1-2011; IN COMMERCE 9-1-2011.

ALYSSA STEEL, EXAMINING ATTORNEY

CLASS 37—(Continued).

SN 85-486,703. SCHRAMMSON, INC., DBA MIDTOWN SWEEPS, LANCASTER, CA. FILED 12-4-2011.

MIDTOWN SWEEPS

THE MARK CONSISTS OF STANDARD CHARACTERS WITHOUT CLAIM TO ANY PARTICULAR FONT, STYLE, SIZE, OR COLOR.

NO CLAIM IS MADE TO THE EXCLUSIVE RIGHT TO USE "SWEEPS", APART FROM THE MARK AS SHOWN.

FOR CLEANING OF VENTS, DUCTS, AND CHIMNEYS OF ALL TYPES, BOTH COMMERCIAL AND RESIDENTIAL; CONSTRUCTION AND REPAIR OF ALL TYPES OF FIREPLACES; CONSTRUCTION AND REPAIR OF WOOD, PELLET, COAL AND GAS STOVES, FURNACES, CHIMNEY LINERS AND CHIMNEYS; INSTALLATION AND MAINTENANCE OF ALL FIREPLACE, STOVE, CHIMNEY AND HOME HEATING APPLIANCES AND ACCESSORIES (U.S. CLS. 100, 103 AND 106).

FIRST USE 4-16-2007; IN COMMERCE 4-16-2007.

ELI HELLMAN, EXAMINING ATTORNEY

SN 85-495,879. REAL FAST MARINE, LLC, WASHINGTON, NC. FILED 12-15-2011.

REAL FAST MARINE

THE MARK CONSISTS OF STANDARD CHARACTERS WITHOUT CLAIM TO ANY PARTICULAR FONT, STYLE, SIZE, OR COLOR.

NO CLAIM IS MADE TO THE EXCLUSIVE RIGHT TO USE "FAST MARINE", APART FROM THE MARK AS SHOWN.

FOR REPAIR OF BOATS (U.S. CLS. 100, 103 AND 106).

RENEE MCCRAY, EXAMINING ATTORNEY

CLASS 37—(Continued).

SN 85-495,937. TEUCHERT, JOSEPH J, MOORES HILL, IN. FILED 12-15-2011.



NO CLAIM IS MADE TO THE EXCLUSIVE RIGHT TO USE "MRO LTD.", APART FROM THE MARK AS SHOWN. THE COLOR(S) BLUE AND GOLD AND SILVER IS/ARE CLAIMED AS A FEATURE OF THE MARK.

THE MARK CONSISTS OF SPHERICAL REPRESENTATION OF THE EARTH LAND ELEMENTS IN GOLD BLUE EARTH'S OUTLINE, LATITUDINAL AND LONGITUDINAL LINES IN BLUE TWO AIRCRAFT CIRCLING SPHERE IN BLUE ARCS REPRESENTING THE TRAIL OF BOTH AIRCRAFT IN BLUE BELOW THE SPHERE AND AIRCRAFT TRAILS A SHADOW OF THE SPHERE IN SILVER "TEAMAIR MRO LTD." IN BLUE "KEEPING AIRCRAFT IN MOTION..." IN GOLD.

FOR REPAIR, MAINTENANCE AND MODIFICATION OF AIRCRAFT (U.S. CLS. 100, 103 AND 106). FIRST USE 12-12-2011; IN COMMERCE 12-12-2011. COLLEEN KEARNEY, EXAMINING ATTORNEY

SN 85-496,826. PRESTIGE INVESTMENT GROUP, LLC, CLARKSVILLE, TN. FILED 12-15-2011.



NO CLAIM IS MADE TO THE EXCLUSIVE RIGHT TO USE "INVESTMENT GROUP", APART FROM THE MARK AS SHOWN.

THE COLOR(S) KENTUCKY BLUE, GRAY, SILVER, WHITE IS/ARE CLAIMED AS A FEATURE OF THE MARK. THE MARK CONSISTS OF A GRAY AND SILVER SHIELD ON THE LEFT SIDE WITH THE LETTER "P" IN KENTUCKY BLUE. THERE IS A BLUE VERTICAL LINE BETWEEN THE SHIELD AND THE WORDS "PRESTIGE INVESTMENT GROUP". THE WORDS ARE IN KENTUCKY BLUE. "PRESTIGE" IS IN LARGE, ALL CAPITAL LETTERS AND THE WORDS "INVESTMENT GROUP" APPEAR UNDERNEATH THE WORD "PRESTIGE". THE BACKGROUND IS IN WHITE.

FOR CONSTRUCTION SERVICES, NAMELY, THE PLANNING, LAYING OUT AND CUSTOM CONSTRUCTION OF RESIDENTIAL BUILDINGS; REAL ESTATE DEVELOPMENT AND CONSTRUCTION OF COMMERCIAL, RESIDENTIAL AND HOTEL PROPERTY (U.S. CLS. 100, 103 AND 106). FLORENTINA BLANDU, EXAMINING ATTORNEY

CLASS 37—(Continued).

SN 85-500,625. INDIAN VALLEY PEST CONTROL, SOUTHERTON, PA. FILED 12-21-2011.

Indian Valley Pest Control

THE MARK CONSISTS OF STANDARD CHARACTERS WITHOUT CLAIM TO ANY PARTICULAR FONT, STYLE, SIZE, OR COLOR.

NO CLAIM IS MADE TO THE EXCLUSIVE RIGHT TO USE "PEST CONTROL", APART FROM THE MARK AS SHOWN.

FOR PEST CONTROL (U.S. CLS. 100, 103 AND 106). FIRST USE 4-2-2001; IN COMMERCE 4-2-2001. YAT SYE, LEE, EXAMINING ATTORNEY

SN 85-504,476. HOLLENBECK, JAMES C, NEW WINDSOR, NY. FILED 12-27-2011.

Hollenbeck your local pest control company, Home of the no annual price increases on maintenance agreements guaranteed

THE MARK CONSISTS OF STANDARD CHARACTERS WITHOUT CLAIM TO ANY PARTICULAR FONT, STYLE, SIZE, OR COLOR.

FOR TERMITE AND PEST CONTROL (U.S. CLS. 100, 103 AND 106).

FIRST USE 8-16-2010; IN COMMERCE 8-16-2010. CHRISTOPHER BUONGIORNO, EXAMINING ATTORNEY

SN 85-507,128. CALBRIDGE (2010) LTD., CALGARY, ALBERTA, CANADA, FILED 1-2-2012.

RIGHT SIZE. RIGHT FIT.

THE MARK CONSISTS OF STANDARD CHARACTERS WITHOUT CLAIM TO ANY PARTICULAR FONT, STYLE, SIZE, OR COLOR.

FOR CONSTRUCTION OF NEW HOMES; LAND DEVELOPMENT SERVICES, NAMELY, PLANNING AND LAYING OUT OF RESIDENTIAL COMMUNITIES; RENOVATION IN THE FIELD OF RESIDENTIAL HOUSES (U.S. CLS. 100, 103 AND 106). DAVID YONTEF, EXAMINING ATTORNEY

CLASS 37—(Continued).

SN 85-507,698. HOME INJURY PREVENTION SERVICES, INC., NEW YORK, NY. FILED 1-3-2012.



NO CLAIM IS MADE TO THE EXCLUSIVE RIGHT TO USE "HOME INJURY PREVENTION SERVICES", APART FROM THE MARK AS SHOWN.

THE MARK CONSISTS OF THE LETTERS "IPS" TO THE RIGHT OF THE LETTER "H" IN A DIAMOND SHAPE WITH THE WORDING "HOME INJURY PREVENTION SERVICES" UNDER "HIPS".

FOR REPAIR, MAINTENANCE CONSTRUCTION AND MODIFICATION OF BUILDINGS AND HOMES FOR SAFETY, MOBILITY AND ACCESSIBILITY (U.S. CLS. 100, 103 AND 106).

JOHN HWANG, EXAMINING ATTORNEY

CLASS 37—(Continued).

SN 85-507,923. VICTOR BONAVITA, NORTH MASSAPEQUA, NY. FILED 1-3-2012.

BATTLE A BUG

THE MARK CONSISTS OF STANDARD CHARACTERS WITHOUT CLAIM TO ANY PARTICULAR FONT, STYLE, SIZE, OR COLOR.

FOR EXTERMINATING SERVICES; EXTERMINATING CONSULTATION; TERMITE CONTROL SERVICES; PEST AND INSECT CONTROL SERVICES; PEST MANAGEMENT; INSECT SPRAYING AND FOGGING; VERMIN EXTERMINATING, OTHER THAN FOR AGRICULTURE; PEST AND INSECT INSPECTION SERVICES; ANIMAL AND WILDLIFE CONTROL MANAGEMENT SERVICES, NAMELY, THE CONTROL, CAPTURING, AND TRAPPING OF NUISANCE WILDLIFE AND PESTS IN HOMES, BUSINESSES AND OTHER RESIDENTIAL AND COMMERCIAL PROPERTIES (U.S. CLS. 100, 103 AND 106).

JOHN HWANG, EXAMINING ATTORNEY

SN 85-507,856. BLUEWATER TECHNOLOGIES, INC., NEWPORT, RI. FILED 1-3-2012.

BLUEWATERTECHNOLOGIES

THE MARK CONSISTS OF STANDARD CHARACTERS WITHOUT CLAIM TO ANY PARTICULAR FONT, STYLE, SIZE, OR COLOR.

FOR PROVIDING CUSTOM SOLUTIONS FOR MARINE ELECTRONICS TECHNOLOGY, NAMELY, INSTALLATION OF PERSONAL COMPUTER BASED NAVIGATION SYSTEMS, PERSONAL USE COMPUTER SYSTEMS, ONBOARD NETWORKING, AUDIO VISUAL ENTERTAINMENT SYSTEMS, MONITORING CONTROL AND SATELLITE COMMUNICATIONS FOR MARINE VESSELS (U.S. CLS. 100, 103 AND 106).

FIRST USE 8-1-2008; IN COMMERCE 8-1-2008.

C. DIONNE CLYBURN, EXAMINING ATTORNEY

SN 85-507,954. PAINTING BY JOHN, L.L.C., GRAYSLAKE, IL. FILED 1-3-2012.



THE COLOR(S) RED, BLACK AND WHITE IS/ARE CLAIMED AS A FEATURE OF THE MARK.

THE MARK CONSISTS OF A STYLIZED PAINT ROLLER IN A PAINT TRAY. THE COLORS BLACK AND RED APPEAR IN THE APPLICATOR OF THE PAINT ROLLER. THE COLORS BLACK AND WHITE APPEAR IN THE PAINT TRAY.

FOR PAINTING (U.S. CLS. 100, 103 AND 106).

FIRST USE 12-1-2002; IN COMMERCE 12-1-2002.

MATTHEW KLINE, EXAMINING ATTORNEY

CLASS 37—(Continued).

SN 85-508,712. ROYAL PAVING STONES INC., SAN PEDRO, CA. FILED 1-4-2012.

ROYAL PAVING STONES INC.

THE MARK CONSISTS OF STANDARD CHARACTERS WITHOUT CLAIM TO ANY PARTICULAR FONT, STYLE, SIZE, OR COLOR.

NO CLAIM IS MADE TO THE EXCLUSIVE RIGHT TO USE "PAVING STONES INC.", APART FROM THE MARK AS SHOWN.

FOR BRICK PAVING SERVICES; BUILDING CONSTRUCTION, REMODELING AND REPAIR; CEMENT PARGING OF INTERIOR AND EXTERIOR STONE BLOCK AND CONCRETE FOUNDATIONS; CONSTRUCTION GRADING SERVICES; CONSTRUCTION OF BUILDINGS; CONSTRUCTION OF ROADS, UNDERGROUND UTILITIES, AND HOUSING PADS; CONSTRUCTION OF DRIVEWAYS, PATIOS, POOL DECKS, WALKWAYS, PORCHES; CONSTRUCTION PLANNING; CONSTRUCTION SERVICES, NAMELY, CONCRETE PAVING, SITE CLEARING, EXCAVATION, PAD PREPARATION, GRADING, AND ASPHALT PAVING SERVICES; CONSULTING SERVICES FOR THE CONSTRUCTION AND INSTALLATION OF MASONRY WALLS AND STRUCTURES; GENERAL CONSTRUCTION CONTRACTING; GENERAL CONTRACTING SERVICES IN THE FIELD OF FLOORING; NATURAL STONE AND TILE RESTORATION SERVICES; PAVING CONTRACTOR SERVICES (U.S. CLS. 100, 103 AND 106).
FIRST USE 4-11-2005; IN COMMERCE 9-13-2006.
RENEE MCCRAY, EXAMINING ATTORNEY

SN 85-508,894. ROYAL PAVING STONES INC., SAN PEDRO, CA. FILED 1-4-2012.



NO CLAIM IS MADE TO THE EXCLUSIVE RIGHT TO USE "PAVING STONES INC.", APART FROM THE MARK AS SHOWN.

THE COLOR(S) BLUE, BLACK, WHITE, AND YELLOW IS/ ARE CLAIMED AS A FEATURE OF THE MARK.

THE MARK CONSISTS OF A YELLOW CROWN WITH A BLACK OUTLINE; THE CROWN HAS FIVE POINTS THAT

CLASS 37—(Continued).

ARE TOPPED BY GOLD CIRCLES WITH BLACK OUTLINE; THE LOWER PORTION OF THE CROWN IS A YELLOW CROSS HATCH WEAVE PATTERN WITH WHITE LINES; A WHITE GLARE LINE LATERAL BISECTS THE CROWN; BELOW THE CROWN ARE THE WORDS "ROYAL PAVING" IN SOLID BLUE LETTERS; BELOW "ROYAL PAVING" IS THE WORDS " STONES INC.", WHICH ARE BLUE AND LARGER THAN "ROYAL PAVING"; A THIN WHITE LINE RUNS HORIZONTALLY THROUGH THE MIDDLE OF ALL OF THE WORDS.

FOR BRICK PAVING SERVICES; BUILDING CONSTRUCTION, REMODELING AND REPAIR; CEMENT PARGING OF INTERIOR AND EXTERIOR STONE BLOCK AND CONCRETE FOUNDATIONS; CONSTRUCTION GRADING SERVICES; CONSTRUCTION OF BUILDINGS; CONSTRUCTION OF ROADS, UNDERGROUND UTILITIES, AND HOUSING PADS; CONSTRUCTION OF DRIVEWAYS, PATIOS, POOL DECKS, WALKWAYS, PORCHES; CONSTRUCTION PLANNING; CONSTRUCTION SERVICES, NAMELY, CONCRETE PAVING, SITE CLEARING, EXCAVATION, PAD PREPARATION, GRADING, AND ASPHALT PAVING SERVICES; CONSULTING SERVICES FOR THE CONSTRUCTION AND INSTALLATION OF MASONRY WALLS AND STRUCTURES; GENERAL CONSTRUCTION CONTRACTING; GENERAL CONTRACTING SERVICES IN THE FIELD OF FLOORING; NATURAL STONE AND TILE RESTORATION SERVICES; PAVING CONTRACTOR SERVICES (U.S. CLS. 100, 103 AND 106).
FIRST USE 4-11-2005; IN COMMERCE 9-13-2006.
RENEE MCCRAY, EXAMINING ATTORNEY

SN 85-509,613. RESICOM CUSTOM PAINTING & MAINTENANCE, INC., LEMONT, IL. FILED 1-5-2012.

**BOLD PURSUIT OF WHAT
NORMAL COULD BE**

THE MARK CONSISTS OF STANDARD CHARACTERS WITHOUT CLAIM TO ANY PARTICULAR FONT, STYLE, SIZE, OR COLOR.

FOR BUILDING CONSTRUCTION, PAINTING, BUILDING RENOVATION, BUILDING MAINTENANCE AND REPAIR, AND CONSULTING SERVICES RELATED THERETO; CONSULTING SERVICES RELATING TO THE DEVELOPMENT AND IMPLEMENTATION OF MAINTENANCE PROCEDURES FOR RETAIL AND COMMERCIAL REAL ESTATE PROPERTIES (U.S. CLS. 100, 103 AND 106).

FIRST USE 2-0-2010; IN COMMERCE 2-0-2010.
HENRY S. ZAK, EXAMINING ATTORNEY

CLASS 37—(Continued).

SN 85-509,621. RESICOM CUSTOM PAINTING & MAINTENANCE, INC., LEMONT, IL. FILED 1-5-2012.

REDEFINING NORMAL

THE MARK CONSISTS OF STANDARD CHARACTERS WITHOUT CLAIM TO ANY PARTICULAR FONT, STYLE, SIZE, OR COLOR.

FOR BUILDING CONSTRUCTION, PAINTING, BUILDING RENOVATION, BUILDING MAINTENANCE AND REPAIR, AND CONSULTING SERVICES RELATED THERETO; CONSULTING SERVICES RELATING TO THE DEVELOPMENT AND IMPLEMENTATION OF MAINTENANCE PROCEDURES FOR RETAIL AND COMMERCIAL REAL ESTATE PROPERTIES (U.S. CLS. 100, 103 AND 106).

FIRST USE 2-0-2010; IN COMMERCE 2-0-2010.
HENRY S. ZAK, EXAMINING ATTORNEY

CLASS 37—(Continued).

SN 85-510,093. PAUL HEMMER COMPANY, FORT MITCHELL, KY. FILED 1-6-2012.



OWNER OF U.S. REG. NOS. 2,622,902, 3,281,962 AND 3,369,441.

THE MARK CONSISTS OF THE WORD "HEMMER" WITH THREE GRADUATED BARS ABOVE EACH LETTER AND THE WORDS "YOUR BUILDING PARTNER".

FOR INDUSTRIAL AND COMMERCIAL BUILDING CONSTRUCTION SERVICES AND REAL ESTATE DEVELOPMENT (U.S. CLS. 100, 103 AND 106).

FIRST USE 6-30-2006; IN COMMERCE 6-30-2006.
THOMAS MANOR, EXAMINING ATTORNEY

SN 85-509,843. BRITE NITES, INC., SANDY, UT. FILED 1-5-2012.

BRITE NITES

THE MARK CONSISTS OF STANDARD CHARACTERS WITHOUT CLAIM TO ANY PARTICULAR FONT, STYLE, SIZE, OR COLOR.

FOR ELECTRICAL REPAIRS, MAINTENANCE, AND INSTALLATION OF ELECTRICAL WIRING, OUTLETS, LIGHT FIXTURES, AND ELECTRICAL PANELS; INSTALLATION AND MAINTENANCE OF INTERIOR AND EXTERIOR CUSTOM SEASONAL DECORATIONS FOR OTHERS; INSTALLATION, MAINTENANCE, AND REMOVAL OF INTERIOR AND EXTERIOR CUSTOM SEASONAL DECORATIONS FOR OTHERS; RENTAL AND LEASING OF LIGHTING APPARATUS AND LIGHTING SYSTEMS FOR USE IN MUNICIPALITY LIGHTING AND PUBLIC EVENTS; REPAIR OR MAINTENANCE OF ELECTRIC LIGHTING APPARATUS; TECHNICAL CONSULTATION IN THE FIELD OF INSTALLATION OF LIGHTING APPARATUS, LIGHTING INSTRUMENTS AND LIGHTING SYSTEMS (U.S. CLS. 100, 103 AND 106).

FIRST USE 3-4-1997; IN COMMERCE 3-4-1997.
WILLIAM ROSSMAN, EXAMINING ATTORNEY



THE COLOR(S) RED IS/ARE CLAIMED AS A FEATURE OF THE MARK.

THE MARK CONSISTS OF THE LETTERS "OOO" IN RED CAPITAL LETTERS THAT ARE TOUCHING EACH OTHER AND HAVE A LINE RUNNING THROUGH THE MIDDLE OF THE LETTERS "OOO" WHICH EXTENDS PAST THE THIRD "O" AND THEN EXPANDS A LITTLE AND TURNS IN A DOWNWARD DIRECTION.

FOR FREEZING EQUIPMENT INSTALLATION AND REPAIR; FURNACE INSTALLATION AND REPAIR; GENERAL CONTRACTOR SERVICES, NAMELY, PLUMBING, HEATING AND AIR CONDITIONING, CARPENTRY, DRYWALL, PAINTING, ELECTRICAL, BUILDING AND FRAMING CONTRACTOR SERVICES; HEATING EQUIPMENT INSTALLATION AND REPAIR; INSTALLATION AND REPAIR OF AIR CONDITIONING APPARATUS; INSTALLATION AND REPAIR OF FREEZING APPARATUS; INSTALLATION AND REPAIR OF HEATING, VENTILATING AND AIR CONDITIONING EQUIPMENT; INSTALLATION AND REPLACEMENT SERVICE FOR HEATING, VENTILATING AND AIR CONDITIONING SYSTEMS; INSTALLATION, MAINTENANCE AND REPAIR OF REFRIGERATION; INSTALLATION, REPAIR AND MAINTENANCE OF HEATING EQUIPMENT (U.S. CLS. 100, 103 AND 106).

FIRST USE 1-1-2003; IN COMMERCE 1-1-2003.
MATTHEW KLINE, EXAMINING ATTORNEY

CLASS 37—(Continued).

SN 85-510,950. SMITH'S ALARMS & ELECTRONICS, INC., NIPOMO, CA. FILED 1-6-2012.

Keeping it Local

THE MARK CONSISTS OF STANDARD CHARACTERS WITHOUT CLAIM TO ANY PARTICULAR FONT, STYLE, SIZE, OR COLOR.

FOR ELECTRICAL CONTRACTING; INSTALLATION AND MAINTENANCE OF SECURITY ALARMS, FIRE ALARMS, BURGLAR ALARMS, SURVEILLANCE SYSTEMS, WIRING, HOME THEATER SYSTEMS, INTERCOMS, CENTRAL VACUUMS, LIGHTING CONTROLS, ACCESS CONTROLS, MONITORING SYSTEMS, AND NETWORK CABLING; LAYING OF CABLE (U.S. CLS. 100, 103 AND 106).

FIRST USE 11-16-2011; IN COMMERCE 11-16-2011.
JULIE WATSON, EXAMINING ATTORNEY

SN 85-511,523. TURFIX, LLC, ST. JOSEPH, MI. FILED 1-9-2012.

TURFIX

THE MARK CONSISTS OF STANDARD CHARACTERS WITHOUT CLAIM TO ANY PARTICULAR FONT, STYLE, SIZE, OR COLOR.

FOR INSTALLATION, MAINTENANCE AND REPAIR OF SYNTHETIC TURF (U.S. CLS. 100, 103 AND 106).

FIRST USE 11-30-2009; IN COMMERCE 12-14-2011.
CHRISTINE MARTIN, EXAMINING ATTORNEY

SN 85-511,613. MAID BRIGADE, INC., ATLANTA, GA. FILED 1-9-2012.

MAID SIMPLE HOUSE CLEANING

THE MARK CONSISTS OF STANDARD CHARACTERS WITHOUT CLAIM TO ANY PARTICULAR FONT, STYLE, SIZE, OR COLOR.

NO CLAIM IS MADE TO THE EXCLUSIVE RIGHT TO USE "HOUSE CLEANING", APART FROM THE MARK AS SHOWN.

FOR CLEANING OF RESIDENTIAL HOUSES (U.S. CLS. 100, 103 AND 106).

JOHN DALIER, EXAMINING ATTORNEY

CLASS 37—(Continued).

SN 85-511,641. DOUBLE D. BUILDERS ROOFING, SIDING, AND GUTTERS, LLC, EVANSVILLE, WI. FILED 1-9-2012.

DOUBLE D BUILDERS

THE MARK CONSISTS OF STANDARD CHARACTERS WITHOUT CLAIM TO ANY PARTICULAR FONT, STYLE, SIZE, OR COLOR.

NO CLAIM IS MADE TO THE EXCLUSIVE RIGHT TO USE "BUILDERS", APART FROM THE MARK AS SHOWN.

FOR GENERAL CONSTRUCTION CONTRACTING; RENOVATION OF BUILDINGS; BUILDING CONSTRUCTION SERVICES, NAMELY RESTORATION AND REPAIR OF ROOFING, SIDING, GUTTERS, WINDOWS, AND FLOORING (U.S. CLS. 100, 103 AND 106).

FIRST USE 0-0-2002; IN COMMERCE 0-0-2002.
BARBARA GAYNOR, EXAMINING ATTORNEY

SN 85-511,651. DOUBLE D. BUILDERS ROOFING, SIDING, AND GUTTERS, LLC, EVANSVILLE, WI. FILED 1-9-2012.



NO CLAIM IS MADE TO THE EXCLUSIVE RIGHT TO USE "BUILDERS", APART FROM THE MARK AS SHOWN.

THE MARK CONSISTS OF AN ANGLED LINE WHICH CONTINUES INTO A HORIZONTAL LINE TO SIMULATE A ROOF TOP; BELOW IS THE WORD "DOUBLE" AND A LETTER "D" WITH THE WORD "BUILDERS" UNDERNEATH, AND TO THE LEFT UNDER THE ANGLE IS A SQUARE WITH A LETTER "D" TILTED TO THE RIGHT LYING ON THE UPPER RIGHT CORNER AND A LETTER "D" TILTED TO THE LEFT LYING ON THE LOWER LEFT CORNER.

FOR GENERAL CONSTRUCTION CONTRACTING; RENOVATION OF BUILDINGS; BUILDING CONSTRUCTION SERVICES, NAMELY, RESTORATION AND REPAIR OF ROOFING, SIDING, GUTTERS, WINDOWS, AND FLOORING (U.S. CLS. 100, 103 AND 106).

FIRST USE 8-0-2009; IN COMMERCE 8-0-2009.
BARBARA GAYNOR, EXAMINING ATTORNEY

CLASS 37—(Continued).

SN 85-511,913. GOFrac, LLC, FORT WORTH, TX. FILED 1-9-2012.



THE COLOR(S) ORANGE, BLUE AND BLACK IS/ARE CLAIMED AS A FEATURE OF THE MARK.

THE MARK CONSISTS OF A 2-DIMENSIONAL ORANGE DIAMOND OF GREATER LENGTH THAN HEIGHT WITH THE WORD "GOFrac" WRITTEN IN BLACK IN THE MIDDLE OF THE DIAMOND, ALL OUTLINED WITH A BLACK LINE ON THE OUTSIDE AND A BLUE LINE IMMEDIATELY INTERIOR TO THE BLACK LINE.

FOR WELL IMPROVEMENT SERVICES, NAMELY, HYDRAULIC FRACTURING OF SUBSURFACE GEOLOGIC FORMATIONS TO ENHANCE WELL PRODUCTION (U.S. CLS. 100, 103 AND 106).

FIRST USE 7-1-2011; IN COMMERCE 8-26-2011.
AMEEN IMAM, EXAMINING ATTORNEY

CLASS 37—(Continued).

SN 85-512,319. IAN FOSTER, DBA IAN FOSTER, NOME, UT. FILED 1-9-2012.



THE MARK CONSISTS OF "SLUICEY" IN ITALICS WITH THE 'Y' UNDERLINING THE PREVIOUS LETTERS IN A SWEEPING FASHION.

FOR DREDGING; UNDERWATER DREDGING (U.S. CLS. 100, 103 AND 106).

FIRST USE 7-6-2011; IN COMMERCE 7-6-2011.
TASHIA BUNCH, EXAMINING ATTORNEY

SN 85-512,207. MOJO ENTERPRISES I, INC., DBA MOJO'S FULL SERVICE CAR WASH & DETAIL CENTER, OMAHA, NE. FILED 1-9-2012.



NO CLAIM IS MADE TO THE EXCLUSIVE RIGHT TO USE "FULL SERVICE CAR WASH & DETAIL CENTER", APART FROM THE MARK AS SHOWN.

THE MARK CONSISTS OF THE WORDS "MOJO'S FULL SERVICE CAR WASH & DETAIL CENTER" IN A UNIQUE DESIGN SURROUNDING AN ORIGINAL CARTOON DOG CHARACTER.

FOR AUTOMOBILE CLEANING AND CAR WASHING; AUTOMOBILE DETAILING; CAR WASHING; VEHICLE DETAILING (U.S. CLS. 100, 103 AND 106).

DAVID MURRAY, EXAMINING ATTORNEY

SN 85-512,760. MAR COR PURIFICATION, INC., SKIPPACK, PA. FILED 1-10-2012.

MICROFREE

THE MARK CONSISTS OF STANDARD CHARACTERS WITHOUT CLAIM TO ANY PARTICULAR FONT, STYLE, SIZE, OR COLOR.

FOR INSTALLATION AND MAINTENANCE OF PURE WATER DISTRIBUTION SYSTEMS COMPRISED OF PLASTIC POLYTETRAFLUOROETHYLENE TUBING FOR USE IN DIALYSIS AND OTHER MEDICAL APPLICATIONS (U.S. CLS. 100, 103 AND 106).

AMY KELLY, EXAMINING ATTORNEY

CLASS 37—(Continued).

SN 85-513,441. ACTON CONSTRUCTION, INC., CAMPBELL, CA. FILED 1-10-2012.

Great Design, Peace of Mind

THE MARK CONSISTS OF STANDARD CHARACTERS WITHOUT CLAIM TO ANY PARTICULAR FONT, STYLE, SIZE, OR COLOR.

FOR BUILDING CONSTRUCTION; BUILDING CONSTRUCTION AND REPAIR; BUILDING CONSTRUCTION SERVICES; BUILDING CONSTRUCTION SUPERVISION; BUILDING CONSTRUCTION, REMODELING AND REPAIR; CONSTRUCTION AND RENOVATION OF BUILDINGS; CONSTRUCTION AND REPAIR OF BUILDINGS; CONSTRUCTION CONSULTATION; CONSTRUCTION MANAGEMENT; CONSTRUCTION OF BUILDINGS; CONSTRUCTION PLANNING; CONSTRUCTION PROJECT MANAGEMENT SERVICES; CONSTRUCTION SUPERVISION; CONSTRUCTION, MAINTENANCE AND RENOVATION OF PROPERTY; CONSULTATION SERVICES IN THE FIELD OF CONSTRUCTION OF ENVIRONMENTALLY-CONSCIOUS BUILDINGS; CONSULTING IN THE FIELD OF BUILDING CONSTRUCTION; CUSTOM CONSTRUCTION AND BUILDING RENOVATION; CUSTOM CONSTRUCTION OF HOMES; GENERAL CONSTRUCTION CONTRACTING; REMODELING OF BUILDINGS; RESIDENTIAL AND BUILDING CONSTRUCTION CONSULTING; RESIDENTIAL AND COMMERCIAL BUILDING CONSTRUCTION; SELF-PERFORM CONSTRUCTION SKILLED TRADES, NAMELY, CONCRETE WORK, CARPENTRY AND SELECTIVE DEMOLITION SERVICES (U.S. CLS. 100, 103 AND 106).
FIRST USE 1-8-2012; IN COMMERCE 1-8-2012.
JAY FLOWERS, EXAMINING ATTORNEY

CLASS 37—(Continued).

SN 85-514,231. TOWNE HOLDINGS, INC., ANNAPOLIS, MD. FILED 1-11-2012.



THE COLOR(S) BLUE AND WHITE IS/ARE CLAIMED AS A FEATURE OF THE MARK.

THE MARK CONSISTS OF A STYLIZED, BLUE ELECTRIC CORD AND PLUG, SUPERIMPOSED OVER A STYLIZED WHITE LETTER P, IN A BLUE SQUARE.
FOR CHARGING STATION SERVICES FOR ELECTRIC VEHICLES (U.S. CLS. 100, 103 AND 106).
LINDSEY RUBIN, EXAMINING ATTORNEY

SN 85-513,725. ILUMINATE, LLC, HOUSTON, TX. FILED 1-11-2012.

ILUMINATE

THE MARK CONSISTS OF STANDARD CHARACTERS WITHOUT CLAIM TO ANY PARTICULAR FONT, STYLE, SIZE, OR COLOR.

FOR RENTAL AND LEASING OF LIGHTING APPARATUS, LIGHTING INSTRUMENTS AND LIGHTING SYSTEMS FOR USE IN DANCE AND MUSICAL PERFORMANCES; TECHNICAL CONSULTATION IN THE FIELD OF INSTALLATION AND USE OF LIGHTING APPARATUS, LIGHTING INSTRUMENTS AND LIGHTING SYSTEMS IN DANCE AND MUSICAL PERFORMANCES (U.S. CLS. 100, 103 AND 106).
FIRST USE 2-28-2010; IN COMMERCE 6-7-2010.
JAY FLOWERS, EXAMINING ATTORNEY

SN 85-514,833. DIXIE DENT, INC., CENTERVILLE, TN. FILED 1-12-2012.

DIXIE DENT

THE MARK CONSISTS OF STANDARD CHARACTERS WITHOUT CLAIM TO ANY PARTICULAR FONT, STYLE, SIZE, OR COLOR.

NO CLAIM IS MADE TO THE EXCLUSIVE RIGHT TO USE "DENT", APART FROM THE MARK AS SHOWN.
FOR PAINTLESS DENT REPAIR SERVICES FOR MOTOR VEHICLES (U.S. CLS. 100, 103 AND 106).
FIRST USE 8-1-1995; IN COMMERCE 8-1-1996.
MICHAEL TANNER, EXAMINING ATTORNEY

CLASS 37—(Continued).

SN 85-515,653. REYNOLDS PLUMBING, INC., FREDERICKSBURG, VA. FILED 1-13-2012.



THE MARK CONSISTS OF THE REPRESENTATION OF A PERSON FORMED BY TWO INTERTWINED PIPES AND A DROP OF WATER.
FOR PLUMBING SERVICES (U.S. CLS. 100, 103 AND 106).
FIRST USE 4-30-2011; IN COMMERCE 4-30-2011.
ALAIN LAPTEK, EXAMINING ATTORNEY

SN 85-515,655. REYNOLDS PLUMBING, INC., FREDERICKSBURG, VA. FILED 1-13-2012.

WATER YOU WAITING FOR?

THE MARK CONSISTS OF STANDARD CHARACTERS WITHOUT CLAIM TO ANY PARTICULAR FONT, STYLE, SIZE, OR COLOR.
FOR PLUMBING SERVICES (U.S. CLS. 100, 103 AND 106).
FIRST USE 4-30-2011; IN COMMERCE 4-30-2011.
ALAIN LAPTEK, EXAMINING ATTORNEY

CLASS 37—(Continued).

SN 85-515,963. MICAN PROPERTIES LLC, SUWANEE, GA. FILED 1-13-2012.



NO CLAIM IS MADE TO THE EXCLUSIVE RIGHT TO USE "CAR WASH", APART FROM THE MARK AS SHOWN.
THE MARK CONSISTS OF A DESIGN OF A SHIELD WITH A CASTLE DESIGN INSIDE WITH THE STYLIZED WORD "CASTLE" ACROSS AND THE STYLIZED WORDS "CAR WASH" UNDERNEATH.
FOR CAR WASHING (U.S. CLS. 100, 103 AND 106).
JAMES LOVELACE, EXAMINING ATTORNEY

SN 85-517,276. AFTERMARKET AUTO PARTS ALLIANCE, INC., SAN ANTONIO, TX. FILED 1-16-2012.

SAFEROUTE ROADSIDE ASSISTANCE

THE MARK CONSISTS OF STANDARD CHARACTERS WITHOUT CLAIM TO ANY PARTICULAR FONT, STYLE, SIZE, OR COLOR.
NO CLAIM IS MADE TO THE EXCLUSIVE RIGHT TO USE "ROADSIDE ASSISTANCE", APART FROM THE MARK AS SHOWN.
FOR EMERGENCY ROADSIDE ASSISTANCE SERVICES FOR AUTOMOTIVE VEHICLES, NAMELY, RESPONDING TO CALLS FOR ROADSIDE ASSISTANCE, FLAT TIRE CHANGING, EMERGENCY FUEL SUPPLYING, AND BATTERY JUMP STARTING (U.S. CLS. 100, 103 AND 106).
FIRST USE 12-1-2011; IN COMMERCE 12-1-2011.
MICHAEL ENGEL, EXAMINING ATTORNEY

SN 85-532,341. CHESAPEAKE ENERGY CORPORATION, OKLAHOMA CITY, OK. FILED 2-2-2012.

GREAT PLAINS OILFIELD RENTAL

THE MARK CONSISTS OF STANDARD CHARACTERS WITHOUT CLAIM TO ANY PARTICULAR FONT, STYLE, SIZE, OR COLOR.
NO CLAIM IS MADE TO THE EXCLUSIVE RIGHT TO USE "OILFIELD RENTAL", APART FROM THE MARK AS SHOWN.
SEC. 2(F).
FOR RENTAL OF OIL WELL DRILLING TOOLS (U.S. CLS. 100, 103 AND 106).
FIRST USE 1-16-2007; IN COMMERCE 1-16-2007.
KATHERINE CHANG, EXAMINING ATTORNEY

CLASS 37—(Continued).

SN 85-532,529. CHESAPEAKE ENERGY CORPORATION, OKLAHOMA CITY, OK. FILED 2-2-2012.

PERFORMANCE TECHNOLOGIES

THE MARK CONSISTS OF STANDARD CHARACTERS WITHOUT CLAIM TO ANY PARTICULAR FONT, STYLE, SIZE, OR COLOR.

NO CLAIM IS MADE TO THE EXCLUSIVE RIGHT TO USE "TECHNOLOGIES", APART FROM THE MARK AS SHOWN.

FOR WELL IMPROVEMENT SERVICES, NAMELY, HYDRAULIC FRACTURING OF SUBSURFACE GEOLOGIC FORMATIONS TO ENHANCE WELL PRODUCTION (U.S. CLS. 100, 103 AND 106).

FIRST USE 10-7-2010; IN COMMERCE 10-7-2010.
KATHERINE CHANG, EXAMINING ATTORNEY

CLASS 38—(Continued).

SN 77-646,435. CHURCH, MICHAEL W., AKA MIKE CHURCH, TORONTO, CANADA, FILED 1-9-2009.

OVATION STAR

CLASS 38—COMMUNICATION

SN 76-498,401. LIBERMAN BROADCASTING OF CALIFORNIA LLC, BURBANK, CA. FILED 3-17-2003.

AQUÍ MANDA LA RAZA

REGISTRATION LIMITED TO THE AREA COMPRISING TEXAS, NEW MEXICO, ARKANSAS, AND OKLAHOMA PURSUANT TO THE CONCURRENT USE PROCEEDING NO. 94002530. CONCURRENT APPLICATION SERIAL NOS. 76213224, 76214043, 76372222, AND 76396687.

COLOR IS NOT CLAIMED AS A FEATURE OF THE MARK.

THE MARK, "AQUÍ MANDA LA RAZA", TRANSLATES INTO ENGLISH AS, "HERE STANDS THE RACE".

FOR RADIO BROADCASTING SERVICES (U.S. CLS. 100, 101 AND 104).

FIRST USE 7-4-2001; IN COMMERCE 7-4-2001.
GEOFFREY FOSDICK, EXAMINING ATTORNEY

SN 76-698,284. MONTEZ, RAYMOND ANTHONY, FARMINGTON, AR. FILED 7-6-2009.

VIVA VISITS

THE MARK CONSISTS OF STANDARD CHARACTERS WITHOUT CLAIM TO ANY PARTICULAR FONT, STYLE, SIZE, OR COLOR.

FOR PROVIDING COMPUTER AIDED VIDEO CONFERENCING FOR INMATES THROUGH A GLOBAL COMPUTER NETWORK (U.S. CLS. 100, 101 AND 104).

MEGHAN REINHART, EXAMINING ATTORNEY

THE MARK CONSISTS OF STANDARD CHARACTERS WITHOUT CLAIM TO ANY PARTICULAR FONT, STYLE, SIZE, OR COLOR.

FOR PROVIDING TELECOMMUNICATIONS CONNECTIONS TO THE INTERNET; ELECTRONIC MAIL SERVICES; STREAMING OF AUDIO AND VIDEO MATERIAL VIA THE INTERNET; TELEVISION BROADCASTING SERVICES VIA THE INTERNET; RADIO BROADCASTING SERVICES VIA THE INTERNET; INSTANT MESSAGING SERVICES AND E-MAIL SERVICES; PROVIDING ONLINE DISCUSSION FORUMS, CHAT ROOMS, NEWS GROUPS, AND BULLETIN BOARDS FOR TRANSMISSION OF MESSAGES AMONG COMPUTER USERS CONCERNING TOPICS OF COMPUTER AND VIDEO GAMES; ELECTRONIC TRANSMISSION OF DATA AND MESSAGES VIA CELLULAR TELEPHONE NETWORKS AND WIRELESS COMMUNICATION NETWORKS, PROVIDING DOWNLOADABLE STREAMING AND TRANSMISSION OF WIRELESS ENTERTAINMENT CONTENT IN THE NATURE OF AUDIO VISUAL WORKS, MOTION PICTURES, TRAILERS, TELEVISION PROGRAMMING, MUSIC, AND GAMES BY MEANS OF A GLOBAL COMPUTER NETWORK AND COMMUNICATION NETWORKS; BROADCAST SERVICES, NAMELY, TELEVISION AND RADIO BROADCAST SERVICES AND INTERNET BROADCAST SERVICES; MOTION PICTURE AND TELEVISION PROGRAM DISTRIBUTION SERVICES, NAMELY, SATELLITE, CABLE AND BROADCAST TRANSMISSION OF MOTION PICTURES, TELEVISION PROGRAM; PROVIDING TELECOMMUNICATION SERVICES VIA A GLOBAL COMPUTER NETWORK, NAMELY, TRANSMISSION OF MOTION PICTURES, TELEVISION PROGRAMS; PROVIDING DOWNLOADABLE STREAMING AND WIRELESS ENTERTAINMENT CONTENT IN THE NATURE OF AUDIOVISUAL WORKS, MOTION PICTURES, TRAILERS, TELEVISION PROGRAMMING, MUSIC, AND GAMES BY MEANS OF A GLOBAL COMPUTER NETWORK AND COMMUNICATIONS NETWORKS (U.S. CLS. 100, 101 AND 104).

MARGERY A. TIERNEY, EXAMINING ATTORNEY

CLASS 38—(Continued).

SN 77-808,981. ADT SERVICES AG, SCHAFFHAUSEN, SWITZERLAND, FILED 8-20-2009.

PULSE

THE MARK CONSISTS OF STANDARD CHARACTERS WITHOUT CLAIM TO ANY PARTICULAR FONT, STYLE, SIZE, OR COLOR.

OWNER OF SWITZERLAND REG. NO. 599586, DATED 12-18-2009, EXPIRES 12-18-2019.

FOR TELECOMMUNICATION SERVICES, NAMELY, PROVIDING ACCESS TO PICTURES, VIDEO, ALARM STATUS, BUILDING PLANS AND OTHER BUILDING AND SECURITY INFORMATION AT A REMOTE STATION; TELECOMMUNICATION SERVICES, NAMELY, ELECTRONIC TRANSMISSION OF VOICE, MESSAGES AND DATA; TELECOMMUNICATION SERVICES, NAMELY, INFORMATION TRANSMISSION VIA ELECTRONIC COMMUNICATIONS NETWORKS; TRANSMISSION OF SOUND, VIDEO AND INFORMATION VIA COMPUTER NETWORKS, TEXT MESSAGES AND VOICE; TRANSMISSION, RECEPTION AND PROCESSING OF CODED AND EMERGENCY SIGNALS; TRANSMISSION OF SOUND, VIDEO AND INFORMATION IN THE FIELDS OF EMERGENCIES, SECURITY, ALARMS, SECURITY SYSTEMS, FIRE ALARMS, ALARM CENTRAL UNITS, ANTI-INTRUSION ALARMS, BURGLAR ALARMS, PERSONAL HEALTH AND SECURITY ALARMS, SMOKE AND GAS ALARMS, HOME SURVEILLANCE SYSTEMS, LIGHTING CONTROLS, HOME AUTOMATION DEVICES, SPRINKLER SYSTEMS FOR FIRE PROTECTION, VEHICLE, PET AND PERSONNEL LOCATION, AUTOMOBILE SAFETY, VEHICLE THEFT, TRAFFIC, ROAD NAVIGATION AND WEATHER; ELECTRONIC MAIL SERVICES; INSTANT MESSAGING SERVICES; ELECTRONIC VOICE MESSAGING, NAMELY, THE RECORDING AND SUBSEQUENT TRANSMISSION OF VOICE MESSAGES BY TELEPHONE; AND PROVIDING A WEBSITE FEATURING TRANSMISSION OF EMERGENCY MESSAGING VIA COMPUTER AND TELECOMMUNICATIONS NETWORKS, ALL OF THE AFOREMENTIONED FOR RESIDENTIAL USE (U.S. CLS. 100, 101 AND 104).

ALEX KEAM, EXAMINING ATTORNEY

SN 85-327,944. YAHYANEJAD, MEHDI, LOS ANGELES, CA. FILED 5-23-2011.

BalaMusic

THE MARK CONSISTS OF STANDARD CHARACTERS WITHOUT CLAIM TO ANY PARTICULAR FONT, STYLE, SIZE, OR COLOR.

THE ENGLISH TRANSLATION OF "BALA" IN THE MARK IS "HIGHER".

FOR STREAMING OF LIVE AND RECORDED MUSIC CONCERTS VIA THE INTERNET (U.S. CLS. 100, 101 AND 104).

FIRST USE 1-1-2011; IN COMMERCE 3-10-2011.
LESLEY LAMOTHE, EXAMINING ATTORNEY

CLASS 38—(Continued).

SN 85-330,295. ALPHA SUN & SPORT - AS & S, LLC, BOCA RATON, FL. FILED 5-25-2011.

ALPHABIT

THE MARK CONSISTS OF STANDARD CHARACTERS WITHOUT CLAIM TO ANY PARTICULAR FONT, STYLE, SIZE, OR COLOR.

FOR TELECOMMUNICATIONS SERVICES, NAMELY, PROVIDING ONLINE AND TELECOMMUNICATION FACILITIES FOR REAL-TIME INTERACTION BETWEEN AND AMONG USERS OF COMPUTERS, MOBILE AND HANDHELD COMPUTERS, AND WIRED AND WIRELESS COMMUNICATION DEVICES CONCERNING TOPICS OF EDUCATION, ACCOMPLISHMENTS IN GRADUATING FROM ACADEMIC PROGRAMS, ACHIEVING DREAM TRAVEL AND TRIPS, OVERCOMING FEARS, AND LEARNING NEW TRADES AND SKILLS, TASTINGS, DINING CRITIQUES, ADVENTURES LIVED AND PLANNED, VACATIONS LIVED AND PLANNED, TRAVELING, AND MENTORING IN THE FIELDS OF TRAVEL, ACADEMICS, SPORTS, MUSIC, CULINARY, WINE TASTING, HOBBIES AND ADVENTURE ACTIVITIES; ELECTRONIC MAIL AND INSTANT MESSAGING SERVICES ENABLING INDIVIDUALS TO SEND AND RECEIVE MESSAGES VIA EMAIL AND INSTANT MESSAGING; PROVIDING ON-LINE FACILITIES VIA A WEBSITE FOR REAL-TIME INTERACTION WITH OTHER COMPUTER USERS CONCERNING TOPICS OF GENERAL INTEREST; PROVIDING ON-LINE CHAT ROOMS AND ELECTRONIC BULLETIN BOARDS FOR TRANSMISSION OF MESSAGES AMONG USERS IN THE FIELD OF GENERAL INTEREST; PROVIDING AN ONLINE COMMUNITY FORUM FOR USERS TO SHARE INFORMATION, PHOTOS, AUDIO AND VIDEO CONTENT ABOUT THEMSELVES, THEIR LIKES AND DISLIKES AND DAILY ACTIVITIES, TO GET FEEDBACK FROM THEIR PEERS, TO FORM VIRTUAL COMMUNITIES, AND TO ENGAGE IN SOCIAL NETWORKING (U.S. CLS. 100, 101 AND 104).

BRENDAN MCCAULEY, EXAMINING ATTORNEY

CLASS 38—(Continued).

SN 85-337,831. GO SOLO TECHNOLOGIES, INC., ST. PETERSBURG, FL. FILED 6-3-2011.



OWNER OF U.S. REG. NO. 2,577,500.
THE MARK CONSISTS OF A STYLIZED MAN WITH OUTSTRETCHED ARMS STANDING ON A PARTIAL DISC SHAPE.

FOR TELECOMMUNICATIONS SERVICES PROVIDED THROUGH A PROPRIETARY NETWORK-BASED PLATFORM, NAMELY, ELECTRONIC TRANSMISSION OF VOICE, DATA, FACSIMILE, ELECTRONIC MAIL, VOICE MAIL, CROSS MEDIA MESSAGING, VIDEO AND INFORMATION VIA COMPUTER INTERFACES AND TELEPHONIC INTERFACES, AND GATEWAY SERVICES IN THE NATURE OF PROVIDING A LINK TO THE GLOBAL INFORMATION INFRASTRUCTURE COMPUTER NETWORK; TELECOMMUNICATIONS AND INTERACTIVE TELECOMMUNICATION SERVICES, NAMELY, TRANSMISSION OF MESSAGES BY TELEPHONE AND FACSIMILE; COMMUNICATION SERVICES, NAMELY, LONG-DISTANCE TELEPHONE COMMUNICATION SERVICES (U.S. CLS. 100, 101 AND 104).

FIRST USE 7-11-2000; IN COMMERCE 7-11-2000.
KATHRYN COWARD, EXAMINING ATTORNEY

SN 85-339,565. GREATER MEDIA, INC., BRAINTREE, MA. FILED 6-7-2011.

BOSTON TALKS

THE MARK CONSISTS OF STANDARD CHARACTERS WITHOUT CLAIM TO ANY PARTICULAR FONT, STYLE, SIZE, OR COLOR.

NO CLAIM IS MADE TO THE EXCLUSIVE RIGHT TO USE "BOSTON", APART FROM THE MARK AS SHOWN.

FOR RADIO BROADCASTING; STREAMING OF AUDIO MATERIAL ON THE INTERNET; WEBCASTING SERVICES (U.S. CLS. 100, 101 AND 104).

FIRST USE 11-30-2009; IN COMMERCE 11-30-2009.
WARREN L. OLANDRIA, EXAMINING ATTORNEY

CLASS 38—(Continued).

SN 85-347,826. BAMBOOM LABS, INC., LONG ISLAND CITY, NY. FILED 6-16-2011.

BAMBOOM

THE MARK CONSISTS OF STANDARD CHARACTERS WITHOUT CLAIM TO ANY PARTICULAR FONT, STYLE, SIZE, OR COLOR.

FOR ELECTRONIC DELIVERY OF AUDIO, VIDEO AND MULTIMEDIA CONTENT VIA COMMUNICATIONS NETWORKS (U.S. CLS. 100, 101 AND 104).

CHRISTOPHER BUONGIORNO, EXAMINING ATTORNEY

SN 85-352,445. REIF, ANGELA, PHOENIX, AZ. FILED 6-22-2011.

LANYAP NETWORKS

THE MARK CONSISTS OF STANDARD CHARACTERS WITHOUT CLAIM TO ANY PARTICULAR FONT, STYLE, SIZE, OR COLOR.

NO CLAIM IS MADE TO THE EXCLUSIVE RIGHT TO USE "NETWORKS", APART FROM THE MARK AS SHOWN.

FOR TELECOMMUNICATIONS RESELLER SERVICES, NAMELY, PROVIDING LONG DISTANCE TELECOMMUNICATION SERVICES, VOICE TELECOMMUNICATION SERVICES, LOCAL TELEPHONE SERVICE, AND INTERNET ACCESS SERVICES (U.S. CLS. 100, 101 AND 104).

MARK RADEMACHER, EXAMINING ATTORNEY

CLASS 38—(Continued).

SN 85-384,766. CIAO TELECOM, INC., EMERYVILLE, CA. FILED 7-29-2011.



THE COLOR(S) RED, WHITE IS/ARE CLAIMED AS A FEATURE OF THE MARK.

THE MARK CONSISTS OF THE STYLIZED WORD "CIAO" IN THE COLOR WHITE, ABOVE ARE TWO TEXT BALLOONS IN WHITE, THE RIGHT BALLOON HAS THREE CURVED LINES WITHIN IN THE COLOR RED, BELOW ARE THE STYLIZED WORDS "INNOVATING YOUR FUTURE" IN THE COLOR WHITE, ALL HOUSED IN A RED SQUARE.

THE ENGLISH TRANSLATION OF "CIAO" IN THE MARK IS "HELLO".

FOR COMMUNICATION SERVICES, NAMELY, TRANSMISSION OF VOICE, AUDIO, VISUAL IMAGES AND DATA BY TELECOMMUNICATIONS NETWORKS, WIRELESS COMMUNICATION NETWORKS, THE INTERNET, INFORMATION SERVICES NETWORKS AND DATA NETWORKS; TELECOMMUNICATION SERVICES, NAMELY, LOCAL AND LONG DISTANCE TRANSMISSION OF VOICE, DATA, GRAPHICS AND VIDEO BY MEANS OF BROADBAND OPTICAL OR WIRELESS NETWORKS; TELECOMMUNICATIONS RESELLER SERVICES FOR BUSINESSES, NAMELY, PROVIDING LONG DISTANCE TELECOMMUNICATION SERVICES, VOICE TELECOMMUNICATION SERVICES, LOCAL TELEPHONE SERVICE, AND INTERNET ACCESS SERVICES (U.S. CLS. 100, 101 AND 104).

FIRST USE 3-1-1999; IN COMMERCE 7-1-2011.

ADA HAN, EXAMINING ATTORNEY

SN 85-399,559. TWENTIETH CENTURY FOX FILM CORPORATION, LOS ANGELES, CA. FILED 8-16-2011.

FX MOVIE CHANNEL

THE MARK CONSISTS OF STANDARD CHARACTERS WITHOUT CLAIM TO ANY PARTICULAR FONT, STYLE, SIZE, OR COLOR.

OWNER OF U.S. REG. NOS. 2,107,517, 3,445,969 AND OTHERS.

NO CLAIM IS MADE TO THE EXCLUSIVE RIGHT TO USE "MOVIE CHANNEL", APART FROM THE MARK AS SHOWN.

FOR TELEVISION TRANSMISSION AND BROADCASTING SERVICES (U.S. CLS. 100, 101 AND 104).

RENEE MCCRAY, EXAMINING ATTORNEY

CLASS 38—(Continued).

SN 85-402,060. PEERLESS MEDIA LTD., IRVINE, CA. FILED 8-19-2011.

WPT

THE MARK CONSISTS OF STANDARD CHARACTERS WITHOUT CLAIM TO ANY PARTICULAR FONT, STYLE, SIZE, OR COLOR.

OWNER OF U.S. REG. NOS. 3,146,382, 3,234,308 AND OTHERS.

FOR TELECOMMUNICATIONS SERVICES, NAMELY, BROADCASTING SERVICES, PROVISION OF TELECOMMUNICATION ACCESS TO VIDEO AND AUDIO CONTENT PROVIDED VIA THE INTERNET; INTERACTIVE DELIVERY TO CUSTOMERS AND USERS OF VOICE, DATA, GRAPHICS, IMAGES, AUDIO AND VIDEO OVER DIGITAL NETWORKS ALL FEATURING INFORMATION ABOUT POKER EVENTS, POKER STRATEGY AND POKER NEWS AND INFORMATION; ELECTRONIC TRANSMISSION OF VOICE, DATA, IMAGES AND MESSAGES ALL RELATING TO POKER EVENTS, POKER STRATEGY AND POKER NEWS AND INFORMATION (U.S. CLS. 100, 101 AND 104).

BERYL GARDNER, EXAMINING ATTORNEY

SN 85-443,344. MUSIC ROW ENTERPRISES, LLC, NASHVILLE, TN. FILED 10-10-2011.

MUSICROW

THE MARK CONSISTS OF STANDARD CHARACTERS WITHOUT CLAIM TO ANY PARTICULAR FONT, STYLE, SIZE, OR COLOR.

SEC. 2(F).

FOR BROADCASTING SERVICES OVER COMPUTER OR OTHER COMMUNICATION NETWORKS, NAMELY, DELIVERY OF DATA, MESSAGES, INFORMATION, IMAGES, TEXT, PHOTOGRAPHS, ELECTRONIC MEDIA, AND MULTI-MEDIA CONTENT VIA ELECTRONIC COMMUNICATIONS NETWORKS, TELEPHONE COMMUNICATIONS AND DIGITAL TRANSMISSION; PROVIDING ACCESS TO COMPUTER, ELECTRONIC AND ON-LINE DATABASES; PROVIDING ELECTRONIC COMMUNICATIONS LINKS TO OTHER LOCAL AND GLOBAL WEB PAGES; PROVIDING ON-LINE FORUMS AND ELECTRONIC BULLETIN BOARDS FOR COMMUNICATION AND TRANSMISSION OF MESSAGES AMONG USERS IN THE FIELDS OF ENTERTAINMENT, MUSIC, MUSICAL ENTERTAINMENT, MUSIC INDUSTRY, MUSIC BUSINESS, ENTERTAINMENT INDUSTRY, ENTERTAINMENT BUSINESS, AND TOPICS OF GENERAL INTEREST; TELECOMMUNICATIONS SERVICES, NAMELY, ELECTRONIC TRANSMISSION OF DATA, MESSAGES, INFORMATION, IMAGES, TEXT, PHOTOGRAPHS, ELECTRONIC MEDIA, AND MULTI-MEDIA CONTENT; TRANSMISSION OF DATA, MESSAGES, INFORMATION, IMAGES, TEXT, PHOTOGRAPHS, ELECTRONIC MEDIA, AND MULTI-MEDIA CONTENT VIA ELECTRONIC COMMUNICATIONS NETWORKS, TELEPHONE COMMUNICATIONS AND DIGITAL MEANS (U.S. CLS. 100, 101 AND 104).

FIRST USE 9-0-2000; IN COMMERCE 9-0-2000.

SEAN CROWLEY, EXAMINING ATTORNEY

CLASS 38—(Continued).

SN 85-451,482. AVOCADO PRODUCERS AND EXPORTING PACKERS ASSOCIATION OF MICHOACÁN (APEAM), AKA AVOCADOS FROM MEXICO, COSTA MESA, CA. FILED 10-19-2011.



OWNER OF U.S. REG. NOS. 2,956,288 AND 3,013,186.
NO CLAIM IS MADE TO THE EXCLUSIVE RIGHT TO USE "AVOCADOS FROM MEXICO THE WORLD'S FINEST", APART FROM THE MARK AS SHOWN.

THE COLOR(S) ORANGE, RED, GRAY, BLACK, WHITE AND GREEN IS/ARE CLAIMED AS A FEATURE OF THE MARK.

THE MARK CONSISTS OF TEXTUAL ELEMENT "TEXT MEX" IN ORANGE BLOCK LETTERS, SHADOWED IN RED, THE TEXTUAL ELEMENT "AVOCADOS FROM MEXICO" APPEARS BELOW THE "TEXT MEX" IN GRAY, THE DESIGN ELEMENT OF A GRAY AND BLACK CELL PHONE WITH THE TEXT "AVOCADOS FROM MEXICO THE WORLD'S FINEST" IN WHITE AND HALVED AVOCADOS ALSO IN WHITE ABOVE THE WORDING APPEARS INSIDE THE DESIGN ELEMENT OF A CELL PHONE ON A GREEN BACKGROUND.

FOR EDUCATIONAL TEXT MESSAGING SERVICES FOR TRANSMISSION OF EDUCATIONAL CONTENT VIA SMS (U.S. CLS. 100, 101 AND 104).

FIRST USE 10-14-2011; IN COMMERCE 10-14-2011.
ROSELLE HERRERA, EXAMINING ATTORNEY

CLASS 38—(Continued).

SN 85-503,139. DOWNPLAY, INC., DBA UANGEL, COSTA MESA, CA. FILED 12-23-2011.



NO CLAIM IS MADE TO THE EXCLUSIVE RIGHT TO USE "VOICE TO KOREA" AND "SMART", APART FROM THE MARK AS SHOWN.

THE COLOR(S) BLACK, RED, WHITE, AND BLUE IS/ARE CLAIMED AS A FEATURE OF THE MARK.

THE MARK CONSISTS OF THE WORD "VOICE" IN BLACK, THE NUMBER "2" FORMED BY AN ARROW WITH A SPEED DESIGN ELEMENT IN RED, THE WORD "KOREA" IN BLACK, AND THE WORD "SMART" IN WHITE SHOWN WITHIN A BLUE BOX DEPICTED OVER THE WORD "KOREA"

FOR TELECOMMUNICATION SERVICES, NAMELY, CELLULAR TELEPHONE SERVICES; TELEPHONE TELECOMMUNICATION SERVICES PROVIDED VIA PREPAID TELEPHONE CALLING CARDS; AND WIRELESS DIGITAL MESSAGING (U.S. CLS. 100, 101 AND 104).

FIRST USE 7-1-2011; IN COMMERCE 7-1-2011.
KATHERINE STOIDES, EXAMINING ATTORNEY

SN 85-459,429. OFFICETREE CORPORATION, SAN DIEGO, CA. FILED 10-28-2011.

OFFICETREE

THE MARK CONSISTS OF STANDARD CHARACTERS WITHOUT CLAIM TO ANY PARTICULAR FONT, STYLE, SIZE, OR COLOR.

FOR TELECOMMUNICATION SERVICES, NAMELY, TRANSMISSION OF VOICE, DATA, IMAGES, AUDIO, VIDEO, AND INFORMATION VIA TELEPHONE, THE INTERNET, WIRED COMMUNICATION NETWORKS, AND WIRELESS COMMUNICATION NETWORKS; TELEPHONY COMMUNICATION SERVICES; UNIFIED TELECOMMUNICATIONS MESSAGING SERVICES; RECEIVING, SENDING, AND FORWARDING VOICE, FAX AND DATA TRANSMISSIONS ELECTRONICALLY; CALL FORWARDING SERVICES; FACSIMILE TRANSMISSION AND RETRIEVAL SERVICES; PROVIDING TELECOMMUNICATIONS ACCESS TO DATABASES RELATING TO BUSINESS, BUSINESS ACTIVITIES, BUSINESS ADMINISTRATION, BUSINESS ORGANIZATION, BUSINESS OPERATIONS, BUSINESS MANAGEMENT, AND BUSINESS ANALYSIS; ELECTRONIC MAIL SERVICES (U.S. CLS. 100, 101 AND 104).

SALLY SHIH, EXAMINING ATTORNEY

SN 85-503,168. DOWNPLAY, INC., DBA UANGEL, ORANGE, CA. FILED 12-23-2011.



THE COLOR(S) BLACK, RED, WHITE, AND GREEN IS/ARE CLAIMED AS A FEATURE OF THE MARK.

THE MARK CONSISTS OF WORD "VOZ" IN BLACK, LETTER "A" IN RED, WORD "FAMILIA" IN BLACK, AND WORD "MAS" IN WHITE WITH GREEN BLOCK AROUND THE WORD.

THE ENGLISH TRANSLATION OF THE WORDS "VOZ A FAMILIA MAS" IN THE MARK "IS MORE VOICE OF FAMILY".

FOR TELECOMMUNICATION SERVICES, NAMELY, CELLULAR TELEPHONE SERVICES; TELEPHONE TELECOMMUNICATION SERVICES PROVIDED VIA PREPAID TELEPHONE CALLING CARDS; AND WIRELESS DIGITAL MESSAGING (U.S. CLS. 100, 101 AND 104).

KATHERINE STOIDES, EXAMINING ATTORNEY

CLASS 38—(Continued).

SN 85-507,278. PETERSEN, CRAIG E., DRAPER, UT. FILED 1-2-2012.

WEBCAMLY

THE MARK CONSISTS OF STANDARD CHARACTERS WITHOUT CLAIM TO ANY PARTICULAR FONT, STYLE, SIZE, OR COLOR.

FOR COMMUNICATION SERVICES, NAMELY, PROVIDING AUDIO TRANSMISSION SERVICES, VIDEO TRANSMISSION SERVICES, AND TEXT DATA TRANSMISSION SERVICES VIA THE INTERNET; STREAMING OF AUDIO-VISUAL MATERIAL VIA THE INTERNET; PROVIDING INTERNET VIDEO CHAT ROOMS (U.S. CLS. 100, 101 AND 104).

JULIE WATSON, EXAMINING ATTORNEY

SN 85-507,694. BRIDGEMOBILE B.V., HAARLEM, NETHERLANDS, FILED 1-3-2012.

FIRMTEL

THE MARK CONSISTS OF STANDARD CHARACTERS WITHOUT CLAIM TO ANY PARTICULAR FONT, STYLE, SIZE, OR COLOR.

FOR PROVIDING TELECOMMUNICATIONS CONNECTIONS TO IT-SYSTEMS, OPERATING MOBILE VIRTUAL NETWORK OPERATOR (MVNO) AND MOBILE VIRTUAL NETWORK ENABLER (MVNE) BUSINESSES; MOBILE TELECOMMUNICATIONS ROUTING AND JUNCTION SERVICES (U.S. CLS. 100, 101 AND 104).

JULIE WATSON, EXAMINING ATTORNEY

SN 85-510,603. NORTH STATE TELEPHONE COMPANY, HIGH POINT, NC. FILED 1-6-2012.

PLEX BLITZ

THE MARK CONSISTS OF STANDARD CHARACTERS WITHOUT CLAIM TO ANY PARTICULAR FONT, STYLE, SIZE, OR COLOR.

OWNER OF U.S. REG. NOS. 3,788,439, 3,788,441 AND OTHERS.

FOR INTERNET SERVICE PROVIDER SERVICES (U.S. CLS. 100, 101 AND 104).

FIRST USE 5-10-2011; IN COMMERCE 5-10-2011.

ANDREW RHIM, EXAMINING ATTORNEY

CLASS 38—(Continued).

SN 85-510,799. ALLAMANDA N.V., CURACAO, CURACAO, FILED 1-6-2012.



THE MARK CONSISTS OF THE LETTERS "SOI" IN A STYLIZED TYPEFACE IN WHICH THE LETTER "O" PARTIALLY ENCLOSES A GLOBE WITH PARALLEL LINES ON THE SURFACE, ALL OF WHICH IS ENCLOSED WITHIN THE TYPE OF BUBBLE TYPICALLY USED TO ENCLOSE DIALOGUE IN COMICS.

THE WORDING "SOI" OR "SOI" HAS NO MEANING IN A FOREIGN LANGUAGE.

FOR BROADCASTING OF VIDEO AND AUDIO PROGRAMMING OVER THE INTERNET; INTERNET BROADCASTING SERVICES; TELEVISION BROADCASTING; WIRELESS BROADCASTING (U.S. CLS. 100, 101 AND 104).

ANDREW LEASER, EXAMINING ATTORNEY

SN 85-511,667. RAYCOM MEDIA, INC., MONTGOMERY, AL. FILED 1-9-2012.

KAIT8

THE MARK CONSISTS OF STANDARD CHARACTERS WITHOUT CLAIM TO ANY PARTICULAR FONT, STYLE, SIZE, OR COLOR.

FOR TELEVISION BROADCASTING SERVICES (U.S. CLS. 100, 101 AND 104).

FIRST USE 7-17-1963; IN COMMERCE 7-17-1963.

CHRISTOPHER SIDOTI, EXAMINING ATTORNEY

CLASS 38—(Continued).

SN 85-511,672. RAYCOM MEDIA, INC., MONTGOMERY, AL. FILED 1-9-2012.

WCSC

THE MARK CONSISTS OF STANDARD CHARACTERS WITHOUT CLAIM TO ANY PARTICULAR FONT, STYLE, SIZE, OR COLOR.

FOR TELEVISION BROADCASTING SERVICES (U.S. CLS. 100, 101 AND 104).

FIRST USE 11-17-1947; IN COMMERCE 11-17-1947.
CHRISTOPHER SIDOTI, EXAMINING ATTORNEY

SN 85-511,704. VIASAT, INC., CARLSBAD, CA. FILED 1-9-2012.

EXEDE

THE MARK CONSISTS OF STANDARD CHARACTERS WITHOUT CLAIM TO ANY PARTICULAR FONT, STYLE, SIZE, OR COLOR.

FOR SATELLITE COMMUNICATION SERVICES; WIRELESS BROADBAND COMMUNICATION SERVICES (U.S. CLS. 100, 101 AND 104).

FIRST USE 1-16-2012; IN COMMERCE 1-16-2012.
STEVEN R. FINE, EXAMINING ATTORNEY

SN 85-511,782. CONTERRA ULTRA BROADBAND, LLC, CHARLOTTE, NC. FILED 1-9-2012.

CONTERRA FIBER SOLUTIONS

THE MARK CONSISTS OF STANDARD CHARACTERS WITHOUT CLAIM TO ANY PARTICULAR FONT, STYLE, SIZE, OR COLOR.

OWNER OF U.S. REG. NOS. 2,785,545, 4,018,180 AND OTHERS.

NO CLAIM IS MADE TO THE EXCLUSIVE RIGHT TO USE "FIBER SOLUTIONS", APART FROM THE MARK AS SHOWN.

THE ENGLISH TRANSLATION OF "CONTERRA" IN THE MARK IS "WILL CONTAIN".

FOR TELECOMMUNICATION SERVICES, NAMELY, TELECOMMUNICATIONS ROUTING AND JUNCTION SERVICES; WIDE AREA NETWORK SERVICES, NAMELY, PROVIDING HIGH SPEED ACCESS TO AREA NETWORKS AND A GLOBAL COMPUTER INFORMATION NETWORK (U.S. CLS. 100, 101 AND 104).

AMY KELLY, EXAMINING ATTORNEY

CLASS 38—(Continued).

SN 85-512,280. FRONTIER COMMUNICATIONS CORPORATION, STAMFORD, CT. FILED 1-9-2012.

FTR

THE MARK CONSISTS OF STANDARD CHARACTERS WITHOUT CLAIM TO ANY PARTICULAR FONT, STYLE, SIZE, OR COLOR.

FOR TELECOMMUNICATION SERVICES, NAMELY, TRANSMITTING VOICE, IMAGE, AUDIO, VIDEO, TEXT, AND DATA INFORMATION VIA COMMUNICATION SATELLITE NETWORKS, WIRED AND WIRELESS NETWORKS, TELEPHONES, HANDHELD COMPUTERS, AND MOBILE DATA RECEIVERS; TRANSMISSION OF DIGITAL DATA VIA TELECOMMUNICATION SYSTEMS, TELEPHONE, PERSONAL DIGITAL ASSISTANTS, HAND-HELD COMPUTERS, MOBILE TELEPHONES, EMAIL, THE INTERNET, COMPUTER NETWORKS, AND OTHER COMMUNICATION DEVICES; VOICE OVER INTERNET PROTOCOL TELECOMMUNICATIONS SERVICES; PROVIDING HIGH SPEED INTERNET ACCESS; PROVIDING MULTIPLE USER ACCESS TO A GLOBAL COMPUTER INFORMATION NETWORK; WIRELESS TELEPHONE SERVICES; WIRELESS MOBILE TELEPHONE CALLING PLANS; LOCAL AND LONG DISTANCE TELEPHONE SERVICES; ELECTRONIC MAIL AND MESSAGING SERVICES; INSTANT MESSAGING SERVICES; VOICE MAIL SERVICES; CALLER IDENTIFICATION SERVICES; PROVIDING ACCESS TO THE INTERNET VIA A NETWORK OF WIRELESS ACCESS POINTS (WAPS) (U.S. CLS. 100, 101 AND 104).

DAVID I, EXAMINING ATTORNEY

SN 85-512,647. WIGSCO LLC, CULVER CITY, CA. FILED 1-10-2012.

WIGS

THE MARK CONSISTS OF STANDARD CHARACTERS WITHOUT CLAIM TO ANY PARTICULAR FONT, STYLE, SIZE, OR COLOR.

FOR COMMUNICATIONS SERVICES, NAMELY, TRANSMITTING STREAMED SOUND AND AUDIO-VISUAL RECORDINGS VIA THE INTERNET, CABLE NETWORKS, WIRELESS NETWORKS, SATELLITE, OR INTERACTIVE MULTIMEDIA NETWORKS; AUDIO AND VIDEO BROADCASTING SERVICES OVER THE INTERNET; TRANSMISSION OF INFORMATION IN THE AUDIO-VISUAL FIELD; TELEVISION BROADCASTING SERVICES; CABLE TELEVISION BROADCASTING; SATELLITE TELEVISION BROADCASTING; MOBILE MEDIA SERVICES IN THE NATURE OF ELECTRONIC TRANSMISSION OF ENTERTAINMENT MEDIA CONTENT; PODCASTING SERVICES; WEBCASTING SERVICES; VIDEO-ON-DEMAND TRANSMISSION SERVICES; PROVIDING ON-LINE CHAT ROOMS AND ELECTRONIC BULLETIN BOARDS FOR TRANSMISSION OF MESSAGES AMONG USERS IN THE FIELD OF GENERAL INTEREST (U.S. CLS. 100, 101 AND 104).

TARAH HARDY, EXAMINING ATTORNEY

CLASS 38—(Continued).

SN 85-513,667. PINE TELEPHONE COMPANY, INC., BROKEN BOW, OK. FILED 1-11-2012.

CLASS 38—(Continued).

SN 85-514,229. DIRECTV, LLC, EL SEGUNDO, CA. FILED 1-11-2012.

MÁS QUE VER TV. DIRECTV

COVERAGE WHERE IT MATTERS MOST

THE MARK CONSISTS OF STANDARD CHARACTERS WITHOUT CLAIM TO ANY PARTICULAR FONT, STYLE, SIZE, OR COLOR.

FOR TELECOMMUNICATION SERVICES, NAMELY, WIRELESS TELEPHONE SERVICES; PROVIDING MULTIPLE USER WIRELESS ACCESS TO THE INTERNET (U.S. CLS. 100, 101 AND 104).

DORITT L. CARROLL, EXAMINING ATTORNEY

THE MARK CONSISTS OF STANDARD CHARACTERS WITHOUT CLAIM TO ANY PARTICULAR FONT, STYLE, SIZE, OR COLOR.

OWNER OF U.S. REG. NOS. 2,639,279, 3,051,286 AND OTHERS.

THE ENGLISH TRANSLATION OF "MÁS QUE VER TV" IN THE MARK IS "MORE THAN WATCHING TV".

FOR SATELLITE TELEVISION BROADCASTING AND TRANSMISSION SERVICES FEATURING INTERACTIVE TELEVISION VIEWING FUNCTIONS THAT PERMIT USERS TO VIEW AND SHARE AUDIO FILES, VIDEO FILES, PHOTOGRAPHS, IMAGES AND OTHER MULTIMEDIA CONTENT BETWEEN AND AMONG COMPUTERS, SET-TOP-BOXES, AND OTHER AUDIO-VISUAL DEVICES; SATELLITE TELEVISION BROADCASTING; SATELLITE TRANSMISSION SERVICES; BROADCASTING PROGRAMS VIA A GLOBAL COMPUTER NETWORK; VIDEO-ON-DEMAND TRANSMISSION SERVICES; TRANSMISSION OF PAY-PER-VIEW TELEVISION AND OTHER AUDIO, VIDEO, AND AUDIOVISUAL MATERIAL; STREAMING OF AUDIO AND VIDEO MATERIAL ON THE INTERNET, OTHER COMPUTER NETWORKS, WIRELESS NETWORKS AND ELECTRONIC COMMUNICATION NETWORKS; ELECTRONIC TRANSMISSION OF DATA VIA GLOBAL COMPUTER NETWORKS, WIRELESS NETWORKS AND ELECTRONIC COMMUNICATION NETWORKS; PROVIDING USER ACCESS TO GLOBAL COMPUTER NETWORKS AND TELECOMMUNICATION NETWORKS FOR TRANSMISSION OR RECEIPT OF DATA (U.S. CLS. 100, 101 AND 104).

ELIZABETH KAJUBI, EXAMINING ATTORNEY

SN 85-514,021. CENTURYLINK, INC., MONROE, LA. FILED 1-11-2012.

SN 85-514,628. DRESS YOUR GUESTS LLC, NEW YORK, NY. FILED 1-12-2012.

YOUR LINK TO WHAT'S NEXT

THE MARK CONSISTS OF STANDARD CHARACTERS WITHOUT CLAIM TO ANY PARTICULAR FONT, STYLE, SIZE, OR COLOR.

FOR ELECTRONIC, ELECTRIC, AND DIGITAL TRANSMISSION OF VOICE, DATA, IMAGES, SIGNALS, AND MESSAGES (U.S. CLS. 100, 101 AND 104).

JAY BESCH, EXAMINING ATTORNEY

DRESS YOUR GUESTS

THE MARK CONSISTS OF STANDARD CHARACTERS WITHOUT CLAIM TO ANY PARTICULAR FONT, STYLE, SIZE, OR COLOR.

FOR PROVIDING AN ONLINE FORUM FOR TRANSMISSION OF MESSAGES, PHOTOS, AUDIO AND VIDEO CONTENT AMONG COMPUTER USERS ALL IN THE FIELD OF EVENT PLANNING AND DRESSING FOR PRIVATE AND PUBLIC EVENTS (U.S. CLS. 100, 101 AND 104).

RAUL CORDOVA, EXAMINING ATTORNEY

CLASS 38—(Continued).

SN 85-515,949. GIT NOW MEDIA, LLC, HOUSTON, TX. FILED 1-13-2012.

scizr

THE MARK CONSISTS OF STANDARD CHARACTERS WITHOUT CLAIM TO ANY PARTICULAR FONT, STYLE, SIZE, OR COLOR.
 FOR PROVIDING ON-LINE CHAT ROOMS FOR SOCIAL NETWORKING (U.S. CLS. 100, 101 AND 104).
 FIRST USE 4-28-2011; IN COMMERCE 4-28-2011.
 JOHN DALIER, EXAMINING ATTORNEY

SN 85-516,251. MAXCOM TELECOMUNICACIONES S.A.B. DE C.V., MEXICO CITY, MEXICO, FILED 1-13-2012.

MEZCALL

THE MARK CONSISTS OF STANDARD CHARACTERS WITHOUT CLAIM TO ANY PARTICULAR FONT, STYLE, SIZE, OR COLOR.
 FOR CELLULAR TELEPHONE SERVICES; VOICE OVER INTERNET PROTOCOL (VOIP) SERVICES (U.S. CLS. 100, 101 AND 104).
 TINA L. SNAPP, EXAMINING ATTORNEY

SN 85-516,253. MAXCOM TELECOMUNICACIONES S.A.B. DE C.V., MEXICO CITY, MEXICO, FILED 1-13-2012.



THE MARK CONSISTS OF A STYLIZED SQUARE WITH THE STYLIZED LETTERS "M" AND "C" WRITTEN INSIDE THE SQUARE. ALSO, TWO CIRCULAR DOTS ARE LOCATED INSIDE THE LETTER "C". ABOVE THE SQUARE IS THE STYLIZED TEXT "MEZCALL".
 FOR CELLULAR TELEPHONE SERVICES; VOICE OVER INTERNET PROTOCOL (VOIP) SERVICES (U.S. CLS. 100, 101 AND 104).
 TINA L. SNAPP, EXAMINING ATTORNEY

CLASS 38—(Continued).

SN 85-516,837. VISIONAIRE FZE, DUBAI, UNITED ARAB EMIR., FILED 1-15-2012.

Arrive EdgeLess Media

THE MARK CONSISTS OF STANDARD CHARACTERS WITHOUT CLAIM TO ANY PARTICULAR FONT, STYLE, SIZE, OR COLOR.
 OWNER OF U.S. REG. NOS. 3,285,987 AND 3,437,385.
 NO CLAIM IS MADE TO THE EXCLUSIVE RIGHT TO USE "MEDIA", APART FROM THE MARK AS SHOWN.
 FOR ELECTRONIC, ELECTRIC, AND DIGITAL TRANSMISSION OF VOICE, DATA, IMAGES, SIGNALS, AND MESSAGES; INFORMATION TRANSMISSION VIA ELECTRONIC COMMUNICATIONS NETWORKS; INTERACTIVE DELIVERY OF VIDEO OVER DIGITAL NETWORKS (U.S. CLS. 100, 101 AND 104).
 FIRST USE 1-13-2012; IN COMMERCE 1-13-2012.
 JENNIFER WILLISTON, EXAMINING ATTORNEY

SN 85-524,223. FUEL TV, INC., LOS ANGELES, CA. FILED 1-24-2012.



NO CLAIM IS MADE TO THE EXCLUSIVE RIGHT TO USE "TV", APART FROM THE MARK AS SHOWN.
 THE MARK CONSISTS OF THE WORDS "FUEL" AND "TV" WITH "TV" APPEARING IN LOWERCASE AND SUPERScript POSITION TO THE RIGHT OF THE WORD "FUEL".
 FOR TELEVISION TRANSMISSION AND BROADCASTING SERVICES (U.S. CLS. 100, 101 AND 104).
 FIRST USE 1-1-2012; IN COMMERCE 1-1-2012.
 DAVID MURRAY, EXAMINING ATTORNEY

SN 85-554,802. THE CARTOON NETWORK, INC., ATLANTA, GA. FILED 2-28-2012.

BOOMERANG GO

THE MARK CONSISTS OF STANDARD CHARACTERS WITHOUT CLAIM TO ANY PARTICULAR FONT, STYLE, SIZE, OR COLOR.
 OWNER OF U.S. REG. NOS. 2,029,598, 3,138,895 AND OTHERS.
 FOR MOBILE MEDIA SERVICES IN THE NATURE OF ELECTRONIC TRANSMISSION, BROADCASTING AND DELIVERY OF AUDIO, VIDEO AND MULTIMEDIA ENTERTAINMENT CONTENT INCLUDING TEXT, DATA, IMAGES, AUDIO, VIDEO AND AUDIOVISUAL FILES BY MEANS OF THE INTERNET, WIRELESS COMMUNICATION, ELECTRONIC COMMUNICATIONS NETWORKS AND COMPUTER NETWORKS (U.S. CLS. 100, 101 AND 104).
 MARK SPARACINO, EXAMINING ATTORNEY

CLASS 38—(Continued).

SN 85-562,990. CONTERRA ULTRA BROADBAND, LLC, CHARLOTTE, NC. FILED 3-7-2012.

CONTERRA TELEHEALTH NETWORKS

THE MARK CONSISTS OF STANDARD CHARACTERS WITHOUT CLAIM TO ANY PARTICULAR FONT, STYLE, SIZE, OR COLOR.

OWNER OF U.S. REG. NOS. 2,785,545, 4,018,180 AND OTHERS.

NO CLAIM IS MADE TO THE EXCLUSIVE RIGHT TO USE "TELEHEALTH NETWORKS", APART FROM THE MARK AS SHOWN.

THE ENGLISH TRANSLATION OF "CONTERRA" IN THE MARK IS "WILL CONTAIN".

FOR TELECOMMUNICATION SERVICES, NAMELY, TELECOMMUNICATIONS ROUTING AND JUNCTION SERVICES; WIDE AREA NETWORK SERVICES, NAMELY, PROVIDING HIGH SPEED ACCESS TO AREA NETWORKS AND A GLOBAL COMPUTER INFORMATION NETWORK (U.S. CLS. 100, 101 AND 104).

AMY KELLY, EXAMINING ATTORNEY

SN 85-563,010. CONTERRA ULTRA BROADBAND, LLC, CHARLOTTE, NC. FILED 3-7-2012.

BROADBAND WITHOUT BORDERS

THE MARK CONSISTS OF STANDARD CHARACTERS WITHOUT CLAIM TO ANY PARTICULAR FONT, STYLE, SIZE, OR COLOR.

NO CLAIM IS MADE TO THE EXCLUSIVE RIGHT TO USE "BROADBAND", APART FROM THE MARK AS SHOWN.

FOR TELECOMMUNICATION SERVICES, NAMELY, TELECOMMUNICATIONS ROUTING AND JUNCTION SERVICES; WIDE AREA NETWORK SERVICES, NAMELY, PROVIDING HIGH SPEED ACCESS TO AREA NETWORKS AND A GLOBAL COMPUTER INFORMATION NETWORK (U.S. CLS. 100, 101 AND 104).

AMY KELLY, EXAMINING ATTORNEY

CLASS 38—(Continued).

SN 85-583,780. MARC BELL CAPITAL PARTNERS LLC, BOCA RATON, FL. FILED 3-29-2012.

MARC BELL

THE MARK CONSISTS OF STANDARD CHARACTERS WITHOUT CLAIM TO ANY PARTICULAR FONT, STYLE, SIZE, OR COLOR.

THE NAME(S), PORTRAIT(S), AND/OR SIGNATURE(S) SHOWN IN THE MARK IDENTIFIES "MARC BELL", WHOSE CONSENT(S) TO REGISTER IS MADE OF RECORD.

FOR TELECOMMUNICATIONS SERVICES, NAMELY, TRANSMISSION AND DELIVERY OF TEXT, GRAPHICS, IMAGES, MOTION PICTURES AND PORTIONS THEREOF, SOUNDS, INFORMATION, DATA, SIGNALS, AND AUDIO, VIDEO AND AUDIOVISUAL CONTENT, WHETHER LIVE OR PRE-RECORDED, WHETHER STREAMED, DOWNLOADED OR OTHERWISE TRANSMITTED, AND WHETHER USER INTERACTIVE OR USER NON-INTERACTIVE, ALL OF THE FOREGOING EITHER VIA THE INTERNET, VIA MOBILE AND WIRELESS TELEPHONE SYSTEMS, VIA TERRESTRIAL TELEVISION SYSTEMS, VIA CABLE TELEVISION SYSTEMS, VIA SATELLITE TELEVISION SYSTEMS, OR VIA OTHER DIGITAL OR ELECTRONIC TRANSMISSION MEANS; PROVIDING ON-LINE CHAT ROOMS FOR TRANSMISSION OF MESSAGES AMONG COMPUTER USERS CONCERNING SOCIAL NETWORKING, VIRTUAL COMMUNITIES, DATING AND RELATIONSHIPS, AND TOPICS OF GENERAL INTEREST; PROVIDING ON-LINE ELECTRONIC BULLETIN BOARDS FOR TRANSMISSION OF MESSAGES AMONG COMPUTER USERS CONCERNING SOCIAL NETWORKING, VIRTUAL COMMUNITIES, DATING AND RELATIONSHIPS, AND TOPICS OF GENERAL INTEREST (U.S. CLS. 100, 101 AND 104).

MARK PILARO, EXAMINING ATTORNEY

CLASS 39—TRANSPORTATION AND STORAGE

SN 85-103,986. THE MI GROUP LTD., MISSISSAUGA, ONTARIO, CANADA. FILED 8-10-2010.



PRIORITY CLAIMED UNDER SEC. 44(D) ON CANADA APPLICATION NO. 1488404, FILED 7-13-2010, REG. NO. TMA812794, DATED 11-28-2011, EXPIRES 11-28-2026.

OWNER OF U.S. REG. NOS. 1,969,984, 3,048,466 AND OTHERS.

NO CLAIM IS MADE TO THE EXCLUSIVE RIGHT TO USE "WORLDWIDE PARTNER NETWORK", APART FROM THE MARK AS SHOWN.

FOR CONSULTING IN THE FIELD OF TRAVEL VISAS FOR PERSONS TRAVELING ABROAD; PACKING ARTICLES FOR TRANSPORTATION; TRANSPORT SERVICES, NAMELY, LOCAL, INTERSTATE AND INTERNATIONAL MOVING SERVICES; TRANSPORTATION OF GOODS (U.S. CLS. 100 AND 105).

SIMON TENG, EXAMINING ATTORNEY

CLASS 39—(Continued).

SN 85-212,062. PANTHER II TRANSPORTATION, INC., SEVILLE, OH. FILED 1-6-2011.

PANTHER ELITE SERVICES

THE MARK CONSISTS OF STANDARD CHARACTERS WITHOUT CLAIM TO ANY PARTICULAR FONT, STYLE, SIZE, OR COLOR.

OWNER OF U.S. REG. NOS. 2,338,784, 3,235,775 AND OTHERS.

NO CLAIM IS MADE TO THE EXCLUSIVE RIGHT TO USE "ELITE SERVICES", APART FROM THE MARK AS SHOWN.

FOR PICK-UP, TRANSPORTATION, STORAGE AND DELIVERY OF DOCUMENTS, PACKAGES AND FREIGHT BY LAND AND AIR (U.S. CLS. 100 AND 105).

FIRST USE 12-30-2005; IN COMMERCE 12-30-2005.

MICHELLE DUBOIS, EXAMINING ATTORNEY

SN 85-259,708. PHILLIPS, RICHARD, BOISE, ID. FILED 3-7-2011.



OWNER OF U.S. REG. NOS. 1,966,868 AND 4,041,338.

NO CLAIM IS MADE TO THE EXCLUSIVE RIGHT TO USE "STORAGE", APART FROM THE MARK AS SHOWN.

THE COLOR(S) WHITE, BLUE, AND RED IS/ARE CLAIMED AS A FEATURE OF THE MARK.

THE MARK CONSISTS OF A BLUE RECTANGULAR BOX WITH ROUNDED CORNERS CONTAINING A WHITE BACKGROUND, AND THE LETTER "R" IN BLUE FOLLOWED BY THE LETTER "S" IN RED WITH A WHITE FIVE-POINTED STAR BETWEEN THE LETTERS "R" AND "S"; BELOW WHICH APPEARS THE WORD "REPUBLIC" IN BLUE LETTERS; BELOW WHICH APPEARS THE WORD "STORAGE" IN RED LETTERS, WITH THE LETTER "O" IN "STORAGE" CONTAINING A WHITE FIVE-POINTED STAR.

FOR PROVIDING SELF-STORAGE FACILITIES FOR OTHERS (U.S. CLS. 100 AND 105).

FIRST USE 12-1-2010; IN COMMERCE 12-1-2010.

ERIN FALK, EXAMINING ATTORNEY

CLASS 39—(Continued).

SN 85-313,477. FIRSTENERGY CORP., AKRON, OH. FILED 5-5-2011.



OWNER OF U.S. REG. NOS. 2,353,295, 2,755,355 AND OTHERS.

NO CLAIM IS MADE TO THE EXCLUSIVE RIGHT TO USE "COMPANY", APART FROM THE MARK AS SHOWN.

THE MARK CONSISTS OF THE TEXT "MONPOWER" WITH A SWOOSH UNDERNEATH IT; UNDERNEATH THE SWOOSH IS THE TEXT "A FIRSTENERGY COMPANY".

SEC. 2(F) AS TO "MONPOWER".

FOR PUBLIC UTILITY SERVICES IN THE NATURE OF THE PROVISION AND DISTRIBUTION OF ELECTRICITY; TRANSMITTING, TRANSPORTING, STORING, AND DISTRIBUTING OF ENERGY COMMODITIES, NAMELY, ELECTRICITY AND NATURAL GAS; ARRANGING FOR TRANSMISSION, TRANSPORTATION, STORAGE, AND DISTRIBUTION OF ENERGY COMMODITIES, NAMELY, ELECTRICITY AND NATURAL GAS (U.S. CLS. 100 AND 105).

ELI HELLMAN, EXAMINING ATTORNEY

SN 85-313,947. TAMPA BAY DREAM CENTER, TAMPA, FL. FILED 5-6-2011.

**DIRECT CHRISTIAN IMPACT
(DCI)**

THE MARK CONSISTS OF STANDARD CHARACTERS WITHOUT CLAIM TO ANY PARTICULAR FONT, STYLE, SIZE, OR COLOR.

NO CLAIM IS MADE TO THE EXCLUSIVE RIGHT TO USE "CHRISTIAN", APART FROM THE MARK AS SHOWN.

FOR COMMUNITY SERVICE ACTIVITIES, NAMELY, ORGANIZING MISSION TRIPS FOR PROMOTION OF RELIGION (U.S. CLS. 100 AND 105).

NAKIA HENRY, EXAMINING ATTORNEY

CLASS 39—(Continued).

SN 85-355,932. GREEN MOTION VEHICLE RENTAL LIMITED, SUTTON, SURREY, UNITED KINGDOM, FILED 6-24-2011.

GREEN MOTION

THE MARK CONSISTS OF STANDARD CHARACTERS WITHOUT CLAIM TO ANY PARTICULAR FONT, STYLE, SIZE, OR COLOR.

OWNER OF ERPNTY TM OFC REG. NO. 005311709, DATED 8-8-2007, EXPIRES 9-13-2016.

NO CLAIM IS MADE TO THE EXCLUSIVE RIGHT TO USE "GREEN", APART FROM THE MARK AS SHOWN.

FOR RENTAL OF MOTOR VEHICLES AND LAND VEHICLES; CONTRACT HIRE AND LEASING OF MOTOR VEHICLES AND LAND VEHICLES (U.S. CLS. 100 AND 105).

CHRISTOPHER SIDOTI, EXAMINING ATTORNEY

SN 85-444,769. PALMAYMESA, LLOYD, SAN DIEGO, CA. FILED 10-11-2011.

North Park Self Storage

THE MARK CONSISTS OF STANDARD CHARACTERS WITHOUT CLAIM TO ANY PARTICULAR FONT, STYLE, SIZE, OR COLOR.

NO CLAIM IS MADE TO THE EXCLUSIVE RIGHT TO USE "SELF STORAGE", APART FROM THE MARK AS SHOWN.

SEC. 2(F).
FOR PROVIDING SELF-STORAGE FACILITIES FOR OTHERS (U.S. CLS. 100 AND 105).

FIRST USE 6-20-1985; IN COMMERCE 6-20-1985.
ALICIA COLLINS, EXAMINING ATTORNEY

SN 85-448,111. AVIOR AIRLINES, C.A., BARCELONA, VENEZUELA, FILED 10-14-2011.

AVIOR AIRLINES

THE MARK CONSISTS OF STANDARD CHARACTERS WITHOUT CLAIM TO ANY PARTICULAR FONT, STYLE, SIZE, OR COLOR.

NO CLAIM IS MADE TO THE EXCLUSIVE RIGHT TO USE "AIRLINES", APART FROM THE MARK AS SHOWN.

FOR AIRLINE TRANSPORTATION SERVICES (U.S. CLS. 100 AND 105).

JAY BESCH, EXAMINING ATTORNEY

CLASS 39—(Continued).

SN 85-456,075. GEORGETOWN RAIL EQUIPMENT COMPANY, GEORGETOWN, TX. FILED 10-25-2011.

DumpTrain

THE MARK CONSISTS OF STANDARD CHARACTERS WITHOUT CLAIM TO ANY PARTICULAR FONT, STYLE, SIZE, OR COLOR.

FOR RAILROAD SERVICES, NAMELY, AGGREGATE CARGO HANDLING SERVICES USING A CONTINUOUS BELT AND BOOM TO OFFLOAD THE AGGREGATE CARGO FROM RAILROAD TRAINS (U.S. CLS. 100 AND 105).

FIRST USE 12-31-1992; IN COMMERCE 12-31-1992.

JACLYN KIDWELL WALKER, EXAMINING ATTORNEY

SN 85-456,123. GEORGETOWN RAIL EQUIPMENT COMPANY, GEORGETOWN, TX. FILED 10-25-2011.

GateSync

THE MARK CONSISTS OF STANDARD CHARACTERS WITHOUT CLAIM TO ANY PARTICULAR FONT, STYLE, SIZE, OR COLOR.

FOR RAILROAD MAINTENANCE SERVICES, NAMELY, FREIGHT AND CARGO LOADING AND UNLOADING USING BALLASTS AT DESIRED LOCATIONS ALONG THE BED OF A RAILROAD TRACK USING REMOTE CONTROLLED GATES ON RAILROAD BALLAST CARS (U.S. CLS. 100 AND 105).

FIRST USE 12-31-2003; IN COMMERCE 12-31-2003.

JACLYN KIDWELL WALKER, EXAMINING ATTORNEY

SN 85-476,802. U.S. TRAVEL ASSOCIATION, WASHINGTON, DE. FILED 11-18-2011.



OWNER OF U.S. REG. NO. 3,111,374.
THE COLOR(S) RED AND BLUE IS/ARE CLAIMED AS A FEATURE OF THE MARK.

THE MARK CONSISTS OF THE WORD "SEE" IN RED LETTERING AND THE WORD "AMERICA" IN BLUE LETTERING, WITH A RED CURVED LINE AND A BLUE CURVED LINE STARTING FROM THE LETTER "M" IN THE WORD "AMERICA" AND ENDING AT A BLUE STAR ABOVE THE LETTER "I" IN THE WORD "AMERICA".

FOR PROVIDING A WEBSITE SHOWCASING INFORMATION ON TRAVEL DESTINATIONS ACROSS THE UNITED STATES (U.S. CLS. 100 AND 105).

VERNA BETH RIRIE, EXAMINING ATTORNEY

CLASS 39—(Continued).

SN 85-478,178. SOURCE HOLDING DELAWARE, LLC, MONTEBELLO, CA. FILED 11-21-2011.



OWNER OF U.S. REG. NO. 3,084,246.
NO CLAIM IS MADE TO THE EXCLUSIVE RIGHT TO USE "LOGISTICS", APART FROM THE MARK AS SHOWN. THE MARK CONSISTS OF RECTANGULAR SHAPES NEXT TO THE WORDS "SOURCE LOGISTICS".

FOR GLOBAL TRANSPORTATION OF FREIGHT FOR OTHERS BY ALL AVAILABLE MEANS; TRANSPORTATION OF PASSENGERS AND/OR GOODS BY TRUCK TRAIN OR AIR; WAREHOUSING SERVICES, NAMELY, STORAGE, DISTRIBUTION, PICK-UP, AND PACKING FOR SHIPMENT OF DOCUMENTS, PACKAGES, RAW MATERIALS, AND OTHER FREIGHT FOR OTHERS (U.S. CLS. 100 AND 105).

FIRST USE 11-21-2011; IN COMMERCE 11-21-2011.
SUE LAWRENCE, EXAMINING ATTORNEY

SN 85-490,212. UNIVERSAL JET AVIATION, INC., BOCA RATON, FL. FILED 12-8-2011.



NO CLAIM IS MADE TO THE EXCLUSIVE RIGHT TO USE "JET", APART FROM THE MARK AS SHOWN.

THE MARK CONSISTS OF A LARGE STYLIZED "U" WITH A DIAGONAL STREAK SUGGESTING A CONTRAIL AFT OF A JET DEPARTING VERTICALLY AND TO THE RIGHT. TO THE RIGHT OF THE STYLIZED "U", "UNIVERSAL" APPEARS EVENLY-SPACED, ALL CAPITAL, SANS-SERIF, ITALICIZED FONT.

FOR AIRLINE TRANSPORTATION SERVICES (U.S. CLS. 100 AND 105).

FIRST USE 0-0-2008; IN COMMERCE 0-0-2008.
WILLIAM BRECKENFELD, EXAMINING ATTORNEY

CLASS 39—(Continued).

SN 85-504,247. SNOWLAND FREIGHT SERVICES, INC., ST. PAUL, MN. FILED 12-27-2011.

SNOWLAND FREIGHT SERVICES

THE MARK CONSISTS OF STANDARD CHARACTERS WITHOUT CLAIM TO ANY PARTICULAR FONT, STYLE, SIZE, OR COLOR.

NO CLAIM IS MADE TO THE EXCLUSIVE RIGHT TO USE "FREIGHT SERVICES", APART FROM THE MARK AS SHOWN.

FOR LOGISTICS SERVICES, NAMELY, PROVIDING TRANSPORTATION AND DELIVERY OF PACKAGES, RAW MATERIALS, AND OTHER FREIGHT FOR OTHERS (U.S. CLS. 100 AND 105).

FIRST USE 0-0-1987; IN COMMERCE 0-0-1987.
TASNEEM HUSSAIN, EXAMINING ATTORNEY

SN 85-505,016. THE ROSEMYR CORPORATION, HENDERSON, NC. FILED 12-28-2011.

SELF STORAGE MADE EASY

THE MARK CONSISTS OF STANDARD CHARACTERS WITHOUT CLAIM TO ANY PARTICULAR FONT, STYLE, SIZE, OR COLOR.

NO CLAIM IS MADE TO THE EXCLUSIVE RIGHT TO USE "SELF STORAGE", APART FROM THE MARK AS SHOWN.

FOR MOVING AND STORAGE SERVICES, NAMELY, RENTAL OF WAREHOUSE STORAGE SPACE, STORAGE OF GOODS, DELIVERY OF HOUSEHOLD, COMMERCIAL AND OFFICE ITEMS, AND RECREATIONAL VEHICLES; AND PICK UP BY MOTOR VEHICLE OF SELF-CONTAINED, PORTABLE STORAGE UNITS (U.S. CLS. 100 AND 105).

FIRST USE 9-30-2005; IN COMMERCE 11-30-2005.
KATINA MISTER, EXAMINING ATTORNEY

SN 85-505,925. PLEASANT AIRCRAFT LEASING, LLC, HONOLULU, HI. FILED 12-29-2011.

ROYAL PACIFIC AIR

THE MARK CONSISTS OF STANDARD CHARACTERS WITHOUT CLAIM TO ANY PARTICULAR FONT, STYLE, SIZE, OR COLOR.

NO CLAIM IS MADE TO THE EXCLUSIVE RIGHT TO USE "AIR", APART FROM THE MARK AS SHOWN.

FOR AIR CHARTER SERVICES; AIR CHARTER TRANSPORTATION SERVICES; AIR TRANSPORTATION OF PASSENGERS AND FREIGHT; AIRLINE TRANSPORTATION SERVICES; AIRPLANE CHARTERING (U.S. CLS. 100 AND 105).

KARANENDRA S. CHHINA, EXAMINING ATTORNEY

CLASS 39—(Continued).

SN 85-506,677. FORTE LIMOUSINE LLC, DBA FORTE LIMOUSINE, BEVERLY HILLS, CA. FILED 12-30-2011.

Forte Limousine

THE MARK CONSISTS OF STANDARD CHARACTERS WITHOUT CLAIM TO ANY PARTICULAR FONT, STYLE, SIZE, OR COLOR.

NO CLAIM IS MADE TO THE EXCLUSIVE RIGHT TO USE "LIMOUSINE", APART FROM THE MARK AS SHOWN.

FOR CHAUFFEUR DRIVEN CAR HIRE SERVICES; CHAUFFEUR SERVICES; LIMOUSINE SERVICES (U.S. CLS. 100 AND 105).

FIRST USE 6-1-2011; IN COMMERCE 8-1-2011.
LINDA LAVACHE, EXAMINING ATTORNEY

CLASS 39—(Continued).

SN 85-508,661. RICARDO BUIL BUIL, AINSA (HUESCA), SPAIN, FILED 1-4-2012.

CENTRALDERESERVAS.COM

THE MARK CONSISTS OF STANDARD CHARACTERS WITHOUT CLAIM TO ANY PARTICULAR FONT, STYLE, SIZE, OR COLOR.

OWNER OF U.S. REG. NO. 3,047,731.

THE ENGLISH TRANSLATION OF "CENTRAL DE RESERVAS" IN THE MARK IS "CENTER OF RESERVATIONS" OR "CENTRAL RESERVATIONS".

SEC. 2(F).

FOR TRAVEL INFORMATION SERVICES; PROVIDING INFORMATION ABOUT AUTOMOBILES FOR LEASE, TRAVEL, AND AIRLINES BY MEANS OF THE INTERNET; PROVIDING LINKS TO WEB SITES OF OTHERS FEATURING TRAVEL AND AIRLINE SERVICES, TRAVEL TOURS AND BOOKINGS (U.S. CLS. 100 AND 105).

FIRST USE 11-0-1998; IN COMMERCE 11-0-1998.

JAY FLOWERS, EXAMINING ATTORNEY

SN 85-509,529. MIDWAY RENT A CAR, INC., LOS ANGELES, CA. FILED 1-5-2012.

WILSHIRE LIMOUSINE SERVICES

THE MARK CONSISTS OF STANDARD CHARACTERS WITHOUT CLAIM TO ANY PARTICULAR FONT, STYLE, SIZE, OR COLOR.

OWNER OF U.S. REG. NO. 3,759,509.

NO CLAIM IS MADE TO THE EXCLUSIVE RIGHT TO USE "LIMOUSINE SERVICES", APART FROM THE MARK AS SHOWN.

SEC. 2(F).

FOR LIMOUSINE AND TRANSPORTATION RESERVATION SERVICES (U.S. CLS. 100 AND 105).

FIRST USE 1-1-2007; IN COMMERCE 1-1-2007.

DOMINICK J. SALEMI, EXAMINING ATTORNEY

SN 85-506,872. DRIVER PLEASE, INC., ROSEVILLE, CA. FILED 12-31-2011.

DRIVER PLEASE

THE MARK CONSISTS OF STANDARD CHARACTERS WITHOUT CLAIM TO ANY PARTICULAR FONT, STYLE, SIZE, OR COLOR.

FOR CHARTERING OF CARS AND BUSES; CHAUFFEUR SERVICES; DESIGNATED DRIVER SERVICES, NAMELY, PROVIDING DRIVERS FOR INDIVIDUALS WHOSE ABILITY TO DRIVE THEIR CARS IS IMPAIRED; HIRED CAR TRANSPORT; LIMOUSINE SERVICES; VEHICLE-DRIVING SERVICES (U.S. CLS. 100 AND 105).

FIRST USE 12-13-2010; IN COMMERCE 12-13-2010.
JESSICA A. POWERS, EXAMINING ATTORNEY

SN 85-509,808. GRAND CANYON TOUR COMPANY, LAS VEGAS, NV. FILED 1-5-2012.

Spirit of the canyon

THE MARK CONSISTS OF STANDARD CHARACTERS WITHOUT CLAIM TO ANY PARTICULAR FONT, STYLE, SIZE, OR COLOR.

FOR TOUR GUIDE SERVICES (U.S. CLS. 100 AND 105).

FIRST USE 4-4-1996; IN COMMERCE 4-4-1996.

JORDAN BAKER, EXAMINING ATTORNEY

CLASS 39—(Continued).

SN 85-509,850. GRAND CANYON TOUR COMPANY, LAS VEGAS, NV. FILED 1-5-2012.

Vipspirit

THE MARK CONSISTS OF STANDARD CHARACTERS WITHOUT CLAIM TO ANY PARTICULAR FONT, STYLE, SIZE, OR COLOR.
FOR TOUR GUIDE SERVICES (U.S. CLS. 100 AND 105).
FIRST USE 2-1-2011; IN COMMERCE 7-15-2011.
JORDAN BAKER, EXAMINING ATTORNEY

CLASS 39—(Continued).

SN 85-511,978. NCL CORPORATION LTD., MIAMI, FL. FILED 1-9-2012.

SEE THE WORLD THE NORWEGIAN WAY

THE MARK CONSISTS OF STANDARD CHARACTERS WITHOUT CLAIM TO ANY PARTICULAR FONT, STYLE, SIZE, OR COLOR.
OWNER OF U.S. REG. NOS. 1,548,650, 2,622,217 AND OTHERS.
SEC. 2(F) AS TO "NORWEGIAN".
FOR ARRANGING OF CRUISES; CRUISE SHIP SERVICES (U.S. CLS. 100 AND 105).
ELISSA GARBER KON, EXAMINING ATTORNEY

SN 85-510,111. THE DIVE APP, INC., TAMPA, FL. FILED 1-6-2012.

THE DIVE APP

THE MARK CONSISTS OF STANDARD CHARACTERS WITHOUT CLAIM TO ANY PARTICULAR FONT, STYLE, SIZE, OR COLOR.
NO CLAIM IS MADE TO THE EXCLUSIVE RIGHT TO USE "DIVE", APART FROM THE MARK AS SHOWN.
FOR CONDUCTING DIVING CHARTERS; CONDUCTING FISHING CHARTERS (U.S. CLS. 100 AND 105).
CHRISTOPHER BUONGIORNO, EXAMINING ATTORNEY

SN 85-512,078. PASSPORT MEDICAL INC., DELTA, B.C., CANADA, FILED 1-9-2012.

PASSPORT MEDICAL

THE MARK CONSISTS OF STANDARD CHARACTERS WITHOUT CLAIM TO ANY PARTICULAR FONT, STYLE, SIZE, OR COLOR.
NO CLAIM IS MADE TO THE EXCLUSIVE RIGHT TO USE "MEDICAL", APART FROM THE MARK AS SHOWN.
FOR MEDICAL TOURISM SERVICES, NAMELY, MAKING TRANSPORTATION RESERVATIONS AND BOOKINGS FOR TRAVEL TO ANOTHER COUNTRY IN ORDER TO OBTAIN HEALTH CARE (U.S. CLS. 100 AND 105).
FIRST USE 9-17-2009; IN COMMERCE 2-24-2010.
ANNE E. GUSTASON, EXAMINING ATTORNEY

SN 85-511,951. NCL CORPORATION LTD., MIAMI, FL. FILED 1-9-2012.

THE NORWEGIAN WAY

THE MARK CONSISTS OF STANDARD CHARACTERS WITHOUT CLAIM TO ANY PARTICULAR FONT, STYLE, SIZE, OR COLOR.
OWNER OF U.S. REG. NOS. 1,548,650, 2,622,217 AND OTHERS.
SEC. 2(F) AS TO "NORWEGIAN".
FOR ARRANGING OF CRUISES; CRUISE SHIP SERVICES (U.S. CLS. 100 AND 105).
ELISSA GARBER KON, EXAMINING ATTORNEY

SN 85-513,503. JUSTIN XAVIER HOWE, OAKDALE, NY. FILED 1-11-2012.

MeetingPointz.com

THE MARK CONSISTS OF STANDARD CHARACTERS WITHOUT CLAIM TO ANY PARTICULAR FONT, STYLE, SIZE, OR COLOR.
FOR TRAVEL AGENCY SERVICES, NAMELY, MAKING RESERVATIONS AND BOOKINGS FOR TRANSPORTATION (U.S. CLS. 100 AND 105).
FIRST USE 1-8-2012; IN COMMERCE 1-8-2012.
ELLEN PERKINS, EXAMINING ATTORNEY

CLASS 39—(Continued).

SN 85-514,567. GEMCAP TRUCKING, INC., MIAMI, FL. FILED 1-11-2012.

YOUR VOYAGE TO WORLD CLASS
TRANSPORTATION

THE MARK CONSISTS OF STANDARD CHARACTERS WITHOUT CLAIM TO ANY PARTICULAR FONT, STYLE, SIZE, OR COLOR.

FOR TRUCKING SERVICES, NAMELY, HAULING OF DRY, REFRIGERATED, HAZARDOUS AND BONDED FREIGHT; SUPPLY CHAIN LOGISTICS AND REVERSE LOGISTICS SERVICES, NAMELY, STORAGE, TRANSPORTATION AND DELIVERY OF GOODS FOR OTHERS BY AIR, RAIL, SHIP OR TRUCK (U.S. CLS. 100 AND 105).

FIRST USE 3-1-2011; IN COMMERCE 3-1-2011.
LAURIE MAYES, EXAMINING ATTORNEY

SN 85-514,663. HOLE N THE SKY LLC, AUSTIN, TX. FILED 1-12-2012.

SKY SPRINGS

THE MARK CONSISTS OF STANDARD CHARACTERS WITHOUT CLAIM TO ANY PARTICULAR FONT, STYLE, SIZE, OR COLOR.

FOR PUBLIC UTILITY SERVICES IN THE NATURE OF WATER DISTRIBUTION; WATER DISTRIBUTION; WATER DISTRIBUTION AND SUPPLY; WATER SUPPLY; WATER SUPPLY AND DISTRIBUTION SERVICES (U.S. CLS. 100 AND 105).

SUE LAWRENCE, EXAMINING ATTORNEY

CLASS 39—(Continued).

SN 85-515,656. DUMPSTER MAN, INC., WASHINGTON, MI. FILED 1-13-2012.



NO CLAIM IS MADE TO THE EXCLUSIVE RIGHT TO USE "LOCAL DUMPSTER RENTAL", APART FROM THE MARK AS SHOWN.

THE COLOR(S) RED, BLACK, BLUE, WHITE, SILVER, TAN AND BROWN IS/ARE CLAIMED AS A FEATURE OF THE MARK.

THE MARK CONSISTS OF LOCAL DUMPSTER RENTAL MAN IN SILVER STYLIZED FONT SHADED WITH BLACK BEING HELD BY A MAN BY BLACK CHAINS. MAN IS TAN WITH BROWN HAIR WEARING RED OVERALLS WITH BLACK STAIN MARKS, A BLUE SHIRT OUTLINED PARTIALLY IN BLACK WITH A WHITE COLLAR AND CUFFS AND BLACK SHOES.

FOR TRASH SERVICES, NAMELY, RENTAL OF DUMPSTERS (U.S. CLS. 100 AND 105).

FIRST USE 12-0-2010; IN COMMERCE 12-0-2010.
ALAIN LAPTER, EXAMINING ATTORNEY

SN 85-515,913. AMERICAN ELECTRIC POWER COMPANY, INC., COLUMBUS, OH. FILED 1-13-2012.

TRANSOURCE

THE MARK CONSISTS OF STANDARD CHARACTERS WITHOUT CLAIM TO ANY PARTICULAR FONT, STYLE, SIZE, OR COLOR.

FOR DISTRIBUTION AND TRANSMISSION OF ELECTRICITY; LEASING THE USE OF POWER LINES TO THIRD PARTIES FOR THE TRANSMISSION OF ELECTRICITY; UTILITY SERVICES, NAMELY, TRANSMISSION OF ELECTRICITY (U.S. CLS. 100 AND 105).

DEBORAH LOBO, EXAMINING ATTORNEY

CLASS 40—MATERIAL TREATMENT

SN 76-708,776. NATIONAL GALVANIZING LP, ELK GROVE VILLAGE, IL. FILED 8-17-2011.

INNERCOTE

THE MARK CONSISTS OF STANDARD CHARACTERS WITHOUT CLAIM TO ANY PARTICULAR FONT, STYLE, SIZE, OR COLOR.
OWNER OF U.S. REG. NO. 1,617,320.
FOR GALVANNEALING IRON OR STEEL (U.S. CLS. 100, 103 AND 106).
FIRST USE 7-17-1989; IN COMMERCE 7-17-1989.
WENDY JUN, EXAMINING ATTORNEY

SN 76-710,303. GALBREATH, ROD W., MARION, OH. FILED 1-18-2012.



NO CLAIM IS MADE TO THE EXCLUSIVE RIGHT TO USE "METALWORKS", APART FROM THE MARK AS SHOWN.
THE MARK CONSISTS OF THE STYLIZED WORDING "CENMAC" ACROSS THE BOTTOM OF A STYLIZED INCOMPLETE CIRCLE CONTAINING THE WORDING "METALWORKS".
FOR TREATMENT OF MATERIALS TO THE ORDER AND SPECIFICATION OF OTHERS, NAMELY, METAL PRESSING, WELDING, METAL FABRICATION, ASSEMBLY OF PRODUCTS FOR OTHERS, STAMPING, CUTTING, MILLING, TURNING, DRILLING, AND GRINDING (U.S. CLS. 100, 103 AND 106).
FIRST USE 1-0-2011; IN COMMERCE 1-0-2011.
ELLEN B. AWRICH, EXAMINING ATTORNEY

CLASS 40—(Continued).

SN 77-396,721. SIGNET ARMORLITE EUROPE LIMITED, GLOUCESTER, UNITED KINGDOM, FILED 2-14-2008.



OWNER OF ERPN CMNTY TM OFC REG. NO. 006054597, DATED 8-8-2011, EXPIRES 8-8-2021.
NO CLAIM IS MADE TO THE EXCLUSIVE RIGHT TO USE "VISION", APART FROM THE MARK AS SHOWN.
THE COLOR(S) BLACK AND ORANGE IS/ARE CLAIMED AS A FEATURE OF THE MARK.
THE MARK CONSISTS OF THE COLOR BLACK IN THE WORDING "VISION" AND THE DESIGN IN ORANGE OF TWO CURVED LINES FORMING A GENERAL OVAL DESIGN.
FOR OPTICAL LENS GRINDING; GRINDING, POLISHING AND TINTING OF GLASS LENSES; OPTICAL GLASS GRINDING SERVICES; CUSTOM MANUFACTURING AND CUSTOM ASSEMBLY SERVICES RELATING TO THE PROVISION OF OPTICAL PHARMACEUTICAL AND MEDICAL PRODUCTS; CUSTOM MANUFACTURING AND CUSTOM ASSEMBLY SERVICES RELATING TO HEARING AIDS AND HEARING RELATED APPARATUS, INSTRUMENTS AND ACCESSORIES (U.S. CLS. 100, 103 AND 106).
ANN E. SAPPENFIELD, EXAMINING ATTORNEY

SN 79-104,330. FURMANITE INTERNATIONAL LIMITED, UNITED KINGDOM, FILED 9-19-2011.



OWNER OF INTERNATIONAL REGISTRATION 1095245 DATED 9-19-2011, EXPIRES 9-19-2021.
THE MARK CONSISTS OF THE LETTERING "SLM" WITH A RECTANGULAR BAND UNDERLINING THE WORDING AND AN ASTERISK STAR DESIGN WITH A LINE, AT THE END OF WHICH IS AN INVERTED TRIANGLE, EXTENDING FROM THE ASTERISK STAR DESIGN INTO THE LETTER "M".
FOR CUTTING, DRILLING, MILLING, BORING, GRINDING, SHAPING AND FINISHING OF METALS (U.S. CLS. 100, 103 AND 106).
DOMINIC J. FERRAIUOLO, EXAMINING ATTORNEY

CLASS 40—(Continued).

SN 85-295,337. UNITED STATES STEEL CORPORATION, PITTSBURGH, PA. FILED 4-14-2011.

**MAKING STEEL WORLD
COMPETITIVE BUILDING
VALUE**

THE MARK CONSISTS OF STANDARD CHARACTERS WITHOUT CLAIM TO ANY PARTICULAR FONT, STYLE, SIZE, OR COLOR.

NO CLAIM IS MADE TO THE EXCLUSIVE RIGHT TO USE "MAKING STEEL" AND "WORLD COMPETITIVE", APART FROM THE MARK AS SHOWN.

FOR CUSTOM MANUFACTURE OF STEEL AND FLAT-ROLLED, COATED, AND TUBULAR STEEL PRODUCTS; CUSTOM MANUFACTURE OF GENERAL PRODUCT LINES IN THE FIELD OF STEEL PIPE AND TUBING (U.S. CLS. 100, 103 AND 106).

FIRST USE 1-2-2002; IN COMMERCE 1-31-2002.
REBECCA SMITH, EXAMINING ATTORNEY

SN 85-318,143. APPLIANCE RECYCLING CENTERS OF AMERICA, INC., MINNEAPOLIS, MN. FILED 5-11-2011.

SMARTVALVE

THE MARK CONSISTS OF STANDARD CHARACTERS WITHOUT CLAIM TO ANY PARTICULAR FONT, STYLE, SIZE, OR COLOR.

FOR REFRIGERANT RECLAMATION SERVICES (U.S. CLS. 100, 103 AND 106).

TARA PATE, EXAMINING ATTORNEY

SN 85-343,599. CALIFORNIA CAKE CLUB, SPRING VALLEY, CA. FILED 6-10-2011.

Cake Camp

THE MARK CONSISTS OF STANDARD CHARACTERS WITHOUT CLAIM TO ANY PARTICULAR FONT, STYLE, SIZE, OR COLOR.

NO CLAIM IS MADE TO THE EXCLUSIVE RIGHT TO USE "CAKE", APART FROM THE MARK AS SHOWN.

FOR CUSTOM CAKE DECORATING SERVICES (U.S. CLS. 100, 103 AND 106).

FIRST USE 1-1-2004; IN COMMERCE 1-1-2004.
HOWARD B. LEVINE, EXAMINING ATTORNEY

CLASS 40—(Continued).

SN 85-457,597. SPRINGBOARD DEVELOPMENT COMPANY INC., ROCHESTER, MN. FILED 10-27-2011.

AFFORDABLEBUTTONS.COM

THE MARK CONSISTS OF STANDARD CHARACTERS WITHOUT CLAIM TO ANY PARTICULAR FONT, STYLE, SIZE, OR COLOR.

OWNER OF U.S. REG. NO. 3,711,517.
FOR CUSTOM IMPRINTING OF PIN BACKED BUTTONS WITH MESSAGES; CUSTOM MANUFACTURE OF PIN BACKED BUTTONS (U.S. CLS. 100, 103 AND 106).

FIRST USE 9-1-2003; IN COMMERCE 9-1-2003.
PAUL MORENO, EXAMINING ATTORNEY

SN 85-476,163. BOOMERANG PROMOTIONS, INC., ALEXANDRIA, VA. FILED 11-18-2011.

Boomerang Tees

THE MARK CONSISTS OF STANDARD CHARACTERS WITHOUT CLAIM TO ANY PARTICULAR FONT, STYLE, SIZE, OR COLOR.

NO CLAIM IS MADE TO THE EXCLUSIVE RIGHT TO USE "TEES", APART FROM THE MARK AS SHOWN.

FOR CUSTOMIZED PRINTING ON ARTICLES OF CLOTHING, NAMELY, WEARING APPAREL, TO THE ORDER AND SPECIFICATION OF OTHERS (U.S. CLS. 100, 103 AND 106).

TARAH HARDY, EXAMINING ATTORNEY

SN 85-481,280. FINAL FRONTIER CONSTRUCTION LLC, ASHTON, MD. FILED 11-28-2011.

Final Frontier Construction

THE MARK CONSISTS OF STANDARD CHARACTERS WITHOUT CLAIM TO ANY PARTICULAR FONT, STYLE, SIZE, OR COLOR.

NO CLAIM IS MADE TO THE EXCLUSIVE RIGHT TO USE "CONSTRUCTION", APART FROM THE MARK AS SHOWN.

FOR CUSTOM CONSTRUCTION OF SPACECRAFT HULLS AND ENVIRONMENTAL REMEDIATION DEVICES (U.S. CLS. 100, 103 AND 106).

FIRST USE 7-1-2011; IN COMMERCE 7-1-2011.
DARRYL SPRUILL, EXAMINING ATTORNEY

CLASS 40—(Continued).

SN 85-482,570. NAPIER-REID LTD, DBA NAPIER-REID LTD, MARKHAM, CANADA, FILED 11-29-2011.

DI FLOAT

THE MARK CONSISTS OF STANDARD CHARACTERS WITHOUT CLAIM TO ANY PARTICULAR FONT, STYLE, SIZE, OR COLOR.

OWNER OF CANADA REG. NO. TMA772248, DATED 7-16-2010, EXPIRES 7-16-2025.

NO CLAIM IS MADE TO THE EXCLUSIVE RIGHT TO USE "FLOAT", APART FROM THE MARK AS SHOWN.

FOR TREATMENT OF WASTE WATER (U.S. CLS. 100, 103 AND 106).

FIRST USE 1-1-2007; IN COMMERCE 1-1-2007.

CIMMERIAN COLEMAN, EXAMINING ATTORNEY

SN 85-483,234. ALWAYS SHRED, INC., RALEIGH, NC. FILED 11-30-2011.

ALLWAYS SHRED

THE MARK CONSISTS OF STANDARD CHARACTERS WITHOUT CLAIM TO ANY PARTICULAR FONT, STYLE, SIZE, OR COLOR.

NO CLAIM IS MADE TO THE EXCLUSIVE RIGHT TO USE "SHRED", APART FROM THE MARK AS SHOWN.

FOR DOCUMENT SHREDDING SERVICES; HARD DRIVE SHREDDING SERVICES (U.S. CLS. 100, 103 AND 106).

KIMBERLY PARKS, EXAMINING ATTORNEY

SN 85-492,683. TONER MACHINING TECHNOLOGIES, INC., MORGANTON, NC. FILED 12-12-2011.

TONER MACHINING TECHNOLOGIES

THE MARK CONSISTS OF STANDARD CHARACTERS WITHOUT CLAIM TO ANY PARTICULAR FONT, STYLE, SIZE, OR COLOR.

NO CLAIM IS MADE TO THE EXCLUSIVE RIGHT TO USE "MACHINING TECHNOLOGIES", APART FROM THE MARK AS SHOWN.

FOR CUSTOM MANUFACTURE OF MACHINES, HYDRAULIC, PNEUMATIC AND MANUAL WORKHOLDING FIXTURES, AND GAGES (U.S. CLS. 100, 103 AND 106).

FIRST USE 11-30-2001; IN COMMERCE 11-30-2001.

EMILY CARLSEN, EXAMINING ATTORNEY

CLASS 40—(Continued).

SN 85-501,072. BAZZ HOUSTON CO., GARDEN GROVE, CA. FILED 12-21-2011.



OWNER OF U.S. REG. NO. 1,669,763.

THE COLOR(S) BLACK AND RED IS/ARE CLAIMED AS A FEATURE OF THE MARK.

THE MARK CONSISTS OF THE LETTERS "BH" APPEARING IN THE COLOR RED WITH THE LEFT STEM OF THE LETTER "H" SHARING THE LEFT STEM OF THE LETTER "B" ALL ENCASED IN A BLACK RECTANGLE APPEARING TO THE LEFT OF THE WORDING "BAZZ HOUSTON" APPEARING WITH BLACK LETTERS.

FOR CUSTOM MANUFACTURING OF COIL AND FLAT SPRINGS AND WIRE FORMS, METAL STAMPING, TOOLING AND ASSEMBLY (U.S. CLS. 100, 103 AND 106).

FIRST USE 1-1-1965; IN COMMERCE 1-1-1965.

SAMUEL E. SHARPER JR., EXAMINING ATTORNEY

SN 85-504,008. RILEY, SUMMER E, AKA SUMMER LOVE, NEW ORLEANS, LA. FILED 12-27-2011.



THE COLOR(S) BLACK, WHITE AND RED IS/ARE CLAIMED AS A FEATURE OF THE MARK.

THE MARK CONSISTS OF WHITE WORDING ON A BLACK BACKGROUND, "DOPE LOVE ADDICTIONS". THE LETTER "O" IN "LOVE" IS REPLACED BY A RED HEART.

FOR IMPRINTING OF DECORATIVE DESIGNS ON T-SHIRTS (U.S. CLS. 100, 103 AND 106).

DOMINIC J. FERRAIUOLO, EXAMINING ATTORNEY

CLASS 40—(Continued).

SN 85-509,874. BURGE, JAMES C., SAN MARINO, CA. FILED 1-5-2012.

Pure Order Brewing Company

THE MARK CONSISTS OF STANDARD CHARACTERS WITHOUT CLAIM TO ANY PARTICULAR FONT, STYLE, SIZE, OR COLOR.

NO CLAIM IS MADE TO THE EXCLUSIVE RIGHT TO USE "PURE" AND "BREWING COMPANY", APART FROM THE MARK AS SHOWN.

FOR BREWERY SERVICES (U.S. CLS. 100, 103 AND 106).

EDWARD NELSON, EXAMINING ATTORNEY

SN 85-510,495. H&W PRINTING, INC., MARIETTA, GA. FILED 1-6-2012.



THE MARK CONSISTS OF A STYLIZED IMAGE OF A RUNNING CHEETAH.

FOR PRINTING SERVICES; BINDERY SERVICES FOR OTHERS, NAMELY, COLLATING, FOLDING, STAPLING, PERFORATING, CUTTING AND BINDING OF PRINTED, PHOTOCOPIED AND TYPEWRITTEN MATERIALS; DIGITAL PRINTING SERVICES (U.S. CLS. 100, 103 AND 106).

FIRST USE 0-0-2011; IN COMMERCE 0-0-2011.

AMY KELLY, EXAMINING ATTORNEY

SN 85-510,546. H&W PRINTING, INC., MARIETTA, GA. FILED 1-6-2012.

SERIOUSLY FAST

THE MARK CONSISTS OF STANDARD CHARACTERS WITHOUT CLAIM TO ANY PARTICULAR FONT, STYLE, SIZE, OR COLOR.

FOR PRINTING SERVICES; BINDERY SERVICES FOR OTHERS, NAMELY, COLLATING, FOLDING, STAPLING, PERFORATING, CUTTING AND BINDING OF PRINTED, PHOTOCOPIED AND TYPEWRITTEN MATERIALS; DIGITAL PRINTING SERVICES (U.S. CLS. 100, 103 AND 106).

FIRST USE 0-0-2011; IN COMMERCE 0-0-2011.

AMY KELLY, EXAMINING ATTORNEY

CLASS 40—(Continued).

SN 85-511,614. SICKELS, JON, LAWRENCEVILLE, GA. FILED 1-9-2012.



NO CLAIM IS MADE TO THE EXCLUSIVE RIGHT TO USE "ENTERPRISES", APART FROM THE MARK AS SHOWN.

THE MARK CONSISTS OF A STAR BURST WITH THE STYLIZED TEXT "RAINBO ENTERPRISES EVERYTHING UNDER THE RAINBO".

FOR CUSTOM IMPRINTING OF COMPANY NAMES AND LOGOS ON THE GOODS OF OTHERS, NAMELY, ON PROMOTIONAL MERCHANDISE, APPAREL AND CORPORATE GIFTS (U.S. CLS. 100, 103 AND 106).

FIRST USE 3-0-2010; IN COMMERCE 5-0-2010.

KATHY DE JONGE, EXAMINING ATTORNEY

SN 85-512,491. NOBIS WORKS, INC., MARIETTA, GA. FILED 1-10-2012.

REWORX

THE MARK CONSISTS OF STANDARD CHARACTERS WITHOUT CLAIM TO ANY PARTICULAR FONT, STYLE, SIZE, OR COLOR.

FOR RECYCLING OF ELECTRONICS (U.S. CLS. 100, 103 AND 106).

KAPIL BHANOT, EXAMINING ATTORNEY

SN 85-512,666. FORTNER, MILLIE, STATESBORO, GA. FILED 1-10-2012.



THE MARK CONSISTS OF A DESIGN OF A .357 MODEL GUN WITH THE WORDS "DO YOU SPEAK" IN THE BARREL AND ".357" COMING OUT OF THE BARREL.

FOR SCREEN PRINTING (U.S. CLS. 100, 103 AND 106).

JORDAN BAKER, EXAMINING ATTORNEY

CLASS 40—(Continued).

SN 85-512,764. FREELON, TERESA, BOLINGBROOK, IL. AND FREELON, WAYMAN K., BOLINGBROOK, IL. FILED 1-10-2012.

BouTEEques

THE MARK CONSISTS OF STANDARD CHARACTERS WITHOUT CLAIM TO ANY PARTICULAR FONT, STYLE, SIZE, OR COLOR.

FOR IMPRINTING MESSAGES ON T-SHIRTS; IMPRINTING MESSAGES ON WEARING APPAREL, ACCESSORIES AND MUGS; IMPRINTING OF DECORATIVE DESIGNS ON T-SHIRTS; T-SHIRT EMBROIDERING SERVICES (U.S. CLS. 100, 103 AND 106). FIRST USE 12-11-2011; IN COMMERCE 12-11-2011. AMY KELLY, EXAMINING ATTORNEY

SN 85-515,222. DINSMORE & ASSOCIATES, INC., COSTA MESA, CA. FILED 1-12-2012.

DFP

THE MARK CONSISTS OF STANDARD CHARACTERS WITHOUT CLAIM TO ANY PARTICULAR FONT, STYLE, SIZE, OR COLOR.

FOR PROTOTYPE FABRICATION OF NEW PRODUCTS FOR OTHERS (U.S. CLS. 100, 103 AND 106). FIRST USE 9-1-2009; IN COMMERCE 9-1-2009. B. PARADEWELAI, EXAMINING ATTORNEY

SN 85-515,385. ARIDUS WINE COMPANY LLC, CAVE CREEK, CA. FILED 1-12-2012.

Aridus

THE MARK CONSISTS OF STANDARD CHARACTERS WITHOUT CLAIM TO ANY PARTICULAR FONT, STYLE, SIZE, OR COLOR.

THE ENGLISH TRANSLATION OF "ARIDUS" IN THE MARK IS "PARCHED" OR "ARID". FOR CUSTOM PRODUCTION OF WINE FOR OTHERS (U.S. CLS. 100, 103 AND 106). SUNG IN, EXAMINING ATTORNEY

CLASS 40—(Continued).

SN 85-515,662. IN-PIPE TECHNOLOGY COMPANY, INC., WHEATON, IL. FILED 1-13-2012.

IN-PIPE

THE MARK CONSISTS OF STANDARD CHARACTERS WITHOUT CLAIM TO ANY PARTICULAR FONT, STYLE, SIZE, OR COLOR.

FOR WASTE WATER TREATMENT SERVICES AND PROVIDING TECHNICAL CONSULTATION IN CONNECTION THEREWITH (U.S. CLS. 100, 103 AND 106). FIRST USE 10-31-2005; IN COMMERCE 10-31-2005. ROBERT C. CLARK JR., EXAMINING ATTORNEY

SN 85-520,351. FREEDA, INC., GREAT NECK, NY. FILED 1-19-2012.

FREEDA

THE MARK CONSISTS OF STANDARD CHARACTERS WITHOUT CLAIM TO ANY PARTICULAR FONT, STYLE, SIZE, OR COLOR.

FOR FITTING OF WIGS (U.S. CLS. 100, 103 AND 106). FIRST USE 0-0-1965; IN COMMERCE 0-0-1965. CURTIS FRENCH, EXAMINING ATTORNEY

SN 85-532,489. CHESAPEAKE ENERGY CORPORATION, OKLAHOMA CITY, OK. FILED 2-2-2012.

COMPASS MANUFACTURING

THE MARK CONSISTS OF STANDARD CHARACTERS WITHOUT CLAIM TO ANY PARTICULAR FONT, STYLE, SIZE, OR COLOR.

NO CLAIM IS MADE TO THE EXCLUSIVE RIGHT TO USE "MANUFACTURING", APART FROM THE MARK AS SHOWN.

FOR MANUFACTURING SERVICES FOR OTHERS IN THE FIELD OF GAS COMPRESSION AND RELATED PRODUCTION EQUIPMENT (U.S. CLS. 100, 103 AND 106).

FIRST USE 11-21-2007; IN COMMERCE 11-21-2007. KATHERINE CHANG, EXAMINING ATTORNEY

CLASS 41—EDUCATION AND ENTERTAINMENT

SN 76-707,806. MICHAEL AND MARISA, LLC, LYNNFIELD, MA. FILED 6-1-2011.

MICHAEL AND MARISA

THE MARK CONSISTS OF STANDARD CHARACTERS WITHOUT CLAIM TO ANY PARTICULAR FONT, STYLE, SIZE, OR COLOR.

THE NAMES "MICHAEL" AND "MARISA" REFER TO MICHAEL KOUROUBACALIS AND MARISA KOUROUBACALIS, WHOSE CONSENTS ARE OF RECORD.

FOR ENTERTAINMENT IN THE NATURE OF LIVE PERFORMANCES BY A GROUP (U.S. CLS. 100, 101 AND 107).

FIRST USE 0-0-2005; IN COMMERCE 0-0-2005.
PAUL E. FAHRENKOPF, EXAMINING ATTORNEY

SN 76-708,147. OCEAN CORPORATION, THE, HOUSTON, TX. FILED 6-27-2011.



OWNER OF U.S. REG. NOS. 2,324,169, 2,326,224 AND 2,360,285.

NO CLAIM IS MADE TO THE EXCLUSIVE RIGHT TO USE "NONDESTRUCTIVE TESTING" OR "CORPORATION", APART FROM THE MARK AS SHOWN.

THE MARK CONSISTS OF THE WORDS "NONDESTRUCTIVE TESTING THE OCEAN CORPORATION" IN A RING SURROUNDING A CIRCLE WITH A HAZARDOUS WASTE TREFOIL SYMBOL OVERLAID WITH A SYMBOL OF AN ATOM WITH THREE ELECTRON ORBITS AROUND A NUCLEUS.

FOR EDUCATIONAL SERVICES, NAMELY, PROVIDING CLASSES AND INSTRUCTION IN COMMERCIAL DIVING AND NONDESTRUCTIVE TESTING; TRAINING IN THE FIELD OF NONDESTRUCTIVE INSPECTION (U.S. CLS. 100, 101 AND 107).

FIRST USE 3-1-2003; IN COMMERCE 3-1-2003.
ALYSSA STEEL, EXAMINING ATTORNEY

CLASS 41—(Continued).

SN 76-708,194. FRITZ TERFLOTH STIFTUNG, D-48149 MUENSTER, FED REP GERMANY, FILED 6-29-2011.

**The Green Pantry**

THE MARK CONSISTS OF THE WORDING "THE GREEN PANTRY" IN STYLIZED FONT WITHIN A DESIGN OF 3 CONCENTRIC CIRCLES FILLED WITH SMALLER CIRCLES AND A TREE DESIGN IN THE CENTER.

FOR EDUCATION, NAMELY, CLASSES AND SEMINARS ALL IN RELATION TO FOODS AND ACTIVITIES THAT ARE BENEFICIAL FOR THE PREVENTION OF ILLNESSES AND AVOIDANCE OF FOODS AND ACTIVITIES WHICH ARE HARMFUL IN THIS RESPECT; EDUCATIONAL AND ENTERTAINMENT SERVICES, NAMELY, PROVIDING MOTIVATIONAL SPEAKING SERVICES IN THE FIELD OF PREVENTION OF ILLNESSES AND AVOIDANCE OF FOODS AND ACTIVITIES WHICH ARE HARMFUL (U.S. CLS. 100, 101 AND 107).

WILLIAM ROSSMAN, EXAMINING ATTORNEY

SN 76-708,587. THE OCEAN CORPORATION, HOUSTON, TX. FILED 8-2-2011.



OWNER OF U.S. REG. NOS. 2,324,169, 2,326,224 AND 2,360,285.

NO CLAIM IS MADE TO THE EXCLUSIVE RIGHT TO USE "CORPORATION", APART FROM THE MARK AS SHOWN.

THE MARK CONSISTS OF THE WORDS "THE OCEAN CORPORATION" IN STYLIZED FONT ABOVE A STYLIZED IMAGE OF A CURLING WAVE.

FOR EDUCATIONAL SERVICES, NAMELY, PROVIDING CLASSES AND INSTRUCTION IN COMMERCIAL DIVING AND NONDESTRUCTIVE TESTING; TRAINING IN THE FIELD OF NONDESTRUCTIVE INSPECTIONS (U.S. CLS. 100, 101 AND 107).

FIRST USE 8-1-1973; IN COMMERCE 8-1-1973.
ALYSSA STEEL, EXAMINING ATTORNEY

CLASS 41—(Continued).

SN 76-709,667. ZEMART LLC, TUCKER, GA. FILED 11-7-2011.

Paint On !

NO CLAIM IS MADE TO THE EXCLUSIVE RIGHT TO USE "PAINT", APART FROM THE MARK AS SHOWN, FOR ART INSTRUCTION (U.S. CLS. 100, 101 AND 107). FIRST USE 10-0-2009; IN COMMERCE 10-0-2009. DAVID HOFFMAN, EXAMINING ATTORNEY

CLASS 41—(Continued).

SN 77-205,252. STORYTELLING PICTURES, LLC, GRAND RAPIDS, MI. FILED 6-13-2007.

STORYTELLING PICTURES

THE MARK CONSISTS OF STANDARD CHARACTERS WITHOUT CLAIM TO ANY PARTICULAR FONT, STYLE, SIZE, OR COLOR.

NO CLAIM IS MADE TO THE EXCLUSIVE RIGHT TO USE "PICTURES", APART FROM THE MARK AS SHOWN, FOR MOTION PICTURE FILM AND VIDEO PRODUCTION SERVICES (U.S. CLS. 100, 101 AND 107). FIRST USE 1-31-1998; IN COMMERCE 1-31-1998. DEIRDRE ROBERTSON, EXAMINING ATTORNEY

SN 76-709,768. RECOVERY - THROUGH CHRIST, MT. JULIET, TN. FILED 11-18-2011.

RECOVERY - THROUGH CHRIST

THE MARK CONSISTS OF STANDARD CHARACTERS WITHOUT CLAIM TO ANY PARTICULAR FONT, STYLE, SIZE, OR COLOR.

FOR EDUCATIONAL SERVICES, NAMELY, CONDUCTING FAITH-BASED CLASSES, SEMINARS, AND WORKSHOPS IN THE FIELD OF ADDICTION AND LIFE STRUGGLE RECOVERY AND DISTRIBUTION OF COURSE MATERIAL IN CONNECTION THEREWITH (U.S. CLS. 100, 101 AND 107). JILL PRATER, EXAMINING ATTORNEY

SN 77-510,441. KENDALL, D. CAEL, MILL VALLEY, CA. FILED 6-27-2008.

FOOTPRINT

THE MARK CONSISTS OF STANDARD CHARACTERS WITHOUT CLAIM TO ANY PARTICULAR FONT, STYLE, SIZE, OR COLOR.

FOR ENTERTAINMENT SERVICES, NAMELY, AN ON-GOING SERIES FEATURING CONTESTANTS AND EVERYDAY PEOPLE ATTEMPTING TO REDUCE THEIR ECOLOGICAL FOOTPRINT PROVIDED THROUGH TELEVISION AND INTERNET MEDIUMS (U.S. CLS. 100, 101 AND 107). RONALD DELGIZZI, EXAMINING ATTORNEY

SN 76-709,786. VOYAGE PRODUCTIONS, LLC, WASHINGTON, DC. FILED 11-18-2011.



NO CLAIM IS MADE TO THE EXCLUSIVE RIGHT TO USE "SOCIAL ENTREPRENEURS", APART FROM THE MARK AS SHOWN.

THE MARK CONSISTS OF A RECTANGLE CARRYING THE TERM "PLAYBACK" WITH TWO LEFT FACING ARROWS, BENEATH THE RECTANGLE ARE THE TERMS "SOCIAL ENTREPRENEURS".

FOR ENTERTAINMENT IN THE NATURE OF AN ONGOING GLOBAL TELEVISION PROGRAM FEATURING BUSINESS MANAGEMENT INNOVATION NEWS AND BUSINESS NEWS IN THE U.S. AND WORLDWIDE (U.S. CLS. 100, 101 AND 107).

ANTHONY RINKER, EXAMINING ATTORNEY

SN 77-602,082. SINGULARITY UNIVERSITY, REDWOOD CITY, CA. FILED 10-28-2008.

SINGULARITY UNIVERSITY

THE MARK CONSISTS OF STANDARD CHARACTERS WITHOUT CLAIM TO ANY PARTICULAR FONT, STYLE, SIZE, OR COLOR.

NO CLAIM IS MADE TO THE EXCLUSIVE RIGHT TO USE "UNIVERSITY", APART FROM THE MARK AS SHOWN.

FOR EDUCATION SERVICES IN THE NATURE OF COURSES AT THE GRADUATE, PROFESSIONAL AND ADVANCED UNIVERSITY LEVELS; EDUCATION SERVICES, NAMELY, PROVIDING LIVE AND ON-LINE SUMMER STUDIES PROGRAMS AND EXECUTIVE PROGRAMS IN THE FIELD OF SCIENCE AND TECHNOLOGY; EDUCATIONAL SERVICES, NAMELY, PROVIDING CONTINUING PROFESSIONAL EDUCATION COURSES IN THE FIELD OF SCIENCE AND TECHNOLOGY (U.S. CLS. 100, 101 AND 107).

YAT SYE, LEE, EXAMINING ATTORNEY

CLASS 41—(Continued).

SN 77-650,791. HALL, MARY, REDONDO BEACH, CA. FILED 1-16-2009.

The Chic Recessionista

THE MARK CONSISTS OF STANDARD CHARACTERS WITHOUT CLAIM TO ANY PARTICULAR FONT, STYLE, SIZE, OR COLOR.

FOR ON-LINE JOURNALS, NAMELY, BLOGS FEATURING TIPS AND EDITORIAL FEATURES ON FASHIONS, SHOPPING, WINE, TRAVEL AND ENTERTAINING DURING THE ECONOMIC DOWNTURN (U.S. CLS. 100, 101 AND 107).

STEPHANIE ALI, EXAMINING ATTORNEY

SN 77-657,526. CARBALLO, TOM, ATLANTA, GA. FILED 1-27-2009.

MOJO

THE MARK CONSISTS OF STANDARD CHARACTERS WITHOUT CLAIM TO ANY PARTICULAR FONT, STYLE, SIZE, OR COLOR.

FOR RADIO ENTERTAINMENT SERVICES, NAMELY, RADIO PROGRAMS FEATURING PERFORMANCES BY A RADIO PERSONALITY (U.S. CLS. 100, 101 AND 107).

FIRST USE 2-21-2000; IN COMMERCE 2-21-2000.

SETH A. RAPPAPORT, EXAMINING ATTORNEY

SN 79-107,731. VIRTUAL 9 CO., LTD, TOKYO, JAPAN, FILED 10-3-2011.

SASUKE

THE MARK CONSISTS OF STANDARD CHARACTERS WITHOUT CLAIM TO ANY PARTICULAR FONT, STYLE, SIZE, OR COLOR.

PRIORITY DATE OF 6-30-2011 IS CLAIMED.

OWNER OF INTERNATIONAL REGISTRATION 1103086 DATED 10-3-2011, EXPIRES 10-3-2021.

THE WORDING "SASUKE" HAS NO MEANING IN A FOREIGN LANGUAGE.

FOR EDUCATIONAL AND INSTRUCTION SERVICES RELATING TO ARTS, CRAFTS, SPORTS OR GENERAL KNOWLEDGE, NAMELY, FLOWER ARRANGEMENT INSTRUCTION, TUTORING AT CRAM SCHOOLS, KARATE INSTRUCTION, INSTRUCTION ON FORMAL WEARING OF KIMONO, KENDO INSTRUCTION, JAPANESE FENCING INSTRUCTION, EDUCATING AT SENIOR HIGH SCHOOLS, LANGUAGE INSTRUCTION, REVIEW COURSES FOR STATE EXAMINATIONS, TEA CEREMONY INSTRUCTION, VEHICLE-DRIVING INSTRUCTION, JUDO INSTRUCTION, TEACHING AT ELEMENTARY SCHOOLS, SWIMMING INSTRUCTION, ABACUS INSTRUCTION, EDUCATING AT UNIVERSITY OR COLLEGES, TEACHING AT JUNIOR HIGH SCHOOLS, TENNIS INSTRUCTION, PIANO INSTRUCTION, BEAUTY ARTS INSTRUCTION, DANCE INSTRUCTION, BOOKKEEPING INSTRUCTION,

CLASS 41—(Continued).

TAILORING OR DRESSMAKING INSTRUCTION, HAIRDRESSING INSTRUCTION, KIMONO-MAKING INSTRUCTION; SPORTS INSTRUCTION SERVICES; ARRANGING, CONDUCTING AND ORGANIZATION OF SEMINARS; PROVIDING OF ELECTRONIC PUBLICATIONS, NAMELY, PUBLISHING OF ELECTRONIC PUBLICATIONS; PROVIDING NON-DOWNLOADABLE MUSIC, SOUND AND IMAGES VIA THE INTERNET; PRESENTATION, NAMELY, PLANNING ARRANGEMENT OF SHOWING MOVIES, SHOWS, PLAYS OR MUSICAL PERFORMANCES; DIRECTION OF MAKING RADIO OR TELEVISION PROGRAMS; PRODUCTION OF MOTION PICTURE FILMS AND TELEVISION PROGRAMS; PRODUCTION OF VIDEOTAPES AND VIDEOCASSETTES FEATURING COMPETITION-BASED ENTERTAINMENT AND COMPANION PROGRAMMING WITH ACTUAL AND/OR FICTIONAL CHARACTERS INVOLVED IN COMEDIC, DRAMATIC, DOCUMENTARY AND ANIMATED STORIES; DESIGN, CREATION, PRODUCTION AND POST-PRODUCTION OF AUDIOVISUAL WORKS, NAMELY, CINEMATIC, TELEVISION AND MULTIMEDIA PROGRAMS; ENTERTAINMENT SERVICES, NAMELY, A CONTINUING COMPETITION-BASED PROGRAM AND COMPANION VARIETY PROGRAMS WITH ACTUAL AND/OR FICTIONAL CHARACTERS IN COMEDIC, DRAMATIC, DOCUMENTARY AND ANIMATED STORIES BROADCAST OVER TELEVISION, SATELLITE, AUDIO AND VIDEO MEDIA, AND VIA A GLOBAL COMPUTER NETWORK; DISTRIBUTION FOR OTHERS OF MOTION PICTURE FILMS AND TELEVISION PROGRAMS; PRODUCTION OF TELEVISION PROGRAMS; ENTERTAINMENT SERVICES, NAMELY, AN ON-GOING TELEVISION SERIES BROADCAST OVER TELEVISION AND PODCAST FEATURING COMPETITION-BASED PROGRAMMING AND COMPANION PROGRAMMING WITH ACTUAL AND/OR FICTIONAL CHARACTERS INVOLVED IN COMEDIC, DRAMATIC, DOCUMENTARY AND ANIMATED STORIES; ENTERTAINMENT SERVICES IN THE NATURE OF VARIETY SHOWS; ORGANIZATION OF SPORTS COMPETITIONS; ORGANIZATION OF ENTERTAINMENT EVENTS, EXCLUDING PRESENTATION/ORGANIZATION OF MOVIES, SHOWS, PLAYS, MUSICAL PERFORMANCES, SPORTS, HORSE RACES, BICYCLE RACES, BOAT RACES AND AUTOMOBILE RACES, NAMELY, LIVE PERFORMANCES BY A MUSICAL BAND; PROVIDING SPORTS FACILITIES, NAMELY, PROVIDING GOLF FACILITIES, PROVIDING SKI SLOPES, PROVIDING SKATING RINKS, PROVIDING GYMNASIUMS, PROVIDING TENNIS COURTS, PROVIDING SWIMMING POOLS, PROVIDING BOWLING ALLEYS, PROVIDING BASEBALL FIELDS, PROVIDING TRACK AND FIELD FACILITIES; PROVIDING AMUSEMENT FACILITIES, NAMELY, PROVIDING GO OR SHOJI SALOONS, PROVIDING KARAOKE EQUIPMENT, PROVIDING SLOT MACHINE PARLORS, PROVIDING DANCE HALLS, PROVIDING PACHINKO PARLORS, PROVIDING BILLIARD ROOMS, PROVIDING MAHJONG PARLORS, PROVIDING AMUSEMENT PARKS; GAME SERVICES PROVIDED ON-LINE FROM A COMPUTER NETWORK; ENTERTAINMENT SERVICES, NAMELY, PROVIDING AN ON-LINE COMPUTER GAME; PROVIDING INFORMATION ON-LINE RELATING TO COMPUTER GAMES AND COMPUTER ENHANCEMENTS FOR GAMES (U.S. CLS. 100, 101 AND 107).

RENEE MCCRAY, EXAMINING ATTORNEY

CLASS 41—(Continued).

SN 79-109,684. KABUSHIKI KAISHA SCRAP, KYOTO 604-0041, JAPAN, FILED 11-17-2011.

real escape game by SCRAP

THE MARK CONSISTS OF STANDARD CHARACTERS WITHOUT CLAIM TO ANY PARTICULAR FONT, STYLE, SIZE, OR COLOR.

OWNER OF INTERNATIONAL REGISTRATION 1108121 DATED 11-17-2011, EXPIRES 11-17-2021.

NO CLAIM IS MADE TO THE EXCLUSIVE RIGHT TO USE "GAME", APART FROM THE MARK AS SHOWN.

FOR ARRANGING, ORGANIZING AND CONDUCTING GAME EVENTS IN THE NATURE OF SOCCER GAMES, POKER GAMES AND GAME SHOWS; ENTERTAINMENT SERVICES, NAMELY, PRODUCTION, PRESENTATION AND ORGANIZATION OF GAME SHOWS; ELECTRONIC GAME SERVICES PROVIDED BY MEANS OF THE INTERNET, NAMELY, PROVISION OF ONLINE VIDEO GAMES (U.S. CLS. 100, 101 AND 107).

HEATHER BIDDULPH, EXAMINING ATTORNEY

CLASS 41—(Continued).

SN 85-171,207. WINSHAPE FOUNDATION, INC., ATLANTA, GA. FILED 11-8-2010.



THE MARK CONSISTS OF THE WORDS "6 KEY EXPERIENCES OF THE" IN A SMALLER FONT ABOVE THE WORDS "DCL LIFE" IN A LARGER FONT.

FOR CHARITABLE SERVICES, NAMELY, PROVIDING EDUCATIONAL PROGRAMS TO ASSIST STUDENTS IN DEVELOPING THEIR CHRISTIAN DISCIPLESHIP, SOCIAL SKILLS, AND LEADERSHIP ABILITIES (U.S. CLS. 100, 101 AND 107).

DAVID C. REIHNER, EXAMINING ATTORNEY

SN 85-032,249. COALITION OF THE WILLING, LLC, ARLINGTON, VA. FILED 5-6-2010.

Skate & Surf Festival

THE MARK CONSISTS OF STANDARD CHARACTERS WITHOUT CLAIM TO ANY PARTICULAR FONT, STYLE, SIZE, OR COLOR.

NO CLAIM IS MADE TO THE EXCLUSIVE RIGHT TO USE "FESTIVAL", APART FROM THE MARK AS SHOWN.

FOR ENTERTAINMENT IN THE NATURE OF LIVE MUSIC CONCERTS, ORGANIZING COMMUNITY SPORTING AND CULTURAL EVENTS (U.S. CLS. 100, 101 AND 107).

SAMUEL E. SHARPER JR., EXAMINING ATTORNEY

SN 85-171,225. WINSHAPE FOUNDATION, INC., ATLANTA, GA. FILED 11-8-2010.

DCL LIFE

THE MARK CONSISTS OF STANDARD CHARACTERS WITHOUT CLAIM TO ANY PARTICULAR FONT, STYLE, SIZE, OR COLOR.

FOR CHARITABLE SERVICES, NAMELY, PROVIDING EDUCATIONAL PROGRAMS TO ASSIST STUDENTS IN DEVELOPING THEIR CHRISTIAN DISCIPLESHIP, SOCIAL SKILLS, AND LEADERSHIP ABILITIES (U.S. CLS. 100, 101 AND 107).

DAVID C. REIHNER, EXAMINING ATTORNEY

SN 85-167,061. LITTLE NUGGET, INC., PLAYA VISTA, CA. FILED 11-2-2010.

CHUY BRAVO

THE MARK CONSISTS OF STANDARD CHARACTERS WITHOUT CLAIM TO ANY PARTICULAR FONT, STYLE, SIZE, OR COLOR.

THE NAME(S), PORTRAIT(S), AND/OR SIGNATURE(S) SHOWN IN THE MARK IDENTIFIES "CHUY BRAVO", WHOSE CONSENT(S) TO REGISTER IS MADE OF RECORD.

FOR ENTERTAINMENT SERVICES, NAMELY, ENTERTAINMENT IN THE NATURE OF TELEvised APPEARANCES BY A PROFESSIONAL ENTERTAINER AS A CO-HOST OF A CONTINUING TELEVISION TALK SHOW AND PERSONAL APPEARANCES BY A PROFESSIONAL ENTERTAINER AS A VARIETY ACT (U.S. CLS. 100, 101 AND 107).

FIRST USE 10-29-2010; IN COMMERCE 10-29-2010. MARGARET POWER, EXAMINING ATTORNEY

CLASS 41—(Continued).

SN 85-173,144. IKRAM, ADEN, PLAYA VISTA, CA. FILED 11-10-2010.



NO CLAIM IS MADE TO THE EXCLUSIVE RIGHT TO USE "URBAN SAMURAI LEAGUE", APART FROM THE MARK AS SHOWN.

THE COLOR(S) RED, BROWN AND PURPLE IS/ARE CLAIMED AS A FEATURE OF THE MARK.

THE MARK CONSISTS OF LETTERS "USL" IN RED COLOR AND THE WORDS "URBAN SAMURAI LEAGUE" IS WRITTEN IN BROWN COLOR BELOW THE LETTER "USL". THERE IS AN IMAGE OF SILHOUETTE OF A BOY IN PURPLE COLOR THAT IS IN JUMPING POSITION ABOVE THE LETTER "L" AS SHOWN IN THE MARK.

FOR EDUCATION AND ENTERTAINMENT SERVICES, NAMELY, IN THE NATURE OF A CONTINUING TELEVISION SERIES FEATURING AN ATHLETIC COMPETITION DELIVERED BY TELEVISION, RADIO, SATELLITE, THE INTERNET, LIVE AND MOBILE COMMUNICATIONS THAT INCLUDE VIDEO, TEXT, PHOTOS, ILLUSTRATIONS AND HYPERTEXT; ENTERTAINMENT SERVICES, NAMELY, ORGANIZING LIVE FREERUNNING AND PARKOUR EVENTS AND COMPETITIONS; ENTERTAINMENT SERVICES, NAMELY, PROVIDING A WEB SITE FEATURING NON-DOWNLOADABLE INSTRUCTIONAL VIDEOS IN THE FIELD OF FREERUNNING AND PARKOUR; PROVIDING A WEBSITE FEATURING INTERACTIVE INFORMATION IN THE FIELD OF ATHLETIC COMPETITIONS AVAILABLE THROUGH ON-LINE AND MOBILE INTERFACES (U.S. CLS. 100, 101 AND 107).

GINA HAYES, EXAMINING ATTORNEY

SN 85-183,924. DOUG MELVILLE, FORT LAUDERDALE, FL. FILED 11-23-2010.

REDCARPETS.COM

THE MARK CONSISTS OF STANDARD CHARACTERS WITHOUT CLAIM TO ANY PARTICULAR FONT, STYLE, SIZE, OR COLOR.

FOR ENTERTAINMENT SERVICES, NAMELY, PROVIDING AN INTERNET WEBSITE PORTAL IN THE FIELD OF ENTERTAINMENT INFORMATION, NAMELY, CELEBRITY EVENTS, POP CULTURE INFORMATION RELATING TO CELEBRITIES AND CURRENT EVENT NEWS (U.S. CLS. 100, 101 AND 107).

SAMUEL E. SHARPER JR., EXAMINING ATTORNEY

CLASS 41—(Continued).

SN 85-199,475. THIS IS A CLUE LLC, DENVER, CO. FILED 12-16-2010.

THIS IS A CLUE

THE MARK CONSISTS OF STANDARD CHARACTERS WITHOUT CLAIM TO ANY PARTICULAR FONT, STYLE, SIZE, OR COLOR.

FOR ENTERTAINMENT SERVICES, NAMELY, PROVIDING GAME SCENARIOS FOR INTERACTIVE IN-PERSON PARTICIPANTS WHICH INVOLVE PHYSICAL AND MENTAL CHALLENGES TO SOLVE MYSTERIES, PROBLEMS, LOCATE HIDDEN ITEMS, GETTING TO SPECIFIC DESTINATIONS, TEAM WORK COMPETITIONS, AND OTHER CREATIVE GAMES SCENARIOS (U.S. CLS. 100, 101 AND 107).

FIRST USE 11-21-2009; IN COMMERCE 11-21-2009.

ODESSA BIBBINS, EXAMINING ATTORNEY

SN 85-205,344. REMEMBERING THE BRAVE INC, PITTSBURGH, PA. FILED 12-23-2010.



THE MARK CONSISTS OF THE WORD "HALL" POSITIONED ABOVE THE WORD "HEROES". THE WORD "OF" AFTER THE WORD "HALL" AND SUPERIMPOSED OVER THE WORD "HEROES". A STAR AT THE BEGINNING AND END OF THE WORD "HEROES".

FOR MOBILE MUSEUM SERVICES (U.S. CLS. 100, 101 AND 107).

FIRST USE 5-1-2008; IN COMMERCE 5-1-2008.

ROBIN CHOSID, EXAMINING ATTORNEY

SN 85-207,704. FLOWER POWER PROJECTS LLC, GLENVIEW, IL. FILED 12-30-2010.

MAKEUP MINUTES

THE MARK CONSISTS OF STANDARD CHARACTERS WITHOUT CLAIM TO ANY PARTICULAR FONT, STYLE, SIZE, OR COLOR.

NO CLAIM IS MADE TO THE EXCLUSIVE RIGHT TO USE "MAKEUP", APART FROM THE MARK AS SHOWN.

FOR PROVIDING EDUCATION SERVICES, NAMELY, PROVIDING TUTORING ABOUT HOW TO APPLY AND USE COSMETICS AND BEAUTY PRODUCTS (U.S. CLS. 100, 101 AND 107).

FIRST USE 4-25-2010; IN COMMERCE 4-25-2010.

H. M. FISHER, EXAMINING ATTORNEY

CLASS 41—(Continued).

SN 85-210,267. QUICKDRAW HOLDINGS, L.P., LOS ANGELES, CA. FILED 1-4-2011.

QUICK DRAW PRODUCTIONS

THE MARK CONSISTS OF STANDARD CHARACTERS WITHOUT CLAIM TO ANY PARTICULAR FONT, STYLE, SIZE, OR COLOR.

NO CLAIM IS MADE TO THE EXCLUSIVE RIGHT TO USE "PRODUCTIONS", APART FROM THE MARK AS SHOWN.

FOR PRODUCTION AND DISTRIBUTION OF MOTION PICTURES (U.S. CLS. 100, 101 AND 107).

APRIL ROACH, EXAMINING ATTORNEY

SN 85-210,689. FANT, KATHY S, CHICAGO, IL. FILED 1-5-2011.

Politipalooza

THE MARK CONSISTS OF STANDARD CHARACTERS WITHOUT CLAIM TO ANY PARTICULAR FONT, STYLE, SIZE, OR COLOR.

FOR MAGAZINE PUBLISHING ON THE SUBJECT OF POLITICS; MULTIMEDIA PUBLISHING OF BOOKS, MAGAZINES, JOURNALS, SOFTWARE, GAMES, MUSIC, AND ELECTRONIC PUBLICATIONS ON THE SUBJECT OF POLITICS; ON-LINE LIBRARY SERVICES, NAMELY, PROVIDING ELECTRONIC LIBRARY SERVICES WHICH FEATURE NEWSPAPERS, MAGAZINES, PHOTOGRAPHS AND PICTURES VIA AN ON-LINE COMPUTER NETWORK ON THE SUBJECT OF POLITICS; PROVIDING A WEBSITE FEATURING NON-DOWNLOADABLE PUBLICATIONS, NAMELY, BOOKS, MAGAZINES, BROCHURES ON THE SUBJECT OF POLITICS, PROVIDING A WEBSITE FEATURING RESOURCES, NAMELY, A WEBSITE PRIMARILY FEATURING NON-DOWNLOADABLE PUBLICATIONS IN THE NATURE OF BOOKS, MAGAZINES, BROCHURES ON THE SUBJECT OF POLITICS, AND ALSO FEATURING NON-DOWNLOADABLE SOFTWARE FOR ACCESSING POLITICAL NEWS, ON THE SUBJECT OF POLITICS, PROVIDING A WEBSITE FEATURING RESOURCES, NAMELY, NON-DOWNLOADABLE PUBLICATIONS IN THE NATURE OF BOOKS, MAGAZINES, BROCHURES ON THE SUBJECT OF POLITICS; PROVIDING ON-LINE MAGAZINES ON THE SUBJECT OF POLITICS; PROVIDING ON-LINE NON-DOWNLOADABLE GENERAL FEATURE MAGAZINES; PROVIDING ON-LINE NON-DOWNLOADABLE MAGAZINES ON THE SUBJECT OF POLITICS; PUBLICATION OF BOOKS, MAGAZINES, ALMANACS AND JOURNALS ON THE SUBJECT OF POLITICS; PUBLICATION OF BOOKS, OF MAGAZINES, OF JOURNALS, OF NEWSPAPERS, OF PERIODICALS, CATALOGS, OR BROCHURES ON THE SUBJECT OF POLITICS; PUBLICATION OF ELECTRONIC MAGAZINES; PUBLICATION OF MAGAZINES ON THE SUBJECT OF POLITICS; PUBLICATION OF TEXTS, BOOKS, MAGAZINES AND OTHER PRINTED MATTER ON THE SUBJECT OF POLITICS; PUBLISHING OF BOOKS ON THE SUBJECT OF POLITICS; PUBLISHING OF MAGAZINES ON THE SUBJECT OF POLITICS; PUBLISHING OF WEB MAGAZINES ON THE SUBJECT OF POLITICS; RENTAL OF MAGAZINES ON THE SUBJECT OF POLITICS (U.S. CLS. 100, 101 AND 107).

WILLIAM P. SHANAHAN, EXAMINING ATTORNEY

CLASS 41—(Continued).

SN 85-213,717. AJ MERONE FITNESS, INC., MT. SINAI, NY. FILED 1-10-2011.



THE COLOR(S) BLUE AND WHITE IS/ARE CLAIMED AS A FEATURE OF THE MARK.

THE MARK CONSISTS OF THE WORD "PROJECT" IN CAPITAL WHITE LETTERS WITH A BLUE HALO AROUND EACH LETTER, A LOWER CASE LETTER "I" IN WHITE WITH A SWEAT DROP DRIPPING OFF THE RIGHT SIDE AND BOTTOM OF THE LETTER IN SHADES OF BLUE SITUATED TO THE LEFT OF THE WORD "SWEAT" IN STYLIZED WHITE LETTERS UNDERNEATH THE WORD "PROJECT". THE COLOR BLACK REPRESENTS BACKGROUND AND IS NOT PART OF THE MARK.

FOR PHYSICAL FITNESS CONSULTATION; PHYSICAL FITNESS INSTRUCTION; PHYSICAL FITNESS TRAINING OF INDIVIDUALS AND GROUPS; PHYSICAL FITNESS TRAINING SERVICES (U.S. CLS. 100, 101 AND 107).

FIRST USE 6-0-2010; IN COMMERCE 7-0-2010.

BARBARA RUTLAND, EXAMINING ATTORNEY

SN 85-232,681. AOL INC., DULLES, VA. FILED 2-2-2011.

indiebride

THE MARK CONSISTS OF STANDARD CHARACTERS WITHOUT CLAIM TO ANY PARTICULAR FONT, STYLE, SIZE, OR COLOR.

FOR ON-LINE PUBLICATION, NAMELY, BLOG AND ONLINE JOURNAL FEATURING WEDDINGS, LIFE BEFORE AND AFTER BEING MARRIED, ETIQUETTE, NEWS, INTERVIEWS, ADVICE, PHOTOGRAPHY, DIARIES AND OPINION-PIECES, ALL RELATING TO WEDDINGS AND MARRIAGE (U.S. CLS. 100, 101 AND 107).

FIRST USE 6-30-2001; IN COMMERCE 6-30-2001.

HELENE LIWINSKI, EXAMINING ATTORNEY

CLASS 41—(Continued).

SN 85-237,576. AMERICAN FARM BUREAU FEDERATION, WASHINGTON, DC. FILED 2-9-2011.



NO CLAIM IS MADE TO THE EXCLUSIVE RIGHT TO USE "LIVE AT VIRGINIA BEACH", APART FROM THE MARK AS SHOWN.

THE MARK CONSISTS OF A GUITAR DESIGN WITH THE WORDS "FARM BUREAU AT VIRGINIA BEACH" WITHIN THE BASE OF THE GUITAR AND A DESIGN OF A GUITAR PICK WITH THE WORD "LIVE" WITHIN THE GUITAR PICK DESIGN.

FOR PROVIDING AMPHITHEATER SERVICES FOR LIVE MUSICAL PERFORMANCES AND OTHER EVENTS (U.S. CLS. 100, 101 AND 107).

KATINA MISTER, EXAMINING ATTORNEY

CLASS 41—(Continued).

SN 85-241,887. EARNING BY LEARNING OF DALLAS, DALLAS, TX. FILED 2-14-2011.

EARNING BY LEARNING

THE MARK CONSISTS OF STANDARD CHARACTERS WITHOUT CLAIM TO ANY PARTICULAR FONT, STYLE, SIZE, OR COLOR.

FOR EDUCATIONAL SERVICES, NAMELY, EDUCATIONAL PROGRAMS TO PROVIDE INCENTIVES TO CHILDREN THROUGH THE ISSUANCE OF AWARDS AND INCENTIVES TO ENCOURAGE LEARNING (U.S. CLS. 100, 101 AND 107).

FIRST USE 6-0-1996; IN COMMERCE 6-0-1996.

CHARISMA HAMPTON, EXAMINING ATTORNEY

SN 85-243,024. EARNING BY LEARNING OF DALLAS, DALLAS, TX. FILED 2-15-2011.

SN 85-237,585. AMERICAN FARM BUREAU FEDERATION, WASHINGTON, DC. FILED 2-9-2011.



NO CLAIM IS MADE TO THE EXCLUSIVE RIGHT TO USE "LIVE AT VIRGINIA BEACH", APART FROM THE MARK AS SHOWN.

THE MARK CONSISTS OF A GUITAR DESIGN TITLED UPWARDS AT THE NECK OF THE GUITAR WITH THE WORDS "FARM BUREAU" WITHIN THE BASE OF THE GUITAR AND A DESIGN OF A GUITAR PICK WITH THE WORD "LIVE" WITHIN THE GUITAR PICK DESIGN ALL ABOVE THE WORDS "AT VIRGINIA BEACH".

FOR PROVIDING AMPHITHEATER SERVICES FOR LIVE MUSICAL PERFORMANCES AND OTHER EVENTS (U.S. CLS. 100, 101 AND 107).

KATINA MISTER, EXAMINING ATTORNEY



THE COLOR(S) PURPLE AND RED IS/ARE CLAIMED AS A FEATURE OF THE MARK.

THE MARK CONSISTS OF THE DESIGN OF A FLOWER COMPRISED OF FIVE PETALS SHAPED LIKE OPEN BOOKS IN THE COLOR RED WITH SPINES AND BORDERS APPEARING IN THE COLOR WHITE THAT REPRESENT SHADING AND TRANSPARENT AREAS AND ARE NOT PART OF THE MARK, AND FIVE PURPLE DOTS POSITIONED ON THE OUTSIDE WEDGE OF EACH OPEN BOOK REPRESENTING PETALS.

FOR EDUCATIONAL SERVICES, NAMELY, EDUCATIONAL PROGRAMS TO PROVIDE INCENTIVES TO CHILDREN THROUGH THE ISSUANCE OF AWARDS AND INCENTIVES TO ENCOURAGE LEARNING (U.S. CLS. 100, 101 AND 107).

FIRST USE 7-0-2003; IN COMMERCE 7-0-2003.

CHARISMA HAMPTON, EXAMINING ATTORNEY

CLASS 41—(Continued).

SN 85-271,604. PARTY FANTASY, INC., WHEELING, IL.
FILED 3-19-2011.



NO CLAIM IS MADE TO THE EXCLUSIVE RIGHT TO USE "PARTY", APART FROM THE MARK AS SHOWN.

THE COLOR(S) RED, PURPLE, PINK, ORANGE, YELLOW, BLUE, BLACK AND GREEN IS/ARE CLAIMED AS A FEATURE OF THE MARK.

THE MARK CONSISTS OF THE WORDS "PARTY FANTASY" IN RED AND OUTLINED IN BLACK UNDERNEATH SIX MULTICOLORED BALLOONS IN BLUE, PURPLE, GREEN, ORANGE, YELLOW AND PINK, WITH RED CONFETTI FLYING IN THE AIR WITH ONE CONFETTI OR DOT TO THE RIGHT OF THE BALLOONS BEING BLACK.

FOR FAMILY RECREATION CENTER WHERE CHILDREN CAN PLAY ON INFLATABLE BOUNCERS, CLIMBING WALL, OR ARCADE (U.S. CLS. 100, 101 AND 107).

FIRST USE 4-9-2010; IN COMMERCE 4-9-2010.
LAURIE MAYES, EXAMINING ATTORNEY

CLASS 41—(Continued).

SN 85-288,626. HOLA, S.L., MADRID, SPAIN, FILED 4-7-2011.

¡HOLA TV!

THE MARK CONSISTS OF STANDARD CHARACTERS WITHOUT CLAIM TO ANY PARTICULAR FONT, STYLE, SIZE, OR COLOR.

OWNER OF U.S. REG. NOS. 1,009,686, 2,772,805 AND OTHERS.

NO CLAIM IS MADE TO THE EXCLUSIVE RIGHT TO USE "TV", APART FROM THE MARK AS SHOWN.

THE ENGLISH TRANSLATION OF "¡HOLA TV!" IN THE MARK IS "¡HELLO TV!"

FOR ENTERTAINMENT SERVICES, NAMELY, THE PROVISION OF CONTINUING SHOWS FEATURING NEWS, SOCIETY, FASHION, BEAUTY, TRENDS AND LIFESTYLES, CELEBRITIES AND FAMILY CONTENT DELIVERED BY TELEVISION AND RADIO; ORGANIZATION OF EVENTS FOR CULTURAL PURPOSES; PUBLICATION OF TEXTS, BOOKS, MAGAZINES AND OTHER PRINTED MATTER; ELECTRONIC PUBLICATION OF BOOKS, NEWSPAPERS AND MAGAZINES ONLINE; PROVIDING ONLINE PUBLICATIONS IN THE NATURE OF TEXTS, BOOKS, MAGAZINES, WORKBOOKS, ARTICLES AND NEWSLETTERS FEATURING GENERAL NEWS INFORMATION IN THE AREA OF CURRENT EVENTS AND ENTERTAINMENT; NEWS REPORTERS SERVICES AND PHOTOGRAPHIC REPORTING; PUBLISHING, EDITING AND PRODUCTION OF RADIO AND TELEVISION PROGRAMS; ENTERTAINMENT IN THE NATURE OF RADIO AND TELEVISION NEWS SHOWS; PROVIDING ENTERTAINMENT INFORMATION AND PROVIDING ON-GOING TELEVISION PROGRAMS IN THE FIELD OF NEWS VIA A GLOBAL COMPUTER NETWORK; TELEVISION SHOW PRODUCTION; FILM PRODUCTION; AUDIO AND VIDEO RECORDING SERVICES (U.S. CLS. 100, 101 AND 107).

JAMES LOVELACE, EXAMINING ATTORNEY

CLASS 41—(Continued).

SN 85-288,777. HOLA, S.L., MADRID, SPAIN, FILED 4-7-2011.



OWNER OF SPAIN REG. NO. 2642556, DATED 9-1-2005, EXPIRES 3-18-2015.

OWNER OF U.S. REG. NOS. 1,009,686, 2,772,805 AND OTHERS.

NO CLAIM IS MADE TO THE EXCLUSIVE RIGHT TO USE "TV", APART FROM THE MARK AS SHOWN.

THE COLOR(S) RED AND WHITE IS/ARE CLAIMED AS A FEATURE OF THE MARK.

THE MARK CONSISTS OF THE WORD ¡HOLA TV! WRITTEN IN UPPERCASE WHITE LETTERS AGAINST A RED RECTANGLE.

THE ENGLISH TRANSLATION OF "HOLA" IN THE MARK IS "HELLO".

FOR ENTERTAINMENT SERVICES, NAMELY, THE PROVISION OF CONTINUING SHOWS FEATURING NEWS, SOCIETY, FASHION, BEAUTY, TRENDS AND LIFESTYLES, CELEBRITIES AND FAMILY CONTENT DELIVERED BY TELEVISION AND RADIO; ORGANIZATION OF EVENTS FOR CULTURAL PURPOSES; PUBLICATION OF TEXTS, BOOKS MAGAZINES AND OTHER PRINTED MATTER; ELECTRONIC PUBLICATION OF BOOKS, NEWSPAPERS AND MAGAZINES ONLINE; PROVIDING ONLINE PUBLICATIONS IN THE NATURE OF TEXTS, BOOKS, MAGAZINES, WORKBOOKS, ARTICLES AND NEWSLETTERS FEATURING GENERAL NEWS INFORMATION IN THE AREA OF CURRENT EVENTS AND ENTERTAINMENT; NEWS REPORTERS SERVICES AND PHOTOGRAPHIC REPORTING; PUBLISHING, EDITING AND PRODUCTION OF RADIO AND TELEVISION PROGRAMS; ENTERTAINMENT IN THE NATURE OF RADIO AND TELEVISION NEWS SHOWS; PROVIDING ENTERTAINMENT INFORMATION AND PROVIDING ON-GOING TELEVISION PROGRAMS IN THE FIELD OF NEWS VIA A GLOBAL COMPUTER NETWORK; TELEVISION SHOW PRODUCTION; FILM PRODUCTION; AUDIO AND VIDEO RECORDING SERVICES (U.S. CLS. 100, 101 AND 107).

JAMES LOVELACE, EXAMINING ATTORNEY

CLASS 41—(Continued).

SN 85-289,767. FAMILY SERVICE AGENCY OF SAN FRANCISCO, SAN FRANCISCO, CA. FILED 4-8-2011.

FELTON INSTITUTE

THE MARK CONSISTS OF STANDARD CHARACTERS WITHOUT CLAIM TO ANY PARTICULAR FONT, STYLE, SIZE, OR COLOR.

NO CLAIM IS MADE TO THE EXCLUSIVE RIGHT TO USE "INSTITUTE", APART FROM THE MARK AS SHOWN. SEC. 2(F).

FOR EDUCATION AND ENTERTAINMENT SERVICES, NAMELY, CLASSES FOR MENTAL HEALTH AND SOCIAL SERVICE PROVIDERS IN THE FIELD OF BEHAVIORAL SCIENCES (U.S. CLS. 100, 101 AND 107).

FIRST USE 4-1-2005; IN COMMERCE 4-1-2005.
GISELLE AGOSTO, EXAMINING ATTORNEY

SN 85-295,719. SONOSITE, INC., BOTHELL, WA. FILED 4-14-2011.

VISUAL MEDICINE

THE MARK CONSISTS OF STANDARD CHARACTERS WITHOUT CLAIM TO ANY PARTICULAR FONT, STYLE, SIZE, OR COLOR.

NO CLAIM IS MADE TO THE EXCLUSIVE RIGHT TO USE "MEDICINE", APART FROM THE MARK AS SHOWN.

FOR EDUCATIONAL SERVICES, NAMELY, PROVIDING ON-LINE AND IN PERSON INSTRUCTION, CLASSES, WORKSHOPS, SEMINARS, AND PROVIDING COURSE MATERIALS THEREWITH IN THE FIELDS OF MEDICINE, MEDICAL IMAGING, AND HEALTH CARE; ON-LINE JOURNALS, NAMELY, BLOGS FEATURING INFORMATION IN THE FIELDS OF MEDICINE, MEDICAL IMAGING, AND HEALTH CARE; PROVIDING ON-LINE NEWSLETTERS AND NEWSLETTER UPDATES FEATURING INFORMATION IN THE FIELDS OF MEDICINE, MEDICAL IMAGING, AND HEALTH CARE; PROVIDING CONTINUING MEDICAL EDUCATION COURSES; EDUCATIONAL DEMONSTRATIONS (U.S. CLS. 100, 101 AND 107).

KEVIN CORWIN, EXAMINING ATTORNEY

CLASS 41—(Continued).

SN 85-309,666. LEVAN, JOEL, KING OF PRUSSIA, PA.
FILED 5-2-2011.

SENTE Martial Systems

THE MARK CONSISTS OF STANDARD CHARACTERS WITHOUT CLAIM TO ANY PARTICULAR FONT, STYLE, SIZE, OR COLOR.

NO CLAIM IS MADE TO THE EXCLUSIVE RIGHT TO USE "MARTIAL SYSTEMS", APART FROM THE MARK AS SHOWN.

FOR MARTIAL ARTS INSTRUCTION; TRAINING SERVICES IN THE FIELD OF SELF-DEFENSE (U.S. CLS. 100, 101 AND 107).

FIRST USE 6-1-2008; IN COMMERCE 5-11-2010.

C. DIONNE CLYBURN, EXAMINING ATTORNEY

CLASS 41—(Continued).

SN 85-313,229. VIDEOLINK, INC., NEWTON, MA. FILED 5-5-2011.



THE COLOR(S) ORANGE, BLUE, BLACK, AND GRAY IS/ ARE CLAIMED AS A FEATURE OF THE MARK.

THE MARK CONSISTS OF THE WORDS "VIDEOLINK" AND "WHEN YOUR IMAGE IS ON THE LINE"; "VIDEO" IS IN BLACK AND "LINK" IS IN GRAY WITH THE WORDS "WHEN YOUR IMAGE IS ON THE LINE" IN ORANGE IN SMALLER FONT BELOW; TO THE LEFT OF THE WORD "VIDEOLINK" IS AN ORANGE BOX WITH A SMALLER ORANGE BOX INSIDE; OUTSIDE THE BOX ARE SEVEN ORANGE AND BLUE DOTS OUTSIDE RADIATING FROM THE BOX; AND THERE ARE SIX BLACK DOTS BETWEEN THE LARGE AND SMALL BOXES.

SEC. 2(F) AS TO "VIDEOLINK".

FOR LIVE BROADCAST PRODUCTION SERVICES OF TELEVISION PROGRAMS AND WEBCASTS IN THE FIELD OF EDUCATION, TRAINING, POLITICS, SPORTS AND BUSINESS; AND LIVE BROADCAST PRODUCTION SERVICES OF CORPORATE VIDEO PROGRAMS FOR EMPLOYEE RELATIONS, INVESTOR RELATIONS, TRAINING, AND VIDEOCONFERENCING (U.S. CLS. 100, 101 AND 107).

FIRST USE 5-31-2002; IN COMMERCE 5-31-2002.

MAYUR VAGHANI, EXAMINING ATTORNEY

SN 85-311,475. INCIPIT GROUP LLC, OCEANSIDE, CA.
FILED 5-3-2011.

The Compound

THE MARK CONSISTS OF STANDARD CHARACTERS WITHOUT CLAIM TO ANY PARTICULAR FONT, STYLE, SIZE, OR COLOR.

FOR PROVIDING FITNESS AND EXERCISE FACILITIES (U.S. CLS. 100, 101 AND 107).

FIRST USE 3-1-2007; IN COMMERCE 3-1-2007.

SAMUEL E. SHARPER JR., EXAMINING ATTORNEY

SN 85-316,064. PRIMROSE SCHOOL FRANCHISING COMPANY, AKA PRIMROSE SCHOOLS, ACWORTH, GA.
FILED 5-9-2011.

JUST ASK A MOM

THE MARK CONSISTS OF STANDARD CHARACTERS WITHOUT CLAIM TO ANY PARTICULAR FONT, STYLE, SIZE, OR COLOR.

FOR EDUCATION INFORMATIONAL SERVICES, NAMELY, PROVIDING A CONTINUING PRERECORDED INSTRUCTIONAL AUDIO PROGRAM IN THE FIELD OF EDUCATIONAL OPPORTUNITIES ACCESSIBLE OVER THE INTERNET AND PROVIDING ADVISORY INFORMATION ON-LINE RELATING TO EDUCATIONAL OPPORTUNITIES IN THE FIELDS OF EDUCATION OF CHILDREN AND PARENTING, ALL OF THE FOREGOING BEING DIRECTED TO PARENTS WHO ARE CONSIDERING ENROLLING THEIR CHILDREN IN EARLY CHILDHOOD EDUCATION PROGRAMS (U.S. CLS. 100, 101 AND 107).

FIRST USE 4-1-2011; IN COMMERCE 4-1-2011.

AMY C. KEAN, EXAMINING ATTORNEY

CLASS 41—(Continued).

SN 85-317,029. VIDEOLINK, INC., NEWTON, MA. FILED 5-10-2011.



THE COLOR(S) ORANGE, BLUE, BLACK, AND GRAY IS/ ARE CLAIMED AS A FEATURE OF THE MARK.

THE MARK CONSISTS OF THE WORDS "VIDEOLINK" AND "WHEN YOUR IMAGE IS ON THE LINE"; "VIDEO" IS IN BLACK AND "LINK" IS IN GRAY WITH THE WORDS "WHEN YOUR IMAGE IS ON THE LINE" IN ORANGE IN SMALLER FONT BELOW; ABOVE THE WORD "VIDEOLINK" IS AN ORANGE BOX WITH A SMALLER ORANGE BOX INSIDE; OUTSIDE THE BOX ARE SEVEN ORANGE AND BLUE DOTS OUTSIDE RADIATING FROM THE BOX; AND THERE ARE SIX BLACK DOTS BETWEEN THE LARGE AND SMALL BOXES.

SEC. 2(F) AS TO "VIDEOLINK".

FOR LIVE BROADCAST PRODUCTION SERVICES OF TELEVISION PROGRAMS AND WEBCASTS IN THE FIELD OF EDUCATION, TRAINING, POLITICS, SPORTS AND BUSINESS; AND LIVE BROADCAST PRODUCTION SERVICES OF CORPORATE VIDEO PROGRAMS FOR EMPLOYEE RELATIONS, INVESTOR RELATIONS, TRAINING, AND VIDEOCONFERENCING (U.S. CLS. 100, 101 AND 107).

FIRST USE 5-31-2002; IN COMMERCE 5-31-2002.
MAYUR VAGHANI, EXAMINING ATTORNEY

SN 85-322,447. ADAMS, JERRY A, DENVER, CO. FILED 5-17-2011.

THE LAST WORLD ORDER

THE MARK CONSISTS OF STANDARD CHARACTERS WITHOUT CLAIM TO ANY PARTICULAR FONT, STYLE, SIZE, OR COLOR.

FOR EDUCATIONAL SERVICES, NAMELY, CONDUCTING TRAINING, COURSES, ONLINE COURSES, MENTORING, AND ONLINE MENTORING IN THE FIELD OF PERSONAL GROWTH, SELF-AWARENESS AND DEVELOPMENT OF SOCIAL SUPPORT GROUPS FOR KIDS, AND DISTRIBUTION OF COURSE AND EDUCATIONAL MATERIALS IN CONNECTION THEREWITH (U.S. CLS. 100, 101 AND 107).

FIRST USE 5-4-2011; IN COMMERCE 5-4-2011.
MARLENE BELL, EXAMINING ATTORNEY

CLASS 41—(Continued).

SN 85-325,045. WOHL PUBLISHING, INC., MORRISTOWN, NJ. FILED 5-19-2011.

WOW FOR TEACHING

THE MARK CONSISTS OF STANDARD CHARACTERS WITHOUT CLAIM TO ANY PARTICULAR FONT, STYLE, SIZE, OR COLOR.

FOR EDUCATIONAL SERVICES, NAMELY, PROVIDING NON-DOWNLOADABLE STUDENT WORKBOOKS AND TEACHER INSTRUCTIONAL GUIDES IN THE FIELDS OF PERSONAL FINANCE, U.S. HISTORY, ECONOMICS, AMERICAN GOVERNMENT AND WORLD HISTORY; PROVIDING NON-DOWNLOADABLE TEACHER INSTRUCTIONAL GUIDES THAT PROVIDE AN INDEX OF EDUCATIONAL WEBSITES THAT HAVE BEEN RESEARCHED, EVALUATED, RATED, ORGANIZED AND IDENTIFIED TO REFLECT THE TOPIC OR SUBJECT, TYPE OF TEACHING STRATEGY, PRIMARY LEARNING MODALITY, DIFFICULTY LEVEL, AND NATIONAL AND STATE CONTENT STANDARD AS WELL AS PROVIDING INSTRUCTIONS FOR TEACHERS ON HOW TO UTILIZE THIS MATERIAL IN THE CLASSROOM (U.S. CLS. 100, 101 AND 107).

MICHAEL TANNER, EXAMINING ATTORNEY

SN 85-325,058. WOHL PUBLISHING, INC., MORRISTOWN, NJ. FILED 5-19-2011.

THE WELL ORGANIZED WEB FOR TEACHING

THE MARK CONSISTS OF STANDARD CHARACTERS WITHOUT CLAIM TO ANY PARTICULAR FONT, STYLE, SIZE, OR COLOR.

FOR EDUCATIONAL SERVICES, NAMELY, PROVIDING NON-DOWNLOADABLE STUDENT WORKBOOKS AND TEACHER INSTRUCTIONAL GUIDES IN THE FIELDS OF PERSONAL FINANCE, U.S. HISTORY, ECONOMICS, AMERICAN GOVERNMENT AND WORLD HISTORY; PROVIDING NON-DOWNLOADABLE TEACHER INSTRUCTIONAL GUIDES THAT PROVIDE AN INDEX OF EDUCATIONAL WEBSITES THAT HAVE BEEN RESEARCHED, EVALUATED, RATED, ORGANIZED AND IDENTIFIED TO REFLECT THE TOPIC OR SUBJECT, TYPE OF TEACHING STRATEGY, PRIMARY LEARNING MODALITY, DIFFICULTY LEVEL, AND NATIONAL AND STATE CONTENT STANDARD AS WELL AS PROVIDING INSTRUCTIONS FOR TEACHERS ON HOW TO UTILIZE THIS MATERIAL IN THE CLASSROOM (U.S. CLS. 100, 101 AND 107).

MICHAEL TANNER, EXAMINING ATTORNEY

CLASS 41—(Continued).

SN 85-329,066. MATTHEW SETTLE, SHERMAN OAKS, CA. FILED 5-24-2011.

Matthew Settle

THE MARK CONSISTS OF STANDARD CHARACTERS WITHOUT CLAIM TO ANY PARTICULAR FONT, STYLE, SIZE, OR COLOR.

THE NAME "MATTHEW SETTLE" IDENTIFIES A LIVING INDIVIDUAL WHOSE CONSENT IS OF RECORD.

FOR ENTERTAINMENT SERVICES, NAMELY, LIVE, TELEVISED AND MOVIE APPEARANCES BY A PROFESSIONAL ENTERTAINER (U.S. CLS. 100, 101 AND 107).

FIRST USE 4-21-2000; IN COMMERCE 4-21-2000.
DAVID HOFFMAN, EXAMINING ATTORNEY

CLASS 41—(Continued).

SN 85-331,201. ABDULLAH LLC, NEWPORT BEACH, CA. FILED 5-26-2011.



THE MARK CONSISTS OF A FOOTBALL PLAYER RUNNING WITH THE BALL, WITH A SHIELD BEHIND THE PLAYER.

FOR CONSULTATION IN THE FIELD OF SPECIAL EVENT PLANNING FOR SOCIAL ENTERTAINMENT PURPOSES; PROVIDING FACILITIES FOR PROFESSIONAL SPORTS TOURNAMENTS; ENTERTAINMENT IN THE NATURE OF FOOTBALL TOURNAMENTS (U.S. CLS. 100, 101 AND 107).

GINA FINK, EXAMINING ATTORNEY

SN 85-330,843. FINANCIAL INSTITUTE ADVISORS, LLC, DURHAM, NC. FILED 5-26-2011.

**CERTIFIED DIVORCE
FINANCIAL ANALYST**

THE MARK CONSISTS OF STANDARD CHARACTERS WITHOUT CLAIM TO ANY PARTICULAR FONT, STYLE, SIZE, OR COLOR.

SEC. 2(F).
FOR PROVIDING EDUCATION IN THE FIELD OF FINANCIAL ANALYSIS RENDERED THROUGH CORRESPONDENCE SCHOOLS; ARRANGING AND CONDUCTING EDUCATIONAL WORKSHOPS, TRAINING COURSES, CONFERENCES AND SEMINARS IN THE FIELD OF FINANCIAL ANALYSIS AND THE DISTRIBUTION OF COURSE MATERIALS IN CONNECTION THEREWITH (U.S. CLS. 100, 101 AND 107).

FIRST USE 10-1-2003; IN COMMERCE 10-1-2003.
LEIGH LOWRY, EXAMINING ATTORNEY

SN 85-331,320. MPS ENTERTAINMENT, LLC, HOWELL, NJ. FILED 5-26-2011.

GTL UNIVERSITY

THE MARK CONSISTS OF STANDARD CHARACTERS WITHOUT CLAIM TO ANY PARTICULAR FONT, STYLE, SIZE, OR COLOR.

FOR ENTERTAINMENT SERVICES, NAMELY, ONGOING SERIAL TELEVISION PROGRAMS IN THE FIELD OF REALITY BASED ENTERTAINMENT; ENTERTAINMENT SERVICES, NAMELY, ONGOING ENTERTAINMENT TELEVISION PROGRAMS IN THE FIELD OF REALITY BASED ENTERTAINMENT RENDERED THROUGH CABLE (U.S. CLS. 100, 101 AND 107).

SETH A. RAPPAPORT, EXAMINING ATTORNEY

CLASS 41—(Continued).

SN 85-332,397. WIZARD WORLD, NEW YORK, NY. FILED 5-27-2011.

POP FI

THE MARK CONSISTS OF STANDARD CHARACTERS WITHOUT CLAIM TO ANY PARTICULAR FONT, STYLE, SIZE, OR COLOR.

FOR ENTERTAINMENT EXHIBITIONS, NAMELY, CONVENTIONS FOR ENTHUSIASTS OF ENTERTAINMENT AND POPULAR CULTURE (U.S. CLS. 100, 101 AND 107).

JEAN IM, EXAMINING ATTORNEY

SN 85-332,903. CLICK ON...ETIQUETTE, LLC, TUCSON, AZ. FILED 5-27-2011.

ARIZONA SCHOOL OF PROTOCOL

THE MARK CONSISTS OF STANDARD CHARACTERS WITHOUT CLAIM TO ANY PARTICULAR FONT, STYLE, SIZE, OR COLOR.

OWNER OF U.S. REG. NO. 2,958,797.

NO CLAIM IS MADE TO THE EXCLUSIVE RIGHT TO USE "SCHOOL OF PROTOCOL", APART FROM THE MARK AS SHOWN.

SEC. 2(F).

FOR ETIQUETTE AND PROTOCOL SCHOOLS; ETIQUETTE AND PROTOCOL INSTRUCTION; ETIQUETTE AND PROTOCOL CAMPS; TRAINING SERVICES IN THE FIELD OF ETIQUETTE AND PROTOCOL; EDUCATIONAL SERVICES, NAMELY, CONDUCTING CLASSES, SEMINARS, CONFERENCES AND WORKSHOPS IN THE FIELD OF ETIQUETTE AND PROTOCOL AND DISTRIBUTING COURSE MATERIALS IN CONNECTION THEREWITH; CONDUCTING WORKSHOPS AND SEMINARS IN PERSONAL AWARENESS; PERSONAL COACHING SERVICES IN THE FIELD OF ETIQUETTE AND PROTOCOL (U.S. CLS. 100, 101 AND 107).

FIRST USE 1-30-2005; IN COMMERCE 1-30-2005.

ANNE E. GUSTASON, EXAMINING ATTORNEY

SN 85-333,135. RUIZ, PEDRO, NEW YORK, NY. FILED 5-28-2011.

The Windows Project

THE MARK CONSISTS OF STANDARD CHARACTERS WITHOUT CLAIM TO ANY PARTICULAR FONT, STYLE, SIZE, OR COLOR.

NO CLAIM IS MADE TO THE EXCLUSIVE RIGHT TO USE "PROJECT", APART FROM THE MARK AS SHOWN.

FOR CHOREOGRAPHY SERVICES FOR OTHERS (U.S. CLS. 100, 101 AND 107).

FIRST USE 3-13-2012; IN COMMERCE 3-13-2012.

TRACY FLETCHER, EXAMINING ATTORNEY

CLASS 41—(Continued).

SN 85-333,197. WEGO GROUP, INC., RALEIGH, NC. FILED 5-29-2011.

WEGO

THE MARK CONSISTS OF STANDARD CHARACTERS WITHOUT CLAIM TO ANY PARTICULAR FONT, STYLE, SIZE, OR COLOR.

FOR ENTERTAINMENT EVENT BOOKING AGENCIES; ENTERTAINMENT IN THE NATURE OF AN AMUSEMENT PARK RIDE; MASTER OF CEREMONY SERVICES FOR PARTIES AND SPECIAL EVENTS; MUSICAL EVENT BOOKING AGENCIES; PARTY AND WEDDING PLANNING AND COORDINATION SERVICES; PARTY PLANNING; PARTY PLANNING CONSULTATION; RENTAL OF AMUSEMENT MACHINES AND APPARATUS (U.S. CLS. 100, 101 AND 107).

FIRST USE 5-28-2011; IN COMMERCE 5-28-2011.

BRIAN CALLAGHAN, EXAMINING ATTORNEY

SN 85-333,703. TUSSOCK BAY, L.L.C., DOUGLAS, GA. FILED 5-31-2011.



NO CLAIM IS MADE TO THE EXCLUSIVE RIGHT TO USE "BAY", APART FROM THE MARK AS SHOWN.

THE COLOR(S) BLACK AND ORANGE IS/ARE CLAIMED AS A FEATURE OF THE MARK.

THE MARK CONSISTS OF THE WORDING "TUSSOCK" IN BLACK AND "BAY" IN ORANGE WITH BLACK TREE, GOOSE, AND WILD GRASS DESIGN DIVIDING THE WORDS, AND AN ORANGE CREST MOON APPEARING TO THE LEFT OF THE TREE.

FOR HUNTING GUIDE SERVICES (U.S. CLS. 100, 101 AND 107).

FIRST USE 1-1-2010; IN COMMERCE 1-1-2010.

ALEXANDER L. POWERS, EXAMINING ATTORNEY

SN 85-336,472. DANIEL D'ARCO, POTTSVILLE, PA. FILED 6-2-2011.

ELDERITE

THE MARK CONSISTS OF STANDARD CHARACTERS WITHOUT CLAIM TO ANY PARTICULAR FONT, STYLE, SIZE, OR COLOR.

FOR ENTERTAINMENT SERVICES, NAMELY, PRODUCTION AND DISTRIBUTION OF MOTION PICTURES; SCRIPT DEVELOPMENT, NAMELY, SCRIPT WRITING SERVICES; PROVIDING ONLINE NEWS AND INFORMATION RELATED TO MOTION PICTURES, SCIENCE FICTION TOPICS AND COMPUTER GAMING; CONSULTING IN THE FIELD OF MOTION PICTURE PRODUCTION (U.S. CLS. 100, 101 AND 107).

SANI KHOURI, EXAMINING ATTORNEY

CLASS 41—(Continued).

SN 85-336,912. MCCLYMONT, DAVID T., JACKSONVILLE, FL. FILED 6-2-2011.



THE MARK CONSISTS OF THE WORD "VIDZSPORT", WITH A BOUNCING BALL IN THE BACKGROUND.
 FOR ENTERTAINMENT SERVICES, NAMELY, PROVIDING A WEBSITE WITH VIDEOS, PHOTOS, AND GENERAL SPORTS TEAM INFORMATION (U.S. CLS. 100, 101 AND 107).

ALLISON HOLTZ, EXAMINING ATTORNEY

SN 85-337,176. ANTHONY BELSER, AKA TONE-X, NORCROSS, GA. FILED 6-3-2011.

Tone-X

THE MARK CONSISTS OF STANDARD CHARACTERS WITHOUT CLAIM TO ANY PARTICULAR FONT, STYLE, SIZE, OR COLOR.

THE NAME(S), PORTRAIT(S), AND/OR SIGNATURE(S) SHOWN IN THE MARK IDENTIFIES THE STAGE NAME OF ANTHONY BELSER, A LIVING INDIVIDUAL, WHOSE CONSENT(S) TO REGISTER IS MADE OF RECORD.

FOR ENTERTAINMENT IN THE NATURE OF LIVE COMEDIC PERFORMANCES BY A PROFESSIONAL COMEDIC ENTERTAINER BROADCAST OVER RADIO, TELEVISION, INTERNET (U.S. CLS. 100, 101 AND 107).

FIRST USE 5-0-1995; IN COMMERCE 5-0-1995.
 ALICIA COLLINS, EXAMINING ATTORNEY

SN 85-337,938. HEREWEGO, INC., NEW YORK, NY. FILED 6-3-2011.

LADY BITS

THE MARK CONSISTS OF STANDARD CHARACTERS WITHOUT CLAIM TO ANY PARTICULAR FONT, STYLE, SIZE, OR COLOR.

FOR ENTERTAINMENT SERVICES, NAMELY, AN ONGOING WEB AND TELEVISION COMEDY SERIES; ENTERTAINMENT SERVICES, NAMELY, A WEBSITE FEATURING A WEB COMEDY SERIES AND RELATED INFORMATION; PROVIDING ONLINE, NON-DOWNLOADABLE COMEDY MULTIMEDIA PROGRAMS AND TELEVISION AND INTERNET PROGRAMMING RELATED TO A COMEDY SERIES; AND PROVIDING PODCASTS IN THE FIELD OF COMEDY PROGRAMMING (U.S. CLS. 100, 101 AND 107).

HEATHER BIDDULPH, EXAMINING ATTORNEY

CLASS 41—(Continued).

SN 85-337,946. ZINO, THOMAS, BRONX, NY. FILED 6-3-2011.



NO CLAIM IS MADE TO THE EXCLUSIVE RIGHT TO USE "GYM", APART FROM THE MARK AS SHOWN.

THE MARK CONSISTS OF AN IMAGE OF A VAN WITH THE STYLIZED TEXT "GYM" WRITTEN ON IT. TO THE RIGHT OF THE VAN IS THE STYLIZED TEXT "ON WHEELS". DASHES TRAIL BEHIND THE VAN, REPRESENTING TIRE MARKS.

FOR EDUCATION SERVICES, NAMELY, PROVIDING CLASSES IN THE FIELD OF GYMNASTICS, SPORTS, KARATE, MUSIC AND LANGUAGE (U.S. CLS. 100, 101 AND 107).

FIRST USE 1-1-2005; IN COMMERCE 1-1-2005.
 DORITT L. CARROLL, EXAMINING ATTORNEY

SN 85-338,680. AKINLOSOTU, MORONKE, LAUREL, MD. FILED 6-6-2011.

RONNIE

THE MARK CONSISTS OF STANDARD CHARACTERS WITHOUT CLAIM TO ANY PARTICULAR FONT, STYLE, SIZE, OR COLOR.

THE NAME "RONNIE" IDENTIFIES A LIVING INDIVIDUAL WHOSE CONSENT IS OF RECORD.

FOR AUDIO AND VIDEO RECORDING SERVICES; AUDIO RECORDING AND PRODUCTION; CONSULTATION AND ADVICE REGARDING MUSICAL SELECTIONS AND ARRANGEMENTS FOR SOUND RECORDINGS AND LIVE PERFORMANCES; EDITING OR RECORDING OF SOUNDS AND IMAGES; ENTERTAINMENT SERVICES BY A MUSICAL ARTIST AND PRODUCER, NAMELY, MUSICAL COMPOSITION FOR OTHERS AND PRODUCTION OF MUSICAL SOUND RECORDINGS; ENTERTAINMENT SERVICES IN THE NATURE OF RECORDING, PRODUCTION AND POST-PRODUCTION SERVICES IN THE FIELD OF MUSIC; ENTERTAINMENT SERVICES, NAMELY, DANCE EVENTS BY A RECORDING ARTIST; ENTERTAINMENT SERVICES, NAMELY, NON-DOWNLOADABLE RINGTONES, PRE-RECORDED MUSIC, AND GRA-

CLASS 41—(Continued).

PHICS PRESENTED TO MOBILE COMMUNICATIONS DEVICES VIA A GLOBAL COMPUTER NETWORK AND WIRELESS NETWORKS; ENTERTAINMENT SERVICES, NAMELY, PROVIDING INFORMATION ABOUT A RECORDING ARTIST VIA AN ONLINE NETWORK; MULTIMEDIA ENTERTAINMENT SERVICES IN THE NATURE OF RECORDING, PRODUCTION AND POST-PRODUCTION SERVICES IN THE FIELDS OF MUSIC, VIDEO, AND FILMS; PRODUCTION OF AUDIO RECORDING; PRODUCTION OF MUSICAL SOUND RECORDING; PRODUCTION OF SOUND AND IMAGE RECORDINGS ON SOUND AND IMAGE CARRIERS; PRODUCTION OF SOUND AND MUSIC VIDEO RECORDINGS; PRODUCTION OF SOUND RECORDINGS; PRODUCTION OF SOUND RECORDINGS, NAMELY, RECORDED MUSIC; PROVIDING VOICE OVERS FOR TAPES, RECORDS AND OTHER RECORDED MEDIA FOR ENTERTAINMENT AND EDUCATION PURPOSES; RECORD MASTER PRODUCTION; RECORD MASTERING; RECORD PRODUCTION; RECORDING STUDIO SERVICES (U.S. CLS. 100, 101 AND 107).

JEAN IM, EXAMINING ATTORNEY

CLASS 41—(Continued).

SN 85-341,338. VALENCIA PRODUCTIONS, INC, WEST HOLLYWOOD, CA. FILED 6-8-2011.

MANNAHATTA PRODUCTIONS

THE MARK CONSISTS OF STANDARD CHARACTERS WITHOUT CLAIM TO ANY PARTICULAR FONT, STYLE, SIZE, OR COLOR.

NO CLAIM IS MADE TO THE EXCLUSIVE RIGHT TO USE "PRODUCTIONS", APART FROM THE MARK AS SHOWN.

FOR PRODUCTION OF TELEVISION PROGRAMS (U.S. CLS. 100, 101 AND 107).

MICHELE SWAIN, EXAMINING ATTORNEY

SN 85-341,867. THE PET SALON, INC., MARGATE CITY, NJ. FILED 6-9-2011.

GROOMY

THE MARK CONSISTS OF STANDARD CHARACTERS WITHOUT CLAIM TO ANY PARTICULAR FONT, STYLE, SIZE, OR COLOR.

FOR PROVIDING RECOGNITION AND INCENTIVES BY THE WAY OF AWARDS TO DEMONSTRATE EXCELLENCE IN THE FIELD OF PET GROOMING (U.S. CLS. 100, 101 AND 107).

KRISTIN CARLSON, EXAMINING ATTORNEY

Hayla

THE MARK CONSISTS OF STANDARD CHARACTERS WITHOUT CLAIM TO ANY PARTICULAR FONT, STYLE, SIZE, OR COLOR.

THE NAME(S), PORTRAIT(S), AND/OR SIGNATURE(S) SHOWN IN THE MARK IDENTIFIES TEHILLA LAUDER, WHOSE CONSENT(S) TO REGISTER IS MADE OF RECORD.

FOR ENTERTAINMENT IN THE NATURE OF LIVE PERFORMANCES BY A RECORDING ARTIST; ENTERTAINMENT IN THE NATURE OF VISUAL AND AUDIO PERFORMANCES BY A RECORDING ARTIST; ENTERTAINMENT SERVICES IN THE NATURE OF LIVE MUSICAL PERFORMANCES; ENTERTAINMENT SERVICES, NAMELY, PROVIDING A WEB SITE FEATURING NON-DOWNLOADABLE MUSICAL PERFORMANCES, MUSICAL VIDEOS, RELATED FILM CLIPS, PHOTOGRAPHS, AND OTHER MULTIMEDIA MATERIALS FEATURING PERFORMANCES BY A RECORDING ARTIST; ENTERTAINMENT, NAMELY, LIVE MUSIC CONCERTS (U.S. CLS. 100, 101 AND 107).

FIRST USE 1-1-2010; IN COMMERCE 1-1-2010.
ZACHARY BELLO, EXAMINING ATTORNEY

SN 85-342,003. THE SUMMIT COUNTY HISTORICAL SOCIETY OF AKRON OHIO, AKRON, OH. FILED 6-9-2011.

**THE SUMMIT COUNTY
HISTORICAL SOCIETY OF
AKRON OHIO**

THE MARK CONSISTS OF STANDARD CHARACTERS WITHOUT CLAIM TO ANY PARTICULAR FONT, STYLE, SIZE, OR COLOR.

NO CLAIM IS MADE TO THE EXCLUSIVE RIGHT TO USE "HISTORICAL SOCIETY", APART FROM THE MARK AS SHOWN.

SEC. 2(F).

FOR HISTORICAL MUSEUM SERVICES, NAMELY, EXHIBITING TO THE PUBLIC SITES AND ITEMS HAVING SIGNIFICANCE TO SUMMIT COUNTY HISTORY (U.S. CLS. 100, 101 AND 107).

FIRST USE 8-4-1924; IN COMMERCE 8-4-1924.
MYRIAH HABEEB, EXAMINING ATTORNEY

CLASS 41—(Continued).

SN 85-342,108. ISCHOOL CAMPUS, LLC, PARK CITY, UT. FILED 6-9-2011.



NO CLAIM IS MADE TO THE EXCLUSIVE RIGHT TO USE "ISCHOOL CAMPUS", APART FROM THE MARK AS SHOWN.

THE MARK CONSISTS OF THE WORDING "ISCHOOL CAMPUS" WITH A SCHOOL HOUSE GRAPHIC SURROUNDING THE LETTER "I" OF THE MARK.

FOR PROVIDING INFORMATION IN THE FIELD OF CHILDREN'S EDUCATION, NAMELY, PROVIDING GUIDANCE TO CHARTER, PRIVATE AND PUBLIC SCHOOL ADMINISTRATORS REGARDING INSTRUCTIONAL MODELS THAT UTILIZE COMPUTER TECHNOLOGY FOR USE IN EDUCATING CHILDREN IN KINDERGARTEN THROUGH 12TH GRADE (U.S. CLS. 100, 101 AND 107).

FIRST USE 6-0-2011; IN COMMERCE 6-0-2011.
STEVEN PEREZ, EXAMINING ATTORNEY

CLASS 41—(Continued).

SN 85-342,317. BARONA GROUP OF THE CAPITAN GRANDE BAND OF MISSION INDIANS, DBA BARONA VALLEY RANCH RESORT AND CASINO, LAKESIDE, CA. FILED 6-9-2011.



NO CLAIM IS MADE TO THE EXCLUSIVE RIGHT TO USE "WAGERING", APART FROM THE MARK AS SHOWN.

THE MARK CONSISTS OF THE WORDING "SOCIAL WAGERING" ON THE RIGHT SIDE OF A DESIGN FEATURING THREE HUMAN OUTLINES FROM THE CHEST UP. WITHIN THE CHEST AREA OF THE THREE OUTLINES ARE A CLUB DESIGN, A HEART DESIGN, AND A SPADE DESIGN, ALL WITHIN A SEMI RECTANGULAR DARK BACKGROUND.

FOR CASINOS; CASINO SERVICES; PROVIDING CASINO FACILITIES (U.S. CLS. 100, 101 AND 107).
KATHY DE JONGE, EXAMINING ATTORNEY

SN 85-342,142. INTERNATIONAL ASSOCIATION OF DRILLING CONTRACTORS, HOUSTON, TX. FILED 6-9-2011.



IADC PUBLICATIONS

NO CLAIM IS MADE TO THE EXCLUSIVE RIGHT TO USE "PUBLICATIONS", APART FROM THE MARK AS SHOWN.

THE COLOR(S) RED, BLACK AND WHITE IS/ARE CLAIMED AS A FEATURE OF THE MARK.

THE MARK CONSISTS OF THE LITERAL ELEMENT "IADC" IN BLACK OUTLINED WHITE LETTERS ENCLOSED IN AN RED OVAL FIELD OUTLINED IN BLACK ALL RUNNING DIAGONALLY DOWN THE FRONT OF A REPRESENTATION OF AN OIL DRILLING DERRICK IN BLACK AND WHITE WITH ALL OF THE AFOREMENTIONED ELEMENTS STACKED ABOVE THE LITERAL PORTION "IADC PUBLICATIONS" IN BLACK.

FOR PUBLICATION OF TEXTS, BOOKS, MANUALS, MAGAZINES, JOURNALS AND OTHER PRINTED MATTER (U.S. CLS. 100, 101 AND 107).

FIRST USE 0-0-2005; IN COMMERCE 0-0-2005.
JAMES A. RAUEN, EXAMINING ATTORNEY

SN 85-343,289. SOUTHWESTERN PERFORMANCE TECHNOLOGY CORP., SANTA ANA, CA. FILED 6-10-2011.

UNLIMITED RACING CHAMPIONSHIP

THE MARK CONSISTS OF STANDARD CHARACTERS WITHOUT CLAIM TO ANY PARTICULAR FONT, STYLE, SIZE, OR COLOR.

NO CLAIM IS MADE TO THE EXCLUSIVE RIGHT TO USE "RACING CHAMPIONSHIP", APART FROM THE MARK AS SHOWN.

FOR ENTERTAINMENT SERVICES IN THE NATURE OF AUTOMOBILE RACING AND EXHIBITIONS (U.S. CLS. 100, 101 AND 107).

BARBARA A. GOLD, EXAMINING ATTORNEY

CLASS 41—(Continued).

SN 85-344,930. ANGUS, VAIL, ROYAL OAK, MI. FILED 6-13-2011.

ARTBLOC

THE MARK CONSISTS OF STANDARD CHARACTERS WITHOUT CLAIM TO ANY PARTICULAR FONT, STYLE, SIZE, OR COLOR.

FOR ENTERTAINMENT SERVICES IN THE NATURE OF PROVIDING ART EXHIBITIONS, LIVE DANCE, THEATRICAL AND MUSICAL PERFORMANCES; RENTAL OF PORTABLE STAGES FOR ENTERTAINMENT PURPOSES, NAMELY, MODULAR, MOBILE DISPLAY AND PERFORMANCE STAGES FOR LIVE MUSICAL, THEATRICAL AND SHOW PERFORMANCES; RENTAL OF MOBILE GALLERY SPACE FOR ENTERTAINMENT PURPOSES, NAMELY, RENTAL OF EXHIBITION STANDS, PANELS AND BOOTHS FOR ART SHOWS AND EXHIBITIONS (U.S. CLS. 100, 101 AND 107).

FIRST USE 7-15-2011; IN COMMERCE 7-15-2011.
STEVEN PEREZ, EXAMINING ATTORNEY

SN 85-345,627. NORTHERN TRUST CORPORATION, CHICAGO, IL. FILED 6-14-2011.

THE PALM LITERARY SOCIETY

THE MARK CONSISTS OF STANDARD CHARACTERS WITHOUT CLAIM TO ANY PARTICULAR FONT, STYLE, SIZE, OR COLOR.

NO CLAIM IS MADE TO THE EXCLUSIVE RIGHT TO USE "LITERARY SOCIETY", APART FROM THE MARK AS SHOWN.

FOR EDUCATIONAL AND ENTERTAINMENT SERVICES, NAMELY, HOSTING PRESENTATIONS BY AUTHORS (U.S. CLS. 100, 101 AND 107).

VERNA BETH RIRIE, EXAMINING ATTORNEY

SN 85-346,767. STEVE KAPLAN, CALABASAS, CA. FILED 6-15-2011.

RAINSTORM ENTERTAINMENT

THE MARK CONSISTS OF STANDARD CHARACTERS WITHOUT CLAIM TO ANY PARTICULAR FONT, STYLE, SIZE, OR COLOR.

NO CLAIM IS MADE TO THE EXCLUSIVE RIGHT TO USE "ENTERTAINMENT", APART FROM THE MARK AS SHOWN.

FOR FILM DISTRIBUTION; MOTION PICTURE FILM PRODUCTION; VIDEOTAPE PRODUCTION (U.S. CLS. 100, 101 AND 107).

FIRST USE 12-1-2001; IN COMMERCE 2-15-2002.
SUNG IN, EXAMINING ATTORNEY

CLASS 41—(Continued).

SN 85-346,919. FIRST TIME FEST LLC, BROOKLYN, NY. FILED 6-15-2011.

FIRST TIME FEST

THE MARK CONSISTS OF STANDARD CHARACTERS WITHOUT CLAIM TO ANY PARTICULAR FONT, STYLE, SIZE, OR COLOR.

NO CLAIM IS MADE TO THE EXCLUSIVE RIGHT TO USE "FEST", APART FROM THE MARK AS SHOWN.

FOR ENTERTAINMENT SERVICES, NAMELY, PLANNING AND CONDUCTING A SERIES OF FILM FESTIVALS FEATURING FILMS OF INTEREST TO THE GENERAL PUBLIC AND THE GENERAL INTEREST FILM INDUSTRY (U.S. CLS. 100, 101 AND 107).

NATALIE POLZER, EXAMINING ATTORNEY

SN 85-350,528. BOARD OF TRUSTEES OF MONTCLAIR STATE UNIVERSITY, AKA MONTCLAIR STATE UNIVERSITY, MONTCLAIR, NJ. FILED 6-20-2011.

Montclair State University

THE MARK CONSISTS OF STANDARD CHARACTERS WITHOUT CLAIM TO ANY PARTICULAR FONT, STYLE, SIZE, OR COLOR.

NO CLAIM IS MADE TO THE EXCLUSIVE RIGHT TO USE "STATE UNIVERSITY", APART FROM THE MARK AS SHOWN.

SEC. 2(F).
FOR EDUCATING AT UNIVERSITY OR COLLEGES (U.S. CLS. 100, 101 AND 107).

FIRST USE 4-14-1994; IN COMMERCE 4-14-1994.
MICHAEL WEBSTER, EXAMINING ATTORNEY

CLASS 41—(Continued).

SN 85-350,712. LIFESTYLE HEALTH NETWORKS, LLC, ATHENS, GA. FILED 6-20-2011.



NO CLAIM IS MADE TO THE EXCLUSIVE RIGHT TO USE "LIFESTYLE HEALTH NETWORKS", APART FROM THE MARK AS SHOWN.

THE COLOR(S) GREEN AND ORANGE IS/ARE CLAIMED AS A FEATURE OF THE MARK.

THE MARK CONSISTS OF A GROUP OF FIVE LEAVES IN VARIOUS SHADES OF GREEN WITH THE CENTER LEAF BEING A STYLIZED RENDITION OF A PERSON WITH ARMS RAISED, BELOW THE LEAVES IS A STYLIZED DEPICTION OF THE WORDS "LIFESTYLE" IN DARK GREEN AND "HEALTH NETWORKS" IN ORANGE.

FOR ONLINE SYSTEMS, APPLICATIONS AND SERVICES OFFERED TO INDIVIDUALS AND AIMED AT PROMOTING AND MANAGING INDIVIDUALIZED HEALTHCARE IN THE NATURE OF EDUCATIONAL SERVICES, NAMELY, CONDUCTING PROGRAMS IN THE FIELD OF HEALTHCARE, HEALTH AND WELLNESS, EXERCISE, DIET AND PERSONAL ACCOUNTABILITY; PERSONAL TRAINING PROVIDED IN CONNECTION WITH WEIGHT LOSS AND EXERCISE PROGRAMS; PHYSICAL FITNESS INSTRUCTION (U.S. CLS. 100, 101 AND 107).

KATHERINE CONNOLLY, EXAMINING ATTORNEY

SN 85-350,758. AZTECA INTERNATIONAL CORPORATION, GLENDALE, CA. FILED 6-20-2011.

LA HORA DE LA VERDAD

THE MARK CONSISTS OF STANDARD CHARACTERS WITHOUT CLAIM TO ANY PARTICULAR FONT, STYLE, SIZE, OR COLOR.

THE ENGLISH TRANSLATION OF "LA HORA DE LA VERDAD" IN THE MARK IS "THE HOUR OF TRUTH".

FOR ENTERTAINMENT SERVICES, NAMELY, AN ONGOING TELEVISION TALK SHOW AND INVESTIGATIVE JOURNALISM SHOW (U.S. CLS. 100, 101 AND 107).

FIRST USE 6-6-2011; IN COMMERCE 6-6-2011.

JOHN SCHUYLER YARD, EXAMINING ATTORNEY

CLASS 41—(Continued).

SN 85-351,815. THE MOREY ORGANIZATION, INC., WILDWOOD, NJ. FILED 6-21-2011.



OWNER OF U.S. REG. NOS. 4,001,296 AND 4,008,335.

THE MARK CONSISTS OF THE WORDS "MOREY'S FEARS TERROR ON THE BOARDWALK" IN STYLIZED LETTERS. THE WORDS "MOREY'S FEARS" AND "TERROR" APPEAR TO HAVE BLOOD DRIPPING FROM THEM. A SKULL APPEARS INSIDE THE LETTER "O" IN THE WORD "TERROR" AND A HAND APPEARS TO THE LEFT OF THE WORD. THERE IS A PILE OF SKULLS UNDERNEATH THE WORDS "ON THE". THE WORD "BOARDWALK" APPEARS TO BE MADE OF BONES WITH BLOOD DRIPPING ON THEM. THERE ARE TAILS TO THE LEFT AND RIGHT OF THE WORDS.

FOR ENTERTAINMENT SERVICES, NAMELY, A HAUNTED ATTRACTION FEATURING AMUSEMENT PIER RIDES AND LIVE SHOWS (U.S. CLS. 100, 101 AND 107).

SHARON MEIER, EXAMINING ATTORNEY

SN 85-352,313. RECORD, DERRELL W, LOS ANGELES, CA. FILED 6-21-2011.

RICH AUDIO RECORDING ENTERTAINMENT

THE MARK CONSISTS OF STANDARD CHARACTERS WITHOUT CLAIM TO ANY PARTICULAR FONT, STYLE, SIZE, OR COLOR.

NO CLAIM IS MADE TO THE EXCLUSIVE RIGHT TO USE "AUDIO RECORDING ENTERTAINMENT", APART FROM THE MARK AS SHOWN.

FOR CONSULTATION AND ADVICE REGARDING MUSICAL SELECTIONS AND ARRANGEMENTS FOR SOUND RECORDINGS AND LIVE PERFORMANCES; ENTERTAINMENT SERVICES IN THE NATURE OF PRESENTING LIVE MUSICAL PERFORMANCES; ENTERTAINMENT SERVICES IN THE NATURE OF RECORDING, PRODUCTION AND POST-PRODUCTION SERVICES IN THE FIELD OF MUSIC; ENTERTAINMENT SERVICES, NAMELY, PROVIDING A WEB SITE FEATURING NON-DOWNLOADABLE MUSICAL PERFORMANCES, MUSICAL VIDEOS, RELATED FILM CLIPS, PHOTOGRAPHS, AND OTHER MULTIMEDIA MATERIALS FEATURING MUSIC AND MUSIC INFORMATION; PRESENTATION OF MUSICAL PERFORMANCE; PROVIDING A WEBSITE FEATURING INFORMATION IN THE FIELD OF MUSIC AND ENTERTAINMENT; PROVISION OF INFORMATION RELATING TO MUSIC (U.S. CLS. 100, 101 AND 107).

ROSELLE HERRERA, EXAMINING ATTORNEY

CLASS 41—(Continued).

SN 85-352,455. RICE, WAYNE, LAKESIDE, CA. FILED 6-22-2011.

BLUEGRASS BIOS

THE MARK CONSISTS OF STANDARD CHARACTERS WITHOUT CLAIM TO ANY PARTICULAR FONT, STYLE, SIZE, OR COLOR.

NO CLAIM IS MADE TO THE EXCLUSIVE RIGHT TO USE "BIOS", APART FROM THE MARK AS SHOWN.

SEC. 2(F) AS TO "BLUEGRASS".

FOR PROVIDING A WEB SITE FEATURING BIOGRAPHICAL INFORMATION ABOUT BLUEGRASS MUSIC ARTISTS (U.S. CLS. 100, 101 AND 107).

FIRST USE 9-1-1988; IN COMMERCE 10-1-1988.

GEOFFREY FOSDICK, EXAMINING ATTORNEY

CLASS 41—(Continued).

SN 85-353,206. DISCOVERY COMMUNICATIONS, LLC, SILVER SPRING, MD. FILED 6-22-2011.

BEST IN THE BUSINESS

THE MARK CONSISTS OF STANDARD CHARACTERS WITHOUT CLAIM TO ANY PARTICULAR FONT, STYLE, SIZE, OR COLOR.

FOR ENTERTAINMENT AND EDUCATIONAL SERVICES IN THE NATURE OF TELEVISION AND MULTIMEDIA PROGRAM SERIES FEATURING SUBJECTS OF GENERAL HUMAN INTEREST DISTRIBUTED VIA VARIOUS PLATFORMS ACROSS MULTIPLE FORMS OF TRANSMISSION MEDIA; PROVIDING ENTERTAINMENT INFORMATION TO OTHERS VIA A GLOBAL COMPUTER NETWORK (U.S. CLS. 100, 101 AND 107).

HOWARD FRIEDMAN, EXAMINING ATTORNEY

SN 85-352,485. GIGGLE GARAGE SDN BHD, SELANGOR DARUL EHSAN, MALAYSIA, FILED 6-22-2011.

ORIGANIMALS

THE MARK CONSISTS OF STANDARD CHARACTERS WITHOUT CLAIM TO ANY PARTICULAR FONT, STYLE, SIZE, OR COLOR.

FOR DIGITAL IMAGING SERVICES; PROVIDING INFORMATION RELATING TO EDUCATIONAL SERVICES; ELECTRONIC DESKTOP PUBLISHING; ENTERTAINMENT IN THE NATURE OF ON-GOING TELEVISION PROGRAMS IN THE FIELDS OF WILDLIFE, SCIENCE, NATURE, ARTS AND CRAFTS, CHILDREN'S ENTERTAINMENT AND EDUCATION; ENTERTAINMENT SERVICES, NAMELY, PROVIDING ON-LINE COMPUTER GAMES ACCESSIBLE VIA COMPUTERS, CONSOLES, TABLETS AND MOBILE DEVICES; PRODUCTION OF FILM, RADIO, TELEVISION PROGRAMMES, SHOWS AND VIDEOTAPE FILM; PROVIDING ON-LINE ELECTRONIC PUBLICATIONS, NOT DOWNLOADABLE, IN THE NATURE OF MAGAZINES, NEWSLETTERS, JOURNALS, CATALOGUES AND E-BOOKS IN THE FIELDS OF WILDLIFE, SCIENCE, NATURE, ARTS AND CRAFTS AND CHILDREN'S ENTERTAINMENT AND EDUCATION; PUBLICATION OF BOOKS, ELECTRONIC BOOKS AND JOURNALS ON-LINE; TEACHING IN THE FIELDS OF WILDLIFE, SCIENCE, NATURE, ARTS AND CRAFTS AND CHILDREN'S ENTERTAINMENT AND EDUCATION (U.S. CLS. 100, 101 AND 107).

GRETTA YAO, EXAMINING ATTORNEY

SN 85-353,576. INNOVATION IP LIMITED, WAIHI 3682, NEW ZEALAND, FILED 6-22-2011.

LIFE CODE MATRIX

THE MARK CONSISTS OF STANDARD CHARACTERS WITHOUT CLAIM TO ANY PARTICULAR FONT, STYLE, SIZE, OR COLOR.

OWNER OF NEW ZEALAND REG. NO. 762743, DATED 4-9-2009, EXPIRES 1-31-2017.

FOR EDUCATION SERVICES, NAMELY, CONDUCTING SEMINARS, WORKSHOPS, RETREATS AND CONFERENCES IN THE FIELDS OF SELF DEVELOPMENT, SELF CONFIDENCE, LIFE DIRECTION AND SELF-ESTEEM FOR INDIVIDUALS, COUPLES OR GROUPS; TRAINING COURSES IN BUILDING RAPPORT BETWEEN INDIVIDUALS AND TEAMS (U.S. CLS. 100, 101 AND 107).

LINDA E. BLOHM, EXAMINING ATTORNEY

CLASS 41—(Continued).

SN 85-354,421. ZOOLOGICAL SOCIETY OF PHILADELPHIA, PHILADELPHIA, PA. FILED 6-23-2011.

X•tink•shun

NO CLAIM IS MADE TO THE EXCLUSIVE RIGHT TO USE "EXTINCTION", APART FROM THE MARK AS SHOWN.

THE MARK CONSISTS OF THE TERM "X TINK SHUN" IN STYLIZED LETTERS WITH A CENTERED SHADED CIRCLE BETWEEN THE "X" AND "TINK" AND A CENTERED SHADED CIRCLE BETWEEN "TINK" AND "SHUN".

FOR EDUCATIONAL AND ENTERTAINMENT SERVICES IN THE NATURE OF LIVE, MULTIMEDIA PERFORMANCES AND PRESENTATIONS FEATURING PUPPETS IN THE FORM OF EXTINCT AND ENDANGERED ANIMALS TELLING STORIES AND PROVIDING SUGGESTIONS ABOUT PROTECTING, PRESERVING, AND SUSTAINING ANIMAL HABITATS (U.S. CLS. 100, 101 AND 107).

FIRST USE 4-8-2011; IN COMMERCE 4-8-2011.
JOHN WILKE, EXAMINING ATTORNEY

CLASS 41—(Continued).

SN 85-354,915. OAK TREE RACING ASSOCIATION, ARCADIA, CA. FILED 6-23-2011.

OAK TREE MILE

THE MARK CONSISTS OF STANDARD CHARACTERS WITHOUT CLAIM TO ANY PARTICULAR FONT, STYLE, SIZE, OR COLOR.

OWNER OF U.S. REG. NO. 2,156,919.

NO CLAIM IS MADE TO THE EXCLUSIVE RIGHT TO USE "MILE", APART FROM THE MARK AS SHOWN.

FOR ENTERTAINMENT, NAMELY, CONDUCTING HORSE RACES AND PROVIDING HORSE RACING ENTERTAINMENT INFORMATION THROUGH VARIOUS FORMS OF MEDIA (U.S. CLS. 100, 101 AND 107).

FIRST USE 0-0-1986; IN COMMERCE 0-0-1986.
LOURDES AYALA, EXAMINING ATTORNEY

SN 85-355,613. NANTUCKET ATHENEUM, INC., NANTUCKET, MA. FILED 6-24-2011.

SN 85-354,806. WEIDER HEALTH AND FITNESS, WOODLAND HILLS, CA. FILED 6-23-2011.

MR. OLYMPIA



THE MARK CONSISTS OF STANDARD CHARACTERS WITHOUT CLAIM TO ANY PARTICULAR FONT, STYLE, SIZE, OR COLOR.

OWNER OF U.S. REG. NOS. 3,951,271, 3,958,216 AND OTHERS.

FOR ENTERTAINMENT SERVICES, NAMELY, ORGANIZING AND CONDUCTING BODYBUILDING CONTESTS AND COMPETITIONS, AND SHOWS FEATURING BODYBUILDERS AND AWARDS CEREMONIES (U.S. CLS. 100, 101 AND 107).

FIRST USE 9-0-1965; IN COMMERCE 9-0-1965.
YAT SYE, LEE, EXAMINING ATTORNEY

THE MARK CONSISTS OF THE TOP CORNER OF A COLUMN.

FOR LENDING AND REFERENCE LIBRARY SERVICES; REFERENCE LIBRARIES OF LITERATURE, SCIENCES, HISTORY AND THE ARTS AND DOCUMENTARY RECORDS; ONLINE ACADEMIC LIBRARY SERVICES; EDUCATIONAL SERVICES AND PROGRAMS, NAMELY, LITERACY CLASSES AND LECTURES; ENTERTAINMENT SERVICES IN THE NATURE OF LIVE MUSICAL AND DANCE PERFORMANCES AND BOOK AND POETRY READINGS; AND CULTURAL PROGRAMMING, NAMELY, ORGANIZATION AND HOSTING OF CULTURAL EVENTS (U.S. CLS. 100, 101 AND 107).

FIRST USE 11-1-2010; IN COMMERCE 11-1-2010.
DAVID MURRAY, EXAMINING ATTORNEY

CLASS 41—(Continued).

SN 85-355,617. NANTUCKET ATHENEUM, INC., NANTUCKET, MA. FILED 6-24-2011.

**NANTUCKET ATHENEUM
ENRICHING ISLAND LIFE
YEAR-ROUND**

THE MARK CONSISTS OF STANDARD CHARACTERS WITHOUT CLAIM TO ANY PARTICULAR FONT, STYLE, SIZE, OR COLOR.

NO CLAIM IS MADE TO THE EXCLUSIVE RIGHT TO USE "NANTUCKET ATHENEUM", APART FROM THE MARK AS SHOWN.

FOR LENDING AND REFERENCE LIBRARY SERVICES; REFERENCE LIBRARIES OF LITERATURE, SCIENCES, HISTORY AND THE ARTS AND DOCUMENTARY RECORDS; ONLINE ACADEMIC LIBRARY SERVICES; EDUCATIONAL SERVICES AND PROGRAMS, NAMELY, LITERACY CLASSES AND LECTURES; ENTERTAINMENT SERVICES IN THE NATURE OF LIVE MUSICAL AND DANCE PERFORMANCES AND BOOK AND POETRY READINGS; AND CULTURAL PROGRAMMING, NAMELY, ORGANIZATION AND HOSTING OF CULTURAL EVENTS (U.S. CLS. 100, 101 AND 107).

FIRST USE 11-1-2010; IN COMMERCE 11-1-2010.
DAVID MURRAY, EXAMINING ATTORNEY

SN 85-356,947. PARTICULATE3D CONVERSIONS, LP, DALLAS, TX. FILED 6-27-2011.

PARTICULATE3D

THE MARK CONSISTS OF STANDARD CHARACTERS WITHOUT CLAIM TO ANY PARTICULAR FONT, STYLE, SIZE, OR COLOR.

FOR CONVERSION OF FILM AND VIDEO CONTENT FROM TWO DIMENSIONAL TO A THREE DIMENSIONAL FORMAT AS WELL AS OTHER PROPRIETARY 3D ALGORITHMIC SERVICES (U.S. CLS. 100, 101 AND 107).

MARLENE BELL, EXAMINING ATTORNEY

SN 85-357,939. 3G STUDIOS, INC., RENO, NV. FILED 6-28-2011.

3G

THE MARK CONSISTS OF STANDARD CHARACTERS WITHOUT CLAIM TO ANY PARTICULAR FONT, STYLE, SIZE, OR COLOR.

SEC. 2(F).
FOR PRODUCTION OF VIDEO AND COMPUTER GAME SOFTWARE (U.S. CLS. 100, 101 AND 107).

FIRST USE 5-1-2006; IN COMMERCE 5-1-2006.
CHERYL CLAYTON, EXAMINING ATTORNEY

CLASS 41—(Continued).

SN 85-358,154. TUCKER, CHARLES, HUNTINGDON VALLEY, PA. AND TUCKER, ROSALIND, HUNTINGDON VALLEY, PA. FILED 6-28-2011.

**You're Just Older. You're
Not Dead.**

THE MARK CONSISTS OF STANDARD CHARACTERS WITHOUT CLAIM TO ANY PARTICULAR FONT, STYLE, SIZE, OR COLOR.

FOR PROVIDING ON-LINE INFORMATION, NEWS AND COMMENTARY TARGETED TO CONSUMERS AGED FIFTY AND OVER IN THE FIELD OF EDUCATION, ENTERTAINMENT, EXERCISE, FITNESS, SPORTS, RECREATION AND LEISURE ACTIVITIES, BOOK REVIEWS, FINE ARTS, PERFORMING ARTS, AND COMEDY SHOWS (U.S. CLS. 100, 101 AND 107).

JIM RINGLE, EXAMINING ATTORNEY

SN 85-358,177. TUCKER, CHARLES, HUNTINGDON VALLEY, PA. AND TUCKER, ROSALIND, HUNTINGDON VALLEY, PA. FILED 6-28-2011.

Justoldernotdead.com

THE MARK CONSISTS OF STANDARD CHARACTERS WITHOUT CLAIM TO ANY PARTICULAR FONT, STYLE, SIZE, OR COLOR.

FOR PROVIDING ON-LINE INFORMATION, NEWS AND COMMENTARY TARGETED TO CONSUMERS AGED FIFTY AND OVER IN THE FIELD OF EDUCATION, ENTERTAINMENT, EXERCISE, FITNESS, SPORTS, RECREATION AND LEISURE ACTIVITIES, BOOK REVIEWS, FINE ARTS, PERFORMING ARTS, AND COMEDY SHOWS (U.S. CLS. 100, 101 AND 107).

JIM RINGLE, EXAMINING ATTORNEY

SN 85-358,406. CREATE ADVANTAGE, INC., STILLWATER, MN. FILED 6-28-2011.

THE MULTIVERSE

THE MARK CONSISTS OF STANDARD CHARACTERS WITHOUT CLAIM TO ANY PARTICULAR FONT, STYLE, SIZE, OR COLOR.

FOR EDUCATIONAL SERVICES, NAMELY, ARRANGING, ORGANIZING AND CONDUCTING CLASSES, SEMINARS, WORKSHOPS, COURSES, TRAINING PROGRAMS, AND CONFERENCES IN THE FIELDS OF EXPERIENCE DESIGN, ORGANIZATIONAL MANAGEMENT AND INNOVATION STRATEGY (U.S. CLS. 100, 101 AND 107).

LINDA LAVACHE, EXAMINING ATTORNEY

CLASS 41—(Continued).

SN 85-358,465. GRAPECITY INCORPORATED, AKA GRAPECITY; GRAPECITY POWERTOOLS, SENDAI, JAPAN, FILED 6-28-2011.

RUSS CAM

THE MARK CONSISTS OF STANDARD CHARACTERS WITHOUT CLAIM TO ANY PARTICULAR FONT, STYLE, SIZE, OR COLOR.

NO CLAIM IS MADE TO THE EXCLUSIVE RIGHT TO USE "CAM", APART FROM THE MARK AS SHOWN.

THE NAME(S), PORTRAIT(S), AND/OR SIGNATURE(S) SHOWN IN THE MARK IDENTIFIES RUSSELL A. FUSTINO, WHOSE CONSENT(S) TO REGISTER IS MADE OF RECORD.

FOR ENTERTAINMENT IN THE NATURE OF AN ONGOING SERIES FEATURING TECHNOLOGY, PEOPLE IN THE TECHNOLOGY FIELD AND THE INTERESTS OF PEOPLE IN THE TECHNOLOGY FIELD (U.S. CLS. 100, 101 AND 107).

DORITT L. CARROLL, EXAMINING ATTORNEY

CLASS 41—(Continued).

SN 85-359,351. MTR GAMING GROUP, INC., CHESTER, WV. FILED 6-29-2011.

PRESQUE ISLE DOWNS & CASINO

THE MARK CONSISTS OF STANDARD CHARACTERS WITHOUT CLAIM TO ANY PARTICULAR FONT, STYLE, SIZE, OR COLOR.

OWNER OF U.S. REG. NOS. 3,525,647 AND 3,529,005.

NO CLAIM IS MADE TO THE EXCLUSIVE RIGHT TO USE "DOWNS & CASINO", APART FROM THE MARK AS SHOWN.

FOR ENTERTAINMENT SERVICES, NAMELY, ORGANIZING AND CONDUCTING HORSE RACES, AND CASINO SERVICES (U.S. CLS. 100, 101 AND 107).

FRANK LATTUCA, EXAMINING ATTORNEY

SN 85-359,607. REWIRED FOR CHANGE, BALTIMORE, MD. FILED 6-29-2011.

SN 85-358,547. GLOBAL EXPERIENCE SPECIALISTS, INC., LAS VEGAS, NV. FILED 6-28-2011.

TOYS THRU TIME

THE MARK CONSISTS OF STANDARD CHARACTERS WITHOUT CLAIM TO ANY PARTICULAR FONT, STYLE, SIZE, OR COLOR.

FOR ORGANIZING AND CONDUCTING INTERACTIVE EXHIBITS AND DISPLAYS, WHICH FEATURE POPULAR GAMES, TOYS AND HOBBIES FROM THE PAST, PRESENT AND FUTURE (U.S. CLS. 100, 101 AND 107).

FIRST USE 0-0-2007, THE MARK WAS FIRST USED ANYWHERE IN A DIFFERENT FORM OTHER THAN THAT SOUGHT TO BE REGISTERED AT LEAST AS EARLY AS 11/03/2004; IN COMMERCE 0-0-2007, THE MARK WAS FIRST USED IN COMMERCE IN A DIFFERENT FORM OTHER THAN THAT SOUGHT TO BE REGISTERED AT LEAST AS EARLY AS 11/03/2004.

ALICIA COLLINS, EXAMINING ATTORNEY

rewired
for change

THE STIPPLING IS A FEATURE OF THE MARK AND DOES NOT INDICATE COLOR.

THE COLOR(S) RED AND BLACK IS/ARE CLAIMED AS A FEATURE OF THE MARK.

THE MARK CONSISTS OF THE WORDING "REWIRED FOR CHANGE" WHEREIN THE LETTERS "RE" ARE IN RED, THE LETTERS "WIRED" AND THE WORDS "FOR CHANGE" ARE IN BLACK.

FOR EDUCATION SERVICES, NAMELY, PROVIDING CLASSES, SEMINARS, AND WORKSHOPS IN THE FIELDS OF NEIGHBORHOOD ADVOCACY, COMMUNITY ORGANIZING, AND LIFE SKILLS DEVELOPMENT, ALL SERVICES PROVIDED TO EMPOWER AT-RISK YOUTH LIVING IN UNDER-SERVED COMMUNITIES (U.S. CLS. 100, 101 AND 107).

FIRST USE 6-1-2009; IN COMMERCE 6-1-2009.

JAMES STEIN, EXAMINING ATTORNEY

CLASS 41—(Continued).

SN 85-360,068. LAJOBI, INC., CRANBURY, NJ. FILED 6-29-2011.



THE MARK CONSISTS OF A TREE WITH BRANCHES THAT HAVE CIRCLES FOR LEAVES, WITH SOME CIRCLES HAVING WHITE CIRCLES WITHIN.

FOR ON-LINE JOURNALS, NAMELY, BLOGS FEATURING INFORMATION ON FURNITURE, BABY NURSERY FURNITURE AND INTERIOR DESIGN, AND GENERAL MATTERS PERTAINING TO CHILDREN AND INFANTS (U.S. CLS. 100, 101 AND 107).

FIRST USE 4-12-2011; IN COMMERCE 4-12-2011.
 NAAKWAMA ANKRAH, EXAMINING ATTORNEY

CLASS 41—(Continued).

SN 85-360,079. BOGATIREV, DMITRO, DBA AGA-BOOM, LAS VEGAS, NV. FILED 6-29-2011.

AGA-BOOM

THE MARK CONSISTS OF STANDARD CHARACTERS WITHOUT CLAIM TO ANY PARTICULAR FONT, STYLE, SIZE, OR COLOR.

FOR ENTERTAINMENT, NAMELY, PRODUCTION OF LIVE STAGE SHOWS AND THEATRICAL PRODUCTIONS FEATURING PHYSICAL COMEDY, CIRCUS ACTS CLOWNS, LIVE AND PRE-RECORDED MUSIC, AND VIDEO PROJECTIONS; PRODUCTION OF TELEVISION PROGRAMS; PRODUCTION OF FILM AUDIO AND VIDEO RECORDINGS IN CLASS 41 (U.S. CLS. 100, 101 AND 107).

FIRST USE 8-3-2004; IN COMMERCE 8-3-2004.
 NAAKWAMA ANKRAH, EXAMINING ATTORNEY

SN 85-360,800. LYNDELL HIGGINS, DBA STRETCH DANCE COMPANY, TRABUCO CANYON, CA. FILED 6-30-2011.

SN 85-360,070. LAJOBI, INC., CRANBURY, NJ. FILED 6-29-2011.



NO CLAIM IS MADE TO THE EXCLUSIVE RIGHT TO USE "NURSERY", APART FROM THE MARK AS SHOWN.

THE MARK CONSISTS OF THE WORD "INSPIRED" IN LOWER CASE LETTERS, FOLLOWED BY A TREE WITH BRANCHES THAT HAVE CIRCLES FOR LEAVES WITH SOME CIRCLES HAVING WHITE CIRCLES WITHIN, FOLLOWED BY THE WORD "NURSERY" IN LOWER CASE.

FOR ON-LINE JOURNALS, NAMELY, BLOGS FEATURING INFORMATION ON FURNITURE, BABY NURSERY FURNITURE AND INTERIOR DESIGN, AND GENERAL MATTERS PERTAINING TO CHILDREN AND INFANTS (U.S. CLS. 100, 101 AND 107).

FIRST USE 4-12-2011; IN COMMERCE 4-12-2011.
 NAAKWAMA ANKRAH, EXAMINING ATTORNEY



NO CLAIM IS MADE TO THE EXCLUSIVE RIGHT TO USE "DANCE COMPANY", APART FROM THE MARK AS SHOWN.

THE MARK CONSISTS OF THE STYLIZED WORDING "STRETCH DANCE COMPANY" AND A SILHOUETTE OF A DANCER.

FOR ENTERTAINMENT SERVICES IN THE NATURE OF LIVE DANCE PERFORMANCES (U.S. CLS. 100, 101 AND 107).

JILL PRATER, EXAMINING ATTORNEY

CLASS 41—(Continued).

SN 85-361,198. LYNDELL HIGGINS, DBA STRETCH DANCE COMPANY, TRABUCO CANYON, CA. FILED 6-30-2011.

STRETCH DANCE COMPANY

THE MARK CONSISTS OF STANDARD CHARACTERS WITHOUT CLAIM TO ANY PARTICULAR FONT, STYLE, SIZE, OR COLOR.

NO CLAIM IS MADE TO THE EXCLUSIVE RIGHT TO USE "DANCE COMPANY", APART FROM THE MARK AS SHOWN.

FOR ENTERTAINMENT SERVICES IN THE NATURE OF LIVE DANCE PERFORMANCES (U.S. CLS. 100, 101 AND 107).

JILL PRATER, EXAMINING ATTORNEY

CLASS 41—(Continued).

SN 85-363,329. HOLA, S.A., 28006 MADRID, SPAIN, FILED 7-5-2011.

HOLA TV AMERICA

THE MARK CONSISTS OF STANDARD CHARACTERS WITHOUT CLAIM TO ANY PARTICULAR FONT, STYLE, SIZE, OR COLOR.

OWNER OF U.S. REG. NOS. 1,009,686, 2,772,805 AND OTHERS.

NO CLAIM IS MADE TO THE EXCLUSIVE RIGHT TO USE "TV AMERICA", APART FROM THE MARK AS SHOWN.

THE ENGLISH TRANSLATION OF "HOLA" IN THE MARK IS "HELLO".

FOR ENTERTAINMENT SERVICES, NAMELY, THE PROVISION OF CONTINUING SHOWS FEATURING NEWS, SOCIETY, FASHION, BEAUTY, TRENDS AND LIFESTYLES, CELEBRITIES AND FAMILY CONTENT DELIVERED BY TELEVISION AND RADIO; ORGANIZATION OF EVENTS FOR CULTURAL PURPOSES; PUBLICATION OF TEXTS, BOOKS, MAGAZINES AND OTHER PRINTED MATTER; ELECTRONIC PUBLICATION OF BOOKS, NEWSPAPERS AND MAGAZINES ONLINE; PROVIDING ONLINE PUBLICATIONS IN THE NATURE OF TEXTS, BOOKS, MAGAZINES, WORKBOOKS, ARTICLES AND NEWSLETTERS FEATURING GENERAL NEWS INFORMATION IN THE AREA OF CURRENT EVENTS AND ENTERTAINMENT; NEWS REPORTERS SERVICES AND PHOTOGRAPHIC REPORTING; PUBLISHING, EDITING AND PRODUCTION OF RADIO AND TELEVISION PROGRAMS; ENTERTAINMENT IN THE NATURE OF RADIO AND TELEVISION NEWS SHOWS; PROVIDING ENTERTAINMENT INFORMATION AND PROVIDING ON-GOING TELEVISION PROGRAMS IN THE FIELD OF NEWS VIA A GLOBAL COMPUTER NETWORK; TELEVISION SHOW PRODUCTION; FILM PRODUCTION; AUDIO AND VIDEO RECORDING SERVICES (U.S. CLS. 100, 101 AND 107).

JAMES LOVELACE, EXAMINING ATTORNEY

SN 85-362,325. HOUMA RECORDING ARTISTS, HOUMA, LA. FILED 7-2-2011.



THE MARK CONSISTS OF AN UPSIDE DOWN DISTRESSED FLEUR DE LIS WITH THE LETTER "S" ON IT'S LEFT SIDE AND THE LETTER "D" ON IT'S RIGHT SIDE. EACH LETTER IS UNDERLINED WITH DECORATIVE LINES.

FOR ENTERTAINMENT SERVICES, NAMELY, LIVE PERFORMANCES BY ROCK GROUP (U.S. CLS. 100, 101 AND 107).

FIRST USE 1-1-2011; IN COMMERCE 1-1-2011. KEVON CHISOLM, EXAMINING ATTORNEY

SN 85-363,506. INEDO PUBLISHING, LLC, BEREA, OH. FILED 7-5-2011.

The Daily WTF

THE MARK CONSISTS OF STANDARD CHARACTERS WITHOUT CLAIM TO ANY PARTICULAR FONT, STYLE, SIZE, OR COLOR.

NO CLAIM IS MADE TO THE EXCLUSIVE RIGHT TO USE "DAILY", APART FROM THE MARK AS SHOWN.

FOR ELECTRONIC PUBLISHING SERVICES, NAMELY, PUBLICATION OF TEXT AND GRAPHIC WORKS OF OTHERS ON THE INTERNET FEATURING TECHNOLOGY, HUMOR, AND EDUCATION (U.S. CLS. 100, 101 AND 107).

FIRST USE 6-1-2004; IN COMMERCE 6-1-2004. STEVEN PEREZ, EXAMINING ATTORNEY

CLASS 41—(Continued).

SN 85-363,813. FIT CREW, BRADENTON, FL. FILED 7-6-2011.



NO CLAIM IS MADE TO THE EXCLUSIVE RIGHT TO USE "FIT", APART FROM THE MARK AS SHOWN.

THE COLOR(S) BLUE, YELLOW, RED AND BLACK IS/ARE CLAIMED AS A FEATURE OF THE MARK.

THE MARK CONSISTS OF A BLACK OUTLINE OF A TRIANGLE. INSIDE THE TRIANGLE IT IS DIVIDED INTO THREE PARTS, THE TOP PORTION IS YELLOW, THE BOTTOM LEFT PORTION IS BLUE, THE BOTTOM RIGHT PORTION IS RED. THE TOP PORTION IS YELLOW AND FEATURES A BLACK NUMBER ONE. THERE IS A RED LIGHTNING BOLT THAT STARTS IN THE YELLOW PORTION AND GOES INTO THE BLUE PORTION. ACROSS THE MIDDLE OF THE TRIANGLE IS A BLACK BAR BELL. AT THE BOTTOM OF THE TRIANGLE IS A YELLOW RECTANGLE THAT FEATURES THE STYLIZED TERMS "FIT CREW" IN BLACK.

FOR PERSONAL TRAINING SERVICES, NAMELY, STRENGTH AND CONDITIONING TRAINING; PERSONAL TRAINING SERVICES, NAMELY, STRENGTH AND CONDITIONING TRAINING AND SPEED TRAINING; PHYSICAL FITNESS CONSULTATION; PHYSICAL FITNESS INSTRUCTION; PHYSICAL FITNESS STUDIO SERVICES, NAMELY, PROVIDING EXERCISE CLASSES, BODY SCULPTING CLASSES, AND GROUP FITNESS CLASSES; PHYSICAL FITNESS TRAINING OF INDIVIDUALS AND GROUPS; PHYSICAL FITNESS TRAINING SERVICES (U.S. CLS. 100, 101 AND 107).

FIRST USE 12-15-2010; IN COMMERCE 12-15-2010.

SALLY SHIH, EXAMINING ATTORNEY

SN 85-365,689. FEATURE SYSTEMS, INC., CARLSTADT, NJ. FILED 7-7-2011.

FEATURE SYSTEMS

THE MARK CONSISTS OF STANDARD CHARACTERS WITHOUT CLAIM TO ANY PARTICULAR FONT, STYLE, SIZE, OR COLOR.

NO CLAIM IS MADE TO THE EXCLUSIVE RIGHT TO USE "FEATURE", APART FROM THE MARK AS SHOWN. SEC. 2(F).

FOR RENTAL OF MOTION PICTURE FILM EQUIPMENT, NAMELY, CAMERA EQUIPMENT, LIGHTING EQUIPMENT AND GRIP EQUIPMENT (U.S. CLS. 100, 101 AND 107).

FIRST USE 12-31-1972; IN COMMERCE 12-31-1972.

ELI HELLMAN, EXAMINING ATTORNEY

CLASS 41—(Continued).

SN 85-365,825. TY LOKE, LLC, NEW YORK, NY. FILED 7-7-2011.

THE TYRA BANKS COMPANY

THE MARK CONSISTS OF STANDARD CHARACTERS WITHOUT CLAIM TO ANY PARTICULAR FONT, STYLE, SIZE, OR COLOR.

OWNER OF U.S. REG. NOS. 3,706,987 AND 3,776,318.

NO CLAIM IS MADE TO THE EXCLUSIVE RIGHT TO USE "COMPANY", APART FROM THE MARK AS SHOWN. THE NAME "TYRA BANKS" IDENTIFIES A LIVING INDIVIDUAL WHOSE CONSENT IS OF RECORD.

FOR ENTERTAINMENT, NAMELY, PERSONAL APPEARANCES BY AN ENTERTAINER, NAMELY, FASHION MODEL, MOVIE STAR, AND MEDIA PERSONALITY; ENTERTAINMENT SERVICES, NAMELY, LIVE, TELEVISED AND MOVIE APPEARANCES BY A PROFESSIONAL ENTERTAINER; ENTERTAINMENT SERVICES, NAMELY, PROVIDING INFORMATION, COMMENTARY AND ARTICLES ABOUT FASHION MODELING, MUSIC, PHYSICAL FITNESS, GENERAL ENTERTAINMENT AND ENTERTAINMENT CONCERNING TELEVISION PROGRAMS AND MOVIES, ALL ONLINE VIA A GLOBAL COMPUTER NETWORK; ENTERTAINMENT SERVICES, NAMELY, PROVIDING A WEB SITE FEATURING MUSICAL PERFORMANCES, MUSICAL VIDEOS, RELATED FILM CLIPS, AND PHOTOGRAPHS; MUSIC PUBLISHING SERVICES; MUSIC COMPOSITION AND TRANSCRIPTION FOR OTHERS; SONG WRITING SERVICES; PUBLICATION OF ONLINE MAGAZINES; PUBLICATION OF BOOKS, OF MAGAZINES, OF JOURNALS, OF NEWSPAPERS, OF PERIODICALS, OF CATALOGS, AND OF BROCHURES; RECORD PRODUCTION; MUSIC PRODUCTION; AUDIO RECORDING AND PRODUCTION; VIDEOTAPE PRODUCTION; MOTION PICTURE SONG PRODUCTION; PRODUCTION OF VIDEO DISCS FOR OTHERS; RECORDING STUDIOS; ENTERTAINMENT SERVICES, NAMELY, PRODUCTION OF MUSICAL AUDIO AND VIDEO RECORDINGS; DISTRIBUTION OF WEBISODES AND RADIO AND TELEVISION PROGRAMS FOR OTHERS FOR BROADCAST; DISTRIBUTION OF MUSICAL AUDIO AND VIDEO RECORDINGS FOR BROADCAST; ENTERTAINMENT IN THE NATURE OF LIVE MUSICAL PERFORMANCES; ENTERTAINMENT, NAMELY, LIVE MUSIC CONCERTS; PRODUCTION OF WEBISODES AND TELEVISION AND RADIO PROGRAMS; WEBISODE AND TELEVISION AND CABLE TELEVISION SHOW PRODUCTION; RADIO ENTERTAINMENT PRODUCTION; MOTION PICTURE FILM PRODUCTION; FILM EDITING; SPECIAL EFFECTS ANIMATION SERVICES FOR FILM AND VIDEO; ENTERTAINMENT IN THE NATURE OF ON-GOING WEBISODES, TELEVISION, CABLE TELEVISION AND RADIO PROGRAMS FEATURING VARIETY, MUSIC, COMEDY, DRAMA, FASHION SHOWS, EXHIBITIONS AND COMPETITIONS AND SPOKEN WORD IN THE FIELD OF MODELING, FASHION, MUSIC AND ACTING; ENTERTAINMENT IN THE NATURE OF ON-GOING WEBISODES AND TELEVISION, CABLE TELEVISION AND RADIO PROGRAMS FEATURING ISSUES CONCERNING RELATIONSHIPS, FAMILY, SELF-ESTEEM, SELF-IMPROVEMENT, LIFESTYLES, HEALTH AND NUTRITION, PHYSICAL FITNESS, TOPICAL NEWS, CELEBRITIES AND POP CULTURE AS WELL AS OTHER ENTERTAINMENT ISSUES IMPORTANT TO YOUNG WOMEN; ENTERTAINMENT, NAMELY, A CONTINUING TALK SHOW, VARIETY SHOW, REALITY SHOW, NEWS SHOW, AND COMEDY SHOW, BROADCAST OVER TELEVISION, CABLE TELEVISION, SATELLITE, WEBCASTS, RADIO, COMPUTER NETWORKS, VIDEO MEDIA; ENTERTAINMENT IN THE NATURE OF ONGOING TELEVISION AND CABLE TELEVISION REALITY SHOWS; PRODUCTION OF WEBISODES, DVDS, VIDEO TAPES AND TELEVISION PROGRAMS FEATURING MUSIC, FASHION, BEAUTY, MODELING, HEALTH AND NUTRITION, PHYSICAL FITNESS, SELF-IMPROVEMENT,

CLASS 41—(Continued).

LIFESTYLES, POP CULTURE, CELEBRITIES, TOPICAL NEWS, AND ENTERTAINMENT ISSUES IMPORTANT TO YOUNG WOMEN; ENTERTAINMENT IN THE NATURE OF BEAUTY PAGEANTS; ENTERTAINMENT IN THE NATURE OF FASHION SHOWS; ENTERTAINMENT IN THE NATURE OF ONGOING WEBISODES AND TELEVISION AND CABLE TELEVISION SHOWS AND PROGRAMS FEATURING MODELING AND BEAUTY COMPETITIONS, EVENTS AND EXHIBITIONS; ENTERTAINMENT SERVICES, NAMELY, CONDUCTING CONTESTS AND PARTIES; ENTERTAINMENT IN THE NATURE OF ORGANIZING AND CONDUCTING TALENT, MODELING AND BEAUTY COMPETITIONS; ENTERTAINMENT IN THE NATURE OF BEAUTY PAGEANTS, MODELING CONTESTS, PHOTO CONTESTS AND ONLINE BEAUTY CONTESTS; MODELING FOR ARTISTS; NIGHT CLUBS; EDUCATIONAL SERVICES IN THE NATURE OF BEAUTY SCHOOLS; EDUCATIONAL SERVICES, NAMELY, CONDUCTING COURSES, CLASSES, SEMINARS, WORKSHOPS, LECTURES AND CONFERENCES IN THE FIELDS OF BEAUTY, FASHION, MODELING, ACTING, MUSIC, THE ARTS, PHYSICAL FITNESS, HEALTH AND NUTRITION, SELF-IMPROVEMENT, SELF-ESTEEM, AND DISTRIBUTING COURSE MATERIALS IN CONNECTION THEREWITH; EDUCATIONAL SERVICES, NAMELY, PROVIDING TUTORIAL SESSIONS AND CONDUCTING PROGRAMS IN THE FIELDS OF BEAUTY, FASHION, MODELING, ACTING, MUSIC, THE ARTS, PHYSICAL FITNESS, HEALTH AND NUTRITION, SELF-IMPROVEMENT AND SELF-ESTEEM; EDUCATIONAL SERVICES, NAMELY, ONE-ON-ONE AND GROUP MENTORING IN THE FIELDS OF BEAUTY, FASHION, MODELING, ACTING, MUSIC, THE ARTS, PHYSICAL FITNESS, HEALTH AND NUTRITION, SELF-IMPROVEMENT, AND SELF-ESTEEM; CHARITABLE SERVICES, NAMELY, ACADEMIC MENTORING OF SCHOOL AGE CHILDREN AND YOUNG ADULTS; ENTERTAINMENT IN THE NATURE OF THEATRE PRODUCTIONS; ENTERTAINMENT SERVICES, NAMELY, PROVIDING AN ON-LINE COMPUTER GAME; PROVIDING A COMPUTER GAME THAT MAY BE ACCESSED NETWORK-WIDE BY NETWORK USERS; RECREATIONAL, SPORT AND SUMMER CAMPS; PHYSICAL FITNESS CONSULTATION AND INSTRUCTION; PROVIDING AN ONLINE COMPUTER DATABASE FEATURING INFORMATION REGARDING PHYSICAL FITNESS AND EXERCISE; PROVIDING FITNESS AND EXERCISE FACILITIES; HEALTH CLUB SERVICES, NAMELY, PROVIDING INSTRUCTION AND EQUIPMENT IN THE FIELD OF PHYSICAL EXERCISE; EDUCATION SERVICES, NAMELY, PROVIDING MENTORING, TUTORING, CLASSES, SEMINARS AND WORKSHOPS IN THE FIELD OF PERSONAL IMAGE DEVELOPMENT AND AWARENESS, PERSONAL WELLNESS, SELF-ESTEEM DEVELOPMENT, SELF-IMPROVEMENT, PERSONAL ACCOUNTABILITY, INTERPERSONAL COMMUNICATION, LIFESTYLE WELLNESS AND NUTRITION, CAREER OBJECTIVES AND GOALS, PROFESSIONAL DEVELOPMENT AND LIFE SKILLS, AND APPRECIATION FOR DIVERSITY; EDUCATIONAL SERVICES, NAMELY, PROVIDING INTERNSHIPS AND APPRENTICESHIPS IN THE FIELDS OF BEAUTY, FASHION, MODELING, ACTING, MUSIC, THE ARTS, ENTERTAINMENT, PHYSICAL FITNESS, AND HEALTH AND NUTRITION; PROVIDING RECOGNITION AND INCENTIVES BY THE WAY OF AWARDS AND CONTESTS TO DEMONSTRATE EXCELLENCE IN PHILANTHROPIC EFFORTS AND CHARITABLE CONTRIBUTIONS DEDICATED TO WOMEN AND GIRLS; ENTERTAINMENT SERVICES, NAMELY, CONTEST AND INCENTIVE AWARD PROGRAMS DESIGNED TO REWARD PROGRAM PARTICIPATING ORGANIZATIONS THAT HELP UNDER-SERVED WOMEN AND GIRLS REACH THEIR FULL POTENTIAL PERSONALLY AND PROFESSIONALLY; EDUCATIONAL SERVICES, NAMELY, PROVIDING INCENTIVES TO ORGANIZATIONS TO DEMONSTRATE EXCELLENCE IN PHILANTHROPY AND CHARITABLE EFFORTS SUPPORTIVE OF UNDER-SERVED WOMEN AND GIRLS; ARRANGING AND CONDUCTING INCENTIVE AWARD PROGRAMS TO ENCOURAGE THE FREQUENT, CONTINUED AND EFFECTIVE PRACTICE OF CHARITABLE CONTRIBUTIONS SERVING UNDER-PRIVILEGED WOMEN AND GIRLS; AWARDS PROGRAM FOR ORGANIZATIONS THAT HAVE MADE SIGNIFICANT CHARITABLE CON-

CLASS 41—(Continued).

TRIBUTIONS FOR UNDER-SERVED WOMEN AND GIRLS; CONDUCTING A SUMMER CAMP FOR THE PURPOSE OF ENHANCING INDEPENDENCE AND SELF-ESTEEM; ENTERTAINMENT SERVICES, NAMELY, PRESENTING NON-DOWNLOADABLE RING TONES, PRE-RECORDED MUSIC, VIDEO AND GRAPHICS TO MOBILE COMMUNICATIONS DEVICES VIA A GLOBAL COMPUTER NETWORK AND WIRELESS NETWORKS; ON-LINE JOURNALS, NAMELY, BLOGS FEATURING INFORMATION IN THE FIELDS OF BEAUTY, FASHION, MODELING, ACTING, MUSIC, THE ARTS, PHYSICAL FITNESS, HEALTH AND NUTRITION, SELF-IMPROVEMENT, AND SELF-ESTEEM; PROVIDING A WEB SITE AND AN INTERACTIVE WEB SITE FEATURING INFORMATION IN THE FIELD OF MUSIC, PHYSICAL FITNESS, GENERAL ENTERTAINMENT AND EDUCATION AND ENTERTAINMENT INFORMATION CONCERNING TELEVISION PROGRAMS AND MOVIES; AMUSEMENT PARK AND THEME PARK SERVICES; PROVIDING THEME PARK SERVICES; ENTERTAINMENT SERVICES, NAMELY, PROVIDING ONLINE COMPUTER GAMES; ENTERTAINMENT SERVICES, NAMELY, PROVIDING ONLINE VIDEO GAMES; ENTERTAINMENT SERVICES, NAMELY, PROVIDING ONLINE ELECTRONIC GAMES; ENTERTAINMENT SERVICES, NAMELY, PROVIDING TEMPORARY USE OF NON-DOWNLOADABLE INTERACTIVE GAMES; ENTERTAINMENT SERVICES, NAMELY, PROVIDING TEMPORARY USE OF NON-DOWNLOADABLE ELECTRONIC GAMES; ENTERTAINMENT SERVICES, NAMELY, PROVIDING TEMPORARY USE OF NON-DOWNLOADABLE COMPUTER GAMES; ENTERTAINMENT SERVICES; ENTERTAINMENT SERVICES, NAMELY, PROVIDING TEMPORARY USE OF NON-DOWNLOADABLE VIDEO GAMES; PROVIDING A COMPUTER GAME FOR USE NETWORK-WIDE BY NETWORK USERS (U.S. CLS. 100, 101 AND 107).
EVELYN BRADLEY, EXAMINING ATTORNEY

SN 85-367,169. MAROLT, MICHAEL, ASPEN, CO. FILED 7-9-2011.

MB MONTEZUMA BASIN ASPEN
COLORADO

THE MARK CONSISTS OF STANDARD CHARACTERS WITHOUT CLAIM TO ANY PARTICULAR FONT, STYLE, SIZE, OR COLOR.

NO CLAIM IS MADE TO THE EXCLUSIVE RIGHT TO USE "MONTEZUMA BASIN ASPEN COLORADO", APART FROM THE MARK AS SHOWN.

FOR MEDIA PRODUCTION SERVICES, NAMELY, VIDEO AND FILM PRODUCTION; MOTION PICTURE FILM PRODUCTION (U.S. CLS. 100, 101 AND 107).

JASON BLAIR, EXAMINING ATTORNEY

CLASS 41—(Continued).

SN 85-369,564. COMPETITOR GROUP, INC., SAN DIEGO, CA. FILED 7-12-2011.



NO CLAIM IS MADE TO THE EXCLUSIVE RIGHT TO USE "MIAMI BEACH 1/2 MARATHON", APART FROM THE MARK AS SHOWN.

THE MARK CONSISTS OF THE WORDS, "LATIN MUSIC MIAMI BEACH 1/2 MARATHON", AND MISCELLANEOUS DESIGNS SURROUNDED BY A RECTANGULAR BORDER. A PICTURE OF A GUITAR ABOVE A BEACH SCENE WITH TREES APPEARS ON THE LEFT WITHIN A SQUARE.

FOR ENTERTAINMENT SERVICES, NAMELY, ARRANGING AND ORGANIZING A SPORTING EVENT IN THE NATURE OF A RUNNING RACE; PROVIDING ENTERTAINMENT EVENTS, NAMELY, ORGANIZING COMMUNITY FESTIVALS FEATURING VENDOR BOOTHS; PARTY PLANNING, NAMELY, PLANNING PARTIES AND SPECIAL-EVENT DINNERS (U.S. CLS. 100, 101 AND 107).

NAKWAMA ANKRAH, EXAMINING ATTORNEY

SN 85-372,048. PREMIERE BOOTH, LLC, FRISCO, TX. FILED 7-15-2011.

PREMIERE BOOTH

THE MARK CONSISTS OF STANDARD CHARACTERS WITHOUT CLAIM TO ANY PARTICULAR FONT, STYLE, SIZE, OR COLOR.

NO CLAIM IS MADE TO THE EXCLUSIVE RIGHT TO USE "BOOTH", APART FROM THE MARK AS SHOWN.

FOR PHOTOGRAPHY SERVICES; RENTAL OF PHOTOGRAPHIC EQUIPMENT; RENTAL OF PORTABLE PHOTOGRAPHY BOOTHS FOR TAKING PICTURES (U.S. CLS. 100, 101 AND 107).

FIRST USE 8-2-2007; IN COMMERCE 9-27-2007.

BARBARA GAYNOR, EXAMINING ATTORNEY

SN 85-373,330. FLAHERTY, MICHAEL ERIN, LOS ANGELES, CA. FILED 7-17-2011.

swim with heart

THE MARK CONSISTS OF STANDARD CHARACTERS WITHOUT CLAIM TO ANY PARTICULAR FONT, STYLE, SIZE, OR COLOR.

FOR PROVIDING SWIMMING INSTRUCTION LESSONS FOR INDIVIDUALS AND SWIMMING TEAMS (U.S. CLS. 100, 101 AND 107).

FIRST USE 10-12-2010; IN COMMERCE 10-12-2010.

EDWARD NELSON, EXAMINING ATTORNEY

CLASS 41—(Continued).

SN 85-373,957. PARAMOUNT PICTURES CORPORATION, HOLLYWOOD, CA. FILED 7-18-2011.

JUST BECAUSE YOU COULD,
DOESN'T MEAN YOU SHOULD

THE MARK CONSISTS OF STANDARD CHARACTERS WITHOUT CLAIM TO ANY PARTICULAR FONT, STYLE, SIZE, OR COLOR.

FOR EDUCATION SERVICES, NAMELY, PROVIDING ONLINE PUBLIC SERVICE ANNOUNCEMENTS IN THE FIELDS OF INTELLECTUAL PROPERTY RIGHTS AND LAWS, NAMELY, LAWS RELATING TO COPYRIGHTS AND TRADEMARKS, AND THE CONSEQUENCES OF INTELLECTUAL PROPERTY RIGHTS VIOLATIONS SUCH AS COUNTERFEITING, COPYRIGHT INFRINGEMENT, AND UNAUTHORIZED ELECTRONIC DISSEMINATION OF INTELLECTUAL PROPERTY (U.S. CLS. 100, 101 AND 107).

ANDREA HACK, EXAMINING ATTORNEY

SN 85-375,365. EDUCATIONAL SERVICES OF AMERICA, NASHVILLE, TN. FILED 7-19-2011.



OWNER OF U.S. REG. NO. 3,342,740.

NO CLAIM IS MADE TO THE EXCLUSIVE RIGHT TO USE "CENTER" AND "SCHOOLS AND PROGRAMS", APART FROM THE MARK AS SHOWN.

THE MARK CONSISTS OF THE PHRASE "SPECTRUM CENTER" IN STYLIZED FONT ABOVE THE PHRASE "SCHOOLS AND PROGRAMS" IN STYLIZED FONT; THE PHRASES ARE SEPARATED BY A THIN HORIZONTAL LINE; A SERIES OF FOUR DIAMOND SHAPED GRAPHICS CREATE A SQUARE TO THE RIGHT OF THE PHRASES AND LINE.

FOR EDUCATING AT SENIOR HIGH SCHOOLS; EDUCATIONAL SERVICES IN THE NATURE OF SPECIAL EDUCATION AND AT-RISK SCHOOLS; EDUCATIONAL SERVICES, NAMELY, PROVIDING COURSES OF INSTRUCTION AT THE ELEMENTARY AND SECONDARY LEVEL; EDUCATIONAL SERVICES, NAMELY, PROVIDING COURSES OF INSTRUCTION AT THE PREK THROUGH SECONDARY LEVEL AND DISTRIBUTION OF COURSE MATERIAL IN CONNECTION THEREWITH; PROVIDING EDUCATIONAL MENTORING SERVICES AND PROGRAMS IN THE FIELD OF AT-RISK STUDENTS AND STUDENTS WITH SPECIAL NEEDS (U.S. CLS. 100, 101 AND 107).

FIRST USE 5-1-2010; IN COMMERCE 5-1-2010.

ERNEST SHOSHO, EXAMINING ATTORNEY

CLASS 41—(Continued).

SN 85-375,929. KERR, KATHI, DBA MELODY MUSIC STUDIOS, RENO, NV. FILED 7-20-2011.

CLASS 41—(Continued).

SN 85-377,810. OBSCURELY FAMOUS MEDIA, LLC, HUNTINGTON, WV. FILED 7-21-2011.

Melody Music Studios

THE MARK CONSISTS OF STANDARD CHARACTERS WITHOUT CLAIM TO ANY PARTICULAR FONT, STYLE, SIZE, OR COLOR.

OWNER OF U.S. REG. NO. 3,251,461.

NO CLAIM IS MADE TO THE EXCLUSIVE RIGHT TO USE "MUSIC STUDIOS", APART FROM THE MARK AS SHOWN.

FOR MUSIC INSTRUCTION SERVICES IN THE FIELDS OF VOICE AND MUSICAL INSTRUMENTS (U.S. CLS. 100, 101 AND 107).

FIRST USE 10-1-1989; IN COMMERCE 11-1-1989.

DAVID H. STINE, EXAMINING ATTORNEY

OBSCURELY FAMOUS GRAVES

SN 85-377,113. MARCY GRACE LIMITED, WOKINGHAM, BERKSHIRE, UNITED KINGDOM, FILED 7-21-2011.

THE TOKYO TIMES

THE MARK CONSISTS OF STANDARD CHARACTERS WITHOUT CLAIM TO ANY PARTICULAR FONT, STYLE, SIZE, OR COLOR.

OWNER OF JAPAN REG. NO. 5349707, DATED 8-27-2010, EXPIRES 8-27-2020.

NO CLAIM IS MADE TO THE EXCLUSIVE RIGHT TO USE "TOKYO", APART FROM THE MARK AS SHOWN.

FOR PROVIDING ON-LINE NON-DOWNLOADABLE NEWSPAPERS; PROVIDING ON-LINE NON-DOWNLOADABLE GENERAL FEATURE MAGAZINES; PROVIDING A WEBSITE FEATURING NON-DOWNLOADABLE PUBLICATIONS IN THE NATURE OF NEWSPAPERS AND MAGAZINES IN THE FIELDS OF JAPANESE NEWS, POLITICS, POLICY, SPORTS, BUSINESS, TECHNOLOGY, ENTERTAINMENT, ARTS, LEISURE, AND TRAVEL, AND INFORMATION (U.S. CLS. 100, 101 AND 107).

MIDGE BUTLER, EXAMINING ATTORNEY

THE MARK CONSISTS OF STANDARD CHARACTERS WITHOUT CLAIM TO ANY PARTICULAR FONT, STYLE, SIZE, OR COLOR.

NO CLAIM IS MADE TO THE EXCLUSIVE RIGHT TO USE "GRAVES", APART FROM THE MARK AS SHOWN.

FOR EDUCATION AND ENTERTAINMENT SERVICES, NAMELY, ONGOING TELEVISION PUBLIC SERVICE ANNOUNCEMENTS AND ONGOING TELEVISION PROGRAMS IN THE FIELD OF HISTORICAL ANALYSIS AND PRESENTATION OF GRAVES, GRAVESITES AND CEMETERIES; EDUCATIONAL AND ENTERTAINMENT SERVICES, NAMELY, A CONTINUING PROGRAM ABOUT GRAVES, GRAVESITES, CEMETERIES AND THE HISTORICAL SIGNIFICANCE OF SPECIFIC DECEASED INDIVIDUALS ACCESSIBLE BY RADIO, TELEVISION, SATELLITE, AUDIO, VIDEO AND COMPUTER NETWORKS; ENTERTAINMENT IN THE NATURE OF AN ON-GOING SPECIAL VARIETY, NEWS, MUSIC OR COMEDY SHOW FEATURING HISTORICAL ANALYSIS AND ANALYSIS AND INFORMATION ABOUT GRAVES, GRAVESITES AND CEMETERIES. BROADCAST OVER TELEVISION, SATELLITE, AUDIO, AND VIDEO MEDIA; ENTERTAINMENT IN THE NATURE OF ON-GOING TELEVISION PROGRAMS IN THE FIELD OF HISTORICAL ANALYSIS AND INFORMATION ABOUT GRAVES, GRAVESITES AND CEMETERIES (U.S. CLS. 100, 101 AND 107).

FIRST USE 1-15-2010; IN COMMERCE 1-15-2010.

TARAH HARDY, EXAMINING ATTORNEY

CLASS 41—(Continued).

SN 85-377,905. WILLARD SMITH, AS PARENT AND GUARDIAN OF WILLOW SMITH, BEVERLY HILLS, CA. FILED 7-21-2011.



THE MARK CONSISTS OF THE LETTER "W" IN A STYLIZED FONT.

FOR ENTERTAINMENT SERVICES IN THE NATURE OF LIVE MUSICAL PERFORMANCES; ENTERTAINMENT, NAMELY, A WEB SITE FEATURING PERFORMANCES IN MUSICAL VIDEOS; PERSONAL APPEARANCES AS A MUSICAL ARTIST; PROVIDING NON-DOWNLOADABLE PRE-RECORDED MUSIC, PROVIDING INFORMATION IN THE FIELD OF MUSIC, COMMENTARY AND ARTICLES ABOUT MUSIC, AND PROVIDING INFORMATION ABOUT LIVE MUSICAL PERFORMANCES, MUSICAL SOUND RECORDINGS, APPEARANCES BY A MUSICAL ARTIST, AND CONTESTS, ALL ONLINE VIA A GLOBAL COMPUTER NETWORK (U.S. CLS. 100, 101 AND 107).

FIRST USE 11-2-2010; IN COMMERCE 11-2-2010.
HOWARD B. LEVINE, EXAMINING ATTORNEY

SN 85-377,907. WILLARD SMITH, AS PARENT AND GUARDIAN OF WILLOW SMITH, BEVERLY HILLS, CA. FILED 7-21-2011.



THE NAME "WILLOW" IDENTIFIES THE STAGE NAME OF "WILLOW SMITH", A LIVING INDIVIDUAL WHOSE CONSENT IS OF RECORD.

THE MARK CONSISTS OF THE SHADED, STYLIZED CAPITAL LETTERS "WILLOW".

FOR ENTERTAINMENT SERVICES IN THE NATURE OF LIVE MUSICAL PERFORMANCES; ENTERTAINMENT, NAMELY, A WEB SITE FEATURING PERFORMANCES IN MUSICAL VIDEOS; PERSONAL APPEARANCES AS A MUSICAL ARTIST; PROVIDING NON-DOWNLOADABLE PRE-RECORDED MUSIC, PROVIDING INFORMATION IN THE FIELD OF MUSIC, COMMENTARY AND ARTICLES ABOUT MUSIC, AND PROVIDING INFORMATION ABOUT LIVE MUSICAL PERFORMANCES, MUSICAL SOUND RECORDINGS, APPEARANCES BY A MUSICAL ARTIST, AND CONTESTS, ALL ONLINE VIA A GLOBAL COMPUTER NETWORK (U.S. CLS. 100, 101 AND 107).

FIRST USE 11-2-2010; IN COMMERCE 11-2-2010.
HOWARD B. LEVINE, EXAMINING ATTORNEY

CLASS 41—(Continued).

SN 85-380,980. CLANCY MCKENZIE, NARBERTH, PA. FILED 7-26-2011.

PSYCHOPHARMACOMANIA

THE MARK CONSISTS OF STANDARD CHARACTERS WITHOUT CLAIM TO ANY PARTICULAR FONT, STYLE, SIZE, OR COLOR.

FOR CONDUCTING EDUCATIONAL CONFERENCES IN THE FIELD OF SCIENCE AND MEDICINE; CONDUCTING EDUCATIONAL COURSES IN THE FIELD OF SCIENCE, MEDICINE, PSYCHIATRY, PSYCHOPHARMACOLOGY, AND NEUROLOGY; PROVIDING SELF STUDY COURSES, NAMELY, PROVIDING EDUCATION IN THE FIELD OF SCIENCE, MEDICINE, PSYCHIATRY, PSYCHOPHARMACOLOGY, AND NEUROLOGY RENDERED THROUGH CORRESPONDENCE COURSES; PUBLICATION OF BOOKS AND JOURNALS IN THE FIELD OF SCIENCE AND MEDICINE; ONLINE PUBLICATION OF ELECTRONIC BOOKS AND JOURNALS IN THE FIELD OF SCIENCE AND MEDICINE; WRITTEN TEXT EDITING SERVICES (U.S. CLS. 100, 101 AND 107).

MARK SPARACINO, EXAMINING ATTORNEY

SN 85-382,186. COURTROOM TELEVISION NETWORK LLC, NEW YORK, NY. FILED 7-27-2011.



NO CLAIM IS MADE TO THE EXCLUSIVE RIGHT TO USE "RECOVERY", APART FROM THE MARK AS SHOWN.

THE MARK CONSISTS OF THE STYLIZED STACKED WORDING "BEAR SWAMP" SHOWN DISPLAYED ON A LICENSE PLATE WITH THE STYLIZED WORD "RECOVERY" BELOW THAT ON A SIGN SIMILAR IN STYLE TO THAT OF A STREET SIGN.

FOR ENTERTAINMENT SERVICES, NAMELY, CONTINUING SCRIPTED AND UNSCRIPTED TELEVISION PROGRAM SERIES IN THE FIELD OF COMEDY, DRAMA, ACTION, ADVENTURE AND/OR REALITY PROVIDED THROUGH CABLE TELEVISION, BROADCAST TELEVISION, INTERNET, VIDEO-ON-DEMAND, AND THROUGH OTHER DISTRIBUTION PLATFORMS; PROVIDING INFORMATION, NAMELY, ENTERTAINMENT INFORMATION OVER THE INTERNET (U.S. CLS. 100, 101 AND 107).

JULIE GUTTADAURO, EXAMINING ATTORNEY

CLASS 41—(Continued).

SN 85-383,518. AEROBICS AND FITNESS ASSOCIATION OF AMERICA, SHERMAN OAKS, CA. FILED 7-28-2011.

TELEBIENESTAR

THE MARK CONSISTS OF STANDARD CHARACTERS WITHOUT CLAIM TO ANY PARTICULAR FONT, STYLE, SIZE, OR COLOR.

OWNER OF U.S. REG. NO. 2,265,575.

THE ENGLISH TRANSLATION OF "TELEBIENESTAR" IN THE MARK IS "TELEWELLNESS".

FOR EDUCATIONAL AND ENTERTAINMENT SERVICES, NAMELY, PROVIDING ONLINE COURSES AND PROVIDING LIVE CLASSES AND WORKSHOPS, ALL IN THE FIELDS OF AEROBICS, FITNESS AND EXERCISE; PROVIDING INFORMATION VIA WEBSITES ON THE INTERNET IN THE FIELDS OF AEROBICS, FITNESS AND EXERCISE (U.S. CLS. 100, 101 AND 107).

TAMARA FRAZIER, EXAMINING ATTORNEY

SN 85-384,240. U.S. DEPARTMENT OF HEALTH AND HUMAN SERVICES, BETHESDA, MD. FILED 7-29-2011.

HIT PRO

THE MARK CONSISTS OF STANDARD CHARACTERS WITHOUT CLAIM TO ANY PARTICULAR FONT, STYLE, SIZE, OR COLOR.

FOR EDUCATIONAL TESTING AND EVALUATION SERVICES, NAMELY, PREPARING, ADMINISTERING, AND SCORING STANDARDIZED TESTS TO DETERMINE PROFESSIONAL COMPETENCY IN THE FIELD OF HEALTH INFORMATION TECHNOLOGY AND DISTRIBUTING TESTING GUIDELINES IN CONNECTION THEREWITH (U.S. CLS. 100, 101 AND 107).

FIRST USE 12-0-2010; IN COMMERCE 12-0-2010.

JASON BLAIR, EXAMINING ATTORNEY

SN 85-385,513. OCULAR IMMUNOLOGY NAD UVEITIS FOUNDATION, AKA OIUF, WESTON, MA. FILED 7-31-2011.

Making A Visible Difference

THE MARK CONSISTS OF STANDARD CHARACTERS WITHOUT CLAIM TO ANY PARTICULAR FONT, STYLE, SIZE, OR COLOR.

FOR EDUCATIONAL SERVICES, NAMELY, PROVIDING HEALTH EDUCATION IN THE FIELDS OF OCULAR INFLAMMATORY AND OTHER EYE DISEASES (U.S. CLS. 100, 101 AND 107).

FIRST USE 1-1-2008; IN COMMERCE 1-1-2008.

EMILY CHUO, EXAMINING ATTORNEY

CLASS 41—(Continued).

SN 85-387,700. ALASKA GEOGRAPHIC ASSOCIATION, ANCHORAGE, AK. FILED 8-2-2011.



THE MARK CONSISTS OF AN IMAGE OF AN INTER-TWINED BEAR AND RAVEN FORMING A CIRCULAR DESIGN.

FOR EDUCATION AND ENTERTAINMENT SERVICES, NAMELY, PROVIDING CLASSES, SEMINARS AND WORKSHOPS IN THE FIELDS OF HISTORY, GEOGRAPHY, NATURE AND ART; EDUCATION SERVICES, NAMELY, ART EVENTS; PROVIDING A WEBSITE FEATURING INFORMATION ON THE STATE OF ALASKA INCLUDING HISTORY, FLORA, FAUNA AND GEOGRAPHY; PRODUCTION AND DISTRIBUTION OF VIDEOS AND DVD'S IN THE FIELD OF HISTORY, NATURE AND GEOGRAPHY; PROVISION OF INFORMATION RELATING TO THE STATE OF ALASKA, AND PUBLISHING OF BOOKS (U.S. CLS. 100, 101 AND 107).

FIRST USE 4-1-2005; IN COMMERCE 4-1-2005.

KELLY TRUSILO, EXAMINING ATTORNEY

SN 85-389,978. CBS RADIO INC., NEW YORK, NY. FILED 8-4-2011.

DEFEND YOUR RIDE

THE MARK CONSISTS OF STANDARD CHARACTERS WITHOUT CLAIM TO ANY PARTICULAR FONT, STYLE, SIZE, OR COLOR.

FOR ENTERTAINMENT SERVICES, NAMELY, PROVIDING ONLINE IMAGES, VIDEO, AND TEXT FEATURING STORIES AND PICTURES ABOUT PEOPLE AND THEIR VEHICLES (U.S. CLS. 100, 101 AND 107).

FIRST USE 7-22-2011; IN COMMERCE 7-22-2011.

JOHN E. MICHOS, EXAMINING ATTORNEY

CLASS 41—(Continued).

SN 85-390,143. GLOBALENGLISH CORPORATION, BRISBANE, CA. FILED 8-4-2011.

GLOBALENGLISH COACH

THE MARK CONSISTS OF STANDARD CHARACTERS WITHOUT CLAIM TO ANY PARTICULAR FONT, STYLE, SIZE, OR COLOR.

OWNER OF U.S. REG. NOS. 2,456,280, 2,823,678 AND OTHERS.

NO CLAIM IS MADE TO THE EXCLUSIVE RIGHT TO USE "COACH", APART FROM THE MARK AS SHOWN.

FOR PROVIDING ONLINE INDIVIDUAL, CUSTOMIZED BUSINESS ENGLISH COACHING SERVICES TO OPTIMIZE CORPORATE GLOBAL COMMUNICATION (U.S. CLS. 100, 101 AND 107).

ROBERT STRUCK, EXAMINING ATTORNEY

SN 85-390,355. MANUFACTURERS ALLIANCE, MAPLE GROVE, MN. FILED 8-5-2011.



NO CLAIM IS MADE TO THE EXCLUSIVE RIGHT TO USE "MANUFACTURERS ALLIANCE", APART FROM THE MARK AS SHOWN.

THE COLOR(S) GREY AND RED IS/ARE CLAIMED AS A FEATURE OF THE MARK.

THE MARK CONSISTS OF THE LETTERS "M" AND "A" OVERLAPPED WITH SMALL TRIANGLES IN EACH LETTER. THE "M" IS COOL GRAY AND THE "A" IS BURNT RED. THE WORDING "MANUFACTURERS ALLIANCE" IS COOL GRAY TO THE RIGHT OF THE LOGO. THE TAG LINE "SHARING EDUCATION AND RESOURCES PEER-TO-PEER" IS BURNT RED BELOW THE COMPANY NAME.

FOR ARRANGING PROFESSIONAL WORKSHOP AND TRAINING COURSES (U.S. CLS. 100, 101 AND 107).

FIRST USE 1-1-1991; IN COMMERCE 1-1-1991.

EMILY CARLSEN, EXAMINING ATTORNEY

SN 85-392,241. KIENZLE, JOHN, DBA ADVANTAGE BOAT CLUB, BURNSVILLE, MN. FILED 8-8-2011.



NO CLAIM IS MADE TO THE EXCLUSIVE RIGHT TO USE "BOAT CLUB", APART FROM THE MARK AS SHOWN.

THE COLOR(S) BLUE, GRAY, WHITE, YELLOW, AND BLACK IS/ARE CLAIMED AS A FEATURE OF THE MARK.

THE MARK CONSISTS OF THE WORD "ADVANTAGE" APPEARS WITH WHITE LETTERING AND GRAY SHADING OF THE UPPER ONE THIRD OF THE LETTER ELEMENTS; THE GRAY SHADING IS OUTLINED IN WHITE; EACH LETTER OF THE WORD "ADVANTAGE" ALSO CONSISTS OF A BLACK SHADOW OUTLINING THE LETTER AND GIVING THE VISUAL EFFECT OF DEPTH; THE WORDS "BOAT CLUB" APPEAR IN YELLOW DIRECTLY BELOW THE WORD "ADVANTAGE", WHERE THE LETTER "B" OVERLAPS THE BOTTOM OF THE

CLASS 41—(Continued).

LETTER "D" IN ADVANTAGE, AND THE LETTER "C" OVERLAPS THE SECOND LETTER "A" IN ADVANTAGE; EACH LETTER OF THE WORDS "BOAT CLUB" ALSO CONSISTS OF A BLACK SHADOW OUTLINING THE LETTER AND GIVING THE VISUAL EFFECT OF DEPTH; A STYLIZED WHITE WAVE APPEARS DIRECTLY BELOW THE LENGTH, AND TO THE RIGHT OF THE WORD "ADVANTAGE" AND ON BOTH SIDES OF THE WORDS "BOAT CLUB"; A STYLIZED BLUE WAVE APPEARS BELOW, BEGINNING AT THE LETTER "T", AND TO THE RIGHT OF THE WORD "ADVANTAGE" AND ON THE RIGHT SIDE OF THE WORDS "BOAT CLUB". THE ENTIRE MARK INCLUDES A BLUE BACKGROUND.

FOR BOAT CLUB SERVICES FOR SEASONAL ACCESS TO POWER BOATS (U.S. CLS. 100, 101 AND 107).

FIRST USE 10-1-2010; IN COMMERCE 10-1-2010.

WILLIAM P. SHANAHAN, EXAMINING ATTORNEY

SN 85-393,002. MORGAN, NICOLLE, DELTAVILLE, VA. FILED 8-9-2011.



NO CLAIM IS MADE TO THE EXCLUSIVE RIGHT TO USE "YOGA", APART FROM THE MARK AS SHOWN.

THE MARK CONSISTS OF A LOTUS FLOWER ON TOP OF THE ITALICIZED WORDS "OLIVE FOR YOGA", AND THEN BELOW THAT ARE THE WORDS "YOGA FOR EVERYONE" IN NON-ITALICS.

FOR MEDITATION TRAINING; PHYSICAL FITNESS INSTRUCTION; YOGA INSTRUCTION (U.S. CLS. 100, 101 AND 107).

FIRST USE 1-8-2011; IN COMMERCE 1-10-2011.

SKYE YOUNG, EXAMINING ATTORNEY

SN 85-393,104. GLR SERVICES, INC., MIAMI, FL. FILED 8-9-2011.

En Voz Alta

THE MARK CONSISTS OF STANDARD CHARACTERS WITHOUT CLAIM TO ANY PARTICULAR FONT, STYLE, SIZE, OR COLOR.

THE ENGLISH TRANSLATION OF "EN VOZ ALTA" IN THE MARK IS "IN A LOUD VOICE".

FOR ENTERTAINMENT, NAMELY, A CONTINUING VARIETY SHOW ON WOMEN'S ISSUES AND CURRENT EVENTS BROADCAST OVER RADIO AND INTERNET (U.S. CLS. 100, 101 AND 107).

MARK SPARACINO, EXAMINING ATTORNEY

CLASS 41—(Continued).

SN 85-393,415. PSC INDUSTRIAL OUTSOURCING, LP,
HOUSTON, TX. FILED 8-9-2011.

TALKING TRASH

THE MARK CONSISTS OF STANDARD CHARACTERS WITHOUT CLAIM TO ANY PARTICULAR FONT, STYLE, SIZE, OR COLOR.

FOR TRAINING AND SEMINARS OF EMPLOYEES AND CLIENTS IN THE AREA OF SPECIALTY WASTE, NAMELY, THE CLASSIFICATION, SEGREGATION, REMOVAL, STORAGE, PACKING, LABELING, TRANSPORT, DISPOSAL AND MANAGEMENT OF PHARMACEUTICAL, UNIVERSAL, HAZARDOUS, LAB PACK, REGULATED MEDICAL AND RECYCLABLE WASTE (U.S. CLS. 100, 101 AND 107).

CAROLINE WOOD, EXAMINING ATTORNEY

SN 85-396,431. PROSPER, INC., PROVO, UT. FILED 8-12-2011.

POLARIS POINT

THE MARK CONSISTS OF STANDARD CHARACTERS WITHOUT CLAIM TO ANY PARTICULAR FONT, STYLE, SIZE, OR COLOR.

FOR EDUCATIONAL SERVICES, NAMELY, PERSONAL COACHING, TRAINING, CLASSES, SYMPOSIUMS, AND CONFERENCES, ALL OF THE FOREGOING BEING IN THE FIELDS OF E-COMMERCE, REAL ESTATE INVESTING, STOCK MARKET INVESTING, PERSONAL FINANCE, SMALL BUSINESS, PERSONAL DEVELOPMENT AND CAREER DEVELOPMENT; TRAINING AND PERSONAL COACHING VIA VIDEO, RADIO, AND ONLINE STREAMING IN THE FIELDS OF E-COMMERCE, REAL ESTATE INVESTING, STOCK MARKET INVESTING, PERSONAL FINANCE, SMALL BUSINESS, PERSONAL DEVELOPMENT AND CAREER DEVELOPMENT; ONLINE NEWSLETTERS AND EDUCATIONAL SPEECHES IN THE FIELDS OF E-COMMERCE, REAL ESTATE INVESTING, STOCK MARKET INVESTING, PERSONAL FINANCE, SMALL BUSINESS, PERSONAL DEVELOPMENT AND CAREER DEVELOPMENT (U.S. CLS. 100, 101 AND 107).

LINDSEY RUBIN, EXAMINING ATTORNEY

CLASS 41—(Continued).

SN 85-396,969. MANKIND ENLIGHTENMENT LOVE, INC.,
ST. LOUIS, MO. FILED 8-12-2011.

HUE FACULTY

THE MARK CONSISTS OF STANDARD CHARACTERS WITHOUT CLAIM TO ANY PARTICULAR FONT, STYLE, SIZE, OR COLOR.

NO CLAIM IS MADE TO THE EXCLUSIVE RIGHT TO USE "FACULTY", APART FROM THE MARK AS SHOWN, FOR EDUCATIONAL SERVICES, NAMELY, CONDUCTING CLASSES, SEMINARS, CONFERENCES AND WORKSHOPS IN THE FIELD OF YOGA, MEDITATION, SELF HEALING, LIFE COACHING, MODERATION, MEDIATION AND CONFLICT MANAGEMENT (U.S. CLS. 100, 101 AND 107).

FIRST USE 12-31-2010; IN COMMERCE 12-31-2010.
JAMES LOVELACE, EXAMINING ATTORNEY

SN 85-397,232. CAMPANARIO ENTERTAINMENT, LLC,
MCALLEN, TX. FILED 8-12-2011.

CAMELIA LA TEXANA

THE MARK CONSISTS OF STANDARD CHARACTERS WITHOUT CLAIM TO ANY PARTICULAR FONT, STYLE, SIZE, OR COLOR.

THE NAME(S), PORTRAIT(S), AND/OR SIGNATURE(S) SHOWN IN THE MARK DOES NOT IDENTIFY A PARTICULAR LIVING INDIVIDUAL.

THE ENGLISH TRANSLATION OF "CAMELIA LA TEXANA" IN THE MARK IS "CAMELIA THE TEXAN".

FOR ENTERTAINMENT IN THE NATURE OF A DRAMATIC TELEVISION SERIES (U.S. CLS. 100, 101 AND 107).

AMY KERTGATE, EXAMINING ATTORNEY

CLASS 41—(Continued).

SN 85-398,896. MONTEPERTUSO, INC., BOCA RATON, FL. FILED 8-16-2011.

BUSTEDCOP

THE MARK CONSISTS OF STANDARD CHARACTERS WITHOUT CLAIM TO ANY PARTICULAR FONT, STYLE, SIZE, OR COLOR.

FOR ENTERTAINMENT SERVICES, NAMELY, PROVIDING ONLINE STORIES, AUDIO AND VIDEOS ABOUT PEOPLE'S ENCOUNTERS WITH LAW ENFORCEMENT OFFICERS (U.S. CLS. 100, 101 AND 107).

FIRST USE 8-15-2011. THE MARK WAS FIRST USED ANYWHERE IN A DIFFERENT FORM OTHER THAN THAT SOUGHT TO BE REGISTERED AT LEAST AS EARLY AS 08/15/2011.; IN COMMERCE 8-15-2011, THE MARK WAS FIRST USED IN COMMERCE IN A DIFFERENT FORM OTHER THAN THAT SOUGHT TO BE REGISTERED AT LEAST AS EARLY AS 08/15/2011..

JOHN HWANG, EXAMINING ATTORNEY

SN 85-399,551. THE CONFEDERATION OF NORTH, CENTRAL AMERICAN AND CARIBBEAN ASSOCIATION FOOTBALL (CONCACAF), NASSAU, BAHAMAS, FILED 8-16-2011.

COPA ORO CONCACAF

THE MARK CONSISTS OF STANDARD CHARACTERS WITHOUT CLAIM TO ANY PARTICULAR FONT, STYLE, SIZE, OR COLOR.

OWNER OF U.S. REG. NOS. 2,108,128, 3,628,073 AND OTHERS.

THE ENGLISH TRANSLATION OF THE WORDS "COPA ORO" IN THE MARK IS "GOLD CUP".

FOR ORGANIZING SPORTING EVENTS, NAMELY, SOCCER MATCHES AND SOCCER TOURNAMENTS; PRODUCTION OF RADIO AND TELEVISION PROGRAMS; PRODUCTION OF CDS AND DVDS FEATURING INFORMATION AND ENTERTAINMENT IN THE FIELD OF SOCCER; PRODUCTION OF FILMS; PROGRAMMING AND PRODUCTION OF TELEVISION, RADIO AND INTERNET PROGRAMS ON A GLOBAL COMPUTER NETWORK; PROVIDING A WEB SITE FEATURING INFORMATION ABOUT SOCCER AND SOCCER TOURNAMENTS; PUBLICATION OF PRINTED MATTER; TICKET RESERVATION AND BOOKING SERVICES FOR SOCCER MATCHES AND SOCCER TOURNAMENTS (U.S. CLS. 100, 101 AND 107).

FIRST USE 1-10-1996; IN COMMERCE 1-10-1996.

TINA BROWN, EXAMINING ATTORNEY

CLASS 41—(Continued).

SN 85-399,556. TWENTIETH CENTURY FOX FILM CORPORATION, LOS ANGELES, CA. FILED 8-16-2011.

FX MOVIE CHANNEL

THE MARK CONSISTS OF STANDARD CHARACTERS WITHOUT CLAIM TO ANY PARTICULAR FONT, STYLE, SIZE, OR COLOR.

OWNER OF U.S. REG. NOS. 2,107,517, 3,445,969 AND OTHERS.

NO CLAIM IS MADE TO THE EXCLUSIVE RIGHT TO USE "MOVIE CHANNEL", APART FROM THE MARK AS SHOWN.

FOR ENTERTAINMENT SERVICES, NAMELY, PROVISION OF ON-GOING MULTIMEDIA PROGRAMS IN THE FIELD OF ACTION, ADVENTURE, COMEDY, DRAMA, MUSIC AND SPORTS DISTRIBUTED VIA VARIOUS PLATFORMS ACROSS MULTIPLE FORMS OF TRANSMISSION MEDIA; PROVIDING ON-LINE ENTERTAINMENT INFORMATION IN THE FIELD OF ACTION, ADVENTURE, COMEDY, DRAMA, MUSIC AND SPORTS (U.S. CLS. 100, 101 AND 107).

RENEE MCCRAY, EXAMINING ATTORNEY

SN 85-400,450. AMERICAN DIABETES ASSOCIATION, INC., ALEXANDRIA, VA. FILED 8-17-2011.

SISTERS STRONG TOGETHER

THE MARK CONSISTS OF STANDARD CHARACTERS WITHOUT CLAIM TO ANY PARTICULAR FONT, STYLE, SIZE, OR COLOR.

FOR EDUCATIONAL SERVICES, NAMELY, CONDUCTING SEMINARS AND WORKSHOPS IN THE FIELD OF DIABETES COMPLICATIONS AND THE WAY TO PREVENT SUCH COMPLICATIONS (U.S. CLS. 100, 101 AND 107).

BILL DAWE, EXAMINING ATTORNEY

CLASS 41—(Continued).

SN 85-401,505. THE COOKING GROUP, LLC, DALLAS, TX. FILED 8-18-2011.



NO CLAIM IS MADE TO THE EXCLUSIVE RIGHT TO USE "CIRQUE MUSICA", APART FROM THE MARK AS SHOWN.

THE MARK CONSISTS OF THE WORDS "CIRQUE MUSICA" (STYLIZED) WITH AN "X" ABOVE THE "I" IN "MUSICA" THAT RESEMBLES A STICK FIGURE WITH ARMS OUTSTRETCHED AND ONE LEG LIFTED. THE DESIGN ALSO INCLUDES TWO DOTS TO THE LEFT OF THE "X", A DOT IN BETWEEN THE LOWER LEGS OF THE "X", AND MUSIC NOTES TO THE RIGHT OF THE "X".

THE ENGLISH TRANSLATION OF "CIRQUE MUSICA" IN THE MARK IS "CIRCUS MUSIC".

FOR ENTERTAINMENT SERVICES FEATURING MUSICAL AND THEATRICAL PERFORMANCES; ENTERTAINMENT SERVICES, NAMELY, DESIGN, CONCEPTION AND PRODUCTION OF MUSICAL AND THEATRICAL PERFORMANCES FEATURING ACROBATICS AND MUSICAL AND THEATRICAL PERFORMERS; PRESENTATION OF LIVE SHOW PERFORMANCES (U.S. CLS. 100, 101 AND 107).
ERNEST SHOSHO, EXAMINING ATTORNEY

SN 85-401,982. TELEvisa, S.A. DE C.V., SANTA FE, MEXICO, FILED 8-19-2011.

EL GRAN SHOW DE LOS PEQUES

THE MARK CONSISTS OF STANDARD CHARACTERS WITHOUT CLAIM TO ANY PARTICULAR FONT, STYLE, SIZE, OR COLOR.

PRIORITY CLAIMED UNDER SEC. 44(D) ON MEXICO APPLICATION NO. 1191107, FILED 6-30-2011, REG. NO. 1252395, DATED 6-30-2011, EXPIRES 6-30-2021.

NO CLAIM IS MADE TO THE EXCLUSIVE RIGHT TO USE "SHOW", APART FROM THE MARK AS SHOWN.

THE ENGLISH TRANSLATION OF "EL GRAN SHOW DE LOS PEQUES" IN THE MARK IS "THE LITTLE ONES GREAT SHOW".

FOR ENTERTAINMENT SERVICES IN THE NATURE OF A CONTINUING CHILDREN TALENT SHOW BROADCAST OVER THE INTERNET AND A CONTINUING CHILDREN TALENT SHOW TELEVISION PROGRAM (U.S. CLS. 100, 101 AND 107).
KATHLEEN LORENZO, EXAMINING ATTORNEY

CLASS 41—(Continued).

SN 85-402,447. U.S. MARINE CORPS, A COMPONENT OF THE U.S. DEPARTMENT OF THE NAVY, WASHINGTON, DC. FILED 8-19-2011.

MARSOC

THE MARK CONSISTS OF STANDARD CHARACTERS WITHOUT CLAIM TO ANY PARTICULAR FONT, STYLE, SIZE, OR COLOR.

FOR ARRANGING AND CONDUCTING ATHLETIC COMPETITIONS; ENTERTAINMENT IN THE NATURE OF COMPETITIONS IN THE FIELD OF ATHLETICS; PROVIDING A WEB SITE FEATURING INFORMATION ON EXERCISE AND FITNESS; PROVIDING A WEB SITE FEATURING SPORTING INFORMATION; PROVIDING AN INTERACTIVE WEBSITE FEATURING INFORMATION AND LINKS RELATING TO FITNESS; PROVIDING EDUCATIONAL INFORMATION IN THE ACADEMIC FIELD OF MILITARY AFFAIRS, MILITARY TACTICS, MILITARY HISTORY AND MILITARY SCIENCE FOR THE PURPOSE OF ACADEMIC STUDY; PROVIDING INFORMATION, NEWS AND COMMENTARY IN THE FIELD OF CURRENT EVENTS RELATING TO MILITARY AFFAIRS, MILITARY TACTICS, MILITARY HISTORY AND MILITARY SCIENCE (U.S. CLS. 100, 101 AND 107).

FIRST USE 2-4-2006; IN COMMERCE 2-4-2006.
DARRYL SPRUILL, EXAMINING ATTORNEY

SN 85-404,025. CENTER FOR LEADERSHIP DEVELOPMENT, INC., INDIANAPOLIS, IN. FILED 8-22-2011.

CENTER FOR LEADERSHIP
DEVELOPMENT
Empowering Youth,
Strengthening Community

THE MARK CONSISTS OF STANDARD CHARACTERS WITHOUT CLAIM TO ANY PARTICULAR FONT, STYLE, SIZE, OR COLOR.

NO CLAIM IS MADE TO THE EXCLUSIVE RIGHT TO USE "CENTER", APART FROM THE MARK AS SHOWN.

SEC. 2(F) AS TO "CENTER FOR LEADERSHIP DEVELOPMENT".

FOR EDUCATIONAL SERVICES, NAMELY, PROVIDING CLASSES, SEMINARS, FORUMS AND PROGRAMS FOR DISADVANTAGED YOUTH IN THE FIELDS OF CHARACTER AND PERSONAL SKILLS DEVELOPMENT, ACADEMIC PREPARATION AND ACHIEVEMENT, AND CAREER OPPORTUNITIES (U.S. CLS. 100, 101 AND 107).

FIRST USE 3-11-2002; IN COMMERCE 3-11-2002.
DOMINICK J. SALEMI, EXAMINING ATTORNEY

CLASS 41—(Continued).

SN 85-409,632. BALTIMORE WOODS NATURE CENTER, INC., MARCELLUS, NY. FILED 8-29-2011.

NATURE IN THE CITY

THE MARK CONSISTS OF STANDARD CHARACTERS WITHOUT CLAIM TO ANY PARTICULAR FONT, STYLE, SIZE, OR COLOR.

SEC. 2(F).

FOR EDUCATIONAL SERVICES, NAMELY, PROVIDING CLASSES, LESSONS, SEMINARS, WORKSHOPS IN THE FIELD OF NATURE AND ECOLOGY FOR STUDENTS IN URBAN SURROUNDINGS (U.S. CLS. 100, 101 AND 107).

FIRST USE 12-31-2003; IN COMMERCE 5-20-2004.
CHRIS WELLS, EXAMINING ATTORNEY

SN 85-410,692. HIN HOLDINGS, INC., WILMINGTON, DE. FILED 8-30-2011.

HOT IMPORT NIGHTS

THE MARK CONSISTS OF STANDARD CHARACTERS WITHOUT CLAIM TO ANY PARTICULAR FONT, STYLE, SIZE, OR COLOR.

OWNER OF U.S. REG. NO. 3,148,014.

NO CLAIM IS MADE TO THE EXCLUSIVE RIGHT TO USE "IMPORT", APART FROM THE MARK AS SHOWN.

FOR ENTERTAINMENT IN THE NATURE OF LIVE AUTOMOTIVE SHOWS FOR ENTERTAINMENT PURPOSES; ENTERTAINMENT SERVICES IN THE NATURE OF LIVE MUSICAL PERFORMANCES; ENTERTAINMENT SERVICES, NAMELY, ARRANGING AND CONDUCTING OF COMPETITIONS FOR MODELS; ENTERTAINMENT SERVICES, NAMELY, CONDUCTING PARTIES (U.S. CLS. 100, 101 AND 107).

FIRST USE 3-1-1998; IN COMMERCE 3-1-1998.

MICHAEL WEBSTER, EXAMINING ATTORNEY

CLASS 41—(Continued).

SN 85-410,759. U.S. MARINE CORPS, A COMPONENT OF THE U.S. DEPARTMENT OF THE NAVY, WASHINGTON, DC. FILED 8-30-2011.



OWNER OF U.S. REG. NOS. 2,565,057, 3,946,745 AND OTHERS.

THE COLOR(S) RED, GOLD, WHITE, BLACK AND GREY IS/ARE CLAIMED AS A FEATURE OF THE MARK.

THE MARK CONSISTS OF A FIELD OR BACKGROUND IN THE COLOR RED, ON WHICH A DESIGN FEATURING AN EAGLE (THE COLOR GOLD AND OUTLINED IN BLACK WITH A WHITE HEAD AND WHITE TAIL FEATHERS), PERCHED ATOP A GLOBE (IN THE COLOR OF GREY, WITH GOLD LAND MASSES OUTLINED IN BLACK, AND WHITE LATITUDE LINES), WITH AN ANCHOR AND ROPE BEHIND IT (BEING THE COLOR GOLD AND BOTH OUTLINED IN BLACK), AND WITHIN THE EAGLE'S BEAK IS A BANNER (IN WHITE WITH GOLD TRIM), WITH THE WORDS (IN RED) "SEMPER FIDELIS," AND BENEATH THE DESIGN A BANNER WITH THE WORDS (IN WHITE WITH GOLD TRIM AND GREY BACKING, WITH THE WORDS IN RED), "UNITED STATES MARINE CORPS", ALL OF WHICH SURROUNDED BY GOLD FRINGES

FOR ENTERTAINMENT IN THE NATURE OF LIVE PERFORMANCES BY COLOR GUARDS, RIFLE TEAMS, ORCHESTRAS AND MARCHING BANDS; ENTERTAINMENT IN THE NATURE OF ORCHESTRA PERFORMANCES; ENTERTAINMENT SERVICES IN THE NATURE OF MUSICAL, MARCHING AND SYNCHRONIZED RIFLE TEAM PERFORMANCES; ENTERTAINMENT, NAMELY, LIVE MUSIC CONCERTS; ENTERTAINMENT, NAMELY, LIVE PERFORMANCES BY A MUSICAL BAND; ENTERTAINMENT, NAMELY, LIVE PERFORMANCES BY MUSICAL BANDS; PRESENTATION OF LIVE SHOW PERFORMANCES; PRESENTATION OF MUSICAL PERFORMANCE; THEATRICAL AND MUSICAL FLOOR SHOWS PROVIDED AT PERFORMANCE VENUES (U.S. CLS. 100, 101 AND 107).

FIRST USE 1-1-1945; IN COMMERCE 1-1-1945.

DARRYL SPRUILL, EXAMINING ATTORNEY

SN 85-411,132. WRIGHT, TARA, MENLO PARK, CA. FILED 8-30-2011.

DUMP YOUR FRUMP

THE MARK CONSISTS OF STANDARD CHARACTERS WITHOUT CLAIM TO ANY PARTICULAR FONT, STYLE, SIZE, OR COLOR.

FOR PROVIDING A WEBSITE FEATURING BLOGS AND NON-DOWNLOADABLE PUBLICATIONS IN THE NATURE OF ARTICLES IN THE FIELDS OF FASHION, BRANDS, HEALTH, BEAUTY, FAMILY, ENTERTAINING AND PRODUCT REVIEWS (U.S. CLS. 100, 101 AND 107).

FIRST USE 6-17-2011; IN COMMERCE 8-1-2011.

BERNICE MIDDLETON, EXAMINING ATTORNEY

CLASS 41—(Continued).

SN 85-415,679. GLOBAL MAGIC FUTURES LIMITED, BERKSWELL, UNITED KINGDOM, FILED 9-6-2011.

CLASS 41—(Continued).

SN 85-415,726. GLOBAL MAGIC FUTURES LIMITED, BERKSWELL, UNITED KINGDOM, FILED 9-6-2011.

MAGIC NUMBER



THE MARK CONSISTS OF STANDARD CHARACTERS WITHOUT CLAIM TO ANY PARTICULAR FONT, STYLE, SIZE, OR COLOR.

PRIORITY CLAIMED UNDER SEC. 44(D) ON ERP N CMNTY TM OFC APPLICATION NO. 10228351, FILED 8-30-2011, REG. NO. 10228351, DATED 3-13-2012, EXPIRES 8-30-2021.

FOR ARRANGING AND CONDUCTING OF CONFERENCES, SEMINARS AND WORKSHOPS IN THE FIELDS OF FINANCIAL PLANNING, LIFESTYLE MANAGEMENT, AND PERSONAL DEVELOPMENT, NAMELY, SELF-IMPROVEMENT AND SELF-FULFILLMENT; EDUCATIONAL SERVICES, NAMELY, CONDUCTING CLASSES AND SEMINARS IN THE FIELDS OF FINANCIAL PLANNING, LIFESTYLE MANAGEMENT, AND PERSONAL DEVELOPMENT, NAMELY, SELF-IMPROVEMENT AND SELF-FULFILLMENT; PROVIDING ENTERTAINMENT INFORMATION VIA THE INTERNET; PROVIDING A WEBSITE FEATURING NON-DOWNLOADABLE PUBLICATIONS IN THE NATURE OF BOOKS, WORKBOOKS, NEWSLETTERS, MAGAZINES, AND PERIODICALS IN THE FIELDS OF FINANCIAL PLANNING, LIFESTYLE MANAGEMENT, AND PERSONAL DEVELOPMENT, NAMELY, SELF-IMPROVEMENT AND SELF-FULFILLMENT; ENTERTAINMENT SERVICES, NAMELY, PROVIDING ONLINE COMPUTER GAMES; TRAINING SERVICES IN THE FIELDS OF FINANCIAL PLANNING, LIFESTYLE MANAGEMENT, AND PERSONAL DEVELOPMENT, NAMELY, SELF-IMPROVEMENT AND SELF-FULFILLMENT (U.S. CLS. 100, 101 AND 107).

JASON TURNER, EXAMINING ATTORNEY

PRIORITY CLAIMED UNDER SEC. 44(D) ON ERP N CMNTY TM OFC APPLICATION NO. 10228427, FILED 8-30-2011, REG. NO. 10228427, DATED 2-22-2012, EXPIRES 8-30-2021.

THE MARK CONSISTS OF THE TERM "MAGICNUMBER.COM" IN STYLIZED LOWERCASE LETTERS, WITH THE PHRASES "TAKE CONTROL", "ACHIEVE MORE" AND "LOVE LIFE!" APPEARING IMMEDIATELY BELOW IN STYLIZED LOWERCASE LETTERS AND SEPARATED BY DOTS, AND AN ORB AND SHADOW DESIGN APPEARING TO THE IMMEDIATE LEFT.

FOR ARRANGING AND CONDUCTING OF CONFERENCES, SEMINARS AND WORKSHOPS IN THE FIELDS OF FINANCIAL PLANNING, LIFESTYLE MANAGEMENT, AND PERSONAL DEVELOPMENT, NAMELY, SELF-IMPROVEMENT AND SELF-FULFILLMENT; EDUCATIONAL SERVICES, NAMELY, CONDUCTING CLASSES AND SEMINARS IN THE FIELDS OF FINANCIAL PLANNING, LIFESTYLE MANAGEMENT, AND PERSONAL DEVELOPMENT, NAMELY, SELF-IMPROVEMENT AND SELF-FULFILLMENT; PROVIDING ENTERTAINMENT INFORMATION VIA THE INTERNET; PROVIDING A WEBSITE FEATURING NON-DOWNLOADABLE PUBLICATIONS IN THE NATURE OF BOOKS, WORKBOOKS, NEWSLETTERS, MAGAZINES, AND PERIODICALS IN THE FIELDS OF FINANCIAL PLANNING, LIFESTYLE MANAGEMENT, AND PERSONAL DEVELOPMENT, NAMELY, SELF-IMPROVEMENT AND SELF-FULFILLMENT; ENTERTAINMENT SERVICES, NAMELY, PROVIDING ONLINE COMPUTER GAMES; TRAINING SERVICES IN THE FIELDS OF FINANCIAL PLANNING, LIFESTYLE MANAGEMENT, AND PERSONAL DEVELOPMENT, NAMELY, SELF-IMPROVEMENT AND SELF-FULFILLMENT (U.S. CLS. 100, 101 AND 107).

JASON TURNER, EXAMINING ATTORNEY

CLASS 41—(Continued).

SN 85-415,821. GLOBAL MAGIC FUTURES LIMITED, BERKSWELL, UNITED KINGDOM, FILED 9-6-2011.

take control • achieve more • love life!

PRIORITY CLAIMED UNDER SEC. 44(D) ON ERPN CMNTY TM OFC APPLICATION NO. 10228591, FILED 8-30-2011, REG. NO. 10228591, DATED 2-17-2012, EXPIRES 8-30-2021.

THE MARK CONSISTS OF THE WORDING "TAKE CONTROL", "ACHIEVE MORE" AND "LOVE LIFE!" A DOT SEPARATES EACH PHRASE.

FOR ARRANGING AND CONDUCTING OF CONFERENCES, SEMINARS AND WORKSHOPS IN THE FIELDS OF FINANCIAL PLANNING, LIFESTYLE MANAGEMENT, AND PERSONAL DEVELOPMENT, NAMELY, SELF-IMPROVEMENT AND SELF-FULFILLMENT; EDUCATIONAL SERVICES, NAMELY, CONDUCTING CLASSES AND SEMINARS IN THE FIELDS OF FINANCIAL PLANNING, LIFESTYLE MANAGEMENT, AND PERSONAL DEVELOPMENT, NAMELY, SELF-IMPROVEMENT AND SELF-FULFILLMENT; PROVIDING ENTERTAINMENT INFORMATION VIA THE INTERNET; PROVIDING A WEBSITE FEATURING NON-DOWNLOADABLE PUBLICATIONS IN THE NATURE OF BOOKS, WORKBOOKS, NEWSLETTERS, MAGAZINES, AND PERIODICALS IN THE FIELDS OF FINANCIAL PLANNING, LIFESTYLE MANAGEMENT, AND PERSONAL DEVELOPMENT, NAMELY, SELF-IMPROVEMENT AND SELF-FULFILLMENT; ENTERTAINMENT SERVICES, NAMELY, PROVIDING ONLINE COMPUTER GAMES; TRAINING SERVICES IN THE FIELDS OF FINANCIAL PLANNING, LIFESTYLE MANAGEMENT, AND PERSONAL DEVELOPMENT, NAMELY, SELF-IMPROVEMENT AND SELF-FULFILLMENT (U.S. CLS. 100, 101 AND 107).

JASON TURNER, EXAMINING ATTORNEY

CLASS 41—(Continued).

SN 85-418,827. MARGARITAVILLE ENTERPRISES, LLC, PALM BEACH, FL. FILED 9-9-2011.

PLAY IN PARADISE . . . NO
PASSPORT REQUIRED

THE MARK CONSISTS OF STANDARD CHARACTERS WITHOUT CLAIM TO ANY PARTICULAR FONT, STYLE, SIZE, OR COLOR.

OWNER OF U.S. REG. NO. 3,759,315.

FOR CASINOS (U.S. CLS. 100, 101 AND 107).

HANNO RITTNER, EXAMINING ATTORNEY

SN 85-419,546. GOSPEL MESSENGERS, KAMPALA, UGANDA, FILED 9-10-2011.

SN 85-417,611. MARGARITAVILLE ENTERPRISES, LLC, PALM BEACH, FL. FILED 9-8-2011.

IMANI MILELE CHILDREN

PLAY IN PARADISE

THE MARK CONSISTS OF STANDARD CHARACTERS WITHOUT CLAIM TO ANY PARTICULAR FONT, STYLE, SIZE, OR COLOR.

NO CLAIM IS MADE TO THE EXCLUSIVE RIGHT TO USE "PLAY", APART FROM THE MARK AS SHOWN.

FOR CASINOS (U.S. CLS. 100, 101 AND 107).

HANNO RITTNER, EXAMINING ATTORNEY

THE MARK CONSISTS OF STANDARD CHARACTERS WITHOUT CLAIM TO ANY PARTICULAR FONT, STYLE, SIZE, OR COLOR.

NO CLAIM IS MADE TO THE EXCLUSIVE RIGHT TO USE "CHILDREN", APART FROM THE MARK AS SHOWN.

THE NAME(S), PORTRAIT(S), AND/OR SIGNATURE(S) SHOWN IN THE MARK DOES NOT IDENTIFY A PARTICULAR LIVING INDIVIDUAL.

THE ENGLISH TRANSLATION OF "IMANI MILELE" IN THE MARK IS "EVERLASTING FAITH".

FOR EDUCATION SERVICES, NAMELY, PROVIDING CLASSES, SEMINARS, WORKSHOPS IN THE FIELDS OF AFRICAN CULTURE AND CHRISTIANITY MUSIC (U.S. CLS. 100, 101 AND 107).

PAUL MORENO, EXAMINING ATTORNEY

CLASS 41—(Continued).

SN 85-419,847. GOSPEL MESSENGERS, KAMPALA, UGANDA, FILED 9-12-2011.



NO CLAIM IS MADE TO THE EXCLUSIVE RIGHT TO USE "CHILDREN", APART FROM THE MARK AS SHOWN.

THE NAME(S), PORTRAIT(S), AND/OR SIGNATURE(S) SHOWN IN THE MARK DOES NOT IDENTIFY A PARTICULAR LIVING INDIVIDUAL.

THE COLOR(S) GREEN, RED, BLUE, YELLOW, ORANGE IS/ARE CLAIMED AS A FEATURE OF THE MARK.

THE MARK CONSISTS OF THE WORD "IMANI" WHEREIN THE LETTERS "IM" ARE WRITTEN IN GREEN COLOR, "NI" ARE WRITTEN IN BLUE COLOR AND THE LETTER "A" IS WRITTEN IN STYLIZED RED FONT HAVING AN IMAGE OF SUN IN YELLOW COLOR BEHIND IT. BELOW THAT THE WORDS "MILELE" AND "CHILDREN" ARE WRITTEN IN ORANGE COLOR AS SHOWN IN THE MARK.

THE ENGLISH TRANSLATION OF "IMANI MILELE" IN THE MARK IS EVERLASTING FAITH.

FOR ENTERTAINMENT, NAMELY, LIVE PERFORMANCES BY A MUSICAL CHOIR (U.S. CLS. 100, 101 AND 107).

PAUL MORENO, EXAMINING ATTORNEY

SN 85-422,874. DISCOVERY COMMUNICATIONS, LLC, SILVER SPRING, MD. FILED 9-14-2011.

SCIENCE OF EVERYDAY LIFE

THE MARK CONSISTS OF STANDARD CHARACTERS WITHOUT CLAIM TO ANY PARTICULAR FONT, STYLE, SIZE, OR COLOR.

FOR EDUCATIONAL SERVICES, NAMELY, PROVIDING OF GENERAL EDUCATIONAL INFORMATION IN THE ACADEMIC FIELD OF SCIENCE DISTRIBUTED VIA VARIOUS PLATFORMS ACROSS MULTIPLE FORMS OF TRANSMISSION MEDIA AND VIA A GLOBAL COMPUTER NETWORK FOR USE BY STUDENTS, PARENTS AND TEACHERS FOR THE PURPOSE OF ACADEMIC STUDY AND LEARNING (U.S. CLS. 100, 101 AND 107).

FIRST USE 10-21-2010; IN COMMERCE 10-21-2010.
RONALD MCMORROW, EXAMINING ATTORNEY

CLASS 41—(Continued).

SN 85-424,246. LINA N. CAROLLO, DELRAN, NJ. FILED 9-16-2011.

BARTENDERTAINMENT

THE MARK CONSISTS OF STANDARD CHARACTERS WITHOUT CLAIM TO ANY PARTICULAR FONT, STYLE, SIZE, OR COLOR.

FOR ENTERTAINMENT SERVICES, NAMELY, CONDUCTING PARTIES (U.S. CLS. 100, 101 AND 107).

FIRST USE 12-3-2010; IN COMMERCE 3-3-2011.
CAROLINE WOOD, EXAMINING ATTORNEY

SN 85-427,288. EASLE ENTERTAINMENT, LLC, ENCINITAS, CA. FILED 9-20-2011.

THE FRENDRY GATHERING

THE MARK CONSISTS OF STANDARD CHARACTERS WITHOUT CLAIM TO ANY PARTICULAR FONT, STYLE, SIZE, OR COLOR.

FOR ARRANGING AND CONDUCTING A NATIONAL TOUR OF LARGE-SCALE ROCK CONCERTS FEATURING MULTIPLE MUSICAL GROUPS AND BANDS; ARRANGING AND CONDUCTING FESTIVALS FEATURING MUSICAL GROUPS, ROCK MUSIC, AND BOOTHS THAT DISTRIBUTE LITERATURE AND INFORMATION ON PUBLIC-INTEREST ISSUES AND ALSO DISTRIBUTE ARTS AND CRAFTS ITEMS WHICH ARE RELATED TO ROCK MUSIC, CAMPING, LIVE ART, SKATEBOARDING, SNOWBOARDING, SURFING; PRODUCING CONCERTS AND CONCERT TOURS; PRODUCING CONCERTS AND MUSIC FESTIVALS BASED AROUND ACTION SPORTS, PROVIDING A WEB SITE ON GLOBAL COMPUTER NETWORKS FEATURING INFORMATION ON MUSIC, MUSICAL PERFORMANCES, CAMPING INFORMATION, LIVE ART, SNOWBOARDING, SKATEBOARDING, SURFING, AND MUSICAL PERFORMERS; PRODUCING AND ARRANGING CONCERTS, EVENTS, NIGHTCLUB PERFORMANCES AND OTHER PERFORMANCES; PRODUCING SILENT DISCOS; PROVIDING INFORMATION IN THE FIELD OF ENTERTAINMENT AND MUSIC BY MEANS OF A GLOBAL COMPUTER NETWORK; ENTERTAINMENT SERVICES, NAMELY, PROVIDING A WEB SITE FEATURING MUSICAL PERFORMANCES, MUSIC VIDEOS, PHOTOGRAPHS, AND OTHER MULTIMEDIA MATERIALS; PROVIDING WEB-BASED INFORMATION IN THE NATURE OF TICKET INFORMATION FOR EVENTS; PROVIDING ON-LINE INFORMATION REGARDING TELEVISION PROGRAMMING, ENTERTAINMENT, SPORTS AND CULTURAL ACTIVITIES; ENTERTAINMENT SERVICES, NAMELY, PROVIDING WIRELESS GAMES, WIRELESS HEADPHONES, AND IMAGES THAT MAY BE ACCESSED BY NETWORK USERS; DISCOTHEQUE AND DANCE CLUB SERVICES, FEATURING LIVE AND PRE-RECORDED ENTERTAINMENT, VIDEOS AND DANCING; PROVIDING ENTERTAINMENT INFORMATION VIA A GLOBAL COMPUTER NETWORK (U.S. CLS. 100, 101 AND 107).

FIRST USE 6-4-2010; IN COMMERCE 6-4-2010.
GINA FINK, EXAMINING ATTORNEY

CLASS 41—(Continued).

SN 85-427,313. SSC IP RESERVE, LLC, PROVO, UT. FILED 9-20-2011.

LEADER FOR LIFE

THE MARK CONSISTS OF STANDARD CHARACTERS WITHOUT CLAIM TO ANY PARTICULAR FONT, STYLE, SIZE, OR COLOR.

FOR EDUCATIONAL SERVICES, NAMELY, PROVIDING ONLINE, LIVE, AND BY SATELLITE TRAINING PROGRAMS, MENTORING AND COACHING SERVICES FOR COLLEGE AND UNIVERSITY STUDENTS IN THE FIELDS OF LEADERSHIP, BUSINESS MANAGEMENT, PERSONAL ACHIEVEMENT AND EXCELLENCE (U.S. CLS. 100, 101 AND 107).

ERNEST SHOSHO, EXAMINING ATTORNEY

SN 85-432,080. TAVANA MEDIA LLC, WHITEFISH, MT. FILED 9-26-2011.

CARTEL

THE MARK CONSISTS OF STANDARD CHARACTERS WITHOUT CLAIM TO ANY PARTICULAR FONT, STYLE, SIZE, OR COLOR.

OWNER OF U.S. REG. NO. 3,951,906.

FOR ENTERTAINMENT SERVICES, NAMELY, MULTIMEDIA PRODUCTION SERVICES OF MULTIMEDIA CONTENT FOR DISTRIBUTION VIA AN ENTERTAINMENT WEBSITE (U.S. CLS. 100, 101 AND 107).

SANI KHOURI, EXAMINING ATTORNEY

SN 85-433,324. MORRIS, KENNETHA, WEST LOS ANGELES, CA. FILED 9-27-2011.

MISS KOKO LOKO

THE MARK CONSISTS OF STANDARD CHARACTERS WITHOUT CLAIM TO ANY PARTICULAR FONT, STYLE, SIZE, OR COLOR.

"MISS KOKO LOKO" IDENTIFIES THE STAGE NAME OF KENNETHA MORRIS, A LIVING INDIVIDUAL WHOSE CONSENT IS OF RECORD.

FOR ENTERTAINMENT SERVICES IN THE NATURE OF LIVE MUSICAL PERFORMANCES (U.S. CLS. 100, 101 AND 107).

JULIE GUTTADAURO, EXAMINING ATTORNEY

CLASS 41—(Continued).

SN 85-433,950. FACE DANCE PRODUCTIONS, LLC, DBA THE DANCE FACTOR, LAS VEGAS, NV. FILED 9-28-2011.

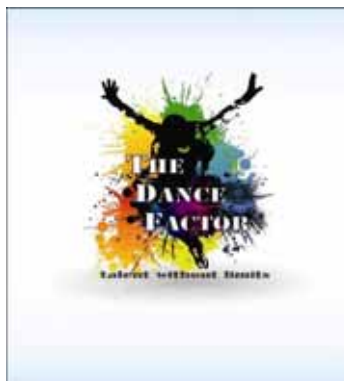

NO CLAIM IS MADE TO THE EXCLUSIVE RIGHT TO USE "DANCE", APART FROM THE MARK AS SHOWN.

THE COLOR(S) RED, YELLOW, ORANGE, GREEN, BLUE, PURPLE, LIGHT BLUE, WHITE AND BLACK IS/ARE CLAIMED AS A FEATURE OF THE MARK.

THE MARK CONSISTS OF THE WORDING "THE DANCE FACTOR" IN WHITE AND CAPITAL LETTERS PLACED IN FRONT OF A BLACK AND WHITE DANCER EMERGING FROM A SERIES OF RED, YELLOW, GREEN, BLUE, PURPLE, YELLOW AND ORANGE PAINT SPLASHES WITH THE WORDING "TALENT WITHOUT LIMITS" IN BLACK AND LOWER CASE LETTERS BELOW THE DANCER ALL INSIDE A RECTANGLE DESIGN WITH LIGHT BLUE AND WHITE SHADING.

FOR DANCE STUDIOS; EDUCATION SERVICES, NAMELY, PROVIDING CLASSES AND INSTRUCTION IN THE FIELD OF DANCE (U.S. CLS. 100, 101 AND 107).

FIRST USE 9-13-2011; IN COMMERCE 9-18-2011.

LINDA ORNDORFF, EXAMINING ATTORNEY

SN 85-434,223. PANTHERS BRHC L.L.C., BOCA RATON, FL. FILED 9-28-2011.

Boca Tots

THE MARK CONSISTS OF STANDARD CHARACTERS WITHOUT CLAIM TO ANY PARTICULAR FONT, STYLE, SIZE, OR COLOR.

SEC. 2(F).

FOR RECREATIONAL CAMPS; RECREATIONAL SERVICES IN THE NATURE OF DAY CAMP ACTIVITIES, SUCH AS BEACH TRIPS, NATURE WALKS, SWIMMING TRIPS, PICNICS AND RECREATIONAL CAMP SERVICES FOR HOTEL AND RESORT GUESTS (U.S. CLS. 100, 101 AND 107).

FIRST USE 7-1-1993; IN COMMERCE 7-1-1993.

SUNG IN, EXAMINING ATTORNEY

CLASS 41—(Continued).

SN 85-434,351. PANTHERS BRHC L.L.C., BOCA RATON, FL. FILED 9-28-2011.

Boca Bunch

THE MARK CONSISTS OF STANDARD CHARACTERS WITHOUT CLAIM TO ANY PARTICULAR FONT, STYLE, SIZE, OR COLOR.

SEC. 2(F).
FOR RECREATIONAL SERVICES IN THE NATURE OF DAY CAMP ACTIVITIES, SUCH AS BEACH TRIPS, NATURE WALKS, SWIMMING TRIPS, PICNICS AND RECREATIONAL CAMP SERVICES FOR HOTEL AND RESORT GUESTS (U.S. CLS. 100, 101 AND 107).
FIRST USE 6-1-1986; IN COMMERCE 6-1-1986.
SUNG IN, EXAMINING ATTORNEY

SN 85-436,911. BROOKS, JERRY, AKA JB SMOOVE, BEVERLY HILLS, CA. FILED 9-30-2011.

JB SMOOVE

THE MARK CONSISTS OF STANDARD CHARACTERS WITHOUT CLAIM TO ANY PARTICULAR FONT, STYLE, SIZE, OR COLOR.

THE NAME(S), PORTRAIT(S), AND/OR SIGNATURE(S) SHOWN IN THE MARK IDENTIFIES JERRY BROOKS, WHOSE CONSENT(S) TO REGISTER IS MADE OF RECORD.
FOR ENTERTAINMENT SERVICES IN THE NATURE OF LIVE MUSICAL PERFORMANCES, DRAMATIC PERFORMANCES AND COMEDIC PERFORMANCES (U.S. CLS. 100, 101 AND 107).
AMY C. KEAN, EXAMINING ATTORNEY

SN 85-437,612. BABCHIK, MICHAEL, BRONX, NY. FILED 10-3-2011.

MAN BANTER

THE MARK CONSISTS OF STANDARD CHARACTERS WITHOUT CLAIM TO ANY PARTICULAR FONT, STYLE, SIZE, OR COLOR.

FOR EDUCATIONAL AND ENTERTAINMENT SERVICES, NAMELY, ONGOING RADIO TALK SHOW SERVICES, ONGOING TELEVISION TALK SHOW SERVICES, MUSIC PRODUCTION SERVICES, MOTION PICTURE PRODUCTION SERVICES, AND ONGOING TALK SHOW SERVICES RENDERED OVER THE GLOBAL COMPUTER NETWORK ALL OF THE FOREMENTIONED FEATURING TOPICS OF INTEREST TO MEN SUCH AS SPORTS, BUSINESS, HEALTH AND OTHER TOPICS OF DAILY LIVING (U.S. CLS. 100, 101 AND 107).
FIRST USE 3-0-2010; IN COMMERCE 3-0-2010.
LINDSEY RUBIN, EXAMINING ATTORNEY

CLASS 41—(Continued).

SN 85-438,282. MYBOOTCAMP LLC, DBA MYBOOTCAMP, GERMANTOWN, MD. FILED 10-3-2011.



NO CLAIM IS MADE TO THE EXCLUSIVE RIGHT TO USE "BOOTCAMP", APART FROM THE MARK AS SHOWN.

THE MARK CONSISTS OF THE WORDING "MY BOOTCAMP" IN LOWER CASE STENCIL-STYLE LETTERING WITH A STAR SURROUNDED BY A BROKEN CIRCLE BETWEEN THE WORDS "MY" AND "BOOTCAMP".
FOR PERSONAL FITNESS TRAINING SERVICES AND CONSULTANCY (U.S. CLS. 100, 101 AND 107).
FIRST USE 8-1-2010; IN COMMERCE 9-1-2010.
KATINA MISTER, EXAMINING ATTORNEY

SN 85-438,356. CREEKSIDE MULTIMEDIA.INC., NORTON, OH. FILED 10-4-2011.

L MAC PHOTOGRAPHY

THE MARK CONSISTS OF STANDARD CHARACTERS WITHOUT CLAIM TO ANY PARTICULAR FONT, STYLE, SIZE, OR COLOR.

NO CLAIM IS MADE TO THE EXCLUSIVE RIGHT TO USE "PHOTOGRAPHY", APART FROM THE MARK AS SHOWN.
FOR PHOTOGRAPHY SERVICES (U.S. CLS. 100, 101 AND 107).
FIRST USE 1-1-2011; IN COMMERCE 4-1-2011.
GRETTA YAO, EXAMINING ATTORNEY

SN 85-442,459. MARK ZUNINO, WEST HOLLYWOOD, CA. FILED 10-7-2011.

MARK ZUNINO

THE MARK CONSISTS OF STANDARD CHARACTERS WITHOUT CLAIM TO ANY PARTICULAR FONT, STYLE, SIZE, OR COLOR.

OWNER OF U.S. REG. NOS. 4,044,814, 4,055,783 AND OTHERS.
THE NAME "MARK ZUNINO" IDENTIFIES A LIVING INDIVIDUAL WHOSE CONSENT IS OF RECORD.
FOR ENTERTAINMENT SERVICES, NAMELY, PERSONAL APPEARANCES BY A CELEBRITY FASHION DESIGNER, ACTING SERVICES IN THE NATURE OF VISUAL AND AUDIO PERFORMANCES BY AN ACTOR, AND APPEARANCES ON TELEVISION PROGRAMS BY A CELEBRITY FASHION DESIGNER (U.S. CLS. 100, 101 AND 107).
FIRST USE 1-1-1998; IN COMMERCE 1-1-2006.
LINDA LAVACHE, EXAMINING ATTORNEY

CLASS 41—(Continued).

SN 85-443,690. PLEET, LAWRENCE, MOUNTAIN CENTER, CA. FILED 10-10-2011.



THE MARK CONSISTS OF CARICATURE OF THREE MUSICIANS WITH INSTRUMENTS PERCHED ON A FLYING CARPET WHICH IS JUST ABOVE A WORLD GLOBE. FOR ENTERTAINMENT IN THE NATURE OF MUSICAL THEATER PRODUCTIONS (U.S. CLS. 100, 101 AND 107).

LINDA LAVACHE, EXAMINING ATTORNEY

SN 85-445,434. CITY OF ALBUQUERQUE CULTURAL SERVICES DEPARTMENT, DBA KIMO THEATRE, ALBUQUERQUE, NM. FILED 10-12-2011.



OWNER OF U.S. REG. NO. 3,351,131.
NO CLAIM IS MADE TO THE EXCLUSIVE RIGHT TO USE "THEATRE", APART FROM THE MARK AS SHOWN.
THE COLOR(S) WHITE AND BROWN IS/ARE CLAIMED AS A FEATURE OF THE MARK.

THE MARK CONSISTS OF THE WORDS "KIMO THEATRE" IN BROWN AND WHITE, WITH A 1/2 COW SKULL WITH ONE HORN IN WHITE AND BROWN, TO THE RIGHT OF THE WORDS.

THE ENGLISH TRANSLATION OF "KIMO" IN THE MARK IS "THE KING OF ITS KIND".

FOR CINEMA THEATERS (U.S. CLS. 100, 101 AND 107).

FIRST USE 9-1-2010; IN COMMERCE 9-1-2010.
TEJBIR SINGH, EXAMINING ATTORNEY

CLASS 41—(Continued).

SN 85-446,613. UNIVISION COMMUNICATIONS INC., LOS ANGELES, CA. FILED 10-13-2011.



NO CLAIM IS MADE TO THE EXCLUSIVE RIGHT TO USE "SOLO PARA HOMBRES", APART FROM THE MARK AS SHOWN.

THE MARK CONSISTS OF CONCENTRIC CIRCLES WITH THE OUTER CIRCLE APPEARING WITH A DARK OUTLINE AND CONTAINING THE WORDING "NOCHE DE PERROS", AND A SMALL DARK CIRCLE AT THE BEGINNING AND END OF THE WORDING "SOLO PARA HOMBRES", WHICH APPEARS IN DARK FONT WITH LIGHTER SHADOWS; THE CENTER OF CIRCLE CONTAINS A DOG.

THE ENGLISH TRANSLATION OF "NOCHE DE PERROS SOLO PARA HOMBRES" IN THE MARK IS "NIGHT OF DOGS ONLY FOR MEN".

FOR ENTERTAINMENT SERVICES, NAMELY, AN ONGOING LATE NIGHT TELEVISION TALK SHOW (U.S. CLS. 100, 101 AND 107).

HEATHER BIDDULPH, EXAMINING ATTORNEY

SN 85-446,895. SEVENSTAR ACADEMY, LLC, CINCINNATI, OH. FILED 10-13-2011.

SEVENSTAR

THE MARK CONSISTS OF STANDARD CHARACTERS WITHOUT CLAIM TO ANY PARTICULAR FONT, STYLE, SIZE, OR COLOR.

OWNER OF U.S. REG. NO. 3,770,489.
FOR EDUCATION SERVICES, NAMELY, PROVIDING LIVE AND ON-LINE COURSES IN THE FIELD OF CHRISTIAN EDUCATION (U.S. CLS. 100, 101 AND 107).

FIRST USE 7-16-2006; IN COMMERCE 7-16-2006.
DAVID TOOLEY, EXAMINING ATTORNEY

CLASS 41—(Continued).

SN 85-447,333. GONZALEZ, NICHOLAS, BROOKLYN, NY. FILED 10-14-2011.

SWEEPYTIMES

THE MARK CONSISTS OF STANDARD CHARACTERS WITHOUT CLAIM TO ANY PARTICULAR FONT, STYLE, SIZE, OR COLOR.

FOR ENTERTAINMENT SERVICES, NAMELY, PROVIDING A WEBSITE FEATURING FUNNY AND AMUSING ONLINE PICTURES OF ANYONE AND ANYTHING THAT HAS TO DO WITH SLEEPING (U.S. CLS. 100, 101 AND 107).

BRIDGETT SMITH, EXAMINING ATTORNEY

CLASS 41—(Continued).

SN 85-449,142. CHICAGO BAPTIST INSTITUTE, CHICAGO, IL. FILED 10-17-2011.

CHICAGO BAPTIST INSTITUTE

THE MARK CONSISTS OF STANDARD CHARACTERS WITHOUT CLAIM TO ANY PARTICULAR FONT, STYLE, SIZE, OR COLOR.

SEC. 2(F).
FOR EDUCATIONAL SERVICES, NAMELY, CONDUCTING CLASSES, SEMINARS, AND WORKSHOPS IN THE FIELD OF BIBLE STUDY (U.S. CLS. 100, 101 AND 107).

FIRST USE 0-0-1934; IN COMMERCE 0-0-1934.
MICHAEL WIENER, EXAMINING ATTORNEY

SN 85-449,151. CHICAGO BAPTIST INSTITUTE, CHICAGO, IL. FILED 10-17-2011.

CHICAGO BAPTIST INSTITUTE
INTERNATIONAL

SN 85-447,881. READY FOR SPANISH, LLC, JOELTON, TN. FILED 10-14-2011.

**READY FOR
SPANISH!**

THE COLOR(S) RED AND GREEN IS/ARE CLAIMED AS A FEATURE OF THE MARK.

THE MARK CONSISTS OF THE STYLIZED WORDING "READY FOR SPANISH!" IN RED LETTERS OUTLINED IN GREEN.

FOR EDUCATION SERVICES IN THE NATURE OF EARLY CHILDHOOD INSTRUCTION; EDUCATIONAL AND ENTERTAINMENT SERVICES FOR CHILDREN, NAMELY, PROVIDING INTERACTIVE PLAY AREAS, INSTRUCTIONAL CLASSES IN THE FIELD OF SPANISH AND OTHER FOREIGN LANGUAGES AND SOCIAL GATHERINGS FOR CHILDREN; EDUCATIONAL SERVICES, NAMELY, CONDUCTING INTERACTIVE SESSION, CONFERENCES, WORKSHOPS, SUMMER CAMPS, SEMINARS AND TRAINING IN THE FIELD OF SPANISH AND FOREIGN LANGUAGE EDUCATION; EDUCATIONAL SERVICES, NAMELY, DEVELOPING, ARRANGING, AND CONDUCTING EDUCATIONAL CONFERENCES AND PROGRAMS AND PROVIDING COURSES OF INSTRUCTION IN THE FIELD OF SPANISH AND FOREIGN LANGUAGE INSTRUCTION (U.S. CLS. 100, 101 AND 107).

FIRST USE 3-1-2010; IN COMMERCE 3-1-2010.
PATRICIA EVANKO, EXAMINING ATTORNEY

THE MARK CONSISTS OF STANDARD CHARACTERS WITHOUT CLAIM TO ANY PARTICULAR FONT, STYLE, SIZE, OR COLOR.

NO CLAIM IS MADE TO THE EXCLUSIVE RIGHT TO USE "INTERNATIONAL", APART FROM THE MARK AS SHOWN.

SEC. 2(F) AS TO "CHICAGO BAPTIST INSTITUTE".
FOR EDUCATIONAL SERVICES, NAMELY, CONDUCTING CLASSES, SEMINARS, AND WORKSHOPS IN THE FIELD OF BIBLE STUDY (U.S. CLS. 100, 101 AND 107).

FIRST USE 11-0-2011; IN COMMERCE 11-0-2011.
MICHAEL WIENER, EXAMINING ATTORNEY

SN 85-449,581. PIERRE-LOUIS, GIOVANNIE, AKA G/O, BROOKLYN, NY. FILED 10-18-2011.

G/O

THE MARK CONSISTS OF CAPITALIZED LETTER "G", A FORWARD SLASH AND CAPITALIZED LETTER "O".

FOR PUBLISHING OF BOOKS, E-BOOKS, AUDIO BOOKS, ILLUSTRATIONS (U.S. CLS. 100, 101 AND 107).

FIRST USE 8-12-2011; IN COMMERCE 8-21-2011.
INGA ERVIN, EXAMINING ATTORNEY

CLASS 41—(Continued).

SN 85-451,952. NATIONAL GROCERS ASSOCIATION, ARLINGTON, VA. FILED 10-20-2011.

EXPRESS LANE

THE MARK CONSISTS OF STANDARD CHARACTERS WITHOUT CLAIM TO ANY PARTICULAR FONT, STYLE, SIZE, OR COLOR.

FOR ONLINE PUBLICATIONS, NAMELY, NEWSLETTERS IN THE FIELD OF RETAIL AND WHOLESALE FOOD INDUSTRY (U.S. CLS. 100, 101 AND 107).

FIRST USE 3-0-2000; IN COMMERCE 3-0-2000.

DEZMONA MIZELLE, EXAMINING ATTORNEY

SN 85-452,817. RG MEDIA ENTERPRISES INC., MISSISSAUGA, ONTARIO, CANADA, FILED 10-21-2011.

OPEN CHEST

THE MARK CONSISTS OF STANDARD CHARACTERS WITHOUT CLAIM TO ANY PARTICULAR FONT, STYLE, SIZE, OR COLOR.

FOR (BASED ON USE IN COMMERCE) ENTERTAINMENT SERVICES, NAMELY, PROVIDING A WEB SITE FEATURING PHOTOGRAPHIC, AUDIO, VIDEO AND PROSE PRESENTATIONS FEATURING CELEBRITIES, ENTERTAINMENT NEWS, AND ENTERTAINMENT EVENTS OF INTEREST TO ALL DEMOGRAPHIC GROUPS; (BASED ON INTENT TO USE) EDUCATIONAL AND ENTERTAINMENT SERVICES, NAMELY, A CONTINUING PROGRAM ABOUT CELEBRITIES, NEWS, AND EVENTS OF INTEREST TO ALL DEMOGRAPHIC GROUPS ACCESSIBLE BY RADIO, TELEVISION, SATELLITE, AUDIO, VIDEO AND COMPUTER NETWORKS (U.S. CLS. 100, 101 AND 107).

FIRST USE 9-0-2008; IN COMMERCE 9-0-2008.

JOHN GARTNER, EXAMINING ATTORNEY

CLASS 41—(Continued).

SN 85-453,792. MILLER, NATALIE, TOLUCA LAKE, CA. FILED 10-22-2011.

REALNESS

THE MARK CONSISTS OF STANDARD CHARACTERS WITHOUT CLAIM TO ANY PARTICULAR FONT, STYLE, SIZE, OR COLOR.

FOR ENTERTAINMENT, NAMELY, PERSONAL APPEARANCES BY AN ENTERTAINER, TELEVISION PERSONALITY, TELEVISION CELEBRITY, AND MODEL; ENTERTAINMENT SERVICES, NAMELY, LIVE, TELEVISED AND MOVIE APPEARANCES BY A PROFESSIONAL ENTERTAINER; ENTERTAINMENT, NAMELY, TELEVISION SHOW PRODUCTION; TELEVISION AND CABLE TELEVISION SHOW PRODUCTION; ENTERTAINMENT IN THE NATURE OF ON-GOING TELEVISION AND CABLE TELEVISION PROGRAMS FEATURING MUSIC, COMEDY, DRAMA, FASHION SHOWS, AND FEATURING EXHIBITIONS, COMPETITIONS AND SPOKEN WORD RELATING TO MUSIC, COMEDY, DRAMA AND FASHION SHOWS; ENTERTAINMENT SERVICES, NAMELY, PROVIDING ON-GOING TELEVISION AND CABLE TELEVISION PROGRAMS FEATURING MUSIC, COMEDY, DRAMA, FASHION SHOWS, AND FEATURING EXHIBITIONS, COMPETITIONS AND SPOKEN WORD RELATING TO MUSIC, COMEDY, DRAMA AND FASHION SHOWS; ENTERTAINMENT IN THE NATURE OF ON-GOING TELEVISION AND CABLE TELEVISION REALITY BASED SHOWS AND PROGRAMS (U.S. CLS. 100, 101 AND 107).

CHRISTOPHER SIDOTI, EXAMINING ATTORNEY

SN 85-454,375. NATIONAL ASSOCIATION OF CONVENIENCE STORES, ALEXANDRIA, VA. FILED 10-24-2011.

**NACS STATE OF THE INDUSTRY
SUMMIT**

THE MARK CONSISTS OF STANDARD CHARACTERS WITHOUT CLAIM TO ANY PARTICULAR FONT, STYLE, SIZE, OR COLOR.

OWNER OF U.S. REG. NOS. 2,868,952, 3,006,928 AND OTHERS.

NO CLAIM IS MADE TO THE EXCLUSIVE RIGHT TO USE "SUMMIT", APART FROM THE MARK AS SHOWN. SEC. 2(F).

FOR EDUCATIONAL SERVICES, NAMELY, CONDUCTING CLASSES, SEMINARS, CONFERENCES, WORKSHOPS IN THE FIELD OF THE CONVENIENCE STORE INDUSTRY AND DISTRIBUTION OF EDUCATIONAL MATERIALS IN CONNECTION THEREWITH (U.S. CLS. 100, 101 AND 107).

FIRST USE 4-0-2002; IN COMMERCE 4-0-2002.

CAROLINE WOOD, EXAMINING ATTORNEY

CLASS 41—(Continued).

SN 85-454,825. CONTAGIOUS CHANGE, LLC, MESA, AZ. FILED 10-24-2011.

CONTAGIOUS CHANGE

THE MARK CONSISTS OF STANDARD CHARACTERS WITHOUT CLAIM TO ANY PARTICULAR FONT, STYLE, SIZE, OR COLOR.

FOR EDUCATIONAL SERVICES, NAMELY, CONDUCTING CLASSES, SEMINARS, CONFERENCES, WORKSHOPS IN THE FIELD OF ORGANIZATIONAL EXCELLENCE, ORGANIZATIONAL LEARNING, ORGANIZATIONAL CHANGE AND DEVELOPMENT, PERFORMANCE IMPROVEMENT, RISK REDUCTION STRATEGIES AND EXECUTION, CHANGE MANAGEMENT, BUSINESS ORGANIZATIONAL DESIGN, INNOVATION AND GROWTH PROCESSES, ORGANIZATIONAL TRANSFORMATION, TALENT MANAGEMENT, STRATEGIES DEVELOPMENT, EXECUTIVE TEAM DEVELOPMENT, CORPORATE GROWTH ANALYSIS, DESIGN AND EXECUTION OF BUSINESS PERFORMANCE IMPROVEMENT METHODOLOGIES, AND DISTRIBUTION OF TRAINING MATERIAL IN CONNECTION THEREWITH (U.S. CLS. 100, 101 AND 107).

FIRST USE 8-0-2010; IN COMMERCE 8-0-2010.
LOURDES AYALA, EXAMINING ATTORNEY

SN 85-454,841. CONTAGIOUS CHANGE, LLC, MESA, AZ. FILED 10-24-2011.



THE MARK CONSISTS OF THE WORDING "CONTAGIOUS CHANGE" WITH A TRIANGLE AND INFINITY SYMBOL BEHIND THE TRIANGLE, ALONG SIDE THE STACKED WORDS "CONTAGIOUS" AND "CHANGE".

FOR EDUCATIONAL SERVICES, NAMELY, CONDUCTING CLASSES, SEMINARS, CONFERENCES, WORKSHOPS IN THE FIELD OF ORGANIZATIONAL EXCELLENCE, ORGANIZATIONAL LEARNING, ORGANIZATIONAL CHANGE AND DEVELOPMENT, PERFORMANCE IMPROVEMENT, RISK REDUCTION STRATEGIES AND EXECUTION, CHANGE MANAGEMENT, BUSINESS ORGANIZATIONAL DESIGN, INNOVATION AND GROWTH PROCESSES, ORGANIZATIONAL TRANSFORMATION, TALENT MANAGEMENT, STRATEGIES DEVELOPMENT, EXECUTIVE TEAM DEVELOPMENT, CORPORATE GROWTH ANALYSIS, DESIGN AND EXECUTION OF BUSINESS PERFORMANCE IMPROVEMENT METHODOLOGIES, AND DISTRIBUTION OF TRAINING MATERIAL IN CONNECTION THEREWITH (U.S. CLS. 100, 101 AND 107).

FIRST USE 8-0-2010; IN COMMERCE 8-0-2010.
LOURDES AYALA, EXAMINING ATTORNEY

CLASS 41—(Continued).

SN 85-455,040. CAHILL, JOHN D, NEW HAVEN, CT. FILED 10-24-2011.

THE BRAIN ROOM

THE MARK CONSISTS OF STANDARD CHARACTERS WITHOUT CLAIM TO ANY PARTICULAR FONT, STYLE, SIZE, OR COLOR.

OWNER OF U.S. REG. NO. 3,952,484.

FOR AUDIO RECORDING AND PRODUCTION; CONSULTATION AND ADVICE REGARDING MUSICAL SELECTIONS AND ARRANGEMENTS FOR SOUND RECORDINGS AND LIVE PERFORMANCES; EDUCATIONAL SERVICES, NAMELY, CONDUCTING WORKSHOPS IN THE FIELDS OF MUSIC, THE ARTS, PHILOSOPHY AND THE PSYCHE AND DISTRIBUTION OF TRAINING MATERIALS IN CONNECTION THEREWITH; ENTERTAINMENT IN THE NATURE OF LIVE PERFORMANCES BY MUSICIANS; ENTERTAINMENT IN THE NATURE OF VISUAL AND AUDIO PERFORMANCES, AND MUSICAL, VARIETY, NEWS AND COMEDY SHOWS; ENTERTAINMENT INFORMATION SERVICES, NAMELY, PROVIDING INFORMATION AND NEWS RELEASES ABOUT A MUSICAL ARTIST; ENTERTAINMENT SERVICES BY A MUSICAL ARTIST AND PRODUCER, NAMELY, MUSICAL COMPOSITION FOR OTHERS AND PRODUCTION OF MUSICAL SOUND RECORDINGS; ENTERTAINMENT SERVICES IN THE NATURE OF LIVE MUSICAL PERFORMANCES; ENTERTAINMENT SERVICES, NAMELY, MULTIMEDIA PRODUCTION SERVICES; ENTERTAINMENT SERVICES, NAMELY, PERSONAL APPEARANCES BY A MUSICIAN; ENTERTAINMENT SERVICES, NAMELY, PROVIDING A WEB SITE FEATURING PHOTOGRAPHIC, AUDIO, VIDEO AND PROSE PRESENTATIONS FEATURING MUSIC, THE ARTS AND PHILOSOPHY; ENTERTAINMENT SERVICES, NAMELY, PROVIDING NON-DOWNLOADABLE PLAYBACK OF MUSIC VIA GLOBAL COMMUNICATIONS NETWORKS; ENTERTAINMENT SERVICES, NAMELY, PROVIDING NON-DOWNLOADABLE PRERECORDED MUSIC, INFORMATION IN THE FIELD OF MUSIC, AND COMMENTARY AND ARTICLES ABOUT MUSIC, ALL ON-LINE VIA A GLOBAL COMPUTER NETWORK; ENTERTAINMENT SERVICES, NAMELY, PROVIDING VIRTUAL ENVIRONMENTS IN WHICH USERS CAN INTERACT FOR RECREATIONAL, LEISURE OR ENTERTAINMENT PURPOSES; ENTERTAINMENT SERVICES, NAMELY, PROVIDING WEBCASTS IN THE FIELD OF MUSIC, THE ARTS, PHILOSOPHY AND THE PSYCHE; FAN CLUBS; PROVIDING A WEB SITE WHERE USERS CAN POST RATINGS, REVIEWS AND RECOMMENDATIONS ON EVENTS AND ACTIVITIES IN THE FIELD OF ENTERTAINMENT AND EDUCATION; PROVIDING A WEBSITE FOR ENTERTAINMENT PURPOSES WHERE USERS CAN VIEW AND POST PROSE, PHOTOGRAPHIC, AUDIO AND VIDEO PRESENTATIONS FEATURING MUSIC, THE ARTS AND PHILOSOPHY; PROVIDING AN INTERNET WEBSITE PORTAL FEATURING LINKS TO MUSICAL ARTIST WEBSITES AND MUSIC PERFORMANCE TICKET INFORMATION; PROVIDING AN ON-LINE PUBLICATION IN THE NATURE OF AN INTERACTIVE ENCYCLOPEDIA IN THE FIELD OF MUSIC, THE ARTS, PHILOSOPHY AND THE PSYCHE (U.S. CLS. 100, 101 AND 107).

TINA MAI, EXAMINING ATTORNEY

CLASS 41—(Continued).

SN 85-456,015. ALEMAN, LUZ MARIA, LANSING, IL. FILED 10-25-2011.



THE MARK CONSISTS OF THE STYLIZED TEXT "CORCEL NEGRO" WITH TWO HORIZONTAL LINES ABOVE THE TEXT AND TWO HORIZONTAL LINES BELOW THE TEXT. TO THE LEFT IS AN IMAGE OF A HORSE STANDING ON TWO LEGS.

THE ENGLISH TRANSLATION OF "CORCEL NEGRO" IN THE MARK IS "BLACK STEED".

FOR ENTERTAINMENT SERVICES IN THE NATURE OF LIVE MUSICAL PERFORMANCES (U.S. CLS. 100, 101 AND 107).

KATHY DE JONGE, EXAMINING ATTORNEY

CLASS 41—(Continued).

SN 85-459,286. JING SI PUBLICATIONS CO., LTD., TAIPEI, TAIWAN, FILED 10-28-2011.

Jing Si Aphorisms

THE MARK CONSISTS OF STANDARD CHARACTERS WITHOUT CLAIM TO ANY PARTICULAR FONT, STYLE, SIZE, OR COLOR.

NO CLAIM IS MADE TO THE EXCLUSIVE RIGHT TO USE "APHORISMS", APART FROM THE MARK AS SHOWN.

THE ENGLISH TRANSLATION OF "JING SI" IS "A SPIRITUAL STATE OF UTTER TRANQUILITY, STILLNESS AND PURITY".

FOR EDUCATIONAL SERVICES, NAMELY, CLASSES, SEMINARS AND WORKSHOPS IN THE FIELDS OF NURSING, MEDICINE, PUBLIC HEALTH, MEDICINE, ENGINEERING, LIBERAL ARTS, BUSINESS MANAGEMENT, RELIGION AND FINE ARTS; PUBLICATION OF BOOKS OR MAGAZINES (U.S. CLS. 100, 101 AND 107).

ELISSA GARBER KON, EXAMINING ATTORNEY

SN 85-459,629. ROSE, WALLACE, HENDERSON, NV. FILED 10-29-2011.

REAL TIME CARICATURE CINEMA

THE MARK CONSISTS OF STANDARD CHARACTERS WITHOUT CLAIM TO ANY PARTICULAR FONT, STYLE, SIZE, OR COLOR.

NO CLAIM IS MADE TO THE EXCLUSIVE RIGHT TO USE "REAL TIME CARICATURE", APART FROM THE MARK AS SHOWN.

FOR DRAWING AND PAINTING PORTRAITS TO THE ORDER AND SPECIFICATION OF OTHERS IN PERSON AND VIA THE INTERNET AND GLOBAL COMPUTER NETWORKS (U.S. CLS. 100, 101 AND 107).

ALICE BENMAMAN, EXAMINING ATTORNEY

SN 85-457,472. HUDSON ANALYTIX, INC., CAMDEN, NJ. FILED 10-27-2011.



SN 85-459,729. CAMP TECHNIQUE, INC., LOS ANGELES, CA. FILED 10-29-2011.

Live in Fitness Enterprise

NO CLAIM IS MADE TO THE EXCLUSIVE RIGHT TO USE "MARITIME TRAINING PROGRAMS", APART FROM THE MARK AS SHOWN.

THE COLOR(S) AQUA BLUE AND BLACK IS/ARE CLAIMED AS A FEATURE OF THE MARK.

THE MARK CONSISTS OF A GRAPHICAL ELEMENT HAVING A REPRESENTATION OF WAVES SUPERIMPOSED OVER AN OVAL, ALL RENDERED IN AQUA BLUE, WITH THE LITERAL ELEMENT OF THE MARK, RENDERED IN BLACK, DISPOSED TO THE RIGHT OF THE GRAPHICAL ELEMENT.

FOR TRAINING IN THE FIELD OF MARITIME OPERATIONS, MANAGEMENT AND SUPPORT VIA CLASSES AND SEMINARS (U.S. CLS. 100, 101 AND 107).

FIRST USE 11-1-2010; IN COMMERCE 11-1-2010.

JACQUELINE A. LAVINE, EXAMINING ATTORNEY

THE MARK CONSISTS OF STANDARD CHARACTERS WITHOUT CLAIM TO ANY PARTICULAR FONT, STYLE, SIZE, OR COLOR.

NO CLAIM IS MADE TO THE EXCLUSIVE RIGHT TO USE "FITNESS ENTERPRISE", APART FROM THE MARK AS SHOWN.

FOR PHYSICAL FITNESS INSTRUCTION; PERSONAL TRAINING PROVIDED IN CONNECTION WITH WEIGHT LOSS AND EXERCISE PROGRAMS (U.S. CLS. 100, 101 AND 107).

FIRST USE 7-1-1997; IN COMMERCE 7-1-1997.

LINDSEY RUBIN, EXAMINING ATTORNEY

CLASS 41—(Continued).

SN 85-459,806. GEFEN, FREDERICK, WOODMERE, NY. FILED 10-30-2011.

SMOKIN' HOTTIES

THE MARK CONSISTS OF STANDARD CHARACTERS WITHOUT CLAIM TO ANY PARTICULAR FONT, STYLE, SIZE, OR COLOR.

FOR ENTERTAINMENT IN THE NATURE OF AN ONGOING SPECIAL VARIETY, NEWS, MUSIC OR COMEDY SHOW FEATURING A PERSONALITY, BEAUTY AND INTELLIGENCE COMPETITION BROADCAST OVER TELEVISION, SATELLITE, AUDIO, AND VIDEO MEDIA (U.S. CLS. 100, 101 AND 107).

HOWARD B. LEVINE, EXAMINING ATTORNEY

CLASS 41—(Continued).

SN 85-463,501. YOLO BOARD, LLC, SANTA ROSA BEACH, FL. FILED 11-3-2011.

YOLO ADVENTURES

THE MARK CONSISTS OF STANDARD CHARACTERS WITHOUT CLAIM TO ANY PARTICULAR FONT, STYLE, SIZE, OR COLOR.

OWNER OF U.S. REG. NOS. 3,473,154 AND 3,596,410. NO CLAIM IS MADE TO THE EXCLUSIVE RIGHT TO USE "ADVENTURES", APART FROM THE MARK AS SHOWN.

FOR ARRANGING AND CONDUCTING ATHLETIC COMPETITIONS; ARRANGING AND CONDUCTING SPECIAL EVENTS FOR SOCIAL ENTERTAINMENT PURPOSES; CONDUCTING FITNESS CLASSES; EDUCATION SERVICES, NAMELY, PROVIDING LESSONS IN THE FIELD OF BOARD SPORTS AND FITNESS; RENTAL OF SPORTS EQUIPMENT; RENTAL OF SURF BOARDS; SPORT CAMPS; SPORTS CAMP SERVICES (U.S. CLS. 100, 101 AND 107).

FIRST USE 3-1-2010; IN COMMERCE 3-1-2010. WON TEAK OH, EXAMINING ATTORNEY

SN 85-462,164. BE FREE WEALTHY AND HEALTHY LLC, HAMPTON, NJ. FILED 11-2-2011.



SN 85-464,179. CHOCOLATE SUNDAES, LOS ANGELES, CA. FILED 11-3-2011.

CHOCOLATE SUNDAES COMEDY SHOW LIVE ON SUNSET STRIP

NO CLAIM IS MADE TO THE EXCLUSIVE RIGHT TO USE "HOLISTIC LIFE COACHING", APART FROM THE MARK AS SHOWN.

THE COLOR(S) BLACK, PINK, GREEN AND WHITE IS/ ARE CLAIMED AS A FEATURE OF THE MARK.

THE MARK CONSISTS OF TWO GREEN TRIANGLES WITH A WHITE INTERIOR TRIANGLE BETWEEN THEM AND A WHITE BACKGROUND. THERE IS A PINK HEART WITHIN THE TRIANGLE AND THE WORDS "MIND", "BODY" AND "SPIRIT" WRITTEN BLACK IN EACH CORNER OF THE TRIANGLE. THE WORDS "HOLISTIC LIFE COACHING" ARE WRITTEN IN BLACK ON TOP OF THE PINK HEART.

FOR PERSONAL COACHING SERVICES IN THE FIELD OF PERSONAL AND PROFESSIONAL DEVELOPMENT (U.S. CLS. 100, 101 AND 107).

FRANK LATTUCA, EXAMINING ATTORNEY

THE MARK CONSISTS OF STANDARD CHARACTERS WITHOUT CLAIM TO ANY PARTICULAR FONT, STYLE, SIZE, OR COLOR.

OWNER OF U.S. REG. NO. 2,924,214. NO CLAIM IS MADE TO THE EXCLUSIVE RIGHT TO USE "COMEDY SHOW LIVE ON SUNSET STRIP", APART FROM THE MARK AS SHOWN.

FOR ENTERTAINMENT SERVICES IN THE NATURE OF COMEDY SHOWS (U.S. CLS. 100, 101 AND 107).

JENNIFER WILLISTON, EXAMINING ATTORNEY

CLASS 41—(Continued).

SN 85-465,046. MARKETRON INTERNATIONAL, LLC, HALEY, ID. FILED 11-4-2011.



OWNER OF U.S. REG. NO. 2,859,976.
THE MARK CONSISTS OF FOUR ADJOINED LETTER "M"'S FORMING A CIRCLE AND CONTAINED INSIDE A GRAPHIC OF A CIRCLE.
FOR COMPUTER EDUCATION TRAINING SERVICES (U.S. CLS. 100, 101 AND 107).
FIRST USE 9-7-2010; IN COMMERCE 9-7-2010.
ALYSSA STEEL, EXAMINING ATTORNEY

SN 85-466,549. ZILLOW, INC., SEATTLE, WA. FILED 11-7-2011.



THE MARK CONSISTS OF A STYLIZED REPRESENTATION OF AN UPRIGHT MAN, WITH THE ARMS AND LEGS REPRESENTED BY CURVED LINES. TO THE RIGHT OF THE STYLIZED MAN IS A CURVED LINE THAT EXTENDS FROM THE "FEET" TO THE "HEAD" OF THE CURVED MAN.

FOR PROVIDING INFORMATION ABOUT PARKS, HISTORICAL SITES, AQUARIUMS, ZOOS, GARDENS, BOTANICAL GARDENS, LIBRARIES, AND SCHOOLS VIA THE INTERNET FOR EDUCATION AND ENTERTAINMENT PURPOSES (U.S. CLS. 100, 101 AND 107).
FIRST USE 11-30-2005; IN COMMERCE 11-30-2005.
PRISCILLA MILTON, EXAMINING ATTORNEY

CLASS 41—(Continued).

SN 85-468,648. NELDA C. AND H.J. LUTCHER STARK FOUNDATION, ORANGE, TX. FILED 11-9-2011.

LUTCHER THEATER

THE MARK CONSISTS OF STANDARD CHARACTERS WITHOUT CLAIM TO ANY PARTICULAR FONT, STYLE, SIZE, OR COLOR.

NO CLAIM IS MADE TO THE EXCLUSIVE RIGHT TO USE "THEATER", APART FROM THE MARK AS SHOWN. SEC. 2(F).

FOR PERFORMING ARTS CENTER (U.S. CLS. 100, 101 AND 107).

FIRST USE 2-0-1980; IN COMMERCE 2-0-1980.
LAURIE KAUFMAN, EXAMINING ATTORNEY

SN 85-470,375. THE ENTREPRENEUR'S SOURCE, INC., SOUTHURY, CT. FILED 11-11-2011.

ZEEPREENEUR

THE MARK CONSISTS OF STANDARD CHARACTERS WITHOUT CLAIM TO ANY PARTICULAR FONT, STYLE, SIZE, OR COLOR.

FOR EDUCATIONAL SERVICES, NAMELY, CONDUCTING TRAINING IN THE FIELDS OF BUSINESS COACHING, BUSINESS DEVELOPMENT, MARKETING, FRANCHISEE/FRANCHISOR RELATIONSHIPS AND RESPONSIBILITIES, AND PROVIDING INSTRUCTIONAL MATERIALS IN CONNECTION THEREWITH (U.S. CLS. 100, 101 AND 107).

KAREN SEVERSON, EXAMINING ATTORNEY

SN 85-471,067. WITHOUT LIMITS PRODUCTIONS, INC., HENDERSON, NV. FILED 11-12-2011.



NO CLAIM IS MADE TO THE EXCLUSIVE RIGHT TO USE "MORGUL BISMARK ROAD RACE", APART FROM THE MARK AS SHOWN.

THE MARK CONSISTS OF STYLIZED LETTERING OF THE FOLLOWING FOUR WORDS: "MORGUL BISMARK ROAD RACE" WITH A MOUNTAIN RANGE IN THE BACKGROUND AND THREE CYCLISTS RIDING SIDE BY SIDE ON A SWOOPING ROAD.

FOR ORGANIZING, ARRANGING, AND CONDUCTING CYCLING AND ROAD RACING EVENTS (U.S. CLS. 100, 101 AND 107).

AISHA CLARKE, EXAMINING ATTORNEY

CLASS 41—(Continued).

SN 85-471,807. BEGINNER TRIATHLETE, LLC, AKRON, OH. FILED 11-14-2011.

Beginner Triathlete

THE MARK CONSISTS OF STANDARD CHARACTERS WITHOUT CLAIM TO ANY PARTICULAR FONT, STYLE, SIZE, OR COLOR.

SEC. 2(F).
FOR PROVIDING ONLINE INFORMATION AND NON-DOWNLOADABLE VIDEOS IN THE FIELD OF TRIATHLONS AND TRIATHLON TRAINING (U.S. CLS. 100, 101 AND 107).

FIRST USE 6-13-2003; IN COMMERCE 6-13-2003.
JOHN GARTNER, EXAMINING ATTORNEY

SN 85-473,065. ARBITRON INC., COLUMBIA, MD. FILED 11-15-2011.

ARB-TV

THE MARK CONSISTS OF STANDARD CHARACTERS WITHOUT CLAIM TO ANY PARTICULAR FONT, STYLE, SIZE, OR COLOR.

FOR PROVIDING NON-DOWNLOADABLE ON-LINE AND ELECTRONIC PUBLICATIONS IN THE NATURE OF MARKET RESEARCH REPORTS AND STUDIES IN THE FIELDS OF ANALYZING TELEVISION VIEWING, ANALYZING TELEVISION ADVERTISING AND MARKETING, TELEVISION AUDIENCE PARTICIPATION RESEARCH, AUDIENCE MEASUREMENT, AUDIENCE EXPOSURE OR MEASUREMENT TO COMMERCIAL ANNOUNCEMENTS, AUDIENCE RATINGS, PUBLIC OPINION, MEDIA EXPOSURE MEASUREMENT, MARKET RESEARCH, MARKET SURVEYS, BUSINESS RESEARCH, DEMOGRAPHICS, GEOGRAPHICS, CONSUMER BEHAVIOR AND CONSUMER TRENDS (U.S. CLS. 100, 101 AND 107).

FIRST USE 6-23-2009; IN COMMERCE 6-23-2009.
MICHAEL TANNER, EXAMINING ATTORNEY

CLASS 41—(Continued).

SN 85-473,114. DANIEL MEHTA, DBA DAN MEHTA, SHERMAN OAKS, CA. FILED 11-15-2011.



THE NAME "DAN MEHTA" IDENTIFIES A LIVING INDIVIDUAL WHOSE CONSENT IS OF RECORD.

THE MARK CONSISTS OF A LOGO OF A CREST SHAPE MADE WITH BIRDS ABOVE THE NAME "DAN MEHTA".

FOR CHARITABLE SERVICES, NAMELY, PROVIDING MUSICAL INSTRUMENTS TO THOSE IN NEED; COMPOSITION OF MUSIC FOR OTHERS; CONSULTATION AND ADVICE REGARDING MUSICAL SELECTIONS AND ARRANGEMENTS FOR SOUND RECORDINGS AND LIVE PERFORMANCES; EDUCATIONAL SERVICES, NAMELY, CONDUCTING WORKSHOPS IN THE FIELD OF BLACK MUSIC; ENTERTAINMENT IN THE NATURE OF VISUAL AND AUDIO PERFORMANCES, AND MUSICAL, VARIETY, NEWS AND COMEDY SHOWS; ENTERTAINMENT IN THE NATURE OF VISUAL AND AUDIO PERFORMANCES, NAMELY, MUSICAL BAND, ROCK GROUP, GYMNASTIC, DANCE, AND BALLET PERFORMANCES; ENTERTAINMENT INFORMATION SERVICES, NAMELY, PROVIDING INFORMATION AND NEWS RELEASES ABOUT A MUSICAL ARTIST; ENTERTAINMENT SERVICES BY A MUSICAL ARTIST AND PRODUCER, NAMELY, MUSICAL COMPOSITION FOR OTHERS AND PRODUCTION OF MUSICAL SOUND RECORDINGS; ENTERTAINMENT SERVICES IN THE NATURE OF LIVE MUSICAL PERFORMANCES; ENTERTAINMENT SERVICES IN THE NATURE OF PRESENTING LIVE MUSICAL PERFORMANCES; ENTERTAINMENT SERVICES IN THE NATURE OF RECORDING, PRODUCTION AND POST-PRODUCTION SERVICES IN THE FIELD OF MUSIC; ENTERTAINMENT SERVICES, NAMELY, AN ON-LINE ACTIVITY WHERE YOU CREATE YOUR OWN MUSIC VIDEOS; ENTERTAINMENT SERVICES, NAMELY, NON-DOWNLOADABLE RINGTONES, PRE-RECORDED MUSIC, AND GRAPHICS PRESENTED TO MOBILE COMMUNICATIONS DEVICES VIA A GLOBAL COMPUTER NETWORK AND WIRELESS NETWORKS; ENTERTAINMENT SERVICES, NAMELY, PROVIDING ADVICE AND INFORMATION FOR MUSIC, VIDEO AND FILM CONCEPT AND SCRIPT DEVELOPMENT; ENTERTAINMENT SERVICES, NAMELY, PROVIDING NON-DOWNLOADABLE PLAYBACK OF MUSIC VIA GLOBAL COMMUNICATIONS NETWORKS; ENTERTAINMENT SERVICES, NAMELY, PROVIDING NON-DOWNLOADABLE PRERECORDED MUSIC, INFORMATION IN THE FIELD OF MUSIC, AND COMMENTARY AND ARTICLES ABOUT MUSIC, ALL ON-LINE VIA A GLOBAL COMPUTER NETWORK; ENTERTAINMENT SERVICES, NAMELY, THE PRESENTATION OF LIVE CHRISTMAS MUSICAL PRODUCTIONS; ENTERTAINMENT, NAMELY, LIVE MUSIC CONCERTS; ENTERTAINMENT, NAMELY, LIVE PERFORMANCES BY A MUSICAL BAND; ENTERTAINMENT, NAMELY, LIVE PERFORMANCES BY MUSICAL BANDS; HOSTING A BACK TO SCHOOL EVENT IN A SHOPPING CENTER FEATURING PRIZES, GAMES, MUSIC, AND A FASHION SHOW; LIVE PERFORMANCES BY A MUSICAL GROUP; MULTIMEDIA ENTERTAINMENT SERVICES IN THE NATURE OF RECORDING, PRODUCTION AND POST-PRODUCTION SERVICES IN THE FIELDS OF MUSIC, VIDEO, AND FILMS; MULTIMEDIA PUBLISH-

CLASS 41—(Continued).

ING OF BOOKS, MAGAZINES, JOURNALS, SOFTWARE, GAMES, MUSIC, AND ELECTRONIC PUBLICATIONS; MUSIC COMPOSITION AND TRANSCRIPTION FOR OTHERS; MUSIC COMPOSITION FOR OTHERS; MUSIC COMPOSITION SERVICES; MUSIC PRODUCTION SERVICES; MUSIC PUBLISHING SERVICES; MUSIC SELECTION SERVICES FOR USE IN TELEVISION, FILM, RADIO AND VIDEO GAMES; MUSIC TRANSCRIPTION FOR OTHERS; MUSIC VIDEO PRODUCTION; MUSICALS; MUSICAL EVENT BOOKING AGENCIES; ORGANIZATION OF EXHIBITIONS FOR MUSICAL ENTERTAINMENT; PLANNING ARRANGEMENT OF SHOWING MOVIES, SHOWS, PLAYS OR MUSICAL PERFORMANCES; POST-PRODUCTION EDITING SERVICES IN THE FIELD OF MUSIC, VIDEOS AND FILM; PRESENTATION OF MUSICAL PERFORMANCE; PRODUCTION OF MUSICAL SOUND RECORDING; PRODUCTION OF MUSICAL VIDEOS; PRODUCTION OF SOUND AND MUSIC VIDEO RECORDINGS; PROVIDING A WEBSITE FEATURING INFORMATION IN THE FIELD OF MUSIC AND ENTERTAINMENT; PROVIDING RATINGS FOR TELEVISION, MOVIE, MUSIC, VIDEO AND VIDEO GAME CONTENT; PROVISION OF INFORMATION RELATING TO MUSIC; PUBLICATION OF MUSICAL TEXTS; PUBLISHING OF BOOKS, E-BOOKS, AUDIO BOOKS, MUSIC AND ILLUSTRATIONS (U.S. CLS. 100, 101 AND 107).
 NAKIA HENRY, EXAMINING ATTORNEY

SN 85-473,390. ASSOCIATION OF AMERICAN MEDICAL COLLEGES, WASHINGTON, DC. FILED 11-15-2011.

MCAT THX

THE MARK CONSISTS OF STANDARD CHARACTERS WITHOUT CLAIM TO ANY PARTICULAR FONT, STYLE, SIZE, OR COLOR.
 OWNER OF U.S. REG. NOS. 1,946,740, 3,869,169 AND OTHERS.
 FOR PROVIDING AN ON-LINE DATABASE FEATURING MEDICAL COLLEGE ENTRANCE EXAMINATION RESULTS AND HISTORICAL TESTING DATA RELATED THERETO (U.S. CLS. 100, 101 AND 107).
 FIRST USE 3-0-2007; IN COMMERCE 3-0-2007.
 MICHAEL TANNER, EXAMINING ATTORNEY

CLASS 41—(Continued).

SN 85-473,464. SAGE PUBLICATIONS, INC., THOUSAND OAKS, CA. FILED 11-15-2011.

SAGE KNOWLEDGE

THE MARK CONSISTS OF STANDARD CHARACTERS WITHOUT CLAIM TO ANY PARTICULAR FONT, STYLE, SIZE, OR COLOR.

OWNER OF U.S. REG. NO. 3,222,063.
 NO CLAIM IS MADE TO THE EXCLUSIVE RIGHT TO USE "KNOWLEDGE", APART FROM THE MARK AS SHOWN.

FOR PROVIDING ONLINE PUBLICATIONS IN THE NATURE OF BOOKS AND DOCUMENTS FEATURING SCHOLARLY INFORMATION, ACADEMIC INFORMATION, POLITICAL INFORMATION, PROFESSIONAL INFORMATION, MEDICAL INFORMATION, SCIENTIFIC INFORMATION AND TECHNICAL RESEARCH INFORMATION INCLUDING EDUCATIONAL INFORMATION IN THE FIELDS OF ACADEMICS, POLITICAL SCIENCE, MEDICINE, BUSINESS, SOCIOLOGY, HISTORY, COMMUNICATIONS AND SCIENCE VIA GLOBAL COMPUTER NETWORKS; PUBLISHING SERVICES, NAMELY, PUBLISHING OF BOOKS, JOURNALS, MAGAZINES, NEWSLETTERS, CATALOGUES, AND DOCUMENTS; MULTI-MEDIA PUBLISHING OF BOOKS, MAGAZINES, JOURNALS, SOFTWARE, AND ELECTRONIC PUBLICATIONS (U.S. CLS. 100, 101 AND 107).
 DEZMONA MIZELLE, EXAMINING ATTORNEY

SN 85-474,815. O'NEIL, FRANCES T., DBA FOODRX, SANTA ANA, CA. FILED 11-17-2011.

FoodRx

THE MARK CONSISTS OF STANDARD CHARACTERS WITHOUT CLAIM TO ANY PARTICULAR FONT, STYLE, SIZE, OR COLOR.
 FOR EDUCATIONAL SERVICES, NAMELY, CONDUCTING CLASSES IN THE FIELD OF COOKING HEALTHY WITH A RICE COOKER AND DISTRIBUTION OF EDUCATIONAL MATERIALS IN CONNECTION THEREWITH (U.S. CLS. 100, 101 AND 107).
 FIRST USE 11-6-2011; IN COMMERCE 11-6-2011.
 MICHELE SWAIN, EXAMINING ATTORNEY

CLASS 41—(Continued).

SN 85-474,914. COOPERSTOWN PROPERTIES, L.L.C., SALISBURY, NC. FILED 11-17-2011.

DREAMS PARK

THE MARK CONSISTS OF STANDARD CHARACTERS WITHOUT CLAIM TO ANY PARTICULAR FONT, STYLE, SIZE, OR COLOR.

OWNER OF U.S. REG. NOS. 2,265,952, 2,904,777 AND 2,996,945.

NO CLAIM IS MADE TO THE EXCLUSIVE RIGHT TO USE "PARK", APART FROM THE MARK AS SHOWN.

FOR ORGANIZING YOUTH BASEBALL LEAGUES AND CONDUCTING YOUTH BASEBALL TOURNAMENTS (U.S. CLS. 100, 101 AND 107).

FIRST USE 12-0-1996; IN COMMERCE 12-0-1996.

ANN E. SAPPENFIELD, EXAMINING ATTORNEY

CLASS 41—(Continued).

SN 85-477,527. HOMOLASH, CLAUDINE Q, PHILADELPHIA, PA. FILED 11-21-2011.

Little Miss Pharma

THE MARK CONSISTS OF STANDARD CHARACTERS WITHOUT CLAIM TO ANY PARTICULAR FONT, STYLE, SIZE, OR COLOR.

NO CLAIM IS MADE TO THE EXCLUSIVE RIGHT TO USE "PHARMA", APART FROM THE MARK AS SHOWN.

FOR ONLINE JOURNALS, NAMELY, BLOGS FEATURING INFORMATION ABOUT THE PHARMACEUTICAL INDUSTRY (U.S. CLS. 100, 101 AND 107).

CHRISTOPHER SIDOTI, EXAMINING ATTORNEY

SN 85-475,426. ELON UNIVERSITY, ELON, NC. FILED 11-17-2011.



OWNER OF U.S. REG. NOS. 2,644,172, 3,143,914 AND OTHERS.

NO CLAIM IS MADE TO THE EXCLUSIVE RIGHT TO USE "COLLEGE", "NORTH CAROLINA" AND "1889", APART FROM THE MARK AS SHOWN.

THE MARK CONSISTS OF A LARGE CIRCLE AND AN INNER CIRCLE WITH THE AREA BETWEEN THE TWO CONTAINING THE WORDING "ELON COLLEGE LUMEN NORTH CAROLINA NUMEN" WITH THE CENTER AREA CONTAINING TWO PARALLEL PILLAR DESIGNS WITH THE NUMBERS "18" AND "89" APPEAR TO THE LEFT AND RIGHT RESPECTFULLY. THE PORTRAYAL OF A STYLIZED EYE APPEARS IN THE UPPER PORTION BETWEEN THE PILLARS WITH LINES RADIATING BELOW THE EYE CONTAINING, FROM TOP TO BOTTOM, THE PORTRAYAL OF AN OIL LAMP ATOP TWO STACKED BOOKS ABOVE AN OPEN BIBLE.

FOR EDUCATION SERVICES, NAMELY, PROVIDING EDUCATIONAL COURSES OF INSTRUCTION AT THE COLLEGE AND GRADUATE LEVEL (U.S. CLS. 100, 101 AND 107).

MICHELLE DUBOIS, EXAMINING ATTORNEY

SN 85-478,278. JAYNE EHRLICH, DANBURY, CT. FILED 11-21-2011.



NO CLAIM IS MADE TO THE EXCLUSIVE RIGHT TO USE "AGENCY", APART FROM THE MARK AS SHOWN.

THE MARK CONSISTS OF THE STYLIZED WORDING "MALIBU MAMAS AGENCY" AS WELL WE THE DEPICTION OF A BOY AND GIRL KISSING. THE WORDING "MALIBU MAMAS" APPEARS ABOVE THE WORDING "AGENCY" ALL OF WHICH APPEARS TO THE RIGHT OF THE DEPICTION OF A GIRL HOLDING A BOUQUET OF FLOWERS KISSING A BOY WITH A HORIZONTAL WAVY LINE. THE GRAY RECTANGLE SURROUNDING THE WORDING AND THE DESIGN OF THE BOY AND GIRL KISSING REPRESENTS BACKGROUND AND IS NOT PART OF THE MARK.

FOR EDUCATIONAL AND ENTERTAINMENT SERVICES, NAMELY, A CONTINUING PROGRAM ABOUT A NANNY AGENCY ACCESSIBLE BY RADIO, TELEVISION, SATELLITE, AUDIO, VIDEO AND COMPUTER NETWORKS (U.S. CLS. 100, 101 AND 107).

MICHAEL TANNER, EXAMINING ATTORNEY

CLASS 41—(Continued).

SN 85-478,304. ICOACH NEW YORK, INC., DBA ICOACH-NEWYORK, NEW YORK, NY. FILED 11-21-2011.

iCoach

THE MARK CONSISTS OF STANDARD CHARACTERS WITHOUT CLAIM TO ANY PARTICULAR FONT, STYLE, SIZE, OR COLOR.

FOR PROFESSIONAL SKILLS TRAINING SERVICES, NAMELY, EXECUTIVE COACHING AND COACH TRAINING SERVICES, INCLUDING TRAINING OF EXECUTIVE COACHES, COACHING OF EXECUTIVES AND LEADERS, AND CONFIDENTIAL SUPERVISION OF EXECUTIVE COACHES; FORMULATION OF INTERNAL COACH DEVELOPMENT PROGRAMS, NAMELY, DEVELOPING CURRICULA FOR OTHERS IN THE FIELD OF COACH DEVELOPMENT PROGRAMS; AND ANCILLARY RELATED ACTIVITIES, NAMELY, CONSULTATION IN THE FIELD OF PROFESSIONAL SKILLS TRAINING PERTAINING TO EXECUTIVE COACHING AND DISTRIBUTION OF COURSE MATERIALS IN CONNECTION WITH THE FOREGOING; THE FOREGOING SERVICES RENDERED EXCLUSIVELY IN PERSON (U.S. CLS. 100, 101 AND 107).

FIRST USE 10-12-2004; IN COMMERCE 10-12-2004.
LIEF MARTIN, EXAMINING ATTORNEY

SN 85-478,665. ERIN K. KIRKLAND, DBA KIRKLAND FAMILY MEDIA, ANCHORAGE, AK. FILED 11-22-2011.

AKontheGO

THE MARK CONSISTS OF STANDARD CHARACTERS WITHOUT CLAIM TO ANY PARTICULAR FONT, STYLE, SIZE, OR COLOR.

NO CLAIM IS MADE TO THE EXCLUSIVE RIGHT TO USE "AK", APART FROM THE MARK AS SHOWN.

FOR PROVIDING A WEBSITE FEATURING CURRENT EVENTS AND ENTERTAINMENT INFORMATION IN THE STATE OF ALASKA CONCERNING OUTDOOR ACTIVITIES, PARKS, AND RECREATION; ON-LINE BLOGS FEATURING ARTICLES AND POSTS ABOUT ACTIVITIES IN THE STATE OF ALASKA (U.S. CLS. 100, 101 AND 107).

FIRST USE 2-1-2009; IN COMMERCE 2-1-2009.
CORY BOONE, EXAMINING ATTORNEY

CLASS 41—(Continued).

SN 85-479,393. SACHS, IAN, PARADISE VALLEY, AZ. FILED 11-22-2011.

FRATCASTLES

THE MARK CONSISTS OF STANDARD CHARACTERS WITHOUT CLAIM TO ANY PARTICULAR FONT, STYLE, SIZE, OR COLOR.

OWNER OF U.S. REG. NO. 4,096,961.

FOR EDUCATIONAL AND ENTERTAINMENT SERVICES, NAMELY, PROVIDING A WEBSITE FEATURING VIRTUAL TOURS OF FRATERNITY AND SORORITY HOUSES ON COLLEGE CAMPUSES AND PROVIDING NEWS AND INFORMATION ABOUT CURRENT EVENTS AND ENTERTAINMENT ON CAMPUS (U.S. CLS. 100, 101 AND 107).

FIRST USE 10-18-2010; IN COMMERCE 10-18-2010.
JOHN LINCOSKI, EXAMINING ATTORNEY

SN 85-482,560. PMLEGACY LLC, BATON ROUGE, LA. FILED 11-29-2011.

The 6th Tool: Elite Mentor Series

THE MARK CONSISTS OF STANDARD CHARACTERS WITHOUT CLAIM TO ANY PARTICULAR FONT, STYLE, SIZE, OR COLOR.

NO CLAIM IS MADE TO THE EXCLUSIVE RIGHT TO USE "ELITE MENTOR SERIES", APART FROM THE MARK AS SHOWN.

FOR PROVIDING EDUCATIONAL MENTORING SERVICES AND PROGRAMS IN THE FIELD OF ATHLETICS (U.S. CLS. 100, 101 AND 107).

CURTIS FRENCH, EXAMINING ATTORNEY

SN 85-483,328. DB FITNESS, NEW YORK, NY. FILED 11-30-2011.

Form Fit

THE MARK CONSISTS OF STANDARD CHARACTERS WITHOUT CLAIM TO ANY PARTICULAR FONT, STYLE, SIZE, OR COLOR.

NO CLAIM IS MADE TO THE EXCLUSIVE RIGHT TO USE "FIT", APART FROM THE MARK AS SHOWN.

FOR PHYSICAL FITNESS INSTRUCTION; PHYSICAL FITNESS TRAINING SERVICES (U.S. CLS. 100, 101 AND 107).

FIRST USE 1-31-2011; IN COMMERCE 4-30-2011.
JENNIFER MARTIN, EXAMINING ATTORNEY

CLASS 41—(Continued).

SN 85-483,356. GUERRILLA FITNESS, LLC, MONTCLAIR, NJ. FILED 11-30-2011.



OWNER OF U.S. REG. NO. 3,984,858.
NO CLAIM IS MADE TO THE EXCLUSIVE RIGHT TO USE "FITNESS", APART FROM THE MARK AS SHOWN.
THE COLOR(S) PRIMARY RED, BLACK AND GRAY IS/ ARE CLAIMED AS A FEATURE OF THE MARK.
THE MARK CONSISTS OF THE WORDS "GUERRILLA FITNESS" IN BLACK AND A RED STAR IN-BETWEEN THE TWO TERMS; UNDERNEATH APPEARS THE WORDING "REVOLUTIONIZING STRENGTH & CONDITIONING" IN GRAY.
FOR PHYSICAL FITNESS TRAINING SERVICES (U.S. CLS. 100, 101 AND 107).
FIRST USE 10-14-2010; IN COMMERCE 10-14-2010.
CHRISTOPHER BUONGIORNO, EXAMINING ATTORNEY

SN 85-483,966. FORDE, MALCOLM, BAY SHORE, NY. FILED 11-30-2011.

DJ GREEDY "GREEDO"

THE MARK CONSISTS OF STANDARD CHARACTERS WITHOUT CLAIM TO ANY PARTICULAR FONT, STYLE, SIZE, OR COLOR.
NO CLAIM IS MADE TO THE EXCLUSIVE RIGHT TO USE "DJ", APART FROM THE MARK AS SHOWN.
THE NAME(S), PORTRAIT(S), AND/OR SIGNATURE(S) SHOWN IN THE MARK IDENTIFIES MALCOLM FORDE, WHOSE CONSENT(S) TO REGISTER IS MADE OF RECORD.
FOR DISC JOCKEY SERVICES; MUSIC PRODUCTION SERVICES; RADIO ENTERTAINMENT SERVICES, NAMELY, RADIO PROGRAMS FEATURING PERFORMANCES BY A RADIO PERSONALITY (U.S. CLS. 100, 101 AND 107).
AHSEN KHAN, EXAMINING ATTORNEY

CLASS 41—(Continued).

SN 85-484,976. PACE UNIVERSITY, NEW YORK, NY. FILED 12-1-2011.



THE MARK CONSISTS OF STANDARD CHARACTERS WITHOUT CLAIM TO ANY PARTICULAR FONT, STYLE, SIZE, OR COLOR.
FOR EDUCATIONAL SERVICES, NAMELY, CONDUCTING PROGRAMS FOR CAPITAL MARKET PROFESSIONALS IN THE FIELDS OF FINANCIAL MARKETS AND REGULATORY COMPLIANCE (U.S. CLS. 100, 101 AND 107).
KATHERINE STOIDES, EXAMINING ATTORNEY

SN 85-485,123. PENTON MEDIA, INC., NEW YORK, NY. FILED 12-1-2011.

Club Industry.com

THE MARK CONSISTS OF STANDARD CHARACTERS WITHOUT CLAIM TO ANY PARTICULAR FONT, STYLE, SIZE, OR COLOR.
OWNER OF U.S. REG. NOS. 1,857,642, 1,904,579 AND 3,746,013.
SEC. 2(F).
FOR EDUCATION SERVICES, NAMELY, PROVIDING LIVE AND ON-LINE CONFERENCES, WORKSHOPS, SEMINARS AND CLASSES IN THE FIELD OF THE HEALTH AND FITNESS INDUSTRIES; ENTERTAINMENT SERVICES, NAMELY, PROVIDING WEBCASTS IN THE FIELD OF THE HEALTH AND FITNESS INDUSTRIES; ON-LINE JOURNALS, NAMELY, BLOGS FEATURING NEWS, INFORMATION AND COMMENTARY IN THE FIELD OF HEALTH AND FITNESS INDUSTRIES; PROVIDING A WEBSITE FEATURING BLOGS AND NON-DOWNLOADABLE PUBLICATIONS IN THE NATURE OF MAGAZINES, NEWSLETTERS, WHITE PAPERS, AND GUIDES IN THE FIELD(S) OF THE HEALTH AND FITNESS INDUSTRIES; PROVIDING NON-DOWNLOADABLE ONLINE NEWSLETTERS IN THE FIELD OF THE HEALTH AND FITNESS INDUSTRIES VIA E-MAIL; PROVIDING ON-LINE PUBLICATIONS IN THE NATURE OF MAGAZINES, NEWSLETTERS, WHITE PAPERS, AND GUIDES IN THE FIELD OF THE HEALTH AND FITNESS INDUSTRIES (U.S. CLS. 100, 101 AND 107).
FIRST USE 8-0-1998; IN COMMERCE 8-0-1998.
TIMOTHY FINNEGAN, EXAMINING ATTORNEY

CLASS 41—(Continued).

SN 85-485,484. THE PAR 3 TOUR LLC., APPLE VALLEY, CA. FILED 12-2-2011.



NO CLAIM IS MADE TO THE EXCLUSIVE RIGHT TO USE "THE PAR 3 TOUR", APART FROM THE MARK AS SHOWN.

THE COLOR(S) BLUE, GREEN, WHITE, AND RED IS/ ARE CLAIMED AS A FEATURE OF THE MARK.

THE MARK CONSISTS OF THE LITERAL ELEMENTS "THE PAR 3 TOUR", "P" WRITTEN IN STYLIZED FORM, WHEREAS THE LETTER "P" IS WRITTEN IN BLUE COLOR WITH AN IMAGE DEPICTING THE GOLF GROUND IN GREEN COLOR AND A WHITE COLORED GOLF BALL AND A RED FLAG WITH WHITE STICK AND AN IMAGE OF A WHITE COLORED GOLF PLAYER IS PLACED AT THE BOTTOM OF THE LETTER "P" AND "3" IS WRITTEN IN STYLIZED FORM PARTLY OVER THE LETTER "P" AND THE WORDS "THE PAR 3 TOUR" ARE WRITTEN IN RED COLOR ABOVE THE LETTER "P" AS SHOWN IN THE MARK.

FOR ENTERTAINMENT IN THE NATURE OF GOLF TOURNAMENTS; ORGANIZATION OF GOLF TOURNAMENT AND COMPETITIONS (U.S. CLS. 100, 101 AND 107).

FIRST USE 7-11-2011; IN COMMERCE 7-26-2011.
DANNEAN HETZEL, EXAMINING ATTORNEY

SN 85-485,585. MOREBEACH, INC., EAST ORLEANS, MA. FILED 12-2-2011.

NESURF raw since 1620

THE MARK CONSISTS OF STANDARD CHARACTERS WITHOUT CLAIM TO ANY PARTICULAR FONT, STYLE, SIZE, OR COLOR.

FOR ENTERTAINMENT SERVICES, NAMELY, PROVIDING A WEB SITE FEATURING PHOTOGRAPHIC AND PROSE PRESENTATIONS FEATURING SURFING, BEACHES AND THE LIKE; ON-LINE JOURNALS, NAMELY, BLOGS FEATURING SURFING, BEACHES AND THE LIKE (U.S. CLS. 100, 101 AND 107).

FIRST USE 6-1-2011; IN COMMERCE 6-1-2011.
WILLIAM P. SHANAHAN, EXAMINING ATTORNEY

CLASS 41—(Continued).

SN 85-485,602. SF GLOBAL LLC, HOUSTON, TX. FILED 12-2-2011.

STREETFUNNY

THE MARK CONSISTS OF THE STYLIZED SYMBOL AND WORDS "STREETFUNNY". THE LETTER "S" IN "STREET" APPEARS AS A DOLLAR SIGN (\$). THE WORD "FUNNY" IS SHOWN ABOVE AND SUBMERGING BELOW TWO HORIZONTAL LINES, WITHIN WHICH APPEARS 4 TRIANGLES.

FOR ON-LINE JOURNALS, NAMELY, BLOGS FEATURING COMEDY (U.S. CLS. 100, 101 AND 107).

FIRST USE 6-9-2011; IN COMMERCE 6-9-2011.
SKYE YOUNG, EXAMINING ATTORNEY

SN 85-486,394. SUSAN M. TOMASINI, DBA TOMASINI TRAINING CENTER, SEBASTOPOL, CA. FILED 12-2-2011.

Fusion Horsemanship

THE MARK CONSISTS OF STANDARD CHARACTERS WITHOUT CLAIM TO ANY PARTICULAR FONT, STYLE, SIZE, OR COLOR.

NO CLAIM IS MADE TO THE EXCLUSIVE RIGHT TO USE "HORSEMANSHIP", APART FROM THE MARK AS SHOWN.

FOR HORSE TRAINING (U.S. CLS. 100, 101 AND 107).
PAUL MORENO, EXAMINING ATTORNEY

SN 85-486,575. SHAMA PATEL, GREENSBORO, NC. FILED 12-3-2011.

Air

THE MARK CONSISTS OF STANDARD CHARACTERS WITHOUT CLAIM TO ANY PARTICULAR FONT, STYLE, SIZE, OR COLOR.

FOR CONDUCTING FITNESS CLASSES; HEALTH CLUB SERVICES, NAMELY, PROVIDING INSTRUCTION AND EQUIPMENT IN THE FIELD OF PHYSICAL EXERCISE; PERSONAL FITNESS TRAINING SERVICES AND CONSULTANCY; PHYSICAL FITNESS TRAINING OF INDIVIDUALS AND GROUPS (U.S. CLS. 100, 101 AND 107).

FIRST USE 5-1-2011; IN COMMERCE 6-13-2011.
CHRISTINA SOBRAL, EXAMINING ATTORNEY

CLASS 41—(Continued).

SN 85-486,952. RSJ ENTERPRISES, P.A., GOTH A, FL. FILED 12-5-2011.



THE COLOR(S) PURPLE, BLUE, YELLOW, BROWN, BLACK, AND WHITE. IS/ARE CLAIMED AS A FEATURE OF THE MARK.

THE MARK CONSISTS OF THE WORDS "LA TIERRA DEL SOL" AND "THE LAND OF THE SUN", AND A FANCIFUL DESIGN OF A SUN WITH A SMILING FACE, SUPERIMPOSED ON A YELLOW AND WHITE BACKGROUND FORMED BY THE RAYS OF THE SUN. THE WORDS "LA TIERRA DEL SOL" ARE IN GRADIENT COLORS OF PURPLE TO LIGHT BLUE, WITH EACH LETTER BORDERED BY WHITE AND BLUE. THE LETTER "L" IN "LA" EXTENDS HORIZONTALLY BENEATH THE "A" IN "LA" AND THE WORD "TIERRA", AND ABOVE THE WORDS "DEL" AND "SOL". THE TOP CURVE OF THE "S" OVERLAPS THE LEG OF THE "L" AND MERGES WITH THE SECOND "R" IN "TIERRA". THE BOTTOM CURVE OF THE "S" FORMS A BORDER AROUND APPROXIMATELY THREE-QUARTERS OF THE FACE OF THE SUN. THE FACE OF THE SUN IS YELLOW, WITH BROWN EYEBROWS, AND BLACK LINES DEPICTING ITS FACIAL FEATURES. THE WORDS "THE LAND OF THE SUN" IN PURPLE ARE BENEATH THE LOWER CURVE OF THE "S" AND THE FACE OF THE SUN.

THE ENGLISH TRANSLATION OF "LA TIERRA DEL SOL" IN THE MARK IS "THE LAND OF THE SUN."

FOR ENTERTAINMENT SERVICES FOR CHILDREN, NAMELY, PROVIDING A WEBSITE FEATURING NON-DOWNLOADABLE MULTIMEDIA ENTERTAINMENT CONTENT FOR CHILDREN, NON-DOWNLOADABLE CARTOON PROGRAMS, AND NON-DOWNLOADABLE ON-LINE BOOKS; DEVELOPMENT, CREATION, PRODUCTION AND POST-PRODUCTION OF MULTIMEDIA ENTERTAINMENT CONTENT FOR CHILDREN (U.S. CLS. 100, 101 AND 107).

MICHAEL ENGEL, EXAMINING ATTORNEY

SN 85-487,527. SAN FRANCISCO FORTY NINERS, LIMITED, SANTA CLARA, CA. FILED 12-5-2011.

WHO'S GOT IT BETTER THAN US? NOBODY!

THE MARK CONSISTS OF STANDARD CHARACTERS WITHOUT CLAIM TO ANY PARTICULAR FONT, STYLE, SIZE, OR COLOR.

FOR EDUCATION AND ENTERTAINMENT SERVICES IN THE NATURE OF PROFESSIONAL FOOTBALL GAMES AND EXHIBITIONS; PROVIDING SPORTS AND SPORTS RELATED ENTERTAINMENT INFORMATION VIA A GLOBAL COMPUTER NETWORK OR A COMMERCIAL ON-LINE SERVICE (U.S. CLS. 100, 101 AND 107).

FIRST USE 9-11-2011; IN COMMERCE 9-11-2011. SHAUNIA CARLYLE, EXAMINING ATTORNEY

CLASS 41—(Continued).

SN 85-487,904. ELVIS A. PENA, PROVIDENCE, RI. FILED 12-6-2011.

DJ Els

THE MARK CONSISTS OF STANDARD CHARACTERS WITHOUT CLAIM TO ANY PARTICULAR FONT, STYLE, SIZE, OR COLOR.

NO CLAIM IS MADE TO THE EXCLUSIVE RIGHT TO USE "DJ", APART FROM THE MARK AS SHOWN.

THE NAME(S), PORTRAIT(S), AND/OR SIGNATURE(S) SHOWN IN THE MARK IDENTIFIES ELVIS A. PENA, WHOSE CONSENT(S) TO REGISTER IS MADE OF RECORD.

FOR DISC JOCKEY SERVICES; DISC JOCKEYS FOR PARTIES AND SPECIAL EVENTS (U.S. CLS. 100, 101 AND 107).

FIRST USE 7-1-2005; IN COMMERCE 7-1-2005. RONALD AIKENS, EXAMINING ATTORNEY

SN 85-488,920. OC FAIR & EVENT CENTER, COSTA MESA, CA. FILED 12-6-2011.

PACIFIC AMPHITHEATRE

THE MARK CONSISTS OF STANDARD CHARACTERS WITHOUT CLAIM TO ANY PARTICULAR FONT, STYLE, SIZE, OR COLOR.

NO CLAIM IS MADE TO THE EXCLUSIVE RIGHT TO USE "AMPHITHEATRE", APART FROM THE MARK AS SHOWN.

FOR ENTERTAINMENT SERVICES IN THE NATURE OF LIVE MUSICAL PERFORMANCES BY MUSICIANS, MUSICAL GROUPS, DANCE GROUPS, AND COMEDIANS; LIVE THEATRICAL PERFORMANCES; ORGANIZATION OF EVENTS FOR CULTURAL PURPOSES (U.S. CLS. 100, 101 AND 107).

FIRST USE 0-0-1983; IN COMMERCE 0-0-1983. TRACY FLETCHER, EXAMINING ATTORNEY

CLASS 41—(Continued).

SN 85-488,921. OC FAIR & EVENT CENTER, COSTA MESA, CA. FILED 12-6-2011.



NO CLAIM IS MADE TO THE EXCLUSIVE RIGHT TO USE "AMPHITHEATRE", APART FROM THE MARK AS SHOWN.

THE MARK CONSISTS OF THE LITERAL ELEMENT "PACIFIC AMPHITHEATRE" SET FORTH ON TWO LINES, CENTERED, IN A STYLIZED FONT, THE FIRST "I" IN "PACIFIC" FORMING THE SHAPE OF A HUMAN FIGURE IN AN OPEN CIRCLE.

FOR ENTERTAINMENT SERVICES IN THE NATURE OF LIVE MUSICAL PERFORMANCES BY MUSICIANS, MUSICAL GROUPS, DANCE GROUPS, AND COMEDIANS; LIVE THEATRICAL PERFORMANCES; ORGANIZATION OF EVENTS FOR CULTURAL PURPOSES (U.S. CLS. 100, 101 AND 107).

FIRST USE 0-0-1983; IN COMMERCE 0-0-1983.
TRACY FLETCHER, EXAMINING ATTORNEY

SN 85-490,335. CWEB, INC., HENDERSON, NV. FILED 12-8-2011.



OWNER OF U.S. REG. NOS. 2,791,645, 3,594,761 AND 3,823,686.

NO CLAIM IS MADE TO THE EXCLUSIVE RIGHT TO USE "SPORTS", APART FROM THE MARK AS SHOWN.

THE COLOR(S) RED, BLUE, YELLOW, GREEN, AND BLACK IS/ARE CLAIMED AS A FEATURE OF THE MARK.

THE MARK CONSISTS OF THE WORD "CWEBSPTS", LETTER "C" IN RED, LETTER "W" IN BLUE, LETTER "E" IN YELLOW, LETTER "B" IN GREEN, LETTERS SPORTS IN BLACK.

FOR ENTERTAINMENT IN THE NATURE OF AN ONGOING SPECIAL VARIETY, NEWS, MUSIC OR COMEDY SHOW FEATURING SPORTS BROADCAST OVER TELEVISION, SATELLITE, AUDIO, AND VIDEO MEDIA; ENTERTAINMENT IN THE NATURE OF ON-GOING TELEVISION PROGRAMS IN THE FIELD OF SPORTS; ENTERTAINMENT IN THE NATURE OF TELEVISION NEWS SHOWS; ENTERTAINMENT INFORMATION SERVICES, NAMELY, PROVIDING INFORMATION AND NEWS RELEASES ABOUT A MUSICAL ARTIST; ENTERTAINMENT SERVICES, NAMELY, PROVIDING NEWS AND INFORMATION VIA A WEBSITE IN THE FIELD OF SKATEBOARDING, THE CULTURE OF SKATEBOARDING AND SKATEBOARD PRODUCT REVIEWS; ENTERTAINMENT, NAMELY, A CONTINUING SPORTS SHOW BROADCAST OVER TELEVISION, SATELLITE, AUDIO, AND VIDEO MEDIA; ENTERTAINMENT, NAMELY, A CONTINUING SPORTS SHOW BROADCAST OVER ONLINE MEDIA, BROADCAST TELEVISION, VIDEO; ENTERTAINMENT, NAMELY, TELEVISION NEWS SHOWS; NEWS AGENCIES, NAMELY, GATHERING AND DISSEMINATION OF NEWS; NEWS REPORTER SERVICES IN THE NATURE OF NEWS ANALYSIS AND NEWS COMMENTARY; NEWS REPORTERS SERVICES; NEWS SYNDICATION FOR THE BROADCASTING INDUSTRY; NEWS SYNDICATION REPORTING; PROVIDING A WEB SITE FEATURING ON-LINE PUBLICATIONS IN THE FIELD OF NEWS ARTICLES FOR CHILDREN; PROVIDING A WEBSITE CONTAINING INFORMATION RELATING TO THE SPORT OF RUGBY, INCLUDING TEAM IN-

CLASS 41—(Continued).

FORMATION, PLAYER STATISTICS AND NEWS; PROVIDING AN INTERNET NEWS PORTAL FEATURING LINKS TO NEWS STORIES AND ARTICLES IN THE FIELD OF CURRENT EVENTS; PROVIDING CURRENT EVENT NEWS AND INFORMATION VIA A GLOBAL COMPUTER NETWORK; PROVIDING INFORMATION AND NEWS IN THE FIELD OF TEACHING METHODOLOGY AND EDUCATION; PROVIDING INFORMATION, NEWS AND COMMENTARY IN THE FIELD OF CURRENT EVENTS RELATING TO THE GAY COMMUNITY; PROVIDING INFORMATION, NEWS AND COMMENTARY IN THE FIELD OF CURRENT EVENTS RELATING TO SPORTS; PROVIDING INFORMATION, NEWS AND COMMENTARY IN THE FIELD OF ENTERTAINMENT; PROVIDING INFORMATION, NEWS AND COMMENTARY IN THE FIELD OF ENTERTAINMENT RELATING TO THE GAY COMMUNITY; PROVIDING INFORMATION, NEWS AND COMMENTARY IN THE FIELD OF RECREATION AND LEISURE ACTIVITIES; PROVIDING NEWS AND INFORMATION IN THE FIELD OF SPORTS; PROVIDING NEWS AND INFORMATION ON THE SPORT OF GOLF; PROVIDING NEWS AND INFORMATION VIA AN INTERNET WEB SITE IN THE FIELD OF COMPETITIVE SAILING; PROVIDING NEWS IN THE NATURE OF CURRENT EVENT REPORTING; PROVIDING WRESTLING NEWS AND INFORMATION VIA A GLOBAL COMPUTER NETWORK (U.S. CLS. 100, 101 AND 107).

FIRST USE 1-1-2003; IN COMMERCE 1-1-2003.
PAUL E. FAHRENKOPF, EXAMINING ATTORNEY

SN 85-490,456. ROSEN, STACI, BROOKLYN, NY. FILED 12-8-2011.

CONCERNING LEARNING

THE MARK CONSISTS OF STANDARD CHARACTERS WITHOUT CLAIM TO ANY PARTICULAR FONT, STYLE, SIZE, OR COLOR.

NO CLAIM IS MADE TO THE EXCLUSIVE RIGHT TO USE "LEARNING", APART FROM THE MARK AS SHOWN.

FOR EDUCATION SERVICES, NAMELY, PROVIDING TUTORING IN THE FIELD OF THE ARTS, MATH, READING, WRITING, SCIENCE, PUBLIC SPEAKING, MUSIC, DRAMA AND MUSICAL THEATRE, STORYTELLING, PUPPETEERING AND TEST PREP; EDUCATION SERVICES, NAMELY, PROVIDING CLASSES, SEMINARS, AND WORKSHOPS IN THE FIELD OF THE ARTS, MATH, READING, WRITING, SCIENCE, PUBLIC SPEAKING, MUSIC, DRAMA AND MUSICAL THEATRE, STORYTELLING, PUPPETEERING AND TEST PREP; CONDUCTING AFTER SCHOOL TUTORING PROGRAMS; PRESENTATION OF LIVE SHOW PERFORMANCES; ENTERTAINMENT SERVICES IN THE NATURE OF LIVE MUSICAL PERFORMANCES; ORGANIZING AND PRESENTING MUSICAL AND PERFORMANCE RECITALS (U.S. CLS. 100, 101 AND 107).

FIRST USE 6-20-2005; IN COMMERCE 6-20-2005.
CIMMERIAN COLEMAN, EXAMINING ATTORNEY

CLASS 41—(Continued).

SN 85-490,521. SHAREEKE EDMEAD-NESE, NEW YORK, NY. FILED 12-8-2011.

Conscious Spender

THE MARK CONSISTS OF STANDARD CHARACTERS WITHOUT CLAIM TO ANY PARTICULAR FONT, STYLE, SIZE, OR COLOR.

NO CLAIM IS MADE TO THE EXCLUSIVE RIGHT TO USE "SPENDER", APART FROM THE MARK AS SHOWN.

FOR EDUCATIONAL SERVICES, NAMELY, CONDUCTING PROFESSIONAL SPEAKING AND TRAINING IN THE FORM OF CAMPS, SEMINARS, AND WORKSHOPS IN THE FIELD OF PERSONAL FINANCIAL MANAGEMENT AND EMPOWERMENT AND DISTRIBUTION OF COURSE MATERIAL IN CONNECTION THEREWITH; PERSONAL COACHING SERVICES IN THE FIELD OF FINANCIAL CONSULTATION, PERSONAL FINANCIAL MANAGEMENT AND EMPOWERMENT; PROFESSIONAL COACHING SERVICES IN THE FIELD OF FINANCIAL CONSULTATION, PERSONAL FINANCIAL MANAGEMENT AND EMPOWERMENT, AND SMALL BUSINESS DEVELOPMENT; PROVIDING GROUP COACHING IN THE FIELD OF FINANCIAL CONSULTATION, PERSONAL FINANCIAL MANAGEMENT AND EMPOWERMENT, AND SMALL BUSINESS DEVELOPMENT (U.S. CLS. 100, 101 AND 107).

FIRST USE 10-21-2010; IN COMMERCE 10-21-2010.
JAY BESCH, EXAMINING ATTORNEY

CLASS 41—(Continued).

SN 85-492,047. DANIELS, NATHAN, BOISE, ID. FILED 12-9-2011.

VELVET INVASION SOUND

THE MARK CONSISTS OF STANDARD CHARACTERS WITHOUT CLAIM TO ANY PARTICULAR FONT, STYLE, SIZE, OR COLOR.

NO CLAIM IS MADE TO THE EXCLUSIVE RIGHT TO USE "SOUND", APART FROM THE MARK AS SHOWN.

FOR MUSIC PRODUCTION SERVICES (U.S. CLS. 100, 101 AND 107).

FIRST USE 1-1-2011; IN COMMERCE 1-1-2011.
NELSON SNYDER, EXAMINING ATTORNEY

SN 85-492,600. ONE WORLD MUSICAL BOOKS, LLC., DBA FROGTOWN, NEHALEM, OR. FILED 12-12-2011.

SN 85-490,749. AVANTAS, LLC, OMAHA, NE. FILED 12-8-2011.

HEALTHCARE WORKING SMARTER

THE MARK CONSISTS OF STANDARD CHARACTERS WITHOUT CLAIM TO ANY PARTICULAR FONT, STYLE, SIZE, OR COLOR.

FOR PROVIDING TRAINING TO THOSE IN THE HEALTHCARE INDUSTRY IN THE FIELDS OF LABOR MANAGEMENT AND THE UTILIZATION OF TECHNOLOGY FOR THE OPTIMIZATION OF EMPLOYEE STAFFING AND SCHEDULING (U.S. CLS. 100, 101 AND 107).

FIRST USE 10-4-2011; IN COMMERCE 10-4-2011.
ELI HELLMAN, EXAMINING ATTORNEY

FROGTOWN

THE MARK CONSISTS OF STANDARD CHARACTERS WITHOUT CLAIM TO ANY PARTICULAR FONT, STYLE, SIZE, OR COLOR.

FOR ENTERTAINMENT SERVICES, NAMELY, CONDUCTING LIVE, MULTI-MEDIA STAGE SHOWS FEATURING MUSIC AND EDUCATION ABOUT CULTURAL DIVERSITY (U.S. CLS. 100, 101 AND 107).

FIRST USE 1-1-2007; IN COMMERCE 1-1-2007.
ANTHONY RINKER, EXAMINING ATTORNEY

CLASS 41—(Continued).

SN 85-492,674. WAITZMAN, KARA ANN, TIPP CITY, OH. FILED 12-12-2011.



NO CLAIM IS MADE TO THE EXCLUSIVE RIGHT TO USE "THERAPY CONSULTANTS" OR "INFANT-DRIVEN EDUCATION", APART FROM THE MARK AS SHOWN.

THE COLOR(S) PURPLE, BLACK AND GREY IS/ARE CLAIMED AS A FEATURE OF THE MARK.

THE MARK CONSISTS OF AN ABSTRACT DESIGN CONSISTING OF A PURPLE CIRCLE AND TWO PURPLE CURVY BANDS, ON TOP OF A GREY SHADOW. THIS APPEARS ABOVE THE STYLIZED PURPLE WORDING "CREATIVE THERAPY CONSULTANTS" AND BLACK WORDING "INFANT-DRIVEN EDUCATION".

FOR EDUCATIONAL SERVICES, NAMELY, CONDUCTING WORKSHOPS, LECTURES AND SEMINARS IN THE FIELDS OF NEONATAL INTENSIVE CARE, NEONATAL MASSAGE, DEVELOPMENTAL INTERVENTIONS AND FEEDING FOR NURSES, THERAPISTS AND OTHER MEDICAL PROFESSIONALS AND DISTRIBUTION OF TRAINING MATERIALS IN CONNECTION THEREWITH, FOR CERTIFICATION OF NURSES, THERAPISTS AND OTHER MEDICAL PROFESSIONALS; PROFESSIONAL AND MEDICAL CONSULTING SERVICES FOR NURSES, THERAPISTS AND OTHER MEDICAL PROFESSIONALS IN THE NEONATAL INTENSIVE CARE (U.S. CLS. 100, 101 AND 107).

FIRST USE 1-0-2011; IN COMMERCE 1-0-2011.
DAWN HAN, EXAMINING ATTORNEY

SN 85-493,775. FEN MEDIA, LLC, LOS ANGELES, CA. FILED 12-13-2011.

THE RISING HOLLYWOOD

THE MARK CONSISTS OF STANDARD CHARACTERS WITHOUT CLAIM TO ANY PARTICULAR FONT, STYLE, SIZE, OR COLOR.

NO CLAIM IS MADE TO THE EXCLUSIVE RIGHT TO USE "HOLLYWOOD", APART FROM THE MARK AS SHOWN.

FOR PROVIDING A WEBSITE FEATURING NON-DOWNLOADABLE PUBLICATIONS IN THE NATURE OF ARTICLES IN THE FIELD OF THE ENTERTAINMENT INDUSTRY (U.S. CLS. 100, 101 AND 107).

FIRST USE 9-1-2011; IN COMMERCE 9-1-2011.
AMY ALFIERI, EXAMINING ATTORNEY

CLASS 41—(Continued).

SN 85-493,928. 5 BATS, LLC, MARINA DEL REY, CA. FILED 12-13-2011.

KFORCE

THE MARK CONSISTS OF STANDARD CHARACTERS WITHOUT CLAIM TO ANY PARTICULAR FONT, STYLE, SIZE, OR COLOR.

FOR ENTERTAINMENT MEDIA PRODUCTION SERVICES FOR MOTION PICTURES, TELEVISION AND INTERNET; ENTERTAINMENT SERVICES, NAMELY, PROVIDING ON-GOING TELEVISION PROGRAMS IN THE FIELD OF ANIMATION/LIVE ACTION CONTENT VIA A GLOBAL COMPUTER NETWORK; ENTERTAINMENT SERVICES, NAMELY, PROVIDING ON-GOING WEBISODES FEATURING ANIMATION/LIVE ACTION CONTENT VIA A GLOBAL COMPUTER NETWORK; ENTERTAINMENT SERVICES, NAMELY, PROVIDING ONLINE ELECTRONIC GAMES (U.S. CLS. 100, 101 AND 107).

FIRST USE 12-13-2011; IN COMMERCE 12-13-2011.
HOWARD B. LEVINE, EXAMINING ATTORNEY

SN 85-494,735. CERTIFICATION PARTNERS, LLC, TEMPE, AZ. FILED 12-14-2011.

CIW

THE MARK CONSISTS OF STANDARD CHARACTERS WITHOUT CLAIM TO ANY PARTICULAR FONT, STYLE, SIZE, OR COLOR.

OWNER OF U.S. REG. NOS. 2,523,668, 2,648,016 AND OTHERS.

FOR EDUCATIONAL SERVICES, NAMELY, CONDUCTING TRAINING COURSES AND DISTRIBUTING EDUCATIONAL MATERIALS THEREWITH IN CORE TECHNOLOGY AREAS RELATING TO GLOBAL COMPUTER INFORMATION NETWORKS (U.S. CLS. 100, 101 AND 107).

FIRST USE 4-3-2000; IN COMMERCE 4-3-2000.
SOPHIA S. KIM, EXAMINING ATTORNEY

CLASS 41—(Continued).

SN 85-494,856. SIRCOACH, FREEHOLD, NJ. FILED 12-14-2011.



NO CLAIM IS MADE TO THE EXCLUSIVE RIGHT TO USE "FINANCIAL ADVISORS", APART FROM THE MARK AS SHOWN.

THE MARK CONSISTS OF A BOX AROUND THE STYLIZED TEXT "BOOT CAMP FOR FINANCIAL ADVISORS". THERE ARE STARS GOING ACROSS THE TOP OF BOX. THERE IS AN ARROW ONE ON EACH SIDE OF THE TEXT "FOR".

FOR TRAINING SERVICES IN THE FIELD OF FINANCIAL ADVISING (U.S. CLS. 100, 101 AND 107).

FIRST USE 3-1-2011; IN COMMERCE 5-11-2011.
SUSAN STIGLITZ, EXAMINING ATTORNEY

CLASS 41—(Continued).

SN 85-496,812. FINK, JAMESON, SEATTLE, WA. FILED 12-15-2011.

Wine Without Worry

THE MARK CONSISTS OF STANDARD CHARACTERS WITHOUT CLAIM TO ANY PARTICULAR FONT, STYLE, SIZE, OR COLOR.

FOR ON-LINE JOURNALS, NAMELY, BLOGS FEATURING MATTERS RELATING TO FOOD AND BEVERAGES AND TRAVEL; NON-DOWNLOADABLE ELECTRONIC PUBLICATIONS IN THE NATURE OF ARTICLES AND BOOKS FEATURING MATTERS RELATING TO FOOD AND BEVERAGES AND TRAVEL (U.S. CLS. 100, 101 AND 107).

FIRST USE 9-8-2011; IN COMMERCE 9-8-2011.
JENNY PARK, EXAMINING ATTORNEY

SN 85-494,891. INTERNATIONAL SOCIETY OF SPORTS NUTRITION, WOODLAND PARK, CO. FILED 12-14-2011.

THE ISSN-WHY GO ANYWHERE ELSE

THE MARK CONSISTS OF STANDARD CHARACTERS WITHOUT CLAIM TO ANY PARTICULAR FONT, STYLE, SIZE, OR COLOR.

OWNER OF U.S. REG. NOS. 3,020,774 AND 3,119,265. FOR EDUCATIONAL SERVICES, NAMELY, CONDUCTING CONFERENCES, SEMINARS, WEBINARS, CLASSES AND WORKSHOPS, AND THE DISTRIBUTION OF COURSE MATERIALS THEREWITH, IN THE FIELD OF SPORTS NUTRITION AND DIETARY SUPPLEMENTS (U.S. CLS. 100, 101 AND 107).

FIRST USE 6-23-2011; IN COMMERCE 6-23-2011.
AMY KELLY, EXAMINING ATTORNEY

SN 85-496,938. JIBJAB MEDIA INC., VENICE, CA. FILED 12-15-2011.

STORYBOTS

THE MARK CONSISTS OF STANDARD CHARACTERS WITHOUT CLAIM TO ANY PARTICULAR FONT, STYLE, SIZE, OR COLOR.

FOR EDUCATIONAL AND ENTERTAINMENT SERVICES, NAMELY, PROVIDING ON-LINE INTERACTIVE CHILDREN'S STORIES; PROVIDING PHOTOGRAPHIC, AUDIO, VIDEO AND PROSE PRESENTATIONS FEATURING CHILDREN'S ENTERTAINMENT ON-LINE AND IN MOBILE WIRELESS FORM; PROVIDING PHOTO-PERSONALIZED CHILDREN'S ENTERTAINMENT ON-LINE AND IN MOBILE WIRELESS FORM, NAMELY, PROVIDING AN INTERACTIVE ACTIVITY WHEREBY A USER CAN INSERT PHOTOGRAPHS INTO A MULTIMEDIA TEMPLATE FEATURING CHILDREN'S ENTERTAINMENT; PROVIDING ONLINE ELECTRONIC GAMES (U.S. CLS. 100, 101 AND 107).

BRIAN PINO, EXAMINING ATTORNEY

CLASS 41—(Continued).

SN 85-497,325. VENEVISION PRODUCTIONS LLC, CORAL GABLES, FL. FILED 12-16-2011.

EL TALISMAN

THE MARK CONSISTS OF STANDARD CHARACTERS WITHOUT CLAIM TO ANY PARTICULAR FONT, STYLE, SIZE, OR COLOR.

THE ENGLISH TRANSLATION OF "EL TALISMAN" IN THE MARK IS "THE TALISMAN".

FOR PRODUCTION OF TELEVISION PROGRAMS; ENTERTAINMENT SERVICES, NAMELY, PRODUCTION AND DISTRIBUTION OF AN ONGOING DRAMATIC TELEVISION SERIES; PROVIDING A WEBSITE WITH INFORMATION ABOUT AN ONGOING DRAMATIC TELEVISION SERIES (U.S. CLS. 100, 101 AND 107).

FIRST USE 1-30-2012; IN COMMERCE 1-30-2012.
PRISCILLA MILTON, EXAMINING ATTORNEY

SN 85-498,678. TATHAM JR., WILLIAM, FRESNO, CA. FILED 12-19-2011.

BARBARIAN SOCCER

THE MARK CONSISTS OF STANDARD CHARACTERS WITHOUT CLAIM TO ANY PARTICULAR FONT, STYLE, SIZE, OR COLOR.

NO CLAIM IS MADE TO THE EXCLUSIVE RIGHT TO USE "SOCCER", APART FROM THE MARK AS SHOWN.

FOR ENTERTAINMENT IN THE NATURE OF SOCCER GAMES (U.S. CLS. 100, 101 AND 107).

JACQUELINE A. LAVINE, EXAMINING ATTORNEY

SN 85-499,592. NEWMAN, BARBARA, BALTIMORE, MD. FILED 12-20-2011.

BEAR BABBLE ONLINE

THE MARK CONSISTS OF STANDARD CHARACTERS WITHOUT CLAIM TO ANY PARTICULAR FONT, STYLE, SIZE, OR COLOR.

NO CLAIM IS MADE TO THE EXCLUSIVE RIGHT TO USE "ONLINE", APART FROM THE MARK AS SHOWN.

FOR ON-LINE JOURNALS, NAMELY, BLOGS FEATURING INFORMATION, OPINION, COMMENTARY, POETRY AND PROSE IN THE FIELD OF GENERAL INTEREST (U.S. CLS. 100, 101 AND 107).

FIRST USE 10-6-2011; IN COMMERCE 10-6-2011.
JESSICA A. POWERS, EXAMINING ATTORNEY

CLASS 41—(Continued).

SN 85-499,852. CAPSIM MANAGEMENT SIMULATIONS, INC, CHICAGO, IL. FILED 12-20-2011.

CAPSIM CHALLENGE

THE MARK CONSISTS OF STANDARD CHARACTERS WITHOUT CLAIM TO ANY PARTICULAR FONT, STYLE, SIZE, OR COLOR.

OWNER OF U.S. REG. NOS. 2,841,606, 3,636,288 AND OTHERS.

NO CLAIM IS MADE TO THE EXCLUSIVE RIGHT TO USE "CHALLENGE", APART FROM THE MARK AS SHOWN.

FOR ARRANGING OF CONTESTS; ENTERTAINMENT SERVICES, NAMELY, CONDUCTING CONTESTS (U.S. CLS. 100, 101 AND 107).

FIRST USE 11-0-2000; IN COMMERCE 11-0-2000.
SANDRA BUJA, EXAMINING ATTORNEY

SN 85-500,683. STRAYLIGHT PUBLISHING, LLC, CHALMETTE, LA. FILED 12-21-2011.



NO CLAIM IS MADE TO THE EXCLUSIVE RIGHT TO USE "PUBLISHING", APART FROM THE MARK AS SHOWN.

THE COLOR(S) PURPLE AND WHITE IS/ARE CLAIMED AS A FEATURE OF THE MARK.

THE MARK CONSISTS OF A RECTANGULAR PURPLE FIELD WITH WHITE STARS ARRANGED IN A STYLIZED "S" PATTERN ABOVE THE PURPLE WORDS "STRAYLIGHT PUBLISHING", ALL INSIDE A RECTANGULAR PURPLE BORDER ON A WHITE BACKGROUND.

FOR PUBLISHING OF BOOKS, E-BOOKS, AUDIO BOOKS, MUSIC AND ILLUSTRATIONS (U.S. CLS. 100, 101 AND 107).

FIRST USE 8-29-2011; IN COMMERCE 10-1-2011.
MARC LEIPZIG, EXAMINING ATTORNEY

CLASS 41—(Continued).

SN 85-501,283. ROCCO WHALEN, ROCKY RIVER, OH.
FILED 12-21-2011.

ROCCO WHALEN'S

THE MARK CONSISTS OF STANDARD CHARACTERS WITHOUT CLAIM TO ANY PARTICULAR FONT, STYLE, SIZE, OR COLOR.

THE NAME(S), PORTRAIT(S), AND/OR SIGNATURE(S) SHOWN IN THE MARK IDENTIFIES "ROCCO WHALEN", WHOSE CONSENT(S) TO REGISTER IS MADE OF RECORD.

FOR ENTERTAINMENT IN THE NATURE OF ONGOING TELEVISION PROGRAMS IN THE FIELD OF COOKING, RECIPES, FOOD AND DRINK (U.S. CLS. 100, 101 AND 107).

KRISTIN DAHLING, EXAMINING ATTORNEY

SN 85-501,288. ROCCO WHALEN, ROCKY RIVER, OH.
FILED 12-21-2011.

CHEF ROCCO WHALEN

THE MARK CONSISTS OF STANDARD CHARACTERS WITHOUT CLAIM TO ANY PARTICULAR FONT, STYLE, SIZE, OR COLOR.

THE NAME(S), PORTRAIT(S), AND/OR SIGNATURE(S) SHOWN IN THE MARK IDENTIFIES "ROCCO WHALEN", WHOSE CONSENT(S) TO REGISTER IS MADE OF RECORD.

FOR ENTERTAINMENT IN THE NATURE OF ONGOING TELEVISION PROGRAMS IN THE FIELD OF COOKING, RECIPES, FOOD AND DRINK (U.S. CLS. 100, 101 AND 107).

KRISTIN DAHLING, EXAMINING ATTORNEY

SN 85-501,811. M.C. WEASEL LLC, LONG VALLEY, NJ.
FILED 12-22-2011.

M.C. WEASEL

THE MARK CONSISTS OF STANDARD CHARACTERS WITHOUT CLAIM TO ANY PARTICULAR FONT, STYLE, SIZE, OR COLOR.

THE NAME(S), PORTRAIT(S), AND/OR SIGNATURE(S) SHOWN IN THE MARK IDENTIFIES MARY E. COLLINS, WHOSE CONSENT(S) TO REGISTER IS MADE OF RECORD.

FOR PUBLISHING OF BOOKS, E-BOOKS AND PERIODICALS; ONLINE PUBLISHING OF BOOKS, E-BOOKS AND PERIODICALS (U.S. CLS. 100, 101 AND 107).

GRETTA YAO, EXAMINING ATTORNEY

CLASS 41—(Continued).

SN 85-501,879. WENDT COMMUNICATION PARTNERS
LLC, MECHANICSBURG, PA. FILED 12-22-2011.

INNOVATION INSTITUTE

THE MARK CONSISTS OF STANDARD CHARACTERS WITHOUT CLAIM TO ANY PARTICULAR FONT, STYLE, SIZE, OR COLOR.

NO CLAIM IS MADE TO THE EXCLUSIVE RIGHT TO USE "INSTITUTE", APART FROM THE MARK AS SHOWN.

FOR EDUCATION SERVICES, NAMELY, PROVIDING LIVE AND ON-LINE SEMINARS, WORKSHOPS AND TRAINING PROGRAMS IN THE FIELD OF MARKETING, ADVERTISING, COMMUNICATIONS, BRANDING AND STRATEGIC BUSINESS PLANNING (U.S. CLS. 100, 101 AND 107).

FIRST USE 6-0-2008; IN COMMERCE 6-0-2008.

BARBARA BROWN, EXAMINING ATTORNEY

SN 85-502,872. INDIA BRAINS INFOTECH, LLC, SAN
RAMON, CA. FILED 12-23-2011.

GREAT ANDHRA

THE MARK CONSISTS OF STANDARD CHARACTERS WITHOUT CLAIM TO ANY PARTICULAR FONT, STYLE, SIZE, OR COLOR.

NO CLAIM IS MADE TO THE EXCLUSIVE RIGHT TO USE "ANDHRA", APART FROM THE MARK AS SHOWN.

FOR ENTERTAINMENT IN THE NATURE OF PROVIDING AN INFORMATIONAL AND ENTERTAINMENT WEBSITE IN THE FIELDS OF CELEBRITY GOSSIP, ENTERTAINMENT, SPORTS AND FITNESS; ENTERTAINMENT SERVICES, NAMELY, PROVIDING A WEB SITE FEATURING PHOTOGRAPHIC, AUDIO, VIDEO AND PROSE PRESENTATIONS FEATURING ENTERTAINMENT NEWS AND GOSSIP; PROVIDING A WEBSITE FEATURING BLOGS AND NON-DOWNLOADABLE PUBLICATIONS IN THE NATURE OF ARTICLES, BLOGS, USER FORUMS AND OTHER CONTENT IN THE FIELD(S) OF ENTERTAINMENT NEWS AND GOSSIP; PROVIDING A WEBSITE FEATURING ENTERTAINMENT INFORMATION; PROVIDING A WEBSITE FOR ENTERTAINMENT PURPOSES WHERE USERS CAN VIEW AND POST ARTICLES, BLOGS, USER FORUMS AND OTHER CONTENT FEATURING ENTERTAINMENT NEWS AND GOSSIP (U.S. CLS. 100, 101 AND 107).

FIRST USE 11-1-2003; IN COMMERCE 11-1-2003.

INGA ERVIN, EXAMINING ATTORNEY

CLASS 41—(Continued).

SN 85-502,878. INDIA BRAINS INFOTECH, LLC, SAN RAMON, CA. FILED 12-23-2011.



THE COLOR(S) BLACK, RED AND GREY IS/ARE CLAIMED AS A FEATURE OF THE MARK.

THE MARK CONSISTS OF THE WORD "GREATANDHRA.COM" IN BLACK WITH A DRAWING OF A FOUNTAIN PEN WRITING TIP IN RED BETWEEN "GREATANDHRA" AND "COM" WITH THE WORDS "DARE TO WRITE" IN GREY UNDER THE WORD "GREATANDHRA".

FOR ENTERTAINMENT IN THE NATURE OF PROVIDING AN INFORMATIONAL AND ENTERTAINMENT WEBSITE IN THE FIELDS OF CELEBRITY GOSSIP, ENTERTAINMENT, SPORTS AND FITNESS; ENTERTAINMENT SERVICES, NAMELY, PROVIDING A WEB SITE FEATURING PHOTOGRAPHIC, AUDIO, VIDEO AND PROSE PRESENTATIONS FEATURING ENTERTAINMENT NEWS AND GOSSIP; PROVIDING A WEBSITE FEATURING BLOGS AND NON-DOWNLOADABLE PUBLICATIONS IN THE NATURE OF ARTICLES, BLOGS, USER FORUMS AND OTHER CONTENT IN THE FIELD(S) OF ENTERTAINMENT NEWS AND GOSSIP; PROVIDING A WEBSITE FEATURING ENTERTAINMENT INFORMATION; PROVIDING A WEBSITE FOR ENTERTAINMENT PURPOSES WHERE USERS CAN VIEW AND POST ARTICLES, BLOGS, USER FORUMS AND OTHER CONTENT FEATURING ENTERTAINMENT NEWS AND GOSSIP (U.S. CLS. 100, 101 AND 107).

FIRST USE 11-1-2003; IN COMMERCE 11-1-2003.
INGA ERVIN, EXAMINING ATTORNEY

SN 85-503,298. UNITED LOGIC PRODUCTIONS, LLC, AKA KING OF THE FAIRWAY, CEDAR PARK, TX. FILED 12-23-2011.



THE MARK CONSISTS OF THE MARK CONSISTS OF A GOLF BALL OVER THE TOP OF A GOLF HOLE. TO THE RIGHT OF THE DESIGN IS THE WORDING "KING OF THE FAIRWAY". ABOVE THE "G" IN "KING" IS A CROWN SITTING ON AN ANGLE.

FOR ENTERTAINMENT IN THE NATURE OF GOLF TOURNAMENTS; ORGANISATION OF GOLF TOURNAMENTS; PLANNING OF PROFESSIONAL GOLF TOURNAMENTS; PROVIDING A WEB-BASED SYSTEM AND ON-LINE PORTAL FOR CUSTOMERS TO PARTICIPATE IN ON-LINE GAMING, OPERATION AND COORDINATION OF GAME TOURNAMENTS, LEAGUES AND TOURS (U.S. CLS. 100, 101 AND 107).

FIRST USE 2-1-2011; IN COMMERCE 9-30-2011.
TARAH HARDY, EXAMINING ATTORNEY

CLASS 41—(Continued).

SN 85-503,314. ESTROFF, SHARON, MARIETTA, GA. FILED 12-23-2011.

Kidsplorations

THE MARK CONSISTS OF STANDARD CHARACTERS WITHOUT CLAIM TO ANY PARTICULAR FONT, STYLE, SIZE, OR COLOR.

FOR EDUCATIONAL SERVICES, NAMELY, DEVELOPING CURRICULUM FOR EDUCATORS; ENTERTAINMENT SERVICES, NAMELY, CONDUCTING PARTIES; PROVIDING AFTER SCHOOL EDUCATIONAL PROGRAMS FOR CHILDREN IN GRADES PRE-K THROUGH 8TH GRADE (U.S. CLS. 100, 101 AND 107).

FIRST USE 9-1-2011; IN COMMERCE 10-1-2011.
JOHN GARTNER, EXAMINING ATTORNEY

SN 85-504,284. BROWN, ANASTASIA W., NASHVILLE, TN. FILED 12-27-2011.

AMERICAN TROUBADOURS

THE MARK CONSISTS OF STANDARD CHARACTERS WITHOUT CLAIM TO ANY PARTICULAR FONT, STYLE, SIZE, OR COLOR.

FOR PRESENTATION OF LIVE SHOW PERFORMANCES; PRODUCTION OF CABLE TELEVISION PROGRAMS; PRODUCTION OF RADIO AND TELEVISION PROGRAMS; TELEVISION SHOW PRODUCTION (U.S. CLS. 100, 101 AND 107).

HEATHER THOMPSON, EXAMINING ATTORNEY

SN 85-505,598. LEDERFEIND, ANNE, NEW YORK, NY. FILED 12-29-2011.

Body Ballet

THE MARK CONSISTS OF STANDARD CHARACTERS WITHOUT CLAIM TO ANY PARTICULAR FONT, STYLE, SIZE, OR COLOR.

NO CLAIM IS MADE TO THE EXCLUSIVE RIGHT TO USE "BALLET", APART FROM THE MARK AS SHOWN. FOR PHYSICAL FITNESS TRAINING OF INDIVIDUALS AND GROUPS (U.S. CLS. 100, 101 AND 107).

FIRST USE 1-1-2006; IN COMMERCE 3-1-2006.
RONALD AIKENS, EXAMINING ATTORNEY

CLASS 41—(Continued).

SN 85-506,259. REBET, FRÉDÉRIC, PARIS, FRANCE, FILED 12-30-2011.

La France Monsieur

THE MARK CONSISTS OF STANDARD CHARACTERS WITHOUT CLAIM TO ANY PARTICULAR FONT, STYLE, SIZE, OR COLOR.

NO CLAIM IS MADE TO THE EXCLUSIVE RIGHT TO USE "LA FRANCE", APART FROM THE MARK AS SHOWN.

FOR ART EXHIBITION SERVICES; AUDIO PRODUCTION SERVICES, NAMELY, CREATING AND PRODUCING AMBIENT SOUNDSCAPES, AND SOUND STORIES FOR MUSEUMS, GALLERIES, ATTRACTIONS, PODCASTS, BROADCASTS, WEBSITES AND GAMES; CONDUCTING ENTERTAINMENT EXHIBITIONS IN THE NATURE OF VISUAL ART; EDITING OR RECORDING OF SOUNDS AND IMAGES; ENTERTAINMENT IN THE NATURE OF LIVE STAGE PERFORMANCES IN THE NATURE OF CONCERTS IN THE FIELD OF VISUAL ART BY AN INDIVIDUAL; ENTERTAINMENT SERVICES BY A MUSICAL ARTIST AND PRODUCER, NAMELY, MUSICAL COMPOSITION FOR OTHERS AND PRODUCTION OF MUSICAL SOUND RECORDINGS; ENTERTAINMENT, NAMELY, LIVE MUSIC CONCERTS; ORGANIZING AND ARRANGING EXHIBITIONS FOR ENTERTAINMENT PURPOSES; ORGANIZING EXHIBITIONS FOR CULTURAL PURPOSE; PRODUCTION OF MUSICAL SOUND RECORDING; PRODUCTION OF SOUND AND IMAGE RECORDINGS ON SOUND AND IMAGE CARRIERS; PRODUCTION OF SOUND AND MUSIC VIDEO RECORDINGS; PRODUCTION OF SOUND RECORDINGS; PRODUCTION OF VISUAL EFFECTS FOR VIDEOS, DVDS, TELEVISION AND FOR INTERNET WEB SITES (U.S. CLS. 100, 101 AND 107).

AMY KELLY, EXAMINING ATTORNEY

SN 85-506,329. EXMORTIS LLC, EAST LANSING, MI. FILED 12-30-2011.



THE MARK CONSISTS OF MULTIPLE LINES INTERCONNECTING AND CROSSING EACH OTHER TO FORM THE WORD "TYRANT". THE FIRST LETTER "T" IS FORMED WITH A VERTICAL LINE WITH A LEFT FACING POINT AND IS CAPPED WITH A DIAMOND SHAPE TO FORM THE TOP PART OF THE "T". THESE LINES ARE CONNECTED WITH THE NEXT SET TO FORM THE "Y". THIS CONSISTS OF TWO LINES CROSSING WITH A LEFT AND RIGHT FACING POINTS TO FORM THE TOP OF THE "Y". THIS IS CONNECTED TO A VERTICAL LINE WITH A LEFT FACING POINT TO FORM THE BOTTOM OF THE "Y". THE RIGHT LINE OF THE TOP PART OF THE "Y" LEADS INTO THE VERTICAL LINE OF THE "R" WHICH HAS A LEFT FACING POINT ON THE BOTTOM. THE TOP

CLASS 41—(Continued).

PART OF THE "R" IS FORMED BY TWO LINES THAT ARE CAPPED BY LEFT AND RIGHT FACING POINTS. THE LEG OF THE "R" CROSSES TO FORM THE LINE IN THE "A" AND PUSHES INTO LEFT LEG OF THE "N". THE "A" IS FORMED BY THE CROSSING LINE AND TWO ANGLED LINES WHICH HAVE LEFT AND RIGHT FACING POINTS. THE "N" IS FORMED A VERTICAL LINE WITH A RIGHT FACING POINT. THIS CONNECTS TO AN ANGLED LINE TO FORM THE MIDDLE SECTION OF THE "N". THIS CONNECTS TO ANOTHER VERTICAL LINE WITH A RIGHT FACING POINT. THE MARK IS FINISHED OFF WITH ANOTHER "T" WHICH IS FORMED WITH A VERTICAL LINE WITH A RIGHT FACING POINT AND IS CAPPED WITH A DIAMOND SHAPE TO FORM THE TOP PART OF THE "T".

FOR ENTERTAINMENT IN THE NATURE OF VISUAL AND AUDIO PERFORMANCES BY A MUSICAL BAND; ENTERTAINMENT SERVICES IN THE NATURE OF LIVE MUSICAL PERFORMANCES; ENTERTAINMENT SERVICES IN THE NATURE OF RECORDING, PRODUCTION AND POST-PRODUCTION SERVICES IN THE FIELD OF MUSIC; ENTERTAINMENT, NAMELY, LIVE MUSIC CONCERTS (U.S. CLS. 100, 101 AND 107).

BRENDAN MCCAULEY, EXAMINING ATTORNEY

SN 85-506,462. A.B.C. HOME FURNISHINGS, INC., NEW YORK, NY. FILED 12-30-2011.

LOVE IN ACTION

THE MARK CONSISTS OF STANDARD CHARACTERS WITHOUT CLAIM TO ANY PARTICULAR FONT, STYLE, SIZE, OR COLOR.

OWNER OF U.S. REG. NO. 3,508,470.

FOR EDUCATIONAL AND ENTERTAINMENT SERVICES, NAMELY, A CONTINUING MULTIMEDIA PROGRAM FEATURING INTERVIEWS OF CELEBRITIES, PUBLIC FIGURES, AND ACTIVISTS IN THE FIELDS OF ENTERTAINMENT, SCIENCE, PHILOSOPHY, PHILANTHROPY, GOVERNMENT, AND THE ENVIRONMENT, DISTRIBUTED VIA VARIOUS PLATFORMS ACROSS MULTIPLE FORMS OF TRANSMISSION MEDIA (U.S. CLS. 100, 101 AND 107).

CHRISTINE MARTIN, EXAMINING ATTORNEY

CLASS 41—(Continued).

SN 85-506,544. SWOPES, PRINCESS JEAN, AKA LAZERWOMAN, SIMI VALLEY, CA. FILED 12-30-2011.

LAZERWOMAN

THE MARK CONSISTS OF STANDARD CHARACTERS WITHOUT CLAIM TO ANY PARTICULAR FONT, STYLE, SIZE, OR COLOR.

OWNER OF U.S. REG. NO. 2,309,391.

THE NAME(S), PORTRAIT(S), AND/OR SIGNATURE(S) SHOWN IN THE MARK IDENTIFIES PRINCESS JEAN SWOPES, WHOSE CONSENT(S) TO REGISTER IS MADE OF RECORD.

FOR ENTERTAINMENT SERVICES, NAMELY, PROVIDING A WEB SITE FEATURING NON-DOWNLOADABLE PRERECORDED VIDEO DANCE AND MUSICAL PERFORMANCES BY AN ENTERTAINER (U.S. CLS. 100, 101 AND 107).

FIRST USE 1-26-2005; IN COMMERCE 7-5-2011.

B. PARADEWELAI, EXAMINING ATTORNEY

CLASS 41—(Continued).

SN 85-506,596. NATIONAL MARINE MANUFACTURERS ASSOCIATION, INC., CHICAGO, IL. FILED 12-30-2011.

FRED'S SHED

THE MARK CONSISTS OF STANDARD CHARACTERS WITHOUT CLAIM TO ANY PARTICULAR FONT, STYLE, SIZE, OR COLOR.

THE NAME(S), PORTRAIT(S), AND/OR SIGNATURE(S) SHOWN IN THE MARK DOES NOT IDENTIFY A PARTICULAR LIVING INDIVIDUAL.

FOR EDUCATIONAL SERVICES, NAMELY, CONDUCTING SEMINARS IN THE FIELD OF BOATING (U.S. CLS. 100, 101 AND 107).

AHSEN KHAN, EXAMINING ATTORNEY

SN 85-506,669. WEIDNER, ALEX, SANTA MONICA, CA. FILED 12-30-2011.

CONNECTED FASHION FESTIVAL

SN 85-506,590. NATIONAL MARINE MANUFACTURERS ASSOCIATION, INC., CHICAGO, IL. FILED 12-30-2011.



THE NAME(S), PORTRAIT(S), AND/OR SIGNATURE(S) SHOWN IN THE MARK DOES NOT IDENTIFY A PARTICULAR LIVING INDIVIDUAL.

THE COLOR(S) BLUE, ORANGE, AND WHITE IS/ARE CLAIMED AS A FEATURE OF THE MARK.

THE MARK CONSISTS OF THE BLUE WORD "FRED'S" IN A CURSIVE FONT ABOVE AN ORANGE TRAPEZOID WITH ROUNDED CORNERS CONTAINING THE WORD "SHED" ABOVE A BLUE WAVE DESIGN ALL CONTAINED WITHIN A BLUE OUTLINED TRAPEZOID WITH ROUNDED CORNERS. THE ORANGE TRAPEZOID PROTRUDES OVER THE BLUE TRAPEZOID, AND THE ENTIRE DESIGN IS ENCIRCLED BY A BLUE BORDER.

FOR EDUCATIONAL SERVICES, NAMELY, CONDUCTING SEMINARS IN THE FIELD OF BOATING (U.S. CLS. 100, 101 AND 107).

AHSEN KHAN, EXAMINING ATTORNEY

THE MARK CONSISTS OF STANDARD CHARACTERS WITHOUT CLAIM TO ANY PARTICULAR FONT, STYLE, SIZE, OR COLOR.

NO CLAIM IS MADE TO THE EXCLUSIVE RIGHT TO USE "FASHION FESTIVAL", APART FROM THE MARK AS SHOWN.

FOR ARRANGING AND CONDUCTING SPECIAL EVENTS FOR SOCIAL ENTERTAINMENT PURPOSES; ENTERTAINMENT IN THE NATURE OF FASHION SHOWS (U.S. CLS. 100, 101 AND 107).

FIRST USE 11-5-2011; IN COMMERCE 11-5-2011.

KATHLEEN M. VANSTON, EXAMINING ATTORNEY

SN 85-506,711. SMB TECHNOLOGY NETWORK, SAN MARINO, CA. FILED 12-30-2011.

SMBTN

THE MARK CONSISTS OF STANDARD CHARACTERS WITHOUT CLAIM TO ANY PARTICULAR FONT, STYLE, SIZE, OR COLOR.

FOR EDUCATIONAL SERVICES OFFERED THROUGH A TRADE ASSOCIATION OF TECHNOLOGY PROFESSIONALS, NAMELY, CONDUCTING TRAINING PROGRAMS IN THE FIELD OF BUSINESS, PROFESSIONAL, AND VENDOR RELATIONS (U.S. CLS. 100, 101 AND 107).

FIRST USE 2-1-2005; IN COMMERCE 2-1-2005.

MARC LEIPZIG, EXAMINING ATTORNEY

CLASS 41—(Continued).

SN 85-506,756. CLANAGAN, JEFF, CALABASAS, CA. FILED 12-31-2011.

PLATINUM COMEDY SERIES

THE MARK CONSISTS OF STANDARD CHARACTERS WITHOUT CLAIM TO ANY PARTICULAR FONT, STYLE, SIZE, OR COLOR.

NO CLAIM IS MADE TO THE EXCLUSIVE RIGHT TO USE "COMEDY SERIES", APART FROM THE MARK AS SHOWN.

FOR ENTERTAINMENT, NAMELY, A CONTINUING COMEDY SHOW BROADCAST OVER TELEVISION, SATELLITE, THE INTERNET, AUDIO, AND VIDEO MEDIA; ENTERTAINMENT SERVICES, NAMELY, THE PROVISION OF CONTINUING SEGMENTS FEATURING COMEDY DELIVERED BY TELEVISION, RADIO, SATELLITE, THE INTERNET, OR LIVE (U.S. CLS. 100, 101 AND 107).

JIM RINGLE, EXAMINING ATTORNEY

SN 85-506,761. GREGORY, ALEX, NEW YORK, NY. FILED 12-31-2011.

COLLABORATIONRX

THE MARK CONSISTS OF STANDARD CHARACTERS WITHOUT CLAIM TO ANY PARTICULAR FONT, STYLE, SIZE, OR COLOR.

FOR PROVIDING CLASSES, SEMINARS, WORKSHOPS, COURSES, AND TRAINING IN THE FIELDS OF INFORMATION MANAGEMENT, VISUALIZATION SOFTWARE, PRODUCTIVITY SOFTWARE, AND DESIGN TOOLS (U.S. CLS. 100, 101 AND 107).

SANI KHOURI, EXAMINING ATTORNEY

SN 85-506,807. D'RIVERA, PAQUITO, NORTH BERGEN, NJ. FILED 12-31-2011.

PAQUITO D'RIVERA

THE MARK CONSISTS OF STANDARD CHARACTERS WITHOUT CLAIM TO ANY PARTICULAR FONT, STYLE, SIZE, OR COLOR.

THE NAME "PAQUITO D'RIVERA" IDENTIFIES A LIVING INDIVIDUAL WHOSE CONSENT IS OF RECORD.

FOR ENTERTAINMENT SERVICES, NAMELY, LIVE MUSICAL PERFORMANCES (U.S. CLS. 100, 101 AND 107).

FIRST USE 0-0-1958; IN COMMERCE 0-0-1958.

JAMES GRIFFIN, EXAMINING ATTORNEY

CLASS 41—(Continued).

SN 85-506,998. YOGINOS: YOGA FOR YOUTH, INC., CORPUS CHRISTI, TX. FILED 12-31-2011.

Ohmazing

THE MARK CONSISTS OF STANDARD CHARACTERS WITHOUT CLAIM TO ANY PARTICULAR FONT, STYLE, SIZE, OR COLOR.

FOR EDUCATIONAL SERVICES, NAMELY, CONDUCTING YOGA CLASSES FOR SCHOOL AGED CHILDREN IN THE FIELD OF PHYSICAL FITNESS AND DISTRIBUTION OF COURSE MATERIAL IN CONNECTION THEREWITH (U.S. CLS. 100, 101 AND 107).

FIRST USE 11-8-2008; IN COMMERCE 11-8-2008.

EDWARD NELSON, EXAMINING ATTORNEY

SN 85-507,107. WEINBERG, MINDY, MONSEY, NY. AND WEINBERG, AMICHAEL, MONSEY, NY. FILED 1-2-2012.



NO CLAIM IS MADE TO THE EXCLUSIVE RIGHT TO USE "CARDIO CLUBBING", APART FROM THE MARK AS SHOWN.

THE MARK CONSISTS OF THE WORDS "CARDIO CLUBBING" IN STYLIZED FONT AND A FIVE-POINTED STAR DESIGN.

FOR DANCE EVENTS; DANCE INSTRUCTION; DANCE INSTRUCTION FOR CHILDREN; DANCE STUDIOS; EDUCATION SERVICES, NAMELY, PROVIDING CLASSES AND INSTRUCTION IN THE FIELD OF DANCE; ENTERTAINMENT IN THE NATURE OF DANCE PERFORMANCES; ENTERTAINMENT IN THE NATURE OF VISUAL AND AUDIO PERFORMANCES, NAMELY, MUSICAL BAND, ROCK GROUP, GYMNAS-TIC, DANCE, AND BALLET PERFORMANCES; ENTERTAINMENT SERVICES IN THE NATURE OF FITNESS AND EXERCISE DANCE PERFORMANCES; ORGANIZATION OF DANCING EVENTS; TRAINING OF DANCE INSTRUCTORS (U.S. CLS. 100, 101 AND 107).

FIRST USE 5-15-2011; IN COMMERCE 5-26-2011.

DAVID YONTEF, EXAMINING ATTORNEY

CLASS 41—(Continued).

SN 85-507,125. PAST MASTER, LLC, CINCINNATI, OH.
FILED 1-2-2012.

The Southgate House Revival

THE MARK CONSISTS OF STANDARD CHARACTERS WITHOUT CLAIM TO ANY PARTICULAR FONT, STYLE, SIZE, OR COLOR.

NO CLAIM IS MADE TO THE EXCLUSIVE RIGHT TO USE "HOUSE REVIVAL", APART FROM THE MARK AS SHOWN.

FOR ARRANGING AND CONDUCTING NIGHTCLUB ENTERTAINMENT EVENTS; ARRANGING AND CONDUCTING SPECIAL EVENTS FOR SOCIAL ENTERTAINMENT PURPOSES; ARRANGING FOR TICKET RESERVATIONS FOR SHOWS AND OTHER ENTERTAINMENT EVENTS; ARRANGING, ORGANIZING, CONDUCTING, AND HOSTING SOCIAL ENTERTAINMENT EVENTS; BOOKING OF ENTERTAINMENT HALLS; EDUCATIONAL AND ENTERTAINMENT SERVICES, NAMELY, A CONTINUING PROGRAM ABOUT MUSIC ACCESSIBLE BY RADIO, TELEVISION, SATELLITE, AUDIO, VIDEO AND COMPUTER NETWORKS; EDUCATIONAL AND ENTERTAINMENT SERVICES, NAMELY, PROVIDING MOTIVATIONAL AND EDUCATIONAL SPEAKERS (U.S. CLS. 100, 101 AND 107).
DAVID YONTEF, EXAMINING ATTORNEY

SN 85-507,126. MARIANA FERRARI, COCONUT GROVE, FL. FILED 1-2-2012.

SIMPLE, SMART & SEXY

THE MARK CONSISTS OF STANDARD CHARACTERS WITHOUT CLAIM TO ANY PARTICULAR FONT, STYLE, SIZE, OR COLOR.

FOR BUSINESS TRAINING CONSULTANCY SERVICES; EDUCATION SERVICES, NAMELY, PROVIDING COURSES OF INSTRUCTION, WORKSHOPS, SEMINARS, PERSONAL AND PROFESSIONAL COACHING AND CONFERENCES IN THE FIELD OF MARKETING (U.S. CLS. 100, 101 AND 107).

FIRST USE 8-1-2010; IN COMMERCE 8-1-2010.
DAVID YONTEF, EXAMINING ATTORNEY

CLASS 41—(Continued).

SN 85-507,160. CUSTOMER FOCUS, INC., ALPHARETTA, GA. FILED 1-2-2012.

The VOICE of the Patient

THE MARK CONSISTS OF STANDARD CHARACTERS WITHOUT CLAIM TO ANY PARTICULAR FONT, STYLE, SIZE, OR COLOR.

OWNER OF U.S. REG. NO. 3,739,278.

FOR EDUCATIONAL SERVICES, NAMELY, CONDUCTING CLINICS, SEMINARS, CLASSES, WORKSHOPS, ONLINE TRAINING, CONFERENCES IN THE FIELD OF HEALTHCARE SERVICE, SAFETY, AND QUALITY IMPROVEMENT AND DISTRIBUTION OF TRAINING MATERIAL IN CONNECTION THEREWITH (U.S. CLS. 100, 101 AND 107).

FIRST USE 11-7-2011; IN COMMERCE 11-7-2011.
JESSICA A. POWERS, EXAMINING ATTORNEY

SN 85-507,237. CABRERA PHOTOGRAPHIC HOUSE, INC., MIAMI, FL. FILED 1-2-2012.

**INTIMATE GLAMOUR
PHOTOGRAPHY**

THE MARK CONSISTS OF STANDARD CHARACTERS WITHOUT CLAIM TO ANY PARTICULAR FONT, STYLE, SIZE, OR COLOR.

NO CLAIM IS MADE TO THE EXCLUSIVE RIGHT TO USE "GLAMOUR PHOTOGRAPHY", APART FROM THE MARK AS SHOWN.

FOR PHOTOGRAPHY SERVICES (U.S. CLS. 100, 101 AND 107).

FIRST USE 5-20-1990; IN COMMERCE 5-20-1990.
AMY KELLY, EXAMINING ATTORNEY

SN 85-507,259. SIMMONS, LEYLAND, NEW YORK, NY. FILED 1-2-2012.

Ballet Noir

THE MARK CONSISTS OF STANDARD CHARACTERS WITHOUT CLAIM TO ANY PARTICULAR FONT, STYLE, SIZE, OR COLOR.

NO CLAIM IS MADE TO THE EXCLUSIVE RIGHT TO USE "BALLET", APART FROM THE MARK AS SHOWN.

FOR ENTERTAINMENT IN THE NATURE OF DANCE PERFORMANCES (U.S. CLS. 100, 101 AND 107).

FIRST USE 10-0-2007; IN COMMERCE 10-0-2007.
AMY KELLY, EXAMINING ATTORNEY

CLASS 41—(Continued).

SN 85-507,324. MASTER BRAZILIAN JIU JITSU, INC., DUNWOODY, GA. FILED 1-3-2012.

ALLIANCE JIU-JITSU

THE MARK CONSISTS OF STANDARD CHARACTERS WITHOUT CLAIM TO ANY PARTICULAR FONT, STYLE, SIZE, OR COLOR.

OWNER OF U.S. REG. NO. 3,185,451.

NO CLAIM IS MADE TO THE EXCLUSIVE RIGHT TO USE "JIU-JITSU", APART FROM THE MARK AS SHOWN.

FOR COACHING IN THE FIELD OF SPORTS; ORGANISATION OF SPORTS COMPETITIONS; ORGANIZING, ARRANGING, AND CONDUCTING BRAZILIAN JIU JITSU EVENTS; PROVIDING A WEBSITE FEATURING INFORMATION RELATING TO THE SPORT OF BRAZILIAN JIU JITSU; SPORTS INSTRUCTION SERVICES; SPORTS TRAINING SERVICES (U.S. CLS. 100, 101 AND 107).

FIRST USE 10-31-1995; IN COMMERCE 1-1-1997.
ROBIN MITTLER, EXAMINING ATTORNEY

CLASS 41—(Continued).

SN 85-507,335. XPX GLOBAL, LLC, WELLESLEY HILLS, MA. FILED 1-3-2012.

OWNERS' ACADEMY

THE MARK CONSISTS OF STANDARD CHARACTERS WITHOUT CLAIM TO ANY PARTICULAR FONT, STYLE, SIZE, OR COLOR.

NO CLAIM IS MADE TO THE EXCLUSIVE RIGHT TO USE "ACADEMY", APART FROM THE MARK AS SHOWN.

FOR CONDUCTING WORKSHOPS AND SEMINARS IN NETWORKING, COLLABORATION AND EDUCATIONAL OPPORTUNITIES FOR ADVISORS, CONSULTANTS, EDUCATORS AND RESEARCHERS FOCUSED ON PREPARING BUSINESS OWNERS FOR THE SUCCESSFUL EXIT OF THEIR BUSINESSES (U.S. CLS. 100, 101 AND 107).

FIRST USE 10-26-2010; IN COMMERCE 10-26-2010.
AMY KELLY, EXAMINING ATTORNEY

SN 85-507,592. COOPERATIVE EDUCATION SERVICE AGENCY NO. 7, AKA CESA 7, GREEN BAY, WI. FILED 1-3-2012.

STANDARDSINSIGHT

THE MARK CONSISTS OF STANDARD CHARACTERS WITHOUT CLAIM TO ANY PARTICULAR FONT, STYLE, SIZE, OR COLOR.

FOR EDUCATION SERVICES, NAMELY, PROVIDING ON-LINE CLASSES, SEMINARS, AND WORKSHOPS FOR USE BY TEACHERS AND ADMINISTRATORS IN STUDYING THE COMMON CORE STATE STANDARDS (U.S. CLS. 100, 101 AND 107).

FIRST USE 12-1-2010; IN COMMERCE 12-21-2010.
GEOFFREY FOSDICK, EXAMINING ATTORNEY

SN 85-507,332. XPX GLOBAL, LLC, WELLESLEY HILLS, MA. FILED 1-3-2012.

XPX

SN 85-507,602. YELLOWSTONE LLC, NEW YORK, NY. FILED 1-3-2012.

THE MARK CONSISTS OF STANDARD CHARACTERS WITHOUT CLAIM TO ANY PARTICULAR FONT, STYLE, SIZE, OR COLOR.

FOR CONDUCTING WORKSHOPS AND SEMINARS IN NETWORKING, COLLABORATION AND EDUCATIONAL OPPORTUNITIES FOR ADVISORS, CONSULTANTS, EDUCATORS AND RESEARCHERS FOCUSED ON PREPARING BUSINESS OWNERS FOR THE SUCCESSFUL EXIT OF THEIR BUSINESSES; ON-LINE JOURNALS, NAMELY, BLOGS FEATURING NETWORKING, COLLABORATION AND EDUCATIONAL OPPORTUNITIES FOR ADVISORS, CONSULTANTS, EDUCATORS AND RESEARCHERS FOCUSED ON PREPARING BUSINESS OWNERS FOR THE SUCCESSFUL EXIT OF THEIR BUSINESSES (U.S. CLS. 100, 101 AND 107).

FIRST USE 3-16-2007; IN COMMERCE 3-16-2007.
AMY KELLY, EXAMINING ATTORNEY

KEY ELEMENT

THE MARK CONSISTS OF STANDARD CHARACTERS WITHOUT CLAIM TO ANY PARTICULAR FONT, STYLE, SIZE, OR COLOR.

FOR CHILDREN'S ENTERTAINMENT AND AMUSEMENT CENTERS, NAMELY, INTERACTIVE PLAY AREAS; EDUCATIONAL AND ENTERTAINMENT SERVICES FOR CHILDREN, NAMELY, PROVIDING INTERACTIVE PLAY AREAS, INSTRUCTIONAL CLASSES IN THE FIELD OF DANCE, ART, MUSIC, LANGUAGES, AND SOCIAL GATHERINGS FOR CHILDREN; SUMMER CAMPS (U.S. CLS. 100, 101 AND 107).

MELISSA VALLILLO, EXAMINING ATTORNEY

CLASS 41—(Continued).

SN 85-507,672. AMERICAN INTERNATIONAL COLLEGE, SPRINGFIELD, MA. FILED 1-3-2012.

AIC

THE MARK CONSISTS OF STANDARD CHARACTERS WITHOUT CLAIM TO ANY PARTICULAR FONT, STYLE, SIZE, OR COLOR.

FOR EDUCATIONAL SERVICES, NAMELY, PROVIDING COURSES OF INSTRUCTION AT THE COLLEGE LEVEL (U.S. CLS. 100, 101 AND 107).

FIRST USE 6-30-1937; IN COMMERCE 6-30-1937.

JULIE WATSON, EXAMINING ATTORNEY

SN 85-507,681. HOODSTARRECORDS, OAKLAND, CA. FILED 1-3-2012.

Papa Don

THE MARK CONSISTS OF STANDARD CHARACTERS WITHOUT CLAIM TO ANY PARTICULAR FONT, STYLE, SIZE, OR COLOR.

THE NAME(S), PORTRAIT(S), AND/OR SIGNATURE(S) SHOWN IN THE MARK IDENTIFIES "DONALD BIRKS", WHOSE CONSENT(S) TO REGISTER IS MADE OF RECORD.

FOR ENTERTAINMENT IN THE NATURE OF LIVE PERFORMANCES BY A MUSICAL ARTIST; ENTERTAINMENT SERVICES IN THE NATURE OF LIVE MUSICAL PERFORMANCES; ENTERTAINMENT, NAMELY, LIVE MUSIC CONCERTS (U.S. CLS. 100, 101 AND 107).

FIRST USE 7-25-2006; IN COMMERCE 7-25-2006.

JESSICA A. POWERS, EXAMINING ATTORNEY

SN 85-507,774. AUREL A. ASTILEAN, EAST HAMPTON, NY. FILED 1-3-2012.

SPEEDFIT

THE MARK CONSISTS OF STANDARD CHARACTERS WITHOUT CLAIM TO ANY PARTICULAR FONT, STYLE, SIZE, OR COLOR.

FOR HEALTH CLUB SERVICES, NAMELY, PROVIDING INSTRUCTION AND EQUIPMENT IN THE FIELD OF PHYSICAL EXERCISE; PHYSICAL FITNESS INSTRUCTION (U.S. CLS. 100, 101 AND 107).

FIRST USE 11-25-2004; IN COMMERCE 11-25-2004.

JIM RINGLE, EXAMINING ATTORNEY

CLASS 41—(Continued).

SN 85-507,785. GOULD, JAMES M., CINCINNATI, OH. FILED 1-3-2012.

A CURRENT LIFE

THE MARK CONSISTS OF STANDARD CHARACTERS WITHOUT CLAIM TO ANY PARTICULAR FONT, STYLE, SIZE, OR COLOR.

FOR ENTERTAINMENT SERVICES IN THE NATURE OF A RADIO INTERVIEW PROGRAM (U.S. CLS. 100, 101 AND 107).

FIRST USE 10-14-2011; IN COMMERCE 10-14-2011.

KEVIN DINALLO, EXAMINING ATTORNEY

SN 85-507,788. THE FLINT INSTITUTE OF MUSIC, FLINT, MI. FILED 1-3-2012.

NO CLAIM IS MADE TO THE EXCLUSIVE RIGHT TO USE "POPS", APART FROM THE MARK AS SHOWN.

THE MARK CONSISTS OF THE WORDS "THE HOLIDAY POPS" IN ALL CAPITAL LETTERS (OF VARYING SIZES AND PROPORTIONS), WITH THE LETTER "D" BEING A MUSICAL NOTE.

FOR ENTERTAINMENT, NAMELY, LIVE MUSIC CONCERTS (U.S. CLS. 100, 101 AND 107).

FIRST USE 11-1-1985; IN COMMERCE 11-1-1985.

TOBY BULLOFF, EXAMINING ATTORNEY

SN 85-507,804. BAILEY DARYL L., DBA BLUESMANWARRIOR, ST.CLOUD, FL. FILED 1-3-2012.

bluesmanwarrior

THE MARK CONSISTS OF STANDARD CHARACTERS WITHOUT CLAIM TO ANY PARTICULAR FONT, STYLE, SIZE, OR COLOR.

FOR ENTERTAINMENT SERVICES IN THE NATURE OF LIVE MUSICAL PERFORMANCES (U.S. CLS. 100, 101 AND 107).

MIDGE BUTLER, EXAMINING ATTORNEY

CLASS 41—(Continued).

SN 85-507,829. STACI SNAIR, INC., RONKONKOMA, NY. FILED 1-3-2012.

SAY IT. THINK IT. FEEL IT.
LIVE IT.

THE MARK CONSISTS OF STANDARD CHARACTERS WITHOUT CLAIM TO ANY PARTICULAR FONT, STYLE, SIZE, OR COLOR.
FOR EDUCATIONAL SERVICES, NAMELY, PROVIDING SEMINARS AND WORKSHOPS IN THE FIELD OF METAPHYSICS; CONDUCTING SEMINARS AND WORKSHOPS IN THE FIELD OF METAPHYSICS (U.S. CLS. 100, 101 AND 107).
FIRST USE 12-11-2011; IN COMMERCE 12-11-2011.
MARK RADEMACHER, EXAMINING ATTORNEY

SN 85-507,949. BUTTENHEIM, MEGHA NANCY, PITTSFIELD, MA. FILED 1-3-2012.

GRACE IN MOTION

THE MARK CONSISTS OF STANDARD CHARACTERS WITHOUT CLAIM TO ANY PARTICULAR FONT, STYLE, SIZE, OR COLOR.
FOR EDUCATIONAL SERVICES, NAMELY, CONDUCTING WORKSHOPS, CLASSES, SEMINARS, CONFERENCES, TEACHER TRAININGS AND RETREATS IN THE FIELD OF DANCE, YOGA, MOVEMENT, BREATH TECHNIQUES, EXPRESSIVE MOVEMENT THERAPY AND SELF-EMPOWERMENT (U.S. CLS. 100, 101 AND 107).
FIRST USE 0-0-1995; IN COMMERCE 0-0-1995.
CAROLINE WOOD, EXAMINING ATTORNEY

CLASS 41—(Continued).

SN 85-508,001. DONNA J. GAGNON, QUEENSBURY, NY. FILED 1-3-2012.

GLife

THE MARK CONSISTS OF STANDARD CHARACTERS WITHOUT CLAIM TO ANY PARTICULAR FONT, STYLE, SIZE, OR COLOR.
FOR EDUCATIONAL AND ENTERTAINMENT SERVICES, NAMELY, A CONTINUING PROGRAM ABOUT LIFESTYLE AND CULTURE ACCESSIBLE BY RADIO, TELEVISION, SATELLITE, AUDIO, VIDEO AND COMPUTER NETWORKS; ENTERTAINMENT SERVICES IN THE NATURE OF AN ONGOING IPTV (INTERNET PROTOCOL TELEVISION), TELEVISION PROGRAMMING SEGMENTS IN THE FIELD OF POSITIVE PSYCHOLOGY, PERSONAL RELATIONSHIPS, THE ART AND SCIENCE OF HAPPINESS; ENTERTAINMENT SERVICES, NAMELY, AN ON-GOING SERIES FEATURING LIFESTYLE AND CULTURE PROVIDED THROUGH TELEVISION, INTERNET, RADIO, SATELLITE COMMUNICATIONS; ENTERTAINMENT SERVICES, NAMELY, PRODUCTION AND DISTRIBUTION OF ONGOING TELEVISION PROGRAMS IN THE FIELD OF LIFESTYLE AND CULTURE; ENTERTAINMENT SERVICES, NAMELY, PROVIDING ON-GOING TELEVISION PROGRAMS IN THE FIELD OF LIFESTYLE AND CULTURE VIA A GLOBAL COMPUTER NETWORK; ENTERTAINMENT, NAMELY, A CONTINUING LIFESTYLE AND CULTURE SHOW BROADCAST OVER TELEVISION, SATELLITE, AUDIO, AND VIDEO MEDIA; ENTERTAINMENT, NAMELY, A CONTINUING LIFESTYLE AND CULTURE SHOW BROADCAST OVER TELEVISION, SATELLITE, AUDIO, VIDEO, AND INTERNET MEDIA; MULTIMEDIA PUBLISHING OF BOOKS, MAGAZINES, JOURNALS, SOFTWARE, GAMES, MUSIC, AND ELECTRONIC PUBLICATIONS; ONLINE ELECTRONIC PUBLISHING OF BOOKS AND PERIODICALS; PROVIDING A WEBSITE FEATURING NON-DOWNLOADABLE PUBLICATIONS IN THE NATURE OF BOOKS, PERIODICALS, BROCHURES, PAMPHLETS, BLOGS, AND MAGAZINES, IN THE FIELD OF LIFESTYLE AND CULTURE; PROVIDING A WEBSITE FEATURING RESOURCES, NAMELY, NON-DOWNLOADABLE PUBLICATIONS IN THE NATURE OF BOOKS, PERIODICALS, BROCHURES, PAMPHLETS, BLOGS, AND MAGAZINES IN THE FIELD OF LIFESTYLE AND CULTURE; PROVIDING ON-LINE MAGAZINES IN THE FIELD OF LIFESTYLE AND CULTURE; PROVIDING ON-LINE NON-DOWNLOADABLE GENERAL FEATURE MAGAZINES; PROVIDING ON-LINE PUBLICATIONS IN THE NATURE OF AN E-BOOK IN THE FIELD OF LIFESTYLE AND CULTURE; PROVIDING ONLINE NON-DOWNLOADABLE COMIC BOOKS AND GRAPHIC NOVELS; PUBLICATION OF BOOKS; PUBLICATION OF BOOKS, MAGAZINES, ALMANACS AND JOURNALS; PUBLICATION OF BOOKS, OF MAGAZINES, OF JOURNALS, OF NEWSPAPERS, OF PERIODICALS, OF CATALOGS, OF BROCHURES; PUBLICATION OF BOOKS, REVIEWS; PUBLICATION OF ELECTRONIC MAGAZINES; PUBLICATION OF PRINTED MATERIALS, NAMELY BOOKS, PERIODICALS, BROCHURES, PAMPHLETS, AND MAGAZINES; PUBLISHING OF BOOKS, E-BOOKS, AUDIO BOOKS, MUSIC AND ILLUSTRATIONS; PUBLISHING OF WEB MAGAZINES (U.S. CLS. 100, 101 AND 107).
MATTHEW EINSTEIN, EXAMINING ATTORNEY

CLASS 41—(Continued).

SN 85-508,344. WOODARD, BRANDI C., DBA BRANDILOU LLC, KUTZTOWN, PA. FILED 1-4-2012.

YODATES

THE MARK CONSISTS OF STANDARD CHARACTERS WITHOUT CLAIM TO ANY PARTICULAR FONT, STYLE, SIZE, OR COLOR.

FOR PHYSICAL FITNESS INSTRUCTION, NAMELY, A SOMATIC EXERCISE PROGRAM (U.S. CLS. 100, 101 AND 107).

FIRST USE 5-1-2001; IN COMMERCE 5-1-2001.
MICHAEL KEATING, EXAMINING ATTORNEY

CLASS 41—(Continued).

SN 85-508,451. EXMORTIS, LLC, EAST LANSING, MI. FILED 1-4-2012.

TYRANT

THE MARK CONSISTS OF STANDARD CHARACTERS WITHOUT CLAIM TO ANY PARTICULAR FONT, STYLE, SIZE, OR COLOR.

FOR ENTERTAINMENT IN THE NATURE OF VISUAL AND AUDIO PERFORMANCES BY A MUSICAL BAND; ENTERTAINMENT SERVICES IN THE NATURE OF LIVE MUSICAL PERFORMANCES; ENTERTAINMENT SERVICES IN THE NATURE OF RECORDING, PRODUCTION AND POST-PRODUCTION SERVICES IN THE FIELD OF MUSIC; ENTERTAINMENT, NAMELY, LIVE MUSIC CONCERTS (U.S. CLS. 100, 101 AND 107).
BRENDAN MCCAULEY, EXAMINING ATTORNEY

SN 85-508,537. TBB FILM INVESTORS LLC, GREENSBORO, NC. FILED 1-4-2012.

DOG RUN PICTURES

SN 85-508,423. DANTZLER, CORNELL, CHICAGO, IL. FILED 1-4-2012.

Black Steps

THE MARK CONSISTS OF STANDARD CHARACTERS WITHOUT CLAIM TO ANY PARTICULAR FONT, STYLE, SIZE, OR COLOR.

NO CLAIM IS MADE TO THE EXCLUSIVE RIGHT TO USE "PICTURES", APART FROM THE MARK AS SHOWN.

FOR ENTERTAINMENT SERVICES IN THE NATURE OF PRODUCTION AND DISTRIBUTION OF MOTION PICTURES (U.S. CLS. 100, 101 AND 107).

VERNA BETH RIRIE, EXAMINING ATTORNEY

SN 85-508,574. ERIKA ABRAHAMSSON, HOUSTON, TX. FILED 1-4-2012.

CareerCram

THE MARK CONSISTS OF STANDARD CHARACTERS WITHOUT CLAIM TO ANY PARTICULAR FONT, STYLE, SIZE, OR COLOR.

FOR CHARITABLE SERVICES, NAMELY, ACADEMIC MENTORING OF SCHOOL AGE CHILDREN; CHARITABLE SERVICES, NAMELY, MENTORING DISADVANTAGED GIRLS IN THE FIELD OF PERSONAL DEVELOPMENT; EDUCATION SERVICES, NAMELY, MENTORING IN THE FIELD OF AT RISK IN ACADEMICS; EDUCATION SERVICES, NAMELY, PRE-KINDERGARTEN THROUGH 12TH GRADE CLASSROOM INSTRUCTION, VOCATIONAL INSTRUCTION, MENTORING, TUTORING, CLASSES, SEMINARS AND WORKSHOPS FOR INDIVIDUALS WITH ENVIRONMENTAL CHALLENGES CAUSING THEM TO BE AT RISK FOR ACADEMIC FAILURE; PROVIDING EDUCATIONAL MENTORING SERVICES AND PROGRAMS IN THE FIELD OF PERSONAL GROWTH; PROVIDING SCIENCE EDUCATIONAL MENTORING SERVICES AND PROGRAMS (U.S. CLS. 100, 101 AND 107).
TASHIA BUNCH, EXAMINING ATTORNEY

THE MARK CONSISTS OF STANDARD CHARACTERS WITHOUT CLAIM TO ANY PARTICULAR FONT, STYLE, SIZE, OR COLOR.

FOR PROVIDING A BLOG FEATURING CAREER ADVICE RELATED TO THE EDUCATIONAL REQUIREMENTS FOR CAREER PLACEMENT AND ADVANCEMENT, COMPETITIVE SALARY OPPORTUNITIES, JOB OPPORTUNITIES, JOB RESOURCES AND LISTINGS, RESUMES, INTERVIEWS, INTERNSHIPS, COLLEGE APPLICATIONS, AND GENERAL CAREER-RELATED INFORMATION, AS IT PERTAINS TO HIGH SCHOOL OR COLLEGE STUDENTS (U.S. CLS. 100, 101 AND 107).
FIRST USE 11-3-2011; IN COMMERCE 11-3-2011.

JUDITH HELFMAN, EXAMINING ATTORNEY

CLASS 41—(Continued).

SN 85-508,604. TAREH, ALI, PINELLAS PARK, FL. FILED 1-4-2012.

PAHLAVAN

THE MARK CONSISTS OF STANDARD CHARACTERS WITHOUT CLAIM TO ANY PARTICULAR FONT, STYLE, SIZE, OR COLOR.

THE ENGLISH TRANSLATION OF "PAHLAVAN" IS "CHAMPION"

FOR ATHLETIC AND SPORTS EVENT SERVICES, NAMELY, ARRANGING, ORGANIZING, OPERATING AND CONDUCTING FIGHTING COMPETITIONS (U.S. CLS. 100, 101 AND 107).

GISELLE AGOSTO, EXAMINING ATTORNEY

SN 85-508,636. TARICANI, JOSEPH, NEWPORT BEACH, CA. FILED 1-4-2012.

BRIGHT RUNNING

THE MARK CONSISTS OF STANDARD CHARACTERS WITHOUT CLAIM TO ANY PARTICULAR FONT, STYLE, SIZE, OR COLOR.

NO CLAIM IS MADE TO THE EXCLUSIVE RIGHT TO USE "RUNNING", APART FROM THE MARK AS SHOWN.

FOR ENTERTAINMENT SERVICES, NAMELY, AN ONGOING RADIO PROGRAM IN THE FIELD OF RUNNING, FITNESS, ACTIVE LIFESTYLES, NUTRITION AND WELLNESS; ENTERTAINMENT SERVICES, NAMELY, PROVIDING WEBCASTS IN THE FIELD OF RUNNING, FITNESS, ACTIVE LIFESTYLES, NUTRITION AND WELLNESS (U.S. CLS. 100, 101 AND 107).

B. PARADEWELAI, EXAMINING ATTORNEY

SN 85-508,669. AMERICAN COLLEGE OF RHEUMATOLOGY, ATLANTA, GA. FILED 1-4-2012.

RHEUMATOLOGY ROUNDUP

THE MARK CONSISTS OF STANDARD CHARACTERS WITHOUT CLAIM TO ANY PARTICULAR FONT, STYLE, SIZE, OR COLOR.

OWNER OF U.S. REG. NOS. 2,041,688, 2,462,442 AND OTHERS.

NO CLAIM IS MADE TO THE EXCLUSIVE RIGHT TO USE "RHEUMATOLOGY", APART FROM THE MARK AS SHOWN.

FOR ORGANIZATION AND PRESENTATION OF LIVE AND ON-LINE CONFERENCES IN THE FIELD OF RHEUMATOLOGY (U.S. CLS. 100, 101 AND 107).

FIRST USE 8-17-2005; IN COMMERCE 12-0-2005.

JAY FLOWERS, EXAMINING ATTORNEY

CLASS 41—(Continued).

SN 85-508,677. PASSION FOR PUMPKINS, INC., OXFORD, MA. FILED 1-4-2012.

JACK-O-LANTERN SPECTACULAR

THE MARK CONSISTS OF STANDARD CHARACTERS WITHOUT CLAIM TO ANY PARTICULAR FONT, STYLE, SIZE, OR COLOR.

NO CLAIM IS MADE TO THE EXCLUSIVE RIGHT TO USE "JACK-O-LANTERN", APART FROM THE MARK AS SHOWN.

FOR CONDUCTING ENTERTAINMENT EXHIBITIONS IN THE NATURE OF PUMPKIN FESTIVALS (U.S. CLS. 100, 101 AND 107).

FIRST USE 10-31-2000; IN COMMERCE 10-31-2000.

REBECCA SMITH, EXAMINING ATTORNEY

SN 85-508,764. REAL ESTATE BUSINESS SERVICES, INC., LOS ANGELES, CA. FILED 1-4-2012.

LEARNMYWAY

THE MARK CONSISTS OF STANDARD CHARACTERS WITHOUT CLAIM TO ANY PARTICULAR FONT, STYLE, SIZE, OR COLOR.

FOR PROVIDING ONLINE EDUCATIONAL COURSES IN THE FIELD OF REAL ESTATE (U.S. CLS. 100, 101 AND 107).

MELISSA VALLILLO, EXAMINING ATTORNEY

SN 85-508,794. FRASSATI CATHOLIC ACADEMY, WAUCONDA, IL. FILED 1-4-2012.



NO CLAIM IS MADE TO THE EXCLUSIVE RIGHT TO USE "CATHOLIC ACADEMY", APART FROM THE MARK AS SHOWN.

THE MARK CONSISTS OF AN ABSTRACT OUTLINE OF A MOUNTAIN RANGE, WITH A FIVE-POINTED STAR ABOVE AND TO THE LEFT OF THE OUTLINE, AND THE WORDS "FRASSATI CATHOLIC ACADEMY", WITH THE "T" IN "FRASSATI" REPRESENTED BY A SYMBOL OF A RELIGIOUS CROSS.

FOR EDUCATIONAL SERVICES, NAMELY, CONDUCTING CLASSES, SEMINARS AND LECTURES IN AN ELEMENTARY; ENTERTAINMENT SERVICES IN THE NATURE OF YOUTH SPORTING EVENTS (U.S. CLS. 100, 101 AND 107).

FIRST USE 9-0-2010; IN COMMERCE 9-0-2010.

WILLIAM ROSSMAN, EXAMINING ATTORNEY

CLASS 41—(Continued).

SN 85-508,868. ROCKETT, IRA L., RADCLIFF, KY. FILED 1-4-2012.

Erryday Ent. X/IV

THE MARK CONSISTS OF STANDARD CHARACTERS WITHOUT CLAIM TO ANY PARTICULAR FONT, STYLE, SIZE, OR COLOR.

NO CLAIM IS MADE TO THE EXCLUSIVE RIGHT TO USE "ENT.", APART FROM THE MARK AS SHOWN.

FOR ARRANGING AND CONDUCTING SPECIAL EVENTS FOR SOCIAL ENTERTAINMENT PURPOSES (U.S. CLS. 100, 101 AND 107).

LOURDES AYALA, EXAMINING ATTORNEY

CLASS 41—(Continued).

SN 85-508,956. PAST MASTER, LLC., DBA THE HISTORIC SOUTHGATE HOUSE, CININNATI, OH. FILED 1-4-2012.

**The Historic Southgate
House**

THE MARK CONSISTS OF STANDARD CHARACTERS WITHOUT CLAIM TO ANY PARTICULAR FONT, STYLE, SIZE, OR COLOR.

NO CLAIM IS MADE TO THE EXCLUSIVE RIGHT TO USE "HISTORIC" AND "HOUSE", APART FROM THE MARK AS SHOWN.

FOR ARRANGING AND CONDUCTING NIGHTCLUB ENTERTAINMENT EVENTS; ARRANGING AND CONDUCTING SPECIAL EVENTS FOR SOCIAL ENTERTAINMENT PURPOSES; ARRANGING FOR TICKET RESERVATIONS FOR SHOWS AND OTHER ENTERTAINMENT EVENTS; ARRANGING, ORGANIZING, CONDUCTING, AND HOSTING SOCIAL ENTERTAINMENT EVENTS; BOOKING OF ENTERTAINMENT HALLS; CONDUCTING ENTERTAINMENT EXHIBITIONS IN THE NATURE OF ART EXHIBITIONS AND LIVE MUSICAL PERFORMANCES; CONSULTATION IN THE FIELD OF SPECIAL EVENT PLANNING FOR SOCIAL ENTERTAINMENT PURPOSES (U.S. CLS. 100, 101 AND 107).

DAVID YONTEF, EXAMINING ATTORNEY

SN 85-508,933. FUEL TV, INC., LOS ANGELES, CA. FILED 1-4-2012.



NO CLAIM IS MADE TO THE EXCLUSIVE RIGHT TO USE "TV", APART FROM THE MARK AS SHOWN.

THE MARK CONSISTS OF THE WORDS "FUEL" AND "TV" WITH "TV" APPEARING IN LOWERCASE AND SUPERSCRIPIT POSITION TO THE RIGHT OF THE WORD "FUEL".

FOR ENTERTAINMENT SERVICES, NAMELY, PROVISION OF ON-GOING MULTIMEDIA PROGRAMS IN THE FIELD OF SPORTS AND NEWS DISTRIBUTED VIA VARIOUS PLATFORMS ACROSS MULTIPLE FORMS OF TRANSMISSION MEDIA; PROVIDING ON-LINE ENTERTAINMENT INFORMATION IN THE FIELD OF SPORTS AND NEWS (U.S. CLS. 100, 101 AND 107).

FIRST USE 1-1-2012; IN COMMERCE 1-1-2012.

DAVID MURRAY, EXAMINING ATTORNEY

SN 85-508,976. PUGH, QUINTON, PINE BLUFF, AR. FILED 1-5-2012.

**LATE NIGHT/EARLY MORNING
MUSIC**

THE MARK CONSISTS OF STANDARD CHARACTERS WITHOUT CLAIM TO ANY PARTICULAR FONT, STYLE, SIZE, OR COLOR.

NO CLAIM IS MADE TO THE EXCLUSIVE RIGHT TO USE "MUSIC", APART FROM THE MARK AS SHOWN.

FOR MUSIC PRODUCTION SERVICES; ENTERTAINMENT SERVICES IN THE NATURE OF RECORDING, PRODUCTION AND POST-PRODUCTION SERVICES IN THE FIELD OF MUSIC; PRODUCTION OF SOUND AND MUSIC VIDEO RECORDINGS; COMPOSITION OF MUSIC FOR OTHERS; MUSIC PUBLISHING SERVICES; PROVIDING AN INTERNET WEBSITE PORTAL IN THE FIELD OF MUSIC; MUSIC TRANSCRIPTION FOR OTHERS; ARRANGING AND CONDUCTING OF CONCERTS (U.S. CLS. 100, 101 AND 107).

KATHERINE CONNOLLY, EXAMINING ATTORNEY

CLASS 41—(Continued).

SN 85-509,071. VHS, INC., MAYNARD, MA. FILED 1-5-2012.

The VHS Collaborative

THE MARK CONSISTS OF STANDARD CHARACTERS WITHOUT CLAIM TO ANY PARTICULAR FONT, STYLE, SIZE, OR COLOR.

OWNER OF U.S. REG. NOS. 2,230,686 AND 2,987,319.

NO CLAIM IS MADE TO THE EXCLUSIVE RIGHT TO USE "COLLABORATIVE", APART FROM THE MARK AS SHOWN.

FOR EDUCATIONAL SERVICES, NAMELY, PROVIDING SECONDARY LEVEL COURSES AND CONTINUING PROFESSIONAL EDUCATION COURSES FOR EDUCATORS IN THE FIELD OF BLENDING TECHNOLOGY WITH TRADITIONAL EDUCATIONAL METHODS; PROVIDING CUSTOMIZED COURSES IN THE FIELD OF SECONDARY EDUCATION; PROVIDING EDUCATIONAL CONSULTING SERVICES RELATED TO THE AFOREMENTIONED SERVICES (U.S. CLS. 100, 101 AND 107).

BRIDGETT SMITH, EXAMINING ATTORNEY

CLASS 41—(Continued).

SN 85-509,279. PDB SPORTS, LTD., ENGLEWOOD, CO. FILED 1-5-2012.

ORANGE RIDE

THE MARK CONSISTS OF STANDARD CHARACTERS WITHOUT CLAIM TO ANY PARTICULAR FONT, STYLE, SIZE, OR COLOR.

NO CLAIM IS MADE TO THE EXCLUSIVE RIGHT TO USE "RIDE", APART FROM THE MARK AS SHOWN.

FOR ENTERTAINMENT IN THE NATURE OF ORGANIZING AND CONDUCTING A BICYCLE RIDE TO PROMOTE A PROFESSIONAL FOOTBALL GAME (U.S. CLS. 100, 101 AND 107).

FIRST USE 9-27-2010; IN COMMERCE 10-17-2010.

MARK RADEMACHER, EXAMINING ATTORNEY

SN 85-509,381. DONNEY, GENE, BOCA RATON, FL. FILED 1-5-2012.

SUPERSTAR SPORTS

THE MARK CONSISTS OF STANDARD CHARACTERS WITHOUT CLAIM TO ANY PARTICULAR FONT, STYLE, SIZE, OR COLOR.

NO CLAIM IS MADE TO THE EXCLUSIVE RIGHT TO USE "SPORTS", APART FROM THE MARK AS SHOWN.

FOR ENTERTAINMENT SERVICES, NAMELY, PROVIDING VIDEO AND AUDIO CONTENT, NAMELY, ONGOING TELEVISION PROGRAMS IN THE NATURE OF CURRENT EVENTS, SPORTS NEWS AND ENTERTAINMENT NEWS ALL TRANSMITTED THROUGH A GLOBAL COMMUNICATIONS NETWORK VIA WIRELESS COMMUNICATION DEVICES, MOBILE PHONES, HAND-HELD DEVICES; PROVIDING INFORMATION IN THE FIELD OF ENTERTAINMENT VIA WIRELESS COMMUNICATION DEVICES, MOBILE PHONES, HAND-HELD DEVICES AND GLOBAL COMMUNICATION DEVICES; INTERACTIVE ONLINE NEWSLETTER PROVIDING SPORTS AND ENTERTAINMENT INFORMATION; ENTERTAINMENT IN THE NATURE OF ONGOING TELEVISION PROGRAMS IN THE FIELD OF SPORTS AND ENTERTAINMENT NEWS; ENTERTAINMENT SERVICES, NAMELY, AN ON-GOING SERIES FEATURING CURRENT EVENTS, SPORTS NEWS AND ENTERTAINMENT NEWS PROVIDED THROUGH TELEVISION BROADCASTS, WEBCASTS AND RADIO BROADCASTS; ON-LINE JOURNALS, NAMELY, BLOGS FEATURING CURRENT EVENTS, SPORTS AND ENTERTAINMENT NEWS; ENTERTAINMENT SERVICES, NAMELY, PROVIDING A WEBSITE FEATURING CURRENT EVENTS, SPORTS AND ENTERTAINMENT NEWS (U.S. CLS. 100, 101 AND 107).

ANDREA HACK, EXAMINING ATTORNEY

SN 85-509,221. FRASSATI CATHOLIC ACADEMY, WAUCONDA, IL. FILED 1-5-2012.

FRASSATI CATHOLIC ACADEMY

THE MARK CONSISTS OF STANDARD CHARACTERS WITHOUT CLAIM TO ANY PARTICULAR FONT, STYLE, SIZE, OR COLOR.

NO CLAIM IS MADE TO THE EXCLUSIVE RIGHT TO USE "CATHOLIC ACADEMY", APART FROM THE MARK AS SHOWN.

FOR EDUCATIONAL SERVICES, NAMELY, CONDUCTING CLASSES, SEMINARS AND LECTURES IN AN ELEMENTARY; ENTERTAINMENT SERVICES IN THE NATURE OF YOUTH SPORTING EVENTS (U.S. CLS. 100, 101 AND 107).

FIRST USE 9-0-2010; IN COMMERCE 9-0-2010.

WILLIAM ROSSMAN, EXAMINING ATTORNEY

CLASS 41—(Continued).

SN 85-509,678. ARKTOS ENTERTAINMENT GROUP LLC, LOS ANGELES, CA. FILED 1-5-2012.

WAR OF MECHS

THE MARK CONSISTS OF STANDARD CHARACTERS WITHOUT CLAIM TO ANY PARTICULAR FONT, STYLE, SIZE, OR COLOR.

FOR ENTERTAINMENT SERVICES, NAMELY, PROVIDING ONLINE ELECTRONIC GAMES (U.S. CLS. 100, 101 AND 107).

GINA HAYES, EXAMINING ATTORNEY

SN 85-509,699. SIMON, JOE, AUSTIN, TX. FILED 1-5-2012.

THE DELIVERY MEN

THE MARK CONSISTS OF STANDARD CHARACTERS WITHOUT CLAIM TO ANY PARTICULAR FONT, STYLE, SIZE, OR COLOR.

FOR FILM PRODUCTION; VIDEO TAPE FILM PRODUCTION; DIGITAL FILM PRODUCTION; COLOR GRADING SERVICES FOR FILM; FILM EDITING; FILM DIRECTING SERVICES; PHOTOGRAPHY; PHOTOGRAPHY SERVICES; PHOTOGRAPHY DIRECTING SERVICES (U.S. CLS. 100, 101 AND 107).

JEFF DEFORD, EXAMINING ATTORNEY

SN 85-509,761. PINEGAR, TAMARA, HENDERSON, NV. AND PINEGAR, KIMBERLY, HENDERSON, NV. FILED 1-5-2012.

WAGS TO RICHES

THE MARK CONSISTS OF STANDARD CHARACTERS WITHOUT CLAIM TO ANY PARTICULAR FONT, STYLE, SIZE, OR COLOR.

FOR ENTERTAINMENT IN THE NATURE OF ONGOING TELEVISION PROGRAMS IN THE FIELD OF FOLLOWING THE LIVES OF RESCUE DOGS AND THEIR OWNERS (U.S. CLS. 100, 101 AND 107).

BILL DAWE, EXAMINING ATTORNEY

CLASS 41—(Continued).

SN 85-509,922. KASSA, DANIEL, NEW YORK, NY. FILED 1-5-2012.

African Post

THE MARK CONSISTS OF STANDARD CHARACTERS WITHOUT CLAIM TO ANY PARTICULAR FONT, STYLE, SIZE, OR COLOR.

OWNER OF U.S. REG. NO. 3,594,493.

NO CLAIM IS MADE TO THE EXCLUSIVE RIGHT TO USE "AFRICAN", APART FROM THE MARK AS SHOWN.

FOR PROVIDING AN INTERNET NEWS PORTAL FEATURING LINKS TO NEWS STORIES AND ARTICLES IN THE FIELD OF CURRENT EVENTS (U.S. CLS. 100, 101 AND 107).

FIRST USE 12-27-2001; IN COMMERCE 12-27-2001.

JORDAN BAKER, EXAMINING ATTORNEY

SN 85-509,954. BRISLAWN, MONICA, SANTA ANA, CA. FILED 1-5-2012.

Light For Your Way

THE MARK CONSISTS OF STANDARD CHARACTERS WITHOUT CLAIM TO ANY PARTICULAR FONT, STYLE, SIZE, OR COLOR.

FOR CONDUCTING WORKSHOPS AND SEMINARS IN RELIGION; EDUCATIONAL SERVICES, NAMELY, CONDUCTING SEMINARS, LECTURES, TALKS IN THE FIELD OF RELIGIOUS EDUCATION AND DISTRIBUTION OF EDUCATIONAL MATERIALS IN CONNECTION THEREWITH; RELIGIOUS INSTRUCTION SERVICES (U.S. CLS. 100, 101 AND 107).

EMILY CHUO, EXAMINING ATTORNEY

SN 85-510,010. ARENDS, SHELLEY, LAGUNA BEACH, CA. FILED 1-5-2012.

RHYTHMCYCLE

THE MARK CONSISTS OF STANDARD CHARACTERS WITHOUT CLAIM TO ANY PARTICULAR FONT, STYLE, SIZE, OR COLOR.

FOR GROUP PHYSICAL INSTRUCTION CLASSES FEATURING AEROBIC EXERCISE THAT FOLLOWS THE BEAT OF MUSIC WHILE EXERCISERS RIDE ON STATIONARY BICYCLES (U.S. CLS. 100, 101 AND 107).

ELIZABETH KAJUBI, EXAMINING ATTORNEY

CLASS 41—(Continued).

SN 85-510,011. ARENDS, SHELLEY, LAGUNA BEACH, CA. FILED 1-5-2012.

RHYTHMRIDE

THE MARK CONSISTS OF STANDARD CHARACTERS WITHOUT CLAIM TO ANY PARTICULAR FONT, STYLE, SIZE, OR COLOR.

FOR GROUP PHYSICAL INSTRUCTION CLASSES FEATURING AEROBIC EXERCISE THAT FOLLOWS THE BEAT OF MUSIC WHILE EXERCISERS RIDE ON STATIONARY BICYCLES (U.S. CLS. 100, 101 AND 107).
ELIZABETH KAJUBI, EXAMINING ATTORNEY

CLASS 41—(Continued).

SN 85-510,092. HEALTH & WELLNESS NETWORK, INC., ST. PETERSBURG, FL. FILED 1-6-2012.

The Wish List

THE MARK CONSISTS OF STANDARD CHARACTERS WITHOUT CLAIM TO ANY PARTICULAR FONT, STYLE, SIZE, OR COLOR.

FOR ENTERTAINMENT IN THE NATURE OF ON-GOING TELEVISION PROGRAMS IN THE FIELD OF HEALTH AND WELLNESS (U.S. CLS. 100, 101 AND 107).
JEFFREY LOOK, EXAMINING ATTORNEY

SN 85-510,034. ANABELLA ASHTON, PLAINVIEW, NY. AND JODI KLASS, SMITHTOWN, NY. AND LENNON ASHTON, PLAINVIEW, NY. AND MADDEN KLASS, SMITHTOWN, NY. FILED 1-6-2012.

Youth Be Told

THE MARK CONSISTS OF STANDARD CHARACTERS WITHOUT CLAIM TO ANY PARTICULAR FONT, STYLE, SIZE, OR COLOR.

FOR ENTERTAINMENT SERVICES IN THE NATURE OF LIVE MUSICAL PERFORMANCES (U.S. CLS. 100, 101 AND 107).
ERIN FALK, EXAMINING ATTORNEY

SN 85-510,094. HEALTH & WELLNESS NETWORK, INC., ST. PETERSBURG, FL. FILED 1-6-2012.

Fresh Take

THE MARK CONSISTS OF STANDARD CHARACTERS WITHOUT CLAIM TO ANY PARTICULAR FONT, STYLE, SIZE, OR COLOR.

FOR ENTERTAINMENT IN THE NATURE OF ON-GOING TELEVISION PROGRAMS IN THE FIELD OF HEALTH AND WELLNESS (U.S. CLS. 100, 101 AND 107).
JEFFREY LOOK, EXAMINING ATTORNEY

SN 85-510,088. HEALTH & WELLNESS NETWORK, INC., ST. PETERSBURG, FL. FILED 1-6-2012.

Momma's Recipe Makeover

THE MARK CONSISTS OF STANDARD CHARACTERS WITHOUT CLAIM TO ANY PARTICULAR FONT, STYLE, SIZE, OR COLOR.

FOR ENTERTAINMENT IN THE NATURE OF ON-GOING TELEVISION PROGRAMS IN THE FIELD OF HEALTH AND WELLNESS (U.S. CLS. 100, 101 AND 107).
JEFFREY LOOK, EXAMINING ATTORNEY

SN 85-510,097. HEALTH & WELLNESS NETWORK, INC., ST. PETERSBURG, FL. FILED 1-6-2012.

Fitswitch

THE MARK CONSISTS OF STANDARD CHARACTERS WITHOUT CLAIM TO ANY PARTICULAR FONT, STYLE, SIZE, OR COLOR.

FOR ENTERTAINMENT IN THE NATURE OF ON-GOING TELEVISION PROGRAMS IN THE FIELD OF HEALTH AND WELLNESS (U.S. CLS. 100, 101 AND 107).
JEFFREY LOOK, EXAMINING ATTORNEY

CLASS 41—(Continued).

SN 85-510,101. HEALTH & WELLNESS NETWORK, INC., ST. PETERSBURG, FL. FILED 1-6-2012.

Healthy, Wealthy & Wise

THE MARK CONSISTS OF STANDARD CHARACTERS WITHOUT CLAIM TO ANY PARTICULAR FONT, STYLE, SIZE, OR COLOR.

FOR ENTERTAINMENT IN THE NATURE OF ONGOING TELEVISION PROGRAMS IN THE FIELD OF HEALTH AND WELLNESS (U.S. CLS. 100, 101 AND 107).
JEFFREY LOOK, EXAMINING ATTORNEY

SN 85-510,107. HEALTH & WELLNESS NETWORK, INC., ST. PETERSBURG, FL. FILED 1-6-2012.

Spin The World

THE MARK CONSISTS OF STANDARD CHARACTERS WITHOUT CLAIM TO ANY PARTICULAR FONT, STYLE, SIZE, OR COLOR.

FOR ENTERTAINMENT IN THE NATURE OF ONGOING TELEVISION PROGRAMS IN THE FIELD OF HEALTH AND WELLNESS (U.S. CLS. 100, 101 AND 107).
JEFFREY LOOK, EXAMINING ATTORNEY

SN 85-510,110. HEALTH & WELLNESS NETWORK, INC., ST. PETERSBURG, FL. FILED 1-6-2012.

The Fitnatics

THE MARK CONSISTS OF STANDARD CHARACTERS WITHOUT CLAIM TO ANY PARTICULAR FONT, STYLE, SIZE, OR COLOR.

FOR ENTERTAINMENT IN THE NATURE OF ONGOING TELEVISION PROGRAMS IN THE FIELD OF HEALTH AND WELLNESS (U.S. CLS. 100, 101 AND 107).
COURTNEY ALVAREZ, EXAMINING ATTORNEY

CLASS 41—(Continued).

SN 85-510,121. HEALTH & WELLNESS NETWORK, INC., ST. PETERSBURG, FL. FILED 1-6-2012.

Reunion Redo

THE MARK CONSISTS OF STANDARD CHARACTERS WITHOUT CLAIM TO ANY PARTICULAR FONT, STYLE, SIZE, OR COLOR.

FOR ENTERTAINMENT IN THE NATURE OF ONGOING TELEVISION PROGRAMS IN THE FIELD OF HEALTH AND WELLNESS (U.S. CLS. 100, 101 AND 107).
JEFFREY LOOK, EXAMINING ATTORNEY

SN 85-510,392. THE DOUGLAS CENTER, DBA THE DOUGLAS CENTER, SKOKIE, IL. FILED 1-6-2012.

Art From The Heart Creations

NO CLAIM IS MADE TO THE EXCLUSIVE RIGHT TO USE "ART" AND "CREATIONS", APART FROM THE MARK AS SHOWN.

THE COLOR(S) BLACK AND RED IS/ARE CLAIMED AS A FEATURE OF THE MARK.

THE MARK CONSISTS OF "ART FROM THE HEART" IS ITALICIZED WITH CAPITAL LETTERS FOR THE BEGINNING OF EACH WORD. (CAPITAL "A", "F", "T", "H"), "CREATIONS" IS NOT ITALICIZED BUT HAS A CAPITAL LETTER "C". ALL WORDS ARE IN BLACK. THE HEART IMAGE IS IN RED.

FOR CHARITABLE SERVICES, NAMELY, PROVIDING TRAINING IN THE FIELD OF ART, RETAIL SKILLS, VOCATIONAL SKILLS, SEWING, INTERPERSONAL SOCIAL, COPING AND COMMUNICATION SKILLS (U.S. CLS. 100, 101 AND 107).

FIRST USE 9-30-2010; IN COMMERCE 10-7-2010.
MATTHEW KLINE, EXAMINING ATTORNEY

SN 85-510,394. TELEVISA, S.A. DE C.V., SANTA FE, MEXICO, FILED 1-6-2012.

LA VIDA ES MEJOR CANTANDO

THE MARK CONSISTS OF STANDARD CHARACTERS WITHOUT CLAIM TO ANY PARTICULAR FONT, STYLE, SIZE, OR COLOR.

THE ENGLISH TRANSLATION OF "LA VIDA ES MEJOR CANTANDO" IN THE MARK IS "LIFE IS BETTER SINGING".

FOR ENTERTAINMENT SERVICES IN THE NATURE OF A SHOW BROADCAST OVER THE INTERNET FEATURING REAL LIFE STORIES TOLD BY COMMON PEOPLE AND/OR ARTISTS THROUGH LIVE MUSICAL PERFORMANCES AND AN ONGOING TV PROGRAM FEATURING REAL LIFE STORIES TOLD BY COMMON PEOPLE AND/OR ARTISTS THROUGH LIVE MUSICAL PERFORMANCES (U.S. CLS. 100, 101 AND 107).
SANDRA BUJA, EXAMINING ATTORNEY

CLASS 41—(Continued).

SN 85-510,412. DEVELOPMENTAL TESTING SERVICE, INC., NORTHAMPTON, MA. FILED 1-6-2012.

DiscoTest

THE MARK CONSISTS OF STANDARD CHARACTERS WITHOUT CLAIM TO ANY PARTICULAR FONT, STYLE, SIZE, OR COLOR.

FOR ANALYZING EDUCATIONAL TESTS SCORES AND DATA FOR OTHERS; CHILDREN'S EDUCATIONAL SERVICES, NAMELY, PROVIDING ACADEMIC PERFORMANCE EVALUATION, GUIDANCE AND MONITORING FOR CHILDREN PRE-KINDERGARTEN THROUGH GRADE 12 VIA THE INTERNET; EDUCATIONAL EXAMINATION SERVICES; EDUCATIONAL SERVICES, NAMELY, DEVELOPING CURRICULUM FOR EDUCATORS; EDUCATIONAL TESTING SERVICES; PREPARING, ADMINISTERING, AND SCORING STANDARDIZED TESTS; PROVIDING EDUCATIONAL ASSESSMENT SERVICES; PROVIDING INFORMATION RELATING TO EDUCATIONAL SERVICES; RESEARCH IN THE FIELD OF EDUCATION VIA THE INTERNET; STANDARDIZED TESTING (U.S. CLS. 100, 101 AND 107).

FIRST USE 2-1-2008; IN COMMERCE 2-1-2008.
VIVIAN MICZNIK FIRST, EXAMINING ATTORNEY

SN 85-510,416. DEVELOPMENTAL TESTING SERVICE, INC., NORTHAMPTON, MA. FILED 1-6-2012.



THE MARK CONSISTS OF INTERLINKED LINE SEGMENTS COMPRISING A RECTANGLE, FOUR THREE-SIDED RECTILINEAR SHAPES AND TWO LINE SEGMENTS.

FOR ANALYZING EDUCATIONAL TESTS SCORES AND DATA FOR OTHERS; CHILDREN'S EDUCATIONAL SERVICES, NAMELY, PROVIDING ACADEMIC PERFORMANCE EVALUATION, GUIDANCE AND MONITORING FOR CHILDREN PRE-KINDERGARTEN THROUGH GRADE 12 VIA THE INTERNET; EDUCATIONAL EXAMINATION SERVICES; EDUCATIONAL SERVICES, NAMELY, DEVELOPING CURRICULUM FOR EDUCATORS; EDUCATIONAL TESTING SERVICES; PREPARING, ADMINISTERING, AND SCORING STANDARDIZED TESTS; PROVIDING EDUCATIONAL ASSESSMENT SERVICES; PROVIDING INFORMATION RELATING TO EDUCATIONAL SERVICES; RESEARCH IN THE FIELD OF EDUCATION VIA THE INTERNET; STANDARDIZED TESTING (U.S. CLS. 100, 101 AND 107).

FIRST USE 5-1-2004; IN COMMERCE 5-1-2004.
VIVIAN MICZNIK FIRST, EXAMINING ATTORNEY

CLASS 41—(Continued).

SN 85-510,418. DEVELOPMENTAL TESTING SERVICE, INC., NORTHAMPTON, MA. FILED 1-6-2012.

DTS

THE MARK CONSISTS OF STANDARD CHARACTERS WITHOUT CLAIM TO ANY PARTICULAR FONT, STYLE, SIZE, OR COLOR.

FOR ANALYZING EDUCATIONAL TESTS SCORES AND DATA FOR OTHERS; CHILDREN'S EDUCATIONAL SERVICES, NAMELY, PROVIDING ACADEMIC PERFORMANCE EVALUATION, GUIDANCE AND MONITORING FOR CHILDREN PRE-KINDERGARTEN THROUGH GRADE 12 VIA THE INTERNET; EDUCATIONAL EXAMINATION SERVICES; EDUCATIONAL SERVICES, NAMELY, DEVELOPING CURRICULUM FOR EDUCATORS; EDUCATIONAL TESTING SERVICES; PREPARING, ADMINISTERING, AND SCORING STANDARDIZED TESTS; PROVIDING EDUCATIONAL ASSESSMENT SERVICES; PROVIDING INFORMATION RELATING TO EDUCATIONAL SERVICES; RESEARCH IN THE FIELD OF EDUCATION VIA THE INTERNET; STANDARDIZED TESTING (U.S. CLS. 100, 101 AND 107).

FIRST USE 5-1-2004; IN COMMERCE 5-1-2004.
VIVIAN MICZNIK FIRST, EXAMINING ATTORNEY

SN 85-510,485. RANDALL HALL SENTER, WEST HOLLYWOOD, CA. FILED 1-6-2012.

SYNESTHOPIA

THE MARK CONSISTS OF STANDARD CHARACTERS WITHOUT CLAIM TO ANY PARTICULAR FONT, STYLE, SIZE, OR COLOR.

FOR AMUSEMENT ARCADES; AMUSEMENT PARKS; COMEDY CLUB SERVICES; DANCE CLUB SERVICES; ENTERTAINMENT IN THE NATURE OF A WATER PARK AND AMUSEMENT CENTER; ENTERTAINMENT SERVICES IN THE NATURE OF AN AMUSEMENT PARK ATTRACTION, NAMELY, A THEMED AREA; HEALTH CLUB SERVICES, NAMELY, PROVIDING INSTRUCTION AND EQUIPMENT IN THE FIELD OF PHYSICAL EXERCISE (U.S. CLS. 100, 101 AND 107).

JULIE WATSON, EXAMINING ATTORNEY

CLASS 41—(Continued).

SN 85-510,628. AMERICAN PSYCHOLOGICAL ASSOCIATION, INC., WASHINGTON, DC. FILED 1-6-2012.

KIDSPSYCH

THE MARK CONSISTS OF STANDARD CHARACTERS WITHOUT CLAIM TO ANY PARTICULAR FONT, STYLE, SIZE, OR COLOR.

SEC. 2(F).

FOR EDUCATIONAL AND ENTERTAINMENT SERVICES, NAMELY, PROVIDING AN ONLINE INTERACTIVE WEB SITE FEATURING GAMES, ACTIVITIES AND LESSONS IN THE AREAS OF PSYCHOLOGY AND THE SOCIAL SCIENCES (U.S. CLS. 100, 101 AND 107).

FIRST USE 1-0-1999; IN COMMERCE 1-0-1999.
RAUL CORDOVA, EXAMINING ATTORNEY

SN 85-510,635. SECTION ON GERIATRICS OF THE AMERICAN PHYSICAL THERAPY ASSOCIATION, MADISON, WI. FILED 1-6-2012.

CEEAA

THE MARK CONSISTS OF STANDARD CHARACTERS WITHOUT CLAIM TO ANY PARTICULAR FONT, STYLE, SIZE, OR COLOR.

FOR PROVIDING TRAINING TO BECOME A CERTIFIED EXERCISE EXPERT FOR AGING ADULTS (U.S. CLS. 100, 101 AND 107).

FIRST USE 3-28-2009; IN COMMERCE 3-28-2009.
MARK SHINER, EXAMINING ATTORNEY

SN 85-510,641. 112 PARK ENTERPRISES, LLC, MEDFORD, NY. FILED 1-6-2012.

COUNTRY FAIR

THE MARK CONSISTS OF STANDARD CHARACTERS WITHOUT CLAIM TO ANY PARTICULAR FONT, STYLE, SIZE, OR COLOR.

OWNER OF U.S. REG. NO. 2,660,936.

FOR ENTERTAINMENT SERVICES IN THE NATURE OF AN AMUSEMENT PARK FEATURING SUCH AMUSEMENT RIDES AS A GO CART TRACK AND ALSO FEATURING SUCH FACILITIES AS MINIATURE GOLF COURSE, GOLF DRIVING RANGE, BATTING CAGE AND SKILL/VIDEO GAMES AND GAME ROOMS AND ARCADES (U.S. CLS. 100, 101 AND 107).

FIRST USE 7-0-2000; IN COMMERCE 7-0-2000.
KIMBERLY PERRY, EXAMINING ATTORNEY

CLASS 41—(Continued).

SN 85-510,683. JABBERS, LLC, NAMPA, ID. FILED 1-6-2012.

JABBERS

THE MARK CONSISTS OF STANDARD CHARACTERS WITHOUT CLAIM TO ANY PARTICULAR FONT, STYLE, SIZE, OR COLOR.

FOR AMUSEMENT CENTERS; CHILDREN'S ENTERTAINMENT AND AMUSEMENT CENTERS, NAMELY, INTERACTIVE PLAY AREAS; PROVIDING CHILDREN'S PARTY CENTERS FOR THE PURPOSE OF ENTERTAINING CHILDREN AND CELEBRATING BIRTHDAYS; PROVIDING RECREATIONAL AREAS IN THE NATURE OF CHILDREN'S PLAY AREAS; PROVIDING RECREATIONAL AREAS IN THE NATURE OF PLAY AREAS FOR CHILDREN (U.S. CLS. 100, 101 AND 107).

FIRST USE 12-10-2010; IN COMMERCE 12-10-2010.
JORDAN BAKER, EXAMINING ATTORNEY

SN 85-510,749. CARLTON SEIBERT, DBA STARZ FRUM MARZ, PHILADELPHIA, PA. FILED 1-6-2012.



THE MARK CONSISTS OF THE STYLIZED WORDS "STARZ FRUM MARZ" WITH TWO LINE DRAWN STARS, ONE TO THE LEFT OF THE "S" IN "STARZ" AND TO THE RIGHT OF THE "Z" IN "MARZ". THE WORDS ARE CENTERED BELOW A DRAWING OF A STAR CONTAINING THE WORDS "I DO BELIEVE IN S.F.M.". THE STAR IS IN FRONT OF A DRAWING OF A HUMAN HEAD. TO THE LEFT OF THE HEAD, EMANATING FROM THE EAR ARE ARCHES IMPLYING SOUND WAVES AND TWO MUSICAL NOTES. BEHIND THE HEAD AND STAR IS A DIAGONAL LIGHTNING BOLT.

FOR DISC JOCKEY SERVICES (U.S. CLS. 100, 101 AND 107).

FIRST USE 6-0-1980; IN COMMERCE 6-0-1980.
BRIAN PINO, EXAMINING ATTORNEY

CLASS 41—(Continued).

SN 85-510,762. BENJAMIN P BOURGEOIS, MALDEN, MA. FILED 1-6-2012.

ANIMAL TALK

THE MARK CONSISTS OF STANDARD CHARACTERS WITHOUT CLAIM TO ANY PARTICULAR FONT, STYLE, SIZE, OR COLOR.

FOR MUSICAL SOUND RECORDING PRODUCTION; ENTERTAINMENT SERVICES IN THE NATURE OF LIVE MUSICAL PERFORMANCES; ENTERTAINMENT SERVICES IN THE NATURE OF MUSICAL PERFORMANCES; ENTERTAINMENT SERVICES, NAMELY, PROVIDING NON-DOWNLOADABLE PLAYBACK OF MUSIC VIA GLOBAL COMMUNICATIONS NETWORKS; ENTERTAINMENT, NAMELY, LIVE MUSIC CONCERTS; PRODUCTION OF MUSICAL SOUND RECORDINGS; PROVIDING A WEBSITE FEATURING ENTERTAINMENT INFORMATION IN THE FIELD OF MUSIC (U.S. CLS. 100, 101 AND 107).

FIRST USE 11-1-2010; IN COMMERCE 4-1-2011.
ANDREW LEASER, EXAMINING ATTORNEY

CLASS 41—(Continued).

SN 85-510,941. ALLEN, ELISE, VAN NUYS, CA. FILED 1-6-2012.

Prankenstein

THE MARK CONSISTS OF STANDARD CHARACTERS WITHOUT CLAIM TO ANY PARTICULAR FONT, STYLE, SIZE, OR COLOR.

FOR ENTERTAINMENT SERVICES IN THE NATURE OF ON-GOING TELEVISION PROGRAMS IN THE FIELD OF CHILDREN'S ENTERTAINMENT (U.S. CLS. 100, 101 AND 107).

JANICE L. MCMORROW, EXAMINING ATTORNEY

SN 85-510,885. MANNINO, MATTHEW, GILBERT, AZ. FILED 1-6-2012.

Quantum Emergence

THE MARK CONSISTS OF STANDARD CHARACTERS WITHOUT CLAIM TO ANY PARTICULAR FONT, STYLE, SIZE, OR COLOR.

FOR EDUCATIONAL SERVICES, NAMELY, CONDUCTING COACHING, SEMINARS, PUBLIC APPEARANCES, AND COURSES IN THE FIELD OF PERSONAL DEVELOPMENT AND HUMAN TRANSFORMATION AND DISTRIBUTION OF TRAINING MATERIAL IN CONNECTION THEREWITH (U.S. CLS. 100, 101 AND 107).

FIRST USE 7-21-2010; IN COMMERCE 7-21-2010.
KATHLEEN M. VANSTON, EXAMINING ATTORNEY

SN 85-510,998. FITNESS BUNCH, INC. LLC, PLAYA DEL REY, CA. FILED 1-6-2012.



SN 85-510,918. KABAM, INC., REDWOOD CITY, CA. FILED 1-6-2012.

FINAL EDEN

THE MARK CONSISTS OF STANDARD CHARACTERS WITHOUT CLAIM TO ANY PARTICULAR FONT, STYLE, SIZE, OR COLOR.

FOR ENTERTAINMENT SERVICES, NAMELY, PROVIDING ON-LINE COMPUTER GAMES (U.S. CLS. 100, 101 AND 107).

FIRST USE 2-8-2012; IN COMMERCE 2-8-2012.
JASON BLAIR, EXAMINING ATTORNEY

THE MARK CONSISTS OF THE STYLIZED LETTERS "FB" DISPOSED WITHIN A TRIANGULAR SHIELD DESIGN.

FOR ENTERTAINMENT SERVICES, NAMELY, PROVIDING AN ON-LINE COMPUTER GAME BY MEANS OF COMMUNICATIONS NETWORKS; ENTERTAINMENT SERVICES IN THE NATURE OF PROVIDING AN ON-LINE MULTI-PLAYER ELECTRONIC COMPUTER GAME; ENTERTAINMENT SERVICES, NAMELY, PROVIDING AN ON-LINE COMPUTER GAME THAT MAY BE ACCESSED BY MEANS OF COMMUNICATIONS NETWORKS; ENTERTAINMENT SERVICES, NAMELY, PROVIDING AN ON-LINE COMPUTER GAME; ENTERTAINMENT SERVICES, NAMELY, PROVIDING ONLINE COMPUTER GAMES THAT HELP EDUCATES PEOPLE ABOUT FITNESS, NUTRITION, COMMUNITY, AND HELPING OTHERS (U.S. CLS. 100, 101 AND 107).

FIRST USE 0-0-2010; IN COMMERCE 0-0-2010.
LINDA M. KING, EXAMINING ATTORNEY

CLASS 41—(Continued).

SN 85-511,059. FITORBIT, INC., LOS ANGELES, CA. FILED 1-6-2012.

Ridiculously Affordable.
Remarkably Successful.

THE MARK CONSISTS OF STANDARD CHARACTERS WITHOUT CLAIM TO ANY PARTICULAR FONT, STYLE, SIZE, OR COLOR.

FOR EDUCATION SERVICES, NAMELY, PROVIDING ON-LINE CLASSES IN THE FIELD OF ON-LINE FITNESS AND NUTRITION; PROVIDING A WEB SITE FEATURING INFORMATION ON EXERCISE AND FITNESS TO MOBILE DEVICES; EDUCATIONAL SERVICES, NAMELY, DEVELOPING AND CONDUCTING WORKOUTS, WORKSHOPS, PRESENTATIONS, RETREATS, AND PERSONAL TRAINING IN FITNESS; COUNSELING SERVICES IN THE FIELD OF PHYSICAL FITNESS; PROVIDING A WEB SITE FEATURING INFORMATION ON EXERCISE AND FITNESS; PROVIDING AN ON-LINE COMPUTER DATABASE FEATURING INFORMATION REGARDING EXERCISE AND FITNESS; PROVIDING ASSISTANCE, PERSONAL TRAINING AND PHYSICAL FITNESS CONSULTATION TO INDIVIDUALS TO HELP THEM MAKE PHYSICAL FITNESS, STRENGTH, CONDITIONING, AND EXERCISE IMPROVEMENT IN THEIR DAILY LIVING (U.S. CLS. 100, 101 AND 107).

FIRST USE 10-13-2011; IN COMMERCE 10-13-2011.
STEVEN R. FINE, EXAMINING ATTORNEY

SN 85-511,071. GRIT AND GRIND FOUNDATION, SOUTH HOLLAND, IL. FILED 1-7-2012.

Grit and Grind

THE MARK CONSISTS OF STANDARD CHARACTERS WITHOUT CLAIM TO ANY PARTICULAR FONT, STYLE, SIZE, OR COLOR.

FOR BASKETBALL CAMPS; CHARITABLE SERVICES, NAMELY, PROVIDING CAMPS FOR CHILDREN; DAY CAMP SERVICES; ENTERTAINMENT IN THE NATURE OF BASKETBALL GAMES; OPERATION OF SPORTS CAMPS; RECREATIONAL CAMPS; SPORT CAMP SERVICES; SPORT CAMPS; SPORTS CAMP SERVICES; SUMMER CAMPS (U.S. CLS. 100, 101 AND 107).

FIRST USE 7-18-2011; IN COMMERCE 7-18-2011.
JOHN DALIER, EXAMINING ATTORNEY

CLASS 41—(Continued).

SN 85-511,109. OHARA, TRACEY M, WEST PALM BEACH, FL. FILED 1-7-2012.

recoga

THE MARK CONSISTS OF STANDARD CHARACTERS WITHOUT CLAIM TO ANY PARTICULAR FONT, STYLE, SIZE, OR COLOR.

FOR YOGA INSTRUCTION (U.S. CLS. 100, 101 AND 107).

FIRST USE 10-10-2010; IN COMMERCE 10-10-2010.
SUNG IN, EXAMINING ATTORNEY

SN 85-511,142. GROWER'S SECRET, INC., HONOLULU, HI. FILED 1-7-2012.

THE BLACK THUMB DIARIES

THE MARK CONSISTS OF STANDARD CHARACTERS WITHOUT CLAIM TO ANY PARTICULAR FONT, STYLE, SIZE, OR COLOR.

FOR PROVIDING A WEBSITE FEATURING NON-DOWNLOADABLE VIDEOS, NAMELY, VIDEO PRESENTATIONS ON TRADITIONAL AND ORGANIC GARDENING (U.S. CLS. 100, 101 AND 107).

DAWN FELDMAN, EXAMINING ATTORNEY

SN 85-511,230. CHAPMAN, JENNIFER B, JACKSONVILLE, FL. FILED 1-7-2012.

Pinstitute

THE MARK CONSISTS OF STANDARD CHARACTERS WITHOUT CLAIM TO ANY PARTICULAR FONT, STYLE, SIZE, OR COLOR.

FOR INSTRUCTION IN THE FIELD OF CRAFTING, HOME IMPROVEMENT, DO-IT-YOURSELF (U.S. CLS. 100, 101 AND 107).

NATALIE POLZER, EXAMINING ATTORNEY

CLASS 41—(Continued).SN 85-511,273. WADDELL, MICHAEL A., HOUSTON, TX.
FILED 1-8-2012.

afelo de se

THE MARK CONSISTS OF STANDARD CHARACTERS WITHOUT CLAIM TO ANY PARTICULAR FONT, STYLE, SIZE, OR COLOR.

THE ENGLISH TRANSLATION OF AFELO DE SE IN THE MARK IS "NON FELONY AGAINST SELF."

FOR CHARITABLE SERVICES, NAMELY, ACADEMIC MENTORING OF SCHOOL AGE CHILDREN; CHARITABLE SERVICES, NAMELY, PROVIDING BOOKS TO YOUNG ADULTS; CONDUCTING WORKSHOPS AND SEMINARS IN SELF AWARENESS; CONDUCTING WORKSHOPS AND SEMINARS IN SELF IMPROVEMENT; EDUCATIONAL AND ENTERTAINMENT SERVICES, NAMELY, PROVIDING MOTIVATIONAL AND EDUCATIONAL SPEAKERS IN THE FIELD OF SELF-AND PERSONAL IMPROVEMENT; EDUCATIONAL AND ENTERTAINMENT SERVICES, NAMELY, PROVIDING MOTIVATIONAL SPEAKING SERVICES IN THE FIELD OF SELF IMPROVEMENT; ENTERTAINMENT SERVICES, NAMELY, CONDUCTING PARTIES FOR THE PURPOSE OF DATING AND SOCIAL INTRODUCTION FOR ADULTS; PROVIDING A WEBSITE FEATURING INFORMATION IN THE FIELDS OF EDUCATION AND ENTERTAINMENT FOR CHILDREN; PROVIDING ADVICE AND INFORMATION IN THE FIELD OF EDUCATIONAL AND ENTERTAINMENT ACTIVITIES AND EVENTS FOR CHILDREN; PROVIDING ADVICE AND INFORMATION TO ADULT FAMILY MEMBERS ON APPROPRIATE ENTERTAINMENT AND LEISURE ACTIVITIES FOR YOUNGER FAMILY MEMBERS; PROVIDING ASSISTANCE, PERSONAL TRAINING AND PHYSICAL FITNESS CONSULTATION TO INDIVIDUALS TO HELP THEM MAKE PHYSICAL FITNESS, STRENGTH, CONDITIONING, AND EXERCISE IMPROVEMENT IN THEIR DAILY LIVING; PROVIDING CAMPS FOR CHILDREN AND ADULTS WITH INTELLECTUAL AND DEVELOPMENTAL DISABILITIES; PROVIDING INFORMATION IN THE FIELD OF CHILDREN'S EDUCATION; WORKSHOPS AND SEMINARS IN THE FIELD OF SELF IMPROVEMENT; WRITING OF ARTICLES FOR JOURNALS OTHER THAN FOR ADVERTISING OR PUBLICITY (U.S. CLS. 100, 101 AND 107).

KATHERINE CONNOLLY, EXAMINING ATTORNEY

SN 85-511,335. PUBLIC FLIPPER LIMITED, LLC, POWAY, CA. FILED 1-8-2012.

FLIPPER

THE MARK CONSISTS OF STANDARD CHARACTERS WITHOUT CLAIM TO ANY PARTICULAR FONT, STYLE, SIZE, OR COLOR.

FOR ENTERTAINMENT, NAMELY, LIVE PERFORMANCES BY A MUSICAL BAND (U.S. CLS. 100, 101 AND 107).

FIRST USE 7-15-1979; IN COMMERCE 7-15-1979.
LESLEY LAMOTHE, EXAMINING ATTORNEY

CLASS 41—(Continued).SN 85-511,367. JAMI EPSTEIN, WEST HOLLYWOOD, CA.
FILED 1-8-2012.

NO CLAIM IS MADE TO THE EXCLUSIVE RIGHT TO USE "CAKES", APART FROM THE MARK AS SHOWN.

THE NAME(S), PORTRAIT(S), AND/OR SIGNATURE(S) SHOWN IN THE MARK IDENTIFIES "JAMI" EPSTEIN, WHOSE CONSENT(S) TO REGISTER IS MADE OF RECORD.

THE MARK CONSISTS OF A WOMAN IN A CHEF'S HAT WITH A SPATULA IN A PLANE FLYING OVER A GLOBE FRAMED WITHIN A STAMP. THE WORDS "JAMI CAKES" ARE BELOW THE STAMP.

FOR ON-LINE JOURNALS, NAMELY, BLOGS IN THE FIELDS OF FOOD, COOKING, TRAVEL, BAKING, DINING, CELEBRITIES, RECIPES AND NUTRITION; PROVIDING ON-LINE NON-DOWNLOADABLE PUBLICATIONS IN THE NATURE OF NEWSLETTERS AND MAGAZINES FEATURING RECIPES AND EDUCATIONAL INFORMATION IN THE FIELDS OF FOOD, COOKING, TRAVEL, BAKING, DINING, CELEBRITIES, RECIPES AND NUTRITION; EDUCATIONAL SERVICES, NAMELY, PROVIDING ONLINE INSTRUCTION IN THE FIELDS OF FOOD, COOKING, TRAVEL, BAKING, DINING, CELEBRITIES, RECIPES AND NUTRITION VIA AN ONLINE WEBSITE (U.S. CLS. 100, 101 AND 107).

FIRST USE 10-1-2010; IN COMMERCE 10-1-2010.
RICHARD WHITE, EXAMINING ATTORNEY

SN 85-511,435. PLAYTIKA LTD., TEL AVIV, ISRAEL, FILED 1-9-2012.



THE COLOR(S) PINK, GREEN, RED, WHITE, BEIGE, BLACK AND BLUE IS/ARE CLAIMED AS A FEATURE OF THE MARK.

THE MARK CONSISTS OF THE WORD "SLOTOMANIA" IN STYLIZED LETTERING WITH "SLOTO" APPEARING IN

CLASS 41—(Continued).

PINK AND "MANIA" APPEARING IN GREEN; A WOMAN WITH BEIGE SKIN, RED HAIR AND EYEBROW, GREEN EYES AND RED LIPS WEARING A WHITE SHIRT, RED VEST AND BLACK SKIRT WITH A NAME TAG BEARING THE WORD "LUCY" AFFIXED TO THE VEST; A RED AND WHITE POKER CHIP WITH THE LETTERS "SM" AND A STAR DESIGN APPEARING IN WHITE ON A RED BACKGROUND; ALL OF THE ABOVE SUPERIMPOSED ON A BLACK AND BLUE BACKGROUND WITH IRREGULAR WHITE CIRCULAR SHAPES.

FOR ENTERTAINMENT SERVICES, NAMELY, PROVIDING ON-LINE COMPUTER GAMES AND GAME APPLICATIONS, ENHANCEMENTS WITHIN ONLINE COMPUTER GAMES, AND GAME APPLICATIONS WITHIN ONLINE COMPUTER GAMES; PROVIDING ONLINE REVIEWS OF COMPUTER GAMES, AND PROVIDING OF INFORMATION RELATING TO COMPUTER GAMES; PROVIDING AN INTERNET WEBSITE PORTAL IN THE FIELD OF COMPUTER GAMES AND GAMING; ENTERTAINMENT SERVICES, NAMELY, PROVIDING VIRTUAL ENVIRONMENTS IN WHICH USERS CAN INTERACT THROUGH SOCIAL GAMES FOR RECREATIONAL, LEISURE OR ENTERTAINMENT PURPOSES (U.S. CLS. 100, 101 AND 107).

FIRST USE 12-16-2010; IN COMMERCE 12-16-2010.
WILLIAM VERHOSEK, EXAMINING ATTORNEY

SN 85-511,448. SEAN KINCHLOW, WINDERMERE, FL. FILED 1-9-2012.



THE MARK CONSISTS OF THE STYLIZED TEXT "IMAGINATION NEXUS" IS WRITTEN OVER STYLIZED ADJOINING PEAKS.

FOR FILM AND VIDEO PRODUCTION; FILM AND VIDEO PRODUCTION CONSULTING SERVICES; MULTIMEDIA ENTERTAINMENT SERVICES IN THE NATURE OF RECORDING, PRODUCTION AND POST-PRODUCTION SERVICES IN THE FIELDS OF MUSIC, VIDEO, AND FILMS (U.S. CLS. 100, 101 AND 107).

FIRST USE 1-1-2006; IN COMMERCE 1-1-2006.
SUSAN BILLHEIMER, EXAMINING ATTORNEY

SN 85-511,450. CHIRICHILLO, DOMINICK, SAN CARLOS, CA. FILED 1-9-2012.

Bacchus Winemaking Club

THE MARK CONSISTS OF STANDARD CHARACTERS WITHOUT CLAIM TO ANY PARTICULAR FONT, STYLE, SIZE, OR COLOR.

OWNER OF U.S. REG. NO. 2,613,961.

NO CLAIM IS MADE TO THE EXCLUSIVE RIGHT TO USE "WINEMAKING CLUB", APART FROM THE MARK AS SHOWN.

FOR INSTRUCTION IN THE FIELD OF WINEMAKING (U.S. CLS. 100, 101 AND 107).

FIRST USE 5-8-2005; IN COMMERCE 5-8-2005.
JAMES STEIN, EXAMINING ATTORNEY

CLASS 41—(Continued).

SN 85-511,459. UNCHARTED WEDDINGS, LAS VEGAS, NV. FILED 1-9-2012.

Uncharted Weddings

THE MARK CONSISTS OF STANDARD CHARACTERS WITHOUT CLAIM TO ANY PARTICULAR FONT, STYLE, SIZE, OR COLOR.

NO CLAIM IS MADE TO THE EXCLUSIVE RIGHT TO USE "WEDDINGS", APART FROM THE MARK AS SHOWN. FOR SPECIAL EVENT PLANNING FOR SOCIAL ENTERTAINMENT PURPOSES; WEDDING PLANNING AND COORDINATION SERVICES (U.S. CLS. 100, 101 AND 107).

REBECCA GILBERT, EXAMINING ATTORNEY

SN 85-511,485. CBS STUDIOS INC., STUDIO CITY, CA. FILED 1-9-2012.

ELEMENTARY

THE MARK CONSISTS OF STANDARD CHARACTERS WITHOUT CLAIM TO ANY PARTICULAR FONT, STYLE, SIZE, OR COLOR.

FOR ENTERTAINMENT SERVICES, NAMELY, A CONTINUING TELEVISION SERIES FEATURING DRAMA RENDERED THROUGH THE MEDIA OF TELEVISION, CABLE, SATELLITE, RADIO, TELEPHONE, AND BROADBAND SYSTEMS, AND VIA THE INTERNET, PORTABLE AND WIRELESS COMMUNICATION DEVICES; AND PROVIDING INFORMATION IN THE FIELD OF ENTERTAINMENT RENDERED VIA THE INTERNET, PORTABLE AND WIRELESS COMMUNICATION DEVICES (U.S. CLS. 100, 101 AND 107).

DOUGLAS LEE, EXAMINING ATTORNEY

SN 85-511,502. AUTOMOBILE RACING CLUB OF AMERICA, INC., TEMPERANCE, MI. FILED 1-9-2012.

ARCA

THE MARK CONSISTS OF STANDARD CHARACTERS WITHOUT CLAIM TO ANY PARTICULAR FONT, STYLE, SIZE, OR COLOR.

OWNER OF U.S. REG. NO. 1,630,403.

FOR REGULATING, GOVERNING, SANCTIONING, ORGANIZING, AND CONDUCTING VEHICLE RACES AND ENTERTAINMENT EXHIBITIONS IN THE FIELD OF MOTORSPORTS (U.S. CLS. 100, 101 AND 107).

FIRST USE 0-0-1964; IN COMMERCE 0-0-1964.
JORDAN BAKER, EXAMINING ATTORNEY

CLASS 41—(Continued).

SN 85-511,581. NEWMAN, BARBARA G., BALTIMORE, MD. FILED 1-9-2012.



THE MARK CONSISTS OF THE TOP HALF OF A FACE, WHICH CONSISTS OF TWO EYES. THE LETTERS "GB" APPEAR AT THE BOTTOM RIGHT SIDE OF THE FACE IN SMALL SCRIPT.

FOR ON-LINE JOURNALS, NAMELY, BLOGS FEATURING INFORMATION, OPINION, COMMENTARY, POETRY AND PROSE IN THE FIELD OF GENERAL INTEREST (U.S. CLS. 100, 101 AND 107).

FIRST USE 12-22-2011; IN COMMERCE 12-22-2011.
RONALD MCMORROW, EXAMINING ATTORNEY

SN 85-511,617. MYSILVERPAGES.ORG LLC, SHELBURNE, VT. FILED 1-9-2012.

ELDERPRENEUR

THE MARK CONSISTS OF STANDARD CHARACTERS WITHOUT CLAIM TO ANY PARTICULAR FONT, STYLE, SIZE, OR COLOR.

FOR PROVIDING RECOGNITION AND INCENTIVES BY THE WAY OF AWARDS TO DEMONSTRATE EXCELLENCE IN THE FIELD OF ENTREPRENEURS OVER THE AGE OF FIFTY-FIVE (U.S. CLS. 100, 101 AND 107).
JOHN DALIER, EXAMINING ATTORNEY

SN 85-511,708. HOWARD HUGHES MEDICAL INSTITUTE, CHEVY CHASE, MD. FILED 1-9-2012.

TANGLED BANK STUDIOS

THE MARK CONSISTS OF STANDARD CHARACTERS WITHOUT CLAIM TO ANY PARTICULAR FONT, STYLE, SIZE, OR COLOR.

NO CLAIM IS MADE TO THE EXCLUSIVE RIGHT TO USE "STUDIOS", APART FROM THE MARK AS SHOWN.

FOR ENTERTAINMENT SERVICES, NAMELY, MULTIMEDIA PRODUCTION SERVICES (U.S. CLS. 100, 101 AND 107).

WILLIAM JACKSON, EXAMINING ATTORNEY

CLASS 41—(Continued).

SN 85-511,709. HOWARD HUGHES MEDICAL INSTITUTE, CHEVY CHASE, MD. FILED 1-9-2012.

TANGLED BANK MEDIA

THE MARK CONSISTS OF STANDARD CHARACTERS WITHOUT CLAIM TO ANY PARTICULAR FONT, STYLE, SIZE, OR COLOR.

NO CLAIM IS MADE TO THE EXCLUSIVE RIGHT TO USE "MEDIA", APART FROM THE MARK AS SHOWN.

FOR ENTERTAINMENT SERVICES, NAMELY, MULTIMEDIA PRODUCTION SERVICES (U.S. CLS. 100, 101 AND 107).

WILLIAM JACKSON, EXAMINING ATTORNEY

SN 85-511,996. THE RIVERBEND GROUP, LLC, ATLANTA, GA. FILED 1-9-2012.

**The CAR Model: Driving
Influence**

THE MARK CONSISTS OF STANDARD CHARACTERS WITHOUT CLAIM TO ANY PARTICULAR FONT, STYLE, SIZE, OR COLOR.

NO CLAIM IS MADE TO THE EXCLUSIVE RIGHT TO USE "MODEL", APART FROM THE MARK AS SHOWN.

FOR PROVIDING ACTIVITY-ORIENTED GROUP WORKSHOPS, ONE-ON-ONE COACHING SESSIONS, SEMINARS, TRAINING AND INSTRUCTIONAL PROGRAMS TO BUSINESS EXECUTIVES AND EMPLOYEES INCLUDING CASE STUDIES, SKITS, ACTIVITIES, BREAKOUTS, GAMES AND BEST PRACTICE SHARING IN THE FIELD OF TEAMBUILDING, LEADERSHIP, VALUES, BEHAVIOR STYLES, STRATEGY AND OPERATIONS, IDEAS AND ACTIONS, CORPORATE CHANGE AND MANAGEMENT STRATEGIES, CRISIS MANAGEMENT, MOTIVATIONAL TECHNIQUES, MANAGEMENT DEVELOPMENT PROGRAMS, FOCUS, PROBLEM SOLVING, PLANNING, EXECUTION, TEAMWORK AND DISCIPLINE, EXECUTIVE OR PROFESSIONAL COACHING, CREATIVE THINKING, BUILDING EFFECTIVE TEAMS, RECRUITING AND INTERVIEWING; AND BUSINESS TRAINING PROGRAMS TO BUILD CAMARADERIE AND ENHANCE RELATIONSHIPS AMONG EMPLOYEES AS THEY ARE LEARNING NEW SKILLS OR EXECUTING BUSINESS APPLICATIONS SUCH AS SALES OBJECTION HANDLING, SALES PROCESS TRAINING, CORE COMPETENCY ROLE-OUTS, PRODUCT LAUNCH, SHARED ACCOUNTABILITY TOWARDS A COMMON GOAL, LEADERSHIP, TRUST AND RESPECT, CHANGE, LEADERSHIP AND MANAGEMENT, BUSINESS PARTNERING, STRATEGIC THINKING, EXECUTION, CONFLICT MANAGEMENT AND RESOLUTION, DELEGATION, PROBLEM SOLVING AND OVERCOMING ADVERSITY (U.S. CLS. 100, 101 AND 107).

MATTHEW EINSTEIN, EXAMINING ATTORNEY

CLASS 41—(Continued).

SN 85-512,188. WISDOMNOOK, LLC, CARLSBAD, CA. FILED 1-9-2012.

WISENOTES

THE MARK CONSISTS OF STANDARD CHARACTERS WITHOUT CLAIM TO ANY PARTICULAR FONT, STYLE, SIZE, OR COLOR.

FOR BOOK PUBLISHING; ELECTRONIC PUBLISHING SERVICES, NAMELY, PUBLICATION OF TEXT AND GRAPHIC WORKS OF OTHERS ON THE INTERNET FEATURING BOOKS; ONLINE ELECTRONIC PUBLISHING OF BOOKS AND PERIODICALS; OPEN-ACCESS PUBLISHING SERVICES, NAMELY, PUBLICATION OF ELECTRONIC BOOKS (U.S. CLS. 100, 101 AND 107).

FIRST USE 12-1-2011; IN COMMERCE 12-1-2011.
DEBRA LEE, EXAMINING ATTORNEY

SN 85-512,205. HESKETH, SHAWN D., HOUSTON, TX. FILED 1-9-2012.

WP101

THE MARK CONSISTS OF STANDARD CHARACTERS WITHOUT CLAIM TO ANY PARTICULAR FONT, STYLE, SIZE, OR COLOR.

FOR EDUCATION SERVICES, NAMELY, PROVIDING LIVE AND ON-LINE VIDEO TUTORIALS, SCREENCASTS, WEBINARS, CLASSES, AND WORKSHOPS IN THE FIELD OF BLOGGING AND WEB CONTENT MANAGEMENT (U.S. CLS. 100, 101 AND 107).

FIRST USE 4-16-2009; IN COMMERCE 4-16-2009.
LESLEY LAMOTHE, EXAMINING ATTORNEY

SN 85-512,211. GEORGE DIBRIL CLARK III, GOLDEN VALLEY, AZ. FILED 1-9-2012.

CABARET GOURMET

THE MARK CONSISTS OF STANDARD CHARACTERS WITHOUT CLAIM TO ANY PARTICULAR FONT, STYLE, SIZE, OR COLOR.

FOR PRODUCTION AND DISTRIBUTION OF VIDEOS IN THE FIELD OF COOKING (U.S. CLS. 100, 101 AND 107).

JOHN DALIER, EXAMINING ATTORNEY

CLASS 41—(Continued).

SN 85-512,297. FRONTIER COMMUNICATIONS CORPORATION, STAMFORD, CT. FILED 1-9-2012.

FTR

THE MARK CONSISTS OF STANDARD CHARACTERS WITHOUT CLAIM TO ANY PARTICULAR FONT, STYLE, SIZE, OR COLOR.

FOR ENTERTAINMENT SERVICES, NAMELY PROVIDING AN INTERNET PORTAL FEATURING COMPUTER GAMES AND GAMING; PROVIDING INFORMATION RELATING TO COMPUTER GAMES FOR SOCIAL AND LEISURE USE; PROVIDING A WEBSITE FEATURING NON-DOWNLOADABLE COMPUTER GAMES, COMPUTER GAME ENHANCEMENTS, AND INFORMATION RELATING TO COMPUTER GAMES; PROVIDING A WEBSITE FEATURING NON-DOWNLOADABLE COMPUTER GAMES CAPABLE OF PERMITTING INTERACTION AMONG MULTIPLE PLAYERS; PROVIDING NON-DOWNLOADABLE SOCIAL AND LEISURE GAMES THAT MAY BE ACCESSED AND PLAYED OVER COMPUTER NETWORKS; PROVIDING TEMPORARY USE OF NON-DOWNLOADABLE SOCIAL AND LEISURE GAMES FOR USE ON PERSONAL COMPUTERS; ORGANIZING, CONDUCTING AND ADMINISTERING ONLINE COMPUTER GAMES WHEREBY MULTIPLE PARTIES PLAY AND COMPETE AGAINST EACH OTHER FOR PRIZES AND RECOGNITION; PROVIDING INFORMATION IN THE FIELDS OF NEWS, WEATHER, SPORTS, ENTERTAINMENT, COMPUTER GAMES, CURRENT EVENTS, AND EDUCATION; PROVIDING AN INTERNET PORTAL FEATURING A MANAGED SELECTION OF HYPERLINKS TO WEBSITES IN THE FIELDS OF NEWS, WEATHER, SPORTS, ENTERTAINMENT, COMPUTER GAMES, CURRENT EVENTS, AND EDUCATION (U.S. CLS. 100, 101 AND 107).

DAVID I, EXAMINING ATTORNEY

SN 85-512,386. PRINCE, CELESTE N, VENICE, CA. FILED 1-10-2012.

CONNECTIVITY

THE MARK CONSISTS OF STANDARD CHARACTERS WITHOUT CLAIM TO ANY PARTICULAR FONT, STYLE, SIZE, OR COLOR.

FOR ENTERTAINMENT SERVICES IN THE NATURE OF PRESENTING LIVE MUSICAL PERFORMANCES; ENTERTAINMENT SERVICES IN THE NATURE OF RECORDING, PRODUCTION AND POST-PRODUCTION SERVICES IN THE FIELD OF MUSIC; ENTERTAINMENT SERVICES, NAMELY, PROVIDING A WEB SITE FEATURING NON-DOWNLOADABLE MUSICAL PERFORMANCES, MUSICAL VIDEOS, RELATED FILM CLIPS, PHOTOGRAPHS, AND OTHER MULTIMEDIA MATERIALS FEATURING MUSIC; MUSIC PRODUCTION SERVICES (U.S. CLS. 100, 101 AND 107).

ERIN FALK, EXAMINING ATTORNEY

CLASS 41—(Continued).

SN 85-512,400. RIP MAGAZINE, LLC, ALEXANDRIA, VA.
FILED 1-10-2012.

RIP

THE MARK CONSISTS OF STANDARD CHARACTERS WITHOUT CLAIM TO ANY PARTICULAR FONT, STYLE, SIZE, OR COLOR.

FOR PROVIDING A WEBSITE FEATURING NEWS, ARTICLES, LIVE PERFORMANCE REVIEWS, ARTIST INTERVIEWS, AND PHOTOGRAPHS IN THE FIELD OF MUSIC AND ENTERTAINMENT (U.S. CLS. 100, 101 AND 107).

FIRST USE 11-11-2011; IN COMMERCE 11-11-2011.
MICHAEL WEBSTER, EXAMINING ATTORNEY

SN 85-512,405. DONNEY, GENE D, BOCA RATON, FL.
FILED 1-10-2012.

SUITECAST

THE MARK CONSISTS OF STANDARD CHARACTERS WITHOUT CLAIM TO ANY PARTICULAR FONT, STYLE, SIZE, OR COLOR.

FOR ENTERTAINMENT SERVICES, NAMELY, PROVIDING VIDEO AND AUDIO CONTENT, NAMELY, ONGOING TELEVISION PROGRAMS IN THE NATURE OF CURRENT EVENTS, SPORTS NEWS AND ENTERTAINMENT NEWS ALL TRANSMITTED THROUGH A GLOBAL COMMUNICATIONS NETWORK VIA WIRELESS COMMUNICATION DEVICES, MOBILE PHONES, HAND-HELD DEVICES; PROVIDING INFORMATION IN THE FIELD OF ENTERTAINMENT VIA WIRELESS COMMUNICATION DEVICES, MOBILE PHONES, HAND-HELD DEVICES AND GLOBAL COMMUNICATION DEVICES; INTERACTIVE ONLINE NEWSLETTER PROVIDING SPORTS AND ENTERTAINMENT INFORMATION; ENTERTAINMENT IN THE NATURE OF ONGOING TELEVISION PROGRAMS IN THE FIELD OF SPORTS AND ENTERTAINMENT NEWS; ENTERTAINMENT SERVICES, NAMELY, AN ON-GOING SERIES FEATURING CURRENT EVENTS, SPORTS NEWS AND ENTERTAINMENT NEWS PROVIDED THROUGH TELEVISION BROADCASTS, WEBCASTS AND RADIO BROADCASTS; ON-LINE JOURNALS, NAMELY, BLOGS FEATURING CURRENT EVENTS, SPORTS AND ENTERTAINMENT NEWS; ENTERTAINMENT SERVICES, NAMELY, PROVIDING A WEBSITE FEATURING CURRENT EVENTS, SPORTS AND ENTERTAINMENT NEWS (U.S. CLS. 100, 101 AND 107).

ANDREA HACK, EXAMINING ATTORNEY

CLASS 41—(Continued).

SN 85-512,419. SIMON SEZ, LLC, RESTON, VA. FILED 1-10-2012.



THE MARK CONSISTS OF AN IMAGE OF A DOG. UNDERNEATH THE IMAGE IS THE WORDING "SIMON SEZ" INSIDE A BOX. THE "I" IN SIMON SEZ IS DOTTED WITH A PAW.

FOR DOG TRAINING (U.S. CLS. 100, 101 AND 107).
ALICE BENMAMAN, EXAMINING ATTORNEY

SN 85-512,471. R SCOTT SIMPSON, LLC, SAN ANTONIO, TX.
FILED 1-10-2012.

THE MARK CONSISTS OF THE STYLIZED TEXT "THE LOVE PLAN". THE LETTER "O" IS REPRESENTED BY A STYLIZED HEART THAT IS FILLED IN WITH INTERLOCKING PUZZLE PIECES.

FOR PROFESSIONAL COACHING SERVICES IN THE FIELD OF RELATIONSHIPS (U.S. CLS. 100, 101 AND 107).

FIRST USE 6-10-2010; IN COMMERCE 6-10-2010.
KIMBERLY FRYE, EXAMINING ATTORNEY

SN 85-512,546. FINK, MICHAEL, LEBANON, PA. FILED 1-10-2012.

PEARL CLINICAL EDUCATION

THE MARK CONSISTS OF STANDARD CHARACTERS WITHOUT CLAIM TO ANY PARTICULAR FONT, STYLE, SIZE, OR COLOR.

NO CLAIM IS MADE TO THE EXCLUSIVE RIGHT TO USE "CLINICAL EDUCATION", APART FROM THE MARK AS SHOWN.

FOR EDUCATIONAL SERVICES, NAMELY, CONDUCTING WORKSHOPS AND SEMINARS IN THE FIELD OF ALLIED HEALTH CARE FOR MEDICAL PROFESSIONALS AND DISTRIBUTION OF TRAINING MATERIAL IN CONNECTION THEREWITH (U.S. CLS. 100, 101 AND 107).

SUSAN LESLIE DUBOIS, EXAMINING ATTORNEY

CLASS 41—(Continued).

SN 85-512,635. VIACOM INTERNATIONAL INC., NEW YORK, NY. FILED 1-10-2012.

MORNING POP

THE MARK CONSISTS OF STANDARD CHARACTERS WITHOUT CLAIM TO ANY PARTICULAR FONT, STYLE, SIZE, OR COLOR.

NO CLAIM IS MADE TO THE EXCLUSIVE RIGHT TO USE "MORNING", APART FROM THE MARK AS SHOWN.

FOR ENTERTAINMENT SERVICES IN THE NATURE OF CONTINUING PROGRAM SERIES, FEATURING LIVE ACTION, COMEDY AND DRAMA PROVIDED THROUGH CABLE TELEVISION, BROADCAST TELEVISION, INTERNET, VIDEO-ON-DEMAND, AND THROUGH OTHER DISTRIBUTION PLATFORMS; PROVIDING ONLINE INFORMATION IN THE FIELD OF ENTERTAINMENT CONCERNING TELEVISION PROGRAMS (U.S. CLS. 100, 101 AND 107).

DAVID C. REIHNER, EXAMINING ATTORNEY

SN 85-512,652. WIGSCO LLC, CULVER CITY, CA. FILED 1-10-2012.

WIGS

THE MARK CONSISTS OF STANDARD CHARACTERS WITHOUT CLAIM TO ANY PARTICULAR FONT, STYLE, SIZE, OR COLOR.

FOR ENTERTAINMENT SERVICES, NAMELY, MULTIMEDIA PROGRAMS IN THE FIELD OF GENERAL HUMAN INTEREST, DISTRIBUTED VIA VARIOUS PLATFORMS ACROSS MULTIPLE FORMS OF TRANSMISSION MEDIA; PROVIDING ENTERTAINMENT INFORMATION REGARDING ONGOING MULTIMEDIA PROGRAMS VIA A GLOBAL COMPUTER NETWORK; PRODUCTION OF TELEVISION PROGRAMS; PRODUCTION OF MULTIMEDIA PROGRAMS (U.S. CLS. 100, 101 AND 107).

TARAH HARDY, EXAMINING ATTORNEY

SN 85-512,659. VIACOM INTERNATIONAL INC., NEW YORK, NY. FILED 1-10-2012.

POWER OF 12

THE MARK CONSISTS OF STANDARD CHARACTERS WITHOUT CLAIM TO ANY PARTICULAR FONT, STYLE, SIZE, OR COLOR.

FOR SERIES OF TELEVISION SPOTS, OFFERED PERIODICALLY, ON POLITICAL AND ELECTION ISSUES (U.S. CLS. 100, 101 AND 107).

DAVID C. REIHNER, EXAMINING ATTORNEY

CLASS 41—(Continued).

SN 85-512,687. SMITH, CHRISTOPHER SHANE, YAZOO CITY, MS. FILED 1-10-2012.

Get Your Stripes

THE MARK CONSISTS OF STANDARD CHARACTERS WITHOUT CLAIM TO ANY PARTICULAR FONT, STYLE, SIZE, OR COLOR.

FOR ENTERTAINMENT SERVICES IN THE NATURE OF AN ON-GOING REALITY BASED TELEVISION PROGRAM (U.S. CLS. 100, 101 AND 107).

YAT SYE, LEE, EXAMINING ATTORNEY

SN 85-513,025. GOODMAN, CATHERINE, DUBUQUE, IA. FILED 1-10-2012.

MISTLETONES

THE MARK CONSISTS OF STANDARD CHARACTERS WITHOUT CLAIM TO ANY PARTICULAR FONT, STYLE, SIZE, OR COLOR.

FOR LIVE PERFORMANCES BY A MUSICAL GROUP (U.S. CLS. 100, 101 AND 107).

FIRST USE 12-15-2002; IN COMMERCE 12-15-2002.

KEVIN DINALLO, EXAMINING ATTORNEY

SN 85-513,305. SONI, MANEESH, FATEHPURA, INDIA, FILED 1-10-2012.

SHABDKOSH

THE MARK CONSISTS OF STANDARD CHARACTERS WITHOUT CLAIM TO ANY PARTICULAR FONT, STYLE, SIZE, OR COLOR.

THE WORDING "SHABDKOSH" HAS NO MEANING IN A FOREIGN LANGUAGE.

FOR PROVIDING ON-LINE NON-DOWNLOADABLE ELECTRONIC DICTIONARIES; PROVIDING ON-LINE NON-DOWNLOADABLE LANGUAGE TRANSLATION SERVICES; ONLINE TRANSLATION SERVICES (U.S. CLS. 100, 101 AND 107).

FIRST USE 11-15-2003; IN COMMERCE 1-27-2004.

LINDA E. BLOHM, EXAMINING ATTORNEY

CLASS 41—(Continued).

SN 85-513,336. DREAMMAKERS MEDIA, BEVERLY HILLS, CA. FILED 1-10-2012.

DREAMMAKERS

THE MARK CONSISTS OF STANDARD CHARACTERS WITHOUT CLAIM TO ANY PARTICULAR FONT, STYLE, SIZE, OR COLOR.

FOR ENTERTAINMENT INFORMATION; ENTERTAINMENT SERVICES IN THE NATURE OF AN ONGOING REALITY BASED TELEVISION PROGRAM; ENTERTAINMENT SERVICES, NAMELY, THE PROVISION OF CONTINUING PROGRAMS FEATURING CAREER ADVICE AND DEVELOPMENT DELIVERED BY THE INTERNET AND AT A PHYSICAL LOCATION (U.S. CLS. 100, 101 AND 107).

ELIZABETH KAJUBI, EXAMINING ATTORNEY

CLASS 41—(Continued).

SN 85-513,677. VIDEOSERPEL, LTD., ZUG, SWITZERLAND, FILED 1-11-2012.

LA MENTIRA

THE MARK CONSISTS OF STANDARD CHARACTERS WITHOUT CLAIM TO ANY PARTICULAR FONT, STYLE, SIZE, OR COLOR.

THE ENGLISH TRANSLATION OF "LA MENTIRA" IN THE MARK IS "THE LIE".

FOR ENTERTAINMENT SERVICES IN THE NATURE OF A CONTINUING DRAMATIC SHOW BROADCAST OVER THE INTERNET AND AN ONGOING DRAMATIC TELEVISION SHOW (U.S. CLS. 100, 101 AND 107).

FIRST USE 1-16-2012; IN COMMERCE 1-16-2012.
ELIZABETH KAJUBI, EXAMINING ATTORNEY

SN 85-513,794. JAMES PANTEL PAUL, SMYRNA, GA. FILED 1-11-2012.



THE MARK CONSISTS OF THE LETTERS "APE" IN STYLIZED FORMAT WITH THE PHRASE "[ADVANCED PERFORMANCE ENHANCEMENT]" DIRECTLY BELOW. THE LETTERS AND WORDS ARE ON TOP OF THE FACE OF AN APE WITH THE APE'S EYES LOOKING OUT THROUGH THE SPACES IN THE LETTERS "A" AND "P".

FOR ATHLETIC TRAINING SERVICES; PERSONAL TRAINING SERVICES, NAMELY, STRENGTH AND CONDITIONING TRAINING; PERSONAL TRAINING SERVICES, NAMELY, STRENGTH AND CONDITIONING TRAINING AND SPEED TRAINING; PHYSICAL FITNESS TRAINING SERVICES (U.S. CLS. 100, 101 AND 107).

FIRST USE 7-2-2011; IN COMMERCE 7-2-2011.
RONALD DELGIZZI, EXAMINING ATTORNEY

SN 85-513,675. WINKELMEDIA, LLC, CAMPBELL, CA. FILED 1-11-2012.



THE MARK CONSISTS OF A PERSON WHO IS IN A SUIT AND TIE WITH A CAMERA IN THE PLACE OF THEIR HEAD; THE CAMERA IS A BIT OVERSIZED FOR EMPHASIS, AND THE TEXT "WINKELMEDIA" ON THE RIGHT OF THE IMAGE.

FOR PRODUCTION OF VISUAL EFFECTS FOR VIDEOS ; PHOTOGRAPHY ; MULTIMEDIA ENTERTAINMENT SERVICES IN THE NATURE OF PRODUCTION AND POST-PRODUCTION SERVICES IN THE FIELDS OF VIDEO AND FILM ; ENTERTAINMENT SERVICES, NAMELY, PRODUCTION OF COMPUTER-GENERATED IMAGERY AND COMPUTER-GENERATED GRAPHICS FOR THE PRODUCTION OF MOTION PICTURES AND VIDEOS (U.S. CLS. 100, 101 AND 107).

ODESSA BIBBINS, EXAMINING ATTORNEY

SN 85-513,829. MAX SIEGEL, INC., FISHERS, IN. FILED 1-11-2012.



THE MARK CONSISTS OF A CROOKED STREET WITH THE LETTERS "REVRACING" UNDERNEATH IN STYLIZED FORM.

FOR ENTERTAINMENT SERVICES, NAMELY, PARTICIPATING IN AUTOMOBILE AND TRUCK RACES (U.S. CLS. 100, 101 AND 107).

ALYSSA STEEL, EXAMINING ATTORNEY

CLASS 41—(Continued).

SN 85-513,836. WORKOUTBOX LTD, DORKING, UNITED KINGDOM, FILED 1-11-2012.

WORKOUTBOX

THE MARK CONSISTS OF STANDARD CHARACTERS WITHOUT CLAIM TO ANY PARTICULAR FONT, STYLE, SIZE, OR COLOR.

FOR PROVIDING AN INTERACTIVE WEBSITE FEATURING INFORMATION AND LINKS RELATING TO FITNESS (U.S. CLS. 100, 101 AND 107).

FIRST USE 3-0-2009; IN COMMERCE 3-0-2009.
ANDREA BUTLER, EXAMINING ATTORNEY

SN 85-513,884. GENERATIONNATION, INC., CHARLOTTE, NC. FILED 1-11-2012.



THE MARK CONSISTS OF THE WORDS "GENERATION-NATION" UNDER A DEPICTION OF UPRAISED HANDS WITH STARS FLOATING ABOVE THEM.

FOR EDUCATIONAL PROGRAMS FOR CHILDREN AND YOUTH FOCUSING ON LEADERSHIP, CIVIC ENGAGEMENT, CIVIC LITERACY AND THE RIGHTS AND DUTIES OF CITIZENSHIP (U.S. CLS. 100, 101 AND 107).

FIRST USE 12-0-2011; IN COMMERCE 12-0-2011.
CHRISIE B. KING, EXAMINING ATTORNEY

SN 85-513,951. DAVISON, JUSTIN, BEVERLY HILLS, CA. FILED 1-11-2012.

Jaboody

THE MARK CONSISTS OF STANDARD CHARACTERS WITHOUT CLAIM TO ANY PARTICULAR FONT, STYLE, SIZE, OR COLOR.

FOR PRODUCTION OF VIDEOS FEATURING COMEDY FOR DISTRIBUTION VIA A GLOBAL COMPUTER NETWORK (U.S. CLS. 100, 101 AND 107).

FIRST USE 8-31-2008; IN COMMERCE 8-31-2008.
ESTHER A. BORSUK, EXAMINING ATTORNEY

CLASS 41—(Continued).

SN 85-513,968. WALTON ISAACSON LLC, LOS ANGELES, CA. FILED 1-11-2012.

VERSES & FLOW

THE MARK CONSISTS OF STANDARD CHARACTERS WITHOUT CLAIM TO ANY PARTICULAR FONT, STYLE, SIZE, OR COLOR.

FOR ENTERTAINMENT SERVICES IN THE NATURE OF AN ON-GOING REALITY BASED TELEVISION PROGRAM; ENTERTAINMENT SERVICES IN THE NATURE OF LIVE POETRY READING AND MUSICAL PERFORMANCES; ENTERTAINMENT SERVICES, NAMELY, AN ON-GOING SERIES FEATURING POETRY READING AND MUSICAL PERFORMANCES PROVIDED THROUGH CABLE TELEVISION AND WEBCASTS; ENTERTAINMENT SERVICES, NAMELY, THE PROVISION OF CONTINUING PROGRAMS FEATURING POETRY READING AND MUSICAL PERFORMANCES DELIVERED BY TELEVISION, INTERNET AND LIVE (U.S. CLS. 100, 101 AND 107).

FIRST USE 11-10-2011; IN COMMERCE 11-10-2011.
JOHN GARTNER, EXAMINING ATTORNEY

SN 85-514,038. T-MACFITNESS, INC., SANTA MONICA, CA. FILED 1-11-2012.

TMAC

THE MARK CONSISTS OF STANDARD CHARACTERS WITHOUT CLAIM TO ANY PARTICULAR FONT, STYLE, SIZE, OR COLOR.

FOR ARRANGING AND CONDUCTING ATHLETIC COMPETITIONS; ARRANGING AND CONDUCTING YOUTH FOOTBALL PROGRAMS; ATHLETIC TRAINING SERVICES; COACHING IN THE FIELD OF SPORTS; CONDUCTING FITNESS CLASSES; CONSULTING SERVICES IN THE FIELDS OF FITNESS AND EXERCISE; EDUCATIONAL AND ENTERTAINMENT SERVICES, NAMELY, PROVIDING MOTIVATIONAL SPEAKING SERVICES IN THE FIELD OF FITNESS AND HEALTH; HEALTH CLUB SERVICES, NAMELY, PROVIDING INSTRUCTION AND EQUIPMENT IN THE FIELD OF PHYSICAL EXERCISE; ORGANISATION OF SPORTS EVENTS IN THE FIELD OF FOOTBALL; ORGANIZING AND CONDUCTING SPORTING EVENTS FOR THE PURPOSE OF HELPING HIGH SCHOOL SENIORS EARN A COLLEGE SCHOLARSHIP IN THEIR RESPECTIVE SPORT; PERSONAL FITNESS TRAINING SERVICES AND CONSULTANCY; PERSONAL TRAINER SERVICES; PERSONAL TRAINING PROVIDED IN CONNEC-

CLASS 41—(Continued).

TION WITH WEIGHT LOSS AND EXERCISE PROGRAMS; PERSONAL TRAINING SERVICES, NAMELY, STRENGTH AND CONDITIONING TRAINING; PERSONAL TRAINING SERVICES, NAMELY, STRENGTH AND CONDITIONING TRAINING AND SPEED TRAINING; PHYSICAL FITNESS CONDITIONING CLASSES; PHYSICAL FITNESS CONSULTATION; PHYSICAL FITNESS INSTRUCTION; PHYSICAL FITNESS STUDIO SERVICES, NAMELY, PROVIDING EXERCISE CLASSES, BODY SCULPTING CLASSES, AND GROUP FITNESS CLASSES; PHYSICAL FITNESS STUDIO SERVICES, NAMELY, PROVIDING GROUP EXERCISE INSTRUCTION, EQUIPMENT, AND FACILITIES; PHYSICAL FITNESS TRAINING OF INDIVIDUALS AND GROUPS; PHYSICAL FITNESS TRAINING SERVICES; PRODUCTION OF DVDS FEATURING FITNESS TRAINING; PROVIDING A WEB SITE FEATURING INFORMATION ON EXERCISE AND FITNESS; PROVIDING A WEBSITE FEATURING INFORMATION ON EXERCISE AND FITNESS; PROVIDING FITNESS AND EXERCISE FACILITIES (U.S. CLS. 100, 101 AND 107).

FIRST USE 4-5-2010; IN COMMERCE 4-5-2010.
JOHN HWANG, EXAMINING ATTORNEY

SN 85-514,122. YORK TECHNICAL COLLEGE, ROCK HILL, SC. FILED 1-11-2012.

One College. Many Opportunities.

THE MARK CONSISTS OF STANDARD CHARACTERS WITHOUT CLAIM TO ANY PARTICULAR FONT, STYLE, SIZE, OR COLOR.

FOR EDUCATIONAL SERVICES, NAMELY, PROVIDING COURSES OF INSTRUCTION AT THE COLLEGE AND VOCATIONAL SCHOOL LEVEL (U.S. CLS. 100, 101 AND 107).

FIRST USE 11-25-2009; IN COMMERCE 11-25-2009.
BRIAN PINO, EXAMINING ATTORNEY

SN 85-514,183. RUDOLF MEDIA, LLC, SEWICKLEY, PA. FILED 1-11-2012.

THENITESPOT.COM

THE MARK CONSISTS OF STANDARD CHARACTERS WITHOUT CLAIM TO ANY PARTICULAR FONT, STYLE, SIZE, OR COLOR.

FOR WEBSITE HAVING INFORMATION ABOUT ENTERTAINMENT EVENTS (U.S. CLS. 100, 101 AND 107).

JANICE L. MCMORROW, EXAMINING ATTORNEY

CLASS 41—(Continued).

SN 85-514,223. DIRECTV, LLC, EL SEGUNDO, CA. FILED 1-11-2012.

MÁS QUE VER TV. DIRECTV

THE MARK CONSISTS OF STANDARD CHARACTERS WITHOUT CLAIM TO ANY PARTICULAR FONT, STYLE, SIZE, OR COLOR.

OWNER OF U.S. REG. NOS. 2,618,102, 2,698,197 AND 2,740,757.

THE ENGLISH TRANSLATION OF "MÁS QUE VER TV" IN THE MARK IS "MORE THAN WATCHING TV".

FOR DISTRIBUTION OF TELEVISION PROGRAMS FOR OTHERS; TELEVISION PROGRAMMING; PROGRAMMING ON A GLOBAL COMPUTER NETWORK; ENTERTAINMENT SERVICES, NAMELY, PROVIDING ONGOING TELEVISION PROGRAMS FEATURING MUSIC, MUSICAL ENTERTAINMENT, INFORMATION ABOUT MUSIC AND ENTERTAINMENT IN THE FIELD OF MUSIC, ALL VIA SATELLITE; PROVIDING ON-LINE INTERACTIVE COMPUTER DATABASES IN THE FIELD OF ENTERTAINMENT INFORMATION FEATURING TELEVISION PROGRAMMING LISTS, PROGRAM SCHEDULES AND PROGRAM-RELATED INFORMATION; PROVIDING ON-LINE INTERACTIVE COMPUTER DATABASES FEATURING ENTERTAINMENT INFORMATION AND SCHEDULES ABOUT TELEVISION PROGRAMMING, MOVIES, AND OTHER DIGITAL IMAGES, AUDIO, VIDEO AND OTHER MULTIMEDIA MATERIALS; ENTERTAINMENT SERVICES, NAMELY, PROVIDING ON-LINE COMPUTER GAMES; PROVIDING COMPUTER GAMES VIA SATELLITE TRANSMISSION; PROVIDING A COMPUTER GAME FOR USE NETWORK-WIDE BY NETWORK USERS; ENTERTAINMENT SERVICES, NAMELY, PROVIDING ONGOING TELEVISION PROGRAMS FEATURING GENERAL NEWS AND LOCAL NEWS THAT ALSO INCLUDE INTERACTIVE FUNCTIONS THAT PERMIT VIEWERS TO VIEW MULTIPLE IMAGES AND SOURCES OF TELEVISION PROGRAMMING SIMULTANEOUSLY; ENTERTAINMENT SERVICES, NAMELY, PROVIDING ONGOING TELEVISION PROGRAMS FEATURING GENERAL NEWS AND LOCAL NEWS AS WELL AS A VARIETY OF INFORMATION OF INTEREST TO SPECIFIC GEOGRAPHIC AREAS THAT ALSO INCLUDE INTERACTIVE COMPONENTS THAT LET VIEWERS CHOOSE WHAT TO WATCH AT VARIOUS TIMES, TO OBTAIN INFORMATION ABOUT POPULAR PROGRAMS IN THEIR LOCAL VIEWING AREA AND TO MORE NARROWLY DEFINE THE TYPES OF RELATED INFORMATION THEY RECEIVE AND PROGRAMS THEY VIEW; ENTERTAINMENT SERVICES, NAMELY, ONGOING TELEVISION PROGRAMS IN THE FIELD OF GEOGRAPHICAL, CATEGORICAL, REAL-TIME PROGRAMMING RATINGS THAT ALSO INCLUDE INTERACTIVE COMPONENTS THAT LET VIEWERS MORE NARROWLY DEFINE THE TYPES OF RELATED INFORMATION THEY RECEIVE AND PROGRAMS THEY VIEW; ENTERTAINMENT SERVICES, NAMELY, PROVIDING ONGOING TELEVISION PROGRAMS FEATURING GENERAL INFORMATION RELATING TO SATELLITE TELEVISION SERVICE, SATELLITE TELEVISION EQUIPMENT AND HARDWARE, SATELLITE TELEVISION PROGRAMMING AND AUDIO, VISUAL AND OTHER MULTIMEDIA CONTENT THAT ALSO INCLUDE INTERACTIVE COMPONENTS THAT ALLOW USERS TO DEFINE THEIR VIEWING PREFERENCE; ON-LINE, NONDOWNLOADABLE NEWSLETTERS FEATURING GENERAL INFORMATION RELATING TO ENTERTAINMENT, NAMELY, TELEVISION, MOVIES AND OTHER MULTIMEDIA

CLASS 41—(Continued).

ENTERTAINMENT-RELATED CONTENT; ON-LINE, NONDOWNLOADABLE NEWSLETTERS FEATURING GENERAL INFORMATION RELATING TO SATELLITE TELECOMMUNICATION SERVICES AND SATELLITE TELECOMMUNICATIONS HARDWARE; AND ENTERTAINMENT SERVICES, NAMELY, PROVIDING ONGOING TELEVISION PROGRAMS IN A WIDE VARIETY OF FIELDS THAT ALSO FEATURE INTERACTIVE TELEVISION VIEWING FUNCTIONS THAT PERMIT VIEWERS TO VIEW AND USE COMPUTER APPLICATIONS SIMULTANEOUSLY WHILE VIEWING TELEVISION PROGRAMS (U.S. CLS. 100, 101 AND 107).
ELIZABETH KAJUBI, EXAMINING ATTORNEY

SN 85-514,273. TASTE OF BLUE, LOS ANGELES, SC. FILED 1-11-2012.

Taste of Blue

THE MARK CONSISTS OF STANDARD CHARACTERS WITHOUT CLAIM TO ANY PARTICULAR FONT, STYLE, SIZE, OR COLOR.

FOR TICKET RESERVATION AND BOOKING SERVICES FOR ENTERTAINMENT, SPORTING AND CULTURAL EVENTS (U.S. CLS. 100, 101 AND 107).

FIRST USE 10-10-2011; IN COMMERCE 11-11-2011.
KAREN K. BUSH, EXAMINING ATTORNEY

SN 85-514,584. VAN DER VELDEN, KARL, SEATTLE, WA. FILED 1-12-2012.

SACRED COWS

THE MARK CONSISTS OF STANDARD CHARACTERS WITHOUT CLAIM TO ANY PARTICULAR FONT, STYLE, SIZE, OR COLOR.

FOR LIVE PERFORMANCE BY MUSICAL GROUP (U.S. CLS. 100, 101 AND 107).
CARYN GLASSER, EXAMINING ATTORNEY

SN 85-514,626. AMERICAN MOVIE CLASSICS COMPANY LLC, NEW YORK, NY. FILED 1-12-2012.

PUTTING THE KA-POW INTO KER-CHING

THE MARK CONSISTS OF STANDARD CHARACTERS WITHOUT CLAIM TO ANY PARTICULAR FONT, STYLE, SIZE, OR COLOR.

FOR ENTERTAINMENT SERVICES IN THE NATURE OF AN ON-GOING REALITY BASED TELEVISION PROGRAM (U.S. CLS. 100, 101 AND 107).

STEVEN R. FINE, EXAMINING ATTORNEY

CLASS 41—(Continued).

SN 85-514,638. ZEDA INC, OAK BROOK, IL. FILED 1-12-2012.

Casinomania

THE MARK CONSISTS OF STANDARD CHARACTERS WITHOUT CLAIM TO ANY PARTICULAR FONT, STYLE, SIZE, OR COLOR.

FOR ELECTRONIC GAMES SERVICES PROVIDED BY MEANS OF THE INTERNET; ENTERTAINMENT SERVICES, NAMELY, PROVIDING GAMES OF CHANCE VIA THE INTERNET (U.S. CLS. 100, 101 AND 107).

LUCY ARANT, EXAMINING ATTORNEY

SN 85-514,644. PLAN FOR WHAT IF, LLC, SARASOTA, FL. FILED 1-12-2012.

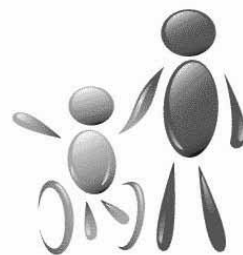

plan for what if

THE MARK CONSISTS OF A STYLIZED DESIGN, CONSISTING OF VARIOUS SHAPES, OF A PERSON STANDING TO THE RIGHT OF A CHILD IN A WHEELCHAIR, WITH THE CHILD AND PERSON SHARING THE SAME ARM, ABOVE THE WORDS "PLAN FOR WHAT IF" IN A STYLIZED FONT.

FOR PROVIDING EDUCATIONAL MENTORING SERVICES AND PROGRAMS IN THE FIELD OF LIFE PLANNING FOR SPECIAL NEEDS FAMILIES (U.S. CLS. 100, 101 AND 107).

FIRST USE 1-6-2012; IN COMMERCE 1-6-2012.
MORGAN WYNNE, EXAMINING ATTORNEY

SN 85-514,654. TSIRBAS, ARISTOMENIS, LOS ANGELES, CA. FILED 1-12-2012.

EXOIDS

THE MARK CONSISTS OF STANDARD CHARACTERS WITHOUT CLAIM TO ANY PARTICULAR FONT, STYLE, SIZE, OR COLOR.

FOR FILM AND VIDEO PRODUCTION (U.S. CLS. 100, 101 AND 107).

DAVID MURRAY, EXAMINING ATTORNEY

CLASS 41—(Continued).

SN 85-514,708. BLACKNELL, SHELLI, LOS ANGELES, CA. FILED 1-12-2012.

Fashion in the City

THE MARK CONSISTS OF STANDARD CHARACTERS WITHOUT CLAIM TO ANY PARTICULAR FONT, STYLE, SIZE, OR COLOR.

FOR ENTERTAINMENT IN THE NATURE OF FASHION SHOWS; SPECIAL EVENT PLANNING FOR SOCIAL ENTERTAINMENT PURPOSES (U.S. CLS. 100, 101 AND 107).

FIRST USE 9-25-2011; IN COMMERCE 9-25-2011.
PATRICIA EVANKO, EXAMINING ATTORNEY

CLASS 41—(Continued).

SN 85-514,771. THOMAS ANDERSON, NEPTUNE BEACH, FL. FILED 1-12-2012.

XERO GRAVITY

THE MARK CONSISTS OF STANDARD CHARACTERS WITHOUT CLAIM TO ANY PARTICULAR FONT, STYLE, SIZE, OR COLOR.

FOR ORGANIZING SPORTING EVENTS, NAMELY, FLOWBOARDING COMPETITIONS, SKATEBOARDING COMPETITIONS, BMX COMPETITIONS, SNOWBOARDING COMPETITIONS AND OTHER BOARD SPORTS COMPETITIONS; PROVIDING FACILITIES FOR RECREATIONAL ACTIVITIES, NAMELY, SNOWBOARDING, SKIING, SKATEBOARDING, FLOWBOARDING, ROLLERBLADING, EXTREME BICYCLING, SURFING, BOOGIEBOARDING AND KNEEBOARDING; PROVIDING VARIOUS FACILITIES FOR AN ARRAY OF SPORTING EVENTS, SPORTS AND ATHLETIC COMPETITIONS AND AWARDS PROGRAMMES; RECREATIONAL SERVICES IN THE NATURE OF SNOWBOARDING, SKIING, SKATEBOARDING, FLOWBOARDING, ROLLERBLADING, EXTREME BICYCLING, SURFING, BOOGIEBOARDING AND KNEEBOARDING (U.S. CLS. 100, 101 AND 107).

KAPIL BHANOT, EXAMINING ATTORNEY

SN 85-514,719. SHARPE, LOUIS, NORTH BERGEN, NJ. FILED 1-12-2012.

The Official TKA

THE MARK CONSISTS OF STANDARD CHARACTERS WITHOUT CLAIM TO ANY PARTICULAR FONT, STYLE, SIZE, OR COLOR.

OWNER OF U.S. REG. NOS. 3,175,605, 3,259,108 AND 3,956,660.

NO CLAIM IS MADE TO THE EXCLUSIVE RIGHT TO USE "THE OFFICIAL", APART FROM THE MARK AS SHOWN.

FOR ENTERTAINMENT IN THE NATURE OF LIVE PERFORMANCES BY A MUSICAL GROUP (U.S. CLS. 100, 101 AND 107).

JENNIFER VASQUEZ, EXAMINING ATTORNEY

SN 85-514,789. TROCHTENBERG, RANDI, NASHVILLE, TN. AND TROCHTENBERG, DAVID, NASHVILLE, TN. FILED 1-12-2012.

Life's Grand Ed-Ventures

THE MARK CONSISTS OF STANDARD CHARACTERS WITHOUT CLAIM TO ANY PARTICULAR FONT, STYLE, SIZE, OR COLOR.

FOR EDUCATION SERVICES, NAMELY, PROVIDING CLASSES, SEMINARS, WORKSHOPS IN THE FIELD OF PERFORMANCE SKILLS, PERSONAL DEVELOPMENT, LIFE SKILL ATTAINMENT, BUSINESS AND LIFE TRANSITIONS, STRESS MANAGEMENT, INTEGRATIVE HEALTH PRACTICES (U.S. CLS. 100, 101 AND 107).

LIEF MARTIN, EXAMINING ATTORNEY

CLASS 41—(Continued).

SN 85-514,804. BRIDGEPOINT EDUCATION, INC., SAN DIEGO, CA. FILED 1-12-2012.

**AN ADVANCED INSTITUTION
FOR TOMORROW'S THOUGHT
LEADERS**

THE MARK CONSISTS OF STANDARD CHARACTERS WITHOUT CLAIM TO ANY PARTICULAR FONT, STYLE, SIZE, OR COLOR.

FOR EDUCATIONAL SERVICES, NAMELY, DEVELOPING AND PROVIDING LIVE CLASSROOM COURSES OF INSTRUCTION, AND ONLINE AND OTHER DISTANCE LEARNING COURSES OF INSTRUCTION IN THE FIELD OF PSYCHOLOGY AT THE GRADUATE LEVEL (U.S. CLS. 100, 101 AND 107).

DAVID C. REIHNER, EXAMINING ATTORNEY

SN 85-514,806. HEINECKE, STUART, SEATTLE, WA. FILED 1-12-2012.

NEXT-GEN

THE MARK CONSISTS OF STANDARD CHARACTERS WITHOUT CLAIM TO ANY PARTICULAR FONT, STYLE, SIZE, OR COLOR.

FOR PUBLICATION OF ELECTRONIC MAGAZINES (U.S. CLS. 100, 101 AND 107).

SALLY SHIH, EXAMINING ATTORNEY

SN 85-514,939. FIJI USA SPORTS AND SOCIAL ASSOCIATION, SACRAMENTO, CA. FILED 1-12-2012.

NAFSA

THE MARK CONSISTS OF STANDARD CHARACTERS WITHOUT CLAIM TO ANY PARTICULAR FONT, STYLE, SIZE, OR COLOR.

FOR ENTERTAINMENT IN THE NATURE OF SOCCER GAMES (U.S. CLS. 100, 101 AND 107).

FIRST USE 7-1-2006; IN COMMERCE 7-1-2006.
FRANK LATTUCA, EXAMINING ATTORNEY

CLASS 41—(Continued).

SN 85-514,974. INNERSTRENGTH, LLC, LIVINGSTON, NJ. FILED 1-12-2012.

INNERSTRENGTH

THE MARK CONSISTS OF STANDARD CHARACTERS WITHOUT CLAIM TO ANY PARTICULAR FONT, STYLE, SIZE, OR COLOR.

FOR PROVIDING FITNESS INSTRUCTION (U.S. CLS. 100, 101 AND 107).

BRIAN PINO, EXAMINING ATTORNEY

SN 85-514,981. ALTIUS EDUCATION, INC., SAN FRANCISCO, CA. FILED 1-12-2012.



OWNER OF U.S. REG. NOS. 3,971,306, 3,982,090 AND OTHERS.

NO CLAIM IS MADE TO THE EXCLUSIVE RIGHT TO USE "UNIVERSITY", APART FROM THE MARK AS SHOWN.

THE MARK CONSISTS OF CURVED LINE OVER "ALTIUS" IN A BOLDED STYLIZED FONT ABOVE "UNIVERSITY".

FOR EDUCATIONAL SERVICES, NAMELY, PROVIDING COURSES OF INSTRUCTION AT THE COLLEGE LEVEL AND DISTRIBUTION OF COURSE MATERIAL IN CONNECTION THEREWITH (U.S. CLS. 100, 101 AND 107).

KAREN K. BUSH, EXAMINING ATTORNEY

SN 85-515,154. CROSSING POINT INCORPORATED, AFTON, VA. FILED 1-12-2012.

**CENTER FOR THE STUDY OF
EXTRATERRESTRIAL
INTELLIGENCE**

THE MARK CONSISTS OF STANDARD CHARACTERS WITHOUT CLAIM TO ANY PARTICULAR FONT, STYLE, SIZE, OR COLOR.

NO CLAIM IS MADE TO THE EXCLUSIVE RIGHT TO USE "CENTER", APART FROM THE MARK AS SHOWN. SEC. 2(F).

FOR EDUCATIONAL SERVICES, NAMELY, CONDUCTING PROGRAMS IN THE FIELD OF AEROSPACE, GOVERNMENT SECRECY AND ENERGY TECHNOLOGIES (U.S. CLS. 100, 101 AND 107).

FIRST USE 1-0-1998; IN COMMERCE 1-0-1998.

JULIE GUTTADAURO, EXAMINING ATTORNEY

CLASS 41—(Continued).

SN 85-515,167. STONE & COMPANY ENTERTAINMENT, INC., LOS ANGELES, CA. FILED 1-12-2012.

Brain Drain

THE MARK CONSISTS OF STANDARD CHARACTERS WITHOUT CLAIM TO ANY PARTICULAR FONT, STYLE, SIZE, OR COLOR.

FOR ENTERTAINMENT, NAMELY, A CONTINUING GAME SHOW BROADCAST OVER TELEVISION, SATELLITE, AUDIO, AND VIDEO MEDIA (U.S. CLS. 100, 101 AND 107).

YAT SYE, LEE, EXAMINING ATTORNEY

SN 85-515,197. DONNEY, GENE, BOCA RATON, FL. FILED 1-12-2012.

SUITESPORTSXCHANGE

THE MARK CONSISTS OF STANDARD CHARACTERS WITHOUT CLAIM TO ANY PARTICULAR FONT, STYLE, SIZE, OR COLOR.

FOR ENTERTAINMENT SERVICES, NAMELY, PROVIDING VIDEO AND AUDIO CONTENT, NAMELY, ONGOING TELEVISION PROGRAMS IN THE NATURE OF CURRENT EVENTS, SPORTS NEWS AND ENTERTAINMENT NEWS ALL TRANSMITTED THROUGH A GLOBAL COMMUNICATIONS NETWORK VIA WIRELESS COMMUNICATION DEVICES, MOBILE PHONES, HAND-HELD DEVICES; PROVIDING INFORMATION IN THE FIELD OF ENTERTAINMENT VIA WIRELESS COMMUNICATION DEVICES, MOBILE PHONES, HAND-HELD DEVICES AND GLOBAL COMMUNICATION DEVICES; INTERACTIVE ONLINE NEWSLETTER PROVIDING SPORTS AND ENTERTAINMENT INFORMATION; ENTERTAINMENT IN THE NATURE OF ONGOING TELEVISION PROGRAMS IN THE FIELD OF SPORTS AND ENTERTAINMENT NEWS; ENTERTAINMENT SERVICES, NAMELY, AN ON-GOING SERIES FEATURING CURRENT EVENTS, SPORTS NEWS AND ENTERTAINMENT NEWS PROVIDED THROUGH TELEVISION BROADCASTS, WEBCASTS AND RADIO BROADCASTS; ON-LINE JOURNALS, NAMELY, BLOGS FEATURING CURRENT EVENTS, SPORTS AND ENTERTAINMENT NEWS; ENTERTAINMENT SERVICES, NAMELY, PROVIDING A WEBSITE FEATURING CURRENT EVENTS, SPORTS AND ENTERTAINMENT NEWS (U.S. CLS. 100, 101 AND 107).

ANDREA HACK, EXAMINING ATTORNEY

CLASS 41—(Continued).

SN 85-515,240. EASTERN AMERICAN STUDIES ASSOCIATION, DBA EASA, MIDDLETOWN, PA. FILED 1-12-2012.

EPSILON ALPHA KAPPA

THE MARK CONSISTS OF STANDARD CHARACTERS WITHOUT CLAIM TO ANY PARTICULAR FONT, STYLE, SIZE, OR COLOR.

FOR PROVIDING AN ACADEMIC HONOR SOCIETY IN WHICH STUDENTS ARE ADMITTED IN RECOGNITION OF ACADEMIC ACHIEVEMENT (U.S. CLS. 100, 101 AND 107).

TRACY FLETCHER, EXAMINING ATTORNEY

SN 85-515,278. WEATHERLY, LAURA JANE, ALEXANDRIA, VA. FILED 1-12-2012.

Engaging Affairs

THE MARK CONSISTS OF STANDARD CHARACTERS WITHOUT CLAIM TO ANY PARTICULAR FONT, STYLE, SIZE, OR COLOR.

FOR PARTY AND WEDDING PLANNING AND COORDINATION SERVICES; PARTY AND WEDDING PLANNING CONSULTATION SERVICES; PARTY AND WEDDING PLANNING, COORDINATION AND CONSULTATION SERVICES; PARTY PLANNING; PROVIDING INFORMATION IN THE FIELD OF WEDDING PARTY PLANNING; PROVIDING INFORMATION REGARDING WEDDING PLANNING FOR WEDDING PARTIES; WEDDING PLANNING AND COORDINATION SERVICES (U.S. CLS. 100, 101 AND 107).

FIRST USE 3-6-1996; IN COMMERCE 3-24-1996.

WILLIAM BRECKENFELD, EXAMINING ATTORNEY

SN 85-515,416. HIERS-BAXLEY FUNERAL SERVICES, INC., OCALA, FL. FILED 1-12-2012.

Life Steps ... Stepping Forward, Remembering Always

THE MARK CONSISTS OF STANDARD CHARACTERS WITHOUT CLAIM TO ANY PARTICULAR FONT, STYLE, SIZE, OR COLOR.

FOR EDUCATION SERVICES, NAMELY, PROVIDING WORKSHOPS IN THE FIELD OF BEREAVEMENT (U.S. CLS. 100, 101 AND 107).

LOURDES AYALA, EXAMINING ATTORNEY

CLASS 41—(Continued).

SN 85-515,576. SHANDRO ENTERTAINMENT, LLC, BOISE, ID. FILED 1-12-2012.

TREEFORT

THE MARK CONSISTS OF STANDARD CHARACTERS WITHOUT CLAIM TO ANY PARTICULAR FONT, STYLE, SIZE, OR COLOR.

FOR ENTERTAINMENT SERVICES IN THE NATURE OF PRESENTING LIVE MUSICAL PERFORMANCES (U.S. CLS. 100, 101 AND 107).

FIRST USE 11-1-2011; IN COMMERCE 11-1-2011.
AMEEN IMAM, EXAMINING ATTORNEY

CLASS 41—(Continued).

SN 85-515,694. WOUND, OSTOMY AND CONTINENCE NURSES SOCIETY, MT. LAUREL, NJ. FILED 1-13-2012.

WTA

THE MARK CONSISTS OF STANDARD CHARACTERS WITHOUT CLAIM TO ANY PARTICULAR FONT, STYLE, SIZE, OR COLOR.

FOR EDUCATIONAL SERVICES, NAMELY, PROVIDING EDUCATIONAL AND TESTING PROGRAMS FOR PROVIDERS OF WOUND CARE (U.S. CLS. 100, 101 AND 107).

WILLIAM JACKSON, EXAMINING ATTORNEY

SN 85-515,635. LEACH, UNDREA, OAKLAND, CA. FILED 1-13-2012.

SIMPLY UNDREA

THE MARK CONSISTS OF STANDARD CHARACTERS WITHOUT CLAIM TO ANY PARTICULAR FONT, STYLE, SIZE, OR COLOR.

FOR ENTERTAINMENT SERVICES IN THE NATURE OF LIVE MUSICAL PERFORMANCES; ENTERTAINMENT SERVICES IN THE NATURE OF LIVE SINGING PERFORMANCES; ENTERTAINMENT IN THE NATURE OF VISUAL AND AUDIO PERFORMANCES BY A SINGER; LIVE PERFORMANCES BY A MUSICAL GROUP (U.S. CLS. 100, 101 AND 107).

PAULA MAHONEY, EXAMINING ATTORNEY

SN 85-515,712. WEBSTER HALL ENTERTAINMENT CORP., NEW YORK, NY. FILED 1-13-2012.

GIRLS & BOYS

THE MARK CONSISTS OF STANDARD CHARACTERS WITHOUT CLAIM TO ANY PARTICULAR FONT, STYLE, SIZE, OR COLOR.

FOR ARRANGING AND CONDUCTING NIGHTCLUB ENTERTAINMENT EVENTS; ENTERTAINMENT, NAMELY, LIVE MUSIC CONCERTS (U.S. CLS. 100, 101 AND 107).

FIRST USE 1-30-2009; IN COMMERCE 1-30-2009.
BARBARA GAYNOR, EXAMINING ATTORNEY

SN 85-515,657. EMPIRE STATE CHAPTER OF THE ASSOCIATED BUILDERS AND CONTRACTORS, INC., EAST SYRACUSE, NY. FILED 1-13-2012.

Construction Training Centers of New York State

THE MARK CONSISTS OF STANDARD CHARACTERS WITHOUT CLAIM TO ANY PARTICULAR FONT, STYLE, SIZE, OR COLOR.

FOR VOCATIONAL EDUCATION IN THE FIELD OF CONSTRUCTION INDUSTRY (U.S. CLS. 100, 101 AND 107).

FIRST USE 9-21-2002; IN COMMERCE 9-21-2002.
ALAIN LAPTEY, EXAMINING ATTORNEY

SN 85-515,841. GREENE, JENNIFER, RICHMOND, VA. FILED 1-13-2012.



flipm
future leaders in project management

THE MARK CONSISTS OF THE STYLIZED TEXT "FLIPM" WITH AN ARROW THAT ARCHES ABOVE THE TEXT FROM THE "L" TO THE "M". BELOW THIS TEXT IS THE STYLIZED TEXT "FUTURE LEADERS IN PROJECT MANAGEMENT".

FOR EDUCATIONAL SERVICES, NAMELY, PROVIDING IN-SCHOOL CURRICULUM TO TEACH CHILDREN PROJECT MANAGEMENT SKILLS FROM 8TH GRADE THROUGH HIGH SCHOOL GRADUATION (U.S. CLS. 100, 101 AND 107).

DARRYL SPRUILL, EXAMINING ATTORNEY

CLASS 41—(Continued).

SN 85-515,957. HOSKINS, ADMERLE, COPPELL, TX. FILED 1-13-2012.



THE MARK CONSISTS OF THE STYLIZED TEXT "THE GREEN BUSTIER" WITH A DESIGN OF A FEMALE BUSTIER WITH LACE.

FOR EDUCATION SERVICES, NAMELY, PROVIDING SEMINARS AND NON-DOWNLOADABLE WEBINARS IN THE FIELD OF WELLNESS FOR WOMEN (U.S. CLS. 100, 101 AND 107).

JAMES LOVELACE, EXAMINING ATTORNEY

SN 85-515,991. ARTISIN, L.L.C., NEWARK, NJ. FILED 1-13-2012.

A2A

THE MARK CONSISTS OF STANDARD CHARACTERS WITHOUT CLAIM TO ANY PARTICULAR FONT, STYLE, SIZE, OR COLOR.

FOR PERSONAL BUSINESS DEVELOPMENT COACHING AND TRAINING SERVICES FOR PERSONS ENGAGED IN FIELDS OF ARTISTIC ENDEAVOR, NAMELY, CONDUCTING INFORMATION SHARING, WORKSHOP, AND TRAINING SESSIONS AND DISSEMINATING INFORMATIONAL MATERIALS AND TOOLS IN CONNECTIONS THEREWITH, ALL WITH THE GENERAL PURPOSE OF IMPROVING PARTICIPANTS' UNDERSTANDING OF SOUND BUSINESS PRACTICES AND ENTREPRENEURIAL TECHNIQUES AND FACILITATING THE IMPLEMENTATION OF THOSE PRACTICES AND TECHNIQUES IN CONNECTION WITH THEIR ARTISTIC ACTIVITIES (U.S. CLS. 100, 101 AND 107).

KRISTINA MORRIS, EXAMINING ATTORNEY

CLASS 41—(Continued).

SN 85-516,123. PREP FOR PREP, NEW YORK, NY. FILED 1-13-2012.

LILAC BALL

THE MARK CONSISTS OF STANDARD CHARACTERS WITHOUT CLAIM TO ANY PARTICULAR FONT, STYLE, SIZE, OR COLOR.

NO CLAIM IS MADE TO THE EXCLUSIVE RIGHT TO USE "BALL", APART FROM THE MARK AS SHOWN.

FOR CONDUCTING AN ANNUAL AWARDS DINNER AND DANCE TO RECOGNIZE THE ACHIEVEMENTS OF PREP SCHOOL MINORITY STUDENTS (U.S. CLS. 100, 101 AND 107).

FIRST USE 3-31-1988; IN COMMERCE 3-31-1988.

JOHN WILKE, EXAMINING ATTORNEY

SN 85-516,140. MARQUET, L. DAVID, LAUREL, FL. FILED 1-13-2012.

Leader-Leader

THE MARK CONSISTS OF STANDARD CHARACTERS WITHOUT CLAIM TO ANY PARTICULAR FONT, STYLE, SIZE, OR COLOR.

FOR EDUCATION AND TRAINING SERVICES, NAMELY, ARRANGING PROFESSIONAL WORKSHOPS AND TRAINING COURSES; PROVIDING ON-LINE TRAINING IN THE FORM OF SEMINARS; ONE-ON-ONE COACHING; PUBLICATION AND ON-LINE PUBLICATION OF PAPERS; AND ON-LINE BLOGS, ALL IN THE FIELD OF LEADERSHIP DEVELOPMENT AND LEADERSHIP CONSULTING (U.S. CLS. 100, 101 AND 107).

FIRST USE 5-25-2009; IN COMMERCE 5-25-2009.

MARK SHINER, EXAMINING ATTORNEY

SN 85-516,176. ARCHIBALD, ALEXANDRA, NEW YORK, NY, AND PFEFFER, LAUREN, NEW YORK, NY. FILED 1-13-2012.

FaceCrimes

THE MARK CONSISTS OF STANDARD CHARACTERS WITHOUT CLAIM TO ANY PARTICULAR FONT, STYLE, SIZE, OR COLOR.

FOR ENTERTAINMENT, NAMELY, LIVE PERFORMANCES BY A MUSICAL BAND; LIVE PERFORMANCES BY A MUSICAL GROUP; PROVIDING A WEBSITE FOR ENTERTAINMENT PURPOSES WHERE USERS CAN VIEW AND POST PHOTOS, VIDEOS AND MUSICAL PERFORMANCES FEATURING THE MUSICAL BAND (U.S. CLS. 100, 101 AND 107).

FIRST USE 2-17-2010; IN COMMERCE 2-17-2010.

EMILY CHUO, EXAMINING ATTORNEY

CLASS 41—(Continued).

SN 85-516,226. THE ERIE COUNTY CHAMBER OF COMMERCE, SANDUSKY, OH. FILED 1-13-2012.

TASTE OF THE NORTH COAST

THE MARK CONSISTS OF STANDARD CHARACTERS WITHOUT CLAIM TO ANY PARTICULAR FONT, STYLE, SIZE, OR COLOR.

FOR ORGANIZING, ARRANGING, AND CONDUCTING FOOD, WINE AND BEER TASTING EVENTS (U.S. CLS. 100, 101 AND 107).

FIRST USE 2-24-2011; IN COMMERCE 2-24-2011.
ANDREW LEASER, EXAMINING ATTORNEY

SN 85-516,245. THE DREW OLIVER COMPANY, LLC, STAMFORD, CT. FILED 1-13-2012.

HUMERUS

THE MARK CONSISTS OF STANDARD CHARACTERS WITHOUT CLAIM TO ANY PARTICULAR FONT, STYLE, SIZE, OR COLOR.

FOR EDUCATIONAL AND ENTERTAINMENT SERVICES, NAMELY, A CONTINUING PROGRAM ABOUT MICROBE AND MICROORGANISM CHARACTERS ACCESSIBLE BY RADIO, TELEVISION, SATELLITE, AUDIO, VIDEO AND COMPUTER NETWORKS; ENTERTAINMENT SERVICES, NAMELY, PROVIDING A WEBSITE FEATURING PHOTOGRAPHIC, AUDIO, VIDEO AND PROSE PRESENTATIONS FEATURING MICROBE AND MICROORGANISM CHARACTERS; ENTERTAINMENT IN THE NATURE OF PROVIDING ON-LINE VIDEO GAMES; ENTERTAINMENT, NAMELY, PRODUCTION OF MOTION PICTURES, TELEVISION PROGRAMS/SHOWS, AND WEBCAST PROGRAMS; ENTERTAINMENT SERVICES IN THE NATURE OF ON-GOING TELEVISION PROGRAMS IN THE FIELD OF CHILDREN'S ENTERTAINMENT; ENTERTAINMENT SERVICES, NAMELY, AN ON-GOING SERIES FEATURING MICROBE AND MICROORGANISM CHARACTERS PROVIDED THROUGH MOTION PICTURES, TELEVISION PROGRAMS/SHOWS, WEBCAST PROGRAMS, ONLINE GAMES VIA INTERNET, AND WEB SITE; ENTERTAINMENT SERVICES, NAMELY, PROVIDING A TELEVISION PROGRAM IN THE FIELD OF CHILDREN'S ENTERTAINMENT VIA A GLOBAL COMPUTER NETWORK; ENTERTAINMENT SERVICES, NAMELY, PROVIDING PODCASTS IN THE FIELD OF CHILDREN'S ENTERTAINMENT; ENTERTAINMENT SERVICES, NAMELY, PROVIDING WEBCASTS IN THE FIELD OF CHILDREN'S ENTERTAINMENT (U.S. CLS. 100, 101 AND 107).

TINA L. SNAPP, EXAMINING ATTORNEY

CLASS 41—(Continued).

SN 85-516,269. NP IP HOLDINGS LLC, LAS VEGAS, NV. FILED 1-13-2012.

STATION CASINOS

THE MARK CONSISTS OF STANDARD CHARACTERS WITHOUT CLAIM TO ANY PARTICULAR FONT, STYLE, SIZE, OR COLOR.

OWNER OF U.S. REG. NOS. 1,863,360, 2,224,338 AND OTHERS.

NO CLAIM IS MADE TO THE EXCLUSIVE RIGHT TO USE "CASINOS", APART FROM THE MARK AS SHOWN.

FOR ENTERTAINMENT SERVICES, NAMELY, PROVIDING GAMES OF CHANCE AND GAMBLING SERVICES VIA CABLE, SATELLITE, BROADCASTING, AND TELECOMMUNICATION DEVICES, AND THE INTERNET; PROVIDING ON-LINE BETTING AND WAGERING SERVICES; PROVIDING ON-LINE CARD, POKER, ROULETTE, BACCARAT, KENO AND CASINO GAMES; PROVIDING INFORMATION IN THE FIELD OF ON-LINE COMPUTER GAMES, ON-LINE CARD GAMES AND ON-LINE CASINO GAMES VIA A GLOBAL COMPUTER NETWORK; PROVIDING NEWS AND INFORMATION IN THE FIELD OF ON-LINE GAMING, ON-LINE COMPUTER POKER GAMES, POKER COMMUNITY GOSSIP, POKER RELATED LINKS, AND POKER NEWS AND INFORMATION VIA A GLOBAL COMPUTER NETWORK (U.S. CLS. 100, 101 AND 107).

ANDREA HACK, EXAMINING ATTORNEY

SN 85-516,287. TAREH, ALI, DBA FIGHT FITNESS CENTER, PINELLAS PARK, FL. FILED 1-13-2012.



NO CLAIM IS MADE TO THE EXCLUSIVE RIGHT TO USE FIGHT FITNESS CENTER, APART FROM THE MARK AS SHOWN.

THE COLOR(S) YELLOW, BLACK, WHITE AND GRAY IS/ARE CLAIMED AS A FEATURE OF THE MARK.

THE MARK CONSISTS OF A FIST WITH THE NAME "ALI'S" IN YELLOW OUTLINED IN BLACK WRITTEN IN A TATTOO STYLE OVER THE FOUR FINGERS. THIS APPEARS INSIDE A CIRCLE SHADED IN GRAY AND OUTLINED IN YELLOW AND BLACK, WITH THE WORDS WRAPPED AROUND THE TOP "FIGHT FITNESS CENTER" AND AT THE BOTTOM THERE IS AN ARCHED BLACK RIBBON OUTLINED IN YELLOW WITH THE INITIALS "FFC" WRITTEN IN YELLOW AND OUTLINED IN BLACK AND WHITE IN BETWEEN TWO WHITE STARS.

FOR ORGANIZING, ARRANGING AND CONDUCTING SPORTS FIGHTING TRAINING (U.S. CLS. 100, 101 AND 107).

GISELLE AGOSTO, EXAMINING ATTORNEY

CLASS 41—(Continued).

SN 85-516,297. NP IP HOLDINGS LLC, LAS VEGAS, NV. FILED 1-13-2012.

MY STATION

THE MARK CONSISTS OF STANDARD CHARACTERS WITHOUT CLAIM TO ANY PARTICULAR FONT, STYLE, SIZE, OR COLOR.

OWNER OF U.S. REG. NO. 3,943,530.

FOR ENTERTAINMENT SERVICES, NAMELY, PROVIDING GAMES OF CHANCE AND GAMBLING SERVICES VIA CABLE, SATELLITE, BROADCASTING, AND TELECOMMUNICATION DEVICES, AND THE INTERNET; PROVIDING ON-LINE BETTING AND WAGERING SERVICES; PROVIDING ON-LINE CARD, POKER, ROULETTE, BACCARAT, KENO AND CASINO GAMES; PROVIDING INFORMATION IN THE FIELD OF ON-LINE COMPUTER GAMES, ON-LINE CARD GAMES AND ON-LINE CASINO GAMES VIA A GLOBAL COMPUTER NETWORK; PROVIDING NEWS AND INFORMATION IN THE FIELD OF ON-LINE GAMING, ON-LINE COMPUTER POKER GAMES, POKER COMMUNITY GOSSIP, POKER RELATED LINKS, AND POKER NEWS AND INFORMATION VIA A GLOBAL COMPUTER NETWORK (U.S. CLS. 100, 101 AND 107).

ANDREA HACK, EXAMINING ATTORNEY

CLASS 41—(Continued).

SN 85-516,376. LINDAHL, BURKHART R., NORTH OLMSTED, OH. FILED 1-13-2012.

King of Bling

THE MARK CONSISTS OF STANDARD CHARACTERS WITHOUT CLAIM TO ANY PARTICULAR FONT, STYLE, SIZE, OR COLOR.

FOR ENTERTAINMENT SERVICES IN THE NATURE OF A REALITY TELEVISION SERIES; PROVIDING INFORMATION ABOUT A REALITY TELEVISION SERIES VIA AN ON-LINE GLOBAL COMPUTER NETWORK (U.S. CLS. 100, 101 AND 107).

KAPIL BHANOT, EXAMINING ATTORNEY

SN 85-516,371. DISCOVERY COMMUNICATIONS, LLC, SILVER SPRING, MD. FILED 1-13-2012.

DEADLY AFFAIRS

THE MARK CONSISTS OF STANDARD CHARACTERS WITHOUT CLAIM TO ANY PARTICULAR FONT, STYLE, SIZE, OR COLOR.

FOR ENTERTAINMENT AND EDUCATIONAL SERVICES IN THE NATURE OF TELEVISION AND MULTIMEDIA PROGRAM SERIES FEATURING SUBJECTS OF GENERAL HUMAN INTEREST DISTRIBUTED VIA VARIOUS PLATFORMS ACROSS MULTIPLE FORMS OF TRANSMISSION MEDIA; PROVIDING ENTERTAINMENT INFORMATION TO OTHERS VIA A GLOBAL COMPUTER NETWORK (U.S. CLS. 100, 101 AND 107).

ANGELA DUONG, EXAMINING ATTORNEY

SN 85-516,745. TELEVISA, S.A. DE C.V., SANTA FE, MEXICO, FILED 1-14-2012.

CANDIDO DE DIA, PEREZ DE NOCHE

THE MARK CONSISTS OF STANDARD CHARACTERS WITHOUT CLAIM TO ANY PARTICULAR FONT, STYLE, SIZE, OR COLOR.

THE NAME(S), PORTRAIT(S), AND/OR SIGNATURE(S) SHOWN IN THE MARK DOES NOT IDENTIFY A PARTICULAR LIVING INDIVIDUAL.

THE ENGLISH TRANSLATION OF "DE DIA" AND "DE NOCHE" IN THE MARK IS "AT DAY" AND "AT NIGHT".

FOR ENTERTAINMENT SERVICES IN THE NATURE OF A CONTINUING COMEDY SHOW BROADCAST OVER THE INTERNET AND AN ONGOING COMEDY TELEVISION SHOW (U.S. CLS. 100, 101 AND 107).

SANDRA BUJA, EXAMINING ATTORNEY

CLASS 41—(Continued).

SN 85-516,847. NEW YORK CHIROPRACTIC COLLEGE, SENECA FALLS, NY. FILED 1-15-2012.

**NEW YORK CHIROPRACTIC
COLLEGE**

THE MARK CONSISTS OF STANDARD CHARACTERS WITHOUT CLAIM TO ANY PARTICULAR FONT, STYLE, SIZE, OR COLOR.

NO CLAIM IS MADE TO THE EXCLUSIVE RIGHT TO USE "CHIROPRACTIC COLLEGE", APART FROM THE MARK AS SHOWN.

SEC. 2(F).

FOR DEVELOPMENT AND DISSEMINATION OF EDUCATIONAL MATERIALS OF OTHERS IN THE FIELD OF CHIROPRACTIC EDUCATION, ACUPUNCTURE, ORIENTAL MEDICINE, APPLIED CLINICAL NUTRITION AND HUMAN ANATOMY AND PHYSIOLOGY INSTRUCTION; EDUCATING AT UNIVERSITY OR COLLEGES; EDUCATIONAL SERVICES, NAMELY, CONDUCTING PROGRAMS IN THE FIELD OF CHIROPRACTIC EDUCATION, ACUPUNCTURE, ORIENTAL MEDICINE, APPLIED CLINICAL NUTRITION AND HUMAN ANATOMY AND PHYSIOLOGY INSTRUCTION; EDUCATIONAL SERVICES, NAMELY, PROVIDING COURSES OF INSTRUCTION AT THE COLLEGE AND POST GRADUATE LEVEL AND DISTRIBUTION OF COURSE MATERIAL IN CONNECTION THEREWITH (U.S. CLS. 100, 101 AND 107).

FIRST USE 12-31-1979; IN COMMERCE 6-30-1990.

HENRY S. ZAK, EXAMINING ATTORNEY

SN 85-516,999. KEMP JR., ABNER, LONG BEACH, CT. FILED 1-16-2012.



NO CLAIM IS MADE TO THE EXCLUSIVE RIGHT TO USE "RECORDS", APART FROM THE MARK AS SHOWN.

THE MARK CONSISTS OF THE HEAD OF A SMILING CHARACTER WEARING A JESTER HAT TO THE LEFT OF THE STYLIZED TEXT "BAD INTENTIONS RECORDS" WHERE EACH WORD APPEARS ABOVE THE NEXT.

FOR ENTERTAINMENT SERVICES IN THE NATURE OF RECORDING, PRODUCTION AND POST-PRODUCTION SERVICES IN THE FIELD OF MUSIC (U.S. CLS. 100, 101 AND 107).

ANDREA HACK, EXAMINING ATTORNEY

CLASS 41—(Continued).

SN 85-517,233. RANDALL HALL SENTER, WEST HOLLYWOOD, CA. FILED 1-16-2012.

THE VOICES MAJIK

THE MARK CONSISTS OF STANDARD CHARACTERS WITHOUT CLAIM TO ANY PARTICULAR FONT, STYLE, SIZE, OR COLOR.

FOR ENTERTAINMENT IN THE NATURE OF VISUAL AND AUDIO PERFORMANCES, NAMELY, MUSICAL BAND, ROCK GROUP, GYMNASTIC, DANCE, AND BALLET PERFORMANCES; ENTERTAINMENT, NAMELY, LIVE PERFORMANCES BY A MUSICAL BAND; ENTERTAINMENT, NAMELY, LIVE PERFORMANCES BY MUSICAL BANDS; ENTERTAINMENT, NAMELY, LIVE PERFORMANCES BY ROCK GROUPS; LIVE PERFORMANCES FEATURING PRERECORDED VOCAL AND INSTRUMENTAL PERFORMANCES VIEWED ON A BIG SCREEN (U.S. CLS. 100, 101 AND 107).

JULIE WATSON, EXAMINING ATTORNEY

SN 85-518,021. WAVECREST ENTERTAINMENT, LLC, NEW YORK, NY. FILED 1-17-2012.

WaveCrest Entertainment

THE MARK CONSISTS OF STANDARD CHARACTERS WITHOUT CLAIM TO ANY PARTICULAR FONT, STYLE, SIZE, OR COLOR.

NO CLAIM IS MADE TO THE EXCLUSIVE RIGHT TO USE "ENTERTAINMENT", APART FROM THE MARK AS SHOWN.

FOR PRODUCTION AND POST-PRODUCTION OF FILM AND VIDEO; PRODUCTION OF VIDEO GAME SOFTWARE (U.S. CLS. 100, 101 AND 107).

FIRST USE 12-29-2010; IN COMMERCE 3-23-2011.

TARAH HARDY, EXAMINING ATTORNEY

CLASS 41—(Continued).

SN 85-518,713. DONNEY, GENE, BOCA RATON, FL. FILED 1-18-2012.

SUITESPORTSNETWORK

THE MARK CONSISTS OF STANDARD CHARACTERS WITHOUT CLAIM TO ANY PARTICULAR FONT, STYLE, SIZE, OR COLOR.

FOR ENTERTAINMENT SERVICES, NAMELY, PROVIDING VIDEO AND AUDIO CONTENT, NAMELY, ONGOING TELEVISION PROGRAMS IN THE NATURE OF CURRENT EVENTS, SPORTS NEWS AND ENTERTAINMENT NEWS ALL TRANSMITTED THROUGH A GLOBAL COMMUNICATIONS NETWORK VIA WIRELESS COMMUNICATION DEVICES, MOBILE PHONES, HAND-HELD DEVICES; PROVIDING INFORMATION IN THE FIELD OF ENTERTAINMENT VIA WIRELESS COMMUNICATION DEVICES, MOBILE PHONES, HAND-HELD DEVICES AND GLOBAL COMMUNICATION DEVICES; INTERACTIVE ONLINE NEWSLETTER PROVIDING SPORTS AND ENTERTAINMENT INFORMATION; ENTERTAINMENT IN THE NATURE OF ONGOING TELEVISION PROGRAMS IN THE FIELD OF SPORTS AND ENTERTAINMENT NEWS; ENTERTAINMENT SERVICES, NAMELY, AN ON-GOING SERIES FEATURING CURRENT EVENTS, SPORTS NEWS AND ENTERTAINMENT NEWS PROVIDED THROUGH TELEVISION BROADCASTS, WEBCASTS AND RADIO BROADCASTS; ON-LINE JOURNALS, NAMELY, BLOGS FEATURING CURRENT EVENTS, SPORTS AND ENTERTAINMENT NEWS; ENTERTAINMENT SERVICES, NAMELY, PROVIDING A WEBSITE FEATURING CURRENT EVENTS, SPORTS AND ENTERTAINMENT NEWS (U.S. CLS. 100, 101 AND 107).

ANDREA HACK, EXAMINING ATTORNEY

SN 85-521,091. NEXT LEVEL LIFTING, LLC, DENVER, CO. FILED 1-20-2012.

NEXT LEVEL LIFTING

THE MARK CONSISTS OF STANDARD CHARACTERS WITHOUT CLAIM TO ANY PARTICULAR FONT, STYLE, SIZE, OR COLOR.

NO CLAIM IS MADE TO THE EXCLUSIVE RIGHT TO USE "LIFTING", APART FROM THE MARK AS SHOWN.

FOR PROVIDING A WEB SITE THAT FEATURES INFORMAL INSTRUCTION ON BODYBUILDING AND WEIGHTLIFTING; PROVIDING A WEBSITE FEATURING BLOGS AND NON-DOWNLOADABLE PUBLICATIONS IN THE NATURE OF ARTICLES IN THE FIELD(S) OF BODYBUILDING AND WEIGHTLIFTING; PROVIDING A WEBSITE FEATURING INFORMATION ON EXERCISE AND FITNESS; PROVIDING A WEBSITE FEATURING INFORMATION RELATING TO THE SPORT OF BODYBUILDING AND WEIGHTLIFTING; PROVIDING AN INTERACTIVE WEBSITE FEATURING INFORMATION AND LINKS RELATING TO FITNESS (U.S. CLS. 100, 101 AND 107).

WENDY JUN, EXAMINING ATTORNEY

CLASS 41—(Continued).

SN 85-521,481. MICHAEL R. SILBERMAN, CHICAGO, IL. FILED 1-20-2012.

REDEFINING ROOTS

THE MARK CONSISTS OF STANDARD CHARACTERS WITHOUT CLAIM TO ANY PARTICULAR FONT, STYLE, SIZE, OR COLOR.

FOR PRODUCTION AND DISTRIBUTION OF VIDEO IN THE FIELD OF ENVIRONMENTALLY SUSTAINABLE LIVING; ORGANIZING AND HOSTING EVENTS PROMOTING ENVIRONMENTALLY SUSTAINABLE LIVING; AND PROVIDING AN INTERNET WEBSITE FEATURING VIDEOS AND INFORMATION ABOUT ENVIRONMENTALLY SUSTAINABLE LIVING (U.S. CLS. 100, 101 AND 107).

FIRST USE 6-1-2011; IN COMMERCE 6-1-2011.

LUCY ARANT, EXAMINING ATTORNEY

SN 85-521,618. MOFFETT, MARK W., GREENPORT, NY. FILED 1-20-2012.

Doctor Bugs

THE MARK CONSISTS OF STANDARD CHARACTERS WITHOUT CLAIM TO ANY PARTICULAR FONT, STYLE, SIZE, OR COLOR.

NO CLAIM IS MADE TO THE EXCLUSIVE RIGHT TO USE "BUGS", APART FROM THE MARK AS SHOWN.

FOR ENTERTAINMENT, NAMELY, A CONTINUING NON-SCRIPTED REALITY-BASED SHOW BROADCAST OVER TELEVISION (U.S. CLS. 100, 101 AND 107).

LUCY ARANT, EXAMINING ATTORNEY

SN 85-522,955. BONILLA, JOSE A, AKA JOE BONILLA, MIAMI, FL. FILED 1-23-2012.

Mira Como Se Mueve

THE MARK CONSISTS OF STANDARD CHARACTERS WITHOUT CLAIM TO ANY PARTICULAR FONT, STYLE, SIZE, OR COLOR.

THE ENGLISH TRANSLATION OF "MIRA COMO SE MUEVE" IS "LOOK AT THE WAY YOU MOVE".

FOR TELEVISION SHOW PRODUCTION (U.S. CLS. 100, 101 AND 107).

Laurie Mayes, EXAMINING ATTORNEY

CLASS 41—(Continued).

SN 85-523,805. HEALTH & WELLNESS NETWORK, INC., ST. PETERSBURG, FL. FILED 1-24-2012.

Life.Love.Longevity

THE MARK CONSISTS OF STANDARD CHARACTERS WITHOUT CLAIM TO ANY PARTICULAR FONT, STYLE, SIZE, OR COLOR.

FOR PRODUCTION OF DVDS, VIDEOTAPES AND TELEVISION PROGRAMS FEATURING HEALTH AND WELLNESS (U.S. CLS. 100, 101 AND 107).

COURTNEY ALVAREZ, EXAMINING ATTORNEY

SN 85-523,912. THE HEALTH AND WELLNESS INSTITUTE, LLC, PROVIDENCE, RI. FILED 1-24-2012.



NO CLAIM IS MADE TO THE EXCLUSIVE RIGHT TO USE "KITCHEN", APART FROM THE MARK AS SHOWN.

THE MARK CONSISTS OF THE WORDS, "HEALTH'S" AND "KITCHEN", SEPARATED BY AN IMAGE OF VEGETABLES ABOVE A FRYING PAN THAT IS ABOVE FLAMES OF A FIRE.

FOR EDUCATION SERVICES, NAMELY, PROVIDING CLASSES, WORKSHOPS AND DEMONSTRATIONS IN THE FIELD OF COOKING, FOOD SAFETY AND NUTRITION (U.S. CLS. 100, 101 AND 107).

PRISCILLA MILTON, EXAMINING ATTORNEY

SN 85-524,656. TELEvisa, S.A. DE C.V., SANTA FE, MEXICO, FILED 1-25-2012.

GOTITA DE AMOR

THE MARK CONSISTS OF STANDARD CHARACTERS WITHOUT CLAIM TO ANY PARTICULAR FONT, STYLE, SIZE, OR COLOR.

OWNER OF MEXICO REG. NO. 881490, DATED 2-1-2005, EXPIRES 2-1-2015.

THE ENGLISH TRANSLATION OF "GOTITA DE AMOR" IN THE MARK IS "LITTLE DROP OF LOVE".

FOR ENTERTAINMENT SERVICES IN THE NATURE OF A CONTINUING DRAMATIC SHOW BROADCAST OVER THE INTERNET AND AN ONGOING DRAMATIC TELEVISION SHOW (U.S. CLS. 100, 101 AND 107).

SANDRA BUJA, EXAMINING ATTORNEY

CLASS 41—(Continued).

SN 85-526,524. AMERICAN TAI CHI ASSOCIATION, PHILADELPHIA, PA. FILED 1-26-2012.

the difference between life and death is Breath

THE MARK CONSISTS OF STANDARD CHARACTERS WITHOUT CLAIM TO ANY PARTICULAR FONT, STYLE, SIZE, OR COLOR.

FOR EDUCATION SERVICES, NAMELY, PROVIDING SEMINARS, WORKSHOPS, TRAINING AND CLASSES IN THE FIELD OF MARTIAL ARTS, HEALTH, FITNESS, NUTRITION, WELLNESS, MEDITATION AND STRESS RELIEF (U.S. CLS. 100, 101 AND 107).

FIRST USE 0-0-1980; IN COMMERCE 0-0-1980.

AMY KELLY, EXAMINING ATTORNEY

SN 85-528,451. AMERICAN LANTERN PRESS, INC., FORT MILL, SC. FILED 1-30-2012.



THE MARK CONSISTS OF THE REPRESENTATION OF A LANTERN IN THE MIDDLE OF A CIRCULAR FIELD.

FOR PUBLICATION OF NEWSLETTERS, REPORTS, BOOKS AND GUIDES (U.S. CLS. 100, 101 AND 107).

FIRST USE 1-0-1999; IN COMMERCE 1-0-1999.

FRANK LATTUCA, EXAMINING ATTORNEY

CLASS 41—(Continued).

SN 85-528,454. RIZZI, RON, BALL GROUND, GA. FILED 1-30-2012.

Keep Your Head Lights On
Accelerate Brain Tumor
Research

THE MARK CONSISTS OF STANDARD CHARACTERS WITHOUT CLAIM TO ANY PARTICULAR FONT, STYLE, SIZE, OR COLOR.

NO CLAIM IS MADE TO THE EXCLUSIVE RIGHT TO USE "ACCELERATE BRAIN TUMOR RESEARCH", APART FROM THE MARK AS SHOWN.

FOR PROVIDING INFORMATION RELATING TO THE ORGANIZING OF EDUCATIONAL, CULTURAL, SPORTING, OR ENTERTAINMENT EXHIBITIONS (U.S. CLS. 100, 101 AND 107).

FIRST USE 1-29-2012; IN COMMERCE 1-29-2012.

NAKIA HENRY, EXAMINING ATTORNEY

SN 85-533,086. EASTERN STATES VETERINARY ASSOCIATION, INC., DBA NORTH AMERICAN VETERINARY CONFERENCE, GAINESVILLE, FL. FILED 2-3-2012.



OWNER OF U.S. REG. NOS. 3,333,122, 3,550,575 AND 4,008,346.

NO CLAIM IS MADE TO THE EXCLUSIVE RIGHT TO USE "INSTITUTE", APART FROM THE MARK AS SHOWN.

THE COLOR(S) THE COLORS DARK BLUE, ORANGE, LIGHT BLUE, YELLOW AND WHITE IS/ARE CLAIMED AS A FEATURE OF THE MARK.

THE MARK CONSISTS OF A STYLIZED LETTER "V" IN DARK BLUE WITH THE WORDING "NAVC" SUPERIMPOSED IN YELLOW LETTERING, LIGHT BLUE OCEAN WAVES, AND A YELLOW AND ORANGE SUN WITHIN A YELLOW SHIELD OUTLINE ON WHICH THE WORDING "INSTITUTE" APPEARS IN BLUE AT THE TOP.

FOR CONTINUING EDUCATION SERVICES, NAMELY, PROVIDING LIVE AND ON-LINE CONTINUING PROFESSIONAL EDUCATION SEMINARS IN THE FIELD OF ANIMAL HOSPITALS AND VETERINARY PRACTICES (U.S. CLS. 100, 101 AND 107).

FIRST USE 1-6-1999; IN COMMERCE 1-6-1999.

JULIE VEPPUMTHARA, EXAMINING ATTORNEY

CLASS 41—(Continued).

SN 85-533,147. CONSUMERS, CONTRACTORS & CARRIERS NETWORK, LLC, OMAHA, NE. FILED 2-3-2012.



NO CLAIM IS MADE TO THE EXCLUSIVE RIGHT TO USE "NETWORK", APART FROM THE MARK AS SHOWN.

THE MARK CONSISTS OF A CIRCLE WHICH CONTAINS THREE INCOMPLETE CIRCLES WHICH CONNECT AND OVERLAP EACH OTHER IN THE CENTER OF THE FULL CIRCLE. A VERTICAL LINE IS TO THE RIGHT OF THE CIRCLE AND TO THE RIGHT OF THE VERTICAL LINE IS "3C" AND THE WORD "NETWORK" IS UNDER "3C".

FOR PROVIDING ROOFING PROFESSIONALS ACCESS TO CONTINUING EDUCATION, CERTIFICATION AND TEST RESULTS RELATED TO THE ROOFING INDUSTRY, NAMELY, PROVIDING TRAINING RELATED TO PROPER INSTALLATION OF ROOFING MATERIALS, INSPECTION METHODS, THE USE OF TOOLS AND RELATED ROOFING TECHNOLOGY, AND OTHER BEST PRACTICES IN THE INDUSTRY (U.S. CLS. 100, 101 AND 107).

WILLIAM ROSSMAN, EXAMINING ATTORNEY

SN 85-533,305. CBS STUDIOS INC., STUDIO CITY, CA. FILED 2-3-2012.

FIRST CUT

THE MARK CONSISTS OF STANDARD CHARACTERS WITHOUT CLAIM TO ANY PARTICULAR FONT, STYLE, SIZE, OR COLOR.

FOR ENTERTAINMENT SERVICES, NAMELY, A DRAMATIC TELEVISION SERIES RENDERED THROUGH THE MEDIA OF TELEVISION, CABLE, SATELLITE, RADIO, TELEPHONE, AND BROADBAND SYSTEMS, AND VIA THE INTERNET, PORTABLE AND WIRELESS COMMUNICATION DEVICES; AND PROVIDING INFORMATION IN THE FIELD OF ENTERTAINMENT RENDERED VIA THE INTERNET, PORTABLE AND WIRELESS COMMUNICATION DEVICES (U.S. CLS. 100, 101 AND 107).

DOUGLAS LEE, EXAMINING ATTORNEY

CLASS 41—(Continued).

SN 85-533,749. TOPCO HOLDINGS, INC., SKOKIE, IL. FILED 2-3-2012.

OVER THE TOP

THE MARK CONSISTS OF STANDARD CHARACTERS WITHOUT CLAIM TO ANY PARTICULAR FONT, STYLE, SIZE, OR COLOR.

FOR PROVIDING INFORMATION IN THE FIELD OF PARTY AND EVENT PLANNING (U.S. CLS. 100, 101 AND 107).

GENE MACIOL, EXAMINING ATTORNEY

SN 85-539,647. PLAYTIKA LTD., TEL AVIV, ISRAEL, FILED 2-10-2012.



THE COLOR(S) BEIGE, RED, GREEN, WHITE, AND BLACK IS/ARE CLAIMED AS A FEATURE OF THE MARK.

THE MARK CONSISTS OF A WOMAN WITH BEIGE SKIN, RED HAIR AND EYEBROW, GREEN EYES AND RED LIPS WEARING A WHITE SHIRT, RED VEST, BLACK SKIRT AND RED SHOES WITH A NAME TAG BEARING THE WORD "LUCY" AFFIXED TO THE VEST.

FOR ENTERTAINMENT SERVICES, NAMELY, PROVIDING ON-LINE COMPUTER GAMES AND GAME APPLICATIONS, ENHANCEMENTS WITHIN ONLINE COMPUTER GAMES, AND GAME APPLICATIONS WITHIN ONLINE COMPUTER GAMES; PROVIDING ONLINE REVIEWS OF COMPUTER GAMES, AND PROVIDING OF INFORMATION RELATING TO COMPUTER GAMES; PROVIDING AN INTERNET WEBSITE PORTAL IN THE FIELD OF COMPUTER GAMES AND GAMING; ENTERTAINMENT SERVICES, NAMELY, PROVIDING VIRTUAL ENVIRONMENTS IN WHICH USERS CAN INTERACT THROUGH SOCIAL GAMES FOR RECREATIONAL, LEISURE OR ENTERTAINMENT PURPOSES (U.S. CLS. 100, 101 AND 107).

FIRST USE 12-16-2010; IN COMMERCE 12-16-2010.
WILLIAM VERHOSEK, EXAMINING ATTORNEY

CLASS 41—(Continued).

SN 85-539,824. ASSOCIATION OF AMERICAN MEDICAL COLLEGES, WASHINGTON D.C., DC. FILED 2-10-2012.

IPEC

THE MARK CONSISTS OF STANDARD CHARACTERS WITHOUT CLAIM TO ANY PARTICULAR FONT, STYLE, SIZE, OR COLOR.

FOR HEALTH CARE EDUCATION SERVICES, NAMELY, DEVELOPMENT OF CURRICULUM AND EDUCATIONAL MATERIALS FOR OTHERS IN THE FIELD OF MULTI-DISCIPLINARY HEALTH CARE EDUCATION FOR STUDENTS SEEKING PROFESSIONAL DEGREES (U.S. CLS. 100, 101 AND 107).

MICHAEL TANNER, EXAMINING ATTORNEY

SN 85-541,239. REVIEW AND HERALD PUBLISHING ASSOCIATION, HAGERSTOWN, MD. FILED 2-13-2012.

VIBRANT LIFE

THE MARK CONSISTS OF STANDARD CHARACTERS WITHOUT CLAIM TO ANY PARTICULAR FONT, STYLE, SIZE, OR COLOR.

OWNER OF U.S. REG. NOS. 1,352,773, 2,441,234 AND 2,736,966.

FOR PROVIDING ON-LINE MAGAZINES IN THE FIELD OF HEALTH AND FITNESS (U.S. CLS. 100, 101 AND 107).

FIRST USE 1-1-1997; IN COMMERCE 1-1-1997.

SALLY SHIH, EXAMINING ATTORNEY

SN 85-551,409. STRONG LOLA, INC., MANSFIELD, TX. FILED 2-23-2012.

STRONG LOLA

THE MARK CONSISTS OF STANDARD CHARACTERS WITHOUT CLAIM TO ANY PARTICULAR FONT, STYLE, SIZE, OR COLOR.

THE NAME(S), PORTRAIT(S), AND/OR SIGNATURE(S) SHOWN IN THE MARK DOES NOT IDENTIFY A PARTICULAR LIVING INDIVIDUAL.

FOR PERSONAL TRAINING PROVIDED IN CONNECTION WITH WEIGHT LOSS AND EXERCISE PROGRAMS; PHYSICAL FITNESS INSTRUCTION; PHYSICAL FITNESS TRAINING SERVICES (U.S. CLS. 100, 101 AND 107).

GINA HAYES, EXAMINING ATTORNEY

CLASS 41—(Continued).

SN 85-551,680. KITCHEN ON FIRE, LLC, BERKELEY, CA. FILED 2-24-2012.

12 Week Basics of Cooking Series

THE MARK CONSISTS OF STANDARD CHARACTERS WITHOUT CLAIM TO ANY PARTICULAR FONT, STYLE, SIZE, OR COLOR.

NO CLAIM IS MADE TO THE EXCLUSIVE RIGHT TO USE "SERIES", APART FROM THE MARK AS SHOWN.

SEC. 2(F).

FOR EDUCATIONAL AND ENTERTAINMENT SERVICES, NAMELY, CONDUCTING SEMINARS, WORKSHOPS, EDUCATIONAL DEMONSTRATIONS, ONLINE INSTRUCTION, AND COURSES OF INSTRUCTION IN THE FIELD OF CULINARY ARTS INCLUDING COOKING, BAKING, MIXOLOGY, FOOD PREPARATION, FOOD PRESENTATION, AND PARTY PLANNING; EDUCATIONAL SERVICES, NAMELY A HANDS-ON MULTI-SERIES WORKSHOP FEATURING EDUCATION IN THE VARIOUS TECHNIQUES OF COOKING, BAKING, MIXOLOGY, FOOD PREPARATION, AND FOOD PRESENTATION (U.S. CLS. 100, 101 AND 107).

FIRST USE 8-29-2006; IN COMMERCE 8-29-2006.
CAROLYN CATALDO, EXAMINING ATTORNEY

SN 85-554,069. CAESARS LICENSE COMPANY, LLC, LAS VEGAS, NV. FILED 2-27-2012.

Hoops on the Strip

THE MARK CONSISTS OF STANDARD CHARACTERS WITHOUT CLAIM TO ANY PARTICULAR FONT, STYLE, SIZE, OR COLOR.

NO CLAIM IS MADE TO THE EXCLUSIVE RIGHT TO USE "ON THE STRIP", APART FROM THE MARK AS SHOWN.

FOR PROVIDING ENTERTAINMENT SERVICES IN THE NATURE OF CASINO AND GAMING ACTIVITIES; CASINO SERVICES; CONDUCTING AND PROVIDING FACILITIES FOR SPECIAL EVENTS FEATURING CASINO AND GAMING CONTESTS (U.S. CLS. 100, 101 AND 107).

FIRST USE 3-15-2012; IN COMMERCE 3-15-2012.
WILLIAM ROSSMAN, EXAMINING ATTORNEY

CLASS 41—(Continued).

SN 85-565,828. KABAM, INC., REDWOOD CITY, IN. FILED 3-9-2012.

MOBILE COMMAND

THE MARK CONSISTS OF STANDARD CHARACTERS WITHOUT CLAIM TO ANY PARTICULAR FONT, STYLE, SIZE, OR COLOR.

FOR ENTERTAINMENT SERVICES, NAMELY, PROVIDING ON-LINE COMPUTER GAMES (U.S. CLS. 100, 101 AND 107).

JASON BLAIR, EXAMINING ATTORNEY

SN 85-566,665. CHUKCHANSI ECONOMIC DEVELOPMENT AUTHORITY, A TRIBAL ENTITY OF THE PICAYUNE RANCHERIA OF THE CHUKCHANSI INDIANS, DBA CHUKCHANSI GOLD RESORT & CASINO, COARSE-GOLD, CA. FILED 3-12-2012.

CHUK CHING

THE MARK CONSISTS OF STANDARD CHARACTERS WITHOUT CLAIM TO ANY PARTICULAR FONT, STYLE, SIZE, OR COLOR.

FOR ENTERTAINMENT SERVICES, NAMELY, CASINO GAMING (U.S. CLS. 100, 101 AND 107).

FIRST USE 8-1-2011; IN COMMERCE 8-1-2011.
KATHY DE JONGE, EXAMINING ATTORNEY

SN 85-579,435. CBS STUDIOS INC., STUDIO CITY, NY. FILED 3-26-2012.

REDO YOU

THE MARK CONSISTS OF STANDARD CHARACTERS WITHOUT CLAIM TO ANY PARTICULAR FONT, STYLE, SIZE, OR COLOR.

FOR ENTERTAINMENT SERVICES, NAMELY, A CONTINUING TELEVISION TALK SHOW SERIES SEGMENT FEATURING NEWS, CONTEMPORARY ISSUES AND LIFESTYLE TOPICS RENDERED THROUGH THE MEDIA OF TELEVISION, CABLE, SATELLITE, RADIO, TELEPHONE, AND BROADBAND SYSTEMS, AND VIA THE INTERNET, PORTABLE AND WIRELESS COMMUNICATION DEVICES; AND PROVIDING INFORMATION IN THE FIELD OF ENTERTAINMENT RENDERED VIA THE INTERNET, PORTABLE AND WIRELESS COMMUNICATION DEVICES (U.S. CLS. 100, 101 AND 107).

FIRST USE 2-27-2012; IN COMMERCE 2-27-2012.
DOUGLAS LEE, EXAMINING ATTORNEY

CLASS 41—(Continued).

SN 85-584,963. ALTIUS EDUCATION, INC., SAN FRANCISCO, CA. FILED 3-30-2012.

HELIX

THE MARK CONSISTS OF STANDARD CHARACTERS WITHOUT CLAIM TO ANY PARTICULAR FONT, STYLE, SIZE, OR COLOR.

FOR POST-SECONDARY EDUCATIONAL SERVICES, NAMELY, PROVIDING COLLEGE-LEVEL COURSEWORK TO STUDENTS VIA AN ONLINE PLATFORM THAT ADAPTS CURRICULUM TO EACH LEARNER'S COMPETENCY LEVELS AND INTERESTS, AND ENABLES A BLEND OF INDIVIDUAL LEARNING, COACHING, PEER-TO-PEER LEARNING, SUPPORT, AND SOCIAL LEARNING EXPERIENCES (U.S. CLS. 100, 101 AND 107).

KAREN K. BUSH, EXAMINING ATTORNEY

SN 85-587,253. SUMMIT CONSULTING GROUP, INC., EAST GREENWICH, RI. FILED 4-3-2012.

ALAN'S ROUNDTABLE

THE MARK CONSISTS OF STANDARD CHARACTERS WITHOUT CLAIM TO ANY PARTICULAR FONT, STYLE, SIZE, OR COLOR.

NO CLAIM IS MADE TO THE EXCLUSIVE RIGHT TO USE "ROUNDTABLE", APART FROM THE MARK AS SHOWN.

FOR PERSONAL COACHING SERVICES IN THE FIELD OF PROFESSIONAL AND PERSONAL GROWTH FOR SMALL GROUPS OF INDIVIDUALS, INCLUDING TELECONFERENCES, PERSONAL ASSESSMENTS, AND ANNUAL MEETINGS (U.S. CLS. 100, 101 AND 107).

FIRST USE 3-15-2012; IN COMMERCE 3-15-2012.

THEODORE MCBRIDE, EXAMINING ATTORNEY

SN 85-588,541. MUSCOGEE (CREEK) NATION, DBA GAMING OPERATIONS AUTHORITY BOARD, TULSA, OK. FILED 4-4-2012.

ONE FIRE CASINO

THE MARK CONSISTS OF STANDARD CHARACTERS WITHOUT CLAIM TO ANY PARTICULAR FONT, STYLE, SIZE, OR COLOR.

NO CLAIM IS MADE TO THE EXCLUSIVE RIGHT TO USE "CASINO", APART FROM THE MARK AS SHOWN.

FOR CONDUCTING AND PROVIDING FACILITIES FOR SPECIAL EVENTS FEATURING CASINO AND GAMING CONTESTS AND TOURNAMENTS (U.S. CLS. 100, 101 AND 107).

FIRST USE 12-1-2011; IN COMMERCE 12-1-2011.

KATHY DE JONGE, EXAMINING ATTORNEY

CLASS 41—(Continued).

SN 85-592,284. BARONA GROUP OF THE CAPITAN GRANDE BAND OF MISSION INDIANS, DBA BARONA VALLEY RANCH RESORT AND CASINO, LAKESIDE, CA. FILED 4-9-2012.

HAPPIEST CASINO ON EARTH

THE MARK CONSISTS OF STANDARD CHARACTERS WITHOUT CLAIM TO ANY PARTICULAR FONT, STYLE, SIZE, OR COLOR.

FOR CASINOS; CASINO SERVICES FEATURING A CASINO PLAYERS REWARDS PROGRAM; PROVIDING CASINO FACILITIES (U.S. CLS. 100, 101 AND 107).

KATHLEEN M. VANSTON, EXAMINING ATTORNEY

SN 85-976,629. BRADLEY COMMUNICATIONS CORP., BROOMAIL, PA. FILED 11-23-2010.

REPORTER CONNECTION

THE MARK CONSISTS OF STANDARD CHARACTERS WITHOUT CLAIM TO ANY PARTICULAR FONT, STYLE, SIZE, OR COLOR.

NO CLAIM IS MADE TO THE EXCLUSIVE RIGHT TO USE "REPORTER", APART FROM THE MARK AS SHOWN.

FOR NON-DOWNLOADABLE ONLINE ELECTRONIC NEWSLETTER IN THE FIELD OF JOURNALISM DELIVERED BY E-MAIL (U.S. CLS. 100, 101 AND 107).

FIRST USE 2-26-2005; IN COMMERCE 12-21-2009.

ROBERT C. CLARK JR., EXAMINING ATTORNEY

CLASS 42—SCIENTIFIC AND COMPUTER SERVICES

CLASS 42—(Continued).

SN 76-710,314. HOUGHTON MIFFLIN HARCOURT PUBLISHING COMPANY, BOSTON, MA. FILED 1-19-2012.

SN 77-798,984. ADT SERVICES AG, SCHAFFHAUSEN, SWITZERLAND, FILED 8-6-2009.

PULSE

THINKFORWARD

THE MARK CONSISTS OF STANDARD CHARACTERS WITHOUT CLAIM TO ANY PARTICULAR FONT, STYLE, SIZE, OR COLOR.

OWNER OF SWITZERLAND REG. NO. 599586, DATED 12-18-2009, EXPIRES 12-18-2019.

FOR TECHNICAL CONSULTATION SERVICES IN THE FIELD OF COMPUTER HARDWARE, COMPUTER PERIPHERALS AND COMPUTER SOFTWARE USED FOR SECURITY SYSTEMS, FIRE ALARMS, ALARM CENTRAL UNITS, ANTI-INTRUSION ALARMS, BURGLAR ALARMS, PERSONAL HEALTH AND SECURITY ALARMS, SMOKE AND GAS ALARMS, HOME SURVEILLANCE SYSTEMS, LIGHTING CONTROLS, HOME AUTOMATION DEVICES, SPRINKLER SYSTEMS FOR FIRE PROTECTION, VEHICLE, PET AND PERSONNEL LOCATION, AUTOMOBILE SAFETY, VEHICLE THEFT, TRAFFIC, AND ROAD NAVIGATION; TECHNICAL SUPPORT SERVICES, NAMELY, TROUBLESHOOTING IN THE NATURE OF DIAGNOSING COMPUTER HARDWARE, COMPUTER PERIPHERAL, AND SOFTWARE PROBLEMS; TECHNICAL CONSULTATION IN THE FIELD OF INTEGRATION OF HOME AUTOMATION SYSTEMS WITH COMPUTER NETWORKS AND MONITORING SYSTEMS; PROVIDING TEMPORARY USE OF ONLINE NON-DOWNLOADABLE COMPUTER SOFTWARE USED TO OPERATE, MANAGE AND MONITOR SECURITY SYSTEMS, FIRE ALARMS, ALARM CENTRAL UNITS, ANTI-INTRUSION ALARMS, BURGLAR ALARMS, PERSONAL HEALTH AND SECURITY ALARMS, SMOKE AND GAS ALARMS, HOME SURVEILLANCE SYSTEMS, LIGHTING CONTROLS AND HOME AUTOMATION DEVICES; PROVIDING TEMPORARY USE OF ONLINE NON-DOWNLOADABLE COMPUTER SOFTWARE USED TO MONITOR AND TRACK MOVEMENT ACTIVITY, HEALTH CONDITIONS AND ENVIRONMENTAL CONDITIONS, AND USED TO TRANSMIT ELECTRONIC MESSAGES AND DATA VIA COMMUNICATIONS NETWORKS; AND WEATHER INFORMATION SERVICES, ALL OF THE AFOREMENTIONED FOR RESIDENTIAL USE (U.S. CLS. 100 AND 101).

THE MARK CONSISTS OF STANDARD CHARACTERS WITHOUT CLAIM TO ANY PARTICULAR FONT, STYLE, SIZE, OR COLOR.

FOR COMPUTER SERVICES, NAMELY, HOSTING ONLINE WEB FACILITIES FOR OTHERS FOR USERS TO ORGANIZE AND CONDUCT ON-LINE DISCUSSIONS AND MAKE CONNECTIONS WITH LIKE-MINDED INDIVIDUALS AND/OR ORGANIZATIONS; COMPUTER SERVICES, NAMELY, CREATING AN ONLINE COMMUNITY THAT PROVIDES USE OF NON-DOWNLOADABLE SOFTWARE THAT ENABLES REGISTERED USERS TO VIEW, SHARE, COMMENT ON AND DOWNLOAD DIGITAL CONTENT PROVIDED BY OTHERS IN THE FIELD OF EDUCATION (U.S. CLS. 100 AND 101).

ELI HELLMAN, EXAMINING ATTORNEY

ALEX KEAM, EXAMINING ATTORNEY

CLASS 42—(Continued).

SN 77-939,959. REC SOLAR, INC., SAN LUIS OBISO, CA. FILED 2-19-2010.



OWNER OF U.S. REG. NOS. 3,111,994 AND 3,328,535.
NO CLAIM IS MADE TO THE EXCLUSIVE RIGHT TO USE "SOLAR", APART FROM THE MARK AS SHOWN.

THE COLOR(S) YELLOW AND BLUE IS/ARE CLAIMED AS A FEATURE OF THE MARK.

THE MARK CONSISTS OF THE WORD "REC" IN BLUE OVER THE WORD "SOLAR" IN YELLOW. TO THE RIGHT IS A YELLOW SQUARE WITH ROUNDED EDGES CONTAINING CONCENTRIC CIRCLES. THE COLOR WHITE REPRESENTS BACKGROUND AND IS NOT PART OF THE MARK.

FOR CONSULTING AND DESIGN SERVICES IN THE FIELD OF SOLAR ENERGY CONVERSION SYSTEMS AND DEVICES; TECHNICAL PLANNING OF SOLAR ENERGY SYSTEMS AND INSTALLATIONS; CONSULTING SERVICES RELATED TO THE EVALUATION AND DESIGN OF OPTIMAL RENEWABLE ENERGY INSTALLATIONS, SYSTEMS AND DEVICES FOR A PARTICULAR SITE; SOLAR SYSTEMS ENGINEERING SERVICES; SOLAR ENERGY TESTING AND CONSULTATION, NAMELY, TESTING OF SOLAR ENERGY CONVERSION SYSTEMS AND DEVICES (U.S. CLS. 100 AND 101).

FIRST USE 3-25-2004; IN COMMERCE 3-31-2004.
LINDA ORNDORFF, EXAMINING ATTORNEY

SN 77-939,967. REC SOLAR, INC., SAN LUIS OBISO, CA. FILED 2-19-2010.

REC SOLAR

THE MARK CONSISTS OF STANDARD CHARACTERS WITHOUT CLAIM TO ANY PARTICULAR FONT, STYLE, SIZE, OR COLOR.

OWNER OF U.S. REG. NOS. 3,111,994 AND 3,328,535.
NO CLAIM IS MADE TO THE EXCLUSIVE RIGHT TO USE "SOLAR", APART FROM THE MARK AS SHOWN.

FOR CONSULTING AND DESIGN SERVICES IN THE FIELD OF SOLAR ENERGY CONVERSION SYSTEMS AND DEVICES; TECHNICAL PLANNING OF SOLAR ENERGY SYSTEMS AND INSTALLATIONS; CONSULTING SERVICES RELATED TO THE EVALUATION AND DESIGN OF OPTIMAL RENEWABLE ENERGY INSTALLATIONS, SYSTEMS AND DEVICES FOR A PARTICULAR SITE; SOLAR SYSTEMS ENGINEERING SERVICES; SOLAR ENERGY TESTING AND CONSULTATION, NAMELY, TESTING OF SOLAR ENERGY CONVERSION SYSTEMS AND DEVICES (U.S. CLS. 100 AND 101).

FIRST USE 3-25-2004; IN COMMERCE 3-31-2004.
LINDA ORNDORFF, EXAMINING ATTORNEY

CLASS 42—(Continued).

SN 79-095,539. SWISS REINSURANCE COMPANY LTD., SWITZERLAND, FILED 3-4-2011.

RISK CONNECT

THE MARK CONSISTS OF STANDARD CHARACTERS WITHOUT CLAIM TO ANY PARTICULAR FONT, STYLE, SIZE, OR COLOR.

PRIORITY DATE OF 2-14-2011 IS CLAIMED.
OWNER OF INTERNATIONAL REGISTRATION 1072451 DATED 3-4-2011, EXPIRES 3-4-2021.

NO CLAIM IS MADE TO THE EXCLUSIVE RIGHT TO USE "RISK", APART FROM THE MARK AS SHOWN.

FOR PROVIDING TEMPORARY USE OF ON-LINE NON-DOWNLOADABLE SOFTWARE FOR FACILITATING BUSINESS COLLABORATION, FOR PROJECT MANAGEMENT, AND FOR EXCHANGING DOCUMENTS WITH COMMENTING AND STORAGE FUNCTIONALITY USING DATABASES, INTERNET PLATFORMS, WEB SITES, ONLINE FORUMS, BLOGS AND INTERNET CHATROOMS ALL FOR THE PURPOSE OF EXPLORING KEY GLOBAL ISSUES AND TRENDS FROM A RISK TRANSFER AND FINANCIAL SERVICES PERSPECTIVE (U.S. CLS. 100 AND 101).

ELI HELLMAN, EXAMINING ATTORNEY

SN 85-020,071. FACEBOOK INC., PALO ALTO, CA. FILED 4-21-2010.



THE MARK CONSISTS OF A THUMBS UP GESTURE FOLLOWED WITH THE WORD "LIKE" IN A RECTANGLE.

FOR COMPUTER SERVICES, NAMELY, CREATING ON-LINE VIRTUAL COMMUNITIES FOR REGISTERED USERS TO ORGANIZE GROUPS AND EVENTS, PARTICIPATE IN DISCUSSIONS, AND ENGAGE IN SOCIAL, BUSINESS AND COMMUNITY NETWORKING; COMPUTER SERVICES, NAMELY, HOSTING ELECTRONIC FACILITIES FOR OTHERS FOR ORGANIZING AND CONDUCTING MEETINGS, EVENTS AND INTERACTIVE DISCUSSIONS VIA COMMUNICATION NETWORKS; APPLICATION SERVICE PROVIDER (ASP) SERVICES, NAMELY, HOSTING COMPUTER SOFTWARE APPLICATIONS OF OTHERS; APPLICATION SERVICE PROVIDER (ASP) FEATURING SOFTWARE TO ENABLE OR FACILITATE THE UPLOADING, DOWNLOADING, STREAMING, POSTING, DISPLAYING, BLOGGING, LINKING, SHARING OR OTHERWISE PROVIDING ELECTRONIC MEDIA OR INFORMATION OVER COMMUNICATION NETWORKS; PROVIDING AN ONLINE NETWORK SERVICE THAT ENABLES USERS TO TRANSFER PERSONAL IDENTITY DATA TO AND SHARE PERSONAL IDENTITY DATA WITH AND AMONG MULTIPLE WEBSITES; PROVIDING A WEB SITE FEATURING TECHNOLOGY THAT ENABLES ONLINE USERS TO CREATE PERSONAL PROFILES FEATURING SOCIAL NETWORKING INFORMATION AND TO TRANSFER AND SHARE SUCH INFORMATION AMONG MULTIPLE WEBSITES; COMPUTER SERVICES, NAMELY, CREATING INDEXES OF INFORMATION, SITES AND OTHER RESOURCES AVAILABLE ON COMPUTER NETWORKS; PROVIDING TEMPORARY USE OF NON-

CLASS 42—(Continued).

DOWNLOADABLE SOFTWARE APPLICATIONS FOR SOCIAL NETWORKING, CREATING A VIRTUAL COMMUNITY, AND TRANSMISSION OF AUDIO, VIDEO, PHOTOGRAPHIC IMAGES, TEXT, GRAPHICS AND DATA; COMPUTER SERVICES IN THE NATURE OF CUSTOMIZED WEB PAGES FEATURING USER-DEFINED OR SPECIFIED INFORMATION, PERSONAL PROFILES, AUDIO, VIDEO, PHOTOGRAPHIC IMAGES, TEXT, GRAPHICS AND DATA; PEER-TO-BROWSER PHOTO SHARING SERVICES, NAMELY, PROVIDING A WEBSITE FEATURING TECHNOLOGY ENABLING USERS TO UPLOAD, VIEW, AND DOWNLOAD DIGITAL PHOTOS; PROVIDING A WEB SITE FEATURING TECHNOLOGY THAT ENABLES USERS TO UPLOAD AND SHARE VIDEO, PHOTOS, TEXT, GRAPHICS AND DATA; CREATING AND MAINTAINING BLOGS FOR OTHERS; PROVIDING A WEB HOSTING PLATFORM FOR USE OF NON-DOWNLOADABLE SOFTWARE IN CONNECTION WITH INTERACTIVE, MULTIPLAYER AND SINGLE PLAYER GAMES FOR THIRD PARTIES (U.S. CLS. 100 AND 101).

MATTHEW PAPPAS, EXAMINING ATTORNEY

CLASS 42—(Continued).

DOWNLOADABLE SOFTWARE APPLICATIONS FOR SOCIAL NETWORKING, CREATING A VIRTUAL COMMUNITY, AND TRANSMISSION OF AUDIO, VIDEO, PHOTOGRAPHIC IMAGES, TEXT, GRAPHICS AND DATA; COMPUTER SERVICES IN THE NATURE OF CUSTOMIZED WEB PAGES FEATURING USER-DEFINED OR SPECIFIED INFORMATION, PERSONAL PROFILES, AUDIO, VIDEO, PHOTOGRAPHIC IMAGES, TEXT, GRAPHICS AND DATA; PEER-TO-BROWSER PHOTO SHARING SERVICES, NAMELY, PROVIDING A WEBSITE FEATURING TECHNOLOGY ENABLING USERS TO UPLOAD, VIEW, AND DOWNLOAD DIGITAL PHOTOS; PROVIDING A WEB SITE FEATURING TECHNOLOGY THAT ENABLES USERS TO UPLOAD AND SHARE VIDEO, PHOTOS, TEXT, GRAPHICS AND DATA; CREATING AND MAINTAINING BLOGS FOR OTHERS; PROVIDING A WEB HOSTING PLATFORM FOR USE OF NON-DOWNLOADABLE SOFTWARE IN CONNECTION WITH INTERACTIVE, MULTIPLAYER AND SINGLE PLAYER GAMES FOR THIRD PARTIES (U.S. CLS. 100 AND 101).

MATTHEW PAPPAS, EXAMINING ATTORNEY

SN 85-020,084. FACEBOOK INC., PALO ALTO, CA. FILED 4-21-2010.

SN 85-153,154. MICROSOFT CORPORATION, REDMOND, WA. FILED 10-14-2010.

LIKE



THE MARK CONSISTS OF STANDARD CHARACTERS WITHOUT CLAIM TO ANY PARTICULAR FONT, STYLE, SIZE, OR COLOR.

FOR COMPUTER SERVICES, NAMELY, CREATING ON-LINE VIRTUAL COMMUNITIES FOR REGISTERED USERS TO ORGANIZE GROUPS AND EVENTS, PARTICIPATE IN DISCUSSIONS, AND ENGAGE IN SOCIAL, BUSINESS AND COMMUNITY NETWORKING; COMPUTER SERVICES, NAMELY, HOSTING ELECTRONIC FACILITIES FOR OTHERS FOR ORGANIZING AND CONDUCTING MEETINGS, EVENTS AND INTERACTIVE DISCUSSIONS VIA COMMUNICATION NETWORKS; APPLICATION SERVICE PROVIDER (ASP) SERVICES, NAMELY, HOSTING COMPUTER SOFTWARE APPLICATIONS OF OTHERS; APPLICATION SERVICE PROVIDER (ASP) FEATURING SOFTWARE TO ENABLE OR FACILITATE THE UPLOADING, DOWNLOADING, STREAMING, POSTING, DISPLAYING, BLOGGING, LINKING, SHARING OR OTHERWISE PROVIDING ELECTRONIC MEDIA OR INFORMATION OVER COMMUNICATION NETWORKS; PROVIDING AN ONLINE NETWORK SERVICE THAT ENABLES USERS TO TRANSFER PERSONAL IDENTITY DATA TO AND SHARE PERSONAL IDENTITY DATA WITH AND AMONG MULTIPLE WEBSITES; PROVIDING A WEB SITE FEATURING TECHNOLOGY THAT ENABLES ONLINE USERS TO CREATE PERSONAL PROFILES FEATURING SOCIAL NETWORKING INFORMATION AND TO TRANSFER AND SHARE SUCH INFORMATION AMONG MULTIPLE WEBSITES; COMPUTER SERVICES, NAMELY, CREATING INDEXES OF INFORMATION, SITES AND OTHER RESOURCES AVAILABLE ON COMPUTER NETWORKS; PROVIDING TEMPORARY USE OF NON-

OWNER OF U.S. REG. NO. 3,883,548.
THE MARK CONSISTS OF STYLIZED VERSION OF WORD "BING" IN LOWER CASE LETTERS.

FOR COMPUTER SERVICES IN THE NATURE OF PROVIDING SEARCH ENGINES FOR OBTAINING DATA OVER COMPUTER NETWORKS, THE INTERNET AND WIRELESS NETWORKS (U.S. CLS. 100 AND 101).
FIRST USE 5-28-2009; IN COMMERCE 5-28-2009.
JEFFREY LOOK, EXAMINING ATTORNEY

SN 85-176,997. GLUE NETWORKS, INC., SACRAMENTO, CA. FILED 11-15-2010.

GLUWARE

THE MARK CONSISTS OF STANDARD CHARACTERS WITHOUT CLAIM TO ANY PARTICULAR FONT, STYLE, SIZE, OR COLOR.

FOR CLOUD COMPUTING SOFTWARE FEATURING SOFTWARE FOR USE TO ENABLE REGIONAL AND GLOBAL CONFIGURATION, PROVISIONING AND AUTOMATION OF VIRTUALIZED SECURE PRIVATE NETWORKS THAT ENABLE A COMPLETE EXTENSION OF CORPORATE NETWORKS TO REMOTE LOCATIONS (U.S. CLS. 100 AND 101).

SUE LAWRENCE, EXAMINING ATTORNEY

CLASS 42—(Continued).

SN 85-184,945. ASTUTE, INC., COLUMBUS, OH. FILED 11-24-2010.

ASTUTE INNOVATIONS

THE MARK CONSISTS OF STANDARD CHARACTERS WITHOUT CLAIM TO ANY PARTICULAR FONT, STYLE, SIZE, OR COLOR.

OWNER OF U.S. REG. NOS. 2,653,794, 2,813,456 AND OTHERS.

FOR DEVELOPING APPLICATION SOFTWARE ACCESSIBLE OVER THE INTERNET; PROFESSIONAL CONSULTING SERVICES AND ADVICE ABOUT ENABLING, MANAGING, OPTIMIZING, AND ANALYZING CUSTOMER INTERACTIONS OF OTHERS THROUGH SOCIAL MEDIA AND MOBILE DEVICES (U.S. CLS. 100 AND 101).

JEFF DEFORD, EXAMINING ATTORNEY

CLASS 42—(Continued).

SN 85-194,575. CORAM, INC., DENVER, CO. FILED 12-9-2010.



SN 85-185,066. ONYX PHARMACEUTICALS, INC., SOUTH SAN FRANCISCO, CA. FILED 11-24-2010.



OWNER OF U.S. REG. NOS. 2,791,902, 3,063,997 AND OTHERS.

NO CLAIM IS MADE TO THE EXCLUSIVE RIGHT TO USE "PHARMACEUTICALS", APART FROM THE MARK AS SHOWN.

THE COLOR(S) RED AND BLACK IS/ARE CLAIMED AS A FEATURE OF THE MARK.

THE MARK CONSISTS OF TWO CURVED RED LINES THAT PARTIALLY INTERSECT AT ONE POINT WITH THE WORDS "ONYX PHARMACEUTICALS" TO THE RIGHT OF THE CURVED LINES. THE COLOR BLACK APPEARS IN THE TEXT OF THE WORDING "ONYX PHARMACEUTICALS".

FOR PHARMACEUTICAL RESEARCH AND DEVELOPMENT; MEDICAL AND SCIENTIFIC RESEARCH, NAMELY, CONDUCTING CLINICAL TRIALS; MEDICAL AND SCIENTIFIC RESEARCH IN THE FIELDS OF TREATMENT FOR CANCER AND ONCOLOGY, AND IN THE FIELDS OF TREATMENT OF INFLAMMATION AND AUTOIMMUNE DISEASES (U.S. CLS. 100 AND 101).

ELI HELLMAN, EXAMINING ATTORNEY

NO CLAIM IS MADE TO THE EXCLUSIVE RIGHT TO USE "PATIENT REGISTRY", APART FROM THE MARK AS SHOWN.

THE MARK CONSISTS OF THE STYLIZED WORDS "IDEAL IMMUNOGLOBULIN, DIAGNOSIS, EVALUATION, AND KEY LEARNINGS PATIENT REGISTRY" AND AN ICON CONSISTING OF TWO RECTANGULAR PILLARS WITH OVAL DISKS ANGLED ABOVE EACH. THIS ICON IS LOCATED TO THE LEFT OF THE STYLIZED WORDS AND DEPICTS A HIGHLY STYLIZED REPRESENTATION OF A MOLECULE.

FOR MEDICAL AND SCIENTIFIC RESEARCH, NAMELY, STUDIES RELATING TO PATIENTS TREATED WITH IMMUNOGLOBULIN; SCIENTIFIC STUDY AND RESEARCH IN THE FIELD OF IMMUNOGLOBULIN; PROVIDING AN ON-LINE SEARCHABLE DATABASE FEATURING MEDICAL AND SCIENTIFIC RESEARCH, INCLUDING CLINICAL TRIALS, CONCERNING IMMUNOGLOBULIN PATIENTS AND THERAPIES; PROVIDING INFORMATION ON MEDICAL AND SCIENTIFIC RESEARCH CONCERNING IMMUNOGLOBULIN PATIENTS AND THERAPIES; PROVIDING MEDICAL AND SCIENTIFIC RESEARCH INFORMATION IN THE FIELD OF CLINICAL TRIALS; PROVIDING MEDICAL RESEARCH AND SCIENTIFIC RESEARCH INFORMATION IN THE FIELD OF IMMUNOGLOBULIN CLINICAL TRIALS (U.S. CLS. 100 AND 101).

FIRST USE 12-15-2009; IN COMMERCE 12-15-2009.
KELLEY WELLS, EXAMINING ATTORNEY

CLASS 42—(Continued).

SN 85-194,583. CORAM, INC., DENVER, CO. FILED 12-9-2010.

**IDEaL Immunoglobulin,
Diagnosis, Evaluation, and
key Learnings Patient
Registry**

THE MARK CONSISTS OF STANDARD CHARACTERS WITHOUT CLAIM TO ANY PARTICULAR FONT, STYLE, SIZE, OR COLOR.

NO CLAIM IS MADE TO THE EXCLUSIVE RIGHT TO USE "PATIENT REGISTRY", APART FROM THE MARK AS SHOWN.

FOR MEDICAL AND SCIENTIFIC RESEARCH, NAMELY, STUDIES RELATING TO PATIENTS TREATED WITH IMMUNOGLOBULIN; SCIENTIFIC STUDY AND RESEARCH IN THE FIELD OF IMMUNOGLOBULIN; PROVIDING AN ON-LINE SEARCHABLE DATABASE FEATURING MEDICAL AND SCIENTIFIC RESEARCH, INCLUDING CLINICAL TRIALS, CONCERNING IMMUNOGLOBULIN PATIENTS AND THERAPIES; PROVIDING INFORMATION ON MEDICAL AND SCIENTIFIC RESEARCH CONCERNING IMMUNOGLOBULIN PATIENTS AND THERAPIES; PROVIDING MEDICAL AND SCIENTIFIC RESEARCH INFORMATION IN THE FIELD OF CLINICAL TRIALS; PROVIDING MEDICAL RESEARCH AND SCIENTIFIC RESEARCH INFORMATION IN THE FIELD OF IMMUNOGLOBULIN CLINICAL TRIALS (U.S. CLS. 100 AND 101).

FIRST USE 12-15-2009; IN COMMERCE 12-15-2009.
KELLEY WELLS, EXAMINING ATTORNEY

SN 85-202,885. ASTUTE, INC., COLUMBUS, OH. FILED 12-21-2010.

mPowerMe

THE MARK CONSISTS OF STANDARD CHARACTERS WITHOUT CLAIM TO ANY PARTICULAR FONT, STYLE, SIZE, OR COLOR.

FOR COMPUTER SOFTWARE DEVELOPMENT IN THE FIELD OF MOBILE APPLICATIONS; CONSULTING SERVICES, NAMELY, COMPUTER SOFTWARE DEVELOPMENT IN THE FIELD OF MOBILE APPLICATIONS AND SOFTWARE (U.S. CLS. 100 AND 101).

JEFF DEFORD, EXAMINING ATTORNEY

CLASS 42—(Continued).

SN 85-236,179. ABUNDANT CLOSET, LLC, ATLANTA, GA. FILED 2-7-2011.

Closet Insights

THE MARK CONSISTS OF STANDARD CHARACTERS WITHOUT CLAIM TO ANY PARTICULAR FONT, STYLE, SIZE, OR COLOR.

FOR APPLICATION SERVICE PROVIDER (ASP) FEATURING SOFTWARE FOR USE IN POPULATING, MAINTAINING, MANAGING AND UTILIZING PERSONAL GARMENT INVENTORIES; COMPUTER CONSULTATION; COMPUTER SERVICES IN THE NATURE OF CUSTOMIZED WEB PAGES FEATURING USER-DEFINED INFORMATION AND PERSONAL PROFILES; COMPUTER SERVICES, NAMELY, DESIGNING AND IMPLEMENTING ON DEMAND WEB SITES IN THE NATURE OF TURNKEY PACKAGES ALLOWING CUSTOMERS TO CREATE ECOMMERCE WEB SITES FOR THE PURPOSE OF UPLOADING PHOTOS AND CREATING OUTFITS; COMPUTER SERVICES, NAMELY, CREATING AN ON-LINE COMMUNITY FOR REGISTERED USERS TO PARTICIPATE IN DISCUSSIONS, GET FEEDBACK FROM THEIR PEERS, FORM VIRTUAL COMMUNITIES, AND ENGAGE IN SOCIAL NETWORKING AND TOPICS ON JEWELRY AND FASHION ACCESSORIES; COMPUTER SERVICES, NAMELY, DESIGNING AND IMPLEMENTING NETWORK WEB PAGES FOR OTHERS; COMPUTER SERVICES, NAMELY, PROVIDING SEARCH PLATFORMS TO ALLOW USERS TO REQUEST CONTENT FROM AND RECEIVE CONTENT TO A MOBILE DEVICE; DATABASE DEVELOPMENT SERVICES; FASHION DESIGN CONSULTING SERVICES; PROVIDING A WEB SITE THAT GIVES COMPUTER USERS THE ABILITY TO UPLOAD, EXCHANGE AND SHARE PHOTOS, VIDEOS AND VIDEO LOGS; PROVIDING GRAPHIC AND MULTIMEDIA DESIGN SERVICES FOR THE PURPOSE OF PROMOTING THE GOODS AND SERVICES OF OTHERS (U.S. CLS. 100 AND 101).

FIRST USE 2-4-2009; IN COMMERCE 6-1-2009.
WANDA KAY PRICE, EXAMINING ATTORNEY

SN 85-243,267. IQR CONSULTING, INC., DBA NONPROFIT EASY, SANTA ROSA, CA. FILED 2-15-2011.

NonProfitEasy

THE MARK CONSISTS OF STANDARD CHARACTERS WITHOUT CLAIM TO ANY PARTICULAR FONT, STYLE, SIZE, OR COLOR.

FOR SOFTWARE AS A SERVICE (SAAS) SERVICES, NAMELY, HOSTING SOFTWARE FOR USE BY OTHERS IN THE NATURE OF NONPROFIT ORGANIZATIONS FOR USE IN DATA MANAGEMENT IN THE FIELD OF DATA RELATING TO VOLUNTEER, MEMBER, PROSPECTIVE DONOR, AND DONOR STAKEHOLDER RELATIONSHIPS (U.S. CLS. 100 AND 101).

FIRST USE 9-1-2010; IN COMMERCE 9-10-2010.
MICHAEL GAFFAR, EXAMINING ATTORNEY

CLASS 42—(Continued).

SN 85-266,255. SX2 MEDIA LABS, LLC, NEW YORK, NY. FILED 3-14-2011.

COMPUTER SHOPPER

THE MARK CONSISTS OF STANDARD CHARACTERS WITHOUT CLAIM TO ANY PARTICULAR FONT, STYLE, SIZE, OR COLOR.

SEC. 2(F).

FOR PROVIDING INFORMATION IN THE FIELDS OF COMPUTER TECHNOLOGY NEWS AND COMPUTER TECHNOLOGY (U.S. CLS. 100 AND 101).

FIRST USE 11-30-1979; IN COMMERCE 11-30-1979.

DOMINICK J. SALEMI, EXAMINING ATTORNEY

SN 85-293,555. CONSOLIDATED ASSET RECOVERY SYSTEMS, INC., RALEIGH, NC. FILED 4-13-2011.

IBEAM

THE MARK CONSISTS OF STANDARD CHARACTERS WITHOUT CLAIM TO ANY PARTICULAR FONT, STYLE, SIZE, OR COLOR.

FOR COMPUTER SOFTWARE DEVELOPMENT IN THE FIELD OF ASSET RECOVERY AND ASSET RE-MARKETING (U.S. CLS. 100 AND 101).

FIRST USE 2-1-2005; IN COMMERCE 2-1-2005.

KEVIN DINALLO, EXAMINING ATTORNEY

SN 85-305,974. PHARMANET DEVELOPMENT GROUP, INC., PRINCETON, NJ. FILED 4-27-2011.

**APPLIED KNOWLEDGE.
INTELLIGENT SOLUTIONS.**

NO CLAIM IS MADE TO THE EXCLUSIVE RIGHT TO USE "SOLUTIONS", APART FROM THE MARK AS SHOWN.

THE MARK CONSISTS OF THE WORDS "APPLIED KNOWLEDGE" DIRECTLY ABOVE THE WORDS "INTELLIGENT SOLUTIONS", WITH A STYLIZED LIGHT BULB APPEARING INSIDE THE "O" IN THE WORD "KNOWLEDGE", AND TWO STYLIZED LABORATORY BEAKERS APPEARING INSIDE THE SECOND "O" IN THE WORD "SOLUTIONS".

FOR CONDUCTING CLINICAL RESEARCH IN THE PHARMACEUTICAL, BIOTECHNOLOGY, AND MEDICAL DEVICE INDUSTRIES; CONSULTING SERVICES IN THE FIELD OF CLINICAL RESEARCH AND DEVELOPMENT OF PHARMACEUTICALS, BIOTECHNOLOGY, AND MEDICAL DEVICES; PROVIDING INFORMATION VIA THE INTERNET IN THE FIELD OF CLINICAL RESEARCH AND DEVELOPMENT OF PHARMACEUTICALS, BIOTECHNOLOGY, AND MEDICAL DEVICES; TECHNICAL CONSULTING AND COMPUTER PROGRAMMING IN CONNECTION WITH CLINICAL RESEARCH AND DEVELOPMENT OF PHARMACEUTICALS, BIOTECHNOLOGY, AND MEDICAL DEVICES (U.S. CLS. 100 AND 101).

FIRST USE 4-15-2011; IN COMMERCE 4-15-2011.

DANNEAN HETZEL, EXAMINING ATTORNEY

CLASS 42—(Continued).

SN 85-316,873. MY LEARNING PLAN INC., GREAT RIVER, NY. FILED 5-10-2011.



THE COLOR(S) BLUE AND GREEN IS/ARE CLAIMED AS A FEATURE OF THE MARK.

THE MARK CONSISTS OF THE STYLIZED WORD "OASYS" WITH THE LETTER "A" IN GREEN AND THE REMAINING LETTERS IN BLUE. THE COLOR WHITE REPRESENTS BACKGROUND, OUTLINING, SHADING, AND/OR TRANSPARENT AREAS AND IS NOT PART OF THE MARK.

FOR COMPUTER SERVICES, NAMELY, PROVIDING A WEBSITE FEATURING TECHNOLOGY THAT ENABLES USERS WHO OBSERVE TEACHERS, PRINCIPALS AND EDUCATIONAL STAFF IN PERSON OR VIA VIDEO CAMERA OR WHO ARE THE SUBJECT OF OBSERVATION, TO SCHEDULE OBSERVATIONS, TO FILL OUT FORMS, TO AGGREGATE AND REPORT DATA FROM MULTIPLE FORMS, AND TO REPORT DATA TO GOVERNMENTAL LICENSING AUTHORITIES (U.S. CLS. 100 AND 101).

FIRST USE 5-20-2010; IN COMMERCE 5-20-2010.

BRENDAN MCCAULEY, EXAMINING ATTORNEY

SN 85-319,894. ENERGY WELDFAB, INC., WHITE OAK, TX. FILED 5-13-2011.

ENERGY WELDFAB

THE MARK CONSISTS OF STANDARD CHARACTERS WITHOUT CLAIM TO ANY PARTICULAR FONT, STYLE, SIZE, OR COLOR.

NO CLAIM IS MADE TO THE EXCLUSIVE RIGHT TO USE "ENERGY", APART FROM THE MARK AS SHOWN.

FOR TESTING, ANALYSIS AND EVALUATION OF THE GOODS AND SERVICES OF OTHERS FOR THE PURPOSE OF CERTIFICATION (U.S. CLS. 100 AND 101).

FIRST USE 0-0-1990; IN COMMERCE 0-0-1990.

RAUL CORDOVA, EXAMINING ATTORNEY

SN 85-319,898. ENERGY WELDFAB, INC., WHITE OAK, TX. FILED 5-13-2011.



NO CLAIM IS MADE TO THE EXCLUSIVE RIGHT TO USE "ENERGY", APART FROM THE MARK AS SHOWN.

THE MARK CONSISTS OF THE WORD "ENERGY" OVER THE WORD "WELDFAB" AND TO THE RIGHTS OF THE WORDS, A FANCIFUL IMAGE OF A WELDING ARC.

FOR TESTING, ANALYSIS AND EVALUATION OF THE GOODS AND SERVICES OF OTHERS FOR THE PURPOSE OF CERTIFICATION (U.S. CLS. 100 AND 101).

FIRST USE 3-0-2011; IN COMMERCE 3-0-2011.

RAUL CORDOVA, EXAMINING ATTORNEY

CLASS 42—(Continued).

SN 85-328,461. BELCAMPO GROUP, INC., OAKLAND, CA. FILED 5-24-2011.

BELCAMPO

THE MARK CONSISTS OF STANDARD CHARACTERS WITHOUT CLAIM TO ANY PARTICULAR FONT, STYLE, SIZE, OR COLOR.

THE ENGLISH TRANSLATION OF THE WORD "BELCAMPO" IN THE MARK IS "BEAUTIFUL LAND" OR "BEAUTIFUL FIELD".

FOR FOOD DEVELOPMENT AND RESEARCH; CUSTOM DEVELOPMENT OF PRODUCTS, NAMELY, FOOD INGREDIENTS, FOR OTHERS; FOOD SAFETY TESTING AND CONSULTATION RELATED THERETO; ACCREDITATION SERVICES, NAMELY, DEVELOPING, EVALUATING AND TESTING STANDARDS FOR FOOD PRODUCTS; QUALITY INSPECTION SERVICES IN THE FIELD OF MEAT PRODUCTS; SCIENTIFIC AND TECHNICAL CONSULTANCY IN RELATION TO THE TECHNICAL RESEARCH IN THE FIELD OF FOOD AND BEVERAGES; PROVIDING INFORMATION IN THE FIELDS OF FOOD RESEARCH, FOOD SAFETY TESTING, ENVIRONMENTAL TESTING AND INSPECTION, AND GLOBAL WARMING AND ITS EFFECT ON NATURE, CLIMATE AND THE ENVIRONMENT VIA THE INTERNET; PROVIDING INFORMATION FURNISHED AND CREATED BY OTHERS IN THE FIELDS OF FOOD RESEARCH, FOOD SAFETY TESTING, ENVIRONMENTAL TESTING AND INSPECTION, AND GLOBAL WARMING AND ITS EFFECT ON NATURE, CLIMATE AND THE ENVIRONMENT VIA THE INTERNET (U.S. CLS. 100 AND 101).

ROBIN CHOSID, EXAMINING ATTORNEY

SN 85-331,919. THERAVIDA, INC., SAN MATEO, CA. FILED 5-26-2011.

TheraVida

THE MARK CONSISTS OF THE WORD "THERAVIDA" WITH A DESIGN OF THE SUN CENTERED BEHIND THE WORD.

FOR DEVELOPMENT OF PHARMACEUTICAL PREPARATIONS AND MEDICINES; PHARMACEUTICAL RESEARCH AND DEVELOPMENT; PROVIDING MEDICAL AND SCIENTIFIC RESEARCH INFORMATION IN THE FIELD OF PHARMACEUTICALS AND CLINICAL TRIALS; RESEARCH AND DEVELOPMENT IN THE PHARMACEUTICAL AND BIOTECHNOLOGY FIELDS (U.S. CLS. 100 AND 101).

FIRST USE 5-15-2007; IN COMMERCE 5-15-2007.
GIANCARLO CASTRO, EXAMINING ATTORNEY

CLASS 42—(Continued).

SN 85-333,025. EAGLE TELE-SERVICES, INC., POWHATAN, VA. FILED 5-28-2011.



OWNER OF U.S. REG. NO. 3,017,362.

NO CLAIM IS MADE TO THE EXCLUSIVE RIGHT TO USE "EDISPATCH" AND "TELE-SERVICES INC.", APART FROM THE MARK AS SHOWN.

THE COLOR(S) BLUE, BLACK, WHITE, GREY, ORANGE AND YELLOW IS/ARE CLAIMED AS A FEATURE OF THE MARK.

THE MARK CONSISTS OF THE PHOTOGRAPH OF A WHITE AND GRAY 18-WHEELER TRUCK WITH ORANGE LIGHTS DRIVING TOWARD THE VIEWER ON A BLACK HIGHWAY ROAD WITH A WHITE RIGHT SHOULDER LINE AND DOUBLE YELLOW CENTER LINES. A BLUE SKY WITH WHITE CLOUDS APPEARS ABOVE AND AROUND THE TRUCK. THE STYLIZED WORD "EDISPATCH" APPEARS IN BLACK WITH WHITE OUTLINING AND GRAY SHADOWING TO THE LEFT OF A BLACK RIGHT-POINTING ARROW WITH GRAY SHADOWING. THE STYLIZED WORDING "POWERED BY EAGLE TELE-SERVICES INC." APPEARS IN GRAY BELOW THE LETTERS "PATCH" IN "EDISPATCH" AND THE STRAIGHT PORTION OF THE ARROW. THE WORDING IN THE MARK APPEARS WITHIN A WHITE RECTANGLE ACROSS THE CENTER OF THE PHOTOGRAPH.

FOR SOFTWARE AS A SERVICE (SAAS) SERVICES FEATURING SOFTWARE FOR USE IN THE OPERATION OF TELEPHONE CALL CENTERS FOR OTHERS (U.S. CLS. 100 AND 101).

AMY KERTGATE, EXAMINING ATTORNEY

SN 85-335,890. ATGAMES DIGITAL MEDIA INC., PACIFIC PALISADES, CA. FILED 6-2-2011.

Dreamcloud

THE MARK CONSISTS OF STANDARD CHARACTERS WITHOUT CLAIM TO ANY PARTICULAR FONT, STYLE, SIZE, OR COLOR.

FOR CLOUD COMPUTING FEATURING SOFTWARE FOR CENTRALIZING GAME PLAYING USED IN INTERACTIVE ENTERTAINMENT AND GAME SERVERS; COMPUTER SERVICES, NAMELY, CLOUD HOSTING PROVIDER SERVICES; COMPUTER SERVICES, NAMELY, INTEGRATION OF PRIVATE AND PUBLIC CLOUD COMPUTING ENVIRONMENTS; CONSULTING SERVICES IN THE FIELD OF CLOUD COMPUTING; PROVIDING VIRTUAL COMPUTER SYSTEMS AND VIRTUAL COMPUTER ENVIRONMENTS THROUGH CLOUD COMPUTING; TECHNICAL CONSULTING SERVICES IN THE FIELDS OF DATACENTER ARCHITECTURE, PUBLIC AND PRIVATE CLOUD COMPUTING SOLUTIONS, AND EVALUATION AND IMPLEMENTATION OF INTERNET TECHNOLOGY AND SERVICES (U.S. CLS. 100 AND 101).

MARK RADEMACHER, EXAMINING ATTORNEY

CLASS 42—(Continued).

SN 85-335,976. MEDIDATA SOLUTIONS, INC., NEW YORK, NY. FILED 6-2-2011.

Optimizing Clinical Trials: Concept to Conclusion

THE MARK CONSISTS OF STANDARD CHARACTERS WITHOUT CLAIM TO ANY PARTICULAR FONT, STYLE, SIZE, OR COLOR.

NO CLAIM IS MADE TO THE EXCLUSIVE RIGHT TO USE "CLINICAL TRIALS", APART FROM THE MARK AS SHOWN.

FOR SOFTWARE AS A SERVICE (SAAS) SERVICES FEATURING SOFTWARE FOR USE IN MANAGING DATA AND INFORMATION IN THE FIELD OF MEDICAL CLINICAL TRIALS AND RESEARCH; MEDICAL AND SCIENTIFIC RESEARCH, NAMELY, CONDUCTING CLINICAL TRIALS; CLINICAL TRIAL PROTOCOL DEVELOPMENT IN THE NATURE OF DEVELOPING PROTOCOLS FOR MEDICAL CLINICAL TRIALS AND RESEARCH; CLINICAL TRIAL PLANNING AND MANAGEMENT IN THE NATURE OF ASSISTING WITH THE DEVELOPMENT OF MEDICAL CLINICAL TRIALS AND RESEARCH AND THE MANAGEMENT OF THE DATA AND INFORMATION GENERATED IN MEDICAL CLINICAL TRIALS AND RESEARCH; CLINICAL TRIAL RANDOMIZATION AND TRIAL SUPPLY MANAGEMENT IN THE NATURE OF THE MANAGEMENT OF DATA AND INFORMATION GENERATED IN MEDICAL CLINICAL TRIALS AND RESEARCH, FOR PATIENT TRACKING AND MANAGEMENT, FOR PATIENT RANDOMIZATION AND ENROLLMENT, FOR PHARMACEUTICAL SUPPLY MANAGEMENT AND DOSING, FOR LOGISTICS MANAGEMENT, AND FOR MATERIAL INVENTORY AND SUPPLY MANAGEMENT; CLINICAL TRIAL MONITORING AND EVENTS CAPTURE IN THE NATURE OF THE GATHERING AND ORGANIZING THE INFORMATION AND DATA GENERATED IN MEDICAL CLINICAL TRIALS AND RESEARCH; CLINICAL DATA CAPTURE, MANAGEMENT AND REPORTING IN THE NATURE OF THE RESULTS OF MEDICAL CLINICAL TRIALS AND RESEARCH; PROVIDING ONLINE NON-DOWNLOADABLE SOFTWARE FOR USE IN MANAGING DATA AND INFORMATION IN THE FIELD OF MEDICAL CLINICAL TRIALS AND RESEARCH; PROVIDING ONLINE NON-DOWNLOADABLE SOFTWARE FOR USE IN MANAGING DATA AND INFORMATION IN THE FIELD OF MEDICAL CLINICAL TRIALS AND RESEARCH, NAMELY, CLINICAL TRIAL PROTOCOL DEVELOPMENT, CLINICAL TRIAL PLANNING AND MANAGEMENT, CLINICAL TRIAL USER AND LEARNING MANAGEMENT, CLINICAL TRIAL RANDOMIZATION AND TRIAL SUPPLY MANAGEMENT, CLINICAL TRIAL MONITORING AND EVENTS CAPTURE, AND CLINICAL DATA CAPTURE, MANAGEMENT AND REPORTING (U.S. CLS. 100 AND 101).

FIRST USE 1-17-2011; IN COMMERCE 1-17-2011.

MEGHAN REINHART, EXAMINING ATTORNEY

CLASS 42—(Continued).

SN 85-344,781. INSTITUTE FOR PERSONALITY AND ABILITY TESTING, INC., CHAMPAIGN, IL. FILED 6-13-2011.

NETASSESS

THE MARK CONSISTS OF STANDARD CHARACTERS WITHOUT CLAIM TO ANY PARTICULAR FONT, STYLE, SIZE, OR COLOR.

OWNER OF U.S. REG. NO. 2,435,209.

FOR ONLINE NON-DOWNLOADABLE SOFTWARE FOR ADMINISTRATION AND SCORING IN THE FIELD OF PSYCHOMETRIC INSTRUMENTS INCLUDING TESTING MATERIALS, NAMELY, MANUALS, TEST BOOKLETS, ANSWER SHEETS, PROFILE SHEETS, NORM TABLES, SCORING KEYS, WORKSHEETS, WORKBOOKS, REPORTS, QUESTIONNAIRES, RECORD FORMS, USER'S GUIDES, AND REFERENCE MATERIALS, NAMELY, HANDBOOKS, TECHNICAL REPORTS, AND BOOKS, ALL IN THE AREA OF PERSONALITY AND BEHAVIORAL TESTING (U.S. CLS. 100 AND 101).

FIRST USE 11-1-1999; IN COMMERCE 11-1-1999.

JAMES MACFARLANE, EXAMINING ATTORNEY

SN 85-345,674. APPLIED INDUSTRIAL TECHNOLOGIES, INC., CLEVELAND, OH. FILED 6-14-2011.



NO CLAIM IS MADE TO THE EXCLUSIVE RIGHT TO USE "ADVANCED TECHNOLOGIES", APART FROM THE MARK AS SHOWN.

THE MARK CONSISTS OF AN UPWARD-POINTING ARROW IN FRONT OF THE WORDS "BAY ADVANCED TECHNOLOGIES".

FOR ENGINEERING, NAMELY, SYSTEMS INTEGRATION SERVICES IN THE FIELD OF PNEUMATIC, FLUID CONTROL, AND ELECTRONIC AUTOMATION TECHNOLOGIES (U.S. CLS. 100 AND 101).

JORDAN BAKER, EXAMINING ATTORNEY

SN 85-345,689. APPLIED INDUSTRIAL TECHNOLOGIES, INC., CLEVELAND, OH. FILED 6-14-2011.



NO CLAIM IS MADE TO THE EXCLUSIVE RIGHT TO USE "AIR TECHNOLOGY", APART FROM THE MARK AS SHOWN.

THE MARK CONSISTS OF AN UPWARD-POINTING ARROW IN FRONT OF THE WORDS "PACIFIC AIR TECHNOLOGY".

FOR ENGINEERING, NAMELY, SYSTEMS INTEGRATION SERVICES IN THE FIELD OF PNEUMATIC, FLUID CONTROL, AND ELECTRONIC AUTOMATION TECHNOLOGIES (U.S. CLS. 100 AND 101).

JORDAN BAKER, EXAMINING ATTORNEY

CLASS 42—(Continued).

SN 85-349,290. MONTANO, GILBERT A., KANSAS CITY, MO. FILED 6-17-2011.

One in a Million Will You Be The One?

THE MARK CONSISTS OF STANDARD CHARACTERS WITHOUT CLAIM TO ANY PARTICULAR FONT, STYLE, SIZE, OR COLOR.

FOR CHARITABLE SERVICES, NAMELY, PROVIDING A WEBSITE THAT FEATURES TECHNOLOGY THAT ENABLES USERS TO PROVIDE FUNDS TO A CHARITY OF THEIR CHOICE (U.S. CLS. 100 AND 101).
CIMMERIAN COLEMAN, EXAMINING ATTORNEY

SN 85-350,379. EXEMPLIFY GROUP, LLC, FORMERLY BROKERTEL, INC., PLANO, TX. FILED 6-20-2011.

eXemplify

THE MARK CONSISTS OF STANDARD CHARACTERS WITHOUT CLAIM TO ANY PARTICULAR FONT, STYLE, SIZE, OR COLOR.

FOR CONSULTING IN THE FIELD OF TELECOMMUNICATIONS TECHNOLOGY, SPECIFICALLY; LOCAL DIAL TONE, LONG DISTANCE SERVICES, INTERNET SERVICES, WIDE AREA NETWORKING SERVICES, AND VOICE OVER INTERNET PROTOCOL SERVICES; CONSULTING SERVICES IN THE FIELD OF CLOUD COMPUTING, SPECIFICALLY; PRIVATE, PUBLIC, AND HYBRID CLOUD COMPUTING SERVICES SUCH AS: DATA CENTER ARCHITECTURE, VIRTUAL DESKTOPS AS A SERVICE, INFRASTRUCTURE AS A SERVICE, DISASTER RECOVERY AS A SERVICE, AND COMMUNICATIONS AS A SERVICE; INFORMATION TECHNOLOGY CONSULTATION, SPECIFICALLY; THE DESIGN OF SECURE LOCAL AREA NETWORK AND WIDE AREA NETWORK INFRASTRUCTURE, INCLUDING DESKTOPS, SERVERS, ROUTERS, SWITCHES, FIREWALLS AND APPLICATIONS (U.S. CLS. 100 AND 101).
FIRST USE 3-23-2011; IN COMMERCE 3-23-2011.
STEPHANIE ALI, EXAMINING ATTORNEY

SN 85-351,664. BELL, RODGER, FAIRFIELD, CA. FILED 6-21-2011.

EXZOTIK

THE MARK CONSISTS OF STANDARD CHARACTERS WITHOUT CLAIM TO ANY PARTICULAR FONT, STYLE, SIZE, OR COLOR.

FOR CONSULTING IN THE FIELD OF ENGINEERING; DESIGN FOR OTHERS IN THE FIELD OF ENGINEERING; MECHANICAL ENGINEERING (U.S. CLS. 100 AND 101).

FIRST USE 3-17-2009; IN COMMERCE 3-17-2009.
FRED CARL, EXAMINING ATTORNEY

CLASS 42—(Continued).

SN 85-352,705. LEVINE, JOSHUA D., CARRBORO, NC. FILED 6-22-2011.

GOGOSCOPE

THE MARK CONSISTS OF STANDARD CHARACTERS WITHOUT CLAIM TO ANY PARTICULAR FONT, STYLE, SIZE, OR COLOR.

FOR HOSTING ONLINE WEB FACILITIES FOR OTHERS FOR ENGAGING IN SOCIAL AND COMMUNITY NETWORKING; PROVIDING ONLINE NETWORK SERVICES, NAMELY, PROVIDING AN ONLINE NETWORK SERVICE THAT ENABLES USERS TO SHARE DATA IN THE FIELD OF PERSONAL IDENTITY AND IDENTIFICATION INFORMATION (U.S. CLS. 100 AND 101).

RENEE MCCRAY, EXAMINING ATTORNEY

SN 85-357,614. HUBWORKS INTERACTIVE LLC, COEUR D'ALENE, ID. FILED 6-27-2011.

HUBWORKS INTERACTIVE

THE MARK CONSISTS OF STANDARD CHARACTERS WITHOUT CLAIM TO ANY PARTICULAR FONT, STYLE, SIZE, OR COLOR.

NO CLAIM IS MADE TO THE EXCLUSIVE RIGHT TO USE "INTERACTIVE", APART FROM THE MARK AS SHOWN.

FOR DESIGN, DEVELOPMENT, INSTALLATION AND MAINTENANCE OF COMPUTER SOFTWARE FOR USE IN THE RESTAURANT AND HOSPITALITY INDUSTRY (U.S. CLS. 100 AND 101).

FIRST USE 5-21-2011; IN COMMERCE 5-21-2011.

B. PARADEWELAI, EXAMINING ATTORNEY

SN 85-360,159. ETRANSMEDIA TECHNOLOGY, INC, TROY, NY. FILED 6-30-2011.

CONNECT2CARE

THE MARK CONSISTS OF STANDARD CHARACTERS WITHOUT CLAIM TO ANY PARTICULAR FONT, STYLE, SIZE, OR COLOR.

FOR APPLICATION SERVICE PROVIDER (ASP) FEATURING SOFTWARE FOR USE BY HOSPITALS, LABORATORIES, AND MANAGED CARE ORGANIZATIONS TO CONNECT AND MANAGE THE CONNECTIONS BETWEEN THEIR INTERNAL SYSTEMS, INTERNAL AND EXTERNAL MANAGED CARE SYSTEMS, AND PRIVATE PHYSICIAN SYSTEMS (U.S. CLS. 100 AND 101).

JOHN SCHUYLER YARD, EXAMINING ATTORNEY

CLASS 42—(Continued).

SN 85-361,478. IPAYMENT, INC., NASHVILLE, TN. FILED 7-1-2011.

IADVANTAGE

THE MARK CONSISTS OF STANDARD CHARACTERS WITHOUT CLAIM TO ANY PARTICULAR FONT, STYLE, SIZE, OR COLOR.

FOR COMPUTER SERVICES, NAMELY, CLOUD HOSTING PROVIDER SERVICES FOR BUSINESSES AND INDIVIDUALS, EXCLUDING SPECIFICALLY SERVICES FOR ENERGY AND UTILITY SERVICE PROVIDERS; PROVIDING A WEBSITE FEATURING NON-DOWNLOADABLE SOFTWARE FOR THE MANAGEMENT OF INVENTORY, EXCLUDING SPECIFICALLY INVENTORY MANAGEMENT SOFTWARE FOR ENERGY AND UTILITY SERVICE PROVIDERS; PROVIDING AN ONLINE LINK TO THE WEBSITES OF OTHERS FEATURING WEATHER FORECASTS (U.S. CLS. 100 AND 101).

JASON TURNER, EXAMINING ATTORNEY

SN 85-362,113. SHIFT4 CORPORATION, LAS VEGAS, NV. FILED 7-1-2011.

TrueToken

THE MARK CONSISTS OF STANDARD CHARACTERS WITHOUT CLAIM TO ANY PARTICULAR FONT, STYLE, SIZE, OR COLOR.

OWNER OF U.S. REG. NO. 3,943,303.

FOR COMPUTER SERVICES, NAMELY, DEVELOPING AND IMPLEMENTING FOR MERCHANTS UNIQUE IDENTIFIERS TO REPLACE ACTUAL CARDHOLDER DATA ASSOCIATED WITH AN ELECTRONIC PAYMENT TRANSACTION THAT CAN BE USED IN THE SAME WAY THAT ACTUAL CARDHOLDER DATA IS USED; COMPUTER SERVICES, NAMELY, PROVIDING ON-LINE SECURITY SERVICES FOR PROCESSING ELECTRONIC PAYMENT TRANSACTIONS BY REPLACING CARDHOLDER PAYMENT DATA WITH A UNIQUE IDENTIFIER AND ENABLING MERCHANTS TO PROCESS AN ELECTRONIC PAYMENT TRANSACTION USING THE UNIQUE IDENTIFIER (U.S. CLS. 100 AND 101).

DAVID H. STINE, EXAMINING ATTORNEY

CLASS 42—(Continued).

SN 85-366,541. INDIANA RESEARCH AND TECHNOLOGY CORPORATION, INDIANAPOLIS, IN. FILED 7-8-2011.

VIROMERICS

THE MARK CONSISTS OF STANDARD CHARACTERS WITHOUT CLAIM TO ANY PARTICULAR FONT, STYLE, SIZE, OR COLOR.

FOR COMPUTER-AIDED DEVELOPMENT OF VACCINES FROM NANOPARTICLES (U.S. CLS. 100 AND 101).

EDWARD FENNESSY, EXAMINING ATTORNEY

SN 85-368,714. PANZIERA, EDOARDO, DBA PRESIDENT, CONCORD, ONTARIO, CANADA, FILED 7-12-2011.

paradigm automation

THE MARK CONSISTS OF STANDARD CHARACTERS WITHOUT CLAIM TO ANY PARTICULAR FONT, STYLE, SIZE, OR COLOR.

NO CLAIM IS MADE TO THE EXCLUSIVE RIGHT TO USE "AUTOMATION", APART FROM THE MARK AS SHOWN.

FOR APPLICATION SERVICE PROVIDER FEATURING NON-DOWNLOADABLE COMPUTER SOFTWARE, NAMELY, DATABASE MANAGEMENT SOFTWARE FOR USE IN MANAGING INFORMATION FROM BUSINESS DATA SOURCES IN THE FIELD OF HMI OR HUMAN-MACHINE-INTERACTION (U.S. CLS. 100 AND 101).

TRACY WHITTAKER-BROWN, EXAMINING ATTORNEY

SN 85-378,954. GLANCY, DAVID, DBA SAN FRANCISCO WINE SCHOOL, SAN FRANCISCO, CA. FILED 7-22-2011.

**CALIFORNIA WINE
APPELLATION SPECIALIST CWAS**

THE MARK CONSISTS OF STANDARD CHARACTERS WITHOUT CLAIM TO ANY PARTICULAR FONT, STYLE, SIZE, OR COLOR.

NO CLAIM IS MADE TO THE EXCLUSIVE RIGHT TO USE "CALIFORNIA WINE APPELLATION SPECIALIST", APART FROM THE MARK AS SHOWN.

FOR TESTING, ANALYSIS, AND EVALUATION OF THE KNOWLEDGE, SKILLS AND ABILITIES OF OTHERS FOR THE PURPOSE OF CERTIFICATION AND RE-CERTIFICATION IN THE FIELD OF CALIFORNIA WINE (U.S. CLS. 100 AND 101).

FIRST USE 7-22-2011; IN COMMERCE 7-22-2011.

DEBORAH LOBO, EXAMINING ATTORNEY

CLASS 42—(Continued).

SN 85-388,192. LASTLINE, INC., SANTA BARBARA, CA. FILED 8-3-2011.

MALSCAPE

THE MARK CONSISTS OF STANDARD CHARACTERS WITHOUT CLAIM TO ANY PARTICULAR FONT, STYLE, SIZE, OR COLOR.

FOR PROVIDING CUSTOMIZED ON-LINE DATA FEED FORMATS FEATURING USER-DEFINED INFORMATION RELATING TO MALICIOUS ACTIVITIES ON THE INTERNET TO IMPROVE COMPUTER SECURITY AND PREVENT COMPUTER RISKS (U.S. CLS. 100 AND 101).

FIRST USE 5-1-2011; IN COMMERCE 5-1-2011.
SETH A. RAPPAPORT, EXAMINING ATTORNEY

CLASS 42—(Continued).

SN 85-390,871. MCGUIRE, ROBERT, HELOTES, TX. FILED 8-5-2011.

McGuire Design

THE MARK CONSISTS OF STANDARD CHARACTERS WITHOUT CLAIM TO ANY PARTICULAR FONT, STYLE, SIZE, OR COLOR.

FOR GRAPHIC DESIGN SERVICES (U.S. CLS. 100 AND 101).

FIRST USE 9-23-2002; IN COMMERCE 8-15-2003.
C. DIONNE CLYBURN, EXAMINING ATTORNEY

SN 85-389,256. VAXFORM, LLC, ROCKVILLE, MD. FILED 8-4-2011.



THE COLOR(S) BLUE, GREEN AND ORANGE IS/ARE CLAIMED AS A FEATURE OF THE MARK.

THE MARK CONSISTS OF A BLUE AND GREEN VORTEX WITH AN ORANGE SPHERE, NEXT TO THE WORD "VAXFORM" IN BLUE.

FOR CONSULTING SERVICES IN THE FIELD OF VACCINE AND BIOLOGICS FORMULATION AND DEVELOPMENT (U.S. CLS. 100 AND 101).

FIRST USE 9-29-2010; IN COMMERCE 2-7-2011.
LINDA ORNDORFF, EXAMINING ATTORNEY

SN 85-398,843. AMAZON TECHNOLOGIES, INC., RENO, NV. FILED 8-16-2011.

LAB126

THE MARK CONSISTS OF STANDARD CHARACTERS WITHOUT CLAIM TO ANY PARTICULAR FONT, STYLE, SIZE, OR COLOR.

FOR DESIGN AND DEVELOPMENT OF COMPUTER HARDWARE AND SOFTWARE (U.S. CLS. 100 AND 101).

FIRST USE 6-18-2006; IN COMMERCE 6-18-2006.
DANIEL CAPSHAW, EXAMINING ATTORNEY

SN 85-390,134. GLOBALENGLISH CORPORATION, BRISBANE, CA. FILED 8-4-2011.

GLOBALENGLISH BLOOM

THE MARK CONSISTS OF STANDARD CHARACTERS WITHOUT CLAIM TO ANY PARTICULAR FONT, STYLE, SIZE, OR COLOR.

OWNER OF U.S. REG. NOS. 2,456,280, 2,823,678 AND OTHERS.

FOR COMPUTER SERVICES, NAMELY, PROVIDING ONLINE NON-DOWNLOADABLE ENTERPRISE PLATFORM SOFTWARE FOR NATIVE AND NON-NATIVE ENGLISH SPEAKERS TO COLLABORATE TO INCREASE GLOBAL ORGANIZATIONAL PRODUCTIVITY, PARTICIPATE IN DISCUSSIONS, GET FEEDBACK FROM THEIR PEERS, FORM VIRTUAL BUSINESS NETWORKS AND ACTIVITIES, AND ENGAGE IN BUSINESS NETWORKING AND ONLINE COLLABORATION (U.S. CLS. 100 AND 101).

ROBERT STRUCK, EXAMINING ATTORNEY

SN 85-398,917. AMAZON TECHNOLOGIES, INC., RENO, NV. FILED 8-16-2011.



THE MARK CONSISTS OF A CIRCLE WITH A LINE INTERSECTING THE MIDDLE OF THE CIRCLE TO BEYOND THE BOTTOM OF THE CIRCLE.

FOR DESIGN AND DEVELOPMENT OF COMPUTER HARDWARE AND SOFTWARE (U.S. CLS. 100 AND 101).

FIRST USE 6-18-2006; IN COMMERCE 6-18-2006.
DANIEL CAPSHAW, EXAMINING ATTORNEY

CLASS 42—(Continued).

SN 85-400,296. NETWORK FOR GOOD, INC., BETHESDA, MD. FILED 8-17-2011.

THE NETWORK FOR GOOD

THE MARK CONSISTS OF STANDARD CHARACTERS WITHOUT CLAIM TO ANY PARTICULAR FONT, STYLE, SIZE, OR COLOR.

NO CLAIM IS MADE TO THE EXCLUSIVE RIGHT TO USE "NETWORK", APART FROM THE MARK AS SHOWN. FOR COMPUTER SERVICES, NAMELY, PROVIDING AN ON-LINE COMMUNITY FOR USERS TO PARTICIPATE IN DISCUSSIONS, GET FEEDBACK, FORM VIRTUAL COMMUNITIES, AND ENGAGE IN SOCIAL NETWORKING IN THE FIELD OF CHARITABLE FUNDRAISING (U.S. CLS. 100 AND 101).

FIRST USE 12-8-2010; IN COMMERCE 12-8-2010.
RONALD AIKENS, EXAMINING ATTORNEY

SN 85-403,087. JAYASEKERA, HARSHA, DBA DINESAFE, VANCOUVER, CANADA, AND ALY AMLANI, DBA DINESAFE, VANCOUVER, CANADA, FILED 8-20-2011.



THE MARK CONSISTS OF THE WORD "DINESAFE" WITH A MAGNIFYING GLASS. INSIDE THE MAGNIFYING GLASS IMAGE IS A FORK AND KNIFE

FOR PROVIDING A WEB SITE FEATURING TECHNOLOGY THAT ENABLES USERS TO FIND HEALTH INSPECTION REPORTS FOR RESTAURANTS AND WRITE REVIEWS OF RESTAURANTS (U.S. CLS. 100 AND 101).

KHANH LE, EXAMINING ATTORNEY

CLASS 42—(Continued).

SN 85-404,478. TRANSCONTINENTAL INTERACTIF INC., MONTREAL, QUEBEC, CANADA, FILED 8-23-2011.



PRIORITY CLAIMED UNDER SEC. 44(D) ON CANADA APPLICATION NO. 1538287, FILED 8-3-2011.

THE MARK CONSISTS OF THE WORDS "PAPERCOTERIE" IN STYLIZED FONT ALONGSIDE A STYLIZED DESIGN COMPRISED OF A FOUR CURVED LINES RESEMBLING A CLOVER FEATURING A CIRCLE WITHIN A SQUARE SHOWN THEREIN AND FOUR DIAGONAL LINES EMANATING FROM THE CURVED LINES ALL WITHIN A SQUARE.

FOR COMPUTER SERVICES, NAMELY, PROVIDING AN INTERACTIVE WEB SITE FEATURING TECHNOLOGY THAT ALLOWS USERS TO CREATE THEIR OWN PERSONALIZED PRINTED PRODUCTS, NAMELY, PRINTED MEMORY BOOKS, PICTURE BOOKS, GUEST BOOKS, CALENDARS, GROWTH CHARTS, ANNOUNCEMENT CARDS, INVITATION CARDS, GREETING CARDS, HOLIDAY CARDS AND RECIPE CARDS, CARDBOARD MEMORY BOXES FOR DISPLAYING AND STORING KEEPSAKES AND MEMENTOS, SCRAPBOOKS, WRITING JOURNALS, POSTERS AND PHOTOGRAPHS (U.S. CLS. 100 AND 101).

FIRST USE 4-4-2011; IN COMMERCE 4-4-2011.
DAVID YONTEF, EXAMINING ATTORNEY

SN 85-408,611. FIRSTBEST SYSTEMS, INC., BEDFORD, MA. FILED 8-26-2011.

FIRSTBEST UMS

THE MARK CONSISTS OF STANDARD CHARACTERS WITHOUT CLAIM TO ANY PARTICULAR FONT, STYLE, SIZE, OR COLOR.

OWNER OF U.S. REG. NO. 3,454,539.

NO CLAIM IS MADE TO THE EXCLUSIVE RIGHT TO USE "UMS", APART FROM THE MARK AS SHOWN.

FOR COMPUTER SOFTWARE DESIGN, COMPUTER PROGRAMMING AND MAINTENANCE OF COMPUTER SOFTWARE; TECHNICAL SUPPORT SERVICES, NAMELY, TROUBLESHOOTING OF COMPUTER SOFTWARE PROBLEMS; PROVIDING ON-LINE NON-DOWNLOADABLE SOFTWARE FOR INSURANCE UNDERWRITING (U.S. CLS. 100 AND 101).

FIRST USE 12-17-2007; IN COMMERCE 12-17-2007.
GIANCARLO CASTRO, EXAMINING ATTORNEY

CLASS 42—(Continued).

SN 85-412,587. BEBANET INC, DBA LINLY DESIGNS, CLARENDON HILLS, IL. FILED 9-1-2011.

ACCESSORY CALL

THE MARK CONSISTS OF STANDARD CHARACTERS WITHOUT CLAIM TO ANY PARTICULAR FONT, STYLE, SIZE, OR COLOR.

FOR INTERIOR DESIGN SERVICES; DESIGN OF INTERIOR DECOR (U.S. CLS. 100 AND 101).

FIRST USE 1-1-2008; IN COMMERCE 1-1-2008.
JAY FLOWERS, EXAMINING ATTORNEY

SN 85-424,278. LANE, THOMAS, ELIZABETH, PA. FILED 9-16-2011.

**YOUR BUSINESS DESERVES A
LITTLE TLC**

THE MARK CONSISTS OF STANDARD CHARACTERS WITHOUT CLAIM TO ANY PARTICULAR FONT, STYLE, SIZE, OR COLOR.

FOR COMPUTER AND TECHNOLOGICAL PROFESSIONAL SERVICES, NAMELY, CONSULTING SERVICES FOR DEVELOPING CUSTOM SOFTWARE, DATABASE DESIGN AND DEVELOPMENT, AND SETTING UP AND CONFIGURING LOCAL AND WIDE AREA NETWORKS (U.S. CLS. 100 AND 101).

FIRST USE 7-10-2001; IN COMMERCE 7-10-2001.
JACLYN KIDWELL WALKER, EXAMINING ATTORNEY

SN 85-429,160. COMMON SENSE, LLC, SAN ANTONIO, TX. FILED 9-22-2011.



THE MARK CONSISTS OF THE TERM "LANDER" WHICH APPEARS WITH AN ARROW ABOVE THE LETTER "N".

FOR PROVIDING ON-LINE NON-DOWNLOADABLE SOFTWARE FOR CREATING, TESTING, AND OPTIMIZING WEBPAGES AND WEBSITES (U.S. CLS. 100 AND 101).

FIRST USE 9-15-2011; IN COMMERCE 9-15-2011.
BILL DAWE, EXAMINING ATTORNEY

CLASS 42—(Continued).

SN 85-438,157. QQUEST SOFTWARE SYSTEMS, INC., SANDY, UT. FILED 10-3-2011.

QFORCE

THE MARK CONSISTS OF STANDARD CHARACTERS WITHOUT CLAIM TO ANY PARTICULAR FONT, STYLE, SIZE, OR COLOR.

FOR PROVIDING TEMPORARY USE OF NON-DOWNLOADABLE COMPUTER APPLICATION SOFTWARE FOR USE IN DATABASE MANAGEMENT, PAYROLL MANAGEMENT AND REPORTING, EMPLOYMENT SERVICES, NAMELY, APPLICANT TRACKING, EMPLOYEE DATA MANAGEMENT, NAMELY, TIME AND ATTENDANCE TRACKING, ASSESSING EMPLOYEE PERFORMANCE, TAX MANAGEMENT AND PROCESSING, GOVERNMENT COMPLIANCE ASSESSMENT, BENEFITS ENROLLMENT AND MANAGEMENT, EARNINGS AND DEDUCTIONS MANAGEMENT, EMPLOYEE SELF SERVICES MANAGEMENT, AND MANAGER SELF SERVICES MANAGEMENT (U.S. CLS. 100 AND 101).

JENNIFER VASQUEZ, EXAMINING ATTORNEY

SN 85-438,329. LEXTRONICA, INC., PALO ALTO, CA. FILED 10-4-2011.

LAWGIVES

THE MARK CONSISTS OF STANDARD CHARACTERS WITHOUT CLAIM TO ANY PARTICULAR FONT, STYLE, SIZE, OR COLOR.

FOR PROVIDING TEMPORARY USE OF ONLINE NON-DOWNLOADABLE COMPUTER SOFTWARE TO CONNECT LAWYERS, LAW STUDENTS, PROSPECTIVE CLIENTS AND THE GENERAL PUBLIC FOR THE PURPOSES OF THE PROVISION OF LEGAL SERVICES, KNOWLEDGE AND EDUCATION; PROVIDING TEMPORARY USE OF ONLINE NON-DOWNLOADABLE COMPUTER SOFTWARE FOR TIMEKEEPING, DOCUMENT MANAGEMENT AND CUSTOMER RELATIONSHIP MANAGEMENT; PROVIDING TEMPORARY USE OF ONLINE NON-DOWNLOADABLE COMPUTER SOFTWARE FOR USE IN, BILLING, IDENTITY VERIFICATION, PRIVATE AND PUBLIC COMMUNICATION, SYNCHRONIZED DOCUMENT COLLABORATION, AUDIO AND VISUAL COLLABORATION, PROVIDED IN CONNECTION WITH LEGAL SERVICES (U.S. CLS. 100 AND 101).

LINDA ESTRADA, EXAMINING ATTORNEY

CLASS 42—(Continued).

SN 85-441,664. ATH POWER CONSULTING CORP., AND-OVER, MA. FILED 10-7-2011.

ANET

THE MARK CONSISTS OF STANDARD CHARACTERS WITHOUT CLAIM TO ANY PARTICULAR FONT, STYLE, SIZE, OR COLOR.

FOR PROVIDING AN INTERACTIVE WEBSITE FEATURING TEMPORARY USE OF NON-DOWNLOADABLE SOFTWARE FOR COLLECTING COMMERCIAL FINANCIAL TRANSACTION DATA AND PROVIDING COMMERCIAL FINANCIAL TRANSACTION DATA, REPORTS, AND BUSINESS INFORMATION TO FINANCIAL SERVICES PROVIDERS; PROVIDING AN INTERACTIVE WEBSITE FEATURING TEMPORARY USE OF NON-DOWNLOADABLE SOFTWARE FOR MARKET RESEARCH AND RECORDING COMMERCIAL TRANSACTIONS IN THE FIELD OF FINANCIAL SERVICES MARKETING; PROVIDING AN INTERACTIVE WEBSITE FEATURING TEMPORARY USE OF NON-DOWNLOADABLE SOFTWARE FOR ORGANIZING CONSUMER DATA AND SURVEY INFORMATION AND PROVIDES SURVEYS AND REPORTS TO FINANCIAL SERVICES PROVIDERS IN THE FIELD OF BUSINESS CONSULTING (U.S. CLS. 100 AND 101).

FIRST USE 8-30-2011; IN COMMERCE 8-30-2011.
JASON TURNER, EXAMINING ATTORNEY

CLASS 42—(Continued).

SN 85-442,138. SECURE FTP HOSTING, LLC., INDIANAPOLIS, IN. FILED 10-7-2011.

SMART IS AS SMART DOES

THE MARK CONSISTS OF STANDARD CHARACTERS WITHOUT CLAIM TO ANY PARTICULAR FONT, STYLE, SIZE, OR COLOR.

FOR FILE SHARING SERVICES, NAMELY, PROVIDING A WEBSITE FEATURING TECHNOLOGY ENABLING USERS TO UPLOAD AND DOWNLOAD ELECTRONIC FILES VIA THE INTERNET (U.S. CLS. 100 AND 101).

CHRISTINA SOBRAL, EXAMINING ATTORNEY

SN 85-450,429. XPEC ENTERTAINMENT INC., TAIPEI, TAIWAN, FILED 10-18-2011.



THE COLOR(S) YELLOW, BLACK, WHITE, BROWN, AND GRAY IS/ARE CLAIMED AS A FEATURE OF THE MARK.

THE MARK CONSISTS OF THE STYLIZED WORDING "WEAPONS OF MYTHOLOGY" IN GRAY AND WHITE, OUTLINED IN BLACK, WITHIN A YELLOW, BROWN, AND WHITE FLOWER DESIGN, OUTLINED IN BLACK.

FOR COMPUTER SOFTWARE DESIGN FOR OTHERS; ANIMATION DESIGN FOR OTHERS; CONSULTANCY IN THE FIELD OF COMPUTER SOFTWARE DESIGN; PLANNING AND DEVELOPMENT OF ELECTRONIC COMMUNICATIONS NETWORKS; DESIGNING WEB PAGES FOR OTHERS; DESIGN OF WEBSITES; INDUSTRIAL DESIGN; PROVIDING INFORMATION IN THE FIELD OF DESIGNING AND DEVELOPING COMPUTER GAME SOFTWARE AND VIDEO GAME SOFTWARE FOR USE WITH COMPUTERS, VIDEO GAME PROGRAM SYSTEMS AND COMPUTER NETWORKS VIA THE INTERNET; COMPUTER PROJECT MANAGEMENT SERVICES IN THE FIELD OF TELECOMMUNICATIONS (U.S. CLS. 100 AND 101).

STEVEN JACKSON, EXAMINING ATTORNEY

SN 85-441,887. HUBWORKS INTERACTIVE LLC, COEUR D'ALENE, ID. FILED 10-7-2011.

HUBWORKS

THE MARK CONSISTS OF STANDARD CHARACTERS WITHOUT CLAIM TO ANY PARTICULAR FONT, STYLE, SIZE, OR COLOR.

FOR DESIGN, DEVELOPMENT, INSTALLATION AND MAINTENANCE OF COMPUTER SOFTWARE FOR USE IN THE RESTAURANT AND HOSPITALITY INDUSTRY (U.S. CLS. 100 AND 101).

B. PARADEWELAI, EXAMINING ATTORNEY

CLASS 42—(Continued).

SN 85-451,355. GDSX, LTD., ALLEN, TX. FILED 10-19-2011.

CETAS

THE MARK CONSISTS OF STANDARD CHARACTERS WITHOUT CLAIM TO ANY PARTICULAR FONT, STYLE, SIZE, OR COLOR.

FOR PROVIDING PROPRIETARY ONLINE NON-DOWNLOADABLE SOFTWARE FOR AUTOMATING PRE-TRIP APPROVAL FOR OTHERS TO ENFORCE COMPLIANCE WITH THEIR CORPORATE TRAVEL POLICIES IN THE FIELD OF CORPORATE TRAVEL MANAGEMENT (U.S. CLS. 100 AND 101).

FIRST USE 5-31-2006; IN COMMERCE 5-31-2006.
LAURIE MAYES, EXAMINING ATTORNEY

CLASS 42—(Continued).

SN 85-452,748. INQSOLUTIONS, INC., APEX, NC. FILED 10-21-2011.



THE MARK CONSISTS OF THE WORDING "INQSHARE" IN STYLIZED FONT, WITH THE LETTER "Q" AND A CIRCULAR DESIGN ELEMENT APPEARING ABOVE THE WORDING.

FOR PROVIDING TEMPORARY USE OF NON-DOWNLOADABLE CLOUD-BASED COMPUTER SOFTWARE FOR DOCUMENT MANAGEMENT, PROJECT MANAGEMENT, AND WORKFLOW MANAGEMENT, ALL HAVING AN ARCHIVING FUNCTION (U.S. CLS. 100 AND 101).

TEJBIR SINGH, EXAMINING ATTORNEY

SN 85-452,628. KINETEK CONSULTING, LLC, WESTON, FL. FILED 10-20-2011.



THE COLOR(S) GOLD AND BLUE IS/ARE CLAIMED AS A FEATURE OF THE MARK.

THE MARK CONSISTS OF THE WORD "KINETEK" COLORED IN BLUE IN INTERLOCKING GOLD COLORED CIRCLES, WITH ONE LETTER OF THE WORD IN EACH OF THE SEVEN CIRCLES. THE COLOR WHITE IN THE DRAWING REPRESENTS BACKGROUND, OUTLINING, SHADING AND/OR TRANSPARENT AREAS AND IS NOT PART OF THE MARK.

FOR BUSINESS TECHNOLOGY SOFTWARE CONSULTATION SERVICES PERTAINING TO THE CONFIGURATION AND DEPLOYMENT OF PERFORMANCE MANAGEMENT SOFTWARE; BUSINESS ASSISTANCE AND SUPPORT SERVICES, NAMELY, CONSULTING IN THE FIELD OF SELECTION OF COMPUTER SOFTWARE FOR OTHERS IN THE FIELD OF PERFORMANCE MANAGEMENT SOFTWARE (U.S. CLS. 100 AND 101).

FIRST USE 7-5-2002; IN COMMERCE 7-5-2002.
MARTHA FROMM, EXAMINING ATTORNEY

SN 85-455,001. NEST LABS, INC., PALO ALTO, CA. FILED 10-24-2011.



THE MARK CONSISTS OF ARCH DESIGN WITH WORD "NEST" IN LOWER CASE LETTERS INSIDE ARCH ON THE CENTER RIGHT.

FOR COMPUTER SERVICES, NAMELY, PROVIDING A WEBSITE FEATURING TECHNOLOGY THAT ALLOWS USERS TO MONITOR AND CONTROL A CLIMATE CONTROL SYSTEM AT A REMOTE LOCATION (U.S. CLS. 100 AND 101).

SUSAN LESLIE DUBOIS, EXAMINING ATTORNEY

CLASS 42—(Continued).

SN 85-457,106. GEORGETOWN RAIL EQUIPMENT COMPANY, GEORGETOWN, TX. FILED 10-26-2011.

AURORA

THE MARK CONSISTS OF STANDARD CHARACTERS WITHOUT CLAIM TO ANY PARTICULAR FONT, STYLE, SIZE, OR COLOR.

FOR RAILROAD TRACK INSPECTION SERVICES, NAMELY, PROVIDING 3D SCAN OF RAILROAD TIES YIELDING A CONDITION ASSESSMENT FOR THE PURPOSE OF INSPECTING RAILROAD TRACKS (U.S. CLS. 100 AND 101).

FIRST USE 12-31-2003; IN COMMERCE 12-31-2003.
JACLYN KIDWELL WALKER, EXAMINING ATTORNEY

SN 85-458,233. CHAMPION COLLEGE SERVICES, INC., TEMPE, AZ. FILED 10-27-2011.

INDEPENDENCE

THE MARK CONSISTS OF STANDARD CHARACTERS WITHOUT CLAIM TO ANY PARTICULAR FONT, STYLE, SIZE, OR COLOR.

FOR CLOUD COMPUTING FEATURING SOFTWARE FOR STUDENT LOAN MANAGEMENT AND LOAN DEFAULT MITIGATION SERVICES FOR EDUCATION PROVIDERS HAVING FORMER STUDENTS WITH STUDENT LOANS; PROVIDING A WEBSITE FEATURING NON-DOWNLOADABLE SOFTWARE FOR STUDENT LOAN MANAGEMENT AND LOAN DEFAULT MITIGATION SERVICES FOR EDUCATION PROVIDERS HAVING FORMER STUDENTS WITH STUDENT LOANS; AND PROVIDING TEMPORARY USE OF ON-LINE NON-DOWNLOADABLE SOFTWARE FOR STUDENT LOAN SERVICES, NAMELY, STUDENT LOAN MANAGEMENT AND LOAN DEFAULT MITIGATION SERVICES FOR EDUCATION PROVIDERS HAVING FORMER STUDENTS WITH STUDENT LOANS (U.S. CLS. 100 AND 101).

FIRST USE 10-10-2011; IN COMMERCE 10-10-2011.
TOBY BULLOFF, EXAMINING ATTORNEY

CLASS 42—(Continued).

SN 85-460,789. ANTHELIO HEALTHCARE SOLUTIONS INC., DALLAS, TX. FILED 10-31-2011.

IT-ology

THE MARK CONSISTS OF STANDARD CHARACTERS WITHOUT CLAIM TO ANY PARTICULAR FONT, STYLE, SIZE, OR COLOR.

FOR COMPUTER TECHNOLOGY SUPPORT SERVICES, NAMELY, HELP DESK SERVICES FOR PHYSICIANS RELATING TO ELECTRONIC HEALTH RECORDS AND HEALTH INFORMATION MANAGEMENT SYSTEMS (U.S. CLS. 100 AND 101).

MICHAEL KEATING, EXAMINING ATTORNEY

SN 85-461,153. VISUAL CONNECTIONS LLC, CHEVY CHASE, MD. FILED 11-1-2011.



NO CLAIM IS MADE TO THE EXCLUSIVE RIGHT TO USE "LLC", APART FROM THE MARK AS SHOWN.

THE MARK CONSISTS OF A STYLIZED IMAGE COMPOSED OF VARIOUS LINES IN A SIX-ARMED, TWELVE-POINTED STAR-LIKE PATTERN RESEMBLING HUMAN LIMBS, WITH HUMAN-HEAD-LIKE OVALS INTERSPERSED WITHIN THE LINES. THERE IS A MIRROR IMAGE OF THE DESIGN BEHIND IT THAT APPEARS TO BE LAYING FLAT. TO THE RIGHT IS THE STYLIZED TEXT "VISUAL" IN WHICH THE LETTER "S" IS COMPOSED OF TWO CURVED ARROWS POINTING TOWARD EACH OTHER. BELOW THIS TEXT IS THE STYLIZED TEXT "CONNECTIONS LLC".

FOR IT CONSULTING SERVICES (U.S. CLS. 100 AND 101).

FIRST USE 3-0-2011; IN COMMERCE 3-0-2011.
BRENDAN REGAN, EXAMINING ATTORNEY

SN 85-464,875. MARTIN APPEL, LAS VEGAS, NV. FILED 11-4-2011.

DUMP HIM

THE MARK CONSISTS OF STANDARD CHARACTERS WITHOUT CLAIM TO ANY PARTICULAR FONT, STYLE, SIZE, OR COLOR.

FOR CREATING AN ON-LINE COMMUNITY FOR PEOPLE INTERESTED IN POLITICS, POLITICAL DISCUSSION, AND THE DEMOCRATIC ELECTION PROCESS FOR THE PURPOSE OF POLITICAL DISCUSSION (U.S. CLS. 100 AND 101).

DAVID C. REIHNER, EXAMINING ATTORNEY

CLASS 42—(Continued).

SN 85-465,037. MARKETRON INTERNATIONAL, LLC, HAI-
LEY, ID. FILED 11-4-2011.

CLASS 42—(Continued).

SN 85-465,771. MY EZ APPLICATIONS, LLC, BROKEN
ARROW, OK. FILED 11-7-2011.



NO CLAIM IS MADE TO THE EXCLUSIVE RIGHT TO USE "SCHEDULE" AND "SOFTWARE DESIGNED BY RETAILERS FOR RETAILERS", APART FROM THE MARK AS SHOWN.

THE MARK CONSISTS OF THE TEXT "MY EZ SCHEDULE SOFTWARE DESIGNED BY RETAILERS FOR RETAILERS" WITH A REPRESENTATION OF A CLOCK FACE WITH THE HOUR AND MINUTE HANDS WITH 4 DOTS REPRESENTING THE NUMBERS AS IF IT WAS A CLOCK FACE.

FOR SOFTWARE AS A SERVICE (SAAS) SERVICES FEATURING SOFTWARE FOR TIME AND ATTENDANCE MONITORING AND RECORDING (U.S. CLS. 100 AND 101).

FIRST USE 6-29-2011; IN COMMERCE 8-0-2011.
MARY ROSSMAN, EXAMINING ATTORNEY

OWNER OF U.S. REG. NOS. 2,855,145, 3,983,767 AND OTHERS.

THE MARK CONSISTS OF FOUR ADJOINED LETTER "M'S" FORMING A CIRCLE AND CONTAINED INSIDE A GRAPHIC OF A CIRCLE.

FOR APPLICATION SERVICE PROVIDER (ASP) AND SOFTWARE AS A SERVICE (SAAS) SERVICES, NAMELY, PROVIDING HOSTING OF NON-DOWNLOADABLE COMPUTER SOFTWARE OF OTHERS FOR USE IN DATABASE MANAGEMENT AND FOR RESEARCHING, NEGOTIATING AND SCHEDULING ADVERTISING SPOTS, FOR MANAGING STATION AD SCHEDULING, INVENTORY MANAGEMENT AND BILLING, AND FOR MANAGING MOBILE BUSINESS, NETWORK BUSINESS, ADVERTISER RELATIONSHIPS AND PAYMENTS, ELECTRONIC ORDERS AND INVOICES, PAYMENT PROCESSING, MEDIA RELATIONSHIP MANAGEMENT, DIGITAL, EXCHANGE, DATA MANAGEMENT AND REPORTING AND ANALYTICS, ALL IN THE FIELD OF MEDIA; APPLICATION SERVICE PROVIDER (ASP) AND SOFTWARE AS A SERVICE (SAAS) SERVICES FEATURING TEMPORARY USE OF ONLINE NON-DOWNLOADABLE SOFTWARE FOR USE BY OTHERS IN DATABASE MANAGEMENT AND FOR RESEARCHING, NEGOTIATING AND SCHEDULING ADVERTISING SPOTS, FOR MANAGING STATION AD SCHEDULING, INVENTORY MANAGEMENT AND BILLING, AND FOR MANAGING MOBILE BUSINESS, NETWORK BUSINESS, ADVERTISER RELATIONSHIPS AND PAYMENTS, ELECTRONIC ORDERS AND INVOICES, PAYMENT PROCESSING, MEDIA RELATIONSHIP MANAGEMENT, DIGITAL, EXCHANGE, DATA MANAGEMENT AND REPORTING AND ANALYTICS, ALL IN THE FIELD OF MEDIA (U.S. CLS. 100 AND 101).

FIRST USE 9-7-2010; IN COMMERCE 9-7-2010.
ALYSSA STEEL, EXAMINING ATTORNEY

SN 85-470,147. AMBROSIAL SENIOR LIVING LLC, DBA AMBROSIAL SENIOR LIVING, CHANTILLY, VA. FILED 11-11-2011.

AMBROSIAL SENIOR LIVING

THE MARK CONSISTS OF STANDARD CHARACTERS WITHOUT CLAIM TO ANY PARTICULAR FONT, STYLE, SIZE, OR COLOR.

NO CLAIM IS MADE TO THE EXCLUSIVE RIGHT TO USE "SENIOR LIVING", APART FROM THE MARK AS SHOWN.

FOR ARCHITECTURAL DESIGN AND DEVELOPMENT OF ARCHITECTURAL DESIGNS AND MODELS IN THE FIELD OF SENIOR LIVING FACILITIES AND RESIDENCES (U.S. CLS. 100 AND 101).

CHRIS WELLS, EXAMINING ATTORNEY

CLASS 42—(Continued).

SN 85-470,555. JUST PARTS ONLINE INCORPORATED, THUNDER BAY, ON, CANADA, FILED 11-11-2011.

CLASS 42—(Continued).

SN 85-473,037. SICKLE CELL DISEASE ASSOCIATION OF AMERICA, INC., BALTIMORE, MD. FILED 11-15-2011.

JustRides

THE MARK CONSISTS OF STANDARD CHARACTERS WITHOUT CLAIM TO ANY PARTICULAR FONT, STYLE, SIZE, OR COLOR.

FOR COMPUTER SERVICES, NAMELY, CREATING AN ON-LINE COMMUNITY FOR REGISTERED USERS TO PARTICIPATE IN DISCUSSIONS, GET FEEDBACK FROM THEIR PEERS, FORM VIRTUAL COMMUNITIES, ENGAGE IN SOCIAL NETWORKING, AND SHOWCASE THEIR HOBBY IN CONNECTION WITH THEIR PERSONAL MOTOR VEHICLES (U.S. CLS. 100 AND 101).

FIRST USE 5-1-2009; IN COMMERCE 10-21-2011.
GIANCARLO CASTRO, EXAMINING ATTORNEY

SICKLE CELL DISEASE ASSOCIATION OF AMERICA, INC.

SN 85-472,811. NEXGEN RXMARKETING, LLC, BENSALLEM, PA. FILED 11-15-2011.

MEETINGDIRECT

THE MARK CONSISTS OF STANDARD CHARACTERS WITHOUT CLAIM TO ANY PARTICULAR FONT, STYLE, SIZE, OR COLOR.

FOR COMPUTER SERVICES, NAMELY, HOSTING ON-LINE WEB FACILITIES FOR OTHERS FOR ORGANIZING AND CONDUCTING ONLINE MEETINGS, GATHERINGS, AND INTERACTIVE DISCUSSIONS (U.S. CLS. 100 AND 101).

FIRST USE 1-1-2011; IN COMMERCE 1-1-2011.
JOHN E. MICHOS, EXAMINING ATTORNEY

THE MARK CONSISTS OF STANDARD CHARACTERS WITHOUT CLAIM TO ANY PARTICULAR FONT, STYLE, SIZE, OR COLOR.

OWNER OF U.S. REG. NOS. 1,866,640 AND 3,239,071.

NO CLAIM IS MADE TO THE EXCLUSIVE RIGHT TO USE "ASSOCIATION" AND "INC.", APART FROM THE MARK AS SHOWN.

SEC. 2(F).

FOR LABORATORY RESEARCH IN THE FIELD OF SICKLE CELL DISEASE; PROVIDING INFORMATION ON THE SUBJECT OF SCIENTIFIC RESEARCH IN THE FIELD OF BIOCHEMISTRY AND BIOTECHNOLOGY; PROVIDING SCIENTIFIC INFORMATION IN THE FIELD OF SICKLE CELL DISEASE; RESEARCH AND ANALYSIS IN THE FIELD OF MEDICINE; SCIENTIFIC INVESTIGATIONS FOR MEDICAL PURPOSES; SCIENTIFIC LABORATORY SERVICES; SCIENTIFIC RESEARCH; SCIENTIFIC RESEARCH AND DEVELOPMENT; SCIENTIFIC RESEARCH FOR MEDICAL PURPOSES IN THE FIELD OF SICKLE CELL DISEASE (U.S. CLS. 100 AND 101).

FIRST USE 8-9-1993; IN COMMERCE 8-9-1993.
LAKEISHA LEWIS, EXAMINING ATTORNEY

CLASS 42—(Continued).

SN 85-473,081. ARBITRON INC., COLUMBIA, MD. FILED 11-15-2011.

ARB-TV

THE MARK CONSISTS OF STANDARD CHARACTERS WITHOUT CLAIM TO ANY PARTICULAR FONT, STYLE, SIZE, OR COLOR.

FOR APPLICATION SERVICE PROVIDER FEATURING APPLICATION PROGRAMMING INTERFACE (API) SOFTWARE FOR ALLOWING DATA RETRIEVAL, ACCESS, MANAGEMENT AND ANALYSIS IN THE FIELDS OF ANALYZING TELEVISION VIEWING, ANALYZING TELEVISION ADVERTISING AND MARKETING, TELEVISION AUDIENCE PARTICIPATION RESEARCH, AUDIENCE MEASUREMENT, AUDIENCE EXPOSURE TO COMMERCIAL MEASUREMENT, AUDIENCE RATINGS, PUBLIC OPINION, MEDIA EXPOSURE MEASUREMENT, MARKET RESEARCH, MARKET SURVEYS, BUSINESS RESEARCH, DEMOGRAPHICS, GEOGRAPHICS, CONSUMER BEHAVIOR AND CONSUMER TRENDS; APPLICATION SERVICE PROVIDER FEATURING APPLICATION PROGRAMMING INTERFACE (API) SOFTWARE FOR CONDUCTING DATA COLLECTION, COMPILATION AND ANALYSIS IN THE FIELDS OF ANALYZING TELEVISION VIEWING, ANALYZING TELEVISION ADVERTISING AND MARKETING, TELEVISION AUDIENCE PARTICIPATION RESEARCH, AUDIENCE MEASUREMENT, AUDIENCE EXPOSURE TO COMMERCIAL MEASUREMENT, AUDIENCE RATINGS, PUBLIC OPINION, MEDIA EXPOSURE MEASUREMENT, MARKET RESEARCH, MARKET SURVEYS, BUSINESS RESEARCH, DEMOGRAPHICS, GEOGRAPHICS, CONSUMER BEHAVIOR AND CONSUMER TRENDS; PROVIDING TEMPORARY USE OF NON-DOWNLOADABLE COMPUTER SOFTWARE FOR REVIEWING AND ORGANIZING TELEVISION AUDIENCE RATING INFORMATION; APPLICATION SERVICE PROVIDER FEATURING APPLICATION PROGRAMMING INTERFACE (API) SOFTWARE FOR CUSTOMERS TO REVIEW AND ORGANIZE TELEVISION AUDIENCE RATING INFORMATION (U.S. CLS. 100 AND 101).

FIRST USE 6-23-2009; IN COMMERCE 6-23-2009.
MICHAEL TANNER, EXAMINING ATTORNEY

SN 85-475,213. BLUKANYON CONSULTING, INC., DBA BLUKANYON CONSULTING, SNOQUALMIE, WA. FILED 11-17-2011.

BluKanyon

THE MARK CONSISTS OF STANDARD CHARACTERS WITHOUT CLAIM TO ANY PARTICULAR FONT, STYLE, SIZE, OR COLOR.

FOR INFORMATION TECHNOLOGY CONSULTING SERVICES; INFORMATION TECHNOLOGY CONSULTING SERVICES, NAMELY, CONSULTATION RELATED TO THE MANAGEMENT OF INFORMATION TECHNOLOGY SYSTEMS (U.S. CLS. 100 AND 101).

FIRST USE 7-7-2011; IN COMMERCE 10-3-2011.
JENNIFER VASQUEZ, EXAMINING ATTORNEY

CLASS 42—(Continued).

SN 85-476,013. ASYMMETRIK LTD., LAUREL, MD. FILED 11-18-2011.



OWNER OF U.S. REG. NO. 3,734,191.

THE COLOR(S) RED, GREY AND BLACK IS/ARE CLAIMED AS A FEATURE OF THE MARK.

THE MARK CONSISTS OF AN ANGLED, STYLIZED LETTER "A" IN RED AND GREY WITH A GREY SHADED SWOOSH ENCIRCLING IT. BELOW IS THE WORD "ASYMMETRIK" WRITTEN IN ETHNOCENTRIC FONT IN BLACK COLOR WITH RED DOWNWARD TRIANGLE FILLING THE UPPER PORTION OF THE LETTER "Y". UNDERNEATH ARE THE WORDS "AGILITY EXPERIENCE RESULTS" WRITTEN IN SMALLER BANK GOTHIC LIGHT FONT IN GREY AND EACH WORD IS SEPARATED BY A GREY VERTICAL LINE.

FOR DESIGN AND DEVELOPMENT OF COMPUTER SOFTWARE FOR OTHERS (U.S. CLS. 100 AND 101).

FIRST USE 2-15-2008; IN COMMERCE 2-15-2008.
WILLIAM P. SHANAHAN, EXAMINING ATTORNEY

SN 85-477,889. LABATE, MICHAEL N., PHILADELPHIA, PA. FILED 11-21-2011.

choozum

THE MARK CONSISTS OF STANDARD CHARACTERS WITHOUT CLAIM TO ANY PARTICULAR FONT, STYLE, SIZE, OR COLOR.

FOR COMPUTER SERVICES, NAMELY, CREATING AN ON-LINE COMMUNITY FOR REGISTERED USERS TO CREATE AND SHARE PUBLIC AND PRIVATE SURVEYS, PARTICIPATE IN PUBLIC AND PRIVATE SURVEYS, ACQUIRE FEEDBACK FROM PARTICIPANTS, PROVIDE FEEDBACK TO PARTICIPANTS, AND ENGAGE IN SOCIAL NETWORKING FOR PURPOSES OF OBTAINING INPUT AND FEEDBACK FROM MULTIPLE PARTICIPANTS (U.S. CLS. 100 AND 101).

FIRST USE 10-1-2011; IN COMMERCE 10-1-2011.
MICHAEL TANNER, EXAMINING ATTORNEY

CLASS 42—(Continued).

SN 85-479,029. SCOTT, DAMIAN, SAN FRANCISCO, CA. FILED 11-22-2011.

BUZZRATE

THE MARK CONSISTS OF STANDARD CHARACTERS WITHOUT CLAIM TO ANY PARTICULAR FONT, STYLE, SIZE, OR COLOR.

FOR PROVIDING TEMPORARY USE OF ON-LINE NON-DOWNLOADABLE SOFTWARE FOR ANALYZING ON-LINE CONSUMER-GENERATED MEDIA, MARKETING EFFICIENCY AND PUBLIC RELATIONS MANAGEMENT, NAMELY, MONITORING KEYWORD MENTIONS MADE ON SOCIAL NETWORKING WEBSITES AND PROVIDING ANALYSIS OF CONSUMER BEHAVIOR IN THE FIELD OF SOCIAL MEDIA IN ORDER TO PROVIDE BRAND REPUTATION MANAGEMENT AND UNDERSTAND MARKET TRENDS; TEXT MINING; PROVIDING TEMPORARY USE OF ON-LINE NON-DOWNLOADABLE SOFTWARE THAT ALLOWS USERS TO MANAGE, TRACK, ANALYZE, AND REPORT DATA IN THE FIELD OF MARKETING, BRAND MONITORING, PROMOTION, SALES, CUSTOMER INFORMATION, CUSTOMER RELATIONSHIP MANAGEMENT AND SALES SUPPORT; PROVIDING TEMPORARY USE OF ON-LINE NON-DOWNLOADABLE SOFTWARE TO FACILITATE COMMUNICATING AMONG PEER PROFESSIONALS IN THE ADVERTISING, MARKETING AND BUSINESS SERVICES FIELDS (U.S. CLS. 100 AND 101).

FIRST USE 8-1-2011; IN COMMERCE 11-21-2011.
JENNY PARK, EXAMINING ATTORNEY

SN 85-479,474. BENCHMARK INTERNET GROUP, DBA BENCHMARK EMAIL, LOS ALAMITOS, CA. FILED 11-22-2011.

BENCHMARK EMAIL

THE MARK CONSISTS OF STANDARD CHARACTERS WITHOUT CLAIM TO ANY PARTICULAR FONT, STYLE, SIZE, OR COLOR.

NO CLAIM IS MADE TO THE EXCLUSIVE RIGHT TO USE "EMAIL", APART FROM THE MARK AS SHOWN.

FOR PROVIDING TEMPORARY USE OF ONLINE, NON-DOWNLOADABLE SOFTWARE FOR MEASURING MARKETING DEMOGRAPHICS VIA ELECTRONIC MAIL, AND FOR MANAGING CONTACT LISTS THAT ARE PERMISSION-BASED (U.S. CLS. 100 AND 101).

FIRST USE 1-1-2005; IN COMMERCE 1-1-2005.
AISHA CLARKE, EXAMINING ATTORNEY

CLASS 42—(Continued).

SN 85-480,410. ROBERT L. O'BLOCK REVOCABLE TRUST, SPRINGFIELD, MO. FILED 11-23-2011.



NO CLAIM IS MADE TO THE EXCLUSIVE RIGHT TO USE "AMERICAN ASSOCIATION OF INTEGRATIVE MEDICINE" AND "AMERICAN BOARD OF INTEGRATIVE HEALTH", APART FROM THE MARK AS SHOWN.

THE MARK CONSISTS OF THE WORDING "AMERICAN ASSOCIATION OF INTEGRATIVE MEDICINE" WITHIN THE CIRCLE; THE WORDING "AMERICAN BOARD OF INTEGRATIVE HEALTH" ON A RIBBON LIKE BANNER; TRIANGLE IN THE CENTER OF THE CIRCLE; IMAGE OF A PERSON DOING YOGA IN THE CENTER.

FOR TESTING, ANALYSIS, AND EVALUATION OF THE SERVICES OF OTHERS FOR THE PURPOSE OF CERTIFICATION IN THE FIELD OF INTEGRATIVE HEALTH (U.S. CLS. 100 AND 101).

FIRST USE 11-17-2011; IN COMMERCE 11-17-2011.
NAAKWAMA ANKRAH, EXAMINING ATTORNEY

SN 85-481,099. ASSISTANTCOACH SYSTEMS, LLC, DBA ACS ATHLETICS, AUSTIN, TX. FILED 11-27-2011.

ACS ATHLETICS

THE MARK CONSISTS OF STANDARD CHARACTERS WITHOUT CLAIM TO ANY PARTICULAR FONT, STYLE, SIZE, OR COLOR.

NO CLAIM IS MADE TO THE EXCLUSIVE RIGHT TO USE "ATHLETICS", APART FROM THE MARK AS SHOWN.

FOR SOFTWARE AS A SERVICE (SAAS) SERVICES FEATURING SOFTWARE FOR MANAGING INFORMATION RELATED TO STUDENT-ATHLETES, ATHLETIC RECRUITING, ATHLETIC TEAM ROSTER MANAGEMENT, ATHLETE HEALTH, ATHLETIC EQUIPMENT INVENTORY AND TEAM ALUMNI, AND FOR FACILITATING COMPLIANCE WITH INSTITUTIONAL, CONFERENCE AND LEAGUE REGULATIONS RELATED TO COLLEGE ATHLETICS, FOR USE ON COMPUTERS, MOBILE PHONES AND OTHER INTERNET ENABLED DEVICES (U.S. CLS. 100 AND 101).

FIRST USE 10-31-2006; IN COMMERCE 10-31-2006.
PRISCILLA MILTON, EXAMINING ATTORNEY

CLASS 42—(Continued).

SN 85-481,102. ASSISTANTCOACH SYSTEMS, LLC, DBA ACS ATHLETICS, AUSTIN, TX. FILED 11-27-2011.



NO CLAIM IS MADE TO THE EXCLUSIVE RIGHT TO USE "ATHLETICS", APART FROM THE MARK AS SHOWN.

THE MARK CONSISTS OF A LARGE TRIANGLE WITH A MEDIUM SIZED TRIANGLE IN FRONT OF IT AND A SMALL TRIANGLE IN FRONT OF THE MEDIUM TRIANGLE, FOLLOWED BY THE WORDS "ACS ATHLETICS".

FOR SOFTWARE AS A SERVICE (SAAS) SERVICES FEATURING SOFTWARE FOR MANAGING INFORMATION RELATED TO STUDENT-ATHLETES, ATHLETIC RECRUITING, ATHLETIC TEAM ROSTER MANAGEMENT, ATHLETE HEALTH, ATHLETIC EQUIPMENT INVENTORY AND TEAM ALUMNI, AND FOR FACILITATING COMPLIANCE WITH INSTITUTIONAL, CONFERENCE AND LEAGUE REGULATIONS RELATED TO COLLEGE ATHLETICS, FOR USE ON COMPUTERS, MOBILE PHONES AND OTHER INTERNET ENABLED DEVICES (U.S. CLS. 100 AND 101).

FIRST USE 10-31-2006; IN COMMERCE 10-31-2006.
PRISCILLA MILTON, EXAMINING ATTORNEY

SN 85-482,272. BUY AND HEDGE LLC, ELLICOTT CITY, MD. FILED 11-29-2011.

BUY AND HEDGE

THE MARK CONSISTS OF STANDARD CHARACTERS WITHOUT CLAIM TO ANY PARTICULAR FONT, STYLE, SIZE, OR COLOR.

NO CLAIM IS MADE TO THE EXCLUSIVE RIGHT TO USE "HEDGE", APART FROM THE MARK AS SHOWN.

FOR PROVIDING A WEB SITE FEATURING NON-DOWNLOADABLE SOFTWARE FOR PORTFOLIO ANALYSIS AND PORTFOLIO RISK MANAGEMENT IN THE FIELD OF FINANCE (U.S. CLS. 100 AND 101).

DAWN HAN, EXAMINING ATTORNEY

SN 85-482,704. IAM TECHNOLOGIES, LLC, SYRACUSE, NY. FILED 11-29-2011.

IamResponding.com

THE MARK CONSISTS OF STANDARD CHARACTERS WITHOUT CLAIM TO ANY PARTICULAR FONT, STYLE, SIZE, OR COLOR.

FOR PROVIDING A WEBSITE FEATURING TECHNOLOGY THAT ENABLES USERS TO ACCESS A DISPLAY THAT LISTS INDIVIDUALS, THEIR RESPONSE STATUS TO AN EVENT, AND THE DESTINATION OF THEIR RESPONSE, IF ANY (U.S. CLS. 100 AND 101).

FIRST USE 8-1-2006; IN COMMERCE 11-1-2006.
PAM WILLIS, EXAMINING ATTORNEY

CLASS 42—(Continued).

SN 85-482,739. NEXGEN RXMARKETING, LLC, BENSALLEM, PA. FILED 11-29-2011.

TRAININGDIRECT

THE MARK CONSISTS OF STANDARD CHARACTERS WITHOUT CLAIM TO ANY PARTICULAR FONT, STYLE, SIZE, OR COLOR.

FOR COMPUTER SERVICES, NAMELY, HOSTING ON-LINE WEB FACILITIES FOR OTHERS FOR ORGANIZING AND CONDUCTING ONLINE MEETINGS, GATHERINGS, AND INTERACTIVE DISCUSSIONS (U.S. CLS. 100 AND 101).

FIRST USE 1-1-2011; IN COMMERCE 1-1-2011.
JOHN E. MICHOS, EXAMINING ATTORNEY

SN 85-486,305. SANDHILL DESIGN GROUP LLC, APPLETON, WI. FILED 12-2-2011.

**Small House Building -
Dream Big, Build Small**

THE MARK CONSISTS OF STANDARD CHARACTERS WITHOUT CLAIM TO ANY PARTICULAR FONT, STYLE, SIZE, OR COLOR.

FOR PROVIDING A WEBSITE FEATURING INFORMATION ABOUT GREEN ARCHITECTURE, INTERIOR DESIGN, SUSTAINABLE COMMUNITY PLANNING AND INFRASTRUCTURE DEVELOPMENT (U.S. CLS. 100 AND 101).

FIRST USE 12-20-2007; IN COMMERCE 12-20-2007.
AMY KELLY, EXAMINING ATTORNEY

SN 85-487,528. HAMILTON, DANIEL, BOISE, ID. FILED 12-5-2011.

EdgeGameServers

THE MARK CONSISTS OF STANDARD CHARACTERS WITHOUT CLAIM TO ANY PARTICULAR FONT, STYLE, SIZE, OR COLOR.

FOR HOSTING THE SOFTWARE, WEBSITES AND OTHER COMPUTER APPLICATIONS OF OTHERS ON A VIRTUAL PRIVATE SERVER (U.S. CLS. 100 AND 101).

FIRST USE 7-1-2011; IN COMMERCE 7-1-2011.
SHAUNIA CARLYLE, EXAMINING ATTORNEY

CLASS 42—(Continued).

SN 85-488,697. DEVONWAY, SAN FRANCISCO, CA. FILED 12-6-2011.

DevonWay

THE MARK CONSISTS OF STANDARD CHARACTERS WITHOUT CLAIM TO ANY PARTICULAR FONT, STYLE, SIZE, OR COLOR.

FOR SOFTWARE AS A SERVICE (SAAS) SERVICES, NAMELY, HOSTING SOFTWARE FOR USE BY OTHERS FOR USE IN ENTERPRISE ASSET MANAGEMENT, KEY PERFORMANCE INDICATORS, PROCESS WORKFLOW MANAGEMENT, HUMAN PERFORMANCE IMPROVEMENT AND CORRECTIVE ACTION FOR USE IN POWER GENERATION AND PROCESS INDUSTRIES (U.S. CLS. 100 AND 101).

FIRST USE 6-1-2005; IN COMMERCE 6-1-2005.
JENNIFER VASQUEZ, EXAMINING ATTORNEY

SN 85-488,713. GAS SENSING TECHNOLOGY CORP., LARAMIE, WY. FILED 12-6-2011.

WELLD OG

THE MARK CONSISTS OF STANDARD CHARACTERS WITHOUT CLAIM TO ANY PARTICULAR FONT, STYLE, SIZE, OR COLOR.

FOR GEOPHYSICAL EXPLORATION FOR THE OIL, GAS AND MINING INDUSTRIES; ANALYSIS SERVICES IN THE FIELD OF GEOPHYSICS, NAMELY, CONDUCTING FEASIBILITY STUDIES TO STUDY FLUID FLOW IN OIL AND GAS RESERVOIRS; ANALYSIS SERVICES IN THE FIELD OF GEOPHYSICS, NAMELY, ANALYSIS OF OIL AND GAS FIELDS; ANALYSIS SERVICES IN THE FIELD OF GEOPHYSICS, NAMELY, ANALYSIS OF OIL SOAKINGS (U.S. CLS. 100 AND 101).

BILL DAWE, EXAMINING ATTORNEY

SN 85-488,773. DEVONWAY, SAN FRANCISCO, CA. FILED 12-6-2011.

ActionWay

THE MARK CONSISTS OF STANDARD CHARACTERS WITHOUT CLAIM TO ANY PARTICULAR FONT, STYLE, SIZE, OR COLOR.

FOR SOFTWARE AS A SERVICE (SAAS) SERVICES, NAMELY, HOSTING SOFTWARE FOR USE BY OTHERS FOR USE IN ENTERPRISE ASSET MANAGEMENT, KEY PERFORMANCE INDICATORS, PROCESS WORKFLOW MANAGEMENT, HUMAN PERFORMANCE IMPROVEMENT AND CORRECTIVE ACTION FOR USE IN POWER GENERATION AND PROCESS INDUSTRIES (U.S. CLS. 100 AND 101).

FIRST USE 1-1-2007; IN COMMERCE 1-1-2007.
JENNIFER VASQUEZ, EXAMINING ATTORNEY

CLASS 42—(Continued).

SN 85-488,803. DEVONWAY, SAN FRANCISCO, CA. FILED 12-6-2011.



THE COLOR(S) BLUE, GREEN, YELLOW AND PURPLE IS/ARE CLAIMED AS A FEATURE OF THE MARK.

THE MARK CONSISTS OF THE SINGLE WORD "DEVONWAY", WRITTEN IN BLUE AND WITH THE LETTERS "D" AND "W" CAPITALIZED. THE WORD "DEVONWAY" CASTS A FAINT BLUE SHADOW BEHIND AND BELOW THE WORDING. THERE IS A SET OF THREE RINGS THAT REPRESENT AN ATOMIC STRUCTURE AND ARE ORBITING THE "O", ONE OF THE RINGS GOES THROUGH THE CENTERS OF BOTH "V" AND "N". THE ATOMIC STRUCTURE APPEARS IN THE COLORS YELLOW, BLUE, GREEN, AND PURPLE.

FOR SOFTWARE AS A SERVICE (SAAS) SERVICES, NAMELY, HOSTING SOFTWARE FOR USE BY OTHERS FOR USE IN ENTERPRISE ASSET MANAGEMENT, KEY PERFORMANCE INDICATORS, PROCESS WORKFLOW MANAGEMENT, HUMAN PERFORMANCE IMPROVEMENT AND CORRECTIVE ACTION FOR USE IN POWER GENERATION AND PROCESS INDUSTRIES (U.S. CLS. 100 AND 101).

FIRST USE 1-1-2006; IN COMMERCE 1-1-2006.
JENNIFER VASQUEZ, EXAMINING ATTORNEY

SN 85-489,183. ADVANCED PATIENT ADVOCACY, LLC, ANNAPOLIS, MD. FILED 12-7-2011.

ADVOCATE 20/20

THE MARK CONSISTS OF STANDARD CHARACTERS WITHOUT CLAIM TO ANY PARTICULAR FONT, STYLE, SIZE, OR COLOR.

NO CLAIM IS MADE TO THE EXCLUSIVE RIGHT TO USE "ADVOCATE", APART FROM THE MARK AS SHOWN. FOR COMPUTER SERVICES IN THE FIELD OF HEALTH CARE, NAMELY, A NON-DOWNLOADABLE, WEB-BASED DATA MANAGEMENT AND ONLINE PORTAL SOFTWARE SYSTEM ENABLING USERS TO COLLECT INFORMATION FROM INDIVIDUALS FOR THE PURPOSE OF CONNECTING THEM TO LOCAL, STATE, FEDERAL OR PRIVATE HEALTH INSURANCE PROGRAMS, TO ORGANIZE, TRACK AND MANAGE APPLICATIONS AND THE ENROLLMENT PROCESS, AND TO SECURELY SHARE INFORMATION ACROSS MULTIPLE ORGANIZATIONS (U.S. CLS. 100 AND 101).

FIRST USE 2-15-2011; IN COMMERCE 2-15-2011.
JAMES A. RAUEN, EXAMINING ATTORNEY

CLASS 42—(Continued).

SN 85-489,212. ADVOCATE PATIENT ADVOCACY, LLC, ANNAPOLIS, MD. FILED 12-7-2011.

ADVOCATE 20/20 COVERAGE
CONNECTOR

THE MARK CONSISTS OF STANDARD CHARACTERS WITHOUT CLAIM TO ANY PARTICULAR FONT, STYLE, SIZE, OR COLOR.

NO CLAIM IS MADE TO THE EXCLUSIVE RIGHT TO USE "ADVOCATE" OR "COVERAGE", APART FROM THE MARK AS SHOWN.

FOR COMPUTER SERVICES IN THE FIELD OF HEALTH CARE, NAMELY, A NON-DOWNLOADABLE, WEB-BASED SOFTWARE TO SCREEN INDIVIDUALS AND COLLECT DATA USED TO IDENTIFY ELIGIBILITY FOR PARTICIPATION IN LOCAL, STATE, FEDERAL OR PRIVATE HEALTH INSURANCE PROGRAMS AND TO MATCH INDIVIDUALS WITH HEALTH CARE BENEFITS AND INSURANCE PLANS (U.S. CLS. 100 AND 101).

FIRST USE 2-15-2011; IN COMMERCE 2-15-2011.
JAMES A. RAUEN, EXAMINING ATTORNEY

CLASS 42—(Continued).

SN 85-490,448. JEFFREY A. SMAGACZ, DBA RISK MANAGEMENT GROUP, LLC, FRANKLIN, TN. FILED 12-8-2011.



THE MARK CONSISTS OF THE STYLIZED WORDING "KAIZENWORKS!" WITH THE LETTER "I" FORMED BY A STICK FIGURE, ALL WITHIN A RECTANGULAR DESIGN. THE ENGLISH TRANSLATION OF "KAIZEN" IN THE MARK IS "CONTINUOUS IMPROVEMENT."

FOR CONSULTATION IN THE FIELD OF ERGONOMICS, NAMELY, DESIGNING WORKPLACE FACILITIES AND EQUIPMENT TO OPTIMIZE EFFICIENCY AND SAFETY (U.S. CLS. 100 AND 101).

NICHOLAS ALTREE, EXAMINING ATTORNEY

SN 85-489,967. COALFIRE GOVERNMENT SYSTEMS, INC, AKA COALFIRE GS, CENTENNIAL, CO. FILED 12-7-2011.



Service Disabled Veteran Owned Small Business

NO CLAIM IS MADE TO THE EXCLUSIVE RIGHT TO USE "SERVICE DISABLED VETERAN OWNED SMALL BUSINESS", APART FROM THE MARK AS SHOWN.

THE COLOR(S) RED, WHITE, BLUE, AND GRAY IS/ARE CLAIMED AS A FEATURE OF THE MARK.

THE MARK CONSISTS OF THE LETTERS "CGS" IN RED, WITH THE DESIGN OF WAVES IN BLUE AND WHITE TO THE LEFT OF THE LETTERS. THE LETTERS AND DESIGN APPEAR ON A WHITE RECTANGLE WITH A GRAY RECTANGULAR BORDER. THE WORDING "SERVICE DISABLED VETERAN OWNED SMALL BUSINESS" APPEARS AT THE BOTTOM IN BLUE.

FOR IT CONSULTING SERVICES (U.S. CLS. 100 AND 101).

FIRST USE 6-0-2009; IN COMMERCE 6-0-2009.
LEIGH CAROLINE CASE, EXAMINING ATTORNEY

SN 85-491,469. MEGATRIS COMP LLC, NEWARK, DE. FILED 12-9-2011.

Affective Smart City

THE MARK CONSISTS OF STANDARD CHARACTERS WITHOUT CLAIM TO ANY PARTICULAR FONT, STYLE, SIZE, OR COLOR.

NO CLAIM IS MADE TO THE EXCLUSIVE RIGHT TO USE "SMART CITY", APART FROM THE MARK AS SHOWN.

FOR ADVANCED PRODUCT RESEARCH IN THE FIELD OF ARTIFICIAL INTELLIGENCE (U.S. CLS. 100 AND 101).

FIRST USE 1-12-2011; IN COMMERCE 9-12-2011.
JACQUELINE A. LAVINE, EXAMINING ATTORNEY

CLASS 42—(Continued).

SN 85-491,770. TRONDENT DEVELOPMENT CORP., BARRINGTON, IL. FILED 12-9-2011.

TRONDENT DEVELOPMENT CORP.

THE MARK CONSISTS OF STANDARD CHARACTERS WITHOUT CLAIM TO ANY PARTICULAR FONT, STYLE, SIZE, OR COLOR.

NO CLAIM IS MADE TO THE EXCLUSIVE RIGHT TO USE "DEVELOPMENT CORP.", APART FROM THE MARK AS SHOWN.

FOR PROVIDING A WEB SITE FEATURING TECHNOLOGY THAT ENABLES USERS TO MANAGE GLOBAL TRAVEL AGENCIES, DELIVER TRAVEL-RELATED DOCUMENTS, MANAGE TRAVEL RISKS, ANALYZE TRAVEL-RELATED COSTS AND MANAGE TRAVEL-RELATED DATA; SOFTWARE AS A SERVICE (SAAS) SERVICES FEATURING SOFTWARE TO MANAGE GLOBAL TRAVEL AGENCIES, DELIVER TRAVEL-RELATED DOCUMENTS, MANAGE TRAVEL RISKS, ANALYZE TRAVEL-RELATED COSTS AND MANAGE TRAVEL-RELATED DATA IN THE FIELD OF GLOBAL TRAVEL-RELATED TECHNOLOGY (U.S. CLS. 100 AND 101).

FIRST USE 11-4-1994; IN COMMERCE 11-4-1994.
KAPIL BHANOT, EXAMINING ATTORNEY

SN 85-494,142. NEW ENGLAND BIOLABS, INC., IPSWICH, MA. FILED 12-13-2011.

POLBASE

THE MARK CONSISTS OF STANDARD CHARACTERS WITHOUT CLAIM TO ANY PARTICULAR FONT, STYLE, SIZE, OR COLOR.

FOR PROVIDING AN ONLINE COMPUTER DATABASE OF INFORMATION IN THE FIELD OF DNA POLYMERASES FOR SCIENTIFIC AND MEDICAL RESEARCH (U.S. CLS. 100 AND 101).

FIRST USE 3-19-2009; IN COMMERCE 3-19-2009.
NELSON SNYDER, EXAMINING ATTORNEY

SN 85-498,076. APPEL, MARTIN, LAS VEGAS, NV. FILED 12-17-2011.

THE RALLY CRY

THE MARK CONSISTS OF STANDARD CHARACTERS WITHOUT CLAIM TO ANY PARTICULAR FONT, STYLE, SIZE, OR COLOR.

FOR CREATING AN ON-LINE COMMUNITY FOR PEOPLE INTERESTED IN POLITICS, POLITICAL DISCOURSE, AND THE DEMOCRATIC ELECTION PROCESS FOR THE PURPOSE OF POLITICAL DISCUSSION (U.S. CLS. 100 AND 101).

DAVID C. REIHNER, EXAMINING ATTORNEY

CLASS 42—(Continued).

SN 85-498,077. APPEL, MARTIN, LAS VEGAS, NV. FILED 12-17-2011.

A POSITIVE CAMPAIGN

THE MARK CONSISTS OF STANDARD CHARACTERS WITHOUT CLAIM TO ANY PARTICULAR FONT, STYLE, SIZE, OR COLOR.

FOR CREATING AN ON-LINE COMMUNITY FOR PEOPLE INTERESTED IN POLITICS, POLITICAL DISCOURSE, AND THE DEMOCRATIC ELECTION PROCESS FOR THE PURPOSE OF POLITICAL DISCUSSION (U.S. CLS. 100 AND 101).

DAVID C. REIHNER, EXAMINING ATTORNEY

SN 85-498,081. APPEL, MARTIN, LAS VEGAS, NV. FILED 12-17-2011.

EVICT HIM

THE MARK CONSISTS OF STANDARD CHARACTERS WITHOUT CLAIM TO ANY PARTICULAR FONT, STYLE, SIZE, OR COLOR.

FOR CREATING AN ON-LINE COMMUNITY FOR PEOPLE INTERESTED IN POLITICS, POLITICAL DISCOURSE, AND THE DEMOCRATIC ELECTION PROCESS FOR THE PURPOSE OF POLITICAL DISCUSSION (U.S. CLS. 100 AND 101).

DAVID C. REIHNER, EXAMINING ATTORNEY

SN 85-498,082. APPEL, MARTIN, LAS VEGAS, NV. FILED 12-17-2011.

SPREAD THE VIRUS

THE MARK CONSISTS OF STANDARD CHARACTERS WITHOUT CLAIM TO ANY PARTICULAR FONT, STYLE, SIZE, OR COLOR.

FOR CREATING AN ON-LINE COMMUNITY FOR PEOPLE INTERESTED IN POLITICS, POLITICAL DISCOURSE, AND THE DEMOCRATIC ELECTION PROCESS FOR THE PURPOSE OF POLITICAL DISCUSSION (U.S. CLS. 100 AND 101).

DAVID C. REIHNER, EXAMINING ATTORNEY

CLASS 42—(Continued).

SN 85-498,365. VIRTUAL CONNECT TECHNOLOGIES, INC., GREER, SC. FILED 12-19-2011.

CLASS 42—(Continued).

SN 85-500,066. WARNER BROS. ENTERTAINMENT INC., BURBANK, CA. FILED 12-20-2011.

TOOLY

THE MARK CONSISTS OF STANDARD CHARACTERS WITHOUT CLAIM TO ANY PARTICULAR FONT, STYLE, SIZE, OR COLOR.

FOR PROVIDING SPECIFIC INFORMATION AS REQUESTED BY CUSTOMERS VIA THE INTERNET; SEARCHING AND RETRIEVING INFORMATION, SITES, AND OTHER RESOURCES AVAILABLE ON COMPUTER NETWORKS FOR OTHERS (U.S. CLS. 100 AND 101).

FIRST USE 9-9-2009; IN COMMERCE 9-9-2009.
CURTIS FRENCH, EXAMINING ATTORNEY

OUT MY WINDOW

SN 85-499,960. WARNER BROS. ENTERTAINMENT INC., BURBANK, CA. FILED 12-20-2011.

OUTMYWINDOW

THE MARK CONSISTS OF STANDARD CHARACTERS WITHOUT CLAIM TO ANY PARTICULAR FONT, STYLE, SIZE, OR COLOR.

FOR PROVIDING TEMPORARY USE OF ON-LINE NON-DOWNLOADABLE SOFTWARE AND APPLICATIONS FOR USE IN UPLOADING, DOWNLOADING, ACCESSING, MANIPULATING, EDITING, INDEXING, CATALOGUING, ENHANCING, POSTING, DISPLAYING, TAGGING, STREAMING, LINKING, STORING, SHARING, PRINTING OR OTHERWISE PROVIDING PHOTOS, IMAGES, GRAPHICS, VIDEO, AUDIO AND OTHER ELECTRONIC MEDIA OR INFORMATION VIA GLOBAL COMMUNICATIONS NETWORKS FOR ACCESS ON COMPUTERS, INTERNET-ENABLED TELEVISIONS, MOBILE PHONES, COMPUTER TABLETS AND OTHER MOBILE DEVICES AND CONSUMER ELECTRONICS; HOSTING OF PHOTOS, IMAGES, GRAPHICS, VIDEO, AUDIO AND OTHER ELECTRONIC MEDIA OR OTHER DIGITAL CONTENT ON THE INTERNET; PEER-TO-BROWSER PHOTO AND VIDEO SHARING SERVICES, NAMELY, PROVIDING A WEBSITE FEATURING TECHNOLOGY ENABLING USERS TO UPLOAD, VIEW AND DOWNLOAD DIGITAL PHOTOS FOR ACCESS ON COMPUTERS, INTERNET-ENABLED TELEVISIONS, MOBILE PHONES, COMPUTER TABLETS AND OTHER MOBILE DEVICES AND CONSUMER ELECTRONICS; CLOUD COMPUTING FEATURING SOFTWARE FOR USE IN ELECTRONIC TRANSMISSION OF DIGITAL PHOTO AND VIDEO FILES AMONG INTERNET USERS, INTERNET-ENABLED TELEVISION USERS, MOBILE PHONE USERS, AND OTHER MOBILE DEVICE AND CONSUMER ELECTRONICS USERS; COMPUTER SERVICES, NAMELY, CLOUD HOSTING PROVIDER SERVICES; ELECTRONIC IMAGE SCANNING, NAMELY, ELECTRONIC SCANNING OF PHOTOGRAPHIC IMAGES (U.S. CLS. 100 AND 101).

THEODORE MCBRIDE, EXAMINING ATTORNEY

THE MARK CONSISTS OF STANDARD CHARACTERS WITHOUT CLAIM TO ANY PARTICULAR FONT, STYLE, SIZE, OR COLOR.

FOR PROVIDING TEMPORARY USE OF ON-LINE NON-DOWNLOADABLE SOFTWARE AND APPLICATIONS FOR USE IN UPLOADING, DOWNLOADING, ACCESSING, MANIPULATING, EDITING, INDEXING, CATALOGUING, ENHANCING, POSTING, DISPLAYING, TAGGING, STREAMING, LINKING, STORING, SHARING, PRINTING OR OTHERWISE PROVIDING PHOTOS, IMAGES, GRAPHICS, VIDEO, AUDIO AND OTHER ELECTRONIC MEDIA OR INFORMATION VIA GLOBAL COMMUNICATIONS NETWORKS FOR ACCESS ON COMPUTERS, INTERNET-ENABLED TELEVISIONS, MOBILE PHONES, COMPUTER TABLETS AND OTHER MOBILE DEVICES AND CONSUMER ELECTRONICS; HOSTING OF PHOTOS, IMAGES, GRAPHICS, VIDEO, AUDIO AND OTHER ELECTRONIC MEDIA OR OTHER DIGITAL CONTENT ON THE INTERNET; PEER-TO-BROWSER PHOTO AND VIDEO SHARING SERVICES, NAMELY, PROVIDING A WEBSITE FEATURING TECHNOLOGY ENABLING USERS TO UPLOAD, VIEW AND DOWNLOAD DIGITAL PHOTOS FOR ACCESS ON COMPUTERS, INTERNET-ENABLED TELEVISIONS, MOBILE PHONES, COMPUTER TABLETS AND OTHER MOBILE DEVICES AND CONSUMER ELECTRONICS USERS; COMPUTER SERVICES, NAMELY, CLOUD HOSTING PROVIDER SERVICES; ELECTRONIC IMAGE SCANNING, NAMELY, ELECTRONIC SCANNING OF PHOTOGRAPHIC IMAGES (U.S. CLS. 100 AND 101).

THEODORE MCBRIDE, EXAMINING ATTORNEY

CLASS 42—(Continued).

SN 85-500,370. WARNER BROS. ENTERTAINMENT INC., BURBANK, CA. FILED 12-20-2011.

OUTMY
WINDOW

THE MARK CONSISTS OF THE TERM "OUTMY" AND DIRECTLY UNDERNEATH IS THE WORD "WINDOW".

FOR PROVIDING TEMPORARY USE OF ON-LINE NON-DOWNLOADABLE SOFTWARE AND APPLICATIONS FOR USE IN UPLOADING, DOWNLOADING, ACCESSING, MANIPULATING, EDITING, INDEXING, CATALOGUING, ENHANCING, POSTING, DISPLAYING, TAGGING, STREAMING, LINKING, STORING, SHARING, PRINTING OR OTHERWISE PROVIDING PHOTOS, IMAGES, GRAPHICS, VIDEO, AUDIO AND OTHER ELECTRONIC MEDIA OR INFORMATION VIA GLOBAL COMMUNICATIONS NETWORKS FOR ACCESS ON COMPUTERS, INTERNET-ENABLED TELEVISIONS, MOBILE PHONES, COMPUTER TABLETS AND OTHER MOBILE DEVICES AND CONSUMER ELECTRONICS; HOSTING OF PHOTOS, IMAGES, GRAPHICS, VIDEO, AUDIO AND OTHER ELECTRONIC MEDIA OR OTHER DIGITAL CONTENT ON THE INTERNET; PEER-TO-BROWSER PHOTO AND VIDEO SHARING SERVICES, NAMELY, PROVIDING A WEBSITE FEATURING TECHNOLOGY ENABLING USERS TO UPLOAD, VIEW AND DOWNLOAD DIGITAL PHOTOS FOR ACCESS ON COMPUTERS, INTERNET-ENABLED TELEVISIONS, MOBILE PHONES, COMPUTER TABLETS AND OTHER MOBILE DEVICES AND CONSUMER ELECTRONICS; CLOUD COMPUTING FEATURING SOFTWARE FOR USE IN ELECTRONIC TRANSMISSION OF DIGITAL PHOTO AND VIDEO FILES AMONG INTERNET USERS, INTERNET-ENABLED TELEVISION USERS, MOBILE PHONE USERS, AND OTHER MOBILE DEVICE AND CONSUMER ELECTRONICS USERS; COMPUTER SERVICES, NAMELY, CLOUD HOSTING PROVIDER SERVICES; ELECTRONIC IMAGE SCANNING, NAMELY, ELECTRONIC SCANNING OF PHOTOGRAPHIC IMAGES (U.S. CLS. 100 AND 101).

THEODORE MCBRIDE, EXAMINING ATTORNEY

CLASS 42—(Continued).

SN 85-500,505. EMPOWER VISI INC., CUPERTINO, CA. FILED 12-21-2011.

Empower ViSi Visual Sales Intelligence

THE MARK CONSISTS OF STANDARD CHARACTERS WITHOUT CLAIM TO ANY PARTICULAR FONT, STYLE, SIZE, OR COLOR.

NO CLAIM IS MADE TO THE EXCLUSIVE RIGHT TO USE "VISUAL SALES INTELLIGENCE", APART FROM THE MARK AS SHOWN.

FOR SOFTWARE AS A SERVICE (SAAS) SERVICES FEATURING SOFTWARE FOR VISUAL SALES PROCESS SIMULATION AND MANAGEMENT (U.S. CLS. 100 AND 101).

FIRST USE 12-12-2011; IN COMMERCE 12-12-2011.
KATHERINE E. HALMEN, EXAMINING ATTORNEY

SN 85-500,868. CLARKSON STOCKWELL LLC, MELBOURNE VIC, AUSTRALIA, FILED 12-21-2011.

ALBINO

THE MARK CONSISTS OF STANDARD CHARACTERS WITHOUT CLAIM TO ANY PARTICULAR FONT, STYLE, SIZE, OR COLOR.

FOR ADVANCED PRODUCT RESEARCH IN THE FIELD OF ARTIFICIAL INTELLIGENCE; ANIMATION AND SPECIAL-EFFECTS DESIGN FOR OTHERS; APPLICATION SERVICE PROVIDER (ASP) FEATURING SOFTWARE FOR USE IN STORING AND COMMUNICATING THE ASSETS, ACTIONS, ATTRIBUTES, STATUSES, AND OTHER INFORMATION OF OBJECTS AND ENTITIES WITH A CLIENT SIDE 2D OR 3D VIRTUAL ENVIRONMENT; AND IN EXECUTING DATA COMMUNICATIONS BETWEEN A HOST SERVER AND A CLIENT SIDE 2D OR 3D VIRTUAL ENVIRONMENT; APPLICATION SERVICE PROVIDER, NAMELY, HOSTING, MANAGING, DEVELOPING, AND MAINTAINING APPLICATIONS, SOFTWARE, AND WEB SITES, IN THE FIELDS OF PERSONAL PRODUCTIVITY, WIRELESS COMMUNICATION, MOBILE INFORMATION ACCESS, AND REMOTE DATA MANAGEMENT FOR WIRELESS DELIVERY OF CONTENT TO HANDHELD COMPUTERS, LAPTOPS AND MOBILE ELECTRONIC DEVICES; COMPUTER PROGRAMMING AND SOFTWARE DESIGN; COMPUTER SERVICES IN THE NATURE OF CUSTOMIZED WEB PAGES AND OTHER DATA FEED FORMATS FEATURING USER-DEFINED INFORMATION; DESIGN AND DEVELOPMENT OF PACKAGING, COMPUTER SYSTEMS, AUDIOVISUAL EQUIPMENT, LOGOS, WEBSITES, ROBOTICS, ELECTRONIC DEVICES, VIDEO GAME ENVIRONMENTS, USER INTERFACES, SOFTWARE APPLICATIONS, AND 3D MODELS FOR THE PURPOSES OF BUSINESS, EDUCATION, FICTION, INFORMATION ORGANIZATION, AND TELECOMMUNICATIONS, NONE OF THE FOREGOING RELATING TO ONLINE PARTY ACTIVITIES; DEVELOPING AND HOSTING A SERVER ON A GLOBAL COMPUTER NETWORK FOR THE PURPOSE OF FACILITATING E-COMMERCE VIA SUCH A SERVER; GRAPHIC DESIGN; PROVIDING ON-LINE NON-DOWNLOADABLE SOFTWARE FOR PROVIDING A GRAPHICAL USER INTERFACE AND APPLICATION PROGRAMMING INTERFACE FOR RETRIEVING, STORING, AND MANIPULATING ENTRIES CONTAINING USER DEFINED INFORMATION WITHIN A DATABASE, ARRAY, OR THIRD PARTY APPLICATION PROGRAMMING INTERFACE; SOFTWARE DEVELOP-

CLASS 42—(Continued).

MENT BY CREATING AND EDITING SOFTWARE CODE AND INSTRUCTIONS USING A GRAPHICAL USER INTERFACE; USER AUTHENTICATION AND IDENTITY MANAGEMENT, SPECIFICALLY THE STORAGE AND RETRIEVAL OF IDENTITY INFORMATION, RELATIONSHIPS, PERMISSIONS, SOFTWARE PREFERENCES, AND PERSONAL INTERESTS OF THE AUTHENTICATED USER, NONE OF THE FOREGOING RELATING TO ONLINE PARTY ACTIVITIES; PROVIDING STORAGE SPACE AND PERMISSION BASED DISTRIBUTION FOR USER GENERATED FILES AND DOCUMENTS PERTAINING TO THE PERSONAL OR BUSINESS INTERESTS OF THE USER, AND EXCLUDING THOSE RELATED TO ONLINE PARTY ACTIVITIES; STORING AND TRANSFERRING PRIVATE MESSAGES AND UPDATES AND PUBLISHING PUBLIC MESSAGES AND UPDATES FOR THE PURPOSE OF COMMUNICATING PERSONAL AND BUSINESS INFORMATION AND CURRENT EVENTS, NONE OF THE FOREGOING RELATING TO ONLINE PARTY ACTIVITIES; ORGANIZING BUSINESS INFORMATION, RECORDS, TRANSACTIONS, COMMUNICATIONS, CUSTOMER RELATIONSHIPS, AND INVENTORY; THE PRODUCTION OF DIGITAL FILES CONTAINING USER GENERATED VECTORS, RASTERS, AND WAVEFORMS FOR BUSINESS, EDUCATION, OR CREATIVE PURPOSES, SUCH DATA BEING UNRELATED TO ONLINE PARTY ACTIVITIES; INDEXING WEB PAGES AND PUBLISHED CONTENT AND PROVIDING A SEARCH ENGINE TO NAVIGATE THE INDEX; USE IN THE FIELD OF AI, NAMELY USING NATURAL LANGUAGE PROCESSING TO GENERATE SEMANTIC DATA; ORGANIZING DIGITAL ASSETS WITHIN THE MUSIC, FILM, AND TECHNOLOGY INDUSTRIES; RESEARCH AND DEVELOPMENT OF 3D CONTENT, 3D TECHNOLOGY AND PROCESSES, STEREOSCOPIC 3D PROJECTION, 3D ANIMATION TECHNOLOGY, 3D PROCESSING POWER, 3D TECHNIQUES, AND FLEXIBLE FORWARD PROJECTION; SOFTWARE AS A SERVICE (SAAS) SERVICES FEATURING SOFTWARE IN THE FIELD OF BUSINESS MANAGEMENT, FINANCE, NEWS, SCIENCE, TELECOMMUNICATIONS, CREATIVITY, AND EDUCATION, NONE OF THE FOREGOING RELATING TO ONLINE PARTY ACTIVITIES (U.S. CLS. 100 AND 101).

FIRST USE 11-1-2011; IN COMMERCE 11-1-2011.
 JOSETTE BEVERLY, EXAMINING ATTORNEY

CLASS 42—(Continued).

SN 85-501,397. X'PRESS MEDICAL SERVICES, INCORPORATED, DBA ADVANCED SPORTS LABS, STRONGSVILLE, OH. FILED 12-21-2011.



SN 85-501,009. BAYER AKTIENGESELLSCHAFT, LEVERKUSEN, FED REP GERMANY, FILED 12-21-2011.

COLABORATOR

THE MARK CONSISTS OF STANDARD CHARACTERS WITHOUT CLAIM TO ANY PARTICULAR FONT, STYLE, SIZE, OR COLOR.

FOR LABORATORY SERVICES, NAMELY, PROVIDING SHARED TEST LABORATORY FACILITIES; MEDICAL LABORATORIES, RENTAL OF LABORATORY APPARATUS AND INSTRUMENTS (U.S. CLS. 100 AND 101).

RONALD AIKENS, EXAMINING ATTORNEY

NO CLAIM IS MADE TO THE EXCLUSIVE RIGHT TO USE "ADVANCED SPORTS LABS" AND THE STAR OF LIFE SYMBOL, APART FROM THE MARK AS SHOWN.

THE COLOR(S) BLUE AND WHITE IS/ARE CLAIMED AS A FEATURE OF THE MARK.

THE MARK CONSISTS OF A WHITE LINE WITH BLUE OUTLINING IN THE SHAPE OF A HALF CIRCLE COMBINED WITH TWO WHITE INTERSECTING LINES WITH BLUE OUTLINING THAT TOGETHER ARE INTENDED TO SUGGEST A COMPASS. AT THE ENDS OF THE INTERSECTING LINES ARE SMALL WHITE CIRCLES WITH BLUE OUTLINING. THE POINTS OF THE COMPASS ARE LABELED WITH THE LETTERS "A", "S", AND "L" IN WHITE WITH BLUE OUTLINING. THE MARK ALSO INCLUDES A STAR OF LIFE MEDICAL SERVICES SYMBOL IN BLUE WITH WHITE AND BLUE OUTLINING. IN THE CENTER OF THE STAR IS A BLUE BOXING STICK FIGURE OUTLINED IN WHITE AND SURROUNDED IN WHITE SHADING. THE WORDS "ADVANCED SPORTS LABS" IN WHITE WITH BLUE OUTLINING ARE DISPLAYED BELOW THE STAR OF LIFE. THE BACKGROUND OF THE IMAGE IS WHITE.

FOR BLOOD ANALYSIS SERVICES (U.S. CLS. 100 AND 101).

FIRST USE 3-10-2011; IN COMMERCE 3-10-2011.
 KIM MONINGHOFF, EXAMINING ATTORNEY

CLASS 42—(Continued).

SN 85-502,938. SUPERTROOP, INC., FORT WORTH, TX.
FILED 12-23-2011.

SUPERTROOP

THE MARK CONSISTS OF STANDARD CHARACTERS WITHOUT CLAIM TO ANY PARTICULAR FONT, STYLE, SIZE, OR COLOR.

FOR PROVIDING TEMPORARY USE OF NON-DOWNLOADABLE CLOUD-BASED SOFTWARE AND RELATED ADMINISTRATIVE SERVICES FOR YOUTH ORGANIZATIONS; CLOUD COMPUTING FEATURING SOFTWARE FOR USE IN DATABASE MANAGEMENT, FOR USE AS A SPREADSHEET, FOR WORD PROCESSING, APPLICATIONS FOR MONITORING, COMMUNICATION, FINANCES, CONTENT AND COLLABORATION; PLATFORM AS A SERVICE FEATURING SOFTWARE PLATFORM FOR OBJECT STORAGE, IDENTITY, RUNTIME, QUEUES, AND DATABASES; REMOTE AND ON-SITE INFRASTRUCTURE MANAGEMENT SERVICES FOR COMPUTING, STORAGE, NETWORKING; PROVIDING VIRTUAL COMPUTER SYSTEMS AND VIRTUAL COMPUTER ENVIRONMENTS THROUGH CLOUD COMPUTING; COMPUTER SERVICES, NAMELY, INTEGRATION OF PRIVATE AND PUBLIC CLOUD COMPUTING ENVIRONMENTS (U.S. CLS. 100 AND 101).

TINA MAI, EXAMINING ATTORNEY

CLASS 42—(Continued).

SN 85-506,792. CRITICAL STRUCTURES, ANAHEIM, CA.
FILED 12-31-2011.

Critical Structures

THE MARK CONSISTS OF STANDARD CHARACTERS WITHOUT CLAIM TO ANY PARTICULAR FONT, STYLE, SIZE, OR COLOR.

NO CLAIM IS MADE TO THE EXCLUSIVE RIGHT TO USE "STRUCTURES", APART FROM THE MARK AS SHOWN.

FOR ARCHITECTURAL AND ENGINEERING SERVICES; CONSULTING IN THE FIELD OF ENGINEERING; CONSULTING IN THE FIELD OF STRUCTURAL ENGINEERING; CONSULTING IN THE FIELDS OF ENGINEERING AND ARCHITECTURE; ENGINEERING (U.S. CLS. 100 AND 101).

FIRST USE 4-8-2009; IN COMMERCE 4-8-2009.
JAMES GRIFFIN, EXAMINING ATTORNEY

SN 85-503,920. INSURANCE TECHNOLOGIES CORPORATION, CARROLLTON, TX. FILED 12-27-2011.

Insurance Website Builder

THE MARK CONSISTS OF STANDARD CHARACTERS WITHOUT CLAIM TO ANY PARTICULAR FONT, STYLE, SIZE, OR COLOR.

NO CLAIM IS MADE TO THE EXCLUSIVE RIGHT TO USE "WEBSITE BUILDER", APART FROM THE MARK AS SHOWN.

SEC. 2(F).

FOR PLANNING, DESIGN, DEVELOPMENT, MAINTENANCE AND OPTIMIZATION OF ONLINE WEBSITES FOR THIRD PARTIES WITHIN THE INSURANCE INDUSTRY (U.S. CLS. 100 AND 101).

FIRST USE 8-3-2005; IN COMMERCE 8-3-2005.
JOHN WILKE, EXAMINING ATTORNEY

SN 85-507,307. HYDROCONFIDENCE, INC., JOHNSTOWN, PA. FILED 1-2-2012.

HYDROCONFIDENCE

THE MARK CONSISTS OF STANDARD CHARACTERS WITHOUT CLAIM TO ANY PARTICULAR FONT, STYLE, SIZE, OR COLOR.

FOR PROVIDING TECHNOLOGY INFORMATION IN THE OIL AND GAS INDUSTRY (U.S. CLS. 100 AND 101).

FIRST USE 11-22-2011; IN COMMERCE 11-22-2011.
GISELLE AGOSTO, EXAMINING ATTORNEY

CLASS 42—(Continued).

SN 85-507,348. YOUNG, GREGG WHEELER, AUSTIN, TX. FILED 1-3-2012.

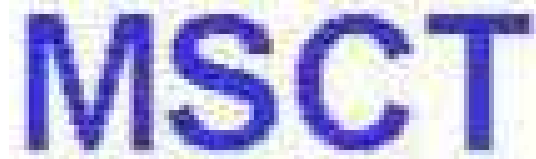

THE COLOR(S) BLUE IS/ARE CLAIMED AS A FEATURE OF THE MARK.

THE MARK CONSISTS OF THE BLUE LETTERS, "MSCT" IN ALL CAPS.

FOR CLOUD COMPUTING FEATURING SOFTWARE FOR USE IN MOBILE SECURE CLOUD COMPUTING; COMPUTER SERVICES, NAMELY, CLOUD HOSTING PROVIDER SERVICES; COMPUTER SERVICES, NAMELY, INTEGRATION OF PRIVATE AND PUBLIC CLOUD COMPUTING ENVIRONMENTS; COMPUTER SERVICES, NAMELY, COMPUTER SERVICES, NAMELY, INTEGRATION OF PRIVATE AND PUBLIC CLOUD COMPUTING (IT) SYSTEMS; COMPUTER SERVICES, NAMELY, REMOTE AND ON-SITE MANAGEMENT OF ELECTRONIC MESSAGING SYSTEMS, INFORMATION TECHNOLOGY (IT) SYSTEMS, SOFTWARE APPLICATIONS OF OTHERS; COMPUTER SERVICES, NAMELY, REMOTE MANAGEMENT OF THE INFORMATION TECHNOLOGY (IT) SYSTEMS OF OTHERS; COMPUTER SERVICES, NAMELY, REMOTE MANAGEMENT OF ELECTRONIC MESSAGING SYSTEMS, INFORMATION TECHNOLOGY (IT) SYSTEMS, SOFTWARE APPLICATIONS FOR OTHERS; CONSULTING SERVICES IN THE FIELD OF CLOUD COMPUTING; INFORMATION TECHNOLOGY CONSULTATION; PROVIDING A WEB SITE FEATURING TECHNOLOGY THAT ENABLES USERS TO PRESENT PRODUCTS, SERVICES, AND PROPOSALS TO OTHERS FOR COMMENT, AND GATHER FEEDBACK FROM THOSE OTHERS ABOUT THOSE PRODUCTS, SERVICES, AND PROPOSALS; PROVIDING A WEBSITE FEATURING TECHNOLOGY THAT ENABLES INVENTORS TO SEARCH FOR INVESTORS; PROVIDING A WEBSITE FEATURING TECHNOLOGY THAT ENABLES SUBSCRIBERS TO TRANSFER FILES TO AND FROM A FILE TRANSFER PROTOCOL SERVER; PROVIDING A WEBSITE FEATURING TECHNOLOGY THAT ENABLES USERS TO ORGANIZE AND MANAGE POSTMARKED E-MAILS; PROVIDING A WEBSITE FEATURING TECHNOLOGY THAT ENABLES USERS TO UPLOAD AND SHARE USER-GENERATED VIDEOS ON A WIDE VARIETY OF TOPICS AND SUBJECTS; PROVIDING A WEBSITE THAT FEATURES TECHNOLOGY THAT ENABLES THE SECURE EXCHANGE OF INFORMATION BY USERS; PROVIDING AN ON-LINE NETWORK ENVIRONMENT THAT FEATURES TECHNOLOGY THAT ENABLES USERS TO SHARE DATA; PROVIDING AN ON-LINE SEARCHABLE DATABASE IN THE FIELD OF MOBILE SECURE CLOUD COMPUTING TECHNOLOGY FOR SCIENTIFIC RESEARCH PURPOSES; PROVIDING AN ONLINE NON-DOWNLOADABLE INTERNET-BASED SYSTEM APPLICATION FEATURING TECHNOLOGY ENABLING USERS TO UTILIZE MOBILE SECURE CLOUD COMPUTING TECHNOLOGY; PROVIDING INFORMATION IN THE FIELDS OF TECHNOLOGY AND SOFTWARE DEVELOPMENT VIA AN ON-LINE WEBSITE; RESEARCH AND DEVELOPMENT OF TECHNOLOGY IN THE FIELD OF MOBILE SECURE CLOUD COMPUTING; RESEARCH IN THE AREA OF SEMICONDUCTOR PROCESSING TECHNOLOGY; RESEARCH IN THE FIELD OF INTELLIGENCE AND SECURITY TECHNOLOGY; TECHNICAL CONSULTING SERVICES IN THE FIELDS OF DATACENTER ARCHITECTURE, PUBLIC AND PRIVATE CLOUD COMPUTING SOLUTIONS, AND EVALUATION AND IMPLEMENTATION OF INTERNET TECHNOLOGY AND SERVICES; TECHNICAL SUPPORT SERVICES, NAMELY, REMOTE AND ON-SITE INFRASTRUCTURE MANAGEMENT SERVICES FOR MONITORING, ADMINISTRATION AND MANAGEMENT OF PUBLIC AND PRIVATE CLOUD COMPUTING IT AND APPLICATION SYSTEMS (U.S. CLS. 100 AND 101).

ODESSA BIBBINS, EXAMINING ATTORNEY

CLASS 42—(Continued).

SN 85-507,685. STORFER, LEESA A, DBA PAWPLE MEDIA LLC, WAKEFIELD, MA. FILED 1-3-2012.



THE MARK CONSISTS OF STANDARD CHARACTERS WITHOUT CLAIM TO ANY PARTICULAR FONT, STYLE, SIZE, OR COLOR.

FOR COMPUTER SERVICES, NAMELY, CREATING AN ON-LINE COMMUNITY FOR REGISTERED USERS TO PARTICIPATE IN DISCUSSIONS, GET FEEDBACK FROM THEIR PEERS, FORM VIRTUAL COMMUNITIES, AND ENGAGE IN SOCIAL NETWORKING SERVICES IN THE FIELD OF SHOW DOGS (U.S. CLS. 100 AND 101).

JESSICA A. POWERS, EXAMINING ATTORNEY

SN 85-507,920. AMPED I, LLC, CHICAGO, IL. FILED 1-3-2012.

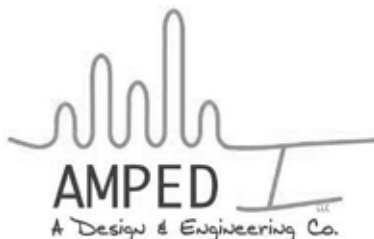

NO CLAIM IS MADE TO THE EXCLUSIVE RIGHT TO USE "DESIGN & ENGINEERING CO." AND "LLC", APART FROM THE MARK AS SHOWN.

THE MARK CONSISTS OF A LINE WITH FIVE WAVES ABOVE THE WORDS "AMPED I LLC" AND "A DESIGN & ENGINEERING CO."

FOR ENGINEERING AND ENGINEERING DESIGN SERVICES IN THE FIELD OF POWER TRANSMISSION AND DISTRIBUTION (U.S. CLS. 100 AND 101).

FIRST USE 6-0-2011; IN COMMERCE 6-0-2011.

KAPIL BHANOT, EXAMINING ATTORNEY

SN 85-507,944. LOEB, JESSE, MANDEVILLE, LA. FILED 1-3-2012.



THE MARK CONSISTS OF STANDARD CHARACTERS WITHOUT CLAIM TO ANY PARTICULAR FONT, STYLE, SIZE, OR COLOR.

FOR COMPUTER SERVICES, NAMELY, CREATING AN ON-LINE COMMUNITY FOR REGISTERED USERS TO PARTICIPATE IN DISCUSSIONS, GET FEEDBACK FROM THEIR PEERS, FORM VIRTUAL COMMUNITIES, AND ENGAGE IN SOCIAL NETWORKING SERVICES IN THE FIELD OF MUSIC COMPOSING AND RECORDING COLLABORATIONS (U.S. CLS. 100 AND 101).

KAPIL BHANOT, EXAMINING ATTORNEY

CLASS 42—(Continued).

SN 85-508,788. TRINNOS TECHNOLOGY LLC, IRVINE, CA. FILED 1-4-2012.

TRINNOS TECHNOLOGY

THE MARK CONSISTS OF STANDARD CHARACTERS WITHOUT CLAIM TO ANY PARTICULAR FONT, STYLE, SIZE, OR COLOR.

NO CLAIM IS MADE TO THE EXCLUSIVE RIGHT TO USE "TECHNOLOGY", APART FROM THE MARK AS SHOWN.

THE WORDING "TRINNOS" HAS NO MEANING IN A FOREIGN LANGUAGE.

FOR APPLICATION SERVICE PROVIDER (ASP) FEATURING SOFTWARE FOR USE IN THE FIELD OF FREIGHT MANAGEMENT; DESIGN, MAINTENANCE, DEVELOPMENT AND UPDATING OF COMPUTER SOFTWARE; PROVIDING ON-LINE NON-DOWNLOADABLE SOFTWARE FOR USE IN THE FIELD OF FREIGHT MANAGEMENT; SOFTWARE AS A SERVICE (SAAS) SERVICES FEATURING SOFTWARE IN THE FIELD OF FREIGHT MANAGEMENT AND TECHNICAL SUPPORT SERVICES RELATED THERETO, NAMELY, TROUBLESHOOTING OF COMPUTER SOFTWARE PROBLEMS (U.S. CLS. 100 AND 101).

FIRST USE 5-3-2011; IN COMMERCE 5-9-2011.
RENEE MCCRAY, EXAMINING ATTORNEY

SN 85-509,586. BG STUDIO INTERNATIONAL INC., NEW YORK, NY. FILED 1-5-2012.

URBANE SIMPLICITY

THE MARK CONSISTS OF STANDARD CHARACTERS WITHOUT CLAIM TO ANY PARTICULAR FONT, STYLE, SIZE, OR COLOR.

FOR ARCHITECTURAL DESIGN; GRAPHIC DESIGN SERVICES; INDUSTRIAL DESIGN; INTERIOR DESIGN SERVICES (U.S. CLS. 100 AND 101).

FIRST USE 7-13-2005; IN COMMERCE 7-13-2005.
ODESSA BIBBINS, EXAMINING ATTORNEY

CLASS 42—(Continued).

SN 85-509,617. MANFREDI, JODI, SAN DIEGO, CA. AND MICHAEL MANFREDI, SAN DIEGO, CA. FILED 1-5-2012.

Share Your Fridge

THE MARK CONSISTS OF STANDARD CHARACTERS WITHOUT CLAIM TO ANY PARTICULAR FONT, STYLE, SIZE, OR COLOR.

FOR PROVIDING TEMPORARY USE OF NON-DOWNLOADABLE SOFTWARE TO ENABLE UPLOADING, CAPTURING, POSTING, SHOWING, EDITING, PLAYING, STREAMING, VIEWING, PREVIEWING, DISPLAYING, TAGGING, BLOGGING, SHARING, MANIPULATING, DISTRIBUTING, PUBLISHING, REPRODUCING, AND OTHERWISE PROVIDING ELECTRONIC MEDIA, MULTIMEDIA CONTENT, VIDEOS, MOVIES, PICTURES, IMAGES, TEXT, PHOTOS, USER-GENERATED CONTENT, AUDIO CONTENT AND INFORMATION VIA THE INTERNET AND OTHER COMMUNICATIONS NETWORKS; PROVIDING TEMPORARY USE OF NON-DOWNLOADABLE SOFTWARE TO ENABLE SHARING OF MULTIMEDIA CONTENT AND COMMENTS AMONG USERS; PROVIDING TEMPORARY USE OF NON-DOWNLOADABLE SOFTWARE TO ENABLE CONTENT PROVIDERS TO TRACK MULTIMEDIA CONTENT; PROVIDING TEMPORARY USE OF NON-DOWNLOADABLE ANALYTICS SOFTWARE, NAMELY, SOFTWARE THAT PROVIDES STATISTICS ABOUT THE BEHAVIOR OF VIEWERS OF ONLINE VIDEOS, MOVIES, PICTURES, IMAGES, TEXT, PHOTOS, GAMES AND OTHER USER-GENERATED CONTENT; HOSTING OF WEBSITES FEATURING MULTIMEDIA CONTENT FOR OTHERS; HOSTING MULTIMEDIA ENTERTAINMENT AND EDUCATIONAL CONTENT FOR OTHERS; PROVIDING A WEB SITE THAT GIVES COMPUTER USERS THE ABILITY TO UPLOAD AND SHARE USER-GENERATED VIDEOS, ESSAYS AND ARTICLES ON A WIDE VARIETY OF TOPICS AND SUBJECTS (U.S. CLS. 100 AND 101).

MICHAEL WEBSTER, EXAMINING ATTORNEY

SN 85-509,822. NFLUENCE MEDIA, INC., SEATTLE, WA. FILED 1-5-2012.

DEALBOARD

THE MARK CONSISTS OF STANDARD CHARACTERS WITHOUT CLAIM TO ANY PARTICULAR FONT, STYLE, SIZE, OR COLOR.

FOR SOFTWARE AS A SERVICE (SAAS) SERVICES FEATURING SOFTWARE FOR ENABLING USERS TO SELF-DEFINE ONLINE PROFILES AND ACCOUNTS FOR PURPOSES OF FACILITATING THE RECEIPT OF RELEVANT ONLINE AND MOBILE ADVERTISING, PROMOTIONAL CONTENT AND INFORMATION AND FOR CREATING AN ON-LINE COMMUNITY FOR CONSUMERS FOR THE PURPOSE OF BRAND ADVERTISING, REVIEWS, CRITICISM AND COMMENTARY (U.S. CLS. 100 AND 101).

THOMAS MANOR, EXAMINING ATTORNEY

CLASS 42—(Continued).

SN 85-509,993. LOADNVOTE LLC, JERICHO, NY. FILED 1-5-2012.

Loadnvote

THE MARK CONSISTS OF STANDARD CHARACTERS WITHOUT CLAIM TO ANY PARTICULAR FONT, STYLE, SIZE, OR COLOR.

FOR PROVIDING A WEBSITE THAT GIVES USERS THE ABILITY TO UPLOAD MEDIA ON A WIDE VARIETY OF TOPICS AND SUBJECTS AND ALSO TO VOTE FOR THEIR FAVORITE UPLOADED MEDIA (U.S. CLS. 100 AND 101).

LINDA E. BLOHM, EXAMINING ATTORNEY

SN 85-509,998. LOADNVOTE LLC, JERICHO, NY. FILED 1-5-2012.



THE MARK CONSISTS OF A CHECKMARK INSIDE A RADIO BUTTON NEXT TO THE PHRASE "LOADNVOTE".

FOR PROVIDING A WEBSITE THAT GIVES USERS THE ABILITY TO UPLOAD MEDIA ON A WIDE VARIETY OF TOPICS AND SUBJECTS AND ALSO TO VOTE FOR THEIR FAVORITE UPLOADED MEDIA (U.S. CLS. 100 AND 101).

LINDA E. BLOHM, EXAMINING ATTORNEY

SN 85-510,000. KUTH/RANIERI ARCHITECTS LLP, SAN FRANCISCO, CA. FILED 1-5-2012.

FOLDING WATER

THE MARK CONSISTS OF STANDARD CHARACTERS WITHOUT CLAIM TO ANY PARTICULAR FONT, STYLE, SIZE, OR COLOR.

NO CLAIM IS MADE TO THE EXCLUSIVE RIGHT TO USE "WATER", APART FROM THE MARK AS SHOWN.

FOR ARCHITECTURAL DESIGN; ARCHITECTURAL DESIGN IN THE FIELD OF HYDROLOGIC INFRASTRUCTURE, LEVEE SYSTEMS AND WATER LEVEL MANAGEMENT CONTROLS.; HYDROLOGIC AND ENGINEERING MODELING AND DESIGN OF MEASURES TO PROTECT AREAS LIKELY TO BE INUNDED BY STORM-WATER AND FLOOD-WATERS (U.S. CLS. 100 AND 101).

MARC LEIPZIG, EXAMINING ATTORNEY

CLASS 42—(Continued).

SN 85-510,023. IMPRESSIONS BY DESIGN INTERIORS, LLC, KATONAH, NY. FILED 1-6-2012.

IMPRESSIONS BY DESIGN

THE MARK CONSISTS OF STANDARD CHARACTERS WITHOUT CLAIM TO ANY PARTICULAR FONT, STYLE, SIZE, OR COLOR.

FOR INTERIOR DESIGN AND CONSULTATION SERVICES, NAMELY, INTERIOR DESIGN, INTERIOR DECORATING AND INTERIOR REDESIGN; INTERIOR DECORATING CONSULTATIONS; PROVIDING INTERIOR DESIGN AND DECORATION CONSULTATION SERVICES TO PREPARE AND SHOWCASE HOMES FOR SALE; INTERIOR DECORATING FOR PARTIES (U.S. CLS. 100 AND 101).

ANDREA HACK, EXAMINING ATTORNEY

SN 85-510,080. WORLDWIDE INTERNET VENTURES, LLC., WEST HEMPSTEAD, NY. FILED 1-6-2012.

MyTrackShop

THE MARK CONSISTS OF STANDARD CHARACTERS WITHOUT CLAIM TO ANY PARTICULAR FONT, STYLE, SIZE, OR COLOR.

FOR PROVIDING A WEBSITE FEATURING TECHNOLOGY THAT ENABLES USERS TO BUY AND SELL CUSTOM DIGITAL MUSIC (U.S. CLS. 100 AND 101).

FIRST USE 2-11-2009; IN COMMERCE 9-26-2011.
MARK SPARACINO, EXAMINING ATTORNEY

SN 85-510,231. DO GOOD WORK, LOS ANGELES, CA. FILED 1-6-2012.

WoodSmithe

THE MARK CONSISTS OF THE TEXT "WOODSMITHE" IN STYLIZED LETTERING WITH A LIGATURE FROM THE "I" TO THE "T".

FOR INDUSTRIAL DESIGN (U.S. CLS. 100 AND 101).
FIRST USE 11-1-2010; IN COMMERCE 11-1-2010.
TINA MAI, EXAMINING ATTORNEY

CLASS 42—(Continued).

SN 85-510,478. 3TRACE DBA TRACE3, IRVINE, CA. FILED 1-6-2012.

TRAINING AS A SERVICE

THE MARK CONSISTS OF STANDARD CHARACTERS WITHOUT CLAIM TO ANY PARTICULAR FONT, STYLE, SIZE, OR COLOR.

FOR CONSULTING IN THE FIELD OF INFORMATION TECHNOLOGY (U.S. CLS. 100 AND 101).

TARAH HARDY, EXAMINING ATTORNEY

SN 85-510,513. INVISIONAPP INC., NEW YORK, NY. FILED 1-6-2012.

INVISION

THE MARK CONSISTS OF STANDARD CHARACTERS WITHOUT CLAIM TO ANY PARTICULAR FONT, STYLE, SIZE, OR COLOR.

FOR COMPUTER SERVICES, NAMELY, HOSTING AND MAINTAINING AN ON-LINE WEB SITE FOR OTHERS FOR COLLABORATION AND DISPLAY OF WEBSITE WIREFRAME, PAGE SCHEMATIC, SCREEN BLUEPRINT AND WEBSITE PROTOTYPE DEVELOPMENT PROJECTS; PROVIDING A WEB SITE FEATURING TEMPORARY USE OF NON-DOWNLOADABLE SOFTWARE FOR CREATING WEBSITE WIREFRAMES, PAGE SCHEMATICS, SCREEN BLUEPRINTS AND WEBSITE PROTOTYPES; PROVIDING TEMPORARY USE OF ON-LINE NON-DOWNLOADABLE SOFTWARE FOR CREATING WEBSITE WIREFRAMES, PAGE SCHEMATICS, SCREEN BLUEPRINTS AND WEBSITE PROTOTYPES (U.S. CLS. 100 AND 101).

FIRST USE 5-17-2011; IN COMMERCE 5-17-2011.

DEBRA LEE, EXAMINING ATTORNEY

CLASS 42—(Continued).

SN 85-510,571. SAASAFRAS LLC, SAN DIEGO, CA. FILED 1-6-2012.

SAASAFRAS

THE MARK CONSISTS OF STANDARD CHARACTERS WITHOUT CLAIM TO ANY PARTICULAR FONT, STYLE, SIZE, OR COLOR.

FOR CONSULTING SERVICES IN THE FIELD OF SOFTWARE AS A SERVICE AND CLOUD COMPUTING; COMPUTER SERVICES, NAMELY, CLOUD HOSTING PROVIDER SERVICES; PROVIDING VIRTUAL COMPUTER SYSTEMS AND VIRTUAL COMPUTER ENVIRONMENTS THROUGH CLOUD COMPUTING; TECHNICAL CONSULTING SERVICES IN THE FIELDS OF DATA-CENTER ARCHITECTURE, PUBLIC AND PRIVATE CLOUD COMPUTING SOLUTIONS, AND EVALUATION AND IMPLEMENTATION OF INTERNET TECHNOLOGY AND SERVICES; SOFTWARE AS A SERVICE (SAAS) SERVICES FEATURING SOFTWARE FOR PORTALS AND SOCIAL COLLABORATION, CASE MANAGEMENT, E-COMMERCE, MOBILITY SOLUTIONS, WEB CONTENT MANAGEMENT, RECORDS MANAGEMENT, DOCUMENT AND FORMS CAPTURE/PROCESSING/STORAGE, COMMUNICATIONS, COMMUNICATIONS AS A SERVICE, COMMUNICATION SERVICE APIS, COMMUNICATIONS-ENABLED BUSINESS PROCESSES, AND BUSINESS PROCESS MANAGEMENT/AUTOMATION, AND APPLICATION STORES; CLOUD COMPUTING FEATURING SOFTWARE FOR USE IN APPLICATION HOSTING, INFRASTRUCTURE AS A SERVICE, PLATFORMS AS A SERVICE, CLOUD-BASED STORAGE, DIGITIZATION SERVICES, NAMELY, NETWORKED FAX SERVERS AND SCANNERS (U.S. CLS. 100 AND 101).

KATINA MISTER, EXAMINING ATTORNEY

SN 85-510,592. USTAC LLC, RANCHO CORDOVA, CA. FILED 1-6-2012.

USTAC

THE MARK CONSISTS OF THE LITERAL ELEMENTS "USTAC" WHEREIN THE LETTER "T" OF "USTAC" DEPICTING AS MAGAZINE OF A RIFLE AS SHOWN IN THE MARK.

FOR DESIGN AND TESTING FOR NEW PRODUCT DEVELOPMENT; DESIGN AND TESTING OF NEW PRODUCTS FOR OTHERS; PRODUCT DESIGN AND DEVELOPMENT IN THE FIELD OF TACTICAL FIREARMS, MILITARY DEFENSE, AND COMMERCIAL CLOTHING AND SPORTING GOODS INDUSTRIES; CONSULTING IN THE FIELD OF PRODUCT DESIGN AND DEVELOPMENT; TESTING, ANALYSIS AND EVALUATION OF THE GOODS OF OTHERS FOR THE PURPOSE OF CERTIFICATION (U.S. CLS. 100 AND 101).

JOHN DALIER, EXAMINING ATTORNEY

CLASS 42—(Continued).

SN 85-510,743. 3TRACE DBA TRACE3, IRVINE, CA. FILED 1-6-2012.

STAFFING AS A SERVICE

THE MARK CONSISTS OF STANDARD CHARACTERS WITHOUT CLAIM TO ANY PARTICULAR FONT, STYLE, SIZE, OR COLOR.
FOR CONSULTING IN THE FIELD OF INFORMATION TECHNOLOGY (U.S. CLS. 100 AND 101).
TARAH HARDY, EXAMINING ATTORNEY

SN 85-510,753. 3TRACE DBA TRACE3, IRVINE, CA. FILED 1-6-2012.

LEADERSHIP AS A SERVICE

THE MARK CONSISTS OF STANDARD CHARACTERS WITHOUT CLAIM TO ANY PARTICULAR FONT, STYLE, SIZE, OR COLOR.
FOR CONSULTING IN THE FIELD OF INFORMATION TECHNOLOGY (U.S. CLS. 100 AND 101).
TARAH HARDY, EXAMINING ATTORNEY

SN 85-510,786. ARCAT, INC., SHELTON, CT. FILED 1-6-2012.

SPECWIZARD

THE MARK CONSISTS OF STANDARD CHARACTERS WITHOUT CLAIM TO ANY PARTICULAR FONT, STYLE, SIZE, OR COLOR.
OWNER OF U.S. REG. NOS. 3,047,153 AND 3,429,955. SEC. 2(F).
FOR APPLICATION SERVICE PROVIDER FEATURING SOFTWARE FOR PROVIDING SPECIFICATIONS FOR BUILDERS AND ARCHITECTS (U.S. CLS. 100 AND 101).
FIRST USE 6-25-2002; IN COMMERCE 6-25-2002.
ANDREW LEASER, EXAMINING ATTORNEY

CLASS 42—(Continued).

SN 85-510,880. TAPLOGIC, LLC, MURRAY, KY. FILED 1-6-2012.

ShapeSAFE

THE MARK CONSISTS OF STANDARD CHARACTERS WITHOUT CLAIM TO ANY PARTICULAR FONT, STYLE, SIZE, OR COLOR.
FOR SOFTWARE AS A SERVICE (SAAS) SERVICES FEATURING SOFTWARE FOR DATABASE MANAGEMENT, FOR AGRICULTURE (U.S. CLS. 100 AND 101).
FIRST USE 6-0-2008; IN COMMERCE 7-22-2010.
DAVID YONTEF, EXAMINING ATTORNEY

SN 85-510,982. JOHN GOVSKY, SANTA CRUZ, CA. FILED 1-6-2012.

EARTHDANCE

THE MARK CONSISTS OF STANDARD CHARACTERS WITHOUT CLAIM TO ANY PARTICULAR FONT, STYLE, SIZE, OR COLOR.
FOR WEBSITE DESIGN AND DEVELOPMENT (U.S. CLS. 100 AND 101).
FIRST USE 12-1-1996; IN COMMERCE 1-23-2001.
SUSAN LESLIE DUBOIS, EXAMINING ATTORNEY

SN 85-511,390. KUSH INFOSYSTEMS PVT. LTD., MUMBAI, INDIA, FILED 1-9-2012.

LINKORBIT

THE MARK CONSISTS OF STANDARD CHARACTERS WITHOUT CLAIM TO ANY PARTICULAR FONT, STYLE, SIZE, OR COLOR.
FOR COMPUTER SERVICES, NAMELY, SEARCH ENGINE OPTIMIZATION; CONSULTATION SERVICES IN THE FIELD OF SEARCH ENGINE OPTIMIZATION; CREATING AND MAINTAINING BLOGS FOR OTHERS; DESIGN AND MAINTENANCE OF WEB SITES FOR OTHERS (U.S. CLS. 100 AND 101).
GINA HAYES, EXAMINING ATTORNEY

CLASS 42—(Continued).

SN 85-511,472. PIVARAL, ALEJANDRO, GUATEMALA, GUATEMALA, FILED 1-9-2012.

VIPness

THE MARK CONSISTS OF STANDARD CHARACTERS WITHOUT CLAIM TO ANY PARTICULAR FONT, STYLE, SIZE, OR COLOR.

FOR PROVIDING TEMPORARY USE OF ON-LINE NON-DOWNLOADABLE SOFTWARE FOR USE IN CALCULATING THE REAL WORLD INFLUENCE OF PEOPLE (U.S. CLS. 100 AND 101).

FIRST USE 11-1-2011; IN COMMERCE 11-1-2011.
KELLY BOULTON, EXAMINING ATTORNEY

SN 85-511,604. OSTER, RANDI, FAIRFIELD, CT. FILED 1-9-2012.

quakecast

THE MARK CONSISTS OF STANDARD CHARACTERS WITHOUT CLAIM TO ANY PARTICULAR FONT, STYLE, SIZE, OR COLOR.

FOR PROVIDING A WEBSITE THAT FEATURES FORECASTS OF EARTHQUAKES AROUND THE WORLD, WITH A SPECIAL EMPHASIS IN THE CALIFORNIA AREA (U.S. CLS. 100 AND 101).

WILLIAM JACKSON, EXAMINING ATTORNEY

SN 85-511,665. HALL, KEN, TORRANCE, CA. FILED 1-9-2012.

HALL-ASS

THE MARK CONSISTS OF STANDARD CHARACTERS WITHOUT CLAIM TO ANY PARTICULAR FONT, STYLE, SIZE, OR COLOR.

FOR AUTOMOBILE DESIGN SERVICES; MOTOR-CYCLE DESIGN SERVICES; MOTOR VEHICLE PARTS DESIGN SERVICES (U.S. CLS. 100 AND 101).

FIRST USE 0-0-1996; IN COMMERCE 0-0-1996.
MAUREEN DALL, EXAMINING ATTORNEY

CLASS 42—(Continued).

SN 85-511,669. M.B. STRATEGIC, LLC, ENCINITAS, CA. FILED 1-9-2012.

RESTAURANT CONNECT

THE MARK CONSISTS OF STANDARD CHARACTERS WITHOUT CLAIM TO ANY PARTICULAR FONT, STYLE, SIZE, OR COLOR.

NO CLAIM IS MADE TO THE EXCLUSIVE RIGHT TO USE "RESTAURANT", APART FROM THE MARK AS SHOWN.

FOR BUILDING AND MAINTAINING WEBSITES; COMPUTER SERVICES, NAMELY, CREATING AN ON-LINE COMMUNITY FOR REGISTERED USERS TO PARTICIPATE IN DISCUSSIONS, GET FEEDBACK FROM THEIR PEERS, FORM VIRTUAL COMMUNITIES, AND ENGAGE IN SOCIAL NETWORKING SERVICES IN THE FIELD OF MANAGEMENT OF RESTAURANT, BARS AND OTHER FOOD AND BEVERAGE SERVICES FOR OTHERS; COMPUTER SERVICES, NAMELY, CREATING COMPUTER NETWORK-BASED INDEXES OF INFORMATION, WEBSITES AND RESOURCES; COMPUTER SERVICES, NAMELY, CREATING, MAINTAINING, DESIGNING, AND IMPLEMENTING WEBSITES FOR OTHERS IN THE FIELD OF RESTAURANTS, BARS AND OTHER FOOD AND BEVERAGE SERVICES; COMPUTER SERVICES, NAMELY, DESIGNING AND IMPLEMENTING WEBSITES, WEBPAGES, HOME PAGES AND INTERNET SITES FOR RESTAURANTS, BARS AND OTHER FOOD AND BEVERAGE SERVICES FOR OTHERS; COMPUTER WEBSITE DESIGN; DESIGN, CREATION, HOSTING AND MAINTENANCE OF INTERNET SITES FOR THIRD PARTIES; DESIGNING WEBSITES FOR OTHERS; DESIGNING, CREATING, MAINTAINING, AND HOSTING RESTAURANTS, BARS AND OTHER FOOD AND BEVERAGE SERVICES WEBSITES FOR OTHERS; HOSTING INTERNET SITES FOR OTHERS; PLANNING, DESIGN, DEVELOPMENT, MAINTENANCE AND OPTIMIZATION OF ONLINE WEBSITES FOR THIRD PARTIES; UPDATING WEBSITES FOR OTHERS; WEB PUBLISHING, NAMELY, CREATING A WEBSITE AND UPLOADING IT ONTO AN INTERNET SERVER; WEBSITE DESIGN AND DEVELOPMENT FOR OTHERS (U.S. CLS. 100 AND 101).

FIRST USE 6-1-2011; IN COMMERCE 6-1-2011.
WILLIAM JACKSON, EXAMINING ATTORNEY

SN 85-511,991. 3 ALPHA, L.P., KATY, TX. FILED 1-9-2012.

TAGSPECTIVE

THE MARK CONSISTS OF STANDARD CHARACTERS WITHOUT CLAIM TO ANY PARTICULAR FONT, STYLE, SIZE, OR COLOR.

FOR PROVIDING A WEBSITE FEATURING NON-DOWNLOADABLE SOFTWARE FOR ESTABLISHING WORKFLOW RESULTS FROM A NEAR FIELD COMMUNICATION ENABLED MOBILE PHONE READING DATA OFF OF A RFID (RADIO FREQUENCY IDENTIFICATION) TAG (U.S. CLS. 100 AND 101).

FIRST USE 1-1-2012; IN COMMERCE 1-1-2012.
LAKEISHA LEWIS, EXAMINING ATTORNEY

CLASS 42—(Continued).

SN 85-512,011. LEE, ANDREW CHRISTOPHER, EAGLE RIVER, AK. FILED 1-9-2012.

SAFONATT

THE MARK CONSISTS OF STANDARD CHARACTERS WITHOUT CLAIM TO ANY PARTICULAR FONT, STYLE, SIZE, OR COLOR.

FOR COMPUTER SERVICES, NAMELY, DESIGNING AND IMPLEMENTING INTERNET SITES, APPLICATIONS, SOFTWARE, WEBPAGES FOR OTHERS (U.S. CLS. 100 AND 101).

FIRST USE 10-0-2001; IN COMMERCE 2-11-2006.
JAY BESCH, EXAMINING ATTORNEY

CLASS 42—(Continued).

SN 85-512,414. ABBOTT LABORATORIES, ABBOTT PARK, IL. FILED 1-10-2012.

TOPAZ

THE MARK CONSISTS OF STANDARD CHARACTERS WITHOUT CLAIM TO ANY PARTICULAR FONT, STYLE, SIZE, OR COLOR.

FOR MEDICAL AND SCIENTIFIC RESEARCH, NAMELY, CONDUCTING CLINICAL TRIALS IN THE FIELD OF HEPATITIS; MEDICAL AND SCIENTIFIC RESEARCH IN THE FIELD OF HEPATITIS (U.S. CLS. 100 AND 101).

YAT SYE, LEE, EXAMINING ATTORNEY

SN 85-512,072. YEEDA LIMITED, HONG KONG, HONG KONG, FILED 1-9-2012.

EASTASIASOFT

THE MARK CONSISTS OF STANDARD CHARACTERS WITHOUT CLAIM TO ANY PARTICULAR FONT, STYLE, SIZE, OR COLOR.

FOR COMPUTER SOFTWARE DEVELOPMENT; VIDEO GAME DEVELOPMENT SERVICES (U.S. CLS. 100 AND 101).

FIRST USE 6-28-2007; IN COMMERCE 6-28-2007.
JORDAN BAKER, EXAMINING ATTORNEY

SN 85-512,416. ABBOTT LABORATORIES, ABBOTT PARK, IL. FILED 1-10-2012.

TURQUOISE

THE MARK CONSISTS OF STANDARD CHARACTERS WITHOUT CLAIM TO ANY PARTICULAR FONT, STYLE, SIZE, OR COLOR.

FOR MEDICAL AND SCIENTIFIC RESEARCH, NAMELY, CONDUCTING CLINICAL TRIALS IN THE FIELD OF HEPATITIS; MEDICAL AND SCIENTIFIC RESEARCH IN THE FIELD OF HEPATITIS (U.S. CLS. 100 AND 101).

YAT SYE, LEE, EXAMINING ATTORNEY

SN 85-512,289. TANTUM TECHNOLOGIES, LLC, STATE-LINE, NV. FILED 1-9-2012.

We make I.T. easy

THE MARK CONSISTS OF STANDARD CHARACTERS WITHOUT CLAIM TO ANY PARTICULAR FONT, STYLE, SIZE, OR COLOR.

FOR COMPUTER SERVICES, NAMELY, CREATING, MAINTAINING, DESIGNING AND IMPLEMENTING WEB SITES FOR OTHERS (U.S. CLS. 100 AND 101).

FIRST USE 6-25-2010; IN COMMERCE 7-0-2010.
GIANCARLO CASTRO, EXAMINING ATTORNEY

SN 85-512,618. IPSEN PHARMA S.A.S., BOULOGNE BILLANCOURT, FRANCE, FILED 1-10-2012.

LUSSY

THE MARK CONSISTS OF STANDARD CHARACTERS WITHOUT CLAIM TO ANY PARTICULAR FONT, STYLE, SIZE, OR COLOR.

FOR MEDICAL RESEARCH NAMELY CONDUCTING CLINICAL STUDIES AND ANALYSIS (U.S. CLS. 100 AND 101).

MICHAEL WIENER, EXAMINING ATTORNEY

CLASS 42—(Continued).

SN 85-512,624. IPSEN PHARMA S.A.S., BOULOGNE BILL-ANCOURT, FRANCE, FILED 1-10-2012.

ELECT

THE MARK CONSISTS OF STANDARD CHARACTERS WITHOUT CLAIM TO ANY PARTICULAR FONT, STYLE, SIZE, OR COLOR.

FOR MEDICAL RESEARCH NAMELY CONDUCTING CLINICAL STUDIES AND ANALYSIS (U.S. CLS. 100 AND 101).

MICHAEL WIENER, EXAMINING ATTORNEY

SN 85-512,693. LIFE2, INC., ATLANTA, GA. FILED 1-10-2012.

LIFE2

THE MARK CONSISTS OF STANDARD CHARACTERS WITHOUT CLAIM TO ANY PARTICULAR FONT, STYLE, SIZE, OR COLOR.

FOR PLATFORM AS A SERVICE (PAAS) FEATURING COMPUTER SOFTWARE PLATFORMS FOR MONITORING PATIENTS' VITAL SIGNS, MOVEMENT AND LOCATION, AND PROVIDING PREDICTIVE ANALYSIS BASED ON THE RESULTS OF THE MONITORING (U.S. CLS. 100 AND 101).

JOHN WILKE, EXAMINING ATTORNEY

SN 85-512,694. LIFE2, INC., ATLANTA, GA. FILED 1-10-2012.

ANALYTICS OF AGING

THE MARK CONSISTS OF STANDARD CHARACTERS WITHOUT CLAIM TO ANY PARTICULAR FONT, STYLE, SIZE, OR COLOR.

FOR PLATFORM AS A SERVICE (PAAS) FEATURING COMPUTER SOFTWARE PLATFORMS FOR MONITORING PATIENTS' VITAL SIGNS, MOVEMENT AND LOCATION, AND PROVIDING PREDICTIVE ANALYSIS BASED ON THE RESULTS OF THE MONITORING (U.S. CLS. 100 AND 101).

JOHN WILKE, EXAMINING ATTORNEY

CLASS 42—(Continued).

SN 85-513,176. HCC CORP., AUSTIN, TX. FILED 1-10-2012.

SpeakerLink

THE MARK CONSISTS OF STANDARD CHARACTERS WITHOUT CLAIM TO ANY PARTICULAR FONT, STYLE, SIZE, OR COLOR.

FOR PROVIDING A WEBSITE FEATURING A SEARCH ENGINE FOR PATIENT ADVOCATE SPEAKERS WHERE THE SEARCH IS BASED ON FUNCTIONS SUCH AS AVAILABILITY, LOCATION, EXPERTISE, EXPERIENCE, TOPIC, VIEWABLE SAMPLE SPEECHES AND RECOMMENDATION LETTERS WHERE THE OUTPUT IS SPEAKER CONTACT INFORMATION (U.S. CLS. 100 AND 101).

FIRST USE 1-10-2012; IN COMMERCE 1-10-2012.

TOBY BULLOFF, EXAMINING ATTORNEY

SN 85-513,442. VEMR, INC., GREAT FALLS, MT. FILED 1-10-2012.

Vaccinatus

THE MARK CONSISTS OF STANDARD CHARACTERS WITHOUT CLAIM TO ANY PARTICULAR FONT, STYLE, SIZE, OR COLOR.

FOR COMPUTER SOFTWARE DEVELOPMENT (U.S. CLS. 100 AND 101).

JAY FLOWERS, EXAMINING ATTORNEY

SN 85-513,514. LANDRY, BLAKE J., THE WOODLANDS, TX. FILED 1-11-2012.

GET WHAT YOU INSPECT, NOT WHAT YOU EXPECT!

THE MARK CONSISTS OF STANDARD CHARACTERS WITHOUT CLAIM TO ANY PARTICULAR FONT, STYLE, SIZE, OR COLOR.

FOR INSPECTIONS OF COATING APPLICATIONS (U.S. CLS. 100 AND 101).

FIRST USE 0-0-2009; IN COMMERCE 0-0-2009.

ALEX KEAM, EXAMINING ATTORNEY

CLASS 42—(Continued).

SN 85-513,736. JADU GLOBAL SOFTWARE LTD., LEICESTER, UNITED KINGDOM, FILED 1-11-2012.

WEEJOT

THE MARK CONSISTS OF STANDARD CHARACTERS WITHOUT CLAIM TO ANY PARTICULAR FONT, STYLE, SIZE, OR COLOR.

FOR SOFTWARE AS A SERVICE (SAAS) SERVICES FEATURING SOFTWARE FOR MANAGING MOBILE WEB APPLICATIONS BASED ON APPLICATIONS THAT CAN BE DEPLOYED TO DEVICES SUPPORTING THE HTML5 AND CSS3 STANDARDS (U.S. CLS. 100 AND 101).

FIRST USE 7-14-2011; IN COMMERCE 10-10-2011.
JAY FLOWERS, EXAMINING ATTORNEY

CLASS 42—(Continued).

SN 85-514,175. CONE DRIVE OPERATIONS, INC., TRAVERSE CITY, MI. FILED 1-11-2012.

ACCUMATE

THE MARK CONSISTS OF STANDARD CHARACTERS WITHOUT CLAIM TO ANY PARTICULAR FONT, STYLE, SIZE, OR COLOR.

OWNER OF U.S. REG. NO. 1,968,752.
FOR PROVIDING ON-LINE NON-DOWNLOADABLE SOFTWARE FOR USE IN SELECTING GEARING PRODUCTS (U.S. CLS. 100 AND 101).

BARBARA GAYNOR, EXAMINING ATTORNEY

SN 85-513,959. TRINNOS TECHNOLOGY LLC, IRVINE, CA. FILED 1-11-2012.



THE MARK CONSISTS OF A SOLID SPHERE, BROKEN BY TWO CAPITAL LETTER "T"'S POSITIONED ON A SLANT TO THE RIGHT WITHIN THE SPHERE, WITH ONE "T" ABOVE THE OTHER AND THE LOWER "T" SLIGHTLY SHORTER THAN THE ONE ABOVE.

FOR APPLICATION SERVICE PROVIDER (ASP) FEATURING SOFTWARE FOR USE IN THE FIELD OF FREIGHT MANAGEMENT; DESIGN, MAINTENANCE, DEVELOPMENT AND UPDATING OF COMPUTER SOFTWARE; PROVIDING ON-LINE NON-DOWNLOADABLE SOFTWARE FOR USE IN THE FIELD OF FREIGHT MANAGEMENT; SOFTWARE AS A SERVICE (SAAS) SERVICES FEATURING SOFTWARE IN THE FIELD OF FREIGHT MANAGEMENT AND TECHNICAL SUPPORT SERVICES RELATED THERETO, NAMELY, TROUBLESHOOTING OF COMPUTER SOFTWARE PROBLEMS (U.S. CLS. 100 AND 101).

FIRST USE 5-3-2011; IN COMMERCE 5-9-2011.
RENEE MCCRAY, EXAMINING ATTORNEY

SN 85-514,639. ELIASSEN GROUP, LLC, WAKEFIELD, MA. FILED 1-12-2012.

EGREX

THE MARK CONSISTS OF STANDARD CHARACTERS WITHOUT CLAIM TO ANY PARTICULAR FONT, STYLE, SIZE, OR COLOR.

FOR APPLICATION SERVICE PROVIDER, NAMELY, PROVIDING INTERNET-BASED SOFTWARE TO AGGREGATE, STANDARDIZE, VIEW, ANALYZE AND REPORT ON CLINICAL TRIAL DATA; PROVIDING ON-LINE NON-DOWNLOADABLE SOFTWARE (VIA SOFTWARE-AS-A-SERVICE) TO ENABLE USERS TO SEARCH AND RETRIEVE CLINICAL DATA FROM CLINICAL TRIALS; COMPUTER SERVICES, NAMELY, PROVIDING SEARCH PLATFORMS TO ALLOW USERS TO OBTAIN RELEVANT CLINICAL DATA; PROVIDING TEMPORARY USE OF NON-DOWNLOADABLE WEB-BASED CLINICAL DATA APPLICATIONS CONSISTING OF COMPUTER SOFTWARE FOR USE IN COLLECTING, ANALYZING AND REPORTING CLINICAL DATA IN THE BIOTECH, PHARMACEUTICAL, MEDICAL DEVICE, AND CLINICAL RESEARCH ORGANIZATIONS INDUSTRIES (U.S. CLS. 100 AND 101).

FIRST USE 7-31-2011; IN COMMERCE 9-0-2011.
PATRICIA EVANKO, EXAMINING ATTORNEY

CLASS 42—(Continued).

SN 85-514,686. PILOT SYSTEMS INTERNATIONAL, LLC, FARMINGTON HILLS, MI. FILED 1-12-2012.

CertTrac

THE MARK CONSISTS OF STANDARD CHARACTERS WITHOUT CLAIM TO ANY PARTICULAR FONT, STYLE, SIZE, OR COLOR.

FOR COMPUTER SERVICES, NAMELY, ACTING AS AN APPLICATION SERVICE PROVIDER IN THE FIELD OF INFORMATION MANAGEMENT TO HOST COMPUTER APPLICATION SOFTWARE FOR THE PURPOSE OF REGULATORY COMPLIANCE AND PRODUCT DEVELOPMENT.; COMPUTER SERVICES, NAMELY, ACTING AS AN APPLICATION SERVICE PROVIDER IN THE FIELD OF KNOWLEDGE MANAGEMENT TO HOST COMPUTER APPLICATION SOFTWARE FOR THE PURPOSE OF REGULATORY COMPLIANCE AND PRODUCT DEVELOPMENT (U.S. CLS. 100 AND 101).

FIRST USE 3-26-2007; IN COMMERCE 3-26-2007.
KATHLEEN LORENZO, EXAMINING ATTORNEY

CLASS 42—(Continued).

SN 85-514,814. IQUMULUS, LLC, AUSTIN, TX. FILED 1-12-2012.

IQUMULUS

THE MARK CONSISTS OF STANDARD CHARACTERS WITHOUT CLAIM TO ANY PARTICULAR FONT, STYLE, SIZE, OR COLOR.

FOR SOFTWARE AS A SERVICE (SAAS) SERVICES FEATURING SOFTWARE DEVELOPMENT TOOLS FOR THE AUTOMATED CREATION OF SOFTWARE APPLICATIONS (U.S. CLS. 100 AND 101).

MICHAEL TANNER, EXAMINING ATTORNEY

SN 85-514,958. VENDSCREEN, INC., PORTLAND, OR. FILED 1-12-2012.

VendScreen

THE MARK CONSISTS OF STANDARD CHARACTERS WITHOUT CLAIM TO ANY PARTICULAR FONT, STYLE, SIZE, OR COLOR.

FOR COMPUTER SERVICES, NAMELY, CLOUD HOSTING PROVIDER SERVICES (U.S. CLS. 100 AND 101).

JULIE VEPPUMTHARA, EXAMINING ATTORNEY

SN 85-514,752. CLEVER SOLUTIONS, LLC A WISCONSIN LIMITED LIABILITY COMPANY, DEFOREST, WI. FILED 1-12-2012.

Cloud-Minded, Business-Grounded

THE MARK CONSISTS OF STANDARD CHARACTERS WITHOUT CLAIM TO ANY PARTICULAR FONT, STYLE, SIZE, OR COLOR.

FOR BUILDING AND MAINTAINING WEBSITES; COMPUTER NETWORK DESIGN FOR OTHERS; COMPUTER SERVICES, NAMELY, CREATING COMPUTER NETWORK-BASED INDEXES OF INFORMATION, WEBSITES AND RESOURCES; COMPUTER SERVICES, NAMELY, CREATING, MAINTAINING, DESIGNING AND IMPLEMENTING WEB SITES FOR OTHERS; COMPUTER SERVICES, NAMELY, DESIGNING AND IMPLEMENTING WEB PAGES FOR OTHERS; COMPUTER SERVICES, NAMELY, DESIGNING AND IMPLEMENTING WEB SITES FOR OTHERS; COMPUTER WEBSITE DESIGN; CONSULTANCY WITH REGARD TO WEBPAGE DESIGN; CONSULTING SERVICES IN THE DESIGN AND IMPLEMENTATION OF COMPUTER-BASED INFORMATION SYSTEMS FOR BUSINESSES (U.S. CLS. 100 AND 101).

FIRST USE 5-1-2011; IN COMMERCE 5-1-2011.
AMY ALFIERI, EXAMINING ATTORNEY

SN 85-515,102. WORLDSQUARE LLC, DURHAM, NC. FILED 1-12-2012.

WorldSquare

THE MARK CONSISTS OF STANDARD CHARACTERS WITHOUT CLAIM TO ANY PARTICULAR FONT, STYLE, SIZE, OR COLOR.

FOR DESIGN, DEVELOPMENT, AND CONSULTING SERVICES RELATED THERETO IN THE FIELD OF COMPUTER SOFTWARE SYSTEMS; THINK TANK SERVICES, NAMELY, PROVIDING NEW IDEAS AND CONCEPTS FOR WEB-BASED APPLICATIONS FOR OTHERS (U.S. CLS. 100 AND 101).

FIRST USE 12-31-2010; IN COMMERCE 12-31-2010.
MICHAEL GAFFAR, EXAMINING ATTORNEY

CLASS 42—(Continued).

SN 85-515,346. BRIGHTFIRE, LLC, LAWRENCEVILLE, GA. FILED 1-12-2012.



THE MARK CONSISTS OF THE WORD "BRIGHTFIRE" ACCOMPANIED BY A CIRCULAR FLAME DESIGN. FOR DESIGN, CREATION, HOSTING, MAINTENANCE OF WEBSITES FOR OTHERS; DESIGNING WEBSITES FOR ADVERTISING PURPOSES; HOSTING OF WEB SITES; HOSTING WEBSITES ON THE INTERNET; MAINTENANCE OF WEBSITES AND HOSTING ON-LINE WEB FACILITIES FOR OTHERS; WEB SITE DESIGN; WEB SITE HOSTING SERVICES (U.S. CLS. 100 AND 101).

FIRST USE 6-20-2011; IN COMMERCE 6-20-2011.
KATINA MISTER, EXAMINING ATTORNEY

CLASS 42—(Continued).

SN 85-515,881. UCONNECT, INC., WALTHAM, MA. FILED 1-13-2012.



THE MARK CONSISTS OF STANDARD CHARACTERS WITHOUT CLAIM TO ANY PARTICULAR FONT, STYLE, SIZE, OR COLOR.

FOR DESIGN, DEVELOPMENT, AND IMPLEMENTATION OF SOFTWARE FOR EDUCATIONAL INSTITUTIONS IN THE FIELDS OF SOCIAL MEDIA AND SOCIAL RECRUITING; CREATION, DESIGN, DEVELOPMENT AND MAINTENANCE OF WEB SITES FOR EDUCATIONAL INSTITUTIONS IN THE FIELDS OF SOCIAL MEDIA AND SOCIAL RECRUITING (U.S. CLS. 100 AND 101).

MARK RADEMACHER, EXAMINING ATTORNEY

SN 85-515,391. TOTALCODE SOFTWARE, INC., MIAMI, FL. FILED 1-12-2012.



THE MARK CONSISTS OF STANDARD CHARACTERS WITHOUT CLAIM TO ANY PARTICULAR FONT, STYLE, SIZE, OR COLOR.

FOR COMPUTER SOFTWARE DESIGN; WEB SITE DESIGN (U.S. CLS. 100 AND 101).

FIRST USE 0-0-2008; IN COMMERCE 0-0-2008.

JULIE VEPPUMTHARA, EXAMINING ATTORNEY

SN 85-515,941. CUBIST PHARMACEUTICALS, INC., LEXINGTON, MA. FILED 1-13-2012.



SN 85-515,877. K & B MOBILE LLC, BROOKLYN, NY. FILED 1-13-2012.



THE MARK CONSISTS OF STANDARD CHARACTERS WITHOUT CLAIM TO ANY PARTICULAR FONT, STYLE, SIZE, OR COLOR.

FOR PROVIDING A WEBSITE FEATURING TECHNOLOGY THAT ENABLES USERS TO CREATE NEW MUSIC TO COMPETE AND COLLABORATE WITH ARTISTS AND PRODUCERS AROUND THE WORLD, UPLOAD AND SHARE VIDEOS (U.S. CLS. 100 AND 101).

JOHN DWYER, EXAMINING ATTORNEY

THE MARK CONSISTS OF STANDARD CHARACTERS WITHOUT CLAIM TO ANY PARTICULAR FONT, STYLE, SIZE, OR COLOR.

FOR PROVIDING MEDICAL AND SCIENTIFIC RESEARCH INFORMATION IN THE FIELD OF CLINICAL TRIALS (U.S. CLS. 100 AND 101).

JOHN DALIER, EXAMINING ATTORNEY

CLASS 42—(Continued).

SN 85-515,946. CONENZA, INC., SEATTLE, WA. FILED S.R. 1-13-2012; AM. P.R. 4-11-2012.

Forté

THE MARK CONSISTS OF STANDARD CHARACTERS WITHOUT CLAIM TO ANY PARTICULAR FONT, STYLE, SIZE, OR COLOR.

FOR PROVIDING ON-LINE NON-DOWNLOADABLE SOFTWARE FOR THE BUILDING OF ONLINE TALENT COMMUNITIES, UPLOADING OF RESUMES AND OTHER PROFESSIONAL DOCUMENTS, CREATING AND MAINTAINING CANDIDATE PROFILES, POSTING OF, SEARCHING FOR, AND APPLYING TO JOBS, SHARING OF JOB POSTING LINKS VIA SOCIAL NETWORKS, TRACKING SOCIAL REFERRALS OF JOB POSTINGS FOR THE PURPOSE OF IDENTIFYING OR REWARDING REFERRERS' SOCIAL SHARING BEHAVIOR, AND MANAGING THE STATUS AND OUTCOMES OF JOB POSTINGS INFORMATION RELATING TO ACTIVE, FILLED, OR CANCELED JOB POSTINGS, FOR USE BY COMPANIES IN THE ACQUISITION OF EMPLOYMENT CANDIDATES VIA ONLINE REFERRAL AND SOCIAL NETWORKING APPLICATIONS (U.S. CLS. 100 AND 101).

FIRST USE 12-21-2011; IN COMMERCE 1-12-2012.
TINA BROWN, EXAMINING ATTORNEY

SN 85-516,047. CLARUS THERAPEUTICS, INC., NORTH-BROOK, IL. FILED 1-13-2012.



THE MARK CONSISTS OF THE LITERAL WORDING, LETTERS AND NUMBERS "EASYT4U" WITH A CURVED LINE EXTENDING UNDERNEATH WHICH IS BROKEN AT THE "Y".

FOR PROVIDING MEDICAL AND SCIENTIFIC RESEARCH INFORMATION IN THE FIELD OF PHARMACEUTICALS AND CLINICAL TRIALS (U.S. CLS. 100 AND 101).

FIRST USE 9-7-2011; IN COMMERCE 9-7-2011.
DEBORAH LOBO, EXAMINING ATTORNEY

CLASS 42—(Continued).

SN 85-516,052. LANESE JR., JOHN, LAS VEGAS, NV. FILED 1-13-2012.

Girls Suck

THE MARK CONSISTS OF STANDARD CHARACTERS WITHOUT CLAIM TO ANY PARTICULAR FONT, STYLE, SIZE, OR COLOR.

NO CLAIM IS MADE TO THE EXCLUSIVE RIGHT TO USE "GIRLS", APART FROM THE MARK AS SHOWN.

FOR COMPUTER SERVICES, NAMELY, CREATING AN ON-LINE COMMUNITY FOR REGISTERED USERS TO SHARE STORIES OF MEN BEING CHEATED ON BY A SIGNIFICANT OTHER, READ MEDIA REPORTS AND DISCUSSIONS ON CELEBRITIES WHO HAVE CHEATED ON A SIGNIFICANT OTHER, AND OBTAIN HELPFUL INFORMATION ABOUT A MAN'S LEGAL RIGHTS, INCLUDING DIVORCE AND CUSTODY, WHEN HE HAS BEEN CHEATED ON; CREATING AN ON-LINE COMMUNITY FOR MEN WHO HAVE BEEN CHEATED ON BY A SIGNIFICANT OTHER; CREATING AN ON-LINE COMMUNITY FOR MEN WHO HAVE BEEN CHEATED ON BY A SIGNIFICANT OTHER FOR THE PURPOSE OF SHARING STORIES OF MEN BEING CHEATED ON BY A SIGNIFICANT OTHER, READING MEDIA REPORTS AND DISCUSSIONS ON CELEBRITIES WHO HAVE CHEATED ON A SIGNIFICANT OTHER, AND OBTAINING HELPFUL INFORMATION ABOUT A MAN'S LEGAL RIGHTS, INCLUDING DIVORCE AND CUSTODY, WHEN HE HAS BEEN CHEATED ON (U.S. CLS. 100 AND 101).

TRACY FLETCHER, EXAMINING ATTORNEY

SN 85-516,095. LANESE JR., JOHN, LAS VEGAS, NV. FILED 1-13-2012.

Guys Suck

THE MARK CONSISTS OF STANDARD CHARACTERS WITHOUT CLAIM TO ANY PARTICULAR FONT, STYLE, SIZE, OR COLOR.

NO CLAIM IS MADE TO THE EXCLUSIVE RIGHT TO USE "GUYS", APART FROM THE MARK AS SHOWN.

FOR COMPUTER SERVICES, NAMELY, CREATING AN ON-LINE COMMUNITY FOR REGISTERED USERS TO SHARE STORIES OF WOMEN BEING CHEATED ON BY A SIGNIFICANT OTHER, READ MEDIA REPORTS AND DISCUSSIONS ON CELEBRITIES WHO HAVE CHEATED ON A SIGNIFICANT OTHER, AND OBTAIN HELPFUL INFORMATION ABOUT A WOMAN'S LEGAL RIGHTS, INCLUDING DIVORCE AND CUSTODY, WHEN SHE HAS BEEN CHEATED ON.; CREATING AN ON-LINE COMMUNITY FOR WOMEN WHO HAVE BEEN CHEATED ON BY A SIGNIFICANT OTHER.; CREATING AN ON-LINE COMMUNITY FOR WOMEN WHO HAVE BEEN CHEATED ON BY A SIGNIFICANT OTHER FOR THE PURPOSE OF SHARING STORIES OF WOMEN BEING CHEATED ON BY A SIGNIFICANT OTHER, READING MEDIA REPORTS AND DISCUSSIONS ON CELEBRITIES WHO HAVE CHEATED ON A SIGNIFICANT OTHER, AND OBTAINING HELPFUL INFORMATION ABOUT A WOMAN'S LEGAL RIGHTS, INCLUDING DIVORCE AND CUSTODY, WHEN SHE HAS BEEN CHEATED ON (U.S. CLS. 100 AND 101).

TRACY FLETCHER, EXAMINING ATTORNEY

CLASS 42—(Continued).

SN 85-516,173. FWIX, INC., SAN FRANCISCO, CA. FILED 1-13-2012.

RADIUS

THE MARK CONSISTS OF STANDARD CHARACTERS WITHOUT CLAIM TO ANY PARTICULAR FONT, STYLE, SIZE, OR COLOR.

FOR PROVIDING TEMPORARY USE OF ONLINE, NON-DOWNLOADABLE SOFTWARE FOR ANALYSIS OF DATA IN THE FIELD OF BUSINESS INTELLIGENCE, CORPORATE PERFORMANCE MANAGEMENT, BUSINESS DATA ANALYTICS, AND BUSINESS DATA COLLECTION (U.S. CLS. 100 AND 101).
EMILY CHUO, EXAMINING ATTORNEY

CLASS 42—(Continued).

SN 85-517,521. TRINNO'S TECHNOLOGY LLC, IRVINE, CA. FILED 1-16-2012.



THE MARK CONSISTS OF A CARTOON DOG DEPICTED FROM ITS MID-SECTION UP WITH ITS LEFT FRONT ARM OUTSTRETCHED WITH PAW FACING UP. THE DOG IS SHOWN WEARING A COLLAR BEARING A TAG ON WHICH A CAPITAL LETTER "T" IS INSCRIBED.

FOR APPLICATION SERVICE PROVIDER (ASP) FEATURING SOFTWARE FOR USE IN THE FIELD OF FREIGHT MANAGEMENT; DESIGN, MAINTENANCE, DEVELOPMENT AND UPDATING OF COMPUTER SOFTWARE; PROVIDING ON-LINE NON-DOWNLOADABLE SOFTWARE FOR USE IN THE FIELD OF FREIGHT MANAGEMENT; SOFTWARE AS A SERVICE (SAAS) SERVICES FEATURING SOFTWARE IN THE FIELD OF FREIGHT MANAGEMENT AND TECHNICAL SUPPORT SERVICES RELATED THERETO, NAMELY, TROUBLESHOOTING OF COMPUTER SOFTWARE PROBLEMS (U.S. CLS. 100 AND 101).

FIRST USE 1-10-2012; IN COMMERCE 1-10-2012.
RENEE MCCRAY, EXAMINING ATTORNEY

SN 85-516,194. DOCASSIST, MIRAMAR, FL. FILED 1-13-2012.

docAssist 

THE MARK CONSISTS OF THE STYLIZED TEXT "DOC-ASSIST". TO THE RIGHT IS FOUR DIAMOND SHAPES ARRANGED IN A DIAMOND FORMATION. THE UPPER RIGHT DIAMOND IS SLIGHTLY SEPARATED FROM THE REST.

FOR CLOUD COMPUTING FEATURING SOFTWARE FOR USE IN DOCUMENT MANAGEMENT; CONSULTING SERVICES IN THE FIELD OF CLOUD COMPUTING (U.S. CLS. 100 AND 101).
FIRST USE 1-0-2005; IN COMMERCE 1-0-2005.
MARK SHINER, EXAMINING ATTORNEY

SN 85-517,614. ABHYANKER, RAJ, MOUNTAIN VIEW, CA. FILED 1-17-2012.

INSTASELL

THE MARK CONSISTS OF STANDARD CHARACTERS WITHOUT CLAIM TO ANY PARTICULAR FONT, STYLE, SIZE, OR COLOR.

FOR PROVIDING A WEBSITE FEATURING ON-LINE NON-DOWNLOADABLE SOFTWARE THAT ENABLES USERS TO UPLOAD, POST, SHOW, DISPLAY, TAG, BLOG, SHARE OR OTHERWISE PROVIDE ELECTRONIC MEDIA OR INFORMATION OVER THE INTERNET OR OTHER COMMUNICATIONS NETWORK; APPLICATION SERVICE PROVIDER FEATURING APPLICATION PROGRAMMING INTERFACE (API) SOFTWARE FOR SOCIAL NETWORKING, BUILDING SOCIAL NETWORKING APPLICATIONS AND FOR ALLOWING DATA RETRIEVAL, UPLOAD, ACCESS AND MANAGEMENT (U.S. CLS. 100 AND 101).

TAMARA FRAZIER, EXAMINING ATTORNEY

CLASS 42—(Continued).

SN 85-519,320. BASF SE, LUDWIGSHAFEN AM RHEIN, FED REP GERMANY, FILED 1-18-2012.



THE MARK CONSISTS OF A LEAF WITH A CHECK-MARK AS ITS STEM, SUPERIMPOSED OVER HORIZONTAL LINES. A PORTION OF THE LEAF, THE HORIZONTAL LINES AND A VERTICAL LINE ARE ALL DISPLAYED WITHIN THE RECTANGLE.

FOR MEASUREMENT, ANALYSIS AND VERIFICATION OF ECOLOGICAL EFFICIENCY OF PAPER-BASED PRODUCTS FOR ENVIRONMENTAL BENEFIT (U.S. CLS. 100 AND 101).

EVELYN BRADLEY, EXAMINING ATTORNEY

SN 85-520,045. DYNAMIC SEARCH, LLC, PHOENIX, AZ. FILED 1-19-2012.

Dynamic Search

THE MARK CONSISTS OF STANDARD CHARACTERS WITHOUT CLAIM TO ANY PARTICULAR FONT, STYLE, SIZE, OR COLOR.

NO CLAIM IS MADE TO THE EXCLUSIVE RIGHT TO USE "SEARCH", APART FROM THE MARK AS SHOWN.

FOR CONSULTING SERVICES IN THE FIELD OF SEARCH ENGINE OPTIMIZATION (U.S. CLS. 100 AND 101).

FIRST USE 9-3-2010; IN COMMERCE 9-3-2010.

WENDY JUN, EXAMINING ATTORNEY

SN 85-521,385. E-WORKS MEDIA, INC., RANCHO MIRAGE, CA. FILED 1-20-2012.

BLOOD, SWEAT AND GEARS

THE MARK CONSISTS OF STANDARD CHARACTERS WITHOUT CLAIM TO ANY PARTICULAR FONT, STYLE, SIZE, OR COLOR.

FOR COMMERCIAL ART DESIGN; COMPUTER SERVICES, NAMELY, DESIGNING AND IMPLEMENTING WEB PAGES FOR OTHERS; DESIGNING WEBSITES FOR OTHERS; GRAPHIC ART DESIGN; PACKAGING DESIGN FOR OTHERS (U.S. CLS. 100 AND 101).

FIRST USE 2-1-1999; IN COMMERCE 3-1-1999.

KAREN SEVERSON, EXAMINING ATTORNEY

CLASS 42—(Continued).

SN 85-523,075. TRINNOS TECHNOLOGY LLC, IRVINE, CA. FILED 1-23-2012.

TRINNOS

THE MARK CONSISTS OF STANDARD CHARACTERS WITHOUT CLAIM TO ANY PARTICULAR FONT, STYLE, SIZE, OR COLOR.

THE WORDING "TRINNOS" HAS NO MEANING IN A FOREIGN LANGUAGE.

FOR APPLICATION SERVICE PROVIDER (ASP) FEATURING SOFTWARE FOR USE IN THE FIELD OF FREIGHT MANAGEMENT; DESIGN, MAINTENANCE, DEVELOPMENT AND UPDATING OF COMPUTER SOFTWARE; PROVIDING ON-LINE NON-DOWNLOADABLE SOFTWARE FOR USE IN THE FIELD OF FREIGHT MANAGEMENT; SOFTWARE AS A SERVICE (SAAS) SERVICES FEATURING SOFTWARE IN THE FIELD OF FREIGHT MANAGEMENT AND TECHNICAL SUPPORT SERVICES RELATED THERETO, NAMELY, TROUBLESHOOTING OF COMPUTER SOFTWARE PROBLEMS (U.S. CLS. 100 AND 101).

FIRST USE 5-3-2011; IN COMMERCE 5-9-2011.

RENEE MCCRAY, EXAMINING ATTORNEY

SN 85-523,120. OMAR SHEIKH, LOS ANGELES, CA. AND TOMAS STERLING FALCONER, LOS ANGELES, CA. FILED 1-23-2012.

Quatern Energy

THE MARK CONSISTS OF STANDARD CHARACTERS WITHOUT CLAIM TO ANY PARTICULAR FONT, STYLE, SIZE, OR COLOR.

NO CLAIM IS MADE TO THE EXCLUSIVE RIGHT TO USE "ENERGY", APART FROM THE MARK AS SHOWN.

FOR CONSULTING SERVICES IN THE FIELDS OF ENERGY MEASUREMENT TO IMPROVE ENERGY EFFICIENCY; ENGINEERING SERVICES IN THE FIELD OF ENERGY EFFICIENCY; RESEARCH AND DEVELOPMENT OF ENVIRONMENTALLY FRIENDLY FORMS OF ENERGY AND POWER; RESEARCH IN THE FIELD OF ENERGY; RESEARCH IN THE FIELD OF RENEWABLE ENERGY; TECHNOLOGICAL CONSULTING SERVICES IN THE FIELD OF ALTERNATIVE ENERGY GENERATION (U.S. CLS. 100 AND 101).

TEJBIR SINGH, EXAMINING ATTORNEY

CLASS 42—(Continued).

SN 85-531,935. TAPLOGIC, LLC, MURRAY, KY. FILED 2-2-2012.

FarmPAD

THE MARK CONSISTS OF STANDARD CHARACTERS WITHOUT CLAIM TO ANY PARTICULAR FONT, STYLE, SIZE, OR COLOR.

FOR SOFTWARE AS A SERVICE (SAAS) SERVICES FEATURING SOFTWARE FOR FARM RECORD KEEPING, DATA PROCESSING, AND DATA HOSTING (U.S. CLS. 100 AND 101).

FIRST USE 3-0-2007; IN COMMERCE 3-0-2007.
DAVID YONTEF, EXAMINING ATTORNEY

SN 85-540,461. DELSON GROUP INC, CUPERTINO, CA. FILED 2-12-2012.

RENREN

THE MARK CONSISTS OF STANDARD CHARACTERS WITHOUT CLAIM TO ANY PARTICULAR FONT, STYLE, SIZE, OR COLOR.

FOR PROVIDING TEMPORARY USE OF NON-DOWNLOADABLE SOFTWARE AND APPLICATIONS FOR USE IN THE POSTING OF CLASSIFIEDS, PARTICIPATION IN VIRTUAL COMMUNITIES, PHOTO SHARING, AND THE TRANSMISSION OF PHOTOGRAPHIC IMAGES IN THE FIELD OF SOCIAL NETWORKING; COMPUTER SERVICES, NAMELY, CREATING ON-LINE VIRTUAL COMMUNITIES FOR REGISTERED USERS TO ORGANIZE GROUPS AND EVENTS, PARTICIPATE IN DISCUSSIONS, AND ENGAGE IN SOCIAL, BUSINESS AND COMMUNITY NETWORKING; COMPUTER SERVICES, NAMELY, HOSTING ON-LINE WEB FACILITIES FOR OTHERS FOR ORGANIZING AND CONDUCTING MEETINGS, EVENTS AND INTERACTIVE DISCUSSIONS VIA COMMUNICATION NETWORKS; APPLICATION SERVICE PROVIDER (ASP) SERVICES, NAMELY, HOSTING COMPUTER SOFTWARE APPLICATIONS OF OTHERS; APPLICATION SERVICE PROVIDER (ASP) FEATURING SOFTWARE TO ENABLE OR FACILITATE THE UPLOADING, DOWNLOADING, STREAMING, POSTING, DISPLAYING, BLOGGING, LINKING, SHARING OF AUDIO AND VIDEO CONTENT, PHOTOGRAPHIC IMAGES, TEXT, GRAPHICS AND DATA IN THE FIELD OF SOCIAL NETWORKING; PROVIDING AN ONLINE NETWORK SERVICE THAT ENABLES USERS TO TRANSFER PERSONAL IDENTITY DATA TO AND SHARE PERSONAL IDENTITY DATA WITH AND AMONG MULTIPLE WEBSITES; PROVIDING A WEB SITE FEATURING TECHNOLOGY THAT ENABLES ONLINE USERS TO CREATE PERSONAL PROFILES FEATURING SOCIAL NETWORKING INFORMATION AND TO TRANSFER AND SHARE SUCH INFORMATION AMONG MULTIPLE WEBSITES; COMPUTER SERVICES, NAMELY, CREATING INDEXES OF INFORMATION, SITES AND OTHER RESOURCES AVAILABLE ON COMPUTER NETWORKS; PROVIDING TEMPORARY USE OF NON-DOWNLOADABLE SOFTWARE AND APPLICATIONS FOR ENABLING, FACILITATING, OR ENHANCING SOCIAL NETWORKING, CREATING A VIRTUAL COMMUNITY, AND TRANSMISSION OF AUDIO, VIDEO, PHOTOGRAPHIC IMAGES, TEXT, GRAPHICS AND DATA IN THE FIELD OF SOCIAL NETWORKING; COMPUTER SERVICES IN THE NATURE OF CUSTOMIZED WEB

CLASS 42—(Continued).

PAGES FEATURING USER-DEFINED OR SPECIFIED INFORMATION, PERSONAL PROFILES, AUDIO AND VIDEO CONTENT, PHOTOGRAPHIC IMAGES, TEXT, GRAPHICS AND DATA; PEER-TO-BROWSER PHOTO SHARING SERVICES, NAMELY, PROVIDING A WEB-SITE FEATURING TECHNOLOGY ENABLING USERS TO UPLOAD, VIEW, AND DOWNLOAD DIGITAL PHOTOS; PROVIDING A WEB SITE FEATURING TECHNOLOGY THAT ENABLES USERS TO UPLOAD AND SHARE VIDEO, PHOTOS, TEXT, GRAPHICS AND DATA IN THE FIELD OF SOCIAL NETWORKING; CREATING AND MAINTAINING BLOGS FOR OTHERS; PROVIDING A WEB HOSTING PLATFORM FEATURING THE TEMPORARY USE OF NON-DOWNLOADABLE SOFTWARE FOR ENABLING, FACILITATING OR ENHANCING INTERACTIVE, MULTIPLAYER AND SINGLE PLAYER GAME SOFTWARE OF THIRD PARTIES; PROVIDING ON-LINE NON-DOWNLOADABLE SOFTWARE FOR USE IN APPLICATION PROGRAM INTERFACE IN THE FIELD OF BUSINESS CUSTOMER RELATIONSHIP MANAGEMENT; COMPUTER SOFTWARE DEVELOPMENT IN THE FIELD OF CUSTOMER RELATIONSHIP MANAGEMENT; APPLICATION SERVICE PROVIDER FEATURING SOFTWARE SERVICES IDENTIFYING, TRACKING, MONITORING, MANAGING, SEARCHING, TAGGING, REGISTERING, ANALYZING AND REPORTING ON ELECTRONIC MEDIA CONTENT, INCLUDING AUDIO, VIDEO, IMAGES AND TEXTS, ON THE GLOBAL COMPUTER NETWORKS IN THE FIELD OF BUSINESS, PERSONAL AND SOCIAL NETWORKING; PROVIDING SEARCH ENGINES FOR THE INTERNET; COMPUTER SERVICES, NAMELY, MANAGING BUSINESS, PERSONAL AND SOCIAL NETWORKING WEB SITES AMONG DIFFERENT SERVICE AND APPLICATION PLATFORMS OF OTHERS; COMPUTER SERVICES FOR INTEGRATING DIFFERENT SOFTWARE SERVICE AND APPLICATION PLATFORMS IN SOCIAL, BUSINESS, PERSONAL AND COMMUNITY NETWORKING; RESEARCH AND DEVELOPMENT IN THE FIELD OF BUSINESS, PERSONAL AND SOCIAL NETWORKING; DESIGN AND DEVELOPMENT OF COMPUTER HARDWARE AND SOFTWARE (U.S. CLS. 100 AND 101).

FIRST USE 10-17-2011; IN COMMERCE 2-2-2012.
JOHN DALIER, EXAMINING ATTORNEY

SN 85-551,001. SYNOVA, INC., SOUTHFIELD, MI. FILED 2-23-2012.



THE COLOR(S) RED, WHITE AND BLACK IS/ARE CLAIMED AS A FEATURE OF THE MARK.

THE MARK CONSISTS OF TWO OFFSET SEMI-CIRCULAR BLACK BANDS SURROUNDING A WHITE CIRCLE WITH A RED CIRCULAR CENTER AND THE LITERAL ELEMENT "CBSI".

FOR COMPUTER CONSULTATION (U.S. CLS. 100 AND 101).

FIRST USE 12-14-2011; IN COMMERCE 12-14-2011.
CHRIS WELLS, EXAMINING ATTORNEY

CLASS 42—(Continued).

SN 85-557,565. ABHYANKER, RAJ, CUPERTINO, CA. FILED 3-1-2012.

INSTAROO

THE MARK CONSISTS OF STANDARD CHARACTERS WITHOUT CLAIM TO ANY PARTICULAR FONT, STYLE, SIZE, OR COLOR.

FOR PROVIDING A WEBSITE FEATURING ON-LINE NON-DOWNLOADABLE SOFTWARE THAT ENABLES USERS TO UPLOAD, POST, SHOW, DISPLAY, TAG, BLOG, SHARE OR OTHERWISE PROVIDE ELECTRONIC MEDIA OR INFORMATION OVER THE INTERNET OR OTHER COMMUNICATIONS NETWORK; APPLICATION SERVICE PROVIDER FEATURING APPLICATION PROGRAMMING INTERFACE (API) SOFTWARE FOR SOCIAL NETWORKING, BUILDING SOCIAL NETWORKING APPLICATIONS AND FOR ALLOWING DATA RETRIEVAL, UPLOAD, ACCESS AND MANAGEMENT (U.S. CLS. 100 AND 101).

TAMARA FRAZIER, EXAMINING ATTORNEY

CLASS 42—(Continued).

SN 85-584,965. ALTIUS EDUCATION, INC., SAN FRANCISCO, CA. FILED 3-30-2012.

HELIX

THE MARK CONSISTS OF STANDARD CHARACTERS WITHOUT CLAIM TO ANY PARTICULAR FONT, STYLE, SIZE, OR COLOR.

FOR PLATFORM AS A SERVICE FEATURING COMPUTER SOFTWARE FOR PROVIDING ONLINE COACHING, TUTORING, PEER-TO-PEER LEARNING, AND FEEDBACK ON STUDENT AND INSTRUCTOR PERFORMANCE IN CONNECTION WITH POST-SECONDARY EDUCATIONAL SERVICES; PLATFORM AS A SERVICE FEATURING COMPUTER SOFTWARE FOR PROVIDING A PERSONALIZED ONLINE LEARNING ENVIRONMENT FOR DELIVERY OF COURSES AND INSTRUCTION IN THE POST-SECONDARY EDUCATION SETTING; PROVIDING AN ONLINE COMMUNITY FOR PEER-TO-PEER LEARNING, TUTORING, AND SOCIAL LEARNING EXPERIENCES IN CONNECTION WITH POST-SECONDARY EDUCATIONAL SERVICES (U.S. CLS. 100 AND 101).

KAREN K. BUSH, EXAMINING ATTORNEY

SN 85-577,774. PRIMAL WEAR, INC., DENVER, CO. FILED 3-23-2012.

PRIMAL

THE MARK CONSISTS OF STANDARD CHARACTERS WITHOUT CLAIM TO ANY PARTICULAR FONT, STYLE, SIZE, OR COLOR.

OWNER OF U.S. REG. NOS. 3,213,870, 3,494,801 AND OTHERS.

FOR CUSTOM DESIGN OF ATHLETIC APPAREL BASED ON PERSONAL SELECTIONS MADE BY THE CUSTOMER; DESIGN AND DEVELOPMENT OF CUSTOM ATHLETIC APPAREL; GRAPHIC ILLUSTRATION SERVICES FOR OTHERS (U.S. CLS. 100 AND 101).

FIRST USE 9-20-1992; IN COMMERCE 9-20-1992.
MARK T. MULLEN, EXAMINING ATTORNEY

CLASS 43—HOTEL AND RESTAURANT SERVICES

SN 76-704,880. O.C. SEACRETS, INC, OCEAN CITY, MD. FILED 10-13-2010.

SEACRETS

THE MARK CONSISTS OF STANDARD CHARACTERS WITHOUT CLAIM TO ANY PARTICULAR FONT, STYLE, SIZE, OR COLOR.

OWNER OF U.S. REG. NOS. 2,102,604, 3,757,755 AND OTHERS.

FOR HOTEL, MOTEL, RESTAURANT, BAR AND CATERING SERVICES (U.S. CLS. 100 AND 101).

FIRST USE 6-30-1988; IN COMMERCE 6-30-1988.
CHRISTINE MARTIN, EXAMINING ATTORNEY

CLASS 43—(Continued).

SN 76-704,881. O.C. SEACRETS, INC, OCEAN CITY, MD. FILED 10-13-2010.



OWNER OF U.S. REG. NOS. 2,102,604, 3,767,755 AND OTHERS.
 THE MARK CONSISTS OF THE STYLIZED WORD "SEACRETS".
 FOR HOTEL, MOTEL, RESTAURANT, BAR AND CATERING SERVICES (U.S. CLS. 100 AND 101).
 FIRST USE 6-30-1988; IN COMMERCE 6-30-1988.
 CHRISTINE MARTIN, EXAMINING ATTORNEY

CLASS 43—(Continued).

SN 77-904,512. THIEF WINE, LLC, MILWAUKEE, WI. FILED 1-4-2010.



SN 76-704,882. O.C. SEACRETS, INC, OCEAN CITY, MD. FILED 10-13-2010.



OWNER OF U.S. REG. NOS. 2,102,604, 3,767,755 AND OTHERS.
 THE MARK CONSISTS OF THE STYLIZED WORD "SEACRETS", WITH THE DESIGN OF A SUN APPEARING BEHIND THE WORD AND TWO STYLIZED BIRDS APPEARING ON THE RIGHT SIDE OF THE SUN.
 FOR HOTEL, MOTEL, RESTAURANT, BAR AND CATERING SERVICES (U.S. CLS. 100 AND 101).
 FIRST USE 6-30-1988; IN COMMERCE 6-30-1988.
 CHRISTINE MARTIN, EXAMINING ATTORNEY

SN 77-904,466. THIEF WINE, LLC, MILWAUKEE, WI. FILED 1-4-2010.

THIEF WINE

THE MARK CONSISTS OF STANDARD CHARACTERS WITHOUT CLAIM TO ANY PARTICULAR FONT, STYLE, SIZE, OR COLOR.
 NO CLAIM IS MADE TO THE EXCLUSIVE RIGHT TO USE "WINE", APART FROM THE MARK AS SHOWN.
 FOR WINE BAR FEATURING DISTINCTIVE WINE FROM AROUND THE WORLD; SOMMELIER SERVICES, NAMELY, PROVIDING ADVICE ON WINE AND WINE AND FOOD PAIRING; PROVIDING INFORMATION ABOUT WINE CHARACTERISTICS (U.S. CLS. 100 AND 101).
 FIRST USE 10-23-2007; IN COMMERCE 4-13-2008.
 CYNTHIA TRIPI, EXAMINING ATTORNEY

NO CLAIM IS MADE TO THE EXCLUSIVE RIGHT TO USE "WINE SHOP & BAR", APART FROM THE MARK AS SHOWN.
 THE COLOR(S) BROWN, GREEN AND WHITE IS/ARE CLAIMED AS A FEATURE OF THE MARK.
 THE MARK CONSISTS OF THE STYLIZED WORDING "THIEF WINE SHOP & BAR" WITH THE WORD "THIEF" IN WHITE, THE WORD "WINE" IN GREEN, AND THE WORDS "SHOP & BAR" IN BROWN; THE WORD "WINE" IS SUPERIMPOSED OVER THE WORD "THIEF" SO THAT THE LOWER PARTS OF THE LETTERS IN THE WORD "THIEF" ARE CUT OFF; THE WORDS "THIEF WINE" APPEAR ON A BROWN RECTANGLE WHICH APPEARS ABOVE THE WORDS "SHOP & BAR".
 FOR WINE BAR FEATURING DISTINCTIVE WINE FROM AROUND THE WORLD; SOMMELIER SERVICES, NAMELY, PROVIDING ADVICE ON WINE AND WINE AND FOOD PAIRING; PROVIDING INFORMATION ABOUT WINE CHARACTERISTICS (U.S. CLS. 100 AND 101).
 FIRST USE 5-22-2008; IN COMMERCE 5-22-2008.
 CYNTHIA TRIPI, EXAMINING ATTORNEY

CLASS 43—(Continued).

SN 79-107,085. MERMOZ CLAUDE, NICE, FRANCE, FILED 10-10-2011.



PRIORITY DATE OF 4-20-2011 IS CLAIMED.
OWNER OF INTERNATIONAL REGISTRATION 1101427 DATED 10-10-2011, EXPIRES 10-10-2021.

NO CLAIM IS MADE TO THE EXCLUSIVE RIGHT TO USE "FRENCH GASTRONOMY", APART FROM THE MARK AS SHOWN.

THE COLOR(S) BLUE, LIGHT BLUE, RED AND GREY IS/ ARE CLAIMED AS A FEATURE OF THE MARK.

THE COLOR BLUE APPEARS IN THE WORDING "FRENCH GASTRONOMY" AND THE BACKGROUND OF THE INNERMOST CIRCLE; THE COLOR LIGHT BLUE APPEARS IN THE BACKGROUND OF THE OUTER CIRCLE AND THE DEPICTION OF THE EIFFEL TOWER; THE COLOR RED APPEARS IN THE OUTLINE OF THE OUTER CIRCLE AND THE EIFFEL TOWER; THE COLOR GREY APPEARS IN THE EIFFEL TOWER.

FOR FOOD AND DRINK CATERING (U.S. CLS. 100 AND 101).

LEIGH LOWRY, EXAMINING ATTORNEY

CLASS 43—(Continued).

SN 85-300,524. PARIS CROISSANT CO., LTD., KYOUNGKI-DO, REPUBLIC OF KOREA, FILED 4-20-2011.



OWNER OF REPUBLIC OF KOREA REG. NO. 0122412, DATED 2-14-2005, EXPIRES 2-14-2015.

THE COLOR(S) GRAY, LIGHT BROWN AND WHITE IS/ ARE CLAIMED AS A FEATURE OF THE MARK.

THE MARK CONSISTS OF THE WORD "WHEATBERRY" THE TERM "WHEAT" APPEARS IN GRAY AND THE TERM "BERRY" APPEARS IN LIGHT BROWN LETTERING BELOW A SQUARE COLORED LIGHT BROWN WITHIN WHICH APPEARS THE REPRESENTATION OF A WHEAT STALK IN THE COLOR WHITE.

FOR CANTEEN SERVICES; TEA ROOMS; RESTAURANTS; SELF-SERVICE RESTAURANTS; SNACK BARS; RESTAURANT SERVICES; FOOD PRESENTATION, NAMELY, SERVING FOOD AND DRINKS; CATERING; CAFÉS, INCLUDING BAKERY CAFÉS; CAFETERIAS; NON-STOP RESTAURANT SERVICES PROVIDED AT HIGHWAY RESTING AREAS (U.S. CLS. 100 AND 101).

CHRISTINA SOBRAL, EXAMINING ATTORNEY

SN 85-289,682. ELEVEN IP HOLDINGS LLC, JACKSONVILLE, FL. FILED 4-7-2011.

ELEVEN

THE MARK CONSISTS OF STANDARD CHARACTERS WITHOUT CLAIM TO ANY PARTICULAR FONT, STYLE, SIZE, OR COLOR.

FOR HOTELS, EXCLUDING RESTAURANT SERVICES; HOTEL SERVICES, NAMELY, PROVIDING LUXURY HOTEL ACCOMMODATIONS, EXCLUDING RESTAURANT SERVICES; RESORT LODGING SERVICES, EXCLUDING RESTAURANT SERVICES; PROVIDING TEMPORARY LODGING SERVICES IN THE NATURE OF A TOURIST HOME, EXCLUDING RESTAURANT SERVICES (U.S. CLS. 100 AND 101).

DEIRDRE ROBERTSON, EXAMINING ATTORNEY

SN 85-315,157. TWO DAUGHTERS, LLC, GREENVILLE, SC. FILED 5-7-2011.

SMELLS LIKE A GOOD TIME

THE MARK CONSISTS OF STANDARD CHARACTERS WITHOUT CLAIM TO ANY PARTICULAR FONT, STYLE, SIZE, OR COLOR.

FOR RESTAURANT, BAR AND CATERING SERVICES (U.S. CLS. 100 AND 101).

FIRST USE 2-7-2011; IN COMMERCE 2-7-2011.

PAUL E. FAHRENKOPF, EXAMINING ATTORNEY

CLASS 43—(Continued).

SN 85-332,647. BLT RESTAURANT GROUP LLC, NEW YORK, NY. FILED 5-27-2011.



THE MARK CONSISTS OF A STYLIZED LETTER "E" WITH A FORK DESIGN INTERTWINED WITH A NOODLE SHAPE TO THE RIGHT OF IT, ALL INSIDE AN OUTLINED CIRCLE.

FOR RESTAURANT SERVICES, MOBILE RESTAURANT SERVICES, CONSULTING SERVICES IN THE FIELD OF HOSPITALITY AND RESTAURANTS (U.S. CLS. 100 AND 101).

FIRST USE 5-18-2011; IN COMMERCE 5-18-2011.
CARYN GLASSER, EXAMINING ATTORNEY

SN 85-339,726. CHERRETT, ALICIA M, CHICAGO, IL. AND CHERRETT, NORMAN RANDOLPH, CHICAGO, IL. FILED 6-7-2011.

Children's Learning Place

THE MARK CONSISTS OF STANDARD CHARACTERS WITHOUT CLAIM TO ANY PARTICULAR FONT, STYLE, SIZE, OR COLOR.

NO CLAIM IS MADE TO THE EXCLUSIVE RIGHT TO USE "LEARNING PLACE", APART FROM THE MARK AS SHOWN.

SEC. 2(F).
FOR PRESCHOOLER AND INFANT CARE AT DAY-CARE CENTERS (U.S. CLS. 100 AND 101).
FIRST USE 9-1-1998; IN COMMERCE 9-1-1998.
HEATHER BIDDULPH, EXAMINING ATTORNEY

CLASS 43—(Continued).

SN 85-348,555. GAZALI, ALI, BAKERSFIELD, CA. FILED 6-16-2011.



NO CLAIM IS MADE TO THE EXCLUSIVE RIGHT TO USE "BURGERS PASTRAMI SHAKES", APART FROM THE MARK AS SHOWN.

THE MARK CONSISTS OF THE STYLIZED TEXT "SHAKE N' BUNS" WITH A SWIRL ON TOP WITH THE WORDING "BURGERS PASTRAMI SHAKES" BELOW IN A RECTANGLE WITH ROUNDED EDGES SUGGESTIVE OF THE BOTTOM OF A BUN.

FOR RESTAURANT SERVICES (U.S. CLS. 100 AND 101).

FIRST USE 5-1-2011; IN COMMERCE 6-1-2011.
JOHN SCHUYLER YARD, EXAMINING ATTORNEY

SN 85-352,222. HACHETTE FILIPACCHI PRESSE, LEVALLOIS-PERRET, FRANCE, FILED 6-21-2011.

ELLE

THE MARK CONSISTS OF STANDARD CHARACTERS WITHOUT CLAIM TO ANY PARTICULAR FONT, STYLE, SIZE, OR COLOR.

OWNER OF FRANCE REG. NO. 05/3.363.763, DATED 6-8-2005, EXPIRES 6-8-2015.

OWNER OF U.S. REG. NOS. 758,137, 3,745,516 AND OTHERS.

THE ENGLISH TRANSLATION OF "ELLE" IN THE MARK IS "SHE".

FOR (BASED ON 44(E)) (BASED ON INTENT TO USE) CAFÉ; CAFETERIA; RESTAURANTS; SELF-SERVICE RESTAURANTS; SNACK BARS; CHOPHOUSE RESTAURANT; BUFFET RESTAURANT; BARS SERVICES; COFFEE, TEA AND JUICE BAR SERVICES; FAST FOOD RESTAURANT SERVICES; TAKE-OUT RESTAURANT SERVICES; CARRY-OUT RESTAURANT; CATERING SERVICES; (BASED ON INTENT TO USE) HOTEL SERVICES, PROVIDING TEMPORARY ACCOMMODATIONS OF ROOMS FOR SOCIAL FUNCTIONS, RENTAL OF ROOMS FOR SOCIAL FUNCTIONS, PROVIDING ROOMS AS FACILITIES FOR CONFERENCES, MEETINGS, SEMINARS, CONGRESSES AND EXHIBITIONS FOR SOCIAL GASTRONOMY AND CULINARY FUNCTIONS (U.S. CLS. 100 AND 101).

JUDITH HELFMAN, EXAMINING ATTORNEY

CLASS 43—(Continued).

SN 85-360,323. OLD KENTUCKY RESTAURANTS LIMITED, BIRMINGHAM, ENGLAND, FILED 6-30-2011.

Tuk Chợ

PRIORITY CLAIMED UNDER SEC. 44(D) ON ERP N CMNTY TM OFC APPLICATION NO. 010060291, FILED 6-20-2011, REG. NO. 010060291, DATED 11-20-2011, EXPIRES 6-20-2021.

THE MARK CONSISTS OF "TUK CHO"; THE LETTER "O" HAS A DESIGN ELEMENT ON ITS SIDE AND A SMALL SQUARE UNDERNEATH IT.

FOR BAR, PUBLIC HOUSE, CAFE AND RESTAURANT SERVICES; PREPARATION OF FOOD AND DRINK; CATERING FOR THE PROVISION OF FOOD AND DRINK; CATERING SERVICES; PROVISION OF FACILITIES FOR PARTIES AND PRIVATE FUNCTIONS; INFORMATION AND ADVISORY SERVICES RELATING TO ALL THE AFORESAID SERVICES (U.S. CLS. 100 AND 101).

MATTHEW EINSTEIN, EXAMINING ATTORNEY

CLASS 43—(Continued).

SN 85-372,889. GENGHIS GRILL FRANCHISE CONCEPTS, LP, DALLAS, TX. FILED 7-15-2011.

KHAN'S KOACH

THE MARK CONSISTS OF STANDARD CHARACTERS WITHOUT CLAIM TO ANY PARTICULAR FONT, STYLE, SIZE, OR COLOR.

OWNER OF U.S. REG. NOS. 3,273,669, 3,926,976 AND OTHERS.

FOR ON-LINE ORDERING SERVICES IN THE FIELD OF RESTAURANT TAKE-OUT AND DELIVERY; RESTAURANT SERVICES; CARRY-OUT RESTAURANT SERVICES; CATERING SERVICES (U.S. CLS. 100 AND 101).

CHRISTINE COOPER, EXAMINING ATTORNEY

SN 85-376,811. PRIVILEGE TASTE FOOD CO.LTD, JEDDAH, SAUDI ARABIA, FILED 7-20-2011.

SN 85-370,839. CEO FOODS, INC., TUCSON, AZ. FILED 7-13-2011.

EEGEE'S



THE MARK CONSISTS OF STANDARD CHARACTERS WITHOUT CLAIM TO ANY PARTICULAR FONT, STYLE, SIZE, OR COLOR.

OWNER OF U.S. REG. NOS. 1,481,822 AND 3,243,394. THE NAME(S), PORTRAIT(S), AND/OR SIGNATURE(S) SHOWN IN THE MARK DOES NOT IDENTIFY A PARTICULAR LIVING INDIVIDUAL.

THE WORD(S) "EEGEE'S" HAS NO MEANING IN A FOREIGN LANGUAGE.

FOR RESTAURANT AND CATERING SERVICES (U.S. CLS. 100 AND 101).

FIRST USE 10-0-1971; IN COMMERCE 10-0-1971.

BILL DAWE, EXAMINING ATTORNEY

NO CLAIM IS MADE TO THE EXCLUSIVE RIGHT TO USE "BURGER", APART FROM THE MARK AS SHOWN.

THE MARK CONSISTS OF QUADRILATERAL SHAPE WITH THE NUMBER "619" CENTERED ON TOP AND THE WORD "BURGER" UNDERLINED AND OVERLINED UNDER INSIDE THE QUADRILATERAL. THEN A SMALL RECTANGLE ATTACHED TO THE BOTTOM ON THE QUADRILATERAL AS A BASE.

FOR RESTAURANT SERVICES, INCLUDING SIT-DOWN SERVICE OF FOOD AND TAKE-OUT RESTAURANT SERVICES (U.S. CLS. 100 AND 101).

FIRST USE 7-1-2011; IN COMMERCE 7-1-2011.

RUSS HERMAN, EXAMINING ATTORNEY

CLASS 43—(Continued).

SN 85-389,531. NEWPORT RESTAURANT VENTURE, LLC, IRVINE, CA. FILED 8-4-2011.

GREAT MAPLE LIBATIONS AND SEASONAL PLATES

THE MARK CONSISTS OF STANDARD CHARACTERS WITHOUT CLAIM TO ANY PARTICULAR FONT, STYLE, SIZE, OR COLOR.

NO CLAIM IS MADE TO THE EXCLUSIVE RIGHT TO USE "LIBATIONS AND SEASONAL PLATES", APART FROM THE MARK AS SHOWN.

FOR BAR AND RESTAURANT SERVICES (U.S. CLS. 100 AND 101).

FIRST USE 7-15-2011; IN COMMERCE 7-15-2011.
BRENDAN MCCAULEY, EXAMINING ATTORNEY

CLASS 43—(Continued).

SN 85-408,606. PANTHERS BRHC L.L.C., NEW YORK, NY. FILED 8-26-2011.

BOCA RATON RESORT & CLUB

THE MARK CONSISTS OF STANDARD CHARACTERS WITHOUT CLAIM TO ANY PARTICULAR FONT, STYLE, SIZE, OR COLOR.

OWNER OF U.S. REG. NOS. 2,272,223, 2,323,314 AND OTHERS.

NO CLAIM IS MADE TO THE EXCLUSIVE RIGHT TO USE "RESORT & CLUB", APART FROM THE MARK AS SHOWN.

SEC. 2(F).

FOR HOTEL RESORT SERVICES; RESTAURANT, BAR AND COCKTAIL LOUNGE SERVICES; NIGHT CLUB SERVICES, NAMELY, ARRANGING FOR COCKTAILS AND TABLE SERVICE RESERVATIONS AT NIGHT CLUBS AND NIGHT CLUB EVENTS; CONTRACT FOOD SERVICES; FOOD PREPARATION SERVICES; CATERING SERVICES; RESORT LODGING SERVICES; PROVISION OF GENERAL-PURPOSE FACILITIES FOR MEETINGS, CONFERENCES AND EXHIBITIONS; PROVISION OF BANQUET AND SOCIAL FUNCTION FACILITIES FOR SPECIAL OCCASIONS; AND RESERVATION SERVICES FOR HOTEL ACCOMMODATIONS FOR OTHERS (U.S. CLS. 100 AND 101).

FIRST USE 1-1-1988; IN COMMERCE 1-1-1988.
SUNG IN, EXAMINING ATTORNEY

SN 85-403,698. CHAKRA, INC., TA RANGOLI INDIAN RESTAURANT, CHANTILLY, VA. FILED 8-22-2011.



SN 85-409,684. DEANY BOY'S LLC, MOUNT LAUREL, NJ. FILED 8-29-2011.

NO CLAIM IS MADE TO THE EXCLUSIVE RIGHT TO USE "INDIA", APART FROM THE MARK AS SHOWN.

THE COLOR(S) MAROON, YELLOW, AND WHITE IS/ ARE CLAIMED AS A FEATURE OF THE MARK.

THE MARK CONSISTS OF THE WORDS "RANGOLI", IN MAROON LETTERS, WITH A CAPITAL "R", WITH THE INTERIOR CIRCLE OF THE "R" AND THE "O" FILLED IN WITH WHITE AND A YELLOW CIRCLE, SO THAT BOTH INTERIOR CIRCLES LOOK LIKE A FRIED EGG; AND DIRECTLY UNDERNEATH "RANGOLI" APPEAR THE WORDS "CELEBRATE INDIA", IN MAROON, LOWER CASE CURSIVE LETTERS; APPEARING ABOVE THE WORD "RANGOLI" IS A LOGO CONSISTING OF A YELLOW CIRCLE SURROUNDED BY A THIN MAROON BORDER; INSIDE THE YELLOW CIRCLE APPEARS A CAPITAL "R" IN MAROON WITH INTERIOR CIRCLE FILLED IN WITH WHITE AND A YELLOW CIRCLE, SO THAT THE INTERIOR CIRCLE LOOK LIKE A FRIED EGG; TO EITHER SIDE OF THE YELLOW CIRCLE ARE TWO MAROON DECORATIONS CONSISTING OF A CURLICUE AND TWO DOTS OF DIFFERENT SIZES.

FOR BAR AND RESTAURANT SERVICES (U.S. CLS. 100 AND 101).

FIRST USE 9-26-2006; IN COMMERCE 9-26-2006.
DEIRDRE ROBERTSON, EXAMINING ATTORNEY



THE NAME "DEANY BOY" AND THE PORTRAIT IDENTIFY A LIVING INDIVIDUAL WHOSE CONSENT IS OF RECORD.

THE MARK CONSISTS OF AN IMAGE OF A BOY'S HEAD INSIDE A CIRCLE. BELOW, AND SLIGHTLY OVERLAPPING THE CIRCLE, IS THE STYLIZED TEXT "DEANY BOY'S".

FOR DELICATESSENS (U.S. CLS. 100 AND 101).
FIRST USE 2-1-2009; IN COMMERCE 4-4-2011.
MARTHA FROMM, EXAMINING ATTORNEY

CLASS 43—(Continued).

SN 85-409,762. GREEN, FELICIA, ATLANTA, GA. FILED 8-29-2011.



NO CLAIM IS MADE TO THE EXCLUSIVE RIGHT TO USE "GOURMET POPCORN", APART FROM THE MARK AS SHOWN.

THE COLOR(S) PURPLE, SILVER, WHITE, BLACK, PINK, AND GRAY IS/ARE CLAIMED AS A FEATURE OF THE MARK.

THE MARK CONSISTS OF THE WORDS "POP POP GOURMET POPCORN" AND LETTERS "PP". THE WORDS "POP POP" ARE PRESENTED IN A STYLIZED WHITE AND BLACK FONT AND ARE PRESENTED IN THE CENTER OF THE DESIGN. OVER THE LETTER "O" IN EACH OF THE WORDS "POP" ARE SILVER COLOR STARS OUTLINED IN BLACK. THE MARK HAS A CIRCULAR SHAPE WHICH IS PINK ON THE INSIDE AND BLACK ON THE OUTSIDE. WITHIN THE CIRCLE ARE PIECES OF POPCORN, SILVER SHINING FROM THE STARS, AND THE WORDS GOURMET POPCORN IN BLACK. PRESENTED OVER THE CIRCLE IS A PURPLE RIBBON. THE WORDS "POP POP" ARE PRESENTED IN THE CENTER OF THE RIBBON AND CIRCLE. IN THE RIGHT LOWER CORNER OF THE RIBBON ARE THE LETTERS "PP" IN WHITE. THE BACKGROUND OF THE MARK IS GRAY.

FOR SNACK-BARS (U.S. CLS. 100 AND 101).
FLORENTINA BLANDU, EXAMINING ATTORNEY

SN 85-415,929. AIKEN, MATTHEW T, BROOKLYN, NY. FILED 9-6-2011.



NO CLAIM IS MADE TO THE EXCLUSIVE RIGHT TO USE "BROOKLYN MANSION", APART FROM THE MARK AS SHOWN.

THE COLOR(S) BLACK, WHITE, GOLD, AND SILVER IS/ARE CLAIMED AS A FEATURE OF THE MARK.

THE MARK CONSISTS OF THE LETTERS "BM" IN STYLIZED FONT, WITH THE LETTER "B" IN GOLD, WHITE AND SILVER, SUPERIMPOSED OVER THE LETTER "M" IN BLACK, WHITE, AND SILVER, ALL OF WHICH IS NEXT TO THE WORDS "THE BROOKLYN MANSION" IN BLACK STYLIZED FONT.

FOR RENTAL OF PRIVATE MANSIONS AS TEMPORARY LIVING ACCOMMODATIONS FOR VACATION STAYS (U.S. CLS. 100 AND 101).

FIRST USE 9-1-2011; IN COMMERCE 6-1-2011.
AMY KELLY, EXAMINING ATTORNEY

CLASS 43—(Continued).

SN 85-444,940. BIG POPOTE, INC., LOS ANGELES, CA. FILED 10-11-2011.

BOBA MIA

THE MARK CONSISTS OF STANDARD CHARACTERS WITHOUT CLAIM TO ANY PARTICULAR FONT, STYLE, SIZE, OR COLOR.

NO CLAIM IS MADE TO THE EXCLUSIVE RIGHT TO USE "BOBA", APART FROM THE MARK AS SHOWN.

THE ENGLISH TRANSLATION OF "MIA" IN THE MARK IS "MY" OR "MINE".

FOR RESTAURANT SERVICES FEATURING SNACKS, JUICES, SMOOTHIES AND DESSERTS (U.S. CLS. 100 AND 101).

STEPHANIE ALI, EXAMINING ATTORNEY

SN 85-445,093. YOGURT IN LOVE, LLC, NORTH MYRTLE BEACH, SC. FILED 10-12-2011.

YOGURT IN LOVE

THE MARK CONSISTS OF STANDARD CHARACTERS WITHOUT CLAIM TO ANY PARTICULAR FONT, STYLE, SIZE, OR COLOR.

NO CLAIM IS MADE TO THE EXCLUSIVE RIGHT TO USE "YOGURT", APART FROM THE MARK AS SHOWN.

FOR FROZEN YOGURT SHOP SERVICES IN THE NATURE OF A RESTAURANT (U.S. CLS. 100 AND 101).

ROBERT STRUCK, EXAMINING ATTORNEY

SN 85-447,605. ZOE, EDWIN, BOULDER, CO. FILED 10-14-2011.

Zoe Ma Ma

THE MARK CONSISTS OF STANDARD CHARACTERS WITHOUT CLAIM TO ANY PARTICULAR FONT, STYLE, SIZE, OR COLOR.

FOR PROVIDING OF FOOD AND DRINK (U.S. CLS. 100 AND 101).

FIRST USE 12-8-2009; IN COMMERCE 12-8-2009.
ADA HAN, EXAMINING ATTORNEY

CLASS 43—(Continued).

SN 85-456,670. BIG ON DOMAINS LIMITED OF CRAIG-MUIR CHAMBERS, ROAD TOWN, TORTOLA, BR.VIRGIN ISLANDS, FILED 10-26-2011.

OKKU

THE MARK CONSISTS OF STANDARD CHARACTERS WITHOUT CLAIM TO ANY PARTICULAR FONT, STYLE, SIZE, OR COLOR.

THE WORD(S) "OKKU" HAS NO MEANING IN A FOREIGN LANGUAGE.

FOR PROVIDING OF FOOD AND DRINK; PREPARATION OF FOOD AND DRINK; PUBLIC HOUSE SERVICES IN THE NATURE OF TOURIST INNS AND BED AND BREAKFASTS; PUBLIC HOUSE SERVICES, NAMELY, TOURIST INNS, BED AND BREAKFASTS, BARS AND RESTAURANTS RELATING TO PROVISION OF FOOD AND DRINK; BAR AND RESTAURANT SERVICES; RESTAURANT SERVICES INCORPORATING LICENSED BAR FACILITIES; RESTAURANT SERVICES FOR THE PROVISION OF FAST FOOD; SELF-SERVICE RESTAURANTS; TAKEAWAY RESTAURANT, CAFE, CAFETERIA, CANTEEN, COFFEE SHOP AND SNACK-BAR SERVICES; WINE BAR SERVICES; COCKTAIL LOUNGE SERVICES; PROVIDING OF FOOD AND DRINK VIA LUNCHEON OR SUPPER CLUBS; PROVIDING OF FOOD AND DRINK VIA SOCIAL CLUBS; PROVIDING OF FOOD AND DRINK VIA COUNTRY CLUBS AND PROVIDING TEMPORARY HOUSING ACCOMMODATION; CATERING SERVICES FOR THE PROVISION OF FOOD AND DRINK; NIGHT CLUB SERVICES IN THE NATURE OF NIGHT CLUB TABLE RESERVATION SERVICES FOR THE PROVISION OF FOOD AND DRINK; ARRANGING FOR THE PROVISION OF COCKTAILS, FOOD AND DRINK AT NIGHT CLUBS; PROVISION OF INFORMATION RELATING TO BARS AND RESTAURANTS; PROVISION OF INFORMATION RELATING TO THE PREPARATION OF FOOD AND DRINK; HOTEL SERVICES; RENTAL OF MEETING ROOMS FOR SOCIAL FUNCTIONS; RESERVATION SERVICES RELATING TO HOTELS, RESTAURANTS, BARS, COCKTAIL LOUNGES, CATERING FACILITIES IN THE NATURE OF BANQUET FACILITIES, CAFETERIAS, CANTEENS, COFFEE SHOPS, SNACK BARS, MEALS AT LUNCHEON AND SUPPER CLUBS, WINE BARS (U.S. CLS. 100 AND 101).

COURTNEY ALVAREZ, EXAMINING ATTORNEY

CLASS 43—(Continued).

SN 85-456,683. BIG ON DOMAINS LIMITED OF CRAIG-MUIR CHAMBERS, ROAD TOWN, TORTOLA, BR.VIRGIN ISLANDS, FILED 10-26-2011.

LOVELIFELOVEFOODLOVEOKKU

THE MARK CONSISTS OF STANDARD CHARACTERS WITHOUT CLAIM TO ANY PARTICULAR FONT, STYLE, SIZE, OR COLOR.

THE WORD(S) "OKKU" HAS NO MEANING IN A FOREIGN LANGUAGE.

FOR PROVIDING OF FOOD AND DRINK; PREPARATION OF FOOD AND DRINK; PUBLIC HOUSE SERVICES IN THE NATURE OF TOURIST INNS AND BED AND BREAKFASTS; PUBLIC HOUSE SERVICES, NAMELY, TOURIST INNS, BED AND BREAKFASTS, BARS AND RESTAURANTS RELATING TO PROVISION OF FOOD AND DRINK; BAR AND RESTAURANT SERVICES; RESTAURANT SERVICES INCORPORATING LICENSED BAR FACILITIES; RESTAURANT SERVICES FOR THE PROVISION OF FAST FOOD; SELF-SERVICE RESTAURANTS; TAKEAWAY RESTAURANT, CAFE, CAFETERIA, CANTEEN, COFFEE SHOP AND SNACK-BAR SERVICES; WINE BAR SERVICES; COCKTAIL LOUNGE SERVICES; PROVIDING OF FOOD AND DRINK VIA LUNCHEON OR SUPPER CLUBS; PROVIDING OF FOOD AND DRINK VIA SOCIAL CLUBS; PROVIDING OF FOOD AND DRINK VIA COUNTRY CLUBS AND PROVIDING TEMPORARY HOUSING ACCOMMODATION; CATERING SERVICES FOR THE PROVISION OF FOOD AND DRINK; NIGHT CLUB SERVICES IN THE NATURE OF NIGHT CLUB TABLE RESERVATION SERVICES FOR THE PROVISION OF FOOD AND DRINK; ARRANGING FOR THE PROVISION OF COCKTAILS, FOOD AND DRINK AT NIGHT CLUBS; PROVISION OF INFORMATION RELATING TO BARS AND RESTAURANTS; PROVISION OF INFORMATION RELATING TO THE PREPARATION OF FOOD AND DRINK; HOTEL SERVICES; RENTAL OF MEETING ROOMS FOR SOCIAL FUNCTIONS; RESERVATION SERVICES RELATING TO HOTELS, RESTAURANTS, BARS, COCKTAIL LOUNGES, CATERING FACILITIES IN THE NATURE OF BANQUET FACILITIES, CAFETERIAS, CANTEENS, COFFEE SHOPS, SNACK BARS, MEALS AT LUNCHEON AND SUPPER CLUBS, WINE BARS (U.S. CLS. 100 AND 101).

COURTNEY ALVAREZ, EXAMINING ATTORNEY

SN 85-462,414. ONATE, INC., ALBEMARLE, NC. FILED 11-2-2011.

LA RIBERA

THE MARK CONSISTS OF STANDARD CHARACTERS WITHOUT CLAIM TO ANY PARTICULAR FONT, STYLE, SIZE, OR COLOR.

THE ENGLISH TRANSLATION OF "LA RIBERA" IN THE MARK IS "THE RIVERSIDE" OR "THE BEACH" OR "THE RIVERBANK".

FOR RESTAURANT SERVICES (U.S. CLS. 100 AND 101).

LINDA M. KING, EXAMINING ATTORNEY

CLASS 43—(Continued).

SN 85-464,441. TALION ENTERPRISES, INC., COCONUT CREEK, FL. FILED 11-4-2011.



NO CLAIM IS MADE TO THE EXCLUSIVE RIGHT TO USE "HOTEL" "RESTAURANT" OR "BAR & MUSIC", APART FROM THE MARK AS SHOWN.

THE MARK CONSISTS OF THE UPPERCASE WORD "HOTEL" IN THE UPPER LEFT, TO THE RIGHT OF THE WORD "HOTEL" IN THE UPPER MIDDLE IS A LARGE UPPERCASE STYLIZED LETTER "V" COMBINED WITH A LARGE UPPERCASE STYLIZED LETTER "H" WHICH OVERLAPS THE "V". THE BOTTOM COLUMNS OF THE "H" HAVE CURVES WITH THE BOTTOM LEFT COLUMN CURVING TO THE LEFT AND THE BOTTOM RIGHT COLUMN CURVING TO THE RIGHT. THE TOP COLUMNS OF THE "V" HAVE RIDGES WITH THE TOP LEFT COLUMN RIDGE FACING TO THE RIGHT AND THE TOP RIGHT COLUMN RIDGE FACING TO THE LEFT. THE "V" HAS A SOLID BORDER LINE THAT TRACES THE OUTSIDE OF THE "V" WITH A SPACE IN BETWEEN THE SOLID BORDER LINE AND THE "V". TO THE LEFT OF THE STYLIZED "V" AND "H", IN THE UPPER RIGHT IS THE UPPERCASE WORD "VENA". BELOW AND SLIGHTLY TO THE RIGHT OF THE WORD "HOTEL" IS A SOLID CENTERED HORIZONTAL LINE WHICH IS FOLLOWED TO THE RIGHT BY THE UPPERCASE WORD "RESTAURANT". AND TO THE RIGHT OF THE WORD "RESTAURANT" IS A SOLID CIRCULAR DOT CENTERED DIRECTLY UNDER THE STYLIZED "V" AND "H". AND TO THE RIGHT OF THE SOLID CIRCULAR DOT IS THE UPPERCASE PHRASE OF THE WORDS "BAR & MUSIC" WHICH IS DIRECTLY FOLLOWED TO THE RIGHT BY A SOLID CENTERED HORIZONTAL LINE.

FOR BAR SERVICES; RESTAURANT AND HOTEL SERVICES (U.S. CLS. 100 AND 101).

LINDA E. BLOHM, EXAMINING ATTORNEY

SN 85-474,275. CHUNMEI LI, DBA JEN'S CHINESE FOOD & CATERING, MASSAPEQUA, NY. FILED 11-16-2011.

JEN'S

THE MARK CONSISTS OF STANDARD CHARACTERS WITHOUT CLAIM TO ANY PARTICULAR FONT, STYLE, SIZE, OR COLOR.

FOR RESTAURANT AND CAFE SERVICES; RESTAURANT AND CATERING SERVICES; RESTAURANT SERVICES; RESTAURANT SERVICES FEATURING CHINESE AND ORIENTAL FOODS; RESTAURANT SERVICES, INCLUDING SIT-DOWN SERVICE OF FOOD AND TAKE-OUT RESTAURANT SERVICES; RESTAURANT SERVICES, NAMELY, PROVIDING OF FOOD AND BEVERAGES FOR CONSUMPTION ON AND OFF THE PREMISES; RESTAURANTS FEATURING HOME DELIVERY; TAKE-OUT RESTAURANT SERVICES (U.S. CLS. 100 AND 101).

FIRST USE 1-1-1991; IN COMMERCE 1-1-1991.

NANCY CLARKE, EXAMINING ATTORNEY

CLASS 43—(Continued).

SN 85-477,522. ML&G DREAMS, INC., MAITLAND, FL. FILED 11-21-2011.



NO CLAIM IS MADE TO THE EXCLUSIVE RIGHT TO USE "COFFEE" AND "95 SOUTH", APART FROM THE MARK AS SHOWN.

THE COLOR(S) WHITE, CREAM, BROWN, AND DARK ORANGE IS/ARE CLAIMED AS A FEATURE OF THE MARK.

THE MARK CONSISTS OF THE NUMERAL AND WORDS "95 SOUTH COFFEE." "95," THE DESIGN OF COFFEE IN CUP WITH SAUCER ALL WITHIN A CIRCULAR BORDER DESIGN. THE TOP AND BELOW BORDERS ON CUP AND SAUCER AND OUTSIDE CIRCULAR BORDER APPEAR IN THE COLOR BROWN. THE INNER CIRCULAR BORDERS AND BACKGROUND BEHIND THE CUP APPEAR IN THE COLOR DARK ORANGE. THE SHADING ON THE CUP AND SAUCER APPEAR IN A CREAM COLOR. THE COLOR WHITE APPEARS ON THE CUP AND SAUCER AND AS BACKGROUND IN THE OVERALL CIRCULAR DESIGN.

FOR PROVIDING OF FOOD AND DRINK (U.S. CLS. 100 AND 101).

FIRST USE 11-1-2011; IN COMMERCE 11-1-2011.

CHRISTOPHER SIDOTI, EXAMINING ATTORNEY

SN 85-478,670. ACH FOOD COMPANIES, INC., CORDOVA, TN. FILED 11-22-2011.

BECOME A BETTER BAKER

THE MARK CONSISTS OF STANDARD CHARACTERS WITHOUT CLAIM TO ANY PARTICULAR FONT, STYLE, SIZE, OR COLOR.

NO CLAIM IS MADE TO THE EXCLUSIVE RIGHT TO USE "BAKER", APART FROM THE MARK AS SHOWN.

FOR PROVIDING ONLINE INFORMATION SERVICES, NAMELY, PROVIDING A WEBSITE WITH INSTRUCTION ON BAKING TECHNIQUES, BAKING TIPS AND RECIPES (U.S. CLS. 100 AND 101).

FIRST USE 10-24-2011; IN COMMERCE 10-24-2011.

EMILY CHUO, EXAMINING ATTORNEY

CLASS 43—(Continued).

SN 85-485,785. KOURELI RESTAURANT GROUP, INC.,
NEW YORK, NY. FILED 12-2-2011.

NERAI

THE MARK CONSISTS OF STANDARD CHARACTERS
WITHOUT CLAIM TO ANY PARTICULAR FONT, STYLE,
SIZE, OR COLOR.

THE ENGLISH TRANSLATION OF THE WORD "NERAI"
IN THE MARK IS "GOAL", "AIM", OR "FOLLOW-UP".

FOR RESTAURANT AND BAR SERVICES; CATERING
SERVICES (U.S. CLS. 100 AND 101).

LOURDES AYALA, EXAMINING ATTORNEY

SN 85-487,730. GLOBAL VISION HOTELS LLC, NEEDHAM,
MA. FILED 12-6-2011.

ENVISION HOTEL

THE MARK CONSISTS OF STANDARD CHARACTERS
WITHOUT CLAIM TO ANY PARTICULAR FONT, STYLE,
SIZE, OR COLOR.

NO CLAIM IS MADE TO THE EXCLUSIVE RIGHT TO
USE "HOTEL", APART FROM THE MARK AS SHOWN.

FOR HOTEL SERVICES (U.S. CLS. 100 AND 101).

PAUL MORENO, EXAMINING ATTORNEY

SN 85-488,993. OLIVIA ENTERPRISES, INC., NEW YORK,
NY. FILED 12-7-2011.

YERBA BUENA

THE MARK CONSISTS OF STANDARD CHARACTERS
WITHOUT CLAIM TO ANY PARTICULAR FONT, STYLE,
SIZE, OR COLOR.

FOR RESTAURANT SERVICES (U.S. CLS. 100 AND
101).

FIRST USE 0-0-2008; IN COMMERCE 0-0-2008.

JOHN WILKE, EXAMINING ATTORNEY

CLASS 43—(Continued).

SN 85-489,427. TASTY COCKTAILS LLC, HENDERSON, NV.
FILED 12-7-2011.

Mango Kush Bar & Frozen Cocktails

THE MARK CONSISTS OF STANDARD CHARACTERS
WITHOUT CLAIM TO ANY PARTICULAR FONT, STYLE,
SIZE, OR COLOR.

NO CLAIM IS MADE TO THE EXCLUSIVE RIGHT TO
USE "MANGO" AND "BAR & FROZEN COCKTAILS",
APART FROM THE MARK AS SHOWN.

THE WORDING "KUSH" IN THE MARK MEANS "MYS-
TERIOUS"

FOR COCKTAIL LOUNGE SERVICES (U.S. CLS. 100
AND 101).

FIRST USE 7-10-2010; IN COMMERCE 7-10-2010.

JANICE KIM, EXAMINING ATTORNEY

SN 85-490,258. MALTA, ROBERT, NEW YORK, NY. FILED
12-8-2011.

ARTE CAFE'

THE MARK CONSISTS OF STANDARD CHARACTERS
WITHOUT CLAIM TO ANY PARTICULAR FONT, STYLE,
SIZE, OR COLOR.

NO CLAIM IS MADE TO THE EXCLUSIVE RIGHT TO
USE "CAFE", APART FROM THE MARK AS SHOWN.

THE ENGLISH TRANSLATION OF "ARTE" IN THE
MARK IS "ART".

FOR RESTAURANT SERVICES, NAMELY, PROVID-
ING OF FOOD AND BEVERAGES FOR CONSUMPTION
ON AND OFF THE PREMISES (U.S. CLS. 100 AND 101).

FIRST USE 6-22-1994; IN COMMERCE 6-22-1994.

STEVEN PEREZ, EXAMINING ATTORNEY

SN 85-496,188. QDOBA RESTAURANT CORPORATION,
WHEAT RIDGE, CO. FILED 12-15-2011.



The logo for Qdoba Mexican Grill features the word "Qdoba" in a large, stylized, handwritten-style font. Below it, the words "MEXICAN GRILL" are written in a smaller, clean, sans-serif font.

OWNER OF U.S. REG. NOS. 2,452,146, 2,574,316 AND
OTHERS.

NO CLAIM IS MADE TO THE EXCLUSIVE RIGHT TO
USE "MEXICAN GRILL", APART FROM THE MARK AS
SHOWN.

THE MARK CONSISTS OF THE WORD "QDOBA"
APPEARING ABOVE THE WORDS "MEXICAN GRILL".

THE WORDING "QDOBA" HAS NO MEANING IN A
FOREIGN LANGUAGE.

FOR RESTAURANT SERVICES (U.S. CLS. 100 AND
101).

GINA FINK, EXAMINING ATTORNEY

CLASS 43—(Continued).

SN 85-496,534. GOMEZ, JAVIER, HENDERSONVILLE, NC. FILED 12-15-2011.

**MAMAS & BEER MEXICAN
RESTAURANT**

THE MARK CONSISTS OF STANDARD CHARACTERS WITHOUT CLAIM TO ANY PARTICULAR FONT, STYLE, SIZE, OR COLOR.

NO CLAIM IS MADE TO THE EXCLUSIVE RIGHT TO USE "BEER" AND "MEXICAN RESTAURANT", APART FROM THE MARK AS SHOWN.

FOR RESTAURANT SERVICES (U.S. CLS. 100 AND 101).

DEZMONA MIZELLE, EXAMINING ATTORNEY

SN 85-498,992. TACO BELL CORP., IRVINE, CA. FILED 12-19-2011.

CANTINA BELL

THE MARK CONSISTS OF STANDARD CHARACTERS WITHOUT CLAIM TO ANY PARTICULAR FONT, STYLE, SIZE, OR COLOR.

OWNER OF U.S. REG. NOS. 1,924,335, 3,501,311 AND OTHERS.

NO CLAIM IS MADE TO THE EXCLUSIVE RIGHT TO USE "CANTINA", APART FROM THE MARK AS SHOWN.

FOR RESTAURANT SERVICES (U.S. CLS. 100 AND 101).

CHRISTOPHER SIDOTI, EXAMINING ATTORNEY

SN 85-501,045. BP INTERNATIONAL RIGHTS HOLDINGS, INC., BRITISH COLUMBIA, CANADA, FILED 12-21-2011.

BOSTON'S GOURMET BEVERAGES

THE MARK CONSISTS OF STANDARD CHARACTERS WITHOUT CLAIM TO ANY PARTICULAR FONT, STYLE, SIZE, OR COLOR.

PRIORITY CLAIMED UNDER SEC. 44(D) ON MEXICO APPLICATION NO. 1216404, FILED 9-30-2011.

OWNER OF U.S. REG. NOS. 1,838,006, 2,865,473 AND 3,038,094.

NO CLAIM IS MADE TO THE EXCLUSIVE RIGHT TO USE "GOURMET BEVERAGES", APART FROM THE MARK AS SHOWN.

FOR RESTAURANT, CAFÉ, AND BAR SERVICES (U.S. CLS. 100 AND 101).

CHARLOTTE CORWIN, EXAMINING ATTORNEY

CLASS 43—(Continued).

SN 85-501,077. ROCCO WHALEN, ROCKY RIVER, OH. FILED 12-21-2011.

CHEF ROCCO WHALEN

THE MARK CONSISTS OF STANDARD CHARACTERS WITHOUT CLAIM TO ANY PARTICULAR FONT, STYLE, SIZE, OR COLOR.

THE NAME(S), PORTRAIT(S), AND/OR SIGNATURE(S) SHOWN IN THE MARK IDENTIFIES "ROCCO WHALEN", WHOSE CONSENT(S) TO REGISTER IS MADE OF RECORD.

FOR BAR SERVICES; RESTAURANT SERVICES (U.S. CLS. 100 AND 101).

KRISTIN DAHLING, EXAMINING ATTORNEY

SN 85-501,087. ROCCO WHALEN, ROCKY RIVER, OH. FILED 12-21-2011.

ROCCO WHALEN'S

THE MARK CONSISTS OF STANDARD CHARACTERS WITHOUT CLAIM TO ANY PARTICULAR FONT, STYLE, SIZE, OR COLOR.

THE NAME(S), PORTRAIT(S), AND/OR SIGNATURE(S) SHOWN IN THE MARK IDENTIFIES "ROCCO WHALEN", WHOSE CONSENT(S) TO REGISTER IS MADE OF RECORD.

FOR BAR SERVICES; RESTAURANT SERVICES (U.S. CLS. 100 AND 101).

KRISTIN DAHLING, EXAMINING ATTORNEY

SN 85-501,252. ROCCO WHALEN, ROCKY RIVER, OH. FILED 12-21-2011.

CHEF ROCCO WHALEN

THE MARK CONSISTS OF STANDARD CHARACTERS WITHOUT CLAIM TO ANY PARTICULAR FONT, STYLE, SIZE, OR COLOR.

THE NAME(S), PORTRAIT(S), AND/OR SIGNATURE(S) SHOWN IN THE MARK IDENTIFIES "ROCCO WHALEN", WHOSE CONSENT(S) TO REGISTER IS MADE OF RECORD.

FOR PROVIDING A DATABASE IN THE FIELD OF RECIPES AND COOKING INFORMATION (U.S. CLS. 100 AND 101).

KRISTIN DAHLING, EXAMINING ATTORNEY

CLASS 43—(Continued).

SN 85-501,265. ROCCO WHALEN, ROCKY RIVER, OH. FILED 12-21-2011.

ROCCO WHALEN'S

THE MARK CONSISTS OF STANDARD CHARACTERS WITHOUT CLAIM TO ANY PARTICULAR FONT, STYLE, SIZE, OR COLOR.

THE NAME(S), PORTRAIT(S), AND/OR SIGNATURE(S) SHOWN IN THE MARK IDENTIFIES "ROCCO WHALEN", WHOSE CONSENT(S) TO REGISTER IS MADE OF RECORD.

FOR PROVIDING A DATABASE IN THE FIELD OF RECIPES AND COOKING INFORMATION (U.S. CLS. 100 AND 101).

KRISTIN DAHLING, EXAMINING ATTORNEY

CLASS 43—(Continued).

SN 85-507,130. MILK BAR, INC., BROOKLYN, NY. FILED 1-2-2012.



NO CLAIM IS MADE TO THE EXCLUSIVE RIGHT TO USE "MILK BAR", APART FROM THE MARK AS SHOWN. THE COLOR(S) BLUE, WHITE AND BLACK IS/ARE CLAIMED AS A FEATURE OF THE MARK.

THE MARK CONSISTS OF A BLUE CIRCLE WITH A RENDERING OF A WHITE MILK BOTTLE, WITH THE WORDS "MILK BAR" IN STYLIZED BLACK LETTERING WRITTEN ACROSS.

FOR RESTAURANT AND CAFE SERVICES (U.S. CLS. 100 AND 101).

FIRST USE 8-0-2009; IN COMMERCE 8-0-2009.

TEJBIR SINGH, EXAMINING ATTORNEY

SN 85-502,725. SHARP KNIVES & WHISKEY, LLC, LAGUNA BEACH, CA. FILED 12-22-2011.

SHARP KNIVES & WHISKEY

THE MARK CONSISTS OF STANDARD CHARACTERS WITHOUT CLAIM TO ANY PARTICULAR FONT, STYLE, SIZE, OR COLOR.

NO CLAIM IS MADE TO THE EXCLUSIVE RIGHT TO USE "WHISKEY", APART FROM THE MARK AS SHOWN.

FOR RESTAURANT SERVICES, NAMELY, PROVIDING OF FOOD AND BEVERAGES FOR CONSUMPTION ON AND OFF THE PREMISES (U.S. CLS. 100 AND 101).

GILBERT SWIFT, EXAMINING ATTORNEY

SN 85-507,208. WIH HOTELS, L.L.C., NEW YORK, NY. FILED 1-2-2012.

Wellesley Inn & Suites

SN 85-503,943. PETRUZZI, BRIAN, GALLOWAY, NJ. FILED 12-27-2011.



THE COLOR(S) WHITE, PURPLE, BLUE, RED AND ORANGE IS/ARE CLAIMED AS A FEATURE OF THE MARK.

THE MARK CONSISTS OF A RED CAPITAL "Y", ORANGE CAPITAL "F" BETWEEN A SPIRAL SPROCKET DESIGN AND A STYLIZED EXCLAMATION POINT. THE SPIRAL SPROCKET IS BLUE AND WHITE AND THE STYLIZED EXCLAMATION POINT IS RED. ALL OF THE ELEMENTS IN THE MARK APPEAR ON A WHITE BACKGROUND AND HAVE A PURPLE SHADOW.

FOR FROZEN YOGURT SHOP SERVICES IN THE NATURE OF A RESTAURANT (U.S. CLS. 100 AND 101).

FIRST USE 6-22-2011; IN COMMERCE 7-16-2011.
KRISTINA MORRIS, EXAMINING ATTORNEY

THE MARK CONSISTS OF STANDARD CHARACTERS WITHOUT CLAIM TO ANY PARTICULAR FONT, STYLE, SIZE, OR COLOR.

OWNER OF U.S. REG. NO. 1,947,411.

NO CLAIM IS MADE TO THE EXCLUSIVE RIGHT TO USE "INNS AND SUITES", APART FROM THE MARK AS SHOWN.

FOR HOTEL SERVICES (U.S. CLS. 100 AND 101).

FIRST USE 9-1-1994; IN COMMERCE 9-1-1994.
CHRISTINE MARTIN, EXAMINING ATTORNEY

CLASS 43—(Continued).

SN 85-507,662. WHITE COAT REBELLION, LLC, LAGUNA BEACH, CA. FILED 1-3-2012.

WHITE COAT REBELLION

THE MARK CONSISTS OF STANDARD CHARACTERS WITHOUT CLAIM TO ANY PARTICULAR FONT, STYLE, SIZE, OR COLOR.

FOR BAR SERVICES; RESTAURANT SERVICES (U.S. CLS. 100 AND 101).

TINA MAI, EXAMINING ATTORNEY

SN 85-507,802. MAGIC MOMENTS OPERATING, LLC, NORCROSS, GA. FILED 1-3-2012.

A Divine Event

THE MARK CONSISTS OF STANDARD CHARACTERS WITHOUT CLAIM TO ANY PARTICULAR FONT, STYLE, SIZE, OR COLOR.

NO CLAIM IS MADE TO THE EXCLUSIVE RIGHT TO USE "EVENT", APART FROM THE MARK AS SHOWN.

FOR CATERING SERVICES (U.S. CLS. 100 AND 101).
FIRST USE 6-30-2008; IN COMMERCE 6-30-2008.

ELI HELLMAN, EXAMINING ATTORNEY

SN 85-507,824. MAGIC MOMENTS OPERATING, LLC, NORCROSS, GA. FILED 1-3-2012.

Wickedly Delicious

THE MARK CONSISTS OF STANDARD CHARACTERS WITHOUT CLAIM TO ANY PARTICULAR FONT, STYLE, SIZE, OR COLOR.

FOR CATERING SERVICES (U.S. CLS. 100 AND 101).

FIRST USE 6-30-2008; IN COMMERCE 6-30-2008.

ELI HELLMAN, EXAMINING ATTORNEY

CLASS 43—(Continued).

SN 85-508,107. ERB ENTERPRISES, INC., VICKSBURG, MI. FILED 1-3-2012.



NO CLAIM IS MADE TO THE EXCLUSIVE RIGHT TO USE "GOURMET PIZZERIA, ITALIAN BISTRO AND PUB", APART FROM THE MARK AS SHOWN.

THE COLOR(S) MAROON, YELLOW, AND WHITE IS/ARE CLAIMED AS A FEATURE OF THE MARK.

THE MARK CONSISTS OF A FIRST SQUARE WITH A MAROON INTERIOR HAVING A WHITE BORDER SURROUNDING THE MAROON INTERIOR AND A YELLOW BORDER SURROUNDING THE WHITE BORDER AROUND THE PERIPHERY OF THE FIRST SQUARE; A SECOND SQUARE FILLED WITH A MAROON AND WHITE CHECKERBOARD HAVING A WHITE BORDER SURROUNDING THE CHECKERBOARD AND A YELLOW BORDER SURROUNDING THE WHITE BORDER ON THE PERIPHERY OF THE SECOND SQUARE; THE SECOND SQUARE BEING PLACED OVER THE FIRST SQUARE AND ROTATED APPROXIMATELY 45 DEGREES WITH RESPECT TO THE FIRST SQUARE; AND A WHITE BANNER EXTENDING HORIZONTALLY OVER THE FIRST AND SECOND SQUARE; THE UPPER AND LOWER PORTIONS OF THE WHITE BANNER HAVING A YELLOW BORDER AND THE WHITE BANNER INCLUDING THE WORDS "ERBELLI'S GOURMET PIZZERIA, ITALIAN BISTRO AND PUB" WRITTEN IN MAROON THEREON.

SEC. 2(F) AS TO THE WORDING "ERBELLI'S".

FOR RESTAURANT SERVICES, INCLUDING SIT-DOWN SERVICE OF FOOD AND TAKE-OUT RESTAURANT SERVICES (U.S. CLS. 100 AND 101).

FIRST USE 7-3-1995; IN COMMERCE 7-3-1995.

WILLIAM ROSSMAN, EXAMINING ATTORNEY

SN 85-508,543. UPRISING, LLC, ROCKVILLE, MD. FILED 1-4-2012.

UPRISING MUFFIN COMPANY

THE MARK CONSISTS OF STANDARD CHARACTERS WITHOUT CLAIM TO ANY PARTICULAR FONT, STYLE, SIZE, OR COLOR.

NO CLAIM IS MADE TO THE EXCLUSIVE RIGHT TO USE "MUFFIN COMPANY", APART FROM THE MARK AS SHOWN.

FOR RESTAURANT AND CATERING SERVICES (U.S. CLS. 100 AND 101).

VERNA BETH RIRIE, EXAMINING ATTORNEY

CLASS 43—(Continued).

SN 85-508,593. BGR HOLDINGS, LLC, LANSDOWNE, VA. FILED 1-4-2012.

BGR THE BURGER JOINT ON TOUR

THE MARK CONSISTS OF STANDARD CHARACTERS WITHOUT CLAIM TO ANY PARTICULAR FONT, STYLE, SIZE, OR COLOR.
FOR RESTAURANT AND CATERING SERVICES (U.S. CLS. 100 AND 101).
DEIRDRE ROBERTSON, EXAMINING ATTORNEY

SN 85-508,913. RHINE & TANZER, INC., DBA ELEPHANT'S DELICATESSEN, PORTLAND, OR. FILED 1-4-2012.



NO CLAIM IS MADE TO THE EXCLUSIVE RIGHT TO USE "DELICATESSEN", APART FROM THE MARK AS SHOWN.
THE MARK CONSISTS OF A DRAWING OF AN ELEPHANT AROUND WHICH ARE TWO CONCENTRIC CIRCLES AND THE WORDS "ELEPHANT'S DELICATESSEN".
FOR RESTAURANT AND CATERING SERVICES (U.S. CLS. 100 AND 101).
FIRST USE 3-0-1979; IN COMMERCE 3-0-1979.
JENNIFER VASQUEZ, EXAMINING ATTORNEY

SN 85-509,591. ACTIUM LLC, UPPER MONTCLAIR, NJ. FILED 1-5-2012.

FLATBREADS...THICK ON TASTE

THE MARK CONSISTS OF STANDARD CHARACTERS WITHOUT CLAIM TO ANY PARTICULAR FONT, STYLE, SIZE, OR COLOR.
FOR RESTAURANT SERVICES (U.S. CLS. 100 AND 101).
FIRST USE 2-1-2007; IN COMMERCE 2-1-2007.
MARK SPARACINO, EXAMINING ATTORNEY

CLASS 43—(Continued).

SN 85-509,605. GS ENTERPRISES LLC, SAN ANTONIO, TX. FILED 1-5-2012.



OWNER OF U.S. REG. NOS. 3,291,918, 3,885,867 AND OTHERS.
NO CLAIM IS MADE TO THE EXCLUSIVE RIGHT TO USE "NEW YORK", APART FROM THE MARK AS SHOWN.
THE COLOR(S) BLACK AND RED IS/ARE CLAIMED AS A FEATURE OF THE MARK.
THE MARK CONSISTS OF A FANCIFUL INTERLOCKING HAND DESIGN IN RED WITH BLACK OUTLINES, LOCATED ABOVE THE TERMS "PEACE & LOVE" IN BLACK STYLIZED FONT, LOCATED ABOVE THE TERM "NEW YORK" IN RED STYLIZED FONT.
FOR RESTAURANT SERVICES (U.S. CLS. 100 AND 101).
MICHAEL WEBSTER, EXAMINING ATTORNEY

SN 85-510,137. IMALLIN CORPORATION, NEW YORK, NY. FILED 1-6-2012.

HopsScotch

THE MARK CONSISTS OF STANDARD CHARACTERS WITHOUT CLAIM TO ANY PARTICULAR FONT, STYLE, SIZE, OR COLOR.
FOR BAR AND RESTAURANT SERVICES (U.S. CLS. 100 AND 101).
CHRISTOPHER BUONGIORNO, EXAMINING ATTORNEY

SN 85-510,467. PHO MI, LLC, DALLAS, TX. FILED 1-6-2012.

DALAT

THE MARK CONSISTS OF STANDARD CHARACTERS WITHOUT CLAIM TO ANY PARTICULAR FONT, STYLE, SIZE, OR COLOR.
FOR BAR SERVICES; RESTAURANT SERVICES; TAKE-OUT RESTAURANT SERVICES (U.S. CLS. 100 AND 101).
MATTHEW PAPPAS, EXAMINING ATTORNEY

CLASS 43—(Continued).

SN 85-510,587. CHEZ ZARA, DEARBORN, MI. FILED 1-6-2012.

Coffee Snobs Welcome

THE MARK CONSISTS OF STANDARD CHARACTERS WITHOUT CLAIM TO ANY PARTICULAR FONT, STYLE, SIZE, OR COLOR.

FOR COFFEE BARS (U.S. CLS. 100 AND 101).
FIRST USE 6-1-2009; IN COMMERCE 5-13-2010.
KATHERINE E. HALMEN, EXAMINING ATTORNEY

SN 85-510,855. JOHN & COOK'S REAL PIT BBQ L.L.C., LAWTON, OK. FILED 1-6-2012.



NO CLAIM IS MADE TO THE EXCLUSIVE RIGHT TO USE "REAL PIT BAR-B-QUE" "PORK" "BEEF" "SINCE 1936", APART FROM THE MARK AS SHOWN.

THE COLOR(S) YELLOW, BLUE, TAN, GREEN, GRAY, WHITE AND ORANGE IS/ARE CLAIMED AS A FEATURE OF THE MARK.

THE MARK CONSISTS OF A GRAY BANNER WITH TAN OUTLINE WITH THE WORDS "JOHN & COOK'S" IN YELLOW AND ORANGE OVER THE BANNER, WITH A BLUE CIRCLE BELOW THE BANNER HAVING A TAN SCROLLED OUTLINE, WITH THE INTERIOR OF THE CIRCLE CONTAINING A TAN PIG WEARING A WHITE CHEF HAT AND WHITE COAT AND CARRYING A GRAY BUTCHER KNIFE, WITH THE PIG SURROUNDED BY ORANGE FLAMES AND THE WORDS "REAL PIT" IN YELLOW AND ORANGE, THE BLUE CIRCLE CONTAINING THE PIG IS FLANKED ON EITHER SIDE BY A GREEN SWIRLED LEAF, AND ALONG THE BOTTOM PORTION OF THE BLUE CIRCLE IS ANOTHER BANNER CONTAINING THE WORDS "PORK BAR-B-QUE BEEF" WITH THE WORDS "PORK" AND "BEEF" IN WHITE AND "BAR-B-QUE" IN YELLOW AND ORANGE, WITH THE BANNER BEING BLUE AND OUTLINED IN TAN AND GREEN, AND BELOW THE BLUE BANNER IS A GREEN, ORANGE AND YELLOW SCROLLED BANNER CONTAINING THE WORDS "SINCE 1936" IN TAN. THE ENTIRE MARK IS ON A TRANSPARENT BACKGROUND.

FOR RESTAURANT SERVICES (U.S. CLS. 100 AND 101).

FIRST USE 4-30-2010; IN COMMERCE 4-30-2010.
DAVID MURRAY, EXAMINING ATTORNEY

CLASS 43—(Continued).

SN 85-510,945. 541 SPRING STREET, LLC, PASO ROBLES, CA. FILED 1-6-2012.

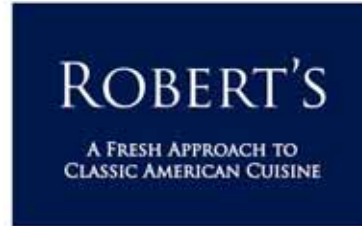

THE COLOR(S) NAVY BLUE AND WHITE IS/ARE CLAIMED AS A FEATURE OF THE MARK.

THE MARK CONSISTS OF AN ELEGANT VERSION OF A NAVY BLUE RECTANGLE, WITH THE WORD "ROBERT'S" AT THE TOP IN ALL CAPS IN WHITE LETTERING, USING THE FONT 'TRAJAN PRO', AND THE WORDS "A FRESH APPROACH TO CLASSIC AMERICAN CUISINE" AT THE BOTTOM IN ALL CAPS IN WHITE LETTERING.

FOR RESTAURANT SERVICES (U.S. CLS. 100 AND 101).

FIRST USE 8-1-2010; IN COMMERCE 12-6-2010.
JANICE L. MCMORROW, EXAMINING ATTORNEY

SN 85-511,180. BRYAN EHRENHOLM, RIVERBANK, CA. FILED 1-7-2012.

PURE JOY

THE MARK CONSISTS OF STANDARD CHARACTERS WITHOUT CLAIM TO ANY PARTICULAR FONT, STYLE, SIZE, OR COLOR.

FOR RESTAURANT SERVICES; RESTAURANT SERVICES FEATURING BAKERY GOODS; RESTAURANT SERVICES, INCLUDING SIT-DOWN SERVICE OF FOOD AND TAKE-OUT RESTAURANT SERVICES (U.S. CLS. 100 AND 101).

BRIAN NEVILLE, EXAMINING ATTORNEY

SN 85-511,315. SYMPATHY FOR THE DELI, LLC, CHAPEL HILL, NC. FILED 1-8-2012.

Sympathy for the Deli

THE MARK CONSISTS OF STANDARD CHARACTERS WITHOUT CLAIM TO ANY PARTICULAR FONT, STYLE, SIZE, OR COLOR.

FOR PROVIDING OF FOOD AND DRINK VIA A MOBILE TRUCK; RESTAURANT AND CATERING SERVICES (U.S. CLS. 100 AND 101).

CHRISTINE MARTIN, EXAMINING ATTORNEY

CLASS 43—(Continued).

SN 85-511,429. BIG FAT CHARIOT LLC, CULVER CITY, CA. FILED 1-9-2012.

BIG FAT CHARIOT

THE MARK CONSISTS OF STANDARD CHARACTERS WITHOUT CLAIM TO ANY PARTICULAR FONT, STYLE, SIZE, OR COLOR.
FOR CATERING OF FOOD AND DRINKS; PROVIDING OF FOOD AND DRINK VIA A MOBILE TRUCK (U.S. CLS. 100 AND 101).
PATRICIA EVANKO, EXAMINING ATTORNEY

SN 85-511,494. EZELL, STEVE, NORTH HOLLYWOOD, CA. FILED 1-9-2012.

Bao Down

THE MARK CONSISTS OF STANDARD CHARACTERS WITHOUT CLAIM TO ANY PARTICULAR FONT, STYLE, SIZE, OR COLOR.
FOR RESTAURANT SERVICES (U.S. CLS. 100 AND 101).
TIMOTHY FINNEGAN, EXAMINING ATTORNEY

SN 85-511,694. DJ BURGERS, INC., EUGENE, OR. FILED 1-9-2012.

WHOLESOME THROUGH & THROUGH

THE MARK CONSISTS OF STANDARD CHARACTERS WITHOUT CLAIM TO ANY PARTICULAR FONT, STYLE, SIZE, OR COLOR.
FOR RESTAURANT SERVICES (U.S. CLS. 100 AND 101).
FIRST USE 3-0-2011; IN COMMERCE 3-0-2011.
ELLEN PERKINS, EXAMINING ATTORNEY

CLASS 43—(Continued).

SN 85-511,938. MAINSAIL EPICUREAN HOTEL, LLLP, TAMPA, FL. FILED 1-9-2012.

THE EPICUREAN HOTEL

THE MARK CONSISTS OF STANDARD CHARACTERS WITHOUT CLAIM TO ANY PARTICULAR FONT, STYLE, SIZE, OR COLOR.
NO CLAIM IS MADE TO THE EXCLUSIVE RIGHT TO USE "HOTEL", APART FROM THE MARK AS SHOWN.
FOR RESORT HOTEL SERVICES (U.S. CLS. 100 AND 101).
JENNIFER VASQUEZ, EXAMINING ATTORNEY

SN 85-512,030. TASMAN, RICHARD, LOUDON, TN. FILED 1-9-2012.

THE COUNTY TAVERN

THE MARK CONSISTS OF STANDARD CHARACTERS WITHOUT CLAIM TO ANY PARTICULAR FONT, STYLE, SIZE, OR COLOR.
NO CLAIM IS MADE TO THE EXCLUSIVE RIGHT TO USE "TAVERN", APART FROM THE MARK AS SHOWN.
FOR RESTAURANT SERVICES (U.S. CLS. 100 AND 101).
HANNO RITTNER, EXAMINING ATTORNEY

SN 85-512,136. PRICE, DAVID, PACIFIC PALISADES, CA. FILED 1-9-2012.



NO CLAIM IS MADE TO THE EXCLUSIVE RIGHT TO USE "MALIBU HOTDOGS", APART FROM THE MARK AS SHOWN.
THE COLOR(S) YELLOW, BLUE, BLACK, RED, TAN, AND LAVENDER IS/ARE CLAIMED AS A FEATURE OF THE MARK.
THE MARK CONSISTS OF TWO DIAGONALLY-

CLASS 43—(Continued).

CROSSED YELLOW SURFBOARDS OUTLINED IN BLUE WITH IDENTICAL BLUE STRIPES ACROSS THEM LENGTH-WISE BEHIND A HORIZONTAL IMAGE OF A RED HOTDOG COVERED IN YELLOW MUSTARD AND PLACED IN A TAN HOTDOG BUN. THE HOTDOG AND BUN ARE OUTLINED IN BLACK. BENEATH THE HOTDOG IS THE TERM "MALIBU" IN BLUE UPPERCASE LETTERS, BENEATH WHICH IS WRITTEN "HOTDOGS" IN YELLOW AND LAVENDER UPPERCASE LETTERS. THE WORDS ARE SHADOWED IN BLACK.

FOR FAST-FOOD RESTAURANT SERVICES; MOBILE CAFE SERVICES FOR PROVIDING FOOD AND DRINK; RESTAURANT AND CATERING SERVICES; RESTAURANT SERVICES; RESTAURANT SERVICES, NAMELY, PROVIDING OF FOOD AND BEVERAGES FOR CONSUMPTION ON AND OFF THE PREMISES; TAKE-OUT RESTAURANT SERVICES (U.S. CLS. 100 AND 101).

FIRST USE 12-20-2011; IN COMMERCE 12-20-2011.
MICHAEL KEATING, EXAMINING ATTORNEY

SN 85-513,787. 681 COMPLEX, INC., HORSHAM, PA. FILED 1-11-2012.

IRON ABBEY

THE MARK CONSISTS OF STANDARD CHARACTERS WITHOUT CLAIM TO ANY PARTICULAR FONT, STYLE, SIZE, OR COLOR.

FOR BAR SERVICES; RESTAURANT SERVICES (U.S. CLS. 100 AND 101).

FIRST USE 1-1-2009; IN COMMERCE 1-1-2011.
RONALD DELGIZZI, EXAMINING ATTORNEY

CLASS 43—(Continued).

SN 85-514,097. KONA ICE, INC., FLORENCE, KY. FILED 1-11-2012.



THE COLOR(S) GREEN, RED, GRAY, BLACK, WHITE, YELLOW, PURPLE, ORANGE, AND BLUE IS/ARE CLAIMED AS A FEATURE OF THE MARK.

THE MARK CONSISTS OF A SMILING GREEN PARROT WITH THREE RED TIPPED FEATHERS ON ITS HEAD AND GRAY EYEBROWS WITH BLACK AND WHITE EYES AND YELLOW BEAK AND YELLOW CHIN AND A PURPLE TONGUE WITH RED INSIDE ITS MOUTH AND TWO FEATHERED WINGS AND FOUR ORANGE TALONS AND A GREEN, RED AND BLUE TIPPED FEATHERED TAIL.

FOR PROVIDING OF FOOD AND DRINK VIA A MOBILE TRUCK (U.S. CLS. 100 AND 101).

FIRST USE 3-1-2009; IN COMMERCE 3-1-2009.
CAROLYN CATALDO, EXAMINING ATTORNEY

SN 85-514,169. KONA ICE, INC., FLORENCE, KY. FILED 1-11-2012.



THE COLOR(S) RED GREEN WHITE BROWN YELLOW BLUE PURPLE AND BLACK IS/ARE CLAIMED AS A FEATURE OF THE MARK.

THE MARK CONSISTS OF RED CRAB WITH GREEN AND WHITE EYES AND SIX LEGS AND TWO CLAWS HOLDING BROWN PAINT BOARD WITH YELLOW, BLUE, AND PURPLE PAINTS IN LEFT CLAW AND GREEN AND WHITE PAINT BRUSH WITH BLACK BRISTLES PARTIALLY COVERED IN YELLOW PAINT IN RIGHT CLAW.

FOR PROVIDING OF FOOD AND DRINK VIA A MOBILE TRUCK (U.S. CLS. 100 AND 101).

FIRST USE 2-1-2010; IN COMMERCE 2-1-2010.
CAROLYN CATALDO, EXAMINING ATTORNEY

CLASS 43—(Continued).

SN 85-514,601. ARORA, RAVEEN, TEMPE, AZ. FILED 1-12-2012.

THE DHABA FOOD STEEPED IN
TRADITION

THE MARK CONSISTS OF STANDARD CHARACTERS WITHOUT CLAIM TO ANY PARTICULAR FONT, STYLE, SIZE, OR COLOR.
FOR RESTAURANT SERVICES (U.S. CLS. 100 AND 101).
FIRST USE 4-30-2003; IN COMMERCE 1-1-2008.
ALAIN LAPTER, EXAMINING ATTORNEY

SN 85-514,679. THOMAS ANDERSON, NEPTUNE BEACH, FL. FILED 1-12-2012.

XERO GRAVITY

THE MARK CONSISTS OF STANDARD CHARACTERS WITHOUT CLAIM TO ANY PARTICULAR FONT, STYLE, SIZE, OR COLOR.
FOR HOTEL SERVICES; RESORT HOTEL SERVICES; RESTAURANT AND HOTEL SERVICES (U.S. CLS. 100 AND 101).
KAPIL BHANOT, EXAMINING ATTORNEY

SN 85-514,848. CLUB QUARTERS FRANCHISE NETWORK LLC, NEW CANAAN, CT. FILED 1-12-2012.



OWNER OF U.S. REG. NOS. 1,912,820 AND 3,475,715.
THE MARK CONSISTS OF THE UPPERCASE LETTERS "C" AND "Q" WITH THE LETTERS CONNECTED.
FOR HOTEL SERVICES (U.S. CLS. 100 AND 101).
FIRST USE 1-1-1991; IN COMMERCE 1-1-1991.
BRENDAN REGAN, EXAMINING ATTORNEY

CLASS 43—(Continued).

SN 85-514,892. PEANUT BUTTER N' WHAT?, KEY WEST, FL. FILED 1-12-2012.

peanut butter n' WHAT?

THE MARK CONSISTS OF STANDARD CHARACTERS WITHOUT CLAIM TO ANY PARTICULAR FONT, STYLE, SIZE, OR COLOR.
FOR RESTAURANT SERVICES; RESTAURANT SERVICES FEATURING SANDWICHES, DESSERTS, PASTAS, RICE, AND WRAPS (U.S. CLS. 100 AND 101).
FIRST USE 8-31-2011; IN COMMERCE 9-16-2011.
CHRISTOPHER BUONGIORNO, EXAMINING ATTORNEY

SN 85-515,444. ELISE WETZEL, PASADENA, CA. FILED 1-12-2012.

FAST-FIRE'D

THE MARK CONSISTS OF STANDARD CHARACTERS WITHOUT CLAIM TO ANY PARTICULAR FONT, STYLE, SIZE, OR COLOR.
FOR RESTAURANTS (U.S. CLS. 100 AND 101).
KELLEY WELLS, EXAMINING ATTORNEY

SN 85-515,542. BLUE BARN & BEYOND, LLC, SAN FRANCISCO, CA. FILED 1-12-2012.

PAPAZOTE

THE MARK CONSISTS OF STANDARD CHARACTERS WITHOUT CLAIM TO ANY PARTICULAR FONT, STYLE, SIZE, OR COLOR.
THE ENGLISH TRANSLATION OF "PAPAZOTE" IN THE MARK IS "BIG DADDY".
FOR BAR SERVICES; RESTAURANT SERVICES (U.S. CLS. 100 AND 101).
NAAKWAMA ANKRAH, EXAMINING ATTORNEY

CLASS 43—(Continued).

SN 85-515,544. BLUE BARN & BEYOND, LLC, SAN FRANCISCO, CA. FILED 1-12-2012.

PAPAZOTE Y MAMACITA

THE MARK CONSISTS OF STANDARD CHARACTERS WITHOUT CLAIM TO ANY PARTICULAR FONT, STYLE, SIZE, OR COLOR.

THE ENGLISH TRANSLATION OF "PAPAZOTE Y MAMACITA" IN THE MARK IS "BIG DADDY AND LITTLE MAMA".

FOR BAR SERVICES; RESTAURANT SERVICES (U.S. CLS. 100 AND 101).

NAAKWAMA ANKRAH, EXAMINING ATTORNEY

SN 85-515,891. ZUPPERIA INC, CHICAGO, IL. FILED 1-13-2012.

Anto Supperia

THE MARK CONSISTS OF STANDARD CHARACTERS WITHOUT CLAIM TO ANY PARTICULAR FONT, STYLE, SIZE, OR COLOR.

FOR RESTAURANT SERVICES, INCLUDING SIT-DOWN SERVICE OF FOOD AND TAKE-OUT RESTAURANT SERVICES (U.S. CLS. 100 AND 101).

WILLIAM JACKSON, EXAMINING ATTORNEY

SN 85-517,077. GWIN'S RESORTS LLC, COOPER LANDING, AK. FILED 1-16-2012.

GWIN'S LODGE

THE MARK CONSISTS OF STANDARD CHARACTERS WITHOUT CLAIM TO ANY PARTICULAR FONT, STYLE, SIZE, OR COLOR.

NO CLAIM IS MADE TO THE EXCLUSIVE RIGHT TO USE "LODGE", APART FROM THE MARK AS SHOWN.

FOR RESORT LODGING SERVICES (U.S. CLS. 100 AND 101).

FIRST USE 11-1-2011; IN COMMERCE 11-1-2011.

TEJBIR SINGH, EXAMINING ATTORNEY

CLASS 43—(Continued).

SN 85-517,188. DASCHOFSKY, ELISABETH, GATESVILLE, TX. AND DASCHOFSKY, FRED, GATESVILLE, TX. FILED 1-16-2012.



NO CLAIM IS MADE TO THE EXCLUSIVE RIGHT TO USE "RIVER RANCH", APART FROM THE MARK AS SHOWN.

THE MARK CONSISTS OF THE STYLIZED TEXT "PEACOCK RIVER RANCH" WITH A DESIGN OF A PEACOCK FEATHER.

FOR PROVIDING BANQUET AND SOCIAL FUNCTION FACILITIES FOR SPECIAL OCCASIONS (U.S. CLS. 100 AND 101).

FIRST USE 5-1-2011; IN COMMERCE 5-1-2011.

TEJBIR SINGH, EXAMINING ATTORNEY

SN 85-517,681. ANDERSON VALLEY ACQUISITION COMPANY, LLC, DBA ANDERSON VALLEY BREWING COMPANY, BOONVILLE, CA. FILED 1-17-2012.

ANDERSON VALLEY BREWING COMPANY

THE MARK CONSISTS OF STANDARD CHARACTERS WITHOUT CLAIM TO ANY PARTICULAR FONT, STYLE, SIZE, OR COLOR.

NO CLAIM IS MADE TO THE EXCLUSIVE RIGHT TO USE "BREWING COMPANY", APART FROM THE MARK AS SHOWN.

SEC. 2(F).

FOR BREWPUB SERVICES (U.S. CLS. 100 AND 101).

FIRST USE 12-31-1987; IN COMMERCE 12-31-1987.

RAMONA ORTIGA, EXAMINING ATTORNEY

SN 85-538,808. DEAN-SMITH, TIMOTHY, CIRENCESTER, UNITED KINGDOM, FILED 2-9-2012.

CHILL DIFFERENT

THE MARK CONSISTS OF STANDARD CHARACTERS WITHOUT CLAIM TO ANY PARTICULAR FONT, STYLE, SIZE, OR COLOR.

FOR HOTEL, RESTAURANT AND BAR SERVICES (U.S. CLS. 100 AND 101).

MARK T. MULLEN, EXAMINING ATTORNEY

CLASS 44—MEDICAL, BEAUTY AND AGRICULTURAL SERVICES

SN 76-707,256. ACTELION PHARMACEUTICALS LTD, ALLSCHWIL, SWITZERLAND, FILED 4-13-2011.

PATHwatch

THE MARK CONSISTS OF STANDARD CHARACTERS WITHOUT CLAIM TO ANY PARTICULAR FONT, STYLE, SIZE, OR COLOR.

FOR PROVIDING A WEBSITE FEATURING MEDICAL INFORMATION IN THE FORM OF MEDICAL PROFILES FOR USE IN PATIENT MANAGEMENT, MONITORING AND CARE; PROVIDING A WEBSITE MAINTAINING A MEDICAL REGISTRY FEATURING MEDICAL INFORMATION AND MAINTAINING PATIENT RECORDS TO ENSURE THE PROPER PRESCRIBING AND DISPENSING OF PHARMACEUTICALS FOR PHYSICIANS, PHARMACISTS, AND PATIENTS; PROVIDING AN INTERNET WEB SITE FOR MEDICAL PROFESSIONALS AND MEDICAL PATIENTS FEATURING MEDICAL INFORMATION FROM REMOTE LOCATIONS THAT IS SENT TO THE WEBSITE AND CAN BE ACCESSED IN REAL-TIME BY MEDICAL PROFESSIONALS FOR PURPOSES OF PATIENT MANAGEMENT, MONITORING AND CARE (U.S. CLS. 100 AND 101).

FIRST USE 0-0-2009; IN COMMERCE 0-0-2009.
SEAN CROWLEY, EXAMINING ATTORNEY

SN 77-804,948. LEHIGH VALLEY HEALTH NETWORK, INC., ALLENTOWN, PA. FILED 8-14-2009.



OWNER OF U.S. REG. NOS. 2,875,800 AND 3,231,405.
NO CLAIM IS MADE TO THE EXCLUSIVE RIGHT TO USE "HEALTH NETWORK", APART FROM THE MARK AS SHOWN.

THE COLOR(S) GREEN, TEAL AND BLUE IS/ARE CLAIMED AS A FEATURE OF THE MARK.

THE MARK CONSISTS OF A LOGO COMPOSED OF THREE INTERWOVEN, CRESCENT SHAPES, EACH CRESCENT HAVING A COLOR OF GREEN, TEAL AND BLUE FOLLOWED BY THE WORDS "LEHIGH VALLEY HEALTH NETWORK".

SEC. 2(F) "LEHIGH VALLEY".
FOR HOSPITAL AND HEALTH CARE SERVICES (U.S. CLS. 100 AND 101).
FIRST USE 9-18-2008; IN COMMERCE 9-18-2008.
ANDREA BUTLER, EXAMINING ATTORNEY

CLASS 44—(Continued).

SN 77-806,694. LEHIGH VALLEY HEALTH NETWORK, ALLENTOWN, PA. FILED 8-18-2009.



OWNER OF U.S. REG. NOS. 2,875,800, 3,231,405 AND 3,710,081.

NO CLAIM IS MADE TO THE EXCLUSIVE RIGHT TO USE "HEALTH NETWORK", APART FROM THE MARK AS SHOWN.

THE COLOR(S) GREEN, TEAL AND BLUE IS/ARE CLAIMED AS A FEATURE OF THE MARK.

THE MARK CONSISTS OF A LOGO COMPOSED OF THREE OVERLAPPED CRESCENT DESIGNS COMPOSED OF THE COLORS GREEN, TEAL AND BLUE FOLLOWED BY THE WORDS "LEHIGH VALLEY HEALTH NETWORK" WITH A LINE UNDERNEATH FOLLOWED BY THE WORDS "A PASSION FOR BETTER MEDICINE".

SEC. 2(F) AS TO "LEHIGH VALLEY".
FOR HOSPITAL AND HEALTH CARE SERVICES (U.S. CLS. 100 AND 101).

FIRST USE 9-18-2008; IN COMMERCE 9-18-2008.
ANDREA BUTLER, EXAMINING ATTORNEY

SN 79-106,344. ANDREW JAMES MARTIN, BRENTFORD, MIDDLESEX TW8 9QH, UNITED KINGDOM, FILED 6-10-2011.

ActiveBacks

THE MARK CONSISTS OF STANDARD CHARACTERS WITHOUT CLAIM TO ANY PARTICULAR FONT, STYLE, SIZE, OR COLOR.

OWNER OF INTERNATIONAL REGISTRATION 0972449 DATED 7-11-2008, EXPIRES 7-11-2018.

FOR CHIROPRACTICS SERVICES (U.S. CLS. 100 AND 101).

MICHAEL ENGEL, EXAMINING ATTORNEY

SN 85-023,722. LAB DOCTOR INC., FORT LAUDERDALE, FL. FILED 4-26-2010.

LAB DOCTOR

THE MARK CONSISTS OF STANDARD CHARACTERS WITHOUT CLAIM TO ANY PARTICULAR FONT, STYLE, SIZE, OR COLOR.

NO CLAIM IS MADE TO THE EXCLUSIVE RIGHT TO USE "LAB", APART FROM THE MARK AS SHOWN.

FOR COLLECTION AND PRESERVATION OF HUMAN BLOOD (U.S. CLS. 100 AND 101).

FIRST USE 1-1-2010; IN COMMERCE 1-15-2010.
JOHN HWANG, EXAMINING ATTORNEY

CLASS 44—(Continued).

SN 85-130,268. BARBARA LANG TOLLEY, PALM BEACH, FL. FILED 9-15-2010.

21st Century Medical Clinic, Inc.

THE MARK CONSISTS OF STANDARD CHARACTERS WITHOUT CLAIM TO ANY PARTICULAR FONT, STYLE, SIZE, OR COLOR.

NO CLAIM IS MADE TO THE EXCLUSIVE RIGHT TO USE "MEDICAL CLINIC, INC.", APART FROM THE MARK AS SHOWN.

FOR MEDICAL CLINIC (U.S. CLS. 100 AND 101).
FIRST USE 7-20-2010; IN COMMERCE 7-20-2010.
MARLENE BELL, EXAMINING ATTORNEY

CLASS 44—(Continued).

SN 85-228,897. JOHNSON & JOHNSON, NEW BRUNSWICK, NJ. FILED 1-28-2011.



THE MARK CONSISTS OF A STYLIZED LETTER "R" LEANING TO THE RIGHT THAT IS FORMED BY FIVE SEPARATED HORIZONTAL LINES OF DIFFERENT LENGTHS THAT STRETCH TO THE LEFT OF THE LETTER AS IF DEPICTING MOTION OF THE LETTER.

FOR PROVIDING INFORMATION RELATING TO EMERGENCY FIRE, MEDICAL AND RESCUE RESPONSE SERVICES (U.S. CLS. 100 AND 101).

ANTHONY RINKER, EXAMINING ATTORNEY

SN 85-243,028. FATHER FLANAGAN'S BOYS' HOME, BOYS TOWN, NE. FILED 2-15-2011.

BOYS TOWN MODEL

THE MARK CONSISTS OF STANDARD CHARACTERS WITHOUT CLAIM TO ANY PARTICULAR FONT, STYLE, SIZE, OR COLOR.

OWNER OF U.S. REG. NOS. 1,334,772, 3,627,959 AND OTHERS.

NO CLAIM IS MADE TO THE EXCLUSIVE RIGHT TO USE "MODEL", APART FROM THE MARK AS SHOWN.

FOR PROVIDING A FULL RANGE OF FAMILY TREATMENT SERVICES, NAMELY, BEHAVIORAL TREATMENT SERVICES FOR YOUTHS, ADOLESCENTS AND CHILDREN; CONSULTING SERVICES IN THE FIELD OF HEALTH CARE; CONSULTING SERVICES IN THE FIELD OF PARENTING PERTAINING TO CHILDREN'S HEALTH (U.S. CLS. 100 AND 101).

FIRST USE 3-1-2008; IN COMMERCE 3-1-2008.
ALEXANDER L. POWERS, EXAMINING ATTORNEY

SN 85-206,549. INTERNATIONAL CANCER ADVOCACY NETWORK (ICAN), PHOENIX, AZ. FILED 12-28-2010.



NO CLAIM IS MADE TO THE EXCLUSIVE RIGHT TO USE "REMISSION", APART FROM THE MARK AS SHOWN.

THE MARK CONSISTS OF THE WORD "REMISSION" BELOW WHICH APPEARS A STYLIZED DNA HELIX, TO THE RIGHT OF WHICH APPEARS THE WORD "COACH", TO THE RIGHT OF WHICH APPEARS THE WORDING "CONNECTING PROACTIVE PATIENTS WITH CLINICAL TRIALS AND INNOVATIVE OPTIONS" IN LOWER CASE LETTERING.

FOR PROVIDING ONLINE INFORMATION IN THE FIELD OF TREATMENT OF PATIENTS WITH CHRONIC OR LETHAL DISEASE; HEALTH CARE SERVICES, NAMELY, PROVIDING ONLINE DATABASES IN THE FIELD OF CHRONIC AND LETHAL DISEASE INFORMATION AND FEATURING INPUTTING AND COLLECTION OF DATA AND INFORMATION FOR TREATMENT AND DIAGNOSTIC PURPOSES FOR PATIENTS WITH CHRONIC OR LETHAL DISEASE (U.S. CLS. 100 AND 101).

EDWARD FENNESSY, EXAMINING ATTORNEY

SN 85-351,880. FORBES, SHANE M., DBA TRY WELLNESS, LANGHORNE, PA. FILED 6-21-2011.

TRY WELLNESS

THE MARK CONSISTS OF STANDARD CHARACTERS WITHOUT CLAIM TO ANY PARTICULAR FONT, STYLE, SIZE, OR COLOR.

NO CLAIM IS MADE TO THE EXCLUSIVE RIGHT TO USE "WELLNESS", APART FROM THE MARK AS SHOWN. FOR HEALTH CARE SERVICES, NAMELY, WELLNESS PROGRAMS (U.S. CLS. 100 AND 101).

FIRST USE 5-27-2008; IN COMMERCE 6-1-2011.
ANTHONY RINKER, EXAMINING ATTORNEY

CLASS 44—(Continued).

SN 85-352,591. SOUTH NASSAU COMMUNITIES HOSPITAL, OCEANSIDE, NY. FILED 6-22-2011.

SOUTH NASSAU COMMUNITIES
HOSPITAL

THE MARK CONSISTS OF STANDARD CHARACTERS WITHOUT CLAIM TO ANY PARTICULAR FONT, STYLE, SIZE, OR COLOR.

NO CLAIM IS MADE TO THE EXCLUSIVE RIGHT TO USE "HOSPITAL", APART FROM THE MARK AS SHOWN. SEC. 2(F).

FOR MEDICAL SERVICES; HOSPITAL SERVICES; SURGICAL SERVICES, AMBULATORY SURGICAL SERVICES, WOMEN'S MEDICAL IMAGING SERVICES, CARDIOVASCULAR EXAMINATION AND ASSESSMENT FOR MEDICAL DIAGNOSTIC PURPOSES, RADIOLOGIC MEDICAL IMAGING SERVICES, RADIOLOGIC SURGICAL SERVICES, BEHAVIORAL HEALTH SERVICES; HEALTH CARE SERVICES, NAMELY, CLINICAL SERVICES, PHYSICIAN SERVICES, DENTISTRY SERVICES, MEDICAL DIAGNOSTIC TESTING SERVICES, AND NURSING CARE SERVICES; MEDICAL COUNSELING; HEALTH CARE CONSULTING SERVICES; MEDICAL, PHYSICAL REHABILITATION AND PHYSICAL THERAPY SERVICES; PROVIDING HEALTH INFORMATION; PROVIDING MEDICAL INFORMATION, CONSULTANCY AND ADVISORY SERVICES; PROVIDING A WEB SITE FEATURING MEDICAL INFORMATION (U.S. CLS. 100 AND 101).

FIRST USE 0-0-1927; IN COMMERCE 0-0-1927.
DOMINIC FATHY, EXAMINING ATTORNEY

SN 85-352,626. SOUTH NASSAU COMMUNITIES HOSPITAL, OCEANSIDE, NY. FILED 6-22-2011.

SOUTH NASSAU

THE MARK CONSISTS OF STANDARD CHARACTERS WITHOUT CLAIM TO ANY PARTICULAR FONT, STYLE, SIZE, OR COLOR.

SEC. 2(F).

FOR MEDICAL SERVICES; HOSPITAL SERVICES; SURGICAL SERVICES, AMBULATORY SURGICAL SERVICES, WOMEN'S MEDICAL IMAGING SERVICES, CARDIOVASCULAR EXAMINATION AND ASSESSMENT FOR MEDICAL DIAGNOSTIC PURPOSES, RADIOLOGIC MEDICAL IMAGING SERVICES, RADIOLOGIC SURGICAL SERVICES, BEHAVIORAL HEALTH SERVICES; HEALTH CARE SERVICES, NAMELY, CLINICAL SERVICES, PHYSICIAN SERVICES, DENTISTRY SERVICES, MEDICAL DIAGNOSTIC TESTING SERVICES, AND NURSING CARE SERVICES; MEDICAL COUNSELING; HEALTH CARE CONSULTING SERVICES; MEDICAL, PHYSICAL REHABILITATION AND PHYSICAL THERAPY SERVICES; PROVIDING HEALTH INFORMATION; PROVIDING MEDICAL INFORMATION, CONSULTANCY AND ADVISORY SERVICES; PROVIDING A WEB SITE FEATURING MEDICAL INFORMATION (U.S. CLS. 100 AND 101).

FIRST USE 0-0-1927; IN COMMERCE 0-0-1927.
DOMINIC FATHY, EXAMINING ATTORNEY

CLASS 44—(Continued).

SN 85-352,666. SOUTH NASSAU COMMUNITIES HOSPITAL, OCEANSIDE, NY. FILED 6-22-2011.



THE MARK CONSISTS OF THE LETTERS "S" AND "N" IN A STYLIZED FORM WITH A CIRCLE APPEARING ABOVE THE LETTER "S".

FOR MEDICAL SERVICES; HOSPITAL SERVICES; SURGICAL SERVICES, AMBULATORY SURGICAL SERVICES, WOMEN'S MEDICAL IMAGING SERVICES, CARDIOVASCULAR EXAMINATION AND ASSESSMENT FOR MEDICAL DIAGNOSTIC PURPOSES, RADIOLOGIC MEDICAL IMAGING SERVICES, RADIOLOGIC SURGICAL SERVICES, BEHAVIORAL HEALTH SERVICES; HEALTH CARE SERVICES, NAMELY, CLINICAL SERVICES, PHYSICIAN SERVICES, DENTISTRY SERVICES, MEDICAL DIAGNOSTIC TESTING SERVICES, AND NURSING CARE SERVICES; MEDICAL COUNSELING; HEALTH CARE CONSULTING SERVICES; MEDICAL, PHYSICAL REHABILITATION AND PHYSICAL THERAPY SERVICES; PROVIDING HEALTH INFORMATION; PROVIDING MEDICAL INFORMATION, CONSULTANCY AND ADVISORY SERVICES; PROVIDING A WEB SITE FEATURING MEDICAL INFORMATION (U.S. CLS. 100 AND 101).

FIRST USE 0-0-1998; IN COMMERCE 0-0-1998.
DOMINIC FATHY, EXAMINING ATTORNEY

SN 85-352,687. SOUTH NASSAU COMMUNITIES HOSPITAL, OCEANSIDE, NY. FILED 6-22-2011.

TOUCHING LIVES, ONE
PATIENT AT A TIME

THE MARK CONSISTS OF STANDARD CHARACTERS WITHOUT CLAIM TO ANY PARTICULAR FONT, STYLE, SIZE, OR COLOR.

FOR MEDICAL SERVICES; HOSPITAL SERVICES; SURGICAL SERVICES, AMBULATORY SURGICAL SERVICES, WOMEN'S MEDICAL IMAGING SERVICES, CARDIOVASCULAR EXAMINATION AND ASSESSMENT FOR MEDICAL DIAGNOSTIC PURPOSES, RADIOLOGIC MEDICAL IMAGING SERVICES, RADIOLOGIC SURGICAL SERVICES, BEHAVIORAL HEALTH SERVICES; HEALTH CARE SERVICES, NAMELY, CLINICAL SERVICES, PHYSICIAN SERVICES, DENTISTRY SERVICES, MEDICAL DIAGNOSTIC TESTING SERVICES, AND NURSING CARE SERVICES; MEDICAL COUNSELING; HEALTH CARE CONSULTING SERVICES; MEDICAL, PHYSICAL REHABILITATION AND PHYSICAL THERAPY SERVICES; PROVIDING HEALTH INFORMATION; PROVIDING MEDICAL INFORMATION, CONSULTANCY AND ADVISORY SERVICES; PROVIDING A WEB SITE FEATURING MEDICAL INFORMATION (U.S. CLS. 100 AND 101).

FIRST USE 0-0-1998; IN COMMERCE 0-0-1998.
DOMINIC FATHY, EXAMINING ATTORNEY

CLASS 44—(Continued).

SN 85-352,741. VENKAT VAJJHALA, WEST WINDSOR, NJ. FILED 6-22-2011.

CLASS 44—(Continued).

SN 85-357,352. JFK/MERIDIAN HOME CARE SERVICES LLC, PLAINFIELD, NJ. FILED 6-27-2011.

Get Good, Give Good

THE MARK CONSISTS OF STANDARD CHARACTERS WITHOUT CLAIM TO ANY PARTICULAR FONT, STYLE, SIZE, OR COLOR.

FOR CHARITABLE SERVICES, NAMELY, PROVIDING BAGS OR KITS OF HEALTHCARE, PERSONAL CARE, TOILETRIES, SAFETY, SURVIVAL OR EDUCATIONAL SUPPLY ITEMS TO PERSONS OR COMMUNITIES IN NEED; SERVICES TO ENABLE CUSTOMERS TO CHOOSE AFORESAID CHARITABLE ITEMS TO PROVIDE TO PERSONS OR COMMUNITIES IN NEED (U.S. CLS. 100 AND 101).

MATTHEW KLINE, EXAMINING ATTORNEY

JFK AT HOME

SN 85-354,716. MOELLEKEN, BRENT R.W., BEVERLY HILLS, CA. FILED 6-23-2011.

STEMCELLFILL

THE MARK CONSISTS OF STANDARD CHARACTERS WITHOUT CLAIM TO ANY PARTICULAR FONT, STYLE, SIZE, OR COLOR.

FOR COSMETIC AND PLASTIC SURGERY (U.S. CLS. 100 AND 101).

FIRST USE 5-0-2007; IN COMMERCE 5-0-2007.

REBECCA EISINGER, EXAMINING ATTORNEY

THE MARK CONSISTS OF STANDARD CHARACTERS WITHOUT CLAIM TO ANY PARTICULAR FONT, STYLE, SIZE, OR COLOR.

NO CLAIM IS MADE TO THE EXCLUSIVE RIGHT TO USE "AT HOME", APART FROM THE MARK AS SHOWN.

FOR HEALTH CARE SERVICES, NAMELY, PROVIDING MEDICAL ASSISTANCE TO OTHERS IN THE FIELD OF HOME HEALTH CARE, MEDICATION MANAGEMENT, CHRONIC DISEASE, END OF LIFE CARE AND CARE GIVING, NUTRITIONAL COUNSELING; PROVIDING IN HOME CERTIFIED HEALTH CARE SERVICES IN THE FIELDS OF PEDIATRIC CARE, MATERNAL-CHILD HEALTH SERVICES, WOUND CARE AND OSTOMY SERVICES, PHYSICAL THERAPY SERVICES, REHABILITATION SERVICES, OCCUPATIONAL THERAPY SERVICES, SPEECH AND LANGUAGE PATHOLOGY SERVICES, PRIVATE DUTY SERVICES, HOSPICE SERVICES, PALLIATIVE CARE SERVICES AND INFUSION THERAPY SERVICES PROVIDED BY REGISTERED NURSES, LICENSED PRACTICAL NURSES, CERTIFIED HOME HEALTH AIDES, SPEECH PATHOLOGISTS, PHYSICAL AND OCCUPATIONAL THERAPISTS, MEDICAL SOCIAL WORKERS, PHARMACISTS, CHAPLAINS, COMPANIONS AND VOLUNTEERS; RENTING AND LEASING DURABLE MEDICAL EQUIPMENT AND DEVICES; PROVIDING DURABLE MEDICAL EQUIPMENT, MEDICAL DEVICES AND MEDICAL SUPPLIES FOR USE IN THE HOME (U.S. CLS. 100 AND 101).

FIRST USE 5-1-2011; IN COMMERCE 5-1-2011.

SALLY SHIH, EXAMINING ATTORNEY

CLASS 44—(Continued).

SN 85-360,630. EAST RIVER ACUPUNCTURE AND MASSAGE THERAPY PLLC, NEW YORK, NY. FILED 6-30-2011.



NO CLAIM IS MADE TO THE EXCLUSIVE RIGHT TO USE "WOMAN", "ACUPUNCTURE" AND "MEDICAL MASSAGE", APART FROM THE MARK AS SHOWN.
 THE COLOR(S) BLUE, LIGHT BLUE AND PINK IS/ARE CLAIMED AS A FEATURE OF THE MARK.
 THE MARK CONSISTS OF A CIRCLE WITH A LIGHT BLUE, PINK AND BLUE KALEIDOSCOPE SURROUNDED BY A PINK CIRCLE WITH THE WORDS "WELL BALANCED WOMAN" APPEARING IN BLUE AND THE WORDS "ACUPUNCTURE + MEDICAL MASSAGE" UNDERNEATH IN LIGHT BLUE.
 FOR ACUPUNCTURE AND MEDICAL MASSAGE SERVICES (U.S. CLS. 100 AND 101).
 FIRST USE 5-1-2011; IN COMMERCE 5-1-2011.
 CHARLES L. JENKINS, EXAMINING ATTORNEY

SN 85-362,367. DELTA DENTAL PLAN OF NEW HAMPSHIRE, INC., CONCORD, NH. FILED 7-2-2011.

HEALTH THROUGH ORAL WELLNESS

THE MARK CONSISTS OF STANDARD CHARACTERS WITHOUT CLAIM TO ANY PARTICULAR FONT, STYLE, SIZE, OR COLOR.
 FOR ORAL HEALTH SERVICES, NAMELY, PATIENT-CENTERED ORAL HEALTH MANAGEMENT PROGRAMS IN THE NATURE OF PROVIDING ORAL HEALTH INFORMATION TO PATIENTS, AND DENTAL AND MEDICAL PROVIDERS, AND PROVIDING ORAL HEALTH DISEASE MANAGEMENT SERVICES TO EMPLOYER GROUPS ON A CONTRACT BASIS (U.S. CLS. 100 AND 101).
 MATTHEW KLINE, EXAMINING ATTORNEY

CLASS 44—(Continued).

SN 85-369,082. MARIA C. SCOTT, ANNAPOLIS, MD. FILED 7-12-2011.



OWNER OF U.S. REG. NOS. 2,943,352 AND 3,014,975.
 NO CLAIM IS MADE TO THE EXCLUSIVE RIGHT TO USE "EYE CARE AND LASER CENTER", APART FROM THE MARK AS SHOWN.
 THE COLOR(S) GREEN, BLACK AND WHITE IS/ARE CLAIMED AS A FEATURE OF THE MARK.
 THE MARK CONSISTS OF THE WORD "CHESAPEAKE" IN GREEN AND THE WORDS "EYE CARE AND LASER CENTER" IN BLACK BENEATH A GREEN AND WHITE SHADED CIRCLE WITH A WAVY BLACK LINE ABOVE THE CIRCLE, ALL INSIDE A BLACK SINGLE LINE RECTANGLE.
 SEC. 2(F) AS TO "CHESAPEAKE EYE CARE AND LASER CENTER".
 FOR OPHTHALMOLOGY SERVICES (U.S. CLS. 100 AND 101).
 FIRST USE 7-0-2007; IN COMMERCE 7-0-2007.
 SARA BENJAMIN, EXAMINING ATTORNEY

SN 85-371,158. GRINGERI, RICHARD, SAN JOSE, CA. FILED 7-14-2011.

the human engine clinic

THE MARK CONSISTS OF STANDARD CHARACTERS WITHOUT CLAIM TO ANY PARTICULAR FONT, STYLE, SIZE, OR COLOR.
 NO CLAIM IS MADE TO THE EXCLUSIVE RIGHT TO USE "CLINIC", APART FROM THE MARK AS SHOWN.
 FOR CHIROPRACTIC SERVICES (U.S. CLS. 100 AND 101).
 FIRST USE 10-1-2008; IN COMMERCE 10-1-2008.
 SEAN CROWLEY, EXAMINING ATTORNEY

CLASS 44—(Continued).

SN 85-380,702. EYE CANDY OPTICAL CENTER, P.C.,
CANONSBURG, PA. FILED 7-26-2011.



THE MARK CONSISTS OF A LOWERCASE LETTER "E" FORMING THE BOUNDARY OF A HUMAN EYE IRIS, BOTH ELEMENTS DEFINED ON A THREE-DIMENSIONALLY APPEARING BEAD WITH SHADOW EFFECTS.
FOR OPTOMETRY SERVICES (U.S. CLS. 100 AND 101).
FIRST USE 9-1-2009; IN COMMERCE 9-1-2009.
LUCY ARANT, EXAMINING ATTORNEY

SN 85-392,871. LASER SPINE INSTITUTE, LLC, DBA LASER SPINE INSTITUTE, TAMPA, FL. FILED 8-9-2011.

Total Z Foraminotomy

THE MARK CONSISTS OF STANDARD CHARACTERS WITHOUT CLAIM TO ANY PARTICULAR FONT, STYLE, SIZE, OR COLOR.
NO CLAIM IS MADE TO THE EXCLUSIVE RIGHT TO USE "FORAMINOTOMY", APART FROM THE MARK AS SHOWN.
FOR SPINAL SURGERY, NAMELY, FORAMINOTOMY PERFORMED FROM AN ANTERIOR AND POSTERIOR ANGLE (U.S. CLS. 100 AND 101).
RICHARD WHITE, EXAMINING ATTORNEY

SN 85-397,435. ROBERTS, OLIVIA, TA OLIVER ROBERTS TA RESOLUTION MAGIC, BOURNEMOUTH, UNITED KINGDOM, FILED 8-14-2011.

Resolution Magic

THE MARK CONSISTS OF STANDARD CHARACTERS WITHOUT CLAIM TO ANY PARTICULAR FONT, STYLE, SIZE, OR COLOR.
PRIORITY CLAIMED UNDER SEC. 44(D) ON UNITED KINGDOM APPLICATION NO. 2582159, FILED 5-23-2011, REG. NO. 2582159, DATED 11-11-2011, EXPIRES 5-23-2021.
FOR PROVIDING A WEBSITE FEATURING INFORMATION CONCERNING ALTERNATIVE HEALTH AND HEALING; STRESS REDUCTION THERAPY (U.S. CLS. 100 AND 101).
TRICIA SONNEBORN, EXAMINING ATTORNEY

CLASS 44—(Continued).

SN 85-411,443. AKITA, INC., WILMINGTON, DE. FILED 8-31-2011.

HEALTH DIRECT (HDI)

THE MARK CONSISTS OF STANDARD CHARACTERS WITHOUT CLAIM TO ANY PARTICULAR FONT, STYLE, SIZE, OR COLOR.
NO CLAIM IS MADE TO THE EXCLUSIVE RIGHT TO USE "HEALTH", APART FROM THE MARK AS SHOWN.
FOR MANAGED HEALTH CARE SERVICES (U.S. CLS. 100 AND 101).
FIRST USE 1-0-1992; IN COMMERCE 1-0-1992.
SUSAN RICHARDS, EXAMINING ATTORNEY

SN 85-420,825. ANDVENTURE, INC., HARRISBURG, PA. FILED 9-12-2011.

LINKS2CARE

THE MARK CONSISTS OF STANDARD CHARACTERS WITHOUT CLAIM TO ANY PARTICULAR FONT, STYLE, SIZE, OR COLOR.
OWNER OF U.S. REG. NO. 2,998,617.
FOR HOME HEALTH CARE SERVICES (U.S. CLS. 100 AND 101).
FIRST USE 10-1-2002; IN COMMERCE 8-22-2007.
DAWN FELDMAN, EXAMINING ATTORNEY

CLASS 44—(Continued).

SN 85-426,541. JACKSON, GINGER J., DBA CUMBERLAND DOCTORS DIET CLINICS, P.C., ESTILL SPRINGS, TN. FILED 9-19-2011.



NO CLAIM IS MADE TO THE EXCLUSIVE RIGHT TO USE "SLIM" AND "RX", APART FROM THE MARK AS SHOWN.

THE COLOR(S) RED, WHITE AND BLACK IS/ARE CLAIMED AS A FEATURE OF THE MARK.

THE MARK CONSISTS OF THE WORDING "SLIM NOW" WITH THE LETTERING BEING LARGER AT EACH END AND SMALLER TOWARDS THE CENTER, THE LETTERS ARE SHOWN IN THE COLOR RED AND INTERSECTED BY A DESIGN OF A TAPE-MEASURE, WITH NUMBERS AND VERTICAL LINES, SHOWN IN THE COLORS BLACK AND WHITE. THE LETTERS "RX" ARE SHOWN IN THE COLOR BLACK AND FOLLOW THE LETTER "W" IN "SLIM NOW".

FOR HEALTH ASSESSMENT SERVICES, NAMELY, PROVIDING METABOLIC ASSESSMENT PROFILES (MAP) TO CLIENTS OBTAINED BY USING A PORTABLE METABOLIC MEASUREMENT SYSTEM IN THE NATURE OF A UNIQUE, HEART-RATE BASED OVERVIEW OF THEIR OWN METABOLISM IN ORDER TO ASSIST IN REACHING WEIGHT LOSS, SPORTS PERFORMANCE, HEALTH, FITNESS, AND WELLNESS-RELATED GOALS; MEDICAL AND PHARMACEUTICAL CONSULTATION; MEDICAL CLINIC PROVIDING WEIGHT LOSS SOLUTIONS, SERVICES AND PROGRAMS, NUTRITION COUNSELING, HORMONE THERAPY, INCLUDING, BIOIDENTICAL HORMONE REPLACEMENT, ANTI AGING THERAPY, AND NATURAL HORMONE THERAPY, MEDICAL AESTHETIC PROCEDURES, INCLUDING, LASER HAIR REMOVAL, LASER PEELS, BOTULINUM TOXIN TREATMENTS, MICRODERMABRASION, LIPOSUCTION, VEIN TREATMENTS, VEIN THERAPY, CELLULITE TREATMENTS, BODY CONTOURING TREATMENTS, INJECTABLE FILLER TREATMENTS, FACIALS, AND SKIN CARE; MEDICAL CLINICS; MEDICAL SERVICES, NAMELY, WEIGHT LOSS MANAGEMENT; NON-INVASIVE COSMETIC MEDICAL PROCEDURES; PREPARATION AND DISPENSING OF MEDICATIONS; PROVIDING A WEB SITE FEATURING MEDICAL INFORMATION; PROVIDING ASSISTANCE, FITNESS EVALUATION AND CONSULTATION TO INDIVIDUALS TO HELP THEM MAKE HEALTH, WELLNESS AND NUTRITIONAL CHANGES IN THEIR DAILY LIVING TO IMPROVE HEALTH; PROVIDING INFORMATION ON MAINTAINING A HEALTHY LIFESTYLE AND LOSING WEIGHT; PROVIDING MEDICAL INFORMATION, CONSULTANCY AND ADVISORY SERVICES; PROVIDING WEIGHT LOSS PROGRAM SERVICES; PROVIDING WEIGHT LOSS PROGRAMS AND COSMETIC BODY CARE SERVICES IN THE NATURE OF NON-SURGICAL BODY CONTOURING; WEIGHT REDUCTION DIET PLANNING AND SUPERVISION (U.S. CLS. 100 AND 101).

FIRST USE 3-9-2009; IN COMMERCE 3-9-2009.
LINDA E. BLOHM, EXAMINING ATTORNEY

CLASS 44—(Continued).

SN 85-428,605. CHILD & ADOLESCENT BIPOLAR FOUNDATION, EVANSTON, IL. FILED 9-21-2011.

THE BALANCED MIND FOUNDATION

THE MARK CONSISTS OF STANDARD CHARACTERS WITHOUT CLAIM TO ANY PARTICULAR FONT, STYLE, SIZE, OR COLOR.

NO CLAIM IS MADE TO THE EXCLUSIVE RIGHT TO USE "FOUNDATION", APART FROM THE MARK AS SHOWN.

FOR PROVIDING A WEBSITE FEATURING HEALTH INFORMATION ON MOOD DISORDERS; PROVIDING A WEBSITE FEATURING INFORMATION IN THE FIELD OF MENTAL HEALTH, NAMELY, MOOD DISORDERS (U.S. CLS. 100 AND 101).

FIRST USE 9-16-2011; IN COMMERCE 9-16-2011.
EMILY CHUO, EXAMINING ATTORNEY

SN 85-446,769. OCEANS HEALTHCARE, LLC, LAKE CHARLES, LA. FILED 10-13-2011.

Oceans Healthcare

THE MARK CONSISTS OF STANDARD CHARACTERS WITHOUT CLAIM TO ANY PARTICULAR FONT, STYLE, SIZE, OR COLOR.

NO CLAIM IS MADE TO THE EXCLUSIVE RIGHT TO USE "HEALTHCARE", APART FROM THE MARK AS SHOWN.

FOR HOSPITALS (U.S. CLS. 100 AND 101).
FIRST USE 0-0-2004; IN COMMERCE 0-0-2004.
ALYSSA STEEL, EXAMINING ATTORNEY

SN 85-446,915. OCEANS HEALTHCARE, LLC, LAKE CHARLES, LA. FILED 10-13-2011.

Oceans Behavioral Hospital

THE MARK CONSISTS OF STANDARD CHARACTERS WITHOUT CLAIM TO ANY PARTICULAR FONT, STYLE, SIZE, OR COLOR.

NO CLAIM IS MADE TO THE EXCLUSIVE RIGHT TO USE "BEHAVIORAL HOSPITAL", APART FROM THE MARK AS SHOWN.

FOR HOSPITALS (U.S. CLS. 100 AND 101).
FIRST USE 0-0-2004; IN COMMERCE 0-0-2004.
ALYSSA STEEL, EXAMINING ATTORNEY

CLASS 44—(Continued).

SN 85-459,768. AXUM INTERNATIONAL GATEWAY, ALEXANDRIA, VA. FILED 10-29-2011.



NO CLAIM IS MADE TO THE EXCLUSIVE RIGHT TO USE "INTERNATIONAL", APART FROM THE MARK AS SHOWN.

THE COLOR(S) YELLOW, GREEN, ORANGE, BLACK AND WHITE IS/ARE CLAIMED AS A FEATURE OF THE MARK.

THE MARK CONSISTS OF A WHITE BACKGROUND TRIANGLE WITH A BLACK OUTLINE, CONTAINING TWO INTERLOCKING HANDS IN ORANGE WITH BLACK DETAIL; THE THUMB, PINKY AND RING FINGER OF THE LEFT IS INTERLOCKED WITH THE THUMB, INDEX AND MIDDLE FINGER OF THE RIGHT HAND. BELOW THIS DESIGN ARE THE WORDS "AXUM INTERNATIONAL", WITH A YELLOW COLOR AT THE TOP OF EACH LETTER SHADING TO GREEN TOWARD THE BOTTOM OF THE LETTERS. BELOW THIS TERM IS THE PHRASE "GATEWAY TO THE NEW WORLD", IN BLACK WITH A GREEN BORDER AROUND EACH LETTER.

FOR HOLISTIC HEALTH SERVICES (U.S. CLS. 100 AND 101).

FIRST USE 7-1-2011; IN COMMERCE 9-1-2011.
HENRY S. ZAK, EXAMINING ATTORNEY

SN 85-462,523. NUTRI/SYSTEM IPHC, INC., WILMINGTON, DE. FILED 11-2-2011.

NUTRISYSTEM SUCCESS

THE MARK CONSISTS OF STANDARD CHARACTERS WITHOUT CLAIM TO ANY PARTICULAR FONT, STYLE, SIZE, OR COLOR.

OWNER OF U.S. REG. NOS. 1,251,922, 3,709,974 AND OTHERS.

FOR HEALTH CARE SERVICES, NAMELY, PROVIDING TREATMENT, PLANNING AND COUNSELING FOR WEIGHT REDUCTION AND OBESITY, WEIGHT MANAGEMENT IN THE NATURE OF WEIGHT LOSS AND/OR WEIGHT MAINTENANCE PROGRAMS, AND WEIGHT REDUCTION DIET SUPERVISION, NAMELY, PROVIDING INDIVIDUALS WITH CUSTOMIZED WEIGHT LOSS AND WEIGHT MANAGEMENT COUNSELING, WEIGHT MANAGEMENT PLANNING AND TRANSITION PLANNING, AND NUTRITION BEHAVIOR MODIFICATION, ALL PROVIDED BY TELEPHONE AND THE INTERNET, AND DISTRIBUTION OF PRINT MATERIALS RELATED THERETO (U.S. CLS. 100 AND 101).

CHARLOTTE CORWIN, EXAMINING ATTORNEY

CLASS 44—(Continued).

SN 85-463,232. NUTRI/SYSTEM IPHC, INC., WILMINGTON, DE. FILED 11-3-2011.

GET ON IT

THE MARK CONSISTS OF STANDARD CHARACTERS WITHOUT CLAIM TO ANY PARTICULAR FONT, STYLE, SIZE, OR COLOR.

FOR HEALTH CARE SERVICES, NAMELY, PROVIDING TREATMENT, PLANNING AND COUNSELING FOR WEIGHT REDUCTION AND OBESITY, WEIGHT MANAGEMENT IN THE NATURE OF WEIGHT LOSS AND/OR WEIGHT MAINTENANCE PROGRAMS, AND WEIGHT REDUCTION DIET SUPERVISION, NAMELY, PROVIDING INDIVIDUALS WITH CUSTOMIZED WEIGHT LOSS AND WEIGHT MANAGEMENT COUNSELING, WEIGHT MANAGEMENT PLANNING AND TRANSITION PLANNING, AND NUTRITION BEHAVIOR MODIFICATION, ALL PROVIDED BY TELEPHONE AND THE INTERNET, AND DISTRIBUTION OF PRINT MATERIALS RELATED THERETO (U.S. CLS. 100 AND 101).

CHARLOTTE CORWIN, EXAMINING ATTORNEY

SN 85-470,775. GOODRUM HEALTH ENTERPRISES, P.A., OLATHE, KS. FILED 11-11-2011.

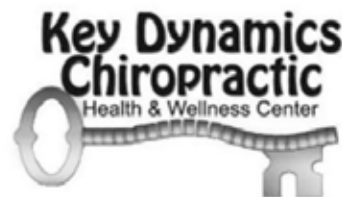

NO CLAIM IS MADE TO THE EXCLUSIVE RIGHT TO USE "CHIROPRACTIC HEALTH & WELLNESS CENTER", APART FROM THE MARK AS SHOWN.

THE MARK CONSISTS OF THE WORDS "KEY DYNAMICS" STACKED ON TOP OF THE WORD "CHIROPRACTIC", WHICH IS STACKED ON TOP OF THE WORDS "HEALTH & WELLNESS CENTER". ALL OF THE WORDS PRESENTED WITH INITIAL CAPITAL LETTERS, AND THE IMAGE OF A SKELETON KEY HAVING A SHANK DEPICTED IN THE FORM OF A STYLIZED HUMAN VERTEBRAL COLUMN.

FOR CHIROPRACTIC SERVICES; NUTRITIONAL GUIDANCE SERVICES; PHYSICAL REHABILITATION SERVICES; PROVIDING CONSULTATION AND GUIDANCE TO INDIVIDUALS REGARDING HEALTH, WELLNESS AND NUTRITION (U.S. CLS. 100 AND 101).

FIRST USE 1-31-2008; IN COMMERCE 1-31-2008.
BARBARA GAYNOR, EXAMINING ATTORNEY

CLASS 44—(Continued).

SN 85-472,190. THE BONNELL FOUNDATION, ROYAL OAK, MI. FILED 11-14-2011.

**ROADMAP TO CF LIVE BREATHE
INSPIRE**

THE MARK CONSISTS OF STANDARD CHARACTERS WITHOUT CLAIM TO ANY PARTICULAR FONT, STYLE, SIZE, OR COLOR.

NO CLAIM IS MADE TO THE EXCLUSIVE RIGHT TO USE "CF", APART FROM THE MARK AS SHOWN.

FOR PROVIDING AN INTERNET WEBSITE VIA A GLOBAL COMPUTER NETWORK FEATURING INFORMATION AND COMPREHENSIVE CONTENT FOR PARENTS, GUARDIANS AND CARETAKERS OF CHILDREN AND OTHER PERSONS WITH CYSTIC FIBROSIS IN THE FIELD OF MANAGING AND TREATING CYSTIC FIBROSIS; PROVIDING AN INTERNET WEBSITE FEATURING INFORMATION ABOUT PATIENT MEDICAL INFORMATION WHERE PATIENTS CAN INQUIRE ABOUT MEDICAL ISSUES AND PROCEDURES FROM OTHER PATIENTS AND CAN RELAY INFORMATION ABOUT THEIR MEDICAL EXPERIENCES FOR SUPPORT AND COMMUNITY IN THE FIELD OF CYSTIC FIBROSIS (U.S. CLS. 100 AND 101).

FIRST USE 7-31-2010; IN COMMERCE 7-31-2010.
DAVID I, EXAMINING ATTORNEY

SN 85-472,275. THE BONNELL FOUNDATION, ROYAL OAK, MI. FILED 11-14-2011.



NO CLAIM IS MADE TO THE EXCLUSIVE RIGHT TO USE "CF", "FOUNDATION" AND "CYSTIC FIBROSIS", APART FROM THE MARK AS SHOWN.

THE COLOR(S) PURPLE, BLUE, YELLOW AND GREEN IS/ARE CLAIMED AS A FEATURE OF THE MARK.

THE MARK CONSISTS OF A PURPLE FAMILY SILHOUETTE DISPOSED ABOVE A CURVED GREEN PATHWAY OUTLINE AT LEFT, WITH WORDING AT RIGHT CONSISTING OF "ROADMAP TO CF" IN BLUE CAPITAL LETTERS, ABOVE THE WORD "LIVE" IN YELLOW CAPITAL LETTERS, A BLUE DOT, THE WORD "BREATHE" IN PURPLE CAPITAL LETTERS, ANOTHER BLUE DOT, AND THE WORD "INSPIRE" IN GREEN CAPITAL LETTERS, ALL DISPOSED ABOVE THE WORDING "THE BONNELL FOUNDATION: LIVING WITH CYSTIC FIBROSIS" IN BLUE LETTERING.

FOR PROVIDING AN INTERNET WEBSITE VIA A GLOBAL COMPUTER NETWORK FEATURING INFORMATION AND COMPREHENSIVE CONTENT FOR PARENTS, GUARDIANS AND CARETAKERS OF CHILDREN AND OTHER PERSONS WITH CYSTIC FIBROSIS IN THE FIELD OF MANAGING AND TREATING CYSTIC FIBROSIS; PROVIDING AN INTERNET WEBSITE FEATURING INFORMATION ABOUT PATIENT MEDICAL INFORMATION WHERE PATIENTS CAN INQUIRE ABOUT MEDICAL ISSUES AND PROCEDURES FROM OTHER PATIENTS AND CAN RELAY INFORMATION ABOUT THEIR MEDICAL EXPERIENCES FOR SUPPORT AND COMMUNITY IN THE FIELD OF CYSTIC FIBROSIS (U.S. CLS. 100 AND 101).

FIRST USE 7-31-2010; IN COMMERCE 7-31-2010.
DAVID I, EXAMINING ATTORNEY

CLASS 44—(Continued).

SN 85-472,361. NYDOO, MANGHI, MARINA DEL REY, CA. FILED 11-14-2011.

Painless Trigger Point

THE MARK CONSISTS OF STANDARD CHARACTERS WITHOUT CLAIM TO ANY PARTICULAR FONT, STYLE, SIZE, OR COLOR.

NO CLAIM IS MADE TO THE EXCLUSIVE RIGHT TO USE "TRIGGER POINT", APART FROM THE MARK AS SHOWN.

FOR BODYWORK THERAPY, USING A NEUROMUSCULAR TECHNIQUE TO AID IN PAIN RELIEF AND MUSCLE TONE RESTORATION (U.S. CLS. 100 AND 101).

FIRST USE 4-7-2007; IN COMMERCE 4-7-2007.
CHARLOTTE CORWIN, EXAMINING ATTORNEY

SN 85-480,483. ERNEST ROBERT WARDIUS, DMD, READING, PA. FILED 11-23-2011.

**DR. ROB'S RETROFIT
TECHNIQUE**

THE MARK CONSISTS OF STANDARD CHARACTERS WITHOUT CLAIM TO ANY PARTICULAR FONT, STYLE, SIZE, OR COLOR.

NO CLAIM IS MADE TO THE EXCLUSIVE RIGHT TO USE "RETROFIT TECHNIQUE", APART FROM THE MARK AS SHOWN.

THE NAME(S), PORTRAIT(S), AND/OR SIGNATURE(S) SHOWN IN THE MARK IDENTIFIES THE NICKNAME OF "DR. ERNEST ROBERT WARDIUS", A LIVING INDIVIDUAL, WHOSE CONSENT(S) TO REGISTER IS MADE OF RECORD.

FOR ORAL SURGERY AND DENTAL IMPLANT SERVICES (U.S. CLS. 100 AND 101).

FIRST USE 6-1-2011; IN COMMERCE 11-1-2011.
LINDA POWELL, EXAMINING ATTORNEY

CLASS 44—(Continued).

SN 85-481,844. SMALLS, HERMAN, GOOSE CREEK, SC. FILED 11-28-2011.

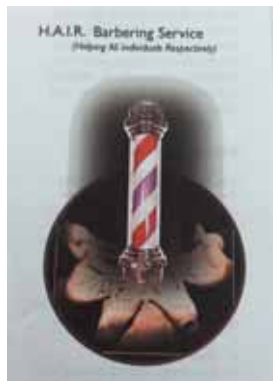

NO CLAIM IS MADE TO THE EXCLUSIVE RIGHT TO USE "H.A.I.R. BARBERING SERVICE", APART FROM THE MARK AS SHOWN.

THE STIPLING IS A FEATURE OF THE MARK.

THE COLOR(S) RED, BLUE, WHITE, SILVER, GREY, AND BLACK IS/ARE CLAIMED AS A FEATURE OF THE MARK.

THE MARK CONSISTS OF A BARBER POLE HAVING THREE STRIPES (RED, BLUE, AND RED). IN BETWEEN EACH COLOR STRIPE IS WHITE AND ON EACH SIDE OF BARBER POLE HAS A WHITE LINING. THE TOP AND BOTTOM OF THE BARBER POLE HAS A TRANSPARENT SILVER COLOR, ALMOST LIKE GLASS. GREY COLORED HANDS APPEAR IN A CIRCLE BELOW THE BARBER POLE, AND THE CIRCLE IS BLACK ON THE INSIDE. ABOVE THE CIRCLE APPEARS A GREY AND WHITE COLORED RECTANGLE INSIDE WHICH THE BARBER POLE APPEARS. THE WORDING "H.A.I.R. BARBERING SERVICES (HELPING ALL INDIVIDUALS RESPECTIVELY)" APPEARS IN A BLACK FONT ABOVE THE DESIGN. THE BACKGROUND BEHIND THE WORDING IS TRANSPARENT.

FOR BARBERING SERVICES (U.S. CLS. 100 AND 101).
ANDREA HACK, EXAMINING ATTORNEY

CLASS 44—(Continued).

SN 85-486,950. MOUNT SINAI MEDICAL CENTER OF FLORIDA, INC., MIAMI BEACH, FL. FILED 12-5-2011.

Test My Relatives

THE MARK CONSISTS OF STANDARD CHARACTERS WITHOUT CLAIM TO ANY PARTICULAR FONT, STYLE, SIZE, OR COLOR.

FOR CHARITABLE HEALTHCARE SERVICES, NAMELY, PROVIDING A MEDICAL SCREENING PROGRAM TO DISCLOSE UNDIAGNOSED CHRONIC DISEASE, INCLUDING DIABETES AND HEART DISEASE, IN THE RELATIVES OF DIAGNOSED INDIVIDUALS; CHARITABLE HEALTHCARE SERVICES, NAMELY, PROVIDING MEDICAL SCREENING KITS AND EQUIPMENT TO GENERATE OR COLLECT CHRONIC DISEASE DATA; PROVIDING A WEBSITE FEATURING INFORMATION ABOUT HEALTH AND WELLNESS, NAMELY, A WEBSITE FOR CHRONIC DISEASE DATA INPUT BY PROGRAM PARTICIPANTS, AS WELL AS PERSONALIZED DISEASE PROGRESS TRACKING, DEMOGRAPHIC STATISTICS, DISEASE RELATED HEALTH AND NUTRITION INFORMATION, AND PHYSICIAN RESOURCES; CHARITABLE HEALTH CARE SERVICES, NAMELY, PROVIDING CHRONIC DISEASE INDIVIDUALIZED PROGRAM PROFILES AND CROSS PROGRAM ANALYSIS BY MEDICAL PROFESSIONALS AND RESEARCHERS FOR THE PURPOSES OF FURTHERING CHRONIC DISEASE PREVENTION IN INDIVIDUALS AND THE GENERAL POPULATION (U.S. CLS. 100 AND 101).

MATTHEW KLINE, EXAMINING ATTORNEY

SN 85-483,144. GERARD BOLLEI SALONS INC., NEW YORK, NY. FILED 11-29-2011.

GERARD BOLLEI

THE MARK CONSISTS OF STANDARD CHARACTERS WITHOUT CLAIM TO ANY PARTICULAR FONT, STYLE, SIZE, OR COLOR.

OWNER OF U.S. REG. NO. 1,179,708.

THE NAME(S), PORTRAIT(S), AND/OR SIGNATURE(S) SHOWN IN THE MARK DOES NOT IDENTIFY A PARTICULAR LIVING INDIVIDUAL.

FOR BEAUTY SALON SERVICES; DAY SPA SERVICES, NAMELY, NAIL CARE, MANICURES, PEDICURES AND NAIL ENHANCEMENTS; HAIR SALON SERVICES, NAMELY, HAIR CUTTING, STYLING, COLORING, AND HAIR EXTENSION SERVICES; HEALTH SPA SERVICES FOR HEALTH AND WELLNESS OF THE BODY AND SPIRIT, NAMELY, PROVIDING MASSAGE, FACIAL AND BODY TREATMENT SERVICES, COSMETIC BODY CARE SERVICES (U.S. CLS. 100 AND 101).
FIRST USE 0-0-1975; IN COMMERCE 0-0-1975.

JAY FLOWERS, EXAMINING ATTORNEY

SN 85-488,625. REX MEDICAL GROUP, DBA REX MEDICAL CARE, DUARTE, CA. FILED 12-6-2011.



NO CLAIM IS MADE TO THE EXCLUSIVE RIGHT TO USE "MEDICAL CARE", APART FROM THE MARK AS SHOWN.

THE COLOR(S) ORANGE, BLUE AND GREEN IS/ARE CLAIMED AS A FEATURE OF THE MARK.

THE MARK CONSISTS OF THREE IMAGES, ONE AT THE TOP IN AN ORANGE COLOR, TWO BELOW, ONE IN BLUE AND ONE IN GREEN. THE IMAGES CAN EACH RESEMBLE A PERSON AND ARE DRAWN BY USING A "V"-SHAPE WITH A DOT OR CIRCLE IN THE CENTER SPACE OF THE "V". TO THE RIGHT OF THE IMAGE, THE TEXT "REX MEDICAL CARE" IS WRITTEN IN BLUE.

FOR MEDICAL CLINICS (U.S. CLS. 100 AND 101).

FIRST USE 10-1-2010; IN COMMERCE 10-1-2011.

CARYN GLASSER, EXAMINING ATTORNEY

CLASS 44—(Continued).

SN 85-495,280. BRIAN K. IRIYE, M.D. & ASSOCIATES, LTD., LAS VEGAS, NV. FILED 12-14-2011.



NO CLAIM IS MADE TO THE EXCLUSIVE RIGHT TO USE "HIGH RISK PREGNANCY CENTER", APART FROM THE MARK AS SHOWN.

THE STIPPLING IS FOR SHADING PURPOSES ONLY. THE MARK CONSISTS OF A CIRCLE AROUND A PREGNANT WOMAN FACING RIGHT. THE WOMAN'S HEAD EXTENDS ABOVE THE TOP BOUNDARY OF THE CIRCLE. TO THE RIGHT ARE THE FOLLOWING STYLIZED PHRASES, EACH STACKED UPON THE NEXT: "HIGH RISK", "PREGNANCY", "CENTER", AND "UNPARALLELED EXPERTISE. FOCUSED ON YOUR PREGNANCY".

FOR OBSTETRIC SERVICES (U.S. CLS. 100 AND 101). WARREN L. OLANDRIA, EXAMINING ATTORNEY

CLASS 44—(Continued).

SN 85-500,601. KNOKE, JOHN, DBA THE LANDSCAPE REPAIRMAN, MELBOURNE BEACH, FL. FILED 12-21-2011.

The Landscape Repairman

THE MARK CONSISTS OF STANDARD CHARACTERS WITHOUT CLAIM TO ANY PARTICULAR FONT, STYLE, SIZE, OR COLOR.

NO CLAIM IS MADE TO THE EXCLUSIVE RIGHT TO USE "LANDSCAPE", APART FROM THE MARK AS SHOWN.

FOR ADVISORY SERVICES IN THE FIELDS OF IRRIGATION AND FERTILIZATION, NAMELY, FERTILIZATION VIA IRRIGATION; GARDEN CARE SERVICES; LAWN MOWING SERVICES; TREE CARE SERVICES; TREE REMOVAL SERVICES (U.S. CLS. 100 AND 101).

FIRST USE 2-4-2002; IN COMMERCE 2-4-2002. ALYSSA STEEL, EXAMINING ATTORNEY

SN 85-501,366. SPALDING, SHELLEY, ASPEN, CO. FILED 12-21-2011.



THE MARK CONSISTS OF THE STYLIZED WORDING "BLOWASPEN" AND STYLIZED DRAWING OF AN OUTLINE OF AN ASPEN LEAF WITH A WAVY LINE.

FOR HAIR SALON SERVICES (U.S. CLS. 100 AND 101). FIRST USE 7-0-2007; IN COMMERCE 11-0-2007. AMEEN IMAM, EXAMINING ATTORNEY

SN 85-498,381. JOANN MERCER, WEST CHESTER, PA. AND GARY MERCER, WEST CHESTER, PA. FILED 12-19-2011.



NO CLAIM IS MADE TO THE EXCLUSIVE RIGHT TO USE "CARB LIGHT", APART FROM THE MARK AS SHOWN.

THE COLOR(S) GREEN, BLUE, YELLOW, GRAY AND BROWN IS/ARE CLAIMED AS A FEATURE OF THE MARK.

THE MARK CONSISTS OF THE LETTERS "CLL" IN A STYLIZED SCRIPT FONT WITH THE LETTER "C" IN BLUE AND THE TWO LETTERS "L" IN GREEN. THE "CLL" LETTERS ARE SURROUNDED BY A STYLIZED TAPE MEASURE DESIGN IN YELLOW WITH BROWN MARKINGS. TO THE RIGHT OF THIS DESIGN IN THE WORDING "CARB LIGHT LIVING" IN INITIAL CAPITAL LETTERS IN A STYLIZED SCRIPT FONT IN YELLOW. THE ENTIRE MARK IS SHOWN ON A BACKGROUND OF SQUARE GRAY TILES.

FOR PROVIDING A WEBSITE FEATURING INFORMATION ON WEIGHT LOSS, HEALTH AND NUTRITION (U.S. CLS. 100 AND 101).

LAURA KOVALSKY, EXAMINING ATTORNEY

SN 85-502,544. BELLY IN BALANCE, LLC, NAMPA, ID. FILED 12-22-2011.



THE COLOR(S) BLACK, ORANGE, WHITE, BLUE, NAVY, GREEN, BROWN, LIGHT BROWN, YELLOW, AND PEACH IS/ARE CLAIMED AS A FEATURE OF THE MARK.

THE MARK CONSISTS OF A COLORFUL FULL BODY

CLASS 44—(Continued).

CARICATURE MAN OUTLINED IN BLACK WITH ORANGE HAIR, PEACH SKIN, BLUE AND WHITE EYES WEARING A NAVY COLORED SHIRT WITH GREEN SLEEVES AND COLLAR, EXPOSED STOMACH, BLACK BELT WITH YELLOW RECTANGLE IN THE CENTER OF THE BELT WITH BLACK IN THAT CENTER OF THE YELLOW RECTANGLE, LIGHT BROWN PANTS, BROWN AND WHITE SHOES, WITH AN UNCOMFORTABLE FACE AND ONE HAND PLACED ON STOMACH AND THE OTHER ON THE FACE.

FOR COLONIC TREATMENTS, NAMELY, IRRIGATION OF THE COLON FOR CLEANSING PURPOSES BY INJECTING LARGE AMOUNTS OF FLUID HIGH INTO THE COLON (U.S. CLS. 100 AND 101).

FIRST USE 10-1-2011; IN COMMERCE 10-1-2011.
SAMUEL E. SHARPER JR., EXAMINING ATTORNEY

SN 85-502,915. REHABILITATION INSTITUTE OF CHICAGO, CHICAGO, IL. FILED 12-23-2011.

THINK ABILITY

THE MARK CONSISTS OF STANDARD CHARACTERS WITHOUT CLAIM TO ANY PARTICULAR FONT, STYLE, SIZE, OR COLOR.

FOR COMPREHENSIVE CONTINUUM OF REHABILITATION SERVICES, NAMELY, INPATIENT, OUTPATIENT, SUBACUTE AND DAY TREATMENT REHABILITATION PATIENT CARE SERVICES; HOME HEALTH CARE SERVICES (U.S. CLS. 100 AND 101).

REGINA DRUMMOND, EXAMINING ATTORNEY

SN 85-503,503. VEGAS IV, LLC, MIAMI BEACH, FL. FILED 12-23-2011.



REVIV

THE MARK CONSISTS OF THE WORD "REVIV" BELOW A PAIR OF TWISTING BUBBLE LINES RISING ABOVE THE CENTER "V" OF "REVIV" IN A HELIX SHAPE.

FOR HYDRATION CLINIC SERVICES, NAMELY, INTRAVENOUS HYDRATION, INTRAVENOUS ELECTROLYTE REPLACEMENT THERAPY, INTRAVENOUS VITAMIN INFUSION THERAPY, INTRAVENOUS FREE RADICAL REDUCTION THERAPY, INTRAVENOUS FLUID CLEANSING THERAPY, INTRAVENOUS HANG-OVER ALLEVIATION THERAPY, SUPPLEMENTAL OXYGEN THERAPY, AND MASSAGE THERAPY (U.S. CLS. 100 AND 101).

TINA MAI, EXAMINING ATTORNEY

CLASS 44—(Continued).

SN 85-504,624. THE FINISHING BAR, LLC, NEW YORK, NY. FILED 12-28-2011.

THE FINISHING BAR

THE MARK CONSISTS OF STANDARD CHARACTERS WITHOUT CLAIM TO ANY PARTICULAR FONT, STYLE, SIZE, OR COLOR.

NO CLAIM IS MADE TO THE EXCLUSIVE RIGHT TO USE "BAR", APART FROM THE MARK AS SHOWN.

FOR BODY WAXING SERVICES; MAKE-UP APPLICATION SERVICES; NAIL CARE SALONS (U.S. CLS. 100 AND 101).

FIRST USE 12-27-2011; IN COMMERCE 12-27-2011.
JERI J. FICKES, EXAMINING ATTORNEY

SN 85-504,759. WOMEN'S HEALTH SPECIALISTS, S.C., APPLETON, WI. FILED 12-28-2011.

**Women's
Health Specialists, S.C.**

NO CLAIM IS MADE TO THE EXCLUSIVE RIGHT TO USE "WOMEN'S HEALTH SPECIALISTS S.C.", APART FROM THE MARK AS SHOWN.

THE MARK CONSISTS OF THE WORDS "WOMEN'S HEALTH SPECIALISTS, S.C." IN STANDARD CHARACTERS BUT WHERE THE WORD "WOMEN'S" APPEARS ABOVE THE WORD "HEALTH" AND WHERE THE "O" IN "WOMEN'S" AND THE "T" IN "HEALTH" ARE COMBINED TO FORM THE FEMALE BIOLOGICAL SYMBOL.

FOR MEDICAL SERVICES (U.S. CLS. 100 AND 101).

FIRST USE 10-0-2009; IN COMMERCE 10-0-2009.
NATALIE POLZER, EXAMINING ATTORNEY

SN 85-505,659. HASENBACK, HANK, ELGIN, OK. FILED 12-29-2011.

**Happy Hollow Animal
Hospital**

THE MARK CONSISTS OF STANDARD CHARACTERS WITHOUT CLAIM TO ANY PARTICULAR FONT, STYLE, SIZE, OR COLOR.

NO CLAIM IS MADE TO THE EXCLUSIVE RIGHT TO USE "ANIMAL HOSPITAL", APART FROM THE MARK AS SHOWN.

FOR VETERINARY SERVICES (U.S. CLS. 100 AND 101).

EUGENIA MARTIN, EXAMINING ATTORNEY

CLASS 44—(Continued).

SN 85-506,415. WEIDNER, ALEX, SANTA MONICA, CA. FILED 12-30-2011.

THE WELL CONNECTED

THE MARK CONSISTS OF STANDARD CHARACTERS WITHOUT CLAIM TO ANY PARTICULAR FONT, STYLE, SIZE, OR COLOR.

FOR HAIR SALON SERVICES (U.S. CLS. 100 AND 101).
KATHLEEN M. VANSTON, EXAMINING ATTORNEY

SN 85-506,468. DOCTOR TATTAWAY, LLC, NORTHAMPTON, PA. FILED 12-30-2011.



NO CLAIM IS MADE TO THE EXCLUSIVE RIGHT TO USE "LASER TATTOO & HAIR REMOVAL", APART FROM THE MARK AS SHOWN.

THE COLOR(S) RED, BLACK AND WHITE IS/ARE CLAIMED AS A FEATURE OF THE MARK.

THE MARK CONSISTS OF THE WORD "DR.TATTAWAY" WITH THE "DR." IN A RED PRISTINA FONT, OUTLINED IN BLACK, WITH THE "D" CAPITALIZED, THE "TATT" WITH A CAPITAL "T" IN BLACK BRITANNIC FONT OUTLINED IN WHITE AND THE "AWAY" IN RED BRITANNIC FONT OUTLINED IN WHITE WITH THE "A" CAPITALIZED; ABOVE A RED LINE THAT EXTENDS PAST THE "DR.TATTAWAY" AND ENDING IN A STARBURST DESIGN OUTLINED IN WHITE WHICH IS THE CENTER OF A STYLIZED SEVEN-PETAL BLACK AND WHITE FLOWER; AND UNDER THE RED LINE THE WORDS "LASER TATTOO & HAIR REMOVAL" IN BLACK LETTERING HYPATIA SANS PRO SEMI-BOLD FONT ALL IN CAPITAL LETTERS WITH AN AMPERSAND IN BETWEEN "LASER TATTOO" AND "HAIR REMOVAL".

FOR PERSONAL HAIR REMOVAL SERVICES, AND LASER TATTOO REMOVAL SERVICES (U.S. CLS. 100 AND 101).

FRANK LATTUCA, EXAMINING ATTORNEY

SN 85-506,475. DOCTOR TATTAWAY, LLC, BETHLEHEM, PA. FILED 12-30-2011.

Dr. TattAway

THE MARK CONSISTS OF STANDARD CHARACTERS WITHOUT CLAIM TO ANY PARTICULAR FONT, STYLE, SIZE, OR COLOR.

FOR PERSONAL HAIR REMOVAL SERVICES, AND LASER TATTOO REMOVAL SERVICES (U.S. CLS. 100 AND 101).

FRANK LATTUCA, EXAMINING ATTORNEY

CLASS 44—(Continued).

SN 85-506,552. IDEAL IMAGE DEVELOPMENT CORPORATION, DBA IDEAL IMAGE, TAMPA, FL. FILED 12-30-2011.

IT'S GO TIME

THE MARK CONSISTS OF STANDARD CHARACTERS WITHOUT CLAIM TO ANY PARTICULAR FONT, STYLE, SIZE, OR COLOR.

FOR LASER AND INTENSE PULSE LIGHT SKIN ENHANCEMENT PROCEDURES (U.S. CLS. 100 AND 101).

KAREN K. BUSH, EXAMINING ATTORNEY

SN 85-506,563. LEMON CREEK WINERY LTD., BERRIEN SPRINGS, MI. FILED 12-30-2011.

**A pure Michigan winery
from the ground up**

THE MARK CONSISTS OF STANDARD CHARACTERS WITHOUT CLAIM TO ANY PARTICULAR FONT, STYLE, SIZE, OR COLOR.

FOR VINEYARD AND WINERY SERVICES, NAMELY, THE CULTIVATION OF GRAPES FOR OTHERS (U.S. CLS. 100 AND 101).

FIRST USE 12-29-2011; IN COMMERCE 12-29-2011.

KATHERINE M. DUBRAY, EXAMINING ATTORNEY

SN 85-506,888. THOMAS H. DALONZO-BAKER, RALEIGH, NC. FILED 12-31-2011.

**Total Motion Physical
Therapy**

THE MARK CONSISTS OF STANDARD CHARACTERS WITHOUT CLAIM TO ANY PARTICULAR FONT, STYLE, SIZE, OR COLOR.

OWNER OF U.S. REG. NOS. 3,054,042 AND 3,216,357.

NO CLAIM IS MADE TO THE EXCLUSIVE RIGHT TO USE "PHYSICAL THERAPY", APART FROM THE MARK AS SHOWN.

FOR MEDICAL, PHYSICAL REHABILITATION AND PHYSICAL THERAPY SERVICES (U.S. CLS. 100 AND 101).

FIRST USE 1-1-2002; IN COMMERCE 1-1-2002.

TINA MAI, EXAMINING ATTORNEY

CLASS 44—(Continued).

SN 85-507,511. MONTIEL, JAMIE, STATEN ISLAND, NY. FILED 1-3-2012.

eatgenius

THE MARK CONSISTS OF STANDARD CHARACTERS WITHOUT CLAIM TO ANY PARTICULAR FONT, STYLE, SIZE, OR COLOR.

FOR HOLISTIC HEALTH CONSULTING; HOLISTIC HEALTH SERVICES, NAMELY, WORKING WITH CLIENTS TO HELP IMPROVE THEIR CONDITION BY EXAMINING THE PHYSICAL, EMOTIONAL, AND PSYCHOSOCIAL ASPECTS OF THEIR BEING AND HOW THEY INTERACT WITH AND ARE INTIMATELY CONNECTED WITH THEIR ENVIRONMENTS AND DETERMINING HOW THESE DYNAMIC INTERACTIONS SHAPE THEIR HEALTH AND WELL-BEING; HOLISTIC HEALTH SERVICES, NAMELY, PROVIDING ASSESSMENTS AND RECOMMENDATIONS IN ORDER TO CREATE HOLISTIC HEALTH PLANS THAT WILL BE SPECIFICALLY TAILORED TO MEET THE CLIENTS' NEEDS AS WELL AS PROVIDING ENCOURAGEMENT AND SUPPORT SO THAT CLIENTS WILL FEEL EMPOWERED IN ORDER TO IMPROVE THE CLIENTS' OVERALL HEALTH AND SENSE OF WELL-BEING AND TO HELP THEM REACH THEIR HEALTH GOALS (U.S. CLS. 100 AND 101).

FIRST USE 12-0-2011; IN COMMERCE 12-0-2011.
LINDA POWELL, EXAMINING ATTORNEY

SN 85-507,963. MERIDEX GROUP, LLC, WILLIS, TX. FILED 1-3-2012.

VIRGINIA'S HOSPICE

THE MARK CONSISTS OF STANDARD CHARACTERS WITHOUT CLAIM TO ANY PARTICULAR FONT, STYLE, SIZE, OR COLOR.

NO CLAIM IS MADE TO THE EXCLUSIVE RIGHT TO USE "HOSPICE", APART FROM THE MARK AS SHOWN.

THE NAME(S), PORTRAIT(S), AND/OR SIGNATURE(S) SHOWN IN THE MARK IDENTIFIES VIRGINICITA YAP, WHOSE CONSENT(S) TO REGISTER IS MADE OF RECORD.

FOR HOSPICES (U.S. CLS. 100 AND 101).
FIRST USE 11-22-2011; IN COMMERCE 11-22-2011.
ELI HELLMAN, EXAMINING ATTORNEY

CLASS 44—(Continued).

SN 85-508,046. FEDERICO R. CALDERON MENDOZA, LAS VEGAS, NV. FILED 1-3-2012.

ISHAH

THE MARK CONSISTS OF STANDARD CHARACTERS WITHOUT CLAIM TO ANY PARTICULAR FONT, STYLE, SIZE, OR COLOR.

FOR BEAUTY CONSULTATION SERVICES; BEAUTY SALON SERVICES; BEAUTY SALONS; BEAUTY SPA SERVICES, NAMELY, COSMETIC BODY CARE; HAIR COLOR SALON SERVICES; HAIR SALON SERVICES; MAKE-UP APPLICATION SERVICES; NAIL CARE SALONS; PROVIDING INFORMATION ABOUT BEAUTY; PROVIDING ON-SITE BEAUTY SERVICES, NAMELY, HAIR STYLING AND MAKE-UP APPLICATION SERVICES; SKIN CARE SALONS; TANNING SALONS; TEETH WHITENING SERVICES (U.S. CLS. 100 AND 101).
ALYSSA STEEL, EXAMINING ATTORNEY

SN 85-508,208. CLAUDIA URIBE-ORRETT, MIAMI, FL. FILED 1-4-2012.

**Blossom's Developmental
Therapy Associates**

THE MARK CONSISTS OF STANDARD CHARACTERS WITHOUT CLAIM TO ANY PARTICULAR FONT, STYLE, SIZE, OR COLOR.

NO CLAIM IS MADE TO THE EXCLUSIVE RIGHT TO USE "DEVELOPMENTAL THERAPY ASSOCIATES", APART FROM THE MARK AS SHOWN.

FOR OCCUPATIONAL THERAPY SERVICES; PHYSICAL THERAPY; SPEECH THERAPY SERVICES (U.S. CLS. 100 AND 101).

FIRST USE 9-1-2011; IN COMMERCE 9-1-2011.
NAKIA HENRY, EXAMINING ATTORNEY

SN 85-508,770. WADE D. THOMPSON, D.D.S., M.S., P.C., OREM, UT. FILED 1-4-2012.



NO CLAIM IS MADE TO THE EXCLUSIVE RIGHT TO USE "ORTHODONTICS", APART FROM THE MARK AS SHOWN.

THE MARK CONSISTS OF THREE SURF BOARDS, EACH BOARD BEING VERTICAL, AND THE BOARDS CLOSE TO

CLASS 44—(Continued).

EACH OTHER AND ARRANGED HORIZONTALLY; THE BOARDS ARE JOINED TOGETHER WITH A SINGLE HORIZONTAL LINE INTERSECTED BY FOUR SQUARES WHICH ARE POSITIONED AT THE MIDDLE OF EACH BOARD; THE LITERAL ELEMENT "THOMPSON" APPEARS BELOW THE SINGLE HORIZONTAL LINE AND THE LITERAL ELEMENT "ORTHODONTICS" APPEARS IN SMALLER FONT JUST BELOW; FROM THE LEFT, THE FIRST BOARD IS POINTED WITH RACING STRIPES AND A PHONE DESIGN AT THE TOP; THE SECOND BOARD IS THE LONGEST, WITH RACING STRIPES AND A STYLIZED DESIGN AT THE TOP; THE THIRD BOARD HAS RACING STRIPES AND A FLOWER DESIGN AT THE TOP.

FOR DENTAL SERVICES, NAMELY, PERFORMING RESTORATIVE AND COSMETIC PROCEDURES AND ORTHODONTIC SERVICES (U.S. CLS. 100 AND 101).

FIRST USE 11-28-2008; IN COMMERCE 11-28-2008.
MELISSA VALLILLO, EXAMINING ATTORNEY

SN 85-509,187. GUZMAN DDS, MARCELLA, CHICAGO, IL.
FILED 1-5-2012.

A Brush Above Family Dentistry

THE MARK CONSISTS OF STANDARD CHARACTERS WITHOUT CLAIM TO ANY PARTICULAR FONT, STYLE, SIZE, OR COLOR.

NO CLAIM IS MADE TO THE EXCLUSIVE RIGHT TO USE "FAMILY DENTISTRY", APART FROM THE MARK AS SHOWN.

FOR DENTIST SERVICES (U.S. CLS. 100 AND 101).
FIRST USE 1-1-1998; IN COMMERCE 1-1-1998.
MATTHEW KLINE, EXAMINING ATTORNEY

SN 85-509,345. INDIANA ORTHOPAEDIC HOSPITAL, LLC,
INDIANAPOLIS, IN. FILED 1-5-2012.

Indiana Orthopaedic Hospital

THE MARK CONSISTS OF STANDARD CHARACTERS WITHOUT CLAIM TO ANY PARTICULAR FONT, STYLE, SIZE, OR COLOR.

OWNER OF U.S. REG. NO. 3,872,671.

NO CLAIM IS MADE TO THE EXCLUSIVE RIGHT TO USE "ORTHOPAEDIC HOSPITAL", APART FROM THE MARK AS SHOWN.

SEC. 2(F).

FOR MEDICAL SERVICES (U.S. CLS. 100 AND 101).

FIRST USE 3-1-2005; IN COMMERCE 3-1-2005.
CHRISTINE MARTIN, EXAMINING ATTORNEY

CLASS 44—(Continued).

SN 85-509,396. PFIZER INC., NEW YORK, NY. FILED 1-5-2012.

PLANT BASED. PEOPLE FOCUSED.

THE MARK CONSISTS OF STANDARD CHARACTERS WITHOUT CLAIM TO ANY PARTICULAR FONT, STYLE, SIZE, OR COLOR.

FOR PROVIDING INFORMATION REGARDING PHARMACEUTICAL PRODUCTS AND HEALTHCARE RELATED TO GAUCHER'S DISEASE TO HEALTHCARE PROFESSIONALS AND PATIENTS VIA THE INTERNET (U.S. CLS. 100 AND 101).

GEORGE LORENZO, EXAMINING ATTORNEY

SN 85-509,490. BARFKNECHT, KRISTIN M., DBA BODY & SOL TANNING BOUTIQUE, YORKTOWN, VA. FILED 1-5-2012.



NO CLAIM IS MADE TO THE EXCLUSIVE RIGHT TO USE "TANNING BOUTIQUE", APART FROM THE MARK AS SHOWN.

THE COLOR(S) BLUE AND YELLOW/GOLD IS/ARE CLAIMED AS A FEATURE OF THE MARK.

THE MARK CONSISTS OF THE COLOR BLUE APPEARING IN THE WORDING "BODY & SOL TANNING BOUTIQUE" WHERE THE WORDING "SOL" REPRESENTS "SUN" IN THE SPANISH LANGUAGE AND THE COLOR YELLOW/GOLD APPEARING IN THE SUN "O" DESIGN IN PLACE OF THE LETTER "O" IN THE WORDING "SOL".

THE ENGLISH TRANSLATION OF "SOL" IN THE MARK IS "SUN".

FOR TANNING SALONS, TANNING SERVICES INCLUDING UV AND UV-FREE TANNING, RED LIGHT THERAPY COLLAGEN, SUNLESS TANNING, AND SUNLESS SPRAY TANNING, AND TEETH WHITENING SERVICES (U.S. CLS. 100 AND 101).

FIRST USE 1-1-2002; IN COMMERCE 2-1-2003.
KIMBERLY PERRY, EXAMINING ATTORNEY

CLASS 44—(Continued).

SN 85-509,701. OPUS MEDICUS, DBA OPUS MEDICUS, LA JOLLA, CA. FILED 1-5-2012.

MELTAP

THE MARK CONSISTS OF STANDARD CHARACTERS WITHOUT CLAIM TO ANY PARTICULAR FONT, STYLE, SIZE, OR COLOR.

FOR MEDICAL DIAGNOSTIC TESTING, MONITORING AND REPORTING SERVICES; MEDICAL SERVICES; MEDICAL TESTING FOR DIAGNOSTIC OR TREATMENT PURPOSES (U.S. CLS. 100 AND 101).

JEFF DEFORD, EXAMINING ATTORNEY

SN 85-509,825. GENTLE GOODBYE, LLC, STAMFORD, CT. FILED 1-5-2012.



NO CLAIM IS MADE TO THE EXCLUSIVE RIGHT TO USE "VETERINARY HOSPICE & AT-HOME EUTHANASIA", APART FROM THE MARK AS SHOWN.

THE MARK CONSISTS OF AN ANGLED HEART WITH A PAW PRINT IN THE LEFT PART OF THE HEART, COMBINED WITH THE WORDS "GENTLE GOODBYE" ON TOP AND "VETERINARY HOSPICE & AT-HOME EUTHANASIA" ON THE BOTTOM; "GENTLE" AND "VETERINARY HOSPICE" ARE INSIDE THE HEART AND "GOODBYE" AND "& AT-HOME EUTHANASIA" ARE OUTSIDE THE HEART.

FOR VETERINARY SERVICES (U.S. CLS. 100 AND 101).

FIRST USE 1-1-2011; IN COMMERCE 12-1-2011.
WILLIAM ROSSMAN, EXAMINING ATTORNEY

SN 85-510,246. EMEDIKON LLC, OCALA, FL. FILED 1-6-2012.

MEDMAP

THE MARK CONSISTS OF STANDARD CHARACTERS WITHOUT CLAIM TO ANY PARTICULAR FONT, STYLE, SIZE, OR COLOR.

FOR PROVIDING MEDICAL INFORMATION, CONSULTANCY AND ADVISORY SERVICES (U.S. CLS. 100 AND 101).

ELLEN PERKINS, EXAMINING ATTORNEY

CLASS 44—(Continued).

SN 85-510,265. THE WELLCARE MANAGEMENT GROUP, INC., TAMPA, FL. FILED 1-6-2012.

RIGHT BY YOU

THE MARK CONSISTS OF STANDARD CHARACTERS WITHOUT CLAIM TO ANY PARTICULAR FONT, STYLE, SIZE, OR COLOR.

FOR HEALTH CARE SERVICES IN THE NATURE OF A HEALTH MAINTENANCE ORGANIZATION FOR BENEFICIARIES OF GOVERNMENT-SPONSORED HEALTH CARE PROGRAMS (U.S. CLS. 100 AND 101).

CHRIS WELLS, EXAMINING ATTORNEY

SN 85-510,597. SIMON, MARJORIE, R., ALEXANDRIA, VA. AND SIMON, JASMINE, C., ALEXANDRIA, VA. FILED 1-6-2012.

**ANYTHING VEGAN:
ANYTHING YOU CAN MAKE
I CAN MAKE VEGAN**

THE MARK CONSISTS OF STANDARD CHARACTERS WITHOUT CLAIM TO ANY PARTICULAR FONT, STYLE, SIZE, OR COLOR.

FOR PROVIDING A WEBSITE FEATURING INFORMATION ABOUT HEALTH, WELLNESS AND NUTRITION; PROVIDING INFORMATION, NEWS AND COMMENTARY IN THE FIELD OF NUTRITION, HEALTH AND WELLNESS (U.S. CLS. 100 AND 101).

FIRST USE 8-1-2009; IN COMMERCE 11-1-2011.
JOHN DALIER, EXAMINING ATTORNEY

SN 85-510,728. RHODE ISLAND MEDICAL IMAGING, INC., EAST GREENWICH, RI. FILED 1-6-2012.

**RHODE ISLAND MEDICAL
IMAGING**

THE MARK CONSISTS OF STANDARD CHARACTERS WITHOUT CLAIM TO ANY PARTICULAR FONT, STYLE, SIZE, OR COLOR.

NO CLAIM IS MADE TO THE EXCLUSIVE RIGHT TO USE "MEDICAL IMAGING", APART FROM THE MARK AS SHOWN.

SEC. 2(F).

FOR MEDICAL IMAGING SERVICES (U.S. CLS. 100 AND 101).

FIRST USE 8-0-1986; IN COMMERCE 8-0-1986.

B. PARADEWELAI, EXAMINING ATTORNEY

CLASS 44—(Continued).

SN 85-510,778. CHI MEDIA GROUP, LLC, LAS VEGAS, NV. FILED 1-6-2012.

TAKE FIVE AND RELAX

THE MARK CONSISTS OF STANDARD CHARACTERS WITHOUT CLAIM TO ANY PARTICULAR FONT, STYLE, SIZE, OR COLOR.

FOR INFORMATION RELATING TO MASSAGE; MASSAGES (U.S. CLS. 100 AND 101).
CURTIS FRENCH, EXAMINING ATTORNEY

SN 85-510,814. CHI MEDIA GROUP, LLC, LAS VEGAS, NV. FILED 1-6-2012.



THE MARK CONSISTS OF THE NUMERAL "5" STYLIZED TO RESEMBLE A HUMAN HAND.

FOR INFORMATION RELATING TO MASSAGE; MASSAGES (U.S. CLS. 100 AND 101).
CURTIS FRENCH, EXAMINING ATTORNEY

SN 85-510,870. MC CORMICK, MARY A, SOUTH BEND, IN. AND MC CORMICK, THOMAS, SOUTH BEND, IN. FILED 1-6-2012.

1855WECUT4U.COM

THE MARK CONSISTS OF STANDARD CHARACTERS WITHOUT CLAIM TO ANY PARTICULAR FONT, STYLE, SIZE, OR COLOR.

FOR LAWN CARE (U.S. CLS. 100 AND 101).
ANNE MADDEN, EXAMINING ATTORNEY

CLASS 44—(Continued).

SN 85-510,878. SCHATTEMAN, CRISTOPHE, BEVERLY HILLS, CA. FILED 1-6-2012.

**because beauty should be
simple**

THE MARK CONSISTS OF STANDARD CHARACTERS WITHOUT CLAIM TO ANY PARTICULAR FONT, STYLE, SIZE, OR COLOR.

FOR BEAUTY SALON SERVICES; BEAUTY SALONS; BEAUTY SPA SERVICES, NAMELY, COSMETIC BODY CARE; DAY SPA SERVICES, NAMELY, NAIL CARE, MANICURES, PEDICURES AND NAIL ENHANCEMENTS; HAIR COLOR SALON SERVICES; HAIR COLORING SERVICES; HAIR CUTTING; HAIR CUTTING SERVICES; HAIR REPLACEMENT, HAIR ADDITION, AND HAIR EXTENSION SERVICES; HAIR SALON SERVICES; HAIR SALON SERVICES, NAMELY, HAIR CUTTING, STYLING, COLORING, AND HAIR EXTENSION SERVICES; HAIR SALON SERVICES, NAMELY, TREATMENTS TO PROTECT HAIR FROM EFFECTS OF EXPOSURE TO SUNLIGHT, HEAT, HUMIDITY AND CHLORINATED WATER; HAIR STYLING; HAIRDRESSING SALONS; HAIRDRESSING SERVICES; NAIL CARE SALONS; NAIL CARE SERVICES; PROVIDING INFORMATION ABOUT BEAUTY; PROVIDING INFORMATION IN THE FIELD OF HAIR STYLING; PROVIDING NEWS AND INFORMATION IN THE FIELD OF PERSONAL BEAUTY; PROVIDING ON-SITE BEAUTY SERVICES, NAMELY, HAIR STYLING AND MAKE-UP APPLICATION SERVICES (U.S. CLS. 100 AND 101).

FIRST USE 12-1-2011; IN COMMERCE 12-16-2011.
ANNE MADDEN, EXAMINING ATTORNEY

SN 85-511,107. INTEGRATED MEDICAL PROFESSIONALS, PLLC, DBA AUCNY, MELVILLE, NY. FILED 1-7-2012.

**DON' T GET BLINDSIDED BY
PROSTATE CANCER**

THE MARK CONSISTS OF STANDARD CHARACTERS WITHOUT CLAIM TO ANY PARTICULAR FONT, STYLE, SIZE, OR COLOR.

FOR MEDICAL DIAGNOSTIC TESTING, MONITORING AND REPORTING SERVICES; MEDICAL SERVICES; PROVIDING CANCER SCREENING SERVICES; PROVIDING INFORMATION IN THE FIELD OF CANCER PREVENTION, SCREENING, DIAGNOSIS AND TREATMENT (U.S. CLS. 100 AND 101).

FIRST USE 1-6-2012; IN COMMERCE 1-6-2012.
JENNIFER WILLISTON, EXAMINING ATTORNEY

CLASS 44—(Continued).

SN 85-511,154. BLOWOUT BOUTIQUE, INC., BIRMINGHAM, AL. FILED 1-7-2012.

We rock what you've got.

THE MARK CONSISTS OF STANDARD CHARACTERS WITHOUT CLAIM TO ANY PARTICULAR FONT, STYLE, SIZE, OR COLOR.

FOR HAIR SALON SERVICES (U.S. CLS. 100 AND 101).
MICHAEL ENGEL, EXAMINING ATTORNEY

SN 85-511,518. THE RANKEN-JORDAN HOME FOR CONVALESCENT CRIPPLED CHILDREN, ST. LOUIS, MO. FILED 1-9-2012.

CARE BEYOND THE BEDSIDE

THE MARK CONSISTS OF STANDARD CHARACTERS WITHOUT CLAIM TO ANY PARTICULAR FONT, STYLE, SIZE, OR COLOR.

FOR MEDICAL SERVICES; THERAPEUTIC SERVICES, NAMELY, PHYSICAL THERAPY, SPEECH-LANGUAGE PATHOLOGY SERVICES, OCCUPATIONAL THERAPY, ART THERAPY AND MUSIC THERAPY (U.S. CLS. 100 AND 101).

CHRISTINE MARTIN, EXAMINING ATTORNEY

SN 85-511,570. DOLLYLOCKS, ST PETERSBURG, FL. FILED 1-9-2012.

Dollylocks

THE MARK CONSISTS OF STANDARD CHARACTERS WITHOUT CLAIM TO ANY PARTICULAR FONT, STYLE, SIZE, OR COLOR.

FOR HAIR SALON SERVICES, NAMELY, HAIR CUTTING, STYLING, COLORING, DREADLOCK/ LOCKING AND HAIR EXTENSION SERVICES (U.S. CLS. 100 AND 101).

FIRST USE 1-1-2001; IN COMMERCE 1-1-2001.
JOHN GARTNER, EXAMINING ATTORNEY

CLASS 44—(Continued).

SN 85-511,612. FIT U LIFE, LLC, BRENTWOOD, TN. FILED 1-9-2012.

NO CLAIM IS MADE TO THE EXCLUSIVE RIGHT TO USE "FIT", APART FROM THE MARK AS SHOWN.

THE MARK CONSISTS OF THE PHRASE "FIT" IN CAPITAL LETTERS, THE LETTER "U", WHICH HAS AN ANGLED LINE ABOVE IT THAT SHOWS AN ARROW SHAPE WITHIN THE AREA BETWEEN THE LETTER "U" AND ANGLED LINE, AND THE PHRASE "LIFE" IN CAPITAL LETTERS BELOW.

FOR CONSULTING SERVICES IN THE FIELD OF HEALTH AND WELLNESS (U.S. CLS. 100 AND 101).
WILLIAM JACKSON, EXAMINING ATTORNEY

SN 85-512,141. APLIN, CHARLES, THOUSAND OAKS, CA. FILED 1-9-2012.

SolveWorkersComp.com

THE MARK CONSISTS OF STANDARD CHARACTERS WITHOUT CLAIM TO ANY PARTICULAR FONT, STYLE, SIZE, OR COLOR.

FOR MEDICAL SERVICES, NAMELY, PRE-EMPLOYMENT DRUG SCREENING (U.S. CLS. 100 AND 101).

FIRST USE 9-8-2010; IN COMMERCE 1-5-2011.
JOHN DALIER, EXAMINING ATTORNEY

SN 85-512,262. AKANDE, RANTI, HAYWARD, CA. FILED 1-9-2012.

Texturally Inspired

THE MARK CONSISTS OF STANDARD CHARACTERS WITHOUT CLAIM TO ANY PARTICULAR FONT, STYLE, SIZE, OR COLOR.

FOR HAIR STYLING (U.S. CLS. 100 AND 101).
ESTHER A. BORSUK, EXAMINING ATTORNEY

CLASS 44—(Continued).

SN 85-512,332. SHARI & STAC LLC, BOCA RATON, FL. FILED 1-9-2012.

SOBLO

THE MARK CONSISTS OF STANDARD CHARACTERS WITHOUT CLAIM TO ANY PARTICULAR FONT, STYLE, SIZE, OR COLOR.
FOR HAIR SALON SERVICES (U.S. CLS. 100 AND 101).
KELLEY WELLS, EXAMINING ATTORNEY

SN 85-512,577. WEATHINGTON HERMAN S, FORT WORTH, TX. FILED 1-10-2012.

50Twice

THE MARK CONSISTS OF STANDARD CHARACTERS WITHOUT CLAIM TO ANY PARTICULAR FONT, STYLE, SIZE, OR COLOR.
FOR CONSULTING IN THE FIELD OF HEALTH AND WELLNESS TO BRING ABOUT PERSONAL HAPPINESS; CONSULTING SERVICES IN THE FIELD OF MENTAL HEALTH AND WELLNESS; COUNSELING SERVICES IN THE FIELDS OF HEALTH, NUTRITION AND LIFESTYLE WELLNESS (U.S. CLS. 100 AND 101).
EMILY CHUO, EXAMINING ATTORNEY

SN 85-512,946. STROM, M.D., CAREY, BEVERLY HILLS, CA. FILED 1-10-2012.

scope out cancer

THE MARK CONSISTS OF STANDARD CHARACTERS WITHOUT CLAIM TO ANY PARTICULAR FONT, STYLE, SIZE, OR COLOR.
FOR PROVIDING CANCER SCREENING SERVICES (U.S. CLS. 100 AND 101).
APRIL ROACH, EXAMINING ATTORNEY

CLASS 44—(Continued).

SN 85-512,976. STROM, M.D., CAREY, BEVERLY HILLS, CA. FILED 1-10-2012.

scoping out cancer

THE MARK CONSISTS OF STANDARD CHARACTERS WITHOUT CLAIM TO ANY PARTICULAR FONT, STYLE, SIZE, OR COLOR.
FOR PROVIDING CANCER SCREENING SERVICES (U.S. CLS. 100 AND 101).
APRIL ROACH, EXAMINING ATTORNEY

SN 85-513,687. DAILYCOLORS NUTRITION CORPORATION, DBA DAILYCOLORS, BRENTWOOD, CA. FILED 1-11-2012.

DailyColors

THE MARK CONSISTS OF STANDARD CHARACTERS WITHOUT CLAIM TO ANY PARTICULAR FONT, STYLE, SIZE, OR COLOR.
FOR PROVIDING INFORMATION AND COUNSELING RELATING TO DIETARY GUIDANCE AND NUTRITION VIA ELECTRONIC COMMUNICATION NETWORKS (U.S. CLS. 100 AND 101).
THOMAS MANOR, EXAMINING ATTORNEY

SN 85-514,279. 20/20 LIFESTLYE CONSULTANTS, INC., ALBANY, NY. FILED 1-11-2012.



THE COLOR(S) GREEN AND BLUE IS/ARE CLAIMED AS A FEATURE OF THE MARK.
THE MARK CONSISTS OF THE STYLIZED TEXT "THE WELLNESS PROFESSOR" WITH THE "W" IN GREEN AND A GREEN LEAF COMING OUT FROM IT. THE REST OF THE LETTERS ARE IN BLUE. BELOW THIS LETTERING IS THE SLOGAN "STAY HEALTHY MY FRIENDS" IN A GREEN COLOR WITH A GREEN HORIZONTAL LINE ON EACH SIDE OF THE TEXT.
FOR COUNSELING SERVICES IN THE FIELDS OF HEALTH, NUTRITION AND LIFESTYLE WELLNESS; WELLNESS AND HEALTH-RELATED CONSULTING SERVICES (U.S. CLS. 100 AND 101).
FIRST USE 11-25-2011; IN COMMERCE 11-25-2011.
KAREN K. BUSH, EXAMINING ATTORNEY

CLASS 44—(Continued).

SN 85-514,408. GR8ALCHEMY, LLC, BOULDER, CO. FILED 1-11-2012.

Gr8 Alchemy

THE MARK CONSISTS OF STANDARD CHARACTERS WITHOUT CLAIM TO ANY PARTICULAR FONT, STYLE, SIZE, OR COLOR.

FOR MEDICAL CLINIC PROVIDING WEIGHT LOSS SOLUTIONS, SERVICES AND PROGRAMS, NUTRITION COUNSELING, HORMONE THERAPY, INCLUDING, BIOIDENTICAL HORMONE REPLACEMENT, ANTI AGING THERAPY, AND NATURAL HORMONE THERAPY, MEDICAL AESTHETIC PROCEDURES, INCLUDING, LASER HAIR REMOVAL, LASER PEELS, BOTULINUM TOXIN TREATMENTS, MICRODERMABRASION, LIPOSUCTION, VEIN TREATMENTS, VEIN THERAPY, CELLULITE TREATMENTS, BODY CONTOURING TREATMENTS, INJECTABLE FILLER TREATMENTS, FACIALS, AND SKIN CARE (U.S. CLS. 100 AND 101).

FIRST USE 12-1-2011; IN COMMERCE 1-1-2012.
COURTNEY ALVAREZ, EXAMINING ATTORNEY

SN 85-514,863. VINES TO WINE, LLC, NAPA, CA. FILED 1-12-2012.

Vines to Wine

THE MARK CONSISTS OF STANDARD CHARACTERS WITHOUT CLAIM TO ANY PARTICULAR FONT, STYLE, SIZE, OR COLOR.

FOR AGRICULTURAL ADVICE; AGRICULTURAL ADVICE, NAMELY, PROVIDING RECOMMENDATIONS FOR PLANT AND SOIL NUTRITION SUPPLEMENTS; PEST CONTROL SERVICES FOR AGRICULTURE, HORTICULTURE OR FORESTRY; VINEYARD AND WINERY SERVICES, NAMELY, THE CULTIVATION OF GRAPES FOR OTHERS (U.S. CLS. 100 AND 101).

FIRST USE 6-0-2007; IN COMMERCE 1-0-2010.
LAURIE MAYES, EXAMINING ATTORNEY

SN 85-515,492. TRESTYN, ERICA H., NEW YORK, NY. FILED 1-12-2012.

CULTIVATE NOURISHMENT

THE MARK CONSISTS OF STANDARD CHARACTERS WITHOUT CLAIM TO ANY PARTICULAR FONT, STYLE, SIZE, OR COLOR.

FOR COUNSELING SERVICES IN THE FIELDS OF HEALTH, NUTRITION AND LIFESTYLE WELLNESS (U.S. CLS. 100 AND 101).

AMY HELLA, EXAMINING ATTORNEY

CLASS 44—(Continued).

SN 85-515,566. DAVID J. GOLDBERG MD, HACKENSACK, NJ. FILED 1-12-2012.

BEAUTY BEHIND THE SCIENCE

THE MARK CONSISTS OF STANDARD CHARACTERS WITHOUT CLAIM TO ANY PARTICULAR FONT, STYLE, SIZE, OR COLOR.

FOR COSMETIC BODY CARE SERVICES; COSMETIC FACE CARE SERVICES; COSMETIC SKIN CARE SERVICES; COSMETIC SURGERY SERVICES; LASER AND INTENSE PULSE LIGHT SKIN ENHANCEMENT PROCEDURES; LASER HAIR REMOVAL SERVICES; LASER TATTOO REMOVAL SERVICE; MEDICAL CONSULTATIONS; MEDICAL, HYGIENIC AND BEAUTY CARE; PROVIDING LASER THERAPY FOR TREATING MEDICAL CONDITIONS (U.S. CLS. 100 AND 101).

FIRST USE 11-28-2011; IN COMMERCE 11-28-2011.
MARK SPARACINO, EXAMINING ATTORNEY

SN 85-516,125. CELGENE CORPORATION, SUMMIT, NJ. FILED 1-13-2012.

INFO-RMM

THE MARK CONSISTS OF STANDARD CHARACTERS WITHOUT CLAIM TO ANY PARTICULAR FONT, STYLE, SIZE, OR COLOR.

FOR PROGRAMS IN THE NATURE OF PROVIDING MEDICAL COUNSELING AND MEDICAL INFORMATION IN THE FIELD OF PHARMACEUTICALS AND SAFETY ISSUES PERTAINING TO PHARMACEUTICALS, AND PROVIDING MEDICAL INFORMATION IN THE FOREMENTIONED FIELDS BY DISTRIBUTING WRITTEN MATERIALS IN CONNECTION THEREWITH; PROGRAMS IN THE NATURE OF PROVIDING MEDICAL COUNSELING AND MEDICAL INFORMATION IN THE FIELD OF POMALIDOMIDE AND SAFETY ISSUES PERTAINING TO POMALIDOMIDE, AND PROVIDING MEDICAL INFORMATION IN THE FOREMENTIONED FIELDS BY DISTRIBUTING WRITTEN MATERIALS IN CONNECTION THEREWITH (U.S. CLS. 100 AND 101).

KELLY TRUSILO, EXAMINING ATTORNEY

SN 85-516,227. ADELGLASS, JEFFREY M., PLANO, TX. FILED 1-13-2012.

SLIMTASTIC

THE MARK CONSISTS OF STANDARD CHARACTERS WITHOUT CLAIM TO ANY PARTICULAR FONT, STYLE, SIZE, OR COLOR.

FOR COSMETIC AND PLASTIC SURGERY; COSMETIC SURGERY SERVICES (U.S. CLS. 100 AND 101).

ANDREW LEASER, EXAMINING ATTORNEY

CLASS 44—(Continued).

SN 85-516,369. TED S. EIENBERG, DBA EAST COAST CENTER FOR COSMETIC BREAST SURGERY, PHILADELPHIA, PA. FILED 1-13-2012.



THE MARK CONSISTS OF THREE "S"-SHAPED LINES INDICATIVE OF THREE BREASTS IN PROFILE. FOR COSMETIC AND PLASTIC SURGERY; COSMETIC SURGERY SERVICES (U.S. CLS. 100 AND 101). FIRST USE 12-8-2009; IN COMMERCE 12-8-2009. JENNIFER VASQUEZ, EXAMINING ATTORNEY

CLASS 44—(Continued).

SN 85-531,594. AKIRO, LLC, BROOKLYN, NY. FILED 2-1-2012.

MISS JESSIE'S CURLBAR

THE MARK CONSISTS OF STANDARD CHARACTERS WITHOUT CLAIM TO ANY PARTICULAR FONT, STYLE, SIZE, OR COLOR. OWNER OF U.S. REG. NOS. 3,252,986 AND 3,482,013. THE MARK DOES NOT IDENTIFY ANY PARTICULAR LIVING INDIVIDUAL. FOR HAIR SALON SERVICES, NAMELY, HAIR STYLING SERVICES (U.S. CLS. 100 AND 101). GENE MACIOL, EXAMINING ATTORNEY

SN 85-531,603. AKIRO, LLC, BROOKLYN, NY. FILED 2-1-2012.

SN 85-523,165. GLAXO GROUP LIMITED, GREENFORD, MIDDLESEX, UNITED KINGDOM, FILED 1-23-2012.



CURLBAR

THE MARK CONSISTS OF STANDARD CHARACTERS WITHOUT CLAIM TO ANY PARTICULAR FONT, STYLE, SIZE, OR COLOR. FOR HAIR SALON SERVICES, NAMELY, HAIR STYLING SERVICES (U.S. CLS. 100 AND 101). GENE MACIOL, EXAMINING ATTORNEY

SN 85-547,022. STANMORE, ROGER, DBA URGENT MED-CARE, HUNTSVILLE, AL. FILED 2-20-2012.

NO CLAIM IS MADE TO THE EXCLUSIVE RIGHT TO USE "RESPIRATORY CARE", APART FROM THE MARK AS SHOWN.

THE MARK CONSISTS OF THE WORDS "RESPIRATORY CARE" AND UNDERNEATH OF THESE WORDS IS THE WORD "CONNECTION". TO THE LEFT OF THE WORDS "RESPIRATORY CARE CONNECTION" IS A CIRCLE WITH TWO CURVED TRIANGLES WITH BRANCH-LIKE FIGURES IN THE MIDDLE FORMING AN IMAGE OF TWO LUNGS.

FOR HEALTH INFORMATION SERVICES, NAMELY, PROVIDING INFORMATION ON RESPIRATORY-RELATED DISEASES AND DISORDERS AND SELF-MANAGEMENT SKILLS FOR PATIENTS WITH RESPIRATORY DISEASES AND/OR DISORDERS THROUGH GLOBAL COMPUTER NETWORKS (U.S. CLS. 100 AND 101). ELISSA GARBER KON, EXAMINING ATTORNEY

+ URGENT CARE CENTER

NO CLAIM IS MADE TO THE EXCLUSIVE RIGHT TO USE "URGENT CARE CENTER", APART FROM THE MARK AS SHOWN.

THE COLOR(S) RED, BLACK AND WHITE IS/ARE CLAIMED AS A FEATURE OF THE MARK.

THE MARK CONSISTS OF A RED PLUS SIGN WITH WHITE PULSE RUNNING THROUGH THE MIDDLE ACCOMPANIED BY BLACK ALL CAPS WRITING "URGENT CARE CENTER".

FOR MEDICAL CLINICS (U.S. CLS. 100 AND 101). FIRST USE 12-1-2010; IN COMMERCE 12-1-2010. DORITT L. CARROLL, EXAMINING ATTORNEY

CLASS 44—(Continued).

SN 85-577,539. TRIWEST HEALTHCARE ALLIANCE CORP., PHOENIX, AZ. FILED 3-22-2012.

CLASS 45—PERSONAL AND LEGAL SERVICES

SN 77-798,980. ADT SERVICES AG, SCHAFFHAUSEN, SWITZERLAND, FILED 8-6-2009.

SERVING THOSE WHO SERVE

PULSE

THE MARK CONSISTS OF STANDARD CHARACTERS WITHOUT CLAIM TO ANY PARTICULAR FONT, STYLE, SIZE, OR COLOR.

FOR MANAGING AND ADMINISTRATING HEALTH CARE PLANS, NAMELY, PREFERRED PROVIDER ORGANIZATION HEALTH CARE PLANS, HEALTH MAINTENANCE ORGANIZATIONS PLANS, AND FEE FOR SERVICE PLANS (U.S. CLS. 100 AND 101).

FIRST USE 10-1-2005; IN COMMERCE 10-1-2005.
ESTHER A. BORSUK, EXAMINING ATTORNEY

THE MARK CONSISTS OF STANDARD CHARACTERS WITHOUT CLAIM TO ANY PARTICULAR FONT, STYLE, SIZE, OR COLOR.

OWNER OF SWITZERLAND REG. NO. 599586, DATED 12-18-2009, EXPIRES 12-18-2019.

FOR ALARM RESPONSE AND VERIFICATION SERVICES; MONITORING OF ALARMS, SECURITY SYSTEMS AND HOME AUTOMATION SYSTEMS FOR SECURITY PURPOSES; REMOTE MONITORING OF ALARMS, SECURITY SYSTEMS AND HOME AUTOMATION SYSTEMS FOR SECURITY PURPOSES; MONITORING OF COMPUTER SYSTEMS FOR SECURITY PURPOSES, NAMELY, REMOTE MONITORING OF COMPUTER SYSTEMS IN THE FIELDS OF SECURITY SYSTEMS, FIRE ALARMS, ALARM CENTRAL UNITS, ANTI-INTRUSION ALARMS, BURGLAR ALARMS, PERSONAL HEALTH AND SECURITY ALARMS, SMOKE AND GAS ALARMS, HOME SURVEILLANCE SYSTEMS, LIGHTING CONTROLS, HOME AUTOMATION DEVICES, SPRINKLER SYSTEMS FOR FIRE PROTECTION, VEHICLE, PET AND PERSONNEL LOCATION, AUTOMOBILE SAFETY, VEHICLE THEFT, TRAFFIC, AND ROAD NAVIGATION, ALL OF THE FOREGOING FOR SECURITY PURPOSES; FIRE ALARM SPRINKLER AND WATER FLOW MONITORING SERVICES FOR FIRE ALARM SECURITY PURPOSES; CONTROL OF BUILDING ENVIRONMENTAL ACCESS AND SECURITY SYSTEMS; MONITORING TELEPHONE CALLS FROM SUBSCRIBERS AND NOTIFYING EMERGENCY FACILITIES; THEFT RECOVERY SERVICES, NAMELY, TRACKING, LOCATING AND MONITORING OF VEHICLES VIA A COMPUTER NETWORK; ELECTRONIC MONITORING SERVICES FOR SECURITY PURPOSES IN THE FIELD OF PETS, HOMES, PEOPLE AND BUSINESS BUILDINGS; PROVIDING SECURITY CONSULTING AND SECURITY CONSULTING VIA TELEPHONE HOTLINE; MONITORING TELEPHONE CALLS AND MESSAGES FROM SUBSCRIBERS AND NOTIFYING EMERGENCY FACILITIES FROM CALL CENTERS IN THE FIELDS OF SECURITY SYSTEMS, FIRE ALARMS, ALARM CENTRAL UNITS, ANTI-INTRUSION ALARMS, BURGLAR ALARMS, PERSONAL HEALTH AND SECURITY ALARMS, SMOKE AND GAS ALARMS, HOME SURVEILLANCE SYSTEMS, LIGHTING CONTROLS, HOME AUTOMATION DEVICES AND SPRINKLER SYSTEMS FOR FIRE PROTECTION; PROVIDING SECURITY CONSULTING VIA TELEPHONE HOTLINE AND MONITORING TELEPHONE CALLS FROM SUBSCRIBERS AND NOTIFYING EMERGENCY FACILITIES FROM CALL CENTERS IN THE FIELDS OF VEHICLE SECURITY AND NAVIGATION; AND CONCIERGE SERVICES FOR OTHERS COMPRISING MAKING REQUESTED PERSONAL ARRANGEMENTS AND RESERVATIONS AND PROVIDING CUSTOMER-SPECIFIC INFORMATION TO MEET INDIVIDUAL NEEDS, ALL OF THE AFOREMENTIONED FOR RESIDENTIAL USE (U.S. CLS. 100 AND 101).

ALEX KEAM, EXAMINING ATTORNEY

SN 85-590,825. EPICGENETICS CORPORATION, SANTA MONICA, CA. FILED 4-6-2012.

ARA - The Rheumatoid Arthritis Test

THE MARK CONSISTS OF STANDARD CHARACTERS WITHOUT CLAIM TO ANY PARTICULAR FONT, STYLE, SIZE, OR COLOR.

NO CLAIM IS MADE TO THE EXCLUSIVE RIGHT TO USE "THE RHEUMATOID ARTHRITIS TEST", APART FROM THE MARK AS SHOWN.

FOR MEDICAL TESTING FOR DIAGNOSTIC OR TREATMENT PURPOSES IN THE FIELD OF RHEUMATOID ARTHRITIS (U.S. CLS. 100 AND 101).

TARAH HARDY, EXAMINING ATTORNEY

CLASS 45—(Continued).

SN 85-186,348. SPIRIT OF FAITH CHRISTIAN CENTER, AKA SPIRIT OF FAITH, TEMPLE HILLS, MD. FILED 11-29-2010.

Spirit of Faith Christian
Center

THE MARK CONSISTS OF STANDARD CHARACTERS WITHOUT CLAIM TO ANY PARTICULAR FONT, STYLE, SIZE, OR COLOR.

NO CLAIM IS MADE TO THE EXCLUSIVE RIGHT TO USE "CHRISTIAN CENTER", APART FROM THE MARK AS SHOWN.

FOR CHRISTIAN MINISTRY SERVICES; RELIGIOUS AND SPIRITUAL SERVICES, NAMELY, CONDUCTING RELIGIOUS WORSHIP, MARRIAGE CEREMONIES, BAPTISMAL CEREMONIES, BABY DEDICATIONS, BE-REAVEMENT CEREMONIES, AND RELIGIOUS COUN-SELING (U.S. CLS. 100 AND 101).

FIRST USE 10-16-1993; IN COMMERCE 8-1-1999.
MICHELE SWAIN, EXAMINING ATTORNEY

CLASS 45—(Continued).

SN 85-338,323. DIANNA L. STAMNESS, DBA SPARKS OF LIGHT, NEW BRIGHTON, MN. FILED 6-5-2011.

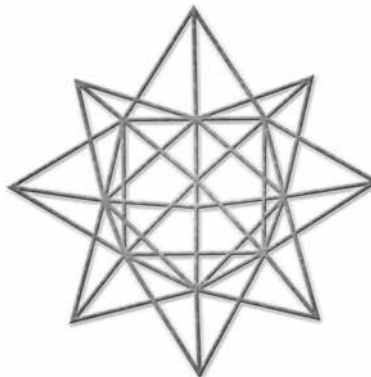

THE MARK CONSISTS OF A STYLIZED STELLATED STAR QUADRAHEDRON.

FOR PROVIDING BOTH IN-PERSON AND ON-LINE HOLISTIC SPIRITUAL COUNSELING SERVICES (U.S. CLS. 100 AND 101).

FIRST USE 4-0-2011; IN COMMERCE 4-0-2011.
SARA BENJAMIN, EXAMINING ATTORNEY

SN 85-345,075. GUTHRIE, RYAN, PICKERING, CANADA, FILED 6-13-2011.

MYCOMMUNITE.COM

SN 85-243,011. FATHER FLANAGAN'S BOYS' HOME, BOYS TOWN, NE. FILED 2-15-2011.

BOYS TOWN IN-HOME FAMILY
SERVICES

THE MARK CONSISTS OF STANDARD CHARACTERS WITHOUT CLAIM TO ANY PARTICULAR FONT, STYLE, SIZE, OR COLOR.

FOR ONLINE SOCIAL NETWORKING FOR BUSINESS AND RESIDENTIAL NEIGHBORS (U.S. CLS. 100 AND 101).

EDWARD FENNESSY, EXAMINING ATTORNEY

SN 85-347,267. SX2 MEDIA LABS, LLC, NEW YORK, NY. FILED 6-15-2011.



THE MARK CONSISTS OF THE WORDS "COMPUTER SHOPPER" IN BLOCK LETTERING IN CAPITAL LETTERS. SEC. 2(F).

FOR PROVIDING INFORMATION IN THE FIELDS OF COMPUTER TECHNOLOGY NEWS AND COMPUTER TECHNOLOGY (U.S. CLS. 100 AND 101).

FIRST USE 11-30-1979; IN COMMERCE 11-30-1979.
DOMINICK J. SALEMI, EXAMINING ATTORNEY

THE MARK CONSISTS OF STANDARD CHARACTERS WITHOUT CLAIM TO ANY PARTICULAR FONT, STYLE, SIZE, OR COLOR.

OWNER OF U.S. REG. NOS. 1,334,772, 3,627,959 AND OTHERS.

NO CLAIM IS MADE TO THE EXCLUSIVE RIGHT TO USE "IN-HOME FAMILY SERVICES", APART FROM THE MARK AS SHOWN.

FOR CONSULTING SERVICES IN THE FIELD OF PARENTING PERTAINING TO INTRAFAMILY RELATIONSHIPS; CONSULTING SERVICES IN THE IMPROVEMENT OF SOCIAL SKILLS (U.S. CLS. 100 AND 101).

FIRST USE 3-1-2008; IN COMMERCE 3-1-2008.
ALEXANDER L. POWERS, EXAMINING ATTORNEY

CLASS 45—(Continued).

SN 85-362,665. KANNEGIETER, TODD L., ERIE, CO. FILED 7-4-2011.

VirtualArmor

THE MARK CONSISTS OF STANDARD CHARACTERS WITHOUT CLAIM TO ANY PARTICULAR FONT, STYLE, SIZE, OR COLOR.

FOR MONITORING OF COMPUTER SYSTEMS FOR SECURITY PURPOSES (U.S. CLS. 100 AND 101).

FIRST USE 10-31-2004; IN COMMERCE 11-15-2004.
SANJEEV VOHRA, EXAMINING ATTORNEY

SN 85-371,817. SPIRITUAL INTERVENTIONS, INC., DBA SPIRITUAL INTERVENTIONS, INC., GOODE, VA. FILED 7-14-2011.



NO CLAIM IS MADE TO THE EXCLUSIVE RIGHT TO USE "SPIRITUAL INTERVENTIONS, INC. CHRIST CENTERED MINISTRY", APART FROM THE MARK AS SHOWN.

THE MARK CONSISTS OF A STYLIZED IMAGE OF A HUMAN BEING REPRESENTED BY A DARK CIRCLE AND TWO DARK VERTICAL LINES THAT BEND AWAY FROM EACH OTHER. THE IMAGE ALSO INCLUDES A HALF CIRCLE AND ADDITIONAL CURVED LINES CREATING A SHADOW EFFECT. THE MARK ALSO INCLUDES THE WORDING "SPIRITUAL INTERVENTIONS, INC. CHRIST CENTERED MINISTRY" AND A HORIZONTAL LINE.

FOR SPIRITUAL COUNSELING (U.S. CLS. 100 AND 101).

FIRST USE 7-3-2009; IN COMMERCE 7-3-2009.
KIM MONINGHOFF, EXAMINING ATTORNEY

CLASS 45—(Continued).

SN 85-376,206. LP INNOVATIONS, INC., MILFORD, MA. FILED 7-20-2011.



THE MARK CONSISTS OF THE CAPITAL LETTERS "LPI" WITH A BRUSHED LINE EXTENDING FROM THE "P" THROUGH THE "L".

FOR LOSS PREVENTION SERVICES FOR BUSINESSES, NAMELY, DEVELOPMENT AND IMPLEMENTATION OF LOSS PREVENTION POLICIES AND PROCEDURES FOR THE REVIEW AND ANALYSIS OF SALES TRANSACTIONS AND RELATED DATA, INVESTIGATIVE SERVICES AND LOSS PREVENTION CONSULTING, NAMELY, SITE SURVEYS AND RISK ANALYSIS; LOSS PREVENTION SERVICES FOR BUSINESSES, NAMELY, BUSINESS OPERATION AUDITS FOR LOSS PREVENTION PURPOSES, INVENTORY PROCESSES AUDITS FOR LOSS PREVENTION PURPOSES, AUDITING PROCESSES FOR DEALING WITH LOSS PREVENTION AND AUDITING PHARMACY COMPLIANCE FOR LOSS PREVENTION PURPOSES; LOSS PREVENTION SERVICES FOR BUSINESSES, NAMELY, MYSTERY SHOPPING SERVICES FOR LOSS PREVENTION PURPOSES (U.S. CLS. 100 AND 101).

FIRST USE 7-15-2010; IN COMMERCE 7-15-2010.
DANIEL CAPSHAW, EXAMINING ATTORNEY

SN 85-377,585. LP INNOVATIONS, INC., MILFORD, MA. FILED 7-21-2011.



NO CLAIM IS MADE TO THE EXCLUSIVE RIGHT TO USE "LP", APART FROM THE MARK AS SHOWN.

THE MARK CONSISTS OF THE WORDS "LP INNOVATIONS" WITH THE "L" AND "P" IN LARGE STYLIZED LETTERS. A BRUSHED LINE EXTENDS FROM THE "P" THROUGH THE "L".

FOR LOSS PREVENTION SERVICES FOR BUSINESSES, NAMELY, DEVELOPMENT AND IMPLEMENTATION OF LOSS PREVENTION POLICIES AND PROCEDURES FOR THE REVIEW AND ANALYSIS OF SALES TRANSACTIONS AND RELATED DATA, INVESTIGATIVE SERVICES AND LOSS PREVENTION CONSULTING, NAMELY, SITE SURVEYS AND RISK ANALYSIS; LOSS PREVENTION SERVICES FOR BUSINESSES, NAMELY, BUSINESS OPERATION AUDITS FOR LOSS PREVENTION PURPOSES, INVENTORY PROCESSES AUDITS FOR LOSS PREVENTION PURPOSES, AUDITING PROCESSES FOR DEALING WITH LOSS PREVENTION AND AUDITING PHARMACY COMPLIANCE FOR LOSS PREVENTION PURPOSES; LOSS PREVENTION SERVICES FOR BUSINESSES, NAMELY, MYSTERY SHOPPING SERVICES FOR LOSS PREVENTION PURPOSES (U.S. CLS. 100 AND 101).

FIRST USE 5-15-2000; IN COMMERCE 5-15-2000.
DANIEL CAPSHAW, EXAMINING ATTORNEY

CLASS 45—(Continued).

SN 85-385,346. RITA'S CARE AT HOME LLC, NASHVILLE, TN. FILED 7-30-2011.



NO CLAIM IS MADE TO THE EXCLUSIVE RIGHT TO USE "CARE AT HOME LLC", APART FROM THE MARK AS SHOWN.

THE MARK CONSISTS OF A CIRCLE WITH AN OUTLINE OF A HOUSE AND A DAISY FLOWER IN THE MIDDLE. THE TEXT "RITA'S" BELOW THE IMAGE, AND "CARE AT HOME LLC" BELOW "RITA'S".

FOR PERSONAL CARE ASSISTANCE OF ACTIVITIES OF DAILY LIVING, SUCH AS BATHING, GROOMING AND PERSONAL MOBILITY FOR MENTALLY OR PHYSICALLY CHALLENGED PEOPLE (U.S. CLS. 100 AND 101).

FIRST USE 8-14-2009; IN COMMERCE 8-14-2009.
JAY BESCH, EXAMINING ATTORNEY

CLASS 45—(Continued).

SN 85-437,249. AEKTRA, LLC, BRENTWOOD, MO. FILED 10-1-2011.



NO CLAIM IS MADE TO THE EXCLUSIVE RIGHT TO USE "LEGAL LLC", APART FROM THE MARK AS SHOWN. THE COLOR(S) BLUE AND PURPLE IS/ARE CLAIMED AS A FEATURE OF THE MARK.

THE MARK CONSISTS OF THE WORDS "AEKTRA LEGAL" FOLLOWED BY "LLC". THE WORD "AEKTRA" IS PURPLE. THE WORDS "LEGAL" AND "LLC" APPEAR IN LIGHT PURPLE. OTHER THAN COLOR, THE DISTINGUISHING FEATURE OF THE MARK IS THE CAPITAL "A" IN "AEKTRA". THE BOTTOM OF THE INSIDE OF THE "A" USES A LIGHT BLUE PARTIAL SEMI-CIRCLE. FROM THEREON, ON TOP OF THE PARTIAL SEMI-CIRCLE AND INSIDE OF THE LETTER "A", THERE ARE A SERIES OF UPWARD POINTING ARROWS LAID ON TOP OF ONE ANOTHER. IN ORDER: LIGHT PURPLE, DARKER PURPLE, EVEN DARKER PURPLE, AND EVEN DARKER PURPLE.

THE WORDING "AEKTRA" HAS NO MEANING IN A FOREIGN LANGUAGE.
FOR LEGAL CONSULTATION SERVICES; LEGAL RESEARCH; LEGAL SERVICES (U.S. CLS. 100 AND 101).
FIRST USE 10-1-2011; IN COMMERCE 10-1-2011.
MARK T. MULLEN, EXAMINING ATTORNEY

SN 85-417,612. JENNA LOGAN INC., GRAND PRAIRIE, TX. FILED 9-8-2011.



THE NAME(S), PORTRAIT(S), AND/OR SIGNATURE(S) SHOWN IN THE MARK DOES NOT IDENTIFY A PARTICULAR LIVING INDIVIDUAL.

THE COLOR(S) GRAY, BROWN, BLUE AND WHITE IS/ARE CLAIMED AS A FEATURE OF THE MARK.

THE MARK CONSISTS OF A BLUE OVAL SURROUNDED BY A BROWN BORDER WITH A WHITE CENTER, WITH THE INITIALS "JL" IN WHITE, ALL OF WHICH IS SUPERIMPOSED ON A GRAY LACEWORK PATTERN WITH THE TERM "JENNA" IN BROWN ON THE LEFT OF THE OVAL AND THE TERM "LOGAN" IN BROWN TO THE RIGHT OF THE OVAL.

FOR RENTAL OF JEWELRY (U.S. CLS. 100 AND 101).
LESLEY LAMOTHE, EXAMINING ATTORNEY

SN 85-452,313. KYRISS, TERRY D, DENVER, CO. FILED 10-20-2011.

Jingle

THE MARK CONSISTS OF STANDARD CHARACTERS WITHOUT CLAIM TO ANY PARTICULAR FONT, STYLE, SIZE, OR COLOR.

FOR COMPUTER DATING SERVICES; DATING SERVICES; DATING SERVICES, NAMELY, PROVIDING AN ON-LINE COMPUTER DATABASE FEATURING SINGLE PEOPLE INTERESTED IN MEETING OTHER SINGLE PEOPLE; INTERNET BASED SOCIAL NETWORKING, INTRODUCTION, AND DATING SERVICES; INTERNET-BASED DATING, SOCIAL INTRODUCTION AND SOCIAL NETWORKING SERVICES; MARRIAGE PARTNER INTRODUCTION OR DATING SERVICES (U.S. CLS. 100 AND 101).

FIRST USE 10-20-2011; IN COMMERCE 10-20-2011.
HAI-LY LAM, EXAMINING ATTORNEY

CLASS 45—(Continued).

SN 85-455,379. SEMPCHECK SERVICES, INC., HOUSTON, TX. FILED 10-25-2011.



OWNER OF U.S. REG. NO. 2,811,026.

NO CLAIM IS MADE TO THE EXCLUSIVE RIGHT TO USE "SERVICES", APART FROM THE MARK AS SHOWN.

THE MARK CONSISTS OF A FIRST TEARDROP ENCLOSED BY A SECOND TEARDROP. THE MARK ALSO INCLUDES THE WORD "SEMPCHECK" SUPERIMPOSED OVER THE FIRST AND SECOND TEARDROPS, WHERE "SEMP" IS CAPITALIZED AND "HECK" IS LOWER-CASE, AND WHERE THE UPPER-RIGHT PORTION OF THE LETTER "K" EXTENDS UPWARD AND RIGHTWARD TO TERMINATE AT A THIRD TEARDROP. THE MARK ALSO INCLUDES THE WORD "SERVICES" SUPERIMPOSED OVER THE FIRST AND SECOND TEARDROPS AND LOCATED BELOW "SEMPCHECK", WHERE "S" IS CAPITALIZED AND "ERVICES" IS LOWER-CASE.

FOR MEASUREMENT AND REPORTING, NAMELY, TRACKING, MONITORING, AND PREPARING COMPLIANCE REPORTS ON REGULATORY REQUIREMENTS IN THE FIELD OF TESTING, CALIBRATION, AND REPORTING REQUIREMENTS FOR EQUIPMENT IN THE GAS AND OIL INDUSTRY FOR REGULATORY COMPLIANCE PURPOSES (U.S. CLS. 100 AND 101).

FIRST USE 3-1-2011; IN COMMERCE 3-1-2011.

LEIGH CAROLINE CASE, EXAMINING ATTORNEY

SN 85-456,817. GODFREY & KAHN, S.C., MILWAUKEE, WI. FILED 10-26-2011.

GODFREY & KAHN S.C.

NO CLAIM IS MADE TO THE EXCLUSIVE RIGHT TO USE "S.C.", APART FROM THE MARK AS SHOWN.

THE MARK CONSISTS OF THE WORDING "GODFREY+KAHN S.C." IN STYLIZED BLOCK LETTERING WITH THE "+" SYMBOL BEING COMPOSED OF TWO SQUARE SHAPES ALTERNATED WITH TWO QUARTER ROUND SHAPES CONFIGURED INTO A LEAF SHAPE DESIGN AND FORMING AN INTERNAL "+" SYMBOL.

FOR LEGAL SERVICES (U.S. CLS. 100 AND 101).

FIRST USE 10-18-2011; IN COMMERCE 10-18-2011.

DAVID H. STINE, EXAMINING ATTORNEY

CLASS 45—(Continued).

SN 85-465,176. AL-SAIGH, JODY, DBA PICTURE PERFECT ORGANIZING, ARLINGTON, VA. FILED 11-4-2011.

PICTURE PERFECT ORGANIZING

THE MARK CONSISTS OF STANDARD CHARACTERS WITHOUT CLAIM TO ANY PARTICULAR FONT, STYLE, SIZE, OR COLOR.

NO CLAIM IS MADE TO THE EXCLUSIVE RIGHT TO USE "ORGANIZING", APART FROM THE MARK AS SHOWN.

FOR ORGANIZATIONAL SERVICES TO INDIVIDUALS FOR HOME OR PERSONAL PURPOSES, NAMELY, ORGANIZING HOME SPACES, SPECIFICALLY, BASEMENTS, ATTICS, STORAGE ROOMS, CLOSETS, GARAGES, KITCHENS, PANTRIES, UTILITY ROOMS, DESKS, FILES, WORKSPACES, PLAYROOMS, DOCUMENT MANAGEMENT, ORGANIZING PHOTOGRAPHS AND MEMORABILIA, AND ORGANIZING BELONGINGS FOR HOUSEHOLD MOVES (U.S. CLS. 100 AND 101).

FIRST USE 4-8-2008; IN COMMERCE 4-8-2008.

ADA HAN, EXAMINING ATTORNEY

SN 85-477,697. THE GRIEF TOOLBOX, INC., NASHUA, NH. FILED 11-21-2011.



NO CLAIM IS MADE TO THE EXCLUSIVE RIGHT TO USE "GRIEF", APART FROM THE MARK AS SHOWN.

THE COLOR(S) RED, BROWN, GRAY, YELLOW AND BLUE IS/ARE CLAIMED AS A FEATURE OF THE MARK.

THE MARK CONSISTS OF A TOOLBOX SHAPED BOX IN THE COLORS RED, BROWN, GRAY AND HUES THEREOF. THE SUN PARTIALLY RISING OUT OF THE BOX IN THE COLOR YELLOW AND HUES THEREOF. THE WORDS "THE GRIEF TOOLBOX" IN THE COLOR BLUE AND HUES THEREOF. THE COLORS BLACK AND WHITE REPRESENT BACKGROUND, OUTLINING, SHADING AND/OR TRANSPARENT AREAS AND ARE NOT PART OF THE MARK.

FOR GRIEF COUNSELING (U.S. CLS. 100 AND 101).

FIRST USE 7-21-2011; IN COMMERCE 7-21-2011.

BARBARA RUTLAND, EXAMINING ATTORNEY

CLASS 45—(Continued).

SN 85-479,002. KARASIC, DAVID P, BEDFORD, MA. FILED 11-22-2011.

Minuteman Legal Services

THE MARK CONSISTS OF STANDARD CHARACTERS WITHOUT CLAIM TO ANY PARTICULAR FONT, STYLE, SIZE, OR COLOR.

NO CLAIM IS MADE TO THE EXCLUSIVE RIGHT TO USE "LEGAL SERVICES", APART FROM THE MARK AS SHOWN.

FOR LEGAL SERVICES (U.S. CLS. 100 AND 101).
JOHN WILKE, EXAMINING ATTORNEY

CLASS 45—(Continued).

SN 85-486,010. HEARTS OF HOPE INSTITUTE, INC., COLUMBUS, OH. FILED 12-2-2011.



THE COLOR(S) RED, PINK AND BROWN IS/ARE CLAIMED AS A FEATURE OF THE MARK.

THE MARK CONSISTS OF THE WORD "HOPE" IN RED STYLIZED FONT DISPLAYED IN A REPEATED PATTERN TO RESEMBLE A HEART DESIGN SUPPORTED BY TWO PINK-COLORED HANDS FEATURING BROWN LINING AND NAIL DEFINITION.

FOR CHARITABLE SERVICES, NAMELY, PROVIDING FOSTER CARE FOR THE ELDERLY AND ADULTS WITH DISABILITIES; CHARITABLE SERVICES, NAMELY, PROVIDING PERSONAL CARE ASSISTANCE OF ACTIVITIES OF DAILY LIVING, SUCH AS BATHING, GROOMING AND PERSONAL MOBILITY FOR THE ELDERLY AND ADULTS WITH DISABILITIES (U.S. CLS. 100 AND 101).

FIRST USE 1-1-2003; IN COMMERCE 1-1-2009.
DAVID YONTEF, EXAMINING ATTORNEY

SN 85-479,822. JOE & CLARA, A CALIFORNIA CORPORATION, WESTLAKE VILLAGE, CA. FILED 11-23-2011.

PILATISTAS.COM

THE MARK CONSISTS OF STANDARD CHARACTERS WITHOUT CLAIM TO ANY PARTICULAR FONT, STYLE, SIZE, OR COLOR.

FOR PROVIDING A SOCIAL NETWORKING WEBSITE FOR PILATES PRACTITIONERS (U.S. CLS. 100 AND 101).

CHRISTOPHER LAW, EXAMINING ATTORNEY

SN 85-486,066. WHITEHARDT, INC., NASHVILLE, TN. FILED 12-2-2011.

EXP

THE MARK CONSISTS OF STANDARD CHARACTERS WITHOUT CLAIM TO ANY PARTICULAR FONT, STYLE, SIZE, OR COLOR.

OWNER OF U.S. REG. NOS. 3,551,264, 4,053,310 AND OTHERS.

FOR CONCIERGE SERVICES FOR TRAVELERS AND TOURISTS COMPRISING MAKING REQUESTED PERSONAL ARRANGEMENTS AND RESERVATIONS AND PROVIDING CUSTOMER-SPECIFIC INFORMATION TO MEET INDIVIDUAL NEEDS RENDERED TOGETHER IN APARTMENT COMPLEXES AND OFFICE BUILDINGS (U.S. CLS. 100 AND 101).

CAROLYN CATALDO, EXAMINING ATTORNEY

CALL ME IT'S JUST THAT EASY!

THE MARK CONSISTS OF STANDARD CHARACTERS WITHOUT CLAIM TO ANY PARTICULAR FONT, STYLE, SIZE, OR COLOR.

FOR LEGAL SERVICES (U.S. CLS. 100 AND 101).
FIRST USE 9-8-2008; IN COMMERCE 9-8-2008.
KAREN K. BUSH, EXAMINING ATTORNEY

CLASS 45—(Continued).

SN 85-490,560. COMIINGLE, DBA COMIINGLE, LA VERNE, CA. FILED S.R. 12-8-2011; AM. P.R. 3-27-2012.

comiingle

THE MARK CONSISTS OF STANDARD CHARACTERS WITHOUT CLAIM TO ANY PARTICULAR FONT, STYLE, SIZE, OR COLOR.

FOR COMPUTER DATING SERVICES; DATING SERVICES; DATING SERVICES, NAMELY, PROVIDING AN ON-LINE COMPUTER DATABASE FEATURING SINGLE PEOPLE INTERESTED IN MEETING OTHER SINGLE PEOPLE; INTERNET BASED SOCIAL NETWORKING, INTRODUCTION, AND DATING SERVICES; INTERNET-BASED DATING, SOCIAL INTRODUCTION AND SOCIAL NETWORKING SERVICES; MARRIAGE PARTNER INTRODUCTION OR DATING SERVICES; PROVIDING A WEB SITE FEATURING INFORMATION AND CONTENT IN THE FIELDS OF PERSONAL RELATIONSHIPS, DATING AND FASHION; VIDEO DATING SERVICES; WEB SITE SERVICES FEATURING ON-LINE DATING CLUB (U.S. CLS. 100 AND 101).

FIRST USE 2-8-2011; IN COMMERCE 2-8-2011.
STEVEN JACKSON, EXAMINING ATTORNEY

SN 85-491,615. METROMIXERS, LLC, FERNDALE, MI. FILED 12-9-2011.



THE COLOR(S) WHITE, GREEN, GRAY, AND BLACK IS/ ARE CLAIMED AS A FEATURE OF THE MARK.

THE MARK CONSISTS OF THE STYLIZED WORD "METROMIXERS" WITH THE "METRO" PART DEPICTED IN WHITE COLOR, THE "MIXERS" PART DEPICTED IN GREEN COLOR, A GRAY COLOR OUTLINE OF THE SKYLINE OF A CITY, AND A BLACK BACKGROUND.

FOR COMPUTER DATING SERVICES; DATING SERVICES; DATING SERVICES, NAMELY, PROVIDING AN ON-LINE COMPUTER DATABASE FEATURING SINGLE PEOPLE INTERESTED IN MEETING OTHER SINGLE PEOPLE; INTERNET BASED SOCIAL NETWORKING, INTRODUCTION, AND DATING SERVICES; INTERNET-BASED DATING, SOCIAL INTRODUCTION AND SOCIAL NETWORKING SERVICES (U.S. CLS. 100 AND 101).

FIRST USE 12-0-2011; IN COMMERCE 12-0-2011.
WILLIAM VERHOSEK, EXAMINING ATTORNEY

CLASS 45—(Continued).

SN 85-492,186. HOME COMPANIONS, INC, SAN ANTONIO, TX. FILED 12-10-2011.

First Step Home Care

THE MARK CONSISTS OF STANDARD CHARACTERS WITHOUT CLAIM TO ANY PARTICULAR FONT, STYLE, SIZE, OR COLOR.

NO CLAIM IS MADE TO THE EXCLUSIVE RIGHT TO USE "HOME CARE", APART FROM THE MARK AS SHOWN.

FOR PERSONAL CARE ASSISTANCE OF ACTIVITIES OF DAILY LIVING, SUCH AS BATHING, GROOMING AND PERSONAL MOBILITY FOR MENTALLY OR PHYSICALLY CHALLENGED PEOPLE; PROVIDING NON-MEDICAL IN-HOME PERSONAL SERVICES FOR INDIVIDUALS INCLUDING CHECKING HOME CONDITION, SUPPLIES AND INDIVIDUAL WELL-BEING, SCHEDULING APPOINTMENTS, RUNNING ERRANDS, MAKING SAFETY CHECKS, AND PROVIDING ON-LINE INFORMATION RELATED TO THESE PERSONAL SERVICES; SOCIAL SERVICE, NAMELY, COMPANIONSHIP SERVICES FOR THE ELDERLY (U.S. CLS. 100 AND 101).

FIRST USE 7-11-2011; IN COMMERCE 7-11-2011.
HENRY S. ZAK, EXAMINING ATTORNEY

SN 85-501,518. HINMAN, CAROLYN STAR, TUCSON, AZ. FILED 12-21-2011.

Lady Portia
&
The Ascended Masters

THE MARK CONSISTS OF STANDARD CHARACTERS WITHOUT CLAIM TO ANY PARTICULAR FONT, STYLE, SIZE, OR COLOR.

THE NAME(S), PORTRAIT(S), AND/OR SIGNATURE(S) SHOWN IN THE MARK DOES NOT IDENTIFY A PARTICULAR LIVING INDIVIDUAL.

FOR PROVIDING BOTH IN-PERSON AND ON-LINE HOLISTIC SPIRITUAL COUNSELING SERVICES (U.S. CLS. 100 AND 101).

FIRST USE 4-30-2011; IN COMMERCE 4-30-2011.
TASHIA BUNCH, EXAMINING ATTORNEY

CLASS 45—(Continued).

SN 85-502,940. COSMIC QUOTIENT, GLEN ROCK, NJ. FILED 12-23-2011.

Cosmic Path of Initiations

THE MARK CONSISTS OF STANDARD CHARACTERS WITHOUT CLAIM TO ANY PARTICULAR FONT, STYLE, SIZE, OR COLOR.

FOR CONSULTING SERVICES IN THE FIELD OF PERSONAL DEVELOPMENT, NAMELY, CONSULTING SERVICES REGARDING PERSONAL IMPROVEMENT FEATURING ASTROLOGICAL READINGS (U.S. CLS. 100 AND 101).

FIRST USE 1-1-2009; IN COMMERCE 1-1-2009. MAUREEN DALL, EXAMINING ATTORNEY

SN 85-503,615. LUXE COLORE, STATEN ISLAND, NY. FILED 12-24-2011.



THE MARK CONSISTS OF CAPITAL LETTERS "L", "U" AND "X" OVERLAPPING EACH OTHER FROM LEFT TO RIGHT. THE LETTERS "L" AND "U" COMBINE TO CREATE A TWO COLUMNS CONNECTED BY THE HORIZONTAL LINE IN THE LETTERS "L" AND "U". THE "X" IS DISPLAYED USING A THIRD COLUMN THAT IS FALLING AND CRISSCROSSING TOWARDS THE VERTICAL LINE IN THE LETTER "U". UNDERNEATH THE CAPITAL LETTERS "LUX" IS THE WORDS "LUXE COLORE" IN SMALLER FONT CAPITAL LETTERS.

THE ENGLISH TRANSLATION OF "LUXE COLORE" IS "LUXURY COLOR".

FOR FASHION INFORMATION; FASHION TREND CONSULTING FOR THE FASHION INDUSTRY; ON-LINE SOCIAL NETWORKING SERVICES PROVIDED THROUGH A FASHION COMMUNITY WEBSITE; PROVIDING INFORMATION IN THE FIELD OF FASHION TRENDS; PROVIDING NEWS AND INFORMATION IN THE FIELD OF FASHION; PROVISION OF A WEB SITE FEATURING INFORMATION ON FASHION (U.S. CLS. 100 AND 101).

FIRST USE 12-12-2011; IN COMMERCE 12-12-2011. MATTHEW KLINE, EXAMINING ATTORNEY

CLASS 45—(Continued).

SN 85-505,303. OBOOK INC., TAIPEI, TAIWAN, FILED 12-28-2011.

OwlTing

THE MARK CONSISTS OF STANDARD CHARACTERS WITHOUT CLAIM TO ANY PARTICULAR FONT, STYLE, SIZE, OR COLOR.

FOR COMMUNITY OUTREACH SERVICES PROVIDED TO PREGNANT WOMEN, NAMELY, ON-LINE SOCIAL NETWORKING SERVICES; CONDUCTING ON-LINE PERSONAL LIFESTYLE PERFORMANCE ASSESSMENTS BASED ON PRINCIPLES OF EMOTIONAL HAPPINESS BY MEANS OF THE USERS' INPUTTED PREFERENCES AND SOCIAL NETWORK; INTERNET BASED SOCIAL NETWORKING, INTRODUCTION, AND DATING SERVICES; INTERNET-BASED DATING, SOCIAL INTRODUCTION AND SOCIAL NETWORKING SERVICES; INTERNET-BASED SOCIAL NETWORKING SERVICES; ON-LINE GAY, LESBIAN AND BISEXUAL SOCIAL NETWORKING SERVICES; ON-LINE SOCIAL NETWORKING SERVICES; ONLINE SOCIAL NETWORKING IN THE FIELD OF FOOD; ONLINE SOCIAL NETWORKING SERVICES PROVIDED THROUGH A COMMUNITY WEBSITE; ONLINE SOCIAL NETWORKING SERVICES PROVIDED THROUGH A FASHION COMMUNITY WEBSITE; ONLINE SOCIAL NETWORKING SERVICES PROVIDED THROUGH A SPORTS COMMUNITY WEBSITE; ONLINE SOCIAL NETWORKING SERVICES IN THE FIELD OF DINING, TRAVEL AND ENTERTAINMENT SERVICES; ONLINE SOCIAL NETWORKING SERVICES IN THE FIELD OF DINING, TRAVEL AND ENTERTAINMENT SERVICES PROVIDED VIA A WEBSITE; PROVIDING A SOCIAL NETWORKING WEBSITE AT WHICH A USER CAN GIVE CHARITABLE GIFTS TO OTHERS; PROVIDING A SOCIAL NETWORKING WEBSITE FOR ENTERTAINMENT PURPOSES; PROVIDING ON-LINE COMPUTER DATABASES AND ON-LINE SEARCHABLE DATABASES IN THE FIELD OF SOCIAL NETWORKING; SOCIAL NETWORKING SERVICES IN THE FIELD OF DINING, TRAVEL AND ENTERTAINMENT SERVICES PROVIDED VIA A WEBSITE (U.S. CLS. 100 AND 101).

FIRST USE 7-28-2011; IN COMMERCE 7-28-2011. KELLEY WELLS, EXAMINING ATTORNEY

SN 85-507,334. MAX'S LOVE PROJECT, INC., TUSTIN, CA. FILED 1-3-2012.



THE COLOR(S) GREEN, YELLOW, BLUE, GREY, WHITE IS/ARE CLAIMED AS A FEATURE OF THE MARK.

THE MARK CONSISTS OF A GREEN RECTANGLE BACKGROUND WITH A THIN WHITE ACCENT LINE

CLASS 45—(Continued).

INSIDE THE RECTANGLE BORDERS, AN ALTERNATING WHITE AND YELLOW STARBURST IN THE CENTER OF THE RECTANGLE, A BLUE SILHOUETTE OF A JUMPING CHILD ON TOP OF THE STARBURST, THE WORDING "MAX'S LOVE PROJECT" IN WHITE SUPERIMPOSED OVER THE CHILD WITH A YELLOW HEART WITH A GREY LIGHTNING BOLT INLAY SERVING AS THE "O" IN "LOVE" AT THE CENTER OF THE CHILD, AND THE WORDING "SUPPORTING SUPERKIDS FIGHTING CANCER" IN WHITE ACROSS THE BOTTOM.

FOR PROVIDING PERSONAL SUPPORT SERVICES FOR PATIENTS AND FAMILIES OF PATIENTS WITH CANCER, NAMELY, EMOTIONAL COUNSELING AND EMOTIONAL SUPPORT (U.S. CLS. 100 AND 101).

FIRST USE 12-20-2011; IN COMMERCE 12-26-2011.
AMY KELLY, EXAMINING ATTORNEY

SN 85-507,336. MAX'S LOVE PROJECT, INC., TUSTIN, CA.
FILED 1-3-2012.

**Max's Love Project,
Supporting SuperKids
Fighting Cancer**

THE MARK CONSISTS OF STANDARD CHARACTERS WITHOUT CLAIM TO ANY PARTICULAR FONT, STYLE, SIZE, OR COLOR.

FOR PROVIDING PERSONAL SUPPORT SERVICES FOR PATIENTS AND FAMILIES OF PATIENTS WITH CANCER, NAMELY, EMOTIONAL COUNSELING AND EMOTIONAL SUPPORT (U.S. CLS. 100 AND 101).

FIRST USE 12-20-2011; IN COMMERCE 12-26-2011.
AMY KELLY, EXAMINING ATTORNEY

SN 85-507,966. CORNING, GINA, LEAGUE CITY, TX. FILED 1-3-2012.

ASTROCHIC

THE MARK CONSISTS OF STANDARD CHARACTERS WITHOUT CLAIM TO ANY PARTICULAR FONT, STYLE, SIZE, OR COLOR.

FOR ASTROLOGY CONSULTATION; HOROSCOPES (U.S. CLS. 100 AND 101).

JUDITH HELFMAN, EXAMINING ATTORNEY

CLASS 45—(Continued).

SN 85-507,988. DREAM BACHELOR & BACHELORETTE, NEW YORK, NY. FILED 1-3-2012.



Single in Stilettos

NO CLAIM IS MADE TO THE EXCLUSIVE RIGHT TO USE "SINGLE", APART FROM THE MARK AS SHOWN.

THE MARK CONSISTS OF A PAIR OF STILETTO SHOES EACH WITH A BOW ON THE BACK ABOVE THE STYLIZED TEXT "SINGLE IN STILETTOS".

FOR DATING SERVICES (U.S. CLS. 100 AND 101).

FIRST USE 7-0-2011; IN COMMERCE 7-0-2011.
JOHN WILKE, EXAMINING ATTORNEY

SN 85-508,345. LINKEN DEFENSE STRATEGIES, AUSTIN, TX. FILED 1-4-2012.



LinKen
Defense Strategies, LLC

NO CLAIM IS MADE TO THE EXCLUSIVE RIGHT TO USE "DEFENSE STRATEGIES, LLC", APART FROM THE MARK AS SHOWN.

THE MARK CONSISTS OF A SHIELD WITH A CROSSHAIR AND THE STYLIZED TEXT "LINKEN DEFENSE STRATEGIES, LLC" IN TWO LINES.

FOR PRIVATE INVESTIGATION; SECURITY GUARD SERVICES (U.S. CLS. 100 AND 101).

MICHAEL KEATING, EXAMINING ATTORNEY

SN 85-509,150. ID ANALYTICS, INC., SAN DIEGO, CA. FILED 1-5-2012.

COMPLY360

THE MARK CONSISTS OF STANDARD CHARACTERS WITHOUT CLAIM TO ANY PARTICULAR FONT, STYLE, SIZE, OR COLOR.

FOR IDENTITY THEFT AND FRAUD PREVENTION AND PROTECTION SERVICES, NAMELY, PROVIDING A RISK-BASED INDICATOR OF POTENTIAL OR ACTUAL IDENTITY FRAUD OR THEFT BASED ON ANALYSIS, ASSESSMENT, SCREENING, MONITORING, OR VALIDATION OF INDIVIDUAL IDENTITY INFORMATION (U.S. CLS. 100 AND 101).

DAVID TOOLEY, EXAMINING ATTORNEY

CLASS 45—(Continued).

SN 85-509,209. CROSS, GUNTER, WITHERSPOON & GALCHUS, P.C., LITTLE ROCK, AR. FILED 1-5-2012.



OWNER OF U.S. REG. NO. 3,090,028.
 NO CLAIM IS MADE TO THE EXCLUSIVE RIGHT TO USE "P.C.", APART FROM THE MARK AS SHOWN.
 THE COLOR(S) ORANGE, BLUE AND GRAY IS/ARE CLAIMED AS A FEATURE OF THE MARK.
 THE MARK CONSISTS OF THE WORDING "CROSS, GUNTER, WITHERSPOON & GALCHUS, P.C." IN STYLIZED GRAY LETTERING AND TWO OVERLAPPING CHEVRONS THAT FORM A MISCELLANEOUS DIAMOND-SHAPED DESIGN WITH THE LEFT CHEVRON APPEARING IN ORANGE AND THE RIGHT CHEVRON APPEARING IN BLUE.
 FOR LEGAL SERVICES (U.S. CLS. 100 AND 101).
 FIRST USE 6-1-2011; IN COMMERCE 6-1-2011.
 JUDITH HELFMAN, EXAMINING ATTORNEY

SN 85-509,486. RICHARDSON SIXTH, LLC, ATLANTA, GA. FILED 1-5-2012.

SIXTH SENSE FOR LAW AND BUSINESS

THE MARK CONSISTS OF STANDARD CHARACTERS WITHOUT CLAIM TO ANY PARTICULAR FONT, STYLE, SIZE, OR COLOR.
 FOR LEGAL SERVICES (U.S. CLS. 100 AND 101).
 FIRST USE 7-5-2011; IN COMMERCE 9-28-2011.
 KIMBERLY PERRY, EXAMINING ATTORNEY

SN 85-509,754. FAEGRE BAKER DANIELS LLP, INDIANAPOLIS, IN. FILED 1-5-2012.

MORE, TOGETHER

THE MARK CONSISTS OF STANDARD CHARACTERS WITHOUT CLAIM TO ANY PARTICULAR FONT, STYLE, SIZE, OR COLOR.
 OWNER OF U.S. REG. NO. 3,577,717.
 FOR LEGAL SERVICES (U.S. CLS. 100 AND 101).
 GENE MACIOL, EXAMINING ATTORNEY

CLASS 45—(Continued).

SN 85-509,855. NAR-ANON FAMILY GROUP HEADQUARTERS, INC., TORRANCE, CA. FILED 1-5-2012.



OWNER OF U.S. REG. NO. 2,512,598.
 NO CLAIM IS MADE TO THE EXCLUSIVE RIGHT TO USE "FAMILY GROUPS", APART FROM THE MARK AS SHOWN.
 THE MARK CONSISTS OF AN INVERTED SQUARE WITH 2 CIRCLES INSIDE THE INVERTED SQUARE WITH THE WORDS "NAR-ANON FAMILY GROUPS" BETWEEN THE 2 CIRCLES ARRANGED IN A CIRCULAR FASHION WITH DARKENED AREAS SURROUNDING THE FIRST CIRCLE.
 FOR PROVIDING EMOTIONAL COUNSELING AND EMOTIONAL SUPPORT SERVICES VIA A 12 STEP PROGRAM FOR FAMILY MEMBERS OF ADDICTS, SUCH SERVICES PROVIDED ON A NON-PROFIT BASIS (U.S. CLS. 100 AND 101).
 FIRST USE 11-1-1965; IN COMMERCE 5-2-2008.
 REBECCA GILBERT, EXAMINING ATTORNEY

SN 85-509,873. NAR-ANON FAMILY GROUP HEADQUARTERS, INC., TORRANCE, CA. FILED 1-5-2012.



THE MARK CONSISTS OF AN INVERTED SQUARE WITH A CIRCLE INSIDE.
 FOR PROVIDING EMOTIONAL COUNSELING AND EMOTIONAL SUPPORT SERVICES VIA A 12 STEP PROGRAM FOR FAMILY MEMBERS OF ADDICTS, SUCH SERVICES PROVIDED ON A NON-PROFIT BASIS (U.S. CLS. 100 AND 101).
 FIRST USE 11-1-1965; IN COMMERCE 5-2-2008.
 REBECCA GILBERT, EXAMINING ATTORNEY

CLASS 45—(Continued).

SN 85-510,212. GOLDEN LIVING AT HOME LLC, FAIRFAX, VA. FILED 1-6-2012.

JOYFUL LIVING AT HOME

THE MARK CONSISTS OF STANDARD CHARACTERS WITHOUT CLAIM TO ANY PARTICULAR FONT, STYLE, SIZE, OR COLOR.

FOR PERSONAL CARE ASSISTANCE OF ACTIVITIES OF DAILY LIVING, SUCH AS BATHING, GROOMING AND PERSONAL MOBILITY FOR MENTALLY OR PHYSICALLY CHALLENGED PEOPLE (U.S. CLS. 100 AND 101).

FIRST USE 1-4-2012; IN COMMERCE 1-4-2012.
MELISSA VALLILLO, EXAMINING ATTORNEY

SN 85-510,331. NATIONAL FORENSIC CONSULTANTS, INC., PENNSAUKEN, NJ. FILED 1-6-2012.

**NATIONAL
FORENSIC
CONSULTANTS**

OWNER OF U.S. REG. NO. 2,793,899.
NO CLAIM IS MADE TO THE EXCLUSIVE RIGHT TO USE "FORENSIC CONSULTANTS", APART FROM THE MARK AS SHOWN.

THE COLOR(S) RED AND BLACK IS/ARE CLAIMED AS A FEATURE OF THE MARK.

THE MARK CONSISTS OF THE LITERAL ELEMENT "NATIONAL FORENSIC CONSULTANTS" IN RED, WHERE A BLACK BULLSEYE SYMBOL IS USED INSTEAD OF THE LETTER "O" IN THE WORD "FORENSIC".

SEC. 2(F) AS TO "NATIONAL FORENSIC CONSULTANTS".

FOR ACCIDENT INVESTIGATIONS; INVESTIGATION SERVICES RELATED TO INSURANCE CLAIMS, PRODUCT LIABILITY CLAIMS, GENERAL LIABILITY CLAIMS, PREMISES LIABILITY CLAIMS, MOLD CLAIMS, ENVIRONMENTAL CLAIMS, GEOTECHNICAL CLAIMS, BLASTING AND VIBRATION CLAIMS, SURETY CLAIMS, SOOT AND SMOKE DAMAGE CLAIMS, PROPERTY ORIGIN AND CAUSE CLAIMS, PROPERTY DAMAGE LIABILITY CLAIMS, CONSTRUCTION DEFECT CLAIMS; TRAFFIC ACCIDENT RECONSTRUCTION SERVICES (U.S. CLS. 100 AND 101).
ELLEN B. AWRICH, EXAMINING ATTORNEY

CLASS 45—(Continued).

SN 85-510,588. ROYALE SECURITY COMPANY INC., BROOKLYN, NY. FILED 1-6-2012.

 **ROYALE SECURITY COMPANY**

NO CLAIM IS MADE TO THE EXCLUSIVE RIGHT TO USE "SECURITY COMPANY", APART FROM THE MARK AS SHOWN.

THE MARK CONSISTS OF AN IMAGE OF A STYLIZED LION WITH A CROWN ABOVE THE HEAD OF THE LION WITH THE TERM "ROYALE SECURITY COMPANY" TO THE LEFT OF THE LION.

FOR SECURITY GUARD SERVICES; SECURITY GUARDING FOR FACILITIES (U.S. CLS. 100 AND 101).

FIRST USE 12-19-2011; IN COMMERCE 12-19-2011.
DANIEL CAPSHAW, EXAMINING ATTORNEY

SN 85-510,905. ALERTCHIRP, INC, MISSOULA, MT. FILED 1-6-2012.

AlertChirp

THE MARK CONSISTS OF STANDARD CHARACTERS WITHOUT CLAIM TO ANY PARTICULAR FONT, STYLE, SIZE, OR COLOR.

FOR SECURITY SERVICES, NAMELY, PROVIDING A WEBSITE NOTIFYING INDIVIDUALS OF A CHANGED STATUS OR CONDITION OF A SENSING DEVICE IN A SECURITY SYSTEM VIA ELECTRONIC MESSAGE ALERTS (U.S. CLS. 100 AND 101).

FIRST USE 11-1-2011; IN COMMERCE 11-1-2011.
JASON BLAIR, EXAMINING ATTORNEY

SN 85-511,043. OATES, ANDREA DANNETTE, PLAINS, GA. FILED 1-6-2012.

LIFE MORE ABUNDANTLY

THE MARK CONSISTS OF STANDARD CHARACTERS WITHOUT CLAIM TO ANY PARTICULAR FONT, STYLE, SIZE, OR COLOR.

FOR CHRISTIAN MINISTRY SERVICES (U.S. CLS. 100 AND 101).

KATHERINE CHANG, EXAMINING ATTORNEY

CLASS 45—(Continued).

SN 85-511,127. JUMBUH LLC, ST. AUGUSTINE, FL. FILED 1-7-2012.



THE COLOR(S) LIGHT BLUE IS/ARE CLAIMED AS A FEATURE OF THE MARK.

THE MARK CONSISTS OF THE STYLIZED WORD "JUMBUH" FOLLOWED BY AN EXCLAMATION MARK. ALL ELEMENTS ARE A SOLID LIGHT BLUE COLOR (HEX #0099FF).

FOR INTERNET-BASED SOCIAL NETWORKING SERVICES (U.S. CLS. 100 AND 101).

FIRST USE 5-1-2011; IN COMMERCE 5-1-2011.
NAKIA HENRY, EXAMINING ATTORNEY

CLASS 45—(Continued).

SN 85-511,209. FRIENDSTIK, INC., NORTH MIAMI, FL. FILED 1-7-2012.



THE MARK CONSISTS OF THE LETTERS "RHYMME" INSIDE AN OVAL SPEECH BALLOON.

FOR INTERNET-BASED SOCIAL NETWORKING SERVICES; ONLINE SOCIAL NETWORKING SERVICES IN THE FIELD OF FRIENDSHIP CONNECTIONS (U.S. CLS. 100 AND 101).

JENNY PARK, EXAMINING ATTORNEY

SN 85-511,202. FRIENDSTIK, INC., NORTH MIAMI, FL. FILED 1-7-2012.



THE COLOR(S) BLACK, LIGHT BLUE, MEDIUM BLUE AND RED IS/ARE CLAIMED AS A FEATURE OF THE MARK.

THE MARK CONSISTS OF "FRIENDSTIK" IN BLACK TO THE LEFT OF A MEDIUM BLUE SQUARE AND A LIGHT BLUE SQUARE OVER A BLACK SQUARE AND A RED SQUARE.

FOR INTERNET-BASED SOCIAL NETWORKING SERVICES; ONLINE SOCIAL NETWORKING SERVICES IN THE FIELD OF FRIENDSHIP CONNECTIONS (U.S. CLS. 100 AND 101).

JENNY PARK, EXAMINING ATTORNEY

SN 85-511,343. SHADOW EDGE SECURITY CONSULTANTS, LLC, LITTLETON, CO. FILED 1-8-2012.



THE COLOR(S) DARK BLUE, BLUE AND LIGHT BLUE IS/ARE CLAIMED AS A FEATURE OF THE MARK.

THE MARK CONSISTS OF THE ARTISTIC RENDERING OF A HUMAN HAND IN BLUE WITH DARK BLUE LINES APPEARING THROUGHOUT THE HAND. INSIDE THE HAND IS THE ARTISTIC RENDERING OF AN ADULT HUMAN HOLDING THE HAND OF A CHILD IN LIGHT BLUE.

FOR FINGERPRINTING AND FINGERPRINT REGISTRATION OF CHILDREN; FINGERPRINTING SERVICES (U.S. CLS. 100 AND 101).

FIRST USE 0-0-2011; IN COMMERCE 0-0-2011.
CHRISTOPHER BUONGIORNO, EXAMINING ATTORNEY

SN 85-511,207. PETSTIK, INC., NORTH MIAMI, FL. FILED 1-7-2012.



THE MARK CONSISTS OF SILHOUETTES OF THE HEADS OF A DOG, A CAT AND A BIRD ON A HORIZONTAL BAR OVER THE WORD "PETSTIK".

FOR INTERNET-BASED SOCIAL NETWORKING SERVICES; ONLINE SOCIAL NETWORKING SERVICES IN THE FIELD OF PET OWNER INTERESTS (U.S. CLS. 100 AND 101).

SALLY SHIH, EXAMINING ATTORNEY

SN 85-511,469. THANKNET, LLC, SARASOTA, FL. FILED 1-9-2012.



THE MARK CONSISTS OF STANDARD CHARACTERS WITHOUT CLAIM TO ANY PARTICULAR FONT, STYLE, SIZE, OR COLOR.

FOR INTERNET-BASED SOCIAL NETWORKING SERVICES (U.S. CLS. 100 AND 101).

FIRST USE 12-0-2011; IN COMMERCE 12-0-2011.
KELLY BOULTON, EXAMINING ATTORNEY

CLASS 45—(Continued).

SN 85-511,476. SHADOWTRACK TECHNOLOGIES, INC., MADISONVILLE, LA. FILED 1-9-2012.

If you need voice, we're
your choice

THE MARK CONSISTS OF STANDARD CHARACTERS WITHOUT CLAIM TO ANY PARTICULAR FONT, STYLE, SIZE, OR COLOR.

FOR PROVIDING SERVICES IN THE FIELD OF INVESTIGATING AND MONITORING THE WHEREABOUTS OF INDIVIDUALS INVOLVED IN THE JUDICIAL SYSTEM (U.S. CLS. 100 AND 101).

FIRST USE 8-18-2011; IN COMMERCE 8-18-2011.
KELLY BOULTON, EXAMINING ATTORNEY

SN 85-511,635. XBORDERS, LLC, NEW HAVEN, CT. FILED 1-9-2012.

XBORDERS

THE MARK CONSISTS OF STANDARD CHARACTERS WITHOUT CLAIM TO ANY PARTICULAR FONT, STYLE, SIZE, OR COLOR.

FOR INTERNET-BASED SOCIAL NETWORKING SERVICES; ON-LINE SOCIAL NETWORKING SERVICES; ONLINE SOCIAL NETWORKING SERVICES PROVIDED THROUGH A COMMUNITY WEBSITE; PROVIDING A SOCIAL NETWORKING WEBSITE FOR ENTERTAINMENT PURPOSES (U.S. CLS. 100 AND 101).

SANJEEV VOHRA, EXAMINING ATTORNEY

SN 85-511,642. XBORDERS, LLC, NEW HAVEN, CT. FILED 1-9-2012.

AMEURASICA

THE MARK CONSISTS OF STANDARD CHARACTERS WITHOUT CLAIM TO ANY PARTICULAR FONT, STYLE, SIZE, OR COLOR.

THE WORDING AMEURASICA HAS NO MEANING IN A FOREIGN LANGUAGE.

FOR INTERNET-BASED SOCIAL NETWORKING SERVICES; ON-LINE SOCIAL NETWORKING SERVICES; ONLINE SOCIAL NETWORKING SERVICES PROVIDED THROUGH A COMMUNITY WEBSITE; PROVIDING A SOCIAL NETWORKING WEBSITE FOR ENTERTAINMENT PURPOSES (U.S. CLS. 100 AND 101).

SANJEEV VOHRA, EXAMINING ATTORNEY

CLASS 45—(Continued).

SN 85-512,165. O'CONNOR, DAVID, THOMPSONS STATIN, TN. FILED 1-9-2012.

O'talks

THE MARK CONSISTS OF STANDARD CHARACTERS WITHOUT CLAIM TO ANY PARTICULAR FONT, STYLE, SIZE, OR COLOR.

FOR PERSONAL GROWTH AND MOTIVATION CONSULTING SERVICES (U.S. CLS. 100 AND 101).

SHAILA SETTLES, EXAMINING ATTORNEY

SN 85-512,496. KIM D. BURRUCKER, TIMBERLAKE, NC. FILED 1-10-2012.

BOW

THE MARK CONSISTS OF STANDARD CHARACTERS WITHOUT CLAIM TO ANY PARTICULAR FONT, STYLE, SIZE, OR COLOR.

FOR CHARITABLE SERVICES FOR HOMELESS AND NEEDY PERSONS, NAMELY PROCURING AND PROVIDING TO SUCH PERSONS KITS CONTAINING ONE OR MORE OF CLOTHING, PREPARED FOOD, RESTAURANT VOUCHERS, TRANSPORTATION PASSES, HEATING PACKS, BEDDING, PERSONAL CARE ITEMS; AND CARRY-ALL BAGS FOR HOMELESS AND NEEDY PERSONS (U.S. CLS. 100 AND 101).

FIRST USE 10-6-2011; IN COMMERCE 10-20-2011.
JOHN E. MICHOS, EXAMINING ATTORNEY

SN 85-512,513. KIM D. BURRUCKER, TIMBERLAKE, NC. FILED 1-10-2012.

BAGS OF WARMTH

THE MARK CONSISTS OF STANDARD CHARACTERS WITHOUT CLAIM TO ANY PARTICULAR FONT, STYLE, SIZE, OR COLOR.

FOR CHARITABLE SERVICES FOR HOMELESS AND NEEDY PERSONS, NAMELY PROCURING AND PROVIDING TO SUCH PERSONS KITS CONTAINING ONE OR MORE OF CLOTHING, PREPARED FOOD, RESTAURANT VOUCHERS, TRANSPORTATION PASSES, HEATING PACKS, BEDDING, PERSONAL CARE ITEMS; AND CARRY-ALL BAGS FOR HOMELESS AND NEEDY PERSONS (U.S. CLS. 100 AND 101).

FIRST USE 10-6-2011; IN COMMERCE 10-20-2011.
JOHN E. MICHOS, EXAMINING ATTORNEY

CLASS 45—(Continued).

SN 85-512,594. MCGOWAN, MOLLY, COHASSET, MA.
FILED 1-10-2012.

THE CLUTTER COACH

THE MARK CONSISTS OF STANDARD CHARACTERS WITHOUT CLAIM TO ANY PARTICULAR FONT, STYLE, SIZE, OR COLOR.

FOR ORGANIZATIONAL SERVICES FOR HOME OR PERSONAL PURPOSES, NAMELY, COMPLETE HOME ORGANIZATION FROM BASEMENT TO ATTIC USING LOGICAL SYSTEMS AND STREAMLINING FOR LONG TERM USE AND MAINTENANCE (U.S. CLS. 100 AND 101).

FIRST USE 3-0-2003; IN COMMERCE 3-0-2003.
LAURIE MAYES, EXAMINING ATTORNEY

SN 85-512,608. KIM D. BURRUCKER, TIMBERLAKE, NC.
FILED 1-10-2012.



THE MARK CONSISTS OF THE WORD "BOW" WITH AN IMAGE OF A BOW SUPERIMPOSED ACROSS THE "O" OF THE DESIGN, ENCLOSED IN A CIRCLE WITH THE WORDS "BAGS OF WARMTH" ALONG THE INNER EDGE OF THE CIRCLE.

FOR CHARITABLE SERVICES FOR HOMELESS AND NEEDY PERSONS, NAMELY PROCURING AND PROVIDING TO SUCH PERSONS KITS CONTAINING ONE OR MORE OF CLOTHING, PREPARED FOOD, RESTAURANT VOUCHERS, TRANSPORTATION PASSES, HEATING PACKS, BEDDING, PERSONAL CARE ITEMS; AND CARRY-ALL BAGS FOR HOMELESS AND NEEDY PERSONS (U.S. CLS. 100 AND 101).

FIRST USE 11-17-2011; IN COMMERCE 11-17-2011.
JOHN E. MICHOS, EXAMINING ATTORNEY

CLASS 45—(Continued).

SN 85-513,901. LAURIE B STYLE, LLC, WEST HOLLYWOOD, CA. FILED 1-11-2012.

LAURIEBSTYLE

THE MARK CONSISTS OF STANDARD CHARACTERS WITHOUT CLAIM TO ANY PARTICULAR FONT, STYLE, SIZE, OR COLOR.

FOR PERSONAL STYLIST SERVICES, NAMELY, EVALUATING THE PHYSICAL ATTRIBUTES, LIFESTYLE, AND FASHION STYLES OF OTHERS AND RECOMMENDING CLOTHING AND ACCESSORIES TO ACHIEVE THE PERSONAL IMAGE DESIRED BY THE CLIENT; PERSONAL WARDROBE STYLING SERVICES; PROVIDING ONLINE FASHION QUESTIONS TO HELP USERS DETERMINE THE STYLE OF CLOTHING BEST SUITED TO THEIR INDIVIDUAL NEEDS AND PREFERENCES (U.S. CLS. 100 AND 101).

FIRST USE 8-1-2010; IN COMMERCE 8-1-2010.
BRIDGETT SMITH, EXAMINING ATTORNEY

SN 85-514,502. WENCOURAGE INC., BOSSIER CITY, LA.
FILED 1-11-2012.

WEncourage

THE MARK CONSISTS OF STANDARD CHARACTERS WITHOUT CLAIM TO ANY PARTICULAR FONT, STYLE, SIZE, OR COLOR.

FOR ON-LINE SOCIAL NETWORKING SERVICES (U.S. CLS. 100 AND 101).

JOHN DALIER, EXAMINING ATTORNEY

CLASS 45—(Continued).

SN 85-515,127. LIFESTYLED, LLC, MARINA DEL REY, CA. FILED 1-12-2012.



NO CLAIM IS MADE TO THE EXCLUSIVE RIGHT TO USE "A BOUTIQUE LIFESTYLE MANAGEMENT FIRM", APART FROM THE MARK AS SHOWN.

THE COLOR(S) BLACK AND GOLDENROD IS/ARE CLAIMED AS A FEATURE OF THE MARK.

THE MARK CONSISTS OF THE WORD "LIFE" AND A COLON (:) IN ALL CAPITAL LETTERS DEPICTED IN THE "FEATURED ITEM" FONT IN BLACK COLOR AND THE WORD "STYLED" AND A PERIOD (.) WHERE ONLY THE "S" IS CAPITALIZED DEPICTED IN THE "AIR CONDITIONER" FONT AND IN GOLDENROD COLOR.

FOR PERSONAL CONCIERGE SERVICES FOR INDIVIDUALS AND BUSINESSES; NAMELY MAKING REQUESTED PERSONAL ARRANGEMENTS AND RESERVATIONS, TRAVEL AND HOSPITALITY ARRANGEMENTS, RUNNING ERRANDS AND PROVIDING CUSTOMER SPECIFIC INFORMATION AND SERVICES TO MEET SUCH CUSTOMER NEEDS, RENDERED IN BUSINESS ESTABLISHMENTS, OFFICE BUILDINGS, HOTELS, RESIDENTIAL COMPLEXES AND HOMES (U.S. CLS. 100 AND 101).

FIRST USE 7-15-2010; IN COMMERCE 7-15-2010.
MATTHEW KLINE, EXAMINING ATTORNEY

SN 85-515,517. ID ANALYTICS, INC., SAN DIEGO, CA. FILED 1-12-2012.

RESOLVE360

THE MARK CONSISTS OF STANDARD CHARACTERS WITHOUT CLAIM TO ANY PARTICULAR FONT, STYLE, SIZE, OR COLOR.

FOR CONSULTATION TO FINANCIAL INSTITUTIONS REGARDING IDENTITY VERIFICATION, IDENTITY RISK AND FRAUDULENT MISREPRESENTATION, AND COMPLIANCE WITH GOVERNMENT REGULATIONS REGARDING THE SAME (U.S. CLS. 100 AND 101).

DAVID TOOLEY, EXAMINING ATTORNEY

SN 85-515,524. ID ANALYTICS, INC., SAN DIEGO, CA. FILED 1-12-2012.

RESOLVE360

THE MARK CONSISTS OF STANDARD CHARACTERS WITHOUT CLAIM TO ANY PARTICULAR FONT, STYLE, SIZE, OR COLOR.

FOR CONSULTING SERVICES IN THE FIELDS OF IDENTITY VERIFICATION, IDENTIFY FRAUD AND IDENTITY THEFT PROTECTION (U.S. CLS. 100 AND 101).

DAVID TOOLEY, EXAMINING ATTORNEY

CLASS 45—(Continued).

SN 85-515,591. DANIEL JAHNSEN, BRIELLE, NJ. FILED 1-12-2012.

RESOLUTE

THE MARK CONSISTS OF STANDARD CHARACTERS WITHOUT CLAIM TO ANY PARTICULAR FONT, STYLE, SIZE, OR COLOR.

FOR ALTERNATIVE DISPUTE RESOLUTION SERVICES (U.S. CLS. 100 AND 101).

CHRISTINA SOBRAL, EXAMINING ATTORNEY

SN 85-515,594. DANIEL JAHNSEN, BRIELLE, NJ. FILED 1-12-2012.

**YOUR RESOURCE FOR GLOBAL
RESOLUTION**

THE MARK CONSISTS OF STANDARD CHARACTERS WITHOUT CLAIM TO ANY PARTICULAR FONT, STYLE, SIZE, OR COLOR.

FOR ALTERNATIVE DISPUTE RESOLUTION SERVICES (U.S. CLS. 100 AND 101).

CHRISTINA SOBRAL, EXAMINING ATTORNEY

SN 85-515,832. CYBERSETTLE HOLDINGS, INC., OLD GREENWICH, CT. FILED 1-13-2012.

**CHANGING THE WAY AMERICA
SETTLES DISPUTES**

THE MARK CONSISTS OF STANDARD CHARACTERS WITHOUT CLAIM TO ANY PARTICULAR FONT, STYLE, SIZE, OR COLOR.

FOR ALTERNATIVE DISPUTE RESOLUTION SERVICES (U.S. CLS. 100 AND 101).

RAUL CORDOVA, EXAMINING ATTORNEY

CLASS 45—(Continued).

SN 85-515,834. CYBERSETTLE HOLDINGS, INC., OLD GREENWICH, CT. FILED 1-13-2012.

CYBERSETTLE

THE MARK CONSISTS OF STANDARD CHARACTERS WITHOUT CLAIM TO ANY PARTICULAR FONT, STYLE, SIZE, OR COLOR.

OWNER OF U.S. REG. NO. 3,191,618.
FOR ALTERNATIVE DISPUTE RESOLUTION SERVICES (U.S. CLS. 100 AND 101).
FIRST USE 8-1-1998; IN COMMERCE 8-1-1998.
RAUL CORDOVA, EXAMINING ATTORNEY

SN 85-516,020. MICHAEL EDWARDS, BOTHELL, WA. FILED 1-13-2012.

ChristMate

THE MARK CONSISTS OF STANDARD CHARACTERS WITHOUT CLAIM TO ANY PARTICULAR FONT, STYLE, SIZE, OR COLOR.

FOR DATING SERVICES, NAMELY, PROVIDING AN ON-LINE COMPUTER DATABASE FEATURING SINGLE PEOPLE INTERESTED IN MEETING OTHER SINGLE PEOPLE (U.S. CLS. 100 AND 101).
FIRST USE 4-28-2009; IN COMMERCE 6-1-2009.
JASON BLAIR, EXAMINING ATTORNEY

SN 85-517,005. HARTWELL, IESHEA, MABLETON, GA. FILED 1-16-2012.



NO CLAIM IS MADE TO THE EXCLUSIVE RIGHT TO USE "MINISTRIES", APART FROM THE MARK AS SHOWN.

THE COLOR(S) BLACK AND GOLD IS/ARE CLAIMED AS A FEATURE OF THE MARK.

THE MARK CONSISTS OF SILHOUETTES OF A MAN

CLASS 45—(Continued).

AND A WOMAN STANDING INSIDE OF TWO SEPARATE RINGS FACING EACH OTHER HOLDING HANDS. THE RING THE WOMAN IS STANDING IN DISPLAYS THE STYLIZED TEXT "R.E.A.L.M." AND THE RING THE MAN IS STANDING IN DISPLAYS THE STYLIZED TEXT "MINISTRIES". BOTH RINGS ARE GOLD IN COLOR. THE MAN AND WOMAN ARE BLACK. TRACING THE OUTLINE OF THE MAN AND WOMAN IS THE STYLIZED TEXT "RELATIONSHIPS ETERNALLY AFFIXED IN LOVE AND MARRIAGE" IN BLACK.

FOR MARRIAGE COUNSELING AND CONSULTING (U.S. CLS. 100 AND 101).

KEVON CHISOLM, EXAMINING ATTORNEY

SN 85-517,831. STAPP, SAMUEL D, PROVO, UT. FILED 1-17-2012.

Crystalblock

THE MARK CONSISTS OF STANDARD CHARACTERS WITHOUT CLAIM TO ANY PARTICULAR FONT, STYLE, SIZE, OR COLOR.

FOR INTERNET-BASED, GEO-CENTRIC SOCIAL NETWORKING SERVICES (U.S. CLS. 100 AND 101).
LAURIE MAYES, EXAMINING ATTORNEY

SN 85-517,844. STAPP, SAMUEL D, PROVO, UT. FILED 1-17-2012.

SparkStream

THE MARK CONSISTS OF STANDARD CHARACTERS WITHOUT CLAIM TO ANY PARTICULAR FONT, STYLE, SIZE, OR COLOR.

FOR INTERNET-BASED, GEO-CENTRIC SOCIAL NETWORKING SERVICES (U.S. CLS. 100 AND 101).

LAURIE MAYES, EXAMINING ATTORNEY

CLASS 45—(Continued).

SN 85-518,792. GOLDEN DAWN ENTERTAINMENT, BURBANK, CA. FILED 1-18-2012.

Coast To Coast Psychics

THE MARK CONSISTS OF STANDARD CHARACTERS WITHOUT CLAIM TO ANY PARTICULAR FONT, STYLE, SIZE, OR COLOR.

NO CLAIM IS MADE TO THE EXCLUSIVE RIGHT TO USE "PSYCHICS", APART FROM THE MARK AS SHOWN. FOR ASTROLOGY CONSULTATION; PSYCHIC READING SERVICES; TAROT CARD READING SERVICES (U.S. CLS. 100 AND 101).

FIRST USE 10-10-2010; IN COMMERCE 10-10-2010. MORGAN WYNNE, EXAMINING ATTORNEY

SN 85-519,678. PETERSON, CHARLES, ROLLING HILLS ESTATES, CA. FILED 1-18-2012.

VIEWLAW

THE MARK CONSISTS OF STANDARD CHARACTERS WITHOUT CLAIM TO ANY PARTICULAR FONT, STYLE, SIZE, OR COLOR.

FOR LEGAL SERVICES (U.S. CLS. 100 AND 101). BRIAN CALLAGHAN, EXAMINING ATTORNEY

CLASS 45—(Continued).

SN 85-542,383. ROTH WHITMAN GROUP, INC., CHICAGO, IL. FILED 2-14-2012.

FINDING LOVE IS FREE AND AS EASY AS 1.2.3.

THE MARK CONSISTS OF STANDARD CHARACTERS WITHOUT CLAIM TO ANY PARTICULAR FONT, STYLE, SIZE, OR COLOR.

FOR COMPUTER DATING SERVICES; DATING SERVICES (U.S. CLS. 100 AND 101).

FIRST USE 1-0-2012; IN COMMERCE 1-0-2012. WILLIAM VERHOSEK, EXAMINING ATTORNEY

SN 85-584,968. ALTIUS EDUCATION, INC., SAN FRANCISCO, CA. FILED 3-30-2012.

HELIX

THE MARK CONSISTS OF STANDARD CHARACTERS WITHOUT CLAIM TO ANY PARTICULAR FONT, STYLE, SIZE, OR COLOR.

FOR ONLINE SOCIAL NETWORKING SERVICES IN CONNECTION WITH POST-SECONDARY EDUCATIONAL SERVICES (U.S. CLS. 100 AND 101).

KAREN K. BUSH, EXAMINING ATTORNEY

* * * * *

SECTION 4.—PRIOR UNITED STATES CLASSIFICATION

APPLICATION IN ONE CLASS

CERTIFICATION MARKS

CLASS A—GOODS
SN 85-416,681. HDCCTV ALLIANCE LIMITED, HOLGATE,
NSW, AUSTRALIA, FILED 9-7-2011.



NO CLAIM IS MADE TO THE EXCLUSIVE RIGHT TO USE "HD CCTV", APART FROM THE MARK AS SHOWN.

THE MARK CONSISTS OF THE LETTERS "HD" IN ALL CAPITALS ABOVE THE LETTERS "CCTV" WITH WHAT APPEAR AS EYES IN THE "C"'S OF "CCTV" WITHIN A RECTANGULAR BOX.

THE CERTIFICATION MARK, AS USED OR INTENDED TO BE USED BY PERSONS AUTHORIZED BY THE CERTIFIER, CERTIFIES OR IS INTENDED TO CERTIFY THAT THE GOODS AND/OR SERVICES PROVIDED ARE IN COMPLIANCE WITH TESTS AS DEFINED BY THE V1.1 HDCCTV COMPLIANCE CERTIFICATION STANDARD.

FOR CLOSED CIRCUIT COMMUNICATION APPARATUS, NAMELY, CLOSED CIRCUIT CAMERAS, DIGITAL SURVEILLANCE VIDEO RECORDERS (DVRs); CLOSED CIRCUIT TELEVISION; CLOSED CIRCUIT TELEVISION APPARATUS, NAMELY, CAMERAS; CLOSED CIRCUIT TELEVISION CAMERAS; CLOSED CIRCUIT TELEVISION INSTRUMENTS, NAMELY, CAMERAS, MULTIPLEXERS; CLOSED CIRCUIT TELEVISION MONITORING APPARATUS, NAMELY, CAMERAS; CLOSED CIRCUIT TELEVISION SECURITY APPARATUS, NAMELY, CLOSED CIRCUIT SURVEILLANCE CAMERAS, AND MULTIPLEXERS; CLOSED CIRCUIT TELEVISION SURVEILLANCE CAMERAS TO DETECT FIRE; CLOSED CIRCUIT VIDEO APPARATUS FOR USE IN ACCESS CONTROL, NAMELY, CAMERAS, HIGH-RESOLUTION CAMERAS; INTEGRATED CIRCUIT CHIPS.

FIRST USE 5-4-2009; IN COMMERCE 7-15-2009.
DOMINICK J. SALEMI, EXAMINING ATTORNEY

SN 85-485,791. IDENTALLOY COUNCIL, INC., GLASTONBURY, CT. FILED 12-2-2011.



NO CLAIM IS MADE TO THE EXCLUSIVE RIGHT TO USE "LITHIUM DISILICATE", "GLASS CERAMIC", AND "LD", APART FROM THE MARK AS SHOWN.

THE MARK CONSISTS OF THE WORDING "LITHIUM DISILICATE", "GLASS CERAMIC", AND THE LETTERS "LD" IN A FOUR-SIDED FIGURE WITH HORIZONTAL BARS IN THE LOWER HALF.

THE CERTIFICATION MARK, AS USED BY AUTHORIZED PERSONS, CERTIFIES THAT THE GOODS BEING PROVIDED TO DENTISTS AND DENTAL LABORATORIES CONTAIN FDA APPROVED COMPONENTS, AND THAT THEY COMPLY WITH THE FORMULATION APPEARING ON THE LABELS AFFIXED TO THE CONTAINERS FOR THE GOODS, THESE LABELS PROVIDED BY THE CERTIFIER TO ITS MANUFACTURERS AND LICENSEES FOR THE PURPOSE OF PROVIDING DOCUMENTATION ON THE CERAMIC MATERIAL CONTENTS.

FOR CERAMIC MATERIALS FOR DENTAL RESTORATIVES.

FIRST USE 11-14-2008; IN COMMERCE 11-14-2008.
JAMES A. RAUEN, EXAMINING ATTORNEY

SN 85-485,849. IDENTALLOY COUNCIL, INC., GLASTONBURY, CT. FILED 12-2-2011.



NO CLAIM IS MADE TO THE EXCLUSIVE RIGHT TO USE "TITANIUM OR TI", APART FROM THE MARK AS SHOWN.

THE MARK CONSISTS OF THE WORD "TITANIUM" AND THE LETTERS "TI" IN A FOUR-SIDED DIAMOND SHAPED FIGURE.

THE CERTIFICATION MARK, AS USED BY AUTHORIZED PERSONS, CERTIFIES THAT THE DENTAL CASTING ALLOY PROVIDED TO THE LABORATORY BY THE MANUFACTURER IS A TITANIUM ALLOY CONTAINING AT LEAST 85% TITANIUM AND THAT THE DENTAL LABORATORY USED TITANIUM ALLOY TO FABRICATE THE PROSTHESIS.

FOR DENTAL ALLOYS.
FIRST USE 2-2-2010; IN COMMERCE 2-2-2010.
JAMES A. RAUEN, EXAMINING ATTORNEY

SN 85-184,695. INTERNATIONAL INSTITUTE OF BUSINESS ANALYSIS, TORONTO, ONTARIO, CANADA, FILED 11-24-2010.

CCBA

SN 85-511,684. COMMUNICATION CERTIFICATION LABORATORY, INC., DBA NEMKO-CCL, INC., SALT LAKE CITY, UT. FILED 1-9-2012.



THE MARK CONSISTS OF THE CAPITAL LETTER "N" SURROUNDED BY A SOLID LINE BOX.

THE CERTIFICATION MARK, AS INTENDED TO BE USED BY AUTHORIZED PERSONS, IS INTENDED TO CERTIFY THAT THE RESPECTIVE PRODUCTS COMPLY WITH CERTAIN GUIDELINES AND STANDARDS REGARDING THE GOODS TESTED. APPLICABLE STANDARDS INCLUDE PRODUCT SAFETY, STRESS RESISTANCE, RELIABILITY, DURABILITY, ENDURANCE, ENVIRONMENTAL SUSTAINABILITY, ENERGY EFFICIENCY, QUALITY, PERFORMANCE, FUNCTIONAL PERFORMANCE, THERMAL PERFORMANCE, FIRE SAFETY, FIRE RESISTANCE, SHOCK HAZARD SAFETY, PUBLIC HEALTH SAFETY, FOOD SAFETY, WATER SAFETY, MATERIAL STRENGTH, FUNCTIONAL PERFORMANCE, DEVICE OPERATION AND/OR PRODUCT COMPOSITION.

FOR ELECTRICAL EQUIPMENT, USUALLY NOT OF A VOLTAGE EXCEEDING 600 VOLTS; LIGHTING EQUIPMENT; ELECTRICAL APPLIANCE AND UTILIZATION EQUIPMENT; ELECTRICAL CONSTRUCTION EQUIPMENT.

CHRISTOPHER SIDOTI, EXAMINING ATTORNEY

THE MARK CONSISTS OF STANDARD CHARACTERS WITHOUT CLAIM TO ANY PARTICULAR FONT, STYLE, SIZE, OR COLOR.

PRIORITY CLAIMED UNDER SEC. 44(D) ON CANADA APPLICATION NO. 1498942, FILED 10-7-2010, REG. NO. TMA810773, DATED 11-1-2011, EXPIRES 11-1-2026.

THE CERTIFICATION MARK, AS INTENDED TO BE USED BY AUTHORIZED PERSONS, IS INTENDED TO CERTIFY THAT PERSONS PERFORMING THE SERVICES LISTED ABOVE HAVE MET THE STANDARDS, QUALIFICATIONS, AND TESTING REQUIREMENTS ESTABLISHED BY THE CERTIFIER.

FOR BUSINESS ANALYSIS SERVICES.
AMY HELLA, EXAMINING ATTORNEY

SN 85-286,822. BURLINGAME INDUSTRIES, INC., RIALTO, CA. FILED 4-5-2011.



OWNER OF U.S. REG. NO. 1,635,497.

NO CLAIM IS MADE TO THE EXCLUSIVE RIGHT TO USE "PREFERRED", "SOLAR" AND "SOLAR ROOFER", APART FROM THE MARK AS SHOWN.

THE MARK CONSISTS OF AN OUTER CIRCLE ENCOMPASSING THE WORDS "EAGLE SOLAR PREFERRED CHOICE SOLAR ROOFER" ACCOMPANIED BY A BIRD, THE SUN, AND A ROOF.

THE CERTIFICATION MARK, AS USED OR INTENDED TO BE USED BY PERSONS AUTHORIZED BY THE CERTIFIER, CERTIFIES OR IS INTENDED TO CERTIFY THAT THE GOODS AND/OR SERVICES PROVIDED HAVE BEEN PROVIDED BY SPECIALIZED CONTRACTORS THAT ARE UNIQUELY LICENSED TO INSTALL SOLAR SYSTEMS ALONG WITH, AND OVER TOP OF WATER RESISTANT ROOFING SYSTEMS.

FOR SOLAR AND ROOFING SERVICES BY ROOFING CONTRACTORS WHO ARE LICENSED ROOFERS AND EITHER POSSESS A SOLAR LICENSE, ELECTRICAL LICENSE, OR GENERAL CONTRACTOR'S LICENSE, OR ARE INVOLVED IN A PARTNERSHIP OR CLOSE ASSOCIATION WITH A SOLAR CONTRACTOR ELECTRICIAN OR GENERAL CONTRACTOR.

FIRST USE 1-0-2011; IN COMMERCE 1-0-2011.
SHAUNIA CARLYLE, EXAMINING ATTORNEY

SN 85-370,551. GLOBAL PROTOCOL, ETIQUETTE & CIVILITY ACADEMY, LLC, DALLAS, TX. FILED 7-13-2011.

CPECP

THE MARK CONSISTS OF STANDARD CHARACTERS WITHOUT CLAIM TO ANY PARTICULAR FONT, STYLE, SIZE, OR COLOR.

THE CERTIFICATION MARK, AS INTENDED TO BE USED BY AUTHORIZED PERSONS, IS INTENDED TO CERTIFY QUALIFIED INSTRUCTION REGARDING PROTOCOL, ETIQUETTE AND CIVILITY.

FOR QUALIFIED INSTRUCTION REGARDING PROTOCOL, ETIQUETTE AND CIVILITY.

DEBORAH LOBO, EXAMINING ATTORNEY

THE CERTIFICATION MARK, AS INTENDED TO BE USED BY AUTHORIZED PERSONS, IS INTENDED TO CERTIFY COMPLIANCE AND/OR CONSISTENCY WITH CERTIFIER'S HOSPITAL OR OTHER APPLICABLE STANDARDS OR CRITERIA RELATING TO STROKE OR CARDIOVASCULAR DISEASE AND/OR CERTIFIER'S MEDICAL OR SCIENCE POSITIONS RELATING THERETO. FOR HOSPITAL SERVICES.

SHANNON TWOHIG, EXAMINING ATTORNEY

SN 85-515,177. PASSIVE HOUSE INSTITUTE U.S., INC., URBANA, IL. FILED 1-12-2012.

SN 85-513,142. AMERICAN HEART ASSOCIATION, DALLAS, TX. FILED 1-10-2012.



THE MARK CONSISTS OF A CHECK MARK WITHIN A HEART.

CPHC

THE MARK CONSISTS OF STANDARD CHARACTERS WITHOUT CLAIM TO ANY PARTICULAR FONT, STYLE, SIZE, OR COLOR.

THE CERTIFICATION MARK, AS USED BY AUTHORIZED PERSONS, CERTIFIES THAT A CONSULTANT HAS MET CERTAIN TRAINING AND TESTING REQUIREMENTS IN THE FIELD OF ENERGY EFFICIENCY ADOPTED BY PASSIVE HOUSE INSTITUTE U.S., INC..

FOR CONSULTATION SERVICES IN THE FIELD OF ENERGY EFFICIENCY.

FIRST USE 1-1-2010; IN COMMERCE 1-1-2010.

JULIE GUTTADAURO, EXAMINING ATTORNEY

* * * * *

TRADEMARK REGISTRATIONS ISSUED

PRINCIPAL REGISTER

SECTION 1.— INTERNATIONAL CLASSIFICATION

The short titles associated below with the international class numbers are terms designed merely for quick identification and are not an official part of the international classification. The full names of international classes are given in section 6.1 of the trademark rules of practice.

The designation "U.S. Cl." appearing in this section refers to the U.S. class in effect prior to Sep. 1, 1973 rather than the international class which applies to applications filed on or after that date. For adoption of international classification see notice in the OFFICIAL GAZETTE of Jun. 26, 1973 (911 O.G. TM 210).

CLASS 1—CHEMICALS

- 4,152,039. **ZARTIN (STANDARD CHARACTER)**. VAN HEES GMBH, (U.S. CLS. 1, 5, 6, 10, 26 AND 46). SN 76-704,866. PUB. 3-20-2012. FILED 10-13-2010.
- 4,152,041. **HIGH PURITY GAS HPG AND DESIGN**. WESTERN INTERNATIONAL GAS & CYLINDERS, INC., MULTIPLE CLASS, (INT. CLS. 1, 4 AND 35), (U.S. CLS. 1, 5, 6, 10, 15, 26, 46, 100, 101 AND 102). SN 76-706,438. PUB. 3-20-2012. FILED 2-17-2011.
- 4,152,044. **FUNGURAN (STANDARD CHARACTER)**. SPIESS-URANIA CHEMICALS GMBH, MULTIPLE CLASS, (INT. CLS. 1 AND 5), (U.S. CLS. 1, 5, 6, 10, 18, 26, 44, 46, 51 AND 52). SN 76-706,961. PUB. 3-20-2012. FILED 3-25-2011.
- 4,152,057. **POLYQUEST (STANDARD CHARACTER)**. POLY-QUEST, INCORPORATED, (U.S. CLS. 1, 5, 6, 10, 26 AND 46). SN 76-708,773. PUB. 3-20-2012. FILED 8-17-2011.
- 4,152,080. **VEO (STANDARD CHARACTER)**. RECKITT & COLMAN (OVERSEAS) LIMITED, MULTIPLE CLASS, (INT. CLS. 1, 3 AND 5), (U.S. CLS. 1, 4, 5, 6, 10, 18, 26, 44, 46, 50, 51 AND 52). SN 77-354,337. PUB. 3-20-2012. FILED 12-18-2007.
- 4,152,087. **MEDICYTE (STANDARD CHARACTER)**. MEDICYTE GMBH, MULTIPLE CLASS, (INT. CLS. 1, 5, 10, 35, 42 AND 44), (U.S. CLS. 1, 5, 6, 10, 18, 26, 39, 44, 46, 51, 52, 100, 101 AND 102). SN 77-423,742. PUB. 4-13-2010. FILED 3-17-2008.
- 4,152,101. **WESTERN SAGE (STANDARD CHARACTER)**. WESTERN SAGE DESIGNS LTD., MULTIPLE CLASS, (INT. CLS. 1, 5, 29 AND 30), (U.S. CLS. 1, 5, 6, 10, 18, 26, 44, 46, 51 AND 52). SN 77-590,788. PUB. 3-20-2012. FILED 10-10-2008.
- 4,152,126. **BROADMAN 20 AND DESIGN**. AGRIMUM INC., (U.S. CLS. 1, 5, 6, 10, 26 AND 46). SN 77-852,272. PUB. 3-20-2012. FILED 10-19-2009.
- 4,152,197. **INNOWA (STANDARD CHARACTER)**. INNOWA MEMBRANE GMBH, MULTIPLE CLASS, (INT. CLS. 1, 7, 9, 11, 17, 24, 40 AND 42), (U.S. CLS. 1, 5, 6, 10, 12, 13, 19, 21, 23, 26, 31, 34, 35, 36, 38, 42, 46, 50, 100, 101, 103 AND 106). SN 79-090,101. PUB. 3-20-2012. FILED 9-28-2010.
- 4,152,205. **CLINIMACS PRODIGY (STANDARD CHARACTER)**. MILTENYI BIOTEC GMBH, MULTIPLE CLASS, (INT. CLS. 1, 2, 5, 9 AND 10), (U.S. CLS. 1, 5, 6, 10, 11, 16, 18, 21, 23, 26, 36, 38, 39, 44, 46, 51 AND 52). SN 79-091,389. PUB. 3-20-2012. FILED 12-8-2010.
- 4,152,229. **VIBROGRAF (STANDARD CHARACTER)**. GREINER VIBROGRAF AG, MULTIPLE CLASS, (INT. CLS. 1, 7, 8, 9, 11, 14, 35 AND 42), (U.S. CLS. 1, 2, 5, 6, 10, 13, 19, 21, 23, 26, 27, 28, 31, 34, 35, 36, 38, 44, 46, 50, 100, 101 AND 102). SN 79-095,503. PUB. 3-20-2012. FILED 1-17-2011.
- 4,152,264. **WTB (STANDARD CHARACTER)**. CASTER, (U.S. CLS. 1, 5, 6, 10, 26 AND 46). SN 79-097,523. PUB. 3-20-2012. FILED 4-8-2011.
- 4,152,269. **DMG AND DESIGN**. ERNST MÜHLBAUER GMBH & CO. KG, MULTIPLE CLASS, (INT. CLS. 1, 3, 5, 7, 10 AND 41), (U.S. CLS. 1, 4, 5, 6, 10, 13, 18, 19, 21, 23, 26, 31, 34, 35, 39, 44, 46, 50, 51, 52, 100, 101 AND 107). SN 79-097,685. PUB. 3-20-2012. FILED 2-4-2011.
- 4,152,299. **HELIO (STANDARD CHARACTER)**. KASPAR WALTER GMBH & CO. KG MASCHINENFABRIK, MULTIPLE CLASS, (INT. CLS. 1 AND 3), (U.S. CLS. 1, 4, 5, 6, 10, 26, 46, 50, 51 AND 52). SN 79-098,712. PUB. 3-20-2012. FILED 1-20-2011.
- 4,152,307. **SANJU (STYLIZED)**. BEIJING SANJU ENVIRONMENTAL PROTECTION AND NEW MATERIAL CO., LTD., (U.S. CLS. 1, 5, 6, 10, 26 AND 46). SN 79-098,883. PUB. 3-20-2012. FILED 3-1-2011.
- 4,152,328. **BAILLY AND DESIGN**. TAIZHOU BAILLY CHEMICAL CO., LTD., (U.S. CLS. 1, 5, 6, 10, 26 AND 46). SN 79-099,715. PUB. 3-20-2012. FILED 3-10-2011.
- 4,152,355. **LATIOHM (STANDARD CHARACTER)**. LATI INDUSTRIA TERMOPLASTICI S.P.A., MULTIPLE CLASS, (INT. CLS. 1 AND 17), (U.S. CLS. 1, 5, 6, 10, 12, 13, 26, 35, 46 AND 50). SN 79-100,846. PUB. 3-20-2012. FILED 5-31-2011.
- 4,152,356. **LATILUB (STANDARD CHARACTER)**. LATI INDUSTRIA TERMOPLASTICI S.P.A., MULTIPLE CLASS, (INT. CLS. 1 AND 17), (U.S. CLS. 1, 5, 6, 10, 12, 13, 26, 35, 46 AND 50). SN 79-100,847. PUB. 3-20-2012. FILED 5-31-2011.
- 4,152,361. **BRANA VITA (STANDARD CHARACTER)**. FUGEA NV, (U.S. CLS. 1, 5, 6, 10, 26 AND 46). SN 79-101,124. PUB. 3-20-2012. FILED 10-4-2010.
- 4,152,393. **BIOCEL (STANDARD CHARACTER)**. LENZING AKTIENGESELLSCHAFT, MULTIPLE CLASS, (INT. CLS. 1, 22 AND 23), (U.S. CLS. 1, 2, 5, 6, 7, 10, 19, 22, 26, 42, 43, 46 AND 50). SN 79-103,514. PUB. 3-20-2012. FILED 6-27-2011.
- 4,152,401. **CRISVON (STANDARD CHARACTER)**. DIC CORPORATION, (U.S. CLS. 1, 5, 6, 10, 26 AND 46). SN 79-104,079. PUB. 3-20-2012. FILED 9-20-2011.
- 4,152,405. **POSTCAP (STANDARD CHARACTER)**. SIEMENS AKTIENGESELLSCHAFT, MULTIPLE CLASS, (INT. CLS. 1, 40 AND 42), (U.S. CLS. 1, 5, 6, 10, 26, 46, 100, 101, 103 AND 106). SN 79-104,191. PUB. 3-20-2012. FILED 9-9-2011.
- 4,152,410. **GOTEC AND DESIGN**. GOTEC GORSCHLUETER GMBH, MULTIPLE CLASS, (INT. CLS. 1, 6 AND 40), (U.S. CLS. 1, 2, 5, 6, 10, 12, 13, 14, 23, 25, 26, 46, 50, 100, 103 AND 106). SN 79-104,408. PUB. 3-20-2012. FILED 7-23-2011.
- 4,152,432. **VONDIC (STANDARD CHARACTER)**. DIC CORPORATION, (U.S. CLS. 1, 5, 6, 10, 26 AND 46). SN 79-106,676. PUB. 3-20-2012. FILED 11-17-2011.
- 4,152,438. **VIASOL (STANDARD CHARACTER)**. VIACOR POLYMER GMBH, MULTIPLE CLASS, (INT. CLS. 1, 37, 40 AND 42), (U.S. CLS. 1, 5, 6, 10, 26, 46, 100, 101, 103 AND 106). SN 79-108,066. PUB. 3-20-2012. FILED 9-7-2011.
- 4,152,477. **CLEANING THE PLANET... ONE DROP AT A TIME! (STANDARD CHARACTER)**. AMADOR. LUZ M, DBA SYSTEMS AND ENGINEERING CONSULTING, (U.S. CLS. 1, 5, 6, 10, 26 AND 46). SN 85-091,144. PUB. 6-28-2011. FILED 7-22-2010.
- 4,152,501. **MYCOLOGIX (STANDARD CHARACTER)**. MYCOLOGIX LIMITED, MULTIPLE CLASS, (INT. CLS. 1, 4, 7, 35, 40 AND 42), (U.S. CLS. 1, 5, 6, 10, 13, 15, 19, 21, 23, 26, 31, 34, 35, 46, 100, 101, 102, 103 AND 106). SN 85-113,338. PUB. 3-20-2012. FILED 8-23-2010.
- 4,152,517. **IGREASE (STANDARD CHARACTER)**. RHEIN CHEMIE RHEINAU GMBH, MULTIPLE CLASS, (INT. CLS. 1, 4 AND 40), (U.S. CLS. 1, 5, 6, 10, 15, 26, 46, 100, 103 AND 106). SN 85-129,561. PUB. 3-20-2012. FILED 9-14-2010.
- 4,152,518. **IGREASE (STYLIZED)**. RHEIN CHEMIE RHEINAU GMBH, MULTIPLE CLASS, (INT. CLS. 1, 4 AND 40),

(U.S. CLS. 1, 5, 6, 10, 15, 26, 46, 100, 103 AND 106). SN 85-129,597. PUB. 3-20-2012. FILED 9-14-2010.

4,152,531. **IDEX (STANDARD CHARACTER)**. FIELD FORENSICS, INC., (U.S. CLS. 1, 5, 6, 10, 26 AND 46). SN 85-137,823. PUB. 3-20-2012. FILED 9-24-2010.

4,152,621. **VHO (STANDARD CHARACTER)**. ADVANCED NUTRIENTS LTD., (U.S. CLS. 1, 5, 6, 10, 26 AND 46). SN 85-224,871. PUB. 3-20-2012. FILED 1-24-2011.

4,152,658. **RIO 2016 AND DESIGN**. COMITÉ INTERNATIONALE OLYMPIQUE, MULTIPLE CLASS, (INT. CLS. 1, 2, 3, 4, 5, 6, 7, 9, 10, 11, 12, 14, 16, 17, 18, 19, 25, 28, 29, 30, 32, 35, 36, 37, 38, 39, 40, 41, 42, 43 AND 44), (U.S. CLS. 1, 2, 3, 4, 5, 6, 10, 11, 12, 13, 14, 15, 16, 18, 19, 21, 22, 23, 25, 26, 27, 28, 29, 31, 33, 34, 35, 36, 37, 38, 39, 41, 44, 45, 46, 48, 50, 51, 52, 100, 101, 102, 103, 104, 105, 106 AND 107). SN 85-256,582. PUB. 3-20-2012. FILED 3-3-2011.

4,152,698. **E (STYLIZED)**. EFTEC EUROPE HOLDING AG, MULTIPLE CLASS, (INT. CLS. 1, 2, 3, 17 AND 37), (U.S. CLS. 1, 4, 5, 6, 10, 11, 12, 13, 16, 26, 35, 46, 50, 51, 52, 100, 103 AND 106). SN 85-279,004. PUB. 3-20-2012. FILED 3-28-2011.

4,152,735. **ZIALAST (STANDARD CHARACTER)**. JJISCO INC., (U.S. CLS. 1, 5, 6, 10, 26 AND 46). SN 85-291,480. PUB. 3-20-2012. FILED 4-11-2011.

4,152,750. **HIREF (STANDARD CHARACTER)**. SILTRONIC AG, MULTIPLE CLASS, (INT. CLS. 1 AND 9), (U.S. CLS. 1, 5, 6, 10, 21, 23, 26, 36, 38 AND 46). SN 85-293,886. PUB. 3-20-2012. FILED 4-13-2011.

4,152,760. **ELASTISEAL (STANDARD CHARACTER)**. ADCO PRODUCTS, INC., MULTIPLE CLASS, (INT. CLS. 1, 2 AND 17), (U.S. CLS. 1, 5, 6, 10, 11, 12, 13, 16, 26, 35, 46 AND 50). SN 85-295,350. PUB. 3-20-2012. FILED S.R. 4-14-2011; AM. P.R. 1-27-2012.

4,153,019. **SCD PROBIOTICS (STANDARD CHARACTER)**. SUSTAINABLE COMMUNITY DEVELOPMENT, L.L.C. D/B/A SCD PROBIOTICS, (U.S. CLS. 1, 5, 6, 10, 26 AND 46). SN 85-353,933. PUB. 3-20-2012. FILED 6-23-2011.

4,153,063. **HYPHER+ION (STANDARD CHARACTER)**. GENERAL CHEMICAL PERFORMANCE PRODUCTS LLC, (U.S. CLS. 1, 5, 6, 10, 26 AND 46). SN 85-369,152. PUB. 3-20-2012. FILED 7-12-2011.

4,153,096. **ICE CUTTER (STANDARD CHARACTER)**. KISSNER MILLING CO. LTD., (U.S. CLS. 1, 5, 6, 10, 26 AND 46). SN 85-379,754. PUB. 3-20-2012. FILED 7-25-2011.

4,153,128. **BLAST SPRAYABLE AND DESIGN**. AQUATROLS CORPORATION OF AMERICA, (U.S. CLS. 1, 5, 6, 10, 26 AND 46). SN 85-390,408. PUB. 3-20-2012. FILED 8-5-2011.

4,153,138. **GEN+ION (STANDARD CHARACTER)**. GENERAL CHEMICAL PERFORMANCE PRODUCTS,LLC, (U.S. CLS. 1, 5, 6, 10, 26 AND 46). SN 85-392,989. PUB. 3-20-2012. FILED 8-9-2011.

4,153,139. **IC-LOC (STANDARD CHARACTER)**. BOB SMITH INDUSTRIES, (U.S. CLS. 1, 5, 6, 10, 26 AND 46). SN 85-393,505. PUB. 3-20-2012. FILED 8-9-2011.

4,153,157. **CHEMICHIBA AND DESIGN**. NAMIKI SHOJI CO., LTD., (U.S. CLS. 1, 5, 6, 10, 26 AND 46). SN 85-396,377. PUB. 3-20-2012. FILED 8-12-2011.

4,153,248. **NOVAGEL SOIL STABILIZING POLYMER (STANDARD CHARACTER)**. GEO-TECH SERVICES, LLC, (U.S. CLS. 1, 5, 6, 10, 26 AND 46). SN 85-415,056. PUB. 3-20-2012. FILED 9-5-2011.

4,153,249. **TERRAGEL POLYMER DRILLING SLURRY (STANDARD CHARACTER)**. GEO-TECH SERVICES, LLC, (U.S. CLS. 1, 5, 6, 10, 26 AND 46). SN 85-415,071. PUB. 3-20-2012. FILED 9-5-2011.

4,153,256. **MISCELLANEOUS DESIGN**. ABRO INDUSTRIES, INC., (U.S. CLS. 1, 5, 6, 10, 26 AND 46). SN 85-416,335. PUB. 3-20-2012. FILED 9-7-2011.

4,153,258. **HUMACARB (STANDARD CHARACTER)**. ADVANCING ECO-AGRICULTURE, LLC, (U.S. CLS. 1, 5, 6, 10, 26 AND 46). SN 85-416,682. PUB. 3-20-2012. FILED 9-7-2011.

4,153,685. **HOTCOATING (STANDARD CHARACTER)**. KLEB-CHEMIE M.G. BECKER GMBH & CO. KG, MULTIPLE CLASS, (INT. CLS. 1 AND 2), (U.S. CLS. 1, 5, 6, 10, 11, 16, 26 AND 46). SN 85-441,309. PUB. 3-20-2012. FILED 10-6-2011.

4,153,732. **FARMER'S PRIDE (STANDARD CHARACTER)**. STOVER, COREY, (U.S. CLS. 1, 5, 6, 10, 26 AND 46). SN 85-441,857. PUB. 3-20-2012. FILED 10-7-2011.

4,154,033. **CHEMSTREAM AND DESIGN**. CHEMSTREAM, INC., MULTIPLE CLASS, (INT. CLS. 1 AND 40), (U.S. CLS. 1, 5, 6, 10, 26, 46, 100, 103 AND 106). SN 85-445,041. PUB. 3-20-2012. FILED 10-12-2011.

4,154,159. **PELPRENE (STANDARD CHARACTER)**. TOYO BOSEKI KABUSHIKI KAISHA, TA TOYOBO CO., LTD., (U.S. CLS. 1, 5, 6, 10, 26 AND 46). SN 85-455,501. PUB. 3-20-2012. FILED 10-25-2011.

CLASS 2—PAINTS

4,152,060. **ACRALYTE (STANDARD CHARACTER)**. HARBOR FURNITURE MANUFACTURING, INC., (U.S. CLS. 6, 11 AND 16). SN 76-708,995. PUB. 3-20-2012. FILED 9-6-2011.

4,152,205 (*See Class 1 for this trademark*).

4,152,255. **PRINT NON STOP AND DESIGN**. UAB "SERVEA", MULTIPLE CLASS, (INT. CLS. 2 AND 37), (U.S. CLS. 6, 11, 16, 100, 103 AND 106). SN 79-097,164. PUB. 3-20-2012. FILED 4-7-2011.

4,152,484. **SP-1288 (STANDARD CHARACTER)**. SPECIALTY POLYMER COATINGS, INC., (U.S. CLS. 6, 11 AND 16). SN 85-098,457. PUB. 3-20-2012. FILED 8-2-2010.

4,152,485. **SP-98130 (STANDARD CHARACTER)**. SPECIALTY POLYMER COATINGS, INC., (U.S. CLS. 6, 11 AND 16). SN 85-098,484. PUB. 3-20-2012. FILED 8-2-2010.

4,152,497. **MASTER WALL (STANDARD CHARACTER)**. MASTER WALL, INC., MULTIPLE CLASS, (INT. CLS. 2 AND 19), (U.S. CLS. 1, 6, 11, 12, 16, 33 AND 50). SN 85-113,010. PUB. 3-20-2012. FILED 8-22-2010.

4,152,658 (*See Class 1 for this trademark*).

4,152,698 (*See Class 1 for this trademark*).

4,152,760 (*See Class 1 for this trademark*).

4,153,021. **ECO DECO AND DESIGN**. SALIM HIOUEL, (U.S. CLS. 6, 11 AND 16). SN 85-354,224. PUB. 3-20-2012. FILED 6-23-2011.

4,153,685 (*See Class 1 for this trademark*).

4,154,158. **LITTLE MASTERS (STANDARD CHARACTER)**. ROCK PAINT DISTRIBUTING CORP., (U.S. CLS. 6, 11 AND 16). SN 85-455,354. PUB. 3-20-2012. FILED 10-25-2011.

CLASS 3—COSMETICS AND CLEANING PREPARATIONS

4,152,071. **NICKEL BAG (STANDARD CHARACTER)**. OLDE GRANDDAD INDUSTRIES, INC., (U.S. CLS. 1, 4, 6, 50, 51 AND 52). SN 76-710,092. PUB. 3-20-2012. FILED 12-23-2011.

4,152,072. **FRESH CONTROL (STANDARD CHARACTER)**. BLUE SKIN S.A., MULTIPLE CLASS, (INT. CLS. 3, 5, 10 AND 25), (U.S. CLS. 1, 4, 6, 18, 22, 26, 39, 44, 46, 50, 51 AND 52). SN 77-031,284. PUB. 3-20-2012. FILED 10-27-2006.

4,152,080 (*See Class 1 for this trademark*).

4,152,128. **PRESTON MARTIN (STANDARD CHARACTER)**. AZZURO HOLDINGS LTD., (U.S. CLS. 1, 4, 6, 50, 51 AND 52). SN 77-861,996. PUB. 3-20-2012. FILED 10-30-2009.

4,152,140. **NOEMIE LENOIR (STANDARD CHARACTER)**. NOEMIE LENOIR, MULTIPLE CLASS, (INT. CLS. 3, 14 AND 25), (U.S. CLS. 1, 2, 4, 6, 22, 27, 28, 39, 50, 51 AND 52). SN 77-922,135. PUB. 3-20-2012. FILED 1-28-2010.

4,152,164. **XY HUGO AND DESIGN**. HUGO BOSS; TRADE MARK MANAGEMENT GMBH & CO. KG, (U.S. CLS. 1, 4, 6, 50, 51 AND 52). SN 79-046,919. PUB. 9-7-2010. FILED 10-26-2007.

4,152,174. **ASSOS (STANDARD CHARACTER)**. ROGER MAIER, MULTIPLE CLASS, (INT. CLS. 3, 12 AND 25), (U.S. CLS. 1, 4, 6, 19, 21, 22, 23, 31, 35, 39, 44, 50, 51 AND 52). SN 79-084,650. PUB. 3-20-2012. FILED 2-17-2010.

4,152,179. **H. DEFENCE (STYLIZED)**. NORDBEAUTY S.R.L., (U.S. CLS. 1, 4, 6, 50, 51 AND 52). SN 79-087,139. PUB. 3-20-2012. FILED 8-4-2010.

4,152,180. **MENO CELL AND DESIGN**. NORDBEAUTY S.R.L., MULTIPLE CLASS, (INT. CLS. 3, 10 AND 44), (U.S. CLS. 1, 4, 6, 26, 39, 44, 50, 51, 52, 100 AND 101). SN 79-087,210. PUB. 3-20-2012. FILED 8-17-2010.

- 4,152,188. **SC SHIATZY CHEN AND DESIGN.** SHIATZY INTERNATIONAL COMPANY LIMITED, MULTIPLE CLASS, (INT. CLS. 3, 9, 14, 18, 20, 24, 25, 26 AND 42), (U.S. CLS. 1, 2, 3, 4, 6, 13, 21, 22, 23, 25, 26, 27, 28, 32, 36, 37, 38, 39, 40, 41, 42, 50, 51, 52, 100 AND 101). SN 79-089,235. PUB. 3-20-2012. FILED 3-24-2010.
- 4,152,193. **EXTREME SAILING SERIES AND DESIGN.** EXTREME SAILING SERIES S.A., MULTIPLE CLASS, (INT. CLS. 3, 9, 14, 16, 18, 28 AND 41), (U.S. CLS. 1, 2, 3, 4, 5, 6, 21, 22, 23, 26, 27, 28, 29, 36, 37, 38, 41, 50, 51, 52, 100, 101 AND 107). SN 79-089,779. PUB. 3-20-2012. FILED 8-25-2010.
- 4,152,198. **A ASSOS AND DESIGN.** ROGER MAIER, MULTIPLE CLASS, (INT. CLS. 3, 5, 9, 12, 18, 25 AND 41), (U.S. CLS. 1, 2, 3, 4, 6, 18, 19, 21, 22, 23, 26, 31, 35, 36, 38, 39, 41, 44, 46, 50, 51, 52, 100, 101 AND 107). SN 79-090,301. PUB. 3-20-2012. FILED 7-21-2010.
- 4,152,226. **KUNGS AND DESIGN.** SINITUOTE OY, MULTIPLE CLASS, (INT. CLS. 3, 8, 12, 20 AND 21), (U.S. CLS. 1, 2, 4, 6, 13, 19, 21, 22, 23, 25, 28, 29, 30, 31, 32, 33, 35, 40, 44, 50, 51 AND 52). SN 79-095,452. PUB. 3-20-2012. FILED 3-23-2011.
- 4,152,261. **UV CITY (STANDARD CHARACTER).** CASTER, (U.S. CLS. 1, 4, 6, 50, 51 AND 52). SN 79-097,473. PUB. 3-20-2012. FILED 4-8-2011.
- 4,152,268. **YUZU MAN (STANDARD CHARACTER).** PARFUMS CARON, (U.S. CLS. 1, 4, 6, 50, 51 AND 52). SN 79-097,658. PUB. 3-20-2012. FILED 4-15-2011.
- 4,152,269 (*See Class 1 for this trademark*).
- 4,152,272. **MISSLYN (STANDARD CHARACTER).** ARTDECO COSMETIC GMBH, MULTIPLE CLASS, (INT. CLS. 3, 8, 14, 18 AND 21), (U.S. CLS. 1, 2, 3, 4, 6, 13, 22, 23, 27, 28, 29, 30, 33, 40, 41, 44, 50, 51 AND 52). SN 79-097,893. PUB. 3-20-2012. FILED 3-4-2011.
- 4,152,273. **SUNIFIC (STANDARD CHARACTER).** CASTER, (U.S. CLS. 1, 4, 6, 50, 51 AND 52). SN 79-097,995. PUB. 3-20-2012. FILED 4-8-2011.
- 4,152,299 (*See Class 1 for this trademark*).
- 4,152,315. **AURA LOEWE (STANDARD CHARACTER).** LOEWE, S.A., (U.S. CLS. 1, 4, 6, 50, 51 AND 52). SN 79-099,272. PUB. 3-20-2012. FILED 4-25-2011.
- 4,152,331. **ALKOS (STANDARD CHARACTER).** ALKOS COSMETIQUES SAS, (U.S. CLS. 1, 4, 6, 50, 51 AND 52). SN 79-099,807. PUB. 3-20-2012. FILED 5-13-2011.
- 4,152,340. **INNO INNO SEARCH AND DESIGN.** INNOSEARCH, S.L., (U.S. CLS. 1, 4, 6, 50, 51 AND 52). SN 79-100,199. PUB. 3-20-2012. FILED 6-2-2011.
- 4,152,374. **DISHMATIC (STANDARD CHARACTER).** EASYDO PRODUCTS LIMITED, (U.S. CLS. 1, 4, 6, 50, 51 AND 52). SN 79-102,420. PUB. 3-20-2012. FILED 7-28-2011.
- 4,152,375. **WELLMAXX (STANDARD CHARACTER).** SP-GMBH & CO. KG, MULTIPLE CLASS, (INT. CLS. 3, 11, 35, 41 AND 42), (U.S. CLS. 1, 4, 6, 13, 21, 23, 31, 34, 50, 51, 52, 100, 101, 102 AND 107). SN 79-102,546. PUB. 3-20-2012. FILED 7-19-2011.
- 4,152,378. **MISCELLANEOUS DESIGN.** KABUSHIKI KAISHA NOEVIR (DOING BUSINESS AS NOEVIR CO., LTD.), (U.S. CLS. 1, 4, 6, 50, 51 AND 52). SN 79-102,679. PUB. 3-20-2012. FILED 8-12-2011.
- 4,152,380. **PURETOPIA (STANDARD CHARACTER).** FROSTBLAND PTY LTD, MULTIPLE CLASS, (INT. CLS. 3, 4 AND 5), (U.S. CLS. 1, 4, 6, 15, 18, 44, 46, 50, 51 AND 52). SN 79-102,761. PUB. 3-20-2012. FILED 6-24-2011.
- 4,152,394. **SPENCER HART PALM SPRINGS (STANDARD CHARACTER).** NICHOLAS RUSSELL HART, MULTIPLE CLASS, (INT. CLS. 3, 18 AND 25), (U.S. CLS. 1, 2, 3, 4, 6, 22, 39, 41, 50, 51 AND 52). SN 79-103,601. PUB. 3-20-2012. FILED 7-9-2011.
- 4,152,416. **MISCELLANEOUS DESIGN.** GLORIA MED S.P.A., MULTIPLE CLASS, (INT. CLS. 3, 5, 10 AND 25), (U.S. CLS. 1, 4, 6, 18, 22, 26, 39, 44, 46, 50, 51 AND 52). SN 79-104,896. PUB. 3-20-2012. FILED 8-11-2011.
- 4,152,436. **MAMARELLA (STANDARD CHARACTER).** FRAU PETRA BEDFORD, MULTIPLE CLASS, (INT. CLS. 3, 14, 18, 24 AND 25), (U.S. CLS. 1, 2, 3, 4, 6, 22, 27, 28, 39, 41, 42, 50, 51 AND 52). SN 79-107,483. PUB. 3-20-2012. FILED 9-7-2011.
- 4,152,451. **EPIPHANY (STANDARD CHARACTER).** AUSTRALIAN GOLD, LLC, (U.S. CLS. 1, 4, 6, 50, 51 AND 52). SN 85-037,555. PUB. 3-20-2012. FILED 5-13-2010.
- 4,152,507. **GSTAAD COME UP-SLOW DOWN AND DESIGN.** GSTAAD SAANENLAND TOURISMUS, MULTIPLE CLASS, (INT. CLS. 3, 7, 9, 11, 12, 14, 16, 18, 20, 21, 22, 28, 29, 30, 33, 34, 35, 39, 41, 43 AND 44), (U.S. CLS. 1, 2, 3, 4, 5, 6, 7, 8, 9, 13, 17, 19, 21, 22, 23, 25, 26, 27, 28, 29, 30, 31, 32, 33, 34, 35, 36, 37, 38, 40, 41, 42, 44, 46, 47, 49, 50, 51, 52, 100, 101, 102, 105 AND 107). SN 85-121,656. PUB. 3-20-2012. FILED 9-2-2010.
- 4,152,539. **BLAZE (STANDARD CHARACTER).** HATTERAS ENTERPRISES, INC., (U.S. CLS. 1, 4, 6, 50, 51 AND 52). SN 85-147,791. PUB. 3-20-2012. FILED 10-7-2010.
- 4,152,558. **WATTS POWER WHITE (STANDARD CHARACTER).** DIRECT 2U WHOLESALE LLC, (U.S. CLS. 1, 4, 6, 50, 51 AND 52). SN 85-162,412. PUB. 3-20-2012. FILED 10-27-2010.
- 4,152,563. **KEIKO MECHERI (STANDARD CHARACTER).** LES PARFUMS KEIKO MECHERI, (U.S. CLS. 1, 4, 6, 50, 51 AND 52). SN 85-166,239. PUB. 3-20-2012. FILED 11-1-2010.
- 4,152,630. **A.CO (STANDARD CHARACTER).** ARDEN HOLDINGS INC., MULTIPLE CLASS, (INT. CLS. 3, 9, 14, 18, 25 AND 26), (U.S. CLS. 1, 2, 3, 4, 6, 21, 22, 23, 26, 27, 28, 36, 37, 38, 39, 40, 41, 42, 50, 51 AND 52). SN 85-234,613. PUB. 2-7-2012. FILED 2-4-2011.
- 4,152,658 (*See Class 1 for this trademark*).
- 4,152,661. **RANDOM (STANDARD CHARACTER).** EVERYDAY SHORTS INCORPORATED, (U.S. CLS. 1, 4, 6, 50, 51 AND 52). SN 85-258,855. PUB. 3-20-2012. FILED 3-5-2011.
- 4,152,698 (*See Class 1 for this trademark*).
- 4,152,902. **ENVI (STANDARD CHARACTER).** IQ PRODUCTS COMPANY, (U.S. CLS. 1, 4, 6, 50, 51 AND 52). SN 85-317,728. PUB. 3-20-2012. FILED 5-11-2011.
- 4,152,950. **Q (STYLIZED).** CHOICE HOTELS INTERNATIONAL, INC., (U.S. CLS. 1, 4, 6, 50, 51 AND 52). SN 85-332,009. PUB. 3-20-2012. FILED 5-27-2011.
- 4,152,978. **MADAME KOITEH (STANDARD CHARACTER).** KOITEH, ZAHRAA, (U.S. CLS. 1, 4, 6, 50, 51 AND 52). SN 85-339,538. PUB. 3-20-2012. FILED 6-7-2011.
- 4,152,980. **MISCELLANEOUS DESIGN.** DIVINE SKIN, INC., DBA DS LABORATORIES, INC., MULTIPLE CLASS, (INT. CLS. 3 AND 5), (U.S. CLS. 1, 4, 6, 18, 44, 46, 50, 51 AND 52). SN 85-340,221. PUB. 3-20-2012. FILED 6-7-2011.
- 4,153,004. **THE SKIN BREATHE (STANDARD CHARACTER).** PLANT DEVAS, INC., (U.S. CLS. 1, 4, 6, 50, 51 AND 52). SN 85-348,510. PUB. 3-20-2012. FILED 6-16-2011.
- 4,153,038. **LITTLE OWL SOAP (STANDARD CHARACTER).** LITTLE OWL SOAP LLC, AKA LITTLE OWL SOAP, (U.S. CLS. 1, 4, 6, 50, 51 AND 52). SN 85-360,336. PUB. 3-20-2012. FILED 6-30-2011.
- 4,153,040. **THE GLAM SHOPPE (STANDARD CHARACTER).** SERRA, DIANIC, DBA DIVA LASH BOUTIQUE, (U.S. CLS. 1, 4, 6, 50, 51 AND 52). SN 85-360,471. PUB. 3-20-2012. FILED 6-30-2011.
- 4,153,043. **SIZE ZERO (STANDARD CHARACTER).** RODIAL LIMITED, (U.S. CLS. 1, 4, 6, 50, 51 AND 52). SN 85-360,898. PUB. 3-20-2012. FILED 6-30-2011.
- 4,153,175. **NEW STANDARDS IN ORGANICS NSIO AND DESIGN.** SUNERGETICS, LLC, (U.S. CLS. 1, 4, 6, 50, 51 AND 52). SN 85-401,320. PUB. 3-20-2012. FILED 8-18-2011.
- 4,153,195. **ORION SKIN CARE AND DESIGN.** SUNERGETICS, LLC, (U.S. CLS. 1, 4, 6, 50, 51 AND 52). SN 85-405,789. PUB. 3-20-2012. FILED 8-24-2011.
- 4,153,273. **QUEEN OF COLOR (STANDARD CHARACTER).** SHOWSEASON ANIMAL PRODUCTS, LLC, (U.S. CLS. 1, 4, 6, 50, 51 AND 52). SN 85-419,373. PUB. 3-20-2012. FILED 9-9-2011.
- 4,153,282. **FRETTE (STANDARD CHARACTER).** EDMUND FRETTE S.A.R.L., MULTIPLE CLASS, (INT. CLS. 3, 8, 18 AND 21), (U.S. CLS. 1, 2, 3, 4, 6, 13, 22, 23, 28, 29, 30, 33, 40, 41, 44, 50, 51 AND 52). SN 85-420,096. PUB. 3-20-2012. FILED 9-12-2011.
- 4,153,339. **DOÑA BELLA (STANDARD CHARACTER).** INTRADEVCO INDUSTRIAL S.A., (U.S. CLS. 1, 4, 6, 50, 51 AND 52). SN 85-425,043. PUB. 3-20-2012. FILED 9-16-2011.
- 4,153,414. **HAUTE POLISH (STANDARD CHARACTER).** JE MATADI, INC., (U.S. CLS. 1, 4, 6, 50, 51 AND 52). SN 85-431,893. PUB. 3-20-2012. FILED 9-26-2011.
- 4,153,467. **DNA HEALTH INSTITUTE (STANDARD CHARACTER).** DNA HEALTH INSTITUTE, CRYOGENIC DIVISION, LLC, (U.S. CLS. 1, 4, 6, 50, 51 AND 52). SN 85-435,760.

- PUB. 3-20-2012. FILED 9-29-2011.
- 4,153,556. **WE ARE LIVING PROOF (STANDARD CHARACTER)**, LIVING PROOF, INC., (U.S. CLS. 1, 4, 6, 50, 51 AND 52). SN 85-438,533. PUB. 3-20-2012. FILED 10-4-2011.
- 4,153,624. **KW (STYLIZED)**, KJAER WEIS, KIRSTEN, (U.S. CLS. 1, 4, 6, 50, 51 AND 52). SN 85-440,208. PUB. 3-20-2012. FILED 10-5-2011.
- 4,153,683. **KLINOL (STYLIZED)**, COSMETICS & CLEANERS INTERNATIONAL, LLC, (U.S. CLS. 1, 4, 6, 50, 51 AND 52). SN 85-441,184. PUB. 3-20-2012. FILED 10-6-2011.
- 4,153,698. **DR. K'S DETAILWERKES (STANDARD CHARACTER)**, TURN3 CREATIVE, INC., (U.S. CLS. 1, 4, 6, 50, 51 AND 52). SN 85-441,543. PUB. 3-20-2012. FILED 10-7-2011.
- 4,153,777. **ANIKA INTERNATIONAL (STANDARD CHARACTER)**, LASHAWNDA ANIKA LEE ROBBINS, (U.S. CLS. 1, 4, 6, 50, 51 AND 52). SN 85-442,288. PUB. 3-20-2012. FILED 10-7-2011.
- 4,153,820. **SPICESTER (STANDARD CHARACTER)**, FOZZY NETWORKS, LLC, DBA SPICESTER, (U.S. CLS. 1, 4, 6, 50, 51 AND 52). SN 85-442,772. PUB. 3-20-2012. FILED 10-8-2011.
- 4,153,828. **WHOLESOME HEALERS (STANDARD CHARACTER)**, PEPI, GRETCHEN, DBA WHOLESOME HEALERS, (U.S. CLS. 1, 4, 6, 50, 51 AND 52). SN 85-442,811. PUB. 3-20-2012. FILED 10-8-2011.
- 4,153,863. **MINERAGE (STANDARD CHARACTER)**, PMC TRADE EXPORT & IMPORT CORP., (U.S. CLS. 1, 4, 6, 50, 51 AND 52). SN 85-443,201. PUB. 3-20-2012. FILED 10-10-2011.
- 4,153,975. **MEDI-SHEEN (STANDARD CHARACTER)**, COMPLETE SOLUTIONS TECHNOLOGIES, LLC, (U.S. CLS. 1, 4, 6, 50, 51 AND 52). SN 85-444,299. PUB. 3-20-2012. FILED 10-11-2011.
- 4,154,055. **VALLEY GREEN NATURALS (STANDARD CHARACTER)**, VALLEY GREEN NATURALS, LLC, (U.S. CLS. 1, 4, 6, 50, 51 AND 52). SN 85-445,674. PUB. 3-20-2012. FILED 10-12-2011.
- 4,154,058. **DERMASENS (STANDARD CHARACTER)**, VALLEY GREEN NATURALS, LLC, (U.S. CLS. 1, 4, 6, 50, 51 AND 52). SN 85-445,700. PUB. 3-20-2012. FILED 10-12-2011.
- 4,154,061. **COOL CLARITY! (STANDARD CHARACTER)**, VALLEY GREEN NATURALS, LLC, (U.S. CLS. 1, 4, 6, 50, 51 AND 52). SN 85-445,719. PUB. 3-20-2012. FILED 10-12-2011.
- 4,154,063. **GARDENER'S GLEE! (STANDARD CHARACTER)**, VALLEY GREEN NATURALS, LLC, (U.S. CLS. 1, 4, 6, 50, 51 AND 52). SN 85-445,730. PUB. 3-20-2012. FILED 10-12-2011.

CLASS 4—LUBRICANTS AND FUELS

- 4,152,041 (*See Class 1 for this trademark*).
- 4,152,091. **BELLA BOUTIQUE AND DESIGN**, GIFTCRAFT LTD., MULTIPLE CLASS, (INT. CLS. 4, 6, 9, 11, 20, 21 AND 28), (U.S. CLS. 1, 2, 6, 12, 13, 14, 15, 21, 22, 23, 25, 26, 29, 30, 31, 32, 33, 34, 36, 38, 40 AND 50). SN 77-515,603. PUB. 3-20-2012. FILED 7-7-2008.
- 4,152,102. **PRISTINE (STANDARD CHARACTER)**, TYLER CANDLE COMPANY, L.L.C., (U.S. CLS. 1, 6 AND 15). SN 77-596,909. PUB. 3-20-2012. FILED 10-21-2008.
- 4,152,380 (*See Class 3 for this trademark*).
- 4,152,501 (*See Class 1 for this trademark*).
- 4,152,516. **BOXCAR CANDLE COMPANY, LLC (STANDARD CHARACTER)**, BOXCAR CANDLE COMPANY, LLC, (U.S. CLS. 1, 6 AND 15). SN 85-128,381. PUB. 3-20-2012. FILED 9-13-2010.
- 4,152,517 (*See Class 1 for this trademark*).
- 4,152,518 (*See Class 1 for this trademark*).
- 4,152,658 (*See Class 1 for this trademark*).
- 4,152,719. **POWERED BY THE FAYETTEVILLE SHALE (STANDARD CHARACTER)**, SOUTHWESTERN ENERGY COMPANY, (U.S. CLS. 1, 6 AND 15). SN 85-287,004. PUB. 3-20-2012. FILED 4-5-2011.
- 4,153,572. **ISEL (STANDARD CHARACTER)**, I.S.E.L., INC., (U.S. CLS. 1, 6 AND 15). SN 85-438,884. PUB. 3-20-2012. FILED 10-4-2011.

CLASS 5—PHARMACEUTICALS

- 4,152,044 (*See Class 1 for this trademark*).
- 4,152,072 (*See Class 3 for this trademark*).
- 4,152,080 (*See Class 1 for this trademark*).
- 4,152,087 (*See Class 1 for this trademark*).
- 4,152,101 (*See Class 1 for this trademark*).
- 4,152,135. **PAXON (STANDARD CHARACTER)**, VETOQUINOL N.-A. INC., (U.S. CLS. 6, 18, 44, 46, 51 AND 52). SN 77-891,489. PUB. 3-20-2012. FILED 12-11-2009.
- 4,152,162. **EQUAVIE (STYLIZED)**, EQUAVIE, MULTIPLE CLASS, (INT. CLS. 5, 29 AND 30), (U.S. CLS. 6, 18, 44, 46, 51 AND 52). SN 79-035,844. PUB. 3-20-2012. FILED 12-20-2006.
- 4,152,186. **CELLINSIGHT (STANDARD CHARACTER)**, CELLMADE SAS, MULTIPLE CLASS, (INT. CLS. 5 AND 44), (U.S. CLS. 6, 18, 44, 46, 51, 52, 100 AND 101). SN 79-088,610. PUB. 3-20-2012. FILED 5-19-2010.
- 4,152,198 (*See Class 3 for this trademark*).
- 4,152,205 (*See Class 1 for this trademark*).
- 4,152,269 (*See Class 1 for this trademark*).
- 4,152,348. **ADAKVEO (STANDARD CHARACTER)**, NOVARTIS AG, (U.S. CLS. 6, 18, 44, 46, 51 AND 52). SN 79-100,532. PUB. 3-20-2012. FILED 7-8-2011.
- 4,152,359. **COFFEWEWELL (STANDARD CHARACTER)**, UNGERSTEDT, JOHAN, AND PALMQVIST, LARS, MULTIPLE CLASS, (INT. CLS. 5 AND 30), (U.S. CLS. 6, 18, 44, 46, 51 AND 52). SN 79-101,060. PUB. 3-20-2012. FILED 5-16-2011.
- 4,152,380 (*See Class 3 for this trademark*).
- 4,152,387. **OCTAGAM (STANDARD CHARACTER)**, OCTAPHARMA AG, (U.S. CLS. 6, 18, 44, 46, 51 AND 52). SN 79-103,174. PUB. 3-20-2012. FILED 9-8-2011.
- 4,152,392. **SCANFLAVOUR (STANDARD CHARACTER)**, SCANFLAVOUR A/S, MULTIPLE CLASS, (INT. CLS. 5, 29 AND 30), (U.S. CLS. 6, 18, 44, 46, 51 AND 52). SN 79-103,510. PUB. 3-20-2012. FILED 9-7-2011.
- 4,152,416 (*See Class 3 for this trademark*).
- 4,152,419. **EBREEZHALER (STANDARD CHARACTER)**, NOVARTIS AG, MULTIPLE CLASS, (INT. CLS. 5 AND 10), (U.S. CLS. 6, 18, 26, 39, 44, 46, 51 AND 52). SN 79-105,008. PUB. 3-20-2012. FILED 9-12-2011.
- 4,152,530. **FOLLIGENIX (STANDARD CHARACTER)**, MARIO DIAB LLC, (U.S. CLS. 6, 18, 44, 46, 51 AND 52). SN 85-137,779. PUB. 3-20-2012. FILED 9-24-2010.
- 4,152,573. **REBOOT (STANDARD CHARACTER)**, MARZ, KEITH, (U.S. CLS. 6, 18, 44, 46, 51 AND 52). SN 85-176,010. PUB. 10-25-2011. FILED 11-12-2010.
- 4,152,658 (*See Class 1 for this trademark*).
- 4,152,696. **VAR 10 (STANDARD CHARACTER)**, DYNAMIC SPORTS NUTRITION, LLC, (U.S. CLS. 6, 18, 44, 46, 51 AND 52). SN 85-278,956. PUB. 3-20-2012. FILED 3-28-2011.
- 4,152,738. **NATURE'S PALLIATIVE (STANDARD CHARACTER)**, NATURE'S PALLIATIVE, (U.S. CLS. 6, 18, 44, 46, 51 AND 52). SN 85-292,037. PUB. 3-20-2012. FILED 4-11-2011.
- 4,152,748. **NUTRITION FOR THE 24-HOUR ATHLETE (STANDARD CHARACTER)**, HERBALIFE INTERNATIONAL, INC., MULTIPLE CLASS, (INT. CLS. 5 AND 32), (U.S. CLS. 6, 18, 44, 45, 46, 48, 51 AND 52). SN 85-293,336. PUB. 3-20-2012. FILED 4-12-2011.
- 4,152,776. **FULLSHARE AND DESIGN**, FULLSHARE GROUP LIMITED, MULTIPLE CLASS, (INT. CLS. 5, 31, 35, 36, 37, 41, 43 AND 44), (U.S. CLS. 1, 6, 18, 44, 46, 51, 52, 100, 101, 102, 103, 106 AND 107). SN 85-297,021. PUB. 3-20-2012. FILED 4-16-2011.
- 4,152,785. **ADVANCE ARTHRO-SYSTEM (STANDARD CHARACTER)**, TEXTILE HI TEC, MULTIPLE CLASS, (INT. CLS. 5 AND 10), (U.S. CLS. 6, 18, 26, 39, 44, 46, 51 AND 52). SN 85-297,375. PUB. 1-24-2012. FILED 4-18-2011.
- 4,152,834. **PKU COOLER (STANDARD CHARACTER)**, SOCIÉTÉ DES PRODUITS NESTLÉ S.A., (U.S. CLS. 6, 18, 44, 46, 51 AND 52). SN 85-305,154. PUB. 3-20-2012. FILED 4-27-2011.
- 4,152,843. **PKU EXPRESS (STANDARD CHARACTER)**, SOCIÉTÉ DES PRODUITS NESTLÉ S.A., (U.S. CLS. 6, 18, 44, 46, 51 AND 52). SN 85-306,254. PUB. 3-20-2012. FILED 4-27-2011.
- 4,152,844. **MSUD COOLER (STANDARD CHARACTER)**, SOCIÉTÉ DES PRODUITS NESTLÉ S.A., (U.S. CLS. 6, 18, 44, 46, 51 AND 52). SN 85-306,271. PUB. 3-20-2012. FILED 4-27-2011.
- 4,152,845. **MSUD EXPRESS (STANDARD CHARACTER)**,

- SOCIÉTÉ DES PRODUITS NESTLÉ S.A., (U.S. CLS. 6, 18, 44, 46, 51 AND 52). SN 85-306,284. PUB. 3-20-2012. FILED 4-27-2011.
- 4,152,857. **SMARTSTRIPS (STANDARD CHARACTER)**. VELOX PRODUCTS, LLC, (U.S. CLS. 6, 18, 44, 46, 51 AND 52). SN 85-308,166. PUB. 3-20-2012. FILED 4-29-2011.
- 4,152,901. **TRIM TONIQ (STANDARD CHARACTER)**. TRUETONIQS, LLC, (U.S. CLS. 6, 18, 44, 46, 51 AND 52). SN 85-317,085. PUB. 3-20-2012. FILED 5-10-2011.
- 4,152,945. **4LIFE AND DESIGN**. 4LIFE TRADEMARKS, LLC, MULTIPLE CLASS, (INT. CLS. 5 AND 29), (U.S. CLS. 6, 18, 44, 46, 51 AND 52). SN 85-330,075. PUB. 3-20-2012. FILED 5-25-2011.
- 4,152,980 (*See Class 3 for this trademark*).
- 4,153,023. **MINKLA (STANDARD CHARACTER)**. BAYER AKTIENGESELLSCHAFT, (U.S. CLS. 6, 18, 44, 46, 51 AND 52). SN 85-355,258. PUB. 3-20-2012. FILED 6-24-2011.
- 4,153,028. **SPRINKLE. EAT. LOSE WEIGHT. (STANDARD CHARACTER)**. SENSА PRODUCTS, LLC, (U.S. CLS. 6, 18, 44, 46, 51 AND 52). SN 85-356,008. PUB. 12-13-2011. FILED 6-24-2011.
- 4,153,044. **DIOSMIN PLUS 900 (STANDARD CHARACTER)**. ARYMAR INC., (U.S. CLS. 6, 18, 44, 46, 51 AND 52). SN 85-361,204. PUB. 12-13-2011. FILED 6-30-2011.
- 4,153,115. **ESSHERB AND DESIGN**. HUANG, JING, (U.S. CLS. 6, 18, 44, 46, 51 AND 52). SN 85-387,681. PUB. 3-20-2012. FILED S.R. 8-2-2011; AM. P.R. 12-19-2011.
- 4,153,151. **RAINBOW LUBE (STANDARD CHARACTER)**. ASHLEY SCRUPPS, (U.S. CLS. 6, 18, 44, 46, 51 AND 52). SN 85-395,313. PUB. 3-20-2012. FILED 8-11-2011.
- 4,153,160. **THE SKINNY PANTRY AND DESIGN**. THE SKINNY PANTRY, (U.S. CLS. 6, 18, 44, 46, 51 AND 52). SN 85-396,924. PUB. 3-20-2012. FILED 8-12-2011.
- 4,153,210. **HALEO (STYLIZED)**. BODYPLUS INTERNATIONAL K.K., MULTIPLE CLASS, (INT. CLS. 5 AND 29), (U.S. CLS. 6, 18, 44, 46, 51 AND 52). SN 85-408,844. PUB. 3-20-2012. FILED 8-26-2011.
- 4,153,211. **BULK SPORTS (STYLIZED)**. BODYPLUS INTERNATIONAL K.K., MULTIPLE CLASS, (INT. CLS. 5 AND 29), (U.S. CLS. 6, 18, 44, 46, 51 AND 52). SN 85-408,847. PUB. 3-20-2012. FILED 8-26-2011.
- 4,153,220. **BLOOD DETECTIVE (STANDARD CHARACTER)**. BLOOD LOGIC, INC., MULTIPLE CLASS, (INT. CLS. 5 AND 9), (U.S. CLS. 6, 18, 21, 23, 26, 36, 38, 44, 46, 51 AND 52). SN 85-411,407. PUB. 3-20-2012. FILED 8-31-2011.
- 4,153,251. **CELIACAID (STANDARD CHARACTER)**. BLANCO, MARIO, DBA CELIACAID, (U.S. CLS. 6, 18, 44, 46, 51 AND 52). SN 85-415,157. PUB. 3-20-2012. FILED 9-6-2011.
- 4,153,399. **DNA (STANDARD CHARACTER)**. MAGNUM NUTRACEUTICALS INC, (U.S. CLS. 6, 18, 44, 46, 51 AND 52). SN 85-430,717. PUB. 3-20-2012. FILED 9-23-2011.
- 4,153,439. **GENDERENDER AND DESIGN**. GENERAL GENETICS, INC., (U.S. CLS. 6, 18, 44, 46, 51 AND 52). SN 85-434,283. PUB. 3-20-2012. FILED 9-28-2011.
- 4,153,466. **BEST BREAKFAST FOR YOUR HEALTH. AND DESIGN**. KLIMENKO, ELENA, (U.S. CLS. 6, 18, 44, 46, 51 AND 52). SN 85-435,684. PUB. 3-20-2012. FILED 9-29-2011.
- 4,153,468. **ALASKA K-LEX (STANDARD CHARACTER)**. SEA HAWK CORP., (U.S. CLS. 6, 18, 44, 46, 51 AND 52). SN 85-435,768. PUB. 3-20-2012. FILED 9-29-2011.
- 4,153,482. **MAJESTY'S BUDDY BITES (STANDARD CHARACTER)**. MAJESTY'S ANIMAL NUTRITION, (U.S. CLS. 6, 18, 44, 46, 51 AND 52). SN 85-436,271. PUB. 3-20-2012. FILED 9-30-2011.
- 4,153,486. **TECO DIAGNOSTICS (STANDARD CHARACTER)**. TECO DIAGNOSTICS, (U.S. CLS. 6, 18, 44, 46, 51 AND 52). SN 85-436,511. PUB. 3-20-2012. FILED 9-30-2011.
- 4,153,503. **AMATE LIFE (STANDARD CHARACTER)**. AMATE LIFE, (U.S. CLS. 6, 18, 44, 46, 51 AND 52). SN 85-437,119. PUB. 3-20-2012. FILED 10-1-2011.
- 4,153,563. **MIMA AND DESIGN**. GOLDEN STAR INC., MULTIPLE CLASS, (INT. CLS. 5, 21 AND 24), (U.S. CLS. 2, 6, 13, 18, 23, 29, 30, 33, 40, 42, 44, 46, 50, 51 AND 52). SN 85-438,672. PUB. 3-20-2012. FILED 10-4-2011.
- 4,153,578. **T FACTOR (STANDARD CHARACTER)**. KINGFISHER MEDIA, LLC, (U.S. CLS. 6, 18, 44, 46, 51 AND 52). SN 85-439,132. PUB. 3-20-2012. FILED 10-4-2011.
- 4,153,699. **XTREME ENERGY XTREME WEIGHT LOSS (STANDARD CHARACTER)**. MARTIN, SCOTT W. (U.S. CLS. 6, 18, 44, 46, 51 AND 52). SN 85-441,561. PUB. 3-20-2012. FILED 10-7-2011.
- 4,153,743. **GLUKIES AND DESIGN**. GLUKIES, (U.S. CLS. 6, 18, 44, 46, 51 AND 52). SN 85-441,969. PUB. 3-20-2012. FILED 10-7-2011.
- 4,153,753. **LINOLIN (STANDARD CHARACTER)**. LEANSLIM, LLC, (U.S. CLS. 6, 18, 44, 46, 51 AND 52). SN 85-442,062. PUB. 3-20-2012. FILED 10-7-2011.
- 4,153,812. **ICB (STANDARD CHARACTER)**. ROCKY MOUNTAIN TISSUE BANK, (U.S. CLS. 6, 18, 44, 46, 51 AND 52). SN 85-442,701. PUB. 3-20-2012. FILED 10-7-2011.
- 4,153,815. **HUMANOFORT (STANDARD CHARACTER)**. DELCZEG INC, (U.S. CLS. 6, 18, 44, 46, 51 AND 52). SN 85-442,741. PUB. 3-20-2012. FILED 10-8-2011.
- 4,154,026. **ACTISTRETCH (STANDARD CHARACTER)**. GEOFFROY, DAVID R, (U.S. CLS. 6, 18, 44, 46, 51 AND 52). SN 85-444,830. PUB. 3-20-2012. FILED 10-11-2011.
- 4,154,128. **GMATE (STANDARD CHARACTER)**. PHILOSOSY INC, MULTIPLE CLASS, (INT. CLS. 5 AND 10), (U.S. CLS. 6, 18, 26, 39, 44, 46, 51 AND 52). SN 85-450,721. PUB. 3-20-2012. FILED 10-19-2011.

CLASS 6—METAL GOODS

- 4,152,079. **SOUTHERN IMPERIAL (STANDARD CHARACTER)**. SOUTHERN IMPERIAL, INC., MULTIPLE CLASS, (INT. CLS. 6, 16 AND 20), (U.S. CLS. 2, 5, 12, 13, 14, 22, 23, 25, 29, 32, 37, 38 AND 50). SN 77-320,099. PUB. 3-20-2012. FILED 11-2-2007.
- 4,152,091 (*See Class 4 for this trademark*).
- 4,152,182. **IONBOND THE SURFACE ENGINEERS AND DESIGN**. IONBOND AG OLTEN, MULTIPLE CLASS, (INT. CLS. 6, 7, 14 AND 40), (U.S. CLS. 2, 12, 13, 14, 19, 21, 23, 25, 27, 28, 31, 34, 35, 50, 100, 103 AND 106). SN 79-087,937. PUB. 3-20-2012. FILED 7-29-2010.
- 4,152,184. **SL30 (STANDARD CHARACTER)**. REMKO MARK B.V., MULTIPLE CLASS, (INT. CLS. 6 AND 19), (U.S. CLS. 1, 2, 12, 13, 14, 23, 25, 33 AND 50). SN 79-088,312. PUB. 3-20-2012. FILED 9-23-2010.
- 4,152,191. **SL30-ISO (STANDARD CHARACTER)**. REMKO MARK B.V., MULTIPLE CLASS, (INT. CLS. 6 AND 19), (U.S. CLS. 1, 2, 12, 13, 14, 23, 25, 33 AND 50). SN 79-089,331. PUB. 3-20-2012. FILED 9-23-2010.
- 4,152,194. **TENNECT (STANDARD CHARACTER)**. CARL STAHL GMBH, MULTIPLE CLASS, (INT. CLS. 6, 7, 8, 20, 22 AND 37), (U.S. CLS. 1, 2, 7, 12, 13, 14, 19, 21, 22, 23, 25, 28, 31, 32, 34, 35, 42, 44, 50, 100, 103 AND 106). SN 79-090,017. PUB. 3-20-2012. FILED 9-28-2010.
- 4,152,220. **GP JOULE (STANDARD CHARACTER)**. OVE PETERSEN, MULTIPLE CLASS, (INT. CLS. 6, 9, 19 AND 25), (U.S. CLS. 1, 2, 12, 13, 14, 21, 22, 23, 25, 26, 33, 36, 38, 39 AND 50). SN 79-094,080. PUB. 3-20-2012. FILED 12-27-2010.
- 4,152,236. **VASTAS AND DESIGN**. VASTAS VALF ARMATÜR SANAYI TICARET ANONIM SİRKETİ, MULTIPLE CLASS, (INT. CLS. 6 AND 7), (U.S. CLS. 2, 12, 13, 14, 19, 21, 23, 25, 31, 34, 35 AND 50). SN 79-095,952. PUB. 3-20-2012. FILED 12-14-2010.
- 4,152,256. **SPIRO (STANDARD CHARACTER)**. SPIRO INTERNATIONAL S.A., MULTIPLE CLASS, (INT. CLS. 6, 7 AND 11), (U.S. CLS. 2, 12, 13, 14, 19, 21, 23, 25, 31, 34, 35 AND 50). SN 79-097,235. PUB. 3-20-2012. FILED 4-29-2011.
- 4,152,336. **SKUDO (STYLIZED)**. SPECIAL SPRINGS S.R.L., MULTIPLE CLASS, (INT. CLS. 6 AND 7), (U.S. CLS. 2, 12, 13, 14, 19, 21, 23, 25, 31, 34, 35 AND 50). SN 79-100,033. PUB. 3-20-2012. FILED 4-27-2011.
- 4,152,341. **PTAH SOCAR (STANDARD CHARACTER)**. MBDA FRANCE, MULTIPLE CLASS, (INT. CLS. 6, 7, 9, 11, 12, 13, 16, 17, 19, 37, 40, 41 AND 42), (U.S. CLS. 1, 2, 5, 9, 12, 13, 14, 19, 21, 22, 23, 25, 26, 29, 31, 33, 34, 35, 36, 37, 38, 44, 50, 100, 101, 103, 106 AND 107). SN 79-100,223. PUB. 3-20-2012. FILED 3-24-2011.
- 4,152,371. **C-TRACK (STANDARD CHARACTER)**. XLNT ADVANCED TECHNOLOGIES B.V., (U.S. CLS. 2, 12, 13, 14, 23, 25 AND 50). SN 79-102,293. PUB. 3-20-2012. FILED 8-4-2011.
- 4,152,377. **FUD (STANDARD CHARACTER)**. FRÖHLICH &

- DÖRKEN GMBH, MULTIPLE CLASS, (INT. CLS. 6, 7 AND 40), (U.S. CLS. 2, 12, 13, 14, 19, 21, 23, 25, 31, 34, 35, 50, 100, 103 AND 106). SN 79-102,634. PUB. 3-20-2012. FILED 7-22-2011.
- 4,152,381. **OS ID AND DESIGN. OS ID AS**, MULTIPLE CLASS, (INT. CLS. 6 AND 20), (U.S. CLS. 2, 12, 13, 14, 22, 23, 25, 32 AND 50). SN 79-102,763. PUB. 3-20-2012. FILED 4-12-2011.
- 4,152,389. **JACKLOC (STANDARD CHARACTER)**, THE JACKLOC COMPANY LIMITED, (U.S. CLS. 2, 12, 13, 14, 23, 25 AND 50). SN 79-103,185. PUB. 3-20-2012. FILED 8-10-2011.
- 4,152,410 (*See Class 1 for this trademark*).
- 4,152,414. **ULTRON AND DESIGN. DOCKWEILER AG**, (U.S. CLS. 2, 12, 13, 14, 23, 25 AND 50). SN 79-104,687. PUB. 3-20-2012. FILED 8-9-2011.
- 4,152,435. **HOMICHEF AND DESIGN. XINHUI RIXING STAINLESS; STEEL PRODUCTS CO., LTD.**, MULTIPLE CLASS, (INT. CLS. 6 AND 20), (U.S. CLS. 2, 12, 13, 14, 22, 23, 25, 32 AND 50). SN 79-107,179. PUB. 3-20-2012. FILED 9-16-2011.
- 4,152,450. **WINGITS (STANDARD CHARACTER)**, WINGITS INNOVATIONS, LLC, MULTIPLE CLASS, (INT. CLS. 6 AND 20), (U.S. CLS. 2, 12, 13, 14, 22, 23, 25, 32 AND 50). SN 85-037,258. PUB. 3-20-2012. FILED 5-13-2010.
- 4,152,460. **NTB (STYLIZED)**, NIPPON STEEL TOPY BRIDGE CO., LTD., MULTIPLE CLASS, (INT. CLS. 6 AND 37), (U.S. CLS. 2, 12, 13, 14, 23, 25, 50, 100, 103 AND 106). SN 85-053,739. PUB. 4-19-2011. FILED 6-3-2010.
- 4,152,461. **WATCHLOCK (STYLIZED)**, MUL-T-LOCK TECHNOLOGIES LTD., AND STARCOM G.P.S SYSTEMS LTD., MULTIPLE CLASS, (INT. CLS. 6 AND 9), (U.S. CLS. 2, 12, 13, 14, 21, 23, 25, 26, 36, 38 AND 50). SN 85-059,856. PUB. 3-20-2012. FILED 6-10-2010.
- 4,152,490. **VITCO (STANDARD CHARACTER)**, UNITED STATES PIPE AND FOUNDRY COMPANY, LLC, (U.S. CLS. 2, 12, 13, 14, 23, 25 AND 50). SN 85-106,072. PUB. 3-20-2012. FILED 8-12-2010.
- 4,152,503. **JAC-RACK (STANDARD CHARACTER)**, JAC-RACK, INC., MULTIPLE CLASS, (INT. CLS. 6 AND 9), (U.S. CLS. 2, 12, 13, 14, 21, 23, 25, 26, 36, 38 AND 50). SN 85-114,462. PUB. 3-20-2012. FILED 8-24-2010.
- 4,152,547. **CAMBRIDGE (STYLIZED)**, GARAGA INC., (U.S. CLS. 2, 12, 13, 14, 23, 25 AND 50). SN 85-153,451. PUB. 3-20-2012. FILED 10-15-2010.
- 4,152,658 (*See Class 1 for this trademark*).
- 4,152,685. **LOAD ARMOUR AND DESIGN. PETELKA INVESTMENTS LTD., AND PETELKA, JEFFREY ROY WILLIAM**, MULTIPLE CLASS, (INT. CLS. 6, 12 AND 22), (U.S. CLS. 1, 2, 7, 12, 13, 14, 19, 21, 22, 23, 25, 31, 35, 42, 44 AND 50). SN 85-272,952. PUB. 3-20-2012. FILED 3-22-2011.
- 4,152,788. **TIDY TINS AND DESIGN. THE HILLMAN GROUP, INC.**, (U.S. CLS. 2, 12, 13, 14, 23, 25 AND 50). SN 85-297,639. PUB. 3-20-2012. FILED 4-18-2011.
- 4,152,806. **ORION (STANDARD CHARACTER)**, AXIP LIMITED, MULTIPLE CLASS, (INT. CLS. 6, 19 AND 45), (U.S. CLS. 1, 2, 12, 13, 14, 23, 25, 33, 50, 100 AND 101). SN 85-299,800. PUB. 3-20-2012. FILED 4-20-2011.
- 4,153,298. **MISCELLANEOUS DESIGN. CONTINUOUS COATING CORP.**, (U.S. CLS. 2, 12, 13, 14, 23, 25 AND 50). SN 85-421,771. PUB. 3-20-2012. FILED 9-13-2011.
- 4,153,550. **SAFETY DELIVERED (STANDARD CHARACTER)**, LEE, ERIC, (U.S. CLS. 2, 12, 13, 14, 23, 25 AND 50). SN 85-438,360. PUB. 3-20-2012. FILED 10-4-2011.
- 4,153,670. **GREEN ZONE AND DESIGN. SUNLOGICS ENERGY SOLUTIONS, LLC**, (U.S. CLS. 2, 12, 13, 14, 23, 25 AND 50). SN 85-440,993. PUB. 3-20-2012. FILED 10-6-2011.
- 4,153,961. **COMPASS ROSE (STANDARD CHARACTER)**, NORTH COUNTRY WIND BELLS, INC., (U.S. CLS. 2, 12, 13, 14, 23, 25 AND 50). SN 85-444,172. PUB. 3-20-2012. FILED 10-11-2011.
- 4,152,055. **G AND DESIGN. FMF OF OREGON, LLC**, (U.S. CLS. 13, 19, 21, 23, 31, 34 AND 35). SN 76-708,617. PUB. 3-20-2012. FILED 8-5-2011.
- 4,152,089. **MICRON CUTTERS AND DESIGN. AKIYAMA INTERNATIONAL CORPORATION (USA)**, (U.S. CLS. 13, 19, 21, 23, 31, 34 AND 35). SN 77-456,540. PUB. 3-20-2012. FILED 4-24-2008.
- 4,152,114. **CORE-TECH (STYLIZED)**, BRIDGESTONE CORPORATION, (U.S. CLS. 13, 19, 21, 23, 31, 34 AND 35). SN 77-722,774. PUB. 12-8-2009. FILED 4-27-2009.
- 4,152,120. **E ENERGY EFFICIENCY AND DESIGN. LG ELECTRONICS INC.**, MULTIPLE CLASS, (INT. CLS. 7, 9, 10, 11 AND 35), (U.S. CLS. 13, 19, 21, 23, 26, 31, 34, 35, 36, 38, 39, 44, 100, 101 AND 102). SN 77-814,446. PUB. 3-20-2012. FILED 8-27-2009.
- 4,152,125. **EUROTEC (STANDARD CHARACTER)**, EUROTEC VERTICAL FLIGHT SOLUTIONS, LLC, MULTIPLE CLASS, (INT. CLS. 7, 9, 12, 37 AND 39), (U.S. CLS. 13, 19, 21, 23, 26, 31, 34, 35, 36, 38, 44, 100, 103, 105 AND 106). SN 77-848,833. PUB. 3-20-2012. FILED 10-14-2009.
- 4,152,161. **TESLA AND DESIGN. TESLA S.R.L.**, MULTIPLE CLASS, (INT. CLS. 7 AND 9), (U.S. CLS. 13, 19, 21, 23, 26, 31, 34, 35, 36 AND 38). SN 79-025,196. PUB. 12-28-2010. FILED 12-13-2005.
- 4,152,163. **COSWORTH (STANDARD CHARACTER)**, COSWORTH LIMITED, MULTIPLE CLASS, (INT. CLS. 7, 12, 25 AND 42), (U.S. CLS. 13, 19, 21, 22, 23, 31, 34, 35, 39, 44, 100 AND 101). SN 79-036,861. PUB. 3-20-2012. FILED 12-22-2006.
- 4,152,170. **FINGER-PATCH (STANDARD CHARACTER)**, CONOPTICA AS, MULTIPLE CLASS, (INT. CLS. 7, 9 AND 42), (U.S. CLS. 13, 19, 21, 23, 26, 31, 34, 35, 36, 38, 100 AND 101). SN 79-077,911. PUB. 3-20-2012. FILED 11-18-2009.
- 4,152,172. **D DUPLOMATIC OLEODINAMICA AND DESIGN. DUPLOMATIC OLEODINAMICA S.P.A.**, (U.S. CLS. 13, 19, 21, 23, 31, 34 AND 35). SN 79-082,886. PUB. 3-20-2012. FILED 4-29-2010.
- 4,152,182 (*See Class 6 for this trademark*).
- 4,152,183. **ZVT ERO (STYLIZED)**, MIRCONA AB, MULTIPLE CLASS, (INT. CLS. 7, 8 AND 9), (U.S. CLS. 13, 19, 21, 23, 26, 28, 31, 34, 35, 36, 38 AND 44). SN 79-088,171. PUB. 3-20-2012. FILED 9-21-2010.
- 4,152,194 (*See Class 6 for this trademark*).
- 4,152,197 (*See Class 1 for this trademark*).
- 4,152,227. **GA.VO MECCANICA AND DESIGN. GA.VO MECCANICA S.N.C. DI TANCREDI & C.**, (U.S. CLS. 13, 19, 21, 23, 31, 34 AND 35). SN 79-095,484. PUB. 3-20-2012. FILED 3-21-2011.
- 4,152,228. **MISCELLANEOUS DESIGN. GREE ELECTRIC APPLIANCES, INC. OF ZHUHAI**, MULTIPLE CLASS, (INT. CLS. 7, 9, 11, 16, 35 AND 37), (U.S. CLS. 2, 5, 13, 19, 21, 22, 23, 26, 29, 31, 34, 35, 36, 37, 38, 50, 100, 101, 102, 103 AND 106). SN 79-095,494. PUB. 3-20-2012. FILED 8-19-2010.
- 4,152,229 (*See Class 1 for this trademark*).
- 4,152,230. **PROCESS GROUP AND DESIGN. PROCESS GROUP PTY LTD**, MULTIPLE CLASS, (INT. CLS. 7, 11, 40 AND 42), (U.S. CLS. 13, 19, 21, 23, 31, 34, 35, 100, 101, 103 AND 106). SN 79-095,558. PUB. 3-20-2012. FILED 10-4-2010.
- 4,152,231. **PROCESS GROUP INTERNATIONAL AND DESIGN. PROCESS GROUP PTY LTD**, MULTIPLE CLASS, (INT. CLS. 7, 11, 40 AND 42), (U.S. CLS. 13, 19, 21, 23, 31, 34, 35, 100, 101, 103 AND 106). SN 79-095,598. PUB. 3-20-2012. FILED 10-4-2010.
- 4,152,236 (*See Class 6 for this trademark*).
- 4,152,249. **RCOM (STYLIZED)**, AUTO ELEX CO., LTD., (U.S. CLS. 13, 19, 21, 23, 31, 34 AND 35). SN 79-096,791. PUB. 3-20-2012. FILED 2-1-2011.
- 4,152,256 (*See Class 6 for this trademark*).
- 4,152,269 (*See Class 1 for this trademark*).
- 4,152,285. **PARDIS AND DESIGN. GECOFIN S.P.A.**, MULTIPLE CLASS, (INT. CLS. 7 AND 42), (U.S. CLS. 13, 19, 21, 23, 31, 34, 35, 100 AND 101). SN 79-098,374. PUB. 3-20-2012. FILED 4-27-2011.
- 4,152,297. **PANOTO AND DESIGN. PAN OTO RADYATÖR MAKINA SANAYI VE TICARET ANONİM ŞİRKETİ**, MULTIPLE CLASS, (INT. CLS. 7 AND 12), (U.S. CLS. 13, 19, 21, 23, 31, 34, 35 AND 44). SN 79-098,697. PUB. 3-20-2012. FILED 8-4-2010.
- 4,152,314. **R RAILBOT AND DESIGN. HYUNDAI HEAVY**

CLASS 7—MACHINERY

- 4,152,042. **CUTNUCLEAR AND DESIGN. CUT NUCLEAR, INC.**, (U.S. CLS. 13, 19, 21, 23, 31, 34 AND 35). SN 76-706,490. PUB. 3-20-2012. FILED 2-22-2011.

- INDUSTRIES CO., LTD., MULTIPLE CLASS, (INT. CLS. 7 AND 9), (U.S. CLS. 13, 19, 21, 23, 26, 31, 34, 35, 36 AND 38). SN 79-099,249. PUB. 3-20-2012. FILED 3-23-2011.
- 4,152,336 (*See Class 6 for this trademark.*).
- 4,152,341 (*See Class 6 for this trademark.*).
- 4,152,346. **STAI D (STANDARD CHARACTER)**. VENTRADE B.V., MULTIPLE CLASS, (INT. CLS. 7 AND 10), (U.S. CLS. 13, 19, 21, 23, 26, 31, 34, 35, 39 AND 44). SN 79-100,486. PUB. 3-20-2012. FILED 6-16-2011.
- 4,152,360. **PE-DESIGN (STANDARD CHARACTER)**. EMITEC GESELLSCHAFT FÜR EMISSIONSTECHNOLOGIE MBH, (U.S. CLS. 13, 19, 21, 23, 31, 34 AND 35). SN 79-101,121. PUB. 3-20-2012. FILED 2-18-2011.
- 4,152,366. **MB AND DESIGN**. UGUR MAKINA SANAYI GIDA INSAAT TAAHHÜT ENDÜSTRİYEL YAPILAR TURIZM TARIM DIS TICARET LIMITED SIRKETI, (U.S. CLS. 13, 19, 21, 23, 31, 34 AND 35). SN 79-101,622. PUB. 3-20-2012. FILED 4-8-2011.
- 4,152,377 (*See Class 6 for this trademark.*).
- 4,152,382. **XTREME (STANDARD CHARACTER)**. BYSTRONIC LASER AG, MULTIPLE CLASS, (INT. CLS. 7, 9 AND 40), (U.S. CLS. 13, 19, 21, 23, 26, 31, 34, 35, 36, 38, 100, 103 AND 106). SN 79-102,829. PUB. 3-20-2012. FILED 7-25-2011.
- 4,152,395. **TURBOTIGHT (STANDARD CHARACTER)**. ATLAS COPCO TOOLS AB, MULTIPLE CLASS, (INT. CLS. 7 AND 9), (U.S. CLS. 13, 19, 21, 23, 26, 31, 34, 35, 36 AND 38). SN 79-103,734. PUB. 3-20-2012. FILED 9-22-2011.
- 4,152,431. **PIVOT (STANDARD CHARACTER)**. APPLIED MATERIALS GMBH & CO. KG, (U.S. CLS. 13, 19, 21, 23, 31, 34 AND 35). SN 79-106,614. PUB. 3-20-2012. FILED 10-24-2011.
- 4,152,501 (*See Class 1 for this trademark.*).
- 4,152,507 (*See Class 3 for this trademark.*).
- 4,152,589. **AQUAS CLEAN MARINA SERIES (STYLIZED)**. ENVIRONMENTAL CONTROL SYSTEMS, INC., DBA AQUASGROUP, MULTIPLE CLASS, (INT. CLS. 7, 11 AND 42), (U.S. CLS. 13, 19, 21, 23, 31, 34, 35, 100 AND 101). SN 85-198,014. PUB. 3-20-2012. FILED 12-15-2010.
- 4,152,619. **GEARBRID (STANDARD CHARACTER)**. THE TRUSTEES OF THE STONERIDGE TRUST, MULTIPLE CLASS, (INT. CLS. 7 AND 12), (U.S. CLS. 13, 19, 21, 23, 31, 34, 35 AND 44). SN 85-224,159. PUB. 3-20-2012. FILED 1-24-2011.
- 4,152,649. **B&B LEADERS IN THE NEW TECHNOLOGY (STANDARD CHARACTER)**. B & B MANUFACTURING CORPORATION, (U.S. CLS. 13, 19, 21, 23, 31, 34 AND 35). SN 85-249,421. PUB. 3-20-2012. FILED 2-23-2011.
- 4,152,658 (*See Class 1 for this trademark.*).
- 4,152,679. **DUALSMIX (STANDARD CHARACTER)**. GLV FINANCE HUNGARY KFT., ACTING THROUGH ITS LUXEMBOURG BRANCH, (U.S. CLS. 13, 19, 21, 23, 31, 34 AND 35). SN 85-271,053. PUB. 3-20-2012. FILED 3-18-2011.
- 4,152,778. **MICROMATIC (STANDARD CHARACTER)**. MICROMATIC, LLC, (U.S. CLS. 13, 19, 21, 23, 31, 34 AND 35). SN 85-297,124. PUB. 3-20-2012. FILED 4-16-2011.
- 4,152,847. **A AND DESIGN**. ATSUMI CAR EQUIPMENT, INC., MULTIPLE CLASS, (INT. CLS. 7 AND 12), (U.S. CLS. 13, 19, 21, 23, 31, 34, 35 AND 44). SN 85-306,651. PUB. 3-20-2012. FILED 4-27-2011.
- 4,152,927. **MEVAC (STANDARD CHARACTER)**. SMS MEVAC GMBH, MULTIPLE CLASS, (INT. CLS. 7, 9 AND 11), (U.S. CLS. 13, 19, 21, 23, 26, 31, 34, 35, 36 AND 38). SN 85-326,048. PUB. 3-20-2012. FILED 5-20-2011.
- 4,152,969. **V JACK AND DESIGN**. TETRA TECHNOLOGIES, INC., (U.S. CLS. 13, 19, 21, 23, 31, 34 AND 35). SN 85-337,905. PUB. 3-20-2012. FILED 6-3-2011.
- 4,153,103. **JS (STANDARD CHARACTER)**. MAP OIL TOOLS, INC., (U.S. CLS. 13, 19, 21, 23, 31, 34 AND 35). SN 85-382,567. PUB. 3-20-2012. FILED 7-27-2011.
- 4,153,143. **POWERFOLD (STANDARD CHARACTER)**. LA-FORGE, MULTIPLE CLASS, (INT. CLS. 7 AND 12), (U.S. CLS. 13, 19, 21, 23, 31, 34, 35 AND 44). SN 85-394,184. PUB. 3-20-2012. FILED 8-10-2011.
- 4,153,156. **K KEEPER AND DESIGN**. HAMPTON PRODUCTS INTERNATIONAL CORPORATION, MULTIPLE CLASS, (INT. CLS. 7 AND 22), (U.S. CLS. 1, 2, 7, 13, 19, 21, 22, 23, 31, 34, 35, 42 AND 50). SN 85-395,967. PUB. 3-20-2012. FILED 8-11-2011.
- 4,153,514. **ROAD SAFETY WARRIOR AND DESIGN**. ADVANT-EDGE PAVING EQUIPMENT, LLC, (U.S. CLS. 13, 19, 21, 23, 31, 34 AND 35). SN 85-437,486. PUB. 3-20-2012. FILED 10-3-2011.
- 4,153,608. **CAB KING (STANDARD CHARACTER)**. REENTEL INTERNATIONAL INC., (U.S. CLS. 13, 19, 21, 23, 31, 34 AND 35). SN 85-439,802. PUB. 3-20-2012. FILED 10-5-2011.
- 4,153,614. **WHIRLPOOL (STANDARD CHARACTER)**. WHIRLPOOL PROPERTIES, INC., (U.S. CLS. 13, 19, 21, 23, 31, 34 AND 35). SN 85-439,896. PUB. 3-20-2012. FILED 10-5-2011.
- 4,153,744. **ENVIROTIP (STANDARD CHARACTER)**. HAYNES CORPORATION, (U.S. CLS. 13, 19, 21, 23, 31, 34 AND 35). SN 85-441,991. PUB. 3-20-2012. FILED 10-7-2011.
- 4,153,901. **DEMACO AND DESIGN**. DEFRANCISCI MACHINE COMPANY LLC, (U.S. CLS. 13, 19, 21, 23, 31, 34 AND 35). SN 85-443,543. PUB. 3-20-2012. FILED 10-10-2011.
- 4,153,915. **AMT (STANDARD CHARACTER)**. AMERICAN MACHINE AND TOOL CO., INC. OF PENNSYLVANIA, (U.S. CLS. 13, 19, 21, 23, 31, 34 AND 35). SN 85-443,680. PUB. 3-20-2012. FILED 10-10-2011.
- 4,154,060. **TI (STANDARD CHARACTER)**. WIELAND DENTAL + TECHNIK GMBH & CO. KG, (U.S. CLS. 13, 19, 21, 23, 31, 34 AND 35). SN 85-445,714. PUB. 3-20-2012. FILED 10-12-2011.
- 4,154,088. **ELFOLIFT (STANDARD CHARACTER)**. ELEVATOR BOUTIQUE LLC, (U.S. CLS. 13, 19, 21, 23, 31, 34 AND 35). SN 85-446,136. PUB. 3-20-2012. FILED 10-13-2011.
- 4,154,089. **SUPERMEC (STANDARD CHARACTER)**. ELEVATOR BOUTIQUE LLC, (U.S. CLS. 13, 19, 21, 23, 31, 34 AND 35). SN 85-446,142. PUB. 3-20-2012. FILED 10-13-2011.

CLASS 8—HAND TOOLS

- 4,152,063. **CROWING ROOSTER AND DESIGN**. PANTHER TRADING, INC., (U.S. CLS. 23, 28 AND 44). SN 76-709,082. PUB. 2-7-2012. FILED 9-16-2011.
- 4,152,132. **SMART TV SOLUTIONS (STANDARD CHARACTER)**. SOMERSET WAREHOUSING PLUS INC., DBA SMART WORKS CONSUMER PRODUCTS, (U.S. CLS. 23, 28 AND 44). SN 77-875,840. PUB. 8-31-2010. FILED 11-18-2009.
- 4,152,183 (*See Class 7 for this trademark.*).
- 4,152,194 (*See Class 6 for this trademark.*).
- 4,152,213. **BERTHOUD (STANDARD CHARACTER)**. EXEL INDUSTRIES, (U.S. CLS. 23, 28 AND 44). SN 79-093,115. PUB. 3-20-2012. FILED 12-3-2010.
- 4,152,221. **RIG-TIG (STANDARD CHARACTER)**. STELTON A/S, MULTIPLE CLASS, (INT. CLS. 8 AND 21), (U.S. CLS. 2, 13, 23, 28, 29, 30, 33, 40, 44 AND 50). SN 79-094,224. PUB. 3-20-2012. FILED 1-6-2011.
- 4,152,226 (*See Class 3 for this trademark.*).
- 4,152,229 (*See Class 1 for this trademark.*).
- 4,152,242. **SAS LE PRINCE ALBERT II DE MONACO AC MADEMOISELLE CHARLENE WITTSTOCK MONACO, LE 2 JUILLET 2011 AND DESIGN**. CABINET GRANGER, MULTIPLE CLASS, (INT. CLS. 8, 14, 16, 18, 20, 21, 24, 26 AND 35), (U.S. CLS. 1, 2, 3, 5, 13, 22, 23, 25, 27, 28, 29, 30, 32, 33, 37, 38, 39, 40, 41, 42, 44, 50, 100, 101 AND 102). SN 79-096,353. PUB. 3-20-2012. FILED 3-2-2011.
- 4,152,272 (*See Class 3 for this trademark.*).
- 4,152,446. **RAPTOR AND DESIGN**. FERGUSON ENTERPRISES, INC., (U.S. CLS. 23, 28 AND 44). SN 85-029,471. PUB. 3-20-2012. FILED 5-4-2010.
- 4,153,282 (*See Class 3 for this trademark.*).
- 4,153,668. **DAXWELL (STANDARD CHARACTER)**. DAXWELL, LLC, MULTIPLE CLASS, (INT. CLS. 8, 10 AND 21), (U.S. CLS. 2, 13, 23, 26, 28, 29, 30, 33, 39, 40, 44 AND 50). SN 85-440,973. PUB. 3-20-2012. FILED 10-6-2011.

CLASS 9—ELECTRICAL AND SCIENTIFIC APPARATUS

- 4,152,036. **MASTERFILE AND DESIGN**. EBRAHIM, MOHIB S., (U.S. CLS. 21, 23, 26, 36 AND 38). SN 76-664,790. PUB. 3-20-2012. FILED 8-17-2006.
- 4,152,050. **ORION (STANDARD CHARACTER)**. SIGNATURE CONTROL SYSTEMS, INC., (U.S. CLS. 21, 23, 26, 36 AND 38). SN 76-707,458. PUB. 3-20-2012. FILED 5-2-2011.
- 4,152,051. **SCS AND DESIGN**. SIGNATURE CONTROL SYSTEMS, INC., MULTIPLE CLASS, (INT. CLS. 9 AND 11), (U.S. CLS. 13, 21, 23, 26, 31, 34, 36 AND 38). SN 76-707,459. PUB. 3-20-2012. FILED 5-2-2011.
- 4,152,052. **SAUL EL JAGUAR AND DESIGN**. TALENT MUSIC GROUP, INC., (U.S. CLS. 21, 23, 26, 36 AND 38). SN 76-707,572. PUB. 3-20-2012. FILED 5-11-2011.
- 4,152,054. **DIRECTSYNC (STANDARD CHARACTER)**. BOX-WAVE CORPORATION, (U.S. CLS. 21, 23, 26, 36 AND 38). SN 76-708,102. PUB. 3-20-2012. FILED 6-23-2011.
- 4,152,076. **WEBAXIS (STANDARD CHARACTER)**. CAD-WORKS, (U.S. CLS. 21, 23, 26, 36 AND 38). SN 77-143,506. PUB. 3-20-2012. FILED 3-29-2007.
- 4,152,091 (*See Class 4 for this trademark*).
- 4,152,100. **AUTHORITY LIGHTING (STANDARD CHARACTER)**. AUTHORITY LIGHTING INC., DBA AUTHORITY LIGHTING, (U.S. CLS. 21, 23, 26, 36 AND 38). SN 77-584,692. PUB. 3-20-2012. FILED 10-2-2008.
- 4,152,109. **APPZERO (STANDARD CHARACTER)**. APPZERO SOFTWARE CORP., MULTIPLE CLASS, (INT. CLS. 9 AND 42), (U.S. CLS. 21, 23, 26, 36, 38, 100 AND 101). SN 77-679,599. PUB. 3-20-2012. FILED 2-27-2009.
- 4,152,120 (*See Class 7 for this trademark*).
- 4,152,125 (*See Class 7 for this trademark*).
- 4,152,127. **MEDICARGER (STANDARD CHARACTER)**. MILUX HOLDING S.A., MULTIPLE CLASS, (INT. CLS. 9, 10 AND 44), (U.S. CLS. 21, 23, 26, 36, 38, 39, 44, 100 AND 101). SN 77-858,115. PUB. 3-20-2012. FILED 10-27-2009.
- 4,152,136. **FROSTT (STANDARD CHARACTER)**. MARINER PARTNERS INC., MULTIPLE CLASS, (INT. CLS. 9 AND 42), (U.S. CLS. 21, 23, 26, 36, 38, 100 AND 101). SN 77-911,979. PUB. 3-20-2012. FILED 1-14-2010.
- 4,152,137. **FROSTT AND DESIGN**. MARINER PARTNERS INC., MULTIPLE CLASS, (INT. CLS. 9 AND 42), (U.S. CLS. 21, 23, 26, 36, 38, 100 AND 101). SN 77-911,984. PUB. 3-20-2012. FILED 1-14-2010.
- 4,152,138. **HBIMED (STANDARD CHARACTER)**. HBIMED AG, MULTIPLE CLASS, (INT. CLS. 9, 10 AND 42), (U.S. CLS. 21, 23, 26, 36, 38, 39, 44, 100 AND 101). SN 77-916,014. PUB. 3-20-2012. FILED 1-20-2010.
- 4,152,143. **MAILSTREAM MANAGER (STANDARD CHARACTER)**. SYNTEL, LLC, (U.S. CLS. 21, 23, 26, 36 AND 38). SN 77-936,977. PUB. 3-20-2012. FILED 2-16-2010.
- 4,152,144. **GEARHEAD RECORDS AND DESIGN**. MICHELLE HAUNOLD, AKA GEARHEAD PRODUCTIONS, INC, (U.S. CLS. 21, 23, 26, 36 AND 38). SN 77-944,202. PUB. 3-20-2012. FILED 2-24-2010.
- 4,152,149. **THE UNIVERSE (STANDARD CHARACTER)**. A&E TELEVISION NETWORKS, LLC, MULTIPLE CLASS, (INT. CLS. 9 AND 41), (U.S. CLS. 21, 23, 26, 36, 38, 100, 101 AND 107). SN 77-952,764. PUB. 3-20-2012. FILED 3-8-2010.
- 4,152,160. **FERRARI HISTORIC CHALLENGE AND DESIGN**. FERRARI S.P.A., MULTIPLE CLASS, (INT. CLS. 9, 16 AND 28), (U.S. CLS. 2, 5, 21, 22, 23, 26, 29, 36, 37, 38 AND 50). SN 78-930,573. PUB. 3-20-2012. FILED 7-17-2006.
- 4,152,161 (*See Class 7 for this trademark*).
- 4,152,168. **FTDI CHIP AND DESIGN**. FUTURE TECHNOLOGY DEVICES; INTERNATIONAL LIMITED, MULTIPLE CLASS, (INT. CLS. 9, 16 AND 42), (U.S. CLS. 2, 5, 21, 22, 23, 26, 29, 36, 37, 38, 50, 100 AND 101). SN 79-075,445. PUB. 5-3-2011. FILED 10-13-2009.
- 4,152,170 (*See Class 7 for this trademark*).
- 4,152,175. **DESIGO (STANDARD CHARACTER)**. SIEMENS SCHWEIZ AG, MULTIPLE CLASS, (INT. CLS. 9 AND 11), (U.S. CLS. 13, 21, 23, 26, 31, 34, 36 AND 38). SN 79-085,374. PUB. 3-20-2012. FILED 6-15-2010.
- 4,152,176. **EVERY CONTROL AND DESIGN**. EVCO S.P.A., MULTIPLE CLASS, (INT. CLS. 9, 11 AND 42), (U.S. CLS. 13, 21, 23, 26, 31, 34, 36, 38, 100 AND 101). SN 79-085,665. PUB. 3-20-2012. FILED 5-19-2010.
- 4,152,177. **EGOS AND DESIGN**. AGENCE SPATIALE EUROPEENNE (ESA), (U.S. CLS. 21, 23, 26, 36 AND 38). SN 79-085,703. PUB. 3-20-2012. FILED 6-16-2010.
- 4,152,178. **TRAYFORMER (STYLIZED)**. ATLANTA INTERNATIONAL B.V., MULTIPLE CLASS, (INT. CLS. 9 AND 20), (U.S. CLS. 2, 13, 21, 22, 23, 25, 26, 32, 36, 38 AND 50). SN 79-086,434. PUB. 3-20-2012. FILED 7-1-2010.
- 4,152,181. **XCEON (STYLIZED)**. APOLLO (ZHUHAI) ELECTRONICS LIMITED COMPANY, MULTIPLE CLASS, (INT. CLS. 9 AND 11), (U.S. CLS. 13, 21, 23, 26, 31, 34, 36 AND 38). SN 79-087,681. PUB. 3-20-2012. FILED 7-1-2010.
- 4,152,183 (*See Class 7 for this trademark*).
- 4,152,185. **MIGHTY EAGLE (STANDARD CHARACTER)**. ROVIO ENTERTAINMENT LTD, MULTIPLE CLASS, (INT. CLS. 9 AND 28), (U.S. CLS. 21, 22, 23, 26, 36, 38 AND 50). SN 79-088,353. PUB. 3-20-2012. FILED 9-14-2010.
- 4,152,187. **ISTOXX (STANDARD CHARACTER)**. STOXX AG, MULTIPLE CLASS, (INT. CLS. 9, 35, 36 AND 41), (U.S. CLS. 21, 23, 26, 36, 38, 100, 101, 102 AND 107). SN 79-088,838. PUB. 3-20-2012. FILED 9-22-2010.
- 4,152,188 (*See Class 3 for this trademark*).
- 4,152,190. **ROTALUX (STANDARD CHARACTER)**. ELINCHROM S.A. (ELINCHROM LTD), MULTIPLE CLASS, (INT. CLS. 9 AND 11), (U.S. CLS. 13, 21, 23, 26, 31, 34, 36 AND 38). SN 79-089,305. PUB. 3-20-2012. FILED 9-17-2010.
- 4,152,193 (*See Class 3 for this trademark*).
- 4,152,195. **MAXLOGIC (STYLIZED)**. MAVILI ELEKTRONIK TIC. VE SAN. A.S., (U.S. CLS. 21, 23, 26, 36 AND 38). SN 79-090,052. PUB. 3-20-2012. FILED 8-22-2009.
- 4,152,197 (*See Class 1 for this trademark*).
- 4,152,198 (*See Class 3 for this trademark*).
- 4,152,199. **CHARGEON (STANDARD CHARACTER)**. KONINKLIJKE PHILIPS ELECTRONICS N.V., (U.S. CLS. 21, 23, 26, 36 AND 38). SN 79-090,364. PUB. 3-20-2012. FILED 11-2-2010.
- 4,152,200. **THE SWEDISH SOLUTION DL DOLPH LUNDGREN (STYLIZED)**. LUNDGREN DOLPH, MULTIPLE CLASS, (INT. CLS. 9, 16 AND 41), (U.S. CLS. 2, 5, 21, 22, 23, 26, 29, 36, 37, 38, 50, 100, 101 AND 107). SN 79-090,505. PUB. 3-20-2012. FILED 10-29-2010.
- 4,152,203. **SMAXTEC (STANDARD CHARACTER)**. SMAXTEC ANIMAL CARE SALES GMBH, MULTIPLE CLASS, (INT. CLS. 9, 10 AND 42), (U.S. CLS. 21, 23, 26, 36, 38, 39, 44, 100 AND 101). SN 79-091,146. PUB. 3-20-2012. FILED 10-27-2010.
- 4,152,205 (*See Class 1 for this trademark*).
- 4,152,207. **TRA.Q (STANDARD CHARACTER)**. Q-CELLS SE, MULTIPLE CLASS, (INT. CLS. 9, 38 AND 42), (U.S. CLS. 21, 23, 26, 36, 38, 100, 101 AND 104). SN 79-091,645. PUB. 3-20-2012. FILED 11-11-2010.
- 4,152,214. **PINZÀ AND DESIGN**. YAGI AKIRA, MULTIPLE CLASS, (INT. CLS. 9, 18, 28, 29, 30, 31, 35 AND 43), (U.S. CLS. 1, 2, 3, 21, 22, 23, 26, 36, 38, 41, 46, 50, 100, 101 AND 102). SN 79-093,157. PUB. 3-20-2012. FILED 9-9-2010.
- 4,152,215. **AVEDIA (STANDARD CHARACTER)**. AVEDIA SYSTEM INC., MULTIPLE CLASS, (INT. CLS. 9 AND 42), (U.S. CLS. 21, 23, 26, 36, 38, 100 AND 101). SN 79-093,162. PUB. 12-13-2011. FILED 11-9-2010.
- 4,152,218. **LUCETTA (STANDARD CHARACTER)**. LONZA COLOGNE AG, MULTIPLE CLASS, (INT. CLS. 9 AND 42), (U.S. CLS. 21, 23, 26, 36, 38, 100 AND 101). SN 79-093,885. PUB. 3-20-2012. FILED 3-24-2010.
- 4,152,220 (*See Class 6 for this trademark*).
- 4,152,222. **MISCELLANEOUS DESIGN**. TESSILFORM SPA, MULTIPLE CLASS, (INT. CLS. 9, 14, 18 AND 25), (U.S. CLS. 1, 2, 3, 21, 22, 23, 26, 27, 28, 36, 38, 39, 41 AND 50). SN 79-094,527. PUB. 12-13-2011. FILED 1-14-2011.
- 4,152,223. **DURAMEM (STANDARD CHARACTER)**. EVONIK MEMBRANE EXTRACTION TECHNOLOGY LTD., MULTIPLE CLASS, (INT. CLS. 9 AND 17), (U.S. CLS. 1, 5, 12, 13, 21, 23, 26, 35, 36, 38 AND 50). SN 79-094,594. PUB. 3-20-2012. FILED 9-3-2010.
- 4,152,228 (*See Class 7 for this trademark*).
- 4,152,229 (*See Class 1 for this trademark*).
- 4,152,238. **CAMELIGHT AND DESIGN**. CAMELION BATTERY CO., LTD., MULTIPLE CLASS, (INT. CLS. 9 AND 11), (U.S. CLS. 13, 21, 23, 26, 31, 34, 36 AND 38). SN 79-096,062. PUB. 3-20-2012. FILED 3-28-2011.
- 4,152,241. **WHITEBOOK TAILORED NOTEBOOKS (STAN-**

- DARD CHARACTER**. PETER ZELLER, MULTIPLE CLASS, (INT. CLS. 9, 16, 18, 35 AND 39), (U.S. CLS. 1, 2, 3, 5, 21, 22, 23, 26, 29, 36, 37, 38, 41, 50, 100, 101, 102 AND 105). SN 79-096,343. PUB. 3-20-2012. FILED 3-9-2011.
- 4,152,245. **MISCELLANEOUS DESIGN**. SPECS SURFACE NANO ANALYSIS GMBH, MULTIPLE CLASS, (INT. CLS. 9, 41 AND 42), (U.S. CLS. 21, 23, 26, 36, 38, 100, 101 AND 107). SN 79-096,748. PUB. 3-20-2012. FILED 2-28-2011.
- 4,152,247. **TYTO (STANDARD CHARACTER)**. SPECS SURFACE NANO ANALYSIS GMBH, MULTIPLE CLASS, (INT. CLS. 9, 41 AND 42), (U.S. CLS. 21, 23, 26, 36, 38, 100, 101 AND 107). SN 79-096,752. PUB. 3-20-2012. FILED 1-19-2011.
- 4,152,250. **BIMLADDER (STANDARD CHARACTER)**. NEDERLANDSE ORGANISATIE VOOR TOEGEPAST-NATUURWETENSCHAPPELIJK ONDERZOEK TNO, MULTIPLE CLASS, (INT. CLS. 9, 35 AND 42), (U.S. CLS. 21, 23, 26, 36, 38, 100, 101 AND 102). SN 79-096,866. PUB. 3-20-2012. FILED 4-7-2011.
- 4,152,251. **FOLLOW YOUR INSTINCT (STANDARD CHARACTER)**. MUSSA ADDIS, MULTIPLE CLASS, (INT. CLS. 9, 25 AND 41), (U.S. CLS. 21, 22, 23, 26, 36, 38, 39, 100, 101 AND 107). SN 79-097,006. PUB. 3-20-2012. FILED 4-4-2011.
- 4,152,257. **MOVE IN PURE POWERED BY CNR AND DESIGN**. COMPAGNIE NATIONALE DU RHÔNE, MULTIPLE CLASS, (INT. CLS. 9, 12, 39 AND 42), (U.S. CLS. 19, 21, 23, 26, 31, 35, 36, 38, 44, 100, 101 AND 105). SN 79-097,254. PUB. 3-20-2012. FILED 3-31-2011.
- 4,152,266. **GUARDIAN OF TIME (STANDARD CHARACTER)**. FONDATION DE LA HAUTE HORLOGERIE, MULTIPLE CLASS, (INT. CLS. 9, 16, 38 AND 41), (U.S. CLS. 2, 5, 21, 22, 23, 26, 29, 36, 37, 38, 50, 100, 101, 104 AND 107). SN 79-097,646. PUB. 3-20-2012. FILED 3-31-2011.
- 4,152,267. **FLYRINGE (STANDARD CHARACTER)**. WEIBEL CDS AG, MULTIPLE CLASS, (INT. CLS. 9 AND 10), (U.S. CLS. 21, 23, 26, 36, 38, 39 AND 44). SN 79-097,654. PUB. 3-20-2012. FILED 4-21-2011.
- 4,152,274. **BIM QUICKSCAN (STANDARD CHARACTER)**. NEDERLANDSE ORGANISATIE VOOR TOEGEPAST-NATUURWETENSCHAPPELIJK ONDERZOEK TNO, MULTIPLE CLASS, (INT. CLS. 9, 16 AND 42), (U.S. CLS. 2, 5, 21, 22, 23, 26, 29, 36, 37, 38, 50, 100 AND 101). SN 79-098,000. PUB. 3-20-2012. FILED 4-7-2011.
- 4,152,279. **POINT (STANDARD CHARACTER)**. SEAWELL LIMITED, MULTIPLE CLASS, (INT. CLS. 9, 37 AND 42), (U.S. CLS. 21, 23, 26, 36, 38, 100, 101, 103 AND 106). SN 79-098,121. PUB. 3-20-2012. FILED 12-16-2010.
- 4,152,282. **CRYSTAL CLEAR SOUND AND DESIGN**. KONINKLIJKE PHILIPS ELECTRONICS N.V., (U.S. CLS. 21, 23, 26, 36 AND 38). SN 79-098,235. PUB. 3-20-2012. FILED 5-24-2011.
- 4,152,286. **INSPIRE AND DESIGN**. GMC SOFTWARE AG, MULTIPLE CLASS, (INT. CLS. 9, 38 AND 42), (U.S. CLS. 21, 23, 26, 36, 38, 100, 101 AND 104). SN 79-098,407. PUB. 3-20-2012. FILED 5-13-2011.
- 4,152,289. **458 ITALIA (STYLIZED)**. FERRARI S.P.A., MULTIPLE CLASS, (INT. CLS. 9, 12, 16, 18, 25, 28 AND 35), (U.S. CLS. 1, 2, 3, 5, 19, 21, 22, 23, 26, 29, 31, 35, 36, 37, 38, 39, 41, 44, 50, 100, 101 AND 102). SN 79-098,423. PUB. 3-20-2012. FILED 12-22-2009.
- 4,152,290. **SWITCHALIVE (STANDARD CHARACTER)**. TRÖNDERENERGI NETT AS, MULTIPLE CLASS, (INT. CLS. 9, 37 AND 42), (U.S. CLS. 21, 23, 26, 36, 38, 100, 101, 103 AND 106). SN 79-098,446. PUB. 3-20-2012. FILED 2-8-2011.
- 4,152,301. **BEKO AIRAUDIT (STANDARD CHARACTER)**. BEKO TECHNOLOGIES GMBH, MULTIPLE CLASS, (INT. CLS. 9, 37 AND 42), (U.S. CLS. 21, 23, 26, 36, 38, 100, 101, 103 AND 106). SN 79-098,717. PUB. 3-20-2012. FILED 4-4-2011.
- 4,152,302. **JOLICLOUD (STANDARD CHARACTER)**. JOLICLOUD, MULTIPLE CLASS, (INT. CLS. 9, 35, 38 AND 42), (U.S. CLS. 21, 23, 26, 36, 38, 100, 101, 102 AND 104). SN 79-098,763. PUB. 3-20-2012. FILED 2-22-2011.
- 4,152,306. **BARÇA (STANDARD CHARACTER)**. FUTBOL CLUB BARCELONA, MULTIPLE CLASS, (INT. CLS. 9 AND 38), (U.S. CLS. 21, 23, 26, 36, 38, 100, 101 AND 104). SN 79-098,878. PUB. 3-20-2012. FILED 1-11-2011.
- 4,152,308. **BIOLOG-ID (STANDARD CHARACTER)**. BIOLOG-ID, MULTIPLE CLASS, (INT. CLS. 9 AND 42), (U.S. CLS. 21, 23, 26, 36, 38, 100 AND 101). SN 79-098,941. PUB. 3-20-2012. FILED 4-26-2011.
- 4,152,309. **NGM (STANDARD CHARACTER)**. NGM ITALIA S.R.L., (U.S. CLS. 21, 23, 26, 36 AND 38). SN 79-098,956. PUB. 3-20-2012. FILED 5-18-2011.
- 4,152,314 (*See Class 7 for this trademark*).
- 4,152,316. **STUDIO HAMBURG DOCLIGHTS (STANDARD CHARACTER)**. STUDIO HAMBURG DOCLIGHTS GMBH, MULTIPLE CLASS, (INT. CLS. 9, 35, 38, 40, 41 AND 45), (U.S. CLS. 21, 23, 26, 36, 38, 100, 101, 102, 103, 104, 106 AND 107). SN 79-099,338. PUB. 3-20-2012. FILED 3-3-2011.
- 4,152,318. **SPEDELIA (STYLIZED)**. ALSTOM, MULTIPLE CLASS, (INT. CLS. 9, 12, 37 AND 39), (U.S. CLS. 19, 21, 23, 26, 31, 35, 36, 38, 44, 100, 103, 105 AND 106). SN 79-099,423. PUB. 3-20-2012. FILED 2-4-2011.
- 4,152,319. **CL COMPANION (STANDARD CHARACTER)**. SWAROVSKI-OPTIK KG, (U.S. CLS. 21, 23, 26, 36 AND 38). SN 79-099,508. PUB. 3-20-2012. FILED 4-28-2011.
- 4,152,323. **EVOLIS PREMIUM SUITE (STYLIZED)**. EVOLIS, MULTIPLE CLASS, (INT. CLS. 9 AND 37), (U.S. CLS. 21, 23, 26, 36, 38, 100, 103 AND 106). SN 79-099,602. PUB. 3-20-2012. FILED 6-6-2011.
- 4,152,332. **PP PIERRE PETIT (STYLIZED)**. JACQUES LEMANS GESMBH, MULTIPLE CLASS, (INT. CLS. 9, 14 AND 16), (U.S. CLS. 2, 5, 21, 22, 23, 26, 27, 28, 29, 36, 37, 38 AND 50). SN 79-099,821. PUB. 3-20-2012. FILED 5-25-2011.
- 4,152,341 (*See Class 6 for this trademark*).
- 4,152,350. **MISCELLANEOUS DESIGN**. FIAT GROUP AUTOMOBILES S.P.A., MULTIPLE CLASS, (INT. CLS. 9, 12 AND 38), (U.S. CLS. 19, 21, 23, 26, 31, 35, 36, 38, 44, 100, 101 AND 104). SN 79-100,571. PUB. 3-20-2012. FILED 6-17-2010.
- 4,152,351. **BLUE&ME (STANDARD CHARACTER)**. FIAT GROUP AUTOMOBILES S.P.A., MULTIPLE CLASS, (INT. CLS. 9, 12 AND 38), (U.S. CLS. 19, 21, 23, 26, 31, 35, 36, 38, 44, 100, 101 AND 104). SN 79-100,572. PUB. 3-20-2012. FILED 6-17-2010.
- 4,152,352. **YALER (STANDARD CHARACTER)**. YALER GMBH, (U.S. CLS. 21, 23, 26, 36 AND 38). SN 79-100,669. PUB. 3-20-2012. FILED 7-6-2011.
- 4,152,357. **QUICKSTEP (STANDARD CHARACTER)**. DOMINO PRINTING SCIENCES PLC, (U.S. CLS. 21, 23, 26, 36 AND 38). SN 79-101,030. PUB. 3-20-2012. FILED 6-27-2011.
- 4,152,362. **MISCELLANEOUS DESIGN**. HELD GMBH, MULTIPLE CLASS, (INT. CLS. 9, 12 AND 25), (U.S. CLS. 19, 21, 22, 23, 26, 31, 35, 36, 38, 39 AND 44). SN 79-101,207. PUB. 3-20-2012. FILED 5-20-2011.
- 4,152,367. **IOPENER INSTITUTE IOPENER INSTITUTE FOR PEOPLE & PERFORMANCE AND DESIGN**. IOPENER HOLDINGS LIMITED, MULTIPLE CLASS, (INT. CLS. 9, 16, 35, 41, 42 AND 45), (U.S. CLS. 2, 5, 21, 22, 23, 26, 29, 36, 37, 38, 50, 100, 101, 102 AND 107). SN 79-101,889. PUB. 3-20-2012. FILED 4-26-2011.
- 4,152,382 (*See Class 7 for this trademark*).
- 4,152,395 (*See Class 7 for this trademark*).
- 4,152,406. **DURIS (STANDARD CHARACTER)**. OSRAM AG, MULTIPLE CLASS, (INT. CLS. 9 AND 11), (U.S. CLS. 13, 21, 23, 26, 31, 34, 36 AND 38). SN 79-104,206. PUB. 3-20-2012. FILED 9-14-2011.
- 4,152,408. **ERNI WOR&D (STANDARD CHARACTER)**. ERNI ELECTRONICS GMBH, MULTIPLE CLASS, (INT. CLS. 9, 17, 35, 37, 40 AND 42), (U.S. CLS. 1, 5, 12, 13, 21, 23, 26, 35, 36, 38, 50, 100, 101, 102, 103 AND 106). SN 79-104,283. PUB. 3-20-2012. FILED 7-21-2011.
- 4,152,415. **3RB (STANDARD CHARACTER)**. SIEMENS AKTIENGESELLSCHAFT, (U.S. CLS. 21, 23, 26, 36 AND 38). SN 79-104,747. PUB. 2-14-2012. FILED 8-9-2010.
- 4,152,417. **NABTO (STANDARD CHARACTER)**. NABTO APS, (U.S. CLS. 21, 23, 26, 36 AND 38). SN 79-104,997. PUB. 3-20-2012. FILED 10-18-2011.
- 4,152,421. **VT (STANDARD CHARACTER)**. MASCHINEN-FABRIK REINHAUSEN GMBH, (U.S. CLS. 21, 23, 26, 36 AND 38). SN 79-105,095. PUB. 3-20-2012. FILED 7-20-2011.
- 4,152,422. **WINDGUARD (STANDARD CHARACTER)**. GN RESOUND A/S, (U.S. CLS. 21, 23, 26, 36 AND 38). SN 79-105,205. PUB. 3-20-2012. FILED 8-20-2011.
- 4,152,423. **LEDULAR (STANDARD CHARACTER)**. OSRAM AG, MULTIPLE CLASS, (INT. CLS. 9 AND 11), (U.S. CLS.

- 13, 21, 23, 26, 31, 34, 36 AND 38). SN 79-105,312. PUB. 3-20-2012. FILED 8-17-2011.
- 4,152,426. **TRUSTEDSAFE (STANDARD CHARACTER)**. EGOV CONSULTING AND DEVELOPMENT GMBH, MULTIPLE CLASS, (INT. CLS. 9, 38 AND 42), (U.S. CLS. 21, 23, 26, 36, 38, 100, 101 AND 104). SN 79-105,564. PUB. 3-20-2012. FILED 11-15-2010.
- 4,152,428. **LINKED4 (STYLIZED)**. UNIT4; BUSINESS SOFTWARE HOLDING B.V., MULTIPLE CLASS, (INT. CLS. 9 AND 42), (U.S. CLS. 21, 23, 26, 36, 38, 100 AND 101). SN 79-106,006. PUB. 3-20-2012. FILED 8-3-2011.
- 4,152,433. **TRACK IQ (STANDARD CHARACTER)**. TRACKSIDE INTELLIGENCE PTY LTD, MULTIPLE CLASS, (INT. CLS. 9 AND 37), (U.S. CLS. 21, 23, 26, 36, 38, 100, 103 AND 106). SN 79-106,705. PUB. 3-20-2012. FILED 8-17-2011.
- 4,152,434. **CONTROLMEC (STANDARD CHARACTER)**. MEC A/S, MULTIPLE CLASS, (INT. CLS. 9, 37 AND 42), (U.S. CLS. 21, 23, 26, 36, 38, 100, 101, 103 AND 106). SN 79-107,121. PUB. 3-20-2012. FILED 10-18-2011.
- 4,152,437. **CLOPV AND DESIGN**. SHANXI CHUANGLING PHOTOVOLTAIC; ELECTRIC CO. LTD., (U.S. CLS. 21, 23, 26, 36 AND 38). SN 79-107,658. PUB. 3-20-2012. FILED 8-26-2011.
- 4,152,440. **PANTA (STANDARD CHARACTER)**. SUMIDA FLEXIBLE CONNECTIONS GMBH, (U.S. CLS. 21, 23, 26, 36 AND 38). SN 85-006,649. PUB. 3-20-2012. FILED 4-5-2010.
- 4,152,448. **SILKSCREEN (STANDARD CHARACTER)**. LG ELECTRONICS INC., (U.S. CLS. 21, 23, 26, 36 AND 38). SN 85-035,323. PUB. 3-20-2012. FILED 5-11-2010.
- 4,152,449. **NANO SILKSCREEN (STANDARD CHARACTER)**. LG ELECTRONICS INC., (U.S. CLS. 21, 23, 26, 36 AND 38). SN 85-035,348. PUB. 3-20-2012. FILED 5-11-2010.
- 4,152,459. **MICROCLAR (STANDARD CHARACTER)**. MEYER, MATIAS, AND MEYER, ALEJANDRO, (U.S. CLS. 21, 23, 26, 36 AND 38). SN 85-049,087. PUB. 3-20-2012. FILED 5-27-2010.
- 4,152,461 (*See Class 6 for this trademark*).
- 4,152,465. **THE HARTFORD | MOBILE (STANDARD CHARACTER)**. HARTFORD FIRE INSURANCE COMPANY, (U.S. CLS. 21, 23, 26, 36 AND 38). SN 85-070,410. PUB. 3-20-2012. FILED 6-24-2010.
- 4,152,466. **THE HARTFORD MOBILE (STANDARD CHARACTER)**. HARTFORD FIRE INSURANCE COMPANY, (U.S. CLS. 21, 23, 26, 36 AND 38). SN 85-070,412. PUB. 3-20-2012. FILED 6-24-2010.
- 4,152,471. **SUNSEP (STANDARD CHARACTER)**. AGC ENGINEERING CO., LTD., MULTIPLE CLASS, (INT. CLS. 9, 10 AND 11), (U.S. CLS. 13, 21, 23, 26, 31, 34, 36, 38, 39 AND 44). SN 85-082,484. PUB. 1-17-2012. FILED 7-12-2010.
- 4,152,473. **BUST A MOVE FOR BREAST HEALTH (STANDARD CHARACTER)**. THE TRUSTEES OF THE QUEEN ELIZABETH II HEALTH SCIENCES CENTRE FOUNDATION, MULTIPLE CLASS, (INT. CLS. 9, 14, 16, 18, 20, 21, 25, 28, 36 AND 41), (U.S. CLS. 1, 2, 3, 5, 13, 21, 22, 23, 25, 26, 27, 28, 29, 30, 32, 33, 36, 37, 38, 39, 40, 41, 50, 100, 101, 102 AND 107). SN 85-085,652. PUB. 1-31-2012. FILED 7-15-2010.
- 4,152,488. **SACA TECHNOLOGIES AND DESIGN**. SACA TECHNOLOGIES, INC., MULTIPLE CLASS, (INT. CLS. 9 AND 42), (U.S. CLS. 21, 23, 26, 36, 38, 100 AND 101). SN 85-103,652. PUB. 3-20-2012. FILED S.R. 8-9-2010; AM. P.R. 8-9-2010.
- 4,152,491. **ROCKET MATH (STANDARD CHARACTER)**. R & D INSTRUCTIONAL SOLUTIONS LLC, MULTIPLE CLASS, (INT. CLS. 9 AND 16), (U.S. CLS. 2, 5, 21, 22, 23, 26, 29, 36, 37, 38 AND 50). SN 85-108,361. PUB. 3-20-2012. FILED 8-16-2010.
- 4,152,493. **DOT NET WORKFLOW (STANDARD CHARACTER)**. PARKER, PATRICK, (U.S. CLS. 21, 23, 26, 36 AND 38). SN 85-110,889. PUB. 3-20-2012. FILED 8-19-2010.
- 4,152,503 (*See Class 6 for this trademark*).
- 4,152,507 (*See Class 3 for this trademark*).
- 4,152,510. **NATIVE UNION AND DESIGN**. DESIGN POOL LIMITED, (U.S. CLS. 21, 23, 26, 36 AND 38). SN 85-122,578. PUB. 3-20-2012. FILED 9-3-2010.
- 4,152,529. **ENBALA POWER NETWORKS (STANDARD CHARACTER)**. ENBALA POWER NETWORKS INC., MULTIPLE CLASS, (INT. CLS. 9 AND 42), (U.S. CLS. 21, 23, 26, 36, 38, 100 AND 101). SN 85-136,979. PUB. 3-20-2012. FILED 9-23-2010.
- 4,152,534. **FLATRON SUPER IMAGE (STANDARD CHARACTER)**. LG ELECTRONICS INC., (U.S. CLS. 21, 23, 26, 36 AND 38). SN 85-143,275. PUB. 3-20-2012. FILED 10-1-2010.
- 4,152,549. **MISCALE (STYLIZED)**. MISCALE, LLC, (U.S. CLS. 21, 23, 26, 36 AND 38). SN 85-155,642. PUB. 3-20-2012. FILED 10-19-2010.
- 4,152,560. **MISCELLANEOUS DESIGN**. KIMPEX INC., MULTIPLE CLASS, (INT. CLS. 9 AND 25), (U.S. CLS. 21, 22, 23, 26, 36, 38 AND 39). SN 85-164,711. PUB. 3-20-2012. FILED 10-29-2010.
- 4,152,571. **WHITES THE COLD WATER SPECIALISTS SINCE 1956 AND DESIGN**. WHITES MANUFACTURING, LTD., MULTIPLE CLASS, (INT. CLS. 9 AND 25), (U.S. CLS. 21, 22, 23, 26, 36, 38 AND 39). SN 85-174,770. PUB. 3-20-2012. FILED 11-11-2010.
- 4,152,577. **MONDOLUX (STANDARD CHARACTER)**. HEINZ-JOSEF, KAPPE, MULTIPLE CLASS, (INT. CLS. 9 AND 11), (U.S. CLS. 13, 21, 23, 26, 31, 34, 36 AND 38). SN 85-184,959. PUB. 3-20-2012. FILED 11-24-2010.
- 4,152,584. **NEUWORLD AND DESIGN**. KIERIG, JEREMY, (U.S. CLS. 21, 23, 26, 36 AND 38). SN 85-190,624. PUB. 3-20-2012. FILED 12-3-2010.
- 4,152,587. **MISCELLANEOUS DESIGN**. ALIBABA GROUP HOLDING LIMITED, MULTIPLE CLASS, (INT. CLS. 9, 16, 35, 36, 38, 39, 41 AND 42), (U.S. CLS. 2, 5, 21, 22, 23, 26, 29, 36, 37, 38, 50, 100, 101, 102, 104, 105 AND 107). SN 85-197,737. PUB. 3-20-2012. FILED 12-14-2010.
- 4,152,596. **THUMBPASS AND DESIGN**. VENDMORE SYSTEMS, LLC, MULTIPLE CLASS, (INT. CLS. 9, 35 AND 38), (U.S. CLS. 21, 23, 26, 36, 38, 100, 101, 102 AND 104). SN 85-208,415. PUB. 3-20-2012. FILED 12-31-2010.
- 4,152,605. **NOTIFY TECHNOLOGY (STANDARD CHARACTER)**. NOTIFY TECHNOLOGY CORPORATION, (U.S. CLS. 21, 23, 26, 36 AND 38). SN 85-214,948. PUB. 3-20-2012. FILED 1-11-2011.
- 4,152,620. **HOBNOB ONLINE AND DESIGN**. SOURCECENTRIX, LLC, DBA HOBNOB ONLINE, (U.S. CLS. 21, 23, 26, 36 AND 38). SN 85-224,481. PUB. 3-20-2012. FILED 1-24-2011.
- 4,152,630 (*See Class 3 for this trademark*).
- 4,152,635. **PASSIVSYSTEMS AND DESIGN**. PASSIVSYSTEMS LIMITED, (U.S. CLS. 21, 23, 26, 36 AND 38). SN 85-240,976. PUB. 3-20-2012. FILED 2-13-2011.
- 4,152,636. **SPECTROVIAL (STANDARD CHARACTER)**. CHEMPLEX INDUSTRIES, INC., (U.S. CLS. 21, 23, 26, 36 AND 38). SN 85-241,330. PUB. 12-13-2011. FILED 2-14-2011.
- 4,152,643. **PROSHIP VELOCITY (STANDARD CHARACTER)**. BEST WAY TECHNOLOGIES, LLC, (U.S. CLS. 21, 23, 26, 36 AND 38). SN 85-246,735. PUB. 3-20-2012. FILED 2-18-2011.
- 4,152,646. **BSM BALANCE SHEET METHODOLOGY AND DESIGN**. WEALTH PLANNING TECHNOLOGY, LLC, (U.S. CLS. 21, 23, 26, 36 AND 38). SN 85-247,312. PUB. 3-20-2012. FILED 2-21-2011.
- 4,152,653. **TUFF KNUCKS (STANDARD CHARACTER)**. KRISTY LEWELLYN, AKA LEWELLYN SAFETY, (U.S. CLS. 21, 23, 26, 36 AND 38). SN 85-252,062. PUB. 3-20-2012. FILED S.R. 2-25-2011; AM. P.R. 7-26-2011.
- 4,152,658 (*See Class 1 for this trademark*).
- 4,152,668. **REEL SPINNER (STANDARD CHARACTER)**. HOLIDAY, LARRY R., (U.S. CLS. 21, 23, 26, 36 AND 38). SN 85-262,404. PUB. 3-20-2012. FILED 3-9-2011.
- 4,152,694. **THE BARMASTER (STANDARD CHARACTER)**. CLEAR-VIEW-TECHNOLOGIES INC., (U.S. CLS. 21, 23, 26, 36 AND 38). SN 85-276,996. PUB. 3-20-2012. FILED 3-25-2011.
- 4,152,695. **TII AND DESIGN**. TII NETWORK TECHNOLOGIES, INC., (U.S. CLS. 21, 23, 26, 36 AND 38). SN 85-277,957. PUB. 3-20-2012. FILED 3-26-2011.
- 4,152,703. **PROTECTSTAR WWW PROTECTSTAR COM AND DESIGN**. PROTECTSTAR, INC., (U.S. CLS. 21, 23, 26, 36 AND 38). SN 85-280,750. PUB. 3-20-2012. FILED 3-30-2011.
- 4,152,716. **INFOWATCH (STANDARD CHARACTER)**. INFODESK, INC., MULTIPLE CLASS, (INT. CLS. 9 AND 42), (U.S. CLS. 21, 23, 26, 36, 38, 100 AND 101). SN 85-286,225. PUB. 3-20-2012. FILED 4-5-2011.
- 4,152,718. **QUAXAR AND DESIGN**. QUAXAR.COM, INC., (U.S. CLS. 21, 23, 26, 36 AND 38). SN 85-286,863. PUB. 3-20-2012. FILED 4-5-2011.
- 4,152,731. **ATOMIC RECORDS (STANDARD CHARACTER)**.

- ATOMIC RECORDS INCORPORATED, (U.S. CLS. 21, 23, 26, 36 AND 38). SN 85-290,783. PUB. 3-20-2012. FILED 4-8-2011.
- 4,152,734. **DUTY POWER HIT AND DESIGN**. BULLET INTERNATIONAL, SA DE CV, (U.S. CLS. 21, 23, 26, 36 AND 38). SN 85-291,413. PUB. 3-20-2012. FILED 4-11-2011.
- 4,152,737. **MOO MOO MUSICA (STANDARD CHARACTER)**. MOO MOO MUSICA, LLC, DBA MOO MOO MUSICA, MULTIPLE CLASS, (INT. CLS. 9 AND 41), (U.S. CLS. 21, 23, 26, 36, 38, 100, 101 AND 107). SN 85-291,899. PUB. 3-20-2012. FILED 4-11-2011.
- 4,152,750 (*See Class 1 for this trademark*).
- 4,152,772. **PLUG-N-TOW (STANDARD CHARACTER)**. ETRAILER CORPORATION, MULTIPLE CLASS, (INT. CLS. 9 AND 12), (U.S. CLS. 19, 21, 23, 26, 31, 35, 36, 38 AND 44). SN 85-296,306. PUB. 3-20-2012. FILED 4-15-2011.
- 4,152,775. **IPRIZE AND DESIGN**. IPRIZE LLC, (U.S. CLS. 21, 23, 26, 36 AND 38). SN 85-297,009. PUB. 3-20-2012. FILED 4-16-2011.
- 4,152,784. **RES Q TIRE AND DESIGN**. JOSN ELECTRONIC CO., LTD., (U.S. CLS. 21, 23, 26, 36 AND 38). SN 85-297,354. PUB. 3-20-2012. FILED 4-18-2011.
- 4,152,787. **HORIZON HOBBY (STANDARD CHARACTER)**. HORIZON HOBBY, INC., MULTIPLE CLASS, (INT. CLS. 9 AND 28), (U.S. CLS. 21, 22, 23, 26, 36, 38 AND 50). SN 85-297,492. PUB. 3-20-2012. FILED 4-18-2011.
- 4,152,800. **APPRESPONSE XPERT (STANDARD CHARACTER)**. OPNET TECHNOLOGIES, INC., (U.S. CLS. 21, 23, 26, 36 AND 38). SN 85-298,925. PUB. 3-20-2012. FILED 4-19-2011.
- 4,152,801. **OCTOPUS JONES (STANDARD CHARACTER)**. CLAY CARLISLE, MULTIPLE CLASS, (INT. CLS. 9 AND 41), (U.S. CLS. 21, 23, 26, 36, 38, 100, 101 AND 107). SN 85-299,017. PUB. 3-20-2012. FILED 4-19-2011.
- 4,152,802. **FRATMEN (STANDARD CHARACTER)**. ICON-NEWMEDIA, INC., MULTIPLE CLASS, (INT. CLS. 9, 16, 38 AND 41), (U.S. CLS. 2, 5, 21, 22, 23, 26, 29, 36, 37, 38, 50, 100, 101, 104 AND 107). SN 85-299,101. PUB. 2-14-2012. FILED 4-19-2011.
- 4,152,811. **VERICOM (STANDARD CHARACTER)**. DUACARRIER ELECTRONICS TECHNOLOGY, INC., (U.S. CLS. 21, 23, 26, 36 AND 38). SN 85-300,106. PUB. 3-20-2012. FILED 4-20-2011.
- 4,152,813. **247 MUSIC LIBRARY AND DESIGN**. VANACORE MUSIC PUBLISHING, LLC, (U.S. CLS. 21, 23, 26, 36 AND 38). SN 85-300,416. PUB. 3-20-2012. FILED 4-20-2011.
- 4,152,825. **ANT AND DESIGN**. ANT PRECISION INDUSTRY CO., LTD, (U.S. CLS. 21, 23, 26, 36 AND 38). SN 85-302,063. PUB. 3-20-2012. FILED 4-22-2011.
- 4,152,826. **VTI (STANDARD CHARACTER)**. VTI GAMES LLC, (U.S. CLS. 21, 23, 26, 36 AND 38). SN 85-302,789. PUB. 3-20-2012. FILED 4-22-2011.
- 4,152,832. **ROAD READY VALUE RIGHT WWW.ROADREADYCASES.COM AND DESIGN**. CIPEX INTERNATIONAL LIMITED, (U.S. CLS. 21, 23, 26, 36 AND 38). SN 85-304,319. PUB. 3-20-2012. FILED 4-25-2011.
- 4,152,833. **INSTALERT (STANDARD CHARACTER)**. FLIR SYSTEMS, INC., (U.S. CLS. 21, 23, 26, 36 AND 38). SN 85-304,620. PUB. 3-20-2012. FILED 4-26-2011.
- 4,152,846. **AQUA LATCH (STANDARD CHARACTER)**. BOROWSKI, JASON, (U.S. CLS. 21, 23, 26, 36 AND 38). SN 85-306,477. PUB. 3-20-2012. FILED 4-27-2011.
- 4,152,855. **PA155 (STANDARD CHARACTER)**. COMMUNICATION DEVICES, INC., (U.S. CLS. 21, 23, 26, 36 AND 38). SN 85-308,010. PUB. 3-20-2012. FILED 4-29-2011.
- 4,152,856. **PA199 (STANDARD CHARACTER)**. COMMUNICATION DEVICES, INC., (U.S. CLS. 21, 23, 26, 36 AND 38). SN 85-308,017. PUB. 3-20-2012. FILED 4-29-2011.
- 4,152,873. **EYES OF ASIA (STANDARD CHARACTER)**. ARISTOCRAT TECHNOLOGIES AUSTRALIA PTY LTD., (U.S. CLS. 21, 23, 26, 36 AND 38). SN 85-312,010. PUB. 3-20-2012. FILED 5-4-2011.
- 4,152,879. **HORIZON H O B B Y AND DESIGN**. HORIZON HOBBY, INC., MULTIPLE CLASS, (INT. CLS. 9 AND 28), (U.S. CLS. 21, 22, 23, 26, 36, 38 AND 50). SN 85-313,158. PUB. 3-20-2012. FILED 5-5-2011.
- 4,152,889. **RADIAN (STANDARD CHARACTER)**. MANIFOLD SOFTWARE LIMITED, (U.S. CLS. 21, 23, 26, 36 AND 38). SN 85-315,477. PUB. 3-20-2012. FILED 5-9-2011.
- 4,152,904. **VXRGB (STANDARD CHARACTER)**. MITSUBISHI CHEMICAL CORPORATION, MULTIPLE CLASS, (INT. CLS. 9 AND 11), (U.S. CLS. 13, 21, 23, 26, 31, 34, 36 AND 38). SN 85-318,502. PUB. 3-20-2012. FILED 5-11-2011.
- 4,152,920. **WILCOXON RESEARCH (STANDARD CHARACTER)**. MEGGITT (MARYLAND), INC., AKA MEGGITT SENSING SYSTEMS, (U.S. CLS. 21, 23, 26, 36 AND 38). SN 85-323,105. PUB. 3-20-2012. FILED 5-17-2011.
- 4,152,927 (*See Class 7 for this trademark*).
- 4,152,934. **EXPERTS ACADEMY (STANDARD CHARACTER)**. THE BURCHARD GROUP LLC, MULTIPLE CLASS, (INT. CLS. 9, 16, 35 AND 41), (U.S. CLS. 2, 5, 21, 22, 23, 26, 29, 36, 37, 38, 50, 100, 101, 102 AND 107). SN 85-328,254. PUB. 3-20-2012. FILED 5-24-2011.
- 4,152,935. **EXPERTS ACADEMY AND DESIGN**. THE BURCHARD GROUP LLC, MULTIPLE CLASS, (INT. CLS. 9, 16, 35 AND 41), (U.S. CLS. 2, 5, 21, 22, 23, 26, 29, 36, 37, 38, 50, 100, 101, 102 AND 107). SN 85-328,292. PUB. 3-20-2012. FILED 5-24-2011.
- 4,152,937. **BRENDON BURCHARD (STANDARD CHARACTER)**. THE BURCHARD GROUP LLC, MULTIPLE CLASS, (INT. CLS. 9, 16, 35 AND 41), (U.S. CLS. 2, 5, 21, 22, 23, 26, 29, 36, 37, 38, 50, 100, 101, 102 AND 107). SN 85-328,401. PUB. 3-20-2012. FILED 5-24-2011.
- 4,152,946. **G-WERX (STANDARD CHARACTER)**. MILLENNIUM FITNESS LTD, DBA G-WERX, MULTIPLE CLASS, (INT. CLS. 9, 16, 25 AND 28), (U.S. CLS. 2, 5, 21, 22, 23, 26, 29, 36, 37, 38, 39 AND 50). SN 85-330,217. PUB. 3-20-2012. FILED 5-25-2011.
- 4,152,959. **INGEGRID (STANDARD CHARACTER)**. INGTEAM, S.A., (U.S. CLS. 21, 23, 26, 36 AND 38). SN 85-335,144. PUB. 3-20-2012. FILED 6-1-2011.
- 4,152,971. **VERSASTUDIO (STYLIZED)**. ROLAND DG CORPORATION, (U.S. CLS. 21, 23, 26, 36 AND 38). SN 85-338,077. PUB. 1-31-2012. FILED 6-3-2011.
- 4,152,973. **OPPORTUNITY, GONE MOBILE. (STANDARD CHARACTER)**. MOBUBBLE, INC, DBA MOBUBBLE, INC, (U.S. CLS. 21, 23, 26, 36 AND 38). SN 85-338,186. PUB. 3-20-2012. FILED 6-4-2011.
- 4,152,999. **COMPUTER CABANA (STANDARD CHARACTER)**. PERLSON, KIP, (U.S. CLS. 21, 23, 26, 36 AND 38). SN 85-347,182. PUB. 3-20-2012. FILED 6-15-2011.
- 4,153,010. **SUPERBOOSTER (STANDARD CHARACTER)**. LASTAR, INC., (U.S. CLS. 21, 23, 26, 36 AND 38). SN 85-349,665. PUB. 3-20-2012. FILED 6-17-2011.
- 4,153,039. **BIOVIGIL (STANDARD CHARACTER)**. BIOVIGIL HYGIENE TECHNOLOGIES, LLC, (U.S. CLS. 21, 23, 26, 36 AND 38). SN 85-360,377. PUB. 3-20-2012. FILED 6-30-2011.
- 4,153,047. **OA ONCOARRAY (STYLIZED)**. FUNDACION PARA LA INVESTIGACION BIOMEDICA DEL HOSPITAL UNIVERSITARIO LA PAZ, MULTIPLE CLASS, (INT. CLS. 9 AND 42), (U.S. CLS. 21, 23, 26, 36, 38, 100 AND 101). SN 85-363,107. PUB. 3-20-2012. FILED 7-5-2011.
- 4,153,049. **VAPP (STANDARD CHARACTER)**. CONDUITYV, LLC, (U.S. CLS. 21, 23, 26, 36 AND 38). SN 85-363,773. PUB. 3-20-2012. FILED 7-6-2011.
- 4,153,052. **IVIDENCE (STANDARD CHARACTER)**. IVIDENCE, MULTIPLE CLASS, (INT. CLS. 9, 35 AND 42), (U.S. CLS. 21, 23, 26, 36, 38, 100, 101 AND 102). SN 85-366,154. PUB. 3-20-2012. FILED 7-8-2011.
- 4,153,055. **SEE NO EVIL (STANDARD CHARACTER)**. ALEX AND ANI, INC., (U.S. CLS. 21, 23, 26, 36 AND 38). SN 85-367,383. PUB. 3-20-2012. FILED 7-10-2011.
- 4,153,057. **MISCELLANEOUS DESIGN**. ALEX AND ANI, INC., MULTIPLE CLASS, (INT. CLS. 9 AND 35), (U.S. CLS. 21, 23, 26, 36, 38, 100, 101 AND 102). SN 85-367,518. PUB. 3-20-2012. FILED 7-10-2011.
- 4,153,058. **ALEX AND ANI (STANDARD CHARACTER)**. ALEX AND ANI, INC., MULTIPLE CLASS, (INT. CLS. 9, 14 AND 35), (U.S. CLS. 2, 21, 23, 26, 27, 28, 36, 38, 50, 100, 101 AND 102). SN 85-367,523. PUB. 3-20-2012. FILED 7-10-2011.
- 4,153,075. **HARDCORE PAWN (STANDARD CHARACTER)**. COURTROOM TELEVISION NETWORK LLC, (U.S. CLS. 21, 23, 26, 36 AND 38). SN 85-373,824. PUB. 3-20-2012. FILED 7-18-2011.
- 4,153,081. **NETTRAINMENT AND DESIGN**. BSH BOSCH UND SIEMENS HAUSGERATE GMBH, MULTIPLE CLASS, (INT. CLS. 9, 35 AND 41), (U.S. CLS. 21, 23, 26, 36, 38, 100,

- 101, 102 AND 107). SN 85-376,039. PUB. 3-20-2012. FILED 7-20-2011.
- 4,153,083. **PEERS (STANDARD CHARACTER)**. SEYMOUR, JONATHAN C., (U.S. CLS. 21, 23, 26, 36 AND 38). SN 85-376,669. PUB. 3-20-2012. FILED 7-20-2011.
- 4,153,114. **SHOCKBOX (STANDARD CHARACTER)**. IMPAKT PROTECTIVE INC., (U.S. CLS. 21, 23, 26, 36 AND 38). SN 85-387,241. PUB. 3-20-2012. FILED 8-2-2011.
- 4,153,116. **GFUELCELL (STANDARD CHARACTER)**. PROCESS SYSTEMS ENTERPRISE LIMITED, MULTIPLE CLASS, (INT. CLS. 9 AND 42), (U.S. CLS. 21, 23, 26, 36, 38, 100 AND 101). SN 85-387,794. PUB. 1-3-2012. FILED 8-3-2011.
- 4,153,117. **GSOLIDS (STANDARD CHARACTER)**. PROCESS SYSTEMS ENTERPRISE LIMITED, MULTIPLE CLASS, (INT. CLS. 9 AND 42), (U.S. CLS. 21, 23, 26, 36, 38, 100 AND 101). SN 85-387,802. PUB. 1-3-2012. FILED 8-3-2011.
- 4,153,118. **GPOWER (STANDARD CHARACTER)**. PROCESS SYSTEMS ENTERPRISE LIMITED, MULTIPLE CLASS, (INT. CLS. 9 AND 42), (U.S. CLS. 21, 23, 26, 36, 38, 100 AND 101). SN 85-387,806. PUB. 1-3-2012. FILED 8-3-2011.
- 4,153,119. **GFLARE (STANDARD CHARACTER)**. PROCESS SYSTEMS ENTERPRISE LIMITED, MULTIPLE CLASS, (INT. CLS. 9 AND 42), (U.S. CLS. 21, 23, 26, 36, 38, 100 AND 101). SN 85-387,808. PUB. 1-3-2012. FILED 8-3-2011.
- 4,153,120. **GCRYSTAL (STANDARD CHARACTER)**. PROCESS SYSTEMS ENTERPRISE LIMITED, MULTIPLE CLASS, (INT. CLS. 9 AND 42), (U.S. CLS. 21, 23, 26, 36, 38, 100 AND 101). SN 85-387,812. PUB. 1-3-2012. FILED 8-3-2011.
- 4,153,135. **EXCELERATOR (STANDARD CHARACTER)**. MARSHALL EXCELSIOR COMPANY, (U.S. CLS. 21, 23, 26, 36 AND 38). SN 85-392,192. PUB. 3-20-2012. FILED 8-8-2011.
- 4,153,176. **KNOWLEDGE CANDY MEDIA (STANDARD CHARACTER)**. KNOWLEDGE CANDY MEDIA, (U.S. CLS. 21, 23, 26, 36 AND 38). SN 85-401,541. PUB. 3-20-2012. FILED 8-18-2011.
- 4,153,189. **FRACTAL DESIGN AND DESIGN**. FD SWEDEN AB, (U.S. CLS. 21, 23, 26, 36 AND 38). SN 85-404,465. PUB. 3-20-2012. FILED 8-23-2011.
- 4,153,203. **DEMOCRACY SUITE (STANDARD CHARACTER)**. DOMINION VOTING SYSTEMS, INC., (U.S. CLS. 21, 23, 26, 36 AND 38). SN 85-407,749. PUB. 3-20-2012. FILED 8-25-2011.
- 4,153,208. **DOW JONES (STANDARD CHARACTER)**. DOW JONES TRADEMARK HOLDINGS LLC, (U.S. CLS. 21, 23, 26, 36 AND 38). SN 85-408,452. PUB. 3-20-2012. FILED 8-26-2011.
- 4,153,220 (*See Class 5 for this trademark*).
- 4,153,227. **MATERIAL EDGE (STANDARD CHARACTER)**. V-MODA, (U.S. CLS. 21, 23, 26, 36 AND 38). SN 85-412,160. PUB. 3-20-2012. FILED 8-31-2011.
- 4,153,231. **SAPPHIRE EDGE HD2 (STANDARD CHARACTER)**. SAPPHIRE TECHNOLOGY LTD., (U.S. CLS. 21, 23, 26, 36 AND 38). SN 85-412,848. PUB. 3-20-2012. FILED 9-1-2011.
- 4,153,246. **GRAFFITI FONTS (STANDARD CHARACTER)**. NAPOLITANO MATTHEW J, DBA HIGHGROUND INDUSTRIES, (U.S. CLS. 21, 23, 26, 36 AND 38). SN 85-414,800. PUB. 3-20-2012. FILED 9-3-2011.
- 4,153,269. **EIGENSTUDIO (STANDARD CHARACTER)**. MH ACOUSTICS, LLC, (U.S. CLS. 21, 23, 26, 36 AND 38). SN 85-418,013. PUB. 3-20-2012. FILED 9-8-2011.
- 4,153,278. **CATCH HIM & KEEP HIM (STANDARD CHARACTER)**. PAGAN, EBEN, (U.S. CLS. 21, 23, 26, 36 AND 38). SN 85-419,572. PUB. 3-20-2012. FILED 9-10-2011.
- 4,153,304. **PARTS PEOPLE (STANDARD CHARACTER)**. PARTS-PEOPLE.COM, INC., (U.S. CLS. 21, 23, 26, 36 AND 38). SN 85-422,282. PUB. 3-20-2012. FILED 9-14-2011.
- 4,153,314. **OPTIMA WAXPLUS (STANDARD CHARACTER)**. MACHEREY-NAGEL & CO. HANDELSGESELLSCHAFT, DBA MACHEREY-NAGEL, (U.S. CLS. 21, 23, 26, 36 AND 38). SN 85-423,144. PUB. 3-20-2012. FILED 9-15-2011.
- 4,153,324. **DTT AND DESIGN**. DRIVE THRU TECHNOLOGY, INC., MULTIPLE CLASS, (INT. CLS. 9 AND 42), (U.S. CLS. 21, 23, 26, 36, 38, 100 AND 101). SN 85-423,598. PUB. 3-20-2012. FILED 9-15-2011.
- 4,153,332. **EAGLE ATM (STANDARD CHARACTER)**. EAGLE ATM, LLC, AKA EAGLE ATM, (U.S. CLS. 21, 23, 26, 36 AND 38). SN 85-424,239. PUB. 3-20-2012. FILED 9-16-2011.
- 4,153,336. **THIS SPOT (STANDARD CHARACTER)**. BEETLE-FARM, LLC, DBA CUBAN COUNCIL, (U.S. CLS. 21, 23, 26, 36 AND 38). SN 85-424,682. PUB. 3-20-2012. FILED 9-16-2011.
- 4,153,363. **PIPEHORN (STANDARD CHARACTER)**. UTILITY TOOL COMPANY, INC., (U.S. CLS. 21, 23, 26, 36 AND 38). SN 85-427,977. PUB. 3-20-2012. FILED 9-21-2011.
- 4,153,367. **ZAXCOM (STANDARD CHARACTER)**. ZAXCOM, INC., (U.S. CLS. 21, 23, 26, 36 AND 38). SN 85-428,406. PUB. 3-20-2012. FILED 9-21-2011.
- 4,153,375. **NINEVEH (STANDARD CHARACTER)**. MORRIS, RUFUS, (U.S. CLS. 21, 23, 26, 36 AND 38). SN 85-429,116. PUB. 3-20-2012. FILED 9-22-2011.
- 4,153,402. **DURALIFE (STANDARD CHARACTER)**. CARL ZEISS VISION GMBH, (U.S. CLS. 21, 23, 26, 36 AND 38). SN 85-430,922. PUB. 3-20-2012. FILED 9-23-2011.
- 4,153,406. **UNIALARM AND DESIGN**. UNITED TECHNOLOGY ALLIANCE INC., (U.S. CLS. 21, 23, 26, 36 AND 38). SN 85-431,363. PUB. 3-20-2012. FILED 9-25-2011.
- 4,153,419. **FRIENDLY SONGS (STANDARD CHARACTER)**. KMCONSOLIDATED, LLC, (U.S. CLS. 21, 23, 26, 36 AND 38). SN 85-432,497. PUB. 3-20-2012. FILED 9-27-2011.
- 4,153,423. **XTRABACKUP AND DESIGN**. PERCONA, INC., (U.S. CLS. 21, 23, 26, 36 AND 38). SN 85-432,596. PUB. 3-20-2012. FILED 9-27-2011.
- 4,153,424. **RECURSION (STANDARD CHARACTER)**. RECURSION VENTURES, MULTIPLE CLASS, (INT. CLS. 9 AND 42), (U.S. CLS. 21, 23, 26, 36, 38, 100 AND 101). SN 85-432,829. PUB. 3-20-2012. FILED 9-27-2011.
- 4,153,428. **BOOM WIRELESS (STANDARD CHARACTER)**. ZIYA BUSINESS INC, DBA Z-CELL, (U.S. CLS. 21, 23, 26, 36 AND 38). SN 85-433,578. PUB. 3-20-2012. FILED 9-27-2011.
- 4,153,435. **PITTSBURGH MARATHON (STANDARD CHARACTER)**. PITTSBURGH THREE RIVERS MARATHON, INC., MULTIPLE CLASS, (INT. CLS. 9, 14, 16, 18, 21 AND 25), (U.S. CLS. 1, 2, 3, 5, 13, 21, 22, 23, 26, 27, 28, 29, 30, 33, 36, 37, 38, 39, 40, 41 AND 50). SN 85-434,127. PUB. 3-20-2012. FILED 9-28-2011.
- 4,153,436. **LAPRAFT (STANDARD CHARACTER)**. RICH, TIMOTHY C., (U.S. CLS. 21, 23, 26, 36 AND 38). SN 85-434,201. PUB. 3-20-2012. FILED 9-28-2011.
- 4,153,437. **217 FILMS (STANDARD CHARACTER)**. A.E.M. HOLDINGS LTD., (U.S. CLS. 21, 23, 26, 36 AND 38). SN 85-434,252. PUB. 3-20-2012. FILED 9-28-2011.
- 4,153,438. **217 RECORDS (STANDARD CHARACTER)**. A.E.M. HOLDINGS LTD., (U.S. CLS. 21, 23, 26, 36 AND 38). SN 85-434,269. PUB. 3-20-2012. FILED 9-28-2011.
- 4,153,440. **PAINTED NEIGHBORS (STANDARD CHARACTER)**. COLE, ANDREW, (U.S. CLS. 21, 23, 26, 36 AND 38). SN 85-434,294. PUB. 3-20-2012. FILED 9-28-2011.
- 4,153,447. **ILOUNGE (STANDARD CHARACTER)**. ILOUNGE, INC., (U.S. CLS. 21, 23, 26, 36 AND 38). SN 85-434,528. PUB. 3-20-2012. FILED 9-28-2011.
- 4,153,465. **DECISION SIMULATION VIRTUAL CASES. REAL RESULTS. AND DESIGN**. DECISION SIMULATION, LLC, (U.S. CLS. 21, 23, 26, 36 AND 38). SN 85-435,679. PUB. 3-20-2012. FILED 9-29-2011.
- 4,153,469. **WORKFORWARD CENTER (STANDARD CHARACTER)**. MÉTIER, LTD., MULTIPLE CLASS, (INT. CLS. 9 AND 42), (U.S. CLS. 21, 23, 26, 36, 38, 100 AND 101). SN 85-435,801. PUB. 3-20-2012. FILED 9-29-2011.
- 4,153,470. **BLACK & WHITE SEVENS (STANDARD CHARACTER)**. BALLY GAMING, INC., DBA BALLY TECHNOLOGIES, (U.S. CLS. 21, 23, 26, 36 AND 38). SN 85-435,857. PUB. 3-20-2012. FILED 9-29-2011.
- 4,153,472. **LESLIE NIELSEN (STANDARD CHARACTER)**. 2ND BEST LLC, (U.S. CLS. 21, 23, 26, 36 AND 38). SN 85-435,912. PUB. 3-20-2012. FILED 9-29-2011.
- 4,153,480. **THE LOVE BOAT (STANDARD CHARACTER)**. AARON SPELLING PRODUCTIONS INC., (U.S. CLS. 21, 23, 26, 36 AND 38). SN 85-436,154. PUB. 3-20-2012. FILED 9-30-2011.
- 4,153,501. **NATUS (STANDARD CHARACTER)**. NATUS MEDICAL INCORPORATED, MULTIPLE CLASS, (INT. CLS. 9 AND 10), (U.S. CLS. 21, 23, 26, 36, 38, 39 AND 44). SN 85-437,060. PUB. 3-20-2012. FILED 9-30-2011.
- 4,153,504. **FIN-MAN (STANDARD CHARACTER)**. GLOBAL PROMOTIONS, INC., MULTIPLE CLASS, (INT. CLS. 9 AND 45), (U.S. CLS. 21, 23, 26, 36, 38, 100 AND 101). SN 85-

- 437,142. PUB. 3-20-2012. FILED 10-1-2011.
- 4,153,520. **PRIVATE PLANROOM PLUS (STANDARD CHARACTER)**, THE BUILDERS EXCHANGE, INC., (U.S. CLS. 21, 23, 26, 36 AND 38). SN 85-437,611. PUB. 3-20-2012. FILED 10-3-2011.
- 4,153,543. **SMART RIDE (STANDARD CHARACTER)**, CODEMASS, INC., (U.S. CLS. 21, 23, 26, 36 AND 38). SN 85-438,139. PUB. 3-20-2012. FILED 10-3-2011.
- 4,153,558. **HIPERPAV (STANDARD CHARACTER)**, THE TRANSTEC GROUP, INC., (U.S. CLS. 21, 23, 26, 36 AND 38). SN 85-438,575. PUB. 3-20-2012. FILED 10-4-2011.
- 4,153,569. **JQUERY (STANDARD CHARACTER)**, SOFTWARE FREEDOM CONSERVANCY, (U.S. CLS. 21, 23, 26, 36 AND 38). SN 85-438,842. PUB. 3-20-2012. FILED 10-4-2011.
- 4,153,583. **CUBESERV (STANDARD CHARACTER)**, SECTOR 42 TECHNOLOGIES INC., (U.S. CLS. 21, 23, 26, 36 AND 38). SN 85-439,258. PUB. 3-20-2012. FILED 10-4-2011.
- 4,153,584. **CUBESTOR (STANDARD CHARACTER)**, SECTOR 42 TECHNOLOGIES INC., (U.S. CLS. 21, 23, 26, 36 AND 38). SN 85-439,265. PUB. 3-20-2012. FILED 10-4-2011.
- 4,153,585. **CUBEWERX (STANDARD CHARACTER)**, SECTOR 42 TECHNOLOGIES INC., (U.S. CLS. 21, 23, 26, 36 AND 38). SN 85-439,270. PUB. 3-20-2012. FILED 10-4-2011.
- 4,153,598. **TOUCHPURE (STANDARD CHARACTER)**, COX, THOMAS M., (U.S. CLS. 21, 23, 26, 36 AND 38). SN 85-439,548. PUB. 3-20-2012. FILED 10-5-2011.
- 4,153,606. **D DRIVE AND DESIGN**, STRICKLAND, RICHARD, D., (U.S. CLS. 21, 23, 26, 36 AND 38). SN 85-439,666. PUB. 3-20-2012. FILED 10-5-2011.
- 4,153,621. **CHIEF GREENBUD (STANDARD CHARACTER)**, HARNETT, SHAWN, MULTIPLE CLASS, (INT. CLS. 9 AND 25), (U.S. CLS. 21, 22, 23, 26, 36, 38 AND 39). SN 85-440,129. PUB. 3-20-2012. FILED 10-5-2011.
- 4,153,639. **CLOUDZOOKA (STANDARD CHARACTER)**, ZOOKAWARE, LLC, (U.S. CLS. 21, 23, 26, 36 AND 38). SN 85-440,616. PUB. 3-20-2012. FILED 10-6-2011.
- 4,153,641. **ZOOKIT (STANDARD CHARACTER)**, ZOOKAWARE, LLC, (U.S. CLS. 21, 23, 26, 36 AND 38). SN 85-440,645. PUB. 3-20-2012. FILED 10-6-2011.
- 4,153,642. **ESV (STANDARD CHARACTER)**, GOOD NEWS PUBLISHERS, (U.S. CLS. 21, 23, 26, 36 AND 38). SN 85-440,648. PUB. 3-20-2012. FILED 10-6-2011.
- 4,153,644. **REGZOOKA (STANDARD CHARACTER)**, ZOOKAWARE, LLC, (U.S. CLS. 21, 23, 26, 36 AND 38). SN 85-440,656. PUB. 3-20-2012. FILED 10-6-2011.
- 4,153,650. **SMARTBUY AND DESIGN**, PRODISC TECHNOLOGY INC., (U.S. CLS. 21, 23, 26, 36 AND 38). SN 85-440,761. PUB. 3-20-2012. FILED 10-6-2011.
- 4,153,657. **RHYTHMIC CIRCUS (STANDARD CHARACTER)**, RHYTHMIC CIRCUS, LLC., DBA RHYTHMIC CIRCUS, MULTIPLE CLASS, (INT. CLS. 9 AND 41), (U.S. CLS. 21, 23, 26, 36, 38, 100, 101 AND 107). SN 85-440,839. PUB. 3-20-2012. FILED 10-6-2011.
- 4,153,662. **J B AND DESIGN**, BERNARDO SHTEREMBERG, (U.S. CLS. 21, 23, 26, 36 AND 38). SN 85-440,898. PUB. 3-20-2012. FILED 10-6-2011.
- 4,153,678. **CHETA (STANDARD CHARACTER)**, COUNTRY HEDGING, INC., (U.S. CLS. 21, 23, 26, 36 AND 38). SN 85-441,126. PUB. 3-20-2012. FILED 10-6-2011.
- 4,153,691. **EVILEGGPLANT STUDIOS (STANDARD CHARACTER)**, EVILEGGPLANT STUDIOS SARL, (U.S. CLS. 21, 23, 26, 36 AND 38). SN 85-441,405. PUB. 3-20-2012. FILED 10-6-2011.
- 4,153,692. **MISCELLANEOUS DESIGN**, EVILEGGPLANT STUDIOS SARL, (U.S. CLS. 21, 23, 26, 36 AND 38). SN 85-441,409. PUB. 3-20-2012. FILED 10-6-2011.
- 4,153,695. **VEHAWK TAKING SAFETY MOBILE AND DESIGN**, CARMAN DEV GROUP LLC - VEHAWK SERIES, (U.S. CLS. 21, 23, 26, 36 AND 38). SN 85-441,432. PUB. 3-20-2012. FILED 10-6-2011.
- 4,153,697. **NEW ENDIAN AND DESIGN**, NEW ENDIAN LLC, DBA NEW ENDIAN, (U.S. CLS. 21, 23, 26, 36 AND 38). SN 85-441,478. PUB. 3-20-2012. FILED S.R. 10-6-2011; AM. P.R. 10-6-2011.
- 4,153,730. **NAME YOUR PRICE AND DESIGN**, PRICE WAITER, LLC, (U.S. CLS. 21, 23, 26, 36 AND 38). SN 85-441,811. PUB. 3-20-2012. FILED 10-7-2011.
- 4,153,762. **POWER INSIDE AND DESIGN**, SAMYA TECHNOLOGY CO., LTD., (U.S. CLS. 21, 23, 26, 36 AND 38). SN 85-442,183. PUB. 3-20-2012. FILED 10-7-2011.
- 4,153,766. **CRITICAL CONNECT (STANDARD CHARACTER)**, CRITICAL MASS MEDIA, INC., (U.S. CLS. 21, 23, 26, 36 AND 38). SN 85-442,211. PUB. 3-20-2012. FILED 10-7-2011.
- 4,153,789. **STREAM LINE (STANDARD CHARACTER)**, LIVE EYEWEAR, INC., (U.S. CLS. 21, 23, 26, 36 AND 38). SN 85-442,460. PUB. 3-20-2012. FILED 10-7-2011.
- 4,153,792. **IMAGE (STANDARD CHARACTER)**, KLIPSCH GROUP, INC., (U.S. CLS. 21, 23, 26, 36 AND 38). SN 85-442,499. PUB. 3-20-2012. FILED 10-7-2011.
- 4,153,794. **MINI SLIM (STANDARD CHARACTER)**, LIVE EYEWEAR, INC., (U.S. CLS. 21, 23, 26, 36 AND 38). SN 85-442,507. PUB. 3-20-2012. FILED 10-7-2011.
- 4,153,798. **SLIM LINE (STANDARD CHARACTER)**, LIVE EYEWEAR, INC., (U.S. CLS. 21, 23, 26, 36 AND 38). SN 85-442,539. PUB. 3-20-2012. FILED 10-7-2011.
- 4,153,804. **WIDE LINE (STANDARD CHARACTER)**, LIVE EYEWEAR, INC., (U.S. CLS. 21, 23, 26, 36 AND 38). SN 85-442,594. PUB. 3-20-2012. FILED 10-7-2011.
- 4,153,811. **SOSBEACON (STANDARD CHARACTER)**, SOSBEACON INC., MULTIPLE CLASS, (INT. CLS. 9 AND 42), (U.S. CLS. 21, 23, 26, 36, 38, 100 AND 101). SN 85-442,696. PUB. 3-20-2012. FILED 10-7-2011.
- 4,153,827. **CACTI (STANDARD CHARACTER)**, CACTI GROUP, INC., (U.S. CLS. 21, 23, 26, 36 AND 38). SN 85-442,810. PUB. 3-20-2012. FILED 10-8-2011.
- 4,153,844. **REBEL MUSIC (STYLIZED)**, ASKARI, KWAME S., MULTIPLE CLASS, (INT. CLS. 9 AND 25), (U.S. CLS. 21, 22, 23, 26, 36, 38 AND 39). SN 85-442,958. PUB. 3-20-2012. FILED 10-9-2011.
- 4,153,848. **ANACREON (STANDARD CHARACTER)**, MOROMISATO, GEORGE, (U.S. CLS. 21, 23, 26, 36 AND 38). SN 85-443,091. PUB. 3-20-2012. FILED 10-10-2011.
- 4,153,857. **BRACHIOSAURUS (STANDARD CHARACTER)**, HEAVY MEDITATIONS, LLC, (U.S. CLS. 21, 23, 26, 36 AND 38). SN 85-443,137. PUB. 3-20-2012. FILED 10-10-2011.
- 4,153,858. **PEI (STYLIZED)**, PENNWELL CORPORATION, (U.S. CLS. 21, 23, 26, 36 AND 38). SN 85-443,138. PUB. 3-20-2012. FILED 10-10-2011.
- 4,153,894. **XYBOARD (STANDARD CHARACTER)**, CELCO PARTNERSHIP, DBA VERIZON WIRELESS, (U.S. CLS. 21, 23, 26, 36 AND 38). SN 85-443,497. PUB. 3-20-2012. FILED 10-10-2011.
- 4,153,897. **DYSE ONE (STANDARD CHARACTER)**, DEL RIO MARKETING, INC., (U.S. CLS. 21, 23, 26, 36 AND 38). SN 85-443,508. PUB. 3-20-2012. FILED 10-10-2011.
- 4,153,910. **ADX (STANDARD CHARACTER)**, BROCADE COMMUNICATIONS SYSTEMS, INC., (U.S. CLS. 21, 23, 26, 36 AND 38). SN 85-443,637. PUB. 3-20-2012. FILED 10-10-2011.
- 4,153,919. **VISION (STANDARD CHARACTER)**, AMERICAN AIMERS, INC., (U.S. CLS. 21, 23, 26, 36 AND 38). SN 85-443,800. PUB. 3-20-2012. FILED 10-10-2011.
- 4,153,924. **BEFIT (STANDARD CHARACTER)**, BEFIT COLLECTIVE LLC, (U.S. CLS. 21, 23, 26, 36 AND 38). SN 85-443,875. PUB. 3-20-2012. FILED 10-10-2011.
- 4,153,925. **PLATEME (STANDARD CHARACTER)**, PLATEME CORPORATION, (U.S. CLS. 21, 23, 26, 36 AND 38). SN 85-443,881. PUB. 3-20-2012. FILED 10-11-2011.
- 4,153,926. **JDS AND DESIGN**, CEN JIEQIANG, (U.S. CLS. 21, 23, 26, 36 AND 38). SN 85-443,884. PUB. 3-20-2012. FILED 10-11-2011.
- 4,153,930. **UNCLE SLAM (STANDARD CHARACTER)**, HANDELABRA STUDIO LLC, (U.S. CLS. 21, 23, 26, 36 AND 38). SN 85-443,983. PUB. 3-20-2012. FILED 10-11-2011.
- 4,153,933. **RETRO ON DEMAND AND DESIGN**, RETRO-FITNESS IP, LLC, (U.S. CLS. 21, 23, 26, 36 AND 38). SN 85-443,997. PUB. 3-20-2012. FILED 10-11-2011.
- 4,153,960. **PLANOMART (STANDARD CHARACTER)**, WOLVERT, TERRY D, (U.S. CLS. 21, 23, 26, 36 AND 38). SN 85-444,168. PUB. 3-20-2012. FILED 10-11-2011.
- 4,153,969. **DLX (STANDARD CHARACTER)**, HAVER ANALYTICS, INC., (U.S. CLS. 21, 23, 26, 36 AND 38). SN 85-444,266. PUB. 3-20-2012. FILED 10-11-2011.
- 4,153,971. **GLOBAL VILLAGE KIDS (STANDARD CHARACTER)**, GLOBAL VILLAGE KIDS, LLC, (U.S. CLS. 21, 23, 26, 36 AND 38). SN 85-444,276. PUB. 3-20-2012. FILED 10-11-

- 2011.
- 4,154,001. **MISCELLANEOUS DESIGN**. LION-WINE PTY LTD, MULTIPLE CLASS, (INT. CLS. 9, 33 AND 43), (U.S. CLS. 21, 23, 26, 36, 38, 47, 49, 100 AND 101). SN 85-444,599. PUB. 3-20-2012. FILED 10-11-2011.
- 4,154,002. **RDU (STANDARD CHARACTER)**. HPI, LLC, (U.S. CLS. 21, 23, 26, 36 AND 38). SN 85-444,610. PUB. 3-20-2012. FILED 10-11-2011.
- 4,154,003. **RNU (STANDARD CHARACTER)**. HPI, LLC, (U.S. CLS. 21, 23, 26, 36 AND 38). SN 85-444,616. PUB. 3-20-2012. FILED 10-11-2011.
- 4,154,007. **EMPAR (STYLIZED)**. LAPOINT BLASE IND. INC., DBA EWR WEATHER RADAR, (U.S. CLS. 21, 23, 26, 36 AND 38). SN 85-444,665. PUB. 3-20-2012. FILED 10-11-2011.
- 4,154,018. **1837 (STANDARD CHARACTER)**. TIFFANY (NJ) LLC, MULTIPLE CLASS, (INT. CLS. 9, 14, 16, 18, 21, 26, 28 AND 34), (U.S. CLS. 1, 2, 3, 5, 8, 9, 13, 17, 21, 22, 23, 26, 27, 28, 29, 30, 33, 36, 37, 38, 39, 40, 41, 42 AND 50). SN 85-444,796. PUB. 3-20-2012. FILED 10-11-2011.
- 4,154,022. **LENSTAR (STANDARD CHARACTER)**. ISGN CORPORATION, MULTIPLE CLASS, (INT. CLS. 9, 36 AND 42), (U.S. CLS. 21, 23, 26, 36, 38, 100, 101 AND 102). SN 85-444,814. PUB. 3-20-2012. FILED 10-11-2011.
- 4,154,025. **MV AND DESIGN**. MAGNATROL VALVE CORPORATION, (U.S. CLS. 21, 23, 26, 36 AND 38). SN 85-444,822. PUB. 3-20-2012. FILED 10-11-2011.
- 4,154,049. **SIDECOM (STANDARD CHARACTER)**. HILL-ROM SERVICES, INC., (U.S. CLS. 21, 23, 26, 36 AND 38). SN 85-445,555. PUB. 3-20-2012. FILED 10-12-2011.
- 4,154,054. **HYPERSTUDIO (STANDARD CHARACTER)**. THE SOFTWARE MACKIEV COMPANY, (U.S. CLS. 21, 23, 26, 36 AND 38). SN 85-445,666. PUB. 3-20-2012. FILED 10-12-2011.
- 4,154,071. **ELLISON AND DESIGN**. ELLISON GLASSWORKS LLC, (U.S. CLS. 21, 23, 26, 36 AND 38). SN 85-445,881. PUB. 3-20-2012. FILED 10-12-2011.
- 4,154,077. **CHARMING CELEBRATIONS (STANDARD CHARACTER)**. JEWEL KADE HOLDINGS LLC, (U.S. CLS. 21, 23, 26, 36 AND 38). SN 85-445,944. PUB. 3-20-2012. FILED 10-12-2011.
- 4,154,081. **BRANSON ON THE ROAD BRANSON ON THE ROAD AND DESIGN**. DEBRA A. HORTON, AND DONALD L. WRIGHT, (U.S. CLS. 21, 23, 26, 36 AND 38). SN 85-445,981. PUB. 3-20-2012. FILED 10-12-2011.
- 4,154,083. **REDAPT (STANDARD CHARACTER)**. REDAPT, INC., (U.S. CLS. 21, 23, 26, 36 AND 38). SN 85-446,013. PUB. 3-20-2012. FILED 10-12-2011.
- 4,154,103. **MISCELLANEOUS DESIGN**. SOUTH BAY TRADING INC., (U.S. CLS. 21, 23, 26, 36 AND 38). SN 85-447,226. PUB. 3-20-2012. FILED 10-13-2011.
- 4,154,104. **BLISS (STANDARD CHARACTER)**. CHOU, BELLE, MULTIPLE CLASS, (INT. CLS. 9 AND 10), (U.S. CLS. 21, 23, 26, 36, 38, 39 AND 44). SN 85-447,239. PUB. 3-20-2012. FILED 10-13-2011.
- 4,154,112. **CRM FOR THE REST OF US (STANDARD CHARACTER)**. PANASUK, CURTIS, (U.S. CLS. 21, 23, 26, 36 AND 38). SN 85-448,269. PUB. 3-20-2012. FILED 10-14-2011.
- 4,154,117. **MISCELLANEOUS DESIGN**. SOLADIGM, INC., MULTIPLE CLASS, (INT. CLS. 9 AND 19), (U.S. CLS. 1, 12, 21, 23, 26, 33, 36, 38 AND 50). SN 85-448,958. PUB. 3-20-2012. FILED 10-17-2011.
- 4,154,120. **TASK FACTORY (STANDARD CHARACTER)**. PRAGMATIC WORKS SOFTWARE, INC, DBA PRAGMATIC WORKS, (U.S. CLS. 21, 23, 26, 36 AND 38). SN 85-449,595. PUB. 3-20-2012. FILED 10-18-2011.
- 4,154,121. **WILD 777 FAMOUS (STANDARD CHARACTER)**. BALLY GAMING, INC., DBA BALLY TECHNOLOGIES, (U.S. CLS. 21, 23, 26, 36 AND 38). SN 85-449,723. PUB. 3-20-2012. FILED 10-18-2011.
- 4,154,124. **FACEBOSS (STANDARD CHARACTER)**. JOY MM DELAWARE, INC., (U.S. CLS. 21, 23, 26, 36 AND 38). SN 85-450,174. PUB. 3-20-2012. FILED 10-18-2011.
- 4,154,133. **77KIDS BY AMERICAN EAGLE (STANDARD CHARACTER)**. RETAIL ROYALTY COMPANY, (U.S. CLS. 21, 23, 26, 36 AND 38). SN 85-451,694. PUB. 3-20-2012. FILED 10-20-2011.
- 4,154,135. **BI DOCUMENTER AND DESIGN**. PRAGMATIC WORKS SOFTWARE, INC, DBA PRAGMATIC WORKS, (U.S. CLS. 21, 23, 26, 36 AND 38). SN 85-452,104. PUB. 3-20-2012. FILED 10-20-2011.
- 4,154,142. **WARMENFAT (STANDARD CHARACTER)**. MCCORMACK, JOHN F., DBA RAINBOW ELECTRONICS, (U.S. CLS. 21, 23, 26, 36 AND 38). SN 85-452,621. PUB. 3-20-2012. FILED 10-20-2011.
- 4,154,152. **MEN'S HEALTH (STANDARD CHARACTER)**. RODALE INC., (U.S. CLS. 21, 23, 26, 36 AND 38). SN 85-454,485. PUB. 3-20-2012. FILED 10-24-2011.
- 4,154,153. **WOMEN'S HEALTH (STANDARD CHARACTER)**. RODALE INC., (U.S. CLS. 21, 23, 26, 36 AND 38). SN 85-454,536. PUB. 3-20-2012. FILED 10-24-2011.
- 4,154,154. **MISCELLANEOUS DESIGN**. HERZENBERG, JANET, (U.S. CLS. 21, 23, 26, 36 AND 38). SN 85-454,595. PUB. 3-20-2012. FILED 10-24-2011.
- 4,154,171. **LABORATORY RECON (STANDARD CHARACTER)**. RURO INCORPORATED, DBA RURO INC., (U.S. CLS. 21, 23, 26, 36 AND 38). SN 85-456,408. PUB. 3-20-2012. FILED 10-26-2011.
- 4,154,172. **VARIETY ARABIA (STANDARD CHARACTER)**. REED ELSEVIER PROPERTIES INC., MULTIPLE CLASS, (INT. CLS. 9 AND 41), (U.S. CLS. 21, 23, 26, 36, 38, 100, 101 AND 107). SN 85-456,536. PUB. 3-20-2012. FILED 10-26-2011.
- 4,154,179. **MISCELLANEOUS DESIGN**. SOUTH BAY TRADING INC., (U.S. CLS. 21, 23, 26, 36 AND 38). SN 85-460,419. PUB. 3-20-2012. FILED 10-31-2011.
- 4,154,190. **MISCELLANEOUS DESIGN**. SOUTH BAY TRADING INC., (U.S. CLS. 21, 23, 26, 36 AND 38). SN 85-464,198. PUB. 3-20-2012. FILED 11-3-2011.
- 4,154,200. **MISCELLANEOUS DESIGN**. SOUTH BAY TRADING INC., (U.S. CLS. 21, 23, 26, 36 AND 38). SN 85-473,582. PUB. 3-20-2012. FILED 11-15-2011.
- 4,154,206. **LUMENPULSE (STANDARD CHARACTER)**. LUMENPULSE LIGHTING, INC., (U.S. CLS. 21, 23, 26, 36 AND 38). SN 85-477,921. PUB. 3-20-2012. FILED 11-21-2011.
- 4,154,209. **MISCELLANEOUS DESIGN**. SOUTH BAY TRADING INC., (U.S. CLS. 21, 23, 26, 36 AND 38). SN 85-480,943. PUB. 3-20-2012. FILED 11-25-2011.
- 4,154,221. **MISCELLANEOUS DESIGN**. KABBALAH CENTRE INTERNATIONAL, INC., (U.S. CLS. 21, 23, 26, 36 AND 38). SN 85-491,798. PUB. 3-20-2012. FILED 12-9-2011.
- 4,154,233. **CLARION CALLS (STANDARD CHARACTER)**. CLARION PARTNERS, LLC, MULTIPLE CLASS, (INT. CLS. 9, 16 AND 41), (U.S. CLS. 2, 5, 21, 22, 23, 26, 29, 36, 37, 38, 50, 100, 101 AND 107). SN 85-510,464. PUB. 3-20-2012. FILED 1-6-2012.
- 4,154,239. **BRAM STOKER (STANDARD CHARACTER)**. BRAM STOKER LLC, (U.S. CLS. 21, 23, 26, 36 AND 38). SN 85-976,229. PUB. 3-20-2012. FILED 2-25-2011.

CLASS 10—MEDICAL APPARATUS

- 4,152,072 (*See Class 3 for this trademark.*)
- 4,152,087 (*See Class 1 for this trademark.*)
- 4,152,120 (*See Class 7 for this trademark.*)
- 4,152,127 (*See Class 9 for this trademark.*)
- 4,152,138 (*See Class 9 for this trademark.*)
- 4,152,180 (*See Class 3 for this trademark.*)
- 4,152,203 (*See Class 9 for this trademark.*)
- 4,152,205 (*See Class 1 for this trademark.*)
- 4,152,212. **ERISMA (STANDARD CHARACTER)**. CLARANCE S.A.S, (U.S. CLS. 26, 39 AND 44). SN 79-093,033. PUB. 3-20-2012. FILED 1-4-2011.
- 4,152,262. **AXCANDIS MICRO VASCULAR INTERVENTIONS (STYLIZED)**. ACANDIS GMBH & CO. KG, (U.S. CLS. 26, 39 AND 44). SN 79-097,488. PUB. 3-20-2012. FILED 4-12-2011.
- 4,152,267 (*See Class 9 for this trademark.*)
- 4,152,269 (*See Class 1 for this trademark.*)
- 4,152,310. **BIPLEX (STANDARD CHARACTER)**. VASCUTEK LIMITED, (U.S. CLS. 26, 39 AND 44). SN 79-098,961. PUB. 3-20-2012. FILED 1-12-2011.
- 4,152,322. **MINI ANTS (STANDARD CHARACTER)**. BERNHARD FÖRSTER GMBH, (U.S. CLS. 26, 39 AND 44). SN 79-099,539. PUB. 3-20-2012. FILED 3-7-2011.
- 4,152,326. **STERICUP (STANDARD CHARACTER)**. IMBERT

- ELLIOT, (U.S. CLS. 26, 39 AND 44). SN 79-099,674. PUB. 3-20-2012. FILED 3-7-2011.
- 4,152,344. **COREIT (STANDARD CHARACTER)**. SSB TECHNOLOGY PTY LTD, (U.S. CLS. 26, 39 AND 44). SN 79-100,413. PUB. 3-20-2012. FILED 5-4-2011.
- 4,152,346 (*See Class 7 for this trademark*).
- 4,152,383. **NO ONE CAN SEE HOW WELL YOU HEAR (STANDARD CHARACTER)**. SONOVA HOLDING AG, (U.S. CLS. 26, 39 AND 44). SN 79-102,861. PUB. 3-20-2012. FILED 1-19-2011.
- 4,152,398. **C4S (COMPRESSION FOR SPORT) (STYLIZED)**. GLORIA MED S.P.A., MULTIPLE CLASS, (INT. CLS. 10 AND 25), (U.S. CLS. 22, 26, 39 AND 44). SN 79-103,855. PUB. 3-20-2012. FILED 8-11-2011.
- 4,152,404. **I MY LEGS BY GLORIA AND DESIGN**. GLORIA MED S.P.A., MULTIPLE CLASS, (INT. CLS. 10, 25 AND 35), (U.S. CLS. 22, 26, 39, 44, 100, 101 AND 102). SN 79-104,179. PUB. 3-20-2012. FILED 8-11-2011.
- 4,152,416 (*See Class 3 for this trademark*).
- 4,152,419 (*See Class 5 for this trademark*).
- 4,152,427. **X - GATE (STANDARD CHARACTER)**. SUMITOMO BAKELITE CO., LTD., (U.S. CLS. 26, 39 AND 44). SN 79-105,939. PUB. 3-20-2012. FILED 10-19-2011.
- 4,152,471 (*See Class 9 for this trademark*).
- 4,152,509. **ANGELSOUNDS (STANDARD CHARACTER)**. SHENZHEN JUMPER MEDICAL EQUIPMENT CO., LTD., (U.S. CLS. 26, 39 AND 44). SN 85-122,411. PUB. 3-20-2012. FILED 9-3-2010.
- 4,152,654. **SERENE INNOVATIONS AND DESIGN**. SERENE INNOVATION, INC., MULTIPLE CLASS, (INT. CLS. 10 AND 21), (U.S. CLS. 2, 13, 23, 26, 29, 30, 33, 39, 40, 44 AND 50). SN 85-253,541. PUB. 3-20-2012. FILED 2-28-2011.
- 4,152,658 (*See Class 1 for this trademark*).
- 4,152,690. **HEAT IN A CLICK AND DESIGN**. MARKETWIZ LIMITED, (U.S. CLS. 26, 39 AND 44). SN 85-276,043. PUB. 3-20-2012. FILED 3-24-2011.
- 4,152,705. **CONFIDENCE (STANDARD CHARACTER)**. SALTS HEALTHCARE LIMITED, (U.S. CLS. 26, 39 AND 44). SN 85-281,422. PUB. 3-20-2012. FILED 3-30-2011.
- 4,152,740. **BAKRI (STANDARD CHARACTER)**. COOK MEDICAL TECHNOLOGIES LLC, (U.S. CLS. 26, 39 AND 44). SN 85-292,658. PUB. 3-20-2012. FILED 4-12-2011.
- 4,152,785 (*See Class 5 for this trademark*).
- 4,152,819. **HYFLEX CM (STANDARD CHARACTER)**. COLTENE/WHALEDENT, INC., (U.S. CLS. 26, 39 AND 44). SN 85-301,457. PUB. 3-20-2012. FILED 4-21-2011.
- 4,152,852. **TRU HEARING AND DESIGN**. TRUHEARING, INC., (U.S. CLS. 26, 39 AND 44). SN 85-307,752. PUB. 3-20-2012. FILED 4-28-2011.
- 4,152,865. **COMPAKSTAR (STANDARD CHARACTER)**. SANOFI, (U.S. CLS. 26, 39 AND 44). SN 85-310,678. PUB. 3-20-2012. FILED 5-3-2011.
- 4,152,866. **INTROSTAR (STANDARD CHARACTER)**. SANOFI, (U.S. CLS. 26, 39 AND 44). SN 85-310,702. PUB. 3-20-2012. FILED 5-3-2011.
- 4,152,870. **S SERIES (STANDARD CHARACTER)**. SONOSITE, INC., (U.S. CLS. 26, 39 AND 44). SN 85-311,541. PUB. 3-20-2012. FILED 5-3-2011.
- 4,152,891. **SENSIFLIP (STANDARD CHARACTER)**. FLIP TECHNOLOGIES LIMITED, (U.S. CLS. 26, 39 AND 44). SN 85-315,625. PUB. 3-20-2012. FILED 5-9-2011.
- 4,152,906. **ACTIVE HEALTH ROLLER (STANDARD CHARACTER)**. NICHOLSON, RANDY, (U.S. CLS. 26, 39 AND 44). SN 85-319,704. PUB. 3-20-2012. FILED 5-12-2011.
- 4,152,918. **BACKTRAX (STANDARD CHARACTER)**. LOWE & LEE MARKETING LLC, (U.S. CLS. 26, 39 AND 44). SN 85-322,921. PUB. 3-20-2012. FILED 5-17-2011.
- 4,153,005. **WADIANA (STANDARD CHARACTER)**. GRIFOLS, S.A., (U.S. CLS. 26, 39 AND 44). SN 85-348,892. PUB. 1-31-2012. FILED 6-17-2011.
- 4,153,107. **XTENDACARE (STANDARD CHARACTER)**. AVATAR ENTERPRISES, INC., DBA COMFORTEX, (U.S. CLS. 26, 39 AND 44). SN 85-383,235. PUB. 3-20-2012. FILED 7-28-2011.
- 4,153,152. **DENTAL USA (STANDARD CHARACTER)**. DENTAL USA, (U.S. CLS. 26, 39 AND 44). SN 85-395,329. PUB. 3-20-2012. FILED 8-11-2011.
- 4,153,163. **BARE (STYLIZED)**. BITTYLAB, LLC, (U.S. CLS. 26, 39 AND 44). SN 85-397,445. PUB. 3-20-2012. FILED 8-14-2011.
- 4,153,319. **ELITY 70 X RAY (STANDARD CHARACTER)**. AGUIAR, TOMAS, (U.S. CLS. 26, 39 AND 44). SN 85-423,257. PUB. 3-20-2012. FILED 9-15-2011.
- 4,153,320. **BRIDGEVAD (STANDARD CHARACTER)**. CALON CARDIO TECHNOLOGY LTD, (U.S. CLS. 26, 39 AND 44). SN 85-423,267. PUB. 3-20-2012. FILED 9-15-2011.
- 4,153,321. **CATHVAD (STANDARD CHARACTER)**. CALON CARDIO TECHNOLOGY LTD, (U.S. CLS. 26, 39 AND 44). SN 85-423,279. PUB. 3-20-2012. FILED 9-15-2011.
- 4,153,501 (*See Class 9 for this trademark*).
- 4,153,510. **THE BACK ORTHOTIC (STANDARD CHARACTER)**. BACKJOY ORTHOTICS, LLC, (U.S. CLS. 26, 39 AND 44). SN 85-437,305. PUB. 3-20-2012. FILED 10-2-2011.
- 4,153,531. **SIFOAM (STYLIZED)**. ROGERS, BARBARA, (U.S. CLS. 26, 39 AND 44). SN 85-437,848. PUB. 3-20-2012. FILED 10-3-2011.
- 4,153,668 (*See Class 8 for this trademark*).
- 4,153,896. **NUBBIN-FINGERS (STANDARD CHARACTER)**. NORBIS INNOVATIONS COMPANY, LLC, (U.S. CLS. 26, 39 AND 44). SN 85-443,500. PUB. 3-20-2012. FILED 10-10-2011.
- 4,153,985. **VITASONIK (STANDARD CHARACTER)**. TECIL-LA COS-MED UG, (U.S. CLS. 26, 39 AND 44). SN 85-444,458. PUB. 3-20-2012. FILED 10-11-2011.
- 4,154,066. **PHOTOPULSE (STANDARD CHARACTER)**. RUF, GARY, (U.S. CLS. 26, 39 AND 44). SN 85-445,791. PUB. 3-20-2012. FILED 10-12-2011.
- 4,154,102. **AUDIOSYNC (STANDARD CHARACTER)**. STARKEY LABORATORIES, INC., (U.S. CLS. 26, 39 AND 44). SN 85-447,206. PUB. 3-20-2012. FILED 10-13-2011.
- 4,154,104 (*See Class 9 for this trademark*).
- 4,154,128 (*See Class 5 for this trademark*).
- 4,154,146. **QUICKDRIVE (STANDARD CHARACTER)**. STRYKER CORPORATION, (U.S. CLS. 26, 39 AND 44). SN 85-453,343. PUB. 3-20-2012. FILED 10-21-2011.
- 4,154,177. **SCORPION TABLES (STANDARD CHARACTER)**. ANTHONY F. BERARDI III, DBA SCORPION TABLES, (U.S. CLS. 26, 39 AND 44). SN 85-458,404. PUB. 3-20-2012. FILED 10-27-2011.
- 4,154,235. **NUPRO FREEDOM (STANDARD CHARACTER)**. DENTSPLY INTERNATIONAL INC., (U.S. CLS. 26, 39 AND 44). SN 85-510,725. PUB. 3-20-2012. FILED 1-6-2012.

CLASS 11—ENVIRONMENTAL CONTROL APPARATUS

- 4,152,049. **DYNEWTECH (STYLIZED)**. PROELL, BRUNO, (U.S. CLS. 13, 21, 23, 31 AND 34). SN 76-707,443. PUB. 3-20-2012. FILED 4-29-2011.
- 4,152,051 (*See Class 9 for this trademark*).
- 4,152,085. **WATERPRESS (STANDARD CHARACTER)**. PATRICIA KIM STURGESS, MULTIPLE CLASS, (INT. CLS. 11 AND 21), (U.S. CLS. 2, 13, 21, 23, 29, 30, 31, 33, 34, 40 AND 50). SN 77-390,367. PUB. 3-20-2012. FILED 2-6-2008.
- 4,152,091 (*See Class 4 for this trademark*).
- 4,152,120 (*See Class 7 for this trademark*).
- 4,152,150. **EAGLE (STANDARD CHARACTER)**. QUEST TECHNOLOGIES, INC, DBA CRYSTAL QUEST MFG, (U.S. CLS. 13, 21, 23, 31 AND 34). SN 77-955,806. PUB. 3-20-2012. FILED 3-10-2010.
- 4,152,155. **MORPHOSYS (STANDARD CHARACTER)**. BAINS ULTRA INC., (U.S. CLS. 13, 21, 23, 31 AND 34). SN 77-965,915. PUB. 3-20-2012. FILED 3-23-2010.
- 4,152,159. **PACIFIC AND DESIGN**. LEYANT INDUSTRY CO., (U.S. CLS. 13, 21, 23, 31 AND 34). SN 78-867,455. PUB. 3-20-2012. FILED 4-22-2006.
- 4,152,166. **VALENTINO (STANDARD CHARACTER)**. VALENTINO S.P.A., MULTIPLE CLASS, (INT. CLS. 11, 36 AND 43), (U.S. CLS. 13, 21, 23, 31, 34, 100, 101 AND 102). SN 79-059,290. PUB. 3-20-2012. FILED 7-22-2008.
- 4,152,169. **LB3 (STANDARD CHARACTER)**. KERAMIK HOLDING AG LAUFEN, MULTIPLE CLASS, (INT. CLS. 11, 20 AND 21), (U.S. CLS. 2, 13, 21, 22, 23, 25, 29, 30, 31, 32, 33, 34, 40 AND 50). SN 79-077,326. PUB. 3-20-2012. FILED 9-4-2009.

- 4,152,175 (*See Class 9 for this trademark.*)
 4,152,176 (*See Class 9 for this trademark.*)
 4,152,181 (*See Class 9 for this trademark.*)
 4,152,190 (*See Class 9 for this trademark.*)
 4,152,196. **SIFIM AND DESIGN.** SIFIM S.R.L., (U.S. CLS. 13, 21, 23, 31 AND 34). SN 79-090,089. PUB. 3-20-2012. FILED 3-30-2010.
 4,152,197 (*See Class 1 for this trademark.*)
 4,152,206. **SPLASH (STANDARD CHARACTER).** EPS HOLDING GMBH, MULTIPLE CLASS, (INT. CLS. 11 AND 44), (U.S. CLS. 13, 21, 23, 31, 34, 100 AND 101). SN 79-091,571. PUB. 3-20-2012. FILED 7-26-2010.
 4,152,209. **ECO BIDET AND DESIGN.** JAMES BOWERS, (U.S. CLS. 13, 21, 23, 31 AND 34). SN 79-092,279. PUB. 3-20-2012. FILED 11-12-2010.
 4,152,228 (*See Class 7 for this trademark.*)
 4,152,229 (*See Class 1 for this trademark.*)
 4,152,230 (*See Class 7 for this trademark.*)
 4,152,231 (*See Class 7 for this trademark.*)
 4,152,238 (*See Class 9 for this trademark.*)
 4,152,256 (*See Class 6 for this trademark.*)
 4,152,292. **LA CORNUE W. (STANDARD CHARACTER).** LA CORNUE, MULTIPLE CLASS, (INT. CLS. 11 AND 20), (U.S. CLS. 2, 13, 21, 22, 23, 25, 31, 32, 34 AND 50). SN 79-098,472. PUB. 3-20-2012. FILED 5-18-2011.
 4,152,335. **SCHOTT NANOTEC (STANDARD CHARACTER).** SCHOTT AKTIENGESELLSCHAFT, MULTIPLE CLASS, (INT. CLS. 11, 20 AND 21), (U.S. CLS. 2, 13, 21, 22, 23, 25, 29, 30, 31, 32, 33, 34, 40 AND 50). SN 79-100,007. PUB. 3-20-2012. FILED 3-24-2011.
 4,152,341 (*See Class 6 for this trademark.*)
 4,152,342. **EDELWASSER (STANDARD CHARACTER).** FIELDPOINT B.V., (U.S. CLS. 13, 21, 23, 31 AND 34). SN 79-100,243. PUB. 3-20-2012. FILED 5-20-2011.
 4,152,375 (*See Class 3 for this trademark.*)
 4,152,384. **ALUSTAR (STANDARD CHARACTER).** NV BEKAERT SA, (U.S. CLS. 13, 21, 23, 31 AND 34). SN 79-103,048. PUB. 3-20-2012. FILED 8-20-2011.
 4,152,406 (*See Class 9 for this trademark.*)
 4,152,413. **RAYSTAR (STANDARD CHARACTER).** OSRAM AG, DBA/KA/TA/FORMERLY OSRAM G.M.B.H., (U.S. CLS. 13, 21, 23, 31 AND 34). SN 79-104,593. PUB. 3-20-2012. FILED 9-9-2011.
 4,152,420. **ACV AND DESIGN.** A.C.V. INTERNATIONAL;; NAAMLOZE VENNOOTSCHAP, (U.S. CLS. 13, 21, 23, 31 AND 34). SN 79-105,043. PUB. 3-20-2012. FILED 9-1-2011.
 4,152,423 (*See Class 9 for this trademark.*)
 4,152,425. **NAVISANI AND DESIGN.** XIAMEN WING TECHNOLOGY CO., LTD, (U.S. CLS. 13, 21, 23, 31 AND 34). SN 79-105,560. PUB. 3-20-2012. FILED 8-10-2011.
 4,152,441. **XUPERNOVA (STANDARD CHARACTER).** LG ELECTRONICS INC., (U.S. CLS. 13, 21, 23, 31 AND 34). SN 85-012,516. PUB. 3-20-2012. FILED 4-13-2010.
 4,152,464. **LIQUIDLENS (STANDARD CHARACTER).** ENTEGRIS, INC., (U.S. CLS. 13, 21, 23, 31 AND 34). SN 85-065,502. PUB. 3-20-2012. FILED 6-17-2010.
 4,152,471 (*See Class 9 for this trademark.*)
 4,152,486. **AC MANAGER (STANDARD CHARACTER).** LG ELECTRONICS INC., (U.S. CLS. 13, 21, 23, 31 AND 34). SN 85-100,151. PUB. 3-20-2012. FILED 8-4-2010.
 4,152,507 (*See Class 3 for this trademark.*)
 4,152,577 (*See Class 9 for this trademark.*)
 4,152,589 (*See Class 7 for this trademark.*)
 4,152,613. **LITTLE WOMBAT AND DESIGN.** LITTLE WOMBAT IP PTY LTD, (U.S. CLS. 13, 21, 23, 31 AND 34). SN 85-221,896. PUB. 1-10-2012. FILED 1-20-2011.
 4,152,634. **RAINLIGHT (STANDARD CHARACTER).** GROHE AG, (U.S. CLS. 13, 21, 23, 31 AND 34). SN 85-240,702. PUB. 1-17-2012. FILED 2-11-2011.
 4,152,658 (*See Class 1 for this trademark.*)
 4,152,714. **GREENTURTLE (STANDARD CHARACTER).** GREEN TURTLE AMERICAS LTD., (U.S. CLS. 13, 21, 23, 31 AND 34). SN 85-286,068. PUB. 3-20-2012. FILED 4-5-2011.
 4,152,715. **GREEN TURTLE AND DESIGN.** GREEN TURTLE AMERICAS LTD., (U.S. CLS. 13, 21, 23, 31 AND 34). SN 85-286,070. PUB. 3-20-2012. FILED 4-5-2011.
 4,152,793. **WILDCAT LIGHTING AND DESIGN.** WILDCAT LIGHTING, LLC, (U.S. CLS. 13, 21, 23, 31 AND 34). SN 85-297,887. PUB. 3-20-2012. FILED 4-18-2011.
 4,152,810. **TOPCAT MARINE LIGHTING SYSTEM (STANDARD CHARACTER).** WILDCAT LIGHTING, LLC, (U.S. CLS. 13, 21, 23, 31 AND 34). SN 85-299,989. PUB. 3-20-2012. FILED 4-20-2011.
 4,152,818. **SIMPLE. SMART. (STANDARD CHARACTER).** WOLFE ELECTRIC, INC., (U.S. CLS. 13, 21, 23, 31 AND 34). SN 85-301,185. PUB. 3-20-2012. FILED 4-21-2011.
 4,152,904 (*See Class 9 for this trademark.*)
 4,152,927 (*See Class 7 for this trademark.*)
 4,152,996. **RITZ PARIS (STANDARD CHARACTER).** THE RITZ HOTEL, LIMITED, (U.S. CLS. 13, 21, 23, 31 AND 34). SN 85-346,632. PUB. 3-20-2012. FILED 6-15-2011.
 4,153,041. **IMBRIUM AND DESIGN.** IMBRIUM SYSTEMS CORPORATION, MULTIPLE CLASS, (INT. CLS. 11, 19 AND 40), (U.S. CLS. 1, 12, 13, 21, 23, 31, 33, 34, 50, 100, 103 AND 106). SN 85-360,561. PUB. 3-20-2012. FILED 6-30-2011.
 4,153,042. **IMBRIUM (STANDARD CHARACTER).** IMBRIUM SYSTEMS CORPORATION, MULTIPLE CLASS, (INT. CLS. 11, 19 AND 40), (U.S. CLS. 1, 12, 13, 21, 23, 31, 33, 34, 50, 100, 103 AND 106). SN 85-360,571. PUB. 3-20-2012. FILED 6-30-2011.
 4,153,069. **NEYCRAFT (STANDARD CHARACTER).** DENTSPLY INTERNATIONAL INC., (U.S. CLS. 13, 21, 23, 31 AND 34). SN 85-372,120. PUB. 3-20-2012. FILED 7-15-2011.
 4,153,173. **APOLLO REEF LED (STANDARD CHARACTER).** APOLLO REEF LED, LLC, AKA APOLLO REEF LED, (U.S. CLS. 13, 21, 23, 31 AND 34). SN 85-400,956. PUB. 3-20-2012. FILED 8-18-2011.
 4,153,198. **BREWI AND DESIGN.** BREWI TECHNOLOGIES, INC., MULTIPLE CLASS, (INT. CLS. 11 AND 30), (U.S. CLS. 13, 21, 23, 31, 34 AND 46). SN 85-406,081. PUB. 3-20-2012. FILED 8-24-2011.
 4,153,237. **O ALIAXIS (STYLIZED).** ALIAXIS S.A., MULTIPLE CLASS, (INT. CLS. 11, 17, 19 AND 35), (U.S. CLS. 1, 5, 12, 13, 21, 23, 31, 33, 34, 35, 50, 100, 101 AND 102). SN 85-414,235. PUB. 3-20-2012. FILED 9-2-2011.
 4,153,389. **IWS-E.COM (STANDARD CHARACTER).** UNIVERSAL HOLDING GROUP, INC., (U.S. CLS. 13, 21, 23, 31 AND 34). SN 85-430,066. PUB. 3-20-2012. FILED 9-23-2011.
 4,153,787. **TELNET (STANDARD CHARACTER).** FRESH CREEK TECHNOLOGIES, INC., MULTIPLE CLASS, (INT. CLS. 11 AND 40), (U.S. CLS. 13, 21, 23, 31, 34, 100, 103 AND 106). SN 85-442,399. PUB. 3-20-2012. FILED 10-7-2011.
 4,153,878. **FLATMAX (STANDARD CHARACTER).** MAXLITE, INC., (U.S. CLS. 13, 21, 23, 31 AND 34). SN 85-443,372. PUB. 3-20-2012. FILED 10-10-2011.
 4,153,922. **LEEFH2 (STANDARD CHARACTER).** HNO GREEN FUELS, INC, (U.S. CLS. 13, 21, 23, 31 AND 34). SN 85-443,848. PUB. 3-20-2012. FILED 10-10-2011.
 4,153,934. **WATER MANAGEMENT TECHNOLOGIES (STANDARD CHARACTER).** WATER MANAGEMENT TECHNOLOGIES, INC., (U.S. CLS. 13, 21, 23, 31 AND 34). SN 85-444,000. PUB. 3-20-2012. FILED 10-11-2011.
 4,153,950. **SUREGRIP (STANDARD CHARACTER).** DE' LONGHI BENELUX S.A., (U.S. CLS. 13, 21, 23, 31 AND 34). SN 85-444,114. PUB. 3-20-2012. FILED 10-11-2011.
 4,153,973. **KMIX (STANDARD CHARACTER).** DE' LONGHI BENELUX S.A., (U.S. CLS. 13, 21, 23, 31 AND 34). SN 85-444,291. PUB. 3-20-2012. FILED 10-11-2011.
 4,153,989. **OPTITEMP (STANDARD CHARACTER).** DE' LONGHI BENELUX S.A., (U.S. CLS. 13, 21, 23, 31 AND 34). SN 85-444,483. PUB. 3-20-2012. FILED 10-11-2011.
 4,153,994. **THERMOGEN (STANDARD CHARACTER).** DE' LONGHI BENELUX S.A., (U.S. CLS. 13, 21, 23, 31 AND 34). SN 85-444,544. PUB. 3-20-2012. FILED 10-11-2011.
 4,154,009. **ENVIROPRO (STANDARD CHARACTER).** KENALL MANUFACTURING COMPANY, (U.S. CLS. 13, 21, 23, 31 AND 34). SN 85-444,675. PUB. 3-20-2012. FILED 10-11-2011.
 4,154,092. **BIMINI BREEZE (STANDARD CHARACTER).** DAN'S FAN CITY, INC., (U.S. CLS. 13, 21, 23, 31 AND 34). SN 85-446,227. PUB. 3-20-2012. FILED 10-13-2011.
 4,154,162. **NU-FLAME (STANDARD CHARACTER).** SRMX CAPITAL, LLC, (U.S. CLS. 13, 21, 23, 31 AND 34). SN 85-455,574. PUB. 3-20-2012. FILED 10-25-2011.

CLASS 12—VEHICLES

- 4,152,125 (*See Class 7 for this trademark.*)
 4,152,151. **THE LOOK SLIDE-KIT STELL HAULERS SLIDING SYSTEM AND DESIGN.** PETELKA INVESTMENTS LTD., (U.S. CLS. 19, 21, 23, 31, 35 AND 44). SN 77-957,837. PUB. 3-20-2012. FILED 3-12-2010.
 4,152,157. **RL (STANDARD CHARACTER).** HONDA MOTOR CO., LTD., (U.S. CLS. 19, 21, 23, 31, 35 AND 44). SN 78-514,746. PUB. 3-20-2012. FILED 11-10-2004.
 4,152,163 (*See Class 7 for this trademark.*)
 4,152,174 (*See Class 3 for this trademark.*)
 4,152,198 (*See Class 3 for this trademark.*)
 4,152,226 (*See Class 3 for this trademark.*)
 4,152,233. **V VENETTA TYRES AND DESIGN.** GRABZOOM PTY LTD, (U.S. CLS. 19, 21, 23, 31, 35 AND 44). SN 79-095,731. PUB. 3-20-2012. FILED 11-11-2010.
 4,152,257 (*See Class 9 for this trademark.*)
 4,152,263. **MIA ELECTRIC AND DESIGN.** MIA ELECTRIC GMBH, MULTIPLE CLASS, (INT. CLS. 12, 35 AND 37), (U.S. CLS. 19, 21, 23, 31, 35, 44, 100, 101, 102, 103 AND 106). SN 79-097,520. PUB. 3-20-2012. FILED 4-5-2011.
 4,152,275. **MISCELLANEOUS DESIGN.** MIA ELECTRIC GMBH, MULTIPLE CLASS, (INT. CLS. 12, 35 AND 37), (U.S. CLS. 19, 21, 23, 31, 35, 44, 100, 101, 102, 103 AND 106). SN 79-098,016. PUB. 3-20-2012. FILED 4-5-2011.
 4,152,289 (*See Class 9 for this trademark.*)
 4,152,297 (*See Class 7 for this trademark.*)
 4,152,312. **VETROTECH SAINT-GOBAIN AND DESIGN.** VETROTECH SAINT-GOBAIN (INTERNATIONAL) AG, MULTIPLE CLASS, (INT. CLS. 12, 19, 21 AND 42), (U.S. CLS. 1, 2, 12, 13, 19, 21, 23, 29, 30, 31, 33, 35, 40, 44, 50, 100 AND 101). SN 79-099,081. PUB. 3-20-2012. FILED 6-8-2011.
 4,152,318 (*See Class 9 for this trademark.*)
 4,152,341 (*See Class 6 for this trademark.*)
 4,152,350 (*See Class 9 for this trademark.*)
 4,152,351 (*See Class 9 for this trademark.*)
 4,152,362 (*See Class 9 for this trademark.*)
 4,152,397. **CARKOON (STANDARD CHARACTER).** JULLIAN JOSHUA PRESTON-POWERS, C/O THERMAHELM LIMITED, (U.S. CLS. 19, 21, 23, 31, 35 AND 44). SN 79-103,841. PUB. 3-20-2012. FILED 6-27-2011.
 4,152,429. **AZIMUT (STANDARD CHARACTER).** AZIMUT-BENETTI S.P.A., (U.S. CLS. 19, 21, 23, 31, 35 AND 44). SN 79-106,317. PUB. 3-20-2012. FILED 10-14-2011.
 4,152,507 (*See Class 3 for this trademark.*)
 4,152,551. **RALLY (STANDARD CHARACTER).** SCAT ENTERPRISES, INC., (U.S. CLS. 19, 21, 23, 31, 35 AND 44). SN 85-157,296. PUB. 3-20-2012. FILED 10-20-2010.
 4,152,565. **OMNIPLUS (STANDARD CHARACTER).** DAIMLER AG, (U.S. CLS. 19, 21, 23, 31, 35 AND 44). SN 85-167,391. PUB. 3-20-2012. FILED 11-2-2010.
 4,152,619 (*See Class 7 for this trademark.*)
 4,152,658 (*See Class 1 for this trademark.*)
 4,152,685 (*See Class 6 for this trademark.*)
 4,152,772 (*See Class 9 for this trademark.*)
 4,152,847 (*See Class 7 for this trademark.*)
 4,152,929. **SUNBURST (STANDARD CHARACTER).** DAIMLER AG, (U.S. CLS. 19, 21, 23, 31, 35 AND 44). SN 85-326,995. PUB. 3-20-2012. FILED 5-23-2011.
 4,153,143 (*See Class 7 for this trademark.*)
 4,153,264. **KRIS HOLM (STANDARD CHARACTER).** KRIS HOLM UNICYCLES LTD., (U.S. CLS. 19, 21, 23, 31, 35 AND 44). SN 85-417,645. PUB. 3-20-2012. FILED 9-8-2011.
 4,153,359. **SUPRACOR (STANDARD CHARACTER).** SUPRACOR, INC., MULTIPLE CLASS, (INT. CLS. 12, 20, 21, 27 AND 28), (U.S. CLS. 2, 13, 19, 20, 21, 22, 23, 25, 29, 30, 31, 32, 33, 35, 37, 38, 40, 42, 44 AND 50). SN 85-427,684. PUB. 3-20-2012. FILED 9-20-2011.
 4,153,418. **PURE FIX CYCLES AND DESIGN.** PURE FIX CYCLES, LLC, (U.S. CLS. 19, 21, 23, 31, 35 AND 44). SN 85-432,473. PUB. 3-20-2012. FILED 9-27-2011.
 4,153,814. **UR ULTRA RACING (STYLIZED).** ULTRA RACING (M) SDN. BHD, (U.S. CLS. 19, 21, 23, 31, 35 AND 44). SN 85-442,722. PUB. 3-20-2012. FILED 10-7-2011.
 4,153,875. **CGC AND DESIGN.** KARPIEL, JAN, (U.S. CLS. 19, 21, 23, 31, 35 AND 44). SN 85-443,363. PUB. 3-20-2012. FILED 10-10-2011.
 4,153,892. **SPEEDSLEEV (STANDARD CHARACTER).** DSR

- PARTNERS, LLC, (U.S. CLS. 19, 21, 23, 31, 35 AND 44). SN 85-443,479. PUB. 3-20-2012. FILED 10-10-2011.
 4,153,904. **DYSE ONE (STANDARD CHARACTER).** DEL RIO MARKETING, INC., (U.S. CLS. 19, 21, 23, 31, 35 AND 44). SN 85-443,566. PUB. 3-20-2012. FILED 10-10-2011.
 4,153,927. **WINDA (STYLIZED).** SHANDONG WANDA BOTO TYRE CO., LTD., (U.S. CLS. 19, 21, 23, 31, 35 AND 44). SN 85-443,918. PUB. 3-20-2012. FILED 10-11-2011.
 4,154,079. **LECTROTRUCK AND DESIGN.** INNOVATIVE MOVING SYSTEMS, (U.S. CLS. 19, 21, 23, 31, 35 AND 44). SN 85-445,948. PUB. 3-20-2012. FILED 10-12-2011.
 4,154,099. **PLATESAFE (STANDARD CHARACTER).** CAMISASCA AUTOMOTIVE MANUFACTURING, INC., (U.S. CLS. 19, 21, 23, 31, 35 AND 44). SN 85-447,042. PUB. 3-20-2012. FILED 10-13-2011.
 4,154,227. **BOYDS WHEELS (STANDARD CHARACTER).** CODDINGTON, BOYD LEE, (U.S. CLS. 19, 21, 23, 31, 35 AND 44). SN 85-497,160. PUB. 3-20-2012. FILED 12-16-2011.

CLASS 13—FIREARMS

- 4,152,341 (*See Class 6 for this trademark.*)
 4,152,757. **MK262 (STANDARD CHARACTER).** BLACK HILLS AMMUNITION, INC., (U.S. CLS. 2 AND 9). SN 85-295,150. PUB. 3-20-2012. FILED 4-14-2011.
 4,152,758. **MK262 MOD 1 (STANDARD CHARACTER).** BLACK HILLS AMMUNITION, INC., (U.S. CLS. 2 AND 9). SN 85-295,152. PUB. 3-20-2012. FILED 4-14-2011.
 4,152,759. **MK262 MOD 0 (STANDARD CHARACTER).** BLACK HILLS AMMUNITION, INC., (U.S. CLS. 2 AND 9). SN 85-295,154. PUB. 3-20-2012. FILED 4-14-2011.
 4,153,016. **PROVEIL AND DESIGN.** FORTNER, TRAVIS C, DBA PROVEIL, (U.S. CLS. 2 AND 9). SN 85-352,862. PUB. 3-20-2012. FILED 6-22-2011.
 4,153,035. **MAG-ID (STANDARD CHARACTER).** THE COILED SNAKE, LLC, MULTIPLE CLASS, (INT. CLS. 13 AND 40), (U.S. CLS. 2, 9, 100, 103 AND 106). SN 85-359,136. PUB. 12-13-2011. FILED 6-29-2011.
 4,153,228. **RIGBY (STANDARD CHARACTER).** RIGBY VENTURES, LLC, (U.S. CLS. 2 AND 9). SN 85-412,227. PUB. 3-20-2012. FILED 8-31-2011.
 4,154,202. **SIG551-A1 (STANDARD CHARACTER).** SIG SAUER INC., (U.S. CLS. 2 AND 9). SN 85-475,005. PUB. 3-20-2012. FILED 11-17-2011.

CLASS 14—JEWELRY

- 4,152,140 (*See Class 3 for this trademark.*)
 4,152,182 (*See Class 6 for this trademark.*)
 4,152,188 (*See Class 3 for this trademark.*)
 4,152,193 (*See Class 3 for this trademark.*)
 4,152,222 (*See Class 9 for this trademark.*)
 4,152,229 (*See Class 1 for this trademark.*)
 4,152,234. **ARIJE (STANDARD CHARACTER).** BRO & SIS HOLDING, MULTIPLE CLASS, (INT. CLS. 14 AND 35), (U.S. CLS. 2, 27, 28, 50, 100, 101 AND 102). SN 79-095,743. PUB. 3-20-2012. FILED 3-18-2011.
 4,152,242 (*See Class 8 for this trademark.*)
 4,152,272 (*See Class 3 for this trademark.*)
 4,152,324. **AGILIT (STANDARD CHARACTER).** UMICORE AG & CO. KG, MULTIPLE CLASS, (INT. CLS. 14, 40 AND 42), (U.S. CLS. 2, 27, 28, 50, 100, 101, 103 AND 106). SN 79-099,617. PUB. 3-20-2012. FILED 3-9-2011.
 4,152,332 (*See Class 9 for this trademark.*)
 4,152,363. **AVIO MILANO AND DESIGN.** TIME STYLE S.R.L., (U.S. CLS. 2, 27, 28 AND 50). SN 79-101,296. PUB. 3-20-2012. FILED 7-12-2011.
 4,152,364. **BOXER MILANO (STYLIZED).** TIME STYLE S.R.L., (U.S. CLS. 2, 27, 28 AND 50). SN 79-101,297. PUB. 3-20-2012. FILED 7-12-2011.
 4,152,388. **KID'SLEEP (STANDARD CHARACTER).** CLAESSENS' KIDS SARL, MULTIPLE CLASS, (INT. CLS. 14 AND 28), (U.S. CLS. 2, 22, 23, 27, 28, 38 AND 50). SN 79-103,177.

- PUB. 3-20-2012. FILED 7-27-2011.
 4,152,436 (*See Class 3 for this trademark*).
 4,152,473 (*See Class 9 for this trademark*).
 4,152,507 (*See Class 3 for this trademark*).
 4,152,630 (*See Class 3 for this trademark*).
 4,152,658 (*See Class 1 for this trademark*).
 4,153,045. **SEA HUNT PEARLS (STANDARD CHARACTER)**. LYNCH, JOHN G., DBA SEA HUNT PEARLS, (U.S. CLS. 2, 27, 28 AND 50). SN 85-361,464. PUB. 3-20-2012. FILED 7-1-2011.
 4,153,056. **BANGLE BAR (STANDARD CHARACTER)**. ALEX AND ANI, INC., (U.S. CLS. 2, 27, 28 AND 50). SN 85-367,506. PUB. 3-20-2012. FILED 7-10-2011.
 4,153,058 (*See Class 9 for this trademark*).
 4,153,435 (*See Class 9 for this trademark*).
 4,153,493. **LITTLE BLUE STUDIO (STANDARD CHARACTER)**. HIGH, MARIA LOUISE, DBA LITTLE BLUE STUDIO, MULTIPLE CLASS, (INT. CLS. 14 AND 26), (U.S. CLS. 2, 27, 28, 37, 39, 40, 42 AND 50). SN 85-436,782. PUB. 3-20-2012. FILED 9-30-2011.
 4,153,560. **SPEXTON (STANDARD CHARACTER)**. MCPHERSON, NATHAN, DBA SPEXTON JEWELRY, (U.S. CLS. 2, 27, 28 AND 50). SN 85-438,608. PUB. 3-20-2012. FILED 10-4-2011.
 4,153,616. **BLING TIME (STANDARD CHARACTER)**. BLING TIME, LLC, (U.S. CLS. 2, 27, 28 AND 50). SN 85-439,990. PUB. 3-20-2012. FILED 10-5-2011.
 4,153,617. **BLING TIME INTERCHANGEABLE ACCESSORIES (STANDARD CHARACTER)**. BLING TIME, LLC, (U.S. CLS. 2, 27, 28 AND 50). SN 85-440,012. PUB. 3-20-2012. FILED 10-5-2011.
 4,153,669. **TGS AND DESIGN**. TGS JEWELERS, LLC, (U.S. CLS. 2, 27, 28 AND 50). SN 85-440,981. PUB. 3-20-2012. FILED 10-6-2011.
 4,153,681. **TOUCH A LIFE COLLECTION (STANDARD CHARACTER)**. UNIVERSAL PACIFIC DIAMONDS & JEWELRY, LLC, (U.S. CLS. 2, 27, 28 AND 50). SN 85-441,178. PUB. 3-20-2012. FILED 10-6-2011.
 4,153,688. **TERAMASU (STANDARD CHARACTER)**. TERAMASU.COM LLC, DBA TERAMASU ACCESSORIES, AND TERAMASU LLC, MULTIPLE CLASS, (INT. CLS. 14, 18 AND 25), (U.S. CLS. 1, 2, 3, 22, 27, 28, 39, 41 AND 50). SN 85-441,382. PUB. 3-20-2012. FILED 10-6-2011.
 4,153,749. **SCARLETT JEWELS (STANDARD CHARACTER)**. SCARLETT DESIGNS, INC., (U.S. CLS. 2, 27, 28 AND 50). SN 85-442,017. PUB. 3-20-2012. FILED 10-7-2011.
 4,153,757. **CREDOR AND DESIGN**. SEIKO HOLDINGS KABUSHIKI KAISHA, TA SEIKO HOLDINGS CORPORATION, (U.S. CLS. 2, 27, 28 AND 50). SN 85-442,099. PUB. 3-20-2012. FILED 10-7-2011.
 4,153,886. **BROOKE LEAF (STANDARD CHARACTER)**. CARLELLE LTD., (U.S. CLS. 2, 27, 28 AND 50). SN 85-443,422. PUB. 3-20-2012. FILED 10-10-2011.
 4,154,018 (*See Class 9 for this trademark*).
 4,154,143. **HARVESTOR INVESTMENTS AND DESIGN**. DOVE, TROY V., DBA HARVESTOR INVESTMENTS, (U.S. CLS. 2, 27, 28 AND 50). SN 85-452,719. PUB. 3-20-2012. FILED 10-21-2011.
 4,154,178. **LASSALE (STANDARD CHARACTER)**. SEIKO HOLDINGS KABUSHIKI KAISHA, TA SEIKO HOLDINGS CORPORATION, (U.S. CLS. 2, 27, 28 AND 50). SN 85-460,372. PUB. 1-24-2012. FILED 10-31-2011.
 4,154,184. **TIFFANY SOLESTE (STANDARD CHARACTER)**. TIFFANY (NJ) LLC, (U.S. CLS. 2, 27, 28 AND 50). SN 85-462,553. PUB. 3-20-2012. FILED 11-2-2011.

CLASS 15—MUSICAL INSTRUMENTS

- 4,154,122. **MAMA MOJO GUITARS (STANDARD CHARACTER)**. BLUESWOMEN WORKS, LLC, (U.S. CLS. 2, 21 AND 36). SN 85-449,933. PUB. 3-20-2012. FILED 10-18-2011.

CLASS 16—PAPER GOODS AND PRINTED MATTER

- 4,152,037. **POWER GLUE AND DESIGN**. CANACHEME INC., (U.S. CLS. 2, 5, 22, 23, 29, 37, 38 AND 50). SN 76-694,854. PUB. 3-20-2012. FILED 12-16-2008.
 4,152,038. **BE THE WALL AND DESIGN**. CHARLOTTE ALLIANCE FOR A SAFE & DRUG FREE COMMUNITY, DBA DRUG FREE CHARLOTTE COUNTY, MULTIPLE CLASS, (INT. CLS. 16, 20 AND 25), (U.S. CLS. 2, 5, 13, 22, 23, 25, 29, 32, 37, 38, 39 AND 50). SN 76-702,331. PUB. 3-20-2012. FILED 4-1-2010.
 4,152,079 (*See Class 6 for this trademark*).
 4,152,111. **AVEOS AND DESIGN**. AVEOS FLEET PERFORMANCE INC., MULTIPLE CLASS, (INT. CLS. 16, 35, 37, 39, 41 AND 42), (U.S. CLS. 2, 5, 22, 23, 29, 37, 38, 50, 100, 101, 102, 103, 105, 106 AND 107). SN 77-709,883. PUB. 3-20-2012. FILED 4-8-2009.
 4,152,112. **A AVEOS AND DESIGN**. AVEOS FLEET PERFORMANCE INC., MULTIPLE CLASS, (INT. CLS. 16, 35, 37, 39, 41 AND 42), (U.S. CLS. 2, 5, 22, 23, 29, 37, 38, 50, 100, 101, 102, 103, 105, 106 AND 107). SN 77-709,908. PUB. 3-20-2012. FILED 4-8-2009.
 4,152,160 (*See Class 9 for this trademark*).
 4,152,167. **BCS AND DESIGN**. THE BRITISH COMPUTER SOCIETY, MULTIPLE CLASS, (INT. CLS. 16, 35, 38, 41 AND 42), (U.S. CLS. 2, 5, 22, 23, 29, 37, 38, 50, 100, 101, 102, 104 AND 107). SN 79-072,894. PUB. 3-20-2012. FILED 7-17-2009.
 4,152,168 (*See Class 9 for this trademark*).
 4,152,171. **ONEKIND (STANDARD CHARACTER)**. ONEKIND CHARITY, MULTIPLE CLASS, (INT. CLS. 16, 35, 36 AND 41), (U.S. CLS. 2, 5, 22, 23, 29, 37, 38, 50, 100, 101, 102 AND 107). SN 79-080,782. PUB. 3-20-2012. FILED 2-26-2010.
 4,152,193 (*See Class 3 for this trademark*).
 4,152,200 (*See Class 9 for this trademark*).
 4,152,228 (*See Class 7 for this trademark*).
 4,152,241 (*See Class 9 for this trademark*).
 4,152,242 (*See Class 8 for this trademark*).
 4,152,248. **I CARTAI AND DESIGN**. STRAWBERRY DESIGN LTD, MULTIPLE CLASS, (INT. CLS. 16 AND 18), (U.S. CLS. 1, 2, 3, 5, 22, 23, 29, 37, 38, 41 AND 50). SN 79-096,790. PUB. 3-20-2012. FILED 4-29-2011.
 4,152,266 (*See Class 9 for this trademark*).
 4,152,274 (*See Class 9 for this trademark*).
 4,152,277. **ESPAÑA AND DESIGN**. INSTITUTO DE TURISMO DE ESPAÑA (TURESPAÑA), MULTIPLE CLASS, (INT. CLS. 16, 39, 41 AND 43), (U.S. CLS. 2, 5, 22, 23, 29, 37, 38, 50, 100, 101, 105 AND 107). SN 79-098,109. PUB. 3-20-2012. FILED 4-7-2011.
 4,152,289 (*See Class 9 for this trademark*).
 4,152,332 (*See Class 9 for this trademark*).
 4,152,341 (*See Class 6 for this trademark*).
 4,152,343. **HIUT (STANDARD CHARACTER)**. HIUT LIMITED, MULTIPLE CLASS, (INT. CLS. 16, 18 AND 25), (U.S. CLS. 1, 2, 3, 5, 22, 23, 29, 37, 38, 39, 41 AND 50). SN 79-100,276. PUB. 3-20-2012. FILED 5-10-2011.
 4,152,365. **GAM 1925 AND DESIGN**. GONZAGAREDI SOCIETA' COOPERATIVA, MULTIPLE CLASS, (INT. CLS. 16, 20 AND 28), (U.S. CLS. 2, 5, 13, 22, 23, 25, 29, 32, 37, 38 AND 50). SN 79-101,401. PUB. 3-20-2012. FILED 4-8-2011.
 4,152,367 (*See Class 9 for this trademark*).
 4,152,409. **OFFICE VIP (STANDARD CHARACTER)**. STATE-SIDE MEDIA LIMITED, MULTIPLE CLASS, (INT. CLS. 16, 35 AND 41), (U.S. CLS. 2, 5, 22, 23, 29, 37, 38, 50, 100, 101, 102 AND 107). SN 79-104,335. PUB. 3-20-2012. FILED 9-22-2011.
 4,152,463. **AMPLEFORTH (STANDARD CHARACTER)**. AMPLEFORTH ABBEY TRUST, MULTIPLE CLASS, (INT. CLS. 16, 30, 32, 33, 41, 43 AND 45), (U.S. CLS. 2, 5, 22, 23, 29, 37, 38, 45, 46, 47, 48, 49, 50, 100, 101 AND 107). SN 85-064,348. PUB. 1-17-2012. FILED 6-16-2010.
 4,152,470. **MODA BRASIL MAGAZINE (STYLIZED)**. MATOS, WANDERLEY A., (U.S. CLS. 2, 5, 22, 23, 29, 37, 38 AND 50). SN 85-082,118. PUB. 3-20-2012. FILED 7-11-2010.
 4,152,473 (*See Class 9 for this trademark*).
 4,152,476. **HOME HOUSE AND DESIGN**. HOME HOUSE LIMITED, MULTIPLE CLASS, (INT. CLS. 16, 41, 43 AND 45), (U.S. CLS. 2, 5, 22, 23, 29, 37, 38, 50, 100, 101 AND 107). SN 85-090,418. PUB. 11-29-2011. FILED 7-22-2010.

- 4,152,478. **AIRZONE XTREME (STANDARD CHARACTER)**. TRACH, ANN, ROSE, (U.S. CLS. 2, 5, 22, 23, 29, 37, 38 AND 50). SN 85-091,152. PUB. 3-20-2012. FILED 7-22-2010.
- 4,152,491 (*See Class 9 for this trademark*).
- 4,152,507 (*See Class 3 for this trademark*).
- 4,152,548. **SMILO DESTINATION MANAGEMENT AND DESIGN**. ORIZONIA DESTINATION MANAGEMENT, S.L., MULTIPLE CLASS, (INT. CLS. 16, 39 AND 43), (U.S. CLS. 2, 5, 22, 23, 29, 37, 38, 50, 100, 101 AND 105). SN 85-153,777. PUB. 8-23-2011. FILED 10-15-2010.
- 4,152,574. **GRENCORE (STANDARD CHARACTER)**. PETOSKEY PLASTICS, INC., MULTIPLE CLASS, (INT. CLS. 16 AND 18), (U.S. CLS. 1, 2, 3, 5, 22, 23, 29, 37, 38, 41 AND 50). SN 85-178,123. PUB. 3-20-2012. FILED 11-16-2010.
- 4,152,587 (*See Class 9 for this trademark*).
- 4,152,603. **GOURMET PILGRIM AND DESIGN**. GOURMET PILGRIM PTY LTD, MULTIPLE CLASS, (INT. CLS. 16 AND 41), (U.S. CLS. 2, 5, 22, 23, 29, 37, 38, 50, 100, 101 AND 107). SN 85-211,696. PUB. 3-20-2012. FILED 1-6-2011.
- 4,152,616. **PERFORMANCE IN EVERY FIBRE (STANDARD CHARACTER)**. KRUGER PRODUCTS L.P., MULTIPLE CLASS, (INT. CLS. 16, 21 AND 35), (U.S. CLS. 2, 5, 13, 22, 23, 29, 30, 33, 37, 38, 40, 50, 100, 101 AND 102). SN 85-223,488. PUB. 3-20-2012. FILED 1-21-2011.
- 4,152,639. **RENAISSANCE SCHOOL IMPROVEMENT (STANDARD CHARACTER)**. RENAISSANCE LEARNING, INC., MULTIPLE CLASS, (INT. CLS. 16 AND 41), (U.S. CLS. 2, 5, 22, 23, 29, 37, 38, 50, 100, 101 AND 107). SN 85-242,286. PUB. 3-20-2012. FILED 2-15-2011.
- 4,152,658 (*See Class 1 for this trademark*).
- 4,152,660. **FUTURE OF HEALTH TECHNOLOGY JOURNAL (STANDARD CHARACTER)**. BUSHKO, RENATA G, DBA FUTURE OF HEALTH TECHNOLOGY INSTITUTE, (U.S. CLS. 2, 5, 22, 23, 29, 37, 38 AND 50). SN 85-257,963. PUB. 3-20-2012. FILED 3-4-2011.
- 4,152,669. **ECCE (STANDARD CHARACTER)**. CAMBRIDGE MICHIGAN LANGUAGE ASSESSMENT LLC, (U.S. CLS. 2, 5, 22, 23, 29, 37, 38 AND 50). SN 85-262,734. PUB. 3-20-2012. FILED 3-9-2011.
- 4,152,683. **BRING YOUR ART TO LIFE (STANDARD CHARACTER)**. GRAPHIK DIMENSIOONS, LTD., MULTIPLE CLASS, (INT. CLS. 16 AND 20), (U.S. CLS. 2, 5, 13, 22, 23, 25, 29, 32, 37, 38 AND 50). SN 85-272,625. PUB. 3-20-2012. FILED 3-21-2011.
- 4,152,697. **GRATITUDE SEASHELLS (STANDARD CHARACTER)**. GRATITUDE SEASHELLS, LLC, (U.S. CLS. 2, 5, 22, 23, 29, 37, 38 AND 50). SN 85-279,000. PUB. 3-20-2012. FILED 3-28-2011.
- 4,152,701. **BÜLOW (STANDARD CHARACTER)**. ALDERAAN HOLDINGS CO. LLC, (U.S. CLS. 2, 5, 22, 23, 29, 37, 38 AND 50). SN 85-279,411. PUB. 3-20-2012. FILED 3-29-2011.
- 4,152,739. **FILERTEK (STANDARD CHARACTER)**. FILERTEK INTERNATIONAL PTY LTD, (U.S. CLS. 2, 5, 22, 23, 29, 37, 38 AND 50). SN 85-292,447. PUB. 3-20-2012. FILED 4-12-2011.
- 4,152,799. **PETER BENCHLEY (STANDARD CHARACTER)**. WENDY W. BENCHLEY, (U.S. CLS. 2, 5, 22, 23, 29, 37, 38 AND 50). SN 85-298,816. PUB. 3-20-2012. FILED 4-19-2011.
- 4,152,802 (*See Class 9 for this trademark*).
- 4,152,861. **BOYER COMMUNICATIONS GROUP MAXIMUM IMPACT / MINIMUM PREP AND DESIGN**. BRADLEY COMMUNICATIONS GROUP, INC., DBA BOYER COMMUNICATIONS GROUP, MULTIPLE CLASS, (INT. CLS. 16 AND 41), (U.S. CLS. 2, 5, 22, 23, 29, 37, 38, 50, 100, 101 AND 107). SN 85-310,205. PUB. 3-20-2012. FILED 5-2-2011.
- 4,152,880. **ROTOREADER (STANDARD CHARACTER)**. ROMANOFF PRODUCTS, INC., (U.S. CLS. 2, 5, 22, 23, 29, 37, 38 AND 50). SN 85-313,912. PUB. 3-20-2012. FILED 5-6-2011.
- 4,152,909. **WORLD CLASS DEALER SERVICES INC. AND DESIGN**. WORLD CLASS DEALER SERVICES INCORPORATED, MULTIPLE CLASS, (INT. CLS. 16 AND 41), (U.S. CLS. 2, 5, 22, 23, 29, 37, 38, 50, 100, 101 AND 107). SN 85-320,455. PUB. 3-20-2012. FILED 5-13-2011.
- 4,152,931. **CREMATION ASSURANCE AND DESIGN**. RIEMANN FUNERAL HOMES, INC., MULTIPLE CLASS, (INT. CLS. 16, 36 AND 45), (U.S. CLS. 2, 5, 22, 23, 29, 37, 38, 50, 100, 101 AND 102). SN 85-327,541. PUB. 3-20-2012. FILED 5-23-2011.
- 4,152,934 (*See Class 9 for this trademark*).
- 4,152,935 (*See Class 9 for this trademark*).
- 4,152,937 (*See Class 9 for this trademark*).
- 4,152,944. **NATIONAL JOURNAL DAILY (STANDARD CHARACTER)**. ATLANTIC MEDIA COMPANY, (U.S. CLS. 2, 5, 22, 23, 29, 37, 38 AND 50). SN 85-329,951. PUB. 3-20-2012. FILED 5-25-2011.
- 4,152,946 (*See Class 9 for this trademark*).
- 4,152,965. **POWER LEARNING (STANDARD CHARACTER)**. EDUPOWER, INC., (U.S. CLS. 2, 5, 22, 23, 29, 37, 38 AND 50). SN 85-336,343. PUB. 3-20-2012. FILED 6-2-2011.
- 4,152,984. **WICKED CATCH (STANDARD CHARACTER)**. SILVERS, JOSHUA, (U.S. CLS. 2, 5, 22, 23, 29, 37, 38 AND 50). SN 85-342,561. PUB. 3-20-2012. FILED 6-9-2011.
- 4,153,025. **EPIC POKER (STANDARD CHARACTER)**. FEDERATED SPORTS & GAMING, INC., MULTIPLE CLASS, (INT. CLS. 16 AND 41), (U.S. CLS. 2, 5, 22, 23, 29, 37, 38, 50, 100, 101 AND 107). SN 85-355,771. PUB. 3-20-2012. FILED 6-24-2011.
- 4,153,026. **EPIC POKER AND DESIGN**. FEDERATED SPORTS & GAMING, INC., MULTIPLE CLASS, (INT. CLS. 16 AND 41), (U.S. CLS. 2, 5, 22, 23, 29, 37, 38, 50, 100, 101 AND 107). SN 85-355,824. PUB. 3-20-2012. FILED 6-24-2011.
- 4,153,098. **REFLECTION CREEK (STANDARD CHARACTER)**. CHOLEWA, OLIVIA MARIA, (U.S. CLS. 2, 5, 22, 23, 29, 37, 38 AND 50). SN 85-380,334. PUB. 3-20-2012. FILED 7-25-2011.
- 4,153,101. **QUALITY IS OUR IMAGE (STANDARD CHARACTER)**. AMERICAN COLLEGE OF RADIOLOGY, MULTIPLE CLASS, (INT. CLS. 16, 35, 41, 42 AND 44), (U.S. CLS. 2, 5, 22, 23, 29, 37, 38, 50, 100, 101, 102 AND 107). SN 85-381,373. PUB. 3-20-2012. FILED 7-26-2011.
- 4,153,131. **EL IMAGENERO (STANDARD CHARACTER)**. DOUGLAS W. GASTELUM, DBA EL IMAGENERO, MULTIPLE CLASS, (INT. CLS. 16 AND 41), (U.S. CLS. 2, 5, 22, 23, 29, 37, 38, 50, 100, 101 AND 107). SN 85-391,511. PUB. 3-20-2012. FILED 8-6-2011.
- 4,153,153. **DURA-TAC (STANDARD CHARACTER)**. MERCHANT GENERAL CORPORATION, (U.S. CLS. 2, 5, 22, 23, 29, 37, 38 AND 50). SN 85-395,632. PUB. 3-20-2012. FILED 8-11-2011.
- 4,153,154. **ACRILUX (STANDARD CHARACTER)**. MERCHANT GENERAL CORPORATION, (U.S. CLS. 2, 5, 22, 23, 29, 37, 38 AND 50). SN 85-395,672. PUB. 3-20-2012. FILED 8-11-2011.
- 4,153,171. **TRAPMAN AND DESIGN**. PETER J. MIELE, (U.S. CLS. 2, 5, 22, 23, 29, 37, 38 AND 50). SN 85-399,086. PUB. 3-20-2012. FILED 8-16-2011.
- 4,153,209. **DOW JONES (STANDARD CHARACTER)**. DOW JONES TRADEMARK HOLDINGS LLC, (U.S. CLS. 2, 5, 22, 23, 29, 37, 38 AND 50). SN 85-408,462. PUB. 3-20-2012. FILED 8-26-2011.
- 4,153,218. **MISCELLANEOUS DESIGN**. PERFECT CIRCLE PUBLISHING, INC., (U.S. CLS. 2, 5, 22, 23, 29, 37, 38 AND 50). SN 85-410,696. PUB. 3-20-2012. FILED 8-30-2011.
- 4,153,281. **QUIZZEL AND DESIGN**. RELENTLESS SOFTWARE LIMITED, MULTIPLE CLASS, (INT. CLS. 16, 25, 28 AND 41), (U.S. CLS. 2, 5, 22, 23, 29, 37, 38, 39, 50, 100, 101 AND 107). SN 85-419,862. PUB. 3-20-2012. FILED 9-12-2011.
- 4,153,305. **THE PILL BAG AND DESIGN**. BUILDING BETTER SOLUTIONS GROUP, INC, (U.S. CLS. 2, 5, 22, 23, 29, 37, 38 AND 50). SN 85-422,350. PUB. 3-20-2012. FILED 9-14-2011.
- 4,153,327. **PETZL FONDATION AND DESIGN**. BIG BANG, MULTIPLE CLASS, (INT. CLS. 16, 41 AND 42), (U.S. CLS. 2, 5, 22, 23, 29, 37, 38, 50, 100, 101 AND 107). SN 85-423,803. PUB. 3-20-2012. FILED 9-15-2011.
- 4,153,361. **EF EPI ENGLISH PROFICIENCY INDEX (STANDARD CHARACTER)**. SIGNUM INTERNATIONAL S.A.R.L., MULTIPLE CLASS, (INT. CLS. 16, 35 AND 41), (U.S. CLS. 2, 5, 22, 23, 29, 37, 38, 50, 100, 101, 102 AND 107). SN 85-427,946. PUB. 3-20-2012. FILED 9-21-2011.
- 4,153,413. **UNIQUE BREEDZ (STANDARD CHARACTER)**. EVERETT HUBER, (U.S. CLS. 2, 5, 22, 23, 29, 37, 38 AND 50). SN 85-431,770. PUB. 3-20-2012. FILED 9-26-2011.
- 4,153,422. **FORTESTA (TESTOSTERONE) GEL CHII AND DESIGN**. ENDO PHARMACEUTICALS INC., MULTIPLE CLASS, (INT. CLS. 16 AND 44), (U.S. CLS. 2, 5, 22, 23, 29, 37, 38, 50, 100 AND 101). SN 85-432,595. PUB. 3-20-2012. FILED 9-27-2011.

4,153,426. **THE CARTOON BANK A NEW YORKER MAGAZINE COMPANY AND DESIGN.** ADVANCE MAGAZINE PUBLISHERS INC., (U.S. CLS. 2, 5, 22, 23, 29, 37, 38 AND 50). SN 85-433,122. PUB. 3-20-2012. FILED 9-27-2011.

4,153,435 (*See Class 9 for this trademark.*)

4,153,542. **ULTRASMOOTH (STANDARD CHARACTER).** EPSON AMERICA, INC., (U.S. CLS. 2, 5, 22, 23, 29, 37, 38 AND 50). SN 85-438,137. PUB. 3-20-2012. FILED 10-3-2011.

4,153,564. **IRON BUTTERFLIES COLLECTION (STANDARD CHARACTER).** THE WHITE DOVE GROUP INC, DBA WHITE DOVE, (U.S. CLS. 2, 5, 22, 23, 29, 37, 38 AND 50). SN 85-438,677. PUB. 3-20-2012. FILED 10-4-2011.

4,153,605. **GET OUT CHATTANOOGA (STANDARD CHARACTER).** CHATTANOOGA PUBLISHING COMPANY, MULTIPLE CLASS, (INT. CLS. 16 AND 41), (U.S. CLS. 2, 5, 22, 23, 29, 37, 38, 50, 100, 101 AND 107). SN 85-439,664. PUB. 3-20-2012. FILED 10-5-2011.

4,153,703. **PROJECT SELECT (STYLIZED).** LINZER PRODUCTS CORP., (U.S. CLS. 2, 5, 22, 23, 29, 37, 38 AND 50). SN 85-441,592. PUB. 3-20-2012. FILED 10-7-2011.

4,153,721. **PREACHING THE WORD (STANDARD CHARACTER).** GOOD NEWS PUBLISHERS, (U.S. CLS. 2, 5, 22, 23, 29, 37, 38 AND 50). SN 85-441,745. PUB. 3-20-2012. FILED 10-7-2011.

4,153,755. **PRISM (STANDARD CHARACTER).** 21ST EDITIONS, INC., (U.S. CLS. 2, 5, 22, 23, 29, 37, 38 AND 50). SN 85-442,071. PUB. 3-20-2012. FILED 10-7-2011.

4,153,826. **BETTERTOGETHER (STANDARD CHARACTER).** REINFELDT, SUSAN, (U.S. CLS. 2, 5, 22, 23, 29, 37, 38 AND 50). SN 85-442,803. PUB. 3-20-2012. FILED 10-8-2011.

4,153,837. **MOONSUNG (STANDARD CHARACTER).** REYNOLDS, JONATHAN HAL, (U.S. CLS. 2, 5, 22, 23, 29, 37, 38 AND 50). SN 85-442,888. PUB. 3-20-2012. FILED 10-9-2011.

4,153,869. **TAME (STANDARD CHARACTER).** RHOADES, CONNIE, (U.S. CLS. 2, 5, 22, 23, 29, 37, 38 AND 50). SN 85-443,262. PUB. 3-20-2012. FILED 10-10-2011.

4,153,870. **EDIBLE MONTEREY BAY (STANDARD CHARACTER).** EDIBLE COMMUNITIES, INC., (U.S. CLS. 2, 5, 22, 23, 29, 37, 38 AND 50). SN 85-443,268. PUB. 3-20-2012. FILED 10-10-2011.

4,153,906. **THE WHY? BEHIND THE BUY (STANDARD CHARACTER).** ACOSTA, INC., (U.S. CLS. 2, 5, 22, 23, 29, 37, 38 AND 50). SN 85-443,585. PUB. 3-20-2012. FILED 10-10-2011.

4,153,917. **TERRACON (STYLIZED).** TT COMPANIES, INC., FORMERLY TERRACON, INC., MULTIPLE CLASS, (INT. CLS. 16 AND 42), (U.S. CLS. 2, 5, 22, 23, 29, 37, 38, 50, 100 AND 101). SN 85-443,770. PUB. 3-20-2012. FILED 10-10-2011.

4,153,923. **ON THE DOT THE PERFECT SPOT AND DESIGN.** ON THE DOT LLC, (U.S. CLS. 2, 5, 22, 23, 29, 37, 38 AND 50). SN 85-443,851. PUB. 3-20-2012. FILED 10-10-2011.

4,153,962. **PINUPS FOR PATRIOTS AND DESIGN.** STARS AND STRIPES MARKETING LLC, (U.S. CLS. 2, 5, 22, 23, 29, 37, 38 AND 50). SN 85-444,174. PUB. 3-20-2012. FILED 10-11-2011.

4,154,018 (*See Class 9 for this trademark.*)

4,154,037. **YOU'RE CLUELESS AND DESIGN.** YOU'RE CLUELESS, INC., MULTIPLE CLASS, (INT. CLS. 16 AND 35), (U.S. CLS. 2, 5, 22, 23, 29, 37, 38, 50, 100, 101 AND 102). SN 85-445,135. PUB. 3-20-2012. FILED 10-12-2011.

4,154,175. **INEO GLOSS AND DESIGN.** CELLMARK PAPER, INC., (U.S. CLS. 2, 5, 22, 23, 29, 37, 38 AND 50). SN 85-458,165. PUB. 3-20-2012. FILED 10-27-2011.

4,154,183. **TROPICAL GETAWAY (STANDARD CHARACTER).** MEADWESTVACO CORPORATION, (U.S. CLS. 2, 5, 22, 23, 29, 37, 38 AND 50). SN 85-462,201. PUB. 3-20-2012. FILED 11-2-2011.

4,154,189. **CITYLIFE (STANDARD CHARACTER).** THE NAVIGATORS, (U.S. CLS. 2, 5, 22, 23, 29, 37, 38 AND 50). SN 85-464,145. PUB. 3-20-2012. FILED 11-3-2011.

4,154,226. **W AND DESIGN.** CRABAR/GBF, INC., MULTIPLE CLASS, (INT. CLS. 16 AND 40), (U.S. CLS. 2, 5, 22, 23, 29, 37, 38, 50, 100, 103 AND 106). SN 85-496,491. PUB. 3-20-2012. FILED 12-15-2011.

4,154,233 (*See Class 9 for this trademark.*)

4,154,236. **PASS ME SAFELEE (STANDARD CHARACTER).** LEE MEMORIAL HEALTH SYSTEM, (U.S. CLS. 2, 5, 22, 23, 29, 37, 38 AND 50). SN 85-517,059. PUB. 3-20-2012. FILED 1-

16-2012.

CLASS 17—RUBBER GOODS

4,152,081. **EPI (STANDARD CHARACTER).** OSTERMAN & COMPANY, INC., MULTIPLE CLASS, (INT. CLS. 17, 35, 40 AND 42), (U.S. CLS. 1, 5, 12, 13, 35, 50, 100, 101, 102, 103 AND 106). SN 77-360,406. PUB. 12-13-2011. FILED 12-27-2007.

4,152,197 (*See Class 1 for this trademark.*)

4,152,223 (*See Class 9 for this trademark.*)

4,152,284. **MORISEI (STYLIZED).** MORISEI KAKO CO., LTD., (U.S. CLS. 1, 5, 12, 13, 35 AND 50). SN 79-098,341. PUB. 3-20-2012. FILED 4-21-2011.

4,152,293. **DESIGNING SILENCE (STANDARD CHARACTER).** TEXAA, MULTIPLE CLASS, (INT. CLS. 17, 20 AND 24), (U.S. CLS. 1, 2, 5, 12, 13, 22, 25, 32, 35, 42 AND 50). SN 79-098,525. PUB. 3-20-2012. FILED 5-10-2011.

4,152,341 (*See Class 6 for this trademark.*)

4,152,355 (*See Class 1 for this trademark.*)

4,152,356 (*See Class 1 for this trademark.*)

4,152,408 (*See Class 9 for this trademark.*)

4,152,487. **AZOTE (STANDARD CHARACTER).** ZOTEFOMAS PLC, (U.S. CLS. 1, 5, 12, 13, 35 AND 50). SN 85-100,395. PUB. 2-14-2012. FILED 8-4-2010.

4,152,658 (*See Class 1 for this trademark.*)

4,152,698 (*See Class 1 for this trademark.*)

4,152,760 (*See Class 1 for this trademark.*)

4,153,237 (*See Class 11 for this trademark.*)

4,153,252. **PINTA (STANDARD CHARACTER).** GOLTERMAN & SABO, INC., (U.S. CLS. 1, 5, 12, 13, 35 AND 50). SN 85-415,632. PUB. 3-20-2012. FILED 9-6-2011.

4,153,882. **SPEEDSET (STANDARD CHARACTER).** ENCORE RAIL SYSTEMS, INC., (U.S. CLS. 1, 5, 12, 13, 35 AND 50). SN 85-443,408. PUB. 3-20-2012. FILED 10-10-2011.

4,153,883. **SPEEDSET AND DESIGN.** ENCORE RAIL SYSTEMS, INC., (U.S. CLS. 1, 5, 12, 13, 35 AND 50). SN 85-443,411. PUB. 3-20-2012. FILED 10-10-2011.

4,154,028. **LCY CHEMICAL CORP. (STANDARD CHARACTER).** LCY ELASTOMERS LP, (U.S. CLS. 1, 5, 12, 13, 35 AND 50). SN 85-444,874. PUB. 3-20-2012. FILED 10-11-2011.

4,154,197. **CERAMAPEEK (STANDARD CHARACTER).** PROFESSIONAL PLASTICS, INC., (U.S. CLS. 1, 5, 12, 13, 35 AND 50). SN 85-467,734. PUB. 3-20-2012. FILED 11-8-2011.

4,154,198. **KAPTREX (STANDARD CHARACTER).** PROFESSIONAL PLASTICS, INC., (U.S. CLS. 1, 5, 12, 13, 35 AND 50). SN 85-467,742. PUB. 3-20-2012. FILED 11-8-2011.

CLASS 18—LEATHER GOODS

4,152,047. **KNIT LOCAL AND DESIGN.** ZEISEL, LAURA, (U.S. CLS. 1, 2, 3, 22 AND 41). SN 76-707,201. PUB. 3-20-2012. FILED 4-11-2011.

4,152,073. **DOES YOUR DOG BARKSTRONG (STYLIZED).** OHMAN, CHRIS, (U.S. CLS. 1, 2, 3, 22 AND 41). SN 77-060,432. PUB. 3-20-2012. FILED 12-8-2006.

4,152,173. **DOXLOCK TECHNICAL K9 EQUIPMENT AND DESIGN.** MICHAEL PRAIG, MULTIPLE CLASS, (INT. CLS. 18, 25 AND 28), (U.S. CLS. 1, 2, 3, 22, 23, 38, 39, 41 AND 50). SN 79-083,995. PUB. 3-20-2012. FILED 4-9-2010.

4,152,188 (*See Class 3 for this trademark.*)

4,152,193 (*See Class 3 for this trademark.*)

4,152,198 (*See Class 3 for this trademark.*)

4,152,208. **STAR BY JULIEN MACDONALD (STANDARD CHARACTER).** JULIEN MACDONALD LIMITED, MULTIPLE CLASS, (INT. CLS. 18, 24 AND 25), (U.S. CLS. 1, 2, 3, 22, 39, 41, 42 AND 50). SN 79-092,178. PUB. 3-20-2012. FILED 11-16-2010.

4,152,214 (*See Class 9 for this trademark.*)

4,152,222 (*See Class 9 for this trademark.*)

4,152,235. **ZONKEY BOOT (STANDARD CHARACTER).** MICHAEL ROLLIG, AND ALEXANDRA-ROXANA DIACONU, MULTIPLE CLASS, (INT. CLS. 18 AND 25), (U.S. CLS. 1, 2, 3, 22, 39 AND 41). SN 79-095,787. PUB. 3-20-2012. FILED

- 3-29-2011.
 4,152,241 (*See Class 9 for this trademark*).
 4,152,242 (*See Class 8 for this trademark*).
 4,152,244. **MONOCROM AND DESIGN**. DAFF SRL, AND ROBERTO DALLARMI, AND SIMONE MELANI, AND RAAL S.R.L., MULTIPLE CLASS, (INT. CLS. 18 AND 25), (U.S. CLS. 1, 2, 3, 22, 39 AND 41). SN 79-096,544. PUB. 3-20-2012. FILED 4-8-2011.
 4,152,248 (*See Class 16 for this trademark*).
 4,152,270. **PROONE 1 (STYLIZED)**. PROVASI ROBERTO, MULTIPLE CLASS, (INT. CLS. 18, 25 AND 28), (U.S. CLS. 1, 2, 3, 22, 23, 38, 39, 41 AND 50). SN 79-097,844. PUB. 3-20-2012. FILED 4-19-2011.
 4,152,271. **PROONE (STANDARD CHARACTER)**. PROVASI ROBERTO, MULTIPLE CLASS, (INT. CLS. 18, 25 AND 28), (U.S. CLS. 1, 2, 3, 22, 23, 38, 39, 41 AND 50). SN 79-097,845. PUB. 3-20-2012. FILED 4-19-2011.
 4,152,272 (*See Class 3 for this trademark*).
 4,152,278. **J.C. RAGS AND DESIGN**. J.C. RAGS B.V., MULTIPLE CLASS, (INT. CLS. 18 AND 25), (U.S. CLS. 1, 2, 3, 22, 39 AND 41). SN 79-098,113. PUB. 3-20-2012. FILED 4-20-2011.
 4,152,283. **ADJANI (STANDARD CHARACTER)**. ISABELLE ADJANI C/O ISIA FILMS, (U.S. CLS. 1, 2, 3, 22 AND 41). SN 79-098,257. PUB. 3-20-2012. FILED 3-16-2011.
 4,152,289 (*See Class 9 for this trademark*).
 4,152,313. **SIR MAX (STANDARD CHARACTER)**. SIR MAX B.V., MULTIPLE CLASS, (INT. CLS. 18, 25 AND 35), (U.S. CLS. 1, 2, 3, 22, 39, 41, 100, 101 AND 102). SN 79-099,188. PUB. 3-20-2012. FILED 12-31-2010.
 4,152,343 (*See Class 16 for this trademark*).
 4,152,354. **F-PAC (STANDARD CHARACTER)**. ALAN WAYNE STRANG, (U.S. CLS. 1, 2, 3, 22 AND 41). SN 79-100,775. PUB. 3-20-2012. FILED 6-20-2011.
 4,152,394 (*See Class 3 for this trademark*).
 4,152,430. **BAMBRELLA FOR A GREENER WORLD AND DESIGN**. WOODSTOCKS INTERNATIONAL LTD.; JAN AUKSTOLIS, MULTIPLE CLASS, (INT. CLS. 18 AND 20), (U.S. CLS. 1, 2, 3, 13, 22, 25, 32, 41 AND 50). SN 79-106,381. PUB. 3-20-2012. FILED 6-3-2011.
 4,152,436 (*See Class 3 for this trademark*).
 4,152,473 (*See Class 9 for this trademark*).
 4,152,507 (*See Class 3 for this trademark*).
 4,152,574 (*See Class 16 for this trademark*).
 4,152,594. **WORK IN PROGRESS (STANDARD CHARACTER)**. CARHARTT, INC., MULTIPLE CLASS, (INT. CLS. 18 AND 25), (U.S. CLS. 1, 2, 3, 22, 39 AND 41). SN 85-201,534. PUB. 3-20-2012. FILED 12-20-2010.
 4,152,622. **HILARY LAMON (STANDARD CHARACTER)**. LAMON, HILARY B., (U.S. CLS. 1, 2, 3, 22 AND 41). SN 85-227,216. PUB. 3-20-2012. FILED 1-26-2011.
 4,152,624. **F1 FORMULA 1 (STYLIZED)**. FORMULA ONE LICENSING BV, (U.S. CLS. 1, 2, 3, 22 AND 41). SN 85-228,567. PUB. 3-20-2012. FILED 1-28-2011.
 4,152,630 (*See Class 3 for this trademark*).
 4,152,658 (*See Class 1 for this trademark*).
 4,152,706. **ROBINSON (STANDARD CHARACTER)**. RIVER LIGHT V, L.P., (U.S. CLS. 1, 2, 3, 22 AND 41). SN 85-281,990. PUB. 3-20-2012. FILED 3-31-2011.
 4,152,770. **EDITH A. MILLER AND DESIGN**. EDITH A. MILLER, LLC, MULTIPLE CLASS, (INT. CLS. 18 AND 25), (U.S. CLS. 1, 2, 3, 22, 39 AND 41). SN 85-296,202. PUB. 3-20-2012. FILED 4-15-2011.
 4,152,771. **EDITH A. MILLER (STANDARD CHARACTER)**. EDITH A. MILLER, LLC, MULTIPLE CLASS, (INT. CLS. 18 AND 25), (U.S. CLS. 1, 2, 3, 22, 39 AND 41). SN 85-296,208. PUB. 3-20-2012. FILED 4-15-2011.
 4,152,897. **SAN ANTONIO STOCK SHOW & RODEO AND DESIGN**. SAN ANTONIO LIVESTOCK EXPOSITION, INC., (U.S. CLS. 1, 2, 3, 22 AND 41). SN 85-316,960. PUB. 3-20-2012. FILED 5-10-2011.
 4,152,916. **CHAMIAN RENEE (STYLIZED)**. DZNR CHIC L.L.C., MULTIPLE CLASS, (INT. CLS. 18, 25 AND 45), (U.S. CLS. 1, 2, 3, 22, 39, 41, 100 AND 101). SN 85-321,858. PUB. 3-20-2012. FILED 5-16-2011.
 4,153,140. **TINNIE BERLINIE (STANDARD CHARACTER)**. ESCOBAR, DELIA P., (U.S. CLS. 1, 2, 3, 22 AND 41). SN 85-393,647. PUB. 3-20-2012. FILED 8-9-2011.
 4,153,181. **MINNETONKA AND DESIGN**. MINNETONKA MOCCASIN COMPANY, INC., MULTIPLE CLASS, (INT. CLS. 18 AND 25), (U.S. CLS. 1, 2, 3, 22, 39 AND 41). SN 85-402,120. PUB. 3-20-2012. FILED 8-19-2011.
 4,153,282 (*See Class 3 for this trademark*).
 4,153,338. **GREAT AMERICAN CANVAS COMPANY (STANDARD CHARACTER)**. URBAN ATTITUDES, (U.S. CLS. 1, 2, 3, 22 AND 41). SN 85-424,788. PUB. 3-20-2012. FILED 9-16-2011.
 4,153,435 (*See Class 9 for this trademark*).
 4,153,688 (*See Class 14 for this trademark*).
 4,153,719. **BAKER SHEET (STANDARD CHARACTER)**. THE CURVON CORPORATION, (U.S. CLS. 1, 2, 3, 22 AND 41). SN 85-441,719. PUB. 3-20-2012. FILED 10-7-2011.
 4,153,720. **5/A (STANDARD CHARACTER)**. THE CURVON CORPORATION, (U.S. CLS. 1, 2, 3, 22 AND 41). SN 85-441,737. PUB. 3-20-2012. FILED 10-7-2011.
 4,153,723. **BAKER (STANDARD CHARACTER)**. THE CURVON CORPORATION, (U.S. CLS. 1, 2, 3, 22 AND 41). SN 85-441,750. PUB. 3-20-2012. FILED 10-7-2011.
 4,153,731. **BAKER BLANKET (STANDARD CHARACTER)**. THE CURVON CORPORATION, (U.S. CLS. 1, 2, 3, 22 AND 41). SN 85-441,816. PUB. 3-20-2012. FILED 10-7-2011.
 4,153,734. **FF AND DESIGN**. LANGE, MIA P., MULTIPLE CLASS, (INT. CLS. 18 AND 25), (U.S. CLS. 1, 2, 3, 22, 39 AND 41). SN 85-441,873. PUB. 3-20-2012. FILED 10-7-2011.
 4,153,877. **TECHUNTER (STANDARD CHARACTER)**. GANDER MOUNTAIN COMPANY, (U.S. CLS. 1, 2, 3, 22 AND 41). SN 85-443,369. PUB. 3-20-2012. FILED 10-10-2011.
 4,154,018 (*See Class 9 for this trademark*).
 4,154,194. **LIVE LAUGH TAN (STANDARD CHARACTER)**. AUSTRALIAN GOLD, LLC, (U.S. CLS. 1, 2, 3, 22 AND 41). SN 85-465,713. PUB. 3-20-2012. FILED 11-7-2011.
 4,154,201. **KEY-PER (STANDARD CHARACTER)**. FOSSIL, INC., (U.S. CLS. 1, 2, 3, 22 AND 41). SN 85-474,228. PUB. 3-20-2012. FILED 11-16-2011.
 4,154,217. **MISCELLANEOUS DESIGN**. KARSTEN MANUFACTURING CORPORATION, (U.S. CLS. 1, 2, 3, 22 AND 41). SN 85-488,664. PUB. 3-6-2012. FILED 12-6-2011.
-
- CLASS 19—NON-METALLIC BUILDING MATERIALS**
- 4,152,184 (*See Class 6 for this trademark*).
 4,152,191 (*See Class 6 for this trademark*).
 4,152,220 (*See Class 6 for this trademark*).
 4,152,312 (*See Class 12 for this trademark*).
 4,152,341 (*See Class 6 for this trademark*).
 4,152,497 (*See Class 2 for this trademark*).
 4,152,527. **STARECASING AND DESIGN**. STARECASING INC., (U.S. CLS. 1, 12, 33 AND 50). SN 85-135,766. PUB. 3-20-2012. FILED 9-22-2010.
 4,152,658 (*See Class 1 for this trademark*).
 4,152,806 (*See Class 6 for this trademark*).
 4,152,921. **EAT, DRINK, & BEAT (STANDARD CHARACTER)**. EAT, DRINK, & BEAT LLC, (U.S. CLS. 1, 12, 33 AND 50). SN 85-323,352. PUB. 3-20-2012. FILED 5-17-2011.
 4,153,041 (*See Class 11 for this trademark*).
 4,153,042 (*See Class 11 for this trademark*).
 4,153,229. **RETROTEN (STANDARD CHARACTER)**. ADVANCE RESEARCH, LTD, (U.S. CLS. 1, 12, 33 AND 50). SN 85-412,446. PUB. 3-20-2012. FILED 8-31-2011.
 4,153,237 (*See Class 11 for this trademark*).
 4,153,364. **MEGADECK (STANDARD CHARACTER)**. SIGNATURE SYSTEMS GROUP, LLC, (U.S. CLS. 1, 12, 33 AND 50). SN 85-428,038. PUB. 3-20-2012. FILED 9-21-2011.
 4,153,450. **HALLMARK LUXURY VINYL (STANDARD CHARACTER)**. HALLMARK HARDWOODS, INC., (U.S. CLS. 1, 12, 33 AND 50). SN 85-434,639. PUB. 3-20-2012. FILED 9-28-2011.
 4,153,451. **VALUEMARK HARDWOODS (STANDARD CHARACTER)**. HALLMARK HARDWOODS, INC., (U.S. CLS. 1, 12, 33 AND 50). SN 85-434,663. PUB. 3-20-2012. FILED 9-28-2011.
 4,153,452. **HALLMARK FLOORS (STANDARD CHARACTER)**. HALLMARK HARDWOODS, INC., (U.S. CLS. 1, 12, 33 AND 50). SN 85-434,689. PUB. 3-20-2012. FILED 9-28-2011.

- 4,153,500. **VINE STREET TILE STUDIOS (STANDARD CHARACTER)**. HAMILTON PARKER COMPANY, LLC, (U.S. CLS. 1, 12, 33 AND 50). SN 85-436,938. PUB. 3-20-2012. FILED 9-30-2011.
- 4,153,623. **QWIK SLATE (STANDARD CHARACTER)**. QWIK SLATE, INC., (U.S. CLS. 1, 12, 33 AND 50). SN 85-440,183. PUB. 3-20-2012. FILED 10-5-2011.
- 4,153,625. **QWIK SLATE AND DESIGN**. QWIK SLATE, INC., (U.S. CLS. 1, 12, 33 AND 50). SN 85-440,210. PUB. 3-20-2012. FILED 10-5-2011.
- 4,153,648. **SWIM (STANDARD CHARACTER)**. MODULAR ARTS, INC., (U.S. CLS. 1, 12, 33 AND 50). SN 85-440,740. PUB. 3-20-2012. FILED 10-6-2011.
- 4,153,716. **GEO-BLUE WOOD (STANDARD CHARACTER)**. BLUE WORLD CRETE, INC. (U.S. CLS. 1, 12, 33 AND 50). SN 85-441,688. PUB. 3-20-2012. FILED 10-7-2011.
- 4,153,914. **LIFE FLOOR AND DESIGN**. MNY GROUP, LLC, (U.S. CLS. 1, 12, 33 AND 50). SN 85-443,672. PUB. 3-20-2012. FILED 10-10-2011.
- 4,154,117 (*See Class 9 for this trademark*).

CLASS 20—FURNITURE AND ARTICLES NOT OTHERWISE CLASSIFIED

- 4,152,038 (*See Class 16 for this trademark*).
- 4,152,061. **TABLETOPICS (STANDARD CHARACTER)**. HARBOR FURNITURE MANUFACTURING, INC., (U.S. CLS. 2, 13, 22, 25, 32 AND 50). SN 76-708,996. PUB. 3-20-2012. FILED 9-6-2011.
- 4,152,079 (*See Class 6 for this trademark*).
- 4,152,091 (*See Class 4 for this trademark*).
- 4,152,169 (*See Class 11 for this trademark*).
- 4,152,178 (*See Class 9 for this trademark*).
- 4,152,188 (*See Class 3 for this trademark*).
- 4,152,194 (*See Class 6 for this trademark*).
- 4,152,201. **SONIA RYKIEL (STANDARD CHARACTER)**. SONIA RYKIEL CREATION ET DIFFUSION DE MODELES, MULTIPLE CLASS, (INT. CLS. 20, 24 AND 26), (U.S. CLS. 2, 13, 22, 25, 32, 37, 39, 40, 42 AND 50). SN 79-090,699. PUB. 3-20-2012. FILED 10-26-2010.
- 4,152,226 (*See Class 3 for this trademark*).
- 4,152,242 (*See Class 8 for this trademark*).
- 4,152,292 (*See Class 11 for this trademark*).
- 4,152,293 (*See Class 17 for this trademark*).
- 4,152,335 (*See Class 11 for this trademark*).
- 4,152,365 (*See Class 16 for this trademark*).
- 4,152,379. **GRAMMER OFFICE (STANDARD CHARACTER)**. SATO OFFICE GMBH, (U.S. CLS. 2, 13, 22, 25, 32 AND 50). SN 79-102,701. PUB. 3-20-2012. FILED 6-14-2011.
- 4,152,381 (*See Class 6 for this trademark*).
- 4,152,430 (*See Class 18 for this trademark*).
- 4,152,435 (*See Class 6 for this trademark*).
- 4,152,450 (*See Class 6 for this trademark*).
- 4,152,473 (*See Class 9 for this trademark*).
- 4,152,507 (*See Class 3 for this trademark*).
- 4,152,683 (*See Class 16 for this trademark*).
- 4,152,836. **BEYOND (STANDARD CHARACTER)**. EBERHARD VON HUENE & ASSOCIATES INC., AKA EVH & ASSOCIATES INC., (U.S. CLS. 2, 13, 22, 25, 32 AND 50). SN 85-305,311. PUB. 3-20-2012. FILED 4-26-2011.
- 4,153,130. **NEW CLASSIC HOME FURNISHINGS, INC. (STYLIZED)**. NEW CLASSIC HOME FURNISHING, INC., (U.S. CLS. 2, 13, 22, 25, 32 AND 50). SN 85-390,782. PUB. 3-20-2012. FILED 8-5-2011.
- 4,153,359 (*See Class 12 for this trademark*).
- 4,153,701. **SEA HORSE AND DESIGN**. TYSON HOLDINGS LIMITED, (U.S. CLS. 2, 13, 22, 25, 32 AND 50). SN 85-441,575. PUB. 3-20-2012. FILED 10-7-2011.
- 4,154,169. **LOOK OUR WAY (STANDARD CHARACTER)**. TORERO SPECIALTY PRODUCTS, LLC, (U.S. CLS. 2, 13, 22, 25, 32 AND 50). SN 85-456,042. PUB. 3-20-2012. FILED 10-25-2011.

CLASS 21—HOUSEWARES AND GLASS

- 4,152,085 (*See Class 11 for this trademark*).
- 4,152,091 (*See Class 4 for this trademark*).
- 4,152,115. **PERFECTEMP (STANDARD CHARACTER)**. CONAIR CORPORATION, (U.S. CLS. 2, 13, 23, 29, 30, 33, 40 AND 50). SN 77-786,687. PUB. 3-20-2012. FILED 7-22-2009.
- 4,152,169 (*See Class 11 for this trademark*).
- 4,152,217. **DISHMATIC (STANDARD CHARACTER)**. EASY-DO PRODUCTS LIMITED, (U.S. CLS. 2, 13, 23, 29, 30, 33, 40 AND 50). SN 79-093,742. PUB. 3-20-2012. FILED 1-14-2011.
- 4,152,221 (*See Class 8 for this trademark*).
- 4,152,226 (*See Class 3 for this trademark*).
- 4,152,242 (*See Class 8 for this trademark*).
- 4,152,272 (*See Class 3 for this trademark*).
- 4,152,303. **SPARKLE AND DESIGN**. CRYSTALEX CZ, S.R.O., MULTIPLE CLASS, (INT. CLS. 21 AND 35), (U.S. CLS. 2, 13, 23, 29, 30, 33, 40, 50, 100, 101 AND 102). SN 79-098,773. PUB. 3-20-2012. FILED 2-8-2011.
- 4,152,312 (*See Class 12 for this trademark*).
- 4,152,335 (*See Class 11 for this trademark*).
- 4,152,462. **UNIVERSITY OF NORTH TEXAS DISCOVER THE POWER OF IDEAS (STANDARD CHARACTER)**. UNIVERSITY OF NORTH TEXAS, MULTIPLE CLASS, (INT. CLS. 21 AND 41), (U.S. CLS. 2, 13, 23, 29, 30, 33, 40, 50, 100, 101 AND 107). SN 85-061,582. PUB. 3-20-2012. FILED 6-13-2010.
- 4,152,473 (*See Class 9 for this trademark*).
- 4,152,474. **VISTA (STANDARD CHARACTER)**. PROTECT PLUS, LLC, (U.S. CLS. 2, 13, 23, 29, 30, 33, 40 AND 50). SN 85-089,606. PUB. 5-10-2011. FILED 7-21-2010.
- 4,152,507 (*See Class 3 for this trademark*).
- 4,152,535. **MISCELLANEOUS DESIGN**. DOSKOCIL MANUFACTURING COMPANY, INC., (U.S. CLS. 2, 13, 23, 29, 30, 33, 40 AND 50). SN 85-143,336. PUB. 3-20-2012. FILED 10-1-2010.
- 4,152,536. **MISCELLANEOUS DESIGN**. DOSKOCIL MANUFACTURING COMPANY, INC., (U.S. CLS. 2, 13, 23, 29, 30, 33, 40 AND 50). SN 85-143,350. PUB. 3-20-2012. FILED 10-1-2010.
- 4,152,616 (*See Class 16 for this trademark*).
- 4,152,654 (*See Class 10 for this trademark*).
- 4,152,898. **SAN ANTONIO STOCK SHOW & RODEO AND DESIGN**. SAN ANTONIO LIVESTOCK EXPOSITION, INC., (U.S. CLS. 2, 13, 23, 29, 30, 33, 40 AND 50). SN 85-316,966. PUB. 3-20-2012. FILED 5-10-2011.
- 4,152,940. **TREASURE VESSEL AND DESIGN**. SUITER, DONALD, (U.S. CLS. 2, 13, 23, 29, 30, 33, 40 AND 50). SN 85-328,761. PUB. 3-20-2012. FILED 5-24-2011.
- 4,153,037. **JOULIES (STANDARD CHARACTER)**. COFFEE JOULIES, LLC, (U.S. CLS. 2, 13, 23, 29, 30, 33, 40 AND 50). SN 85-359,627. PUB. 3-20-2012. FILED 6-29-2011.
- 4,153,259. **IWORK (STANDARD CHARACTER)**. JPJ INVESTMENT HOLDING CO., (U.S. CLS. 2, 13, 23, 29, 30, 33, 40 AND 50). SN 85-416,732. PUB. 3-20-2012. FILED 9-7-2011.
- 4,153,282 (*See Class 3 for this trademark*).
- 4,153,359 (*See Class 12 for this trademark*).
- 4,153,435 (*See Class 9 for this trademark*).
- 4,153,443. **VIVINT (STYLIZED)**. VIVINT, INC., (U.S. CLS. 2, 13, 23, 29, 30, 33, 40 AND 50). SN 85-434,450. PUB. 3-20-2012. FILED 9-28-2011.
- 4,153,527. **DIRECT TOP FEED (STANDARD CHARACTER)**. WAYNE E WOLF, DBA MODULARHYDRO, (U.S. CLS. 2, 13, 23, 29, 30, 33, 40 AND 50). SN 85-437,768. PUB. 3-20-2012. FILED 10-3-2011.
- 4,153,563 (*See Class 5 for this trademark*).
- 4,153,668 (*See Class 8 for this trademark*).
- 4,153,773. **PASSION BREWS PB AND DESIGN**. BRAY, MICHAEL S., (U.S. CLS. 2, 13, 23, 29, 30, 33, 40 AND 50). SN 85-442,249. PUB. 3-20-2012. FILED 10-7-2011.
- 4,153,782. **SUPER PEEL (STANDARD CHARACTER)**. EXO PRODUCTS, INC., (U.S. CLS. 2, 13, 23, 29, 30, 33, 40 AND 50). SN 85-442,324. PUB. 3-20-2012. FILED 10-7-2011.
- 4,154,018 (*See Class 9 for this trademark*).
- 4,154,085. **AEROSTREAM (STANDARD CHARACTER)**. STEMPNOWSKI, RICHARD, (U.S. CLS. 2, 13, 23, 29, 30, 33, 40 AND 50). SN 85-446,062. PUB. 3-20-2012. FILED 10-12-2011.
- 4,154,123. **MILLS FLEET FARM (STANDARD CHARACTER)**. FLEET WHOLESALE SUPPLY CO., INC., (U.S. CLS. 2, 13,

23, 29, 30, 33, 40 AND 50). SN 85-449,957. PUB. 3-20-2012. FILED 10-18-2011.
 4,154,180. **TRAVEL SMART (STANDARD CHARACTER)**. CONAIR CORPORATION, (U.S. CLS. 2, 13, 23, 29, 30, 33, 40 AND 50). SN 85-460,786. PUB. 3-20-2012. FILED 10-31-2011.

CLASS 22—CORDAGE AND FIBERS

4,152,194 (*See Class 6 for this trademark*).
 4,152,393 (*See Class 1 for this trademark*).
 4,152,507 (*See Class 3 for this trademark*).
 4,152,685 (*See Class 6 for this trademark*).
 4,152,791. **GENNIUS (STYLIZED)**. DURASOL AWNINGS, INC., (U.S. CLS. 1, 2, 7, 19, 22, 42 AND 50). SN 85-297,811. PUB. 3-20-2012. FILED 4-18-2011.
 4,153,156 (*See Class 7 for this trademark*).

CLASS 23—YARNS AND THREADS

4,152,393 (*See Class 1 for this trademark*).

CLASS 24—FABRICS

4,152,156. **THE WORLD FLAG (STANDARD CHARACTER)**. PAUL CARROLL, MULTIPLE CLASS, (INT. CLS. 24 AND 25), (U.S. CLS. 22, 39, 42 AND 50). SN 77-983,160. PUB. 2-8-2011. FILED 3-1-2010.
 4,152,188 (*See Class 3 for this trademark*).
 4,152,197 (*See Class 1 for this trademark*).
 4,152,201 (*See Class 20 for this trademark*).
 4,152,208 (*See Class 18 for this trademark*).
 4,152,242 (*See Class 8 for this trademark*).
 4,152,260. **TRAP EXPERIENCE AND DESIGN**. RICHARD LÖFFLER, MULTIPLE CLASS, (INT. CLS. 24 AND 25), (U.S. CLS. 22, 39, 42 AND 50). SN 79-097,471. PUB. 3-20-2012. FILED 4-5-2011.
 4,152,265. **LE GIOVENTÙ AND DESIGN**. NINGBO YOUNG-OR WORSTED SPINNING WEAVING & DYEING CO., LTD., (U.S. CLS. 42 AND 50). SN 79-097,577. PUB. 3-20-2012. FILED 1-4-2011.
 4,152,293 (*See Class 17 for this trademark*).
 4,152,436 (*See Class 3 for this trademark*).
 4,152,659. **ZZZZ AND DESIGN**. JBZ ENTERPRISES LLC, MULTIPLE CLASS, (INT. CLS. 24 AND 25), (U.S. CLS. 22, 39, 42 AND 50). SN 85-257,315. PUB. 3-20-2012. FILED 3-3-2011.
 4,153,397. **BLANKIE & ME (STANDARD CHARACTER)**. KAHN LUCAS LANCASTER, INC., MULTIPLE CLASS, (INT. CLS. 24 AND 28), (U.S. CLS. 22, 23, 38, 42 AND 50). SN 85-430,705. PUB. 3-20-2012. FILED 9-23-2011.
 4,153,563 (*See Class 5 for this trademark*).
 4,153,715. **CYPRESS (STANDARD CHARACTER)**. MONARCH TOWEL COMPANY, INC., MULTIPLE CLASS, (INT. CLS. 24 AND 27), (U.S. CLS. 19, 20, 37, 42 AND 50). SN 85-441,676. PUB. 3-20-2012. FILED 10-7-2011.
 4,153,958. **SALBAKOS (STANDARD CHARACTER)**. MAKRO-TEKS TEXTILE, LLC, (U.S. CLS. 42 AND 50). SN 85-444,163. PUB. 3-20-2012. FILED 10-11-2011.
 4,154,040. **NOVASPAN (STANDARD CHARACTER)**. NOVAWALL SYSTEMS, INC., (U.S. CLS. 42 AND 50). SN 85-445,164. PUB. 3-20-2012. FILED 10-12-2011.

CLASS 25—CLOTHING

4,152,038 (*See Class 16 for this trademark*).
 4,152,043. **KEEZ CLOTHING AND DESIGN**. MEHDI LAISSAOUI, AKA MOROCCO YANKEE, (U.S. CLS. 22 AND 39). SN 76-706,631. PUB. 3-20-2012. FILED 3-2-2011.

4,152,053. **MENERVIA M DARE U TO BE U AND DESIGN**. AKERS, MENERVIA M., (U.S. CLS. 22 AND 39). SN 76-707,725. PUB. 3-20-2012. FILED 5-20-2011.
 4,152,072 (*See Class 3 for this trademark*).
 4,152,090. **PAL FASHIONS N NAARI EMBROIDERY PYAARI SUNDAR NAARI AND DESIGN**. ACE IMPEX, (U.S. CLS. 22 AND 39). SN 77-513,739. PUB. 3-20-2012. FILED 7-2-2008.
 4,152,099. **VICTORIA PARK AND DESIGN**. 6751342 CANADA, INC., MULTIPLE CLASS, (INT. CLS. 25, 41 AND 44), (U.S. CLS. 22, 39, 100, 101 AND 107). SN 77-583,300. PUB. 3-20-2012. FILED 10-1-2008.
 4,152,140 (*See Class 3 for this trademark*).
 4,152,141. **SANMARCO (STANDARD CHARACTER)**. VIANA CANADA INC., (U.S. CLS. 22 AND 39). SN 77-922,445. PUB. 3-20-2012. FILED 1-28-2010.
 4,152,142. **SQUIRE AUSTRALIA (STANDARD CHARACTER)**. CLICKERS PTY LTD, (U.S. CLS. 22 AND 39). SN 77-933,388. PUB. 3-20-2012. FILED 2-11-2010.
 4,152,156 (*See Class 24 for this trademark*).
 4,152,163 (*See Class 7 for this trademark*).
 4,152,173 (*See Class 18 for this trademark*).
 4,152,174 (*See Class 3 for this trademark*).
 4,152,188 (*See Class 3 for this trademark*).
 4,152,198 (*See Class 3 for this trademark*).
 4,152,208 (*See Class 18 for this trademark*).
 4,152,210. **SFC SEVILLA FUTBOL CLUB AND DESIGN**. SEVILLA FUTBOL CLUB SOCIEDAD DEPORTIVA, S.A.D., MULTIPLE CLASS, (INT. CLS. 25, 35 AND 41), (U.S. CLS. 22, 39, 100, 101, 102 AND 107). SN 79-092,764. PUB. 3-20-2012. FILED 1-24-2011.
 4,152,220 (*See Class 6 for this trademark*).
 4,152,222 (*See Class 9 for this trademark*).
 4,152,232. **DLX (STANDARD CHARACTER)**. JACOBS & TURNER LIMITED, (U.S. CLS. 22 AND 39). SN 79-095,717. PUB. 3-20-2012. FILED 3-29-2011.
 4,152,235 (*See Class 18 for this trademark*).
 4,152,243. **Y YHEHS' CLOTHING AND DESIGN**. FRANCISCO JAVIER PUJOLAR PLA, (U.S. CLS. 22 AND 39). SN 79-096,483. PUB. 3-20-2012. FILED 4-6-2011.
 4,152,244 (*See Class 18 for this trademark*).
 4,152,251 (*See Class 9 for this trademark*).
 4,152,260 (*See Class 24 for this trademark*).
 4,152,270 (*See Class 18 for this trademark*).
 4,152,271 (*See Class 18 for this trademark*).
 4,152,276. **PADDOCK'S (STANDARD CHARACTER)**. OSPIG GMBH & CO. KG, (U.S. CLS. 22 AND 39). SN 79-098,041. PUB. 3-20-2012. FILED 5-23-2011.
 4,152,278 (*See Class 18 for this trademark*).
 4,152,289 (*See Class 9 for this trademark*).
 4,152,295. **BACON (STANDARD CHARACTER)**. BARRAS S.R.L., (U.S. CLS. 22 AND 39). SN 79-098,570. PUB. 3-20-2012. FILED 4-11-2011.
 4,152,311. **PIERRE GEORGES AND DESIGN**. POTH PIERRE, MULTIPLE CLASS, (INT. CLS. 25 AND 35), (U.S. CLS. 22, 39, 100, 101 AND 102). SN 79-099,028. PUB. 3-20-2012. FILED 5-25-2011.
 4,152,313 (*See Class 18 for this trademark*).
 4,152,334. **MONTECARLO OFFSHORE AND DESIGN**. MONDO S.P.A., (U.S. CLS. 22 AND 39). SN 79-100,004. PUB. 3-20-2012. FILED 2-25-2011.
 4,152,343 (*See Class 16 for this trademark*).
 4,152,345. **JOHN LAING (STYLIZED)**. DAWSON INTERNATIONAL HOLDINGS (UK) LIMITED, (U.S. CLS. 22 AND 39). SN 79-100,478. PUB. 3-20-2012. FILED 5-25-2011.
 4,152,362 (*See Class 9 for this trademark*).
 4,152,394 (*See Class 3 for this trademark*).
 4,152,398 (*See Class 10 for this trademark*).
 4,152,399. **MAISON ESPIN MADE WITH LOVE AND DESIGN**. FIVE SEASONS S.R.L., (U.S. CLS. 22 AND 39). SN 79-103,908. PUB. 3-20-2012. FILED 7-28-2011.
 4,152,404 (*See Class 10 for this trademark*).
 4,152,416 (*See Class 3 for this trademark*).
 4,152,436 (*See Class 3 for this trademark*).
 4,152,442. **LAZY DAZE AND DESIGN**. RICHARD COHEN, (U.S. CLS. 22 AND 39). SN 85-020,347. PUB. 3-20-2012. FILED 4-22-2010.
 4,152,455. **EXTREMES (STANDARD CHARACTER)**. CARHARTT, INC., (U.S. CLS. 22 AND 39). SN 85-045,744. PUB.

- 3-20-2012. FILED 5-22-2010.
4,152,473 (*See Class 9 for this trademark*).
- 4,152,513. **RAG RECYCLE RA—RE RAG RESTYLE AND DESIGN**. FLASH & PARTNERS S.P.A., (U.S. CLS. 22 AND 39). SN 85-125,974. PUB. 3-20-2012. FILED 9-9-2010.
- 4,152,515. **MISCELLANEOUS DESIGN**. SHALOND ESSIX, DBA CAPSTONE CLOTHING COMPANY, (U.S. CLS. 22 AND 39). SN 85-127,620. PUB. 3-20-2012. FILED 9-12-2010.
- 4,152,560 (*See Class 9 for this trademark*).
- 4,152,571 (*See Class 9 for this trademark*).
- 4,152,575. **BE BOLD BE SEXY BE GLAM BE CHIC (STANDARD CHARACTER)**. SPECIALTY FASHION GROUP LTD, MULTIPLE CLASS, (INT. CLS. 25 AND 35), (U.S. CLS. 22, 39, 100, 101 AND 102). SN 85-180,718. PUB. 3-20-2012. FILED 11-19-2010.
- 4,152,578. **TINSLEY TRANSFERS AND DESIGN**. TINSLEY TRANSFERS, INC., (U.S. CLS. 22 AND 39). SN 85-185,456. PUB. 3-20-2012. FILED 11-26-2010.
- 4,152,588. **MOJO SPORTSWEAR COMPANY (STYLIZED)**. MOJO SPORTSWEAR COMPANY INC., (U.S. CLS. 22 AND 39). SN 85-197,988. PUB. 3-20-2012. FILED 12-15-2010.
- 4,152,594 (*See Class 18 for this trademark*).
- 4,152,598. **FLAUNT (STANDARD CHARACTER)**. THE GIFT SHOPPE, INC., DBA FLAUNT, (U.S. CLS. 22 AND 39). SN 85-210,155. PUB. 3-20-2012. FILED 1-4-2011.
- 4,152,607. **BONNIE BABY (STANDARD CHARACTER)**. GERSON & GERSON, INC., (U.S. CLS. 22 AND 39). SN 85-217,285. PUB. 3-20-2012. FILED 1-13-2011.
- 4,152,630 (*See Class 3 for this trademark*).
- 4,152,631. **DA DESTROY ATHLETICS AND DESIGN**. DESTROY ATHLETICS, LLC, (U.S. CLS. 22 AND 39). SN 85-234,992. PUB. 3-20-2012. FILED 2-5-2011.
- 4,152,658 (*See Class 1 for this trademark*).
- 4,152,659 (*See Class 24 for this trademark*).
- 4,152,678. **SIERRA JULIAN SJ AND DESIGN**. SOPHIE JAWORSKI, (U.S. CLS. 22 AND 39). SN 85-269,863. PUB. 3-20-2012. FILED 3-17-2011.
- 4,152,708. **SUFFOLK POINTE COMPANY (STANDARD CHARACTER)**. DREW LAYNE, L.L.C., (U.S. CLS. 22 AND 39). SN 85-282,307. PUB. 3-20-2012. FILED 3-31-2011.
- 4,152,727. **B (STYLIZED)**. BURLIN CORPORATION, (U.S. CLS. 22 AND 39). SN 85-288,564. PUB. 3-20-2012. FILED 4-7-2011.
- 4,152,728. **W AND DESIGN**. SHARON ANN DEWALD, AND CRAIG L. DEWALD, (U.S. CLS. 22 AND 39). SN 85-289,215. PUB. 3-20-2012. FILED 4-7-2011.
- 4,152,755. **TUNICLOVE (STANDARD CHARACTER)**. BUTANI CAPITAL PARTNERS LLC, (U.S. CLS. 22 AND 39). SN 85-294,691. PUB. 8-30-2011. FILED 4-13-2011.
- 4,152,770 (*See Class 18 for this trademark*).
- 4,152,771 (*See Class 18 for this trademark*).
- 4,152,790. **YOGAMONKEYKIDS TEACHING TO THE MIND, BODY AND SPIRIT AND DESIGN**. YOGA MONKEY KIDS, LLC, MULTIPLE CLASS, (INT. CLS. 25 AND 41), (U.S. CLS. 22, 39, 100, 101 AND 107). SN 85-297,764. PUB. 3-20-2012. FILED 4-18-2011.
- 4,152,814. **CHRISTIANO BALDINUCCI (STANDARD CHARACTER)**. LMSJ LIMITED, (U.S. CLS. 22 AND 39). SN 85-300,417. PUB. 3-20-2012. FILED 4-20-2011.
- 4,152,817. **SACHIN + BABI (STANDARD CHARACTER)**. ANKASA LTD, (U.S. CLS. 22 AND 39). SN 85-300,911. PUB. 3-20-2012. FILED 4-21-2011.
- 4,152,863. **PEACE IS MY INTENTION (STANDARD CHARACTER)**. RIDDEL, HOLLY M., (U.S. CLS. 22 AND 39). SN 85-310,380. PUB. 3-20-2012. FILED 5-2-2011.
- 4,152,871. **KAM & KAM (STANDARD CHARACTER)**. GOLDEN TRIM SPORTS, INC., (U.S. CLS. 22 AND 39). SN 85-311,610. PUB. 3-20-2012. FILED 5-3-2011.
- 4,152,892. **CUT EM (STANDARD CHARACTER)**. CHRIS FASH, MULTIPLE CLASS, (INT. CLS. 25 AND 28), (U.S. CLS. 22, 23, 38, 39 AND 50). SN 85-315,995. PUB. 10-18-2011. FILED 5-9-2011.
- 4,152,903. **2KOOL 2B TRUE (STANDARD CHARACTER)**. SMART BRANDS USA INTL, LLC, (U.S. CLS. 22 AND 39). SN 85-317,828. PUB. 3-20-2012. FILED 5-11-2011.
- 4,152,916 (*See Class 18 for this trademark*).
- 4,152,926. **ONTOUR AND DESIGN**. TRIMARK SPORTSWEAR CANADA INC., MULTIPLE CLASS, (INT. CLS. 25 AND 35), (U.S. CLS. 22, 39, 100, 101 AND 102). SN 85-325,843. PUB. 3-20-2012. FILED 5-20-2011.
- 4,152,930. **BE THE BREATH INHALE. EXHALE. LIVE. (STANDARD CHARACTER)**. BE THE BREATH, LLC, MULTIPLE CLASS, (INT. CLS. 25, 28 AND 41), (U.S. CLS. 22, 23, 38, 39, 50, 100, 101 AND 107). SN 85-327,087. PUB. 10-18-2011. FILED 5-23-2011.
- 4,152,946 (*See Class 9 for this trademark*).
- 4,152,949. **LACE UP (STANDARD CHARACTER)**. EST 19XX, LLC, (U.S. CLS. 22 AND 39). SN 85-331,735. PUB. 3-20-2012. FILED 5-26-2011.
- 4,152,962. **AIR COMMANDO AND DESIGN**. COOK, KEVIN, (U.S. CLS. 22 AND 39). SN 85-336,194. PUB. 3-20-2012. FILED 6-2-2011.
- 4,152,985. **BLESSLAND AND DESIGN**. CHANG CHIH-CHEN, (U.S. CLS. 22 AND 39). SN 85-342,813. PUB. 3-20-2012. FILED 6-10-2011.
- 4,152,994. **HAOWEI AND DESIGN**. JIAN, WANG, (U.S. CLS. 22 AND 39). SN 85-346,384. PUB. 12-13-2011. FILED 6-15-2011.
- 4,153,001. **RED IRISH (STANDARD CHARACTER)**. NYGREN, WESTEN, (U.S. CLS. 22 AND 39). SN 85-347,682. PUB. 3-20-2012. FILED 6-16-2011.
- 4,153,032. **LION I CLOTHING (STANDARD CHARACTER)**. ROGERS, LYSSA, (U.S. CLS. 22 AND 39). SN 85-357,346. PUB. 3-20-2012. FILED 6-27-2011.
- 4,153,085. **2TONE CLEAT COVERS (STANDARD CHARACTER)**. CUMMINGS, MICHAEL, (U.S. CLS. 22 AND 39). SN 85-377,065. PUB. 3-20-2012. FILED 7-21-2011.
- 4,153,102. **JUICE AND DESIGN**. NG, ISABELLE, (U.S. CLS. 22 AND 39). SN 85-382,194. PUB. 3-20-2012. FILED 7-27-2011.
- 4,153,112. **LIU (STANDARD CHARACTER)**. LONG ISLAND UNIVERSITY, MULTIPLE CLASS, (INT. CLS. 25 AND 41), (U.S. CLS. 22, 39, 100, 101 AND 107). SN 85-386,223. PUB. 3-20-2012. FILED 8-1-2011.
- 4,153,137. **CLASSIC WHIMSY (STANDARD CHARACTER)**. SMOCKED RUNWAY, LLC, (U.S. CLS. 22 AND 39). SN 85-392,507. PUB. 3-20-2012. FILED 8-8-2011.
- 4,153,141. **C. MANZINI (STANDARD CHARACTER)**. SOXLAND INDUSTRIAL, INC., (U.S. CLS. 22 AND 39). SN 85-393,833. PUB. 3-20-2012. FILED 8-9-2011.
- 4,153,142. **YVES FRANC CLAIRE (STANDARD CHARACTER)**. SOXLAND INDUSTRIAL, INC., (U.S. CLS. 22 AND 39). SN 85-393,928. PUB. 3-20-2012. FILED 8-10-2011.
- 4,153,145. **LOVLI AND DESIGN**. GYPSY 05, INC., (U.S. CLS. 22 AND 39). SN 85-394,297. PUB. 3-20-2012. FILED 8-10-2011.
- 4,153,155. **LAKE IS GREAT. (STYLIZED)**. ARMSTRONG, JENNIFER, (U.S. CLS. 22 AND 39). SN 85-395,893. PUB. 3-20-2012. FILED 8-11-2011.
- 4,153,159. **JACK & JINGER (STANDARD CHARACTER)**. GARY LEGATOR, (U.S. CLS. 22 AND 39). SN 85-396,737. PUB. 3-20-2012. FILED 8-12-2011.
- 4,153,181 (*See Class 18 for this trademark*).
- 4,153,191. **LIVE LIFE 7 DAYS A WEEK. ONE DAY AT A TIME. (STANDARD CHARACTER)**. KAM INTER VIVOS TRUST, (U.S. CLS. 22 AND 39). SN 85-404,719. PUB. 3-20-2012. FILED 8-23-2011.
- 4,153,194. **ENLAML AND DESIGN**. GUANGDONG YINGNANER APPAREL COMPANY LIMITED, (U.S. CLS. 22 AND 39). SN 85-405,433. PUB. 3-20-2012. FILED 8-24-2011.
- 4,153,226. **FALEO EST. 2008 1 AND DESIGN**. FILIPINO-AMERICAN LAW ENFORCEMENT OFFICERS ASSOCIATION, (U.S. CLS. 22 AND 39). SN 85-411,984. PUB. 3-20-2012. FILED 8-31-2011.
- 4,153,247. **DOGI (STANDARD CHARACTER)**. CANALES MARES, FRANCISCO JAVIER, (U.S. CLS. 22 AND 39). SN 85-414,996. PUB. 3-20-2012. FILED 9-5-2011.
- 4,153,263. **HANFEISE (STANDARD CHARACTER)**. HANFEISE INTERNATIONAL FASHION CO., LTD., DBA HANFEISE INTERNATIONAL CO., LTD., (U.S. CLS. 22 AND 39). SN 85-417,445. PUB. 3-20-2012. FILED 9-8-2011.
- 4,153,266. **MISCELLANEOUS DESIGN**. AGGRESSIVE COMBATIVES LIMITED, (U.S. CLS. 22 AND 39). SN 85-417,669. PUB. 3-20-2012. FILED 9-8-2011.
- 4,153,281 (*See Class 16 for this trademark*).
- 4,153,293. **IT'S HERE! THE ORIGINAL CHIPWICH CHOCOLATE CHIP COOKIE ICE CREAM SANDWICH AND DESIGN**. KAPLAN, JEFFREY, (U.S. CLS. 22 AND 39). SN

- 85-421,384. PUB. 3-20-2012. FILED 9-13-2011.
- 4,153,297. **KOA PUNA (STANDARD CHARACTER)**. KOA PUNA MOTORCYCLE CLUB, MULTIPLE CLASS, (INT. CLS. 25 AND 35), (U.S. CLS. 22, 39, 100, 101 AND 102). SN 85-421,546. PUB. 3-20-2012. FILED 9-13-2011.
- 4,153,341. **MOB INK TATTOOS (STANDARD CHARACTER)**. BALENA, DANNY, (U.S. CLS. 22 AND 39). SN 85-425,270. PUB. 3-20-2012. FILED 9-16-2011.
- 4,153,348. **SUPERIOR MORGUL CLASSIC (STANDARD CHARACTER)**. TOWN OF SUPERIOR, COLORADO, MULTIPLE CLASS, (INT. CLS. 25, 35 AND 41), (U.S. CLS. 22, 39, 100, 101, 102 AND 107). SN 85-426,176. PUB. 3-20-2012. FILED 9-19-2011.
- 4,153,355. **METAL WORKOUT (STANDARD CHARACTER)**. BIGIO, PABLO, (U.S. CLS. 22 AND 39). SN 85-427,051. PUB. 3-20-2012. FILED 9-20-2011.
- 4,153,369. **FLAGSTICK GOLF APPAREL AND DESIGN**. HARRELL, RODNEY D, (U.S. CLS. 22 AND 39). SN 85-428,804. PUB. 3-20-2012. FILED 9-21-2011.
- 4,153,370. **THE DRIVE INSIDE AND DESIGN**. STRICKLING, JONATHAN S., DBA THE DRIVE INSIDE, (U.S. CLS. 22 AND 39). SN 85-428,822. PUB. 3-20-2012. FILED 9-21-2011.
- 4,153,400. **SF SOUTHERN FRATTIRE CLASSIC FRATERNITY ATTIRE AND DESIGN**. SOUTHERN FRATTIRE, (U.S. CLS. 22 AND 39). SN 85-430,884. PUB. 3-20-2012. FILED 9-23-2011.
- 4,153,403. **SHESEA CREATIONS AND DESIGN**. FAZIO, NANCY, AND BOBB, ASHLEY, (U.S. CLS. 22 AND 39). SN 85-431,183. PUB. 3-20-2012. FILED 9-24-2011.
- 4,153,421. **DASOUL (STANDARD CHARACTER)**. NOWELL, ANDREW M, DBA DASOUL, (U.S. CLS. 22 AND 39). SN 85-432,528. PUB. 3-20-2012. FILED 9-27-2011.
- 4,153,435 (*See Class 9 for this trademark*).
- 4,153,454. **MISCELLANEOUS DESIGN**. CANDICE BOEHM, (U.S. CLS. 22 AND 39). SN 85-435,057. PUB. 3-20-2012. FILED 9-29-2011.
- 4,153,455. **RN (STYLIZED)**. RAUCUS NATURE, INC., (U.S. CLS. 22 AND 39). SN 85-435,066. PUB. 3-20-2012. FILED 9-29-2011.
- 4,153,456. **RAUCUS NATURE CURE FOR THE COMMON CLOTHES MEDICATE DAILY AND DESIGN**. RAUCUS NATURE, INC., (U.S. CLS. 22 AND 39). SN 85-435,090. PUB. 3-20-2012. FILED 9-29-2011.
- 4,153,477. **JERSEY SURF (STANDARD CHARACTER)**. JERSEY SURF INC., A NEW JERSEY NOT FOR PROFIT CORP, (U.S. CLS. 22 AND 39). SN 85-436,063. PUB. 3-20-2012. FILED 9-30-2011.
- 4,153,496. **HAWAIIABERA (STANDARD CHARACTER)**. ROBERT ROBINSON, (U.S. CLS. 22 AND 39). SN 85-436,872. PUB. 3-20-2012. FILED 9-30-2011.
- 4,153,541. **POST-MOD (STANDARD CHARACTER)**. BEAKS OF EAGLES, (U.S. CLS. 22 AND 39). SN 85-438,100. PUB. 3-20-2012. FILED 10-3-2011.
- 4,153,544. **SEW CREEPY (STANDARD CHARACTER)**. BEAKS OF EAGLES, (U.S. CLS. 22 AND 39). SN 85-438,156. PUB. 3-20-2012. FILED 10-3-2011.
- 4,153,580. **FUVIC (STYLIZED)**. BRIDGET MARSH, (U.S. CLS. 22 AND 39). SN 85-439,174. PUB. 3-20-2012. FILED 10-4-2011.
- 4,153,597. **OAKLAND UNIVERSITY (STANDARD CHARACTER)**. OAKLAND UNIVERSITY, MULTIPLE CLASS, (INT. CLS. 25 AND 41), (U.S. CLS. 22, 39, 100, 101 AND 107). SN 85-439,540. PUB. 3-20-2012. FILED 10-5-2011.
- 4,153,621 (*See Class 9 for this trademark*).
- 4,153,634. **BORN ATHLETE (STANDARD CHARACTER)**. ATHLETIC ALL PURPOSE PRODUCTS, L.L.C., (U.S. CLS. 22 AND 39). SN 85-440,467. PUB. 3-20-2012. FILED 10-6-2011.
- 4,153,649. **DBT (STANDARD CHARACTER)**. DBT WORLDWIDE, LLC, (U.S. CLS. 22 AND 39). SN 85-440,747. PUB. 3-20-2012. FILED 10-6-2011.
- 4,153,654. **JUST A RUMOR (STANDARD CHARACTER)**. ALL ACCESS APPAREL, INC., (U.S. CLS. 22 AND 39). SN 85-440,813. PUB. 3-20-2012. FILED 10-6-2011.
- 4,153,666. **SEXSIE (STANDARD CHARACTER)**. WESTLAND, DEVON, (U.S. CLS. 22 AND 39). SN 85-440,924. PUB. 3-20-2012. FILED 10-6-2011.
- 4,153,667. **KANGOL (STANDARD CHARACTER)**. KANGOL LIMITED, (U.S. CLS. 22 AND 39). SN 85-440,935. PUB. 3-20-2012. FILED 10-6-2011.
- 4,153,679. **HEROIC (STANDARD CHARACTER)**. HEROIC RACING APPAREL, LLC, (U.S. CLS. 22 AND 39). SN 85-441,142. PUB. 3-20-2012. FILED 10-6-2011.
- 4,153,682. **SP-R (STANDARD CHARACTER)**. HEROIC RACING APPAREL, LLC, (U.S. CLS. 22 AND 39). SN 85-441,179. PUB. 3-20-2012. FILED 10-6-2011.
- 4,153,688 (*See Class 14 for this trademark*).
- 4,153,702. **ARCHPORT (STANDARD CHARACTER)**. NEW MANAGEMENT, INC., (U.S. CLS. 22 AND 39). SN 85-441,591. PUB. 3-20-2012. FILED 10-7-2011.
- 4,153,704. **MISCELLANEOUS DESIGN**. NEW MANAGEMENT, INC., (U.S. CLS. 22 AND 39). SN 85-441,593. PUB. 3-20-2012. FILED 10-7-2011.
- 4,153,734 (*See Class 18 for this trademark*).
- 4,153,737. **TOM NEVER'S C. 1685 N AND DESIGN**. GRABOWSKI, CAREY, (U.S. CLS. 22 AND 39). SN 85-441,908. PUB. 3-20-2012. FILED 10-7-2011.
- 4,153,738. **ALASKA ORIGIN (STANDARD CHARACTER)**. SWOPE, GAILE, (U.S. CLS. 22 AND 39). SN 85-441,944. PUB. 3-20-2012. FILED 10-7-2011.
- 4,153,759. **NOTTIBIANCHE (STANDARD CHARACTER)**. DILLARDS, (U.S. CLS. 22 AND 39). SN 85-442,164. PUB. 3-20-2012. FILED 10-7-2011.
- 4,153,780. **ILPRADIO (STANDARD CHARACTER)**. DADDI, LLC, DBA ILPRADIO, (U.S. CLS. 22 AND 39). SN 85-442,295. PUB. 3-20-2012. FILED 10-7-2011.
- 4,153,791. **JAUNT (STANDARD CHARACTER)**. GELLER, ANA L., (U.S. CLS. 22 AND 39). SN 85-442,494. PUB. 3-20-2012. FILED 10-7-2011.
- 4,153,793. **ACCESS SCIENCES (STANDARD CHARACTER)**. ACCESS SCIENCES CORPORATION, (U.S. CLS. 22 AND 39). SN 85-442,504. PUB. 3-20-2012. FILED 10-7-2011.
- 4,153,810. **BEAUTY IN BREAST AND DESIGN**. ROBERTSON, JARRUN TERON, (U.S. CLS. 22 AND 39). SN 85-442,682. PUB. 3-20-2012. FILED 10-7-2011.
- 4,153,833. **LIFE IS LACROSSE (STANDARD CHARACTER)**. LAX GAL, LLC, (U.S. CLS. 22 AND 39). SN 85-442,859. PUB. 3-20-2012. FILED 10-9-2011.
- 4,153,835. **TRUE ARTIST (STANDARD CHARACTER)**. MACK, RHIANNA, (U.S. CLS. 22 AND 39). SN 85-442,881. PUB. 3-20-2012. FILED 10-9-2011.
- 4,153,843. **LILY'S LAUNDRY (STANDARD CHARACTER)**. NEIL, LAURA, DBA LILY'S LAUNDRY, MULTIPLE CLASS, (INT. CLS. 25 AND 41), (U.S. CLS. 22, 39, 100, 101 AND 107). SN 85-442,956. PUB. 3-20-2012. FILED 10-9-2011.
- 4,153,844 (*See Class 9 for this trademark*).
- 4,153,860. **GOLDDUST (STANDARD CHARACTER)**. DINGWELL, VANESSA, AND ZAL, ROXANA, (U.S. CLS. 22 AND 39). SN 85-443,176. PUB. 3-20-2012. FILED 10-10-2011.
- 4,153,865. **BE LOV'ESH (STANDARD CHARACTER)**. JANELL CIRKL, (U.S. CLS. 22 AND 39). SN 85-443,228. PUB. 3-20-2012. FILED 10-10-2011.
- 4,153,868. **FO THIRTY (STANDARD CHARACTER)**. SWAG OUTDOORS, (U.S. CLS. 22 AND 39). SN 85-443,254. PUB. 3-20-2012. FILED 10-10-2011.
- 4,153,891. **AKUAKU (STANDARD CHARACTER)**. FIERRES, INC., (U.S. CLS. 22 AND 39). SN 85-443,476. PUB. 3-20-2012. FILED 10-10-2011.
- 4,153,902. **RESPECT MY KICKS (STANDARD CHARACTER)**. PAUL NESBIHAL CLOTHING, LLC, (U.S. CLS. 22 AND 39). SN 85-443,546. PUB. 3-20-2012. FILED 10-10-2011.
- 4,153,903. **PAPER HART (STANDARD CHARACTER)**. GARRETT, MEREDITH, (U.S. CLS. 22 AND 39). SN 85-443,565. PUB. 3-20-2012. FILED 10-10-2011.
- 4,153,932. **YOU'RE MY STEAM AND I'M YOUR PUNK (STANDARD CHARACTER)**. CORO, PETER, (U.S. CLS. 22 AND 39). SN 85-443,996. PUB. 3-20-2012. FILED 10-11-2011.
- 4,153,935. **DNK AND DESIGN**. DUMB LUCK DESIGNS, (U.S. CLS. 22 AND 39). SN 85-444,012. PUB. 3-20-2012. FILED 10-11-2011.
- 4,153,983. **OUDDADA WADDA (STANDARD CHARACTER)**. DIRK HOFFIUS, (U.S. CLS. 22 AND 39). SN 85-444,438. PUB. 3-20-2012. FILED 10-11-2011.
- 4,153,996. **HOORAY FOR BOOBIES! (STANDARD CHARACTER)**. HOORAY FOR BOOBIES!, INC., (U.S. CLS. 22 AND 39). SN 85-444,560. PUB. 3-20-2012. FILED 10-11-2011.
- 4,154,011. **MISCELLANEOUS DESIGN**. NOCTIS INK, LLC,

- (U.S. CLS. 22 AND 39). SN 85-444,684. PUB. 3-20-2012. FILED 10-11-2011.
- 4,154,016. **DEADTOWN (STYLIZED)**. THE BETTER FOR BRIAN FOUNDATION, DBA DEADTOWN CLOTHING COMPANY, (U.S. CLS. 22 AND 39). SN 85-444,770. PUB. 3-20-2012. FILED 10-11-2011.
- 4,154,017. **THE MINUS TOUCH (STANDARD CHARACTER)**. VA BIEN INTERNATIONAL, INC., (U.S. CLS. 22 AND 39). SN 85-444,784. PUB. 3-20-2012. FILED 10-11-2011.
- 4,154,023. **F AND DESIGN**. FREEDUMS, (U.S. CLS. 22 AND 39). SN 85-444,816. PUB. 3-20-2012. FILED 10-11-2011.
- 4,154,073. **FIRO (STYLIZED)**. TITAN SPORT TECH CO., LTD., (U.S. CLS. 22 AND 39). SN 85-445,911. PUB. 3-20-2012. FILED 10-12-2011.
- 4,154,091. **SB AND DESIGN**. SKY B NATION LLC, (U.S. CLS. 22 AND 39). SN 85-446,217. PUB. 3-20-2012. FILED 10-13-2011.
- 4,154,100. **BUGMASTER (STANDARD CHARACTER)**. SHELTER-PRO, LLC, (U.S. CLS. 22 AND 39). SN 85-447,070. PUB. 3-20-2012. FILED 10-13-2011.
- 4,154,105. **VERY VOLATILE (STANDARD CHARACTER)**. PALOS VERDES FOOTWEAR, INC., (U.S. CLS. 22 AND 39). SN 85-447,273. PUB. 3-20-2012. FILED 10-13-2011.
- 4,154,106. **LL (STYLIZED)**. SOOK HAN LIM, AKA MADDIE LIM, (U.S. CLS. 22 AND 39). SN 85-447,285. PUB. 3-20-2012. FILED 10-13-2011.
- 4,154,108. **INTERNATIONAL STYLE ICON (STANDARD CHARACTER)**. CHANTELE K. OLUWABUNMI ABDUL, (U.S. CLS. 22 AND 39). SN 85-447,384. PUB. 3-20-2012. FILED 10-14-2011.
- 4,154,110. **VANESSA'S (STANDARD CHARACTER)**. ADVANCE SALES GROUP, INC., (U.S. CLS. 22 AND 39). SN 85-447,553. PUB. 3-20-2012. FILED 10-14-2011.
- 4,154,160. **AIRMATRIX AND DESIGN**. CHANG, JAIME, (U.S. CLS. 22 AND 39). SN 85-455,523. PUB. 3-20-2012. FILED 10-25-2011.
- 4,154,186. **NOBODY KNOWS (STANDARD CHARACTER)**. SHIN, KEVIN, (U.S. CLS. 22 AND 39). SN 85-463,644. PUB. 3-20-2012. FILED 11-3-2011.
- 4,154,210. **BOWLMOR LANES AND DESIGN**. STRIKE HOLDINGS LLC, MULTIPLE CLASS, (INT. CLS. 25, 41 AND 43), (U.S. CLS. 22, 39, 100, 101 AND 107). SN 85-482,606. PUB. 3-20-2012. FILED 11-29-2011.

CLASS 26—FANCY GOODS

- 4,152,188 (*See Class 3 for this trademark.*)
- 4,152,201 (*See Class 20 for this trademark.*)
- 4,152,242 (*See Class 8 for this trademark.*)
- 4,152,630 (*See Class 3 for this trademark.*)
- 4,152,896. **SAN ANTONIO STOCK SHOW & RODEO AND DESIGN**. SAN ANTONIO LIVESTOCK EXPOSITION, INC., (U.S. CLS. 37, 39, 40, 42 AND 50). SN 85-316,949. PUB. 3-20-2012. FILED 5-10-2011.
- 4,153,190. **SPB SO PRETTY BABY (STYLIZED)**. TROIKA INTERNATIONAL, INC., (U.S. CLS. 37, 39, 40, 42 AND 50). SN 85-404,628. PUB. 3-20-2012. FILED 8-23-2011.
- 4,153,493 (*See Class 14 for this trademark.*)
- 4,153,735. **FLOPPETS (STANDARD CHARACTER)**. ZYDECO STUDIOS, (U.S. CLS. 37, 39, 40, 42 AND 50). SN 85-441,874. PUB. 3-20-2012. FILED 10-7-2011.
- 4,153,795. **NATURE LOCKS (STANDARD CHARACTER)**. MOORE, DIANA, (U.S. CLS. 37, 39, 40, 42 AND 50). SN 85-442,510. PUB. 3-20-2012. FILED 10-7-2011.
- 4,154,018 (*See Class 9 for this trademark.*)

CLASS 27—FLOOR COVERINGS

- 4,152,259. **ETERNAL (STANDARD CHARACTER)**. FORBO FINANCIAL SERVICES AG, (U.S. CLS. 19, 20, 37, 42 AND 50). SN 79-097,419. PUB. 3-20-2012. FILED 4-8-2011.
- 4,152,280. **BASMAT (STANDARD CHARACTER)**. BAGLINOX, S.L., (U.S. CLS. 19, 20, 37, 42 AND 50). SN 79-098,172. PUB. 3-

- 20-2012. FILED 4-19-2011.
- 4,152,390. **ALTRO AQUARIUS (STANDARD CHARACTER)**. ALTRO LIMITED, (U.S. CLS. 19, 20, 37, 42 AND 50). SN 79-103,251. PUB. 3-20-2012. FILED 8-5-2011.
- 4,152,707. **STATICSMART (STANDARD CHARACTER)**. JULIE INDUSTRIES, INC., (U.S. CLS. 19, 20, 37, 42 AND 50). SN 85-282,092. PUB. 3-20-2012. FILED 3-31-2011.
- 4,153,359 (*See Class 12 for this trademark.*)
- 4,153,715 (*See Class 24 for this trademark.*)
- 4,153,768. **PEBBLE BEACH (STANDARD CHARACTER)**. HOME DYNAMIX, LLC, (U.S. CLS. 19, 20, 37, 42 AND 50). SN 85-442,216. PUB. 3-20-2012. FILED 10-7-2011.
- 4,153,981. **UNISCRAPER (STANDARD CHARACTER)**. UNIFIRST CORPORATION, (U.S. CLS. 19, 20, 37, 42 AND 50). SN 85-444,360. PUB. 3-20-2012. FILED 10-11-2011.

CLASS 28—TOYS AND SPORTING GOODS

- 4,152,091 (*See Class 4 for this trademark.*)
- 4,152,105. **SKY SHARK PRO (STANDARD CHARACTER)**. SPIN MASTER LTD., (U.S. CLS. 22, 23, 38 AND 50). SN 77-626,475. PUB. 3-20-2012. FILED 12-4-2008.
- 4,152,160 (*See Class 9 for this trademark.*)
- 4,152,165. **STRIDING AND DESIGN**. FINLEASE S.R.L., (U.S. CLS. 22, 23, 38 AND 50). SN 79-054,979. PUB. 3-24-2009. FILED 5-6-2008.
- 4,152,173 (*See Class 18 for this trademark.*)
- 4,152,185 (*See Class 9 for this trademark.*)
- 4,152,193 (*See Class 3 for this trademark.*)
- 4,152,204. **RUYI (STANDARD CHARACTER)**. ZHEJIANG RUYI GIFTS & CRAFT CO.,LTD., (U.S. CLS. 22, 23, 38 AND 50). SN 79-091,331. PUB. 3-20-2012. FILED 4-5-2010.
- 4,152,214 (*See Class 9 for this trademark.*)
- 4,152,270 (*See Class 18 for this trademark.*)
- 4,152,271 (*See Class 18 for this trademark.*)
- 4,152,289 (*See Class 9 for this trademark.*)
- 4,152,353. **JIADA AND DESIGN**. GUANGDONG JIADA ELECTRONIC TECHNOLOGY HOLDING CO., LTD., (U.S. CLS. 22, 23, 38 AND 50). SN 79-100,763. PUB. 3-20-2012. FILED 6-1-2011.
- 4,152,365 (*See Class 16 for this trademark.*)
- 4,152,388 (*See Class 14 for this trademark.*)
- 4,152,391. **SAKURA AND DESIGN**. SAKURAI HIROKATSU, (U.S. CLS. 22, 23, 38 AND 50). SN 79-103,476. PUB. 3-20-2012. FILED 8-9-2011.
- 4,152,418. **SNAP-X (STANDARD CHARACTER)**. LYKKE.IT S.R.L., (U.S. CLS. 22, 23, 38 AND 50). SN 79-105,007. PUB. 3-20-2012. FILED 8-8-2011.
- 4,152,445. **IT'S NOT THE WORKOUT BUT THE INTENSITY (STANDARD CHARACTER)**. UPFRONT MEGATAINMENT, INC., MULTIPLE CLASS, (INT. CLS. 28 AND 41), (U.S. CLS. 22, 23, 38, 50, 100, 101 AND 107). SN 85-027,873. PUB. 3-20-2012. FILED 4-30-2010.
- 4,152,473 (*See Class 9 for this trademark.*)
- 4,152,480. **BATTLE CLAW (STANDARD CHARACTER)**. MATTEL, INC., (U.S. CLS. 22, 23, 38 AND 50). SN 85-094,529. PUB. 3-20-2012. FILED 7-28-2010.
- 4,152,507 (*See Class 3 for this trademark.*)
- 4,152,557. **STEAM ROLLER (STANDARD CHARACTER)**. MATTEL, INC., (U.S. CLS. 22, 23, 38 AND 50). SN 85-161,836. PUB. 3-20-2012. FILED 10-26-2010.
- 4,152,600. **CHIPN AND DESIGN**. PINHIPARTNERS, LLC, (U.S. CLS. 22, 23, 38 AND 50). SN 85-210,472. PUB. 3-20-2012. FILED 1-4-2011.
- 4,152,657. **MISCELLANEOUS DESIGN**. I-STAR ENTERTAINMENT LLC, (U.S. CLS. 22, 23, 38 AND 50). SN 85-256,034. PUB. 3-20-2012. FILED 3-2-2011.
- 4,152,658 (*See Class 1 for this trademark.*)
- 4,152,665. **START A FEEDING FRENZY (STANDARD CHARACTER)**. EBSCO INDUSTRIES, INC., (U.S. CLS. 22, 23, 38 AND 50). SN 85-260,392. PUB. 3-20-2012. FILED 3-7-2011.
- 4,152,725. **HOLE HOPPER (STANDARD CHARACTER)**. HERRMANN, JOHN, (U.S. CLS. 22, 23, 38 AND 50). SN 85-288,486. PUB. 3-20-2012. FILED 4-7-2011.
- 4,152,765. **CHAOS THE BEAR (STANDARD CHARACTER)**. ALEXANDER DOLL COMPANY, INC., (U.S. CLS. 22, 23,

- 38 AND 50). SN 85-295,808. PUB. 3-20-2012. FILED 4-14-2011.
- 4,152,766. **BABY ALEXANDER (STANDARD CHARACTER)**. ALEXANDER DOLL COMPANY, INC., (U.S. CLS. 22, 23, 38 AND 50). SN 85-295,816. PUB. 3-20-2012. FILED 4-14-2011.
- 4,152,767. **HUGGABLE HUGUMS (STANDARD CHARACTER)**. ALEXANDER DOLL COMPANY, INC., (U.S. CLS. 22, 23, 38 AND 50). SN 85-295,822. PUB. 3-20-2012. FILED 4-14-2011.
- 4,152,768. **HUGGUMS (STANDARD CHARACTER)**. ALEXANDER DOLL COMPANY, INC., (U.S. CLS. 22, 23, 38 AND 50). SN 85-295,836. PUB. 3-20-2012. FILED 4-14-2011.
- 4,152,787 (*See Class 9 for this trademark*).
- 4,152,879 (*See Class 9 for this trademark*).
- 4,152,892 (*See Class 25 for this trademark*).
- 4,152,930 (*See Class 25 for this trademark*).
- 4,152,946 (*See Class 9 for this trademark*).
- 4,152,987. **BOGO (STANDARD CHARACTER)**. RAZOR USA LLC, (U.S. CLS. 22, 23, 38 AND 50). SN 85-343,698. PUB. 3-20-2012. FILED 6-10-2011.
- 4,152,997. **THE ART OF DISGUISE (STANDARD CHARACTER)**. HERSEY, MORGAN, (U.S. CLS. 22, 23, 38 AND 50). SN 85-346,974. PUB. 3-20-2012. FILED 6-15-2011.
- 4,153,031. **UNITEDPLAY (STANDARD CHARACTER)**. RICHTER SPIELGERAETE GMBH, (U.S. CLS. 22, 23, 38 AND 50). SN 85-357,013. PUB. 3-20-2012. FILED 6-27-2011.
- 4,153,070. **IF YOU SPRAY IT THEY WILL COME (STANDARD CHARACTER)**. CHARLES HOLMES, (U.S. CLS. 22, 23, 38 AND 50). SN 85-373,108. PUB. 3-20-2012. FILED 7-16-2011.
- 4,153,123. **MOTION MECHANICS (STANDARD CHARACTER)**. NOVOSSEL, JOHN M. SR., (U.S. CLS. 22, 23, 38 AND 50). SN 85-389,125. PUB. 3-20-2012. FILED 8-4-2011.
- 4,153,167. **BLAST PAD (STANDARD CHARACTER)**. MARKY SPARKY, INC., DBA CALIFORNIA CHARIOT COMPANY, (U.S. CLS. 22, 23, 38 AND 50). SN 85-398,214. PUB. 3-20-2012. FILED 8-15-2011.
- 4,153,219. **BOMBSHELL (STANDARD CHARACTER)**. CAS-TALIA OUTDOORS, INC., (U.S. CLS. 22, 23, 38 AND 50). SN 85-411,155. PUB. 2-14-2012. FILED 8-30-2011.
- 4,153,239. **DISC-OFF.COM (STANDARD CHARACTER)**. ROCK WALL CORPORATION, DBA DISC-OFF, (U.S. CLS. 22, 23, 38 AND 50). SN 85-414,555. PUB. 3-20-2012. FILED 9-2-2011.
- 4,153,242. **SILTLOM AND DESIGN**. HAESUNG ENTERPRISE CO., LTD., (U.S. CLS. 22, 23, 38 AND 50). SN 85-414,661. PUB. 3-20-2012. FILED 9-2-2011.
- 4,153,244. **EXSUM (STYLIZED)**. HAESUNG ENTERPRISE CO., LTD., (U.S. CLS. 22, 23, 38 AND 50). SN 85-414,699. PUB. 3-20-2012. FILED 9-2-2011.
- 4,153,281 (*See Class 16 for this trademark*).
- 4,153,300. **GRASSROOTS POWDERSURFING (STANDARD CHARACTER)**. JENSEN, JEREMY LEVI, DBA JEREMY JENSEN MEDIA, (U.S. CLS. 22, 23, 38 AND 50). SN 85-421,988. PUB. 3-20-2012. FILED 9-14-2011.
- 4,153,359 (*See Class 12 for this trademark*).
- 4,153,360. **YOU CAN FIGHT (STANDARD CHARACTER)**. UNITED TACTICALS HOLDING LLC, (U.S. CLS. 22, 23, 38 AND 50). SN 85-427,805. PUB. 3-20-2012. FILED 9-21-2011.
- 4,153,397 (*See Class 24 for this trademark*).
- 4,153,417. **MUSCLE MACHINES (STANDARD CHARACTER)**. SCHULTZ, BRUCE, DBA BODYLINES, (U.S. CLS. 22, 23, 38 AND 50). SN 85-432,389. PUB. 3-20-2012. FILED 9-26-2011.
- 4,153,490. **MONSTER WHEELS (STYLIZED)**. PLAYZONE INC, (U.S. CLS. 22, 23, 38 AND 50). SN 85-436,706. PUB. 3-20-2012. FILED 9-30-2011.
- 4,153,577. **TOWN & COUNTRY TOYS (STANDARD CHARACTER)**. SMITH, JAMES H., (U.S. CLS. 22, 23, 38 AND 50). SN 85-439,052. PUB. 3-20-2012. FILED 10-4-2011.
- 4,153,640. **MI-X (STANDARD CHARACTER)**. TGIB MARKETING INC., (U.S. CLS. 22, 23, 38 AND 50). SN 85-440,632. PUB. 3-20-2012. FILED 10-6-2011.
- 4,153,653. **DUKK THE WOODCHUCK GAME (STANDARD CHARACTER)**. MAY WILHELM, LLC, (U.S. CLS. 22, 23, 38 AND 50). SN 85-440,812. PUB. 3-20-2012. FILED 10-6-2011.
- 4,153,725. **DOUBLEMATE (STANDARD CHARACTER)**. GLEN A. MCCOY, (U.S. CLS. 22, 23, 38 AND 50). SN 85-441,757. PUB. 3-20-2012. FILED 10-7-2011.
- 4,153,763. **DO YOGA ANYWHERE (STANDARD CHARACTER)**. JAMIE TARA-ANN GETZWILLER, (U.S. CLS. 22, 23, 38 AND 50). SN 85-442,191. PUB. 3-20-2012. FILED 10-7-2011.
- 4,153,786. **MISCELLANEOUS DESIGN**. MARUKYU CO., LTD., (U.S. CLS. 22, 23, 38 AND 50). SN 85-442,391. PUB. 3-20-2012. FILED 10-7-2011.
- 4,153,864. **AINOFEA AND DESIGN**. PASCUA, VANCE J., (U.S. CLS. 22, 23, 38 AND 50). SN 85-443,219. PUB. 3-20-2012. FILED 10-10-2011.
- 4,154,018 (*See Class 9 for this trademark*).
- 4,154,036. **COOL IN SCHOOL (STANDARD CHARACTER)**. SUPER DUPER, INC., DBA SUPER DUPER PUBLICATIONS, (U.S. CLS. 22, 23, 38 AND 50). SN 85-445,108. PUB. 3-20-2012. FILED 10-12-2011.
- 4,154,042. **THE ART OF PLAY (STANDARD CHARACTER)**. PARK PLACE RECREATION DESIGNS, INC., (U.S. CLS. 22, 23, 38 AND 50). SN 85-445,178. PUB. 3-20-2012. FILED 10-12-2011.
- 4,154,087. **JD JIN XING DA AND DESIGN**. QIU WENRUI, (U.S. CLS. 22, 23, 38 AND 50). SN 85-446,120. PUB. 3-20-2012. FILED 10-12-2011.
- 4,154,116. **H HO-B MAX AND DESIGN**. HO-B MAX, (U.S. CLS. 22, 23, 38 AND 50). SN 85-448,936. PUB. 3-20-2012. FILED 10-17-2011.
- 4,154,127. **SUMMIT (STANDARD CHARACTER)**. EBSCO INDUSTRIES, INC., (U.S. CLS. 22, 23, 38 AND 50). SN 85-450,486. PUB. 3-20-2012. FILED 10-18-2011.
- 4,154,212. **MISCELLANEOUS DESIGN**. KARSTEN MANUFACTURING CORPORATION, (U.S. CLS. 22, 23, 38 AND 50). SN 85-486,309. PUB. 3-6-2012. FILED 12-2-2011.
- 4,154,220. **IRON TRACK AND DESIGN**. EGRANDBUY, INC, (U.S. CLS. 22, 23, 38 AND 50). SN 85-491,656. PUB. 3-20-2012. FILED 12-9-2011.

CLASS 29—MEATS AND PROCESSED FOODS

- 4,152,101 (*See Class 1 for this trademark*).
- 4,152,131. **IN CUISIN (STANDARD CHARACTER)**. ALIMENTS IN FOODS INC., MULTIPLE CLASS, (INT. CLS. 29 AND 30), (U.S. CL. 46). SN 77-870,207. PUB. 3-20-2012. FILED 11-11-2009.
- 4,152,134. **BLARNEY STONE (STANDARD CHARACTER)**. SQUARE-H BRANDS, INC., (U.S. CL. 46). SN 77-886,843. PUB. 3-20-2012. FILED 12-4-2009.
- 4,152,152. **VV SUPREMO AND DESIGN**. V&V SUPREMO FOODS, INC., MULTIPLE CLASS, (INT. CLS. 29 AND 30), (U.S. CL. 46). SN 77-961,312. PUB. 3-20-2012. FILED 3-17-2010.
- 4,152,162 (*See Class 5 for this trademark*).
- 4,152,202. **KAANLAR AND DESIGN**. KANLAR GIDA SANAYI VE TICARET ANONIM SIRKETI, (U.S. CL. 46). SN 79-091,073. PUB. 3-20-2012. FILED 6-16-2010.
- 4,152,214 (*See Class 9 for this trademark*).
- 4,152,300. **EATING WELL STARTS WITH PICCOLINI (STANDARD CHARACTER)**. BARILLA G.E.R. FRATELLI - SOCIETA' PER AZIONI, MULTIPLE CLASS, (INT. CLS. 29 AND 30), (U.S. CL. 46). SN 79-098,716. PUB. 3-20-2012. FILED 3-18-2011.
- 4,152,305. **HILL'S COLLECTION (STYLIZED)**. OAK LAWN MARKETING, INC., (U.S. CL. 46). SN 79-098,873. PUB. 3-20-2012. FILED 11-29-2010.
- 4,152,339. **EL VENTERO AND DESIGN**. LACTALIS FORLASA, S.L.U., (U.S. CL. 46). SN 79-100,162. PUB. 3-20-2012. FILED 5-5-2011.
- 4,152,347. **AURI (STANDARD CHARACTER)**. SJØTROLL HAVBRUK AS C/O SJØTROLL AS, MULTIPLE CLASS, (INT. CLS. 29, 31 AND 42), (U.S. CLS. 1, 46, 100 AND 101). SN 79-100,500. PUB. 3-20-2012. FILED 5-25-2011.
- 4,152,358. **BLUE PIROGUE (STANDARD CHARACTER)**. RACINES SA, (U.S. CL. 46). SN 79-101,045. PUB. 3-20-2012. FILED 7-8-2011.
- 4,152,368. **KROON (STANDARD CHARACTER)**. FRIESLAND BRANDS B.V., (U.S. CL. 46). SN 79-101,988. PUB. 3-20-2012. FILED 7-11-2011.
- 4,152,392 (*See Class 5 for this trademark*).
- 4,152,400. **BRADAM ABEH-E3EP AND DESIGN**. FER-MERSKE GOSPODARSTVO "VLADAM", MULTIPLE

- CLASS. (INT. CLS. 29, 30, 31 AND 32), (U.S. CLS. 1, 45, 46 AND 48). SN 79-104,046. PUB. 3-20-2012. FILED 6-14-2011.
- 4,152,412. **NOBERASCO (STANDARD CHARACTER)**. NOBERASCO S.P.A., (U.S. CL. 46). SN 79-104,494. PUB. 3-20-2012. FILED 9-23-2011.
- 4,152,424. **MAMBA (STYLIZED)**. AUGUST STORCK KG, MULTIPLE CLASS, (INT. CLS. 29 AND 30), (U.S. CL. 46). SN 79-105,325. PUB. 3-20-2012. FILED 8-6-2010.
- 4,152,507 (*See Class 3 for this trademark*).
- 4,152,520. **HIGH RIVER ANGUS (STANDARD CHARACTER)**. COLORADO BOXED BEEF CO., (U.S. CL. 46). SN 85-131,439. PUB. 3-20-2012. FILED 9-16-2010.
- 4,152,524. **BAMBU SNACKS & COFFEE SHOPPE (STANDARD CHARACTER)**. NGUYEN, KIMHONG THI, DBA BAMBU SNACKS AND COFFEE CORPORATION, MULTIPLE CLASS, (INT. CLS. 29, 30, 32 AND 43), (U.S. CLS. 45, 46, 48, 100 AND 101). SN 85-133,833. PUB. 3-20-2012. FILED 9-20-2010.
- 4,152,561. **OMEGACRANS (STANDARD CHARACTER)**. DECAS CRANBERRY PRODUCTS INC, (U.S. CL. 46). SN 85-165,009. PUB. 3-20-2012. FILED 10-29-2010.
- 4,152,582. **MURAMATZ AND DESIGN**. MARUHACHI MURAMATSU, INC., MULTIPLE CLASS, (INT. CLS. 29, 30 AND 31), (U.S. CLS. 1 AND 46). SN 85-186,423. PUB. 3-20-2012. FILED 11-29-2010.
- 4,152,647. **PARKER HOUSE (STANDARD CHARACTER)**. PARKER HOUSE SAUSAGE COMPANY, (U.S. CL. 46). SN 85-248,133. PUB. 3-20-2012. FILED 2-22-2011.
- 4,152,658 (*See Class 1 for this trademark*).
- 4,152,945 (*See Class 5 for this trademark*).
- 4,152,952. **MOZZARELLA DI BUFALA CAMPANA AND DESIGN**. CONSORZIO PER LA TUTELA DEL FORMAGGIO MOZZARELLA DI BUFALA CAMPANA CONSORTIUM ITALY, (U.S. CL. 46). SN 85-332,305. PUB. 3-20-2012. FILED 5-27-2011.
- 4,152,982. **WILBUR'S REVENGE (STANDARD CHARACTER)**. FAMOUS DAVE'S OF AMERICA, INC., MULTIPLE CLASS, (INT. CLS. 29 AND 30), (U.S. CL. 46). SN 85-340,908. PUB. 3-20-2012. FILED 6-8-2011.
- 4,153,012. **EVERYDAY MEALS (STANDARD CHARACTER)**. KFC CORPORATION, (U.S. CL. 46). SN 85-351,892. PUB. 3-20-2012. FILED 6-21-2011.
- 4,153,046. **CARAFFA (STANDARD CHARACTER)**. CARAFFA OLIVES, INC., (U.S. CL. 46). SN 85-362,042. PUB. 3-20-2012. FILED 7-1-2011.
- 4,153,146. **WOOD RIVER CREAMERY (STANDARD CHARACTER)**. BURNETT DAIRY COOPERATIVE, (U.S. CL. 46). SN 85-394,366. PUB. 3-20-2012. FILED 8-10-2011.
- 4,153,182. **S SMOKY MARKET AND DESIGN**. SMOKY SYSTEMS, LLC, (U.S. CL. 46). SN 85-402,599. PUB. 3-20-2012. FILED 8-19-2011.
- 4,153,210 (*See Class 5 for this trademark*).
- 4,153,211 (*See Class 5 for this trademark*).
- 4,153,334. **JUTI (STANDARD CHARACTER)**. LIVING YOUR BEST LLC, (U.S. CL. 46). SN 85-424,550. PUB. 3-20-2012. FILED 9-16-2011.
- 4,153,433. **GEORGE AND DESIGN**. ZOE'S MEATS, DBA YIORYO, (U.S. CL. 46). SN 85-433,857. PUB. 3-20-2012. FILED 9-28-2011.
- 4,153,570. **SMACZNY (STANDARD CHARACTER)**. KERIVAN, JAMES, DBA INTRA CUSTOM DISTRIBUTORS, (U.S. CL. 46). SN 85-438,865. PUB. 3-20-2012. FILED 10-4-2011.
- 4,153,573. **POLISH DELIGHT (STANDARD CHARACTER)**. KERIVAN, JAMES, DBA INTRA CUSTOM DISTRIBUTORS, (U.S. CL. 46). SN 85-438,888. PUB. 3-20-2012. FILED 10-4-2011.
- 4,153,861. **DEMAIZ (STANDARD CHARACTER)**. SERGIO RICARDO DIAZ FLORES, (U.S. CL. 46). SN 85-443,180. PUB. 3-20-2012. FILED 10-10-2011.
- 4,154,096. **THE MOTHER LOAF (STANDARD CHARACTER)**. THE MEATLOAF BAKERY LLC, (U.S. CL. 46). SN 85-446,363. PUB. 3-20-2012. FILED 10-13-2011.
- 4,154,097. **LOAF-A-ROMA (STANDARD CHARACTER)**. THE MEATLOAF BAKERY LLC, (U.S. CL. 46). SN 85-446,462. PUB. 3-20-2012. FILED 10-13-2011.
- 4,154,130. **GARDEN RUSH (STANDARD CHARACTER)**. POOR RICHARD'S DISTRIBUTING CORPORATION, MULTIPLE CLASS, (INT. CLS. 29 AND 32), (U.S. CLS. 45, 46 AND 48). SN 85-451,402. PUB. 3-20-2012. FILED 10-19-2011.
- 4,154,149. **CHERKEES (STANDARD CHARACTER)**. EELTOWN ENTERPRISES, LLC, (U.S. CL. 46). SN 85-454,245. PUB. 3-20-2012. FILED 10-24-2011.
- 4,154,150. **BEEF JERKY, MEET POTATO CHIP (STANDARD CHARACTER)**. EELTOWN ENTERPRISES, LLC, (U.S. CL. 46). SN 85-454,261. PUB. 3-20-2012. FILED 10-24-2011.
- 4,154,166. **OBBERGOOD (STANDARD CHARACTER)**. PRINCESS & THE P, LLC, (U.S. CL. 46). SN 85-455,809. PUB. 3-20-2012. FILED 10-25-2011.
-
- CLASS 30—STAPLE FOODS**
- 4,152,066. **CULINARY CONCEPTS (STANDARD CHARACTER)**. DORINA/SO-GOOD, INC., (U.S. CL. 46). SN 76-709,310. PUB. 3-20-2012. FILED 10-4-2011.
- 4,152,094. **MINK (STANDARD CHARACTER)**. MINK CHOCOLATES INC., MULTIPLE CLASS, (INT. CLS. 30 AND 43), (U.S. CLS. 46, 100 AND 101). SN 77-568,713. PUB. 3-20-2012. FILED 9-12-2008.
- 4,152,101 (*See Class 1 for this trademark*).
- 4,152,131 (*See Class 29 for this trademark*).
- 4,152,152 (*See Class 29 for this trademark*).
- 4,152,162 (*See Class 5 for this trademark*).
- 4,152,214 (*See Class 9 for this trademark*).
- 4,152,298. **CRACOTTI (STANDARD CHARACTER)**. IAN ADRIAN DAVID RUSSELL, AND RACHEL VICTORIA RUSSELL, (U.S. CL. 46). SN 79-098,703. PUB. 3-20-2012. FILED 9-8-2010.
- 4,152,300 (*See Class 29 for this trademark*).
- 4,152,359 (*See Class 5 for this trademark*).
- 4,152,369. **HV AND DESIGN**. SATO & TAO (SOCIÉTÉ PAR ACTIONS SIMPLIFIÉE), MULTIPLE CLASS, (INT. CLS. 30, 35 AND 43), (U.S. CLS. 46, 100, 101 AND 102). SN 79-102,091. PUB. 3-20-2012. FILED 7-22-2011.
- 4,152,370. **HUGO & VICTOR (STYLIZED)**. SATO ET TAO (SOCIÉTÉ PAR ACTIONS SIMPLIFIÉE), MULTIPLE CLASS, (INT. CLS. 30, 35 AND 43), (U.S. CLS. 46, 100, 101 AND 102). SN 79-102,133. PUB. 3-20-2012. FILED 7-22-2011.
- 4,152,392 (*See Class 5 for this trademark*).
- 4,152,400 (*See Class 29 for this trademark*).
- 4,152,424 (*See Class 29 for this trademark*).
- 4,152,463 (*See Class 16 for this trademark*).
- 4,152,482. **FLUFF ICE (STANDARD CHARACTER)**. FLUFF ICE, LLC, DBA FLUFF ICE, (U.S. CL. 46). SN 85-097,651. PUB. 3-20-2012. FILED 8-1-2010.
- 4,152,507 (*See Class 3 for this trademark*).
- 4,152,512. **ATOMIC (STANDARD CHARACTER)**. FERRARA PAN CANDY CO., INC., (U.S. CL. 46). SN 85-125,636. PUB. 3-20-2012. FILED 9-9-2010.
- 4,152,524 (*See Class 29 for this trademark*).
- 4,152,538. **WELLABY'S AND DESIGN**. UNISMACK ANONYMI VIOMICHANIKI KE EMPORIKI ETERIA TROFIMON, TA U&S UNISMACK AVEE, (U.S. CL. 46). SN 85-145,257. PUB. 3-20-2012. FILED 10-5-2010.
- 4,152,566. **MILK CHOCOLATE REESE'S PEANUT BUTTER CUPS MINIATURES PERFECT REESE'S MINIATURES AND DESIGN**. HERSHEY CHOCOLATE & CONFECTIONERY CORPORATION, (U.S. CL. 46). SN 85-171,361. PUB. 3-20-2012. FILED 11-8-2010.
- 4,152,582 (*See Class 29 for this trademark*).
- 4,152,610. **TWIZZLERS TWISTS LOW FAT SNACK TOTALLY TWISTED MADE WITH REAL HERSHEY'S CHOCOLATE NATURALLY AND ARTIFICIALLY FLAVORED AND DESIGN**. HERSHEY CHOCOLATE & CONFECTIONERY CORPORATION, (U.S. CL. 46). SN 85-219,749. PUB. 3-20-2012. FILED 1-18-2011.
- 4,152,628. **SHROOMZILLA (STANDARD CHARACTER)**. CHECKERS DRIVE-IN RESTAURANTS, INC., (U.S. CL. 46). SN 85-231,732. PUB. 3-20-2012. FILED 2-1-2011.
- 4,152,651. **CHEEKY SANDWICHES AND DESIGN**. HIPPOE HOLDINGS, LLC, DBA CHEEKY SANDWICHES, (U.S. CL. 46). SN 85-250,498. PUB. 3-20-2012. FILED 2-24-2011.
- 4,152,658 (*See Class 1 for this trademark*).

- 4,152,684. **HANGTIME ORIGINAL HOT SAUCE BURNS SO GOOD AND DESIGN.** TEDKO, AKA HANGTIME HOT SAUCE, (U.S. CL. 46). SN 85-272,895. PUB. 3-20-2012. FILED 3-21-2011.
- 4,152,693. **BOBBILICIOUS BAKING COMPANY (STANDARD CHARACTER).** BOBBILICIOUS BAKING COMPANY LLC, (U.S. CL. 46). SN 85-276,544. PUB. 3-20-2012. FILED 3-25-2011.
- 4,152,721. **ANDERSON VALLEY BREWING COMPANY BOONVILLE CALIFORNIA AND DESIGN.** ANDERSON VALLEY ACQUISITION COMPANY, LLC, DBA ANDERSON VALLEY BREWING COMPANY, (U.S. CL. 46). SN 85-287,261. PUB. 3-20-2012. FILED 4-5-2011.
- 4,152,732. **NUDEFOOD (STANDARD CHARACTER).** CRYSTAL RIVER ORGANICS LLC, (U.S. CL. 46). SN 85-290,789. PUB. 3-20-2012. FILED 4-8-2011.
- 4,152,743. **MISCELLANEOUS DESIGN.** JUST POP IN, INC., (U.S. CL. 46). SN 85-293,028. PUB. 3-20-2012. FILED 4-12-2011.
- 4,152,761. **FIVE VILLAGE FIRE SZECHUAN (STANDARD CHARACTER).** HUHOT MONGOLIAN GRILLS, LLC, (U.S. CL. 46). SN 85-295,554. PUB. 3-20-2012. FILED 4-14-2011.
- 4,152,894. **DESTINY CHOCOLATES AND DESIGN.** DESTINY CHOCOLATES, LLC, (U.S. CL. 46). SN 85-316,836. PUB. 3-20-2012. FILED 5-10-2011.
- 4,152,953. **MISCELLANEOUS DESIGN.** MEI HUA SIANG CO., LTD., (U.S. CL. 46). SN 85-333,104. PUB. 3-20-2012. FILED 5-28-2011.
- 4,152,968. **MUSKOKA ROASTERY COFFEE CO. 100% CERTIFIED HANDCRAFTED AND DESIGN.** 1147785 ONTARIO LTD., DBA MUSKOKA ROASTERY COFFEE COMPANY, MULTIPLE CLASS, (INT. CLS. 30, 35 AND 40), (U.S. CLS. 46, 100, 101, 102, 103 AND 106). SN 85-337,832. PUB. 3-20-2012. FILED 6-3-2011.
- 4,152,982 (*See Class 29 for this trademark*).
- 4,152,986. **CHEF NIGEL'S (STANDARD CHARACTER).** CHEF NIGEL, INC., (U.S. CL. 46). SN 85-342,954. PUB. 3-20-2012. FILED 6-10-2011.
- 4,153,030. **SAINTS' WORLD'S BEST COFFEE AND DESIGN.** SAINT'S COFFEE IMPORT, INC., (U.S. CL. 46). SN 85-356,565. PUB. 3-20-2012. FILED 6-27-2011.
- 4,153,089. **BEANO'S AND DESIGN.** CONROY FOODS, INC., (U.S. CL. 46). SN 85-378,106. PUB. 3-20-2012. FILED 7-22-2011.
- 4,153,198 (*See Class 11 for this trademark*).
- 4,153,215. **SALSA RIO (STANDARD CHARACTER).** FRITOLAY NORTH AMERICA, INC., (U.S. CL. 46). SN 85-410,395. PUB. 3-20-2012. FILED 8-30-2011.
- 4,153,284. **DAILY DOSE OF DARK AND DESIGN.** NIBMOR PROJECT, LLC., (U.S. CL. 46). SN 85-420,439. PUB. 3-20-2012. FILED 9-12-2011.
- 4,153,292. **RIZZUTO FOODS (STANDARD CHARACTER).** T.R. RIZZUTO PIZZA CRUST, INC., (U.S. CL. 46). SN 85-421,313. PUB. 3-20-2012. FILED 9-13-2011.
- 4,153,474. **POPPED AND DESIGN.** POPPED.LLC, (U.S. CL. 46). SN 85-436,042. PUB. 3-20-2012. FILED 9-30-2011.
- 4,153,521. **CAMANO ISLAND COFFEE ROASTERS AND DESIGN.** CAMANO ISLAND MANAGEMENT, INC., (U.S. CL. 46). SN 85-437,628. PUB. 3-20-2012. FILED 10-3-2011.
- 4,153,535. **MISCELLANEOUS DESIGN.** MADAVA SUGAR MAPLE, LLC, (U.S. CL. 46). SN 85-437,896. PUB. 3-20-2012. FILED 10-3-2011.
- 4,153,540. **MISCELLANEOUS DESIGN.** MADECASSE, LLC, (U.S. CL. 46). SN 85-438,085. PUB. 3-20-2012. FILED 10-3-2011.
- 4,153,549. **GOLESTAN AND DESIGN.** MAHALAXMI EXPORTS FZE, (U.S. CL. 46). SN 85-438,344. PUB. 3-20-2012. FILED 10-4-2011.
- 4,153,586. **BUMBLEBEE BAKESHOP (STANDARD CHARACTER).** BUMBLEBEE CELEBRATIONS LLC, DBA BUMBLEBEE BAKESHOP, (U.S. CL. 46). SN 85-439,285. PUB. 3-20-2012. FILED 10-4-2011.
- 4,153,629. **MISCELLANEOUS DESIGN.** CHICKEN IN A BARREL BBQ, MULTIPLE CLASS, (INT. CLS. 30 AND 43), (U.S. CLS. 46, 100 AND 101). SN 85-440,290. PUB. 3-20-2012. FILED 10-5-2011.
- 4,153,674. **DREAM CAKES (STANDARD CHARACTER).** MAGGIEMOO'S FRANCHISE BRANDS, LLC, (U.S. CL. 46). SN 85-441,020. PUB. 3-20-2012. FILED 10-6-2011.
- 4,153,684. **NOONDAY PICANTE (STANDARD CHARACTER).** SMITH, BOBBY, (U.S. CL. 46). SN 85-441,202. PUB. 3-20-2012. FILED 10-6-2011.
- 4,153,726. **BULLET (STANDARD CHARACTER).** REUNION ISLAND COFFEE LIMITED, (U.S. CL. 46). SN 85-441,759. PUB. 3-20-2012. FILED 10-7-2011.
- 4,153,727. **CANNONBALL (STANDARD CHARACTER).** REUNION ISLAND COFFEE LIMITED, (U.S. CL. 46). SN 85-441,767. PUB. 3-20-2012. FILED 10-7-2011.
- 4,153,728. **FIREFLY (STANDARD CHARACTER).** REUNION ISLAND COFFEE LIMITED, (U.S. CL. 46). SN 85-441,774. PUB. 3-20-2012. FILED 10-7-2011.
- 4,153,802. **JUAN'S SALSA AND DESIGN.** WALKER, JON, (U.S. CL. 46). SN 85-442,575. PUB. 3-20-2012. FILED 10-7-2011.
- 4,153,818. **15 MINUTES. EASY TO MAKE. MANY TO LOVE. (STANDARD CHARACTER).** GARDETTO'S BAKERY, INC., (U.S. CL. 46). SN 85-442,757. PUB. 3-20-2012. FILED 10-8-2011.
- 4,153,959. **WHERE GREAT PIZZA BEGINS (STANDARD CHARACTER).** VENICE BAKING COMPANY, (U.S. CL. 46). SN 85-444,165. PUB. 3-20-2012. FILED 10-11-2011.
- 4,153,972. **DRESSED UP (STANDARD CHARACTER).** J & A, LLC, (U.S. CL. 46). SN 85-444,287. PUB. 3-20-2012. FILED 10-11-2011.
- 4,154,032. **LITTLE BIRD BAKING COMPANY (STANDARD CHARACTER).** DAVISSON, DJ, (U.S. CL. 46). SN 85-444,973. PUB. 3-20-2012. FILED 10-11-2011.
- 4,154,052. **MAGICAL FLAVORS (STANDARD CHARACTER).** HAIDER, SAM, (U.S. CL. 46). SN 85-445,613. PUB. 3-20-2012. FILED 10-12-2011.
- 4,154,094. **CABLE CARFAITS (STANDARD CHARACTER).** INTERNATIONAL FRANCHISE INC., (U.S. CL. 46). SN 85-446,312. PUB. 3-20-2012. FILED 10-13-2011.
- 4,154,101. **DREAM COOKIES (STANDARD CHARACTER).** MADRONA SPECIALTY FOODS, LLC, (U.S. CL. 46). SN 85-447,125. PUB. 3-20-2012. FILED 10-13-2011.
- 4,154,115. **THE NEW INGREDIENT AND RECIPE FOR SIMPLY SENSATIONAL CHOCOLATE CHIP COOKIES (STANDARD CHARACTER).** SIMPLY MORSELS, LLC, (U.S. CL. 46). SN 85-448,935. PUB. 3-20-2012. FILED 10-17-2011.
- 4,154,144. **DELUXE (STANDARD CHARACTER).** COLLIN STREET BAKERY, INC, (U.S. CL. 46). SN 85-452,980. PUB. 3-20-2012. FILED 10-21-2011.
- 4,154,167. **R U NUTZ (STANDARD CHARACTER).** UMPQUA OATS, INC., (U.S. CL. 46). SN 85-455,945. PUB. 3-20-2012. FILED 10-25-2011.
- 4,154,173. **FAIRWINDS (STANDARD CHARACTER).** JBR, INC., (U.S. CL. 46). SN 85-456,567. PUB. 3-20-2012. FILED 10-26-2011.
- 4,154,214. **MISCELLANEOUS DESIGN.** KELLOGG NORTH AMERICA COMPANY, (U.S. CL. 46). SN 85-487,978. PUB. 3-20-2012. FILED 12-6-2011.
- 4,154,215. **MISCELLANEOUS DESIGN.** KELLOGG NORTH AMERICA COMPANY, (U.S. CL. 46). SN 85-488,026. PUB. 3-20-2012. FILED 12-6-2011.
- 4,154,231. **MINI MELTS (STANDARD CHARACTER).** MINI MELTS, INC., (U.S. CL. 46). SN 85-502,968. PUB. 3-20-2012. FILED 12-23-2011.
- 4,154,234. **CLOVER BREWED (STANDARD CHARACTER).** STARBUCKS CORPORATION, DBA STARBUCKS COFFEE COMPANY, (U.S. CL. 46). SN 85-510,602. PUB. 3-20-2012. FILED 1-6-2012.

CLASS 31—NATURAL AGRICULTURAL PRODUCTS

- 4,152,046. **THE ULTIMATE TREAT FOR DOGS! (STANDARD CHARACTER).** EURO-CAN MANUFACTURING INC., (U.S. CLS. 1 AND 46). SN 76-707,180. PUB. 3-20-2012. FILED 4-8-2011.
- 4,152,214 (*See Class 9 for this trademark*).
- 4,152,347 (*See Class 29 for this trademark*).

4,152,400 (*See Class 29 for this trademark.*)
 4,152,582 (*See Class 29 for this trademark.*)
 4,152,776 (*See Class 5 for this trademark.*)
 4,152,796. **BLUE MYSTIQUE AND DESIGN.** BLUE MYSTIQUE, INC., (U.S. CLS. 1 AND 46). SN 85-298,591. PUB. 3-20-2012. FILED 4-19-2011.
 4,152,887. **NUTRICARE (STANDARD CHARACTER).** TEO PET L.L.C., DBA TEOPET, (U.S. CLS. 1 AND 46). SN 85-315,283. PUB. 3-20-2012. FILED 5-9-2011.
 4,152,956. **EAST BEACH BLONDE (STANDARD CHARACTER).** PAPA, NICHOLAS, AND ARNOUX, JIM, (U.S. CLS. 1 AND 46). SN 85-333,662. PUB. 3-20-2012. FILED 5-31-2011.
 4,153,036. **FRESH & LIGHT (STANDARD CHARACTER).** OIL-DRI CORPORATION OF AMERICA, (U.S. CLS. 1 AND 46). SN 85-359,482. PUB. 12-13-2011. FILED 6-29-2011.
 4,153,129. **MOJAVE (STANDARD CHARACTER).** FOUR STAR GREENHOUSE, INC., (U.S. CLS. 1 AND 46). SN 85-390,694. PUB. 3-20-2012. FILED 8-5-2011.
 4,153,265. **PREMIUM MANGOS FRUTAS FINAS SOCONUSCO PREMIUM MANGOS AND DESIGN.** INTEGRADORA DE FRUTAS FINAS SOCONUSCO S.A. DE C.V., TA FRUTAS FINAS SOCONUSCO, (U.S. CLS. 1 AND 46). SN 85-417,668. PUB. 3-20-2012. FILED 9-8-2011.
 4,153,291. **CLASSIC ANIMAL NUTRITION (STANDARD CHARACTER).** GAK ENTERPRISES, INC., (U.S. CLS. 1 AND 46). SN 85-421,279. PUB. 3-20-2012. FILED 9-13-2011.
 4,154,140. **ULTRA ADVANTAGE (STANDARD CHARACTER).** PET KENNEL COMPANY, LLC, (U.S. CLS. 1 AND 46). SN 85-452,509. PUB. 3-20-2012. FILED 10-20-2011.

CLASS 32—LIGHT BEVERAGES

4,152,121. **BIG WHEEL (STANDARD CHARACTER).** 2008474 ONTARIO INC., (U.S. CLS. 45, 46 AND 48). SN 77-818,998. PUB. 3-29-2011. FILED 9-2-2009.
 4,152,122. **STRENGTH (STANDARD CHARACTER).** DS WATERS OF AMERICA, INC., (U.S. CLS. 45, 46 AND 48). SN 77-829,805. PUB. 3-20-2012. FILED 9-18-2009.
 4,152,400 (*See Class 29 for this trademark.*)
 4,152,463 (*See Class 16 for this trademark.*)
 4,152,524 (*See Class 29 for this trademark.*)
 4,152,554. **COLOMBIANA LA NUESTRA AND DESIGN.** GASEOSAS COLOMBIANAS S.A., (U.S. CLS. 45, 46 AND 48). SN 85-159,292. PUB. 3-20-2012. FILED 10-22-2010.
 4,152,658 (*See Class 1 for this trademark.*)
 4,152,748 (*See Class 5 for this trademark.*)
 4,152,881. **BLONDE BOMBSHELL (STANDARD CHARACTER).** INDIGO IMP BREWERY, LTD., (U.S. CLS. 45, 46 AND 48). SN 85-313,975. PUB. 3-20-2012. FILED 5-6-2011.
 4,152,914. **HARVEST FRESH PELLETS AND DESIGN.** ROY FARMS, INC., (U.S. CLS. 45, 46 AND 48). SN 85-321,705. PUB. 3-20-2012. FILED 5-16-2011.
 4,152,963. **SIBERIA NITRATE FREE AND DESIGN.** NITRATE FREE, INC., DBA SIBERIA WATERS, (U.S. CLS. 45, 46 AND 48). SN 85-336,269. PUB. 3-20-2012. FILED 6-2-2011.
 4,153,243. **WHEAT WACKER INDIA-STYLE WHEAT ALE (STANDARD CHARACTER).** BLACK DIAMOND BREWING COMPANY, INC., (U.S. CLS. 45, 46 AND 48). SN 85-414,694. PUB. 3-20-2012. FILED 9-2-2011.
 4,153,453. **GREAT LAKES BREWING CO. BURNING RIVER A HANDCRAFTED PALE ALE CLEVELAND, OHIO AND DESIGN.** THE GREAT LAKES BREWING CO., (U.S. CLS. 45, 46 AND 48). SN 85-435,018. PUB. 3-20-2012. FILED 9-29-2011.
 4,153,457. **GREAT LAKES BREWING CO. THE WRIGHT PILS A HANDCRAFTED PILSNER CLEVELAND, OHIO AND DESIGN.** THE GREAT LAKES BREWING CO., (U.S. CLS. 45, 46 AND 48). SN 85-435,145. PUB. 3-20-2012. FILED 9-29-2011.
 4,153,458. **GREAT LAKES BREWING CO. "DON'T GIVE UP THE SIP" COMMODORE PERRY A HANDCRAFTED INDIA PALE ALE CLEVELAND, OHIO AND DESIGN.** THE GREAT LAKES BREWING CO., (U.S. CLS. 45, 46 AND 48). SN 85-435,175. PUB. 3-20-2012. FILED 9-29-2011.
 4,153,459. **GREAT LAKES BREWING CO. EDMUND FITZGERALD A HANDCRAFTED PORTER CLEVELAND,**

OHIO AND DESIGN. THE GREAT LAKES BREWING CO., (U.S. CLS. 45, 46 AND 48). SN 85-435,260. PUB. 3-20-2012. FILED 9-29-2011.
 4,153,462. **GREAT LAKES BREWING CO. HOLY MOSES WHITE ALE A HANDCRAFTED WHITE ALE WITH SPICES AND CHAMOMILE CLEVELAND, OHIO AND DESIGN.** THE GREAT LAKES BREWING CO., (U.S. CLS. 45, 46 AND 48). SN 85-435,372. PUB. 3-20-2012. FILED 9-29-2011.
 4,153,463. **GREAT LAKES BREWING CO. CHRISTMAS ALE A HANDCRAFTED ALE WITH SPICES AND HONEY CLEVELAND, OHIO AND DESIGN.** THE GREAT LAKES BREWING CO., (U.S. CLS. 45, 46 AND 48). SN 85-435,418. PUB. 3-20-2012. FILED 9-29-2011.
 4,153,511. **COOL TROPICS RIPS SLUSH (STANDARD CHARACTER).** TROPICAL PARADISE, INC., (U.S. CLS. 45, 46 AND 48). SN 85-437,417. PUB. 3-20-2012. FILED 10-3-2011.
 4,154,008. **MYSTERIUM (STANDARD CHARACTER).** DUC-LAW BREWERY LLC, (U.S. CLS. 45, 46 AND 48). SN 85-444,674. PUB. 3-20-2012. FILED 10-11-2011.
 4,154,031. **PIMPSNHOFENFEST (STANDARD CHARACTER).** BARLEY AND HOPS TAVERN, (U.S. CLS. 45, 46 AND 48). SN 85-444,959. PUB. 3-20-2012. FILED 10-11-2011.
 4,154,044. **OCCUPATION (STANDARD CHARACTER).** MAD SCIENTISTS BREWING PARTNERS LLC, DBA SIXPOINT CRAFT ALES, (U.S. CLS. 45, 46 AND 48). SN 85-445,200. PUB. 3-20-2012. FILED 10-12-2011.
 4,154,130 (*See Class 29 for this trademark.*)
 4,154,138. **DIVINE RETRIBUTION (STANDARD CHARACTER).** DUCLAW BREWERY LLC, (U.S. CLS. 45, 46 AND 48). SN 85-452,372. PUB. 3-20-2012. FILED 10-20-2011.
 4,154,207. **NAKED FISH (STANDARD CHARACTER).** DUC-LAW BREWERY LLC, (U.S. CLS. 45, 46 AND 48). SN 85-479,749. PUB. 3-20-2012. FILED 11-23-2011.
 4,154,223. **LIVE LIFE UNFILTERED (STANDARD CHARACTER).** ANHEUSER-BUSCH, LLC, (U.S. CLS. 45, 46 AND 48). SN 85-492,562. PUB. 3-20-2012. FILED 12-12-2011.
 4,154,238. **THE ORIGINAL BROOKLYN WATER BOTTLING CO. (STANDARD CHARACTER).** THE ORIGINAL BROOKLYN WATER BAGEL CO., INC., (U.S. CLS. 45, 46 AND 48). SN 85-975,716. PUB. 3-20-2012. FILED 2-4-2011.

CLASS 33—WINES AND SPIRITS

4,152,097. **MISCELLANEOUS DESIGN.** PEARL FAMILY VINEYARDS INC., DBA PEARLMORISSETTE, (U.S. CLS. 47 AND 49). SN 77-571,972. PUB. 9-7-2010. FILED 9-17-2008.
 4,152,104. **ZZ (STANDARD CHARACTER).** ZORZAL INCORPORATED, (U.S. CLS. 47 AND 49). SN 77-624,524. PUB. 3-20-2012. FILED 12-2-2008.
 4,152,153. **ANTOINE DE CLAIRVOY (STANDARD CHARACTER).** CPC CELLARS LLC, (U.S. CLS. 47 AND 49). SN 77-962,614. PUB. 3-20-2012. FILED 3-18-2010.
 4,152,154. **CHATEAU DE CLAIRVOY (STANDARD CHARACTER).** CPC CELLARS LLC, (U.S. CLS. 47 AND 49). SN 77-962,624. PUB. 3-20-2012. FILED 3-18-2010.
 4,152,211. **LOMBARD (STANDARD CHARACTER).** LOMBARD & MEDOT (SOCIÉTÉ ANONYME À DIRECTOIRE ET CONSEIL DE SURVEILLANCE), MULTIPLE CLASS, (INT. CLS. 33 AND 35), (U.S. CLS. 47, 49, 100, 101 AND 102). SN 79-092,802. PUB. 3-20-2012. FILED 1-13-2011.
 4,152,225. **JULIA KEMPER (STANDARD CHARACTER).** CESCE - SOCIEDADE AGRÍCOLA, EXPLORAÇÃO, TRANSFORMAÇÃO E COMERCIALIZAÇÃO AGRÍCOLAS, S.A., (U.S. CLS. 47 AND 49). SN 79-095,146. PUB. 3-20-2012. FILED 2-18-2011.
 4,152,258. **AFFENTALER WINZERGENOSSENSCHAFT AND DESIGN.** AFFENTALER WINZERGENOSSENSCHAFT BÜHL EG, (U.S. CLS. 47 AND 49). SN 79-097,275. PUB. 3-20-2012. FILED 4-23-2011.
 4,152,287. **PI (STANDARD CHARACTER).** LODESTAR ANSTALT (A LIECHTENSTEIN COMPANY), (U.S. CLS. 47 AND 49). SN 79-098,415. PUB. 3-20-2012. FILED 1-27-2011.
 4,152,288. **22 OVER 7 (STANDARD CHARACTER).** LODESTAR ANSTALT (A LIECHTENSTEIN COMPANY), (U.S. CLS. 47 AND 49). SN 79-098,417. PUB. 3-20-2012. FILED 1-

- 27-2011.
- 4,152,291. **CHAMPAGNOTHÈQUE AND DESIGN**. VAUTHIER, ERIC, MULTIPLE CLASS, (INT. CLS. 33 AND 41), (U.S. CLS. 47, 49, 100, 101 AND 107). SN 79-098,458. PUB. 3-20-2012. FILED 3-28-2011.
- 4,152,294. **CHATEAU SMITH HAUT LAFITTE GRAND CRU CLASSE DE GRAVES 2008 PRESSAC LEONAN DANIEL ET FLORENCE CATHIARD AND DESIGN**. SAS D. CATHIARD, (U.S. CLS. 47 AND 49). SN 79-098,538. PUB. 3-20-2012. FILED 2-22-2011.
- 4,152,304. **MISCELLANEOUS DESIGN**. CHIVAS HOLDINGS (IP) LIMITED, (U.S. CLS. 47 AND 49). SN 79-098,869. PUB. 3-20-2012. FILED 4-20-2011.
- 4,152,327. **RECHTÄLER AND DESIGN**. LIDL STIFTUNG & CO. KG, (U.S. CLS. 47 AND 49). SN 79-099,676. PUB. 3-20-2012. FILED 1-26-2011.
- 4,152,329. **SIETESIETE (STANDARD CHARACTER)**. BODEGA LA SOTERRAÑA, S.L., (U.S. CLS. 47 AND 49). SN 79-099,751. PUB. 3-20-2012. FILED 3-23-2011.
- 4,152,373. **VIGNA DOGARINA (STANDARD CHARACTER)**. AZIENDA AGRICOLA VIGNA DOGARINA SAS DI TONUS GUIDO & C., MULTIPLE CLASS, (INT. CLS. 33, 35 AND 43), (U.S. CLS. 47, 49, 100, 101 AND 102). SN 79-102,415. PUB. 3-20-2012. FILED 6-24-2011.
- 4,152,407. **D. ORIGEN TORO AND DESIGN**. CONSEJO REGULADOR DE LA DENOMINACION DE ORIGEN TORO, (U.S. CLS. 47 AND 49). SN 79-104,250. PUB. 3-20-2012. FILED 8-18-2011.
- 4,152,463 (*See Class 16 for this trademark*).
- 4,152,507 (*See Class 3 for this trademark*).
- 4,152,625. **F1 FORMULA 1 (STYLIZED)**. FORMULA ONE LICENSING BV, (U.S. CLS. 47 AND 49). SN 85-228,584. PUB. 3-20-2012. FILED 1-28-2011.
- 4,152,671. **KALARIS (STANDARD CHARACTER)**. KALARIS, CONSTANTINE, (U.S. CLS. 47 AND 49). SN 85-265,753. PUB. 3-20-2012. FILED 3-14-2011.
- 4,152,681. **EQUUA VALLE DE GUADALUPE (STANDARD CHARACTER)**. MALAGON, RACHEL, (U.S. CLS. 47 AND 49). SN 85-271,399. PUB. 3-20-2012. FILED 3-18-2011.
- 4,152,804. **OUTER LIMITS (STANDARD CHARACTER)**. MONTES S.A., (U.S. CLS. 47 AND 49). SN 85-299,407. PUB. 3-20-2012. FILED 4-19-2011.
- 4,152,899. **SAN ANTONIO STOCK SHOW & RODEO AND DESIGN**. SAN ANTONIO LIVESTOCK EXPOSITION, INC., (U.S. CLS. 47 AND 49). SN 85-316,970. PUB. 3-20-2012. FILED 5-10-2011.
- 4,153,053. **LEONA VALLEY WINERY (STANDARD CHARACTER)**. DAVID REYNOLDS, DBA LEONA VALLEY WINERY, (U.S. CLS. 47 AND 49). SN 85-366,491. PUB. 3-20-2012. FILED 7-8-2011.
- 4,153,311. **NORTH (STANDARD CHARACTER)**. ALBAN VINEYARDS, INC., (U.S. CLS. 47 AND 49). SN 85-422,840. PUB. 3-20-2012. FILED 9-14-2011.
- 4,153,473. **OLIVER TWIST (STANDARD CHARACTER)**. KEIRAN WYATT-NICOLLE, (U.S. CLS. 47 AND 49). SN 85-435,996. PUB. 3-20-2012. FILED 9-30-2011.
- 4,153,512. **SAMBALLA (STANDARD CHARACTER)**. SAZERAC COMPANY, INC., (U.S. CLS. 47 AND 49). SN 85-437,422. PUB. 3-20-2012. FILED 10-3-2011.
- 4,153,643. **REDDLE VALLEY (STANDARD CHARACTER)**. KMBJ INC., (U.S. CLS. 47 AND 49). SN 85-440,649. PUB. 3-20-2012. FILED 10-6-2011.
- 4,153,800. **DUTCH HARBOR BREEZE (STANDARD CHARACTER)**. YOGD, LLC, (U.S. CLS. 47 AND 49). SN 85-442,564. PUB. 3-20-2012. FILED 10-7-2011.
- 4,153,801. **GOOD MORNING GLORY (STANDARD CHARACTER)**. YOGD, LLC, (U.S. CLS. 47 AND 49). SN 85-442,568. PUB. 3-20-2012. FILED 10-7-2011.
- 4,153,842. **SPARKLING WINE OF THE STARS (STANDARD CHARACTER)**. OLIVER EUGENE ANDERSON, AND CHARLES LORENZO HAYES, (U.S. CLS. 47 AND 49). SN 85-442,955. PUB. 3-20-2012. FILED 10-9-2011.
- 4,154,000. **COWHOUSE (STANDARD CHARACTER)**. LION NATHAN USA, INC., (U.S. CLS. 47 AND 49). SN 85-444,576. PUB. 3-20-2012. FILED 10-11-2011.
- 4,154,001 (*See Class 9 for this trademark*).
- 4,154,069. **MISCELLANEOUS DESIGN**. ROUND HILL CELLARS, DBA RUTHERFORD WINE COMPANY, (U.S. CLS.

- 47 AND 49). SN 85-445,858. PUB. 3-20-2012. FILED 10-12-2011.
- 4,154,111. **MAISON MONNET COGNAC FONDÉE EN 1838 VSOP AND DESIGN**. THOMAS HINE & CO, (U.S. CLS. 47 AND 49). SN 85-447,842. PUB. 3-20-2012. FILED 10-14-2011.
- 4,154,131. **SEA SPRAY (STANDARD CHARACTER)**. DAVIDS PINOT VINEYARDS, INC., DBA SEA SMOKE CELLARS, (U.S. CLS. 47 AND 49). SN 85-451,421. PUB. 3-20-2012. FILED 10-19-2011.
- 4,154,151. **TWEEKA (STANDARD CHARACTER)**. GUTEKUNST, BRENT L, (U.S. CLS. 47 AND 49). SN 85-454,358. PUB. 3-20-2012. FILED 10-24-2011.
- 4,154,213. **SHAKETAILES (STANDARD CHARACTER)**. PASSION FOOD SIX, LLC, DBA BURGER TAP AND SHAKE, (U.S. CLS. 47 AND 49). SN 85-486,853. PUB. 3-20-2012. FILED 12-5-2011.

CLASS 34—SMOKERS' ARTICLES

- 4,152,507 (*See Class 3 for this trademark*).
- 4,152,850. **MARLBORO SKYLINE (STANDARD CHARACTER)**. PHILIP MORRIS USA INC., (U.S. CLS. 2, 8, 9 AND 17). SN 85-307,244. PUB. 3-20-2012. FILED 4-28-2011.
- 4,152,928. **SNUFF SKINS (STANDARD CHARACTER)**. WATTENBARGER, JOSEPH, AND OSBORNE, THOMAS, (U.S. CLS. 2, 8, 9 AND 17). SN 85-326,102. PUB. 3-20-2012. FILED 5-20-2011.
- 4,153,230. **VK (STANDARD CHARACTER)**. FOREFRONT ENTERPRISES, LLC, (U.S. CLS. 2, 8, 9 AND 17). SN 85-412,636. PUB. 2-14-2012. FILED 9-1-2011.
- 4,153,415. **CLUB MODIANO (STANDARD CHARACTER)**. BBK TOBACCO & FOODS, LLP, DBA HBI INTERNATIONAL, (U.S. CLS. 2, 8, 9 AND 17). SN 85-431,938. PUB. 3-20-2012. FILED 9-26-2011.
- 4,153,594. **WANT2VAPE (STANDARD CHARACTER)**. DCW REHABS, LLC, (U.S. CLS. 2, 8, 9 AND 17). SN 85-439,489. PUB. 3-20-2012. FILED 10-5-2011.
- 4,153,943. **TOTAL (STANDARD CHARACTER)**. KENTASH, LLC, DBA NJ SMOKES, (U.S. CLS. 2, 8, 9 AND 17). SN 85-444,074. PUB. 3-20-2012. FILED 10-11-2011.
- 4,154,018 (*See Class 9 for this trademark*).
- 4,154,064. **ESCALADE (STANDARD CHARACTER)**. XIKAR, INC., (U.S. CLS. 2, 8, 9 AND 17). SN 85-445,756. PUB. 3-20-2012. FILED 10-12-2011.
- 4,154,078. **SHADY LADY (STANDARD CHARACTER)**. TAQSEEM, INC., (U.S. CLS. 2, 8, 9 AND 17). SN 85-445,947. PUB. 3-20-2012. FILED 10-12-2011.

SERVICE MARKS

CLASS 35—ADVERTISING AND BUSINESS

- 4,152,040. **DATAGEAR (STANDARD CHARACTER)**. DATAGEAR, INC., MULTIPLE CLASS, (INT. CLS. 35, 37 AND 42), (U.S. CLS. 100, 101, 102, 103 AND 106). SN 76-705,393. PUB. 3-20-2012. FILED 11-18-2010.
- 4,152,041 (*See Class 1 for this trademark*).
- 4,152,067. **IAB AND DESIGN**. INDEPENDENT ASSOCIATION OF BUSINESSES, (U.S. CLS. 100, 101 AND 102). SN 76-709,363. PUB. 3-20-2012. FILED 10-11-2011.
- 4,152,070. **QUIVER (STANDARD CHARACTER)**. QUIVER, LLC, (U.S. CLS. 100, 101 AND 102). SN 76-709,473. PUB. 3-20-2012. FILED 10-21-2011.
- 4,152,075. **FINE TOUCH (STANDARD CHARACTER)**. FINE TOUCH DENTAL MANAGEMENT CORPORATION, MULTIPLE CLASS, (INT. CLS. 35 AND 36), (U.S. CLS. 100, 101 AND 102). SN 77-136,853. PUB. 3-20-2012. FILED 3-21-2007.
- 4,152,077. **USFALCON (STANDARD CHARACTER)**. USFALCON, INC., MULTIPLE CLASS, (INT. CLS. 35, 37 AND 42), (U.S. CLS. 100, 101, 102, 103 AND 106). SN 77-157,793. PUB. 3-20-2012. FILED 4-16-2007.

- 4,152,078. **V AND DESIGN**. VB VENTURES PTY LTD, MULTIPLE CLASS, (INT. CLS. 35, 36, 39, 41 AND 43), (U.S. CLS. 100, 101, 102, 105 AND 107). SN 77-240,719. PUB. 9-8-2009. FILED 7-27-2007.
- 4,152,081 (*See Class 17 for this trademark*).
- 4,152,082. **MEZZANOVE 9 CAPITAL (STYLIZED)**. BI-INVEST HOLDINGS S.A., MULTIPLE CLASS, (INT. CLS. 35 AND 36), (U.S. CLS. 100, 101 AND 102). SN 77-368,264. PUB. 3-20-2012. FILED 1-10-2008.
- 4,152,083. **MEZZANOVE 9 MEZZANINE (STYLIZED)**. BI-INVEST HOLDINGS S.A., MULTIPLE CLASS, (INT. CLS. 35 AND 36), (U.S. CLS. 100, 101 AND 102). SN 77-368,267. PUB. 3-20-2012. FILED 1-10-2008.
- 4,152,086. **MISCELLANEOUS DESIGN**. SIGNET ARMOR-LITE EUROPE LIMITED, (U.S. CLS. 100, 101 AND 102). SN 77-396,647. PUB. 8-24-2010. FILED 12-14-2008.
- 4,152,087 (*See Class 1 for this trademark*).
- 4,152,098. **HSB SARAVANA BHAVAN AND DESIGN**. SARAVANA BHAVAN HOLDINGS LIMITED, MULTIPLE CLASS, (INT. CLS. 35 AND 43), (U.S. CLS. 100, 101 AND 102). SN 77-572,335. PUB. 3-20-2012. FILED 9-17-2008.
- 4,152,107. **INFINITY HEALTHCARE AND DESIGN**. INFINITY HEALTHCARE, INC., MULTIPLE CLASS, (INT. CLS. 35, 36 AND 41), (U.S. CLS. 100, 101, 102 AND 107). SN 77-640,272. PUB. 3-20-2012. FILED 12-28-2008.
- 4,152,108. **BUFFALO WILD WINGS (STANDARD CHARACTER)**. BUFFALO WILD WINGS, INC., (U.S. CLS. 100, 101 AND 102). SN 77-654,679. PUB. 3-20-2012. FILED 1-22-2009.
- 4,152,110. **H2U (STANDARD CHARACTER)**. A&B BUSINESS, INC, (U.S. CLS. 100, 101 AND 102). SN 77-683,467. PUB. 3-20-2012. FILED 3-4-2009.
- 4,152,111 (*See Class 16 for this trademark*).
- 4,152,112 (*See Class 16 for this trademark*).
- 4,152,120 (*See Class 7 for this trademark*).
- 4,152,123. **BUZZMAMA (STANDARD CHARACTER)**. MABEL'S LABELS INC., (U.S. CLS. 100, 101 AND 102). SN 77-841,153. PUB. 3-20-2012. FILED 10-5-2009.
- 4,152,167 (*See Class 16 for this trademark*).
- 4,152,171 (*See Class 16 for this trademark*).
- 4,152,187 (*See Class 9 for this trademark*).
- 4,152,189. **T TRIENNALE DI MILANO (STYLIZED)**. LA TRIENNALE DI MILANO, MULTIPLE CLASS, (INT. CLS. 35, 41, 42 AND 43), (U.S. CLS. 100, 101, 102 AND 107). SN 79-089,274. PUB. 3-20-2012. FILED 7-15-2010.
- 4,152,192. **CLIMATE FRIENDLY (STANDARD CHARACTER)**. CLIMATE FRIENDLY PTY LTD, MULTIPLE CLASS, (INT. CLS. 35, 36, 42 AND 45), (U.S. CLS. 100, 101 AND 102). SN 79-089,656. PUB. 3-20-2012. FILED 9-1-2010.
- 4,152,210 (*See Class 25 for this trademark*).
- 4,152,211 (*See Class 33 for this trademark*).
- 4,152,214 (*See Class 9 for this trademark*).
- 4,152,216. **EXPLOROTEL.COM (STYLIZED)**. WIHP, MULTIPLE CLASS, (INT. CLS. 35, 38, 42 AND 43), (U.S. CLS. 100, 101, 102 AND 104). SN 79-093,236. PUB. 3-20-2012. FILED 11-16-2010.
- 4,152,219. **DONNER DES AILES AU TALENT (STYLIZED)**. FONDATION BETTENCOURT SCHUELLER, MULTIPLE CLASS, (INT. CLS. 35, 36, 41, 42 AND 45), (U.S. CLS. 100, 101, 102 AND 107). SN 79-094,003. PUB. 3-20-2012. FILED 11-30-2010.
- 4,152,228 (*See Class 7 for this trademark*).
- 4,152,229 (*See Class 1 for this trademark*).
- 4,152,234 (*See Class 14 for this trademark*).
- 4,152,237. **MASTERTAG (STANDARD CHARACTER)**. ZANOX.DE AG, MULTIPLE CLASS, (INT. CLS. 35, 38 AND 42), (U.S. CLS. 100, 101, 102 AND 104). SN 79-095,963. PUB. 12-13-2011. FILED 3-3-2011.
- 4,152,239. **NEUROAWARENESS AND DESIGN**. FRANÇOIS BOGACZ, MULTIPLE CLASS, (INT. CLS. 35 AND 41), (U.S. CLS. 100, 101, 102 AND 107). SN 79-096,142. PUB. 3-20-2012. FILED 2-11-2011.
- 4,152,241 (*See Class 9 for this trademark*).
- 4,152,242 (*See Class 8 for this trademark*).
- 4,152,250 (*See Class 9 for this trademark*).
- 4,152,252. **JETTS (STANDARD CHARACTER)**. 24/7 BRANDS PTY LTD, MULTIPLE CLASS, (INT. CLS. 35 AND 41), (U.S. CLS. 100, 101, 102 AND 107). SN 79-097,066. PUB. 3-20-2012. FILED 2-7-2011.
- 4,152,253. **ETAPARA (STANDARD CHARACTER)**. ETAPARA AG, MULTIPLE CLASS, (INT. CLS. 35, 38 AND 42), (U.S. CLS. 100, 101, 102 AND 104). SN 79-097,079. PUB. 3-20-2012. FILED 11-9-2010.
- 4,152,254. **CRITYCWORLD (STANDARD CHARACTER)**. BENAYOUN STÉPHANE PAUL, MULTIPLE CLASS, (INT. CLS. 35, 38, 41 AND 42), (U.S. CLS. 100, 101, 102, 104 AND 107). SN 79-097,163. PUB. 3-20-2012. FILED 10-25-2010.
- 4,152,263 (*See Class 12 for this trademark*).
- 4,152,275 (*See Class 12 for this trademark*).
- 4,152,289 (*See Class 9 for this trademark*).
- 4,152,296. **SEATS2MEET.COM (STANDARD CHARACTER)**. C.D.E.F. HOLDING B.V., MULTIPLE CLASS, (INT. CLS. 35, 41, 42 AND 45), (U.S. CLS. 100, 101, 102 AND 107). SN 79-098,649. PUB. 3-20-2012. FILED 2-11-2011.
- 4,152,302 (*See Class 9 for this trademark*).
- 4,152,303 (*See Class 21 for this trademark*).
- 4,152,311 (*See Class 25 for this trademark*).
- 4,152,313 (*See Class 18 for this trademark*).
- 4,152,316 (*See Class 9 for this trademark*).
- 4,152,325. **MARMOMACC STONE ACADEMY AND DESIGN**. ENTE AUTONOMO PER LE FIERE DI VERONA, MULTIPLE CLASS, (INT. CLS. 35, 41 AND 43), (U.S. CLS. 100, 101, 102 AND 107). SN 79-099,628. PUB. 3-20-2012. FILED 1-26-2011.
- 4,152,333. **S2M AND DESIGN**. C.D.E.F. HOLDING B.V., MULTIPLE CLASS, (INT. CLS. 35, 41, 42 AND 45), (U.S. CLS. 100, 101, 102 AND 107). SN 79-099,998. PUB. 3-20-2012. FILED 2-7-2011.
- 4,152,367 (*See Class 9 for this trademark*).
- 4,152,369 (*See Class 30 for this trademark*).
- 4,152,370 (*See Class 30 for this trademark*).
- 4,152,373 (*See Class 33 for this trademark*).
- 4,152,375 (*See Class 3 for this trademark*).
- 4,152,376. **INSIDE. (STANDARD CHARACTER)**. LIWE ESPAÑOLA, S.A., (U.S. CLS. 100, 101 AND 102). SN 79-102,623. PUB. 3-20-2012. FILED 7-4-2011.
- 4,152,403. **GASTROECONOMY AND DESIGN**. MARTA FERNANDEZ GUADAÑO, (U.S. CLS. 100, 101 AND 102). SN 79-104,170. PUB. 3-20-2012. FILED 7-29-2011.
- 4,152,404 (*See Class 10 for this trademark*).
- 4,152,408 (*See Class 9 for this trademark*).
- 4,152,409 (*See Class 16 for this trademark*).
- 4,152,411. **HOLIDAYCHECK AND DESIGN**. HOLIDAYCHECK AG, MULTIPLE CLASS, (INT. CLS. 35, 38, 39, 41, 42 AND 43), (U.S. CLS. 100, 101, 102, 104, 105 AND 107). SN 79-104,479. PUB. 3-20-2012. FILED 5-6-2011.
- 4,152,447. **WARMWISE AND DESIGN**. NISOURCE CORPORATE SERVICES COMPANY, (U.S. CLS. 100, 101 AND 102). SN 85-029,996. PUB. 3-20-2012. FILED 5-4-2010.
- 4,152,452. **THE LOCKER ROOM 08069 AND DESIGN**. DILLARD PROPERTIES LLC, (U.S. CLS. 100, 101 AND 102). SN 85-038,026. PUB. 3-20-2012. FILED 5-13-2010.
- 4,152,453. **1 FIRST AID DISASTER RESPONSE PLAN AND DESIGN**. BLUSKY RESTORATION CONTRACTORS, INC., (U.S. CLS. 100, 101 AND 102). SN 85-038,879. PUB. 12-13-2011. FILED 5-14-2010.
- 4,152,456. **LIVE LOCAL . SEARCH LOCAL . ELOCAL (STANDARD CHARACTER)**. ELOCAL USA LLC, (U.S. CLS. 100, 101 AND 102). SN 85-046,022. PUB. 3-20-2012. FILED 5-24-2010.
- 4,152,457. **ELOCAL (STANDARD CHARACTER)**. ELOCAL USA LLC, (U.S. CLS. 100, 101 AND 102). SN 85-046,046. PUB. 3-20-2012. FILED 5-24-2010.
- 4,152,467. **SAVINGSMANIA (STANDARD CHARACTER)**. SCHMIDT, DIANE, (U.S. CLS. 100, 101 AND 102). SN 85-075,933. PUB. 3-20-2012. FILED 7-1-2010.
- 4,152,475. **THINKING OUTSIDE THE BIG BOX (STANDARD CHARACTER)**. MITCHELL ARMATA, (U.S. CLS. 100, 101 AND 102). SN 85-090,381. PUB. 3-20-2012. FILED 7-22-2010.
- 4,152,479. **STYLUS (STANDARD CHARACTER)**. STYLUS MEDIA GROUP LIMITED, (U.S. CLS. 100, 101 AND 102). SN 85-091,687. PUB. 3-20-2012. FILED 7-23-2010.
- 4,152,489. **IPEX (STANDARD CHARACTER)**. INSTITUTE OF FOOD TECHNOLOGISTS, (U.S. CLS. 100, 101 AND 102). SN 85-104,844. PUB. 3-20-2012. FILED 8-11-2010.
- 4,152,494. **WHICHWAYTOPAY AND DESIGN**. WHICH WAY TO PAY LTD, MULTIPLE CLASS, (INT. CLS. 35 AND 36),

- (U.S. CLS. 100, 101 AND 102). SN 85-110,935. PUB. 3-20-2012. FILED 8-19-2010.
- 4,152,495. **VRC (STANDARD CHARACTER)**. VITAL HOLDINGS, LLC, MULTIPLE CLASS, (INT. CLS. 35, 39, 40 AND 41), (U.S. CLS. 100, 101, 102, 103, 105, 106 AND 107). SN 85-112,018. PUB. 3-20-2012. FILED 8-20-2010.
- 4,152,496. **VITALWEB (STANDARD CHARACTER)**. VITAL HOLDINGS, LLC, MULTIPLE CLASS, (INT. CLS. 35 AND 39), (U.S. CLS. 100, 101, 102 AND 105). SN 85-112,032. PUB. 3-20-2012. FILED 8-20-2010.
- 4,152,498. **VITALSCAN (STANDARD CHARACTER)**. VITAL HOLDINGS, LLC, MULTIPLE CLASS, (INT. CLS. 35, 39 AND 41), (U.S. CLS. 100, 101, 102, 105 AND 107). SN 85-113,121. PUB. 3-20-2012. FILED 8-23-2010.
- 4,152,499. **VITALRF (STANDARD CHARACTER)**. VITAL HOLDINGS, LLC, MULTIPLE CLASS, (INT. CLS. 35 AND 39), (U.S. CLS. 100, 101, 102 AND 105). SN 85-113,181. PUB. 3-20-2012. FILED 8-23-2010.
- 4,152,500. **VITALTRAC (STANDARD CHARACTER)**. VITAL HOLDINGS, LLC, MULTIPLE CLASS, (INT. CLS. 35 AND 39), (U.S. CLS. 100, 101, 102 AND 105). SN 85-113,201. PUB. 3-20-2012. FILED 8-23-2010.
- 4,152,501 (*See Class 1 for this trademark*).
- 4,152,504. **CITITRENDS AND DESIGN**. CITI TRENDS, INC., (U.S. CLS. 100, 101 AND 102). SN 85-117,316. PUB. 2-15-2011. FILED 8-27-2010.
- 4,152,507 (*See Class 3 for this trademark*).
- 4,152,523. **AMI CLUBWEAR (STANDARD CHARACTER)**. DESE ENTERPRISE, INC., (U.S. CLS. 100, 101 AND 102). SN 85-133,492. PUB. 3-20-2012. FILED 9-20-2010.
- 4,152,532. **HAVE YOU SEEN ME? (STANDARD CHARACTER)**. VALASSIS COMMUNICATIONS, INC., (U.S. CLS. 100, 101 AND 102). SN 85-139,112. PUB. 3-20-2012. FILED 9-27-2010.
- 4,152,540. **PROGRAM PULSE (STANDARD CHARACTER)**. BRIDGE ENTERTAINMENT, INC., (U.S. CLS. 100, 101 AND 102). SN 85-148,031. PUB. 3-20-2012. FILED 10-8-2010.
- 4,152,542. **NATURAL NEWS NETWORK (STANDARD CHARACTER)**. ADAMS, MICHAEL A., (U.S. CLS. 100, 101 AND 102). SN 85-150,143. PUB. 3-20-2012. FILED 10-11-2010.
- 4,152,543. **REUTERS INSIDER (STANDARD CHARACTER)**. THOMSON REUTERS CANADA LIMITED, MULTIPLE CLASS, (INT. CLS. 35, 36 AND 41), (U.S. CLS. 100, 101, 102 AND 107). SN 85-150,590. PUB. 3-20-2012. FILED 10-12-2010.
- 4,152,545. **CCS PRESENTATION SYSTEMS (STANDARD CHARACTER)**. COMMERCIAL COMPUTER SERVICES, INC., MULTIPLE CLASS, (INT. CLS. 35, 37 AND 41), (U.S. CLS. 100, 101, 102, 103, 106 AND 107). SN 85-150,918. PUB. 3-20-2012. FILED 10-12-2010.
- 4,152,550. **COUNCIL OF SUPPLY CHAIN MANAGEMENT PROFESSIONALS (STANDARD CHARACTER)**. COUNCIL OF SUPPLY CHAIN MANAGEMENT PROFESSIONALS, (U.S. CLS. 100, 101 AND 102). SN 85-157,257. PUB. 3-20-2012. FILED 10-20-2010.
- 4,152,555. **NEIGHBORHOOD UNITY FOUNDATION (STANDARD CHARACTER)**. NEIGHBORHOOD UNITY FOUNDATION, MULTIPLE CLASS, (INT. CLS. 35 AND 36), (U.S. CLS. 100, 101 AND 102). SN 85-159,509. PUB. 3-20-2012. FILED 10-22-2010.
- 4,152,562. **KID GLOVE DIVA (STANDARD CHARACTER)**. WIEDEMANN, HARTY, (U.S. CLS. 100, 101 AND 102). SN 85-166,063. PUB. 3-20-2012. FILED 11-1-2010.
- 4,152,564. **CMAX AND DESIGN**. REPROCAD ASSOCIATES, INC., DBA REPRMAX, MULTIPLE CLASS, (INT. CLS. 35 AND 37), (U.S. CLS. 100, 101, 102, 103 AND 106). SN 85-166,587. PUB. 3-20-2012. FILED 11-1-2010.
- 4,152,567. **I AND DESIGN**. LEVY, JEFFREY, (U.S. CLS. 100, 101 AND 102). SN 85-172,388. PUB. 3-20-2012. FILED 11-9-2010.
- 4,152,572. **ONE HANDED WORLD (STANDARD CHARACTER)**. KELLEY STYRING, (U.S. CLS. 100, 101 AND 102). SN 85-175,631. PUB. 3-20-2012. FILED 11-12-2010.
- 4,152,575 (*See Class 25 for this trademark*).
- 4,152,576. **SG ENT (STYLIZED)**. PIPPENBURG, AUTUMN DOLORES, DBA SHOWGIRLZ ENTERTAINMENT, INC., (U.S. CLS. 100, 101 AND 102). SN 85-181,742. PUB. 3-20-2012. FILED 11-19-2010.
- 4,152,585. **FLOW CONSULTING AND DESIGN**. FLOW CONSULTING, INC., (U.S. CLS. 100, 101 AND 102). SN 85-194,008. PUB. 3-20-2012. FILED 12-9-2010.
- 4,152,586. **CALL 4 EAT (STANDARD CHARACTER)**. JUST-GOB LLC, (U.S. CLS. 100, 101 AND 102). SN 85-196,959. PUB. 3-20-2012. FILED 12-13-2010.
- 4,152,587 (*See Class 9 for this trademark*).
- 4,152,592. **RI RESEARCH INSTITUTE BATRUSHOLLWEG AND DESIGN**. BATRUS HOLLWEG INTERNATIONAL SELECTION SERVICES, LTD., (U.S. CLS. 100, 101 AND 102). SN 85-200,156. PUB. 3-20-2012. FILED 12-16-2010.
- 4,152,593. **SOCIAL DECISION SUPPORT (STANDARD CHARACTER)**. ANALYX SP. Z O.O. SP.K., MULTIPLE CLASS, (INT. CLS. 35 AND 42), (U.S. CLS. 100, 101 AND 102). SN 85-201,278. PUB. 3-20-2012. FILED S.R. 12-18-2010; AM. P.R. 12-5-2011.
- 4,152,596 (*See Class 9 for this trademark*).
- 4,152,597. **TRADEFLOW OPTIMIZATION (STANDARD CHARACTER)**. SOFTWARE PARADIGMS INTERNATIONAL GROUP LLC, MULTIPLE CLASS, (INT. CLS. 35 AND 42), (U.S. CLS. 100, 101 AND 102). SN 85-208,466. PUB. 3-20-2012. FILED 12-31-2010.
- 4,152,601. **G.D. 1865 L'ETOILE ROYALE AND DESIGN**. L'ETOILE ROYALE, (U.S. CLS. 100, 101 AND 102). SN 85-210,752. PUB. 3-20-2012. FILED 1-5-2011.
- 4,152,602. **FT AVERAGE DAILY GLOBAL AUDIENCE (STANDARD CHARACTER)**. FINANCIAL TIMES LIMITED, THE, MULTIPLE CLASS, (INT. CLS. 35, 38 AND 41), (U.S. CLS. 100, 101, 102, 104 AND 107). SN 85-210,987. PUB. 3-20-2012. FILED 1-5-2011.
- 4,152,608. **PACIFIC STANDARD TIME (STANDARD CHARACTER)**. THE J. PAUL GETTY TRUST, (U.S. CLS. 100, 101 AND 102). SN 85-218,568. PUB. 3-20-2012. FILED 1-14-2011.
- 4,152,609. **TRAVEL NETWORK (STANDARD CHARACTER)**. REZCONNECT TECHNOLOGIES, INC. DBA TRAVEL NETWORK, (U.S. CLS. 100, 101 AND 102). SN 85-219,747. PUB. 3-20-2012. FILED 1-18-2011.
- 4,152,616 (*See Class 16 for this trademark*).
- 4,152,623. **BUYSMART AND DESIGN**. BUYSMART, AKA BUYSMARTAUTONOW.COM, (U.S. CLS. 100, 101 AND 102). SN 85-227,819. PUB. 3-20-2012. FILED 1-27-2011.
- 4,152,626. **SWYPE (STANDARD CHARACTER)**. CONSUMER BENEFIT SERVICES, INC., DBA CBSI, (U.S. CLS. 100, 101 AND 102). SN 85-229,626. PUB. 3-20-2012. FILED 1-30-2011.
- 4,152,633. **ASPEN AND DESIGN**. ASPEN SEARCH ADVISORS, LLC, (U.S. CLS. 100, 101 AND 102). SN 85-237,881. PUB. 3-20-2012. FILED 2-9-2011.
- 4,152,640. **ARROW ROCK & STONE LLC AND DESIGN**. ARROW ROCK & STONE, LLC, (U.S. CLS. 100, 101 AND 102). SN 85-244,345. PUB. 3-20-2012. FILED 2-16-2011.
- 4,152,644. **FULL CIRCLE FLOORING YOUR GREEN FLOORING STORE AND DESIGN**. TOP QUALITY FLOORS INC., DBA FULL CIRCLE FLOORING, MULTIPLE CLASS, (INT. CLS. 35 AND 37), (U.S. CLS. 100, 101, 102, 103 AND 106). SN 85-247,129. PUB. 3-20-2012. FILED S.R. 2-20-2011; AM. P.R. 10-20-2011.
- 4,152,645. **FIND GRIND MIND (STANDARD CHARACTER)**. PERFORMANCE INSIGHTS INC., (U.S. CLS. 100, 101 AND 102). SN 85-247,188. PUB. 3-20-2012. FILED 2-21-2011.
- 4,152,650. **ANNUALCREDITREPORT (STANDARD CHARACTER)**. CENTRAL SOURCE LLC, (U.S. CLS. 100, 101 AND 102). SN 85-249,432. PUB. 10-18-2011. FILED 2-23-2011.
- 4,152,656. **E3 AND DESIGN**. EFFICIENCY3 CORP, MULTIPLE CLASS, (INT. CLS. 35 AND 42), (U.S. CLS. 100, 101 AND 102). SN 85-255,855. PUB. 3-20-2012. FILED 3-2-2011.
- 4,152,658 (*See Class 1 for this trademark*).
- 4,152,663. **PART-TIME CFO (STANDARD CHARACTER)**. B2B CFO, LLC, (U.S. CLS. 100, 101 AND 102). SN 85-259,769. PUB. 3-20-2012. FILED 3-7-2011.
- 4,152,664. **MISCELLANEOUS DESIGN**. CHINA DEMOCRACY JOURNAL, INC., MULTIPLE CLASS, (INT. CLS. 35 AND 38), (U.S. CLS. 100, 101, 102 AND 104). SN 85-260,092. PUB. 3-20-2012. FILED 3-7-2011.
- 4,152,670. **S24 (STANDARD CHARACTER)**. SECURE-24, INC., MULTIPLE CLASS, (INT. CLS. 35, 37, 39, 42 AND 45), (U.S. CLS. 100, 101, 102, 103, 105 AND 106). SN 85-263,811. PUB. 3-20-2012. FILED 3-10-2011.
- 4,152,674. **CAN MANUFACTURERS INSTITUTE (STANDARD CHARACTER)**. CAN MANUFACTURERS INSTITUTE,

- INC., MULTIPLE CLASS, (INT. CLS. 35 AND 40), (U.S. CLS. 100, 101, 102, 103 AND 106). SN 85-267,462. PUB. 3-20-2012. FILED 3-15-2011.
- 4,152,689. **GOODBIDDING.ORG (STANDARD CHARACTER)**. GOODBIDDING FOUNDATION, INC., (U.S. CLS. 100, 101 AND 102). SN 85-275,924. PUB. 3-20-2012. FILED 3-24-2011.
- 4,152,702. **SCRIPT TO SCREEN DIRECT THINKING FOR DIRECT RESPONSE AND DESIGN**. SCRIPT TO SCREEN PRODUCTIONS, (U.S. CLS. 100, 101 AND 102). SN 85-280,085. PUB. 3-20-2012. FILED 3-29-2011.
- 4,152,704. **LEADBRIDGE (STANDARD CHARACTER)**. LEADBRIDGE PARTNERS, LLC, AKA LEADBRIDGE, (U.S. CLS. 100, 101 AND 102). SN 85-280,933. PUB. 3-20-2012. FILED 3-30-2011.
- 4,152,709. **MANAGEMENT DIRECT (STANDARD CHARACTER)**. FRANCHISE DIRECT USA, INC., (U.S. CLS. 100, 101 AND 102). SN 85-282,621. PUB. 3-20-2012. FILED 3-31-2011.
- 4,152,711. **AHHE ASSOCIATION OF HISPANIC HEALTHCARE EXECUTIVES DEDICATED TO PROMOTING ACCESS TO HEALTHCARE FOR THE HISPANIC COMMUNITY AND DESIGN**. AHHE EAST COAST CHAPTER, INC., (U.S. CLS. 100, 101 AND 102). SN 85-283,153. PUB. 3-20-2012. FILED 3-31-2011.
- 4,152,730. **PRSONA (STYLIZED)**. BOLLINGER, BRANSON, DBA PRSONA, AND BOLLINGER, BRENDON, DBA PRSONA, (U.S. CLS. 100, 101 AND 102). SN 85-290,714. PUB. 3-20-2012. FILED 4-8-2011.
- 4,152,733. **FAN PAGE GENERATOR (STANDARD CHARACTER)**. FAN PAGE GENERATOR, LLC, MULTIPLE CLASS, (INT. CLS. 35, 41 AND 42), (U.S. CLS. 100, 101, 102 AND 107). SN 85-291,149. PUB. 3-20-2012. FILED 4-10-2011.
- 4,152,736. **MIREGO (STANDARD CHARACTER)**. MIREGO INC., MULTIPLE CLASS, (INT. CLS. 35 AND 42), (U.S. CLS. 100, 101 AND 102). SN 85-291,760. PUB. 3-20-2012. FILED 4-11-2011.
- 4,152,742. **PARTRIDGE HILL (STANDARD CHARACTER)**. ADAMS, DANIEL NELSON, JR., (U.S. CLS. 100, 101 AND 102). SN 85-293,027. PUB. 3-20-2012. FILED 4-12-2011.
- 4,152,744. **PARTRIDGE HILL AND DESIGN**. ADAMS, DANIEL NELSON, JR., (U.S. CLS. 100, 101 AND 102). SN 85-293,067. PUB. 3-20-2012. FILED 4-12-2011.
- 4,152,746. **BIZHUB (STANDARD CHARACTER)**. BIZHUB LLC, (U.S. CLS. 100, 101 AND 102). SN 85-293,203. PUB. 3-20-2012. FILED 4-12-2011.
- 4,152,747. **BIZHUB AND DESIGN**. BIZHUB LLC, (U.S. CLS. 100, 101 AND 102). SN 85-293,222. PUB. 3-20-2012. FILED 4-12-2011.
- 4,152,751. **KANSAS CITY SPORTS COMMISSION AND DESIGN**. THE GREATER KANSAS CITY SPORTS COMMISSION, (U.S. CLS. 100, 101 AND 102). SN 85-294,181. PUB. 3-20-2012. FILED 4-13-2011.
- 4,152,754. **BIG HARRY DEALS (STANDARD CHARACTER)**. BIG HARRY DEALS, INC., (U.S. CLS. 100, 101 AND 102). SN 85-294,382. PUB. 3-20-2012. FILED 4-13-2011.
- 4,152,756. **KINETIC BY KURT (STANDARD CHARACTER)**. KURT MANUFACTURING COMPANY, INC., MULTIPLE CLASS, (INT. CLS. 35 AND 36), (U.S. CLS. 100, 101 AND 102). SN 85-295,110. PUB. 3-20-2012. FILED 4-14-2011.
- 4,152,764. **OPEN DATA CENTER ALLIANCE AND DESIGN**. OPEN DATA CENTER ALLIANCE, INC., MULTIPLE CLASS, (INT. CLS. 35 AND 42), (U.S. CLS. 100, 101 AND 102). SN 85-295,717. PUB. 3-20-2012. FILED 4-14-2011.
- 4,152,776 (*See Class 5 for this trademark*).
- 4,152,777. **MARS MARTIAL ARTS RATING SYSTEM AND DESIGN**. KARATE INSTITUTE, INC., MULTIPLE CLASS, (INT. CLS. 35 AND 41), (U.S. CLS. 100, 101, 102 AND 107). SN 85-297,083. PUB. 3-20-2012. FILED 4-16-2011.
- 4,152,781. **IT CHAIR (STANDARD CHARACTER)**. SOBHE, ASHKAN, (U.S. CLS. 100, 101 AND 102). SN 85-297,176. PUB. 3-20-2012. FILED 4-17-2011.
- 4,152,783. **APPEALPROPERTYTAX.COM AND DESIGN**. APPEALPROPERTYTAX.COM, INC., (U.S. CLS. 100, 101 AND 102). SN 85-297,279. PUB. 3-20-2012. FILED 4-17-2011.
- 4,152,786. **M MANAGED MARKETING AND DESIGN**. MANAGED MARKETING, LLC, MULTIPLE CLASS, (INT. CLS. 35 AND 41), (U.S. CLS. 100, 101, 102 AND 107). SN 85-297,409. PUB. 3-20-2012. FILED 4-18-2011.
- 4,152,792. **WILDCAT LIGHTING AND DESIGN**. WILDCAT LIGHTING, LLC, (U.S. CLS. 100, 101 AND 102). SN 85-297,860. PUB. 3-20-2012. FILED 4-18-2011.
- 4,152,795. **LIGHT BULBS UNLIMITED (STANDARD CHARACTER)**. LBU INTERNATIONAL, INC., (U.S. CLS. 100, 101 AND 102). SN 85-298,098. PUB. 3-20-2012. FILED 4-18-2011.
- 4,152,798. **AUBYN (STANDARD CHARACTER)**. JENKINSON, PHILIP, MULTIPLE CLASS, (INT. CLS. 35, 36 AND 45), (U.S. CLS. 100, 101 AND 102). SN 85-298,784. PUB. 3-20-2012. FILED 4-19-2011.
- 4,152,803. **CITY OF MURPHY AND DESIGN**. CITY OF MURPHY, TEXAS, (U.S. CLS. 100, 101 AND 102). SN 85-299,189. PUB. 3-20-2012. FILED 4-19-2011.
- 4,152,807. **WHERE IT ALL BEGINS (STANDARD CHARACTER)**. INFORMATION TECHNOLOGY INDUSTRY COUNCIL, LTD., MULTIPLE CLASS, (INT. CLS. 35 AND 42), (U.S. CLS. 100, 101 AND 102). SN 85-299,864. PUB. 3-20-2012. FILED 4-20-2011.
- 4,152,808. **SOUP OF THE DAY SEARCH AND DESIGN**. L. RAND INC., DBA SOUP OF THE DAY SEARCH, AND WILDERSON, LESLIE RAND, (U.S. CLS. 100, 101 AND 102). SN 85-299,882. PUB. 3-20-2012. FILED 4-20-2011.
- 4,152,809. **INTERNATIONAL COMMITTEE FOR INFORMATION TECHNOLOGY STANDARDS (STANDARD CHARACTER)**. INFORMATION TECHNOLOGY INDUSTRY COUNCIL, LTD., MULTIPLE CLASS, (INT. CLS. 35 AND 42), (U.S. CLS. 100, 101 AND 102). SN 85-299,885. PUB. 3-20-2012. FILED 4-20-2011.
- 4,152,820. **LEE'S SIGNATURE AND DESIGN**. LEE'S SANDWICHES INTERNATIONAL, INC., (U.S. CLS. 100, 101 AND 102). SN 85-301,603. PUB. 3-20-2012. FILED 4-21-2011.
- 4,152,822. **EARTH FRIENDS CONSERVATION FUND (STANDARD CHARACTER)**. EARTH FRIENDS CONSERVATION FUND, MULTIPLE CLASS, (INT. CLS. 35 AND 36), (U.S. CLS. 100, 101 AND 102). SN 85-301,717. PUB. 3-20-2012. FILED 4-21-2011.
- 4,152,823. **CONSERVATION DESERVES MORE THAN 2% (STANDARD CHARACTER)**. EARTH FRIENDS CONSERVATION FUND, MULTIPLE CLASS, (INT. CLS. 35 AND 36), (U.S. CLS. 100, 101 AND 102). SN 85-301,719. PUB. 3-20-2012. FILED 4-21-2011.
- 4,152,827. **VMG CREATIVE (STANDARD CHARACTER)**. VMG CREATIVE, LLC, (U.S. CLS. 100, 101 AND 102). SN 85-303,241. PUB. 3-20-2012. FILED 4-25-2011.
- 4,152,828. **TOPLINE MD (STANDARD CHARACTER)**. FEMWELL GROUP HEALTH, INC., (U.S. CLS. 100, 101 AND 102). SN 85-303,442. PUB. 3-20-2012. FILED 4-25-2011.
- 4,152,835. **FLOCK 12 (STANDARD CHARACTER)**. FLOCK 12, INC, (U.S. CLS. 100, 101 AND 102). SN 85-305,189. PUB. 3-20-2012. FILED 4-26-2011.
- 4,152,838. **SUNSOLUTIONS (STANDARD CHARACTER)**. SUNDANCE REHABILITATION CORPORATION, MULTIPLE CLASS, (INT. CLS. 35, 36 AND 41), (U.S. CLS. 100, 101, 102 AND 107). SN 85-305,989. PUB. 3-20-2012. FILED 4-27-2011.
- 4,152,841. **TAKE5 SOLUTIONS AND DESIGN**. TAKE 5 SOLUTIONS, LLC, MULTIPLE CLASS, (INT. CLS. 35 AND 42), (U.S. CLS. 100, 101 AND 102). SN 85-306,127. PUB. 3-20-2012. FILED 4-27-2011.
- 4,152,842. **MILLION DOLLAR EMPLOYEE (STANDARD CHARACTER)**. G&A OUTSOURCING, INC., DBA G&A PARTNERS, MULTIPLE CLASS, (INT. CLS. 35 AND 36), (U.S. CLS. 100, 101 AND 102). SN 85-306,187. PUB. 3-20-2012. FILED 4-27-2011.
- 4,152,851. **VIASOUND (STANDARD CHARACTER)**. PAUL HADJUK, DBA VIASOUND, (U.S. CLS. 100, 101 AND 102). SN 85-307,307. PUB. 3-20-2012. FILED 4-28-2011.
- 4,152,860. **THE CEDALIUS GROUP AND DESIGN**. CEDALION ENTERPRISES LLC, MULTIPLE CLASS, (INT. CLS. 35 AND 45), (U.S. CLS. 100, 101 AND 102). SN 85-309,309. PUB. 3-20-2012. FILED 5-1-2011.
- 4,152,862. **SELECT MEDIA SERVICES (STANDARD CHARACTER)**. SELECT MEDIA SERVICES, LLC, MULTIPLE CLASS, (INT. CLS. 35 AND 39), (U.S. CLS. 100, 101, 102 AND 105). SN 85-310,280. PUB. 3-20-2012. FILED 5-2-2011.
- 4,152,867. **TREASURED FOR GENERATIONS (STANDARD CHARACTER)**. HARDWOOD FEDERATION, DBA AMERICAN HARDWOODS, (U.S. CLS. 100, 101 AND 102). SN 85-310,847. PUB. 3-20-2012. FILED 5-3-2011.

- 4,152,913. **SUNSOLUTIONS CONSULTING AND DESIGN. SUNDANCE REHABILITATION CORPORATION, MULTIPLE CLASS, (INT. CLS. 35, 36 AND 41), (U.S. CLS. 100, 101, 102 AND 107).** SN 85-321,639. PUB. 3-20-2012. FILED 5-16-2011.
- 4,152,917. **POSTERS.MOBI AND DESIGN. METAVERSE CORPORATION, (U.S. CLS. 100, 101 AND 102).** SN 85-322,176. PUB. 3-20-2012. FILED 5-16-2011.
- 4,152,926 (*See Class 25 for this trademark.*).
- 4,152,934 (*See Class 9 for this trademark.*).
- 4,152,935 (*See Class 9 for this trademark.*).
- 4,152,936. **LIQUORVILLE (STANDARD CHARACTER).** 10 CLAY ENTERPRISES, LLC, DBA LIQUORVILLE, (U.S. CLS. 100, 101 AND 102). SN 85-328,320. PUB. 3-20-2012. FILED 5-24-2011.
- 4,152,937 (*See Class 9 for this trademark.*).
- 4,152,938. **DOLL AVENUE (STANDARD CHARACTER).** MILLER, KAREN, (U.S. CLS. 100, 101 AND 102). SN 85-328,487. PUB. 3-20-2012. FILED 5-24-2011.
- 4,152,951. **HORSECLICKS (STANDARD CHARACTER).** FRIDAY MEDIA GROUP LIMITED, (U.S. CLS. 100, 101 AND 102). SN 85-332,021. PUB. 3-20-2012. FILED 5-27-2011.
- 4,152,954. **STRATEGY STRATEGIC CLARITY RESULTS INTEGRATED SYSTEMS LEADERSHIP TALENT COMMON APPROACH COLLABORATION EFFECTIVE STRUCTURE AND DESIGN. 3D RESULTS, LLC, MULTIPLE CLASS, (INT. CLS. 35, 41 AND 42), (U.S. CLS. 100, 101, 102 AND 107).** SN 85-333,471. PUB. 3-20-2012. FILED 5-30-2011.
- 4,152,955. **EXCELLENCE LIVES HERE (STANDARD CHARACTER).** KING SPORTS GROUP, LLC, (U.S. CLS. 100, 101 AND 102). SN 85-333,481. PUB. 3-20-2012. FILED 5-30-2011.
- 4,152,958. **PURCHASING INTELLIGENCE (STANDARD CHARACTER).** ESS TECHNOLOGIES, LLC, (U.S. CLS. 100, 101 AND 102). SN 85-334,367. PUB. 3-20-2012. FILED 5-31-2011.
- 4,152,960. **RESPONDER INTELLIGENCE (STANDARD CHARACTER).** AGR MARKETING SOLUTIONS, LLC, (U.S. CLS. 100, 101 AND 102). SN 85-335,228. PUB. 3-20-2012. FILED 6-1-2011.
- 4,152,961. **THE WELLNESS PROVIDER NETWORK AND DESIGN. THE WELLNESS PROVIDER NETWORK LLC, (U.S. CLS. 100, 101 AND 102).** SN 85-335,620. PUB. 3-20-2012. FILED 6-1-2011.
- 4,152,968 (*See Class 30 for this trademark.*).
- 4,152,976. **EAT ME! (STANDARD CHARACTER).** FUZZY'S TACO HOLDINGS, LLC, (U.S. CLS. 100, 101 AND 102). SN 85-338,987. PUB. 3-20-2012. FILED 6-6-2011.
- 4,152,992. **BROOK MAYS (STANDARD CHARACTER).** UNIVERSAL MELODY SERVICES, LLC, DBA BROOK MAYS MUSIC COMPANY, MULTIPLE CLASS, (INT. CLS. 35, 37 AND 41), (U.S. CLS. 100, 101, 102, 103, 106 AND 107). SN 85-345,170. PUB. 3-20-2012. FILED 6-14-2011.
- 4,152,995. **POVADDO (STANDARD CHARACTER).** POVADDO LLC, (U.S. CLS. 100, 101 AND 102). SN 85-346,450. PUB. 3-20-2012. FILED 6-15-2011.
- 4,153,003. **GET SWABBED (STANDARD CHARACTER).** GIFT OF LIFE BONE MARROW FOUNDATION, INC., (U.S. CLS. 100, 101 AND 102). SN 85-347,892. PUB. 3-20-2012. FILED 6-16-2011.
- 4,153,006. **GO SWAB YOURSELF (STANDARD CHARACTER).** GIFT OF LIFE BONE MARROW FOUNDATION, INC., (U.S. CLS. 100, 101 AND 102). SN 85-348,931. PUB. 3-20-2012. FILED 6-17-2011.
- 4,153,007. **PREDICTABLE PROFITS (STANDARD CHARACTER).** MANAGED MARKETING, LLC, MULTIPLE CLASS, (INT. CLS. 35 AND 41), (U.S. CLS. 100, 101, 102 AND 107). SN 85-349,199. PUB. 3-20-2012. FILED 6-17-2011.
- 4,153,008. **GO SWAB YOURSELF AND DESIGN. GIFT OF LIFE BONE MARROW FOUNDATION, INC., (U.S. CLS. 100, 101 AND 102).** SN 85-349,402. PUB. 3-20-2012. FILED 6-17-2011.
- 4,153,014. **LIBERTY PL SERVICES (STANDARD CHARACTER).** LIBERTY PL SERVICES, LLC, AKA LIBERTY PIPELINE SERVICES, LLC, (U.S. CLS. 100, 101 AND 102). SN 85-352,693. PUB. 3-20-2012. FILED 6-22-2011.
- 4,153,015. **LIBERTY PIPELINE SERVICES (STANDARD CHARACTER).** LIBERTY PL SERVICES, LLC, AKA LIBERTY PIPELINE SERVICES, LLC, (U.S. CLS. 100, 101 AND 102). SN 85-352,772. PUB. 3-20-2012. FILED 6-22-2011.
- 4,153,017. **APARTSTYLE (STANDARD CHARACTER).** ILYON LIMITED, (U.S. CLS. 100, 101 AND 102). SN 85-352,901. PUB. 3-20-2012. FILED 6-22-2011.
- 4,153,018. **OUTLAWZ C.C. BAKERSFIELD CA AND DESIGN.** ARAUJO, WILLIAM, (U.S. CLS. 100, 101 AND 102). SN 85-353,427. PUB. 3-20-2012. FILED 6-22-2011.
- 4,153,022. **NOVUSWORKS (STANDARD CHARACTER).** NOVUSWORKS LLC, MULTIPLE CLASS, (INT. CLS. 35 AND 42), (U.S. CLS. 100, 101 AND 102). SN 85-354,992. PUB. 3-20-2012. FILED 6-24-2011.
- 4,153,024. **ZAPUNITED (STANDARD CHARACTER).** HETICH, DOMINIK, (U.S. CLS. 100, 101 AND 102). SN 85-355,576. PUB. 3-20-2012. FILED 6-24-2011.
- 4,153,029. **APPROVAL TREE (STANDARD CHARACTER).** NET CYLINDER, INC., DBA APPROVALTREE.COM, (U.S. CLS. 100, 101 AND 102). SN 85-356,303. PUB. 3-20-2012. FILED 6-25-2011.
- 4,153,033. **APPROVAL TREE AND DESIGN.** NET CYLINDER, INC., DBA APPROVALTREE.COM, (U.S. CLS. 100, 101 AND 102). SN 85-357,792. PUB. 3-20-2012. FILED 6-28-2011.
- 4,153,034. **MORE BETTER EASIER AND DESIGN.** MANHEIM, INC., (U.S. CLS. 100, 101 AND 102). SN 85-358,556. PUB. 3-20-2012. FILED 6-28-2011.
- 4,153,051. **NIPSCO AND DESIGN.** NISOURCE CORPORATE SERVICES COMPANY, MULTIPLE CLASS, (INT. CLS. 35, 36, 37, 39 AND 42), (U.S. CLS. 100, 101, 102, 103, 105 AND 106). SN 85-364,095. PUB. 3-20-2012. FILED 7-6-2011.
- 4,153,052 (*See Class 9 for this trademark.*).
- 4,153,057 (*See Class 9 for this trademark.*).
- 4,153,058 (*See Class 9 for this trademark.*).
- 4,153,059. **DOC POPCORN (STANDARD CHARACTER).** DOC POPCORN FRANCHISING, INC., MULTIPLE CLASS, (INT. CLS. 35 AND 43), (U.S. CLS. 100, 101 AND 102). SN 85-367,799. PUB. 3-20-2012. FILED 7-11-2011.
- 4,153,064. **NIVAL (STANDARD CHARACTER).** ZZIMA INTERNATIONAL, SARL, MULTIPLE CLASS, (INT. CLS. 35, 38, 41, 42 AND 45), (U.S. CLS. 100, 101, 102, 104 AND 107). SN 85-369,691. PUB. 3-20-2012. FILED 7-12-2011.
- 4,153,068. **RUNNING ON EMPTY \$ AND DESIGN.** AMERICANS FOR PROSPERITY FOUNDATION, MULTIPLE CLASS, (INT. CLS. 35 AND 36), (U.S. CLS. 100, 101 AND 102). SN 85-371,661. PUB. 3-20-2012. FILED 7-14-2011.
- 4,153,072. **VANTAGE ALWAYS AWARE (STANDARD CHARACTER).** LOREX TECHNOLOGY INC., (U.S. CLS. 100, 101 AND 102). SN 85-373,734. PUB. 3-20-2012. FILED 7-18-2011.
- 4,153,073. **LIVE SIMPLY AWARE (STANDARD CHARACTER).** LOREX TECHNOLOGY INC., (U.S. CLS. 100, 101 AND 102). SN 85-373,741. PUB. 3-20-2012. FILED 7-18-2011.
- 4,153,076. **EDUCATION STATION (STANDARD CHARACTER).** ACCELMED, LLC, MULTIPLE CLASS, (INT. CLS. 35 AND 41), (U.S. CLS. 100, 101, 102 AND 107). SN 85-374,747. PUB. 3-20-2012. FILED 7-19-2011.
- 4,153,081 (*See Class 9 for this trademark.*).
- 4,153,082. **HUNGRY GENIUS (STANDARD CHARACTER).** HUNGRYGENIUS HOLDING CO., (U.S. CLS. 100, 101 AND 102). SN 85-376,069. PUB. 3-20-2012. FILED 7-20-2011.
- 4,153,087. **THE POWER OF INSIGHT (STANDARD CHARACTER).** PINE HILL GROUP, LLC, MULTIPLE CLASS, (INT. CLS. 35 AND 36), (U.S. CLS. 100, 101 AND 102). SN 85-377,383. PUB. 3-20-2012. FILED S.R. 7-21-2011; AM. P.R. 1-31-2012.
- 4,153,092. **MOBOZILLA (STANDARD CHARACTER).** JMC BRANDS, LLC, DBA JMC BRANDS, LLC, (U.S. CLS. 100, 101 AND 102). SN 85-379,376. PUB. 3-20-2012. FILED 7-24-2011.
- 4,153,095. **LIVE LIFE INSPIRED (STANDARD CHARACTER).** BREATHE YOGA & JUICE BAR, INC., MULTIPLE CLASS, (INT. CLS. 35, 41, 43 AND 44), (U.S. CLS. 100, 101, 102 AND 107). SN 85-379,645. PUB. 3-20-2012. FILED 7-25-2011.
- 4,153,101 (*See Class 16 for this trademark.*).
- 4,153,104. **GREEN60 (STANDARD CHARACTER).** ROWSHAN, SOHRAB, (U.S. CLS. 100, 101 AND 102). SN 85-382,926. PUB. 3-20-2012. FILED 7-27-2011.
- 4,153,105. **CLEARTHRU (STANDARD CHARACTER).** JUNCTION SOLUTIONS, INC., (U.S. CLS. 100, 101 AND 102). SN 85-383,072. PUB. 3-20-2012. FILED 7-28-2011.
- 4,153,108. **EMPLOYEE STAFF YOUR EMPLOYEE SERVICE**

- PROVIDER AND DESIGN. EMPLOYEE STAFF, LLC.** MULTIPLE CLASS, (INT. CLS. 35 AND 36), (U.S. CLS. 100, 101 AND 102). SN 85-383,421. PUB. 3-20-2012. FILED 7-28-2011.
- 4,153,113. **LAPORTE CPAS & BUSINESS ADVISORS AND DESIGN.** LAPORTE, A PROFESSIONAL ACCOUNTING CORPORATION, FORMERLY LAPORTE, SEHRT, ROMIG AND HAND, A PROFESSIONAL ACCOUNTING CORPORATION, (U.S. CLS. 100, 101 AND 102). SN 85-386,381. PUB. 3-20-2012. FILED 8-1-2011.
- 4,153,122. **NAVITAS AND DESIGN.** NAVITAS WEALTH ADVISORS, INC., MULTIPLE CLASS, (INT. CLS. 35 AND 36), (U.S. CLS. 100, 101 AND 102). SN 85-388,542. PUB. 3-20-2012. FILED 8-3-2011.
- 4,153,149. **MISCELLANEOUS DESIGN.** SINGER NY, LLC, (U.S. CLS. 100, 101 AND 102). SN 85-395,084. PUB. 3-20-2012. FILED 8-11-2011.
- 4,153,150. **SINGER AND DESIGN.** SINGER EQUIPMENT COMPANY, INC., (U.S. CLS. 100, 101 AND 102). SN 85-395,086. PUB. 3-20-2012. FILED 8-11-2011.
- 4,153,161. **IBLD I'M BROKE LETS DEAL AND DESIGN.** KOSAREFF, MICHAEL JOHN, DBA IBLD.COM, (U.S. CLS. 100, 101 AND 102). SN 85-397,203. PUB. 3-20-2012. FILED 8-12-2011.
- 4,153,165. **BLOGRAPHY (STANDARD CHARACTER).** PAUL BARNETT, INC., DBA NOW WHAT RESEARCH, (U.S. CLS. 100, 101 AND 102). SN 85-398,037. PUB. 3-20-2012. FILED 8-15-2011.
- 4,153,166. **TABLE TENTS (STANDARD CHARACTER).** LIQUID COMMON, LLC, (U.S. CLS. 100, 101 AND 102). SN 85-398,174. PUB. 3-20-2012. FILED 8-15-2011.
- 4,153,168. **DARE TO CARE (STANDARD CHARACTER).** COPSIDAS JR, FRANK, (U.S. CLS. 100, 101 AND 102). SN 85-398,284. PUB. 3-20-2012. FILED 8-15-2011.
- 4,153,169. **DARE 2 CARE (STANDARD CHARACTER).** FRANK COPSIDAS JR, (U.S. CLS. 100, 101 AND 102). SN 85-398,290. PUB. 3-20-2012. FILED 8-15-2011.
- 4,153,170. **MISCELLANEOUS DESIGN.** KONTAGENT, INC., MULTIPLE CLASS, (INT. CLS. 35 AND 42), (U.S. CLS. 100, 101 AND 102). SN 85-398,372. PUB. 3-20-2012. FILED 8-15-2011.
- 4,153,177. **CHOCOLATE VILLA (STANDARD CHARACTER).** FIVE DEGREES CONSULTING, LLC, MULTIPLE CLASS, (INT. CLS. 35 AND 41), (U.S. CLS. 100, 101, 102 AND 107). SN 85-401,778. PUB. 3-20-2012. FILED 8-18-2011.
- 4,153,178. **FEDERAL RESERVE BANK OF DALLAS (STANDARD CHARACTER).** FEDERAL RESERVE BANK OF DALLAS, MULTIPLE CLASS, (INT. CLS. 35 AND 36), (U.S. CLS. 100, 101 AND 102). SN 85-401,805. PUB. 3-20-2012. FILED 8-18-2011.
- 4,153,180. **GTLS: GAS TO LIQUID SYSTEMS (STANDARD CHARACTER).** CHART INDUSTRIES, INC., MULTIPLE CLASS, (INT. CLS. 35, 37, 40 AND 42), (U.S. CLS. 100, 101, 102, 103 AND 106). SN 85-402,094. PUB. 3-20-2012. FILED 8-19-2011.
- 4,153,192. **VERGE (STANDARD CHARACTER).** INDY FOUNDERS, LLC, (U.S. CLS. 100, 101 AND 102). SN 85-404,792. PUB. 3-20-2012. FILED 8-23-2011.
- 4,153,197. **MORE CALLS, MORE SALES, MORE PROFITS (STANDARD CHARACTER).** 800RESPONSE MARKETING, LLC, MULTIPLE CLASS, (INT. CLS. 35 AND 38), (U.S. CLS. 100, 101, 102 AND 104). SN 85-405,891. PUB. 3-20-2012. FILED 8-24-2011.
- 4,153,199. **NEW HEALTH AGE (STANDARD CHARACTER).** NEW HEALTH AGE ADVISORS, LLC, MULTIPLE CLASS, (INT. CLS. 35, 41 AND 44), (U.S. CLS. 100, 101, 102 AND 107). SN 85-406,280. PUB. 3-20-2012. FILED 8-24-2011.
- 4,153,205. **MISCELLANEOUS DESIGN.** THE SUSAN G. KOMEN BREAST CANCER FOUNDATION, INC., MULTIPLE CLASS, (INT. CLS. 35, 36 AND 41), (U.S. CLS. 100, 101, 102 AND 107). SN 85-408,296. PUB. 3-20-2012. FILED 8-26-2011.
- 4,153,206. **MISCELLANEOUS DESIGN.** THE SUSAN G. KOMEN BREAST CANCER FOUNDATION, INC., MULTIPLE CLASS, (INT. CLS. 35, 36 AND 41), (U.S. CLS. 100, 101, 102 AND 107). SN 85-408,318. PUB. 3-20-2012. FILED 8-26-2011.
- 4,153,207. **CATALYST SEARCH PARTNERS (STANDARD CHARACTER).** CATALYST SEARCH PARTNERS LLC, (U.S. CLS. 100, 101 AND 102). SN 85-408,322. PUB. 3-20-2012. FILED 8-26-2011.
- 4,153,213. **IAP WORLDWIDE SERVICES (STANDARD CHARACTER).** IAP WORLDWIDE SERVICES, INC., MULTIPLE CLASS, (INT. CLS. 35, 37, 40 AND 45), (U.S. CLS. 100, 101, 102, 103 AND 106). SN 85-409,862. PUB. 3-20-2012. FILED 8-29-2011.
- 4,153,217. **ETC AND DESIGN.** EMPLOYEE TRANSFER CORPORATION, MULTIPLE CLASS, (INT. CLS. 35 AND 36), (U.S. CLS. 100, 101 AND 102). SN 85-410,693. PUB. 3-20-2012. FILED 8-30-2011.
- 4,153,221. **CORPORATE SOCIALANTHROPY (STANDARD CHARACTER).** WILCOX, DAWN, (U.S. CLS. 100, 101 AND 102). SN 85-411,473. PUB. 3-20-2012. FILED 8-31-2011.
- 4,153,222. **REWARD STYLE (STYLIZED).** NASTYGOAT CORPORATION, (U.S. CLS. 100, 101 AND 102). SN 85-411,623. PUB. 3-20-2012. FILED 8-31-2011.
- 4,153,223. **REWARDSTYLE (STANDARD CHARACTER).** NASTYGOAT CORPORATION, (U.S. CLS. 100, 101 AND 102). SN 85-411,633. PUB. 3-20-2012. FILED 8-31-2011.
- 4,153,224. **IMS EXPERTSERVICES AND DESIGN.** INTELLIGENT MANAGEMENT SOLUTIONS, INC, (U.S. CLS. 100, 101 AND 102). SN 85-411,786. PUB. 3-20-2012. FILED 8-31-2011.
- 4,153,235. **EVENPRO MARKETING GROUP E (STYLIZED).** EVENPRO MARKETING GROUP, LLC, (U.S. CLS. 100, 101 AND 102). SN 85-413,431. PUB. 3-20-2012. FILED 9-1-2011.
- 4,153,237 (See Class 11 for this trademark).
- 4,153,240. **STUPID TEXT DEALS (STANDARD CHARACTER).** VOGLER ENTERPRISES, INC., (U.S. CLS. 100, 101 AND 102). SN 85-414,572. PUB. 3-20-2012. FILED 9-2-2011.
- 4,153,254. **TRAY TALK COMMUNITIES FOR HEALTHY SCHOOL MEALS AND DESIGN.** SCHOOL NUTRITION ASSOCIATION, (U.S. CLS. 100, 101 AND 102). SN 85-416,290. PUB. 3-20-2012. FILED 9-7-2011.
- 4,153,257. **WM AND DESIGN.** THE COLLEGE OF WILLIAM AND MARY IN VIRGINIA, (U.S. CLS. 100, 101 AND 102). SN 85-416,483. PUB. 3-20-2012. FILED 9-7-2011.
- 4,153,270. **SMACKDAB AND DESIGN.** CONEXUS MEDIA TECHNOLOGIES, INC., (U.S. CLS. 100, 101 AND 102). SN 85-419,016. PUB. 3-20-2012. FILED 9-9-2011.
- 4,153,271. **SMART TUITION (STANDARD CHARACTER).** SMART, LLC, (U.S. CLS. 100, 101 AND 102). SN 85-419,028. PUB. 3-20-2012. FILED 9-9-2011.
- 4,153,274. **CIGNIFI (STANDARD CHARACTER).** GMH INTERNATIONAL INC., DBA CIGNIFI, (U.S. CLS. 100, 101 AND 102). SN 85-419,446. PUB. 3-20-2012. FILED 9-9-2011.
- 4,153,275. **ALFA ELECTRONICS AND DESIGN.** ALFA ELECTRONICS LTD., (U.S. CLS. 100, 101 AND 102). SN 85-419,475. PUB. 3-20-2012. FILED 9-9-2011.
- 4,153,276. **HEX (STANDARD CHARACTER).** AUGUST HAT COMPANY, INC., (U.S. CLS. 100, 101 AND 102). SN 85-419,487. PUB. 3-20-2012. FILED 9-9-2011.
- 4,153,283. **CUASTERISK.COM (STANDARD CHARACTER).** CU* ANSWERS, INC., (U.S. CLS. 100, 101 AND 102). SN 85-420,434. PUB. 3-20-2012. FILED 9-12-2011.
- 4,153,287. **MISCELLANEOUS DESIGN.** DOLLAR FINANCIAL GROUP, INC., MULTIPLE CLASS, (INT. CLS. 35 AND 36), (U.S. CLS. 100, 101 AND 102). SN 85-420,520. PUB. 3-20-2012. FILED 9-12-2011.
- 4,153,289. **WINDY CITY STRATEGIES AND DESIGN.** WINDY CITY STRATEGIES, INC., MULTIPLE CLASS, (INT. CLS. 35 AND 42), (U.S. CLS. 100, 101 AND 102). SN 85-421,239. PUB. 3-20-2012. FILED 9-13-2011.
- 4,153,294. **E FMLA AND DESIGN.** EFMLA, INC., MULTIPLE CLASS, (INT. CLS. 35 AND 45), (U.S. CLS. 100, 101 AND 102). SN 85-421,473. PUB. 3-20-2012. FILED 9-13-2011.
- 4,153,296. **KOA PUNA AND DESIGN.** KOA PUNA MOTORCYCLE CLUB, (U.S. CLS. 100, 101 AND 102). SN 85-421,540. PUB. 3-20-2012. FILED 9-13-2011.
- 4,153,297 (See Class 25 for this trademark).
- 4,153,316. **MY STARBUCKS REWARDS (STANDARD CHARACTER).** STARBUCKS CORPORATION, DBA STARBUCKS COFFEE COMPANY, MULTIPLE CLASS, (INT. CLS. 35 AND 36), (U.S. CLS. 100, 101 AND 102). SN 85-423,162. PUB. 3-20-2012. FILED 9-15-2011.
- 4,153,326. **NETGROCER (STANDARD CHARACTER).** NET-

- GROCER, LLC, (U.S. CLS. 100, 101 AND 102). SN 85-423,730. PUB. 3-20-2012. FILED 9-15-2011.
- 4,153,330. **AWIATECH (STANDARD CHARACTER)**. AWIATECH CORPORATION, (U.S. CLS. 100, 101 AND 102). SN 85-424,076. PUB. 3-20-2012. FILED 9-15-2011.
- 4,153,331. **EMPLOYEE PARTNER (STANDARD CHARACTER)**. PRESS GANEY ASSOCIATES, INC, (U.S. CLS. 100, 101 AND 102). SN 85-424,217. PUB. 3-20-2012. FILED 9-15-2011.
- 4,153,342. **PHYSICIAN PARTNER (STANDARD CHARACTER)**. PRESS GANEY ASSOCIATES, INC, (U.S. CLS. 100, 101 AND 102). SN 85-425,572. PUB. 3-20-2012. FILED 9-19-2011.
- 4,153,343. **BRAND NAMES. CLOSEOUT PRICES. (STANDARD CHARACTER)**. CONSOLIDATED PROPERTY HOLDINGS, INC., (U.S. CLS. 100, 101 AND 102). SN 85-425,642. PUB. 3-20-2012. FILED 9-19-2011.
- 4,153,344. **O.I. OPERATION INTERDEPENDENCE WWW.OI-DELIVERS.ORG AND DESIGN. OPERATION INTERDEPENDENCE**, (U.S. CLS. 100, 101 AND 102). SN 85-425,757. PUB. 3-20-2012. FILED 9-19-2011.
- 4,153,348 (*See Class 25 for this trademark*).
- 4,153,350. **HRA PROVIDER PAID AND DESIGN. BLUE CROSS BLUE SHIELD OF ALABAMA**, (U.S. CLS. 100, 101 AND 102). SN 85-426,689. PUB. 3-20-2012. FILED 9-20-2011.
- 4,153,354. **STONEMUFFIN.COM AND DESIGN. LEFTHAND DISTRIBUTION LLC**, (U.S. CLS. 100, 101 AND 102). SN 85-426,895. PUB. 3-20-2012. FILED 9-20-2011.
- 4,153,361 (*See Class 16 for this trademark*).
- 4,153,362. **FORGOTTEN SONS MOTORCYCLE CLUB (STANDARD CHARACTER)**. MILLER, RYAN, (U.S. CLS. 100, 101 AND 102). SN 85-427,953. PUB. 3-20-2012. FILED 9-21-2011.
- 4,153,371. **THE HOSPITAL INDICATOR REPORT (STANDARD CHARACTER)**. PRESS GANEY ASSOCIATES, INC, (U.S. CLS. 100, 101 AND 102). SN 85-428,847. PUB. 3-20-2012. FILED 9-22-2011.
- 4,153,372. **PROVIDER PARTNER (STANDARD CHARACTER)**. PRESS GANEY ASSOCIATES, INC, (U.S. CLS. 100, 101 AND 102). SN 85-428,879. PUB. 3-20-2012. FILED 9-22-2011.
- 4,153,373. **THE INTELLIGENT BUSINESS PROGRAM (STANDARD CHARACTER)**. IBUSINESS SOLUTIONS, INC., MULTIPLE CLASS, (INT. CLS. 35 AND 41), (U.S. CLS. 100, 101, 102 AND 107). SN 85-428,947. PUB. 3-20-2012. FILED 9-22-2011.
- 4,153,374. **COMMUNICATE. INFLUENCE. ANTICIPATE. (STANDARD CHARACTER)**. IBUSINESS SOLUTIONS, INC., MULTIPLE CLASS, (INT. CLS. 35 AND 41), (U.S. CLS. 100, 101, 102 AND 107). SN 85-428,952. PUB. 3-20-2012. FILED 9-22-2011.
- 4,153,383. **THE DAY OF THE WEEK REPORT (STANDARD CHARACTER)**. PRESS GANEY ASSOCIATES, INC, (U.S. CLS. 100, 101 AND 102). SN 85-430,007. PUB. 3-20-2012. FILED 9-23-2011.
- 4,153,384. **PRESS GANEY PERFORMANCE CONSULTING SUITE (STANDARD CHARACTER)**. PRESS GANEY ASSOCIATES, INC, (U.S. CLS. 100, 101 AND 102). SN 85-430,011. PUB. 3-20-2012. FILED 9-23-2011.
- 4,153,385. **VALUE-BASED PURCHASING OPTIMIZER (STANDARD CHARACTER)**. PRESS GANEY ASSOCIATES, INC, (U.S. CLS. 100, 101 AND 102). SN 85-430,013. PUB. 3-20-2012. FILED 9-23-2011.
- 4,153,386. **OPPORTUNITY ASSESSMENT OPTIMIZER (STANDARD CHARACTER)**. PRESS GANEY ASSOCIATES, INC, (U.S. CLS. 100, 101 AND 102). SN 85-430,018. PUB. 3-20-2012. FILED 9-23-2011.
- 4,153,387. **CLINICAL PERFORMER OPTIMIZER (STANDARD CHARACTER)**. PRESS GANEY ASSOCIATES, INC, (U.S. CLS. 100, 101 AND 102). SN 85-430,019. PUB. 3-20-2012. FILED 9-23-2011.
- 4,153,388. **PATIENTFLOW OPTIMIZER (STANDARD CHARACTER)**. PRESS GANEY ASSOCIATES, INC, (U.S. CLS. 100, 101 AND 102). SN 85-430,031. PUB. 3-20-2012. FILED 9-23-2011.
- 4,153,409. **THE DENTIST'S WIFE (STANDARD CHARACTER)**. THE DENTISTS WIFE HOLDINGS LLC, (U.S. CLS. 100, 101 AND 102). SN 85-431,473. PUB. 3-20-2012. FILED 9-26-2011.
- 4,153,410. **INSIDECPA (STANDARD CHARACTER)**. BROOKSHIER, RANDALL, (U.S. CLS. 100, 101 AND 102). SN 85-431,581. PUB. 3-20-2012. FILED 9-26-2011.
- 4,153,416. **AMERICAN SOCIOLOGICAL ASSOCIATION (STANDARD CHARACTER)**. AMERICAN SOCIOLOGICAL ASSOCIATION, (U.S. CLS. 100, 101 AND 102). SN 85-432,202. PUB. 3-20-2012. FILED 9-26-2011.
- 4,153,420. **PALISADES (STANDARD CHARACTER)**. PALISADES CORPORATION, MULTIPLE CLASS, (INT. CLS. 35 AND 44), (U.S. CLS. 100, 101 AND 102). SN 85-432,503. PUB. 3-20-2012. FILED 9-27-2011.
- 4,153,430. **GE GREEN EYE AUTO PARTS (STYLIZED)**. MEEKO LLC, DBA GREEN EYE AUTO PARTS, (U.S. CLS. 100, 101 AND 102). SN 85-433,769. PUB. 3-20-2012. FILED 9-28-2011.
- 4,153,431. **WE'VE GOT IT! (STANDARD CHARACTER)**. DISCOUNT STEEL, INC., (U.S. CLS. 100, 101 AND 102). SN 85-433,834. PUB. 3-20-2012. FILED 9-28-2011.
- 4,153,434. **ABLE HARDWARE THE INDUSTRIAL EDGE (STANDARD CHARACTER)**. DISCOUNT STEEL, INC., (U.S. CLS. 100, 101 AND 102). SN 85-433,869. PUB. 3-20-2012. FILED 9-28-2011.
- 4,153,441. **MICREMA (STANDARD CHARACTER)**. LA DUNI CONCEPTS, LLC, (U.S. CLS. 100, 101 AND 102). SN 85-434,322. PUB. 3-20-2012. FILED 9-28-2011.
- 4,153,449. **CVG AND DESIGN. KENTON COUNTY AIRPORT BOARD, DBA CINCINNATI/NORTHERN KENTUCKY INTERNATIONAL AIRPORT, MULTIPLE CLASS, (INT. CLS. 35 AND 39), (U.S. CLS. 100, 101, 102 AND 105)**. SN 85-434,568. PUB. 3-20-2012. FILED 9-28-2011.
- 4,153,476. **GETTING YOU THERE (STANDARD CHARACTER)**. DESTINATION ATHLETE LLC, MULTIPLE CLASS, (INT. CLS. 35 AND 41), (U.S. CLS. 100, 101, 102 AND 107). SN 85-436,062. PUB. 3-20-2012. FILED 9-30-2011.
- 4,153,478. **A ALLEGORY STUDIOS AND DESIGN. ALLEGORY STUDIOS, INC.**, (U.S. CLS. 100, 101 AND 102). SN 85-436,124. PUB. 3-20-2012. FILED 9-30-2011.
- 4,153,479. **MISCELLANEOUS DESIGN. COVENANT HOUSE, MULTIPLE CLASS, (INT. CLS. 35, 36, 41, 43, 44 AND 45), (U.S. CLS. 100, 101, 102 AND 107)**. SN 85-436,147. PUB. 3-20-2012. FILED 9-30-2011.
- 4,153,481. **TRADE PLUS (STANDARD CHARACTER)**. COLLINS AUTO GROUP, LLC, (U.S. CLS. 100, 101 AND 102). SN 85-436,262. PUB. 3-20-2012. FILED 9-30-2011.
- 4,153,483. **SVRA SPORTSCAR VINTAGE RACING ASSOCIATION AND DESIGN. CHICAGO-SOFT, LTD, DBA SPORTSCAR VINTAGE RACING ASSOCIATION, (U.S. CLS. 100, 101 AND 102)**. SN 85-436,334. PUB. 3-20-2012. FILED 9-30-2011.
- 4,153,484. **I INTERNATIONAL RETAIL & SUPPLY CHAIN DATALECTICS, LLC. AND DESIGN. HEFFNER, CARL, (U.S. CLS. 100, 101 AND 102)**. SN 85-436,427. PUB. 3-20-2012. FILED 9-30-2011.
- 4,153,492. **LITTLE BLUE STUDIO (STANDARD CHARACTER)**. HIGH, MARIA LOUISE, DBA LITTEL BLUE STUDIO, (U.S. CLS. 100, 101 AND 102). SN 85-436,763. PUB. 3-20-2012. FILED 9-30-2011.
- 4,153,513. **THE HUB OF BOSTON LAW (STANDARD CHARACTER)**. BOSTON BAR ASSOCIATION, (U.S. CLS. 100, 101 AND 102). SN 85-437,466. PUB. 3-20-2012. FILED 10-3-2011.
- 4,153,515. **NORTHEAST ELECTRICAL DISTRIBUTORS (STANDARD CHARACTER)**. SONEPAR DISTRIBUTION NEW ENGLAND, INC., (U.S. CLS. 100, 101 AND 102). SN 85-437,520. PUB. 3-20-2012. FILED 10-3-2011.
- 4,153,516. **VALUEIDEAS (STANDARD CHARACTER)**. MATHUR ENTERPRISES, L.L.C., DBA VALUEIDEAS, (U.S. CLS. 100, 101 AND 102). SN 85-437,524. PUB. 3-20-2012. FILED 10-3-2011.
- 4,153,517. **WE ARE HALLOWEEN (STANDARD CHARACTER)**. CITCO ENTERPRISES, (U.S. CLS. 100, 101 AND 102). SN 85-437,525. PUB. 3-20-2012. FILED 10-3-2011.
- 4,153,519. **VALUELAB (STANDARD CHARACTER)**. MATHUR ENTERPRISES, L.L.C., DBA VALUEIDEAS, (U.S. CLS. 100, 101 AND 102). SN 85-437,581. PUB. 3-20-2012. FILED 10-3-2011.
- 4,153,526. **ATHENACOORDINATOR (STANDARD CHARACTER)**. ATHENAHEALTH, INC., MULTIPLE CLASS, (INT. CLS. 35 AND 42), (U.S. CLS. 100, 101 AND 102). SN 85-

- 437,761. PUB. 3-20-2012. FILED 10-3-2011.
- 4,153,536. **DEROYAL IMPROVING CARE. IMPROVING BUSINESS. (STANDARD CHARACTER).** DEROYAL INDUSTRIES, INC., (U.S. CLS. 100, 101 AND 102). SN 85-437,981. PUB. 3-20-2012. FILED 10-3-2011.
- 4,153,537. **SERVICE OFFICE AND DESIGN. SERVICE OFFICE & SUPPLY, INC., AKA SERVICE OFFICE,** (U.S. CLS. 100, 101 AND 102). SN 85-437,982. PUB. 3-20-2012. FILED 10-3-2011.
- 4,153,538. **IMPROVING CARE. IMPROVING BUSINESS. (STANDARD CHARACTER).** DEROYAL INDUSTRIES, INC., (U.S. CLS. 100, 101 AND 102). SN 85-438,003. PUB. 3-20-2012. FILED 10-3-2011.
- 4,153,547. **THE MOST TRUSTED AIRSOFT RETAILER IN AMERICA (STANDARD CHARACTER).** AIRSOFT ZONE CORPORATION, (U.S. CLS. 100, 101 AND 102). SN 85-438,251. PUB. 3-20-2012. FILED 10-3-2011.
- 4,153,555. **AMERICAN ASSOCIATION OF PROFESSIONAL LANDMEN (STANDARD CHARACTER).** AMERICAN ASSOCIATION OF PROFESSIONAL LANDMEN, (U.S. CLS. 100, 101 AND 102). SN 85-438,515. PUB. 3-20-2012. FILED 10-4-2011.
- 4,153,559. **FRED'S BEDS AND DESIGN. SUNSET SLEEP CENTER INC.,** (U.S. CLS. 100, 101 AND 102). SN 85-438,589. PUB. 3-20-2012. FILED 10-4-2011.
- 4,153,562. **PROSKORE (STANDARD CHARACTER).** START-UP FLORIDA INC., (U.S. CLS. 100, 101 AND 102). SN 85-438,639. PUB. 3-20-2012. FILED 10-4-2011.
- 4,153,574. **TELMETRICS (STANDARD CHARACTER).** TELMETRICS, INC., (U.S. CLS. 100, 101 AND 102). SN 85-438,940. PUB. 3-20-2012. FILED 10-4-2011.
- 4,153,575. **MOTIV METALS (STANDARD CHARACTER).** MOTIV METALS, LLC, (U.S. CLS. 100, 101 AND 102). SN 85-438,944. PUB. 3-20-2012. FILED 10-4-2011.
- 4,153,581. **CAPTAIN RECRUITER (STANDARD CHARACTER).** CAPTAIN RECRUITER LLC, (U.S. CLS. 100, 101 AND 102). SN 85-439,204. PUB. 3-20-2012. FILED 10-4-2011.
- 4,153,588. **GAMEPLAY AND DESIGN. GAMEPLAY LLC,** (U.S. CLS. 100, 101 AND 102). SN 85-439,406. PUB. 3-20-2012. FILED 10-5-2011.
- 4,153,589. **PEACE, LOVE AND LITTLE DONUTS (STANDARD CHARACTER).** PEACE, LOVE AND LITTLE DONUTS, (U.S. CLS. 100, 101 AND 102). SN 85-439,413. PUB. 3-20-2012. FILED 10-5-2011.
- 4,153,592. **TED RX (STANDARD CHARACTER).** WELLFOUNT, CORPORATION, DBA WELLFOUNT PHARMACY, (U.S. CLS. 100, 101 AND 102). SN 85-439,444. PUB. 3-20-2012. FILED 10-5-2011.
- 4,153,593. **TED RX AND DESIGN.** WELLFOUNT, CORPORATION, DBA WELLFOUNT PHARMACY, (U.S. CLS. 100, 101 AND 102). SN 85-439,447. PUB. 3-20-2012. FILED 10-5-2011.
- 4,153,595. **EMECREATIVE (STYLIZED).** BRYANT JR., CURTIS G., (U.S. CLS. 100, 101 AND 102). SN 85-439,491. PUB. 3-20-2012. FILED 10-5-2011.
- 4,153,599. **UNCLAIMED BAGGAGE CENTER (STANDARD CHARACTER).** OCS, INCORPORATED, FORMERLY UNCLAIMED BAGGAGE CENTER, INC., MULTIPLE CLASS, (INT. CLS. 35 AND 41), (U.S. CLS. 100, 101, 102 AND 107). SN 85-439,578. PUB. 3-20-2012. FILED 10-5-2011.
- 4,153,600. **UNCLAIMED BAGGAGE CENTER AND DESIGN.** OCS, INCORPORATED, FORMERLY UNCLAIMED BAGGAGE CENTER, INC., MULTIPLE CLASS, (INT. CLS. 35 AND 41), (U.S. CLS. 100, 101, 102 AND 107). SN 85-439,586. PUB. 3-20-2012. FILED 10-5-2011.
- 4,153,607. **VELOSMITH (STANDARD CHARACTER).** VELOSMITH BICYCLE STUDIO, INC., (U.S. CLS. 100, 101 AND 102). SN 85-439,801. PUB. 3-20-2012. FILED 10-5-2011.
- 4,153,609. **SIGN POSTMAN (STANDARD CHARACTER).** SIGN POSTMAN, LLC, (U.S. CLS. 100, 101 AND 102). SN 85-439,815. PUB. 3-20-2012. FILED 10-5-2011.
- 4,153,610. **PIANO WORLD (STANDARD CHARACTER).** BAXTER, FRANK, DBA PIANO WORLD, MULTIPLE CLASS, (INT. CLS. 35 AND 38), (U.S. CLS. 100, 101, 102 AND 104). SN 85-439,852. PUB. 3-20-2012. FILED 10-5-2011.
- 4,153,612. **NINE INNINGS OF NETWORKING (STANDARD CHARACTER).** AMERICAN BASEBALL COMPANY LLC, (U.S. CLS. 100, 101 AND 102). SN 85-439,874. PUB. 3-20-2012. FILED 10-5-2011.
- 4,153,626. **A-PLAY CLUB (STANDARD CHARACTER).** AFFINITY GAMING, LLC, (U.S. CLS. 100, 101 AND 102). SN 85-440,237. PUB. 3-20-2012. FILED 10-5-2011.
- 4,153,646. **OPERATION STARS & STRIPES, INC. AND DESIGN.** OPERATION STARS & STRIPES, INC., MULTIPLE CLASS, (INT. CLS. 35 AND 36), (U.S. CLS. 100, 101 AND 102). SN 85-440,663. PUB. 3-20-2012. FILED 10-6-2011.
- 4,153,655. **BIOKEEN (STANDARD CHARACTER).** BIOKEEN INC., (U.S. CLS. 100, 101 AND 102). SN 85-440,835. PUB. 3-20-2012. FILED 10-6-2011.
- 4,153,664. **I LIKE IT WILD! (STANDARD CHARACTER).** THE WILDERNESS SOCIETY, (U.S. CLS. 100, 101 AND 102). SN 85-440,921. PUB. 3-20-2012. FILED 10-6-2011.
- 4,153,673. **HEARTIVATION (STANDARD CHARACTER).** HEARTIVATION, LLC, (U.S. CLS. 100, 101 AND 102). SN 85-441,011. PUB. 3-20-2012. FILED 10-6-2011.
- 4,153,676. **WINE AND BEER MAKERS OUTLET W&B SINCE 1982 AND DESIGN.** WINE MASTERS ACADEMY, INC., (U.S. CLS. 100, 101 AND 102). SN 85-441,056. PUB. 3-20-2012. FILED 10-6-2011.
- 4,153,677. **CURT (STANDARD CHARACTER).** THE CONSTRUCTION USERS ROUNDTABLE, (U.S. CLS. 100, 101 AND 102). SN 85-441,104. PUB. 3-20-2012. FILED 10-6-2011.
- 4,153,680. **MISCELLANEOUS DESIGN.** LOTHAMER FRANCHISE CORPORATION, (U.S. CLS. 100, 101 AND 102). SN 85-441,176. PUB. 3-20-2012. FILED 10-6-2011.
- 4,153,687. **ETHNO-MEDICINE PRESERVATION PROJECT (STANDARD CHARACTER).** ETHNOMEDICINE PRESERVATION PROJECT, (U.S. CLS. 100, 101 AND 102). SN 85-441,360. PUB. 3-20-2012. FILED 10-6-2011.
- 4,153,700. **SHOE LOVERS CARE (STANDARD CHARACTER).** DSW SHOE WAREHOUSE, INC., (U.S. CLS. 100, 101 AND 102). SN 85-441,569. PUB. 3-20-2012. FILED 10-7-2011.
- 4,153,708. **ARIVA (STANDARD CHARACTER).** 1ST CHAIR SKIN CARE, INC., DBA ARIVA, (U.S. CLS. 100, 101 AND 102). SN 85-441,623. PUB. 3-20-2012. FILED 10-7-2011.
- 4,153,709. **POWERRAIL (STANDARD CHARACTER).** POWERRAIL DISTRIBUTION INC., (U.S. CLS. 100, 101 AND 102). SN 85-441,624. PUB. 3-20-2012. FILED 10-7-2011.
- 4,153,712. **SKINI (STANDARD CHARACTER).** SKINI, INC., (U.S. CLS. 100, 101 AND 102). SN 85-441,646. PUB. 3-20-2012. FILED 10-7-2011.
- 4,153,713. **EPOWERRAIL (STANDARD CHARACTER).** POWERRAIL DISTRIBUTION INC., (U.S. CLS. 100, 101 AND 102). SN 85-441,657. PUB. 3-20-2012. FILED 10-7-2011.
- 4,153,729. **PRICWAITER (STANDARD CHARACTER).** PRICE WAITER, LLC, (U.S. CLS. 100, 101 AND 102). SN 85-441,803. PUB. 3-20-2012. FILED 10-7-2011.
- 4,153,736. **YOUR MARKETPLACE FOR YOUR WORKSPACE (STANDARD CHARACTER).** DOBBS, KENNETH J., (U.S. CLS. 100, 101 AND 102). SN 85-441,878. PUB. 3-20-2012. FILED 10-7-2011.
- 4,153,746. **PUT UP A TREE. LIFT UP A CHILD. (STANDARD CHARACTER).** PEARL MINISTRIES, INC., MULTIPLE CLASS, (INT. CLS. 35 AND 36), (U.S. CLS. 100, 101 AND 102). SN 85-442,008. PUB. 3-20-2012. FILED 10-7-2011.
- 4,153,748. **BUY AN ORNAMENT. BLESS A CHILD. (STANDARD CHARACTER).** PEARL MINISTRIES, INC., MULTIPLE CLASS, (INT. CLS. 35 AND 36), (U.S. CLS. 100, 101 AND 102). SN 85-442,016. PUB. 3-20-2012. FILED 10-7-2011.
- 4,153,752. **PEGAWORLD (STANDARD CHARACTER).** PEGASYSTEMS INC., (U.S. CLS. 100, 101 AND 102). SN 85-442,061. PUB. 3-20-2012. FILED 10-7-2011.
- 4,153,754. **SEQUIN (STYLIZED).** SEQUIN, LLC, (U.S. CLS. 100, 101 AND 102). SN 85-442,070. PUB. 3-20-2012. FILED 10-7-2011.
- 4,153,758. **LASTING IMPRINT (STANDARD CHARACTER).** LASTING IMPRINT, INC., MULTIPLE CLASS, (INT. CLS. 35 AND 36), (U.S. CLS. 100, 101 AND 102). SN 85-442,133. PUB. 3-20-2012. FILED 10-7-2011.
- 4,153,760. **LLC AND DESIGN.** LOOSE LEAF CONCEPTS, LLC, MULTIPLE CLASS, (INT. CLS. 35 AND 42), (U.S. CLS. 100, 101 AND 102). SN 85-442,175. PUB. 3-20-2012. FILED 10-7-2011.
- 4,153,771. **FLORIDA 305 FILMS MIAMI AND DESIGN.** 305 FILMS, INC, MULTIPLE CLASS, (INT. CLS. 35 AND 41), (U.S. CLS. 100, 101, 102 AND 107). SN 85-442,230. PUB. 3-20-

2012. FILED 10-7-2011.
- 4,153,774. **KUKADS (STANDARD CHARACTER). CLICKHOSTELS LLC**, (U.S. CLS. 100, 101 AND 102). SN 85-442,263. PUB. 3-20-2012. FILED 10-7-2011.
- 4,153,783. **ARMS (STANDARD CHARACTER). AFFILIATES RISK MANAGEMENT SERVICES, INC.**, (U.S. CLS. 100, 101 AND 102). SN 85-442,337. PUB. 3-20-2012. FILED 10-7-2011.
- 4,153,788. **VOW TO GET ORGANIZED (STANDARD CHARACTER). THE CONTAINER STORE, INC.**, (U.S. CLS. 100, 101 AND 102). SN 85-442,452. PUB. 3-20-2012. FILED 10-7-2011.
- 4,153,797. **A+C ACCOUNTING CONNECTIONS LLC AND DESIGN. ACCOUNTING CONNECTIONS, LLC**, (U.S. CLS. 100, 101 AND 102). SN 85-442,537. PUB. 3-20-2012. FILED 10-7-2011.
- 4,153,799. **APPLIED STORYTELLING FOR COMPANIES, PRODUCTS AND BRANDS. (STANDARD CHARACTER). APPLIED STORYTELLING, INC.**, (U.S. CLS. 100, 101 AND 102). SN 85-442,554. PUB. 3-20-2012. FILED 10-7-2011.
- 4,153,807. **GUMGUM (STANDARD CHARACTER). GUMGUM, INC.**, (U.S. CLS. 100, 101 AND 102). SN 85-442,640. PUB. 3-20-2012. FILED 10-7-2011.
- 4,153,830. **MATH CONCERT (STANDARD CHARACTER). WWW.LETTERMATCH.COM LLC**, (U.S. CLS. 100, 101 AND 102). SN 85-442,826. PUB. 3-20-2012. FILED 10-8-2011.
- 4,153,832. **REDI-MED (STANDARD CHARACTER). NEIDIG HEALTH CARE LTD, DBA MEDI-WISE LTC PHARMACY**, (U.S. CLS. 100, 101 AND 102). SN 85-442,855. PUB. 3-20-2012. FILED 10-9-2011.
- 4,153,838. **LEIHUT (STANDARD CHARACTER). STORYMANAGER, INC.**, (U.S. CLS. 100, 101 AND 102). SN 85-442,906. PUB. 3-20-2012. FILED 10-9-2011.
- 4,153,845. **BECAUSE THERE IS STILL HOPE. (STANDARD CHARACTER). THE CHICAGO LIGHTHOUSE FOR PEOPLE WHO ARE BLIND OR VISUALLY IMPAIRED, MULTIPLE CLASS, (INT. CLS. 35, 41 AND 44), (U.S. CLS. 100, 101, 102 AND 107).** SN 85-443,035. PUB. 3-20-2012. FILED 10-10-2011.
- 4,153,846. **CRUSHIQ (STANDARD CHARACTER). CRUSHIQ, LLC, MULTIPLE CLASS, (INT. CLS. 35 AND 41), (U.S. CLS. 100, 101, 102 AND 107).** SN 85-443,045. PUB. 3-20-2012. FILED 10-10-2011.
- 4,153,849. **HAYER ANALYTICS (STANDARD CHARACTER). HAYER ANALYTICS, INC.**, (U.S. CLS. 100, 101 AND 102). SN 85-443,095. PUB. 3-20-2012. FILED 10-10-2011.
- 4,153,850. **RETAIL BRAND HEALTH AND DESIGN. CROSSMARK, INC.**, (U.S. CLS. 100, 101 AND 102). SN 85-443,104. PUB. 3-20-2012. FILED 10-10-2011.
- 4,153,851. **N CROSSVIEW AND DESIGN. CROSSMARK, INC.**, (U.S. CLS. 100, 101 AND 102). SN 85-443,110. PUB. 3-20-2012. FILED 10-10-2011.
- 4,153,852. **CROSSVIEW (STANDARD CHARACTER). CROSSMARK, INC.**, (U.S. CLS. 100, 101 AND 102). SN 85-443,112. PUB. 3-20-2012. FILED 10-10-2011.
- 4,153,866. **CYBER COMBUSTION AND DESIGN. DUNCAN MEADOWS**, (U.S. CLS. 100, 101 AND 102). SN 85-443,233. PUB. 3-20-2012. FILED 10-10-2011.
- 4,153,871. **SNEAKERHEAD (STANDARD CHARACTER). DEVICOM INTERNATIONAL, INC., DBA SNEAKERHEAD**, (U.S. CLS. 100, 101 AND 102). SN 85-443,279. PUB. 3-20-2012. FILED 10-10-2011.
- 4,153,880. **ALPHA SIGMA ALPHA DEVELOPING WOMEN OF POISE AND PURPOSE AND DESIGN. ALPHA SIGMA ALPHA**, (U.S. CLS. 100, 101 AND 102). SN 85-443,397. PUB. 3-20-2012. FILED 10-10-2011.
- 4,153,895. **ENERGYMAESTRO (STANDARD CHARACTER). MW ENGINEERING SPRL**, (U.S. CLS. 100, 101 AND 102). SN 85-443,498. PUB. 3-20-2012. FILED 10-10-2011.
- 4,153,913. **HDA (STANDARD CHARACTER). NATIONAL SPORTING GOODS ASSOCIATION, MULTIPLE CLASS, (INT. CLS. 35 AND 41), (U.S. CLS. 100, 101, 102 AND 107).** SN 85-443,670. PUB. 3-20-2012. FILED 10-10-2011.
- 4,153,936. **STOP & SHOP LOCAL ROUTE AND DESIGN. AHOLD LICENSING SARL**, (U.S. CLS. 100, 101 AND 102). SN 85-444,013. PUB. 3-20-2012. FILED 10-11-2011.
- 4,153,945. **BLACKSTONE ACCELERATES GROWTH (STANDARD CHARACTER). BLACKSTONE TM L.L.C., MULTIPLE CLASS, (INT. CLS. 35 AND 36), (U.S. CLS. 100, 101 AND 102).** SN 85-444,079. PUB. 3-20-2012. FILED 10-11-2011.
- 4,153,957. **ADFISH AND DESIGN. TRANCOS, INC.**, (U.S. CLS. 100, 101 AND 102). SN 85-444,160. PUB. 3-20-2012. FILED 10-11-2011.
- 4,153,963. **COUPONGY.COM AND DESIGN. COUPONGY, INC.**, (U.S. CLS. 100, 101 AND 102). SN 85-444,188. PUB. 3-20-2012. FILED 10-11-2011.
- 4,153,966. **G AND DESIGN. VALLEY SOLUTIONS, INC., DBA TOWING.COM, MULTIPLE CLASS, (INT. CLS. 35 AND 39), (U.S. CLS. 100, 101, 102 AND 105).** SN 85-444,248. PUB. 3-20-2012. FILED 10-11-2011.
- 4,153,970. **INCOMERCIALS (STANDARD CHARACTER). GOTTSCHALK, DAVE, DBA INCOMERCIALS LLC**, (U.S. CLS. 100, 101 AND 102). SN 85-444,267. PUB. 3-20-2012. FILED 10-11-2011.
- 4,153,974. **CHOICE PROPERTY RESOURCES, INC. AND DESIGN. CHOICE PROPERTY RESOURCES, INC.**, (U.S. CLS. 100, 101 AND 102). SN 85-444,292. PUB. 3-20-2012. FILED 10-11-2011.
- 4,153,976. **CHOICE PROPERTY RESOURCES (STANDARD CHARACTER). CHOICE PROPERTY RESOURCES, INC.**, (U.S. CLS. 100, 101 AND 102). SN 85-444,312. PUB. 3-20-2012. FILED 10-11-2011.
- 4,153,993. **HIDDEN BARREL (STANDARD CHARACTER). LION NATHAN USA, INC.**, (U.S. CLS. 100, 101 AND 102). SN 85-444,521. PUB. 3-20-2012. FILED 10-11-2011.
- 4,153,997. **HIDDEN BARREL AND DESIGN. LION NATHAN USA, INC.**, (U.S. CLS. 100, 101 AND 102). SN 85-444,563. PUB. 3-20-2012. FILED 10-11-2011.
- 4,153,998. **GUARANTEED CAR! GUARANTEED CREDIT! SAME DAY! (STANDARD CHARACTER). NACIONAL NAME HOLDING, LLC, MULTIPLE CLASS, (INT. CLS. 35, 36 AND 37), (U.S. CLS. 100, 101, 102, 103 AND 106).** SN 85-444,568. PUB. 3-20-2012. FILED 10-11-2011.
- 4,154,005. **MAKE BEAUTIFUL THINGS (STANDARD CHARACTER). ONYX CREATIVE GROUP, INC.**, (U.S. CLS. 100, 101 AND 102). SN 85-444,629. PUB. 3-20-2012. FILED 10-11-2011.
- 4,154,013. **WISH4 AND DESIGN. SHOLTIS, STEVEN**, (U.S. CLS. 100, 101 AND 102). SN 85-444,702. PUB. 3-20-2012. FILED 10-11-2011.
- 4,154,014. **THE AMERICAN STILL LIFE COLLECTION (STANDARD CHARACTER). THE COUNTRY VINTNER**, (U.S. CLS. 100, 101 AND 102). SN 85-444,703. PUB. 3-20-2012. FILED 10-11-2011.
- 4,154,015. **THE AMERICAN STILL LIFE COLLECTION AND DESIGN. THE COUNTRY VINTNER**, (U.S. CLS. 100, 101 AND 102). SN 85-444,708. PUB. 3-20-2012. FILED 10-11-2011.
- 4,154,019. **CAN CRUSADE AND DESIGN. THE ALUMINUM ASSOCIATION INC.**, (U.S. CLS. 100, 101 AND 102). SN 85-444,798. PUB. 3-20-2012. FILED 10-11-2011.
- 4,154,020. **ZEROWASTEUSA (STANDARD CHARACTER). ZERO WASTE ENERGY SYSTEMS USA LLC**, (U.S. CLS. 100, 101 AND 102). SN 85-444,801. PUB. 3-20-2012. FILED 10-11-2011.
- 4,154,021. **CORPORATE FINESSE (STYLIZED). SHIRLEY, DEBORAH**, (U.S. CLS. 100, 101 AND 102). SN 85-444,806. PUB. 3-20-2012. FILED 10-11-2011.
- 4,154,035. **STEC SPECIALIZED TURF EQUIPMENT COMPANY AND DESIGN. STEC, INC.**, (U.S. CLS. 100, 101 AND 102). SN 85-445,050. PUB. 3-20-2012. FILED 10-12-2011.
- 4,154,037 (*See Class 16 for this trademark*).
- 4,154,038. **MGENOME (STANDARD CHARACTER). EXCO INTOUCH LTD.**, (U.S. CLS. 100, 101 AND 102). SN 85-445,141. PUB. 3-20-2012. FILED 10-12-2011.
- 4,154,045. **FIDA (STANDARD CHARACTER). NATIONAL SPORTING GOODS ASSOCIATION, MULTIPLE CLASS, (INT. CLS. 35 AND 41), (U.S. CLS. 100, 101, 102 AND 107).** SN 85-445,388. PUB. 3-20-2012. FILED 10-12-2011.
- 4,154,046. **YOUR FUTURE IS > EVER. (STANDARD CHARACTER). UNITEDHEALTH GROUP INCORPORATED**, (U.S. CLS. 100, 101 AND 102). SN 85-445,400. PUB. 3-20-2012. FILED 10-12-2011.
- 4,154,047. **START A CAREER THAT IS > YOUR EXPECTATIONS. (STANDARD CHARACTER). UNITEDHEALTH GROUP INCORPORATED**, (U.S. CLS. 100, 101 AND 102). SN 85-445,409. PUB. 3-20-2012. FILED 10-12-2011.
- 4,154,048. **>THERE'S SOMETHING GREATER AT WORK**

HERE (STANDARD CHARACTER). UNITEDHEALTH GROUP INCORPORATED, (U.S. CLS. 100, 101 AND 102). SN 85-445,411. PUB. 3-20-2012. FILED 10-12-2011.

4,154,051. **THE WISHING WORD (STANDARD CHARACTER)**. THE WISHING WORD INC., (U.S. CLS. 100, 101 AND 102). SN 85-445,595. PUB. 3-20-2012. FILED 10-12-2011.

4,154,059. **WOMEN'S GLOBAL LEADERSHIP CONFERENCE (STANDARD CHARACTER)**. GULF PUBLISHING COMPANY, (U.S. CLS. 100, 101 AND 102). SN 85-445,711. PUB. 3-20-2012. FILED 10-12-2011.

4,154,109. **MISCELLANEOUS DESIGN**. BIKEPATH COUNTRY, INC., (U.S. CLS. 100, 101 AND 102). SN 85-447,493. PUB. 3-20-2012. FILED 10-14-2011.

4,154,125. **STUDIOCODE (STANDARD CHARACTER)**. SPORTSTEC LIMITED, MULTIPLE CLASS, (INT. CLS. 35 AND 41), (U.S. CLS. 100, 101, 102 AND 107). SN 85-450,276. PUB. 3-20-2012. FILED 10-18-2011.

4,154,129. **FOODS YOU LOVE THAT LOVE YOU BACK! (STANDARD CHARACTER)**. KOYA'S IP, (U.S. CLS. 100, 101 AND 102). SN 85-450,752. PUB. 3-20-2012. FILED 10-19-2011.

4,154,134. **COUPON CRAZE \$ AND DESIGN**. FLASHVIC, INC., (U.S. CLS. 100, 101 AND 102). SN 85-451,734. PUB. 3-20-2012. FILED 10-20-2011.

4,154,139. **AN AMERICAN TRADITION THAT WORKS (STANDARD CHARACTER)**. AMERICAN PUBLIC POWER ASSOCIATION, (U.S. CLS. 100, 101 AND 102). SN 85-452,430. PUB. 3-20-2012. FILED 10-20-2011.

4,154,145. **SUNKIST NUTRITION BUREAU (STANDARD CHARACTER)**. SUNKIST GROWERS, INC., (U.S. CLS. 100, 101 AND 102). SN 85-453,196. PUB. 3-20-2012. FILED 10-21-2011.

4,154,155. **SPRIM (STANDARD CHARACTER)**. SPRIM USA, DBA SPRIM USA, MULTIPLE CLASS, (INT. CLS. 35 AND 42), (U.S. CLS. 100, 101 AND 102). SN 85-454,688. PUB. 3-20-2012. FILED 10-24-2011.

4,154,164. **CETALUS (STANDARD CHARACTER)**. CETALUS LLC, MULTIPLE CLASS, (INT. CLS. 35 AND 45), (U.S. CLS. 100, 101 AND 102). SN 85-455,596. PUB. 3-20-2012. FILED 10-25-2011.

4,154,176. **VILKN AND INTERNATIONAL SHIPPING AND LOGISTICS AND DESIGN**. VILKON N.A., INC., DBA VILKON NORTH AMERICA, MULTIPLE CLASS, (INT. CLS. 35 AND 39), (U.S. CLS. 100, 101, 102 AND 105). SN 85-458,319. PUB. 3-20-2012. FILED 10-27-2011.

4,154,185. **GOMO (STANDARD CHARACTER)**. GOOGLE INC., MULTIPLE CLASS, (INT. CLS. 35 AND 42), (U.S. CLS. 100, 101 AND 102). SN 85-463,479. PUB. 3-20-2012. FILED 11-3-2011.

4,154,195. **RENT-A-CENTER (STANDARD CHARACTER)**. RENT-A-CENTER WEST, INC., (U.S. CLS. 100, 101 AND 102). SN 85-466,404. PUB. 3-20-2012. FILED 11-7-2011.

4,154,204. **SOLIDARITY SLEEP OUT: CEO EDITION (STANDARD CHARACTER)**. COVENANT HOUSE, MULTIPLE CLASS, (INT. CLS. 35 AND 36), (U.S. CLS. 100, 101 AND 102). SN 85-476,137. PUB. 3-20-2012. FILED 11-18-2011.

4,154,224. **HOLLY THE HOLIDAY ELF AND DESIGN**. DSW SHOE WAREHOUSE, INC., (U.S. CLS. 100, 101 AND 102). SN 85-493,664. PUB. 3-20-2012. FILED 12-13-2011.

4,154,225. **ANIMARKETING (STANDARD CHARACTER)**. TIME FRAME PHOTOGRAPHY & ART ILLUSTRATION, (U.S. CLS. 100, 101 AND 102). SN 85-495,222. PUB. 3-20-2012. FILED 12-14-2011.

4,154,228. **FRENZY ALERT (STANDARD CHARACTER)**. DSW SHOE WAREHOUSE, INC., (U.S. CLS. 100, 101 AND 102). SN 85-498,816. PUB. 3-20-2012. FILED 12-19-2011.

4,154,230. **MEDFOX (STANDARD CHARACTER)**. LIVON LABORATORIES, INC., MULTIPLE CLASS, (INT. CLS. 35, 41 AND 44), (U.S. CLS. 100, 101, 102 AND 107). SN 85-502,641. PUB. 3-20-2012. FILED 12-22-2011.

4,154,237. **POOLCORP (STANDARD CHARACTER)**. ALLIANCE TRADING, INC., (U.S. CLS. 100, 101 AND 102). SN 85-975,036. PUB. 3-20-2012. FILED 6-23-2010.

4,154,240. **YOUR IDENTITY IS COUNTING ON YOU (STANDARD CHARACTER)**. INTERSECTIONS INC., MULTIPLE CLASS, (INT. CLS. 35, 36 AND 45), (U.S. CLS. 100, 101 AND 102). SN 85-976,666. PUB. 8-16-2011. FILED 8-18-2010.

CLASS 36—INSURANCE AND FINANCIAL

4,152,075 (*See Class 35 for this trademark*).

4,152,078 (*See Class 35 for this trademark*).

4,152,082 (*See Class 35 for this trademark*).

4,152,083 (*See Class 35 for this trademark*).

4,152,088. **MISCELLANEOUS DESIGN**. TRAFIGURA BEHEER BV, MULTIPLE CLASS, (INT. CLS. 36, 37 AND 39), (U.S. CLS. 100, 101, 102, 103, 105 AND 106). SN 77-453,449. PUB. 10-5-2010. FILED 4-21-2008.

4,152,093. **WACHOVIA TRADEWORKS (STANDARD CHARACTER)**. WELLS FARGO & COMPANY, (U.S. CLS. 100, 101 AND 102). SN 77-567,901. PUB. 3-20-2012. FILED 9-11-2008.

4,152,107 (*See Class 35 for this trademark*).

4,152,113. **MUNICIPAY (STANDARD CHARACTER)**. NATIONWIDE PAYMENT SOLUTIONS, LLC, (U.S. CLS. 100, 101 AND 102). SN 77-717,136. PUB. 3-20-2012. FILED 4-20-2009.

4,152,133. **MY HARLEYSVILLE LIFELINK (STYLIZED)**. HARLEYSVILLE MUTUAL INSURANCE COMPANY, (U.S. CLS. 100, 101 AND 102). SN 77-884,016. PUB. 3-20-2012. FILED 12-2-2009.

4,152,148. **IOWNIT. (STANDARD CHARACTER)**. METRO CREDIT UNION, (U.S. CLS. 100, 101 AND 102). SN 77-950,481. PUB. 3-20-2012. FILED 3-4-2010.

4,152,166 (*See Class 11 for this trademark*).

4,152,171 (*See Class 16 for this trademark*).

4,152,187 (*See Class 9 for this trademark*).

4,152,192 (*See Class 35 for this trademark*).

4,152,219 (*See Class 35 for this trademark*).

4,152,224. **VB VAKIFBANK BURASI SIZIN YERINIZ (STYLIZED)**. TÜRKIYE VAKIFLAR BANKASI T.A.O., (U.S. CLS. 100, 101 AND 102). SN 79-095,011. PUB. 3-20-2012. FILED 1-10-2011.

4,152,281. **MISCELLANEOUS DESIGN**. BLUEBAY ASSET MANAGEMENT LTD, (U.S. CLS. 100, 101 AND 102). SN 79-098,184. PUB. 1-17-2012. FILED 5-5-2011.

4,152,337. **UBS NEO (STANDARD CHARACTER)**. UBS AG, (U.S. CLS. 100, 101 AND 102). SN 79-100,082. PUB. 3-20-2012. FILED 6-24-2011.

4,152,402. **LGLOBAL (STANDARD CHARACTER)**. LION GLOBAL INVESTORS LIMITED, (U.S. CLS. 100, 101 AND 102). SN 79-104,141. PUB. 3-20-2012. FILED 7-18-2011.

4,152,454. **PBT. PHYSICIANS' BENEFITS TRUST . LIFE INSURANCE COMPANY AND DESIGN**. ISMIE MUTUAL INSURANCE COMPANY, (U.S. CLS. 100, 101 AND 102). SN 85-042,403. PUB. 3-20-2012. FILED 5-19-2010.

4,152,472. **DEAL LINE-UP (STANDARD CHARACTER)**. MAVERICK ANGELS, LLC, (U.S. CLS. 100, 101 AND 102). SN 85-083,886. PUB. 3-20-2012. FILED 7-13-2010.

4,152,473 (*See Class 9 for this trademark*).

4,152,494 (*See Class 35 for this trademark*).

4,152,502. **THE CHANGE GROUP AND DESIGN**. THE CHANGE GROUP INTERNATIONAL PLC, (U.S. CLS. 100, 101 AND 102). SN 85-113,458. PUB. 3-20-2012. FILED 8-23-2010.

4,152,511. **C CENTER FOR A SECURE RETIREMENT AND DESIGN**. BANKERS LIFE AND CASUALTY COMPANY, (U.S. CLS. 100, 101 AND 102). SN 85-122,847. PUB. 3-20-2012. FILED 9-3-2010.

4,152,543 (*See Class 35 for this trademark*).

4,152,544. **RSI RESTORING SIGHT INTERNATIONAL AND DESIGN**. RESTORING SIGHT INTERNATIONAL, INC., MULTIPLE CLASS, (INT. CLS. 36 AND 41), (U.S. CLS. 100, 101, 102 AND 107). SN 85-150,880. PUB. 10-4-2011. FILED 10-12-2010.

4,152,546. **SM AND DESIGN**. SM INVESTMENTS CORPORATION, (U.S. CLS. 100, 101 AND 102). SN 85-152,580. PUB. 9-13-2011. FILED 10-14-2010.

4,152,555 (*See Class 35 for this trademark*).

4,152,556. **TRADENOMIX (STANDARD CHARACTER)**. TRADENOMIX INC., (U.S. CLS. 100, 101 AND 102). SN 85-160,398. PUB. 3-20-2012. FILED 10-25-2010.

4,152,580. **THE SCHWARTZ CENTER FOR COMPASSIONATE HEALTHCARE (STANDARD CHARACTER)**. COHEN, ELLEN, MULTIPLE CLASS, (INT. CLS. 36 AND 41), (U.S. CLS. 100, 101, 102 AND 107). SN 85-186,174. PUB. 3-20-2012. FILED 11-29-2010.

4,152,581. **THE SCHWARTZ CENTER FOR COMPASSIO-**

- NATE HEALTHCARE AND DESIGN, COHEN, ELLEN, MULTIPLE CLASS, (INT. CLS. 36 AND 41), (U.S. CLS. 100, 101, 102 AND 107). SN 85-186,209. PUB. 3-20-2012. FILED 11-29-2010.
- 4,152,583. **SOLUTIONS AT HOME (STANDARD CHARACTER)**, JEWISH HOME LIFECARE, MULTIPLE CLASS, (INT. CLS. 36, 37, 43, 44 AND 45), (U.S. CLS. 100, 101, 102, 103 AND 106). SN 85-190,054. PUB. 3-20-2012. FILED 12-3-2010.
- 4,152,587 (*See Class 9 for this trademark*).
- 4,152,599. **MAKING A DIFFERENCE SPECTRUM ASSOCIATION MANAGEMENT, LP AND DESIGN**, HILL, ANDREW W, AND NELSON, CHADE V, (U.S. CLS. 100, 101 AND 102). SN 85-210,420. PUB. 3-20-2012. FILED 1-4-2011.
- 4,152,611. **TOLLESON WEALTH MANAGEMENT (STANDARD CHARACTER)**, TOLLESON WEALTH MANAGEMENT, INC., (U.S. CLS. 100, 101 AND 102). SN 85-221,339. PUB. 3-20-2012. FILED 1-19-2011.
- 4,152,612. **TOLLESON PRIVATE BANK (STANDARD CHARACTER)**, TOLLESON WEALTH MANAGEMENT, INC., (U.S. CLS. 100, 101 AND 102). SN 85-221,345. PUB. 3-20-2012. FILED 1-19-2011.
- 4,152,627. **HOT PROPERTY (STANDARD CHARACTER)**, WALTERS, CHAZ, (U.S. CLS. 100, 101 AND 102). SN 85-231,383. PUB. 3-20-2012. FILED 2-1-2011.
- 4,152,632. **IKON GLOBAL MARKETS, INC. (STANDARD CHARACTER)**, IKON GLOBAL MARKETS, INC., DBA IKON GLOBAL MARKETS, INC., (U.S. CLS. 100, 101 AND 102). SN 85-235,526. PUB. 3-20-2012. FILED 2-7-2011.
- 4,152,658 (*See Class 1 for this trademark*).
- 4,152,675. **SUZI Q BAIL BONDS (STANDARD CHARACTER)**, SUZI Q BAIL BONDS INC., (U.S. CLS. 100, 101 AND 102). SN 85-267,863. PUB. 3-20-2012. FILED 3-15-2011.
- 4,152,691. **SELFRELIANCE UKRAINIAN AMERICAN FEDERAL CREDIT UNION AND DESIGN**, SELFRELIANCE UKRAINIAN AMERICAN FEDERAL CREDIT UNION, (U.S. CLS. 100, 101 AND 102). SN 85-276,104. PUB. 3-20-2012. FILED 3-24-2011.
- 4,152,729. **F.A.M.I.L.Y. ~ FORGET ABOUT ME I LOVE YOU (STANDARD CHARACTER)**, MICHAEL J MANHARDT, DBA FAMILY WRISTBANDS, (U.S. CLS. 100, 101 AND 102). SN 85-289,228. PUB. 3-20-2012. FILED 4-7-2011.
- 4,152,756 (*See Class 35 for this trademark*).
- 4,152,776 (*See Class 5 for this trademark*).
- 4,152,782. **FIGHTER FOUNDATION (STANDARD CHARACTER)**, FIGHTER FOUNDATION, DBA FIGHTER FOUNDATION, (U.S. CLS. 100, 101 AND 102). SN 85-297,255. PUB. 3-20-2012. FILED 4-17-2011.
- 4,152,798 (*See Class 35 for this trademark*).
- 4,152,815. **TEXAS HOME-LAND REALTY "LET US HELP PUT YOUR BRAND ON TEXAS LAND" (STANDARD CHARACTER)**, TEXAS HOME-LAND REALTY, (U.S. CLS. 100, 101 AND 102). SN 85-300,555. PUB. 3-20-2012. FILED 4-20-2011.
- 4,152,821. **LUNDSTROM (STANDARD CHARACTER)**, LUNDSTROM INSURANCE AGENCY, INC., (U.S. CLS. 100, 101 AND 102). SN 85-301,615. PUB. 3-20-2012. FILED 4-21-2011.
- 4,152,822 (*See Class 35 for this trademark*).
- 4,152,823 (*See Class 35 for this trademark*).
- 4,152,830. **BANKITIS (STANDARD CHARACTER)**, PUBLIC SERVICE CREDIT UNION, (U.S. CLS. 100, 101 AND 102). SN 85-303,896. PUB. 3-20-2012. FILED 4-25-2011.
- 4,152,838 (*See Class 35 for this trademark*).
- 4,152,842 (*See Class 35 for this trademark*).
- 4,152,859. **HIGHLAND PRIVATE WEALTH MANAGEMENT (STANDARD CHARACTER)**, HIGHLAND PRIVATE WEALTH MANAGEMENT, LLC, (U.S. CLS. 100, 101 AND 102). SN 85-308,836. PUB. 3-20-2012. FILED 4-29-2011.
- 4,152,872. **CAMBIA (STANDARD CHARACTER)**, CAMBIA HEALTH SOLUTIONS, INC., MULTIPLE CLASS, (INT. CLS. 36, 44 AND 45), (U.S. CLS. 100, 101 AND 102). SN 85-311,734. PUB. 3-20-2012. FILED 5-4-2011.
- 4,152,874. **CAMBIA HEALTH SOLUTIONS (STANDARD CHARACTER)**, CAMBIA HEALTH SOLUTIONS, INC., MULTIPLE CLASS, (INT. CLS. 36, 44 AND 45), (U.S. CLS. 100, 101 AND 102). SN 85-312,030. PUB. 3-20-2012. FILED 5-4-2011.
- 4,152,875. **TRUSTNODE (STANDARD CHARACTER)**, TRUSTNODE, INC., MULTIPLE CLASS, (INT. CLS. 36, 41 AND 42), (U.S. CLS. 100, 101, 102 AND 107). SN 85-312,519. PUB. 3-20-2012. FILED 5-4-2011.
- 4,152,876. **CAFÉ PREPAY (STANDARD CHARACTER)**, HEARTLAND PAYMENT SYSTEMS, INC., (U.S. CLS. 100, 101 AND 102). SN 85-312,641. PUB. 3-20-2012. FILED 5-4-2011.
- 4,152,911. **ENDURING WEALTH ADVISORS AND DESIGN**, ENDURING WEALTH ADVISORS, FORMERLY JENICLYN, INC., (U.S. CLS. 100, 101 AND 102). SN 85-321,169. PUB. 10-25-2011. FILED 5-14-2011.
- 4,152,913 (*See Class 35 for this trademark*).
- 4,152,925. **INSURANCE WITHOUT BORDERS (STANDARD CHARACTER)**, GLOBAL BENEFITS GROUP, INC., (U.S. CLS. 100, 101 AND 102). SN 85-325,157. PUB. 12-13-2011. FILED 5-19-2011.
- 4,152,931 (*See Class 16 for this trademark*).
- 4,152,947. **PROSPECT MORTGAGE AND DESIGN**, PROSPECT MORTGAGE, LLC, (U.S. CLS. 100, 101 AND 102). SN 85-331,547. PUB. 3-20-2012. FILED 5-26-2011.
- 4,152,967. **RIVER GREEN BLENDED ASSET FUND (STANDARD CHARACTER)**, RIVER GREEN GROUP, (U.S. CLS. 100, 101 AND 102). SN 85-337,336. PUB. 3-20-2012. FILED 6-3-2011.
- 4,152,974. **RIVER GREEN INVESTMENT MANAGEMENT (STANDARD CHARACTER)**, RIVER GREEN INVESTMENT MANAGEMENT, (U.S. CLS. 100, 101 AND 102). SN 85-338,657. PUB. 3-20-2012. FILED 6-6-2011.
- 4,152,975. **HARTFORD'S PERSONAL RETIREMENT MANAGER (STANDARD CHARACTER)**, HARTFORD FIRE INSURANCE COMPANY, (U.S. CLS. 100, 101 AND 102). SN 85-338,901. PUB. 3-20-2012. FILED 6-6-2011.
- 4,152,979. **RIVER GREEN AND DESIGN**, RIVER GREEN INVESTMENT MANAGEMENT, (U.S. CLS. 100, 101 AND 102). SN 85-339,635. PUB. 3-20-2012. FILED 6-7-2011.
- 4,153,048. **THE METLIFE GOOD FOR YOU RATE (STANDARD CHARACTER)**, METROPOLITAN LIFE INSURANCE COMPANY, (U.S. CLS. 100, 101 AND 102). SN 85-363,210. PUB. 10-18-2011. FILED 7-5-2011.
- 4,153,050. **FIVEBROTHERS AND DESIGN**, FIVE BROTHERS MORTGAGE COMPANY SERVICES AND SECURING, INC., MULTIPLE CLASS, (INT. CLS. 36, 37 AND 42), (U.S. CLS. 100, 101, 102, 103 AND 106). SN 85-363,911. PUB. 3-20-2012. FILED 7-6-2011.
- 4,153,051 (*See Class 35 for this trademark*).
- 4,153,054. **HEALTHY WORKPLACE AND DESIGN**, BLUE CROSS & BLUE SHIELD OF MISSISSIPPI, A MUTUAL INSURANCE COMPANY, (U.S. CLS. 100, 101 AND 102). SN 85-367,283. PUB. 3-20-2012. FILED 7-9-2011.
- 4,153,068 (*See Class 35 for this trademark*).
- 4,153,078. **BVL THE BOWLERS TO VETERANS LINK AND DESIGN**, BOWLERS TO VETERANS LINK, INC., (U.S. CLS. 100, 101 AND 102). SN 85-375,819. PUB. 3-20-2012. FILED 7-20-2011.
- 4,153,079. **BVL (STANDARD CHARACTER)**, BOWLERS TO VETERANS LINK, INC., (U.S. CLS. 100, 101 AND 102). SN 85-375,830. PUB. 3-20-2012. FILED 7-20-2011.
- 4,153,087 (*See Class 35 for this trademark*).
- 4,153,088. **HOMESTRONG USA (STANDARD CHARACTER)**, JBCM, LLC, MULTIPLE CLASS, (INT. CLS. 36, 37 AND 41), (U.S. CLS. 100, 101, 102, 103, 106 AND 107). SN 85-378,077. PUB. 3-20-2012. FILED 7-22-2011.
- 4,153,090. **HOMESTRONG USA AND DESIGN**, JBCM, LLC, MULTIPLE CLASS, (INT. CLS. 36, 37 AND 41), (U.S. CLS. 100, 101, 102, 103, 106 AND 107). SN 85-378,120. PUB. 3-20-2012. FILED 7-22-2011.
- 4,153,108 (*See Class 35 for this trademark*).
- 4,153,122 (*See Class 35 for this trademark*).
- 4,153,124. **MISCELLANEOUS DESIGN**, SPRINT COMMUNICATIONS COMPANY L.P., (U.S. CLS. 100, 101 AND 102). SN 85-389,522. PUB. 3-20-2012. FILED 8-4-2011.
- 4,153,125. **CENTRASIGHT (STANDARD CHARACTER)**, VISIONCARE OPHTHALMIC TECHNOLOGIES, INC., MULTIPLE CLASS, (INT. CLS. 36 AND 44), (U.S. CLS. 100, 101 AND 102). SN 85-389,611. PUB. 3-20-2012. FILED 8-4-2011.
- 4,153,147. **A AND DESIGN**, BOSTON PROPERTIES LIMITED PARTNERSHIP, (U.S. CLS. 100, 101 AND 102). SN 85-394,399. PUB. 3-20-2012. FILED 8-10-2011.

- 4,153,148. **ATLANTIC WHARF (STANDARD CHARACTER)**. BOSTON PROPERTIES LIMITED PARTNERSHIP, (U.S. CLS. 100, 101 AND 102). SN 85-394,409. PUB. 3-20-2012. FILED 8-10-2011.
- 4,153,162. **ZAFFERANO CAPITAL (STANDARD CHARACTER)**. ZAFFERANO CAPITAL LIMITED, (U.S. CLS. 100, 101 AND 102). SN 85-397,443. PUB. 3-20-2012. FILED 8-14-2011.
- 4,153,164. **JOHN DEERE (STANDARD CHARACTER)**. DEERE & COMPANY, (U.S. CLS. 100, 101 AND 102). SN 85-397,771. PUB. 3-20-2012. FILED 8-15-2011.
- 4,153,178 (*See Class 35 for this trademark*).
- 4,153,179. **HORIZON ASSET MANAGEMENT (STANDARD CHARACTER)**. HORIZON ASSET MANAGEMENT LLC, (U.S. CLS. 100, 101 AND 102). SN 85-402,019. PUB. 3-20-2012. FILED 8-19-2011.
- 4,153,196. **PATCHES BADGES FOR KIDS197 AND DESIGN**. PATCHES AND BADGES FOR KIDS, NFP, (U.S. CLS. 100, 101 AND 102). SN 85-405,817. PUB. 3-20-2012. FILED 8-24-2011.
- 4,153,204. **CONTRACTORS HEALTH TRUST AND DESIGN**. CONTRACTORS HEALTH TRUST, (U.S. CLS. 100, 101 AND 102). SN 85-408,160. PUB. 3-20-2012. FILED 8-26-2011.
- 4,153,205 (*See Class 35 for this trademark*).
- 4,153,206 (*See Class 35 for this trademark*).
- 4,153,217 (*See Class 35 for this trademark*).
- 4,153,260. **TOUCHING LIVES, IMPROVING RESULTS (STANDARD CHARACTER)**. FINCOR HOLDINGS, INC., MULTIPLE CLASS, (INT. CLS. 36 AND 41), (U.S. CLS. 100, 101, 102 AND 107). SN 85-417,048. PUB. 3-20-2012. FILED 9-7-2011.
- 4,153,272. **AMERICAN HIGH-INCOME TRUST (STANDARD CHARACTER)**. AMERICAN HIGH-INCOME MUNICIPAL BOND FUND, (U.S. CLS. 100, 101 AND 102). SN 85-419,180. PUB. 3-20-2012. FILED 9-9-2011.
- 4,153,287 (*See Class 35 for this trademark*).
- 4,153,308. **JHL AND DESIGN**. JHL CAPITAL GROUP LLC, (U.S. CLS. 100, 101 AND 102). SN 85-422,623. PUB. 3-20-2012. FILED 9-14-2011.
- 4,153,309. **MISCELLANEOUS DESIGN**. TRI-STATE CONSUMER INSURANCE COMPANY, DBA TSC DIRECT, (U.S. CLS. 100, 101 AND 102). SN 85-422,709. PUB. 3-20-2012. FILED 9-14-2011.
- 4,153,315. **PRAIRIE VIEW A&M FOUNDATION PVAMF SUPPORTING THE LEGACY FOUNDED IN 1876 AND DESIGN**. PRAIRIE VIEW A&M FOUNDATION, (U.S. CLS. 100, 101 AND 102). SN 85-423,160. PUB. 3-20-2012. FILED 9-15-2011.
- 4,153,316 (*See Class 35 for this trademark*).
- 4,153,335. **G GUIGNARD COMPANY SURETY BONDS AN UNCOMMON BOND AND DESIGN**. GUIGNARD COMPANY, (U.S. CLS. 100, 101 AND 102). SN 85-424,629. PUB. 3-20-2012. FILED 9-16-2011.
- 4,153,366. **TACTICAL VOLATILITY ROTATION (STANDARD CHARACTER)**. TRUCOLOR CAPITAL MANAGEMENT, LLC, (U.S. CLS. 100, 101 AND 102). SN 85-428,308. PUB. 3-20-2012. FILED 9-21-2011.
- 4,153,405. **THE BAIL DEPOT BAIL BONDS (STANDARD CHARACTER)**. THE MCMANUS GROUP, INC., (U.S. CLS. 100, 101 AND 102). SN 85-431,288. PUB. 3-20-2012. FILED 9-24-2011.
- 4,153,461. **MISCELLANEOUS DESIGN**. DAUGHTERS OF PENELOPE FOUNDATION INCORPORATION, (U.S. CLS. 100, 101 AND 102). SN 85-435,363. PUB. 3-20-2012. FILED 9-29-2011.
- 4,153,475. **FWC CHARITIES, INC. FORT WORTH CREW CHARITIES, INC. AND DESIGN**. FORT WORTH CREW CHARITIES, INC., (U.S. CLS. 100, 101 AND 102). SN 85-436,043. PUB. 3-20-2012. FILED 9-30-2011.
- 4,153,479 (*See Class 35 for this trademark*).
- 4,153,539. **SCRIPPS HEALTH (STANDARD CHARACTER)**. SCRIPPSHEALTH, (U.S. CLS. 100, 101 AND 102). SN 85-438,038. PUB. 3-20-2012. FILED 10-3-2011.
- 4,153,604. **THE PINK GAVEL LUNCHEON AND DESIGN**. SOCIAL ESQUIRE, (U.S. CLS. 100, 101 AND 102). SN 85-439,662. PUB. 3-20-2012. FILED 10-5-2011.
- 4,153,615. **MISCELLANEOUS DESIGN**. SKYWARD PARTNERS, LLC, (U.S. CLS. 100, 101 AND 102). SN 85-439,912. PUB. 3-20-2012. FILED 10-5-2011.
- 4,153,618. **MIDWEST EQUITY MORTGAGE (STANDARD CHARACTER)**. MIDWEST EQUITY MORTGAGE, LLC, DBA MIDWEST EQUITY MORTGAGE, (U.S. CLS. 100, 101 AND 102). SN 85-440,027. PUB. 3-20-2012. FILED 10-5-2011.
- 4,153,620. **VERACITY COMMUNITY FOUNDATION (STANDARD CHARACTER)**. VERACITY PAYMENT SOLUTIONS, (U.S. CLS. 100, 101 AND 102). SN 85-440,085. PUB. 3-20-2012. FILED 10-5-2011.
- 4,153,622. **SYMPHONY PAYMENT SUITE (STANDARD CHARACTER)**. VERACITY PAYMENT SOLUTIONS, (U.S. CLS. 100, 101 AND 102). SN 85-440,136. PUB. 3-20-2012. FILED 10-5-2011.
- 4,153,632. **TOTAL IRA AND DESIGN**. INSPIRAFS, INC., DBA TOTAL IRA, (U.S. CLS. 100, 101 AND 102). SN 85-440,463. PUB. 3-20-2012. FILED 10-6-2011.
- 4,153,635. **BUYSECURITYGUARDINSURANCE.COM AND DESIGN**. VENTURE PACIFIC INSURANCE SERVICES, INC., (U.S. CLS. 100, 101 AND 102). SN 85-440,494. PUB. 3-20-2012. FILED 10-6-2011.
- 4,153,646 (*See Class 35 for this trademark*).
- 4,153,656. **STONESTREET CAPITAL (STANDARD CHARACTER)**. STONE STREET CAPITAL, LLC, (U.S. CLS. 100, 101 AND 102). SN 85-440,838. PUB. 3-20-2012. FILED 10-6-2011.
- 4,153,658. **BLUFI (STANDARD CHARACTER)**. BLUFI LENDING CORPORATION, (U.S. CLS. 100, 101 AND 102). SN 85-440,848. PUB. 3-20-2012. FILED 10-6-2011.
- 4,153,724. **MGC MORTGAGE (STANDARD CHARACTER)**. MGC MORTGAGE, INC., (U.S. CLS. 100, 101 AND 102). SN 85-441,755. PUB. 3-20-2012. FILED 10-7-2011.
- 4,153,741. **NTPP AND DESIGN**. NARANJA PAWN, INC., (U.S. CLS. 100, 101 AND 102). SN 85-441,958. PUB. 3-20-2012. FILED 10-7-2011.
- 4,153,746 (*See Class 35 for this trademark*).
- 4,153,748 (*See Class 35 for this trademark*).
- 4,153,758 (*See Class 35 for this trademark*).
- 4,153,778. **SHORT OR STAY CALCULATOR AND DESIGN**. FONDER CONSULTING, LLC, DBA DIRECT BUSINESS MARKETING, (U.S. CLS. 100, 101 AND 102). SN 85-442,289. PUB. 3-20-2012. FILED 10-7-2011.
- 4,153,784. **CLARION PARTNERS (STANDARD CHARACTER)**. CLARION PARTNERS, LLC, (U.S. CLS. 100, 101 AND 102). SN 85-442,346. PUB. 3-20-2012. FILED 10-7-2011.
- 4,153,796. **PALOS VERDES HOMES AND DESIGN**. COHEN, DANIEL, (U.S. CLS. 100, 101 AND 102). SN 85-442,535. PUB. 3-20-2012. FILED 10-7-2011.
- 4,153,831. **VINHEART (STANDARD CHARACTER)**. LA GROU, JOHN, DBA VINHEART, (U.S. CLS. 100, 101 AND 102). SN 85-442,830. PUB. 3-20-2012. FILED 10-8-2011.
- 4,153,855. **ECAREPAK (STANDARD CHARACTER)**. CANON U.S.A., INC., (U.S. CLS. 100, 101 AND 102). SN 85-443,128. PUB. 3-20-2012. FILED 10-10-2011.
- 4,153,945 (*See Class 35 for this trademark*).
- 4,153,946. **COMEY & SHEPHERD (STANDARD CHARACTER)**. COMEY & SHEPHERD HOLDING COMPANY, INC., (U.S. CLS. 100, 101 AND 102). SN 85-444,085. PUB. 3-20-2012. FILED 10-11-2011.
- 4,153,948. **RENT-A-CENTER (STANDARD CHARACTER)**. RENT-A-CENTER WEST, INC., (U.S. CLS. 100, 101 AND 102). SN 85-444,100. PUB. 3-20-2012. FILED 10-11-2011.
- 4,153,977. **AEF (STANDARD CHARACTER)**. ARIZONA EDUCATIONAL FOUNDATION, INC., (U.S. CLS. 100, 101 AND 102). SN 85-444,320. PUB. 3-20-2012. FILED 10-11-2011.
- 4,153,978. **GIVING SOLES AND DESIGN**. SHOBACCA, LTD., (U.S. CLS. 100, 101 AND 102). SN 85-444,326. PUB. 3-20-2012. FILED 10-11-2011.
- 4,153,986. **GIVING SOLES (STANDARD CHARACTER)**. SHOBACCA, LTD., (U.S. CLS. 100, 101 AND 102). SN 85-444,464. PUB. 3-20-2012. FILED 10-11-2011.
- 4,153,998 (*See Class 35 for this trademark*).
- 4,154,006. **WATER CHANGES EVERYTHING (STANDARD CHARACTER)**. CHARITY GLOBAL, INC., (U.S. CLS. 100, 101 AND 102). SN 85-444,635. PUB. 3-20-2012. FILED 10-11-2011.
- 4,154,022 (*See Class 9 for this trademark*).
- 4,154,043. **ENTERATE (STANDARD CHARACTER)**. ENTERATE INSURANCE, LLC, (U.S. CLS. 100, 101 AND 102). SN 85-445,179. PUB. 3-20-2012. FILED 10-12-2011.

- 4,154,093. **FFGA.COM (STANDARD CHARACTER)**. FIRST FINANCIAL ADMINISTRATORS, INC., (U.S. CLS. 100, 101 AND 102). SN 85-446,247. PUB. 3-20-2012. FILED 10-13-2011.
- 4,154,126. **FINANCIAL MOXE EXPERIENCE THE POWER OF PLANNING AND DESIGN**. KRISTEN J. HAFNER, (U.S. CLS. 100, 101 AND 102). SN 85-450,294. PUB. 3-20-2012. FILED 10-18-2011.
- 4,154,141. **TRIO (STANDARD CHARACTER)**. CASCADIA EQUITY LEASING, LLC, (U.S. CLS. 100, 101 AND 102). SN 85-452,569. PUB. 3-20-2012. FILED 10-20-2011.
- 4,154,165. **LIFE POLICY PAYOUT TURN YOUR LIFE INSURANCE POLICY INTO CASH AND DESIGN**. VESPERA LIFE, LLC, (U.S. CLS. 100, 101 AND 102). SN 85-455,726. PUB. 3-20-2012. FILED 10-25-2011.
- 4,154,170. **MY E-BANC (STANDARD CHARACTER)**. BAC FLORIDA BANK, (U.S. CLS. 100, 101 AND 102). SN 85-456,271. PUB. 3-20-2012. FILED 10-26-2011.
- 4,154,191. **WHOLE PLANET FOUNDATION MICROLOAN A MONTH FUND AND DESIGN**. WHOLE FOODS MARKET IP, L.P., (U.S. CLS. 100, 101 AND 102). SN 85-464,942. PUB. 3-20-2012. FILED 11-4-2011.
- 4,154,192. **WHOLE PLANET FOUNDATION TEN THOUSAND DOLLAR FUND AND DESIGN**. WHOLE FOODS MARKET IP, L.P., (U.S. CLS. 100, 101 AND 102). SN 85-464,964. PUB. 3-20-2012. FILED 11-4-2011.
- 4,154,193. **WHOLE PLANET FOUNDATION SUPPLIER ALLIANCE FOR MICROCREDIT AND DESIGN**. WHOLE FOODS MARKET IP, L.P., (U.S. CLS. 100, 101 AND 102). SN 85-464,985. PUB. 3-20-2012. FILED 11-4-2011.
- 4,154,196. **RAC ACCEPTANCE (STANDARD CHARACTER)**. RENT-A-CENTER WEST, INC., (U.S. CLS. 100, 101 AND 102). SN 85-466,418. PUB. 3-20-2012. FILED 11-7-2011.
- 4,154,204 (*See Class 35 for this trademark*).
- 4,154,222. **THE WORLD PEACE BANKING KIOSK (STANDARD CHARACTER)**. HERRERA, ORLANDO A., AND GOLDMEER, CONSTANCE, AND THE WORLD PEACE PROGRAM, LLC, (U.S. CLS. 100, 101 AND 102). SN 85-492,260. PUB. 3-20-2012. FILED 12-10-2011.
- 4,154,232. **PARTNEROPTIONS (STANDARD CHARACTER)**. THE CHUBB CORPORATION, (U.S. CLS. 100, 101 AND 102). SN 85-508,493. PUB. 3-20-2012. FILED 1-4-2012.
- 4,154,240 (*See Class 35 for this trademark*).
- 4,152,323 (*See Class 9 for this trademark*).
- 4,152,341 (*See Class 6 for this trademark*).
- 4,152,386. **YACHTONUS (STANDARD CHARACTER)**. AXVECO B.V., (U.S. CLS. 100, 103 AND 106). SN 79-103,129. PUB. 3-20-2012. FILED 9-5-2011.
- 4,152,408 (*See Class 9 for this trademark*).
- 4,152,433 (*See Class 9 for this trademark*).
- 4,152,434 (*See Class 9 for this trademark*).
- 4,152,438 (*See Class 1 for this trademark*).
- 4,152,460 (*See Class 6 for this trademark*).
- 4,152,483. **HOTTANDHANDY (STANDARD CHARACTER)**. DUFFY GALLEGOS LLC, (U.S. CLS. 100, 103 AND 106). SN 85-097,739. PUB. 3-20-2012. FILED 8-2-2010.
- 4,152,525. **FUSION UV (STANDARD CHARACTER)**. FUSION UV SYSTEMS, INC., MULTIPLE CLASS, (INT. CLS. 37 AND 42), (U.S. CLS. 100, 101, 103 AND 106). SN 85-134,050. PUB. 3-20-2012. FILED 9-20-2010.
- 4,152,545 (*See Class 35 for this trademark*).
- 4,152,564 (*See Class 35 for this trademark*).
- 4,152,583 (*See Class 36 for this trademark*).
- 4,152,644 (*See Class 35 for this trademark*).
- 4,152,658 (*See Class 1 for this trademark*).
- 4,152,670 (*See Class 35 for this trademark*).
- 4,152,698 (*See Class 1 for this trademark*).
- 4,152,753. **GREEN CLEAN AND DESIGN**. MAXONS RESTORATIONS, INC., MULTIPLE CLASS, (INT. CLS. 37 AND 42), (U.S. CLS. 100, 101, 103 AND 106). SN 85-294,234. PUB. 3-20-2012. FILED 4-13-2011.
- 4,152,773. **CANYON VILLAGE (STANDARD CHARACTER)**. LAND TEJAS COMPANIES, LTD., (U.S. CLS. 100, 103 AND 106). SN 85-296,568. PUB. 3-20-2012. FILED 4-15-2011.
- 4,152,776 (*See Class 5 for this trademark*).
- 4,152,868. **EDIS (STANDARD CHARACTER)**. EDIS COMPANY, INC., (U.S. CLS. 100, 103 AND 106). SN 85-311,410. PUB. 3-20-2012. FILED 5-3-2011.
- 4,152,869. **EDIS SINCE 1908 AND DESIGN**. EDIS COMPANY, INC., (U.S. CLS. 100, 103 AND 106). SN 85-311,417. PUB. 3-20-2012. FILED 5-3-2011.
- 4,152,943. **DELIVERING 21ST CENTURY TECHNOLOGY (STANDARD CHARACTER)**. DOCTORDOS CONSULTING, LTD., DBA PROFESSIONAL NERDS, MULTIPLE CLASS, (INT. CLS. 37 AND 42), (U.S. CLS. 100, 101, 103 AND 106). SN 85-329,216. PUB. 3-20-2012. FILED 5-24-2011.
- 4,152,972. **CONSOLE DOCTOR (STANDARD CHARACTER)**. GRANT, KYLE D, (U.S. CLS. 100, 103 AND 106). SN 85-338,125. PUB. 3-20-2012. FILED 6-4-2011.
- 4,152,992 (*See Class 35 for this trademark*).
- 4,153,050 (*See Class 36 for this trademark*).
- 4,153,051 (*See Class 35 for this trademark*).
- 4,153,077. **PALMETTO MARINE CONSTRUCTION, INC. AND DESIGN**. PALMETTO MARINE CONSTRUCTION, INC., (U.S. CLS. 100, 103 AND 106). SN 85-375,276. PUB. 3-20-2012. FILED 7-19-2011.
- 4,153,088 (*See Class 36 for this trademark*).
- 4,153,090 (*See Class 36 for this trademark*).
- 4,153,172. **DMI. DESERT MECHANICAL INCORPORATED AND DESIGN**. DESERT MECHANICAL, INC., (U.S. CLS. 100, 103 AND 106). SN 85-400,124. PUB. 3-20-2012. FILED 8-17-2011.
- 4,153,180 (*See Class 35 for this trademark*).
- 4,153,213 (*See Class 35 for this trademark*).
- 4,153,236. **PAINTOHOLICS LLC (STANDARD CHARACTER)**. PAINTOHOLICS LLC, (U.S. CLS. 100, 103 AND 106). SN 85-413,492. PUB. 3-20-2012. FILED 9-1-2011.
- 4,153,346. **IMAGE PROPERTY SERVICES... AND DESIGN**. VANTAUZ INCORPORATED, DBA IMAGE PROPERTY SERVICES, (U.S. CLS. 100, 103 AND 106). SN 85-426,052. PUB. 3-20-2012. FILED 9-19-2011.
- 4,153,411. **TRUX TEX (STANDARD CHARACTER)**. VALLEY TIRE CO., INC., (U.S. CLS. 100, 103 AND 106). SN 85-431,714. PUB. 3-20-2012. FILED 9-26-2011.
- 4,153,464. **FLEET CLEAN AND DESIGN**. GROSS, KEITH, AND MARR, SCOTT, (U.S. CLS. 100, 103 AND 106). SN 85-435,650. PUB. 3-20-2012. FILED 9-29-2011.
- 4,153,534. **SAFE ZONES CREATORS OF SAFER SOLUTIONS AND DESIGN**. DE LA MORA, ROBERT, (U.S. CLS. 100, 103 AND 106). SN 85-437,891. PUB. 3-20-2012. FILED 10-3-2011.
- 4,153,552. **POOP BUSTERS (STANDARD CHARACTER)**.

CLASS 37—CONSTRUCTION AND REPAIR

- 4,152,040 (*See Class 35 for this trademark*).
- 4,152,077 (*See Class 35 for this trademark*).
- 4,152,088 (*See Class 36 for this trademark*).
- 4,152,092. **S.T.A.R PROGRAMME AND DESIGN**. SAMSUNG ELECTRONICS CO., LTD., MULTIPLE CLASS, (INT. CLS. 37 AND 40), (U.S. CLS. 100, 103 AND 106). SN 77-529,819. PUB. 3-20-2012. FILED 7-23-2008.
- 4,152,111 (*See Class 16 for this trademark*).
- 4,152,112 (*See Class 16 for this trademark*).
- 4,152,125 (*See Class 7 for this trademark*).
- 4,152,194 (*See Class 6 for this trademark*).
- 4,152,228 (*See Class 7 for this trademark*).
- 4,152,246. **PRINTERA (STYLIZED)**. UAB SERVEA, (U.S. CLS. 100, 103 AND 106). SN 79-096,751. PUB. 3-20-2012. FILED 4-7-2011.
- 4,152,255 (*See Class 2 for this trademark*).
- 4,152,263 (*See Class 12 for this trademark*).
- 4,152,275 (*See Class 12 for this trademark*).
- 4,152,279 (*See Class 9 for this trademark*).
- 4,152,290 (*See Class 9 for this trademark*).
- 4,152,301 (*See Class 9 for this trademark*).
- 4,152,318 (*See Class 9 for this trademark*).
- 4,152,320. **INTERWELL AND DESIGN**. INTERWELL NORWAY AS, MULTIPLE CLASS, (INT. CLS. 37 AND 42), (U.S. CLS. 100, 101, 103 AND 106). SN 79-099,512. PUB. 3-20-2012. FILED 4-19-2011.
- 4,152,321. **INTERWELL (STANDARD CHARACTER)**. INTERWELL NORWAY AS, MULTIPLE CLASS, (INT. CLS. 37 AND 42), (U.S. CLS. 100, 101, 103 AND 106). SN 79-099,513. PUB. 3-20-2012. FILED 4-19-2011.

FRAZIER, DEBORAH, (U.S. CLS. 100, 103 AND 106). SN 85-438,409. PUB. 3-20-2012. FILED 10-4-2011.

4,153,576. **FIRE STOP AMERICA AND DESIGN**. BURMAN ENTERPRISES, INC., DBA FIRE STOP AMERICA, (U.S. CLS. 100, 103 AND 106). SN 85-438,979. PUB. 3-20-2012. FILED 10-4-2011.

4,153,579. **THE YES MAN CAN. (STANDARD CHARACTER)**. AMERICAN RESIDENTIAL SERVICES LLC, (U.S. CLS. 100, 103 AND 106). SN 85-439,146. PUB. 3-20-2012. FILED 10-4-2011.

4,153,636. **BATES TROY QUALITY DRY CLEANING (STANDARD CHARACTER)**. BATES TROY, INC., (U.S. CLS. 100, 103 AND 106). SN 85-440,495. PUB. 3-20-2012. FILED 10-6-2011.

4,153,647. **WORTHY OF THE INVESTMENT (STANDARD CHARACTER)**. CHRISTOPHER CLEMENTE, (U.S. CLS. 100, 103 AND 106). SN 85-440,737. PUB. 3-20-2012. FILED 10-6-2011.

4,153,661. **BATES TROY AND DESIGN**. BATES TROY, INC., (U.S. CLS. 100, 103 AND 106). SN 85-440,894. PUB. 3-20-2012. FILED 10-6-2011.

4,153,710. **HEAT-N-AIR GUYS AND DESIGN**. HEAT-N-AIR GUYS, (U.S. CLS. 100, 103 AND 106). SN 85-441,628. PUB. 3-20-2012. FILED 10-7-2011.

4,153,745. **I CARE MANAGED SERVICES AND DESIGN**. THE I.T. WORKSHOP, L.L.C., (U.S. CLS. 100, 103 AND 106). SN 85-442,005. PUB. 3-20-2012. FILED 10-7-2011.

4,153,776. **BATS, BIRDS, & MORE (STANDARD CHARACTER)**. ARNOLD, ERIC M, DBA BATS, BIRDS, & MORE, (U.S. CLS. 100, 103 AND 106). SN 85-442,273. PUB. 3-20-2012. FILED 10-7-2011.

4,153,785. **SAYING WE'LL TAKE CARE OF YOU ISN'T ENOUGH. DOING IT IS WHAT COUNTS. CRAIN CONSTRUCTION AND DESIGN**. CRAIN CONSTRUCTION, INC., (U.S. CLS. 100, 103 AND 106). SN 85-442,349. PUB. 3-20-2012. FILED 10-7-2011.

4,153,808. **DOME CLEANING (STANDARD CHARACTER)**. DOME CLEANING, INC., (U.S. CLS. 100, 103 AND 106). SN 85-442,659. PUB. 3-20-2012. FILED 10-7-2011.

4,153,813. **GOLDEN CLASS G CLASS AND DESIGN**. GOLDEN CLASS AUTO ENTERPRISES INC., (U.S. CLS. 100, 103 AND 106). SN 85-442,704. PUB. 3-20-2012. FILED 10-7-2011.

4,153,862. **BALLADE SPORTS (STANDARD CHARACTER)**. DOAN, ALEX, (U.S. CLS. 100, 103 AND 106). SN 85-443,185. PUB. 3-20-2012. FILED 10-10-2011.

4,153,881. **MISCELLANEOUS DESIGN**. ADVANCED ENERGY EFFICIENCY AND ENVIRONMENTAL QUALITY, MULTIPLE CLASS, (INT. CLS. 37 AND 41), (U.S. CLS. 100, 101, 103, 106 AND 107). SN 85-443,400. PUB. 3-20-2012. FILED 10-10-2011.

4,153,949. **NATIONWIDE LIFTS (STANDARD CHARACTER)**. S & H ENTERPRISES, INC., DBA NATIONWIDE LIFTS, (U.S. CLS. 100, 103 AND 106). SN 85-444,111. PUB. 3-20-2012. FILED 10-11-2011.

4,153,998 (*See Class 35 for this trademark*).

4,154,010. **IT DRAINS OR IT'S FREE (STANDARD CHARACTER)**. RESCUE RESPONSE GROUP INC, DBA MR. DRAIN INC, (U.S. CLS. 100, 103 AND 106). SN 85-444,679. PUB. 3-20-2012. FILED 10-11-2011.

4,154,050. **OMG KLEEN (STANDARD CHARACTER)**. OMG KLEEN, LLC, (U.S. CLS. 100, 103 AND 106). SN 85-445,562. PUB. 3-20-2012. FILED 10-12-2011.

4,154,057. **SANDRIDGE AND DESIGN**. SANDRIDGE ENERGY, INC., (U.S. CLS. 100, 103 AND 106). SN 85-445,693. PUB. 3-20-2012. FILED 10-12-2011.

4,154,113. **KOMATSU CARE (STANDARD CHARACTER)**. KOMATSU AMERICA CORP., (U.S. CLS. 100, 103 AND 106). SN 85-448,577. PUB. 3-20-2012. FILED 10-17-2011.

4,154,114. **KOMATSU CARE AND DESIGN**. KOMATSU AMERICA CORP., (U.S. CLS. 100, 103 AND 106). SN 85-448,590. PUB. 3-20-2012. FILED 10-17-2011.

4,154,132. **UGLY POOL GUY (STANDARD CHARACTER)**. UGLY POOLS USA, INC., (U.S. CLS. 100, 103 AND 106). SN 85-451,608. PUB. 3-20-2012. FILED 10-19-2011.

CLASS 38—COMMUNICATION

4,152,139. **INFOJOBS (STANDARD CHARACTER)**. INFOJOBS, S.A., (U.S. CLS. 100, 101 AND 104). SN 77-916,077. PUB. 3-20-2012. FILED 1-20-2010.

4,152,158. **VORTEX (STANDARD CHARACTER)**. YTV CANADA, INC., MULTIPLE CLASS, (INT. CLS. 38 AND 41), (U.S. CLS. 100, 101, 104 AND 107). SN 78-549,933. PUB. 1-24-2012. FILED 1-19-2005.

4,152,167 (*See Class 16 for this trademark*).

4,152,207 (*See Class 9 for this trademark*).

4,152,216 (*See Class 35 for this trademark*).

4,152,237 (*See Class 35 for this trademark*).

4,152,253 (*See Class 35 for this trademark*).

4,152,254 (*See Class 35 for this trademark*).

4,152,266 (*See Class 9 for this trademark*).

4,152,286 (*See Class 9 for this trademark*).

4,152,302 (*See Class 9 for this trademark*).

4,152,306 (*See Class 9 for this trademark*).

4,152,316 (*See Class 9 for this trademark*).

4,152,349. **GESAT (STANDARD CHARACTER)**. GESAT GELLSCHAFT FÜR SOFTWARE, AUTOMATISIERUNG + TECHNIK MBH, (U.S. CLS. 100, 101 AND 104). SN 79-100,555. PUB. 3-20-2012. FILED 6-15-2011.

4,152,350 (*See Class 9 for this trademark*).

4,152,351 (*See Class 9 for this trademark*).

4,152,385. **SES YOUR SATELLITE COMPANY AND DESIGN**. SES S.A., (U.S. CLS. 100, 101 AND 104). SN 79-103,068. PUB. 3-20-2012. FILED 7-14-2011.

4,152,396. **ADVENTEER (STANDARD CHARACTER)**. ALLAN TORP JENSEN, MULTIPLE CLASS, (INT. CLS. 38, 39 AND 43), (U.S. CLS. 100, 101, 104 AND 105). SN 79-103,822. PUB. 3-20-2012. FILED 4-19-2011.

4,152,411 (*See Class 35 for this trademark*).

4,152,426 (*See Class 9 for this trademark*).

4,152,508. **GLOBAL ANIMAL (STANDARD CHARACTER)**. JEON, ARTHUR, (U.S. CLS. 100, 101 AND 104). SN 85-122,301. PUB. 3-20-2012. FILED 9-2-2010.

4,152,587 (*See Class 9 for this trademark*).

4,152,596 (*See Class 9 for this trademark*).

4,152,602 (*See Class 35 for this trademark*).

4,152,658 (*See Class 1 for this trademark*).

4,152,664 (*See Class 35 for this trademark*).

4,152,802 (*See Class 9 for this trademark*).

4,152,805. **TOTALLY PUMPED (STANDARD CHARACTER)**. YOUNG, RICHARD, DBA TOTALLY PUMPED, MULTIPLE CLASS, (INT. CLS. 38 AND 41), (U.S. CLS. 100, 101, 104 AND 107). SN 85-299,448. PUB. 3-20-2012. FILED 4-20-2011.

4,152,840. **MY.ABILITI (STANDARD CHARACTER)**. INTRAPACE, INC., MULTIPLE CLASS, (INT. CLS. 38, 42 AND 45), (U.S. CLS. 100, 101 AND 104). SN 85-306,062. PUB. 3-20-2012. FILED 4-27-2011.

4,152,849. **PARK2GETHER (STANDARD CHARACTER)**. DAIMLER AG, MULTIPLE CLASS, (INT. CLS. 38 AND 39), (U.S. CLS. 100, 101, 104 AND 105). SN 85-307,155. PUB. 3-20-2012. FILED 4-28-2011.

4,152,893. **WEBLESSON (STANDARD CHARACTER)**. GOLFTEC INTELLECTUAL PROPERTY LLC, MULTIPLE CLASS, (INT. CLS. 38 AND 41), (U.S. CLS. 100, 101, 104 AND 107). SN 85-316,193. PUB. 3-20-2012. FILED 5-9-2011.

4,153,064 (*See Class 35 for this trademark*).

4,153,197 (*See Class 35 for this trademark*).

4,153,267. **POPCORN (STANDARD CHARACTER)**. POPCORN, LLC, MULTIPLE CLASS, (INT. CLS. 38 AND 42), (U.S. CLS. 100, 101 AND 104). SN 85-417,795. PUB. 3-20-2012. FILED 9-8-2011.

4,153,351. **CVN CYCLEVISION NETWORK AND DESIGN**. CYCLEVISION NETWORK, INC, (U.S. CLS. 100, 101 AND 104). SN 85-426,763. PUB. 3-20-2012. FILED 9-20-2011.

4,153,358. **RAISE YOUR VOICE (STANDARD CHARACTER)**. RAISE YOUR VOICE, INC., MULTIPLE CLASS, (INT. CLS. 38 AND 42), (U.S. CLS. 100, 101 AND 104). SN 85-427,561. PUB. 3-20-2012. FILED 9-20-2011.

4,153,442. **VOOH AND DESIGN**. GREAT OUTDOOR NETWORK, INC., (U.S. CLS. 100, 101 AND 104). SN 85-434,343. PUB. 3-20-2012. FILED 9-28-2011.

4,153,518. **FLUIDCAST AND DESIGN**. VOD MEDIA TECH, INC., (U.S. CLS. 100, 101 AND 104). SN 85-437,567. PUB. 3-20-2012. FILED 10-3-2011.

- 4,153,610 (*See Class 35 for this trademark*).
- 4,153,821. **CLEVVVER (STANDARD CHARACTER)**. CLEVVVER MEDIA, LLC, MULTIPLE CLASS, (INT. CLS. 38 AND 41), (U.S. CLS. 100, 101, 104 AND 107). SN 85-442,785. PUB. 3-20-2012. FILED 10-8-2011.
- 4,153,822. **CLEVVVERTV (STANDARD CHARACTER)**. CLEVVVER MEDIA, LLC, MULTIPLE CLASS, (INT. CLS. 38 AND 41), (U.S. CLS. 100, 101, 104 AND 107). SN 85-442,790. PUB. 3-20-2012. FILED 10-8-2011.
- 4,153,867. **HAYER ANALYTICS (STANDARD CHARACTER)**. HAYER ANALYTICS, INC., (U.S. CLS. 100, 101 AND 104). SN 85-443,240. PUB. 3-20-2012. FILED 10-10-2011.
- 4,153,873. **MURGENCY (STANDARD CHARACTER)**. ALPHATREK, INC., (U.S. CLS. 100, 101 AND 104). SN 85-443,347. PUB. 3-20-2012. FILED 10-10-2011.
- 4,153,952. **FWOOSH (STANDARD CHARACTER)**. PAUL G. WOLF, (U.S. CLS. 100, 101 AND 104). SN 85-444,127. PUB. 3-20-2012. FILED 10-11-2011.
- 4,153,956. **PRECISION + SPEED + ACCESS = CONFIDENCE (STANDARD CHARACTER)**. HAYER ANALYTICS, INC., (U.S. CLS. 100, 101 AND 104). SN 85-444,158. PUB. 3-20-2012. FILED 10-11-2011.
- 4,154,027. **SPIDDIT (STANDARD CHARACTER)**. RAHMAN, IBRAHIM L, MULTIPLE CLASS, (INT. CLS. 38 AND 41), (U.S. CLS. 100, 101, 104 AND 107). SN 85-444,853. PUB. 3-20-2012. FILED 10-11-2011.
- 4,154,039. **STRATEGIC EXPRESSIONS (STYLIZED)**. STRATEGIC EXPRESSIONS, LLC, (U.S. CLS. 100, 101 AND 104). SN 85-445,146. PUB. 3-20-2012. FILED 10-12-2011.
- 4,154,070. **VIBE ON IT (STANDARD CHARACTER)**. GKRAADIO, LLC, DBA GOOD KARMA RADIO, (U.S. CLS. 100, 101 AND 104). SN 85-445,876. PUB. 3-20-2012. FILED 10-12-2011.

CLASS 39—TRANSPORTATION AND STORAGE

- 4,152,078 (*See Class 35 for this trademark*).
- 4,152,084. **FLY KINGFISHER (STANDARD CHARACTER)**. KINGFISHER AIRLINES LIMITED, (U.S. CLS. 100 AND 105). SN 77-385,713. PUB. 3-20-2012. FILED 1-31-2008.
- 4,152,088 (*See Class 36 for this trademark*).
- 4,152,111 (*See Class 16 for this trademark*).
- 4,152,112 (*See Class 16 for this trademark*).
- 4,152,125 (*See Class 7 for this trademark*).
- 4,152,241 (*See Class 9 for this trademark*).
- 4,152,257 (*See Class 9 for this trademark*).
- 4,152,277 (*See Class 16 for this trademark*).
- 4,152,318 (*See Class 9 for this trademark*).
- 4,152,372. **LAND OF BEOWULF (STANDARD CHARACTER)**. PETER JARTOFT, (U.S. CLS. 100 AND 105). SN 79-102,367. PUB. 3-20-2012. FILED 8-4-2011.
- 4,152,396 (*See Class 38 for this trademark*).
- 4,152,411 (*See Class 35 for this trademark*).
- 4,152,458. **ROADRUNNER FOOD BANK (STANDARD CHARACTER)**. ROADRUNNER FOOD BANK, INC., (U.S. CLS. 100 AND 105). SN 85-048,637. PUB. 12-13-2011. FILED 5-26-2010.
- 4,152,495 (*See Class 35 for this trademark*).
- 4,152,496 (*See Class 35 for this trademark*).
- 4,152,498 (*See Class 35 for this trademark*).
- 4,152,499 (*See Class 35 for this trademark*).
- 4,152,500 (*See Class 35 for this trademark*).
- 4,152,507 (*See Class 3 for this trademark*).
- 4,152,519. **TRAVELER OVERSEAS (STANDARD CHARACTER)**. TRAVELER OVERSEAS MAGAZINE, L.L.C., (U.S. CLS. 100 AND 105). SN 85-130,342. PUB. 3-20-2012. FILED 9-15-2010.
- 4,152,522. **EISHIP AND DESIGN**. RAPID ENTERPRISES, INC., (U.S. CLS. 100 AND 105). SN 85-132,605. PUB. 3-20-2012. FILED 9-17-2010.
- 4,152,548 (*See Class 16 for this trademark*).
- 4,152,559. **ROAD AMERICA A MAPFRE COMPANY AND DESIGN**. BRICKELL FINANCIAL SERVICES-MOTOR CLUB, INC., MULTIPLE CLASS, (INT. CLS. 39 AND 45), (U.S. CLS. 100, 101 AND 105). SN 85-164,048. PUB. 3-20-2012. FILED 10-28-2010.
- 4,152,587 (*See Class 9 for this trademark*).
- 4,152,658 (*See Class 1 for this trademark*).
- 4,152,670 (*See Class 35 for this trademark*).
- 4,152,849 (*See Class 38 for this trademark*).
- 4,152,853. **GREEN SHIELD SERVICES (STANDARD CHARACTER)**. THERMO FLUIDS INC., MULTIPLE CLASS, (INT. CLS. 39 AND 40), (U.S. CLS. 100, 103, 105 AND 106). SN 85-307,778. PUB. 3-20-2012. FILED 4-28-2011.
- 4,152,862 (*See Class 35 for this trademark*).
- 4,152,905. **THE SUSTAINABLE MOVE (STANDARD CHARACTER)**. ADVANCE RELOCATION AND STORAGE INC., MULTIPLE CLASS, (INT. CLS. 39 AND 43), (U.S. CLS. 100, 101 AND 105). SN 85-319,325. PUB. 3-20-2012. FILED 5-12-2011.
- 4,152,942. **E-SUGAR (STANDARD CHARACTER)**. BRADLEY RAGUSE, (U.S. CLS. 100 AND 105). SN 85-329,042. PUB. 3-20-2012. FILED 5-24-2011.
- 4,152,977. **WWPC WORLDWIDE PROJECT CONSORTIUM CONTACT WWPC AND DESIGN**. WORLDWIDE PROJECT CONSORTIUM (HOLDINGS) LIMITED, (U.S. CLS. 100 AND 105). SN 85-339,489. PUB. 3-20-2012. FILED 6-7-2011.
- 4,153,051 (*See Class 35 for this trademark*).
- 4,153,099. **THE CUPCAKE DELIVERS AND DESIGN**. THE CUPCAKE DELIVERS, (U.S. CLS. 100 AND 105). SN 85-380,902. PUB. 3-20-2012. FILED 7-26-2011.
- 4,153,127. **BIENVENIDOSABORDO.COM AND DESIGN**. TORRES, LUIS EDUARDO DE LA VEGA, (U.S. CLS. 100 AND 105). SN 85-390,223. PUB. 3-20-2012. FILED 8-4-2011.
- 4,153,201. **IDEELI (STANDARD CHARACTER)**. IDEELI INC., MULTIPLE CLASS, (INT. CLS. 39 AND 41), (U.S. CLS. 100, 101, 105 AND 107). SN 85-407,032. PUB. 3-20-2012. FILED 8-25-2011.
- 4,153,268. **CLICK AND RIDE COM AND DESIGN**. STANDARD PARKING CORPORATION, (U.S. CLS. 100 AND 105). SN 85-417,965. PUB. 3-20-2012. FILED 9-8-2011.
- 4,153,307. **BTX GLOBAL LOGISTICS WWW.BTXAIR.COM AND DESIGN**. BACARELLA TRANSPORTATION SERVICES, INC., (U.S. CLS. 100 AND 105). SN 85-422,579. PUB. 3-20-2012. FILED 9-14-2011.
- 4,153,323. **MISCELLANEOUS DESIGN**. WELCOME HOME RELOCATION, INC., MULTIPLE CLASS, (INT. CLS. 39, 41 AND 45), (U.S. CLS. 100, 101, 105 AND 107). SN 85-423,564. PUB. 3-20-2012. FILED 9-15-2011.
- 4,153,449 (*See Class 35 for this trademark*).
- 4,153,491. **BLACKHAWK INDUSTRIAL (STANDARD CHARACTER)**. BLACKHAWK INDUSTRIAL DISTRIBUTION, INC., (U.S. CLS. 100 AND 105). SN 85-436,713. PUB. 3-20-2012. FILED 9-30-2011.
- 4,153,554. **KO OLINA (STANDARD CHARACTER)**. KO OLINA INTANGIBLES, LLC, MULTIPLE CLASS, (INT. CLS. 39, 41, 43 AND 44), (U.S. CLS. 100, 101, 105 AND 107). SN 85-438,469. PUB. 3-20-2012. FILED 10-4-2011.
- 4,153,568. **CES AND DESIGN**. COMBINED ENERGY SERVICES, (U.S. CLS. 100 AND 105). SN 85-438,773. PUB. 3-20-2012. FILED 10-4-2011.
- 4,153,739. **EMBARQ AND DESIGN**. WORLD RESOURCES INSTITUTE, (U.S. CLS. 100 AND 105). SN 85-441,952. PUB. 3-20-2012. FILED 10-7-2011.
- 4,153,824. **VAGANGA (STANDARD CHARACTER)**. GEISTWERK, LLC, (U.S. CLS. 100 AND 105). SN 85-442,793. PUB. 3-20-2012. FILED 10-8-2011.
- 4,153,908. **YOUR SECRET DOOR TO ITALY (STANDARD CHARACTER)**. ITALY HOTLINE PRIVATE AND CUSTOM TOURS LLC, DBA ITALY HOTLINE PRIVATE AND CUSTOM TOURS LLC, (U.S. CLS. 100 AND 105). SN 85-443,630. PUB. 3-20-2012. FILED 10-10-2011.
- 4,153,909. **MOMS HELPING MOMS (STANDARD CHARACTER)**. LINKSUS CORPORATION, (U.S. CLS. 100 AND 105). SN 85-443,632. PUB. 3-20-2012. FILED 10-10-2011.
- 4,153,929. **WH WILLHOLDER AND DESIGN**. KOVALLI, IREN, AND MCVAY, GARY, (U.S. CLS. 100 AND 105). SN 85-443,945. PUB. 3-20-2012. FILED 10-11-2011.
- 4,153,966 (*See Class 35 for this trademark*).
- 4,153,967. **EXPLORE TOURS (STANDARD CHARACTER)**. EXPLORE TOURS, LLC, MULTIPLE CLASS, (INT. CLS. 39 AND 43), (U.S. CLS. 100, 101 AND 105). SN 85-444,259. PUB. 3-20-2012. FILED 10-11-2011.

4,153,999. **SCHUYLKILL BANKS (STANDARD CHARACTER)**. SCHUYLKILL RIVER DEVELOPMENT CORPORATION, MULTIPLE CLASS, (INT. CLS. 39 AND 41), (U.S. CLS. 100, 101, 105 AND 107). SN 85-444,575. PUB. 3-20-2012. FILED 10-11-2011.

4,154,056. **AMFORWARD (STANDARD CHARACTER)**. AMBOY TECHNOLOGIES LLC, (U.S. CLS. 100 AND 105). SN 85-445,680. PUB. 3-20-2012. FILED 10-12-2011.

4,154,176 (*See Class 35 for this trademark*).

4,154,187. **PREFERRED OIL AND DESIGN**. MAHONEY LIMITED PARTNERSHIP, MULTIPLE CLASS, (INT. CLS. 39 AND 40), (U.S. CLS. 100, 103, 105 AND 106). SN 85-463,815. PUB. 3-20-2012. FILED 11-3-2011.

CLASS 40—MATERIAL TREATMENT

4,152,081 (*See Class 17 for this trademark*).

4,152,092 (*See Class 37 for this trademark*).

4,152,182 (*See Class 6 for this trademark*).

4,152,197 (*See Class 1 for this trademark*).

4,152,230 (*See Class 7 for this trademark*).

4,152,231 (*See Class 7 for this trademark*).

4,152,316 (*See Class 9 for this trademark*).

4,152,324 (*See Class 14 for this trademark*).

4,152,330. **EXXELENS (STANDARD CHARACTER)**. LUXEXCEL HOLDING B.V., (U.S. CLS. 100, 103 AND 106). SN 79-099,768. PUB. 3-20-2012. FILED 5-27-2011.

4,152,341 (*See Class 6 for this trademark*).

4,152,377 (*See Class 6 for this trademark*).

4,152,382 (*See Class 7 for this trademark*).

4,152,405 (*See Class 1 for this trademark*).

4,152,408 (*See Class 9 for this trademark*).

4,152,410 (*See Class 1 for this trademark*).

4,152,438 (*See Class 1 for this trademark*).

4,152,439. **ORGANIC COLOR PLAY BY SAVERGLASS AND DESIGN**. SAVERGLASS, (U.S. CLS. 100, 103 AND 106). SN 79-975,203. PUB. 3-20-2012. FILED 3-22-2011.

4,152,495 (*See Class 35 for this trademark*).

4,152,501 (*See Class 1 for this trademark*).

4,152,517 (*See Class 1 for this trademark*).

4,152,518 (*See Class 1 for this trademark*).

4,152,658 (*See Class 1 for this trademark*).

4,152,674 (*See Class 35 for this trademark*).

4,152,712. **PRINTNINJA (STANDARD CHARACTER)**. PRINT NINJA, LLC, (U.S. CLS. 100, 103 AND 106). SN 85-284,815. PUB. 3-20-2012. FILED 4-3-2011.

4,152,853 (*See Class 39 for this trademark*).

4,152,968 (*See Class 30 for this trademark*).

4,152,970. **MOYER MACHINE AND TOOL, LLC. AND DESIGN**. MOYER MACHINE AND TOOL, LLC., (U.S. CLS. 100, 103 AND 106). SN 85-337,940. PUB. 3-20-2012. FILED 6-3-2011.

4,153,035 (*See Class 13 for this trademark*).

4,153,041 (*See Class 11 for this trademark*).

4,153,042 (*See Class 11 for this trademark*).

4,153,136. **LAB SMARTER (STANDARD CHARACTER)**. DENTSPLY INTERNATIONAL INC., (U.S. CLS. 100, 103 AND 106). SN 85-392,416. PUB. 3-20-2012. FILED 8-8-2011.

4,153,180 (*See Class 35 for this trademark*).

4,153,200. **BAY AREA GRAPHICS (STANDARD CHARACTER)**. HARRISON, LESLEY, (U.S. CLS. 100, 103 AND 106). SN 85-406,601. PUB. 3-20-2012. FILED 8-24-2011.

4,153,213 (*See Class 35 for this trademark*).

4,153,285. **INSACO (STANDARD CHARACTER)**. INSACO INCORPORATED, (U.S. CLS. 100, 103 AND 106). SN 85-420,447. PUB. 3-20-2012. FILED 9-12-2011.

4,153,401. **LIGHTHOUSE (STANDARD CHARACTER)**. LIGHTHOUSE PRINTING, INC., (U.S. CLS. 100, 103 AND 106). SN 85-430,902. PUB. 3-20-2012. FILED 9-23-2011.

4,153,693. **PROMOTION STORE (STANDARD CHARACTER)**. PROMOTION STORE, LLC, (U.S. CLS. 100, 103 AND 106). SN 85-441,418. PUB. 3-20-2012. FILED 10-6-2011.

4,153,751. **MISCELLANEOUS DESIGN**. RENEWABLE ENERGY DEVELOPMENT CORPORATION, DBA REDCO, (U.S. CLS. 100, 103 AND 106). SN 85-442,035. PUB. 3-20-2012. FILED 10-7-2011.

4,153,787 (*See Class 11 for this trademark*).

4,153,955. **WE PRINT THE DOTS IN COMMUNICATION (STANDARD CHARACTER)**. CARDINAL COLORGROUP PRINTING CORPORATION, (U.S. CLS. 100, 103 AND 106). SN 85-444,155. PUB. 3-20-2012. FILED 10-11-2011.

4,154,033 (*See Class 1 for this trademark*).

4,154,187 (*See Class 39 for this trademark*).

4,154,226 (*See Class 16 for this trademark*).

CLASS 41—EDUCATION AND ENTERTAINMENT

4,152,045. **CARNEVALE "THE FESTIVAL OF THE PEOPLE" (STANDARD CHARACTER)**. MIND'S EYE ENTERPRISES INCORPORATED, (U.S. CLS. 100, 101 AND 107). SN 76-707,074. PUB. 3-20-2012. FILED 4-1-2011.

4,152,056. **SUCCESSFUL CLASSROOM MANAGEMENT INITIATIVE AND DESIGN**. MCCOLLUM, DELORES L., (U.S. CLS. 100, 101 AND 107). SN 76-708,742. PUB. 3-20-2012. FILED 8-15-2011.

4,152,058. **THE ACT FORMULA (STYLIZED)**. FOCUSED, LLC, (U.S. CLS. 100, 101 AND 107). SN 76-708,818. PUB. 3-20-2012. FILED 8-22-2011.

4,152,064. **QFIT4LIFE AND DESIGN**. QFIT4LIFE, LLC, (U.S. CLS. 100, 101 AND 107). SN 76-709,163. PUB. 3-20-2012. FILED 9-21-2011.

4,152,065. **DOCUTAINMENT (STANDARD CHARACTER)**. GENESIS COMMUNICATIONS II, INC., (U.S. CLS. 100, 101 AND 107). SN 76-709,264. PUB. 3-20-2012. FILED 9-30-2011.

4,152,069. **DARKSIDE (STANDARD CHARACTER)**. O.C. SEACRETS, INC., MULTIPLE CLASS, (INT. CLS. 41 AND 43), (U.S. CLS. 100, 101 AND 107). SN 76-709,413. PUB. 3-20-2012. FILED 10-17-2011.

4,152,074. **PIN STRIKES (STANDARD CHARACTER)**. ASHEEV LLC, (U.S. CLS. 100, 101 AND 107). SN 77-135,957. PUB. 3-29-2011. FILED 3-20-2007.

4,152,078 (*See Class 35 for this trademark*).

4,152,095. **LIVE LARGE FOR LESS (STANDARD CHARACTER)**. RADIO SHOPPING SHOW, INC., (U.S. CLS. 100, 101 AND 107). SN 77-568,778. PUB. 3-20-2012. FILED 9-12-2008.

4,152,099 (*See Class 25 for this trademark*).

4,152,103. **DPALS (STANDARD CHARACTER)**. DPALS LIMITED, (U.S. CLS. 100, 101 AND 107). SN 77-604,287. PUB. 3-20-2012. FILED 10-30-2008.

4,152,106. **SANDPLAY (STANDARD CHARACTER)**. SANDPLAY THERAPISTS OF AMERICA, (U.S. CLS. 100, 101 AND 107). SN 77-638,828. PUB. 3-20-2012. FILED 12-23-2008.

4,152,107 (*See Class 35 for this trademark*).

4,152,111 (*See Class 16 for this trademark*).

4,152,112 (*See Class 16 for this trademark*).

4,152,117. **I AM ROGUE (STANDARD CHARACTER)**. RML JACKSON, LLC, (U.S. CLS. 100, 101 AND 107). SN 77-803,712. PUB. 3-20-2012. FILED 8-13-2009.

4,152,118. **ARE YOU ROGUE? (STANDARD CHARACTER)**. RML JACKSON, LLC, (U.S. CLS. 100, 101 AND 107). SN 77-808,146. PUB. 3-20-2012. FILED 8-19-2009.

4,152,119. **IAMROGUE (STANDARD CHARACTER)**. RML JACKSON, LLC, (U.S. CLS. 100, 101 AND 107). SN 77-810,025. PUB. 3-20-2012. FILED 8-21-2009.

4,152,130. **HUNTING WITH A HERO (STANDARD CHARACTER)**. GOODING III, WILLIAM RONEL, DBA HUNTING WITH A HERO, (U.S. CLS. 100, 101 AND 107). SN 77-869,712. PUB. 3-20-2012. FILED 11-10-2009.

4,152,145. **HOME OF PURDUE HALF MARATHON (STANDARD CHARACTER)**. THE TRUSTEES OF PURDUE UNIVERSITY, (U.S. CLS. 100, 101 AND 107). SN 77-946,677. PUB. 7-20-2010. FILED 2-27-2010.

4,152,147. **HOME OF PURDUE HALF MARATHON AND DESIGN**. THE TRUSTEES OF PURDUE UNIVERSITY, (U.S. CLS. 100, 101 AND 107). SN 77-948,002. PUB. 7-20-2010. FILED 3-2-2010.

4,152,149 (*See Class 9 for this trademark*).

4,152,158 (*See Class 38 for this trademark*).

4,152,167 (*See Class 16 for this trademark*).

4,152,171 (*See Class 16 for this trademark*).

- 4,152,187 (*See Class 9 for this trademark.*)
 4,152,189 (*See Class 35 for this trademark.*)
 4,152,193 (*See Class 3 for this trademark.*)
 4,152,198 (*See Class 3 for this trademark.*)
 4,152,200 (*See Class 9 for this trademark.*)
 4,152,210 (*See Class 25 for this trademark.*)
 4,152,219 (*See Class 35 for this trademark.*)
 4,152,239 (*See Class 35 for this trademark.*)
 4,152,240. **KWC.FI KARAOKE WORLD CHAMPIONSHIPS AND DESIGN.** OY KWC ORGANIZATION LTD. (U.S. CLS. 100, 101 AND 107). SN 79-096,208. PUB. 3-20-2012. FILED 7-15-2010.
 4,152,245 (*See Class 9 for this trademark.*)
 4,152,247 (*See Class 9 for this trademark.*)
 4,152,251 (*See Class 9 for this trademark.*)
 4,152,252 (*See Class 35 for this trademark.*)
 4,152,254 (*See Class 35 for this trademark.*)
 4,152,266 (*See Class 9 for this trademark.*)
 4,152,269 (*See Class 1 for this trademark.*)
 4,152,277 (*See Class 16 for this trademark.*)
 4,152,291 (*See Class 33 for this trademark.*)
 4,152,296 (*See Class 35 for this trademark.*)
 4,152,316 (*See Class 9 for this trademark.*)
 4,152,325 (*See Class 35 for this trademark.*)
 4,152,333 (*See Class 35 for this trademark.*)
 4,152,338. **THE BISCUIT READINGS (STANDARD CHARACTER).** BARKING SPIDER VISUAL THEATRE INC. (U.S. CLS. 100, 101 AND 107). SN 79-100,142. PUB. 3-20-2012. FILED 6-27-2011.
 4,152,341 (*See Class 6 for this trademark.*)
 4,152,367 (*See Class 9 for this trademark.*)
 4,152,375 (*See Class 3 for this trademark.*)
 4,152,409 (*See Class 16 for this trademark.*)
 4,152,411 (*See Class 35 for this trademark.*)
 4,152,445 (*See Class 28 for this trademark.*)
 4,152,462 (*See Class 21 for this trademark.*)
 4,152,463 (*See Class 16 for this trademark.*)
 4,152,468. **SH'BAM (STANDARD CHARACTER).** LES MILLS INTERNATIONAL LIMITED. (U.S. CLS. 100, 101 AND 107). SN 85-077,837. PUB. 3-20-2012. FILED 7-5-2010.
 4,152,473 (*See Class 9 for this trademark.*)
 4,152,476 (*See Class 16 for this trademark.*)
 4,152,495 (*See Class 35 for this trademark.*)
 4,152,498 (*See Class 35 for this trademark.*)
 4,152,507 (*See Class 3 for this trademark.*)
 4,152,521. **SKY (STANDARD CHARACTER).** THE LEARNING INTERNET, INC., MULTIPLE CLASS, (INT. CLS. 41 AND 42), (U.S. CLS. 100, 101 AND 107). SN 85-132,170. PUB. 3-20-2012. FILED 9-17-2010.
 4,152,533. **MIDWEST DAIRY ASSOCIATION (STANDARD CHARACTER).** MIDWEST DAIRY ASSOCIATION, MULTIPLE CLASS, (INT. CLS. 41 AND 44), (U.S. CLS. 100, 101 AND 107). SN 85-140,818. PUB. 3-20-2012. FILED 9-29-2010.
 4,152,541. **SLEEPXCEL SLEEP WELL. PLAY WELL. (STANDARD CHARACTER).** BARKER SLEEP MEDICINE PROFESSIONALS, PLLC, (U.S. CLS. 100, 101 AND 107). SN 85-149,896. PUB. 3-20-2012. FILED 10-11-2010.
 4,152,543 (*See Class 35 for this trademark.*)
 4,152,544 (*See Class 36 for this trademark.*)
 4,152,545 (*See Class 35 for this trademark.*)
 4,152,552. **FEARLESS KID (STANDARD CHARACTER).** LATIBEAUDIÈRE DELMAR O, AKA FEARLESS KID, (U.S. CLS. 100, 101 AND 107). SN 85-157,348. PUB. 3-20-2012. FILED 10-20-2010.
 4,152,553. **BEST DRESSED OF LOUISVILLE (STANDARD CHARACTER).** BLUE EQUITY PUBLISHING LOUISVILLE LLC, (U.S. CLS. 100, 101 AND 107). SN 85-158,146. PUB. 3-20-2012. FILED 10-21-2010.
 4,152,569. **IFEELGOOD 24/7 (STANDARD CHARACTER).** IFEELGOOD 24/7 PTY LTD, (U.S. CLS. 100, 101 AND 107). SN 85-173,791. PUB. 9-13-2011. FILED 11-10-2010.
 4,152,579. **INTENTIONAL TALK (STANDARD CHARACTER).** MAJOR LEAGUE BASEBALL PROPERTIES, INC., (U.S. CLS. 100, 101 AND 107). SN 85-185,887. PUB. 3-20-2012. FILED 11-29-2010.
 4,152,580 (*See Class 36 for this trademark.*)
 4,152,581 (*See Class 36 for this trademark.*)
 4,152,587 (*See Class 9 for this trademark.*)
 4,152,602 (*See Class 35 for this trademark.*)
 4,152,603 (*See Class 16 for this trademark.*)
 4,152,604. **SAN DIEGO ZOO SAFARI PARK (STANDARD CHARACTER).** ZOOLOGICAL SOCIETY OF SAN DIEGO, (U.S. CLS. 100, 101 AND 107). SN 85-214,390. PUB. 3-20-2012. FILED 1-10-2011.
 4,152,606. **M MOXIE ATHLETICS AND DESIGN.** MOXIE ATHLETICS, MULTIPLE CLASS, (INT. CLS. 41 AND 44), (U.S. CLS. 100, 101 AND 107). SN 85-216,101. PUB. 3-20-2012. FILED 1-12-2011.
 4,152,615. **YOUR HEALTH FIRST (STANDARD CHARACTER).** CIGNA INTELLECTUAL PROPERTY, INC., MULTIPLE CLASS, (INT. CLS. 41 AND 44), (U.S. CLS. 100, 101 AND 107). SN 85-223,097. PUB. 3-20-2012. FILED 1-21-2011.
 4,152,617. **MISCELLANEOUS DESIGN.** THE J. PAUL GETTY TRUST, (U.S. CLS. 100, 101 AND 107). SN 85-223,758. PUB. 3-20-2012. FILED 1-21-2011.
 4,152,618. **URBAN GIRL SQUAD AND DESIGN.** URBAN GIRL SQUAD LLC, MULTIPLE CLASS, (INT. CLS. 41 AND 45), (U.S. CLS. 100, 101 AND 107). SN 85-223,993. PUB. 3-20-2012. FILED 1-23-2011.
 4,152,638. **IWT IMPACT WORLD TOUR AND DESIGN.** CHURCH ON THE MOVE INTL. INC, (U.S. CLS. 100, 101 AND 107). SN 85-242,085. PUB. 3-20-2012. FILED 2-14-2011.
 4,152,639 (*See Class 16 for this trademark.*)
 4,152,641. **MELEARNING (STANDARD CHARACTER).** FLORIDA VIRTUAL SCHOOL, (U.S. CLS. 100, 101 AND 107). SN 85-244,854. PUB. 3-20-2012. FILED 2-17-2011.
 4,152,642. **NATURE TECHNOLOGY EFFICIENCY AND DESIGN.** K. HOV IP, II, INC., (U.S. CLS. 100, 101 AND 107). SN 85-245,885. PUB. 3-20-2012. FILED 2-18-2011.
 4,152,648. **GOLFMIX AND DESIGN.** GOLFMIX, INC., MULTIPLE CLASS, (INT. CLS. 41 AND 45), (U.S. CLS. 100, 101 AND 107). SN 85-248,721. PUB. 2-28-2012. FILED 2-22-2011.
 4,152,658 (*See Class 1 for this trademark.*)
 4,152,667. **SUBSCRIBE TO A BETTER VOICE (STANDARD CHARACTER).** SINGING SUCCESS INCORPORATED, (U.S. CLS. 100, 101 AND 107). SN 85-262,323. PUB. 3-20-2012. FILED 3-9-2011.
 4,152,672. **BANGKOK BOXING AND DESIGN.** BANGKOK BOXING & ENTERTAINMENT, LLC, (U.S. CLS. 100, 101 AND 107). SN 85-266,159. PUB. 3-20-2012. FILED 3-14-2011.
 4,152,677. **W.A.R. WORKOUT ADDICTION RECOVERY (STANDARD CHARACTER).** HAWKINS, DUSTIN LEE, (U.S. CLS. 100, 101 AND 107). SN 85-269,809. PUB. 3-20-2012. FILED 3-17-2011.
 4,152,680. **STREETKIND (STANDARD CHARACTER).** SWEETPINE RECORDS, LLC, (U.S. CLS. 100, 101 AND 107). SN 85-271,252. PUB. 3-20-2012. FILED 3-18-2011.
 4,152,682. **JACKSONVILLE UPSCALE MOVEMENT (STANDARD CHARACTER).** TASCOTT CAPITAL, LLC, (U.S. CLS. 100, 101 AND 107). SN 85-271,876. PUB. 3-20-2012. FILED 3-21-2011.
 4,152,688. **SKEETOX (STANDARD CHARACTER).** SCOTT KEENEY, (U.S. CLS. 100, 101 AND 107). SN 85-275,457. PUB. 3-20-2012. FILED 3-24-2011.
 4,152,692. **WORTHWHILE FILMS (STANDARD CHARACTER).** BRAKER, STEVE ABBOT, DBA WORTHWHILE FILMS, (U.S. CLS. 100, 101 AND 107). SN 85-276,443. PUB. 3-20-2012. FILED S.R. 3-25-2011; AM. P.R. 8-18-2011.
 4,152,699. **MEMORIAL HEALTH SERVICES (STANDARD CHARACTER).** MEMORIAL HEALTH SERVICES, MULTIPLE CLASS, (INT. CLS. 41 AND 44), (U.S. CLS. 100, 101 AND 107). SN 85-279,158. PUB. 3-20-2012. FILED 3-28-2011.
 4,152,700. **MEMORIALCARE HEALTH SYSTEM (STANDARD CHARACTER).** MEMORIAL HEALTH SERVICES, MULTIPLE CLASS, (INT. CLS. 41 AND 44), (U.S. CLS. 100, 101 AND 107). SN 85-279,164. PUB. 3-20-2012. FILED 3-28-2011.
 4,152,710. **YACHTMASTER (STANDARD CHARACTER).** ROYAL YACHTING ASSOCIATION, (U.S. CLS. 100, 101 AND 107). SN 85-282,631. PUB. 3-20-2012. FILED 3-31-2011.
 4,152,733 (*See Class 35 for this trademark.*)
 4,152,737 (*See Class 9 for this trademark.*)
 4,152,749. **BABY BARRE (STANDARD CHARACTER).** BARRE N9NE STUDIO, (U.S. CLS. 100, 101 AND 107). SN 85-293,581. PUB. 3-20-2012. FILED 4-13-2011.
 4,152,752. **PRODIGIO RTS (STANDARD CHARACTER).** MPOWER TRADING SYSTEMS, LLC, MULTIPLE CLASS,

- (INT. CLS. 41 AND 42), (U.S. CLS. 100, 101 AND 107). SN 85-294,189. PUB. 3-20-2012. FILED 4-13-2011.
- 4,152,762. **ONE 2 ONE COACHING DOLLARS TO SENSE AND DESIGN**. TFG, INC., (U.S. CLS. 100, 101 AND 107). SN 85-295,673. PUB. 3-20-2012. FILED 4-14-2011.
- 4,152,774. **AMERICAN TAI CHI ASSOCIATION (STANDARD CHARACTER)**. AMERICAN TAI CHI ASSOCIATION, (U.S. CLS. 100, 101 AND 107). SN 85-296,780. PUB. 3-20-2012. FILED 4-15-2011.
- 4,152,776 (*See Class 5 for this trademark*).
- 4,152,777 (*See Class 35 for this trademark*).
- 4,152,780. **PEACE ISLANDS INSTITUTE (STANDARD CHARACTER)**. SENATES, BEKIR, (U.S. CLS. 100, 101 AND 107). SN 85-297,163. PUB. 3-20-2012. FILED 4-17-2011.
- 4,152,786 (*See Class 35 for this trademark*).
- 4,152,789. **SHOP: THE INDUSTRY INFORMANT (STANDARD CHARACTER)**. MARS ADVERTISING, INC., (U.S. CLS. 100, 101 AND 107). SN 85-297,762. PUB. 3-20-2012. FILED 4-18-2011.
- 4,152,790 (*See Class 25 for this trademark*).
- 4,152,797. **GREAT SCIENTISTS AND DESIGN**. GOLD-DWOR-KIN, HEIDI, (U.S. CLS. 100, 101 AND 107). SN 85-298,779. PUB. 3-20-2012. FILED 4-19-2011.
- 4,152,801 (*See Class 9 for this trademark*).
- 4,152,802 (*See Class 9 for this trademark*).
- 4,152,805 (*See Class 38 for this trademark*).
- 4,152,812. **VANACORE MUSIC AND DESIGN**. VANACORE MUSIC PUBLISHING, LLC, (U.S. CLS. 100, 101 AND 107). SN 85-300,415. PUB. 3-20-2012. FILED 4-20-2011.
- 4,152,831. **BAWDY STORYTELLING (STANDARD CHARACTER)**. URBAN RACONTEUR INC., DBA BAWDY STORY-TELLING, (U.S. CLS. 100, 101 AND 107). SN 85-304,134. PUB. 3-20-2012. FILED 4-25-2011.
- 4,152,838 (*See Class 35 for this trademark*).
- 4,152,861 (*See Class 16 for this trademark*).
- 4,152,875 (*See Class 36 for this trademark*).
- 4,152,878. **SISTER R.E.I.G.N. (STANDARD CHARACTER)**. JENKINS, COZETTA A., AKA SISTER R.E.I.G.N., (U.S. CLS. 100, 101 AND 107). SN 85-312,728. PUB. 3-20-2012. FILED 5-4-2011.
- 4,152,882. **THE SPAZMatics AND DESIGN**. PWE PRODUCTIONS LLC, (U.S. CLS. 100, 101 AND 107). SN 85-314,011. PUB. 3-20-2012. FILED 5-6-2011.
- 4,152,883. **MISCELLANEOUS DESIGN**. PWE PRODUCTIONS LLC, (U.S. CLS. 100, 101 AND 107). SN 85-314,282. PUB. 3-20-2012. FILED 5-6-2011.
- 4,152,884. **ECONOMIC FAIRY TALES (STANDARD CHARACTER)**. PROSPERITY PRANA, LLC, (U.S. CLS. 100, 101 AND 107). SN 85-314,893. PUB. 3-20-2012. FILED 5-6-2011.
- 4,152,885. **GUILT-FREE RESULTS (STANDARD CHARACTER)**. VICTORIA COOK, DBA THE GUILT-FREE COACH, (U.S. CLS. 100, 101 AND 107). SN 85-315,237. PUB. 3-20-2012. FILED 5-8-2011.
- 4,152,888. **I HELP WRITERS BECOME AUTHORS (STANDARD CHARACTER)**. SFP MEDIA, INC., (U.S. CLS. 100, 101 AND 107). SN 85-315,293. PUB. 3-20-2012. FILED 5-9-2011.
- 4,152,893 (*See Class 38 for this trademark*).
- 4,152,900. **GUILLA BOYZ (STANDARD CHARACTER)**. GUILLA BOYZ ENTERTAINMENT, (U.S. CLS. 100, 101 AND 107). SN 85-317,010. PUB. 3-20-2012. FILED 5-10-2011.
- 4,152,907. **LISTEN TO YOUR MOTHER (STANDARD CHARACTER)**. LISTEN TO YOUR MOTHER, LLC, (U.S. CLS. 100, 101 AND 107). SN 85-320,001. PUB. 3-20-2012. FILED 5-13-2011.
- 4,152,908. **MSAR (STANDARD CHARACTER)**. ASSOCIATION OF AMERICAN MEDICAL COLLEGES, (U.S. CLS. 100, 101 AND 107). SN 85-320,365. PUB. 3-20-2012. FILED 5-13-2011.
- 4,152,909 (*See Class 16 for this trademark*).
- 4,152,910. **SCHOOL OF MATHEMATICS SINCE 1997 AND DESIGN**. THE RUSSIAN SCHOOL OF MATHEMATICS, INC., (U.S. CLS. 100, 101 AND 107). SN 85-320,595. PUB. 3-20-2012. FILED 5-13-2011.
- 4,152,913 (*See Class 35 for this trademark*).
- 4,152,919. **KAREN DILLARD'S COLLEGE PREP (STANDARD CHARACTER)**. KAREN DILLARD'S COLLEGE PREP, L.P., (U.S. CLS. 100, 101 AND 107). SN 85-322,992. PUB. 3-20-2012. FILED 5-17-2011.
- 4,152,930 (*See Class 25 for this trademark*).
- 4,152,933. **COVEY CLAYS (STANDARD CHARACTER)**. WAL-TEL, JOSEPH, (U.S. CLS. 100, 101 AND 107). SN 85-328,064. PUB. 3-20-2012. FILED 5-23-2011.
- 4,152,934 (*See Class 9 for this trademark*).
- 4,152,935 (*See Class 9 for this trademark*).
- 4,152,937 (*See Class 9 for this trademark*).
- 4,152,948. **PRACTICEWISE AND DESIGN**. PRACTICEWISE, LLC, MULTIPLE CLASS, (INT. CLS. 41, 42 AND 44), (U.S. CLS. 100, 101 AND 107). SN 85-331,560. PUB. 3-20-2012. FILED 5-26-2011.
- 4,152,954 (*See Class 35 for this trademark*).
- 4,152,991. **C A M P AND DESIGN**. ERUDISTIC, (U.S. CLS. 100, 101 AND 107). SN 85-345,139. PUB. 3-20-2012. FILED 6-13-2011.
- 4,152,992 (*See Class 35 for this trademark*).
- 4,152,993. **WOODWARD (STANDARD CHARACTER)**. POWDR-WOODWARD PA LLC, (U.S. CLS. 100, 101 AND 107). SN 85-345,566. PUB. 3-20-2012. FILED 6-14-2011.
- 4,153,000. **TYVARIAN (STANDARD CHARACTER)**. GIOVANNI HOLDINGS, LLC, (U.S. CLS. 100, 101 AND 107). SN 85-347,279. PUB. 3-20-2012. FILED 6-15-2011.
- 4,153,007 (*See Class 35 for this trademark*).
- 4,153,013. **BRIGHT LIGHT EDUCATION AND DESIGN**. BRIGHT LIGHT EDUCATION LLC, AKA BRIGHT LIGHT EDUCATION, (U.S. CLS. 100, 101 AND 107). SN 85-352,407. PUB. 12-13-2011. FILED 6-22-2011.
- 4,153,025 (*See Class 16 for this trademark*).
- 4,153,026 (*See Class 16 for this trademark*).
- 4,153,027. **KID IN A MAN'S WORLD (STANDARD CHARACTER)**. PIOLI, SCOTT P., (U.S. CLS. 100, 101 AND 107). SN 85-355,921. PUB. 3-20-2012. FILED 6-24-2011.
- 4,153,060. **TANGO BUENOS AIRES (STANDARD CHARACTER)**. BAUZA, MARIA DEL ROSARIO, (U.S. CLS. 100, 101 AND 107). SN 85-369,067. PUB. 3-20-2012. FILED 7-12-2011.
- 4,153,064 (*See Class 35 for this trademark*).
- 4,153,071. **HARDCORE PAWN (STANDARD CHARACTER)**. COURTROOM TELEVISION NETWORK LLC, (U.S. CLS. 100, 101 AND 107). SN 85-373,629. PUB. 3-20-2012. FILED 7-18-2011.
- 4,153,074. **MERIDIUM QUICK COURSE E-LEARNING PRODUCTS E AND DESIGN**. MERIDIUM, INC., (U.S. CLS. 100, 101 AND 107). SN 85-373,806. PUB. 3-20-2012. FILED 7-18-2011.
- 4,153,076 (*See Class 35 for this trademark*).
- 4,153,080. **BESTSELLINGCAR AWARD AND DESIGN**. BEST-SELLINGCAR AWARD, INC., DBA BESTSELLINGCAR AWARD, INC., (U.S. CLS. 100, 101 AND 107). SN 85-375,945. PUB. 3-20-2012. FILED 7-20-2011.
- 4,153,081 (*See Class 9 for this trademark*).
- 4,153,084. **CDHL (STANDARD CHARACTER)**. BEN FRANK, DBA 212 SPORTS, LLC, (U.S. CLS. 100, 101 AND 107). SN 85-376,760. PUB. 3-20-2012. FILED 7-20-2011.
- 4,153,086. **GLUTENFREEWORLD (STANDARD CHARACTER)**. CREATIVE CONTROL FILMS, INC., (U.S. CLS. 100, 101 AND 107). SN 85-377,137. PUB. 3-20-2012. FILED 7-21-2011.
- 4,153,088 (*See Class 36 for this trademark*).
- 4,153,090 (*See Class 36 for this trademark*).
- 4,153,093. **IMAGINE THE GOOD (STANDARD CHARACTER)**. GOULD, CHERYL, DBA IMAGINE THE GOOD, (U.S. CLS. 100, 101 AND 107). SN 85-379,400. PUB. 3-20-2012. FILED 7-24-2011.
- 4,153,094. **THE CONDITIONALS (STANDARD CHARACTER)**. THE CONDITIONALS, (U.S. CLS. 100, 101 AND 107). SN 85-379,621. PUB. 3-20-2012. FILED 7-25-2011.
- 4,153,095 (*See Class 35 for this trademark*).
- 4,153,097. **THE NEW YORK WORLD (STANDARD CHARACTER)**. THE TRUSTEES OF COLUMBIA UNIVERSITY OF THE CITY OF NEW YORK, (U.S. CLS. 100, 101 AND 107). SN 85-380,080. PUB. 3-20-2012. FILED 7-25-2011.
- 4,153,100. **THE SLANTED LENS (STANDARD CHARACTER)**. THE SLANTED LENS, DBA JAY P. MORGAN, (U.S. CLS. 100, 101 AND 107). SN 85-381,309. PUB. 3-20-2012. FILED S.R. 7-26-2011; AM. P.R. 2-13-2012.
- 4,153,101 (*See Class 16 for this trademark*).
- 4,153,106. **RUNNYMEDE (STANDARD CHARACTER)**. RUN- NYMEDE FARM, INC., MULTIPLE CLASS, (INT. CLS. 41

- AND 44), (U.S. CLS. 100, 101 AND 107). SN 85-383,079. PUB. 3-20-2012. FILED 7-28-2011.
- 4,153,109. **NETTRAINMENT (STANDARD CHARACTER)**. BSH BOSCH UND SIEMENS HAUSGERATE GMBH, (U.S. CLS. 100, 101 AND 107). SN 85-383,675. PUB. 3-20-2012. FILED 7-28-2011.
- 4,153,110. **IT'S ABOUT LIVING (STANDARD CHARACTER)**. CREATIVE CONTROL FILMS, INC., (U.S. CLS. 100, 101 AND 107). SN 85-384,245. PUB. 3-20-2012. FILED 7-29-2011.
- 4,153,111. **THE WON WOMEN'S OUTDOOR NEWS AND DESIGN**. DISA, (U.S. CLS. 100, 101 AND 107). SN 85-385,914. PUB. 1-3-2012. FILED 8-1-2011.
- 4,153,112 (*See Class 25 for this trademark*).
- 4,153,131 (*See Class 16 for this trademark*).
- 4,153,132. **NEXT GENERATION FOCUS BECAUSE EVERY CHILD DESERVES A CHANCE AND DESIGN**. NEXT GENERATION FOCUS, INC., (U.S. CLS. 100, 101 AND 107). SN 85-391,835. PUB. 3-20-2012. FILED 8-8-2011.
- 4,153,134. **DEVELOPMENTOR WRITE CODE DAY & NIGHT GUERRILLA EVENTS AND DESIGN**. DIGITAL AGE LEARNING, DBA DEVELOPMENTOR, (U.S. CLS. 100, 101 AND 107). SN 85-392,160. PUB. 3-20-2012. FILED 8-8-2011.
- 4,153,144. **BYE JUNE (STANDARD CHARACTER)**. KLINE, GIL, (U.S. CLS. 100, 101 AND 107). SN 85-394,208. PUB. 3-20-2012. FILED 8-10-2011.
- 4,153,158. **KIDSTOCK (STANDARD CHARACTER)**. WOODSTOCK VENTURES LC, (U.S. CLS. 100, 101 AND 107). SN 85-396,723. PUB. 3-20-2012. FILED 8-12-2011.
- 4,153,174. **INDY CREATIVE AGING (STANDARD CHARACTER)**. CICOA AGING & IN-HOME SOLUTIONS, (U.S. CLS. 100, 101 AND 107). SN 85-401,194. PUB. 3-20-2012. FILED 8-18-2011.
- 4,153,177 (*See Class 35 for this trademark*).
- 4,153,186. **DANCE DAZE (STANDARD CHARACTER)**. DANCE DAZE, (U.S. CLS. 100, 101 AND 107). SN 85-403,162. PUB. 3-20-2012. FILED 8-21-2011.
- 4,153,187. **SPIRIT JUNKIE (STANDARD CHARACTER)**. BERNSTEIN, GABRIELLE, (U.S. CLS. 100, 101 AND 107). SN 85-403,501. PUB. 3-20-2012. FILED 8-22-2011.
- 4,153,199 (*See Class 35 for this trademark*).
- 4,153,201 (*See Class 39 for this trademark*).
- 4,153,202. **FLORIDA LOTTERY (STANDARD CHARACTER)**. THE STATE OF FLORIDA DEPARTMENT OF THE LOTTERY, (U.S. CLS. 100, 101 AND 107). SN 85-407,460. PUB. 3-20-2012. FILED 8-25-2011.
- 4,153,205 (*See Class 35 for this trademark*).
- 4,153,206 (*See Class 35 for this trademark*).
- 4,153,214. **PERFORMANCE . FITNESS STUDIO AND DESIGN**. BIANCHI CORPORATION, (U.S. CLS. 100, 101 AND 107). SN 85-410,018. PUB. 3-20-2012. FILED 8-29-2011.
- 4,153,216. **PLANNED PARTYHOOD (STANDARD CHARACTER)**. LODER, JORDAN N., DBA PLANNED PARTYHOOD, (U.S. CLS. 100, 101 AND 107). SN 85-410,547. PUB. 3-20-2012. FILED 8-30-2011.
- 4,153,234. **PET MENTALIST (STANDARD CHARACTER)**. HERZON, RANDALL GARRETT, (U.S. CLS. 100, 101 AND 107). SN 85-412,875. PUB. 3-20-2012. FILED 9-1-2011.
- 4,153,238. **ADVANCE BEATZ (STANDARD CHARACTER)**. BRINSON, AVIN, (U.S. CLS. 100, 101 AND 107). SN 85-414,384. PUB. 3-20-2012. FILED 9-2-2011.
- 4,153,245. **JUMP AROUND PARTY RENTALS (STANDARD CHARACTER)**. JUMP AROUND PARTY RENTALS, LLC, MULTIPLE CLASS, (INT. CLS. 41 AND 43), (U.S. CLS. 100, 101 AND 107). SN 85-414,784. PUB. 3-20-2012. FILED 9-3-2011.
- 4,153,255. **TITANIC 100 YEARS 1912-2012 COURAGE RESPECT HONOR BRANSON MISSOURI AND DESIGN**. CEDAR BAY ENTERTAINMENT LLC, (U.S. CLS. 100, 101 AND 107). SN 85-416,318. PUB. 3-20-2012. FILED 9-7-2011.
- 4,153,260 (*See Class 36 for this trademark*).
- 4,153,261. **HDSERENESCAPES AND DESIGN**. WAYNE WILLIAMS STUDIO, LLC, (U.S. CLS. 100, 101 AND 107). SN 85-417,113. PUB. 3-20-2012. FILED 9-7-2011.
- 4,153,262. **TANYA TATE (STANDARD CHARACTER)**. TRACEY PALUMBO, (U.S. CLS. 100, 101 AND 107). SN 85-417,238. PUB. 3-20-2012. FILED 9-7-2011.
- 4,153,280. **STEELCUTAUDIO (STANDARD CHARACTER)**. STEEL CUT AUDIO LLC, (U.S. CLS. 100, 101 AND 107). SN 85-419,619. PUB. 3-20-2012. FILED 9-10-2011.
- 4,153,281 (*See Class 16 for this trademark*).
- 4,153,288. **PROTECTION INSTITUTE AMAT VICTORIA CURAM AND DESIGN**. THE PROTECTION INSTITUTE LLC, (U.S. CLS. 100, 101 AND 107). SN 85-420,546. PUB. 3-20-2012. FILED 9-12-2011.
- 4,153,290. **NEW YORK CHIROPRACTIC COLLEGE FOUNDED 1919 VIRTUS ANIMUSQUE SCIENCE ART PHILOSOPHY AND DESIGN**. NEW YORK CHIROPRACTIC COLLEGE, (U.S. CLS. 100, 101 AND 107). SN 85-421,271. PUB. 3-20-2012. FILED 9-13-2011.
- 4,153,295. **BARKA'DA CIRCLE AND DESIGN**. BARKADA CREATIVE, LLC, (U.S. CLS. 100, 101 AND 107). SN 85-421,504. PUB. 3-20-2012. FILED 9-13-2011.
- 4,153,301. **PR EHEALTH CONNECTIVITY EXPO AND DESIGN**. MMM HOLDINGS, INC., (U.S. CLS. 100, 101 AND 107). SN 85-422,110. PUB. 3-20-2012. FILED 9-14-2011.
- 4,153,302. **ROSIE'S THEATER KIDS (STANDARD CHARACTER)**. KID RO PRODUCTIONS, INC., (U.S. CLS. 100, 101 AND 107). SN 85-422,133. PUB. 3-20-2012. FILED 9-14-2011.
- 4,153,306. **SOUTH KENT SCHOOL (STANDARD CHARACTER)**. THE SOUTH KENT SCHOOL CORPORATION, (U.S. CLS. 100, 101 AND 107). SN 85-422,380. PUB. 3-20-2012. FILED 9-14-2011.
- 4,153,310. **K1 SPEED AND DESIGN**. K1 SPEED, INC., (U.S. CLS. 100, 101 AND 107). SN 85-422,731. PUB. 3-20-2012. FILED 9-14-2011.
- 4,153,312. **ARC AND DESIGN**. GOOD SPORT PLUS LTD., (U.S. CLS. 100, 101 AND 107). SN 85-422,889. PUB. 3-20-2012. FILED 9-14-2011.
- 4,153,323 (*See Class 39 for this trademark*).
- 4,153,325. **DR. PAUL BEARER (STANDARD CHARACTER)**. RICHARD KOON, (U.S. CLS. 100, 101 AND 107). SN 85-423,639. PUB. 3-20-2012. FILED 9-15-2011.
- 4,153,327 (*See Class 16 for this trademark*).
- 4,153,328. **CAMP OF CHAMPIONS (STANDARD CHARACTER)**. THE SNOBOARD SHOP INC., (U.S. CLS. 100, 101 AND 107). SN 85-423,912. PUB. 3-20-2012. FILED 9-15-2011.
- 4,153,340. **JAMI CAKES (STANDARD CHARACTER)**. EPSTEIN, JAMI, (U.S. CLS. 100, 101 AND 107). SN 85-425,049. PUB. 3-20-2012. FILED 9-16-2011.
- 4,153,347. **THE LITTLE BRATS (STANDARD CHARACTER)**. HARMONY HEARTH LLC, (U.S. CLS. 100, 101 AND 107). SN 85-426,075. PUB. 3-20-2012. FILED 9-19-2011.
- 4,153,348 (*See Class 25 for this trademark*).
- 4,153,349. **MUEVETE (MOVE) USA (STANDARD CHARACTER)**. NATIONAL ASSOCIATION OF HISPANIC NURSES, (U.S. CLS. 100, 101 AND 107). SN 85-426,211. PUB. 3-20-2012. FILED 9-19-2011.
- 4,153,352. **THE ART OF YING WINNING IN CHINA AND DESIGN**. THE ART OF YING, (U.S. CLS. 100, 101 AND 107). SN 85-426,788. PUB. 3-20-2012. FILED 9-20-2011.
- 4,153,356. **NAEMT SERVING OUR NATION'S EMS PRACTITIONERS AND DESIGN**. NATIONAL ASSOCIATION OF EMERGENCY MEDICAL TECHNICIANS, AKA NAEMT, (U.S. CLS. 100, 101 AND 107). SN 85-427,326. PUB. 3-20-2012. FILED 9-20-2011.
- 4,153,361 (*See Class 16 for this trademark*).
- 4,153,373 (*See Class 35 for this trademark*).
- 4,153,374 (*See Class 35 for this trademark*).
- 4,153,376. **HEARBUILDER (STANDARD CHARACTER)**. SUPER DUPER INC., DBA SUPER DUPER PUBLICATIONS, (U.S. CLS. 100, 101 AND 107). SN 85-429,229. PUB. 3-20-2012. FILED 9-22-2011.
- 4,153,391. **HEAL 2B FREE AND DESIGN**. HEAL2BFREE, LLC, MULTIPLE CLASS, (INT. CLS. 41 AND 44), (U.S. CLS. 100, 101 AND 107). SN 85-430,491. PUB. 3-20-2012. FILED 9-23-2011.
- 4,153,393. **SPACE DISCOVERY INSTITUTE AND DESIGN**. ELDRIDGE, ARTHUR, (U.S. CLS. 100, 101 AND 107). SN 85-430,585. PUB. 3-20-2012. FILED 9-23-2011.
- 4,153,394. **CHESAPEAKE IRB (STANDARD CHARACTER)**. CHESAPEAKE RESEARCH REVIEW, INC., MULTIPLE CLASS, (INT. CLS. 41 AND 45), (U.S. CLS. 100, 101 AND 107). SN 85-430,648. PUB. 3-20-2012. FILED 9-23-2011.
- 4,153,395. **CHESAPEAKE RESEARCH REVIEW, INC. (STAN-**

- DARD CHARACTER**), CHESAPEAKE RESEARCH REVIEW, INC., MULTIPLE CLASS, (INT. CLS. 41 AND 45), (U.S. CLS. 100, 101 AND 107). SN 85-430,679. PUB. 3-20-2012. FILED 9-23-2011.
- 4,153,404. **DYNAMITE GYMNASTICS CENTER AND DESIGN**. DYNAMITE GYMNASTICS CENTER, LLC, (U.S. CLS. 100, 101 AND 107). SN 85-431,243. PUB. 3-20-2012. FILED 9-24-2011.
- 4,153,407. **SEE "STAY TUNED, THERE'S MUCH MORE TO SEE." AND DESIGN**. NICO EAST, (U.S. CLS. 100, 101 AND 107). SN 85-431,444. PUB. 3-20-2012. FILED 9-26-2011.
- 4,153,412. **SMS SATURDAY MORNING SCIENCE AND DESIGN**. PHILLIPS, JAMES L., (U.S. CLS. 100, 101 AND 107). SN 85-431,720. PUB. 3-20-2012. FILED 9-26-2011.
- 4,153,425. **MONTANA ROADHOUSE BAND AND DESIGN**. JOHNSTON, MARIANA A., (U.S. CLS. 100, 101 AND 107). SN 85-432,930. PUB. 3-20-2012. FILED 9-27-2011.
- 4,153,432. **PITTSBURGH MARATHON AND DESIGN**. PITTSBURGH THREE RIVERS MARATHON, INC., (U.S. CLS. 100, 101 AND 107). SN 85-433,845. PUB. 3-20-2012. FILED 9-28-2011.
- 4,153,444. **LVH (STANDARD CHARACTER)**. COLONY RESORTS LVH ACQUISITIONS, LLC, MULTIPLE CLASS, (INT. CLS. 41 AND 43), (U.S. CLS. 100, 101 AND 107). SN 85-434,477. PUB. 3-20-2012. FILED 9-28-2011.
- 4,153,445. **LVH LAS VEGAS HOTEL & CASINO (STANDARD CHARACTER)**. COLONY RESORTS LVH ACQUISITIONS, LLC, MULTIPLE CLASS, (INT. CLS. 41 AND 43), (U.S. CLS. 100, 101 AND 107). SN 85-434,490. PUB. 3-20-2012. FILED 9-28-2011.
- 4,153,446. **FIRST LADIES OF ROCK (STANDARD CHARACTER)**. KIELB, FRANK, (U.S. CLS. 100, 101 AND 107). SN 85-434,524. PUB. 3-20-2012. FILED 9-28-2011.
- 4,153,448. **PRETTYBIRD AND DESIGN**. PRETTY BIRD PICTURES, INC., (U.S. CLS. 100, 101 AND 107). SN 85-434,536. PUB. 3-20-2012. FILED 9-28-2011.
- 4,153,460. **STAR (STRATEGIC TECHNOLOGY ADVISER & RESOURCES) (STANDARD CHARACTER)**. LENAGHAN, DONNA, (U.S. CLS. 100, 101 AND 107). SN 85-435,268. PUB. 3-20-2012. FILED 9-29-2011.
- 4,153,476 (*See Class 35 for this trademark*).
- 4,153,479 (*See Class 35 for this trademark*).
- 4,153,485. **PETRO-DRILL, GV AND DESIGN**. PETRO-DRILL CORPORATION, (U.S. CLS. 100, 101 AND 107). SN 85-436,452. PUB. 3-20-2012. FILED 9-30-2011.
- 4,153,489. **XOXO WEDDING STUDIO AND DESIGN**. FALK, KEVIN A., (U.S. CLS. 100, 101 AND 107). SN 85-436,700. PUB. 3-20-2012. FILED 9-30-2011.
- 4,153,495. **DOCICEO TO AND DESIGN**. 2ND CHANCE ENTERPRISES, LLC, (U.S. CLS. 100, 101 AND 107). SN 85-436,814. PUB. 3-20-2012. FILED 9-30-2011.
- 4,153,502. **THE RIGHTEOUS CONVERSATIONS PROJECT (STANDARD CHARACTER)**. REMEMBER US: THE HOLOCAUST BNAI MITZVAH PROJECT, (U.S. CLS. 100, 101 AND 107). SN 85-437,111. PUB. 3-20-2012. FILED 10-1-2011.
- 4,153,505. **NICK CARTER GREEN (STANDARD CHARACTER)**. GREEN, NICHOLAS TYLER, (U.S. CLS. 100, 101 AND 107). SN 85-437,159. PUB. 3-20-2012. FILED 10-1-2011.
- 4,153,508. **YOU CAN DO ANYTHING (STANDARD CHARACTER)**. YOU CAN DO ANYTHING LLC, (U.S. CLS. 100, 101 AND 107). SN 85-437,245. PUB. 3-20-2012. FILED 10-1-2011.
- 4,153,509. **YOU CAN DO ANYTHING AND DESIGN**. YOU CAN DO ANYTHING LLC, (U.S. CLS. 100, 101 AND 107). SN 85-437,247. PUB. 3-20-2012. FILED 10-1-2011.
- 4,153,522. **MITCHELL'S MARTIAL ARTS AND DESIGN**. MITCHELL'S MARTIAL ARTS, INC., (U.S. CLS. 100, 101 AND 107). SN 85-437,660. PUB. 3-20-2012. FILED 10-3-2011.
- 4,153,523. **PHOTOGRAPHY BY DAVID'S BRIDAL (STANDARD CHARACTER)**. DBD, INC., (U.S. CLS. 100, 101 AND 107). SN 85-437,699. PUB. 3-20-2012. FILED 10-3-2011.
- 4,153,525. **CAMP X MITCHELL'S MARTIAL ARTS AND DESIGN**. MITCHELL'S MARTIAL ARTS, INC., (U.S. CLS. 100, 101 AND 107). SN 85-437,746. PUB. 3-20-2012. FILED 10-3-2011.
- 4,153,529. **AN INVESTMENT IN LATINO YOUTH (STANDARD CHARACTER)**. ASPIRA ASSOCIATION, INC., (U.S. CLS. 100, 101 AND 107). SN 85-437,821. PUB. 3-20-2012. FILED 10-3-2011.
- 4,153,530. **LIGHTHOUSE LADIES (STANDARD CHARACTER)**. ACELERANT INCORPORATED, DBA STINGRAY TACKLE COMPANY, (U.S. CLS. 100, 101 AND 107). SN 85-437,837. PUB. 3-20-2012. FILED 10-3-2011.
- 4,153,545. **THE BOSTON GLOBE (STANDARD CHARACTER)**. NYT MANAGEMENT SERVICES, INC., (U.S. CLS. 100, 101 AND 107). SN 85-438,234. PUB. 3-20-2012. FILED 10-3-2011.
- 4,153,546. **POLITE POST (STANDARD CHARACTER)**. GOODING, MELISSA, (U.S. CLS. 100, 101 AND 107). SN 85-438,236. PUB. 3-20-2012. FILED 10-3-2011.
- 4,153,551. **ASIS ASSETS PROTECTION COURSE (STANDARD CHARACTER)**. ASIS INTERNATIONAL, INC., (U.S. CLS. 100, 101 AND 107). SN 85-438,393. PUB. 3-20-2012. FILED 10-4-2011.
- 4,153,554 (*See Class 39 for this trademark*).
- 4,153,567. **POWERFUL IDEAS PROVEN RESULTS (STANDARD CHARACTER)**. THE BOARD OF REGENTS OF THE UNIVERSITY OF WISCONSIN SYSTEM, (U.S. CLS. 100, 101 AND 107). SN 85-438,683. PUB. 3-20-2012. FILED 10-4-2011.
- 4,153,571. **THE HACKER ACADEMY (STANDARD CHARACTER)**. MAD SECURITY, LLC, (U.S. CLS. 100, 101 AND 107). SN 85-438,877. PUB. 3-20-2012. FILED 10-4-2011.
- 4,153,597 (*See Class 25 for this trademark*).
- 4,153,599 (*See Class 35 for this trademark*).
- 4,153,600 (*See Class 35 for this trademark*).
- 4,153,602. **THE GOSSIPING HEIFERS AND DESIGN**. THOMPSONS MARKETING LLC, (U.S. CLS. 100, 101 AND 107). SN 85-439,603. PUB. 3-20-2012. FILED 10-5-2011.
- 4,153,605 (*See Class 16 for this trademark*).
- 4,153,611. **CEJA (STANDARD CHARACTER)**. CEJA VINEYARDS, INC., (U.S. CLS. 100, 101 AND 107). SN 85-439,871. PUB. 3-20-2012. FILED 10-5-2011.
- 4,153,619. **KNOCKOUT CHAMPIONSHIP (STANDARD CHARACTER)**. DARREN MATSUBARA, (U.S. CLS. 100, 101 AND 107). SN 85-440,074. PUB. 3-20-2012. FILED 10-5-2011.
- 4,153,627. **A-PLAY CLUB (STANDARD CHARACTER)**. AFFINITY GAMING, LLC, (U.S. CLS. 100, 101 AND 107). SN 85-440,245. PUB. 3-20-2012. FILED 10-5-2011.
- 4,153,631. **SNC AND DESIGN**. ST. NORBERT COLLEGE, INC., (U.S. CLS. 100, 101 AND 107). SN 85-440,379. PUB. 3-20-2012. FILED 10-5-2011.
- 4,153,637. **SHUT UP + RUN (STANDARD CHARACTER)**. RISDON, ELIZABETH, (U.S. CLS. 100, 101 AND 107). SN 85-440,525. PUB. 3-20-2012. FILED 10-6-2011.
- 4,153,657 (*See Class 9 for this trademark*).
- 4,153,665. **WORK FIT. LIVE FIT. (STANDARD CHARACTER)**. FIT COMPANY INSTITUTE LLC, (U.S. CLS. 100, 101 AND 107). SN 85-440,923. PUB. 3-20-2012. FILED 10-6-2011.
- 4,153,671. **LOGAN (STANDARD CHARACTER)**. SYX SERVICES INC., (U.S. CLS. 100, 101 AND 107). SN 85-440,995. PUB. 3-20-2012. FILED 10-6-2011.
- 4,153,675. **ATLA CPLI (STANDARD CHARACTER)**. AMERICAN THEOLOGICAL LIBRARY ASSOCIATION, (U.S. CLS. 100, 101 AND 107). SN 85-441,054. PUB. 3-20-2012. FILED 10-6-2011.
- 4,153,686. **MAH JONGG MADNESS (STANDARD CHARACTER)**. STOCK DISTRIBUTORS, INC., (U.S. CLS. 100, 101 AND 107). SN 85-441,351. PUB. 3-20-2012. FILED 10-6-2011.
- 4,153,689. **CAUTION NO BULLY ZONE AND DESIGN**. DREAM BELIEVE KNOW IT FOUNDATION, AKA DBK, (U.S. CLS. 100, 101 AND 107). SN 85-441,387. PUB. 3-20-2012. FILED 10-6-2011.
- 4,153,694. **NEW MEXICO FILM RENTALS AND DESIGN**. SHAUGHNESSY, THOMAS J., (U.S. CLS. 100, 101 AND 107). SN 85-441,430. PUB. 3-20-2012. FILED 10-6-2011.
- 4,153,696. **SHUT UP AND DO IT! (STANDARD CHARACTER)**. GARCIA, RICHARD, (U.S. CLS. 100, 101 AND 107). SN 85-441,446. PUB. 3-20-2012. FILED 10-6-2011.
- 4,153,714. **MONSTER TRUCKS XL TOUR (STANDARD CHARACTER)**. SUPER T EVENTS, LLC, (U.S. CLS. 100, 101 AND 107). SN 85-441,666. PUB. 3-20-2012. FILED 10-7-2011.
- 4,153,718. **GARQUEST AND DESIGN**. MCINTYRE, MARTY, TA GARQUEST, (U.S. CLS. 100, 101 AND 107). SN 85-

- 441,708. PUB. 3-20-2012. FILED 10-7-2011.
- 4,153,733. **LIQUID MOTION (STANDARD CHARACTER)**. JANOVER, JENNIFER, (U.S. CLS. 100, 101 AND 107). SN 85-441,865. PUB. 3-20-2012. FILED 10-7-2011.
- 4,153,756. **CAUGHT ON FILM (STANDARD CHARACTER)**. THE UNGAR GROUP, LLC, DBA U/S SPORTS ADVISORS, (U.S. CLS. 100, 101 AND 107). SN 85-442,088. PUB. 3-20-2012. FILED 10-7-2011.
- 4,153,761. **FILMBOT (STANDARD CHARACTER)**. FRIEND, MAX DANIEL, MULTIPLE CLASS, (INT. CLS. 41 AND 42), (U.S. CLS. 100, 101 AND 107). SN 85-442,178. PUB. 3-20-2012. FILED 10-7-2011.
- 4,153,764. **ADVANCE BEAUTY COLLEGE (STANDARD CHARACTER)**. ADVANCE BEAUTY COLLEGE, LLC, MULTIPLE CLASS, (INT. CLS. 41 AND 44), (U.S. CLS. 100, 101 AND 107). SN 85-442,196. PUB. 3-20-2012. FILED 10-7-2011.
- 4,153,765. **BLUEPRINT FOR A PERINATAL PALLIATIVE CARE PROGRAM (STANDARD CHARACTER)**. GUNDERSEN LUTHERAN MEDICAL FOUNDATION, INC., (U.S. CLS. 100, 101 AND 107). SN 85-442,209. PUB. 3-20-2012. FILED 10-7-2011.
- 4,153,767. **ELAINE STEVEN BEAUTY COLLEGE (STANDARD CHARACTER)**. ELAINE STEVEN BEAUTY COLLEGE, INC., MULTIPLE CLASS, (INT. CLS. 41 AND 44), (U.S. CLS. 100, 101 AND 107). SN 85-442,215. PUB. 3-20-2012. FILED 10-7-2011.
- 4,153,771 (*See Class 35 for this trademark*).
- 4,153,772. **CJC CJC ENTERTAINMENT AND DESIGN**. EPHRIAM, CHARLES, AND EPHRIAM, JESTIN, AND EPHRIAM, CHRISTIAN, (U.S. CLS. 100, 101 AND 107). SN 85-442,248. PUB. 3-20-2012. FILED 10-7-2011.
- 4,153,775. **PRE K ACADEMY AND DESIGN**. JILL L. LESHIN, DBA THE TRAVELING TUTOR, LLC, (U.S. CLS. 100, 101 AND 107). SN 85-442,267. PUB. 3-20-2012. FILED 10-7-2011.
- 4,153,790. **ESCAPE HATCHER (STANDARD CHARACTER)**. BAKER, SUSAN M, (U.S. CLS. 100, 101 AND 107). SN 85-442,492. PUB. 3-20-2012. FILED 10-7-2011.
- 4,153,805. **D(——)B TEAMBACKPACK AND DESIGN**. TEAMBACKPACK, (U.S. CLS. 100, 101 AND 107). SN 85-442,634. PUB. 3-20-2012. FILED 10-7-2011.
- 4,153,821 (*See Class 38 for this trademark*).
- 4,153,822 (*See Class 38 for this trademark*).
- 4,153,825. **SFMAI (STANDARD CHARACTER)**. SOCIETY FOR MARTIAL ARTS INSTRUCTION, (U.S. CLS. 100, 101 AND 107). SN 85-442,800. PUB. 3-20-2012. FILED 10-8-2011.
- 4,153,834. **CYDARA (STANDARD CHARACTER)**. WHITE PAPER ENTERTAINMENT LLC, (U.S. CLS. 100, 101 AND 107). SN 85-442,867. PUB. 3-20-2012. FILED 10-9-2011.
- 4,153,839. **THE PEACEFUL PACK (STANDARD CHARACTER)**. THE PEACEFUL PACK, INC., MULTIPLE CLASS, (INT. CLS. 41, 43 AND 44), (U.S. CLS. 100, 101 AND 107). SN 85-442,935. PUB. 3-20-2012. FILED 10-9-2011.
- 4,153,840. **MISCELLANEOUS DESIGN**. THE PEACEFUL PACK, INC., MULTIPLE CLASS, (INT. CLS. 41, 43 AND 44), (U.S. CLS. 100, 101 AND 107). SN 85-442,941. PUB. 3-20-2012. FILED 10-9-2011.
- 4,153,841. **THE BIG GAME (STANDARD CHARACTER)**. DINNING, BRIAN RAY, DBA THE BIG GAME TV SHOW, (U.S. CLS. 100, 101 AND 107). SN 85-442,949. PUB. 3-20-2012. FILED 10-9-2011.
- 4,153,843 (*See Class 25 for this trademark*).
- 4,153,845 (*See Class 35 for this trademark*).
- 4,153,846 (*See Class 35 for this trademark*).
- 4,153,847. **S SPORTSBALLER AND DESIGN**. SPORTSBALLER LLC, (U.S. CLS. 100, 101 AND 107). SN 85-443,068. PUB. 3-20-2012. FILED 10-10-2011.
- 4,153,854. **ON MY Q (STANDARD CHARACTER)**. THE UNGAR GROUP, LLC, DBA U/S SPORTS ADVISORS, (U.S. CLS. 100, 101 AND 107). SN 85-443,121. PUB. 3-20-2012. FILED 10-10-2011.
- 4,153,856. **WE ARE PROJECT CONTACT AND DESIGN**. THE 6TH MAN FOUNDATION, MULTIPLE CLASS, (INT. CLS. 41 AND 44), (U.S. CLS. 100, 101 AND 107). SN 85-443,134. PUB. 3-20-2012. FILED 10-10-2011.
- 4,153,876. **CARING IS OUR CALLING (STANDARD CHARACTER)**. CALIFORNIA HOSPITAL ASSOCIATION, (U.S. CLS. 100, 101 AND 107). SN 85-443,367. PUB. 3-20-2012. FILED 10-10-2011.
- 4,153,881 (*See Class 37 for this trademark*).
- 4,153,884. **MISCELLANEOUS DESIGN**. JESSICA OLTMANS, (U.S. CLS. 100, 101 AND 107). SN 85-443,412. PUB. 3-20-2012. FILED 10-10-2011.
- 4,153,885. **HANDYMAN SHOW (STANDARD CHARACTER)**. H & S ASSOCIATES, INC., (U.S. CLS. 100, 101 AND 107). SN 85-443,421. PUB. 3-20-2012. FILED 10-10-2011.
- 4,153,887. **KALYN'S KITCHEN (STANDARD CHARACTER)**. KALYN DENNY, DBA KALYN'S KITCHEN, (U.S. CLS. 100, 101 AND 107). SN 85-443,432. PUB. 3-20-2012. FILED 10-10-2011.
- 4,153,889. **LAKESIDE PRIDE (STANDARD CHARACTER)**. LAKESIDE PRIDE MUSIC ENSEMBLES, INC., (U.S. CLS. 100, 101 AND 107). SN 85-443,453. PUB. 3-20-2012. FILED 10-10-2011.
- 4,153,899. **YS PALOOZA (STANDARD CHARACTER)**. REAL RESOURCES, INC., (U.S. CLS. 100, 101 AND 107). SN 85-443,530. PUB. 3-20-2012. FILED 10-10-2011.
- 4,153,907. **AS CUTE AS IT GETS (STANDARD CHARACTER)**. THISELTON, DOVE, DBA AS CUTE AS IT GETS, (U.S. CLS. 100, 101 AND 107). SN 85-443,586. PUB. 3-20-2012. FILED 10-10-2011.
- 4,153,911. **YUKON MAUI (STANDARD CHARACTER)**. R. WAVE PARTNERS LLC, (U.S. CLS. 100, 101 AND 107). SN 85-443,646. PUB. 3-20-2012. FILED 10-10-2011.
- 4,153,913 (*See Class 35 for this trademark*).
- 4,153,916. **MAKE TRAINING STICK (STANDARD CHARACTER)**. CARNES AND ASSOCIATES, INC., (U.S. CLS. 100, 101 AND 107). SN 85-443,744. PUB. 3-20-2012. FILED 10-10-2011.
- 4,153,921. **QUANTUM RELOAD (STANDARD CHARACTER)**. FATHIPOUR, MO, (U.S. CLS. 100, 101 AND 107). SN 85-443,841. PUB. 3-20-2012. FILED 10-10-2011.
- 4,153,931. **FE THE FEELING YOU GET FROM BEING FIT ESTEEM AND DESIGN**. FIT ESTEEM, LLC, (U.S. CLS. 100, 101 AND 107). SN 85-443,990. PUB. 3-20-2012. FILED 10-11-2011.
- 4,153,951. **FWOOSH (STANDARD CHARACTER)**. PAUL G. WOLF, (U.S. CLS. 100, 101 AND 107). SN 85-444,122. PUB. 3-20-2012. FILED 10-11-2011.
- 4,153,953. **FIT ESTEEM (STANDARD CHARACTER)**. FIT ESTEEM, LLC, (U.S. CLS. 100, 101 AND 107). SN 85-444,134. PUB. 3-20-2012. FILED 10-11-2011.
- 4,153,979. **AEF (STANDARD CHARACTER)**. ARIZONA EDUCATIONAL FOUNDATION, INC., (U.S. CLS. 100, 101 AND 107). SN 85-444,333. PUB. 3-20-2012. FILED 10-11-2011.
- 4,153,980. **M AND DESIGN**. MATER ACADEMY, INC., (U.S. CLS. 100, 101 AND 107). SN 85-444,344. PUB. 3-20-2012. FILED 10-11-2011.
- 4,153,984. **W-A-Y PROGRAM WIDENING ADVANCEMENTS FOR YOUTH (STANDARD CHARACTER)**. W-A-Y WIDENING ADVANCEMENTS FOR YOUTH, (U.S. CLS. 100, 101 AND 107). SN 85-444,455. PUB. 3-20-2012. FILED 10-11-2011.
- 4,153,987. **THE LATIN BREED (STANDARD CHARACTER)**. LATIN BREED, INC., (U.S. CLS. 100, 101 AND 107). SN 85-444,471. PUB. 3-20-2012. FILED 10-11-2011.
- 4,153,990. **YOUTH OUTDOOR SAFARI DAY (STANDARD CHARACTER)**. SAFARI CLUB INTERNATIONAL, LOS ANGELES AND ORANGE COUNTY CHAPTERS, (U.S. CLS. 100, 101 AND 107). SN 85-444,495. PUB. 3-20-2012. FILED 10-11-2011.
- 4,153,991. **SUCCESS PROMISE (STANDARD CHARACTER)**. WESTON DISTANCE LEARNING, INC., (U.S. CLS. 100, 101 AND 107). SN 85-444,500. PUB. 3-20-2012. FILED 10-11-2011.
- 4,153,999 (*See Class 39 for this trademark*).
- 4,154,004. **TRUSCRIBE (STANDARD CHARACTER)**. PURCELL ROAD MEDIA, LLC, MULTIPLE CLASS, (INT. CLS. 41 AND 42), (U.S. CLS. 100, 101 AND 107). SN 85-444,621. PUB. 3-20-2012. FILED 10-11-2011.
- 4,154,012. **CAPTURE THE PASSION! (STANDARD CHARACTER)**. CLUVER, RENNIE, (U.S. CLS. 100, 101 AND 107). SN 85-444,699. PUB. 3-20-2012. FILED 10-11-2011.
- 4,154,024. **LIVING IN THE ENDTIMES (STANDARD CHARACTER)**. GXP CONSULTING LLC, DBA GXP CONSULTING LLC, (U.S. CLS. 100, 101 AND 107). SN 85-444,821. PUB. 3-20-2012. FILED 10-11-2011.

4,154,027 (*See Class 38 for this trademark.*)
 4,154,045 (*See Class 35 for this trademark.*)
 4,154,053. **SEE THE LIGHT (STANDARD CHARACTER).** CORNING CABLE SYSTEMS BRANDS, INC., (U.S. CLS. 100, 101 AND 107). SN 85-445,646. PUB. 3-20-2012. FILED 10-12-2011.
 4,154,062. **PERSONALITY ASSETS (STANDARD CHARACTER).** MACOMBER, LESLIE, (U.S. CLS. 100, 101 AND 107). SN 85-445,724. PUB. 3-20-2012. FILED 10-12-2011.
 4,154,065. **ALPHABET MARATHON (STANDARD CHARACTER).** WELLNESS, INC., (U.S. CLS. 100, 101 AND 107). SN 85-445,779. PUB. 3-20-2012. FILED 10-12-2011.
 4,154,067. **THIRD SKY (STANDARD CHARACTER).** THIRD SKY, INC., MULTIPLE CLASS, (INT. CLS. 41 AND 42), (U.S. CLS. 100, 101 AND 107). SN 85-445,812. PUB. 3-20-2012. FILED 10-12-2011.
 4,154,074. **GIRL WITH CURVES (STANDARD CHARACTER).** AWASTHI, TANESHA, DBA GIRL WITH CURVES, (U.S. CLS. 100, 101 AND 107). SN 85-445,928. PUB. 3-20-2012. FILED 10-12-2011.
 4,154,082. **ADVENTURE RUN (STANDARD CHARACTER).** GOTFREDSON, MICHAEL B., (U.S. CLS. 100, 101 AND 107). SN 85-446,005. PUB. 3-20-2012. FILED 10-12-2011.
 4,154,090. **WKL WORLD KICKBOXING LEAGUE (STANDARD CHARACTER).** WORLD KICKBOXING LEAGUE, (U.S. CLS. 100, 101 AND 107). SN 85-446,175. PUB. 3-20-2012. FILED 10-13-2011.
 4,154,095. **AMERICA'S MASTER HANDYMAN (STANDARD CHARACTER).** H & S ASSOCIATES, INC., (U.S. CLS. 100, 101 AND 107). SN 85-446,352. PUB. 3-20-2012. FILED 10-13-2011.
 4,154,118. **BRILLBABY (STANDARD CHARACTER).** BRILLKIDS, INC., (U.S. CLS. 100, 101 AND 107). SN 85-449,406. PUB. 3-20-2012. FILED 10-18-2011.
 4,154,125 (*See Class 35 for this trademark.*)
 4,154,147. **THE LITTLE KITCHEN (STANDARD CHARACTER).** JULIE DEILY, (U.S. CLS. 100, 101 AND 107). SN 85-453,729. PUB. 3-20-2012. FILED 10-21-2011.
 4,154,161. **MEDTALENT (STANDARD CHARACTER).** MEDAXIOM CARDIOLOGY, LLC, (U.S. CLS. 100, 101 AND 107). SN 85-455,524. PUB. 3-20-2012. FILED 10-25-2011.
 4,154,172 (*See Class 9 for this trademark.*)
 4,154,199. **LAST STEPS (STANDARD CHARACTER).** GUNDERSEN LUTHERAN MEDICAL FOUNDATION, INC., (U.S. CLS. 100, 101 AND 107). SN 85-473,137. PUB. 3-20-2012. FILED 11-15-2011.
 4,154,203. **DJ KEVIN BROWN (STANDARD CHARACTER).** BROWN, KEVIN, (U.S. CLS. 100, 101 AND 107). SN 85-475,217. PUB. 3-20-2012. FILED 11-17-2011.
 4,154,205. **SAFE HYDRAULICS (STANDARD CHARACTER).** THE GATES CORPORATION, (U.S. CLS. 100, 101 AND 107). SN 85-476,634. PUB. 3-20-2012. FILED 11-18-2011.
 4,154,208. **FIP YOUR SCHOOL (STANDARD CHARACTER).** BATTELLE FOR KIDS, (U.S. CLS. 100, 101 AND 107). SN 85-480,534. PUB. 3-20-2012. FILED 11-23-2011.
 4,154,210 (*See Class 25 for this trademark.*)
 4,154,216. **MR. KATE (STANDARD CHARACTER).** ALBRECHT, KATE, DBA MR. KATE, (U.S. CLS. 100, 101 AND 107). SN 85-488,254. PUB. 3-20-2012. FILED 12-6-2011.
 4,154,218. **HOOK, LINE & DINNER (STANDARD CHARACTER).** COOKING CHANNEL, LLC, (U.S. CLS. 100, 101 AND 107). SN 85-489,091. PUB. 3-20-2012. FILED 12-7-2011.
 4,154,219. **CAFE MOX (STANDARD CHARACTER).** CARD KINGDOM, INC., MULTIPLE CLASS, (INT. CLS. 41 AND 43), (U.S. CLS. 100, 101 AND 107). SN 85-491,079. PUB. 3-20-2012. FILED 12-8-2011.
 4,154,229. **LEADAMERICA (STANDARD CHARACTER).** NATIONAL YOUTH EDUCATION COUNCIL, LLC, (U.S. CLS. 100, 101 AND 107). SN 85-499,700. PUB. 3-20-2012. FILED 12-20-2011.
 4,154,230 (*See Class 35 for this trademark.*)
 4,154,233 (*See Class 9 for this trademark.*)

CLASS 42—SCIENTIFIC AND COMPUTER SERVICES

4,152,040 (*See Class 35 for this trademark.*)
 4,152,048. **MAGENIC (STANDARD CHARACTER).** MAGENIC TECHNOLOGIES, INC., (U.S. CLS. 100 AND 101). SN 76-707,324. PUB. 3-20-2012. FILED 4-18-2011.
 4,152,059. **I 2 CONTACT (STYLIZED).** INTEGRATED BANK TECHNOLOGIES, INC., (U.S. CLS. 100 AND 101). SN 76-708,827. PUB. 3-20-2012. FILED 8-22-2011.
 4,152,077 (*See Class 35 for this trademark.*)
 4,152,081 (*See Class 17 for this trademark.*)
 4,152,087 (*See Class 1 for this trademark.*)
 4,152,096. **ZING TECHNOLOGIES AND DESIGN.** ZING TECHNOLOGIES, LLC, (U.S. CLS. 100 AND 101). SN 77-570,481. PUB. 3-20-2012. FILED 9-15-2008.
 4,152,109 (*See Class 9 for this trademark.*)
 4,152,111 (*See Class 16 for this trademark.*)
 4,152,112 (*See Class 16 for this trademark.*)
 4,152,116. **EYEWITNESS AND DESIGN.** THE SIROKY GROUP INC., (U.S. CLS. 100 AND 101). SN 77-786,867. PUB. 3-20-2012. FILED 7-22-2009.
 4,152,124. **SEOVB (STANDARD CHARACTER).** KA, TAT-YIK JARVIS, (U.S. CLS. 100 AND 101). SN 77-846,148. PUB. 3-20-2012. FILED 10-11-2009.
 4,152,136 (*See Class 9 for this trademark.*)
 4,152,137 (*See Class 9 for this trademark.*)
 4,152,138 (*See Class 9 for this trademark.*)
 4,152,163 (*See Class 7 for this trademark.*)
 4,152,167 (*See Class 16 for this trademark.*)
 4,152,168 (*See Class 9 for this trademark.*)
 4,152,170 (*See Class 7 for this trademark.*)
 4,152,176 (*See Class 9 for this trademark.*)
 4,152,188 (*See Class 3 for this trademark.*)
 4,152,189 (*See Class 35 for this trademark.*)
 4,152,192 (*See Class 35 for this trademark.*)
 4,152,197 (*See Class 1 for this trademark.*)
 4,152,203 (*See Class 9 for this trademark.*)
 4,152,207 (*See Class 9 for this trademark.*)
 4,152,215 (*See Class 9 for this trademark.*)
 4,152,216 (*See Class 35 for this trademark.*)
 4,152,218 (*See Class 9 for this trademark.*)
 4,152,219 (*See Class 35 for this trademark.*)
 4,152,229 (*See Class 1 for this trademark.*)
 4,152,230 (*See Class 7 for this trademark.*)
 4,152,231 (*See Class 7 for this trademark.*)
 4,152,237 (*See Class 35 for this trademark.*)
 4,152,245 (*See Class 9 for this trademark.*)
 4,152,247 (*See Class 9 for this trademark.*)
 4,152,250 (*See Class 9 for this trademark.*)
 4,152,253 (*See Class 35 for this trademark.*)
 4,152,254 (*See Class 35 for this trademark.*)
 4,152,257 (*See Class 9 for this trademark.*)
 4,152,274 (*See Class 9 for this trademark.*)
 4,152,279 (*See Class 9 for this trademark.*)
 4,152,285 (*See Class 7 for this trademark.*)
 4,152,286 (*See Class 9 for this trademark.*)
 4,152,290 (*See Class 9 for this trademark.*)
 4,152,296 (*See Class 35 for this trademark.*)
 4,152,301 (*See Class 9 for this trademark.*)
 4,152,302 (*See Class 9 for this trademark.*)
 4,152,308 (*See Class 9 for this trademark.*)
 4,152,312 (*See Class 12 for this trademark.*)
 4,152,320 (*See Class 37 for this trademark.*)
 4,152,321 (*See Class 37 for this trademark.*)
 4,152,324 (*See Class 14 for this trademark.*)
 4,152,333 (*See Class 35 for this trademark.*)
 4,152,341 (*See Class 6 for this trademark.*)
 4,152,347 (*See Class 29 for this trademark.*)
 4,152,367 (*See Class 9 for this trademark.*)
 4,152,375 (*See Class 3 for this trademark.*)
 4,152,405 (*See Class 1 for this trademark.*)
 4,152,408 (*See Class 9 for this trademark.*)
 4,152,411 (*See Class 35 for this trademark.*)
 4,152,426 (*See Class 9 for this trademark.*)
 4,152,428 (*See Class 9 for this trademark.*)
 4,152,434 (*See Class 9 for this trademark.*)
 4,152,438 (*See Class 1 for this trademark.*)
 4,152,469. **TURTLE CONSERVANCY . T.C. AND DESIGN.**

- TURTLE CONSERVANCY, (U.S. CLS. 100 AND 101). SN 85-079,266. PUB. 3-20-2012. FILED 7-7-2010.
- 4,152,481. **ECOLAB (STANDARD CHARACTER)**. ECOLAB USA INC., (U.S. CLS. 100 AND 101). SN 85-094,770. PUB. 3-20-2012. FILED 7-28-2010.
- 4,152,488 (*See Class 9 for this trademark*).
- 4,152,492. **DOELEGAL (STANDARD CHARACTER)**. DOELEGAL, LLC, (U.S. CLS. 100 AND 101). SN 85-110,712. PUB. 3-20-2012. FILED 8-18-2010.
- 4,152,501 (*See Class 1 for this trademark*).
- 4,152,505. **CE COLORADO ENERGY (STYLIZED)**. COLORADO ENERGY MANAGEMENT, LLC, (U.S. CLS. 100 AND 101). SN 85-117,587. PUB. 3-20-2012. FILED 8-27-2010.
- 4,152,514. **PEFIL AND DESIGN**. ARACELI SOLIS RABAGO, (U.S. CLS. 100 AND 101). SN 85-126,799. PUB. 3-20-2012. FILED 9-10-2010.
- 4,152,521 (*See Class 41 for this trademark*).
- 4,152,525 (*See Class 37 for this trademark*).
- 4,152,528. **BAI I-MODIFY (STANDARD CHARACTER)**. BANK ADMINISTRATION INSTITUTE, (U.S. CLS. 100 AND 101). SN 85-136,877. PUB. 3-20-2012. FILED 9-23-2010.
- 4,152,529 (*See Class 9 for this trademark*).
- 4,152,537. **DISPATCHNOW (STANDARD CHARACTER)**. TIBURON, INC., (U.S. CLS. 100 AND 101). SN 85-144,275. PUB. 3-20-2012. FILED 10-4-2010.
- 4,152,587 (*See Class 9 for this trademark*).
- 4,152,589 (*See Class 7 for this trademark*).
- 4,152,590. **SPARKHOUND (STANDARD CHARACTER)**. SPARKHOUND, INC., (U.S. CLS. 100 AND 101). SN 85-199,770. PUB. 3-20-2012. FILED 12-16-2010.
- 4,152,591. **FEROCIOUS TALENT, BRED FOR SERVICE. (STANDARD CHARACTER)**. SPARKHOUND, INC., (U.S. CLS. 100 AND 101). SN 85-199,794. PUB. 3-20-2012. FILED 12-16-2010.
- 4,152,593 (*See Class 35 for this trademark*).
- 4,152,595. **GLI GREENLIGHT INITIATIVE WWW.LEDNYC.COM AND DESIGN**. GREEN LIGHT INITIATIVE CORP., (U.S. CLS. 100 AND 101). SN 85-206,467. PUB. 3-20-2012. FILED 12-28-2010.
- 4,152,597 (*See Class 35 for this trademark*).
- 4,152,629. **HUBASE (STANDARD CHARACTER)**. CROWN BIOSCIENCE INC., (U.S. CLS. 100 AND 101). SN 85-232,455. PUB. 3-20-2012. FILED 2-2-2011.
- 4,152,656 (*See Class 35 for this trademark*).
- 4,152,658 (*See Class 1 for this trademark*).
- 4,152,662. **CENTRIX SOLUTIONS INC AND DESIGN**. CENTRIX SOLUTIONS INC, (U.S. CLS. 100 AND 101). SN 85-259,659. PUB. 3-20-2012. FILED 3-7-2011.
- 4,152,670 (*See Class 35 for this trademark*).
- 4,152,687. **GREENBEV (STANDARD CHARACTER)**. GREENBEV LLC, (U.S. CLS. 100 AND 101). SN 85-274,621. PUB. 3-20-2012. FILED 3-23-2011.
- 4,152,716 (*See Class 9 for this trademark*).
- 4,152,724. **CES (STANDARD CHARACTER)**. CONTINENTAL ENGINEERING SERVICES GMBH, (U.S. CLS. 100 AND 101). SN 85-288,082. PUB. 3-20-2012. FILED 4-6-2011.
- 4,152,726. **FUNDINGSHIELD (STANDARD CHARACTER)**. FUNDINGSHIELD, MULTIPLE CLASS, (INT. CLS. 42 AND 45), (U.S. CLS. 100 AND 101). SN 85-288,501. PUB. 3-20-2012. FILED 4-7-2011.
- 4,152,733 (*See Class 35 for this trademark*).
- 4,152,736 (*See Class 35 for this trademark*).
- 4,152,752 (*See Class 41 for this trademark*).
- 4,152,753 (*See Class 37 for this trademark*).
- 4,152,763. **MEMORIAL HEALTHTECH LABORATORIES (STANDARD CHARACTER)**. MEMORIAL HEALTH SERVICES, (U.S. CLS. 100 AND 101). SN 85-295,714. PUB. 3-20-2012. FILED 4-14-2011.
- 4,152,764 (*See Class 35 for this trademark*).
- 4,152,769. **INSURETRACK (STANDARD CHARACTER)**. SOFTWARE SERVICE AND DEVELOPMENT, INC., (U.S. CLS. 100 AND 101). SN 85-296,016. PUB. 3-20-2012. FILED 4-15-2011.
- 4,152,779. **MICROMATIC AND MICRO AND MATIC AND DESIGN**. MICROMATIC LLC, (U.S. CLS. 100 AND 101). SN 85-297,140. PUB. 3-20-2012. FILED 4-16-2011.
- 4,152,794. **M.E.R.I.T. SYSTEM MULTIPLE EQUIPMENT RECORD INFORMATION TRACKING SYSTEM (STANDARD CHARACTER)**. M.E.R.I.T. INVESTIGATIVE SERVICES, INC., (U.S. CLS. 100 AND 101). SN 85-297,908. PUB. 3-20-2012. FILED 4-18-2011.
- 4,152,807 (*See Class 35 for this trademark*).
- 4,152,809 (*See Class 35 for this trademark*).
- 4,152,816. **APPNOSTIC (STANDARD CHARACTER)**. EPROJECTS GROUP LIMITED LIABILITY COMPANY, (U.S. CLS. 100 AND 101). SN 85-300,855. PUB. 3-20-2012. FILED 4-21-2011.
- 4,152,824. **ULTRALINE (STANDARD CHARACTER)**. ULTRALINE, LLC, (U.S. CLS. 100 AND 101). SN 85-301,802. PUB. 3-20-2012. FILED 4-21-2011.
- 4,152,829. **LAJULE DESIGNS AND DESIGN**. WILDER, LAHANA, (U.S. CLS. 100 AND 101). SN 85-303,612. PUB. 3-20-2012. FILED 4-25-2011.
- 4,152,840 (*See Class 38 for this trademark*).
- 4,152,841 (*See Class 35 for this trademark*).
- 4,152,848. **DAVINCI BIOSCIENCES (STANDARD CHARACTER)**. DAVINCI BIOSCIENCES LLC, (U.S. CLS. 100 AND 101). SN 85-306,858. PUB. 3-20-2012. FILED 4-28-2011.
- 4,152,854. **BRIGHTLINE (STANDARD CHARACTER)**. BRIGHTLINE CPAS AND ASSOCIATES, INC., (U.S. CLS. 100 AND 101). SN 85-307,986. PUB. 3-20-2012. FILED 4-29-2011.
- 4,152,858. **U AND DESIGN**. USABLENET INC., (U.S. CLS. 100 AND 101). SN 85-308,243. PUB. 3-20-2012. FILED 4-29-2011.
- 4,152,875 (*See Class 36 for this trademark*).
- 4,152,912. **PAPER AND PIGTAILS (STANDARD CHARACTER)**. KORI M CLARK, DBA PAPER AND PIGTAILS, (U.S. CLS. 100 AND 101). SN 85-321,286. PUB. 3-20-2012. FILED 5-15-2011.
- 4,152,922. **TASTE FOR LIFE (STANDARD CHARACTER)**. SYMRISE AG, (U.S. CLS. 100 AND 101). SN 85-323,742. PUB. 3-20-2012. FILED 5-18-2011.
- 4,152,923. **MYCO SUITE AND DESIGN**. MYCO SUITE LIMITED, (U.S. CLS. 100 AND 101). SN 85-324,123. PUB. 3-20-2012. FILED 5-18-2011.
- 4,152,924. **CLOUDPAPERS (STANDARD CHARACTER)**. B2LEAD, LLC, DBA CLOUDPAPERS, (U.S. CLS. 100 AND 101). SN 85-324,522. PUB. 3-20-2012. FILED 5-19-2011.
- 4,152,932. **TECH ROCK STARS.COM AND DESIGN**. STEVEN PRICE, DBA TECH ROCKSTARS, (U.S. CLS. 100 AND 101). SN 85-327,707. PUB. 3-20-2012. FILED 5-23-2011.
- 4,152,939. **PREPMUNCH (STYLIZED)**. PREPMUNCH INC., (U.S. CLS. 100 AND 101). SN 85-328,616. PUB. 3-20-2012. FILED 5-24-2011.
- 4,152,943 (*See Class 37 for this trademark*).
- 4,152,948 (*See Class 41 for this trademark*).
- 4,152,954 (*See Class 35 for this trademark*).
- 4,152,964. **VIEWVANTAGE (STANDARD CHARACTER)**. AEDAS LTD., MULTIPLE CLASS, (INT. CLS. 42 AND 44), (U.S. CLS. 100 AND 101). SN 85-336,309. PUB. 3-20-2012. FILED 6-2-2011.
- 4,152,981. **LIGHTEN UP (STANDARD CHARACTER)**. SYMRISE AG, (U.S. CLS. 100 AND 101). SN 85-340,393. PUB. 3-20-2012. FILED 6-7-2011.
- 4,153,022 (*See Class 35 for this trademark*).
- 4,153,047 (*See Class 9 for this trademark*).
- 4,153,050 (*See Class 36 for this trademark*).
- 4,153,051 (*See Class 35 for this trademark*).
- 4,153,052 (*See Class 9 for this trademark*).
- 4,153,061. **R&D CLOUD AND DESIGN**. R&D CLOUD, INC., (U.S. CLS. 100 AND 101). SN 85-369,068. PUB. 3-20-2012. FILED 7-12-2011.
- 4,153,062. **RDC AND DESIGN**. R&D CLOUD, INC., (U.S. CLS. 100 AND 101). SN 85-369,073. PUB. 3-20-2012. FILED 7-12-2011.
- 4,153,064 (*See Class 35 for this trademark*).
- 4,153,065. **GMELIN (STANDARD CHARACTER)**. ELSEVIER PROPERTIES SA, (U.S. CLS. 100 AND 101). SN 85-369,908. PUB. 3-20-2012. FILED 7-13-2011.
- 4,153,066. **MEDATRAX (STANDARD CHARACTER)**. FOUR-D SOFTWARE, INC, (U.S. CLS. 100 AND 101). SN 85-370,421. PUB. 12-13-2011. FILED 7-13-2011.
- 4,153,101 (*See Class 16 for this trademark*).
- 4,153,116 (*See Class 9 for this trademark*).
- 4,153,117 (*See Class 9 for this trademark*).
- 4,153,118 (*See Class 9 for this trademark*).

- 4,153,119 (*See Class 9 for this trademark*).
- 4,153,120 (*See Class 9 for this trademark*).
- 4,153,121. **CS TECHNOLOGY (STANDARD CHARACTER)**. CS TECHNOLOGY, INC., (U.S. CLS. 100 AND 101). SN 85-387,965. PUB. 3-20-2012. FILED 8-3-2011.
- 4,153,170 (*See Class 35 for this trademark*).
- 4,153,180 (*See Class 35 for this trademark*).
- 4,153,184. **SOUTHSTAR ENGINEERING & CONSULTING, INC. AND DESIGN**. SOUTHSTAR ENGINEERING & CONSULTING, INC., (U.S. CLS. 100 AND 101). SN 85-402,966. PUB. 3-20-2012. FILED 8-20-2011.
- 4,153,188. **DESIGN SAVVY (STANDARD CHARACTER)**. STEVENS, JESSICA, DBA DESIGN SAVVY, (U.S. CLS. 100 AND 101). SN 85-403,960. PUB. 3-20-2012. FILED 8-22-2011.
- 4,153,193. **CARELIVE (STANDARD CHARACTER)**. LIVE SOFTWARE LLC, (U.S. CLS. 100 AND 101). SN 85-404,826. PUB. 3-20-2012. FILED 8-23-2011.
- 4,153,267 (*See Class 38 for this trademark*).
- 4,153,286. **NCLAB (STANDARD CHARACTER)**. FEMHUB INC., (U.S. CLS. 100 AND 101). SN 85-420,518. PUB. 3-20-2012. FILED 9-12-2011.
- 4,153,289 (*See Class 35 for this trademark*).
- 4,153,299. ... **DIFFERENT BY DESIGN! (STYLIZED)**. GREENBAUM, KENNETH S, (U.S. CLS. 100 AND 101). SN 85-421,865. PUB. 3-20-2012. FILED 9-13-2011.
- 4,153,303. **PUBLISHERALLEY (STANDARD CHARACTER)**. YANKEE BOOK PEDDLER, INC., (U.S. CLS. 100 AND 101). SN 85-422,142. PUB. 3-20-2012. FILED 9-14-2011.
- 4,153,313. **JTI AND DESIGN**. JOHNSTEK, INC., (U.S. CLS. 100 AND 101). SN 85-423,063. PUB. 3-20-2012. FILED 9-14-2011.
- 4,153,318. **VDESKTOP (STANDARD CHARACTER)**. HORIZON TECHNOLOGY, LLC, (U.S. CLS. 100 AND 101). SN 85-423,250. PUB. 3-20-2012. FILED 9-15-2011.
- 4,153,322. **DTT SURVEILLANCE AND DESIGN**. DRIVE THRU TECHNOLOGY, INC., (U.S. CLS. 100 AND 101). SN 85-423,470. PUB. 3-20-2012. FILED 9-15-2011.
- 4,153,324 (*See Class 9 for this trademark*).
- 4,153,327 (*See Class 16 for this trademark*).
- 4,153,333. **YOGOTLISTINGS (STANDARD CHARACTER)**. YOU GOT LISTINGS, INC., (U.S. CLS. 100 AND 101). SN 85-424,439. PUB. 3-20-2012. FILED 9-16-2011.
- 4,153,337. **TEGA TECHNOLOGIES AND DESIGN**. TEGA TECHNOLOGIES, LLC, (U.S. CLS. 100 AND 101). SN 85-424,766. PUB. 3-20-2012. FILED S.R. 9-16-2011; AM. P.R. 10-18-2011.
- 4,153,345. **BRAIN TYPING (STANDARD CHARACTER)**. NIEDNAGEL, JONATHAN P., (U.S. CLS. 100 AND 101). SN 85-426,030. PUB. 3-20-2012. FILED 9-19-2011.
- 4,153,357. **SATELLITE WEBSITE TARGETED WEB TRAFFIC AND DESIGN**. SATELLITE WEBSITE CORPORATION, (U.S. CLS. 100 AND 101). SN 85-427,382. PUB. 3-20-2012. FILED 9-20-2011.
- 4,153,358 (*See Class 38 for this trademark*).
- 4,153,365. **THE INDEPENDENT HOME (STANDARD CHARACTER)**. KESSLER MCGUINNESS & ASSOCIATES, DBA KESSLER MCGUINNESS & ASSOCIATES, (U.S. CLS. 100 AND 101). SN 85-428,214. PUB. 3-20-2012. FILED 9-21-2011.
- 4,153,379. **RETICKR (STANDARD CHARACTER)**. RETICKR LLC, (U.S. CLS. 100 AND 101). SN 85-429,591. PUB. 3-20-2012. FILED 9-22-2011.
- 4,153,380. **RETICKR AND DESIGN**. RETICKR LLC, (U.S. CLS. 100 AND 101). SN 85-429,603. PUB. 3-20-2012. FILED 9-22-2011.
- 4,153,390. **MISCELLANEOUS DESIGN**. TBH TECHNOLOGY LLC, MULTIPLE CLASS, (INT. CLS. 42 AND 44), (U.S. CLS. 100 AND 101). SN 85-430,370. PUB. 3-20-2012. FILED 9-23-2011.
- 4,153,424 (*See Class 9 for this trademark*).
- 4,153,429. **CRM SWITCH (STANDARD CHARACTER)**. LEXNET CONSULTING GROUP, (U.S. CLS. 100 AND 101). SN 85-433,589. PUB. 3-20-2012. FILED 9-27-2011.
- 4,153,469 (*See Class 9 for this trademark*).
- 4,153,471. **JILL TEEPLES DESIGN (STYLIZED)**. TEEPLES, JILL, (U.S. CLS. 100 AND 101). SN 85-435,911. PUB. 3-20-2012. FILED 9-29-2011.
- 4,153,487. **BETA ANALYTIC (STANDARD CHARACTER)**. BETA ANALYTIC, INC., (U.S. CLS. 100 AND 101). SN 85-436,585. PUB. 3-20-2012. FILED 9-30-2011.
- 4,153,526 (*See Class 35 for this trademark*).
- 4,153,533. **SPYPEEPS AND DESIGN**. CYBERSPACE TO PARADISE, INC., (U.S. CLS. 100 AND 101). SN 85-437,853. PUB. 3-20-2012. FILED 10-3-2011.
- 4,153,548. **KRISIMAGERY (STANDARD CHARACTER)**. OGILVIE, KRISTY, (U.S. CLS. 100 AND 101). SN 85-438,259. PUB. 3-20-2012. FILED 10-3-2011.
- 4,153,565. **PAGODA BOX (STYLIZED)**. PAGODA BOX, INC., (U.S. CLS. 100 AND 101). SN 85-438,679. PUB. 3-20-2012. FILED 10-4-2011.
- 4,153,566. **PAGODA BOX (STANDARD CHARACTER)**. PAGODA BOX, INC., (U.S. CLS. 100 AND 101). SN 85-438,682. PUB. 3-20-2012. FILED 10-4-2011.
- 4,153,587. **MY EDITOR (STANDARD CHARACTER)**. VANTAGE LEARNING (USA), LLC, DBA VANTAGE LEARNING, (U.S. CLS. 100 AND 101). SN 85-439,359. PUB. 3-20-2012. FILED 10-5-2011.
- 4,153,591. **ASCENDUM (STANDARD CHARACTER)**. ASCENDUM SOLUTIONS, LLC, (U.S. CLS. 100 AND 101). SN 85-439,430. PUB. 3-20-2012. FILED 10-5-2011.
- 4,153,613. **THEME BLVD (STANDARD CHARACTER)**. BOBICH, JASON, (U.S. CLS. 100 AND 101). SN 85-439,877. PUB. 3-20-2012. FILED 10-5-2011.
- 4,153,630. **MOBILE APPS FOR BUSINESSES MADE EASY (STANDARD CHARACTER)**. BUSINESS APPS, (U.S. CLS. 100 AND 101). SN 85-440,303. PUB. 3-20-2012. FILED 10-5-2011.
- 4,153,663. **CLICKDIMENSIONS (STANDARD CHARACTER)**. CLICKDIMENSIONS, LLC, (U.S. CLS. 100 AND 101). SN 85-440,900. PUB. 3-20-2012. FILED 10-6-2011.
- 4,153,717. **VIM (STANDARD CHARACTER)**. VERISOLV TECHNOLOGIES, INC., (U.S. CLS. 100 AND 101). SN 85-441,698. PUB. 3-20-2012. FILED 10-7-2011.
- 4,153,722. **NO MORE PENCILS DOWN (STANDARD CHARACTER)**. WEBFILINGS LLC, FORMERLY WEB FILINGS, LLC, (U.S. CLS. 100 AND 101). SN 85-441,749. PUB. 3-20-2012. FILED 10-7-2011.
- 4,153,747. **KLARIFY (STANDARD CHARACTER)**. VERI-GREEN ENERGY & LIGHT SOLUTIONS, LLC, (U.S. CLS. 100 AND 101). SN 85-442,010. PUB. 3-20-2012. FILED 10-7-2011.
- 4,153,750. **PISTASHIO (STANDARD CHARACTER)**. BRIDGE WORKER'S UNION, INC., (U.S. CLS. 100 AND 101). SN 85-442,034. PUB. 3-20-2012. FILED 10-7-2011.
- 4,153,760 (*See Class 35 for this trademark*).
- 4,153,761 (*See Class 41 for this trademark*).
- 4,153,809. **VTAAS (STANDARD CHARACTER)**. DRZAL, JEREMY, (U.S. CLS. 100 AND 101). SN 85-442,665. PUB. 3-20-2012. FILED 10-7-2011.
- 4,153,811 (*See Class 9 for this trademark*).
- 4,153,819. **MY TUTOR (STANDARD CHARACTER)**. VANTAGE LEARNING (USA), LLC, DBA VANTAGE LEARNING, (U.S. CLS. 100 AND 101). SN 85-442,771. PUB. 3-20-2012. FILED 10-8-2011.
- 4,153,829. **STABILIX (STANDARD CHARACTER)**. STABILIX CORPORATION, (U.S. CLS. 100 AND 101). SN 85-442,814. PUB. 3-20-2012. FILED 10-8-2011.
- 4,153,836. **THE GRAPHIC MIND (STANDARD CHARACTER)**. LAWRENCE Q. MARKX, (U.S. CLS. 100 AND 101). SN 85-442,886. PUB. 3-20-2012. FILED 10-9-2011.
- 4,153,853. **INTUITIVE (STANDARD CHARACTER)**. INTUITIVE RESEARCH AND TECHNOLOGY CORPORATION, (U.S. CLS. 100 AND 101). SN 85-443,116. PUB. 3-20-2012. FILED 10-10-2011.
- 4,153,879. **BLACKDIVINE (STANDARD CHARACTER)**. BLACKDIVINE, (U.S. CLS. 100 AND 101). SN 85-443,383. PUB. 3-20-2012. FILED 10-10-2011.
- 4,153,888. **TAGASAURIS (STANDARD CHARACTER)**. TAGASAURIS, INC., (U.S. CLS. 100 AND 101). SN 85-443,449. PUB. 3-20-2012. FILED 10-10-2011.
- 4,153,890. **INTERPRO (STANDARD CHARACTER)**. INTERPRO TECHNOLOGY, INC., (U.S. CLS. 100 AND 101). SN 85-443,454. PUB. 3-20-2012. FILED 10-10-2011.
- 4,153,898. **STABLE PATH (STANDARD CHARACTER)**. WIRE-SPEED NETWORKS, INC., DBA STABLEPATH, (U.S. CLS. 100 AND 101). SN 85-443,524. PUB. 3-20-2012. FILED 10-10-2011.
- 4,153,900. **STABLE PATH AND DESIGN**. WIRE-SPEED NETWORKS, INC., DBA STABLEPATH, (U.S. CLS. 100 AND

- 101). SN 85-443,535. PUB. 3-20-2012. FILED 10-10-2011.
- 4,153,912. **MAPNSAV (STYLIZED)**, 10KINFO, INC., (U.S. CLS. 100 AND 101). SN 85-443,666. PUB. 3-20-2012. FILED 10-10-2011.
- 4,153,917 (*See Class 16 for this trademark.*).
- 4,153,918. **AUTHORBEE (STANDARD CHARACTER)**, BRADLEY, STEPHEN T., DBA AUTHORBEE, (U.S. CLS. 100 AND 101). SN 85-443,782. PUB. 3-20-2012. FILED 10-10-2011.
- 4,153,928. **ADVIROGUARD (STANDARD CHARACTER)**, EARTHTEC SOLUTIONS LLC, (U.S. CLS. 100 AND 101). SN 85-443,937. PUB. 3-20-2012. FILED 10-11-2011.
- 4,153,937. **SITEWRENCH (STANDARD CHARACTER)**, SAVAGE, JACOB W., (U.S. CLS. 100 AND 101). SN 85-444,043. PUB. 3-20-2012. FILED 10-11-2011.
- 4,153,938. **QUONIX (STANDARD CHARACTER)**, QUONIX NETWORKS, INC., (U.S. CLS. 100 AND 101). SN 85-444,049. PUB. 3-20-2012. FILED 10-11-2011.
- 4,153,939. **MISCELLANEOUS DESIGN**, SYMPHONIC SOURCE, (U.S. CLS. 100 AND 101). SN 85-444,053. PUB. 3-20-2012. FILED 10-11-2011.
- 4,153,940. **CHASES DOWN AND ELIMINATES DUPLICATE DATA (STANDARD CHARACTER)**, SYMPHONIC SOURCE, (U.S. CLS. 100 AND 101). SN 85-444,058. PUB. 3-20-2012. FILED 10-11-2011.
- 4,153,941. **EVERCHURCH (STANDARD CHARACTER)**, SAVAGE, JACOB W., (U.S. CLS. 100 AND 101). SN 85-444,061. PUB. 3-20-2012. FILED 10-11-2011.
- 4,153,942. **HAVERSELECT (STANDARD CHARACTER)**, HAVER ANALYTICS, INC., (U.S. CLS. 100 AND 101). SN 85-444,062. PUB. 3-20-2012. FILED 10-11-2011.
- 4,153,944. **DELIVR (STANDARD CHARACTER)**, DELIVR, (U.S. CLS. 100 AND 101). SN 85-444,077. PUB. 3-20-2012. FILED 10-11-2011.
- 4,153,947. **CROWDNEWS (STANDARD CHARACTER)**, MEDIA SPOON, LLC, (U.S. CLS. 100 AND 101). SN 85-444,096. PUB. 3-20-2012. FILED 10-11-2011.
- 4,153,995. **FRIENDS THRU FRIENDS (STANDARD CHARACTER)**, EASY APP OVEN, LLC, (U.S. CLS. 100 AND 101). SN 85-444,549. PUB. 3-20-2012. FILED 10-11-2011.
- 4,154,004 (*See Class 41 for this trademark.*).
- 4,154,022 (*See Class 9 for this trademark.*).
- 4,154,041. **ONCPROTECH (STANDARD CHARACTER)**, ONC-PROTECH LLC, (U.S. CLS. 100 AND 101). SN 85-445,174. PUB. 3-20-2012. FILED 10-12-2011.
- 4,154,067 (*See Class 41 for this trademark.*).
- 4,154,068. **HALL ENGINEERING GROUP (STANDARD CHARACTER)**, HALL ENGINEERING GROUP, INC., (U.S. CLS. 100 AND 101). SN 85-445,828. PUB. 3-20-2012. FILED 10-12-2011.
- 4,154,075. **PETEXEC AND DESIGN**, PETEXEC, (U.S. CLS. 100 AND 101). SN 85-445,935. PUB. 3-20-2012. FILED 10-12-2011.
- 4,154,080. **REDAPT (STANDARD CHARACTER)**, REDAPT, INC., (U.S. CLS. 100 AND 101). SN 85-445,950. PUB. 3-20-2012. FILED 10-12-2011.
- 4,154,098. **TRUSTABLES (STANDARD CHARACTER)**, GUTEKUNST, BRENT L., (U.S. CLS. 100 AND 101). SN 85-446,544. PUB. 3-20-2012. FILED 10-13-2011.
- 4,154,148. **INTELLIGRATE (STANDARD CHARACTER)**, IVOGHLI, SEAN, (U.S. CLS. 100 AND 101). SN 85-453,906. PUB. 3-20-2012. FILED 10-22-2011.
- 4,154,155 (*See Class 35 for this trademark.*).
- 4,154,157. **MISCELLANEOUS DESIGN**, SYMPHONIC SOURCE, (U.S. CLS. 100 AND 101). SN 85-455,216. PUB. 3-20-2012. FILED 10-25-2011.
- 4,154,163. **CONSUMMATE AGS (STANDARD CHARACTER)**, ALANDA LLC, (U.S. CLS. 100 AND 101). SN 85-455,580. PUB. 3-20-2012. FILED 10-25-2011.
- 4,154,168. **JK STUDIO (STANDARD CHARACTER)**, JEWEL KADE HOLDINGS LLC, (U.S. CLS. 100 AND 101). SN 85-455,979. PUB. 3-20-2012. FILED 10-25-2011.
- 4,154,185 (*See Class 35 for this trademark.*).
- DBA CHOWPATTY, (U.S. CLS. 100 AND 101). SN 76-709,023. PUB. 3-20-2012. FILED 9-9-2011.
- 4,152,068. **FOR LOCALS ONLY ... AND THOSE WHO WISH THEY WERE (STANDARD CHARACTER)**, O.C. SEACRETS, INC., (U.S. CLS. 100 AND 101). SN 76-709,412. PUB. 3-20-2012. FILED 10-17-2011.
- 4,152,069 (*See Class 41 for this trademark.*).
- 4,152,078 (*See Class 35 for this trademark.*).
- 4,152,094 (*See Class 30 for this trademark.*).
- 4,152,098 (*See Class 35 for this trademark.*).
- 4,152,166 (*See Class 11 for this trademark.*).
- 4,152,189 (*See Class 35 for this trademark.*).
- 4,152,214 (*See Class 9 for this trademark.*).
- 4,152,216 (*See Class 35 for this trademark.*).
- 4,152,277 (*See Class 16 for this trademark.*).
- 4,152,325 (*See Class 35 for this trademark.*).
- 4,152,369 (*See Class 30 for this trademark.*).
- 4,152,370 (*See Class 30 for this trademark.*).
- 4,152,373 (*See Class 33 for this trademark.*).
- 4,152,396 (*See Class 38 for this trademark.*).
- 4,152,411 (*See Class 35 for this trademark.*).
- 4,152,443. **SHH! HOTELS (STANDARD CHARACTER)**, THE RICHDALÉ GROUP, (U.S. CLS. 100 AND 101). SN 85-023,895. PUB. 3-20-2012. FILED 4-27-2010.
- 4,152,463 (*See Class 16 for this trademark.*).
- 4,152,476 (*See Class 16 for this trademark.*).
- 4,152,507 (*See Class 3 for this trademark.*).
- 4,152,524 (*See Class 29 for this trademark.*).
- 4,152,526. **3 EYED FISH (STANDARD CHARACTER)**, CINDY GOULET, DBA FLORENTYNAS, (U.S. CLS. 100 AND 101). SN 85-134,863. PUB. 3-20-2012. FILED 9-21-2010.
- 4,152,548 (*See Class 16 for this trademark.*).
- 4,152,583 (*See Class 36 for this trademark.*).
- 4,152,614. **YELLOW CAFE (STANDARD CHARACTER)**, YELLOW HOUSE CAFE, INC., DBA YELLOW CAFE, (U.S. CLS. 100 AND 101). SN 85-222,457. PUB. 3-20-2012. FILED 1-20-2011.
- 4,152,655. **MY YOGURT BLISS AND DESIGN**, YOGURT BLISS, LLC, (U.S. CLS. 100 AND 101). SN 85-255,287. PUB. 3-20-2012. FILED 3-2-2011.
- 4,152,658 (*See Class 1 for this trademark.*).
- 4,152,722. **HANDLE IT (STANDARD CHARACTER)**, YO FRESH, LLC, (U.S. CLS. 100 AND 101). SN 85-287,485. PUB. 3-20-2012. FILED 4-6-2011.
- 4,152,776 (*See Class 5 for this trademark.*).
- 4,152,837. **YUMYUM WARRIOR (STANDARD CHARACTER)**, YUMYUM WARRIOR, INC., (U.S. CLS. 100 AND 101). SN 85-305,626. PUB. 3-20-2012. FILED 4-27-2011.
- 4,152,839. **PLAN B ADULT CARE SOLUTIONS (STANDARD CHARACTER)**, PLAN B - ADULT CARE SOLUTIONS, LLC, DBA PLAN B - ADULT CARE SOLUTIONS, MULTIPLE CLASS, (INT. CLS. 43 AND 45), (U.S. CLS. 100 AND 101). SN 85-306,022. PUB. 3-20-2012. FILED 4-27-2011.
- 4,152,890. **PALM BEACH GRILL (STANDARD CHARACTER)**, HILLSTONE RESTAURANT GROUP, INC., (U.S. CLS. 100 AND 101). SN 85-315,507. PUB. 3-20-2012. FILED 5-9-2011.
- 4,152,905 (*See Class 39 for this trademark.*).
- 4,152,915. **FAMOUS FOR OUR FOOD LEGENDARY FOR OUR MARGARITAS (STANDARD CHARACTER)**, LOPEZ FOODS, INC., DBA JORGE'S MEXICAN CAFE, (U.S. CLS. 100 AND 101). SN 85-321,838. PUB. 3-20-2012. FILED 5-16-2011.
- 4,152,957. **COPPERHEAD GRILLE (STANDARD CHARACTER)**, DKM INC., (U.S. CLS. 100 AND 101). SN 85-333,671. PUB. 3-20-2012. FILED 5-31-2011.
- 4,152,966. **SAMMY'S WOODFIRED PIZZA AND DESIGN**, THE TRUSTEE OF THE SAMI LADEKI TRUST, (U.S. CLS. 100 AND 101). SN 85-336,885. PUB. 3-20-2012. FILED 6-2-2011.
- 4,153,002. **C COMICX RESTAURANT BAR AND DESIGN**, COMICX, S.A. DE C.V., (U.S. CLS. 100 AND 101). SN 85-347,849. PUB. 3-20-2012. FILED 6-16-2011.
- 4,153,009. **TRIPLE HAPPINESS DRINKS DIM SUM STREET FARE AND DESIGN**, P.F. CHANG'S CHINA BISTRO, INC., (U.S. CLS. 100 AND 101). SN 85-349,561. PUB. 3-20-2012. FILED 6-17-2011.
- 4,153,011. **WINESLINGER (STANDARD CHARACTER)**, KANE, RUSSELL D., (U.S. CLS. 100 AND 101). SN 85-

CLASS 43—HOTEL AND RESTAURANT SERVICES

- 4,152,062. **CHOWPATTY AND DESIGN**, PATEL, SANDIP,

- 351,159. PUB. 1-3-2012. FILED 6-20-2011.
4,153,059 (*See Class 35 for this trademark*).
4,153,091. **TODAY TASTES SO GOOD AND DESIGN**. KFC CORPORATION, (U.S. CLS. 100 AND 101), SN 85-378,142. PUB. 3-20-2012. FILED 7-22-2011.
4,153,095 (*See Class 35 for this trademark*).
4,153,126. **UMAMI BURGER (STANDARD CHARACTER)**. UMAMI BURGER LICENSING USA, LLC, (U.S. CLS. 100 AND 101), SN 85-389,895. PUB. 3-20-2012. FILED 8-4-2011.
4,153,183. **UPTOWN KITCHEN (STANDARD CHARACTER)**. THE CLEAN PLATE CLUB, INC., (U.S. CLS. 100 AND 101), SN 85-402,795. PUB. 3-20-2012. FILED 8-19-2011.
4,153,185. **UPTOWN KITCHEN BREAKFAST . LUNCH . DINNER AND DESIGN**. THE CLEAN PLATE CLUB, INC., (U.S. CLS. 100 AND 101), SN 85-403,089. PUB. 3-20-2012. FILED 8-20-2011.
4,153,245 (*See Class 41 for this trademark*).
4,153,253. **PIERRE LOTI WINE BAR & RESTAURANT (STANDARD CHARACTER)**. H.O.C. WINE INC., (U.S. CLS. 100 AND 101), SN 85-416,143. PUB. 3-20-2012. FILED 9-6-2011.
4,153,277. **THE MODERN HONOLULU (STANDARD CHARACTER)**. MODERN MANAGEMENT SERVICES, LLC, (U.S. CLS. 100 AND 101), SN 85-419,514. PUB. 3-20-2012. FILED 9-9-2011.
4,153,329. **GRILLIT FRESH AUTHENTIC GRILL EST. 2011 AND DESIGN**. HEALTHY & TASTY VENTURES, LLC, (U.S. CLS. 100 AND 101), SN 85-423,968. PUB. 3-20-2012. FILED 9-15-2011.
4,153,368. **CITYDOG! CLUB (STANDARD CHARACTER)**. CITYDOG! CLUB, LLC, (U.S. CLS. 100 AND 101), SN 85-428,750. PUB. 3-20-2012. FILED 9-21-2011.
4,153,396. **CLAREHOUSE (STANDARD CHARACTER)**. CLAREHOUSE INC., MULTIPLE CLASS, (INT. CLS. 43 AND 45), (U.S. CLS. 100 AND 101), SN 85-430,691. PUB. 3-20-2012. FILED 9-23-2011.
4,153,398. **A LOVING ALTERNATIVE FOR END-OF-LIFE CARE (STANDARD CHARACTER)**. CLAREHOUSE INC., MULTIPLE CLASS, (INT. CLS. 43 AND 45), (U.S. CLS. 100 AND 101), SN 85-430,714. PUB. 3-20-2012. FILED 9-23-2011.
4,153,444 (*See Class 41 for this trademark*).
4,153,445 (*See Class 41 for this trademark*).
4,153,479 (*See Class 35 for this trademark*).
4,153,488. **YOGO -N- SWEETS AND DESIGN**. LAKSHMI INC, DBA YOGO -N- SWEETS, (U.S. CLS. 100 AND 101), SN 85-436,675. PUB. 3-20-2012. FILED 9-30-2011.
4,153,497. **ROCK & ROLL PIZZA R AND DESIGN**. VIEIRA, DAVID, AND VIEIRA, PETRA, (U.S. CLS. 100 AND 101), SN 85-436,883. PUB. 3-20-2012. FILED 9-30-2011.
4,153,528. **HD 2010 AND DESIGN**. HOP DODDY, LLC, (U.S. CLS. 100 AND 101), SN 85-437,801. PUB. 3-20-2012. FILED 10-3-2011.
4,153,553. **BANGKOK CITY (STANDARD CHARACTER)**. BANGKOK CITY, INC., (U.S. CLS. 100 AND 101), SN 85-438,465. PUB. 3-20-2012. FILED 10-4-2011.
4,153,554 (*See Class 39 for this trademark*).
4,153,628. **TUPELO HONEY CAFE AND DESIGN**. SD AUTO, LLC, (U.S. CLS. 100 AND 101), SN 85-440,253. PUB. 3-20-2012. FILED 10-5-2011.
4,153,629 (*See Class 30 for this trademark*).
4,153,638. **BOOKBOTTLES (STANDARD CHARACTER)**. BOOKBOTTLES, LLC, (U.S. CLS. 100 AND 101), SN 85-440,613. PUB. 3-20-2012. FILED 10-6-2011.
4,153,651. **SEA WATCH (STANDARD CHARACTER)**. SEA WATCH RESORT, LLC, (U.S. CLS. 100 AND 101), SN 85-440,772. PUB. 3-20-2012. FILED 10-6-2011.
4,153,672. **BUBBA (STYLIZED)**. BUBBA FOODS, LLC, (U.S. CLS. 100 AND 101), SN 85-441,007. PUB. 3-20-2012. FILED 10-6-2011.
4,153,803. **MAGIC FOUNTAIN HOMEMADE ICE CREAM (STANDARD CHARACTER)**. FOUNTAIN OF MAGIC, INC., (U.S. CLS. 100 AND 101), SN 85-442,584. PUB. 3-20-2012. FILED 10-7-2011.
4,153,839 (*See Class 41 for this trademark*).
4,153,840 (*See Class 41 for this trademark*).
4,153,893. **TWISTED NOODLES (STANDARD CHARACTER)**. TWISTED NOODLES EXPRESS, CORP., (U.S. CLS. 100 AND 101), SN 85-443,492. PUB. 3-20-2012. FILED 10-10-2011.
4,153,954. **MISCELLANEOUS DESIGN**. LANDRY'S TRADE-MARK, INC., (U.S. CLS. 100 AND 101), SN 85-444,151. PUB. 3-20-2012. FILED 10-11-2011.
4,153,967 (*See Class 39 for this trademark*).
4,153,992. **HOMEHOP (STANDARD CHARACTER)**. HOMEHOP, (U.S. CLS. 100 AND 101), SN 85-444,507. PUB. 3-20-2012. FILED 10-11-2011.
4,154,001 (*See Class 9 for this trademark*).
4,154,084. **HAMBURGER HIGH SINCE 2011 AND DESIGN**. BASEY DEVELOPMENT, INC, (U.S. CLS. 100 AND 101), SN 85-446,034. PUB. 3-20-2012. FILED 10-12-2011.
4,154,086. **BANGO! (STYLIZED)**. BANGO CATERING FRANCHISE INTERNATIONAL GROUP LIMITED, (U.S. CLS. 100 AND 101), SN 85-446,115. PUB. 3-20-2012. FILED 10-12-2011.
4,154,107. **LAMORAGA (STANDARD CHARACTER)**. ANDALUSIAN GOURMET CONCEPT S.L., (U.S. CLS. 100 AND 101), SN 85-447,288. PUB. 3-20-2012. FILED 10-13-2011.
4,154,136. **SIP BACK AND RELAX (STANDARD CHARACTER)**. FIREBIRDS INTERNATIONAL LLC, (U.S. CLS. 100 AND 101), SN 85-452,113. PUB. 3-20-2012. FILED 10-20-2011.
4,154,137. **JOIN US FOR FIREWORKS EVERY NIGHT (STANDARD CHARACTER)**. FIREBIRDS INTERNATIONAL LLC, (U.S. CLS. 100 AND 101), SN 85-452,124. PUB. 3-20-2012. FILED 10-20-2011.
4,154,181. **MEATLOAF-A-GO-GO (STANDARD CHARACTER)**. THE MEATLOAF BAKERY LLC, (U.S. CLS. 100 AND 101), SN 85-461,460. PUB. 3-20-2012. FILED 11-1-2011.
4,154,210 (*See Class 25 for this trademark*).
4,154,219 (*See Class 41 for this trademark*).
-
- CLASS 44—MEDICAL, BEAUTY AND AGRICULTURAL SERVICES**
- 4,152,087 (*See Class 1 for this trademark*).
4,152,099 (*See Class 25 for this trademark*).
4,152,127 (*See Class 9 for this trademark*).
4,152,129. **CPRX (STANDARD CHARACTER)**. ADVANCED MEDICAL/MENTAL HEALTH OUTREACH SERVICES TEAM, INC., (U.S. CLS. 100 AND 101), SN 77-866,879. PUB. 3-20-2012. FILED 11-6-2009.
4,152,180 (*See Class 3 for this trademark*).
4,152,186 (*See Class 5 for this trademark*).
4,152,206 (*See Class 11 for this trademark*).
4,152,444. **CLEARCHOICE IS THE PERFECT CHOICE (STANDARD CHARACTER)**. CLEARCHOICE HOLDINGS, LLC, (U.S. CLS. 100 AND 101), SN 85-027,270. PUB. 3-20-2012. FILED 4-30-2010.
4,152,506. **HPI HAIR PROSTHESIS INSTITUTE (STYLIZED)**. HAIR PROSTHESIS INSTITUTE, (U.S. CLS. 100 AND 101), SN 85-119,104. PUB. 3-20-2012. FILED 8-30-2010.
4,152,507 (*See Class 3 for this trademark*).
4,152,533 (*See Class 41 for this trademark*).
4,152,568. **VIVASMILES (STANDARD CHARACTER)**. RUTH GOMES, D.M.D., INC., (U.S. CLS. 100 AND 101), SN 85-173,378. PUB. 3-20-2012. FILED 11-10-2010.
4,152,570. **AICA (STANDARD CHARACTER)**. ACCIDENT INJURY CENTERS OF ATLANTA, INC., (U.S. CLS. 100 AND 101), SN 85-174,740. PUB. 3-20-2012. FILED 11-11-2010.
4,152,583 (*See Class 36 for this trademark*).
4,152,606 (*See Class 41 for this trademark*).
4,152,615 (*See Class 41 for this trademark*).
4,152,637. **GARDEN OF EVE (STANDARD CHARACTER)**. EVE BUCWINSKI, (U.S. CLS. 100 AND 101), SN 85-241,647. PUB. 3-20-2012. FILED 2-14-2011.
4,152,652. **DYNAMIC DENTAL P.L.L.C. AND DESIGN**. DYNAMIC DENTAL PLLC, (U.S. CLS. 100 AND 101), SN 85-251,723. PUB. 3-20-2012. FILED 2-25-2011.
4,152,658 (*See Class 1 for this trademark*).
4,152,666. **BEAT BY COOL (STANDARD CHARACTER)**. BEAT COSMETICS LLC, (U.S. CLS. 100 AND 101), SN 85-261,204. PUB. 3-20-2012. FILED 3-8-2011.
4,152,676. **AZ PAINCENTERS (STANDARD CHARACTER)**. PAIN CENTERS IP, LLC, (U.S. CLS. 100 AND 101), SN 85-269,674. PUB. 10-18-2011. FILED 3-17-2011.
4,152,686. **REIKI IN A BOTTLE (STANDARD CHARACTER)**.

- THORPE, K. L., (U.S. CLS. 100 AND 101), SN 85-274,008. PUB. 3-20-2012. FILED 3-22-2011.
- 4,152,699 (*See Class 41 for this trademark.*).
- 4,152,700 (*See Class 41 for this trademark.*).
- 4,152,723. **VISITING PHYSICIANS ASSOCIATION (STANDARD CHARACTER)**, U.S. MEDICAL MANAGEMENT, LLC, (U.S. CLS. 100 AND 101), SN 85-288,049. PUB. 3-20-2012. FILED 4-6-2011.
- 4,152,741. **NUTRITION CARE MANUAL (STANDARD CHARACTER)**, ACADEMY OF NUTRITION AND DIETETICS, (U.S. CLS. 100 AND 101), SN 85-292,859. PUB. 3-20-2012. FILED 4-12-2011.
- 4,152,776 (*See Class 5 for this trademark.*).
- 4,152,872 (*See Class 36 for this trademark.*).
- 4,152,874 (*See Class 36 for this trademark.*).
- 4,152,877. **HONOR A LIFE (STANDARD CHARACTER)**, FOREST LAWN MORTUARY, MULTIPLE CLASS, (INT. CLS. 44 AND 45), (U.S. CLS. 100 AND 101), SN 85-312,682. PUB. 3-20-2012. FILED 5-4-2011.
- 4,152,886. **ONE SMILE ONE WORLD ONE LOVE (STANDARD CHARACTER)**, MISSION SAVE A SMILE, (U.S. CLS. 100 AND 101), SN 85-315,264. PUB. 3-20-2012. FILED 5-8-2011.
- 4,152,895. **VASOLABS (STANDARD CHARACTER)**, VASOLABS, INC., DBA VASOLABS, (U.S. CLS. 100 AND 101), SN 85-316,900. PUB. 3-20-2012. FILED 5-10-2011.
- 4,152,941. **NAKED HAIR SALON & MORE! (STANDARD CHARACTER)**, NAKED HAIR SALON, (U.S. CLS. 100 AND 101), SN 85-328,785. PUB. 3-20-2012. FILED 5-24-2011.
- 4,152,948 (*See Class 41 for this trademark.*).
- 4,152,964 (*See Class 42 for this trademark.*).
- 4,152,988. **PETSULTANT (STANDARD CHARACTER)**, INPETNET, LLC, (U.S. CLS. 100 AND 101), SN 85-344,060. PUB. 3-20-2012. FILED 6-12-2011.
- 4,152,998. **NUVIEW HEALTH (STANDARD CHARACTER)**, NUVIEW HEALTH, LLC, DBA NUVIEW HEALTH, LLC, (U.S. CLS. 100 AND 101), SN 85-347,132. PUB. 3-20-2012. FILED S.R. 6-15-2011; AM. P.R. 2-13-2012.
- 4,153,020. **MISCELLANEOUS DESIGN, WELLNESS DESIGNED BY AMY, LLC**, (U.S. CLS. 100 AND 101), SN 85-353,988. PUB. 3-20-2012. FILED 6-23-2011.
- 4,153,095 (*See Class 35 for this trademark.*).
- 4,153,101 (*See Class 16 for this trademark.*).
- 4,153,106 (*See Class 41 for this trademark.*).
- 4,153,125 (*See Class 36 for this trademark.*).
- 4,153,199 (*See Class 35 for this trademark.*).
- 4,153,212. **FLOSSY AND DESIGN**, ONG SHAO DENTAL, INC., DBA SUNRISE DENTAL CENTER, (U.S. CLS. 100 AND 101), SN 85-409,648. PUB. 3-20-2012. FILED 8-29-2011.
- 4,153,225. **BARBOUR VINEYARDS (STANDARD CHARACTER)**, BARBOUR VINEYARDS LLC, (U.S. CLS. 100 AND 101), SN 85-411,936. PUB. 3-20-2012. FILED 8-31-2011.
- 4,153,241. **GEMINI DENTAL CENTER AND DESIGN**, KYRIAKAKIS DENTAL INCORPORATED, DBA GEMINI DENTAL, (U.S. CLS. 100 AND 101), SN 85-414,594. PUB. 3-20-2012. FILED 9-2-2011.
- 4,153,279. **HEALING HEART DOGS AND DESIGN**, HEALING HEART THERAPY DOGS, INC., (U.S. CLS. 100 AND 101), SN 85-419,592. PUB. 3-20-2012. FILED 9-10-2011.
- 4,153,317. **ESSENCE HEALING AND DESIGN**, ESSENCE HEALING, INC., (U.S. CLS. 100 AND 101), SN 85-423,226. PUB. 3-20-2012. FILED 9-15-2011.
- 4,153,377. **LIFE ADJUSTMENT TEAM (STANDARD CHARACTER)**, D. W. MANAGEMENT ENTERPRISES INC., (U.S. CLS. 100 AND 101), SN 85-429,406. PUB. 3-20-2012. FILED 9-22-2011.
- 4,153,381. **MYBODYCOUNT (STYLIZED)**, O'KEEFE, TERESA ANN, (U.S. CLS. 100 AND 101), SN 85-429,678. PUB. 3-20-2012. FILED 9-22-2011.
- 4,153,382. **PEPPER PASTOR SALON (STANDARD CHARACTER)**, PASTOR, JENNIFER, (U.S. CLS. 100 AND 101), SN 85-429,951. PUB. 3-20-2012. FILED 9-22-2011.
- 4,153,390 (*See Class 42 for this trademark.*).
- 4,153,391 (*See Class 41 for this trademark.*).
- 4,153,420 (*See Class 35 for this trademark.*).
- 4,153,422 (*See Class 16 for this trademark.*).
- 4,153,479 (*See Class 35 for this trademark.*).
- 4,153,494. **FAMILY PAWS (STANDARD CHARACTER)**, FAMILY PAWS LLC, (U.S. CLS. 100 AND 101), SN 85-436,809. PUB. 3-20-2012. FILED 9-30-2011.
- 4,153,498. **SUPPORT FOR LIFE (STANDARD CHARACTER)**, MELMED CENTER, (U.S. CLS. 100 AND 101), SN 85-436,905. PUB. 3-20-2012. FILED 9-30-2011.
- 4,153,499. **ASK A GROWER AND DESIGN**, SAN DIEGO HYDROPONICS & ORGANICS, (U.S. CLS. 100 AND 101), SN 85-436,926. PUB. 3-20-2012. FILED 9-30-2011.
- 4,153,532. **HOME HEALTH CARE OF FLORIDA THERE IS A DIFFERENCE...YOU DESERVE THE BEST! AND DESIGN**, HOME HEALTH CARE OF FLORIDA, (U.S. CLS. 100 AND 101), SN 85-437,850. PUB. 3-20-2012. FILED 10-3-2011.
- 4,153,554 (*See Class 39 for this trademark.*).
- 4,153,557. **WAG IN. WAG OUT. (STANDARD CHARACTER)**, BUBBLES PET SPA, (U.S. CLS. 100 AND 101), SN 85-438,544. PUB. 3-20-2012. FILED 10-4-2011.
- 4,153,590. **HEARTS WITH HELPING HANDS LIFE IS ABOUT GOALS, OBJECTIVE AND STRATEGIES AND DESIGN**, C LA FUNCH CONSULTING, DBA HEARTS WITH HELPING HANDS, (U.S. CLS. 100 AND 101), SN 85-439,421. PUB. 3-20-2012. FILED 10-5-2011.
- 4,153,596. **HEADWAY EMOTIONAL HEALTH SERVICES AND DESIGN**, HEADWAY EMOTIONAL HEALTH SERVICES, MULTIPLE CLASS, (INT. CLS. 44 AND 45), (U.S. CLS. 100 AND 101), SN 85-439,495. PUB. 3-20-2012. FILED 10-5-2011.
- 4,153,601. **ONSITE AND DESIGN**, JASON M. GRINTER, D.D.S., P.C., (U.S. CLS. 100 AND 101), SN 85-439,589. PUB. 3-20-2012. FILED 10-5-2011.
- 4,153,690. **DASHEN (STANDARD CHARACTER)**, LUCA MOSCHINI, (U.S. CLS. 100 AND 101), SN 85-441,389. PUB. 3-20-2012. FILED 10-6-2011.
- 4,153,705. **FRIENDSHIP HOSPITAL FOR ANIMALS (STANDARD CHARACTER)**, FRIENDSHIP HOSPITAL FOR ANIMALS, INC., (U.S. CLS. 100 AND 101), SN 85-441,600. PUB. 3-20-2012. FILED 10-7-2011.
- 4,153,706. **FRIENDSHIP TO GO (STANDARD CHARACTER)**, FRIENDSHIP HOSPITAL FOR ANIMALS, INC., (U.S. CLS. 100 AND 101), SN 85-441,602. PUB. 3-20-2012. FILED 10-7-2011.
- 4,153,707. **GORGEOUS GLO (STANDARD CHARACTER)**, VENTURE VI, LLC, (U.S. CLS. 100 AND 101), SN 85-441,610. PUB. 3-20-2012. FILED 10-7-2011.
- 4,153,711. **ARIVA (STANDARD CHARACTER)**, 1ST CHAIR SKIN CARE, INC., DBA ARIVA, (U.S. CLS. 100 AND 101), SN 85-441,640. PUB. 3-20-2012. FILED 10-7-2011.
- 4,153,742. **RDH EVILLAGE (STYLIZED)**, PENNWELL CORPORATION, (U.S. CLS. 100 AND 101), SN 85-441,959. PUB. 3-20-2012. FILED 10-7-2011.
- 4,153,764 (*See Class 41 for this trademark.*).
- 4,153,767 (*See Class 41 for this trademark.*).
- 4,153,779. **BEHIND PANTY LINES (STANDARD CHARACTER)**, BAXTER, JENNIFER B., (U.S. CLS. 100 AND 101), SN 85-442,292. PUB. 3-20-2012. FILED 10-7-2011.
- 4,153,781. **MY CONCIERGE NURSES (STANDARD CHARACTER)**, MY CONCIERGE NURSE, LLC, (U.S. CLS. 100 AND 101), SN 85-442,303. PUB. 3-20-2012. FILED 10-7-2011.
- 4,153,806. **WALDO WELLNESS GROUP (STANDARD CHARACTER)**, WALDO WELLNESS GROUP, (U.S. CLS. 100 AND 101), SN 85-442,636. PUB. 3-20-2012. FILED 10-7-2011.
- 4,153,816. **THE PROPER BARBERSHOP (STANDARD CHARACTER)**, MOREY, VINCENT, (U.S. CLS. 100 AND 101), SN 85-442,750. PUB. 3-20-2012. FILED 10-8-2011.
- 4,153,817. **NORTHSTAR VETS (STANDARD CHARACTER)**, NORTHSTAR VETS, FORMERLY VETERINARY SURGICAL AND DIAGNOSTIC SPECIALISTS, (U.S. CLS. 100 AND 101), SN 85-442,753. PUB. 3-20-2012. FILED 10-8-2011.
- 4,153,839 (*See Class 41 for this trademark.*).
- 4,153,840 (*See Class 41 for this trademark.*).
- 4,153,845 (*See Class 35 for this trademark.*).
- 4,153,856 (*See Class 41 for this trademark.*).
- 4,153,874. **FETCHMATES (STANDARD CHARACTER)**, FETCH MATES PET SERVICES INCORPORATED, DBA FETCH MATES PET SERVICES INCORPORATED, (U.S. CLS. 100 AND 101), SN 85-443,354. PUB. 3-20-2012. FILED 10-10-2011.
- 4,153,905. **EAT GOOD. FEEL GOOD. (STANDARD CHARACTER)**, WHOLE SHIFT LLC, (U.S. CLS. 100 AND 101), SN 85-

- 443,576. PUB. 3-20-2012. FILED 10-10-2011.
 4,153,965. **MODERN ALCHEMY (STANDARD CHARACTER)**. MONTES DE OCA, CARLYN, (U.S. CLS. 100 AND 101). SN 85-444,230. PUB. 3-20-2012. FILED 10-11-2011.
 4,153,988. **SKINSMART DERMATOLOGY (STANDARD CHARACTER)**. ELIZABETH F. CALLAHAN, M.D., LLC, DBA SKINSMART DERMATOLOGY, (U.S. CLS. 100 AND 101). SN 85-444,472. PUB. 3-20-2012. FILED 10-11-2011.
 4,154,072. **LIFESTYLE ENGINEER (STANDARD CHARACTER)**. PYBUS, TREVOR, (U.S. CLS. 100 AND 101). SN 85-445,900. PUB. 3-20-2012. FILED 10-12-2011.
 4,154,076. **WHERE YOU NOW HAVE A FRIEND WHO'S A DOCTOR (STANDARD CHARACTER)**. NEIL F. NEIMARK, M.D., INC., (U.S. CLS. 100 AND 101). SN 85-445,939. PUB. 3-20-2012. FILED 10-12-2011.
 4,154,119. **HEALTHTRONICS (STANDARD CHARACTER)**. HEALTHTRONICS, INC., (U.S. CLS. 100 AND 101). SN 85-449,506. PUB. 3-20-2012. FILED 10-18-2011.
 4,154,230 (*See Class 35 for this trademark*).

CLASS 45—PERSONAL AND LEGAL SERVICES

- 4,152,192 (*See Class 35 for this trademark*).
 4,152,219 (*See Class 35 for this trademark*).
 4,152,296 (*See Class 35 for this trademark*).
 4,152,316 (*See Class 9 for this trademark*).
 4,152,317. **THEBESTDAY (STANDARD CHARACTER)**. THE-BESTDAY PTY LTD, (U.S. CLS. 100 AND 101). SN 79-099,346. PUB. 3-20-2012. FILED 6-10-2011.
 4,152,333 (*See Class 35 for this trademark*).
 4,152,367 (*See Class 9 for this trademark*).
 4,152,463 (*See Class 16 for this trademark*).
 4,152,476 (*See Class 16 for this trademark*).
 4,152,559 (*See Class 39 for this trademark*).
 4,152,583 (*See Class 36 for this trademark*).
 4,152,618 (*See Class 41 for this trademark*).
 4,152,648 (*See Class 41 for this trademark*).
 4,152,670 (*See Class 35 for this trademark*).
 4,152,673. **SNAPGREET AND DESIGN**. SNAP GREET LLC, (U.S. CLS. 100 AND 101). SN 85-267,047. PUB. 3-20-2012. FILED 3-15-2011.
 4,152,713. **AVE HUMANITATEM DEUS ANIMAE NOSTRE AND DESIGN**. HIPPOCRATES UNIVERSITY, AND ANTONIN HRABAL, (U.S. CLS. 100 AND 101). SN 85-285,935. PUB. 3-20-2012. FILED 4-4-2011.
 4,152,717. **MSA SECURITY AND DESIGN**. MICHAEL STAPLETON ASSOCIATES, LTD., (U.S. CLS. 100 AND 101). SN 85-286,836. PUB. 3-20-2012. FILED 4-5-2011.
 4,152,720. **SHAREASCARE (STANDARD CHARACTER)**. BOYUKLIEV, DIMITRE, (U.S. CLS. 100 AND 101). SN 85-287,217. PUB. 3-20-2012. FILED 4-5-2011.
 4,152,726 (*See Class 42 for this trademark*).
 4,152,745. **MI METRO ONE AND DESIGN**. LOSS PREVENTION GROUP, INC., THE, DBA METRO LOSS PREVENTION SERVICES GROUP, (U.S. CLS. 100 AND 101). SN 85-293,114. PUB. 3-20-2012. FILED 4-12-2011.
 4,152,798 (*See Class 35 for this trademark*).
 4,152,806 (*See Class 6 for this trademark*).
 4,152,839 (*See Class 43 for this trademark*).
 4,152,840 (*See Class 38 for this trademark*).
 4,152,860 (*See Class 35 for this trademark*).
 4,152,864. **LIFE TREASURE COLLECTOR (STANDARD CHARACTER)**. MARIA FOTIADOU, (U.S. CLS. 100 AND 101). SN 85-310,436. PUB. 3-20-2012. FILED 5-2-2011.
 4,152,872 (*See Class 36 for this trademark*).
 4,152,874 (*See Class 36 for this trademark*).
 4,152,877 (*See Class 44 for this trademark*).
 4,152,916 (*See Class 18 for this trademark*).
 4,152,931 (*See Class 16 for this trademark*).
 4,152,983. **MISCELLANEOUS DESIGN**. AHMADIYYA MOVEMENT IN ISLAM, INC., (U.S. CLS. 100 AND 101). SN 85-340,955. PUB. 3-20-2012. FILED 6-8-2011.
 4,153,064 (*See Class 35 for this trademark*).
 4,153,067. **VELYKA RODYNA (STANDARD CHARACTER)**. GLOBAL EYE CLINIC, INC., (U.S. CLS. 100 AND 101). SN 85-371,429. PUB. 3-20-2012. FILED 7-14-2011.
 4,153,133. **SIMPLICITY LAW (STANDARD CHARACTER)**. SIMPLICITY LAW, INC., (U.S. CLS. 100 AND 101). SN 85-392,081. PUB. 3-20-2012. FILED 8-8-2011.
 4,153,213 (*See Class 35 for this trademark*).
 4,153,232. **KRITTER KOUNTRY (STANDARD CHARACTER)**. HERZON, RANDALL GARRETT, (U.S. CLS. 100 AND 101). SN 85-412,870. PUB. 3-20-2012. FILED 9-1-2011.
 4,153,233. **KARE FOR ALL KRITTERS (STANDARD CHARACTER)**. HERZON, RANDALL GARRETT, (U.S. CLS. 100 AND 101). SN 85-412,873. PUB. 3-20-2012. FILED 9-1-2011.
 4,153,250. **LEGACY CENTER (STANDARD CHARACTER)**. CLARK, MR. DAVID, (U.S. CLS. 100 AND 101). SN 85-415,102. PUB. 3-20-2012. FILED 9-5-2011.
 4,153,294 (*See Class 35 for this trademark*).
 4,153,323 (*See Class 39 for this trademark*).
 4,153,353. **QUEEN OF ERRANDS (STANDARD CHARACTER)**. MARY JACKSON, (U.S. CLS. 100 AND 101). SN 85-426,808. PUB. 3-20-2012. FILED 9-20-2011.
 4,153,392. **MEMORY BISTRO AND DESIGN**. MEMORYBISTRO CORPORATION, (U.S. CLS. 100 AND 101). SN 85-430,583. PUB. 3-20-2012. FILED 9-23-2011.
 4,153,394 (*See Class 41 for this trademark*).
 4,153,395 (*See Class 41 for this trademark*).
 4,153,396 (*See Class 43 for this trademark*).
 4,153,398 (*See Class 43 for this trademark*).
 4,153,408. **THE PARADISE PROJECT (STANDARD CHARACTER)**. THE PARADISE PROJECT, DBA THE PARADISE PROJECT, (U.S. CLS. 100 AND 101). SN 85-431,453. PUB. 3-20-2012. FILED 9-26-2011.
 4,153,427. **ÜBER AND DESIGN**. EVANS, LAURA, (U.S. CLS. 100 AND 101). SN 85-433,173. PUB. 3-20-2012. FILED 9-27-2011.
 4,153,479 (*See Class 35 for this trademark*).
 4,153,504 (*See Class 9 for this trademark*).
 4,153,506. **SCIENCE + LAW (STANDARD CHARACTER)**. SYNTHESIS INTELLECTUAL PROPERTY, LLC, AKA SYNTHESIS IP, (U.S. CLS. 100 AND 101). SN 85-437,165. PUB. 3-20-2012. FILED 10-1-2011.
 4,153,507. **HIS HOUSE CHRISTIAN FELLOWSHIP AND DESIGN**. MICHIGAN CHRISTIAN CAMPUS MINISTRIES, INC., DBA HIS HOUSE CHRISTIAN FELLOWSHIP, (U.S. CLS. 100 AND 101). SN 85-437,193. PUB. 3-20-2012. FILED 10-1-2011.
 4,153,561. **PETMETRIC (STANDARD CHARACTER)**. ANDRASIK, BENJAMIN D, DBA PETMETRIC, (U.S. CLS. 100 AND 101). SN 85-438,635. PUB. 3-20-2012. FILED 10-4-2011.
 4,153,582. **WEST & ASSOCIATES (STANDARD CHARACTER)**. WEST & ASSOCIATES, A PC, (U.S. CLS. 100 AND 101). SN 85-439,208. PUB. 3-20-2012. FILED 10-4-2011.
 4,153,596 (*See Class 44 for this trademark*).
 4,153,603. **TIXNIX (STANDARD CHARACTER)**. TACITLOGIC, INC., (U.S. CLS. 100 AND 101). SN 85-439,605. PUB. 3-20-2012. FILED 10-5-2011.
 4,153,633. **THE BEASLEY FIRM, LLC (STANDARD CHARACTER)**. THE BEASLEY FIRM, LLC, (U.S. CLS. 100 AND 101). SN 85-440,466. PUB. 3-20-2012. FILED 10-6-2011.
 4,153,645. **DEKEUNITED (STANDARD CHARACTER)**. DELTA KAPPA EPSILON FRATERNITY, (U.S. CLS. 100 AND 101). SN 85-440,661. PUB. 3-20-2012. FILED 10-6-2011.
 4,153,652. **DOMAINCONTEXT (STANDARD CHARACTER)**. DOMAINCONTEXT INC., (U.S. CLS. 100 AND 101). SN 85-440,773. PUB. 3-20-2012. FILED 10-6-2011.
 4,153,659. **AIM HIGH! TIPS (STANDARD CHARACTER)**. BRADLEY IAN BERGER, (U.S. CLS. 100 AND 101). SN 85-440,856. PUB. 3-20-2012. FILED 10-6-2011.
 4,153,660. **AIM HIGH! 101 TIPS (STANDARD CHARACTER)**. BRADLEY IAN BERGER, (U.S. CLS. 100 AND 101). SN 85-440,873. PUB. 3-20-2012. FILED 10-6-2011.
 4,153,740. **MISCELLANEOUS DESIGN**. REY'WA, LLC, (U.S. CLS. 100 AND 101). SN 85-441,953. PUB. 3-20-2012. FILED 10-7-2011.
 4,153,769. **WE CAN WORK IT OUT. (STANDARD CHARACTER)**. ANASTASI & ASSOCIATE, P.A., (U.S. CLS. 100 AND 101). SN 85-442,223. PUB. 3-20-2012. FILED 10-7-2011.
 4,153,770. **LOOPLANE (STANDARD CHARACTER)**. LOOPLANE.COM, LLC, (U.S. CLS. 100 AND 101). SN 85-442,228.

- PUB. 3-20-2012. FILED 10-7-2011.
- 4,153,823. **STARSELF (STANDARD CHARACTER)**, RICHARD ALESSANDRO DICLEMENTE, DBA STARSELF, (U.S. CLS. 100 AND 101). SN 85-442,791. PUB. 3-20-2012. FILED 10-8-2011.
- 4,153,859. **MOUNTAINTOP MINISTRIES WORLDWIDE AND DESIGN**. MOUNTAINTOP MINISTRIES WORLDWIDE INC., (U.S. CLS. 100 AND 101). SN 85-443,142. PUB. 3-20-2012. FILED 10-10-2011.
- 4,153,872. **LOUDER THAN WORDS (STANDARD CHARACTER)**. THE UNGAR GROUP, LLC, DBA U/S SPORTS ADVISORS, (U.S. CLS. 100 AND 101). SN 85-443,322. PUB. 3-20-2012. FILED 10-10-2011.
- 4,153,920. **HISLUT (STANDARD CHARACTER)**. HAJI, BEHNAM, (U.S. CLS. 100 AND 101). SN 85-443,822. PUB. 3-20-2012. FILED 10-10-2011.
- 4,153,964. **CRESCENTTIDE FUNERALS . CREMATION AND DESIGN**. CRESCENT TIDE LLC, (U.S. CLS. 100 AND 101). SN 85-444,228. PUB. 3-20-2012. FILED 10-11-2011.
- 4,153,968. **JC'S GIRLS (STANDARD CHARACTER)**. BROWN, SHERI, AND SCHER, THERESA, (U.S. CLS. 100 AND 101). SN 85-444,263. PUB. 3-20-2012. FILED 10-11-2011.
- 4,153,982. **WHERE'S YOUR JEW CREW? (STANDARD CHARACTER)**. JESSICA MORENO, (U.S. CLS. 100 AND 101). SN 85-444,385. PUB. 3-20-2012. FILED 10-11-2011.
- 4,154,029. **360° INSIGHT (STANDARD CHARACTER)**. HILLARD HEINTZE, LLC, (U.S. CLS. 100 AND 101). SN 85-444,927. PUB. 3-20-2012. FILED 10-11-2011.
- 4,154,030. **MISCELLANEOUS DESIGN**. HILLARD HEINTZE, LLC, (U.S. CLS. 100 AND 101). SN 85-444,955. PUB. 3-20-2012. FILED 10-11-2011.
- 4,154,034. **MANARCHY (STANDARD CHARACTER)**. BRIAN J. PLACHTA, (U.S. CLS. 100 AND 101). SN 85-445,044. PUB. 3-20-2012. FILED 10-12-2011.
- 4,154,156. **CLEARSTAR INNOVATOR (STANDARD CHARACTER)**. CLEARSTAR, INC., (U.S. CLS. 100 AND 101). SN 85-455,195. PUB. 3-20-2012. FILED 10-25-2011.
- 4,154,164 (*See Class 35 for this trademark*).
- 4,154,174. **LAWGENIE (STANDARD CHARACTER)**. BOURBEAU & BONILLA, LLP, (U.S. CLS. 100 AND 101). SN 85-457,136. PUB. 3-20-2012. FILED 10-26-2011.
- 4,154,182. **EVOX IMAGES AND DESIGN**. EVOX PRODUCTIONS, LLC, (U.S. CLS. 100 AND 101). SN 85-461,776. PUB. 3-20-2012. FILED 11-1-2011.
- 4,154,188. **CITYLIFE (STANDARD CHARACTER)**. THE NAVIGATORS, (U.S. CLS. 100 AND 101). SN 85-464,142. PUB. 3-20-2012. FILED 11-3-2011.
- 4,154,211. **AIM HIGH! TIPS JUKEBOX (STANDARD CHARACTER)**. BRADLEY IAN BERGER, (U.S. CLS. 100 AND 101). SN 85-486,214. PUB. 3-20-2012. FILED 12-2-2011.
- 4,154,240 (*See Class 35 for this trademark*).

* * * * *

SECTION 2.—PRIOR UNITED STATES CLASSIFICATION

COLLECTIVE MEMBERSHIP MARKS

CLASS 200—COLLECTIVE MEMBERSHIP

4,152,146. **TORCH BEARERS THE TEMPLE OF THE PRESENCE AND DESIGN. THE TEMPLE OF THE PRESENCE, INC.**, SN 77-946,850. PUB. 3-20-2012. FILED 2-28-2010.

4,153,524. **SUFU SOCIETY URODYNAMICS FEMALE PELVIC MEDICINE & UROGENITAL RECONSTRUCTION AND DESIGN. SOCIETY OF URODYNAMICS, FEMALE PELVIC MEDICINE & UROGENITAL RECONSTRUCTION**, SN 85-437,728. PUB. 3-20-2012. FILED 10-3-2011.

CERTIFICATION MARKS

CLASS A—GOODS

4,153,378. **SOLAR RATING & CERTIFICATION CORPORATION SRCC OG-100 CERTIFIED ESTABLISHED 1980 AND DESIGN. SOLAR RATING & CERTIFICATION CORPORATION (SRCC)**, SN 85-429,450. PUB. 3-20-2012. FILED 9-22-2011.

CLASS B—SERVICES

4,152,989. **QP QUALITYPRO THE MARK OF EXCELLENCE IN PEST MANAGEMENT AND DESIGN. FOUNDATION FOR PROFESSIONAL PEST MANAGEMENT, DBA QUALITYPRO**, SN 85-344,273. PUB. 3-20-2012. FILED 6-13-2011.

4,152,990. **GREEN PRO CERTIFIED ECO-EFFECTIVE AND DESIGN. FOUNDATION FOR PROFESSIONAL PEST MANAGEMENT, DBA GREENPRO**, SN 85-344,290. PUB. 3-20-2012. FILED 6-13-2011.

* * * * *

TRADEMARK REGISTRATIONS ISSUED UNDER SECTION 1(d)

The following marks have registered on the Principal Register pursuant to the intent-to-use provisions of Section 1(d) of the Trademark Act of 1946, as amended.

SECTION 1.— INTERNATIONAL CLASSIFICATION

The short titles associated below with the international class numbers are terms designed merely for quick identification and are not an official part of the international classification. The full names of international classes are given in section 6.1 of the trademark rules of practice.

The designation "U.S. Cl." appearing in this section refers to the U.S. class in effect prior to Sep. 1, 1973 rather than the international class which applies to applications filed on or after that date. For adoption of international classification see notice in the OFFICIAL GAZETTE of Jun. 26, 1973 (911 O.G. TM 210).

Application in more than one class

4,154,241. SAFEWAY INC., PLEASANTON, CA. SN 76-669,345. PUB. 6-9-2009, FILED 11-21-2006.

4,154,242. NUROTRON BIOTECHNOLOGY, INC., IRVINE, CA. SN 76-679,311. PUB. 6-17-2008, FILED 7-9-2007.



THE COLOR(S) GREEN AND WHITE IS/ARE CLAIMED AS A FEATURE OF THE MARK.

THE COLOR GREEN APPEARS IN THE BACKGROUND OF THE ENTIRE MARK, AND IN THE WORDING "EATING" AND "UNITING FLAVOR & NUTRITION"; THE COLOR WHITE APPEARS IN THE WORDING "RIGHT".

CLASS 30—STAPLE FOODS

FOR FROZEN, PREPARED OR PACKAGED ENTREES AND MEALS CONSISTING PRIMARILY OF PASTA OR RICE; PASTA; BAKERY GOODS; BREAKFAST CEREALS, CANDIES; FLOUR-BASED, CORN-BASED OR GRAIN-BASED CHIPS; FROZEN CONFECTIONS, FROZEN YOGURT, ICE CREAM FOOD AND BEVERAGE PRODUCTS; MACARONI AND CHEESE; NOODLES, SAUCE, AND SEASONING TOPPING COMBINED IN UNITARY PACKAGES; FROZEN AND PREPARED PIZZAS; SALAD DRESSINGS; SAUCES; SANDWICHES; COOKIES; CRACKERS; GRANOLA-BASED SNACK BARS; OATMEAL; GRAIN-BASED FOOD BARS ALSO CONTAINING DRIED FRUIT; MUFFINS; BREAD AND WAFFLES (U.S. CL. 46).

FIRST USE 9-13-2009; IN COMMERCE 9-13-2009.

CLASS 35—ADVERTISING AND BUSINESS

FOR RETAIL GROCERY STORE SERVICES (U.S. CLS. 100, 101 AND 102).

FIRST USE 3-24-2007; IN COMMERCE 3-24-2007.

NUROTRON

THE MARK CONSISTS OF STANDARD CHARACTERS WITHOUT CLAIM TO ANY PARTICULAR FONT, STYLE, SIZE, OR COLOR.

CLASS 9—ELECTRICAL AND SCIENTIFIC APPARATUS

FOR COMPUTER SOFTWARE FOR OPERATING EYE IMPLANTS, HEARING AIDS, AND COCHLEAR IMPLANTS (U.S. CLS. 21, 23, 26, 36 AND 38).

FIRST USE 3-15-2007; IN COMMERCE 8-31-2008.

CLASS 10—MEDICAL APPARATUS

FOR MEDICAL DEVICES, NAMELY, EYE IMPLANTS, HEARING AIDS, COCHLEAR IMPLANTS AND COMPUTER OPERATING SOFTWARE SOLD AS A UNIT (U.S. CLS. 26, 39 AND 44).

FIRST USE 3-15-2007; IN COMMERCE 8-31-2008.

4,154,246. JOHNSON & JOHNSON, NEW BRUNSWICK, NJ. SN 76-696,329. PUB. 12-29-2009, FILED 3-16-2009.

LENS ON TALENT

THE MARK CONSISTS OF STANDARD CHARACTERS WITHOUT CLAIM TO ANY PARTICULAR FONT, STYLE, SIZE, OR COLOR.

CLASS 36—INSURANCE AND FINANCIAL

FOR FINANCIAL SPONSORSHIP OF AMATEUR FILMMAKING VIA ON-GOING TELEVISION AND CABLE TELEVISION PROGRAMS (U.S. CLS. 100, 101 AND 102).

FIRST USE 6-23-2011; IN COMMERCE 6-23-2011.

CLASS 41—EDUCATION AND ENTERTAINMENT

FOR ENTERTAINMENT SERVICES, NAMELY, CONDUCTING CONTESTS IN THE FIELD OF FILMMAKING, SPECIFICALLY, VIDEOGRAPHY, OFFERED VIA A WEBSITE (U.S. CLS. 100, 101 AND 107).

FIRST USE 6-23-2011; IN COMMERCE 6-23-2011.

CLASS 6—METAL GOODS

FOR METAL NON-JEWELRY LOCKS; METAL GATES; METAL NON-JEWELRY KEYLESS LOCKS (U.S. CLS. 2, 12, 13, 14, 23, 25 AND 50).

FIRST USE 6-18-2010; IN COMMERCE 8-18-2010.

CLASS 41—EDUCATION AND ENTERTAINMENT

FOR SPECIAL EVENT PLANNING FOR SOCIAL ENTERTAINMENT PURPOSES; AND PARTY AND WEDDING PLANNING SERVICE (U.S. CLS. 100, 101 AND 107).

FIRST USE 6-18-2010; IN COMMERCE 8-18-2010.

4,154,247. WORLD MAGIC INTERNATIONAL (W.M.I) AVV, ORANJESTAD, ARUBA. SN 76-701,440. PUB. 7-26-2011, FILED 2-1-2010.

EZAMA

THE MARK CONSISTS OF STANDARD CHARACTERS WITHOUT CLAIM TO ANY PARTICULAR FONT, STYLE, SIZE, OR COLOR.

PRIORITY CLAIMED UNDER SEC. 44(D) ON EUROPEAN UNION APPLICATION NO. 8,720,443, FILED 11-30-2009.

CLASS 28—TOYS AND SPORTING GOODS

FOR MAGIC TRICKS, NAMELY, CONJURER'S BOXES, MAGIC KITS, CONSISTING PRIMARILY OF MAGIC TRICKS, NOVELTY ITEMS, ETC (U.S. CLS. 22, 23, 38 AND 50).

FIRST USE 6-15-2011; IN COMMERCE 6-15-2011.

CLASS 41—EDUCATION AND ENTERTAINMENT

FOR CONDUCTING ENTERTAINMENT EXHIBITIONS IN THE NATURE OF MAGIC SHOWS; ENTERTAINMENT IN THE NATURE OF MAGIC SHOWS (U.S. CLS. 100, 101 AND 107).

FIRST USE 6-15-2011; IN COMMERCE 6-15-2011.

4,154,249. LOVELOCKS AT LOVER'S GATE, ST. GEORGE, UT. SN 76-702,701. PUB. 4-26-2011, FILED 4-29-2010.



THE MARK CONSISTS OF THE WORD "LOVELOCKS", WHERE THE FIRST "L" OF THE WORD APPEARS BACK-TO-BACK WITH A BACKWARDS "L"; THE TWO ADJACENT "L'S" APPEAR LOCKED BY A STYLIZED LOCK DESIGN WHERE THE BOTTOM PORTION OF THE LOCK IS IN THE SHAPE OF A HEART.

4,154,272. LEAR CORPORATION, SOUTHFIELD, MI. SN 77-172,306. PUB. 7-1-2008, FILED 5-3-2007.

AVENTINO

THE MARK CONSISTS OF STANDARD CHARACTERS WITHOUT CLAIM TO ANY PARTICULAR FONT, STYLE, SIZE, OR COLOR.

THE TERM "AVENTINO" HAS NO MEANING IN A FOREIGN LANGUAGE.

CLASS 12—VEHICLES

FOR SEAT COVERS FOR VEHICLES; FITTED VEHICLE COVERS; COVERS FOR VEHICLE INTERIORS, NAMELY, COVERS FOR STEERING WHEELS, GEAR SHIFTS, DASHBOARD COVERS, CONSOLES AND ARMRESTS; UPHOLSTERY FOR VEHICLES PREPARED WITH THE USE OF LEATHER (U.S. CLS. 19, 21, 23, 31, 35 AND 44).

FIRST USE 1-8-2007; IN COMMERCE 1-8-2007.

CLASS 24—FABRICS

FOR UNFITTED COVERS FOR SEATING FURNITURE NOT OF PAPER AND PREPARED WITH THE USE OF LEATHER (U.S. CLS. 42 AND 50).

FIRST USE 1-8-2007; IN COMMERCE 1-8-2007.

4,154,280. FELLERS, JAMES D., ROUND ROCK, TX. SN 77-305,668. PUB. 8-12-2008, FILED 10-17-2007.



THE MARK CONSISTS OF A CIRCLE UPON WHICH A STYLIZED LOWER-CASE LETTER "I" IS SUPERIMPOSED; THE STYLIZED LETTER "I" WITHIN THE CIRCLE IS FOLLOWED BY A STYLIZED LOWERCASE "N", WHICH STRADDLES THE OUTER EDGE OF THE CIRCLE, FOLLOWED BY THE STYLIZED LETTERS "F", "O", "B", "O", "O", "K", RESPECTIVELY.

CLASS 35—ADVERTISING AND BUSINESS

FOR ADVERTISING SERVICES, NAMELY, PROMOTING THE GOODS AND SERVICES OF OTHERS BY PREPARING AND PLACING ADVERTISEMENTS IN DIRECTORY LISTING DATABASES ACCESSED THROUGH A GLOBAL INFORMATION NETWORK; PROVIDING RETAIL STORE INFORMATION, SHOPPERS GUIDE INFORMATION AND BUSINESS LISTINGS BY ELECTRONIC MEANS; COMPUTER SERVICES, NAMELY, PROVIDING INFORMATION VIA A GLOBAL COMPUTER INFORMATION NETWORK IN THE FIELD OF COMMERCIAL INFORMATION DIRECTORIES ABOUT BUSINESSES AND INDIVIDUALS (U.S. CLS. 100, 101 AND 102).

FIRST USE 3-9-2012; IN COMMERCE 3-9-2012.

CLASS 38—COMMUNICATION

FOR TELECOMMUNICATIONS SERVICES, NAMELY, ELECTRONIC TRANSMISSION OF DATA, IMAGES, AND DOCUMENTS VIA COMPUTER TERMINALS AND AUDIOVISUAL EQUIPMENT; PREPAID LONG DISTANCE TELEPHONE COMMUNICATION SERVICES; ELECTRONIC MAIL SERVICES; AND FACSIMILE TRANSMISSION; PROVIDING WORKGROUP COMMUNICATION SERVICES OVER COMPUTER NETWORKS; PROVIDING MULTIPLE USER ACCESS TO PROPRIETARY COLLECTIONS OF INFORMATION BY MEANS OF GLOBAL COMPUTER INFORMATION NETWORKS; CABLE AND SATELLITE TELEVISION BROADCASTING (U.S. CLS. 100, 101 AND 104).

FIRST USE 3-9-2012; IN COMMERCE 3-9-2012.

CLASS 41—EDUCATION AND ENTERTAINMENT

FOR PROVIDING INFORMATION IN THE FIELD OF MUSIC, ARTS, CULTURE AND HISTORY VIA COMPUTER NETWORKS; PROVIDING NEWS IN THE NATURE OF CURRENT EVENTS REPORTING; ENTERTAINMENT SERVICES IN THE NATURE OF CABLE AND SATELLITE TELEVISION PROGRAMMING; ARRANGING LIVE CONCERTS, TELEVISION AWARD SHOWS, AND SEMINARS (U.S. CLS. 100, 101 AND 107).

FIRST USE 3-9-2012; IN COMMERCE 3-9-2012.

CLASS 42—SCIENTIFIC AND COMPUTER SERVICES

FOR COMPUTER SERVICES, NAMELY, PROVIDING CUSTOMIZED ONLINE WEB PAGES FEATURING USER-DEFINED INFORMATION, SEARCH ENGINES AND ONLINE WEB LINKS TO NEWS, WEATHER, SPORTS, CURRENT EVENTS, REFERENCE MATERIALS, AND CUSTOMIZED E-MAIL MESSAGES, CONCERNING USER-DEFINED TOPICS OF GENERAL INTEREST; GRAPHIC ART SERVICES FOR USE IN THE DEVELOPMENT OF WEB PAGES; PROVIDING SOFTWARE INTERFACES AVAILABLE OVER A NETWORK IN ORDER TO CREATE A PERSONALIZED ONLINE INFORMATION SERVICE; EXTRACTION AND RETRIEVAL OF INFORMATION AND DATA MINING BY MEANS OF GLOBAL COMPUTER NETWORKS; CREATING INDEXES OF INFORMATION, INDEXES OF WEB SITES AND INDEXES OF OTHER INFORMATION SOURCES IN CONNECTION WITH GLOBAL COMPUTER NETWORKS (U.S. CLS. 100 AND 101).

FIRST USE 3-9-2012; IN COMMERCE 3-9-2012.

4,154,291. OMKASA, HIGHLANDS RANCH, CO. SN 77-396,891. PUB. 1-13-2009, FILED 2-14-2008.

OMKASA

THE MARK CONSISTS OF STANDARD CHARACTERS WITHOUT CLAIM TO ANY PARTICULAR FONT, STYLE, SIZE, OR COLOR.

THE WORDING "OMKASA" HAS NO MEANING IN A FOREIGN LANGUAGE.

CLASS 24—FABRICS

FOR TEXTILES AND TEXTILE GOODS, NAMELY, CUSHION COVERS, PILLOW COVERS; DRAPERIES; THROWS; TAPESTRIES OF TEXTILE; TABLE LINEN, NAMELY, PLACE MATS, TABLE RUNNERS, NAPKINS, COASTERS, FABRIC NAPKIN RINGS, FABRICS FOR TEXTILE USE; WALL HANGINGS OF TEXTILE, CURTAINS OF TEXTILE (U.S. CLS. 42 AND 50).

FIRST USE 4-7-2012; IN COMMERCE 4-7-2012.

CLASS 35—ADVERTISING AND BUSINESS

FOR ONLINE RETAIL STORE SERVICES FEATURING CURTAINS, DRAPERIES, THROWS, CUSHIONS, PILLOWS, PLACE MATS, TABLE RUNNERS, COASTERS, NAPKINS, NAPKIN RINGS, PURSES, HAND BAGS, SHAWLS, JEWELRY OF PRECIOUS METAL, STONES AND GEMSTONES (U.S. CLS. 100, 101 AND 102).

FIRST USE 4-7-2012; IN COMMERCE 4-7-2012.

4,154,293. COOL EARTH ACTION, LONDON, UNITED KINGDOM. SN 77-400,589. PUB. 4-6-2010, FILED 2-19-2008.



THE COLOR(S) BLUE AND GREEN IS/ARE CLAIMED AS A FEATURE OF THE MARK.

THE MARK CONSISTS OF THE WORDS "COOL" AND "EARTH" WITH THE COLOR BLUE APPEARING IN THE LETTERS "COO" AND THE BRANCH DESIGN, AND THE COLOR GREEN APPEARING IN THE WORD "EARTH" AND IN THE CIRCULAR TREE DESIGN.

CLASS 36—INSURANCE AND FINANCIAL

FOR CHARITABLE SERVICES, NAMELY, PROVIDING FINANCIAL SUPPORT TO PEOPLE FROM DISADVANTAGED COUNTRIES FOR THE PURPOSE OF FACILITATING EDUCATIONAL OPPORTUNITIES; CHARITABLE SERVICES, NAMELY, GRANTING FUNDS TO SCHOOLS; CHARITABLE FUNDRAISING SERVICES FOR CONSERVATION AND PROTECTION OF THE ENVIRONMENT AND RAINFORESTS; PROVISION OF CHARITABLE FUNDRAISING SERVICES IN RELATION TO CARBON OFFSETTING; COMMODITIES TRADING FOR OTHERS; TRADING OF EMISSIONS ALLOWANCES AND OTHER EMISSIONS AND ENVIRONMENTAL COMMODITIES FOR OTHERS; COMMODITIES INVESTMENT ADVICE SERVICES; PROVISION OF PRICING INFORMATION OF COMMODITIES; CAPITAL INVESTMENT SERVICES; INVESTMENT OF FUNDS FOR OTHERS; TRADING IN THE FIELDS OF OPTIONS, STOCKS, EMISSIONS ALLOWANCES, AND EQUITIES; FINANCING OF ACQUISITIONS; INFORMATION, ADVISORY AND CONSULTANCY SERVICES RELATING TO THE AFORESAID SERVICES; INFORMATION, ADVISORY AND CONSULTANCY SERVICES RELATING TO THE AFORESAID SERVICES PROVIDED ON-LINE FROM A COMPUTER DATABASE OR THE INTERNET (U.S. CLS. 100, 101 AND 102).

FIRST USE 3-16-2009; IN COMMERCE 3-16-2009.

CLASS 41—EDUCATION AND ENTERTAINMENT

FOR EDUCATIONAL SERVICES, NAMELY, PROVIDING CLASSES, SEMINARS, AND WORKSHOPS RELATING TO CONSERVATION AND PROTECTION OF THE ENVIRONMENT AND RAINFORESTS, AND DISTRIBUTION OF COURSE MATERIALS RELATING TO CONSERVATION AND PROTECTION OF THE ENVIRONMENT AND RAINFORESTS, INCLUDING INSTRUCTIONAL MANUALS; INFORMATION, ADVISORY AND CONSULTANCY SERVICES RELATING TO THE AFORESAID SERVICES; INFORMATION, ADVISORY AND CONSULTANCY SERVICES RELATING TO THE AFORESAID SERVICES PROVIDED ON-LINE FROM A COMPUTER DATABASE OR THE INTERNET (U.S. CLS. 100, 101 AND 107).

FIRST USE 3-16-2009; IN COMMERCE 3-16-2009.

CLASS 42—SCIENTIFIC AND COMPUTER SERVICES

FOR PROVIDING SCIENTIFIC INFORMATION RELATING TO ENVIRONMENTAL CONSERVATION AND ISSUES INCLUDING ENVIRONMENTAL IMPACT ANALYSIS; INFORMATION SERVICES RELATING TO ENVIRONMENTAL AWARENESS, NAMELY, PROVIDING A WEBSITE FEATURING INFORMATION ABOUT GLOBAL WARMING AND ITS EFFECT ON NATURE AND THE ENVIRONMENT; SCIENTIFIC RESEARCH RELATING TO ENVIRONMENTAL ISSUES; SCIENTIFIC RESEARCH RELATING TO AGRICULTURAL, HORTICULTURAL AND FORESTRY ISSUES; PROVIDING SCIENTIFIC INFORMATION SERVICES RELATING TO CARBON OFFSETTING; SCIENTIFIC RESEARCH RELATING TO CARBON OFFSETTING; INFORMATION, ADVISORY AND CONSULTANCY SERVICES RELATING TO THE AFORESAID SERVICES; INFORMATION, ADVISORY AND CONSULTANCY SERVICES RELATING TO THE AFORESAID SERVICES PROVIDED ON-LINE FROM A COMPUTER DATABASE OR THE INTERNET (U.S. CLS. 100 AND 101).

FIRST USE 3-16-2009; IN COMMERCE 3-16-2009.

CLASS 44—MEDICAL, BEAUTY AND AGRICULTURAL SERVICES

FOR AGRICULTURAL, HORTICULTURAL AND FORESTRY SERVICES RELATING TO CONSERVATION AND PROTECTION OF THE ENVIRONMENT AND RAINFORESTS, NAMELY, THE CULTIVATION, TREATMENT AND CARE OF LAND, TREES, AND PLANTS; INFORMATION, ADVISORY AND CONSULTANCY SERVICES RELATING TO THE AFORESAID SERVICES PROVIDED ON-LINE FROM A COMPUTER DATABASE OR THE INTERNET (U.S. CLS. 100 AND 101).

FIRST USE 3-16-2009; IN COMMERCE 3-16-2009.

4,154,297. NOVALOGIC, INC., MALIBU, CA. SN 77-413,611. PUB. 7-22-2008, FILED 3-5-2008.

ANGEL FALLS

THE MARK CONSISTS OF STANDARD CHARACTERS WITHOUT CLAIM TO ANY PARTICULAR FONT, STYLE, SIZE, OR COLOR.

CLASS 9—ELECTRICAL AND SCIENTIFIC APPARATUS

FOR COMPUTER AND VIDEO GAME SOFTWARE, COMPUTER PROGRAMS RECORDED ON CD-ROMS AND COMPACT DISCS FEATURING COMPUTER GAMES; ACCESSORIES FOR PLAYING ELECTRONIC COMPUTER GAMES, NAMELY, GAME CONTROLLERS, CUSTOM COVERS FOR GAME CONSOLES, COMPUTER CASES AND PERIPHERAL DEVICES (U.S. CLS. 21, 23, 26, 36 AND 38).

FIRST USE 10-14-2011; IN COMMERCE 10-14-2011.

CLASS 41—EDUCATION AND ENTERTAINMENT

FOR ENTERTAINMENT SERVICES, NAMELY, PROVIDING ON-LINE COMPUTER GAMES (U.S. CLS. 100, 101 AND 107).

FIRST USE 10-14-2011; IN COMMERCE 10-14-2011.

4,154,313. KEE ACTION SPORTS I LLC, SEWELL, NJ. SN 77-498,591. PUB. 12-30-2008, FILED 6-13-2008.

BATTLE TESTED

THE MARK CONSISTS OF STANDARD CHARACTERS WITHOUT CLAIM TO ANY PARTICULAR FONT, STYLE, SIZE, OR COLOR.

CLASS 28—TOYS AND SPORTING GOODS

FOR PAINTBALL MARKER GUNS; PAINTBALL MARKER GUN PARTS AND ACCESSORIES, NAMELY, PAINTBALL MARKER BARRELS; PAINTBALL SPORT EQUIPMENT, NAMELY, PAINTBALL LOADERS, PAINTBALL HARNESES, PAINTBALL SPORT GLOVES, PAINTBALL SPORT VESTS, AND PAINTBALL SPORT CHEST PROTECTORS (U.S. CLS. 22, 23, 38 AND 50).

FIRST USE 7-0-2008; IN COMMERCE 7-0-2008.

CLASS 35—ADVERTISING AND BUSINESS

FOR WHOLESALE DISTRIBUTORSHIPS IN THE FIELD OF PAINTBALL SPORT EQUIPMENT (U.S. CLS. 100, 101 AND 102).

FIRST USE 7-0-2008; IN COMMERCE 7-0-2008.

4,154,315. BISON CAPITAL LLC, VENICE, FL. SN 77-505,100. PUB. 12-30-2008, FILED 6-23-2008.

Three Springs Bottling
Company

THE MARK CONSISTS OF STANDARD CHARACTERS WITHOUT CLAIM TO ANY PARTICULAR FONT, STYLE, SIZE, OR COLOR.

NO CLAIM IS MADE TO THE EXCLUSIVE RIGHT TO USE "BOTTLING COMPANY", APART FROM THE MARK AS SHOWN.

CLASS 32—LIGHT BEVERAGES

FOR NON-ALCOHOLIC MALT BEVERAGES, NON-ALCOHOLIC COCKTAILS, AND BOTTLED WATER (U.S. CLS. 45, 46 AND 48).

FIRST USE 11-14-2011; IN COMMERCE 11-14-2011.

CLASS 33—WINES AND SPIRITS

FOR DISTILLED SPIRITS (U.S. CLS. 47 AND 49).
FIRST USE 10-24-2011; IN COMMERCE 10-24-2011.

4,154,318. DEVEDIA HOLDINGS, INC., WASHINGTON, DC. SN 77-509,775. PUB. 8-25-2009, FILED 6-27-2008.



NO CLAIM IS MADE TO THE EXCLUSIVE RIGHT TO USE "1797" AND "MUENCHEN", APART FROM THE MARK AS SHOWN.

THE MARK CONSISTS OF THE WORDING "1797 PRANTL MUENCHEN" IN A STYLIZED FONT BENEATH A DESIGN COMPRISING TWO HERALDIC LIONS WEAR-

ING CROWNS AND STANDING UPRIGHT ON AN ORNAMENTAL LEAFY DESIGN ON EITHER SIDE OF A SHIELD-LIKE CREST AND A CROWN. UPON THE CREST ARE FOUND DEPICTIONS OF LIONS AND GEOMETRIC DESIGNS. THE COAT OF ARMS DEPICTED IN THE MARK HAS NO MEANING OTHER THAN TRADEMARK SIGNIFICANCE.

THE ENGLISH TRANSLATION OF "MUENCHEN" IS "MUNICH".

CLASS 16—PAPER GOODS AND PRINTED MATTER

FOR ART PAPER; OFFICE PAPER STATIONERY; PAINT BRUSHES; PAPER AND CARDBOARD; PAPER STOCK; PARCHMENT PAPER; POSTCARD PAPER; PRINTED PAPER SIGNS; STATIONERY WRITING PAPER AND ENVELOPES (U.S. CLS. 2, 5, 22, 23, 29, 37, 38 AND 50).

FIRST USE 1-1-1995; IN COMMERCE 1-1-1995.

CLASS 35—ADVERTISING AND BUSINESS

FOR ADVERTISING AND BUSINESS MANAGEMENT CONSULTANCY; RETAIL GIFT SHOPS; RETAIL JEWELRY STORES; RETAIL STORE SERVICES FEATURING PAPER GOODS, PRECIOUS METALS, ALLOYS AND OTHER CONSUMER GOODS IN THE STATIONERY AND JEWELRY SECTORS (U.S. CLS. 100, 101 AND 102).

FIRST USE 1-1-1995; IN COMMERCE 1-1-1995.

4,154,319. HAGN, CLAUDIA, ROSENGARTEN, FED REP GERMANY. SN 77-513,117. PUB. 6-16-2009, FILED 7-2-2008.

THE NAME "CLAUDIA HAGN" IDENTIFIES A LIVING INDIVIDUAL WHOSE CONSENT IS OF RECORD.

CLASS 24—FABRICS

FOR TEXTILES AND TEXTILE GOODS, NAMELY, BED COVERS, BED SPREADS, BED SHEETS, TABLE CLOTH COVERS AND NAPKINS NOT OF PAPER; CURTAINS; HOME TEXTILE PRODUCTS, NAMELY, DRAPERY; FABRICS FOR TEXTILE USE; GOODS OF TERRY-TOWELING, NAMELY, TERRY TOWELS (U.S. CLS. 42 AND 50).

FIRST USE 1-0-2011; IN COMMERCE 1-0-2012.

CLASS 25—CLOTHING

FOR CLOTHING, NAMELY, BATH ROBES, SWIMWEAR, SHIRTS, T-SHIRTS, LINGERIE, TROUSERS, LEGGINGS, BOXER SHORTS, FOOTWEAR AND HEADWEAR (U.S. CLS. 22 AND 39).

FIRST USE 1-0-2011; IN COMMERCE 1-0-2012.

4,154,320. ELECTROCRAFT, INC., DOVER, NH. SN 77-521,121. PUB. 12-23-2008, FILED 7-14-2008.

4,154,322. ELECTROCRAFT, INC., DOVER, NH. SN 77-521,124. PUB. 12-23-2008, FILED 7-14-2008.

ELECTROCRAFT COMPLETEPOWER

THE MARK CONSISTS OF STANDARD CHARACTERS WITHOUT CLAIM TO ANY PARTICULAR FONT, STYLE, SIZE, OR COLOR.

OWNER OF U.S. REG. NOS. 1,572,910, 2,752,092, AND 2,758,207.

CLASS 7—MACHINERY

FOR INTEGRATED MOTOR DRIVES, OTHER THAN FOR LAND VEHICLES (U.S. CLS. 13, 19, 21, 23, 31, 34 AND 35).

FIRST USE 3-12-2012; IN COMMERCE 3-12-2012.

CLASS 9—ELECTRICAL AND SCIENTIFIC APPARATUS

FOR ELECTRIC CIRCUITS FOR THE CONTROL AND REGULATION OF ELECTRIC MOTORS; ELECTRIC CONTROLS FOR ELECTRIC MOTORS; MOTOR SPEED CONTROLS; SERVO DRIVES, NAMELY, ELECTRONIC SERVO MOTOR CONTROLS; AMPLIFIERS FOR ELECTRIC MOTORS; POSITION CONTROLS FOR ELECTRIC MOTORS; ELECTRIC MOTOR SPEED SENSORS; STEPPING CONTROLS FOR ELECTRIC MOTORS; STEPPING DRIVES, NAMELY, ELECTRONIC STEPPER MOTOR CONTROLS (U.S. CLS. 21, 23, 26, 36 AND 38).

FIRST USE 1-0-2007; IN COMMERCE 1-0-2007.

CLASS 12—VEHICLES

FOR INTEGRATED MOTOR DRIVES, FOR LAND VEHICLES (U.S. CLS. 19, 21, 23, 31, 35 AND 44).

FIRST USE 3-12-2012; IN COMMERCE 3-12-2012.

4,154,321. ELECTROCRAFT, INC., DOVER, NH. SN 77-521,122. PUB. 12-23-2008, FILED 7-14-2008.

ELECTROCRAFT DIRECTPOWER

THE MARK CONSISTS OF STANDARD CHARACTERS WITHOUT CLAIM TO ANY PARTICULAR FONT, STYLE, SIZE, OR COLOR.

OWNER OF U.S. REG. NOS. 1,572,910, 2,752,092, AND 2,758,207.

CLASS 7—MACHINERY

FOR DC MOTORS, DC GEAR MOTORS, DC MOTOR GENERATORS, DC SERVO MOTORS, OTHER THAN FOR LAND VEHICLES (U.S. CLS. 13, 19, 21, 23, 31, 34 AND 35).

FIRST USE 12-0-2009; IN COMMERCE 12-0-2009.

CLASS 12—VEHICLES

FOR DC MOTORS, DC GEAR MOTORS, FOR LAND VEHICLES (U.S. CLS. 19, 21, 23, 31, 35 AND 44).

FIRST USE 12-0-2009; IN COMMERCE 10-0-2011.

ELECTROCRAFT MOBILEPOWER

THE MARK CONSISTS OF STANDARD CHARACTERS WITHOUT CLAIM TO ANY PARTICULAR FONT, STYLE, SIZE, OR COLOR.

OWNER OF U.S. REG. NOS. 1,572,910, 2,752,092, AND 2,758,207.

CLASS 7—MACHINERY

FOR MACHINE TRANSAXLE DRIVES, GEARBOXES, OTHER THAN FOR LAND VEHICLES (U.S. CLS. 13, 19, 21, 23, 31, 34 AND 35).

FIRST USE 2-0-2012; IN COMMERCE 2-0-2012.

CLASS 12—VEHICLES

FOR MACHINE TRANSAXLE DRIVES, GEARBOXES, FOR LAND VEHICLES (U.S. CLS. 19, 21, 23, 31, 35 AND 44).

FIRST USE 2-0-2012; IN COMMERCE 2-0-2012.

4,154,323. ELECTROCRAFT, INC., DOVER, NH. SN 77-521,125. PUB. 12-23-2008, FILED 7-14-2008.

ELECTROCRAFT RAPIDPOWER

THE MARK CONSISTS OF STANDARD CHARACTERS WITHOUT CLAIM TO ANY PARTICULAR FONT, STYLE, SIZE, OR COLOR.

OWNER OF U.S. REG. NOS. 1,572,910, 2,752,092, AND 2,758,207.

CLASS 7—MACHINERY

FOR BRUSHLESS MOTORS, BRUSHLESS GEAR MOTORS, BRUSHLESS SERVO MOTORS, INTEGRATED BRUSHLESS MOTOR DRIVES, OTHER THAN FOR LAND VEHICLES (U.S. CLS. 13, 19, 21, 23, 31, 34 AND 35).

FIRST USE 3-13-2012; IN COMMERCE 3-13-2012.

CLASS 12—VEHICLES

FOR BRUSHLESS MOTORS, BRUSHLESS GEAR MOTORS, INTEGRATED BRUSHLESS MOTOR DRIVES, FOR LAND VEHICLES (U.S. CLS. 19, 21, 23, 31, 35 AND 44).

FIRST USE 3-13-2012; IN COMMERCE 3-13-2012.

4,154,324. ELECTROCRAFT, INC., DOVER, NH. SN 77-521,130. PUB. 12-23-2008, FILED 7-14-2008.

4,154,345. FIGG ENGINEERING GROUP, TALLAHASSEE, FL. SN 77-555,075. PUB. 1-20-2009, FILED 8-25-2008.

ELECTROCRAFT TORQUEPOWER

THE MARK CONSISTS OF STANDARD CHARACTERS WITHOUT CLAIM TO ANY PARTICULAR FONT, STYLE, SIZE, OR COLOR.

OWNER OF U.S. REG. NOS. 1,572,910, 2,752,092, AND 2,758,207.

CLASS 7—MACHINERY

FOR STEPPING MOTORS, OTHER THAN FOR LAND VEHICLES (U.S. CLS. 13, 19, 21, 23, 31, 34 AND 35). FIRST USE 3-12-2012; IN COMMERCE 3-12-2012.

CLASS 12—VEHICLES

FOR STEPPING MOTORS, FOR LAND VEHICLES (U.S. CLS. 19, 21, 23, 31, 35 AND 44). FIRST USE 3-12-2012; IN COMMERCE 3-12-2012.

4,154,327. GAINES GROUP, LLC, HOUSTON, TX. SN 77-531,727. PUB. 12-23-2008, FILED 7-25-2008.

Blooming Diffuser

THE MARK CONSISTS OF STANDARD CHARACTERS WITHOUT CLAIM TO ANY PARTICULAR FONT, STYLE, SIZE, OR COLOR.

NO CLAIM IS MADE TO THE EXCLUSIVE RIGHT TO USE "DIFFUSER", APART FROM THE MARK AS SHOWN.

CLASS 3—COSMETICS AND CLEANING PREPARATIONS

FOR ROOM FRAGRANCE REFILLS FOR NON-ELECTRIC ROOM FRAGRANCE DISPENSERS; ROOM FRAGRANCES (U.S. CLS. 1, 4, 6, 50, 51 AND 52). FIRST USE 1-1-2010; IN COMMERCE 1-1-2010.

CLASS 5—PHARMACEUTICALS

FOR ROOM FRESHENERS (U.S. CLS. 6, 18, 44, 46, 51 AND 52). FIRST USE 1-1-2010; IN COMMERCE 1-1-2010.

EcoBridge

THE MARK CONSISTS OF STANDARD CHARACTERS WITHOUT CLAIM TO ANY PARTICULAR FONT, STYLE, SIZE, OR COLOR.

CLASS 37—CONSTRUCTION AND REPAIR

FOR CONSTRUCTION SERVICES, NAMELY, PLANNING, LAYING OUT AND CUSTOM CONSTRUCTION OF BRIDGES (U.S. CLS. 100, 103 AND 106). FIRST USE 4-12-2012; IN COMMERCE 4-12-2012.

CLASS 42—SCIENTIFIC AND COMPUTER SERVICES

FOR DESIGN AND ENGINEERING SERVICES IN THE FIELD OF BRIDGES (U.S. CLS. 100 AND 101). FIRST USE 4-12-2012; IN COMMERCE 4-12-2012.

4,154,356. SMARTDRIVE SYSTEMS, INC., SAN DIEGO, CA. SN 77-569,029. PUB. 8-23-2011, FILED 9-12-2008.



OWNER OF U.S. REG. NOS. 3,819,803 AND 3,823,581.

THE MARK CONSISTS OF THE WORDING "SMARTDRIVE" TO THE RIGHT OF A SQUIGGLE DESIGN WITH THE APPEARANCE OF A DIVIDED ROADWAY.

CLASS 9—ELECTRICAL AND SCIENTIFIC APPARATUS

FOR VIDEO, AUDIO AND EVENT DIAGNOSTIC RECORDERS FOR USE IN VEHICLES; VIDEO, AUDIO AND EVENT RECORDERS FOR THE PURPOSE OF RECORDING, ANALYZING, SCORING OR TRENDING DRIVER BEHAVIOR AND INFORMATION; VIDEO, AUDIO AND EVENT RECORDERS FOR THE PURPOSE OF RECORDING, DOWNLOADING AND TRANSMITTING VEHICLE, DRIVING AND DRIVER INFORMATION (U.S. CLS. 21, 23, 26, 36 AND 38). FIRST USE 4-6-2008; IN COMMERCE 5-23-2008.

CLASS 35—ADVERTISING AND BUSINESS

FOR TRACKING, LOCATING AND MONITORING OF VEHICLES FOR COMMERCIAL PURPOSES; INFORMATION AND DATA COMPILING AND ANALYZING RELATING TO BUSINESS MANAGEMENT, SPECIFICALLY FOR THE REVIEW AND RATING OF RECORDED VIDEO, AUDIO AND EVENT INFORMATION CONCERNING VEHICLES, VEHICLE DRIVING BEHAVIOR AND DRIVER INFORMATION FOR FLEET MANAGERS, OWNERS AND VEHICLE MANUFACTURERS (U.S. CLS. 100, 101 AND 102). FIRST USE 4-6-2008; IN COMMERCE 5-23-2008.

CLASS 38—COMMUNICATION

FOR ON-LINE DELIVERY VIA A GLOBAL COMPUTER NETWORK OF RECORDED VIDEO, AUDIO AND EVENT INFORMATION CONCERNING VEHICLES, VEHICLE DRIVING BEHAVIOR AND DRIVER INFORMATION FOR FLEET MANAGERS, OWNERS AND VEHICLE MANUFACTURERS (U.S. CLS. 100, 101 AND 104).

FIRST USE 4-6-2008; IN COMMERCE 5-23-2008.

4,154,371. RELADYNE, LLC, SHARONVILLE, OH. SN 77-616,021. PUB. 12-15-2009, FILED 11-17-2008.

4,154,362. PREGEL AMERICA, INC., CONCORD, NC. SN 77-589,526. PUB. 7-7-2009, FILED 10-9-2008.

WHYGELATO.COM

THE MARK CONSISTS OF STANDARD CHARACTERS WITHOUT CLAIM TO ANY PARTICULAR FONT, STYLE, SIZE, OR COLOR.

CLASS 16—PAPER GOODS AND PRINTED MATTER

FOR GROCERY BAGS, PENS, BANNERS, BUMPER STICKERS, DECALS, PAMPHLETS IN THE FIELD OF DESSERTS, BROCHURES IN THE FIELD OF DESSERTS, TEMPORARY TATTOOS (U.S. CLS. 2, 5, 22, 23, 29, 37, 38 AND 50).

FIRST USE 8-0-2008; IN COMMERCE 8-0-2008.

CLASS 25—CLOTHING

FOR T-SHIRTS, HATS (U.S. CLS. 22 AND 39).
FIRST USE 8-0-2008; IN COMMERCE 8-0-2008.

4,154,365. PURELINE, LLC, CHEYENNE, WY. SN 77-599,622. PUB. 4-14-2009, FILED 10-24-2008.

HYDROLINE

THE MARK CONSISTS OF STANDARD CHARACTERS WITHOUT CLAIM TO ANY PARTICULAR FONT, STYLE, SIZE, OR COLOR.

CLASS 9—ELECTRICAL AND SCIENTIFIC APPARATUS

FOR ELECTRONIC WATER METERS FOR USE IN GROUNDWATER QUALITY SAMPLING (U.S. CLS. 21, 23, 26, 36 AND 38).

FIRST USE 3-0-2009; IN COMMERCE 3-0-2009.

CLASS 11—ENVIRONMENTAL CONTROL APPARATUS

FOR GROUNDWATER FILTERS FOR USE IN GROUNDWATER QUALITY SAMPLING (U.S. CLS. 13, 21, 23, 31 AND 34).

FIRST USE 3-0-2009; IN COMMERCE 3-0-2009.

RELADYNE

THE MARK CONSISTS OF STANDARD CHARACTERS WITHOUT CLAIM TO ANY PARTICULAR FONT, STYLE, SIZE, OR COLOR.

CLASS 4—LUBRICANTS AND FUELS

FOR ALL PURPOSE LUBRICANTS; AUTOMOBILE, TRUCK AND HEAVY EQUIPMENT LUBRICANTS; LUBRICANTS FOR INDUSTRIAL MACHINERY; LUBRICANTS FOR AIRCRAFT ENGINES; INDUSTRIAL LUBRICANTS (U.S. CLS. 1, 6 AND 15).

FIRST USE 11-9-2010; IN COMMERCE 11-9-2010.

CLASS 35—ADVERTISING AND BUSINESS

FOR DISTRIBUTORSHIP SERVICES IN THE FIELD OF LUBRICANTS, SPECIALTY LUBRICATION PRODUCTS, SPECIALTY LUBRICATION RELATED PRODUCTS AND LUBRICATION RELIABILITY RELATED PRODUCTS FOR OTHERS (U.S. CLS. 100, 101 AND 102).

FIRST USE 11-9-2010; IN COMMERCE 11-9-2010.

CLASS 37—CONSTRUCTION AND REPAIR

FOR MAINTENANCE SERVICES IN THE FIELD OF LUBRICATION AND EQUIPMENT RELIABILITY; LUBRICATION MAINTENANCE, NAMELY, FLUID FILTRATION AND FLUSHING SERVICE; CONSULTATION AND ADVISORY SERVICES RELATING TO LUBRICANTS AND LUBRICATION OF MACHINERY AND ENGINES (U.S. CLS. 100, 103 AND 106).

FIRST USE 11-9-2010; IN COMMERCE 11-9-2010.

CLASS 40—MATERIAL TREATMENT

FOR CUSTOM MANUFACTURE OF LUBRICANTS, SPECIALTY LUBRICATION PRODUCTS AND SPECIALTY LUBRICATION RELATED PRODUCTS FOR OTHERS (U.S. CLS. 100, 103 AND 106).

FIRST USE 11-9-2010; IN COMMERCE 11-9-2010.

CLASS 41—EDUCATION AND ENTERTAINMENT

FOR ONLINE AND CLASSROOM LUBRICATION AND EQUIPMENT RELIABILITY TRAINING SERVICES (U.S. CLS. 100, 101 AND 107).

FIRST USE 11-9-2010; IN COMMERCE 11-9-2010.

CLASS 42—SCIENTIFIC AND COMPUTER SERVICES

FOR LABORATORY TESTING AND ANALYSIS OF LUBRICANTS AND LUBRICATION RELATED FLUIDS FOR THE PURPOSE OF IDENTIFYING EFFECTIVENESS AND IMPROVEMENT OPPORTUNITIES; TESTING SERVICES, NAMELY, THERMAL IMAGING, VIBRATION ANALYSIS AND ULTRASOUND TESTING TO DETERMINE LUBRICATION SUFFICIENCY AND EFFICIENCY; CUSTOM DESIGN AND ENGINEERING OF CUSTOMIZED FLUID FILTRATION AND FLUSHING SERVICES FOR OTHERS; CUSTOM DESIGN AND ENGINEERING OF LUBRICANTS, SPECIALTY LUBRICATION PRODUCTS, SPECIALTY LUBRICATION RELATED PRODUCTS AND LUBRICATION RELIABILITY PRODUCTS FOR OTHERS; CUSTOMIZED DESIGN AND ENGINEERING OF LUBRICATION AND RELIABILITY SERVICES FOR COMMERCIAL AND INDUSTRIAL CUSTOMERS; CUSTOMIZED DESIGN AND ENGINEERING OF EQUIPMENT RELIABILITY PRODUCTS AND SERVICES FOR COMMERCIAL AND INDUSTRIAL CUSTOMERS (U.S. CLS. 100 AND 101).

FIRST USE 11-9-2010; IN COMMERCE 11-9-2010.

CLASS 42—SCIENTIFIC AND COMPUTER SERVICES

FOR DAMAGED PROPERTY INSPECTION OF COMMERCIAL AND RESIDENTIAL REAL ESTATE; INSPECTION OF COMMERCIAL AND RESIDENTIAL REAL ESTATE THAT IS IN A STATE OF FORECLOSURE; VERIFICATION OF OCCUPANCY AND RELATED INSPECTION SERVICES FOR COMMERCIAL AND RESIDENTIAL REAL ESTATE (U.S. CLS. 100 AND 101).

FIRST USE 10-8-2008; IN COMMERCE 10-8-2008.

4,154,387. FERRING B.V., 2132 JX HOOFDDORP, NETHERLANDS. SN 77-656,964. PUB. 6-9-2009, FILED 1-26-2009.

MIQ

4,154,378. ASSURANT, INC., NEW YORK, NY. SN 77-648,050. PUB. 7-12-2011, FILED 1-13-2009.

ASSURANT PROPERTY ADVANTAGE

THE MARK CONSISTS OF STANDARD CHARACTERS WITHOUT CLAIM TO ANY PARTICULAR FONT, STYLE, SIZE, OR COLOR.

OWNER OF U.S. REG. NOS. 2,543,367, 3,124,333, AND OTHERS.

NO CLAIM IS MADE TO THE EXCLUSIVE RIGHT TO USE "PROPERTY", APART FROM THE MARK AS SHOWN.

THE MARK CONSISTS OF STANDARD CHARACTERS WITHOUT CLAIM TO ANY PARTICULAR FONT, STYLE, SIZE, OR COLOR.

CLASS 16—PAPER GOODS AND PRINTED MATTER

FOR QUESTIONNAIRES FOR USE IN OBTAINING INFORMATION ABOUT, IDENTIFYING, DIAGNOSING, AND TREATING MENORRHAGIA (U.S. CLS. 2, 5, 22, 23, 29, 37, 38 AND 50).

FIRST USE 3-2-2012; IN COMMERCE 3-2-2012.

CLASS 42—SCIENTIFIC AND COMPUTER SERVICES

FOR PROVIDING AN ON-LINE QUESTIONNAIRE FOR USE IN OBTAINING INFORMATION ABOUT, IDENTIFYING, DIAGNOSING AND TREATING MENORRHAGIA (U.S. CLS. 100 AND 101).

FIRST USE 3-2-2012; IN COMMERCE 3-2-2012.

CLASS 36—INSURANCE AND FINANCIAL

FOR FINANCIAL SERVICES, NAMELY, MORTGAGE SERVICING; PROPERTY APPRAISAL AND VALUATION SERVICES ON BEHALF OF MORTGAGE LENDERS INVOLVED WITH UNDER- OR NON-PERFORMING MORTGAGE LOANS, PRE- AND POST-MORTGAGE FORECLOSURE SERVICES; REAL ESTATE MANAGEMENT SERVICES, NAMELY, EVICTION SERVICE AND PROPERTY PRESERVATION SERVICES ON BEHALF OF MORTGAGE LENDERS INVOLVED WITH UNDER- OR NON-PERFORMING MORTGAGE LOANS, PRE- AND POST-MORTGAGE FORECLOSURE SERVICES (U.S. CLS. 100, 101 AND 102).

FIRST USE 10-8-2008; IN COMMERCE 10-8-2008.

4,154,389. RENSON HEALTH CARE SUPPLIES INCORPORATED, MASPETH, NY. SN 77-663,096. PUB. 1-25-2011, FILED 2-4-2009.

RENSOW

CLASS 37—CONSTRUCTION AND REPAIR

FOR REAL ESTATE MANAGEMENT SERVICES, NAMELY, MAINTENANCE, RESTORATION, REHABILITATION, AND PRESERVATION OF COMMERCIAL AND RESIDENTIAL REAL ESTATE THAT IS IN A STATE OF FORECLOSURE (U.S. CLS. 100, 103 AND 106).

FIRST USE 10-8-2008; IN COMMERCE 10-8-2008.

THE MARK CONSISTS OF STANDARD CHARACTERS WITHOUT CLAIM TO ANY PARTICULAR FONT, STYLE, SIZE, OR COLOR.

OWNER OF U.S. REG. NO. 2,665,622.

CLASS 3—COSMETICS AND CLEANING PREPARATIONS

FOR HOUSE MARK FOR NON-MEDICATED PERSONAL HYGIENE AND PERSONAL CARE PRODUCTS AND PREPARATIONS, NAMELY, DENTURE CLEANSERS, EMERY BOARDS, MOUTH WASH, NAIL POLISH REMOVER PADS, SUN BLOCK PREPARATIONS, TALCUM POWDER, TOOTHPASTE; CLEANING PREPARATIONS; LAUNDRY PREPARATIONS, NAMELY, LAUNDRY DETERGENTS, LAUNDRY SOAPS, FABRIC SOFTENERS, LAUNDRY PRE-SOAK, LAUNDRY STARCH AND LAUNDRY BLEACH (U.S. CLS. 1, 4, 6, 50, 51 AND 52).

FIRST USE 3-1-2009; IN COMMERCE 3-1-2009.

CLASS 5—PHARMACEUTICALS

FOR HOUSE MARK FOR MEDICATED, MEDICAL PHARMACEUTICAL, DENTAL AND SANITARY PRODUCTS AND PREPARATIONS, NAMELY, ANTI-FUNGAL CREAMS AND POWDERS, WOUND CARE PRODUCTS NAMELY, DRESSINGS, NYLON STRIPS FOR USE AS BANDAGES FOR DRESSINGS, COTTON BALLS AND COTTON SWABS FOR MEDICAL USE, TOPICAL FIRST AID GEL, TOPICAL GEL FOR MEDICAL AND THERAPEUTIC TREATMENT OF WOUND CARE; SANITARY BELTS, SANITARY PADS, TAMPONS, ORAL WOUND RINSE, PRE-MOISTENED MEDICAL WIPES, AIR DEODORIZERS, DISINFECTANTS FOR HYGIENIC AND SANITARY PURPOSES, DISINFECTANTS FOR MEDICAL INSTRUMENTS, INCONTINENCE GARMENTS AND PADS, ADULT DIAPERS; INCONTINENCE CLOTH DIAPERS FOR HOSPITAL PATIENTS; NUTRITIONAL AND DIETARY VITAMINS AND SUPPLEMENTS IN POWDER, TABLET AND LIQUID FORM; DISINFECTANTS FOR MEDICAL USE; DENTAL ADHESIVES; NASAL SPRAY PREPARATIONS, PLASTIC BANDAGES IN THE NATURE OF BANDAGES FOR DRESSINGS (U.S. CLS. 6, 18, 44, 46, 51 AND 52).

FIRST USE 3-1-2009; IN COMMERCE 3-1-2009.

CLASS 10—MEDICAL APPARATUS

FOR HOUSE MARK FOR SURGICAL, MEDICAL AND DENTAL APPARATUS, INSTRUMENTS, APPLIANCES, AND SUPPLIES, NAMELY, ABDOMINAL BELTS, OXYGEN TUBING AND BAGS, BLOOD LANCETS, SPECIMEN CONTAINERS, ORAL AND RECTAL THERMOMETERS, ABSORBENT SURGICAL SPONGES, EMESIS BASINS AND COVERS, PLASTIC BANDAGES IN THE NATURE OF COMPRESSION BANDAGES, ENEMA KITS COMPRISED OF PLASTIC BUCKET, TUBE, PLASTIC CLAMP, CASTILE SOAP PACKET, AND MOISTURE-PROOF UNDERPAD; BED PAN COVERS, HAND PROTECTORS FOR MEDICAL USE IN THE NATURE OF WRIST AND HAND SUPPORTS AND POSITIONERS, PROTECTIVE GLOVES AND SHIELDS TO PROTECT THE HAND FROM SPLASHING LIQUIDS, STRETCHERS AND BELTS FOR MEDICAL PURPOSES, SINGLE USE COLD AND HOT COMPRESSES, BIOHAZARD BAGS FOR STORING MEDICAL WASTE, SHARPS CONTAINERS, URINE COLLECTOR FOR MEDICAL USE AND MEDICAL SPECIMEN CONTAINER; MEDICAL SPECIMEN COLLECTORS, DENTURE CONTAINERS; ELASTIC BANDAGES; ELASTIC WRAPS IN THE NATURE OF COMPRESSION BANDAGES; ABDOMINAL PADS, PADDING FOR ORTHOPEDIC CASTS; INCONTINENCE UNDERPADS USED FOR BEDDING; SAFETY ALARMS FOR MEDICAL USE IN THE NATURE OF PATIENT MONITORING SENSORS AND ALARMS; SURGICAL SHOE COVERS; MEDICAL WEARING APPAREL, NAMELY, CAPS, SHOES AND GLOVES; BODY MASS INDEX CALCULATORS IN THE NATURE OF CALIPERS; SAFETY ALARMS FOR PERSONAL USE, NAMELY, PATIENT MONITORING SENSORS AND ALARMS (U.S. CLS. 26, 39 AND 44).

FIRST USE 3-1-2009; IN COMMERCE 3-1-2009.

CLASS 21—HOUSEWARES AND GLASS

FOR HOUSE MARK FOR PITCHERS, TUMBLERS, DISPENSERS FOR PRODUCTS IN LIQUID, PASTE, OR GEL FORM, NAMELY, SOAP DISPENSERS, SOAP HOLDERS, TOILET PAPER HOLDERS, SOAP HOLDERS, PLASTIC PLATES, PLASTIC CUPS; HOUSEHOLD AND COOKING UTENSILS, NAMELY, WIRE BASKETS, SPATULAS, TURNERS, STRAINERS, SIEVES, SKIMMERS, TONGS, POURING AND STRAINING SPOUTS; TOOTHBRUSH HOLDERS; HAIR BRUSHES AND COMBS; LINT REMOVERS, NAMELY, LINT BRUSHES; HAIR BRUSHES AND COMBS, BATTERY-OPERATING LINT REMOVERS; ELECTRIC LINT REMOVERS; ABSORBENT BATH SPONGES; ABSORBENT CLEANING SPONGES; PATIENT UTENSILS, NAMELY, CARAFES, TRAYS, PITCHERS, TUMBLERS, DRINKING GLASSES, AND PLATES; TOOTHBRUSHES (U.S. CLS. 2, 13, 23, 29, 30, 33, 40 AND 50).

FIRST USE 3-1-2009; IN COMMERCE 3-1-2009.

CLASS 24—FABRICS

FOR HOUSE MARK FOR TOWELS, UNDERPADS USED IN BEDDING, GAUZE FABRICS (U.S. CLS. 42 AND 50).

FIRST USE 3-1-2009; IN COMMERCE 3-1-2009.

CLASS 25—CLOTHING

FOR HOUSE MARK FOR INFANT CLOTH DIAPERS FOR USE IN HOSPITALS, NOT FOR MEDICAL USE; FOOTWEAR, HEADWEAR AND GLOVES AS CLOTHING FOR USE BY HOSPITAL PATIENTS AND PERSONNEL, NOT FOR MEDICAL USE (U.S. CLS. 22 AND 39).

FIRST USE 3-1-2009; IN COMMERCE 3-1-2009.

CLASS 35—ADVERTISING AND BUSINESS

FOR RETAIL AND WHOLESALE STORE SERVICES FEATURING HEALTHCARE, MEDICAL, NURSING, PHARMACEUTICAL AND HOUSEHOLD PRODUCTS; MAIL ORDER CATALOGUE STORE SERVICES AND ONLINE STORE SERVICES FEATURING HEALTHCARE, MEDICAL, NURSING, PHARMACEUTICAL AND HOUSEHOLD PRODUCTS (U.S. CLS. 100, 101 AND 102).

FIRST USE 3-1-2009; IN COMMERCE 3-1-2009.

4,154,392. GENERATIONS COMMUNITY WELLNESS CENTERS, SUNNYVALE, CA. SN 77-675,902. PUB. 11-24-2009, FILED 2-23-2009.



THE MARK CONSISTS OF A STYLIZED LETTER "G" INSIDE A CIRCLE WITH A DOT INSIDE THE "G".

CLASS 41—EDUCATION AND ENTERTAINMENT

FOR PROVIDING INFORMATION ON PHYSICAL FITNESS AND EXERCISE VIA OPTICAL AND ELECTRONIC COMMUNICATIONS NETWORKS (U.S. CLS. 100, 101 AND 107).

FIRST USE 12-19-2011; IN COMMERCE 12-19-2011.

CLASS 44—MEDICAL, BEAUTY AND AGRICULTURAL SERVICES

FOR PROVIDING INFORMATION CONCERNING NUTRITION AND LIFESTYLE WELLNESS VIA OPTICAL AND ELECTRONIC COMMUNICATIONS NETWORKS (U.S. CLS. 100 AND 101).

FIRST USE 11-9-2011; IN COMMERCE 11-9-2011.

CLASS 9—ELECTRICAL AND SCIENTIFIC APPARATUS

FOR AUDIO AND VIDEO RECORDINGS IN THE FIELD OF PERSONAL IMPROVEMENT, FINANCIAL IMPROVEMENT AND SALES TRAINING (U.S. CLS. 21, 23, 26, 36 AND 38).

FIRST USE 0-0-1980; IN COMMERCE 0-0-1980.

CLASS 41—EDUCATION AND ENTERTAINMENT

FOR EDUCATIONAL SERVICES, NAMELY, CONDUCTING CLASSES AND SEMINARS IN THE FIELDS OF PERSONAL IMPROVEMENT, FINANCIAL IMPROVEMENT AND SALES TRAINING (U.S. CLS. 100, 101 AND 107).

FIRST USE 0-0-1980; IN COMMERCE 0-0-1980.

4,154,394. KICKBALL CONCEPTS LLC, GREAT FALLS, VA. SN 77-680,128. PUB. 7-14-2009, FILED 2-27-2009.

ENVIRO CARE

THE MARK CONSISTS OF STANDARD CHARACTERS WITHOUT CLAIM TO ANY PARTICULAR FONT, STYLE, SIZE, OR COLOR.

CLASS 20—FURNITURE AND ARTICLES NOT OTHERWISE CLASSIFIED

FOR MATTRESSES AND PILLOWS (U.S. CLS. 2, 13, 22, 25, 32 AND 50).

FIRST USE 10-9-2009; IN COMMERCE 10-9-2009.

CLASS 24—FABRICS

FOR BEDDING ARTICLES, NAMELY, BED LINENS, MATTRESS PADS, MATTRESS TICKING FABRIC, BED SKIRTS, BED SHEETS, COMFORTERS, PILLOW CASES, PILLOW SHAMS AND BED SPREADS (U.S. CLS. 42 AND 50).

FIRST USE 3-15-2012; IN COMMERCE 3-15-2012.

4,154,395. ROBBINS RESEARCH INTERNATIONAL, INC., ESCONDIDO, CA. SN 77-680,528. PUB. 7-7-2009, FILED 2-27-2009.

TONY ROBBINS

THE MARK CONSISTS OF STANDARD CHARACTERS WITHOUT CLAIM TO ANY PARTICULAR FONT, STYLE, SIZE, OR COLOR.

OWNER OF U.S. REG. NOS. 2,305,962 AND 3,354,887.

THE NAME "TONY ROBBINS" IDENTIFIES A LIVING INDIVIDUAL WHOSE CONSENT IS OF RECORD.

4,154,396. SERENA WILLIAMS, NEW YORK, NY. SN 77-681,525. PUB. 1-12-2010, FILED 3-2-2009.



THE NAME "SERENA WILLIAMS" IDENTIFIES A LIVING INDIVIDUAL WHOSE CONSENT IS OF RECORD.

THE MARK CONSISTS OF A STYLIZED HEART WITH THE PHRASE "SERENA WILLIAMS" TO THE RIGHT AND "SIGNATURE STATEMENT" TO THE BOTTOM LEFT OF THE DESIGN.

CLASS 14—JEWELRY

FOR JEWELRY, NAMELY, BRACELETS, CHARMS, EARRINGS, NECKLACES, PENDANTS AND RINGS (U.S. CLS. 2, 27, 28 AND 50).

FIRST USE 4-0-2009; IN COMMERCE 4-0-2009.

CLASS 18—LEATHER GOODS

FOR LEATHER AND NON-LEATHER PURSES, TOTE BAGS AND CLUTCHES (U.S. CLS. 1, 2, 3, 22 AND 41).

FIRST USE 4-0-2009; IN COMMERCE 4-0-2009.

CLASS 25—CLOTHING

FOR CLOTHING, NAMELY, BELTS, CARDIGANS, DRESSES, SCARVES, SWEATERS AND WRAPS; AND FOOTWEAR, NAMELY, FLIP-FLOPS (U.S. CLS. 22 AND 39).

FIRST USE 4-0-2009; IN COMMERCE 4-0-2009.

4,154,405. TYJA CORPORATION, CALVERTON, NY. SN 77-695,049. PUB. 6-8-2010, FILED 3-19-2009.

TYJA

THE MARK CONSISTS OF STANDARD CHARACTERS WITHOUT CLAIM TO ANY PARTICULAR FONT, STYLE, SIZE, OR COLOR.

CLASS 18—LEATHER GOODS

FOR DUFFLE BAGS (U.S. CLS. 1, 2, 3, 22 AND 41).
FIRST USE 12-0-2010; IN COMMERCE 1-3-2011.

CLASS 24—FABRICS

FOR TEAM EMBELLISHED TOWELS; SPORT TOWELS (U.S. CLS. 42 AND 50).
FIRST USE 3-0-2010; IN COMMERCE 1-0-2011.

4,154,406. MIPI ALLIANCE, INC., PISCATAWAY, NJ. SN 77-695,709. PUB. 7-28-2009, FILED 3-20-2009.

M-PHY

THE MARK CONSISTS OF STANDARD CHARACTERS WITHOUT CLAIM TO ANY PARTICULAR FONT, STYLE, SIZE, OR COLOR.

CLASS 35—ADVERTISING AND BUSINESS

FOR BUSINESS SERVICES, NAMELY, BUSINESS CONSULTING SERVICES; ASSOCIATION SERVICES, NAMELY, PROMOTING THE INTERESTS OF MOBILE COMMUNICATIONS DEVICES COMPANIES; ADVERTISING SERVICES FOR OTHERS, NAMELY, PROMOTING A STANDARD FOR AN INTERFACE BETWEEN COMPUTER CHIPS AND PERIPHERAL DEVICES (U.S. CLS. 100, 101 AND 102).
FIRST USE 2-3-2005; IN COMMERCE 4-26-2007.

CLASS 42—SCIENTIFIC AND COMPUTER SERVICES

FOR DEVELOPING TECHNICAL SPECIFICATIONS FOR MOBILE COMMUNICATIONS DEVICES, NAMELY, A STANDARD FOR AN INTERFACE BETWEEN COMPUTER CHIPS AND PERIPHERAL DEVICES; IMPLEMENTING TECHNICAL SPECIFICATIONS FOR MOBILE COMMUNICATIONS DEVICES, NAMELY, A STANDARD FOR AN INTERFACE BETWEEN COMPUTER CHIPS AND PERIPHERAL DEVICES; DESIGNING TECHNICAL SPECIFICATIONS FOR MOBILE COMMUNICATIONS DEVICES, NAMELY, A STANDARD FOR AN INTERFACE BETWEEN COMPUTER CHIPS AND PERIPHERAL DEVICES; CONSULTING ON TECHNICAL SPECIFICATIONS FOR MOBILE COMMUNICATIONS DEVICES, NAMELY, A STANDARD FOR AN INTERFACE BETWEEN COMPUTER CHIPS AND PERIPHERAL DEVICES (U.S. CLS. 100 AND 101).
FIRST USE 2-3-2005; IN COMMERCE 4-26-2007.

4,154,409. PHANTOM MFG. (INT'L) LTD, ABBOTSFORD, CANADA. SN 77-702,180. PUB. 7-28-2009, FILED 3-30-2009.

PHANTOM LEGACY

THE MARK CONSISTS OF STANDARD CHARACTERS WITHOUT CLAIM TO ANY PARTICULAR FONT, STYLE, SIZE, OR COLOR.

PRIORITY CLAIMED UNDER SEC. 44(D) ON CANADA APPLICATION NO. 1422537, FILED 12-19-2008.

OWNER OF U.S. REG. NOS. 1,983,857, 2,266,669, AND OTHERS.

CLASS 6—METAL GOODS

FOR METAL SCREENS, NAMELY, RETRACTABLE INSECT SCREENS AND SUNSCREENS FOR DOORS, WINDOWS, AND SKYLIGHTS (U.S. CLS. 2, 12, 13, 14, 23, 25 AND 50).

FIRST USE 2-17-2012; IN COMMERCE 2-17-2012.

CLASS 19—NON-METALLIC BUILDING MATERIALS

FOR NON-METAL SCREENS, NAMELY, RETRACTABLE INSECT SCREENS AND SUNSCREENS FOR DOORS, WINDOWS, AND SKYLIGHTS (U.S. CLS. 1, 12, 33 AND 50).

FIRST USE 2-17-2012; IN COMMERCE 2-17-2012.

4,154,411. VISTAPRINT LIMITED, HAMILTON, BERMUDA. SN 77-706,349. PUB. 1-5-2010, FILED 4-3-2009.



OWNER OF U.S. REG. NOS. 2,978,792, 3,183,063, AND OTHERS.

THE MARK CONSISTS OF THREE ARCHES ABOVE THE WORD "VISTAPRINT".

CLASS 9—ELECTRICAL AND SCIENTIFIC APPARATUS

FOR MOUSE PADS; DECORATIVE MAGNETS (U.S. CLS. 21, 23, 26, 36 AND 38).

FIRST USE 6-1-2008; IN COMMERCE 6-1-2008.

CLASS 16—PAPER GOODS AND PRINTED MATTER

FOR PRINTED PRODUCTS, NAMELY, BUSINESS CARDS, STATIONERY, FOLDERS, CUSTOM BROCHURES AND INFORMATIONAL FLYERS CONTAINING INFORMATION SUPPLIED BY OTHERS, INFORMATIONAL RACK CARDS, ADDRESS LABELS, ENVELOPES, LETTERHEAD, POSTCARDS, DECALS, POSTERS, CALENDARS, NOTE PADS, NOTE CARDS, CALLING CARDS, GIFT TAGS, BANK CHECKS, ANNOUNCEMENT CARDS, HOLIDAY CARDS, THANK YOU CARDS, INVITATIONS AND SIGNS; BUSINESS CARD HOLDERS; NOTE PAD HOLDERS; RUBBER STAMPS; STAMP INK PADS; PENS (U.S. CLS. 2, 5, 22, 23, 29, 37, 38 AND 50).

FIRST USE 6-1-2008; IN COMMERCE 6-1-2008.

CLASS 18—LEATHER GOODS

FOR TOTE BAGS (U.S. CLS. 1, 2, 3, 22 AND 41).
FIRST USE 4-6-2009; IN COMMERCE 4-6-2009.

CLASS 20—FURNITURE AND ARTICLES NOT OTHERWISE CLASSIFIED

FOR PLASTIC KEY CHAINS; PLASTIC BANNERS (U.S. CLS. 2, 13, 22, 25, 32 AND 50).
FIRST USE 1-13-2009; IN COMMERCE 1-13-2009.

CLASS 21—HOUSEWARES AND GLASS

FOR MUGS (U.S. CLS. 2, 13, 23, 29, 30, 33, 40 AND 50).
FIRST USE 8-5-2009; IN COMMERCE 8-5-2009.

CLASS 25—CLOTHING

FOR HATS; SHIRTS (U.S. CLS. 22 AND 39).
FIRST USE 6-1-2008; IN COMMERCE 6-1-2008.

CLASS 35—ADVERTISING AND BUSINESS

FOR DIRECT MAIL ADVERTISING SERVICES; WRITING OF ADVERTISING AND MARKETING TEXT FOR OTHERS (U.S. CLS. 100, 101 AND 102).
FIRST USE 6-1-2008; IN COMMERCE 6-1-2008.

CLASS 38—COMMUNICATION

FOR E-MAIL SERVICES (U.S. CLS. 100, 101 AND 104).
FIRST USE 3-13-2009; IN COMMERCE 3-13-2009.

CLASS 40—MATERIAL TREATMENT

FOR PRINTING SERVICES; PRINTING OF IMAGES ONTO PAPER OR MERCHANDISE (U.S. CLS. 100, 103 AND 106).
FIRST USE 6-1-2008; IN COMMERCE 6-1-2008.

CLASS 42—SCIENTIFIC AND COMPUTER SERVICES

FOR GRAPHIC DESIGN SERVICES; PROVIDING TEMPORARY USE OF ONLINE SOFTWARE TOOLS FOR USE IN DESIGNING AND ORDERING ELECTRONIC AND PRINTED PRODUCTS; WEBSITE HOSTING SERVICES; LOGO DESIGN SERVICES (U.S. CLS. 100 AND 101).
FIRST USE 6-1-2008; IN COMMERCE 6-1-2008.

4,154,416. NEUROBRANDS LLC, SANTA MONICA, CA. SN 77-715,898. PUB. 8-25-2009, FILED 4-17-2009.

NEUROBLAST

THE MARK CONSISTS OF STANDARD CHARACTERS WITHOUT CLAIM TO ANY PARTICULAR FONT, STYLE, SIZE, OR COLOR.

CLASS 5—PHARMACEUTICALS

FOR DIETARY AND NUTRITIONAL SUPPLEMENTS; DIETARY BEVERAGE SUPPLEMENTS FOR HUMAN CONSUMPTION (U.S. CLS. 6, 18, 44, 46, 51 AND 52).
FIRST USE 3-9-2009; IN COMMERCE 10-3-2011.

CLASS 32—LIGHT BEVERAGES

FOR NON-ALCOHOLIC BEVERAGES, NAMELY, CARBONATED BEVERAGES AND ENERGY DRINKS (U.S. CLS. 45, 46 AND 48).
FIRST USE 3-9-2009; IN COMMERCE 10-3-2011.

4,154,424. IGA, INC., CHICAGO, IL. SN 77-746,016. PUB. 12-22-2009, FILED 5-27-2009.



THE MARK CONSISTS OF A FARM HOUSE, BARN AND SILO, WITH A WINDMILL BEHIND THE FARM HOUSE, ALL ON HILLY LAND WITH CLOUDS IN THE BACKGROUND.

CLASS 3—COSMETICS AND CLEANING PREPARATIONS

FOR ALL-PURPOSE DETERGENT FOR HOUSEHOLD USE; FABRIC SOFTENER SHEETS; CLEANING PREPARATIONS, NAMELY, LAUNDRY SOAPS AND DETERGENTS, LIQUID FABRIC SOFTENER, ALL-PURPOSE HOUSEHOLD CLEANERS, DISHWASHING LIQUID DETERGENTS, AUTOMATIC DISHWASHING DETERGENT, LIQUID WINDOW CLEANING SOLUTIONS AND GLASS CLEANERS, LAUNDRY BLEACH, GENERAL PURPOSE CLEANING, DISH DETERGENT; ANTIBACTERIAL SOAP; BABY WIPES (U.S. CLS. 1, 4, 6, 50, 51 AND 52).
FIRST USE 3-1-2011; IN COMMERCE 3-1-2011.

CLASS 4—LUBRICANTS AND FUELS

FOR CHARCOAL LIGHTER FLUID (U.S. CLS. 1, 6 AND 15).
FIRST USE 3-1-2011; IN COMMERCE 3-1-2011.

CLASS 6—METAL GOODS

FOR ALUMINUM FOIL (U.S. CLS. 2, 12, 13, 14, 23, 25 AND 50).
FIRST USE 3-1-2011; IN COMMERCE 3-1-2011.

CLASS 8—HAND TOOLS

FOR PLASTIC FORKS AND PLASTIC SPOONS (U.S. CLS. 23, 28 AND 44).
FIRST USE 3-1-2011; IN COMMERCE 3-1-2011.

CLASS 16—PAPER GOODS AND PRINTED MATTER

FOR PLASTIC WRAP, PAPER TOWELS, PAPER NAPKINS, PAPER FILTERS FOR COFFEE MAKERS; LUNCH BAGS; TRASH, GARBAGE AND KITCHEN TRASH BAGS; LAWN AND LEAF DISPOSAL BAGS; SANDWICH AND FREEZER BAGS; FOOD STORAGE BAGS; BATHROOM AND FACIAL TISSUE; MAGAZINES IN THE FIELD OF GROCERIES PUBLISHED PERIODICALLY (U.S. CLS. 2, 5, 22, 23, 29, 37, 38 AND 50).
FIRST USE 3-1-2011; IN COMMERCE 3-1-2011.

CLASS 29—MEATS AND PROCESSED FOODS

FOR BLANCHED, SHELLED, ROASTED AND PROCESSED NUTS; RAISINS; FROZEN, CUT, PROCESSED, PRESERVED, DRIED, CANNED, AND COOKED FRUITS AND VEGETABLES; ONION RINGS; CRANBERRY SAUCE; PICKLES; FRUIT SALAD; PEANUT BUTTER; JELLIES, JAMS AND FRUIT PRESERVES; APPLE SAUCE; BOLOGNA; BOUILLON; SOUPS, SOUP MIXES, BROTHS, SOUP BROTHS; SAUERKRAUT; BREAKFAST SAUSAGE LINKS, SAUSAGES AND BRATWURST; BACON AND BACON BITS; BUTTER; MARGARINE; VEGETABLE BASED SPREADS; CHILI WITH AND WITHOUT BEANS; FLAKED COCONUT; COOKING OIL, COOKING OIL SPRAY; VEGETABLE AND ANIMAL SHORTENING; EDIBLE OIL; VEGETABLE OIL; OLIVE OIL; COTTAGE CHEESE; SOUR CREAM; EGGS; TOMATO PASTE AND PUREE; NON DAIRY CREAMER; DIPS AND SNACK DIPS; FRUIT-BASED SNACK FOOD; PROCESSED EDIBLE SEEDS; FRUIT BASED FILLINGS FOR PIES AND CAKES; MILK AND DAIRY PRODUCTS EXCLUDING ICE CREAM, ICE MILK AND FROZEN YOGURT; EVAPORATED AND CONDENSED MILK; MILK POWDER; YOGURT; CHEESE; CHEESE FOOD; CREAM CHEESE; CHEESE SPREAD; POTATO CHIPS; WHIPPED CREAM; WHIPPED TOPPING; MEAT; LUNCHEON MEATS; HAM; BEEF, BEEF STEW; CORNED BEEF AND CORNED BEEF HASH; CHICKEN AND POULTRY; CORN DOGS; FISH, FISH FILLETS, FRANKFURTERS; CANNED PORK AND BEANS; INSTANT POTATOES, FRIED POTATOES, FRENCH FRIED POTATOES; SALADS EXCEPT MACARONI, RICE AND PASTA SALAD; PREPARED CHICKEN SALAD, PREPARED POTATO SALAD, AND COLE SLAW; SEAFOOD; TUNA FISH; CANNED GOODS, NAMELY, FRUITS, BERRIES, VEGETABLES, FOWL, MEATS; FROZEN GOODS, NAMELY, FRUIT, BERRIES, VEGETABLES, VEGETABLE JUICES FOR COOKING, MEAT, FOWL, SOUPS, FRUIT-BASED FILLING FOR PIES; SALTED, SMOKED AND SPICED GOODS, NAMELY, FISH, CHICKEN AND MEATS; PREPARED DEVILLED MEAT AND SAUSAGE; CONDIMENTS, NAMELY, PICKLES, PROCESSED OLIVES AND PROCESSED PIMENTOS; CHEESE; EVAPORATED MILK; PRESERVES AND MARMALADES; SALAD OIL; BAKED BEANS (U.S. CL. 46).
FIRST USE 3-1-2011; IN COMMERCE 3-1-2011.

CLASS 30—STAPLE FOODS

FOR STARCH, SALT, CANDY; CARAMELS, CANDY MINTS, BUBBLE GUM; BAGELS, BREAD, ROLLS AND BUNS; ENGLISH MUFFINS; BREAD CRUMBS AND BREAD DOUGH; BREADSTICKS; GARLIC BREAD, BREADSTICKS AND TOAST; BISCUITS AND BUTTER BISCUITS; PASTRIES; CONFECTIONERY BAKING CHIPS FOR BAKING; MIXES FOR BAKERY GOODS; CAKE MIXES; EDIBLE CAKE DECORATIONS; FROSTINGS BAKING SODA; BAKING POWDER; ICE CREAM; ICE CREAM BARS, ICE CREAM SANDWICHES AND FUDGE BARS; SHERBET; FROZEN YOGURT; CONES FOR ICE CREAM; FLAVORED AND SWEETENED GELATINS; BREAKFAST CEREALS; OATMEAL; PROCESSED OATS; SPICES, CHILI POWDER, CINNAMON, CINNAMON POWDER; GARLIC POWDER AND SALT; SALT; PEPPER; SEASONINGS, SEASONING MIXES; SLOPPY JOE SEASONING MIX; VANILLA EXTRACT; COFFEE, TEA, ICED TEA, TEA BAGS, SUGAR, RICE,

PASTA, NOODLES, FLOUR; FLOUR MIXES; CORN MEAL; SUGAR SUBSTITUTE; COOKIES; WAFERS; CRACKERS; CHEESE FLAVORED SNACKS, NAMELY, CHEESE CURLS AND CHEESE PUFFS; CHEESE FLAVORED PUFFED CORN SNACKS; GRAIN-BASED FOOD BARS ALSO CONTAINING FRUIT; GRANOLA BASED SNACK BARS; SALAD DRESSINGS; GRAVIES AND GRAVY MIXES; SAUCES; SAUCE MIXES; CHEESE SAUCE; MARINADES; GRITS AND HOMINY GRITS; HOMINY; HONEY; MUSTARD; KETCHUP; MAYONNAISE; VINEGAR; SALAD DRESSINGS; SALSA; MACARONI AND CHEESE; MARSHMALLOWS; PANCAKES AND PANCAKE MIXES; WAFFLES; WAFFLE MIXES; PIE CRUST; PUDDINGS AND PUDDING MIXES; TOPPING SYRUP; CHOCOLATE SYRUP; CORN SYRUP; MAPLE SYRUP; TACO SHELLS; FROZEN, MIXES FOR MAKING COMBINED NOODLE OR RICE AND SAUCE DISHES; PIZZA, PREPARED PIZZAS AND BITE-SIZED PIZZA APPETIZERS; MICROWAVE POPCORN, RICE-BASED SNACK FOODS; STUFFING MIXES CONTAINING BREAD; FOOD FLAVORING EXTRACTS; CORNMEAL; CHOCOLATE POWDER FOR MAKING HOT CHOCOLATE; SAUCES; CONDIMENTS, NAMELY, PICKLE RELISHES; UNPOPPED POPCORN (U.S. CL. 46).
FIRST USE 3-1-2011; IN COMMERCE 3-1-2011.

CLASS 31—NATURAL AGRICULTURAL PRODUCTS

FOR PET FOOD, CAT LITTER; FRESH FRUITS AND VEGETABLES (U.S. CLS. 1 AND 46).
FIRST USE 3-1-2011; IN COMMERCE 3-1-2011.

CLASS 32—LIGHT BEVERAGES

FOR GINGER ALE, SOFT DRINKS AND CARBONATED WATERS; CANNED, BOTTLED AND FROZEN GOODS, NAMELY, POWDERED SOFT DRINKS, FRUIT JUICES AS COCKTAIL MIXES, VEGETABLE JUICE (U.S. CLS. 45, 46 AND 48).
FIRST USE 3-1-2011; IN COMMERCE 3-1-2011.

4,154,425. IGA, INC., CHICAGO, IL. SN 77-746,027. PUB. 12-22-2009, FILED 5-27-2009.



OWNER OF U.S. REG. NOS. 997,353, 1,095,531, AND OTHERS.

THE COLOR(S) RED, WHITE AND BLACK IS/ARE CLAIMED AS A FEATURE OF THE MARK.

THE MARK CONSISTS OF THE WORDING "IGA" IN WHITE CONTAINED IN AN OVAL WITH A RED BACKGROUND WITH A WHITE BORDER AND BLACK OUTLINING THAT IS THICKER AT THE BOTTOM RIGHT OF THE OVAL. THERE ARE WHITE RAYS EMANATING FROM BEHIND THE OVAL DESIGN ELEMENT. THE RAYS ARE OUTLINED IN BLACK TO DEFINE THIS FEATURE ONLY AND THE COLOR BLACK IS NOT CLAIMED AS A FEATURE OF THIS PORTION OF THE MARK.

CLASS 3—COSMETICS AND CLEANING PREPARATIONS

FOR ALL-PURPOSE DETERGENT FOR HOUSEHOLD USE; FABRIC SOFTENER SHEETS; CLEANING PREPARATIONS, NAMELY, LAUNDRY SOAPS AND DETERGENTS, LIQUID FABRIC SOFTENER, ALL-PURPOSE HOUSEHOLD CLEANERS, DISHWASHING LIQUID DETERGENTS, AUTOMATIC DISHWASHING DETERGENT, LIQUID WINDOW CLEANING SOLUTIONS AND GLASS CLEANERS, LAUNDRY BLEACH, GENERAL PURPOSE CLEANING, DISH DETERGENT; ANTIBACTERIAL SOAP; BABY WIPES (U.S. CLS. 1, 4, 6, 50, 51 AND 52).

FIRST USE 3-1-2011; IN COMMERCE 3-1-2011.

CLASS 6—METAL GOODS

FOR ALUMINUM FOIL (U.S. CLS. 2, 12, 13, 14, 23, 25 AND 50).

FIRST USE 3-1-2011; IN COMMERCE 3-1-2011.

CLASS 8—HAND TOOLS

FOR PLASTIC FORKS AND PLASTIC SPOONS (U.S. CLS. 23, 28 AND 44).

FIRST USE 3-1-2011; IN COMMERCE 3-1-2011.

CLASS 16—PAPER GOODS AND PRINTED MATTER

FOR PLASTIC WRAP, PAPER BAGS AND PAPER SACKS; PAPER TOWELS, PAPER NAPKINS, DISPOSABLE DIAPERS; PAPER FILTERS FOR COFFEE MAKERS; LUNCH BAGS; TRASH, GARBAGE AND KITCHEN TRASH BAGS; LAWN AND LEAF DISPOSAL BAGS; SANDWICH AND FREEZER BAGS; FOOD STORAGE BAGS; BATHROOM AND FACIAL TISSUE; ADHESIVE TAPE FOR STATIONERY OR HOUSEHOLD PURPOSES; MAGAZINES IN THE FIELD OF GROCERIES PUBLISHED PERIODICALLY; DISPOSABLE WIPES NOT IMPREGNATED WITH CHEMICALS OR COMPOUNDS FOR HOUSEHOLD USE (U.S. CLS. 2, 5, 22, 23, 29, 37, 38 AND 50).

FIRST USE 3-1-2011; IN COMMERCE 3-1-2011.

CLASS 29—MEATS AND PROCESSED FOODS

FOR BLANCHED, SHELLED, ROASTED AND PROCESSED NUTS; RAISINS; FROZEN, CUT, PROCESSED, PRESERVED, DRIED, CANNED, AND COOKED FRUITS AND VEGETABLES; ONION RINGS; CRANBERRY SAUCE; PICKLES; FRUIT SALAD; PEANUT BUTTER; JELLIES, JAMS AND FRUIT PRESERVES; APPLE SAUCE; BOLOGNA; BOUILLON; SOUPS, SOUP MIXES, BROTHS, SOUP BROTHS; SAUERKRAUT; BREAKFAST SAUSAGE LINKS, SAUSAGES AND BRATWURST; BACON AND BACON BITS; BUTTER; MARGARINE; VEGETABLE BASED SPREADS; CHILI WITH AND WITHOUT BEANS; FLAKED COCONUT; COOKING OIL, COOKING OIL SPRAY; VEGETABLE AND ANIMAL SHORTENING; EDIBLE OIL; VEGETABLE OIL; OLIVE OIL; COTTAGE CHEESE; SOUR CREAM; EGGS; TOMATO PASTE AND PUREE; NON DAIRY CREAMER; DIPS AND SNACK DIPS; FRUIT-BASED SNACK FOOD; PROCESSED EDIBLE SEEDS; FRUIT BASED FILLINGS FOR PIES AND CAKES; MILK AND DAIRY PRODUCTS EXCLUDING ICE CREAM, ICE MILK AND FROZEN YOGURT; EVAPORATED AND CONDENSED MILK; MILK POWDER; YOGURT; CHEESE; CHEESE FOOD; CREAM CHEESE; CHEESE SPREAD; POTATO CHIPS; WHIPPED CREAM; WHIPPED TOPPING; MEAT; LUNCHEON MEATS; HAM; BEEF, BEEF STEW; CORNED BEEF AND CORNED BEEF HASH; CHICKEN AND POULTRY; CORN DOGS; FISH, FISH FILLETS, FRANKFURTERS; CANNED PORK AND BEANS; INSTANT POTATOES, FRIED POTATOES, FRENCH FRIED POTATOES; SALADS EXCEPT MACARONI, RICE AND PASTA SALAD; PREPARED CHICKEN SALAD, PREPARED POTATO SALAD, AND COLE SLAW; SEAFOOD; TUNA FISH; CANNED GOODS, NAMELY, FRUITS, BERRIES, VEGETABLES, FOWL, MEATS; FROZEN GOODS, NAMELY, FRUIT, BERRIES, VEGETABLES, VEGETABLE JUICES FOR COOKING, MEAT, FOWL, SOUPS, FRUIT-BASED FILLING FOR PIES; SALTED, SMOKED AND SPICED GOODS, NAMELY, FISH, CHICKEN AND MEATS; PREPARED DEVILLED MEAT AND SAUSAGE; CONDIMENTS, NAMELY, PICKLES, PROCESSED OLIVES AND PROCESSED PIMENTOS; CHEESE; EVAPORATED MILK; PRESERVES AND MARMALADES; SALAD OIL; BAKED BEANS (U.S. CL. 46).

FIRST USE 3-1-2011; IN COMMERCE 3-1-2011.

CLASS 30—STAPLE FOODS

FOR STARCH, NAMELY, SALT, CANDY; CARAMELS, CANDY MINTS, BUBBLE GUM; BAGELS, BREAD, ROLLS AND BUNS; ENGLISH MUFFINS; BREAD CRUMBS AND BREAD DOUGH; BREADSTICKS; GARLIC BREAD, BREADSTICKS AND TOAST; BISCUITS AND BUTTER BISCUITS; PASTRIES; CONFECTIONERY BAKING CHIPS FOR BAKING; MIXES FOR BAKERY GOODS; CAKE MIXES; EDIBLE CAKE DECORATIONS; FROSTINGS BAKING SODA; BAKING POWDER; ICE CREAM; ICE CREAM BARS, ICE CREAM SANDWICHES AND FUDGE BARS; SHERBET; FROZEN YOGURT; CONES FOR ICE CREAM; FLAVORED AND SWEETENED GELATINS; BREAKFAST CEREALS; OATMEAL; PROCESSED OATS; SPICES, CHILI POWDER, CINNAMON, CINNAMON POWDER; GARLIC POWDER AND SALT; SALT; PEPPER; SEASONINGS, SEASONING MIXES; SLOPPY JOE SEASONING MIX; VANILLA EXTRACT; COFFEE, TEA, ICED TEA, TEA BAGS, SUGAR, RICE, PASTA, NOODLES, FLOUR; FLOUR MIXES; CORN MEAL; SUGAR SUBSTITUTE; COOKIES; WAFERS; CRACKERS; CHEESE FLAVORED SNACKS, NAMELY, CHEESE CURLS AND CHEESE PUFFS; CHEESE FLAVORED PUFFED CORN SNACKS; GRAIN-BASED FOOD BARS ALSO CONTAINING FRUIT; GRANOLA BASED SNACK BARS; SALAD DRESSINGS; GRAVIES AND GRAVY MIXES; SAUCES; SAUCE MIXES; CHEESE SAUCE; MARINADES; GRITS AND HOMINY GRITS; HOMINY; HONEY; MUSTARD; KETCHUP; MAYONNAISE; VINEGAR; SALAD DRESSINGS; SALSA; MACARONI AND CHEESE; MARSHMALLOWS; PANCAKES AND PANCAKE MIXES;

WAFFLES; WAFFLE MIXES; PIE CRUST; PUDDINGS AND PUDDING MIXES; TOPPING SYRUP; CHOCOLATE SYRUP; CORN SYRUP; MAPLE SYRUP; TACO SHELLS; FROZEN, MIXES FOR MAKING COMBINED NOODLE OR RICE AND SAUCE DISHES; PIZZA, PREPARED PIZZAS AND BITE-SIZED PIZZA APPETIZERS; MICROWAVE POPCORN, RICE-BASED SNACK FOODS; STUFFING MIXES CONTAINING BREAD; FOOD FLAVORING EXTRACTS; CORNMEAL; CHOCOLATE POWDER FOR MAKING HOT CHOCOLATE; SAUCES; CONDIMENTS, NAMELY, PICKLE RELISHES; UNPOPPED POPCORN (U.S. CL. 46).

FIRST USE 3-1-2011; IN COMMERCE 3-1-2011.

CLASS 31—NATURAL AGRICULTURAL PRODUCTS

FOR PET FOOD, CAT LITTER; FRESH FRUITS AND VEGETABLES (U.S. CLS. 1 AND 46).

FIRST USE 3-1-2011; IN COMMERCE 3-1-2011.

CLASS 32—LIGHT BEVERAGES

FOR GINGER ALE, SOFT DRINKS AND CARBONATED WATERS; CANNED, BOTTLED AND FROZEN GOODS, NAMELY, POWDERED SOFT DRINKS, FRUIT JUICES AS COCKTAIL MIXES, VEGETABLE JUICE (U.S. CLS. 45, 46 AND 48).

FIRST USE 3-1-2011; IN COMMERCE 3-1-2011.

4,154,427. FREDERICK BUECHNER LITERARY ASSETS, LLC, CAMBRIDGE, MA. SN 77-746,406. PUB. 2-16-2010, FILED 5-28-2009.



THE NAME(S), PORTRAIT(S), AND/OR SIGNATURE(S) SHOWN IN THE MARK IDENTIFIES A LIVING INDIVIDUAL, WHOSE CONSENT(S) TO REGISTER IS MADE OF RECORD.

THE MARK CONSISTS OF STYLIZED LETTERS "FREDERICK BUECHNER".

CLASS 16—PAPER GOODS AND PRINTED MATTER

FOR A SERIES OF NON-FICTION BOOKS IN THE FIELD OF RELIGION, MORALITY AND SELF-AWARENESS; SERIES OF FICTION BOOKS; PERIODIC NEWSLETTERS IN THE FIELD OF RELIGION, MORALITY AND SELF AWARENESS; PRINTED INSTRUCTIONAL AND TEACHING MATERIALS, NAMELY, WORKBOOKS IN THE FIELD OF RELIGION, MORALITY AND SELF AWARENESS; BOOKMARKS; POSTERS; CALENDARS; MAPS; GREETING CARDS; POSTCARDS; PAPER PENNANTS; STICKER ALBUMS; STICKERS; DECALS; STATIONERY; NOTEBOOKS; PENCILS; PENS; CASES FOR PENCILS AND PENS; ERASERS; CRAYONS; MARKERS; COLORED PENCILS; PAINTING SETS FOR CHILDREN; DRAFTING RULERS AND DRAWING RULERS; CHECK BOOK COVERS; ADDRESS BOOKS; CHILDREN'S BOOKS; PUZZLE BOOKS; SCRAP BOOKS; DIARIES; CHILDREN'S ACTIVITY BOOKS; COLORING BOOKS; COMPOSITION BOOKS, PAPER BOOK COVERS; ART PRINTS; PAPER SHOPPING BAGS; PAPER TABLECLOTHS; PAPER PARTY FAVORS; PAPER PARTY DECORATIONS, NAMELY, PAPER NAPKINS, PAPER DOILIES, PAPER PLACE MATS, CREPE PAPER, PRINTED INVITATIONS, PAPER CAKE DECORATIONS; WRAPPING PAPER; PHOTOGRAPH ALBUMS (U.S. CLS. 2, 5, 22, 23, 29, 37, 38 AND 50).

FIRST USE 2-1-2012; IN COMMERCE 2-1-2012.

CLASS 28—TOYS AND SPORTING GOODS

FOR PLAYING CARDS (U.S. CLS. 22, 23, 38 AND 50). FIRST USE 2-1-2012; IN COMMERCE 2-1-2012.

4,154,436. RESPONSE GENETICS, INC., LOS ANGELES, CA. SN 77-768,260. PUB. 12-29-2009, FILED 6-25-2009.

RESPONSEDX: GASTRIC

THE MARK CONSISTS OF STANDARD CHARACTERS WITHOUT CLAIM TO ANY PARTICULAR FONT, STYLE, SIZE, OR COLOR.

NO CLAIM IS MADE TO THE EXCLUSIVE RIGHT TO USE "GASTRIC", APART FROM THE MARK AS SHOWN.

CLASS 42—SCIENTIFIC AND COMPUTER SERVICES

FOR MEDICAL RESEARCH; SCIENTIFIC RESEARCH AND DEVELOPMENT; PROVIDING SCIENTIFIC RESEARCH INFORMATION IN THE FIELD OF PHARMACEUTICALS AND CLINICAL TRIALS; PROVIDING AN ON-LINE COMPUTER DATABASE FOR OTHERS IN THE FIELDS OF MEDICINE DEVELOPMENT, SCIENTIFIC RESEARCH INFORMATION IN THE FIELD OF CANCER DIAGNOSIS, SCIENTIFIC RESEARCH INFORMATION IN THE FIELD OF CLINICAL TRIAL DESIGN AND SCIENTIFIC RESEARCH INFORMATION IN THE FIELD OF BIOTECHNOLOGY; PRODUCT DEVELOPMENT SERVICES FOR OTHERS IN THE BIOMEDICAL, GENOMICS, PHARMACOGENOMICS, DIAGNOSTIC, CLINICAL TRIAL DESIGN AND BIOTECHNOLOGY FIELD (U.S. CLS. 100 AND 101).

FIRST USE 6-1-2009; IN COMMERCE 6-1-2009.

CLASS 44—MEDICAL, BEAUTY AND AGRICULTURAL SERVICES

FOR PROVIDING MEDICAL DIAGNOSTIC TESTING SERVICES FOR DIAGNOSTIC AND PROGNOSTIC PURPOSES; AND PROVIDING MEDICAL INFORMATION (U.S. CLS. 100 AND 101).

FIRST USE 6-1-2009; IN COMMERCE 6-1-2009.

4,154,438. PEDI-BEAR, LLC, FURLONG, PA. SN 77-772,747. PUB. 2-22-2011, FILED 7-1-2009.

GROW FOOD

THE MARK CONSISTS OF STANDARD CHARACTERS WITHOUT CLAIM TO ANY PARTICULAR FONT, STYLE, SIZE, OR COLOR.

NO CLAIM IS MADE TO THE EXCLUSIVE RIGHT TO USE "FOOD", APART FROM THE MARK AS SHOWN.

CLASS 16—PAPER GOODS AND PRINTED MATTER

FOR PRINTED INSTRUCTIONAL, EDUCATIONAL, AND TEACHING MATERIALS, NAMELY, COURSE BOOKS, WORK BOOKS, AND TEACHING ACTIVITY GUIDES IN THE FIELD OF NUTRITION; PRINTED MATERIALS, NAMELY, BOOKS IN THE FIELD OF NUTRITION; CALENDARS AND FLASH CARDS, AND NONE OF THE FOREGOING RELATED TO THE GROWING OF FOOD (U.S. CLS. 2, 5, 22, 23, 29, 37, 38 AND 50).
FIRST USE 3-2-2012; IN COMMERCE 3-2-2012.

CLASS 28—TOYS AND SPORTING GOODS

FOR PUZZLES; EDUCATIONAL TOYS FOR THE PURPOSE OF TEACHING CHILDREN ABOUT PROPER NUTRITION, AND NONE OF THE FOREGOING RELATED TO THE GROWING OF FOOD (U.S. CLS. 22, 23, 38 AND 50).
FIRST USE 3-2-2012; IN COMMERCE 3-2-2012.

4,154,439. THE BANK OF EAST ASIA, LIMITED, CENTRAL HONG KONG, HONG KONG. SN 77-773,932. PUB. 7-27-2010, FILED 7-2-2009.

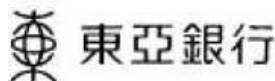

OWNER OF U.S. REG. NOS. 1,439,475, 3,081,200, AND OTHERS.

NO CLAIM IS MADE TO THE EXCLUSIVE RIGHT TO USE THE NON-LATIN CHARACTERS IN THE MARK WHOSE TRANSLITERATION IS "NGAN HONG" IN CANTONESE AND "YIN HANG" IN MANDARIN, AND WHICH TRANSLATE INTO ENGLISH AS "BANK", APART FROM THE MARK AS SHOWN.

THE MARK CONSISTS OF A DESIGN OF A STYLIZED GLOBE WITH THE CHINESE CHARACTERS FOR THE WORDS THE BANK OF EAST ASIA .

THE ENGLISH TRANSLATION OF FOREIGN WORDING IN THE MARK IS "THE BANK OF EAST ASIA".

THE NON-LATIN CHARACTERS IN THE MARK TRANSLITERATE TO TUNG NGA NGAN HONG IN CATONESE AND DONG YA YIN HANG IN MANDARIN AND THIS MEANS "THE BANK OF EAST ASIA" IN ENGLISH.

SEC. 2(F) AS TO "TUNG NGA NGAN HONG" IN CANTONESE AND "DONG YA YIN HANG" IN MANDARIN AND THAT TRANSLATE INTO ENGLISH AS "BANK OF EAST ASIA".

CLASS 16—PAPER GOODS AND PRINTED MATTER

FOR PRINTED MATTER AND PRINTED PUBLICATIONS, NAMELY, NEWSLETTERS RELATING TO BANKING AND FINANCIAL SERVICES (U.S. CLS. 2, 5, 22, 23, 29, 37, 38 AND 50).

FIRST USE 4-8-1990; IN COMMERCE 4-8-1990.

CLASS 36—INSURANCE AND FINANCIAL

FOR LOAN FINANCING; BANK DEPOSITORY SERVICES, NAMELY, CHECKING ACCOUNT SERVICES, CERTIFICATE OF DEPOSIT ACCOUNT SERVICES AND MONEY MARKET ACCOUNT SERVICES (U.S. CLS. 100, 101 AND 102).

FIRST USE 4-8-1990; IN COMMERCE 4-8-1990.

4,154,441. WPP PROPERTIES, NEW YORK, NY. SN 77-783,932. PUB. 3-1-2011, FILED 7-17-2009.

WPP GROUP TECHNOLOGY SERVICES

THE MARK CONSISTS OF STANDARD CHARACTERS WITHOUT CLAIM TO ANY PARTICULAR FONT, STYLE, SIZE, OR COLOR.

OWNER OF U.S. REG. NO. 3,224,489.

NO CLAIM IS MADE TO THE EXCLUSIVE RIGHT TO USE "GROUP TECHNOLOGY SERVICES", APART FROM THE MARK AS SHOWN.

CLASS 35—ADVERTISING AND BUSINESS

FOR PROVIDING BUSINESS CONSULTING SERVICES IN THE FIELD OF INFORMATION TECHNOLOGY (U.S. CLS. 100, 101 AND 102).

FIRST USE 12-15-2010; IN COMMERCE 12-15-2010.

CLASS 42—SCIENTIFIC AND COMPUTER SERVICES

FOR PROVIDING INFORMATION TECHNOLOGY INFRASTRUCTURE AND TECHNICAL SUPPORT SERVICES, NAMELY, TROUBLESHOOTING IN THE NATURE OF DIAGNOSING COMPUTER HARDWARE AND SOFTWARE PROBLEMS, AND REMOTE AND ON-SITE INFRASTRUCTURE MANAGEMENT SERVICES FOR MONITORING, ADMINISTRATION AND MANAGEMENT OF PUBLIC AND PRIVATE CLOUD COMPUTING IT AND APPLICATION SYSTEMS (U.S. CLS. 100 AND 101).

FIRST USE 12-15-2010; IN COMMERCE 12-15-2010.

4,154,448. P4Q ELECTRONICS, S.L., ALONSOTEGI (VIZCAYA), SPAIN. SN 77-798,891. PUB. 1-5-2010, FILED 8-6-2009.



THE COLOR(S) BLUE IS/ARE CLAIMED AS A FEATURE OF THE MARK.

THE MARK CONSISTS OF TWO TRIANGLES IN BLUE FACING IN OPPOSITE DIRECTIONS FOLLOWED BY THE LETTERS "P4Q" IN BLUE.

CLASS 9—ELECTRICAL AND SCIENTIFIC APPARATUS

FOR ELECTRIC AND ELECTRONIC CIRCUITS, ELECTRIC CONTROL APPARATUS AND DEVICES, NAMELY, ELECTRIC CONTROL DEVICES FOR HEATING AND ENERGY MANAGEMENT AND ELECTRIC CONTROL PANELS; MEASUREMENT DATA TRANSMISSION, NAMELY, ELECTRONICAL SENSORS FOR MEASURING SOLAR RADIATION AND INSTRUMENTS FOR MEASURING LENGTH; PHOTOVOLTAIC INSTALLATION CONTROLLERS AND SOLAR CONTROLLERS, NAMELY, ELECTRIC CONTROLLERS (U.S. CLS. 21, 23, 26, 36 AND 38).

FIRST USE 5-31-1999; IN COMMERCE 1-31-2009.

CLASS 37—CONSTRUCTION AND REPAIR

FOR INSTALLATION AND MAINTENANCE OF ELECTRONIC CIRCUITS, INSTALLATION AND MAINTENANCE OF ELECTRONIC CONTROL SYSTEMS FOR MACHINES, INSTALLATION AND MAINTENANCE OF RADIATION-MEASURING INSTRUMENTS AND RESISTANCE MEASURING INSTRUMENTS, INSTALLATION AND MAINTENANCE OF PHOTOVOLTAIC INSTALLATIONS, INSTALLATION AND MAINTENANCE OF CONTROLLERS AND SOLAR CONTROLLERS, NAMELY, ELECTRIC CONTROLLERS (U.S. CLS. 100, 103 AND 106).

FIRST USE 5-31-1999; IN COMMERCE 1-31-2009.

CLASS 42—SCIENTIFIC AND COMPUTER SERVICES

FOR TECHNICAL DESIGN SERVICES, NAMELY, STRUCTURAL ENGINEERING DESIGN SERVICES; ELECTRONIC CIRCUITS ENGINEERING PROJECTS AND ELECTRONIC CONTROL APPARATUS AND DEVICES ENGINEERING PROJECTS AND MEASUREMENT DATA TRANSMISSION ENGINEERING PROJECTS, NAMELY, ENGINEERING; PHOTOVOLTAIC INSTALLATION CONTROLLERS AND SOLAR CONTROLLERS, NAMELY, TECHNICAL PLANNING OF PHOTOVOLTAIC INSTALLATIONS AND TECHNICAL PLANNING OF SOLAR THERMAL INSTALLATIONS, ENGINEERING SERVICES FOR OTHERS IN THE FIELD OF ENERGY EFFICIENCY; COMPUTER SOFTWARE DESIGN AND DEVELOPMENT (U.S. CLS. 100 AND 101).

FIRST USE 5-31-1999; IN COMMERCE 1-31-2009.

4,154,449. GARCIA, BERNARDO BALDERRAMA, SINALOA, MEXICO. SN 77-804,423. PUB. 11-17-2009, FILED 8-13-2009.

SELVA MAYA

THE MARK CONSISTS OF STANDARD CHARACTERS WITHOUT CLAIM TO ANY PARTICULAR FONT, STYLE, SIZE, OR COLOR.

CLASS 30—STAPLE FOODS

FOR COFFEE BEANS, NAMELY, GROUND COFFEE BEANS, ROASTED COFFEE BEANS AND WHOLE COFFEE BEANS; COFFEE BEVERAGES; COFFEE-BASED BEVERAGES; GREEN COFFEE; CAFFEINE-FREE COFFEE (U.S. CL. 46).

FIRST USE 5-6-2010; IN COMMERCE 9-1-2011.

CLASS 40—MATERIAL TREATMENT

FOR COFFEE ROASTING AND PROCESSING (U.S. CLS. 100, 103 AND 106).

FIRST USE 7-19-2011; IN COMMERCE 9-1-2011.

4,154,452. WELLS FARGO & COMPANY, MINNEAPOLIS, MN. SN 77-808,734. PUB. 8-3-2010, FILED 8-20-2009.

TREASURY ONLINE PLUS

THE MARK CONSISTS OF STANDARD CHARACTERS WITHOUT CLAIM TO ANY PARTICULAR FONT, STYLE, SIZE, OR COLOR.

NO CLAIM IS MADE TO THE EXCLUSIVE RIGHT TO USE "TREASURY ONLINE", APART FROM THE MARK AS SHOWN.

CLASS 35—ADVERTISING AND BUSINESS

FOR ACCOUNTS RECEIVABLE MANAGEMENT SERVICES; ACCOUNTS RECEIVABLE SERVICES; ADMINISTRATION AND RECONCILIATION OF ACCOUNTS ON BEHALF OF OTHERS; PREPARATION OF FINANCIAL REPORTS FOR OTHERS, NAMELY, PROVISION OF CONSOLIDATED REPORTS AND DOCUMENT IMAGES OF BANKING AND FINANCIAL ACTIVITY (U.S. CLS. 100, 101 AND 102).

FIRST USE 10-17-2011; IN COMMERCE 2-21-2012.

CLASS 36—INSURANCE AND FINANCIAL

FOR BANKING SERVICES; FINANCIAL SERVICES, NAMELY, CASH MANAGEMENT SERVICES, TREASURY MANAGEMENT SERVICES; ACCOUNTS PAYABLE DEBITING SERVICES; FOREIGN EXCHANGE SERVICES, NAMELY, FOREIGN EXCHANGE TRANSACTIONS, FOREIGN EXCHANGE INFORMATION SERVICES; ONLINE BUSINESS BANKING SERVICES; ELECTRONIC FUNDS TRANSFER SERVICES (U.S. CLS. 100, 101 AND 102).

FIRST USE 10-17-2011; IN COMMERCE 2-21-2012.

CLASS 45—PERSONAL AND LEGAL SERVICES

FOR PROVIDING FRAUD DETECTION SERVICES IN THE FIELD OF ELECTRONIC FUNDS TRANSFER AND ELECTRONIC CHECK TRANSACTIONS (U.S. CLS. 100 AND 101).

FIRST USE 10-17-2011; IN COMMERCE 2-21-2012.

4,154,453. WIND SONG PRODUCTIONS, FRESNO, CA. SN 77-809,555. PUB. 1-25-2011, FILED 8-20-2009.

WINDSONG PRODUCTIONS

THE MARK CONSISTS OF STANDARD CHARACTERS WITHOUT CLAIM TO ANY PARTICULAR FONT, STYLE, SIZE, OR COLOR.

NO CLAIM IS MADE TO THE EXCLUSIVE RIGHT TO USE "PRODUCTIONS", APART FROM THE MARK AS

SHOWN.

CLASS 35—ADVERTISING AND BUSINESS

FOR ADVERTISING SERVICES, NAMELY, PROMOTING AND MARKETING THE GOODS AND SERVICES OF OTHERS THROUGH ALL COMMUNICATION MEDIA; PUBLIC RELATIONS; RESELLER SERVICES, NAMELY, DISTRIBUTORSHIP SERVICES FEATURING PROMOTIONAL PRODUCTS IN THE AUTOMOTIVE, CIVIC EDUCATION, HEALTH AND BEAUTY, HOME BUILDERS, HOME IMPROVEMENT, MEDICAL, RESTAURANT, AND RETAIL UTILITIES FIELDS; PRODUCT MERCHANDISING; PROVIDING MARKETING AND PROMOTION OF SPECIAL EVENTS FOR OTHERS; CONSUMER MARKETING RESEARCH AND CONSULTING RELATED THERETO; CONSUMER MARKETING RESEARCH IN THE AUTOMOTIVE, BUSINESS TO BUSINESS, EDUCATION, GAMING/ENTERTAINMENT, HEALTH AND BEAUTY, HOME BUILDERS, HOME IMPROVEMENT, MEDICAL, RESTAURANTS, RETAIL, UTILITIES, AND CIVIC INDUSTRIES AND CONSULTING RELATED THERETO; ADVERTISING SERVICES, NAMELY, THE PRODUCTION OF ADVERTISING MATTER, COMMERCIALS, AND PROMOTIONAL PRESENTATIONS IN THE NATURE OF MUSIC COMPOSITIONS AND AUDIO-VISUAL MATERIAL; CONSULTING SERVICES RELATED TO THE SELECTION OF AUDIO AND AUDIO-VISUAL MEDIA FOR ADVERTISING AND MARKETING PURPOSES; PRODUCTION OF ORIGINAL AND SYNDICATED PROMOTIONAL MATERIALS FOR CASINOS (U.S. CLS. 100, 101 AND 102).

FIRST USE 9-27-2011; IN COMMERCE 9-27-2011.

CLASS 41—EDUCATION AND ENTERTAINMENT

FOR ARRANGING AND CONDUCTING SPECIAL EVENTS FOR OTHERS; ENTERTAINMENT SERVICES IN THE NATURE OF CREATION, PRODUCTION, POST-PRODUCTION, AND ARRANGEMENT OF MUSIC COMPOSITIONS AND AUDIO AND AUDIO-VISUAL MATERIAL; PRODUCTION OF VIDEO; PRODUCTION OF MOTION PICTURES, SHORT FILMS, TELEVISIONS SERIES, AND MADE FOR TELEVISION MOTION PICTURES; PHOTOGRAPHY SERVICES (U.S. CLS. 100, 101 AND 107).

FIRST USE 8-1-2011; IN COMMERCE 8-1-2011.

4,154,457. NAVAJO NATION GAMING ENTERPRISE, CHURCH ROCK, NM. SN 77-814,567. PUB. 5-11-2010, FILED 8-27-2009.

**NAVAJO NATION GAMING
ENTERPRISE**

THE MARK CONSISTS OF STANDARD CHARACTERS WITHOUT CLAIM TO ANY PARTICULAR FONT, STYLE, SIZE, OR COLOR.

NO CLAIM IS MADE TO THE EXCLUSIVE RIGHT TO USE "GAMING ENTERPRISE", APART FROM THE MARK AS SHOWN.

CLASS 37—CONSTRUCTION AND REPAIR

FOR REAL ESTATE DEVELOPMENT OF CASINOS, GAMING FACILITIES AND RESORTS (U.S. CLS. 100, 103 AND 106).

FIRST USE 9-0-2006; IN COMMERCE 9-0-2006.

CLASS 41—EDUCATION AND ENTERTAINMENT

FOR PROVIDING CASINOS AND GAMING FACILITIES (U.S. CLS. 100, 101 AND 107).

FIRST USE 11-19-2008; IN COMMERCE 11-19-2008.

4,154,460. ELBO, INC., GRAPEVINE, TX. SN 77-818,890. PUB. 12-15-2009, FILED 9-2-2009.

BUCK

THE MARK CONSISTS OF STANDARD CHARACTERS WITHOUT CLAIM TO ANY PARTICULAR FONT, STYLE, SIZE, OR COLOR.

CLASS 35—ADVERTISING AND BUSINESS

FOR RETAIL STORE SERVICES AND ONLINE RETAIL STORE SERVICES PROVIDED VIA A GLOBAL COMPUTER NETWORK FEATURING NEW AND USED COMPUTER, VIDEO AND ELECTRONIC GAMES, VIDEOS, DVDS, MOVIES, BOOKS, MAGAZINES, STRATEGY GUIDES, COMPUTER HARDWARE, COMPUTER ACCESSORIES, TOYS AND ACTION FIGURES; PROMOTING THE SALE OF NEW AND USED COMPUTER, VIDEO AND ELECTRONIC GAMES, VIDEOS, DVDS, MOVIES, BOOKS, MAGAZINES, STRATEGY GUIDES, COMPUTER HARDWARE, COMPUTER ACCESSORIES, TOYS AND ACTION FIGURES THROUGH THE ADMINISTRATION OF A CUSTOMER INCENTIVE AWARD AND DISCOUNT PROGRAM (U.S. CLS. 100, 101 AND 102).

FIRST USE 3-8-2012; IN COMMERCE 3-8-2012.

CLASS 41—EDUCATION AND ENTERTAINMENT

FOR PROVIDING A WEB SITE CONTAINING ENTERTAINMENT INFORMATION, NAMELY, PROVIDING INFORMATION ABOUT NEW AND USED COMPUTER, VIDEO AND ELECTRONIC GAMES, VIDEO GAME CONSOLES, HAND-HELD VIDEO GAME PLAYERS, DIGITAL MEDIA PLAYERS AND RECORDERS, VIDEOS, DVDS, MOVIES, ROLE-PLAYING CARDS GAMES, GAME CARDS, BOOKS AND MAGAZINES FEATURING COMPUTER GAMES, STRATEGY GUIDES FOR COMPUTER GAMES, COMPUTER GAME HARDWARE, COMPUTER GAME ACCESSORIES, TOYS AND ACTION FIGURES; ENTERTAINMENT SERVICES, NAMELY, CONDUCTING CONTESTS AND SWEEPSTAKES AND CONDUCTING CONTESTS AND SWEEPSTAKES OVER A GLOBAL COMPUTER NETWORK (U.S. CLS. 100, 101 AND 107).

FIRST USE 3-8-2012; IN COMMERCE 3-8-2012.

4,154,462. NORTHERN TOOL & EQUIPMENT COMPANY, INC., BURNSVILLE, MN. SN 77-823,699. PUB. 9-21-2010, FILED 9-10-2009.

ROUGHNECK

THE MARK CONSISTS OF STANDARD CHARACTERS

WITHOUT CLAIM TO ANY PARTICULAR FONT, STYLE, SIZE, OR COLOR.

OWNER OF U.S. REG. NOS. 1,178,879 AND 3,028,748.

CLASS 7—MACHINERY

FOR FUEL TRANSFER PUMPS FOR LAND VEHICLES; BATTERY-POWERED AND PNEUMATIC GREASE GUNS; POWER-OPERATED GREASE AND FUEL HOSE REELS; POWER-OPERATED GREASE PUMPS; POWER-OPERATED OIL PUMPS FOR LAND VEHICLES; POWER-OPERATED FUEL PUMPS FOR LAND VEHICLES; PNEUMATIC GREASE GUN ACCESSORIES, NAMELY, GREASE DISPENSERS, GREASE VALVES AND GREASE NOZZLES; POWER-OPERATED OIL PUMP ACCESSORIES, NAMELY, OIL DISPENSERS, OIL VALVES AND OIL NOZZLES (U.S. CLS. 13, 19, 21, 23, 31, 34 AND 35).

FIRST USE 8-31-2011; IN COMMERCE 8-31-2011.

CLASS 8—HAND TOOLS

FOR HAND-OPERATED GREASE, OIL AND FUEL PUMPS; HAND-OPERATED GREASE GUNS; HAND-OPERATED GREASE AND FUEL HOSE REELS; HAND TOOLS, NAMELY, WASTE OIL DRAINS (U.S. CLS. 23, 28 AND 44).

FIRST USE 8-31-2011; IN COMMERCE 8-31-2011.

CLASS 9—ELECTRICAL AND SCIENTIFIC APPARATUS

FOR FUEL METERS (U.S. CLS. 21, 23, 26, 36 AND 38).

FIRST USE 8-31-2011; IN COMMERCE 8-31-2011.

CLASS 12—VEHICLES

FOR FUEL CARTS (U.S. CLS. 19, 21, 23, 31, 35 AND 44).

FIRST USE 8-31-2011; IN COMMERCE 8-31-2011.

4,154,466. DWYER FRANCHISING LLC, WACO, TX. SN 77-828,101. PUB. 2-9-2010, FILED 9-16-2009.

THE GROUNDS GUYS

THE MARK CONSISTS OF STANDARD CHARACTERS WITHOUT CLAIM TO ANY PARTICULAR FONT, STYLE, SIZE, OR COLOR.

NO CLAIM IS MADE TO THE EXCLUSIVE RIGHT TO USE "GROUNDS", APART FROM THE MARK AS SHOWN.

CLASS 37—CONSTRUCTION AND REPAIR

FOR SNOW REMOVAL SERVICES (U.S. CLS. 100, 103 AND 106).

FIRST USE 4-30-2011; IN COMMERCE 4-30-2011.

CLASS 39—TRANSPORTATION AND STORAGE

FOR JUNK, TRASH AND DEBRIS REMOVAL (U.S. CLS. 100 AND 105).

FIRST USE 4-30-2011; IN COMMERCE 4-30-2011.

CLASS 44—MEDICAL, BEAUTY AND AGRICULTURAL SERVICES

FOR TREE CARE SERVICES; LANDSCAPE DESIGN; LANDSCAPE GARDENING; HORTICULTURAL SERVICES, NAMELY, INSTALLING SOD AND LAWN AND VEGETATION FERTILIZATION AND TREATMENT (U.S. CLS. 100 AND 101).

FIRST USE 4-30-2011; IN COMMERCE 4-30-2011.

4,154,467. SPOON IT UP FROZEN YOGURT, LLC, INDEPENDENCE, OH. SN 77-829,550. PUB. 11-1-2011, FILED 9-18-2009.



NO CLAIM IS MADE TO THE EXCLUSIVE RIGHT TO USE "FROZEN YOGURT", APART FROM THE MARK AS SHOWN.

THE COLOR(S) BLUE, GREEN, LIGHT PINK AND DARK PINK IS/ARE CLAIMED AS A FEATURE OF THE MARK.

THE MARK CONSISTS OF THE STYLIZED WORDING "SPOON IT UP! FROZEN YOGURT" AND DESIGN. THE WORDS "SPOON IT UP!" ARE BLUE WITH A GREEN BORDER AND CENTERED IN A GREEN OVAL. PART OF THE OVAL IS FORMED BY THE WORDING "FROZEN YOGURT" IN THE COLOR GREEN. THE "P" IN "SPOON" IS A BLUE SPOON FEATURING A LIGHT AND DARK PINK SWIRL.

CLASS 30—STAPLE FOODS

FOR DESSERTS, NAMELY, FROZEN YOGURT, YOGURT-BASED FROZEN CONFECTIONS, FROZEN YOGURT SHAKES, FROZEN YOGURT PIES AND CAKES; FROZEN CONFECTIONS (U.S. CL. 46).

FIRST USE 2-8-2010; IN COMMERCE 2-8-2010.

CLASS 43—HOTEL AND RESTAURANT SERVICES

FOR RESTAURANT SERVICES FEATURING FROZEN CONFECTIONS, NAMELY, SELF-SERVE FROZEN YOGURT AND SHAVED ICE (U.S. CLS. 100 AND 101).

FIRST USE 2-8-2010; IN COMMERCE 2-8-2010.

4,154,472. MINNESOTA VIKINGS FOOTBALL, LLC, EDEN PRAIRIE, MN. SN 77-835,404. PUB. 3-16-2010, FILED 9-25-2009.

SHOW YOUR HORNS

THE MARK CONSISTS OF STANDARD CHARACTERS WITHOUT CLAIM TO ANY PARTICULAR FONT, STYLE,

SIZE, OR COLOR.

CLASS 16—PAPER GOODS AND PRINTED MATTER

FOR STICKERS, PRINTED TICKETS TO SPORTS GAMES AND EVENTS; PAPER PARTY DECORATIONS, SOUVENIR PROGRAMS FOR SPORTS EVENTS (U.S. CLS. 2, 5, 22, 23, 29, 37, 38 AND 50).
FIRST USE 6-0-2009; IN COMMERCE 6-0-2009.

CLASS 24—FABRICS

FOR TOWELS (U.S. CLS. 42 AND 50).
FIRST USE 6-0-2009; IN COMMERCE 6-0-2009.

CLASS 28—TOYS AND SPORTING GOODS

FOR PAPER PARTY HATS (U.S. CLS. 22, 23, 38 AND 50).
FIRST USE 6-0-2009; IN COMMERCE 6-0-2009.

CLASS 36—INSURANCE AND FINANCIAL

FOR CHARITABLE FUNDRAISING SERVICES; PHILANTHROPIC SERVICES CONCERNING MONETARY DONATIONS; CHARITABLE FUNDRAISING SERVICES AND PHILANTHROPIC SERVICES CONCERNING MONETARY DONATIONS IN SUPPORT OF EDUCATIONAL AND COMMUNITY NEEDS; CHARITABLE AND PHILANTHROPIC FUNDRAISING SERVICES IN CONNECTION WITH PROFESSIONAL FOOTBALL GAMES AND EXHIBITIONS (U.S. CLS. 100, 101 AND 102).
FIRST USE 6-0-2009; IN COMMERCE 6-0-2009.

CLASS 41—EDUCATION AND ENTERTAINMENT

FOR ENTERTAINMENT SERVICES, NAMELY, PRESENTATIONS IN THE NATURE OF PROFESSIONAL FOOTBALL GAMES AND EXHIBITIONS (U.S. CLS. 100, 101 AND 107).
FIRST USE 6-0-2009; IN COMMERCE 6-0-2009.

4,154,474. SHMIRSHKY UNIVERSAL, LLC, CORONADO, CA. SN 77-837,644. PUB. 2-15-2011, FILED 9-29-2009.



THE MARK CONSISTS OF A POLYGONAL PATCH OF SCROLLWORK RESEMBLING HAIR WITH THE LETTER "S" INSIDE.

CLASS 16—PAPER GOODS AND PRINTED MATTER

FOR PRINTED MATTER, NAMELY, BOOKS IN THE FIELD OF WOMEN'S ISSUES, AND STATIONERY (U.S. CLS. 2, 5, 22, 23, 29, 37, 38 AND 50).
FIRST USE 3-2-2010; IN COMMERCE 3-2-2010.

CLASS 25—CLOTHING

FOR CLOTHING, NAMELY, WOMEN'S EXERCISE CLOTHES, NAMELY, FITNESS TOPS, SHIRTS (U.S. CLS. 22 AND 39).
FIRST USE 3-2-2010; IN COMMERCE 3-2-2010.

4,154,475. CORRELATED MAGNETICS RESEARCH, LLC, NEW HOPE, AL. SN 77-838,223. PUB. 8-17-2010, FILED 9-30-2009.



THE MARK CONSISTS OF THE LETTERS "CMR" IN A STYLIZED FORM WITH ITS MIRRORED REFLECTION BELOW.

CLASS 40—MATERIAL TREATMENT

FOR CUSTOM MANUFACTURE OF MAGNETS FOR OTHERS (U.S. CLS. 100, 103 AND 106).
FIRST USE 10-2-2009; IN COMMERCE 10-2-2009.

CLASS 42—SCIENTIFIC AND COMPUTER SERVICES

FOR CUSTOM DESIGN OF MAGNETS FOR OTHERS (U.S. CLS. 100 AND 101).
FIRST USE 10-2-2009; IN COMMERCE 10-2-2009.

4,154,480. FREEMAN, ALGEANIA WARREN, MCCORDSVILLE, IN. SN 77-840,335. PUB. 4-6-2010, FILED 10-2-2009.



THE MARK CONSISTS OF THE STYLIZED WORDING "STEP UP SISTER", WITH THE SILHOUETTE OF A WOMAN CLIMBING STEPS ABOVE THE LETTER "P" IN "STEP" AND THE LETTER "U" IN "UP".

CLASS 16—PAPER GOODS AND PRINTED MATTER

FOR NOTE PADS, NOTE BOOKS, POSTERS, POSTCARDS, GREETING CARDS, PRINTED MATTER, NAMELY, BOOKS CONCERNING PERSONAL AND SPIRITUAL GROWTH AND LIFE IMPROVEMENT FOR WOMEN, STATIONERY, PENS, AND BOOK MARKS (U.S. CLS. 2, 5, 22, 23, 29, 37, 38 AND 50).

FIRST USE 3-16-2012; IN COMMERCE 3-16-2012.

CLASS 41—EDUCATION AND ENTERTAINMENT

FOR EDUCATIONAL SERVICES, NAMELY, CONDUCTING CLASSES, SEMINARS, CONFERENCE, WORKSHOPS IN THE FIELD OF PERSONAL AND SPIRITUAL GROWTH AND LIFE PLANNING (U.S. CLS. 100, 101 AND 107).

FIRST USE 3-16-2012; IN COMMERCE 3-16-2012.

4,154,489. NORTH SHORE-LONG ISLAND JEWISH HEALTH SYSTEM, INC., GREAT NECK, NY. SN 77-860,665. PUB. 4-6-2010, FILED 10-29-2009.

NORTH SHORE-LIJ ELECTRONIC
HEALTH RECORD

THE MARK CONSISTS OF STANDARD CHARACTERS WITHOUT CLAIM TO ANY PARTICULAR FONT, STYLE, SIZE, OR COLOR.

NO CLAIM IS MADE TO THE EXCLUSIVE RIGHT TO USE "ELECTRONIC HEALTH RECORD", APART FROM THE MARK AS SHOWN.

CLASS 9—ELECTRICAL AND SCIENTIFIC APPARATUS

FOR SOFTWARE FOR PROVIDING A SECURE WEBSITE FEATURING PATIENT MEDICAL RECORDS (U.S. CLS. 21, 23, 26, 36 AND 38).

FIRST USE 1-1-2010; IN COMMERCE 1-1-2010.

CLASS 35—ADVERTISING AND BUSINESS

FOR MEDICAL INFORMATION SERVICES, NAMELY, PROVIDING A SECURE WEBSITE FEATURING PATIENT MEDICAL RECORDS; CONSULTING SERVICES RELATED TO IMPLEMENTING AND UPDATING A DATABASE FOR PATIENT MEDICAL RECORDS (U.S. CLS. 100, 101 AND 102).

FIRST USE 3-30-2011; IN COMMERCE 3-30-2011.

4,154,492. THE OFFICE CLUB, INC., BOCA RATON, FL. SN 77-868,918. PUB. 9-7-2010, FILED 11-10-2009.

IE

THE MARK CONSISTS OF STANDARD CHARACTERS WITHOUT CLAIM TO ANY PARTICULAR FONT, STYLE, SIZE, OR COLOR.

CLASS 9—ELECTRICAL AND SCIENTIFIC APPARATUS

FOR COMPUTER HARDWARE AND ACCESSORIES, NAMELY, KEYPADS, KEYBOARDS, COMPUTER MOUSE, MOUSE PADS, WRIST RESTS, FLASH DRIVES, FLASH CARDS, FLOPPY DISK DRIVES, NETWORK CARDS, WIRELESS DSL ROUTERS, USB HUBS, NOTEBOOK COMPUTER COOLING PADS, COMPUTER INTERCONNECT CABLES, ELECTRONIC CARD READERS, LAPTOP ROLLING AND CARRYING CASES, BATTERIES, BATTERY CHARGERS, POWER ADAPTERS FOR COMPUTERS, EXTERNAL AUDIO COMPUTER SPEAKERS, COMPUTER MICROPHONE, COMPUTER EARPHONES; ELECTRONIC PERSONAL ORGANIZER; USB CABLES, ELECTRICAL POWER DISTRIBUTION UNITS, NAMELY, OUTLET POWER STRIP (U.S. CLS. 21, 23, 26, 36 AND 38).

FIRST USE 7-24-2009; IN COMMERCE 7-24-2009.

CLASS 16—PAPER GOODS AND PRINTED MATTER

FOR STATIONERY PRODUCTS AND DESKTOP ACCESSORIES, NAMELY, DESK PADS, BINDERS, WRITING PADS, NOTEBOOKS, LEGAL PADS, PERSONAL ORGANIZERS, BUSINESS FORMS AND MEMO PADS, PAPER EXPANDING FILES, APPOINTMENT BOOKS, DAILY AND DESKTOP PLANNERS, PADFOLIOS, NOTE PADS, BLANK BUSINESS JOURNALS, BLANK JOURNALS, WRITING JOURNAL SHEETS, CALENDARS AND DIARIES, TELEPHONE NUMBER AND ADDRESS BOOKS AND EMBROIDERY DESIGN PATTERNS PRINTED ON PAPER; DESKTOP BUSINESS CARD AND CREDIT CARD HOLDERS; PASSPORT CASES, COVERS AND HOLDERS; PEN AND PENCIL CUPS AND HOLDERS; TRAYS, NAMELY, FILE TRAYS, LETTER TRAYS, PEN AND PENCIL TRAYS; FILE BOXES FOR STORAGE OF MAGAZINES; PAPER CLIP HOLDERS; BOOK ENDS; HOLDERS FOR DESK ACCESSORIES; OFFICE SUPPLIES, NAMELY, BINDER CLIPS, PAPER CLIPS, PAPER FASTENERS, THUMBTRACKS, PAPER CLIP HOLDER, STAPLES, STAPLERS, RUBBER BANDS, RUBBER ERASERS, MARKERS, HIGHLIGHTING PENS AND HIGHLIGHTING MARKERS, OFFICE HOLE PUNCHERS, SCISSORS, DESKTOP REVOLVING ROTARY CARD FILES, CARD FILES, PAPER EXPANDING FILES, FOLDERS, DOCUMENT PLASTIC COVERS, DOCUMENT PORTFOLIOS, CLIP BOARDS AND PLASTIC ENVELOPES FOR STATIONERY USE (U.S. CLS. 2, 5, 22, 23, 29, 37, 38 AND 50).

FIRST USE 7-24-2009; IN COMMERCE 7-24-2009.

CLASS 18—LEATHER GOODS

FOR BAGS, NAMELY, TOTE BAGS, WHEELED CASES AND BAGS, MESSENGER BAGS, DUFFEL BAGS, LUGGAGE, TRAVEL BAGS, BACKPACKS, CARRY-ON BAGS, BOOK BAGS, HANDBAGS; BRIEFCASES, CARRYING CASES, KEY CASES, BUSINESS CASES, BUSINESS CARD CASES AND HOLDERS, DOCUMENT CASES, CREDIT CARD CASES, PURSES AND WALLETS, LUGGAGE TAGS, TRAVEL CASES, COSMETIC CASES SOLD EMPTY, TOILETRY CASES SOLD EMPTY, NON-MOTORIZED CARTS FOR LUGGAGE AND BAGS, AND UMBRELLAS (U.S. CLS. 1, 2, 3, 22 AND 41).

FIRST USE 7-24-2009; IN COMMERCE 7-24-2009.

4,154,493. THE OFFICE CLUB, INC., BOCA RATON, FL. SN 77-868,922. PUB. 8-10-2010, FILED 11-10-2009.



THE MARK CONSISTS OF THE LETTERS "IE" IN APPEARING INSIDE A BOX.

CLASS 9—ELECTRICAL AND SCIENTIFIC APPARATUS

FOR COMPUTER HARDWARE AND ACCESSORIES, NAMELY, KEYPADS, KEYBOARDS, COMPUTER MOUSE, MOUSE PADS, WRIST RESTS, FLASH DRIVES, FLASH CARDS, FLOPPY DISK DRIVES, NETWORK CARDS, WIRELESS DSL ROUTERS, USB HUBS, NOTEBOOK COMPUTER COOLING PADS, COMPUTER INTERCONNECT CABLES, ELECTRONIC CARD READERS, LAPTOP ROLLING AND CARRYING CASES, BATTERIES, BATTERY CHARGERS, POWER ADAPTERS FOR COMPUTERS, EXTERNAL AUDIO COMPUTER SPEAKERS, COMPUTER MICROPHONE, COMPUTER EARPHONES; ELECTRONIC PERSONAL ORGANIZER; USB CABLE; ELECTRICAL POWER DISTRIBUTION UNITS, NAMELY, OUTLET POWER STRIP (U.S. CLS. 21, 23, 26, 36 AND 38).

FIRST USE 7-24-2009; IN COMMERCE 7-24-2009.

CLASS 16—PAPER GOODS AND PRINTED MATTER

FOR STATIONERY PRODUCTS AND DESKTOP ACCESSORIES, NAMELY, DESK PADS, BINDERS, WRITING PADS, NOTEBOOKS, LEGAL PADS, PERSONAL ORGANIZERS, BUSINESS FORMS AND MEMO PADS, PAPER EXPANDING FILES, APPOINTMENT BOOKS, DAILY AND DESKTOP PLANNERS, PADFOLIOS, NOTE PADS, BLANK BUSINESS JOURNALS, BLANK JOURNALS, WRITING JOURNAL SHEETS, CALENDARS AND DIARIES, TELEPHONE NUMBER AND ADDRESS BOOKS AND EMBROIDERY DESIGN PATTERNS PRINTED ON PAPER; DESKTOP BUSINESS CARD AND CREDIT CARD HOLDERS; PASSPORT CASES, COVERS AND HOLDERS; PEN AND PENCIL CUPS AND HOLDERS; TRAYS, NAMELY, FILE TRAYS, LETTER TRAYS, PEN AND PENCIL TRAYS; FILE BOXES FOR STORAGE OF MAGAZINES; PAPER CLIP HOLDERS; BOOK ENDS; HOLDERS FOR DESK ACCESSORIES; OFFICE SUPPLIES, NAMELY, BINDER CLIPS, PAPER CLIPS, PAPER FASTENERS, THUMB TACKS, PAPER CLIP HOLDER, STAPLES, STAPLERS, RUBBER BANDS, RUBBER ERASERS, MARKERS, HIGHLIGHTING PENS AND HIGHLIGHTING MARKERS, OFFICE HOLE PUNCHERS, SCISSORS, DESKTOP REVOLVING ROTARY CARD FILES, CARD FILES, PAPER EXPANDING FILES, FOLDERS, DOCUMENT PLASTIC COVERS, DOCUMENT PORTFOLIOS, CLIP BOARDS AND PLASTIC ENVELOPES FOR STATIONERY USE (U.S. CLS. 2, 5, 22, 23, 29, 37, 38 AND 50).

FIRST USE 7-24-2009; IN COMMERCE 7-24-2009.

CLASS 18—LEATHER GOODS

FOR BAGS, NAMELY, TOTE BAGS, WHEELED CASES AND BAGS, MESSENGER BAGS, DUFFEL BAGS, LUGGAGE, TRAVEL BAGS, BACKPACKS, CARRY-ON BAGS, BOOK BAGS, HANDBAGS; BRIEFCASES, CARRYING CASES, KEY CASES, BUSINESS CASES, BUSINESS CARD CASES AND HOLDERS, DOCUMENT CASES, CREDIT CARD CASES, PURSES AND WALLET CASES, LUGGAGE TAGS, TRAVEL CASES, COSMETIC CASES SOLD EMPTY, TOILETRY CASES SOLD EMPTY, NON-MOTORIZED CARTS FOR LUGGAGE AND BAGS, AND UMBRELLAS (U.S. CLS. 1, 2, 3, 22 AND 41).

FIRST USE 7-24-2009; IN COMMERCE 7-24-2009.

4,154,504. ATLANTA ART LICENSING AND MARKETING, INC., DULUTH, GA. SN 77-880,637. PUB. 4-6-2010, FILED 11-25-2009.

BOOTS ON THE GROUND

THE MARK CONSISTS OF STANDARD CHARACTERS WITHOUT CLAIM TO ANY PARTICULAR FONT, STYLE, SIZE, OR COLOR.

CLASS 14—JEWELRY

FOR JEWELRY, NAMELY, PERSONAL JEWELRY CHARMS, NECKLACES, PENDANTS, LAPEL PINS, TIE TACKS, KEY CHAINS AS JEWELRY, EARRINGS, RINGS, MEDALS, COLLECTIBLE COINS (U.S. CLS. 2, 27, 28 AND 50).

FIRST USE 2-21-2011; IN COMMERCE 2-21-2011.

CLASS 16—PAPER GOODS AND PRINTED MATTER

FOR DECALS (U.S. CLS. 2, 5, 22, 23, 29, 37, 38 AND 50).

FIRST USE 5-31-2010; IN COMMERCE 5-31-2010.

CLASS 25—CLOTHING

FOR CLOTHING, NAMELY, T-SHIRTS, HATS, BASEBALL CAPS, POLO SHIRTS, SCARVES, BANDANAS (U.S. CLS. 22 AND 39).

FIRST USE 5-26-2010; IN COMMERCE 5-26-2010.

4,154,508. JOHNSON & JOHNSON, NEW BRUNSWICK, NJ. SN 77-892,424. PUB. 10-26-2010, FILED 12-14-2009.

COUPLES PLACE

THE MARK CONSISTS OF STANDARD CHARACTERS WITHOUT CLAIM TO ANY PARTICULAR FONT, STYLE, SIZE, OR COLOR.

CLASS 3—COSMETICS AND CLEANING PREPARATIONS

FOR MESSAGE OILS; NON-MEDICATED TOPICAL PREPARATIONS, NAMELY, SPRAYS, GELS AND CREAMS FOR ENHANCING SEXUAL AROUSAL (U.S. CLS. 1, 4, 6, 50, 51 AND 52).

FIRST USE 12-31-2009; IN COMMERCE 12-31-2009.

CLASS 5—PHARMACEUTICALS

FOR PERSONAL LUBRICANTS; VAGINAL MOISTURIZERS (U.S. CLS. 6, 18, 44, 46, 51 AND 52).

FIRST USE 12-31-2009; IN COMMERCE 12-31-2009.

CLASS 45—PERSONAL AND LEGAL SERVICES

FOR PROVIDING A WEBSITE FEATURING INFORMATION ON ROMANCE AND INTERPERSONAL RELATIONSHIPS (U.S. CLS. 100 AND 101).

FIRST USE 12-31-2009; IN COMMERCE 12-31-2009.

CLASS 29—MEATS AND PROCESSED FOODS

FOR FROZEN VEGETABLES, NAMELY, EDAMAME, SOY BEANS, BROAD BEANS, BAMBOO SHOOTS, CHINESE SPINACH, MASTER GREENS IN THE NATURE OF MUSTARD GREENS AND COLLARD GREENS, CALTROP, CABBAGE, CARROTS, CORN KERNELS, PEAS, WATER CHESTNUTS, MUSHROOMS, MIXED VEGETABLES, ASTER INDICUS, AND TARO; FROZEN, PROCESSED NUTS, NAMELY, PEELED CHESTNUTS; PROCESSED NUTS; PROCESSED YELLOW EEL STRIP; TOFU, NAMELY, SOYA SHEETS AND SOYA SHEET KNOTS; PROCESSED SOY BEANS; BEAN CURD, NAMELY, SHREDDED BEAN CURD; TOFU, NAMELY, CHICKEN AND VEGETARIAN TOFU CAKES; MEAT, FISH, POULTRY; DRIED BEANS, NAMELY, DRIED RED BEANS, DRIED MUNG BEANS, DRIED SOY BEANS, DRIED BLACK BEANS, DRIED PEANUTS; DRIED JUJUBE FRUITS; DRIED RED DATES; DRIED MUSHROOMS; DRIED BLACK FUNGUS; DRIED EDIBLE SEAWEED; DRIED LOTUS NUTS; PROCESSED ROOTS FOR HUMAN CONSUMPTION, NAMELY, LOTUS ROOTS (U.S. CL. 46).

FIRST USE 12-0-2009; IN COMMERCE 12-0-2009.

CLASS 30—STAPLE FOODS

FOR DRIED EDIBLE SPICES, NAMELY, ANISEED, FIVE SPICE POWDER, PEPPER, MUSTARD, GARLIC, GINGER; BARLEY, NAMELY, CRUSHED BARLEY, HUSKED BARLEY, PEARLED BARLEY, EGG BARLEY, BEAN STICK IN THE NATURE OF BEAN PASTE IN STICK FORM; GLUTEN (U.S. CL. 46).

FIRST USE 12-0-2009; IN COMMERCE 12-0-2009.

4,154,509. KAM MAN FOOD INC., EDISON, NJ. SN 77-893,886. PUB. 5-3-2011, FILED 12-15-2009.



NO CLAIM IS MADE TO THE EXCLUSIVE RIGHT TO USE "SPECIALTY FOODS" AND THE NON-LATIN CHARACTERS THAT MEAN "BRAND", APART FROM THE MARK AS SHOWN.

THE NAME(S), PORTRAIT(S), AND/OR SIGNATURE(S) SHOWN IN THE MARK IDENTIFIES WELLMAN WU, WHOSE CONSENT(S) TO REGISTER IS MADE OF RECORD.

THE COLOR(S) BLACK, WHITE AND RED IS/ARE CLAIMED AS A FEATURE OF THE MARK.

THE MARK CONSISTS OF A BLACK AND WHITE PORTRAIT OF AN ASIAN MAN WITH GLASSES ON A RED, OVAL-SHAPED BACKGROUND OUTLINED IN WHITE AND RED; AT THE LEFT EDGE OF THE RED OVAL BACKGROUND APPEAR WRITTEN ASIAN CHARACTERS IN THE COLOR WHITE; ABOVE THE OVAL BACKGROUND APPEARS A CURVED RED ARC, ATOP WHICH SITS THE WORDING "WELL MAN" IN THE COLORS BLACK AND WHITE; BENEATH THE RED OVAL DESIGN APPEARS A CURVED RED ARC ATOP WHICH APPEARS THE BLACK WORDING "SPECIALTY FOODS" IN INITIAL CAPS TYPEFACE.

THE NON-LATIN CHARACTERS IN THE MARK TRANSLITERATE TO "HAO REN PAI" AND THIS MEANS "GOOD PERSON BRAND" IN ENGLISH.

4,154,512. LEADERSHIP CONFERENCE ON CIVIL RIGHTS, WASHINGTON, DC. SN 77-899,006. PUB. 7-26-2011, FILED 12-22-2009.



THE MARK CONSISTS OF DESIGN OF A BRIDGE.

CLASS 16—PAPER GOODS AND PRINTED MATTER

FOR PRINTED PUBLICATIONS, NAMELY, POLICY BRIEFS, SUMMARIES, REPORTS, BROCHURES, PAMPHLETS, BOOKS AND BOOKLETS ON THE SUBJECTS OF EQUAL RIGHTS AND SOCIAL AND ECONOMIC JUSTICE (U.S. CLS. 2, 5, 22, 23, 29, 37, 38 AND 50).

FIRST USE 1-21-2010; IN COMMERCE 1-21-2010.

CLASS 35—ADVERTISING AND BUSINESS

FOR PUBLIC ADVOCACY SERVICES, NAMELY, PROVIDING RESEARCH IN THE FIELD OF EQUAL RIGHTS AND SOCIAL AND ECONOMIC JUSTICE; PROMOTING THE INTERESTS OF ANYONE WHOSE CIVIL RIGHTS HAVE BEEN THREATENED OR VIOLATED, AND PROMOTING PUBLIC AWARENESS OF SOCIAL AND ECONOMIC EQUALITY, DIVERSITY AND ANTI-DISCRIMINATION POLICIES; PROVIDING PUBLIC ADVOCACY INFORMATION BY MEANS OF EDUCATIONAL TEXTS, MANUALS AND RELATED EDUCATIONAL MATERIALS PROMOTING AWARENESS OF THE NEED FOR NATIONAL POLICIES THAT SUPPORT EQUAL RIGHTS AND SOCIAL AND ECONOMIC JUSTICE; AWARDS PROGRAMS TO PROMOTE PUBLIC AWARENESS OF SOCIAL AND ECONOMIC EQUALITY, DIVERSITY AND ANTI-DISCRIMINATION POLICIES (U.S. CLS. 100, 101 AND 102).

FIRST USE 2-0-2010; IN COMMERCE 2-0-2010.

CLASS 41—EDUCATION AND ENTERTAINMENT

FOR PROVIDING ONLINE PUBLICATIONS IN THE NATURE OF EDUCATIONAL TEXTS, CURRICULA, REPORTS, ARTICLES, AND NEWSLETTERS, ALL IN THE FIELD OF PROMOTING THE NEED FOR NATIONAL POLICIES THAT SUPPORT EQUAL RIGHTS AND SOCIAL AND ECONOMIC JUSTICE; EDUCATIONAL SERVICES, NAMELY, CONDUCTING CLASSES, SEMINARS, PROGRAMS, AND WORKSHOPS IN THE FIELD OF EQUAL RIGHTS AND SOCIAL AND ECONOMIC JUSTICE, AND DISTRIBUTING EDUCATIONAL MATERIALS IN CONNECTION THEREWITH (U.S. CLS. 100, 101 AND 107).

FIRST USE 2-0-2010; IN COMMERCE 2-0-2010.

4,154,513. DREAMSTAR CASH, S.L., 03580 ALTEA (ALICANTE), SPAIN. SN 77-899,318. PUB. 4-12-2011, FILED 12-22-2009.



THE COLOR(S) RED, ORANGE, BLACK, WHITE AND GRAY IS/ARE CLAIMED AS A FEATURE OF THE MARK.

THE MARK CONSISTS OF A STYLIZED TELEVISION WITH A WINKING SMILING FACE TO THE LEFT OF THE WORDING "4TUBE.COM" IN STYLIZED FONT WITH A TADPOLE ABOVE THE WORD PORTION "4TUB" SWIMMING TOWARDS THE TELEVISION. THE COLOR ORANGE APPEARS IN THE TELEVISION AND THE WORD "TUBE". THE COLOR BLACK APPEARS IN THE OUTLINE OF THE TELEVISION, THE OUTLINE OF THE SMILING FACE, THE INSIDE OF THE MOUTH, THE PUPIL OF THE EYE, AND THE NUMBER "4". THE COLOR RED APPEARS IN THE MOUTH IN THE TONGUE. THE COLOR WHITE APPEARS IN THE FACE, THE OPEN EYE, AND THE TEETH. THE COLOR GRAY APPEARS IN THE TADPOLE, THE WORDING ".COM" AND IN THE SHADOWING AROUND THE MARK.

CLASS 9—ELECTRICAL AND SCIENTIFIC APPARATUS

FOR DOWNLOADABLE VIDEO RECORDINGS FEATURING PORNOGRAPHIC CONTENT DELIVERED VIA THE INTERNET (U.S. CLS. 21, 23, 26, 36 AND 38).

FIRST USE 11-3-2008; IN COMMERCE 11-3-2008.

CLASS 38—COMMUNICATION

FOR ENTERTAINMENT SERVICES AND AMUSEMENTS, NAMELY, VIDEO BROADCASTING SERVICES OVER THE INTERNET OR OTHER COMMUNICATIONS NETWORK FEATURING THE UPLOADED, POSTED AND TAGGED VIDEOS OF OTHERS; VIDEO BROADCASTING SERVICES OVER THE INTERNET OR OTHER COMMUNICATIONS NETWORK, NAMELY, ELECTRONICALLY TRANSMITTING VIDEO CLIPS; INTERNET BROADCASTING SERVICES (U.S. CLS. 100, 101 AND 104).

FIRST USE 11-3-2008; IN COMMERCE 11-3-2008.

CLASS 41—EDUCATION AND ENTERTAINMENT

FOR ENTERTAINMENT SERVICES AND AMUSEMENTS, NAMELY, PROVIDING A WEBSITE FEATURING NON-DOWNLOADABLE VIDEOS FEATURING PORNOGRAPHIC CONTENT DELIVERED VIA THE INTERNET (U.S. CLS. 100, 101 AND 107).

FIRST USE 11-3-2008; IN COMMERCE 11-3-2008.

4,154,516. INSPHERE INSURANCE SOLUTIONS, INC., NORTH RICHLAND HILLS, TX. SN 77-909,027. PUB. 4-19-2011, FILED 1-11-2010.

INSPHERE INTOUCH

THE MARK CONSISTS OF STANDARD CHARACTERS WITHOUT CLAIM TO ANY PARTICULAR FONT, STYLE, SIZE, OR COLOR.

CLASS 36—INSURANCE AND FINANCIAL

FOR PROVIDING INFORMATION REGARDING AGENT SALES FINANCIAL COMPENSATION FOR INSURANCE AGENTS BY MEANS OF A SUPPORT HOTLINE (U.S. CLS. 100, 101 AND 102).

FIRST USE 12-0-2009; IN COMMERCE 12-0-2009.

CLASS 42—SCIENTIFIC AND COMPUTER SERVICES

FOR COMPUTER TECHNOLOGY SUPPORT SERVICES, NAMELY, HELP DESK SERVICES FOR INSURANCE AGENTS BY MEANS OF A SUPPORT HOTLINE (U.S. CLS. 100 AND 101).

FIRST USE 12-0-2009; IN COMMERCE 12-0-2009.

4,154,518. PENNSYLVANIA LIQUOR CONTROL BOARD, HARRISBURG, PA. SN 77-913,082. PUB. 9-14-2010, FILED 1-15-2010.



OWNER OF U.S. REG. NO. 3,322,730.

NO CLAIM IS MADE TO THE EXCLUSIVE RIGHT TO USE "FINE WINE", "SELECTION" AND "UNIQUE VINTAGES AT EXCEPTIONAL VALUES", APART FROM THE MARK AS SHOWN.

THE MARK CONSISTS OF THE WORDS "FINE WINE & GOOD SPIRITS", "CHAIRMAN'S SELECTION", AND "UNIQUE VINTAGES AT EXCEPTIONAL VALUES", ALL SHOWN IN A CIRCULAR SEAL DESIGN. THE LETTERS ARE ALL SHOWN IN UPPERCASE FORM.

CLASS 16—PAPER GOODS AND PRINTED MATTER

FOR PAPER SHOPPING BAGS; PLASTIC SHOPPING BAGS; GIFT CARDS; MAGAZINES PUBLISHED PERIODICALLY ON THE SUBJECT OF WINE OR SPIRITS (U.S. CLS. 2, 5, 22, 23, 29, 37, 38 AND 50).

FIRST USE 5-31-2010; IN COMMERCE 5-31-2010.

CLASS 18—LEATHER GOODS

FOR REUSABLE SHOPPING BAGS, CANVAS SHOPPING BAGS; LEATHER SHOPPING BAGS; MESH SHOPPING BAGS (U.S. CLS. 1, 2, 3, 22 AND 41).

FIRST USE 5-31-2010; IN COMMERCE 5-31-2010.

CLASS 35—ADVERTISING AND BUSINESS

FOR ONLINE RETAIL STORE AND RETAIL STORE SERVICES FEATURING ALCOHOLIC BEVERAGES, NAMELY, WINE, DISTILLED SPIRITS AND DISTILLED LIQUOR (U.S. CLS. 100, 101 AND 102).

FIRST USE 5-31-2010; IN COMMERCE 5-31-2010.

4,154,520. SANFORD, L.P., OAK BROOK, IL. SN 77-919,314. PUB. 9-7-2010, FILED 1-25-2010.

ART UNINHIBITED

THE MARK CONSISTS OF STANDARD CHARACTERS WITHOUT CLAIM TO ANY PARTICULAR FONT, STYLE, SIZE, OR COLOR.

NO CLAIM IS MADE TO THE EXCLUSIVE RIGHT TO USE "ART", APART FROM THE MARK AS SHOWN.

CLASS 2—PAINTS

FOR AEROSOL SPRAY COATINGS USED TO ADD TEXTURE TO A PIECE OF ART OR TO PROVIDE A PROTECTIVE FINISH TO A PIECE OF ART (U.S. CLS. 6, 11 AND 16).

FIRST USE 7-20-2011; IN COMMERCE 7-20-2011.

CLASS 16—PAPER GOODS AND PRINTED MATTER

FOR ART PRODUCTS, NAMELY, COLORED PENCILS, ERASERS, CHARCOAL PENCILS, SKETCHING PENCILS, PENCIL SHARPENERS, TORTILLIONS IN THE NATURE OF ARTISTS' TOOLS COMPRISED OF A PAPER PENCIL FOR SMUDGING AND BLENDING ARTISTS' DRAWINGS, PENCIL EXTENDERS, ART MARKERS, ILLUSTRATION MARKERS, COLORLESS ART BLENDING MEDIUM IN THE NATURE OF MARKERS; COLORLESS ART BLENDING MEDIUM IN THE NATURE OF PENCILS, ARTIST'S PASTELS (U.S. CLS. 2, 5, 22, 23, 29, 37, 38 AND 50).

FIRST USE 7-20-2011; IN COMMERCE 7-20-2011.

4,154,521. AMER SPORTS INTERNATIONAL OY, HELSINKI, FINLAND. SN 77-919,500. PUB. 2-1-2011, FILED 1-25-2010.

PREVA

THE MARK CONSISTS OF STANDARD CHARACTERS WITHOUT CLAIM TO ANY PARTICULAR FONT, STYLE, SIZE, OR COLOR.

CLASS 9—ELECTRICAL AND SCIENTIFIC APPARATUS

FOR INTEGRATED MULTI-MEDIA INFORMATION AND ENTERTAINMENT SYSTEMS AND CONTROL SYSTEMS FOR FITNESS MACHINES, NAMELY, PERSONAL VIEWING SCREENS, VIDEO MONITORS, LIQUID CRYSTAL DISPLAYS, TOUCH SCREEN LIQUID CRYSTAL DISPLAYS, SOUND SYSTEMS COMPRISING, REMOTE CONTROLS, AMPLIFIERS, LOUSPEAKERS AND COMPONENTS THEREFOR, AUDIO SPEAKERS, PDA ELECTRONIC DOCKING STATIONS, RFID PROGRAMMERS IN THE NATURE OF RF READERS AND ACTIVE AND PASSIVE TAGS, COMPUTER SERIAL AND USB PORTS, INDIVIDUAL ELECTRONIC CONTROLLER FOR CONTROLLING FITNESS MACHINES, ELECTRONIC CONTROLS FOR CONTROLLING FITNESS MACHINES, WIRELESS REMOTE CONTROLS FOR FITNESS MACHINES, TELEVISION RECEIVERS, SINGLE AND MULTI-CHANNEL RECEIVERS AND TRANSMITTERS FOR WIRELESS AND ETHERNET INTERNET CONNECTIVITY, AND HEAD PHONE JACKS IN THE NATURE OF SURFACE MOUNTED ELECTRONIC CONNECTORS (U.S. CLS. 21, 23, 26, 36 AND 38).

FIRST USE 4-1-2011; IN COMMERCE 6-1-2011.

CLASS 28—TOYS AND SPORTING GOODS

FOR EXERCISE EQUIPMENT, NAMELY, UPPER AND LOWER BODY CARDIO-VASCULAR EXERCISE CONDITIONING MACHINES, ELLIPTICAL EXERCISE MACHINES, TREADMILLS, EXERCISE CYCLES, STEPPING MACHINES, ROWING MACHINES, WEIGHT LIFTING MACHINES, TORSO-ROTATION EXERCISE MACHINES, TRUNK EXTENSION/FLEXION EXERCISE MACHINES, EXERCISE BENCHES, AND STRETCHING STATIONS (U.S. CLS. 22, 23, 38 AND 50).

FIRST USE 4-1-2011; IN COMMERCE 6-1-2011.

CLASS 41—EDUCATION AND ENTERTAINMENT

FOR PROVIDING FITNESS TRAINING, NAMELY, WORKING WITH INDIVIDUALS AND THIRD PARTIES TO IDENTIFY, CREATE, DELIVER AND RECORD ONE OR MORE PERSONAL FITNESS GOALS AND MOTIVATIONAL CONTENT, CREATING AND DEFINING A FITNESS PROGRAM OR TRAINING PROTOCOLS TAILORED TO AN INDIVIDUAL'S FITNESS LEVEL AND GOALS, ADJUSTING AN INDIVIDUAL'S FITNESS PROGRAM AND TRAINING PROTOCOL, AND TUTORIALS FOR FITNESS EQUIPMENT USE AND FITNESS PROGRAM IMPLEMENTATION (U.S. CLS. 100, 101 AND 107).

FIRST USE 4-1-2011; IN COMMERCE 6-1-2011.

4,154,522. FATTY LE ROCK LLC, TEANECK, NJ. SN 77-920,893. PUB. 2-22-2011, FILED 1-26-2010.

Jay Sean

THE MARK CONSISTS OF STANDARD CHARACTERS WITHOUT CLAIM TO ANY PARTICULAR FONT, STYLE, SIZE, OR COLOR.

THE NAME "JAY SEAN" IDENTIFIES A LIVING INDIVIDUAL WHO CONSENTS TO THE REGISTRATION OF THIS MARK.

CLASS 9—ELECTRICAL AND SCIENTIFIC APPARATUS

FOR PRE-RECORDED AUDIO AND VIDEO GOODS IN THE NATURE OF RECORDS, TAPES, DISCS, AND COMPUTER FILE FORMATS OF MP3, M4A, WMA, WAV, MP4, AVI AND WMV FILES, FEATURING MUSICAL ENTERTAINMENT (U.S. CLS. 21, 23, 26, 36 AND 38).

FIRST USE 12-30-2003; IN COMMERCE 5-28-2005.

CLASS 25—CLOTHING

FOR CLOTHING AND MERCHANDISE, NAMELY, SHIRTS, PANTS FOR MALES AND FEMALES (U.S. CLS. 22 AND 39).

FIRST USE 12-30-2003; IN COMMERCE 5-28-2005.

CLASS 41—EDUCATION AND ENTERTAINMENT

FOR LIVE ARTS AND ENTERTAINMENT PERFORMANCES, NAMELY, MUSICAL PERFORMANCES (U.S. CLS. 100, 101 AND 107).

FIRST USE 12-30-2003; IN COMMERCE 5-28-2005.

4,154,523. SCRUM ALLIANCE, INC., INDIANAPOLIS, IN. SN 77-923,574. PUB. 12-21-2010, FILED 1-29-2010.

SCRUM ALLIANCE REP

THE MARK CONSISTS OF STANDARD CHARACTERS

WITHOUT CLAIM TO ANY PARTICULAR FONT, STYLE, SIZE, OR COLOR.

OWNER OF U.S. REG. NOS. 3,529,737, 3,738,535, AND OTHERS.

NO CLAIM IS MADE TO THE EXCLUSIVE RIGHT TO USE "REP", APART FROM THE MARK AS SHOWN.

SEC. 2(F) AS TO "SCRUM ALLIANCE".

CLASS 41—EDUCATION AND ENTERTAINMENT

FOR TRAINING, MENTORING, AND TUTORING SERVICES IN THE FIELDS OF PRODUCT DEVELOPMENT, PRODUCT DESIGN, PROJECT MANAGEMENT, PRODUCT DEVELOPMENT CONSULTATION, PRODUCT MANUFACTURING CONSULTATION, COMPUTER SOFTWARE DEVELOPMENT AND COMPUTER SOFTWARE DEVELOPMENT MANAGEMENT; EDUCATIONAL SERVICES, NAMELY, CONDUCTING CLASSES, SEMINARS, AND WORKSHOPS IN THE FIELDS OF PRODUCT DEVELOPMENT, PRODUCT DESIGN, PROJECT MANAGEMENT, PRODUCT DEVELOPMENT CONSULTATION, PRODUCT MANUFACTURING CONSULTATION, COMPUTER SOFTWARE DEVELOPMENT AND COMPUTER SOFTWARE DEVELOPMENT MANAGEMENT (U.S. CLS. 100, 101 AND 107).

FIRST USE 7-0-2010; IN COMMERCE 7-0-2010.

CLASS 42—SCIENTIFIC AND COMPUTER SERVICES

FOR PROVIDING INFORMATION IN THE FIELDS OF PRODUCT DEVELOPMENT, PRODUCT DESIGN, SOFTWARE PROJECT MANAGEMENT, PRODUCT DEVELOPMENT CONSULTATION, COMPUTER SOFTWARE DEVELOPMENT AND COMPUTER SOFTWARE DEVELOPMENT MANAGEMENT; ANALYSIS AND EVALUATION OF SOFTWARE PROJECT AND PRODUCT DEVELOPMENT, DESIGN, AND MANAGEMENT PROCESSES UNDERTAKEN BY OTHERS, FOR PURPOSES OF CERTIFICATION (U.S. CLS. 100 AND 101).

FIRST USE 7-0-2010; IN COMMERCE 7-0-2010.

4,154,532. BARNESANDNOBLE.COM LLC, NEW YORK, NY. SN 77-934,299. PUB. 8-10-2010, FILED 2-12-2010.

TIKATOK

THE MARK CONSISTS OF STANDARD CHARACTERS WITHOUT CLAIM TO ANY PARTICULAR FONT, STYLE, SIZE, OR COLOR.

THE WORDING "TIKATOK" HAS NO MEANING IN A FOREIGN LANGUAGE.

CLASS 9—ELECTRICAL AND SCIENTIFIC APPARATUS

FOR ELECTRONIC PUBLICATIONS, NAMELY, ELECTRONIC BOOKS ON CHILDREN'S EXPERIENCES AND CREATED BY CHILDREN RECORDED ON COMPUTER MEDIA (U.S. CLS. 21, 23, 26, 36 AND 38).

FIRST USE 10-31-2009; IN COMMERCE 10-31-2009.

CLASS 16—PAPER GOODS AND PRINTED MATTER

FOR PUBLICATIONS, NAMELY, SERIES OF FICTION BOOKS AND SERIES OF NON-FICTION BOOKS ON CHILDREN'S EXPERIENCES AND CREATED BY CHILDREN (U.S. CLS. 2, 5, 22, 23, 29, 37, 38 AND 50).

FIRST USE 10-31-2009; IN COMMERCE 10-31-2009.

CLASS 41—EDUCATION AND ENTERTAINMENT

FOR BOOK PUBLISHING SERVICES; ONLINE ELECTRONIC PUBLISHING OF BOOKS (U.S. CLS. 100, 101 AND 107).

FIRST USE 10-31-2009; IN COMMERCE 10-31-2009.

CLASS 42—SCIENTIFIC AND COMPUTER SERVICES

FOR PROVIDING A WEB-BASED SERVICE FEATURING TECHNOLOGY THAT ENABLES USERS TO MANAGE THE PRODUCTION AND PUBLICATION OF ELECTRONIC BOOKS (E-BOOKS), HARD AND SOFT-COVER BOOKS AND RELATED DIGITAL CONTENT AND OFFER THEM FOR SALE TO THE GENERAL PUBLIC (U.S. CLS. 100 AND 101).

FIRST USE 10-31-2009; IN COMMERCE 10-31-2009.

CLASS 16—PAPER GOODS AND PRINTED MATTER

FOR PUBLICATIONS, NAMELY, SERIES OF FICTION BOOKS AND SERIES OF NON-FICTION BOOKS ON CHILDREN'S EXPERIENCES AND CREATED BY CHILDREN (U.S. CLS. 2, 5, 22, 23, 29, 37, 38 AND 50).

FIRST USE 10-31-2009; IN COMMERCE 10-31-2009.

CLASS 41—EDUCATION AND ENTERTAINMENT

FOR BOOK PUBLISHING SERVICES; ONLINE ELECTRONIC PUBLISHING OF BOOKS (U.S. CLS. 100, 101 AND 107).

FIRST USE 10-31-2009; IN COMMERCE 10-31-2009.

CLASS 42—SCIENTIFIC AND COMPUTER SERVICES

FOR PROVIDING A WEB-BASED SERVICE FEATURING TECHNOLOGY THAT ENABLES USERS TO MANAGE THE PRODUCTION AND PUBLICATION OF ELECTRONIC BOOKS (E-BOOKS), HARD AND SOFT-COVER BOOKS AND RELATED DIGITAL CONTENT AND OFFER THEM FOR SALE TO THE GENERAL PUBLIC (U.S. CLS. 100 AND 101).

FIRST USE 10-31-2009; IN COMMERCE 10-31-2009.

4,154,533. BARNESANDNOBLE.COM LLC, NEW YORK, NY. SN 77-934,305. PUB. 8-3-2010, FILED 2-12-2010.

4,154,540. J.V. DRIVER CORPORATION INC., LEDUC, ALBERTA, CANADA. SN 77-941,639. PUB. 7-19-2011, FILED 2-22-2010.



THE COLOR(S) RED, YELLOW, BLUE, PINK, PURPLE, LIGHT BLUE, VIOLET AND WHITE IS/ARE CLAIMED AS A FEATURE OF THE MARK.

THE MARK CONSISTS OF THE WORD "TIKATOK" IN WHITE LETTERS WITHIN OVERLAPPING VERTICAL COLORED RECTANGLES, WITH SEVEN RECTANGLES OF DIFFERENT LENGTHS AND COLOR. THE COLORED RECTANGLES ARE ARRANGED AT AN ANGLE AND APPEAR IN THE COLOR ORDER, FROM LEFT TO RIGHT, RED, YELLOW, BLUE, PINK, PURPLE, LIGHT BLUE, AND VIOLET.

THE WORDING "TIKATOK" HAS NO MEANING IN A FOREIGN LANGUAGE.

CLASS 9—ELECTRICAL AND SCIENTIFIC APPARATUS

FOR ELECTRONIC PUBLICATIONS, NAMELY, ELECTRONIC BOOKS ON CHILDREN'S EXPERIENCES AND CREATED BY CHILDREN RECORDED ON COMPUTER MEDIA (U.S. CLS. 21, 23, 26, 36 AND 38).

FIRST USE 10-31-2009; IN COMMERCE 10-31-2009.

THINK SAFE, WORK SAFE, BE
SAFE

THE MARK CONSISTS OF STANDARD CHARACTERS WITHOUT CLAIM TO ANY PARTICULAR FONT, STYLE, SIZE, OR COLOR.

CLASS 37—CONSTRUCTION AND REPAIR

FOR INDUSTRIAL CONSTRUCTION SERVICES, NAMELY, CONSTRUCTION AND MAINTENANCE OF INDUSTRIAL PLANTS, COMMERCIAL BUILDINGS, WAREHOUSES, ROADS AND STREETS; CIVIL AND STRUCTURAL CONSTRUCTION SERVICES, NAMELY, PROVISION OF EARTHWORKS, CONCRETE, REBAR, STRUCTURAL STEEL; ELECTRICAL AND INSTRUMENTATION SERVICES, NAMELY, MAINTENANCE OF OPERATING PLANTS AND GENERAL INDUSTRIAL INSTALLATIONS; REFRACTORY AND TILE INSTALLATION SERVICES; CRANE RENTAL AND LEASING FOR CONSTRUCTION PURPOSES; CONSTRUCTION SUPERVISION, NAMELY, PROVIDING MANPOWER SERVICES; AND CONSTRUCTION PLANNING AND CONSULTING SERVICES (U.S. CLS. 100, 103 AND 106).

FIRST USE 8-30-2000; IN COMMERCE 3-31-2010.

CLASS 40—MATERIAL TREATMENT

FOR CUSTOM FABRICATION OF TANK AND PRESSURE VESSELS, PIPES AND METAL; MACHINE SHOP SERVICES, NAMELY, MACHINING PARTS FOR OTHERS (U.S. CLS. 100, 103 AND 106).

FIRST USE 8-30-2000; IN COMMERCE 3-31-2010.

4,154,546. AMERICAN MODULAR SYSTEMS, INC., MANTECA, CA. SN 77-948,805. PUB. 2-15-2011, FILED 3-2-2010.

GEN-7

THE MARK CONSISTS OF STANDARD CHARACTERS WITHOUT CLAIM TO ANY PARTICULAR FONT, STYLE, SIZE, OR COLOR.

CLASS 6—METAL GOODS

FOR PRE-FABRICATED BUILDINGS OF METAL (U.S. CLS. 2, 12, 13, 14, 23, 25 AND 50).
FIRST USE 6-1-2009; IN COMMERCE 6-1-2009.

CLASS 40—MATERIAL TREATMENT

FOR MANUFACTURE AND ASSEMBLY OF PRE-FABRICATED BUILDINGS FOR OTHERS (U.S. CLS. 100, 103 AND 106).
FIRST USE 6-1-2009; IN COMMERCE 6-1-2009.

4,154,552. THE CANCER RESEARCH INSTITUTE, NEW YORK, NY. SN 77-957,459. PUB. 2-15-2011, FILED 3-12-2010.



NO CLAIM IS MADE TO THE EXCLUSIVE RIGHT TO USE "CANCER IMMUNOTHERAPY CONSORTIUM", APART FROM THE MARK AS SHOWN.

THE MARK CONSISTS OF THE CAPITAL LETTERS "CIC". THE DESIGN OF THREE (3) IMMUNE CELLS AND THREE ANTIBODIES APPEAR ALONG THE OUTER RIM OF THE FIRST LETTER "C". FOUR (4) CIRCLES APPEAR ON THE INSIDE OF THE FIRST LETTER "C" IN "CIC". THE WORDS "CANCER IMMUNOTHERAPY CONSORTIUM" APPEAR TO THE RIGHT OF THE LETTERS "CIC". THE FIRST LETTER OF EACH OF THE WORDS "CANCER IMMUNOTHERAPY CONSORTIUM" APPEAR IN CAPITAL LETTERS WHILE THE REST OF EACH WORD APPEAR IN LOWER CASE LETTERS.

CLASS 41—EDUCATION AND ENTERTAINMENT

FOR ORGANIZING AND CONDUCTING CONFERENCES REGARDING CANCER VACCINE RESEARCH AND DEVELOPMENT (U.S. CLS. 100, 101 AND 107).
FIRST USE 2-5-2010; IN COMMERCE 3-18-2010.

CLASS 42—SCIENTIFIC AND COMPUTER SERVICES

FOR MEDICAL RESEARCH SERVICES IN THE FIELD OF CANCER VACCINE RESEARCH AND DEVELOPMENT (U.S. CLS. 100 AND 101).
FIRST USE 2-5-2010; IN COMMERCE 3-18-2010.

4,154,555. TWIN MAPLES, INC., BLOCK ISLAND, RI. SN 77-960,136. PUB. 8-2-2011, FILED 3-16-2010.



THE MARK CONSISTS OF WORDS "EAT FISH" IN STYLIZED LETTERS.

CLASS 16—PAPER GOODS AND PRINTED MATTER

FOR PRINTED MATTER, NAMELY, BUMPER STICKERS, INFORMATIONAL FLYERS FEATURING GENERAL FISHING TIPS, FISHING GUIDES AND TIDE CHARTS (U.S. CLS. 2, 5, 22, 23, 29, 37, 38 AND 50).
FIRST USE 8-0-2008; IN COMMERCE 6-30-2010.

CLASS 25—CLOTHING

FOR T-SHIRTS, SWEAT SHIRTS, TOPS, HEADWEAR, ATHLETIC APPAREL, NAMELY, SWEATPANTS, JACKETS; BABY BODYSUITS, ONE PIECE GARMENT FOR CHILDREN AND TODDLERS, BIBS NOT MADE OF PAPER, BOXER SHORTS (U.S. CLS. 22 AND 39).
FIRST USE 7-3-1981; IN COMMERCE 7-3-1981.

4,154,568. CAMUTO CONSULTING, INC., DBA CAMUTO GROUP, GREENWICH, CT. SN 77-966,527. PUB. 8-17-2010, FILED 3-23-2010.

VINCE CAMUTO

THE MARK CONSISTS OF STANDARD CHARACTERS WITHOUT CLAIM TO ANY PARTICULAR FONT, STYLE, SIZE, OR COLOR.

OWNER OF U.S. REG. NO. 3,161,347.

THE NAME "VINCE CAMUTO" IDENTIFIES A LIVING INDIVIDUAL WHOSE CONSENT IS OF RECORD.

CLASS 9—ELECTRICAL AND SCIENTIFIC APPARATUS

FOR EYEGLASS AND EYEWEAR CASES; EYEGLASS FRAMES; EYEWEAR; EYEWEAR ACCESSORIES, NAMELY, STRAPS, NECK CORDS, CHAINS AND HEAD STRAPS WHICH RESTRAIN EYEWEAR FROM MOVEMENT ON A WEARER AND EYEWEAR CASES (U.S. CLS. 21, 23, 26, 36 AND 38).
FIRST USE 10-1-2010; IN COMMERCE 2-1-2011.

CLASS 14—JEWELRY

FOR JEWELRY, NAMELY, NECKLACES, BRACELETS, EARRINGS, BROOCHES, PINS, WATCHES, ANKLETS AND RINGS (U.S. CLS. 2, 27, 28 AND 50).
FIRST USE 3-1-2011; IN COMMERCE 7-1-2011.

CLASS 25—CLOTHING

FOR CLOTHING, NAMELY, ATHLETIC SHOES; BATHING SUITS; BEACHWEAR; BELTS; BLAZERS; BLOUSES; BODY SUITS; BOOTS; BRAS; BRASSIERES; BRIEFS; BUSTIERS; CAMISOLES; CAPES; CAPS; CAPRI PANTS; CARDIGANS; CARGO PANTS; COATS; DRESSES; FLIP-FLOPS; FOOTWEAR; GLOVES; HATS; HEADBANDS; HEADWEAR; HOSIERY; JACKETS; JEANS; JERSEYS; KNEE HIGHS; LEGGINGS; LINGERIE; LOUNGEWEAR; MITTENS; NECKWEAR; NEG-LIGEES; NIGHT GOWNS; NIGHT SHIRTS; PAJAMAS; PANTIES; PANTS; PANTYHOSE; PARKAS; POLO SHIRTS; PULLOVERS; RAINWEAR; ROBES; SANDALS; SCARVES; SHIRTS; SHOES; SHORTS; SKIRTS; SLACKS; SLEEPWEAR; SLIPPERS; SOCKS; STOCKINGS; SUITS; SURF WEAR; SWEATERS; SWIMWEAR; TANK TOPS; TIGHTS; TOPS; T-SHIRTS; TURTLENECKS; UNDER-CLOTHES; UNDERWEAR; VESTS; WRAPS (U.S. CLS. 22 AND 39).

FIRST USE 7-1-2006; IN COMMERCE 1-1-2006.

CLASS 35—ADVERTISING AND BUSINESS

FOR ON-LINE AND IN-STORE RETAIL STORE SERVICES IN THE FIELDS OF CLOTHING, FOOTWEAR, HANDBAGS AND TOTE BAGS, SMALL LEATHER ACCESSORIES, JEWELRY, AND EYEWEAR (U.S. CLS. 100, 101 AND 102).

FIRST USE 7-1-2008; IN COMMERCE 7-1-2008.

CLASS 35—ADVERTISING AND BUSINESS

FOR MANAGING, TARGETING, TRACKING AND ANALYZING MEDIA PLANNING, MEDIA BUYING AND MARKETING EFFORTS OF OTHERS; ADVERTISING AND MARKETING SERVICES, NAMELY, CREATION OF MARKETING TOOLS DESIGNED TO INCREASE A CLIENT COMPANY'S KNOWLEDGE OF CUSTOMER NEEDS, ADVERTISING STRATEGY AND SALES STRATEGY, PREPARATION AND REALIZATION OF MEDIA AND ADVERTISING PLANS AND CONCEPTS, BUSINESS CONSULTATION AND MANAGEMENT REGARDING MARKETING ACTIVITIES AND LAUNCHING OF NEW PRODUCTS, BUSINESS MARKETING CONSULTING SERVICES, CONDUCTING MARKETING STUDIES, DEVELOPMENT OF MARKETING STRATEGIES AND CONCEPTS, MARKETING CONSULTING, STATISTICAL EVALUATIONS OF MARKETING DATA (U.S. CLS. 100, 101 AND 102).

FIRST USE 1-26-2010; IN COMMERCE 1-26-2010.

CLASS 42—SCIENTIFIC AND COMPUTER SERVICES

FOR PROVIDING TEMPORARY USE OF ON-LINE NON-DOWNLOADABLE SOFTWARE FOR CREATING, MANAGING, TARGETING, TRACKING, ANALYZING, AND SERVICING MEDIA PLANNING, MEDIA BUYING AND MARKETING EFFORTS OF OTHERS; COMPUTER SERVICES, NAMELY, DESIGN OF COMPUTER SOFTWARE FOR OTHERS; TECHNICAL SUPPORT SERVICES, NAMELY, TROUBLESHOOTING IN THE NATURE OF DIAGNOSING COMPUTER HARDWARE AND SOFTWARE PROBLEMS (U.S. CLS. 100 AND 101).

FIRST USE 1-26-2010; IN COMMERCE 1-26-2010.

4,154,575. X PLUS ONE SOLUTIONS, INC., NEW YORK, NY. SN 77-968,512. PUB. 11-2-2010, FILED 3-25-2010.

4,154,577. ADVANCE MAGAZINE PUBLISHERS INC., NEW YORK, NY. SN 77-980,863. PUB. 4-27-2010, FILED 6-24-2009.

Open Data Bridge

THE MARK CONSISTS OF STANDARD CHARACTERS WITHOUT CLAIM TO ANY PARTICULAR FONT, STYLE, SIZE, OR COLOR.

NO CLAIM IS MADE TO THE EXCLUSIVE RIGHT TO USE "OPEN DATA", APART FROM THE MARK AS SHOWN.

CLASS 9—ELECTRICAL AND SCIENTIFIC APPARATUS

FOR COMPUTER SOFTWARE TO ENABLE THE CREATION, MANAGING, TARGETING, TRACKING, ANALYZING, AND SERVICING OF ADVERTISING AND MARKETING CONTENT AND CAMPAIGNS VIA WEB SITES, ONLINE AND INTERACTIVE MEDIA AND COMPUTER NETWORKS (U.S. CLS. 21, 23, 26, 36 AND 38).

FIRST USE 1-26-2010; IN COMMERCE 1-26-2010.

FASHION'S NIGHT OUT

THE MARK CONSISTS OF STANDARD CHARACTERS WITHOUT CLAIM TO ANY PARTICULAR FONT, STYLE, SIZE, OR COLOR.

NO CLAIM IS MADE TO THE EXCLUSIVE RIGHT TO USE "FASHION'S", APART FROM THE MARK AS SHOWN.

CLASS 41—EDUCATION AND ENTERTAINMENT

FOR ENTERTAINMENT IN THE NATURE OF LIVE MUSICAL PERFORMANCES; FASHION SHOWS; ARRANGING AND CONDUCTING PARTIES AND SPECIAL EVENTS FOR THE PURPOSE OF FASHION AWARENESS (U.S. CLS. 100, 101 AND 107).

FIRST USE 9-0-2009; IN COMMERCE 9-0-2009.

CLASS 45—PERSONAL AND LEGAL SERVICES

FOR PROVIDING A WEBSITE IN THE FIELD OF FASHION (U.S. CLS. 100 AND 101).

FIRST USE 9-0-2009; IN COMMERCE 9-0-2009.

4,154,582. L2T, INC., ALHAMBRA, CA. SN 77-982,977. PUB. 6-1-2010, FILED 1-28-2010.

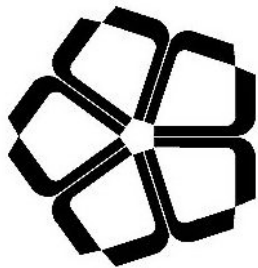

THE MARK CONSISTS OF A PENTAGONAL FLOWER DESIGN CONSISTING OF 5 SUBSTANTIALLY CLOSED PETALS EACH FORMED BY TWO SOLID LINES RADIATING FROM A CENTRAL PENTAGON, THE SOLID LINES RADIATING OF ADJACENT PETALS EXTENDING FROM AND PERPENDICULAR TO ONE SIDE OF THE CENTRAL PENTAGON, AND THE OUTWARD ENDS OF THE PETALS FORMED BY ALMOST TOUCHING SOLID LINES EXTENDING INWARD FROM THE RADIATING LINES.

CLASS 9—ELECTRICAL AND SCIENTIFIC APPARATUS

FOR SUNGLASSES AND CASES FOR SUNGLASSES (U.S. CLS. 21, 23, 26, 36 AND 38).
FIRST USE 3-22-2010; IN COMMERCE 5-9-2010.

CLASS 20—FURNITURE AND ARTICLES NOT OTHERWISE CLASSIFIED

FOR PILLOWS, CUSHIONS, OUTDOOR CUSHIONS (U.S. CLS. 2, 13, 22, 25, 32 AND 50).
FIRST USE 4-25-2008; IN COMMERCE 4-25-2008.

CLASS 24—FABRICS

FOR BED SPREADS, PILLOW CASES, PILLOW SHAMS, BED BLANKETS, TOWELS; TEXTILE FABRICS FOR HOME AND COMMERCIAL INTERIORS (U.S. CLS. 42 AND 50).
FIRST USE 4-3-2011; IN COMMERCE 4-3-2011.

CLASS 25—CLOTHING

FOR WOMEN'S CLOTHING, NAMELY, TOPS, BOTTOMS, DRESSES, SWEATERS, COATS, JACKETS, SKIRTS, SCARVES AND HATS, GLOVES, SWIMWEAR, RAINCOATS, TRENCH COATS; MEN'S CLOTHING; NAMELY, SHIRTS; TIES; BOXER SHORTS; COATS; WAISTCOATS; HATS; JACKETS; TROUSERS; PANTS; ROBES; CARDIGANS; SWEATERS; TOPS; SWIMWEAR; T-SHIRTS; SWEATSHIRTS (U.S. CLS. 22 AND 39).
FIRST USE 7-7-2009; IN COMMERCE 9-9-2009.

CLASS 27—FLOOR COVERINGS

FOR RUGS (U.S. CLS. 19, 20, 37, 42 AND 50).
FIRST USE 4-25-2008; IN COMMERCE 4-25-2008.

CLASS 35—ADVERTISING AND BUSINESS

FOR RETAIL STORE SERVICES FEATURING CLOTHING, LEATHER GOODS, SUNGLASSES, FABRIC BED AND BATH PRODUCTS, FURNITURE, PATIOWARE, KITCHENWARE, HOME ACCESSORIES, NAMELY, LAMPS, PICTURE FRAMES, MIRRORS, INTERIOR DECORATING BOOKS, GIFT ITEMS; ONLINE RETAIL STORE SERVICES FEATURING CLOTHING, LEATHER GOODS, SUNGLASSES, FABRIC BED AND BATH PRODUCTS, FURNITURE, PATIOWARE, HOME ACCESSORIES, NAMELY, INTERIOR DECORATING BOOKS, GIFT ITEMS (U.S. CLS. 100, 101 AND 102).
FIRST USE 9-9-2009; IN COMMERCE 9-9-2009.

4,154,583. SEVENTH GENERATION, INC., BURLINGTON, VT. SN 77-983,069. PUB. 6-23-2009, FILED 1-25-2008.



OWNER OF U.S. REG. NO. 1,847,543.

THE MARK CONSISTS OF THE WORD ELEMENTS "SEVENTH GENERATION" IN A STYLIZED LEAF WITH A STYLIZED ASTERISK DINGBAT DISPLAYED NEXT TO THE UPPER RIGHT OF THE LEAF.

CLASS 3—COSMETICS AND CLEANING PREPARATIONS

FOR BATH SOAP, TOILET SOAP, LAUNDRY BLEACH, LAUNDRY CLEANING PREPARATIONS, AUTOMATIC DISHWASHER DETERGENTS; DISH WASHING PREPARATIONS, GLASS CLEANING PREPARATIONS, TOILET CLEANING PREPARATIONS, ALL-PURPOSE CLEANING PREPARATIONS, HOUSEHOLD SURFACE CLEANING PREPARATIONS; GLASS CLEANING PREPARATIONS; TUB AND TILE CLEANING PREPARATIONS; SHOWER CLEANING PREPARATIONS; CARPET CLEANERS AND PRE-MOISTENED NON-MEDICATED BABY WIPES (U.S. CLS. 1, 4, 6, 50, 51 AND 52).
FIRST USE 10-31-2008; IN COMMERCE 10-31-2008.

CLASS 5—PHARMACEUTICALS

FOR FEMININE HYGIENE PADS AND PANTY LINERS; TAMPONS (U.S. CLS. 6, 18, 44, 46, 51 AND 52).
FIRST USE 10-31-2009; IN COMMERCE 10-31-2009.

CLASS 9—ELECTRICAL AND SCIENTIFIC APPARATUS

FOR ON-LINE DOWNLOADABLE ELECTRONIC NEWSLETTERS IN THE FIELD OF ENVIRONMENTAL AND SOCIAL INITIATIVES, IMPLICATIONS OF USE OF ENVIRONMENTALLY SENSITIVE PRODUCTS, EARTH-FRIENDLY CONSUMER STRATEGIES AND INITIATIVES AND ENVIRONMENTAL RESOURCES (U.S. CLS. 21, 23, 26, 36 AND 38).
FIRST USE 3-2-2012; IN COMMERCE 3-2-2012.

CLASS 16—PAPER GOODS AND PRINTED MATTER

FOR DISPOSABLE DIAPERS; DISPOSABLE CHILDREN'S TRAINING PANTS; NEWSLETTERS IN THE FIELD OF ENVIRONMENTAL AND SOCIAL INITIATIVES, IMPLICATIONS OF USE OF ENVIRONMENTALLY SENSITIVE PRODUCTS, EARTH-FRIENDLY CONSUMER STRATEGIES AND INITIATIVES AND ENVIRONMENTAL RESOURCES (U.S. CLS. 2, 5, 22, 23, 29, 37, 38 AND 50).

FIRST USE 11-30-2009; IN COMMERCE 11-30-2009.

CLASS 35—ADVERTISING AND BUSINESS

FOR ON-LINE RETAIL STORE SERVICES FEATURING HOUSEHOLD CLEANING PRODUCTS, BABY CARE PRODUCTS, HOUSEHOLD TRASH DISPOSAL PRODUCTS, HOUSEHOLD PAPER GOODS, CLOTHING AND PERSONAL CARE PRODUCTS; PROVIDING ON-LINE EDUCATIONAL INFORMATION CONCERNING ENVIRONMENTAL AND SOCIAL INITIATIVES, NAMELY, PROMOTING ENVIRONMENTAL AWARENESS BY DETAILING IMPLICATIONS OF USE OF ENVIRONMENTALLY SENSITIVE PRODUCTS, EARTH-FRIENDLY CONSUMER STRATEGIES AND INITIATIVES AND ENVIRONMENTAL RESOURCES USED FOR POVERTY RELIEF, SOCIAL RESPONSIBILITY AND CONSERVATION; CHARITABLE SERVICES, NAMELY, PROVIDING ONLINE INFORMATION CONCERNING CHARITABLE PROGRAMS, NAMELY, ORGANIZING AND CONDUCTING VOLUNTEER PROGRAM AND COMMUNITY SERVICE PROJECTS (U.S. CLS. 100, 101 AND 102).

FIRST USE 3-2-2012; IN COMMERCE 3-2-2012.

CLASS 38—COMMUNICATION

FOR PROVIDING ON-LINE FORUMS, CHAT-ROOMS AND MESSAGE BOARDS FOR TRANSMISSION OF MESSAGES AMONG COMPUTER USERS IN THE FIELD OF ENVIRONMENTAL AND SOCIAL INITIATIVES, IMPLICATIONS OF USE OF ENVIRONMENTALLY SENSITIVE PRODUCTS, EARTH-FRIENDLY CONSUMER STRATEGIES AND INITIATIVES AND ENVIRONMENTAL RESOURCES (U.S. CLS. 100, 101 AND 104).

FIRST USE 4-30-2010; IN COMMERCE 4-30-2010.

4,154,586. NATIONAL GEOGRAPHIC SOCIETY, WASHINGTON, DC. SN 77-983,109. PUB. 5-19-2009, FILED 8-10-2007.



OWNER OF U.S. REG. NOS. 2,589,756 AND 2,613,378.

NO CLAIM IS MADE TO THE EXCLUSIVE RIGHT TO USE "MUSIC", APART FROM THE MARK AS SHOWN.

THE COLOR(S) YELLOW AND GRAY IS/ARE CLAIMED AS A FEATURE OF THE MARK.

THE MARK CONSISTS OF A RECTANGULAR BORDER DESIGN IN YELLOW THAT APPEARS NEXT TO THE WORDS "NAT GEO MUSIC". THE WORDS "NAT GEO" APPEAR IN LIGHT GRAY WHILE THE WORD "MUSIC" APPEARS IN DARK GRAY.

CLASS 9—ELECTRICAL AND SCIENTIFIC APPARATUS

FOR PRE-RECORDED DATA CARRIERS, NAMELY, DISCS, TAPES, DIGITAL AUDIO AND VIDEO COMPRESSION SOFTWARE FILES, ALL FEATURING ENTERTAINMENT, CULTURAL OR MUSIC TOPICS; DOWNLOADABLE RING TONES, MUSIC, MP3S, GRAPHICS, IMAGES AND VIDEOS VIA WIRELESS COMMUNICATION DEVICES; PROVIDING DATABASES FEATURING DOWNLOADABLE RECORDED MUSIC FILES (U.S. CLS. 21, 23, 26, 36 AND 38).

FIRST USE 2-0-2006; IN COMMERCE 2-0-2006.

CLASS 35—ADVERTISING AND BUSINESS

FOR RETAIL STORE SERVICES IN THE FIELD OF ENTERTAINMENT, NAMELY, MUSICAL AND AUDIO-VISUAL WORKS AND RELATED MERCHANDISE, PHOTOGRAPHS, POSTERS, STICKERS, ARTWORK, SONG TITLES, LYRICS, CONCERT PROGRAMS, MUSIC REVIEWS, BOOKS (U.S. CLS. 100, 101 AND 102).

FIRST USE 2-0-2006; IN COMMERCE 2-0-2006.

CLASS 38—COMMUNICATION

FOR AUDIO BROADCASTING; CABLE TELEVISION BROADCASTING; DIRECT BROADCAST SATELLITE TELEVISION; TELEVISION BROADCASTING; VIDEO BROADCASTING; RADIO BROADCASTING; RADIO PROGRAMMING; ELECTRONIC TRANSMISSION OF INFORMATION, TEXT, SOUND AND IMAGES; SATELLITE TRANSMISSION SERVICES; CABLE RADIO TRANSMISSION AND BROADCASTING; BROADCASTING AND TRANSMISSION OF RADIO AND TELEVISION PROGRAMS VIA COMPUTER OR COMMUNICATIONS NETWORKS; ELECTRONIC TRANSMISSION OF SOUND, IMAGES AND DATA, INCLUDING STREAMING AUDIO AND VIDEO MATERIAL ACROSS BROAD BAND NETWORKS AND A GLOBAL COMPUTER NETWORK; ELECTRONIC TRANSMISSION VIA COMPUTER OF SOUND, IMAGES, DATA AND RADIO AND TELEVISION PROGRAMS; WIRELESS COMMUNICATION SERVICES, NAMELY, TRANSMISSION OF RING TONES, LOGO GRAPHICS, SOUND, MUSIC, INFORMATION AND DATA TO MOBILE TELEPHONES, WIRELESS DEVICES AND PERSONAL COMMUNICATIONS DEVICES (U.S. CLS. 100, 101 AND 104).

FIRST USE 2-0-2006; IN COMMERCE 2-0-2006.

CLASS 41—EDUCATION AND ENTERTAINMENT

FOR PRODUCTION OF TELEVISION AND RADIO PROGRAMS; ON-LINE CONTENT IN THE FIELDS OF MUSIC, CULTURE, ENTERTAINMENT AND EDUCATION, NAMELY, AUDIO FILES, VIDEO FILES, METADATA, GRAPHICS; MUSIC PRODUCTION SERVICES; RECORD LABEL SERVICES, NAMELY, MUSIC RECORD PRODUCTION; PROVIDING ENTERTAINMENT AND EDUCATIONAL INFORMATION ON MUSIC AND CULTURE; RADIO PROGRAMMING (U.S. CLS. 100, 101 AND 107).

FIRST USE 2-0-2006; IN COMMERCE 2-0-2006.

4,154,591. SAN DIEGO COUNTY CREDIT UNION, SAN DIEGO, CA. SN 78-477,138. PUB. 9-13-2005, FILED 9-1-2004.

FLY MILES PLUS

THE MARK CONSISTS OF STANDARD CHARACTERS WITHOUT CLAIM TO ANY PARTICULAR FONT, STYLE, SIZE, OR COLOR.

OWNER OF U.S. REG. NOS. 2,298,158 AND 2,307,415.

NO CLAIM IS MADE TO THE EXCLUSIVE RIGHT TO USE "PLUS", APART FROM THE MARK AS SHOWN.

CLASS 35—ADVERTISING AND BUSINESS

FOR INCENTIVE AWARD PROGRAM PROMOTING THE USE OF CREDIT CARDS; INCENTIVE AWARD PROGRAM PROMOTING THE SALE OF CREDIT CARDS; PROMOTING THE SERVICES OF OTHERS THROUGH LOYALTY AND INCENTIVE REWARD PROGRAMS AND ON-LINE PROMOTIONS (U.S. CLS. 100, 101 AND 102).

FIRST USE 10-15-2004; IN COMMERCE 10-15-2004.

CLASS 36—INSURANCE AND FINANCIAL

FOR FINANCIAL INFORMATION PROVIDED BY ELECTRONIC MEANS; PROVIDING FINANCIAL ACCOUNT MANAGEMENT AND INFORMATION; PROVIDING FINANCIAL ACCOUNT AND DATA MANAGEMENT, NAMELY, PROVIDING AGGREGATION OF INFORMATION ABOUT MULTIPLE FINANCIAL ACCOUNTS AND DATA VIA A GLOBAL COMPUTER NETWORK AND TELECOMMUNICATIONS NETWORKS; ELECTRONIC FINANCIAL TRANSACTION PROCESSING FOR PROGRAM MEMBERS AND PARTICIPATING MERCHANTS (U.S. CLS. 100, 101 AND 102).

FIRST USE 10-15-2004; IN COMMERCE 10-15-2004.

4,154,594. LIFTED RESEARCH GROUP INC., IRVINE, CA. SN 78-724,710. PUB. 1-6-2009, FILED 10-1-2005.

LRG

THE MARK CONSISTS OF STANDARD CHARACTERS WITHOUT CLAIM TO ANY PARTICULAR FONT, STYLE, SIZE, OR COLOR.

OWNER OF U.S. REG. NO. 2,633,832.

CLASS 16—PAPER GOODS AND PRINTED MATTER

FOR PRINTED MATERIAL, NAMELY, STICKERS, CATALOGS FEATURING APPAREL PRODUCTS, BAGS, ACCESSORIES, AND WATCHES (U.S. CLS. 2, 5, 22, 23, 29, 37, 38 AND 50).

FIRST USE 1-9-2010; IN COMMERCE 1-9-2010.

CLASS 24—FABRICS

FOR BED BLANKETS, TOWELS (U.S. CLS. 42 AND 50). FIRST USE 1-9-2010; IN COMMERCE 1-9-2010.

CLASS 28—TOYS AND SPORTING GOODS

FOR SPORTING GOODS, NAMELY, SKATEBOARDS AND COMPONENT PARTS THEREOF, SNOWBOARDS AND COMPONENT PARTS THEREOF, SKIMBOARDS, BEACHBALLS, BASKETBALLS (U.S. CLS. 22, 23, 38 AND 50).

FIRST USE 1-9-2010; IN COMMERCE 1-9-2010.

4,154,597. PHARMA MEDICO UK LIMITED, BRISTOL, UNITED KINGDOM. SN 78-885,425. PUB. 1-1-2008, FILED 5-17-2006.



NO CLAIM IS MADE TO THE EXCLUSIVE RIGHT TO USE "PHARMA" AND "MEDICO", APART FROM THE MARK AS SHOWN.

THE MARK CONSISTS OF THE CONFIGURATION OF THE PORTION OF THE MARK COMPRISED OF A CROSS DESIGN IS NOT DISPLAYED IN THE COLOR RED OR A COLORABLE IMITATION THEREOF; AND IS NOT USE AND WILL NOT BE USED IN THE COLOR RED OR A COLORABLE IMITATION THEREOF.

THE ENGLISH TRANSLATION OF THE WORD "MEDICO" IN THE MARK IS "MEDICAL".

CLASS 3—COSMETICS AND CLEANING PREPARATIONS

FOR CREAMS, NAMELY, ANTI-AGING CREAMS, ANTI-WRINKLE CREAMS, BEAUTY CREAMS, FACE AND BODY CREAMS, HAIR CREAMS, NON-MEDICATED SCALP TREATMENT CREAM, NON-MEDICATED SKIN CREAMS, SKIN CREAMS; LOTIONS FOR SKIN, HAIR, FACE AND BODY, COSMETICS; NON-MEDICATED TOILETRIES; SUN PROTECTION CREAMS AND SUN-BLOCK LOTIONS; ANTI-WRINKLE AND ANTI-CELLULITE CREAMS AND LOTIONS (U.S. CLS. 1, 4, 6, 50, 51 AND 52).

FIRST USE 7-1-1997; IN COMMERCE 3-17-2005.

CLASS 5—PHARMACEUTICALS

FOR PHARMACEUTICAL PREPARATIONS AND SUBSTANCES FOR THE TREATMENT OF SKIN PROBLEMS, HAIR LOSS PROBLEMS AND WEIGHT PROBLEMS; CREAMS, NAMELY, MEDICATED BODY AND FACE CREAMS; LOTIONS, NAMELY, MEDICATED BODY AND FACE LOTIONS; MEDICATED SUN PROTECTION CREAMS; MEDICATED ANTI-WRINKLE AND ANTI-CELLULITE CREAMS AND LOTIONS; ANTI-ITCH OINTMENTS, MULTIPURPOSE MEDICATED ANALGESIC BALM AND MENTHOLATED SALVES (U.S. CLS. 6, 18, 44, 46, 51 AND 52).

FIRST USE 7-1-1997; IN COMMERCE 3-17-2005.

4,154,598. UNITED FOOD IMPORT, INC., DAYTON, NJ. SN 78-892,757. PUB. 8-2-2011, FILED 5-30-2006.



OWNER OF U.S. REG. NO. 3,398,369.
 THE MARK CONSISTS OF 3 ARABIC LETTERS WHICH TRANSLITERATE TO "BASMA" IN THE ROUNDED UPPER PORTION OF A BANNER DESIGN AND THE LATIN LETTERS FOR "BASMA" APPEARING IN THE BOTTOM PORTION OF THE BANNER DESIGN.

THE FOREIGN WORDING IN THE MARK TRANSLATES INTO ENGLISH AS SMILE.

THE NON-LATIN CHARACTER(S) IN THE MARK TRANSLITERATE INTO "BASMA", AND THIS MEANS "SMILE" IN ENGLISH.

CLASS 29—MEATS AND PROCESSED FOODS

FOR CANNED COOKED MEAT; DRIED BEANS; DRIED MEAT; FRANKFURTERS ; LENTILS; PICKLES; PROCESSED BEANS; PROCESSED PEPPERS; REFRIED BEANS; STUFFED EGGPLANTS; STUFFED GRAPE LEAVES; GREEN PEPPERS STUFFED WITH RICE (U.S. CL. 46).

FIRST USE 1-1-2000; IN COMMERCE 1-1-2000.

CLASS 30—STAPLE FOODS

FOR FILO LEAVES; PROCESSED GRAINS, NAMELY, RICE (U.S. CL. 46).

FIRST USE 1-1-2000; IN COMMERCE 1-1-2000.

CLASS 32—LIGHT BEVERAGES

FOR APPLE JUICE BEVERAGES; FRUIT JUICES; FRUIT JUICES, NAMELY, APPLE, GRAPE, NECTAR, MANGO, POMEGRANITE, LEMON, KIWI, JUICE; HERBAL JUICES (U.S. CLS. 45, 46 AND 48).

FIRST USE 6-1-2006; IN COMMERCE 6-1-2006.

4,154,606. PLANPRESCRIBER, INC., MAYNARD, MA. SN 85-001,804. PUB. 8-10-2010, FILED 3-30-2010.

We Cure Confusion

THE MARK CONSISTS OF STANDARD CHARACTERS WITHOUT CLAIM TO ANY PARTICULAR FONT, STYLE, SIZE, OR COLOR.

CLASS 35—ADVERTISING AND BUSINESS

FOR INSURANCE LEAD COLLECTION AND MATCHING SERVICES, NAMELY, MATCHING CONSUMER REQUESTS FOR INSURANCE POLICY QUOTES COLLECTED OVER THE INTERNET TO PRE-QUALIFIED INSURANCE BROKERS, AGENTS AND AGENCIES INTERESTED IN THOSE REQUESTS; PROVIDING INSURANCE AGENT REFERRALS; PROVIDING SALES LEADS FOR THE INSURANCE INDUSTRY (U.S. CLS. 100, 101 AND 102).

FIRST USE 12-19-2011; IN COMMERCE 12-19-2011.

CLASS 36—INSURANCE AND FINANCIAL

FOR CONSULTING AND INFORMATION CONCERNING INSURANCE; INSURANCE CONSULTATION; INSURANCE INFORMATION (U.S. CLS. 100, 101 AND 102).

FIRST USE 12-19-2011; IN COMMERCE 12-19-2011.

4,154,611. KNOWLEDGEWORKS FOUNDATION, CINCINNATI, OH. SN 85-003,872. PUB. 8-24-2010, FILED 4-1-2010.



KnowledgeWorks

OWNER OF U.S. REG. NO. 2,825,512.

THE MARK CONSISTS OF THE WORD "KNOWLEDGEWORKS" AND ON TOP OF THE WORD "WORKS" IS AN ARTISTIC RENDITION OF A FLAME.

CLASS 16—PAPER GOODS AND PRINTED MATTER

FOR PRINTED MATERIALS, NAMELY, BOOKS, PAMPHLETS AND NEWSLETTERS IN THE FIELD OF EDUCATION (U.S. CLS. 2, 5, 22, 23, 29, 37, 38 AND 50).

FIRST USE 5-1-2010; IN COMMERCE 5-1-2010.

CLASS 41—EDUCATION AND ENTERTAINMENT

FOR CONSULTING SERVICES IN THE FIELD OF EDUCATION, NAMELY, PROVIDING CONSULTING TO TEACHERS, STAFF AND ADMINISTRATORS IN THE IMPLEMENTATION OF EDUCATIONAL REFORM MODELS; PROVIDING A WEB SITE FEATURING INFORMATION, REPORTS, NEWSLETTERS, EDUCATIONAL RESEARCH, WEBCASTS AND VIDEOS IN THE FIELD OF EDUCATION; EDUCATIONAL RESEARCH SERVICES (U.S. CLS. 100, 101 AND 107).

FIRST USE 5-1-2010; IN COMMERCE 5-1-2010.

4,154,615. CINTAS HOLDINGS, LLC, MASON, OH. SN 85-005,179. PUB. 8-24-2010, FILED 4-2-2010.

LOCKDOWN

THE MARK CONSISTS OF STANDARD CHARACTERS WITHOUT CLAIM TO ANY PARTICULAR FONT, STYLE, SIZE, OR COLOR.

CLASS 39—TRANSPORTATION AND STORAGE

FOR ELECTRONIC DOCUMENT STORAGE SERVICES AND DOCUMENT STORAGE SERVICES (U.S. CLS. 100 AND 105).

FIRST USE 3-31-2010; IN COMMERCE 3-31-2010.

CLASS 41—EDUCATION AND ENTERTAINMENT

FOR DIGITAL IMAGING SERVICES (U.S. CLS. 100, 101 AND 107).

FIRST USE 3-31-2010; IN COMMERCE 3-31-2010.

4,154,621. COLAS, BOULOGNE BILLANCOURT, FRANCE.
SN 85-007,607. PUB. 2-8-2011, FILED 4-6-2010.

ECOPRIME

THE MARK CONSISTS OF STANDARD CHARACTERS WITHOUT CLAIM TO ANY PARTICULAR FONT, STYLE, SIZE, OR COLOR.

CLASS 1—CHEMICALS

FOR CHEMICAL PREPARATIONS FOR STABILIZING SOIL AND AGGREGATES FOR USE IN CONSTRUCTION, REPAIR AND MAINTENANCE OF ROADS, HIGHWAYS AND OTHER TRAFFIC WAYS AND SURFACES; HYDROCARBON-BASED CHEMICAL PREPARATIONS AND EMULSIFIERS FOR STABILIZING SOIL AND AGGREGATES FOR USE IN CONSTRUCTION, REPAIR AND MAINTENANCE OF ROADS, HIGHWAYS AND OTHER TRAFFIC WAYS AND SURFACES (U.S. CLS. 1, 5, 6, 10, 26 AND 46).

FIRST USE 1-13-2010; IN COMMERCE 1-13-2010.

CLASS 19—NON-METALLIC BUILDING MATERIALS

FOR NON-METALLIC BITUMINOUS MATERIALS, NAMELY, ASPHALT SEALANTS, BITUMEN EMULSION, BITUMEN ASPHALT, SEALING COAT, ASPHALT AND AGGREGATES COMPOSED OF CRUSHED GRAVEL FOR MAKING AND COATING ROADS AS WELL AS OTHER TRAFFIC WAYS AND SURFACES (U.S. CLS. 1, 12, 33 AND 50).

FIRST USE 1-13-2010; IN COMMERCE 1-13-2010.

CLASS 37—CONSTRUCTION AND REPAIR

FOR CONSTRUCTION AND REPAIR SERVICES IN THE FIELD OF ROADS, HIGHWAYS AND OTHER TRAFFIC WAYS AND SURFACES UTILIZING NON-METALLIC BUILDING MATERIALS FOR ROAD SURFACE TREATMENT IN THE NATURE OF CHIP SEALING AGGREGATES, SURFACE DRESSING MADE OF ASPHALT AND BITUMEN, ASPHALT EMULSIONS, WEARING COURSE, OVERLAY, FLOORS, ASPHALT, PITCH AND BITUMEN ASPHALT (U.S. CLS. 100, 103 AND 106).

FIRST USE 1-13-2010; IN COMMERCE 1-13-2010.

4,154,629. VEGAS WOOD INDUSTRIES, INC., LAS VEGAS, NV. SN 85-023,565. PUB. 3-1-2011, FILED 4-26-2010.

VEGASWOOD

THE MARK CONSISTS OF STANDARD CHARACTERS WITHOUT CLAIM TO ANY PARTICULAR FONT, STYLE, SIZE, OR COLOR.

CLASS 9—ELECTRICAL AND SCIENTIFIC APPARATUS

FOR DOWNLOADABLE MOTION PICTURES AND TELEVISION SHOWS ABOUT ACTION, ADVENTURE, ANIMATION, BIOGRAPHIES, COMEDY, CRIME, DOCUMENTARY SUBJECTS, DRAMA, FAMILY ENTERTAINMENT, FANTASY, FILM-NOIR, HISTORY, HORROR, MUSIC, MUSICALS, MYSTERY, ROMANCE, SCIENCE FICTION, SPORTS, THRILLERS, WARS, AND WESTERNS; DOWNLOADABLE TELEVISION SHOWS, NAMELY, GAME SHOWS, NEWS SHOWS, REALITY TELEVISION SHOWS, TALK SHOWS; MOTION PICTURE FILMS ABOUT ACTION, ADVENTURE, ANIMATION, BIOGRAPHIES, COMEDY, CRIME, DOCUMENTARY SUBJECTS, DRAMA, FAMILY ENTERTAINMENT, FANTASY, FILM-NOIR, HISTORY, HORROR, MUSIC, MUSICALS, MYSTERY, ROMANCE, SCIENCE FICTION, SPORTS, THRILLERS, WARS, AND WESTERNS (U.S. CLS. 21, 23, 26, 36 AND 38).

FIRST USE 8-3-2004; IN COMMERCE 9-1-2011.

CLASS 41—EDUCATION AND ENTERTAINMENT

FOR DISTRIBUTION OF MOTION PICTURE FILMS; ENTERTAINMENT MEDIA PRODUCTION SERVICES FOR MOTION PICTURES, TELEVISION AND INTERNET; ENTERTAINMENT SERVICES, NAMELY, PRODUCTION OF COMPUTER-GENERATED IMAGERY FOR USE IN MOTION PICTURES; ENTERTAINMENT SERVICES, NAMELY, PRODUCTION OF SPECIAL EFFECTS INCLUDING MODEL-MAKING SERVICES AND RELATED PHYSICAL PRODUCTION ELEMENTS FOR USE IN MOTION PICTURES; ENTERTAINMENT SERVICES, NAMELY, PRODUCTION OF SPECIAL EFFECTS INCLUDING MODEL-MAKING SERVICES, COMPUTER-GENERATED IMAGERY AND COMPUTER-GENERATED GRAPHICS FOR THE PRODUCTION OF MOTION PICTURES, VIDEOS, AND MOVIE TRAILERS; MOTION PICTURE FILM PRODUCTION; MOTION PICTURE SONG PRODUCTION; PRODUCTION AND DISTRIBUTION OF INDEPENDENT MOTION PICTURES; PRODUCTION AND DISTRIBUTION OF MOTION PICTURES (U.S. CLS. 100, 101 AND 107).

FIRST USE 8-3-2004; IN COMMERCE 8-3-2004.

4,154,633. HOSLEY INTERNATIONAL, INC., LYNWOOD, IL. SN 85-028,553. PUB. 4-5-2011, FILED 5-3-2010.

NATURE'S BOUNTY

THE MARK CONSISTS OF STANDARD CHARACTERS WITHOUT CLAIM TO ANY PARTICULAR FONT, STYLE, SIZE, OR COLOR.

CLASS 3—COSMETICS AND CLEANING PREPARATIONS

FOR POTPOURRI AND FRAGRANCES (U.S. CLS. 1, 4, 6, 50, 51 AND 52).
FIRST USE 7-0-2011; IN COMMERCE 7-0-2011.

CLASS 31—NATURAL AGRICULTURAL PRODUCTS

FOR DRIED FLOWERS, DRIED FLORAL ARRANGEMENTS, DRIED PLANTS (U.S. CLS. 1 AND 46).
FIRST USE 7-0-2011; IN COMMERCE 7-0-2011.

4,154,644. FUJI FOOD PRODUCTS, INC., SANTA FE SPRINGS, CA. SN 85-045,410. PUB. 4-5-2011, FILED 5-21-2010.

A Trend to Healthy Eating

THE MARK CONSISTS OF STANDARD CHARACTERS WITHOUT CLAIM TO ANY PARTICULAR FONT, STYLE, SIZE, OR COLOR.

CLASS 29—MEATS AND PROCESSED FOODS

FOR ASIAN-STYLE PREPARED MEALS CONSISTING PRIMARILY OF MEAT, FISH, POULTRY OR VEGETABLES; INSTANT OR PRE-COOKED SOUP; PREPARED VEGETABLES; ASIAN-STYLE PREPARED APPETIZERS CONSISTING PRIMARILY OF MEAT, FISH, POULTRY OR VEGETABLES (U.S. CL. 46).
FIRST USE 7-25-2010; IN COMMERCE 7-25-2010.

CLASS 30—STAPLE FOODS

FOR ASIAN CONDIMENTS, NAMELY, PREPARED WASABI, PREPARED GINGER, ASIAN SAUCES; SUSHI (U.S. CL. 46).
FIRST USE 7-25-2010; IN COMMERCE 7-25-2010.

4,154,645. HARTE-HANKS DATA TECHNOLOGIES, INC., SAN ANTONIO, TX. SN 85-049,530. PUB. 4-12-2011, FILED 5-27-2010.

TrilliumApps

THE MARK CONSISTS OF STANDARD CHARACTERS WITHOUT CLAIM TO ANY PARTICULAR FONT, STYLE, SIZE, OR COLOR.

CLASS 9—ELECTRICAL AND SCIENTIFIC APPARATUS

FOR COMPUTER APPLICATION SOFTWARE FOR USE IN CUSTOMIZATION OF DATA MANAGEMENT SOFTWARE (U.S. CLS. 21, 23, 26, 36 AND 38).
FIRST USE 11-22-2011; IN COMMERCE 11-22-2011.

CLASS 42—SCIENTIFIC AND COMPUTER SERVICES

FOR PROVIDING A SECURE, WEB-BASED SYSTEM AND ONLINE PORTAL FOR CUSTOMERS TO DOWNLOAD, DESIGN AND EXCHANGE COMPUTER SOFTWARE BUSINESS RULES, PROCESS STEPS, AND PROJECTS FOR USE IN ENHANCING COMPUTER SOFTWARE FUNCTIONALITY IN THE FIELD OF DATA MANAGEMENT SOFTWARE (U.S. CLS. 100 AND 101).
FIRST USE 11-22-2011; IN COMMERCE 11-22-2011.

4,154,648. TRUSTEE OF THE HERMAN FAMILY TRUST, LOS ANGELES, CA. SN 85-057,780. PUB. 7-26-2011, FILED 6-8-2010.

SOLCA

THE MARK CONSISTS OF STANDARD CHARACTERS WITHOUT CLAIM TO ANY PARTICULAR FONT, STYLE, SIZE, OR COLOR.

CLASS 18—LEATHER GOODS

FOR HANDBAGS; PURSES; WALLETS (U.S. CLS. 1, 2, 3, 22 AND 41).
FIRST USE 8-0-2009; IN COMMERCE 8-0-2009.

CLASS 25—CLOTHING

FOR BLOUSES; COVERUPS; DRESSES; FOOTWEAR; HEADWEAR; JACKETS; PANTS; SHIRTS; SHORTS; SKIRTS; SOCKS; SWEAT PANTS; SWEAT SHIRTS; SWEATERS; T-SHIRTS; VESTS (U.S. CLS. 22 AND 39).
FIRST USE 8-0-2009; IN COMMERCE 8-0-2009.

4,154,654. BRACCI, STEPHEN P., NEW YORK, NY. SN 85-063,164. PUB. 11-16-2010, FILED 6-15-2010.

DAILY SQUEEZE

THE MARK CONSISTS OF STANDARD CHARACTERS WITHOUT CLAIM TO ANY PARTICULAR FONT, STYLE, SIZE, OR COLOR.

NO CLAIM IS MADE TO THE EXCLUSIVE RIGHT TO USE "DAILY", APART FROM THE MARK AS SHOWN.

CLASS 3—COSMETICS AND CLEANING PREPARATIONS

FOR NON-MEDICATED SKIN CARE PREPARATIONS; BODY CARE PRODUCTS, NAMELY, BODY LOTION (U.S. CLS. 1, 4, 6, 50, 51 AND 52).
FIRST USE 5-1-2011; IN COMMERCE 5-1-2011.

CLASS 5—PHARMACEUTICALS

FOR MEDICATED SKIN CARE PREPARATIONS (U.S. CLS. 6, 18, 44, 46, 51 AND 52).
FIRST USE 1-15-2007; IN COMMERCE 1-15-2007.

4,154,660. DEMOCRASOFT, INC., SANTA ROSA, CA. SN 85-068,566. PUB. 3-1-2011, FILED 6-22-2010.

COLLABORIZE CLASSROOM

THE MARK CONSISTS OF STANDARD CHARACTERS WITHOUT CLAIM TO ANY PARTICULAR FONT, STYLE, SIZE, OR COLOR.

OWNER OF U.S. REG. NO. 3,812,206.

CLASS 9—ELECTRICAL AND SCIENTIFIC APPARATUS

FOR COMPUTER SOFTWARE TO FACILITATE VOTING OVER COMPUTER AND IP COMMUNICATION NETWORKS; COMPUTER SOFTWARE FOR CREATING AN ON-LINE COMMUNITY FOR USERS TO PARTICIPATE IN DISCUSSIONS, GET FEEDBACK FROM OTHER USERS, FORM VIRTUAL COMMUNITIES, ENGAGE IN SOCIAL NETWORKING, AND VOTE ON ISSUES RELEVANT TO THE COMMUNITY (U.S. CLS. 21, 23, 26, 36 AND 38).

FIRST USE 1-31-2012; IN COMMERCE 1-31-2012.

CLASS 42—SCIENTIFIC AND COMPUTER SERVICES

FOR PROVIDING TEMPORARY USE OF ONLINE NON-DOWNLOADABLE SOFTWARE TO FACILITATE VOTING OVER COMPUTER AND IP COMMUNICATION NETWORKS; PROVIDING TEMPORARY USE OF ONLINE NON-DOWNLOADABLE SOFTWARE FOR CREATING AN ON-LINE COMMUNITY FOR USERS TO PARTICIPATE IN DISCUSSIONS, GET FEEDBACK FROM OTHER USERS, FORM VIRTUAL COMMUNITIES, ENGAGE IN SOCIAL NETWORKING, AND VOTE ON ISSUES RELEVANT TO THE COMMUNITY; COMPUTER SERVICES, NAMELY, CREATING AN ON-LINE COMMUNITY FOR REGISTERED USERS TO PARTICIPATE IN DISCUSSIONS, GET FEEDBACK FROM THEIR PEERS, FORM VIRTUAL COMMUNITIES, ENGAGE IN SOCIAL NETWORKING, AND VOTE ON ISSUES RELEVANT TO THE COMMUNITY; PROVIDING TEMPORARY USE OF ONLINE NON-DOWNLOADABLE SOFTWARE FOR COMMUNICATION AND COLLABORATION AMONG NETWORK USERS (U.S. CLS. 100 AND 101).

FIRST USE 9-1-2010; IN COMMERCE 9-1-2010.

4,154,668. WHR HOLDINGS, LLC, HOLLYWOOD, FL. SN 85-074,006. PUB. 6-7-2011, FILED 6-29-2010.

WILKINSON HI-RISE

THE MARK CONSISTS OF STANDARD CHARACTERS WITHOUT CLAIM TO ANY PARTICULAR FONT, STYLE, SIZE, OR COLOR.

OWNER OF U.S. REG. NO. 2,797,205.

NO CLAIM IS MADE TO THE EXCLUSIVE RIGHT TO USE "HIGH-RISE", APART FROM THE MARK AS SHOWN.

CLASS 6—METAL GOODS

FOR METAL BINS, NAMELY, RECYCLING BINS OF METAL FOR COLLECTION OF RECYCLABLE ITEMS, AND TRASH BINS OF METAL; METAL DOORS FOR TRASH CHUTES, NAMELY, INTAKE DOORS AND DISCHARGE DOORS; METAL DOORS FOR LAUNDRY CHUTES NAMELY, INTAKE DOORS AND DISCHARGE DOORS; TRASH CHUTES, NAMELY, METAL TRASH CHUTES IN THE NATURE OF BUILDING MATERIALS; LAUNDRY CHUTES NAMELY, METAL LAUNDRY CHUTES IN THE NATURE OF BUILDING MATERIALS; METAL STORAGE LOCKERS, NAMELY, GENERAL PURPOSE METAL STORAGE LOCKERS FOR INDUSTRIAL OR COMMERCIAL USE; AND METAL WIRE MESH PARTITION WALLS FOR STORAGE LOCKERS (U.S. CLS. 2, 12, 13, 14, 23, 25 AND 50).

FIRST USE 1-18-2012; IN COMMERCE 1-18-2012.

CLASS 7—MACHINERY

FOR TRASH COMPACTORS AND REPLACEMENT PARTS THEREFOR; SORTING MACHINES FOR SORTING RECYCLABLE ITEMS, AND REPLACEMENT PARTS THEREFOR (U.S. CLS. 13, 19, 21, 23, 31, 34 AND 35).

FIRST USE 1-21-2012; IN COMMERCE 1-21-2012.

4,154,670. BRIDGEWATER, INC., SALT LAKE CITY, UT. SN 85-077,381. PUB. 1-3-2012, FILED 7-2-2010.

GREEN BALANCE

THE MARK CONSISTS OF STANDARD CHARACTERS WITHOUT CLAIM TO ANY PARTICULAR FONT, STYLE, SIZE, OR COLOR.

NO CLAIM IS MADE TO THE EXCLUSIVE RIGHT TO USE "GREEN", APART FROM THE MARK AS SHOWN.

CLASS 1—CHEMICALS

FOR FABRIC PROTECTANTS FOR CARPET, UPHOLSTERY, AND TEXTILES; CHEMICAL ADDITIVES FOR USE IN CLEANING PREPARATIONS FOR CARPET, UPHOLSTERY, AND FABRIC; ALL OF THE FOREGOING ARE ENVIRONMENTALLY FRIENDLY (U.S. CLS. 1, 5, 6, 10, 26 AND 46).

FIRST USE 6-21-2010; IN COMMERCE 6-21-2010.

CLASS 3—COSMETICS AND CLEANING PREPARATIONS

FOR CLEANING AGENTS AND PREPARATIONS; WASHING AND POLISHING PREPARATIONS; CLEANING PREPARATIONS FOR CARPET, FABRIC AND UPHOLSTERY, NAMELY, CLEANING AGENTS, PRE-SPRAY CLEANING AGENTS, NEUTRALIZING AGENTS, COLOR BLEED PREVENTATIVE AGENTS, SPOT AND STAIN REMOVERS; AND RINSE AGENTS; WOOD CLEANER FOR CLEANING HARDWOOD FLOORS; ALL OF THE FOREGOING ARE ENVIRONMENTALLY FRIENDLY (U.S. CLS. 1, 4, 6, 50, 51 AND 52).

FIRST USE 6-21-2010; IN COMMERCE 6-21-2010.

CLASS 5—PHARMACEUTICALS

FOR ENVIRONMENTALLY FRIENDLY HOUSEHOLD AND COMMERCIAL DEODORIZERS FOR CARPET, UPHOLSTERY, FABRIC AND DRAPERIES (U.S. CLS. 6, 18, 44, 46, 51 AND 52).

FIRST USE 6-21-2010; IN COMMERCE 6-21-2010.

4,154,672. QWIZDOM, INC., PUYALLUP, WA. SN 85-080,903.
PUB. 7-12-2011, FILED 7-8-2010.

QTOPIA

THE MARK CONSISTS OF STANDARD CHARACTERS WITHOUT CLAIM TO ANY PARTICULAR FONT, STYLE, SIZE, OR COLOR.

CLASS 38—COMMUNICATION

FOR PROVIDING AN ON-LINE FORUM FOR SHARING AND TRANSMISSION OF INFORMATION AND ELECTRONIC MEDIA CONCERNING EDUCATION (U.S. CLS. 100, 101 AND 104).
FIRST USE 2-0-2011; IN COMMERCE 2-0-2011.

CLASS 41—EDUCATION AND ENTERTAINMENT

FOR EDUCATION SERVICES, NAMELY, PROVIDING AN ONLINE INTERACTIVE DATABASE FOR TRACKING, MONITORING AND RECORDING STUDENT ACADEMIC PERFORMANCE DATA; PROVIDING ONLINE EDUCATIONAL INFORMATION, NAMELY, COURSE MATERIALS, STUDY AND HOMEWORK EXERCISES, AND TEST QUESTIONS AND QUIZZES IN THE FIELDS OF MATH, SCIENCE, SOCIAL STUDIES, READING AND WRITING; PROVIDING ONLINE EDUCATIONAL PUBLICATIONS, NAMELY, INSTRUCTIONAL, EDUCATIONAL AND TEACHING MATERIALS IN THE FIELDS OF MATH, SCIENCE, SOCIAL STUDIES, READING AND WRITING (U.S. CLS. 100, 101 AND 107).
FIRST USE 2-0-2011; IN COMMERCE 2-0-2011.

4,154,673. ENGINEERING & RESEARCH ASSOCIATES, INC., TUCSON, AZ. SN 85-082,414. PUB. 12-28-2010, FILED 7-12-2010.



THE MARK CONSISTS OF THE TERM "VANTE" IN COMBINATION WITH A LOGO CONSISTING OF THE LETTER "V" PARTIALLY ENCLOSED WITHIN A LARGER "V" HAVING A ROUNDED TAIL EXTENDING FROM ONE ARM.

THE ENGLISH TRANSLATION OF "VANTE" IN THE MARK IS PRAISE.

CLASS 7—MACHINERY

FOR POWER TOOLS, NAMELY, PORTABLE AND FIXED LOCATION INSTRUMENTS FOR FORMING, EXTRUDING, SHAPING OR WELDING THERMOPLASTIC ELEMENTS (U.S. CLS. 13, 19, 21, 23, 31, 34 AND 35).
FIRST USE 5-31-2011; IN COMMERCE 5-31-2011.

CLASS 8—HAND TOOLS

FOR HAND TOOLS FOR FORMING, EXTRUDING, SHAPING OR WELDING PLASTIC TUBING (U.S. CLS. 23, 28 AND 44).
FIRST USE 5-31-2011; IN COMMERCE 5-31-2011.

4,154,677. AKA KIDS, INC., MIAMI, FL. SN 85-083,269. PUB. 12-14-2010, FILED 7-13-2010.

THE ALL-IN-ONE NAPTIME SOLUTION

THE MARK CONSISTS OF STANDARD CHARACTERS WITHOUT CLAIM TO ANY PARTICULAR FONT, STYLE, SIZE, OR COLOR.

CLASS 20—FURNITURE AND ARTICLES NOT OTHERWISE CLASSIFIED

FOR CHILDREN'S MATS USED FOR SLEEPING; NAP SACKS; SLEEPING BAG PADS; SLEEPING BAGS; SLEEPING MATS (U.S. CLS. 2, 13, 22, 25, 32 AND 50).
FIRST USE 7-1-2011; IN COMMERCE 7-1-2011.

CLASS 35—ADVERTISING AND BUSINESS

FOR ON-LINE WHOLESALE AND RETAIL STORE SERVICES FEATURING CHILDREN'S MATS USED FOR SLEEPING, NAP SACKS, SLEEPING BAG PADS, SLEEPING BAGS, SLEEPING MATS CLASS (U.S. CLS. 100, 101 AND 102).
FIRST USE 7-1-2011; IN COMMERCE 7-1-2011.

4,154,679. ZERONINES TECHNOLOGY, INC., CASTLE ROCK, CO. SN 85-084,376. PUB. 12-14-2010, FILED 7-14-2010.

ZENVAULT

THE MARK CONSISTS OF STANDARD CHARACTERS WITHOUT CLAIM TO ANY PARTICULAR FONT, STYLE, SIZE, OR COLOR.

CLASS 9—ELECTRICAL AND SCIENTIFIC APPARATUS

FOR COMPUTER SOFTWARE FOR USE IN THE SAFEGUARDING OF DIGITAL FILES, INCLUDING AUDIO, VIDEO, TEXT, BINARY, STILL IMAGES, GRAPHICS AND MULTIMEDIA FILES; COMPUTER SOFTWARE THAT PROVIDES WEB-BASED ACCESS TO APPLICATIONS AND SERVICES THROUGH A WEB OPERATING SYSTEM OR PORTAL INTERFACE (U.S. CLS. 21, 23, 26, 36 AND 38).
FIRST USE 9-13-2010; IN COMMERCE 9-13-2010.

CLASS 39—TRANSPORTATION AND STORAGE

FOR STORAGE SERVICES FOR ARCHIVING DATABASES, IMAGES AND OTHER ELECTRONIC DATA (U.S. CLS. 100 AND 105).

FIRST USE 9-13-2010; IN COMMERCE 9-13-2010.

4,154,692. COMPLETE GENOMICS, INC., MOUNTAIN VIEW, CA. SN 85-093,738. PUB. 1-11-2011, FILED 7-27-2010.

CGA

4,154,683. BC CARD CO., LTD., SEOUL, REPUBLIC OF KOREA. SN 85-087,658. PUB. 7-26-2011, FILED 7-19-2010.

THE MARK CONSISTS OF STANDARD CHARACTERS WITHOUT CLAIM TO ANY PARTICULAR FONT, STYLE, SIZE, OR COLOR.

CLASS 42—SCIENTIFIC AND COMPUTER SERVICES

FOR BIOTECHNOLOGY RESEARCH AND DEVELOPMENT SERVICES FOR OTHERS, NAMELY, GENOME SEQUENCING, GENOME MAPPING, GENOME AND NUCLEIC ACID ANALYSIS, GENOME AMPLIFICATION, GENOME SCANNING, AND HIGH PERFORMANCE COMPUTING SERVICES FOR GENOME SEQUENCING (U.S. CLS. 100 AND 101).

FIRST USE 6-30-2010; IN COMMERCE 6-30-2010.

CLASS 45—PERSONAL AND LEGAL SERVICES

FOR LICENSING OF COMPUTER SOFTWARE IN THE FIELD OF GENOME RESEARCH AND DEVELOPMENT (U.S. CLS. 100 AND 101).

FIRST USE 6-30-2010; IN COMMERCE 6-30-2010.



THE COLOR(S) RED AND WHITE IS/ARE CLAIMED AS A FEATURE OF THE MARK.

THE MARK CONSISTS OF THE LETTERS "BC" IN WHITE CONTAINED IN A RED CIRCLE.

CLASS 9—ELECTRICAL AND SCIENTIFIC APPARATUS

FOR MAGNETICALLY ENCODED CREDIT CARDS; MAGNETICALLY ENCODED DEBIT CARDS; ELECTRONICALLY ENCODED CREDIT CARDS; MAGNETICALLY ENCODED DEBIT CARDS; CASH DISPENSING MACHINES, NAMELY, AUTOMATED TELLER MACHINES (ATM) (U.S. CLS. 21, 23, 26, 36 AND 38).

FIRST USE 7-19-2010; IN COMMERCE 7-19-2010.

CLASS 36—INSURANCE AND FINANCIAL

FOR CREDIT CARD, DEBIT CARD, CHARGE CARD, AND STORED VALUE SMART CARD SERVICES; ELECTRONIC CREDIT AND DEBIT TRANSACTIONS, NAMELY, ELECTRONIC TRANSFERS OF MONEY, ELECTRONIC CASH DISBURSEMENT, CASH REPLACEMENT RENDERED BY CREDIT CARDS AND DEBIT CARDS, AND AUTOMATED TELLER MACHINE SERVICES; CREDIT CARD AND DEBIT CARD VERIFICATION, PAYMENT TRANSACTION PROCESSING, CREDIT AND DEBIT CARD AUTHENTICATION AND CREDIT AND DEBIT CARD VERIFICATION SERVICES; CURRENCY EXCHANGE AND TRANSFER OF ELECTRONIC FUNDS (U.S. CLS. 100, 101 AND 102).

FIRST USE 7-19-2010; IN COMMERCE 7-19-2010.

4,154,695. ROADS SAFE HOLDINGS, INC., CHICAGO, IL. SN 85-096,521. PUB. 7-19-2011, FILED 7-30-2010.

ROADSAFE

THE MARK CONSISTS OF STANDARD CHARACTERS WITHOUT CLAIM TO ANY PARTICULAR FONT, STYLE, SIZE, OR COLOR.

OWNER OF U.S. REG. NO. 3,652,009.

CLASS 37—CONSTRUCTION AND REPAIR

FOR RENTAL AND INSTALLATION OF CRASH SYSTEMS, NAMELY, TRUCK-MOUNTED IMPACT ATTENUATORS, CRASH CUSHIONS, SAND BARREL ARRAYS, AND WATER-FILLED BARRIERS; AND PAVEMENT MARKING SERVICES AND TRAFFIC SIGN INSTALLATION SERVICES; RENTAL, INSTALLATION AND RELOCATION OF TRAFFIC SAFETY DEVICES, NAMELY, BARRELS, WATER BARRIERS, AND BARRICADES; INSTALLATION AND RELOCATION OF MESSAGE BOARDS AND TRAFFIC SIGNAGE, AND TRAFFIC CONES, WITH ALL OF THE FOREGOING USED FOR THE MANAGEMENT AND CONTROL OF VEHICULAR AND PEDESTRIAN TRAFFIC (U.S. CLS. 100, 103 AND 106).

FIRST USE 1-0-2008; IN COMMERCE 1-0-2008.

CLASS 45—PERSONAL AND LEGAL SERVICES

FOR RENTAL OF TRAFFIC SAFETY DEVICES, NAMELY, MESSAGE BOARDS AND TRAFFIC SIGNAGE, AND TRAFFIC CONES WITH ALL OF THE FOREGOING USED FOR THE MANAGEMENT AND CONTROL OF VEHICULAR AND PEDESTRIAN TRAFFIC (U.S. CLS. 100 AND 101).

FIRST USE 1-0-2008; IN COMMERCE 1-0-2008.

4,154,701. CHIPPENHOOK SERVICES, LLC, LEWISVILLE, TX. SN 85-099,829. PUB. 6-14-2011, FILED 8-4-2010.

AGILUS

THE MARK CONSISTS OF STANDARD CHARACTERS WITHOUT CLAIM TO ANY PARTICULAR FONT, STYLE, SIZE, OR COLOR.

CLASS 20—FURNITURE AND ARTICLES NOT OTHERWISE CLASSIFIED

FOR CABINETS FOR USE IN RETAIL AND COMMERCIAL OUTLETS; DISPLAY CASES, BOARDS, RACKS AND STANDS FOR MERCHANDISE (U.S. CLS. 2, 13, 22, 25, 32 AND 50).

FIRST USE 2-28-2011; IN COMMERCE 2-29-2012.

CLASS 40—MATERIAL TREATMENT

FOR MANUFACTURING SERVICES FOR OTHERS IN THE FIELD OF STORE FIXTURES AND DISPLAYS, MILLWORK, AND CABINETRY FOR USE IN RETAIL AND COMMERCIAL OUTLETS (U.S. CLS. 100, 103 AND 106).

FIRST USE 2-23-2011; IN COMMERCE 2-23-2011.

4,154,705. H&H ASIA LTD., TAIPEI, TAIWAN. SN 85-101,029. PUB. 7-19-2011, FILED 8-5-2010.

NATURAL ELEMENTS

THE MARK CONSISTS OF STANDARD CHARACTERS WITHOUT CLAIM TO ANY PARTICULAR FONT, STYLE, SIZE, OR COLOR.

CLASS 8—HAND TOOLS

FOR WOODEN COOKING SPOONS; MORTAR AND PESTLES; NON-ELECTRIC HAND-OPERATED FOOD CHOPPERS (U.S. CLS. 23, 28 AND 44).

FIRST USE 9-0-2008; IN COMMERCE 9-0-2008.

CLASS 21—HOUSEWARES AND GLASS

FOR WOODEN HOUSEHOLD UTENSILS, NAMELY, SPATULAS, TURNERS, KITCHEN TONGS, SERVING SPOONS, MIXING SPOONS, SLOTTED SPOONS; WOKS (NON-ELECTRIC); CHOPPING BOARDS FOR KITCHEN USE; WOODEN CHOPPING BOARDS FOR KITCHEN USE; BAKING DISHES; CASSEROLE DISHES; ROASTING DISHES; SERVING DISHES; BAKE WARE; DISPENSERS FOR PAPER TOWELS; ROLLING PINS; COOKING UTENSILS, NAMELY, SPATULAS, TURNERS, KITCHEN TONGS; LEMON SQUEEZERS; CREAMER PITCHERS; POT LIDS (U.S. CLS. 2, 13, 23, 29, 30, 33, 40 AND 50).

FIRST USE 9-0-2008; IN COMMERCE 9-0-2008.

4,154,707. THE IOWA CLINIC, P.C., WEST DES MOINES, IA. SN 85-101,819. PUB. 10-11-2011, FILED 8-6-2010.

RUIDESMOINES

THE MARK CONSISTS OF STANDARD CHARACTERS WITHOUT CLAIM TO ANY PARTICULAR FONT, STYLE, OR COLOR.

NO CLAIM IS MADE TO THE EXCLUSIVE RIGHT TO USE "DES MOINES", APART FROM THE MARK AS SHOWN.

CLASS 35—ADVERTISING AND BUSINESS

FOR ARRANGING AND CONDUCTING OF FAIRS AND EXHIBITIONS FEATURING PRODUCTS AND SERVICES FOR WOMEN FOR COMMERCIAL AND ADVERTISING PURPOSES, NAMELY, EXHIBITIONS SELLING ART, ACCESSORIES, JEWELRY, HEALTH AND WELLNESS PRODUCTS, BATH AND BODY PRODUCTS, SPA SERVICES, AND PURSES (U.S. CLS. 100, 101 AND 102).

FIRST USE 9-23-2010; IN COMMERCE 9-23-2010.

CLASS 41—EDUCATION AND ENTERTAINMENT

FOR EDUCATIONAL ENTERTAINMENT SERVICES, NAMELY, ARRANGING AND CONDUCTING SPECIAL EVENTS FOR WOMEN FOR EDUCATIONAL SOCIAL ENTERTAINMENT PURPOSES, NAMELY, PHOTOGRAPHY CLASSES, COOKING CLASSES, GOLF LESSONS, HEALTHY COOKING AND NUTRITION CLASSES, ART AND CRAFT GLASS DEMONSTRATIONS, WINE TASTING, COSMETIC SURGERY AND SKIN CARE DEMONSTRATIONS, LIVE PILATES DEMONSTRATIONS, LIVE BOTULINUM TOXIN DEMONSTRATIONS, LIVE VEIN THERAPY DEMONSTRATIONS (U.S. CLS. 100, 101 AND 107).

FIRST USE 9-23-2010; IN COMMERCE 9-23-2010.

4,154,713. TMP INTELLECTUAL PROPERTY HOLDINGS, LLC, NEW YORK, NY. SN 85-103,470. PUB. 11-1-2011, FILED 8-9-2010.



OWNER OF U.S. REG. NOS. 2,150,279, 2,151,852, AND

2,749,473.

THE MARK CONSISTS OF THE WORDS "TMP WORLD-WIDE" AND A SPHERICAL DESIGN.

CLASS 35—ADVERTISING AND BUSINESS

FOR ADVERTISING AGENCY SERVICES, NAMELY, DESIGNING, CREATING AND PLACING EMPLOYMENT RECRUITMENT ADVERTISING FOR OTHERS AND FORWARDING RESPONSES TO SUCH ADVERTISING; DESIGNING, CREATING AND PLACING EMPLOYMENT RECRUITMENT ADVERTISING FOR OTHERS; EMPLOYMENT HIRING, RECRUITING, PLACEMENT, STAFFING AND CAREER NETWORKING SERVICES; BUSINESS MARKETING CONSULTING SERVICES; RESEARCH SERVICES IN THE FIELD OF JOB PLACEMENT; DESIGNING AND CONDUCTING EMPLOYMENT RECRUITMENT MARKETING SERVICES AND MARKETING STUDIES SERVICES, DISTRIBUTED VIA INTERACTIVE COMPUTER DATABASES INCLUDING A WEB SITE ON A GLOBAL COMPUTER INFORMATION NETWORK AND SOCIAL NETWORKING WEB SITES; PUBLIC RELATIONS SERVICES; EMPLOYER BRANDING SERVICES (U.S. CLS. 100, 101 AND 102).

FIRST USE 3-2-2011; IN COMMERCE 3-2-2011.

CLASS 38—COMMUNICATION

FOR ELECTRONIC TRANSMISSION OF ADVERTISEMENTS, RESUMES AND OTHER RESPONSES TO EMPLOYMENT RECRUITMENT ADVERTISING VIA INTERACTIVE AND SOCIAL NETWORKING WEB SITES; ELECTRONIC STORE-AND-FORWARD MESSAGING (U.S. CLS. 100, 101 AND 104).

FIRST USE 3-2-2011; IN COMMERCE 3-2-2011.

CLASS 42—SCIENTIFIC AND COMPUTER SERVICES

FOR WEB SITE DESIGN SERVICES (U.S. CLS. 100 AND 101).

FIRST USE 3-2-2011; IN COMMERCE 3-2-2011.

4,154,715. COLD FORGED PRODUCTS NO.1 PTY LTD, TA COLD FORGED PRODUCTS, CARINGBAH, NSW, AUSTRALIA. SN 85-103,569. PUB. 10-18-2011, FILED 8-9-2010.

GageLok

THE MARK CONSISTS OF STANDARD CHARACTERS WITHOUT CLAIM TO ANY PARTICULAR FONT, STYLE, SIZE, OR COLOR.

CLASS 6—METAL GOODS

FOR METAL FASTENERS, NAMELY, RAIL SCREWS FOR RAILWAY CONSTRUCTION (U.S. CLS. 2, 12, 13, 14, 23, 25 AND 50).

FIRST USE 10-19-2010; IN COMMERCE 10-19-2010.

CLASS 14—JEWELRY

FOR TIE FASTENERS (U.S. CLS. 2, 27, 28 AND 50).

FIRST USE 10-19-2010; IN COMMERCE 10-19-2010.

4,154,716. CLICK SUITE LIMITED, WELLINGTON, NEW ZEALAND. SN 85-103,580. PUB. 1-25-2011, FILED 8-9-2010.

CLICKSUITE

THE MARK CONSISTS OF STANDARD CHARACTERS WITHOUT CLAIM TO ANY PARTICULAR FONT, STYLE, SIZE, OR COLOR.

CLASS 9—ELECTRICAL AND SCIENTIFIC APPARATUS

FOR COMPUTER HARDWARE AND COMPUTER SOFTWARE PROGRAMS FOR THE INTEGRATION OF TEXT, AUDIO, GRAPHICS, STILL IMAGES AND MOVING PICTURES INTO AN INTERACTIVE DELIVERY FOR MULTIMEDIA APPLICATIONS (U.S. CLS. 21, 23, 26, 36 AND 38).

FIRST USE 1-22-2009; IN COMMERCE 1-3-2009.

CLASS 38—COMMUNICATION

FOR COMMUNICATION SERVICES, NAMELY, ELECTRONIC TRANSMISSION OF DATA AND DOCUMENTS AMONG USERS OF COMPUTERS; COMMUNICATION SERVICES, NAMELY, TRANSMISSION OF VOICE, AUDIO, VISUAL IMAGES AND DATA BY TELECOMMUNICATIONS NETWORKS, WIRELESS COMMUNICATION NETWORKS, THE INTERNET, INFORMATION SERVICES NETWORKS AND DATA NETWORKS; INTERNET SERVICE PROVIDER (ISP); PROVIDING USER ACCESS TO A GLOBAL COMPUTER NETWORK; PROVISION OF ACCESS TO A GLOBAL COMPUTER NETWORK; WEBCASTING SERVICES (U.S. CLS. 100, 101 AND 104).

FIRST USE 1-22-2009; IN COMMERCE 1-3-2009.

CLASS 41—EDUCATION AND ENTERTAINMENT

FOR MULTIMEDIA PUBLISHING OF BOOKS, MAGAZINES, JOURNALS, SOFTWARE, GAMES, MUSIC, AND ELECTRONIC PUBLICATIONS (U.S. CLS. 100, 101 AND 107).

FIRST USE 1-22-2009; IN COMMERCE 1-3-2009.

CLASS 42—SCIENTIFIC AND COMPUTER SERVICES

FOR COMPUTER CONSULTATION; COMPUTER HARDWARE AND SOFTWARE CONSULTING SERVICES; COMPUTER HARDWARE AND SOFTWARE DESIGN; CONSULTANCY IN THE FIELD OF SOFTWARE DESIGN; CONSULTANCY WITH REGARD TO WEBPAGE DESIGN; DESIGN AND CREATING WEB SITES FOR OTHERS; DESIGN AND DEVELOPMENT OF COMPUTER HARDWARE AND SOFTWARE; DESIGN AND DEVELOPMENT OF MULTIMEDIA PRODUCTS; DESIGN OF HOME PAGES, COMPUTER SOFTWARE AND WEB SITES; DESIGN, DEVELOPMENT AND IMPLEMENTATION OF SOFTWARE; WEBSITE DESIGN AND DEVELOPMENT FOR OTHERS (U.S. CLS. 100 AND 101).

FIRST USE 1-22-2009; IN COMMERCE 1-3-2009.

4,154,717. YELLOWPAGES.COM, LLC, GLENDALE, CA. SN 85-103,843. PUB. 2-1-2011, FILED 8-10-2010.

CLICK LESS. LIVE MORE.

THE MARK CONSISTS OF STANDARD CHARACTERS WITHOUT CLAIM TO ANY PARTICULAR FONT, STYLE, SIZE, OR COLOR.

CLASS 35—ADVERTISING AND BUSINESS

FOR PROVIDING ADVERTISEMENT SERVICES FOR OTHERS VIA A GLOBAL COMPUTER NETWORK; PROVIDING ONLINE INFORMATION AND COMMUNICATION SERVICES IN THE FORM OF INTERACTIVE DIRECTORIES AND ADVERTISEMENTS OVER A GLOBAL COMPUTER NETWORK (U.S. CLS. 100, 101 AND 102).

FIRST USE 8-10-2010; IN COMMERCE 8-10-2010.

CLASS 41—EDUCATION AND ENTERTAINMENT

FOR PROVIDING AN ONLINE INTERACTIVE DATABASE FEATURING ENTERTAINMENT INFORMATION IN THE FIELDS OF LIVE MUSICAL PERFORMANCES, LIVE THEATRICAL PERFORMANCES, LIVE DRAMATIC PERFORMANCES, MOTION PICTURE FILMS AND SPORTING EVENTS, NAMELY, FOOTBALL, BASEBALL, BASKETBALL, TENNIS, SWIMMING AND MOTOR SPORTS EVENTS; PROVIDING ONLINE NON-DOWNLOADABLE PUBLICATIONS THAT FEATURE ADVERTISEMENTS FOR THE GOODS AND SERVICES OF OTHERS, NAMELY, TELEPHONE DIRECTORIES IN THE FIELDS OF BUSINESS, RESIDENTIAL, COMMERCIAL AND GOVERNMENT (U.S. CLS. 100, 101 AND 107).

FIRST USE 8-10-2010; IN COMMERCE 8-10-2010.

4,154,720. HARQEN LLC, MILWAUKEE, WI. SN 85-104,248. PUB. 7-19-2011, FILED 8-10-2010.

VOICE ADVANTAGE

THE MARK CONSISTS OF STANDARD CHARACTERS WITHOUT CLAIM TO ANY PARTICULAR FONT, STYLE, SIZE, OR COLOR.

NO CLAIM IS MADE TO THE EXCLUSIVE RIGHT TO USE "VOICE", APART FROM THE MARK AS SHOWN.

CLASS 35—ADVERTISING AND BUSINESS

FOR AUDIO ASSET MANAGEMENT, NAMELY, MANAGEMENT OF DATABASES CONTAINING AUDIO DATA (U.S. CLS. 100, 101 AND 102).

FIRST USE 8-1-2010; IN COMMERCE 8-1-2010.

CLASS 38—COMMUNICATION

FOR TRANSMISSION OF AUDIO DATA VIA A GLOBAL COMPUTER NETWORK OR THE INTERNET (U.S. CLS. 100, 101 AND 104).

FIRST USE 8-1-2010; IN COMMERCE 8-1-2010.

CLASS 39—TRANSPORTATION AND STORAGE

FOR AUDIO ASSET MANAGEMENT, NAMELY, STORAGE OF ELECTRONIC MEDIA IN THE NATURE OF AUDIO DATA; AUDIO ASSET MANAGEMENT, NAMELY, STORAGE SERVICES FOR ARCHIVING ELECTRONIC AUDIO DATA (U.S. CLS. 100 AND 105).

FIRST USE 8-1-2010; IN COMMERCE 8-1-2010.

4,154,736. JOHNSTON, MATTHEW, DBA SUPLOVE, COSTA MESA, CA. SN 85-108,719. PUB. 7-19-2011, FILED 8-16-2010.

Suplove

THE MARK CONSISTS OF STANDARD CHARACTERS WITHOUT CLAIM TO ANY PARTICULAR FONT, STYLE, SIZE, OR COLOR.

CLASS 12—VEHICLES

FOR CANOE PADDLES; KAYAK PADDLES; OUT-RIGGER PADDLES (U.S. CLS. 19, 21, 23, 31, 35 AND 44).

FIRST USE 6-1-2009; IN COMMERCE 3-1-2011.

CLASS 25—CLOTHING

FOR SURF WEAR (U.S. CLS. 22 AND 39).

FIRST USE 11-30-2008; IN COMMERCE 4-1-2010.

CLASS 28—TOYS AND SPORTING GOODS

FOR LEASHES USED IN CONJUNCTION WITH SURFING; PADDLE BOARDS; PADDLE SURFBOARDS; PADDLES FOR USE WITH SURFBOARDS; STAND-UP SURF PADDLES; SURF BOARDS; SURF FINS; SURF PADDLES (U.S. CLS. 22, 23, 38 AND 50).

FIRST USE 11-30-2008; IN COMMERCE 4-1-2010.

CLASS 41—EDUCATION AND ENTERTAINMENT

FOR INSTRUCTION IN THE FIELD OF STAND UP PADDLE; PHYSICAL FITNESS INSTRUCTION; PROVIDING A WEB SITE FEATURING INFORMATION NEEDED FOR THE SPORT OF SURFING, NAMELY, WAVE CONDITIONS, WAVE LOCATIONS AND DURATION OF SURFING SESSION; RENTAL OF SURF BOARDS (U.S. CLS. 100, 101 AND 107).

FIRST USE 6-1-2009; IN COMMERCE 6-1-2010.

4,154,745. L&M COMPANIES, INC., RALEIGH, NC. SN 85-110,448. PUB. 7-26-2011, FILED 8-18-2010.

WELL GROUNDED

THE MARK CONSISTS OF STANDARD CHARACTERS WITHOUT CLAIM TO ANY PARTICULAR FONT, STYLE, SIZE, OR COLOR.

CLASS 39—TRANSPORTATION AND STORAGE

FOR PACKING FRUITS AND VEGETABLES FOR OTHERS (U.S. CLS. 100 AND 105).
FIRST USE 10-31-2011; IN COMMERCE 10-31-2011.

CLASS 44—MEDICAL, BEAUTY AND AGRICULTURAL SERVICES

FOR CONTRACT FARMING FOR OTHERS, NAMELY, GROWING AND HARVESTING FRUITS AND VEGETABLES FOR OTHERS (U.S. CLS. 100 AND 101).
FIRST USE 10-31-2011; IN COMMERCE 10-31-2011.

4,154,746. YOASIS FRANCHISING SYSTEMS, LLC, SALT LAKE CITY, UT. SN 85-110,944. PUB. 8-2-2011, FILED 8-19-2010.

EARTHFRUITS

THE MARK CONSISTS OF STANDARD CHARACTERS WITHOUT CLAIM TO ANY PARTICULAR FONT, STYLE, SIZE, OR COLOR.

CLASS 29—MEATS AND PROCESSED FOODS

FOR YOGURT; YOGURT-BASED BEVERAGES (U.S. CL. 46).
FIRST USE 7-10-2010; IN COMMERCE 7-10-2010.

CLASS 30—STAPLE FOODS

FOR FROZEN YOGURT; FROZEN YOGURT CONFECTIONS (U.S. CL. 46).
FIRST USE 7-30-2010; IN COMMERCE 7-30-2010.

CLASS 32—LIGHT BEVERAGES

FOR SMOOTHIES FRUIT BEVERAGES; SMOOTHIES WITH FRUIT PREDOMINATING (U.S. CLS. 45, 46 AND 48).
FIRST USE 7-10-2010; IN COMMERCE 7-10-2010.

4,154,747. YOASIS FRANCHISING SYSTEMS, LLC, SALT LAKE CITY, UT. SN 85-110,946. PUB. 8-2-2011, FILED 8-19-2010.

EARTHFRUITS YOGURT

THE MARK CONSISTS OF STANDARD CHARACTERS WITHOUT CLAIM TO ANY PARTICULAR FONT, STYLE, SIZE, OR COLOR.

NO CLAIM IS MADE TO THE EXCLUSIVE RIGHT TO USE "YOGURT", APART FROM THE MARK AS SHOWN.

CLASS 29—MEATS AND PROCESSED FOODS

FOR YOGURT; YOGURT-BASED BEVERAGES (U.S. CL. 46).
FIRST USE 7-10-2010; IN COMMERCE 7-10-2010.

CLASS 30—STAPLE FOODS

FOR FROZEN YOGURT; FROZEN YOGURT CONFECTIONS (U.S. CL. 46).
FIRST USE 7-30-2010; IN COMMERCE 7-30-2010.

CLASS 32—LIGHT BEVERAGES

FOR SMOOTHIES FRUIT BEVERAGES; SMOOTHIES WITH FRUIT PREDOMINATING (U.S. CLS. 45, 46 AND 48).
FIRST USE 7-10-2010; IN COMMERCE 7-10-2010.

4,154,750. SALON DEVELOPMENT, INC., DBA SALON DEVELOPMENT CORPORATION, ST. PAUL, MN. SN 85-113,649. PUB. 8-2-2011, FILED 8-23-2010.



THE MARK CONSISTS OF THE WORD "STEP" IS ABOVE THE WORD "UP", WITH THE LETTER "S" REPRESENTED AS A DOLLAR SIGN; A HORIZONTAL LINE BELOW THE WORD "UP" CURVES TO EXTEND VERTICALLY AFTER THE WORD "UP" AND TERMINATES WITH AN ARROW; A PERIOD ADJACENT TO THE WORD "UP" SEPARATES THE HORIZONTAL LINE FROM THE VERTICAL LINE; THE WORDS "FAST TRACK TO WEALTH" IS BENEATH THE HORIZONTAL LINE.

CLASS 16—PAPER GOODS AND PRINTED MATTER

FOR PRINTED INSTRUCTIONAL AND TEACHING MATERIAL IN THE FIELDS OF COSMETOLOGY, ESTHIOLOGY, MASSAGE THERAPY, HAIR CARE, BODY AND SKIN CARE, SPA THERAPY, SALON AND SPA MANAGEMENT AND CLIENT RELATIONS (U.S. CLS. 2, 5, 22, 23, 29, 37, 38 AND 50).
FIRST USE 3-1-2012; IN COMMERCE 3-1-2012.

CLASS 41—EDUCATION AND ENTERTAINMENT

FOR EDUCATIONAL SERVICES, NAMELY, PROVIDING CLASSES, SEMINARS AND WORKSHOPS IN THE FIELDS OF COSMETOLOGY, ESTHIOLOGY, MASSAGE THERAPY, HAIR CARE, BODY AND SKIN CARE, SPA THERAPY, SALON AND SPA MANAGEMENT AND CLIENT RELATIONS AND DISTRIBUTION OF COURSE MATERIAL AND WRITTEN CURRICULUM IN CONNECTION THEREWITH (U.S. CLS. 100, 101 AND 107).
FIRST USE 3-1-2012; IN COMMERCE 3-1-2012.

4,154,759. QEP RESOURCES, INC., DENVER, CO. SN 85-116,982. PUB. 3-15-2011, FILED 8-26-2010.

QEP ENERGY

THE MARK CONSISTS OF STANDARD CHARACTERS WITHOUT CLAIM TO ANY PARTICULAR FONT, STYLE, SIZE, OR COLOR.

NO CLAIM IS MADE TO THE EXCLUSIVE RIGHT TO USE "ENERGY", APART FROM THE MARK AS SHOWN.

CLASS 4—LUBRICANTS AND FUELS

FOR NATURAL GAS, LIQUEFIED NATURAL GAS AND CRUDE OIL (U.S. CLS. 1, 6 AND 15).
FIRST USE 7-31-2010; IN COMMERCE 7-31-2010.

CLASS 35—ADVERTISING AND BUSINESS

FOR OPERATING OIL AND GAS WELLS FOR OTHERS (U.S. CLS. 100, 101 AND 102).
FIRST USE 7-31-2010; IN COMMERCE 7-31-2010.

CLASS 37—CONSTRUCTION AND REPAIR

FOR DRILLING AND COMPLETING OIL AND GAS WELLS; EQUIPPING OIL AND GAS WELLS, NAMELY, INSTALLING CASING, TUBING, AND PIPES INTO OIL AND GAS WELLS (U.S. CLS. 100, 103 AND 106).
FIRST USE 7-31-2010; IN COMMERCE 7-31-2010.

CLASS 42—SCIENTIFIC AND COMPUTER SERVICES

FOR OIL AND GAS EXPLORATION (U.S. CLS. 100 AND 101).
FIRST USE 7-31-2010; IN COMMERCE 7-31-2010.

4,154,767. QRHERE LLC, NASHVILLE, TN. SN 85-119,808. PUB. 8-2-2011, FILED 8-31-2010.

QRHERE

THE MARK CONSISTS OF STANDARD CHARACTERS WITHOUT CLAIM TO ANY PARTICULAR FONT, STYLE, SIZE, OR COLOR.

CLASS 9—ELECTRICAL AND SCIENTIFIC APPARATUS

FOR COMPUTER APPLICATION SOFTWARE FOR MOBILE PHONES, PORTABLE MEDIA PLAYERS AND HANDHELD COMPUTERS, NAMELY, SOFTWARE FOR MANAGEMENT, ORGANIZATION, AND TRACKING OF QR CODES AND CONNECTION OF DIGITAL CONTENT TO PRODUCTS, PRODUCT DISPLAYS, PRODUCT AND SERVICE SIGNAGE AND ADVERTISEMENTS, REAL ESTATE PROPERTY SIGNAGE, AND PRINTED MATERIALS USING QR CODES (U.S. CLS. 21, 23, 26, 36 AND 38).
FIRST USE 1-31-2011; IN COMMERCE 1-31-2011.

CLASS 42—SCIENTIFIC AND COMPUTER SERVICES

FOR PROVIDING A WEBSITE FEATURING TECHNOLOGY THAT ENABLES USERS TO MANAGE, ORGANIZE, AND TRACK QR CODES AND CONNECT DIGITAL CONTENT TO PRODUCTS, PRODUCT DISPLAYS, PRODUCT AND SERVICE SIGNAGE AND ADVERTISEMENTS, REAL ESTATE PROPERTY SIGNAGE, AND PRINTED MATERIALS USING QR CODES (U.S. CLS. 100 AND 101).
FIRST USE 4-22-2010; IN COMMERCE 4-22-2010.

4,154,768. QRHERE LLC, NASHVILLE, TN. SN 85-120,026. PUB. 8-2-2011, FILED 8-31-2010.

QRHere

THE COLOR(S) BLUE AND ORANGE IS/ARE CLAIMED AS A FEATURE OF THE MARK.

THE MARK CONSISTS OF THE TERM "QRHERE" IN BLUE LETTERS WITH THE TAIL OF THE "Q" ENDING IN AN ORANGE ARROW.

CLASS 9—ELECTRICAL AND SCIENTIFIC APPARATUS

FOR COMPUTER APPLICATION SOFTWARE FOR MOBILE PHONES, PORTABLE MEDIA PLAYERS AND HANDHELD COMPUTERS, NAMELY, SOFTWARE FOR MANAGEMENT, ORGANIZATION, AND TRACKING OF QR CODES AND CONNECTION OF DIGITAL CONTENT TO PRODUCTS, PRODUCT DISPLAYS, PRODUCT AND SERVICE SIGNAGE AND ADVERTISEMENTS, REAL ESTATE PROPERTY SIGNAGE, AND PRINTED MATERIALS USING QR CODES (U.S. CLS. 21, 23, 26, 36 AND 38).
FIRST USE 1-31-2011; IN COMMERCE 1-31-2011.

CLASS 42—SCIENTIFIC AND COMPUTER SERVICES

FOR PROVIDING A WEBSITE FEATURING TECHNOLOGY THAT ENABLES USERS TO MANAGE, ORGANIZE, AND TRACK QR CODES AND CONNECT DIGITAL CONTENT TO PRODUCTS, PRODUCT DISPLAYS, PRODUCT AND SERVICE SIGNAGE AND ADVERTISEMENTS, REAL ESTATE PROPERTY SIGNAGE, AND PRINTED MATERIALS USING QR CODES (U.S. CLS. 100 AND 101).
FIRST USE 4-22-2010; IN COMMERCE 4-22-2010.

4,154,769. A. GUMINIAC, JEFFREY, LEHIGH ACRES, FL. SN 85-120,484. PUB. 8-9-2011, FILED 9-1-2010.

IMCA
INDEPENDENT Movers Co-op of America

NO CLAIM IS MADE TO THE EXCLUSIVE RIGHT TO USE "INDEPENDENT MOVERS CO-OP OF AMERICA", APART FROM THE MARK AS SHOWN.

THE MARK CONSISTS OF THE LARGE LETTERS

"IMCA" WITH THE LETTER "A" INCLUDING AN ARROW AND THE WORDING "INDEPENDENT MOVERS CO-OP OF AMERICA" IN SMALLER LETTERING UNDERNEATH.

CLASS 35—ADVERTISING AND BUSINESS

FOR ASSOCIATION SERVICES, NAMELY, PROMOTING THE INTERESTS OF MOVING COMPANIES (U.S. CLS. 100, 101 AND 102).

FIRST USE 3-0-2011; IN COMMERCE 3-0-2011.

CLASS 39—TRANSPORTATION AND STORAGE

FOR MOVING COMPANY SERVICES; STORAGE AND DELIVERY OF GOODS; SUPPLY CHAIN LOGISTICS AND REVERSE LOGISTICS SERVICES, NAMELY, STORAGE, TRANSPORTATION AND DELIVERY OF DOCUMENTS, PACKAGES, RAW MATERIALS, AND OTHER FREIGHT FOR OTHERS BY AIR, RAIL, SHIP OR TRUCK (U.S. CLS. 100 AND 105).

FIRST USE 3-0-2011; IN COMMERCE 3-0-2011.

4,154,771. QUINTILES TRANSNATIONAL CORP., DURHAM, NC. SN 85-121,017. PUB. 2-22-2011, FILED 9-1-2010.



OWNER OF U.S. REG. NOS. 1,516,618, 3,565,448, AND OTHERS.

THE COLOR(S) PURPLE AND GRAY IS/ARE CLAIMED AS A FEATURE OF THE MARK.

THE MARK CONSISTS OF A DESIGN COMPRISED OF FIVE ROWS OF DIFFERING NUMBERS OF RANDOMLY ORGANIZED SQUARES IN VARYING SHADES OF PURPLE TO THE LEFT OF THE STYLIZED WORD "QUINTILES" IN GRAY STACKED OVER THE DIFFERENTLY STYLIZED CAPITALIZED WORD "INFOSARIO" IN PURPLE IN A LARGER FONT.

THE MARK HAS NO MEANING IN A FOREIGN LANGUAGE.

CLASS 42—SCIENTIFIC AND COMPUTER SERVICES

FOR PROVIDING TEMPORARY USE OF WEB-BASED SOFTWARE APPLICATION FOR PROVIDING ACCESS TO INFORMATION AND DATA IN THE PHARMACEUTICAL, PHARMACOGENOMIC, BIOTECHNICAL AND MEDICAL PRODUCTS AND DEVICES, LIFE SCIENCES, MEDICAL, HEALTH CARE, HEALTH MANAGEMENT AND DISEASE MANAGEMENT FIELDS AND FOR ORGANIZING AND ANALYZING SAID DATA AND INFORMATION AND PREPARING REPORTS THEREFROM; PROVIDING INFORMATION RELATING TO THE DEVELOPMENT AND VALIDATION OF DRUGS, PHARMACEUTICAL PRODUCTS, MEDICAL PRODUCTS, MEDICAL DEVICES AND BIOLOGICS; PROVIDING AN INTERNET WEBSITE PORTAL IN THE FIELDS OF PHARMACEUTICAL RESEARCH, PHARMACOGENOMIC CONSULTATION, BIOTECHNOLOGY CONSULTATION, INVESTIGATIONAL MEDICAL PRODUCTS AND DEVICES, LIFE SCIENCES RESEARCH, AND MEDICAL RESEARCH; PROVIDING AN ONLINE SEARCHABLE DATABASE VIA THE INTERNET IN THE FIELDS OF PHARMACEUTICAL RESEARCH, PHARMACOGENOMIC CONSULTATION, BIOTECHNOLOGY CONSULTATION, INVESTIGATIONAL MEDICAL PRODUCTS AND DEVICES, LIFE SCIENCES RESEARCH, AND MEDICAL RESEARCH (U.S. CLS. 100 AND 101).

FIRST USE 6-13-2011; IN COMMERCE 6-13-2011.

CLASS 44—MEDICAL, BEAUTY AND AGRICULTURAL SERVICES

FOR PROVIDING AN INTERNET WEBSITE PORTAL IN THE FIELDS OF MEDICAL SERVICES, HEALTH CARE, HEALTH MANAGEMENT AND DISEASE MANAGEMENT; PROVIDING AN ONLINE SEARCHABLE DATABASE VIA THE INTERNET IN THE FIELDS OF MEDICAL SERVICES, HEALTH CARE, HEALTH MANAGEMENT AND DISEASE MANAGEMENT; PROVIDING HEALTH MANAGEMENT AND DISEASE MANAGEMENT INFORMATION TO OTHERS (U.S. CLS. 100 AND 101).

FIRST USE 6-13-2011; IN COMMERCE 6-13-2011.

4,154,774. PRECISION LABORATORIES, INC., COTTONWOOD, AZ. SN 85-122,571. PUB. 3-22-2011, FILED 9-3-2010.

PRECISION STRIPAK

THE MARK CONSISTS OF STANDARD CHARACTERS WITHOUT CLAIM TO ANY PARTICULAR FONT, STYLE, SIZE, OR COLOR.

CLASS 1—CHEMICALS

FOR CHEMICALLY TREATED COLOR INDICATOR TEST STRIPS FOR MONITORING AQUEOUS SOLUTIONS FOR NON-MEDICAL PURPOSES (U.S. CLS. 1, 5, 6, 10, 26 AND 46).

FIRST USE 6-21-2011; IN COMMERCE 6-21-2011.

CLASS 5—PHARMACEUTICALS

FOR CHEMICALLY TREATED COLOR INDICATOR STRIPS FOR MONITORING AQUEOUS SOLUTIONS FOR MEDICAL PURPOSES (U.S. CLS. 6, 18, 44, 46, 51 AND 52).

FIRST USE 6-21-2011; IN COMMERCE 6-21-2011.

4,154,776. CONSUMER PROGRAMS INCORPORATED, ST. LOUIS, MO. SN 85-123,160. PUB. 7-19-2011, FILED 9-3-2010.

SHOOTING STARS PORTRAIT STUDIO

THE MARK CONSISTS OF STANDARD CHARACTERS WITHOUT CLAIM TO ANY PARTICULAR FONT, STYLE, SIZE, OR COLOR.

NO CLAIM IS MADE TO THE EXCLUSIVE RIGHT TO USE "PORTRAIT STUDIO", APART FROM THE MARK AS SHOWN.

CLASS 40—MATERIAL TREATMENT

FOR PHOTOGRAPHIC SERVICES, NAMELY, PHOTOGRAPHIC ENLARGING (U.S. CLS. 100, 103 AND 106).

FIRST USE 8-12-2008; IN COMMERCE 8-12-2008.

CLASS 41—EDUCATION AND ENTERTAINMENT

FOR PORTRAIT PHOTOGRAPHY, PHOTOGRAPHIC SERVICES, NAMELY, PHOTOGRAPHIC CAPTURE (U.S. CLS. 100, 101 AND 107).

FIRST USE 8-12-2008; IN COMMERCE 8-12-2008.

4,154,786. CREATIVE DISTINCTIONS, LLC, MIAMI, FL. SN 85-127,039. PUB. 7-19-2011, FILED 9-10-2010.



4,154,777. EHMKE MANUFACTURING, INC., PHILADELPHIA, PA. SN 85-123,751. PUB. 5-10-2011, FILED 9-7-2010.

HIGH GROUND

THE MARK CONSISTS OF STANDARD CHARACTERS WITHOUT CLAIM TO ANY PARTICULAR FONT, STYLE, SIZE, OR COLOR.

CLASS 5—PHARMACEUTICALS

FOR MEDICAL SUPPLY PACKS AND POUCHES COMPRISED OF FIRST-AID KITS (U.S. CLS. 6, 18, 44, 46, 51 AND 52).

FIRST USE 11-15-2010; IN COMMERCE 11-15-2010.

CLASS 9—ELECTRICAL AND SCIENTIFIC APPARATUS

FOR BAGS, CASES AND POUCHES FOR STORING AND CARRYING PORTABLE ELECTRONICS, NAMELY, PERSONAL DIGITAL ASSISTANTS (PDAS), RADIOS, CELL PHONES, COMMUNICATIONS EQUIPMENT, COMPUTERS, CAMERAS, CAMERA EQUIPMENT, GPS NAVIGATION EQUIPMENT; BODY ARMOR PLATE CARRIERS FOR MILITARY AND LAW ENFORCEMENT OPERATIONS, NAMELY, CARRIER VESTS, HARNESSES AND WAIST-BELTS; BODY ARMOR PLATES; ARMOUR-BEARING VESTS (U.S. CLS. 21, 23, 26, 36 AND 38).

FIRST USE 11-15-2010; IN COMMERCE 11-15-2010.

CLASS 13—FIREARMS

FOR MILITARY AND LAW ENFORCEMENT TACTICAL OPERATIONS ACCESSORIES, NAMELY, BELTS, VESTS AND HARNESSES USED FOR CARRYING TACTICAL EQUIPMENT, NAMELY, AMMUNITION; WEAPONRY, AMMUNITION, MUNITIONS; TACTICAL EQUIPMENT POUCHES, NAMELY, MAGAZINE POUCHES, GRENADE POUCHES, RIFLE SHELL POUCHES, CARTRIDGE POUCHES; BATON POUCHES, POUCHES FOR WEAPONRY; WEAPON RETENTION SYSTEMS, NAMELY, HOLSTERS; TACTICAL GEAR, NAMELY, RUCKSACKS, POUCHES, AND FIELD BAGS USED FOR CARRYING MILITARY AND FIELD EQUIPMENT, NAMELY, AMMUNITION; POUCHES USED FOR CARRYING AMMUNITION, MUNITIONS, AND WEAPONRY; TACTICAL GEAR, NAMELY, CARRIER VESTS, LOAD-BEARING VESTS, AND LOAD-BEARING WAIST BELTS USED FOR CARRYING ATTACHABLE AMMUNITION BAGS AND POUCHES (U.S. CLS. 2 AND 9).

FIRST USE 11-15-2010; IN COMMERCE 11-15-2010.

NO CLAIM IS MADE TO THE EXCLUSIVE RIGHT TO USE "MIAMI", APART FROM THE MARK AS SHOWN.

THE MARK CONSISTS OF A HEART SHAPE DESIGN LOCATED ABOVE THE STYLIZED WORD "MIAMI", BOTH SET AGAINST A CIRCULAR BACKGROUND.

CLASS 21—HOUSEWARES AND GLASS

FOR MUGS (U.S. CLS. 2, 13, 23, 29, 30, 33, 40 AND 50). FIRST USE 11-7-2011; IN COMMERCE 11-7-2011.

CLASS 25—CLOTHING

FOR CLOTHING, NAMELY, T-SHIRTS, CAPS (U.S. CLS. 22 AND 39). FIRST USE 11-7-2011; IN COMMERCE 11-7-2011.

4,154,790. GT VIRTUAL CONCEPTS LLC, NEWNAN, GA. SN 85-129,544. PUB. 8-16-2011, FILED 9-14-2010.



THE MARK CONSISTS OF THE STYLIZED LETTERS "G", "T", AND "V" ENCLOSED IN A LETTER "C".

CLASS 13—FIREARMS

FOR FIREARMS AND PARTS THEREOF (U.S. CLS. 2 AND 9).

FIRST USE 4-1-2012; IN COMMERCE 4-1-2012.

CLASS 42—SCIENTIFIC AND COMPUTER SERVICES

FOR PROTOTYPING SERVICES, NAMELY, NEW PRODUCT DESIGN SERVICES FEATURING MEDICAL DEVICES AND PARTS THEREOF, FIREARMS AND PARTS THEREOF, PLASTIC PARTS, AND PRECISION PARTS (U.S. CLS. 100 AND 101).

FIRST USE 4-1-2012; IN COMMERCE 4-1-2012.

4,154,795. OSBORNE PROPERTIES LIMITED PARTNERSHIP, DBA KRAUS-ANDERSON INSURANCE, BURNSVILLE, MN. SN 85-132,333. PUB. 10-4-2011, FILED 9-17-2010.

COMPTROL

THE MARK CONSISTS OF STANDARD CHARACTERS WITHOUT CLAIM TO ANY PARTICULAR FONT, STYLE, SIZE, OR COLOR.

CLASS 36—INSURANCE AND FINANCIAL

FOR MANAGING WORKERS' COMPENSATION INSURANCE CLAIMS FOR OTHERS; CONSULTING IN THE FIELD OF WORKERS' COMPENSATION INSURANCE CLAIMS (U.S. CLS. 100, 101 AND 102).

FIRST USE 10-31-2009; IN COMMERCE 10-31-2009.

CLASS 42—SCIENTIFIC AND COMPUTER SERVICES

FOR PROVIDING TEMPORARY USE OF ON-LINE, NON-DOWNLOADABLE SOFTWARE FOR COLLECTING, ORGANIZING AND ANALYZING WORKERS' COMPENSATION AND WORKPLACE SAFETY DATA (U.S. CLS. 100 AND 101).

FIRST USE 10-31-2009; IN COMMERCE 10-31-2009.

4,154,796. OSBORNE PROPERTIES LIMITED PARTNERSHIP, DBA KRAUS-ANDERSON INSURANCE, BURNSVILLE, MN. SN 85-132,367. PUB. 10-4-2011, FILED 9-17-2010.

COMPTROL ZERO

THE MARK CONSISTS OF STANDARD CHARACTERS WITHOUT CLAIM TO ANY PARTICULAR FONT, STYLE, SIZE, OR COLOR.

CLASS 36—INSURANCE AND FINANCIAL

FOR INSURANCE CONSULTING IN THE FIELD OF LOSS PREVENTION (U.S. CLS. 100, 101 AND 102).

FIRST USE 10-31-2009; IN COMMERCE 10-31-2009.

CLASS 41—EDUCATION AND ENTERTAINMENT

FOR EDUCATIONAL SERVICES, NAMELY, CONDUCTING WORKPLACE SAFETY TRAINING (U.S. CLS. 100, 101 AND 107).

FIRST USE 10-31-2009; IN COMMERCE 10-31-2009.

CLASS 45—PERSONAL AND LEGAL SERVICES

FOR CONSULTING IN THE FIELD OF WORKPLACE SAFETY; CONSULTING IN THE FIELD OF WORKPLACE SAFETY ABOUT WORKPLACE CONDITIONS THAT IMPACT THE HEALTH AND SAFETY OF EMPLOYEES; REGULATORY COMPLIANCE CONSULTING IN THE FIELDS OF EMPLOYEE HEALTH AND SAFETY AND WORKPLACE SAFETY; CONDUCTING WORKPLACE SAFETY INSPECTION AUDITS (U.S. CLS. 100 AND 101).

FIRST USE 10-31-2009; IN COMMERCE 10-31-2009.

4,154,798. U.S. DEPARTMENT OF HEALTH AND HUMAN SERVICES, BETHESDA, MD. SN 85-133,255. PUB. 8-2-2011, FILED 9-20-2010.



THE MARK CONSISTS OF A STYLIZED LOWER CASE "R" CONNECTING TO A LOWER CASE "P" WITH THE NUMBER "2" PRESENTED UNDER THE CURVED PORTION OF THE LETTER "R". BOTH THE "R" AND "P" ARE SHADED WHILE THE "2" IS OUTLINED WITH A PLAIN SINGLE LINE AND UNSHADED.

CLASS 9—ELECTRICAL AND SCIENTIFIC APPARATUS

FOR PRE-RECORDED DVDS, CDS, AND DOWNLOADABLE ELECTRONIC MEDIA, NAMELY, E-NEWSLETTERS AND FACT SHEETS FEATURING INFORMATION ON THE SUBJECT OF REDUCING WORKPLACE INJURIES, ILLNESS, AND FATALITIES AND THE TRANSFER AND TRANSLATION OF KNOWLEDGE, INTERVENTIONS, AND TECHNOLOGIES DESIGNED TO REDUCE WORKPLACE INJURIES, ILLNESS, AND FATALITIES (U.S. CLS. 21, 23, 26, 36 AND 38).

FIRST USE 10-0-2010; IN COMMERCE 10-0-2010.

CLASS 16—PAPER GOODS AND PRINTED MATTER

FOR PRINTED MATERIALS, NAMELY, A SERIES OF SCIENTIFIC ARTICLES, AND BROCHURES, AND POSTERS FEATURING INFORMATION ON THE SUBJECT OF OCCUPATIONAL SAFETY AND HEALTH RESEARCH AND REDUCTION OF WORKPLACE INJURIES, ILLNESS, AND FATALITIES, AND THE TRANSFER AND TRANSLATION OF KNOWLEDGE, INTERVENTIONS, AND TECHNOLOGIES DESIGNED TO REDUCE WORKPLACE INJURIES, ILLNESS, AND FATALITIES (U.S. CLS. 2, 5, 22, 23, 29, 37, 38 AND 50).
FIRST USE 7-0-2011; IN COMMERCE 7-0-2011.

CLASS 42—SCIENTIFIC AND COMPUTER SERVICES

FOR RESEARCH ON OCCUPATIONAL SAFETY AND HEALTH AND THE REDUCTION OF WORKPLACE INJURIES, ILLNESS, AND FATALITIES; PROVIDING A WEBSITE FEATURING INFORMATION ABOUT COMPUTER TECHNOLOGIES DESIGNED TO REDUCE WORKPLACE INJURIES, ILLNESS AND FATALITIES (U.S. CLS. 100 AND 101).
FIRST USE 5-0-2011; IN COMMERCE 5-0-2011.

CLASS 45—PERSONAL AND LEGAL SERVICES

FOR PROVIDING A WEBSITE FEATURING INFORMATION ON WORKPLACE SAFETY, NAMELY, THE INTERPERSONAL COMMUNICATIONS REQUIRED TO TRANSFER AND TRANSLATE KNOWLEDGE BETWEEN INDIVIDUALS AND ADVICE CONCERNING INTERVENTIONS, DESIGNED TO REDUCE WORKPLACE INJURIES, ILLNESS, AND FATALITIES (U.S. CLS. 100 AND 101).
FIRST USE 9-0-2010; IN COMMERCE 9-0-2010.

4,154,807. H & H CLOTHING, LLC, LAS VEGAS, NV. SN 85-137,015. PUB. 7-19-2011, FILED 9-23-2010.

HART AND HUNTINGTON

THE MARK CONSISTS OF STANDARD CHARACTERS WITHOUT CLAIM TO ANY PARTICULAR FONT, STYLE, SIZE, OR COLOR.

CLASS 9—ELECTRICAL AND SCIENTIFIC APPARATUS

FOR SUNGLASSES; PROTECTIVE HELMETS FOR SPORTS; GOGGLES FOR SPORTS (U.S. CLS. 21, 23, 26, 36 AND 38).
FIRST USE 0-0-2009; IN COMMERCE 0-0-2009.

CLASS 18—LEATHER GOODS

FOR HANDBAGS; TRAVELING BAGS; MESSENGER BAGS; ATHLETIC BAGS; BOOK BAGS; SCHOOL BAGS; ALL-PURPOSE SPORTS BAGS; OVERNIGHT BAGS; LEATHER AND IMITATION LEATHER BAGS; ALL-PURPOSE CARRYING BAGS; BACKPACKS; PURSES; WALLETS (U.S. CLS. 1, 2, 3, 22 AND 41).
FIRST USE 9-9-2005; IN COMMERCE 9-9-2005.

CLASS 25—CLOTHING

FOR CLOTHING, NAMELY, TOPS, BOTTOMS, SHIRTS, TANK TOPS, PANTS, JEANS, SHORTS, SWEAT SHIRTS, JACKETS, BELTS, COATS, JERSEYS, SWEAT PANTS, PULLOVERS, DRESSES, COVER-UPS, PAJAMAS, SLEEP WEAR, INFANT WEAR, BEACHWEAR, LOUNGE WEAR, SWIM WEAR, UNDERCLOTHES, WRIST BANDS, SOCKS, SURF WEAR, GLOVES; HEAD WEAR; FOOTWEAR (U.S. CLS. 22 AND 39).
FIRST USE 3-28-2004; IN COMMERCE 3-28-2004.

CLASS 35—ADVERTISING AND BUSINESS

FOR RETAIL STORE SERVICES AND ONLINE RETAIL STORE SERVICES FEATURING CLOTHING, SPORTSWEAR, HEADWEAR, FOOTWEAR, ACCESSORIES, PRINTED MATTER, POSTERS, BAGS, WALLETS, PURSES, LEATHER GOODS, DECALS, JEWELRY, BELT BUCKLES, SOUVENIR ITEMS, KEY CHAINS; RETAIL STORE AND ONLINE RETAIL STORE FEATURING A WIDE VARIETY OF CONSUMER GOODS OF OTHERS (U.S. CLS. 100, 101 AND 102).
FIRST USE 3-28-2004; IN COMMERCE 3-28-2004.

4,154,815. EMTURN, LLC, WASHINGTON, DC. SN 85-139,735. PUB. 7-19-2011, FILED 9-28-2010.



THE MARK CONSISTS OF THE STYLIZED LETTERS "E" AND "T" WITH A DIAGONAL HASH MARK ON THE LEFT HAND SIDE, SURROUNDED BY A STYLIZED BORDER FEATURING TRIANGLES ON THE LEFT AND RIGHT SIDES.

CLASS 18—LEATHER GOODS

FOR BACKPACKS (U.S. CLS. 1, 2, 3, 22 AND 41).
FIRST USE 12-15-2011; IN COMMERCE 12-15-2011.

CLASS 25—CLOTHING

FOR FOOTWEAR; HATS; JACKETS; PANTS; SHIRTS; SHORTS; SOCKS; TANK TOPS (U.S. CLS. 22 AND 39).
FIRST USE 12-15-2011; IN COMMERCE 12-15-2011.

4,154,825. FLATWORLD SOLUTIONS INC., PRINCETON, NJ. SN 85-144,943. PUB. 7-26-2011, FILED 10-5-2010.

HEALTHCARE CONNECTS HERE

THE MARK CONSISTS OF STANDARD CHARACTERS WITHOUT CLAIM TO ANY PARTICULAR FONT, STYLE, SIZE, OR COLOR.

NO CLAIM IS MADE TO THE EXCLUSIVE RIGHT TO USE "HEALTHCARE", APART FROM THE MARK AS SHOWN.

CLASS 35—ADVERTISING AND BUSINESS

FOR ON-LINE BUSINESS NETWORKING SERVICES; BUSINESS SERVICES, NAMELY, COMBINED STRATEGIC GOODS OR SERVICES SOURCING FOR OTHERS (U.S. CLS. 100, 101 AND 102).
FIRST USE 3-5-2012; IN COMMERCE 3-5-2012.

CLASS 42—SCIENTIFIC AND COMPUTER SERVICES

FOR SOFTWARE AS A SERVICE (SAAS) SERVICES FEATURING SOFTWARE FOR ON-LINE BUSINESS NETWORKING SERVICES, GOODS OR SERVICES SOURCING, AND SOLICITING BUSINESS ON A GLOBAL COMPUTER NETWORK (U.S. CLS. 100 AND 101).
FIRST USE 3-5-2012; IN COMMERCE 3-5-2012.

4,154,826. FLATWORLD SOLUTIONS INC., PRINCETON, NJ. SN 85-144,948. PUB. 7-26-2011, FILED 10-5-2010.

COMMERCE CONNECTS HERE

THE MARK CONSISTS OF STANDARD CHARACTERS WITHOUT CLAIM TO ANY PARTICULAR FONT, STYLE, SIZE, OR COLOR.

NO CLAIM IS MADE TO THE EXCLUSIVE RIGHT TO USE "COMMERCE", APART FROM THE MARK AS SHOWN.

CLASS 35—ADVERTISING AND BUSINESS

FOR ON-LINE BUSINESS NETWORKING SERVICES; BUSINESS SERVICES, NAMELY, COMBINED STRATEGIC GOODS OR SERVICES SOURCING FOR OTHERS (U.S. CLS. 100, 101 AND 102).

FIRST USE 9-10-2010; IN COMMERCE 9-10-2010.

CLASS 42—SCIENTIFIC AND COMPUTER SERVICES

FOR SOFTWARE AS A SERVICE (SAAS) SERVICES FEATURING SOFTWARE FOR ON-LINE BUSINESS NETWORKING SERVICES, GOODS OR SERVICES SOURCING, AND SOLICITING BUSINESS ON A GLOBAL COMPUTER NETWORK (U.S. CLS. 100 AND 101).

FIRST USE 9-10-2010; IN COMMERCE 9-10-2010.

4,154,827. FLATWORLD SOLUTIONS INC., PRINCETON, NJ. SN 85-144,951. PUB. 7-26-2011, FILED 10-5-2010.

TRADING CONNECTS HERE

THE MARK CONSISTS OF STANDARD CHARACTERS WITHOUT CLAIM TO ANY PARTICULAR FONT, STYLE, SIZE, OR COLOR.

NO CLAIM IS MADE TO THE EXCLUSIVE RIGHT TO USE "TRADING", APART FROM THE MARK AS SHOWN.

CLASS 35—ADVERTISING AND BUSINESS

FOR ON-LINE BUSINESS NETWORKING SERVICES; BUSINESS SERVICES, NAMELY, COMBINED STRATEGIC GOODS OR SERVICES SOURCING FOR OTHERS (U.S. CLS. 100, 101 AND 102).

FIRST USE 3-5-2012; IN COMMERCE 3-5-2012.

CLASS 42—SCIENTIFIC AND COMPUTER SERVICES

FOR SOFTWARE AS A SERVICE (SAAS) SERVICES FEATURING SOFTWARE FOR ON-LINE BUSINESS NETWORKING SERVICES, GOODS OR SERVICES SOURCING, AND SOLICITING BUSINESS ON A GLOBAL COMPUTER NETWORK (U.S. CLS. 100 AND 101).
FIRST USE 3-5-2012; IN COMMERCE 3-5-2012.

4,154,828. FLATWORLD SOLUTIONS INC., PRINCETON, NJ. SN 85-145,021. PUB. 7-26-2011, FILED 10-5-2010.

BUSINESS CONNECTS HERE

THE MARK CONSISTS OF STANDARD CHARACTERS WITHOUT CLAIM TO ANY PARTICULAR FONT, STYLE, SIZE, OR COLOR.

NO CLAIM IS MADE TO THE EXCLUSIVE RIGHT TO USE "BUSINESS", APART FROM THE MARK AS SHOWN.

CLASS 35—ADVERTISING AND BUSINESS

FOR ON-LINE BUSINESS NETWORKING SERVICES; BUSINESS SERVICES, NAMELY, COMBINED STRATEGIC GOODS OR SERVICES SOURCING FOR OTHERS (U.S. CLS. 100, 101 AND 102).

FIRST USE 3-5-2012; IN COMMERCE 3-5-2012.

CLASS 42—SCIENTIFIC AND COMPUTER SERVICES

FOR SOFTWARE AS A SERVICE (SAAS) SERVICES FEATURING SOFTWARE FOR ON-LINE BUSINESS NETWORKING SERVICES, GOODS OR SERVICES SOURCING, AND SOLICITING BUSINESS ON A GLOBAL COMPUTER NETWORK (U.S. CLS. 100 AND 101).

FIRST USE 3-5-2012; IN COMMERCE 3-5-2012.

4,154,832. BOARD OF REGENTS OF THE UNIVERSITY SYSTEM OF GEORGIA, ATLANTA, GA. SN 85-145,996. PUB. 1-11-2011, FILED 10-6-2010.



THE MARK CONSISTS OF LETTERS "G" AND "C" WITH THE LOWER RIGHT PORTION OF THE LETTER "G" OVERLAPPING THE TOP LEFT PORTION OF THE LETTER "C".

CLASS 6—METAL GOODS

FOR METAL KEY CHAINS (U.S. CLS. 2, 12, 13, 14, 23, 25 AND 50).

FIRST USE 10-1-2011; IN COMMERCE 10-20-2011.

CLASS 14—JEWELRY

FOR PENDANTS (U.S. CLS. 2, 27, 28 AND 50).
FIRST USE 10-1-2011; IN COMMERCE 10-20-2011.

CLASS 16—PAPER GOODS AND PRINTED MATTER

FOR PENS (U.S. CLS. 2, 5, 22, 23, 29, 37, 38 AND 50).
FIRST USE 11-1-2011; IN COMMERCE 11-1-2011.

CLASS 18—LEATHER GOODS

FOR MESSENGER BAGS (U.S. CLS. 1, 2, 3, 22 AND 41).
FIRST USE 9-20-2011; IN COMMERCE 9-25-2011.

CLASS 21—HOUSEWARES AND GLASS

FOR CUPS AND MUGS (U.S. CLS. 2, 13, 23, 29, 30, 33,
40 AND 50).
FIRST USE 10-11-2011; IN COMMERCE 10-15-2011.

CLASS 25—CLOTHING

FOR T-SHIRTS (U.S. CLS. 22 AND 39).
FIRST USE 10-10-2011; IN COMMERCE 10-15-2011.

CLASS 41—EDUCATION AND ENTERTAINMENT

FOR ENTERTAINMENT IN THE NATURE OF COMPETITIONS IN THE FIELD OF ATHLETICS (U.S. CLS. 100, 101 AND 107).
FIRST USE 9-1-2011; IN COMMERCE 9-1-2011.

4,154,833. BOARD OF REGENTS OF THE UNIVERSITY SYSTEM OF GEORGIA, ATLANTA, GA. SN 85-146,000. PUB. 1-11-2011, FILED 10-6-2010.

GEORGIA COLLEGE

THE MARK CONSISTS OF STANDARD CHARACTERS WITHOUT CLAIM TO ANY PARTICULAR FONT, STYLE, SIZE, OR COLOR.

OWNER OF U.S. REG. NOS. 2,398,983, 3,725,163, AND OTHERS.

NO CLAIM IS MADE TO THE EXCLUSIVE RIGHT TO USE "COLLEGE", APART FROM THE MARK AS SHOWN. SEC. 2(F) AS TO "GEORGIA".

CLASS 6—METAL GOODS

FOR METAL KEY CHAINS (U.S. CLS. 2, 12, 13, 14, 23, 25 AND 50).
FIRST USE 10-15-2011; IN COMMERCE 10-30-2011.

CLASS 14—JEWELRY

FOR PENDANTS (U.S. CLS. 2, 27, 28 AND 50).
FIRST USE 11-10-2011; IN COMMERCE 11-20-2011.

CLASS 16—PAPER GOODS AND PRINTED MATTER

FOR BINDERS; DECALS; PENS (U.S. CLS. 2, 5, 22, 23, 29, 37, 38 AND 50).
FIRST USE 10-1-2011; IN COMMERCE 10-20-2011.

CLASS 18—LEATHER GOODS

FOR BOOK BAGS (U.S. CLS. 1, 2, 3, 22 AND 41).
FIRST USE 8-1-2011; IN COMMERCE 8-1-2011.

CLASS 21—HOUSEWARES AND GLASS

FOR CUPS AND MUGS (U.S. CLS. 2, 13, 23, 29, 30, 33,
40 AND 50).
FIRST USE 11-1-2011; IN COMMERCE 11-15-2011.

CLASS 25—CLOTHING

FOR GOLF SHIRTS; HATS; PANTS; SHIRTS; SHORTS; SWEAT SHIRTS; T-SHIRTS (U.S. CLS. 22 AND 39).
FIRST USE 8-1-2011; IN COMMERCE 8-1-2011.

CLASS 41—EDUCATION AND ENTERTAINMENT

FOR EDUCATIONAL SERVICES, NAMELY, PROVIDING COURSES OF INSTRUCTION AT THE UNIVERSITY LEVEL AND DISTRIBUTION OF COURSE MATERIAL IN CONNECTION THEREWITH; ENTERTAINMENT IN THE NATURE OF COMPETITIONS IN THE FIELD OF ATHLETICS (U.S. CLS. 100, 101 AND 107).
FIRST USE 1-1-1971; IN COMMERCE 1-1-1971.

4,154,835. CHUN YU WORKS & CO., LTD., KAOHSIUNG COUNTY, TAIWAN. SN 85-146,278. PUB. 9-13-2011, FILED 10-6-2010.



OWNER OF U.S. REG. NO. 1,733,934.

NO CLAIM IS MADE TO THE EXCLUSIVE RIGHT TO USE "LOGISTIC" AND "SINCE 1949", APART FROM THE MARK AS SHOWN.

THE MARK CONSISTS OF AN IMAGE DEPICTING A LION ON TOP OF A CURVED LINE WITH THE WORDING "SINCE 1949" BELOW THE CURVED LINE AND THE WORDING "CHUN YU LOGISTIC" BELOW THE WORDING "SINCE 1949".

THE ENGLISH TRANSLATION OF "CHUN YU" IN THE MARK IS "SPRING RAIN".

CLASS 6—METAL GOODS

FOR METAL FASTENERS, NAMELY, NUTS, SCREWS, BOLTS, NAILS AND WASHERS, BRIGHT STEEL BARS, POWER OPERATED SCREW GUNS AND ACCESSORIES IN THE NATURE OF METAL SCREWS, SCREW GUN ATTACHMENTS FOR INSTANT COLLATED SCREW AUTO-FEED ACTION AND COUNTERSINK ADJUSTMENT, METAL SCREW GUN ADAPTERS (U.S. CLS. 2, 12, 13, 14, 23, 25 AND 50).
FIRST USE 7-16-2011; IN COMMERCE 2-1-2012.

CLASS 7—MACHINERY

FOR POWER TOOLS, NAMELY, DRILL HAMMERS, COLLATED SCREW DRIVING SYSTEM COMPRISED OF SCREW GUN ADAPTERS, DRIVING BITS AND EXTENSION POLES, MACHINE PARTS, NAMELY, AIR HOSE COUPLERS, POWER OPERATED SCREW GUNS AND ACCESSORIES IN THE NATURE OF METAL SCREWS, SCREW GUNS, SCREW GUN ATTACHMENTS, SCREW GUN ADAPTERS AND COLLATED SCREWS SOLD AS A UNIT THEREFOR, POWER TOOL ACCESSORIES, NAMELY, HANDLE BAR EXTENSIONS FOR POWER TOOLS, POWER TOOL ACCESSORIES, NAMELY, EXTENSION POLES FOR COLLATED SCREW DRIVING SYSTEM, MACHINES FOR MAKING SCREWS, BOLTS, NUTS, NAILS, WASHERS AND BRIGHT STEEL BARS; METAL FINISHING MACHINES; MACHINE FOR SORTING SCREWS; WORK PROCESSING MACHINES FOR THE THREAD CUTTING OF METALS (U.S. CLS. 13, 19, 21, 23, 31, 34 AND 35).

FIRST USE 7-16-2011; IN COMMERCE 2-1-2012.

CLASS 35—ADVERTISING AND BUSINESS

FOR ON-LINE BUSINESS NETWORKING SERVICES; BUSINESS SERVICES, NAMELY, COMBINED STRATEGIC GOODS OR SERVICES SOURCING FOR OTHERS; ON-LINE PROFESSIONAL NETWORKING SERVICES IN THE FIELD OF EDUCATION (U.S. CLS. 100, 101 AND 102).

FIRST USE 3-5-2012; IN COMMERCE 3-5-2012.

CLASS 42—SCIENTIFIC AND COMPUTER SERVICES

FOR SOFTWARE AS A SERVICE (SAAS) SERVICES FEATURING SOFTWARE FOR ON-LINE BUSINESS NETWORKING SERVICES, AND SOLICITING BUSINESS ON A GLOBAL COMPUTER NETWORK; SOFTWARE AS A SERVICE (SAAS) SERVICES FEATURING SOFTWARE FOR ON-LINE SOCIAL NETWORKING IN THE FIELD OF EDUCATION (U.S. CLS. 100 AND 101).

FIRST USE 3-5-2012; IN COMMERCE 3-5-2012.

4,154,836. UT BATTELLE, LLC, OAK RIDGE, TN. SN 85-146,594. PUB. 3-22-2011, FILED 10-6-2010.

4,154,847. SE2, INC., TOPEKA, KS. SN 85-150,320. PUB. 8-16-2011, FILED 10-12-2010.

GAUSSTEMPER

THE MARK CONSISTS OF STANDARD CHARACTERS WITHOUT CLAIM TO ANY PARTICULAR FONT, STYLE, SIZE, OR COLOR.

ADVANCE YOUR WORLD.

CLASS 6—METAL GOODS

FOR A METALLIC ALLOY TREATED USING A THERMO-MAGNETIC PROCESS (U.S. CLS. 2, 12, 13, 14, 23, 25 AND 50).

FIRST USE 12-8-2011; IN COMMERCE 12-8-2011.

CLASS 40—MATERIAL TREATMENT

FOR A PROCESS FOR THERMO-MAGNETICALLY TREATING METALS AND THEIR ALLOYS (U.S. CLS. 100, 103 AND 106).

FIRST USE 12-8-2011; IN COMMERCE 12-8-2011.

THE MARK CONSISTS OF STANDARD CHARACTERS WITHOUT CLAIM TO ANY PARTICULAR FONT, STYLE, SIZE, OR COLOR.

CLASS 35—ADVERTISING AND BUSINESS

FOR BUSINESS PROCESS OUTSOURCING SERVICES FOR INSURANCE COMPANIES, NAMELY, REGISTERING, SCREENING, AND CREDENTIALING THIRD-PARTY CONTRACTORS IN THE NATURE OF INSURANCE AGENTS AND BROKER-DEALER REPRESENTATIVES; RECEIVING, SORTING, AND HANDLING MAIL ON LIFE INSURANCE POLICIES AND ANNUITY CONTRACTS; BILLING PAYMENTS FOR LIFE INSURANCE POLICIES AND ANNUITY CONTRACTS; RECONCILIATION OF ACCOUNTS ON BEHALF OF OTHERS, NAMELY, RECONCILING PAYMENTS AGAINST BILLINGS ON LIFE INSURANCE POLICIES AND ANNUITY CONTRACTS; DIGITAL COPYING AND DATA PROCESSING IN THE FIELD OF LIFE INSURANCE POLICIES AND ANNUITY CONTRACTS; PREPARING AND MANAGING BUSINESS RECORDS FOR LIFE INSURANCE COMPANIES; OPERATION OF TELEPHONE CALL CENTERS FOR OTHERS; CUSTOMER SERVICE IN THE FIELD OF LIFE INSURANCE POLICIES AND ANNUITY CONTRACTS; REGULATORY COMPLIANCE SERVICES FOR LIFE INSURANCE COMPANIES, NAMELY, DATA COMPILING IN THE FIELD OF LIFE INSURANCE AND ANNUITY CONTRACTS FOR USE BY LIFE INSURANCE COMPANIES TO PREPARE REPORTS TO GOVERNMENT AGENCIES AND INDUSTRY ASSOCIATIONS (U.S. CLS. 100, 101 AND 102).

FIRST USE 2-0-2011; IN COMMERCE 2-0-2011.

4,154,839. FLATWORLD SOLUTIONS INC., PRINCETON, NJ. SN 85-148,630. PUB. 7-26-2011, FILED 10-8-2010.

EDUCATION CONNECTS HERE

THE MARK CONSISTS OF STANDARD CHARACTERS WITHOUT CLAIM TO ANY PARTICULAR FONT, STYLE, SIZE, OR COLOR.

NO CLAIM IS MADE TO THE EXCLUSIVE RIGHT TO USE "EDUCATION", APART FROM THE MARK AS SHOWN.

CLASS 36—INSURANCE AND FINANCIAL

FOR INSURANCE ADMINISTRATION, NAMELY, PROCESSING APPLICATIONS FOR NEW AND REPLACEMENT LIFE INSURANCE POLICIES AND ANNUITY CONTRACTS; INSURANCE ADMINISTRATION, NAMELY, ISSUING LIFE INSURANCE POLICIES AND ANNUITY CONTRACTS FOR LIFE INSURANCE COMPANIES; INSURANCE CLAIMS ADMINISTRATION, NAMELY, PROCESSING AND PAYING CLAIMS IN THE FIELD OF LIFE INSURANCE POLICIES AND ANNUITY CONTRACTS; INSURANCE ADMINISTRATION, NAMELY, PROCESSING ORDERS FOR THE ALLOCATION OR REALLOCATION OF VARIABLE ANNUITY OR VARIABLE UNIVERSAL LIFE INSURANCE POLICY ASSETS AMONG FUND INVESTMENT OPTIONS; FINANCIAL SERVICES, NAMELY, CALCULATING AND PAYING COMMISSIONS ON SALES OF LIFE INSURANCE POLICIES AND ANNUITY CONTRACTS FOR OTHERS (U.S. CLS. 100, 101 AND 102).

FIRST USE 2-0-2011; IN COMMERCE 2-0-2011.

CLASS 42—SCIENTIFIC AND COMPUTER SERVICES

FOR DATA CONVERSION OF COMPUTER PROGRAM DATA AND INFORMATION FOR INSURANCE COMPANIES (U.S. CLS. 100 AND 101).

FIRST USE 2-0-2011; IN COMMERCE 2-0-2011.

4,154,849. NASE WORLDWIDE, INC., JACKSONVILLE, FL.
SN 85-150,629. PUB. 8-30-2011, FILED 10-12-2010.

SCUBALIFE

THE MARK CONSISTS OF STANDARD CHARACTERS WITHOUT CLAIM TO ANY PARTICULAR FONT, STYLE, SIZE, OR COLOR.

CLASS 9—ELECTRICAL AND SCIENTIFIC APPARATUS

FOR SCUBA MASKS, SCUBA SNORKELS, REGULATORS FOR USE IN SCUBA DIVING, BUOYANCY COMPENSATION JACKETS FOR USE IN SCUBA DIVING, PRESSURE GAUGES FOR USE IN SCUBA DIVING, DEPTH GAUGES FOR USE IN SCUBA DIVING (U.S. CLS. 21, 23, 26, 36 AND 38).

FIRST USE 3-16-2012; IN COMMERCE 3-16-2012.

CLASS 28—TOYS AND SPORTING GOODS

FOR SCUBA FINS (U.S. CLS. 22, 23, 38 AND 50).
FIRST USE 3-16-2012; IN COMMERCE 3-16-2012.

CLASS 39—TRANSPORTATION AND STORAGE

FOR ARRANGING SCUBA DIVING TRAVEL TOURS (U.S. CLS. 100 AND 105).
FIRST USE 3-16-2012; IN COMMERCE 3-16-2012.

4,154,875. INTEMATIX CORPORATION, FREMONT, CA. SN
85-165,602. PUB. 4-5-2011, FILED 10-30-2010.

ChromaLit

THE MARK CONSISTS OF STANDARD CHARACTERS WITHOUT CLAIM TO ANY PARTICULAR FONT, STYLE, SIZE, OR COLOR.

CLASS 1—CHEMICALS

FOR CHEMICALS, NAMELY, PHOSPHORS AND SCINTILLATORS, NAMELY, SUBSTANCES THAT REACT TO A HIGH ENERGY PARTICLE NOT INTENDED FOR WATCHES AND THEIR PARTS (U.S. CLS. 1, 5, 6, 10, 26 AND 46).

FIRST USE 4-0-2011; IN COMMERCE 4-0-2011.

CLASS 11—ENVIRONMENTAL CONTROL APPARATUS

FOR LED (LIGHT EMITTING DIODE) LIGHTING FIXTURES; LED LIGHT BULBS (U.S. CLS. 13, 21, 23, 31 AND 34).

FIRST USE 4-0-2011; IN COMMERCE 4-0-2011.

4,154,883. ALLIANCE DATA SYSTEMS CORPORATION,
PLANO, TX. SN 85-173,323. PUB. 3-1-2011, FILED 11-10-2010.

COMENITY

THE MARK CONSISTS OF STANDARD CHARACTERS WITHOUT CLAIM TO ANY PARTICULAR FONT, STYLE, SIZE, OR COLOR.

CLASS 35—ADVERTISING AND BUSINESS

FOR PROMOTING THE SALE OF CREDIT CARD ACCOUNTS THROUGH THE ADMINISTRATION OF INCENTIVE AWARD PROGRAMS; PROMOTING THE SALE OF GOODS AND SERVICES OF OTHERS BY AWARDED PURCHASE POINTS FOR CREDIT CARD USE (U.S. CLS. 100, 101 AND 102).

FIRST USE 11-14-2011; IN COMMERCE 11-14-2011.

CLASS 36—INSURANCE AND FINANCIAL

FOR BANKING AND FINANCING SERVICES; CHARGE CARD AND CREDIT CARD SERVICES; CREDIT CARD AND DEBIT CARD SERVICES; CREDIT CARD AND PAYMENT CARD SERVICES; CREDIT CARD PAYMENT PROCESSING SERVICES; CREDIT CARD SERVICES; CREDIT RECOVERY AND COLLECTION; ISSUING OF CREDIT CARDS; PROVIDING CASH AND OTHER REBATES FOR CREDIT CARD USE AS PART OF A CUSTOMER LOYALTY PROGRAM; PROVIDING ELECTRONIC PROCESSING OF ELECTRONIC FUNDS TRANSFER, ACH, CREDIT CARD, DEBIT CARD, ELECTRONIC CHECK AND ELECTRONIC PAYMENTS (U.S. CLS. 100, 101 AND 102).

FIRST USE 11-14-2011; IN COMMERCE 11-14-2011.

4,154,891. EPPCO ENTERPRISES, INC., CLEVELAND, OH.
SN 85-178,238. PUB. 10-18-2011, FILED 11-16-2010.



THE MARK CONSISTS OF AN ANIMATED DRAWING OF AN AUTOMOBILE MECHANIC WITH HIS HAT TURNED BACKWARDS. THE WORD "EPPCO" APPEARS ON THE SHIRT POCKET. THE MECHANIC HAS GLOVES ON EACH HAND. ONE HAND IS HOLDING A WRENCH. THE OTHER HAND IS AN EXTENDED FIST.

CLASS 9—ELECTRICAL AND SCIENTIFIC APPARATUS

FOR PROTECTIVE WORK GLOVES (U.S. CLS. 21, 23, 26, 36 AND 38).
FIRST USE 10-1-2010; IN COMMERCE 11-1-2011.

CLASS 12—VEHICLES

FOR PROTECTIVE MECHANICS FENDER COVERS (U.S. CLS. 19, 21, 23, 31, 35 AND 44).
FIRST USE 10-1-2010; IN COMMERCE 1-1-2011.

4,154,894. PROSPERITY PRODUCTIONS, INC., NEW YORK, NY. SN 85-181,977. PUB. 8-9-2011, FILED 11-21-2010.

Lori Hamilton Enterprises

THE MARK CONSISTS OF STANDARD CHARACTERS WITHOUT CLAIM TO ANY PARTICULAR FONT, STYLE, SIZE, OR COLOR.

NO CLAIM IS MADE TO THE EXCLUSIVE RIGHT TO USE "ENTERPRISES", APART FROM THE MARK AS SHOWN.

THE NAME(S), PORTRAIT(S), AND/OR SIGNATURE(S) SHOWN IN THE MARK IDENTIFIES "LORI HAMILTON", WHOSE CONSENT(S) TO REGISTER IS MADE OF RECORD.

CLASS 35—ADVERTISING AND BUSINESS

FOR MARKETING CONSULTING; MARKETING RESEARCH SERVICES (U.S. CLS. 100, 101 AND 102).
FIRST USE 4-7-2011; IN COMMERCE 4-7-2011.

CLASS 41—EDUCATION AND ENTERTAINMENT

FOR ENTERTAINMENT AND EDUCATIONAL SERVICES, NAMELY, PROVIDING ADVICE AND INFORMATION FOR MUSIC, VIDEO AND FILM CONCEPT AND SCRIPT DEVELOPMENT; MULTIMEDIA ENTERTAINMENT SERVICES IN THE NATURE OF DEVELOPMENT, PRODUCTION AND POST-PRODUCTION SERVICES IN THE FIELDS OF VIDEO AND FILMS; PRODUCTION OF TELEVISION PROGRAMS; PRODUCTION OF VIDEO AND CREATION OF VISUAL EFFECTS FOR OTHERS FOR USE IN DVDS, TELEVISION PROGRAMS AND ON WEB SITES; SCRIPT WRITING SERVICES (U.S. CLS. 100, 101 AND 107).

FIRST USE 4-7-2011; IN COMMERCE 4-7-2011.

4,154,910. CISCO COMPANIES, THE, INDIANAPOLIS, IN. SN 85-189,452. PUB. 8-23-2011, FILED 12-2-2010.



THE COLOR(S) BLUE IS/ARE CLAIMED AS A FEATURE OF THE MARK.

THE MARK CONSISTS OF THE WORD "POND" AND A SUBSCRIPT "2" AND THE LETTER "O" WHICH IS STYLIZED SO THAT IT HAS THE APPEARANCE OF A CIRCLE SURROUNDING A WATER DROPLET. ALL LETTERS AND NUMERALS ARE IN THE COLOR BLUE. THE COLOR WHITE ONLY APPEARS AS BACKGROUND SHADING AND IS NOT PART OF THE MARK.

CLASS 2—PAINTS

FOR DYES FOR COMMERCIAL AND RESIDENTIAL RETENTION PONDS AND FARM PONDS (U.S. CLS. 6, 11 AND 16).

FIRST USE 2-20-2012; IN COMMERCE 3-12-2012.

CLASS 3—COSMETICS AND CLEANING PREPARATIONS

FOR CHEMICAL CLEANERS FOR USE IN COMMERCIAL AND RESIDENTIAL RETENTION PONDS AND FARM PONDS (U.S. CLS. 1, 4, 6, 50, 51 AND 52).

FIRST USE 2-29-2012; IN COMMERCE 2-29-2012.

4,154,911. INSPIRATO, LLC., DENVER, CO. SN 85-190,548. PUB. 7-26-2011, FILED 12-3-2010.

INSPIRATO

THE MARK CONSISTS OF STANDARD CHARACTERS WITHOUT CLAIM TO ANY PARTICULAR FONT, STYLE, SIZE, OR COLOR.

THE ENGLISH TRANSLATION OF "INSPIRATO" IN THE MARK IS "INSPIRED".

CLASS 36—INSURANCE AND FINANCIAL

FOR REAL ESTATE SERVICES, NAMELY, RENTAL, BROKERAGE, LEASING AND MANAGEMENT OF VACATION HOMES AND COMMERCIAL PROPERTY (U.S. CLS. 100, 101 AND 102).
FIRST USE 1-1-2011; IN COMMERCE 1-1-2011.

4,154,912. MERENDINO CEMETERY CARE, LLC, LINDEN, NJ. SN 85-190,848. PUB. 6-21-2011, FILED 12-5-2010.

CLASS 41—EDUCATION AND ENTERTAINMENT

FOR ENTERTAINMENT AND RECREATION SERVICES, NAMELY, GOLF AND COUNTRY CLUB SERVICES; PHYSICAL FITNESS TRAINING SERVICES; PROVIDING INFORMATION IN BOTH ONLINE AND NON-ONLINE FORM TO OTHERS REGARDING ENTERTAINMENT, SPORTING, AND CULTURAL ACTIVITIES AND EVENTS IN PARTICULAR GEOGRAPHIC AREAS; ARRANGING FOR TICKET RESERVATIONS FOR SHOWS AND OTHER ENTERTAINMENT EVENTS REGARDING ENTERTAINMENT, SPORTING, AND CULTURAL ACTIVITIES AND EVENTS IN PARTICULAR GEOGRAPHIC AREAS; PROVIDING INFORMATION IN BOTH ONLINE AND NON-ONLINE FORM TO OTHERS REGARDING COUNTRY CLUBS, NIGHT CLUBS (U.S. CLS. 100, 101 AND 107).
FIRST USE 1-1-2011; IN COMMERCE 1-1-2011.



NO CLAIM IS MADE TO THE EXCLUSIVE RIGHT TO USE "CEMETERY CARE", APART FROM THE MARK AS SHOWN.

THE COLOR(S) RED, BLUE AND WHITE IS/ARE CLAIMED AS A FEATURE OF THE MARK.

THE MARK CONSISTS OF A TRIANGULAR FOLDED AMERICAN FLAG BEARING SIX WHITE STARS ON BLUE WITH SHADES OF BLUE IN THE FOLD OF THE FLAG AND PLACED ABOVE THE WORD "MERENDINO" IN BLUE, UNDERLINED IN RED, WITH THE WORDS "CEMETERY CARE" APPEARING IN BLUE BELOW THE RED LINE.

CLASS 43—HOTEL AND RESTAURANT SERVICES

FOR RESORT LODGING SERVICES, RESORT HOTELS; HEALTH RESORT SERVICES, NAMELY, PROVIDING FOOD AND LODGING THAT SPECIALIZE IN PROMOTING PATRONS' GENERAL HEALTH AND WELL-BEING; VACATION CLUB SERVICES, NAMELY, PROVIDING TEMPORARY LODGING ACCOMMODATIONS; ARRANGING FOR ACCESS TO RESORT AMENITIES, NAMELY, RESTAURANTS; PROVIDING INFORMATION IN BOTH ONLINE AND NON-ONLINE FORM TO OTHERS RELATED TO RESORT LODGING SERVICES, AMENITIES RELATED THERETO, AND THE AVAILABILITY THEREOF; PROVIDING INFORMATION IN BOTH ONLINE AND NON-ONLINE FORM TO OTHERS REGARDING RESTAURANTS, AND OTHER ESTABLISHMENTS FOR THE CONSUMPTION OF FOOD AND DRINK; PROVIDING INFORMATION IN BOTH ONLINE AND NON-ONLINE FORM TO OTHERS REGARDING MEMBERSHIP IN A LUXURY RESIDENCE CLUB FEATURING TEMPORARY ACCOMMODATIONS; PROVIDING INFORMATION IN BOTH ONLINE AND NON-ONLINE FORM TO OTHERS RELATED TO RESORT LODGING SERVICES; PRIVATE RESORT CLUB SERVICES, NAMELY, PROVISION TO CLUB MEMBERS OF TEMPORARY ACCOMMODATIONS IN COMPANY OWNED OR LEASED PRIVATE RESIDENCES (U.S. CLS. 100 AND 101).
FIRST USE 1-1-2011; IN COMMERCE 1-1-2011.

CLASS 35—ADVERTISING AND BUSINESS

FOR FRANCHISING, NAMELY, OFFERING BUSINESS MANAGEMENT ASSISTANCE IN THE ESTABLISHMENT AND/OR OPERATION OF A CEMETERY CARE BUSINESS, PROVIDING FACILITIES MANAGEMENT, INCLUDING LAWN CARE, MONUMENT INSTALLATIONS, MAUSOLEUM MAINTENANCE, BURIALS AND FLORIST SERVICES TO CEMETERIES (U.S. CLS. 100, 101 AND 102).
FIRST USE 5-1-2010; IN COMMERCE 1-24-2011.

CLASS 44—MEDICAL, BEAUTY AND AGRICULTURAL SERVICES

FOR CEMETERY PLOT BEAUTIFICATION AND MAINTENANCE AND CONTINUAL UPKEEP OF FAMILY CEMETERY PLOTS; LANDSCAPE GARDENING (U.S. CLS. 100 AND 101).
FIRST USE 5-1-2010; IN COMMERCE 1-24-2011.

CLASS 44—MEDICAL, BEAUTY AND AGRICULTURAL SERVICES

FOR HEALTH SPA SERVICES FOR HEALTH AND WELLNESS OF THE BODY AND SPIRIT (U.S. CLS. 100 AND 101).
FIRST USE 1-1-2011; IN COMMERCE 1-1-2011.

4,154,921. CONGRATS BOOKS INC., POMPANO BEACH, FL. SN 85-197,987. PUB. 11-22-2011, FILED 12-15-2010.

CLASS 45—PERSONAL AND LEGAL SERVICES

FOR PERSONAL CONCIERGE SERVICES FOR OTHERS COMPRISING MAKING REQUESTED PERSONAL ARRANGEMENTS AND RESERVATIONS, RUNNING ERRANDS AND PROVIDING CUSTOMER SPECIFIC INFORMATION TO MEET INDIVIDUAL NEEDS, ALL RENDERED IN BUSINESS ESTABLISHMENTS, OFFICE BUILDINGS, HOTELS, RESIDENTIAL COMPLEXES AND HOMES (U.S. CLS. 100 AND 101).
FIRST USE 1-1-2011; IN COMMERCE 1-1-2011.

CONGRATULATIONS

THE MARK CONSISTS OF STANDARD CHARACTERS WITHOUT CLAIM TO ANY PARTICULAR FONT, STYLE, SIZE, OR COLOR.

CLASS 9—ELECTRICAL AND SCIENTIFIC APPARATUS

FOR COMPUTER AND SOFTWARE PRODUCTS, NAMELY, DOWNLOADABLE ELECTRONIC PUBLICATIONS IN THE NATURE OF A SERIES OF BOOKS IN THE FIELD OF ADVICE AND SELF-HELP FOR CONSUMERS OF ALL AGES; COMPUTER AND SOFTWARE PRODUCTS, NAMELY, ELECTRONIC PUBLICATIONS IN THE NATURE OF A SERIES OF BOOKS IN THE FIELD OF ADVICE AND SELF-HELP RECORDED ON COMPUTER MEDIA FOR CONSUMERS OF ALL AGES; DOWNLOADABLE MULTIMEDIA FILES FEATURING GOAL MAPS, VISUAL AIDS AND WEBINARS IN THE FIELD OF ADVICE AND SELF-HELP FOR CONSUMERS OF ALL AGES (U.S. CLS. 21, 23, 26, 36 AND 38).

FIRST USE 12-1-2009; IN COMMERCE 12-1-2009.

CLASS 16—PAPER GOODS AND PRINTED MATTER

FOR SERIES OF PAPER GOODS AND PRINTED MATERIALS, NAMELY, A SERIES OF BOOKS IN THE NATURE OF ADVICE AND SELF-HELP; PRINTED MATTER, NAMELY, CALENDARS, PAPER NOTEBOOKS, PENS, BOOKMARKS; STATIONERY; PLASTIC MATERIALS FOR PACKAGING, NAMELY, GENERAL PURPOSE PLASTIC BAGS FOR CONSUMERS OF ALL AGES (U.S. CLS. 2, 5, 22, 23, 29, 37, 38 AND 50).

FIRST USE 12-1-2009; IN COMMERCE 12-1-2009.

CLASS 41—EDUCATION AND ENTERTAINMENT

FOR EDUCATION AND ENTERTAINMENT SERVICES, NAMELY, PROVIDING SEMINARS IN THE FIELD OF ADVICE AND SELF-HELP; VOCATIONAL GUIDANCE; PROVIDING MOTIVATIONAL AND EDUCATIONAL SPEAKERS; CAREER COUNSELING (U.S. CLS. 100, 101 AND 107).

FIRST USE 12-1-2009; IN COMMERCE 12-1-2009.

CLASS 45—PERSONAL AND LEGAL SERVICES

FOR PROVIDING ADVISORY SERVICES IN THE FIELD OF SELF-IMPROVEMENT (U.S. CLS. 100 AND 101).

FIRST USE 12-1-2009; IN COMMERCE 12-1-2009.

4,154,927. MICROSOFT CORPORATION, REDMOND, WA. SN 85-200,057. PUB. 9-13-2011, FILED 12-16-2010.

POSTBOX

THE MARK CONSISTS OF STANDARD CHARACTERS WITHOUT CLAIM TO ANY PARTICULAR FONT, STYLE, SIZE, OR COLOR.

CLASS 35—ADVERTISING AND BUSINESS

FOR ON-LINE BUSINESS DIRECTORIES FEATURING RESTAURANTS, BARS, NIGHTCLUBS, TOURIST ATTRACTIONS, ENTERTAINMENT AND SPORTS EVENTS, SEASONAL AND HOLIDAY EVENTS (U.S. CLS. 100, 101 AND 102).

FIRST USE 2-2-2011; IN COMMERCE 2-2-2011.

CLASS 41—EDUCATION AND ENTERTAINMENT

FOR PROVIDING ONLINE INFORMATION CONCERNING NIGHTCLUBS, TOURIST ATTRACTIONS, SPORTING EVENTS, AND LOCAL ENTERTAINMENT, SEASONAL AND HOLIDAY EVENTS (U.S. CLS. 100, 101 AND 107).

FIRST USE 2-2-2011; IN COMMERCE 2-2-2011.

CLASS 43—HOTEL AND RESTAURANT SERVICES

FOR PROVIDING ONLINE INFORMATION CONCERNING RESTAURANTS AND BARS (U.S. CLS. 100 AND 101).

FIRST USE 2-2-2011; IN COMMERCE 2-2-2011.

4,154,936. CULTIVE FRANCHISE, LLC, DAVIS, CA. SN 85-202,701. PUB. 4-5-2011, FILED 12-21-2010.



THE MARK CONSISTS OF A FLOWER WITH EIGHT RADially EXTENDING PEDALS WHEREIN SEVEN ARE THE SAME SIZE AND ONE IS LARGER AND DETACHED FROM THE REMAINDER OF THE FLOWER.

CLASS 30—STAPLE FOODS

FOR FROZEN YOGURT AND FROZEN YOGURT BASED DESSERTS (U.S. CL. 46).

FIRST USE 2-11-2012; IN COMMERCE 2-11-2012.

CLASS 43—HOTEL AND RESTAURANT SERVICES

FOR RESTAURANT SERVICES FEATURING FROZEN YOGURT AND FROZEN YOGURT BASED DESSERTS FOR ON AND OFF PREMISES CONSUMPTION (U.S. CLS. 100 AND 101).

FIRST USE 2-11-2012; IN COMMERCE 2-11-2012.

4,154,937. BATH & BODY WORKS BRAND MANAGEMENT, INC., REYNOLDSBURG, OH. SN 85-202,865. PUB. 11-1-2011, FILED 12-21-2010.

MARSHMALLOW FIRESIDE

THE MARK CONSISTS OF STANDARD CHARACTERS WITHOUT CLAIM TO ANY PARTICULAR FONT, STYLE,

SIZE, OR COLOR.

NO CLAIM IS MADE TO THE EXCLUSIVE RIGHT TO USE "MARSHMALLOW", APART FROM THE MARK AS SHOWN.

CLASS 3—COSMETICS AND CLEANING PREPARATIONS

FOR ROOM FRAGRANCE REFILLS FOR NON-ELECTRIC AND ELECTRIC ROOM FRAGRANCE DISPENSERS, FRAGRANCES FOR AUTOMOBILES, ROOM FRAGRANCES, HOME FRAGRANCE OILS, FRAGRANCE REEDS, FRAGRANT ROOM SPRAY (U.S. CLS. 1, 4, 6, 50, 51 AND 52).

FIRST USE 9-5-2011; IN COMMERCE 9-5-2011.

CLASS 4—LUBRICANTS AND FUELS

FOR CANDLES (U.S. CLS. 1, 6 AND 15).
FIRST USE 9-5-2011; IN COMMERCE 9-5-2011.

4,154,943. GOVERNMENTAL AND EDUCATIONAL ASSISTANCE CORP., HOPKINS, MN. SN 85-204,338. PUB. 5-3-2011, FILED 12-22-2010.

VISTA PRAIRIE COMMUNITIES

THE MARK CONSISTS OF STANDARD CHARACTERS WITHOUT CLAIM TO ANY PARTICULAR FONT, STYLE, SIZE, OR COLOR.

NO CLAIM IS MADE TO THE EXCLUSIVE RIGHT TO USE "COMMUNITIES", APART FROM THE MARK AS SHOWN.

CLASS 43—HOTEL AND RESTAURANT SERVICES

FOR PROVIDING ASSISTANCE TO SENIOR CITIZENS SEEKING TO DETERMINE ASSISTED LIVING FACILITIES APPROPRIATE FOR THEIR NEEDS; PROVIDING ASSISTED LIVING FACILITIES; PROVIDING COMMUNITY CENTERS FOR SOCIAL GATHERINGS AND MEETINGS; RETIREMENT HOMES (U.S. CLS. 100 AND 101).

FIRST USE 12-1-2011; IN COMMERCE 12-1-2011.

CLASS 45—PERSONAL AND LEGAL SERVICES

FOR PERSONAL CARE ASSISTANCE OF ACTIVITIES OF DAILY LIVING, SUCH AS BATHING, GROOMING AND PERSONAL MOBILITY FOR MENTALLY OR PHYSICALLY CHALLENGED PEOPLE; PROVIDING NON-MEDICAL ASSISTED LIVING SERVICES FOR PERSONAL PURPOSES IN THE NATURE OF SCHEDULING APPOINTMENTS, ANSWERING THE TELEPHONE, CHECKING MESSAGES, MAIL SORTING, MAIL HANDLING, MAIL RECEIVING AND SECRETARIAL AND CLERICAL SERVICES; PROVIDING NON-MEDICAL PERSONAL ASSISTANT SERVICES FOR OTHERS IN THE NATURE OF PLANNING, ORGANIZING, COORDINATING, ARRANGING AND ASSISTING INDIVIDUALS TO PERFORM DAILY TASKS (U.S. CLS. 100 AND 101).

FIRST USE 12-1-2011; IN COMMERCE 12-1-2011.

4,154,945. RIVERA AMPLIFICATION INC., BURBANK, CA. SN 85-204,715. PUB. 3-29-2011, FILED 12-23-2010.



THE MARK CONSISTS OF A TOAD WITH ITS TONGUE EXTENDED, WITH A MUSICAL NOTE JUST ABOVE THE TIP OF THE TONGUE.

CLASS 9—ELECTRICAL AND SCIENTIFIC APPARATUS

FOR ELECTRONIC EFFECT PEDALS FOR USE WITH SOUND AMPLIFIERS (U.S. CLS. 21, 23, 26, 36 AND 38).
FIRST USE 1-18-2011; IN COMMERCE 1-18-2011.

CLASS 15—MUSICAL INSTRUMENTS

FOR ELECTRONIC EFFECTS PEDALS FOR USE WITH MUSICAL INSTRUMENTS; FOOT PEDALS FOR USE IN CONNECTION WITH MUSICAL INSTRUMENTS; GUITAR PEDALS; SOUND EFFECT PEDALS FOR MUSICAL INSTRUMENTS (U.S. CLS. 2, 21 AND 36).
FIRST USE 1-18-2011; IN COMMERCE 1-18-2011.

4,154,948. MIDBASS DISTRIBUTION LIMITED, SUTTON COLDFIELD, ENGLAND. SN 85-205,171. PUB. 7-12-2011, FILED 12-23-2010.

FLI Underground

THE MARK CONSISTS OF STANDARD CHARACTERS WITHOUT CLAIM TO ANY PARTICULAR FONT, STYLE, SIZE, OR COLOR.

CLASS 9—ELECTRICAL AND SCIENTIFIC APPARATUS

FOR APPARATUS FOR RECORDING, TRANSMISSION OR REPRODUCTION OF SOUND OR IMAGES; LOUDSPEAKERS, LOUDSPEAKER AND SOUND SYSTEMS; SOUND AMPLIFIERS, SOUND CONTROL APPARATUS; ELECTRO-MECHANICAL ACOUSTIC CONVERTERS; LOUDSPEAKER ENCLOSURES; AND PARTS, FITTINGS, AND ACCESSORIES FOR THE AFOREMENTIONED GOODS, NAMELY, CABLING, CONNECTORS, REMOTE CONTROLS, POWER CAPACITORS, LINE DRIVERS, DISTRIBUTION BOXES, SOUND DAMPENING, ANTIRESONANCE MATERIALS, LOUDSPEAKER ENCLOSURE PORTS, LOUDSPEAKER ENCLOSURE COSMETIC ENHANCEMENTS AND LOUDSPEAKER ENCLOSURE PROTECTION (U.S. CLS. 21, 23, 26, 36 AND 38).

FIRST USE 12-31-2010; IN COMMERCE 12-31-2010.

CLASS 35—ADVERTISING AND BUSINESS

FOR ADVERTISING; BUSINESS MANAGEMENT; BUSINESS ADMINISTRATION; THE BRINGING TOGETHER FOR THE BENEFIT OF OTHERS, OF A VARIETY OF GOODS, ENABLING CUSTOMERS TO CONVENIENTLY VIEW AND PURCHASE THOSE GOODS FROM A RETAIL AUDIO SPECIALIST STORE, OR FROM AN AUDIO SPECIALIST CATALOGUE OR INTERNET WEBSITE SPECIALISING IN THE SALE OF AUDIO EQUIPMENT AND BY MAIL ORDER OR BY MEANS OF TELECOMMUNICATIONS; CONSULTANCY, ADVISORY AND INFORMATION SERVICES TO THE AFOREMENTIONED SERVICES (U.S. CLS. 100, 101 AND 102).

FIRST USE 12-31-2010; IN COMMERCE 12-31-2010.

CLASS 42—SCIENTIFIC AND COMPUTER SERVICES

FOR PROVISION OF TECHNICAL INFORMATION AND TECHNICAL ADVICE RELATING TO LOUDSPEAKERS AND AUDIO SYSTEMS; TECHNICAL TESTING SERVICES FOR SOUND SYSTEMS AND LOUDSPEAKER SYSTEMS; RESEARCH AND DESIGN SERVICES FOR LOUDSPEAKERS AND AUDIO SYSTEMS (U.S. CLS. 100 AND 101).

FIRST USE 12-31-2010; IN COMMERCE 12-31-2010.

4,154,958. HARVARD MAINTENANCE, INC., NEW YORK, NY. SN 85-209,849. PUB. 5-17-2011, FILED 1-4-2011.



OWNER OF U.S. REG. NOS. 2,825,189 AND 2,825,190.

THE COLOR(S) DARK BLUE AND GRAY IS/ARE CLAIMED AS A FEATURE OF THE MARK.

THE MARK CONSISTS OF THE TERM "HARVARD" IN DARK BLUE, WITH THE RIGHT SIDE OF THE "V" EXTENDING ABOVE THE OTHER LETTERS, FOLLOWED BY THE TERM "PLUS" IN GRAY.

CLASS 37—CONSTRUCTION AND REPAIR

FOR CLEANING OF BUILDINGS AND FACILITIES; MAINTENANCE AND RENOVATION OF BUILDINGS AND FACILITIES; JANITORIAL SERVICES; CARPET AND RUG CLEANING AND SHAMPOOING; WINDOW CLEANING; TRASH COLLECTION; WASTE DISPOSAL FOR OTHERS; CLEANING, BUFFING AND POLISHING OF METAL AND STONE; DOOR MAINTENANCE AND REPAIR SERVICES; FURNITURE RESTORATION, REPAIR AND MAINTENANCE; FLOOR SANDING; PEST CONTROL AND EXTERMINATION OTHER THAN FOR AGRICULTURE (U.S. CLS. 100, 103 AND 106).

FIRST USE 4-27-2011; IN COMMERCE 4-27-2011.

CLASS 45—PERSONAL AND LEGAL SERVICES

FOR SECURITY GUARD SERVICES; MONITORING SECURITY SYSTEMS (U.S. CLS. 100 AND 101).

FIRST USE 4-27-2011; IN COMMERCE 4-27-2011.

4,154,959. U-GO STATIONS, INC., PHILADELPHIA, PA. SN 85-210,101. PUB. 7-26-2011, FILED 1-4-2011.



NO CLAIM IS MADE TO THE EXCLUSIVE RIGHT TO USE "STATIONS", APART FROM THE MARK AS SHOWN. THE COLOR(S) BLUE, GREEN, AND BLACK IS/ARE CLAIMED AS A FEATURE OF THE MARK.

THE MARK CONSISTS OF THE WORDING "U GO STATIONS" WITH A CORD AND PLUG DESIGN EXTENDING FROM THE "U" AND INTO THE WORD "GO". THE WORDING "GO STATIONS" IS BLACK. THE LETTER "U" IS BLUE, AND THE PLUG SHADES FROM BLUE INTO GREEN.

CLASS 9—ELECTRICAL AND SCIENTIFIC APPARATUS

FOR ELECTRICAL APPARATUS, NAMELY, CHARGING STATIONS FOR CHARGING ELECTRIC VEHICLES (U.S. CLS. 21, 23, 26, 36 AND 38).

FIRST USE 11-0-2010; IN COMMERCE 8-5-2011.

CLASS 37—CONSTRUCTION AND REPAIR

FOR CHARGING STATION SERVICES FOR ELECTRIC VEHICLES (U.S. CLS. 100, 103 AND 106).

FIRST USE 3-15-2011; IN COMMERCE 3-15-2011.

4,154,976. MIDMARK CORPORATION, VERSAILLES, OH. SN 85-214,692. PUB. 8-9-2011, FILED 1-11-2011.



THE MARK CONSISTS OF STANDARD CHARACTERS WITHOUT CLAIM TO ANY PARTICULAR FONT, STYLE, SIZE, OR COLOR.

OWNER OF U.S. REG. NO. 3,659,092.

CLASS 9—ELECTRICAL AND SCIENTIFIC APPARATUS

FOR OPERATING SOFTWARE FOR X-RAY APPARATUS FOR VETERINARY USE AND ANIMAL PATIENT MONITORING SENSORS (U.S. CLS. 21, 23, 26, 36 AND 38).

FIRST USE 8-0-2011; IN COMMERCE 8-0-2011.

CLASS 10—MEDICAL APPARATUS

FOR X-RAY APPARATUS FOR VETERINARY USE AND OPERATING SOFTWARE SOLD AS A UNIT; ANIMAL PATIENT MONITORING SENSORS AND OPERATING SOFTWARE SOLD AS A UNIT; ACCESSORIES RELATED TO X-RAY APPARATUS FOR VETERINARY USE AND ANIMAL PATIENT MONITORING SENSORS, NAMELY, DIGITAL SENSOR HEADS, MOUNTING PLATES, HANDLES, APPARATUS ARMS, CONTROL PANELS, AND SENSOR CABLING (U.S. CLS. 26, 39 AND 44).

FIRST USE 8-0-2011; IN COMMERCE 8-0-2011.

4,154,994. THE NPD GROUP, INC., PORT WASHINGTON, NY. SN 85-221,476. PUB. 10-18-2011, FILED 1-19-2011.

DECISIONKEY

THE MARK CONSISTS OF STANDARD CHARACTERS WITHOUT CLAIM TO ANY PARTICULAR FONT, STYLE, SIZE, OR COLOR.

4,154,981. DOMINANT BRANDS LLC, BAYSIDE, NY. SN 85-216,555. PUB. 9-13-2011, FILED 1-13-2011.



NO CLAIM IS MADE TO THE EXCLUSIVE RIGHT TO USE "FIRST BOSTON CORPORATION", APART FROM THE MARK AS SHOWN.

THE MARK CONSISTS OF A THREE-MASTED SHIP DESIGN SUPERIMPOSED OVER A GLOBE CIRCUMSCRIBED BY THE WORDS "THE FIRST BOSTON CORPORATION" INSIDE OF A CIRCLE.

CLASS 35—ADVERTISING AND BUSINESS

FOR COMMERCIAL BUSINESS MANAGEMENT, BUSINESS ADMINISTRATION CONSULTANCY, CONSULTING IN THE FIELDS OF BUSINESS ORGANIZATION AND MANAGEMENT, BUSINESS INTERMEDIARY SERVICES AND ADVISORY SERVICES IN THE FIELD OF SELLING PRODUCTS AND RENDERING SERVICES, ACCOUNTING FOR THIRD PARTIES, ECONOMIC FORECASTING AND ANALYSIS, COLLECTION, PREPARATION, COMPOSITION, PROCESSING, ACQUISITION AND PROVISION OF BUSINESS INFORMATION, DATA, STATISTICS, AND INDICES; PROVIDING STATISTICAL INFORMATION, COMPILATION AND PROVISION OF TRADE AND BUSINESS PRICE AND STATISTICAL INFORMATION; PERSONNEL MANAGEMENT, HUMAN CAPITAL MANAGEMENT OUTSOURCING, ORGANIZING AND CONDUCTING TRADE FAIRS AND EXHIBITIONS FOR ECONOMIC AND ADVERTISING PURPOSES, ARRANGING AND CONDUCTING AUCTION SALES (U.S. CLS. 100, 101 AND 102).

FIRST USE 3-22-2012; IN COMMERCE 3-22-2012.

CLASS 36—INSURANCE AND FINANCIAL

FOR INVESTMENT BANKING SERVICES, FINANCIAL ADVISORY SERVICES, AND INVESTMENT ADVISORY SERVICES AND BROKERAGE SERVICES IN THE FIELD OF SECURITIES; FINANCIAL MANAGEMENT (U.S. CLS. 100, 101 AND 102).

FIRST USE 3-22-2012; IN COMMERCE 3-22-2012.

CLASS 35—ADVERTISING AND BUSINESS

FOR MARKET RESEARCH SERVICES (U.S. CLS. 100, 101 AND 102).

FIRST USE 3-6-2012; IN COMMERCE 3-6-2012.

CLASS 42—SCIENTIFIC AND COMPUTER SERVICES

FOR PROVIDING NON-DOWNLOADABLE WEB-BASED INTERFACE SOFTWARE FOR ALLOWING CLIENTS TO ACCESS, MANIPULATE, AND PRESENT MARKET RESEARCH DATA (U.S. CLS. 100 AND 101).

FIRST USE 3-6-2012; IN COMMERCE 3-6-2012.

4,154,996. SHARSHERET, INC., TEANECK, NJ. SN 85-221,768. PUB. 8-30-2011, FILED 1-20-2011.



THE MARK CONSISTS OF ONE SMALL RIBBON, ONE MEDIUM RIBBON AND ONE LARGE RIBBON ENCLOSED IN A CIRCLE.

CLASS 44—MEDICAL, BEAUTY AND AGRICULTURAL SERVICES

FOR PROVIDING INFORMATION CONCERNING THE CAUSES, DETECTION, DIAGNOSIS, AND TREATMENT OF BREAST CANCER AND OVARIAN CANCER AND RELATED MEDICAL AND PSYCHOLOGICAL ISSUES TO BREAST AND OVARIAN CANCER PATIENTS AND THEIR FAMILIES, TO THE PUBLIC, AND TO HEALTH-CARE PROFESSIONALS; PROVIDING INFORMATION IN THE FIELD OF BREAST AND OVARIAN CANCER AND RELATED MEDICAL AND PSYCHOLOGICAL ISSUES VIA THE INTERNET; TELEPHONE HOT LINE SERVICES TO PROVIDE MEDICAL INFORMATION IN THE FIELD OF BREAST AND OVARIAN CANCER INCLUDING RELATED PSYCHOLOGICAL ISSUES TO BREAST AND OVARIAN CANCER PATIENTS (U.S. CLS. 100 AND 101).

FIRST USE 1-4-2011; IN COMMERCE 1-4-2011.

CLASS 45—PERSONAL AND LEGAL SERVICES

FOR TELEPHONE HOT LINE SERVICES TO PROVIDE SUPPORTIVE EMOTIONAL COUNSELING TO BREAST AND OVARIAN CANCER PATIENTS; PROVIDING PERSONAL AND EMOTIONAL SUPPORT TO BREAST AND OVARIAN CANCER PATIENTS THROUGH A NETWORK OF BREAST AND OVARIAN CANCER SURVIVORS AND OTHER VOLUNTEERS (U.S. CLS. 100 AND 101).

FIRST USE 1-4-2011; IN COMMERCE 1-4-2011.

4,155,004. SLP PERFORMANCE PARTS, INC., TOMS RIVER, NJ. SN 85-226,282. PUB. 5-31-2011, FILED 1-26-2011.

**CREATING TOMORROW'S
CLASSICS TODAY!**

THE MARK CONSISTS OF STANDARD CHARACTERS WITHOUT CLAIM TO ANY PARTICULAR FONT, STYLE, SIZE, OR COLOR.

CLASS 12—VEHICLES

FOR AUTOMOBILES (U.S. CLS. 19, 21, 23, 31, 35 AND 44).

FIRST USE 8-31-2011; IN COMMERCE 8-31-2011.

CLASS 37—CONSTRUCTION AND REPAIR

FOR AUTOMOBILE CUSTOMIZATION SERVICES; AUTOMOTIVE UPGRADE SERVICES, NAMELY, SUPERCHARGING, TURBOCHARGING AND PERFORMANCE UPGRADES OF AUTOMOBILES (U.S. CLS. 100, 103 AND 106).

FIRST USE 8-31-2011; IN COMMERCE 8-31-2011.

4,155,012. FIST ENTERPRISES, WEST PALM BEACH, FL. SN 85-228,886. PUB. 1-10-2012, FILED 1-28-2011.

FIST ENTERPRISES

THE MARK CONSISTS OF STANDARD CHARACTERS WITHOUT CLAIM TO ANY PARTICULAR FONT, STYLE, SIZE, OR COLOR.

NO CLAIM IS MADE TO THE EXCLUSIVE RIGHT TO USE "ENTERPRISES", APART FROM THE MARK AS SHOWN.

CLASS 9—ELECTRICAL AND SCIENTIFIC APPARATUS

FOR ELECTRICAL APPARATUS, NAMELY, BIOMETRIC SECURITY SYSTEMS CONSISTING ESSENTIALLY OF FINGER PRINT SWIPE APPARATUS AND BIOMETRIC FINGER PRINT LOCKS USED FOR ATM SECURITY, ROOM SECURITY IN HOTELS AND CRUISE SHIPS, HOUSE SECURITY, AND SAFE SECURITY (U.S. CLS. 21, 23, 26, 36 AND 38).

FIRST USE 1-28-2011; IN COMMERCE 1-30-2012.

CLASS 12—VEHICLES

FOR ANTI-THEFT SECURITY DEVICES FOR AUTOMOBILES, MOTORCYCLES, BOATS, CAR STARTER DEVICES WITH FINGERPRINT SWIPE AND FINGERPRINT READER CAPABILITIES; CAR ALARMS, BOAT ALARMS, AND AUTOMOBILE ALARMS (U.S. CLS. 19, 21, 23, 31, 35 AND 44).

FIRST USE 1-28-2011; IN COMMERCE 1-30-2012.

4,155,013. BLYTH, ALISON, REHOBOTH BEACH, DE. SN 85-229,387. PUB. 6-7-2011, FILED 1-29-2011.

GO BRIT!

THE MARK CONSISTS OF STANDARD CHARACTERS WITHOUT CLAIM TO ANY PARTICULAR FONT, STYLE, SIZE, OR COLOR.

CLASS 25—CLOTHING

FOR CLOTHING, NAMELY, TOPS, BOTTOMS, T-SHIRTS, SWEATSHIRTS, JERSEYS, HATS, CAPS, HEADWEAR (U.S. CLS. 22 AND 39).

FIRST USE 3-8-2012; IN COMMERCE 3-8-2012.

CLASS 43—HOTEL AND RESTAURANT SERVICES

FOR RESTAURANT AND BAR SERVICES (U.S. CLS. 100 AND 101).

FIRST USE 3-8-2012; IN COMMERCE 3-8-2012.

4,155,016. THE LAMBS FARM, INC., LIBERTYVILLE, IL. SN 85-231,046. PUB. 12-13-2011, FILED 2-1-2011.



OWNER OF U.S. REG. NO. 1,856,727.

NO CLAIM IS MADE TO THE EXCLUSIVE RIGHT TO USE "FARM", APART FROM THE MARK AS SHOWN.

THE MARK CONSISTS OF A STYLIZED TREE WITH THE WORDS "LAMBS FARM WHERE PEOPLE GROW".

CLASS 29—MEATS AND PROCESSED FOODS

FOR FRUIT AND TOMATO PRESERVES, JELLY, PEANUT BUTTER AND FRUIT CLUSTERS (U.S. CL. 46).

FIRST USE 10-12-2010; IN COMMERCE 7-18-2011.

CLASS 30—STAPLE FOODS

FOR FLAVORED MUSTARDS, CHOCOLATES, FUDGE, TOFFEE, HONEY AND HONEY SPREADS, MUFFINS, BREADS, COOKIES, BROWNIES, PIES, CHILI SAUCE, BARBEQUE SAUCE, PASTA SAUCES AND CANDY (U.S. CL. 46).

FIRST USE 10-12-2010; IN COMMERCE 7-18-2011.

CLASS 35—ADVERTISING AND BUSINESS

FOR EMPLOYMENT PLACEMENT SERVICES FOR PERSONS WITH DEVELOPMENTAL DISABILITIES (U.S. CLS. 100, 101 AND 102).

FIRST USE 10-12-2010; IN COMMERCE 2-17-2011.

CLASS 36—INSURANCE AND FINANCIAL

FOR PROVIDING HOUSING ACCOMMODATIONS FOR PEOPLE WITH DEVELOPMENTAL DISABILITIES, NAMELY, ADMINISTRATION AND MANAGEMENT OF HOUSING ACCOMMODATIONS FOR PEOPLE WITH DEVELOPMENTAL DISABILITIES (U.S. CLS. 100, 101 AND 102).

FIRST USE 10-12-2010; IN COMMERCE 2-17-2011.

CLASS 41—EDUCATION AND ENTERTAINMENT

FOR PROVIDING LEISURE AND RECREATIONAL ACTIVITIES AND SERVICES, NAMELY, MINIATURE GOLF AND MINIATURE TRAIN RIDES, CONDUCTING EDUCATIONAL HOBBY CLASSES; PROVIDING ATHLETICS, NAMELY, ATHLETIC TRAINING SERVICE AND ARRANGING AND CONDUCTING ATHLETIC COMPETITIONS; PETTING ZOOS; PONY RIDES; ENTERTAINMENT IN THE NATURE OF AN AMUSEMENT PARK RIDE; VOCATIONAL SERVICES, NAMELY, JOB TRAINING (U.S. CLS. 100, 101 AND 107).

FIRST USE 10-12-2010; IN COMMERCE 2-17-2011.

CLASS 42—SCIENTIFIC AND COMPUTER SERVICES

FOR RETAIL SHOPS AND MAIL ORDER SERVICES FEATURING PETS, PET FOODS AND SUPPLIES, GREETING CARDS, BOOKS, HOUSEHOLD ITEMS, CLOTHING, JEWELRY AND BAKED GOODS (U.S. CLS. 100 AND 101).

FIRST USE 10-12-2010; IN COMMERCE 7-18-2011.

4,155,018. RUGBY XV, INC, AKA RXV, RUGBY XV, ALTADENA, CA. SN 85-231,406. PUB. 6-21-2011, FILED 2-1-2011.



THE MARK CONSISTS OF TWO STYLIZED HOOKS OR SINGLE BARB ARROW LIKE PATTERNS ONE FROM LEFT TO RIGHT DIRECTION THE OTHER INVERTED AND BEING SHOWN IN A RIGHT TO LEFT DIRECTION WITH THE LETTERS "RXV" BELOW EACH ELEMENT AND LETTERS CAN BE COLORED EITHER AS A GROUP OR INDIVIDUALLY.

CLASS 25—CLOTHING

FOR HATS; RUGBY SHIRTS; RUGBY SHORTS; SOCKS; TRACKSUITS (U.S. CLS. 22 AND 39).

FIRST USE 11-15-2010; IN COMMERCE 11-15-2010.

CLASS 28—TOYS AND SPORTING GOODS

FOR ATHLETIC PROTECTIVE PADS FOR TACKLING; FOOTBALL OR SOCCER GOALS; RUGBY BALLS; SAFETY PADDING FOR GOAL POST UPRIGHTS; SPORTS FIELD EQUIPMENT, NAMELY, CORNER FLAGS (U.S. CLS. 22, 23, 38 AND 50).

FIRST USE 11-15-2010; IN COMMERCE 11-15-2010.

CLASS 41—EDUCATION AND ENTERTAINMENT

FOR PROVIDING A WEB SITE FEATURING SPORTING INFORMATION; PROVIDING A WEBSITE CONTAINING INFORMATION RELATING TO THE SPORT OF RUGBY, INCLUDING TEAM INFORMATION, PLAYER STATISTICS AND NEWS (U.S. CLS. 100, 101 AND 107).

FIRST USE 1-1-2012; IN COMMERCE 1-1-2012.

4,155,022. AMERICAN CANCER SOCIETY, INC., ATLANTA, GA. SN 85-232,533. PUB. 8-9-2011, FILED 2-2-2011.

RELAY FIELD DAY

THE MARK CONSISTS OF STANDARD CHARACTERS WITHOUT CLAIM TO ANY PARTICULAR FONT, STYLE, SIZE, OR COLOR.

OWNER OF U.S. REG. NOS. 1,907,602, 3,045,212, AND 3,840,251.

SEC. 2(F) AS TO "RELAY".

CLASS 35—ADVERTISING AND BUSINESS

FOR PROMOTING PUBLIC AWARENESS OF CANCER RESEARCH, EDUCATION, ADVOCACY, PREVENTION, DETECTION, TREATMENT, AND PATIENT AND FAMILY SERVICES (U.S. CLS. 100, 101 AND 102).

FIRST USE 9-0-2011; IN COMMERCE 9-0-2011.

CLASS 36—INSURANCE AND FINANCIAL

FOR CHARITABLE FUNDRAISING SERVICES TO SUPPORT CANCER RESEARCH, EDUCATION, ADVOCACY, PREVENTION, DETECTION, TREATMENT, AND PATIENT AND FAMILY SERVICES (U.S. CLS. 100, 101 AND 102).

FIRST USE 9-0-2011; IN COMMERCE 9-0-2011.

4,155,023. AMERICAN CANCER SOCIETY, INC., ATLANTA, GA. SN 85-232,549. PUB. 8-9-2011, FILED 2-2-2011.

RELAY RECESS

THE MARK CONSISTS OF STANDARD CHARACTERS WITHOUT CLAIM TO ANY PARTICULAR FONT, STYLE, SIZE, OR COLOR.

OWNER OF U.S. REG. NOS. 1,907,602, 3,045,212, AND 3,840,251.

SEC. 2(F) AS TO "RELAY".

CLASS 35—ADVERTISING AND BUSINESS

FOR PROMOTING PUBLIC AWARENESS OF CANCER RESEARCH, EDUCATION, ADVOCACY, PREVENTION, DETECTION, TREATMENT, AND PATIENT AND FAMILY SERVICES (U.S. CLS. 100, 101 AND 102).

FIRST USE 12-0-2011; IN COMMERCE 12-0-2011.

CLASS 36—INSURANCE AND FINANCIAL

FOR CHARITABLE FUNDRAISING SERVICES TO SUPPORT CANCER RESEARCH, EDUCATION, ADVOCACY, PREVENTION, DETECTION, TREATMENT, AND PATIENT AND FAMILY SERVICES (U.S. CLS. 100, 101 AND 102).

FIRST USE 12-0-2011; IN COMMERCE 12-0-2011.

4,155,033. INFOSTREAM GROUP, INC., LAS VEGAS, NV.
SN 85-234,943. PUB. 6-14-2011, FILED 2-4-2011.

Whats Your Price

THE MARK CONSISTS OF STANDARD CHARACTERS WITHOUT CLAIM TO ANY PARTICULAR FONT, STYLE, SIZE, OR COLOR.

CLASS 41—EDUCATION AND ENTERTAINMENT

FOR EDUCATIONAL AND ENTERTAINMENT SERVICES, NAMELY, A CONTINUING PROGRAM ABOUT ON-LINE DATING, MATCHING MAKING, SOCIAL INTRODUCTIONS SERVICES AND SOCIAL NETWORKING ACCESSIBLE BY RADIO, TELEVISION, SATELLITE, AUDIO, VIDEO AND COMPUTER NETWORKS; ENTERTAINMENT SERVICES, NAMELY, NON-DOWNLOADABLE RINGTONES, PRE-RECORDED MUSIC, AND GRAPHICS PRESENTED TO MOBILE COMMUNICATIONS DEVICES VIA A GLOBAL COMPUTER NETWORK AND WIRELESS NETWORKS; PRODUCTION AND DISTRIBUTION OF RADIO PROGRAMS; RADIO PROGRAM SYNDICATION (U.S. CLS. 100, 101 AND 107).

FIRST USE 4-8-2011; IN COMMERCE 4-8-2011.

CLASS 45—PERSONAL AND LEGAL SERVICES

FOR INTERNET-BASED DATING, SOCIAL INTRODUCTION AND SOCIAL NETWORKING SERVICES (U.S. CLS. 100 AND 101).

FIRST USE 4-8-2011; IN COMMERCE 4-8-2011.

4,155,052. EXP GLOBAL INC., BRAMPTON, ONTARIO, CANADA. SN 85-238,767. PUB. 6-28-2011, FILED 2-10-2011.



THE MARK CONSISTS OF THE LETTERS "EXP" WITH A CLUSTER OF CIRCULAR DESIGNS TO THE TOP LEFT AND A PERIOD AFTER THE LETTER "P".

CLASS 37—CONSTRUCTION AND REPAIR

FOR BUILDING AND ROAD CONSTRUCTION MANAGEMENT SERVICES (U.S. CLS. 100, 103 AND 106).
FIRST USE 4-4-2011; IN COMMERCE 4-4-2011.

CLASS 42—SCIENTIFIC AND COMPUTER SERVICES

FOR ENGINEERING AND ARCHITECTURAL CONSULTING; ENGINEERING PROJECT MANAGEMENT; LANDSCAPE ARCHITECTURAL DESIGN SERVICES; URBAN PLANNING SERVICES AND LAND SURVEYING SERVICES; CONSULTING SERVICES IN THE FIELD OF ENVIRONMENTAL ASSESSMENT AND PLANNING (U.S. CLS. 100 AND 101).

FIRST USE 4-4-2011; IN COMMERCE 4-4-2011.

4,155,054. MARK FRIEL, CALGARY, ALBERTA, CANADA.
SN 85-239,109. PUB. 8-23-2011, FILED 2-10-2011.

SPACEMATS

THE MARK CONSISTS OF STANDARD CHARACTERS WITHOUT CLAIM TO ANY PARTICULAR FONT, STYLE, SIZE, OR COLOR.

CLASS 16—PAPER GOODS AND PRINTED MATTER

FOR MAT BOARDS; PAPER FLOOR MATS; PAPER MATS; PAPER PLACE MATS (U.S. CLS. 2, 5, 22, 23, 29, 37, 38 AND 50).

FIRST USE 9-30-2011; IN COMMERCE 9-30-2011.

CLASS 24—FABRICS

FOR PLACE MATS OF TEXTILE MATERIAL; PLACE MATS, NOT OF PAPER; PLASTIC PLACE MATS; TEXTILE PLACE MATS; VINYL PLACE MATS (U.S. CLS. 42 AND 50).

FIRST USE 9-30-2011; IN COMMERCE 9-30-2011.

4,155,079. THE BAILEY COMPANY, LLLP, GOLDEN, CO.
SN 85-243,662. PUB. 7-26-2011, FILED 2-16-2011.

CONNECTION THROUGH GIVING

THE MARK CONSISTS OF STANDARD CHARACTERS WITHOUT CLAIM TO ANY PARTICULAR FONT, STYLE, SIZE, OR COLOR.

CLASS 35—ADVERTISING AND BUSINESS

FOR CHARITABLE SERVICES, NAMELY, COORDINATION OF NON-MONETARY CONTRIBUTIONS TO CHARITIES AND NON-PROFIT ORGANIZATIONS (U.S. CLS. 100, 101 AND 102).

FIRST USE 3-10-2011; IN COMMERCE 4-19-2011.

CLASS 36—INSURANCE AND FINANCIAL

FOR CHARITABLE FUNDRAISING SERVICES; CHARITABLE SERVICES, NAMELY, ACCEPTING AND ADMINISTERING MONETARY CHARITABLE CONTRIBUTIONS TO CHARITIES AND NON-PROFIT ORGANIZATIONS (U.S. CLS. 100, 101 AND 102).

FIRST USE 3-10-2011; IN COMMERCE 4-19-2011.

4,155,082. BIOFINA, INC., CONCORD, CA. SN 85-243,951. PUB. 6-28-2011, FILED 2-16-2011.

PLASTIFINA

THE MARK CONSISTS OF STANDARD CHARACTERS WITHOUT CLAIM TO ANY PARTICULAR FONT, STYLE, SIZE, OR COLOR.

CLASS 16—PAPER GOODS AND PRINTED MATTER

FOR PLASTIC BAGS FOR GENERAL PURPOSE; PLASTIC BAGS FOR UNDERGARMENT DISPOSAL; PLASTIC BUBBLE PACKS; PLASTIC FOOD STORAGE BAGS FOR HOUSEHOLD USE; PLASTIC BAGS FOR HOUSEHOLD USE; PLASTIC PAGES FOR HOLDING CARDS; PLASTIC SANDWICH BAGS; PLASTIC SHEETS AND LABELS FOR WRITING, PRINTING AND MARKING; AND PLASTIC GARBAGE BAGS (U.S. CLS. 2, 5, 22, 23, 29, 37, 38 AND 50).

FIRST USE 8-23-2011; IN COMMERCE 8-23-2011.

CLASS 17—RUBBER GOODS

FOR PLASTIC IN THE FORM OF BARS, PELLETS, RODS, SHEETS AND TUBES FOR GENERAL INDUSTRIAL USE; PLASTIC IN EXTRUDED FORM FOR GENERAL INDUSTRIAL USE; PLASTIC IN THE FORM OF BARS, PELLETS, RODS, SHEETS AND TUBES FOR USE IN MANUFACTURING; PLASTIC PACKING FOR SHIPPING CONTAINERS; PLASTIC SHEETING FOR PREVENTING WEED GROWTH; PLASTIC SHEETING FOR USE AS DROP CLOTHS; PLASTIC TAPE FOR USE IN COMMERCIAL MANUFACTURING (U.S. CLS. 1, 5, 12, 13, 35 AND 50).

FIRST USE 8-23-2011; IN COMMERCE 8-23-2011.

CLASS 21—HOUSEWARES AND GLASS

FOR PLASTIC GLOVES FOR HOUSEHOLD USE; PLASTIC CUPS (U.S. CLS. 2, 13, 23, 29, 30, 33, 40 AND 50).

FIRST USE 8-23-2011; IN COMMERCE 8-23-2011.

4,155,086. GORDINI U.S.A. INC., ESSEX JUNCTION, VT. SN 85-244,263. PUB. 8-16-2011, FILED 2-16-2011.

MAD GRIP

THE MARK CONSISTS OF STANDARD CHARACTERS WITHOUT CLAIM TO ANY PARTICULAR FONT, STYLE, SIZE, OR COLOR.

OWNER OF U.S. REG. NO. 3,828,668.

NO CLAIM IS MADE TO THE EXCLUSIVE RIGHT TO USE "GRIP", APART FROM THE MARK AS SHOWN.

CLASS 21—HOUSEWARES AND GLASS

FOR WORK GLOVES; GARDENING GLOVES; GLOVES FOR HOUSEHOLD PURPOSES; LIGHT DUTY UTILITY GLOVES (U.S. CLS. 2, 13, 23, 29, 30, 33, 40 AND 50).

FIRST USE 6-9-2010; IN COMMERCE 6-9-2010.

CLASS 28—TOYS AND SPORTING GOODS

FOR FOOTBALL GLOVES, KAYAK GLOVES, WIND-SURFING GLOVES (U.S. CLS. 22, 23, 38 AND 50).

FIRST USE 6-0-2010; IN COMMERCE 6-0-2010.

4,155,110. PRONTO GENERAL AGENCY, LTD. BROWNSVILLE, TX. SN 85-246,628. PUB. 6-28-2011, FILED 2-18-2011.



THE MARK CONSISTS OF AN SUPERHERO IN A STANDING POSE.

CLASS 35—ADVERTISING AND BUSINESS

FOR INCOME TAX CONSULTATION; INCOME TAX PREPARATION; TAX CONSULTATION (U.S. CLS. 100, 101 AND 102).

FIRST USE 2-23-2012; IN COMMERCE 2-23-2012.

CLASS 36—INSURANCE AND FINANCIAL

FOR ARRANGING OF LOANS; FINANCIAL CONSULTANCY AND INSURANCE CONSULTANCY; INSTALLMENT LOANS; INSURANCE AGENCY AND BROKERAGE; INSURANCE BROKERAGE SERVICES; PROVIDING TEMPORARY LOANS (U.S. CLS. 100, 101 AND 102).

FIRST USE 2-23-2012; IN COMMERCE 2-23-2012.

4,155,118. ASSISTED LIVING TECHNOLOGIES, INC., MERIDEN, CT. SN 85-248,361. PUB. 12-6-2011, FILED 2-22-2011.



NO CLAIM IS MADE TO THE EXCLUSIVE RIGHT TO USE "ASSISTED LIVING TECHNOLOGIES INC.", APART FROM THE MARK AS SHOWN.

THE COLOR(S) BLACK, WHITE, PURPLE, GREEN, RED, AND ORANGE IS/ARE CLAIMED AS A FEATURE OF THE MARK.

THE MARK CONSISTS OF A HORIZONTAL PURPLE LINE HAVING A SOLID CIRCLE AT ONE END ADJACENT TO THREE UPRIGHT AND SPACED ARCHED SEGMENTS IN GREEN, RED, AND ORANGE COLOR; ABOVE THE HORIZONTAL LINE ARE THE WORDS, "ASSISTED LIVING" IN BLACK; BELOW THE HORIZONTAL LINE ARE THE WORDS, "TECHNOLOGIES INC." IN BLACK WHEREIN INC. IS WRITTEN VERTICALLY NEXT TO THE "S" OF "TECHNOLOGIES". ADDITIONALLY, UNDERNEATH THE WORDS "TECHNOLOGIES INC." IS AN ELONGATED PURPLE OVAL WITHIN WHICH ARE THE WORDS "TECHNOLOGY SOLUTIONS FOR AGING IN PLACE" IN WHITE COLOR.

CLASS 35—ADVERTISING AND BUSINESS

FOR RETAIL STORE SERVICES FEATURING ACTIVITY MONITORING AND EMERGENCY DETECTION SYSTEMS AND PRODUCTS FOR IN-HOME MONITORING OR ASSISTED LIVING FACILITY MONITORING OF THE ELDERLY OR INFIRM; ON-LINE RETAIL STORE SERVICES FEATURING ACTIVITY MONITORING AND EMERGENCY DETECTION SYSTEMS AND PRODUCTS FOR IN-HOME MONITORING OR ASSISTED LIVING FACILITY MONITORING OF THE ELDERLY OR INFIRM (U.S. CLS. 100, 101 AND 102).

FIRST USE 10-0-2010; IN COMMERCE 11-14-2010.

CLASS 37—CONSTRUCTION AND REPAIR

FOR INSTALLATION AND MAINTENANCE OF ACTIVITY MONITORING AND EMERGENCY DETECTION SYSTEMS AND PRODUCTS USED IN THE FIELD OF IN-HOME MONITORING OF THE ELDERLY OR INFIRM, NAMELY, DOOR, CABINET AND BED USE SENSORS, APPLIANCE USE SENSORS, INFRARED MOTION DETECTORS, MOTION SENSING SYSTEMS, MOVEMENT SENSING SYSTEMS, MONITORED MEDICAL PRODUCT DISPENSING DEVICES, SMOKE DETECTORS, BURGLAR DETECTION SYSTEMS, WIRELESS NETWORK DEVICES, REMOTELY MONITORED IN-HOME ACTIVITY MONITORING AND EMERGENCY DETECTION SYSTEMS (U.S. CLS. 100, 103 AND 106).

FIRST USE 10-0-2010; IN COMMERCE 11-14-2010.

4,155,121. MAKING YOUR EVENT SPECIAL LLC, CARMEL, IN. SN 85-249,284. PUB. 7-12-2011, FILED 2-23-2011.

PRETTY PEAR BRIDE

THE MARK CONSISTS OF STANDARD CHARACTERS

WITHOUT CLAIM TO ANY PARTICULAR FONT, STYLE, SIZE, OR COLOR.

NO CLAIM IS MADE TO THE EXCLUSIVE RIGHT TO USE "BRIDE", APART FROM THE MARK AS SHOWN.

CLASS 35—ADVERTISING AND BUSINESS

FOR BUSINESS RESEARCH RELATING TO WEDDING PLANNING; PROVIDING AN ONLINE BUSINESS DIRECTORY INFORMATION SERVICE FEATURING INFORMATION REGARDING VENDORS OF PRODUCTS AND SERVICES RELATED TO WEDDINGS AND ENGAGEMENTS; PROMOTING AND SHOWCASING THE GOODS OF OTHERS IN THE FIELD OF WEDDING PLANNING BY MEANS OF A WEBSITE WITH ADVERTISEMENTS OF OTHERS (U.S. CLS. 100, 101 AND 102).

FIRST USE 4-24-2011; IN COMMERCE 4-24-2011.

CLASS 41—EDUCATION AND ENTERTAINMENT

FOR PROVIDING INFORMATION, ADVICE, AND CONSULTANCY RELATING TO WEDDING PLANNING (U.S. CLS. 100, 101 AND 107).

FIRST USE 4-24-2011; IN COMMERCE 4-24-2011.

4,155,123. SURVEY PLANET, LLC., SANTA MONICA, CA. SN 85-249,495. PUB. 9-6-2011, FILED 2-23-2011.

SURVEY PLANET

THE MARK CONSISTS OF STANDARD CHARACTERS WITHOUT CLAIM TO ANY PARTICULAR FONT, STYLE, SIZE, OR COLOR.

NO CLAIM IS MADE TO THE EXCLUSIVE RIGHT TO USE "SURVEY", APART FROM THE MARK AS SHOWN.

CLASS 35—ADVERTISING AND BUSINESS

FOR MARKET RESEARCH SERVICES; PROVIDING AN INTERACTIVE WEB SITE FEATURING EDUCATIONAL INFORMATION AND TEST QUESTIONS IN THE FIELD OF MARKET RESEARCH (U.S. CLS. 100, 101 AND 102).

FIRST USE 2-3-2012; IN COMMERCE 2-3-2012.

CLASS 42—SCIENTIFIC AND COMPUTER SERVICES

FOR HOSTING AN ONLINE COMMUNITY WEBSITE FOR USERS TO PARTICIPATE, CONDUCT AND MANAGE SURVEYS; PROVIDING TEMPORARY USE OF NON-DOWNLOADABLE COMPUTER APPLICATION FOR MOBILE DEVICES FOR CONDUCTING CONSUMER SURVEYS (U.S. CLS. 100 AND 101).

FIRST USE 2-3-2012; IN COMMERCE 2-3-2012.

4,155,124. SURVEY PLANET, LLC, SANTA MONICA, CA. SN 85-249,505. PUB. 9-6-2011, FILED 2-23-2011.

WHERE THE ANSWERS LIVE

THE MARK CONSISTS OF STANDARD CHARACTERS WITHOUT CLAIM TO ANY PARTICULAR FONT, STYLE, SIZE, OR COLOR.

CLASS 35—ADVERTISING AND BUSINESS

FOR MARKET RESEARCH SERVICES; PROVIDING AN INTERACTIVE WEB SITE FEATURING EDUCATIONAL INFORMATION AND TEST QUESTIONS IN THE FIELD OF MARKET RESEARCH (U.S. CLS. 100, 101 AND 102).

FIRST USE 2-3-2012; IN COMMERCE 2-3-2012.

CLASS 42—SCIENTIFIC AND COMPUTER SERVICES

FOR HOSTING AN ONLINE COMMUNITY WEBSITE FOR USERS TO PARTICIPATE, CONDUCT AND MANAGE SURVEYS; PROVIDING TEMPORARY USE OF NON-DOWNLOADABLE COMPUTER APPLICATION FOR MOBILE DEVICES FOR CONDUCTING CONSUMER SURVEYS (U.S. CLS. 100 AND 101).

FIRST USE 2-3-2012; IN COMMERCE 2-3-2012.

4,155,128. VOTEBLAST, INC., WEST HOLLYWOOD, CA. SN 85-250,333. PUB. 7-19-2011, FILED 2-24-2011.



THE COLOR(S) RED, YELLOW, GREEN AND BLUE IS/ ARE CLAIMED AS A FEATURE OF THE MARK.

THE MARK CONSISTS OF A RED FROWN FACE, YELLOW NEUTRAL FACE, GREEN SMILEY FACE, AND BLUE CIRCLE DESIGN WITH STARS. THE COLOR GRAY APPEARS AS A SHADOW REFLECTION BEHIND THE FACES AND CIRCLE IN THE MARK BUT IS NOT CLAIMED AS A FEATURE OF THE MARK.

CLASS 35—ADVERTISING AND BUSINESS

FOR ADVERTISING, MARKETING AND PROMOTION SERVICES; MARKETING SERVICES, NAMELY, PROMOTING THE GOODS AND SERVICES OF OTHERS; BRAND IMAGERY CONSULTING SERVICES; MARKET OPINION POLLING STUDIES; CONDUCTING BUSINESS AND MARKET RESEARCH SURVEYS; PROVIDING A SEARCHABLE WEBSITE FEATURING THE GOODS AND SERVICES OF OTHER VENDORS; PROVIDING A WEBSITE WHERE USERS CAN POST RATINGS, REVIEWS AND RECOMMENDATIONS ON PRODUCTS AND SERVICES FOR COMMERCIAL PURPOSES (U.S. CLS. 100, 101 AND 102).

FIRST USE 11-0-2010; IN COMMERCE 11-0-2010.

CLASS 42—SCIENTIFIC AND COMPUTER SERVICES

FOR COMPUTER SERVICE, NAMELY, ACTING AS AN APPLICATION SERVICE PROVIDER IN THE FIELD OF INFORMATION MANAGEMENT TO HOST COMPUTER APPLICATION SOFTWARE FOR THE PURPOSE OF DISPLAY, COLLECTION, EDITING, ORGANIZING, MODIFYING, TRANSMISSION, STORAGE AND SHARING OF DATA AND INFORMATION IN THE FIELD OF SURVEY AND OPINION SERVICES (U.S. CLS. 100 AND 101).

FIRST USE 11-0-2010; IN COMMERCE 11-0-2010.

4,155,129. VOTEBLAST, INC., WEST HOLLYWOOD, CA. SN 85-250,389. PUB. 7-19-2011, FILED 2-24-2011.

VOTEBLAST

THE MARK CONSISTS OF STANDARD CHARACTERS WITHOUT CLAIM TO ANY PARTICULAR FONT, STYLE, SIZE, OR COLOR.

CLASS 35—ADVERTISING AND BUSINESS

FOR ADVERTISING, MARKETING AND PROMOTION SERVICES; MARKETING SERVICES, NAMELY, PROMOTING THE GOODS AND SERVICES OF OTHERS; BRAND IMAGERY CONSULTING SERVICES; MARKET OPINION POLLING STUDIES; CONDUCTING BUSINESS AND MARKET RESEARCH SURVEYS; PROVIDING A SEARCHABLE WEBSITE FEATURING THE GOODS AND SERVICES OF OTHER VENDORS; PROVIDING A WEBSITE WHERE USERS CAN POST RATINGS, REVIEWS AND RECOMMENDATIONS ON PRODUCTS AND SERVICES FOR COMMERCIAL PURPOSES (U.S. CLS. 100, 101 AND 102).

FIRST USE 11-0-2010; IN COMMERCE 11-0-2010.

CLASS 42—SCIENTIFIC AND COMPUTER SERVICES

FOR COMPUTER SERVICE, NAMELY, ACTING AS AN APPLICATION SERVICE PROVIDER IN THE FIELD OF INFORMATION MANAGEMENT TO HOST COMPUTER APPLICATION SOFTWARE FOR THE PURPOSE OF DISPLAY, COLLECTION, EDITING, ORGANIZING, MODIFYING, TRANSMISSION, STORAGE AND SHARING OF DATA AND INFORMATION IN THE FIELD OF SURVEY AND OPINION SERVICES (U.S. CLS. 100 AND 101).

FIRST USE 11-0-2010; IN COMMERCE 11-0-2010.

4,155,131. VOTEBLAST, INC., WEST HOLLYWOOD, CA. SN 85-250,469. PUB. 7-19-2011, FILED 2-24-2011.



THE MARK CONSISTS OF A FROWN FACE, NEUTRAL FACE, SMILEY FACE, AND A CIRCLE DESIGN WITH STARS.

CLASS 35—ADVERTISING AND BUSINESS

FOR ADVERTISING, MARKETING AND PROMOTION SERVICES; MARKETING SERVICES, NAMELY, PROMOTING THE GOODS AND SERVICES OF OTHERS; BRAND IMAGERY CONSULTING SERVICES; MARKET OPINION POLLING STUDIES; CONDUCTING BUSINESS AND MARKET RESEARCH SURVEYS; PROVIDING A SEARCHABLE WEBSITE FEATURING THE GOODS AND SERVICES OF OTHER VENDORS; PROVIDING A WEBSITE WHERE USERS CAN POST RATINGS, REVIEWS AND RECOMMENDATIONS ON PRODUCTS AND SERVICES FOR COMMERCIAL PURPOSES (U.S. CLS. 100, 101 AND 102).

FIRST USE 11-0-2010; IN COMMERCE 11-0-2010.

CLASS 42—SCIENTIFIC AND COMPUTER SERVICES

FOR COMPUTER SERVICE, NAMELY, ACTING AS AN APPLICATION SERVICE PROVIDER IN THE FIELD OF INFORMATION MANAGEMENT TO HOST COMPUTER APPLICATION SOFTWARE FOR THE PURPOSE OF DISPLAY, COLLECTION, EDITING, ORGANIZING, MODIFYING, TRANSMISSION, STORAGE AND SHARING OF DATA AND INFORMATION IN THE FIELD OF SURVEY AND OPINION SERVICES (U.S. CLS. 100 AND 101).

FIRST USE 11-0-2010; IN COMMERCE 11-0-2010.

4,155,137. THE ARELI GROUP, LLC, BLOOMSBURY, NJ. SN 85-250,762. PUB. 7-19-2011, FILED 2-24-2011.

PROMOVERSE

THE MARK CONSISTS OF STANDARD CHARACTERS WITHOUT CLAIM TO ANY PARTICULAR FONT, STYLE, SIZE, OR COLOR.

CLASS 9—ELECTRICAL AND SCIENTIFIC APPARATUS

FOR COMPUTER APPLICATION SOFTWARE FOR MOBILE PHONES AND HANDHELD COMPUTERS, NAMELY, SOFTWARE FOR USE IN DISTRIBUTING ADVERTISING AND PROMOTIONAL INFORMATION (U.S. CLS. 21, 23, 26, 36 AND 38).

FIRST USE 10-20-2011; IN COMMERCE 10-20-2011.

CLASS 35—ADVERTISING AND BUSINESS

FOR ADVERTISING SERVICES (U.S. CLS. 100, 101 AND 102).

FIRST USE 10-20-2011; IN COMMERCE 10-20-2011.

4,155,151. LIBERTY MUTUAL INSURANCE COMPANY, BOSTON, MA. SN 85-252,019. PUB. 6-14-2011, FILED 2-25-2011.

VANTAGEPORT

THE MARK CONSISTS OF STANDARD CHARACTERS

WITHOUT CLAIM TO ANY PARTICULAR FONT, STYLE, SIZE, OR COLOR.

CLASS 36—INSURANCE AND FINANCIAL

FOR PROVIDING A WEBSITE FEATURING INSURANCE INFORMATION FOR INSURED, AGENTS AND BROKERS (U.S. CLS. 100, 101 AND 102).

FIRST USE 3-12-2012; IN COMMERCE 3-12-2012.

CLASS 42—SCIENTIFIC AND COMPUTER SERVICES

FOR COMPUTER SERVICES, NAMELY, PROVIDING A WEB-BASED SYSTEM AND ONLINE PORTAL FEATURING ON-LINE NONDOWNLOADABLE SOFTWARE THAT ENABLES CONSUMERS, AGENTS, AND BROKERS TO ACCESS INFORMATION AND MARKETING MATERIALS IN THE FIELD OF INSURANCE (U.S. CLS. 100 AND 101).

FIRST USE 3-12-2012; IN COMMERCE 3-12-2012.

4,155,159. GENERAL ELECTRIC COMPANY, SCHENECTADY, NY. SN 85-253,046. PUB. 7-5-2011, FILED 2-28-2011.

MYFLEET

THE MARK CONSISTS OF STANDARD CHARACTERS WITHOUT CLAIM TO ANY PARTICULAR FONT, STYLE, SIZE, OR COLOR.

CLASS 9—ELECTRICAL AND SCIENTIFIC APPARATUS

FOR SOFTWARE FOR POWER PLANT OPTIMIZATION AND PLANT HEALTH OVERVIEW; HARDWARE FOR POWER PLANT OPTIMIZATION (U.S. CLS. 21, 23, 26, 36 AND 38).

FIRST USE 3-10-2011; IN COMMERCE 3-10-2011.

CLASS 37—CONSTRUCTION AND REPAIR

FOR MAINTENANCE SERVICES IN THE FIELD OF POWER PLANT OPTIMIZATION (U.S. CLS. 100, 103 AND 106).

FIRST USE 3-10-2011; IN COMMERCE 3-10-2011.

CLASS 42—SCIENTIFIC AND COMPUTER SERVICES

FOR CONSULTING SERVICES IN THE FIELD OF POWER PLANT OPTIMIZATION; ENGINEERING SERVICES IN THE FIELD OF POWER PLANT OPTIMIZATION (U.S. CLS. 100 AND 101).

FIRST USE 3-10-2011; IN COMMERCE 3-10-2011.

4,155,160. UNITED SITE SERVICES, INC., WESTBOROUGH, MA. SN 85-253,052. PUB. 12-6-2011, FILED 2-28-2011.

UNITED EVENT SERVICES

THE MARK CONSISTS OF STANDARD CHARACTERS WITHOUT CLAIM TO ANY PARTICULAR FONT, STYLE, SIZE, OR COLOR.

OWNER OF U.S. REG. NOS. 2,489,124, 2,954,365, AND OTHERS.

NO CLAIM IS MADE TO THE EXCLUSIVE RIGHT TO USE "EVENT SERVICES", APART FROM THE MARK AS SHOWN.

CLASS 37—CONSTRUCTION AND REPAIR

FOR RENTAL OF TEMPORARY SITE FENCING (U.S. CLS. 100, 103 AND 106).
FIRST USE 9-8-2011; IN COMMERCE 9-8-2011.

CLASS 39—TRANSPORTATION AND STORAGE

FOR RENTAL OF STORAGE CONTAINERS AND MOBILE OFFICE TRAILERS FOR EVENTS AND ACTIVITIES (U.S. CLS. 100 AND 105).
FIRST USE 9-8-2011; IN COMMERCE 9-8-2011.

CLASS 44—MEDICAL, BEAUTY AND AGRICULTURAL SERVICES

FOR RENTAL OF SANITARY FACILITIES AND PORTABLE WATER SUPPLY UNITS (U.S. CLS. 100 AND 101).
FIRST USE 9-8-2011; IN COMMERCE 9-8-2011.

4,155,161. UNITED SITE SERVICES, INC., WESTBOROUGH, MA. SN 85-253,100. PUB. 12-6-2011, FILED 2-28-2011.

UNITED AGRICULTURAL SERVICES

THE MARK CONSISTS OF STANDARD CHARACTERS WITHOUT CLAIM TO ANY PARTICULAR FONT, STYLE, SIZE, OR COLOR.

OWNER OF U.S. REG. NOS. 2,489,124, 2,954,365, AND OTHERS.

NO CLAIM IS MADE TO THE EXCLUSIVE RIGHT TO USE "AGRICULTURAL SERVICES", APART FROM THE MARK AS SHOWN.

CLASS 37—CONSTRUCTION AND REPAIR

FOR RENTAL OF TEMPORARY SITE FENCING (U.S. CLS. 100, 103 AND 106).
FIRST USE 1-3-2012; IN COMMERCE 1-3-2012.

CLASS 39—TRANSPORTATION AND STORAGE

FOR RENTAL OF STORAGE CONTAINERS AND MOBILE OFFICE TRAILERS FOR EVENTS AND ACTIVITIES (U.S. CLS. 100 AND 105).
FIRST USE 1-3-2012; IN COMMERCE 1-3-2012.

CLASS 44—MEDICAL, BEAUTY AND AGRICULTURAL SERVICES

FOR RENTAL OF SANITARY FACILITIES AND PORTABLE WATER SUPPLY UNITS (U.S. CLS. 100 AND 101).
FIRST USE 1-3-2012; IN COMMERCE 1-3-2012.

4,155,171. ADAMS, JASON, LOGANDALE, NV. SN 85-253,775. PUB. 7-5-2011, FILED 2-28-2011.



THE MARK CONSISTS OF A STYLIZED "X", WITH A LINE VERTICALLY BISECTING THE "X", AND A LINE CONNECTING EACH TINE OF THE "X" WITH THE TINE IMMEDIATELY PARALLEL.

CLASS 9—ELECTRICAL AND SCIENTIFIC APPARATUS

FOR FRAMES FOR SPECTACLES AND SUNGLASSES; LENSES FOR SUNGLASSES; SUNGLASS CHAINS AND CORDS; SUNGLASSES; SUNGLASSES AND SPECTACLES (U.S. CLS. 21, 23, 26, 36 AND 38).
FIRST USE 5-1-2011; IN COMMERCE 8-1-2011.

CLASS 25—CLOTHING

FOR FOOTWEAR; HATS; HOODS; JACKETS; LOUNGEWEAR; SHIRTS AND SHORT-SLEEVED SHIRTS; SHORT-SLEEVED OR LONG-SLEEVED T-SHIRTS; SWEAT PANTS; SWEAT SHIRTS; TANK TOPS (U.S. CLS. 22 AND 39).
FIRST USE 5-1-2011; IN COMMERCE 8-1-2011.

4,155,179. SPANGLER, MARY, FULLERTON, CA. SN 85-254,319. PUB. 7-26-2011, FILED 3-1-2011.

Eat n' Run fitness

THE MARK CONSISTS OF STANDARD CHARACTERS WITHOUT CLAIM TO ANY PARTICULAR FONT, STYLE, SIZE, OR COLOR.

NO CLAIM IS MADE TO THE EXCLUSIVE RIGHT TO USE "FITNESS", APART FROM THE MARK AS SHOWN.

CLASS 41—EDUCATION AND ENTERTAINMENT

FOR PERSONAL FITNESS TRAINING SERVICES AND CONSULTANCY (U.S. CLS. 100, 101 AND 107). FIRST USE 6-8-2011; IN COMMERCE 6-9-2011.

CLASS 44—MEDICAL, BEAUTY AND AGRICULTURAL SERVICES

FOR DIETARY AND NUTRITIONAL GUIDANCE (U.S. CLS. 100 AND 101). FIRST USE 6-8-2011; IN COMMERCE 6-9-2011.

CLASS 36—INSURANCE AND FINANCIAL

FOR ELECTRONIC PAYMENT, NAMELY, ELECTRONIC PROCESSING AND TRANSMISSION OF BILL PAYMENT DATA; BILL PAYMENT SERVICES PROVIDED THROUGH A WEBSITE; ONLINE PAYMENT COLLECTION SERVICES FOR OTHERS; PAYMENT PROCESSING SERVICES, NAMELY, CREDIT CARD AND DEBIT CARD TRANSACTION PROCESSING SERVICES; PROVIDING SECURED CREDIT CARD PAYMENT PROCESSING VIA THE INTERNET; MERCHANT SERVICES, NAMELY, PAYMENT TRANSACTION PROCESSING SERVICES; PROVIDING ELECTRONIC PROCESSING OF CREDIT CARD TRANSACTIONS AND ELECTRONIC PAYMENTS VIA A GLOBAL COMPUTER NETWORK; MERCHANT SERVICES, NAMELY, PAYMENT TRANSACTION PROCESSING SERVICES (U.S. CLS. 100, 101 AND 102). FIRST USE 3-17-2011; IN COMMERCE 3-17-2011.

4,155,181. BRIGHT MARKET, LLC, DBA FASTSPRING, SANTA BARBARA, CA. SN 85-254,658. PUB. 9-13-2011, FILED 3-1-2011.

SAASY

THE MARK CONSISTS OF STANDARD CHARACTERS WITHOUT CLAIM TO ANY PARTICULAR FONT, STYLE, SIZE, OR COLOR.

CLASS 35—ADVERTISING AND BUSINESS

FOR FACILITATING E-COMMERCE BUSINESS TRANSACTIONS BY PROCESSING ELECTRONIC ORDERS OF PURCHASES OF GOODS AND SERVICES VIA A GLOBAL COMPUTER NETWORK FOR OTHERS; FULFILLMENT OF ELECTRONIC ORDERS FOR SOFTWARE, E-BOOKS, ELECTRONIC GAMES, SOFTWARE AS A SERVICE (SAAS) SERVICES, AND OTHER DIGITAL CONTENT AND PRODUCTS VIA A GLOBAL COMPUTER NETWORK; ON-LINE ORDER FULFILLMENT SERVICES FOR OTHERS; ON-LINE RETAIL STORE SERVICES FEATURING COMPUTER SOFTWARE, E-BOOKS, ELECTRONIC GAMES, SOFTWARE AS A SERVICE (SAAS) SERVICES, AND OTHER DIGITAL CONTENT AND PRODUCTS; ON-LINE MARKETING SERVICES FOR SELLERS OF COMPUTER SOFTWARE, E-BOOKS, ELECTRONIC GAMES, SOFTWARE AS A SERVICE (SAAS) SERVICES, AND OTHER DIGITAL CONTENT AND PRODUCTS, NAMELY, DEVELOPING AND IMPLEMENTING ONLINE MARKETING AND ADVERTISING THROUGH THE USE OF PARTNERSHIPS BETWEEN SOFTWARE PUBLISHERS, DISTRIBUTORS, ADVERTISERS, AFFILIATES AND RESELLERS TO INCREASE SALES AND REVENUES; ADVERTISING, MARKETING AND PROMOTIONAL SERVICES; SUBSCRIPTION MANAGEMENT SERVICES AS A SUBSCRIPTION AGENT BETWEEN PUBLISHERS AND CUSTOMERS FOR E-COMMERCE SERVICES; PROVIDING CROSS-SELLING OPPORTUNITIES TO CUSTOMERS THAT SELL SUBSCRIPTION E-COMMERCE SERVICES AND SOFTWARE AS A SERVICE (SAAS) SERVICES, NAMELY, PROMOTING THE SALE OF GOODS AND SERVICES OF OTHERS BY SUGGESTING COMPLEMENTARY CROSS-SELL GOODS OR SERVICES TO ALREADY PURCHASED GOODS OR SERVICES; ONLINE BILLING; CUSTOMER RELATIONSHIP MANAGEMENT; CUSTOMER SERVICE MANAGEMENT FOR OTHERS; BUSINESS MANAGEMENT SERVICES, NAMELY, CUSTOMER RESPONSE-HANDLING AND PAYMENT SERVICES RELATING TO SUBSCRIPTION E-COMMERCE SERVICES (U.S. CLS. 100, 101 AND 102). FIRST USE 3-17-2011; IN COMMERCE 3-17-2011.

CLASS 42—SCIENTIFIC AND COMPUTER SERVICES

FOR APPLICATION SERVICE PROVIDER (ASP) FEATURING SOFTWARE FOR E-COMMERCE PAYMENT PROCESSING, MERCHANDISING, SUBSCRIPTION MANAGEMENT, AND FULFILLMENT SERVICES, FOR USE IN THE DISTRIBUTION, PUBLICATION, SALE AND LICENSING OF E-BOOKS, SOFTWARE, ELECTRONIC GAMES, SOFTWARE AS A SERVICE (SAAS) SERVICES, AND OTHER DIGITAL PRODUCTS AND CONTENT; SOFTWARE AS A SERVICE (SAAS) SERVICES, NAMELY, HOSTING SOFTWARE FOR USE BY OTHERS FOR USE WITH E-COMMERCE PAYMENT PROCESSING, MERCHANDISING, SUBSCRIPTION MANAGEMENT, AND FULFILLMENT SERVICES, FOR USE IN THE DISTRIBUTION, PUBLICATION, SALE AND LICENSING OF E-BOOKS, SOFTWARE, ELECTRONIC GAMES, SOFTWARE AS A SERVICE (SAAS) SERVICES, AND OTHER DIGITAL PRODUCTS AND CONTENT; SOFTWARE AS A SERVICE (SAAS) SERVICES FEATURING SOFTWARE FOR USE WITH E-COMMERCE PAYMENT PROCESSING, MERCHANDISING, SUBSCRIPTION MANAGEMENT, AND FULFILLMENT SERVICES, FOR USE IN THE DISTRIBUTION, PUBLICATION, SALE AND LICENSING OF E-BOOKS, SOFTWARE, ELECTRONIC GAMES, SOFTWARE AS A SERVICE (SAAS) SERVICES, AND OTHER DIGITAL PRODUCTS AND CONTENT; SOFTWARE AS A SERVICE (SAAS) SERVICES FEATURING SOFTWARE FOR USE WITH E-COMMERCE PAYMENT PROCESSING, MERCHANDISING, SUBSCRIPTION MANAGEMENT, AND FULFILLMENT SERVICES, FOR USE IN THE DISTRIBUTION, PUBLICATION, SALE AND LICENSING OF E-BOOKS, SOFTWARE, ELECTRONIC GAMES, SOFTWARE AS A SERVICE (SAAS) SERVICES, AND OTHER DIGITAL PRODUCTS AND CONTENT; SOFTWARE AS A SERVICE (SAAS) SERVICES FEATURING SOFTWARE FOR USE WITH E-COMMERCE PAYMENT PROCESSING, MERCHANDISING, SUBSCRIPTION MANAGEMENT, AND FULFILLMENT SERVICES, FOR USE IN THE DISTRIBUTION, PUBLICATION, SALE AND LICENSING OF E-BOOKS, SOFTWARE, ELECTRONIC GAMES, SOFTWARE AS A SERVICE (SAAS) SERVICES, AND OTHER DIGITAL PRODUCTS AND CONTENT; DESIGN AND DEVELOPMENT OF COMPUTER SOFTWARE FOR THE IMPROVEMENTS OF PURCHASING FUNCTIONS OF BUSINESSES; DESIGN OF COMPUTER NETWORKS AND SOFTWARE FOR

OTHERS FOR THE FACILITATION OF E-COMMERCE BUSINESS TRANSACTIONS; PROVIDING A WEBSITE FEATURING NON-DOWNLOADABLE SOFTWARE FOR E-COMMERCE PAYMENT PROCESSING, MERCHANDISING, SUBSCRIPTION MANAGEMENT, AND FULFILLMENT SERVICES, FOR USE IN THE DISTRIBUTION, PUBLICATION, SALE AND LICENSING OF E-BOOKS, SOFTWARE, ELECTRONIC GAMES, SOFTWARE AS A SERVICE (SAAS) SERVICES, AND OTHER DIGITAL PRODUCTS AND CONTENT; PROVIDING TEMPORARY USE OF A WEB-BASED SOFTWARE APPLICATION FOR E-COMMERCE PAYMENT PROCESSING, MERCHANDISING, SUBSCRIPTION MANAGEMENT, AND FULFILLMENT SERVICES, FOR USE IN THE DISTRIBUTION, PUBLICATION, SALE AND LICENSING OF E-BOOKS, SOFTWARE, ELECTRONIC GAMES, SOFTWARE AS A SERVICE (SAAS) SERVICES, AND OTHER DIGITAL PRODUCTS AND CONTENT; PROVIDING TEMPORARY USE OF ON-LINE NON-DOWNLOADABLE SOFTWARE AND APPLICATIONS FOR E-COMMERCE PAYMENT PROCESSING, MERCHANDISING, SUBSCRIPTION MANAGEMENT, AND FULFILLMENT SERVICES, FOR USE IN THE DISTRIBUTION, PUBLICATION, SALE AND LICENSING OF E-BOOKS, SOFTWARE, ELECTRONIC GAMES, SOFTWARE AS A SERVICE (SAAS) SERVICES, AND OTHER DIGITAL PRODUCTS AND CONTENT (U.S. CLS. 100 AND 101).

FIRST USE 3-17-2011; IN COMMERCE 3-17-2011.

4,155,182. BRIGHT MARKET, LLC, DBA FASTSPRING, SANTA BARBARA, CA. SN 85-254,666. PUB. 9-13-2011, FILED 3-1-2011.

SAASY A FastSpring Service

THE MARK CONSISTS OF STANDARD CHARACTERS WITHOUT CLAIM TO ANY PARTICULAR FONT, STYLE, SIZE, OR COLOR.

OWNER OF U.S. REG. NO. 3,327,275.

NO CLAIM IS MADE TO THE EXCLUSIVE RIGHT TO USE "SERVICE", APART FROM THE MARK AS SHOWN.

CLASS 35—ADVERTISING AND BUSINESS

FOR FACILITATING E-COMMERCE BUSINESS TRANSACTIONS BY PROCESSING ELECTRONIC ORDERS OF PURCHASES OF GOODS AND SERVICES VIA A GLOBAL COMPUTER NETWORK FOR OTHERS; FULFILLMENT OF ELECTRONIC ORDERS FOR SOFTWARE, E-BOOKS, ELECTRONIC GAMES, SOFTWARE AS A SERVICE (SAAS) SERVICES, AND OTHER DIGITAL CONTENT AND PRODUCTS VIA A GLOBAL COMPUTER NETWORK; ON-LINE ORDER FULFILLMENT SERVICES FOR OTHERS; ON-LINE RETAIL STORE SERVICES FEATURING COMPUTER SOFTWARE, E-BOOKS, ELECTRONIC GAMES, SOFTWARE AS A SERVICE (SAAS) SERVICES, AND OTHER DIGITAL CONTENT AND PRODUCTS; ON-LINE MARKETING SERVICES FOR SELLERS OF COMPUTER SOFTWARE, E-BOOKS, ELECTRONIC GAMES, SOFTWARE AS A SERVICE (SAAS) SERVICES, AND OTHER DIGITAL CONTENT AND PRODUCTS, NAMELY, DEVELOPING AND IMPLEMENTING ONLINE MARKETING AND ADVERTISING THROUGH THE USE OF PARTNERSHIPS BETWEEN SOFTWARE PUBLISHERS, DISTRIBUTORS, ADVERTISERS, AFFILIATES AND RESELLERS TO INCREASE SALES AND REVENUES; ADVERTISING, MARKETING AND PROMOTIONAL SERVICES; SUBSCRIPTION MANAGEMENT SERVICES AS A SUBSCRIPTION AGENT BETWEEN PUBLISHERS AND CUSTOMERS FOR E-COMMERCE SERVICES; PROVIDING CROSS-SELLING OPPORTUNITIES TO CUSTOMERS THAT SELL SUBSCRIPTION E-COMMERCE SERVICES AND SOFTWARE AS A SERVICE (SAAS) SERVICES, NAMELY, PROMOTING THE SALE OF GOODS AND SERVICES OF OTHERS BY SUGGESTING COMPLEMENTARY CROSS-SELL GOODS AND SERVICES TO ALREADY PURCHASED GOODS OR SERVICES; ONLINE BILLING; CUSTOMER RELATIONSHIP MANAGEMENT; CUSTOMER SERVICE MANAGEMENT FOR OTHERS; BUSINESS MANAGEMENT SERVICES, NAMELY, CUSTOMER RESPONSE-HANDLING AND PAYMENT SERVICES RELATING TO SUBSCRIPTION E-COMMERCE SERVICES (U.S. CLS. 100, 101 AND 102).

FIRST USE 3-17-2011; IN COMMERCE 3-17-2011.

CLASS 36—INSURANCE AND FINANCIAL

FOR ELECTRONIC PAYMENT, NAMELY, ELECTRONIC PROCESSING AND TRANSMISSION OF BILL PAYMENT DATA; BILL PAYMENT SERVICES PROVIDED THROUGH A WEBSITE; ONLINE PAYMENT COLLECTION SERVICES FOR OTHERS; PAYMENT PROCESSING SERVICES, NAMELY, CREDIT CARD AND DEBIT CARD TRANSACTION PROCESSING SERVICES; PROVIDING SECURED CREDIT CARD PAYMENT PROCESSING VIA THE INTERNET; MERCHANT SERVICES, NAMELY, PAYMENT TRANSACTION PROCESSING SERVICES; PROVIDING ELECTRONIC PROCESSING OF CREDIT CARD TRANSACTIONS AND ELECTRONIC PAYMENTS VIA A GLOBAL COMPUTER NETWORK; MERCHANT SERVICES, NAMELY, PAYMENT TRANSACTION PROCESSING SERVICES (U.S. CLS. 100, 101 AND 102).

FIRST USE 3-17-2011; IN COMMERCE 3-17-2011.

CLASS 42—SCIENTIFIC AND COMPUTER SERVICES

FOR APPLICATION SERVICE PROVIDER (ASP) FEATURING SOFTWARE FOR E-COMMERCE PAYMENT PROCESSING, MERCHANDISING, SUBSCRIPTION MANAGEMENT, AND FULFILLMENT SERVICES, FOR USE IN THE DISTRIBUTION, PUBLICATION, SALE AND LICENSING OF E-BOOKS, SOFTWARE, ELECTRONIC GAMES, SOFTWARE AS A SERVICE (SAAS) SERVICES, AND OTHER DIGITAL PRODUCTS AND CONTENT; SOFTWARE AS A SERVICE (SAAS) SERVICES, NAMELY, HOSTING SOFTWARE FOR USE BY OTHERS FOR USE WITH E-COMMERCE PAYMENT PROCESSING, MERCHANDISING, SUBSCRIPTION MANAGEMENT, AND FULFILLMENT SERVICES, FOR USE IN THE DISTRIBUTION, PUBLICATION, SALE AND LICENSING OF E-BOOKS, SOFTWARE, ELECTRONIC GAMES, SOFTWARE AS A SERVICE (SAAS) SERVICES, AND OTHER DIGITAL PRODUCTS AND CONTENT; SOFTWARE AS A SERVICE (SAAS) SERVICES FEATURING SOFTWARE FOR USE WITH E-

COMMERCE PAYMENT PROCESSING, MERCHANDISING, SUBSCRIPTION MANAGEMENT, AND FULFILLMENT SERVICES, FOR USE IN THE DISTRIBUTION, PUBLICATION, SALE AND LICENSING OF E-BOOKS, SOFTWARE, ELECTRONIC GAMES, SOFTWARE AS A SERVICE (SAAS) SERVICES, AND OTHER DIGITAL PRODUCTS AND CONTENT; SOFTWARE AS A SERVICE (SAAS) SERVICES FEATURING SOFTWARE FOR SUBSCRIPTION SERVICE MANAGEMENT, CUSTOMER SERVICE, AND BILLING AND PAYMENT TRACKING, ANALYSIS, AND MANAGEMENT; DEVELOPING AND HOSTING A SERVER ON A GLOBAL COMPUTER NETWORK FOR THE PURPOSE OF FACILITATING E-COMMERCE VIA SUCH A SERVER; COMPUTER SERVICES, NAMELY, PROVIDING A WEB-BASED SYSTEM AND ONLINE PORTAL FOR CUSTOMERS TO REMOTELY MANAGE, AND MODIFY THEIR END USER COMPUTER DEVICES, DATA AND SOFTWARE APPLICATIONS; COMPUTER SERVICES, NAMELY, COMPUTER SYSTEMS INTEGRATION; CREATION, DESIGN, DEVELOPMENT AND MAINTENANCE OF WEB SITES FOR THIRD PARTIES, NAMELY, CUSTOMIZING A HOSTED WEB PAGE THAT INTEGRATES WITH THE EXISTING WEBSITES OF OTHERS, AND IS DISPLAYED TO CUSTOMERS IN THEIR LOCAL LANGUAGE AND CURRENCY; COMPUTER SERVICES, NAMELY, ACTING AS AN APPLICATION SERVICE PROVIDER IN THE FIELD OF INFORMATION MANAGEMENT TO HOST COMPUTER APPLICATION SOFTWARE FOR THE PURPOSE OF HOSTING ORDER PAGES FOR CUSTOMERS, FOR USE IN THE DISTRIBUTION, PUBLICATION, SALE AND LICENSING OF E-BOOKS, SOFTWARE, ELECTRONIC GAMES, SOFTWARE AS A SERVICE (SAAS) SERVICES, AND OTHER DIGITAL PRODUCTS AND CONTENT; CLOUD COMPUTING FEATURING SOFTWARE FOR USE WITH E-COMMERCE PAYMENT PROCESSING, MERCHANDISING, SUBSCRIPTION MANAGEMENT, AND FULFILLMENT SERVICES, FOR USE IN THE DISTRIBUTION, PUBLICATION, SALE AND LICENSING OF E-BOOKS, SOFTWARE, ELECTRONIC GAMES, SOFTWARE AS A SERVICE (SAAS) SERVICES, AND OTHER DIGITAL PRODUCTS AND CONTENT; DESIGN AND DEVELOPMENT OF COMPUTER SOFTWARE FOR THE IMPROVEMENTS OF PURCHASING FUNCTIONS OF BUSINESSES; DESIGN OF COMPUTER NETWORKS AND SOFTWARE FOR OTHERS FOR THE FACILITATION OF E-COMMERCE BUSINESS TRANSACTIONS; PROVIDING A WEBSITE FEATURING NON-DOWNLOADABLE SOFTWARE FOR E-COMMERCE PAYMENT PROCESSING, MERCHANDISING, SUBSCRIPTION MANAGEMENT, AND FULFILLMENT SERVICES, FOR USE IN THE DISTRIBUTION, PUBLICATION, SALE AND LICENSING OF E-BOOKS, SOFTWARE, ELECTRONIC GAMES, SOFTWARE AS A SERVICE (SAAS) SERVICES, AND OTHER DIGITAL PRODUCTS AND CONTENT; PROVIDING TEMPORARY USE OF A WEB-BASED SOFTWARE APPLICATION FOR E-COMMERCE PAYMENT PROCESSING, MERCHANDISING, SUBSCRIPTION MANAGEMENT, AND FULFILLMENT SERVICES, FOR USE IN THE DISTRIBUTION, PUBLICATION, SALE AND LICENSING OF E-BOOKS, SOFTWARE, ELECTRONIC GAMES, SOFTWARE AS A SERVICE (SAAS) SERVICES, AND OTHER DIGITAL PRODUCTS AND CONTENT; PROVIDING TEMPORARY USE OF ONLINE NON-DOWNLOADABLE SOFTWARE AND APPLICATIONS FOR E-COMMERCE PAYMENT PROCESSING, MERCHANDISING, SUBSCRIPTION MANAGEMENT, AND FULFILLMENT SERVICES, FOR USE IN THE DISTRIBUTION, PUBLICATION, SALE AND LICENSING OF E-BOOKS, SOFTWARE, ELECTRONIC GAMES, SOFTWARE AS A SERVICE (SAAS) SERVICES, AND OTHER DIGITAL PRODUCTS AND CONTENT (U.S. CLS. 100 AND 101).

FIRST USE 3-17-2011; IN COMMERCE 3-17-2011.

4,155,190. MR. CARPET COMPANY, CHICAGO, IL. SN 85-255,014. PUB. 8-9-2011, FILED 3-1-2011.

WE LIVE CARPET SO YOU CAN
LIVE ON IT

THE MARK CONSISTS OF STANDARD CHARACTERS WITHOUT CLAIM TO ANY PARTICULAR FONT, STYLE, SIZE, OR COLOR.

CLASS 35—ADVERTISING AND BUSINESS

FOR ON-LINE RETAIL STORE AND SHOP-AT-HOME SERVICES, ALL IN THE FIELDS OF CARPETING, FLOORING, FLOOR REFINISHING, STAIR RUNNERS, CUSTOM CLOSETS, AND WINDOW TREATMENTS (U.S. CLS. 100, 101 AND 102).

FIRST USE 4-2-2012; IN COMMERCE 4-2-2012.

CLASS 37—CONSTRUCTION AND REPAIR

FOR INSTALLATION SERVICES IN THE FIELDS OF CARPETING, FLOORING, FLOOR REFINISHING, STAIR RUNNERS, CUSTOM CLOSETS, AND WINDOW TREATMENTS (U.S. CLS. 100, 103 AND 106).

FIRST USE 4-2-2012; IN COMMERCE 4-2-2012.

4,155,243. FOREVERCARDS LLC, FORT LAUDERDALE, FL. SN 85-261,028. PUB. 8-9-2011, FILED 3-8-2011.

The Forevercard

THE MARK CONSISTS OF STANDARD CHARACTERS WITHOUT CLAIM TO ANY PARTICULAR FONT, STYLE, SIZE, OR COLOR.

CLASS 16—PAPER GOODS AND PRINTED MATTER

FOR GREETING CARDS; GREETINGS CARDS AND POSTCARDS; MINI PHOTO ALBUMS; MUSICAL GREETING CARDS; POSTCARDS AND GREETING CARDS; PRINTED GREETING CARDS WITH ELECTRONIC INFORMATION STORED THEREIN; SCRAPBOOK PAGES (U.S. CLS. 2, 5, 22, 23, 29, 37, 38 AND 50).

FIRST USE 8-1-2011; IN COMMERCE 8-1-2011.

CLASS 20—FURNITURE AND ARTICLES NOT OTHERWISE CLASSIFIED

FOR MAGNETIZED PHOTO FRAMES; PAPER PHOTO FRAMES (U.S. CLS. 2, 13, 22, 25, 32 AND 50).

FIRST USE 8-1-2011; IN COMMERCE 8-1-2011.

4,155,248. WHAT A PIX, INC., HOUSTON, TX. SN 85-261,851.
PUB. 8-23-2011, FILED 3-9-2011.

4,155,258. MITCHELL GROUP USA LLC, MIAMI, FL. SN 85-
262,376. PUB. 7-5-2011, FILED 3-9-2011.

WHATAPIX

THE MARK CONSISTS OF STANDARD CHARACTERS WITHOUT CLAIM TO ANY PARTICULAR FONT, STYLE, SIZE, OR COLOR.

CLASS 9—ELECTRICAL AND SCIENTIFIC APPARATUS

FOR DOWNLOADABLE SOFTWARE FOR USE IN CREATING PERSONALIZED PHOTO BOOKS, CALENDARS, CARDS, AND POSTERS (U.S. CLS. 21, 23, 26, 36 AND 38).

FIRST USE 12-10-2009; IN COMMERCE 10-25-2010.

CLASS 40—MATERIAL TREATMENT

FOR DIGITAL ON DEMAND PRINTING SERVICES OF PERSONALIZED PHOTO BOOKS, CALENDARS, CARDS, AND POSTERS (U.S. CLS. 100, 103 AND 106).

FIRST USE 12-10-2009; IN COMMERCE 10-25-2010.

4,155,249. WHAT A PIX, INC., HOUSTON, TX. SN 85-261,870.
PUB. 8-23-2011, FILED 3-9-2011.

THE MARK CONSISTS OF THE STYLIZED WORD "WHATAPIX" WHEREIN THE TERM "PIX" IS LOCATED INSIDE A SKEWED SQUARE AND THE LETTER "I" IN THE TERM "PIX" IS SHOWN AS AN EXCLAMATION POINT LOCATED BETWEEN THE LETTERS "P" AND THE "X".

CLASS 9—ELECTRICAL AND SCIENTIFIC APPARATUS

FOR DOWNLOADABLE SOFTWARE FOR USE IN CREATING PERSONALIZED PHOTO BOOKS, CALENDARS, CARDS, AND POSTERS (U.S. CLS. 21, 23, 26, 36 AND 38).

FIRST USE 11-1-2010; IN COMMERCE 11-1-2010.

CLASS 40—MATERIAL TREATMENT

FOR DIGITAL ON DEMAND PRINTING SERVICES OF PERSONALIZED PHOTO BOOKS, CALENDARS, CARDS, AND POSTERS (U.S. CLS. 100, 103 AND 106).

FIRST USE 11-1-2010; IN COMMERCE 11-1-2010.

OWNER OF U.S. REG. NOS. 3,440,165, 3,756,088, AND OTHERS.

THE MARK CONSISTS OF THE WORD "OMIC" WITH A MACRON ABOVE THE "O" AND A PLUS SIGN (+) AFTER THE "C" SURROUNDED BY A FLATTENED OVAL WITH A HORIZONTAL BAR ABOVE.

CLASS 3—COSMETICS AND CLEANING PREPARATIONS

FOR BAR SOAP; BATH SOAPS; BATH SOAPS IN LIQUID, SOLID OR GEL FORM; BODY CREAMS; BODY LOTIONS; BODY OILS; CONCEALERS FOR FACE AND SKIN; COSMETIC CREAMS FOR SKIN CARE; COSMETIC PREPARATIONS FOR SKIN CARE; COSMETIC PREPARATIONS FOR SKIN RENEWAL; COSMETIC PRODUCTS IN THE FORM OF AEROSOLS FOR SKIN CARE; COSMETIC SOAPS; COSMETIC SUN-PROTECTING PREPARATIONS; COSMETICS; EXFOLIANT CREAMS; EXFOLIANTS FOR SKIN AND FACE; FACE AND BODY CREAMS; FACE AND BODY LOTIONS; FACE CREAMS FOR COSMETIC USE; FACIAL CREAMS; FACIAL LOTION; HAND SOAPS; LIQUID SOAPS FOR HANDS, FACE AND BODY; LOTIONS FOR FACE AND BODY CARE; LOTIONS FOR FACE AND SKIN; NON-MEDICATED ACNE TREATMENT PREPARATIONS; NON-MEDICATED PREPARATIONS ALL FOR THE CARE OF SKIN, HAIR AND SCALP; NON-MEDICATED SKIN CARE CREAMS AND LOTIONS; NON-MEDICATED SKIN CARE PREPARATIONS; NON-MEDICATED SKIN CARE PREPARATIONS, NAMELY, CREAMS, LOTIONS, GELS, TONERS, CLEANSERS AND PEELS; NON-MEDICATED SKIN CREAMS; NON-MEDICATED STIMULATING LOTIONS FOR THE SKIN; NON-MEDICATED SUN CARE PREPARATIONS; SKIN ABRASIVE PREPARATIONS; SKIN AND BODY TOPICAL LOTIONS, CREAMS AND OILS FOR COSMETIC USE; SKIN CARE PREPARATION, NAMELY, BODY POLISH; SKIN CARE PREPARATIONS, NAMELY, SKIN PEELS; SKIN CLARIFIERS; SKIN CLEANSERS; SKIN CLEANSING CREAM; SKIN CONDITIONERS; SKIN CONDITIONING CREAMS FOR COSMETIC PURPOSES; SKIN CREAMS; SKIN CREAMS IN LIQUID AND SOLID FORM; SKIN EMOLLIENTS; SKIN FRESHENERS; SKIN LIGHTENERS; SKIN LIGHTENING CREAMS; SKIN LOTIONS; SKIN MASKS; SKIN MOISTURIZER; SKIN SOAP; SKIN TEXTURIZERS; SKIN TONERS; SOAPS FOR BODY CARE; SUN SCREEN; SUN SCREEN PREPARATIONS (U.S. CLS. 1, 4, 6, 50, 51 AND 52).

FIRST USE 7-0-2004; IN COMMERCE 7-0-2004.

CLASS 5—PHARMACEUTICALS

FOR ACNE TREATMENT PREPARATIONS; MEDICATED LOTIONS FOR FACE AND SKIN; MEDICATED SKIN CARE PREPARATIONS; MEDICATED SKIN CARE PREPARATIONS, NAMELY, CREAMS, LOTIONS, GELS, TONERS, CLEANERS AND PEELS; MEDICINAL CREAMS FOR SKIN CARE (U.S. CLS. 6, 18, 44, 46, 51 AND 52).

FIRST USE 12-5-2009; IN COMMERCE 12-5-2009.

4,155,263. CHEVAL AMOUR, INC., CRESWELL, OR. SN 85-262,835. PUB. 7-26-2011, FILED 3-9-2011.



THE MARK CONSISTS OF STYLIZED HORSES PERFORMING LEVADES INCORPORATED INTO A FLEUR-DE-LIS.

4,155,262. CHEVAL AMOUR, INC., CRESWELL, OR. SN 85-262,774. PUB. 7-26-2011, FILED 3-9-2011.

Cheval Amour

THE MARK CONSISTS OF STANDARD CHARACTERS WITHOUT CLAIM TO ANY PARTICULAR FONT, STYLE, SIZE, OR COLOR.

THE ENGLISH TRANSLATION OF "CHEVAL AMOUR" IN THE MARK IS "HORSE LOVE".

CLASS 18—LEATHER GOODS

FOR ALL-PURPOSE CARRYING BAGS; BAGS FOR SPORTS; CARRY-ALL BAGS; CARRY-ON BAGS; CLOTHING FOR ANIMALS; CLUTCH BAGS; CLUTCH PURSES; DUFFEL BAGS; HANDBAGS, PURSES AND WALLETS; HOBO BAGS; LEATHER AND IMITATION LEATHER BAGS; LEATHER PURSES; PURSES AND WALLETS; SHOULDER BAGS; TOTE BAGS; TRAVEL BAGS (U.S. CLS. 1, 2, 3, 22 AND 41).

FIRST USE 3-16-2012; IN COMMERCE 3-16-2012.

CLASS 18—LEATHER GOODS

FOR ALL-PURPOSE CARRYING BAGS; BAGS FOR SPORTS; CARRY-ALL BAGS; CARRY-ON BAGS; CLOTHING FOR ANIMALS; CLUTCH BAGS; CLUTCH PURSES; DUFFEL BAGS; HANDBAGS, PURSES AND WALLETS; HOBO BAGS; LEATHER AND IMITATION LEATHER BAGS; LEATHER PURSES; PURSES AND WALLETS; SHOULDER BAGS; TOTE BAGS; TRAVEL BAGS (U.S. CLS. 1, 2, 3, 22 AND 41).

FIRST USE 3-16-2012; IN COMMERCE 3-16-2012.

CLASS 25—CLOTHING

FOR ATHLETIC APPAREL, NAMELY, SHIRTS, PANTS, JACKETS, FOOTWEAR, HATS AND CAPS, ATHLETIC UNIFORMS; BELTS; BUTTON DOWN SHIRTS; COATS; COLLARED SHIRTS; DRESS SHIRTS; GOLF SHIRTS; HOODED SWEAT SHIRTS; JACKETS; LEATHER BELTS; LONG-SLEEVED SHIRTS; MEN'S AND WOMEN'S JACKETS, COATS, TROUSERS, VESTS; MOISTURE-WICKING SPORTS SHIRTS; OVER COATS; POLO SHIRTS; RAIN COATS; RIDING COATS; SHOULDER SCARVES; SHOULDER WRAPS; SWEAT SHIRTS; T-SHIRTS; TOPS; TRENCH COATS; WEARABLE GARMENTS AND CLOTHING, NAMELY, SHIRTS; WIND COATS; WOMEN'S CLOTHING, NAMELY, SHIRTS, DRESSES, SKIRTS, BLOUSES (U.S. CLS. 22 AND 39).

FIRST USE 12-7-2011; IN COMMERCE 12-12-2011.

CLASS 35—ADVERTISING AND BUSINESS

FOR ON-LINE RETAIL STORE SERVICES FEATURING CLOTHING (U.S. CLS. 100, 101 AND 102).

FIRST USE 12-7-2011; IN COMMERCE 12-12-2011.

CLASS 25—CLOTHING

FOR ATHLETIC APPAREL, NAMELY, SHIRTS, PANTS, JACKETS, FOOTWEAR, HATS AND CAPS, ATHLETIC UNIFORMS; BELTS; BUTTON DOWN SHIRTS; COATS; COLLARED SHIRTS; DRESS SHIRTS; JACKETS; LEATHER BELTS; SHOULDER WRAPS; TOPS; WEARABLE GARMENTS AND CLOTHING, NAMELY, SHIRTS; WOMEN'S CLOTHING, NAMELY, SHIRTS, DRESSES, SKIRTS, BLOUSES (U.S. CLS. 22 AND 39).

FIRST USE 12-7-2011; IN COMMERCE 12-12-2011.

4,155,275. STORMES, SEAN, LENEXA, KS. SN 85-263,723. PUB. 7-26-2011, FILED 3-10-2011.

THE THIRD DOOR
Beyond Competitive
Advantage

CLASS 35—ADVERTISING AND BUSINESS

FOR ON-LINE RETAIL STORE SERVICES FEATURING CLOTHING (U.S. CLS. 100, 101 AND 102).

FIRST USE 12-7-2011; IN COMMERCE 12-12-2011.

THE MARK CONSISTS OF STANDARD CHARACTERS WITHOUT CLAIM TO ANY PARTICULAR FONT, STYLE, SIZE, OR COLOR.

CLASS 9—ELECTRICAL AND SCIENTIFIC APPARATUS

FOR PRERECORDED ELECTRONIC MEDIA, NAMELY, AUDIO AND VIDEO CASSETTES, CDS AND DVDS ALL FEATURING INFORMATION ON BUSINESS, COMMUNICATION, COMMERCIAL SKILLS, FINANCES, LEADERSHIP, MANAGEMENT, MARKETING, MOTIVATION, NEGOTIATION AND SALES TRAINING; DOWNLOADABLE PODCASTS ALL FEATURING INFORMATION ON BUSINESS, COMMUNICATION, COMMERCIAL SKILLS, FINANCES, LEADERSHIP, MANAGEMENT, MARKETING, MOTIVATION, NEGOTIATION AND SALES TRAINING (U.S. CLS. 21, 23, 26, 36 AND 38).

FIRST USE 4-11-2011; IN COMMERCE 4-11-2011.

CLASS 16—PAPER GOODS AND PRINTED MATTER

FOR PAPER AND PRINTED MATTER, NAMELY, A SERIES OF ARTICLES FOR PUBLICATION IN BOOKS, CATALOGS, GUIDES, HANDOUTS, MAGAZINES, MANUALS AND NEWSLETTERS ALL FEATURING INFORMATION ON BUSINESS, COMMUNICATION, COMMERCIAL SKILLS, FINANCES, LEADERSHIP, MANAGEMENT, MARKETING, MOTIVATION, NEGOTIATION AND SALES TRAINING; FLASH CARDS; PAPERWEIGHTS, PHOTOGRAPHS MOUNTED AND UNMOUNTED; POSTERS; POSTCARDS; PRINTED GREETING CARDS; PRINTED EDUCATIONAL, INSTRUCTIONAL AND TEACHING MATERIALS ALL FEATURING INFORMATION ON BUSINESS, COMMUNICATION, COMMERCIAL SKILLS, FINANCES, LEADERSHIP, MANAGEMENT, MARKETING, MOTIVATION, NEGOTIATION AND SALES TRAINING; SERIES OF NON-FICTION BOOKS ALL FEATURING INFORMATION ON BUSINESS, COMMUNICATION, COMMERCIAL SKILLS, FINANCES, LEADERSHIP, MANAGEMENT, MARKETING, MOTIVATION, NEGOTIATION AND SALES TRAINING; FOLDERS, PENS, PENCILS, STICKERS AND WRITING PADS (U.S. CLS. 2, 5, 22, 23, 29, 37, 38 AND 50).

FIRST USE 4-11-2011; IN COMMERCE 4-11-2011.

CLASS 35—ADVERTISING AND BUSINESS

FOR ARRANGING AND CONDUCTING BUSINESS CONFERENCES AND PROMOTIONAL MARKETING EVENT PLANNING; BUSINESS MARKETING AND MANAGEMENT CONSULTING SERVICES; PROVIDING INFORMATION SERVICES VIA A GLOBAL COMPUTER NETWORK FEATURING INFORMATION ON BUSINESS, COMMUNICATION, COMMERCIAL SKILLS, FINANCES, LEADERSHIP, MANAGEMENT, MARKETING, MOTIVATION, NEGOTIATION AND SALES TRAINING (U.S. CLS. 100, 101 AND 102).

FIRST USE 4-11-2011; IN COMMERCE 4-11-2011.

CLASS 38—COMMUNICATION

FOR VIDEO AND AUDIO TELECONFERENCING SERVICES VIA THE INTERNET; INTERNET COMMUNICATION SERVICES, NAMELY, PODCASTING, BROADCASTING AND WEBCASTING SERVICES ALL FEATURING INFORMATION ON BUSINESS, COMMUNICATION, COMMERCIAL SKILLS, FINANCES, LEADERSHIP, MANAGEMENT, MARKETING, MOTIVATION, NEGOTIATION AND SALES TRAINING; BROADCASTING OF RADIO AND TELEVISION PROGRAMS (U.S. CLS. 100, 101 AND 104).

FIRST USE 2-15-2012; IN COMMERCE 2-15-2012.

CLASS 41—EDUCATION AND ENTERTAINMENT

FOR EDUCATIONAL AND INSTRUCTIONAL SERVICES, NAMELY, CONDUCTING EDUCATIONAL CLASSES, CONFERENCES, RETREATS, SEMINARS AND WORKSHOPS ALL FEATURING INFORMATION ON BUSINESS, COMMUNICATION, COMMERCIAL SKILLS, FINANCES, LEADERSHIP, MANAGEMENT, MARKETING, MOTIVATION, NEGOTIATION AND SALES TRAINING, AND DISTRIBUTING INSTRUCTIONAL MATERIALS IN CONNECTION THEREWITH; ENTERTAINMENT SERVICES, NAMELY, LIVE SPEAKING PERFORMANCES AND SPEAKING ENGAGEMENTS ALL FEATURING INFORMATION ON BUSINESS, COMMUNICATION, COMMERCIAL SKILLS, FINANCES, LEADERSHIP, MANAGEMENT, MARKETING, MOTIVATION, NEGOTIATION AND SALES TRAINING; ENTERTAINMENT SERVICES, NAMELY, PROVIDING PODCASTS FEATURING INFORMATION ON BUSINESS, COMMUNICATION, COMMERCIAL SKILLS, FINANCES, LEADERSHIP, MANAGEMENT, MARKETING, MOTIVATION, NEGOTIATION AND SALES TRAINING (U.S. CLS. 100, 101 AND 107).

FIRST USE 4-11-2011; IN COMMERCE 4-11-2011.

4,155,285. AFC ENTERPRISES, INC., ATLANTA, GA. SN 85-265,741. PUB. 8-9-2011, FILED 3-14-2011.



NO CLAIM IS MADE TO THE EXCLUSIVE RIGHT TO USE "KIDS MEAL", APART FROM THE MARK AS SHOWN.

THE MARK CONSISTS OF THE WORDS "GET UP & GEAUX!" IN STYLIZED LETTERS WITHIN AN OVAL SHAPE, RESTING ON TOP OF A RECTANGLE SHAPE WITH THE WORDS "KIDS MEAL" IN STYLIZED LETTERS WITHIN THE RECTANGLE, WITH A FLEUR DE LYS DOTTING THE "I" IN "KIDS".

CLASS 29—MEATS AND PROCESSED FOODS

FOR PREPARED CHICKEN AND SEAFOOD FOR CONSUMPTION ON AND OFF THE PREMISES (U.S. CL. 46).

FIRST USE 5-30-2011; IN COMMERCE 5-30-2011.

CLASS 43—HOTEL AND RESTAURANT SERVICES

FOR RESTAURANT AND CATERING SERVICES (U.S. CLS. 100 AND 101).

FIRST USE 5-30-2011; IN COMMERCE 5-30-2011.

4,155,287. AFC ENTERPRISES, INC., ATLANTA, GA. SN 85-266,120. PUB. 8-9-2011, FILED 3-14-2011.

4,155,293. BEAN, COLLIN W., EXCELSIOR, MN. SN 85-266,569. PUB. 7-26-2011, FILED 3-14-2011.

LOUISIANA LEAUX

THE MARK CONSISTS OF STANDARD CHARACTERS WITHOUT CLAIM TO ANY PARTICULAR FONT, STYLE, SIZE, OR COLOR.

OWNER OF U.S. REG. NOS. 3,681,086, 3,681,087, AND 3,681,089.

NO CLAIM IS MADE TO THE EXCLUSIVE RIGHT TO USE "LOUISIANA", APART FROM THE MARK AS SHOWN.

CLASS 29—MEATS AND PROCESSED FOODS

FOR PREPARED CHICKEN AND SEAFOOD FOR CONSUMPTION ON OR OFF THE PREMISES (U.S. CL. 46).

FIRST USE 5-30-2011; IN COMMERCE 5-30-2011.

CLASS 43—HOTEL AND RESTAURANT SERVICES

FOR RESTAURANT AND CATERING SERVICES (U.S. CLS. 100 AND 101).

FIRST USE 5-30-2011; IN COMMERCE 5-30-2011.

4,155,288. AFC ENTERPRISES, INC., ATLANTA, GA. SN 85-266,170. PUB. 8-9-2011, FILED 3-14-2011.



OWNER OF U.S. REG. NOS. 3,681,086, 3,681,087, AND 3,681,089.

NO CLAIM IS MADE TO THE EXCLUSIVE RIGHT TO USE "LOUISIANA", APART FROM THE MARK AS SHOWN.

THE MARK CONSISTS OF THE WORDS "LOUISIANA LEAUX GET UP & GEAUX!" DISPLAYED WITHIN A GEOMETRIC SHAPE WITH A FLEUR DE LYS WITHIN A HEART SHAPE ABOVE THE "S" IN "LOUISIANA".

CLASS 29—MEATS AND PROCESSED FOODS

FOR PREPARED CHICKEN AND SEAFOOD FOR CONSUMPTION ON OR OFF THE PREMISES (U.S. CL. 46).

FIRST USE 5-30-2011; IN COMMERCE 5-30-2011.

CLASS 43—HOTEL AND RESTAURANT SERVICES

FOR RESTAURANT SERVICES (U.S. CLS. 100 AND 101).

FIRST USE 5-30-2011; IN COMMERCE 5-30-2011.

EMPTY THRONE

THE MARK CONSISTS OF STANDARD CHARACTERS WITHOUT CLAIM TO ANY PARTICULAR FONT, STYLE, SIZE, OR COLOR.

CLASS 25—CLOTHING

FOR CLOTHING, NAMELY, SHIRTS, T-SHIRTS, SWEATSHIRTS, HOODED SWEATSHIRTS, AND JACKETS; HEADGEAR, NAMELY, CAPS, HATS AND BASEBALL CAPS; WRIST BANDS (U.S. CLS. 22 AND 39).

FIRST USE 3-10-2011; IN COMMERCE 3-10-2011.

CLASS 41—EDUCATION AND ENTERTAINMENT

FOR PROVIDING A WEB SITE FEATURING INFORMATION IN THE FIELD OF MUSIC, VIDEO, ENTERTAINMENT, FASHION, AND POPULAR CULTURE; INTERACTIVE ONLINE JOURNAL, NAMELY, A WEB BLOG FEATURING INFORMATION ON MUSIC, VIDEO, ENTERTAINMENT, FASHION AND POPULAR CULTURE (U.S. CLS. 100, 101 AND 107).

FIRST USE 1-26-2011; IN COMMERCE 1-26-2011.

4,155,310. PREFERRED FREEZER SERVICES, LLC, CHATHAM, NJ. SN 85-268,091. PUB. 8-2-2011, FILED 3-16-2011.

WE GET IT DONE

THE MARK CONSISTS OF STANDARD CHARACTERS WITHOUT CLAIM TO ANY PARTICULAR FONT, STYLE, SIZE, OR COLOR.

CLASS 39—TRANSPORTATION AND STORAGE

FOR HANDLING AND STORING OF FOOD (U.S. CLS. 100 AND 105).

FIRST USE 12-1-2011; IN COMMERCE 12-1-2011.

CLASS 40—MATERIAL TREATMENT

FOR FREEZING OF FOOD FOR OTHERS (U.S. CLS. 100, 103 AND 106).

FIRST USE 12-1-2011; IN COMMERCE 12-1-2011.

4,155,317. SCHULTZ, SHANNON H, CHARLOTTE, NC. SN 85-269,014. PUB. 8-2-2011, FILED 3-16-2011.

The Furry North Carolinian

THE MARK CONSISTS OF STANDARD CHARACTERS WITHOUT CLAIM TO ANY PARTICULAR FONT, STYLE, SIZE, OR COLOR.

CLASS 18—LEATHER GOODS

FOR ANIMAL LEASHES; COLLARS FOR PETS (U.S. CLS. 1, 2, 3, 22 AND 41).
FIRST USE 3-5-2012; IN COMMERCE 3-21-2012.

CLASS 20—FURNITURE AND ARTICLES NOT OTHERWISE CLASSIFIED

FOR BEDS FOR HOUSEHOLD PETS (U.S. CLS. 2, 13, 22, 25, 32 AND 50).
FIRST USE 3-5-2012; IN COMMERCE 3-21-2012.

CLASS 28—TOYS AND SPORTING GOODS

FOR PET TOYS (U.S. CLS. 22, 23, 38 AND 50).
FIRST USE 3-5-2012; IN COMMERCE 3-21-2012.

4,155,320. EVERWARE INTERNATIONAL, DIAMOND BAR, CA. SN 85-269,155. PUB. 9-20-2011, FILED 3-17-2011.



THE MARK CONSISTS OF A STYLIZED LETTERS "EVERWARE" AND A CIRCLE WITH GRADIENT OUT-LINE THICKNESS.

CLASS 8—HAND TOOLS

FOR BIODEGRADABLE CUTLERY, NAMELY, KNIVES, FORKS AND SPOONS; BOXES SPECIALLY ADAPTED FOR THE STORAGE OF CUTLERY AND FLATWARE; CAN OPENERS; CUTLERY; CUTLERY, NAMELY, FORKS, SPOONS, AND KNIVES; EGG SLICERS; FLATWARE; FLATWARE, NAMELY, FORKS, KNIVES, AND SPOONS; HAND TOOLS, NAMELY, SPATULAS; MEAT TENDERIZER, NAMELY, A KITCHEN Mallet; PIZZA CUTTERS; TABLEWARE, NAMELY, KNIVES, FORKS AND SPOONS (U.S. CLS. 23, 28 AND 44).
FIRST USE 1-1-2010; IN COMMERCE 1-1-2011.

CLASS 21—HOUSEWARES AND GLASS

FOR BASKETS FOR DOMESTIC USE, NOT OF METAL; BASKETS FOR WASTE PAPER LITTERING; BASKETS OF PLASTIC; BREAD BASKETS FOR DOMESTIC USE; FLOWER BASKETS; LAUNDRY BASKETS; PICNIC BASKETS SOLD EMPTY; PLANT BASKETS; PLASTIC HAND-HELD SHOPPING BASKETS; WASTE BASKETS; BAKEWARE; BARWARE, NAMELY, SELTZER BOTTLES; BEVERAGEWARE; BOTTLE OPENERS; BOTTLE STANDS; BOTTLES, SOLD EMPTY; COFFEE MUGS; COOKING UTENSIL, NAMELY, BATTER DISPENSER; COOKING UTENSILS, NAMELY, GRILL COVERS; COOKING UTENSILS, NAMELY, GRILLS; COOKING UTENSILS, NAMELY, WIRE BASKETS; CORKSCREWS; DISPOSABLE PAPERBOARD BAKEWARE; GLASS BEVERAGEWARE; GLASS MUGS; HOUSEHOLD UTENSILS, NAMELY, SERVING SPOONS, MIXING SPOONS, SLOTTED SPOONS, SERVING TURNERS, SERVING LADLES, STRAINERS, ICE CREAM DISHERS, MIXING PADDLES, SERVING TONGS, KITCHEN SPATULAS, ROLLING PINS; ICE SCOOPS; MEAL TRAYS; MUGS; NAPKIN HOLDERS; NATURAL AND SYNTHETIC FIBER COCO LINERS FITTED FOR PLANT BOXES, PLANT POTS, AND PLANT BASKETS; NON-METALLIC TRAYS; PIZZA PEELS; SERVING FORKS; SERVING LADLES; SERVING PITCHERS HAVING A THUMB SHIELD TO PREVENT A WAITER'S THUMB FROM CONTACTING INTERNAL CONTENTS WHILE POURING; SERVING PLATTERS; SERVING SPOONS; SERVING TONGS; SERVING TRAYS; SERVINGWARE FOR SERVING FOOD AND DRINKS; UTENSILS FOR BARBECUES, NAMELY, FORKS, TONGS, TURNERS (U.S. CLS. 2, 13, 23, 29, 30, 33, 40 AND 50).
FIRST USE 1-1-2011; IN COMMERCE 1-1-2011.

4,155,337. STYLE HUNTERS, LLC, HIGH POINT, NC. SN 85-271,994. PUB. 1-24-2012, FILED 3-21-2011.

STYLE HUNTERS

THE MARK CONSISTS OF STANDARD CHARACTERS WITHOUT CLAIM TO ANY PARTICULAR FONT, STYLE, SIZE, OR COLOR.

NO CLAIM IS MADE TO THE EXCLUSIVE RIGHT TO USE "STYLE", APART FROM THE MARK AS SHOWN.

CLASS 35—ADVERTISING AND BUSINESS

FOR CONSULTANCY FOR DEVELOPMENT OF CORPORATE BRAND IMAGE FOR TV, VIDEOS, WEB, PRINT, CATALOG, SOCIAL MEDIA, MOBILE (U.S. CLS. 100, 101 AND 102).
FIRST USE 3-28-2010; IN COMMERCE 3-28-2010.

CLASS 42—SCIENTIFIC AND COMPUTER SERVICES

FOR PROVIDING CONSULTANCY ON THE DESIGN OF FASHION, WARDROBE AND PROPS FOR THE ENTERTAINMENT AND ADVERTISING INDUSTRIES (U.S. CLS. 100 AND 101).
FIRST USE 3-28-2010; IN COMMERCE 3-28-2010.

4,155,368. DECOART, INC., STANFORD, KY. SN 85-278,202.
PUB. 1-17-2012, FILED 3-28-2011.

4,155,372. YIANOLATOS, LINDA, SOUTH ORANGE, NJ. SN
85-278,473. PUB. 8-9-2011, FILED 3-28-2011.



NO CLAIM IS MADE TO THE EXCLUSIVE RIGHT TO USE "PAINT", APART FROM THE MARK AS SHOWN.

THE COLOR(S) BROWN, TAN, WHITE, DARK BLUE, LIGHT BLUE, GREEN, PINK, DARK GRAY, LIGHT GRAY AND BLACK IS/ARE CLAIMED AS A FEATURE OF THE MARK.

THE MARK CONSISTS OF THE WORD "SOCIAL" IN GREEN LETTERS ABOVE THE WORD "ARTWORKING" WITH THE LETTERS "ARTWORK" IN A DARK GRAY AND THE LETTERS "ING" IN LIGHT GRAY ABOVE A PINK BOX OUTLINED IN GREEN WITH THE WORDS "PAINT CONNECT CREATE" IN WHITE LETTERS WITH THE WORDS SEPARATED BY WHITE DOTS ALL CONTAINED IN THE BOX; TO THE LEFT OF A WORDS "SOCIAL ARTWORKING" IS A FEMALE SILHOUETTE IN PINK HOLDING A PINK PAINT BRUSH AND A PINK PAINT PALETTE IN FRONT OF A FEMALE SILHOUETTE IN GREEN HOLDING A GREEN PAINT BRUSH AND A GREEN PAINT PALETTE, BOTH OF WHICH ARE IN FRONT OF A FIGURE OF A FEMALE PAINTER WITH TAN SKIN, BLACK AND BROWN HAIR AND WEARING A DARK BLUE SHIRT, A LIGHT BLUE SKIRT, AND A WHITE APRON AND HOLDING A LIGHT GRAY PAINT BRUSH AND A LIGHT GRAY PAINT PALETTE WITH PINK, GREEN AND DARK BLUE PAINT THEREON; TO THE RIGHT OF THE WORD "SOCIAL" IS A LIGHT GRAY EASEL HOLDING A PAINTING OF A PINK DRINK IN A BLACK-OUTLINED MARTINI GLASS ON A GREEN BACKGROUND WITH TWO WHITE DOTS ON THE SURFACE OF THE DRINK, PINK BUBBLES ARISING FROM THE DRINK, A BLACK SWIZZLE STICK WITH A DARK BLUE AND BLACK SPHERE ON THE SWIZZLE STICK AND THREE WHITE STARBURSTS SURROUNDING THE MARTINI GLASS.

CLASS 2—PAINTS

FOR PAINTS; VARNISHES (U.S. CLS. 6, 11 AND 16).
FIRST USE 5-27-2011; IN COMMERCE 5-27-2011.

CLASS 16—PAPER GOODS AND PRINTED MATTER

FOR ARTISTS' BRUSHES; PAINT BRUSHES; EASELS; CANVAS FOR PAINTING; PATTERNS FOR PAINTING; PRINTED INSTRUCTIONAL, EDUCATIONAL, AND TEACHING MATERIALS IN THE FIELD OF DECORATIVE PAINTING (U.S. CLS. 2, 5, 22, 23, 29, 37, 38 AND 50).
FIRST USE 5-27-2011; IN COMMERCE 5-27-2011.

THE MARK CONSISTS OF SEMICIRCLE FLOWER DESIGN WITH HEART SHAPE AT CENTER SURROUNDED BY THE TERMS "WE ARE ETERNAL WE ARE ETERNAL WE ARE ETERNAL WE ARE ETERNAL".

CLASS 14—JEWELRY

FOR JEWELRY (U.S. CLS. 2, 27, 28 AND 50).
FIRST USE 1-25-2012; IN COMMERCE 1-25-2012.

CLASS 21—HOUSEWARES AND GLASS

FOR DRINKING VESSELS (U.S. CLS. 2, 13, 23, 29, 30, 33, 40 AND 50).
FIRST USE 1-25-2012; IN COMMERCE 1-25-2012.

CLASS 25—CLOTHING

FOR HEADWEAR; TOPS (U.S. CLS. 22 AND 39).
FIRST USE 1-25-2012; IN COMMERCE 1-25-2012.

4,155,389. J. WALTER THOMPSON COMPANY, NEW YORK, NY. SN 85-281,029. PUB. 7-26-2011, FILED 3-30-2011.

WORLDMADE

THE MARK CONSISTS OF STANDARD CHARACTERS WITHOUT CLAIM TO ANY PARTICULAR FONT, STYLE, SIZE, OR COLOR.

CLASS 35—ADVERTISING AND BUSINESS

FOR ADVERTISING AGENCY SERVICES; PUBLIC RELATIONS SERVICES; PUBLICITY SERVICES; DIRECT MARKETING ADVERTISING SERVICES FOR OTHERS; RECRUITMENT ADVERTISING AGENCY SERVICES; MARKETING CONSULTING; MARKET RESEARCH, SURVEYS AND ANALYSIS; MEDIA PLANNING AND BUYING SERVICES, NAMELY, CONSULTING AND ADVISING ON THE APPROPRIATE MEDIA TO ADVERTISE IN, AND PURCHASING MEDIA TIME AND SPACE; PLACING ADVERTISEMENTS FOR OTHERS; SALES PROMOTION SERVICES, NAMELY, PROMOTING THE GOODS AND SERVICES OF VARIOUS INDUSTRIES THROUGH THE DISTRIBUTION OF PROMOTIONAL MATERIALS AND BY RENDERING SALES PROMOTION ADVICE; CUSTOMER RELATIONSHIP MARKETING SERVICES; BUSINESS AND MARKETING CONSULTING SERVICES RELATED TO ADVERTISING, MARKETING AND BRAND DEVELOPMENT; EVENT MARKETING, NAMELY, ARRANGING AND CONDUCTING MARKETING PROMOTIONAL EVENTS FOR OTHERS; DIRECT RESPONSE MARKETING; BUSINESS MARKETING CONSULTING SERVICES RELATING TO BRANDS AND BRAND DEVELOPMENT, ASSESSMENT, ANALYSIS, EXPLOITATION AND PROMOTION; DIGITAL AND INTERACTIVE ADVERTISING; BUSINESS CONSULTING IN THE FIELD OF SPONSORSHIP OF SPORTS AND ENTERTAINMENT EVENTS (U.S. CLS. 100, 101 AND 102).

FIRST USE 6-1-2011; IN COMMERCE 6-1-2011.

CLASS 42—SCIENTIFIC AND COMPUTER SERVICES

FOR WEB SITE DESIGN AND DEVELOPMENT SERVICES FOR OTHERS; CONSULTING SERVICES RELATING TO THE CREATION, DEVELOPMENT AND OPERATION OF INTERNET WEBSITES; CONSULTING SERVICES RELATING TO THE USE OF DIGITAL PLATFORMS AND MEDIA IN THE FIELD OF ADVERTISING AND MARKETING; HOSTING INTERNET WEBSITES IN THE FIELD OF ADVERTISING AND MARKETING; GRAPHIC DESIGN SERVICES; RESEARCH AND CONSULTING SERVICES RELATING TO WEBSITE DESIGN, GRAPHIC DESIGN AND PRODUCT AND PACKAGING DESIGN; DESIGN AND DEVELOPMENT OF CONSUMER PRODUCTS AND PACKAGING OF OTHERS; INDUSTRIAL DESIGN SERVICES (U.S. CLS. 100 AND 101).

FIRST USE 6-1-2011; IN COMMERCE 6-1-2011.

4,155,394. WILDGAME INNOVATIONS, LLC, BROUSSARD, LA. SN 85-281,836. PUB. 8-30-2011, FILED 3-30-2011.

SUGARBEET CRUSH

THE MARK CONSISTS OF STANDARD CHARACTERS WITHOUT CLAIM TO ANY PARTICULAR FONT, STYLE, SIZE, OR COLOR.

NO CLAIM IS MADE TO THE EXCLUSIVE RIGHT TO USE "SUGARBEET", APART FROM THE MARK AS SHOWN.

CLASS 28—TOYS AND SPORTING GOODS

FOR DEER ATTRACTANTS IN POWDER FORM, LIQUID FORM OR SOLID BLOCK FORM (U.S. CLS. 22, 23, 38 AND 50).

FIRST USE 5-13-2011; IN COMMERCE 5-13-2011.

CLASS 31—NATURAL AGRICULTURAL PRODUCTS

FOR DEER FEED IN POWDER FORM, LIQUID FORM OR SOLID BLOCK FORM (U.S. CLS. 1 AND 46).

FIRST USE 5-13-2011; IN COMMERCE 5-13-2011.

4,155,398. JMI SPORTSWEAR, PTE. LTD., SINGAPORE, SINGAPORE. SN 85-282,488. PUB. 11-15-2011, FILED 3-31-2011.

DO IT WITH YOUR GLOVES ON

THE MARK CONSISTS OF STANDARD CHARACTERS WITHOUT CLAIM TO ANY PARTICULAR FONT, STYLE, SIZE, OR COLOR.

CLASS 9—ELECTRICAL AND SCIENTIFIC APPARATUS

FOR GLOVES SPECIALLY ADAPTED TO BE USED WITH TOUCH-SENSITIVE DEVICES, NAMELY, TOUCH PADS, TOUCH PANELS AND COMPUTER TOUCH SCREENS; COMPUTER STYLUSES FOR INTERACTING WITH TOUCH-SENSITIVE DEVICES; DEVICES FOR INTERACTING WITH TOUCH-SENSITIVE DEVICES, NAMELY, INSTRUMENTS TO FACILITATE OPERATING THE DEVICES IN THE NATURE OF A STYLUS-TYPE DEVICE ATTACHED TO THE HAND FOR USE IN CONJUNCTION WITH PERSONAL DIGITAL ASSISTANTS, SMARTPHONES AND HANDHELD COMPUTERS (U.S. CLS. 21, 23, 26, 36 AND 38).

FIRST USE 7-25-2011; IN COMMERCE 7-25-2011.

CLASS 25—CLOTHING

FOR CLOTHING, NAMELY, GLOVES INCORPORATING TOUCH-SENSITIVE TECHNOLOGY (U.S. CLS. 22 AND 39).

FIRST USE 7-25-2011; IN COMMERCE 7-25-2011.

4,155,408. TW CRYOGENICS LLC, THEODORE, AL. SN 85-283,691. PUB. 9-6-2011, FILED 4-1-2011.

**CRYOSCIENCE by
Taylor-Wharton**

THE MARK CONSISTS OF STANDARD CHARACTERS WITHOUT CLAIM TO ANY PARTICULAR FONT, STYLE, SIZE, OR COLOR.

OWNER OF U.S. REG. NO. 2,197,016.

NO CLAIM IS MADE TO THE EXCLUSIVE RIGHT TO USE "CRYOSCIENCE", APART FROM THE MARK AS SHOWN.

CLASS 6—METAL GOODS

FOR CRYOGENIC PRODUCTS, NAMELY, BULK METAL STORAGE TANKS, METAL LIQUID CYLINDERS AND HIGH PRESSURE CYLINDERS SOLD EMPTY (U.S. CLS. 2, 12, 13, 14, 23, 25 AND 50).

FIRST USE 3-1-2010; IN COMMERCE 3-1-2010.

CLASS 11—ENVIRONMENTAL CONTROL APPARATUS

FOR CRYOGENIC PRODUCTS, NAMELY, FREEZERS, REFRIGERATORS AND DEWARs (U.S. CLS. 13, 21, 23, 31 AND 34).

FIRST USE 3-1-2010; IN COMMERCE 3-1-2010.

4,155,409. TW CRYOGENICS LLC, THEODORE, AL. SN 85-283,695. PUB. 9-6-2011, FILED 4-1-2011.



The logo for CRYOSCIENCE by Taylor-Wharton features the word "CRYOSCIENCE" in a bold, sans-serif font. The letter "O" is replaced by a circular graphic containing a grid of smaller circles. Below "CRYOSCIENCE" is the text "by Taylor-Wharton" in a smaller, lowercase font.

OWNER OF U.S. REG. NO. 2,197,016.

NO CLAIM IS MADE TO THE EXCLUSIVE RIGHT TO USE "CRYOSCIENCE", APART FROM THE MARK AS SHOWN.

THE MARK CONSISTS OF THE WORD "CRYOSCIENCE" WITH THE CENTER OF THE FIRST "C" CONTAINING A SHADED CIRCLE FILLED WITH 14 SMALLER UNSHADED CIRCLES AND THE WORDS "BY TAYLOR-WHARTON" ON THE SECOND LINE OFFSET TO THE RIGHT UNDER "SCIENCE".

CLASS 6—METAL GOODS

FOR CRYOGENIC PRODUCTS, NAMELY, BULK METAL STORAGE TANKS, METAL LIQUID CYLINDERS AND HIGH PRESSURE CYLINDERS SOLD EMPTY (U.S. CLS. 2, 12, 13, 14, 23, 25 AND 50).

FIRST USE 3-1-2010; IN COMMERCE 3-1-2010.

CLASS 11—ENVIRONMENTAL CONTROL APPARATUS

FOR CRYOGENIC PRODUCTS, NAMELY, FREEZERS, REFRIGERATORS AND DEWARs (U.S. CLS. 13, 21, 23, 31 AND 34).

FIRST USE 3-1-2010; IN COMMERCE 3-1-2010.

4,155,414. CDOC, INC., CARMEL, IN. SN 85-283,904. PUB. 7-26-2011, FILED 4-1-2011.

WNBIZLINK.COM

THE MARK CONSISTS OF STANDARD CHARACTERS WITHOUT CLAIM TO ANY PARTICULAR FONT, STYLE, SIZE, OR COLOR.

OWNER OF U.S. REG. NOS. 3,263,912, 3,263,914, AND OTHERS.

CLASS 35—ADVERTISING AND BUSINESS

FOR INSURANCE SERVICES, NAMELY, PROVIDING POLICY RATES AND PRODUCT INFORMATION FOR ALL TYPES OF INSURANCE, PROVIDING FORMS FOR INSURANCE SALES AND INSURANCE CLAIMS (U.S. CLS. 100, 101 AND 102).

FIRST USE 9-1-2011; IN COMMERCE 9-1-2011.

CLASS 36—INSURANCE AND FINANCIAL

FOR PROVIDING ONLINE AND ELECTRONIC PROCESSING OF INSURANCE APPLICATIONS AND ACCESS TO SALES AND PAYMENT DATA OVER A WEB-BASED COMPUTER NETWORK (U.S. CLS. 100, 101 AND 102).

FIRST USE 9-1-2011; IN COMMERCE 9-1-2011.

4,155,428. INTERNUM, LLC, HOUSTON, TX. SN 85-285,766. PUB. 8-2-2011, FILED 4-4-2011.

INTERNUM

THE MARK CONSISTS OF STANDARD CHARACTERS WITHOUT CLAIM TO ANY PARTICULAR FONT, STYLE, SIZE, OR COLOR.

CLASS 20—FURNITURE AND ARTICLES NOT OTHERWISE CLASSIFIED

FOR FURNITURE (U.S. CLS. 2, 13, 22, 25, 32 AND 50).

FIRST USE 6-30-2011; IN COMMERCE 6-30-2011.

CLASS 35—ADVERTISING AND BUSINESS

FOR RETAIL STORES FEATURING FURNITURE AND HOME ACCESSORIES (U.S. CLS. 100, 101 AND 102).

FIRST USE 6-30-2011; IN COMMERCE 6-30-2011.

4,155,434. VEOLIA WATER AMERICAS, LLC, CHICAGO, IL. SN 85-286,634. PUB. 8-9-2011, FILED 4-5-2011.

GROWINGBLUE

THE MARK CONSISTS OF STANDARD CHARACTERS WITHOUT CLAIM TO ANY PARTICULAR FONT, STYLE, SIZE, OR COLOR.

CLASS 41—EDUCATION AND ENTERTAINMENT

FOR EDUCATIONAL SERVICES, NAMELY, PROVIDING EDUCATIONAL SEMINARS IN THE FIELDS OF WATER, WATER ISSUES, DEVELOPMENT, SUSTAINABILITY AND PROTECTION OF WATER RESOURCES ON A LOCAL AND GLOBAL LEVEL (U.S. CLS. 100, 101 AND 107).

FIRST USE 12-3-2010; IN COMMERCE 5-18-2011.

CLASS 42—SCIENTIFIC AND COMPUTER SERVICES

FOR PROVIDING A WEBSITE FEATURING ENVIRONMENTAL INFORMATION ABOUT WATER AND WATER ISSUES, DEVELOPMENT, SUSTAINABILITY AND PROTECTION OF WATER RESOURCES ON A LOCAL AND GLOBAL LEVEL (U.S. CLS. 100 AND 101).

FIRST USE 12-3-2010; IN COMMERCE 5-18-2011.

4,155,437. BLACKROCK, INC., NEW YORK, NY. SN 85-287,157. PUB. 1-17-2012, FILED 4-5-2011.

4,155,463. TRADINGSCREEN, INC., NEW YORK, NY. SN 85-295,065. PUB. 9-6-2011, FILED 4-14-2011.

ATN

THE MARK CONSISTS OF STANDARD CHARACTERS WITHOUT CLAIM TO ANY PARTICULAR FONT, STYLE, SIZE, OR COLOR.

CLASS 36—INSURANCE AND FINANCIAL

FOR PROVIDING FINANCIAL RISK MANAGEMENT SERVICES; FINANCIAL MANAGEMENT SERVICES AND SECURITIES TRADING; FINANCIAL RESEARCH; FINANCIAL ANALYSIS AND CONSULTING; FINANCIAL INFORMATION (U.S. CLS. 100, 101 AND 102).
FIRST USE 9-1-2011; IN COMMERCE 9-1-2011.

CLASS 42—SCIENTIFIC AND COMPUTER SERVICES

FOR TEMPORARY USE OF ONLINE NON-DOWNLOADABLE COMPUTER SOFTWARE FOR USE BY OTHERS IN PROVIDING FINANCIAL SERVICES, NAMELY, FINANCIAL INFORMATION, FINANCIAL MANAGEMENT, SECURITIES TRADING, INVESTMENT MANAGEMENT, AND TRADING FINANCIAL INSTRUMENTS VIA AN ONLINE TRADING PLATFORM; PROVIDING A TRADING PLATFORM FOR PLACING AND EXECUTING ORDERS TO PURCHASE OR SELL SECURITIES, OPTIONS, FUTURES, FOREIGN EXCHANGE AND OTHER FINANCIAL INSTRUMENTS (U.S. CLS. 100 AND 101).
FIRST USE 9-1-2011; IN COMMERCE 9-1-2011.

4,155,445. EMI YOSHI INC., NORTH BRUNSWICK, NJ. SN 85-289,291. PUB. 8-16-2011, FILED 4-7-2011.

INSPIRED ENTERTAINING

THE MARK CONSISTS OF STANDARD CHARACTERS WITHOUT CLAIM TO ANY PARTICULAR FONT, STYLE, SIZE, OR COLOR.

CLASS 8—HAND TOOLS

FOR FLATWARE, NAMELY, FORKS, KNIVES, AND SPOONS (U.S. CLS. 23, 28 AND 44).
FIRST USE 1-18-2012; IN COMMERCE 1-18-2012.

CLASS 21—HOUSEWARES AND GLASS

FOR DINNERWARE, NAMELY, PLATES, CUPS, SAUCERS, SERVING TRAYS, BOWLS, TUMBLERS, COFFEE MUGS AND DISPOSABLE BEVERAGEWARE (U.S. CLS. 2, 13, 23, 29, 30, 33, 40 AND 50).
FIRST USE 8-11-2001; IN COMMERCE 8-11-2001.

ANALYTICS-IN-A-BOX

THE MARK CONSISTS OF STANDARD CHARACTERS WITHOUT CLAIM TO ANY PARTICULAR FONT, STYLE, SIZE, OR COLOR.

CLASS 9—ELECTRICAL AND SCIENTIFIC APPARATUS

FOR DOWNLOADABLE COMPUTER SOFTWARE FOR USE IN ANALYZING FINANCIAL TRADES AND GENERATING REPORTS BASED ON THAT ANALYSIS (U.S. CLS. 21, 23, 26, 36 AND 38).
FIRST USE 4-30-2011; IN COMMERCE 4-30-2011.

CLASS 42—SCIENTIFIC AND COMPUTER SERVICES

FOR PROVIDING ONLINE TOOLS, NAMELY, PROVIDING TEMPORARY USE OF ON-LINE NON-DOWNLOADABLE SOFTWARE DEVELOPMENT TOOLS FOR USE IN ANALYZING FINANCIAL TRADES AND GENERATING REPORTS BASED ON THAT ANALYSIS (U.S. CLS. 100 AND 101).
FIRST USE 4-30-2011; IN COMMERCE 4-30-2011.

4,155,478. OFL ONLINE FUTURE LTD., NICOSIA, CYPRUS. SN 85-298,479. PUB. 8-30-2011, FILED 4-19-2011.

RICHFACE

THE MARK CONSISTS OF STANDARD CHARACTERS WITHOUT CLAIM TO ANY PARTICULAR FONT, STYLE, SIZE, OR COLOR.

CLASS 25—CLOTHING

FOR BASEBALL CAPS AND HATS; BELTS FOR CLOTHING; CHEMISES; CUSTOM MADE TO MEASURE SUITS FOR MEN AND WOMEN; HATS; MEN'S SUITS; MEN'S SUITS, WOMEN'S SUITS; POLO SHIRTS; SHORT SETS; SOCKS; SPORTS CAPS AND HATS; SPORTS JACKETS; SPORTS JERSEYS; T-SHIRTS; TIES; TOPS; TROUSERS; WOMEN'S CLOTHING, NAMELY, SHIRTS, DRESSES, SKIRTS, BLOUSES (U.S. CLS. 22 AND 39).
FIRST USE 12-31-2011; IN COMMERCE 12-31-2011.

CLASS 45—PERSONAL AND LEGAL SERVICES

FOR CONDUCTING ON-LINE PERSONAL LIFESTYLE PERFORMANCE ASSESSMENTS BASED ON PRINCIPLES OF EMOTIONAL HAPPINESS BY MEANS OF THE USERS' INPUTTED PREFERENCES AND SOCIAL NETWORK; INTERNET BASED SOCIAL NETWORKING, INTRODUCTION, AND DATING SERVICES; INTERNET-BASED DATING, SOCIAL INTRODUCTION AND SOCIAL NETWORKING SERVICES; INTERNET-BASED SOCIAL NETWORKING SERVICES; ONLINE SOCIAL NETWORKING SERVICES PROVIDED THROUGH A COMMUNITY WEBSITE; ONLINE SOCIAL NETWORKING SERVICES PROVIDED THROUGH A FASHION COMMUNITY WEBSITE (U.S. CLS. 100 AND 101).

FIRST USE 4-1-2012; IN COMMERCE 4-1-2012.

4,155,508. SEAI AMERICA, INC., IRVINE, CA. SN 85-306,502. PUB. 9-13-2011, FILED 4-27-2011.

S-ENERGY

THE MARK CONSISTS OF STANDARD CHARACTERS WITHOUT CLAIM TO ANY PARTICULAR FONT, STYLE, SIZE, OR COLOR.

CLASS 11—ENVIRONMENTAL CONTROL APPARATUS

FOR HEATING SYSTEMS FOR RESIDENTIAL AND COMMERCIAL BUILDINGS COMPRISED OF BIOMASS BURNERS, BOILERS, VALVES, PIPES, MANIFOLDS, SOLAR PANELS, CONTROL PANELS, SWITCHES AND ELECTRICAL WIRE, ALL SOLD AS A UNIT; HEATING SYSTEMS FOR RESIDENTIAL AND COMMERCIAL BUILDINGS COMPRISED OF BOILERS, VALVES, PIPES, MANIFOLDS, SOLAR PANELS, CONTROL PANEL, SWITCHES AND ELECTRICAL WIRE, ALL SOLD AS A UNIT; PARABOLIC MIRRORS DESIGNED FOR THE COLLECTION OF SOLAR ENERGY; PHOTOVOLTAIC-BASED POWER PLANTS; SOLAR COLLECTORS; SOLAR COLLECTORS FOR HEATING; SOLAR ENERGY BASED COOLING APPARATUS; SOLAR ENERGY RECEIVERS; SOLAR HEAT COLLECTION PANELS; SOLAR LIGHT FIXTURES, NAMELY, INDOOR AND OUTDOOR SOLAR POWERED LIGHTING UNITS AND FIXTURES; SOLAR REACTORS; SOLAR THERMAL AIR SYSTEMS FOR HEATING PURPOSES; SOLAR THERMAL INSTALLATIONS, NAMELY, SOLAR THERMAL MODULES; SOLAR THERMAL-BASED POWER PLANTS; SOLAR WATER HEATERS; SOLAR-POWERED ALL-WEATHER LIGHTS; SOLAR-POWERED COOLING UNITS (U.S. CLS. 13, 21, 23, 31 AND 34).

FIRST USE 12-21-2011; IN COMMERCE 12-21-2011.

CLASS 37—CONSTRUCTION AND REPAIR

FOR INSTALLATION AND MAINTENANCE OF PHOTOVOLTAIC INSTALLATIONS; INSTALLATION AND MAINTENANCE OF PHOTOVOLTAIC/SOLAR THERMAL HYBRID INSTALLATIONS; INSTALLATION AND MAINTENANCE OF SOLAR ENERGY BASED POWER PLANTS; INSTALLATION AND MAINTENANCE OF SOLAR THERMAL INSTALLATIONS; INSTALLATION OF SOLAR ENERGY SYSTEMS AND ALTERNATIVE ENERGY PRODUCTS FOR RESIDENTIAL AND COMMERCIAL USE; REPAIR AND INSTALLATION SERVICES, NAMELY, THE INSTALLATION OF HEATING, COOLING AND ENVIRONMENTAL CONTROL SYSTEMS PRIMARILY USING SOLAR ENERGY, RENEWABLE ENERGY RESOURCES AND RAIN-WATER (U.S. CLS. 100, 103 AND 106).

FIRST USE 11-9-2011; IN COMMERCE 11-9-2011.

4,155,510. VISUAL GRAPHIC SYSTEMS INC., CARLSTADT, NJ. SN 85-308,038. PUB. 9-20-2011, FILED 4-29-2011.

SignCare

THE MARK CONSISTS OF STANDARD CHARACTERS WITHOUT CLAIM TO ANY PARTICULAR FONT, STYLE, SIZE, OR COLOR.

CLASS 6—METAL GOODS

FOR NON-LUMINOUS AND NON-MECHANICAL METAL SIGNS (U.S. CLS. 2, 12, 13, 14, 23, 25 AND 50).

FIRST USE 4-0-2011; IN COMMERCE 4-0-2011.

CLASS 19—NON-METALLIC BUILDING MATERIALS

FOR NON-LUMINOUS, NON-MECHANICAL SIGNS NOT OF METAL (U.S. CLS. 1, 12, 33 AND 50).

FIRST USE 9-0-2011; IN COMMERCE 9-0-2011.

4,155,512. VITONOMY, LLC, PHOENIX, AZ. SN 85-308,506. PUB. 9-13-2011, FILED 4-29-2011.

VITONOMY

THE MARK CONSISTS OF STANDARD CHARACTERS WITHOUT CLAIM TO ANY PARTICULAR FONT, STYLE, SIZE, OR COLOR.

CLASS 5—PHARMACEUTICALS

FOR NUTRITIONAL SUPPLEMENTS, DIETARY SUPPLEMENTS, AND LIQUID DIETARY SUPPLEMENTS; NUTRITIONALLY FORTIFIED FRUIT-BASED BEVERAGES; WEIGHT LOSS PREPARATIONS; HERBAL SUPPLEMENTS, HERBAL EXTRACTS, ENZYMES, VITAMINS AND MINERALS (U.S. CLS. 6, 18, 44, 46, 51 AND 52).

FIRST USE 8-16-2011; IN COMMERCE 8-16-2011.

CLASS 16—PAPER GOODS AND PRINTED MATTER

FOR CATALOGS, BROCHURES, AND NEWSLETTERS FEATURING NUTRITIONAL SUPPLEMENTS, DIETARY SUPPLEMENTS, VITAMIN, MINERAL AND HERBAL SUPPLEMENTS, NUTRITIOUS FOODS, SNACKS AND BEVERAGES; NEWSLETTERS AND PRINTED INSTRUCTIONAL AND EDUCATIONAL MATERIALS IN THE FIELDS OF PERSONAL CARE PRODUCTS, HOME CARE PRODUCTS, NUTRITIONAL AND DIETARY SUPPLEMENTS, AND EXERCISE, NUTRITION, FITNESS AND WELLNESS (U.S. CLS. 2, 5, 22, 23, 29, 37, 38 AND 50).

FIRST USE 8-16-2011; IN COMMERCE 8-16-2011.

CLASS 32—LIGHT BEVERAGES

FOR FRUIT-BASED BEVERAGES THAT ARE ALSO NUTRITIONALLY FORTIFIED AND SPORTS DRINKS (U.S. CLS. 45, 46 AND 48).

FIRST USE 8-16-2011; IN COMMERCE 8-16-2011.

CLASS 35—ADVERTISING AND BUSINESS

FOR ONLINE ORDERING SERVICES FEATURING NUTRITIONAL SUPPLEMENTS, DIETARY SUPPLEMENTS, VITAMIN, MINERAL AND HERBAL SUPPLEMENTS, WEIGHT LOSS PRODUCTS, NUTRITIOUS FOODS, BEVERAGES; DISTRIBUTORSHIP SERVICES IN THE FIELDS OF NUTRITIONAL PRODUCTS, PERSONAL CARE PRODUCTS, AND HOME CARE PRODUCTS (U.S. CLS. 100, 101 AND 102).

FIRST USE 8-16-2011; IN COMMERCE 8-16-2011.

CLASS 42—SCIENTIFIC AND COMPUTER SERVICES

FOR CLOUD COMPUTING FEATURING SOFTWARE FOR USE IN ENHANCING COMMUNICATIONS BETWEEN INDIVIDUALS AND BETWEEN CONSUMERS AND BUSINESSES INCLUDING, BUT NOT LIMITED TO, LEVERAGING VOICE AND DATA CHANNELS SIMULTANEOUSLY; SOFTWARE DEVELOPMENT AND PRODUCT DEVELOPMENT IN THE FIELD OF ENHANCING COMMUNICATIONS BETWEEN INDIVIDUALS AND BETWEEN CONSUMERS AND BUSINESSES INCLUDING, BUT NOT LIMITED TO, LEVERAGING VOICE AND DATA CHANNELS SIMULTANEOUSLY (U.S. CLS. 100 AND 101).

FIRST USE 8-2-2011; IN COMMERCE 8-2-2011.

4,155,514. APPTERA, INC., SUNNYVALE, CA. SN 85-309,259.
PUB. 8-23-2011, FILED 5-1-2011.

4,155,515. APPTERA, INC., SUNNYVALE, CA. SN 85-309,261.
PUB. 8-23-2011, FILED 5-1-2011.



THE COLOR(S) GREEN AND GREY IS/ARE CLAIMED AS A FEATURE OF THE MARK.

THE MARK CONSISTS OF "POPTUIT" WITH "POP" IN GREEN WITH THREE GREEN LINES ABOVE THE "O" AND "TUIT" IN GREY.

CLASS 9—ELECTRICAL AND SCIENTIFIC APPARATUS

FOR DOWNLOADABLE SOFTWARE IN THE NATURE OF A MOBILE APPLICATION FOR ENHANCING COMMUNICATIONS BETWEEN INDIVIDUALS AND BETWEEN CONSUMERS AND BUSINESSES INCLUDING, BUT NOT LIMITED TO, LEVERAGING VOICE AND DATA CHANNELS SIMULTANEOUSLY (U.S. CLS. 21, 23, 26, 36 AND 38).

FIRST USE 8-2-2011; IN COMMERCE 8-2-2011.

CLASS 35—ADVERTISING AND BUSINESS

FOR ADVERTISING AND MARKETING SERVICES PROVIDED BY MEANS OF DIRECT AND INDIRECT METHODS OF MARKETING COMMUNICATIONS, NAMELY, SOCIAL MEDIA, SEARCH ENGINE MARKETING, INQUIRY MARKETING, INTERNET MARKETING, MOBILE MARKETING, GEOGRAPHIC LOCATION BASED MARKETING, BLOGGING AND OTHER FORMS OF PASSIVE, SHARABLE OR VIRAL COMMUNICATIONS CHANNELS (U.S. CLS. 100, 101 AND 102).

FIRST USE 8-2-2011; IN COMMERCE 8-2-2011.

CLASS 38—COMMUNICATION

FOR WIRELESS ELECTRONIC TRANSMISSION SIMULTANEOUSLY OF VOICE SIGNALS, DATA, FACSIMILES, IMAGES AND INFORMATIONS (U.S. CLS. 100, 101 AND 104).

FIRST USE 8-2-2011; IN COMMERCE 8-2-2011.



THE COLOR(S) WHITE, GREEN, RED, YELLOW, ORANGE, LIGHT BLUE, DARK BLUE, AND PURPLE IS/ARE CLAIMED AS A FEATURE OF THE MARK.

THE MARK CONSISTS OF THREE OVERLAPPING CIRCLES ARRANGED WITH TWO ON THE BOTTOM AND ONE CENTERED OVER THEM ON THE TOP, WITH THE TOP CIRCLE IN YELLOW WITH A WHITE SMILEY FACE CONSISTING OF TWO EYES AND A SMILE FACING NINETY DEGREES COUNTERCLOCKWISE, THE BOTTOM LEFT CIRCLE IN GREEN WITH A SMALL TRIANGLE ON THE BOTTOM LEFT SIDE CREATING A SPEECH BUBBLE, AND THE BOTTOM RIGHT CIRCLE IN LIGHT BLUE WITH A TRIANGLE ON THE LEFT SIDE TO CREATE A TEARDROP SHAPE AND WITH AN OPEN WHITE CIRCLE CENTERED IN THE LARGER CIRCLE. THE OVERLAP BETWEEN THE YELLOW AND GREEN CIRCLES IS RED WITH A CURVED WHITE LINE SEPARATING THE GREEN AND RED, THE OVERLAP BETWEEN THE YELLOW AND LIGHT BLUE CIRCLES IS ORANGE, THE OVERLAP BETWEEN THE LIGHT BLUE AND GREEN CIRCLES IS DARK BLUE WITH A CURVED WHITE LINE SEPARATING THE DARK BLUE AND LIGHT BLUE, AND THE OVERLAP BETWEEN ALL THREE CIRCLES IS PURPLE.

CLASS 9—ELECTRICAL AND SCIENTIFIC APPARATUS

FOR DOWNLOADABLE SOFTWARE IN THE NATURE OF A MOBILE APPLICATION FOR ENHANCING COMMUNICATIONS BETWEEN INDIVIDUALS AND BETWEEN CONSUMERS AND BUSINESSES INCLUDING, BUT NOT LIMITED TO, LEVERAGING VOICE AND DATA CHANNELS SIMULTANEOUSLY (U.S. CLS. 21, 23, 26, 36 AND 38).

FIRST USE 8-2-2011; IN COMMERCE 8-2-2011.

CLASS 35—ADVERTISING AND BUSINESS

FOR ADVERTISING AND MARKETING SERVICES PROVIDED BY MEANS OF DIRECT AND INDIRECT METHODS OF MARKETING COMMUNICATIONS, NAMELY, SOCIAL MEDIA, SEARCH ENGINE MARKETING, INQUIRY MARKETING, INTERNET MARKETING, MOBILE MARKETING, GEOGRAPHIC LOCATION BASED MARKETING, BLOGGING AND OTHER FORMS OF PASSIVE, SHARABLE OR VIRAL COMMUNICATIONS CHANNELS (U.S. CLS. 100, 101 AND 102).

FIRST USE 8-2-2011; IN COMMERCE 8-2-2011.

CLASS 38—COMMUNICATION

FOR WIRELESS ELECTRONIC TRANSMISSION SIMULTANEOUSLY OF VOICE SIGNALS, DATA, FACSIMILES, IMAGES AND INFORMATIONS (U.S. CLS. 100, 101 AND 104).

FIRST USE 8-2-2011; IN COMMERCE 8-2-2011.

CLASS 42—SCIENTIFIC AND COMPUTER SERVICES

FOR CLOUD COMPUTING FEATURING SOFTWARE FOR USE IN ENHANCING COMMUNICATIONS BETWEEN INDIVIDUALS AND BETWEEN CONSUMERS AND BUSINESSES INCLUDING, BUT NOT LIMITED TO, LEVERAGING VOICE AND DATA CHANNELS SIMULTANEOUSLY; SOFTWARE DEVELOPMENT AND PRODUCT DEVELOPMENT IN THE FIELD OF ENHANCING COMMUNICATIONS BETWEEN INDIVIDUALS AND BETWEEN CONSUMERS AND BUSINESSES INCLUDING, BUT NOT LIMITED TO, LEVERAGING VOICE AND DATA CHANNELS SIMULTANEOUSLY (U.S. CLS. 100 AND 101).

FIRST USE 8-2-2011; IN COMMERCE 8-2-2011.

4,155,524. KOHL'S ILLINOIS, INC., AURORA, IL. SN 85-312,563. PUB. 12-20-2011, FILED 5-4-2011.

Kitchen
{à la carte}

NO CLAIM IS MADE TO THE EXCLUSIVE RIGHT TO USE "KITCHEN", APART FROM THE MARK AS SHOWN. THE MARK CONSISTS OF THE WORD "KITCHEN" ABOVE THE WORDS "À LA CARTE" WHICH ARE WITHIN BRACKETS.

CLASS 8—HAND TOOLS

FOR KITCHEN KNIVES (U.S. CLS. 23, 28 AND 44).
FIRST USE 0-0-2011; IN COMMERCE 0-0-2011.

CLASS 21—HOUSEWARES AND GLASS

FOR COOKWARE, NAMELY, POTS, PANS, AND LIDS (U.S. CLS. 2, 13, 23, 29, 30, 33, 40 AND 50).
FIRST USE 0-0-2011; IN COMMERCE 0-0-2011.

4,155,553. RENSON GROUP, LTD., MALVERN, PA. SN 85-323,606. PUB. 10-18-2011, FILED 5-18-2011.

Gender Effect

THE MARK CONSISTS OF STANDARD CHARACTERS WITHOUT CLAIM TO ANY PARTICULAR FONT, STYLE, SIZE, OR COLOR.

CLASS 35—ADVERTISING AND BUSINESS

FOR CONSULTING SERVICES IN BUSINESS LEADERSHIP DEVELOPMENT AND BUSINESS MANAGEMENT; GENERAL BUSINESS MERCHANDISING SERVICES, NAMELY, MARKETING (U.S. CLS. 100, 101 AND 102).

FIRST USE 4-21-2011; IN COMMERCE 4-21-2011.

CLASS 41—EDUCATION AND ENTERTAINMENT

FOR ARRANGING PROFESSIONAL WORKSHOP AND TRAINING COURSES; BUSINESS EDUCATION AND TRAINING SERVICES, NAMELY, DEVELOPING AND FACILITATING CUSTOMIZED LEADERSHIP AND EXECUTIVE DEVELOPMENT PROGRAMS, PROVIDING EXECUTIVE COACHING SERVICES, AND PROVIDING BUSINESS EDUCATION PROGRAMS TO EMPLOYEES AND EXECUTIVES; BUSINESS EDUCATION AND TRAINING SERVICES, NAMELY, DEVELOPING, AND FACILITATING CUSTOMIZED IN-COMPANY LEADERSHIP AND EXECUTIVE DEVELOPMENT PROGRAMS, PROVIDING EXECUTIVE COACHING SERVICES, AND PROVIDING PUBLIC AND IN-COMPANY KEYNOTE PRESENTATIONS TO BUSINESS LEADERS; BUSINESS TRAINING; BUSINESS TRAINING CONSULTANCY SERVICES; CONTINUING EDUCATION SERVICES, NAMELY, PROVIDING LIVE AND ON-LINE CONTINUING PROFESSIONAL EDUCATION SEMINARS IN THE FIELD OF BUSINESS AND FINANCE (U.S. CLS. 100, 101 AND 107).

FIRST USE 4-21-2011; IN COMMERCE 4-21-2011.

4,155,554. PEARISON, INC., CYNTHIANA, IN. SN 85-324,086. PUB. 10-11-2011, FILED 5-18-2011.

SUPERIOR CHEER

THE MARK CONSISTS OF STANDARD CHARACTERS WITHOUT CLAIM TO ANY PARTICULAR FONT, STYLE, SIZE, OR COLOR.

CLASS 3—COSMETICS AND CLEANING PREPARATIONS

FOR FACIAL MAKE-UP (U.S. CLS. 1, 4, 6, 50, 51 AND 52).
FIRST USE 1-19-2012; IN COMMERCE 1-19-2012.

CLASS 9—ELECTRICAL AND SCIENTIFIC APPARATUS

FOR MEGAPHONES (U.S. CLS. 21, 23, 26, 36 AND 38).
FIRST USE 1-19-2012; IN COMMERCE 1-19-2012.

CLASS 14—JEWELRY

FOR JEWELRY (U.S. CLS. 2, 27, 28 AND 50).
FIRST USE 1-19-2012; IN COMMERCE 1-19-2012.

CLASS 18—LEATHER GOODS

FOR ATHLETIC BAGS (U.S. CLS. 1, 2, 3, 22 AND 41).
FIRST USE 1-19-2012; IN COMMERCE 1-19-2012.

CLASS 24—FABRICS

FOR CLOTH BANNERS (U.S. CLS. 42 AND 50).
FIRST USE 1-19-2012; IN COMMERCE 1-19-2012.

CLASS 25—CLOTHING

FOR BODY SUITS; BRIEFS; SHOES; SHORTS; SOCKS;
T-SHIRTS; UNIFORMS; WARM UP OUTFITS (U.S. CLS.
22 AND 39).
FIRST USE 1-19-2012; IN COMMERCE 1-19-2012.

CLASS 26—FANCY GOODS

FOR HAIR BOWS (U.S. CLS. 37, 39, 40, 42 AND 50).
FIRST USE 1-19-2012; IN COMMERCE 1-19-2012.

CLASS 28—TOYS AND SPORTING GOODS

FOR CHEERLEADING POM-POMS (U.S. CLS. 22, 23,
38 AND 50).
FIRST USE 1-19-2012; IN COMMERCE 1-19-2012.

4,155,559. UNCOMMON KNOWLEDGE AND ACHIEVE-
MENT, INC., NEW YORK, NY. SN 85-325,713. PUB. 10-
18-2011, FILED 5-20-2011.

RELAY SCHOOL OF EDUCATION

THE MARK CONSISTS OF STANDARD CHARACTERS
WITHOUT CLAIM TO ANY PARTICULAR FONT, STYLE,
SIZE, OR COLOR.

NO CLAIM IS MADE TO THE EXCLUSIVE RIGHT TO
USE "SCHOOL OF EDUCATION", APART FROM THE
MARK AS SHOWN.

CLASS 35—ADVERTISING AND BUSINESS

FOR SUPPORT OF TRAINING PROGRAMS FOR
TEACHERS, NAMELY, SCHEDULING AND MANA-
GING OF TRAINING COURSES AND PROGRAMS,
ALL IN THE FIELD OF PROGRAMS FOR TEACHER'S
THAT LEAD TO A MASTER'S DEGREE AND STATE
CERTIFICATION, AS WELL AS FOR ONGOING TEA-
CHER TRAINING; EMPLOYMENT RECRUITING IN
THE FIELD OF QUALIFIED TEACHERS (U.S. CLS. 100,
101 AND 102).
FIRST USE 2-8-2011; IN COMMERCE 2-8-2011.

**CLASS 41—EDUCATION AND ENTERTAIN-
MENT**

FOR DEVELOPING TRAINING SYSTEMS AND
LEARNING METHODOLOGIES FOR OTHERS,
NAMELY, TEACHERS, THAT LEAD TO A MASTER'S
DEGREE AND STATE CERTIFICATION, AS WELL AS
FOR ONGOING TEACHER TRAINING; EDUCATIONAL
SERVICES, NAMELY, DEVELOPING CURRICULUM
FOR EDUCATION AND FOR TEACHERS; DEVELOP-
MENT OF ADVANCED LEARNING TECHNOLOGIES
AND TEACHING METHODS (U.S. CLS. 100, 101 AND
107).
FIRST USE 2-8-2011; IN COMMERCE 2-8-2011.

4,155,560. UNCOMMON KNOWLEDGE AND ACHIEVE-
MENT, INC., NEW YORK, NY. SN 85-325,735. PUB. 10-
18-2011, FILED 5-20-2011.

RSE

THE MARK CONSISTS OF STANDARD CHARACTERS
WITHOUT CLAIM TO ANY PARTICULAR FONT, STYLE,
SIZE, OR COLOR.

CLASS 35—ADVERTISING AND BUSINESS

FOR SUPPORT OF TRAINING PROGRAMS FOR
TEACHERS, NAMELY, SCHEDULING AND MANA-
GING OF TRAINING COURSES AND PROGRAMS,
ALL IN THE FIELD OF PROGRAMS FOR TEACHER'S
THAT LEAD TO A MASTER'S DEGREE AND STATE
CERTIFICATION, AS WELL AS FOR ONGOING TEA-
CHER TRAINING; EMPLOYMENT RECRUITING IN
THE FIELD OF QUALIFIED TEACHERS (U.S. CLS. 100,
101 AND 102).
FIRST USE 2-8-2011; IN COMMERCE 2-8-2011.

**CLASS 41—EDUCATION AND ENTERTAIN-
MENT**

FOR DEVELOPING TRAINING SYSTEMS AND
LEARNING METHODOLOGIES FOR OTHERS,
NAMELY, TEACHERS, THAT LEAD TO A MASTER'S
DEGREE AND STATE CERTIFICATION, AS WELL AS
FOR ONGOING TEACHER TRAINING; EDUCATIONAL
SERVICES, NAMELY, DEVELOPING CURRICULUM
FOR EDUCATION AND FOR TEACHERS; DEVELOP-
MENT OF ADVANCED LEARNING TECHNOLOGIES
AND TEACHING METHODS (U.S. CLS. 100, 101 AND
107).
FIRST USE 2-8-2011; IN COMMERCE 2-8-2011.

4,155,565. PRECISION FOODS, INC., ST. LOUIS, MO. SN 85-
328,472. PUB. 1-24-2012, FILED 5-24-2011.



OWNER OF U.S. REG. NOS. 1,807,762, 2,395,879, AND
4,012,508.

THE MARK CONSISTS OF THE WORDS "ORRINGTON
FARMS" OVER A FARM SCENE CONSISTING OF A BARN,
SILO, WINDMILL, FENCE AND FIELDS.

CLASS 29—MEATS AND PROCESSED FOODS

FOR SOUP AND SOUP BASE MIXES (U.S. CL. 46).
FIRST USE 6-30-2011; IN COMMERCE 6-30-2011.

CLASS 30—STAPLE FOODS

FOR FOOD SEASONINGS; FOOD MIXES FOR GRAVIES AND AU JUS (U.S. CL. 46).
FIRST USE 6-30-2011; IN COMMERCE 6-30-2011.

4,155,567. YOTEL LIMITED, LONDON W1W 8DH, UNITED KINGDOM. SN 85-328,909. PUB. 12-27-2011, FILED 5-24-2011.

YOBOT

THE MARK CONSISTS OF STANDARD CHARACTERS WITHOUT CLAIM TO ANY PARTICULAR FONT, STYLE, SIZE, OR COLOR.

CLASS 7—MACHINERY

FOR INDUSTRIAL ROBOTS; INDUSTRIAL ROBOTS FOR STORING LUGGAGE (U.S. CLS. 13, 19, 21, 23, 31, 34 AND 35).
FIRST USE 6-0-2011; IN COMMERCE 6-0-2011.

CLASS 43—HOTEL AND RESTAURANT SERVICES

FOR HOTEL SERVICES; MOTEL SERVICES; PROVISION OF TEMPORARY ACCOMMODATION; ARRANGING ACCOMMODATION, NAMELY, MAKING RESERVATIONS AND BOOKING FOR TEMPORARY LODGING; RENTAL OF PORTABLE, SELF-CONTAINED ROOMS USED FOR TEMPORARY ACCOMMODATIONS AND INFORMATION, ADVICE AND CONSULTANCY SERVICES IN RELATION THERETO (U.S. CLS. 100 AND 101).
FIRST USE 6-0-2011; IN COMMERCE 6-0-2011.

4,155,578. MICHAEL & SUSAN DELL FOUNDATION, AUSTIN, TX. SN 85-334,028. PUB. 1-10-2012, FILED 5-31-2011.

ED-FI

THE MARK CONSISTS OF STANDARD CHARACTERS WITHOUT CLAIM TO ANY PARTICULAR FONT, STYLE, SIZE, OR COLOR.

CLASS 35—ADVERTISING AND BUSINESS

FOR PROMOTING STANDARD INFORMATION COLLECTION PRACTICES AND FORMATS FOR EDUCATIONAL INSTITUTIONS; BUSINESS SERVICES, NAMELY, FORMULATION OF BEST PRACTICES FOR INFORMATION COLLECTION, FORMATTING, USE, AND REPORTING; COLLECTION AND COMPILATION OF INFORMATION INTO COMPUTER DATABASES IN THE FIELD OF EDUCATIONAL INSTITUTION ADMINISTRATION (U.S. CLS. 100, 101 AND 102).
FIRST USE 7-1-2011; IN COMMERCE 7-1-2011.

CLASS 42—SCIENTIFIC AND COMPUTER SERVICES

FOR DEVELOPMENT OF VOLUNTARY STANDARDS FOR DATA IN EDUCATIONAL SETTINGS; DEVELOPMENT OF STANDARD INFORMATION COLLECTION PRACTICES AND FORMATS FOR EDUCATIONAL INSTITUTIONS; DEVELOPING VOLUNTARY STANDARDS FOR INFORMATION PROTOCOLS FOR EDUCATIONAL INSTITUTIONS; SOFTWARE DESIGN AND DEVELOPMENT (U.S. CLS. 100 AND 101).
FIRST USE 7-1-2011; IN COMMERCE 7-1-2011.

4,155,579. MICHAEL & SUSAN DELL FOUNDATION, AUSTIN, TX. SN 85-334,062. PUB. 1-10-2012, FILED 5-31-2011.



THE MARK CONSISTS OF A PINWHEEL DESIGN BEFORE THE STYLIZED LETTERING "ED-FI".

CLASS 35—ADVERTISING AND BUSINESS

FOR PROMOTING STANDARD INFORMATION COLLECTION PRACTICES AND FORMATS FOR EDUCATIONAL INSTITUTIONS; BUSINESS SERVICES, NAMELY, FORMULATION OF BEST PRACTICES FOR INFORMATION COLLECTION, FORMATTING, USE, AND REPORTING; COLLECTION AND COMPILATION OF INFORMATION INTO COMPUTER DATABASES IN THE FIELD OF EDUCATIONAL INSTITUTION ADMINISTRATION (U.S. CLS. 100, 101 AND 102).
FIRST USE 7-1-2011; IN COMMERCE 7-1-2011.

CLASS 42—SCIENTIFIC AND COMPUTER SERVICES

FOR DEVELOPMENT OF VOLUNTARY STANDARDS FOR DATA IN EDUCATIONAL SETTINGS; DEVELOPMENT OF STANDARD INFORMATION COLLECTION PRACTICES AND FORMATS FOR EDUCATIONAL INSTITUTIONS; DEVELOPING VOLUNTARY STANDARDS FOR INFORMATION PROTOCOLS FOR EDUCATIONAL INSTITUTIONS; SOFTWARE DESIGN AND DEVELOPMENT (U.S. CLS. 100 AND 101).
FIRST USE 7-1-2011; IN COMMERCE 7-1-2011.

4,155,580. MICHAEL & SUSAN DELL FOUNDATION, AUSTIN, TX. SN 85-334,095. PUB. 1-10-2012, FILED 5-31-2011.

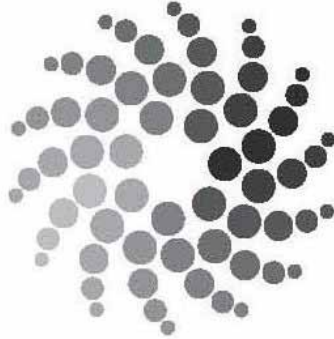

THE MARK CONSISTS OF A PINWHEEL DESIGN.

CLASS 35—ADVERTISING AND BUSINESS

FOR PROMOTING STANDARD INFORMATION COLLECTION PRACTICES AND FORMATS FOR EDUCATIONAL INSTITUTIONS; BUSINESS SERVICES, NAMELY, FORMULATION OF BEST PRACTICES FOR INFORMATION COLLECTION, FORMATTING, USE, AND REPORTING; COLLECTION AND COMPILATION OF INFORMATION INTO COMPUTER DATABASES IN THE FIELD OF EDUCATIONAL INSTITUTION ADMINISTRATION (U.S. CLS. 100, 101 AND 102).
FIRST USE 7-1-2011; IN COMMERCE 7-1-2011.

CLASS 42—SCIENTIFIC AND COMPUTER SERVICES

FOR DEVELOPMENT OF VOLUNTARY STANDARDS FOR DATA IN EDUCATIONAL SETTINGS; DEVELOPMENT OF STANDARD INFORMATION COLLECTION PRACTICES AND FORMATS FOR EDUCATIONAL INSTITUTIONS; DEVELOPING VOLUNTARY STANDARDS FOR INFORMATION PROTOCOLS FOR EDUCATIONAL INSTITUTIONS; SOFTWARE DESIGN AND DEVELOPMENT (U.S. CLS. 100 AND 101).
FIRST USE 7-1-2011; IN COMMERCE 7-1-2011.

CLASS 43—HOTEL AND RESTAURANT SERVICES

FOR RENTAL OF TABLE LINENS (U.S. CLS. 100 AND 101).
FIRST USE 4-29-1959; IN COMMERCE 4-29-1959.

CLASS 45—PERSONAL AND LEGAL SERVICES

FOR RENTAL OF CLOTHING; RENTAL OF UNIFORMS (U.S. CLS. 100 AND 101).
FIRST USE 4-29-1959; IN COMMERCE 4-29-1959.

4,155,600. SKAGGS, MARK, OAK HARBOR, WA. SN 85-342,279. PUB. 12-6-2011, FILED 6-9-2011.



4,155,582. NEW ENGLAND LINEN SUPPLY, PAWTUCKET, RI. SN 85-335,021. PUB. 11-15-2011, FILED 6-1-2011.



NO CLAIM IS MADE TO THE EXCLUSIVE RIGHT TO USE "NEW ENGLAND LINEN SUPPLY", APART FROM THE MARK AS SHOWN.

THE MARK CONSISTS OF THE WORDS "NEW ENGLAND LINEN SUPPLY" WITH CAPITALIZATION OF THE INITIAL LETTER OF "NEW" AND "LINEN" AND THE LAST LETTER OF "ENGLAND" AND "SUPPLY" SURROUNDING OPPOSED SCROLLS.

NO CLAIM IS MADE TO THE EXCLUSIVE RIGHT TO USE "SURF & SKATE", APART FROM THE MARK AS SHOWN.

THE MARK CONSISTS OF AN ELONGATED OVAL CONTAINING THE STYLIZED TEXT "ATOMIC SURF & SKATE". THE WORD "ATOMIC" IS ABOVE THE WORDS "SURF & SKATE". THERE IS A RADIATION SYMBOL ON EACH SIDE OF THE WORD "ATOMIC".

CLASS 25—CLOTHING

FOR DRESS SHIRTS; HATS; PANTS; SHORTS; T-SHIRTS (U.S. CLS. 22 AND 39).
FIRST USE 2-1-2012; IN COMMERCE 2-1-2012.

CLASS 28—TOYS AND SPORTING GOODS

FOR KNEE PADS FOR ATHLETIC USE; SKATEBOARDS; SNOWBOARDS; SURFBOARDS (U.S. CLS. 22, 23, 38 AND 50).
FIRST USE 2-1-2012; IN COMMERCE 2-1-2012.

4,155,601. PROFESSIONAL LIABILITY UNDERWRITING SOCIETY, MINNEAPOLIS, MN. SN 85-342,913. PUB. 11-15-2011, FILED 6-10-2011.

4,155,602. PROFESSIONAL LIABILITY UNDERWRITING SOCIETY, MINNEAPOLIS, MN. SN 85-342,921. PUB. 11-15-2011, FILED 6-10-2011.



THE MARK CONSISTS OF A CIRCLE INTERSECTED BY HORIZONTAL AND VERTICAL BANDS WHICH FORM A PLUS SIGN AND DIVIDE THE CIRCLE INTO FOUR QUADRANTS

CLASS 9—ELECTRICAL AND SCIENTIFIC APPARATUS

FOR DOWNLOADABLE ELECTRONIC PUBLICATIONS IN THE NATURE OF JOURNALS FEATURING INFORMATION IN THE FIELD OF PROFESSIONAL LIABILITY (U.S. CLS. 21, 23, 26, 36 AND 38).
FIRST USE 11-0-2011; IN COMMERCE 11-0-2011.

CLASS 16—PAPER GOODS AND PRINTED MATTER

FOR JOURNALS IN THE FIELD OF PROFESSIONAL LIABILITY (U.S. CLS. 2, 5, 22, 23, 29, 37, 38 AND 50).
FIRST USE 11-0-2011; IN COMMERCE 11-0-2011.

CLASS 35—ADVERTISING AND BUSINESS

FOR ASSOCIATION SERVICES, NAMELY, PROMOTING THE INTERESTS OF THE PROFESSIONAL LIABILITY UNDERWRITING INSURANCE INDUSTRY (U.S. CLS. 100, 101 AND 102).
FIRST USE 11-0-2011; IN COMMERCE 11-0-2011.

CLASS 41—EDUCATION AND ENTERTAINMENT

FOR EDUCATIONAL SERVICES, NAMELY, PROVIDING CONTINUING EDUCATION COURSES IN THE FIELD OF PROFESSIONAL LIABILITY; DISTRIBUTION OF COURSE MATERIALS IN CONNECTION WITH ALL OF THE ABOVE SERVICES; PROVIDING ONLINE JOURNALS FEATURING INFORMATION IN THE FIELD OF PROFESSIONAL LIABILITY (U.S. CLS. 100, 101 AND 107).
FIRST USE 11-0-2011; IN COMMERCE 11-0-2011.



THE COLOR(S) ORANGE, GOLD, PURPLE, AND GREY IS/ARE CLAIMED AS A FEATURE OF THE MARK.

THE MARK CONSISTS OF A CIRCLE INTERSECTED BY HORIZONTAL AND VERTICAL BANDS WHICH FORM A PLUS SIGN AND DIVIDE THE CIRCLE INTO FOUR QUADRANTS, WITH THE UPPER LEFT QUADRANT IN ORANGE, THE UPPER RIGHT QUADRANT IN GOLD, THE LOWER LEFT QUADRANT IN PURPLE, AND THE LOWER RIGHT QUADRANT IN GREY.

CLASS 9—ELECTRICAL AND SCIENTIFIC APPARATUS

FOR DOWNLOADABLE ELECTRONIC PUBLICATIONS IN THE NATURE OF JOURNALS FEATURING INFORMATION IN THE FIELD OF PROFESSIONAL LIABILITY (U.S. CLS. 21, 23, 26, 36 AND 38).
FIRST USE 11-0-2011; IN COMMERCE 11-0-2011.

CLASS 16—PAPER GOODS AND PRINTED MATTER

FOR JOURNALS IN THE FIELD OF PROFESSIONAL LIABILITY (U.S. CLS. 2, 5, 22, 23, 29, 37, 38 AND 50).
FIRST USE 11-0-2011; IN COMMERCE 11-0-2011.

CLASS 35—ADVERTISING AND BUSINESS

FOR ASSOCIATION SERVICES, NAMELY, PROMOTING THE INTERESTS OF THE PROFESSIONAL LIABILITY UNDERWRITING INSURANCE INDUSTRY (U.S. CLS. 100, 101 AND 102).
FIRST USE 11-0-2011; IN COMMERCE 11-0-2011.

CLASS 41—EDUCATION AND ENTERTAINMENT

FOR EDUCATIONAL SERVICES, NAMELY, PROVIDING CONTINUING EDUCATION COURSES IN THE FIELD OF PROFESSIONAL LIABILITY; DISTRIBUTION OF COURSE MATERIALS IN CONNECTION WITH ALL OF THE ABOVE SERVICES; PROVIDING ONLINE JOURNALS FEATURING INFORMATION IN THE FIELD OF PROFESSIONAL LIABILITY (U.S. CLS. 100, 101 AND 107).
FIRST USE 11-0-2011; IN COMMERCE 11-0-2011.

4,155,603. O'NEIL GUM COMPANY, LLC, CORONA DEL MAR, CA. SN 85-343,511. PUB. 11-22-2011, FILED 6-10-2011.

Immuno Gum

THE MARK CONSISTS OF STANDARD CHARACTERS WITHOUT CLAIM TO ANY PARTICULAR FONT, STYLE, SIZE, OR COLOR.

NO CLAIM IS MADE TO THE EXCLUSIVE RIGHT TO USE "GUM", APART FROM THE MARK AS SHOWN.

CLASS 5—PHARMACEUTICALS

FOR MEDICATED CHEWING GUM (U.S. CLS. 6, 18, 44, 46, 51 AND 52).
FIRST USE 9-15-2011; IN COMMERCE 10-1-2011.

CLASS 30—STAPLE FOODS

FOR CHEWING GUM (U.S. CL. 46).
FIRST USE 9-15-2011; IN COMMERCE 10-1-2011.

4,155,605. INSIGHTFUL DEVELOPMENTS, LLC, MERRICK, NY. SN 85-344,722. PUB. 1-3-2012, FILED 6-13-2011.



NO CLAIM IS MADE TO THE EXCLUSIVE RIGHT TO USE "OJO", APART FROM THE MARK AS SHOWN.

THE MARK CONSISTS OF THE LETTERS "E", "F", "P", "T", "O", "Z" IN AN EYE CHART FORM OVER THE STYLIZED WORD "OJO".

THE ENGLISH TRANSLATION OF "OJO" IN THE MARK IS "EYE".

CLASS 5—PHARMACEUTICALS

FOR DIETARY SUPPLEMENTAL DRINKS IN THE NATURE OF VITAMIN AND MINERAL BEVERAGES; NUTRITIONAL SUPPLEMENTS; VITAMIN FORTIFIED BEVERAGES (U.S. CLS. 6, 18, 44, 46, 51 AND 52).
FIRST USE 3-0-2011; IN COMMERCE 3-0-2011.

CLASS 32—LIGHT BEVERAGES

FOR DRINKING WATER WITH VITAMINS; NON-ALCOHOLIC BEVERAGES CONTAINING FRUIT JUICES (U.S. CLS. 45, 46 AND 48).
FIRST USE 3-0-2011; IN COMMERCE 3-0-2011.

4,155,624. COMPLIANCE IMPLEMENTATION SERVICES, AKA CIS, MEDIA, PA. SN 85-348,441. PUB. 1-24-2012, FILED 6-16-2011.

ClaimsPartner

CLASS 35—ADVERTISING AND BUSINESS

FOR REGULATORY SUBMISSION MANAGEMENT, NAMELY, ASSISTING OTHERS IN PREPARING AND FILING APPLICATIONS FOR MEDICAID CLAIMS AND CLAIMS ADJUSTMENTS; MEDICAL CLAIMS MANAGEMENT SERVICES RELATING TO MEDICAID, NAMELY, RECEIVING, DATA ENTERING, AND REPRICING OF TRANSACTIONS THAT ARE ORIGINATED BY PHYSICIANS, HOSPITALS, AND ANCILLARY MEDICAL CARE PROVIDERS; ADMINISTRATIVE PROCESSING OF MEDICAID CLAIMS (U.S. CLS. 100, 101 AND 102).
FIRST USE 3-29-2010; IN COMMERCE 3-29-2010.

CLASS 36—INSURANCE AND FINANCIAL

FOR MEDICAL INSURANCE CASE AND UTILIZATION REVIEW AND INSURANCE CLAIMS ADJUSTMENT SERVICES FOR HEALTHCARE PURCHASERS AND PAYORS AND PROVIDERS AND MEDICARE BENEFICIARIES; PROVIDING A DATABASE FOR TRACKING, MONITORING, AND GENERATING REPORTS ON INFORMATION AND STATISTICS ABOUT PATIENT REIMBURSEMENT AND INSURANCE COVERAGE FOR PHARMACEUTICALS AND MEDICAL DEVICES (U.S. CLS. 100, 101 AND 102).

FIRST USE 3-29-2010; IN COMMERCE 3-29-2010.

CLASS 45—PERSONAL AND LEGAL SERVICES

FOR PROVIDING INFORMATION ON GOVERNMENT MEDICAL AND PHARMACEUTICAL PROGRAMS; REGULATORY COMPLIANCE CONSULTING IN THE FIELD OF MEDICAID CLAIMS PROCESSING (U.S. CLS. 100 AND 101).

FIRST USE 3-29-2010; IN COMMERCE 3-29-2010.

4,155,625. COMPLIANCE IMPLEMENTATION SERVICES, AKA CIS, MEDIA, PA. SN 85-348,842. PUB. 1-10-2012, FILED 6-17-2011.

ScriptPartner

CLASS 35—ADVERTISING AND BUSINESS

FOR MANAGED CARE SERVICES, NAMELY, UTILIZATION REVIEW AND PRE-CERTIFICATION SERVICES; PHARMACEUTICAL COST MANAGEMENT SERVICES AND DRUG UTILIZATION REVIEW SERVICE; HEALTH CARE UTILIZATION AND REVIEW SERVICES; ADMINISTERING MEDICATION REIMBURSEMENT PROGRAMS AND SERVICES; MANAGEMENT AND COMPILATION OF COMPUTERIZED DATABASES IN THE FIELD PRESCRIPTIONS AND MEDICINE REIMBURSEMENTS (U.S. CLS. 100, 101 AND 102).

FIRST USE 7-26-2011; IN COMMERCE 7-27-2011.

CLASS 36—INSURANCE AND FINANCIAL

FOR MEDICAL INSURANCE CASE AND UTILIZATION REVIEW AND INSURANCE CLAIMS ADJUSTMENT SERVICES FOR HEALTHCARE PURCHASERS AND PAYORS AND PROVIDERS AND MEDICARE BENEFICIARIES; PROVIDING A DATABASE FOR TRACKING, MONITORING, AND GENERATING REPORTS ON INFORMATION AND STATISTICS ABOUT PATIENT REIMBURSEMENT AND INSURANCE COVERAGE FOR PHARMACEUTICALS AND MEDICAL DEVICES (U.S. CLS. 100, 101 AND 102).

FIRST USE 7-26-2011; IN COMMERCE 7-27-2011.

CLASS 45—PERSONAL AND LEGAL SERVICES

FOR REGULATORY COMPLIANCE CONSULTING IN THE FIELD OF PHARMACEUTICAL, MEDICAL SERVICES, MANAGED CARE AND GOVERNMENT REIMBURSEMENT (U.S. CLS. 100 AND 101).

FIRST USE 7-26-2011; IN COMMERCE 7-27-2011.

4,155,626. COMMUNITY PARTNERSHIP FOR HOMELESS, INC., MIAMI, FL. SN 85-349,129. PUB. 1-3-2012, FILED 6-17-2011.



THE MARK CONSISTS OF THE OUTLINE OF A HOUSE WITH THREE STICK FIGURES WITHIN THE HOUSE REPRESENTING PEOPLE. THE HOUSE AND PEOPLE ARE WITHIN A CIRCLE.

CLASS 35—ADVERTISING AND BUSINESS

FOR BUSINESS SERVICES, NAMELY, ASSISTING OTHERS IN THE ESTABLISHMENT OF CHARITABLE ORGANIZATIONS; ORGANIZING AND CONDUCTING VOLUNTEER PROGRAMS AND COMMUNITY SERVICE PROJECTS; EMPLOYMENT COUNSELING SERVICES FOR THOSE LIVING IN POVERTY IN THE AREAS OF PREPARING FOR, OBTAINING, MAINTAINING AND ADVANCING IN EMPLOYMENT OPPORTUNITIES (U.S. CLS. 100, 101 AND 102).

FIRST USE 9-15-2011; IN COMMERCE 9-15-2011.

CLASS 36—INSURANCE AND FINANCIAL

FOR CHARITABLE FUND RAISING SERVICES; ACCEPTING AND ADMINISTERING MONETARY CHARITABLE CONTRIBUTIONS (U.S. CLS. 100, 101 AND 102).

FIRST USE 9-15-2011; IN COMMERCE 9-15-2011.

CLASS 41—EDUCATION AND ENTERTAINMENT

FOR CHARITABLE SERVICES, NAMELY, PROVIDING TOYS AND SCHOOL SUPPLIES TO NEEDY CHILDREN; PROVIDING ACADEMIC MENTORING OF SCHOOL AGE CHILDREN; PROVIDING VOCATIONAL TRAINING IN THE FIELDS OF CULINARY ARTS, ENVIRONMENT, NAMELY, HYDROPONICS, AND SECURITY GUARD SERVICES; CHARITABLE SERVICES, NAMELY, PROVIDING BOOKS TO THE INDIGENT, AND VOCATIONAL GUIDANCE AND CAREER COUNSELING TO INDIGENT PERSONS SEEKING EMPLOYMENT (U.S. CLS. 100, 101 AND 107).

FIRST USE 9-15-2011; IN COMMERCE 9-15-2011.

CLASS 43—HOTEL AND RESTAURANT SERVICES

FOR CHARITABLE SERVICES, NAMELY, PROVIDING FOOD, BLANKETS, AND HOUSEHOLD FURNISHINGS FOR HOMES IN THE NATURE OF FURNITURE AND UTENSILS, TO NEEDY PERSONS, AND PROVIDING TEMPORARY SHELTER FOR THE HOMELESS (U.S. CLS. 100 AND 101).

FIRST USE 9-15-2011; IN COMMERCE 9-15-2011.

CLASS 44—MEDICAL, BEAUTY AND AGRICULTURAL SERVICES

FOR CHARITABLE SERVICES, PROVIDING CARE PACKAGES CONSISTING PRIMARILY OF PERSONAL CARE ITEMS (U.S. CLS. 100 AND 101).

FIRST USE 9-15-2011; IN COMMERCE 9-15-2011.

CLASS 45—PERSONAL AND LEGAL SERVICES

FOR CHARITABLE SERVICES, NAMELY, PROVIDING LEGAL SERVICES TO HOMELESS PEOPLE (U.S. CLS. 100 AND 101).

FIRST USE 9-15-2011; IN COMMERCE 9-15-2011.

4,155,629. STANOJEVIC, DEJAN, DOWNEY, CA. SN 85-349,662. PUB. 10-25-2011, FILED 6-17-2011.

THE MARK CONSISTS OF THE STYLIZED TEXT "RIDONKULOUS!".

CLASS 25—CLOTHING

FOR HATS; JACKETS; JEANS; LONG-SLEEVED SHIRTS; SHORTS; SWEATERS; SWIMWEAR; T-SHIRTS; UNDERGARMENTS (U.S. CLS. 22 AND 39).

FIRST USE 10-1-2011; IN COMMERCE 2-1-2012.

CLASS 41—EDUCATION AND ENTERTAINMENT

FOR ENTERTAINMENT IN THE NATURE OF A SCRIPTED ONGOING SITCOM FOR TELEVISION, INTERNET, SATELLITE AND RADIO (U.S. CLS. 100, 101 AND 107).

FIRST USE 10-1-2011; IN COMMERCE 2-1-2012.

4,155,654. SPORTWORKS NORTHWEST, INC., WOODINVILLE, WA. SN 85-358,754. PUB. 11-29-2011, FILED 6-28-2011.

No Scratch

THE MARK CONSISTS OF STANDARD CHARACTERS WITHOUT CLAIM TO ANY PARTICULAR FONT, STYLE, SIZE, OR COLOR.

CLASS 6—METAL GOODS

FOR BICYCLE STORAGE RACKS OF METAL (U.S. CLS. 2, 12, 13, 14, 23, 25 AND 50).
FIRST USE 8-1-2011; IN COMMERCE 12-2-2011.

CLASS 12—VEHICLES

FOR RACKS FOR VEHICLES FOR BICYCLES (U.S. CLS. 19, 21, 23, 31, 35 AND 44).
FIRST USE 8-1-2011; IN COMMERCE 1-5-2012.

4,155,668. CEDAR FARMS CO., INC., PHILADELPHIA, PA. SN 85-362,834. PUB. 12-13-2011, FILED 7-5-2011.



THE NAME "CHEF PANTELIS" DOES NOT IDENTIFY THE NAME OF A LIVING INDIVIDUAL.

THE MARK CONSISTS OF A CHEF HOLDING A COVERED SERVING PLATE IN ONE HAND AND A THUMB UP WITH THE OTHER HAND. THE IMAGE IS DISPLAYED IN A CIRCULAR BORDER WITH THE STYLIZED WORDING "CHEF PANTELIS" APPEARING IMMEDIATELY BELOW.

CLASS 6—METAL GOODS

FOR ALUMINUM FOIL (U.S. CLS. 2, 12, 13, 14, 23, 25 AND 50).
FIRST USE 1-1-2012; IN COMMERCE 1-1-2012.

CLASS 8—HAND TOOLS

FOR CUTLERY, NAMELY, FORKS, SPOONS, AND KNIVES (U.S. CLS. 23, 28 AND 44).
FIRST USE 1-1-2012; IN COMMERCE 1-1-2012.

CLASS 16—PAPER GOODS AND PRINTED MATTER

FOR PLASTIC FOOD STORAGE BAGS FOR HOUSEHOLD USE; PLASTIC WRAP; SANDWICH BAGS; TRASH BAGS; TRASH CAN LINERS (U.S. CLS. 2, 5, 22, 23, 29, 37, 38 AND 50).

FIRST USE 1-1-2012; IN COMMERCE 1-1-2012.

CLASS 20—FURNITURE AND ARTICLES NOT OTHERWISE CLASSIFIED

FOR DRINKING STRAWS; PLASTIC LIDS (U.S. CLS. 2, 13, 22, 25, 32 AND 50).

FIRST USE 1-1-2012; IN COMMERCE 1-1-2012.

CLASS 21—HOUSEWARES AND GLASS

FOR ABRASIVE PADS FOR KITCHEN AND DOMESTIC PURPOSES; BOWLS; CLEANING SPONGES; DISPOSABLE DINNERWARE, NAMELY, PLATES, BOWLS AND SERVING TRAYS; DISPOSABLE PLASTIC GLOVES FOR USE IN THE FOOD SERVICE INDUSTRY; GLOVES FOR HOUSEHOLD PURPOSES; PAPER AND PLASTIC CUPS; PLASTIC STORAGE CONTAINERS FOR HOUSEHOLD OR DOMESTIC USE; SOAP DISPENSERS; TOOTHPICKS (U.S. CLS. 2, 13, 23, 29, 30, 33, 40 AND 50).
FIRST USE 1-1-2012; IN COMMERCE 1-1-2012.

CLASS 29—MEATS AND PROCESSED FOODS

FOR FROZEN MEATS; MOZZARELLA STICKS; CHICKEN BREAST BREADED; CHICKEN FINGERS; CHICKEN NUGGETS; CHICKEN WINGS; EGGS; FRENCH FRIES; FROZEN FRUITS; BREADED VEGETABLES; BEEF BURGER PATTIES; TURKEY BURGER PATTIES; DELI MEATS; MEATBALLS; ONION RINGS; HASH BROWNS; PREPARED FROZEN FOOD ENTREES CONSISTING PRIMARILY OF MEAT, FISH, POULTRY OR VEGETABLES; FROZEN SEAFOOD; FROZEN SOUPS; FROZEN TURKEY; FROZEN VEAL; FROZEN VEGETABLES; BUTTER; BUTTER BLENDS; BUTTER SUBSTITUTES; CHEESES; SPECIALTY CHEESES; CULTURED CHEESES; FRESH MEATS; GROUND MEATS; SMOKED MEATS; COOKED TURKEY; FRESH CHICKEN; BONELESS CHICKEN BREASTS; WHOLE CHICKEN; FRESH TURKEY; BROTH AND SOUP BASE; CANNED AND PACKAGED CHEESE; FRUIT BASED PIE FILLINGS; CANNED FRUIT BASED PIE FILLINGS; JELLY AND PRESERVES; PROCESSED NUTS; EDIBLE OILS AND PREPS, NAMELY, BOUILLON; PICKLES AND PROCESSED PEPPERS; CANNED MEAT; SHORTENINGS; CANNED SOUPS; CANNED TOMATOES; CANNED VEGETABLES; PIZZA TOPPINGS, NAMELY, MEAT AND CHEESE TOPPINGS; DRY TOPPINGS, NAMELY, NUT TOPPINGS; HORS D'OEUVRES AND APPETIZERS EACH MADE PRIMARILY OF MEAT, FISH, POULTRY OR VEGETABLES; SNACKS, NAMELY, CANDIED-FRUIT SNACKS, MEAT-BASED SNACK FOOD, VEGETABLE-BASED SNACK FOODS, NUT-BASED SNACK FOODS, POTATO-BASED SNACK FOODS, POTATO CHIPS, AND TRAIL-MIX CONSISTING PRIMARILY OF PROCESSED NUTS, SEEDS, DRIED FRUIT AND ALSO INCLUDING CHOCOLATE; FROZEN CLAM JUICE; STOCK CUBES; FRESH AND/OR PREPARED FRUIT SALADS, VEGETABLE SALADS AND GARDEN SALADS (U.S. CL. 46).
FIRST USE 6-1-2011; IN COMMERCE 6-1-2011.

CLASS 30—STAPLE FOODS

FOR FROZEN PIES; BAKERY DESSERTS AND CAKES; BREADS AND ROLLS; TORTILLAS; HORS D'OEUVRES AND APPETIZERS EACH MADE PRIMARILY OF PASTA OR RICE; FROZEN DOUGH, NAMELY, COOKIE DOUGH, FROZEN DOUGH FOR USE AS PIZZA, BREAD OR OTHER BREAD-TYPE PRODUCTS; FROZEN PASTA; FROZEN PIZZA; STEAK SANDWICHES; PIZZA TOPPINGS, NAMELY, PIZZA SAUCE; FROZEN PASTRY ITEMS; DRY BAKING ITEMS, NAMELY, BAKING POWDERS, FLOUR, SUGAR AND BAKING SODA; MIXES FOR MAKING BREADS AND BAKING BATTERS; BREAD CRUMBS; BREAKFAST CEREALS, PROCESSED CEREALS; COFFEE; TEA; DRINK MIXES, NAMELY, POWDERED COCOA DRINK

MIXES, POWDERED COFFEE DRINK, AND DRINK MIXES FOR MAKING TEA; DRESSINGS FOR FOOD; EXTRACT USED AS FLAVORING; FLOUR; KETCHUP; MAYONNAISE; MUSTARD; BAKING MIXES, NAMELY, CAKE MIXES, COOKIE MIXES, BROWNIE MIXES AND BREAD MIXES; PANCAKE AND WAFFLE MIXES; PASTA DRY; FLAVORED SWEETENED GELATIN AND PUDDING; SAUCES AND GRAVY; SPICES; FOOD SEASONINGS; FOOD FLAVOR BASES, NAMELY, FLAVOR ENHANCERS USED IN FOOD; SYRUPS, NAMELY, CORN SYRUP AND MAPLE SYRUP; VINEGAR; DRY TOPPINGS, NAMELY, CHOCOLATE TOPPINGS; SNACKS, NAMELY, NUTS, GRAIN-BASED SNACK FOODS, CORN-BASED SNACK FOODS, POPCORN, PRETZELS, TORTILLA CHIPS, CHOCOLATE-BASED SNACK FOODS AND CHEESE FLAVORED SNACKS, NAMELY, CHEESE CURLS; FROZEN FOODS, NAMELY, GRAIN AND BREAD BASED APPETIZERS AND HORS D'OEUVRES; BEEF BURGER SANDWICHES; TURKEY BURGER SANDWICHES; PREPARED FROZEN FOOD ENTREES CONSISTING PRIMARILY OF PASTA OR RICE; CHOCOLATE AND CUSTARD PIE FILLINGS; CANNED CHOCOLATE AND CUSTARD BASED PIE FILLINGS; SUGARED NUTS; FRESH AND/OR PREPARED MACARONI SALADS, PASTA SALADS AND RICE SALADS; PROCESSED GRAINS (U.S. CL. 46).
FIRST USE 6-1-2011; IN COMMERCE 6-1-2011.

CLASS 31—NATURAL AGRICULTURAL PRODUCTS

FOR FRESH OLIVES; FRESH PEPPERS; RAW FRESH NUTS; UNPROCESSED CEREALS; UNPROCESSED GRAINS (U.S. CLS. 1 AND 46).
FIRST USE 1-1-2012; IN COMMERCE 1-1-2012.

CLASS 32—LIGHT BEVERAGES

FOR DRINK MIXES, NAMELY, CONCENTRATES, SYRUPS, AND POWDERS FOR MAKING FRUIT DRINKS, FLAVORED WATER AND SOFT DRINKS; FROZEN FRUIT JUICES, SYRUPS FOR MAKING BEVERAGES (U.S. CLS. 45, 46 AND 48).
FIRST USE 6-1-2011; IN COMMERCE 6-1-2011.

CLASS 33—WINES AND SPIRITS

FOR COOKING WINES (U.S. CLS. 47 AND 49).
FIRST USE 1-1-2012; IN COMMERCE 1-1-2012.

4,155,678. NRG ENERGY, INC., PRINCETON, NJ. SN 85-363,794. PUB. 11-15-2011, FILED 7-6-2011.

The power to change life.
The energy to make it
happen.

THE MARK CONSISTS OF STANDARD CHARACTERS WITHOUT CLAIM TO ANY PARTICULAR FONT, STYLE, SIZE, OR COLOR.

CLASS 35—ADVERTISING AND BUSINESS

FOR ENERGY MANAGEMENT SERVICES, NAMELY, PROVIDING A SERVICE THAT ALLOWS CUSTOMERS TO PURCHASE ENERGY, NAMELY, ELECTRICITY AND RENEWABLE ENERGY; CONSULTATION SERVICES IN THE FIELD OF MANAGING ELECTRIC GENERATION FACILITIES (U.S. CLS. 100, 101 AND 102).
FIRST USE 12-1-2011; IN COMMERCE 12-1-2011.

CLASS 36—INSURANCE AND FINANCIAL

FOR BROKERAGE OF ENERGY, NAMELY, ELECTRIC POWER; CONSULTATION SERVICES IN THE FIELD OF COMMODITY TRADING, NAMELY, TRADING OF ELECTRICITY (U.S. CLS. 100, 101 AND 102).
FIRST USE 11-1-2011; IN COMMERCE 11-1-2011.

CLASS 37—CONSTRUCTION AND REPAIR

FOR CONSTRUCTION PLANNING AND CUSTOM CONSTRUCTION OF ELECTRIC POWER PLANTS, NAMELY, WIND, SOLAR, COAL FIRED POWER PLANTS AND PLANTS USING BIO-MASS FUELS; INSTALLATION AND MAINTENANCE OF POWER PLANTS, NAMELY, WIND, SOLAR, NUCLEAR, COAL FIRED POWER PLANTS AND PLANTS USING BIO-MASS FUELS (U.S. CLS. 100, 103 AND 106).
FIRST USE 11-1-2011; IN COMMERCE 11-1-2011.

CLASS 40—MATERIAL TREATMENT

FOR CONSULTATION SERVICES IN THE FIELDS OF POWER GENERATION (U.S. CLS. 100, 103 AND 106).
FIRST USE 11-1-2011; IN COMMERCE 11-1-2011.

4,155,691. JUMIO INC., MOUNTAIN VIEW, CA. SN 85-366,748. PUB. 12-6-2011, FILED 7-8-2011.



The logo for "netswipe" features the word "net" in a white, lowercase, sans-serif font inside a black rounded rectangle, followed by the word "swipe" in a bold, lowercase, sans-serif font.

THE MARK CONSISTS OF THE WORD "NETSWIPE" WITH THE LETTERS "NET" ENCLOSED IN A RECTANGLE.

CLASS 9—ELECTRICAL AND SCIENTIFIC APPARATUS

FOR COMPUTER SOFTWARE FOR PROCESSING ELECTRONIC PAYMENTS AND TRANSFERRING FUNDS TO AND FROM OTHERS AND FOR CREDIT AND DEBIT CARD TRANSACTION PROCESSING (U.S. CLS. 21, 23, 26, 36 AND 38).
FIRST USE 2-1-2011; IN COMMERCE 3-1-2011.

CLASS 36—INSURANCE AND FINANCIAL

FOR FINANCIAL TRANSACTION SERVICES, NAMELY, PROVIDING SECURE AUTHORIZATION AND SECURE PROCESSING SERVICES FOR ELECTRONIC PAYMENTS, CREDIT CARDS, AND DEBIT CARDS (U.S. CLS. 100, 101 AND 102).
FIRST USE 2-1-2011; IN COMMERCE 3-1-2011.

4,155,693. PROGNOSYS BIOSCIENCES, INC., LA JOLLA, CA. SN 85-366,859. PUB. 12-6-2011, FILED 7-8-2011.

4,155,700. RENOVATION REALTY, INC., LA MESA, CA. SN 85-369,707. PUB. 12-6-2011, FILED 7-12-2011.



THE COLOR(S) BLUE AND GRAY IS/ARE CLAIMED AS A FEATURE OF THE MARK.

THE MARK CONSISTS OF A BLUE X-SHAPED CROSS DESIGN BELOW A BLUE CIRCLE AND ABOVE THREE DIAGONAL GRAY STRIPES.

CLASS 1—CHEMICALS

FOR REAGENTS FOR USE IN BIOLOGICAL, BIO-CHEMICAL OR CHEMICAL ANALYSIS; REAGENTS FOR CHEMICAL ANALYSES; REAGENTS FOR USE IN SCIENTIFIC APPARATUS FOR BIOLOGICAL ANALYSIS; AND BIOCHEMICAL REAGENTS USED FOR NON-MEDICAL PURPOSES (U.S. CLS. 1, 5, 6, 10, 26 AND 46).
FIRST USE 6-27-2011; IN COMMERCE 6-27-2011.

CLASS 9—ELECTRICAL AND SCIENTIFIC APPARATUS

FOR KITS FOR ANALYSIS OF BIOLOGICAL, BIO-CHEMICAL OR CHEMICAL MATERIALS, NAMELY, KITS COMPRISING MICROARRAYS, OLIGONUCLEOTIDES, ENZYMES, SEQUENCING REAGENTS, SAMPLE PREPARATION REAGENTS, AND REACTION CHAMBERS, FOR DETECTION AND ANALYSIS OF NORMAL AND VARIANT PROTEINS, INCLUDING QUANTITATION AND/OR ANALYSIS OF ACTIVITY OF PROTEINS AND FOR ANALYSIS OF NORMAL AND VARIANT NUCLEIC ACIDS, INCLUDING THE DETECTION AND QUANTITATION OF SEQUENCE VARIANTS; COMPUTER SOFTWARE FOR ANALYSIS OF BIOLOGICAL, BIOCHEMICAL OR CHEMICAL MATERIALS; APPARATUS AND KITS FOR ANALYSIS OF BIOLOGICAL, BIOCHEMICAL OR CHEMICAL MATERIALS, NAMELY, LABORATORY KITS FOR THE DETECTION OF GENETIC SEQUENCES AND SEQUENCE VARIATIONS IN A BIOLOGICAL SAMPLE FOR RESEARCH USE; COMPUTER SOFTWARE FOR USE IN THE ANALYSIS OF BIOLOGICAL, BIOCHEMICAL OR CHEMICAL MATERIALS (U.S. CLS. 21, 23, 26, 36 AND 38).
FIRST USE 6-27-2011; IN COMMERCE 6-27-2011.

CLASS 42—SCIENTIFIC AND COMPUTER SERVICES

FOR BIOLOGICAL, BIOCHEMICAL, OR CHEMICAL RESEARCH AND ANALYSIS; DNA ANALYSIS SERVICES (U.S. CLS. 100 AND 101).
FIRST USE 6-27-2011; IN COMMERCE 6-27-2011.

WE RENOVATE. WE SELL. YOU
PROFIT.

THE MARK CONSISTS OF STANDARD CHARACTERS WITHOUT CLAIM TO ANY PARTICULAR FONT, STYLE, SIZE, OR COLOR.

CLASS 35—ADVERTISING AND BUSINESS

FOR REAL ESTATE ADVERTISING SERVICES; REAL ESTATE MARKETING SERVICES IN THE FIELD OF RESIDENTIAL PROPERTIES (U.S. CLS. 100, 101 AND 102).

FIRST USE 9-12-2011; IN COMMERCE 9-12-2011.

CLASS 36—INSURANCE AND FINANCIAL

FOR APPRAISAL AND EVALUATION OF REAL ESTATE; PROVIDING INFORMATION IN THE FIELD OF REAL ESTATE VIA THE INTERNET; REAL ESTATE BROKERAGE; REAL ESTATE CONSULTANCY; REAL ESTATE LISTING (U.S. CLS. 100, 101 AND 102).

FIRST USE 9-12-2011; IN COMMERCE 9-12-2011.

CLASS 37—CONSTRUCTION AND REPAIR

FOR CONSTRUCTION AND RENOVATION OF BUILDINGS; PROVIDING INFORMATION IN THE FIELD OF HOME RENOVATIONS AND REPAIRS (U.S. CLS. 100, 103 AND 106).

FIRST USE 9-12-2011; IN COMMERCE 9-12-2011.

4,155,709. WEST VIRGINIA UNIVERSITY, MORGANTOWN, WV. SN 85-371,005. PUB. 1-10-2012, FILED 7-14-2011.

F4F

THE MARK CONSISTS OF STANDARD CHARACTERS WITHOUT CLAIM TO ANY PARTICULAR FONT, STYLE, SIZE, OR COLOR.

CLASS 41—EDUCATION AND ENTERTAINMENT

FOR PHYSICAL FITNESS CONSULTATION, FEATURING A MULTIDISCIPLINARY EXERCISE PROGRAM BASED ON THE EVALUATION OF AN INDIVIDUAL'S BODY MASS INDEX, HABITUAL PHYSICAL ACTIVITY AND INFLAMMATORY MARKERS ASSOCIATED WITH RECURRENCE IN OBESE BREAST CANCER SURVIVORS (U.S. CLS. 100, 101 AND 107).

FIRST USE 3-5-2012; IN COMMERCE 3-5-2012.

CLASS 44—MEDICAL, BEAUTY AND AGRICULTURAL SERVICES

FOR COUNSELING SERVICES IN THE FIELD OF HEALTH AND NUTRITION, NAMELY, PROVIDING DIETARY AND NUTRITIONAL GUIDANCE BASED ON EVALUATING AN INDIVIDUAL'S BODY MASS INDEX, HABITUAL PHYSICAL ACTIVITY AND INFLAMMATORY MARKERS ASSOCIATED WITH RECURRENCE IN OBESE BREAST CANCER SURVIVORS (U.S. CLS. 100 AND 101).

FIRST USE 3-5-2012; IN COMMERCE 3-5-2012.

4,155,765. COMPLIANCE IMPLEMENTATION SERVICES, AKA CIS, MEDIA, PA. SN 85-392,021. PUB. 1-10-2012, FILED 8-8-2011.

CRPartner

CLASS 35—ADVERTISING AND BUSINESS

FOR DATA MANAGEMENT SERVICES IN THE NATURE OF DATA COLLECTION, COMPILATION SYSTEMIZATION, VERIFICATION, AND RECONCILIATION IN THE FIELDS OF PHARMACEUTICAL AND MEDICAL DEVICE SALES FOR BUSINESS PURPOSES; ELECTRONIC DATA COLLECTION AND DATA SUBMISSION SERVICES FOR BUSINESS PURPOSES IN THE FIELDS OF MEDICINE AND HEALTHCARE; RECORD-KEEPING FOR REGULATORY COMPLIANCE PURPOSES IN THE CLINICAL, MEDICAL, AND COMMERCIAL FIELDS (U.S. CLS. 100, 101 AND 102).

FIRST USE 8-15-2011; IN COMMERCE 8-15-2011.

4,155,726. NOVALASH, INC., HOUSTON, TX. SN 85-376,182. PUB. 12-27-2011, FILED 7-20-2011.

NEWS FLASH

THE MARK CONSISTS OF THE WORDING "FLASH" IN STYLIZED FONT WITH THE WORD "NEWS" DEPICTED VERTICALLY ALONG THE LETTER "F"

CLASS 45—PERSONAL AND LEGAL SERVICES

FOR REGULATORY COMPLIANCE CONSULTING IN THE FIELD OF PHARMACEUTICALS AND MEDICAL DEVICE SALES; TRACKING AND MONITORING REGULATORY REQUIREMENTS IN THE FIELD OF PHARMACEUTICALS FOR REGULATORY COMPLIANCE PURPOSES; PROVIDING INFORMATION ON GOVERNMENT MEDICAL AND PHARMACEUTICAL PROGRAMS; ANALYSIS OF HEALTH DATA, BILLINGS DATA, AND STATE AND FEDERAL GOVERNMENT REPORTING IN CONNECTION WITH FEDERAL AND STATE COMPLIANCE AND REPORTING OBLIGATIONS (U.S. CLS. 100 AND 101).

FIRST USE 8-15-2011; IN COMMERCE 8-15-2011.

CLASS 9—ELECTRICAL AND SCIENTIFIC APPARATUS

FOR DOWNLOADABLE ELECTRONIC PUBLICATIONS, NAMELY, A MAGAZINE IN THE FIELD OF COSMETICS FEATURING AN EVENTS CALENDAR, CONTESTS, PROFESSIONAL PROFILES, INDUSTRY INFORMATION AND UPDATES, TRAINING AND CERTIFICATION INFORMATION, AN ONLINE DIRECTORY, PRODUCT CATALOG, PRODUCT HEALTH AND SAFETY INFORMATION, ANSWERS TO FREQUENTLY ASKED QUESTIONS, PHOTOGRAPH GALLERY, ARTICLES, INFORMATION AND ADVERTISEMENTS FOR ARTIFICIAL EYELASHES, FALSE EYELASH EXTENSIONS, ARTIFICIAL EYELASH APPLIQUES AND ADHESIVES FOR ATTACHING ARTIFICIAL EYELASHES (U.S. CLS. 21, 23, 26, 36 AND 38).

FIRST USE 10-31-2008; IN COMMERCE 10-31-2008.

CLASS 16—PAPER GOODS AND PRINTED MATTER

FOR MAGAZINE IN THE FIELD OF COSMETICS FEATURING AN EVENTS CALENDAR, CONTESTS, PROFESSIONAL PROFILES, INDUSTRY INFORMATION AND UPDATES, TRAINING AND CERTIFICATION INFORMATION, AN ONLINE DIRECTORY, PRODUCT CATALOG, PRODUCT HEALTH AND SAFETY INFORMATION, ANSWERS TO FREQUENTLY ASKED QUESTIONS, PHOTOGRAPH GALLERY, ARTICLES, INFORMATION AND ADVERTISEMENTS FOR ARTIFICIAL EYELASHES, FALSE EYELASH EXTENSIONS, ARTIFICIAL EYELASH APPLIQUES AND ADHESIVES FOR ATTACHING ARTIFICIAL EYELASHES (U.S. CLS. 2, 5, 22, 23, 29, 37, 38 AND 50).

FIRST USE 10-31-2008; IN COMMERCE 10-31-2008.

4,155,781. S. C. JOHNSON & SON, INC., RACINE, WI. SN 85-401,130. PUB. 1-17-2012, FILED 8-18-2011.

PÉTALOS ESTÁMPADOS

THE MARK CONSISTS OF STANDARD CHARACTERS WITHOUT CLAIM TO ANY PARTICULAR FONT, STYLE, SIZE, OR COLOR.

THE ENGLISH TRANSLATION OF "PÉTALOS ESTÁMPADOS" IN THE MARK IS "STAMPED PETALS".

CLASS 4—LUBRICANTS AND FUELS

FOR CANDLES (U.S. CLS. 1, 6 AND 15).
FIRST USE 2-14-2012; IN COMMERCE 2-14-2012.

CLASS 5—PHARMACEUTICALS

FOR AIR FRESHENERS (U.S. CLS. 6, 18, 44, 46, 51 AND 52).
FIRST USE 2-16-2012; IN COMMERCE 2-16-2012.

4,155,782. S. C. JOHNSON & SON, INC., RACINE, WI. SN 85-401,139. PUB. 1-17-2012, FILED 8-18-2011.

SORBETE DE SOL

THE MARK CONSISTS OF STANDARD CHARACTERS WITHOUT CLAIM TO ANY PARTICULAR FONT, STYLE, SIZE, OR COLOR.

THE ENGLISH TRANSLATION OF "SORBETE DE SOL" IN THE MARK IS "SUNSHINE SHERBET".

CLASS 4—LUBRICANTS AND FUELS

FOR CANDLES (U.S. CLS. 1, 6 AND 15).
FIRST USE 2-7-2012; IN COMMERCE 2-7-2012.

CLASS 5—PHARMACEUTICALS

FOR AIR FRESHENERS (U.S. CLS. 6, 18, 44, 46, 51 AND 52).
FIRST USE 2-5-2012; IN COMMERCE 2-5-2012.

4,155,783. S. C. JOHNSON & SON, INC., RACINE, WI. SN 85-401,154. PUB. 1-17-2012, FILED 8-18-2011.

PRADERA MÁGICA

THE MARK CONSISTS OF STANDARD CHARACTERS WITHOUT CLAIM TO ANY PARTICULAR FONT, STYLE, SIZE, OR COLOR.

THE ENGLISH TRANSLATION OF "PRADERA MÁGICA" IN THE MARK IS "MAGIC PRAIRIE".

CLASS 4—LUBRICANTS AND FUELS

FOR CANDLES (U.S. CLS. 1, 6 AND 15).
FIRST USE 2-22-2012; IN COMMERCE 2-22-2012.

CLASS 5—PHARMACEUTICALS

FOR AIR FRESHENERS (U.S. CLS. 6, 18, 44, 46, 51 AND 52).
FIRST USE 2-17-2012; IN COMMERCE 2-17-2012.

4,155,784. S. C. JOHNSON & SON, INC., RACINE, WI. SN 85-401,163. PUB. 1-17-2012, FILED 8-18-2011.

MAGIC MEADOW

THE MARK CONSISTS OF STANDARD CHARACTERS WITHOUT CLAIM TO ANY PARTICULAR FONT, STYLE, SIZE, OR COLOR.

CLASS 4—LUBRICANTS AND FUELS

FOR CANDLES (U.S. CLS. 1, 6 AND 15).
FIRST USE 2-22-2012; IN COMMERCE 2-22-2012.

CLASS 5—PHARMACEUTICALS

FOR AIR FRESHENERS (U.S. CLS. 6, 18, 44, 46, 51 AND 52).
FIRST USE 2-17-2012; IN COMMERCE 2-17-2012.

4,155,810. TUTTLE, DEXTER, FORT WORTH, TX. SN 85-436,995. PUB. 1-3-2012, FILED 9-30-2011.

BUY A PRODUCT THAT PAYS FOR ITSELF

THE MARK CONSISTS OF STANDARD CHARACTERS WITHOUT CLAIM TO ANY PARTICULAR FONT, STYLE, SIZE, OR COLOR.

CLASS 1—CHEMICALS

FOR CHEMICAL ADDITIVES FOR USE WITH INTERNAL COMBUSTION ENGINE FUELS (U.S. CLS. 1, 5, 6, 10, 26 AND 46).
FIRST USE 6-1-2011; IN COMMERCE 9-13-2011.

CLASS 4—LUBRICANTS AND FUELS

FOR NON-CHEMICAL ENGINE TREATMENTS AND ADDITIVES FOR GASOLINE AND DIESEL FUELS (U.S. CLS. 1, 6 AND 15).
FIRST USE 6-1-2011; IN COMMERCE 9-13-2011.

4,155,824. PRINCIPLE POWER, INC., SEATTLE, WA. SN 85-975,880. PUB. 1-11-2011, FILED 5-5-2010.

WINDFLOAT

THE MARK CONSISTS OF STANDARD CHARACTERS WITHOUT CLAIM TO ANY PARTICULAR FONT, STYLE, SIZE, OR COLOR.

CLASS 7—MACHINERY

FOR WIND TURBINES AND STRUCTURAL PARTS THEREFOR (U.S. CLS. 13, 19, 21, 23, 31, 34 AND 35).
FIRST USE 8-5-2009; IN COMMERCE 8-5-2009.

CLASS 37—CONSTRUCTION AND REPAIR

FOR CONSTRUCTION OF WIND TURBINES (U.S. CLS. 100, 103 AND 106).
FIRST USE 8-5-2009; IN COMMERCE 8-5-2009.

CLASS 42—SCIENTIFIC AND COMPUTER SERVICES

FOR DESIGN FOR OTHERS OF WIND TURBINES (U.S. CLS. 100 AND 101).
FIRST USE 8-5-2009; IN COMMERCE 8-5-2009.

4,155,834. PAN AMERICAN WORLD AIRWAYS, INC., DOVER, NH. SN 85-976,562. PUB. 8-2-2011, FILED 7-20-2010.



4,155,830. SURVEY PLANET, LLC, SANTA MONICA, CA. SN 85-976,512. PUB. 12-6-2011, FILED 6-8-2011.



OWNER OF U.S. REG. NOS. 3,166,414, 3,171,135, AND OTHERS.

THE MARK CONSISTS OF THE OUTLINE OF A GLOBE WITH THE WORDS "PAN AM" ACROSS IT.

CLASS 14—JEWELRY

FOR WATCHES; CUFFLINKS (U.S. CLS. 2, 27, 28 AND 50).
FIRST USE 5-31-2008; IN COMMERCE 5-31-2008.

CLASS 18—LEATHER GOODS

FOR WALLETS (U.S. CLS. 1, 2, 3, 22 AND 41).
FIRST USE 2-28-2010; IN COMMERCE 2-28-2010.

CLASS 25—CLOTHING

FOR BELTS (U.S. CLS. 22 AND 39).
FIRST USE 10-31-2010; IN COMMERCE 10-31-2010.

CLASS 41—EDUCATION AND ENTERTAINMENT

FOR ENTERTAINMENT SERVICES IN THE NATURE OF AN ON-GOING DRAMATIC TELEVISION PROGRAM (U.S. CLS. 100, 101 AND 107).
FIRST USE 9-30-2011; IN COMMERCE 9-30-2011.

THE MARK CONSISTS OF AN ALIEN FORM HAVING AN OVAL BODY AND A SINGLE EYE.

CLASS 35—ADVERTISING AND BUSINESS

FOR MARKET RESEARCH SERVICES; PROVIDING AN INTERACTIVE WEB SITE FEATURING EDUCATIONAL INFORMATION AND TEST QUESTIONS IN THE FIELD OF MARKET RESEARCH (U.S. CLS. 100, 101 AND 102).
FIRST USE 2-3-2012; IN COMMERCE 2-3-2012.

CLASS 42—SCIENTIFIC AND COMPUTER SERVICES

FOR HOSTING AN ONLINE COMMUNITY WEBSITE FOR USERS TO PARTICIPATE IN, CONDUCT AND MANAGE SURVEYS; PROVIDING TEMPORARY USE OF NON-DOWNLOADABLE COMPUTER SOFTWARE APPLICATION FOR MOBILE DEVICES FOR CONDUCTING CONSUMER SURVEYS (U.S. CLS. 100 AND 101).
FIRST USE 2-3-2012; IN COMMERCE 2-3-2012.

4,155,837. VISPRONET, INC., HARRISBURG, PA. SN 85-976,593. PUB. 8-16-2011, FILED 11-24-2010.

DISPLAYFLIX

THE MARK CONSISTS OF STANDARD CHARACTERS WITHOUT CLAIM TO ANY PARTICULAR FONT, STYLE, SIZE, OR COLOR.

CLASS 6—METAL GOODS

FOR BEARERS AND SUPPORT CONSTRUCTIONS, IN THE FORM OF METAL PIPES AND METAL POLES FOR ADVERTISING SURFACES; METAL POLES, NAMELY, POLES FOR DISPLAYING ADVERTISING AND DECORATIVE BANNERS, FLAGS, DISPLAYS, PANELS, AND THE LIKE; METAL ACCESSORIES FOR METALLIC DISPLAY STANDS FOR PRESENTING PRINTED AND UNPRINTED ADVERTISING MATERIAL, NAMELY, CONNECTORS FOR CONNECTING TWO OR MORE FRAMES OR BASES; METALLIC FRAMEWORK; METALLIC RUNNERS, NAMELY, RAILS FOR FIXING WELT-SEAMED DISPLAY MATERIALS; METAL WALL-MOUNTED BOARDS, PANELS AND PLATES FOR EXHIBITIONS, DISPLAYS AND PARTITIONING (U.S. CLS. 2, 12, 13, 14, 23, 25 AND 50).

FIRST USE 4-9-2012; IN COMMERCE 4-9-2012.

CLASS 20—FURNITURE AND ARTICLES NOT OTHERWISE CLASSIFIED

FOR NON-METAL POLES, NAMELY, POLES MADE OF SYNTHETIC MATERIAL FOR DISPLAYING ADVERTISING AND DECORATIVE BANNERS, FLAGS, DISPLAYS, PANELS, AND THE LIKE; NON-METALLIC DISPLAY STANDS FOR PRESENTING PRINTED AND UNPRINTED ADVERTISING MATERIAL, MADE OF PLASTIC, REINFORCED PLASTIC OR WOOD; ACCESSORIES FOR THE NON-METAL POLES AND DISPLAY STANDS FOR DISPLAYING ADVERTISING AND DECORATIVE BANNERS, FLAGS, DISPLAYS, PANELS, AND THE LIKE, NAMELY, CLAMPS, ADAPTERS IN THE NATURE OF SPRINGS, HOOKS AND CLIPS, FASTENERS IN THE NATURE OF SCREWS AND DISPLAY BOARDS, PANELS AND PLATES, ALL MADE OF PLASTIC, REINFORCED PLASTIC OR WOOD; NON-METALLIC FRAMEWORKS FOR DISPLAY STANDS FOR PRESENTING PRINTED AND UNPRINTED ADVERTISING MATERIAL MADE OF PLASTIC, REINFORCED PLASTIC OR WOOD; NON-METALLIC FRAME STRIPS IN THE NATURE OF DISPLAY FRAMES FOR PRESENTING ADVERTISING MATERIAL; METALLIC DISPLAY STANDS FOR PRESENTING PRINTED AND UNPRINTED ADVERTISING MATERIAL; METALLIC FRAMEWORK, NAMELY, METAL-BASED DISPLAY STAND FRAMES FOR USE WITH INTERCHANGEABLE BANNERS, FLAGS AND THE LIKE; METALLIC FRAME STRIPS, NAMELY, METAL-BASED DISPLAY FRAMES FOR PRESENTING ADVERTISING MATERIAL (U.S. CLS. 2, 13, 22, 25, 32 AND 50).

FIRST USE 4-9-2012; IN COMMERCE 4-9-2012.

CLASS 24—FABRICS

FOR SINGLE AND MULTI-LAYERED PRINTED AND NOT PRINTED TEXTILES USED FOR ADVERTISING PURPOSES, NAMELY, FLAGS, PENNANTS, STREAMERS, BANNERS AND CLOTH FLAGS WITH DIFFERENT SHAPES FOR INDOOR AND OUTDOOR DECORATION PURPOSES; SINGLE AND MULTI-LAYERED COATED AND NON-COATED TEXTILE FABRICS FOR PRESENTING ADVERTISING MATERIAL (U.S. CLS. 42 AND 50).

FIRST USE 4-9-2012; IN COMMERCE 4-9-2012.

CLASS 40—MATERIAL TREATMENT

FOR PRINTING SERVICES (U.S. CLS. 100, 103 AND 106).

FIRST USE 4-9-2012; IN COMMERCE 4-9-2012.

4,155,838. ARCODE CORPORATION, BETHESDA, MD. SN 85-976,632. PUB. 1-3-2012, FILED 7-8-2011.

INKY

THE MARK CONSISTS OF STANDARD CHARACTERS WITHOUT CLAIM TO ANY PARTICULAR FONT, STYLE, SIZE, OR COLOR.

CLASS 9—ELECTRICAL AND SCIENTIFIC APPARATUS

FOR DOWNLOADABLE SOFTWARE FOR ENSURING THE SECURITY OF ELECTRONIC MAIL; DOWNLOADABLE COMPUTER SEARCH ENGINE SOFTWARE (U.S. CLS. 21, 23, 26, 36 AND 38).

FIRST USE 10-25-2011; IN COMMERCE 10-25-2011.

CLASS 38—COMMUNICATION

FOR ELECTRONIC MAIL AND MESSAGING SERVICES (U.S. CLS. 100, 101 AND 104).

FIRST USE 10-25-2011; IN COMMERCE 10-25-2011.

CLASS 42—SCIENTIFIC AND COMPUTER SERVICES

FOR PROVIDING TEMPORARY USE OF NONDOWNLOADABLE SOFTWARE FOR ENSURING THE SECURITY OF ELECTRONIC MAIL AND FOR USE AS SEARCH ENGINE SOFTWARE (U.S. CLS. 100 AND 101).

FIRST USE 10-25-2011; IN COMMERCE 10-25-2011.

4,155,842. ROBOT ENTERTAINMENT, INC., PLANO, TX. SN 85-976,684. PUB. 10-4-2011, FILED 1-11-2011.

ORCS MUST DIE

THE MARK CONSISTS OF STANDARD CHARACTERS WITHOUT CLAIM TO ANY PARTICULAR FONT, STYLE, SIZE, OR COLOR.

CLASS 9—ELECTRICAL AND SCIENTIFIC APPARATUS

FOR VIDEO AND COMPUTER GAME PROGRAMS; INTERACTIVE VIDEO GAME PROGRAMS; COMPUTER GAME SOFTWARE FOR USE WITH PERSONAL COMPUTERS AND HOME VIDEO GAME CONSOLES; COMPUTER GAME SOFTWARE FOR USE ON MOBILE AND CELLULAR PHONES (U.S. CLS. 21, 23, 26, 36 AND 38).

FIRST USE 2-0-2011; IN COMMERCE 2-0-2011.

CLASS 25—CLOTHING

FOR ARTICLES OF CLOTHING, NAMELY, SWEATSHIRTS AND HOODED SWEATSHIRTS; T-SHIRTS; HATS; CAPS (U.S. CLS. 22 AND 39).

FIRST USE 2-0-2011; IN COMMERCE 2-0-2011.

CLASS 41—EDUCATION AND ENTERTAINMENT

FOR ENTERTAINMENT SERVICES, NAMELY, PROVIDING ONLINE VIDEO GAMES AND COMPUTER GAMES; ENTERTAINMENT SERVICES, NAMELY, PROVIDING VIDEO GAMES ON-LINE AND IN MOBILE WIRELESS FORM (U.S. CLS. 100, 101 AND 107).
FIRST USE 2-0-2011; IN COMMERCE 2-0-2011.

* * * * *

SECTION 2.— INTERNATIONAL CLASSIFICATION

The short titles associated below with the international class numbers are terms designed merely for quick identification and are not an official part of the international classification. The full names of international classes are given in section 6.1 of the trademark rules of practice.

The designation "U.S. Cl." appearing in this section refers to the U.S. class in effect prior to Sep. 1, 1973 rather than the international class which applies to applications filed on or after that date. For adoption of international classification see notice in the OFFICIAL GAZETTE of Jun. 26, 1973 (911 O.G. TM 210).

Application in one class

CLASS 1—CHEMICALS

4,154,244. KLINGEMANN, HANS, BOSTON, MA. SN 76-690,929. PUB. 3-23-2010, FILED 6-30-2008.

NK-92

THE MARK CONSISTS OF STANDARD CHARACTERS WITHOUT CLAIM TO ANY PARTICULAR FONT, STYLE, SIZE, OR COLOR.

FOR CELLS FOR SCIENTIFIC, LABORATORY OR MEDICAL RESEARCH (U.S. CLS. 1, 5, 6, 10, 26 AND 46). FIRST USE 6-1-1994; IN COMMERCE 6-1-1994.

4,154,276. SUMITOMO CHEMICAL CO., LTD., TOKYO, JAPAN. SN 77-252,957. PUB. 1-13-2009, FILED 8-10-2007.

بترورابغ

THE MARK CONSISTS OF BLACK ARABIC LETTERING. THE ENGLISH TRANSLATION OF THE ARABIC LETTERING IN THE MARK IS PETRORABIGH.

THE ENGLISH TRANSLITERATION OF THE NON-LATIN WORDING IN THE MARK IS "PETRORABIGH".

FOR ARTIFICIAL RESIN, UNPROCESSED PLASTICS IN THE FORM OF POWDER, GRANULES, LIQUID OR PASTE; CHEMICALS USED IN INDUSTRIAL MATERIALS OR PRODUCTS, PLANTS, LABORATORIES, AND PHOTOGRAPHY, NAMELY, ETHYLENE GLYCOL AND PROPYLENE OXIDE; CHEMICALS USED IN AGRICULTURE, HORTICULTURE AND FORESTRY, NAMELY, ETHYLENE GLYCOL AND PROPYLENE OXIDE (U.S. CLS. 1, 5, 6, 10, 26 AND 46). FIRST USE 4-4-2009; IN COMMERCE 4-4-2010.

CLASS 1—(Continued).

4,154,435. VOGEL SEED & FERTILIZER, INC., DBA SPRING VALLEY TURF PRODUCTS, JACKSON, WI. SN 77-768,212. PUB. 11-24-2009, FILED 6-25-2009.

TENDER FOOT

THE MARK CONSISTS OF STANDARD CHARACTERS WITHOUT CLAIM TO ANY PARTICULAR FONT, STYLE, SIZE, OR COLOR.

FOR CHEMICAL PREPARATION FOR MELTING ICE AND SNOW (U.S. CLS. 1, 5, 6, 10, 26 AND 46). FIRST USE 11-8-2011; IN COMMERCE 11-8-2011.

4,154,544. CHANTEST CORPORATION, CLEVELAND, OH. SN 77-947,399. PUB. 7-27-2010, FILED 3-1-2010.

EZCELLS

THE MARK CONSISTS OF STANDARD CHARACTERS WITHOUT CLAIM TO ANY PARTICULAR FONT, STYLE, SIZE, OR COLOR.

FOR CELLS FOR SCIENTIFIC, LABORATORY OR MEDICAL RESEARCH (U.S. CLS. 1, 5, 6, 10, 26 AND 46). FIRST USE 4-7-2008; IN COMMERCE 4-7-2008.

CLASS 1—(Continued).

4,154,643. WESTLAKE LONGVIEW CORPORATION, HOUSTON, TX. SN 85-043,415. PUB. 10-19-2010, FILED 5-20-2010.

TYMAX

THE MARK CONSISTS OF STANDARD CHARACTERS WITHOUT CLAIM TO ANY PARTICULAR FONT, STYLE, SIZE, OR COLOR.

FOR SYNTHETIC, ADHESIVE RESINS IN PELLET FORM FOR USE IN FURTHER MANUFACTURE (U.S. CLS. 1, 5, 6, 10, 26 AND 46).

FIRST USE 5-20-2010; IN COMMERCE 5-20-2010.

4,154,730. FREMONT INDUSTRIES, INC., SHAKOPEE, MN. SN 85-107,071. PUB. 8-2-2011, FILED 8-13-2010.



OWNER OF U.S. REG. NO. 1,623,176.

NO CLAIM IS MADE TO THE EXCLUSIVE RIGHT TO USE "GREEN TECHNOLOGY" AND "INDUSTRIES", APART FROM THE MARK AS SHOWN.

THE COLOR(S) LIGHT BLUE, DARK BLUE AND GREEN IS/ARE CLAIMED AS A FEATURE OF THE MARK.

THE MARK CONSISTS OF THE WORDS "FREMONT INDUSTRIES ULTRA GREEN TECHNOLOGY", PLACED WITHIN A GREEN CIRCLE. THE WORDS "FREMONT INDUSTRIES" AND THE WORDS "GREEN TECHNOLOGY" ARE SHOWN IN GREEN. THE WORD "ULTRA" INCORPORATES THE COLORS GREEN, DARK BLUE AND LIGHT BLUE. BETWEEN THE WORDS "FREMONT INDUSTRIES" AND "ULTRA" THERE IS A DEPICTION OF PLANET EARTH IN DARK BLUE AND LIGHT BLUE RESTING WITHIN A GREEN LEAF.

FOR WATER CONDITIONING CHEMICALS FOR USE IN BOILER AND COOLING WATER INSTALLATIONS (U.S. CLS. 1, 5, 6, 10, 26 AND 46).

FIRST USE 10-8-2010; IN COMMERCE 10-13-2010.

CLASS 1—(Continued).

4,154,732. FREMONT INDUSTRIES, INC., SHAKOPEE, MN. SN 85-107,103. PUB. 8-2-2011, FILED 8-13-2010.



NO CLAIM IS MADE TO THE EXCLUSIVE RIGHT TO USE "GREEN TECHNOLOGY", APART FROM THE MARK AS SHOWN.

THE COLOR(S) LIGHT BLUE, DARK BLUE, GREEN AND WHITE IS/ARE CLAIMED AS A FEATURE OF THE MARK.

THE MARK CONSISTS OF THE WORDS "ULTRA GREEN TECHNOLOGY" PLACED TO THE RIGHT OF A DEPICTION OF PLANET EARTH IN LIGHT BLUE AND DARK BLUE RESTING WITHIN A GREEN LEAF. THE WORD "ULTRA" INCORPORATES THE COLORS LIGHT BLUE TO DARK BLUE TO GREEN RISING FROM THE BOTTOM, AND PLACED OVER THE WORDS "GREEN TECHNOLOGY". THE WORDS "GREEN TECHNOLOGY" ARE DEPICTED IN WHITE AND ARE PLACED WITHIN A GREEN POLYGON.

FOR WATER CONDITIONING CHEMICALS FOR USE IN BOILER AND COOLING WATER INSTALLATIONS (U.S. CLS. 1, 5, 6, 10, 26 AND 46).

FIRST USE 8-6-2010; IN COMMERCE 8-10-2010.

4,154,742. CHEMPLEX AUTOMOTIVE GROUP, INC., FULLERTON, CA. SN 85-110,110. PUB. 8-9-2011, FILED 8-18-2010.

COOLER COOLANT

THE MARK CONSISTS OF STANDARD CHARACTERS WITHOUT CLAIM TO ANY PARTICULAR FONT, STYLE, SIZE, OR COLOR.

NO CLAIM IS MADE TO THE EXCLUSIVE RIGHT TO USE "COOLANT", APART FROM THE MARK AS SHOWN. FOR CHEMICAL ADDITIVE FOR RADIATOR PROTECTION (U.S. CLS. 1, 5, 6, 10, 26 AND 46).

FIRST USE 9-14-2010; IN COMMERCE 1-3-2011.

CLASS 1—(Continued).

4,154,794. ARYLESSENCE, INC., MARIETTA, GA. SN 85-131,853. PUB. 2-15-2011, FILED 9-17-2010.

DeoBoost

THE MARK CONSISTS OF STANDARD CHARACTERS WITHOUT CLAIM TO ANY PARTICULAR FONT, STYLE, SIZE, OR COLOR.

FOR DEODORIZING AND FRAGRANCING CHEMICAL ADDITIVES FOR USE IN THE MANUFACTURING OF HOUSEHOLD, AIR CARE, PERSONAL, INDUSTRIAL, INSTITUTIONAL, AGRICULTURAL AND CONSUMER PRODUCTS (U.S. CLS. 1, 5, 6, 10, 26 AND 46).
FIRST USE 10-12-2011; IN COMMERCE 10-12-2011.

4,154,811. SUAN FARMA, INC., HACKENSACK, NJ. SN 85-139,132. PUB. 8-30-2011, FILED 9-27-2010.



NO CLAIM IS MADE TO THE EXCLUSIVE RIGHT TO USE "ORGANIC" OR "GROW", APART FROM THE MARK AS SHOWN.

THE MARK CONSISTS OF A RAINDROP-SHAPED OUTLINE WITH THE WORDING "PERFECT GROW" AT THE BOTTOM. ABOVE THIS WORDING IS THE WORD "ORGANIC" ON A RIBBON. AT THE TOP RIGHT OF THE RAINDROP IS A BUTTERFLY. UNDERNEATH THE RAINDROP IS THE WORDING "ESSENCE OF NATURE".

FOR ORGANIC PLANT FOOD (U.S. CLS. 1, 5, 6, 10, 26 AND 46).
FIRST USE 11-17-2011; IN COMMERCE 11-17-2011.

CLASS 1—(Continued).

4,154,872. SMG BRANDS, INC., WILMINGTON, DE. SN 85-163,052. PUB. 2-15-2011, FILED 10-27-2010.

BOLD BLOOMS

THE MARK CONSISTS OF STANDARD CHARACTERS WITHOUT CLAIM TO ANY PARTICULAR FONT, STYLE, SIZE, OR COLOR.

FOR PLANT FOOD AND FERTILIZER (U.S. CLS. 1, 5, 6, 10, 26 AND 46).
FIRST USE 2-17-2012; IN COMMERCE 2-17-2012.

4,154,985. SWIFT BIOSCIENCES, INC., ANN ARBOR, MI. SN 85-218,373. PUB. 4-5-2011, FILED 1-14-2011.

myT

THE MARK CONSISTS OF STANDARD CHARACTERS WITHOUT CLAIM TO ANY PARTICULAR FONT, STYLE, SIZE, OR COLOR.

FOR DIAGNOSTIC REAGENTS FOR CLINICAL OR MEDICAL LABORATORY USE; DIAGNOSTIC REAGENTS FOR IN VITRO USE IN BIOCHEMISTRY, CLINICAL CHEMISTRY AND MICROBIOLOGY; DIAGNOSTIC REAGENTS FOR SCIENTIFIC OR RESEARCH USE (U.S. CLS. 1, 5, 6, 10, 26 AND 46).
FIRST USE 2-20-2012; IN COMMERCE 2-20-2012.

4,155,198. LEICA BIOSYSTEMS RICHMOND, INC., RICHMOND, IL. SN 85-255,872. PUB. 7-26-2011, FILED 3-2-2011.

PARALAST

THE MARK CONSISTS OF STANDARD CHARACTERS WITHOUT CLAIM TO ANY PARTICULAR FONT, STYLE, SIZE, OR COLOR.

FOR CHEMICAL PREPARATIONS FOR SCIENTIFIC, LABORATORY, MEDICAL LABORATORY AND RESEARCH PURPOSES IN THE NATURE OF CLEARING AGENTS FOR HISTOLOGY AND CYTOLOGY (U.S. CLS. 1, 5, 6, 10, 26 AND 46).
FIRST USE 10-24-2011; IN COMMERCE 10-24-2011.

CLASS 1—(Continued).

4,155,252. SWIFT BIOSCIENCES, INC., ANN ARBOR, MI. SN 85-261,967. PUB. 12-13-2011, FILED 3-9-2011.



NO CLAIM IS MADE TO THE EXCLUSIVE RIGHT TO USE "BIOSCIENCES", APART FROM THE MARK AS SHOWN.

THE MARK CONSISTS OF THE WORD "SWIFT" IN LARGE LETTERS, WITH A THIN CURVED LINE RUNNING THROUGH THE LETTERS LEADING TO THE IMAGE OF A FLYING BIRD, BOTH ABOVE THE WORD "BIOSCIENCES" IN SMALLER LETTERS.

FOR CHEMICAL REAGENTS FOR OTHER THAN MEDICAL AND VETERINARY PURPOSES; REAGENTS FOR RESEARCH PURPOSES; REAGENTS FOR SCIENTIFIC OR MEDICAL RESEARCH USE (U.S. CLS. 1, 5, 6, 10, 26 AND 46).

FIRST USE 2-20-2012; IN COMMERCE 2-20-2012.

4,155,253. SWIFT BIOSCIENCES, INC., ANN ARBOR, MI. SN 85-261,973. PUB. 12-13-2011, FILED 3-9-2011.

SWIFT BIOSCIENCES

THE MARK CONSISTS OF STANDARD CHARACTERS WITHOUT CLAIM TO ANY PARTICULAR FONT, STYLE, SIZE, OR COLOR.

NO CLAIM IS MADE TO THE EXCLUSIVE RIGHT TO USE "BIOSCIENCES", APART FROM THE MARK AS SHOWN.

FOR CHEMICAL REAGENTS FOR OTHER THAN MEDICAL AND VETERINARY PURPOSES; REAGENTS FOR RESEARCH PURPOSES; REAGENTS FOR SCIENTIFIC OR MEDICAL RESEARCH USE (U.S. CLS. 1, 5, 6, 10, 26 AND 46).

FIRST USE 2-20-2012; IN COMMERCE 2-20-2012.

4,155,272. D & L DISTRIBUTION, LLC, LANCASTER, PA. SN 85-263,469. PUB. 9-6-2011, FILED 3-10-2011.

POP UP POWER

THE MARK CONSISTS OF STANDARD CHARACTERS WITHOUT CLAIM TO ANY PARTICULAR FONT, STYLE, SIZE, OR COLOR.

CLASS 1—(Continued).

NO CLAIM IS MADE TO THE EXCLUSIVE RIGHT TO USE "POP UP", APART FROM THE MARK AS SHOWN.

FOR FOLIAR PLANT GROWTH MICRONUTRIENTS FOR AGRICULTURAL CROPS (U.S. CLS. 1, 5, 6, 10, 26 AND 46).

FIRST USE 3-11-2011; IN COMMERCE 3-11-2011.

4,155,312. WILBUR-ELLIS COMPANY, SAN FRANCISCO, CA. SN 85-268,342. PUB. 7-5-2011, FILED 3-16-2011.

MAX SET ULTRA

THE MARK CONSISTS OF STANDARD CHARACTERS WITHOUT CLAIM TO ANY PARTICULAR FONT, STYLE, SIZE, OR COLOR.

OWNER OF U.S. REG. NO. 3,619,370. FOR FERTILIZERS (U.S. CLS. 1, 5, 6, 10, 26 AND 46). FIRST USE 4-25-2011; IN COMMERCE 4-25-2011.

4,155,348. COLOMBIAN SWEEPER COMPANY CSC S.A.S, BARRANQUILLA, COLOMBIA. SN 85-274,101. PUB. 8-9-2011, FILED 3-23-2011.

GRIPGUARD

THE MARK CONSISTS OF STANDARD CHARACTERS WITHOUT CLAIM TO ANY PARTICULAR FONT, STYLE, SIZE, OR COLOR.

FOR ANTI-SLIP CHEMICAL PREPARATIONS THAT ARE APPLIED TO HORIZONTAL SURFACES TO PREVENT SLIP AND FALL ACCIDENTS; ADHESIVES AND GLUES FOR INDUSTRIAL AND COMMERCIAL USE (U.S. CLS. 1, 5, 6, 10, 26 AND 46).

FIRST USE 7-20-2007; IN COMMERCE 1-20-2009.

CLASS 1—(Continued).

4,155,349. COLOMBIAN SWEEPER COMPANY CSC S.A.S, BARRANQUILLA, COLOMBIA. SN 85-274,104. PUB. 8-9-2011, FILED 3-23-2011.



THE COLOR(S) ORANGE, WHITE AND GREY IS/ARE CLAIMED AS A FEATURE OF THE MARK.
THE MARK CONSISTS OF WORD "GRIPGUARD" WHEREIN THE WORD "GUARD" IS IN WHITE COLOR AND THE DOT ABOVE THE LETTER "I" OF THE WORD "GRIP" IS IN WHITE COLOR AND THE WORD "GRIP" IS IN GREY COLOR; THE LETTERS "GG" IS WRITTEN ABOVE THE WORD "GRIPGUARD" IN WHITE AND GREY COLOR ON THE ORANGE COLOR BACKGROUND AS SHOWN IN THE MARK.
FOR ANTI-SLIP CHEMICAL PREPARATIONS THAT ARE APPLIED TO HORIZONTAL SURFACES TO PREVENT SLIP AND FALL ACCIDENTS; ADHESIVES AND GLUES FOR INDUSTRIAL AND COMMERCIAL USE (U.S. CLS. 1, 5, 6, 10, 26 AND 46).
FIRST USE 7-20-2007; IN COMMERCE 1-20-2009.

CLASS 1—(Continued).

4,155,750. TOTAL COAT DE VENEZUELA, C.A., VALENCIA, CARABOBO, VENEZUELA. SN 85-386,305. PUB. 1-17-2012, FILED 8-1-2011.



NO CLAIM IS MADE TO THE EXCLUSIVE RIGHT TO USE "COAT", APART FROM THE MARK AS SHOWN.
THE COLOR(S) RED, BLUE AND WHITE IS/ARE CLAIMED AS A FEATURE OF THE MARK.
THE MARK CONSISTS OF THE WORDS "TOTAL COAT" IN STYLIZED LETTERS. THE WORD "TOTAL" APPEARS ABOVE THE WORD "COAT". THE WORD "COAT" APPEARS INSIDE A RECTANGLE. THE COLOR BLUE APPEARS IN THE WORD "TOTAL" AND IN THE RECTANGULAR BACKGROUND OF THE WORD "COAT". THE COLOR WHITE APPEARS IN THE INNER OF THE TWO OUTER BORDERS OF THE WORD "TOTAL" AND IN THE WORD "COAT". THE COLOR RED APPEARS IN THE OUTER BORDER OF THE WORD "TOTAL" AND IN THE HORIZONTAL LINE THAT APPEARS BELOW THE RECTANGLE.
FOR CHEMICAL ADDITIVES FOR USE IN THE MANUFACTURE OF PROTECTIVE PLASTIC COATINGS; CHEMICALS FOR USE IN INDUSTRY AND SCIENCE; DEGREASING AGENTS; PHOTOGRAPHIC CHEMICALS (U.S. CLS. 1, 5, 6, 10, 26 AND 46).
FIRST USE 6-12-2002; IN COMMERCE 6-12-2002.

4,155,433. MARCO INDUSTRIES INC., PORTLAND, OR. SN 85-286,419. PUB. 8-30-2011, FILED 4-5-2011.

BIONIX

THE MARK CONSISTS OF STANDARD CHARACTERS WITHOUT CLAIM TO ANY PARTICULAR FONT, STYLE, SIZE, OR COLOR.
FOR SOIL AMENDMENTS, PLANTING SOIL, POTTING SOIL, PLANT FOODS, GROWING MEDIA FOR PLANTS (U.S. CLS. 1, 5, 6, 10, 26 AND 46).
FIRST USE 10-21-2011; IN COMMERCE 10-21-2011.

CLASS 2—PAINTS

4,154,337. VALSPAR SOURCING, INC., MINNEAPOLIS, MN. SN 77-546,099. PUB. 12-30-2008, FILED 8-13-2008.

VALFLEX

THE MARK CONSISTS OF STANDARD CHARACTERS WITHOUT CLAIM TO ANY PARTICULAR FONT, STYLE, SIZE, OR COLOR.
FOR COATINGS IN THE NATURE OF COATINGS FOR METAL SUBSTRATES (U.S. CLS. 6, 11 AND 16).
FIRST USE 5-6-2009; IN COMMERCE 5-6-2009.

CLASS 2—(Continued).

4,154,622. CASTIEL, MAURICE, DBA EUROPEAN & FOREIGN IMPORTS., INC., LAS VEGAS, NV. SN 85-008,765. PUB. 8-31-2010, FILED 4-7-2010.

SUN-READERS

THE MARK CONSISTS OF STANDARD CHARACTERS WITHOUT CLAIM TO ANY PARTICULAR FONT, STYLE, SIZE, OR COLOR.

FOR GLASS COATINGS AND TINT LAMINATIONS (U.S. CLS. 6, 11 AND 16).
FIRST USE 1-1-2011; IN COMMERCE 1-1-2011.

4,154,751. DYNA-COATINGS GROUP, LLC, KANSAS CITY, MO. SN 85-114,493. PUB. 2-1-2011, FILED 8-24-2010.

DYNA-TEK

THE MARK CONSISTS OF STANDARD CHARACTERS WITHOUT CLAIM TO ANY PARTICULAR FONT, STYLE, SIZE, OR COLOR.

FOR COATINGS, NAMELY, FINISHES FOR EXTERIOR AND INTERIOR USE ON A VARIETY OF SUBSTRATES (U.S. CLS. 6, 11 AND 16).

FIRST USE 12-0-2010; IN COMMERCE 12-0-2010.

4,154,848. MU LEI, MONROVIA, CA. SN 85-150,382. PUB. 2-22-2011, FILED 10-12-2010.

FIREAL

THE MARK CONSISTS OF STANDARD CHARACTERS WITHOUT CLAIM TO ANY PARTICULAR FONT, STYLE, SIZE, OR COLOR.

THE WORDING "FIREAL" HAS NO MEANING IN A FOREIGN LANGUAGE.

FOR FIRE RESISTANT, FIRE RETARDANT, ANTI-FIRE PAINTS AND COATINGS (U.S. CLS. 6, 11 AND 16).
FIRST USE 2-1-2012; IN COMMERCE 2-1-2012.

CLASS 2—(Continued).

4,154,924. COLOR MAKE, INC, MIAMI, FL. SN 85-198,694. PUB. 11-8-2011, FILED 12-15-2010.



NO CLAIM IS MADE TO THE EXCLUSIVE RIGHT TO USE "COLOR", APART FROM THE MARK AS SHOWN.

THE COLOR(S) BLUE, MAGENTA, YELLOW, GRAY AND BLACK IS/ARE CLAIMED AS A FEATURE OF THE MARK.

THE MARK CONSIST OF THE STYLIZED WORDING "COLOR MAKE" IN THE COLORS GRAY AND BLACK WITH A PARTIAL REFLECTION OF THE WORD "MAKE" IN GRAY, AND A DESIGN OF A BALL FORMED FROM A MISCELLANEOUS CURVED BLUE SHAPE ON THE RIGHT WITH SEVERAL IRREGULAR CIRCLE-LIKE SHAPES PLACED IN A CURVED PATTERN THAT FORMS THE LEFT SIDE OF THE BALL. THE CIRCLE-LIKE SHAPES APPEAR IN THE COLORS BLUE, MAGENTA, YELLOW, AND BLACK. THERE IS A REFLECTION OF THE BALL THAT APPEARS IN THE COLORS GRAY AND BLUE.

FOR DRY INKS; FILLED INK CARTRIDGES; INK CARTRIDGES FOR PRINTERS; INK FOR MULTIFUNCTION ELECTRONIC DEVICES FOR USE IN COPYING, PRINTING, SCANNING, VIDEO CAPTURE OR TRANSMITTING DOCUMENTS AND IMAGES; INK JET CARTRIDGES; INK JET PRINTER INK; INK-DRYING PREPARATIONS SOLD AS A COMPONENT OF INKS; INKS, TONERS AND DYES FOR USE WITH OR ON TEXTILES AND FABRICS; METALLIC INKS; PRINTING INKS (U.S. CLS. 6, 11 AND 16).

FIRST USE 12-1-2011; IN COMMERCE 1-16-2012.

4,155,166. VALSPAR CORPORATION, THE, MINNEAPOLIS, MN. SN 85-253,411. PUB. 7-19-2011, FILED 2-28-2011.

THAT'S PRO.

THE MARK CONSISTS OF STANDARD CHARACTERS WITHOUT CLAIM TO ANY PARTICULAR FONT, STYLE, SIZE, OR COLOR.

FOR PAINTS; COATINGS IN THE NATURE OF WOOD FINISHES (U.S. CLS. 6, 11 AND 16).
FIRST USE 4-4-2011; IN COMMERCE 4-4-2011.

CLASS 2—(Continued).

4,155,517. DDH HOLDINGS, LLC, BIRMINGHAM, AL. SN 85-309,872. PUB. 9-20-2011, FILED 5-2-2011.

WARRIOR 100

THE MARK CONSISTS OF STANDARD CHARACTERS WITHOUT CLAIM TO ANY PARTICULAR FONT, STYLE, SIZE, OR COLOR.

FOR A HIGH SOLIDS, ABRASION RESISTANT, DIRECT-TO-METAL COATING OR OVERCOAT DESIGNED FOR CORROSION RESISTANCE AND PHYSICAL PROTECTION OF CARBON STEEL FOR USE IN DIRECTIONAL DRILLING, THRUST BORE, AND ROUGH TERRAIN APPLICATIONS, BUT NOT FOR USE AS A COATING FOR TRUCK BEDS (U.S. CLS. 6, 11 AND 16).

FIRST USE 5-13-2010; IN COMMERCE 10-31-2011.

4,155,526. LANXESS DEUTSCHLAND GMBH, LEVERKUSEN, FED REP GERMANY. SN 85-313,040. PUB. 9-27-2011, FILED 5-5-2011.

HYDROCOL

THE MARK CONSISTS OF STANDARD CHARACTERS WITHOUT CLAIM TO ANY PARTICULAR FONT, STYLE, SIZE, OR COLOR.

FOR COLORANTS AND WATER DISPERSED PIGMENTS FOR USE IN COLORING CONCRETE AND OTHER CEMENTITIOUS PRODUCTS; PIGMENTS FOR COLORING GARDEN MULCH (U.S. CLS. 6, 11 AND 16).

FIRST USE 1-31-2012; IN COMMERCE 1-31-2012.

CLASS 3—COSMETICS AND CLEANING PREPARATIONS

CLASS 3—(Continued).

4,154,251. MAYBE TONIGHT, INC., WINDERMERE, FL. SN 76-704,514. PUB. 3-1-2011, FILED 9-16-2010.



THE DESIGN CONSISTS OF A STYLIZED QUESTION MARK AND A PAIR OF WOMAN'S LIPS IN PLACE OF THE STANDARD DOT.

FOR INTIMACY KIT CONTAINING PERSONAL FEMININE HYGIENE PRODUCTS, NAMELY, A KIT COMPRISED PRIMARILY OF FEMININE HYGIENE CLEANSING TOWELETTS AND ALSO COSMETICS, PERSONAL LUBRICANTS, AND CONDOMS (U.S. CLS. 1, 4, 6, 50, 51 AND 52).

FIRST USE 12-9-2011; IN COMMERCE 12-9-2011.

4,154,308. JOHN B. STETSON COMPANY, HOBOKEN, NJ. SN 77-478,167. PUB. 2-17-2009, FILED 5-19-2008.

MADE OF AMERICA

THE MARK CONSISTS OF STANDARD CHARACTERS WITHOUT CLAIM TO ANY PARTICULAR FONT, STYLE, SIZE, OR COLOR.

FOR FRAGRANCES; PERSONAL CARE PRODUCTS, NAMELY, AFTER-SHAVE (U.S. CLS. 1, 4, 6, 50, 51 AND 52).

FIRST USE 2-0-2012; IN COMMERCE 2-0-2012.

4,154,309. JONES, DENNIS R., CHESAPEAKE, VA. SN 77-489,570. PUB. 10-7-2008, FILED 6-3-2008.

LIPURA

THE MARK CONSISTS OF STANDARD CHARACTERS WITHOUT CLAIM TO ANY PARTICULAR FONT, STYLE, SIZE, OR COLOR.

THE MARK "LIPURA" HAS NO MEANING IN A FOREIGN LANGUAGE

FOR LIP BALM (U.S. CLS. 1, 4, 6, 50, 51 AND 52).

FIRST USE 1-3-2011; IN COMMERCE 3-1-2011.

CLASS 3—(Continued).

4,154,420. BEAUTY SPECIALS LLC, ORANGE, CA. SN 77-732,074. PUB. 9-15-2009, FILED 5-7-2009.

HEAVENLY STRANDS

THE MARK CONSISTS OF STANDARD CHARACTERS WITHOUT CLAIM TO ANY PARTICULAR FONT, STYLE, SIZE, OR COLOR.

FOR 3-IN-1 HAIR SHAMPOOS; AROMATHERAPY BODY CARE PRODUCTS, NAMELY, BODY LOTION, SHOWER GEL, CUTICLE CREAM, SHAMPOO, CONDITIONER, NON-MEDICATED LIP BALM, SOAP, BODY POLISH, BODY AND FOOT SCRUB AND NON-MEDICATED FOOT CREAM; BABY SHAMPOO; HAIR RINSES; HAIR SHAMPOO; HAIR SHAMPOOS AND CONDITIONERS; HAIR STYLING FIXATIVE IN THE NATURE OF HAIR WAX; HAIR STYLING GEL; HAIR STYLING PREPARATIONS; HAIR STYLING SPRAY; SHAMPOO-CONDITIONERS; SHAMPOOS; SHAMPOOS FOR BABIES; STYLING CLAY FOR HAIR; STYLING FOAM FOR HAIR; STYLING GELS; STYLING LOTIONS; STYLING MOUSSE; STYLING PASTE FOR HAIR (U.S. CLS. 1, 4, 6, 50, 51 AND 52).

FIRST USE 6-29-2010; IN COMMERCE 6-29-2010.

4,154,428. GOLDEN PRODUCTS LLC., HOWARD BEACH, NY. SN 77-748,759. PUB. 12-8-2009, FILED 6-1-2009.

VITAPASTE

THE MARK CONSISTS OF STANDARD CHARACTERS WITHOUT CLAIM TO ANY PARTICULAR FONT, STYLE, SIZE, OR COLOR.

OWNER OF U.S. REG. NOS. 3,532,755, 3,607,044, AND OTHERS.

FOR ORAL HYGIENE PRODUCTS, NAMELY, DENTIFRICES AND TOOTHPASTE (U.S. CLS. 1, 4, 6, 50, 51 AND 52).

FIRST USE 3-29-2012; IN COMMERCE 3-29-2012.

CLASS 3—(Continued).

4,154,565. LINMAR TECHNOLOGY INC., BROOKLYN, NY. SN 77-965,832. PUB. 8-23-2011, FILED 3-23-2010.

MAGICLEAR

THE MARK CONSISTS OF THE WORD "MAGICLEAR" WITH A HORIZONTAL LINE APPEARING ABOVE THE LETTERS "MAGIC" IN THE MARK, AND A HORIZONTAL LINE APPEARING BELOW THE LETTERS "CLEAR" IN THE MARK.

FOR CONCENTRATE USED FOR CLEANING WINDSHIELDS AND WIPER BLADES (U.S. CLS. 1, 4, 6, 50, 51 AND 52).

FIRST USE 6-15-2010; IN COMMERCE 6-15-2010.

4,154,590. MAJEED, MUHAMMED, EDISON, NJ. SN 78-232,029. PUB. 9-7-2010, FILED 3-31-2003.

JOHARA

THE MARK CONSISTS OF STANDARD CHARACTERS WITHOUT CLAIM TO ANY PARTICULAR FONT, STYLE, SIZE, OR COLOR.

THE ENGLISH TRANSLATION OF "JOHARA" IS JEWEL FOR (BASED ON USE IN COMMERCE) COSMETICS (U.S. CLS. 1, 4, 6, 50, 51 AND 52).

FIRST USE 5-15-2001; IN COMMERCE 7-1-2002.

4,154,596. MALLYGIRL LLC, TOWSON, MD. SN 78-863,934. PUB. 12-5-2006, FILED 4-18-2006.

LIP ILLUSION

THE MARK CONSISTS OF STANDARD CHARACTERS WITHOUT CLAIM TO ANY PARTICULAR FONT, STYLE, SIZE, OR COLOR.

NO CLAIM IS MADE TO THE EXCLUSIVE RIGHT TO USE "LIP", APART FROM THE MARK AS SHOWN.

FOR COSMETICS AND MAKE UP, NAMELY, LIPSTICK, LIP COLOR AND LIP GLOSS (U.S. CLS. 1, 4, 6, 50, 51 AND 52).

FIRST USE 9-0-2006; IN COMMERCE 1-0-2007.

CLASS 3—(Continued).

4,154,636. LEFFINGWELL, APRIL A, SAN DIEGO, CA. SN 85-031,324. PUB. 10-5-2010, FILED 5-5-2010.

SHEA CHIC

THE MARK CONSISTS OF STANDARD CHARACTERS WITHOUT CLAIM TO ANY PARTICULAR FONT, STYLE, SIZE, OR COLOR.

NO CLAIM IS MADE TO THE EXCLUSIVE RIGHT TO USE "SHEA", APART FROM THE MARK AS SHOWN.

FOR PERSONAL CARE PREPARATIONS, NAMELY, SKIN MOISTURIZERS, LOTIONS, CREAMS, BALMS, BUTTERS, OILS, SCRUBS, EXFOLIANTS, GELS, AND FRAGRANCE SPRAYS (U.S. CLS. 1, 4, 6, 50, 51 AND 52).
FIRST USE 9-1-2009; IN COMMERCE 9-1-2009.

CLASS 3—(Continued).

4,154,758. ALEXANDER, ADRIAN, MIAMI, FL. SN 85-116,963. PUB. 7-26-2011, FILED 8-26-2010.



THE MARK CONSISTS OF TWO CURSIVE LETTERS "L" FROM THE NAME BRAND "LICK & LUCK" ARE BACK TO BACK INSIDE AN INTERSTATE SHAPED SIGN. THE TWO LETTERS "L" WHEN BACK TO BACK LOOKS LIKE THE SHAPE OF AN ANIMALS FACE WITH EYES, EARS, MOUTH, NOSE, MUSTACHE SIMILAR TO THAT OF A CAT'S OR DOG'S FACE. THE "&" SYMBOL INSIDE THE LOGO RESEMBLES THE NOSE. THE WORDING "LICK & LUCK" APPEARS BENEATH THE TWO LETTER "L" DESIGN.

FOR BLEACHING PREPARATIONS FOR COSMETIC PURPOSES; BODY AND BEAUTY CARE COSMETICS; CLEANSING CREAMS; COLOGNES, PERFUMES AND COSMETICS; COMPACTS CONTAINING MAKE-UP; CONCEALERS; COSMETIC CREAMS; COSMETIC CREAMS FOR SKIN CARE; COSMETIC MASSAGE CREAMS; COSMETIC PADS; COSMETIC PENCILS; COSMETIC PREPARATIONS; COSMETIC PREPARATIONS, NAMELY, FIRING CREAMS; COSMETIC PREPARATIONS, NAMELY, FIRING LOTIONS; COSMETICS AND COSMETIC PREPARATIONS; COSMETICS AND MAKE-UP; COSMETICS IN GENERAL, INCLUDING PERFUMES; COSMETICS, NAMELY, LIP PRIMER; DEPILATORY WAX; EYE MAKE-UP; EYE MAKE-UP REMOVER; EYEBROW COSMETICS; EYES MAKE-UP; FACE CREAMS FOR COSMETIC USE; FACIAL MAKE-UP; FOUNDATION MAKE-UP; LOTIONS FOR COSMETIC PURPOSES; MAKE UP FOUNDATIONS; MAKE UP REMOVING PREPARATIONS; MAKE-UP; MAKE-UP FOR THE FACE AND BODY; MAKE-UP FOUNDATIONS; MAKE-UP KITS COMPRISED OF FOUNDATION, FACE POWDER, LIP GLOSS, BRUSHES, CONCEALERS, PRIMER, FACE LOTIONS; MAKE-UP PENCILS; MAKE-UP POWDER; MAKE-UP PREPARATIONS; MAKE-UP PREPARATIONS FOR THE FACE AND BODY; MAKE-UP REMOVER; MAKE-UP REMOVING LOTIONS; MAKE-UP REMOVING MILK, GEL, LOTIONS AND CREAMS; MAKE-UP REMOVING MILKS; MAKE-UP REMOVING PREPARATIONS; PRIVATE LABEL COSMETICS (U.S. CLS. 1, 4, 6, 50, 51 AND 52).

FIRST USE 12-1-2009; IN COMMERCE 12-1-2009.

4,154,703. ECOPHARMA, LLC, NEW YORK, NY. SN 85-100,026. PUB. 8-16-2011, FILED 8-4-2010.

SLIMCELL

THE MARK CONSISTS OF STANDARD CHARACTERS WITHOUT CLAIM TO ANY PARTICULAR FONT, STYLE, SIZE, OR COLOR.

FOR COSMETIC PREPARATIONS FOR SLIMMING PURPOSES, NAMELY, GEL FOR SLIMMING AND CELLULITE REDUCTION (U.S. CLS. 1, 4, 6, 50, 51 AND 52).
FIRST USE 11-1-2011; IN COMMERCE 11-1-2011.

CLASS 3—(Continued).

4,154,783. MARY KAY INC., ADDISON, TX. SN 85-126,729. PUB. 2-8-2011, FILED 9-10-2010.

NOURISHINE PLUS

THE MARK CONSISTS OF STANDARD CHARACTERS WITHOUT CLAIM TO ANY PARTICULAR FONT, STYLE, SIZE, OR COLOR.

OWNER OF U.S. REG. NO. 3,406,988.
FOR COSMETICS (U.S. CLS. 1, 4, 6, 50, 51 AND 52).
FIRST USE 11-26-2011; IN COMMERCE 11-26-2011.

4,154,809. KELLY VAN GOGH HAIR COLOR COSMETICS, LLC, NEW YORK, NY. SN 85-137,717. PUB. 3-8-2011, FILED 9-24-2010.

GET NOTICED GUARANTEE

THE MARK CONSISTS OF STANDARD CHARACTERS WITHOUT CLAIM TO ANY PARTICULAR FONT, STYLE, SIZE, OR COLOR.

FOR NON-MEDICATED HAIR CARE PREPARATIONS, NAMELY, SHAMPOOS, CONDITIONERS, GELS, COLORANTS, AND TONICS; HAIR CARE KITS COMPRISING NON-MEDICATED HAIR CARE PREPARATIONS, NAMELY, SHAMPOOS, CONDITIONERS, GELS, COLORANTS, AND TONICS, AND HAIR CARE PREPARATION APPLICATION TOOLS, NAMELY, APPLICATORS AND MIXING RECEPTACLES ALL OF WHICH ARE SOLD TOGETHER AS A UNIT (U.S. CLS. 1, 4, 6, 50, 51 AND 52).
FIRST USE 6-0-2010; IN COMMERCE 6-0-2010.

4,154,890. A.B.C. COMPOUNDING COMPANY, INC., MORROW, GA. SN 85-177,740. PUB. 12-6-2011, FILED 11-16-2010.

BIO LIVE

THE MARK CONSISTS OF STANDARD CHARACTERS WITHOUT CLAIM TO ANY PARTICULAR FONT, STYLE, SIZE, OR COLOR.

NO CLAIM IS MADE TO THE EXCLUSIVE RIGHT TO USE "LIVE", APART FROM THE MARK AS SHOWN.
FOR CLEANING PREPARATIONS (U.S. CLS. 1, 4, 6, 50, 51 AND 52).
FIRST USE 12-3-2010; IN COMMERCE 12-3-2010.

CLASS 3—(Continued).

4,154,900. THIRD MAN, INC., NEW YORK, NY. SN 85-184,989. PUB. 5-3-2011, FILED 11-24-2010.

EAU MODERNE

THE MARK CONSISTS OF STANDARD CHARACTERS WITHOUT CLAIM TO ANY PARTICULAR FONT, STYLE, SIZE, OR COLOR.

THE ENGLISH TRANSLATION OF "EAU" IN THE MARK IS "WATER".
FOR COLOGNE; EAU DE TOILETTE; EAU DE COLOGNE; FRAGRANCES FOR PERSONAL USE; PERFUMES; TOILET WATER (U.S. CLS. 1, 4, 6, 50, 51 AND 52).
FIRST USE 11-0-2011; IN COMMERCE 11-0-2011.

4,154,905. PROCTER & GAMBLE COMPANY, THE, CINCINNATI, OH. SN 85-188,419. PUB. 3-8-2011, FILED 12-1-2010.

DUAL*BLAST

THE MARK CONSISTS OF STANDARD CHARACTERS WITHOUT CLAIM TO ANY PARTICULAR FONT, STYLE, SIZE, OR COLOR.

FOR DENTIFRICES AND MOUTHWASHES (U.S. CLS. 1, 4, 6, 50, 51 AND 52).
FIRST USE 7-25-2011; IN COMMERCE 7-25-2011.

4,154,909. FARIAS VILLARREAL, MARTIN JESUS GERARDO, HOUSTON, TX. SN 85-188,983. PUB. 5-3-2011, FILED 12-2-2010.

Mr. Look T Transforma

THE MARK CONSISTS OF STANDARD CHARACTERS WITHOUT CLAIM TO ANY PARTICULAR FONT, STYLE, SIZE, OR COLOR.

CLASS 3—(Continued).

THE ENGLISH TRANSLATION OF THE WORD "TRANSFORMA" IN THE MARK IS TO TRANSFORM.
 FOR HAIR CARE CREAMS; HAIR CARE LOTIONS; HAIR CARE PREPARATIONS; HAIR COLOR; HAIR COLORANTS; HAIR CONDITIONER; HAIR CONDITIONERS; HAIR CREAMS; HAIR GEL; HAIR GEL AND HAIR MOUSSE; HAIR GELS; HAIR LOTIONS; HAIR MOUSSE; HAIR MOUSSES; HAIR POMADES; HAIR SHAMPOO; HAIR SHAMPOOS AND CONDITIONERS; HAIR SHEEN SPRAY; HAIR SPRAYS AND HAIR GELS; HAIR STYLING GEL; HAIR STYLING PREPARATIONS; HAIR TONIC; HAIR WAX (U.S. CLS. 1, 4, 6, 50, 51 AND 52).
 FIRST USE 6-1-2011; IN COMMERCE 6-1-2011.

4,154,923. V BEAUTE LLC, NEW YORK, NY. SN 85-198,665. PUB. 11-29-2011, FILED 12-15-2010.

IT KIT

THE MARK CONSISTS OF STANDARD CHARACTERS WITHOUT CLAIM TO ANY PARTICULAR FONT, STYLE, SIZE, OR COLOR.
 NO CLAIM IS MADE TO THE EXCLUSIVE RIGHT TO USE "KIT", APART FROM THE MARK AS SHOWN.
 FOR COSMETICS; NON-MEDICATED SKIN CARE PRODUCTS (U.S. CLS. 1, 4, 6, 50, 51 AND 52).
 FIRST USE 11-1-2011; IN COMMERCE 11-1-2011.

4,154,925. L'OREAL USA CREATIVE, INC., NEW YORK, NY. SN 85-198,777. PUB. 2-22-2011, FILED 12-15-2010.

ARGAN-6

THE MARK CONSISTS OF STANDARD CHARACTERS WITHOUT CLAIM TO ANY PARTICULAR FONT, STYLE, SIZE, OR COLOR.
 FOR HAIR CARE PREPARATION (U.S. CLS. 1, 4, 6, 50, 51 AND 52).
 FIRST USE 9-1-2011; IN COMMERCE 9-1-2011.

CLASS 3—(Continued).

4,154,940. DJF ENTERPRISES, NEW YORK, NY. SN 85-204,013. PUB. 4-26-2011, FILED 12-22-2010.

SMASHBOX FULL EXPOSURE

THE MARK CONSISTS OF STANDARD CHARACTERS WITHOUT CLAIM TO ANY PARTICULAR FONT, STYLE, SIZE, OR COLOR.
 OWNER OF U.S. REG. NOS. 1,763,490 AND 2,392,373.
 FOR COSMETICS (U.S. CLS. 1, 4, 6, 50, 51 AND 52).
 FIRST USE 2-24-2011; IN COMMERCE 2-24-2011.

4,154,966. PURE & NATURAL COMPANY, SCOTTSDALE, AZ. SN 85-212,521. PUB. 4-26-2011, FILED 1-7-2011.

GET YOUR DIRT ON WE'LL GET IT OFF

THE MARK CONSISTS OF STANDARD CHARACTERS WITHOUT CLAIM TO ANY PARTICULAR FONT, STYLE, SIZE, OR COLOR.
 FOR BATH SOAPS; BODY WASH; LIQUID SOAPS (U.S. CLS. 1, 4, 6, 50, 51 AND 52).
 FIRST USE 1-28-2011; IN COMMERCE 1-28-2011.

4,155,005. MINNTECH CORPORATION, MINNEAPOLIS, MN. SN 85-226,677. PUB. 8-9-2011, FILED 1-26-2011.

MEDICLEAN EZ

THE MARK CONSISTS OF STANDARD CHARACTERS WITHOUT CLAIM TO ANY PARTICULAR FONT, STYLE, SIZE, OR COLOR.
 FOR ENZYMATIC DETERGENTS IN THE NATURE OF CLEANING PREPARATIONS FOR USE IN ENDOSCOPE REPROCESSING (U.S. CLS. 1, 4, 6, 50, 51 AND 52).
 FIRST USE 6-27-2011; IN COMMERCE 6-27-2011.

CLASS 3—(Continued).

4,155,041. V BEAUTE LLC, NEW YORK, NY. SN 85-236,718.
PUB. 7-12-2011, FILED 2-8-2011.



THE COLOR(S) PURPLE IS/ARE CLAIMED AS A FEATURE OF THE MARK.

THE MARK CONSISTS OF THE LETTER "V" IN PURPLE. FOR COSMETICS; NON-MEDICATED SKIN CARE PRODUCTS (U.S. CLS. 1, 4, 6, 50, 51 AND 52). FIRST USE 11-1-2011; IN COMMERCE 11-1-2011.

4,155,053. CONOPCO, INC., ENGLEWOOD CLIFFS, NJ. SN 85-238,922. PUB. 6-28-2011, FILED 2-10-2011.

KERALOCK

THE MARK CONSISTS OF STANDARD CHARACTERS WITHOUT CLAIM TO ANY PARTICULAR FONT, STYLE, SIZE, OR COLOR.

FOR HAIR CARE PRODUCTS, NAMELY, HAIR COLORANTS, HAIR DYES, HAIR LOTIONS, HAIR WAVING PREPARATIONS, SHAMPOOS, CONDITIONERS, HAIR SPRAYS, HAIR DRESSINGS, HAIR LACQUERS, HAIR MOUSSES, HAIR GLAZES, HAIR GELS, HAIR MOISTURIZERS, HAIR PRESERVATION TREATMENTS, HAIR OILS, HAIR TONIC, HAIR CREAMS, NON-MEDICATED PREPARATIONS FOR THE BATH AND/OR SHOWER (U.S. CLS. 1, 4, 6, 50, 51 AND 52). FIRST USE 12-4-2010; IN COMMERCE 12-4-2010.

CLASS 3—(Continued).

4,155,064. V BEAUTE LLC, NEW YORK, NY. SN 85-241,090.
PUB. 7-12-2011, FILED 2-13-2011.

LITE UP

THE MARK CONSISTS OF STANDARD CHARACTERS WITHOUT CLAIM TO ANY PARTICULAR FONT, STYLE, SIZE, OR COLOR.

FOR COSMETICS AND NON-MEDICATED SKIN CARE PREPARATIONS (U.S. CLS. 1, 4, 6, 50, 51 AND 52). FIRST USE 11-1-2011; IN COMMERCE 11-1-2011.

4,155,092. PHITEN USA, INC., TORRANCE, CA, CA. SN 85-245,459. PUB. 9-20-2011, FILED 2-17-2011.

ANTI-FRIZZ BY YUKO

THE MARK CONSISTS OF STANDARD CHARACTERS WITHOUT CLAIM TO ANY PARTICULAR FONT, STYLE, SIZE, OR COLOR.

NO CLAIM IS MADE TO THE EXCLUSIVE RIGHT TO USE "ANTI-FRIZZ", APART FROM THE MARK AS SHOWN.

THE NAME(S), PORTRAIT(S), AND/OR SIGNATURE(S) SHOWN IN THE MARK IDENTIFIES "YUKO", WHOSE CONSENT(S) TO REGISTER IS MADE OF RECORD.

FOR HAIR RELAXING PREPARATIONS, NAMELY, HAIR RELAXING SOLUTIONS, HAIR SHAMPOO, HAIR RINSES, HAIR CONDITIONER AND NON-MEDICATED HAIR TREATMENT PREPARATIONS FOR COSMETIC PURPOSES (U.S. CLS. 1, 4, 6, 50, 51 AND 52). FIRST USE 1-28-2012; IN COMMERCE 1-28-2012.

4,155,122. PARIS PRESENTS INCORPORATED, GURNEE, IL. SN 85-249,380. PUB. 7-5-2011, FILED 2-23-2011.

NONSTOP MOISTURE

THE MARK CONSISTS OF STANDARD CHARACTERS WITHOUT CLAIM TO ANY PARTICULAR FONT, STYLE, SIZE, OR COLOR.

NO CLAIM IS MADE TO THE EXCLUSIVE RIGHT TO USE "MOISTURE", APART FROM THE MARK AS SHOWN. FOR LIP BALM; LIP GLOSS (U.S. CLS. 1, 4, 6, 50, 51 AND 52).

FIRST USE 2-1-2011; IN COMMERCE 2-1-2011.

CLASS 3—(Continued).

4,155,144. US MILK CORPORATION, CORONA, CA. SN 85-251,316. PUB. 7-19-2011, FILED 2-24-2011.



NO CLAIM IS MADE TO THE EXCLUSIVE RIGHT TO USE "US MILK", APART FROM THE MARK AS SHOWN. THE MARK CONSISTS OF A FLAG WITH THE STYLIZED TEXT "US MILK".
FOR COSMETICS (U.S. CLS. 1, 4, 6, 50, 51 AND 52).
FIRST USE 2-1-2012; IN COMMERCE 2-1-2012.

CLASS 3—(Continued).

4,155,203. ALETHIA SKIN CARE LLC, ARDMORE, PA. SN 85-256,821. PUB. 8-2-2011, FILED 3-3-2011.

THE POWER OF LIGHT, INSIDE

THE MARK CONSISTS OF STANDARD CHARACTERS WITHOUT CLAIM TO ANY PARTICULAR FONT, STYLE, SIZE, OR COLOR.
FOR NON-MEDICATED SKIN CARE PREPARATIONS, NAMELY, CREAMS, LOTIONS, GELS, TONERS, CLEANERS AND PEELS; HAIR CARE PRODUCTS, NAMELY, SHAMPOOS AND CONDITIONERS (U.S. CLS. 1, 4, 6, 50, 51 AND 52).
FIRST USE 2-14-2011; IN COMMERCE 2-14-2011.

4,155,164. WOLF, CARL, DBA ATLANTIC BEAUTY SALES, CHERRY HILL, NJ. SN 85-253,235. PUB. 7-19-2011, FILED 2-28-2011.

LOTUS NAILS

THE MARK CONSISTS OF STANDARD CHARACTERS WITHOUT CLAIM TO ANY PARTICULAR FONT, STYLE, SIZE, OR COLOR.
NO CLAIM IS MADE TO THE EXCLUSIVE RIGHT TO USE "NAILS", APART FROM THE MARK AS SHOWN.
FOR ADHESIVES FOR ARTIFICIAL NAILS; COSMETIC PREPARATIONS FOR NAIL DRYING; FALSE NAILS; LOTIONS FOR STRENGTHENING THE NAILS; NAIL ART STICKERS; NAIL BUFFING PREPARATIONS; NAIL CARE KITS COMPRISING NAIL POLISH; NAIL CARE PREPARATIONS; NAIL CARE PREPARATIONS, NAMELY, NAIL SOFTENERS; NAIL CREAM; NAIL ENAMEL REMOVERS; NAIL ENAMELS; NAIL GEL; NAIL GLITTER; NAIL GROOMING PRODUCTS, NAMELY, TIPS, GLUE, LACQUER AND GLITTER; NAIL HARDENERS; NAIL POLISH; NAIL POLISH BASE COAT; NAIL POLISH PROTECTOR IN THE NATURE OF A THIN PLASTIC COVERING APPLIED TO NAILS; NAIL POLISH REMOVERS; NAIL POLISH TOP COAT; NAIL REPAIR PRODUCTS, NAMELY, NAIL WRAPS; NAIL STENCILS; NAIL STRENGTHENERS; NAIL TIPS; NAIL VARNISHES; NON-MEDICATED NAIL CARE PREPARATIONS (U.S. CLS. 1, 4, 6, 50, 51 AND 52).
FIRST USE 11-18-2011; IN COMMERCE 11-18-2011.

4,155,237. TSAI, JASON LEE, JERSEY CITY, NJ. SN 85-260,529. PUB. 7-26-2011, FILED 3-8-2011.

BEAUNIQUE

THE MARK CONSISTS OF STANDARD CHARACTERS WITHOUT CLAIM TO ANY PARTICULAR FONT, STYLE, SIZE, OR COLOR.
FOR ARTIFICIAL EYELASHES; BATH SOAPS IN LIQUID, SOLID OR GEL FORM; BODY LOTION; COSMETIC PREPARATIONS FOR SKIN CARE; EYE MAKE-UP; FRAGRANCES AND PERFUMERY; LIP BALM; LIP GLOSS; LOTIONS FOR FACE AND BODY CARE; MOISTURIZING PREPARATIONS FOR THE SKIN; NAIL CARE PREPARATIONS; NAIL CARE PREPARATIONS, NAMELY, NAIL SOFTENERS; NAIL CREAM; NAIL HARDENERS; NAIL POLISH; NAIL POLISH TOP COAT; NAIL STRENGTHENERS; NAIL-POLISH REMOVERS; NON-MEDICATED LIP CARE PREPARATIONS; NON-MEDICATED PREPARATIONS ALL FOR THE CARE OF SKIN, HAIR AND SCALP; NON-MEDICATED SKIN CARE PREPARATIONS, NAMELY, CREAMS, LOTIONS, GELS, TONERS, CLEANERS AND PEELS; NON-MEDICATED TOILETRIES; SKIN BRONZER; SKIN EMOLLIENTS; SKIN MOISTURIZER; SKIN SOAP (U.S. CLS. 1, 4, 6, 50, 51 AND 52).
FIRST USE 10-1-2011; IN COMMERCE 10-1-2011.

CLASS 3—(Continued).

4,155,256. COREBEAUTY, LLC, SAN DIEGO, CA. SN 85-262,130. PUB. 7-26-2011, FILED 3-9-2011.

MAKE MY YOURS

THE MARK CONSISTS OF STANDARD CHARACTERS WITHOUT CLAIM TO ANY PARTICULAR FONT, STYLE, SIZE, OR COLOR.

FOR NON-MEDICATED SKIN CREAMS, NON-MEDICATED SKIN LOTIONS, NON-MEDICATED SKIN SERUMS (U.S. CLS. 1, 4, 6, 50, 51 AND 52).

FIRST USE 3-15-2012; IN COMMERCE 3-15-2012.

4,155,278. DISNEY ENTERPRISES, INC., BURBANK, CA. SN 85-264,439. PUB. 7-26-2011, FILED 3-11-2011.

A PRINCESS WISH

THE MARK CONSISTS OF STANDARD CHARACTERS WITHOUT CLAIM TO ANY PARTICULAR FONT, STYLE, SIZE, OR COLOR.

FOR COSMETICS; NON-MEDICATED TOILETRIES; FRAGRANCES; PERFUMES (U.S. CLS. 1, 4, 6, 50, 51 AND 52).

FIRST USE 3-19-2012; IN COMMERCE 3-19-2012.

4,155,289. THE VERA COMPANY, LLC, DBA THE VERA COMPANY, ATLANTA, GA. SN 85-266,260. PUB. 11-8-2011, FILED 3-14-2011.



OWNER OF U.S. REG. NOS. 683,332, 3,703,608, AND OTHERS.

THE NAME(S), PORTRAIT(S), AND/OR SIGNATURE(S) SHOWN IN THE MARK DOES NOT IDENTIFY A PARTICULAR LIVING INDIVIDUAL.

CLASS 3—(Continued).

THE MARK CONSISTS OF THE STYLIZED WORDING "VERA".

FOR MAKEUP PRODUCTS, NAMELY, MAKEUP POWDER, MAKEUP FOUNDATION, MAKEUP PENCILS, BLUSH, LIPSTICK, LIP GLOSS, EYE SHADOWS, AND NAIL POLISH (U.S. CLS. 1, 4, 6, 50, 51 AND 52).

FIRST USE 2-9-2012. THE MARK WAS FIRST USED ANYWHERE IN A DIFFERENT FORM OTHER THAN THAT SOUGHT TO BE REGISTERED AT LEAST AS EARLY AS 03/31/1980.; IN COMMERCE 2-9-2012. THE MARK WAS FIRST USED IN COMMERCE IN A DIFFERENT FORM OTHER THAN THAT SOUGHT TO BE REGISTERED AT LEAST AS EARLY AS 07/01/1947..

4,155,292. HARRINGTON, SEAN PATRICK, PROVINCE-TOWN, MA. SN 85-266,545. PUB. 7-26-2011, FILED 3-14-2011.

PREVISE

THE MARK CONSISTS OF STANDARD CHARACTERS WITHOUT CLAIM TO ANY PARTICULAR FONT, STYLE, SIZE, OR COLOR.

FOR NON-MEDICATED SKIN CARE PREPARATIONS (U.S. CLS. 1, 4, 6, 50, 51 AND 52).

FIRST USE 2-9-2012; IN COMMERCE 2-9-2012.

4,155,298. JOHNSON & JOHNSON, NEW BRUNSWICK, NJ. SN 85-266,919. PUB. 8-2-2011, FILED 3-15-2011.

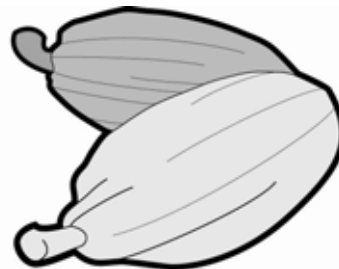

THE MARK CONSISTS OF IMAGE OF COCOA SHEA BEANS.

FOR BODY LOTIONS AND BODY CREAMS (U.S. CLS. 1, 4, 6, 50, 51 AND 52).

FIRST USE 6-3-2010; IN COMMERCE 6-3-2010.

CLASS 3—(Continued).

4,155,299. JOHNSON & JOHNSON, NEW BRUNSWICK, NJ. SN 85-266,920. PUB. 8-2-2011, FILED 3-15-2011.



THE MARK CONSISTS OF IMAGE OF LAVENDER AND JASMINE FLOWER.
FOR BODY LOTIONS AND BODY CREAMS (U.S. CLS. 1, 4, 6, 50, 51 AND 52).
FIRST USE 12-12-2011; IN COMMERCE 12-12-2011.

CLASS 3—(Continued).

4,155,367. CRYSTALLINE HEALTH & BEAUTY FROM THE DEAD SEA LTD, TEL AVIV, ISRAEL. SN 85-278,012. PUB. 8-30-2011, FILED 3-27-2011.

Deep from the Dead Sea

THE MARK CONSISTS OF STANDARD CHARACTERS WITHOUT CLAIM TO ANY PARTICULAR FONT, STYLE, SIZE, OR COLOR.

NO CLAIM IS MADE TO THE EXCLUSIVE RIGHT TO USE "FROM THE DEAD SEA", APART FROM THE MARK AS SHOWN.

FOR ALOE VERA GEL FOR COSMETIC PURPOSES; ANTI-AGING CREAM; ANTI-AGING CREAMS; ANTI-AGING MOISTURIZER; ANTI-AGING TONER; ANTI-WRINKLE CREAM; ANTI-WRINKLE CREAMS; AROMATIC BODY CARE PRODUCTS, NAMELY, BODY LOTION, SHOWER GEL, CUTICLE CREAM, SHAMPOO, CONDITIONER, NON-MEDICATED LIP BALM, SOAP, BODY POLISH, BODY AND FOOT SCRUB AND NON-MEDICATED FOOT CREAM; BATH AND SHOWER GELS AND SALTS NOT FOR MEDICAL PURPOSES; BATH BEADS; BATH CREAM; BATH CRYSTALS; BATH FIZZIES; BATH FLAKES; BATH FOAM; BATH FOAMS; BATH GEL; BATH GELS; BATH LOTION; BATH MILKS; BATH OIL; BATH OILS; BATH OILS AND BATH SALTS; BATH OILS FOR COSMETIC PURPOSES; BATH SALTS; BATH SOAPS; BATH SOAPS IN LIQUID, SOLID OR GEL FORM; BATHING LOTIONS; BEAUTY LOTIONS; BODY LOTION; BODY LOTIONS; BODY OIL; BODY SCRUB; BUBBLE BATH; COSMETIC BATH SALTS; COSMETIC CREAMS FOR SKIN CARE; COSMETIC OILS; COSMETIC PREPARATIONS FOR BATH AND SHOWER; COSMETIC PREPARATIONS FOR PROTECTING THE SKIN FROM THE SUN'S RAYS; COSMETIC PREPARATIONS FOR SKIN CARE; COSMETIC PREPARATIONS FOR SKIN RENEWAL; COSMETIC SKIN FRESHENERS; COSMETICS IN THE FORM OF MILKS, LOTIONS AND EMULSIONS; CUTICLE CREAM; EXFOLIANTS FOR SKIN CARE; EYE GELS; EYE LOTIONS; FACE AND BODY LOTIONS; FACE MILK AND LOTIONS; FACIAL LOTION; FACIAL SCRUBS; FACIAL WASHES; FOAM BATH; FOOT SCRUBS; FRAGRANCED BODY CARE PREPARATIONS, NAMELY, SALT SCRUB; GIFT BASKETS CONTAINING NON-MEDICATED BATH PREPARATIONS AND COSMETIC PREPARATIONS; HAIR SHAMPOO; HAIR SHampoos AND CONDITIONERS; HAND SCRUBS; LIQUID BATH SOAPS; LIQUID SOAP USED IN FOOT BATH; LOTIONS FOR COSMETIC PURPOSES; LOTIONS FOR FACE AND BODY CARE; MINERAL SALT IN THE NATURE OF BATH SALTS NOT FOR MEDICAL PURPOSES; MOISTURIZING PREPARATIONS FOR THE SKIN; MOISTURIZING SOLUTIONS FOR THE SKIN; NON-MEDICATED ANTI-AGING SERUM; NON-MEDICATED BATH PREPARATIONS; NON-MEDICATED BATH SALTS; NON-MEDICATED BUBBLE BATH PREPARATIONS; NON-MEDICATED FOOT LOTIONS; NON-MEDICATED PREPARATIONS ALL FOR THE CARE OF SKIN, HAIR AND SCALP; NON-MEDICATED SKIN CARE CREAMS AND LOTIONS; NON-MEDICATED SKIN CARE PREPARATION, NAMELY, BODY MIST; NON-MEDICATED SKIN CARE PREPARATIONS; NON-MEDICATED SKIN CARE PREPARATIONS, NAMELY, CREAMS, LOTIONS, GELS, TONERS, CLEANERS AND PEELS; NON-MEDICATED

4,155,301. RETAIL ROYALTY COMPANY, LAS VEGAS, NV. SN 85-267,190. PUB. 7-19-2011, FILED 3-15-2011.

CHEERFUL CHEEKS

THE MARK CONSISTS OF STANDARD CHARACTERS WITHOUT CLAIM TO ANY PARTICULAR FONT, STYLE, SIZE, OR COLOR.

NO CLAIM IS MADE TO THE EXCLUSIVE RIGHT TO USE "CHEEKS", APART FROM THE MARK AS SHOWN.

FOR COSMETICS, NAMELY, BLUSH (U.S. CLS. 1, 4, 6, 50, 51 AND 52).

FIRST USE 10-0-2011; IN COMMERCE 10-0-2011.

4,155,340. TRACIE MARTYN INTERNATIONAL LLC, NEW YORK, NY. SN 85-272,475. PUB. 8-2-2011, FILED 3-21-2011.

ISCULPT

THE MARK CONSISTS OF STANDARD CHARACTERS WITHOUT CLAIM TO ANY PARTICULAR FONT, STYLE, SIZE, OR COLOR.

FOR NON-MEDICATED SKIN CARE PREPARATIONS (U.S. CLS. 1, 4, 6, 50, 51 AND 52).

FIRST USE 3-2-2012; IN COMMERCE 3-2-2012.

CLASS 3—(Continued).

SKIN CREAMS; NON-MEDICATED SKIN CREAMS WITH ESSENTIAL OILS FOR USE IN AROMATHERAPY; NON-MEDICATED STIMULATING LOTIONS FOR THE SKIN; OIL BATHS FOR HAIR CARE; SCENTED BATHING SALTS; SHAMPOO-CONDITIONERS; SHAMPOOS; SHOWER AND BATH FOAM; SHOWER AND BATH GEL; SHOWER GEL; SHOWER GELS; SKIN CARE PREPARATIONS, NAMELY, SKIN PEELS; SKIN CARE PRODUCTS, NAMELY, NON-MEDICATED SKIN SERUM; SKIN CLEANSERS; SKIN CLEANSING CREAM; SKIN CLEANSING LOTION; SKIN CONDITIONERS; SKIN CONDITIONING CREAMS FOR COSMETIC PURPOSES; SKIN CREAM; SKIN CREAMS; SKIN CREAMS IN LIQUID AND IN SOLID FORM; SKIN CREAMS IN LIQUID AND SOLID; SKIN LOTION; SKIN LOTIONS; SKIN MASKS; SKIN MOISTURIZER; SKIN MOISTURIZER MASKS; SKIN MOISTURIZING GEL; SKIN SOAP; SKIN TONERS ALL OF THE FOREGOING GOODS CONSISTING IN WHOLE OR SIGNIFICANT PART OF MINERALS OR OTHER INGREDIENTS FROM THE DEAD SEA (U.S. CLS. 1, 4, 6, 50, 51 AND 52).

FIRST USE 11-23-2011; IN COMMERCE 12-20-2011.

4,155,378. DISPROMEDICA LLC, MIAMI, FL. SN 85-279,210. PUB. 8-9-2011, FILED 3-28-2011.

VITILDERM

THE MARK CONSISTS OF STANDARD CHARACTERS WITHOUT CLAIM TO ANY PARTICULAR FONT, STYLE, SIZE, OR COLOR.

FOR COSMETIC PREPARATIONS FOR BODY CARE (U.S. CLS. 1, 4, 6, 50, 51 AND 52).

FIRST USE 3-15-2012; IN COMMERCE 3-15-2012.

4,155,400. BENEFIT COSMETICS LLC, SAN FRANCISCO, CA. SN 85-282,961. PUB. 9-6-2011, FILED 3-31-2011.

HELLO FLAWLESS OXYGEN WOW

THE MARK CONSISTS OF STANDARD CHARACTERS WITHOUT CLAIM TO ANY PARTICULAR FONT, STYLE, SIZE, OR COLOR.

OWNER OF U.S. REG. NO. 3,652,510.

NO CLAIM IS MADE TO THE EXCLUSIVE RIGHT TO USE "OXYGEN", APART FROM THE MARK AS SHOWN.

FOR COSMETICS; FOUNDATION (U.S. CLS. 1, 4, 6, 50, 51 AND 52).

FIRST USE 11-0-2011; IN COMMERCE 2-0-2012.

CLASS 3—(Continued).

4,155,406. L'OREAL USA CREATIVE, INC., NEW YORK, NY. SN 85-283,435. PUB. 8-9-2011, FILED 4-1-2011.

MASTER SHAPE

THE MARK CONSISTS OF STANDARD CHARACTERS WITHOUT CLAIM TO ANY PARTICULAR FONT, STYLE, SIZE, OR COLOR.

FOR COSMETICS, NAMELY, EYEBROW LINERS AND PENCILS (U.S. CLS. 1, 4, 6, 50, 51 AND 52).

FIRST USE 1-0-2012; IN COMMERCE 1-0-2012.

4,155,477. MINT MCKINLEY LLC, ADA, OK. SN 85-298,180. PUB. 9-13-2011, FILED 4-18-2011.

**Mint McKinley 20,320 Ft.
of Freshness**

THE MARK CONSISTS OF STANDARD CHARACTERS WITHOUT CLAIM TO ANY PARTICULAR FONT, STYLE, SIZE, OR COLOR.

FOR BREATH MINTS FOR USE AS A BREATH FRESHENER (U.S. CLS. 1, 4, 6, 50, 51 AND 52).

FIRST USE 2-1-2011; IN COMMERCE 5-18-2011.

4,155,488. AVON PRODUCTS, INC., NEW YORK, NY. SN 85-299,962. PUB. 8-16-2011, FILED 4-20-2011.



OWNER OF U.S. REG. NOS. 1,982,608, 3,373,763, AND OTHERS.

THE MARK CONSISTS OF A STYLIZED DESIGN OF A MOLECULE MODEL WITH THE STYLIZED WORDING "ANEW GENICS".

FOR EYE CREAM; FACIAL CREAMS (U.S. CLS. 1, 4, 6, 50, 51 AND 52).

FIRST USE 9-1-2011; IN COMMERCE 9-1-2011.

CLASS 3—(Continued).

4,155,490. DECHNER, ITZHAK, OAK PARK, CA. AND DECHNER, DANIEL, OAK PARK, CA. SN 85-300,267. PUB. 9-13-2011, FILED 4-20-2011.

ITAY MINERAL COSMETICS

THE MARK CONSISTS OF STANDARD CHARACTERS WITHOUT CLAIM TO ANY PARTICULAR FONT, STYLE, SIZE, OR COLOR.

NO CLAIM IS MADE TO THE EXCLUSIVE RIGHT TO USE "MINERAL COSMETICS", APART FROM THE MARK AS SHOWN.

FOR COSMETICS AND MAKE-UP; NATURAL MINERAL MAKE-UP (U.S. CLS. 1, 4, 6, 50, 51 AND 52). FIRST USE 3-1-2011; IN COMMERCE 7-1-2011.

4,155,503. TELEBRANDS CORP., FAIRFIELD, NJ. SN 85-305,078. PUB. 10-25-2011, FILED 4-26-2011.

DR. GEORGE'S PLAQUE BLAST

THE MARK CONSISTS OF STANDARD CHARACTERS WITHOUT CLAIM TO ANY PARTICULAR FONT, STYLE, SIZE, OR COLOR.

NO CLAIM IS MADE TO THE EXCLUSIVE RIGHT TO USE "PLAQUE", APART FROM THE MARK AS SHOWN.

THE NAME(S), PORTRAIT(S), AND/OR SIGNATURE(S) SHOWN IN THE MARK IDENTIFIES "GEORGE" MADRAY, WHOSE CONSENT(S) TO REGISTER IS MADE OF RECORD.

FOR NON-MEDIATED PLAQUE REMOVAL SPRAY FOR PETS (U.S. CLS. 1, 4, 6, 50, 51 AND 52).

FIRST USE 5-31-2011; IN COMMERCE 5-31-2011.

4,155,507. LILY ORGANICS, INC, DBA LILY FARM FRESH SKIN CARE, HENDERSON, CO. SN 85-306,385. PUB. 9-13-2011, FILED 4-27-2011.

LILY FARM FRESH

THE MARK CONSISTS OF STANDARD CHARACTERS WITHOUT CLAIM TO ANY PARTICULAR FONT, STYLE, SIZE, OR COLOR.

OWNER OF U.S. REG. NOS. 2,287,469 AND 3,317,402.

SEC. 2(F) AS TO "LILY".

FOR SKIN CARE PREPARATIONS, NAMELY, LOTIONS AND CREAMS FOR THE HANDS, FACE AND BODY, ESSENTIAL OILS FOR PERSONAL USE, LIP MOISTURIZERS, SKIN TONERS, SKIN CLEANERS (U.S. CLS. 1, 4, 6, 50, 51 AND 52).

FIRST USE 2-6-2012; IN COMMERCE 2-6-2012.

CLASS 3—(Continued).

4,155,540. OWEN, LINDA, GOTHA, FL. SN 85-319,619. PUB. 10-4-2011, FILED 5-12-2011.

TAYLOR OWEN

THE MARK CONSISTS OF STANDARD CHARACTERS WITHOUT CLAIM TO ANY PARTICULAR FONT, STYLE, SIZE, OR COLOR.

THE NAME(S), PORTRAIT(S), AND/OR SIGNATURE(S) SHOWN IN THE MARK DOES NOT IDENTIFY A PARTICULAR LIVING INDIVIDUAL.

FOR COSMETICS; MAKE-UP (U.S. CLS. 1, 4, 6, 50, 51 AND 52).

FIRST USE 0-0-2011; IN COMMERCE 0-0-2011.

4,155,555. KYPKE, CAMIE, DBA WILD ABOUT SKIN, ABILENE, TX. SN 85-324,541. PUB. 10-25-2011, FILED 5-19-2011.

WILD ABOUT SKIN

THE MARK CONSISTS OF STANDARD CHARACTERS WITHOUT CLAIM TO ANY PARTICULAR FONT, STYLE, SIZE, OR COLOR.

NO CLAIM IS MADE TO THE EXCLUSIVE RIGHT TO USE "SKIN", APART FROM THE MARK AS SHOWN.

FOR COSMETICS FOR SKIN AND BODY REJUVENATION, NAMELY, LOTIONS FOR SKIN AND BODY, TONERS, BODY SCRUBS, BEAUTY SERUMS, SKIN MOISTURIZERS, FACE AND BODY CREAMS, BODY BALMS, OILS FOR COSMETIC PURPOSES, BODY AND FACE POWDERS, FOUNDATIONS, BEAUTY GELS, BODY BUTTERS, NON-MEDICATED OINTMENT FOR TREATMENT OF SUNBURN, MOISTURIZING SOLUTIONS FOR THE SKIN, BODY AND FACIAL MASKS, BLUSH, EYE SHADOWS, LIP STICK, BODY POLISH, SOAPS, BODY SPRAYS, SHAMPOOS, NAIL CARE PREPARATIONS, CONDITIONER, HAIR MOUSSE, NON-MEDICATED LIP CARE PREPARATIONS, EXFOLIANT CREAMS, BATH SALTS, BUBBLE BATH, OIL BATHS FOR HAIR CARE, LIP GLOSSES, NAIL POLISH REMOVERS, SKIN CLEANSERS, EYE LINERS, LIP LINERS, MASCARA, MAKE-UP MINERAL POWDERS, SKIN BRONZERS, LIP PRIMERS, FACIAL CONCEALERS, EYELASH TINTS, BODY SPRAYS, POMADES, SEALS, FOAMS, COSMETIC SUNSCREEN PREPARATIONS, SUN BLOCK, BODY WASH, HAIR RINSES, NAIL LACQUERS, PRE-MOISTENED COSMETIC TOWELLETTES, COSMETIC PADS, COSMETIC PREPARATIONS FOR SKIN CARE (U.S. CLS. 1, 4, 6, 50, 51 AND 52).

FIRST USE 2-6-2012; IN COMMERCE 2-6-2012.

CLASS 3—(Continued).

4,155,591. STEVEN CAMPS, DBA RKG CAMPS, HUNTINGTON BEACH, CA. SN 85-339,022. PUB. 10-25-2011, FILED 6-6-2011.

GlassBlast

THE MARK CONSISTS OF STANDARD CHARACTERS WITHOUT CLAIM TO ANY PARTICULAR FONT, STYLE, SIZE, OR COLOR.

FOR GLASS GRANULES USED AS ABRASIVES IN BLASTING SERVICES (U.S. CLS. 1, 4, 6, 50, 51 AND 52). FIRST USE 1-17-2012; IN COMMERCE 1-19-2012.

4,155,638. THE CLOROX COMPANY, OAKLAND, CA. SN 85-352,806. PUB. 12-27-2011, FILED 6-22-2011.

TRIPLESOLVE

THE MARK CONSISTS OF STANDARD CHARACTERS WITHOUT CLAIM TO ANY PARTICULAR FONT, STYLE, SIZE, OR COLOR.

FOR LAUNDRY ADDITIVES IN THE NATURE OF STAIN REMOVING PREPARATIONS (U.S. CLS. 1, 4, 6, 50, 51 AND 52).

FIRST USE 12-9-2011; IN COMMERCE 12-9-2011.

4,155,652. VICTORIA'S SECRET STORES BRAND MANAGEMENT, INC., REYNOLDSBURG, OH. SN 85-357,177. PUB. 11-15-2011, FILED 6-27-2011.

INCREDIBLE DARING

THE MARK CONSISTS OF STANDARD CHARACTERS WITHOUT CLAIM TO ANY PARTICULAR FONT, STYLE, SIZE, OR COLOR.

FOR BODY LOTION; BODY WASH; EAU DE PARFUM; NON-MEDICATED SKIN CARE PREPARATION, NAMELY, BODY MIST (U.S. CLS. 1, 4, 6, 50, 51 AND 52). FIRST USE 2-5-2012; IN COMMERCE 2-5-2012.

CLASS 3—(Continued).

4,155,690. TUPPERWARE PRODUCTS S.A., FRIBOURG, SWITZERLAND. SN 85-366,192. PUB. 1-17-2012, FILED 7-8-2011.

BEBE TENDER PLUS+

THE MARK CONSISTS OF STANDARD CHARACTERS WITHOUT CLAIM TO ANY PARTICULAR FONT, STYLE, SIZE, OR COLOR.

NO CLAIM IS MADE TO THE EXCLUSIVE RIGHT TO USE "BEBE", APART FROM THE MARK AS SHOWN.

THE ENGLISH TRANSLATION OF "BEBE" IN THE MARK IS "BABY."

FOR PERFUMERY; SOAPS; TALCUM POWDER; NON-MEDICATED SKIN CARE PREPARATIONS; AND NON-MEDICATED HAIR CARE PREPARATIONS (U.S. CLS. 1, 4, 6, 50, 51 AND 52).

FIRST USE 3-8-2012; IN COMMERCE 3-8-2012.

4,155,704. JAFRA COSMETICS INTERNATIONAL, INC., WESTLAKE VILLAGE, CA. SN 85-370,137. PUB. 12-6-2011, FILED 7-13-2011.

CLARESTA

THE MARK CONSISTS OF STANDARD CHARACTERS WITHOUT CLAIM TO ANY PARTICULAR FONT, STYLE, SIZE, OR COLOR.

FOR FRAGRANCES (U.S. CLS. 1, 4, 6, 50, 51 AND 52). FIRST USE 1-21-2012; IN COMMERCE 1-21-2012.

4,155,712. L'OREAL USA CREATIVE, INC., NEW YORK, NY. SN 85-371,662. PUB. 1-3-2012, FILED 7-14-2011.



OWNER OF U.S. REG. NOS. 3,032,170, 3,670,892, AND OTHERS.

NO CLAIM IS MADE TO THE EXCLUSIVE RIGHT TO USE "NEW YORK CITY", APART FROM THE MARK AS SHOWN.

CLASS 3—(Continued).

THE MARK CONSISTS OF A STYLIZED LETTER "K" INCORPORATING A MORTAR AND PESTLE ELEMENT APPEARING INSIDE A WINGED CIRCLE DESIGN WITH THE WORDS "NEW YORK CITY" APPEARING IN A BANNER UNDERNEATH.
 FOR NON-MEDICATED SKIN CARE PREPARATIONS, LIP BALM, AND FACIAL CLEANSING PREPARATIONS (U.S. CLS. 1, 4, 6, 50, 51 AND 52).
 FIRST USE 4-2-2012; IN COMMERCE 4-2-2012.

4,155,766. VICTORIA'S SECRET STORES BRAND MANAGEMENT, INC., REYNOLDSBURG, OH. SN 85-392,022. PUB. 1-3-2012, FILED 8-8-2011.

VERY SEXY TOUCH

THE MARK CONSISTS OF STANDARD CHARACTERS WITHOUT CLAIM TO ANY PARTICULAR FONT, STYLE, SIZE, OR COLOR.
 OWNER OF U.S. REG. NOS. 2,725,765, 3,480,549, AND OTHERS.
 FOR BODY LOTION; EAU DE PARFUM; NON-MEDICATED SKIN CARE PREPARATION, NAMELY, BODY MIST (U.S. CLS. 1, 4, 6, 50, 51 AND 52).
 FIRST USE 2-10-2012; IN COMMERCE 2-10-2012.

4,155,786. KRAS, AMANDA J., HIGHLANDS, NJ. SN 85-403,187. PUB. 2-7-2012, FILED 8-21-2011.



NO CLAIM IS MADE TO THE EXCLUSIVE RIGHT TO USE "CREME", APART FROM THE MARK AS SHOWN.
 THE MARK CONSISTS OF THE WORDING "SAILORS CREME" IN BLACK WITH THREE BLACK BIRDS FLYING ABOVE THE TEXT.
 FOR NON-MEDICATED SKIN CARE CREAMS AND LOTIONS (U.S. CLS. 1, 4, 6, 50, 51 AND 52).
 FIRST USE 4-3-2012; IN COMMERCE 4-3-2012.

CLASS 3—(Continued).

4,155,802. VICTORIA'S SECRET STORES BRAND MANAGEMENT, INC., REYNOLDSBURG, OH. SN 85-418,402. PUB. 1-3-2012, FILED 9-9-2011.

TRUE ESCAPE

THE MARK CONSISTS OF STANDARD CHARACTERS WITHOUT CLAIM TO ANY PARTICULAR FONT, STYLE, SIZE, OR COLOR.
 FOR BODY CREAM; BODY LOTION; BODY SCRUB; BODY WASH; NON-MEDICATED SKIN CARE PREPARATION, NAMELY, BODY MIST (U.S. CLS. 1, 4, 6, 50, 51 AND 52).
 FIRST USE 2-18-2012; IN COMMERCE 2-18-2012.

4,155,809. AUSTRALIAN GOLD, LLC, INDIANAPOLIS, IN. SN 85-435,085. PUB. 1-3-2012, FILED 9-29-2011.

PEACE, LOVE & CUPCAKES

THE MARK CONSISTS OF STANDARD CHARACTERS WITHOUT CLAIM TO ANY PARTICULAR FONT, STYLE, SIZE, OR COLOR.
 FOR INDOOR AND OUTDOOR NON-MEDICATED SKIN TANNING PREPARATIONS (U.S. CLS. 1, 4, 6, 50, 51 AND 52).
 FIRST USE 11-1-2011; IN COMMERCE 11-1-2011.

4,155,841. L'OREAL USA CREATIVE, INC., NEW YORK, NY. SN 85-976,658. PUB. 1-25-2011, FILED 11-22-2010.

I AM DARK AND LOVELY

THE MARK CONSISTS OF STANDARD CHARACTERS WITHOUT CLAIM TO ANY PARTICULAR FONT, STYLE, SIZE, OR COLOR.
 OWNER OF U.S. REG. NOS. 963,797, 1,393,705, AND 3,262,867.
 FOR HAIR CARE PREPARATIONS AND HAIR RELAXERS (U.S. CLS. 1, 4, 6, 50, 51 AND 52).
 FIRST USE 9-0-2011; IN COMMERCE 9-0-2011.

CLASS 4—LUBRICANTS AND FUELS

CLASS 4—(Continued).

4,154,307. THE COMFORT CANDLE COMPANY, L.C., COMFORT, TX. SN 77-467,541. PUB. 7-19-2011, FILED 5-7-2008.

Comfort Candle Co.

NO CLAIM IS MADE TO THE EXCLUSIVE RIGHT TO USE "CANDLE CO.", APART FROM THE MARK AS SHOWN.

THE MARK CONSISTS OF THE LITERAL ELEMENT "COMFORT CANDLE CO." IN A STYLIZED FONT. FOR CANDLES; SCENTED CANDLES (U.S. CLS. 1, 6 AND 15).

FIRST USE 12-0-2008; IN COMMERCE 12-0-2008.

4,155,133. SUNMARKS, LLC, WILMINGTON, DE. SN 85-250,681. PUB. 7-5-2011, FILED 2-24-2011.

SS 100

THE MARK CONSISTS OF STANDARD CHARACTERS WITHOUT CLAIM TO ANY PARTICULAR FONT, STYLE, SIZE, OR COLOR.

FOR FUELS (U.S. CLS. 1, 6 AND 15).
FIRST USE 4-20-2011; IN COMMERCE 4-20-2011.

4,155,321. SUNMARKS, LLC, WILMINGTON, DE. SN 85-269,314. PUB. 7-5-2011, FILED 3-17-2011.

EXO2

THE MARK CONSISTS OF STANDARD CHARACTERS WITHOUT CLAIM TO ANY PARTICULAR FONT, STYLE, SIZE, OR COLOR.

FOR FUELS (U.S. CLS. 1, 6 AND 15).
FIRST USE 1-18-2011; IN COMMERCE 1-18-2011.

CLASS 5—PHARMACEUTICALS**CLASS 5—(Continued).**

4,154,252. MIRZA, ASMA, PISCATAWAY, NJ. SN 76-705,249. PUB. 7-19-2011, FILED 11-8-2010.

MIZMAAR

THE MARK CONSISTS OF STANDARD CHARACTERS WITHOUT CLAIM TO ANY PARTICULAR FONT, STYLE, SIZE, OR COLOR.

FOR DIETARY AND NUTRITIONAL SUPPLEMENTS FOR PROVIDING AND MAINTAINING HEALTHY HAIR; NUTRITIONAL SUPPLEMENTS FOR MEDICAL USE; NUTRITIONAL ADDITIVES FOR MEDICAL PURPOSES USED IN FOOD PRODUCTS FOR HUMAN CONSUMPTION; NUTRITIONAL ADDITIVES FOR MEDICAL PURPOSES AND DIETARY SUPPLEMENTS FOR HUMAN CONSUMPTION FOR PROVIDING AND MAINTAINING HEALTHY HAIR; DIETARY AND NUTRITIONAL SUPPLEMENTS FOR STIMULATING HAIR GROWTH, AND PREVENTING HAIR LOSS; DIETARY AND NUTRITIONAL SUPPLEMENTS TO PREVENT AND REVERSE GRAYING HAIR (U.S. CLS. 6, 18, 44, 46, 51 AND 52).

FIRST USE 2-16-2012; IN COMMERCE 2-16-2012.

4,154,264. COOPER, FRANK, J., FOUNTAIN VALLEY, CA. SN 76-707,159. PUB. 8-30-2011, FILED 4-8-2011.

SUPERMAX

THE MARK CONSISTS OF STANDARD CHARACTERS WITHOUT CLAIM TO ANY PARTICULAR FONT, STYLE, SIZE, OR COLOR.

FOR MENTHOLATED ANALGESIC SPRAY, MENTHOLATED ANALGESIC CREAM, MENTHOLATED ANALGESIC GEL (U.S. CLS. 6, 18, 44, 46, 51 AND 52).

FIRST USE 1-9-2012; IN COMMERCE 1-9-2012.

4,154,287. APPLIED BIOSYSTEMS, LLC, FOSTER CITY, CA. SN 77-379,613. PUB. 1-20-2009, FILED 1-24-2008.

APPLIED BIOSYSTEMS

THE MARK CONSISTS OF STANDARD CHARACTERS WITHOUT CLAIM TO ANY PARTICULAR FONT, STYLE, SIZE, OR COLOR.

CLASS 5—(Continued).

OWNER OF U.S. REG. NOS. 2,260,626, 2,369,769, AND OTHERS.

FOR DIAGNOSTIC REAGENTS AND KITS COMPRISED OF DIAGNOSTIC REAGENTS FOR CLINICAL OR MEDICAL LABORATORY USE; MEDICAL DIAGNOSTIC REAGENTS AND KITS COMPRISED OF MEDICAL DIAGNOSTIC REAGENTS; CLINICAL MEDICAL REAGENTS AND KITS COMPRISED OF CLINICAL MEDICAL REAGENTS (U.S. CLS. 6, 18, 44, 46, 51 AND 52).

FIRST USE 7-1-2011; IN COMMERCE 7-1-2011.

4,154,311. HEB GROCERY COMPANY, LP, SAN ANTONIO, TX. SN 77-490,701. PUB. 5-19-2009, FILED 6-4-2008.

HILL COUNTRY ESSENTIALS

THE MARK CONSISTS OF STANDARD CHARACTERS WITHOUT CLAIM TO ANY PARTICULAR FONT, STYLE, SIZE, OR COLOR.

OWNER OF U.S. REG. NOS. 2,151,066, 2,890,694, AND OTHERS.

FOR ACNE TREATMENT PREPARATIONS, NAMELY, LOTIONS, CREAMS AND TONERS, ANTI-CAVITY DENTAL COATING PREPARATIONS CONTAINING FLUORIDE (U.S. CLS. 6, 18, 44, 46, 51 AND 52).

FIRST USE 8-5-2008; IN COMMERCE 8-5-2008.

4,154,326. PHARMATHENE, INC., ANNAPOLIS, MD. SN 77-528,587. PUB. 1-20-2009, FILED 7-22-2008.

SPARVAX

THE MARK CONSISTS OF STANDARD CHARACTERS WITHOUT CLAIM TO ANY PARTICULAR FONT, STYLE, SIZE, OR COLOR.

FOR PHARMACEUTICAL PREPARATIONS FOR TREATMENT AND PREVENTION OF INFECTIOUS DISEASE; PHARMACEUTICAL PREPARATIONS FOR TREATMENT AND PREVENTION OF ANTHRAX; VACCINES FOR TREATMENT AND PREVENTION OF INFECTIOUS DISEASE; VACCINES FOR TREATMENT AND PREVENTION OF ANTHRAX; PHARMACEUTICAL PREPARATIONS FOR COUNTERACTING, DETERING, OR AS A DEFENSE AGAINST BIOLOGICAL OR CHEMICAL WEAPONS (U.S. CLS. 6, 18, 44, 46, 51 AND 52).

FIRST USE 2-21-2012; IN COMMERCE 2-21-2012.

CLASS 5—(Continued).

4,154,336. FMC CORPORATION, DBA FMC CORPORATION, PHILADELPHIA, PA. SN 77-543,844. PUB. 12-30-2008, FILED 8-11-2008.

ZEUS

THE MARK CONSISTS OF STANDARD CHARACTERS WITHOUT CLAIM TO ANY PARTICULAR FONT, STYLE, SIZE, OR COLOR.

FOR PREPARATIONS FOR THE DESTRUCTION OF VERMIN AND WEEDS, PESTICIDES, HERBICIDES, AND FUNGICIDES (U.S. CLS. 6, 18, 44, 46, 51 AND 52).

FIRST USE 2-16-2012; IN COMMERCE 2-16-2012.

4,154,350. ELI LILLY AND COMPANY, INDIANAPOLIS, IN. SN 77-560,292. PUB. 1-13-2009, FILED 9-2-2008.

HYGROMIX

THE MARK CONSISTS OF STANDARD CHARACTERS WITHOUT CLAIM TO ANY PARTICULAR FONT, STYLE, SIZE, OR COLOR.

FOR ANTIBIOTIC ANTHELMINTIC USED TO CONTROL AND ELIMINATE WORMS IN SWINE AND POULTRY (U.S. CLS. 6, 18, 44, 46, 51 AND 52).

FIRST USE 3-21-2012; IN COMMERCE 3-21-2012.

4,154,366. ELI LILLY AND COMPANY, INDIANAPOLIS, IN. SN 77-601,955. PUB. 2-10-2009, FILED 10-28-2008.

ZYPREXA RELPREVV

THE MARK CONSISTS OF STANDARD CHARACTERS WITHOUT CLAIM TO ANY PARTICULAR FONT, STYLE, SIZE, OR COLOR.

OWNER OF U.S. REG. NO. 2,072,867.

THE MARK HAS NO MEANING IN A FOREIGN LANGUAGE.

FOR PHARMACEUTICAL PREPARATIONS, NAMELY, ANTIPSYCHOTICS (U.S. CLS. 6, 18, 44, 46, 51 AND 52).

FIRST USE 3-30-2010; IN COMMERCE 3-30-2010.

CLASS 5—(Continued).

4,154,415. REPUBLIC OF TEA, INC., THE, NOVATO, CA. SN 77-715,341. PUB. 2-2-2010, FILED 4-16-2009.

GET HYDRATED

THE MARK CONSISTS OF STANDARD CHARACTERS WITHOUT CLAIM TO ANY PARTICULAR FONT, STYLE, SIZE, OR COLOR.

OWNER OF U.S. REG. NOS. 3,596,054, 3,596,056, AND OTHERS.

FOR HERB TEAS FOR MEDICINAL PURPOSES (U.S. CLS. 6, 18, 44, 46, 51 AND 52).

FIRST USE 4-2-2012; IN COMMERCE 4-2-2012.

4,154,477. BALCHEM CORPORATION, NEW HAMPTON, NY. SN 77-838,560. PUB. 1-19-2010, FILED 9-30-2009.

VITACHOLINE

THE MARK CONSISTS OF STANDARD CHARACTERS WITHOUT CLAIM TO ANY PARTICULAR FONT, STYLE, SIZE, OR COLOR.

FOR CHOLINE AS AN ESSENTIAL NUTRIENT FOR USE IN FOODS AND NUTRIENT SUPPLEMENTS (U.S. CLS. 6, 18, 44, 46, 51 AND 52).

FIRST USE 3-31-2012; IN COMMERCE 3-31-2012.

4,154,566. GASPARI NUTRITION, INC., LAKEWOOD, NJ. SN 77-966,493. PUB. 3-8-2011, FILED 3-23-2010.

VASOTROPIN

THE MARK CONSISTS OF STANDARD CHARACTERS WITHOUT CLAIM TO ANY PARTICULAR FONT, STYLE, SIZE, OR COLOR.

FOR DIETARY AND NUTRITIONAL SUPPLEMENTS (U.S. CLS. 6, 18, 44, 46, 51 AND 52).

FIRST USE 1-15-2012; IN COMMERCE 1-15-2012.

CLASS 5—(Continued).

4,154,570. VALENT U.S.A. CORPORATION, WALNUT CREEK, CA. SN 77-967,609. PUB. 6-22-2010, FILED 3-24-2010.

FIERCE

THE MARK CONSISTS OF STANDARD CHARACTERS WITHOUT CLAIM TO ANY PARTICULAR FONT, STYLE, SIZE, OR COLOR.

FOR HERBICIDE (U.S. CLS. 6, 18, 44, 46, 51 AND 52). FIRST USE 3-26-2012; IN COMMERCE 3-26-2012.

4,154,619. JOHNSON & JOHNSON, NEW BRUNSWICK, NJ. SN 85-006,949. PUB. 2-22-2011, FILED 4-6-2010.



NO CLAIM IS MADE TO THE EXCLUSIVE RIGHT TO USE "HEALTH INFO", APART FROM THE MARK AS SHOWN.

THE MARK CONSISTS OF THE STYLIZED WORD "HI!" INSIDE A CARTOON-STYLE SPEECH BALLOON WITH THE STYLIZED WORDS "HEALTH INFO!" FOLLOWING IT. FOR PHARMACEUTICAL PREPARATIONS, NAMELY, ANALGESICS (U.S. CLS. 6, 18, 44, 46, 51 AND 52).

FIRST USE 8-22-2011; IN COMMERCE 8-22-2011.

4,154,620. JOHNSON & JOHNSON, NEW BRUNSWICK, NJ. SN 85-006,951. PUB. 2-22-2011, FILED 4-6-2010.



NO CLAIM IS MADE TO THE EXCLUSIVE RIGHT TO USE "HEALTH INFO", APART FROM THE MARK AS SHOWN.

THE COLOR(S) RED AND WHITE IS/ARE CLAIMED AS A FEATURE OF THE MARK.

CLASS 5—(Continued).

THE MARK CONSISTS OF THE STYLIZED WORD "HI!" IN WHITE INSIDE A RED CARTOON-STYLE SPEECH BALLOON WITH THE STYLIZED WORDS "HEALTH INFO!" IN RED FOLLOWING IT.

FOR ANALGESICS (U.S. CLS. 6, 18, 44, 46, 51 AND 52).
FIRST USE 8-22-2011; IN COMMERCE 8-22-2011.

4,154,635. GE HEALTHCARE LIMITED, BUCKINGHAMSHIRE, UNITED KINGDOM. SN 85-029,347. PUB. 10-5-2010, FILED 5-4-2010.

DATSCAN

THE MARK CONSISTS OF STANDARD CHARACTERS WITHOUT CLAIM TO ANY PARTICULAR FONT, STYLE, SIZE, OR COLOR.

FOR CONTRAST MEDIA FOR USE WITH IMAGING MEDICAL EQUIPMENT; DIAGNOSTIC PREPARATIONS FOR MEDICAL PURPOSES (U.S. CLS. 6, 18, 44, 46, 51 AND 52).

FIRST USE 6-28-2011; IN COMMERCE 6-28-2011.

4,154,637. MEDLINE INDUSTRIES, INC., CHICAGO, IL. SN 85-032,188. PUB. 9-21-2010, FILED 5-6-2010.



OWNER OF U.S. REG. NOS. 1,471,161, 1,762,357, AND 2,925,125.

THE MARK CONSISTS OF THE WORDS "PROTECTION PLUS CLASSIC" IN STYLIZED FONT, A DESIGN OF A TEAR DROP WITH A CROSS LOCATED IN THE CENTER OF THE TEAR DROP, THE TEAR DROP DESIGN LOCATED BETWEEN THE WORDS "PROTECTION" AND "PLUS", AND A RECTANGULAR SHAPE DESIGN LOCATED HORIZONTALLY BELOW THE WORDS "PROTECTION PLUS" AND THE WORD "CLASSIC" LOCATED WITHIN THE RECTANGULAR DESIGN.

FOR DISPOSABLE ABSORBENT PRODUCTS, NAMELY, PROTECTIVE INCONTINENCE UNDERWEAR (U.S. CLS. 6, 18, 44, 46, 51 AND 52).

FIRST USE 4-30-2010; IN COMMERCE 4-30-2010.

CLASS 5—(Continued).

4,154,638. SHAKLEE CORPORATION, PLEASANTON, CA. SN 85-035,898. PUB. 5-10-2011, FILED 5-11-2010.

VITA-D₃

THE MARK CONSISTS OF THE TERM "VITA-D3" WITH THE "3" BEING IN SUBSCRIPT.

FOR DIETARY AND NUTRITIONAL SUPPLEMENTS CONTAINING VITAMIN D (U.S. CLS. 6, 18, 44, 46, 51 AND 52).

FIRST USE 8-1-2010; IN COMMERCE 8-1-2010.

4,154,647. PHOENIX ENVIRONMENTAL CARE, LLC, VALDOSTA, GA. SN 85-053,064. PUB. 4-26-2011, FILED 6-2-2010.

MERLIN

THE MARK CONSISTS OF STANDARD CHARACTERS WITHOUT CLAIM TO ANY PARTICULAR FONT, STYLE, SIZE, OR COLOR.

FOR PESTICIDES, NAMELY, AN INSECTICIDE FOR USE IN THE TURF, NURSERY AND ORNAMENTAL MARKETS (U.S. CLS. 6, 18, 44, 46, 51 AND 52).

FIRST USE 7-1-2010; IN COMMERCE 7-1-2010.

4,154,682. SOMMERS, ALLISON, PALMETTO BAY, FL. SN 85-086,105. PUB. 8-2-2011, FILED 7-16-2010.

FREEZE

THE MARK CONSISTS OF STANDARD CHARACTERS WITHOUT CLAIM TO ANY PARTICULAR FONT, STYLE, SIZE, OR COLOR.

FOR BOTULINUM TOXIN FOR MEDICAL USE FOR USE IN THE TREATMENT OF EXCESSIVE SWEATING, EXCESSIVE EYE BLINKING, NEUROPATHY PAIN, AND MUSCULAR CRAMPS AND SPASMS, AND FOR USE IN THE PARALYSIS OR WEAKENING OF MUSCLES (U.S. CLS. 6, 18, 44, 46, 51 AND 52).

FIRST USE 3-13-2012; IN COMMERCE 3-13-2012.

CLASS 5—(Continued).

4,154,689. WINN, ROBERT T., DBA TEXAS CREEK FARMS, BIG SANDY, TX. SN 85-092,229. PUB. 2-8-2011, FILED 7-24-2010.

Range Buster

THE MARK CONSISTS OF STANDARD CHARACTERS WITHOUT CLAIM TO ANY PARTICULAR FONT, STYLE, SIZE, OR COLOR.

NO CLAIM IS MADE TO THE EXCLUSIVE RIGHT TO USE "RANGE", APART FROM THE MARK AS SHOWN.

FOR ANIMAL FEED SUPPLEMENTS (U.S. CLS. 6, 18, 44, 46, 51 AND 52).

FIRST USE 7-24-2010; IN COMMERCE 7-24-2010.

4,154,718. MERIDIAN MEDICAL TECHNOLOGIES, INC., COLUMBIA, MD. SN 85-104,183. PUB. 1-25-2011, FILED 8-10-2010.



THE MARK CONSISTS OF THE WORD "ALSUMA" CENTERED BETWEEN A SQUARE DESIGN AND AN ARROW DESIGN.

FOR PHARMACEUTICAL PREPARATIONS FOR THE PREVENTION, TREATMENT AND ALLEVIATION OF MIGRAINES AND OTHER FORMS OF HEADACHES; AUTOINJECTORS SOLD FILLED WITH PHARMACEUTICAL PREPARATIONS FOR THE PREVENTION, TREATMENT AND ALLEVIATION OF MIGRAINES AND OTHER FORMS OF HEADACHES, AND PLASTIC CONTAINERS AND CARRYING CASES, SOLD AS A UNIT THEREFOR (U.S. CLS. 6, 18, 44, 46, 51 AND 52).

FIRST USE 2-28-2011; IN COMMERCE 2-28-2011.

4,154,820. M&S CRENEAU, INC., PALM BEACH GARDENS, FL. SN 85-140,906. PUB. 3-8-2011, FILED 9-29-2010.

OPT 2 THRIVE

THE MARK CONSISTS OF STANDARD CHARACTERS WITHOUT CLAIM TO ANY PARTICULAR FONT, STYLE, SIZE, OR COLOR.

FOR DIETARY AND NUTRITIONAL SUPPLEMENTS (U.S. CLS. 6, 18, 44, 46, 51 AND 52).

FIRST USE 9-29-2010; IN COMMERCE 2-19-2012.

CLASS 5—(Continued).

4,154,823. WYETH LLC, MADISON, NJ. SN 85-142,851. PUB. 1-25-2011, FILED 10-1-2010.

MINSETA

THE MARK CONSISTS OF STANDARD CHARACTERS WITHOUT CLAIM TO ANY PARTICULAR FONT, STYLE, SIZE, OR COLOR.

FOR PHARMACEUTICAL PREPARATIONS FOR THE TREATMENT OF THE CENTRAL NERVOUS SYSTEM (U.S. CLS. 6, 18, 44, 46, 51 AND 52).

FIRST USE 1-25-2012; IN COMMERCE 1-25-2012.

4,154,829. AMERICAN SKIN LABS, INC., DELRAY BEACH, FL. SN 85-145,404. PUB. 3-22-2011, FILED 10-5-2010.

TRULY CLEAR

THE MARK CONSISTS OF STANDARD CHARACTERS WITHOUT CLAIM TO ANY PARTICULAR FONT, STYLE, SIZE, OR COLOR.

NO CLAIM IS MADE TO THE EXCLUSIVE RIGHT TO USE "CLEAR", APART FROM THE MARK AS SHOWN.

FOR ACNE MEDICATIONS; ACNE TREATMENT PREPARATIONS; FACE CREAMS AND CLEANSERS CONTAINING BENZOYL PEROXIDE FOR MEDICAL PURPOSES, NAMELY, THE TREATMENT OF ACNE (U.S. CLS. 6, 18, 44, 46, 51 AND 52).

FIRST USE 10-1-2010; IN COMMERCE 11-1-2010.

4,154,830. BISCO, INC., SCHAUMBURG, IL. SN 85-145,428. PUB. 3-1-2011, FILED 10-5-2010.

THERACAL LC

THE MARK CONSISTS OF STANDARD CHARACTERS WITHOUT CLAIM TO ANY PARTICULAR FONT, STYLE, SIZE, OR COLOR.

NO CLAIM IS MADE TO THE EXCLUSIVE RIGHT TO USE "LC", APART FROM THE MARK AS SHOWN.

FOR DENTAL MATERIALS, NAMELY, A DENTAL PULP CAPPING AND LINING MATERIAL (U.S. CLS. 6, 18, 44, 46, 51 AND 52).

FIRST USE 12-2-2011; IN COMMERCE 12-2-2011.

CLASS 5—(Continued).

4,154,885. FRANKLIN T.Y. NG, BROOKLYN, NY. SN 85-175,580. PUB. 6-7-2011, FILED 11-12-2010.



THE MARK CONSISTS OF THE WORDING "KIJANI" AND A LOGO OF A CIRCLE TO ITS LEFT. THERE ARE THREE LEAVES IN THE UPPER PART OF THE CIRCLE AND THREE CARTOON HUMAN FIGURES BENEATH THESE LEAVES.

THE ENGLISH TRANSLATION OF "KIJANI" IN THE MARK IS "BABY NAME", "GREEN" OR "A SINGLE LEAF". FOR DIETARY FOOD SUPPLEMENTS, MEDICINAL HERBS AND HERBAL TEA FOR MEDICINAL PURPOSES (U.S. CLS. 6, 18, 44, 46, 51 AND 52).

FIRST USE 12-1-2011; IN COMMERCE 12-1-2011.

CLASS 5—(Continued).

4,154,972. ORIONS THREE KINGS, UNION, NJ. SN 85-214,296. PUB. 5-3-2011, FILED 1-10-2011.



THE MARK CONSISTS OF THREE KINGS HOLDING HERBS IN THEIR HANDS. THERE IS ALSO A CROWN WITH THE STYLIZED TEXT "JOLLY 3 KINGS".

FOR HERBAL SUPPLEMENTS (U.S. CLS. 6, 18, 44, 46, 51 AND 52).

FIRST USE 6-15-2011; IN COMMERCE 6-15-2011.

4,154,914. WINDMILL HEALTH PRODUCTS, LLC, W. CALDWELL, NJ. SN 85-193,113. PUB. 5-10-2011, FILED 12-8-2010.

CARBFIGHTER

THE MARK CONSISTS OF STANDARD CHARACTERS WITHOUT CLAIM TO ANY PARTICULAR FONT, STYLE, SIZE, OR COLOR.

FOR DIETARY AND NUTRITIONAL SUPPLEMENTS IN BAR FORM (U.S. CLS. 6, 18, 44, 46, 51 AND 52).

FIRST USE 10-22-2001; IN COMMERCE 10-22-2001.

4,154,993. SARAH GRACE LLC, MOUNT HOREB, WI. SN 85-221,086. PUB. 5-31-2011, FILED 1-19-2011.

RIVETING

THE MARK CONSISTS OF STANDARD CHARACTERS WITHOUT CLAIM TO ANY PARTICULAR FONT, STYLE, SIZE, OR COLOR.

FOR MEDICATED MOISTURIZERS (U.S. CLS. 6, 18, 44, 46, 51 AND 52).

FIRST USE 8-12-2011; IN COMMERCE 8-12-2011.

4,154,915. CELSIUS PROPERTY B.V. AMSTERDAM (NL), 8200 SCHAFFHAUSEN, SWITZERLAND. SN 85-193,193. PUB. 4-26-2011, FILED 12-8-2010.

INCOGNITO

THE MARK CONSISTS OF STANDARD CHARACTERS WITHOUT CLAIM TO ANY PARTICULAR FONT, STYLE, SIZE, OR COLOR.

FOR PESTICIDES, FUNGICIDES, INSECTICIDES AND HERBICIDES (U.S. CLS. 6, 18, 44, 46, 51 AND 52).

FIRST USE 6-16-2011; IN COMMERCE 6-16-2011.

4,155,002. VALL LABORATORIES CONSORTIUM GROUP LLC, MIAMI, FL. SN 85-226,265. PUB. 9-27-2011, FILED 1-26-2011.



THE COLOR(S) RED, BLUE AND WHITE IS/ARE CLAIMED AS A FEATURE OF THE MARK.

CLASS 5—(Continued).

THE MARK CONSISTS OF THE WORD "HEPALIVE FORTE" IN A RECTANGLE WHITE, THE LETTERS "HEPA" IN RED, FOLLOWED BY THE LETTERS "LIVE" IN BLUE UNDERLINED ALL OF THE WORD "HEPALIVE" WITH A RED LINE, ON THE RIGHT HAND SIDE CORNER AT THE BOTTOM THE WORD "FORTE" IN WHITE WITH A BACKGROUND IN RED AND NEXT TO THIS WORD SEVERAL WHITE LINES.

FOR NATURAL FOOD SUPPLEMENTS IN THE NATURE OF HERBAL AND BOTANICAL SUPPLEMENTS FOR HUMAN CONSUMPTION; MEDICINAL HERBAL AND BOTANICAL PREPARATIONS IN THE NATURE OF MEDICINES FOR HUMAN CONSUMPTION (U.S. CLS. 6, 18, 44, 46, 51 AND 52).

FIRST USE 1-1-2009; IN COMMERCE 1-1-2011.

4,155,003. VALL LABORATORIES CONSORTIUM GROUP LLC, MIAMI, FL. SN 85-226,273. PUB. 10-4-2011, FILED 1-26-2011.



THE COLOR(S) GREEN, WHITE AND BLUE IS/ARE CLAIMED AS A FEATURE OF THE MARK.

THE MARK CONSISTS OF WORD "INMUNOLIVE" WHICH IS IN A RECTANGLE WITH A WHITE BACKGROUND. THE LETTERS "INMUNO" ARE IN GREEN FOLLOWED BY THE LETTERS "LIVE" IN WHITE. BEHIND THE LETTERS "LIVE" ARE TWO BLUE CIRCLES OF DIFFERENT SIZES.

FOR NATURAL FOOD SUPPLEMENTS, NATURAL MEDICINAL HERBAL AND BOTANICAL PREPARATIONS IN THE NATURE OF MEDICINES FOR HUMAN CONSUMPTION, AND VITAMINS (U.S. CLS. 6, 18, 44, 46, 51 AND 52).

FIRST USE 1-1-2009; IN COMMERCE 10-1-2011.

4,155,036. RE-BODY, LLC, TAMPA, FL. SN 85-235,617. PUB. 6-14-2011, FILED 2-7-2011.

SAFSLIM

THE MARK CONSISTS OF STANDARD CHARACTERS WITHOUT CLAIM TO ANY PARTICULAR FONT, STYLE, SIZE, OR COLOR.

FOR DIETARY SUPPLEMENTS FOR WEIGHT-LOSS CONTAINING AS A PRIMARY INGREDIENT SAFFLOWER OIL, EXCLUDING POWDERED DRINK MIXES, SHAKES, READY-TO-DRINK BEVERAGES, AND NUTRITIONAL BARS (U.S. CLS. 6, 18, 44, 46, 51 AND 52).

FIRST USE 2-22-2011; IN COMMERCE 2-22-2011.

CLASS 5—(Continued).

4,155,173. PHYSICIAN'S SCIENCE & NATURE, INC., NEWPORT BEACH, CA. SN 85-253,959. PUB. 7-26-2011, FILED 2-28-2011.



THE COLOR(S) YELLOW, BROWN, GREEN AND BEIGE IS/ARE CLAIMED AS A FEATURE OF THE MARK.

THE MARK CONSISTS OF A YELLOW SUNFLOWER WITH BROWN CENTER TO THE RIGHT OF A GREEN LEAF, AND BELOW A MARBLE BEIGE MORTAR AND PESTLE, ALL ON A GRANITE BROWN BACKGROUND.

FOR DIETARY AND NUTRITIONAL SUPPLEMENTS; LAXATIVES; TOPICAL ANTIBIOTIC, ANALGESIC, SKIN PROTECTANT AND WOUND CARE PREPARATIONS (U.S. CLS. 6, 18, 44, 46, 51 AND 52).

FIRST USE 10-31-2006; IN COMMERCE 1-30-2007.

4,155,193. QUALITY OF LIFE LABORATORIES, INC., PURCHASE, NY. SN 85-255,414. PUB. 7-19-2011, FILED 3-2-2011.

PEPTISOL

THE MARK CONSISTS OF STANDARD CHARACTERS WITHOUT CLAIM TO ANY PARTICULAR FONT, STYLE, SIZE, OR COLOR.

FOR DIETARY AND NUTRITIONAL SUPPLEMENTS (U.S. CLS. 6, 18, 44, 46, 51 AND 52).

FIRST USE 3-9-2012; IN COMMERCE 3-9-2012.

4,155,194. CHEMTURA CORPORATION, MIDDLEBURY, CT. SN 85-255,448. PUB. 7-19-2011, FILED 3-2-2011.

VIGILANT

THE MARK CONSISTS OF STANDARD CHARACTERS WITHOUT CLAIM TO ANY PARTICULAR FONT, STYLE, SIZE, OR COLOR.

CLASS 5—(Continued).

OWNER OF U.S. REG. NO. 1,364,123.
 FOR ACARACIDES AND MITICIDES FOR AGRICULTURAL USE (U.S. CLS. 6, 18, 44, 46, 51 AND 52).
 FIRST USE 5-31-2011; IN COMMERCE 5-31-2011.

4,155,302. HEALTH EVER BIO-TECH CO., LTD., TAIPEI, TAIWAN. SN 85-267,219. PUB. 7-26-2011, FILED 3-15-2011.

MUSPhyto

THE MARK CONSISTS OF STANDARD CHARACTERS WITHOUT CLAIM TO ANY PARTICULAR FONT, STYLE, SIZE, OR COLOR.
 OWNER OF U.S. REG. NO. 3,659,202.
 FOR DIETARY AND NUTRITIONAL SUPPLEMENTS (U.S. CLS. 6, 18, 44, 46, 51 AND 52).
 FIRST USE 3-1-2012; IN COMMERCE 3-1-2012.

4,155,383. GUTHY-RENKER LLC, PALM DESERT, CA. SN 85-279,748. PUB. 10-25-2011, FILED 3-29-2011.

SHEER COVER

THE MARK CONSISTS OF STANDARD CHARACTERS WITHOUT CLAIM TO ANY PARTICULAR FONT, STYLE, SIZE, OR COLOR.
 OWNER OF U.S. REG. NOS. 2,729,563 AND 2,823,868.
 FOR PHARMACEUTICAL PREPARATIONS, NAMELY, VITAMINS, MINERAL SUPPLEMENTS, DIETARY SUPPLEMENTS, NUTRITIONAL SUPPLEMENTS (U.S. CLS. 6, 18, 44, 46, 51 AND 52).
 FIRST USE 1-20-2008; IN COMMERCE 1-20-2008.

4,155,425. SEMPRAE LABORATORIES, INC., SADDLE BROOK, NJ. SN 85-284,911. PUB. 8-16-2011, FILED 4-4-2011.

ZESTRA BLISS

THE MARK CONSISTS OF STANDARD CHARACTERS WITHOUT CLAIM TO ANY PARTICULAR FONT, STYLE, SIZE, OR COLOR.

CLASS 5—(Continued).

OWNER OF U.S. REG. NOS. 3,019,637, 3,222,491, AND 3,741,842.
 FOR NON-PRESCRIPTION HERBAL SEXUAL AID, NAMELY, GELS FOR USE AS A PERSONAL LUBRICANT (U.S. CLS. 6, 18, 44, 46, 51 AND 52).
 FIRST USE 5-12-2011; IN COMMERCE 5-12-2011.

4,155,436. THE PROCTER & GAMBLE COMPANY, CINCINNATI, OH. SN 85-286,755. PUB. 9-13-2011, FILED 4-5-2011.

ALWAYS ULTRA THIN SLENDER

THE MARK CONSISTS OF STANDARD CHARACTERS WITHOUT CLAIM TO ANY PARTICULAR FONT, STYLE, SIZE, OR COLOR.
 OWNER OF U.S. REG. NOS. 1,601,853, 2,470,616, AND 3,538,549.
 NO CLAIM IS MADE TO THE EXCLUSIVE RIGHT TO USE "ULTRA THIN", APART FROM THE MARK AS SHOWN.
 FOR CATAMENIAL PRODUCTS, NAMELY, MAXI PADS, MINI PADS AND PANTILINERS (U.S. CLS. 6, 18, 44, 46, 51 AND 52).
 FIRST USE 7-31-2011; IN COMMERCE 7-31-2011.

4,155,464. SHAKLEE CORPORATION, PLEASANTON, CA. SN 85-295,111. PUB. 8-30-2011, FILED 4-14-2011.

SLOW AGING AT THE CELLULAR LEVEL

THE MARK CONSISTS OF STANDARD CHARACTERS WITHOUT CLAIM TO ANY PARTICULAR FONT, STYLE, SIZE, OR COLOR.
 FOR DIETARY AND NUTRITIONAL SUPPLEMENTS (U.S. CLS. 6, 18, 44, 46, 51 AND 52).
 FIRST USE 8-1-2011; IN COMMERCE 8-1-2011.

4,155,465. FREEMAN, JERAMY K., EAST SYRACUSE, NY. SN 85-295,615. PUB. 8-23-2011, FILED 4-14-2011.

UPGRADE

THE MARK CONSISTS OF STANDARD CHARACTERS WITHOUT CLAIM TO ANY PARTICULAR FONT, STYLE, SIZE, OR COLOR.
 FOR DIETARY AND NUTRITIONAL SUPPLEMENTS (U.S. CLS. 6, 18, 44, 46, 51 AND 52).
 FIRST USE 1-0-2011; IN COMMERCE 1-0-2011.

CLASS 5—(Continued).

4,155,541. S.H.E. 4.LIFE, LLC, MARION, IN. SN 85-319,728.
PUB. 10-4-2011, FILED 5-12-2011.



THE MARK CONSISTS OF THE WORDS/TERMS "SHE" AND "4LIFE" WITH A RIBBON DEPICTED THEREBETWEEN, AND THE WORDS "SURVIVE" "HOPE", AND "EMPOWER" WRITTEN BENEATH.

FOR AIR FRESHENERS (U.S. CLS. 6, 18, 44, 46, 51 AND 52).

FIRST USE 10-31-2011; IN COMMERCE 10-31-2011.

4,155,566. MISSION PRODUCT HOLDINGS, INC., NEW YORK, NY. SN 85-328,871. PUB. 11-8-2011, FILED 5-24-2011.

BLISTER ARMOUR

THE MARK CONSISTS OF STANDARD CHARACTERS WITHOUT CLAIM TO ANY PARTICULAR FONT, STYLE, SIZE, OR COLOR.

NO CLAIM IS MADE TO THE EXCLUSIVE RIGHT TO USE "BLISTER", APART FROM THE MARK AS SHOWN.

FOR MEDICATED PREPARATIONS FOR THE PROTECTION OF SKIN AGAINST PRESSURE AND FRICTION FOR PREVENTION OF BLISTERS AND CALLUSES (U.S. CLS. 6, 18, 44, 46, 51 AND 52).

FIRST USE 9-9-2011; IN COMMERCE 9-9-2011.

4,155,595. LOUD TRUCK EFG, LLC, SPOKANE, WA. SN 85-340,016. PUB. 12-27-2011, FILED 6-7-2011.



NO CLAIM IS MADE TO THE EXCLUSIVE RIGHT TO USE "ENERGY GUMMI BEARS", APART FROM THE MARK AS SHOWN.

CLASS 5—(Continued).

THE MARK CONSISTS OF A GUMMI BEAR WITH A LIGHTNING BOLT ON ITS FOREHEAD WITH STYLIZED TEXT "ENERGY GUMMI BEARS" DIRECTLY BELOW THE HEAD COVERING PART OF THE GUMMI BEAR BODY.

FOR DIETARY FOOD SUPPLEMENTS; VITAMINS (U.S. CLS. 6, 18, 44, 46, 51 AND 52).

FIRST USE 3-15-2011; IN COMMERCE 3-15-2011.

4,155,607. QUINNOVA PHARMACEUTICALS, INC., JAMISON, PA. SN 85-345,469. PUB. 1-3-2012, FILED 6-14-2011.

ATRAPRO

THE MARK CONSISTS OF STANDARD CHARACTERS WITHOUT CLAIM TO ANY PARTICULAR FONT, STYLE, SIZE, OR COLOR.

FOR DERMATOLOGICAL PHARMACEUTICAL PRODUCTS; PHARMACEUTICAL PREPARATIONS FOR TREATING SKIN DISORDERS; PHARMACEUTICAL PREPARATIONS FOR USE IN DERMATOLOGY (U.S. CLS. 6, 18, 44, 46, 51 AND 52).

FIRST USE 1-30-2012; IN COMMERCE 1-30-2012.

4,155,628. LEKITHOS, INC., PALM BEACH GARDENS, FL. SN 85-349,609. PUB. 1-10-2012, FILED 6-17-2011.

LEKITHOS

THE MARK CONSISTS OF STANDARD CHARACTERS WITHOUT CLAIM TO ANY PARTICULAR FONT, STYLE, SIZE, OR COLOR.

THE ENGLISH TRANSLATION OF "LEKITHOS" IN THE MARK IS "YOLK".

FOR DIETARY SUPPLEMENTS (U.S. CLS. 6, 18, 44, 46, 51 AND 52).

FIRST USE 12-1-2011; IN COMMERCE 12-1-2011.

CLASS 5—(Continued).

4,155,725. RETTIG, HEIDI K., WINCHESTER, VA. SN 85-376,139. PUB. 12-13-2011, FILED 7-20-2011.

THE ANTIDOTE FOR EGO

THE MARK CONSISTS OF STANDARD CHARACTERS WITHOUT CLAIM TO ANY PARTICULAR FONT, STYLE, SIZE, OR COLOR.

FOR AROMATHERAPY CREAMS FOR RELAXATION AND RELIEVING STRESS; AROMATHERAPY OILS, OTHER THAN ESSENTIAL OILS, FOR TREATING ANXIETY; AROMATHERAPY SPRAYS FOR RELAXATION AND RELIEVING STRESS (U.S. CLS. 6, 18, 44, 46, 51 AND 52).

FIRST USE 11-0-2011; IN COMMERCE 11-0-2011.

4,155,794. GEAR DOG LLC, KENNESAW, GA. SN 85-408,988. PUB. 1-24-2012, FILED 8-27-2011.



NO CLAIM IS MADE TO THE EXCLUSIVE RIGHT TO USE "GEAR", APART FROM THE MARK AS SHOWN.

THE COLOR(S) BLUE, YELLOW AND BLACK IS/ARE CLAIMED AS A FEATURE OF THE MARK.

THE MARK CONSISTS OF THE WORD "GEAR" STACKED ON TOP OF THE WORD "DOG" IN ALL CAPITAL LETTERS, USING IMPACT FONT. THE WORDS "GEAR" AND "DOG" ARE BLUE TO BLACK IN VERTICAL GRADIENT. THE WORDS "PLAY LIKE A DOG, DON'T SMELL LIKE ONE", IN BLACK COLOR AND IMPACT FONT IS A TAG LINE AND IS BELOW THE STACKED WORDS "GEAR" AND "DOG". A UNIQUE AND STYLIZED YELLOW DOG IS JUMPING THROUGH THE LETTER "O" IN "DOG".

FOR ANTIBACTERIAL SPRAY; CARPET FRESHENERS AND ODOR ELIMINATORS; CLEANING PREPARATIONS, NAMELY, ODOR ELIMINATORS NOT FOR PERSONAL USE; CLEANING PREPARATIONS, NAMELY, ODOR NEUTRALIZERS NOT FOR PERSONAL USE; ODOR NEUTRALIZING PREPARATIONS FOR GENERAL USE ON VARIOUS SURFACES; ODOR NEUTRALIZING PREPARATIONS FOR USE ON FABRIC, SPORTS EQUIPMENT, SHOES, SPORTS BAGS (U.S. CLS. 6, 18, 44, 46, 51 AND 52).

FIRST USE 1-18-2012; IN COMMERCE 1-18-2012.

CLASS 5—(Continued).

4,155,795. RETTIG, HEIDI K., WINCHESTER, VA. SN 85-410,332. PUB. 12-13-2011, FILED 8-30-2011.

APATHY

THE MARK CONSISTS OF STANDARD CHARACTERS WITHOUT CLAIM TO ANY PARTICULAR FONT, STYLE, SIZE, OR COLOR.

FOR AROMATHERAPY CREAMS FOR RELAXATION AND RELIEVING STRESS; AROMATHERAPY OILS, OTHER THAN ESSENTIAL OILS, FOR TREATING ANXIETY; AROMATHERAPY SPRAYS FOR RELAXATION AND RELIEVING STRESS (U.S. CLS. 6, 18, 44, 46, 51 AND 52).

FIRST USE 11-0-2011; IN COMMERCE 11-0-2011.

4,155,796. RETTIG, HEIDI K., WINCHESTER, VA. SN 85-410,335. PUB. 12-13-2011, FILED 8-30-2011.

PASSIVE

THE MARK CONSISTS OF STANDARD CHARACTERS WITHOUT CLAIM TO ANY PARTICULAR FONT, STYLE, SIZE, OR COLOR.

FOR AROMATHERAPY CREAMS FOR RELAXATION AND RELIEVING STRESS; AROMATHERAPY OILS, OTHER THAN ESSENTIAL OILS, FOR TREATING ANXIETY; AROMATHERAPY SPRAYS FOR RELAXATION AND RELIEVING STRESS (U.S. CLS. 6, 18, 44, 46, 51 AND 52).

FIRST USE 11-0-2011; IN COMMERCE 11-0-2011.

4,155,797. RETTIG, HEIDI K., WINCHESTER, VA. SN 85-410,340. PUB. 12-13-2011, FILED 8-30-2011.

AGGRESSIVE

THE MARK CONSISTS OF STANDARD CHARACTERS WITHOUT CLAIM TO ANY PARTICULAR FONT, STYLE, SIZE, OR COLOR.

FOR AROMATHERAPY CREAMS FOR RELAXATION AND RELIEVING STRESS; AROMATHERAPY OILS, OTHER THAN ESSENTIAL OILS, FOR TREATING ANXIETY; AROMATHERAPY SPRAYS FOR RELAXATION AND RELIEVING STRESS (U.S. CLS. 6, 18, 44, 46, 51 AND 52).

FIRST USE 11-0-2011; IN COMMERCE 11-0-2011.

CLASS 6—METAL GOODS

4,154,430. IPH INTERNATIONAL PTY. LTD., ORMEAU, QUEENSLAND, AUSTRALIA. SN 77-756,600. PUB. 11-3-2009, FILED 6-10-2009.

CRIMSAFE-S-CAPE

THE MARK CONSISTS OF STANDARD CHARACTERS WITHOUT CLAIM TO ANY PARTICULAR FONT, STYLE, SIZE, OR COLOR.

OWNER OF U.S. REG. NOS. 3,671,032 AND 3,671,033.

FOR MESH SCREENS OF METAL FOR USE AS SECURITY SCREENS AND INSECT SCREENS FOR WINDOWS; MESH DOORS OF METAL IN THE NATURE OF SECURITY DOORS, DOORS FOR INSECT SCREENING; PREFABRICATED BUILDING ASSEMBLY KITS COMPRISING MESH SCREENS OF METAL FOR USE AS SECURITY SCREENS AND INSECT SCREENS FOR WINDOWS AND DOORS, AND FRAMES OF IRON, STEEL, NON-FERROUS METALS AND THEIR ALLOYS; MESH DOORS AND WINDOWS OF METAL IN THE NATURE OF QUICK RELEASE SECURITY DOORS AND SECURITY WINDOWS TO ALLOW EXITING FROM A BUILDING (U.S. CLS. 2, 12, 13, 14, 23, 25 AND 50).

FIRST USE 11-30-2010; IN COMMERCE 11-30-2010.

4,154,482. BAL SEAL ENGINEERING, FOOTHILL RANCH, CA. SN 77-843,748. PUB. 6-22-2010, FILED 10-7-2009.

Bal Seal Canted Coil Spring

THE MARK CONSISTS OF STANDARD CHARACTERS WITHOUT CLAIM TO ANY PARTICULAR FONT, STYLE, SIZE, OR COLOR.

OWNER OF U.S. REG. NO. 2,924,860.

NO CLAIM IS MADE TO THE EXCLUSIVE RIGHT TO USE "SEAL" AND "CANTED COIL SPRING", APART FROM THE MARK AS SHOWN.

FOR METAL HARDWARE, NAMELY, CANTED COIL SPRINGS FOR USE IN CONNECTORS, NAMELY, ELECTRICAL, MEDICAL, AND MECHANICAL CONNECTORS (U.S. CLS. 2, 12, 13, 14, 23, 25 AND 50).

FIRST USE 7-27-2011; IN COMMERCE 7-27-2011.

CLASS 6—(Continued).

4,154,483. LF, LLC, MOUNT MOURNE, NC. SN 77-846,545. PUB. 9-21-2010, FILED 10-12-2009.



THE MARK CONSISTS OF A FLYING HAWK WITH THE WORDS "BLUE HAWK" TO THE RIGHT OF THE IMAGE.

FOR METAL CHAINS; NON-ELECTRIC CABLES MADE OF METAL; ACCESSORIES FOR USE WITH CHAIN AND ROPE, NAMELY, CLAMPS, FERRULE AND STOPS, GRAB HOOKS, CARABINERS, QUICK LINKS, PULLEYS, EYES, SWIVELS, SAFETY LATCH SLIP HOOKS, ROPE TIGHTENERS, CLINCHES, AND HITCH RINGS ALL MADE OF METAL (U.S. CLS. 2, 12, 13, 14, 23, 25 AND 50).

FIRST USE 8-0-2011; IN COMMERCE 8-0-2011.

4,154,676. GILBERT, STEPHEN, SPOKANE, WA. SN 85-082,904. PUB. 9-20-2011, FILED 7-12-2010.

IN THE HOLE

THE MARK CONSISTS OF STANDARD CHARACTERS WITHOUT CLAIM TO ANY PARTICULAR FONT, STYLE, SIZE, OR COLOR.

FOR THREADED MOUNT FOR GOLF CART ACCESSORIES COMPRISED OF METAL FASTENERS FOR HOLDING BALL MARKERS, STROKE COUNTERS, GLOVES, HATS, JACKETS, AND SUNGLASSES (U.S. CLS. 2, 12, 13, 14, 23, 25 AND 50).

FIRST USE 12-1-2011; IN COMMERCE 12-1-2011.

4,154,709. BAILEY METAL PRODUCTS LIMITED, CONCORD, ONTARIO, CANADA. SN 85-103,224. PUB. 1-25-2011, FILED 8-9-2010.

COMSLAB

THE MARK CONSISTS OF STANDARD CHARACTERS WITHOUT CLAIM TO ANY PARTICULAR FONT, STYLE, SIZE, OR COLOR.

FOR METAL BUILDING COMPONENTS, NAMELY, PROFILED METAL DECKS FOR USE IN CONSTRUCTING CONCRETE FLOORS AND ROOFS (U.S. CLS. 2, 12, 13, 14, 23, 25 AND 50).

FIRST USE 1-7-2010; IN COMMERCE 11-1-2011.

CLASS 6—(Continued).

4,154,781. ARLINGTON STEEL BUILDINGS COMPANY LLC, WILMINGTON, DE. SN 85-125,978. PUB. 3-1-2011, FILED 9-9-2010.

TURTLE STEEL BUILDINGS

THE MARK CONSISTS OF STANDARD CHARACTERS WITHOUT CLAIM TO ANY PARTICULAR FONT, STYLE, SIZE, OR COLOR.

NO CLAIM IS MADE TO THE EXCLUSIVE RIGHT TO USE "STEEL BUILDINGS", APART FROM THE MARK AS SHOWN.

FOR PREFABRICATED AND PRE-ENGINEERED STEEL BUILDINGS (U.S. CLS. 2, 12, 13, 14, 23, 25 AND 50).

FIRST USE 3-15-2012; IN COMMERCE 3-15-2012.

4,155,076. INGOT METAL COMPANY LIMITED, NORTH YORK, ONTARIO, CANADA. SN 85-243,486. PUB. 6-28-2011, FILED 2-16-2011.

M34

THE MARK CONSISTS OF STANDARD CHARACTERS WITHOUT CLAIM TO ANY PARTICULAR FONT, STYLE, SIZE, OR COLOR.

FOR ALLOYS USED FOR CASTING; COPPER-BASE ALLOY INGOTS; INGOTS OF COMMON METAL; METAL ALLOYS FOR FURTHER MANUFACTURING; METALS AND METAL ALLOYS (U.S. CLS. 2, 12, 13, 14, 23, 25 AND 50).

FIRST USE 3-16-2012; IN COMMERCE 3-16-2012.

4,155,120. ROTARY DRILLING TOOLS USA, BEASLY, TX. SN 85-249,200. PUB. 7-19-2011, FILED 2-23-2011.

WEAR KNOT

THE MARK CONSISTS OF STANDARD CHARACTERS WITHOUT CLAIM TO ANY PARTICULAR FONT, STYLE, SIZE, OR COLOR.

FOR PIPE, NAMELY, DRILL PIPE FOR USE IN DRILLING OPERATIONS (U.S. CLS. 2, 12, 13, 14, 23, 25 AND 50).

FIRST USE 2-28-2011; IN COMMERCE 2-28-2011.

CLASS 6—(Continued).

4,155,380. ONEIDA VICTOR, INC., LTD., EUCLID, OH. SN 85-279,377. PUB. 9-6-2011, FILED 3-29-2011.

BLAKE & LAMB

THE MARK CONSISTS OF STANDARD CHARACTERS WITHOUT CLAIM TO ANY PARTICULAR FONT, STYLE, SIZE, OR COLOR.

FOR WILD ANIMAL TRAPS (U.S. CLS. 2, 12, 13, 14, 23, 25 AND 50).

FIRST USE 6-23-2011; IN COMMERCE 6-23-2011.

4,155,547. SOLAR GROUP, INC., BUFFALO, NY. SN 85-321,988. PUB. 10-11-2011, FILED 5-16-2011.

Mailsafe

THE MARK CONSISTS OF STANDARD CHARACTERS WITHOUT CLAIM TO ANY PARTICULAR FONT, STYLE, SIZE, OR COLOR.

OWNER OF U.S. REG. NO. 1,984,693.
FOR METAL MAILBOXES (U.S. CLS. 2, 12, 13, 14, 23, 25 AND 50).

FIRST USE 3-31-2007; IN COMMERCE 3-31-2007.

4,155,556. ALCOA INC., PITTSBURGH, PA. SN 85-325,018. PUB. 10-11-2011, FILED 5-19-2011.

FC43

THE MARK CONSISTS OF STANDARD CHARACTERS WITHOUT CLAIM TO ANY PARTICULAR FONT, STYLE, SIZE, OR COLOR.

FOR METAL FASTENERS, NAMELY, PANEL FASTENERS (U.S. CLS. 2, 12, 13, 14, 23, 25 AND 50).

FIRST USE 2-22-2012; IN COMMERCE 2-22-2012.

CLASS 6—(Continued).

4,155,705. DER SHENG CO., LTD., CHANGHUA COUNTY, TAIWAN. SN 85-370,254. PUB. 12-20-2011, FILED 7-13-2011.

RESOLUTE

THE MARK CONSISTS OF STYLIZED LETTERS FORMING THE WORD "RESOLUTE".
FOR METAL CASTERS AND WHEELS FOR METAL CASTERS (U.S. CLS. 2, 12, 13, 14, 23, 25 AND 50).
FIRST USE 10-21-2010; IN COMMERCE 10-21-2010.

CLASS 7—(Continued).

4,154,515. GABRIEL W. SHARP, DBA HAY N' SPRAY, TALCO, TX. SN 77-906,949. PUB. 6-1-2010, FILED 1-7-2010.

CROSSFIRE

THE MARK CONSISTS OF STANDARD CHARACTERS WITHOUT CLAIM TO ANY PARTICULAR FONT, STYLE, SIZE, OR COLOR.
FOR POWER-OPERATED SPRAYER (U.S. CLS. 13, 19, 21, 23, 31, 34 AND 35).
FIRST USE 1-0-2012; IN COMMERCE 1-0-2012.

CLASS 7—MACHINERY

4,154,253. COLUMBIA ELEVATOR PRODUCTS CO., INC., BRIDGEPORT, CT. SN 76-705,289. PUB. 7-12-2011, FILED 11-10-2010.

INSTACAB

THE MARK CONSISTS OF STANDARD CHARACTERS WITHOUT CLAIM TO ANY PARTICULAR FONT, STYLE, SIZE, OR COLOR.
OWNER OF U.S. REG. NO. 2,120,289.
FOR ELEVATOR CAR ENCLOSURES (U.S. CLS. 13, 19, 21, 23, 31, 34 AND 35).
FIRST USE 2-14-2012; IN COMMERCE 2-14-2012.

4,154,479. MAYTAG PROPERTIES, LLC, ST. JOSEPH, MI. SN 77-839,923. PUB. 2-2-2010, FILED 10-2-2009.



THE MARK CONSISTS OF LEAF DESIGN.
FOR CLOTHES WASHING MACHINES (U.S. CLS. 13, 19, 21, 23, 31, 34 AND 35).
FIRST USE 10-12-2009; IN COMMERCE 10-21-2009.

4,154,541. SCHROEDER INDUSTRIES, LEETSDALE, PA. SN 77-942,081. PUB. 1-18-2011, FILED 2-23-2010.

GEOSEAL

THE MARK CONSISTS OF STANDARD CHARACTERS WITHOUT CLAIM TO ANY PARTICULAR FONT, STYLE, SIZE, OR COLOR.

THE WORDING "GEOSEAL" HAS NO MEANING IN A FOREIGN LANGUAGE.

FOR FILTER ELEMENT BUSHING FOR RECEIVING A DROP IN FILTER ELEMENT FOR GENERAL INDUSTRIAL USE FOR THE PURIFICATION OF AIR AND INDUSTRIAL FLUIDS; FILTER ASSEMBLY HAVING DROP IN FILTER ELEMENT FOR GENERAL INDUSTRIAL USE FOR THE PURIFICATION OF AIR AND INDUSTRIAL FLUIDS (U.S. CLS. 13, 19, 21, 23, 31, 34 AND 35).

FIRST USE 12-6-2010; IN COMMERCE 12-6-2010.

4,154,592. POOLMAID (USA) INC., OAKLAND PARK, FL. SN 78-670,379. PUB. 10-17-2006, FILED 7-14-2005.

Pool Maid

THE MARK CONSISTS OF STANDARD CHARACTERS WITHOUT CLAIM TO ANY PARTICULAR FONT, STYLE, SIZE, OR COLOR.

NO CLAIM IS MADE TO THE EXCLUSIVE RIGHT TO USE "POOL", APART FROM THE MARK AS SHOWN.

FOR SWIMMING POOL CLEANERS, NAMELY, POOL VACUUMS; SWIMMING POOL CLEANERS, NAMELY, POOL SWEEPERS (U.S. CLS. 13, 19, 21, 23, 31, 34 AND 35).

FIRST USE 12-0-1995; IN COMMERCE 12-0-1995.

CLASS 7—(Continued).

4,154,658. SHINMAYWA INDUSTRIES, LTD., HYOGO, JAPAN. SN 85-068,481. PUB. 8-16-2011, FILED 6-22-2010.

ShinMaywa

OWNER OF U.S. REG. NO. 2,109,501.
THE MARK CONSISTS OF THE TERM "SHINMAYWA" IN STYLIZED LETTERING.

THE WORD "SHIN" MEANS "NEW", THE WORD "MAY" MEANS "BRIGHTNESS", AND THE WORD "WA" MEANS "HARMONY OR PEACE."

FOR AUTOMATIC WIRE PROCESSORS, NAMELY, ELECTRIC WIRE PROCESSING MACHINES; PUMPS, NAMELY, ELECTRIC PUMPS; POWER OPERATED BLOWERS; AERATORS; MIXERS, NAMELY, ELECTRIC MIXERS FOR INDUSTRIAL PURPOSES; SPINDLE MOTORS; DIRECT DRIVE MOTORS (U.S. CLS. 13, 19, 21, 23, 31, 34 AND 35).

FIRST USE 4-1-1992; IN COMMERCE 4-1-1992.

4,154,678. ELECTROLUX HOME CARE PRODUCTS, INC., CHARLOTTE, NC. SN 85-083,280. PUB. 12-14-2010, FILED 7-13-2010.

SUCTIONSEAL

THE MARK CONSISTS OF STANDARD CHARACTERS WITHOUT CLAIM TO ANY PARTICULAR FONT, STYLE, SIZE, OR COLOR.

FOR VACUUM CLEANERS (U.S. CLS. 13, 19, 21, 23, 31, 34 AND 35).

FIRST USE 1-26-2012; IN COMMERCE 1-26-2012.

4,154,681. WOOLSLAYER COMPANIES, INC., TULSA, OK. SN 85-085,767. PUB. 4-26-2011, FILED 7-15-2010.

xS MAST

THE MARK CONSISTS OF STANDARD CHARACTERS WITHOUT CLAIM TO ANY PARTICULAR FONT, STYLE, SIZE, OR COLOR.

CLASS 7—(Continued).

NO CLAIM IS MADE TO THE EXCLUSIVE RIGHT TO USE "MAST", APART FROM THE MARK AS SHOWN.

FOR OIL FIELD EQUIPMENT, NAMELY, EXTENSION MAST CRANE, A SCOPING DOG ASSEMBLY COMPRISED OF A WHEELED BODY MOVEABLE ON A TRACK OR BEAM AND AN EXTENDING AND RETRACTING MECHANISM (U.S. CLS. 13, 19, 21, 23, 31, 34 AND 35).

FIRST USE 5-3-2010; IN COMMERCE 10-15-2010.

4,154,722. PHG ENERGY, LLC, LA VERGNE, TN. SN 85-104,708. PUB. 2-22-2011, FILED 8-11-2010.



NO CLAIM IS MADE TO THE EXCLUSIVE RIGHT TO USE "ENERGY", APART FROM THE MARK AS SHOWN.

THE MARK CONSISTS OF A FLAME DESIGN APPEARING IMMEDIATELY TO THE LEFT OF THE WORDS "PHG ENERGY".

FOR GASIFIERS FOR GENERATING RENEWABLE ENERGY THROUGH GASIFICATION OF BIOMASS PRODUCTS AND REPLACEMENT PARTS THEREOF; GASIFIERS FOR PRODUCING CLEAN GAS FROM CARBON-BASED MATERIALS AND REPLACEMENT PARTS THEREOF (U.S. CLS. 13, 19, 21, 23, 31, 34 AND 35).

FIRST USE 11-0-2011; IN COMMERCE 11-0-2011.

4,154,740. VAN BORTEL AIRCRAFT, INC., ARLINGTON, TX. SN 85-109,237. PUB. 2-15-2011, FILED 8-17-2010.

BE GENUINE

THE MARK CONSISTS OF STANDARD CHARACTERS WITHOUT CLAIM TO ANY PARTICULAR FONT, STYLE, SIZE, OR COLOR.

FOR AIRCRAFT ENGINES AND PARTS FOR AIRCRAFT ENGINES, NAMELY, AIR FILTERS, OIL FILTERS, SPARK PLUGS, ALTERNATORS, STARTERS, GENERATORS, FUEL PUMPS, VACUUM PUMPS, TURBO CHARGERS, MAGNETOS, ENGINE MOUNTS, FLUID POWER HOSE KITS COMPRISING HOSES AND CLAMPS SOLD AS A UNIT FOR USE IN MACHINERY, FLUID POWER HOSES FOR USE IN MACHINERY, AND EXHAUST SYSTEMS (U.S. CLS. 13, 19, 21, 23, 31, 34 AND 35).

FIRST USE 10-12-2011; IN COMMERCE 10-12-2011.

CLASS 7—(Continued).

4,154,933. MARK D. BOSSES, BOCA RATON, FL. SN 85-201,258. PUB. 6-14-2011, FILED 12-18-2010.



THE MARK CONSISTS OF A CIRCLE WITH STYLIZED "S" ON FRONT OF THE CIRCLE.

FOR VACUUM CLEANERS AND THEIR COMPONENTS; BAGS FOR VACUUM CLEANERS; FILTERS FOR VACUUM CLEANERS (U.S. CLS. 13, 19, 21, 23, 31, 34 AND 35).

FIRST USE 12-13-2011; IN COMMERCE 12-13-2011.

4,154,955. AIRFLOW CATALYST SYSTEMS, INC., ROCHESTER, NY. SN 85-209,301. PUB. 12-20-2011, FILED 1-3-2011.

EZDoc

THE MARK CONSISTS OF STANDARD CHARACTERS WITHOUT CLAIM TO ANY PARTICULAR FONT, STYLE, SIZE, OR COLOR.

FOR DIESEL EMISSION REDUCTION UNITS FOR ENGINES, NAMELY, CATALYTIC CONVERTERS (U.S. CLS. 13, 19, 21, 23, 31, 34 AND 35).

FIRST USE 6-3-2011; IN COMMERCE 6-3-2011.

4,155,057. PUROLATOR FILTERS NA LLC, FAYETTEVILLE, NC. SN 85-240,084. PUB. 12-27-2011, FILED 2-11-2011.

GROUP 7

THE MARK CONSISTS OF STANDARD CHARACTERS WITHOUT CLAIM TO ANY PARTICULAR FONT, STYLE, SIZE, OR COLOR.

OWNER OF U.S. REG. NO. 886,320.

FOR OIL, AIR AND FUEL FILTERS FOR MOTORS AND ENGINES; FILTER ELEMENTS FOR OIL, AIR AND FUEL FILTERS (U.S. CLS. 13, 19, 21, 23, 31, 34 AND 35).

FIRST USE 12-31-2009; IN COMMERCE 12-31-2009.

CLASS 7—(Continued).

4,155,070. G.A. BRAUN, INC., N. SYRACUSE, NY. SN 85-242,248. PUB. 1-10-2012, FILED 2-15-2011.

SafeLoad Shuttle System

THE MARK CONSISTS OF STANDARD CHARACTERS WITHOUT CLAIM TO ANY PARTICULAR FONT, STYLE, SIZE, OR COLOR.

NO CLAIM IS MADE TO THE EXCLUSIVE RIGHT TO USE "SHUTTLE SYSTEM", APART FROM THE MARK AS SHOWN.

FOR AN AUTOMATED INDUSTRIAL AND COMMERCIAL LAUNDRY HANDLING SYSTEM COMPRISED OF A TRACK AND/OR RAIL MOUNTED SELF PROPELLED AND SELF ALIGNING BULK LAUNDRY RECEIVING AND DISCHARGING CONTAINER FOR TRANSFERRING BULK LAUNDRY ITEMS BETWEEN LARGE COMMERCIAL LAUNDRY WASHING AND DRYING MACHINES INCORPORATING FEATURES AND FACILITIES IN THE NATURE OF AN OPERATORS CAB OR CAGE FOR THE SAFETY AND PROTECTION OF AN ONBOARD OPERATOR (U.S. CLS. 13, 19, 21, 23, 31, 34 AND 35).

FIRST USE 11-30-2010; IN COMMERCE 6-25-2011.

4,155,170. TRACTOR SUPPLY CO. OF TEXAS, LP, BRENTWOOD, TN. SN 85-253,672. PUB. 8-30-2011, FILED 2-28-2011.

HUSKEE

THE MARK CONSISTS OF STANDARD CHARACTERS WITHOUT CLAIM TO ANY PARTICULAR FONT, STYLE, SIZE, OR COLOR.

OWNER OF U.S. REG. NOS. 1,183,496 AND 1,713,048.

FOR SNOW BLOWERS (U.S. CLS. 13, 19, 21, 23, 31, 34 AND 35).

FIRST USE 8-30-2008; IN COMMERCE 8-30-2008.

4,155,276. SANC MATERIALS, INC., RANCHO CUCAMONGA, CA. SN 85-263,957. PUB. 7-26-2011, FILED 3-10-2011.

GoldStone

THE MARK CONSISTS OF THE WORDING "GOLD STONE" WITH A DIAMOND IN THE MIDDLE.

FOR DIAMOND SAW BLADES FOR USE WITH POWER SAWS AND GRINDERS; DIAMOND POWER-OPERATED GRINDING WHEELS FOR USE WITH GRINDERS (U.S. CLS. 13, 19, 21, 23, 31, 34 AND 35).

FIRST USE 2-28-2011; IN COMMERCE 2-17-2012.

CLASS 7—(Continued).

4,155,403. HI-TECH COMPRESSOR & PUMP PRODUCTS, INC., TULLYTOWN, PA. SN 85-283,058. PUB. 8-9-2011, FILED 3-31-2011.



THE MARK CONSISTS OF A STYLIZED HORIZONTAL LINE/BAR BELOW THE STYLIZED TEXT "EFPACKING". FOR RECIPROCATING COMPRESSOR PISTON ROD PACKING USED TO CONTROL FUGITIVE EMISSIONS (U.S. CLS. 13, 19, 21, 23, 31, 34 AND 35). FIRST USE 3-31-2011; IN COMMERCE 5-10-2011.

4,155,453. THE GORMAN-RUPP COMPANY, MANSFIELD, OH. SN 85-290,292. PUB. 9-6-2011, FILED 4-8-2011.

PAH SERIES

THE MARK CONSISTS OF STANDARD CHARACTERS WITHOUT CLAIM TO ANY PARTICULAR FONT, STYLE, SIZE, OR COLOR.
OWNER OF U.S. REG. NO. 2,316,046.
NO CLAIM IS MADE TO THE EXCLUSIVE RIGHT TO USE "SERIES", APART FROM THE MARK AS SHOWN.
FOR CENTRIFUGAL PUMPS (U.S. CLS. 13, 19, 21, 23, 31, 34 AND 35).
FIRST USE 2-15-2012; IN COMMERCE 2-15-2012.

4,155,573. INTEGRADIGM CORPORATION, FORT WAYNE, IN. SN 85-332,046. PUB. 10-25-2011, FILED 5-27-2011.

MUFLERCO

THE MARK CONSISTS OF STANDARD CHARACTERS WITHOUT CLAIM TO ANY PARTICULAR FONT, STYLE, SIZE, OR COLOR.
FOR RECEIVERS FOR EXHAUST AND EMISSION SYSTEMS, NAMELY, MUFFLERS AND SOUND DEADENING DEVICES (U.S. CLS. 13, 19, 21, 23, 31, 34 AND 35).
FIRST USE 11-28-2010; IN COMMERCE 1-23-2012.

CLASS 7—(Continued).

4,155,618. REGAL BELOIT EPC INC., BELOIT, WI. SN 85-346,966. PUB. 11-1-2011, FILED 6-15-2011.

2GREEN

THE MARK CONSISTS OF STANDARD CHARACTERS WITHOUT CLAIM TO ANY PARTICULAR FONT, STYLE, SIZE, OR COLOR.
FOR ELECTRIC MOTORS FOR USE WITH SWIMMING POOL PUMPS (U.S. CLS. 13, 19, 21, 23, 31, 34 AND 35).
FIRST USE 2-11-2011; IN COMMERCE 2-11-2011.

4,155,643. SUPER PRODUCTS LLC, NEW BERLIN, WI. SN 85-355,224. PUB. 1-3-2012, FILED 6-24-2011.

DURASUCKER

THE MARK CONSISTS OF STANDARD CHARACTERS WITHOUT CLAIM TO ANY PARTICULAR FONT, STYLE, SIZE, OR COLOR.
FOR HEAVY DUTY TRUCK MOUNTED INDUSTRIAL VACUUM LOADERS IN THE NATURE OF VACUUM PUMPS AND STRUCTURAL PARTS THEREFOR (U.S. CLS. 13, 19, 21, 23, 31, 34 AND 35).
FIRST USE 9-23-2011; IN COMMERCE 9-23-2011.

CLASS 8—HAND TOOLS

4,154,332. NOXELL CORPORATION, HUNT VALLEY, MD. SN 77-541,431. PUB. 12-23-2008, FILED 8-7-2008.



OWNER OF U.S. REG. NOS. 1,021,850, 3,201,578, AND OTHERS.
THE MARK CONSISTS OF OVERLAPPING STYLIZED LETTERS "C" AND "G".
FOR TWEEZERS, CLIPPERS, NIPPERS, SCISSORS; NAIL FILES; MANICURE SETS; PEDICURE SETS (U.S. CLS. 23, 28 AND 44).
FIRST USE 12-15-2011; IN COMMERCE 12-15-2011.

CLASS 8—(Continued).

4,154,333. NOXELL CORPORATION, HUNT VALLEY, MD. SN 77-541,473. PUB. 12-30-2008, FILED 8-7-2008.



OWNER OF U.S. REG. NOS. 1,021,850, 3,201,578, AND OTHERS.

THE MARK CONSISTS OF OVERLAPPING STYLIZED LETTERS "C" AND "G".
FOR EYELASH CURLERS (U.S. CLS. 23, 28 AND 44).
FIRST USE 12-15-2011; IN COMMERCE 12-15-2011.

4,154,367. GABRIELLE STUDIO, INC., NEW YORK, NY. SN 77-603,069. PUB. 2-10-2009, FILED 10-29-2008.

DONNA KARAN

THE MARK CONSISTS OF STANDARD CHARACTERS WITHOUT CLAIM TO ANY PARTICULAR FONT, STYLE, SIZE, OR COLOR.

OWNER OF U.S. REG. NOS. 2,142,132, 3,014,041, AND 3,069,157.

THE NAME "DONNA KARAN" IDENTIFIES A LIVING INDIVIDUAL WHOSE CONSENT IS OF RECORD.

FOR FLATWARE AND TABLEWARE, NAMELY, FORKS, KNIVES AND SPOONS MADE OF STAINLESS STEEL, CAKE CUTTERS, CHEESE SLICERS (U.S. CLS. 23, 28 AND 44).

FIRST USE 10-0-2010; IN COMMERCE 10-0-2010.

CLASS 8—(Continued).

4,155,085. ACERO Y ARTES DE TOLEDO, S.L., OLIAS DEL REY (TOLEDO), SPAIN. SN 85-244,129. PUB. 8-9-2011, FILED 2-16-2011.



THE MARK CONSISTS OF THE LITERAL ELEMENT "BERMEJO" DISPLAYED USING A SANS-SERIF FONT-TYPE. THE LETTERS "E" IN "BERMEJO" ARE DEPICTED AS TO RESEMBLE TWO SWORDS POINTING DOWNWARD AND CROSSING IN THE MIDDLE. ANOTHER STYLIZED SWORD APPEARS PARALLEL AND ABOVE THE WORD "BERMEJO" WITH A DOT DISPLAYED ON ITS RIGHT. A DOT APPEARS IN THE LETTER "B" AND "J" IN "BERMEJO".

THE ENGLISH TRANSLATION OF "BERMEJO" IN THE MARK IS "REDDISH".

FOR SWORDS, SABRES, DAGGERS, RAPIERS, KNIVES, AXES, MACHETES AND MACES (U.S. CLS. 23, 28 AND 44).

FIRST USE 2-28-2011; IN COMMERCE 2-28-2011.

4,155,787. MARCHFIVE, LLC, WYNDMOOR, PA. SN 85-403,980. PUB. 2-7-2012, FILED 8-22-2011.

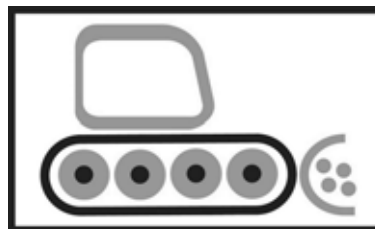

THE MARK CONSISTS OF BULLDOZER WITH FOUR WHEELS AND FOUR CIRCULAR DOTS INSIDE OF THE BULLDOZER BIN, ENCLOSED INSIDE SOLID LINED RECTANGULAR BORDER.

FOR HAND OPERATED TOOL IN THE NATURE OF A SCOOP FOR SCOOPING UP TOYS AND PLACING INSIDE TOY BIN FOR QUICK CLEANUP (U.S. CLS. 23, 28 AND 44).

FIRST USE 3-10-2012; IN COMMERCE 3-10-2012.

CLASS 9—ELECTRICAL AND SCIENTIFIC APPARATUS

CLASS 9—(Continued).

4,154,254. HENNESSY INDUSTRIES, INC., LAVERGNE, TN. SN 76-705,532. PUB. 2-15-2011, FILED 12-1-2010.

CLASS 9—(Continued).

4,154,267. J.A. WOOLLAM CO., INC., LINCOLN, NE. SN 76-707,791. PUB. 11-22-2011, FILED 5-31-2011.

PRORIDE

THZ-VASE

THE MARK CONSISTS OF STANDARD CHARACTERS WITHOUT CLAIM TO ANY PARTICULAR FONT, STYLE, SIZE, OR COLOR.

FOR VEHICLE WHEEL BALANCING MACHINES (U.S. CLS. 21, 23, 26, 36 AND 38).

FIRST USE 9-15-2011; IN COMMERCE 9-15-2011.

THE MARK CONSISTS OF STANDARD CHARACTERS WITHOUT CLAIM TO ANY PARTICULAR FONT, STYLE, SIZE, OR COLOR.

OWNER OF U.S. REG. NOS. 2,349,099, 2,534,923, AND OTHERS.

FOR EQUIPMENT, NAMELY, ELLIPSOMETER BASED APPARATUS FOR MEASURING THICKNESS, TEMPERATURE CAUSED EFFECTS, AND OPTICAL PROPERTIES OF SEMICONDUCTORS, DISK DRIVES, MAGNETIC DATA STORAGE MEDIA, OPTICAL DATA STORAGE MEDIA, THIN FILMS, MULTIPLE LAYER FILMS AND COATINGS ON SUBSTRATES, AND COMPUTER PROGRAMS NECESSARY FOR CONTROLLING THE ELLIPSOMETER BASED APPARATUS AND FOR ANALYZING ACQUIRED ELLIPSOMETRIC DATA (U.S. CLS. 21, 23, 26, 36 AND 38).

FIRST USE 12-2-2011; IN COMMERCE 12-2-2011.

4,154,266. RUSS, YOACHIM C., ANNAPOLIS, MD. SN 76-707,530. PUB. 12-20-2011, FILED 5-9-2011.

4,154,279. WESTEK ELECTRONICS, INC., WATSONVILLE, CA. SN 77-289,651. PUB. 7-15-2008, FILED 9-26-2007.

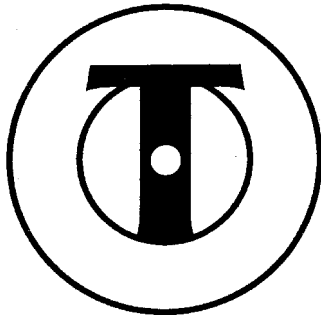

TUFF CONNECT

THE MARK CONSISTS OF A TARGET DESIGN COMPRISED OF TWO CONCENTRIC CIRCLES, WITH A LETTER "T" IN THE CENTER AND A CIRCLE IN THE MIDDLE OF THE LETTER "T".

FOR TELESCOPIC SIGHTS, OPTICAL LENS GUN SCOPES; OPTICAL LENS SIGHTS FOR FIREARMS; SPOTTING SCOPES; LASER RANGEFINDERS; COMPONENT OF OPTICAL LENS SIGHTS IN THE NATURE OF A USER-DEFINED AIMING ENHANCEMENT FEATURE WITHIN THE OPTICAL LENS SCOPE DISPLAY (U.S. CLS. 21, 23, 26, 36 AND 38).

FIRST USE 7-14-2011; IN COMMERCE 7-14-2011.

THE MARK CONSISTS OF STANDARD CHARACTERS WITHOUT CLAIM TO ANY PARTICULAR FONT, STYLE, SIZE, OR COLOR.

NO CLAIM IS MADE TO THE EXCLUSIVE RIGHT TO USE "CONNECT", APART FROM THE MARK AS SHOWN.

FOR ELECTRICAL COMMUNICATION CORD WITH PLUGS (U.S. CLS. 21, 23, 26, 36 AND 38).

FIRST USE 10-5-2011; IN COMMERCE 10-5-2011.

CLASS 9—(Continued).

4,154,282. TARGUS GROUP INTERNATIONAL, INC., ANAHEIM, CA. SN 77-334,056. PUB. 1-13-2009, FILED 11-20-2007.

ECOSMART

THE MARK CONSISTS OF STANDARD CHARACTERS WITHOUT CLAIM TO ANY PARTICULAR FONT, STYLE, SIZE, OR COLOR.

FOR COMPUTER CARRYING CASES; MESSENGER BAGS ESPECIALLY DESIGNED FOR HOLDING LAPTOPS AND NOTEBOOK COMPUTERS; BACKPACKS ESPECIALLY ADAPTED FOR HOLDING LAPTOPS AND NOTEBOOK COMPUTERS (U.S. CLS. 21, 23, 26, 36 AND 38).

FIRST USE 6-5-2009; IN COMMERCE 6-5-2009.

4,154,286. KNOWLES, MATHEW, HOUSTON, TX. SN 77-377,989. PUB. 12-23-2008, FILED 1-22-2008.

MUSIC WORLD KIDS

THE MARK CONSISTS OF STANDARD CHARACTERS WITHOUT CLAIM TO ANY PARTICULAR FONT, STYLE, SIZE, OR COLOR.

NO CLAIM IS MADE TO THE EXCLUSIVE RIGHT TO USE "KIDS" AND "MUSIC", APART FROM THE MARK AS SHOWN.

FOR CDS AND CD-ROMS FEATURING ANIMATED CHARACTERS; DVDS, PRE-RECORDED VIDEO CASSETTES, DIGITAL VIDEO DISCS, DIGITAL VERSATILE DISCS, DOWNLOADABLE AUDIO AND VIDEO RECORDINGS, DVDS, AND HIGH DEFINITION DIGITAL DISKS FEATURING ENTERTAINMENT COMPRISING OF MUSICAL PERFORMANCES, DRAMATIC PERFORMANCES AND COMEDIC PERFORMANCES (U.S. CLS. 21, 23, 26, 36 AND 38).

FIRST USE 11-4-2008; IN COMMERCE 11-0-2008.

CLASS 9—(Continued).

4,154,331. PARADIGM GEOPHYSICAL CORP., HOUSTON, TX. SN 77-539,033. PUB. 8-2-2011, FILED 8-5-2008.

ECHOS

THE MARK CONSISTS OF STANDARD CHARACTERS WITHOUT CLAIM TO ANY PARTICULAR FONT, STYLE, SIZE, OR COLOR.

FOR COMPUTER SOFTWARE, NAMELY, COMPUTER PROGRAMS THAT PROCESS SEISMIC DATA FOR USE IN CREATING TWO DIMENSIONAL AND THREE DIMENSIONAL IMAGES OF THE SUBSURFACE OF THE EARTH FOR USE IN RELATION TO EXPLORATION AND PRODUCTION OF OIL AND GAS (U.S. CLS. 21, 23, 26, 36 AND 38).

FIRST USE 9-11-2009; IN COMMERCE 9-11-2009.

4,154,334. NETPROPAGATE CORPORATION, LOS ANGELES, CA. SN 77-543,720. PUB. 12-30-2008, FILED 8-11-2008.

NETPROPAGATE

THE MARK CONSISTS OF STANDARD CHARACTERS WITHOUT CLAIM TO ANY PARTICULAR FONT, STYLE, SIZE, OR COLOR.

FOR COMMUNICATION SOFTWARE FOR PROVIDING ACCESS TO THE INTERNET; COMMUNICATIONS SOFTWARE FOR CONNECTING NETWORK USERS; COMPUTER E-COMMERCE SOFTWARE TO ALLOW USERS TO PERFORM ELECTRONIC BUSINESS TRANSACTIONS VIA A GLOBAL COMPUTER NETWORK; COMPUTER HARDWARE AND SOFTWARE FOR SETTING UP AND CONFIGURING LOCAL AREA NETWORKS; COMPUTER HARDWARE AND SOFTWARE FOR SETTING UP AND CONFIGURING WIDE AREA NETWORKS; COMPUTER HARDWARE AND SOFTWARE SYSTEM FOR REMOTELY MONITORING ENVIRONMENTAL CONDITIONS AND CONTROLLING DEVICES WITHIN A BUILDING, FACILITY, GROUNDS, OR DESIGNATED SPATIAL AREA; COMPUTER PROGRAMS FOR SEARCHING THE CONTENTS OF COMPUTERS AND COMPUTER NETWORKS BY REMOTE CONTROL; COMPUTER SOFTWARE FOR ACCESSING INFORMATION DIRECTORIES THAT MAY BE DOWNLOADED FROM THE GLOBAL COMPUTER NETWORK; COMPUTER SOFTWARE FOR ADMINISTRATION OF COMPUTER LOCAL AREA NETWORKS; COMPUTER SOFTWARE FOR ADMINISTRATION OF COMPUTER NETWORKS; COMPUTER SOFTWARE FOR WIRELESS CONTENT DELIVERY; COMPUTER SOFTWARE, NAMELY, SOFTWARE DEVELOPMENT TOOLS FOR THE CREATION OF MOBILE INTERNET APPLICATIONS AND CLIENT INTERFACES; COMPUTER STORAGE DEVICES, NAMELY, HIGH-SPEED STORAGE SUBSYSTEMS FOR STORAGE AND BACKUP OF ELECTRONIC DATA EITHER LOCALLY OR VIA A TELECOMMUNICATIONS NETWORK; CONTINGENCY

CLASS 9—(Continued).

RESPONSE COMMUNICATION SYSTEM DESIGNED TO PROVIDE RADIO INTEROPERABILITY, STREAMING VIDEO, WIRELESS INTERNET, AND VOIP PHONE; FACILITIES MANAGEMENT SOFTWARE, NAMELY, SOFTWARE TO CONTROL BUILDING ENVIRONMENT, ACCESS AND SECURITY SYSTEMS; HOME AND OFFICE AUTOMATION SYSTEMS COMPRISING WIRELESS AND WIRED CONTROLLERS, CONTROLLED DEVICES, AND SOFTWARE FOR LIGHTING, HVAC, SECURITY, SAFETY AND OTHER HOME AND OFFICE MONITORING AND CONTROL APPLICATIONS; INTERNET PHONES; INTERNET SERVERS; INTEROPERABLE COMMUNICATION SYSTEM DESIGNED TO PROVIDE RADIO, STREAMING VIDEO, WIRELESS INTERNET, AND VOIP PHONE; NETWORK ACCESS SERVER OPERATING SOFTWARE; SOFTWARE FOR ENSURING THE SECURITY OF ELECTRONIC MAIL; TELECOMMUNICATIONS HARDWARE AND SOFTWARE FOR MONITORING AND ALERTING REMOTE SENSOR STATUS VIA THE INTERNET (U.S. CLS. 21, 23, 26, 36 AND 38).

FIRST USE 9-29-2011; IN COMMERCE 9-29-2011.

4,154,335. NETPROPAGATE CORPORATION, LOS ANGELES, CA. SN 77-543,732. PUB. 12-30-2008, FILED 8-11-2008.

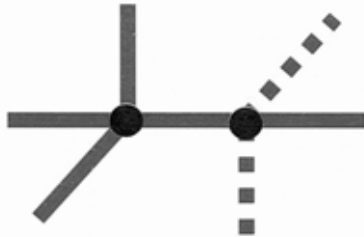

THE MARK CONSISTS OF A SOLID HORIZONTAL LINE INTERSECTED TWICE AT ONE-THIRD AND AT TWO-THIRDS OF ITS LENGTH BY A VERTICAL LINE AND A SOLID CIRCLE. THE BOTTOM HALF OF THE LEFTMOST VERTICAL LINE ANGLES LEFT AT 45 DEGREES. THE TOP HALF OF THE RIGHTMOST VERTICAL LINE ANGLES RIGHT AT 45 DEGREES. THE RIGHTMOST VERTICAL LINE CONSISTS OF SQUARED DOTS.

FOR COMMUNICATION SOFTWARE FOR PROVIDING ACCESS TO THE INTERNET; COMMUNICATIONS SOFTWARE FOR CONNECTING NETWORK USERS; COMPUTER E-COMMERCE SOFTWARE TO ALLOW USERS TO PERFORM ELECTRONIC BUSINESS TRANSACTIONS VIA A GLOBAL COMPUTER NETWORK; COMPUTER HARDWARE AND SOFTWARE FOR SETTING UP AND CONFIGURING LOCAL AREA NETWORKS; COMPUTER HARDWARE AND SOFTWARE FOR SETTING UP AND CONFIGURING WIDE AREA NETWORKS; COMPUTER HARDWARE AND SOFTWARE SYSTEM FOR REMOTELY MONITORING ENVIRONMENTAL CONDITIONS AND CONTROLLING DEVICES WITHIN A BUILDING, FACILITY, GROUNDS, OR DESIGNATED SPATIAL AREA; COMPUTER PROGRAMS FOR SEARCHING THE CONTENTS OF COMPUTERS AND COMPUTER NETWORKS BY REMOTE CONTROL; COMPUTER SOFTWARE FOR ACCESSING INFORMATION DIRECTORIES THAT MAY BE DOWNLOADED FROM THE GLOBAL COMPUTER NETWORK; COMPUTER SOFTWARE FOR ADMINISTRATION OF COMPUTER LOCAL AREA NETWORKS; COMPUTER SOFTWARE FOR ADMINISTRATION OF COMPUTER NETWORKS; COMPUTER SOFTWARE FOR WIRELESS CONTENT DELIVERY; COMPUTER SOFTWARE, NAMELY, SOFTWARE DEVELOPMENT TOOLS FOR THE CREATION OF MOBILE INTERNET APPLICATIONS AND CLIENT INTERFACES; COMPUTER STORAGE DEVICES, NAMELY, HIGH-SPEED STORAGE SUBSYSTEMS FOR STORAGE AND BACKUP OF ELEC-

CLASS 9—(Continued).

TRONIC DATA EITHER LOCALLY OR VIA A TELECOMMUNICATIONS NETWORK; CONTINGENCY RESPONSE COMMUNICATION SYSTEM DESIGNED TO PROVIDE RADIO INTEROPERABILITY, STREAMING VIDEO, WIRELESS INTERNET, AND VOIP PHONE; FACILITIES MANAGEMENT SOFTWARE, NAMELY, SOFTWARE TO CONTROL BUILDING ENVIRONMENT, ACCESS AND SECURITY SYSTEMS; HOME AND OFFICE AUTOMATION SYSTEMS COMPRISING WIRELESS AND WIRED CONTROLLERS, CONTROLLED DEVICES, AND SOFTWARE FOR LIGHTING, HVAC, SECURITY, SAFETY AND OTHER HOME AND OFFICE MONITORING AND CONTROL APPLICATIONS; INTERNET PHONES; INTERNET SERVERS; INTEROPERABLE COMMUNICATION SYSTEM DESIGNED TO PROVIDE RADIO, STREAMING VIDEO, WIRELESS INTERNET, AND VOIP PHONE; NETWORK ACCESS SERVER OPERATING SOFTWARE; SOFTWARE FOR ENSURING THE SECURITY OF ELECTRONIC MAIL; TELECOMMUNICATIONS HARDWARE AND SOFTWARE FOR MONITORING AND ALERTING REMOTE SENSOR STATUS VIA THE INTERNET (U.S. CLS. 21, 23, 26, 36 AND 38).

FIRST USE 9-29-2011; IN COMMERCE 9-29-2011.

4,154,339. DDI GLOBAL CORP., ANAHEIM, CA. SN 77-547,587. PUB. 7-21-2009, FILED 8-14-2008.

HDI-LINK

THE MARK CONSISTS OF STANDARD CHARACTERS WITHOUT CLAIM TO ANY PARTICULAR FONT, STYLE, SIZE, OR COLOR.

FOR PRINTED CIRCUIT BOARDS (U.S. CLS. 21, 23, 26, 36 AND 38).
FIRST USE 8-14-2008; IN COMMERCE 3-26-2012.

4,154,340. DDI GLOBAL CORP., ANAHEIM, CA. SN 77-547,608. PUB. 12-30-2008, FILED 8-14-2008.

DPSMV

THE MARK CONSISTS OF STANDARD CHARACTERS WITHOUT CLAIM TO ANY PARTICULAR FONT, STYLE, SIZE, OR COLOR.

FOR PRINTED CIRCUIT BOARDS (U.S. CLS. 21, 23, 26, 36 AND 38).
FIRST USE 8-14-2008; IN COMMERCE 3-26-2012.

CLASS 9—(Continued).

4,154,341. POULIN HOLDINGS LLC, BOSTON, MA. SN 77-548,199. PUB. 1-6-2009, FILED 8-15-2008.

CENTIMENT

THE MARK CONSISTS OF STANDARD CHARACTERS WITHOUT CLAIM TO ANY PARTICULAR FONT, STYLE, SIZE, OR COLOR.

FOR SOFTWARE THAT PROVIDES ASSET TRADING RECOMMENDATIONS; SOFTWARE THAT PROVIDES ASSET TRADING AND ASSET TRADING RECOMMENDATIONS; SOFTWARE FOR ANALYZING LINGUISTIC DATA SOURCES (U.S. CLS. 21, 23, 26, 36 AND 38).
FIRST USE 12-31-2011; IN COMMERCE 12-31-2011.

4,154,349. ENTERPRISEDB CORPORATION, BEDFORD, MA. SN 77-560,094. PUB. 1-20-2009, FILED 9-2-2008.

DynaTune

THE MARK CONSISTS OF STANDARD CHARACTERS WITHOUT CLAIM TO ANY PARTICULAR FONT, STYLE, SIZE, OR COLOR.

FOR COMPUTER SOFTWARE FOR INFORMATION PROCESSING, NAMELY, DATABASE MANAGEMENT AND DEVELOPMENT (U.S. CLS. 21, 23, 26, 36 AND 38).
FIRST USE 8-24-2006; IN COMMERCE 8-24-2006.

4,154,351. STRATEGIC SYSTEMS & TECHNOLOGY CORP., SUWANEE, GA. SN 77-564,542. PUB. 1-27-2009, FILED 9-8-2008.

HIGHGROUND

THE MARK CONSISTS OF STANDARD CHARACTERS WITHOUT CLAIM TO ANY PARTICULAR FONT, STYLE, SIZE, OR COLOR.

FOR COMPUTER SOFTWARE FOR WORK ORDER MANAGEMENT RELATING TO FACILITIES PROJECTS, REPAIRS, FIELD SERVICE, AND PREVENTATIVE MAINTENANCE (U.S. CLS. 21, 23, 26, 36 AND 38).
FIRST USE 2-13-2012; IN COMMERCE 2-13-2012.

CLASS 9—(Continued).

4,154,353. IMI INNOVATIONS, INC., NAPERVILLE, IL. SN 77-564,962. PUB. 8-4-2009, FILED 9-8-2008.

!NMULT

THE MARK CONSISTS OF STANDARD CHARACTERS WITHOUT CLAIM TO ANY PARTICULAR FONT, STYLE, SIZE, OR COLOR.

FOR COMPUTER SOFTWARE THAT EXPANDS THE HUMAN-COMPUTER INTERFACE BY ALLOWING SIMULTANEOUS AND INDEPENDENT MULTIPLE INPUTS FROM MULTIPLE CONTROL SOURCES; SOFTWARE DEVELOPMENT KIT CONSISTING PRIMARILY OF SOFTWARE AND SAMPLE SOURCE CODE FOR THE DEVELOPMENT OF COMPUTER SOFTWARE THAT EXPANDS THE HUMAN-COMPUTER INTERFACE BY ALLOWING SIMULTANEOUS AND INDEPENDENT MULTIPLE INPUTS FROM MULTIPLE CONTROL SOURCES (U.S. CLS. 21, 23, 26, 36 AND 38).
FIRST USE 4-1-2012; IN COMMERCE 4-1-2012.

4,154,354. IMI INNOVATIONS, INC., NAPERVILLE, IL. SN 77-564,965. PUB. 8-4-2009, FILED 9-8-2008.

INMULT

THE MARK CONSISTS OF STANDARD CHARACTERS WITHOUT CLAIM TO ANY PARTICULAR FONT, STYLE, SIZE, OR COLOR.

FOR COMPUTER SOFTWARE FOR USE IN EXPANDING THE HUMAN-COMPUTER INTERFACE BY ALLOWING SIMULTANEOUS AND INDEPENDENT MULTIPLE INPUTS FROM MULTIPLE CONTROL SOURCES; SOFTWARE DEVELOPMENT KIT CONSISTING PRIMARILY OF SOFTWARE AND SAMPLE SOURCE CODE FOR THE DEVELOPMENT OF COMPUTER SOFTWARE THAT EXPANDS THE HUMAN-COMPUTER INTERFACE BY ALLOWING SIMULTANEOUS AND INDEPENDENT MULTIPLE INPUTS FROM MULTIPLE CONTROL SOURCES (U.S. CLS. 21, 23, 26, 36 AND 38).
FIRST USE 4-1-2012; IN COMMERCE 4-1-2012.

CLASS 9—(Continued).

4,154,372. JOHN VONS LLC, NEW YORK, NY. SN 77-621,316. PUB. 12-22-2009, FILED 11-25-2008.

YOFO

THE MARK CONSISTS OF STANDARD CHARACTERS WITHOUT CLAIM TO ANY PARTICULAR FONT, STYLE, SIZE, OR COLOR.

THE WORDING "YOFO" HAS NO MEANING IN A FOREIGN LANGUAGE.

FOR ACCESSORIES FOR ELECTRONICS, NAMELY, GRIP, HOLDER AND STAND ALL SOLD AS A UNIT FOR USE WITH MOBILE PHONES, MP3 PLAYERS, AND PORTABLE MEDIA PLAYERS (U.S. CLS. 21, 23, 26, 36 AND 38).

FIRST USE 9-20-2011; IN COMMERCE 10-11-2011.

CLASS 9—(Continued).

4,154,391. M.E.P. CAD, INC., RENO, NV. SN 77-673,881. PUB. 9-29-2009, FILED 2-19-2009.

CONSLVR

THE MARK CONSISTS OF STANDARD CHARACTERS WITHOUT CLAIM TO ANY PARTICULAR FONT, STYLE, SIZE, OR COLOR.

FOR COMPUTER SOFTWARE FOR RECOGNIZING AND RESOLVING CONFLICTS BETWEEN VISUAL OBJECTS IN VISUAL DISPLAY SOFTWARE (U.S. CLS. 21, 23, 26, 36 AND 38).

FIRST USE 8-5-2011; IN COMMERCE 8-5-2011.

4,154,373. FIRESTORM EMERGENCY SERVICES LTD., RIVERSIDE, CA. SN 77-627,177. PUB. 4-14-2009, FILED 12-5-2008.

TigerStrike

THE MARK CONSISTS OF STANDARD CHARACTERS WITHOUT CLAIM TO ANY PARTICULAR FONT, STYLE, SIZE, OR COLOR.

FOR RADIO RECEIVER, NAMELY, DIRECTION FINDER (U.S. CLS. 21, 23, 26, 36 AND 38).

FIRST USE 1-15-2012; IN COMMERCE 1-15-2012.

4,154,410. QUALCOMM INCORPORATED, SAN DIEGO, CA. SN 77-702,274. PUB. 2-2-2010, FILED 3-30-2009.

PLAZA RETAIL

THE MARK CONSISTS OF STANDARD CHARACTERS WITHOUT CLAIM TO ANY PARTICULAR FONT, STYLE, SIZE, OR COLOR.

NO CLAIM IS MADE TO THE EXCLUSIVE RIGHT TO USE "RETAIL", APART FROM THE MARK AS SHOWN.

FOR COMPUTER SOFTWARE, NAMELY, COMPUTER SOFTWARE DEVELOPMENT TOOLS; COMPUTER SOFTWARE USED TO FACILITATE INTERFACES BETWEEN COMPUTER SOFTWARE OR COMPUTER HARDWARE USED IN WIRELESS COMMUNICATION DEVICES, OR WITHIN NETWORKS EMPLOYING WIRELESS AND NON-WIRELESS COMMUNICATION DEVICES; COMPUTER SOFTWARE APPLICATIONS FOR CERTIFYING THAT OTHER COMPUTER SOFTWARE APPLICATIONS MEET CERTAIN STANDARDS; COMPUTER SOFTWARE USED TO INTERPRET INFORMATION, AND TO INTEGRATE, INTERPRET AND ORGANIZE DATA BETWEEN DIFFERENT WIRELESS OR NON-WIRELESS DEVICES AND COMPUTER SOFTWARE APPLICATIONS; COMPUTER SOFTWARE FOR DEVELOPING AND MANAGING DISTRIBUTED APPLICATION COMPUTER SOFTWARE IN A WIRELESS OR MIXED NETWORK EMPLOYING WIRELESS AND NON-WIRELESS COMMUNICATION INTERFACES; COMPUTER SOFTWARE FOR USE IN ADVERTISING AND MARKETING, NAMELY, PROMOTING THE GOODS AND SERVICES OF OTHERS; COMPUTER SOFTWARE FOR DISSEMINATION OF ADVERTISING FOR OTHERS VIA AN ON-LINE COMMUNICATIONS NETWORK ON THE INTERNET; COMPUTER SOFTWARE FOR MARKETING, ADVERTISING AND PROMOTING THE RETAIL GOODS AND SERVICES OF OTHERS TO WIRELESS COMMUNICATION DEVICES OR COMPUTERS (U.S. CLS. 21, 23, 26, 36 AND 38).

FIRST USE 10-2-2009; IN COMMERCE 10-2-2009.

4,154,379. ETEL S.A., CH-2112 MOTIERS, SWITZERLAND. SN 77-649,590. PUB. 11-24-2009, FILED 1-14-2009.

TRANSNET

THE MARK CONSISTS OF STANDARD CHARACTERS WITHOUT CLAIM TO ANY PARTICULAR FONT, STYLE, SIZE, OR COLOR.

OWNER OF SWITZERLAND REG. NO. 563581, DATED 11-6-2007, EXPIRES 6-21-2017.

FOR ELECTRONIC CONTROLLERS FOR ELECTRONIC MOTORS FOR POSITIONING AN OBJECT, NAMELY, COMMUNICATION CONNECTORS AND INTERFACES FOR TRANSMITTING SIGNALS FROM HAND CONTROLS TO MOTION CONTROL DEVICES (U.S. CLS. 21, 23, 26, 36 AND 38).

FIRST USE 1-1-2009; IN COMMERCE 1-1-2009.

CLASS 9—(Continued).

4,154,417. FEDERAL APD INCORPORATED, NOVI, MI. SN 77-716,045. PUB. 8-18-2009, FILED 4-17-2009.

ELEMENT

THE MARK CONSISTS OF STANDARD CHARACTERS WITHOUT CLAIM TO ANY PARTICULAR FONT, STYLE, SIZE, OR COLOR.

FOR FACILITY MANAGEMENT SOFTWARE FOR CONTROL OF BUILDING SYSTEMS, CONTROL DEVICES AND FUNCTIONS, SECURITY MONITORING AND FACILITY MANAGEMENT AND OPERATION (U.S. CLS. 21, 23, 26, 36 AND 38).

FIRST USE 3-0-2011; IN COMMERCE 12-20-2011.

4,154,442. TIM BORN, CHAMPAIGN, IL. SN 77-785,471. PUB. 1-25-2011, FILED 7-21-2009.

FIRSTRATE

THE MARK CONSISTS OF STANDARD CHARACTERS WITHOUT CLAIM TO ANY PARTICULAR FONT, STYLE, SIZE, OR COLOR.

FOR DOWNLOADABLE COMPUTER-READABLE ELECTRIC GENERATOR RELATED ELECTRONIC DATA FILES, NAMELY, DATA FILES FEATURING FUEL TYPE, FUEL COST AND CALCULATED COST PER MW-HR, FOR USE WITH COMPUTER SOFTWARE (U.S. CLS. 21, 23, 26, 36 AND 38).

FIRST USE 12-1-2011; IN COMMERCE 12-1-2011.

4,154,444. NAMCO BANDAI GAMES INC., TOKYO, JAPAN. SN 77-796,765. PUB. 12-29-2009, FILED 8-4-2009.

**FRAGILE DREAMS: FAREWELL
RUINS OF THE MOON**

THE MARK CONSISTS OF STANDARD CHARACTERS WITHOUT CLAIM TO ANY PARTICULAR FONT, STYLE, SIZE, OR COLOR.

FOR COMPUTER GAME PROGRAMS; COMPUTER GAME SOFTWARE; INTERACTIVE MULTIMEDIA COMPUTER GAME PROGRAMS; DOWNLOADABLE COMPUTER GAME SOFTWARE USED AND PLAYED ON HOME CONSOLES; AND VIDEO GAME SOFTWARE (U.S. CLS. 21, 23, 26, 36 AND 38).

FIRST USE 3-16-2010; IN COMMERCE 3-16-2010.

CLASS 9—(Continued).

4,154,446. HANBITSOFT, INC., SEOUL, REPUBLIC OF KOREA. SN 77-797,862. PUB. 12-29-2009, FILED 8-5-2009.

MYTHOS

THE MARK CONSISTS OF STANDARD CHARACTERS WITHOUT CLAIM TO ANY PARTICULAR FONT, STYLE, SIZE, OR COLOR.

FOR COMPUTER GAME SOFTWARE; VIDEO GAME SOFTWARE (U.S. CLS. 21, 23, 26, 36 AND 38).

FIRST USE 2-0-2012; IN COMMERCE 2-0-2012.

4,154,451. IGT, RENO, NV. SN 77-807,404. PUB. 12-22-2009, FILED 8-18-2009.

SIZZLING RUBIES

THE MARK CONSISTS OF STANDARD CHARACTERS WITHOUT CLAIM TO ANY PARTICULAR FONT, STYLE, SIZE, OR COLOR.

OWNER OF U.S. REG. NOS. 2,050,175 AND 3,555,314. FOR GAMING MACHINES, NAMELY, DEVICES WHICH ACCEPT A WAGER (U.S. CLS. 21, 23, 26, 36 AND 38).

FIRST USE 12-23-2011; IN COMMERCE 12-23-2011.

4,154,476. CORRELATED MAGNETICS RESEARCH, LLC. NEW HOPE, AL. SN 77-838,444. PUB. 8-17-2010, FILED 9-30-2009.

Hoverfield

THE MARK CONSISTS OF STANDARD CHARACTERS WITHOUT CLAIM TO ANY PARTICULAR FONT, STYLE, SIZE, OR COLOR.

FOR MAGNETS; COMPUTER SOFTWARE AND COMPUTER PROGRAMS FOR DETERMINING, MANIPULATING, AND PROGRAMMING THE MAGNETIC FIELDS OF MAGNETS OR MAGNETIC STRUCTURES (U.S. CLS. 21, 23, 26, 36 AND 38).

FIRST USE 11-0-2009; IN COMMERCE 3-31-2010.

CLASS 9—(Continued).

4,154,511. KIA MOTORS AMERICA, INC., IRVINE, CA. SN 77-895,034. PUB. 8-24-2010, FILED 12-16-2009.

KIA UVO

THE MARK CONSISTS OF STANDARD CHARACTERS WITHOUT CLAIM TO ANY PARTICULAR FONT, STYLE, SIZE, OR COLOR.

THE WORDING "UVO" HAS NO MEANING IN A FOREIGN LANGUAGE.

FOR APPARATUS IN AUTOMOBILE FOR VIDEO MONITORING AND DISPLAY OF THE REAR OF AUTOMOBILES, NAMELY, AN ON-BOARD AUTOMOBILE SURVEILLANCE SYSTEM COMPRISED OF CAMERAS AND MONITORS; ELECTRONIC CONTROL UNIT IN AUTOMOBILE FOR TRACKING AND DISPLAYING WEAR INFORMATION FOR AUTOMOBILE PARTS; ELECTRONIC CONTROL UNIT IN AUTOMOBILE FOR TRACKING AND DISPLAYING REMOTE DOOR UNLOCK, THEFT DETECTION AND NOTIFICATION STATUS, STOLEN VEHICLE TRACKING, AUTOMATIC NOTIFICATION OF AIR BAG DEPLOYMENT, AND INTERACTING WITH A CUSTOMER SERVICE CENTER; ELECTRONIC CONTROL UNIT IN AUTOMOBILE FOR INTERACTING WITH AN AUTOMOBILE CUSTOMER SERVICE CENTER AND DISPLAYING INFORMATION; DIAGNOSTIC UNITS IN AUTOMOBILES, NAMELY, SENSORS AND DETECTORS FOR USE IN TRACKING, DISPLAYING AND CONTROLLING THE ACTUATION AND OPERATION OF SAFETY APPARATUS AND EQUIPMENT; ELECTRONIC CONTROL UNIT IN AUTOMOBILE FOR NAVIGATION; ELECTRONIC CONTROL UNIT IN AUTOMOBILE FOR RECEIVING, TRANSMITTING, STORING, AND DISPLAYING SOUND, DATA, MUSIC, VIDEO AND TEXT; ELECTRONIC CONTROL UNIT IN AUTOMOBILES FOR USE WITH RADIO AND ELECTRONIC MEDIA PLAYERS; ELECTRONIC CONTROL UNIT IN AUTOMOBILES FOR TRANSMITTING VEHICLE DIAGNOSTIC INFORMATION, FOR TRANSMITTING VEHICLE STATUS INFORMATION TO EMERGENCY AND SERVICE PERSONNEL, FOR RECEIVING AND DISPLAYING TRAFFIC STATUS INFORMATION, AND FOR PROVIDING AND DISPLAYING DIRECTIONAL GUIDANCE INFORMATION (U.S. CLS. 21, 23, 26, 36 AND 38).

FIRST USE 5-31-2011; IN COMMERCE 5-31-2011.

4,154,529. HONEYWELL INTERNATIONAL INC., MORRISTOWN, NJ. SN 77-930,738. PUB. 5-10-2011, FILED 2-8-2010.

HONEYWELL FIELD ADVISOR

THE MARK CONSISTS OF STANDARD CHARACTERS WITHOUT CLAIM TO ANY PARTICULAR FONT, STYLE, SIZE, OR COLOR.

CLASS 9—(Continued).

NO CLAIM IS MADE TO THE EXCLUSIVE RIGHT TO USE "FIELD ADVISOR", APART FROM THE MARK AS SHOWN.

FOR COMPUTER HARDWARE; COMPUTER SOFTWARE FOR USE IN CONNECTION WITH INDUSTRIAL PROCESS CONTROL SYSTEMS, NAMELY, SOFTWARE THAT RECORDS, ANALYZES, AND REPORTS WORKFLOW DATA FROM REMOTE LOCATIONS TO PLANT TECHNICIANS, ENGINEERS AND MANAGERS AND MAKES RECOMMENDATIONS FOR INCREASING PRODUCTIVITY, EFFICIENCY, SAFETY, AND RELIABILITY (U.S. CLS. 21, 23, 26, 36 AND 38).

FIRST USE 6-30-2010; IN COMMERCE 12-31-2011.

4,154,538. AZZURRO SYSTEMS INTEGRATION LLC, NORTHVALE, NJ. SN 77-941,218. PUB. 8-10-2010, FILED 2-22-2010.

ASI

THE MARK CONSISTS OF STANDARD CHARACTERS WITHOUT CLAIM TO ANY PARTICULAR FONT, STYLE, SIZE, OR COLOR.

FOR VIDEO AND AUDIO PRODUCTION, POST-PRODUCTION, BROADCAST AND TRANSMISSION EQUIPMENT, NAMELY, VIDEO CAMERAS, TELECINES, ELECTRONIC SWITCHERS FOR AUDIO AND VIDEO SIGNALS, AUDIO MIXERS, DIGITAL-TO-ANALOG AND ANALOG-TO-DIGITAL SIGNAL CONVERTERS, VIDEO GRAPHICS GENERATORS AND ANALOG TO HIGH-DEFINITION CONVERTERS AND MONITORS (U.S. CLS. 21, 23, 26, 36 AND 38).

FIRST USE 12-31-2008; IN COMMERCE 12-31-2008.

4,154,562. KONAMI GAMING, INC., LAS VEGAS, NV. SN 77-964,022. PUB. 8-10-2010, FILED 3-20-2010.

VICTORY'S FAVOR

THE MARK CONSISTS OF STANDARD CHARACTERS WITHOUT CLAIM TO ANY PARTICULAR FONT, STYLE, SIZE, OR COLOR.

FOR ELECTRONIC GAME PROGRAMS; GAMING EQUIPMENT, NAMELY, SLOT MACHINES WITH OR WITHOUT VIDEO OUTPUT; GAMING MACHINES; MACHINES FOR PLAYING GAMES OF CHANCE; SLOT MACHINES (U.S. CLS. 21, 23, 26, 36 AND 38).

FIRST USE 10-0-2011; IN COMMERCE 10-0-2011.

CLASS 9—(Continued).

4,154,563. QUADO MEDIA INC., SUNNYVALE, CA. SN 77-964,076. PUB. 7-19-2011, FILED 3-20-2010.

QUADO

THE MARK CONSISTS OF STANDARD CHARACTERS WITHOUT CLAIM TO ANY PARTICULAR FONT, STYLE, SIZE, OR COLOR.

THE WORDING "QUADO" HAS NO MEANING IN A FOREIGN LANGUAGE.

FOR DIGITAL BOARD GAMES, NAMELY, ELECTRONIC INTERACTIVE BOARD GAMES FOR USE WITH EXTERNAL MONITORS (U.S. CLS. 21, 23, 26, 36 AND 38).

FIRST USE 9-30-2010; IN COMMERCE 9-30-2010.

4,154,576. GUARINO, JOSEPH M., TRENTON, NJ. SN 77-968,552. PUB. 8-17-2010, FILED 3-25-2010.

BETTER VIEW

THE MARK CONSISTS OF STANDARD CHARACTERS WITHOUT CLAIM TO ANY PARTICULAR FONT, STYLE, SIZE, OR COLOR.

FOR AUDIO AND VIDEO RECORDINGS FEATURING MUSIC AND ARTISTIC PERFORMANCES; COMPACT DISCS FEATURING MUSIC; DIGITAL MUSIC DOWNLOADABLE FROM THE INTERNET; DOWNLOADABLE MUSICAL SOUND RECORDINGS; DOWNLOADABLE RING TONES, GRAPHICS AND MUSIC VIA A GLOBAL COMPUTER NETWORK AND WIRELESS DEVICES (U.S. CLS. 21, 23, 26, 36 AND 38).

FIRST USE 9-1-2011; IN COMMERCE 9-1-2011.

4,154,588. EMERSON RADIO CORP., HACKENSACK, NJ. SN 77-983,135. PUB. 8-24-2010, FILED 9-29-2009.



OWNER OF U.S. REG. NOS. 409,629, 3,497,331, AND OTHERS.

THE MARK CONSISTS OF A STYLIZED FORM OF THE WORD "EMERSON" ALONG WITH A SQUARE DESIGN PARTIALLY SHADED TO FORM A CLEF SYMBOL.

FOR CAMCORDER (U.S. CLS. 21, 23, 26, 36 AND 38).
FIRST USE 9-30-2011; IN COMMERCE 9-30-2011.

CLASS 9—(Continued).

4,154,593. INVENSYS SYSTEMS, INC., FOXBORO, MA. SN 78-676,313. PUB. 11-14-2006, FILED 7-22-2005.

INFUSION

THE MARK CONSISTS OF STANDARD CHARACTERS WITHOUT CLAIM TO ANY PARTICULAR FONT, STYLE, SIZE, OR COLOR.

FOR COMPUTER-BASED INDUSTRIAL AUTOMATION AND INFORMATION SYSTEM; COMPUTER SOFTWARE AND HARDWARE FOR CONNECTION WITH INDUSTRIAL INSTRUMENTATION INCLUDING VALVES, PUMPS, MOTORS, FLOW MEASUREMENT DEVICES, PRESSURE MEASUREMENT DEVICES, LEVEL MEASUREMENT DEVICES, TEMPERATURE MEASUREMENT DEVICES, CHEMICAL COMPOSITION MEASUREMENT DEVICES, EQUIPMENT CONDITION MONITORING DEVICES; COMPUTER HARDWARE AND SOFTWARE FOR INDUSTRIAL PROCESS CONTROL AND LOGIC CONTROL, COMPUTER HARDWARE AND SOFTWARE FOR INDUSTRIAL OPERATOR CONSOLES, MAINTENANCE CONSOLES, ENGINEERING WORKSTATIONS, SUPERVISION CONSOLES AND MANAGEMENT INTERFACING; COMPUTER-BASED HARDWARE AND SOFTWARE FOR INDUSTRIAL INFORMATION MANAGEMENT INCLUDING PROCESS HISTORIAN, INDUSTRIAL ALARM MANAGEMENT, INDUSTRIAL MODELING AND SIMULATION; COMPUTER-BASED SOFTWARE FOR ADVANCE OPERATIONS AND MAINTENANCE SUPERVISION INCLUDING ADVANCED PROCESS CONTROL, MULTIVARIABLE PREDICTIVE CONTROL, STATISTICAL CONTROL, LINEAR OPTIMIZATION AND NONLINEAR OPTIMIZATION, PREDICTIVE MAINTENANCE, AND PLANT ASSET MANAGEMENT; COMPUTER SOFTWARE FOR THE INTEROPERATION WITH THIRD PARTY INTELLIGENT PLANT DEVICES EXISTING IN THE INDUSTRIAL PLANT INCLUDING DDE DEVICE DRIVERS AND DATA ACQUISITION SERVERS; COMPUTER-BASED SOFTWARE FOR THE INTEROPERATION WITH THIRD PARTY ENTERPRISE BUSINESS SOFTWARE INCLUDING ENTERPRISE MESSAGING SERVICES, WEB SERVICES, AND FILE TRANSFER MECHANISMS (U.S. CLS. 21, 23, 26, 36 AND 38).

FIRST USE 7-22-2005; IN COMMERCE 9-30-2006.

4,154,599. BEST BRANDS CONSUMER PRODUCTS, INC., NEW YORK, NY. SN 78-900,501. PUB. 8-9-2011, FILED 6-5-2006.

iDREAM

THE MARK CONSISTS OF STANDARD CHARACTERS WITHOUT CLAIM TO ANY PARTICULAR FONT, STYLE, SIZE, OR COLOR.

FOR AUDIO SPEAKERS; HEADPHONES; RADIOS INCORPORATING CLOCKS (U.S. CLS. 21, 23, 26, 36 AND 38).

FIRST USE 5-11-2011; IN COMMERCE 5-11-2011.

CLASS 9—(Continued).

4,154,605. HORIZONS INCORPORATED, CLEVELAND, OH.
SN 85-001,568. PUB. 9-6-2011, FILED 3-30-2010.

SimTouch

THE MARK CONSISTS OF STANDARD CHARACTERS WITHOUT CLAIM TO ANY PARTICULAR FONT, STYLE, SIZE, OR COLOR.

OWNER OF U.S. REG. NO. 3,583,887.
FOR INTERFACE DEVICES FOR USE WITH COMPUTERS AND ELECTRONIC DEVICES FOR NAVIGATION OF MENU LISTS (U.S. CLS. 21, 23, 26, 36 AND 38).
FIRST USE 5-0-2011; IN COMMERCE 5-0-2011.

4,154,610. JOHN MEZZALINGUA ASSOCIATES, INC., DBA PPC, EAST SYRACUSE, NY. SN 85-003,568. PUB. 7-20-2010, FILED 3-31-2010.

Perfect Prep

THE MARK CONSISTS OF THE TERMS "PERFECT PREP" SEPARATED BY A DESIGN OF A CIRCLE INTERSECTED BY AN ARROW.

FOR CONNECTION CABLES (U.S. CLS. 21, 23, 26, 36 AND 38).
FIRST USE 10-0-2011; IN COMMERCE 10-0-2011.

4,154,630. ARISTOCRAT TECHNOLOGIES AUSTRALIA PTY LTD, NORTH RYDE, NSW, AUSTRALIA. SN 85-023,884. PUB. 8-10-2010, FILED 4-27-2010.

VICTORY QUEST

THE MARK CONSISTS OF STANDARD CHARACTERS WITHOUT CLAIM TO ANY PARTICULAR FONT, STYLE, SIZE, OR COLOR.

FOR GAMING MACHINES, NAMELY, DEVICES WHICH ACCEPT A WAGER (U.S. CLS. 21, 23, 26, 36 AND 38).
FIRST USE 1-1-2012; IN COMMERCE 1-1-2012.

CLASS 9—(Continued).

4,154,652. BANOM, INC., WAYNE, PA. SN 85-060,974. PUB. 11-9-2010, FILED 6-11-2010.

TRAXX

THE MARK CONSISTS OF STANDARD CHARACTERS WITHOUT CLAIM TO ANY PARTICULAR FONT, STYLE, SIZE, OR COLOR.

FOR PROTECTIVE GLOVES FOR INDUSTRIAL USE (U.S. CLS. 21, 23, 26, 36 AND 38).
FIRST USE 2-22-2012; IN COMMERCE 2-22-2012.

4,154,661. THE NAVIGATORS, COLORADO SPRINGS, CO. SN 85-068,715. PUB. 12-6-2011, FILED 6-22-2010.

NavPress Discipleship Inside Out

THE MARK CONSISTS OF STANDARD CHARACTERS WITHOUT CLAIM TO ANY PARTICULAR FONT, STYLE, SIZE, OR COLOR.

OWNER OF U.S. REG. NO. 1,170,131.
NO CLAIM IS MADE TO THE EXCLUSIVE RIGHT TO USE "DISCIPLESHIP", APART FROM THE MARK AS SHOWN.

FOR DOWNLOADABLE ELECTRONIC PUBLICATIONS, NAMELY, CATALOGS, NEWSLETTERS, BOOKS, AND BROCHURES IN THE FIELD OF CHRISTIAN MINISTRY (U.S. CLS. 21, 23, 26, 36 AND 38).
FIRST USE 5-1-2010; IN COMMERCE 5-1-2010.

4,154,667. SIMIOSYS, LLC, OVIEDO, FL. SN 85-072,066. PUB. 11-23-2010, FILED 6-25-2010.

Mission: LEAP

THE MARK CONSISTS OF STANDARD CHARACTERS WITHOUT CLAIM TO ANY PARTICULAR FONT, STYLE, SIZE, OR COLOR.

FOR COMPUTER SOFTWARE FOR THE DATABASING, VISUALIZATION, MANIPULATION, VIRTUAL REALITY IMMERSION AND INTEGRATION OF GEOGRAPHIC INFORMATION WITH ON-LINE MEMBER COMMUNITIES (U.S. CLS. 21, 23, 26, 36 AND 38).
FIRST USE 10-15-2008; IN COMMERCE 7-1-2010.

CLASS 9—(Continued).

4,154,680. ZERONINES TECHNOLOGY, INC., CASTLE ROCK, CO. SN 85-084,645. PUB. 12-14-2010, FILED 7-14-2010.

ZENCODE

THE MARK CONSISTS OF STANDARD CHARACTERS WITHOUT CLAIM TO ANY PARTICULAR FONT, STYLE, SIZE, OR COLOR.

FOR COMPUTER SOFTWARE FOR USE IN THE ENCRYPTION AND DECRYPTION OF DIGITAL FILES, INCLUDING AUDIO, VIDEO, TEXT, BINARY, STILL IMAGES, GRAPHICS AND MULTIMEDIA FILES; COMPUTER SOFTWARE FOR USE IN THE SAFEGUARDING OF DIGITAL FILES, INCLUDING AUDIO, VIDEO, TEXT, BINARY, STILL IMAGES, GRAPHICS AND MULTIMEDIA FILES (U.S. CLS. 21, 23, 26, 36 AND 38).
FIRST USE 9-13-2010; IN COMMERCE 9-13-2010.

4,154,697. MH ACOUSTICS, LLC, SUMMIT, NJ. SN 85-096,738. PUB. 1-25-2011, FILED 7-30-2010.

BEAMSTER

THE MARK CONSISTS OF STANDARD CHARACTERS WITHOUT CLAIM TO ANY PARTICULAR FONT, STYLE, SIZE, OR COLOR.

FOR ACOUSTIC TRANSDUCERS, MICROPHONES, AND MICROPHONE ARRAYS, AND SOFTWARE SOLD AS A UNIT THEREWITH; MOBILE, LANDLINE, INTERNET, AND VOICE-OVER-INTERNET-PROTOCOL (VOIP) COMMUNICATIONS APPARATUS; AND HEADSETS, HEADPHONES, EARPIECES, SPEAKERS, AND MICROPHONES FOR COMPUTERS AND FOR MOBILE, LANDLINE, INTERNET, AND VOICE-OVER-INTERNET-PROTOCOL (VOIP) COMMUNICATIONS (U.S. CLS. 21, 23, 26, 36 AND 38).
FIRST USE 8-13-2010; IN COMMERCE 8-13-2010.

CLASS 9—(Continued).

4,154,699. ELECTRONIC ARTS INC., REDWOOD CITY, CA. SN 85-097,374. PUB. 5-10-2011, FILED 7-30-2010.

SYNDICATE

THE MARK CONSISTS OF STANDARD CHARACTERS WITHOUT CLAIM TO ANY PARTICULAR FONT, STYLE, SIZE, OR COLOR.

FOR COMPUTER GAME SOFTWARE; DOWNLOADABLE COMPUTER GAME SOFTWARE VIA A GLOBAL COMPUTER NETWORK; VIDEO GAME SOFTWARE (U.S. CLS. 21, 23, 26, 36 AND 38).

FIRST USE 2-10-2012; IN COMMERCE 2-10-2012.

4,154,700. GENAL STRAP, INC., LONG ISLAND CITY, NY. SN 85-099,112. PUB. 8-9-2011, FILED 8-3-2010.

DEFINE PETITE OPTICS

THE MARK CONSISTS OF STANDARD CHARACTERS WITHOUT CLAIM TO ANY PARTICULAR FONT, STYLE, SIZE, OR COLOR.

NO CLAIM IS MADE TO THE EXCLUSIVE RIGHT TO USE "PETITE OPTICS", APART FROM THE MARK AS SHOWN.

FOR EYE GLASSES; SUNGLASSES; EYE-WEAR FRAMES (U.S. CLS. 21, 23, 26, 36 AND 38).

FIRST USE 8-0-2010; IN COMMERCE 1-0-2011.

4,154,702. CORSAIR MEMORY INC., FREEMONT, CA. SN 85-099,972. PUB. 7-26-2011, FILED 8-4-2010.

CORSAIR

THE MARK CONSISTS OF STANDARD CHARACTERS WITHOUT CLAIM TO ANY PARTICULAR FONT, STYLE, SIZE, OR COLOR.

CLASS 9—(Continued).

OWNER OF U.S. REG. NO. 3,209,882.
 FOR COMPUTER COMPONENTS AND INSTRUCTION MANUALS PACKAGED AND SOLD AS A UNIT THEREWITH, NAMELY, MEMORY MODULES, POWER SUPPLY UNITS, SOLID-STATE DRIVES, LIQUID-COOLING SOLUTIONS FOR CPUS AND MEMORY MODULES, AIR-COOLING SOLUTIONS FOR CPUS AND MEMORY MODULES, FANS, AND CASES AND ENCLOSURES FOR COMPUTERS; COMPUTER PERIPHERALS, COMPUTER HARDWARE, AND INSTRUCTIONS MANUALS PACKAGED AS A UNIT THEREWITH, NAMELY, USB FLASH DRIVES, EXTERNAL SOLID-STATE DRIVES, MICE, KEYBOARDS; COMPUTER PERIPHERALS, COMPUTER HARDWARE, AND INSTRUCTION MANUALS PACKAGED AS A UNIT THEREWITH, NAMELY, JOYSTICKS, GAME CONTROLLERS, STEERING WHEELS, FLIGHT CONTROLLERS, AND SPECIALIZED MICE AND KEYBOARDS USED AS INPUT DEVICES FOR COMPUTER GAMES AND CONSOLE GAMES; COMPUTER HARDWARE, AND INSTRUCTION MANUALS PACKAGED AS A UNIT THEREWITH, NAMELY, HEADSETS, HEADPHONES, AND MULTIMEDIA SPEAKERS (U.S. CLS. 21, 23, 26, 36 AND 38).
 FIRST USE 1-0-1994; IN COMMERCE 1-0-1994.

4,154,704. CORSAIR MEMORY INC., FREEMONT, CA. SN 85-100,682. PUB. 7-26-2011, FILED 8-5-2010.



OWNER OF U.S. REG. NO. 3,209,882.
 THE MARK CONSISTS OF SAILS OFFSET IN FRONT OF EACH OTHER.
 FOR COMPUTER COMPONENTS AND INSTRUCTION MANUALS PACKAGED AND SOLD AS A UNIT THEREWITH, NAMELY, MEMORY MODULES, POWER SUPPLY UNITS, SOLID-STATE DRIVES, LIQUID-COOLING SOLUTIONS FOR CPUS AND MEMORY MODULES, AIR-COOLING SOLUTIONS FOR CPUS AND MEMORY MODULES, FANS, AND CASES AND ENCLOSURES FOR COMPUTERS; COMPUTER PERIPHERALS, COMPUTER HARDWARE, AND INSTRUCTION MANUALS PACKAGED AS A UNIT THEREWITH, NAMELY, JOYSTICKS, GAME CONTROLLERS, STEERING WHEELS, FLIGHT CONTROLLERS, AND SPECIALIZED MICE AND KEYBOARDS USED AS INPUT DEVICES FOR COMPUTER GAMES AND CONSOLE GAMES; COMPUTER HARDWARE, AND INSTRUCTION MANUALS PACKAGED AS A UNIT THEREWITH, NAMELY, HEADSETS, HEADPHONES, AND MULTIMEDIA SPEAKERS (U.S. CLS. 21, 23, 26, 36 AND 38).
 FIRST USE 1-0-1994; IN COMMERCE 1-0-1994.

CLASS 9—(Continued).

4,154,710. 31, INC., NEWCOMERSTOWN, OH. SN 85-103,252. PUB. 7-19-2011, FILED 8-9-2010.

XoTRA SEAL ONE TO ONE SENSOR

OWNER OF U.S. REG. NOS. 2,188,672 AND 2,249,824.
 NO CLAIM IS MADE TO THE EXCLUSIVE RIGHT TO USE "SEAL" AND "SENSOR", APART FROM THE MARK AS SHOWN.
 THE MARK CONSISTS OF THE WORDS "XTRA SEAL ONE TO ONE SENSOR" WITH AN ELEVATED SMALL "O" BETWEEN THE LETTERS "X" AND "T" OF THE WORD "XTRA".
 FOR VEHICLE SAFETY EQUIPMENT, NAMELY, ELECTRONIC TIRE PRESSURE MONITORS (U.S. CLS. 21, 23, 26, 36 AND 38).
 FIRST USE 8-1-2010; IN COMMERCE 8-1-2010.

4,154,714. GEBLER, KATHRYN, BELL CANYON, CA. SN 85-103,566. PUB. 7-19-2011, FILED 8-9-2010.

THE COTTONTAIL CANDY CO.

THE MARK CONSISTS OF STANDARD CHARACTERS WITHOUT CLAIM TO ANY PARTICULAR FONT, STYLE, SIZE, OR COLOR.
 NO CLAIM IS MADE TO THE EXCLUSIVE RIGHT TO USE "CANDY CO.", APART FROM THE MARK AS SHOWN.
 FOR COTTON CANDY VENDING MACHINES (U.S. CLS. 21, 23, 26, 36 AND 38).
 FIRST USE 10-15-2010; IN COMMERCE 10-15-2010.

4,154,728. LATHEM TIME CORPORATION, ATLANTA, GA. SN 85-106,767. PUB. 1-25-2011, FILED 8-13-2010.

FaceIN

THE MARK CONSISTS OF STANDARD CHARACTERS WITHOUT CLAIM TO ANY PARTICULAR FONT, STYLE, SIZE, OR COLOR.
 FOR INPUT/OUTPUT DEVICE, NAMELY, AN ELECTRONIC SENSOR FOR BIOMETRIC FACE RECOGNITION FOR TIME AND ATTENDANCE, AND ACCESS CONTROL (U.S. CLS. 21, 23, 26, 36 AND 38).
 FIRST USE 9-1-2010; IN COMMERCE 9-1-2010.

CLASS 9—(Continued).

4,154,733. AVANTEXT, INC., CONSHOHOCKEN, PA. SN 85-107,312. PUB. 7-19-2011, FILED 8-13-2010.

**Avantext...
sentinel**

OWNER OF U.S. REG. NO. 3,443,940.
THE MARK CONSISTS OF THE WORD "AVANTEXT" WITH A TRIANGLE SERVING AS THE CROSS IN THE FIRST LETTER "A" FOLLOWED BY THREE DOTS ABOVE THE WORD "SENTINEL" WITH THE LAST DOT COMPRISING THE DOT FOR THE LETTER "I".

FOR COMPUTER SOFTWARE FEATURING REGULATORY INFORMATION REGARDING AIRWORTHINESS FOR THE AERONAUTICAL INDUSTRY AND AVIATORS (U.S. CLS. 21, 23, 26, 36 AND 38).

FIRST USE 2-6-2012; IN COMMERCE 2-9-2012.

4,154,734. AVANTEXT, INC., CONSHOHOCKEN, PA. SN 85-107,358. PUB. 1-25-2011, FILED 8-13-2010.

AVANTEXT SENTINEL

THE MARK CONSISTS OF STANDARD CHARACTERS WITHOUT CLAIM TO ANY PARTICULAR FONT, STYLE, SIZE, OR COLOR.

OWNER OF U.S. REG. NO. 3,443,940.
FOR COMPUTER SOFTWARE FEATURING REGULATORY INFORMATION REGARDING AIRWORTHINESS FOR THE AERONAUTICAL INDUSTRY AND AVIATORS (U.S. CLS. 21, 23, 26, 36 AND 38).

FIRST USE 2-6-2012; IN COMMERCE 2-9-2012.

CLASS 9—(Continued).

4,154,760. OSCAR E. ONTIVEROS, EL PASO, TX. SN 85-117,846. PUB. 2-8-2011, FILED 8-27-2010.

ONTY'S

THE MARK CONSISTS OF STANDARD CHARACTERS WITHOUT CLAIM TO ANY PARTICULAR FONT, STYLE, SIZE, OR COLOR.

FOR CONTROLLERS, NAMELY, ELECTRONIC CONTROLLERS; ELECTRONIC CONTROLLERS FOR ELECTRIC DEVICES; ELECTRONIC CONTROLLERS FOR REDUCING POWER CONSUMPTION (U.S. CLS. 21, 23, 26, 36 AND 38).

FIRST USE 11-5-2010; IN COMMERCE 11-5-2010.

4,154,761. ROCKET GAMING SYSTEMS, LLC, GROVE, OK. SN 85-117,993. PUB. 1-4-2011, FILED 8-27-2010.

Golden Wishes

THE MARK CONSISTS OF STANDARD CHARACTERS WITHOUT CLAIM TO ANY PARTICULAR FONT, STYLE, SIZE, OR COLOR.

FOR GAMING MACHINES, NAMELY, BINGO-RELATED GAMES AND SLOT MACHINES (U.S. CLS. 21, 23, 26, 36 AND 38).

FIRST USE 4-6-2011; IN COMMERCE 6-27-2011.

4,154,770. PTG TOOLS, INC., TYNGSBORO, MA. SN 85-120,659. PUB. 7-26-2011, FILED 9-1-2010.

ESDeyeguard

NO CLAIM IS MADE TO THE EXCLUSIVE RIGHT TO USE "ESDEYEGUARD", APART FROM THE MARK AS SHOWN.

THE MARK CONSISTS OF A LIGHTING BOLT INSIDE A CIRCLE AND THE STYLIZED TEXT "ESDEYEGUARD" WITH A SWOOSH AT THE BOTTOM.

FOR PROTECTIVE EYEWEAR AND COMPONENT PARTS THEREOF (U.S. CLS. 21, 23, 26, 36 AND 38).

FIRST USE 1-1-2011; IN COMMERCE 1-1-2011.

CLASS 9—(Continued).

4,154,787. UMEGASTAR, BRONXVILLE, NY. SN 85-127,345. PUB. 8-16-2011, FILED 9-10-2010.

Brooklyn Prince

THE MARK CONSISTS OF STANDARD CHARACTERS WITHOUT CLAIM TO ANY PARTICULAR FONT, STYLE, SIZE, OR COLOR.

NO CLAIM IS MADE TO THE EXCLUSIVE RIGHT TO USE "BROOKLYN", APART FROM THE MARK AS SHOWN.

FOR DOWNLOADABLE MUSICAL SOUND RECORDINGS; MUSICAL SOUND RECORDINGS; VIDEO RECORDINGS FEATURING MUSIC (U.S. CLS. 21, 23, 26, 36 AND 38).

FIRST USE 1-7-2011; IN COMMERCE 3-1-2011.

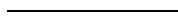

4,154,800. EFI GLOBAL, INC., HUMBLE, TX. SN 85-134,644. PUB. 2-8-2011, FILED 9-21-2010.

WINDO

THE MARK CONSISTS OF STANDARD CHARACTERS WITHOUT CLAIM TO ANY PARTICULAR FONT, STYLE, SIZE, OR COLOR.

FOR MICROMETER GAUGE FOR MEASURING PLANAR SURFACES (U.S. CLS. 21, 23, 26, 36 AND 38).

FIRST USE 9-0-2009; IN COMMERCE 9-0-2009.



4,154,831. EASTMAN KODAK COMPANY, ROCHESTER, NY. SN 85-145,641. PUB. 3-15-2011, FILED 10-5-2010.

PLAYFULL

THE MARK CONSISTS OF STANDARD CHARACTERS WITHOUT CLAIM TO ANY PARTICULAR FONT, STYLE, SIZE, OR COLOR.

FOR VIDEO CAMERAS (U.S. CLS. 21, 23, 26, 36 AND 38).

FIRST USE 3-8-2011; IN COMMERCE 3-8-2011.

CLASS 9—(Continued).

4,154,840. IGT, RENO, NV. SN 85-148,666. PUB. 2-15-2011, FILED 10-8-2010.

JOKERS PAY

THE MARK CONSISTS OF STANDARD CHARACTERS WITHOUT CLAIM TO ANY PARTICULAR FONT, STYLE, SIZE, OR COLOR.

OWNER OF U.S. REG. NOS. 2,888,275 AND 3,098,080. FOR GAMING MACHINES, NAMELY, DEVICES WHICH ACCEPT A WAGER (U.S. CLS. 21, 23, 26, 36 AND 38).

FIRST USE 11-23-2011; IN COMMERCE 11-23-2011.



4,154,851. PARTICLE MEASURING SYSTEMS, INC., BOULDER, CO. SN 85-151,842. PUB. 9-13-2011, FILED 10-13-2010.

BIOLAZ

THE MARK CONSISTS OF STANDARD CHARACTERS WITHOUT CLAIM TO ANY PARTICULAR FONT, STYLE, SIZE, OR COLOR.

FOR DETECTORS, NAMELY, DETECTORS FOR DETECTING, COUNTING OR SIZING AIRBORNE MICROBE PARTICLES; REAL-TIME MICROBIAL MONITOR (U.S. CLS. 21, 23, 26, 36 AND 38).

FIRST USE 11-30-2010; IN COMMERCE 11-30-2010.



4,154,858. METRIC INSIGHTS, INC., SAN FRANCISCO, CA. SN 85-154,586. PUB. 4-26-2011, FILED 10-18-2010.

METRIC INSIGHTS

THE MARK CONSISTS OF STANDARD CHARACTERS WITHOUT CLAIM TO ANY PARTICULAR FONT, STYLE, SIZE, OR COLOR.

FOR BUSINESS INTELLIGENCE SOFTWARE, NAMELY, SOFTWARE FOR USE IN REPORTING, TRENDING, AND ANALYSIS OF DATA STORED IN DATABASES AND ACCESSED THROUGH WEB SERVICES (U.S. CLS. 21, 23, 26, 36 AND 38).

FIRST USE 4-28-2011; IN COMMERCE 4-28-2011.

CLASS 9—(Continued).

4,154,862. CISCO TECHNOLOGY, INC., SAN JOSE, CA. SN 85-158,582. PUB. 3-8-2011, FILED 10-21-2010.

CISCO SOCIALMINER

THE MARK CONSISTS OF STANDARD CHARACTERS WITHOUT CLAIM TO ANY PARTICULAR FONT, STYLE, SIZE, OR COLOR.

OWNER OF U.S. REG. NOS. 3,709,076, 3,759,451, AND OTHERS.

FOR COMPUTER SOFTWARE FOR BRAND MONITORING AND FOR MANAGEMENT OF CUSTOMER SERVICE, NAMELY, SOFTWARE FOR SEARCHING, ANALYZING AND MONITORING COMMUNITY WEBSITES, BLOGS, AND OTHER ONLINE SOCIAL MEDIA, AND FOR GENERATING INFORMATION AND REPORTS RELATED THERETO (U.S. CLS. 21, 23, 26, 36 AND 38).

FIRST USE 1-28-2011; IN COMMERCE 1-28-2011.

4,154,867. MEI, INC., WEST CHESTER, PA. SN 85-159,886. PUB. 8-16-2011, FILED 10-24-2010.

MEI SC ADVANCE

THE MARK CONSISTS OF STANDARD CHARACTERS WITHOUT CLAIM TO ANY PARTICULAR FONT, STYLE, SIZE, OR COLOR.

OWNER OF U.S. REG. NOS. 2,789,405, 2,830,358, AND OTHERS.

FOR BILL ACCEPTING AND VALIDATING MACHINES, NAMELY, ELECTRONIC APPARATUS FOR ACCEPTING, DENOMINATING, VALIDATING, STORING, AND POTENTIALLY REJECTING BANK NOTES (U.S. CLS. 21, 23, 26, 36 AND 38).

FIRST USE 2-0-2012; IN COMMERCE 2-0-2012.

4,154,878. COURTROOM TELEVISION NETWORK LLC, NEW YORK, NY. SN 85-169,458. PUB. 10-25-2011, FILED 11-4-2010.

TRUTV PRESENTS: WORLD'S DUMBEST...

THE MARK CONSISTS OF STANDARD CHARACTERS WITHOUT CLAIM TO ANY PARTICULAR FONT, STYLE, SIZE, OR COLOR.

CLASS 9—(Continued).

OWNER OF U.S. REG. NOS. 3,493,740, 3,664,198, AND 3,669,937.

FOR DOWNLOADABLE TELEVISION PROGRAMS FEATURING COMEDY, DRAMA, ACTION, ADVENTURE AND/OR REALITY PROVIDED VIA THE INTERNET AND WIRELESS COMMUNICATIONS NETWORKS (U.S. CLS. 21, 23, 26, 36 AND 38).

FIRST USE 6-30-2011; IN COMMERCE 6-30-2011.

4,154,880. SCOTT TECHNOLOGIES, INC., BOCA RATON, FL. SN 85-170,391. PUB. 10-4-2011, FILED 11-5-2010.

SMART FILL

THE MARK CONSISTS OF STANDARD CHARACTERS WITHOUT CLAIM TO ANY PARTICULAR FONT, STYLE, SIZE, OR COLOR.

NO CLAIM IS MADE TO THE EXCLUSIVE RIGHT TO USE "SMART", APART FROM THE MARK AS SHOWN.

FOR OXYGEN BREATHING UNIT AIR CHARGING SYSTEMS COMPRISED OF A HOUSING AND INTERLINKED PNEUMATIC VALVES FOR CONTROLLING THE FILLING OF SELF-CONTAINED BREATHING APPARATUS CYLINDERS FOR USE BY FIREFIGHTERS, LAW ENFORCEMENT PERSONNEL, EMERGENCY PERSONNEL, HAZARDOUS MATERIALS PERSONNEL, MILITARY PERSONNEL AND INDUSTRIAL PERSONNEL (U.S. CLS. 21, 23, 26, 36 AND 38).

FIRST USE 2-0-2011; IN COMMERCE 2-0-2011.

4,154,881. TREK BICYCLE CORPORATION, WATERLOO, WI. SN 85-172,156. PUB. 2-22-2011, FILED 11-9-2010.

Oracle

THE MARK CONSISTS OF STANDARD CHARACTERS WITHOUT CLAIM TO ANY PARTICULAR FONT, STYLE, SIZE, OR COLOR.

FOR BICYCLE HELMETS (U.S. CLS. 21, 23, 26, 36 AND 38).

FIRST USE 4-1-2011; IN COMMERCE 12-15-2011.

CLASS 9—(Continued).

4,154,886. FOHAWX, LLC, BAYONNE, NJ. SN 85-176,313. PUB. 9-20-2011, FILED 11-14-2010.

FOHAWX

THE MARK CONSISTS OF STANDARD CHARACTERS WITHOUT CLAIM TO ANY PARTICULAR FONT, STYLE, SIZE, OR COLOR.

FOR ACCESSORIES SPECIALLY DESIGNED FOR ATTACHMENT TO SAFETY HELMETS, NAMELY, NON-METAL DECORATIVE ELEMENTS FOR REMOVABLE FIXTURE TO THE OUTER SURFACE OF SAFETY HELMETS, NAMELY, HAIR-LIKE EXTENSIONS, SPIKE-STYLE HAIR-LIKE EXTENSIONS, PUNK-STYLE HAIR-LIKE EXTENSIONS, WHIMSICAL ORNAMENTAL EXTENSIONS, HORN-LIKE EXTENSIONS, AND TENTACLE-LIKE EXTENSIONS (U.S. CLS. 21, 23, 26, 36 AND 38).

FIRST USE 7-7-2010; IN COMMERCE 3-10-2012.

4,154,888. FOHAWX, LLC, BAYONNE, NJ. SN 85-176,993. PUB. 9-20-2011, FILED 11-15-2010.

föhawx!

THE MARK CONSISTS OF THE WORD "FOHAWX!" IN STYLIZED LETTERING WITH TWO DOTS APPEARING OVER THE LETTER "O", A DESIGN OF AN EYE AND MOUTH APPEARING INSIDE THE LETTER "A", AND A SPIKED HAIR DESIGN APPEARING ABOVE THE LETTER "A".

FOR ACCESSORIES SPECIALLY DESIGNED FOR ATTACHMENT TO SAFETY HELMETS, NAMELY, NON-METAL DECORATIVE ELEMENTS FOR REMOVABLE FIXTURE TO THE OUTER SURFACE OF SAFETY HELMETS, NAMELY, HAIR-LIKE EXTENSIONS, SPIKE-STYLE HAIR-LIKE EXTENSIONS, PUNK-STYLE HAIR-LIKE EXTENSIONS, WHIMSICAL ORNAMENTAL EXTENSIONS, HORN-LIKE EXTENSIONS, AND TENTACLE-LIKE EXTENSIONS (U.S. CLS. 21, 23, 26, 36 AND 38).

FIRST USE 7-7-2010; IN COMMERCE 3-10-2012.

CLASS 9—(Continued).

4,154,898. CADILLAC JACK, INC., DULUTH, GA. SN 85-184,080. PUB. 10-18-2011, FILED 11-23-2010.

MAGIC HAT XTRA BONUS

THE MARK CONSISTS OF STANDARD CHARACTERS WITHOUT CLAIM TO ANY PARTICULAR FONT, STYLE, SIZE, OR COLOR.

FOR GAMING DEVICES, NAMELY, GAMING MACHINES, SLOT MACHINES, BINGO MACHINES, WITH OR WITHOUT VIDEO OUTPUT (U.S. CLS. 21, 23, 26, 36 AND 38).

FIRST USE 3-29-2012; IN COMMERCE 3-29-2012.

4,154,904. GRIDSENSE INC., WEST SACRAMENTO, CA. SN 85-188,227. PUB. 7-26-2011, FILED 12-1-2010.

BushingIQ

THE MARK CONSISTS OF STANDARD CHARACTERS WITHOUT CLAIM TO ANY PARTICULAR FONT, STYLE, SIZE, OR COLOR.

FOR AUTOMATED PROCESS CONTROL SYSTEM, NAMELY, MICRO-PROCESSOR BASED HARDWARE AND SOFTWARE SCALABLE ONLINE MONITORING SYSTEM COMPRISED OF ADVANCED SENSOR AND SOFTWARE FOR MONITORING TRANSFORMER BUSHINGS AND LIGHTNING ARRESTORS USED TO MONITOR THE STATUS OF INDUSTRIAL PROCESSES, NAMELY, POWER GENERATION, ELECTRICAL DISTRIBUTION AND OIL AND GAS PROCESSING (U.S. CLS. 21, 23, 26, 36 AND 38).

FIRST USE 7-20-2010; IN COMMERCE 10-1-2010.

4,154,907. IGT, RENO, NV. SN 85-188,660. PUB. 4-12-2011, FILED 12-1-2010.

BOINGY BEANS

THE MARK CONSISTS OF STANDARD CHARACTERS WITHOUT CLAIM TO ANY PARTICULAR FONT, STYLE, SIZE, OR COLOR.

FOR GAMING MACHINES, NAMELY, DEVICES WHICH ACCEPT A WAGER (U.S. CLS. 21, 23, 26, 36 AND 38).

FIRST USE 3-5-2012; IN COMMERCE 3-5-2012.

CLASS 9—(Continued).

4,154,916. VIGNATURE, INC., FRISCO, TX. SN 85-193,624. PUB. 4-19-2011, FILED 12-8-2010.

Vignature

THE MARK CONSISTS OF STANDARD CHARACTERS WITHOUT CLAIM TO ANY PARTICULAR FONT, STYLE, SIZE, OR COLOR.

FOR SOFTWARE, NAMELY, ELECTRONIC SIGNATURE CAPTURE SOFTWARE FOR E-COMMERCE TRANSACTIONS; COMPUTER SOFTWARE FOR USE IN IDENTITY AUTHENTICATION, NAMELY, SOFTWARE ENCRYPTION, DATA COLLECTION, AND DOCUMENT CREATION THAT CAPTURES ELECTRONIC SIGNATURES AND ASSOCIATED IMAGES; SOFTWARE FOR MOBILE, CLIENT, AND SERVER COMPUTERS FOR USE IN CREATING, MANAGING, AND DISTRIBUTING ELECTRONIC SIGNATURES; SOFTWARE FOR USE WITH ELECTRONIC DATA VERIFICATION, NAMELY, TO FACILITATE CREATION OF A LEGALLY BINDING ELECTRONIC SIGNATURE TO A DOCUMENT OR FILE FOR COMMUNICATION VIA A GLOBAL COMPUTER NETWORK (U.S. CLS. 21, 23, 26, 36 AND 38).

FIRST USE 5-4-2011; IN COMMERCE 5-4-2011.

4,154,932. MIDBASS DISTRIBUTION LIMITED, SUTTON COLDFIELD, ENGLAND. SN 85-201,257. PUB. 7-12-2011, FILED 12-18-2010.

FLI

THE MARK CONSISTS OF STANDARD CHARACTERS WITHOUT CLAIM TO ANY PARTICULAR FONT, STYLE, SIZE, OR COLOR.

FOR APPARATUS FOR RECORDING, TRANSMISSION OR REPRODUCTION OF SOUND OR IMAGES; LOUSPEAKERS, LOUSPEAKER AND SOUND SYSTEMS; SOUND AMPLIFIERS, SOUND CONTROL APPARATUS; ELECTRO-MECHANICAL ACOUSTIC CONVERTERS; LOUSPEAKER ENCLOSURES; AND PARTS, FITTINGS, AND ACCESSORIES FOR THE AFOREMENTIONED GOODS, NAMELY, CABLING, CONNECTORS, REMOTE CONTROLS, POWER CAPACITORS, LINE DRIVERS, DISTRIBUTION BOXES, SOUND DAMPENING, ANTIRESONANCE MATERIALS, LOUSPEAKER ENCLOSURE PORTS, LOUSPEAKER ENCLOSURE COSMETIC ENHANCEMENTS AND LOUSPEAKER ENCLOSURE PROTECTION (U.S. CLS. 21, 23, 26, 36 AND 38).

FIRST USE 3-31-2005; IN COMMERCE 1-31-2009.

CLASS 9—(Continued).

4,154,944. BALLY GAMING, INC., DBA BALLY TECHNOLOGIES, LAS VEGAS, NV. SN 85-204,458. PUB. 11-29-2011, FILED 12-22-2010.

VEGAS HITS ROAD TRIP

THE MARK CONSISTS OF STANDARD CHARACTERS WITHOUT CLAIM TO ANY PARTICULAR FONT, STYLE, SIZE, OR COLOR.

OWNER OF U.S. REG. NO. 3,908,953.

NO CLAIM IS MADE TO THE EXCLUSIVE RIGHT TO USE "VEGAS", APART FROM THE MARK AS SHOWN.

FOR COMPUTER GAMING SOFTWARE, GAMING SOFTWARE THAT GENERATES OR DISPLAYS WAGER OUTCOMES OF GAMING MACHINES, DOWNLOADABLE COMPUTER GAME SOFTWARE FOR GAMING, GAMING MACHINES, NAMELY, DEVICES THAT ACCEPT A WAGER; SLOT MACHINES (U.S. CLS. 21, 23, 26, 36 AND 38).

FIRST USE 9-16-2011; IN COMMERCE 9-16-2011.

4,154,949. PREMIER MANUFACTURING GROUP, INC., SHELTON, CT. SN 85-205,628. PUB. 11-29-2011, FILED 12-25-2010.

CABLE COMBER

THE MARK CONSISTS OF STANDARD CHARACTERS WITHOUT CLAIM TO ANY PARTICULAR FONT, STYLE, SIZE, OR COLOR.

NO CLAIM IS MADE TO THE EXCLUSIVE RIGHT TO USE "CABLE", APART FROM THE MARK AS SHOWN.

FOR ELECTRICAL DUCTS FOR ELECTRICAL WIRES AND CABLES; RIGID AND FLEXIBLE ELECTRICAL RACEWAYS FOR HOLDING AND ORGANIZING ELECTRICAL WIRES AND CABLES (U.S. CLS. 21, 23, 26, 36 AND 38).

FIRST USE 3-31-2011; IN COMMERCE 3-31-2011.

4,154,950. PREMIER MANUFACTURING GROUP, INC., SHELTON, CT. SN 85-205,630. PUB. 11-29-2011, FILED 12-25-2010.

CABLE CANAL

THE MARK CONSISTS OF STANDARD CHARACTERS WITHOUT CLAIM TO ANY PARTICULAR FONT, STYLE, SIZE, OR COLOR.

CLASS 9—(Continued).

NO CLAIM IS MADE TO THE EXCLUSIVE RIGHT TO USE "CABLE", APART FROM THE MARK AS SHOWN.

FOR ELECTRICAL DUCTS FOR ELECTRICAL WIRES AND CABLES; RIGID AND FLEXIBLE ELECTRICAL RACEWAYS FOR HOLDING AND ORGANIZING ELECTRICAL WIRES AND CABLES (U.S. CLS. 21, 23, 26, 36 AND 38).

FIRST USE 7-7-2011; IN COMMERCE 7-7-2011.

4,154,963. GRAND VISION GAMING, LLC, BILLINGS, MT.
SN 85-211,453. PUB. 4-19-2011, FILED 1-5-2011.

QUICK CASH

THE MARK CONSISTS OF STANDARD CHARACTERS WITHOUT CLAIM TO ANY PARTICULAR FONT, STYLE, SIZE, OR COLOR.

NO CLAIM IS MADE TO THE EXCLUSIVE RIGHT TO USE "CASH", APART FROM THE MARK AS SHOWN.

FOR GAMING MACHINES (U.S. CLS. 21, 23, 26, 36 AND 38).

FIRST USE 2-8-2012; IN COMMERCE 2-8-2012.

4,154,969. CRASCHE NEW YORK LLC, WOODBURY, NY.
SN 85-214,152. PUB. 12-6-2011, FILED 1-10-2011.

CRASCHE

THE MARK CONSISTS OF STANDARD CHARACTERS WITHOUT CLAIM TO ANY PARTICULAR FONT, STYLE, SIZE, OR COLOR.

FOR PROTECTIVE HEADWEAR FOR PROTECTION AGAINST INJURY TO THE HEAD; PROTECTIVE HEADWEAR FOR SPORTS TO PROTECT AGAINST INJURY TO THE HEAD; SPORTS EQUIPMENT, NAMELY, PROTECTIVE HEADWEAR FOR PROTECTION AGAINST INJURY TO THE HEAD; PROTECTIVE INSERTS FOR SPORTS HEADWEAR TO PROTECT AGAINST INJURY TO THE HEAD; PROTECTIVE HEADWEAR AND PROTECTIVE INSERTS FOR HEADWEAR, ALL FOR PROTECTION AGAINST INJURY TO THE HEAD IN BIKING, CYCLING, SKATE BOARDING, ROLLER SKATING, INLINE SKATING, FIELD HOCKEY, LACROSSE, TOUCH FOOTBALL, FLAG FOOTBALL AND SKIING (U.S. CLS. 21, 23, 26, 36 AND 38).

FIRST USE 1-29-2012; IN COMMERCE 1-29-2012.

CLASS 9—(Continued).

4,154,977. MITSUBISHI ELECTRIC CORPORATION, CHIYODA-KU, TOKYO, JAPAN. SN 85-215,053. PUB. 10-18-2011, FILED 1-11-2011.

Arms

THE MARK CONSISTS OF STANDARD CHARACTERS WITHOUT CLAIM TO ANY PARTICULAR FONT, STYLE, SIZE, OR COLOR.

FOR SIGNAL PROCESSING APPARATUS FOR TRANSMITTING THE INFORMATION RELATING TO THE OPERATING STATUS AND CONDITIONS OF ELECTRICAL SWITCHGEARS, CIRCUIT BREAKERS AND/OR TRANSFORMERS INSTALLED WITHIN ELECTRICAL POWER PLANT OR ELECTRICAL SUBSTATION TO THE SUPERVISING AND CONTROLLING NETWORK; REMOTE ELECTRONIC APPARATUS FOR THE REMOTE CONTROL OF POWER GENERATING OPERATIONS FOR ELECTRICAL SWITCHGEARS, CIRCUIT BREAKERS AND/OR TRANSFORMERS INSTALLED WITHIN ELECTRICAL POWER PLANT OR ELECTRICAL SUBSTATION (U.S. CLS. 21, 23, 26, 36 AND 38).

FIRST USE 2-29-2012; IN COMMERCE 2-29-2012.

4,154,978. SERCHLITE MULTIMEDIA, WINDEMERE, FL.
SN 85-215,338. PUB. 5-24-2011, FILED 1-11-2011.

YOU RANG

THE MARK CONSISTS OF STANDARD CHARACTERS WITHOUT CLAIM TO ANY PARTICULAR FONT, STYLE, SIZE, OR COLOR.

FOR COMPUTER APPLICATION SOFTWARE FOR MOBILE PHONES, NAMELY, SOFTWARE FOR SEARCHING A REAL ESTATE DIRECTORY AND DATABASE FOR CONTRACTORS, REAL ESTATE AGENTS, AND SERVICE PROVIDERS, FOR USE BY ANYONE IN THE REAL ESTATE FIELD OR INTERESTED IN REAL ESTATE (U.S. CLS. 21, 23, 26, 36 AND 38).

FIRST USE 1-0-2010; IN COMMERCE 1-0-2010.

4,154,983. AU OPTRONICS CORP., HSINCHU CITY, TAIWAN. SN 85-217,243. PUB. 8-16-2011, FILED 1-13-2011.



OWNER OF TAIWAN REG. NO. 01260605, DATED 5-1-2007, EXPIRES 4-30-2017.

THE MARK CONSISTS OF STYLIZED LETTERS "AMVA" WITH WAVY HORIZONTAL LINES BELOW THE LETTERS.

CLASS 9—(Continued).

THE WORD(S) "AMVA" HAS NO MEANING IN A FOREIGN LANGUAGE.

FOR FLAT PANEL DISPLAY SCREENS; LIQUID CRYSTAL DISPLAYS; LOW TEMPERATURE POLY-SILICON LIQUID CRYSTAL DISPLAYS; ORGANIC LIGHT EMITTING DIODE DISPLAYS; COLOR THIN FILM TRANSISTOR LIQUID CRYSTAL DISPLAYS (U.S. CLS. 21, 23, 26, 36 AND 38).

FIRST USE 10-21-2005; IN COMMERCE 1-5-2006.

4,154,998. APPICLE, OLATHE, KS. SN 85-223,160. PUB. 5-31-2011, FILED 1-21-2011.



THE STIPPLING IS FOR SHADING PURPOSES ONLY. THE MARK CONSISTS OF A CHESSBOARD, OVERLAID WITH A RECTANGULAR BANNER AND "CHESSSCRIBE" WRITTEN ON IT. A GLOWING LIGHT IS RIGHT BELOW THE TWO "SS" OF THE WORD "CHESS".

FOR COMPUTER SOFTWARE FOR CHESS NOTATION (U.S. CLS. 21, 23, 26, 36 AND 38).

FIRST USE 7-30-2011; IN COMMERCE 7-30-2011.

4,155,015. BK FRAMES, CORP., MIAMI BEACH, FL. SN 85-230,868. PUB. 1-24-2012, FILED 2-1-2011.

RAZZI

THE MARK CONSISTS OF STANDARD CHARACTERS WITHOUT CLAIM TO ANY PARTICULAR FONT, STYLE, SIZE, OR COLOR.

THE ENGLISH TRANSLATION OF "RAZZI" IN THE MARK IS "ROCKETS".

FOR EYEGLASS FRAMES; EYEGLASSES; SUNGLASSES (U.S. CLS. 21, 23, 26, 36 AND 38).

FIRST USE 2-1-2004; IN COMMERCE 2-1-2004.

CLASS 9—(Continued).

4,155,048. GEOEYE IMAGERY COLLECTION SYSTEMS INC., DULLES, VA. SN 85-238,384. PUB. 6-14-2011, FILED 2-9-2011.

ELEVATING INSIGHT

THE MARK CONSISTS OF STANDARD CHARACTERS WITHOUT CLAIM TO ANY PARTICULAR FONT, STYLE, SIZE, OR COLOR.

FOR DOWNLOADABLE IMAGES OF THE EARTH; SOFTWARE FOR VIEWING AND MANIPULATING DIGITAL IMAGERY OF THE EARTH (U.S. CLS. 21, 23, 26, 36 AND 38).

FIRST USE 3-0-2011; IN COMMERCE 3-0-2011.

4,155,080. VERSARIES, LLC, FAIRFIELD, OH. SN 85-243,831. PUB. 7-12-2011, FILED 2-16-2011.

VERSARIES

THE MARK CONSISTS OF STANDARD CHARACTERS WITHOUT CLAIM TO ANY PARTICULAR FONT, STYLE, SIZE, OR COLOR.

FOR COMPUTER APPLICATION SOFTWARE FOR MOBILE DEVICES, MOBILE PHONES, DESKTOP, LAPTOP OR PALMTOP COMPUTERS, NAMELY, SOFTWARE FOR USE IN FACILITATING SOCIAL INTERACTION BETWEEN AND AMONG COMPUTER USERS VIA EMAIL AND COMPUTER NETWORKS REGARDING SOCIAL EVENTS AND OCCASIONS (U.S. CLS. 21, 23, 26, 36 AND 38).

FIRST USE 6-30-2011; IN COMMERCE 6-30-2011.

4,155,081. VERSARIES, LLC, FAIRFIELD, OH. SN 85-243,838. PUB. 7-12-2011, FILED 2-16-2011.

VERSARY

THE MARK CONSISTS OF STANDARD CHARACTERS WITHOUT CLAIM TO ANY PARTICULAR FONT, STYLE, SIZE, OR COLOR.

FOR COMPUTER APPLICATION SOFTWARE FOR MOBILE DEVICES, MOBILE PHONES, DESKTOP, LAPTOP OR PALMTOP COMPUTERS, NAMELY, SOFTWARE FOR USE IN FACILITATING SOCIAL INTERACTION BETWEEN AND AMONG COMPUTER USERS VIA EMAIL AND COMPUTER NETWORKS REGARDING SOCIAL EVENTS AND OCCASIONS (U.S. CLS. 21, 23, 26, 36 AND 38).

FIRST USE 6-30-2011; IN COMMERCE 6-30-2011.

CLASS 9—(Continued).

4,155,097. EW STEREOEAST INC., FRISCO, TX. SN 85-245,586. PUB. 5-31-2011, FILED 2-18-2011.

EPIASURE

THE MARK CONSISTS OF STANDARD CHARACTERS WITHOUT CLAIM TO ANY PARTICULAR FONT, STYLE, SIZE, OR COLOR.
FOR LOUDSPEAKERS (U.S. CLS. 21, 23, 26, 36 AND 38).
FIRST USE 8-22-2011; IN COMMERCE 8-22-2011.

CLASS 9—(Continued).

4,155,100. TASSERON SENSORS, INC., WILLIAMSPORT, PA. SN 85-245,756. PUB. 7-5-2011, FILED 2-18-2011.



THE COLOR(S) RED, GRAY AND BLACK IS/ARE CLAIMED AS A FEATURE OF THE MARK.
THE MARK CONSISTS OF A RED, GRAY AND BLACK DIAL OR METER THAT REPRESENTS THE LETTER "Q", FOLLOWED BY "QWIK" IN BLACK, FOLLOWED BY "IMMERSION" IN RED.
FOR TEMPERATURE SENSORS; THERMISTORS (U.S. CLS. 21, 23, 26, 36 AND 38).
FIRST USE 2-28-2011; IN COMMERCE 2-28-2011.

4,155,098. ESTEREL TECHNOLOGIES, INC., MOUNTAIN VIEW, CA. SN 85-245,667. PUB. 6-28-2011, FILED 2-18-2011.

SCADE LifeCycle

THE MARK CONSISTS OF STANDARD CHARACTERS WITHOUT CLAIM TO ANY PARTICULAR FONT, STYLE, SIZE, OR COLOR.
OWNER OF U.S. REG. NO. 3,144,740.
FOR COMPUTER SOFTWARE DEVELOPMENT TOOLS; COMPUTER SOFTWARE FOR USE IN AVIONICS AND COCKPIT DISPLAYS SYSTEMS (U.S. CLS. 21, 23, 26, 36 AND 38).
FIRST USE 6-30-2011; IN COMMERCE 6-30-2011.

4,155,101. TASSERON SENSORS, INC., WILLIAMSPORT, PA. SN 85-245,762. PUB. 7-5-2011, FILED 2-18-2011.



THE COLOR(S) RED, GRAY AND BLACK IS/ARE CLAIMED AS A FEATURE OF THE MARK.
THE MARK CONSISTS OF A RED, GRAY AND BLACK DIAL OR METER THAT REPRESENTS THE LETTER "Q", FOLLOWED BY "QWIK" IN BLACK, FOLLOWED BY "MINI" IN RED.
FOR TEMPERATURE SENSORS; THERMISTORS (U.S. CLS. 21, 23, 26, 36 AND 38).
FIRST USE 2-28-2011; IN COMMERCE 2-28-2011.

4,155,099. TASSERON SENSORS, INC., WILLIAMSPORT, PA. SN 85-245,741. PUB. 7-5-2011, FILED 2-18-2011.



THE COLOR(S) RED, GRAY AND BLACK IS/ARE CLAIMED AS A FEATURE OF THE MARK.
THE MARK CONSISTS OF A RED, GRAY AND BLACK DIAL OR METER THAT REPRESENTS THE LETTER "Q", FOLLOWED BY "QWIK" IN BLACK, FOLLOWED BY "BOX" IN RED.
FOR TEMPERATURE SENSORS; THERMISTORS (U.S. CLS. 21, 23, 26, 36 AND 38).
FIRST USE 2-28-2011; IN COMMERCE 2-28-2011.

4,155,102. TASSERON SENSORS, INC., WILLIAMSPORT, PA. SN 85-245,767. PUB. 7-5-2011, FILED 2-18-2011.



THE COLOR(S) RED, GRAY AND BLACK IS/ARE CLAIMED AS A FEATURE OF THE MARK.
THE MARK CONSISTS OF A RED, GRAY AND BLACK DIAL OR METER THAT REPRESENTS THE LETTER "Q", FOLLOWED BY "QWIK" IN BLACK, FOLLOWED BY "OUTDOOR" IN RED.
FOR TEMPERATURE SENSORS; THERMISTORS (U.S. CLS. 21, 23, 26, 36 AND 38).
FIRST USE 2-28-2011; IN COMMERCE 2-28-2011.

CLASS 9—(Continued).

4,155,103. TASSERON SENSORS, INC., WILLIAMSPORT, PA. SN 85-245,781. PUB. 7-5-2011, FILED 2-18-2011.



THE COLOR(S) RED, GRAY AND BLACK IS/ARE CLAIMED AS A FEATURE OF THE MARK.

THE MARK CONSISTS OF A RED, GRAY AND BLACK DIAL OR METER THAT REPRESENTS THE LETTER "Q", FOLLOWED BY "QWIK" IN BLACK, FOLLOWED BY "ROOM" IN RED.

FOR TEMPERATURE SENSORS; THERMISTORS (U.S. CLS. 21, 23, 26, 36 AND 38).

FIRST USE 2-28-2011; IN COMMERCE 2-28-2011.

4,155,104. TASSERON SENSORS, INC., WILLIAMSPORT, PA. SN 85-245,797. PUB. 7-5-2011, FILED 2-18-2011.



THE COLOR(S) RED, GRAY AND BLACK IS/ARE CLAIMED AS A FEATURE OF THE MARK.

THE MARK CONSISTS OF A RED, GRAY AND BLACK DIAL OR METER THAT REPRESENTS THE LETTER "Q", FOLLOWED BY "QWIK" IN BLACK, FOLLOWED BY "STRAP" IN RED.

FOR TEMPERATURE SENSORS; THERMISTORS (U.S. CLS. 21, 23, 26, 36 AND 38).

FIRST USE 2-28-2011; IN COMMERCE 2-28-2011.

4,155,112. WMS GAMING INC., WAUKEGAN, IL. SN 85-247,336. PUB. 6-28-2011, FILED 2-21-2011.

PIRATES OF THE DEEP

THE MARK CONSISTS OF STANDARD CHARACTERS WITHOUT CLAIM TO ANY PARTICULAR FONT, STYLE, SIZE, OR COLOR.

FOR COMPONENTS FOR GAMING MACHINES THAT GENERATE OR DISPLAY WAGER OUTCOMES, NAMELY, CONTROLLERS, DISPLAYS, BUTTON PANELS, BOLSTERS, ELECTRICAL WIRING, AND COMPUTER HARDWARE AND SOFTWARE ASSOCIATED THEREWITH; GAMING MACHINES, NAMELY, DEVICES WHICH ACCEPT A WAGER; GAMING SOFTWARE THAT GENERATES OR DISPLAYS WAGER OUTCOMES OF GAMING MACHINES (U.S. CLS. 21, 23, 26, 36 AND 38).

FIRST USE 10-4-2011; IN COMMERCE 10-4-2011.

CLASS 9—(Continued).

4,155,145. KABUSHIKI KAISHA TOPCON, TOKYO 174-8580, JAPAN. SN 85-251,407. PUB. 7-5-2011, FILED 2-25-2011.

Aquila

THE MARK CONSISTS OF STANDARD CHARACTERS WITHOUT CLAIM TO ANY PARTICULAR FONT, STYLE, SIZE, OR COLOR.

FOR APPARATUS AND INSTRUMENTS FOR ANALYZING AND INSPECTING SEMICONDUCTOR WAFER, SCANNING ELECTRON MICROSCOPES, OPTICAL MICROSCOPES, INTERFEROMETER, LASER INTERFEROMETER (U.S. CLS. 21, 23, 26, 36 AND 38).

FIRST USE 10-4-2011; IN COMMERCE 10-4-2011.

4,155,147. GROUPLAGIC, INC., ARLINGTON, VA. SN 85-251,706. PUB. 7-19-2011, FILED 2-25-2011.

mobileEcho

THE MARK CONSISTS OF STANDARD CHARACTERS WITHOUT CLAIM TO ANY PARTICULAR FONT, STYLE, SIZE, OR COLOR.

FOR COMPUTER SOFTWARE FOR BUSINESSES THAT ALLOWS USERS TO PERFORM ELECTRONIC BUSINESS TRANSACTIONS, COMMUNICATE WITH OTHER USERS, AND ACCESS AND EXCHANGE INFORMATION STORED ON A FILE SERVER VIA MOBILE DEVICES AND TABLET COMPUTERS (U.S. CLS. 21, 23, 26, 36 AND 38).

FIRST USE 5-23-2011; IN COMMERCE 5-23-2011.

4,155,175. KONAMI GAMING, INC., LAS VEGAS, NV. SN 85-254,072. PUB. 7-5-2011, FILED 2-28-2011.

CHINA DREAM

THE MARK CONSISTS OF STANDARD CHARACTERS WITHOUT CLAIM TO ANY PARTICULAR FONT, STYLE, SIZE, OR COLOR.

OWNER OF U.S. REG. NOS. 3,098,847 AND 3,865,443. FOR ELECTRONIC GAME PROGRAMS; GAMING EQUIPMENT, NAMELY, SLOT MACHINES WITH OR WITHOUT VIDEO OUTPUT; GAMING MACHINES; MACHINES FOR PLAYING GAMES OF CHANCE; SLOT MACHINES (U.S. CLS. 21, 23, 26, 36 AND 38).

FIRST USE 10-0-2011; IN COMMERCE 10-0-2011.

CLASS 9—(Continued).

4,155,176. KONAMI GAMING, INC., LAS VEGAS, NV. SN 85-254,082. PUB. 7-5-2011, FILED 2-28-2011.

HOT TWIN PHOENIXES

THE MARK CONSISTS OF STANDARD CHARACTERS WITHOUT CLAIM TO ANY PARTICULAR FONT, STYLE, SIZE, OR COLOR.

OWNER OF U.S. REG. NOS. 3,331,650, 3,886,898, AND OTHERS.

FOR ELECTRONIC GAME PROGRAMS; GAMING EQUIPMENT, NAMELY, SLOT MACHINES WITH OR WITHOUT VIDEO OUTPUT; GAMING MACHINES; MACHINES FOR PLAYING GAMES OF CHANCE; SLOT MACHINES (U.S. CLS. 21, 23, 26, 36 AND 38).

FIRST USE 10-0-2011; IN COMMERCE 10-0-2011.

4,155,177. KONAMI GAMING, INC., LAS VEGAS, NV. SN 85-254,098. PUB. 7-5-2011, FILED 2-28-2011.

CHINA FESTIVAL

THE MARK CONSISTS OF STANDARD CHARACTERS WITHOUT CLAIM TO ANY PARTICULAR FONT, STYLE, SIZE, OR COLOR.

OWNER OF U.S. REG. NO. 3,865,443.

FOR ELECTRONIC GAME PROGRAMS; GAMING EQUIPMENT, NAMELY, SLOT MACHINES WITH OR WITHOUT VIDEO OUTPUT; GAMING MACHINES; MACHINES FOR PLAYING GAMES OF CHANCE; SLOT MACHINES (U.S. CLS. 21, 23, 26, 36 AND 38).

FIRST USE 10-0-2011; IN COMMERCE 10-0-2011.

4,155,178. KONAMI GAMING, INC., LAS VEGAS, NV. SN 85-254,103. PUB. 7-5-2011, FILED 2-28-2011.

GRAND POWER OF AFRICA

THE MARK CONSISTS OF STANDARD CHARACTERS WITHOUT CLAIM TO ANY PARTICULAR FONT, STYLE, SIZE, OR COLOR.

OWNER OF U.S. REG. NOS. 2,512,871, 3,321,268, AND OTHERS.

FOR ELECTRONIC GAME PROGRAMS; GAMING EQUIPMENT, NAMELY, SLOT MACHINES WITH OR WITHOUT VIDEO OUTPUT; GAMING MACHINES; MACHINES FOR PLAYING GAMES OF CHANCE; SLOT MACHINES (U.S. CLS. 21, 23, 26, 36 AND 38).

FIRST USE 10-0-2011; IN COMMERCE 10-0-2011.

CLASS 9—(Continued).

4,155,180. CONCEPT ENGINEERING GMBH, 79111 FREIBURG, FED REP GERMANY. SN 85-254,381. PUB. 7-19-2011, FILED 3-1-2011.

STARVISION

THE MARK CONSISTS OF STANDARD CHARACTERS WITHOUT CLAIM TO ANY PARTICULAR FONT, STYLE, SIZE, OR COLOR.

FOR COMPUTER SOFTWARE, NAMELY, SOFTWARE FOR GENERATING AND DISPLAYING SCHEMATIC REPRESENTATIONS OF ELECTRONIC CIRCUITS (U.S. CLS. 21, 23, 26, 36 AND 38).

FIRST USE 10-31-2011; IN COMMERCE 10-31-2011.

4,155,184. ELKHART BRASS MANUFACTURING COMPANY, INC., ELKHART, IN. SN 85-254,773. PUB. 8-16-2011, FILED 3-1-2011.

SPIT-FIRE

THE MARK CONSISTS OF STANDARD CHARACTERS WITHOUT CLAIM TO ANY PARTICULAR FONT, STYLE, SIZE, OR COLOR.

FOR FIRE FIGHTING EQUIPMENT, NAMELY, FIRE FIGHTING MONITORS THAT SPRAY FOAM OR LIQUIDS ON FIRES (U.S. CLS. 21, 23, 26, 36 AND 38).

FIRST USE 4-29-2005; IN COMMERCE 4-29-2005.

4,155,186. ELKHART BRASS MANUFACTURING COMPANY, INC., ELKHART, IN. SN 85-254,797. PUB. 8-16-2011, FILED 3-1-2011.

COPPERHEAD

THE MARK CONSISTS OF STANDARD CHARACTERS WITHOUT CLAIM TO ANY PARTICULAR FONT, STYLE, SIZE, OR COLOR.

FOR FIRE FIGHTING EQUIPMENT, NAMELY, FIRE FIGHTING MONITORS THAT SPRAY FOAM OR LIQUIDS ON FIRES (U.S. CLS. 21, 23, 26, 36 AND 38).

FIRST USE 1-27-2003; IN COMMERCE 1-27-2003.

CLASS 9—(Continued).

4,155,187. GARMIN SWITZERLAND GMBH, SCHAFFHAUSEN, SWITZERLAND. SN 85-254,837. PUB. 7-19-2011, FILED 3-1-2011.

MONTANA

THE MARK CONSISTS OF STANDARD CHARACTERS WITHOUT CLAIM TO ANY PARTICULAR FONT, STYLE, SIZE, OR COLOR.

FOR HANDHELD SATELLITE NAVIGATIONAL SYSTEM, NAMELY, A GLOBAL POSITIONING SYSTEM (GPS) (U.S. CLS. 21, 23, 26, 36 AND 38).

FIRST USE 6-0-2011; IN COMMERCE 6-0-2011.

4,155,197. PASSTOUCH, LLC, SURF CITY, NC. SN 85-255,865. PUB. 7-19-2011, FILED 3-2-2011.

PASSTOUCH

THE MARK CONSISTS OF STANDARD CHARACTERS WITHOUT CLAIM TO ANY PARTICULAR FONT, STYLE, SIZE, OR COLOR.

FOR COMPUTER SOFTWARE, NAMELY, GRAPHICAL INTERFACES FOR USER AUTHENTICATION AND IDENTIFICATION (U.S. CLS. 21, 23, 26, 36 AND 38).

FIRST USE 8-13-2011; IN COMMERCE 8-13-2011.

4,155,201. ZHEJIANG DAHUA TECHNOLOGY CO., LTD., HANGZHOU, CHINA. SN 85-256,371. PUB. 7-12-2011, FILED 3-2-2011.

@lhua

THE MARK CONSISTS OF THE STYLIZED WORD "AJHUA" WITH THE LETTER "A" INSIDE AN INCOMPLETE CIRCLE.

THE WORDING "AJHUA" HAS NO MEANING IN A FOREIGN LANGUAGE.

FOR ALARM MONITORING SYSTEMS; CAMCORDERS; CARDS WITH INTEGRATED CIRCUITS; COMPUTER HARDWARE; COMPUTER MONITORS; COMPUTER OPERATING PROGRAMS, RECORDED; COMPUTER PERIPHERAL DEVICES; THEFT ALARMS; VIDEO RECORDERS; VIDEO TELEPHONES (U.S. CLS. 21, 23, 26, 36 AND 38).

FIRST USE 3-12-2001; IN COMMERCE 9-10-2011.

CLASS 9—(Continued).

4,155,208. ZYLOWARE CORPORATION, PORT CHESTER, NY. SN 85-257,023. PUB. 7-19-2011, FILED 3-3-2011.

I-STAMP

THE MARK CONSISTS OF STANDARD CHARACTERS WITHOUT CLAIM TO ANY PARTICULAR FONT, STYLE, SIZE, OR COLOR.

FOR OPTICAL FRAMES (U.S. CLS. 21, 23, 26, 36 AND 38).

FIRST USE 9-30-2011; IN COMMERCE 9-30-2011.

4,155,216. PASSTOUCH, LLC, SURF CITY, NC. SN 85-257,768. PUB. 7-19-2011, FILED 3-4-2011.



THE MARK CONSISTS OF CONTINUOUS SPIRALING CURVE.

FOR COMPUTER SOFTWARE, NAMELY, GRAPHICAL INTERFACES FOR USER AUTHENTICATION AND IDENTIFICATION (U.S. CLS. 21, 23, 26, 36 AND 38).

FIRST USE 8-13-2011; IN COMMERCE 8-13-2011.

4,155,218. ENERGY EYE, INC., POWAY, CA. SN 85-258,175. PUB. 7-26-2011, FILED 3-4-2011.

EYEPOWER

THE MARK CONSISTS OF STANDARD CHARACTERS WITHOUT CLAIM TO ANY PARTICULAR FONT, STYLE, SIZE, OR COLOR.

CLASS 9—(Continued).

OWNER OF U.S. REG. NO. 3,967,353.

FOR OCCUPANCY SENSORS, NAMELY, ELECTRONIC DEVICES WHICH DETECT THE PRESENCE OF OCCUPANTS AND CONTROL THE LIGHTING SYSTEM ACCORDINGLY; RESIDENTIAL AND COMMERCIAL AUTOMATION SYSTEMS COMPRISING WIRELESS AND WIRED CONTROLLERS, CONTROLLED DEVICES, AND SOFTWARE FOR LIGHTING, HVAC, SAFETY AND OTHER MONITORING AND CONTROL APPLICATIONS; FACILITIES MANAGEMENT SOFTWARE, NAMELY, SOFTWARE TO CONTROL BUILDING ENVIRONMENT; ELECTRONIC DEVICES, NAMELY, ENERGY METERS, SUBMETERS, AND RADIO FREQUENCY REPEATERS USED IN LONG RANGE COMMUNICATION, ALL FOR TRACKING AND MONITORING ENERGY USAGE AND SOFTWARE IN THE FIELD OF BUILDING MANAGEMENT FOR USE IN ENERGY AUDITING, ENERGY MONITORING, DATA COLLECTION AND ANALYSIS OF ENERGY CONSUMPTION, ENERGY UTILIZATION AND ENERGY MONITORING (U.S. CLS. 21, 23, 26, 36 AND 38).

FIRST USE 11-1-2009; IN COMMERCE 11-1-2009.

4,155,221. NAMCO BANDAI GAMES INC., SHINAGAWA-KU TOKYO, JAPAN. SN 85-258,485. PUB. 6-21-2011, FILED 3-4-2011.

PAC-CHOMP

THE MARK CONSISTS OF STANDARD CHARACTERS WITHOUT CLAIM TO ANY PARTICULAR FONT, STYLE, SIZE, OR COLOR.

FOR COMPUTER GAME PROGRAMS; COMPUTER GAME SOFTWARE; DOWNLOADABLE COMPUTER GAME PROGRAMS; DOWNLOADABLE COMPUTER GAME SOFTWARE VIA A GLOBAL COMPUTER NETWORK AND WIRELESS DEVICES; VIDEO GAME SOFTWARE (U.S. CLS. 21, 23, 26, 36 AND 38).

FIRST USE 4-21-2011; IN COMMERCE 4-21-2011.

4,155,223. ROCHHOLZ, ROBERT, COUPEVILLE, WA. SN 85-258,924. PUB. 7-26-2011, FILED 3-5-2011.

CHIN SKIN

THE MARK CONSISTS OF STANDARD CHARACTERS WITHOUT CLAIM TO ANY PARTICULAR FONT, STYLE, SIZE, OR COLOR.

NO CLAIM IS MADE TO THE EXCLUSIVE RIGHT TO USE "CHIN", APART FROM THE MARK AS SHOWN.

FOR CHIN STRAPS FOR FOOTBALL HELMETS; PROTECTIVE SPORTS HELMET ACCESSORIES THAT ATTACH TO THE HELMETS, NAMELY, MOUTH GUARDS, EAR PADS, THROAT PROTECTORS, CHIN STRAPS, FACE MASKS, JAW PADS AND EYE SHIELDS (U.S. CLS. 21, 23, 26, 36 AND 38).

FIRST USE 7-13-2011; IN COMMERCE 7-13-2011.

CLASS 9—(Continued).

4,155,228. THINGWORX, INC., EXTON, PA. SN 85-259,672. PUB. 8-9-2011, FILED 3-7-2011.

THE 1ST APPLICATION PLATFORM FOR A CONNECTED WORLD

THE MARK CONSISTS OF STANDARD CHARACTERS WITHOUT CLAIM TO ANY PARTICULAR FONT, STYLE, SIZE, OR COLOR.

NO CLAIM IS MADE TO THE EXCLUSIVE RIGHT TO USE "APPLICATION PLATFORM", APART FROM THE MARK AS SHOWN.

FOR SOFTWARE APPLICATION PLATFORM FOR CONNECTING PEOPLE, SERVICES AND DEVICES TO THE INTERNET (U.S. CLS. 21, 23, 26, 36 AND 38).

FIRST USE 2-0-2011; IN COMMERCE 2-0-2011.

4,155,232. ENWAVE OPTRONICS, INC., IRVINE, CA. SN 85-260,203. PUB. 7-5-2011, FILED 3-7-2011.

ASSUR_R

THE MARK CONSISTS OF THE LETTERS: "ASSU" ALL IN CAPS, WITH AN "RX" SYMBOL AT THE END.

FOR SPECTROMETERS, AND PARTS AND FITTINGS THEREFOR (U.S. CLS. 21, 23, 26, 36 AND 38).

FIRST USE 12-2-2009; IN COMMERCE 3-20-2010.

4,155,269. SAMSUNG ELECTRONICS CO., LTD., SUWON-SI, GYEONGGI-DO, REPUBLIC OF KOREA. SN 85-263,281. PUB. 7-26-2011, FILED 3-10-2011.

SAMSUNG COMMENT

THE MARK CONSISTS OF STANDARD CHARACTERS WITHOUT CLAIM TO ANY PARTICULAR FONT, STYLE, SIZE, OR COLOR.

OWNER OF U.S. REG. NOS. 2,929,519, 3,503,660, AND OTHERS.

THE ENGLISH TRANSLATION OF "SAMSUNG" IN THE MARK IS THREE STARS.

FOR MOBILE PHONES; SMARTPHONES (U.S. CLS. 21, 23, 26, 36 AND 38).

FIRST USE 8-24-2011; IN COMMERCE 8-24-2011.

CLASS 9—(Continued).

4,155,270. SAMSUNG ELECTRONICS CO., LTD., SUWON-SI, GYEONGGI-DO, REPUBLIC OF KOREA. SN 85-263,338. PUB. 7-26-2011, FILED 3-10-2011.

SAMSUNG CHARACTER

THE MARK CONSISTS OF STANDARD CHARACTERS WITHOUT CLAIM TO ANY PARTICULAR FONT, STYLE, SIZE, OR COLOR.

OWNER OF U.S. REG. NOS. 2,929,519, 3,503,660, AND OTHERS.

THE ENGLISH TRANSLATION OF "SAMSUNG" IN THE MARK IS THREE STARS.

FOR MOBILE PHONES; SMARTPHONES (U.S. CLS. 21, 23, 26, 36 AND 38).

FIRST USE 7-28-2011; IN COMMERCE 7-28-2011.

4,155,271. SAMSUNG ELECTRONICS CO., LTD., SUWON-SI, GYEONGGI-DO, REPUBLIC OF KOREA. SN 85-263,354. PUB. 7-26-2011, FILED 3-10-2011.

REPLENISH

THE MARK CONSISTS OF STANDARD CHARACTERS WITHOUT CLAIM TO ANY PARTICULAR FONT, STYLE, SIZE, OR COLOR.

FOR MOBILE PHONES; SMARTPHONES (U.S. CLS. 21, 23, 26, 36 AND 38).

FIRST USE 4-15-2011; IN COMMERCE 4-15-2011.

4,155,304. NAMCO BANDAI GAMES INC., SHINAGAWA-KU TOKYO, JAPAN. SN 85-267,483. PUB. 6-21-2011, FILED 3-15-2011.

PAC-MOTOS

THE MARK CONSISTS OF STANDARD CHARACTERS WITHOUT CLAIM TO ANY PARTICULAR FONT, STYLE, SIZE, OR COLOR.

FOR COMPUTER GAME PROGRAMS; COMPUTER GAME SOFTWARE; DOWNLOADABLE COMPUTER GAME PROGRAMS; DOWNLOADABLE COMPUTER GAME SOFTWARE VIA A GLOBAL COMPUTER NETWORK AND WIRELESS DEVICES; VIDEO GAME SOFTWARE (U.S. CLS. 21, 23, 26, 36 AND 38).

FIRST USE 10-23-2007; IN COMMERCE 10-23-2007.

CLASS 9—(Continued).

4,155,328. DFLABS S.R.L., 26013 CREMA CR, ITALY. SN 85-270,406. PUB. 8-2-2011, FILED 3-18-2011.

DFLabs

THE MARK CONSISTS OF STANDARD CHARACTERS WITHOUT CLAIM TO ANY PARTICULAR FONT, STYLE, SIZE, OR COLOR.

FOR COMPUTER SOFTWARE FOR USE IN NETWORK SECURITY, INFORMATION SECURITY STRATEGY, INCIDENT/FRAUD PREVENTION AND RESPONSE, DIGITAL FORENSICS, ELECTRONIC LITIGATION DISCOVERY, LITIGATION SUPPORT, INFOSECURITY TRAINING, INTRUSION PREVENTION, AND LOG AND VULNERABILITY MANAGEMENT (U.S. CLS. 21, 23, 26, 36 AND 38).

FIRST USE 1-1-2004; IN COMMERCE 1-1-2004.

4,155,332. IGT, RENO, NV. SN 85-270,858. PUB. 7-5-2011, FILED 3-18-2011.

COOL BEANS

THE MARK CONSISTS OF STANDARD CHARACTERS WITHOUT CLAIM TO ANY PARTICULAR FONT, STYLE, SIZE, OR COLOR.

FOR GAMING MACHINES, NAMELY, DEVICES WHICH ACCEPT A WAGER (U.S. CLS. 21, 23, 26, 36 AND 38).

FIRST USE 3-5-2012; IN COMMERCE 3-5-2012.

4,155,343. ZHONG RENKANG, SHENZHEN, CHINA. SN 85-272,936. PUB. 8-2-2011, FILED 3-22-2011.

Miusta

THE MARK CONSISTS OF THE STYLIZED WORD "MIUSTA" WITH THE DOT OF THE CHARACTER I REPLACED BY A HEART, AND A HORIZONTAL CURVED BAND CUTTING THE WORD "MIUSTA" INTO TWO PARTS.

CLASS 9—(Continued).

THE WORDING "MIUSTA" HAS NO MEANING IN A FOREIGN LANGUAGE.
 FOR CAMCORDERS; CASES FOR PHOTOGRAPHIC APPARATUS; CASES FOR POCKET CALCULATORS; CASES FOR TELEPHONES; COMPUTER KEYBOARDS; COMPUTER PERIPHERAL DEVICES; DISTANCE MEASURING APPARATUS; GALVANIC BATTERIES; PERSONAL SECURITY ALARMS; THEFT ALARMS (U.S. CLS. 21, 23, 26, 36 AND 38).
 FIRST USE 3-10-2011; IN COMMERCE 4-22-2011.

4,155,345. BANOM, INC., WAYNE, PA. SN 85-273,049. PUB. 8-2-2011, FILED 3-22-2011.

45

THE MARK CONSISTS OF STANDARD CHARACTERS WITHOUT CLAIM TO ANY PARTICULAR FONT, STYLE, SIZE, OR COLOR.
 FOR PROTECTIVE GLOVES FOR INDUSTRIAL USE (U.S. CLS. 21, 23, 26, 36 AND 38).
 FIRST USE 2-16-2012; IN COMMERCE 3-5-2012.

4,155,353. MEDICOMP SYSTEMS, INC., CHANTILLY, VA. SN 85-274,880. PUB. 7-26-2011, FILED 3-23-2011.



THE COLOR(S) BLUE, WHITE, LIGHT BLUE AND GRAY IS/ARE CLAIMED AS A FEATURE OF THE MARK.
 THE MARK CONSISTS OF A BLUE BOX CONTAINING A STYLIZED CADUCEUS IN LIGHT BLUE AND WHITE SUPERIMPOSED ON AN ANGEL IN WHITE WITH GRAY ON THE BOTTOM.
 FOR COMPUTER SOFTWARE FOR CONTROLLING AND MANAGING PATIENT MEDICAL INFORMATION (U.S. CLS. 21, 23, 26, 36 AND 38).
 FIRST USE 8-0-2011; IN COMMERCE 8-0-2011.

CLASS 9—(Continued).

4,155,357. BDSRCO, INC., WILMINGTON, DE. SN 85-276,119. PUB. 8-23-2011, FILED 3-24-2011.

REEL LEGENDS

THE MARK CONSISTS OF STANDARD CHARACTERS WITHOUT CLAIM TO ANY PARTICULAR FONT, STYLE, SIZE, OR COLOR.
 OWNER OF U.S. REG. NO. 2,755,158.
 FOR SUNGLASSES (U.S. CLS. 21, 23, 26, 36 AND 38).
 FIRST USE 11-1-2009; IN COMMERCE 11-1-2009.

4,155,359. EMERSON CLIMATE TECHNOLOGIES, INC., SIDNEY, OH. SN 85-276,222. PUB. 8-23-2011, FILED 3-24-2011.

COPELAND X-REF

THE MARK CONSISTS OF STANDARD CHARACTERS WITHOUT CLAIM TO ANY PARTICULAR FONT, STYLE, SIZE, OR COLOR.
 OWNER OF U.S. REG. NOS. 890,471, 3,697,065, AND OTHERS.
 FOR COMPUTER APPLICATION SOFTWARE FOR MOBILE PHONES AND FOR SMARTPHONES, NAMELY, COMPUTER SOFTWARE FOR USE IN CROSS REFERENCING COMPRESSOR MODEL INFORMATION; DOWNLOADABLE SOFTWARE IN THE NATURE OF A MOBILE APPLICATION FOR USE IN CROSS REFERENCING COMPRESSOR MODEL INFORMATION (U.S. CLS. 21, 23, 26, 36 AND 38).
 FIRST USE 9-21-2011; IN COMMERCE 9-21-2011.

4,155,360. BLACK-I TECHNOLOGIES, LLC, BAY HARBOR IS., FL. SN 85-276,449. PUB. 8-9-2011, FILED 3-25-2011.

BLACK-I

THE MARK CONSISTS OF STANDARD CHARACTERS WITHOUT CLAIM TO ANY PARTICULAR FONT, STYLE, SIZE, OR COLOR.
 FOR COMPUTER UTILITY SOFTWARE; COMPUTER SOFTWARE FOR USE IN MAINTENANCE OF COMPUTER SECURITY AND PREVENTION OF COMPUTER RISKS (U.S. CLS. 21, 23, 26, 36 AND 38).
 FIRST USE 2-18-2012; IN COMMERCE 2-18-2012.

CLASS 9—(Continued).

4,155,361. CLINICAL INK, INC., WINSTON-SALEM, NC. SN 85-276,567. PUB. 8-2-2011, FILED 3-25-2011.

SURESTART

THE MARK CONSISTS OF STANDARD CHARACTERS WITHOUT CLAIM TO ANY PARTICULAR FONT, STYLE, SIZE, OR COLOR.

FOR COMPUTER SOFTWARE USED TO CAPTURE AND ORGANIZE CLINICAL TRIAL PROTOCOL REQUIREMENTS, DATA FIELD EDIT CHECKS AND ASSOCIATED INFORMATION REQUIRED TO CREATE ELECTRONIC SOURCE DOCUMENTS (U.S. CLS. 21, 23, 26, 36 AND 38).

FIRST USE 8-9-2011; IN COMMERCE 8-9-2011.

4,155,364. S A S SAFETY CORP., LONG BEACH, CA. SN 85-277,563. PUB. 8-9-2011, FILED 3-25-2011.

LIGHTCRAFTERS

THE MARK CONSISTS OF STANDARD CHARACTERS WITHOUT CLAIM TO ANY PARTICULAR FONT, STYLE, SIZE, OR COLOR.

FOR BIFOCAL MAGNIFYING LENSES WITH BUILT-IN LED LIGHTS (U.S. CLS. 21, 23, 26, 36 AND 38).

FIRST USE 12-1-2011; IN COMMERCE 12-1-2011.

4,155,374. THE 3/50 PROJECT LLC, GOLDEN VALLEY, MN. SN 85-278,549. PUB. 7-12-2011, FILED 3-28-2011.

LOOK LOCAL

THE MARK CONSISTS OF STANDARD CHARACTERS WITHOUT CLAIM TO ANY PARTICULAR FONT, STYLE, SIZE, OR COLOR.

CLASS 9—(Continued).

NO CLAIM IS MADE TO THE EXCLUSIVE RIGHT TO USE "LOCAL", APART FROM THE MARK AS SHOWN.

FOR DOWNLOADABLE SOFTWARE FOR MOBILE DEVICES, CELLULAR PHONES, PERSONAL COMMUNICATIONS SERVICE (PCS) PHONES, PERSONAL DIGITAL ASSISTANTS (PDAS), HANDHELD COMPUTERS, COMPUTERS, PORTABLE MEDIA PLAYERS FOR USE IN SEARCHING FOR, RETRIEVING AND BROWSING INFORMATION, WEBSITES AND OTHER RESOURCES AND FOR COMMUNICATING BETWEEN USERS; MOBILE DEVICE SOFTWARE APPLICATION FOR USE IN SEARCHING FOR, RETRIEVING AND BROWSING BUSINESS LISTINGS, WEBSITES, ADDRESSES, TELEPHONE NUMBERS AND OTHER INFORMATION AND FOR ENABLING USERS TO UPLOAD, POST, SHOW, DISPLAY, TAG, BLOG, SHARE OR OTHERWISE PROVIDE ELECTRONIC MEDIA OR INFORMATION OVER THE INTERNET OR OTHER COMMUNICATION NETWORKS (U.S. CLS. 21, 23, 26, 36 AND 38).

FIRST USE 8-9-2011; IN COMMERCE 8-9-2011.

4,155,382. CELLCO PARTNERSHIP, DBA VERIZON WIRELESS, BASKING RIDGE, NJ. SN 85-279,446. PUB. 7-26-2011, FILED 3-29-2011.

ADAMANT

THE MARK CONSISTS OF STANDARD CHARACTERS WITHOUT CLAIM TO ANY PARTICULAR FONT, STYLE, SIZE, OR COLOR.

FOR WIRELESS TELECOMMUNICATIONS DEVICE FEATURING TRANSMISSION OF VOICE, DATA, IMAGE AND VIDEO, INCLUDING VOICE, TEXT, PICTURE AND VIDEO MESSAGING, INTERNET ACCESS, ACCESS TO NAVIGATION AND DIRECTIONAL SERVICE OVER THE AIR, THE ABILITY TO DOWNLOAD MUSIC, VIDEOS AND APPLICATIONS OVER THE AIR, AND WHICH HAS A MUSIC PLAYER AND A STILL IMAGE AND VIDEO CAMERA (U.S. CLS. 21, 23, 26, 36 AND 38).

FIRST USE 12-14-2011; IN COMMERCE 12-14-2011.

4,155,386. ARCSOFT, INC., FREMONT, CA. SN 85-280,473. PUB. 10-11-2011, FILED 3-29-2011.

ARCSOFT SYSTEMSAVE

THE MARK CONSISTS OF STANDARD CHARACTERS WITHOUT CLAIM TO ANY PARTICULAR FONT, STYLE, SIZE, OR COLOR.

OWNER OF U.S. REG. NOS. 2,334,476, 3,091,316, AND OTHERS.

NO CLAIM IS MADE TO THE EXCLUSIVE RIGHT TO USE "SYSTEM SAVE", APART FROM THE MARK AS SHOWN.

FOR COMPUTER SOFTWARE FOR DATA AND SYSTEM PROTECTION, RECOVERY, BACKUP, RESTORATION AND RETRIEVAL (U.S. CLS. 21, 23, 26, 36 AND 38).

FIRST USE 10-1-2011; IN COMMERCE 10-1-2011.

CLASS 9—(Continued).

4,155,411. MATTEL, INC., EL SEGUNDO, CA. SN 85-283,792.
PUB. 8-23-2011, FILED 4-1-2011.

GHOUL BOX

THE MARK CONSISTS OF STANDARD CHARACTERS WITHOUT CLAIM TO ANY PARTICULAR FONT, STYLE, SIZE, OR COLOR.

FOR VIDEO GAME SOFTWARE FOR MOBILE DEVICES AND TABLETS (U.S. CLS. 21, 23, 26, 36 AND 38).
FIRST USE 2-15-2012; IN COMMERCE 2-15-2012.

CLASS 9—(Continued).

4,155,446. LUNHE INVESTMENT LTD., LAS VEGAS, NV. SN 85-289,713. PUB. 12-6-2011, FILED 4-8-2011.

Vivick

THE MARK CONSISTS OF THE STYLIZED LETTERING "VIVICK".

THE WORDING "VIVICK" HAS NO MEANING IN A FOREIGN LANGUAGE.

FOR COMPUTER PERIPHERAL DEVICES; COMPUTER SOFTWARE AND DOWNLOADABLE COMPUTER PROGRAMS FOR USE IN DATABASE MANAGEMENT, USE AS SPREADSHEET AND WORD PROCESSING; NOTEBOOK COMPUTERS; DOWNLOADABLE ELECTRONIC PUBLICATIONS IN THE NATURE OF BOOKS, MAGAZINES, AND MANUALS FOR USE IN DATABASE MANAGEMENT, FOR USE AS A SPREADSHEET, FOR WORD PROCESSING; PERSONAL STEREOS; MOUSE PADS; COMPUTER PROGRAMS, NAMELY, DOWNLOADABLE SOFTWARE; PROTECTIVE CASES FOR USE WITH TABLET COMPUTERS AND PORTABLE AND HAND-HELD DIGITAL ELECTRONIC DEVICES; COMPUTER SOFTWARE DEVELOPMENT TOOLS FOR THE CREATION OF MOBILE INTERNET APPLICATIONS AND CLIENT INTERFACES, ELECTRONIC FINANCIAL PLATFORMS THAT ACCOMMODATE MULTIPLE TYPES OF PAYMENT AND DEBT TRANSACTIONS USING AN INTEGRATED MOBILE PHONE, PDA, AND WEB BASED ENVIRONMENT; DOWNLOADABLE COMPUTER PROGRAMS, NAMELY, DOWNLOADABLE ELECTRONIC DATA FILES AND DATABASES, NAMELY, BUSINESS AND TAX FORMS, FOR USE WITH COMPUTER SOFTWARE; DOWNLOADABLE COMPUTER GAME SOFTWARE VIA A GLOBAL COMPUTER NETWORK AND WIRELESS DEVICES; COMPUTER GAME PROGRAMS (U.S. CLS. 21, 23, 26, 36 AND 38).

FIRST USE 6-10-2011; IN COMMERCE 6-20-2011.

4,155,412. CDOC, INC., CARMEL, IN. SN 85-283,876. PUB. 7-26-2011, FILED 4-1-2011.

WNEZBILL

THE MARK CONSISTS OF STANDARD CHARACTERS WITHOUT CLAIM TO ANY PARTICULAR FONT, STYLE, SIZE, OR COLOR.

FOR COMPUTER SOFTWARE FOR USE IN SUPPORTING AN ELECTRONIC INSURANCE APPLICATION SYSTEM (U.S. CLS. 21, 23, 26, 36 AND 38).
FIRST USE 9-1-2011; IN COMMERCE 9-1-2011.

4,155,456. MIAMI TRIBE OF OKLAHOMA BUSINESS DEVELOPMENT AUTHORITY, A TRIBAL ENTERPRISE OF THE MIAMI TRIBE OF OKLAHOMA, MIAMI, OK. SN 85-291,603. PUB. 6-7-2011, FILED 4-11-2011.

LONDON TIMES

4,155,413. CDOC, INC., CARMEL, IN. SN 85-283,879. PUB. 7-26-2011, FILED 4-1-2011.

WNEZAPP2.0

THE MARK CONSISTS OF STANDARD CHARACTERS WITHOUT CLAIM TO ANY PARTICULAR FONT, STYLE, SIZE, OR COLOR.

FOR COMPUTER SOFTWARE FOR USE IN SUPPORTING AN ELECTRONIC INSURANCE APPLICATION SYSTEM (U.S. CLS. 21, 23, 26, 36 AND 38).
FIRST USE 9-1-2011; IN COMMERCE 9-1-2011.

THE MARK CONSISTS OF STANDARD CHARACTERS WITHOUT CLAIM TO ANY PARTICULAR FONT, STYLE, SIZE, OR COLOR.

FOR GAMING MACHINES, NAMELY, BINGO-RELATED GAMES AND SLOT MACHINES (U.S. CLS. 21, 23, 26, 36 AND 38).
FIRST USE 3-29-2012; IN COMMERCE 4-2-2012.

CLASS 9—(Continued).

4,155,494. POWER ASSURE, INC., SANTA CLARA, CA. SN 85-302,824. PUB. 7-12-2011, FILED 4-23-2011.

EM/4

THE MARK CONSISTS OF STANDARD CHARACTERS WITHOUT CLAIM TO ANY PARTICULAR FONT, STYLE, SIZE, OR COLOR.

FOR COMPUTER PROGRAMS FOR ENERGY MANAGEMENT AND OPTIMIZATION OF BUILDINGS, DATA CENTERS, COOLING, HEATING, POWER, NETWORK AND INFORMATION TECHNOLOGY EQUIPMENT; AND COMPUTER SOFTWARE FOR MONITORING AND ANALYZING ENERGY CONSUMPTION RELATING TO BUILDINGS, DATA CENTERS, COOLING, HEATING, POWER, NETWORK AND INFORMATION TECHNOLOGY EQUIPMENT (U.S. CLS. 21, 23, 26, 36 AND 38).

FIRST USE 9-1-2011; IN COMMERCE 9-1-2011.

4,155,505. CITY THEATRICAL, INC., CARLSTADT, NJ. SN 85-305,951. PUB. 9-27-2011, FILED 4-27-2011.

SHOW DMX NEO

THE MARK CONSISTS OF STANDARD CHARACTERS WITHOUT CLAIM TO ANY PARTICULAR FONT, STYLE, SIZE, OR COLOR.

OWNER OF U.S. REG. NO. 3,607,242.
NO CLAIM IS MADE TO THE EXCLUSIVE RIGHT TO USE "DMX", APART FROM THE MARK AS SHOWN.

FOR RADIO TRANSCEIVERS (U.S. CLS. 21, 23, 26, 36 AND 38).

FIRST USE 3-12-2012; IN COMMERCE 3-12-2012.

4,155,506. CITY THEATRICAL, INC., CARLSTADT, NJ. SN 85-305,958. PUB. 9-27-2011, FILED 4-27-2011.

SHOW DMX SHOW BABY

THE MARK CONSISTS OF STANDARD CHARACTERS WITHOUT CLAIM TO ANY PARTICULAR FONT, STYLE, SIZE, OR COLOR.

OWNER OF U.S. REG. NO. 3,607,242.
NO CLAIM IS MADE TO THE EXCLUSIVE RIGHT TO USE "DMX", APART FROM THE MARK AS SHOWN.

FOR RADIO TRANSCEIVERS (U.S. CLS. 21, 23, 26, 36 AND 38).

FIRST USE 1-3-2012; IN COMMERCE 1-3-2012.

CLASS 9—(Continued).

4,155,509. ALBERT METZ GMBH & CO. KG, BLUMBERG, FED REP GERMANY. SN 85-307,318. PUB. 8-23-2011, FILED 4-28-2011.



THE COLOR(S) BLACK AND BLUE IS/ARE CLAIMED AS A FEATURE OF THE MARK.

THE MARK CONSISTS OF THE LETTERS "MCQTECH" IN BLACK STYLIZED LETTERING WITH THE LETTER "M" INSIDE A BLUE QUADRILATERAL.

FOR ELECTRICAL TERMINAL BLOCKS, ELECTRICAL HEADERS AND ELECTRICAL PLUGS FOR USE WITH CONNECTION OF PRINTED CIRCUIT BOARDS; ELECTRICAL CONNECTOR PLUGS, ELECTRICAL CONNECTOR SOCKETS, ELECTRICAL CONNECTOR TERMINALS, ELECTRICAL ADAPTERS, ELECTRICAL CONNECTION BOXES, PATCH PANELS FOR DATA AND TELECOMMUNICATION NETWORKS, ELECTRIC RELAYS, ELECTRIC SWITCHES, ELECTRICAL CABLES AND CIRCUIT TESTERS FOR USE DURING INSTALLATION, ALL AFOREMENTIONED GOODS FOR ELECTRICAL NETWORKS AND FIBER OPTIC NETWORKS FOR DATA TRANSMISSION AND TELECOMMUNICATION (U.S. CLS. 21, 23, 26, 36 AND 38).

FIRST USE 10-4-2011; IN COMMERCE 10-4-2011.

4,155,519. GAOLI, XI'AN, SHAANXI PROVINCE, CHINA. SN 85-311,632. PUB. 9-20-2011, FILED 5-4-2011.



THE MARK CONSISTS OF THE WORDING "MOTOREBEL" AND DESIGN WHICH REPRESENT A MOTORCYCLE.

CLASS 9—(Continued).

THE WORDING "MOTOREBEL" HAS NO MEANING IN A FOREIGN LANGUAGE.

FOR BABY MONITORS; BATTERY MONITORS; COMPUTER MONITORS; COMPUTER PERIPHERAL DEVICES; ELECTRIC ACCUMULATORS; FLASHING SAFETY LIGHTS; FLASHLIGHTS FOR USE IN PHOTOGRAPHY; INTERACTIVE VIDEO GAMES OF VIRTUAL REALITY COMPRISED OF COMPUTER HARDWARE FOR USE WITH AN EXTERNAL MONITOR AND SOFTWARE; LEVEL INDICATORS; OPTICAL CHARACTER READERS; PRESSURE INDICATORS; REMOTE CONTROLS FOR ELECTRO-DYNAMIC APPARATUS; ROTATING LIGHTS; SIGNAL CONDITIONING AND COMMUNICATION DEVICES FOR INDUSTRIAL PROCESS CONTROL; SPEED INDICATORS; TECHNICAL MEASURING, TESTING AND CHECKING APPARATUS AND INSTRUMENTS FOR MEASURING, TESTING AND CHECKING THE TEMPERATURE, PRESSURE, QUANTITY AND CONCENTRATION OF GAS AND LIQUIDS; TELEVISION MONITORS; TEMPERATURE INDICATORS; TRANSMITTERS OF ELECTRONIC SIGNALS; VIDEO MONITORS; WATER LEVEL INDICATORS (U.S. CLS. 21, 23, 26, 36 AND 38).

FIRST USE 7-15-2009; IN COMMERCE 7-15-2009.

4,155,577. TRIMBLE NAVIGATION LIMITED, SUNNYVALE, CA. SN 85-333,936. PUB. 11-1-2011, FILED 5-31-2011.

INPHO

THE MARK CONSISTS OF STANDARD CHARACTERS WITHOUT CLAIM TO ANY PARTICULAR FONT, STYLE, SIZE, OR COLOR.

FOR COMPUTER SOFTWARE FOR USE IN PHOTOGRAMMETRY (U.S. CLS. 21, 23, 26, 36 AND 38).

FIRST USE 0-0-1987; IN COMMERCE 0-0-1987.

4,155,585. GREENVITY COMMUNICATIONS, INC., MILPITAS, CA. SN 85-336,170. PUB. 10-25-2011, FILED 6-2-2011.

HYBRII

THE MARK CONSISTS OF STANDARD CHARACTERS WITHOUT CLAIM TO ANY PARTICULAR FONT, STYLE, SIZE, OR COLOR.

FOR SEMICONDUCTOR CHIPS, CIRCUIT BOARDS (U.S. CLS. 21, 23, 26, 36 AND 38).

FIRST USE 9-0-2011; IN COMMERCE 9-0-2011.

CLASS 9—(Continued).

4,155,590. ATTENTION, INC., ROANOKE, VA. SN 85-338,763. PUB. 12-13-2011, FILED 6-6-2011.

ATTENTION POINT

THE MARK CONSISTS OF STANDARD CHARACTERS WITHOUT CLAIM TO ANY PARTICULAR FONT, STYLE, SIZE, OR COLOR.

NO CLAIM IS MADE TO THE EXCLUSIVE RIGHT TO USE "ATTENTION", APART FROM THE MARK AS SHOWN.

FOR SOFTWARE FOR ASSESSING ATTENTION IMPAIRMENT, NAMELY, COMPUTER SOFTWARE FOR COMPILING AND ASSESSING MEDICAL DATA OBTAINED FROM CLINICAL DECISION SUPPORT TOOLS; COMPUTER SOFTWARE FOR ASSESSMENT OF ATTENTION IMPAIRMENT, INCLUDING ATTENTION DEFICIT HYPERACTIVITY DISORDER (U.S. CLS. 21, 23, 26, 36 AND 38).

FIRST USE 3-6-2012; IN COMMERCE 3-6-2012.

4,155,592. NINTENDO OF AMERICA INC., REDMOND, WA. SN 85-339,554. PUB. 8-23-2011, FILED 6-7-2011.

KIRBY MASS ATTACK

THE MARK CONSISTS OF STANDARD CHARACTERS WITHOUT CLAIM TO ANY PARTICULAR FONT, STYLE, SIZE, OR COLOR.

FOR CARTRIDGES AND MEMORY CARDS FEATURING ENTERTAINMENT, EDUCATIONAL AND INFORMATIONAL CONTENT, NAMELY, VIDEO GAMES AND STORIES; ELECTRONIC GAME PROGRAMS; ELECTRONIC GAME SOFTWARE; VIDEO GAME CARTRIDGES; VIDEO GAME MEMORY CARDS; VIDEO GAME PROGRAMS; VIDEO GAME SOFTWARE (U.S. CLS. 21, 23, 26, 36 AND 38).

FIRST USE 9-19-2011; IN COMMERCE 9-19-2011.

CLASS 9—(Continued).

4,155,596. JOHNSON CONTROLS TECHNOLOGY COMPANY, HOLLAND, MI. SN 85-340,320. PUB. 10-18-2011, FILED 6-7-2011.

PANOPTIX

THE MARK CONSISTS OF STANDARD CHARACTERS WITHOUT CLAIM TO ANY PARTICULAR FONT, STYLE, SIZE, OR COLOR.

FOR COMPUTER SOFTWARE FOR THE COLLECTION, TRANSMISSION, STORAGE, SHARING, DIAGNOSIS AND REPORTING OF DATA AND INFORMATION RELATED TO BUILDING ENVIRONMENT, ACCESS AND SECURITY SYSTEMS; COMPUTER SOFTWARE FOR THE MEASUREMENT AND VERIFICATION OF CARBON DIOXIDE AND OTHER GREENHOUSE GAS EMISSION OFFSETS; COMPUTER SOFTWARE FOR USE IN DETERMINING ENERGY CONSUMPTION AND PEAK DEMAND SAVINGS; SOFTWARE FOR CONTROLLING BUILDING ENVIRONMENT, ACCESS AND SECURITY SYSTEMS (U.S. CLS. 21, 23, 26, 36 AND 38).

FIRST USE 10-0-2011; IN COMMERCE 10-0-2011.

4,155,606. HUAWEI TECHNOLOGIES CO., LTD., SHENZHEN, CHINA. SN 85-344,772. PUB. 8-9-2011, FILED 6-13-2011.

MediaPad

THE MARK CONSISTS OF THE TERM "MEDIAPAD" IN A STYLIZED FONT.

FOR TABLET COMPUTERS (U.S. CLS. 21, 23, 26, 36 AND 38).

FIRST USE 6-20-2011; IN COMMERCE 2-3-2012.

4,155,612. BECAID, LLC, NEW HAVEN, CT. SN 85-346,606. PUB. 1-10-2012, FILED 6-15-2011.

C8 SCIENCES

THE MARK CONSISTS OF STANDARD CHARACTERS WITHOUT CLAIM TO ANY PARTICULAR FONT, STYLE, SIZE, OR COLOR.

CLASS 9—(Continued).

NO CLAIM IS MADE TO THE EXCLUSIVE RIGHT TO USE "SCIENCES", APART FROM THE MARK AS SHOWN.

FOR COMPUTER PROGRAMS FEATURING INTERACTIVE COGNITIVE GAMES AND PHYSICAL EXERCISES FOR USE IN IMPROVING COGNITIVE DEVELOPMENT, COGNITIVE FUNCTION AND LEARNING CAPACITY (U.S. CLS. 21, 23, 26, 36 AND 38). FIRST USE 3-3-2012; IN COMMERCE 3-3-2012.

4,155,613. C&C TECHNOLOGIES, INC., LAFAYETTE, LA. SN 85-346,642. PUB. 1-24-2012, FILED 6-15-2011.

C-Nav7000

THE MARK CONSISTS OF STANDARD CHARACTERS WITHOUT CLAIM TO ANY PARTICULAR FONT, STYLE, SIZE, OR COLOR.

OWNER OF U.S. REG. NOS. 3,168,556, 3,989,042, AND 3,992,776.

FOR COMPUTER HARDWARE FOR RECEIVING AND PROCESSING GLOBAL NAVIGATION SATELLITE SYSTEMS DATA FOR DERIVING A CORRECTED GLOBAL POSITION (U.S. CLS. 21, 23, 26, 36 AND 38).

FIRST USE 6-30-2011; IN COMMERCE 6-30-2011.

4,155,617. GID DEVELOPMENT CORPORATION, YORBA LINDA, CA. SN 85-346,794. PUB. 1-31-2012, FILED 6-15-2011.

BODYDOCK

THE MARK CONSISTS OF STANDARD CHARACTERS WITHOUT CLAIM TO ANY PARTICULAR FONT, STYLE, SIZE, OR COLOR.

FOR COVERS FOR MOBILE DEVICES, NAMELY, MOBILE PHONES, PORTABLE MUSIC PLAYERS, AND PORTABLE TABLET COMPUTER DEVICES (U.S. CLS. 21, 23, 26, 36 AND 38).

FIRST USE 4-11-2011; IN COMMERCE 4-11-2011.

CLASS 9—(Continued).

4,155,635. DIGITAL INNOVATIONS, LLC, ARLINGTON HEIGHTS, IL. SN 85-350,994. PUB. 11-1-2011, FILED 6-20-2011.

ALL TERRAIN

THE MARK CONSISTS OF STANDARD CHARACTERS WITHOUT CLAIM TO ANY PARTICULAR FONT, STYLE, SIZE, OR COLOR.

FOR COMPUTER MICE (U.S. CLS. 21, 23, 26, 36 AND 38).

FIRST USE 12-1-2011; IN COMMERCE 12-1-2011.

CLASS 9—(Continued).

4,155,667. ANDUPWARDS, INC., BRANDON, FL. SN 85-362,186. PUB. 11-29-2011, FILED 7-1-2011.

Dime Bags

THE MARK CONSISTS OF STANDARD CHARACTERS WITHOUT CLAIM TO ANY PARTICULAR FONT, STYLE, SIZE, OR COLOR.

FOR DOWNLOADABLE ELECTRONIC BOOKS FEATURING HUMOROUS FICTIONAL SHORT STORIES (U.S. CLS. 21, 23, 26, 36 AND 38).

FIRST USE 6-11-2011; IN COMMERCE 7-21-2011.

4,155,639. C & E VISION SERVICES, INC., SAN CLEMENTE, CA. SN 85-353,170. PUB. 12-6-2011, FILED 6-22-2011.

isight

THE MARK CONSISTS OF STANDARD CHARACTERS WITHOUT CLAIM TO ANY PARTICULAR FONT, STYLE, SIZE, OR COLOR.

FOR CONTACT LENSES AND LENSES FOR EYE-GLASSES (U.S. CLS. 21, 23, 26, 36 AND 38).

FIRST USE 12-15-2011; IN COMMERCE 12-15-2011.

4,155,659. APPLE INC., CUPERTINO, CA. SN 85-359,955. PUB. 1-10-2012, FILED 6-29-2011.

SMART COVER

THE MARK CONSISTS OF STANDARD CHARACTERS WITHOUT CLAIM TO ANY PARTICULAR FONT, STYLE, SIZE, OR COLOR.

PRIORITY CLAIMED UNDER SEC. 44(D) ON JAMAICA APPLICATION NO. 57174, FILED 1-6-2011.

NO CLAIM IS MADE TO THE EXCLUSIVE RIGHT TO USE "COVER", APART FROM THE MARK AS SHOWN.

FOR ACCESSORY FOR A HANDHELD MOBILE DIGITAL ELECTRONIC DEVICE THAT FUNCTIONS AS A PROTECTIVE AND DECORATIVE COVER AND A STAND (U.S. CLS. 21, 23, 26, 36 AND 38).

FIRST USE 3-11-2011; IN COMMERCE 3-11-2011.

4,155,674. DAY, STEPHANIE, CHANDLER, AZ. SN 85-363,737. PUB. 12-27-2011, FILED 7-6-2011.

ARTSPOT

THE MARK CONSISTS OF STANDARD CHARACTERS WITHOUT CLAIM TO ANY PARTICULAR FONT, STYLE, SIZE, OR COLOR.

FOR DOWNLOADABLE COMPUTER APPLICATION SOFTWARE FOR MOBILE PHONES ALLOWING USERS TO PHOTOGRAPH AN OBJECT AND SHARE ITS GEOLOCATION AND INTERACT WITH OTHER USERS THROUGH POSTING REVIEWS AND COMMENTS TO SOCIAL NETWORKS, SOCIAL GAMING AND GPS-BASED TREASURE HUNTING GAMES WITH VIRTUAL PRIZES AND COUPONS (U.S. CLS. 21, 23, 26, 36 AND 38).

FIRST USE 8-1-2011; IN COMMERCE 1-15-2012.

4,155,675. DAY, STEPHANIE, CHANDLER, AZ. SN 85-363,743. PUB. 12-27-2011, FILED 7-6-2011.

ARTSPOT

THE COLOR(S) RED AND GRAY IS/ARE CLAIMED AS A FEATURE OF THE MARK.

CLASS 9—(Continued).

THE MARK CONSISTS OF THE WORD "ARTSPOT" WHEREIN THE LETTERS "ART" IS SHADED IN RED COLOR AND THE LETTERS "SPOT" IS SHADED IN GRAY COLOR AND LETTER "O" DEPICTING A RIFLE SCOPE AS SHOWN IN THE MARK.

FOR DOWNLOADABLE COMPUTER APPLICATION SOFTWARE FOR MOBILE PHONES ALLOWING USERS TO PHOTOGRAPH AN OBJECT AND SHARE ITS GEOLOCATION AND INTERACT WITH OTHER USERS THROUGH POSTING REVIEWS AND COMMENTS TO SOCIAL NETWORKS, SOCIAL GAMING AND GPS-BASED TREASURE HUNTING GAMES WITH VIRTUAL PRIZES AND COUPONS (U.S. CLS. 21, 23, 26, 36 AND 38).

FIRST USE 8-1-2011; IN COMMERCE 1-15-2012.

4,155,683. PODNOD INC., BERKELEY, CA. SN 85-365,089. PUB. 1-24-2012, FILED 7-7-2011.

PODNOD

THE MARK CONSISTS OF STANDARD CHARACTERS WITHOUT CLAIM TO ANY PARTICULAR FONT, STYLE, SIZE, OR COLOR.

FOR DOWNLOADABLE SOFTWARE IN THE NATURE OF A MOBILE APPLICATION FOR ASKING FOR SHOPPING ADVICE AND SHARING INFORMATION ABOUT SHOPPING EXPERIENCES (U.S. CLS. 21, 23, 26, 36 AND 38).

FIRST USE 10-5-2011; IN COMMERCE 10-11-2011.

4,155,697. FREEZE TAG, INC., TUSTIN, CA. SN 85-368,208. PUB. 12-6-2011, FILED 7-11-2011.

ROCKET WEASEL

THE MARK CONSISTS OF STANDARD CHARACTERS WITHOUT CLAIM TO ANY PARTICULAR FONT, STYLE, SIZE, OR COLOR.

FOR COMPUTER GAME SOFTWARE; VIDEO GAME SOFTWARE; ELECTRONIC GAME PROGRAMS; DOWNLOADABLE ELECTRONIC GAME PROGRAMS; ELECTRONIC GAME SOFTWARE; COMPUTER GAME PROGRAMS; DOWNLOADABLE COMPUTER GAME PROGRAMS; INTERACTIVE GAME PROGRAMS; INTERACTIVE GAME SOFTWARE; COMPUTER AND VIDEO GAME SOFTWARE FOR USE ON ELECTRONIC DEVICES, INCLUDING HANDHELD DEVICES AND WIRELESS DEVICES (U.S. CLS. 21, 23, 26, 36 AND 38).

FIRST USE 2-2-2012; IN COMMERCE 2-2-2012.

CLASS 9—(Continued).

4,155,702. NIKON CORPORATION, TOKYO, JAPAN. SN 85-369,859. PUB. 10-25-2011, FILED 7-13-2011.

Force XR

THE MARK CONSISTS OF STANDARD CHARACTERS WITHOUT CLAIM TO ANY PARTICULAR FONT, STYLE, SIZE, OR COLOR.

FOR RIFLESCOPES (U.S. CLS. 21, 23, 26, 36 AND 38).

FIRST USE 11-1-2011; IN COMMERCE 11-1-2011.

4,155,703. NIKON CORPORATION, TOKYO, JAPAN. SN 85-369,869. PUB. 10-11-2011, FILED 7-13-2011.



THE MARK CONSISTS OF A TRIANGULAR SHIELD SHAPE CARRYING THE LARGE STYLIZED LETTER "F" NEXT AND TO THE LEFT OF THE SMALLER CONNECTED LETTERS "XR".

FOR RIFLESCOPES (U.S. CLS. 21, 23, 26, 36 AND 38).

FIRST USE 11-1-2011; IN COMMERCE 11-1-2011.

4,155,732. SEIKO HOLDINGS KABUSHIKI KAISHA, TA SEIKO HOLDINGS CORPORATION, TOKYO, JAPAN. SN 85-378,649. PUB. 10-25-2011, FILED 7-22-2011.

SEIKO PCWIDE

THE MARK CONSISTS OF STANDARD CHARACTERS WITHOUT CLAIM TO ANY PARTICULAR FONT, STYLE, SIZE, OR COLOR.

FOR LENSES FOR EYEGLASSES (U.S. CLS. 21, 23, 26, 36 AND 38).

FIRST USE 9-1-2011; IN COMMERCE 9-1-2011.

CLASS 9—(Continued).

4,155,756. WU, JACK, NEW YORK, NY. SN 85-388,756. PUB. 1-3-2012, FILED 8-3-2011.

Jack Mikele

THE MARK CONSISTS OF STANDARD CHARACTERS WITHOUT CLAIM TO ANY PARTICULAR FONT, STYLE, SIZE, OR COLOR.

THE NAME(S), PORTRAIT(S), AND/OR SIGNATURE(S) SHOWN IN THE MARK DOES NOT IDENTIFY A PARTICULAR LIVING INDIVIDUAL.

FOR EYEGLASS CASES; EYEWEAR; EYEWEAR, NAMELY, SUNGLASSES, EYEGLASSES, AND EYEGLASS FRAMES (U.S. CLS. 21, 23, 26, 36 AND 38). FIRST USE 11-5-2011; IN COMMERCE 11-5-2011.

CLASS 9—(Continued).

4,155,767. WESTWARD LEANING, SAN FRANCISCO, CA. SN 85-393,045. PUB. 1-10-2012, FILED 8-9-2011.

WESTWARD LEANING

THE MARK CONSISTS OF STANDARD CHARACTERS WITHOUT CLAIM TO ANY PARTICULAR FONT, STYLE, SIZE, OR COLOR.

FOR SUNGLASSES (U.S. CLS. 21, 23, 26, 36 AND 38). FIRST USE 8-1-2011; IN COMMERCE 11-15-2011.

4,155,772. WINEGARD COMPANY, BURLINGTON, IA. SN 85-396,384. PUB. 1-17-2012, FILED 8-12-2011.

BatWave

THE MARK CONSISTS OF STANDARD CHARACTERS WITHOUT CLAIM TO ANY PARTICULAR FONT, STYLE, SIZE, OR COLOR.

FOR TELEVISION ANTENNAS (U.S. CLS. 21, 23, 26, 36 AND 38). FIRST USE 11-0-2011; IN COMMERCE 11-0-2011.

4,155,757. ATLAS PROGRAMMING MANAGEMENT, INC., LAFAYETTE, CA. SN 85-388,817. PUB. 1-24-2012, FILED 8-3-2011.



4,155,790. ESES GLOBAL, INC., NEW YORK, NY. SN 85-406,202. PUB. 2-7-2012, FILED 8-24-2011.

GlassesCOVE

THE COLOR(S) BLUE AND BLACK IS/ARE CLAIMED AS A FEATURE OF THE MARK.

THE MARK CONSISTS OF A BLOCK DESIGN CONSISTING OF TWO ROWS OF EQUALLY SIZED EQUALLY SPACED BLUE COLOR SHAPES WHEREIN THE TOP ROW CONSISTS OF A CIRCLE/SQUARE AND THE BOTTOM ROW CONSISTS OF SQUARE/SQUARE POSITIONED DIRECTLY BELOW THE TOP ROW SHAPES AND BLACK BLOCK LETTERS "XAT" POSITIONED TO THE RIGHT OF THE BLOCK DESIGN WHEREIN THE LETTERS CONTAIN A STYLIZED "A" AS SHOWN.

FOR COMPUTER APPLICATION SOFTWARE FOR MOBILE AND STATIONARY COMPUTING DEVICES, NAMELY, SOFTWARE FOR TESTING OF USER PROFICIENCY IN MICROSOFT EXCEL (U.S. CLS. 21, 23, 26, 36 AND 38). FIRST USE 2-20-2008; IN COMMERCE 11-1-2011.

NO CLAIM IS MADE TO THE EXCLUSIVE RIGHT TO USE "GLASSES", APART FROM THE MARK AS SHOWN.

THE MARK CONSISTS OF THE STYLIZED WORDS "GLASSES COVE".

FOR EYEGLASS FRAMES; EYEWEAR, NAMELY, SUNGLASSES, EYEGLASSES AND OPHTHALMIC FRAMES AND CASES THEREFOR; FRAMES FOR SPECTACLES AND SUNGLASSES (U.S. CLS. 21, 23, 26, 36 AND 38). FIRST USE 9-0-2011; IN COMMERCE 9-0-2011.

CLASS 9—(Continued).

4,155,800. DISH NETWORK L.L.C., ENGLEWOOD, CO. SN 85-415,484. PUB. 12-13-2011, FILED 9-6-2011.

JOEY

THE MARK CONSISTS OF STANDARD CHARACTERS WITHOUT CLAIM TO ANY PARTICULAR FONT, STYLE, SIZE, OR COLOR.

FOR DIGITAL VIDEO RECORDERS; ELECTRONIC APPARATUS AND DEVICES FOR CONTROLLING ACCESS TO PAY-TELEVISION SERVICES; COMMUNICATIONS EQUIPMENT, NAMELY, SIGNAL FREQUENCY RECEIVERS; COMMUNICATIONS EQUIPMENT, NAMELY, SET-TOP BOXES FOR RECEIVING VIDEO PROGRAMMING; TELEVISION RECEIVERS; SATELLITE RECEIVERS; SET-TOP BOXES; UNIVERSAL REMOTE CONTROLS FOR HOME ELECTRONIC DEVICES, NAMELY, TELEVISIONS, VCRS, DVD PLAYERS, DIGITAL VIDEO RECORDERS, SATELLITE RECEIVERS, STEREO RECEIVERS, AND STEREO AMPLIFIERS; ELECTRONIC DEVICES, NAMELY, DIGITAL MEDIA STREAMING DEVICES (U.S. CLS. 21, 23, 26, 36 AND 38). FIRST USE 1-9-2012; IN COMMERCE 3-15-2012.

4,155,801. DISH NETWORK L.L.C., ENGLEWOOD, CO. SN 85-415,859. PUB. 12-13-2011, FILED 9-6-2011.

HOPPER

THE MARK CONSISTS OF STANDARD CHARACTERS WITHOUT CLAIM TO ANY PARTICULAR FONT, STYLE, SIZE, OR COLOR.

FOR DIGITAL VIDEO RECORDERS; ELECTRONIC APPARATUS AND DEVICES FOR CONTROLLING ACCESS TO PAY-TELEVISION SERVICES; COMMUNICATIONS EQUIPMENT, NAMELY, SET-TOP BOXES FOR RECEIVING VIDEO PROGRAMMING; TELEVISION RECEIVERS; SATELLITE RECEIVERS; SET-TOP BOXES; UNIVERSAL REMOTE CONTROLS FOR HOME ELECTRONIC DEVICES, NAMELY, TELEVISIONS, VCRS, DVD PLAYERS, DIGITAL VIDEO RECORDERS, SATELLITE RECEIVERS, STEREO RECEIVERS, AND STEREO AMPLIFIERS; COMPUTER HARDWARE AND SOFTWARE FOR STREAMING AUDIO, VIDEO, IMAGE AND DATA INFORMATION TO A VARIETY OF NETWORK DEVICES, NAMELY, PERSONAL COMPUTERS, MOBILE PHONES, PERSONAL DIGITAL ASSISTANTS (PDA), AND STAND-ALONE HARDWARE DECODERS, NAMELY, AUDIO DECODERS AND VIDEO DECODERS; ELECTRONIC DEVICES, NAMELY, DIGITAL MEDIA STREAMING DEVICES (U.S. CLS. 21, 23, 26, 36 AND 38).

FIRST USE 1-9-2012; IN COMMERCE 3-15-2012.

CLASS 9—(Continued).

4,155,807. WINEGARD COMPANY, BURLINGTON, IA. SN 85-426,977. PUB. 1-17-2012, FILED 9-20-2011.

FlatWave

THE MARK CONSISTS OF STANDARD CHARACTERS WITHOUT CLAIM TO ANY PARTICULAR FONT, STYLE, SIZE, OR COLOR.

FOR TELEVISION ANTENNAS (U.S. CLS. 21, 23, 26, 36 AND 38). FIRST USE 11-0-2011; IN COMMERCE 11-0-2011.

4,155,822. WESTWARD LEANING, SAN FRANCISCO, CA. SN 85-457,613. PUB. 1-10-2012, FILED 10-27-2011.



THE MARK CONSISTS OF A DOUBLE BACKSLASH. FOR SUNGLASSES (U.S. CLS. 21, 23, 26, 36 AND 38). FIRST USE 8-1-2011; IN COMMERCE 11-15-2011.

CLASS 10—MEDICAL APPARATUS

4,154,301. ARO MEDICAL, LLC, NORTH ANDOVER, MA. SN 77-442,615. PUB. 2-24-2009, FILED 4-8-2008.

ARO

THE MARK CONSISTS OF STANDARD CHARACTERS WITHOUT CLAIM TO ANY PARTICULAR FONT, STYLE, SIZE, OR COLOR.

FOR SPINAL IMPLANTS COMPOSED OF ARTIFICIAL MATERIAL; SURGICAL INSTRUMENTS FOR USE IN ORTHOPEDIC AND SPINAL SURGERY (U.S. CLS. 26, 39 AND 44).

FIRST USE 9-20-2011; IN COMMERCE 9-20-2011.

CLASS 10—(Continued).

4,154,364. HYBRIDYNE IMAGING TECHNOLOGIES, INC., BLUE BELL, PA. SN 77-592,038. PUB. 3-3-2009, FILED 10-14-2008.

PROXISCAN

THE MARK CONSISTS OF STANDARD CHARACTERS WITHOUT CLAIM TO ANY PARTICULAR FONT, STYLE, SIZE, OR COLOR.

FOR MEDICAL DEVICES, NAMELY, PROBES FOR THE DIAGNOSIS AND TREATMENT OF CANCER (U.S. CLS. 26, 39 AND 44).

FIRST USE 5-18-2011; IN COMMERCE 5-18-2011.

4,154,374. KNEE CREATIONS, LLC, WEST CHESTER, PA. SN 77-629,996. PUB. 11-3-2009, FILED 12-10-2008.

SUBCHONDROPLASTY

THE MARK CONSISTS OF STANDARD CHARACTERS WITHOUT CLAIM TO ANY PARTICULAR FONT, STYLE, SIZE, OR COLOR.

FOR MEDICAL AND SURGICAL INSTRUMENTS FOR USE IN ORTHOPEDIC SURGERY; SURGICAL ACCESS DEVICES; MEDICAL AND SURGICAL KITS CONTAINING MEDICAL AND SURGICAL INSTRUMENTS FOR USE IN ORTHOPEDIC SURGERY AND SURGICAL ACCESS DEVICES (U.S. CLS. 26, 39 AND 44).

FIRST USE 2-29-2012; IN COMMERCE 2-29-2012.

4,154,404. OLYMPUS MEDICAL SYSTEMS CORP., TOKYO, JAPAN. SN 77-694,959. PUB. 7-7-2009, FILED 3-19-2009.

SONICBEAT

THE MARK CONSISTS OF STANDARD CHARACTERS WITHOUT CLAIM TO ANY PARTICULAR FONT, STYLE, SIZE, OR COLOR.

FOR MEDICAL AND SURGICAL APPARATUS AND INSTRUMENTS, NAMELY, ULTRASONIC ENERGY DEVICES AND SURGICAL KNIVES AND SCISSORS THAT INCISE AND COAGULATE BY USING ULTRASONIC TECHNOLOGY (U.S. CLS. 26, 39 AND 44).

FIRST USE 3-1-2012; IN COMMERCE 3-1-2012.

CLASS 10—(Continued).

4,154,408. CAROLON COMPANY, RURAL HALL, NC. SN 77-697,579. PUB. 2-9-2010, FILED 3-24-2009.

SMART SLEEVE

THE MARK CONSISTS OF STANDARD CHARACTERS WITHOUT CLAIM TO ANY PARTICULAR FONT, STYLE, SIZE, OR COLOR.

NO CLAIM IS MADE TO THE EXCLUSIVE RIGHT TO USE "SLEEVE", APART FROM THE MARK AS SHOWN.

FOR MEDICAL LIMB OR BODY GARMENT CONTAINING SENSORS FOR MONITORING HEALTH PARAMETERS (U.S. CLS. 26, 39 AND 44).

FIRST USE 2-15-2012; IN COMMERCE 2-15-2012.

4,154,490. J.T. POSEY COMPANY, ARCADIA, CA. SN 77-861,817. PUB. 2-2-2010, FILED 10-30-2009.

SITTER ELITE

THE MARK CONSISTS OF STANDARD CHARACTERS WITHOUT CLAIM TO ANY PARTICULAR FONT, STYLE, SIZE, OR COLOR.

OWNER OF U.S. REG. NO. 2,443,288.
FOR MONITORS FOR DETECTING PATIENT MOVEMENT (U.S. CLS. 26, 39 AND 44).

FIRST USE 3-30-2012; IN COMMERCE 3-30-2012.

4,154,506. COOK INCORPORATED, BLOOMINGTON, IN. SN 77-882,873. PUB. 3-23-2010, FILED 12-1-2009.

ARC TECHNOLOGY

THE MARK CONSISTS OF STANDARD CHARACTERS WITHOUT CLAIM TO ANY PARTICULAR FONT, STYLE, SIZE, OR COLOR.

NO CLAIM IS MADE TO THE EXCLUSIVE RIGHT TO USE "TECHNOLOGY", APART FROM THE MARK AS SHOWN.

FOR DEVICE MIGRATION DETERRENT SYSTEM INCORPORATED AS A FEATURE IN ENDOVASCULAR STENTS (U.S. CLS. 26, 39 AND 44).

FIRST USE 8-0-2011; IN COMMERCE 8-0-2011.

CLASS 10—(Continued).

4,154,507. DOMAIN SURGICAL, INC., SALT LAKE CITY, UT. SN 77-886,514. PUB. 10-26-2010, FILED 12-4-2009.

DOMAIN SURGICAL

THE MARK CONSISTS OF STANDARD CHARACTERS WITHOUT CLAIM TO ANY PARTICULAR FONT, STYLE, SIZE, OR COLOR.

NO CLAIM IS MADE TO THE EXCLUSIVE RIGHT TO USE "SURGICAL", APART FROM THE MARK AS SHOWN.

FOR SURGICAL AND MEDICAL APPARATUS AND INSTRUMENTS FOR USE IN SURGERY (U.S. CLS. 26, 39 AND 44).

FIRST USE 12-15-2011; IN COMMERCE 3-19-2012.

4,154,545. JOHNSON & JOHNSON, NEW BRUNSWICK, NJ. SN 77-948,178. PUB. 2-1-2011, FILED 3-2-2010.

EVERPOINT

THE MARK CONSISTS OF STANDARD CHARACTERS WITHOUT CLAIM TO ANY PARTICULAR FONT, STYLE, SIZE, OR COLOR.

FOR SUTURE NEEDLES AND NEEDLES SOLD AS AN INTEGRAL COMPONENT OF A SUTURE (U.S. CLS. 26, 39 AND 44).

FIRST USE 2-2-2012; IN COMMERCE 2-2-2012.

4,154,549. BIO-MEDICAL RESEARCH LIMITED, GALWAY, IRELAND. SN 77-954,556. PUB. 8-3-2010, FILED 3-9-2010.

AVIVAFIX

THE MARK CONSISTS OF STANDARD CHARACTERS WITHOUT CLAIM TO ANY PARTICULAR FONT, STYLE, SIZE, OR COLOR.

FOR ELECTROTHERAPY APPARATUS FOR STIMULATING THE MUSCLES AND NERVES OF THE NECK, SHOULDER, ELBOW, WRIST, UPPER BACK, LOWER BACK, HIP, KNEE AND ANKLE AND CONDUCTIVE GARMENTS SPECIALLY ADAPTED FOR USE THEREWITH (U.S. CLS. 26, 39 AND 44).

FIRST USE 1-0-2012; IN COMMERCE 1-0-2012.

CLASS 10—(Continued).

4,154,550. ASCENTIA HEALTH, INC., ROCKFORD, IL. SN 77-955,133. PUB. 8-3-2010, FILED 3-10-2010.



NO CLAIM IS MADE TO THE EXCLUSIVE RIGHT TO USE "TMD", APART FROM THE MARK AS SHOWN.

THE COLOR(S) BLUE, BLACK, WHITE AND GREEN IS/ARE CLAIMED AS A FEATURE OF THE MARK.

THE MARK CONSISTS OF THE LETTERS "TMD" PRESENTED IN THE COLOR BLUE FOLLOWED BY THE LETTER "E" IN WHITE WITH A CIRCULAR BLACK BACKGROUND FOLLOWED BY A STYLIZED LETTER "S" IN BLACK. TO THE RIGHT OF THE STYLIZED "S" IS A STYLIZED GREEN CURVED BAND, WHICH IN COMBINATION WITH THE STYLIZED "S", AND CIRCULAR FIELD RESEMBLES AN EAR. GREEN SHADED CIRCLES OF VARYING SIZE ARRANGED IN AN ARC APPEAR ABOVE THE LETTERS "TMD" IN THE MARK.

FOR MEDICAL DEVICE, NAMELY, INTRA-AURAL DEVICE FOR TREATING TEMPOROMANDIBULAR JOINT DISORDER; MEDICAL DEVICE, NAMELY, INTRA-AURAL DEVICE FOR TREATING HEADACHES (U.S. CLS. 26, 39 AND 44).

FIRST USE 4-11-2011; IN COMMERCE 5-3-2011.

4,154,573. BREATHE TECHNOLOGIES, INC., IRVINE, CA. SN 77-967,915. PUB. 8-17-2010, FILED 3-24-2010.

NIOV

THE MARK CONSISTS OF STANDARD CHARACTERS WITHOUT CLAIM TO ANY PARTICULAR FONT, STYLE, SIZE, OR COLOR.

FOR MEDICAL DEVICES TO TREAT RESPIRATORY AND AIRWAY DISORDERS IN INDIVIDUALS (U.S. CLS. 26, 39 AND 44).

FIRST USE 12-0-2011; IN COMMERCE 12-0-2011.

CLASS 10—(Continued).

4,154,612. LOTIONS LIMITED, LLC, MADISON, WI. SN 85-004,510. PUB. 8-24-2010, FILED 4-1-2010.

VAGINAL RENEWAL

THE MARK CONSISTS OF STANDARD CHARACTERS WITHOUT CLAIM TO ANY PARTICULAR FONT, STYLE, SIZE, OR COLOR.

NO CLAIM IS MADE TO THE EXCLUSIVE RIGHT TO USE "VAGINAL", APART FROM THE MARK AS SHOWN.

FOR ADULT SEXUAL STIMULATION AIDS, NAMELY, VIBRATORS AND ARTIFICIAL STIMULATORS (U.S. CLS. 26, 39 AND 44).

FIRST USE 1-1-2010; IN COMMERCE 11-30-2010.

4,154,813. CLON 3D, ALBUQUERQUE, NM. SN 85-139,198. PUB. 3-8-2011, FILED 9-27-2010.

CLON IODIS

THE MARK CONSISTS OF STANDARD CHARACTERS WITHOUT CLAIM TO ANY PARTICULAR FONT, STYLE, SIZE, OR COLOR.

FOR DIGITAL ORAL IMPRESSION DEVICE FOR TAKING MEASUREMENTS OF TEETH (U.S. CLS. 26, 39 AND 44).

FIRST USE 8-1-2009; IN COMMERCE 8-1-2009.

4,154,893. BENCHMARK BRANDS, INC., NORCROSS, GA. SN 85-181,356. PUB. 3-8-2011, FILED 11-19-2010.

HEATFREEZE

THE MARK CONSISTS OF STANDARD CHARACTERS WITHOUT CLAIM TO ANY PARTICULAR FONT, STYLE, SIZE, OR COLOR.

FOR HOT AND COLD THERAPY FOOT MASSAGER (U.S. CLS. 26, 39 AND 44).

FIRST USE 11-19-2010; IN COMMERCE 12-30-2011.

CLASS 10—(Continued).

4,154,922. XENOLITH MEDICAL, LTD, KIRYAT GAT, ISRAEL. SN 85-198,170. PUB. 6-7-2011, FILED 12-15-2010.

Xenolith Medical

THE MARK CONSISTS OF STANDARD CHARACTERS WITHOUT CLAIM TO ANY PARTICULAR FONT, STYLE, SIZE, OR COLOR.

NO CLAIM IS MADE TO THE EXCLUSIVE RIGHT TO USE "MEDICAL", APART FROM THE MARK AS SHOWN. FOR MEDICAL GUIDEWIRES (U.S. CLS. 26, 39 AND 44).

FIRST USE 7-1-2010; IN COMMERCE 11-1-2011.

4,154,990. COOPERSURGICAL, INC., TRUMBULL, CT. SN 85-220,060. PUB. 8-16-2011, FILED 1-18-2011.

KOH-EFFICIENT

THE MARK CONSISTS OF STANDARD CHARACTERS WITHOUT CLAIM TO ANY PARTICULAR FONT, STYLE, SIZE, OR COLOR.

FOR MEDICAL INSTRUMENTS FOR USE IN THE FIELD OF OBSTETRICS AND GYNECOLOGY, NAMELY, A SLEEVE THAT INCORPORATES A COLPOTOMY CUP AND PNEUMO OCCLUSION BALLOON FOR LAPAROSCOPIC HYSTERECTOMY (U.S. CLS. 26, 39 AND 44).

FIRST USE 11-8-2010; IN COMMERCE 2-8-2011.

4,155,008. MIDMARK CORPORATION, VERSAILLES, OH. SN 85-227,955. PUB. 9-20-2011, FILED 1-27-2011.

CLEARVISION

THE MARK CONSISTS OF STANDARD CHARACTERS WITHOUT CLAIM TO ANY PARTICULAR FONT, STYLE, SIZE, OR COLOR.

FOR A DIGITAL INTRAORAL SENSOR SYSTEM COMPRISED OF DIGITAL SENSORS, CAMERAS, SOFTWARE, AND INTERFACE DISPLAY MODULES USED TO CAPTURE AND DISPLAY DENTAL IMAGES (U.S. CLS. 26, 39 AND 44).

FIRST USE 12-0-2011; IN COMMERCE 12-0-2011.

CLASS 10—(Continued).

4,155,130. KIM, TAE-WEON, SEOUL 140-774, REPUBLIC OF KOREA. SN 85-250,444. PUB. 7-5-2011, FILED 2-24-2011.

 The logo for eCligner features the word "eCligner" in a bold, lowercase, sans-serif font. Above the letter "i" is a horizontal arc of seven dots.

THE MARK CONSISTS OF "ECLIGNER" IN STYLIZED FORM WITH AN ARC OF DOTS.
FOR DIGITAL ORTHODONTIC APPLIANCES; ORTHODONTIC APPLIANCES (U.S. CLS. 26, 39 AND 44).
FIRST USE 2-17-2012; IN COMMERCE 2-17-2012.

4,155,214. TELCARE, INC., BETHESDA, MD. SN 85-257,726. PUB. 1-10-2012, FILED 3-4-2011.

Telcare

THE MARK CONSISTS OF STANDARD CHARACTERS WITHOUT CLAIM TO ANY PARTICULAR FONT, STYLE, SIZE, OR COLOR.

FOR INTEGRATED HEALTH MONITORING SYSTEM AND ASSOCIATED SOFTWARE FOR TRANSMITTING, PROCESSING, RECEIVING AND DISPLAYING DATA VIA TELECOMMUNICATION AND GLOBAL COMPUTER NETWORKS FOR MEDICAL TREATMENT AND PATIENT REMOTE USE COMPRISING WIRELESS ENABLED MEDICAL DEVICES FOR MONITORING BLOOD GLUCOSE FOR MEDICAL PURPOSES (U.S. CLS. 26, 39 AND 44).

FIRST USE 2-9-2012; IN COMMERCE 2-9-2012.

4,155,215. TELCARE, INC., BETHESDA, MD. SN 85-257,732. PUB. 7-19-2011, FILED 3-4-2011.

Telcare BGM

THE MARK CONSISTS OF STANDARD CHARACTERS WITHOUT CLAIM TO ANY PARTICULAR FONT, STYLE, SIZE, OR COLOR.

FOR INTEGRATED HEALTH MONITORING SYSTEM COMPRISING WIRELESS ENABLED BLOOD GLUCOSE MONITORS AND SOFTWARE FOR TRANSMITTING, PROCESSING, RECEIVING AND DISPLAYING DATA VIA TELECOMMUNICATION AND GLOBAL COMPUTER NETWORKS FOR MEDICAL TREATMENT OF DIABETES AND PATIENT REMOTE USE (U.S. CLS. 26, 39 AND 44).

FIRST USE 2-9-2012; IN COMMERCE 2-9-2012.

CLASS 10—(Continued).

4,155,296. ADVANCED WELLNESS, MARLBORO, NJ. SN 85-266,765. PUB. 8-2-2011, FILED 3-14-2011.

FasciaPro

THE MARK CONSISTS OF STANDARD CHARACTERS WITHOUT CLAIM TO ANY PARTICULAR FONT, STYLE, SIZE, OR COLOR.

FOR MASSAGE APPARATUS FOR MEDICAL PURPOSES (U.S. CLS. 26, 39 AND 44).

FIRST USE 4-1-2011; IN COMMERCE 4-1-2011.

4,155,352. CURVEBEAM, LLC, WARRINGTON, PA. SN 85-274,658. PUB. 8-23-2011, FILED 3-23-2011.

PEDCAT

THE MARK CONSISTS OF STANDARD CHARACTERS WITHOUT CLAIM TO ANY PARTICULAR FONT, STYLE, SIZE, OR COLOR.

FOR MEDICAL IMAGING DEVICES, NAMELY, COMPACT CONE BEAM COMPUTED TOMOGRAPHY DEVICES FOR 3-D IMAGING OF FEET IN BOTH LOAD BEARING AND NON-LOAD BEARING POSITIONS (U.S. CLS. 26, 39 AND 44).

FIRST USE 3-1-2012; IN COMMERCE 3-1-2012.

4,155,369. OPTEC USA, INC., LAWRENCEVILLE, GA. SN 85-278,203. PUB. 8-30-2011, FILED 3-28-2011.

GLADIATOR

THE MARK CONSISTS OF STANDARD CHARACTERS WITHOUT CLAIM TO ANY PARTICULAR FONT, STYLE, SIZE, OR COLOR.

FOR KNEE BRACES FOR MEDICAL USE (U.S. CLS. 26, 39 AND 44).

FIRST USE 1-13-2012; IN COMMERCE 1-13-2012.

CLASS 10—(Continued).

4,155,395. WAHL CLIPPER CORPORATION, STERLING, IL. SN 85-282,280. PUB. 11-1-2011, FILED 3-31-2011.

FLEX THERAPY

THE MARK CONSISTS OF STANDARD CHARACTERS WITHOUT CLAIM TO ANY PARTICULAR FONT, STYLE, SIZE, OR COLOR.

NO CLAIM IS MADE TO THE EXCLUSIVE RIGHT TO USE "THERAPY", APART FROM THE MARK AS SHOWN. FOR HAND-HELD MASSAGE APPARATUS (U.S. CLS. 26, 39 AND 44).

FIRST USE 6-0-2011; IN COMMERCE 6-0-2011.

4,155,469. SNYDER, KENNETH C., WHITEHALL, PA. SN 85-295,946. PUB. 9-20-2011, FILED 4-15-2011.

ICY FEET

THE MARK CONSISTS OF STANDARD CHARACTERS WITHOUT CLAIM TO ANY PARTICULAR FONT, STYLE, SIZE, OR COLOR.

NO CLAIM IS MADE TO THE EXCLUSIVE RIGHT TO USE "FEET", APART FROM THE MARK AS SHOWN.

FOR A MOLDED ICE PACK ARRANGED FOR ATTACHMENT TO THE FOOT FOR APPLYING COLD THERAPY THERETO FOR TREATING INFLAMMATIONS AND AILMENTS OF THE FOOT (U.S. CLS. 26, 39 AND 44).

FIRST USE 3-10-2012; IN COMMERCE 3-10-2012.

4,155,489. LANX, INC., BROOMFIELD, CO. SN 85-300,141. PUB. 8-9-2011, FILED 4-20-2011.

TIMBERLINE

THE MARK CONSISTS OF STANDARD CHARACTERS WITHOUT CLAIM TO ANY PARTICULAR FONT, STYLE, SIZE, OR COLOR.

FOR MEDICAL DEVICES, NAMELY, SPINAL IMPLANTS OF ARTIFICIAL MATERIAL; SURGICAL INSTRUMENTS FOR FACILITATING IMPLANTATION OF SPINAL IMPLANTS (U.S. CLS. 26, 39 AND 44).

FIRST USE 4-0-2011; IN COMMERCE 4-0-2011.

CLASS 10—(Continued).

4,155,539. CORELINK, LLC, ST. LOUIS, MO. SN 85-319,127. PUB. 11-29-2011, FILED 5-12-2011.

TIGER

THE MARK CONSISTS OF STANDARD CHARACTERS WITHOUT CLAIM TO ANY PARTICULAR FONT, STYLE, SIZE, OR COLOR.

FOR MEDICAL DEVICES, NAMELY, SPINAL FIXATION DEVICES, NAMELY, SCREWS, BARS, AND PLATES USED IN SPINAL DISC REPAIR PROCEDURES (U.S. CLS. 26, 39 AND 44).

FIRST USE 3-21-2012; IN COMMERCE 3-21-2012.

4,155,636. SYNERON BEAUTY INC., CAMBRIDGE, ONTARIO, CANADA. SN 85-351,670. PUB. 2-14-2012, FILED 6-21-2011.

TANDA ZAP

THE MARK CONSISTS OF STANDARD CHARACTERS WITHOUT CLAIM TO ANY PARTICULAR FONT, STYLE, SIZE, OR COLOR.

PRIORITY CLAIMED UNDER SEC. 44(D) ON CANADA APPLICATION NO. 1508890, FILED 12-22-2010.

OWNER OF U.S. REG. NO. 3,694,648.

FOR MEDICAL AESTHETIC HAND-HELD DEVICE, USING AN LED (LIGHT EMITTING DIODE) SOURCE FOR THERAPEUTIC AND AESTHETIC SKIN TREATMENTS (U.S. CLS. 26, 39 AND 44).

FIRST USE 6-1-2011; IN COMMERCE 6-1-2011.

4,155,660. SMITH & NEPHEW, INC., MEMPHIS, TN. SN 85-360,188. PUB. 11-29-2011, FILED 6-30-2011.

STRUCSURE

THE MARK CONSISTS OF STANDARD CHARACTERS WITHOUT CLAIM TO ANY PARTICULAR FONT, STYLE, SIZE, OR COLOR.

FOR BONE VOID FILLERS MADE FROM ARTIFICIAL MATERIALS; BONE GRAFT IMPLANTS MADE FROM ARTIFICIAL MATERIALS (U.S. CLS. 26, 39 AND 44).

FIRST USE 10-1-2011; IN COMMERCE 10-1-2011.

CLASS 10—(Continued).

4,155,741. MERIT MEDICAL SYSTEMS, INC., SOUTH JORDAN, UT. SN 85-384,513. PUB. 12-27-2011, FILED 7-29-2011.

TRAM

THE MARK CONSISTS OF STANDARD CHARACTERS WITHOUT CLAIM TO ANY PARTICULAR FONT, STYLE, SIZE, OR COLOR.

FOR MEDICAL DEVICES, NAMELY, MANIFOLDS WITH INTEGRATED TRANSDUCERS FOR USE IN TRANSFERRING FLUID AND INVASIVE BLOOD PRESSURE MONITORING (U.S. CLS. 26, 39 AND 44).

FIRST USE 6-9-2010; IN COMMERCE 6-9-2010.

4,155,742. RANIR, LLC, GRAND RAPIDS, MI. SN 85-384,529. PUB. 12-20-2011, FILED 7-29-2011.

EASEBETWEEN

THE MARK CONSISTS OF STANDARD CHARACTERS WITHOUT CLAIM TO ANY PARTICULAR FONT, STYLE, SIZE, OR COLOR.

OWNER OF U.S. REG. NOS. 2,815,657 AND 3,468,772.

FOR DENTAL PICKS (U.S. CLS. 26, 39 AND 44).

FIRST USE 1-11-2011; IN COMMERCE 1-11-2011.

4,155,761. ULTRA ATHLETE LLC, INDIANAPOLIS, IN. SN 85-389,722. PUB. 1-3-2012, FILED 8-4-2011.

Ultra HIGH-5

THE MARK CONSISTS OF STANDARD CHARACTERS WITHOUT CLAIM TO ANY PARTICULAR FONT, STYLE, SIZE, OR COLOR.

OWNER OF U.S. REG. NOS. 2,608,148 AND 3,709,532.

FOR ATHLETIC ANKLE BRACES FOR MEDICAL USE; BRACES FOR LIMBS AND JOINTS, FOR MEDICAL USE; ORTHOPEDIC BRACES; SUPPORTS FOR ANKLES FOR MEDICAL USE (U.S. CLS. 26, 39 AND 44).

FIRST USE 1-23-2012; IN COMMERCE 1-23-2012.

CLASS 10—(Continued).

4,155,762. ULTRA ATHLETE LLC, INDIANAPOLIS, IN. SN 85-389,746. PUB. 1-3-2012, FILED 8-4-2011.

Ultra Zoom

THE MARK CONSISTS OF STANDARD CHARACTERS WITHOUT CLAIM TO ANY PARTICULAR FONT, STYLE, SIZE, OR COLOR.

OWNER OF U.S. REG. NOS. 2,608,148 AND 3,709,532.

FOR ATHLETIC ANKLE BRACES FOR MEDICAL USE; BRACES FOR LIMBS AND JOINTS, FOR MEDICAL USE; ORTHOPEDIC BRACES; SUPPORTS FOR ANKLES FOR MEDICAL USE (U.S. CLS. 26, 39 AND 44).

FIRST USE 1-23-2012; IN COMMERCE 1-23-2012.

4,155,774. ADVANCED TECHNOLOGY & CAPITAL INC., ENGLEWOOD CLIFFS, NJ. SN 85-397,131. PUB. 1-10-2012, FILED 8-12-2011.

Leéject

THE MARK CONSISTS OF THE STYLIZED TEXT "LEEJECT".

FOR SYRINGES FOR DENTAL AND MEDICAL PURPOSES (U.S. CLS. 26, 39 AND 44).

FIRST USE 2-16-2012; IN COMMERCE 2-16-2012.

CLASS 11—ENVIRONMENTAL CONTROL APPARATUS

4,154,245. REV-A-SHELF COMPANY, LLC, JEFFERSON-TOWN, KY. SN 76-695,977. PUB. 6-23-2009, FILED 2-25-2009.

ELLI

THE MARK CONSISTS OF STANDARD CHARACTERS WITHOUT CLAIM TO ANY PARTICULAR FONT, STYLE, SIZE, OR COLOR.

FOR LOW VOLTAGE LED COMMERCIAL AND RESIDENTIAL ELECTRIC LIGHTING FIXTURES AND ASSOCIATED MOUNTING STRUCTURES, SOLD AS A UNIT (U.S. CLS. 13, 21, 23, 31 AND 34).

FIRST USE 11-30-2009; IN COMMERCE 11-30-2009.

CLASS 11—(Continued).

4,154,328. ECLIPSE, INC., ROCKFORD, IL. SN 77-535,059.
PUB. 12-23-2008, FILED 7-30-2008.

FLOAT FIRE

THE MARK CONSISTS OF STANDARD CHARACTERS WITHOUT CLAIM TO ANY PARTICULAR FONT, STYLE, SIZE, OR COLOR.

FOR AUXILIARY HEATING SYSTEM COMPOSED OF INDUSTRIAL GAS BURNERS, GAS AND AIR PRESSURE REGULATORS AND ELECTRONIC CONTROLS (U.S. CLS. 13, 21, 23, 31 AND 34).

FIRST USE 0-0-2007; IN COMMERCE 0-0-2007.

4,154,329. HONEYWELL INTERNATIONAL INC., MORRISTOWN, NJ. SN 77-536,296. PUB. 1-10-2012, FILED 7-31-2008.

TRUEDRY

THE MARK CONSISTS OF STANDARD CHARACTERS WITHOUT CLAIM TO ANY PARTICULAR FONT, STYLE, SIZE, OR COLOR.

FOR DEHUMIDIFIERS (U.S. CLS. 13, 21, 23, 31 AND 34).

FIRST USE 7-28-2008; IN COMMERCE 7-28-2008.

4,154,348. OLTMANN'S, STEVEN W., STERLING, IL. SN 77-559,768. PUB. 1-20-2009, FILED 9-1-2008.

Show to Glow

THE MARK CONSISTS OF STANDARD CHARACTERS WITHOUT CLAIM TO ANY PARTICULAR FONT, STYLE, SIZE, OR COLOR.

FOR CHEMICALLY-ACTIVATED LIGHT STICKS (U.S. CLS. 13, 21, 23, 31 AND 34).

FIRST USE 3-1-2012; IN COMMERCE 3-1-2012.

CLASS 11—(Continued).

4,154,380. BIONEST TECHNOLOGIES INC., GRAND-MÈRE, CANADA. SN 77-649,602. PUB. 7-5-2011, FILED 1-14-2009.

BIONEST SOLO

THE MARK CONSISTS OF STANDARD CHARACTERS WITHOUT CLAIM TO ANY PARTICULAR FONT, STYLE, SIZE, OR COLOR.

PRIORITY CLAIMED UNDER SEC. 44(D) ON CANADA APPLICATION NO. 1,424,349, FILED 1-13-2009, REG. NO. TMA785034, DATED 12-15-2010, EXPIRES 12-15-2025.

OWNER OF U.S. REG. NOS. 3,142,548 AND 3,317,353.

NO CLAIM IS MADE TO THE EXCLUSIVE RIGHT TO USE "SOLO", APART FROM THE MARK AS SHOWN.

FOR ADVANCED WASTEWATER TREATMENT SYSTEMS (U.S. CLS. 13, 21, 23, 31 AND 34).

FIRST USE 6-2-2010; IN COMMERCE 6-11-2010.

4,154,418. DELO INDUSTRIAL ADHESIVES LLC, HAUPPAUGE, NY. SN 77-719,240. PUB. 8-25-2009, FILED 4-22-2009.

Coldguide

THE MARK CONSISTS OF STANDARD CHARACTERS WITHOUT CLAIM TO ANY PARTICULAR FONT, STYLE, SIZE, OR COLOR.

FOR LAMPS (U.S. CLS. 13, 21, 23, 31 AND 34).

FIRST USE 1-1-2010; IN COMMERCE 3-19-2012.

4,154,443. FLAT-OUT BACKEN', BLACKFOOT, ID. SN 77-793,828. PUB. 12-29-2009, FILED 7-30-2009.

FLAT-OUT BACKEN'

THE MARK CONSISTS OF STANDARD CHARACTERS WITHOUT CLAIM TO ANY PARTICULAR FONT, STYLE, SIZE, OR COLOR.

FOR FOLDING CAMPING WOOD COOK STOVE (U.S. CLS. 13, 21, 23, 31 AND 34).

FIRST USE 1-2-2012; IN COMMERCE 1-15-2012.

CLASS 11—(Continued).

4,154,461. MAYTAG PROPERTIES, LLC, ST. JOSEPH, MI. SN 77-823,508. PUB. 2-2-2010, FILED 9-10-2009.

ECOCONSERVE

THE MARK CONSISTS OF STANDARD CHARACTERS WITHOUT CLAIM TO ANY PARTICULAR FONT, STYLE, SIZE, OR COLOR.

FOR CLOTHES DRYERS (U.S. CLS. 13, 21, 23, 31 AND 34).

FIRST USE 10-21-2009; IN COMMERCE 10-21-2009.

4,154,478. MAYTAG PROPERTIES, LLC, ST. JOSEPH, MI. SN 77-839,919. PUB. 2-2-2010, FILED 10-2-2009.



THE MARK CONSISTS OF A LEAF DESIGN. FOR CLOTHES DRYERS (U.S. CLS. 13, 21, 23, 31 AND 34).

FIRST USE 10-21-2009; IN COMMERCE 10-21-2009.

4,154,539. SCHROEDER INDUSTRIES, LEETSDALE, PA. SN 77-941,488. PUB. 1-18-2011, FILED 2-22-2010.

Z MEDIA

THE MARK CONSISTS OF STANDARD CHARACTERS WITHOUT CLAIM TO ANY PARTICULAR FONT, STYLE, SIZE, OR COLOR.

NO CLAIM IS MADE TO THE EXCLUSIVE RIGHT TO USE "MEDIA", APART FROM THE MARK AS SHOWN.

CLASS 11—(Continued).

THE WORDING "Z MEDIA" HAS NO MEANING IN A FOREIGN LANGUAGE.

FOR SYNTHETIC FILTERING MEDIA FOR GENERAL INDUSTRIAL USE IN THE PURIFICATION OF AIR AND INDUSTRIAL FLUIDS (U.S. CLS. 13, 21, 23, 31 AND 34).

FIRST USE 3-16-2000; IN COMMERCE 3-16-2000.

4,154,543. PURELY ENTERPRISES, LLC, KNOXVILLE, TN. SN 77-946,266. PUB. 9-13-2011, FILED 2-26-2010.

Healthy CFL

THE MARK CONSISTS OF STANDARD CHARACTERS WITHOUT CLAIM TO ANY PARTICULAR FONT, STYLE, SIZE, OR COLOR.

NO CLAIM IS MADE TO THE EXCLUSIVE RIGHT TO USE "CFL", APART FROM THE MARK AS SHOWN.

FOR AIR PURIFYING, COMPACT FLUORESCENT LIGHT BULBS THAT INCORPORATE BUILT-IN NEGATIVE ION GENERATORS TO ATTRACT POSITIVELY CHARGED AIRBORNE ALLERGENS FOR THE TREATMENT AND PURIFICATION OF AMBIENT AIR (U.S. CLS. 13, 21, 23, 31 AND 34).

FIRST USE 11-1-2010; IN COMMERCE 11-1-2010.

4,154,556. VIDA LIFESTYLE, INC., NORTH HOLLYWOOD, CA. SN 77-961,211. PUB. 8-17-2010, FILED 3-17-2010.

WYNDHAM COLLECTION

THE MARK CONSISTS OF STANDARD CHARACTERS WITHOUT CLAIM TO ANY PARTICULAR FONT, STYLE, SIZE, OR COLOR.

NO CLAIM IS MADE TO THE EXCLUSIVE RIGHT TO USE "COLLECTION", APART FROM THE MARK AS SHOWN.

FOR SHOWER TUBS (U.S. CLS. 13, 21, 23, 31 AND 34). FIRST USE 1-16-2012; IN COMMERCE 1-16-2012.

CLASS 11—(Continued).

4,154,571. MSI, LLC, TA MSI-SSL, DEERFIELD BEACH, FL. SN 77-967,819. PUB. 8-17-2010, FILED 3-24-2010.

iPAR

THE MARK CONSISTS OF STANDARD CHARACTERS WITHOUT CLAIM TO ANY PARTICULAR FONT, STYLE, SIZE, OR COLOR.

FOR LED LIGHT BULBS (U.S. CLS. 13, 21, 23, 31 AND 34).
FIRST USE 9-1-2009; IN COMMERCE 2-1-2010.

4,154,614. MAYTAG PROPERTIES, LLC, ST. JOSEPH, MI. SN 85-005,150. PUB. 8-24-2010, FILED 4-2-2010.

SOUNDGUARD

THE MARK CONSISTS OF STANDARD CHARACTERS WITHOUT CLAIM TO ANY PARTICULAR FONT, STYLE, SIZE, OR COLOR.

FOR CLOTHES DRYERS (U.S. CLS. 13, 21, 23, 31 AND 34).
FIRST USE 11-1-2010; IN COMMERCE 11-1-2010.

4,154,641. MSLO SHARED IP SUB LLC, NEW YORK, NY. SN 85-042,798. PUB. 4-12-2011, FILED 5-19-2010.

EMERIL

THE MARK CONSISTS OF STANDARD CHARACTERS WITHOUT CLAIM TO ANY PARTICULAR FONT, STYLE, SIZE, OR COLOR.

OWNER OF U.S. REG. NOS. 2,176,213, 2,467,770, AND OTHERS.

CLASS 11—(Continued).

THE NAME "EMERIL" IDENTIFIES A LIVING INDIVIDUAL WHOSE CONSENT IS OF RECORD.

FOR BARBECUE GRILLS; GRILL LIGHTS, NAMELY, LIGHTING FIXTURES FOR GRILLS; ROTISSERIES; WARMING RACKS FOR GRILLS; SMOKER BOXES IN THE NATURE OF BARBECUE SMOKERS; GAS CONVERSION KITS COMPRISED PRIMARILY OF NATURAL GAS REGULATORS AND GRILL BURNER ORIFICES FOR CONVERTING A PROPANE GAS GRILL TO A NATURAL GAS GRILL; ELECTRIC GRIDDLES; BARBECUE ACCESSORIES, NAMELY, CONVECTION PLATES, CERAMIC BRIQUETTES FOR USE IN BARBECUE GRILLS; STRUCTURAL PARTS FOR BARBECUE GRILLS; GRILL GRATES; GRILL ACCESSORIES, NAMELY, FISH RACKS, MEAT RACKS AND VEGETABLE RACKS IN THE NATURE OF WARMING TRAYS; ELECTRIC ROASTERS; ROASTERS POWERED BY PROPANE GAS (U.S. CLS. 13, 21, 23, 31 AND 34).

FIRST USE 4-1-2011; IN COMMERCE 4-1-2011.

4,154,642. CONAIR CORPORATION, STAMFORD, CT. SN 85-043,392. PUB. 2-1-2011, FILED 5-20-2010.

BAMBINO

THE MARK CONSISTS OF STANDARD CHARACTERS WITHOUT CLAIM TO ANY PARTICULAR FONT, STYLE, SIZE, OR COLOR.

THE ENGLISH TRANSLATION OF THE WORD "BAMBINO" IN THE MARK IS BABY.

FOR HAND-HELD ELECTRIC HAIR DRYERS (U.S. CLS. 13, 21, 23, 31 AND 34).
FIRST USE 10-0-2011; IN COMMERCE 10-0-2011.

4,154,657. CR MINERALS LLC, DBA CR MINERALS, LLC, SAN JUAN PUEBLO, NM. SN 85-067,415. PUB. 12-28-2010, FILED 6-21-2010.

PFM (Pumice Filtration Media)

THE MARK CONSISTS OF STANDARD CHARACTERS WITHOUT CLAIM TO ANY PARTICULAR FONT, STYLE, SIZE, OR COLOR.

NO CLAIM IS MADE TO THE EXCLUSIVE RIGHT TO USE "PUMICE FILTRATION MEDIA", APART FROM THE MARK AS SHOWN.

FOR WATER PURIFICATION, SEDIMENTATION AND FILTRATION APPARATUS FOR CLARIFICATION, THICKENING AND FILTRATION OF WATER, WASTE WATER AND INDUSTRIAL WATER (U.S. CLS. 13, 21, 23, 31 AND 34).

FIRST USE 3-30-2011; IN COMMERCE 3-30-2011.

CLASS 11—(Continued).

4,154,748. ENERGY FOCUS, INC., SOLON, OH. SN 85-111,205. PUB. 2-1-2011, FILED 8-19-2010.

INTELLITUBE

THE MARK CONSISTS OF STANDARD CHARACTERS WITHOUT CLAIM TO ANY PARTICULAR FONT, STYLE, SIZE, OR COLOR.

FOR LIGHT EMITTING DIODE (LED) LAMPS FOR ENERGY-EFFICIENT REPLACEMENT OF FLUORESCENT LAMPS; LED (LIGHT EMITTING DIODE) LAMPS (U.S. CLS. 13, 21, 23, 31 AND 34).

FIRST USE 12-20-2011; IN COMMERCE 12-20-2011.

4,154,784. BSH HOME APPLIANCES CORPORATION, HUNTINGTON BEACH, CA. SN 85-126,884. PUB. 1-11-2011, FILED 9-10-2010.

QUICKCLEAN

THE MARK CONSISTS OF STANDARD CHARACTERS WITHOUT CLAIM TO ANY PARTICULAR FONT, STYLE, SIZE, OR COLOR.

FOR DOMESTIC COOKING OVEN TOP BASES, ELECTRIC RANGE TOP BASES, GAS RANGE TOP BASES, ELECTRIC COOK TOP BASES, AND GAS COOK TOP BASES, SOLD AS COMPONENTS OF HOUSEHOLD AND KITCHEN MACHINES AND EQUIPMENT, NAMELY, DOMESTIC COOKING OVENS, ELECTRIC AND GAS RANGES, AND ELECTRIC AND GAS COOK TOPS (U.S. CLS. 13, 21, 23, 31 AND 34).

FIRST USE 8-15-2011; IN COMMERCE 8-15-2011.

4,154,785. BSH HOME APPLIANCES CORPORATION, HUNTINGTON BEACH, CA. SN 85-126,899. PUB. 2-1-2011, FILED 9-10-2010.

QUICKCLEAN BASE

THE MARK CONSISTS OF STANDARD CHARACTERS WITHOUT CLAIM TO ANY PARTICULAR FONT, STYLE, SIZE, OR COLOR.

CLASS 11—(Continued).

NO CLAIM IS MADE TO THE EXCLUSIVE RIGHT TO USE "BASE", APART FROM THE MARK AS SHOWN.

FOR DOMESTIC COOKING OVEN TOP BASES, ELECTRIC RANGE TOP BASES, GAS RANGE TOP BASES, ELECTRIC COOK TOP BASES, AND GAS COOK TOP BASES, SOLD AS COMPONENTS OF HOUSEHOLD AND KITCHEN MACHINES AND EQUIPMENT, NAMELY, DOMESTIC COOKING OVENS, ELECTRIC AND GAS RANGES, AND ELECTRIC AND GAS COOK TOPS (U.S. CLS. 13, 21, 23, 31 AND 34).

FIRST USE 8-15-2011; IN COMMERCE 8-15-2011.

4,154,803. PROBE INVESTMENTS, INC, DBA PROBE INVESTMENTS, COVINGTON, LA. SN 85-136,287. PUB. 3-22-2011, FILED 9-23-2010.

E-PELLET

THE MARK CONSISTS OF STANDARD CHARACTERS WITHOUT CLAIM TO ANY PARTICULAR FONT, STYLE, SIZE, OR COLOR.

FOR INDUSTRIAL OVEN, NAMELY, A CONVECTION OVEN CONTAINING A CONVEYOR THAT EXTERNALLY HEATS THE WOOD PELLET VIA AN INFRARED HEATING SOURCE FOR USE IN A WOOD PELLET PLANT (U.S. CLS. 13, 21, 23, 31 AND 34).

FIRST USE 1-10-2012; IN COMMERCE 1-15-2012.

4,154,856. KEURIG, INCORPORATED, READING, MA. SN 85-153,994. PUB. 3-22-2011, FILED 10-15-2010.

VUE

THE MARK CONSISTS OF STANDARD CHARACTERS WITHOUT CLAIM TO ANY PARTICULAR FONT, STYLE, SIZE, OR COLOR.

FOR ELECTRIC COFFEE, TEA AND HOT COCOA BREWING MACHINES FOR DOMESTIC AND COMMERCIAL USE (U.S. CLS. 13, 21, 23, 31 AND 34).

FIRST USE 3-5-2012; IN COMMERCE 3-5-2012.

CLASS 11—(Continued).

4,154,864. PHOSEON TECHNOLOGY, INC., HILLSBORO, OR. SN 85-159,098. PUB. 10-18-2011, FILED 10-22-2010.

FIREJET

THE MARK CONSISTS OF STANDARD CHARACTERS WITHOUT CLAIM TO ANY PARTICULAR FONT, STYLE, SIZE, OR COLOR.

FOR LIGHT CURING SYSTEMS COMPOSED PRIMARILY OF LIGHT EMITTING DIODES FOR INDUSTRIAL APPLICATIONS; UV CURING SYSTEMS COMPOSED PRIMARILY OF LIGHT EMITTING DIODES, FOR COMMERCIAL APPLICATIONS, NAMELY, FOR CURING INKS, COATINGS, ADHESIVES, AND A VARIETY OF OTHER MATERIALS (U.S. CLS. 13, 21, 23, 31 AND 34).

FIRST USE 8-0-2010; IN COMMERCE 8-0-2010.

4,154,865. PHOSEON TECHNOLOGY, INC., HILLSBORO, OR. SN 85-159,134. PUB. 10-18-2011, FILED 10-22-2010.

FIREPOWER

THE MARK CONSISTS OF STANDARD CHARACTERS WITHOUT CLAIM TO ANY PARTICULAR FONT, STYLE, SIZE, OR COLOR.

FOR LIGHT CURING SYSTEMS COMPOSED PRIMARILY OF LIGHT EMITTING DIODES FOR INDUSTRIAL APPLICATIONS; UV CURING SYSTEMS COMPOSED PRIMARILY OF LIGHT EMITTING DIODES, FOR COMMERCIAL APPLICATIONS, NAMELY, FOR CURING INKS, COATINGS, ADHESIVES, AND A VARIETY OF OTHER MATERIALS (U.S. CLS. 13, 21, 23, 31 AND 34).

FIRST USE 3-5-2012; IN COMMERCE 3-5-2012.

4,154,884. CLARION BATHWARE, INC., SHIPPENVILLE, PA. SN 85-175,505. PUB. 6-21-2011, FILED 11-12-2010.

E-Z PIN

THE MARK CONSISTS OF STANDARD CHARACTERS WITHOUT CLAIM TO ANY PARTICULAR FONT, STYLE, SIZE, OR COLOR.

NO CLAIM IS MADE TO THE EXCLUSIVE RIGHT TO USE "PIN", APART FROM THE MARK AS SHOWN.

FOR SHOWERS AND SHOWER TUBS HAVING SELF-ALIGNING AND ATTACHING FEATURES; SHOWER TUBS WITH SHOWER SURROUNDS (U.S. CLS. 13, 21, 23, 31 AND 34).

FIRST USE 9-15-2011; IN COMMERCE 9-15-2011.

CLASS 11—(Continued).

4,154,899. SUNLIGHT MANUFACTURING, INC., OTTAWA, KS. SN 85-184,612. PUB. 8-9-2011, FILED 11-24-2010.

Patriot Light

THE MARK CONSISTS OF STANDARD CHARACTERS WITHOUT CLAIM TO ANY PARTICULAR FONT, STYLE, SIZE, OR COLOR.

NO CLAIM IS MADE TO THE EXCLUSIVE RIGHT TO USE "LIGHT", APART FROM THE MARK AS SHOWN.

FOR SOLAR LIGHT FIXTURES, NAMELY, A SOLAR POWERED LIGHT UNIT CONFIGURED AS A FINIAL BALL FOR ATTACHMENT ATOP A FLAG POLE TO DOWNWARDLY ILLUMINATE A FLAG DURING DARKNESS OR DIM LIGHT (U.S. CLS. 13, 21, 23, 31 AND 34).

FIRST USE 12-10-2011; IN COMMERCE 12-10-2011.

4,154,931. AMERICAN DE ROSA LAMPARTS LLC, COMMERCE, CA. SN 85-201,057. PUB. 4-26-2011, FILED 12-17-2010.

LUMINANCE

THE MARK CONSISTS OF STANDARD CHARACTERS WITHOUT CLAIM TO ANY PARTICULAR FONT, STYLE, SIZE, OR COLOR.

FOR ELECTRIC LIGHTING FIXTURES (U.S. CLS. 13, 21, 23, 31 AND 34).

FIRST USE 1-1-2012; IN COMMERCE 1-1-2012.

4,154,934. THE MARLEY-WYLAIN COMPANY, MICHIGAN CITY, IN. SN 85-201,737. PUB. 4-26-2011, FILED 12-20-2010.

GL

THE MARK CONSISTS OF STANDARD CHARACTERS WITHOUT CLAIM TO ANY PARTICULAR FONT, STYLE, SIZE, OR COLOR.

FOR WATER HEATERS (U.S. CLS. 13, 21, 23, 31 AND 34).

FIRST USE 1-29-2011; IN COMMERCE 1-29-2011.

CLASS 11—(Continued).

4,155,030. DAIHATSU INDÚSTRIA E COMÉRCIO DE MÓVEIS E APARELHOS DOMÉSTICOS LTDA., SÃO PAULO, BRAZIL. SN 85-234,185. PUB. 7-26-2011, FILED 2-4-2011.



OWNER OF U.S. REG. NOS. 2,647,308, 2,973,022, AND OTHERS.

THE MARK CONSISTS OF THE WORDS "TAIFF" IN STYLIZED FONT ABOVE THE WORD "ENERGY" SEPARATED BY A LINE WITH THE WORD "TAIFF" APPEARING ABOVE THE "ENE" OF "ENERGY".

FOR HAIR DRYERS (U.S. CLS. 13, 21, 23, 31 AND 34). FIRST USE 2-4-2011; IN COMMERCE 2-4-2011.

4,155,109. MEHRKENS, LORI, DBA ABOVE ALL LIGHTING & BULBS INC, ROCKVILLE CENTRE, NY. SN 85-246,492. PUB. 8-16-2011, FILED 2-18-2011.

Absolute Light

THE MARK CONSISTS OF STANDARD CHARACTERS WITHOUT CLAIM TO ANY PARTICULAR FONT, STYLE, SIZE, OR COLOR.

NO CLAIM IS MADE TO THE EXCLUSIVE RIGHT TO USE "LIGHT", APART FROM THE MARK AS SHOWN.

FOR LIGHTING FIXTURES (U.S. CLS. 13, 21, 23, 31 AND 34).

FIRST USE 2-1-2012; IN COMMERCE 2-1-2012.

4,155,116. VOGELZANG INTERNATIONAL CORPORATION, HOLLAND, MI. SN 85-247,924. PUB. 1-24-2012, FILED 2-22-2011.

PONDEROSA

THE MARK CONSISTS OF STANDARD CHARACTERS WITHOUT CLAIM TO ANY PARTICULAR FONT, STYLE, SIZE, OR COLOR.

FOR WOOD BURNING STOVES (U.S. CLS. 13, 21, 23, 31 AND 34).

FIRST USE 1-31-2012; IN COMMERCE 1-31-2012.

CLASS 11—(Continued).

4,155,183. B-K LIGHTING, INC., MADERA, CA. SN 85-254,686. PUB. 7-19-2011, FILED 3-1-2011.

ADJUST-E-LUME

THE MARK CONSISTS OF STANDARD CHARACTERS WITHOUT CLAIM TO ANY PARTICULAR FONT, STYLE, SIZE, OR COLOR.

FOR ELECTRIC LIGHTING FIXTURES (U.S. CLS. 13, 21, 23, 31 AND 34).

FIRST USE 10-15-2011; IN COMMERCE 10-15-2011.

4,155,226. CARBON FIBER HEATING TECHNOLOGIES, LLC, FORESTVILLE, CT. SN 85-259,536. PUB. 7-26-2011, FILED 3-7-2011.

ZEN HEAT

THE MARK CONSISTS OF STANDARD CHARACTERS WITHOUT CLAIM TO ANY PARTICULAR FONT, STYLE, SIZE, OR COLOR.

NO CLAIM IS MADE TO THE EXCLUSIVE RIGHT TO USE "HEAT", APART FROM THE MARK AS SHOWN.

FOR CARBON FIBER ELECTRIC HEATERS FOR COMMERCIAL USE SOLD AS AN INTEGRAL COMPONENT OF ELECTRIC COOKWARE (U.S. CLS. 13, 21, 23, 31 AND 34).

FIRST USE 2-28-2012; IN COMMERCE 2-28-2012.

4,155,283. GUANGDONG YINGAO KITCHEN UTENSILS CO., LTD., SHUNDE, FOSHAN, CHINA. SN 85-265,718. PUB. 10-25-2011, FILED 3-14-2011.



NO CLAIM IS MADE TO THE EXCLUSIVE RIGHT TO USE THE NON-LATIN CHARACTERS THAT TRANSLITERATE TO CHU JU, APART FROM THE MARK AS SHOWN.

CLASS 11—(Continued).

THE MARK CONSISTS OF FOUR CHINESE CHARACTERS APPEARING INSIDE A SHADED SQUARE BACKGROUND.

THE NON-LATIN CHARACTERS IN THE MARK TRANSLITERATE TO "YING"; "AO"; "CHU"; "JU" AND THIS MEANS CHERRY; ABSTRUSE; KITCHEN; UTENSIL IN ENGLISH.

FOR BATHS, BATHTUBS, WHIRLPOOL BATHS AND BATH INSTALLATIONS; ELECTRIC COOKING STOVES; EXTRACTOR HOODS FOR KITCHENS; GAS BURNERS; HYDRANTS; LAMP MANTLES; LAMPS; PIPES FOR HEATING BOILERS; SINKS; STERILIZERS (U.S. CLS. 13, 21, 23, 31 AND 34).

FIRST USE 5-10-2005; IN COMMERCE 4-15-2008.

CLASS 11—(Continued).

4,155,426. CONAIR CORPORATION, STAMFORD, CT. SN 85-285,400. PUB. 8-9-2011, FILED 4-4-2011.

YOU ADORE YOUR CURLS

4,155,330. LENNOX HEARTH PRODUCTS LLC, NASHVILLE, TN. SN 85-270,572. PUB. 8-2-2011, FILED 3-18-2011.

RHAPSODY

THE MARK CONSISTS OF STANDARD CHARACTERS WITHOUT CLAIM TO ANY PARTICULAR FONT, STYLE, SIZE, OR COLOR.

FOR HAND-HELD ELECTRIC HAIR DRYERS (U.S. CLS. 13, 21, 23, 31 AND 34).

FIRST USE 8-0-2011; IN COMMERCE 8-0-2011.

THE MARK CONSISTS OF STANDARD CHARACTERS WITHOUT CLAIM TO ANY PARTICULAR FONT, STYLE, SIZE, OR COLOR.

FOR FIREPLACES (U.S. CLS. 13, 21, 23, 31 AND 34).

FIRST USE 2-1-2012; IN COMMERCE 2-1-2012.

4,155,472. KEURIG, INCORPORATED, READING, MA. SN 85-296,117. PUB. 1-17-2012, FILED 4-15-2011.

BREW STRONGER. BREW BIGGER. BREW HOTTER

4,155,388. ULTRAVIOLET DEVICES, INC., VALENCIA, CA. SN 85-280,718. PUB. 8-9-2011, FILED 3-30-2011.

V-360°

THE MARK CONSISTS OF STANDARD CHARACTERS WITHOUT CLAIM TO ANY PARTICULAR FONT, STYLE, SIZE, OR COLOR.

FOR AIR AND SURFACE DISINFECTION UNITS USING ULTRAVIOLET LAMP FIXTURES (U.S. CLS. 13, 21, 23, 31 AND 34).

FIRST USE 9-26-2011; IN COMMERCE 2-27-2012.

THE MARK CONSISTS OF STANDARD CHARACTERS WITHOUT CLAIM TO ANY PARTICULAR FONT, STYLE, SIZE, OR COLOR.

FOR ELECTRIC BREWING MACHINES FOR BREWING BEVERAGES FOR DOMESTIC AND COMMERCIAL USE (U.S. CLS. 13, 21, 23, 31 AND 34).

FIRST USE 3-5-2012; IN COMMERCE 3-5-2012.

CLASS 11—(Continued).

4,155,599. LIN, AI GUO, JINJIANG CITY, CHINA. SN 85-342,150. PUB. 11-1-2011, FILED 6-9-2011.



THE MARK CONSISTS OF THE STYLIZED LETTERS "FF" FORMING A CHEVRON DESIGN AND UNDERNEATH IS WORDS "FREE FORCE".

FOR ELECTRIC LIGHT BULBS; FLASHLIGHTS; FLUORESCENT ELECTRIC LIGHT BULBS; LAMP BULBS; LAMPS; LED (LIGHT EMITTING DIODE) LIGHTING FIXTURES; LED (LIGHT EMITTING DIODES) LIGHTING FIXTURES FOR USE IN DISPLAY, COMMERCIAL, INDUSTRIAL, RESIDENTIAL, AND ARCHITECTURAL ACCENT LIGHTING APPLICATIONS; LED LIGHT ASSEMBLIES FOR STREET LIGHTS, SIGNS, COMMERCIAL LIGHTING, AUTOMOBILES, BUILDINGS, AND OTHER ARCHITECTURAL USES; LED LIGHT BULBS; LED LIGHTING FIXTURES FOR INDOOR AND OUTDOOR LIGHTING APPLICATIONS; LED LUMINAIRES; LIGHT BULBS; LIGHTING TUBES; LIGHTS FOR VEHICLES; LUMINAIRES, USING LIGHT EMITTING DIODES (LEDS) AS A LIGHT SOURCE, FOR STREET OR ROADWAY LIGHTING (U.S. CLS. 13, 21, 23, 31 AND 34).

FIRST USE 1-1-2012; IN COMMERCE 1-1-2012.

4,155,701. DELTA T CORPORATION, LEXINGTON, KY. SN 85-369,853. PUB. 9-13-2011, FILED 7-13-2011.

POETRY IN MOTION

THE MARK CONSISTS OF STANDARD CHARACTERS WITHOUT CLAIM TO ANY PARTICULAR FONT, STYLE, SIZE, OR COLOR.

FOR ELECTRIC FANS (U.S. CLS. 13, 21, 23, 31 AND 34).

FIRST USE 2-0-2012; IN COMMERCE 2-0-2012.

CLASS 11—(Continued).

4,155,815. COOPER TECHNOLOGIES COMPANY, HOUSTON, TX. SN 85-444,528. PUB. 12-20-2011, FILED 10-11-2011.

ARCDUO

THE MARK CONSISTS OF STANDARD CHARACTERS WITHOUT CLAIM TO ANY PARTICULAR FONT, STYLE, SIZE, OR COLOR.

FOR ELECTRIC LIGHTING FIXTURES (U.S. CLS. 13, 21, 23, 31 AND 34).

FIRST USE 12-11-2011; IN COMMERCE 12-11-2011.

CLASS 12—VEHICLES

4,154,711. THOR TECH, INC., JACKSON CENTER, OH. SN 85-103,385. PUB. 7-5-2011, FILED 8-9-2010.

G-FORCE

THE MARK CONSISTS OF STANDARD CHARACTERS WITHOUT CLAIM TO ANY PARTICULAR FONT, STYLE, SIZE, OR COLOR.

FOR BUSES (U.S. CLS. 19, 21, 23, 31, 35 AND 44).

FIRST USE 0-0-2010; IN COMMERCE 0-0-2010.

4,154,772. THOR TECH, INC., JACKSON CENTER, OH. SN 85-121,158. PUB. 7-26-2011, FILED 9-1-2010.

ASPEN TRAIL

THE MARK CONSISTS OF STANDARD CHARACTERS WITHOUT CLAIM TO ANY PARTICULAR FONT, STYLE, SIZE, OR COLOR.

FOR RECREATIONAL VEHICLES, NAMELY, TRAVEL TRAILERS (U.S. CLS. 19, 21, 23, 31, 35 AND 44).

FIRST USE 0-0-2010; IN COMMERCE 0-0-2010.

CLASS 12—(Continued).

4,154,919. PRECISION FLEET BRAKES, INC., AUSTIN, TX. SN 85-196,712. PUB. 8-16-2011, FILED 12-13-2010.

FLEET PHYSICS

THE MARK CONSISTS OF STANDARD CHARACTERS WITHOUT CLAIM TO ANY PARTICULAR FONT, STYLE, SIZE, OR COLOR.

NO CLAIM IS MADE TO THE EXCLUSIVE RIGHT TO USE "FLEET", APART FROM THE MARK AS SHOWN.

FOR BRAKE COMPONENTS FOR LAND VEHICLES, NAMELY, DRUMS, ROTORS, PADS, CALIPERS AND BEARINGS (U.S. CLS. 19, 21, 23, 31, 35 AND 44). FIRST USE 10-1-2010; IN COMMERCE 10-1-2010.

4,154,941. REYNOLDS CYCLING, L.L.C., DBA PACIFIC RIMS USA, WEST JORDAN, UT. SN 85-204,025. PUB. 6-14-2011, FILED 12-22-2010.

PACIFIC RIMS

THE MARK CONSISTS OF STANDARD CHARACTERS WITHOUT CLAIM TO ANY PARTICULAR FONT, STYLE, SIZE, OR COLOR.

FOR BICYCLE WHEELS; BICYCLE WHEEL RIMS; BICYCLE WHEEL HUBS; BICYCLE WHEEL SPOKES; BICYCLE WHEEL SPOKE FASTENERS; BICYCLE WHEEL BRAKE PADS; BICYCLE WHEEL TIRES; BICYCLE WHEEL INNER TUBES; BICYCLE WATER BOTTLE CAGES; BICYCLE WHEEL ACCESSORIES NAMELY, AXLES, AXLE END CAPS, FREEHUB BODIES, GEARS, QUICK RELEASE SKEWERS, RIM STRIPS, TUBELESS RIM TAPE, VALVES, VALVE EXTENDERS, WHEEL BAGS AND CASES (U.S. CLS. 19, 21, 23, 31, 35 AND 44). FIRST USE 9-0-2010; IN COMMERCE 9-0-2010.

4,155,089. BRODA ENTERPRISES INC., KITCHENER, ONTARIO, CANADA. SN 85-244,657. PUB. 8-2-2011, FILED 2-17-2011.

CLEARPATH

THE MARK CONSISTS OF STANDARD CHARACTERS WITHOUT CLAIM TO ANY PARTICULAR FONT, STYLE, SIZE, OR COLOR.

CLASS 12—(Continued).

PRIORITY CLAIMED UNDER SEC. 44(D) ON CANADA APPLICATION NO. 1,512,216, FILED 1-21-2011.

FOR HEALTHCARE SEATING AND MOBILITY DEVICES, NAMELY, WHEELED CHAIRS (U.S. CLS. 19, 21, 23, 31, 35 AND 44). FIRST USE 6-3-2011; IN COMMERCE 6-24-2011.

4,155,435. TAP WORLDWIDE, LLC, COMPTON, CA. SN 85-286,635. PUB. 7-19-2011, FILED 4-5-2011.

OFF-ROAD DRIVEN!

THE MARK CONSISTS OF STANDARD CHARACTERS WITHOUT CLAIM TO ANY PARTICULAR FONT, STYLE, SIZE, OR COLOR.

NO CLAIM IS MADE TO THE EXCLUSIVE RIGHT TO USE "OFF-ROAD", APART FROM THE MARK AS SHOWN.

FOR AUTOMOBILE AND TRUCK STRUCTURAL PARTS AND ACCESSORIES SPECIALLY ADAPTED FOR AUTOMOBILES AND TRUCKS, NAMELY, STRUCTURAL PARTS FOR AUTOMOBILES, WHEELS, WHEEL RIMS, TIRES, SHOCK ABSORBERS, SHOCK ABSORBER MOUNTS, SHOCK ABSORBER BRACKETS, PITMAN ARMS, STEERING ARMS, TIRE RODS, STEERING DAMPENERS, SUSPENSION SYSTEMS FOR AUTOMOBILES FEATURING REAR STABILIZER BARS, AUTOMOBILE AND TRUCK BODY PARTS IN THE NATURE OF SIDEBARS, BUMPERS, BRUSH GUARDS, GRILL GUARDS (U.S. CLS. 19, 21, 23, 31, 35 AND 44). FIRST USE 5-1-2011; IN COMMERCE 6-1-2011.

4,155,520. CHRYSLER GROUP LLC, AUBURN HILLS, MI. SN 85-311,779. PUB. 8-23-2011, FILED 5-4-2011.

GUTS. GLORY. RAM.

THE MARK CONSISTS OF STANDARD CHARACTERS WITHOUT CLAIM TO ANY PARTICULAR FONT, STYLE, SIZE, OR COLOR.

OWNER OF U.S. REG. NOS. 1,169,189, 2,999,082, AND OTHERS.

FOR MOTOR VEHICLES, NAMELY, PASSENGER AUTOMOBILES, THEIR STRUCTURAL PARTS, TRIM AND BADGES (U.S. CLS. 19, 21, 23, 31, 35 AND 44). FIRST USE 6-0-2011; IN COMMERCE 6-0-2011.

CLASS 12—(Continued).

4,155,665. WERNER PADDLES, INC., SULTAN, WA. SN 85-361,674. PUB. 12-6-2011, FILED 7-1-2011.

SMART-VIEW

THE MARK CONSISTS OF STANDARD CHARACTERS WITHOUT CLAIM TO ANY PARTICULAR FONT, STYLE, SIZE, OR COLOR.

FOR KAYAK PADDLES (U.S. CLS. 19, 21, 23, 31, 35 AND 44).

FIRST USE 8-4-2011; IN COMMERCE 9-30-2011.

4,155,804. THOR TECH, INC., JACKSON CENTER, OH. SN 85-420,317. PUB. 1-17-2012, FILED 9-12-2011.

PALAZZO

THE MARK CONSISTS OF STANDARD CHARACTERS WITHOUT CLAIM TO ANY PARTICULAR FONT, STYLE, SIZE, OR COLOR.

FOR MOTOR HOMES (U.S. CLS. 19, 21, 23, 31, 35 AND 44).

FIRST USE 0-0-2011; IN COMMERCE 0-0-2011.

CLASS 14—JEWELRY

4,154,290. THE TOPLINE CORPORATION, BELLEVUE, WA. SN 77-396,001. PUB. 1-13-2009, FILED 2-13-2008.

REPORT SIGNATURE

THE MARK CONSISTS OF STANDARD CHARACTERS WITHOUT CLAIM TO ANY PARTICULAR FONT, STYLE, SIZE, OR COLOR.

OWNER OF U.S. REG. NOS. 2,169,637, 3,246,085, AND 3,358,128.

FOR WOMEN'S JEWELRY; WOMEN'S WATCHES (U.S. CLS. 2, 27, 28 AND 50).

FIRST USE 7-0-2010; IN COMMERCE 7-0-2010.

CLASS 14—(Continued).

4,154,561. KIM INTERNATIONAL MFG. L.P., DALLAS, TX. SN 77-963,854. PUB. 8-2-2011, FILED 3-19-2010.

ROMANCE DIAMOND

THE MARK CONSISTS OF STANDARD CHARACTERS WITHOUT CLAIM TO ANY PARTICULAR FONT, STYLE, SIZE, OR COLOR.

NO CLAIM IS MADE TO THE EXCLUSIVE RIGHT TO USE "DIAMOND", APART FROM THE MARK AS SHOWN. FOR DIAMOND JEWELRY (U.S. CLS. 2, 27, 28 AND 50).

FIRST USE 9-0-2010; IN COMMERCE 9-0-2010.

4,154,567. CHAIN & CHARM, INC., LOS ANGELES, CA. SN 77-966,517. PUB. 8-10-2010, FILED 3-23-2010.

AUCARA

THE MARK CONSISTS OF STANDARD CHARACTERS WITHOUT CLAIM TO ANY PARTICULAR FONT, STYLE, SIZE, OR COLOR.

FOR JEWELRY (U.S. CLS. 2, 27, 28 AND 50).

FIRST USE 2-1-2012; IN COMMERCE 2-1-2012.

4,154,609. KEEP A BREAST FOUNDATION, CARLSBAD, CA. SN 85-002,391. PUB. 8-17-2010, FILED 3-30-2010.



THE MARK CONSISTS OF A HEART SUPERIMPOSED ON TWO HALF CIRCLES REPRESENTING ABSTRACT BREASTS.

FOR JEWELRY, NAMELY, RINGS, WATCHES (U.S. CLS. 2, 27, 28 AND 50).

FIRST USE 6-6-2011; IN COMMERCE 6-6-2011.

CLASS 14—(Continued).

4,154,723. NUTZO, LLC, LOS ANGELES, CA. SN 85-105,564. PUB. 8-2-2011, FILED 8-11-2010.



"KIARRA KENNEDY" DOES NOT IDENTIFY A LIVING INDIVIDUAL.

THE MARK CONSISTS OF THE STYLIZED WORDS "KIARRA KENNEDY" SEPARATED BY A FANCIFUL DESIGN. THE DESIGN CONSISTS OF TWO STYLIZED LETTER "K"'S WITHIN A HEXAGON WITH A DECORATIVE BORDER. ABOVE THE HEXAGON IS AN ORNAMENTAL DESIGN WITH HEARTS. THE STYLIZED WORDING "WHERE KIDS ARE ROYALTY" APPEARS BELOW.

FOR JEWELRY (U.S. CLS. 2, 27, 28 AND 50). FIRST USE 1-20-2011; IN COMMERCE 1-20-2011.

4,154,729. TIFFANY (NJ) LLC, PARSIPPANY, NJ. SN 85-106,946. PUB. 3-1-2011, FILED 8-13-2010.

TIFFANY GALLERY

THE MARK CONSISTS OF STANDARD CHARACTERS WITHOUT CLAIM TO ANY PARTICULAR FONT, STYLE, SIZE, OR COLOR.

OWNER OF U.S. REG. NOS. 2,639,539, 3,218,687, AND OTHERS.

NO CLAIM IS MADE TO THE EXCLUSIVE RIGHT TO USE "GALLERY", APART FROM THE MARK AS SHOWN.

FOR WATCHES (U.S. CLS. 2, 27, 28 AND 50). FIRST USE 10-0-2011; IN COMMERCE 10-0-2011.

4,154,737. A. JAFFE, INC., NEW YORK, NY. SN 85-109,011. PUB. 2-1-2011, FILED 8-17-2010.

Where it's At

THE MARK CONSISTS OF STANDARD CHARACTERS WITHOUT CLAIM TO ANY PARTICULAR FONT, STYLE, SIZE, OR COLOR.

FOR JEWELRY (U.S. CLS. 2, 27, 28 AND 50). FIRST USE 6-1-2011; IN COMMERCE 6-1-2011.

CLASS 14—(Continued).

4,154,756. A. JAFFE, INC., NEW YORK, NY. SN 85-116,342. PUB. 2-1-2011, FILED 8-26-2010.

Forever Begins Today

THE MARK CONSISTS OF STANDARD CHARACTERS WITHOUT CLAIM TO ANY PARTICULAR FONT, STYLE, SIZE, OR COLOR.

FOR JEWELRY (U.S. CLS. 2, 27, 28 AND 50). FIRST USE 3-29-2012; IN COMMERCE 3-29-2012.

4,154,861. HACHETTE FILIPACCHI PRESSE, LEVALLOIS-PERRET CEDEX, FRANCE. SN 85-157,949. PUB. 8-9-2011, FILED 10-21-2010.



OWNER OF U.S. REG. NOS. 758,137, 2,120,688, AND OTHERS.

NO CLAIM IS MADE TO THE EXCLUSIVE RIGHT TO USE "BIJOUX", APART FROM THE MARK AS SHOWN.

THE COLOR(S) RED, WHITE AND BLACK IS/ARE CLAIMED AS A FEATURE OF THE MARK.

THE MARK CONSISTS OF THE WORD "ELLE" IN WHITE LETTERS ON A RED BACKGROUND AND THE WORD "BIJOUX" IN BLACK LETTERS ON A WHITE BACKGROUND.

THE ENGLISH TRANSLATION OF "ELLE" IN THE MARK IS "SHE".

FOR COSTUME JEWELLERY, FASHION JEWELLERY, IMITATION JEWELLERY, JEWELLERY AND PRECIOUS STONES IN GENERAL, NECKLACES, PENDANTS, EARRINGS, BRACELETS, BANGLES, RINGS, TRINKETS IN THE NATURE OF RINGS (U.S. CLS. 2, 27, 28 AND 50).

FIRST USE 11-30-2011; IN COMMERCE 11-30-2011.

4,154,913. RU MINDAN, BEIJING, 100061, CHINA. SN 85-191,743. PUB. 9-6-2011, FILED 12-6-2010.



THE NAME(S), PORTRAIT(S), AND/OR SIGNATURE(S) SHOWN IN THE MARK DOES NOT IDENTIFY A PARTICULAR LIVING INDIVIDUAL.

THE COLOR(S) BLACK, ORANGE AND GREY IS/ARE CLAIMED AS A FEATURE OF THE MARK.

CLASS 14—(Continued).

THE MARK CONSISTS OF THE WORDS "LISA LEE" IN BLACK COLOR WITH A CIRCULAR DEVICE BETWEEN THE TWO WORDS. THE CIRCULAR DEVICE HAS AN ORANGE BACKGROUND AND CONSISTS OF A GREY MOON-SHAPED DEVICE AND A GREY STYLIZED LETTER "L".

FOR EARRINGS; JEWELRY; NECKLACES; ORNAMENTS OF PRECIOUS METAL; PEARLS; PRECIOUS METAL ALLOYS; PRECIOUS STONES; RINGS; SEMI-PRECIOUS STONES; SPINELS (U.S. CLS. 2, 27, 28 AND 50).

FIRST USE 4-10-2010; IN COMMERCE 4-10-2010.

4,154,975. MOCHINSKI, JACOB, DBA AIRCRAFTKEEPERS, EVERETT, WA. SN 85-214,560. PUB. 7-19-2011, FILED 1-11-2011.

jaggedfashion

THE MARK CONSISTS OF STANDARD CHARACTERS WITHOUT CLAIM TO ANY PARTICULAR FONT, STYLE, SIZE, OR COLOR.

FOR CHOKERS; NECKLACES (U.S. CLS. 2, 27, 28 AND 50).

FIRST USE 8-1-2011; IN COMMERCE 8-1-2011.

MY OWN kidz

THE MARK CONSISTS OF STANDARD CHARACTERS WITHOUT CLAIM TO ANY PARTICULAR FONT, STYLE, SIZE, OR COLOR.

CLASS 14—(Continued).

NO CLAIM IS MADE TO THE EXCLUSIVE RIGHT TO USE "KIDS", APART FROM THE MARK AS SHOWN.

FOR BRACELETS; BRACELETS AND JEWELRY FEATURING ELECTRONIC CHIPS FOR ATTRACTING ENERGY TO THE BODY WHEREIN THE ELECTRONIC CHIPS INCREASE IN POWER IN THE PRESENCE OF ELECTROMAGNETIC FIELDS, FOR THE PURPOSE OF RE-BALANCING THE HUMAN ENERGY FIELD; CHARMS FOR COLLAR JEWELRY AND BRACELET; CHRONOGRAPHS AS WATCHES; CHRONOGRAPHS FOR USE AS WATCHES; CHRONOMETRIC INSTRUMENTS AND WATCH MOVEMENTS; CLOCK AND WATCH HANDS; CLOCKS AND WATCHES; DIVING WATCHES; DRESS WATCHES; IDENTIFICATION BRACELETS; INEXPENSIVE NON-JEWELRY WATCHES; JEWELLERY AND WATCHES; JEWELRY WATCHES; JEWELRY, NAMELY, BRACELETS, WRISTBANDS AND NECKLACES THAT ALSO PROVIDES NOTIFICATION TO THE WEARER OF A PENDING MEDICAL RELATED TASK; MECHANICAL AND AUTOMATIC WATCHES; PLASTIC BRACELETS IN THE NATURE OF JEWELRY; RUBBER OR SILICON WRISTBANDS IN THE NATURE OF A BRACELET; SPORTS WATCHES; STAINLESS STEEL JEWELRY BRACELETS; WATCH BANDS; WATCH BANDS AND STRAPS; WATCH BRACELETS; WATCH STRAPS; WATCH STRAPS MADE OF METAL OR LEATHER OR PLASTIC; WATCHES; WATCHES AND CLOCKS; WATCHES AND JEWELLERY; WATCHES AND JEWELRY; WATCHES AND STRAPS FOR WATCHES; WATCHES FOR OUTDOOR USE; WATCHES FOR SPORTING USE; WATCHES MADE OF PRECIOUS METALS OR COATED THEREWITH; WATCHES, CLOCKS; WATCHES, CLOCKS, JEWELLERY AND IMITATION JEWELLERY; WATCHES, CLOCKS, JEWELRY AND IMITATION JEWELRY; WOMEN'S WATCHES; WRIST WATCHES (U.S. CLS. 2, 27, 28 AND 50).

FIRST USE 7-27-2011; IN COMMERCE 7-27-2011.

4,154,988. MY OWN KIDZ LLC, NORTH RICHLAND HILLS, TX. SN 85-219,042. PUB. 5-31-2011, FILED 1-17-2011.

MY OWN id

THE MARK CONSISTS OF STANDARD CHARACTERS WITHOUT CLAIM TO ANY PARTICULAR FONT, STYLE, SIZE, OR COLOR.

NO CLAIM IS MADE TO THE EXCLUSIVE RIGHT TO USE "ID", APART FROM THE MARK AS SHOWN.

FOR BRACELETS; BRACELETS; BRACELETS AND JEWELRY FEATURING ELECTRONIC CHIPS FOR ATTRACTING ENERGY TO THE BODY WHEREIN THE ELECTRONIC CHIPS INCREASE IN POWER IN THE PRESENCE OF ELECTROMAGNETIC FIELDS, FOR THE PURPOSE OF RE-BALANCING THE HUMAN ENERGY FIELD; BRACELETS OF PRECIOUS METAL; CHARMS FOR COLLAR JEWELRY AND BRACELET; CHRONOGRAPHS AS WATCHES; CHRONOGRAPHS FOR USE AS WATCHES; CHRONOMETRIC INSTRUMENTS AND WATCH MOVEMENTS; CLOCKS AND WATCHES; DIVING WATCHES; DRESS WATCHES; IDENTIFICATION BRACELETS; INEXPENSIVE NON-JEWELRY WATCHES; JEWELLERY AND WATCHES; JEWELLERY, CLOCKS AND WATCHES; JEWELRY WATCHES; JEWELRY, NAMELY, BRACELETS, WRISTBANDS AND NECKLACES THAT ALSO PROVIDES NOTIFICATION TO THE WEARER OF A PENDING MEDICAL RELATED

CLASS 14—(Continued).

TASK; MECHANICAL AND AUTOMATIC WATCHES; PLASTIC BRACELETS IN THE NATURE OF JEWELRY; RUBBER OR SILICON WRISTBANDS IN THE NATURE OF A BRACELET; SLAP BRACELETS; SLAPBAND BRACELETS; SPORTS WATCHES; STAINLESS STEEL JEWELRY BRACELETS; WATCH BANDS; WATCH BANDS AND STRAPS; WATCH BRACELETS; WATCH STRAPS; WATCH STRAPS MADE OF METAL OR LEATHER OR PLASTIC; WATCHES; WATCHES AND CLOCKS; WATCHES AND JEWELLERY; WATCHES AND JEWELRY; WATCHES AND STRAPS FOR WATCHES; WATCHES CONTAINING A GAME FUNCTION; WATCHES CONTAINING AN ELECTRONIC GAME FUNCTION; WATCHES FOR OUTDOOR USE; WATCHES FOR SPORTING USE; WATCHES MADE OF PRECIOUS METALS OR COATED THEREWITH; WATCHES, CLOCKS; WATCHES, CLOCKS, JEWELLERY AND IMITATION JEWELLERY; WATCHES, CLOCKS, JEWELRY AND IMITATION JEWELRY; WOMEN'S WATCHES; WRIST WATCHES (U.S. CLS. 2, 27, 28 AND 50).

FIRST USE 7-27-2011; IN COMMERCE 7-27-2011.

4,154,995. INNER CIRCLE DESIGNS, LLC, MARIETTA, GA. SN 85-221,682. PUB. 5-31-2011, FILED 1-19-2011.

HOTLOKS

THE MARK CONSISTS OF STANDARD CHARACTERS WITHOUT CLAIM TO ANY PARTICULAR FONT, STYLE, SIZE, OR COLOR.

OWNER OF U.S. REG. NO. 3,626,683.
FOR JEWELRY FOR ATTACHMENT TO CLOTHING (U.S. CLS. 2, 27, 28 AND 50).
FIRST USE 2-5-2012; IN COMMERCE 2-5-2012.

4,155,069. LUXE VAULT LTD., NEW YORK, NY. SN 85-241,991. PUB. 6-14-2011, FILED 2-14-2011.

LUXE  VAULT

THE MARK CONSISTS OF A SOLID KEY-HOLE SHAPE BETWEEN THE WORDS "LUXE" AND "VAULT".
FOR JEWELRY (U.S. CLS. 2, 27, 28 AND 50).
FIRST USE 8-0-2011; IN COMMERCE 8-0-2011.

CLASS 14—(Continued).

4,155,279. SPOON, SANDRA, SAHUARITA, AZ. SN 85-264,666. PUB. 7-26-2011, FILED 3-11-2011.



THE MARK CONSISTS OF "WHIMSIES" WRITTEN ACROSS AN OVAL BACKGROUND. "SPOON'S" WRITTEN ON THE TOP PART OF THE OVAL. FILIGREE DESIGNS FILL THE SIDES OF THE OVAL.

FOR JEWELRY (U.S. CLS. 2, 27, 28 AND 50).
FIRST USE 3-1-2011; IN COMMERCE 10-22-2011.

4,155,282. PURE JOY JEWELRY, PONTIAC, MI. SN 85-265,694. PUB. 8-9-2011, FILED 3-13-2011.

Pure Joy Jewelry

THE MARK CONSISTS OF STANDARD CHARACTERS WITHOUT CLAIM TO ANY PARTICULAR FONT, STYLE, SIZE, OR COLOR.

NO CLAIM IS MADE TO THE EXCLUSIVE RIGHT TO USE "JEWELRY", APART FROM THE MARK AS SHOWN.
FOR BRACELETS; BROACHES; GEMSTONE JEWELRY; JEWELRY, NAMELY, ANKLETS; JEWELRY, NAMELY, CROSSES; JEWELRY, NAMELY, MAGNETIC NECKLACES; JEWELRY, NAMELY, MAGNETIC PENDANTS; JEWELRY, NAMELY, STONE PENDANTS; STAINLESS STEEL JEWELRY BRACELETS; WOMEN'S JEWELRY (U.S. CLS. 2, 27, 28 AND 50).
FIRST USE 1-6-2010; IN COMMERCE 1-6-2010.

4,155,356. BDSRCO, INC., WILMINGTON, DE. SN 85-276,029. PUB. 8-23-2011, FILED 3-24-2011.

WURL

THE MARK CONSISTS OF STANDARD CHARACTERS WITHOUT CLAIM TO ANY PARTICULAR FONT, STYLE, SIZE, OR COLOR.

OWNER OF U.S. REG. NOS. 3,386,143 AND 3,742,838.
FOR JEWELRY (U.S. CLS. 2, 27, 28 AND 50).
FIRST USE 10-1-2009; IN COMMERCE 10-1-2009.

CLASS 14—(Continued).

4,155,363. J.S. JOHNSON, LTD., COLUMBUS, OH. SN 85-277,250. PUB. 10-4-2011, FILED 3-25-2011.

YOUR FAMILY CROSS

THE MARK CONSISTS OF STANDARD CHARACTERS WITHOUT CLAIM TO ANY PARTICULAR FONT, STYLE, SIZE, OR COLOR.

NO CLAIM IS MADE TO THE EXCLUSIVE RIGHT TO USE "CROSS", APART FROM THE MARK AS SHOWN.

FOR JEWELLERY AND PRECIOUS STONES; JEWELRY (U.S. CLS. 2, 27, 28 AND 50).

FIRST USE 11-17-2011; IN COMMERCE 11-17-2011.

4,155,457. SHIELER TRADING CORP., NEW YORK, NY. SN 85-292,628. PUB. 8-23-2011, FILED 4-12-2011.

DAVID [®] RAPHAEL

THE NAME(S), PORTRAIT(S), AND/OR SIGNATURE(S) SHOWN IN THE MARK IDENTIFIES A LIVING INDIVIDUAL, WHOSE CONSENT(S) TO REGISTER IS MADE OF RECORD.

THE MARK CONSISTS OF THE WORDS "DAVID RAPHAEL" WITH THE LETTERS "D & R" INTERTWINED IN BETWEEN THEM.

FOR JEWELRY, NAMELY, NECKLACES, RINGS, EARRINGS, BRACELETS, PENDANTS AND CUFF LINKS MADE OF GOLD, SILVER, DIAMONDS, PRECIOUS STONES AND SEMI-PRECIOUS STONES; WATCHES (U.S. CLS. 2, 27, 28 AND 50).

FIRST USE 7-1-2011; IN COMMERCE 7-1-2011.

4,155,627. J. PAUL BUCHANAN & ASSOCIATES, INC., CARLSBAD, CA. SN 85-349,588. PUB. 11-15-2011, FILED 6-17-2011.

BELLA IDEALE

THE MARK CONSISTS OF STANDARD CHARACTERS WITHOUT CLAIM TO ANY PARTICULAR FONT, STYLE, SIZE, OR COLOR.

THE ENGLISH TRANSLATION OF "BELLA IDEALE" IN THE MARK IS BEAUTIFUL IDEAL.

FOR JEWELLERY; WATCHES (U.S. CLS. 2, 27, 28 AND 50).

FIRST USE 9-19-2010; IN COMMERCE 2-15-2011.

CLASS 14—(Continued).

4,155,746. MARKET AMERICA, INC., GREENSBORO, NC. SN 85-385,766. PUB. 1-3-2012, FILED 8-1-2011.

YOURS

THE MARK CONSISTS OF STANDARD CHARACTERS WITHOUT CLAIM TO ANY PARTICULAR FONT, STYLE, SIZE, OR COLOR.

OWNER OF U.S. REG. NO. 3,948,741.

FOR JEWELRY (U.S. CLS. 2, 27, 28 AND 50).

FIRST USE 9-8-2011; IN COMMERCE 12-12-2011.

4,155,747. MARKET AMERICA, INC., GREENSBORO, NC. SN 85-385,770. PUB. 1-10-2012, FILED 8-1-2011.

YOURS BY LOREN

THE MARK CONSISTS OF STANDARD CHARACTERS WITHOUT CLAIM TO ANY PARTICULAR FONT, STYLE, SIZE, OR COLOR.

OWNER OF U.S. REG. NO. 3,948,741.

FOR JEWELRY (U.S. CLS. 2, 27, 28 AND 50).

FIRST USE 9-8-2011; IN COMMERCE 12-12-2011.

4,155,776. G.I. GROUP LLC, FLUSHING, NY. SN 85-397,495. PUB. 1-31-2012, FILED 8-14-2011.

GALILI
Jewelry with Personal Touch

NO CLAIM IS MADE TO THE EXCLUSIVE RIGHT TO USE "JEWELRY", APART FROM THE MARK AS SHOWN.

THE MARK CONSISTS OF STYLIZED VERSIONS OF THE WORD "GALILI" WITH A LINE UNDERNEATH IT. BELOW THE LINE IS THE STYLIZED WORDING "JEWELRY WITH PERSONAL TOUCH".

FOR DIAMONDS; JEWELRY (U.S. CLS. 2, 27, 28 AND 50).

FIRST USE 12-5-2011; IN COMMERCE 12-5-2011.

CLASS 14—(Continued).

4,155,780. NEDRY, MADELINE, POMPANO BEACH, FL. SN 85-399,978. PUB. 1-31-2012, FILED 8-17-2011.



NO CLAIM IS MADE TO THE EXCLUSIVE RIGHT TO USE ".COM", APART FROM THE MARK AS SHOWN.

THE COLOR(S) BLACK, PINK, PURPLE, BLUE, ORANGE, SILVER, GREEN AND YELLOW IS/ARE CLAIMED AS A FEATURE OF THE MARK.

THE MARK CONSISTS OF THE WORDS "FRIENDLY-BANDS .COM LINKING FRIENDS TOGETHER" AND A DESIGN. THE WORDING "FRIENDLY BANDS", ".COM", AND "LINKING FRIENDS TOGETHER" IS PRESENTED IN VARIOUS COLORS OF ORANGE, PINK, PURPLE AND BLUE. THE WORDS "LINKING", "FRIENDS", "TOGETHER" ARE CONNECTED BY SILVER CHAINS. ALL OF THE WORDS EXCEPT FOR ".COM" ARE PRESENTED IN A CIRCULAR FORM. INSIDE OF THE CIRCULAR FORM ARE TWO HANDS HOLDING EACH OTHER. THE LEFT HAND IS WEARING TWO MULTI-COLORED BRACELETS AND THE RIGHT HAND IS WEARING ONE MULTI-COLORED BRACELET; THE BRACELETS CONTAIN THE COLORS PINK, ORANGE, YELLOW, GREEN, AND BLUE. THE HANDS ARE OUTLINED IN BLACK. THE WHITE IN THE HANDS REPRESENTS TRANSPARENCY AND IS NOT CLAIMED AS A FEATURE OF THE MARK.

FOR BRACELETS (U.S. CLS. 2, 27, 28 AND 50).
FIRST USE 3-1-2012; IN COMMERCE 3-1-2012.

4,155,827. AUTODROMO LLC, BROOKLYN, NY. SN 85-976,271. PUB. 10-18-2011, FILED 5-23-2011.



THE MARK CONSISTS OF TWO INTERSECTING POLYGONAL FIGURES DRAWN TO RESEMBLE A SMALL SEGMENT OF A TIRE TREAD.

FOR WATCHES (U.S. CLS. 2, 27, 28 AND 50).
FIRST USE 11-14-2011; IN COMMERCE 11-14-2011.

CLASS 14—(Continued).

4,155,844. CLOELLE DESIGNS INC., TORONTO, CANADA. SN 85-976,686. PUB. 2-22-2011, FILED 9-9-2010.

CLOELLE

THE MARK CONSISTS OF STANDARD CHARACTERS WITHOUT CLAIM TO ANY PARTICULAR FONT, STYLE, SIZE, OR COLOR.

THE NAME "CLOELLE" DOES NOT IDENTIFY A LIVING INDIVIDUAL.

FOR JEWELRY (U.S. CLS. 2, 27, 28 AND 50).
FIRST USE 9-14-2010; IN COMMERCE 3-27-2012.

CLASS 16—PAPER GOODS AND PRINTED MATTER

4,154,243. FRED & BARREL, INC., CLARKSVILLE, MD. SN 76-681,925. PUB. 3-31-2009, FILED 9-17-2007.

FRED & BARREL

THE MARK CONSISTS OF STANDARD CHARACTERS WITHOUT CLAIM TO ANY PARTICULAR FONT, STYLE, SIZE, OR COLOR.

FOR PRINTED MATTER, NAMELY, COMIC BOOKS; SERIES OF FICTION WORKS, NAMELY, NOVELS AND BOOKS (U.S. CLS. 2, 5, 22, 23, 29, 37, 38 AND 50).

FIRST USE 12-20-2011; IN COMMERCE 2-11-2012.

4,154,300. DISNEY ENTERPRISES, INC., BURBANK, CA. SN 77-435,727. PUB. 1-6-2009, FILED 3-31-2008.

D23

THE MARK CONSISTS OF STANDARD CHARACTERS WITHOUT CLAIM TO ANY PARTICULAR FONT, STYLE, SIZE, OR COLOR.

FOR DIARIES; WRITING PAPER; PENS; WRITING IMPLEMENTS; ART PRINTS; PRINTED CERTIFICATES (U.S. CLS. 2, 5, 22, 23, 29, 37, 38 AND 50).

FIRST USE 8-31-2011; IN COMMERCE 8-31-2011.

CLASS 16—(Continued).

4,154,302. GABBIDON, ANDREW, QUEENS VILLAGE, NY, AND GABBIDON, KISHA, QUEENS VILLAGE, NY. SN 77-452,883. PUB. 3-24-2009, FILED 4-20-2008.

MOCHA BRIDE

THE MARK CONSISTS OF STANDARD CHARACTERS WITHOUT CLAIM TO ANY PARTICULAR FONT, STYLE, SIZE, OR COLOR.

NO CLAIM IS MADE TO THE EXCLUSIVE RIGHT TO USE "BRIDE", APART FROM THE MARK AS SHOWN.

FOR GENERAL FEATURE MAGAZINES; BRIDAL MAGAZINES; MULTICULTURAL MAGAZINES (U.S. CLS. 2, 5, 22, 23, 29, 37, 38 AND 50).

FIRST USE 3-24-2012; IN COMMERCE 3-24-2012.

4,154,370. ARMSTRONG, STEPHEN GEOFFREY, TORONTO, CANADA. SN 77-613,460. PUB. 1-12-2010, FILED 11-13-2008.

Reuse

THE MARK CONSISTS OF STANDARD CHARACTERS WITHOUT CLAIM TO ANY PARTICULAR FONT, STYLE, SIZE, OR COLOR.

FOR SINGLE-USE, DISPOSABLE PLASTIC GARBAGE BAGS; SINGLE-USE, DISPOSABLE PLASTIC TRASH BAGS; SINGLE-USE, DISPOSABLE PLASTIC TRASH BAGS; SINGLE-USE, DISPOSABLE PLASTIC TRASH CAN LINERS (U.S. CLS. 2, 5, 22, 23, 29, 37, 38 AND 50).

FIRST USE 3-0-2009; IN COMMERCE 3-0-2009.

4,154,501. HOUSEY, AMBER J., TROY, MI. SN 77-874,203. PUB. 10-12-2010, FILED 11-17-2009.

FLIP SIDE STORIES

THE MARK CONSISTS OF STANDARD CHARACTERS WITHOUT CLAIM TO ANY PARTICULAR FONT, STYLE, SIZE, OR COLOR.

NO CLAIM IS MADE TO THE EXCLUSIVE RIGHT TO USE "STORIES", APART FROM THE MARK AS SHOWN.

FOR CHILDREN'S STORIES, NAMELY, BOOKS AND PRINTED ARTICLES AND PAMPHLETS IN THE FIELD OF LIFE'S LESSONS (U.S. CLS. 2, 5, 22, 23, 29, 37, 38 AND 50).

FIRST USE 6-1-2011; IN COMMERCE 6-1-2011.

CLASS 16—(Continued).

4,154,525. STERLING PUBLISHING CO., INC., NEW YORK, NY. SN 77-927,961. PUB. 8-24-2010, FILED 2-4-2010.

FOCUS:

THE MARK CONSISTS OF THE WORD "FOCUS:" WITH THE LETTER "O" FORMING A CAMERA LENS.

FOR PUBLICATIONS, NAMELY, A SERIES OF BOOKS FEATURING PHOTOGRAPHS ON A VARIETY OF THEMES AND TOPICS (U.S. CLS. 2, 5, 22, 23, 29, 37, 38 AND 50).

FIRST USE 3-31-2010; IN COMMERCE 3-31-2010.

4,154,659. THE NAVIGATORS, COLORADO SPRINGS, CO. SN 85-068,528. PUB. 12-13-2011, FILED 6-22-2010.

**NavPress Discipleship
Inside Out**

THE MARK CONSISTS OF STANDARD CHARACTERS WITHOUT CLAIM TO ANY PARTICULAR FONT, STYLE, SIZE, OR COLOR.

OWNER OF U.S. REG. NO. 1,170,131.

NO CLAIM IS MADE TO THE EXCLUSIVE RIGHT TO USE "DISCIPLESHIP", APART FROM THE MARK AS SHOWN.

FOR BROCHURES, BOOKS, BIBLE STUDY GUIDES, BOOKLETS, PAMPHLETS AND CATALOGS IN THE FIELD OF CHRISTIAN MINISTRY (U.S. CLS. 2, 5, 22, 23, 29, 37, 38 AND 50).

FIRST USE 5-1-2010; IN COMMERCE 5-1-2010.

4,154,690. K & COMPANY LLC, KANSAS CITY, MO 64108, MO. SN 85-092,545. PUB. 11-2-2010, FILED 7-26-2010.

EDAMAME

THE MARK CONSISTS OF STANDARD CHARACTERS WITHOUT CLAIM TO ANY PARTICULAR FONT, STYLE, SIZE, OR COLOR.

FOR ART PADS; BRAG BOOKS; MEMORY BOOKS; SCRAP BOOKS; STICKERS (U.S. CLS. 2, 5, 22, 23, 29, 37, 38 AND 50).

FIRST USE 11-30-2011; IN COMMERCE 11-30-2011.

CLASS 16—(Continued).

4,154,691. K & COMPANY LLC, KANSAS CITY, MO 64108, MO. SN 85-092,554. PUB. 2-22-2011, FILED 7-26-2010.

ISABELLA GRACE

THE MARK CONSISTS OF STANDARD CHARACTERS WITHOUT CLAIM TO ANY PARTICULAR FONT, STYLE, SIZE, OR COLOR.

THE NAME "ISABELLA GRACE" DOES NOT IDENTIFY A LIVING INDIVIDUAL.

FOR ART PADS; BRAG BOOKS; MEMORY BOOKS; STICKERS (U.S. CLS. 2, 5, 22, 23, 29, 37, 38 AND 50).

FIRST USE 3-15-2012; IN COMMERCE 3-15-2012.



4,154,694. K & COMPANY LLC, KANSAS CITY, MO 64108, MO. SN 85-095,489. PUB. 11-2-2010, FILED 7-29-2010.

ENGRAVED GARDEN

THE MARK CONSISTS OF STANDARD CHARACTERS WITHOUT CLAIM TO ANY PARTICULAR FONT, STYLE, SIZE, OR COLOR.

FOR STICKERS (U.S. CLS. 2, 5, 22, 23, 29, 37, 38 AND 50).

FIRST USE 2-1-2012; IN COMMERCE 2-1-2012.



4,154,755. TACKETT HOLDINGS, INC., DBA ISHOP-X, HOPKINSVILLE, KY. SN 85-115,689. PUB. 2-8-2011, FILED 8-25-2010.

iShop-X

THE MARK CONSISTS OF STANDARD CHARACTERS WITHOUT CLAIM TO ANY PARTICULAR FONT, STYLE, SIZE, OR COLOR.

FOR HAND TOWELS OF PAPER (U.S. CLS. 2, 5, 22, 23, 29, 37, 38 AND 50).

FIRST USE 1-0-2010; IN COMMERCE 3-15-2012.

CLASS 16—(Continued).

4,154,887. PICALATA PRODUCTIONS, LLC, PONTE VEDRA, FL. SN 85-176,840. PUB. 4-19-2011, FILED 11-15-2010.

PICALATA KIDS

THE MARK CONSISTS OF STANDARD CHARACTERS WITHOUT CLAIM TO ANY PARTICULAR FONT, STYLE, SIZE, OR COLOR.

FOR CHILDREN'S BOOKS (U.S. CLS. 2, 5, 22, 23, 29, 37, 38 AND 50).

FIRST USE 2-9-2011; IN COMMERCE 2-9-2011.



4,154,896. MERCK SHARP & DOHME CORP., WHITEHOUSE STATION, NJ. SN 85-183,757. PUB. 9-6-2011, FILED 11-23-2010.

ZEPHYR

THE MARK CONSISTS OF STANDARD CHARACTERS WITHOUT CLAIM TO ANY PARTICULAR FONT, STYLE, SIZE, OR COLOR.

FOR BOOKLETS AND PAMPHLETS CONCERNING RESPIRATORY ISSUES AND ASTHMA (U.S. CLS. 2, 5, 22, 23, 29, 37, 38 AND 50).

FIRST USE 3-24-2011; IN COMMERCE 3-24-2011.



4,154,946. METCALF, ANDREA, CHICAGO, IL. SN 85-204,716. PUB. 6-28-2011, FILED 12-23-2010.

Naked Fitness

THE MARK CONSISTS OF STANDARD CHARACTERS WITHOUT CLAIM TO ANY PARTICULAR FONT, STYLE, SIZE, OR COLOR.

NO CLAIM IS MADE TO THE EXCLUSIVE RIGHT TO USE "FITNESS", APART FROM THE MARK AS SHOWN.

FOR BOOKS IN THE FIELD OF PHYSICAL FITNESS AND EXERCISE (U.S. CLS. 2, 5, 22, 23, 29, 37, 38 AND 50).

FIRST USE 7-10-2010; IN COMMERCE 1-1-2011.

CLASS 16—(Continued).

4,154,960. ROBBINS, NORMAN, FRESNO, CA. SN 85-210,700. PUB. 5-24-2011, FILED 1-5-2011.



THE MARK CONSISTS OF FOUR "A"'S PLAYING CARDS. BELOW THERE IS A CIRCLE WITH A SPADE AND THE STYLIZED TEXT "ACEMAN".
FOR COMIC BOOKS (U.S. CLS. 2, 5, 22, 23, 29, 37, 38 AND 50).

FIRST USE 7-9-2011; IN COMMERCE 9-10-2011.

4,155,049. GEOEYE IMAGERY COLLECTION SYSTEMS INC., DULLES, VA. SN 85-238,390. PUB. 6-14-2011, FILED 2-9-2011.

ELEVATING INSIGHT

THE MARK CONSISTS OF STANDARD CHARACTERS WITHOUT CLAIM TO ANY PARTICULAR FONT, STYLE, SIZE, OR COLOR.

FOR POSTERS; PHOTOGRAPHS; CALENDARS; MAPS (U.S. CLS. 2, 5, 22, 23, 29, 37, 38 AND 50).

FIRST USE 12-15-2011; IN COMMERCE 12-15-2011.

4,155,105. ADVANCE MAGAZINE PUBLISHERS INC., NEW YORK, NY. SN 85-245,798. PUB. 8-16-2011, FILED 2-18-2011.

WHAT AMERICA EATS

THE MARK CONSISTS OF STANDARD CHARACTERS WITHOUT CLAIM TO ANY PARTICULAR FONT, STYLE, SIZE, OR COLOR.

OWNER OF U.S. REG. NO. 2,438,666.

FOR ANNUALLY ISSUED GENERAL INTEREST MAGAZINES FOCUSING ON CULINARY ISSUES; SYNDICATED COLUMNS DEALING WITH CULINARY ISSUES (U.S. CLS. 2, 5, 22, 23, 29, 37, 38 AND 50).

FIRST USE 10-25-1987; IN COMMERCE 10-25-1987.

CLASS 16—(Continued).

4,155,234. GUERRERO HOWE, LLC, CHICAGO, IL. SN 85-260,374. PUB. 9-13-2011, FILED 3-7-2011.

NEW AMERICAN LUXURY

THE MARK CONSISTS OF STANDARD CHARACTERS WITHOUT CLAIM TO ANY PARTICULAR FONT, STYLE, SIZE, OR COLOR.

NO CLAIM IS MADE TO THE EXCLUSIVE RIGHT TO USE "AMERICAN LUXURY", APART FROM THE MARK AS SHOWN.

FOR MAGAZINES IN THE FIELD OF LUXURY HOMES, LUXURY BUILDINGS, LUXURY GOODS AND LUXURY SERVICES (U.S. CLS. 2, 5, 22, 23, 29, 37, 38 AND 50).

FIRST USE 11-1-2011; IN COMMERCE 11-1-2011.

4,155,246. SIERRA PACKAGING & CONVERTING, LLC, SPARKS, NV. SN 85-261,507. PUB. 8-9-2011, FILED 3-8-2011.

REVEAL-A-ZIP

THE MARK CONSISTS OF STANDARD CHARACTERS WITHOUT CLAIM TO ANY PARTICULAR FONT, STYLE, SIZE, OR COLOR.

FOR PLASTIC FLEXIBLE PACKAGING BAGS AND POUCHES HAVING A PULL TAB OPENING AND SOLD IN BULK TO INDUSTRIAL AND COMMERCIAL MANUFACTURERS FOR MERCHANDISE PACKAGING (U.S. CLS. 2, 5, 22, 23, 29, 37, 38 AND 50).

FIRST USE 9-30-2011; IN COMMERCE 9-30-2011.

4,155,259. ARETE VENTURES, LLC, CINCINNATI, OH. SN 85-262,523. PUB. 7-26-2011, FILED 3-9-2011.

Baby Unplugged

THE MARK CONSISTS OF STANDARD CHARACTERS WITHOUT CLAIM TO ANY PARTICULAR FONT, STYLE, SIZE, OR COLOR.

FOR CHILDREN'S BOOKS (U.S. CLS. 2, 5, 22, 23, 29, 37, 38 AND 50).

FIRST USE 6-1-2011; IN COMMERCE 6-1-2011.

CLASS 16—(Continued).

4,155,260. ARETE VENTURES, LLC, CINCINNATI, OH. SN 85-262,536. PUB. 7-26-2011, FILED 3-9-2011.

In tune with tots

THE MARK CONSISTS OF STANDARD CHARACTERS WITHOUT CLAIM TO ANY PARTICULAR FONT, STYLE, SIZE, OR COLOR.
FOR CHILDREN'S BOOKS (U.S. CLS. 2, 5, 22, 23, 29, 37, 38 AND 50).
FIRST USE 6-1-2011; IN COMMERCE 6-1-2011.

4,155,266. ARETE VENTURES, LLC, CINCINNATI, OH. SN 85-263,061. PUB. 7-26-2011, FILED 3-10-2011.



THE COLOR(S) YELLOW, ORANGE, LIGHT BLUE IS/ ARE CLAIMED AS A FEATURE OF THE MARK.
THE MARK CONSISTS OF A HAND-DRAWN YELLOW SUN, OUTLINED IN ORANGE, WITH ORANGE SUNBEAMS, AND WITH ORANGE EYES AND AN ORANGE SMILE DRAWN IN THE SUN'S CENTER. THE SUNBEAM ON THE LOWER LEFT SIDE ALSO REPRESENTS AN ELECTRIC CORD, AND THERE IS A LIGHT BLUE ELECTRIC PLUG, OUTLINED IN ORANGE, IN THE LOWER LEFT OF THE MARK AT THE END OF THE SUNBEAM/ CORD.
FOR CHILDREN'S BOOKS (U.S. CLS. 2, 5, 22, 23, 29, 37, 38 AND 50).
FIRST USE 6-1-2011; IN COMMERCE 6-1-2011.

CLASS 16—(Continued).

4,155,375. PRETTYTROUBLE, LLC, SCHWENKSVILLE, PA. SN 85-278,931. PUB. 8-9-2011, FILED 3-28-2011.

PRETTYTROUBLE

THE MARK CONSISTS OF STANDARD CHARACTERS WITHOUT CLAIM TO ANY PARTICULAR FONT, STYLE, SIZE, OR COLOR.
FOR GREETING CARDS; NOTE BOOKS; NOTE PADS; PRINTED PAPER SIGNS (U.S. CLS. 2, 5, 22, 23, 29, 37, 38 AND 50).
FIRST USE 2-14-2012; IN COMMERCE 2-14-2012.

4,155,423. TRIPLEGIFT, INC., PLEASANTON, CA. SN 85-284,455. PUB. 8-9-2011, FILED 4-1-2011.

TRIPLEGIFT

THE MARK CONSISTS OF STANDARD CHARACTERS WITHOUT CLAIM TO ANY PARTICULAR FONT, STYLE, SIZE, OR COLOR.
FOR GREETING CARDS (U.S. CLS. 2, 5, 22, 23, 29, 37, 38 AND 50).
FIRST USE 10-1-2011; IN COMMERCE 10-21-2011.

4,155,430. ARETE VENTURES, LLC, CINCINNATI, OH. SN 85-286,211. PUB. 8-2-2011, FILED 4-5-2011.

SOME ASSEMBLY INSPIRED

THE MARK CONSISTS OF STANDARD CHARACTERS WITHOUT CLAIM TO ANY PARTICULAR FONT, STYLE, SIZE, OR COLOR.
FOR GIFT BOXES (U.S. CLS. 2, 5, 22, 23, 29, 37, 38 AND 50).
FIRST USE 5-1-2011; IN COMMERCE 5-1-2011.

CLASS 16—(Continued).

4,155,439. AMERICAN COMPOSERS FORUM, ST. PAUL, MN. SN 85-287,409. PUB. 8-16-2011, FILED 4-6-2011.

CLASS 16—(Continued).

4,155,448. RISING PHOENIX ENTERPRISES, INC., BEVERLY HILLS, CA. SN 85-289,722. PUB. 8-23-2011, FILED 4-8-2011.

CHORALQUEST

THE MARK CONSISTS OF STANDARD CHARACTERS WITHOUT CLAIM TO ANY PARTICULAR FONT, STYLE, SIZE, OR COLOR.

FOR PRINTED MATTER, NAMELY, SHEET MUSIC AND TEACHING MATERIALS IN THE FIELD OF MUSIC (U.S. CLS. 2, 5, 22, 23, 29, 37, 38 AND 50).
FIRST USE 9-1-2011; IN COMMERCE 9-1-2011.



4,155,440. AMERICAN COMPOSERS FORUM, ST. PAUL, MN. SN 85-287,412. PUB. 8-16-2011, FILED 4-6-2011.



THE MARK CONSISTS OF A STYLIZED DRAWING OF FIVE MUSIC NOTES IN A ROW RISING OUT OF THE CENTER OF A LINE WITH A SLIGHT ARCH AND FORMING THE IMAGE OF AN ADULT HUMAN WITH THEIR ARMS AROUND FOUR CHILDREN.

FOR PRINTED MATTER, NAMELY, SHEET MUSIC AND TEACHING MATERIALS IN THE FIELD OF MUSIC (U.S. CLS. 2, 5, 22, 23, 29, 37, 38 AND 50).
FIRST USE 9-1-2011; IN COMMERCE 9-1-2011.

YOUR LIFE DOES NOT HAVE TO BE A SOAP OPERA

THE MARK CONSISTS OF STANDARD CHARACTERS WITHOUT CLAIM TO ANY PARTICULAR FONT, STYLE, SIZE, OR COLOR.

FOR A SERIES OF BOOKS AND WRITTEN ARTICLES IN THE FIELD OF SELF-HELP, SPIRITUALITY, AND MOTIVATIONAL TOPICS; BOOKS IN THE FIELD OF SELF-HELP, SPIRITUALITY, AND MOTIVATIONAL TOPICS; EDUCATIONAL BOOKS FEATURING SELF-HELP, SPIRITUALITY, AND MOTIVATIONAL TOPICS; SERIES OF NON-FICTION BOOKS IN THE FIELD OF SELF-HELP, SPIRITUALITY, AND MOTIVATIONAL TOPICS (U.S. CLS. 2, 5, 22, 23, 29, 37, 38 AND 50).
FIRST USE 3-5-2012; IN COMMERCE 3-5-2012.



4,155,527. AU, HAMLIN, LITTLE ROCK, AR. SN 85-313,401. PUB. 9-20-2011, FILED 5-5-2011.

THE MINIBEE

THE MARK CONSISTS OF STANDARD CHARACTERS WITHOUT CLAIM TO ANY PARTICULAR FONT, STYLE, SIZE, OR COLOR.

FOR EDUCATIONAL PUBLICATIONS, NAMELY, BOOKS IN THE FIELD OF MUSIC (U.S. CLS. 2, 5, 22, 23, 29, 37, 38 AND 50).
FIRST USE 11-15-2011; IN COMMERCE 11-15-2011.

CLASS 16—(Continued).

4,155,583. GRUPO YSANT C.A, EL HATILLO, MIRANDA, VENEZUELA. SN 85-335,684. PUB. 10-25-2011, FILED 6-1-2011.

ychux

THE MARK CONSISTS OF STANDARD CHARACTERS WITHOUT CLAIM TO ANY PARTICULAR FONT, STYLE, SIZE, OR COLOR.

FOR ADHESIVE LABELS; ADHESIVE NOTE PADS; ADHESIVE NOTE PAPER; ADHESIVE TAPE DISPENSERS; ADHESIVE TAPES FOR STATIONERY PURPOSES; ADHESIVE-APPLYING MACHINES FOR HOME AND OFFICE USE; ARTISTS' BRUSHES; ARTISTS' PASTELS; ARTISTS' PENCILS; ARTISTS' PENS; AUTOMATIC ADHESIVE DISPENSERS FOR OFFICE USE; BOXES OF CARDBOARD OR PAPER; BOXES, CARTONS, STORAGE CONTAINERS, AND PACKAGING CONTAINERS MADE OF PAPER OR CARDBOARD; BOXES, CONTAINERS, AND CARTONS OF PAPERBOARD OR CARDBOARD FOR COMMERCIAL OR INDUSTRIAL PACKAGING; CANVAS PANELS FOR ARTISTS; CARDBOARD; CORRECTING FLUID FOR TYPE; CRAFT PAPER; CREPE PAPER; CYANOACRYLATE ADHESIVES FOR HOME AND HOBBY USE; DIGITAL PRINTING PAPER; DRAWING PAPER; ELECTRIC PAPER HOLE PERFORATORS BEING OFFICE REQUISITES AND PARTS THEREFOR, NAMELY, BORING BITS, PROTECTION PLATES, AND GRINDERS; ELECTRIC PAPER HOLE PUNCHES; ELECTRIC PAPER HOLE PUNCHES BEING OFFICE REQUISITES AND PARTS THEREFOR, NAMELY, BORING BITS, PROTECTION PLATES, AND GRINDERS; EMBROIDERY DESIGN PATTERNS; ENVELOPE PAPER; FINGER-STALLS; FRANKING MACHINES; GIFT WRAP PAPER; GUMMED PAPER; INK STAMPS; LAMINATED PAPER; LASER PRINTING PAPER; LETTER PAPER; LETTER-HEAD PAPER; MAGAZINE PAPER; MARKING STAMPS; NEWSPRINT PAPER; NOTE PAPER; OFFICE REQUISITES, NAMELY, ENVELOPE SEALING MACHINES; PACKING PAPER; PAPER AND CARDBOARD; PAPER BAGS AND SACKS; PAPER BOXES; PAPER CONTAINERS; PAPER EMBOSSERS; PAPER FOLDERS; PAPER FOLDING MACHINES AS OFFICE REQUISITES; PAPER FOR USE IN THE GRAPHIC ARTS INDUSTRY; PAPER GIFT BAGS; PAPER GIFT WRAP; PAPER LABELS; PAPER NAPKINS; PAPER NOTE TABLETS; PAPER NOTEBOOKS; PAPER PARTY DECORATIONS; PAPER PARTY FAVORS; PAPER PLACE MATS; PAPER SIGNBOARDS; PAPER STATIONERY; PAPER TAGS; PAPER TAPES; PAPER TISSUES; PAPER TOWELS; PAPER TRIMMERS; PLASTIC ADHESIVES FOR HOUSEHOLD OR DOMESTIC USE; PLASTIC BAGS FOR PACKAGING; PLASTIC BAGS FOR PACKING; PLASTIC COATED COPYING PAPER; PLASTIC FOILS; PLASTIC GIFT WRAP; PLASTIC OR PAPER BAGS FOR HOUSEHOLD USE; PLASTIC SANDWICH BAGS; PLASTIC SHEETS FOR WRITING, PRINTING, AND MARKING; PLASTIC SHOPPING BAGS; PLASTIC TRANSPAREN-

CLASS 16—(Continued).

CIES; PLASTIC TRASH BAGS; PLASTIC WRAP; PLASTIC-COATED COPYING PAPER; PRESSURE SENSITIVE ADHESIVE IMAGES IN THE NATURE OF DOUBLESIDED TAPE THAT CAN ADHERE TO A SURFACE ON ONE SIDE AND RECEIVE AND RETAIN DECORATIVE MATERIALS ON AN OPPOSING SIDE FOR DECORATIVE HOUSEHOLD PURPOSES; PRINTED MATTER, NAMELY, PAPER SIGNS, BOOKS, MANUALS, CURRICULUM, NEWSLETTERS, INFORMATIONAL CARDS AND BROCHURES IN THE FIELD OF EDUCATION AND PROFESSIONAL DEVELOPMENT; PRINTED TEACHING MATERIALS IN THE FIELD OF EDUCATION AND PROFESSIONAL DEVELOPMENT; PRINTING BLOCKS; PUNCHES; RUBBER BANDS; RUBBER DOCUMENT STAMPS; RUBBER STAMPS; SELF-ADHESIVE PLASTIC SHEETS FOR LINING SHELVES; SELF-ADHESIVE TAPES FOR STATIONERY AND HOUSEHOLD PURPOSES; STAMP INKS; STAMP PAD INKS; STAMP PADS; STAPLERS; STENCIL PAPER; STENCIL PAPER; STENCILS (U.S. CLS. 2, 5, 22, 23, 29, 37, 38 AND 50).

FIRST USE 9-1-2011; IN COMMERCE 9-1-2011.

4,155,584. GRUPO YSANT C.A, EL HATILLO, MIRANDA, VENEZUELA. SN 85-335,692. PUB. 10-25-2011, FILED 6-1-2011.



THE COLOR(S) CYAN IS/ARE CLAIMED AS A FEATURE OF THE MARK.

THE MARK CONSISTS OF THE WORD, "YCHUX", IN A STYLISTIC, CYAN FONT, NEXT TO THE STYLISTIC IMAGE OF A BUTTERFLY, ALSO IN CYAN.

FOR ADHESIVE LABELS; ADHESIVE NOTE PADS; ADHESIVE NOTE PAPER; ADHESIVE TAPE DISPENSERS; ADHESIVE TAPES FOR STATIONERY PURPOSES; ADHESIVE-APPLYING MACHINES FOR HOME AND OFFICE USE; ARTISTS' BRUSHES; ARTISTS' PASTELS; ARTISTS' PENCILS; ARTISTS' PENS; AUTOMATIC ADHESIVE DISPENSERS FOR OFFICE USE; BOXES OF CARDBOARD OR PAPER; BOXES, CARTONS, STORAGE CONTAINERS, AND PACKAGING CONTAINERS MADE OF PAPER OR CARDBOARD; BOXES, CONTAINERS, AND CARTONS OF PAPERBOARD OR CARDBOARD FOR COMMERCIAL OR INDUSTRIAL PACKAGING; CANVAS PANELS FOR ARTISTS; CARDBOARD; CORRECTING FLUID FOR TYPE; CRAFT PAPER; CREPE PAPER; CYANOACRYLATE ADHESIVES FOR HOME AND HOBBY USE; DIGITAL PRINTING PAPER; DRAWING PAPER; ELECTRIC PAPER HOLE PERFORATORS BEING OFFICE REQUISITES AND PARTS THEREFOR, NAMELY, BORING BITS, PROTECTION PLATES, AND GRINDERS; ELECTRIC PAPER HOLE PUNCHES; ELECTRIC PAPER HOLE PUNCHES BEING OFFICE REQUISITES AND PARTS THEREFOR, NAMELY, BORING BITS, PROTECTION PLATES, AND GRINDERS; EMBROIDERY DESIGN PATTERNS; ENVELOPE PAPER; FINGER-STALLS; FRANKING MACHINES; GIFT WRAP PAPER; GUMMED PAPER; INK STAMPS; LAMINATED PAPER; LASER PRINTING PAPER; LETTER PAPER; LETTER-HEAD PAPER; MAGAZINE PAPER; MARKING STAMPS; NEWSPRINT PAPER; NOTE PAPER; OFFICE REQUISITES, NAMELY, ENVELOPE SEALING MACHINES; PACKING PAPER; PAPER AND CARDBOARD; PAPER BAGS AND SACKS; PAPER BOXES; PAPER CONTAINERS; PAPER EMBOSSERS; PAPER FOLDERS; PAPER FOLDING MACHINES AS OFFICE REQUISITES; PAPER FOR USE IN THE GRAPHIC ARTS INDUSTRY; PAPER GIFT BAGS; PAPER GIFT WRAP; PAPER LABELS; PAPER NAPKINS; PAPER NOTE TABLETS; PA-

CLASS 16—(Continued).

PER NOTEBOOKS; PAPER PARTY DECORATIONS; PAPER PARTY FAVORS; PAPER PLACE MATS; PAPER SIGNBOARDS; PAPER STATIONERY; PAPER TAGS; PAPER TAPES; PAPER TISSUES; PAPER TOWELS; PAPER TRIMMERS; PLASTIC ADHESIVES FOR HOUSEHOLD OR DOMESTIC USE; PLASTIC BAGS FOR PACKAGING; PLASTIC BAGS FOR PACKING; PLASTIC COATED COPYING PAPER; PLASTIC FOILS; PLASTIC GIFT WRAP; PLASTIC OR PAPER BAGS FOR HOUSEHOLD USE; PLASTIC SANDWICH BAGS; PLASTIC SHEETS FOR WRITING, PRINTING, AND MARKING; PLASTIC SHOPPING BAGS; PLASTIC TRANSPARENCIES; PLASTIC TRASH BAGS; PLASTIC WRAP; PLASTIC-COATED COPYING PAPER; PRESSURE SENSITIVE ADHESIVE IMAGES IN THE NATURE OF DOUBLE-SIDED TAPE THAT CAN ADHERE TO A SURFACE ON ONE SIDE AND RECEIVE AND RETAIN DECORATIVE MATERIALS ON AN OPPOSING SIDE FOR DECORATIVE HOUSEHOLD PURPOSES; PRINTED MATTER, NAMELY, PAPER SIGNS, BOOKS, MANUALS, CURRICULUM, NEWSLETTERS, INFORMATIONAL CARDS AND BROCHURES IN THE FIELD OF EDUCATION AND PROFESSIONAL DEVELOPMENT; PRINTED TEACHING MATERIALS IN THE FIELD OF EDUCATION AND PROFESSIONAL DEVELOPMENT; PRINTING BLOCKS; PUNCHES; RUBBER BANDS; RUBBER DOCUMENT STAMPS; RUBBER STAMPS; SELF-ADHESIVE PLASTIC SHEETS FOR LINING SHELVES; SELF-ADHESIVE TAPES FOR STATIONERY AND HOUSEHOLD PURPOSES; STAMP INKS; STAMP PAD INKS; STAMP PADS; STAPLERS; STENCIL PAPER; STENCIL PAPER; STENCILS (U.S. CLS. 2, 5, 22, 23, 29, 37, 38 AND 50).

FIRST USE 9-1-2011; IN COMMERCE 9-1-2011.

CLASS 16—(Continued).

4,155,611. SANTANA, ANGEL, MILLBURY, MA. SN 85-346,375. PUB. 11-29-2011, FILED 6-15-2011.

BAD BABY COMICS

THE MARK CONSISTS OF STANDARD CHARACTERS WITHOUT CLAIM TO ANY PARTICULAR FONT, STYLE, SIZE, OR COLOR.

NO CLAIM IS MADE TO THE EXCLUSIVE RIGHT TO USE "COMICS", APART FROM THE MARK AS SHOWN.

FOR COMIC BOOKS; POSTERS; PRINTED COLLECTOR CARDS MADE OF PAPER (U.S. CLS. 2, 5, 22, 23, 29, 37, 38 AND 50).

FIRST USE 2-15-2011; IN COMMERCE 1-22-2012.

4,155,644. LEVINE, LORRAINE, PACIFIC PALISADES, CA. SN 85-355,317. PUB. 8-16-2011, FILED 6-24-2011.

Chefanistas

THE MARK CONSISTS OF STANDARD CHARACTERS WITHOUT CLAIM TO ANY PARTICULAR FONT, STYLE, SIZE, OR COLOR.

FOR ADDRESS BOOKS; BLANK JOURNALS; BOXES OF PAPER OR CARDBOARD; CALENDARS; GIFT WRAP PAPER; GREETING CARDS; NOTE CARDS; NOTEPADS; PAPER BAGS; PRINTED RECIPE CARDS (U.S. CLS. 2, 5, 22, 23, 29, 37, 38 AND 50).

FIRST USE 3-7-2012; IN COMMERCE 3-7-2012.

4,155,588. THOMAS, DEBBIE, PACIFIC GROVE, CA. SN 85-337,007. PUB. 12-20-2011, FILED 6-3-2011.

D.Lee Visuals Photography

THE MARK CONSISTS OF STANDARD CHARACTERS WITHOUT CLAIM TO ANY PARTICULAR FONT, STYLE, SIZE, OR COLOR.

NO CLAIM IS MADE TO THE EXCLUSIVE RIGHT TO USE "VISUALS PHOTOGRAPHY", APART FROM THE MARK AS SHOWN.

THE NAME(S), PORTRAIT(S), AND/OR SIGNATURE(S) SHOWN IN THE MARK IDENTIFIES DEBBIE LEE THOMAS, WHOSE CONSENT(S) TO REGISTER IS MADE OF RECORD.

FOR GREETING CARDS (U.S. CLS. 2, 5, 22, 23, 29, 37, 38 AND 50).

FIRST USE 12-1-2011; IN COMMERCE 12-1-2011.

4,155,670. MEGA BRANDS INTERNATIONAL, LUXEMBOURG, ZUG BRANCH, ZUG, SWITZERLAND. SN 85-363,185. PUB. 10-18-2011, FILED 7-5-2011.

SMOOTHTECH

THE MARK CONSISTS OF STANDARD CHARACTERS WITHOUT CLAIM TO ANY PARTICULAR FONT, STYLE, SIZE, OR COLOR.

FOR INK FOR WRITING INSTRUMENTS; PENS (U.S. CLS. 2, 5, 22, 23, 29, 37, 38 AND 50).

FIRST USE 12-0-2011; IN COMMERCE 12-0-2011.

CLASS 16—(Continued).

4,155,679. MEYER, BRETT, SAN DIEGO, CA. SN 85-363,936. PUB. 11-29-2011, FILED 7-6-2011.

Tele-Ments

THE MARK CONSISTS OF STANDARD CHARACTERS WITHOUT CLAIM TO ANY PARTICULAR FONT, STYLE, SIZE, OR COLOR.

FOR EDUCATIONAL PUBLICATIONS, NAMELY, TRAINING MANUALS IN THE FIELD OF TELEMEDICINE; INSTRUCTION SHEETS IN THE FIELD OF TELEMEDICINE; MANUALS IN THE FIELD OF TELEMEDICINE; PAMPHLETS IN THE FIELD OF TELEMEDICINE (U.S. CLS. 2, 5, 22, 23, 29, 37, 38 AND 50).

FIRST USE 3-16-2012; IN COMMERCE 3-16-2012.

4,155,743. MARK HART, STATELINE, NV. SN 85-385,028. PUB. 1-3-2012, FILED 7-29-2011.

Timeless Wine Storage

THE MARK CONSISTS OF STANDARD CHARACTERS WITHOUT CLAIM TO ANY PARTICULAR FONT, STYLE, SIZE, OR COLOR.

NO CLAIM IS MADE TO THE EXCLUSIVE RIGHT TO USE "WINE STORAGE", APART FROM THE MARK AS SHOWN.

FOR PLASTIC BAGS FOR PRESERVING WINE (U.S. CLS. 2, 5, 22, 23, 29, 37, 38 AND 50).

FIRST USE 7-21-2011; IN COMMERCE 1-19-2012.

4,155,744. MARK HART, STATELINE, NV. SN 85-385,042. PUB. 1-17-2012, FILED 7-29-2011.

Tahoe Vineyards

THE MARK CONSISTS OF STANDARD CHARACTERS WITHOUT CLAIM TO ANY PARTICULAR FONT, STYLE, SIZE, OR COLOR.

FOR PLASTIC BAGS FOR PRESERVING WINE (U.S. CLS. 2, 5, 22, 23, 29, 37, 38 AND 50).

FIRST USE 7-21-2011; IN COMMERCE 1-19-2012.

CLASS 16—(Continued).

4,155,745. MANCIN, SABRINA, CORAL GABLES, FL. AND NOCITA, JOHN, CORAL GABLES, FL. SN 85-385,505. PUB. 12-27-2011, FILED 7-31-2011.

GELATICIAN

THE MARK CONSISTS OF STANDARD CHARACTERS WITHOUT CLAIM TO ANY PARTICULAR FONT, STYLE, SIZE, OR COLOR.

FOR MAGAZINES FEATURING CULINARY ARTS AND RESTAURANT NEWS; MAGAZINES IN THE FIELD OF ENTREPRENEURSHIP, BUSINESS MANAGEMENT, FOOD PREPARATION; GENERAL FEATURE MAGAZINE IN INNOVATIONS IN FLAVOR, EQUIPMENT, MARKETPLACE STRATEGY AND NEWS IN THE RESTAURANT BUSINESS; GENERAL FEATURE MAGAZINE IN FOOD AND RESTAURANT BUSINESS FEATURING TOPICS OF NEWS AND EVENTS, CELEBRITY ARTICLES, CASE STUDIES, EQUIPMENT AND MACHINERY ESSENTIALS, COOKING LESSONS, TRENDS AND MARKETING NEWS, SELECTING RAW MATERIALS, FOOD PREPARATION TECHNIQUES (U.S. CLS. 2, 5, 22, 23, 29, 37, 38 AND 50).

FIRST USE 1-17-2012; IN COMMERCE 1-17-2012.

4,155,836. MD WELLSPRING, LLC, ATLANTA, GA. SN 85-976,588. PUB. 11-22-2011, FILED 6-29-2011.



THE MARK CONSISTS OF A HORIZONTAL LINE BELOW WHICH IS THE WORDING "MD WELLSPRING" AND ABOVE WHICH IS A DESIGN. THE DESIGN CONSISTS OF A VERTICAL LINE WITH A CIRCULAR SHAPE AT THE TOP. BELOW THE CIRCLE SHAPE AND ON EACH SIDE OF THE VERTICAL LINE ARE TWO SMALL CRESCENT SHAPES AND TWO LARGE CRESCENT SHAPES, WITH THE SMALL CRESCENT SHAPES ABOVE THE TWO LARGE CRESCENT SHAPES. THE SMALL AND LARGE CRESCENT SHAPES ARE SYMMETRICALLY PLACED ON EACH SIDE OF THE VERTICAL LINE AND POINT DOWNWARD.

FOR PUBLICATIONS, NAMELY, BOOKS IN THE FIELDS OF SPIRITUAL DEVELOPMENT, DEVOTIONAL TOPICS, PERSONAL DEVELOPMENT, PRAYER, AND RELIGION (U.S. CLS. 2, 5, 22, 23, 29, 37, 38 AND 50).

FIRST USE 10-31-2010; IN COMMERCE 10-31-2010.

CLASS 17—RUBBER GOODS

CLASS 17—(Continued).

4,154,468. ERICKSON INTERNATIONAL LLC, AKA AMERICAN STANDARD WINDOW FILM, LAS VEGAS, NV. SN 77-831,263. PUB. 5-31-2011, FILED 9-21-2009.

Excel

THE MARK CONSISTS OF STANDARD CHARACTERS WITHOUT CLAIM TO ANY PARTICULAR FONT, STYLE, SIZE, OR COLOR.

FOR HEAT REFLECTIVE PLASTIC FILM TO BE APPLIED TO GLASS OF THE WINDOWS; LAMINATED PLASTIC FILMS FOR USE ON GLASS OF THE WINDOWS; PLASTIC FILM THAT IS TINTED FOR USE ON AUTO WINDOWS; TINTED, LAMINATED AND REFLECTIVE PLASTIC FILMS FOR USE ON AUTO WINDOWS (U.S. CLS. 1, 5, 12, 13, 35 AND 50).

FIRST USE 10-1-2009; IN COMMERCE 10-1-2009.

CLASS 17—(Continued).

4,154,799. ENTEGRIS, INC., BILLERICA, MA. SN 85-134,390. PUB. 9-6-2011, FILED 9-21-2010.

PRIMELOCK

THE MARK CONSISTS OF STANDARD CHARACTERS WITHOUT CLAIM TO ANY PARTICULAR FONT, STYLE, SIZE, OR COLOR.

FOR FLUOROPOLYMER PLASTIC FITTING FOR THE ATTACHMENT TO PLASTIC TUBING AND PIPE FOR USE IN LABORATORIES AND INDUSTRIAL INSTALLATIONS REQUIRING CHEMICAL RESISTANCE TO AND PURITY OF CONVEYED LIQUIDS (U.S. CLS. 1, 5, 12, 13, 35 AND 50).

FIRST USE 5-31-2011; IN COMMERCE 5-31-2011.

4,154,655. NANOPORE INSULATION LLC, ALBUQUERQUE, NM. SN 85-066,243. PUB. 6-14-2011, FILED 6-18-2010.



THE MARK CONSISTS OF A SMALLER CIRCLE APPEARING OFF CENTER INSIDE A LARGER CIRCLE, SUPERIMPOSED OVER A POLYGON MADE UP OF SIX HEXAGONS.

FOR THERMAL INSULATION, NAMELY, VACUUM INSULATION PANELS FOR INSULATING SHIPPING CONTAINERS, PIPING, REFRIGERATION UNITS, COOLERS, ELECTRONIC DEVICES AND CRYOGENIC DEVICES (U.S. CLS. 1, 5, 12, 13, 35 AND 50).

FIRST USE 4-20-2011; IN COMMERCE 4-20-2011.

4,154,935. DUAL ACOUSTICS LLC, OAK PARK, IL. SN 85-202,190. PUB. 11-8-2011, FILED 12-20-2010.



NO CLAIM IS MADE TO THE EXCLUSIVE RIGHT TO USE "ACOUSTICS", APART FROM THE MARK AS SHOWN.

THE MARK CONSISTS OF FOUR LINES THAT GET INCREASINGLY LARGER FOLLOWED BY A MIRROR IMAGE OF THOSE FOUR LINES (GETTING DECREASINGLY SMALLER). THE SECOND FOUR LINES ARE ENCASED IN A RECTANGLE WITH ROUNDED CORNERS. TO THE RIGHT OF THE RECTANGLE ARE THE STACKED WORDS "DUAL ACOUSTICS" IN ALL CAPS AND THEY ARE LEFT ALIGNED.

FOR ARCHITECTURAL ACOUSTIC PRODUCTS, NAMELY, SOUND ABSORBERS AND DIFFUSERS (U.S. CLS. 1, 5, 12, 13, 35 AND 50).

FIRST USE 12-27-2010; IN COMMERCE 4-23-2011.

CLASS 17—(Continued).

4,155,355. CORE PRODUCTS GROUP LLC, LIVONIA, MI. SN 85-275,803. PUB. 8-2-2011, FILED 3-24-2011.

MUTEX

THE MARK CONSISTS OF STANDARD CHARACTERS WITHOUT CLAIM TO ANY PARTICULAR FONT, STYLE, SIZE, OR COLOR.

FOR ACOUSTIC SOUND-PROOFING MATERIAL, NAMELY, ACOUSTICAL INSULATION FOR FLOORS, WALLS OR CEILINGS (U.S. CLS. 1, 5, 12, 13, 35 AND 50).
FIRST USE 3-23-2012; IN COMMERCE 3-23-2012.

4,155,597. VEKA INC., FOMBELL, PA. SN 85-340,648. PUB. 12-6-2011, FILED 6-8-2011.



THE COLOR(S) BLACK, WHITE, AND GREEN IS/ARE CLAIMED AS A FEATURE OF THE MARK.

THE MARK CONSISTS OF THE WORDING "DUAL" IN LOWER CASE BLACK LETTERS BEHIND A WHITE BACKGROUND, THE WORDING "EDGE" IN LOWER CASE WHITE LETTERS BEHIND A GREEN BACKGROUND, ABOVE THE LETTER "U" ARE TWO LEAVES, A GREEN AND A WHITE LEAF.

FOR A CO-EXTRUDED PVC PROFILE WHERE THE SUBSTRATE MATERIAL CONSISTS OF PRE-CONSUMER, RECYCLED PVC CONTENT FOR USE IN THE MANUFACTURE OF INDOOR AND OUTDOOR CONSUMER BUILDING PRODUCTS (U.S. CLS. 1, 5, 12, 13, 35 AND 50).

FIRST USE 1-25-2012; IN COMMERCE 1-25-2012.

4,155,723. IMERYS KAOLIN, INC., ROSWELL, GA. SN 85-374,653. PUB. 12-13-2011, FILED 7-19-2011.

KAOPOLITE

THE MARK CONSISTS OF STANDARD CHARACTERS WITHOUT CLAIM TO ANY PARTICULAR FONT, STYLE, SIZE, OR COLOR.

OWNER OF U.S. REG. NO. 921,774.
FOR MICA (U.S. CLS. 1, 5, 12, 13, 35 AND 50).
FIRST USE 1-0-2012; IN COMMERCE 1-0-2012.

CLASS 18—LEATHER GOODS

CLASS 18—(Continued).

4,154,281. SKECHERS U.S.A., INC. II, MANHATTAN BEACH, CA. SN 77-323,915. PUB. 1-20-2009, FILED 11-7-2007.

MARK NASON

THE MARK CONSISTS OF STANDARD CHARACTERS WITHOUT CLAIM TO ANY PARTICULAR FONT, STYLE, SIZE, OR COLOR.

OWNER OF U.S. REG. NOS. 2,865,769 AND 3,133,663.
THE NAME(S), PORTRAIT(S), AND/OR SIGNATURE(S) SHOWN IN THE MARK IDENTIFIES "MARK NASON", WHOSE CONSENT(S) TO REGISTER IS SUBMITTED.

FOR LEATHER BAGS, NAMELY, PURSES, HANDBAGS, WALLETS, DUFFLE BAGS, AND MESSENGER BAGS (U.S. CLS. 1, 2, 3, 22 AND 41).

FIRST USE 7-3-2007; IN COMMERCE 7-3-2007.

4,154,347. PRUFROCK LLC, LOS ANGELES, CA. SN 77-559,722. PUB. 1-13-2009, FILED 9-1-2008.

PURSE PONCHO

THE MARK CONSISTS OF STANDARD CHARACTERS WITHOUT CLAIM TO ANY PARTICULAR FONT, STYLE, SIZE, OR COLOR.

NO CLAIM IS MADE TO THE EXCLUSIVE RIGHT TO USE "PURSE", APART FROM THE MARK AS SHOWN.

FOR FITTED AND UNFITTED PURSE, HANDBAG AND CLUTCH COVERING TO PROTECT THE PURSE, HANDBAG AND CLUTCH FROM WATER OR OTHER DAMAGE (U.S. CLS. 1, 2, 3, 22 AND 41).

FIRST USE 4-3-2012; IN COMMERCE 4-3-2012.

4,154,791. JILL JOANNE, LLC, NEWPORT COAST, CA. SN 85-129,754. PUB. 9-6-2011, FILED 9-15-2010.

JILL JOANNE

THE MARK CONSISTS OF STANDARD CHARACTERS WITHOUT CLAIM TO ANY PARTICULAR FONT, STYLE, SIZE, OR COLOR.

THE NAME(S), PORTRAIT(S), AND/OR SIGNATURE(S) SHOWN IN THE MARK IDENTIFIES "JILL HANKEY", WHOSE CONSENT(S) TO REGISTER IS MADE OF RECORD.

FOR PURSES AND HANDBAGS MADE OF LEATHER AND CLOTH (U.S. CLS. 1, 2, 3, 22 AND 41).
FIRST USE 6-10-2010; IN COMMERCE 3-17-2012.

CLASS 18—(Continued).

4,154,821. PRL USA HOLDINGS, INC., NEW YORK, NY. SN 85-141,103. PUB. 8-2-2011, FILED 9-29-2010.



OWNER OF U.S. REG. NOS. 2,042,967, 2,207,011, AND 3,764,868.

NO CLAIM IS MADE TO THE EXCLUSIVE RIGHT TO USE "TRADEMARK AND EST. 1967", APART FROM THE MARK AS SHOWN.

THE NAME(S), PORTRAIT(S), AND/OR SIGNATURE(S) SHOWN IN THE MARK IDENTIFIES AN INDIVIDUAL, WHOSE CONSENT(S) TO REGISTER IS MADE OF RECORD.

THE MARK CONSISTS OF A CROWN DESIGN BETWEEN THE WORDS "TRADE" AND "MARK", ABOVE THE WORDS "LAUREN R.L.", WHICH IS ABOVE THE ROMAN NUMERALS "MCMLXVII", WHICH IS ABOVE "EST. 1967", ABOVE "RALPH LAUREN". ALL OF THIS IS SURROUNDED BY A SIX-SIDED POLYGON. THE MATTER DEPICTED IN BROKEN LINES IS NOT PART OF THE MARK AND SERVES ONLY TO SHOW THE POSITION OF THE MARK.

FOR CARRYING CASES; COSMETIC CASES SOLD EMPTY; HANDBAGS; WALLET(S); WRISTLET BAGS (U.S. CLS. 1, 2, 3, 22 AND 41).

FIRST USE 1-25-2011; IN COMMERCE 1-25-2011.

4,154,992. MRM HOLDINGS LIMITED, PORT LOUIS, MAURITIUS. SN 85-220,759. PUB. 1-10-2012, FILED 1-19-2011.



NO CLAIM IS MADE TO THE EXCLUSIVE RIGHT TO USE "RFID", APART FROM THE MARK AS SHOWN.

CLASS 18—(Continued).

THE MARK CONSISTS OF THE WORDING "RFID SAFE" WHERE "SAFE" IS UNDER THE LETTERS "RFI" AND A STYLIZED PROPAGATING WAVE DESIGN COMPRISED OF 4 CURVED LINES IS LOCATED UNDER THE LETTER "D". THE MARK IS UNDERLINED.

FOR WIRE AND POLYMER REINFORCED ALL-PURPOSE CARRYING BAGS; WIRE AND POLYMER REINFORCED TRAVEL BAGS; LOCKABLE REINFORCED ALL-PURPOSE CARRYING BAGS; LOCKABLE REINFORCED TRAVEL BAGS; LOCKABLE ALL-PURPOSE CARRYING BAGS; LOCKABLE TRAVEL BAGS; BAGS FOR TRAVEL IN THE NATURE OF TRAVEL BAGS; ALL-PURPOSE CARRYING BAGS FOR CAMPING; TRAVEL BAGS FOR CAMPING; BACKPACKS; DAYPACKS; ACROSS BODY PACKS, NAMELY, SLING BAGS THAT EXTEND ACROSS OR ON FRONT OF A BODY; ACROSS BODY TRAVEL PACKS, NAMELY, SLING BAGS THAT EXTEND ACROSS OR ON FRONT OF A BODY; WAIST BAGS; SPORT EQUIPMENT BAGS IN THE NATURE OF ALL PURPOSE SPORT BAGS; LOCKABLE SECURITY TRAVEL BAGS; SECURITY POUCHES OF TEXTILE; SECURITY WALLETS, PURSES AND FANNY PACKS; COURIER BAGS IN THE NATURE OF MESSENGER BAGS; DOCUMENT BAGS IN THE NATURE OF BACKPACKS AND BRIEFCASES; HUNTING BAGS; ALL-PURPOSE CARRYING BAGS FOR SECURING PERSONAL ITEMS; TOTE BAGS FOR SECURING PERSONAL ITEMS; DUFFEL BAGS FOR SECURING PERSONAL ITEMS; WEATHER PROOF LUGGAGE; BAG COVERS AND CONTAINERS, NAMELY, LOCKABLE COVERS TO PROTECT TRAVEL BAGS (U.S. CLS. 1, 2, 3, 22 AND 41). FIRST USE 12-0-2011; IN COMMERCE 12-0-2011.

4,155,035. HIGH SIERRA SPORT COMPANY, VERNON HILLS, IL. SN 85-235,393. PUB. 11-29-2011, FILED 2-7-2011.

GRIP BY HIGH SIERRA

THE MARK CONSISTS OF STANDARD CHARACTERS WITHOUT CLAIM TO ANY PARTICULAR FONT, STYLE, SIZE, OR COLOR.

OWNER OF U.S. REG. NOS. 1,193,991, 2,135,635, AND OTHERS.

FOR ALL PURPOSE SPORT BAGS; BACKPACKS; LUGGAGE; TOTE BAGS (U.S. CLS. 1, 2, 3, 22 AND 41). FIRST USE 10-0-2010; IN COMMERCE 5-0-2011.

CLASS 18—(Continued).

4,155,061. MARC ICEBERG, ORLANDO, FL. SN 85-240,569. PUB. 6-21-2011, FILED 2-11-2011.

PROTECT YOUR GAME

THE MARK CONSISTS OF STANDARD CHARACTERS WITHOUT CLAIM TO ANY PARTICULAR FONT, STYLE, SIZE, OR COLOR.

FOR ALL PURPOSE SPORT BAGS; ALL-PURPOSE ATHLETIC BAGS; ALL-PURPOSE CARRYING BAGS; ALL-PURPOSE REUSABLE CARRYING BAGS; ATHLETIC BAGS; BAGS FOR SPORTS; SPORT BAGS; SPORTS BAGS (U.S. CLS. 1, 2, 3, 22 AND 41).
FIRST USE 1-26-2011; IN COMMERCE 2-22-2012.

4,155,095. GUANGZHOU CANUDILO FASHION & ACCESSORIES CO., LTD., GUANGZHOU, GUANGDONG, CHINA. SN 85-245,560. PUB. 6-28-2011, FILED 2-17-2011.

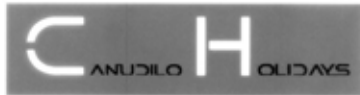

THE MARK CONSISTS OF THE STYLIZED WORDS "CANUDILO HOLIDAYS" WITH A RECTANGULAR BACKGROUND.

THE WORDING "CANUDILO" HAS NO MEANING IN A FOREIGN LANGUAGE.

FOR ATTACHE CASES; BRIEFCASES; BUSINESS CARD CASES; HANDBAGS; KEY CASES; PURSES; SCHOOL SATCHELS; TRAVELLING BAGS; TRAVELLING CASES OF LEATHER; UMBRELLAS (U.S. CLS. 1, 2, 3, 22 AND 41).
FIRST USE 11-22-2010; IN COMMERCE 2-17-2011.

4,155,233. T.H.Y. AND ASSOCIATES, INC., KEAAU, HI. SN 85-260,347. PUB. 7-26-2011, FILED 3-7-2011.



OWNER OF U.S. REG. NO. 3,038,713.

CLASS 18—(Continued).

THE MARK CONSISTS OF THE WORD "LOCALS" IN A STYLIZED CURSIVE FONT.

FOR ALL-PURPOSE CARRYING BAGS; ALL-PURPOSE REUSABLE CARRYING BAGS; ATHLETIC BAGS; BACKPACKS; CLUTCH BAGS; FANNY PACKS; FASHION HANDBAGS; REUSABLE SHOPPING BAGS; SCHOOL BAGS; SCHOOLCHILDREN'S BACKPACKS; SHOULDER BAGS; SMALL BACKPACKS; TEXTILE SHOPPING BAGS; TRAVELING BAGS (U.S. CLS. 1, 2, 3, 22 AND 41).
FIRST USE 2-1-2012; IN COMMERCE 2-1-2012.

4,155,344. ZHONG RENKANG, SHENZHEN, CHINA. SN 85-272,942. PUB. 8-2-2011, FILED 3-22-2011.



THE MARK CONSISTS OF THE STYLIZED WORD "MIUSTA" WITH THE DOT OF THE CHARACTER I REPLACED BY A HEART, AND A HORIZONTAL CURVED BAND CUTTING THE WORD "MIUSTA" INTO TWO PARTS.

THE WORDING "MIUSTA" HAS NO MEANING IN A FOREIGN LANGUAGE.

FOR ANIMAL SKINS; BAGS FOR PACKAGING OF LEATHER; COLLARS FOR ANIMALS; LEATHER; LEATHER FOR FURNITURE; LEATHER STRAPS; MOUNTAINEERING STICKS; TRAVELLING BAGS; UMBRELLAS (U.S. CLS. 1, 2, 3, 22 AND 41).
FIRST USE 3-10-2011; IN COMMERCE 4-22-2011.

4,155,410. GROUP III INTERNATIONAL LTD., INC., POMPANO BEACH, FL. SN 85-283,750. PUB. 8-9-2011, FILED 4-1-2011.

NEVER SO LITE

THE MARK CONSISTS OF STANDARD CHARACTERS WITHOUT CLAIM TO ANY PARTICULAR FONT, STYLE, SIZE, OR COLOR.

FOR BACKPACKS; BRIEFCASES; CARRY-ON BAGS; HANDBAGS; LUGGAGE; TOTE BAGS (U.S. CLS. 1, 2, 3, 22 AND 41).
FIRST USE 8-9-2011; IN COMMERCE 8-9-2011.

CLASS 18—(Continued).

4,155,450. KATE SPADE LLC, NEW YORK, NY. SN 85-289,992. PUB. 8-9-2011, FILED 4-8-2011.



OWNER OF U.S. REG. NOS. 3,092,920, 3,271,494, AND OTHERS.

NO CLAIM IS MADE TO THE EXCLUSIVE RIGHT TO USE "NEW YORK", APART FROM THE MARK AS SHOWN. THE NAME "KATE SPADE" IDENTIFIES A LIVING INDIVIDUAL WHOSE CONSENT IS OF RECORD.

THE MARK CONSISTS OF A SPADE DESIGN WITH THE WORDS "KATE SPADE NEW YORK" UNDERNEATH.

FOR BACKPACKS; BEACH BAGS; CARD WALLETS; CLUTCH BAGS; CLUTCH PURSES; COSMETIC BAGS SOLD EMPTY; COSMETIC CASES SOLD EMPTY; CREDIT CARD CASES; HANDBAGS; KEY BAGS; KEY CASES; KEY WALLETS; LUGGAGE; PURSES; SPORT BAGS; TOTE BAGS; TRAVEL BAGS; TRAVEL CASES; UMBRELLAS; WALLETS (U.S. CLS. 1, 2, 3, 22 AND 41).

FIRST USE 1-2-2011; IN COMMERCE 1-2-2011.

CLASS 18—(Continued).

4,155,534. BUTLER, DAVID O., TARPON SPRINGS, FL. SN 85-316,103. PUB. 11-22-2011, FILED 5-9-2011.

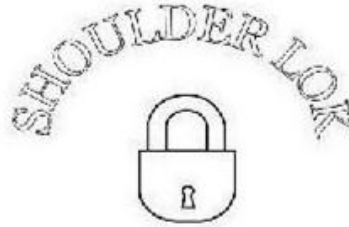

THE MARK CONSISTS OF THE WORDS "SHOULDER LOK" ARCHED OVER A LOCK.

FOR SHOULDER STRAPS; STRAPS FOR CARRYING CASES; STRAPS FOR HANDBAGS; STRAPS FOR LUGGAGE (U.S. CLS. 1, 2, 3, 22 AND 41).

FIRST USE 7-20-2011; IN COMMERCE 3-8-2012.

4,155,631. JD KOA ENTERPRISES, LLC, THOUSAND OAKS, CA. SN 85-350,282. PUB. 11-8-2011, FILED 6-20-2011.



THE MARK CONSISTS OF THE STYLIZED WORD "PUPJAMAS". IMAGES OF SPOTS WITHIN THE LETTERS AND A PAW PRINT OVER THE LETTER "J".

FOR DOG CLOTHING (U.S. CLS. 1, 2, 3, 22 AND 41).

FIRST USE 2-20-2012; IN COMMERCE 2-20-2012.

4,155,518. GOT SHADES, INC., EL MONTE, CA. SN 85-310,489. PUB. 8-16-2011, FILED 5-3-2011.



THE MARK CONSISTS OF A CROWNED LION HEAD. FOR BACKPACKS; DUFFLE BAGS; HANDBAGS; LUGGAGE; MESSENGER BAGS; PURSES; SHOULDER BAGS; SUITCASES; TOTE BAGS; WALLETS (U.S. CLS. 1, 2, 3, 22 AND 41).

FIRST USE 3-18-2010; IN COMMERCE 3-18-2010.

4,155,753. CHOZEN INC., LAS VEGAS, NV. SN 85-387,615. PUB. 1-17-2012, FILED 8-2-2011.

CHOZEN

THE MARK CONSISTS OF STANDARD CHARACTERS WITHOUT CLAIM TO ANY PARTICULAR FONT, STYLE, SIZE, OR COLOR.

OWNER OF U.S. REG. NOS. 3,525,560, 3,951,808, AND OTHERS.

FOR BACKPACKS, BOOK BAGS, SPORTS BAGS, BUM BAGS, WALLETS AND HANDBAGS; DUFFEL BAGS; LUGGAGE; PURSE CHARMS; PURSES; SUITCASES; TOTE BAGS; UMBRELLAS (U.S. CLS. 1, 2, 3, 22 AND 41).

FIRST USE 3-17-2012; IN COMMERCE 3-17-2012.

CLASS 18—(Continued).

4,155,770. BUXTON ACQUISITION CO., L.L.C., SPRINGFIELD, MA. SN 85-394,335. PUB. 1-24-2012, FILED 8-10-2011.



THE MARK CONSISTS OF A GRAPHIC DESIGN RESEMBLING A HEART MONITOR SHOWING EXCITED HEART RHYTHMS.

FOR SMALL LEATHER GOODS, NAMELY, HANDBAGS, WALLETS, KEY CASES, CHANGE PURSES, COSMETIC BAGS AND POUCHES SOLD EMPTY, TOILETRY CASES SOLD EMPTY, BRIEFCASE-TYPE PORTFOLIOS, BILLFOLDS, LUGGAGE, OVERNIGHT CASES SOLD EMPTY, CREDIT CARD HOLDERS, AND BUSINESS CARD HOLDERS IN THE NATURE OF WALLETS (U.S. CLS. 1, 2, 3, 22 AND 41).

FIRST USE 2-15-2012; IN COMMERCE 2-15-2012.

CLASS 18—(Continued).

4,155,840. SUMMIT ENTERTAINMENT, LLC, SANTA MONICA, CA. SN 85-976,638. PUB. 7-12-2011, FILED 4-6-2010.



THE MARK CONSISTS OF A CIRCULAR TRIBAL TATTOO DESIGN DEPICTING TWO WOLVES FACING ONE ANOTHER IN A HOWLING POSITION, SET AMONGST NUMEROUS INTERWOVEN LINES AND SHAPES AND ALL WITHIN THE CIRCLE.

FOR ALL PURPOSE CARRYING CASES; COSMETIC CARRYING CASES SOLD EMPTY; WALLETS; ALL PURPOSE CARRYING BAGS; BACK PACKS; HANDBAGS; MAKEUP BAGS SOLD EMPTY; MESSENGER BAGS; PURSES (U.S. CLS. 1, 2, 3, 22 AND 41).

FIRST USE 10-1-2009; IN COMMERCE 10-1-2009.

4,155,833. MORTON & HUDSON, LLC, SAN DIEGO, CA. SN 85-976,546. PUB. 11-8-2011, FILED 6-21-2011.

MORTON & HUDSON

THE MARK CONSISTS OF STANDARD CHARACTERS WITHOUT CLAIM TO ANY PARTICULAR FONT, STYLE, SIZE, OR COLOR.

FOR ALL-PURPOSE CARRYING BAGS, CARRY-ALL BAGS, HANDBAGS, PURSES, SHOULDER BAGS, TOILETRY BAGS (U.S. CLS. 1, 2, 3, 22 AND 41).

FIRST USE 9-29-2011; IN COMMERCE 9-29-2011.

CLASS 19—NON-METALLIC BUILDING MATERIALS

4,154,265. BENCHMARK, LLC, ASOTIN, WA. SN 76-707,177. PUB. 8-16-2011, FILED 4-8-2011.

REDIFORM

THE MARK CONSISTS OF STANDARD CHARACTERS WITHOUT CLAIM TO ANY PARTICULAR FONT, STYLE, SIZE, OR COLOR.

FOR NON-METAL CASTING FORMS FOR CONCRETE (U.S. CLS. 1, 12, 33 AND 50).

FIRST USE 1-21-2011; IN COMMERCE 1-21-2011.

CLASS 19—(Continued).

4,154,285. KRONOTEX U.S.A. HOLDINGS, INC., BARNWELL, SC. SN 77-365,075. PUB. 11-1-2011, FILED 1-6-2008.

BELLEZZA

THE MARK CONSISTS OF STANDARD CHARACTERS WITHOUT CLAIM TO ANY PARTICULAR FONT, STYLE, SIZE, OR COLOR.

THE FOREIGN WORDING IN THE MARK TRANSLATES INTO ENGLISH AS BEAUTIFUL.

FOR LAMINATE FLOORING (U.S. CLS. 1, 12, 33 AND 50).

FIRST USE 1-31-2008; IN COMMERCE 1-31-2008.

4,154,481. THE DOW CHEMICAL COMPANY, MIDLAND, MI. SN 77-842,021. PUB. 1-19-2010, FILED 10-6-2009.

POWERHOUSE

THE MARK CONSISTS OF STANDARD CHARACTERS WITHOUT CLAIM TO ANY PARTICULAR FONT, STYLE, SIZE, OR COLOR.

FOR NON-METAL ROOFING SHINGLES FOR USE IN BUILDING AND CONSTRUCTION (U.S. CLS. 1, 12, 33 AND 50).

FIRST USE 1-27-2012; IN COMMERCE 1-27-2012.

4,154,551. UNITED DURALUME PRODUCTS INC., FULLERTON, CA. SN 77-955,912. PUB. 8-9-2011, FILED 3-10-2010.



NO CLAIM IS MADE TO THE EXCLUSIVE RIGHT TO USE "PATIOS", APART FROM THE MARK AS SHOWN.

THE COLOR(S) YELLOW, BROWN, BLUE, TAN IS/ARE CLAIMED AS A FEATURE OF THE MARK.

THE MARK CONSISTS OF A YELLOW SUN AND THE SUN'S REFLECTIONS IN YELLOW BOUNCING OFF A BROWN ROOF. BELOW THE ROOF IS THE WORDING "DURACOO" IN BLUE AND "PATIOS" IN TAN.

FOR BUILDING MATERIALS, NAMELY, MANUFACTURED BRICK VENEER FOR USE ON INTERIOR AND EXTERIOR WALLS, FLOORS AND SURFACES, PATIOS, POOLSIDES AND DRIVEWAYS (U.S. CLS. 1, 12, 33 AND 50).

FIRST USE 3-1-1981; IN COMMERCE 3-1-1981.

CLASS 19—(Continued).

4,154,804. CROSSVILLE, INC., CROSSVILLE, TN. SN 85-136,708. PUB. 8-30-2011, FILED 9-23-2010.

GET PLANKED

THE MARK CONSISTS OF STANDARD CHARACTERS WITHOUT CLAIM TO ANY PARTICULAR FONT, STYLE, SIZE, OR COLOR.

FOR CERAMIC AND PORCELAIN TILES OF VARIED SIZES AND COLORS AND SHAPED LIKE PLANKS (U.S. CLS. 1, 12, 33 AND 50).

FIRST USE 11-13-2009; IN COMMERCE 12-18-2009.

4,154,805. CROSSVILLE, INC., CROSSVILLE, TN. SN 85-136,749. PUB. 8-30-2011, FILED 9-23-2010.



THE MARK CONSISTS OF FOUR SHADED HORIZONTAL RECTANGLES REPRESENTING PLANKS STACKED ON TOP OF EACH OTHER AND EACH RECTANGLE SLIGHTLY STAGGERED TO THE RIGHT FROM THE ONE ABOVE IT, WITH THE TERM "GET" ON THE SECOND PLANK DOWN FROM THE TOP, AND THE TERM "PLANKED" ON THE THIRD PLANK DOWN FROM THE TOP.

FOR CERAMIC AND PORCELAIN TILES OF VARIED SIZES AND COLORS AND SHAPED LIKE PLANKS (U.S. CLS. 1, 12, 33 AND 50).

FIRST USE 11-13-2009; IN COMMERCE 12-18-2009.

CLASS 19—(Continued).

4,154,953. COVAS, JACQUELINE ANN, NEW YORK, NY. AND GIRTEN, CODEY, NEW YORK, NY. SN 85-209,067. PUB. 9-27-2011, FILED 1-3-2011.

DANCE DOT

THE MARK CONSISTS OF STANDARD CHARACTERS WITHOUT CLAIM TO ANY PARTICULAR FONT, STYLE, SIZE, OR COLOR.

NO CLAIM IS MADE TO THE EXCLUSIVE RIGHT TO USE "DANCE", APART FROM THE MARK AS SHOWN.

FOR PORTABLE DANCE FLOORS (U.S. CLS. 1, 12, 33 AND 50).

FIRST USE 9-5-2010; IN COMMERCE 3-23-2011.

4,154,999. INVIA PAVEMENT TECHNOLOGIES, RICHMOND, VA. SN 85-224,961. PUB. 7-19-2011, FILED 1-24-2011.

Lynx

THE MARK CONSISTS OF STANDARD CHARACTERS WITHOUT CLAIM TO ANY PARTICULAR FONT, STYLE, SIZE, OR COLOR.

FOR COLD-POUR CRACK FILLING, NAMELY, ASPHALT PAVING COMPOSITIONS USED FOR ASPHALT PAVING (U.S. CLS. 1, 12, 33 AND 50).

FIRST USE 6-7-2011; IN COMMERCE 6-7-2011.

4,155,195. STATICWORX, INC., WATERTOWN, MA. SN 85-255,610. PUB. 7-19-2011, FILED 3-2-2011.

GROUNDSAFE

THE MARK CONSISTS OF STANDARD CHARACTERS WITHOUT CLAIM TO ANY PARTICULAR FONT, STYLE, SIZE, OR COLOR.

FOR VINYL FLOORING, RUBBER FLOORING, AND EPOXY FLOORING (U.S. CLS. 1, 12, 33 AND 50).

FIRST USE 2-1-2012; IN COMMERCE 2-1-2012.

CLASS 19—(Continued).

4,155,227. ROHNEX, AKA ROHNEX LLC, ATLANTA, GA. SN 85-259,643. PUB. 7-26-2011, FILED 3-7-2011.

VALLEY FORGE

THE MARK CONSISTS OF STANDARD CHARACTERS WITHOUT CLAIM TO ANY PARTICULAR FONT, STYLE, SIZE, OR COLOR.

FOR LAMINATE FLOORING; UNDERLAY FOR LAMINATE FLOORING; VINYL FLOORING (U.S. CLS. 1, 12, 33 AND 50).

FIRST USE 10-1-2011; IN COMMERCE 10-1-2011.

4,155,268. DSI - DIMONA SILICA INDUSTRIES LTD, DIMONA, ISRAEL. SN 85-263,138. PUB. 8-9-2011, FILED 3-10-2011.



THE MARK CONSISTS OF THE STYLIZED WORD "IBIND" ON AN OVAL.

FOR NON-METAL BUILDING MATERIALS, NAMELY, ACTIVATED MINERALS USED AS A STABILIZER IN STONE MASTIC ASPHALT; ASPHALT (U.S. CLS. 1, 12, 33 AND 50).

FIRST USE 10-31-2010; IN COMMERCE 1-31-2011.

4,155,350. STORM SOLUTIONS, INC., ESSEX, CT. SN 85-274,154. PUB. 8-9-2011, FILED 3-23-2011.

SITSCREEN

THE MARK CONSISTS OF STANDARD CHARACTERS WITHOUT CLAIM TO ANY PARTICULAR FONT, STYLE, SIZE, OR COLOR.

FOR NON-METAL WINDOW SCREENS; NONMETAL WIND PROTECTION SCREENS FOR PROTECTING LARGE OPENINGS SUCH AS LANAIS, STORE FRONTS, WINDOWS, ENTRY WAYS AND GARAGES AGAINST STRONG WINDS AND BLOWING DEBRIS (U.S. CLS. 1, 12, 33 AND 50).

FIRST USE 4-20-2011; IN COMMERCE 12-14-2011.

CLASS 19—(Continued).

4,155,417. RAW ENERGY MATERIALS CORPORATION, POMPANO BEACH, FL. SN 85-284,057. PUB. 1-10-2012, FILED 4-1-2011.

RockMesh

THE MARK CONSISTS OF STANDARD CHARACTERS WITHOUT CLAIM TO ANY PARTICULAR FONT, STYLE, SIZE, OR COLOR.

FOR NON-METALLIC REINFORCEMENTS FOR CONCRETE BUILDING CONSTRUCTION, NAMELY, PLATES, RODS, AND BARS (U.S. CLS. 1, 12, 33 AND 50). FIRST USE 4-11-2011; IN COMMERCE 4-11-2011.

4,155,419. RAW ENERGY MATERIALS CORPORATION, POMPANO BEACH, FL. SN 85-284,105. PUB. 1-10-2012, FILED 4-1-2011.

RockRebar

THE MARK CONSISTS OF STANDARD CHARACTERS WITHOUT CLAIM TO ANY PARTICULAR FONT, STYLE, SIZE, OR COLOR.

FOR NON-METALLIC REINFORCEMENTS FOR CONCRETE BUILDING CONSTRUCTION, NAMELY, PLATES, RODS, AND BARS (U.S. CLS. 1, 12, 33 AND 50). FIRST USE 6-9-2009; IN COMMERCE 6-9-2009.

4,155,589. FILTREXX INTERNATIONAL LLC, GRAFTON, OH. SN 85-337,303. PUB. 10-4-2011, FILED 6-3-2011.

DURASOXX

THE MARK CONSISTS OF STANDARD CHARACTERS WITHOUT CLAIM TO ANY PARTICULAR FONT, STYLE, SIZE, OR COLOR.

FOR EROSION CONTROL FABRIC (U.S. CLS. 1, 12, 33 AND 50). FIRST USE 3-15-2012; IN COMMERCE 3-15-2012.

CLASS 19—(Continued).

4,155,634. RITCHIE, RYAN, DBA GARDEN LOVE STONES, WEST HILLS, CA. SN 85-350,800. PUB. 12-6-2011, FILED 6-20-2011.

GARDENLOVESTONES

THE MARK CONSISTS OF STANDARD CHARACTERS WITHOUT CLAIM TO ANY PARTICULAR FONT, STYLE, SIZE, OR COLOR.

FOR NON-PRECIOUS STONES FOR GARDEN OR ORNAMENTAL USE (U.S. CLS. 1, 12, 33 AND 50). FIRST USE 7-1-2011; IN COMMERCE 7-15-2011.

CLASS 20—FURNITURE AND ARTICLES NOT OTHERWISE CLASSIFIED

4,154,399. RICHARDS HOMEWARES, INC., PORTLAND, OR. SN 77-685,307. PUB. 11-24-2009, FILED 3-6-2009.

IT'S YOUR PLANET

THE MARK CONSISTS OF STANDARD CHARACTERS WITHOUT CLAIM TO ANY PARTICULAR FONT, STYLE, SIZE, OR COLOR.

FOR CLOTHES HANGERS (U.S. CLS. 2, 13, 22, 25, 32 AND 50). FIRST USE 6-30-2009; IN COMMERCE 6-30-2009.

4,154,421. LOUISVILLE BEDDING COMPANY, LOUISVILLE, KY. SN 77-737,341. PUB. 7-28-2009, FILED 5-14-2009.

ADJUSTAFIL

THE MARK CONSISTS OF STANDARD CHARACTERS WITHOUT CLAIM TO ANY PARTICULAR FONT, STYLE, SIZE, OR COLOR.

FOR PILLOWS AND BED PILLOWS THAT FEATURE A UNIQUE PLUSH MATERIAL FOR SUPPORT AND RESILIENCY (U.S. CLS. 2, 13, 22, 25, 32 AND 50). FIRST USE 9-4-2009; IN COMMERCE 9-4-2009.

CLASS 20—(Continued).

4,154,585. SUMMIT ENTERTAINMENT, LLC, SANTA MONICA, CA. SN 77-983,095. PUB. 11-3-2009, FILED 6-30-2009.



THE MARK CONSISTS OF AN ORNATE CAPITAL "V" HAVING FOUR LEAVES AND A LARGE OVAL-SHAPED JEWEL RESTING ATOP THE "V" AND A SMALLER DIAMOND-SHAPED JEWEL AT THE BOTTOM POINT OF THE "V", WITH THE FURTHER DESIGN OF A CREST NESTLED IN THE CENTER OF THE "V", THE CREST BEING DIVIDED INTO FOUR SECTIONS AND CONTAINING A BIRD IN FLIGHT IN THE TOP RIGHT AND BOTTOM LEFT SECTIONS AND A TREE WITH BARE BRANCHES IN THE TOP LEFT AND BOTTOM RIGHT SECTIONS OF THE DIVIDED CREST.

FOR PLASTIC KEY CHAINS (U.S. CLS. 2, 13, 22, 25, 32 AND 50).

FIRST USE 6-0-2010; IN COMMERCE 6-0-2010.

4,154,617. SUMMIT ENTERTAINMENT, LLC, SANTA MONICA, CA. SN 85-006,914. PUB. 7-12-2011, FILED 4-6-2010.



THE MARK CONSISTS OF A CIRCULAR TRIBAL TATTOO DESIGN DEPICTING TWO WOLVES FACING ONE ANOTHER IN A HOWLING POSITION, SET AMONGST NUMEROUS INTERWOVEN LINES AND SHAPES AND ALL WITHIN THE CIRCLE.

FOR DREAMCATCHERS; DECORATIVE THROW PILLOWS; KEY CHAINS OF PLASTIC; PLASTIC BANNERS; AND VINYL APPLIQUES FOR ATTACHMENT TO WINDOWS, MIRRORS AND OTHER SOLID SURFACES (U.S. CLS. 2, 13, 22, 25, 32 AND 50).

FIRST USE 10-1-2009; IN COMMERCE 10-1-2009.

CLASS 20—(Continued).

4,154,735. PILSZAK, GEORGE H., FRANKLIN, PA. SN 85-108,458. PUB. 1-25-2011, FILED 8-16-2010.

MOONROCK

THE MARK CONSISTS OF STANDARD CHARACTERS WITHOUT CLAIM TO ANY PARTICULAR FONT, STYLE, SIZE, OR COLOR.

FOR STATUETTES MADE OF PLASTIC (U.S. CLS. 2, 13, 22, 25, 32 AND 50).

FIRST USE 8-0-1997; IN COMMERCE 8-0-1997.

4,154,743. TIME CUFFS, LLC, NORTH CHARLESTON, SC. SN 85-110,307. PUB. 2-1-2011, FILED 8-18-2010.

STARRS

THE MARK CONSISTS OF STANDARD CHARACTERS WITHOUT CLAIM TO ANY PARTICULAR FONT, STYLE, SIZE, OR COLOR.

FOR PLASTIC HANDCUFFS INCORPORATING DISPOSABLE STRIPS AND A TIME ACTUATED CUTTER (U.S. CLS. 2, 13, 22, 25, 32 AND 50).

FIRST USE 5-25-2010; IN COMMERCE 5-16-2011.

4,154,788. EASY-SIT, INC., CHEYENNE, WY. SN 85-127,579. PUB. 8-9-2011, FILED 9-11-2010.



THE COLOR(S) WHITE, BLACK, AND PINK IS/ARE CLAIMED AS A FEATURE OF THE MARK.

THE MARK CONSISTS OF THE WORD "SWEETSPOT" IN WHITE, STYLIZED SERIF TYPE WITH THE LETTER "O" APPEARING IN PINK AND THE COLOR BLACK APPEARING AS BACKGROUND.

FOR SEATING DEVICE IN THE NATURE OF A STRAP (U.S. CLS. 2, 13, 22, 25, 32 AND 50).

FIRST USE 3-7-2012; IN COMMERCE 3-7-2012.

CLASS 20—(Continued).

4,154,801. RAYNOR MARKETING LTD., DBA THE RAYNOR GROUP, WEST HEMPSTEAD, NY. SN 85-135,549. PUB. 2-15-2011, FILED 9-22-2010.

·C·H·A·K·R·A·
by karim rashid

THE NAME(S), PORTRAIT(S), AND/OR SIGNATURE(S) SHOWN IN THE MARK IDENTIFIES "KARIM RASHID", WHOSE CONSENT(S) TO REGISTER IS MADE OF RECORD.

THE MARK CONSISTS OF THE STYLIZED WORD "CHAKRA" WITH A SHADED-IN CIRCLE CENTERED BEFORE AND AFTER EACH LETTER IN THE WORD AND THE WORDING "BY KARIM RASHID" DIRECTLY BELOW THE TERM "CHAKRA".

FOR CHAIRS; OFFICE CHAIRS; SEAT CUSHIONS; SEATING FURNITURE (U.S. CLS. 2, 13, 22, 25, 32 AND 50).

FIRST USE 1-23-2012; IN COMMERCE 1-23-2012.

4,154,951. GOODWIN, ROBERT W., BELLINGHAM, WA. SN 85-206,913. PUB. 4-26-2011, FILED 12-28-2010.



THE MARK CONSISTS OF A FOREFRONT LETTER "D" OVER A BACKGROUND "D" WITH TWO LINES EXTENDING FROM THE MIDDLE AND UPPER LEFT SIDE OF THE FOREFRONT "D" AND WITH ONE LINE EXTENDING FROM THE UPPER LEFT SIDE OF THE BACKGROUND "D".

FOR SEAT CUSHIONS (U.S. CLS. 2, 13, 22, 25, 32 AND 50).

FIRST USE 1-1-2012; IN COMMERCE 1-1-2012.

4,155,150. BUTTERFLY SAFETY PRODUCTS LLC, BUFFALO, NY. SN 85-252,006. PUB. 7-19-2011, FILED 2-25-2011.

Butterfly Smoke Seal

THE MARK CONSISTS OF STANDARD CHARACTERS WITHOUT CLAIM TO ANY PARTICULAR FONT, STYLE, SIZE, OR COLOR.

CLASS 20—(Continued).

NO CLAIM IS MADE TO THE EXCLUSIVE RIGHT TO USE "SMOKE SEAL", APART FROM THE MARK AS SHOWN.

FOR SMOKE GUARDS, NAMELY, A STUFFED TEXTILE TUBE SMOKE STOPPERS FOR DOORS TO PREVENT THE PASSAGE OF SMOKE (U.S. CLS. 2, 13, 22, 25, 32 AND 50).

FIRST USE 11-1-2011; IN COMMERCE 11-1-2011.

4,155,172. BORGREN, THOMAS M. DULUTH, MN. SN 85-253,861. PUB. 7-19-2011, FILED 2-28-2011.

Boner Bee Gone

THE MARK CONSISTS OF STANDARD CHARACTERS WITHOUT CLAIM TO ANY PARTICULAR FONT, STYLE, SIZE, OR COLOR.

FOR NOVELTY GOODS IN THE NATURE OF A PLACEBO SPRAY USED TO ALTER ONE'S REACTION TO A SITUATION (U.S. CLS. 2, 13, 22, 25, 32 AND 50).

FIRST USE 10-1-2010; IN COMMERCE 9-1-2011.

4,155,196. BUSHONG, ELIZABETH, C., DBA LIZ BUSHONG, JOHNSON CITY, TN. SN 85-255,786. PUB. 7-19-2011, FILED 3-2-2011.

SASSYSCAPES

THE MARK CONSISTS OF STANDARD CHARACTERS WITHOUT CLAIM TO ANY PARTICULAR FONT, STYLE, SIZE, OR COLOR.

FOR DINING ROOM TABLES; DISPLAY TABLES (U.S. CLS. 2, 13, 22, 25, 32 AND 50).

FIRST USE 4-21-2011; IN COMMERCE 4-21-2011.

CLASS 20—(Continued).

4,155,213. WESTERN INDUSTRIES, INC., WINFIELD, KS. SN 85-257,363. PUB. 7-19-2011, FILED 3-3-2011.

BUILT TO USE EVERY DAY,
NOT JUST TO STORE AWAY

THE MARK CONSISTS OF STANDARD CHARACTERS WITHOUT CLAIM TO ANY PARTICULAR FONT, STYLE, SIZE, OR COLOR.

FOR STORAGE AND ORGANIZATION SYSTEMS FOR LAWN AND GARDEN EQUIPMENT, HOUSEHOLD AND GARAGE EQUIPMENT, CAMPING AND HIKING EQUIPMENT, HUNTING AND SPORTING EQUIPMENT, AND CONSTRUCTION AND CONTRACTOR EQUIPMENT, COMPRISING SHELVES, CABINETS, DRAWERS, BASKETS, STORAGE HOOKS, STORAGE BINS, STORAGE CONTAINERS, STORAGE LOCKERS, CUPBOARDS, TOTES, SOLD AS A UNIT (U.S. CLS. 2, 13, 22, 25, 32 AND 50).

FIRST USE 2-15-2011; IN COMMERCE 2-15-2011.

4,155,238. ARTA PLAST AB, TYRESO, SWEDEN. SN 85-260,582. PUB. 8-9-2011, FILED 3-8-2011.

1-Seal

THE MARK CONSISTS OF STANDARD CHARACTERS WITHOUT CLAIM TO ANY PARTICULAR FONT, STYLE, SIZE, OR COLOR.

FOR PLASTIC CONTAINERS AND COVERS FOR THE FOOD INDUSTRY (U.S. CLS. 2, 13, 22, 25, 32 AND 50).

FIRST USE 1-1-2005; IN COMMERCE 1-1-2005.

4,155,277. DISNEY ENTERPRISES, INC., BURBANK, CA. SN 85-263,999. PUB. 7-26-2011, FILED 3-10-2011.

AIRLINE_009

THE MARK CONSISTS OF STANDARD CHARACTERS WITHOUT CLAIM TO ANY PARTICULAR FONT, STYLE, SIZE, OR COLOR.

FOR FURNITURE (U.S. CLS. 2, 13, 22, 25, 32 AND 50).

FIRST USE 12-31-2010; IN COMMERCE 12-31-2010.

CLASS 20—(Continued).

4,155,319. ECHO DELTA, INC., LOS ANGELES, CA. SN 85-269,124. PUB. 9-6-2011, FILED 3-17-2011.

UPSHELF

THE MARK CONSISTS OF STANDARD CHARACTERS WITHOUT CLAIM TO ANY PARTICULAR FONT, STYLE, SIZE, OR COLOR.

FOR SHELVES, NAMELY, A DETACHABLE SHELF ADAPTABLE TO A PATIO UMBRELLA POLE, TENT OR CANOPY POLE, OR OTHER VERTICAL STRUCTURE, FOR USE PRINCIPALLY AS AN ACCESSORY TO OUTDOOR AND PATIO FURNITURE (U.S. CLS. 2, 13, 22, 25, 32 AND 50).

FIRST USE 3-10-2012; IN COMMERCE 4-9-2012.

4,155,377. BLUMENTHAL DISTRIBUTING, INC., DBA OFFICE STAR PRODUCTS, INC., ONTARIO, CA. SN 85-279,122. PUB. 8-30-2011, FILED 3-28-2011.

OSP ACCENTS

THE MARK CONSISTS OF STANDARD CHARACTERS WITHOUT CLAIM TO ANY PARTICULAR FONT, STYLE, SIZE, OR COLOR.

OWNER OF U.S. REG. NOS. 3,440,465 AND 3,517,819. NO CLAIM IS MADE TO THE EXCLUSIVE RIGHT TO USE "ACCENTS", APART FROM THE MARK AS SHOWN.

FOR OFFICE FURNITURE (U.S. CLS. 2, 13, 22, 25, 32 AND 50).

FIRST USE 6-7-2011; IN COMMERCE 6-7-2011.

4,155,486. PACIFIC COAST FEATHER COMPANY, SEATTLE, WA. SN 85-299,860. PUB. 12-13-2011, FILED 4-20-2011.

DOWN LOFT

THE MARK CONSISTS OF STANDARD CHARACTERS WITHOUT CLAIM TO ANY PARTICULAR FONT, STYLE, SIZE, OR COLOR.

NO CLAIM IS MADE TO THE EXCLUSIVE RIGHT TO USE "DOWN", APART FROM THE MARK AS SHOWN.

FOR DOWN PILLOWS (U.S. CLS. 2, 13, 22, 25, 32 AND 50).

FIRST USE 9-11-2011; IN COMMERCE 9-11-2011.

CLASS 20—(Continued).

4,155,529. PCA DESIGN, INC., RED LION, PA. SN 85-313,735. PUB. 1-10-2012, FILED 5-5-2011.



NO CLAIM IS MADE TO THE EXCLUSIVE RIGHT TO USE "WINDOW", APART FROM THE MARK AS SHOWN.

THE MARK CONSISTS OF A STYLED SHIELD WITH THE STYLIZED TEXT "WINDOW WARDEN".

FOR CHILD SAFETY PRODUCT INDIVIDUALLY COMPRISED OF BOTH METAL AND NON-METAL MATERIALS, NAMELY, A WINDOW-OPENING LIMITING DEVICE (U.S. CLS. 2, 13, 22, 25, 32 AND 50).

FIRST USE 6-29-2010; IN COMMERCE 6-29-2011.

4,155,557. SWALLOW, JAMES, WOOD DALE, IL. SN 85-325,022. PUB. 10-11-2011, FILED 5-19-2011.

**COUCH SHELF IT'S NOT JUST
A SHELF**

THE MARK CONSISTS OF STANDARD CHARACTERS WITHOUT CLAIM TO ANY PARTICULAR FONT, STYLE, SIZE, OR COLOR.

FOR FURNITURE (U.S. CLS. 2, 13, 22, 25, 32 AND 50).

FIRST USE 10-20-2011; IN COMMERCE 10-20-2011.

4,155,681. TIFFANY ANNE LLC, HOPE SOUND, FL. SN 85-363,983. PUB. 11-29-2011, FILED 7-6-2011.



THE NAME "TIFFANY ANNE" PRICE IDENTIFIES A LIVING INDIVIDUAL WHOSE CONSENT IS OF RECORD.

THE MARK CONSISTS OF THE STYLIZED TEXT "TIFFANY ANNE".

FOR HOME DECOR ITEMS, NAMELY, EMBELLISHED SEASHELLS (U.S. CLS. 2, 13, 22, 25, 32 AND 50).

FIRST USE 10-1-2011; IN COMMERCE 10-1-2011.

CLASS 20—(Continued).

4,155,707. DER SHENG CO., LTD., CHANGHUA COUNTY, TAIWAN. SN 85-370,311. PUB. 12-6-2011, FILED 7-13-2011.

RESOLUTE

THE MARK CONSISTS OF STYLIZED LETTERS FORMING THE WORD "RESOLUTE".

FOR NON-METAL CASTERS AND WHEELS FOR NON-METAL CASTERS (U.S. CLS. 2, 13, 22, 25, 32 AND 50).

FIRST USE 10-21-2010; IN COMMERCE 10-21-2010.

4,155,719. TARGET BRANDS, INC., MINNEAPOLIS, MN. SN 85-373,840. PUB. 12-20-2011, FILED 7-18-2011.

BROOKS ISLAND

THE MARK CONSISTS OF STANDARD CHARACTERS WITHOUT CLAIM TO ANY PARTICULAR FONT, STYLE, SIZE, OR COLOR.

FOR OUTDOOR PATIO FURNITURE (U.S. CLS. 2, 13, 22, 25, 32 AND 50).

FIRST USE 1-1-2012; IN COMMERCE 1-1-2012.

4,155,720. DREAMWELL, LTD., LAS VEGAS, NV. SN 85-373,891. PUB. 1-10-2012, FILED 7-18-2011.

AIRCOOL

THE MARK CONSISTS OF STANDARD CHARACTERS WITHOUT CLAIM TO ANY PARTICULAR FONT, STYLE, SIZE, OR COLOR.

FOR MATTRESS COMPONENTS, NAMELY, MATTRESS FOAM, MESH BORDERS, FOAM CORES, ELASTIC GEL MATERIAL LOCATED IN THE TOP UPHOLSTERY LAYER OF MATTRESSES, ALL SOLD AS INTEGRAL COMPONENTS OF A MATTRESS (U.S. CLS. 2, 13, 22, 25, 32 AND 50).

FIRST USE 7-31-2011; IN COMMERCE 7-31-2011.

CLASS 21—HOUSEWARES AND GLASS

CLASS 21—(Continued).

4,154,250. MIAMICA OF NEW YORK, INC., A DIVISION OF SHALOM INTERNATIONAL, CORP., PERTH AMBOY, NJ. SN 76-703,591. PUB. 6-14-2011, FILED 6-30-2010.

INNER BOOTIE

THE MARK CONSISTS OF STANDARD CHARACTERS WITHOUT CLAIM TO ANY PARTICULAR FONT, STYLE, SIZE, OR COLOR.

FOR INNER SUPPORT FOR MEN AND WOMEN'S BOOTS, NAMELY, INFLATABLE BOOT SHAPERS IN THE NATURE OF INFLATABLE SHOE-TREES MADE OF PLASTIC, AND FOR USE WHEN SAID PRODUCTS ARE NOT BEING WORN (U.S. CLS. 2, 13, 23, 29, 30, 33, 40 AND 50).

FIRST USE 9-21-2010; IN COMMERCE 9-21-2010.

CLASS 21—(Continued).

4,154,358. BAR NND RANCHES, LLC, MIDLAND, TX. SN 77-582,572. PUB. 4-14-2009, FILED 9-30-2008.



THE MARK CONSISTS OF A FANCIFUL DEER WITH ANTLERS HOLDING A COFFEE MUG WHICH HAS THE WORDS "UNGULATE".

FOR MUGS; THERMAL INSULATED CONTAINERS FOR FOOD OR BEVERAGE (U.S. CLS. 2, 13, 23, 29, 30, 33, 40 AND 50).

FIRST USE 9-30-2008; IN COMMERCE 12-15-2011.

4,154,298. APOC RESTAURANT, INC., NEW YORK, NY. SN 77-432,880. PUB. 12-30-2008, FILED 3-27-2008.

COPACABANA

THE MARK CONSISTS OF STANDARD CHARACTERS WITHOUT CLAIM TO ANY PARTICULAR FONT, STYLE, SIZE, OR COLOR.

OWNER OF U.S. REG. NOS. 1,210,093 AND 1,280,161.

FOR COFFEE CUPS, TEA CUPS AND MUGS (U.S. CLS. 2, 13, 23, 29, 30, 33, 40 AND 50).

FIRST USE 12-1-2011; IN COMMERCE 12-1-2011.

4,154,368. GABRIELLE STUDIO, INC., NEW YORK, NY. SN 77-603,074. PUB. 2-10-2009, FILED 10-29-2008.

DONNA KARAN

THE MARK CONSISTS OF STANDARD CHARACTERS WITHOUT CLAIM TO ANY PARTICULAR FONT, STYLE, SIZE, OR COLOR.

OWNER OF U.S. REG. NOS. 2,142,132, 3,014,041, AND 3,069,157.

THE NAME "DONNA KARAN" IDENTIFIES A LIVING INDIVIDUAL WHOSE CONSENT IS OF RECORD.

FOR DINNERWARE, NAMELY, PLATES, DISHES, CHARGERS, BOWLS, CUPS AND SAUCERS; STEMWARE, BEVERAGEWARE; DECANTERS; SERVING PLATTERS AND TRAYS NOT OF PRECIOUS METAL; MUGS; SUGAR BOWLS AND CREAMERS, NAMELY, CONTAINERS FOR SERVING CREAM NOT MADE OF PRECIOUS METAL; NON-ELECTRIC TEA POTS; CANDLESICK HOLDERS NOT OF PRECIOUS METAL, VASES (U.S. CLS. 2, 13, 23, 29, 30, 33, 40 AND 50).

FIRST USE 10-0-2010; IN COMMERCE 10-0-2010.

CLASS 21—(Continued).

4,154,422. HILTON, PARIS, BEVERLY HILLS, CA. SN 77-740,209. PUB. 12-29-2009, FILED 5-19-2009.



OWNER OF U.S. REG. NOS. 3,059,587, 3,550,627, AND OTHERS.

THE NAME(S), PORTRAIT(S), AND/OR SIGNATURE(S) SHOWN IN THE MARK IDENTIFIES "PARIS HILTON", WHOSE CONSENT(S) TO REGISTER IS MADE OF RECORD.

THE MARK CONSISTS OF A CROWN DESIGN WITH A STYLIZED "P" AND DIAMOND PERIOD DESIGN, A SWIRL DESIGN ON EACH SIDE OF THE "P" AND THE WORDS "PARIS HILTON".

FOR HAIR BRUSHES AND HAIR COMBS (U.S. CLS. 2, 13, 23, 29, 30, 33, 40 AND 50).

FIRST USE 12-2-2009; IN COMMERCE 12-2-2009.

CLASS 21—(Continued).

4,154,627. YUMI ECOSOLUTIONS, INC., WESTPORT, CT. SN 85-019,941. PUB. 2-8-2011, FILED 4-21-2010.

THE THROW AWAY THAT GOES AWAY

THE MARK CONSISTS OF STANDARD CHARACTERS WITHOUT CLAIM TO ANY PARTICULAR FONT, STYLE, SIZE, OR COLOR.

FOR BIODEGRADABLE DISPOSABLE DINNERWARE, NAMELY, PLATES, BOWLS, CUPS, TRAYS, LIDS SPECIFICALLY ADAPTED FOR PLATES, BOWLS, CUPS AND TRAYS, SERVING FORKS, SERVING SPOONS, TRAYS, NAMELY, SINGLE AND MULTI-COMPARTMENT TRAYS WITH ATTACHED LIDS (U.S. CLS. 2, 13, 23, 29, 30, 33, 40 AND 50).

FIRST USE 2-1-2012; IN COMMERCE 2-1-2012.

4,154,631. ALLSTAR MARKETING GROUP, LLC, HAWTHORNE, NY. SN 85-027,864. PUB. 8-31-2010, FILED 4-30-2010.

PERFECT MEATLOAF

THE MARK CONSISTS OF STANDARD CHARACTERS WITHOUT CLAIM TO ANY PARTICULAR FONT, STYLE, SIZE, OR COLOR.

NO CLAIM IS MADE TO THE EXCLUSIVE RIGHT TO USE "MEATLOAF", APART FROM THE MARK AS SHOWN, FOR BAKEWARE (U.S. CLS. 2, 13, 23, 29, 30, 33, 40 AND 50).

FIRST USE 4-25-2011; IN COMMERCE 4-25-2011.

4,154,437. NEW WAVE ENVIRO PRODUCTS, INC., GREENWOOD VILLAGE, CO. SN 77-770,641. PUB. 4-20-2010, FILED 6-29-2009.

ECO-NOMICAL

THE MARK CONSISTS OF STANDARD CHARACTERS WITHOUT CLAIM TO ANY PARTICULAR FONT, STYLE, SIZE, OR COLOR.

FOR BOTTLES, SOLD EMPTY; DRINKING FLASKS; DRINKING VESSELS (U.S. CLS. 2, 13, 23, 29, 30, 33, 40 AND 50).

FIRST USE 6-29-2009; IN COMMERCE 6-29-2009.

4,154,797. BRAINSTORMPRODUCTS, LLC, LA JOLLA, CA. SN 85-132,635. PUB. 3-1-2011, FILED 9-17-2010.

GLASS WORLD

THE MARK CONSISTS OF STANDARD CHARACTERS WITHOUT CLAIM TO ANY PARTICULAR FONT, STYLE, SIZE, OR COLOR.

NO CLAIM IS MADE TO THE EXCLUSIVE RIGHT TO USE "GLASS", APART FROM THE MARK AS SHOWN, FOR FIGURINES OF GLASS (U.S. CLS. 2, 13, 23, 29, 30, 33, 40 AND 50).

FIRST USE 3-31-2011; IN COMMERCE 3-31-2011.

CLASS 21—(Continued).

4,154,956. CONAIR CORPORATION, STAMFORD, CT. SN 85-209,774. PUB. 5-3-2011, FILED 1-4-2011.

CUISINART CROWN

THE MARK CONSISTS OF STANDARD CHARACTERS WITHOUT CLAIM TO ANY PARTICULAR FONT, STYLE, SIZE, OR COLOR.

OWNER OF U.S. REG. NOS. 1,048,883, 2,313,580, AND OTHERS.

FOR NON-ELECTRIC KETTLES (U.S. CLS. 2, 13, 23, 29, 30, 33, 40 AND 50).

FIRST USE 3-0-2011; IN COMMERCE 3-0-2011.

CLASS 21—(Continued).

4,154,974. HEWY WINE CHILLERS, LLC, ORLANDO, FL. SN 85-214,510. PUB. 5-3-2011, FILED 1-10-2011.

Corkcicle

THE MARK CONSISTS OF STANDARD CHARACTERS WITHOUT CLAIM TO ANY PARTICULAR FONT, STYLE, SIZE, OR COLOR.

FOR BOTTLE STOPPERS SPECIALLY ADAPTED FOR USE WITH WINE BOTTLES; COOLERS FOR WINE (U.S. CLS. 2, 13, 23, 29, 30, 33, 40 AND 50).

FIRST USE 9-20-2011; IN COMMERCE 9-20-2011.

4,154,957. CONAIR CORPORATION, STAMFORD, CT. SN 85-209,829. PUB. 5-3-2011, FILED 1-4-2011.

CUISINART PRODIGY

THE MARK CONSISTS OF STANDARD CHARACTERS WITHOUT CLAIM TO ANY PARTICULAR FONT, STYLE, SIZE, OR COLOR.

OWNER OF U.S. REG. NOS. 1,048,883, 2,313,580, AND OTHERS.

FOR NON-ELECTRIC KETTLES (U.S. CLS. 2, 13, 23, 29, 30, 33, 40 AND 50).

FIRST USE 2-0-2011; IN COMMERCE 2-0-2011.

4,154,982. EVRIHOLDER PRODUCTS LLC, ANAHEIM, CA. SN 85-217,059. PUB. 7-26-2011, FILED 1-13-2011.

FROST-EAZE

THE MARK CONSISTS OF STANDARD CHARACTERS WITHOUT CLAIM TO ANY PARTICULAR FONT, STYLE, SIZE, OR COLOR.

FOR DECORATING SETS SOLD AS A UNIT COMPRISED OF DECORATING TUBES, COUPLERS AND TIPS FOR BAKED GOODS, NAMELY, CAKES, COOKIES AND CUP-CAKES (U.S. CLS. 2, 13, 23, 29, 30, 33, 40 AND 50).

FIRST USE 6-13-2011; IN COMMERCE 7-18-2011.

4,154,961. CONAIR CORPORATION, STAMFORD, CT. SN 85-210,742. PUB. 5-3-2011, FILED 1-5-2011.

CUISINART VALOR

THE MARK CONSISTS OF STANDARD CHARACTERS WITHOUT CLAIM TO ANY PARTICULAR FONT, STYLE, SIZE, OR COLOR.

OWNER OF U.S. REG. NOS. 1,048,883, 2,313,580, AND OTHERS.

FOR NON-ELECTRIC KETTLES (U.S. CLS. 2, 13, 23, 29, 30, 33, 40 AND 50).

FIRST USE 2-0-2011; IN COMMERCE 2-0-2011.

4,155,255. LMC PARTNERS, SOUTH SAN FRANCISCO, CA. SN 85-262,028. PUB. 7-26-2011, FILED 3-9-2011.

Scoop-2-Clean

THE MARK CONSISTS OF STANDARD CHARACTERS WITHOUT CLAIM TO ANY PARTICULAR FONT, STYLE, SIZE, OR COLOR.

FOR SCOOPS FOR THE DISPOSAL OF PET WASTE (U.S. CLS. 2, 13, 23, 29, 30, 33, 40 AND 50).

FIRST USE 10-20-2011; IN COMMERCE 10-20-2011.

CLASS 21—(Continued).

4,155,284. GUANGDONG YINGAO KITCHEN UTENSILS CO., LTD., SHUNDE, FOSHAN, CHINA. SN 85-265,719. PUB. 10-25-2011, FILED 3-14-2011.



NO CLAIM IS MADE TO THE EXCLUSIVE RIGHT TO USE THE NON-LATIN CHARACTERS THAT TRANSLITERATE TO CHU JU, APART FROM THE MARK AS SHOWN.

THE MARK CONSISTS OF FOUR CHINESE CHARACTERS APPEARING INSIDE A SHADED SQUARE BACKGROUND.

THE NON-LATIN CHARACTERS IN THE MARK TRANSLITERATE TO YING; AO; CHU; JU AND THIS MEANS CHERRY; ABSTRUSE; KITCHEN; UTENSIL IN ENGLISH.

FOR BASINS; CERAMIC SCULPTURES, VASES, VESSELS, BOWLS, PLATES AND POTS; CLEANING BRUSHES FOR HOUSEHOLD USE; CLEANING CLOTHS; CLEANING SPONGES; CONTAINERS FOR HOUSEHOLD OR KITCHEN USE; DRINKING VESSELS; ENAMELLED GLASS; GLASS JARS; HOUSEHOLD UTENSILS, NAMELY, KITCHEN TONGS; HOUSEHOLD UTENSILS, NAMELY, POT AND PAN SCRAPERS, ROLLING PINS, SPATULAS, TURNERS, WHISKS; INSULATED CONTAINERS FOR FOOD OR BEVERAGE FOR DOMESTIC USE; WATER TROUGHS (U.S. CLS. 2, 13, 23, 29, 30, 33, 40 AND 50).

FIRST USE 5-10-2005; IN COMMERCE 4-15-2008.

CLASS 21—(Continued).

4,155,354. BERRY PLASTICS CORPORATION, EVANSVILLE, IN. SN 85-275,491. PUB. 8-9-2011, FILED 3-24-2011.

ICONIC

THE MARK CONSISTS OF STANDARD CHARACTERS WITHOUT CLAIM TO ANY PARTICULAR FONT, STYLE, SIZE, OR COLOR.

FOR PLASTIC CUPS (U.S. CLS. 2, 13, 23, 29, 30, 33, 40 AND 50).

FIRST USE 9-0-2011; IN COMMERCE 9-0-2011.

4,155,479. KATE SPADE LLC, NEW YORK, NY. SN 85-298,818. PUB. 8-9-2011, FILED 4-19-2011.



4,155,305. GREYSTAR PRODUCTS, INC., SAN JUAN CAPISTRANO, CA. SN 85-267,692. PUB. 8-16-2011, FILED 3-15-2011.

Greystar Bird Safe

THE MARK CONSISTS OF STANDARD CHARACTERS WITHOUT CLAIM TO ANY PARTICULAR FONT, STYLE, SIZE, OR COLOR.

NO CLAIM IS MADE TO THE EXCLUSIVE RIGHT TO USE "BIRD", APART FROM THE MARK AS SHOWN.

FOR BIRD FEEDERS AND SUPPORT POLES SPECIALLY ADAPTED FOR USE WITH BIRD FEEDERS (U.S. CLS. 2, 13, 23, 29, 30, 33, 40 AND 50).

FIRST USE 11-1-2011; IN COMMERCE 4-4-2012.

OWNER OF U.S. REG. NOS. 2,841,312, 3,095,754, AND OTHERS.

NO CLAIM IS MADE TO THE EXCLUSIVE RIGHT TO USE "NEW YORK", APART FROM THE MARK AS SHOWN.

THE NAME "KATE SPADE" IDENTIFIES A LIVING INDIVIDUAL WHOSE CONSENT IS OF RECORD.

THE MARK CONSISTS OF A SPADE DESIGN WITH THE WORDS "KATE SPADE NEW YORK" UNDERNEATH.

FOR BATH ACCESSORIES, NAMELY, CUP HOLDERS; CUPS; LOTION CONTAINERS SOLD EMPTY FOR DOMESTIC USE; SOAP DISHES; SOAP DISPENSERS; SOAP HOLDERS; TOOTHBRUSH HOLDERS; WASTE BASKETS (U.S. CLS. 2, 13, 23, 29, 30, 33, 40 AND 50).

FIRST USE 1-2-2011; IN COMMERCE 1-2-2011.

CLASS 21—(Continued).

4,155,480. BKD ACQUISITION, INC., OAKBROOK, IL. SN 85-298,926. PUB. 7-5-2011, FILED 4-19-2011.

LOOP

THE MARK CONSISTS OF STANDARD CHARACTERS WITHOUT CLAIM TO ANY PARTICULAR FONT, STYLE, SIZE, OR COLOR.

FOR CADDIES FOR HOLDING DIAPERS AND DIAPER-CHANGING ACCESSORIES (U.S. CLS. 2, 13, 23, 29, 30, 33, 40 AND 50).

FIRST USE 9-25-2011; IN COMMERCE 9-25-2011.

4,155,521. LUFT INDUSTRIE, INC., OAKLAND, CA. SN 85-311,946. PUB. 1-17-2012, FILED 5-4-2011.

EAZY SQUEEZY

THE MARK CONSISTS OF STANDARD CHARACTERS WITHOUT CLAIM TO ANY PARTICULAR FONT, STYLE, SIZE, OR COLOR.

FOR LIQUID, FLUID, AND LOTION CONTAINERS SOLD EMPTY FOR PERSONAL, FAMILY, AND DOMESTIC USE (U.S. CLS. 2, 13, 23, 29, 30, 33, 40 AND 50).

FIRST USE 5-1-2011; IN COMMERCE 3-19-2012.

4,155,532. TABLETOPS UNLIMITED, INC., CARSON, CA. SN 85-314,953. PUB. 8-9-2011, FILED 5-6-2011.

Smart Rest-A-Lid

THE MARK CONSISTS OF STANDARD CHARACTERS WITHOUT CLAIM TO ANY PARTICULAR FONT, STYLE, SIZE, OR COLOR.

FOR HANDLES SOLD AS AN INTEGRAL COMPONENT OF COOKWARE; COOKWARE HANDLES; POTS AND PANS; COOKWARE, NAMELY, STEAMERS, FRYING PANS, CASSEROLE DISHES, SAUCE PANS, AND DUTCH OVENS (U.S. CLS. 2, 13, 23, 29, 30, 33, 40 AND 50).

FIRST USE 1-17-2012; IN COMMERCE 1-17-2012.

CLASS 21—(Continued).

4,155,663. ADC MARKETING, INC., DBA MAGELLAN GROUP, LTD., BLAINE, WA. SN 85-361,098. PUB. 1-24-2012, FILED 6-30-2011.

H2H

THE MARK CONSISTS OF STANDARD CHARACTERS WITHOUT CLAIM TO ANY PARTICULAR FONT, STYLE, SIZE, OR COLOR.

FOR KITCHENWARE, NAMELY, ROASTING PAN FOR USE IN OVENS; STOVE-TOP POPCORN POPPER; BREADING PANS; FOOD PRESS FOR PRESSING MEATS AND POULTRY WHILE COOKING; PASTRY SCRAPERS; PERFORATED GRILLING PANS; PIE PANS; RIB COOKING STAND; PERFORATED AND MESH BASKETS FOR STEAMING, FRYING AND BOILING FOODS; CERAMIC FRY PANS, DUTCH OVENS, SAUTE PANS, CHICKEN ROASTERS AND SAUCE PANS (U.S. CLS. 2, 13, 23, 29, 30, 33, 40 AND 50).

FIRST USE 2-1-2011; IN COMMERCE 3-12-2012.

4,155,736. RELIANT CORP, EDISON, NJ. SN 85-380,272. PUB. 2-7-2012, FILED 7-25-2011.

BOOT LEGGERS

THE MARK CONSISTS OF STANDARD CHARACTERS WITHOUT CLAIM TO ANY PARTICULAR FONT, STYLE, SIZE, OR COLOR.

NO CLAIM IS MADE TO THE EXCLUSIVE RIGHT TO USE "BOOT", APART FROM THE MARK AS SHOWN.

FOR BOOT STRETCHERS AND BOOT TREES, NAMELY, BOOT FORM INSERT COMPOSED OF PLASTIC TO HELP A BOOT HOLD ITS SHAPE AND BOOT SHAPER COMPOSED OF PLASTIC TO HELP A BOOT HOLD ITS SHAPE WHEN NOT BEING WORN (U.S. CLS. 2, 13, 23, 29, 30, 33, 40 AND 50).

FIRST USE 3-15-2012; IN COMMERCE 3-15-2012.

CLASS 21—(Continued).

4,155,788. BAMBINOS!, LLC, EVERGREEN, CO. SN 85-404,529. PUB. 2-7-2012, FILED 8-23-2011.



NO CLAIM IS MADE TO THE EXCLUSIVE RIGHT TO USE "BAMBINOS!", APART FROM THE MARK AS SHOWN. THE COLOR(S) RED, WHITE, BROWN, GREEN AND YELLOW IS/ARE CLAIMED AS A FEATURE OF THE MARK.

THE MARK CONSISTS OF THE STYLIZED WORDING "BAMBINOS!" IN RED BENEATH A DRAWING OF A TORSO OF A CHILD IN WHITE OUTLINED IN BROWN WITH BROWN EYES, HAIR AND MOUTH, WEARING A LIGHT GREEN SHIRT; THE CHILD HAS FOLDED ARMS AND IS LEANING ITS CHIN ON ITS HANDS; BEHIND AND SURROUNDING THE CHILD IS A YELLOW CIRCLE WITH SMALLER YELLOW DOTS EVENLY SPACED AROUND ALL BUT THE LOWER EDGE OF ITS CIRCUMFERENCE SUGGESTIVE OF THE SUN.

THE ENGLISH TRANSLATION OF THE WORD "BAMBINOS" IN THE MARK IS "CHILDREN".

FOR MEAL TRAYS (U.S. CLS. 2, 13, 23, 29, 30, 33, 40 AND 50).

FIRST USE 9-23-2011; IN COMMERCE 9-23-2011.

CLASS 22—CORDAGE AND FIBERS

4,154,942. E3 DESIGN LLC, HAYDEN LAKE, ID. SN 85-204,217. PUB. 7-19-2011, FILED 12-22-2010.

LYNX Hooks

THE MARK CONSISTS OF STANDARD CHARACTERS WITHOUT CLAIM TO ANY PARTICULAR FONT, STYLE, SIZE, OR COLOR.

NO CLAIM IS MADE TO THE EXCLUSIVE RIGHT TO USE "HOOKS", APART FROM THE MARK AS SHOWN.

FOR NON-METAL TIE DOWNS WHICH MAY BE CONNECTED TOGETHER IN DIFFERENT LENGTHS AND CONFIGURATIONS (U.S. CLS. 1, 2, 7, 19, 22, 42 AND 50).

FIRST USE 1-9-2012; IN COMMERCE 2-29-2012.

CLASS 22—(Continued).

4,155,334. TREVOR BRAZILE, DECATUR, TX. SN 85-271,315. PUB. 7-5-2011, FILED 3-18-2011.

FREEDOM

THE MARK CONSISTS OF STANDARD CHARACTERS WITHOUT CLAIM TO ANY PARTICULAR FONT, STYLE, SIZE, OR COLOR.

FOR ROPES (U.S. CLS. 1, 2, 7, 19, 22, 42 AND 50).
FIRST USE 7-1-2011; IN COMMERCE 7-1-2011.

4,155,447. LIANG, DANIEL, AKA LIANG, CHIA TUNG, CERRITOS, CA. SN 85-289,721. PUB. 8-23-2011, FILED 4-8-2011.

Mega Straps

THE MARK CONSISTS OF STANDARD CHARACTERS WITHOUT CLAIM TO ANY PARTICULAR FONT, STYLE, SIZE, OR COLOR.

NO CLAIM IS MADE TO THE EXCLUSIVE RIGHT TO USE "STRAPS", APART FROM THE MARK AS SHOWN.

FOR CARGO AND CARRIER EQUIPMENT FOR VEHICLES, NAMELY, TOW ROPES, TOW STRAPS, RATCHET TIE-DOWN STRAPS, QUICK RELEASE TIE DOWN STRAPS, LASHING STRAPS, AND TARP STRAPS (U.S. CLS. 1, 2, 7, 19, 22, 42 AND 50).

FIRST USE 3-22-2012; IN COMMERCE 3-22-2012.

4,155,449. LIANG, DANIEL, AKA LIANG, CHIA TUNG, CERRITOS, CA. SN 85-289,729. PUB. 8-23-2011, FILED 4-8-2011.

Tie Safe Straps

THE MARK CONSISTS OF STANDARD CHARACTERS WITHOUT CLAIM TO ANY PARTICULAR FONT, STYLE, SIZE, OR COLOR.

NO CLAIM IS MADE TO THE EXCLUSIVE RIGHT TO USE "TIE" AND "STRAPS", APART FROM THE MARK AS SHOWN.

FOR CARGO AND CARRIER EQUIPMENT FOR VEHICLES, NAMELY, TOW ROPES, TOW STRAPS, RATCHET TIE-DOWN STRAPS, QUICK RELEASE TIE DOWN STRAPS, LASHING STRAPS, AND TARP STRAPS (U.S. CLS. 1, 2, 7, 19, 22, 42 AND 50).

FIRST USE 3-26-2012; IN COMMERCE 3-26-2012.

CLASS 23—YARNS AND THREADS

4,154,901. HOBBY LOBBY STORES, INC., OKLAHOMA CITY, OK. SN 85-185,006. PUB. 4-5-2011, FILED 11-24-2010.

ARTISTE

THE MARK CONSISTS OF STANDARD CHARACTERS WITHOUT CLAIM TO ANY PARTICULAR FONT, STYLE, SIZE, OR COLOR.

FOR EMBROIDERY FLOSS; THREAD (U.S. CL. 43).
FIRST USE 7-22-2011; IN COMMERCE 7-22-2011.

CLASS 24—(Continued).

4,154,488. FABRICTECH 2000, LLC, CEDAR GROVE, NJ. SN 77-857,985. PUB. 4-6-2010, FILED 10-27-2009.

SLEEP SHIELD

THE MARK CONSISTS OF STANDARD CHARACTERS WITHOUT CLAIM TO ANY PARTICULAR FONT, STYLE, SIZE, OR COLOR.

FOR MATTRESS COVERS, BOX SPRING COVERS, AND PILLOW COVERS (U.S. CLS. 42 AND 50).
FIRST USE 3-0-2011; IN COMMERCE 3-0-2011.

CLASS 24—FABRICS

4,154,306. TRUE TEXTILES, INC., GRAND RAPIDS, MI. SN 77-459,892. PUB. 9-23-2008, FILED 4-28-2008.



FOR FABRIC FOR USE IN THE MANUFACTURE OF VEHICLES AND OFFICE FURNITURE (U.S. CLS. 42 AND 50).

FIRST USE 7-25-2011; IN COMMERCE 7-25-2011.

4,154,749. AMERICAN BLINDS AND DRAPERIES, INC., HAYWARD, CA. SN 85-113,513. PUB. 2-8-2011, FILED 8-23-2010.

DEFENDER DRAPES

THE MARK CONSISTS OF STANDARD CHARACTERS WITHOUT CLAIM TO ANY PARTICULAR FONT, STYLE, SIZE, OR COLOR.

NO CLAIM IS MADE TO THE EXCLUSIVE RIGHT TO USE "DRAPES", APART FROM THE MARK AS SHOWN.

FOR DRAPES AND CURTAINS; SECURITY DRAPES AND CURTAINS; ANTI-BACTERIAL DRAPES AND CURTAINS; ANTI-MICROBIAL DRAPES AND CURTAINS (U.S. CLS. 42 AND 50).

FIRST USE 2-9-2009; IN COMMERCE 2-9-2009.

4,154,459. KMJ BBRAND HOLDINGS LLC, NEW YORK, NY. SN 77-818,585. PUB. 1-19-2010, FILED 9-2-2009.

MAC & JAC

THE MARK CONSISTS OF STANDARD CHARACTERS WITHOUT CLAIM TO ANY PARTICULAR FONT, STYLE, SIZE, OR COLOR.

OWNER OF U.S. REG. NOS. 1,984,545, 3,027,545, AND 3,123,450.

THE NAME "MAC & JAC" DOES NOT IDENTIFY A LIVING INDIVIDUAL.

FOR BATH LINEN; BATH TOWELS; BED BLANKETS; BED COVERS; BED LINEN; BED SHEETS; BED SKIRTS; BED SPREADS; BLANKET TROWS; COMFORTERS; CURTAIN TIE-BACKS; CURTAINS AND TOWELS; DINING LINENS; DRAPERY; DUVET COVERS; KITCHEN LINENS; KITCHEN TOWELS; PILLOW CASES; PILLOW COVERS; PILLOW SHAMS; SHOWER CURTAINS; TABLE LINEN; TROWS (U.S. CLS. 42 AND 50).

FIRST USE 6-0-2010; IN COMMERCE 6-0-2010.

4,155,125. PONCHILLOW, SAN CLEMENTE, CA. SN 85-250,086. PUB. 7-5-2011, FILED 2-23-2011.



THE MARK CONSISTS OF CLOUDS FILLED WITH LETTERS SPELLING OUT "PONCHILLOW", AND "NEVER FORGET YOUR PILLOW" WRITTEN UNDERNEATH "PONCHILLOW".

FOR FLEECE PONCHO STYLE BLANKET WITH AN ATTACHED PILLOW, HOOD, POCKETS, AND POUCHES (U.S. CLS. 42 AND 50).

FIRST USE 3-8-2011; IN COMMERCE 7-1-2011.

CLASS 24—(Continued).

4,155,192. SPRINGS CREATIVE PRODUCTS GROUP, LLC, ROCK HILL, SC. SN 85-255,340. PUB. 7-19-2011, FILED 3-2-2011.

FLUIDSTRETCH

THE MARK CONSISTS OF STANDARD CHARACTERS WITHOUT CLAIM TO ANY PARTICULAR FONT, STYLE, SIZE, OR COLOR.

FOR MATTRESS COVERS; BED SHEETS; AND FABRIC FOR COVERING MATTRESSES, NAMELY, POLYESTER AND SPANDEX BLENDED FABRIC FOR USE AS A TEXTILE IN THE MANUFACTURE OF MATTRESSES, FABRICS FOR THE MANUFACTURE OF MATTRESSES AND FABRIC MATTRESS COVERS (U.S. CLS. 42 AND 50).

FIRST USE 1-0-2012; IN COMMERCE 1-0-2012.

4,155,475. KATE SPADE LLC, NEW YORK, NY. SN 85-297,677. PUB. 8-9-2011, FILED 4-18-2011.



OWNER OF U.S. REG. NOS. 2,841,312, 3,095,754, AND OTHERS.

NO CLAIM IS MADE TO THE EXCLUSIVE RIGHT TO USE "NEW YORK", APART FROM THE MARK AS SHOWN.

THE NAME "KATE SPADE" IDENTIFIES A LIVING INDIVIDUAL WHOSE CONSENT IS OF RECORD.

THE MARK CONSISTS OF A SPADE DESIGN WITH THE WORDS "KATE SPADE NEW YORK" UNDERNEATH.

FOR BED BLANKETS; BED SHEETS; BED SKIRTS; BED THROWS; BEDSPREADS; COMFORTERS; COVERS FOR CUSHIONS; CRIB BUMPER PADS; CRIB BUMPERS; CRIB CANOPIES; CURTAINS; DRAPERIES; DUST RUFFLES; DUVET COVERS; DUVETS; HANDKERCHIEFS; KITCHEN LINENS; KITCHEN TOWELS; MATTRESS COVERS; MATTRESS PADS; PILLOW COVERS; PILLOW SHAMS; PILLOWCASES; POT HOLDERS; QUILTS; SHOWER CURTAINS; TABLE LINEN, NAMELY, COASTERS, NAPKINS, PLACE MATS AND TABLECLOTHS; TOWELS; WASH CLOTHS (U.S. CLS. 42 AND 50).

FIRST USE 1-2-2011; IN COMMERCE 1-2-2011.

CLASS 24—(Continued).

4,155,491. PRYM CONSUMER USA INC., SPARTANBURG, SC. SN 85-300,286. PUB. 8-2-2011, FILED 4-20-2011.



NO CLAIM IS MADE TO THE EXCLUSIVE RIGHT TO USE "PROTECTORS", APART FROM THE MARK AS SHOWN.

THE MARK CONSISTS OF THE WORDING "PROTECTORS" IN A STYLIZED FONT, TO THE LEFT OF THE DESIGN OF A TABLE, ALL WITHIN A CIRCLE WITH THREE SEPARATE LINES DEPICTING THE LEFT AND BOTTOM EDGES.

FOR SURFACE PROTECTORS IN THE NATURE OF PLASTIC TABLE COVERS; FELT TABLE PADS (U.S. CLS. 42 AND 50).

FIRST USE 2-1-2012; IN COMMERCE 2-1-2012.

CLASS 25—CLOTHING

4,154,256. GRIP COLLECTIONS, INC., BROOKLYN, NY. SN 76-705,862. PUB. 7-12-2011, FILED 1-3-2011.

PRESTIGE EDGE

THE MARK CONSISTS OF STANDARD CHARACTERS WITHOUT CLAIM TO ANY PARTICULAR FONT, STYLE, SIZE, OR COLOR.

FOR LADIES GARMENTS, NAMELY, FOUNDATION GARMENTS; LADIES SLEEPWEAR; INTIMATE APPAREL, NAMELY, BRAS AND PANTIES AND LINGERIE; SLIPPERS, AND SOCKS (U.S. CLS. 22 AND 39).

FIRST USE 11-14-2011; IN COMMERCE 11-14-2011.

CLASS 25—(Continued).

4,154,262. MAYS TFJ REALTY, L.L.C., NEW YORK, NY. SN 76-706,980. PUB. 8-2-2011, FILED 3-28-2011.

HOSTER

THE MARK CONSISTS OF STANDARD CHARACTERS WITHOUT CLAIM TO ANY PARTICULAR FONT, STYLE, SIZE, OR COLOR.

FOR PANTS, SHIRTS, SKIRTS, BLOUSES, JEANS, UNDERWEAR, HOSIERY, HATS, SCARVES, GLOVES, JACKETS, SWEATERS AND FOOTWEAR (U.S. CLS. 22 AND 39).

FIRST USE 9-0-2011; IN COMMERCE 9-0-2011.

4,154,278. CHESNEY, KENNY, ATLANTA, GA. SN 77-269,582. PUB. 9-30-2008, FILED 8-31-2007.

BLUE CHAIR BAY

THE MARK CONSISTS OF STANDARD CHARACTERS WITHOUT CLAIM TO ANY PARTICULAR FONT, STYLE, SIZE, OR COLOR.

FOR CLOTHING, NAMELY, BATHING SUITS, BEACHWEAR, BLOUSES, DRESSES, JACKETS, PANTS, POLO SHIRTS, SHORTS, SWEATSHIRTS, SWIMWEAR, FOOTWEAR (U.S. CLS. 22 AND 39).

FIRST USE 2-0-2010; IN COMMERCE 2-0-2010.

4,154,283. NA, CHUN KYUN, SEOUL, REPUBLIC OF KOREA. SN 77-339,376. PUB. 11-3-2009, FILED 11-28-2007.



THE COLOR(S) RED AND BLACK IS/ARE CLAIMED AS A FEATURE OF THE MARK.

THE MARK CONSISTS OF THE FANCIFUL WORD "NADAKS" WITH A DESIGN ELEMENT IN FRONT AND A STYLIZED "K" MAKING A FANCIFUL STICK PERSON. THE COLOR BLACK APPEARS IN THE LETTERS "NADA" AND "S", AND IN THE OUTER PERIMETER OF THE DESIGN TO THE LEFT OF THE WORDING "NADAKS". THE COLOR RED APPEARS IN THE PORTION OF THE DESIGN ELEMENT TO THE LEFT OF THE WORDING "NADAKS". THE LETTER "K" WHICH FORMS A FANCIFUL STICK PERSON APPEARS IN THE COLOR BLACK.

FOR SHOES (U.S. CLS. 22 AND 39).
FIRST USE 8-15-2011; IN COMMERCE 10-21-2011.

CLASS 25—(Continued).

4,154,294. VC COLLECTION LIMITED, KOWLOON, HONG KONG. SN 77-405,873. PUB. 1-20-2009, FILED 2-26-2008.



THE MARK CONSISTS OF THE LETTERS "V" AND "C" STYLIZED.

FOR CLOTHING, NAMELY, DRESSES, COATS, GOWNS, GLOVES, FOOTWEAR, HEADGEAR, NAMELY, CAPS AND HATS (U.S. CLS. 22 AND 39).

FIRST USE 6-4-2007; IN COMMERCE 6-13-2007.

4,154,296. SYSCO GUEST SUPPLY, LLC, MONMOUTH JUNCTION, NJ. SN 77-413,290. PUB. 7-22-2008, FILED 3-5-2008.

GUEST READY

THE MARK CONSISTS OF STANDARD CHARACTERS WITHOUT CLAIM TO ANY PARTICULAR FONT, STYLE, SIZE, OR COLOR.

FOR ROBES; SLIPPERS (U.S. CLS. 22 AND 39).

FIRST USE 3-8-2011; IN COMMERCE 3-8-2011.

4,154,338. BERKSHIRE BLANKET INC., WARE, MA. SN 77-547,569. PUB. 1-13-2009, FILED 8-14-2008.

A TOUCH DIFFERENT

THE MARK CONSISTS OF STANDARD CHARACTERS WITHOUT CLAIM TO ANY PARTICULAR FONT, STYLE, SIZE, OR COLOR.

FOR ROBES AND WEARABLE WRAPS (U.S. CLS. 22 AND 39).

FIRST USE 5-0-2011; IN COMMERCE 5-0-2011.

CLASS 25—(Continued).

4,154,342. FREIXE, HÉLÈNE LAURÉ, NEW YORK, NY. SN 77-551,941. PUB. 1-20-2009, FILED 8-20-2008.

JAMMIES BY HÉLÈNE LAURÉ

THE MARK CONSISTS OF STANDARD CHARACTERS WITHOUT CLAIM TO ANY PARTICULAR FONT, STYLE, SIZE, OR COLOR.

NO CLAIM IS MADE TO THE EXCLUSIVE RIGHT TO USE "JAMMIES", APART FROM THE MARK AS SHOWN. FOR SLEEPWEAR (U.S. CLS. 22 AND 39). FIRST USE 4-13-2012; IN COMMERCE 4-13-2012.

4,154,357. VENA, DEBORAH, HESPERIA, CA. SN 77-574,028. PUB. 2-10-2009, FILED 9-19-2008.

Goddess Union

THE MARK CONSISTS OF STANDARD CHARACTERS WITHOUT CLAIM TO ANY PARTICULAR FONT, STYLE, SIZE, OR COLOR.

FOR T-SHIRTS, HATS; JACKETS; PANTS; SHOES (U.S. CLS. 22 AND 39). FIRST USE 4-2-2011; IN COMMERCE 5-1-2011.

4,154,361. CALIFORNIA MILK PROCESSOR BOARD, SAN CLEMENTE, CA. SN 77-586,468. PUB. 1-20-2009, FILED 10-6-2008.

got breastmilk?

OWNER OF U.S. REG. NOS. 1,903,870 AND 2,689,741. NO CLAIM IS MADE TO THE EXCLUSIVE RIGHT TO USE "BREASTMILK", APART FROM THE MARK AS SHOWN.

THE MARK CONSISTS OF THE WORDING "GOT BREASTMILK?" IN ALL LOWER CASE LETTERS IN PHENIX AMERICAN FONT.

FOR CLOTHING, NAMELY, T-SHIRTS, SHIRTS, SHORT-SLEEVED SHIRTS, INFANT BODYSUITS, AND INFANT UNDERWEAR (U.S. CLS. 22 AND 39). FIRST USE 12-31-2011; IN COMMERCE 12-31-2011.

CLASS 25—(Continued).

4,154,369. WOLVERINE WORLD WIDE, INC., ROCKFORD, MI. SN 77-608,127. PUB. 1-27-2009, FILED 11-5-2008.

WOLVERINE ICS

THE MARK CONSISTS OF STANDARD CHARACTERS WITHOUT CLAIM TO ANY PARTICULAR FONT, STYLE, SIZE, OR COLOR.

FOR FOOTWEAR (U.S. CLS. 22 AND 39). FIRST USE 10-21-2011; IN COMMERCE 10-21-2011.

4,154,377. H.H. BROWN SHOE COMPANY, INC., GREENWICH, CT. SN 77-646,218. PUB. 4-28-2009, FILED 1-9-2009.

LIFE BOOK

THE MARK CONSISTS OF STANDARD CHARACTERS WITHOUT CLAIM TO ANY PARTICULAR FONT, STYLE, SIZE, OR COLOR.

FOR FOOTWEAR AND CLOTHING, NAMELY, BELTS, DRESSES, GLOVES, JACKETS, NECKWEAR, NIGHTWEAR, PANTS, SUITS, SWIMWEAR, SKIRTS, TOPS, BOTTOMS, UNDERWEAR, HEADWEAR, UNIFORMS, SHIRTS, SWEATSHIRTS, SWEATPANTS, SHORTS, SWEATERS, COATS, WRISTBANDS, SOCKS, HOSIERY, T-SHIRTS, SCARVES, CAPS, VESTS, AND PULLOVERS (U.S. CLS. 22 AND 39).

FIRST USE 6-9-2009; IN COMMERCE 6-9-2009.

4,154,381. LATHAM JR, CHARLES W, CHARLESTON, SC. SN 77-650,393. PUB. 9-8-2009, FILED 1-15-2009.

Hard Bodii

THE MARK CONSISTS OF STANDARD CHARACTERS WITHOUT CLAIM TO ANY PARTICULAR FONT, STYLE, SIZE, OR COLOR.

FOR TEE SHIRTS, ATHLETIC PANTS, ATHLETIC SHORTS, POLO SHIRTS, DRESS SHIRTS, DENIM PANTS, SWEAT PANTS, SWEAT SHIRTS, HOODED SWEAT SHIRTS, HOODED TEE SHIRTS, ATHLETIC JACKETS, BASEBALL CAPS, CASUAL SHIRTS, BOXER SHORTS, UNDERWEAR, SOCKS, COLLARED SHIRTS (U.S. CLS. 22 AND 39).

FIRST USE 1-20-2009; IN COMMERCE 1-25-2009.

CLASS 25—(Continued).

4,154,382. HERON, PETER, C, DBA I AM NOT A VIRGIN, NEW YORK, NY. SN 77-654,366. PUB. 5-5-2009, FILED 1-22-2009.

I AM NOT A VIRGIN

THE MARK CONSISTS OF STANDARD CHARACTERS WITHOUT CLAIM TO ANY PARTICULAR FONT, STYLE, SIZE, OR COLOR.
FOR JEANS (U.S. CLS. 22 AND 39).
FIRST USE 3-10-2012; IN COMMERCE 3-10-2012.

CLASS 25—(Continued).

4,154,413. BIBIT, LLC, SPOKANE, WA. SN 77-709,819. PUB. 8-24-2010, FILED 4-8-2009.

Believe It. Be It.

THE MARK CONSISTS OF STANDARD CHARACTERS WITHOUT CLAIM TO ANY PARTICULAR FONT, STYLE, SIZE, OR COLOR.
FOR ATHLETIC APPAREL, NAMELY, SHIRTS, PANTS, JACKETS, FOOTWEAR, HATS AND CAPS, ATHLETIC UNIFORMS (U.S. CLS. 22 AND 39).
FIRST USE 4-1-2012; IN COMMERCE 4-1-2012.

4,154,393. SKECHERS U.S.A., INC. II, MANHATTAN BEACH, CA. SN 77-677,565. PUB. 1-19-2010, FILED 2-24-2009.

SKECHERS SHAPE-UPS

THE MARK CONSISTS OF STANDARD CHARACTERS WITHOUT CLAIM TO ANY PARTICULAR FONT, STYLE, SIZE, OR COLOR.
OWNER OF U.S. REG. NOS. 1,851,977, 2,362,883, AND OTHERS.
FOR FOOTWEAR (U.S. CLS. 22 AND 39).
FIRST USE 11-14-2008; IN COMMERCE 11-14-2008.

4,154,419. COLUMBIA INSURANCE COMPANY, OMAHA, NE. SN 77-729,215. PUB. 11-10-2009, FILED 5-5-2009.

BÜNDE

THE MARK CONSISTS OF STANDARD CHARACTERS WITHOUT CLAIM TO ANY PARTICULAR FONT, STYLE, SIZE, OR COLOR.
THE WORDING "BÜNDE" HAS NO MEANING IN A FOREIGN LANGUAGE.
FOR FOOTWEAR AND CLOTHING, NAMELY, BELTS, DRESSES, GLOVES, JACKETS, NECKWEAR, NIGHTWEAR, PANTS, SUITS, SWIMWEAR, SKIRTS, TOPS, BOTTOMS, UNDERWEAR, HEADWEAR, UNIFORMS, SHIRTS, SWEATSHIRTS, SWEATPANTS, SHORTS, SWEATERS, COATS, WRISTBANDS, SOCKS, HOSIERY, T-SHIRTS, SCARVES, CAPS, VESTS, AND PULLOVERS (U.S. CLS. 22 AND 39).
FIRST USE 6-9-2009; IN COMMERCE 6-9-2009.

4,154,400. ACADEMI LLC, MOYOCK, NC. SN 77-687,408. PUB. 7-7-2009, FILED 3-10-2009.



THE MARK CONSISTS OF STYLIZED LETTERING OF THE NAME "XE".
FOR SHIRTS; T-SHIRTS (U.S. CLS. 22 AND 39).
FIRST USE 4-30-2009; IN COMMERCE 4-30-2009.

4,154,431. LA HERRADURA LTD., KEY BISCAYNE, FL. SN 77-758,808. PUB. 7-27-2010, FILED 6-12-2009.

JUANES

THE MARK CONSISTS OF STANDARD CHARACTERS WITHOUT CLAIM TO ANY PARTICULAR FONT, STYLE, SIZE, OR COLOR.
OWNER OF U.S. REG. NOS. 3,291,984, 3,320,709, AND 3,421,609.
"JUANES" IDENTIFIES JUAN ESTEBAN ARISTIZABAL VASQUEZ, A LIVING INDIVIDUAL WHOSE CONSENT IS OF RECORD.
FOR BELTS; CAPS; HEADWEAR; JACKETS; JERSEYS; PANTS; PULLOVERS; SHIRTS; SHORTS; SWEATERS; T-SHIRTS; TOPS (U.S. CLS. 22 AND 39).
FIRST USE 3-1-2005; IN COMMERCE 3-1-2005.

CLASS 25—(Continued).

4,154,445. SINGLETON, WILLIAM, CLEVELAND HEIGHTS, OH. SN 77-797,620. PUB. 1-5-2010, FILED 8-5-2009.



THE MARK CONSISTS OF HUMAN-SHAPED FIGURE, FOR WEARING APPAREL, NAMELY, HATS, DRESS SHIRTS, SPORT SHIRTS, KNIT SHIRTS, SWEATSHIRTS, T-SHIRTS, AND PULL-OVER SHIRTS (U.S. CLS. 22 AND 39).

FIRST USE 2-0-2012; IN COMMERCE 2-0-2012.

4,154,455. RUN ATHLETICS INTERNATIONAL, LLC, NEW YORK, NY. SN 77-812,378. PUB. 7-27-2010, FILED 8-25-2009.

CHIVALROUS CULTURE

THE MARK CONSISTS OF STANDARD CHARACTERS WITHOUT CLAIM TO ANY PARTICULAR FONT, STYLE, SIZE, OR COLOR.

FOR FOOTWEAR AND WEARING APPAREL, NAMELY, POLO SHIRTS, T-SHIRTS, HOODED JACKETS, TRACK JACKETS, SWEAT SHIRTS, JACKETS, TOPS, AND SWEATERS (U.S. CLS. 22 AND 39).

FIRST USE 9-1-2010; IN COMMERCE 9-1-2010.

4,154,470. BLAKENSHIP, BRAD, DALLAS, TX. SN 77-832,273. PUB. 8-31-2010, FILED 9-22-2009.

GLOVE BRANDERS

THE MARK CONSISTS OF STANDARD CHARACTERS WITHOUT CLAIM TO ANY PARTICULAR FONT, STYLE, SIZE, OR COLOR.

CLASS 25—(Continued).

NO CLAIM IS MADE TO THE EXCLUSIVE RIGHT TO USE "GLOVE", APART FROM THE MARK AS SHOWN.

FOR APPAREL AND ACCESSORIES CUSTOMIZED FOR SELECTED BRANDS, NAMELY, GLOVES AND SHIRTS (U.S. CLS. 22 AND 39).

FIRST USE 7-1-2009; IN COMMERCE 1-1-2010.

4,154,473. SHMIRSHKY UNIVERSAL, LLC, CORONADO, CA. SN 77-837,032. PUB. 2-15-2011, FILED 9-29-2009.

THINK INSIDE THE BOX

THE MARK CONSISTS OF STANDARD CHARACTERS WITHOUT CLAIM TO ANY PARTICULAR FONT, STYLE, SIZE, OR COLOR.

FOR CLOTHING, NAMELY, WOMEN'S EXERCISE CLOTHES, NAMELY, FITNESS TOPS, SHIRTS (U.S. CLS. 22 AND 39).

FIRST USE 3-2-2010; IN COMMERCE 3-2-2010.

4,154,485. POTBELLY SANDWICH WORKS, LLC, CHICAGO, IL. SN 77-852,416. PUB. 1-26-2010, FILED 10-20-2009.

POTBELLY SANDWICH SHOP

THE MARK CONSISTS OF STANDARD CHARACTERS WITHOUT CLAIM TO ANY PARTICULAR FONT, STYLE, SIZE, OR COLOR.

OWNER OF U.S. REG. NOS. 2,178,589, 2,332,173, AND OTHERS.

FOR HATS, CAPS, SHIRTS, T-SHIRTS AND POLO SHIRTS (U.S. CLS. 22 AND 39).

FIRST USE 3-16-2012; IN COMMERCE 3-16-2012.

4,154,519. TOSETTI, LINDA, DBA LEGAL REPRESENTATIVE FOR THE HEIRS OF DOROTHY RUTH PIRONE, DURHAM, CT. AND STEVENS, JULIA RUTH, CONWAY, NH, AND BABE RUTH LEAGUE, INC, TRENTON, NJ. SN 77-918,479. PUB. 9-21-2010, FILED 1-22-2010.

BABE RUTH

THE MARK CONSISTS OF STANDARD CHARACTERS WITHOUT CLAIM TO ANY PARTICULAR FONT, STYLE, SIZE, OR COLOR.

CLASS 25—(Continued).

OWNER OF U.S. REG. NOS. 614,107, 1,863,687, AND OTHERS.
SEC. 2(F).

FOR ATHLETIC APPAREL, NAMELY, SHIRTS, PANTS, JACKETS, HATS AND CAPS, ATHLETIC UNIFORMS; BOTTOMS; JERSEYS; SHORT SETS; T-SHIRTS; TOPS (U.S. CLS. 22 AND 39).

FIRST USE 4-11-1986. THE MARK WAS FIRST USED ANYWHERE IN A DIFFERENT FORM OTHER THAN THAT SOUGHT TO BE REGISTERED AT LEAST AS EARLY AS 04/11/1986.; IN COMMERCE 4-11-1986, THE MARK WAS FIRST USED IN COMMERCE IN A DIFFERENT FORM OTHER THAN THAT SOUGHT TO BE REGISTERED AT LEAST AS EARLY AS 04/11/1986..

4,154,534. JUDY B. SWARTZ, WEST HOLLYWOOD, CA. SN 77-939,308. PUB. 11-29-2011, FILED 2-18-2010.

POP UP COUTURE

THE MARK CONSISTS OF STANDARD CHARACTERS WITHOUT CLAIM TO ANY PARTICULAR FONT, STYLE, SIZE, OR COLOR.

NO CLAIM IS MADE TO THE EXCLUSIVE RIGHT TO USE "COUTURE", APART FROM THE MARK AS SHOWN.

FOR CLOTHING, NAMELY, T-SHIRTS, BLOUSES, DRESSES, JEANS, PANTS, SHORTS, SKIRTS, SWEATERS, VESTS, HATS (U.S. CLS. 22 AND 39).

FIRST USE 9-12-2010; IN COMMERCE 9-12-2010.

4,154,558. HANNA, MICHAEL, MIAMI, FL. SN 77-961,788. PUB. 2-15-2011, FILED 3-18-2010.

LOVE IS LIFE

THE MARK CONSISTS OF STANDARD CHARACTERS WITHOUT CLAIM TO ANY PARTICULAR FONT, STYLE, SIZE, OR COLOR.

FOR CLOTHING PRODUCTS, NAMELY, TOPS, BOTTOMS, SKIRTS, PANTS, UNDERWEAR, DRESSES, JACKETS, COATS, BELTS, NECKWEAR, BEACHWEAR, SLEEPWEAR, FOOTWEAR AND HEADWEAR FOR CONSUMERS (U.S. CLS. 22 AND 39).

FIRST USE 3-12-2011; IN COMMERCE 3-27-2011.

CLASS 25—(Continued).

4,154,560. SPANX, INC., ATLANTA, GA. SN 77-963,384. PUB. 1-10-2012, FILED 3-19-2010.

ON TOP AND IN CONTROL

THE MARK CONSISTS OF STANDARD CHARACTERS WITHOUT CLAIM TO ANY PARTICULAR FONT, STYLE, SIZE, OR COLOR.

FOR WOMEN'S APPAREL, NAMELY, CAMISOLES, BODY SHAPERS, SHIRTS (U.S. CLS. 22 AND 39).

FIRST USE 5-10-2010; IN COMMERCE 5-10-2010.

4,154,572. WILDFOX COUTURE IP HOLDINGS, LLC. LOS ANGELES, CA. SN 77-967,826. PUB. 8-17-2010, FILED 3-24-2010.

WILDFOX

THE MARK CONSISTS OF STANDARD CHARACTERS WITHOUT CLAIM TO ANY PARTICULAR FONT, STYLE, SIZE, OR COLOR.

OWNER OF U.S. REG. NO. 3,719,999.

FOR FOOTWEAR (U.S. CLS. 22 AND 39).

FIRST USE 3-0-2012; IN COMMERCE 3-0-2012.

4,154,574. PRINCESS FREE ZONE, INC., TUCKER, GA. SN 77-968,423. PUB. 8-17-2010, FILED 3-25-2010.



THE MARK CONSISTS OF A CROWN INSIDE THE UNIVERSAL PROHIBITION SYMBOL.

FOR PULLOVERS; SHIRTS (U.S. CLS. 22 AND 39).

FIRST USE 6-11-2011; IN COMMERCE 6-11-2011.

CLASS 25—(Continued).

4,154,578. QUIKSILVER AMERICAS, INC., HUNTINGTON BEACH, CA. SN 77-982,276. PUB. 5-4-2010, FILED 5-20-2009.

QUIKSILVER WATERMAN COLLECTION

THE MARK CONSISTS OF STANDARD CHARACTERS WITHOUT CLAIM TO ANY PARTICULAR FONT, STYLE, SIZE, OR COLOR.

OWNER OF U.S. REG. NOS. 1,431,266, 1,800,150, AND OTHERS.

NO CLAIM IS MADE TO THE EXCLUSIVE RIGHT TO USE "COLLECTION", APART FROM THE MARK AS SHOWN.

FOR CLOTHING, NAMELY, SHIRTS, T-SHIRTS, SWEATSHIRTS, CASUAL TOPS WITH LONG AND SHORT SLEEVES, TANK TOPS, JACKETS, SWEATERS, PANTS, SWEATPANTS, SHORTS, SWIMWEAR, BOARD-SHORTS AND JEANS; FOOTWEAR, NAMELY, SHOES AND SANDALS; HEADWEAR, NAMELY, HATS, BEANIES, CAPS AND VISORS (U.S. CLS. 22 AND 39).

FIRST USE 11-25-2009; IN COMMERCE 11-25-2009.

4,154,579. SUMMIT ENTERTAINMENT, LLC, SANTA MONICA, CA. SN 77-982,919. PUB. 4-20-2010, FILED 6-30-2009.



THE MARK CONSISTS OF AN ORNATE CAPITAL "V" HAVING FOUR LEAVES AND A LARGE OVAL-SHAPED JEWEL RESTING ATOP THE "V" AND A SMALLER DIAMOND-SHAPED JEWEL AT THE BOTTOM POINT OF THE "V". WITH THE FURTHER DESIGN OF A CREST NESTLED IN THE CENTER OF THE "V", THE CREST BEING DIVIDED INTO FOUR SECTIONS AND CONTAINING A BIRD IN FLIGHT IN THE TOP RIGHT AND BOTTOM LEFT SECTIONS AND A TREE WITH BARE BRANCHES IN THE TOP LEFT AND BOTTOM RIGHT SECTIONS OF THE DIVIDED CREST.

FOR CLOTHING, NAMELY, T-SHIRTS, SWEATSHIRTS, SHIRTS, AND HOODED SHIRTS; WRIST BANDS; SCARVES; AND HEADWEAR (U.S. CLS. 22 AND 39).

FIRST USE 10-1-2009; IN COMMERCE 10-1-2009.

CLASS 25—(Continued).

4,154,613. REYNOSO, DANIEL, RIVERSIDE, CA. AND MANZANO, FRANKIE, RIVERSIDE, CA. SN 85-004,732. PUB. 8-24-2010, FILED 4-1-2010.



THE MARK CONSISTS OF THE LETTERS "MMM" STYLIZED.

FOR CLOTHING, NAMELY, TEE-SHIRTS (U.S. CLS. 22 AND 39).

FIRST USE 3-15-2007; IN COMMERCE 1-15-2012.

4,154,634. ZAPPOS IP, INC., HENDERSON, NV. SN 85-029,151. PUB. 2-8-2011, FILED 5-3-2010.

CULTURE PHIT

THE MARK CONSISTS OF STANDARD CHARACTERS WITHOUT CLAIM TO ANY PARTICULAR FONT, STYLE, SIZE, OR COLOR.

THE WORDING "CULTURE PHIT" HAS NO MEANING IN A FOREIGN LANGUAGE.

FOR CLOTHING, NAMELY, COATS; DRESSES; HOSIERY; JACKETS; PANTS; SHIRTS; SKIRTS; LOUNGE WEAR; SWEATERS; UNDERGARMENTS; SHOES; FOOTWEAR (U.S. CLS. 22 AND 39).

FIRST USE 11-8-2011; IN COMMERCE 11-8-2011.

4,154,656. COLUMBIA INSURANCE COMPANY, OMAHA, NE. SN 85-066,862. PUB. 5-31-2011, FILED 6-18-2010.

VIENNESE

THE MARK CONSISTS OF STANDARD CHARACTERS WITHOUT CLAIM TO ANY PARTICULAR FONT, STYLE, SIZE, OR COLOR.

FOR FOOTWEAR; CLOTHING, NAMELY, BELTS, DRESSES, GLOVES, JACKETS, NECKWEAR, NIGHTWEAR, PANTS, SUITS, SWIMWEAR, SKIRTS, TOPS, BOTTOMS, UNDERWEAR, HEADWEAR, UNIFORMS, SHIRTS, WRISTBANDS, SOCKS, HOSIERY, T-SHIRTS, SWEATSHIRTS, SWEATPANTS, SHORTS, SWEATERS, COATS, SCARVES, CAPS, PULLOVERS, VESTS (U.S. CLS. 22 AND 39).

FIRST USE 6-9-2010; IN COMMERCE 6-9-2010.

CLASS 25—(Continued).

4,154,664. TREO HOLDINGS, LLC, COLUMBUS, OH. SN 85-071,139. PUB. 3-8-2011, FILED 6-24-2010.

CF WRESTLING

THE MARK CONSISTS OF STANDARD CHARACTERS WITHOUT CLAIM TO ANY PARTICULAR FONT, STYLE, SIZE, OR COLOR.

OWNER OF U.S. REG. NO. 3,673,010.

NO CLAIM IS MADE TO THE EXCLUSIVE RIGHT TO USE "WRESTLING", APART FROM THE MARK AS SHOWN.

FOR CLOTHING AND APPAREL, NAMELY, SHIRTS (U.S. CLS. 22 AND 39).

FIRST USE 10-1-2011; IN COMMERCE 10-1-2011.

4,154,666. LOPEMAN, JAMIE, RICHMOND, IN. AND JOHNSON, MICHAEL, SENECA, PA. SN 85-071,977. PUB. 6-14-2011, FILED 6-25-2010.



THE MARK CONSISTS OF THE WORD "SHINETIME" IN A PARTICULAR SCRIPT WITH STARS OVER THE LETTERS "I".

FOR CLOTHING, NAMELY, BOTTOMS, FLEECE PULLOVERS, HATS, SHORTS, SHORT-SLEEVED OR LONG-SLEEVED T-SHIRTS, TOPS, T-SHIRTS, JERSEYS (U.S. CLS. 22 AND 39).

FIRST USE 4-1-2010; IN COMMERCE 4-1-2010.

4,154,719. SHROOMBOB, LLC, BOZEMAN, MT. SN 85-104,185. PUB. 1-25-2011, FILED 8-10-2010.



THE MARK CONSISTS OF STANDARD CHARACTERS WITHOUT CLAIM TO ANY PARTICULAR FONT, STYLE, SIZE, OR COLOR.

FOR SKI WEAR (U.S. CLS. 22 AND 39).

FIRST USE 4-15-2011; IN COMMERCE 3-17-2012.

CLASS 25—(Continued).

4,154,727. RAGGIO, JEREMY A, LANCASTER, CA. SN 85-106,523. PUB. 7-26-2011, FILED 8-12-2010.

DIRTY MINDZ

THE MARK CONSISTS OF STANDARD CHARACTERS WITHOUT CLAIM TO ANY PARTICULAR FONT, STYLE, SIZE, OR COLOR.

FOR ADHESIVE BRAS; ANKLE SOCKS; ANKLETS; ANTI-PERSPIRANT SOCKS; APRONS; ATHLETIC APPAREL, NAMELY, SHIRTS, PANTS, JACKETS, FOOTWEAR, HATS AND CAPS, ATHLETIC UNIFORMS; BABY BODYSUITS; BABY BOTTOMS; BABY DOLL PYJAMAS; BABY LAYETTES FOR CLOTHING; BABY TOPS; BELTS; BOARD SHORTS; BOTTOMS; BOXER SHORTS; BRAS; BUTTON DOWN SHIRTS; CHILDREN'S HEADWEAR; COLLARED SHIRTS; DRESSES; FLEECE SHORTS; FLIP FLOPS; FOOTWEAR; HATS FOR INFANTS, BABIES, TODDLERS AND CHILDREN; HEAD WEAR; HEADWEAR; HOODED SWEAT SHIRTS; INFANT AND TODDLER ONE PIECE CLOTHING; INFANT WEAR; JACKETS; LONG-SLEEVED SHIRTS; ONE PIECE GARMENT FOR INFANTS AND TODDLERS; PAJAMAS; PANTIES, SHORTS AND BRIEFS; PANTS; SHIRTS; SHIRTS FOR INFANTS, BABIES, TODDLERS AND CHILDREN; SHORT-SLEEVED SHIRTS; SHORTS; SOCKS; SPORT SHIRTS; SWEAT JACKETS; SWEAT PANTS; SWEAT SHIRTS; SWEAT SHORTS; SWEAT SUITS; SWIM WEAR; SWIM WEAR FOR GENTLEMEN AND LADIES; SWIMWEAR; T-SHIRTS; TOPS; UNDERWEAR (U.S. CLS. 22 AND 39).

FIRST USE 10-27-2010; IN COMMERCE 10-27-2010.

4,154,754. CONFLUENCE HOLDINGS CORP., EASLEY, SC. SN 85-115,672. PUB. 8-2-2011, FILED 8-25-2010.

WILDERNESS SYSTEMS

THE MARK CONSISTS OF STANDARD CHARACTERS WITHOUT CLAIM TO ANY PARTICULAR FONT, STYLE, SIZE, OR COLOR.

OWNER OF U.S. REG. NO. 2,158,103.

FOR APPAREL, NAMELY, MEN'S AND WOMEN'S PANTS, JACKETS, FOOTWEAR, HATS, CAPS, ATHLETIC SHOES, HAT BANDS, ALL MADE OF NATURAL OR SYNTHETIC MATERIALS OR NEOPRENE, KNIT AND MOISTURE-WICKING LONG SLEEVED AND SHORT SLEEVED SHIRTS AND T-SHIRTS, SLEEP SHIRTS, SPORTS SHIRTS, SWEAT SHIRTS, WIND SHIRTS, SHORTS, SWEAT SHORTS, AND SWIMSUITS (U.S. CLS. 22 AND 39).

FIRST USE 9-0-2010; IN COMMERCE 9-0-2010.

CLASS 25—(Continued).

4,154,817. HEROLDT, SCOTT A., PHOENIX, AZ. SN 85-140,425. PUB. 3-8-2011, FILED 9-28-2010.

DUTY HAPPENS

THE MARK CONSISTS OF STANDARD CHARACTERS WITHOUT CLAIM TO ANY PARTICULAR FONT, STYLE, SIZE, OR COLOR.

FOR HATS; JACKETS; PANTS; SHIRTS; SHOES (U.S. CLS. 22 AND 39).

FIRST USE 1-5-2010; IN COMMERCE 10-9-2010.

4,154,818. LANER, STEVE, PARKER, CO. SN 85-140,565. PUB. 3-8-2011, FILED 9-29-2010.

KAS

THE MARK CONSISTS OF THE WORDS "KAS" IN STYLIZED FORM.

FOR CLOTHING, NAMELY, CYCLING JERSEYS (U.S. CLS. 22 AND 39).

FIRST USE 5-1-2011; IN COMMERCE 5-1-2011.

4,154,834. MAGNUS INTERNATIONAL, LLC, WALNUT, CA. SN 85-146,212. PUB. 3-15-2011, FILED 10-6-2010.

MAGNUS

THE MARK CONSISTS OF THE STYLIZED WORD "MAGNUS".

FOR BELTS; BOXER BRIEFS; CARGO PANTS; HATS; JEANS; SHIRTS; SHOES; SHORTS; SOCKS; T-SHIRTS; UNDERGARMENTS (U.S. CLS. 22 AND 39).

FIRST USE 2-0-2012; IN COMMERCE 2-0-2012.

CLASS 25—(Continued).

4,154,838. TOM JAMES COMPANY, FRANKLIN, TN. SN 85-148,340. PUB. 7-12-2011, FILED 10-8-2010.

TJWOMEN

THE MARK CONSISTS OF STANDARD CHARACTERS WITHOUT CLAIM TO ANY PARTICULAR FONT, STYLE, SIZE, OR COLOR.

FOR WOMEN'S CLOTHING, NAMELY, SUITS, BLOUSES, CAMISOLES, DRESS SHIRTS, PANTS, SKIRTS, SHIRTS, TOP COATS, DRESSES, SWEATERS, JEANS, SHOES, SCARVES, HATS, GLOVES, AND STOCKINGS (U.S. CLS. 22 AND 39).

FIRST USE 3-6-2012; IN COMMERCE 3-6-2012.

4,154,863. SAZZI FOOTWEAR, LLC, NEWPORT BEACH, CA. SN 85-159,077. PUB. 9-6-2011, FILED 10-22-2010.

SAZZI

THE MARK CONSISTS OF STANDARD CHARACTERS WITHOUT CLAIM TO ANY PARTICULAR FONT, STYLE, SIZE, OR COLOR.

FOR CLOTHING, NAMELY, ATHLETIC AND CASUAL OUTERWEAR, NAMELY, CAPES, COATS, JACKETS, PANTS, JEANS, PARKAS, PONCHOS, RAINCOATS, WIND RESISTANT JACKETS, PULLOVERS, SHIRTS, SHORTS, T-SHIRTS AND SOCKS; SWIMWEAR, NAMELY, BATHING SUITS, BRIEFS, AND TRUNKS; GYM WEAR, NAMELY, BODYSUITS, RUNNING SHORTS, SWEATPANTS, SWEAT SHIRTS, TANK-TOPS AND WARM-UP SUITS; CASUAL WEAR, NAMELY, JEANS, KNIT TOPS, PANTS, PULLOVERS, SHIRTS, SHORTS, T-SHIRTS AND VESTS; FOOTWEAR, NAMELY, SNEAKERS, SPORT SHOES, BOOTS, CASUAL SHOES, HIKING BOOTS, WATER SHOES, BOOTIES, NEOPRENE BOOTS, TRAIL HIKING BOOTS, BABY FOOTWEAR, SLIPPERS, THONGS, DRESS SHOES, SKI SHOES, SHOES, SANDALS AND BOOTS; AND HEADGEAR, NAMELY, CAPS, BANDANNAS, VISORS AND HATS (U.S. CLS. 22 AND 39).

FIRST USE 1-15-2012; IN COMMERCE 1-15-2012.

CLASS 25—(Continued).

4,154,917. ETIENNE MARCEL LLC, LOS ANGELES, CA. SN 85-194,591. PUB. 6-14-2011, FILED 12-9-2010.

CLASS 25—(Continued).

4,154,984. TAKE 'EM OFFS, LTD., NEW YORK, NY. SN 85-218,184. PUB. 5-31-2011, FILED 1-14-2011.

ETIENNE MARCEL

THE MARK CONSISTS OF STANDARD CHARACTERS WITHOUT CLAIM TO ANY PARTICULAR FONT, STYLE, SIZE, OR COLOR.

THE NAME(S), PORTRAIT(S), AND/OR SIGNATURE(S) SHOWN IN THE MARK DOES NOT IDENTIFY A PARTICULAR LIVING INDIVIDUAL.

FOR A-SHIRTS; APPAREL FOR DANCERS, NAMELY, TEE SHIRTS, SWEATSHIRTS, PANTS, LEGGINGS, SHORTS AND JACKETS; ATHLETIC APPAREL, NAMELY, SHIRTS, PANTS, JACKETS, FOOTWEAR, HATS AND CAPS, ATHLETIC UNIFORMS; BANDANAS; BANDEAU TOPS; BATHING SUITS; BEACH COVERUPS; BEACH COVERUPS; BEACHWEAR; BELTS; BELTS FOR CLOTHING; BELTS MADE OF LEATHER; BLAZERS; BLOUSES; BOMBER JACKETS; BUTTON DOWN SHIRTS; CAPS; CARGO PANTS; COATS; COATS FOR MEN AND WOMEN; COLLARED SHIRTS; CREW NECK SWEATERS; CREW NECKS; CROP TOPS; DENIM JACKETS; DENIMS; HEAVY COATS; HEAVY JACKETS; HOODED PULLOVERS; HOODED SWEAT SHIRTS; HOODED SWEATSHIRTS; JACKETS; JEGGINGS, NAMELY, PANTS THAT ARE PARTIALLY JEANS AND PARTIALLY LEGGINGS; JERSEYS; KNIT JACKETS; KNIT SHIRTS; KNIT SKIRTS; KNIT TOPS; LEATHER COATS; LEATHER JACKETS; LEATHER PANTS; LONG-SLEEVED SHIRTS; MEN'S AND WOMEN'S JACKETS, COATS, TROUSERS, VESTS; OUTER JACKETS; OVER COATS; OVER SHIRTS; POLO KNIT TOPS; POLO SHIRTS; RAIN COATS; RAIN JACKETS; SHIRTS; SHORT-SLEEVED OR LONG-SLEEVED T-SHIRTS; T-SHIRTS; V-NECK SWEATERS (U.S. CLS. 22 AND 39).
FIRST USE 6-6-2011; IN COMMERCE 8-22-2011.



4,154,967. HBI BRANDED APPAREL LIMITED, INC., WINSTON-SALEM, NC. SN 85-212,765. PUB. 3-22-2011, FILED 1-7-2011.



OWNER OF U.S. REG. NOS. 847,649, 2,121,985, AND OTHERS.

THE MARK CONSISTS OF THE WORD "HANES" IN LOWER CASE LETTERING NEXT TO THE LETTER "H" IN SCRIPT WRITING.

FOR HOSIERY (U.S. CLS. 22 AND 39).
FIRST USE 9-19-2011; IN COMMERCE 9-19-2011.

THE MARK CONSISTS OF A STYLIZED LETTER "T".
FOR CLOTHING, NAMELY, WOMEN'S UNDERWEAR AND BRAS (U.S. CLS. 22 AND 39).
FIRST USE 4-9-2012; IN COMMERCE 4-9-2012.

CLASS 25—(Continued).

4,155,000. ROTELLINI, BRANDON C., MURRIETA, CA. AND BATES, JENNIFER N., MURRIETA, CA. SN 85-225,038. PUB. 7-12-2011, FILED 1-24-2011.



THE MARK CONSISTS OF A SKELETAL BACKWARD FACING HAND CONCEALING THE THUMB AND LITTLE FINGER WHILE EXPOSING THE RING, MIDDLE, AND INDEX FINGERS WITH THE STYLIZED LETTERS "RDGAF" WRITTEN IN A DOWNWARD DIAGONAL DIRECTION STARTING WITH THE LETTER "R" IN THE UPPER LEFT CORNER ABOVE THE FOREHAND AND FINISHING WITH THE LETTER "F" ON THE LOWER RIGHT CORNER OF THE FOREHAND.

FOR ADULT NOVELTY GAG CLOTHING ITEM, NAMELY, SOCKS; BABY LAYETTES FOR CLOTHING; BELTS; BELTS FOR CLOTHING; BELTS MADE OUT OF CLOTH; BIBS NOT OF CLOTH OR PAPER; BOTTOMS; CHILDREN'S AND INFANTS' CLOTH BIBS; CHILDREN'S CLOTH EATING BIBS; CLOTH BIBS; CLOTH BIBS FOR ADULT DINERS; CLOTH BIBS FOR USE BY SENIOR CITIZENS OR PHYSICALLY- OR MENTALLY- CHALLENGED PERSONS; CLOTH DIAPERS; CLOTHING EXTENSION USED TO EXTEND THE NORMAL SIZE RANGE OF CLOTHING ITEMS TO ACCOMMODATE PREGNANCY SIZE CHANGES; CLOTHING FOR ATHLETIC USE, NAMELY, PADDED ELBOW COMPRESSION SLEEVES BEING PART OF AN ATHLETIC GARMENT; CLOTHING FOR ATHLETIC USE, NAMELY, PADDED PANTS; CLOTHING FOR ATHLETIC USE, NAMELY, PADDED SHIRTS; CLOTHING FOR ATHLETIC USE, NAMELY, PADDED SHORTS; CLOTHING FOR BABIES, TODDLERS AND CHILDREN, TREATED WITH FIRE AND HEAT RETARDANTS, NAMELY, PAJAMAS, JACKETS, SHIRTS, JUMPERS; CLOTHING FOR WEAR IN JUDO PRACTICES; CLOTHING FOR WEAR IN WRESTLING GAMES; CLOTHING ITEMS, NAMELY, ADHESIVE POCKETS THAT MAY BE AFFIXED DIRECTLY TO THE BODY AS A DECORATIVE PIECE OF CLOTHING WITH UTILITY; CLOTHING ITEMS, NAMELY, ADHESIVE POCKETS THAT MAY BE AFFIXED DIRECTLY TO THE INSIDE OF CLOTHING FOR STORAGE AND SAFEKEEPING OF PERSONAL ITEMS; CLOTHING SHIELDS, NAMELY, PADS APPLIED TO THE UNDERARMS OF SHIRTS, BLOUSES AND SWEATERS; CLOTHING, NAMELY, ARM WARMERS; CLOTHING, NAMELY, ATHLETIC SLEEVES; CLOTHING, NAMELY, BASE LAYERS; CLOTHING, NAMELY, COWLS AND SMOKE RING SCARVES; CLOTHING, NAMELY, FOLK COSTUMES; CLOTHING, NAMELY, HAND-WARMERS; CLOTHING, NAMELY, KHAKIS; CLOTHING, NAMELY, KNEE WARMERS; CLOTHING, NAMELY, MATERNITY BANDS; CLOTHING, NAMELY, NECK TUBES; CLOTHING, NAMELY, THOBES; CLOTHING, NAMELY, WRAP-AROUNDS; CORSETS; DUSTERS; EYESHADES; FABRIC SOLD AS AN INTEGRAL COMPONENT OF FINISHED CLOTHING ITEMS, NAMELY, JERSEYS; FOULARDS; GLOVES AS CLOTHING; HEADBANDS FOR CLOTHING; HOODS; INFANT AND TODDLER ONE PIECE CLOTHING; INFANT CLOTH DIAPERS; INSERTS SPECIALLY ADAPTED FOR CLOTH DIAPERS MADE OF BAMBOO; INSERTS SPECIALLY ADAPTED FOR CLOTH DIAPERS MADE OF HEMP; INSERTS SPECIALLY

CLASS 25—(Continued).

ADAPTED FOR CLOTH DIAPERS MADE OF MICRO-FIBER; JACKETS; JERSEYS; LEATHER BELTS; MANTLES; MUFFLERS; NON-DISPOSABLE CLOTH TRAINING PANTS; PAPER HATS FOR USE AS CLOTHING ITEMS; PARTS OF CLOTHING, NAMELY, GUSSETS FOR TIGHTS, GUSSETS FOR STOCKINGS, GUSSETS FOR BATHING SUITS, GUSSETS FOR UNDERWEAR, GUSSETS FOR LEOTARDS AND GUSSETS FOR FOOTLETS; PARTS OF CLOTHING, NAMELY, UNDERARM GUSSETS; PARTY HATS; PERSPIRATION ABSORBENT UNDERWEAR CLOTHING; POCKET SQUARES; SHIRTS; SHORT SETS; SHOULDER WRAPS; SHOULDER WRAPS FOR CLOTHING; SWADDLING CLOTHES; TIES; TOPS; TRAVEL CLOTHING CONTAINED IN A PACKAGE COMPRISING REVERSIBLE JACKETS, PANTS, SKIRTS, TOPS AND A BELT OR SCARF; TRIATHLON CLOTHING, NAMELY, TRIATHLON TIGHTS, TRIATHLON SHORTS, TRIATHLON SINGLET, TRIATHLON SHIRTS, TRIATHLON SUITS; UNDERARM CLOTHING SHIELDS; WEARABLE GARMENTS AND CLOTHING, NAMELY, SHIRTS; WRAPS (U.S. CLS. 22 AND 39).

FIRST USE 2-5-2012; IN COMMERCE 2-7-2012.

4,155,006. GET YOUR MOTIVATION ON, EVERGREEN PARK, IL. SN 85-227,003. PUB. 3-15-2011, FILED 1-26-2011.

THE MARK CONSISTS OF THE STYLIZED TEXT "GYM ON GET YOUR MOTIVATION ON" FOR CAPS; FLEECE TOPS; SHIRTS (U.S. CLS. 22 AND 39).

FIRST USE 10-20-2010; IN COMMERCE 12-27-2010.

CLASS 25—(Continued).

4,155,014. TANDARICH, MICHAEL R, KENNETT SQUARE, PA, PA. SN 85-229,731. PUB. 6-28-2011, FILED 1-31-2011.

DARE TO DEFY

THE MARK CONSISTS OF STANDARD CHARACTERS WITHOUT CLAIM TO ANY PARTICULAR FONT, STYLE, SIZE, OR COLOR.

FOR A-SHIRTS; ADHESIVE BRAS; ADULT NOVELTY GAG CLOTHING ITEM, NAMELY, SOCKS; AFTER SKI BOOTS; ALBS; AMERICAN FOOTBALL BIBS; ANGLERS' SHOES; ANKLE BOOTS; ANKLE SOCKS; ANKLETS; ANORAK; ANORAKS; ANTI-PERSPIRANT SOCKS; APPAREL FOR DANCERS, NAMELY, TEE SHIRTS, SWEATSHIRTS, PANTS, LEGGINGS, SHORTS AND JACKETS; APRES-SKI SHOES; APRONS; AQUA SHOES; ARTIFICIAL FLOWER HEADDRESSES; ASCOTS; ATHLETIC APPAREL, NAMELY, SHIRTS, PANTS, JACKETS, FOOTWEAR, HATS AND CAPS, ATHLETIC UNIFORMS; ATHLETIC FOOTWEAR; ATHLETIC SHOES; ATHLETIC TIGHTS; ATHLETIC UNIFORMS; BABUSHKAS; BABY BIBS NOT OF PAPER; BABY BODYSUITS; BABY BOTTOMS; BABY BUNTING; BABY DOLL PYJAMAS; BABY LAYETTES FOR CLOTHING; BABY TOPS; BALACLAVAS; BALL GOWNS; BALLET SHOES; BALLET SLIPPERS; BALLOON PANTS; BALLROOM DANCING SHOES; BALLROOM DANCING UNIFORMS; BANDANAS; BANDEAU TOPS; BANDEAUX; BARBER SMOCKS; BASEBALL CAPS; BASEBALL CAPS AND HATS; BASEBALL SHOES; BASEBALL UNIFORMS; BASELAYER BOTTOMS; BASELAYER TOPS; BASKETBALL SNEAKERS; BATH SLIPPERS; BATHING CAPS; BATHING COSTUMES; BATHING COSTUMES FOR WOMEN; BATHING SUITS; BATHING SUITS FOR MEN; BATHING TRUNKS; BATHROBES; BEACH COVER-UPS; BEACH COVERUPS; BEACH FOOTWEAR; BEACH SHOES; BEACHWEAR; BEANIES; BED JACKETS; BELTS; BELTS FOR CLOTHING; BELTS MADE FROM IMITATION LEATHER; BELTS MADE OF LEATHER; BELTS MADE OUT OF CLOTH; BELTS OF TEXTILE; BELTS THAT ARE DESIGNED TO ACCOMMODATE PREGNANCY SIZE CHANGES; BERETS; BERMUDA SHORTS; BIB OVERALLS; BIB OVERALLS FOR HUNTING; BIB SHORTS; BIB TIGHTS; BIBS NOT OF CLOTH OR PAPER; BIBS NOT OF PAPER; BICYCLE GLOVES; BICYCLING GLOVES; BIKINIS; BLAZERS; BLOOMERS; BLOUSES; BLOUSONS; BOARD SHORTS; BOAS; BOAT SHOES; BODICES; BODY LINEN; BODY SHAPERS; BODY SHIRTS; BODY STOCKINGS; BODY SUITS; BOLEROS; BOLO TIES; BOMBER JACKETS; BONNETS; BOOTIES; BOOTS; BOOTS FOR MOTORCYCLING; BOOTS FOR SPORT; BOTTOMS; BOW TIES; BOWLING SHOES; BOXER BRIEFS; BOXER SHORTS; BOXING SHOES; BOXING SHORTS; BRACES; BRALLETTES; BRAS; BRASSIERES; BREECHES; BRIDESMAID DRESSES; BRIEFS; BRIEFS; BUCKET CAPS; BUSTIERS; BUSTLE HOLDER BANDS FOR OBI (OBIAGE); BUSTLES FOR OBI-KNOTS (OBIAGE-SHIN); BUTTON DOWN SHIRTS; BUTTON-FRONT ALOHA SHIRTS; CAFTANS; CAGOULES; CAMISETTES; CAMISOLES; CAMOUFLAGE GLOVES; CAMOUFLAGE JACKETS; CAMOUFLAGE PANTS; CAMOUFLAGE SHIRTS; CAMOUFLAGE VESTS; CAMP SHIRTS; CANVAS SHOES; CAP PEAKS; CAP VISORS; CAPELETS; CAPES; CAPES FOR USE IN SALONS AND BARBER SHOPS; CAPRI PANTS; CAPRIS; CAPS; CAPS WITH VISORS; CARDIGANS; CARGO PANTS; CASSOCKS; CAT SUITS; CAT SUITS; CHAPS; CHASUBLES; CHEF'S COATS; CHEF'S HATS; CHEMISES; CHEMISSETTES; CHILDREN'S AND INFANT'S APPAREL, NAMELY, JUMPERS, OVERALL SLEEPWEAR, PAJAMAS, ROMPERS AND ONE-PIECE GARMENTS; CHILDREN'S AND INFANTS' APPAREL TREATED WITH FIRE AND HEAT RETARDANTS, NAMELY, JUMPERS, OVERALL SLEEPWEAR, PAJAMAS, ROMPERS AND ONE-PIECE GARMENTS; CHILDREN'S AND INFANTS' CLOTH BIBS; CHILDREN'S CLOTH EATING BIBS; CHILDREN'S HEADWEAR;

CLASS 25—(Continued).

CHOIR ROBES; CLAM DIGGERS; CLEATS FOR ATTACHMENT TO SPORTS SHOES; CLIMBING BOOTS; CLIMBING FOOTWEAR; CLIMBING SHOES; CLOAKS; CLOGS; CLOTH BIBS; CLOTH BIBS FOR ADULT DINERS; CLOTH BIBS FOR USE BY SENIOR CITIZENS OR PHYSICALLY- OR MENTALLY-CHALLENGED PERSONS; CLOTH DIAPERS; CLOTHING EXTENSION USED TO EXTEND THE NORMAL SIZE RANGE OF CLOTHING ITEMS TO ACCOMMODATE PREGNANCY SIZE CHANGES; CLOTHING FOR ATHLETIC USE, NAMELY, PADDED ELBOW COMPRESSION SLEEVES BEING PART OF AN ATHLETIC GARMENT; CLOTHING FOR ATHLETIC USE, NAMELY, PADDED PANTS; CLOTHING FOR ATHLETIC USE, NAMELY, PADDED SHIRTS; CLOTHING FOR ATHLETIC USE, NAMELY, PADDED SHORTS; CLOTHING FOR BABIES, TODDLERS AND CHILDREN, TREATED WITH FIRE AND HEAT RETARDANTS, NAMELY, PAJAMAS, JACKETS, SHIRTS, PANTS, JUMPERS; CLOTHING FOR WEAR IN JUDO PRACTICES; CLOTHING FOR WEAR IN WRESTLING GAMES; CLOTHING ITEMS, NAMELY, ADHESIVE POCKETS THAT MAY BE AFFIXED DIRECTLY TO THE BODY AS A DECORATIVE PIECE OF CLOTHING WITH UTILITY; CLOTHING ITEMS, NAMELY, ADHESIVE POCKETS THAT MAY BE AFFIXED DIRECTLY TO THE INSIDE OF CLOTHING FOR STORAGE AND SAFEKEEPING OF PERSONAL ITEMS; CLOTHING SHIELDS, NAMELY, PADS APPLIED TO THE UNDERARMS OF SHIRTS, BLOUSES AND SWEATERS; CLOTHING, NAMELY, ARM WARMERS; CLOTHING, NAMELY, ATHLETIC SLEEVES; CLOTHING, NAMELY, BASE LAYERS; CLOTHING, NAMELY, COWLS AND SMOKE RING SCARVES; CLOTHING, NAMELY, FOLK COSTUMES; CLOTHING, NAMELY, HAND-WARMERS; CLOTHING, NAMELY, KHAKIS; CLOTHING, NAMELY, KNEE WARMERS; CLOTHING, NAMELY, MATERNITY BANDS; CLOTHING, NAMELY, NECK TUBES; CLOTHING, NAMELY, THOBES; CLOTHING, NAMELY, WRAP-AROUNDS; COATS; COATS FOR MEN AND WOMEN; COATS MADE OF COTTON; COATS OF DENIM; COBBLERS' APRONS; COLLAR PROTECTORS; COLLARED SHIRTS; COLLARS; COMBATIVE SPORTS UNIFORMS; COMBINATIONS; COMPETITORS' NUMBERS OF TEXTILE; COMPRESSION GARMENTS FOR ATHLETIC OR OTHER NON-MEDICAL USE, NAMELY, SOCKS, LEGGINS, JERSEYS, VESTS; CORSELETS; CORSETS; COSTUMES FOR USE IN CHILDREN'S DRESS UP PLAY; COSTUMES FOR USE IN ROLE-PLAYING GAMES; COSTUMES FOR USE IN THE AMUSEMENT INDUSTRY; COVERALLS; COVERUPS; CRAVATES; CRAVATS; CREEPERS; CREW NECK SWEATERS; CREW NECKS; CROP TOPS; CROSS-COUNTRY GLOVES; CROSS-COUNTRY MITTENS; CUFFS; CULOTTES; CUMMERBUNDS; CUSTOM MADE TO MEASURE SUITS FOR MEN AND WOMEN; CYCLING SHOES; CYCLING SHORTS; CYCLISTS' JERSEYS; DANCE COSTUMES; DANCE SHOES; DANCE SLIPPERS; DECK-SHOES; DENIM JACKETS; DENIMS; DETACHABLE NECKPIECES FOR KIMONOS (HANERI); DISPOSABLE SLIPPERS; DISPOSABLE UNDERWEAR; DO RAGS; DOWN JACKETS; DOWN SUITS; DRESS PANTS; DRESS SHIELDS; DRESS SHIRTS; DRESS SUITS; DRESSES; DRESSES MADE FROM SKINS; DRESSES THAT MAY ALSO BE USED AS TOWELS; DRESSING GOWNS; DRESSING GOWNS AND BATH ROBES; DRIVERS; DRY SUITS; DUNGAREES; DUST COATS; DUSTERS; EAR BANDS; EAR MUFFS; EAR WARMERS; EARBANDS; EMBOSSED SOLES AND HEELS OF RUBBER OR OF PLASTIC MATERIALS; ESPADRILLES; EUROPEAN FOOTBALL BIBS; EVENING DRESSES; EVENING GOWNS; EYESHADES; FABRIC BELTS; FABRIC SOLD AS AN INTEGRAL COMPONENT OF FINISHED CLOTHING ITEMS, NAMELY, COVERALLS, BOOTS, SHIRTS, CAPS; FICHUS; FIGURE SKATING CLOTHING, NAMELY, PANTS, HAT, LEGGINS, SWEAT PANTS AND SWEAT SHIRTS, GLOVES; FINISHED TEXTILE LININGS FOR GARMENTS; FISHERMEN'S JACKETS; FISHING SHIRTS; FISHING VESTS; FISHING WADERS; FITTED SHOE OR BOOT COVERING TO PROTECT THE SHOES OR BOOT FROM WATER OR OTHER DAMAGE; FITTED SWIMMING COSTUMES WITH BRA CUPS; FLEECE BOTTOMS; FLEECE PULLOVERS; FLEECE SHORTS; FLEECE TOPS; FLEECE VESTS; FLIGHT SUITS; FLIP FLOPS; FOAM PEDICURE SLIPPERS; FOOTBALL BOOTS; FOOTBALL BOOTS AND STUDES THEREFOR; FOOTBALL SHOES; FOOTIES; FOOT-

CLASS 25—(Continued).

WEAR; FOOTWEAR; FOOTWEAR FOR MEN; FOOTWEAR FOR MEN AND WOMEN; FOOTWEAR FOR TRACK AND FIELD ATHLETICS; FOOTWEAR FOR WOMEN; FOOTWEAR MADE OF WOOD; FOOTWEAR NOT FOR SPORTS; FOOTWEAR, NAMELY, PUMPS; FOOTWEAR, NAMELY, RUBBERS; FOOTWEAR, NAMELY, WORK BOOTS; FOUL WEATHER GEAR; FOULARDS; FOUNDATION GARMENTS; FOUNDATION GARMENTS WORN AROUND THE MIDSECTION OR THIGHS TO KEEP THE STOMACH IN AND CREATE A SLIMMING EFFECT; FROCKS; FULL-LENGTH KIMONOS (NAGAGI); FUR CLOAKS; FUR COATS; FUR COATS AND JACKETS; FUR HATS; FUR JACKETS; FUR MUFFS; FUR STOLLES; G-STRINGS; GABERDINES; GAITERS; GAITERS OF LEATHER; GALOSHES; GARTER BELTS; GARTERS; GAUCHOS; GIFT PACKAGES SOLD AS A UNIT CONSISTING PRIMARILY OF A SWEATSHIRT AND ALSO INCLUDING A PHOTO FRAME, A COFFEE MUG, AND A TOTE BAG; GILETS; GIRDLES; GLOVES; GLOVES AS CLOTHING; GLOVES FOR APPAREL; GLOVES FOR PERSONAL HAND CONDITIONING USE; GLOVES INCLUDING THOSE MADE OF SKIN, HIDE OR FUR; GOLF CAPS; GOLF CLEATS; GOLF PANTS; SHIRTS AND SKIRTS; GOLF SHIRTS; GOLF SHOES; GOLF SHORTS; GOLF SPIKES; GOLF TROUSERS; GOWNS; GREATCOATS; GYM BOOTS; GYM PANTS; GYM SHORTS; GYM SUITS; GYMNAS TIC SHOES; HALLOWEEN COSTUMES; HALLOWEEN COSTUMES AND MASKS SOLD IN CONNECTION THEREWITH; HALTER TOPS; HANDBALL SHOES; HAT BANDS; HATBANDS; HATS; HATS FOR INFANTS, BABIES, TODDLERS AND CHILDREN; HEAD SCARVES; HEAD SWEATBANDS; HEAD WEAR; HEADBANDS; HEADBANDS AGAINST SWEATING; HEADBANDS FOR CLOTHING; HEADGEAR, NAMELY, CAPS, HEADBANDS AND HATS; HEADWEAR; HEAVY COATS; HEAVY JACKETS; HEEL INSERTS; HEEL PIECES FOR SHOES; HEELS; HIGH RAIN CLOGS (ASHIDA); HIKING BOOTS; HIP-GUARDS ESPECIALLY MADE FOR FISHING; HOCKEY SHOES; HOODED PULLOVERS; HOODED SWEAT SHIRTS; HOODED SWEATSHIRTS; HOODS; HOODS; HORSE-RIDING BOOTS; HOSIERY; HOUSECOATS; HUNTING BOOT BAGS; HUNTING JACKETS; HUNTING PANTS; HUNTING SHIRTS; HUNTING VESTS; INFANT AND TODDLER ONE PIECE CLOTHING; INFANT CLOTH DIAPERS; INFANT DIAPER COVERS; INFANT SLEEPERS; INFANT WEAR; INFANT WEARABLE BLANKETS; INFANTS' SHOES AND BOOTS; INFANTS' TROUSERS; INFANTWEAR; INNER SOLES; INSERTS SPECIALLY ADAPTED FOR CLOTH DIAPERS MADE OF BAMBOO; INSERTS SPECIALLY ADAPTED FOR CLOTH DIAPERS MADE OF HEMP; INSERTS SPECIALLY ADAPTED FOR CLOTH DIAPERS MADE OF MICROFIBER; INSOLES; INSOLES FOR FOOTWEAR; JACKET LINERS; JACKETS; JACKETS AND SOCKS; JANDALS; JAPANESE FOOTWEAR OF RICE STRAW (WARAJI); JAPANESE SLEEPING ROBES (NEMAKI); JAPANESE SPLIT-TOED WORK FOOTWEAR (JIKATABI); JAPANESE STYLE CLOGS AND SANDALS; JAPANESE STYLE SANDALS (ZORI); JAPANESE STYLE SANDALS OF FELT; JAPANESE STYLE SANDALS OF LEATHER; JAPANESE STYLE SOCKS (TABI COVERS); JAPANESE STYLE SOCKS (TABI); JAPANESE STYLE WOODEN CLOGS (GETA); JAPANESE TOE-STRAP SANDALS (ASAURA-ZORI); JEANS; JEGGINGS, NAMELY, PANTS THAT ARE PARTIALLY JEANS AND PARTIALLY LEGGINGS; JERKINS; JERSEYS; JODHPURS; JOGGING OUTFITS; JOGGING PANTS; JOGGING SUITS; JUDO SUITS; JUMP SUITS; JUMPERS; JUMPSUITS; KAFTANS; KARATE SUITS; KENDO OUTFITS; KERCHIEFS; KILTS; KIMONOS; KNEE HIGHS; KNEE-HIGH STOCKINGS; KNICKERS; KNIT BOTTOMS; KNIT DRESSES; KNIT FACE MASKS; KNIT JACKETS; KNIT SHIRTS; KNIT SKIRTS; KNIT TOPS; KNITTED CAPS; KNITTED GLOVES; KNITTED UNDERWEAR; KNOT CAPS; KNOTTED CAPS; LAB COATS; LACE BOOTS; LADIES' BOOTS; LADIES' SUITS; LADIES' UNDERWEAR; LAYETTES; LEATHER BELTS; LEATHER BOOTS; LEATHER COATS; LEATHER HATS; LEATHER HEADWEAR; LEATHER JACKETS; LEATHER PANTS; LEATHER SHIRTS; LEATHER SHOES; LEATHER SKIRTS; LEATHER SLIPPERS; LEATHER VESTS; LEG SHAPERS; LEG SHIELDING DEVICE, ATTACHABLE TO AND DETACHABLE FROM A PERSON'S PANTS, COMPRISED OF PADDING TO SHIELD THE LEGS FROM FLYING DEBRIS WHEN MOWING WITH A STRING

CLASS 25—(Continued).

TRIMMER; LEG WARMERS; LEG-WARMERS; LEGGINGS; LEGGINS; LEISURE SHOES; LEISURE SUITS; LEOTARDS; LEOTARDS AND TIGHTS FOR WOMEN, MEN AND CHILDREN OF NYLON, COTTON OR OTHER TEXTILE FIBERS; LIGHT-REFLECTING COATS; LIGHT-REFLECTING JACKETS; LINGERIE; LINGERIE ACCESSORIES, NAMELY, REMOVABLE SILICONE BREAST ENHANCER PADS USED IN A BRA; LIVERIES; LOAFERS; LONG JACKETS; LONG JOHNS; LONG SLEEVE PULLOVERS; LONG SLEEVED VESTS; LONG UNDERWEAR; LONG-SLEEVED SHIRTS; LOUNGE PANTS; LOUNGEWEAR; LOW WOODEN CLOGS (HIYORI-GETA); LOW WOODEN CLOGS (KOMA-GETA); MAILLOTS; MANIPLES; MANTILLAS; MANTLES; MANTLES; MARTIAL ARTS UNIFORMS; MARTIAL ARTS UNIFORMS, NAMELY, GIS; MASQUERADE COSTUMES; MASQUERADE COSTUMES AND MASKS SOLD IN CONNECTION THEREWITH; MATERNITY BRAS; MATERNITY LEGGINGS, NAMELY, LEGGINGS FEATURING BUILT-IN MATERNITY BANDS; MATERNITY LINGERIE; MATERNITY SLEEPWEAR; MEN'S AND WOMEN'S JACKETS, COATS, TROUSERS, VESTS; MEN'S DRESS SOCKS; MEN'S SOCKS; MEN'S SUITS; MEN'S SUITS, WOMEN'S SUITS; MEN'S UNDERWEAR; METAL FITTINGS FOR JAPANESE STYLE WOODEN CLOGS; MILLINERY, NAMELY, FASCINATORS; MINISKIRTS; MITTENS; MITTENS MODIFIED TO COVER THE HAND AND AN ANIMAL LEASH HANDLE OR OTHER LOOP; MIXED MARTIAL ARTS SUITS; MOCCASINS; MOCK TURTLE-NECK SWEATERS; MOCKNECKS; MOISTURE-WICKING SPORTS BRAS; MOISTURE-WICKING SPORTS PANTS; MOISTURE-WICKING SPORTS SHIRTS; MONEY BELTS; MORNING COATS; MOTORCYCLE GLOVES; MOTORCYCLE JACKETS; MOTORCYCLE RAIN SUITS; MOTORCYCLIST BOOTS; MOUNTAINEERING BOOTS; MOUNTAINEERING SHOES; MUFFLERS; MUFFLERS; MUFFS; MUKLUKS; MULES; MUSCLE TOPS; MUU MUU; NECK BANDS; NECK GAITERS; NECKERCHIEFS; NECKERCHIEVES; NECKTIES; NECKWEAR; NEGLIGES; NIGHT GOWNS; NIGHT SHIRTS; NIGHTCAPS; NIGHTDRESSES; NIGHTGOWNS; NIGHTTIES; NIGHTSHIRTS; NIGHTWEAR; NIPPLE COVERS, NAMELY, PASTIES; NON-DISPOSABLE CLOTH TRAINING PANTS; NON-SLIP SOLES FOR FOOTWEAR; NON-SLIP SOLES FOR FOOTWEAR, NAMELY, FOR SLIPPERS; NOVELTY HEADWEAR WITH ATTACHED WIGS; NURSE DRESSES; NURSE OVERALLS; NURSE PANTS; NURSE'S APPAREL, NAMELY, COVERALLS AND FROCKS; OBIS; ONE PIECE GARMENT FOR INFANTS AND TODDLERS; ONE-PIECE GARMENTS FOR CHILDREN; ONE-PIECE PLAY SUITS; OPEN-NECKED SHIRTS; OUTDOOR GLOVES; OUTDOOR MITTENS; OUTER JACKETS; OVER COATS; OVER SHIRTS; OVER-TROUSERS; OVERALLS; OVERALLS FOR USE IN SALONS AND BARBER SHOPS; OVERCOATS; OVERSHOES; PADDED JACKETS; PADDING JACKETS; PAJAMA BOTTOMS; PAJAMAS TREATED WITH FIRE AND HEAT RETARDANTS; PANTALOONS; PANTIES; PANTIES, SHORTS AND BRIEFS; PANTS; PANTSUITS; PANTYHOSE; PAPER APRONS; PAPER HATS FOR USE AS CLOTHING ITEMS; PAPER SHOES USED WHEN GOING THROUGH METAL DETECTORS TO KEEP FEET AND SOCKS CLEAN; PARAMENTS; PAREOS; PAREU; PAREUS; PARKAS; PARTS OF CLOTHING, NAMELY, GUSSETS FOR TIGHTS, GUSSETS FOR STOCKINGS, GUSSETS FOR BATHING SUITS, GUSSETS FOR UNDERWEAR, GUSSETS FOR LEOTARDS AND GUSSETS FOR FOOTLETS; PARTS OF CLOTHING, NAMELY, UNDERARM GUSSETS; PARTY HATS; PATIENT SLIPPERS; PEACOATS; PEDAL PUSHERS; PEDICURE SANDALS; PEDICURE SLIPPERS; PEIGNOIRS; PELERINES; PELISSES; PERSPIRATION ABSORBENT STRAP TO BE USED IN THE BILL OF A HAT; PERSPIRATION ABSORBENT UNDERWEAR CLOTHING; PETTI-PANTS; PETTICOATS; PINAFORES; PINNIES IN THE NATURE OF SCRIMMAGE VESTS FOR USE IN SPORTS; PIQUE SHIRTS; PLASTIC APRONS; PLASTIC BABY BIBS; PLAY SUITS; PLEATED SKIRTS FOR FORMAL KIMONOS (HAKAMA); PLIMSOLLS; PLUS FOURS; POCKET SQUARES; POLO KNIT TOPS; POLO SHIRTS; POLYMER CUSTOM CUSHIONED SHOE INSERTS FOR PRIMARILY NON-ORTHOPEDIC PURPOSES; PONCHOS; PRAM SUITS; PROTECTIVE METAL MEMBERS FOR SHOES AND BOOTS; PROTECTIVE NECK AND ARM GUARDS MADE OF NEOPRENE OR OTHER MATERIALS TO PREVENT WETSUIT CHAF-

CLASS 25—(Continued).

ING; PULLOVERS; PUMPS; PUTTEES AND GAITERS; PYJAMAS; QUILTED VESTS; RACE NUMBER BELTS THAT HOLD A PAPER NUMBER ON THE RACE PARTICIPANT'S FRONT OR BACK DURING COMPETITION; RAIN BOOTS; RAIN COATS; RAIN HATS; RAIN JACKETS; RAIN SLICKERS; RAIN SUITS; RAIN TROUSERS; RAIN WEAR; RAINCOATS; RAINPROOF JACKETS; RAINWEAR; RASH GUARDS; REDINGOTES; REMOVABLE COLLARS; REVERSIBLE JACKETS; RIDING BOOTS; RIDING COATS; RIDING GLOVES; RIDING SHOES; ROBES; ROMPERS; RUANAS; RUBBER SHOES; RUBBER SOLES FOR JIKATABI; RUBBERS; RUGBY SHIRTS; RUGBY SHOES; RUGBY SHORTS; RUGBY TOPS; RUNNING PADS THAT STRAP ONTO SHOES; RUNNING SHOES; RUNNING SUITS; SABOTS; SAILOR SUITS; SALOPETTES; SANDAL-CLOGS; SANDALS; SANDALS AND BEACH SHOES; SAREES; SARIS; SARONGS; SASH BANDS FOR KIMONO (OBI); SASHERS; SCARFS; SCARVES; SCHOOL UNIFORMS; SCIENTIFIC AND TECHNOLOGICAL APPAREL, NAMELY, SHIRTS, PANTS, JACKETS, FOOTWEAR, HATS AND CAPS, UNIFORMS; SCRUBS NOT FOR MEDICAL PURPOSES; SEDGE HATS (SUGE-GASA); SERAPES; SHAMPOO CAPES; SHAPEWEAR, NAMELY, LEGGINS, BRAS, GIRDLES, SWEAT PANTS AND SWEAT SHIRTS; SHAWLS; SHAWLS; SHAWLS AND HEADSCARVES; SHAWLS AND STOLERS; SHELL JACKETS; SHIFTS; SHIRT FRONTS; SHIRT INSERTS, NAMELY, DICKIES; SHIRT YOKES; SHIRTS; SHIRTS AND SHORT-SLEEVED SHIRTS; SHIRTS AND SLIPS; SHIRTS FOR INFANTS, BABIES, TODDLERS AND CHILDREN; SHIRTS FOR SUITS; SHOE COVERS FOR USE WHEN WEARING SHOES; SHOE DOWELS; SHOE INSERTS FOR PRIMARILY NON-ORTHOPEDIC PURPOSES; SHOE PEGS; SHOE SOLES; SHOE STRAPS; SHOES; SHOES SOLES FOR REPAIR; SHOES WITH HOOK AND PILE FASTENING TAPES; SHORT OVERCOAT FOR KIMONO (HAORI); SHORT PETTICOATS; SHORT SETS; SHORT TROUSERS; SHORT-SLEEVED OR LONG-SLEEVED T-SHIRTS; SHORT-SLEEVED SHIRTS; SHORTALLS; SHORTS; SHOULDER SCARVES; SHOULDER WRAPS; SHOULDER WRAPS FOR CLOTHING; SHOWER CAPS; SHRUGS; SILK SCARVES; SINGLETS; SKATING OUTFITS; SKI AND SNOWBOARD SHOES AND PARTS THEREOF; SKI BIBS; SKI BOOT BAGS; SKI BOOT CASES; SKI BOOTS; SKI GLOVES; SKI JACKETS; SKI MASKS; SKI PANTS; SKI SUITS; SKI SUITS FOR COMPETITION; SKI TROUSERS; SKI WEAR; SKIING SHOES; SKIRT SUITS; SKIRTS; SKIRTS AND DRESSES; SKIWEAR; SKOOTERS; SKORTS; SKULL CAPS; SKULLIES; SLACKS; SLEEP MASKS; SLEEP PANTS; SLEEP SHIRTS; SLEEPING GARMENTS; SLEEPWEAR; SLEEPWEAR TREATED WITH FIRE AND HEAT RETARDANTS; SLEEVED OR SLEEVELESS JACKETS; SLEEVELESS JERSEYS; SLEEVES WORN SEPARATE AND APART FROM BLOUSES, SHIRTS AND OTHER TOPS; SLIDING SHORTS; SLIPOVERS; SLIPPER SOCKS; SLIPPER SOLES; SLIPPERS; SLIPS; SMALL HATS; SMOCKS; SMOKING JACKETS; SNEAKERS; SNOW BOARDING SUITS; SNOW BOOTS; SNOW PANTS; SNOW SUITS; SNOWBOARD BOOTS; SNOWBOARD GLOVES; SNOWBOARD JACKETS; SNOWBOARD MITTENS; SNOWBOARD PANTS; SNOWBOARD TROUSERS; SOCCER BIBS; SOCCER BOOTS; SOCCER SHOES; SOCK SUSPENDERS; SOCKS; SOCKS AND STOCKINGS; SOLES; SOLES FOR FOOTWEAR; SOLES FOR JAPANESE STYLE SANDALS; SPORT COATS; SPORT SHIRTS; SPORT STOCKINGS; SPORTS BRA; SPORTS BRAS; SPORTS CAPS AND HATS; SPORTS JACKETS; SPORTS JERSEYS; SPORTS JERSEYS AND BREECHES FOR SPORTS; SPORTS OVER UNIFORMS; SPORTS OVERUNIFORMS; SPORTS PANTS; SPORTS SHIRTS; SPORTS SHIRTS WITH SHORT SLEEVES; SPORTS VESTS; STILETTO HEELS; STOCKING SUSPENDERS; STOCKINGS; STOCKINGS; STOLERS; STRAPLESS BRAS; STRAPS FOR BRAS; STRETCH PANTS; STRING FASTENERS FOR HAORI (HAORI-HIMO); STUDS FOR FOOTBALL BOOTS; STUFF JACKETS; SUEDE JACKETS; SUIT COATS; SUITS; SUITS OF LEATHER; SUN LEGGINGS; SUN SLEEVES; SUN VISORS; SUN DRESSES; SUNSUITS; SURF WEAR; SUSPENDER BELTS; SUSPENDER BELTS FOR MEN; SUSPENDER BELTS FOR WOMEN; SUSPENDERS; SUSPENDERS; SWADDLING CLOTHES; SWEAT BANDS; SWEAT JACKETS; SWEAT PANTS; SWEAT SHIRTS; SWEAT SHORTS; SWEAT SUITS; SWEATBANDS; SWEATERS; SWEATPANTS; SWEATSHIRTS; SWEATSOCKS; SWEATSUITS;

CLASS 25—(Continued).

SWIM CAPS; SWIM SUITS; SWIM TRUNKS; SWIM WEAR; SWIM WEAR FOR GENTLEMEN AND LADIES; SWIMMING CAPS; SWIMMING CAPS; SWIMMING COSTUMES; SWIMMING TRUNKS; SWIMSUITS; SWIMWEAR; T-SHIRTS; TABARDS; TAILLEURS; TAMS; TANK TOPS; TANK-TOPS; TANKINIS; TAP PANTS; TAP SHOES; TEDDIES; TEE SHIRTS; TENNIS DRESSES; TENNIS SHOES; TENNIS WEAR; TEXTILE DIAPERS; TEXTILE NAPPIES; THERMAL SOCKS; THERMAL UNDERWEAR; THONGS; THONGS; TIES; TIGHTENING-UP STRINGS FOR KIMONOS (DATEJIME); TIGHTS; TIPS FOR FOOTWEAR; TOBOGGAN HATS, PANTS AND CAPS; TOE BOXES; TOE CAPS; TOE STRAPS FOR JAPANESE STYLE SANDALS; TOE STRAPS FOR JAPANESE STYLE WOODEN CLOGS; TOGAS; TONGUE OR PULLSTRAP FOR SHOES AND BOOTS; TOP COATS; TOPCOATS; TOPS; TOQUES; TRACK AND FIELD SHOES; TRACK JACKETS; TRACK PANTS; TRACK SUITS; TRACKSUITS; TRAINING SHOES; TRAINING SUITS; TRAVEL CLOTHING CONTAINED IN A PACKAGE COMPRISING REVERSIBLE JACKETS, PANTS, SKIRTS, TOPS AND A BELT OR SCARF; TREKKING BOOTS; TRENCH COATS; TRIATHLON CLOTHING, NAMELY, TRIATHLON TIGHTS, TRIATHLON SHORTS, TRIATHLON SINGLETS, TRIATHLON SHIRTS, TRIATHLON SUITS; TROUSERS; TROUSERS FOR SWEATING; TROUSERS OF LEATHER; TRUNKS; TUBE TOPS; TUNICS; TUQUES; TURBANS; TURTLE NECK SHIRTS; TURTLENECK PULLOVERS; TURTLENECK SWEATERS; TURTLENECKS; TUXEDO BELTS; TUXEDOS; TWIN SETS; UNDER GARMENTS; UNDERARM CLOTHING SHIELDS; UNDERCLOTHES; UNDERGARMENT ACCESSORIES, NAMELY, REMOVABLE SILICONE BUTTOCK ENHANCER PADS; UNDERGARMENTS; UNDERGARMENTS, NAMELY, WASPIES; UNDERPANTS; UNDERSHIRTS FOR KIMONOS (JUBAN); UNDERSHIRTS FOR KIMONOS (KOSHIMAKI); UNDERSKIRTS; UNDERWEAR; UNDERWEAR, NAMELY, BOY SHORTS; UNIFORMS; UNION SUITS; UNITARDS; UPPERS FOR JAPANESE STYLE SANDALS; UPPERS OF WOVEN RATTAN FOR JAPANESE STYLE SANDALS; V-NECK SWEATERS; VEILS; VEST EXTENDERS; VESTED SUITS; VESTS; VISCOUS GEL POLYMER SOLD AS A COMPONENT OF FINISHED CUSTOM CUSHIONED FOOTWEAR FOR NON-ORTHOPEDIC PURPOSES AND APPAREL; VISORS; VOLLEYBALL JERSEYS; VOLLEYBALL SHOES; WAIST BANDS; WAIST BELTS; WAIST CINCHERS; WAIST STRINGS FOR KIMONOS (KOSHIHIMO); WAISTBANDS; WAISTCOATS; WALKING SHORTS; WARM UP OUTFITS; WARM UP SUITS; WARM-UP SUITS; WATER PROOF BOOTS; WATER REPELLING BOOTS; WATER REPELLING FOOTWEAR; WATER REPELLING LEATHER BOOTS; WATER REPELLING LEATHER SHOES AND BOOTS; WATER SOCKS; WATERPROOF FOOTWEAR; WATERPROOF JACKETS AND PANTS; WATERPROOF LEATHER BOOTS; WATERPROOF LEATHER SHOES; WATERPROOF LEATHER SHOES AND BOOTS; WEARABLE BLANKETS IN THE NATURE OF BLANKETS WITH SLEEVES; WEARABLE GARMENTS AND CLOTHING, NAMELY, SHIRTS; WEDDING DRESSES; WEDDING GOWNS; WELTS FOR BOOTS AND SHOES; WET SUIT GLOVES; WET SUITS; WET SUITS FOR WATER-SKIING AND SUB-AQUA; WETSUITS; WETSUITS FOR WATER-SKIING; WIMPLES; WIND COATS; WIND PANTS; WIND RESISTANT JACKETS; WIND SHIRTS; WIND VESTS; WIND-JACKETS; WINDCHEATERS; WINDJAMMERS; WINDSHIRTS; WINTER BOOTS; WOMEN'S ATHLETIC TOPS WITH BUILT-IN BRAS; WOMEN'S CEREMONIAL DRESSES; WOMEN'S FOLDABLE SLIPPERS; WOMEN'S HATS AND HOODS; WOMEN'S SHOES; WOMEN'S SHOES, NAMELY, FOLDABLE FLATS; WOMEN'S TOPS, NAMELY, CAMIS; WOMEN'S UNDERWEAR; WOODEN CLOGS; WOODEN MAIN BODIES OF JAPANESE STYLE WOODEN CLOGS; WOODEN SHOES; WOODEN SUPPORTS OF JAPANESE STYLE WOODEN CLOGS; WOOLLEN SOCKS; WOOLLEN TIGHTS; WOOLLY HATS; WORK SHOES AND BOOTS; WORKING OVERALLS; WOVEN BOTTOMS; WOVEN DRESSES; WOVEN OR KNITTED UNDERWEAR; WOVEN SKIRTS; WOVEN TOPS; WRAP BELTS FOR KIMONOS (DATEMAKI); WRAPS; WRIST BANDS; WRISTBANDS; WRISTBANDS CONTAINING A COOLING SUBSTANCE TO COOL THE WEARER; YASHMAGHS; YOGA PANTS; YOGA SHIRTS; ZOOT SUITS; ZORI (U.S. CLS. 22 AND 39).

FIRST USE 6-0-2008; IN COMMERCE 2-0-2010.

CLASS 25—(Continued).

4,155,017. LOLA KIMONI INC., PACIFIC PALISADES, CA. SN 85-231,076. PUB. 7-26-2011, FILED 2-1-2011.

LOLA KIMONI

THE MARK CONSISTS OF STANDARD CHARACTERS WITHOUT CLAIM TO ANY PARTICULAR FONT, STYLE, SIZE, OR COLOR.

FOR BEACH COVER-UPS; DRESSES (U.S. CLS. 22 AND 39).

FIRST USE 1-0-2011; IN COMMERCE 4-0-2011.

4,155,020. UNDER ARMOUR, INC., BALTIMORE, MD. SN 85-231,693. PUB. 1-24-2012, FILED 2-1-2011.

4D FOAM

THE MARK CONSISTS OF STANDARD CHARACTERS WITHOUT CLAIM TO ANY PARTICULAR FONT, STYLE, SIZE, OR COLOR.

NO CLAIM IS MADE TO THE EXCLUSIVE RIGHT TO USE "FOAM", APART FROM THE MARK AS SHOWN.

FOR ATHLETIC FOOTWEAR, EXCLUDING CYCLING FOOTWEAR; FOOTWEAR, EXCLUDING CYCLING FOOTWEAR (U.S. CLS. 22 AND 39).

FIRST USE 3-0-2011; IN COMMERCE 3-0-2011.

4,155,032. ALAN J. PIVEN MANAGEMENT GROUP, LLC, NEW YORK, NY. SN 85-234,922. PUB. 6-14-2011, FILED 2-4-2011.

HIGH GEAR MOTORCYCLE CLUB

THE MARK CONSISTS OF STANDARD CHARACTERS WITHOUT CLAIM TO ANY PARTICULAR FONT, STYLE, SIZE, OR COLOR.

NO CLAIM IS MADE TO THE EXCLUSIVE RIGHT TO USE "MOTORCYCLE CLUB", APART FROM THE MARK AS SHOWN.

FOR SHIRTS (U.S. CLS. 22 AND 39).

FIRST USE 4-10-2012; IN COMMERCE 4-10-2012.

CLASS 25—(Continued).

4,155,062. SAUTER, WENDY A, MISSION VIEJO, CA. SN 85-240,816. PUB. 6-21-2011, FILED 2-12-2011.

PRAYORITY

THE MARK CONSISTS OF STANDARD CHARACTERS WITHOUT CLAIM TO ANY PARTICULAR FONT, STYLE, SIZE, OR COLOR.

FOR ATHLETIC APPAREL, NAMELY, SHIRTS, PANTS, JACKETS, FOOTWEAR, HATS AND CAPS, ATHLETIC UNIFORMS (U.S. CLS. 22 AND 39).

FIRST USE 10-19-2011; IN COMMERCE 10-19-2011.

4,155,072. FME JEANS, LLC, LOS ANGELES, CA. SN 85-242,590. PUB. 7-19-2011, FILED 2-15-2011.

FME

THE MARK CONSISTS OF STANDARD CHARACTERS WITHOUT CLAIM TO ANY PARTICULAR FONT, STYLE, SIZE, OR COLOR.

FOR APPAREL, NAMELY, JEANS, PANTS, SHORTS, SKIRTS, SHIRTS, CAMISOLES, UNDERGARMENTS (U.S. CLS. 22 AND 39).

FIRST USE 9-28-2011; IN COMMERCE 6-1-2011.

4,155,073. HYBRID NATION, NORTHFIELD, MN. SN 85-243,153. PUB. 6-21-2011, FILED 2-15-2011.

HybridNation

THE MARK CONSISTS OF STANDARD CHARACTERS WITHOUT CLAIM TO ANY PARTICULAR FONT, STYLE, SIZE, OR COLOR.

FOR HATS; JACKETS; SHIRTS; SWEATSHIRTS (U.S. CLS. 22 AND 39).

FIRST USE 1-1-2011; IN COMMERCE 5-1-2011.

CLASS 25—(Continued).

4,155,078. THOMPSON, ROBERT, BROOKLYN, NY. SN 85-243,651. PUB. 6-28-2011, FILED 2-16-2011.

CAMPUS RIVAL

THE MARK CONSISTS OF STANDARD CHARACTERS WITHOUT CLAIM TO ANY PARTICULAR FONT, STYLE, SIZE, OR COLOR.

NO CLAIM IS MADE TO THE EXCLUSIVE RIGHT TO USE "CAMPUS", APART FROM THE MARK AS SHOWN.

FOR BOOTS; COATS; GLOVES; HATS; JEANS; KNIT TOPS; NECKTIES; PANTS; SHIRTS; SHOES; SHORTS; SNEAKERS; SUITS; SWEATERS; T-SHIRTS; UNDERGARMENTS; WOVEN TOPS (U.S. CLS. 22 AND 39).

FIRST USE 1-6-2012; IN COMMERCE 1-6-2012.

4,155,096. GUANGZHOU CANUDILO FASHION & ACCESSORIES CO., LTD., GUANGZHOU, GUANGDONG, CHINA. SN 85-245,564. PUB. 6-28-2011, FILED 2-17-2011.



THE MARK CONSISTS OF THE STYLIZED WORDS "CANUDILO HOLIDAYS" WITH A RECTANGULAR BACKGROUND.

THE WORDING "CANUDILO" HAS NO MEANING IN A FOREIGN LANGUAGE.

FOR DRESSES; FOOTWEAR; GIRDLES; HEADWEAR; HOSIERY; JACKETS; LEATHER COATS; NECKTIES; SHIRTS; T-SHIRTS; TROUSERS; UNIFORMS (U.S. CLS. 22 AND 39).

FIRST USE 11-22-2010; IN COMMERCE 2-17-2011.

4,155,111. THOMPSON, LEVI, CONYERS, GA. SN 85-247,006. PUB. 6-28-2011, FILED 2-19-2011.

BODY TANTRA

THE MARK CONSISTS OF STANDARD CHARACTERS WITHOUT CLAIM TO ANY PARTICULAR FONT, STYLE, SIZE, OR COLOR.

FOR WEARABLE GARMENTS AND CLOTHING, NAMELY, SHIRTS (U.S. CLS. 22 AND 39).

FIRST USE 8-7-2011; IN COMMERCE 2-1-2012.

CLASS 25—(Continued).

4,155,113. SOUTH MOON SALES, INC., BERLIN, MD. SN 85-247,345. PUB. 6-28-2011, FILED 2-21-2011.

ABELLINE

THE MARK CONSISTS OF STANDARD CHARACTERS WITHOUT CLAIM TO ANY PARTICULAR FONT, STYLE, SIZE, OR COLOR.

FOR CLOTHING, NAMELY, TOPS, BOTTOMS, UNDERWEAR, FOOTWEAR, DRAWERS, JACKETS, DRESSES, PANTS, SKIRTS, HOSIERY, SOCKS, SCARVES, NECKWEAR, SWIMWEAR, SHORTS (U.S. CLS. 22 AND 39).

FIRST USE 12-31-2010; IN COMMERCE 4-30-2011.

4,155,114. SPEEDCAP, LLC, THOMASVILLE, PA. SN 85-247,401. PUB. 7-5-2011, FILED 2-21-2011.

SPEEDCAP

THE MARK CONSISTS OF STANDARD CHARACTERS WITHOUT CLAIM TO ANY PARTICULAR FONT, STYLE, SIZE, OR COLOR.

FOR HEADGEAR, NAMELY, NOVELTY HATS SHAPED LIKE CARS (U.S. CLS. 22 AND 39).

FIRST USE 2-11-2012; IN COMMERCE 2-11-2012.

4,155,138. BULLET GEAR LLC, AUBURN HILLS, MI. SN 85-251,089. PUB. 7-26-2011, FILED 2-24-2011.

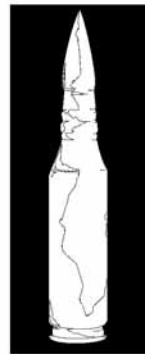

THE MARK CONSISTS OF A DESIGN OF A .50 CALIBER BULLET INSIDE A SQUARE.

FOR SHIRTS; SWEATERS (U.S. CLS. 22 AND 39).

FIRST USE 6-20-2011; IN COMMERCE 7-1-2011.

CLASS 25—(Continued).

4,155,149. FORTUNE DYNAMIC INC., CITY OF INDUSTRY, CA. SN 85-251,714. PUB. 7-19-2011, FILED 2-25-2011.

HAPPY SODA

THE MARK CONSISTS OF STANDARD CHARACTERS WITHOUT CLAIM TO ANY PARTICULAR FONT, STYLE, SIZE, OR COLOR.

OWNER OF U.S. REG. NOS. 2,331,057, 2,931,439, AND 3,531,885.

FOR FOOTWEAR (U.S. CLS. 22 AND 39).

FIRST USE 3-1-2012; IN COMMERCE 3-1-2012.

CLASS 25—(Continued).

4,155,158. COLDWORLD ENTERPRISES, LOS ANGELES, CA. SN 85-252,854. PUB. 7-19-2011, FILED 2-27-2011.

LEAGUE ME

THE MARK CONSISTS OF STANDARD CHARACTERS WITHOUT CLAIM TO ANY PARTICULAR FONT, STYLE, SIZE, OR COLOR.

FOR SHIRTS AND SWEAT SHIRTS (U.S. CLS. 22 AND 39).

FIRST USE 7-1-2010; IN COMMERCE 7-1-2010.

4,155,154. SHIRK, TRAVIS M., LEBANON, PA. SN 85-252,426. PUB. 9-6-2011, FILED 2-25-2011.

**"The Thrill Seeker"
Sage Strong**

THE MARK CONSISTS OF STANDARD CHARACTERS WITHOUT CLAIM TO ANY PARTICULAR FONT, STYLE, SIZE, OR COLOR.

THE NAME "SAGE STRONG" IDENTIFIES A LIVING INDIVIDUAL WHOSE CONSENT IS OF RECORD.

FOR CLOTHING, NAMELY, T-SHIRTS, SWEAT-SHIRTS, JERSEYS, SHORTS, SWEAT PANTS, JACKETS, GLOVES, NECKTIES, PAJAMAS, ROBES, NIGHT SHIRTS, UNDERWEAR, HEAD BANDS, SWIMSUITS, SHIRTS, TANK TOPS, PANTS, COATS, SWEATERS, SOCKS, BELTS, RAIN WEAR, FOOTWEAR AND HEAD WEAR (U.S. CLS. 22 AND 39).

FIRST USE 12-3-2011; IN COMMERCE 12-3-2011.

4,155,163. CHARETTE, PATRICIA M., BEVERLY, MA. SN 85-253,187. PUB. 7-19-2011, FILED 2-28-2011.

WACKO WESTIE

THE MARK CONSISTS OF STANDARD CHARACTERS WITHOUT CLAIM TO ANY PARTICULAR FONT, STYLE, SIZE, OR COLOR.

FOR MITTENS MODIFIED TO COVER THE HAND AND AN ANIMAL LEASH HANDLE OR OTHER LOOP (U.S. CLS. 22 AND 39).

FIRST USE 11-19-2011; IN COMMERCE 11-19-2011.

4,155,155. REZK, ELINOR C., DBA INVISIBLE SUN, WALL TOWNSHIP, NJ. SN 85-252,446. PUB. 8-9-2011, FILED 2-25-2011.

Invisible Sun

THE MARK CONSISTS OF STANDARD CHARACTERS WITHOUT CLAIM TO ANY PARTICULAR FONT, STYLE, SIZE, OR COLOR.

FOR HATS; SCARVES; T-SHIRTS (U.S. CLS. 22 AND 39).

FIRST USE 9-10-2011; IN COMMERCE 9-10-2011.

4,155,174. LAWRENCE DARNELL STUART, DBA FIVE LIONS ENTERTAINMENT, RESEDA, CA. SN 85-253,983. PUB. 7-19-2011, FILED 2-28-2011.

AIJI

THE MARK CONSISTS OF STANDARD CHARACTERS WITHOUT CLAIM TO ANY PARTICULAR FONT, STYLE, SIZE, OR COLOR.

FOR ATHLETIC APPAREL, NAMELY, SHIRTS, PANTS, JACKETS, FOOTWEAR, HATS AND CAPS, ATHLETIC UNIFORMS (U.S. CLS. 22 AND 39).

FIRST USE 9-1-2011; IN COMMERCE 1-1-2012.

CLASS 25—(Continued).

4,155,189. LUDWICK, MATTHEW, BURBANK, CA. SN 85-254,890. PUB. 7-19-2011, FILED 3-1-2011.

CLASS 25—(Continued).

4,155,307. YFY, LLC, CRYSTAL LAKE, IL. SN 85-267,815. PUB. 7-19-2011, FILED 3-15-2011.

Moto Meccanica

THE MARK CONSISTS OF STANDARD CHARACTERS WITHOUT CLAIM TO ANY PARTICULAR FONT, STYLE, SIZE, OR COLOR.

THE ENGLISH TRANSLATION OF "MOTO MECCANICA" IN THE MARK IS "MECHANICAL MOTORCYCLE".

FOR CLOTHING, NAMELY, LONG AND SHORT SLEEVE T-SHIRTS, LONG AND SHORT SLEEVE SHIRTS, COATS, AND HEADWEAR (U.S. CLS. 22 AND 39).

FIRST USE 2-3-2012; IN COMMERCE 2-3-2012.



4,155,225. PINCKNEY, CRAIG, CHESTER, VA. SN 85-259,432. PUB. 8-2-2011, FILED 3-7-2011.

AKGM

THE MARK CONSISTS OF STANDARD CHARACTERS WITHOUT CLAIM TO ANY PARTICULAR FONT, STYLE, SIZE, OR COLOR.

FOR HATS; JACKETS; PANTS; SHIRTS; SHORTS; SWEATSHIRTS; UNDERWEAR (U.S. CLS. 22 AND 39).

FIRST USE 3-1-2012; IN COMMERCE 3-1-2012.



4,155,242. RASOLLI FOOTWEAR CORP., NEW YORK, NY. SN 85-260,892. PUB. 7-26-2011, FILED 3-8-2011.

RINNATI

THE MARK CONSISTS OF STANDARD CHARACTERS WITHOUT CLAIM TO ANY PARTICULAR FONT, STYLE, SIZE, OR COLOR.

FOR WOMEN'S FOOTWEAR, NAMELY, SHOES, BOOTS, SLIPPERS, SANDALS AND SNEAKERS; WOMEN'S CLOTHING, NAMELY, SHIRTS, BLOUSES, SWEATERS, TEE SHIRTS, SKIRTS, SCARVES, HATS; WOMEN'S LINGERIES, NAMELY, NIGHT GOWNS, PAJAMAS, UNDER PANTS, BRAS (U.S. CLS. 22 AND 39).

FIRST USE 9-7-2011; IN COMMERCE 9-7-2011.

YUMZ GOURMET FROZEN YOGURT

THE MARK CONSISTS OF STANDARD CHARACTERS WITHOUT CLAIM TO ANY PARTICULAR FONT, STYLE, SIZE, OR COLOR.

OWNER OF U.S. REG. NO. 3,935,658.

FOR T-SHIRTS; TOPS; HATS; HEADWEAR (U.S. CLS. 22 AND 39).

FIRST USE 10-0-2011; IN COMMERCE 10-0-2011.



4,155,308. YFY, LLC, CRYSTAL LAKE, IL. SN 85-267,837. PUB. 7-19-2011, FILED 3-15-2011.



OWNER OF U.S. REG. NO. 3,935,658.

THE MARK CONSISTS OF A RECTANGULAR SHAPE ENCLOSING THE DESIGN OF SOFT-SERVE FROZEN YOGURT WITH THE END OF A SPOON STICKING OUT OF IT AND THE STYLIZED TEXT "YUMZ GOURMET FROZEN YOGURT" TO THE RIGHT OF THE DESIGN.

FOR HATS; HEADWEAR; T-SHIRTS; TOPS (U.S. CLS. 22 AND 39).

FIRST USE 10-0-2011; IN COMMERCE 10-0-2011.

CLASS 25—(Continued).

4,155,316. SMITH, RUSSELL, LONGWOOD, FL. SN 85-268,806. PUB. 8-2-2011, FILED 3-16-2011.



THE MARK CONSISTS OF THE STYLIZED LETTERS "KN" INSIDE A CIRCULAR SHAPED DESIGN. THE LETTERS ARE PLACED VERTICALLY.

FOR CAPS; FOOTWEAR; JEANS; SHORTS; T-SHIRTS (U.S. CLS. 22 AND 39).
FIRST USE 1-1-2009; IN COMMERCE 1-1-2010.

4,155,318. HAWTHORNE, STEPHANIE, EL MONTE, CA. SN 85-269,067. PUB. 10-4-2011, FILED 3-16-2011.



NO CLAIM IS MADE TO THE EXCLUSIVE RIGHT TO USE "VINTAGE", APART FROM THE MARK AS SHOWN. THE COLOR(S) BLACK, WHITE AND RED IS/ARE CLAIMED AS A FEATURE OF THE MARK.

THE MARK CONSISTS OF A FRONT VIEW OF AN ANTIQUE CAR IN BLACK AND WHITE WITH A RED HEXAGONAL HOOD ORNAMENT LINED IN BLACK AND THE WORDS "SH VINTAGE ROAD" WRITTEN IN RED FONT ACROSS THE RECTANGULAR-SHAPED BUMPER OF THE CAR.

FOR CLOTHING, NAMELY, T-SHIRTS AND TANK TOPS (U.S. CLS. 22 AND 39).
FIRST USE 2-28-2012; IN COMMERCE 2-28-2012.

CLASS 25—(Continued).

4,155,331. GARCIA, ANTONIO, SYILMAR, CA. SN 85-270,714. PUB. 8-2-2011, FILED 3-18-2011.

ANIMATE

THE MARK CONSISTS OF STANDARD CHARACTERS WITHOUT CLAIM TO ANY PARTICULAR FONT, STYLE, SIZE, OR COLOR.

FOR CLOTHING; NAMELY, T-SHIRTS, SHIRTS, LONG SLEEVE T-SHIRTS, POLO SHIRTS, SHORTS, PANTS, SWEATERS, SWEATPANTS, SWEATSHIRTS, TANK TOPS, JACKETS, GLOVES; HEADWEAR, NAMELY, HATS, CAPS AND SCARVES; FOOTWEAR (U.S. CLS. 22 AND 39).

FIRST USE 6-18-2011; IN COMMERCE 12-17-2011.

4,155,338. MOREHEAD, JESSE, STAFFORD, KS. SN 85-272,128. PUB. 8-2-2011, FILED 3-21-2011.

NERVES OF STEEL

THE MARK CONSISTS OF STANDARD CHARACTERS WITHOUT CLAIM TO ANY PARTICULAR FONT, STYLE, SIZE, OR COLOR.

FOR SHIRTS (U.S. CLS. 22 AND 39).

FIRST USE 7-6-2011; IN COMMERCE 1-4-2012.

4,155,373. MATTHEW LUDWICK, BURBANK, CA. SN 85-278,483. PUB. 8-9-2011, FILED 3-28-2011.

vinmota

THE MARK CONSISTS OF STANDARD CHARACTERS WITHOUT CLAIM TO ANY PARTICULAR FONT, STYLE, SIZE, OR COLOR.

FOR ATHLETIC APPAREL, NAMELY, SHIRTS, JACKETS, HATS AND CAPS (U.S. CLS. 22 AND 39).
FIRST USE 2-3-2012; IN COMMERCE 2-3-2012.

CLASS 25—(Continued).

4,155,429. FAYE BENNETT, HAYWARD, CA. AND OCTAVIO BENNETT, HAYWARD, CA. SN 85-285,986. PUB. 8-9-2011, FILED 4-4-2011.



THE STIPPLING IS FOR SHADING PURPOSES ONLY. THE NAME "LOLA BUDS" DOES NOT IDENTIFY A LIVING INDIVIDUAL.

THE MARK CONSISTS OF THE WORDS "LOLA BUDS" IN BAUHAUS93 FONT ARCHED ABOVE THE PICTURES OF THE 4 GIRLS. THE FOUR GIRLS ARE STANDING IN FRONT OF A FLOWER. FIRST GIRL FROM THE LEFT IS TAN WITH BLACK HAIR. SHE IS WEARING A LONG DRESS, HAS LONG WAIVE HAIR WITH A FLOWER IN IT. THE SECOND GIRL FROM THE LEFT HAS A AFRO PUFF WITH A RIBBON IN HER HAIR. SHE IS WEARING A SWEATER WITH BUTTONS, A SKIRT, TIGHTS, AND SHOES. THE THIRD GIRL FROM THE LEFT HAS A ANGEL HAIRCUT. SHE IS WEARING A JUMPER WITH POCKET ON FRONT AND A SHIRT UNDERNEATH. SHE HAS A BELT ON AND SHOES. THE FOURTH GIRL FROM THE LEFT HAS LONG HAIR. SHE IS WEARING A SWEATSUIT WITH A POCKET IN FRONT. SHE IS WEARING SHOES.

FOR CHILDREN'S AND INFANT'S APPAREL, NAMELY, JUMPERS, OVERALL SLEEPWEAR, PAJAMAS, ROMPERS AND ONE-PIECE GARMENTS; HATS; T-SHIRTS; T-SHIRTS FOR BABIES, CHILDREN, WOMEN; TANK TOPS; TOPS (U.S. CLS. 22 AND 39). FIRST USE 3-15-2012; IN COMMERCE 3-15-2012.

CLASS 25—(Continued).

4,155,451. KATE SPADE LLC, NEW YORK, NY. SN 85-290,002. PUB. 8-9-2011, FILED 4-8-2011.



OWNER OF U.S. REG. NOS. 2,578,942, 3,271,494, AND OTHERS.

NO CLAIM IS MADE TO THE EXCLUSIVE RIGHT TO USE "NEW YORK", APART FROM THE MARK AS SHOWN. THE NAME "KATE SPADE" IDENTIFIES A LIVING INDIVIDUAL WHOSE CONSENT IS OF RECORD.

THE MARK CONSISTS OF A SPADE DESIGN WITH THE WORDS "KATE SPADE NEW YORK" UNDERNEATH.

FOR BELTS; BLAZERS; BLOUSES; BOTTOMS; BRAS; COATS; DRESSES; FOOTWEAR; GLOVES; HEADWEAR; HOSIERY; JACKETS; JEANS; KNIT TOPS; LINGERIE; LOUNGWEAR; NECKWEAR; PANTS; SCARVES; SHIRTS; SHORTS; SKIRTS; SLEEPWEAR; SOCKS; SUITS; SWEATERS; SWIMWEAR; T-SHIRTS; TANK TOPS; TOPS; UNDERWEAR (U.S. CLS. 22 AND 39). FIRST USE 1-2-2012; IN COMMERCE 1-2-2012.

4,155,441. HANNAH BAJOR, CHESHIRE, CT. SN 85-288,123. PUB. 8-16-2011, FILED 4-6-2011.

LUMALOVE

THE MARK CONSISTS OF STANDARD CHARACTERS WITHOUT CLAIM TO ANY PARTICULAR FONT, STYLE, SIZE, OR COLOR.

OWNER OF U.S. REG. NO. 3,777,763. FOR BABY LAYETTES FOR CLOTHING; DRESSES; MATERNITY BRAS; MATERNITY LINGERIE; PANTS; SHIRTS; SKIRTS; SOCKS (U.S. CLS. 22 AND 39). FIRST USE 3-14-2012; IN COMMERCE 3-14-2012.

4,155,460. THRASHER, BENJAMIN, LONG BEACH, CA. SN 85-293,245. PUB. 8-23-2011, FILED 4-12-2011.

People Are the Reason

THE MARK CONSISTS OF STANDARD CHARACTERS WITHOUT CLAIM TO ANY PARTICULAR FONT, STYLE, SIZE, OR COLOR.

FOR JACKETS; PANTS; SHIRTS (U.S. CLS. 22 AND 39). FIRST USE 10-7-2007; IN COMMERCE 7-15-2010.

CLASS 25—(Continued).

4,155,462. MOLLAHAN, NATHAN, PORTLAND, OR. SN 85-294,942. PUB. 9-6-2011, FILED 4-14-2011.

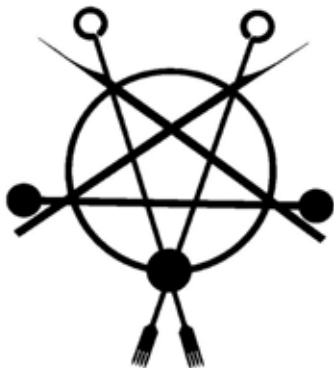

THE MARK CONSISTS OF A PENTAGRAM DESIGN COMPRISED IN PART OF THE REPRESENTATION OF TATTOO NEEDLES, PIERCING NEEDLES AND BODY JEWELRY.

FOR HATS; HOODED SWEATSHIRTS; JACKETS; LINGERIE; PANTS; SHIRTS; SHOES (U.S. CLS. 22 AND 39). FIRST USE 6-6-2006; IN COMMERCE 6-6-2006.

4,155,466. L & L MANUFACTURING CO., INC., EL SEGUNDO, CA. SN 85-295,660. PUB. 8-23-2011, FILED 4-14-2011.

JOHNNY FOUND

THE MARK CONSISTS OF STANDARD CHARACTERS WITHOUT CLAIM TO ANY PARTICULAR FONT, STYLE, SIZE, OR COLOR.

THE NAME(S), PORTRAIT(S), AND/OR SIGNATURE(S) SHOWN IN THE MARK DOES NOT IDENTIFY A PARTICULAR LIVING INDIVIDUAL.

FOR CAPS; HOODED SWEATSHIRTS; KNIT TOPS; SWEATERS; SWEATSHIRTS; T-SHIRTS; TOPS (U.S. CLS. 22 AND 39).

FIRST USE 1-5-2012; IN COMMERCE 1-5-2012.

4,155,468. PALIDIUM, INC., HUGO, MN. SN 85-295,716. PUB. 8-23-2011, FILED 4-14-2011.

ZEROTIE

THE MARK CONSISTS OF THE WORD "ZEROTIE", THE "O" IN THE WORD BEING FORMED BY THE DESIGN OF A RATCHET WHEEL.

FOR FOOTWEAR (U.S. CLS. 22 AND 39). FIRST USE 3-12-2012; IN COMMERCE 3-12-2012.

CLASS 25—(Continued).

4,155,470. LF 20, INC., FRANKLIN SQUARE, NY. SN 85-296,017. PUB. 8-30-2011, FILED 4-15-2011.

FL 20

THE MARK CONSISTS OF STANDARD CHARACTERS WITHOUT CLAIM TO ANY PARTICULAR FONT, STYLE, SIZE, OR COLOR.

FOR MEN'S, WOMEN'S AND CHILDREN'S CLOTHING, NAMELY, T-SHIRTS, PANTS, SHIRTS, COATS, SWEATSHIRTS, SUITS, KNIT SHIRTS, JEANS, DRESS SHIRTS, VESTS, SWEATERS, SHORTS, SWIMWEAR, JACKETS, RAINWEAR, BLOUSES, DRESSES, SOCKS, HOSIERY, UNDERWEAR, PAJAMAS, SLEEPWEAR, BOXER SHORTS AND WOMEN'S LINGERIE; FASHION ACCESSORIES, NAMELY, BELTS, LEATHER GLOVES, SCARVES, HATS, HEAD BANDS, BANDANAS AND NECK TIES; FOOTWEAR (U.S. CLS. 22 AND 39).

FIRST USE 12-8-2011; IN COMMERCE 1-4-2012.

4,155,471. LF 20, INC., FRANKLIN SQUARE, NY. SN 85-296,070. PUB. 8-30-2011, FILED 4-15-2011.

fL20

THE MARK CONSISTS OF THE LETTERS "F" AND "L" AND THE NUMBER "20" IN STYLIZED PRINT.

FOR MEN'S, WOMEN'S AND CHILDREN'S CLOTHING, NAMELY, T-SHIRTS, PANTS, SHIRTS, COATS, SWEATSHIRTS, SUITS, KNIT SHIRTS, JEANS, DRESS SHIRTS, VESTS, SWEATERS, SHORTS, SWIMWEAR, JACKETS, RAINWEAR, BLOUSES, DRESSES, SOCKS, HOSIERY, UNDERWEAR, PAJAMAS, SLEEPWEAR, BOXER SHORTS AND WOMEN'S LINGERIE; FASHION ACCESSORIES, NAMELY, BELTS, LEATHER GLOVES, SCARVES, HATS, HEAD BANDS, BANDANAS AND NECK TIES; FOOTWEAR (U.S. CLS. 22 AND 39).

FIRST USE 12-8-2011; IN COMMERCE 1-4-2012.

CLASS 25—(Continued).

4,155,473. DIVALISH DESIGNS, LLC, SILVER SPRING, MD. SN 85-296,679. PUB. 9-27-2011, FILED 4-15-2011.



NO CLAIM IS MADE TO THE EXCLUSIVE RIGHT TO USE "DESIGNS", APART FROM THE MARK AS SHOWN.

THE MARK CONSISTS OF THE STYLIZED WORDS "DIVALISH DESIGNS". IN-BETWEEN THE WORDS IS A STYLIZED FEMALE DEVIL CARRYING A TRIDENT. SHE IS SURROUNDED BY A HALF RING OF FLAMES. HER TAIL IS IN THE SHAPE OF A HEART WITH AN ARROW AT THE END ALSO DISPLAYING FLAMES.

FOR WOMEN'S APPAREL, NAMELY, BIKINIS, ONE-PIECE BATHING SUITS, BEACH COVER UPS, PANTIES, BRAS, LINGERIE, PAJAMAS, BOXER BRIEFS, TANK TOP AND BOXER BRIEFS SETS, TANK TOP AND CAPRI SETS, TANK TOP AND SHORTS SETS, SLEEP SHIRTS, TEE SHIRT AND PANTS SETS, CAMISOLE AND CAPRI SETS, LONG SLEEVE SHIRTS AND SHORTS SETS, TEE SHIRTS AND SHORT SETS, TANK TOP AND BOXER BRIEFS SETS, T-SHIRTS, BABY DOLL TEES, TANK TOPS, HALTER TOPS, BLOUSES, JEANS, DENIM SHORTS, CAPRIS, SWEAT PANTS AND SWEAT SHORTS (U.S. CLS. 22 AND 39).

FIRST USE 6-0-2011; IN COMMERCE 6-0-2011.

4,155,516. BROWN, PAUL, NEWPORT BEACH, CA. AND BROWN, BLAKE, NEWPORT BEACH, CA. SN 85-309,690. PUB. 10-4-2011, FILED 5-2-2011.



NO CLAIM IS MADE TO THE EXCLUSIVE RIGHT TO USE "BEACH APPAREL", APART FROM THE MARK AS SHOWN.

THE MARK CONSISTS OF A DESIGN OF A BEE INSIDE OF A TRIANGLE WITH THE STYLIZED TEXT "BIG B BEACH APPAREL" WRITTEN INSIDE THE TRIANGLE BORDER.

FOR HATS; JACKETS; SHIRTS; SWEATSHIRTS; T-SHIRTS (U.S. CLS. 22 AND 39).

FIRST USE 3-22-2012; IN COMMERCE 3-22-2012.

CLASS 25—(Continued).

4,155,528. BROOKS SPORTS, INC., BOTHELL, WA. SN 85-313,603. PUB. 9-27-2011, FILED 5-5-2011.

JUBRALEE

THE MARK CONSISTS OF STANDARD CHARACTERS WITHOUT CLAIM TO ANY PARTICULAR FONT, STYLE, SIZE, OR COLOR.

FOR CLOTHING, NAMELY, SPORTS BRAS (U.S. CLS. 22 AND 39).

FIRST USE 4-4-2011; IN COMMERCE 4-4-2011.

4,155,542. S.H.E. 4.LIFE, LLC, MARION, IN. SN 85-319,739. PUB. 10-4-2011, FILED 5-12-2011.



THE MARK CONSISTS OF THE WORDS/TERMS "SHE" AND "4LIFE" WITH A RIBBON DEPICTED THEREBETWEEN, AND THE WORDS "SURVIVE", "HOPE", AND "EMPOWER" WRITTEN BENEATH.

FOR SPORTSWEAR, NAMELY, T-SHIRTS, SWEATSHIRTS, AND HATS (U.S. CLS. 22 AND 39).

FIRST USE 10-31-2011; IN COMMERCE 10-31-2011.

4,155,574. STANOJEVIC, DEJAN, DOWNEY, CA. SN 85-332,134. PUB. 10-25-2011, FILED 5-27-2011.



THE MARK CONSISTS OF THE STYLIZED TEXT "R" IN A BOX.

FOR HATS; SHIRTS; SHORTS; T-SHIRTS (U.S. CLS. 22 AND 39).

FIRST USE 10-1-2011; IN COMMERCE 1-1-2012.

CLASS 25—(Continued).

4,155,587. WOHALI OUTDOORS, LLC, CLAREMORE, OK. SN 85-336,360. PUB. 11-1-2011, FILED 6-2-2011.

TEN BUCK

THE MARK CONSISTS OF STANDARD CHARACTERS WITHOUT CLAIM TO ANY PARTICULAR FONT, STYLE, SIZE, OR COLOR.

FOR FISHING SHIRTS; HUNTING SHIRTS; LONG-SLEEVED SHIRTS; SHIRTS; SHIRTS AND SHORT-SLEEVED SHIRTS; SHORT-SLEEVED OR LONG-SLEEVED T-SHIRTS; SHORT-SLEEVED SHIRTS; SPORT SHIRTS; SPORTS SHIRTS WITH SHORT SLEEVES; SWEAT SHIRTS; T-SHIRTS; TEE SHIRTS; WEARABLE GARMENTS AND CLOTHING, NAMELY, SHIRTS (U.S. CLS. 22 AND 39).

FIRST USE 6-25-2011; IN COMMERCE 6-25-2011.

4,155,609. BROOKS SPORTS, INC., BOTHELL, WA. SN 85-346,326. PUB. 10-4-2011, FILED 6-14-2011.

QW-K

THE MARK CONSISTS OF STANDARD CHARACTERS WITHOUT CLAIM TO ANY PARTICULAR FONT, STYLE, SIZE, OR COLOR.

FOR FOOTWEAR (U.S. CLS. 22 AND 39).

FIRST USE 5-15-2011; IN COMMERCE 5-15-2011.

4,155,619. LIN, AI GUO, JINJIANG CITY, CHINA. SN 85-347,171. PUB. 11-1-2011, FILED 6-15-2011.



THE MARK CONSISTS OF TWO CHEVRONS PATTERN. FOR BELTS; BOOTS; COATS; FOOTWEAR; HATS; JACKETS; JEANS; SHIRTS; SHOES; SHORTS; SKIRTS; SLIPPERS; SOCKS; SUITS; TIES (U.S. CLS. 22 AND 39). FIRST USE 1-1-2012; IN COMMERCE 1-1-2012.

CLASS 25—(Continued).

4,155,657. DOORN DESIGN LLC, STILLWATER, MN. SN 85-359,829. PUB. 12-6-2011, FILED 6-29-2011.



THE MARK CONSISTS OF A DESIGN OF A HOCKEY SKATE.

FOR BASEBALL CAPS; BEANIES; BELTS; BOXER BRIEFS; COATS; HATS; JERSEYS; PANTS; SHOES; SHORTS; SOCKS; SWEATPANTS; SWEATSHIRTS; T-SHIRTS; TRUNKS; WARM UP SUITS (U.S. CLS. 22 AND 39).

FIRST USE 7-1-2011; IN COMMERCE 11-15-2011.

4,155,669. CHEVEUX CORP., NEW YORK, NY. SN 85-363,092. PUB. 12-6-2011, FILED 7-5-2011.



THE MARK CONSISTS OF THE WORDING "SMART-TIPS" HAVING ITS CHARACTER "I" OVERLAPPED WITH AN INDEX FINGER OF A HAND DESIGN BELOW AND WITH A SYMBOL OF ELECTROMAGNETIC WAVE ABOVE. FOR GLOVES WITH FINGER TIPS PERMITTING USE OF TOUCH SCREENS (U.S. CLS. 22 AND 39). FIRST USE 8-0-2011; IN COMMERCE 8-0-2011.

CLASS 25—(Continued).

4,155,676. LEHIGH VALLEY DISCOUNTS & MORE (LVD), ALLENTOWN, PA. SN 85-363,749. PUB. 12-27-2011, FILED 7-6-2011.

A FAN OF!

THE MARK CONSISTS OF STANDARD CHARACTERS WITHOUT CLAIM TO ANY PARTICULAR FONT, STYLE, SIZE, OR COLOR.

FOR CLOTHING, NAMELY, TOPS, BOTTOMS, HATS, T-SHIRTS, BOXER BRIEFS AND SHORTS, HOODED SWEATSHIRTS, SWEATSHIRTS, POLO SHIRTS, SOCKS, UNDERWEAR (U.S. CLS. 22 AND 39).

FIRST USE 6-1-2011; IN COMMERCE 6-1-2011.

4,155,708. NGUYEN, MAI-TRANG THI, SANTA CLARA, CA. SN 85-370,656. PUB. 12-13-2011, FILED 7-13-2011.

Life is a school of compassion

THE MARK CONSISTS OF STANDARD CHARACTERS WITHOUT CLAIM TO ANY PARTICULAR FONT, STYLE, SIZE, OR COLOR.

FOR HATS; SCARVES; T-SHIRTS (U.S. CLS. 22 AND 39).

FIRST USE 4-20-2000; IN COMMERCE 4-20-2000.

4,155,730. HORSEADAD.COM, EAST AMHERST, NY. SN 85-377,795. PUB. 1-10-2012, FILED 7-21-2011.



NO CLAIM IS MADE TO THE EXCLUSIVE RIGHT TO USE ".COM", APART FROM THE MARK AS SHOWN.

THE MARK CONSISTS OF THE STYLIZED WORDS "HORSE DAD .COM", AN IMAGE OF A HORSE BETWEEN THE WORD "HORSE" AND "DAD".

FOR HATS; SHIRTS (U.S. CLS. 22 AND 39). FIRST USE 1-1-2009; IN COMMERCE 6-1-2011.

CLASS 25—(Continued).

4,155,759. BISSLAND, MARVIN, MT PLEASANT, SC. SN 85-389,366. PUB. 1-3-2012, FILED 8-4-2011.

Sip Without Slippin'

THE MARK CONSISTS OF STANDARD CHARACTERS WITHOUT CLAIM TO ANY PARTICULAR FONT, STYLE, SIZE, OR COLOR.

FOR SLIPPERS; SOCKS; T-SHIRTS (U.S. CLS. 22 AND 39).

FIRST USE 1-11-2012; IN COMMERCE 2-23-2012.

4,155,763. AMERICAN KNOCKOUT WEAR, LLC, DUMFRIES, VA. SN 85-390,679. PUB. 1-24-2012, FILED 8-5-2011.

Fight Responsibly

THE MARK CONSISTS OF STANDARD CHARACTERS WITHOUT CLAIM TO ANY PARTICULAR FONT, STYLE, SIZE, OR COLOR.

FOR ATHLETIC APPAREL, NAMELY, SHIRTS, PANTS, JACKETS, FOOTWEAR, HATS AND CAPS, ATHLETIC UNIFORMS (U.S. CLS. 22 AND 39).

FIRST USE 3-1-2012; IN COMMERCE 3-1-2012.

4,155,803. HANKY PANKY LTD., NEW YORK, NY. SN 85-418,895. PUB. 1-10-2012, FILED 9-9-2011.

THE NAME ON EVERYONE'S HIPS

THE MARK CONSISTS OF STANDARD CHARACTERS WITHOUT CLAIM TO ANY PARTICULAR FONT, STYLE, SIZE, OR COLOR.

FOR G-STRINGS, THONGS, UNDERPANTS, BRALLETTES, BRAS, CAMISOLES, CORSETS, BOYSHORTS, CHEMISES, SLIPS, GOWNS, ROBES, AND SLEEPWEAR (U.S. CLS. 22 AND 39).

FIRST USE 1-20-2012; IN COMMERCE 1-20-2012.

CLASS 26—FANCY GOODS

CLASS 26—(Continued).

4,154,500. SASSY STRINGS, LLC, FT. MYERS, FL. SN 77-873,798. PUB. 10-18-2011, FILED 11-16-2009.



NO CLAIM IS MADE TO THE EXCLUSIVE RIGHT TO USE "STRINGS", APART FROM THE MARK AS SHOWN.

THE MARK CONSISTS OF A BUST OF A LADY WITH THE STYLIZED TEXT "SASSY STRINGS" TO THE RIGHT OF THE BUST WITH A HORIZONTAL LINE BELOW THE BUST AND "SASSY STRINGS". BELOW THE LINE, THERE IS THE STYLIZED TEXT "SO AWESOME SOMEONE STOPS YOU".

FOR HAIR EXTENSIONS (U.S. CLS. 37, 39, 40, 42 AND 50).

FIRST USE 11-17-2009; IN COMMERCE 1-1-2010.

4,154,778. HENNESSY, MOLLY DUGAN, ATLANTA, GA. SN 85-125,232. PUB. 7-26-2011, FILED 9-8-2010.

Cuff It

THE MARK CONSISTS OF STANDARD CHARACTERS WITHOUT CLAIM TO ANY PARTICULAR FONT, STYLE, SIZE, OR COLOR.

FOR PANTS ACCESSORIES COMPRISED OF SOFT BLEND MATERIALS, NAMELY, PANTS BANDS AND PANTS CLIPS FOR SECURING PANT LEGS TO WEARERS' LEGS (U.S. CLS. 37, 39, 40, 42 AND 50).

FIRST USE 10-16-2010; IN COMMERCE 10-16-2010.

4,154,779. HENNESSY, MOLLY DUGAN, ATLANTA, GA. SN 85-125,261. PUB. 7-26-2011, FILED 9-8-2010.

Cuff It Sportz

THE MARK CONSISTS OF STANDARD CHARACTERS WITHOUT CLAIM TO ANY PARTICULAR FONT, STYLE, SIZE, OR COLOR.

NO CLAIM IS MADE TO THE EXCLUSIVE RIGHT TO USE "SPORTS", APART FROM THE MARK AS SHOWN.

FOR PANTS ACCESSORIES COMPRISED OF SOFT BLEND MATERIALS, NAMELY, PANTS BANDS AND PANTS CLIPS FOR SECURING PANT LEGS TO WEARERS' LEGS (U.S. CLS. 37, 39, 40, 42 AND 50).

FIRST USE 10-16-2010; IN COMMERCE 10-16-2010.

CLASS 26—(Continued).

4,154,780. HENNESSY, MOLLY DUGAN, ATLANTA, GA. SN 85-125,275. PUB. 7-26-2011, FILED 9-8-2010.

Cuff It Kidz

THE MARK CONSISTS OF STANDARD CHARACTERS WITHOUT CLAIM TO ANY PARTICULAR FONT, STYLE, SIZE, OR COLOR.

NO CLAIM IS MADE TO THE EXCLUSIVE RIGHT TO USE "KIDS", APART FROM THE MARK AS SHOWN.

FOR PANTS ACCESSORIES COMPRISED OF SOFT BLEND MATERIALS, NAMELY, PANTS BANDS AND PANTS CLIPS FOR SECURING PANT LEGS TO WEARERS' LEGS (U.S. CLS. 37, 39, 40, 42 AND 50).

FIRST USE 10-16-2010; IN COMMERCE 10-16-2010.

4,154,854. SHAKE-N-GO FASHION, INC., PORT WASHINGTON, NY. SN 85-153,422. PUB. 2-15-2011, FILED 10-15-2010.

WEAVING NAPE

THE MARK CONSISTS OF STANDARD CHARACTERS WITHOUT CLAIM TO ANY PARTICULAR FONT, STYLE, SIZE, OR COLOR.

FOR HAIR PRODUCTS, NAMELY, HAIR PIECES, WIGS, HAIR EXTENSIONS, AND PONYTAIL HAIR PIECES (U.S. CLS. 37, 39, 40, 42 AND 50).

FIRST USE 2-8-2011; IN COMMERCE 2-8-2011.

4,154,986. CLEVELETTE AUSTIN, MIAMI, FL. SN 85-218,646. PUB. 12-6-2011, FILED 1-15-2011.

BRIDAL HEADLINES BY CLEVÉ

THE MARK CONSISTS OF STANDARD CHARACTERS WITHOUT CLAIM TO ANY PARTICULAR FONT, STYLE, SIZE, OR COLOR.

NO CLAIM IS MADE TO THE EXCLUSIVE RIGHT TO USE "BRIDAL", APART FROM THE MARK AS SHOWN.

FOR HAIR ACCESSORIES, NAMELY, HAIR BARRETTES AND HAIR CLIPS (U.S. CLS. 37, 39, 40, 42 AND 50).

FIRST USE 2-25-2011; IN COMMERCE 2-25-2011.

CLASS 26—(Continued).

4,155,563. SNAPTAGZ, LLC, BROOKLYN, NY. SN 85-326,357. PUB. 11-8-2011, FILED 5-20-2011.

SNAPTAGZ

THE MARK CONSISTS OF STANDARD CHARACTERS WITHOUT CLAIM TO ANY PARTICULAR FONT, STYLE, SIZE, OR COLOR.

FOR CLOTHING ORNAMENT, NAMELY, PLASTIC CLIPS THAT ATTACH TO ALL CLOTHING (U.S. CLS. 37, 39, 40, 42 AND 50).

FIRST USE 5-6-2011; IN COMMERCE 2-29-2012.

CLASS 26—(Continued).

4,155,845. SUMMIT ENTERTAINMENT, LLC, SANTA MONICA, CA. SN 85-976,693. PUB. 8-24-2010, FILED 4-6-2010.



THE MARK CONSISTS OF A CIRCULAR TRIBAL TATTOO DESIGN DEPICTING TWO WOLVES FACING ONE ANOTHER IN A HOWLING POSITION, SET AMONGST NUMEROUS INTERWOVEN LINES AND SHAPES AND ALL WITHIN THE CIRCLE.

FOR ORNAMENTAL NOVELTY BUTTONS, EMBROIDERED PATCHES FOR CLOTHING, AND ARMBANDS (U.S. CLS. 37, 39, 40, 42 AND 50).

FIRST USE 10-1-2009; IN COMMERCE 10-1-2009.

4,155,820. EVA GABOR INTERNATIONAL, LTD., KANSAS CITY, MO. SN 85-451,422. PUB. 1-10-2012, FILED 10-19-2011.

3D SUN FX

THE MARK CONSISTS OF STANDARD CHARACTERS WITHOUT CLAIM TO ANY PARTICULAR FONT, STYLE, SIZE, OR COLOR.

FOR WIGS, HAIRPIECES, HAIR EXTENSIONS, AND ADD-IN AND ADD-ON HAIR ACCESSORIES CONSTRUCTED PRIMARILY OF SYNTHETIC AND/OR HUMAN HAIR (U.S. CLS. 37, 39, 40, 42 AND 50).

FIRST USE 11-0-2011; IN COMMERCE 11-0-2011.

CLASS 27—FLOOR COVERINGS

4,155,011. ILLUMINUP LLC, SAN JACINTO, CA. SN 85-228,744. PUB. 6-7-2011, FILED 1-28-2011.

ILLUMINUP

THE MARK CONSISTS OF STANDARD CHARACTERS WITHOUT CLAIM TO ANY PARTICULAR FONT, STYLE, SIZE, OR COLOR.

FOR FLOOR MATS; FLOOR MATS FOR USE UNDER AUTOMOBILES; FLOOR MATS FOR VEHICLES, NAMELY, MATS USED TO LIGHT UP FLOOR SURFACES UNDER OR AROUND VEHICLES (U.S. CLS. 19, 20, 37, 42 AND 50).

FIRST USE 1-15-2011; IN COMMERCE 1-15-2011.

CLASS 27—(Continued).

4,155,645. SUNDANCE MARKETING SOLUTIONS, INC., LAS VEGAS, NV. SN 85-355,931. PUB. 11-22-2011, FILED 6-24-2011.

TURF-N THE WORLD

THE MARK CONSISTS OF STANDARD CHARACTERS WITHOUT CLAIM TO ANY PARTICULAR FONT, STYLE, SIZE, OR COLOR.

FOR ARTIFICIAL TURF; SYNTHETIC GRASS (U.S. CLS. 19, 20, 37, 42 AND 50).
FIRST USE 7-0-2011; IN COMMERCE 7-0-2011.

4,155,646. SUNDANCE MARKETING SOLUTIONS, INC., LAS VEGAS, NV. SN 85-355,937. PUB. 11-29-2011, FILED 6-24-2011.



THE MARK CONSISTS OF THE TERM "TURF-N" IN LIGHT SHADED LETTERING AGAINST A DARK SURFBOARD.

FOR ARTIFICIAL TURF; SYNTHETIC GRASS (U.S. CLS. 19, 20, 37, 42 AND 50).
FIRST USE 4-0-2007; IN COMMERCE 10-0-2007.

CLASS 28—TOYS AND SPORTING GOODS

CLASS 28—(Continued).

4,154,284. STARRY LTD., QUARRY BAY, HONG KONG. SN 77-339,801. PUB. 12-30-2008, FILED 11-29-2007.



FOR TOYS AND RELATED GOODS, NAMELY, TOY VEHICLES, RIDE-ON TOYS, TOY CARS, BOARD GAMES, TOY BUILDING BRICKS, DOLLS AND TOY FIGURES AND ACCESSORIES FOR THE AFORESAID, BEAN BAG DOLLS, DOLL PLAYSETS, MUSICAL TOYS, BATH TOYS, INFLATABLE TOYS, PLUSH AND CLOTH TOYS, SPORT BALLS, BALLS FOR GAMES, BALLOONS, HAND HELD BATTERY OPERATED GAMES, PUZZLES, EDUCATIONAL TOYS, NAMELY, MANIPULATIVE BLOCKS FOR DISPLAYING PATTERNS AND GROUPINGS, ELECTRONIC EDUCATIONAL GAME MACHINES FOR CHILDREN, MANIPULATIVE GAMES, TOY ROBOTS, MECHANICAL TOYS, TOY MOBILES, CHILDREN'S MULTIPLE ACTIVITY TOYS, ELECTRIC ACTION TOYS, ELECTRONIC GAMES, NAMELY, ELECTRONIC GAMES OTHER THAN THOSE ADAPTED FOR USE WITH TELEVISION RECEIVERS ONLY, RADIO-CONTROLLED TOY VEHICLES, BATTERY OPERATED REMOTE CONTROLLED TOY VEHICLES, CARD GAMES, ELECTRONICALLY OPERATED INTERACTIVE TOY FIGURES, SCALE MODEL FIGURES, SCALE MODEL VEHICLES, PARTS AND FITTINGS FOR THE AFORESAID (U.S. CLS. 22, 23, 38 AND 50).
FIRST USE 12-22-2011; IN COMMERCE 12-22-2011.

4,154,295. HERSCH AND COMPANY, LOS ANGELES, CA. SN 77-412,772. PUB. 7-22-2008, FILED 3-4-2008.



THE COLOR(S) RED, WHITE AND BLACK IS/ARE CLAIMED AS A FEATURE OF THE MARK.

CLASS 28—(Continued).

THE MARK CONSISTS OF A RED BACKGROUND SQUARE. THE LETTER "Y" IS WHITE. THE LETTER "Y" IS SURROUNDED BY THE COLOR BLACK.

FOR BOARD GAMES; PARLOUR GAMES (U.S. CLS. 22, 23, 38 AND 50).
FIRST USE 10-14-2011; IN COMMERCE 10-14-2011.

4,154,346. PARTYDRAGON LIMITED, CENTRAL, HONG KONG. SN 77-558,809. PUB. 6-23-2009, FILED 8-29-2008.

PARTY DRAGON

THE MARK CONSISTS OF STANDARD CHARACTERS WITHOUT CLAIM TO ANY PARTICULAR FONT, STYLE, SIZE, OR COLOR.

NO CLAIM IS MADE TO THE EXCLUSIVE RIGHT TO USE "PARTY", APART FROM THE MARK AS SHOWN.
FOR LATEX BALLOONS (U.S. CLS. 22, 23, 38 AND 50).
FIRST USE 9-14-2011; IN COMMERCE 9-14-2011.

4,154,390. THE MUPPETS STUDIO, LLC, BURBANK, CA. SN 77-666,779. PUB. 12-8-2009, FILED 2-9-2009.

FOZZIE BEAR

THE MARK CONSISTS OF STANDARD CHARACTERS WITHOUT CLAIM TO ANY PARTICULAR FONT, STYLE, SIZE, OR COLOR.

NO CLAIM IS MADE TO THE EXCLUSIVE RIGHT TO USE "BEAR", APART FROM THE MARK AS SHOWN.
FOR DOLLS (U.S. CLS. 22, 23, 38 AND 50).
FIRST USE 10-31-2011; IN COMMERCE 10-31-2011.

4,154,487. RUBLE, SCOTT, J, SANTA CRUZ, CA. SN 77-855,302. PUB. 9-28-2010, FILED 10-22-2009.



NO CLAIM IS MADE TO THE EXCLUSIVE RIGHT TO USE "PADDLE SURF", APART FROM THE MARK AS SHOWN.

CLASS 28—(Continued).

THE MARK CONSISTS OF A STAND UP PADDLE SURFER HOLDING A PADDLE AND SURFING A WAVE ABOVE THE WORD "COVEWATER" ABOVE THE WORDS "PADDLE" AND "SURF" WITH A SINGLE LINE DIAMOND BETWEEN THE WORDS "PADDLE" AND "SURF" WITH A PADDLE BLADE AND A SHORT PORTION OF A PADDLE SHAFT INSIDE OF IT.

FOR PADDLE SURFBOARDS; PADDLES FOR USE WITH SURFBOARDS; STAND-UP SURF PADDLES; SURF PADDLES (U.S. CLS. 22, 23, 38 AND 50).
FIRST USE 1-25-2012; IN COMMERCE 1-25-2012.

4,154,517. LIFESTYLE BRANDS CORPORATION, ENGLEWOOD, CO. SN 77-910,808. PUB. 6-8-2010, FILED 1-13-2010.



THE MARK CONSISTS OF THE WORD "MITEREDGE" TO THE LEFT OF AND BELOW AN IMAGE OF A MITER RULER.

FOR SNOWBOARD DECKS; SNOWBOARDS, AND NOT INCLUDING SOCCER BALLS, RUGBY BALLS, VOLLEYBALLS, FOOTBALLS AND WHISTLES" (U.S. CLS. 22, 23, 38 AND 50).
FIRST USE 11-1-2009; IN COMMERCE 9-1-2010.

4,154,559. KUUSAMON UISTIN OY, KUUSAMO, FINLAND. SN 77-962,842. PUB. 8-10-2010, FILED 3-18-2010.



THE MARK CONSISTS OF THE TERMS "FINN" AND "GRIP" EXTENDING HORIZONTALLY AND CONNECTED TO EACH OTHER BUT STAGGERED FROM EACH OTHER IN THE VERTICAL DIRECTION.

FOR SKI BINDINGS (U.S. CLS. 22, 23, 38 AND 50).
FIRST USE 5-8-1987; IN COMMERCE 2-29-2012.

CLASS 28—(Continued).

4,154,581. BELLATOR SPORT WORLDWIDE LLC, CHICAGO, IL. SN 77-982,923. PUB. 8-24-2010, FILED 12-16-2008.



NO CLAIM IS MADE TO THE EXCLUSIVE RIGHT TO USE "FIGHTING CHAMPIONSHIPS", APART FROM THE MARK AS SHOWN.

THE COLOR(S) METALLIC GRAY, RED, AND BLACK IS/ARE CLAIMED AS A FEATURE OF THE MARK.

THE MARK CONSISTS OF THE WORD "BELLATOR" IN METALLIC GRAY STYLIZED SCRIPT OUTLINED IN RED, ABOVE THE WORDS "FIGHTING CHAMPIONSHIPS" IN METALLIC GRAY STYLIZED SCRIPT, AND SURROUNDED BY A RED RECTANGULAR BORDER WITH A BLACK BACKGROUND, BELOW A DESIGN OF A MAN WEARING A METALLIC GRAY WARRIOR'S HELMET WITH RED FEATHERS AND A RED STRIPE DOWN THE CENTER AND BLACK SHADOWING, ALL APPEARING WITHIN A METALLIC GRAY AND RED CONCENTRIC OVAL FRAME WITH A BLACK BACKGROUND.

FOR TRAINING APPARATUS FOR BOXING, MARTIAL ARTS AND SIMILAR SPORTS; BOXING GLOVES; MIXED MARTIAL ARTS GLOVES; SPORTS EQUIPMENT FOR BOXING, MARTIAL ARTS, AND THE LIKE, NAMELY, PROTECTIVE BRAS; EXERCISING EQUIPMENT, NAMELY, WEIGHT LIFTING MACHINES; EXERCISE WEIGHTS; JUMP ROPES; ATHLETIC PROTECTIVE PADS FOR MIXED MARTIAL ARTS, BOXING, WRESTLING AND OTHER MARTIAL ARTS; MEDICINE BALLS; PUNCHING BAGS; PUNCHING BALLS (U.S. CLS. 22, 23, 38 AND 50).

FIRST USE 12-16-2008; IN COMMERCE 3-5-2010.

4,154,616. PUJOL, JAIME, MIAMI, FL. SN 85-005,817. PUB. 11-30-2010, FILED 4-4-2010.

UNSINKABLE DREAM

THE MARK CONSISTS OF STANDARD CHARACTERS WITHOUT CLAIM TO ANY PARTICULAR FONT, STYLE, SIZE, OR COLOR.

FOR FLOATS FOR RECREATIONAL USE, NAMELY, FOAM FLOATS (U.S. CLS. 22, 23, 38 AND 50).

FIRST USE 8-28-2011; IN COMMERCE 1-20-2012.

CLASS 28—(Continued).

4,154,789. NAMCO BANDAI GAMES INC., SHINAGAWA-KU TOKYO, JAPAN. SN 85-129,317. PUB. 1-25-2011, FILED 9-14-2010.

DEADSTORM PIRATES

THE MARK CONSISTS OF STANDARD CHARACTERS WITHOUT CLAIM TO ANY PARTICULAR FONT, STYLE, SIZE, OR COLOR.

NO CLAIM IS MADE TO THE EXCLUSIVE RIGHT TO USE "PIRATES", APART FROM THE MARK AS SHOWN.

FOR COIN-OPERATED AMUSEMENT MACHINES (U.S. CLS. 22, 23, 38 AND 50).

FIRST USE 5-24-2010; IN COMMERCE 5-24-2010.

4,154,814. AQUA-LEISURE INDUSTRIES, INC., AVON, MA. SN 85-139,680. PUB. 8-23-2011, FILED 9-28-2010.

WATER LIFE

THE MARK CONSISTS OF STANDARD CHARACTERS WITHOUT CLAIM TO ANY PARTICULAR FONT, STYLE, SIZE, OR COLOR.

NO CLAIM IS MADE TO THE EXCLUSIVE RIGHT TO USE "WATER", APART FROM THE MARK AS SHOWN.

FOR INFLATABLE FLOATING RECREATIONAL LOUNGE CHAIRS, CHAIRS, RECLINING CHAIRS AND INFLATABLE TUBES FOR USE IN AND AROUND WATER (U.S. CLS. 22, 23, 38 AND 50).

FIRST USE 2-0-2011; IN COMMERCE 2-0-2011.

4,154,816. YARN GAMES AND MORE, LLC, SAN FRANCISCO, CA. SN 85-139,931. PUB. 3-15-2011, FILED 9-28-2010.



COLOR IS NOT CLAIMED AS A FEATURE OF THE MARK.

CLASS 28—(Continued).

THE MARK CONSISTS OF FOUR SHEEP, ONE OF WHICH IS HOLDING KNITTING NEEDLES AND STANDING ABOVE ANOTHER HOLDING YARN AND KNITTING NEEDLES, ANOTHER HOLDING YARN AND ANOTHER HOLDING NOTHING, WITH A BANNER CONTAINING THE WORDING "LAST KNITTER STANDING" AND THE WORDING "A KNITTING GAME".

FOR KNITTING GAMES (U.S. CLS. 22, 23, 38 AND 50).
FIRST USE 1-10-2010; IN COMMERCE 4-15-2011.

CLASS 28—(Continued).

4,154,928. PATCH PRODUCTS, INC., BELOIT, WI. SN 85-200,133. PUB. 4-26-2011, FILED 12-16-2010.

4,154,824. YIPE MEDIA, INC., ROCHESTER, WA. SN 85-143,288. PUB. 3-15-2011, FILED 10-1-2010.

DESIGN 'N' DOODLE

BASTARDBLASTERS

THE MARK CONSISTS OF STANDARD CHARACTERS WITHOUT CLAIM TO ANY PARTICULAR FONT, STYLE, SIZE, OR COLOR.

FOR CLAY PIGEON TARGETS; NOVELTY ITEMS, NAMELY, CLAY PIGEON TARGETS BEARING CARTOON IMAGES OF POLITICIANS (U.S. CLS. 22, 23, 38 AND 50).

FIRST USE 12-10-2010; IN COMMERCE 12-10-2010.

THE MARK CONSISTS OF STANDARD CHARACTERS WITHOUT CLAIM TO ANY PARTICULAR FONT, STYLE, SIZE, OR COLOR.

FOR PLAYSETS FOR MAGNETIC AND DRY ERASE ACTIVITY BOARDS (U.S. CLS. 22, 23, 38 AND 50).

FIRST USE 2-1-2011; IN COMMERCE 2-1-2011.

4,154,859. WEAVER'S OUTDOOR, INC., HUMMELSTOWN, PA. SN 85-156,659. PUB. 4-12-2011, FILED 10-20-2010.

4,154,929. PATCH PRODUCTS, INC., BELOIT, WI. SN 85-200,509. PUB. 4-26-2011, FILED 12-17-2010.



SWIVEL

OWNER OF U.S. REG. NOS. 1,438,149 AND 3,150,441.
THE MARK CONSISTS OF A STYLIZED REPRESENTATION OF A WASP.

FOR ARCHERY AND CROSSBOW EQUIPMENT, NAMELY, BOLTS (U.S. CLS. 22, 23, 38 AND 50).
FIRST USE 5-5-2011; IN COMMERCE 5-5-2011.

THE MARK CONSISTS OF STANDARD CHARACTERS WITHOUT CLAIM TO ANY PARTICULAR FONT, STYLE, SIZE, OR COLOR.

FOR BOARD GAMES; PARLOUR GAMES (U.S. CLS. 22, 23, 38 AND 50).
FIRST USE 2-1-2011; IN COMMERCE 2-1-2011.

CLASS 28—(Continued).

4,155,045. TONY B. WHITESIDE, SHEPHERDSVILLE, KY.
SN 85-237,775. PUB. 6-14-2011, FILED 2-9-2011.



THE MARK CONSISTS OF AN INVERTED ARCH LOCATED ABOVE TWO SLIGHTLY ARCHED FIGURES AND A "V" SHAPE WITH POINTED END DOWN LOCATED BELOW THE TWO SLIGHTLY ARCHED FIGURES DEPICTING A FACE.

FOR REMOTE-CONTROL MODEL AIRCRAFT, REMOTE-CONTROL MODEL HELICOPTERS, AND REPLACEMENT PARTS AND ACCESSORIES FOR THE AFORESAID GOODS (U.S. CLS. 22, 23, 38 AND 50).
FIRST USE 11-25-2011; IN COMMERCE 12-15-2011.

4,155,084. QUBICAAMF WORLDWIDE, S.A.R.L., LUXEMBOURG, LUXEMBOURG. SN 85-244,087. PUB. 6-28-2011, FILED 2-16-2011.

SMARTGUARD

THE MARK CONSISTS OF STANDARD CHARACTERS WITHOUT CLAIM TO ANY PARTICULAR FONT, STYLE, SIZE, OR COLOR.

OWNER OF U.S. REG. NOS. 1,900,000 AND 2,040,903.
FOR BOWLING PINSETTERS AND PARTS THEREFOR (U.S. CLS. 22, 23, 38 AND 50).
FIRST USE 9-30-2010; IN COMMERCE 2-20-2011.

4,155,090. MULTIPET INTERNATIONAL, INC., MOONACHIE, NJ. SN 85-244,943. PUB. 7-19-2011, FILED 2-17-2011.

Woofie Cushion

THE MARK CONSISTS OF STANDARD CHARACTERS WITHOUT CLAIM TO ANY PARTICULAR FONT, STYLE, SIZE, OR COLOR.

CLASS 28—(Continued).

NO CLAIM IS MADE TO THE EXCLUSIVE RIGHT TO USE "CUSHION", APART FROM THE MARK AS SHOWN.
FOR PET TOYS (U.S. CLS. 22, 23, 38 AND 50).
FIRST USE 2-29-2012; IN COMMERCE 2-29-2012.

4,155,240. REQUISITE SOLUTIONS INCORPORATED, CHICAGO, IL. SN 85-260,821. PUB. 8-9-2011, FILED 3-8-2011.

The Science of Attraction

THE MARK CONSISTS OF STANDARD CHARACTERS WITHOUT CLAIM TO ANY PARTICULAR FONT, STYLE, SIZE, OR COLOR.

FOR EDUCATIONAL TOY MAGNETIC PLAYSETS COMPRISED OF FLEXIBLE AND NON-FLEXIBLE MAGNETS AND MAGNETIC PLAY SURFACES DESIGNED TO HOUSE AND ATTRACT MAGNETS AND MAGNETIC COMPONENTS THAT MAY BE SET UP FOR PORTABLE AND STATIONARY USE (U.S. CLS. 22, 23, 38 AND 50).

FIRST USE 11-28-2003; IN COMMERCE 3-1-2012.

4,155,311. EASTMAN OUTDOORS, INC., FLUSHING, MI. SN 85-268,266. PUB. 7-19-2011, FILED 3-16-2011.

LA FEMME DANGEREUSE

THE MARK CONSISTS OF STANDARD CHARACTERS WITHOUT CLAIM TO ANY PARTICULAR FONT, STYLE, SIZE, OR COLOR.

THE ENGLISH TRANSLATION OF "LA FEMME DANGEREUSE" IN THE MARK IS THE DANGEROUS WOMAN.
FOR ARROWS (U.S. CLS. 22, 23, 38 AND 50).
FIRST USE 5-0-2011; IN COMMERCE 5-0-2011.

4,155,314. SRI SPORTS LIMITED, KOBE-SHI, HYOGO, JAPAN. SN 85-268,596. PUB. 8-2-2011, FILED 3-16-2011.

CONNOISSEUR

THE MARK CONSISTS OF STANDARD CHARACTERS WITHOUT CLAIM TO ANY PARTICULAR FONT, STYLE, SIZE, OR COLOR.

FOR GOLF CLUBS, NAMELY, PUTTERS (U.S. CLS. 22, 23, 38 AND 50).
FIRST USE 7-0-2011; IN COMMERCE 7-0-2011.

CLASS 28—(Continued).

4,155,329. WIZARDS OF THE COAST LLC, PAWTUCKET, RI. SN 85-270,510. PUB. 8-9-2011, FILED 3-18-2011.

THE LEGEND OF DRIZZT

THE MARK CONSISTS OF STANDARD CHARACTERS WITHOUT CLAIM TO ANY PARTICULAR FONT, STYLE, SIZE, OR COLOR.

OWNER OF U.S. REG. NO. 3,512,975.
FOR TOYS, GAMES AND PLAYTHINGS, NAMELY, BOARD GAMES AND ACCESSORIES FOR USE THEREWITH (U.S. CLS. 22, 23, 38 AND 50).
FIRST USE 10-18-2011; IN COMMERCE 10-18-2011.

4,155,336. BIG FISH AMERICA, L.L.C., BEMIDJI, MN. SN 85-271,525. PUB. 8-2-2011, FILED 3-19-2011.

SLICK STICK

THE MARK CONSISTS OF STANDARD CHARACTERS WITHOUT CLAIM TO ANY PARTICULAR FONT, STYLE, SIZE, OR COLOR.

NO CLAIM IS MADE TO THE EXCLUSIVE RIGHT TO USE "STICK", APART FROM THE MARK AS SHOWN.
FOR FISHING TACKLE (U.S. CLS. 22, 23, 38 AND 50).
FIRST USE 2-1-2012; IN COMMERCE 2-2-2012.

4,155,405. INNOVATIVE DESIGN & SOURCING, LLC, MILFORD, CT. SN 85-283,368. PUB. 7-5-2011, FILED 4-1-2011.

TAIL WAGGIN' FUN

THE MARK CONSISTS OF STANDARD CHARACTERS WITHOUT CLAIM TO ANY PARTICULAR FONT, STYLE, SIZE, OR COLOR.

FOR TOYS FOR DOMESTIC PETS (U.S. CLS. 22, 23, 38 AND 50).
FIRST USE 11-14-2011; IN COMMERCE 12-9-2011.

CLASS 28—(Continued).

4,155,432. ANDREA M. GRISWELL, STONE MOUNTAIN, GA. SN 85-286,408. PUB. 8-23-2011, FILED 4-5-2011.

THE 21ST CENTURY TEDDY BEAR

THE MARK CONSISTS OF STANDARD CHARACTERS WITHOUT CLAIM TO ANY PARTICULAR FONT, STYLE, SIZE, OR COLOR.

NO CLAIM IS MADE TO THE EXCLUSIVE RIGHT TO USE "TEDDY BEAR", APART FROM THE MARK AS SHOWN.

FOR TOYS, NAMELY, PLUSH DOLLS (U.S. CLS. 22, 23, 38 AND 50).
FIRST USE 3-15-2012; IN COMMERCE 3-15-2012.

4,155,461. NORTH AMERICAN SOCCER LEAGUE, LLC, MIAMI, FL. SN 85-293,460. PUB. 9-6-2011, FILED 4-12-2011.



NO CLAIM IS MADE TO THE EXCLUSIVE RIGHT TO USE THE GEOGRAPHIC DESIGN OF NORTH AMERICA, APART FROM THE MARK AS SHOWN.

THE MARK CONSISTS OF THE LETTERS "NASL" ABOVE A DESIGN OF A SOCCER BALL WITH STARS AND A DEPICTION OF NORTH AMERICAN WITHIN A SHIELD.

FOR SOCCER BALLS (U.S. CLS. 22, 23, 38 AND 50).
FIRST USE 7-4-2011; IN COMMERCE 7-4-2011.

CLASS 28—(Continued).

4,155,549. NATIONAL ASSOCIATION FOR STOCK CAR AUTO RACING, INC., DAYTONA BEACH, FL. SN 85-322,537. PUB. 8-30-2011, FILED 5-17-2011.

NASCAR AUTHENTICS

THE MARK CONSISTS OF STANDARD CHARACTERS WITHOUT CLAIM TO ANY PARTICULAR FONT, STYLE, SIZE, OR COLOR.

OWNER OF U.S. REG. NOS. 817,553, 1,054,100, AND OTHERS.

NO CLAIM IS MADE TO THE EXCLUSIVE RIGHT TO USE "AUTHENTICS", APART FROM THE MARK AS SHOWN.

FOR TOYS, GAMES AND PLAYTHINGS, NAMELY, DIE CAST MINIATURE CARS, DIE CAST MINIATURE TRUCKS, DIE CAST MINIATURE CARS CONVERTING INTO OTHER VISUAL TOY FORMS, DIE CAST MINIATURE TRUCKS CONVERTING INTO OTHER VISUAL TOY FORMS, BOARD GAMES, CARD GAMES, ACTION FIGURES, ACTION FIGURE PLAY SETS, ACTION FIGURE PLAY SETS WITH MOVEABLE PARTS AND AUDIO CAPABILITIES, PROTECTIVE CARRYING CASES SPECIALLY ADAPTED FOR HANDHELD VIDEO GAMES, CHARACTER FIGURES, CHARACTER FIGURES WITH MOVEABLE PARTS AND AUDIO CAPABILITIES, TOY BUILDING SETS, ELECTRONIC ACTION TOYS, RACE TRACK PLAY SETS, ELECTRONIC RACE TRACK PLAY SETS, RACE TRACK PLAY SETS WITH REMOVABLE PARTS, REMOTE CONTROL CARS, REMOTE CONTROL TRUCKS, HAND-HELD GAMES OTHER THAN THOSE ADAPTED FOR USE WITH AN EXTERNAL DISPLAY SCREEN OR MONITOR (U.S. CLS. 22, 23, 38 AND 50).

FIRST USE 1-31-2012; IN COMMERCE 1-31-2012.

4,155,550. NATIONAL ASSOCIATION FOR STOCK CAR AUTO RACING, INC., DAYTONA BEACH, FL. SN 85-322,547. PUB. 8-30-2011, FILED 5-17-2011.

NASCAR FULL BLAST

THE MARK CONSISTS OF STANDARD CHARACTERS WITHOUT CLAIM TO ANY PARTICULAR FONT, STYLE, SIZE, OR COLOR.

CLASS 28—(Continued).

OWNER OF U.S. REG. NOS. 817,553, 1,054,100, AND OTHERS.

FOR TOYS, GAMES AND PLAYTHINGS, NAMELY, DIE CAST MINIATURE CARS, DIE CAST MINIATURE TRUCKS, DIE CAST MINIATURE CARS CONVERTING INTO OTHER VISUAL TOY FORMS, DIE CAST MINIATURE TRUCKS CONVERTING INTO OTHER VISUAL TOY FORMS, BOARD GAMES, CARD GAMES, ACTION FIGURES, ACTION FIGURE PLAY SETS, ACTION FIGURE PLAY SETS WITH MOVEABLE PARTS AND AUDIO CAPABILITIES, PROTECTIVE CARRYING CASES SPECIALLY ADAPTED FOR HANDHELD VIDEO GAMES, CHARACTER FIGURES, CHARACTER FIGURES WITH MOVEABLE PARTS AND AUDIO CAPABILITIES, TOY BUILDING SETS, ELECTRONIC ACTION TOYS, RACE TRACK PLAY SETS, ELECTRONIC RACE TRACK PLAY SETS, RACE TRACK PLAY SETS WITH REMOVABLE PARTS, REMOTE CONTROL CARS, REMOTE CONTROL TRUCKS, HAND-HELD GAMES OTHER THAN THOSE ADAPTED FOR USE WITH AN EXTERNAL DISPLAY SCREEN OR MONITOR (U.S. CLS. 22, 23, 38 AND 50).

FIRST USE 1-31-2012; IN COMMERCE 1-31-2012.

4,155,561. FOX 40 INTERNATIONAL INC., STONEY CREEK, ONTARIO, CANADA. SN 85-325,780. PUB. 10-11-2011, FILED 5-20-2011.

GRIPPGUARD

THE MARK CONSISTS OF STANDARD CHARACTERS WITHOUT CLAIM TO ANY PARTICULAR FONT, STYLE, SIZE, OR COLOR.

FOR ATHLETIC EQUIPMENT, NAMELY, MOUTH GUARDS; MOUTH GUARDS FOR ATHLETIC USE (U.S. CLS. 22, 23, 38 AND 50).

FIRST USE 1-1-2011; IN COMMERCE 1-1-2011.

4,155,562. FOX 40 INTERNATIONAL INC., STONEY CREEK, ONTARIO, CANADA. SN 85-325,799. PUB. 10-11-2011, FILED 5-20-2011.

FLEXXGUARD

THE MARK CONSISTS OF STANDARD CHARACTERS WITHOUT CLAIM TO ANY PARTICULAR FONT, STYLE, SIZE, OR COLOR.

FOR ATHLETIC EQUIPMENT, NAMELY, MOUTH GUARDS; MOUTH GUARDS FOR ATHLETIC USE (U.S. CLS. 22, 23, 38 AND 50).

FIRST USE 1-1-2011; IN COMMERCE 1-1-2011.

CLASS 28—(Continued).

4,155,623. LIMAX INTERNATIONAL INC., TAIPEI CITY 105, TAIWAN. SN 85-348,437. PUB. 11-1-2011, FILED 6-16-2011.



THE MARK CONSISTS OF THE STYLIZED WORDING "GOELLIPTICAL" WITH A CONCAVE SHAPE PLACED ABOVE AND TO THE RIGHT OF THE WORDING.

FOR ACCESSORIES FOR MANUALLY-OPERATED EXERCISE EQUIPMENT, NAMELY, ACCESSORY ATTACHMENTS TO INCREASE MUSCLE RESISTANCE; ATHLETIC EQUIPMENT, NAMELY, HAND WRAPS; ATHLETIC PROTECTIVE PADS FOR PARTS OF SPORTS SUITS; ELLIPTICAL EXERCISE MACHINES; EXERCISE APPARATUS, NAMELY, SLOSH BARS, MANUALLY OPERATED JOGGING MACHINES, STAIR-STEPPING MACHINES, CHEST EXPANDERS, NECK AND SHOULDER SUPPORTED WEIGHTS FOR TWISTING AND LIFTING EXERCISES; EXERCISE EQUIPMENT, NAMELY, EXERCISE BANDS, TRAINING BARS, ROWING MACHINES (NOT FOR PHYSICAL THERAPY PURPOSES); EXERCISE MACHINES; EXERCISE MACHINES INCORPORATING ELECTRONIC AND VIDEO GAME CONTROLLERS; EXERCISE PLATFORMS; EXERCISE TREADMILLS; EXERCISE WEIGHTS; EXERCISE WRIST WEIGHTS; EXERCISING EQUIPMENT, NAMELY, MANUALLY OPERATED JOGGING MACHINES, POWERED TREADMILLS FOR RUNNING; FITNESS MACHINES AND EQUIPMENT, NAMELY, WEIGHTS, TREADMILLS, ROWING MACHINES, STAIR STEPPING MACHINES, RESISTANCE MACHINES, STATIONARY CYCLES; GIFT BASKETS COMPRISED PRIMARILY OF IMITATION TOYS SPORTS PRODUCTS, NAMELY, TOY GAME BALLS AND ACCESSORIES THEREFOR; MANUALLY-OPERATED EXERCISE EQUIPMENT; PERSONAL EXERCISE MATS; PHYSICAL FITNESS EQUIPMENT, NAMELY, EXERCISE BANDS, TRAINING BARS; STORAGE APPARATUS COMPRISING HOOKS, SUPPORT ARMS, AND SHELVING SPECIALLY ADAPTED FOR SPORTS EQUIPMENT; STORAGE RACKS FOR ATHLETIC EQUIPMENT; TOY MODEL CARS; STATIONARY EXERCISE BICYCLES; BODY-BUILDING APPARATUS (U.S. CLS. 22, 23, 38 AND 50).

FIRST USE 10-20-2011; IN COMMERCE 10-20-2011.

4,155,630. BAY TEK GAMES, INC., PULASKI, WI. SN 85-350,165. PUB. 11-8-2011, FILED 6-20-2011.

THE GRAND FUN-ALLEY

THE MARK CONSISTS OF STANDARD CHARACTERS WITHOUT CLAIM TO ANY PARTICULAR FONT, STYLE, SIZE, OR COLOR.

FOR ARCADE GAMES, NAMELY, A BOWLING GAME FEATURING A COMPUTERIZED SCORING SYSTEM TO TRACK THE SCORES OF MULTIPLE PLAYERS (U.S. CLS. 22, 23, 38 AND 50).

FIRST USE 2-1-2012; IN COMMERCE 2-1-2012.

CLASS 28—(Continued).

4,155,648. HUBBARD, JODINE, DBA THE OTHER SIDE OF GOOD, SARASOTA, FL. SN 85-356,361. PUB. 12-13-2011, FILED 6-25-2011.

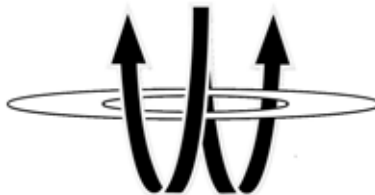

THE COLOR(S) BLACK AND WHITE IS/ARE CLAIMED AS A FEATURE OF THE MARK.

THE MARK CONSISTS OF BLACK LETTER "W" WITH ARROWS AT THE FIRST AND THIRD UPWARD PART OF THE "W", WHITE OVAL HALO WOUND INSIDE THE FIRST LEG OF THE "W" AND OUTSIDE THE LAST LEG OF THE "W", INCLUDING WHITE SHADOWING AROUND THE "W" AND ARROWS.

FOR GAMES, NAMELY, BOARD GAMES; PARTY GAMES; CARD GAMES (U.S. CLS. 22, 23, 38 AND 50).

FIRST USE 2-12-2009; IN COMMERCE 3-10-2012.

4,155,664. PETSPOUR USA, INC., PITTSBURG, CA. SN 85-361,210. PUB. 11-22-2011, FILED 6-30-2011.

DISCUS MAXIMUS

THE MARK CONSISTS OF STANDARD CHARACTERS WITHOUT CLAIM TO ANY PARTICULAR FONT, STYLE, SIZE, OR COLOR.

FOR PET TOYS (U.S. CLS. 22, 23, 38 AND 50).

FIRST USE 3-7-2012; IN COMMERCE 3-7-2012.

4,155,688. MATTEL, INC., EL SEGUNDO, CA. SN 85-365,674. PUB. 12-6-2011, FILED 7-7-2011.

FRUITY DRINK TIME!

THE MARK CONSISTS OF STANDARD CHARACTERS WITHOUT CLAIM TO ANY PARTICULAR FONT, STYLE, SIZE, OR COLOR.

FOR DOLL ACCESSORIES (U.S. CLS. 22, 23, 38 AND 50).

FIRST USE 3-29-2012; IN COMMERCE 3-29-2012.

CLASS 28—(Continued).

4,155,737. JANLYNN CORP., CHICOPEE, MA. SN 85-380,666. PUB. 12-20-2011, FILED 7-26-2011.

STITCHABLES

THE MARK CONSISTS OF STANDARD CHARACTERS WITHOUT CLAIM TO ANY PARTICULAR FONT, STYLE, SIZE, OR COLOR.

FOR HOBBY NEEDLECRAFT KITS COMPRISING THREAD, EMBROIDERY FLOSS, YARN, NEEDLES, FABRIC, PLASTIC SHEETS, RIBBONS, PATTERNS, BATTING, FRAMES, MOUNTING BOARDS, BASE BOARDS AND INSTRUCTIONS (U.S. CLS. 22, 23, 38 AND 50).

FIRST USE 1-18-2012; IN COMMERCE 1-18-2012.

4,155,760. KAATZ, EVELYN, BELMONT, MA. SN 85-389,377. PUB. 1-24-2012, FILED 8-4-2011.

JUMPIN' CHIPS

THE MARK CONSISTS OF STANDARD CHARACTERS WITHOUT CLAIM TO ANY PARTICULAR FONT, STYLE, SIZE, OR COLOR.

NO CLAIM IS MADE TO THE EXCLUSIVE RIGHT TO USE "CHIPS", APART FROM THE MARK AS SHOWN.

FOR BOARD GAMES FOR MATHEMATICAL INSTRUCTION (U.S. CLS. 22, 23, 38 AND 50).

FIRST USE 3-13-2012; IN COMMERCE 3-13-2012.

4,155,775. YARITZ, BRADLEY JOHN, DBA CATCH IT!, WHITE BEAR LAKE, MN. SN 85-397,142. PUB. 1-10-2012, FILED 8-12-2011.



THE MARK CONSISTS OF THE LETTERS IN "ECO-JIG" CONTAIN TWO CAPITALS, ONE "E" AND ONE "J". THE TWO WORDS ARE SEPARATED BY A HYPHEN. ALL TEXT IS IN CALIFORNIAN FB.

FOR FISHING TACKLE (U.S. CLS. 22, 23, 38 AND 50). FIRST USE 3-15-2011; IN COMMERCE 1-12-2012.

CLASS 29—MEATS AND PROCESSED FOODS**CLASS 29—(Continued).**

4,154,260. TROPICAL CHEESE INDUSTRIES, INC., PERTH AMBOY, NJ. SN 76-706,812. PUB. 7-26-2011, FILED 3-15-2011.

EL SABOR DE QUISQUEYA

THE MARK CONSISTS OF STANDARD CHARACTERS WITHOUT CLAIM TO ANY PARTICULAR FONT, STYLE, SIZE, OR COLOR.

OWNER OF U.S. REG. NOS. 2,298,804, 3,481,153, AND OTHERS.

NO CLAIM IS MADE TO THE EXCLUSIVE RIGHT TO USE "QUISQUEYA", APART FROM THE MARK AS SHOWN.

THE ENGLISH TRANSLATION OF THE MARK IS "THE FLAVOR OF QUISQUEYA".

FOR CHEESES, MEATS, DRINKABLE YOGURTS, AND DAIRY CREAMS (U.S. CL. 46).

FIRST USE 7-10-2011; IN COMMERCE 7-10-2011.

4,154,261. TROPICAL CHEESE INDUSTRIES, INC., PERTH AMBOY, NJ. SN 76-706,813. PUB. 7-26-2011, FILED 3-15-2011.

FLAVOR OF QUISQUEYA

THE MARK CONSISTS OF STANDARD CHARACTERS WITHOUT CLAIM TO ANY PARTICULAR FONT, STYLE, SIZE, OR COLOR.

OWNER OF U.S. REG. NOS. 2,298,804, 3,481,153, AND OTHERS.

NO CLAIM IS MADE TO THE EXCLUSIVE RIGHT TO USE "QUISQUEYA", APART FROM THE MARK AS SHOWN.

FOR CHEESES, MEATS, DRINKABLE YOGURTS, AND DAIRY CREAMS (U.S. CL. 46).

FIRST USE 7-10-2011; IN COMMERCE 7-10-2011.

4,154,292. RADLO FOODS LLC, WATERTOWN, MA. SN 77-398,168. PUB. 1-13-2009, FILED 2-15-2008.

BORN FREE

THE MARK CONSISTS OF STANDARD CHARACTERS WITHOUT CLAIM TO ANY PARTICULAR FONT, STYLE, SIZE, OR COLOR.

OWNER OF U.S. REG. NO. 2,741,175.

FOR POULTRY AND DAIRY PRODUCTS, NAMELY, MILK (U.S. CL. 46).

FIRST USE 12-19-2011; IN COMMERCE 12-19-2011.

CLASS 29—(Continued).

4,154,498. MICHAEL FOODS OF DELAWARE, INC., MINNEAPOLIS, MN. SN 77-871,860. PUB. 1-10-2012, FILED 11-13-2009.

SIMPLY POTATOES STEAMABLES

THE MARK CONSISTS OF STANDARD CHARACTERS WITHOUT CLAIM TO ANY PARTICULAR FONT, STYLE, SIZE, OR COLOR.

OWNER OF U.S. REG. NOS. 1,596,986, 1,766,860, AND 2,374,745.

NO CLAIM IS MADE TO THE EXCLUSIVE RIGHT TO USE "POTATOES STEAMABLES", APART FROM THE MARK AS SHOWN.

FOR MICROWAVABLE PROCESSED POTATOES PURCHASED REFRIGERATED (U.S. CL. 46).

FIRST USE 1-31-2012; IN COMMERCE 1-31-2012.

CLASS 29—(Continued).

THE MARK CONSISTS OF STYLIZED LETTERS WITH A DRAWING OF A RED PEPPER. THE PEPPER STEM AND WORDING APPEAR IN BLACK ON A WHITE BACKGROUND.

FOR FROZEN PRE-PACKAGED ENTREES CONSISTING PRIMARILY OF SEAFOOD; PREPARED ENTREES CONSISTING PRIMARILY OF SEAFOOD; FROZEN ENTREES CONSISTING PRIMARILY OF MEAT, FISH, POULTRY OR VEGETABLES; FROZEN MEALS CONSISTING PRIMARILY OF MEAT, FISH, POULTRY OR VEGETABLES; FROZEN VEGETABLE-BASED ENTREES (U.S. CL. 46).

FIRST USE 10-31-2007; IN COMMERCE 5-30-2011.

4,154,688. RECKITT BENCKISER LLC, PARSIPPANY, NJ. SN 85-091,088. PUB. 8-16-2011, FILED 7-22-2010.

FRENCH'S STAY FRESH CAN

THE MARK CONSISTS OF STANDARD CHARACTERS WITHOUT CLAIM TO ANY PARTICULAR FONT, STYLE, SIZE, OR COLOR.

OWNER OF U.S. REG. NOS. 545,030, 3,313,754, AND OTHERS.

NO CLAIM IS MADE TO THE EXCLUSIVE RIGHT TO USE "STAY FRESH CAN", APART FROM THE MARK AS SHOWN.

FOR PROCESSED ONIONS, NAMELY, FRENCH FRIED ONIONS (U.S. CL. 46).

FIRST USE 9-19-2011; IN COMMERCE 9-19-2011.

4,154,542. FRESHLY WILD, INC., PORTLAND, OR. SN 77-943,082. PUB. 8-24-2010, FILED 2-23-2010.

FRESHLY WILD SUPER FOODS

THE MARK CONSISTS OF STANDARD CHARACTERS WITHOUT CLAIM TO ANY PARTICULAR FONT, STYLE, SIZE, OR COLOR.

NO CLAIM IS MADE TO THE EXCLUSIVE RIGHT TO USE "SUPER FOODS", APART FROM THE MARK AS SHOWN.

FOR VEGETABLE CHIPS AND CRISPS (U.S. CL. 46).

FIRST USE 3-31-2012; IN COMMERCE 3-31-2012.

4,154,841. GLOBAL PERFORMANCE GROUP, INC., CABOT, AR. SN 85-148,857. PUB. 7-12-2011, FILED 10-8-2010.

4,154,564. BANGKOK INTERNATIONAL CUISINE CO., LTD, KLONG TOEI, BANGKOK, THAILAND. SN 77-964,321. PUB. 8-17-2010, FILED 3-21-2010.



NO CLAIM IS MADE TO THE EXCLUSIVE RIGHT TO USE "FINE THAI DINING", APART FROM THE MARK AS SHOWN.

THE COLOR(S) RED, WHITE AND BLACK IS/ARE CLAIMED AS A FEATURE OF THE MARK.



NO CLAIM IS MADE TO THE EXCLUSIVE RIGHT TO USE "MEALS-TO-GO FOR 4", APART FROM THE MARK AS SHOWN.

THE MARK CONSISTS OF THE WORDING "MEALS-TO-GO FOR 4" AND DESIGNS WITHIN AN IRREGULAR

CLASS 29—(Continued).

TRIANGULAR SHAPE. THE WORDING IS IN BLUE WITH WHITE OUTLINES AND "FOR" APPEARS BELOW "MEALS" AND "4" BELOW "FOR." AT THE TOP LEFT OF THE MARK, THERE IS A DIVISION OF THE OVERALL SHAPE INTO A SEMICIRCULAR PURPLE FIELD CONTAINING YELLOW SILVERWARE AND PLATE. THE REST OF THE TRIANGULAR SHAPE IS YELLOW, WITH A GRAY, SQUIGGLING ARROW ON THE LOWER RIGHT PORTION. THE OUTLINES OF THE TRIANGULAR SHAPE AND OTHER DESIGNS ARE BLACK.

FOR FROZEN MEALS CONSISTING PRIMARILY OF MEAT, FISH, POULTRY OR VEGETABLES (U.S. CL. 46).
FIRST USE 11-5-2010; IN COMMERCE 11-5-2010.

CLASS 29—(Continued).

THE MARK CONSISTS OF A CIRCLE OUTLINED WITH BLACK, WHICH IS FILLED IN WITH GREEN, WITH A GOLD IMAGE OUTLINED WITH BLACK OF THE STATE OF CALIFORNIA IN THE MIDDLE WITH SUNBURST GOLD COLORS COMING FROM BEHIND IT, AND THE WORDS "MADE FROM FRESH CALIFORNIA TOMATOES" IN THE GREEN AREA.

FOR CANNED FRUITS AND VEGETABLES (U.S. CL. 46).

FIRST USE 11-1-2011; IN COMMERCE 1-1-2012.

4,154,842. GLOBAL PERFORMANCE GROUP, INC., CABOT, AR. SN 85-148,878. PUB. 1-31-2012, FILED 10-8-2010.



NO CLAIM IS MADE TO THE EXCLUSIVE RIGHT TO USE "FEAST", APART FROM THE MARK AS SHOWN.

THE COLOR(S) BLACK, RED, AND YELLOW IS/ARE CLAIMED AS A FEATURE OF THE MARK.

THE MARK CONSISTS OF THE WORDING "FANTASTIC FEAST" AND DESIGNS WITHIN A RECTANGULAR BORDER WITH A ROUNDED SIDE. THE WORD "FANTASTIC" AND THE RECTANGULAR BORDER ARE BLACK. THE WORD "FEAST" AND THE DOT ABOVE THE "I" ARE RED. THE DOT ABOVE THE "I" ALSO FORMS THE CENTER OF A SUN WITH YELLOW RAYS. THE RECTANGULAR BORDER ENCLOSES A YELLOW BACKGROUND.

FOR FROZEN MEALS CONSISTING PRIMARILY OF MEAT, FISH, OR POULTRY (U.S. CL. 46).
FIRST USE 11-5-2010; IN COMMERCE 11-5-2010.

4,154,989. WERNER GOURMET MEAT SNACKS, INC., TILLAMOOK, OR. SN 85-220,053. PUB. 5-31-2011, FILED 1-18-2011.

ENERGIZE ME

THE MARK CONSISTS OF STANDARD CHARACTERS WITHOUT CLAIM TO ANY PARTICULAR FONT, STYLE, SIZE, OR COLOR.

FOR MEAT-BASED SNACK FOODS (U.S. CL. 46).
FIRST USE 2-10-2012; IN COMMERCE 2-10-2012.

4,154,980. PACIFIC COAST PRODUCERS, LODI, CA. SN 85-215,929. PUB. 5-31-2011, FILED 1-12-2011.



NO CLAIM IS MADE TO THE EXCLUSIVE RIGHT TO USE "MADE FROM FRESH CALIFORNIA TOMATOES" AND THE REPRESENTATION OF THE STATE OF CALIFORNIA, APART FROM THE MARK AS SHOWN.

THE COLOR(S) GREEN, GOLD, WHITE AND BLACK IS/ARE CLAIMED AS A FEATURE OF THE MARK.

4,154,991. WERNER GOURMET MEAT SNACKS, INC., TILLAMOOK, OR. SN 85-220,064. PUB. 5-31-2011, FILED 1-18-2011.

ENERGIZING BEEF JERKY

THE MARK CONSISTS OF STANDARD CHARACTERS WITHOUT CLAIM TO ANY PARTICULAR FONT, STYLE, SIZE, OR COLOR.

NO CLAIM IS MADE TO THE EXCLUSIVE RIGHT TO USE "BEEF JERKY", APART FROM THE MARK AS SHOWN.

FOR MEAT-BASED SNACK FOODS (U.S. CL. 46).
FIRST USE 2-10-2012; IN COMMERCE 2-10-2012.

CLASS 29—(Continued).

4,155,141. RIO GRANDE PRODUCTS, INC., LAUREL, MD. SN 85-251,149. PUB. 7-5-2011, FILED 2-24-2011.

YORITO

THE MARK CONSISTS OF STANDARD CHARACTERS WITHOUT CLAIM TO ANY PARTICULAR FONT, STYLE, SIZE, OR COLOR.
 FOR CHEESE; DAIRY-BASED SPREADS (U.S. CL. 46).
 FIRST USE 4-4-2011; IN COMMERCE 4-4-2011.

4,155,300. BEECH-NUT NUTRITION CORPORATION, AMSTERDAM, NY. SN 85-266,959. PUB. 8-2-2011, FILED 3-15-2011.

STAGE 2 1/2

THE MARK CONSISTS OF STANDARD CHARACTERS WITHOUT CLAIM TO ANY PARTICULAR FONT, STYLE, SIZE, OR COLOR.
 OWNER OF U.S. REG. NOS. 1,756,410, 1,756,412, AND OTHERS.
 FOR PUREED FRUITS; PUREED VEGETABLES; PUREED FRUITS AND VEGETABLES (U.S. CL. 46).
 FIRST USE 7-1-2011; IN COMMERCE 7-1-2011.

4,155,393. BOB EVANS FARMS, INC., COLUMBUS, OH. SN 85-281,763. PUB. 7-5-2011, FILED 3-30-2011.

**MADE WHEN YOU'RE READY,
 NOT READY-MADE.**

THE MARK CONSISTS OF STANDARD CHARACTERS WITHOUT CLAIM TO ANY PARTICULAR FONT, STYLE, SIZE, OR COLOR.
 FOR SALADS EXCEPT MACARONI, RICE, AND PASTA SALAD (U.S. CL. 46).
 FIRST USE 3-0-2008; IN COMMERCE 3-0-2008.

CLASS 29—(Continued).

4,155,651. SF INVESTMENTS, INC., WILMINGTON, DE. SN 85-356,919. PUB. 8-23-2011, FILED 6-27-2011.

SUMMER SPIRAL

THE MARK CONSISTS OF STANDARD CHARACTERS WITHOUT CLAIM TO ANY PARTICULAR FONT, STYLE, SIZE, OR COLOR.
 NO CLAIM IS MADE TO THE EXCLUSIVE RIGHT TO USE "SPIRAL", APART FROM THE MARK AS SHOWN.
 FOR HAM (U.S. CL. 46).
 FIRST USE 7-31-2010; IN COMMERCE 7-31-2010.

4,155,832. LIDESTRI FOODS, INC., FAIRPORT, NY. SN 85-976,538. PUB. 7-26-2011, FILED 3-8-2011.

OWNER OF U.S. REG. NOS. 1,354,502, 3,500,657, AND OTHERS.
 THE NAME(S), PORTRAIT(S), AND/OR SIGNATURE(S) SHOWN IN THE MARK DOES NOT IDENTIFY A PARTICULAR LIVING INDIVIDUAL.
 THE MARK CONSISTS OF THE WORDING "FRANCESCO RINALDI" IN A STYLIZED FONT.
 FOR BLENDED OIL; CANOLA OIL; COOKING OIL; EDIBLE OIL; NUTRITIONAL OILS FOR FOOD PURPOSES; OLIVE OIL; VEGETABLE OILS (U.S. CL. 46).
 FIRST USE 11-1-2009; IN COMMERCE 11-1-2009.

CLASS 30—STAPLE FOODS

4,154,255. EL PEKA FOODS LLC, NEW LONDON, CT. SN 76-705,636. PUB. 5-17-2011, FILED 12-9-2010.

**MISS HORTENCIA'S ORIGINAL
 MEXICAN**

THE MARK CONSISTS OF STANDARD CHARACTERS WITHOUT CLAIM TO ANY PARTICULAR FONT, STYLE, SIZE, OR COLOR.
 NO CLAIM IS MADE TO THE EXCLUSIVE RIGHT TO USE "ORIGINAL MEXICAN", APART FROM THE MARK AS SHOWN.
 MISS HORTENCIA DOES NOT IDENTIFY A LIVING INDIVIDUAL.
 FOR HOT SAUCE (U.S. CL. 46).
 FIRST USE 9-28-2011; IN COMMERCE 10-17-2011.

CLASS 30—(Continued).

4,154,271. BIG FISH CANDY COMPANY LLC, NEW YORK, NY. SN 77-099,075. PUB. 5-27-2008, FILED 2-5-2007.

BIG FISH CANDY CO.

THE MARK CONSISTS OF STANDARD CHARACTERS WITHOUT CLAIM TO ANY PARTICULAR FONT, STYLE, SIZE, OR COLOR.

NO CLAIM IS MADE TO THE EXCLUSIVE RIGHT TO USE "CANDY", APART FROM THE MARK AS SHOWN.

FOR CANDY; CHOCOLATE CANDIES; TOFFEES; CARAMELS; MARSHMALLOWS; CHOCOLATE COVERED MARSHMALLOW COOKIES; LOLLIPOPS; LICORICE; TRUFFLES; GANACHE CANDIES; MOLDED CHOCOLATES WITH FILLINGS; GUMMY CANDIES; CHOCOLATE COVERED CANDY BARS; CHOCOLATE COVERED NOUGAT BARS; MINTS (U.S. CL. 46).

FIRST USE 8-16-2011; IN COMMERCE 8-16-2011.

4,154,375. CONAGRA FOODS RDM, INC., OMAHA, NE. SN 77-639,573. PUB. 3-31-2009, FILED 12-24-2008.

SEE IT POP

THE MARK CONSISTS OF STANDARD CHARACTERS WITHOUT CLAIM TO ANY PARTICULAR FONT, STYLE, SIZE, OR COLOR.

FOR UNPOPPED POPCORN (U.S. CL. 46).

FIRST USE 1-25-2011; IN COMMERCE 2-7-2011.

4,154,386. CENTRIC GROUP, LLC, ST. LOUIS, MO. SN 77-656,811. PUB. 7-26-2011, FILED 1-26-2009.



NO CLAIM IS MADE TO THE EXCLUSIVE RIGHT TO USE "SNACKS", APART FROM THE MARK AS SHOWN.

CLASS 30—(Continued).

THE MARK CONSISTS OF FOUR CONCENTRIC OVALS WITH THE WORDING "GOLDEN VALLEY" ON THE UPPER PORTION OF THE OVAL AND THE WORD "SNACKS" ON THE LOWER PORTION. THE WORDING "A TASTE OF HOME" IS DIVIDED IN THE MIDDLE BY A DESIGN FEATURING FOUR STALKS OF GRAIN OR WHEAT.

FOR CRACKERS, BAGELS, BREAD, FIG BARS, PIZZA KITS CONSISTING OF MICROWAVABLE PIZZA CRUSTS AND SAUCES (U.S. CL. 46).

FIRST USE 6-0-2009; IN COMMERCE 6-0-2009.

4,154,433. REAL KOSHER ICE CREAM, INC., BROOKLYN, NY. SN 77-764,853. PUB. 11-3-2009, FILED 6-22-2009.

Alpen Zauber

THE MARK CONSISTS OF STANDARD CHARACTERS WITHOUT CLAIM TO ANY PARTICULAR FONT, STYLE, SIZE, OR COLOR.

THE ENGLISH TRANSLATION OF "ALPEN ZAUBER" IN THE MARK IS "ALPINE MAGIC".

FOR ICE CREAM (U.S. CL. 46).

FIRST USE 2-8-2012; IN COMMERCE 2-8-2012.

4,154,440. BEATRIZ CILANTRO SALSA CORP., DELRAY BEACH, FL. SN 77-777,332. PUB. 12-15-2009, FILED 7-9-2009.

BEATRIZ CILANTRO SALSA

THE MARK CONSISTS OF STANDARD CHARACTERS WITHOUT CLAIM TO ANY PARTICULAR FONT, STYLE, SIZE, OR COLOR.

NO CLAIM IS MADE TO THE EXCLUSIVE RIGHT TO USE "CILANTRO SALSA", APART FROM THE MARK AS SHOWN.

THE NAME "BEATRIZ RAMIREZ" IDENTIFIES A LIVING INDIVIDUAL WHOSE CONSENT IS OF RECORD.

FOR SALSA CONTAINING CILANTRO (U.S. CL. 46).

FIRST USE 3-9-2012; IN COMMERCE 3-9-2012.

CLASS 30—(Continued).

4,154,469. DUMPLOADS ON US, WALNUT CREEK, CA. SN 77-832,075. PUB. 3-9-2010, FILED 9-22-2009.

CHEESE ZOMBIES

THE MARK CONSISTS OF STANDARD CHARACTERS WITHOUT CLAIM TO ANY PARTICULAR FONT, STYLE, SIZE, OR COLOR.
NO CLAIM IS MADE TO THE EXCLUSIVE RIGHT TO USE "CHEESE", APART FROM THE MARK AS SHOWN.
FOR FILLED BAKERY PRODUCTS (U.S. CL. 46).
FIRST USE 9-22-2009; IN COMMERCE 2-28-2012.

CLASS 30—(Continued).

4,154,618. SUMMIT ENTERTAINMENT, LLC, SANTA MONICA, CA. SN 85-006,924. PUB. 8-17-2010, FILED 4-6-2010.



THE MARK CONSISTS OF A CIRCULAR TRIBAL TATTOO DESIGN DEPICTING TWO WOLVES FACING ONE ANOTHER IN A HOWLING POSITION, SET AMONGST NUMEROUS INTERWOVEN LINES AND SHAPES AND ALL WITHIN THE CIRCLE.
FOR CANDY AND CHEWING GUM (U.S. CL. 46).
FIRST USE 10-1-2009; IN COMMERCE 10-1-2009.

4,154,536. ODZA, AGIM TONY, ANNA, TX. SN 77-940,718. PUB. 1-18-2011, FILED 2-20-2010.



NO CLAIM IS MADE TO THE EXCLUSIVE RIGHT TO USE "HOUSE ITALIAN DRESSING", APART FROM THE MARK AS SHOWN.
THE MARK CONSISTS OF THE PROMINENT WORDING "TONY'S OWN", ABOVE THE WORDING "HOUSE ITALIAN", ABOVE THE WORD "DRESSING", ABOVE THE WORDING "CHI MANGIA BENE VIVE BENE".
THE ENGLISH TRANSLATION OF "CHI MANGIA BENE VIVE BENE" IN THE MARK IS WHO EATS WELL LIVES WELL.
FOR SALAD DRESSINGS (U.S. CL. 46).
FIRST USE 5-0-2010; IN COMMERCE 5-0-2010.

4,154,649. BLANKEN, DOUGLAS P., BATESVILLE, IN. AND BLANKEN, KATHRYN ELOIZA, BATESVILLE, IN. SN 85-058,590. PUB. 4-5-2011, FILED 6-9-2010.

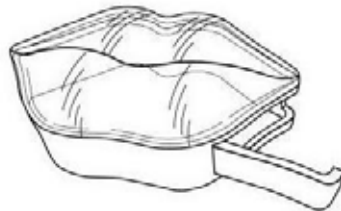

OWNER OF U.S. REG. NO. 3,765,106.
THE MARK CONSISTS OF THE THREE DIMENSIONAL CONFIGURATION OF THE PACKAGING FOR THE GOODS, NAMELY, A CONTAINER FOR BREATH MINTS HAVING A LOWER RECEPTACLE SECTION AND AN UPPER, TRANSPARENT LID SECTION BOTH OF WHICH ARE LIP-SHAPED. THE UPPER SURFACE OF THE LID SECTION IS CONFIGURED TO RESEMBLE A PAIR OF RAISED LIPS.
SEC. 2(F).
FOR CANDY MINTS (U.S. CL. 46).
FIRST USE 5-13-2011; IN COMMERCE 5-13-2011.

CLASS 30—(Continued).

4,154,706. WELCH'S FOODS INC., A COOPERATIVE, CONCORD, MA. SN 85-101,260. PUB. 1-25-2011, FILED 8-5-2010.

WELCH'S

THE MARK CONSISTS OF STANDARD CHARACTERS WITHOUT CLAIM TO ANY PARTICULAR FONT, STYLE, SIZE, OR COLOR.

OWNER OF U.S. REG. NO. 2,682,886.
FOR FROZEN CONFECTIONS (U.S. CL. 46).
FIRST USE 4-0-2010; IN COMMERCE 4-0-2010.

4,154,782. THE KROGER CO. OF MICHIGAN, NOVI, MI. SN 85-126,353. PUB. 2-22-2011, FILED 9-9-2010.

DIP 'EM LOVE 'EM

THE MARK CONSISTS OF STANDARD CHARACTERS WITHOUT CLAIM TO ANY PARTICULAR FONT, STYLE, SIZE, OR COLOR.

FOR COOKIES (U.S. CL. 46).
FIRST USE 2-6-2012; IN COMMERCE 2-6-2012.

4,154,853. FOOD AND CULINARY TECHNOLOGY GROUP, INC., CALGARY, CANADA. SN 85-153,277. PUB. 3-22-2011, FILED 10-15-2010.

FIRST IN FIBER

THE MARK CONSISTS OF STANDARD CHARACTERS WITHOUT CLAIM TO ANY PARTICULAR FONT, STYLE, SIZE, OR COLOR.

FOR BREAD MIXES; BROWNIE MIXES; CAKE MIXES; CAKE MIXES, NAMELY, CAKE BASES; COOKIE MIXES; INSTANT DOUGHNUT MIXES; INSTANT PANCAKE MIXES; MIXES FOR MAKING BAKING BATTERS; MIXES FOR MAKING BREADING; MUFFIN MIXES (U.S. CL. 46).
FIRST USE 8-1-2011; IN COMMERCE 8-1-2011.

CLASS 30—(Continued).

4,154,892. THE QUAKER OATS COMPANY, CHICAGO, IL. SN 85-180,172. PUB. 2-15-2011, FILED 11-18-2010.

CRUNCHTIME

THE MARK CONSISTS OF STANDARD CHARACTERS WITHOUT CLAIM TO ANY PARTICULAR FONT, STYLE, SIZE, OR COLOR.

FOR READY-TO-EAT CEREALS (U.S. CL. 46).
FIRST USE 2-28-2012; IN COMMERCE 2-28-2012.

4,155,044. GOUVEA'S & PURITY FOODS, INC., HONOLULU, HI. SN 85-237,710. PUB. 7-19-2011, FILED 2-9-2011.

HAWAIIAN BRAND PIGGY PUPS

THE MARK CONSISTS OF STANDARD CHARACTERS WITHOUT CLAIM TO ANY PARTICULAR FONT, STYLE, SIZE, OR COLOR.

NO CLAIM IS MADE TO THE EXCLUSIVE RIGHT TO USE "HAWAIIAN BRAND" OR "PUPS", APART FROM THE MARK AS SHOWN.

FOR SAUSAGES WRAPPED IN BREAD (U.S. CL. 46).
FIRST USE 11-30-2010; IN COMMERCE 12-30-2011.

4,155,065. ARETE USA I LLC, NEW YORK, NY. SN 85-241,377. PUB. 10-11-2011, FILED 2-14-2011.



THE MARK CONSISTS OF THE LETTERS "V","A","S" IN STYLIZED FONT ABOVE THE WORDS "VALUE ADDED AT THE SOURCE" WITH THE LETTERS "V","A" AND "S" IN BOLD FONT ALL ENCLOSED IN A BORDER IN A FANCIFUL SHAPE.

FOR COFFEE (U.S. CL. 46).
FIRST USE 11-11-2011; IN COMMERCE 11-11-2011.

CLASS 30—(Continued).

4,155,066. ARETE USA I LLC, NEW YORK, NY. SN 85-241,411. PUB. 7-26-2011, FILED 2-14-2011.



THE MARK CONSISTS OF THE WORD "AZAHAR" WITH A FANCIFUL DESIGN OF A FLOWER IN A SHAPE REMINISCENT OF AN ESPRESSO CUP WITH A HANDLE ABOVE THE WORD AND AN ARCH EXTENDING OVER THE FLORAL DESIGN INSIDE A CIRCLE THAT IS INSIDE A SQUARE BACKGROUND.
FOR COFFEE (U.S. CL. 46).
FIRST USE 11-11-2011; IN COMMERCE 11-11-2011.

4,155,068. POPARUBA, LLC, DENVER, CO. SN 85-241,568. PUB. 6-28-2011, FILED 2-14-2011.

POPARUBA

THE MARK CONSISTS OF STANDARD CHARACTERS WITHOUT CLAIM TO ANY PARTICULAR FONT, STYLE, SIZE, OR COLOR.
FOR CONFECTIONERY PRODUCTS, NAMELY, PETIT FOURS, CAKES, AND PASTRIES (U.S. CL. 46).
FIRST USE 1-11-2011; IN COMMERCE 1-11-2011.

4,155,091. VITALICO LLC, SAN MATEO, CA. SN 85-245,150. PUB. 8-23-2011, FILED 2-17-2011.

EXQUINA

THE MARK CONSISTS OF STANDARD CHARACTERS WITHOUT CLAIM TO ANY PARTICULAR FONT, STYLE, SIZE, OR COLOR.
FOR FOOD THICKENING AND BINDING AGENTS MADE OF NATURAL PLANT INGREDIENTS (U.S. CL. 46).
FIRST USE 2-0-2008; IN COMMERCE 2-0-2008.

CLASS 30—(Continued).

4,155,148. E. WALDO WARD & SON, INC., SIERRA MADRE, CA. SN 85-251,708. PUB. 7-5-2011, FILED 2-25-2011.

WESTERN RANCH

THE MARK CONSISTS OF STANDARD CHARACTERS WITHOUT CLAIM TO ANY PARTICULAR FONT, STYLE, SIZE, OR COLOR.
FOR SAUCES, NAMELY, BARBECUE SAUCE (U.S. CL. 46).
FIRST USE 6-30-2011; IN COMMERCE 6-30-2011.

4,155,185. ZHANGZHOU GUANGZHAOREN TEA CO., LTD., FUJIAN, CHINA. SN 85-254,783. PUB. 7-19-2011, FILED 3-1-2011.

光照人

3H-SENDER

THE MARK CONSISTS OF THE WORDING "3H-SENDER" BENEATH THREE CHINESE CHARACTERS.
THE NON-LATIN CHARACTERS IN THE MARK TRANSLITERATE TO "GUANG ZHAO REN" AND THIS HAS NO MEANING IN A FOREIGN LANGUAGE.
FOR COFFEE; TEA; SUGAR; CONFECTIONERY MADE OF SUGAR; HONEY; WHEAT FLOUR FOR FOOD; SAUCES; SEASONINGS; YEAST; FOOD FLAVORINGS; COFFEE SUBSTITUTES (ARTIFICIAL COFFEE OR VEGETABLE PREPARATIONS FOR USE AS COFFEE); TEA-BASED BEVERAGES (U.S. CL. 46).
FIRST USE 12-1-2005; IN COMMERCE 12-10-2010.

4,155,191. ARRINDELL, CHARLES, OAKVILLE, CT. SN 85-255,113. PUB. 7-12-2011, FILED 3-1-2011.

king wing a ling

THE MARK CONSISTS OF STANDARD CHARACTERS WITHOUT CLAIM TO ANY PARTICULAR FONT, STYLE, SIZE, OR COLOR.
FOR FOOD FLAVORINGS; MARINADES; SAUCES, SEASONINGS, AND SPICES FOR FOOD OR FOOD PRODUCTS; CONDIMENTS IN THE NATURE OF HOT SAUCES; COATINGS AND SEASONINGS FOR FOOD, NAMELY, SEASONED COATING FOR MEAT, FISH, AND POULTRY (U.S. CL. 46).
FIRST USE 9-1-2000; IN COMMERCE 11-2-2011.

CLASS 30—(Continued).

4,155,202. CARLSON, BRIAN LESLEY, PORT WASHINGTON, WI. SN 85-256,477. PUB. 1-3-2012, FILED 3-3-2011.

Sconies

THE MARK CONSISTS OF STANDARD CHARACTERS WITHOUT CLAIM TO ANY PARTICULAR FONT, STYLE, SIZE, OR COLOR.

FOR SCONES (U.S. CL. 46).
FIRST USE 7-30-2011; IN COMMERCE 7-30-2011.

4,155,206. CIRCLE CITY MARKETING & DISTRIBUTING, INC., CARMEL, IN. SN 85-256,886. PUB. 7-26-2011, FILED 3-3-2011.

SMOG BALLS

THE MARK CONSISTS OF STANDARD CHARACTERS WITHOUT CLAIM TO ANY PARTICULAR FONT, STYLE, SIZE, OR COLOR.

NO CLAIM IS MADE TO THE EXCLUSIVE RIGHT TO USE "BALLS", APART FROM THE MARK AS SHOWN.

FOR CANDY (U.S. CL. 46).
FIRST USE 9-25-2011; IN COMMERCE 9-25-2011.

4,155,207. ASPEN, MARILYN JEAN, PARK CITY, UT. SN 85-257,019. PUB. 8-16-2011, FILED 3-3-2011.

LEANBAKER'S

THE MARK CONSISTS OF STANDARD CHARACTERS WITHOUT CLAIM TO ANY PARTICULAR FONT, STYLE, SIZE, OR COLOR.

FOR FOOD PRODUCTS, NAMELY, MIXES FOR BAKERY GOODS, BAKING MIXES FOR MAKING MUFFINS, AND MUFFIN MIXES (U.S. CL. 46).

FIRST USE 4-18-2011; IN COMMERCE 10-11-2011.

CLASS 30—(Continued).

4,155,244. LIDESTRI FOODS, INC., FAIRPORT, NY. SN 85-261,229. PUB. 7-26-2011, FILED 3-8-2011.



THE MARK CONSISTS OF A CARTOON IMAGE OF A CACTUS WITH ANTHROPOMORPHIC QUALITIES, INCLUDING A SMILING FACE, SPINES ON THE TOP OF THE CACTUS CHARACTER'S "HEAD" DEPICTED AS A HUMAN'S SPIKED HAIR, TWO "ARMS" AND THE WEARING OF SUNGLASSES.

FOR BARBEQUE SAUCE; CHILI SAUCE; CONDIMENT, NAMELY, PEPPER SAUCE; DIPPING SAUCES; HOT SAUCE; MARINADES; PICANTE SAUCE; READY-MADE SAUCES; SALSA; SAUCES (U.S. CL. 46).

FIRST USE 1-6-2011; IN COMMERCE 1-6-2011.

4,155,264. GO TROPPO, INC., BROOKLINE, MA. SN 85-263,042. PUB. 7-19-2011, FILED 3-10-2011.

ICE CREAM THAT ROCKS

THE MARK CONSISTS OF STANDARD CHARACTERS WITHOUT CLAIM TO ANY PARTICULAR FONT, STYLE, SIZE, OR COLOR.

FOR ICE CREAM; FROZEN YOGURT; ICE CREAM DESSERTS AND FROZEN CONFECTIONS; ICE CREAM PIZZA; CHOCOLATES; BAKERY GOODS; HOT FUDGE; CANDY; CARAMEL; BUTTERSCOTCH; AND FUDGE (U.S. CL. 46).

FIRST USE 9-0-2004; IN COMMERCE 9-0-2004.

CLASS 30—(Continued).

4,155,325. S-L SNACKS NATIONAL, LLC, CHARLOTTE, NC. SN 85-269,733. PUB. 8-2-2011, FILED 3-17-2011.

THE GOODNESS IS BAKED IN.

THE MARK CONSISTS OF STANDARD CHARACTERS WITHOUT CLAIM TO ANY PARTICULAR FONT, STYLE, SIZE, OR COLOR.
FOR CRACKERS (U.S. CL. 46).
FIRST USE 3-31-2011; IN COMMERCE 3-31-2011.

CLASS 30—(Continued).

4,155,387. BROOKSIDE FARMS HOMEMADE, CLARKESVILLE, GA. SN 85-280,597. PUB. 8-23-2011, FILED 3-29-2011.

Bellflower Mountain Bakery

THE MARK CONSISTS OF STANDARD CHARACTERS WITHOUT CLAIM TO ANY PARTICULAR FONT, STYLE, SIZE, OR COLOR.
NO CLAIM IS MADE TO THE EXCLUSIVE RIGHT TO USE "BAKERY", APART FROM THE MARK AS SHOWN.
FOR BISCUITS; COOKIES; ROLLS (U.S. CL. 46).
FIRST USE 3-14-2012; IN COMMERCE 3-14-2012.

4,155,339. HASTINGS, RAYMOND P., HADDON HEIGHTS, NJ. SN 85-272,400. PUB. 8-2-2011, FILED 3-21-2011.

SQOOKIE

THE MARK CONSISTS OF STANDARD CHARACTERS WITHOUT CLAIM TO ANY PARTICULAR FONT, STYLE, SIZE, OR COLOR.
FOR BAKED GOODS, NAMELY, COOKIES AND BAKERY DESSERTS (U.S. CL. 46).
FIRST USE 2-2-2012; IN COMMERCE 2-2-2012.

4,155,392. RAST, LISA, CHANDLER, AZ. SN 85-281,665. PUB. 8-2-2011, FILED 3-30-2011.

NUTWHATS

THE MARK CONSISTS OF STANDARD CHARACTERS WITHOUT CLAIM TO ANY PARTICULAR FONT, STYLE, SIZE, OR COLOR.
FOR CONFECTIONS, NAMELY, BRITTLES, TOFFEES, FUDGE; CHOCOLATE CREATIONS, NAMELY, CHOCOLATE TRUFFLES, LOLLIPOPS, AND CINNAMON AND SUGAR COATED NUTS (U.S. CL. 46).
FIRST USE 10-30-2011; IN COMMERCE 10-30-2011.

4,155,347. DORA'S NATURALS, INC., SOUTH HACKENSACK, NJ. SN 85-273,441. PUB. 8-9-2011, FILED 3-22-2011.

Zen

THE MARK CONSISTS OF STANDARD CHARACTERS WITHOUT CLAIM TO ANY PARTICULAR FONT, STYLE, SIZE, OR COLOR.
FOR FLAVORED AND SWEETENED GELATINS AND EDIBLE GELS, NAMELY, FRUIT GELS MADE WITH FRUIT JUICE (U.S. CL. 46).
FIRST USE 8-23-2011; IN COMMERCE 8-23-2011.

4,155,431. HEB GROCERY COMPANY, LP, SAN ANTONIO, TX. SN 85-286,295. PUB. 8-30-2011, FILED 4-5-2011.

H-E-B BUTTER SUPREMES

THE MARK CONSISTS OF STANDARD CHARACTERS WITHOUT CLAIM TO ANY PARTICULAR FONT, STYLE, SIZE, OR COLOR.
OWNER OF U.S. REG. NOS. 1,867,930, 3,873,586, AND OTHERS.
NO CLAIM IS MADE TO THE EXCLUSIVE RIGHT TO USE "BUTTER", APART FROM THE MARK AS SHOWN.
FOR CRACKERS (U.S. CL. 46).
FIRST USE 7-31-2011; IN COMMERCE 7-31-2011.

CLASS 30—(Continued).

4,155,499. HERSHEY CHOCOLATE & CONFECTIONERY CORPORATION, WHEAT RIDGE, CO. SN 85-304,357. PUB. 10-11-2011, FILED 4-25-2011.



OWNER OF U.S. REG. NOS. 1,074,163, 3,934,544, AND OTHERS.

NO CLAIM IS MADE TO THE EXCLUSIVE RIGHT TO USE "PEANUT BUTTER CUPS" AND "WHITE", APART FROM THE MARK AS SHOWN.

THE COLOR(S) ORANGE, BROWN, YELLOW, WHITE AND TAN IS/ARE CLAIMED AS A FEATURE OF THE MARK.

THE MARK CONSISTS OF "REESE'S" IN YELLOW STYLIZED SCRIPT LETTERS OUTLINED IN THE COLOR BROWN ABOVE THE WORDS "PEANUT BUTTER CUPS" IN YELLOW LETTERS, A STYLIZED PARTIAL DESIGN LOGO OF AN ELONGATED SIDE OF A PEANUT BUTTER CUP, THE WORDS "WHITE" AND "MINIATURES" IN WHITE LETTERS OUTLINED IN BROWN, A STYLIZED DESIGN OF TWO WHITE PEANUT BUTTER CUPS WITH ONE PARTIALLY EATEN STYLIZED DESIGN OF A PEANUT BUTTER CUP SHOWING TAN FILLING, ALL ON AN ORANGE BACKGROUND. THE DOTTED LINING SHOWN IN THE MARK IS FOR PLACEMENT PURPOSES AND IS NOT A FEATURE OF THE MARK.

SEC. 2(F) AS TO MINIATURES.

FOR CANDY (U.S. CL. 46).

FIRST USE 4-30-2010; IN COMMERCE 4-30-2010.

4,155,513. RAINDANCER COFFEE, LLC, PORTLAND, OR. SN 85-308,859. PUB. 9-27-2011, FILED 4-29-2011.



NO CLAIM IS MADE TO THE EXCLUSIVE RIGHT TO USE "COFFEE", APART FROM THE MARK AS SHOWN.

THE MARK CONSISTS OF THE DEPICTION OF A PROFILED HEAD OF A PERSON WEARING A HEAD-DRESS THAT APPEARS ABOVE THE STYLIZED WORDING "RAINDANCER" WHICH APPEARS ABOVE THE STYLIZED WORDING "COFFEE".

FOR COFFEE (U.S. CL. 46).

FIRST USE 3-1-2011; IN COMMERCE 3-1-2011.

CLASS 30—(Continued).

4,155,537. SCHWAN'S IP, LLC, MARSHALL, MN. SN 85-317,673. PUB. 1-24-2012, FILED 5-11-2011.

VILLA PRIMA

THE MARK CONSISTS OF STANDARD CHARACTERS WITHOUT CLAIM TO ANY PARTICULAR FONT, STYLE, SIZE, OR COLOR.

FOR PIZZA (U.S. CL. 46).

FIRST USE 5-1-2011; IN COMMERCE 5-1-2011.

4,155,569. RD SPECIALTIES LTD, DBA RD SPECIALTIES LTD, DES PLAINES, IL. SN 85-329,121. PUB. 11-1-2011, FILED 5-24-2011.



THE MARK CONSISTS OF THE WORDS "LORD OF THE BEANS" IN A STYLIZED MANNER WITH A DECORATIVE OVAL DESIGN CONTAINING COFFEE BEANS ABOVE IT.

FOR COFFEE BEANS (U.S. CL. 46).

FIRST USE 11-1-2011; IN COMMERCE 3-1-2012.

4,155,593. GENERAL MILLS, INC., MINNEAPOLIS, MN. SN 85-339,634. PUB. 9-13-2011, FILED 6-7-2011.

NATURE AT ITS MOST DELICIOUS

THE MARK CONSISTS OF STANDARD CHARACTERS WITHOUT CLAIM TO ANY PARTICULAR FONT, STYLE, SIZE, OR COLOR.

FOR READY TO EAT, CEREAL DERIVED FOOD BARS (U.S. CL. 46).

FIRST USE 3-5-2012; IN COMMERCE 3-5-2012.

CLASS 30—(Continued).

4,155,604. LEU, MEI, SAN FRANCISCO, CA. SN 85-344,176. PUB. 10-25-2011, FILED 6-13-2011.

PRECIOUS AND RARE

THE MARK CONSISTS OF STANDARD CHARACTERS WITHOUT CLAIM TO ANY PARTICULAR FONT, STYLE, SIZE, OR COLOR.
FOR CHOCOLATE, CANDY (U.S. CL. 46).
FIRST USE 8-16-2011; IN COMMERCE 8-16-2011.

4,155,615. VICTORIOUS SOLUTIONS LLC, MONROE, NY. SN 85-346,652. PUB. 11-8-2011, FILED 6-15-2011.

VERI PERI

THE MARK CONSISTS OF STANDARD CHARACTERS WITHOUT CLAIM TO ANY PARTICULAR FONT, STYLE, SIZE, OR COLOR.
FOR CONDIMENT, NAMELY, PEPPER SAUCE (U.S. CL. 46).
FIRST USE 1-1-1994; IN COMMERCE 2-1-2012.

4,155,640. SMUSH LLC, HOBOKEN, NJ. SN 85-353,258. PUB. 11-8-2011, FILED 6-22-2011.



NO CLAIM IS MADE TO THE EXCLUSIVE RIGHT TO USE "NY" AND "DESSERTS", APART FROM THE MARK AS SHOWN.

CLASS 30—(Continued).

THE MARK CONSISTS OF A THE STYLIZED IMAGE OF AN ICE CREAM SANDWICH IN THE FORM OF A PENGUIN WEARING A HAT, WITH THE LITERAL ELEMENT "SMUSH" POSITIONED ABOVE THE PENGUIN, AND "THE NY DELI OF DESSERTS" POSITIONED BE NEATH. THE PENGUIN IS POSITIONED WITHIN AN INCOMPLETE, SEMI-CIRCULAR SHAPED FIGURE.
FOR ICE CREAM DESSERTS; ICE CREAM SANDWICHES (U.S. CL. 46).
FIRST USE 5-1-2011; IN COMMERCE 5-1-2011.

4,155,647. ROSENFELD, RICHARD A., BASALT, CO. SN 85-355,954. PUB. 12-6-2011, FILED 6-24-2011.

Paisley Tea Co.

THE MARK CONSISTS OF STANDARD CHARACTERS WITHOUT CLAIM TO ANY PARTICULAR FONT, STYLE, SIZE, OR COLOR.
NO CLAIM IS MADE TO THE EXCLUSIVE RIGHT TO USE "TEA CO.", APART FROM THE MARK AS SHOWN.
FOR BLACK TEA; COFFEE AND TEA; HERBAL TEA; ICED TEA; INSTANT TEA; JAPANESE GREEN TEA (U.S. CL. 46).
FIRST USE 2-1-2012; IN COMMERCE 3-17-2012.

4,155,655. CALIFORNIA CUSTOM FRUITS AND FLAVORS, INC., DBA CALIFORNIA CUSTOM FRUITS AND FLAVORS, INC., IRWINDALE, CA. SN 85-359,075. PUB. 11-22-2011, FILED 6-29-2011.

Sweet-hancer

THE MARK CONSISTS OF STANDARD CHARACTERS WITHOUT CLAIM TO ANY PARTICULAR FONT, STYLE, SIZE, OR COLOR.
FOR FLAVOR ENHANCERS USED IN FOOD AND BEVERAGE PRODUCTS (U.S. CL. 46).
FIRST USE 1-26-2012; IN COMMERCE 2-2-2012.

CLASS 30—(Continued).

4,155,729. ADVANCEPIERRE FOODS, INC., CINCINNATI, OH. SN 85-377,579. PUB. 12-20-2011, FILED 7-21-2011.

DRIVE THRU

THE MARK CONSISTS OF STANDARD CHARACTERS WITHOUT CLAIM TO ANY PARTICULAR FONT, STYLE, SIZE, OR COLOR.

FOR FULLY-COOKED SANDWICHES CONTAINING BEEF, CHICKEN OR PORK SOLD FROZEN IN RETAIL GROCERY STORES (U.S. CL. 46).

FIRST USE 11-1-2011; IN COMMERCE 11-1-2011.

4,155,739. GAY COFFEE, WILLIAMSBURG, MA. SN 85-384,422. PUB. 1-17-2012, FILED 7-29-2011.

GAY COFFEE

THE MARK CONSISTS OF STANDARD CHARACTERS WITHOUT CLAIM TO ANY PARTICULAR FONT, STYLE, SIZE, OR COLOR.

NO CLAIM IS MADE TO THE EXCLUSIVE RIGHT TO USE "COFFEE", APART FROM THE MARK AS SHOWN.

FOR COFFEE; GROUND COFFEE BEANS; ROASTED COFFEE BEANS (U.S. CL. 46).

FIRST USE 11-1-2011; IN COMMERCE 11-1-2011.

4,155,792. IMPACT CONFECTIONS, INC., LITTLETON, CO. SN 85-406,908. PUB. 2-7-2012, FILED 8-25-2011.

SOUR DIPPERS

THE MARK CONSISTS OF STANDARD CHARACTERS WITHOUT CLAIM TO ANY PARTICULAR FONT, STYLE, SIZE, OR COLOR.

NO CLAIM IS MADE TO THE EXCLUSIVE RIGHT TO USE "SOUR", APART FROM THE MARK AS SHOWN.

FOR CANDY (U.S. CL. 46).

FIRST USE 1-1-2012; IN COMMERCE 1-1-2012.

CLASS 31—NATURAL AGRICULTURAL PRODUCTS**CLASS 31—(Continued).**

4,154,426. FUTURE FRUIT, LLC, VISALIA, CA. SN 77-746,058. PUB. 10-20-2009, FILED 5-27-2009.

LEMORA

THE MARK CONSISTS OF STANDARD CHARACTERS WITHOUT CLAIM TO ANY PARTICULAR FONT, STYLE, SIZE, OR COLOR.

THE WORDING "LEMORA" HAS NO MEANING IN A FOREIGN LANGUAGE.

FOR FRESH CITRUS FRUIT (U.S. CLS. 1 AND 46).

FIRST USE 2-10-2012; IN COMMERCE 2-10-2012.

4,154,526. LATTIG, MICHAEL D., DBA CLEARWATER NATIVE NURSERY, REDMOND, OR. SN 77-929,462. PUB. 4-5-2011, FILED 2-5-2010.

CLEARWATER NATIVE PLANT NURSERY

THE MARK CONSISTS OF STANDARD CHARACTERS WITHOUT CLAIM TO ANY PARTICULAR FONT, STYLE, SIZE, OR COLOR.

NO CLAIM IS MADE TO THE EXCLUSIVE RIGHT TO USE "NATIVE PLANT NURSERY", APART FROM THE MARK AS SHOWN.

FOR LIVE SHRUBS; LIVE TREES; NATURAL PLANTS AND FLOWERS (U.S. CLS. 1 AND 46).

FIRST USE 6-1-2002; IN COMMERCE 6-1-2002.

4,154,589. PIONEER HI-BRED INTERNATIONAL, INC., JOHNSTON, IA. SN 77-983,147. PUB. 12-8-2009, FILED 7-17-2009.



THE MARK CONSISTS OF THE WORD "PLENISH" IN A STYLIZED FORMAT WITH THE LETTERS "P" AND "H" SPROUTING BUDS.

FOR AGRICULTURAL SEEDS (U.S. CLS. 1 AND 46).

FIRST USE 5-3-2011; IN COMMERCE 5-3-2011.

CLASS 31—(Continued).

4,154,744. L&M COMPANIES, INC., RALEIGH, NC. SN 85-110,391. PUB. 2-1-2011, FILED 8-18-2010.

WELL GROUNDED

THE MARK CONSISTS OF STANDARD CHARACTERS WITHOUT CLAIM TO ANY PARTICULAR FONT, STYLE, SIZE, OR COLOR.
FOR FRESH FRUIT AND FRESH VEGETABLES (U.S. CLS. 1 AND 46).
FIRST USE 10-31-2011; IN COMMERCE 1-1-2012.

4,154,869. MEEHL, DR. CHRIS, LYNNFIELD, MA. SN 85-161,436. PUB. 2-8-2011, FILED 10-26-2010.

SIMPLE CARE

THE MARK CONSISTS OF STANDARD CHARACTERS WITHOUT CLAIM TO ANY PARTICULAR FONT, STYLE, SIZE, OR COLOR.
FOR PET FOOD (U.S. CLS. 1 AND 46).
FIRST USE 4-3-2012; IN COMMERCE 4-3-2012.

4,155,047. ANDERSON, R. HARRY, WEATHERFORD, TX. SN 85-238,063. PUB. 12-27-2011, FILED 2-9-2011.

TOTAL EQUINE

THE MARK CONSISTS OF STANDARD CHARACTERS WITHOUT CLAIM TO ANY PARTICULAR FONT, STYLE, SIZE, OR COLOR.
NO CLAIM IS MADE TO THE EXCLUSIVE RIGHT TO USE "EQUINE", APART FROM THE MARK AS SHOWN.
FOR EXTRUDED HORSE FEED (U.S. CLS. 1 AND 46).
FIRST USE 6-15-2000; IN COMMERCE 7-13-2000.

CLASS 31—(Continued).

4,155,117. TRACTOR SUPPLY CO. OF TEXAS, LP, BRENTWOOD, TN. SN 85-248,068. PUB. 6-28-2011, FILED 2-22-2011.

RETRIEVER

THE MARK CONSISTS OF STANDARD CHARACTERS WITHOUT CLAIM TO ANY PARTICULAR FONT, STYLE, SIZE, OR COLOR.
OWNER OF U.S. REG. NOS. 1,826,539 AND 3,257,566.
FOR PET TREATS (U.S. CLS. 1 AND 46).
FIRST USE 5-31-2006; IN COMMERCE 5-31-2006.

4,155,326. GREEN FUSE BOTANICALS, INC., SANTA MONICA, CA. SN 85-270,127. PUB. 8-2-2011, FILED 3-17-2011.

BABY SLIPPERS

THE MARK CONSISTS OF STANDARD CHARACTERS WITHOUT CLAIM TO ANY PARTICULAR FONT, STYLE, SIZE, OR COLOR.
FOR LIVE PLANTS, NAMELY, STREPTOCARPUS (U.S. CLS. 1 AND 46).
FIRST USE 2-1-2012; IN COMMERCE 2-1-2012.

4,155,444. GREGORY GARRETT, NEWPORT NEWS, VA. SN 85-289,075. PUB. 8-16-2011, FILED 4-7-2011.

FORBIDDEN OYSTERS

THE MARK CONSISTS OF STANDARD CHARACTERS WITHOUT CLAIM TO ANY PARTICULAR FONT, STYLE, SIZE, OR COLOR.
NO CLAIM IS MADE TO THE EXCLUSIVE RIGHT TO USE "OYSTERS", APART FROM THE MARK AS SHOWN.
FOR OYSTERS (U.S. CLS. 1 AND 46).
FIRST USE 3-19-2012; IN COMMERCE 3-9-2012.

CLASS 31—(Continued).

4,155,455. J. FRANK SCHMIDT & SON CO., BORING, OR. SN 85-291,515. PUB. 8-23-2011, FILED 4-11-2011.

BEACON

THE MARK CONSISTS OF STANDARD CHARACTERS WITHOUT CLAIM TO ANY PARTICULAR FONT, STYLE, SIZE, OR COLOR.
FOR LIVING ORNAMENTAL TREES (U.S. CLS. 1 AND 46).
FIRST USE 2-16-2012; IN COMMERCE 2-16-2012.

4,155,495. SCHIPPER & COMPANY U.S.A., INC., BRIDGEPORT, CT. SN 85-303,216. PUB. 9-6-2011, FILED 4-25-2011.

TIMED RELEASE

THE MARK CONSISTS OF STANDARD CHARACTERS WITHOUT CLAIM TO ANY PARTICULAR FONT, STYLE, SIZE, OR COLOR.
FOR LIVING PLANTS, NAMELY, FLOWER BULBS AND LIVE FLOWERING PLANTS (U.S. CLS. 1 AND 46).
FIRST USE 7-15-2011; IN COMMERCE 7-15-2011.

4,155,523. SOCIETE DES PRODUITS NESTLE S.A., VEVEY, SWITZERLAND. SN 85-312,423. PUB. 9-13-2011, FILED 5-4-2011.

CARVERY CREATIONS

THE MARK CONSISTS OF STANDARD CHARACTERS WITHOUT CLAIM TO ANY PARTICULAR FONT, STYLE, SIZE, OR COLOR.
FOR PET FOOD (U.S. CLS. 1 AND 46).
FIRST USE 1-3-2012; IN COMMERCE 1-3-2012.

CLASS 31—(Continued).

4,155,551. SUNBURST FARMS, INC., MIAMI, FL. SN 85-323,202. PUB. 10-18-2011, FILED 5-17-2011.

FLOWERNET

THE MARK CONSISTS OF STANDARD CHARACTERS WITHOUT CLAIM TO ANY PARTICULAR FONT, STYLE, SIZE, OR COLOR.
FOR CUT FLOWERS (U.S. CLS. 1 AND 46).
FIRST USE 8-1-1989; IN COMMERCE 8-1-1989.

4,155,839. C.H. ROBINSON WORLDWIDE, INC., EDEN PRAIRIE, MN. SN 85-976,633. PUB. 2-8-2011, FILED 8-24-2010.

Produce for People

THE MARK CONSISTS OF STANDARD CHARACTERS WITHOUT CLAIM TO ANY PARTICULAR FONT, STYLE, SIZE, OR COLOR.
NO CLAIM IS MADE TO THE EXCLUSIVE RIGHT TO USE "PRODUCE", APART FROM THE MARK AS SHOWN.
FOR FRESH FRUIT AND FRESH VEGETABLES (U.S. CLS. 1 AND 46).
FIRST USE 7-1-2011; IN COMMERCE 7-1-2011.

CLASS 32—LIGHT BEVERAGES

4,154,344. PRUFROCK LLC, LOS ANGELES, CA. SN 77-553,643. PUB. 1-13-2009, FILED 8-22-2008.

CAUSE COLA

THE MARK CONSISTS OF STANDARD CHARACTERS WITHOUT CLAIM TO ANY PARTICULAR FONT, STYLE, SIZE, OR COLOR.
NO CLAIM IS MADE TO THE EXCLUSIVE RIGHT TO USE "COLA", APART FROM THE MARK AS SHOWN.
FOR SOFT DRINKS, NAMELY, CARBONATED SOFT DRINKS, LOW CALORIE SOFT DRINKS, NON-CARBONATED SOFT DRINKS, COLAS, NON-ALCOHOLIC CARBONATED BEVERAGES AND NON-ALCOHOLIC FRUIT JUICE BEVERAGES; FRUIT JUICES AND FRUIT DRINKS; COFFEE-FLAVORED AND TEA-FLAVORED SOFT DRINK (U.S. CLS. 45, 46 AND 48).
FIRST USE 4-9-2012; IN COMMERCE 4-9-2012.

CLASS 32—(Continued).

4,154,397. NEW BELGIUM BREWING COMPANY, INC., FORT COLLINS, CO. SN 77-681,763. PUB. 6-23-2009, FILED 3-2-2009.

SNOWDAY

THE MARK CONSISTS OF STANDARD CHARACTERS WITHOUT CLAIM TO ANY PARTICULAR FONT, STYLE, SIZE, OR COLOR.
FOR BEER (U.S. CLS. 45, 46 AND 48).
FIRST USE 11-4-2011; IN COMMERCE 11-4-2011.

4,154,454. DRINKOLOGY, LLC, DALLAS, TX. SN 77-810,944. PUB. 2-16-2010, FILED 8-24-2009.

Bloody Mary Christmas

THE MARK CONSISTS OF STANDARD CHARACTERS WITHOUT CLAIM TO ANY PARTICULAR FONT, STYLE, SIZE, OR COLOR.
NO CLAIM IS MADE TO THE EXCLUSIVE RIGHT TO USE "BLOODY MARY", APART FROM THE MARK AS SHOWN.
FOR NON-ALCOHOLIC COCKTAIL MIX (U.S. CLS. 45, 46 AND 48).
FIRST USE 10-15-2011; IN COMMERCE 12-20-2011.

4,154,587. GENERAL MEDIA COMMUNICATIONS, INC., BOCA RATON, FL. SN 77-983,118. PUB. 4-12-2011, FILED 3-29-2007.

PENTHOUSE

THE MARK CONSISTS OF STANDARD CHARACTERS WITHOUT CLAIM TO ANY PARTICULAR FONT, STYLE, SIZE, OR COLOR.
OWNER OF U.S. REG. NOS. 880,922, 3,007,070, AND OTHERS.
FOR NON-ALCOHOLIC BEVERAGES, NAMELY, ENERGY DRINKS (U.S. CLS. 45, 46 AND 48).
FIRST USE 8-0-2011; IN COMMERCE 8-0-2011.

CLASS 32—(Continued).

4,154,725. JONES SODA CO. (USA) INC., SEATTLE, WA. SN 85-106,389. PUB. 7-26-2011, FILED 8-12-2010.



OWNER OF U.S. REG. NOS. 2,721,730, 3,788,694, AND OTHERS.
NO CLAIM IS MADE TO THE EXCLUSIVE RIGHT TO USE "EST. 96", APART FROM THE MARK AS SHOWN.
THE MARK CONSISTS OF A CROSSLIKE DESIGN WITH THE WORD "JONES" POSITIONED AT A FIRST END OF THE DESIGN, THE WORD "WHOOPASS" POSITIONED IN THE MIDDLE PORTION OF THE DESIGN, AND THE TERM "EST. 96" POSITIONED AT A SECOND END OF THE DESIGN.
FOR ENERGY DRINKS (U.S. CLS. 45, 46 AND 48).
FIRST USE 1-1-2011; IN COMMERCE 1-1-2011.

4,154,806. KRAFT FOODS GLOBAL BRANDS LLC, NORTH-FIELD, IL. SN 85-136,852. PUB. 2-1-2011, FILED 9-23-2010.



THE MARK CONSISTS OF A STYLIZED LETTER "M" WITH THE TWO INNER SECTIONS OF THE LETTER INTERSECTING TO FORM A DROP SHAPE IN THE CENTER.
FOR PREPARATIONS FOR MAKING BEVERAGES, NAMELY, FRUIT DRINKS, SOFT DRINKS, TEA-FLAVORED DRINKS, FLAVORED WATERS, SPORTS DRINKS AND ENERGY DRINKS (U.S. CLS. 45, 46 AND 48).
FIRST USE 3-7-2011; IN COMMERCE 3-7-2011.

CLASS 32—(Continued).

4,154,819. COLD SPRING BREWING COMPANY, COLD SPRINGS, MN. SN 85-140,828. PUB. 2-15-2011, FILED 9-29-2010.

THIRD STREET

THE MARK CONSISTS OF STANDARD CHARACTERS WITHOUT CLAIM TO ANY PARTICULAR FONT, STYLE, SIZE, OR COLOR.
FOR BEER, ALE, LAGER, STOUT AND PORTER (U.S. CLS. 45, 46 AND 48).
FIRST USE 3-1-2012; IN COMMERCE 3-1-2012.

4,154,868. TOPCO HOLDINGS, INC., SKOKIE, IL. SN 85-160,988. PUB. 8-9-2011, FILED 10-26-2010.

**A LIGHTER WAY TO STAY
HYDRATED**

THE MARK CONSISTS OF STANDARD CHARACTERS WITHOUT CLAIM TO ANY PARTICULAR FONT, STYLE, SIZE, OR COLOR.
FOR POWDERS FOR MAKING NON-CARBONATED TEA-FLAVORED BEVERAGES; POWDERS USED IN THE PREPARATION OF NON-CARBONATED SPORTS AND ENERGY DRINKS (U.S. CLS. 45, 46 AND 48).
FIRST USE 3-0-2011; IN COMMERCE 3-0-2011.

4,155,024. TERRY D KROLL, DBA MAXIM MANUFACTURING & MARKETING, ALISO VIEJO, CA. SN 85-232,641. PUB. 6-7-2011, FILED 2-2-2011.

REVA

THE MARK CONSISTS OF STANDARD CHARACTERS WITHOUT CLAIM TO ANY PARTICULAR FONT, STYLE, SIZE, OR COLOR.
FOR COCONUT-BASED BEVERAGES; COCONUT-BASED NON-ALCOHOLIC BEVERAGES (U.S. CLS. 45, 46 AND 48).
FIRST USE 6-1-2011; IN COMMERCE 6-1-2011.

CLASS 32—(Continued).

4,155,027. THE MASTERS OF BEVERAGES, LLC, CORONA, CA. SN 85-233,757. PUB. 6-14-2011, FILED 2-3-2011.

DRINK WHAT YOU FEAR!

THE MARK CONSISTS OF STANDARD CHARACTERS WITHOUT CLAIM TO ANY PARTICULAR FONT, STYLE, SIZE, OR COLOR.
FOR ENERGY DRINKS (U.S. CLS. 45, 46 AND 48).
FIRST USE 2-24-2011; IN COMMERCE 2-24-2011.

4,155,028. MASTERS OF BEVERAGES, LLC, THE, CORONA, CA. SN 85-233,761. PUB. 6-14-2011, FILED 2-3-2011.

WIDOW MAKER

THE MARK CONSISTS OF STANDARD CHARACTERS WITHOUT CLAIM TO ANY PARTICULAR FONT, STYLE, SIZE, OR COLOR.
FOR ENERGY DRINKS (U.S. CLS. 45, 46 AND 48).
FIRST USE 2-24-2011; IN COMMERCE 2-24-2011.

4,155,046. EINSTOK BEER COMPANY, L.P., PACIFIC PALISADES, CA. SN 85-237,994. PUB. 6-14-2011, FILED 2-9-2011.



THE MARK CONSISTS OF A DRAWING DEPICTING A VIKING.
FOR BEER (U.S. CLS. 45, 46 AND 48).
FIRST USE 5-0-2011; IN COMMERCE 5-0-2011.

CLASS 32—(Continued).

4,155,059. ORCA BEVERAGE, INC., MUKILTEO, WA. SN 85-240,298. PUB. 6-14-2011, FILED 2-11-2011.

GOODY

THE MARK CONSISTS OF STANDARD CHARACTERS WITHOUT CLAIM TO ANY PARTICULAR FONT, STYLE, SIZE, OR COLOR.

FOR SOFT DRINKS (U.S. CLS. 45, 46 AND 48).
FIRST USE 10-10-2011; IN COMMERCE 10-13-2011.

CLASS 32—(Continued).

4,155,108. JOSEPH M. MCGRATH, CRESTWOOD, IL. SN 85-246,420. PUB. 7-5-2011, FILED 2-18-2011.

CITRALEMON

THE MARK CONSISTS OF STANDARD CHARACTERS WITHOUT CLAIM TO ANY PARTICULAR FONT, STYLE, SIZE, OR COLOR.

FOR NON-ALCOHOLIC BEVERAGES, NAMELY, CITRUS FLAVORED ENERGY DRINKS (U.S. CLS. 45, 46 AND 48).
FIRST USE 4-0-2011; IN COMMERCE 4-0-2011.

4,155,063. LEOKADIA PTY LTD., MANLY, AUSTRALIA. SN 85-241,048. PUB. 7-12-2011, FILED 2-13-2011.



OWNER OF U.S. REG. NO. 3,705,588.

THE MARK CONSISTS OF A STYLIZED DESIGN OF A BIRD TO THE LEFT OF THE STACKED STYLIZED WORDING "BUDGY SMUGGLER".

FOR ALCOHOL FREE BEER; ALCOHOLIC BEERS; BEER; BEER WORT; BITTER BEER; BLACK BEER; DARK BEER; DE-ALCOHOLISED BEER; EXTRACTS OF HOPS FOR MAKING BEER; FRUIT BEERS; GINGER BEER; MALT BEER; MALT CONTAINING BEVERAGES IN THE NATURE OF BEERS; MALT-CONTAINING BEVERAGES IN THE NATURE OF NON-ALCOHOLIC MALT COOLERS, AND NOT BEING BEERS; NON-ALCOHOLIC BEERS; PILSNER BEER; SOFT DRINKS IN THE NATURE OF ROOT BEER; AERATED BEVERAGES IN THE NATURE OF NON-ALCOHOLIC SOFT DRINKS AND CIDER; LOW ALCOHOL BEVERAGES CONTAINING NOT MORE THAN 1.15% BY VOLUME OF ALCOHOL, NAMELY, LOW-ALCOHOL BEERS, WINE AND CIDER; SPRING WATER, OTHER THAN FOR MEDICAL PURPOSES; DRINKING WATER OTHER THAN FOR MEDICAL USE; DRINKING WATERS; FRESH FRUIT JUICES; FRUIT JUICES; AERATED DRINKS IN THE NATURE OF FRUIT JUICES AND CIDER; CARBONATED NON-ALCOHOLIC DRINKS IN THE NATURE OF SOFT DRINKS; FRUIT DRINKS; NON-ALCOHOLIC DRINKS OTHER THAN FOR MEDICAL USE IN THE NATURE OF SOFT DRINKS AND CIDER; SOFT DRINKS; NON-MEDICATED SPORTS DRINKS; MINERAL WATER; ALCOHOL FREE DRINKS, IN THE NATURE OF SOFT DRINKS AND CIDER; BOTTLED FRUIT DRINKS; ISOTONIC DRINKS NOT FOR MEDICAL PURPOSES; AERATED MINERAL WATERS; AERATED WATER; BOTTLED WATER NOT FOR MEDICAL PURPOSES; CARBONATED WATER; DRINKING WATER; SODA WATER; DRINKING WATER, NAMELY, TONIC WATER BEING NON-MEDICATED BEVERAGES; ORANGE JUICE; LAGER; STOUT (U.S. CLS. 45, 46 AND 48).
FIRST USE 10-27-2008; IN COMMERCE 1-9-2012.

4,155,153. BONA VITA RX CORPORATION, CHULA VISTA, CA. SN 85-252,307. PUB. 7-5-2011, FILED 2-25-2011.

Age Defense Water Bona Vita Rx

THE MARK CONSISTS OF STANDARD CHARACTERS WITHOUT CLAIM TO ANY PARTICULAR FONT, STYLE, SIZE, OR COLOR.

NO CLAIM IS MADE TO THE EXCLUSIVE RIGHT TO USE "WATER", APART FROM THE MARK AS SHOWN.

FOR BOTTLED DRINKING WATER; DRINKING WATER WITH VITAMINS; ENERGY DRINKS; FLAVORED WATERS (U.S. CLS. 45, 46 AND 48).
FIRST USE 9-1-2010; IN COMMERCE 4-28-2011.

4,155,205. MILLERCOORS LLC, CHICAGO, IL. SN 85-256,867. PUB. 12-13-2011, FILED 3-3-2011.



NO CLAIM IS MADE TO THE EXCLUSIVE RIGHT TO USE "RECYCLES", APART FROM THE MARK AS SHOWN.

THE MARK CONSISTS OF THE SHADED WORD "COORS" WITH A BORDER, IN A STYLIZED SCRIPT, WITH THE WORD "RECYCLES" WITH A SHADED BORDER IN A STYLIZED BLOCK LETTERING TO THE RIGHT OF "COORS" WITH FOUR MOUNTAIN PEAKS IN THE BACKGROUND BEHIND THE WORDING.

FOR BEER (U.S. CLS. 45, 46 AND 48).
FIRST USE 3-30-2011; IN COMMERCE 3-30-2011.

CLASS 32—(Continued).

4,155,229. RED ROCK BREWING COMPANY, SALT LAKE CITY, UT. SN 85-259,892. PUB. 7-26-2011, FILED 3-7-2011.

ELEPHINO

THE MARK CONSISTS OF STANDARD CHARACTERS WITHOUT CLAIM TO ANY PARTICULAR FONT, STYLE, SIZE, OR COLOR.
FOR BEER (U.S. CLS. 45, 46 AND 48).
FIRST USE 2-28-2011; IN COMMERCE 4-7-2011.

4,155,327. MARKHAM, THOMAS WOODSON, RESTON, VA. SN 85-270,323. PUB. 8-2-2011, FILED 3-18-2011.



THE MARK CONSISTS OF A GLASS WITH A STEM AND THE STEM IS A NECK TO FEET SILHOUETTE OF A WOMAN. THE WOMAN'S ARMS ARE TO HER SIDE WITH HER HANDS ON HER HIPS. THE WORD "TRIM" APPEARS TO THE LEFT OF THE GLASS STEM AND THE WORD "RITA" APPEARS TO THE RIGHT OF THE GLASS STEM. THERE IS A SLICE OF LIME ON THE RIGHT SIDE RIM OF THE GLASS. THERE IS A MEASURING TAPE BELOW THE BASE OF THE GLASS.

FOR NON-ALCOHOLIC COCKTAIL MIXES (U.S. CLS. 45, 46 AND 48).
FIRST USE 2-25-2012; IN COMMERCE 2-26-2012.

4,155,637. RESCH, JACKIE, AKA JOHN C. RESCH, BASALT, CO. SN 85-352,060. PUB. 12-6-2011, FILED 6-21-2011.

RODEO COLD

THE MARK CONSISTS OF STANDARD CHARACTERS WITHOUT CLAIM TO ANY PARTICULAR FONT, STYLE, SIZE, OR COLOR.
OWNER OF U.S. REG. NO. 2,068,069.

CLASS 32—(Continued).

NO CLAIM IS MADE TO THE EXCLUSIVE RIGHT TO USE "COLD", APART FROM THE MARK AS SHOWN.
FOR BEER, ALE AND LAGER (U.S. CLS. 45, 46 AND 48).
FIRST USE 9-9-1996; IN COMMERCE 9-26-1997.

4,155,710. SOMERVILLE BREWING COMPANY, SOMERVILLE, MA. SN 85-371,112. PUB. 12-13-2011, FILED 7-14-2011.

SLUMBREW

THE MARK CONSISTS OF STANDARD CHARACTERS WITHOUT CLAIM TO ANY PARTICULAR FONT, STYLE, SIZE, OR COLOR.
FOR BEER, ALE, LAGER, STOUT AND PORTER (U.S. CLS. 45, 46 AND 48).
FIRST USE 2-4-2011; IN COMMERCE 11-29-2011.

4,155,715. DAVID E. CHILTON, DBA DC COMPANY, ANTI-OCH, TN. SN 85-372,734. PUB. 12-20-2011, FILED 7-15-2011.

H2O4

THE MARK CONSISTS OF STANDARD CHARACTERS WITHOUT CLAIM TO ANY PARTICULAR FONT, STYLE, SIZE, OR COLOR.
FOR FLAVORED WATERS; GLACIAL WATER; MINERAL WATER; SPARKLING WATER; SPRING WATER (U.S. CLS. 45, 46 AND 48).
FIRST USE 11-1-2011; IN COMMERCE 11-1-2011.

4,155,823. QUIKTRIP WEST, INC., WICHITA, KS. SN 85-461,230. PUB. 1-10-2012, FILED 11-1-2011.

QT ENERGY SHOT

THE MARK CONSISTS OF STANDARD CHARACTERS WITHOUT CLAIM TO ANY PARTICULAR FONT, STYLE, SIZE, OR COLOR.
OWNER OF U.S. REG. NOS. 1,094,059, 1,926,167, AND OTHERS.

CLASS 32—(Continued).

NO CLAIM IS MADE TO THE EXCLUSIVE RIGHT TO USE "ENERGY SHOT", APART FROM THE MARK AS SHOWN. FOR SPORTS DRINKS, NAMELY, ENERGY DRINKS (U.S. CLS. 45, 46 AND 48).
FIRST USE 1-15-2012; IN COMMERCE 1-15-2012.

CLASS 33—WINES AND SPIRITS

4,154,269. TASTY COCKTAILS, LLC, HENDERSON, NV. SN 76-979,202. PUB. 7-19-2011, FILED 9-13-2010.

UP ALL NIGHT

THE MARK CONSISTS OF STANDARD CHARACTERS WITHOUT CLAIM TO ANY PARTICULAR FONT, STYLE, SIZE, OR COLOR.

FOR DRINKS, NAMELY, ALCOHOLIC BEVERAGES CONTAINING FRUIT, WINE, RUM, FLAVOR INFUSED WHISKEY, WINE COOLERS, DISTILLED SPIRITS AND FLAVORED BREWED MALT BEVERAGES (U.S. CLS. 47 AND 49).

FIRST USE 7-10-2010; IN COMMERCE 7-10-2010.

4,154,288. BISON CAPITAL LLC, VENICE, FL. SN 77-381,274. PUB. 12-30-2008, FILED 1-25-2008.

Rum Creek

THE MARK CONSISTS OF STANDARD CHARACTERS WITHOUT CLAIM TO ANY PARTICULAR FONT, STYLE, SIZE, OR COLOR.

NO CLAIM IS MADE TO THE EXCLUSIVE RIGHT TO USE "RUM", APART FROM THE MARK AS SHOWN.

FOR DISTILLED SPIRITS (U.S. CLS. 47 AND 49).
FIRST USE 11-14-2011; IN COMMERCE 11-14-2011.

4,154,317. CHATAM INTERNATIONAL INCORPORATED, WILMINGTON, DE. SN 77-508,814. PUB. 12-30-2008, FILED 6-26-2008.

WINTERHAVEN FARMS

THE MARK CONSISTS OF STANDARD CHARACTERS WITHOUT CLAIM TO ANY PARTICULAR FONT, STYLE, SIZE, OR COLOR.

FOR PREPARED ALCOHOLIC COCKTAIL (U.S. CLS. 47 AND 49).

FIRST USE 10-23-2008; IN COMMERCE 10-23-2008.

CLASS 33—(Continued).

4,154,376. QUEENSWAY INVESTMENT HOLDINGS, LLC, DEL MAR, CA. SN 77-640,481. PUB. 6-9-2009, FILED 12-29-2008.

LA GRANJA

THE MARK CONSISTS OF STANDARD CHARACTERS WITHOUT CLAIM TO ANY PARTICULAR FONT, STYLE, SIZE, OR COLOR.

THE ENGLISH TRANSLATION OF "LA GRANJA" IS "THE FARM".

FOR WINES (U.S. CLS. 47 AND 49).

FIRST USE 12-20-2011; IN COMMERCE 12-20-2011.

4,154,465. GRUPO PENAFLORES S.A., BUENOS AIRES, ARGENTINA. SN 77-826,686. PUB. 3-2-2010, FILED 9-15-2009.



OWNER OF U.S. REG. NO. 1,975,823.

THE NAME(S), PORTRAIT(S), AND/OR SIGNATURE(S) SHOWN IN THE MARK DOES NOT IDENTIFY A PARTICULAR LIVING INDIVIDUAL.

THE COLOR(S) BLUE, YELLOW, GREEN, WHITE AND BROWN IS/ARE CLAIMED AS A FEATURE OF THE MARK.

THE MARK CONSISTS OF A BLUE SKY WITH A YELLOW SUN, A BLUE AND BROWN MOUNTAIN RANGE IN THE BACKGROUND, WITH ROWS OF GREEN PLANTS AND CACTI, A WHITE SHEEP ON THE LEFT AND A BLUE STREAM ON THE RIGHT, ALL ENCASED IN A BLUE RECTANGLE. ABOVE THE WORDING "MICHEL TORINO CUMA" IN BROWN IN A WHITE RECTANGLE WITH BLUE OUTLINES UNDERNEATH THE DESIGN PORTION.

FOR WINES (U.S. CLS. 47 AND 49).

FIRST USE 11-15-2006; IN COMMERCE 9-1-2007.

4,154,491. UNITED STATES DISTILLED PRODUCTS COMPANY, PRINCETON, MN. SN 77-866,219. PUB. 9-21-2010, FILED 11-5-2009.

DECADENT

THE MARK CONSISTS OF STANDARD CHARACTERS WITHOUT CLAIM TO ANY PARTICULAR FONT, STYLE, SIZE, OR COLOR.

FOR DISTILLED SPIRITS (U.S. CLS. 47 AND 49).

FIRST USE 2-29-2012; IN COMMERCE 2-29-2012.

CLASS 33—(Continued).

4,154,502. MAN IN BLACK LLC, EL PASO, TX. SN 77-875,136.
PUB. 4-27-2010, FILED 11-18-2009.

MAN IN BLACK

THE MARK CONSISTS OF STANDARD CHARACTERS WITHOUT CLAIM TO ANY PARTICULAR FONT, STYLE, SIZE, OR COLOR.
FOR DISTILLED SPIRITS (U.S. CLS. 47 AND 49).
FIRST USE 1-28-2012; IN COMMERCE 1-28-2012.

CLASS 33—(Continued).

4,154,595. HANSEN, CHRISTOPHER JOHN, BEVERLY HILLS, CA. SN 78-745,393. PUB. 1-16-2007, FILED 11-2-2005.

A stylized, cursive logo for the word "Blue". The letters are elegant and flowing, with a prominent 'B' and 'l'.

4,154,527. PROXIMO SPIRITS, INC., JERSEY CITY, NJ. SN 77-929,627. PUB. 1-25-2011, FILED 2-5-2010.

THREE OLIVES SUPERCOLA

THE MARK CONSISTS OF STANDARD CHARACTERS WITHOUT CLAIM TO ANY PARTICULAR FONT, STYLE, SIZE, OR COLOR.
OWNER OF U.S. REG. NOS. 3,253,658, 3,559,615, AND OTHERS.
FOR VODKA WITH A COLA FLAVOR (U.S. CLS. 47 AND 49).
FIRST USE 2-6-2012; IN COMMERCE 2-6-2012.

THE MARK CONSISTS OF THE STYLIZED WORD "BLUE".
FOR 100% BLUE AGAVE TEQUILA (U.S. CLS. 47 AND 49).
FIRST USE 5-15-2010; IN COMMERCE 6-10-2010.

4,154,553. SOUTH COAST WINERY, INC., SANTA ANA, CA. SN 77-958,578. PUB. 8-3-2010, FILED 3-14-2010.

ZINDEPENDENCE

THE MARK CONSISTS OF STANDARD CHARACTERS WITHOUT CLAIM TO ANY PARTICULAR FONT, STYLE, SIZE, OR COLOR.
FOR WINE (U.S. CLS. 47 AND 49).
FIRST USE 3-20-2012; IN COMMERCE 3-20-2012.

4,154,625. FOUR BRIX, LLC, DBA FOUR BRIX WINERY, SIMI VALLEY, CA. SN 85-014,606. PUB. 1-10-2012, FILED 4-15-2010.

A stylized logo for the word "Smitten". The letters are in a cursive, handwritten style. A small heart is placed above the letter 'i'.

THE MARK CONSISTS OF THE WORD "SMITTEN", WITH A HEART USED TO DOT THE "I", IS THE NAME BRAND FOR OUR WHITE WINE BLEND.
FOR RED WINE; WHITE WINE (U.S. CLS. 47 AND 49).
FIRST USE 5-1-2010; IN COMMERCE 5-15-2010.

CLASS 33—(Continued).

4,154,646. VINOS Y LICORES AZTECA. S.A. DE C.V., ZAPOPAN, JALISCO, MEXICO. SN 85-051,783. PUB. 12-13-2011, FILED 6-1-2010.



THE MARK CONSISTS OF A THREE-DIMENSIONAL CONFIGURATION OF A BOTTLE COMPRISED OF THREE SEPARATE STACKABLE 200 ML BOTTLES CONTAINING THE GOODS. THE BASE OF EACH OF THE BOTTLES CONTAINS A LARGE CONCAVE INDENTION WITH TWO ROUNDED EDGES. THE AREAS DEPICTED IN DOTTED LINES ARE NOT CLAIMED AS A FEATURE OF THE MARK AND ARE ONLY USED TO SHOW THE POSITION OF THE MARK ON THE CONTAINERS FOR THE GOODS.
 FOR TEQUILA (U.S. CLS. 47 AND 49).
 FIRST USE 1-1-2010; IN COMMERCE 7-1-2011.

4,154,698. CIA. MONTERROSAS, S.A. DE C.V., PUEBLA, MEXICO. SN 85-097,053. PUB. 8-30-2011, FILED 7-30-2010.

EL TEMERARIO

THE MARK CONSISTS OF STANDARD CHARACTERS WITHOUT CLAIM TO ANY PARTICULAR FONT, STYLE, SIZE, OR COLOR.
 THE ENGLISH TRANSLATION OF "EL TEMERARIO" IN THE MARK IS "THE BOLD".
 FOR TEQUILA (U.S. CLS. 47 AND 49).
 FIRST USE 8-10-2011; IN COMMERCE 8-10-2011.

CLASS 33—(Continued).

4,154,721. ASPIRE CELLARS LLC, DBA CELLAR 426, ASHLAND, NE. SN 85-104,618. PUB. 2-8-2011, FILED 8-10-2010.

Cellar 426

THE MARK CONSISTS OF STANDARD CHARACTERS WITHOUT CLAIM TO ANY PARTICULAR FONT, STYLE, SIZE, OR COLOR.
 NO CLAIM IS MADE TO THE EXCLUSIVE RIGHT TO USE "CELLAR", APART FROM THE MARK AS SHOWN.
 FOR FRUIT WINE; RED WINE; WHITE WINE; WINE (U.S. CLS. 47 AND 49).
 FIRST USE 5-10-2010; IN COMMERCE 3-29-2012.

4,154,738. DEUTSCHES WEINTOR EG, ILBESHEIM, FED REP GERMANY. SN 85-109,014. PUB. 7-26-2011, FILED 8-17-2010.

RED GATE

THE MARK CONSISTS OF STANDARD CHARACTERS WITHOUT CLAIM TO ANY PARTICULAR FONT, STYLE, SIZE, OR COLOR.
 NO CLAIM IS MADE TO THE EXCLUSIVE RIGHT TO USE "RED", APART FROM THE MARK AS SHOWN.
 FOR ALCOHOLIC BEVERAGES, NAMELY, WINE (U.S. CLS. 47 AND 49).
 FIRST USE 4-11-2011; IN COMMERCE 4-11-2011.

4,154,739. DEUTSCHES WEINTOR EG, ILBESHEIM, FED REP GERMANY. SN 85-109,021. PUB. 7-26-2011, FILED 8-17-2010.

WHITE GATE

THE MARK CONSISTS OF STANDARD CHARACTERS WITHOUT CLAIM TO ANY PARTICULAR FONT, STYLE, SIZE, OR COLOR.
 NO CLAIM IS MADE TO THE EXCLUSIVE RIGHT TO USE "WHITE", APART FROM THE MARK AS SHOWN.
 FOR ALCOHOLIC BEVERAGES, NAMELY, WINE (U.S. CLS. 47 AND 49).
 FIRST USE 4-11-2011; IN COMMERCE 4-11-2011.

CLASS 33—(Continued).

4,154,895. SOCIETE COOPERATIVE VINICOLE DE LUGNY "L'AUREOLE", LUGNY, FRANCE. SN 85-182,457. PUB. 9-20-2011, FILED 11-22-2010.

LA COTE BLANCHE

THE MARK CONSISTS OF STANDARD CHARACTERS WITHOUT CLAIM TO ANY PARTICULAR FONT, STYLE, SIZE, OR COLOR.

THE ENGLISH TRANSLATION OF "LA COTE BLANCHE" IS "THE WHITE SLOPE".

FOR WINES; WINES WITH A PROTECTED DESIGNATION OF ORIGIN; WINES WITH A PROTECTED DESIGNATION OF ORIGIN OF BURGUNDY; CHARDONNAY WINES (U.S. CLS. 47 AND 49).

FIRST USE 9-0-2009; IN COMMERCE 5-31-2011.

CLASS 33—(Continued).

4,154,968. INTERCONTINENTAL PACKAGING CO., ST. PAUL, MN. SN 85-213,007. PUB. 5-24-2011, FILED 1-7-2011.

AVO

THE MARK CONSISTS OF STANDARD CHARACTERS WITHOUT CLAIM TO ANY PARTICULAR FONT, STYLE, SIZE, OR COLOR.

THE ENGLISH TRANSLATION OF "AVO" IN THE MARK IS "GRANFATHER" OR "ANCESTOR".

FOR WINES (U.S. CLS. 47 AND 49).
FIRST USE 1-1-2011; IN COMMERCE 3-1-2011.

4,154,902. GOLAN HEIGHTS WINERY LTD., GOLAN HEIGHTS, ISRAEL. SN 85-186,555. PUB. 4-12-2011, FILED 11-29-2010.

GILGAL

THE MARK CONSISTS OF STANDARD CHARACTERS WITHOUT CLAIM TO ANY PARTICULAR FONT, STYLE, SIZE, OR COLOR.

FOR WINE (U.S. CLS. 47 AND 49).

FIRST USE 4-1-2010; IN COMMERCE 3-1-2011.

4,154,926. A KIERAN COLLECTION LLC, MINNEAPOLIS, MN. SN 85-199,355. PUB. 11-1-2011, FILED 12-16-2010.

2 GINGERS

THE MARK CONSISTS OF STANDARD CHARACTERS WITHOUT CLAIM TO ANY PARTICULAR FONT, STYLE, SIZE, OR COLOR.

FOR WHISKEY (U.S. CLS. 47 AND 49).

FIRST USE 3-16-2011; IN COMMERCE 3-16-2011.

4,155,019. MOET HENNESSY USA, INC., NEW YORK, NY. SN 85-231,583. PUB. 8-2-2011, FILED 2-1-2011.



OWNER OF U.S. REG. NOS. 2,288,293, 3,029,109, AND OTHERS.

THE MARK CONSISTS OF A BOTTLE LABEL WITH A SOLID BORDER AT THE TOP AND BOTTOM. IN THE CENTER OF THE LABEL IS THE WORD "CHANDON" WITH THE DESIGN OF AN ARC WITH A STAR ON THE END APPEARING BETWEEN THE LETTERS "A" AND "N". THERE IS A THIN LINE ABOVE AND BELOW THE WORD "CHANDON". THE OVERALL SHAPE OF THE LABEL IS RECTANGULAR. THE MIDDLE SECTION THAT CONTAINS THE WORD "CHANDON" EXTENDS HORIZONTALLY BEYOND THE SIDES OF THE RECTANGLE.

THE WORD(S) "CHANDON" HAS NO MEANING IN A FOREIGN LANGUAGE.

FOR WINES AND SPARKLING WINES (U.S. CLS. 47 AND 49).

FIRST USE 8-19-2010; IN COMMERCE 8-19-2010.

CLASS 33—(Continued).

4,155,031. SCHEID VINEYARDS CALIFORNIA INC., SALINAS, CA. SN 85-234,793. PUB. 12-6-2011, FILED 2-4-2011.

DISTRICT 7

THE MARK CONSISTS OF STANDARD CHARACTERS WITHOUT CLAIM TO ANY PARTICULAR FONT, STYLE, SIZE, OR COLOR.
FOR ALCOHOLIC BEVERAGES EXCEPT BEERS (U.S. CLS. 47 AND 49).
FIRST USE 1-3-2012; IN COMMERCE 1-3-2012.

4,155,043. INTERCONTINENTAL PACKAGING CO., ST. PAUL, MN. SN 85-237,515. PUB. 5-3-2011, FILED 2-9-2011.

LE CLUZET

THE MARK CONSISTS OF STANDARD CHARACTERS WITHOUT CLAIM TO ANY PARTICULAR FONT, STYLE, SIZE, OR COLOR.
THE ENGLISH TRANSLATION OF "LE" IN THE MARK IS THE. THE WORDING "CLUZET" HAS NO MEANING IN A FOREIGN LANGUAGE.
FOR WINES (U.S. CLS. 47 AND 49).
FIRST USE 4-1-2011; IN COMMERCE 5-1-2011.

4,155,060. INFANTE INTERNATIONAL, UPLAND, CA. SN 85-240,443. PUB. 6-21-2011, FILED 2-11-2011.

INOLVIDABLE INFANTE

THE MARK CONSISTS OF STANDARD CHARACTERS WITHOUT CLAIM TO ANY PARTICULAR FONT, STYLE, SIZE, OR COLOR.
THE ENGLISH TRANSLATION OF THE WORDS "INOLVIDABLE INFANTE" IN THE MARK IS UNFORGETTABLE INFANT.
FOR TEQUILA (U.S. CLS. 47 AND 49).
FIRST USE 2-11-2011; IN COMMERCE 2-11-2011.

CLASS 33—(Continued).

4,155,071. HALTER WINERY LLC, PASO ROBLES, CA. SN 85-242,499. PUB. 8-16-2011, FILED 2-15-2011.

ANCESTOR

THE MARK CONSISTS OF STANDARD CHARACTERS WITHOUT CLAIM TO ANY PARTICULAR FONT, STYLE, SIZE, OR COLOR.
FOR WINES (U.S. CLS. 47 AND 49).
FIRST USE 7-1-2005; IN COMMERCE 10-8-2007.

4,155,074. DIOSA SPIRITS, LLC, N. LAS VEGAS, NV. SN 85-243,253. PUB. 10-11-2011, FILED 2-15-2011.

DIOSA

THE MARK CONSISTS OF STANDARD CHARACTERS WITHOUT CLAIM TO ANY PARTICULAR FONT, STYLE, SIZE, OR COLOR.
THE ENGLISH TRANSLATION OF "DIOSA" IN THE MARK IS "GODDESS, FEMALE GOD OR EXTREMELY BEAUTIFUL WOMAN".
FOR TEQUILA (U.S. CLS. 47 AND 49).
FIRST USE 2-1-2012; IN COMMERCE 2-1-2012.

4,155,156. DIOSA SPIRITS, LLC, N. LAS VEGAS, NV. SN 85-252,449. PUB. 10-4-2011, FILED 2-25-2011.



THE MARK CONSISTS OF A FANCIFUL DESIGN OF THE SILHOUETTE OF A WOMAN WITH ANGEL'S WINGS.
FOR TEQUILA (U.S. CLS. 47 AND 49).
FIRST USE 2-1-2012; IN COMMERCE 2-1-2012.

CLASS 33—(Continued).

4,155,168. JACK JOHN INVESTMENTS, INC., PASA ROBLES, CA. SN 85-253,425. PUB. 7-19-2011, FILED 2-28-2011.



THE MARK CONSISTS OF AN UNCLOSED CIRCULAR DESIGN WITH THE WORD "MALSTRIA" IN THE CENTER OF THE CIRCLE AND WITH THE SAME WORD "MALSTRIA" UPSIDE DOWN UNDER "MALSTRIA".

FOR WINES (U.S. CLS. 47 AND 49).
FIRST USE 2-21-2012; IN COMMERCE 2-21-2012.

CLASS 33—(Continued).

4,155,274. JIM BEAM BRANDS CO., DEERFIELD, IL. SN 85-263,720. PUB. 7-26-2011, FILED 3-10-2011.



OWNER OF U.S. REG. NOS. 2,535,369, 2,638,476, AND 2,665,405.

THE MARK CONSISTS OF THE WORD "PUCKER" WITH THE LETTER "E" IN A STYLIZED LIPS DESIGN.

FOR ALCOHOLIC BEVERAGES, NAMELY, VODKA (U.S. CLS. 47 AND 49).

FIRST USE 3-29-2011; IN COMMERCE 3-29-2011.

4,155,210. GLJR WINE LLC, NAPA, CA. SN 85-257,112. PUB. 7-19-2011, FILED 3-3-2011.



THE MARK CONSISTS OF STANDARD CHARACTERS WITHOUT CLAIM TO ANY PARTICULAR FONT, STYLE, SIZE, OR COLOR.

FOR WINE (U.S. CLS. 47 AND 49).
FIRST USE 9-15-2011; IN COMMERCE 9-15-2011.

4,155,294. MADRONA PROPERTY COMPANY, SAN FRANCISCO, CA. SN 85-266,635. PUB. 7-26-2011, FILED 3-14-2011.



THE MARK CONSISTS OF STANDARD CHARACTERS WITHOUT CLAIM TO ANY PARTICULAR FONT, STYLE, SIZE, OR COLOR.

FOR WINE (U.S. CLS. 47 AND 49).
FIRST USE 1-15-2012; IN COMMERCE 1-15-2012.

4,155,217. ARTISTIC CAFES INC., DBA BON VIVANT CAFE, SAN JOSE, CA. SN 85-257,841. PUB. 7-26-2011, FILED 3-4-2011.



THE MARK CONSISTS OF STANDARD CHARACTERS WITHOUT CLAIM TO ANY PARTICULAR FONT, STYLE, SIZE, OR COLOR.

NO CLAIM IS MADE TO THE EXCLUSIVE RIGHT TO USE "COSMOPOLITAN", APART FROM THE MARK AS SHOWN.

FOR ALCOHOLIC BEVERAGES EXCEPT BEERS (U.S. CLS. 47 AND 49).
FIRST USE 3-1-2012; IN COMMERCE 3-1-2012.

4,155,341. SAN ANTONIO WINERY, INC., LOS ANGELES, CA. SN 85-272,490. PUB. 7-5-2011, FILED 3-21-2011.



THE MARK CONSISTS OF STANDARD CHARACTERS WITHOUT CLAIM TO ANY PARTICULAR FONT, STYLE, SIZE, OR COLOR.

THE ENGLISH TRANSLATION OF "ANGELES DE ORO" IN THE MARK IS ANGELS OF GOLD.

FOR DISTILLED SPIRITS, NAMELY, TEQUILA (U.S. CLS. 47 AND 49).
FIRST USE 3-8-2012; IN COMMERCE 3-20-2012.

CLASS 33—(Continued).

4,155,346. MISSISSIPPI RIVER DISTILLING COMPANY, LE CLAIRE, IA. SN 85-273,121. PUB. 8-2-2011, FILED 3-22-2011.

Cody Road

THE MARK CONSISTS OF STANDARD CHARACTERS WITHOUT CLAIM TO ANY PARTICULAR FONT, STYLE, SIZE, OR COLOR.
FOR BOURBON; BOURBON WHISKY (U.S. CLS. 47 AND 49).
FIRST USE 12-2-2011; IN COMMERCE 12-2-2011.

CLASS 33—(Continued).

4,155,483. BANFI PRODUCTS CORPORATION, OLD BROOKVILLE, NY. SN 85-299,594. PUB. 8-30-2011, FILED 4-20-2011.

SOGNO D'ITALIA

THE MARK CONSISTS OF STANDARD CHARACTERS WITHOUT CLAIM TO ANY PARTICULAR FONT, STYLE, SIZE, OR COLOR.
THE ENGLISH TRANSLATION OF "SOGNO D'ITALIA" IN THE MARK IS DREAM OF ITALY.
FOR WINES (U.S. CLS. 47 AND 49).
FIRST USE 9-0-2011; IN COMMERCE 9-0-2011.

4,155,351. VINA CASA SILVA S.A., SAN FERNANDO, CHILE. SN 85-274,195. PUB. 8-9-2011, FILED 3-23-2011.

FERVOR

THE MARK CONSISTS OF STANDARD CHARACTERS WITHOUT CLAIM TO ANY PARTICULAR FONT, STYLE, SIZE, OR COLOR.
FOR WINE (U.S. CLS. 47 AND 49).
FIRST USE 3-15-2012; IN COMMERCE 3-15-2012.

4,155,530. JF STROTHMAN DISTILLERY, INC., GRAND JUNCTION, CO. SN 85-314,614. PUB. 8-23-2011, FILED 5-6-2011.

SMOKEY JOES

THE MARK CONSISTS OF STANDARD CHARACTERS WITHOUT CLAIM TO ANY PARTICULAR FONT, STYLE, SIZE, OR COLOR.
FOR DISTILLED SPIRITS (U.S. CLS. 47 AND 49).
FIRST USE 2-11-2012; IN COMMERCE 2-11-2012.

4,155,407. VAL DU CHARRON WINES (PTY) LTD, CENTURY CITY, SOUTH AFRICA. SN 85-283,470. PUB. 9-6-2011, FILED 4-1-2011.

BLACK COUNTESS

THE MARK CONSISTS OF STANDARD CHARACTERS WITHOUT CLAIM TO ANY PARTICULAR FONT, STYLE, SIZE, OR COLOR.
FOR ALCOHOLIC BEVERAGES EXCEPT BEERS (U.S. CLS. 47 AND 49).
FIRST USE 9-1-2011; IN COMMERCE 9-1-2011.

4,155,535. AZAR DISTILLING, LLC, SAN ANTONIO, TX. SN 85-317,316. PUB. 8-16-2011, FILED 5-10-2011.

Cinco Five Star Vodka

THE MARK CONSISTS OF STANDARD CHARACTERS WITHOUT CLAIM TO ANY PARTICULAR FONT, STYLE, SIZE, OR COLOR.
NO CLAIM IS MADE TO THE EXCLUSIVE RIGHT TO USE "VODKA", APART FROM THE MARK AS SHOWN.
THE ENGLISH TRANSLATION OF "CINCO" IN THE MARK IS "FIVE".
FOR VODKA (U.S. CLS. 47 AND 49).
FIRST USE 10-26-2011; IN COMMERCE 10-26-2011.

CLASS 33—(Continued).

4,155,622. COALE, ANSLEY J., UKIAH, CA. SN 85-348,397.
PUB. 1-10-2012, FILED 6-16-2011.

Fluid Dynamics

THE MARK CONSISTS OF STANDARD CHARACTERS WITHOUT CLAIM TO ANY PARTICULAR FONT, STYLE, SIZE, OR COLOR.

FOR ALCOHOLIC BEVERAGES EXCEPT BEERS; DISTILLED SPIRITS (U.S. CLS. 47 AND 49).
FIRST USE 10-12-2011; IN COMMERCE 10-12-2011.

CLASS 33—(Continued).

4,155,777. INTERCONTINENTAL PACKAGING CO., ST. PAUL, MN. SN 85-398,858. PUB. 1-17-2012, FILED 8-16-2011.

HAWTHORNE HILLS

THE MARK CONSISTS OF STANDARD CHARACTERS WITHOUT CLAIM TO ANY PARTICULAR FONT, STYLE, SIZE, OR COLOR.

FOR ALCOHOLIC BEVERAGES EXCEPT BEERS (U.S. CLS. 47 AND 49).
FIRST USE 10-1-2011; IN COMMERCE 12-1-2011.

4,155,727. SNEAKY COCKTAILS, LLC, ROSWELL, GA. SN 85-376,831. PUB. 1-17-2012, FILED 7-21-2011.

Sneaky Rita Margarita Mix

THE MARK CONSISTS OF STANDARD CHARACTERS WITHOUT CLAIM TO ANY PARTICULAR FONT, STYLE, SIZE, OR COLOR.

NO CLAIM IS MADE TO THE EXCLUSIVE RIGHT TO USE "MARGARITA MIX", APART FROM THE MARK AS SHOWN.

FOR ALCOHOLIC COCKTAIL MIXES, NAMELY, MARGARITA MIXES (U.S. CLS. 47 AND 49).
FIRST USE 7-1-2011; IN COMMERCE 7-1-2011.

4,155,799. INTERCONTINENTAL PACKAGING CO., ST. PAUL, MN. SN 85-413,774. PUB. 1-17-2012, FILED 9-2-2011.

URBAN TALES

THE MARK CONSISTS OF STANDARD CHARACTERS WITHOUT CLAIM TO ANY PARTICULAR FONT, STYLE, SIZE, OR COLOR.

FOR ALCOHOLIC BEVERAGES EXCEPT BEERS (U.S. CLS. 47 AND 49).
FIRST USE 4-1-2011; IN COMMERCE 5-1-2011.

4,155,764. GANDONA, INC., ST. HELENA, CA. SN 85-391,941.
PUB. 1-10-2012, FILED 8-8-2011.

GANDONA

THE MARK CONSISTS OF STANDARD CHARACTERS WITHOUT CLAIM TO ANY PARTICULAR FONT, STYLE, SIZE, OR COLOR.

FOR WINE (U.S. CLS. 47 AND 49).
FIRST USE 2-0-2006; IN COMMERCE 2-29-2012.

4,155,811. INTERCONTINENTAL PACKAGING CO., ST. PAUL, MN. SN 85-438,420. PUB. 1-17-2012, FILED 10-4-2011.

MI CHIAMO TURCHI

THE MARK CONSISTS OF STANDARD CHARACTERS WITHOUT CLAIM TO ANY PARTICULAR FONT, STYLE, SIZE, OR COLOR.

THE ENGLISH TRANSLATION OF "MI CHIAMO TURCHI" IN THE MARK IS "MY NAME IS TURCHI".
FOR ALCOHOLIC BEVERAGES EXCEPT BEERS (U.S. CLS. 47 AND 49).

FIRST USE 11-1-2011; IN COMMERCE 1-1-2012.

CLASS 33—(Continued).

4,155,814. INTERCONTINENTAL PACKAGING CO., ST. PAUL, MN. SN 85-443,446. PUB. 1-17-2012, FILED 10-10-2011.

LUNA FIORE

THE MARK CONSISTS OF STANDARD CHARACTERS WITHOUT CLAIM TO ANY PARTICULAR FONT, STYLE, SIZE, OR COLOR.

THE ENGLISH TRANSLATION OF "LUNA FIORE" IN THE MARK IS "MOON FLOWER".

FOR ALCOHOLIC BEVERAGES EXCEPT BEERS (U.S. CLS. 47 AND 49).

FIRST USE 11-1-2011; IN COMMERCE 12-1-2011.

4,155,816. WINERY EXCHANGE, INC., NOVATO, CA. SN 85-446,992. PUB. 2-7-2012, FILED 10-13-2011.

SPIRITO D'ITALIA

THE MARK CONSISTS OF STANDARD CHARACTERS WITHOUT CLAIM TO ANY PARTICULAR FONT, STYLE, SIZE, OR COLOR.

THE ENGLISH TRANSLATION OF "SPIRITO D'ITALIA" IN THE MARK IS "SPIRIT OF ITALY".

FOR ALCOHOLIC BEVERAGES EXCEPT BEERS (U.S. CLS. 47 AND 49).

FIRST USE 1-0-2012; IN COMMERCE 1-0-2012.

4,155,818. INTERCONTINENTAL PACKAGING CO., ST. PAUL, MN. SN 85-449,815. PUB. 1-17-2012, FILED 10-18-2011.

REAL DEL PEDRO

THE MARK CONSISTS OF STANDARD CHARACTERS WITHOUT CLAIM TO ANY PARTICULAR FONT, STYLE, SIZE, OR COLOR.

THE ENGLISH TRANSLATION OF "REAL DEL PEDRO" IN THE MARK IS "ROYAL OF PETER".

FOR ALCOHOLIC BEVERAGES EXCEPT BEERS (U.S. CLS. 47 AND 49).

FIRST USE 11-1-2011; IN COMMERCE 12-1-2011.

CLASS 33—(Continued).

4,155,819. INTERCONTINENTAL PACKAGING CO., ST. PAUL, MN. SN 85-449,820. PUB. 1-17-2012, FILED 10-18-2011.

PRIMA MAZZO

THE MARK CONSISTS OF STANDARD CHARACTERS WITHOUT CLAIM TO ANY PARTICULAR FONT, STYLE, SIZE, OR COLOR.

THE ENGLISH TRANSLATION OF "PRIMA MAZZO" IN THE MARK IS "FIRST DECK".

FOR ALCOHOLIC BEVERAGES EXCEPT BEERS (U.S. CLS. 47 AND 49).

FIRST USE 12-1-2011; IN COMMERCE 3-1-2012.

4,155,821. INTERCONTINENTAL PACKAGING CO., ST. PAUL, MN. SN 85-456,440. PUB. 1-17-2012, FILED 10-26-2011.

DEMON KILLER

THE MARK CONSISTS OF STANDARD CHARACTERS WITHOUT CLAIM TO ANY PARTICULAR FONT, STYLE, SIZE, OR COLOR.

FOR ALCOHOLIC BEVERAGES EXCEPT BEERS (U.S. CLS. 47 AND 49).

FIRST USE 8-1-2010; IN COMMERCE 10-1-2010.

CLASS 33—(Continued).

4,155,825. JIM BEAM BRANDS CO., DEERFIELD, IL. SN 85-975,974. PUB. 1-25-2011, FILED 9-17-2010.



THE MARK CONSISTS OF THE SILHOUETTE OF A WOMAN DRESSED IN A TOP AND A SKIRT, WITH A COCKTAIL SHAKER IN THE RIGHT HAND, AND A COCKTAIL IN THE LEFT HAND.

FOR ALCOHOLIC COCKTAIL MIXES (U.S. CLS. 47 AND 49).

FIRST USE 9-23-2009; IN COMMERCE 9-23-2009.

4,155,826. THE WINE GROUP LLC, TRACY, CA. SN 85-976,205. PUB. 2-22-2011, FILED 9-22-2010.

TO EACH, THEIR OWN

THE MARK CONSISTS OF STANDARD CHARACTERS WITHOUT CLAIM TO ANY PARTICULAR FONT, STYLE, SIZE, OR COLOR.

FOR SPIRITS (U.S. CLS. 47 AND 49).

FIRST USE 2-29-2012; IN COMMERCE 2-29-2012.

CLASS 34—SMOKERS' ARTICLES

4,154,569. PAN PARAG INDIA LIMITED, KANPUR, INDIA. SN 77-966,530. PUB. 10-4-2011, FILED 3-23-2010.



THE MARK CONSISTS OF THE WORDS "PAN PARAG" ACROSS AN ARCHED BANNER.

FOR CHEWING TOBACCO (U.S. CLS. 2, 8, 9 AND 17).

FIRST USE 1-22-1996; IN COMMERCE 1-22-1996.

CLASS 34—(Continued).

4,154,997. DOMINICAN TOBACCO PRODUCTS LLC, MIAMI, FL. SN 85-222,527. PUB. 5-31-2011, FILED 1-20-2011.

STAR BLUNT

THE MARK CONSISTS OF STANDARD CHARACTERS WITHOUT CLAIM TO ANY PARTICULAR FONT, STYLE, SIZE, OR COLOR.

NO CLAIM IS MADE TO THE EXCLUSIVE RIGHT TO USE "BLUNT", APART FROM THE MARK AS SHOWN.

FOR CIGAR WRAPS; CIGARILLOS; CIGARS; TOBACCO (U.S. CLS. 2, 8, 9 AND 17).

FIRST USE 3-25-2010; IN COMMERCE 3-25-2010.

4,155,241. CLARKSVILLE TRADING COMPANY, LLC, MIDLOTHIAN, VA. SN 85-260,828. PUB. 7-26-2011, FILED 3-8-2011.

DREAM CATCHER

THE MARK CONSISTS OF STANDARD CHARACTERS WITHOUT CLAIM TO ANY PARTICULAR FONT, STYLE, SIZE, OR COLOR.

FOR CIGARETTES CONTAINING TOBACCO SUBSTITUTES NOT FOR MEDICAL PURPOSES; HAND-HELD MACHINES FOR INJECTING TOBACCO INTO CIGARETTE TUBES; HAND-ROLLING TOBACCO; HOOKAH TOBACCO; MACHINES ALLOWING SMOKERS TO MAKE CIGARETTES BY THEMSELVES; PIPE TOBACCO; ROLL YOUR OWN TOBACCO; SMOKELESS TOBACCO; SMOKER'S ARTICLES, NAMELY, FILTER TUBES; SMOKING TOBACCO; TOBACCO; TOBACCO, CIGARS AND CIGARETTES (U.S. CLS. 2, 8, 9 AND 17).

FIRST USE 2-0-2012; IN COMMERCE 2-0-2012.

4,155,594. REYNOLDS INNOVATIONS INC., WINSTON-SALEM, NC. SN 85-339,921. PUB. 10-4-2011, FILED 6-7-2011.

IMPROBABLY FRESH

THE MARK CONSISTS OF STANDARD CHARACTERS WITHOUT CLAIM TO ANY PARTICULAR FONT, STYLE, SIZE, OR COLOR.

NO CLAIM IS MADE TO THE EXCLUSIVE RIGHT TO USE "FRESH", APART FROM THE MARK AS SHOWN.

FOR CIGARETTES (U.S. CLS. 2, 8, 9 AND 17).

FIRST USE 8-29-2011; IN COMMERCE 8-29-2011.

CLASS 34—(Continued).

SERVICE MARKS

CLASS 35—ADVERTISING AND BUSINESS

4,154,270. IDEAL PROMOTIONS, INC., CHICAGO, IL. SN 77-058,934. PUB. 7-19-2011, FILED 12-7-2006.



NO CLAIM IS MADE TO THE EXCLUSIVE RIGHT TO USE "BEVERAGE NETWORK", APART FROM THE MARK AS SHOWN.

THE COLOR(S) RED, ORANGE, YELLOW, BLACK, AND WHITE IS/ARE CLAIMED AS A FEATURE OF THE MARK. THE MARK CONSISTS OF AN ARRAY OF BOTTLES. BELOW THE BOTTLES ARE THE WORDS "IDEAL" AND "BEVERAGE NETWORK" IN WHITE RECTANGULAR SHAPES OUTLINED IN BLACK. THE COLOR RED APPEARS IN THE SECOND AND FOURTH BOTTLE DESIGN, THE COLOR ORANGE APPEARS IN THE THIRD AND SIXTH BOTTLE DESIGN, THE COLOR YELLOW APPEARS IN THE FIRST AND FIFTH BOTTLE DESIGN, THE COLOR WHITE APPEARS ON EACH BOTTLE AS A MEANS OF SHOWING THEIR CONTOURS, AND THE COLOR BLACK APPEARS IN THE TEXT "IDEAL BEVERAGE NETWORK".

FOR BUSINESS MANAGEMENT AND MARKETING CONSULTING SERVICES FOR ALCOHOLIC BEVERAGE MANUFACTURERS AND RETAILERS, IN THE FIELD OF RETAIL ALCOHOLIC BEVERAGE SALES (U.S. CLS. 100, 101 AND 102).

FIRST USE 12-31-2007; IN COMMERCE 12-31-2007.

CLASS 35—(Continued).

4,154,275. THE GREEN SQUAD, INC., TARPON SPRINGS, FL. SN 77-240,225. PUB. 4-15-2008, FILED 7-27-2007.

Green Squad

THE MARK CONSISTS OF STANDARD CHARACTERS WITHOUT CLAIM TO ANY PARTICULAR FONT, STYLE, SIZE, OR COLOR.

NO CLAIM IS MADE TO THE EXCLUSIVE RIGHT TO USE "GREEN", APART FROM THE MARK AS SHOWN.

FOR DISTRIBUTORSHIP, RETAIL STORE AND ON-LINE RETAIL STORE SERVICES IN THE FIELD OF ENERGY EFFICIENT AND ENVIRONMENTALLY FRIENDLY PRODUCTS, NAMELY, TANKLESS HOT WATER HEATERS, ENERGY RECOVERY UNITS, HIGH EFFICIENCY AIR CONDITIONING UNITS, AIR AND WATER FILTERS, SOLAR HEATING UNITS, INSULATED WINDOWS, TINTED WINDOWS, WINDOW FILM, FOAM INSULATION, RECYCLED CLOTHING AND PAPER PRODUCTS, INSULATED ROOFING, ATTIC FANS AND VENTS, SOLAR ROOF FANS, WIND ENERGY GENERATORS, LOW FLOW TOILETS AND SINK FAUCETS, INSULATED DOORS, WEATHER STRIPPING, ENERGY EFFICIENT LIGHTING, COMPACT FLUORESCENT LIGHT BULBS, LOW WATER LANDSCAPING SYSTEMS, ZEROSCAPE LANDSCAPING SYSTEMS, LOW WATER IRRIGATION SYSTEMS, DRIP AND MAT IRRIGATIONS SYSTEMS, NON TOXIC CLEANING PRODUCTS FOR CLOTHES, BATHROOMS, KITCHENS AND FLOORS, FERTILIZERS AND PEST CONTROL CHEMICALS AND BUILDING PRODUCTS, NAMELY, PAINT, FLOORING, CARPET, TILES; CONSULTATION SERVICES RELATED TO ENERGY EFFICIENT PRODUCTS IN THE NATURE OF TANKLESS HOT WATER HEATERS, ENERGY RECOVERY UNITS, HIGH EFFICIENCY AIR CONDITIONING UNITS, AIR AND WATER FILTERS, SOLAR HEATING UNITS, INSULATED WINDOWS, TINTED WINDOWS, WINDOW FILM, FOAM INSULATION, RECYCLED CLOTHING AND PAPER PRODUCTS, INSULATED ROOFING, ATTIC FANS AND VENTS, SOLAR ROOF FANS, WIND ENERGY GENERATORS, LOW FLOW TOILETS AND SINK FAUCETS, INSULATED DOORS, WEATHER STRIPPING, ENERGY EFFICIENT LIGHTING, COMPACT FLUORESCENT LIGHT BULBS, LOW WATER LANDSCAPING SYSTEMS, ZEROSCAPE LANDSCAPING SYSTEMS, LOW WATER IRRIGATION SYSTEMS, DRIP AND MAT IRRIGATIONS SYSTEMS, NON TOXIC CLEANING PRODUCTS FOR CLOTHES, BATHROOMS, KITCHENS AND FLOORS, FERTILIZERS AND PEST CONTROL CHEMICALS AND BUILDING PRODUCTS, NAMELY, PAINT, FLOORING, CARPET, TILES (U.S. CLS. 100, 101 AND 102).

FIRST USE 10-5-2011; IN COMMERCE 10-5-2011.

4,154,274. AVID TECHNOLOGY, INC., BURLINGTON, MA. SN 77-217,843. PUB. 4-21-2009, FILED 6-28-2007.

AVID

THE MARK CONSISTS OF STANDARD CHARACTERS WITHOUT CLAIM TO ANY PARTICULAR FONT, STYLE, SIZE, OR COLOR.

FOR BUSINESS CONSULTING AND INFORMATION SERVICES IN THE FIELDS OF COMPUTER HARDWARE, COMPUTER SOFTWARE, COMPUTER PERIPHERALS, ENTERTAINMENT, MUSIC, AUDIO, TELEVISION, FILM, BROADCAST, VIDEO, GAMING, 3D, SPECIAL EFFECTS AND ANIMATION; BUSINESS RESEARCH AND SURVEYS IN THE FIELDS OF COMPUTER HARDWARE, COMPUTER SOFTWARE, COMPUTER PERIPHERALS, ENTERTAINMENT, MUSIC, AUDIO, TELEVISION, FILM, BROADCAST, VIDEO, GAMING, 3D, SPECIAL EFFECTS AND ANIMATION; ON-LINE RETAIL STORE SERVICES FEATURING COMPUTER HARDWARE, COMPUTER SOFTWARE, PERIPHERALS, MUSICAL INSTRUMENTS, AUDIO EQUIPMENT, AND VIDEO EQUIPMENT (U.S. CLS. 100, 101 AND 102).

FIRST USE 4-0-1996; IN COMMERCE 4-0-1996.

CLASS 35—(Continued).

4,154,299. PROMETRIC INC., BALTIMORE, MD. SN 77-435,466. PUB. 3-17-2009, FILED 3-31-2008.



OWNER OF U.S. REG. NO. 2,276,211.
 FOR COMPUTERIZED DATABASE MANAGEMENT SERVICES IN THE FIELD OF TEST QUESTION INVENTORY AND USAGE; STATISTICAL INFORMATION SERVICES IN THE FIELDS OF EDUCATIONAL, PROFESSIONAL, AND VOCATIONAL TESTING AND TEST QUESTION VALIDITY (U.S. CLS. 100, 101 AND 102).
 FIRST USE 9-0-2008; IN COMMERCE 9-0-2008.

CLASS 35—(Continued).

4,154,305. ALBERTSSON, CANDICE, NORTH TONAWANDA, NY. SN 77-459,742. PUB. 3-17-2009, FILED 4-28-2008.



4,154,304. ALBERTSSON, CANDICE, NORTH TONAWANDA, NY. SN 77-459,698. PUB. 3-31-2009, FILED 4-28-2008.



THE COLOR(S) WHITE, BLUE AND BLACK IS/ARE CLAIMED AS A FEATURE OF THE MARK.

THE COLOR WHITE IN THE BACKGROUND AND IN THE DESIGN OF THE INTERLOCKING SQUARES, THE COLOR BLUE APPEARS IN THE LARGER SQUARE BACKGROUND BETWEEN THE WORDING, AND THE COLOR BLACK APPEARS IN THE WORDING "DEVELOPMENT EXPERIENCES BLUEPRINT".

FOR BUSINESS CONSULTING SERVICES, NAMELY, THE IDENTIFICATION AND DEFINING OF EXPERIENCES REQUIRED FOR SUCCESS WITHIN A BUSINESS ORGANIZATION; BUSINESS CONSULTING SERVICES, NAMELY, THE IDENTIFICATION, EVALUATION, AND DEVELOPMENT OF KEY EMPLOYEES WITHIN A BUSINESS ORGANIZATION; BUSINESS CONSULTING SERVICES, NAMELY, THE DEVELOPMENT, EVALUATION, AND FACILITATION OF MANAGERIAL SUCCESSION PLANNING WITHIN A BUSINESS ORGANIZATION; AND BUSINESS CONSULTING SERVICES, NAMELY, THE DEVELOPMENT, EVALUATION, AND FACILITATION OF SUCCESSION MANAGEMENT PROCESSES WITHIN A BUSINESS ORGANIZATION (U.S. CLS. 100, 101 AND 102).
 FIRST USE 12-12-2011; IN COMMERCE 12-12-2011.

NO CLAIM IS MADE TO THE EXCLUSIVE RIGHT TO USE "CONSULTING" AND "LEADERSHIP DEVELOPMENT", APART FROM THE MARK AS SHOWN.

THE COLOR(S) WHITE, BLUE AND BLACK IS/ARE CLAIMED AS A FEATURE OF THE MARK.

THE COLOR WHITE IS IN THE BACKGROUND AND IN THE DESIGN OF THE STYLIZED ARROWHEAD, THE COLOR BLUE APPEARS IN THE LARGE SQUARE BACKGROUND BETWEEN THE WORDING, AND THE COLOR BLACK APPEARS IN THE WORDING "ALBERTSSON CONSULTING LEADERSHIP DEVELOPMENT".

FOR BUSINESS CONSULTING SERVICES, NAMELY, THE IDENTIFICATION, EVALUATION, DEVELOPMENT AND SUCCESSION OF EMPLOYEES WITHIN A BUSINESS ORGANIZATION; BUSINESS CONSULTING SERVICES, NAMELY, THE DEVELOPMENT OF A STRATEGIC PLAN, FRAMEWORK, METHOD OR PROCESS FOR THE IDENTIFICATION, EVALUATION, DEVELOPMENT AND SUCCESSION OF EMPLOYEES WITHIN A BUSINESS ORGANIZATION; BUSINESS CONSULTING SERVICES, NAMELY, THE IDENTIFICATION OF COMPETENCIES AND EXPERIENCES REQUIRED FOR SUCCESS OF EMPLOYEES WITHIN A BUSINESS ORGANIZATION; BUSINESS CONSULTING SERVICES, NAMELY, THE DESIGN AND DEVELOPMENT OF PROGRAMS, PROCESSES AND TOOLS TO EVALUATE AND DEVELOP INDIVIDUAL EMPLOYEES' COMPETENCIES AND EXPERIENCES WITHIN A BUSINESS ORGANIZATION; BUSINESS CONSULTING SERVICES, NAMELY, THE DESIGN AND DEVELOPMENT OF PROGRAMS, PROCESSES AND TOOLS TO IDENTIFY, EVALUATE AND DEVELOP HIGH POTENTIAL AND KEY EMPLOYEES WITHIN A BUSINESS ORGANIZATION; BUSINESS CONSULTING SERVICES, NAMELY, THE DESIGNING, DEVELOPING, ANALYZING, EVALUATING AND FACILITATING SUCCESSION PLANNING AND SUCCESSION MANAGEMENT PROCESSES AND TOOLS WITHIN A BUSINESS ORGANIZATION; BUSINESS CONSULTING SERVICES, NAMELY, THE DESIGNING, DEVELOPING AND FACILITATING TEAMBUILDING EXERCISES AND EVENTS WITHIN A BUSINESS ORGANIZATION (U.S. CLS. 100, 101 AND 102).
 FIRST USE 12-12-2011; IN COMMERCE 12-12-2011.

CLASS 35—(Continued).

CLASS 35—(Continued).

4,154,316. GOODRICH, ROBERT, AMARILLO, TX. SN 77-506,975. PUB. 12-16-2008, FILED 6-24-2008.

TEXAS EMBASSY

THE MARK CONSISTS OF STANDARD CHARACTERS WITHOUT CLAIM TO ANY PARTICULAR FONT, STYLE, SIZE, OR COLOR.

OWNER OF U.S. REG. NO. 2,958,097.

NO CLAIM IS MADE TO THE EXCLUSIVE RIGHT TO USE "TEXAS", APART FROM THE MARK AS SHOWN.

FOR PROMOTING PUBLIC AWARENESS OF TEXAS CULTURE, HISTORY AND LANDMARKS (U.S. CLS. 100, 101 AND 102).

FIRST USE 3-24-2007; IN COMMERCE 3-24-2007.



4,154,343. ALIZZANO, LLC, SANTA MONICA, CA. SN 77-552,944. PUB. 1-13-2009, FILED 8-21-2008.

READYBAR

THE MARK CONSISTS OF STANDARD CHARACTERS WITHOUT CLAIM TO ANY PARTICULAR FONT, STYLE, SIZE, OR COLOR.

FOR RETAIL BAKERY SHOPS; TAKE-OUT BAKERY SERVICES (U.S. CLS. 100, 101 AND 102).

FIRST USE 1-1-2008; IN COMMERCE 1-1-2008.



4,154,458. LE, TRAMERICA Q., DBA TRADE EMBASSY, SAN DIEGO, CA. SN 77-818,019. PUB. 8-23-2011, FILED 9-1-2009.

Trade Embassy

THE MARK CONSISTS OF STANDARD CHARACTERS WITHOUT CLAIM TO ANY PARTICULAR FONT, STYLE, SIZE, OR COLOR.

NO CLAIM IS MADE TO THE EXCLUSIVE RIGHT TO USE "TRADE", APART FROM THE MARK AS SHOWN.

FOR PROVIDING A SEARCHABLE ON-LINE ADVERTISING GUIDE FEATURING THE GOODS AND SERVICES OF OTHER ON-LINE VENDORS ON THE INTERNET; PROVIDING ON-LINE VIDEO BUSINESS DIRECTORY; PROVIDING BUSINESS SERVICES, NAMELY, TELEPRESENCE ENVIRONMENTS OF OTHERS; PROVIDING AN ON-LINE ELECTRONIC DATABASE ON GLOBAL COMPUTER NETWORKS FEATURING BUSINESS INFORMATION IN THE FIELDS OF INFORMATION TECHNOLOGY, BUSINESS MANAGEMENT SERVICES INCLUDING PROMOTION OF BRAND IDENTITY, BRANDING STRATEGY, ACCOUNTING, FINANCIAL MANAGEMENT SERVICES, MARKETING, BUSINESS PROJECT MANAGEMENT, AND BUSINESS DEVELOPMENT; PROVIDING ON-LINE ADVERTISING, MARKETING, AND PROMOTIONAL SERVICES; PROVIDING BUSINESS INFORMATION, ON-LINE ADVERTISING ON COMPUTER COMMUNICATION NETWORKS, SERVICES RELATING TO THE ANALYSIS, EVALUATION, CREATION, PROTECTION OF INTELLECTUAL PROPERTY RIGHTS AND BRAND ESTABLISHMENT OF TRADEMARKS, TRADE NAMES AND DOMAIN NAMES; PROJECT MANAGEMENT SERVICES FOR OTHERS IN THE FIELDS OF LANGUAGE TRANSLATION, CUSTOM WRITING, TEXT ADAPTATION, INTERPRETING AND PROOFREADING; FOREIGN AND GLOBAL TRADE CONSULTATION; PROVIDING ONLINE VIRTUAL WORLDS RETAIL STORE SERVICES FEATURING VIRTUAL GOODS, CONDUCTING EVENT PLANNINGS AND TRADE SHOWS IN THE FIELD OF INTELLECTUAL PROPERTY, INTERNATIONAL TRADE, IMPORT, EXPORT, TOURISM, EDUCATION, INFORMATION TECHNOLOGY, HEALTHCARE, BUSINESS MANAGEMENT SERVICES INCLUDING PROMOTION OF BRAND IDENTITY, BRANDING STRATEGY, MARKETING, BUSINESS PROJECT MANAGEMENT, AND BUSINESS DEVELOPMENT, BUSINESS NETWORKING VIA SOCIAL MEDIA NETWORKS AND PROVIDING AN ON-LINE ELECTRONIC DATABASE ON GLOBAL COMPUTER NETWORKS FEATURING BUSINESS INFORMATION IN THE FIELDS OF INTELLECTUAL PROPERTY, INTERNATIONAL TRADE, IMPORT/EXPORT POLICIES, IMPORT/EXPORT FOREIGN AUTHORITIES, FOREIGN CURRENCIES, INTERNATIONAL IMPORT/EXPORT COMPANIES, INTERNATIONAL TRADE REPRESENTATIVES, INTERNATIONAL TRADE SHOWS, INTERNATIONAL CONVENTION FACILITIES AND INTERNATIONAL TRADE HOUSES, FOREIGN EMBASSIES, FOREIGN TRADE ORGANIZATIONS AND ASSOCIATIONS, FOREIGN TRADE DEVELOPMENT ORGANIZATIONS AND FOREIGN CHAMBERS OF COMMERCE, HEALTHCARE, EDUCATION, INFORMATION TECHNOLOGY AND TOURISM; COMPUTER SERVICES, NAMELY, PROVIDING AN ON-LINE ELECTRONIC DATABASE ON GLOBAL COMPUTER NETWORKS FEATURING BUSINESS INFORMATION IN THE FIELDS OF INTERNATIONAL TRADE, INTERNATIONAL AND NATIONAL CUSTOMS REGULATIONS, INTERNATIONAL TAX REGULATIONS AND INTERNATIONAL SHIPPING REGULATIONS (U.S. CLS. 100, 101 AND 102).

FIRST USE 1-24-2005; IN COMMERCE 7-15-2005.

CLASS 35—(Continued).

4,154,464. KARL BISSINGER, INC., ST. LOUIS, MO. SN 77-825,708. PUB. 2-9-2010, FILED 9-14-2009.



OWNER OF U.S. REG. NOS. 438,968, 2,788,791, AND 2,923,071.

NO CLAIM IS MADE TO THE EXCLUSIVE RIGHT TO USE "CHOCOLATE", APART FROM THE MARK AS SHOWN.

THE MARK CONSISTS OF A STYLIZED LETTER "B" WITHIN A CIRCLE DESIGN WITH SCROLLWORK, AND THE WORDING "BISSINGER'S A CHOCOLATE EXPERIENCE", FRAMED BY SCROLLWORK.

FOR RETAIL CANDY STORES (U.S. CLS. 100, 101 AND 102).

FIRST USE 1-0-2011; IN COMMERCE 1-0-2011.

4,154,497. SEMPRIS, LLC, MINNEAPOLIS, MN. SN 77-871,710. PUB. 8-17-2010, FILED 11-12-2009.

FUNTIME SAVINGS

THE MARK CONSISTS OF STANDARD CHARACTERS WITHOUT CLAIM TO ANY PARTICULAR FONT, STYLE, SIZE, OR COLOR.

OWNER OF U.S. REG. NO. 3,514,891.

NO CLAIM IS MADE TO THE EXCLUSIVE RIGHT TO USE "SAVINGS", APART FROM THE MARK AS SHOWN.

FOR BUYING CLUB SERVICES; PROMOTING THE SALE OF THE GOODS AND SERVICES OF OTHERS THROUGH THE DISTRIBUTION OF DISCOUNT OFFERS (U.S. CLS. 100, 101 AND 102).

FIRST USE 3-1-2012; IN COMMERCE 3-1-2012.

4,154,503. FANATICS, LLC, JACKSONVILLE, FL. SN 77-875,829. PUB. 8-3-2010, FILED 11-18-2009.

SPORTS FANATICS

THE MARK CONSISTS OF STANDARD CHARACTERS WITHOUT CLAIM TO ANY PARTICULAR FONT, STYLE, SIZE, OR COLOR.

OWNER OF U.S. REG. NOS. 2,538,045, 3,607,516, AND OTHERS.

CLASS 35—(Continued).

NO CLAIM IS MADE TO THE EXCLUSIVE RIGHT TO USE "SPORTS", APART FROM THE MARK AS SHOWN.

FOR BUSINESS MARKETING CONSULTING SERVICES; CUSTOMER SERVICE IN THE FIELD OF ON-LINE RETAIL STORE SERVICES; ON-LINE RETAIL STORE SERVICES FEATURING SPORTS RELATED AND SPORTS TEAM BRANDED CLOTHING AND MERCHANDISE; ORDER FULFILLMENT SERVICES; PRODUCT MERCHANDISING (U.S. CLS. 100, 101 AND 102).
FIRST USE 3-21-2012; IN COMMERCE 3-21-2012.

4,154,510. KAM MAN FOOD INC., EDISON, NJ. SN 77-893,930. PUB. 7-26-2011, FILED 12-15-2009.



NO CLAIM IS MADE TO THE EXCLUSIVE RIGHT TO USE "FOOD", APART FROM THE MARK AS SHOWN.

THE COLOR(S) BLACK, WHITE AND RED IS/ARE CLAIMED AS A FEATURE OF THE MARK.

THE MARK CONSISTS OF FOUR RED ASIAN CHARACTERS APPEARING TO THE RIGHT OF A STYLIZED LOGO OF THE WHITE LETTER "K" APPEARING ON A RED, M-SHAPED BACKGROUND; THE WORDING "KAM MAN FOOD" APPEARS IN BLACK INITIAL CAPS BELOW THE ASIAN CHARACTERS; ALL OF THE AFOREMENTIONED APPEARS ON A WHITE BACKGROUND.

THE NON-LATIN CHARACTERS IN THE MARK TRANSLITERATE TO JING MEN CAO SHI AND THIS MEANS THE GOLDEN DOOR OR THE GOLDEN GATE IN ENGLISH.

FOR RETAIL, WHOLESALE, ONLINE, PHONE AND CATALOG STORE SERVICES FEATURING ASIAN FOOD PRODUCTS (U.S. CLS. 100, 101 AND 102).

FIRST USE 12-16-2009; IN COMMERCE 12-16-2009.

4,154,531. HOTELS.COM, LP, DALLAS, TX. SN 77-931,429. PUB. 7-5-2011, FILED 2-9-2010.



OWNER OF U.S. REG. NOS. 3,719,415 AND 3,723,187.
NO CLAIM IS MADE TO THE EXCLUSIVE RIGHT TO USE "REWARDS", APART FROM THE MARK AS SHOWN.

THE MARK CONSISTS OF THE DESIGN OF A GIFT BOX APPEARING BETWEEN "WELCOME" AND "REWARDS".

FOR CONDUCTING INCENTIVE AWARD PROGRAMS TO PROMOTE THE SALE OF ACCOMMODATIONS, HOTEL AND MOTEL ROOMS; CONSUMER LOYALTY SERVICES FOR COMMERCIAL, PROMOTIONAL, AND ADVERTISING PURPOSES, NAMELY, ADMINISTRATION OF FREQUENT TRAVELER PROGRAM; CUSTOMER LOYALTY SERVICES AND CUSTOMER CLUB SERVICES, FOR COMMERCIAL, PROMOTIONAL AND/OR ADVERTISING PURPOSES (U.S. CLS. 100, 101 AND 102).

FIRST USE 8-0-2009; IN COMMERCE 8-0-2009.

CLASS 35—(Continued).

4,154,535. ADVANCED BALLOT SOLUTIONS LLC, OMAHA, NE. SN 77-940,327. PUB. 2-15-2011, FILED 2-19-2010.

CLASS 35—(Continued).

4,154,607. REVIVO, ZION, NORTHRIDGE, CA. SN 85-001,806. PUB. 8-10-2010, FILED 3-30-2010.

INTEGRA-VOTE

ZAPPTA

THE MARK CONSISTS OF STANDARD CHARACTERS WITHOUT CLAIM TO ANY PARTICULAR FONT, STYLE, SIZE, OR COLOR.

FOR ELECTION DATA PROCESSING SERVICES, NAMELY, PROCESSING OF ELECTION BALLOTS (U.S. CLS. 100, 101 AND 102).

FIRST USE 8-31-2010; IN COMMERCE 8-31-2010.

THE MARK CONSISTS OF STANDARD CHARACTERS WITHOUT CLAIM TO ANY PARTICULAR FONT, STYLE, SIZE, OR COLOR.

THE WORDING "ZAPPTA" HAS NO MEANING IN A FOREIGN LANGUAGE.

FOR OPERATING ON-LINE MARKETPLACES FOR SELLERS OF GOODS AND/OR SERVICES (U.S. CLS. 100, 101 AND 102).

FIRST USE 3-1-2012; IN COMMERCE 3-1-2012.

4,154,554. PLANPRESCRIBER, INC., MAYNARD, MA. SN 77-959,817. PUB. 8-10-2010, FILED 3-16-2010.

4,154,624. SUPERMEDIA LLC, DFW AIRPORT, TX. SN 85-013,458. PUB. 8-3-2010, FILED 4-14-2010.

FairCompare

CLICK. RING. KNOCK.

THE MARK CONSISTS OF STANDARD CHARACTERS WITHOUT CLAIM TO ANY PARTICULAR FONT, STYLE, SIZE, OR COLOR.

FOR INSURANCE LEAD COLLECTION AND MATCHING SERVICES, NAMELY, MATCHING CONSUMER REQUESTS FOR INSURANCE POLICY QUOTES COLLECTED OVER THE INTERNET TO PRE-QUALIFIED INSURANCE BROKERS, AGENTS AND AGENCIES INTERESTED IN THOSE REQUESTS; PROMOTION OF FINANCIAL AND INSURANCE SERVICES, ON BEHALF OF THIRD PARTIES; PROVIDING INSURANCE AGENT REFERRALS (U.S. CLS. 100, 101 AND 102).

FIRST USE 12-19-2011; IN COMMERCE 12-19-2011.

THE MARK CONSISTS OF STANDARD CHARACTERS WITHOUT CLAIM TO ANY PARTICULAR FONT, STYLE, SIZE, OR COLOR.

FOR DISSEMINATION OF ADVERTISING FOR OTHERS VIA THE INTERNET, NAMELY, BY INCLUDING ADVERTISING IN PROPRIETARY DATABASES FROM WHICH THE GENERAL PUBLIC CAN RETRIEVE IT, VIA PRINT, NAMELY, BY PUBLISHING ADVERTISING IN ALPHABETICAL AND CLASSIFIED TELEPHONE DIRECTORIES, AND VIA DIRECT MAIL, NAMELY, BY MAILING PERSONALLY ADDRESSED ADVERTISING TO RECIPIENTS IN A PARTICULAR GEOGRAPHIC AREA (U.S. CLS. 100, 101 AND 102).

FIRST USE 1-0-2010; IN COMMERCE 1-0-2010.

4,154,602. BREATHE NEW HAMPSHIRE, MANCHESTER, NH. SN 78-972,656. PUB. 1-3-2012, FILED 9-12-2006.

4,154,639. SALAS O'BRIEN ENGINEERS, INC., DBA SALAS O'BRIEN, SAN JOSE, CA. SN 85-038,023. PUB. 7-19-2011, FILED 5-13-2010.

BREATHE NEW HAMPSHIRE

CARBON SCOUT

THE MARK CONSISTS OF STANDARD CHARACTERS WITHOUT CLAIM TO ANY PARTICULAR FONT, STYLE, SIZE, OR COLOR.

NO CLAIM IS MADE TO THE EXCLUSIVE RIGHT TO USE "NEW HAMPSHIRE", APART FROM THE MARK AS SHOWN.

FOR PROMOTING PUBLIC AWARENESS OF LUNG HEALTH AND THE CAUSES, TREATMENTS AND CURES OF LUNG DISEASES (U.S. CLS. 100, 101 AND 102).

FIRST USE 7-1-2007; IN COMMERCE 7-1-2007.

THE MARK CONSISTS OF STANDARD CHARACTERS WITHOUT CLAIM TO ANY PARTICULAR FONT, STYLE, SIZE, OR COLOR.

NO CLAIM IS MADE TO THE EXCLUSIVE RIGHT TO USE "CARBON", APART FROM THE MARK AS SHOWN.

FOR CONSULTING SERVICES IN THE FIELD OF ENERGY USAGE AND MANAGEMENT AND ENERGY EFFICIENCY (U.S. CLS. 100, 101 AND 102).

FIRST USE 10-21-2010; IN COMMERCE 11-14-2010.

CLASS 35—(Continued).

4,154,650. GANDER MOUNTAIN COMPANY, ST. PAUL, MN. SN 85-058,627. PUB. 10-19-2010, FILED 6-9-2010.

GANDER MTN. TECH CENTER

THE MARK CONSISTS OF STANDARD CHARACTERS WITHOUT CLAIM TO ANY PARTICULAR FONT, STYLE, SIZE, OR COLOR.

OWNER OF U.S. REG. NOS. 2,864,302, 3,705,856, AND 3,705,857.

NO CLAIM IS MADE TO THE EXCLUSIVE RIGHT TO USE "TECH CENTER", APART FROM THE MARK AS SHOWN.

FOR RETAIL SPORTING GOODS STORES, RETAIL MAIL ORDER AND ELECTRONIC CATALOG SERVICES, AND ON-LINE RETAIL STORE SERVICES, EACH FEATURING OUTDOOR SPORTSMAN'S SUPPLIES, HUNTING, FISHING, CAMPING, FITNESS, AND MARINE EQUIPMENT, ELECTRONICS, COMMUNICATION EQUIPMENT, CAMERAS AND ACCESSORIES, VEHICLE ACCESSORIES, FOOTWEAR AND CLOTHING AND APPAREL (U.S. CLS. 100, 101 AND 102).

FIRST USE 2-11-2011; IN COMMERCE 2-11-2011.

4,154,651. WEBSTER FINANCIAL CORPORATION, WATERBURY, CT. SN 85-059,116. PUB. 3-8-2011, FILED 6-10-2010.

EXPECT BETTER BANKING

THE MARK CONSISTS OF STANDARD CHARACTERS WITHOUT CLAIM TO ANY PARTICULAR FONT, STYLE, SIZE, OR COLOR.

NO CLAIM IS MADE TO THE EXCLUSIVE RIGHT TO USE "BANKING", APART FROM THE MARK AS SHOWN.

FOR TAX PLANNING, REPORTING AND CONSULTATION SERVICES; TRUST, ESTATE AND INVESTMENT CUSTODY, ADMINISTRATION, RECORD KEEPING AND REPORTING SERVICES, NAMELY, PREPARING TAX LETTERS, STATEMENTS, SUMMARIES AND REPORTS, AND SHAREHOLDER RECORD KEEPING SERVICES; PROVIDING INFORMATION IN THE FIELD OF TAXES VIA THE INTERNET, GLOBAL NETWORKS, TELEPHONE, FACSIMILE OR OTHER MEANS (U.S. CLS. 100, 101 AND 102).

FIRST USE 4-1-2010; IN COMMERCE 4-1-2010.

CLASS 35—(Continued).

4,154,665. GRACE LITES CORPORATION, TEMECULA, CA. SN 85-071,201. PUB. 5-17-2011, FILED 6-24-2010.



NO CLAIM IS MADE TO THE EXCLUSIVE RIGHT TO USE "LITES CORPORATION", APART FROM THE MARK AS SHOWN.

THE COLOR(S) RED, BLACK IS/ARE CLAIMED AS A FEATURE OF THE MARK.

THE MARK CONSISTS OF THE WORD "GRACE" IN STYLIZED LETTERS IN RED, AND THE WORDS "LITES CORPORATION" IN BLACK.

FOR PROCUREMENT, NAMELY, PURCHASING FOR OTHERS OF LIGHTING CONTROLLERS FOR STAGE LIGHTING AND TELEVISION, PROJECTOR LAMPS, REFLECTOR LAMPS, FANCY LAMPS FOR DECORATING, ARCHITECTURAL LIGHTS, MOVING LIGHTS FOR USE IN TELEVISION AND IN PROVIDING CORPORATE PRESENTATIONS; RETAIL STORES FEATURING LIGHTING CONTROLLERS FOR STAGE LIGHTING AND TELEVISION, PROJECTION EQUIPMENT, PROJECTOR LAMPS, REFLECTOR LAMPS, FANCY LAMPS FOR DECORATING, ARCHITECTURAL LIGHTS, MOVING LIGHTS FOR USE IN TELEVISION AND IN PROVIDING CORPORATE PRESENTATIONS (U.S. CLS. 100, 101 AND 102).

FIRST USE 7-0-2007; IN COMMERCE 7-0-2007.

4,154,671. KRUSH INC., CAMBRIDGE, MA. SN 85-079,228. PUB. 12-6-2011, FILED 7-7-2010.

KRUSH

THE MARK CONSISTS OF STANDARD CHARACTERS WITHOUT CLAIM TO ANY PARTICULAR FONT, STYLE, SIZE, OR COLOR.

FOR PROVISION OF A WEB SITE FEATURING COMMERCIAL INFORMATION ON SHOPPING FOR CONSUMERS; ADMINISTRATION OF A PROGRAM FOR ENABLING PARTICIPANTS TO OBTAIN DISCOUNTS ON GOODS AND SERVICES; PROMOTING THE GOODS OF OTHERS, NAMELY, PROVIDING TO CONSUMERS INFORMATION REGARDING DISCOUNTS, COUPONS, REBATES, VOUCHERS AND SPECIAL OFFERS FOR THE GOODS OF OTHERS (U.S. CLS. 100, 101 AND 102).

FIRST USE 11-1-2010; IN COMMERCE 11-1-2010.

CLASS 35—(Continued).

4,154,724. JARROLD, THOMAS, NEW YORK, NY. AND SCRIVENS, MATTHEW, NEW YORK, NY. SN 85-106,162. PUB. 1-25-2011, FILED 8-12-2010.

JET/MMS

THE MARK CONSISTS OF STANDARD CHARACTERS WITHOUT CLAIM TO ANY PARTICULAR FONT, STYLE, SIZE, OR COLOR.

FOR ADVERTISING AND MARKETING SERVICES; MARKETING SERVICES, NAMELY, PROVIDING MARKETING STRATEGY AND MARKETING COMMUNICATIONS PLANNING IN THE FIELD OF DIGITAL AND BRANDED ENTERTAINMENT FOR OTHERS, NAMELY, THE CREATION, DESIGN, PRODUCTION AND DISTRIBUTION OF ORIGINAL MARKETING CONTENT IN THE FIELDS OF RADIO, TELEVISION, PRINT, ONLINE, SOCIAL AND MOBILE MARKETING (U.S. CLS. 100, 101 AND 102).

FIRST USE 1-1-2012; IN COMMERCE 1-1-2012.

4,154,752. MEDIATEC PUBLISHING, INC., CHICAGO, IL. SN 85-114,808. PUB. 8-30-2011, FILED 8-24-2010.

LearningElite

THE MARK CONSISTS OF STANDARD CHARACTERS WITHOUT CLAIM TO ANY PARTICULAR FONT, STYLE, SIZE, OR COLOR.

FOR PROVIDING BUSINESS EVALUATION, ASSESSMENT, AND AWARDS TO PUBLIC, PRIVATE, FOR-PROFIT, NON-FOR-PROFIT, GOVERNMENT, AND ACADEMIC INSTITUTIONS WITH RESPECT TO HOW EFFECTIVELY THOSE ORGANIZATIONS DEVELOP AND TRAIN THEIR WORKFORCE, PARTNERS, AND SUPPLIERS TO DELIVER SIGNIFICANT BUSINESS RESULTS TO THEIR ORGANIZATION (U.S. CLS. 100, 101 AND 102).

FIRST USE 5-24-2010; IN COMMERCE 9-14-2010.

CLASS 35—(Continued).

4,154,763. SECURUS TECHNOLOGIES, INC., DALLAS, TX. SN 85-118,345. PUB. 1-25-2011, FILED 8-30-2010.

SECURUS

THE MARK CONSISTS OF STANDARD CHARACTERS WITHOUT CLAIM TO ANY PARTICULAR FONT, STYLE, SIZE, OR COLOR.

FOR TELECOMMUNICATIONS NETWORK MANAGEMENT SERVICES, NAMELY, THE OPERATION AND ADMINISTRATION OF TELECOMMUNICATION SYSTEMS AND NETWORKS FOR OTHERS; ADVERTISING AND MARKETING SERVICES, NAMELY, PROVIDING INFORMATION AS TO THE AVAILABILITY OF TELECOMMUNICATION SERVICES AT CORRECTIONAL INSTITUTIONS; BUSINESS INFORMATION SERVICES/MANAGEMENT, NAMELY, GATHERING, ANALYZING AND REPORTING INFORMATION REGARDING THE FINANCIAL AND USAGE DATA FOR TELECOMMUNICATIONS SYSTEMS PROVIDED TO PRISON INMATES AND RELATED PARTIES (U.S. CLS. 100, 101 AND 102).

FIRST USE 8-6-2004; IN COMMERCE 8-6-2004.

4,154,775. SHOPPER SCIENTIST LLC, CORBETT, OR. SN 85-123,155. PUB. 2-15-2011, FILED 9-3-2010.

SHOPPER ACCELERATION

THE MARK CONSISTS OF STANDARD CHARACTERS WITHOUT CLAIM TO ANY PARTICULAR FONT, STYLE, SIZE, OR COLOR.

FOR BUSINESS CONSULTING AND INFORMATION SERVICES (U.S. CLS. 100, 101 AND 102).

FIRST USE 2-1-2012; IN COMMERCE 2-1-2012.

CLASS 35—(Continued).

4,154,843. VISION SERVICE PLAN, DBA VSP, RANCHO CORDOVA, CA. SN 85-149,664. PUB. 2-22-2011, FILED 10-11-2010.

eyeconic
• com

THE MARK CONSISTS OF THE WORD "EYECONIC" SPELLED USING STYLIZED LETTERS WITH THE "I" ALSO FORMING AN EXCLAMATION POINT, THE DOT OF WHICH IS USED AS THE PERIOD IN ".COM", THE LATTER ALSO SPELLED USING STYLIZED LETTERS AND SITUATED IMMEDIATELY BELOW "EYECONIC".

FOR PROVIDING A WEBSITE USED TO PLACE ONLINE ORDERS FOR OPTOMETRIC MATERIALS, NAMELY, FRAMES FOR SUNGLASSES AND EYEGLASSES AND CONTACT LENSES (U.S. CLS. 100, 101 AND 102).

FIRST USE 7-18-2011; IN COMMERCE 7-18-2011.

CLASS 35—(Continued).

BRANDS, NAMELY, PROVIDING ADVERTISING AND/OR PUBLIC RELATIONS SERVICES TO SUPPORT ESTABLISHED PRODUCTS OR COMPANIES; PROVIDING BUSINESS MARKETING ADVICE RELATED TO THE ARRANGING, DESIGNING AND CONDUCTING OF TRADE SHOWS, NAMELY, TRADE SHOW BOOTHS, AND TO THE DESIGN OF CONCEPT STORES; BRAND BUILDING, NAMELY, ADVERTISING SERVICES, FEATURING THE CREATION OF BRAND IDENTITY FOR OTHERS THROUGH BOTH TRADITIONAL AND NEW MEDIA; ADVERTISING SERVICES, NAMELY, CREATING LOGOS FOR OTHERS AND DESIGN OF ADVERTISING MATERIALS FOR OTHERS IN THE NATURE OF BUSINESS CARDS, NOTE CARDS, SHOPPING BAGS, BOXES AND PRODUCT PACKAGING; ADVERTISING SERVICES IN THE NATURE OF THE DEVELOPMENT OF ADVERTISING CAMPAIGNS FOR BUSINESSES INVOLVED IN THE SALE OF GOODS AND SERVICES TO OTHERS IN VARIOUS SELLING PLATFORMS, NAMELY, RETAIL, INTERNET, AND DIRECT SALES (U.S. CLS. 100, 101 AND 102).

FIRST USE 1-0-2011; IN COMMERCE 1-0-2011.

4,154,850. DORIS CLAYTON ENTERPRISE, FAYETTEVILLE, NC. SN 85-151,472. PUB. 5-3-2011, FILED 10-13-2010.

4,154,846. IDENTITY ATELIER, LLC, NEW YORK, NY. SN 85-149,897. PUB. 8-9-2011, FILED 10-11-2010.

IDENTITY ATELIER

THE MARK CONSISTS OF STANDARD CHARACTERS WITHOUT CLAIM TO ANY PARTICULAR FONT, STYLE, SIZE, OR COLOR.

NO CLAIM IS MADE TO THE EXCLUSIVE RIGHT TO USE "IDENTITY", APART FROM THE MARK AS SHOWN.

FOR BUSINESS MANAGEMENT, BRAND AND CONCEPT BUILDING, CREATIVE ASSET BUILDING AND PUBLIC RELATIONS SERVICES, NAMELY, THE DEVELOPMENT, EXECUTION, AND MAINTENANCE OF ADVERTISING, MARKETING AND SALES CAMPAIGNS FOR BUSINESSES; BRAND AND REPUTATION MANAGEMENT, NAMELY, MONITORING AND EVALUATING A CLIENT'S BRAND AND REPUTATION AND PROVIDING ARTISTIC, ADVERTISING AND/OR MEDIA RELATIONS SERVICES TO ENHANCE A CLIENT'S BRAND AND REPUTATION AND PROVIDING SPECIFIC CRITERIA FOR PRODUCTS, PACKAGING, LABELING, PHOTOGRAPHY, BRAND DESIGN AND PRODUCT ASSORTMENT STRATEGY; BUSINESS CONSULTATION AND MANAGEMENT REGARDING MARKETING ACTIVITIES AND NEW PRODUCT LAUNCHES, MARKETING SUPPORT FOR EXISTING



NO CLAIM IS MADE TO THE EXCLUSIVE RIGHT TO USE "ENTERPRISE", APART FROM THE MARK AS SHOWN.

THE NAME "DORIS CLAYTON" IDENTIFIES A LIVING INDIVIDUAL WHOSE CONSENT IS OF RECORD.

THE MARK CONSISTS OF A GLOBE WITH THE STYLIZED TEXT "DORIS CLAYTON ENTERPRISE".

FOR ON-LINE RETAIL STORE SERVICES FEATURING A WIDE VARIETY OF CONSUMER GOODS OF OTHERS, EXCLUDING FOOD ITEMS (U.S. CLS. 100, 101 AND 102).

FIRST USE 5-1-2011; IN COMMERCE 5-1-2011.

CLASS 35—(Continued).

4,154,871. WAYMAN, GARY, VISTA, CA. SN 85-162,456. PUB. 7-5-2011, FILED 10-27-2010.



MUSCLE MOB
MOTORSPORTS

NO CLAIM IS MADE TO THE EXCLUSIVE RIGHT TO USE "MUSCLE" AND "MOTORSPORTS", APART FROM THE MARK AS SHOWN.

THE MARK CONSISTS OF "MUSCLE MOB MOTORSPORTS" IN STYLIZED FONT.

FOR WHOLESALE AND RETAIL STORE SERVICES AND ON-LINE RETAIL AND WHOLESALE STORE SERVICES FEATURING AUTOMOTIVE PARTS AND CLOTHING (U.S. CLS. 100, 101 AND 102).

FIRST USE 12-1-2011; IN COMMERCE 12-1-2011.

4,154,889. YELLOWBOOK INC., UNIONDALE, NY. SN 85-177,623. PUB. 11-29-2011, FILED 11-16-2010.



chatterhub

THE MARK CONSISTS OF THE WORD "CHATTERHUB" AND A DESIGN COMPRISED OF A GROUPING OF THREE CONVERSATION BALLOONS.

FOR ONLINE ADVERTISING AND MARKETING SERVICES; BUSINESS MARKETING SERVICES, NAMELY, REPUTATION MANAGEMENT MARKETING AND MONITORING SERVICES FOR BUSINESSES; SOCIAL MEDIA MARKETING CONSULTING SERVICES IN THE FIELD OF SOCIAL MEDIA OPTIMIZATION; BUSINESS MARKETING CONSULTING SERVICES REGARDING THE CAPTURE, MEASUREMENT, EVALUATION, IMPROVEMENT AND COMMUNICATION OF ONLINE BUSINESS REPUTATION INFORMATION AND RELATED BUSINESS INFORMATION WITHIN ONLINE SOCIAL MEDIA (U.S. CLS. 100, 101 AND 102).

FIRST USE 10-0-2010; IN COMMERCE 10-0-2010.

4,154,897. CLAIMS-X-CHANGE, LLC, MADISON, WI. SN 85-183,768. PUB. 7-12-2011, FILED 11-23-2010.

Claims XO

THE MARK CONSISTS OF STANDARD CHARACTERS WITHOUT CLAIM TO ANY PARTICULAR FONT, STYLE, SIZE, OR COLOR.

CLASS 35—(Continued).

NO CLAIM IS MADE TO THE EXCLUSIVE RIGHT TO USE "CLAIMS", APART FROM THE MARK AS SHOWN.

FOR MEDICAL BILLING AND CODING FEATURING MEDICAL PROVIDER CODES USED TO SUBSTANTIATE CLAIMS FOR MEDICAL REIMBURSEMENT IN THE CAFETERIA AND HSA PLANS (U.S. CLS. 100, 101 AND 102).

FIRST USE 4-30-2010; IN COMMERCE 4-30-2010.

4,154,954. HUMAN INTELLIGENCE LLC, LEBANON, CT. SN 85-209,194. PUB. 9-6-2011, FILED 1-3-2011.

HUMAN INTELLIGENCE

THE MARK CONSISTS OF STANDARD CHARACTERS WITHOUT CLAIM TO ANY PARTICULAR FONT, STYLE, SIZE, OR COLOR.

FOR BUSINESS CONSULTING PROVIDED TO BUSINESS, GOVERNMENT, AND THE ENTERTAINMENT INDUSTRY, IN THE NATURE OF PROVIDING HISTORY AND SOCIOECONOMIC INFORMATION ABOUT OTHER COUNTRIES FOR BUSINESS PURPOSES (U.S. CLS. 100, 101 AND 102).

FIRST USE 12-13-2011; IN COMMERCE 12-13-2011.

4,154,964. NETWORK BRANDED PREPAID CARD ASSOCIATION, MONTVALE, NJ. SN 85-212,109. PUB. 1-3-2012, FILED 1-6-2011.

POWER OF PREPAID

THE MARK CONSISTS OF STANDARD CHARACTERS WITHOUT CLAIM TO ANY PARTICULAR FONT, STYLE, SIZE, OR COLOR.

NO CLAIM IS MADE TO THE EXCLUSIVE RIGHT TO USE "PREPAID", APART FROM THE MARK AS SHOWN.

FOR PROMOTING AND CONDUCTING A TRADE SHOW FOR THE PREPAID AND STORED VALUE INDUSTRY (U.S. CLS. 100, 101 AND 102).

FIRST USE 9-1-2011; IN COMMERCE 9-1-2011.

CLASS 35—(Continued).

4,154,970. BENCHMARK SOLUTIONS HOLDINGS INC., NEW YORK, NY. SN 85-214,274. PUB. 7-19-2011, FILED 1-10-2011.

MARKET CALIBRATED FRAMEWORK

THE MARK CONSISTS OF STANDARD CHARACTERS WITHOUT CLAIM TO ANY PARTICULAR FONT, STYLE, SIZE, OR COLOR.

NO CLAIM IS MADE TO THE EXCLUSIVE RIGHT TO USE "MARKET", APART FROM THE MARK AS SHOWN.

FOR FINANCIAL SERVICES, NAMELY, ANALYZING MARKET DATA AND PRICING ANALYTICS SERVICES FOR MEASURING THE PERFORMANCE OF FINANCIAL MARKETS FOR ASSET CLASSES WITHIN THE CAPITAL MARKETS, INCLUDING FIXED INCOME PRODUCTS (U.S. CLS. 100, 101 AND 102).

FIRST USE 7-18-2011; IN COMMERCE 7-18-2011.

4,154,971. BENCHMARK SOLUTIONS HOLDINGS INC., NEW YORK, NY. SN 85-214,290. PUB. 7-12-2011, FILED 1-10-2011.

ENLIGHTENING THE CAPITAL MARKETS

THE MARK CONSISTS OF STANDARD CHARACTERS WITHOUT CLAIM TO ANY PARTICULAR FONT, STYLE, SIZE, OR COLOR.

NO CLAIM IS MADE TO THE EXCLUSIVE RIGHT TO USE "CAPITAL MARKETS", APART FROM THE MARK AS SHOWN.

FOR FINANCIAL SERVICES, NAMELY, ANALYZING MARKET DATA AND PRICING ANALYTICS SERVICES FOR MEASURING THE PERFORMANCE OF FINANCIAL MARKETS FOR ASSET CLASSES WITHIN THE CAPITAL MARKETS, INCLUDING FIXED INCOME PRODUCTS (U.S. CLS. 100, 101 AND 102).

FIRST USE 1-15-2010; IN COMMERCE 1-15-2010.

4,154,973. BENCHMARK SOLUTIONS HOLDINGS INC., NEW YORK, NY. SN 85-214,330. PUB. 7-12-2011, FILED 1-10-2011.

BENCHMARK SOLUTIONS

THE MARK CONSISTS OF STANDARD CHARACTERS WITHOUT CLAIM TO ANY PARTICULAR FONT, STYLE, SIZE, OR COLOR.

CLASS 35—(Continued).

NO CLAIM IS MADE TO THE EXCLUSIVE RIGHT TO USE "SOLUTIONS", APART FROM THE MARK AS SHOWN.

FOR FINANCIAL SERVICES, NAMELY, ANALYZING MARKET DATA AND PRICING ANALYTICS SERVICES FOR MEASURING THE PERFORMANCE OF FINANCIAL MARKETS FOR ASSET CLASSES WITHIN THE CAPITAL MARKETS, INCLUDING FIXED INCOME PRODUCTS (U.S. CLS. 100, 101 AND 102).

FIRST USE 11-15-2009; IN COMMERCE 11-15-2009.

4,155,025. CARPETS OF EDEN, LITTLETON, CO. SN 85-232,727. PUB. 1-24-2012, FILED 2-2-2011.

Carpets of Eden

THE MARK CONSISTS OF STANDARD CHARACTERS WITHOUT CLAIM TO ANY PARTICULAR FONT, STYLE, SIZE, OR COLOR.

NO CLAIM IS MADE TO THE EXCLUSIVE RIGHT TO USE "CARPETS", APART FROM THE MARK AS SHOWN.

FOR RETAIL STORES FEATURING CARPET, RUGS, AND RETAIL HOME ACCESSORIES; WHOLESALE DISTRIBUTORSHIPS FEATURING HOME ACCESSORIES (U.S. CLS. 100, 101 AND 102).

FIRST USE 3-15-2011; IN COMMERCE 3-15-2011.

CLASS 35—(Continued).

4,155,034. AVERBUG, ANDRE, POTOMAC, MD. SN 85-235,091. PUB. 10-25-2011, FILED 2-5-2011.



THE MARK CONSISTS OF A STYLIZED FROG DRAWING/ICON, NEXT TO THE WORD "RANKPAD".

FOR PROVIDING AN INTERACTIVE WEB SITE FOR USERS TO RANK, LIST, RATE, RECOMMEND AND REVIEW PRODUCTS, SERVICES, BUSINESSES, BRANDS, EXPERIENCES, PEOPLE, PLACES, CONTENT AND THINGS; PROVIDING INFORMATION IN THE FIELD OF PUBLIC OPINIONS VIA THE INTERNET; PROVIDING AN ONLINE COMPUTER DATABASE IN THE FIELD OF CONSUMER PRODUCT AND SERVICE REVIEWS, AS WELL AS RANKS AND CLASSIFICATIONS OF BUSINESSES, BRANDS, EXPERIENCES, PEOPLE, PLACES, CONTENT AND THINGS; PROVIDING AN ONLINE COMPUTER DATABASE FOR THE PROVISION OF BUSINESS INTELLIGENCE SERVICES; PROVIDING MARKETING, PROMOTION AND ADVERTISING SERVICES; DISPLAYING ADVERTISEMENTS FOR OTHERS; ELECTRONIC COMMERCE SERVICES, NAMELY, PROVIDING INFORMATION ON PRODUCTS, SERVICES, BUSINESSES, EXPERIENCES, PEOPLE, PLACES, CONTENT AND THINGS VIA THE INTERNET OR OTHER COMPUTER OR COMMUNICATIONS NETWORKS FOR ADVERTISING AND SALES PURPOSES; PROVIDING CONSUMER INFORMATION REGARDING THE SELECTION OF GOODS, SERVICES AND OTHER CONTENT VIA MOBILE TELEPHONES AND DESKTOP AND LAPTOP COMPUTERS; PROVIDING A SEARCHABLE DATABASE IN THE NATURE OF AN ONLINE ADVERTISING GUIDE FEATURING THE GOODS, SERVICES AND OTHER CONTENT OF OTHERS VIA THE INTERNET OR OTHER COMPUTER, MOBILE OR COMMUNICATIONS NETWORKS (U.S. CLS. 100, 101 AND 102).

FIRST USE 10-4-2011; IN COMMERCE 10-4-2011.

4,155,039. REVCO ELECTRICAL SUPPLY, INC., SOUTHAMPTON, NY. SN 85-235,816. PUB. 8-23-2011, FILED 2-7-2011.



NO CLAIM IS MADE TO THE EXCLUSIVE RIGHT TO USE "INC. LIGHTING AND ELECTRICAL SUPPLY", APART FROM THE MARK AS SHOWN.

THE MARK CONSISTS OF THE STYLIZED WORDING "REVCO INC." ABOVE THE STYLIZED WORDING "LIGHTING + ELECTRICAL SUPPLY", WHERE THE WORDING "INC." IS INSIDE THE LETTER "C" OF "REVCO".

FOR DISTRIBUTION SERVICES, NAMELY, DISTRIBUTORSHIPS IN THE FIELD OF ELECTRIC LIGHTING AND LIGHTING SUPPLIES; RETAIL STORE SERVICES FEATURING ELECTRIC LIGHTING AND LIGHTING SUPPLIES (U.S. CLS. 100, 101 AND 102).

FIRST USE 9-1-2010; IN COMMERCE 9-1-2010.

CLASS 35—(Continued).

4,155,042. DINIUS, MICHAEL, DBA PERFORMANCE MANAGEMENT CONSULTING, LLC, RICHLAND, WA. SN 85-237,309. PUB. 7-19-2011, FILED 2-8-2011.

earning employee excellence

THE MARK CONSISTS OF STANDARD CHARACTERS WITHOUT CLAIM TO ANY PARTICULAR FONT, STYLE, SIZE, OR COLOR.

NO CLAIM IS MADE TO THE EXCLUSIVE RIGHT TO USE "EMPLOYEE", APART FROM THE MARK AS SHOWN. FOR CONSULTING SERVICES IN THE FIELDS OF BUSINESS MANAGEMENT, HUMAN RESOURCES, AND BUSINESS ORGANIZATIONAL DESIGN (U.S. CLS. 100, 101 AND 102).

FIRST USE 2-11-2012; IN COMMERCE 2-11-2012.

4,155,050. GEOEYE IMAGERY COLLECTION SYSTEMS INC., DULLES, VA. SN 85-238,395. PUB. 6-14-2011, FILED 2-9-2011.

ELEVATING INSIGHT

THE MARK CONSISTS OF STANDARD CHARACTERS WITHOUT CLAIM TO ANY PARTICULAR FONT, STYLE, SIZE, OR COLOR.

FOR ONLINE RETAIL STORE SERVICES FEATURING IMAGERY OF THE EARTH; SUBSCRIPTION SERVICE TO IMAGERY OF THE EARTH TAKEN BY AIRCRAFT AND SATELLITES (U.S. CLS. 100, 101 AND 102).

FIRST USE 3-0-2011; IN COMMERCE 3-0-2011.

CLASS 35—(Continued).

4,155,055. LUXGEN MOTOR CO., LTD., MIAOLI COUNTY 367, TAIWAN. SN 85-239,603. PUB. 6-21-2011, FILED 2-11-2011.



THE MARK CONSISTS OF THE WORD "LUXGEN" IN STYLIZED FORM.

FOR RETAIL AUTOMOBILE STORES; RETAIL AUTOMOBILE PARTS AND ACCESSORIES STORES (U.S. CLS. 100, 101 AND 102).

FIRST USE 8-19-2009; IN COMMERCE 8-19-2009.

4,155,067. REMARK USA, INC., MINNETONKA, MN. SN 85-241,538. PUB. 6-28-2011, FILED 2-14-2011.



THE COLOR(S) RED AND BLACK IS/ARE CLAIMED AS A FEATURE OF THE MARK.

THE MARK CONSISTS OF A DRAWING OF A STOPWATCH SHOWN IN THE COLOR RED. THE TERM "INSQUOTENOW.COM" BEGINS IN THE CENTER OF THE STOPWATCH DESIGN, WITH THE DOT ABOVE THE LETTER "I" FORMING THE BASE OF THE TIMER HAND. THE TIMER HAND, THE LETTERS "INSQUOTE" AND THE LETTERS ".COM" APPEAR IN THE COLOR BLACK. THE LETTERS "NOW" APPEAR IN THE COLOR RED. BELOW THE TERM "INSQUOTENOW.COM" THE WORDS "STOP WAITING. START SAVING." APPEAR IN THE COLOR RED.

FOR LEAD GENERATION SERVICES FOR INSURANCE, NAMELY, PROVIDING INFORMATION REGARDING CONSUMERS INTERESTED IN RECEIVING COMPETITIVE QUOTES FOR NEW OR REPLACEMENT INSURANCE TO AGENTS, BROKERS AND INSURERS INTERESTED IN PROVIDING THESE SERVICES (U.S. CLS. 100, 101 AND 102).

FIRST USE 6-15-2011; IN COMMERCE 6-15-2011.

CLASS 35—(Continued).

4,155,093. GSENSE INC., BRIARCLIFF MANOR, NY. SN 85-245,490. PUB. 7-19-2011, FILED 2-17-2011.

Diet Exchange

THE MARK CONSISTS OF STANDARD CHARACTERS WITHOUT CLAIM TO ANY PARTICULAR FONT, STYLE, SIZE, OR COLOR.

NO CLAIM IS MADE TO THE EXCLUSIVE RIGHT TO USE "DIET", APART FROM THE MARK AS SHOWN.

FOR AD SERVING, NAMELY, PLACING ADVERTISEMENTS ON WEBSITES FOR OTHERS USING SPECIALIZED COMPUTER SOFTWARE; ADVERTISEMENT AND PUBLICITY SERVICES BY TELEVISION, RADIO, MAIL; ADVERTISEMENT FOR OTHERS ON THE INTERNET; ADVERTISEMENT HOARDING RENTAL; ADVERTISEMENT VIA MOBILE PHONE NETWORKS; ADVERTISING AGENCIES; ADVERTISING AGENCIES PROVIDING THE STRATEGY, DESIGN AND EXECUTION OF PROGRAMS TO PROMOTE BUSINESSES IN THE FOOD AND FOODSERVICE INDUSTRIES; ADVERTISING AGENCIES, NAMELY, PROMOTING THE GOODS AND SERVICES OF OTHERS; ADVERTISING AGENCIES, NAMELY, PROMOTING HEALTH PRODUCTS THROUGH THE DISTRIBUTION OF PRINTED AND AUDIO PROMOTIONAL MATERIALS AND BY RENDERING SALES PROMOTION ADVICE; ADVERTISING AGENCY SPECIALIZING IN THE DESIGN AND EXECUTION OF WORD OF MOUTH, VIRAL, BUZZ AND EXPERIENTIAL MARKETING PROGRAMS; ADVERTISING AND ADVERTISEMENT SERVICES; ADVERTISING AND BUSINESS ADVICE RELATING TO TELEMATICS SERVICES; ADVERTISING AND BUSINESS MANAGEMENT CONSULTANCY; ADVERTISING AND BUSINESS SERVICES, NAMELY, PROVIDING AN ONLINE WEBSITE WHERE ADVERTISERS, MARKETERS, AND CONTENT PROVIDERS CAN INTERACT WITH USERS FOR ADVERTISING, BRANDING, AND PROMOTING KNOWLEDGE, PRODUCTS, AND SERVICES, AND TRADESHOWS, ON BEHALF OF THEMSELVES AND OTHERS, AND FOR EVALUATING AND RATING THE SAME, ALL THE FOREGOING RELEVANT TO HUMAN ACTIVITIES AFFECTING CLIMATE CHANGE AND RELATED FIELDS; ADVERTISING AND BUSINESS SERVICES, NAMELY, SECURING AIRTIME ON ALL FORMS OF MEDIA COMMUNICATIONS STATIONS, SYSTEMS, NETWORKS, AND SERVICES FOR THE PURPOSE OF PROMOTING THE GOODS AND SERVICES OF OTHERS; ADVERTISING AND COMMERCIAL INFORMATION SERVICES, VIA THE INTERNET; ADVERTISING AND DIRECTORY SERVICES, NAMELY, PROMOTING THE SERVICES OF OTHERS BY PROVIDING A WEB PAGE FEATURING LINKS TO THE WEBSITES OF OTHERS; ADVERTISING AND MARKETING; ADVERTISING AND MARKETING CONSULTANCY; ADVERTISING AND MARKETING SERVICES PROVIDED BY MEANS OF INDIRECT METHODS OF MARKETING COMMUNICATIONS, NAMELY, SOCIAL MEDIA, SEARCH ENGINE MARKETING, INQUIRY MARKETING, INTERNET MARKETING, MOBILE MARKETING, BLOGGING AND OTHER FORMS OF PASSIVE, SHARABLE OR VIRAL COMMUNICATIONS CHANNELS; ADVERTISING AND MARKETING SERVICES, NAMELY, PROMOTING THE GOODS AND SERVICES OF OTHERS; ADVERTISING AND PROMOTING THE GOODS AND SERVICES OF A VISUAL ARTIST; ADVERTISING AND PROMOTION SERVICES AND RELATED CONSULTING; ADVERTISING AND PROMOTIONAL SERVICES; ADVERTISING AND PUBLICITY SERVICES; ADVERTISING AND PUBLICITY SERVICES, NAMELY, PROMOTING THE GOODS, SERVICES, BRAND IDENTITY AND COMMERCIAL INFORMATION AND NEWS OF THIRD PARTIES THROUGH PRINT, AUDIO, VIDEO, DIGITAL AND ONLINE MEDIUM; ADVERTISING BUSINESS ESPECIALLY IN THE FIELD OF TELEMATIC AND TELEPHONE NETWORKS; ADVERTISING BY

CLASS 35—(Continued).

TRANSMISSION OF ON-LINE PUBLICITY FOR THIRD PARTIES THROUGH ELECTRONIC COMMUNICATIONS NETWORKS; ADVERTISING CONSULTATION; ADVERTISING COPYWRITING; ADVERTISING FLYER DISTRIBUTION; ADVERTISING IN PERIODICALS, BROCHURES AND NEWSPAPERS; ADVERTISING IN THE POPULAR AND PROFESSIONAL PRESS; ADVERTISING OF COMMERCIAL OR RESIDENTIAL REAL ESTATE; ADVERTISING OF THE PUBLISHED TEXTS OF OTHERS; ADVERTISING ON THE INTERNET FOR OTHERS; ADVERTISING PARTICULARLY SERVICES FOR THE PROMOTION OF GOODS; ADVERTISING RELATING TO PHARMACEUTICAL PRODUCTS AND IN-VIVO IMAGING PRODUCTS; ADVERTISING RELATING TO TRANSPORT AND DELIVERY; ADVERTISING SERVICES; ADVERTISING SERVICES FOR PROMOTING THE BROKERAGE OF STOCKS AND OTHER SECURITIES; ADVERTISING SERVICES OF A RADIO AND TELEVISION ADVERTISING AGENCY; ADVERTISING SERVICES RELATING TO SANDWICHES; ADVERTISING SERVICES, FOR THIRD PARTIES, IN CONNECTION WITH THE COMMERCIALIZATION AND SALE OF PERFUMERY AND COSMETIC ARTICLES, PRODUCTS FOR HOUSEHOLD PURPOSES, OPTICAL PRODUCTS, CLOCKS AND TIMEPIECES, JEWELLERY, FURNISHING ARTICLES; ADVERTISING SERVICES, NAMELY, COST-PER-ACTION ON-LINE ADVERTISING; ADVERTISING SERVICES, NAMELY, CREATING CORPORATE AND BRAND IDENTITY FOR OTHERS; ADVERTISING SERVICES, NAMELY, CREATING CORPORATE LOGOS FOR OTHERS; ADVERTISING SERVICES, NAMELY, CREATING PROMOTIONAL MURALS AND PAINTING SIGNS AND WALLS ADVERTISING THE GOODS AND SERVICES OF OTHERS; ADVERTISING SERVICES, NAMELY, PRODUCTION OF SPECIAL EFFECTS INCLUDING MODEL-MAKING SERVICES, COMPUTER-GENERATED IMAGERY AND COMPUTER-GENERATED GRAPHICS FOR THE PRODUCTION OF COMMERCIALS; ADVERTISING SERVICES, NAMELY, PROMOTING AND MARKETING THE GOODS AND SERVICES OF OTHERS IN THE FIELD OF UPSCALE CHOICES SUCH AS CULTURAL EVENTS, RESTAURANTS, SHOPPING, AND TRAVEL VIA PRINT AND ELECTRONIC MEDIA; ADVERTISING SERVICES, NAMELY, PROMOTING AND MARKETING THE GOODS AND SERVICES OF OTHERS THROUGH ALL PUBLIC COMMUNICATION MEANS; ADVERTISING SERVICES, NAMELY, PROMOTING CAR DEALERSHIPS OF OTHERS; ADVERTISING SERVICES, NAMELY, PROMOTING PROPERTIES FOR SALE BY OWNER VIA THE INTERNET; ADVERTISING SERVICES, NAMELY, PROMOTING THE BOOKS OF OTHERS IN THE FIELD OF LAW BY MEANS OF NEWS AND REVIEWS REGARDING SAME; ADVERTISING SERVICES, NAMELY, PROMOTING THE BRANDS, GOODS AND SERVICES OF OTHERS; ADVERTISING SERVICES, NAMELY, PROMOTING THE FOOD AND WINE OF OTHERS; ADVERTISING SERVICES, NAMELY, PROMOTING THE GIFT CARDS OF OTHERS; ADVERTISING SERVICES, NAMELY, PROMOTING THE POWER SPORTS DEALERSHIPS OF OTHERS; ADVERTISING SERVICES, NAMELY, PROMOTING THE SANDWICHES OF OTHERS; ADVERTISING SERVICES, NAMELY, PROVIDING A WEBSITE FOR THE PROMOTION OF THE BOOKS OF OTHERS IN THE FIELD OF LAW, INCLUDING NEWS AND REVIEWS REGARDING SAME; ADVERTISING SERVICES, NAMELY, PROVIDING ADVERTISING SPACE IN A PERIODICAL; ADVERTISING SERVICES, NAMELY, PROVIDING INFORMATION AS TO THE AVAILABILITY OF INFORMATIONAL PRODUCTS FOR RENT OR PURCHASE; ADVERTISING SERVICES, PUBLIC RELATIONS AND MARKETING SERVICES, NAMELY, PROMOTING AND MARKETING THE GOODS AND SERVICES OF OTHERS THROUGH ALL PUBLIC COMMUNICATION MEANS; ADVERTISING TEXT PUBLICATION SERVICES; ADVERTISING THE SERVICES OF OTHERS VIA WEB PAGES OPTIMIZED FOR ONLINE SEARCH ENGINES; ADVERTISING THROUGH ALL PUBLIC COMMUNICATION MEANS; ADVERTISING VIA ELECTRONIC MEDIA AND SPECIFICALLY THE INTERNET; ADVERTISING, INCLUDING ON-LINE ADVERTISING ON A COMPUTER NETWORK; ADVERTISING, INCLUDING PROMOTION OF PRODUCTS AND SERVICES OF THIRD PARTIES THROUGH SPONSORING ARRANGEMENTS AND LI-

CLASS 35—(Continued).

CENSE AGREEMENTS RELATING TO INTERNATIONAL SPORTS EVENTS; ADVERTISING, INCLUDING PROMOTION RELATING TO THE SALE OF ARTICLES AND SERVICES FOR THIRD PARTIES BY THE TRANSMISSION OF ADVERTISING MATERIAL AND THE DISSEMINATION OF ADVERTISING MESSAGES ON COMPUTER NETWORKS; ADVERTISING, MARKETING AND PROMOTING THE GOODS AND SERVICES OF OTHERS USING KIOSKS; ADVERTISING, MARKETING AND PROMOTION SERVICES; ADVERTISING, MARKETING AND PROMOTION SERVICES, NAMELY, PROMOTING THE GOODS AND SERVICES OF OTHERS BY PROVIDING CUSTOMIZED EXHIBITS; ADVERTISING, MARKETING AND PROMOTIONAL SERVICES FOR AUTOMOTIVE DEALERSHIPS; ADVERTISING, MARKETING AND PROMOTIONAL SERVICES FOR LIGHT AND HEAVY EQUIPMENT DEALERSHIPS; ADVERTISING, MARKETING AND PROMOTIONAL SERVICES FOR THE DONATION OF HUMAN BLOOD THAT EXACTLY MATCHES THE BLOOD TYPE OF INDIVIDUALS NEEDING TRANSFUSIONS; ADVERTISING, MARKETING AND PROMOTIONAL SERVICES RELATED TO ALL INDUSTRIES FOR THE PURPOSE OF FACILITATING NETWORKING AND SOCIALIZING OPPORTUNITIES FOR BUSINESS PURPOSES; ADVERTISING, PROMOTION AND MARKETING SERVICES BASED ON CONSUMER CREDIT REPORTS AND SCORES OF OTHERS; ADVERTISING, PROMOTION AND MARKETING SERVICES IN THE NATURE OF E-MAIL BLAST CAMPAIGNS FOR OTHERS; AGENCIES FOR ADVERTISING TIME AND SPACE; ANALYSIS OF ADVERTISING RESPONSE; ARRANGING AND CONDUCTING OF FAIRS AND EXHIBITIONS FOR BUSINESS AND ADVERTISING PURPOSES; ARRANGING AND CONDUCTING SPECIAL EVENTS FOR COMMERCIAL, PROMOTIONAL OR ADVERTISING PURPOSES; BANNER ADVERTISING; BUSINESS MANAGEMENT AND CONSULTING SERVICES FOR THE HEALTH CARE INDUSTRY, NAMELY, CUSTOMER SERVICE, ACCOUNTING SERVICES, AND WEB-BASED ADVERTISING AND MARKETING SERVICES; BUSINESS SERVICES, NAMELY, TRACKING AND MONITORING OF CALLS FOR OTHERS IN RESPONSE TO ADVERTISING ADS; CINEMA ADVERTISING; CLASSIFIED ADVERTISING SERVICES; COMPILATION OF ADVERTISEMENTS FOR USE AS WEB PAGES ON THE INTERNET; COMPILATION, PRODUCTION AND DISSEMINATION OF ADVERTISING MATTER; CONDUCTING, ARRANGING AND ORGANIZING TRADE SHOWS AND TRADE FAIRS FOR COMMERCIAL AND ADVERTISING PURPOSES; CONSUMER LOYALTY SERVICES FOR COMMERCIAL, PROMOTIONAL, AND/OR ADVERTISING PURPOSES, NAMELY, ADMINISTRATION OF FREQUENT FLYER PROGRAM THAT ALLOWS MEMBERS TO REDEEM MILES FOR POINTS OR AWARDS OFFERED BY OTHER LOYALTY PROGRAMS; COOPERATIVE ADVERTISING AND MARKETING; COOPERATIVE ADVERTISING AND MARKETING SERVICES BY WAY OF SOLICITATION, CUSTOMER SERVICE AND PROVIDING MARKETING INFORMATION VIA WEB SITES ON A GLOBAL COMPUTER NETWORK; COOPERATIVE ADVERTISING AND MARKETING SERVICES, NAMELY, OFFERING DISCOUNTS TO CLIENTS THROUGH THE JOINT PARTICIPATION OF MEMBER BEAUTY SALONS.; CREATING AND UPDATING ADVERTISING MATERIAL; CREATION OF MARKETING TOOLS DESIGNED TO INCREASE A CLIENT COMPANY'S KNOWLEDGE OF CUSTOMER NEEDS, AND ITS COMPETITORS' PRODUCTS AND SERVICES, PRICING, ADVERTISING STRATEGY AND SALES STRATEGY; CUSTOMER LOYALTY SERVICES AND CUSTOMER CLUB SERVICES, FOR COMMERCIAL, PROMOTIONAL AND/OR ADVERTISING PURPOSES; DESIGN OF ADVERTISING BROCHURES FOR OTHERS; DESIGN OF ADVERTISING FLYERS FOR OTHERS; DESIGN OF ADVERTISING MATERIALS FOR OTHERS; DESIGN OF INTERNET ADVERTISING; DEVELOPING ADVERTISING CAMPAIGNS FOR OTHERS GEARED TOWARD ENVIRONMENTAL ISSUES; DEVELOPMENT, OPERATION AND ADMINISTRATION OF DIGITAL SIGNAGE SYSTEMS AND DIGITAL ADVERTISING SYSTEMS FOR OTHERS, NAMELY, PROVIDING ADVERTISING SPACE BY ELECTRONIC MEANS AND GLOBAL COMPUTER INFORMATION NETWORKS; DIRECT MAIL ADVERTISING SERVICES; DIRECT MARKETING ADVERTISING FOR OTHERS; DISPLAYING ADVERTISEMENTS FOR OTHERS; DISSEMINATION OF ADVERTISE-

CLASS 35—(Continued).

MENTS; DISSEMINATION OF ADVERTISEMENTS AND OF ADVERTISING MATERIAL; DISSEMINATION OF ADVERTISING FOR OTHERS VIA AN ON-LINE COMMUNICATIONS NETWORK ON THE INTERNET; DISSEMINATION OF ADVERTISING FOR OTHERS VIA PUBLIC AND PRIVATE WIRELESS NETWORKS FOR DISPLAY ON MOBILE DEVICES; DISSEMINATION OF ADVERTISING FOR OTHERS VIA THE INTERNET; DISSEMINATION OF ADVERTISING MATERIAL; DISSEMINATION OF ADVERTISING MATTER; DISSEMINATION OF ADVERTISING, SCHEDULING AND MANAGING OF TRAINING COURSES AND PROGRAMS FOR OTHERS VIA A GLOBAL COMPUTER NETWORK; DISSEMINATION SERVICES OF ADVERTISEMENT MATTER; DISTRIBUTION AND DISSEMINATION OF ADVERTISING MATERIALS; DISTRIBUTION OF ADVERTISEMENTS AND COMMERCIAL ANNOUNCEMENTS; DISTRIBUTION OF ADVERTISING MAIL AND OF ADVERTISING SUPPLEMENTS ATTACHED TO REGULAR EDITIONS; DISTRIBUTION OF ADVERTISING MATERIAL; DISTRIBUTION OF ADVERTISING MATERIALS; DISTRIBUTION OF PRODUCTS FOR ADVERTISING PURPOSES; ELECTRONIC BILLBOARD ADVERTISING; ELECTRONIC COMMERCE SERVICES, NAMELY, PROVIDING INFORMATION ABOUT PRODUCTS VIA TELECOMMUNICATION NETWORKS FOR ADVERTISING AND SALES PURPOSES; ENTERTAINMENT MARKETING SERVICES, NAMELY, MARKETING, PROMOTION AND ADVERTISING FOR INDEPENDENT RECORDING ARTISTS; ENTERTAINMENT MARKETING SERVICES, NAMELY, MARKETING, PROMOTION AND ADVERTISING FOR RECORDING AND PERFORMING ARTISTS; EVENT PLANNING AND MANAGEMENT FOR MARKETING, BRANDING, PROMOTING OR ADVERTISING THE GOODS AND SERVICES OF OTHERS; INTERNATIONAL BUSINESS CONSULTING SERVICES RELATING TO MERCHANDISE TRADING, HUMAN RESOURCE INTERCHANGE, MANAGEMENT SUPPORT, MARKETING, ADVERTISING, PROMOTION, AND DOMESTIC AND INTERNATIONAL MARKET RESEARCH AND DEVELOPMENT; INTERNET ADVERTISING SERVICES; ISSUING AND UPDATING OF ADVERTISING TEXTS; LAYOUT SERVICES FOR ADVERTISING PURPOSES; MANAGEMENT OF ADVERTISING THROUGH A COMMAND AND CONTROL CENTER FOR BOTH MOVIE THEATRE ON-SCREEN ADVERTISING AND OVER THE INTERNET; MARKETING AND ADVERTISING SERVICES FOR AUTOMOBILE DEALERSHIPS; MARKETING, ADVERTISING AND PROMOTING THE GOODS AND SERVICES OF OTHERS IN THE FIELD OF TRAVEL AND TOURISM, NAMELY, PROVIDING INFORMATION VIA MAIL AND ELECTRONIC MAIL; MARKETING, ADVERTISING, AND PROMOTING THE RETAIL GOODS AND SERVICES OF OTHERS TO WIRELESS ELECTRONIC DEVICES; MARKETING, PROMOTIONAL AND ADVERTISING SERVICES PROVIDED BY MOBILE TELEPHONE CONNECTIONS; MEDIA BUYING ADVICE, NAMELY, ADVISING THE CLIENT HOW MUCH MEDIA TIME, AND AT WHAT TIMES THE CLIENT SHOULD BE PURCHASING ADVERTISING; MEDIA PLANNING, NAMELY, ADVISING THE CLIENT ON THE CORRECT TIMES AND STATIONS TO ADVERTISE BASED ON MEDIA ANALYSIS OF THE MARKET FOR THAT MEDIA; MEDIA PRODUCTION LOCATION SCOUTING SERVICES FOR ADVERTISING PURPOSES; MEDIATION OF ADVERTISING; MODELING FOR ADVERTISING OR SALES PROMOTION; MODELING SERVICES FOR ADVERTISING OR SALES PROMOTION; MUSIC SELECTION SERVICES FOR USE IN ADVERTISING; ON-LINE ADVERTISING AND MARKETING SERVICES; ON-LINE ADVERTISING ON COMPUTER COMMUNICATION NETWORKS; ON-LINE ADVERTISING ON COMPUTER NETWORKS; ON-LINE ADVERTISING SERVICES FOR OTHERS; ONLINE ADVERTISEMENTS; ONLINE ADVERTISING AND PROMOTIONAL SERVICES; ONLINE ADVERTISING VIA A COMPUTER COMMUNICATIONS NETWORK; ORGANISATION AND HOLDING OF FAIRS FOR COMMERCIAL OR ADVERTISING PURPOSES; ORGANISATION OF EXHIBITIONS AND EVENTS FOR COMMERCIAL OR ADVERTISING PURPOSES; ORGANISATION OF EXHIBITIONS FOR COMMERCIAL OR ADVERTISING PURPOSES; ORGANISING EXHIBITIONS FOR COMMERCIAL OR ADVERTISING PURPOSES; ORGANIZATION OF EVENTS, EXHIBITIONS, FAIRS AND SHOWS

CLASS 35—(Continued).

FOR COMMERCIAL, PROMOTIONAL AND ADVERTISING PURPOSES; ORGANIZATION OF EXHIBITIONS FOR COMMERCIAL OR ADVERTISING PURPOSES; ORGANIZATION OF FAIRS AND EXHIBITIONS FOR COMMERCIAL AND ADVERTISING PURPOSES; ORGANIZATION OF FAIRS FOR COMMERCIAL AND ADVERTISING PURPOSES; ORGANIZING BUSINESS EXPOSITIONS FOR HEALTH PRODUCTS; ORGANIZING EXHIBITIONS FOR COMMERCIAL OR ADVERTISING PURPOSES; OUT-OF-HOME ADVERTISING SERVICES, NAMELY, RENTAL OF ADVERTISING SPACE, AND PREPARING AND PLACING ADVERTISEMENTS FOR OTHERS; PAY PER CLICK (PPC) ADVERTISING MANAGEMENT SERVICES; PLACING ADVERTISEMENTS FOR OTHERS; PLANNING AND CONDUCTING OF TRADE FAIRS, EXHIBITIONS AND PRESENTATIONS FOR ECONOMIC OR ADVERTISING PURPOSES; PREPARATION AND REALIZATION OF MEDIA AND ADVERTISING PLANS AND CONCEPTS; PREPARATION OF CUSTOM ADVERTISEMENTS FOR OTHERS; PREPARATION OF CUSTOM OR NON-CUSTOM ADVERTISING FOR BUSINESSES FOR DISSEMINATION VIA THE WEB, CD OR DVD FOR OPTIONAL UPLOAD OR DOWNLOAD TO A COMPUTER; PREPARING ADVERTISEMENTS FOR OTHERS; PREPARING ADVERTISEMENTS FOR OTHERS, NAMELY, PREPARING VIDEO ADVERTISING AND PROMOTIONAL VIDEOS FOR COMMERCIAL USE VIA THE INTERNET AND TELEVISION, DIGITAL CABLE AND VIDEO-ON-DEMAND OR DOWNLOAD; PREPARING AND PLACING ADVERTISEMENTS FOR OTHERS; PREPARING AND PLACING OF ADVERTISEMENTS; PREPARING AND PLACING OUTDOOR ADVERTISEMENTS FOR OTHERS; PREPARING AUDIOVISUAL PRESENTATIONS FOR USE IN ADVERTISING; PREPARING SPEECHES AND ORAL PRESENTATIONS FOR OTHERS FOR USE IN ADVERTISING; PROCESSING TELEPHONE INQUIRIES REGARDING ADVERTISED GOODS AND SERVICES; PRODUCTION OF ADVERTISING MATTER AND COMMERCIALS; PRODUCTION OF FILM AND TELEVISION ADVERTISING; PROMOTING AND MARKETING THE GOODS AND SERVICES OF OTHERS BY DISTRIBUTING ADVERTISING MATERIAL, COUPONS AND DISCOUNT OFFERS VIA TEXT MESSAGES; PROMOTING AND SHOWCASING THE GOODS OF OTHERS IN THE FIELD OF HEALTH PRODUCTS BY MEANS OF AN ON-LINE SHOPPING SITE WITH LINKS TO THE RETAIL ADVERTISEMENTS OF OTHERS; PROMOTING THE GOODS AND SERVICES OF OTHERS BY DISTRIBUTING ADVERTISING MATERIALS THROUGH A VARIETY OF METHODS; PROMOTING THE GOODS AND SERVICES OF OTHERS BY MEANS OF DISTRIBUTING ADVERTISING ON THE INTERNET; PROMOTING THE GOODS AND SERVICES OF OTHERS BY PREPARING AND PLACING ADVERTISEMENTS IN AN ELECTRONIC MAGAZINE ACCESSED THROUGH A GLOBAL COMPUTER NETWORK; PROMOTING, ADVERTISING AND MARKETING OF THE BRANDS, PRODUCTS, SERVICES OR ONLINE WEBSITES OF INDIVIDUALS, BUSINESSES AND NONPROFIT ORGANIZATIONS; PROMOTING, ADVERTISING AND MARKETING OF THE ON-LINE WEB SITES OF OTHERS; PROMOTING, ADVERTISING AND MARKETING THE ON-LINE DATABASES AND ELECTRONIC PUBLICATIONS OF OTHERS; PROMOTION, ADVERTISING AND MARKETING OF ON-LINE WEBSITES; PROMOTIONAL SERVICES, NAMELY, DISTRIBUTION OF ADVERTISING FLYERS, COUPONS, CATALOGS AND PROMOTIONAL ITEMS OF OTHERS; PROVIDING A SEARCHABLE ON-LINE ADVERTISING WEBSITE AND GUIDE FEATURING THE GOODS AND SERVICES OF OTHER VENDORS VIA THE INTERNET; PROVIDING A SEARCHABLE ONLINE ADVERTISING GUIDE FEATURING THE GOODS AND SERVICES OF ONLINE VENDORS; PROVIDING A SEARCHABLE ON-LINE ADVERTISING GUIDE FEATURING THE GOODS AND SERVICES OF OTHER ON-LINE VENDORS ON THE INTERNET; PROVIDING A SEARCHABLE ONLINE ADVERTISING WEBSITE AND INFORMATIONAL GUIDE FEATURING THE GOODS AND SERVICES OF OTHER VENDORS VIA THE INTERNET IN THE FIELD OF HEALTH PRODUCTS; PROVIDING A WEB SITE AT WHICH FITNESS PROFESSIONALS AND FACILITIES CAN POST PROMOTIONAL PROFILES AND RESPOND TO ADVERTISEMENTS FOR THEIR SERVICES; PROVIDING A WEB SITE WHERE USERS CAN POST ITEMS FOR SALE THROUGH ON-LINE CLASSIFIED ADVER-

CLASS 35—(Continued).

TISEMENTS; PROVIDING A WEB SITE WHICH FEATURES ADVERTISEMENTS FOR THE GOODS AND SERVICES OF OTHERS ON A GLOBAL COMPUTER NETWORK; PROVIDING ADVERTISING AND ADVERTISEMENT SERVICES; PROVIDING ADVERTISING SERVICE TO DISTRIBUTE ADVERTISEMENTS FOR DISPLAY ON INTERNET, NAMELY, IN WEBSITES, SOCIAL CONVERSATIONS OVER THE INTERNET, E-MAILS, MICROBLOGS, BLOGS, ELECTRONIC MESSAGES, INSTANT MESSAGES, TEXT MESSAGES, MULTIMEDIA MESSAGES, SOCIAL NETWORKS, STATUS UPDATES, FORUMS, ELECTRONIC BULLETIN BOARDS; PROVIDING ADVERTISING SERVICES; PROVIDING ADVERTISING SERVICES USING 3D AND ANIMATION DESIGNS; PROVIDING ADVERTISING SPACE IN PERIODICALS, NEWSPAPERS AND MAGAZINES; PROVIDING ADVERTISING SPACE ON BILLBOARDS AND IN KIOSKS; PROVIDING ADVERTISING SPACE ON FREE-STANDING VISUAL ADVERTISING SYSTEMS FEATURING THE GOODS AND SERVICES OF OTHERS; PROVIDING ADVERTISING, MARKETING AND PROMOTIONAL SERVICES FOR THE PHARMACEUTICAL AND MEDICAL INDUSTRY; PROVIDING ADVERTISING, MARKETING AND PROMOTIONAL SERVICES FOR THE PHARMACEUTICAL AND MEDICAL PRODUCTS OF OTHERS; PROVIDING ADVERTISING, MARKETING AND PROMOTIONAL SERVICES, NAMELY, DEVELOPMENT OF ADVERTISING CAMPAIGNS FOR THE HEALTH INDUSTRY; PROVIDING ADVERTISING, MARKETING AND PROMOTIONAL SERVICES, NAMELY, DEVELOPMENT OF ADVERTISING CAMPAIGNS PROVIDED THROUGH CABLE TELEVISION BROADCAST, WEB CASTS, RADIO BROADCASTS, NEWSPAPERS, MAGAZINES, ONLINE BANNERS, OUTDOOR BILLBOARDS, WILD POSTINGS, BUS AND SUBWAY ADS; PROVIDING AN INTERNET WEB SITE FOR CLASSIFIED ADVERTISING TO BUY AND SELL UKRAINIAN RELATED WARES, ART, ANTIQUES, BOOKS, EMBROIDERY, COSTUMES, COLLECTIBLES, INSTRUMENTS, MEMORABILIA AND OTHER ONE-OF-A-KIND ITEMS; PROVIDING AN INTERNET WEB SITE TO ADVERTISE SERVICES OF INTEREST TO THE UKRAINIAN COMMUNITY IN THE UNITED STATES OF AMERICA AND CANADA AND TO ADVERTISE SERVICES PROVIDED BY INDIVIDUALS OF UKRAINIAN ORIGIN; PROVIDING AN INTERNET WEBSITE PORTAL FEATURING PROMOTION AND ADVERTISING FOR HOME SERVICE PROVIDERS AND PRODUCT MANUFACTURERS; PROVIDING AN ONLINE DIRECTORY INFORMATION SERVICE FEATURING INFORMATION REGARDING VEHICLES IN THE NATURE OF CLASSIFIED ADVERTISEMENTS; PROVIDING AND RENTAL OF ADVERTISING SPACE ON THE INTERNET; PROVIDING ONLINE BUSINESS INFORMATION OF OTHERS, NAMELY, ADVERTISEMENTS OR SOLICITATIONS; PROVIDING SPACE AT A WEB SITE FOR THE ADVERTISEMENT OF THE GOODS AND SERVICES OF OTHERS; PROVIDING TELEVISION ADVERTISING FOR OTHERS; PROVISION OF ADVERTISING SPACE BY ELECTRONIC MEANS AND GLOBAL INFORMATION NETWORKS; PROVISION OF SPACE ON WEBSITES FOR ADVERTISING GOODS AND SERVICES; PUBLIC RELATIONS, ADVERTISING AND MARKETING SERVICES FOR THE TOURISM AND CONVENTION INDUSTRY, NAMELY, ORGANIZING AND HOSTING SITE INSPECTIONS AND FAMILIARIZATION TOURS FOR WHOLESALERS, TOUR OPERATORS, TRAVEL AGENTS, MEETING AND INCENTIVE TRAVEL PLANNERS AND TRAVEL MEDIA; PUBLISHING OF ADVERTISING TEXTS; REAL ESTATE ADVERTISING SERVICES; RECRUITMENT ADVERTISEMENT SERVICES, NAMELY, POSTING OF CLINICAL TRIAL NOTICES FOR THE PURPOSE OF RECRUITING PATIENTS FOR PARTICIPATION IN CLINICAL TRIALS

CLASS 35—(Continued).

FOR THE TESTING OF DRUGS; RENTAL OF ADVERTISEMENT SPACE AND ADVERTISING MATERIAL; RENTAL OF ADVERTISING SPACE; RENTAL OF ADVERTISING SPACE ON WEB SITES; RENTAL OF SIGNS FOR ADVERTISING PURPOSES; RENTING OF ADVERTISING SPACES; SERVICES OF ADVERTISING AGENCIES; SERVICES TO DETERMINE THE AUDIENCE AFFECTED BY ADVERTISEMENTS; SPECIAL EVENT PLANNING FOR COMMERCIAL, PROMOTIONAL OR ADVERTISING PURPOSES; SPECIALTY MERCHANDISING SERVICES, NAMELY, PROMOTING THE GOODS AND SERVICES OF OTHERS THROUGH THE DISTRIBUTION OF CUSTOMIZED ADVERTISING MATERIALS, NAMELY, PENS AND CATALOGS; TELEVISION ADVERTISING AGENCIES; VENDOR-ON-PREMISE SERVICES, NAMELY, THE ADMINISTRATION OF THE EMPLOYMENT PROCESS ON-SITE, INCLUDING RESUME REVIEW AND CHECKING, EMPLOYMENT APPLICATION ACQUISITION, ADVERTISING FOR RECRUITMENT, CONDUCT OF INTERVIEWS, AND REFERENCE CHECKING (U.S. CLS. 100, 101 AND 102).
FIRST USE 7-20-2011; IN COMMERCE 2-20-2012.

4,155,094. GSENSE INC., BRIARCLIFF MANOR, NY. SN 85-245,508. PUB. 7-19-2011, FILED 2-17-2011.

License Anything

THE MARK CONSISTS OF STANDARD CHARACTERS WITHOUT CLAIM TO ANY PARTICULAR FONT, STYLE, SIZE, OR COLOR.

OWNER OF U.S. REG. NO. 3,790,012.

NO CLAIM IS MADE TO THE EXCLUSIVE RIGHT TO USE "LICENSE", APART FROM THE MARK AS SHOWN.

FOR AD SERVING, NAMELY, PLACING ADVERTISEMENTS ON WEBSITES FOR OTHERS USING SPECIALIZED COMPUTER SOFTWARE; ADVERTISEMENT AND PUBLICITY SERVICES BY TELEVISION, RADIO, MAIL; ADVERTISEMENT FOR OTHERS ON THE INTERNET; ADVERTISEMENT HOARDING RENTAL; ADVERTISEMENT VIA MOBILE PHONE NETWORKS; ADVERTISING AGENCIES; ADVERTISING AGENCIES PROVIDING THE STRATEGY, DESIGN AND EXECUTION OF PROGRAMS TO PROMOTE BUSINESSES IN THE FOOD AND FOODSERVICE INDUSTRIES; ADVERTISING AGENCIES, NAMELY, PROMOTING THE GOODS AND SERVICES OF OTHERS; ADVERTISING AGENCY SPECIALIZING IN THE DESIGN AND EXECUTION OF WORD OF MOUTH, VIRAL, BUZZ AND EXPERIENTIAL MARKETING PROGRAMS; ADVERTISING AND ADVERTISEMENT SERVICES; ADVERTISING AND BUSINESS ADVICE RELATING TO 'TELEMATICS' SERVICES; ADVERTISING AND BUSINESS MANAGEMENT CONSULTANCY; ADVERTISING AND BUSINESS SERVICES, NAMELY, PROVIDING AN ONLINE WEBSITE WHERE ADVERTISERS, MARKETERS, AND CONTENT PROVIDERS CAN INTERACT WITH USERS FOR ADVERTISING, BRANDING, AND PROMOTING KNOWLEDGE, PRODUCTS, AND SERVICES, AND TRADESHOWS, ON BEHALF OF THEMSELVES AND OTHERS, AND FOR EVALUATING AND RATING THE SAME, ALL THE FOREGOING RELEVANT TO HUMAN ACTIVITIES AFFECTING CLIMATE CHANGE AND RELATED FIELDS; ADVERTISING AND BUSINESS SERVICES, NAMELY, SECURING AIRTIME ON ALL FORMS OF MEDIA COMMUNICATIONS STATIONS, SYSTEMS, NETWORKS, AND SERVICES FOR THE PURPOSE OF PROMOTING THE GOODS AND SERVICES OF OTHERS; ADVERTISING AND COMMERCIAL INFORMATION SERVICES, VIA THE INTERNET; ADVERTISING AND DIRECTORY SERVICES, NAMELY, PROMOTING THE SERVICES OF OTHERS BY PROVIDING A WEB PAGE FEATURING LINKS TO

CLASS 35—(Continued).

THE WEBSITES OF OTHERS; ADVERTISING AND MARKETING; ADVERTISING AND MARKETING CONSULTANCY; ADVERTISING AND MARKETING SERVICES PROVIDED BY MEANS OF INDIRECT METHODS OF MARKETING COMMUNICATIONS, NAMELY, SOCIAL MEDIA, SEARCH ENGINE MARKETING, INQUIRY MARKETING, INTERNET MARKETING, MOBILE MARKETING, BLOGGING AND OTHER FORMS OF PASSIVE, SHARABLE OR VIRAL COMMUNICATIONS CHANNELS; ADVERTISING AND MARKETING SERVICES, NAMELY, PROMOTING THE GOODS AND SERVICES OF OTHERS; ADVERTISING AND PROMOTING THE GOODS AND SERVICES OF A VISUAL ARTIST; ADVERTISING AND PROMOTION SERVICES AND RELATED CONSULTING; ADVERTISING AND PROMOTIONAL SERVICES; ADVERTISING AND PUBLICITY SERVICES; ADVERTISING AND PUBLICITY SERVICES, NAMELY, PROMOTING THE GOODS, SERVICES, BRAND IDENTITY AND COMMERCIAL INFORMATION AND NEWS OF THIRD PARTIES THROUGH PRINT, AUDIO, VIDEO, DIGITAL AND ON-LINE MEDIUM; ADVERTISING BUSINESS ESPECIALLY IN THE FIELD OF TELEMATIC AND TELEPHONE NETWORKS; ADVERTISING BY TRANSMISSION OF ON-LINE PUBLICITY FOR THIRD PARTIES THROUGH ELECTRONIC COMMUNICATIONS NETWORKS; ADVERTISING CONSULTATION; ADVERTISING COPYWRITING; ADVERTISING FLYER DISTRIBUTION; ADVERTISING IN PERIODICALS, BROCHURES AND NEWSPAPERS; ADVERTISING IN THE POPULAR AND PROFESSIONAL PRESS; ADVERTISING OF COMMERCIAL OR RESIDENTIAL REAL ESTATE; ADVERTISING OF THE PUBLISHED TEXTS OF OTHERS; ADVERTISING ON THE INTERNET FOR OTHERS; ADVERTISING PARTICULARLY SERVICES FOR THE PROMOTION OF GOODS; ADVERTISING RELATING TO PHARMACEUTICAL PRODUCTS AND IN-VIVO IMAGING PRODUCTS; ADVERTISING RELATING TO TRANSPORT AND DELIVERY; ADVERTISING SERVICES; ADVERTISING SERVICES FOR PROMOTING THE BROKERAGE OF STOCKS AND OTHER SECURITIES; ADVERTISING SERVICES OF A RADIO AND TELEVISION ADVERTISING AGENCY; ADVERTISING SERVICES RELATING TO SANDWICHES; ADVERTISING SERVICES, FOR THIRD PARTIES, IN CONNECTION WITH THE COMMERCIALIZATION AND SALE OF PERFUMERY AND COSMETIC ARTICLES, PRODUCTS FOR HOUSEHOLD PURPOSES, OPTICAL PRODUCTS, CLOCKS AND TIMEPIECES, JEWELLERY, FURNISHING ARTICLES; ADVERTISING SERVICES, NAMELY, COST-PER-ACTION ON-LINE ADVERTISING; ADVERTISING SERVICES, NAMELY, CREATING CORPORATE AND BRAND IDENTITY FOR OTHERS; ADVERTISING SERVICES, NAMELY, CREATING CORPORATE LOGOS FOR OTHERS; ADVERTISING SERVICES, NAMELY, CREATING PROMOTIONAL MURALS AND PAINTING SIGNS AND WALLS ADVERTISING THE GOODS AND SERVICES OF OTHERS; ADVERTISING SERVICES, NAMELY, PRODUCTION OF SPECIAL EFFECTS INCLUDING MODEL-MAKING SERVICES, COMPUTER-GENERATED IMAGERY AND COMPUTER-GENERATED GRAPHICS FOR THE PRODUCTION OF COMMERCIALS; ADVERTISING SERVICES, NAMELY, PROMOTING AND MARKETING THE GOODS AND SERVICES OF OTHERS IN THE FIELD OF UPSCALE CHOICES SUCH AS CULTURAL EVENTS, RESTAURANTS, SHOPPING, AND TRAVEL VIA PRINT AND ELECTRONIC MEDIA; ADVERTISING SERVICES, NAMELY, PROMOTING AND MARKETING THE GOODS AND SERVICES OF OTHERS THROUGH ALL PUBLIC COMMUNICATION MEANS; ADVERTISING SERVICES, NAMELY, PROMOTING CAR DEALERSHIPS OF OTHERS; ADVERTISING SERVICES, NAMELY, PROMOTING PROPERTIES FOR SALE BY OWNER VIA THE INTERNET; ADVERTISING SERVICES, NAMELY, PROMOTING THE BOOKS OF OTHERS IN THE FIELD OF LAW BY MEANS OF NEWS AND REVIEWS REGARDING SAME; ADVERTISING SERVICES, NAMELY, PROMOTING THE BRANDS, GOODS AND SERVICES OF OTHERS; ADVERTISING SERVICES, NAMELY, PROMOTING THE FOOD AND WINE OF OTHERS; ADVERTISING SERVICES, NAMELY, PROMOTING THE GIFT CARDS OF OTHERS; ADVERTISING SERVICES, NAMELY, PROMOTING THE POWER SPORTS DEALERSHIPS OF OTHERS; ADVERTISING SERVICES, NAMELY, PRO-

CLASS 35—(Continued).

MOTING THE SANDWICHES OF OTHERS; ADVERTISING SERVICES, NAMELY, PROVIDING A WEBSITE FOR THE PROMOTION OF THE BOOKS OF OTHERS IN THE FIELD OF LAW, INCLUDING NEWS AND REVIEWS REGARDING SAME; ADVERTISING SERVICES, NAMELY, PROVIDING ADVERTISING SPACE IN A PERIODICAL; ADVERTISING SERVICES, NAMELY, PROVIDING INFORMATION AS TO THE AVAILABILITY OF MULTIMEDIA PRODUCTS FOR RENT OR PURCHASE; ADVERTISING SERVICES, PUBLIC RELATIONS AND MARKETING SERVICES, NAMELY, PROMOTING AND MARKETING THE GOODS AND SERVICES OF OTHERS THROUGH ALL PUBLIC COMMUNICATION MEANS; ADVERTISING TEXT PUBLICATION SERVICES; ADVERTISING THE SERVICES OF OTHERS VIA WEB PAGES OPTIMIZED FOR ONLINE SEARCH ENGINES; ADVERTISING THROUGH ALL PUBLIC COMMUNICATION MEANS; ADVERTISING VIA ELECTRONIC MEDIA AND SPECIFICALLY THE INTERNET; ADVERTISING, INCLUDING ON-LINE ADVERTISING ON A COMPUTER NETWORK; ADVERTISING, INCLUDING PROMOTION OF PRODUCTS AND SERVICES OF THIRD PARTIES THROUGH SPONSORING ARRANGEMENTS AND LICENSE AGREEMENTS RELATING TO INTERNATIONAL SPORTS EVENTS; ADVERTISING, INCLUDING PROMOTION RELATING TO THE SALE OF ARTICLES AND SERVICES FOR THIRD PARTIES BY THE TRANSMISSION OF ADVERTISING MATERIAL AND THE DISSEMINATION OF ADVERTISING MESSAGES ON COMPUTER NETWORKS; ADVERTISING, MARKETING AND PROMOTING THE GOODS AND SERVICES OF OTHERS USING KIOSKS; ADVERTISING, MARKETING AND PROMOTION SERVICES; ADVERTISING, MARKETING AND PROMOTION SERVICES, NAMELY, PROMOTING THE GOODS AND SERVICES OF OTHERS BY PROVIDING CUSTOMIZED EXHIBITS; ADVERTISING, MARKETING AND PROMOTIONAL SERVICES FOR AUTOMOTIVE DEALERSHIPS; ADVERTISING, MARKETING AND PROMOTIONAL SERVICES FOR LIGHT AND HEAVY EQUIPMENT DEALERSHIPS; ADVERTISING, MARKETING AND PROMOTIONAL SERVICES FOR THE DONATION OF HUMAN BLOOD THAT EXACTLY MATCHES THE BLOOD TYPE OF INDIVIDUALS NEEDING TRANSFUSIONS; ADVERTISING, MARKETING AND PROMOTIONAL SERVICES RELATED TO ALL INDUSTRIES FOR THE PURPOSE OF FACILITATING NETWORKING AND SOCIALIZING OPPORTUNITIES FOR BUSINESS PURPOSES; ADVERTISING, PROMOTION AND MARKETING SERVICES BASED ON CONSUMER CREDIT REPORTS AND SCORES OF OTHERS; ADVERTISING, PROMOTION AND MARKETING SERVICES IN THE NATURE OF E-MAIL BLAST CAMPAIGNS FOR OTHERS; ADVERTISING, PROMOTION, AND MARKETING SERVICES IN THE NATURE OF VIRAL MARKETING PROGRAM FOR WEB AND MOBILE PHONE USERS; AGENCIES FOR ADVERTISING TIME AND SPACE; ANALYSIS OF ADVERTISING RESPONSE; ARRANGING AND CONDUCTING OF FAIRS AND EXHIBITIONS FOR BUSINESS AND ADVERTISING PURPOSES; ARRANGING AND CONDUCTING SPECIAL EVENTS FOR COMMERCIAL, PROMOTIONAL OR ADVERTISING PURPOSES; BANNER ADVERTISING; BUSINESS MANAGEMENT AND CONSULTING SERVICES FOR THE HEALTH CARE INDUSTRY, NAMELY, CUSTOMER SERVICE, ACCOUNTING SERVICES, AND WEB-BASED ADVERTISING AND MARKETING SERVICES; BUSINESS SERVICES, NAMELY, TRACKING AND MONITORING OF CALLS FOR OTHERS IN RESPONSE TO ADVERTISING ADS; CINEMA ADVERTISING; CLASSIFIED ADVERTISING SERVICES; COMPILATION OF ADVERTISEMENTS FOR USE AS WEB PAGES ON THE INTERNET; COMPILATION, PRODUCTION AND DISSEMINATION OF ADVERTISING MATTER; CONDUCTING, ARRANGING AND ORGANIZING TRADE SHOWS AND TRADE FAIRS FOR COMMERCIAL AND ADVERTISING PURPOSES; CONSUMER LOYALTY SERVICES FOR COMMERCIAL, PROMOTIONAL, AND/OR ADVERTISING PURPOSES, NAMELY, ADMINISTRATION OF FREQUENT FLYER PROGRAM THAT ALLOWS MEMBERS TO REDEEM MILES FOR POINTS OR AWARDS OFFERED BY OTHER LOYALTY PROGRAMS; COOPERATIVE ADVERTISING AND MARKETING; COOPERATIVE ADVERTISING AND MARKETING SERVICES BY WAY OF SOLICITATION, CUSTOMER SER-

CLASS 35—(Continued).

VICE AND PROVIDING MARKETING INFORMATION VIA WEB SITES ON A GLOBAL COMPUTER NETWORK; COOPERATIVE ADVERTISING AND MARKETING SERVICES, NAMELY, OFFERING DISCOUNTS TO CLIENTS THROUGH THE JOINT PARTICIPATION OF MEMBER BEAUTY SALONS.; CREATING AND UPDATING ADVERTISING MATERIAL; CREATION OF MARKETING TOOLS DESIGNED TO INCREASE A CLIENT COMPANY'S KNOWLEDGE OF CUSTOMER NEEDS, AND ITS COMPETITORS' PRODUCTS AND SERVICES, PRICING, ADVERTISING STRATEGY AND SALES STRATEGY; CUSTOMER LOYALTY SERVICES AND CUSTOMER CLUB SERVICES, FOR COMMERCIAL, PROMOTIONAL AND/OR ADVERTISING PURPOSES; DESIGN OF ADVERTISING BROCHURES FOR OTHERS; DESIGN OF ADVERTISING FLYERS FOR OTHERS; DESIGN OF ADVERTISING MATERIALS FOR OTHERS; DESIGN OF INTERNET ADVERTISING; DEVELOPING ADVERTISING CAMPAIGNS FOR OTHERS GEARED TOWARD ENVIRONMENTAL ISSUES; DEVELOPMENT, OPERATION AND ADMINISTRATION OF DIGITAL SIGNAGE SYSTEMS AND DIGITAL ADVERTISING SYSTEMS FOR OTHERS, NAMELY, PROVIDING ADVERTISING SPACE BY ELECTRONIC MEANS AND GLOBAL COMPUTER INFORMATION NETWORKS; DIRECT MAIL ADVERTISING SERVICES; DIRECT MARKETING ADVERTISING FOR OTHERS; DISPLAYING ADVERTISEMENTS FOR OTHERS; DISSEMINATION OF ADVERTISEMENTS; DISSEMINATION OF ADVERTISEMENTS AND OF ADVERTISING MATERIAL; DISSEMINATION OF ADVERTISING FOR OTHERS VIA AN ON-LINE COMMUNICATIONS NETWORK ON THE INTERNET; DISSEMINATION OF ADVERTISING FOR OTHERS VIA PUBLIC AND PRIVATE WIRELESS NETWORKS FOR DISPLAY ON MOBILE DEVICES; DISSEMINATION OF ADVERTISING FOR OTHERS VIA THE INTERNET; DISSEMINATION OF ADVERTISING MATERIAL; DISSEMINATION OF ADVERTISING MATTER; DISSEMINATION OF ADVERTISING, SCHEDULING AND MANAGING OF TRAINING COURSES AND PROGRAMS FOR OTHERS VIA A GLOBAL COMPUTER NETWORK; DISSEMINATION SERVICES OF ADVERTISEMENT MATTER; DISTRIBUTION AND DISSEMINATION OF ADVERTISING MATERIALS; DISTRIBUTION OF ADVERTISEMENTS AND COMMERCIAL ANNOUNCEMENTS; DISTRIBUTION OF ADVERTISING MAIL AND OF ADVERTISING SUPPLEMENTS ATTACHED TO REGULAR EDITIONS; DISTRIBUTION OF ADVERTISING MATERIAL; DISTRIBUTION OF ADVERTISING MATERIALS; DISTRIBUTION OF PRODUCTS FOR ADVERTISING PURPOSES; ELECTRONIC BILLBOARD ADVERTISING; ELECTRONIC COMMERCE SERVICES, NAMELY, PROVIDING INFORMATION ABOUT PRODUCTS VIA TELECOMMUNICATION NETWORKS FOR ADVERTISING AND SALES PURPOSES; ENTERTAINMENT MARKETING SERVICES, NAMELY, MARKETING, PROMOTION AND ADVERTISING FOR INDEPENDENT RECORDING ARTISTS; ENTERTAINMENT MARKETING SERVICES, NAMELY, MARKETING, PROMOTION AND ADVERTISING FOR RECORDING AND PERFORMING ARTISTS; EVENT PLANNING AND MANAGEMENT FOR MARKETING, BRANDING, PROMOTING OR ADVERTISING THE GOODS AND SERVICES OF OTHERS; INTERNATIONAL BUSINESS CONSULTING SERVICES RELATING TO MERCHANDISE TRADING, HUMAN RESOURCE INTERCHANGE, MANAGEMENT SUPPORT, MARKETING, ADVERTISING, PROMOTION, AND DOMESTIC AND INTERNATIONAL MARKET RESEARCH AND DEVELOPMENT; INTERNET ADVERTISING SERVICES; ISSUING AND UPDATING OF ADVERTISING TEXTS; LAYOUT SERVICES FOR ADVERTISING PURPOSES; MANAGEMENT OF ADVERTISING THROUGH A COMMAND AND CONTROL CENTER FOR BOTH MOVIE THEATRE ON-SCREEN ADVERTISING AND OVER THE INTERNET; MARKETING AND ADVERTISING SERVICES FOR AUTOMOBILE DEALERSHIPS; MARKETING, ADVERTISING AND PROMOTING THE GOODS AND SERVICES OF OTHERS IN THE FIELD OF TRAVEL AND TOURISM, NAMELY, PROVIDING INFORMATION VIA MAIL AND ELECTRONIC MAIL; MARKETING, ADVERTISING, AND PROMOTING THE RETAIL GOODS AND SERVICES OF OTHERS TO WIRELESS ELECTRONIC DEVICES; MARKETING, PROMOTIONAL AND ADVERTISING SERVICES PROVIDED BY MOBILE TELEPHONE CONNECTIONS; MEDIA BUYING ADVICE,

CLASS 35—(Continued).

NAMELY, ADVISING THE CLIENT HOW MUCH MEDIA TIME, AND AT WHAT TIMES THE CLIENT SHOULD BE PURCHASING ADVERTISING; MEDIA PLANNING, NAMELY, ADVISING THE CLIENT ON THE CORRECT TIMES AND STATIONS TO ADVERTISE BASED ON MEDIA ANALYSIS OF THE MARKET FOR THAT MEDIA; MEDIA PRODUCTION LOCATION SCOUTING SERVICES FOR ADVERTISING PURPOSES; MEDIATION OF ADVERTISING; MODELING FOR ADVERTISING OR SALES PROMOTION; MODELING SERVICES FOR ADVERTISING OR SALES PROMOTION; MUSIC SELECTION SERVICES FOR USE IN ADVERTISING; ON-LINE ADVERTISING AND MARKETING SERVICES; ON-LINE ADVERTISING ON COMPUTER COMMUNICATION NETWORKS; ON-LINE ADVERTISING ON COMPUTER NETWORKS; ON-LINE ADVERTISING SERVICES FOR OTHERS; ONLINE ADVERTISEMENTS; ONLINE ADVERTISING AND PROMOTIONAL SERVICES; ONLINE ADVERTISING VIA A COMPUTER COMMUNICATIONS NETWORK; ORGANISATION AND HOLDING OF FAIRS FOR COMMERCIAL OR ADVERTISING PURPOSES; ORGANISATION OF EXHIBITIONS AND EVENTS FOR COMMERCIAL OR ADVERTISING PURPOSES; ORGANISATION OF EXHIBITIONS FOR COMMERCIAL OR ADVERTISING PURPOSES; ORGANISING EXHIBITIONS FOR COMMERCIAL OR ADVERTISING PURPOSES; ORGANIZATION OF EVENTS, EXHIBITIONS, FAIRS AND SHOWS FOR COMMERCIAL, PROMOTIONAL AND ADVERTISING PURPOSES; ORGANIZATION OF EXHIBITIONS FOR COMMERCIAL OR ADVERTISING PURPOSES; ORGANIZATION OF FAIRS AND EXHIBITIONS FOR COMMERCIAL AND ADVERTISING PURPOSES; ORGANIZATION OF FAIRS FOR COMMERCIAL AND ADVERTISING PURPOSES; ORGANIZING BUSINESS EXPOSITIONS FOR ADVERTISING PRODUCTS; ORGANIZING EXHIBITIONS FOR COMMERCIAL OR ADVERTISING PURPOSES; ORGANIZING EXHIBITIONS FOR ADVERTISING PRODUCTS; OUT-OF-HOME ADVERTISING SERVICES, NAMELY, RENTAL OF ADVERTISING SPACE, AND PREPARING AND PLACING ADVERTISEMENTS FOR OTHERS; PAY PER CLICK (PPC) ADVERTISING MANAGEMENT SERVICES; PLACING ADVERTISEMENTS FOR OTHERS; PLANNING AND CONDUCTING OF TRADE FAIRS, EXHIBITIONS AND PRESENTATIONS FOR ECONOMIC OR ADVERTISING PURPOSES; PREPARATION AND REALIZATION OF MEDIA AND ADVERTISING PLANS AND CONCEPTS; PREPARATION OF CUSTOM ADVERTISEMENTS FOR OTHERS; PREPARATION OF CUSTOM OR NON-CUSTOM ADVERTISING FOR BUSINESSES FOR DISSEMINATION VIA THE WEB, CD OR DVD FOR OPTIONAL UPLOAD OR DOWNLOAD TO A COMPUTER; PREPARING ADVERTISEMENTS FOR OTHERS; PREPARING ADVERTISEMENTS FOR OTHERS, NAMELY, PREPARING VIDEO ADVERTISING AND PROMOTIONAL VIDEOS FOR COMMERCIAL USE VIA THE INTERNET AND TELEVISION, DIGITAL CABLE AND VIDEO-ON-DEMAND OR DOWNLOAD; PREPARING AND PLACING ADVERTISEMENTS FOR OTHERS; PREPARING AND PLACING OF ADVERTISEMENTS; PREPARING AND PLACING OUTDOOR ADVERTISEMENTS FOR OTHERS; PREPARING AUDIOVISUAL PRESENTATIONS FOR USE IN ADVERTISING; PREPARING SPEECHES AND ORAL PRESENTATIONS FOR OTHERS FOR USE IN ADVERTISING; PROCESSING TELEPHONE INQUIRIES REGARDING ADVERTISED GOODS AND SERVICES; PRODUCTION OF ADVERTISING MATTER AND COMMERCIALS; PRODUCTION OF FILM AND TELEVISION ADVERTISING; PROMOTING AND MARKETING THE GOODS AND SERVICES OF OTHERS BY DISTRIBUTING ADVERTISING MATERIAL, COUPONS AND DISCOUNT OFFERS VIA TEXT MESSAGES; PROMOTING AND SHOWCASING THE GOODS OF OTHERS IN THE FIELD OF ENTERTAINMENT BY MEANS OF AN ON-LINE SHOPPING SITE WITH LINKS TO THE RETAIL ADVERTISEMENTS OF OTHERS; PROMOTING THE GOODS AND SERVICES OF OTHERS BY DISTRIBUTING ADVERTISING MATERIALS THROUGH A VARIETY OF METHODS; PROMOTING THE GOODS AND SERVICES OF OTHERS BY MEANS OF DISTRIBUTING ADVERTISING ON THE INTERNET; PROMOTING THE GOODS AND SERVICES OF OTHERS BY PREPARING AND PLACING ADVERTISEMENTS IN AN ELECTRONIC MAGAZINE ACCESSED THROUGH A GLOBAL COMPUTER NETWORK; PROMOTING, ADVERTISING AND MAR-

CLASS 35—(Continued).

KETING OF THE BRANDS, PRODUCTS, SERVICES OR ONLINE WEBSITES OF INDIVIDUALS, BUSINESSES AND NONPROFIT ORGANIZATIONS; PROMOTING, ADVERTISING AND MARKETING OF THE ON-LINE WEB SITES OF OTHERS; PROMOTING, ADVERTISING AND MARKETING THE ON-LINE DATABASES AND ELECTRONIC PUBLICATIONS OF OTHERS; PROMOTION, ADVERTISING AND MARKETING OF ON-LINE WEBSITES; PROMOTIONAL SERVICES, NAMELY, DISTRIBUTION OF ADVERTISING FLYERS, COUPONS, CATALOGS AND PROMOTIONAL ITEMS OF OTHERS; PROVIDING A SEARCHABLE ON-LINE ADVERTISING WEBSITE AND GUIDE FEATURING THE GOODS AND SERVICES OF OTHER VENDORS VIA THE INTERNET; PROVIDING A SEARCHABLE ONLINE ADVERTISING GUIDE FEATURING THE GOODS AND SERVICES OF ONLINE VENDORS; PROVIDING A SEARCHABLE ON-LINE ADVERTISING GUIDE FEATURING THE GOODS AND SERVICES OF OTHER ON-LINE VENDORS ON THE INTERNET; PROVIDING A SEARCHABLE ONLINE ADVERTISING WEBSITE AND INFORMATIONAL GUIDE FEATURING THE GOODS AND SERVICES OF OTHER VENDORS VIA THE INTERNET IN THE FIELD OF ENTERTAINMENT; PROVIDING A WEB SITE AT WHICH FITNESS PROFESSIONALS AND FACILITIES CAN POST PROMOTIONAL PROFILES AND RESPOND TO ADVERTISEMENTS FOR THEIR SERVICES; PROVIDING A WEB SITE WHERE USERS CAN POST ITEMS FOR SALE THROUGH ON-LINE CLASSIFIED ADVERTISEMENTS; PROVIDING A WEB SITE WHICH FEATURES ADVERTISEMENTS FOR THE GOODS AND SERVICES OF OTHERS ON A GLOBAL COMPUTER NETWORK; PROVIDING ADVERTISING AND ADVERTISEMENT SERVICES; PROVIDING ADVERTISING SERVICE TO DISTRIBUTE ADVERTISEMENTS FOR DISPLAY ON INTERNET, NAMELY, IN WEBSITES, SOCIAL CONVERSATIONS OVER THE INTERNET, E-MAILS, MICROBLOGS, BLOGS, ELECTRONIC MESSAGES, INSTANT MESSAGES, TEXT MESSAGES, MULTIMEDIA MESSAGES, SOCIAL NETWORKS, STATUS UPDATES, FORUMS, ELECTRONIC BULLETIN BOARDS; PROVIDING ADVERTISING SERVICES; PROVIDING ADVERTISING SERVICES USING 3D AND ANIMATION DESIGNS; PROVIDING ADVERTISING SPACE IN PERIODICALS, NEWSPAPERS AND MAGAZINES; PROVIDING ADVERTISING SPACE ON BILLBOARDS AND IN KIOSKS; PROVIDING ADVERTISING SPACE ON FREE-STANDING VISUAL ADVERTISING SYSTEMS FEATURING THE GOODS AND SERVICES OF OTHERS; PROVIDING ADVERTISING, MARKETING AND PROMOTIONAL SERVICES FOR THE PHARMACEUTICAL AND MEDICAL INDUSTRY; PROVIDING ADVERTISING, MARKETING AND PROMOTIONAL SERVICES FOR THE PHARMACEUTICAL AND MEDICAL PRODUCTS OF OTHERS; PROVIDING ADVERTISING, MARKETING AND PROMOTIONAL SERVICES, NAMELY, DEVELOPMENT OF ADVERTISING CAMPAIGNS FOR ONLINE USERS; PROVIDING ADVERTISING, MARKETING AND PROMOTIONAL SERVICES, NAMELY, DEVELOPMENT OF ADVERTISING CAMPAIGNS PROVIDED THROUGH CABLE TELEVISION BROADCAST, WEB CASTS, RADIO BROADCASTS, NEWSPAPERS, MAGAZINES, ONLINE BANNERS, OUTDOOR BILLBOARDS, WILD POSTINGS, BUS AND SUBWAY ADS; PROVIDING AN INTERNET WEB SITE FOR CLASSIFIED ADVERTISING TO BUY AND SELL UKRAINIAN RELATED WARES, ART, ANTIQUES, BOOKS, EMBROIDERY, COSTUMES, COLLECTIBLES, INSTRUMENTS, MEMORABILIA AND OTHER ONE-OF-A-KIND ITEMS; PROVIDING AN INTERNET WEB SITE TO ADVERTISE SERVICES OF INTEREST TO THE UKRAINIAN COMMUNITY IN THE UNITED STATES OF AMERICA AND CANADA AND TO ADVERTISE SERVICES PROVIDED BY INDIVIDUALS OF UKRAINIAN ORIGIN; PROVIDING AN INTERNET WEBSITE PORTAL FEATURING PROMOTION AND ADVERTISING FOR HOME SERVICE PROVIDERS AND PRODUCT MANUFACTURERS; PROVIDING AN ONLINE DIRECTORY INFORMATION SERVICE FEATURING INFORMATION REGARDING VEHICLES IN THE NATURE OF CLASSIFIED ADVERTISEMENTS; PROVIDING AND RENTAL OF ADVERTISING SPACE ON THE INTERNET; PROVIDING ON-LINE BUSINESS INFORMATION OF OTHERS, NAMELY, ADVERTISEMENTS OR SOLICITATIONS; PROVIDING SPACE AT A WEB SITE FOR THE ADVERTISEMENT OF THE GOODS AND SERVICES OF

CLASS 35—(Continued).

OTHERS; PROVIDING TELEVISION ADVERTISING FOR OTHERS; PROVISION OF ADVERTISING SPACE BY ELECTRONIC MEANS AND GLOBAL INFORMATION NETWORKS; PROVISION OF SPACE ON WEBSITES FOR ADVERTISING GOODS AND SERVICES; PUBLIC RELATIONS, ADVERTISING AND MARKETING SERVICES FOR THE TOURISM AND CONVENTION INDUSTRY, NAMELY, ORGANIZING AND HOSTING SITE INSPECTIONS AND FAMILIARIZATION TOURS FOR WHOLESALERS, TOUR OPERATORS, TRAVEL AGENTS, MEETING AND INCENTIVE TRAVEL PLANNERS AND TRAVEL MEDIA; PUBLISHING OF ADVERTISING TEXTS; REAL ESTATE ADVERTISING SERVICES; RECRUITMENT ADVERTISEMENT SERVICES, NAMELY, POSTING OF CLINICAL TRIAL NOTICES FOR THE PURPOSE OF RECRUITING PATIENTS FOR PARTICIPATION IN CLINICAL TRIALS FOR THE TESTING OF DRUGS; RENTAL OF ADVERTISEMENT SPACE AND ADVERTISING MATERIAL; RENTAL OF ADVERTISING SPACE; RENTAL OF ADVERTISING SPACE ON WEB SITES; RENTAL OF SIGNS FOR ADVERTISING PURPOSES; RENTING OF ADVERTISING SPACES; SERVICES OF ADVERTISING AGENCIES; SERVICES TO DETERMINE THE AUDIENCE AFFECTED BY ADVERTISEMENTS; SPECIAL EVENT PLANNING FOR COMMERCIAL, PROMOTIONAL OR ADVERTISING PURPOSES; SPECIALTY MERCHANDISING SERVICES, NAMELY, PROMOTING THE GOODS AND SERVICES OF OTHERS THROUGH THE DISTRIBUTION OF CUSTOMIZED ADVERTISING MATERIALS, NAMELY, PENS AND CATALOGS; TELEVISION ADVERTISING AGENCIES; VENDOR-ON-PREMISE SERVICES, NAMELY, THE ADMINISTRATION OF THE EMPLOYMENT PROCESS ON-SITE, INCLUDING RESUME REVIEW AND CHECKING, EMPLOYMENT APPLICATION ACQUISITION, ADVERTISING FOR RECRUITMENT, CONDUCT OF INTERVIEWS, AND REFERENCE CHECKING (U.S. CLS. 100, 101 AND 102).
FIRST USE 8-20-2011; IN COMMERCE 2-24-2012.

4,155,119. AMIN LAW OFFICES, LTD., SCHAUMBURG, IL.
SN 85-248,935. PUB. 7-5-2011, FILED 2-22-2011.

YO CHILL

THE MARK CONSISTS OF STANDARD CHARACTERS WITHOUT CLAIM TO ANY PARTICULAR FONT, STYLE, SIZE, OR COLOR.
FOR SELF-SERVE YOGURT SHOP SERVICES (U.S. CLS. 100, 101 AND 102).
FIRST USE 1-1-2011; IN COMMERCE 4-9-2011.

4,155,132. PREMIER VALUE ALLIANCE, LLC, BOCA RATON, FL. SN 85-250,647. PUB. 7-5-2011, FILED 2-24-2011.

PREMIER VALUE ALLIANCE

THE MARK CONSISTS OF STANDARD CHARACTERS WITHOUT CLAIM TO ANY PARTICULAR FONT, STYLE, SIZE, OR COLOR.

CLASS 35—(Continued).

NO CLAIM IS MADE TO THE EXCLUSIVE RIGHT TO USE "ALLIANCE", APART FROM THE MARK AS SHOWN.

FOR BUYING GROUP AND PROCUREMENT SERVICES, NAMELY, PURCHASING PHARMACEUTICAL PRESCRIPTION PRODUCTS FOR PHARMACIES; PROVIDING INFORMATION PERTAINING TO PROCUREMENT, BUYING, SELLING AND TENDERING INFORMATION AND OPPORTUNITIES RELATING TO PHARMACY RELATED GOODS AND SERVICES VIA COMPUTER, COMPUTER NETWORKS, TELEPHONE, THE INTERNET OR ELECTRONIC MAIL (U.S. CLS. 100, 101 AND 102).
FIRST USE 2-28-2011; IN COMMERCE 2-28-2011.

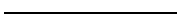

4,155,140. BENCHMARK SOLUTIONS HOLDINGS INC., NEW YORK, NY. SN 85-251,146. PUB. 7-19-2011, FILED 2-24-2011.

PRICE INSPECTOR

THE MARK CONSISTS OF STANDARD CHARACTERS WITHOUT CLAIM TO ANY PARTICULAR FONT, STYLE, SIZE, OR COLOR.

NO CLAIM IS MADE TO THE EXCLUSIVE RIGHT TO USE "PRICE", APART FROM THE MARK AS SHOWN.

FOR FINANCIAL SERVICES, NAMELY, ANALYZING MARKET DATA AND PRICING ANALYTICS SERVICES FOR MEASURING THE PERFORMANCE OF FINANCIAL MARKETS FOR ASSET CLASSES WITHIN THE CAPITAL MARKETS, INCLUDING FIXED INCOME PRODUCTS (U.S. CLS. 100, 101 AND 102).
FIRST USE 7-18-2011; IN COMMERCE 7-18-2011.



4,155,142. BENCHMARK SOLUTIONS HOLDINGS INC., NEW YORK, NY. SN 85-251,152. PUB. 8-9-2011, FILED 2-24-2011.

BMARK ATTRIBUTION

THE MARK CONSISTS OF STANDARD CHARACTERS WITHOUT CLAIM TO ANY PARTICULAR FONT, STYLE, SIZE, OR COLOR.

FOR FINANCIAL SERVICES, NAMELY, ANALYZING MARKET DATA AND PRICING ANALYTICS SERVICES FOR MEASURING THE PERFORMANCE OF FINANCIAL MARKETS FOR ASSET CLASSES WITHIN THE CAPITAL MARKETS, INCLUDING FIXED INCOME PRODUCTS (U.S. CLS. 100, 101 AND 102).
FIRST USE 7-18-2011; IN COMMERCE 7-18-2011.

CLASS 35—(Continued).

4,155,143. BENCHMARK SOLUTIONS HOLDINGS INC., NEW YORK, NY. SN 85-251,157. PUB. 7-19-2011, FILED 2-24-2011.

BMARK

THE MARK CONSISTS OF STANDARD CHARACTERS WITHOUT CLAIM TO ANY PARTICULAR FONT, STYLE, SIZE, OR COLOR.

FOR FINANCIAL SERVICES, NAMELY, ANALYZING MARKET DATA AND PRICING ANALYTICS SERVICES FOR MEASURING THE PERFORMANCE OF FINANCIAL MARKETS FOR ASSET CLASSES WITHIN THE CAPITAL MARKETS, INCLUDING FIXED INCOME PRODUCTS (U.S. CLS. 100, 101 AND 102).
FIRST USE 7-18-2011; IN COMMERCE 7-18-2011.

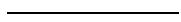

4,155,157. WEEKS, RHONDA H., DBA SPHERE CONTROL, BATON ROUGE, LA. SN 85-252,455. PUB. 7-5-2011, FILED 2-25-2011.

Sphere Control

THE MARK CONSISTS OF STANDARD CHARACTERS WITHOUT CLAIM TO ANY PARTICULAR FONT, STYLE, SIZE, OR COLOR.

FOR ADVERTISING AND MARKETING SERVICES PROVIDED BY MEANS OF INDIRECT METHODS OF MARKETING COMMUNICATIONS, NAMELY, SOCIAL MEDIA, SEARCH ENGINE MARKETING, INQUIRY MARKETING, INTERNET MARKETING, MOBILE MARKETING, BLOGGING AND OTHER FORMS OF PASSIVE, SHARABLE OR VIRAL COMMUNICATIONS CHANNELS (U.S. CLS. 100, 101 AND 102).
FIRST USE 5-1-2011; IN COMMERCE 5-15-2011.

CLASS 35—(Continued).

4,155,165. FORT WORTH PROMOTIONAL AND DEVELOPMENT FUND, FORT WORTH, TX. SN 85-253,268. PUB. 7-5-2011, FILED 2-28-2011.



THE MARK CONSISTS OF AN IMAGE OF A FOOTBALL WITH STYLIZED LONGHORN STEER HORNS ON EACH SIDE OF THE FOOTBALL.

FOR PROMOTING THE ECONOMIC DEVELOPMENT OF THE CITY OF FORT WORTH THROUGH TOURISM, CULTURE AND SPECIAL EVENTS (U.S. CLS. 100, 101 AND 102).

FIRST USE 7-21-2010; IN COMMERCE 7-21-2010.

4,155,169. SUGAR PUBLISHING INCORPORATED, SAN FRANCISCO, CA. SN 85-253,534. PUB. 8-16-2011, FILED 2-28-2011.

POPSUGAR CITY

THE MARK CONSISTS OF STANDARD CHARACTERS WITHOUT CLAIM TO ANY PARTICULAR FONT, STYLE, SIZE, OR COLOR.

OWNER OF U.S. REG. NO. 3,334,918.

FOR PROMOTING THE SALE OF GOODS AND SERVICES OF OTHERS THROUGH ELECTRONIC COUPONING, PROMOTIONS AND DISCOUNTS; PROVIDING A SEARCHABLE ON-LINE ADVERTISING WEBSITE AND GUIDE FEATURING THE GOODS AND SERVICES OF OTHERS VIA EMAIL AND THE INTERNET; PROMOTING THE GOODS AND SERVICES OF OTHERS BY PROVIDING A WEBSITE FEATURING COUPONS, REBATES, REVIEWS, LINKS TO THE RETAIL WEBSITES OF OTHERS, AND DISCOUNT INFORMATION (U.S. CLS. 100, 101 AND 102).

FIRST USE 3-3-2011; IN COMMERCE 3-3-2011.

CLASS 35—(Continued).

4,155,188. ASLAN GLOBAL MANAGEMENT, LLC, NAPLES, FL. SN 85-254,872. PUB. 8-30-2011, FILED 3-1-2011.

Aslan Global Management

THE MARK CONSISTS OF STANDARD CHARACTERS WITHOUT CLAIM TO ANY PARTICULAR FONT, STYLE, SIZE, OR COLOR.

NO CLAIM IS MADE TO THE EXCLUSIVE RIGHT TO USE "GLOBAL MANAGEMENT", APART FROM THE MARK AS SHOWN.

THE ENGLISH TRANSLATION OF "ASLAN" IN THE MARK IS "LION".

FOR BUSINESS CONSULTING SERVICES IN THE AGRICULTURAL FIELD; BUSINESS CONSULTING, MANAGEMENT, PLANNING AND SUPERVISION; MANAGEMENT AND BUSINESS CONSULTING SERVICES IN THE FIELD OF BUSINESS AND AGRICULTURAL ENTERPRISES THAT PROMOTE ECONOMIC, SOCIAL AND SPIRITUAL DEVELOPMENT IN THE THIRD WORLD (U.S. CLS. 100, 101 AND 102).

FIRST USE 8-1-2011; IN COMMERCE 8-1-2011.

4,155,199. STREETCARSHOPS.COM, LLC, PRAIRIEVILLE, LA. SN 85-255,949. PUB. 7-19-2011, FILED 3-2-2011.

REWARDS FOR LIVING LOCALLY

THE MARK CONSISTS OF STANDARD CHARACTERS WITHOUT CLAIM TO ANY PARTICULAR FONT, STYLE, SIZE, OR COLOR.

FOR ADVERTISING AND MARKETING SERVICES, NAMELY, PROMOTING THE GOODS AND SERVICES OF OTHERS (U.S. CLS. 100, 101 AND 102).

FIRST USE 5-26-2010; IN COMMERCE 5-26-2010.

4,155,200. ARTAZAAR, LLC, STOCKTON, CA. SN 85-256,259. PUB. 8-2-2011, FILED 3-2-2011.

Artazaar

THE MARK CONSISTS OF STANDARD CHARACTERS WITHOUT CLAIM TO ANY PARTICULAR FONT, STYLE, SIZE, OR COLOR.

FOR ONLINE RETAIL STORE SERVICES FEATURING MUSICAL SOUND RECORDINGS AND ART; ONLINE AUCTION SERVICES; MARKETING SERVICES, NAMELY, PROMOTING THE GOODS AND SERVICES OF OTHERS (U.S. CLS. 100, 101 AND 102).

FIRST USE 3-26-2012; IN COMMERCE 3-26-2012.

CLASS 35—(Continued).

4,155,220. WP COMPANY LLC, WASHINGTON, DC. SN 85-258,403. PUB. 8-2-2011, FILED 3-4-2011.

THE CAPITOL DEAL

THE MARK CONSISTS OF STANDARD CHARACTERS WITHOUT CLAIM TO ANY PARTICULAR FONT, STYLE, SIZE, OR COLOR.

OWNER OF U.S. REG. NOS. 3,966,507 AND 3,970,502.

NO CLAIM IS MADE TO THE EXCLUSIVE RIGHT TO USE "DEAL", APART FROM THE MARK AS SHOWN.

FOR PROMOTING THE GOODS AND SERVICES OF OTHERS VIA THE INTERNET AND OTHER ELECTRONIC COMMUNICATIONS NETWORKS BY FEATURING DAILY COUPONS, DISCOUNTS, DEAL OF THE DAY OFFERS, DINING EVENTS AND/OR SPECIAL EVENTS (U.S. CLS. 100, 101 AND 102).

FIRST USE 3-8-2010; IN COMMERCE 3-8-2010.

4,155,230. GIOVACCHINI, CINDY L., GROVER BEACH, CA. SN 85-259,977. PUB. 8-2-2011, FILED 3-7-2011.

Rock The Vine

THE MARK CONSISTS OF STANDARD CHARACTERS WITHOUT CLAIM TO ANY PARTICULAR FONT, STYLE, SIZE, OR COLOR.

FOR ADVERTISING, INCLUDING PROMOTION OF PRODUCTS AND SERVICES OF THIRD PARTIES THROUGH SPONSORING ARRANGEMENTS AND LICENSE AGREEMENTS RELATING TO INTERNATIONAL SPORTS EVENTS; BUSINESS MANAGEMENT CONSULTANCY IN THE FIELD OF INSOURCING, NAMELY, ASSISTING BUSINESSES IN THE DEVELOPMENT OF PROCESSES FOR THE ANALYSIS AND THE IMPLEMENTATION OF THE DELEGATION OF OPERATIONS OR JOBS FROM PRODUCTION WITHIN A BUSINESS TO AN INTERNAL ENTITY THAT SPECIALIZES IN THAT OPERATION; HUMAN RESOURCES SERVICES IN THE FIELD OF EDUCATION, NAMELY, RECRUITING AND PLACING TEACHERS AT INTERNATIONAL SCHOOLS; INTERNATIONAL BUSINESS CONSULTING SERVICES RELATING TO MERCHANDISE TRADING, HUMAN RESOURCE INTERCHANGE, MANAGEMENT SUPPORT, MARKETING, ADVERTISING, PROMOTION, AND DOMESTIC AND INTERNATIONAL MARKET RESEARCH AND DEVELOPMENT; LOBBYING SERVICES, NAMELY, PROMOTING THE INTERESTS OF INTERNATIONAL, REAL ESTATE AND NONPROFIT COMPANIES IN THE FIELDS OF POLITICS, LEGISLATION, AND REGULATION; MAIL SERVICES, NAMELY, RECEIVING AND PROCESSING INTERNATIONAL AND DOMESTIC MAIL FOR INFUSION INTO ESTABLISHED POSTAL SERVICES; PROVIDING AN INTERNET WEBSITE FEATURING NEWS AND INFORMATION IN THE FIELD OF NATIONAL AND INTERNATIONAL POLITICS (U.S. CLS. 100, 101 AND 102).

FIRST USE 1-1-2012; IN COMMERCE 3-13-2012.

CLASS 35—(Continued).

4,155,239. BEYOND MEDICINE, LLC, THOMASVILLE, GA. SN 85-260,676. PUB. 8-2-2011, FILED 3-8-2011.



THE MARK CONSISTS OF HALF OF A SCALES OF JUSTICE COMBINED WITH HALF A CADUCEUS.

FOR LAWYER REFERRAL SERVICES, NAMELY, PROVIDING DOCTORS NAMES OF LAWYERS SKILLED IN EMPLOYMENT LAW (U.S. CLS. 100, 101 AND 102).

FIRST USE 3-5-2012; IN COMMERCE 3-5-2012.

4,155,261. LANCASTER, JANET, DBA SAVE THE PLANET JANET, SAN DIEGO, CA. SN 85-262,717. PUB. 7-26-2011, FILED 3-9-2011.

EARTH'S LIVING

THE MARK CONSISTS OF STANDARD CHARACTERS WITHOUT CLAIM TO ANY PARTICULAR FONT, STYLE, SIZE, OR COLOR.

FOR ON-LINE RETAIL STORE SERVICES FEATURING POWDERED DRINKING CLAY FOR INTERNAL USE; POWDERED CLAY FOR USE AS A SUPPLEMENT; POWDERED CLAY FOR USE IN BATHS, POWDERED CLAY FOR USE AS POUltICES AND FACE MASKS; POWDERED CLAY BASED BODY LOTION; BODY AND FACE CREAM; BODY SOAP; SKIN CARE PRODUCTS, NAMELY, CLEANSERS, EXFOLIANTS, EYE TREATMENTS, TREATMENT MASKS, CREAMS, OILS, SOAPS, MOISTURIZERS, HAIR CARE PRODUCTS; BODY PRODUCTS, NAMELY, BATH SALTS, BODY LOTION, FOOT CREAM; CLAY BASED PET PRODUCTS, NAMELY, HOT SPOT HEALER; FLEA POWDER; ON-LINE WHOLESALE AND RETAIL STORE SERVICES FEATURING POWDERED DRINKING CLAY FOR INTERNAL USE; POWDERED CLAY FOR USE AS A SUPPLEMENT; POWDERED CLAY FOR USE IN BATHS, POWDERED CLAY FOR USE AS POUltICES AND FACE MASKS; POWDERED CLAY BASED BODY LOTION; BODY AND FACE CREAM; BODY SOAP; SKIN CARE PRODUCTS, NAMELY, CLEANSERS, EXFOLIANTS, EYE TREATMENTS, TREATMENT MASKS, CREAMS, OILS, SOAPS, MOISTURIZERS, HAIR CARE PRODUCTS; BODY PRODUCTS, NAMELY, BATH SALTS, BODY LOTION, FOOT CREAM; CLAY BASED PET PRODUCTS, NAMELY, HOT SPOT HEALER; FLEA POWDER (U.S. CLS. 100, 101 AND 102).

FIRST USE 3-19-2012; IN COMMERCE 3-19-2012.

CLASS 35—(Continued).

4,155,265. VILLAGE FARMS L.P., EATONTOWN, NJ. SN 85-263,050. PUB. 7-26-2011, FILED 3-10-2011.

CMAP

THE MARK CONSISTS OF STANDARD CHARACTERS WITHOUT CLAIM TO ANY PARTICULAR FONT, STYLE, SIZE, OR COLOR.

FOR BUSINESS CONSULTING SERVICES RELATING TO MONITORING, CONTROLLING AND MANAGING GREENHOUSE ENVIRONMENTS OF OTHERS (U.S. CLS. 100, 101 AND 102).

FIRST USE 2-6-2012; IN COMMERCE 2-6-2012.

4,155,280. WHITELINE MARKETING, INC., DBA TACK-IT, GRAND HAVEN, MI. SN 85-265,294. PUB. 7-26-2011, FILED 3-11-2011.

Post & Print

THE MARK CONSISTS OF STANDARD CHARACTERS WITHOUT CLAIM TO ANY PARTICULAR FONT, STYLE, SIZE, OR COLOR.

FOR PROVIDING A WEB SITE WHERE USERS CAN POST ITEMS FOR SALE THROUGH ON-LINE CLASSIFIED ADVERTISEMENTS (U.S. CLS. 100, 101 AND 102).

FIRST USE 7-2-2011; IN COMMERCE 7-2-2011.

4,155,286. SACRAMENTO MUNICIPAL UTILITY DISTRICT, AKA SMUD, SACRAMENTO, CA. SN 85-265,958. PUB. 7-26-2011, FILED 3-14-2011.

SMUD Clear Terms

THE MARK CONSISTS OF STANDARD CHARACTERS WITHOUT CLAIM TO ANY PARTICULAR FONT, STYLE, SIZE, OR COLOR.

FOR PROVIDING CONSUMER INFORMATION IN THE FIELD OF PUBLIC UTILITY SERVICES IN THE NATURE OF ELECTRICITY DISTRIBUTION (U.S. CLS. 100, 101 AND 102).

FIRST USE 4-7-2011; IN COMMERCE 4-7-2011.

CLASS 35—(Continued).

4,155,315. DRAKE-MCLAUGHLIN, MIGUEL, BROOKLYN, NY. AND SELKOWITZ, ADRIAN A, HARRISBURG, PA. SN 85-268,629. PUB. 8-2-2011, FILED 3-16-2011.

Cowboy Bear Ninja

THE MARK CONSISTS OF STANDARD CHARACTERS WITHOUT CLAIM TO ANY PARTICULAR FONT, STYLE, SIZE, OR COLOR.

FOR ADVERTISING AND PUBLICITY SERVICES, NAMELY, PROMOTING THE GOODS, SERVICES, BRAND IDENTITY AND COMMERCIAL INFORMATION AND NEWS OF THIRD PARTIES THROUGH PRINT, AUDIO, VIDEO, DIGITAL AND ON-LINE MEDIUM; POST-PRODUCTION EDITING SERVICES FOR VIDEO AND AUDIO COMMERCIALS; PREPARING ADVERTISEMENTS FOR OTHERS, NAMELY, PREPARING VIDEO ADVERTISING AND PROMOTIONAL VIDEOS FOR COMMERCIAL USE VIA THE INTERNET AND TELEVISION, DIGITAL CABLE AND VIDEO-ON-DEMAND OR DOWNLOAD; PRODUCING AUDIO OR VIDEO INFOMERCIALS; PRODUCING PROMOTIONAL VIDEOTAPES, VIDEO DISCS, AND AUDIO VISUAL RECORDINGS; PROVIDING A WEB SITE FEATURING BUSINESS INFORMATION IN THE FORM OF AUDIO AND VIDEO INTERVIEWS, TRANSCRIPTS AND OTHER EDUCATIONAL MATERIALS (U.S. CLS. 100, 101 AND 102).

FIRST USE 5-24-2006; IN COMMERCE 1-1-2011.

4,155,335. WILD OWL, VALERIE, HOPEDALE, MA. SN 85-271,361. PUB. 8-16-2011, FILED 3-18-2011.

Turquoise Witch Metaphysical

THE MARK CONSISTS OF STANDARD CHARACTERS WITHOUT CLAIM TO ANY PARTICULAR FONT, STYLE, SIZE, OR COLOR.

NO CLAIM IS MADE TO THE EXCLUSIVE RIGHT TO USE "METAPHYSICAL", APART FROM THE MARK AS SHOWN.

FOR RETAIL STORE SERVICES FEATURING METAPHYSICAL PRODUCTS (U.S. CLS. 100, 101 AND 102).

FIRST USE 9-10-2011; IN COMMERCE 9-10-2011.

CLASS 35—(Continued).

4,155,358. NEWSOM, LINDA J., OKLAHOMA CITY, OK. SN 85-276,134. PUB. 8-9-2011, FILED 3-24-2011.

PAYMATE

THE MARK CONSISTS OF STANDARD CHARACTERS WITHOUT CLAIM TO ANY PARTICULAR FONT, STYLE, SIZE, OR COLOR.

FOR ADMINISTRATION OF BUSINESS PAYROLL FOR OTHERS; PAYROLL ADMINISTRATION AND MANAGEMENT SERVICES; PAYROLL PREPARATION; PAYROLL PROCESSING SERVICES; WAGE PAYROLL PREPARATION; PAYROLL TAX DEBITING SERVICES; PROFESSIONAL EMPLOYER ORGANIZATION SERVICES IN THE NATURE OF EMPLOYEE LEASING; EMPLOYEE LEASING (U.S. CLS. 100, 101 AND 102).

FIRST USE 1-1-2012; IN COMMERCE 1-1-2012.

CLASS 35—(Continued).

4,155,376. WORLD TRADE VALLEY, INC, MIAMI, FL. SN 85-279,094. PUB. 8-9-2011, FILED 3-28-2011.

ESTANZAS

THE MARK CONSISTS OF STANDARD CHARACTERS WITHOUT CLAIM TO ANY PARTICULAR FONT, STYLE, SIZE, OR COLOR.

THE WORDING "ESTANZAS" HAS NO MEANING IN A FOREIGN LANGUAGE.

FOR PROVIDING A SEARCHABLE ONLINE ADVERTISING WEBSITE AND INFORMATIONAL GUIDE FEATURING THE GOODS AND SERVICES OF OTHER VENDORS VIA THE INTERNET IN THE FIELD OF HOTELS (U.S. CLS. 100, 101 AND 102).

FIRST USE 4-1-2012; IN COMMERCE 4-1-2012.

4,155,366. SZYMANSKI, ERIK, CANONSBURG, PA. SN 85-277,817. PUB. 8-9-2011, FILED 3-26-2011.

Amporium

THE MARK CONSISTS OF STANDARD CHARACTERS WITHOUT CLAIM TO ANY PARTICULAR FONT, STYLE, SIZE, OR COLOR.

FOR PROVIDING ON-LINE DIRECTORY INFORMATION SERVICES ALSO FEATURING HYPERLINKS TO OTHER WEB SITES (U.S. CLS. 100, 101 AND 102).

FIRST USE 11-15-2011; IN COMMERCE 3-6-2012.

4,155,384. CITY OF POMPANO BEACH FLORIDA, POMPANO BEACH, FL. SN 85-279,951. PUB. 11-1-2011, FILED 3-29-2011.

FLORIDA'S WARMEST WELCOME

THE MARK CONSISTS OF STANDARD CHARACTERS WITHOUT CLAIM TO ANY PARTICULAR FONT, STYLE, SIZE, OR COLOR.

NO CLAIM IS MADE TO THE EXCLUSIVE RIGHT TO USE "FLORIDA'S", APART FROM THE MARK AS SHOWN.

FOR BUSINESS MARKETING SERVICES, NAMELY, PROMOTING THE ECONOMIC DEVELOPMENT AND TOURISM IN THE CITY OF POMPANO BEACH, FLORIDA (U.S. CLS. 100, 101 AND 102).

FIRST USE 3-29-2011; IN COMMERCE 3-29-2011.

4,155,371. LOS ANGELES POLICE PROTECTIVE LEAGUE, LOS ANGELES, CA. SN 85-278,413. PUB. 9-6-2011, FILED 3-28-2011.



NO CLAIM IS MADE TO THE EXCLUSIVE RIGHT TO USE "PUBLIC SAFETY", APART FROM THE MARK AS SHOWN.

THE MARK CONSISTS OF THE WORDS "PUBLIC SAFETY" ABOVE THE WORD "FIRST" WITH THE PROFILE OF A POLICE OFFICER AND TWO CITIZENS WITHIN THE BOUNDARIES OF A RECTANGULAR BOX.

FOR PROMOTING PUBLIC AWARENESS OF THE IMPORTANCE OF PUBLIC SAFETY AND CRIME PREVENTION (U.S. CLS. 100, 101 AND 102).

FIRST USE 2-17-2011; IN COMMERCE 2-17-2011.

4,155,396. INTERNATIONAL SECURITIES EXCHANGE, LLC, NEW YORK, NY. SN 85-282,390. PUB. 8-9-2011, FILED 3-31-2011.

Black Swan

THE MARK CONSISTS OF STANDARD CHARACTERS WITHOUT CLAIM TO ANY PARTICULAR FONT, STYLE, SIZE, OR COLOR.

FOR COMPILING FINANCIAL, SECURITIES, STOCK EXCHANGE, TRADE AND QUOTE, INDEX VALUE AND OTHER FINANCIAL MARKET INFORMATION FOR BUSINESS PURPOSES (U.S. CLS. 100, 101 AND 102).

FIRST USE 2-27-2012; IN COMMERCE 2-27-2012.

CLASS 35—(Continued).

4,155,397. INTERNATIONAL SECURITIES EXCHANGE, LLC, NEW YORK, NY. SN 85-282,403. PUB. 8-9-2011, FILED 3-31-2011.

ISE Black Swan

THE MARK CONSISTS OF STANDARD CHARACTERS WITHOUT CLAIM TO ANY PARTICULAR FONT, STYLE, SIZE, OR COLOR.

FOR COMPILING FINANCIAL, SECURITIES, STOCK EXCHANGE, TRADE AND QUOTE, INDEX VALUE AND OTHER FINANCIAL MARKET INFORMATION FOR BUSINESS PURPOSES (U.S. CLS. 100, 101 AND 102).
FIRST USE 2-27-2012; IN COMMERCE 2-27-2012.

4,155,402. GREEN STREET DEVELOPMENT, LLC, SCOTTS-DALE, AZ. SN 85-283,037. PUB. 8-30-2011, FILED 3-31-2011.

G BUILD

THE MARK CONSISTS OF STANDARD CHARACTERS WITHOUT CLAIM TO ANY PARTICULAR FONT, STYLE, SIZE, OR COLOR.

NO CLAIM IS MADE TO THE EXCLUSIVE RIGHT TO USE "BUILD", APART FROM THE MARK AS SHOWN.

FOR CONSULTATION IN THE FIELD OF ENERGY EFFICIENCY RELATED TO CONSTRUCTION FOR IMPROVING THE ENERGY EFFICIENCY OF EXISTING RESIDENTIAL BUILDINGS (U.S. CLS. 100, 101 AND 102).

FIRST USE 1-31-2011; IN COMMERCE 1-31-2011.

4,155,404. GREEN STREET DEVELOPMENT, LLC, SCOTTS-DALE, AZ. SN 85-283,089. PUB. 8-30-2011, FILED 3-31-2011.

G HOME

THE MARK CONSISTS OF STANDARD CHARACTERS WITHOUT CLAIM TO ANY PARTICULAR FONT, STYLE, SIZE, OR COLOR.

NO CLAIM IS MADE TO THE EXCLUSIVE RIGHT TO USE "HOME", APART FROM THE MARK AS SHOWN.

FOR CONSULTATION IN THE FIELD OF ENERGY EFFICIENCY RELATED TO CONSTRUCTION FOR IMPROVING THE ENERGY EFFICIENCY OF EXISTING RESIDENTIAL BUILDINGS (U.S. CLS. 100, 101 AND 102).

FIRST USE 1-31-2011; IN COMMERCE 1-31-2011.

CLASS 35—(Continued).

4,155,415. CDOC, INC., CARMEL, IN. SN 85-283,920. PUB. 7-26-2011, FILED 4-1-2011.

WNEZAPPOINT

THE MARK CONSISTS OF STANDARD CHARACTERS WITHOUT CLAIM TO ANY PARTICULAR FONT, STYLE, SIZE, OR COLOR.

OWNER OF U.S. REG. NOS. 3,263,912, 3,263,914, AND OTHERS.

FOR BUSINESS SERVICES, NAMELY, PROVIDING ONLINE, NON-DOWNLOADABLE PUBLICATIONS IN THE NATURE OF AN INTERVIEW TEMPLATE FOR USE IN ENTERING INTO CONTRACTUAL RELATIONSHIPS WITH INSURANCE COMPANIES (U.S. CLS. 100, 101 AND 102).

FIRST USE 9-1-2011; IN COMMERCE 9-1-2011.

4,155,416. CDOC, INC., CARMEL, IN. SN 85-283,947. PUB. 7-26-2011, FILED 4-1-2011.

WNEZLEAD

THE MARK CONSISTS OF STANDARD CHARACTERS WITHOUT CLAIM TO ANY PARTICULAR FONT, STYLE, SIZE, OR COLOR.

OWNER OF U.S. REG. NOS. 3,263,912, 3,263,914, AND OTHERS.

FOR ADVERTISING AND BUSINESS SERVICES, NAMELY, GENERATION OF INSURANCE SALES MATERIALS FOR USE WITH PROSPECTIVE CLIENTS (U.S. CLS. 100, 101 AND 102).

FIRST USE 9-1-2011; IN COMMERCE 9-1-2011.

CLASS 35—(Continued).

4,155,424. DAMIAN ROSS, DBA GLOBOOGIE, IRVING, TX. SN 85-284,576. PUB. 12-13-2011, FILED 4-2-2011.



THE COLOR(S) BLUE, BLACK AND WHITE IS/ARE CLAIMED AS A FEATURE OF THE MARK.

THE MARK CONSISTS OF THE WORD "GLOBOOGIE" IN WHITE, WRITTEN ACROSS A PICTURE OF A BLUE EARTH WITH BLACK CONTINENTS, CENTERED ON A BLACK SQUARE BACKGROUND.

FOR PROVIDING A SEARCHABLE ONLINE ADVERTISING WEBSITE AND INFORMATIONAL GUIDE FEATURING THE GOODS AND SERVICES OF OTHER VENDORS VIA THE INTERNET IN THE FIELD OF ENTERTAINMENT AND EVENT LISTINGS (U.S. CLS. 100, 101 AND 102).

FIRST USE 1-2-2012; IN COMMERCE 1-2-2012.

4,155,452. KATE SPADE LLC, NEW YORK, NY. SN 85-290,010. PUB. 8-9-2011, FILED 4-8-2011.



OWNER OF U.S. REG. NOS. 3,092,920, 3,271,494, AND OTHERS.

NO CLAIM IS MADE TO THE EXCLUSIVE RIGHT TO USE "NEW YORK", APART FROM THE MARK AS SHOWN.

THE NAME "KATE SPADE" IDENTIFIES A LIVING INDIVIDUAL WHOSE CONSENT IS OF RECORD.

THE MARK CONSISTS OF A SPADE DESIGN WITH THE WORDS "KATE SPADE NEW YORK" UNDERNEATH.

FOR RETAIL STORE AND ON-LINE RETAIL STORE SERVICES FEATURING APPAREL, FASHION ACCESSORIES, HANDBAGS, JEWELRY, LEATHER GOODS, EYEWEAR, FOOTWEAR, FRAGRANCE AND COSMETICS, AND HOME PRODUCTS (U.S. CLS. 100, 101 AND 102).

FIRST USE 1-2-2011; IN COMMERCE 1-2-2011.

CLASS 35—(Continued).

4,155,459. URBAN BASEBALL FOUNDATION, DBA UBF, WASHINGTON, DC. SN 85-293,221. PUB. 1-10-2012, FILED 4-12-2011.



NO CLAIM IS MADE TO THE EXCLUSIVE RIGHT TO USE "URBAN BASEBALL FOUNDATION" AND THE PICTORIAL MAP OF THE DISTRICT OF COLUMBIA AND "A 501(C)3 DEDICATED TO SUPPORTING INNER-CITY YOUTH BASEBALL", APART FROM THE MARK AS SHOWN.

THE COLOR(S) RED, WHITE, AND BLUE IS/ARE CLAIMED AS A FEATURE OF THE MARK.

THE MARK CONSISTS OF A WHITE MAP OF THE DISTRICT OF COLUMBIA WITH TWO RED BASEBALL THREADS AND SUPERIMPOSED THEREUPON IS "UBF" IN BLUE LETTERING, TO THE RIGHT OF WHICH APPEARS THE WORDING "URBAN BASEBALL FOUNDATION" IN WHITE LETTERING AND BELOW WHICH APPEARS THE WORDING "A 501(C)3 DEDICATED TO SUPPORTING INNER-CITY YOUTH BASEBALL", WHICH APPEARS IN WHITE LETTERING, ALL OF WHICH IS SUPERIMPOSED UPON A BLUE BACKGROUND.

FOR PROMOTING THE INTERESTS OF PEOPLE INVOLVED AND CONCERNED WITH YOUTH SPORTS (U.S. CLS. 100, 101 AND 102).

FIRST USE 1-1-2012; IN COMMERCE 1-1-2012.

4,155,474. PINNACLE ENTERTAINMENT, INC., LAS VEGAS, NV. SN 85-296,810. PUB. 8-30-2011, FILED 4-15-2011.

MYCASH

THE MARK CONSISTS OF STANDARD CHARACTERS WITHOUT CLAIM TO ANY PARTICULAR FONT, STYLE, SIZE, OR COLOR.

FOR CUSTOMER LOYALTY SERVICES, NAMELY, CUSTOMER LOYALTY PROGRAMS FEATURING LOYALTY POINTS THAT PROVIDE CASINO, HOTEL, RETAIL, AND RESTAURANT BENEFITS TO REWARD REPEAT CUSTOMERS (U.S. CLS. 100, 101 AND 102).

FIRST USE 4-1-2011; IN COMMERCE 4-1-2011.

CLASS 35—(Continued).

4,155,476. FASTENAL IP COMPANY, WINONA, MN. SN 85-298,010. PUB. 8-9-2011, FILED 4-18-2011.

THE BLUE TEAM

THE MARK CONSISTS OF STANDARD CHARACTERS WITHOUT CLAIM TO ANY PARTICULAR FONT, STYLE, SIZE, OR COLOR.

FOR WHOLESALE DISTRIBUTORSHIP AND WHOLESALE OUTLET STORES FEATURING FASTENERS, ELECTRICAL TOOLS AND WIRING, GLOVES, PROTECTIVE EYEWEAR, FIRST AID PRODUCTS, BUILDING CONSTRUCTION TOOLS AND EQUIPMENT USED FOR PLUMBING PURPOSES, JANITORIAL EQUIPMENT AND SUPPLIES USED FOR INDUSTRIAL, INSTITUTIONAL AND COMMERCIAL PURPOSES; BUSINESS MANAGEMENT CONSULTING SERVICES IN THE BUILDING CONSTRUCTION TOOLS INDUSTRY; MOBILE VENDING SERVICES IN THE FIELDS OF MAINTENANCE, REPAIR AND OPERATION SUPPLIES AND OFFICE SUPPLIES (U.S. CLS. 100, 101 AND 102).
FIRST USE 8-24-2011; IN COMMERCE 8-24-2011.

4,155,492. REMAR, INC., LEBANON, TN. SN 85-300,824. PUB. 9-6-2011, FILED 4-21-2011.



THE MARK CONSISTS OF THE LETTER "R" WITHOUT THE STEM AND IN PLACE OF THE STEM AND OVAL IN THE CENTER OF THE "R" ARE THREE NARROWING SWOOSHES COMING TOGETHER IN THE FRONT CENTER OF THE "R".

FOR BUSINESS MARKETING AND DIRECT MAIL CONSULTING SERVICES; DIRECT MAIL ADVERTISING SERVICES; ORDER FULFILLMENT SERVICES; TRANSPORTATION LOGISTICS SERVICES, NAMELY, ARRANGING THE TRANSPORTATION OF GOODS FOR OTHERS (U.S. CLS. 100, 101 AND 102).
FIRST USE 7-1-2011; IN COMMERCE 7-1-2011.

CLASS 35—(Continued).

4,155,497. GAP (APPAREL), LLC, SAN FRANCISCO, CA. SN 85-304,189. PUB. 8-16-2011, FILED 4-25-2011.

BE WHAT'S POSSIBLE

THE MARK CONSISTS OF STANDARD CHARACTERS WITHOUT CLAIM TO ANY PARTICULAR FONT, STYLE, SIZE, OR COLOR.

FOR CHARITABLE SERVICES, NAMELY, ORGANIZING AND CONDUCTING VOLUNTEER PROGRAMS AND COMMUNITY SERVICE PROJECTS (U.S. CLS. 100, 101 AND 102).

FIRST USE 7-31-2006; IN COMMERCE 7-31-2006.

4,155,502. PIVOTSTONE GROUP, LLC, FAIRFAX, VA. SN 85-304,963. PUB. 9-13-2011, FILED 4-26-2011.

PIVOTSTONE

THE MARK CONSISTS OF STANDARD CHARACTERS WITHOUT CLAIM TO ANY PARTICULAR FONT, STYLE, SIZE, OR COLOR.

FOR BUSINESS MANAGEMENT CONSULTING (U.S. CLS. 100, 101 AND 102).

FIRST USE 3-16-2011; IN COMMERCE 3-16-2011.

4,155,504. BLUESTEM LEARNING, LLC, PRAIRIE VILLAGE, KS. SN 85-305,907. PUB. 10-4-2011, FILED 4-27-2011.

seq.innovation

THE MARK CONSISTS OF STANDARD CHARACTERS WITHOUT CLAIM TO ANY PARTICULAR FONT, STYLE, SIZE, OR COLOR.

FOR BUSINESS MANAGEMENT CONSULTING WITH RELATION TO STRATEGY FOR THIRD SECTOR ORGANIZATIONS, NAMELY, NOT-FOR PROFIT ORGANIZATIONS, AND FOURTH SECTOR ORGANIZATIONS, NAMELY, FOR PROFIT OR FOR BENEFIT ORGANIZATIONS (U.S. CLS. 100, 101 AND 102).

FIRST USE 3-2-2012; IN COMMERCE 3-2-2012.

CLASS 35—(Continued).

4,155,522. MARK C. SCAMMEL, CPA LLC, DALLAS, TX. SN 85-312,337. PUB. 9-20-2011, FILED 5-4-2011.



THE COLOR(S) GREEN AND GOLD IS/ARE CLAIMED AS A FEATURE OF THE MARK.

THE MARK CONSISTS OF A SHIELD DESIGN. THE SHIELD ELEMENTS ARE GREEN BACKGROUND; A GOLD BANNER IN THE TOP FIELD OF THE SHIELD WITH GREEN LETTERS "M", "C" AND "S" CENTERED; GOLD SYMBOLS EURO, DOLLAR AND YEN CENTERED IN THE CENTER FIELD OF THE SHIELD AND A GOLD SYMBOL POUND IN THE BOTTOM FIELD OF THE SHIELD; A GOLD HORIZONTAL STRIPE CONTAINING SEVEN GREEN CROSSES IN THE BOTTOM FIELD.

FOR ACCOUNTING SERVICES (U.S. CLS. 100, 101 AND 102).

FIRST USE 6-16-2011; IN COMMERCE 6-16-2011.



4,155,531. FIRST AMERICAN FINANCIAL CORPORATION, SANTA ANA, CA. SN 85-314,882. PUB. 9-27-2011, FILED 5-6-2011.



THE MARK CONSISTS OF A DEPICTION OF A COW. FOR PROMOTING THE GOODS AND SERVICES OF OTHERS BY PROVIDING A WEB SITE FEATURING A CUSTOMIZED DISCOUNT PROGRAM AND LINKS TO THE WEB SITES OF OTHERS WHO PARTICIPATE IN THE DISCOUNT PROGRAM (U.S. CLS. 100, 101 AND 102).

FIRST USE 12-5-2011; IN COMMERCE 12-5-2011.

CLASS 35—(Continued).

4,155,581. HONEYWELL INTERNATIONAL INC., MORRISTOWN, NJ. SN 85-334,123. PUB. 10-11-2011, FILED 5-31-2011.

OPUS ORCHESTRATOR

THE MARK CONSISTS OF STANDARD CHARACTERS WITHOUT CLAIM TO ANY PARTICULAR FONT, STYLE, SIZE, OR COLOR.

FOR PROVIDING AN INTERNET WEBSITE PORTAL TO VIEW ENERGY USAGE MANAGEMENT REPORTS (U.S. CLS. 100, 101 AND 102).

FIRST USE 10-16-2011; IN COMMERCE 10-16-2011.



4,155,632. AUTOZONE PARTS, INC., MEMPHIS, TN. SN 85-350,437. PUB. 11-1-2011, FILED 6-20-2011.

**PARTS ARE JUST PART OF
WHAT WE DO**

THE MARK CONSISTS OF STANDARD CHARACTERS WITHOUT CLAIM TO ANY PARTICULAR FONT, STYLE, SIZE, OR COLOR.

FOR RETAIL AUTO PARTS STORE SERVICES (U.S. CLS. 100, 101 AND 102).

FIRST USE 6-27-2011; IN COMMERCE 6-27-2011.



4,155,642. LEWIS, THOMAS, SAN ANTONIO, TX. SN 85-355,205. PUB. 11-15-2011, FILED 6-24-2011.

tradechex

THE MARK CONSISTS OF STANDARD CHARACTERS WITHOUT CLAIM TO ANY PARTICULAR FONT, STYLE, SIZE, OR COLOR.

FOR ISSUING GIFT CERTIFICATES WHICH MAY THEN BE REDEEMED FOR GOODS OR SERVICES (U.S. CLS. 100, 101 AND 102).

FIRST USE 6-12-2011; IN COMMERCE 6-12-2011.

CLASS 35—(Continued).

4,155,696. OREGON HEALTHCARE ENTERPRISES, INC., LAKE OSWEGO, OR. SN 85-368,078. PUB. 1-10-2012, FILED 7-11-2011.

APPRISE HEALTH INSIGHTS

THE MARK CONSISTS OF STANDARD CHARACTERS WITHOUT CLAIM TO ANY PARTICULAR FONT, STYLE, SIZE, OR COLOR.

NO CLAIM IS MADE TO THE EXCLUSIVE RIGHT TO USE "HEALTH", APART FROM THE MARK AS SHOWN.

FOR BUSINESS INFORMATION SERVICES, NAMELY, THE COLLECTION, REVIEW, ANALYSIS, EDITING, VERIFICATION AND REPORTING OF HOSPITAL FINANCIAL, UTILIZATION, AND QUALITY INFORMATION FOR BUSINESS PURPOSES (U.S. CLS. 100, 101 AND 102).

FIRST USE 9-29-2011; IN COMMERCE 9-29-2011.

4,155,698. COMPANY DATA TREES, INC., SAN DIEGO, CA. SN 85-368,285. PUB. 1-10-2012, FILED 7-11-2011.

Need Scoring

THE MARK CONSISTS OF STANDARD CHARACTERS WITHOUT CLAIM TO ANY PARTICULAR FONT, STYLE, SIZE, OR COLOR.

NO CLAIM IS MADE TO THE EXCLUSIVE RIGHT TO USE "SCORING", APART FROM THE MARK AS SHOWN.

FOR MARKETING CONSULTING (U.S. CLS. 100, 101 AND 102).

FIRST USE 7-1-2011; IN COMMERCE 10-10-2011.

CLASS 35—(Continued).

4,155,699. DANIEL HARI VASWANI, UNION CITY, CA. SN 85-368,324. PUB. 1-3-2012, FILED 7-11-2011.



NO CLAIM IS MADE TO THE EXCLUSIVE RIGHT TO USE "GLOBAL COMMERCE THE SMART WAY", APART FROM THE MARK AS SHOWN.

THE MARK CONSISTS OF A THREE-QUARTERS OVAL SHAPE WITH A BIRD'S HEAD FACING RIGHT WITH A SINGLE EYE IN THE OVAL DESIGN. THE MARK CUTS OFF AT THE BOTTOM WITH A STRAIT LINE CUTTING OFF THE OVAL SHAPE PREMATURELY. THE WORDING "KAGU9" APPEARS IN STYLIZED LETTERS LOCATED IN THE LEFT-CENTER PORTION, AND THE WORDING "GLOBAL COMMERCE THE SMART WAY" IN STYLIZED WRITING LOCATED UNDER THE STRAIT LINE CUTTING OFF THE OVAL SHAPE.

FOR BUSINESS ADVISORY AND CONSULTANCY SERVICES RELATING TO EXPORT, EXPORT SERVICES, EXPORT PROMOTION INFORMATION AND SERVICES; EXPORT AGENCY SERVICES FOR THE GOODS OF OTHERS; EXPORT AND IMPORT AGENCIES; GOODS IMPORT-EXPORT AGENCIES; IMPORT AND EXPORT AGENCIES (U.S. CLS. 100, 101 AND 102).

FIRST USE 5-1-2011; IN COMMERCE 8-21-2011.

4,155,722. LAS VEGAS CONVENTION AND VISITORS AUTHORITY, LAS VEGAS, NV. SN 85-374,160. PUB. 12-13-2011, FILED 7-18-2011.

VEGAS HOWL-O-WEEKEND

THE MARK CONSISTS OF STANDARD CHARACTERS WITHOUT CLAIM TO ANY PARTICULAR FONT, STYLE, SIZE, OR COLOR.

NO CLAIM IS MADE TO THE EXCLUSIVE RIGHT TO USE "VEGAS", APART FROM THE MARK AS SHOWN.

FOR PROMOTING THE LAS VEGAS, NEVADA AREA AS A DESTINATION FOR LEISURE AND VACATION TRAVEL (U.S. CLS. 100, 101 AND 102).

FIRST USE 10-6-2011; IN COMMERCE 10-6-2011.

CLASS 35—(Continued).

4,155,731. KURTH, JOHN, HUNTINGTON BEACH, CA. SN 85-378,005. PUB. 1-24-2012, FILED 7-22-2011.

THE SYNTAX OF SUCCESS

THE MARK CONSISTS OF STANDARD CHARACTERS WITHOUT CLAIM TO ANY PARTICULAR FONT, STYLE, SIZE, OR COLOR.

FOR BUSINESS CONSULTING SERVICES IN THE FIELD OF SALES SCRIPT CREATION, MODIFICATION AND DELIVERY (U.S. CLS. 100, 101 AND 102).
FIRST USE 8-0-2011; IN COMMERCE 9-0-2011.

4,155,733. KURTH, JOHN, HUNTINGTON BEACH, CA. SN 85-378,751. PUB. 1-24-2012, FILED 7-22-2011.

SYNTACTICS SALES SCRIPTING

THE MARK CONSISTS OF STANDARD CHARACTERS WITHOUT CLAIM TO ANY PARTICULAR FONT, STYLE, SIZE, OR COLOR.

NO CLAIM IS MADE TO THE EXCLUSIVE RIGHT TO USE "SALES SCRIPTING", APART FROM THE MARK AS SHOWN.

FOR BUSINESS CONSULTING SERVICES IN THE FIELD OF SALES SCRIPT CREATION, MODIFICATION AND DELIVERY (U.S. CLS. 100, 101 AND 102).
FIRST USE 8-0-2011; IN COMMERCE 9-0-2011.

4,155,748. MUNSTERER, REBECCA J, NORWICH, VT. SN 85-385,814. PUB. 1-24-2012, FILED 8-1-2011.

Novel Nibble

THE MARK CONSISTS OF STANDARD CHARACTERS WITHOUT CLAIM TO ANY PARTICULAR FONT, STYLE, SIZE, OR COLOR.

NO CLAIM IS MADE TO THE EXCLUSIVE RIGHT TO USE "NOVEL", APART FROM THE MARK AS SHOWN.

FOR LITERARY AGENCIES; PROMOTING THE GOODS AND SERVICES OF OTHERS BY PROVIDING A WEBSITE FEATURING A COMPILATION OF LITERARY NOVELS WRITTEN IN THE GENRE OF ONE PAGE PER DAY; PROMOTING, ADVERTISING AND MARKETING OF THE BRANDS, PRODUCTS, SERVICES AND ONLINE WEBSITES OF INDIVIDUALS, BUSINESSES AND NONPROFIT ORGANIZATIONS (U.S. CLS. 100, 101 AND 102).
FIRST USE 1-1-2012; IN COMMERCE 1-1-2012.

CLASS 35—(Continued).

4,155,754. COLLINS, ASHA, WINTER PARK, FL. SN 85-387,981. PUB. 1-3-2012, FILED 8-3-2011.



THE MARK CONSISTS OF THE STYLIZED WORDS "WWW.THEWHIMSICALPEACOCK.COM THE WHIMSICAL PEACOCK.COM WHIMSICAL ARTWORK, EC-CENTRIC ODDITIES & FUNKY FINDS". AN IMAGE OF A PEACOCK FEATHER INSIDE A RECTANGULAR BOX.

FOR ON-LINE RETAIL STORE SERVICES FEATURING CUSTOM ART GOODS (U.S. CLS. 100, 101 AND 102).
FIRST USE 8-2-2011; IN COMMERCE 11-20-2011.

4,155,755. WORLD CLASS TECHNOLOGY CORPORATION, MCMINNVILLE, OR. SN 85-388,516. PUB. 1-3-2012, FILED 8-3-2011.

ORTHOVEND

THE MARK CONSISTS OF STANDARD CHARACTERS WITHOUT CLAIM TO ANY PARTICULAR FONT, STYLE, SIZE, OR COLOR.

FOR VENDING MACHINE SERVICES (U.S. CLS. 100, 101 AND 102).
FIRST USE 5-11-2011; IN COMMERCE 5-11-2011.

4,155,785. AMERICAN INSTITUTE OF CERTIFIED PUBLIC ACCOUNTANTS, NEW YORK, NY. SN 85-402,527. PUB. 1-17-2012, FILED 8-19-2011.

CPA HORIZONS 2025

THE MARK CONSISTS OF STANDARD CHARACTERS WITHOUT CLAIM TO ANY PARTICULAR FONT, STYLE, SIZE, OR COLOR.

CLASS 35—(Continued).

NO CLAIM IS MADE TO THE EXCLUSIVE RIGHT TO USE "CPA" AND "2025", APART FROM THE MARK AS SHOWN.

FOR ASSOCIATION SERVICES, NAMELY, PROMOTING THE INTERESTS OF ACCOUNTANTS; PROVIDING A WEBSITE FEATURING INFORMATION ABOUT ACCOUNTING AND THE FIELD OF ACCOUNTING; AND PROVIDING INFORMATION AND ADVICE IN THE FIELD OF ACCOUNTANCY (U.S. CLS. 100, 101 AND 102).

FIRST USE 11-2-2010; IN COMMERCE 1-5-2011.

4,155,791. NRG ENERGY, INC., PRINCETON, NJ. SN 85-406,300. PUB. 1-24-2012, FILED 8-24-2011.



OWNER OF U.S. REG. NOS. 2,182,531, 3,959,771, AND OTHERS.

NO CLAIM IS MADE TO THE EXCLUSIVE RIGHT TO USE "SERVICE", APART FROM THE MARK AS SHOWN.

THE MARK CONSISTS OF THE WORD "SIMPLYSMART" WITH "SMART" BOLD, FOLLOWED BY A DESIGN OF THREE INTERLOCKING CROSSES WITH LIGHT TO DARK SHADING AND THEN THE WORDS "AN NRG SERVICE" POSITIONED DIRECTLY BELOW.

FOR PROVIDING BACK OFFICE SUPPORT SERVICES FOR GAS AND ELECTRIC COMPANIES AS WELL AS RETAIL ENERGY SUPPLIERS, NAMELY, BILLING SERVICES AND CALL CENTER OPERATIONS FOR OTHERS (U.S. CLS. 100, 101 AND 102).

FIRST USE 11-1-2011; IN COMMERCE 11-1-2011.

4,155,798. MAHFUZ, EDUARDO, JACKSONVILLE, FL. SN 85-413,325. PUB. 1-24-2012, FILED 9-1-2011.



THE MARK CONSISTS OF A GLASS OF WINE WITH THE STYLIZED TEXT "W90+".

FOR RETAIL STORE SERVICES FEATURING WINES, WINE ACCESSORIES, CHEESES, AND BREADS (U.S. CLS. 100, 101 AND 102).

FIRST USE 1-8-2011; IN COMMERCE 4-11-2011.

CLASS 35—(Continued).

4,155,829. TEXT APPEAL LIMITED, LONDON, UNITED KINGDOM. SN 85-976,464. PUB. 7-12-2011, FILED 8-11-2010.

TEXTAPPEAL

THE MARK CONSISTS OF STANDARD CHARACTERS WITHOUT CLAIM TO ANY PARTICULAR FONT, STYLE, SIZE, OR COLOR.

FOR ADVERTISING AGENCIES; CREATION AND DISSEMINATION OF ADVERTISING MATTER; PUBLICITY COLUMNS AND PREPARATION OF MARKETING MATERIALS IN THE NATURE OF FACSIMILES; DIRECT MAIL ADVERTISING; PUBLICATION OF PUBLICITY TEXTS; CONSULTANCY IN THE FIELDS OF MULTILINGUAL MARKETING COMMUNICATIONS, MARKETING (U.S. CLS. 100, 101 AND 102).

FIRST USE 4-0-2007; IN COMMERCE 4-0-2007.

4,155,835. AVENUE K MARKETING, LLC, LOS ANGELES, CA. SN 85-976,570. PUB. 5-17-2011, FILED 1-3-2011.

AVENUE K

THE MARK CONSISTS OF STANDARD CHARACTERS WITHOUT CLAIM TO ANY PARTICULAR FONT, STYLE, SIZE, OR COLOR.

FOR ADVERTISING; ADVERTISING AGENCY; ADVERTISING, PROMOTION AND MARKETING SERVICES FOR OTHERS, AND ADVERTISING FOR OTHERS IN AND ON PARKING FACILITIES AND ON COMMERCIAL PROPERTIES; PRODUCT DEMONSTRATION SERVICES; MARKETING CONSULTING; ADVERTISING, MARKETING AND PROMOTION SERVICES; DEVELOPING ADVERTISING AND PROMOTIONAL CAMPAIGNS FOR BUSINESSES; DEVELOPMENT OF MARKETING STRATEGIES AND CONCEPTS (U.S. CLS. 100, 101 AND 102).

FIRST USE 8-15-2011; IN COMMERCE 8-15-2011.

4,155,843. WYNDHAM TM CORP., LAS VEGAS, NV. SN 85-976,685. PUB. 2-15-2011, FILED 10-19-2010.

BLUE HARMONY

THE MARK CONSISTS OF STANDARD CHARACTERS WITHOUT CLAIM TO ANY PARTICULAR FONT, STYLE, SIZE, OR COLOR.

OWNER OF U.S. REG. NO. 3,687,423.
FOR RETAIL GIFT SHOP OFFERING TOILETRIES, INCLUDING SOAPS, LOTIONS, HAIR SHAMPOOS AND CONDITIONERS, AND COSMETICS (U.S. CLS. 100, 101 AND 102).

FIRST USE 10-1-2011; IN COMMERCE 10-1-2011.

CLASS 36—INSURANCE AND FINANCIAL

4,154,257. NATIONAL WESTERN LIFE INSURANCE COMPANY, AUSTIN, TX. SN 76-706,706. PUB. 7-19-2011, FILED 3-9-2011.

NWL IMPACT 7S

THE MARK CONSISTS OF STANDARD CHARACTERS WITHOUT CLAIM TO ANY PARTICULAR FONT, STYLE, SIZE, OR COLOR.

OWNER OF U.S. REG. NOS. 2,589,454, 2,744,049, AND OTHERS.

FOR ANNUITY UNDERWRITING SERVICES (U.S. CLS. 100, 101 AND 102).

FIRST USE 8-31-2011; IN COMMERCE 8-31-2011.

4,154,258. NATIONAL WESTERN LIFE INSURANCE COMPANY, AUSTIN, TX. SN 76-706,707. PUB. 7-19-2011, FILED 3-9-2011.

NWL IMPACT 10

THE MARK CONSISTS OF STANDARD CHARACTERS WITHOUT CLAIM TO ANY PARTICULAR FONT, STYLE, SIZE, OR COLOR.

OWNER OF U.S. REG. NOS. 2,589,454, 2,744,049, AND OTHERS.

FOR ANNUITY UNDERWRITING SERVICES (U.S. CLS. 100, 101 AND 102).

FIRST USE 3-31-2011; IN COMMERCE 3-31-2011.

4,154,259. NATIONAL WESTERN LIFE INSURANCE COMPANY, AUSTIN, TX. SN 76-706,708. PUB. 7-19-2011, FILED 3-9-2011.

NWL IMPACT 7

THE MARK CONSISTS OF STANDARD CHARACTERS WITHOUT CLAIM TO ANY PARTICULAR FONT, STYLE, SIZE, OR COLOR.

OWNER OF U.S. REG. NOS. 2,589,454, 2,744,049, AND OTHERS.

FOR ANNUITY UNDERWRITING SERVICES (U.S. CLS. 100, 101 AND 102).

FIRST USE 3-31-2011; IN COMMERCE 3-31-2011.

CLASS 36—(Continued).

4,154,273. MASTERCARD INTERNATIONAL INCORPORATED, PURCHASE, NY. SN 77-183,804. PUB. 8-10-2010, FILED 5-17-2007.

MasterCard
MoneySend

OWNER OF U.S. REG. NOS. 1,186,117, 2,321,914, AND OTHERS.

THE MARK CONSISTS OF THE WORDING "MASTERCARD", WITH THE WORDING "MONEYSSEND" APPEARING AS ONE WORD, DIRECTLY BELOW THE WORDING "MASTERCARD".

FOR FINANCIAL SERVICES IN THE NATURE OF PERSONAL BANKING AND MONEY TRANSFER SERVICES IN THE NATURE OF WEB-BASED MONEY TRANSFERS PROVIDED BY MEANS OF A GLOBAL COMPUTER NETWORK; PROVIDING MONETARY PAYMENT SERVICES TO CONSUMERS AND BUSINESSES VIA A GLOBAL COMPUTER NETWORK IN THE NATURE OF PERSON TO PERSON, PERSON TO BUSINESS AND BUSINESS TO BUSINESS PAYMENTS; ELECTRONIC FINANCIAL CLEARING HOUSE SERVICES; ELECTRONIC PAYMENT, NAMELY, ELECTRONIC PROCESSING AND TRANSMISSION OF BILL PAYMENT DATA; STORED VALUE ELECTRONIC PURSE SERVICES, NAMELY, PROVIDING ON-LINE STORED VALUE ACCOUNTS IN AN ELECTRONIC ENVIRONMENT; PROVIDING ELECTRONIC FUNDS AND CURRENCY TRANSFER SERVICES; ELECTRONIC PAYMENT SERVICES FOR PERSONAL BANKING IN THE NATURE OF ELECTRONIC FUNDS TRANSFER AND FINANCIAL CLEARINGHOUSE SERVICES VIA A GLOBAL COMPUTER NETWORK; ELECTRONIC BILL PAYMENT; CLEARING AND RECONCILING FINANCIAL TRANSACTIONS VIA A GLOBAL COMPUTER NETWORK; PERSON-TO-PERSON AND PERSON-TO-BUSINESS MONEY TRANSFER SERVICES TRANSACTED BY MEANS OF A COMPUTER NETWORK; BILL PAYMENT REMITTANCE SERVICES; ELECTRONIC TRANSFER OF MONEY FROM CUSTOMER TO CUSTOMER; CHEQUE VERIFICATION SERVICES; THE PROVISION OF FINANCIAL INFORMATION FOR THE SUPPORT OF RETAIL SERVICES PROVIDED ON-LINE, THROUGH NETWORKS OR OTHER ELECTRONIC MEANS USING ELECTRONICALLY DIGITIZED INFORMATION, IN THE NATURE OF BILL REMITTANCE AND PAYMENT DATA; ELECTRONIC BILL PAYMENT SERVICES PROVIDED THROUGH A WEBSITE; ON-LINE BANKING; FINANCIAL SERVICES IN THE NATURE OF WEB-BASED MONEY TRANSFER PROVIDED OVER THE TELEPHONE AND BY MEANS OF A GLOBAL COMPUTER NETWORK OR THE INTERNET (U.S. CLS. 100, 101 AND 102).

FIRST USE 11-1-2007; IN COMMERCE 11-1-2007.

CLASS 36—(Continued).

4,154,312. MONTANA STATE UNIVERSITY, BOZEMAN, MT. SN 77-496,319. PUB. 5-5-2009, FILED 6-11-2008.

UNIVERSITY OF THE YELLOWSTONE

THE MARK CONSISTS OF STANDARD CHARACTERS WITHOUT CLAIM TO ANY PARTICULAR FONT, STYLE, SIZE, OR COLOR.

NO CLAIM IS MADE TO THE EXCLUSIVE RIGHT TO USE "UNIVERSITY", APART FROM THE MARK AS SHOWN.

FOR FUND RAISING SERVICES FOR UNIVERSITY AND COLLEGE EDUCATION AND RESEARCH (U.S. CLS. 100, 101 AND 102).

FIRST USE 5-5-2011; IN COMMERCE 1-27-2012.

4,154,398. EMAT CAPITAL MANAGEMENT, INC., LOS ANGELES, CA. SN 77-685,196. PUB. 2-9-2010, FILED 3-6-2009.

REALITYCOMFORTZONE

THE MARK CONSISTS OF STANDARD CHARACTERS WITHOUT CLAIM TO ANY PARTICULAR FONT, STYLE, SIZE, OR COLOR.

FOR INVESTMENT SERVICES, NAMELY, ASSET ACQUISITION, CONSULTATION, DEVELOPMENT AND MANAGEMENT SERVICES (U.S. CLS. 100, 101 AND 102).

FIRST USE 2-23-2012; IN COMMERCE 2-23-2012.

4,154,600. HUELER INVESTMENT SERVICES, INC., EDEN PRAIRIE, MN. SN 78-964,142. PUB. 3-20-2007, FILED 8-30-2006.

HUELER INCOME SOLUTIONS

THE MARK CONSISTS OF STANDARD CHARACTERS WITHOUT CLAIM TO ANY PARTICULAR FONT, STYLE, SIZE, OR COLOR.

OWNER OF U.S. REG. NO. 2,933,664.

SEC. 2(F) AS TO "INCOME SOLUTIONS".

FOR INVESTMENT SERVICES, NAMELY, FINANCIAL TRANSACTION PROCESSING AND ANNUITY SERVICES AND PROVIDING ON-LINE FINANCIAL TRANSACTION PROCESSING AND ANNUITY SERVICES (U.S. CLS. 100, 101 AND 102).

FIRST USE 3-9-2012; IN COMMERCE 3-9-2012.

CLASS 36—(Continued).

4,154,696. ADMIRALS BANK, CRANSTON, RI. SN 85-096,617. PUB. 7-19-2011, FILED 7-30-2010.

ADMIRALS BANK

THE MARK CONSISTS OF STANDARD CHARACTERS WITHOUT CLAIM TO ANY PARTICULAR FONT, STYLE, SIZE, OR COLOR.

NO CLAIM IS MADE TO THE EXCLUSIVE RIGHT TO USE "BANK", APART FROM THE MARK AS SHOWN.

FOR FINANCIAL SERVICES, NAMELY, BANKING SERVICES; INTERNET AND ONLINE BANKING SERVICES; PERSONAL AND COMMERCIAL BANKING SERVICES; CHECKING ACCOUNT SERVICES; SAVINGS ACCOUNT SERVICES; DIRECT DEPOSIT SERVICES; DEPOSIT SERVICES IN THE NATURE OF ACCEPTANCE OF DEPOSITS; SAFETY DEPOSIT BOX SERVICES; FINANCIAL TRANSACTION SERVICES, NAMELY, CERTIFICATES OF DEPOSIT; ONLINE BANKING; ONLINE BILL PAYMENT SERVICES; MONEY WIRE TRANSFER SERVICES; AUTOMATED TELLER MACHINE SERVICES; ELECTRONIC FUNDS TRANSFER SERVICES; CERTIFIED CHECK SERVICES; PROVIDING BANK ACCOUNT INFORMATION BY TELEPHONE, INTERNET OR ELECTRONIC MEANS; DEBIT CARD SERVICES; CONSUMER AND COMMERCIAL LENDING SERVICES, NAMELY, PROVIDING, ACQUIRING AND SERVICING COMMERCIAL AND RESIDENTIAL MORTGAGE LOANS (INCLUDING REFINANCINGS), CONSTRUCTION LOANS, HOME IMPROVEMENT LOANS, CAR LOANS, HOME EQUITY LOANS, ISSUING LETTERS OF CREDIT (U.S. CLS. 100, 101 AND 102).

FIRST USE 11-1-2010; IN COMMERCE 11-1-2010.

4,154,708. ASSURED GUARANTY LTD., HAMILTON HM 08, BERMUDA. SN 85-102,070. PUB. 1-18-2011, FILED 8-6-2010.

AGO

THE MARK CONSISTS OF STANDARD CHARACTERS WITHOUT CLAIM TO ANY PARTICULAR FONT, STYLE, SIZE, OR COLOR.

OWNER OF U.S. REG. NOS. 2,998,809 AND 3,330,076.

FOR INSURANCE SERVICES, NAMELY, UNDERWRITING FINANCIAL GUARANTY INSURANCE AND REINSURANCE FOR MUNICIPAL AND STRUCTURED FINANCE OBLIGATIONS AND MORTGAGE GUARANTY INSURANCE AND REINSURANCE (U.S. CLS. 100, 101 AND 102).

FIRST USE 3-21-2011; IN COMMERCE 3-21-2011.

CLASS 36—(Continued).

4,154,855. PRIDE MOBILITY PRODUCTS CORPORATION, EXETER, PA. SN 85-153,639. PUB. 9-20-2011, FILED 10-15-2010.

GALAXY

THE MARK CONSISTS OF STANDARD CHARACTERS WITHOUT CLAIM TO ANY PARTICULAR FONT, STYLE, SIZE, OR COLOR.

FOR LENDING AND FINANCING SERVICES, NAMELY, COMMERCIAL FINANCING AND LOAN SERVICES AND COMMERCIAL EQUIPMENT FINANCING SERVICES PROVIDED TO DEALERS IN CONNECTION WITH THE PURCHASE OF PERSONAL MOBILITY PRODUCTS, NAMELY, POWER CHAIRS, SCOOTERS, LIFT CHAIRS, WHEEL CHAIRS AND LIFTS AND RAMPS THEREFOR, FOR RE-SALE OR LEASE TO ELDERLY, INFIRM AND DISABLED PERSONS (U.S. CLS. 100, 101 AND 102).
FIRST USE 1-31-2011; IN COMMERCE 1-31-2011.

4,154,857. PRIDE MOBILITY PRODUCTS CORPORATION, EXETER, PA. SN 85-154,496. PUB. 9-20-2011, FILED 10-17-2010.

GALAXY MOBILITY

THE MARK CONSISTS OF STANDARD CHARACTERS WITHOUT CLAIM TO ANY PARTICULAR FONT, STYLE, SIZE, OR COLOR.

NO CLAIM IS MADE TO THE EXCLUSIVE RIGHT TO USE "MOBILITY", APART FROM THE MARK AS SHOWN.
FOR LENDING AND FINANCING SERVICES, NAMELY, COMMERCIAL FINANCING AND LOAN SERVICES AND COMMERCIAL EQUIPMENT FINANCING SERVICES PROVIDED TO DEALERS IN CONNECTION WITH THE PURCHASE OF PERSONAL MOBILITY PRODUCTS, NAMELY, POWER CHAIRS, SCOOTERS, LIFT CHAIRS, WHEEL CHAIRS AND LIFTS AND RAMPS THEREFOR, FOR RE-SALE OR LEASE TO ELDERLY, INFIRM AND DISABLED PERSONS (U.S. CLS. 100, 101 AND 102).
FIRST USE 1-31-2011; IN COMMERCE 1-31-2011.

CLASS 36—(Continued).

4,154,876. U-HAUL INTERNATIONAL, INC., PHOENIX, AZ. SN 85-166,963. PUB. 8-16-2011, FILED 11-2-2010.

INVESTING MADE EASIER

THE MARK CONSISTS OF STANDARD CHARACTERS WITHOUT CLAIM TO ANY PARTICULAR FONT, STYLE, SIZE, OR COLOR.

NO CLAIM IS MADE TO THE EXCLUSIVE RIGHT TO USE "INVESTING", APART FROM THE MARK AS SHOWN.
FOR FINANCIAL AND INVESTMENT SERVICES IN THE NATURE OF AN INVESTMENT SECURITY; FINANCIAL AND INVESTMENT SERVICES, NAMELY, ADMINISTERING THE ISSUANCE AND DISTRIBUTION OF SECURITIES (U.S. CLS. 100, 101 AND 102).
FIRST USE 2-3-2011; IN COMMERCE 2-3-2011.

4,154,952. BRENNAN AGENCY, INC., OVERLAND PARK, KS. SN 85-208,920. PUB. 5-3-2011, FILED 1-3-2011.

THE SAFE MONEY GUY

THE MARK CONSISTS OF STANDARD CHARACTERS WITHOUT CLAIM TO ANY PARTICULAR FONT, STYLE, SIZE, OR COLOR.

FOR INSURANCE BROKERAGE; FINANCIAL PLANNING SERVICES; ESTATE PLANNING SERVICES (U.S. CLS. 100, 101 AND 102).
FIRST USE 8-1-2011; IN COMMERCE 8-1-2011.

4,155,009. AVEN CORPORATION, TEMECULA, CA. SN 85-227,999. PUB. 7-19-2011, FILED 1-27-2011.

NETT-GROSS GROUP

THE MARK CONSISTS OF STANDARD CHARACTERS WITHOUT CLAIM TO ANY PARTICULAR FONT, STYLE, SIZE, OR COLOR.

NO CLAIM IS MADE TO THE EXCLUSIVE RIGHT TO USE "GROUP", APART FROM THE MARK AS SHOWN.
FOR REAL ESTATE MANAGEMENT SERVICES (U.S. CLS. 100, 101 AND 102).
FIRST USE 9-15-2011; IN COMMERCE 9-15-2011.

CLASS 36—(Continued).

4,155,029. KAUFMAN ANALYTICS, LTD., FREEPORT, BAHAMAS. SN 85-234,019. PUB. 6-28-2011, FILED 2-4-2011.

CLASS 36—(Continued).

4,155,058. REBEL BAIL BONDS, INC., DUCHESNE, UT. SN 85-240,270. PUB. 6-21-2011, FILED 2-11-2011.

AQK CATENA INDEX

THE MARK CONSISTS OF STANDARD CHARACTERS WITHOUT CLAIM TO ANY PARTICULAR FONT, STYLE, SIZE, OR COLOR.

NO CLAIM IS MADE TO THE EXCLUSIVE RIGHT TO USE "INDEX", APART FROM THE MARK AS SHOWN.

FOR INVESTMENT MANAGEMENT SERVICES; INVESTMENT FUND SERVICES, NAMELY, INVESTMENT OF FUNDS FOR OTHERS; FINANCIAL SERVICES IN THE NATURE OF AN INVESTMENT SECURITY (U.S. CLS. 100, 101 AND 102).

FIRST USE 8-22-2011; IN COMMERCE 8-22-2011.

THE MARK CONSISTS OF SKULL WITH WINGS. FOR BAIL BONDING (U.S. CLS. 100, 101 AND 102). FIRST USE 12-6-2011; IN COMMERCE 12-6-2011.

4,155,038. AMERICAN SOCIETY FOR TECHNION - ISRAEL INSTITUTE OF TECHNOLOGY, INC., NEW YORK, NY. SN 85-235,783. PUB. 7-26-2011, FILED 2-7-2011.

4,155,087. GENWORTH FINANCIAL WEALTH MANAGEMENT, INC., PLEASANT HILL, CA. SN 85-244,530. PUB. 6-28-2011, FILED 2-17-2011.

The Imagination of Israel**GUIDEMARK**

THE MARK CONSISTS OF STANDARD CHARACTERS WITHOUT CLAIM TO ANY PARTICULAR FONT, STYLE, SIZE, OR COLOR.

NO CLAIM IS MADE TO THE EXCLUSIVE RIGHT TO USE "ISRAEL", APART FROM THE MARK AS SHOWN.

FOR CHARITABLE FUNDRAISING SERVICES AND PROMOTE TECHNOLOGICAL EDUCATION AND ORGANIZING FUNDRAISING EVENTS IN FURTHERANCE OF TECHNOLOGICAL EDUCATION (U.S. CLS. 100, 101 AND 102).

FIRST USE 4-7-2011; IN COMMERCE 4-7-2011.

THE MARK CONSISTS OF STANDARD CHARACTERS WITHOUT CLAIM TO ANY PARTICULAR FONT, STYLE, SIZE, OR COLOR.

FOR FINANCIAL SERVICES, NAMELY, MUTUAL FUND INVESTMENT SERVICES, INVESTMENT ADVISORY SERVICES, WEALTH MANAGEMENT AND FINANCIAL PLANNING SERVICES, AND INVESTMENT CONSULTATION AND ASSET ALLOCATION SERVICES (U.S. CLS. 100, 101 AND 102).

FIRST USE 3-3-2011; IN COMMERCE 3-3-2011.

CLASS 36—(Continued).

4,155,088. GENWORTH FINANCIAL WEALTH MANAGEMENT, INC., PLEASANT HILL, CA. SN 85-244,533. PUB. 6-28-2011, FILED 2-17-2011.

GUIDEPATH

THE MARK CONSISTS OF STANDARD CHARACTERS WITHOUT CLAIM TO ANY PARTICULAR FONT, STYLE, SIZE, OR COLOR.

FOR FINANCIAL SERVICES, NAMELY, MUTUAL FUND INVESTMENT SERVICES, INVESTMENT ADVISORY SERVICES, WEALTH MANAGEMENT AND FINANCIAL PLANNING SERVICES, AND INVESTMENT CONSULTATION AND ASSET ALLOCATION SERVICES (U.S. CLS. 100, 101 AND 102).

FIRST USE 3-29-2011; IN COMMERCE 3-29-2011.

4,155,127. ALLIANCE BANK, N.A., SYRACUSE, NY. SN 85-250,315. PUB. 8-23-2011, FILED 2-24-2011.

PERSONAL eSUITE

THE MARK CONSISTS OF STANDARD CHARACTERS WITHOUT CLAIM TO ANY PARTICULAR FONT, STYLE, SIZE, OR COLOR.

NO CLAIM IS MADE TO THE EXCLUSIVE RIGHT TO USE "PERSONAL", APART FROM THE MARK AS SHOWN.

FOR ONLINE FINANCIAL SERVICES, NAMELY, BANKING SERVICES, BILL PAYMENT SERVICES, AND FINANCIAL MANAGEMENT SERVICES (U.S. CLS. 100, 101 AND 102).

FIRST USE 8-19-2011; IN COMMERCE 8-19-2011.

4,155,139. GENEROUS ART, LLC, AUSTIN, TX. SN 85-251,101. PUB. 7-19-2011, FILED 2-24-2011.

Generous Art

THE MARK CONSISTS OF STANDARD CHARACTERS WITHOUT CLAIM TO ANY PARTICULAR FONT, STYLE, SIZE, OR COLOR.

NO CLAIM IS MADE TO THE EXCLUSIVE RIGHT TO USE "ART", APART FROM THE MARK AS SHOWN.

FOR CHARITABLE FUNDRAISING SERVICES BY MEANS OF SELLING ARTWORK TO RAISE FUNDS FOR NON-PROFIT ORGANIZATIONS (U.S. CLS. 100, 101 AND 102).

FIRST USE 2-28-2011; IN COMMERCE 2-28-2011.

CLASS 36—(Continued).

4,155,211. WELLS FARGO & COMPANY, MINNEAPOLIS, MN. SN 85-257,173. PUB. 7-19-2011, FILED 3-3-2011.

INDEPENDENCE, SIMPLIFIED

THE MARK CONSISTS OF STANDARD CHARACTERS WITHOUT CLAIM TO ANY PARTICULAR FONT, STYLE, SIZE, OR COLOR.

FOR FINANCIAL AND INVESTMENT SERVICES, NAMELY, BROKERAGE SERVICES IN THE FIELDS OF STOCKS, BONDS, OPTIONS, MUTUAL FUNDS, COMMODITIES, FUTURES, AND OTHER SECURITIES; PROPRIETARY TRADING SERVICES, NAMELY, FUND INVESTMENT SERVICES FEATURING THE TRADING OF AN ACCOUNT HOLDER'S SECURITIES ACCORDING TO PREVIOUSLY ESTABLISHED CRITERIA IN ORDER TO MAINTAIN A PREDETERMINED LEVEL OF PAYMENTS TO THE ACCOUNT HOLDER; INVESTMENT BANKING SERVICES; SECURITIES BROKERAGE; EQUITY CAPITAL INVESTMENT SERVICES; PRIVATE PLACEMENTS OF HEDGE FUNDS, PRIVATE EQUITY FUNDS, SECURITIES AND DERIVATIVES FOR OTHERS; INVESTMENT OF FUNDS FOR OTHERS; SECURITIES TRADING AND INVESTING SERVICES FOR OTHERS VIA THE INTERNET; INVESTMENT ADVISORY SERVICES; INVESTMENT CONSULTATION SERVICES; INVESTMENT MANAGEMENT SERVICES; PROVIDING INFORMATION AND ADVICE IN THE FIELD OF FINANCE, FINANCIAL INVESTMENTS, FINANCIAL VALUATIONS, AND THE FINANCIAL ASPECTS OF RETIREMENT THROUGH A GLOBAL COMPUTER NETWORK; FINANCIAL PLANNING; CASH MANAGEMENT ACCOUNT SERVICES; PROVIDING FINANCIAL PORTFOLIO MANAGEMENT SERVICES; PROVIDING AN INTERACTIVE ONLINE COMPUTER DATABASE IN THE FIELD OF FINANCIAL PORTFOLIO MANAGEMENT, FINANCIAL DECISION MAKING, INVESTMENT RESEARCH, MONITORING INVESTMENT VALUE AND PERFORMANCE OF INVESTMENTS, ANALYZING INVESTMENT PERFORMANCE, EVALUATING ASSET ALLOCATION, RISK TOLERANCE, FINANCIAL ALTERNATIVE PLANS, AND INVESTMENT TIME FRAMES (U.S. CLS. 100, 101 AND 102).

FIRST USE 4-1-2010; IN COMMERCE 4-1-2010.

4,155,267. BB&T CORPORATION, WINSTON-SALEM, NC. SN 85-263,123. PUB. 7-19-2011, FILED 3-10-2011.

BB&T VANTAGE

THE MARK CONSISTS OF STANDARD CHARACTERS WITHOUT CLAIM TO ANY PARTICULAR FONT, STYLE, SIZE, OR COLOR.

OWNER OF U.S. REG. NOS. 3,091,256, 3,337,198, AND OTHERS.

FOR BANKING AND RELATED FINANCIAL SERVICES, NAMELY, CHECKING, DEBIT AND CREDIT CARD SERVICES (U.S. CLS. 100, 101 AND 102).

FIRST USE 4-11-2011; IN COMMERCE 4-11-2011.

CLASS 36—(Continued).

4,155,273. PATHFINDER PAYMENT SOLUTIONS, INC., COLUMBIA, MD. SN 85-263,692. PUB. 7-26-2011, FILED 3-10-2011.

PATHFINDER PAYMENT SOLUTIONS

THE MARK CONSISTS OF STANDARD CHARACTERS WITHOUT CLAIM TO ANY PARTICULAR FONT, STYLE, SIZE, OR COLOR.

NO CLAIM IS MADE TO THE EXCLUSIVE RIGHT TO USE "PAYMENT SOLUTIONS", APART FROM THE MARK AS SHOWN.

FOR CREDIT CARD TRANSACTION PROCESSING SERVICES; PAYMENT PROCESSING SERVICES, NAMELY, CREDIT CARD AND DEBIT CARD TRANSACTION PROCESSING SERVICES; PROCESSING ELECTRONIC PAYMENTS MADE THROUGH PREPAID CARDS; PROVIDING ELECTRONIC PROCESSING OF ACH AND CREDIT CARD TRANSACTIONS AND ELECTRONIC PAYMENTS VIA A GLOBAL COMPUTER NETWORK; PROVIDING ELECTRONIC PROCESSING OF CREDIT CARD TRANSACTIONS AND ELECTRONIC PAYMENTS VIA A GLOBAL COMPUTER NETWORK; PROVIDING ELECTRONIC PROCESSING OF ELECTRONIC FUNDS TRANSFER, ACH, CREDIT CARD, DEBIT CARD, ELECTRONIC CHECK AND ELECTRONIC PAYMENTS (U.S. CLS. 100, 101 AND 102).

FIRST USE 9-19-2011; IN COMMERCE 9-19-2011.

4,155,309. ENERGY LAND CONSULTANTS, EDMOND, OK. SN 85-268,076. PUB. 8-16-2011, FILED 3-16-2011.

THE ENERGY OF US

THE MARK CONSISTS OF STANDARD CHARACTERS WITHOUT CLAIM TO ANY PARTICULAR FONT, STYLE, SIZE, OR COLOR.

NO CLAIM IS MADE TO THE EXCLUSIVE RIGHT TO USE "ENERGY", APART FROM THE MARK AS SHOWN.

FOR CONSULTING SERVICES IN THE FIELD OF OIL AND GAS INDUSTRY LAND ACQUISITION AND MANAGEMENT (U.S. CLS. 100, 101 AND 102).

FIRST USE 3-16-2011; IN COMMERCE 3-16-2011.

CLASS 36—(Continued).

4,155,322. TUTTLE, KRIS, BOSTON, MA. SN 85-269,487. PUB. 8-2-2011, FILED 3-17-2011.

SoundView

THE MARK CONSISTS OF STANDARD CHARACTERS WITHOUT CLAIM TO ANY PARTICULAR FONT, STYLE, SIZE, OR COLOR.

FOR EQUITY CAPITAL INVESTMENT; INFORMATION, ADVISORY, CONSULTANCY AND RESEARCH SERVICES RELATING TO FINANCE AND INVESTMENTS (U.S. CLS. 100, 101 AND 102).

FIRST USE 11-1-2011; IN COMMERCE 3-15-2012.

4,155,323. ONEMAIN FINANCIAL HOLDINGS, INC., WILMINGTON, DE. SN 85-269,690. PUB. 2-7-2012, FILED 3-17-2011.

ONEMAIN

THE MARK CONSISTS OF STANDARD CHARACTERS WITHOUT CLAIM TO ANY PARTICULAR FONT, STYLE, SIZE, OR COLOR.

PRIORITY CLAIMED UNDER SEC. 44(D) ON ICELAND APPLICATION NO. 25702010, FILED 9-28-2010.

FOR FINANCIAL SERVICES, NAMELY, CONSUMER LENDING, CREDIT AND FINANCING SERVICES; CREDIT INSURANCE UNDERWRITING SERVICES; MORTGAGE LENDING SERVICES; LOAN SERVICES; INSURANCE SERVICES, NAMELY, UNDERWRITING, BROKERAGE, ADMINISTRATION AND AGENCY SERVICES IN CONNECTION WITH LIFE, ACCIDENT, DISABILITY, PROPERTY AND CASUALTY, HOMEOWNERS, AUTO, CREDIT, DEBT PROTECTION AND FIRE; INSURANCE ACTUARIAL SERVICES (U.S. CLS. 100, 101 AND 102).

FIRST USE 7-1-2011; IN COMMERCE 7-1-2011.

4,155,324. ONEMAIN FINANCIAL HOLDINGS, INC., WILMINGTON, DE. SN 85-269,706. PUB. 2-7-2012, FILED 3-17-2011.

ONEMAIN FINANCIAL

THE MARK CONSISTS OF STANDARD CHARACTERS WITHOUT CLAIM TO ANY PARTICULAR FONT, STYLE, SIZE, OR COLOR.

PRIORITY CLAIMED UNDER SEC. 44(D) ON ICELAND APPLICATION NO. 26722010, FILED 10-11-2010.

CLASS 36—(Continued).

NO CLAIM IS MADE TO THE EXCLUSIVE RIGHT TO USE "FINANCIAL", APART FROM THE MARK AS SHOWN.
 FOR FINANCIAL SERVICES, NAMELY, CONSUMER LENDING, CREDIT AND FINANCING SERVICES; CREDIT INSURANCE UNDERWRITING SERVICES; MORTGAGE LENDING SERVICES; LOAN SERVICES (U.S. CLS. 100, 101 AND 102).
 FIRST USE 7-1-2011; IN COMMERCE 7-1-2011.

4,155,362. UNITED AUTO CREDIT CORPORATION, IRVINE, CA. SN 85-277,064. PUB. 8-9-2011, FILED 3-25-2011.

DRIVEN TO MAKE A DIFFERENCE

THE MARK CONSISTS OF STANDARD CHARACTERS WITHOUT CLAIM TO ANY PARTICULAR FONT, STYLE, SIZE, OR COLOR.
 FOR LOAN FINANCING SERVICES (U.S. CLS. 100, 101 AND 102).
 FIRST USE 5-18-2011; IN COMMERCE 5-18-2011.

4,155,370. GENERAL ELECTRIC COMPANY, SCHENECTADY, NY. SN 85-278,396. PUB. 7-5-2011, FILED 3-28-2011.

MORE THAN A LANDLORD. YOUR PARTNER.

THE MARK CONSISTS OF STANDARD CHARACTERS WITHOUT CLAIM TO ANY PARTICULAR FONT, STYLE, SIZE, OR COLOR.
 FOR LEASING OF REAL ESTATE; REAL ESTATE BROKERAGE; REAL ESTATE CONSULTATION; REAL ESTATE MANAGEMENT SERVICES (U.S. CLS. 100, 101 AND 102).
 FIRST USE 3-25-2011; IN COMMERCE 3-25-2011.

4,155,379. DIGITAL PROCESSING SOLUTIONS, INC., MELVILLE, NY. SN 85-279,359. PUB. 8-30-2011, FILED 3-29-2011.

Charitable Giving Made Easy

THE MARK CONSISTS OF STANDARD CHARACTERS WITHOUT CLAIM TO ANY PARTICULAR FONT, STYLE, SIZE, OR COLOR.

CLASS 36—(Continued).

NO CLAIM IS MADE TO THE EXCLUSIVE RIGHT TO USE "CHARITABLE GIVING", APART FROM THE MARK AS SHOWN.
 FOR PROVIDING ELECTRONIC PROCESSING OF ELECTRONIC FUNDS TRANSFER, ACH, CREDIT CARD, DEBIT CARD, ELECTRONIC CHECK AND ELECTRONIC PAYMENTS (U.S. CLS. 100, 101 AND 102).
 FIRST USE 2-4-2011; IN COMMERCE 6-14-2011.

4,155,390. MONDAY LIFE, THE, CHAPEL HILL, NC. SN 85-281,119. PUB. 8-9-2011, FILED 3-30-2011.

THE MONDAY LIFE

THE MARK CONSISTS OF STANDARD CHARACTERS WITHOUT CLAIM TO ANY PARTICULAR FONT, STYLE, SIZE, OR COLOR.
 FOR CHARITABLE FUNDRAISING (U.S. CLS. 100, 101 AND 102).
 FIRST USE 11-21-2011; IN COMMERCE 11-21-2011.

4,155,482. SHAMOOIL, DANIEL, GREAT NECK, NY. SN 85-299,496. PUB. 9-6-2011, FILED 4-20-2011.

VORO

THE MARK CONSISTS OF STANDARD CHARACTERS WITHOUT CLAIM TO ANY PARTICULAR FONT, STYLE, SIZE, OR COLOR.
 FOR REAL ESTATE BROKERAGE; REAL ESTATE LISTING; REAL ESTATE CONSULTANCY; REAL ESTATE APPRAISAL AND VALUATION; PROVIDING REAL ESTATE LISTINGS AND REAL ESTATE INFORMATION VIA THE INTERNET; LEASING OF REAL ESTATE (U.S. CLS. 100, 101 AND 102).
 FIRST USE 4-1-2011; IN COMMERCE 6-1-2011.

CLASS 36—(Continued).

4,155,498. GAP (APPAREL), LLC, SAN FRANCISCO, CA. SN 85-304,191. PUB. 8-23-2011, FILED 4-25-2011.

CLASS 36—(Continued).

4,155,571. THE PNC FINANCIAL SERVICES GROUP, INC., PITTSBURGH, PA. SN 85-329,942. PUB. 8-16-2011, FILED 5-25-2011.

BE WHAT'S POSSIBLE

THE MARK CONSISTS OF STANDARD CHARACTERS WITHOUT CLAIM TO ANY PARTICULAR FONT, STYLE, SIZE, OR COLOR.

FOR CHARITABLE FOUNDATION SERVICES, NAMELY, PROVIDING FINANCIAL ASSISTANCE FOR PROGRAMS AND SERVICES OF OTHERS (U.S. CLS. 100, 101 AND 102).

FIRST USE 7-31-2006; IN COMMERCE 7-31-2006.

PNC SMARTACCESS

THE MARK CONSISTS OF STANDARD CHARACTERS WITHOUT CLAIM TO ANY PARTICULAR FONT, STYLE, SIZE, OR COLOR.

OWNER OF U.S. REG. NO. 1,416,898.

FOR PREPAID RELOADABLE DEBIT CARD SERVICES (U.S. CLS. 100, 101 AND 102).

FIRST USE 1-30-2012; IN COMMERCE 1-30-2012.

4,155,525. ONEXONE FOUNDATION, MONTREAL, QUEBEC, CANADA. SN 85-313,003. PUB. 7-19-2011, FILED 5-5-2011.

ONEUP

THE MARK CONSISTS OF STANDARD CHARACTERS WITHOUT CLAIM TO ANY PARTICULAR FONT, STYLE, SIZE, OR COLOR.

FOR CHARITABLE FUNDRAISING (U.S. CLS. 100, 101 AND 102).

FIRST USE 8-0-2011; IN COMMERCE 8-0-2011.

4,155,610. ARBALEST LEGAL FUNDING LLC, BOULDER, CO. SN 85-346,348. PUB. 11-1-2011, FILED 6-14-2011.

Arbalest**PUT THE VETERAN BACK IN
VETERANS DAY**

THE MARK CONSISTS OF STANDARD CHARACTERS WITHOUT CLAIM TO ANY PARTICULAR FONT, STYLE, SIZE, OR COLOR.

FOR CHARITABLE FUNDRAISING SERVICES (U.S. CLS. 100, 101 AND 102).

FIRST USE 9-7-2011; IN COMMERCE 9-7-2011.

THE MARK CONSISTS OF STANDARD CHARACTERS WITHOUT CLAIM TO ANY PARTICULAR FONT, STYLE, SIZE, OR COLOR.

FOR COMMERCIAL FACTORING, NAMELY, THE BUSINESS OF BUYING EARNED ATTORNEY FEES AT A DISCOUNT (U.S. CLS. 100, 101 AND 102).

FIRST USE 10-18-2011; IN COMMERCE 10-18-2011.

CLASS 36—(Continued).

4,155,650. ESF FINANCIAL, INC., MANHATTAN BEACH, CA. SN 85-356,834. PUB. 11-15-2011, FILED 6-27-2011.

SELF OR HELP

THE MARK CONSISTS OF STANDARD CHARACTERS WITHOUT CLAIM TO ANY PARTICULAR FONT, STYLE, SIZE, OR COLOR.

FOR MUTUAL FUND INVESTMENT SERVICES; RETIREMENT FUND INVESTMENT SERVICES; INVESTMENT MANAGEMENT SERVICES; FINANCIAL PLANNING; SECURITIES BROKERAGE SERVICES; MONEY MANAGEMENT; FINANCIAL ANALYSIS; PROVIDING FINANCIAL INFORMATION BY ELECTRONIC MEANS; PROVIDING PERSONALIZED INVESTMENT INFORMATION, INVESTMENT ACCOUNT MANAGEMENT AND SECURITIES BROKERAGE SERVICES, ALL BY MEANS OF WIRELESS COMMUNICATION DEVICES AND BY MEANS OF THE INTERNET; RESEARCH IN THE FIELD OF INVESTMENTS AND FINANCE; SECURITIES BROKERAGE SERVICES PROVIDED TO HOLDERS OF STOCK OPTIONS; FINANCIAL SERVICES, NAMELY, AGENCY SERVICES IN THE FIELD OF SECURITIES; FINANCIAL MARKET INFORMATION SERVICES, NAMELY, COMPILING AND PROVIDING INFORMATION REGARDING SECURITIES; PROVIDING PERSONALIZED INVESTMENT INFORMATION BY ELECTRONIC MAIL; FINANCIAL AND INVESTMENT SERVICES, NAMELY, ASSET AND INVESTMENT ACQUISITION, CONSULTATION, ADVISORY AND DEVELOPMENT AND MANAGEMENT AND BROKERAGE IN THE FIELDS OF STOCKS, BONDS, OPTIONS, COMMODITIES, FUTURES AND OTHER SECURITIES, AND THE INVESTMENT OF FUNDS OF OTHERS (U.S. CLS. 100, 101 AND 102).

FIRST USE 3-13-2012; IN COMMERCE 3-13-2012.

4,155,685. 4WARRANTY CORPORATION, ORANGE PARK, FL. SN 85-365,147. PUB. 12-6-2011, FILED 7-7-2011.

SureSleep 

THE MARK CONSISTS OF THE WORDS "SURESLLEEP" TO THE LEFT OF THE IMAGE OF A INDIVIDUAL LAYING ON THEIR BACK WITH THEIR LEGS CROSSED.

FOR PROVIDING WARRANTIES ON BEDS AND MATTRESSES MANUFACTURED BY OTHERS (U.S. CLS. 100, 101 AND 102).

FIRST USE 7-0-2011; IN COMMERCE 7-0-2011.

CLASS 36—(Continued).

4,155,686. JEFFERSON BANK, SAN ANTONIO, TX. SN 85-365,148. PUB. 12-6-2011, FILED 7-7-2011.

THIS IS PERSONAL TO US

THE MARK CONSISTS OF STANDARD CHARACTERS WITHOUT CLAIM TO ANY PARTICULAR FONT, STYLE, SIZE, OR COLOR.

FOR BANKING AND FINANCING SERVICES; MORTGAGE BANKING; ON-LINE BANKING SERVICES; FINANCIAL SERVICES, NAMELY, WEALTH MANAGEMENT SERVICES (U.S. CLS. 100, 101 AND 102). FIRST USE 2-21-2012; IN COMMERCE 2-21-2012.

4,155,713. STRUCTURED INVESTMENT MANAGEMENT, INC., NEW YORK, NY. SN 85-371,677. PUB. 12-6-2011, FILED 7-14-2011.

CAPITAL DEFENDER FUND

THE MARK CONSISTS OF STANDARD CHARACTERS WITHOUT CLAIM TO ANY PARTICULAR FONT, STYLE, SIZE, OR COLOR.

NO CLAIM IS MADE TO THE EXCLUSIVE RIGHT TO USE "CAPITAL" AND "FUND", APART FROM THE MARK AS SHOWN.

FOR FUNDS INVESTMENT; INVESTMENT SERVICES, NAMELY, MUTUAL FUND INVESTMENT SERVICES; INVESTMENT OF FUNDS FOR OTHERS; FUNDS INVESTMENT CONSULTATION (U.S. CLS. 100, 101 AND 102).

FIRST USE 8-31-2011; IN COMMERCE 8-31-2011.

4,155,721. ST. LOUIS COMMUNITY CREDIT UNION, ST. LOUIS, MO. SN 85-373,945. PUB. 1-24-2012, FILED 7-18-2011.

RED DOUGH

THE MARK CONSISTS OF STANDARD CHARACTERS WITHOUT CLAIM TO ANY PARTICULAR FONT, STYLE, SIZE, OR COLOR.

NO CLAIM IS MADE TO THE EXCLUSIVE RIGHT TO USE "DOUGH", APART FROM THE MARK AS SHOWN.

FOR DEBIT CARD SERVICES; ISSUING RELOADABLE PREPAID DEBIT CARDS; CREDIT UNION SERVICES (U.S. CLS. 100, 101 AND 102).

FIRST USE 11-0-2011; IN COMMERCE 11-0-2011.

CLASS 36—(Continued).

4,155,734. IMPERA WEALTH MANAGEMENT, LLC, METAIRIE, LA. SN 85-378,843. PUB. 1-24-2012, FILED 7-22-2011.

WEALTH IN ORDER

THE MARK CONSISTS OF STANDARD CHARACTERS WITHOUT CLAIM TO ANY PARTICULAR FONT, STYLE, SIZE, OR COLOR.

FOR INVESTMENT MANAGEMENT; FINANCIAL PORTFOLIO MANAGEMENT; INVESTMENT BROKERAGE; CONSULTING SERVICES IN THE FIELD OF RETIREMENT PLAN ADMINISTRATION; FINANCIAL ADMINISTRATION OF RETIREMENT PLANS; FINANCIAL PLANNING FOR RETIREMENT; ESTATE PLANNING; FINANCIAL PLANNING; INSURANCE INFORMATION AND CONSULTANCY; FINANCIAL RISK MANAGEMENT (U.S. CLS. 100, 101 AND 102).
FIRST USE 5-31-2011; IN COMMERCE 5-31-2011.

4,155,789. SANFORD, FARGO, ND. SN 85-404,691. PUB. 2-7-2012, FILED 8-23-2011.

Care Hope Cure

THE MARK CONSISTS OF STANDARD CHARACTERS WITHOUT CLAIM TO ANY PARTICULAR FONT, STYLE, SIZE, OR COLOR.

FOR CHARITABLE FUNDRAISING (U.S. CLS. 100, 101 AND 102).
FIRST USE 8-17-2011; IN COMMERCE 8-17-2011.

4,155,806. SCBT FINANCIAL CORPORATION, COLUMBIA, SC. SN 85-426,699. PUB. 12-13-2011, FILED 9-20-2011.

SCBT WHOLESALE MORTGAGE

THE MARK CONSISTS OF STANDARD CHARACTERS WITHOUT CLAIM TO ANY PARTICULAR FONT, STYLE, SIZE, OR COLOR.

OWNER OF U.S. REG. NOS. 2,907,585, 3,748,058, AND OTHERS.

NO CLAIM IS MADE TO THE EXCLUSIVE RIGHT TO USE "WHOLESALE MORTGAGE", APART FROM THE MARK AS SHOWN.

FOR MORTGAGE BROKERAGE SERVICES IN THE FIELD OF WHOLESALE MORTGAGE LOANS IN THE SECONDARY MORTGAGE MARKETS (U.S. CLS. 100, 101 AND 102).

FIRST USE 7-22-2011; IN COMMERCE 7-22-2011.

CLASS 36—(Continued).

4,155,812. LOYAL AMERICAN LIFE INSURANCE COMPANY, TA LOYAL AMERICAN LIFE INSURANCE COMPANY, AUSTIN, TX. SN 85-440,785. PUB. 1-24-2012, FILED 10-6-2011.

**Loyal American
Supplemental Series**

THE MARK CONSISTS OF STANDARD CHARACTERS WITHOUT CLAIM TO ANY PARTICULAR FONT, STYLE, SIZE, OR COLOR.

OWNER OF U.S. REG. NO. 2,647,611.

NO CLAIM IS MADE TO THE EXCLUSIVE RIGHT TO USE "AMERICAN" AND "SUPPLEMENTAL SERIES", APART FROM THE MARK AS SHOWN.

FOR INSURANCE SERVICES, NAMELY, UNDERWRITING, ISSUANCE AND ADMINISTRATION OF SUPPLEMENTAL HEALTH INSURANCE (U.S. CLS. 100, 101 AND 102).

FIRST USE 11-11-2011; IN COMMERCE 11-11-2011.

4,155,828. SEARS BRANDS, LLC, HOFFMAN ESTATES, IL. SN 85-976,422. PUB. 11-15-2011, FILED 7-5-2011.

MONEYHUB

THE MARK CONSISTS OF STANDARD CHARACTERS WITHOUT CLAIM TO ANY PARTICULAR FONT, STYLE, SIZE, OR COLOR.

FOR ISSUING STORED VALUE CARDS (U.S. CLS. 100, 101 AND 102).

FIRST USE 3-1-2012; IN COMMERCE 3-1-2012.

CLASS 37—CONSTRUCTION AND REPAIR

CLASS 37—(Continued).

4,154,486. DECIMUS, JEAN D, BROOKLYN, NY. SN 77-854,818. PUB. 9-6-2011, FILED 10-22-2009.



NO CLAIM IS MADE TO THE EXCLUSIVE RIGHT TO USE "H.V.A.C.", APART FROM THE MARK AS SHOWN.
 THE MARK CONSISTS OF "FRESH START H.V.A.C. F S ONE" INSIDE A DOUBLE CIRCLE. "FRESH START H.V.A.C." APPEARS IN A CIRCULAR FASHION BETWEEN THE FIRST AND SECOND CIRCLE, WHILE "F S ONE" APPEARS IN STYLIZED FORM WITHIN THE FIRST CIRCLE. A STAR WITH FOUR RADIATING LINES IS DEPICTED AT THE UPPER LEFT OF THE LETTER "F" IN "F S ONE".
 FOR INSTALLATION, MAINTENANCE AND REPAIR OF HEATING, VENTILATION, AIR CONDITIONING, AND REFRIGERATION (HVAC/R) SYSTEMS (U.S. CLS. 100, 103 AND 106).
 FIRST USE 1-1-2009; IN COMMERCE 1-1-2009.

4,154,765. MOBIX CAR SERVICES LLC, BARRINGTON, RI. SN 85-119,336. PUB. 1-24-2012, FILED 8-31-2010.

MOBIX

THE MARK CONSISTS OF STANDARD CHARACTERS WITHOUT CLAIM TO ANY PARTICULAR FONT, STYLE, SIZE, OR COLOR.
 FOR CONSTRUCTION AND REPAIR SERVICES, NAMELY, ON-SITE CAR REPAIR AND MAINTENANCE (U.S. CLS. 100, 103 AND 106).
 FIRST USE 5-1-2010; IN COMMERCE 9-9-2010.

CLASS 37—(Continued).

4,154,947. FILTHY GRILL, INC., AGOURA HILLS, CA. SN 85-204,908. PUB. 12-6-2011, FILED 12-23-2010.

FILTHYGRILL

THE MARK CONSISTS OF STANDARD CHARACTERS WITHOUT CLAIM TO ANY PARTICULAR FONT, STYLE, SIZE, OR COLOR.
 FOR CLEANING, REPAIR AND MAINTENANCE SERVICES FOR BARBEQUES, GRILLS, AND OUTDOOR KITCHENS (U.S. CLS. 100, 103 AND 106).
 FIRST USE 5-0-2004; IN COMMERCE 10-18-2011.

4,155,040. WASH & ROLL, LLC, RALEIGH, NC. SN 85-236,607. PUB. 7-19-2011, FILED 2-8-2011.

WASH & ROLL

THE MARK CONSISTS OF STANDARD CHARACTERS WITHOUT CLAIM TO ANY PARTICULAR FONT, STYLE, SIZE, OR COLOR.
 NO CLAIM IS MADE TO THE EXCLUSIVE RIGHT TO USE "WASH", APART FROM THE MARK AS SHOWN.
 FOR CAR WASH SERVICES (U.S. CLS. 100, 103 AND 106).
 FIRST USE 8-31-2011; IN COMMERCE 8-31-2011.

CLASS 37—(Continued).

4,155,056. LUXGEN MOTOR CO., LTD., MIAOLI COUNTY 367, TAIWAN. SN 85-239,605. PUB. 6-21-2011, FILED 2-11-2011.



THE MARK CONSISTS OF THE WORD "LUXGEN" IN STYLIZED FORM.

FOR VEHICLE MAINTENANCE AND REPAIR; VEHICLE MAINTENANCE; ANTI-RUST TREATMENT FOR VEHICLES; AUTOMOBILE LUBRICATION; AUTOMOBILE CLEANING AND CAR WASHING; AUTOMOBILE SERVICE STATION SERVICES; MOTOR VEHICLE MAINTENANCE AND REPAIR; TIRE RETREADING; AUTOMOBILE POLISHING; BUFFING AND POLISHING (U.S. CLS. 100, 103 AND 106).

FIRST USE 8-19-2009; IN COMMERCE 8-19-2009.

CLASS 37—(Continued).

4,155,538. CLEAN FACILITIES GROUP, INC., WALTHAM, MA. SN 85-317,687. PUB. 10-25-2011, FILED 5-11-2011.



NO CLAIM IS MADE TO THE EXCLUSIVE RIGHT TO USE "CLEAN FACILITIES GROUP, INC.", APART FROM THE MARK AS SHOWN.

THE COLOR(S) GREEN, BLUE AND WHITE IS/ARE CLAIMED AS A FEATURE OF THE MARK.

THE MARK CONSISTS OF A CIRCLE IN BLUE AND GREEN WHICH CONTAINS THE STYLIZED LETTERS "CFG" IN WHITE. A CURVED LINE IN WHITE APPEARS TO GO THROUGH THE LETTER "G". FOUR INTERSECTING LINES IN WHITE FORM AN EIGHT POINTED STAR WHICH TOUCHES THE TOP OF THE CURVED LINE AND APPEARS TO THE RIGHT OF THE LETTER "C" IN "CFG". TO THE RIGHT OF THE CIRCLE ARE THE BLUE STYLIZED WORDS "CLEAN FACILITIES GROUP INC." ABOVE A GREEN LINE.

FOR BUILDING MAINTENANCE AND REPAIR; JANITORIAL SERVICES; LAUNDRY SERVICES (U.S. CLS. 100, 103 AND 106).

FIRST USE 0-0-2011; IN COMMERCE 0-0-2011.

4,155,381. NATIONAL ASSOCIATION FOR STOCK CAR AUTO RACING, INC., DAYTONA BEACH, FL. SN 85-279,383. PUB. 8-30-2011, FILED 3-29-2011.



OWNER OF U.S. REG. NOS. 817,553, 1,054,100, AND OTHERS.

NO CLAIM IS MADE TO THE EXCLUSIVE RIGHT TO USE "CAR WASH", APART FROM THE MARK AS SHOWN.

THE MARK CONSISTS OF SLANTED BAR LINES, THE WORDS "NASCAR" AND "CAR WASH" INSIDE AN OVAL DESIGN WITH WATER DROP EFFECT.

FOR AUTOMOBILE WASHING AND AUTOMOBILE DETAILING SERVICES (U.S. CLS. 100, 103 AND 106).

FIRST USE 9-15-2011; IN COMMERCE 9-15-2011.

4,155,728. DEERPOINT GROUP, INC., FRESNO, CA. SN 85-377,531. PUB. 1-10-2012, FILED 7-21-2011.

Got Plugging?

THE MARK CONSISTS OF STANDARD CHARACTERS WITHOUT CLAIM TO ANY PARTICULAR FONT, STYLE, SIZE, OR COLOR.

NO CLAIM IS MADE TO THE EXCLUSIVE RIGHT TO USE "PLUGGING", APART FROM THE MARK AS SHOWN.

FOR MAINTENANCE OF IRRIGATION SYSTEMS, NAMELY, MAINTENANCE TO PREVENT AND/OR REMEDY PLUGGING IN IRRIGATION SYSTEMS (U.S. CLS. 100, 103 AND 106).

FIRST USE 1-26-2011; IN COMMERCE 1-26-2011.

CLASS 37—(Continued).

4,155,771. CB OPERATORS, LLC, SAN ANTONIO, TX. SN 85-394,758. PUB. 1-10-2012, FILED 8-10-2011.



NO CLAIM IS MADE TO THE EXCLUSIVE RIGHT TO USE "CAR WASH", APART FROM THE MARK AS SHOWN. THE COLOR(S) BLUE, RED, BLACK, AND WHITE IS/ARE CLAIMED AS A FEATURE OF THE MARK.

THE MARK CONSISTS OF THE WORDS "CLEAR BLUE" IN A BLUE FONT OVER THE WORDS "CAR WASH" IN A SMALLER RED FONT, WITH STYLIZED BLUE AND WHITE BUBBLES ABOVE AND WITHIN THE WORDS "CLEAR BLUE", AND WITH A STYLIZED RED CAR HAVING A BLUE UNDERCARRIAGE, WHITE WHEEL COVERS, WHITE WINDOWS, A WHITE BUMPER IN THE SHAPE OF A SMILE, AND WHITE AND BLACK HEADLIGHTS IN THE SHAPE OF EYES WITH BLACK EYELASHES, THE STYLIZED CAR POSITIONED OVER THE BUBBLES.

FOR AUTOMOBILE CLEANING AND CAR WASHING (U.S. CLS. 100, 103 AND 106).

FIRST USE 10-0-2011; IN COMMERCE 10-0-2011.

4,155,817. 8NET, INC., CERRITOS, CA. SN 85-448,454. PUB. 1-10-2012, FILED 10-16-2011.



NO CLAIM IS MADE TO THE EXCLUSIVE RIGHT TO USE "RECYCLING CENTER" AND THE UNIVERSAL SYMBOL FOR RECYCLING, APART FROM THE MARK AS SHOWN.

THE COLOR(S) RED AND GREEN IS/ARE CLAIMED AS A FEATURE OF THE MARK.

THE MARK CONSISTS OF THE WORDING "IN & OUT" WITH THE "I" IN RED AND LOWERCASE, THE "N" IN RED AND UPPERCASE, THE "&" IN GREEN AND SURROUNDED BY THE UNIVERSAL RECYCLING SYMBOL IN GREEN, THE "O" IN RED AND UPPERCASE, THE "UT" IN RED AND LOWERCASE ALL ABOVE THE WORDING "RECYCLING CENTER" IN GREEN AND UNDERLINED IN GREEN.

FOR BOTTLE AND CAN COLLECTION FOR RECYCLING; COLLECTION CENTERS FOR METAL CANS AND OTHER RECYCLABLE ITEMS; PAPER AND CARDBOARD COLLECTION FOR RECYCLING (U.S. CLS. 100, 103 AND 106).

FIRST USE 4-2-2012; IN COMMERCE 4-2-2012.

CLASS 38—COMMUNICATION

4,154,663. SKYPE, DUBLIN 2, IRELAND. SN 85-070,119. PUB. 8-9-2011, FILED 6-23-2010.

SKYPE TO GO

THE MARK CONSISTS OF STANDARD CHARACTERS WITHOUT CLAIM TO ANY PARTICULAR FONT, STYLE, SIZE, OR COLOR.

PRIORITY CLAIMED UNDER SEC. 44(D) ON ERPN CMNTY TM OFC APPLICATION NO. 008782931, FILED 12-24-2009, REG. NO. 008782931, DATED 6-18-2010, EXPIRES 12-24-2019.

OWNER OF U.S. REG. NOS. 3,005,039, 3,403,727, AND 3,773,537.

FOR COMMUNICATION SERVICES, NAMELY, TRANSMISSION OF AUDIO BY MEANS OF TELECOMMUNICATIONS NETWORKS, WIRELESS COMMUNICATION NETWORKS; COMMUNICATION SERVICES ACCESSED BY MEANS OF AN ACCESS NUMBER, NAMELY, TRANSMISSION OF VOICE BY TELECOMMUNICATIONS NETWORKS, WIRELESS COMMUNICATION NETWORKS (U.S. CLS. 100, 101 AND 104).

FIRST USE 6-8-2007; IN COMMERCE 6-8-2007.

4,154,757. SHOWTIME NETWORKS INC., NEW YORK, NY. SN 85-116,928. PUB. 8-2-2011, FILED 8-26-2010.

MOVIES THAT MOVE YOU

THE MARK CONSISTS OF STANDARD CHARACTERS WITHOUT CLAIM TO ANY PARTICULAR FONT, STYLE, SIZE, OR COLOR.

NO CLAIM IS MADE TO THE EXCLUSIVE RIGHT TO USE "MOVIES", APART FROM THE MARK AS SHOWN.

FOR BROADCASTING SERVICES, NAMELY, TRANSMITTING, DOWNLOADING AND STREAMING OF AUDIO, VIDEO AND MULTIMEDIA ENTERTAINMENT CONTENT INCLUDING GRAPHICS, TEXT AND DATA, RENDERED THROUGH THE MEDIA OF TELEVISION, CABLE, SATELLITE, RADIO, TELEPHONE AND BROADBAND SYSTEMS, AND VIA THE INTERNET, PORTABLE AND WIRELESS COMMUNICATION DEVICES (U.S. CLS. 100, 101 AND 104).

FIRST USE 10-25-2010; IN COMMERCE 10-25-2010.

CLASS 38—(Continued).

4,154,764. SECURUS TECHNOLOGIES, INC., DALLAS, TX. SN 85-118,346. PUB. 1-25-2011, FILED 8-30-2010.

SECURUS

THE MARK CONSISTS OF STANDARD CHARACTERS WITHOUT CLAIM TO ANY PARTICULAR FONT, STYLE, SIZE, OR COLOR.

FOR COMMUNICATION SERVICES, NAMELY, TRANSMISSION OF VOICE, AUDIO, VISUAL IMAGES AND DATA BY TELECOMMUNICATIONS NETWORKS, WIRELESS COMMUNICATION NETWORKS, THE INTERNET, INFORMATION SERVICES NETWORKS AND DATA NETWORKS; DATA COMMUNICATION BY ELECTRONIC MAIL; DATA TRANSMISSION AND RECEPTION SERVICES VIA TELECOMMUNICATION MEANS; DELIVERY OF MESSAGES BY ELECTRONIC TRANSMISSION; ELECTRONIC MAIL AND MESSAGING SERVICES; ELECTRONIC MAIL SERVICES; ELECTRONIC VOICE MESSAGING, NAMELY, THE RECORDING AND SUBSEQUENT TRANSMISSION OF VOICE MESSAGES BY TELEPHONE; INFORMATION TRANSMISSION VIA ELECTRONIC COMMUNICATIONS NETWORKS; PREPAID LOCAL AND LONG DISTANCE TELEPHONE SERVICES; PROVIDING FACILITIES AND EQUIPMENT FOR TELEPRESENCE CONFERENCING; PROVIDING TECHNICAL SUPPORT SERVICES REGARDING THE USAGE OF COMMUNICATIONS EQUIPMENT; VOICEMAIL SERVICES (U.S. CLS. 100, 101 AND 104).

FIRST USE 8-6-2004; IN COMMERCE 8-6-2004.

4,154,792. AT&T INTELLECTUAL PROPERTY II, L.P., RENO, NV. SN 85-129,806. PUB. 7-26-2011, FILED 9-15-2010.

AT&T UC CENTRAL

THE MARK CONSISTS OF STANDARD CHARACTERS WITHOUT CLAIM TO ANY PARTICULAR FONT, STYLE, SIZE, OR COLOR.

OWNER OF U.S. REG. NOS. 1,296,936, 1,970,579, AND OTHERS.

NO CLAIM IS MADE TO THE EXCLUSIVE RIGHT TO USE "UC", APART FROM THE MARK AS SHOWN.

FOR TELECOMMUNICATIONS SERVICES, NAMELY, TRANSMISSION OF VOICE AND AUDIO BY MEANS OF TELECOMMUNICATIONS NETWORKS, WIRELESS COMMUNICATION NETWORKS, AND THE INTERNET; PROVIDING INSTANT MESSAGING, EMAIL, WEB CONFERENCING, TELECONFERENCING AND VIDEO TELECONFERENCING SERVICES (U.S. CLS. 100, 101 AND 104).

FIRST USE 1-26-2012; IN COMMERCE 1-26-2012.

CLASS 38—(Continued).

4,155,152. READY MOBILE LLC, HIAWATHA, IA. SN 85-252,102. PUB. 7-5-2011, FILED 2-25-2011.

AIRFAIR

THE MARK CONSISTS OF STANDARD CHARACTERS WITHOUT CLAIM TO ANY PARTICULAR FONT, STYLE, SIZE, OR COLOR.

FOR CELLULAR TELEPHONE TELECOMMUNICATIONS SERVICES PROVIDED VIA PREPAID AIR TIME CELLULAR TELEPHONES AND PREPAID AIR TIME CELLULAR TELEPHONE CALLING CARD SERVICES; CELLULAR TELEPHONE TELECOMMUNICATIONS SERVICES, NAMELY, THE TRANSMISSION OF VOICE, DATA, IMAGES, AUDIO, AND VIDEO VIA TELEPHONE; WIRELESS MOBILE TELEPHONY AND BROADBAND COMMUNICATION SERVICES (U.S. CLS. 100, 101 AND 104).

FIRST USE 3-0-2011; IN COMMERCE 3-0-2011.

4,155,291. ADELMAN TRAVEL SYSTEMS, INC., MILWAUKEE, WI. SN 85-266,396. PUB. 10-25-2011, FILED 3-14-2011.

VIDEOTRavel

THE MARK CONSISTS OF STANDARD CHARACTERS WITHOUT CLAIM TO ANY PARTICULAR FONT, STYLE, SIZE, OR COLOR.

FOR VIDEO CONFERENCING SERVICES AND CONSULTING SERVICES RELATED TO VIDEOCONFERENCING; PROVIDING TECHNICAL SUPPORT SERVICES REGARDING THE USAGE OF VIDEOCONFERENCING EQUIPMENT (U.S. CLS. 100, 101 AND 104).

FIRST USE 9-0-2011; IN COMMERCE 9-0-2011.

4,155,399. ELECTRONIC REMEDY, INC., NATICK, MA. SN 85-282,884. PUB. 8-9-2011, FILED 3-31-2011.

purepractice

THE MARK CONSISTS OF STANDARD CHARACTERS WITHOUT CLAIM TO ANY PARTICULAR FONT, STYLE, SIZE, OR COLOR.

FOR ELECTRONIC DATA INTERCHANGE SERVICES IN THE FIELD OF HEALTHCARE TRANSACTIONS SUCH AS CLAIMS, ELIGIBILITY, CLAIM STATUS, ELECTRONIC REMITTANCE ADVICE, PRIOR AUTHORIZATIONS, ATTACHMENTS AND REFERRALS THAT ALLOW DIRECT TRANSACTION AND PAYMENT COMMUNICATIONS BETWEEN HEALTHCARE PROVIDERS AND PAYERS (U.S. CLS. 100, 101 AND 104).

FIRST USE 1-27-2010; IN COMMERCE 10-19-2011.

CLASS 38—(Continued).

4,155,769. CABLE NEWS NETWORK, INC., ATLANTA, GA. SN 85-394,306. PUB. 1-3-2012, FILED 8-10-2011.



OWNER OF U.S. REG. NOS. 3,791,013, 3,804,102, AND OTHERS.

NO CLAIM IS MADE TO THE EXCLUSIVE RIGHT TO USE ".COM", APART FROM THE MARK AS SHOWN.

THE MARK CONSISTS OF A BRACKET WITH THE LETTERS "HLNTV.COM" ENCLOSED.

FOR CABLE TELEVISION AND SATELLITE BROADCASTING SERVICES, STREAMING OF AUDIO, VIDEO AND AUDIO/VIDEO MATERIALS OVER THE INTERNET, OTHER THAN BROADCAST OF LIVE SPORTING EVENTS OR LIVE COLLEGIATE SPORTING ACTIVITIES AND THE STREAMING OVER THE INTERNET OF LIVE SPORTING EVENTS OR LIVE COLLEGIATE SPORTING ACTIVITIES (U.S. CLS. 100, 101 AND 104).

FIRST USE 10-27-2011; IN COMMERCE 10-27-2011.

CLASS 39—(Continued).

4,154,584. SEARS BRANDS, LLC, HOFFMAN ESTATES, IL. SN 77-983,088. PUB. 12-8-2009, FILED 2-10-2009.



THE MARK CONSISTS OF A DESIGN OF AN UPSIDE DOWN SHOPPING CART.

FOR PERSONAL DELIVERY SERVICES, NAMELY, DELIVERY OF GOODS BY BICYCLE, CAR, TRUCK AND AIR (U.S. CLS. 100 AND 105).

FIRST USE 4-0-2009; IN COMMERCE 4-0-2009.

4,155,146. SAZERAC NORTH AMERICA, INC., FRANKFORT, KY. SN 85-251,693. PUB. 7-5-2011, FILED 2-25-2011.

CLASS 39—TRANSPORTATION AND STORAGE

4,154,402. DISNEY ENTERPRISES, INC., BURBANK, CA. SN 77-687,747. PUB. 7-7-2009, FILED 3-10-2009.



DISNEY FANTASY

THE MARK CONSISTS OF STANDARD CHARACTERS WITHOUT CLAIM TO ANY PARTICULAR FONT, STYLE, SIZE, OR COLOR.

FOR PASSENGER CRUISE SHIP SERVICES (U.S. CLS. 100 AND 105).

FIRST USE 3-31-2012; IN COMMERCE 3-31-2012.

THE MARK CONSISTS OF THE CAPITAL LETTER "B" IN A CIRCLE TO THE LEFT OF THE WORD "BARTON", WHICH IS IN ALL CAPS.

FOR BOTTLING SERVICES; PACKING, CRATING AND WAREHOUSING SERVICES; SHIPPING OF GOODS; WAREHOUSING SERVICES, NAMELY, STORAGE, DISTRIBUTION, PICK-UP, PACKING, AND SHIPPING OF DISTILLED SPIRITS; ARRANGING AND CONDUCTING DISTILLERY TOURS (U.S. CLS. 100 AND 105).

FIRST USE 5-30-2011; IN COMMERCE 5-30-2011.

CLASS 39—(Continued).

4,155,576. KHM CONSULTING INC., DBA KHM TRAVEL GROUP, BRUNSWICK, OH. SN 85-333,854. PUB. 10-25-2011, FILED 5-31-2011.

Luxevo

THE MARK CONSISTS OF STANDARD CHARACTERS WITHOUT CLAIM TO ANY PARTICULAR FONT, STYLE, SIZE, OR COLOR.

FOR TRAVEL CLUBS (U.S. CLS. 100 AND 105).
FIRST USE 5-31-2011; IN COMMERCE 10-10-2011.

4,155,738. KHM CONSULTING, INC., DBA KHM TRAVEL GROUP, BRUNSWICK, OH. SN 85-381,251. PUB. 12-13-2011, FILED 7-26-2011.



NO CLAIM IS MADE TO THE EXCLUSIVE RIGHT TO USE "TRAVEL", APART FROM THE MARK AS SHOWN.

THE COLOR(S) BLACK, WHITE, LIGHT GOLD, AND DARK GOLD IS/ARE CLAIMED AS A FEATURE OF THE MARK.

THE MARK CONSISTS OF THE WORD "LUXEVO" IN A BLACK STYLIZED FONT WITH A GOLD GRADIENT OUTLINE. THE LETTER "E" HAS A MACRON OR LATIN LONG MARK APPEARING AS A BLACK HORIZONTAL LINE OVER THE LETTER. A STYLIZED GLOBE WITH WHITE LONGITUDE AND LATITUDE LINES AND WHITE CONTINENTS APPEARS BEHIND THE LETTER "L", FADING FROM DARK GOLD AT THE TOP TO LIGHT GOLD AT THE BOTTOM. THE WORDS "THE EVOLUTION OF TRAVEL" APPEAR IN A BLACK STYLIZED FONT BELOW THE WORD "LUXEVO".

FOR TRAVEL CLUBS (U.S. CLS. 100 AND 105).
FIRST USE 5-31-2011; IN COMMERCE 10-10-2011.

CLASS 40—MATERIAL TREATMENT

4,154,325. COMPACTION TECHNOLOGIES, INC., MENDOTA HEIGHTS, MN. SN 77-528,395. PUB. 6-1-2010, FILED 7-22-2008.



NO CLAIM IS MADE TO THE EXCLUSIVE RIGHT TO USE "COMPACTION TECHNOLOGIES, INC", APART FROM THE MARK AS SHOWN.

CLASS 40—(Continued).

THE MARK CONSISTS OF TWO WINDING ARROWS APPEARING NEXT TO THE WORDS "COMPACTION TECHNOLOGIES, INC. MAKE AN IMPACT".

FOR CONSULTING SERVICES IN THE FIELD OF WASTE MANAGEMENT (U.S. CLS. 100, 103 AND 106).
FIRST USE 2-2-2007; IN COMMERCE 2-8-2008.

4,154,874. WILLEMS COMMERCIAL PRINTING, INC., FOWLER, CA. SN 85-164,225. PUB. 4-12-2011, FILED 10-28-2010.



NO CLAIM IS MADE TO THE EXCLUSIVE RIGHT TO USE "PRINT", APART FROM THE MARK AS SHOWN.

THE MARK CONSISTS OF A PARROT ILLUSTRATION AND THE WORDS "PARROT PRINT".

FOR PRINTING; PRINTING OF ADVERTISING BROCHURES FOR OTHERS (U.S. CLS. 100, 103 AND 106).
FIRST USE 10-15-2010; IN COMMERCE 10-15-2010.

4,155,021. RAY PRODUCTS COMPANY, INC., ONTARIO, CA. SN 85-231,828. PUB. 6-28-2011, FILED 2-1-2011.



OWNER OF U.S. REG. NOS. 930,034 AND 3,760,622.

NO CLAIM IS MADE TO THE EXCLUSIVE RIGHT TO USE "PRODUCTS CO., INC.", APART FROM THE MARK AS SHOWN.

THE COLOR(S) BLUE, WHITE AND LIGHT GRAY IS/ARE CLAIMED AS A FEATURE OF THE MARK.

THE MARK CONSISTS OF THE WORD "RAY" IN THE COLOR WHITE INSIDE A BLUE RECTANGLE; THE WORDS "PRODUCTS CO., INC." ARE ALSO IN WHITE ARE BELOW THE WORD "RAY". A PARTIAL LIGHT GRAY RECTANGLE APPEARS AS A SHADOW BEHIND THE BLUE RECTANGLE ON THE BOTTOM AND RIGHT SIDES.

FOR THERMOFORMING SERVICES, NAMELY, THERMOFORMING HEAVY GAUGE THERMOPLASTIC MATERIALS TO THE ORDER AND/OR SPECIFICATION OF OTHERS (U.S. CLS. 100, 103 AND 106).

FIRST USE 2-10-2011; IN COMMERCE 2-10-2011.

CLASS 40—(Continued).

4,155,077. JOSEPH P. WHITE, BERLIN, CT. SN 85-243,588. PUB. 7-12-2011, FILED 2-16-2011.

The Nameplate Pundit

THE MARK CONSISTS OF STANDARD CHARACTERS WITHOUT CLAIM TO ANY PARTICULAR FONT, STYLE, SIZE, OR COLOR.

NO CLAIM IS MADE TO THE EXCLUSIVE RIGHT TO USE "NAMEPLATE", APART FROM THE MARK AS SHOWN.

FOR CUSTOM MANUFACTURE OF NAMEPLATES, PRODUCT LABELS, AND DECALS TO THE ORDER AND SPECIFICATION OF OTHERS (U.S. CLS. 100, 103 AND 106).

FIRST USE 2-25-2010; IN COMMERCE 2-25-2010.

CLASS 40—(Continued).

4,155,391. TIME-CAP LABORATORIES, INC., FARMINGDALE, NY. SN 85-281,627. PUB. 8-9-2011, FILED 3-30-2011.

PROVIDING A SOLID DOSE OF INNOVATION

THE MARK CONSISTS OF STANDARD CHARACTERS WITHOUT CLAIM TO ANY PARTICULAR FONT, STYLE, SIZE, OR COLOR.

FOR CONTRACT MANUFACTURE OF PHARMACEUTICAL PRODUCTS TO THE ORDER AND SPECIFICATIONS OF OTHERS (U.S. CLS. 100, 103 AND 106).

FIRST USE 6-1-2011; IN COMMERCE 6-1-2011.

4,155,167. VOIGT & SCHWEITZER, LLC, COLUMBUS, OH. SN 85-253,420. PUB. 7-12-2011, FILED 2-28-2011.

MICROZINQ

THE MARK CONSISTS OF STANDARD CHARACTERS WITHOUT CLAIM TO ANY PARTICULAR FONT, STYLE, SIZE, OR COLOR.

OWNER OF U.S. REG. NOS. 2,341,569 AND 2,428,081. FOR GALVANIZING (U.S. CLS. 100, 103 AND 106).

FIRST USE 3-5-2012; IN COMMERCE 3-5-2012.

4,155,290. ODL, INCORPORATED, ZEELAND, MI. SN 85-266,272. PUB. 7-26-2011, FILED 3-14-2011.

THE POWER OF 10

THE MARK CONSISTS OF STANDARD CHARACTERS WITHOUT CLAIM TO ANY PARTICULAR FONT, STYLE, SIZE, OR COLOR.

FOR CUSTOM MANUFACTURE OF WINDOWS, NAMELY, DOORGLASS (U.S. CLS. 100, 103 AND 106).

FIRST USE 3-20-2011; IN COMMERCE 3-20-2011.

CLASS 41—EDUCATION AND ENTERTAINMENT

4,154,268. CREIGHTON UNIVERSITY, OMAHA, NE. SN 76-709,130. PUB. 12-6-2011, FILED 9-19-2011.

CREIGHTON EDGE

THE MARK CONSISTS OF STANDARD CHARACTERS WITHOUT CLAIM TO ANY PARTICULAR FONT, STYLE, SIZE, OR COLOR.

OWNER OF U.S. REG. NO. 2,938,718.

FOR EDUCATIONAL SERVICES, NAMELY, PROVIDING INSTRUCTION AT THE COLLEGE AND POST-GRADUATE LEVEL (U.S. CLS. 100, 101 AND 107).

FIRST USE 10-23-2011; IN COMMERCE 10-23-2011.

4,154,277. PARK RIDGE SECURITIES CORP., LYFORD CAY, NEW PROVIDENCE, BAHAMAS. SN 77-263,879. PUB. 1-6-2009, FILED 8-24-2007.

ALBANY GOLF & BEACH CLUB

THE MARK CONSISTS OF STANDARD CHARACTERS WITHOUT CLAIM TO ANY PARTICULAR FONT, STYLE, SIZE, OR COLOR.

CLASS 41—(Continued).

NO CLAIM IS MADE TO THE EXCLUSIVE RIGHT TO USE "GOLF & BEACH CLUB", APART FROM THE MARK AS SHOWN.

FOR HEALTH CLUB SERVICES, NAMELY, PROVIDING INSTRUCTION AND EQUIPMENT IN THE FIELD OF PHYSICAL EXERCISE; PROVIDING GOLF COURSE FACILITIES, PROVIDING GOLF INSTRUCTION AND ENTERTAINMENT IN THE NATURE OF GOLF TOURNAMENTS, AND PROVIDING EDUCATIONAL SERVICES, NAMELY, CONDUCTING SEMINARS, WORKSHOPS AND CLASSES IN THE FIELD OF GOLF; PROVIDING PHYSICAL FITNESS INFORMATION AND CONSULTATION (U.S. CLS. 100, 101 AND 107).

FIRST USE 10-4-2010; IN COMMERCE 10-4-2010.

4,154,310. SHASHINKA, LINDA, SANDY SPRINGS, GA. SN 77-489,700. PUB. 5-5-2009, FILED S.R. 6-3-2008; AM. P.R. 3-17-2009.

ReadyEditor

THE MARK CONSISTS OF STANDARD CHARACTERS WITHOUT CLAIM TO ANY PARTICULAR FONT, STYLE, SIZE, OR COLOR.

FOR CUSTOM WRITING SERVICES; PUBLICATION AND EDITING OF PRINTED MATTER; WRITING OF ARTICLES FOR JOURNALS OTHER THAN FOR ADVERTISING OR PUBLICITY; WRITING OF ARTICLES FOR PERIODICALS OTHER THAN FOR ADVERTISING OR PUBLICITY; WRITING OF ARTICLES FOR PROFESSIONAL JOURNALS OTHER THAN FOR ADVERTISING OR PUBLICITY; WRITING OF TEXTS; WRITING OF TEXTS OTHER THAN PUBLICITY TEXTS; WRITTEN TEXT EDITING (U.S. CLS. 100, 101 AND 107).

FIRST USE 1-3-2005; IN COMMERCE 1-3-2005.

4,154,352. PATERSON, PAGE, WILMINGTON, NC. SN 77-564,560. PUB. 2-3-2009, FILED 9-8-2008.

EAST MEETS WEST

THE MARK CONSISTS OF STANDARD CHARACTERS WITHOUT CLAIM TO ANY PARTICULAR FONT, STYLE, SIZE, OR COLOR.

FOR PROVIDING ON-LINE TRAINING TO WESTERN HEALTHCARE PRACTITIONERS IN THE FORM OF COURSES, SEMINARS AND WORKSHOPS IN THE FIELD OF EASTERN MEDICINE (U.S. CLS. 100, 101 AND 107).

FIRST USE 1-6-2012; IN COMMERCE 1-6-2012.

CLASS 41—(Continued).

4,154,359. ANSON & HIGGINS PLASTIC SURGERY ASSOCIATES, LLP, LAS VEGAS, NV. SN 77-582,652. PUB. 2-17-2009, FILED 9-30-2008.

THE CUTTING EDGE OF BEAUTY

THE MARK CONSISTS OF STANDARD CHARACTERS WITHOUT CLAIM TO ANY PARTICULAR FONT, STYLE, SIZE, OR COLOR.

FOR EDUCATIONAL AND ENTERTAINMENT SERVICES, NAMELY, A CONTINUING PROGRAM ABOUT COSMETIC AND PLASTIC SURGERY ACCESSIBLE BY AUDIO, VIDEO AND COMPUTER NETWORKS (U.S. CLS. 100, 101 AND 107).

FIRST USE 2-0-2012; IN COMMERCE 2-0-2012.

4,154,360. ANSON & HIGGINS PLASTIC SURGERY ASSOCIATES, LLP, LAS VEGAS, NV. SN 77-582,661. PUB. 2-17-2009, FILED 9-30-2008.

BEAUTY'S CUTTING EDGE

THE MARK CONSISTS OF STANDARD CHARACTERS WITHOUT CLAIM TO ANY PARTICULAR FONT, STYLE, SIZE, OR COLOR.

FOR EDUCATIONAL AND ENTERTAINMENT SERVICES, NAMELY, A CONTINUING PROGRAM ABOUT COSMETIC AND PLASTIC SURGERY ACCESSIBLE BY AUDIO, VIDEO AND COMPUTER NETWORKS (U.S. CLS. 100, 101 AND 107).

FIRST USE 2-0-2012; IN COMMERCE 2-0-2012.

4,154,383. LITEMAN, GODNI AMIR, NEW YORK, NY. SN 77-655,612. PUB. 9-14-2010, FILED 1-23-2009.



THE MARK CONSISTS OF VIOLIN ON THE LEFT, A HARP ON THE RIGHT AND IN BETWEEN THEM A FIVE-SIDED SHAPE CONTAINING TWELVE SQUARES AND A SCROLL/FLORAL BACKGROUND DESIGN AND DIAMOND SHAPE AT THE BOTTOM CONTAINING A HORN; A CROWN APPEARS AT THE TOP OF THE MARK AND A SCROLL/FLORAL DESIGN APPEARS AT THE BOTTOM; THE FOLLOWING CULTURAL/RELIGIOUS SYMBOLS APPEAR WITHIN THE TWELVE SQUARES: THE STAR OF DAVID, REPRESENTING JUDAISM; THE CRESCENT AND STAR, REPRESENTING ISLAM; THE CROSS, REPRESENTING CHRISTIANITY; THE OM CHARACTER, REPRESENTING HINDUISM; THE HAND, REPRESENTING JAINISM;

CLASS 41—(Continued).

THE YIN AND YANG, REPRESENTING TAOISM; THE CHINESE CHARACTER, REPRESENTING CONFUCIANISM; THE INSCRIBED CIRCLE, REPRESENTING PAGANISM; THE PAGODA SYMBOL, REPRESENTING SHINTOISM; THE FLOWER INSCRIBED IN A CIRCLE, REPRESENTING BUDDHISM; THE 9-POINTED STAR-BURST, REPRESENTING BAHAI; AND THE KHANDA (A DOUBLE-EDGED SWORD SURROUNDED BY A CIRCLE AND TWO SWORDS ON THE OUTSIDE), REPRESENTING SIKHISM.

FOR ENTERTAINMENT IN THE NATURE OF ORCHESTRA PERFORMANCES; ENTERTAINMENT IN THE NATURE OF VISUAL AND AUDIO PERFORMANCES, NAMELY, MUSICAL BAND, ROCK GROUP, GYMNASTIC, DANCE, AND BALLET PERFORMANCES; ENTERTAINMENT SERVICES IN THE NATURE OF LIVE MUSICAL PERFORMANCES; ENTERTAINMENT SERVICES, NAMELY, PROVIDING A WEB SITE FEATURING PHOTOGRAPHIC, AUDIO, VIDEO AND PROSE PRESENTATIONS FEATURING MUSIC AND DANCE PERFORMANCE; ENTERTAINMENT SERVICES, NAMELY, PROVIDING A WEB SITE FEATURING MUSICAL PERFORMANCES, MUSICAL VIDEOS, RELATED FILM CLIPS, PHOTOGRAPHS, AND OTHER MULTIMEDIA MATERIALS FEATURING MUSIC AND DANCE PERFORMANCES; ENTERTAINMENT SERVICES, NAMELY, PROVIDING PRERECORDED MUSIC, INFORMATION IN THE FIELD OF MUSIC, AND COMMENTARY AND ARTICLES ABOUT MUSIC, ALL ONLINE VIA A GLOBAL COMPUTER NETWORK; ENTERTAINMENT, NAMELY, LIVE PERFORMANCES BY A MUSICAL BAND; ENTERTAINMENT, NAMELY, PRODUCTION OF CDS, DVDS, AUDIO AND VIDEO (U.S. CLS. 100, 101 AND 107).

FIRST USE 1-1-2010; IN COMMERCE 1-1-2011.

4,154,384. LITEMAN, GODNI AMIR, NEW YORK, NY. SN 77-655,657. PUB. 9-14-2010, FILED 1-23-2009.



THE COLOR(S) GOLD, SILVER, BLACK, COPPER, GREY AND WHITE IS/ARE CLAIMED AS A FEATURE OF THE MARK.

THE MARK CONSISTS OF A BIRD WITH WINGS SPREAD OPEN CARRYING A CROWN ON ITS HEAD AND A COAT OF ARMS DESIGN CONTAINING THE FOLLOWING ON ITS BACK: A VIOLIN ON THE LEFT, A HARP ON THE RIGHT AND IN BETWEEN THEM A FIVE-SIDED SHAPE CONTAINING TWELVE SQUARES, A SCROLL/FLOREAL BACKGROUND DESIGN AND DIAMOND SHAPE AT THE BOTTOM CONTAINING A HORN; A SCROLL/FLOREAL DESIGN APPEARS BELOW THE FIVE-SIDED SHAPE; THE FOLLOWING CULTURAL/RELIGIOUS SYMBOLS APPEAR WITHIN THE TWELVE SQUARES: THE STAR OF DAVID, REPRESENTING JUDAISM; THE CRESCENT AND STAR, REPRESENTING ISLAM; THE CROSS, REPRESENTING CHRISTIANITY; THE OM CHARACTER, REPRESENTING HINDUISM; THE HAND, REPRESENTING JAINISM; THE YIN AND YANG, REPRESENTING TAOISM; THE CHINESE CHARACTER, REPRESENTING CONFUCIANISM; THE INSCRIBED CIRCLE, REPRESENTING PAGANISM; THE PAGODA SYMBOL, REPRESENTING SHINTOISM; THE FLOWER INSCRIBED IN A CIRCLE, REPRESENTING BUDDHISM; THE 9-POINTED STAR-BURST, REPRESENTING BAHAI; AND THE KHANDA (A

CLASS 41—(Continued).

DOUBLE-EDGED SWORD SURROUNDED BY A CIRCLE AND TWO SWORDS ON THE OUTSIDE), REPRESENTING SIKHISM. THE COLOR GREY APPEARS IN THE OUTLINE OF THE VIOLIN AND HARP AND IN THE HARP STRINGS; THE COLOR SILVER APPEARS IN THE FIVE-SIDED SHAPE, THE VIOLIN, THE CROWN AND THE HORN; THE COLOR BLACK APPEARS IN THE TWELVE SQUARE AND IN THE BIRD'S BEAKS; THE COLOR GOLD APPEARS IN THE VIOLIN, CROWN, HORN, HARP AND BIRD DESIGNS, IN TWO SIDES OF THE DIAMOND SHAPE AND IN THE CULTURAL/RELIGIOUS SYMBOLS/DESIGNS; THE COLOR COPPER APPEARS IN THE VIOLIN, CROWN, HORN, HARP AND BIRD DESIGNS; THE COLOR WHITE APPEARS IN THE CULTURAL/RELIGIOUS SYMBOLS/DESIGNS, IN THE CROWN, IN THE VIOLIN, IN THE BIRD DESIGN AND AS A BACKGROUND COLOR IN THE FIVE-SIDED DESIGN.

FOR ENTERTAINMENT IN THE NATURE OF ORCHESTRA PERFORMANCES; ENTERTAINMENT IN THE NATURE OF VISUAL AND AUDIO PERFORMANCES, NAMELY, MUSICAL BAND, ROCK GROUP, GYMNASTIC, DANCE, AND BALLET PERFORMANCES; ENTERTAINMENT SERVICES IN THE NATURE OF LIVE MUSICAL PERFORMANCES; ENTERTAINMENT SERVICES, NAMELY, PROVIDING A WEB SITE FEATURING PHOTOGRAPHIC, AUDIO, VIDEO AND PROSE PRESENTATIONS FEATURING MUSIC AND DANCE PERFORMANCE; ENTERTAINMENT SERVICES, NAMELY, PROVIDING A WEB SITE FEATURING MUSICAL PERFORMANCES, MUSICAL VIDEOS, RELATED FILM CLIPS, PHOTOGRAPHS, AND OTHER MULTIMEDIA MATERIALS FEATURING MUSIC AND DANCE PERFORMANCES; ENTERTAINMENT SERVICES, NAMELY, PROVIDING PRERECORDED MUSIC, INFORMATION IN THE FIELD OF MUSIC, AND COMMENTARY AND ARTICLES ABOUT MUSIC, ALL ONLINE VIA A GLOBAL COMPUTER NETWORK; ENTERTAINMENT, NAMELY, LIVE PERFORMANCES BY A MUSICAL BAND; ENTERTAINMENT, NAMELY, PRODUCTION OF CDS, DVDS, AUDIO AND VIDEO (U.S. CLS. 100, 101 AND 107).

FIRST USE 1-1-2010; IN COMMERCE 1-1-2011.

4,154,385. LITEMAN, GODNI AMIR, NEW YORK, NY. SN 77-655,664. PUB. 9-14-2010, FILED 1-23-2009.

A FREE BIRD

THE MARK CONSISTS OF STANDARD CHARACTERS WITHOUT CLAIM TO ANY PARTICULAR FONT, STYLE, SIZE, OR COLOR.

FOR ENTERTAINMENT IN THE NATURE OF ORCHESTRA PERFORMANCES; ENTERTAINMENT IN THE NATURE OF VISUAL AND AUDIO PERFORMANCES, NAMELY, MUSICAL BAND, ROCK GROUP, GYMNASTIC, DANCE, AND BALLET PERFORMANCES; ENTERTAINMENT SERVICES IN THE NATURE OF LIVE MUSICAL PERFORMANCES; ENTERTAINMENT SERVICES, NAMELY, PROVIDING A WEB SITE FEATURING PHOTOGRAPHIC, AUDIO, VIDEO AND PROSE PRESENTATIONS FEATURING MUSIC AND DANCE PERFORMANCE; ENTERTAINMENT SERVICES, NAMELY, PROVIDING A WEB SITE FEATURING MUSICAL PERFORMANCES, MUSICAL VIDEOS, RELATED FILM CLIPS, PHOTOGRAPHS, AND OTHER MULTIMEDIA MATERIALS FEATURING MUSIC AND DANCE PERFORMANCES; ENTERTAINMENT SERVICES, NAMELY, PROVIDING PRERECORDED MUSIC, INFORMATION IN THE FIELD OF MUSIC, AND COMMENTARY AND ARTICLES ABOUT MUSIC, ALL ONLINE VIA A GLOBAL COMPUTER NETWORK; ENTERTAINMENT, NAMELY, LIVE PERFORMANCES BY A MUSICAL BAND; ENTERTAINMENT, NAMELY, PRODUCTION OF CDS, DVDS, AUDIO AND VIDEO (U.S. CLS. 100, 101 AND 107).

FIRST USE 1-1-2010; IN COMMERCE 1-1-2010.

CLASS 41—(Continued).

4,154,403. COOKING MAMA LIMITED, KOWLOON, HONG KONG, CHINA. SN 77-688,116. PUB. 7-14-2009, FILED 3-11-2009.

CRAFTING MAMA

THE MARK CONSISTS OF STANDARD CHARACTERS WITHOUT CLAIM TO ANY PARTICULAR FONT, STYLE, SIZE, OR COLOR.

FOR PROVIDING ON-LINE COMPUTER GAMES (U.S. CLS. 100, 101 AND 107).

FIRST USE 1-31-2012; IN COMMERCE 1-31-2012.

4,154,412. KIMBERLY KEARNEY, VAN NUYS, CA. SN 77-707,681. PUB. 7-19-2011, FILED 4-6-2009.

BIG GIRLS NEED LOVE TOO

THE MARK CONSISTS OF STANDARD CHARACTERS WITHOUT CLAIM TO ANY PARTICULAR FONT, STYLE, SIZE, OR COLOR.

FOR ENTERTAINMENT SERVICES, NAMELY, AN ON-GOING SERIES FEATURING PLUS SIZED PEOPLE LOOKING FOR LOVE PROVIDED THROUGH TELEVISION, WEBCASTS, PODCASTS AND FILM (U.S. CLS. 100, 101 AND 107).

FIRST USE 3-13-2012; IN COMMERCE 3-13-2012.

4,154,414. COOKING MAMA LIMITED, KOWLOON, HONG KONG, CHINA. SN 77-715,158. PUB. 7-14-2009, FILED 4-16-2009.

BABYSITTING MAMA

THE MARK CONSISTS OF STANDARD CHARACTERS WITHOUT CLAIM TO ANY PARTICULAR FONT, STYLE, SIZE, OR COLOR.

NO CLAIM IS MADE TO THE EXCLUSIVE RIGHT TO USE "BABYSITTING", APART FROM THE MARK AS SHOWN.

FOR PROVIDING ON-LINE COMPUTER GAMES (U.S. CLS. 100, 101 AND 107).

FIRST USE 1-31-2012; IN COMMERCE 1-31-2012.

CLASS 41—(Continued).

4,154,423. MIAMI MARLINS, L.P., MIAMI, FL. SN 77-745,136. PUB. 4-13-2010, FILED 5-27-2009.

MIAMI MARLINS

THE MARK CONSISTS OF STANDARD CHARACTERS WITHOUT CLAIM TO ANY PARTICULAR FONT, STYLE, SIZE, OR COLOR.

OWNER OF U.S. REG. NOS. 1,807,380, 1,909,332, AND OTHERS.

NO CLAIM IS MADE TO THE EXCLUSIVE RIGHT TO USE "MIAMI", APART FROM THE MARK AS SHOWN.

FOR ENTERTAINMENT SERVICES, NAMELY, ORGANIZING AND CONDUCTING AN ARRAY OF ATHLETIC EVENTS RENDERED LIVE AND RECORDED FOR DISTRIBUTION THROUGH BROADCAST MEDIA; BASEBALL CAMPS, CLINICS; ORGANIZING AND CONDUCTING SPORTS CONTESTS AND SWEEPSTAKES; PRODUCTION AND PROVISION OF ON-GOING TELEVISION, INTERNET AND RADIO PROGRAMS IN THE FIELD OF SPORTS; PROVIDING NEWS, INFORMATION, PODCASTS, WEBCASTS, ONLINE NEWSLETTERS, AND ONLINE JOURNALS, NAMELY, BLOGS, ALL OF THE FOREGOING IN THE FIELD OF SPORTS; ORGANIZING COMMUNITY SPORTING AND CULTURAL EVENTS; ENTERTAINMENT IN THE NATURE OF LIVE PERFORMANCES BY COSTUMED MASCOTS, CHEERLEADERS AND DANCE GROUPS; FAN CLUBS; FESTIVALS FEATURING A VARIETY OF SPORTS AND ENTERTAINMENT ACTIVITIES; PROVIDING SPORTS FACILITIES (U.S. CLS. 100, 101 AND 107).

FIRST USE 9-26-2011; IN COMMERCE 9-26-2011.

4,154,432. MEDITOUREXPO LLC, LAS VEGAS, NV. SN 77-760,732. PUB. 12-21-2010, FILED 6-16-2009.

THE MARK CONSISTS OF THE TEXT "MTE" WITH A STYLIZED CENTER LINE FOR THE "E", A LINE UNDERNEATH THE TEXT, AND THE TEXT "MEDITOUREXPO" BELOW IT.

FOR ORGANIZING AND CONDUCTING EXHIBITIONS, CONFERENCES, MEETINGS, SYMPOSIA, SEMINARS, WORKSHOPS, CLASSES, LECTURES, DEMONSTRATIONS AND AUDIO AND VISUAL PRESENTATIONS IN THE FIELDS OF MEDICINE, HEALTH CARE AND MEDICAL TOURISM; MEDICAL AND HEALTH CARE TRAINING; PROVIDING ONLINE PUBLICATIONS IN THE NATURE OF JOURNALS, BLOGS AND BULLETINS IN THE FIELDS OF MEDICINE, HEALTH CARE AND MEDICAL TOURISM VIA A GLOBAL COMPUTER NETWORK AND WIRELESS COMMUNICATIONS NETWORK (U.S. CLS. 100, 101 AND 107).

FIRST USE 5-23-2011; IN COMMERCE 5-23-2011.

CLASS 41—(Continued).

4,154,434. EXIT STRATEGY INC., CHICAGO, IL. SN 77-767,982. PUB. 11-17-2009, FILED 6-25-2009.

BEACH MONEY

THE MARK CONSISTS OF STANDARD CHARACTERS WITHOUT CLAIM TO ANY PARTICULAR FONT, STYLE, SIZE, OR COLOR.

FOR LIVE CLASSES, WORKSHOPS, AND SEMINARS IN THE FIELD OF NETWORK MARKETING, LEADERSHIP, WEALTH CREATION, ENTREPRENEURSHIP, BUILDING BUSINESS RELATIONSHIPS, CHARITABLE GIVING, AND PHILANTHROPY (U.S. CLS. 100, 101 AND 107).

FIRST USE 4-16-2012; IN COMMERCE 4-16-2012.



4,154,447. HANBITSOFT, INC., SEOUL, REPUBLIC OF KOREA. SN 77-797,868. PUB. 12-29-2009, FILED 8-5-2009.

MYTHOS

THE MARK CONSISTS OF STANDARD CHARACTERS WITHOUT CLAIM TO ANY PARTICULAR FONT, STYLE, SIZE, OR COLOR.

FOR ENTERTAINMENT SERVICES, NAMELY, PROVIDING AN ON-LINE COMPUTER GAME (U.S. CLS. 100, 101 AND 107).

FIRST USE 2-0-2012; IN COMMERCE 2-0-2012.



4,154,450. MICHAEL WALTRIP RACING HOLDINGS, LLC, CORNELIUS, NC. SN 77-805,776. PUB. 3-1-2011, FILED 8-17-2009.

56

THE MARK CONSISTS OF STANDARD CHARACTERS WITHOUT CLAIM TO ANY PARTICULAR FONT, STYLE, SIZE, OR COLOR.

FOR ENTERTAINMENT SERVICES IN THE NATURE OF PARTICIPATING IN PROFESSIONAL AUTOMOBILE RACES AND AUTO RACING EXHIBITIONS (U.S. CLS. 100, 101 AND 107).

FIRST USE 8-1-2009; IN COMMERCE 1-1-2010.

CLASS 41—(Continued).

4,154,494. SMART COUNSEL, LLC, GREENSBURG, PA. SN 77-870,665. PUB. 4-20-2010, FILED 11-11-2009.

THE SMART COUNSEL LAW SCHOOL FOR DOCTORS

THE MARK CONSISTS OF STANDARD CHARACTERS WITHOUT CLAIM TO ANY PARTICULAR FONT, STYLE, SIZE, OR COLOR.

NO CLAIM IS MADE TO THE EXCLUSIVE RIGHT TO USE "COUNSEL LAW SCHOOL FOR DOCTORS", APART FROM THE MARK AS SHOWN.

FOR CONTINUING EDUCATION SERVICES, NAMELY, PROVIDING LIVE, ON-LINE, WORKSHOPS, AND TELE-SEMINARS AND, CONTINUING PROFESSION EDUCATION SEMINARS IN THE LEGAL FIELD AND MEDICAL FIELDS, AND DISTRIBUTING EDUCATIONAL MATERIALS IN THE FIELD OF CONTINUING PROFESSION EDUCATION IN THE LEGAL AND MEDICAL FIELDS IN CONNECTION THEREWITH (U.S. CLS. 100, 101 AND 107).

FIRST USE 3-26-2012; IN COMMERCE 3-26-2012.



4,154,495. SMART COUNSEL, LLC, GREENSBURG, PA. SN 77-870,669. PUB. 4-20-2010, FILED 11-11-2009.

THE SMART COUNSEL LAW SCHOOL FOR NURSES

THE MARK CONSISTS OF STANDARD CHARACTERS WITHOUT CLAIM TO ANY PARTICULAR FONT, STYLE, SIZE, OR COLOR.

NO CLAIM IS MADE TO THE EXCLUSIVE RIGHT TO USE "COUNSEL LAW SCHOOL FOR NURSES", APART FROM THE MARK AS SHOWN.

FOR CONTINUING EDUCATION SERVICES, NAMELY, PROVIDING LIVE, ON-LINE, WORKSHOPS, AND TELE-SEMINARS AND, CONTINUING PROFESSION EDUCATION SEMINARS IN THE LEGAL FIELD AND MEDICAL FIELDS, AND DISTRIBUTING EDUCATIONAL MATERIALS IN THE FIELD OF CONTINUING PROFESSION EDUCATION IN THE LEGAL AND MEDICAL FIELDS IN CONNECTION THEREWITH (U.S. CLS. 100, 101 AND 107).

FIRST USE 3-27-2012; IN COMMERCE 3-27-2012.

CLASS 41—(Continued).

4,154,496. SMART COUNSEL, LLC, GREENSBURG, PA. SN 77-870,675. PUB. 4-20-2010, FILED 11-11-2009.

THE SMART COUNSEL MEDICAL
SCHOOL FOR ATTORNEYS

THE MARK CONSISTS OF STANDARD CHARACTERS WITHOUT CLAIM TO ANY PARTICULAR FONT, STYLE, SIZE, OR COLOR.

NO CLAIM IS MADE TO THE EXCLUSIVE RIGHT TO USE "COUNSEL MEDICAL SCHOOL FOR ATTORNEYS", APART FROM THE MARK AS SHOWN.

FOR CONTINUING EDUCATION SERVICES, NAMELY, PROVIDING LIVE, ON-LINE, WORKSHOPS, AND TELE-SEMINARS AND, CONTINUING PROFESSION EDUCATION SEMINARS IN THE LEGAL FIELD AND MEDICAL FIELDS, AND DISTRIBUTING EDUCATIONAL MATERIALS IN THE FIELD OF CONTINUING PROFESSION EDUCATION IN THE LEGAL AND MEDICAL FIELDS IN CONNECTION THEREWITH (U.S. CLS. 100, 101 AND 107).

FIRST USE 3-26-2012; IN COMMERCE 3-26-2012.

4,154,505. MADSTONE COMPANY, INC., NEW YORK, NY. SN 77-880,791. PUB. 8-16-2011, FILED 11-25-2009.



THE MARK CONSISTS OF THE WORD "MAD STONE" BELOW THE DESIGN ELEMENT OF A MAN SITTING ON A ROCK.

FOR FILM PRODUCTION (U.S. CLS. 100, 101 AND 107).

FIRST USE 4-0-2008; IN COMMERCE 4-0-2008.

CLASS 41—(Continued).

4,154,537. MAMALAW MEDIA GROUP, SILVER SPRING, MD. SN 77-940,935. PUB. 1-18-2011, FILED 2-21-2010.

BLOGALICIOUS

THE MARK CONSISTS OF STANDARD CHARACTERS WITHOUT CLAIM TO ANY PARTICULAR FONT, STYLE, SIZE, OR COLOR.

FOR ONLINE JOURNALS, NAMELY, BLOGS FEATURING CONTENT RELATED TO TOPICS CONCERNING WOMEN, MARRIAGE, PARENTING, FAMILY, PERSONAL RELATIONSHIPS, HEALTH, WELLNESS, FITNESS, CAREERS AND WORK-LIFE BALANCE, FASHION, ENTREPRENEURSHIP AND BUSINESS, PERSONAL FINANCE, POLITICS, RELIGION, TECHNOLOGY, TRAVEL AND ENTERTAINMENT, RECREATION, AND ISSUES OF INTEREST TO FEMALE BLOGGERS; PROVIDING INFORMATION, NEWS, AND COMMENTARY IN THE FIELD OF SOCIAL MEDIA, ESSAY FICTION, AND NON-FICTION WRITING, AND JOURNALISM; EDUCATIONAL AND EVENT SERVICES, NAMELY, CONDUCTING SEMINARS, CONFERENCES, WORKSHOPS, AND SOCIAL EVENTS FOCUSING ON DIVERSITY IN SOCIAL MEDIA, MARKETING TO WOMEN OF COLOR, AND TOPICS CONCERNING WOMEN BLOGGERS (U.S. CLS. 100, 101 AND 107).

FIRST USE 5-0-2009; IN COMMERCE 5-0-2009.

4,154,548. SNYDER, VIRGINIE, TOPANGA, CA. SN 77-952,533. PUB. 8-31-2010, FILED 3-7-2010.



NO CLAIM IS MADE TO THE EXCLUSIVE RIGHT TO USE "RANCH", APART FROM THE MARK AS SHOWN.

THE COLOR(S) GREEN AND BURGUNDY IS/ARE CLAIMED AS A FEATURE OF THE MARK.

CLASS 41—(Continued).

THE MARK CONSISTS OF A SYCAMORE LEAF WHICH HAS GREENS AND BURGUNDIES AND THE WORDING "ER" AND "EVOLUTION RANCH", ALL IN BURGUNDY. THE STEM OF THE LEAF EXTENDS UPWARD OUT OF THE LETTER "R" IN "ER". THE WORD "EVOLUTION" IS BELOW "ER" AND ABOVE "RANCH", WHICH IS FLANKED BY LINES IN BURGUNDY. THE DESIGN IS BORDERED BY A BURGUNDY RECTANGLE WITH THE TOP SIDE CURVED UPWARD.

FOR PROVIDING FACILITIES FOR RECREATIONAL ACTIVITIES, NAMELY, A NATURE CONSERVANCY CENTER; PROVIDING FACILITIES FOR EDUCATIONAL TRAINING IN PERSONAL GROWTH AND ENVIRONMENTAL AWARENESS (U.S. CLS. 100, 101 AND 107).

FIRST USE 9-10-2008; IN COMMERCE 9-10-2008.

4,154,557. SNOWDEN, DONTRELL, WESTMINSTER, MD. SN 77-961,678. PUB. 8-17-2010, FILED 3-17-2010.

Black Olympus Entertainment

THE MARK CONSISTS OF STANDARD CHARACTERS WITHOUT CLAIM TO ANY PARTICULAR FONT, STYLE, SIZE, OR COLOR.

NO CLAIM IS MADE TO THE EXCLUSIVE RIGHT TO USE "ENTERTAINMENT", APART FROM THE MARK AS SHOWN.

FOR MULTIMEDIA ENTERTAINMENT SERVICES IN THE NATURE OF RECORDING, PRODUCTION AND POST-PRODUCTION SERVICES IN THE FIELDS OF MUSIC, VIDEO, AND FILMS (U.S. CLS. 100, 101 AND 107).

FIRST USE 1-6-2009; IN COMMERCE 9-1-2009.

4,154,601. CASHFLOW TECHNOLOGIES, INC., SCOTTS-DALE, AZ. SN 78-965,495. PUB. 7-21-2009, FILED 8-31-2006.

CHOOSE TO BE RICH

THE MARK CONSISTS OF STANDARD CHARACTERS WITHOUT CLAIM TO ANY PARTICULAR FONT, STYLE, SIZE, OR COLOR.

FOR PROVIDING ONLINE, NON-DOWNLOADABLE ELECTRONIC PUBLICATIONS, NAMELY, PAMPHLETS, BROCHURES AND NEWSLETTERS, IN THE FIELD OF FINANCIAL EDUCATION (U.S. CLS. 100, 101 AND 107).

FIRST USE 11-0-2002; IN COMMERCE 11-0-2002.

CLASS 41—(Continued).

4,154,603. THE ONE CAMPAIGN, WASHINGTON, DC. SN 78-980,967. PUB. 3-4-2008, FILED 7-8-2005.

(RED)

THE MARK CONSISTS OF STANDARD CHARACTERS WITHOUT CLAIM TO ANY PARTICULAR FONT, STYLE, SIZE, OR COLOR.

FOR ARRANGING AND CONDUCTING EDUCATIONAL CONFERENCES, SYMPOSIUMS AND EXHIBITIONS CONCERNING AIDS IN AFRICA AND OTHER HUMANITARIAN RELIEF EFFORTS; ONLINE JOURNALS, NAMELY, BLOGS DISCUSSING AND FOR THE PURPOSE OF PROMOTING AWARENESS ABOUT AIDS IN AFRICA AND OTHER HUMANITARIAN RELIEF EFFORTS (U.S. CLS. 100, 101 AND 107).

FIRST USE 10-13-2006; IN COMMERCE 10-13-2006.

4,154,604. RICHARD BROWN, NEW YORK, NY. SN 85-000,378. PUB. 8-17-2010, FILED 3-29-2010.

PRIVATE SCREENINGS

THE MARK CONSISTS OF STANDARD CHARACTERS WITHOUT CLAIM TO ANY PARTICULAR FONT, STYLE, SIZE, OR COLOR.

FOR EDUCATIONAL AND ENTERTAINMENT SERVICES, NAMELY, CONDUCTING SEMINARS, DISCUSSIONS AND INTERVIEWS ON FILMMAKING AND THE FILM INDUSTRY (U.S. CLS. 100, 101 AND 107).

FIRST USE 8-3-1987; IN COMMERCE 10-14-2011.

4,154,623. GROWTH-FOCUSED LIVING, INC., ROGERS, AR. SN 85-009,558. PUB. 3-1-2011, FILED 4-8-2010.

EMOTIONAL AND RELATIONAL INTELLIGENCE (ERQ)

THE MARK CONSISTS OF STANDARD CHARACTERS WITHOUT CLAIM TO ANY PARTICULAR FONT, STYLE, SIZE, OR COLOR.

NO CLAIM IS MADE TO THE EXCLUSIVE RIGHT TO USE "EMOTIONAL AND RELATIONAL INTELLIGENCE", APART FROM THE MARK AS SHOWN.

FOR EDUCATIONAL SERVICES, NAMELY, PROVIDING CLASSES, SEMINARS, AND WORKSHOPS IN THE FIELD OF PERSONAL DEVELOPMENT, NAMELY, SELF-IMPROVEMENT, SELF-FULFILLMENT, AND INTERPERSONAL COMMUNICATION (U.S. CLS. 100, 101 AND 107).

FIRST USE 10-26-2011; IN COMMERCE 10-26-2011.

CLASS 41—(Continued).

4,154,628. TWENTIETH CENTURY FOX FILM CORPORATION, LOS ANGELES, CA. SN 85-020,928. PUB. 2-1-2011, FILED 4-22-2010.

CHIPWRECKED

THE MARK CONSISTS OF STANDARD CHARACTERS WITHOUT CLAIM TO ANY PARTICULAR FONT, STYLE, SIZE, OR COLOR.

FOR PRODUCTION AND DISTRIBUTION OF MOTION PICTURE FILMS; PROVIDING ON-LINE INFORMATION IN THE FIELD OF MOTION PICTURE FILM AND VIDEO ENTERTAINMENT VIA THE INTERNET; ENTERTAINMENT SERVICES IN THE NATURE OF NON-DOWNLOADABLE VIDEOS AND IMAGES FEATURING MOTION PICTURE FILM AND ENTERTAINMENT TRANSMITTED VIA THE INTERNET AND WIRELESS COMMUNICATION NETWORKS (U.S. CLS. 100, 101 AND 107).

FIRST USE 11-1-2011; IN COMMERCE 11-1-2011.

4,154,640. PACIFIC ENTERTAINMENT CORPORATION, SAN DIEGO, CA. SN 85-040,645. PUB. 10-26-2010, FILED 5-17-2010.

CIRCLE OF EDUCATION

THE MARK CONSISTS OF STANDARD CHARACTERS WITHOUT CLAIM TO ANY PARTICULAR FONT, STYLE, SIZE, OR COLOR.

NO CLAIM IS MADE TO THE EXCLUSIVE RIGHT TO USE "EDUCATION", APART FROM THE MARK AS SHOWN.

FOR EDUCATION SERVICES IN THE NATURE OF EARLY CHILDHOOD INSTRUCTION; EDUCATION SERVICES, NAMELY, PROVIDING LIVE AND ON-LINE CLASSES, SEMINARS, LECTURES AND/OR WORKSHOPS IN THE FIELD OF EARLY LEARNING AND/OR PARENTING; EDUCATIONAL AND ENTERTAINMENT SERVICES, NAMELY, PROVIDING ON-LINE INTERACTIVE CHILDREN'S STORIES; EDUCATIONAL SERVICES, NAMELY, DEVELOPING CURRICULUM FOR EDUCATORS; EDUCATIONAL SERVICES, NAMELY, PROVIDING A CONTINUING PRERECORDED AUDIO PROGRAM IN THE FIELD OF EARLY LEARNING AND/OR PARENTING ACCESSIBLE OVER THE INTERNET; ENTERTAINMENT SERVICES, NAMELY, PROVIDING A WEB SITE FEATURING NON-DOWNLOADABLE MUSICAL PERFORMANCES, MUSICAL VIDEOS, RELATED FILM CLIPS, PHOTOGRAPHS, AND OTHER MULTIMEDIA MATERIALS FEATURING EARLY LEARNING AND/OR PARENTING; ENTERTAINMENT SERVICES, NAMELY, PROVIDING NON-DOWNLOADABLE PLAYBACK OF MUSIC VIA GLOBAL COMMUNICATIONS NETWORKS; ENTERTAINMENT SERVICES, NAMELY, PROVIDING TEMPORARY USE OF NON-DOWNLOADABLE COMPUTER GAMES; ENTERTAINMENT SERVICES,

CLASS 41—(Continued).

NAMELY, PROVIDING TEMPORARY USE OF NON-DOWNLOADABLE COMPUTER LEARNING GAMES; ENTERTAINMENT SERVICES, NAMELY, PROVIDING TEMPORARY USE OF NON-DOWNLOADABLE INTERACTIVE GAMES; ENTERTAINMENT SERVICES, NAMELY, PROVIDING TEMPORARY USE OF NON-DOWNLOADABLE VIDEO GAMES; INFORMATION IN THE FIELD OF PARENTING CONCERNING EDUCATION OF CHILDREN; ON-LINE ELECTRONIC NEWSLETTERS DELIVERED BY EMAIL IN THE FIELD OF EARLY LEARNING AND/OR PARENTING; PROVIDING A WEBSITE FEATURING EDUCATION AND ENTERTAINMENT FOR CHILDREN; PROVIDING ON-LINE E-ZINES IN THE FIELD OF EARLY LEARNING AND/OR PARENTING; PROVIDING ON-LINE MAGAZINES IN THE FIELD OF EARLY LEARNING AND/OR PARENTING; PROVISION OF INFORMATION IN THE FIELD OF CHILDREN'S EDUCATION; PROVISION OF NON-DOWNLOADABLE FILMS AND TELEVISION PROGRAMMES VIA A VIDEO-ON-DEMAND SERVICE (U.S. CLS. 100, 101 AND 107).

FIRST USE 5-0-2009; IN COMMERCE 5-0-2009.

4,154,653. APRIL MALMSTEEN, MIAMI, FL. AND YNGWIE MALMSTEEN, MIAMI, FL. SN 85-062,873. PUB. 11-16-2010, FILED 6-15-2010.

UNLEASH THE FURY

THE MARK CONSISTS OF STANDARD CHARACTERS WITHOUT CLAIM TO ANY PARTICULAR FONT, STYLE, SIZE, OR COLOR.

FOR AUDIO RECORDING AND PRODUCTION; DIGITAL VIDEO, AUDIO, AND MULTIMEDIA PUBLISHING SERVICES; ELECTRONIC PUBLISHING SERVICES, NAMELY, PUBLICATION OF TEXT AND GRAPHIC WORKS OF OTHERS ON CDS, DVDS AND ONLINE FEATURING MUSIC, MUSICAL PERFORMANCES AND DRAMATIC WORKS; ENTERTAINMENT IN THE NATURE OF LIVE RADIO PERSONALITY PERFORMANCES; ENTERTAINMENT INFORMATION SERVICES, NAMELY, PROVIDING INFORMATION AND NEWS RELEASES ABOUT A MUSICAL ARTIST; ENTERTAINMENT SERVICES, NAMELY, PROVIDING A WEB SITE FEATURING PHOTOGRAPHIC, VIDEO AND PROSE PRESENTATIONS FEATURING MUSIC, MUSICAL PERFORMANCES AND DRAMATIC WORKS; ENTERTAINMENT SERVICES, NAMELY, PROVIDING INFORMATION BY MEANS OF A GLOBAL COMPUTER NETWORK IN THE FIELDS OF CELEBRITIES, ENTERTAINMENT, AND POPULAR CULTURE; ENTERTAINMENT SERVICES, NAMELY, PROVIDING NONDOWNLOADABLE PRERECORDED MUSIC, INFORMATION IN THE FIELD OF MUSIC, AND COMMENTARY AND ARTICLES ABOUT MUSIC, ALL ONLINE VIA A GLOBAL COMPUTER NETWORK; ENTERTAINMENT, NAMELY, LIVE MUSIC CONCERTS; FILM AND VIDEO PRODUCTION; FILM AND VIDEO PRODUCTION CONSULTING SERVICES; MUSIC PUBLISHING SERVICES; PRODUCTION OF AUDIO RECORDING; PRODUCTION OF MUSICAL SOUND RECORDING; PRODUCTION OF SOUND RECORDINGS (U.S. CLS. 100, 101 AND 107).

FIRST USE 6-1-2005; IN COMMERCE 2-1-2012.

CLASS 41—(Continued).

4,154,685. BALE/DONEEN METHOD LLC, SPOKANE, WA. SN 85-089,759. PUB. 6-21-2011, FILED 7-21-2010.

BALE/DONEEN

THE MARK CONSISTS OF STANDARD CHARACTERS WITHOUT CLAIM TO ANY PARTICULAR FONT, STYLE, SIZE, OR COLOR.

FOR EDUCATIONAL SERVICES, NAMELY, PROVIDING INSTRUCTION IN THE NATURE OF CLASSES, COURSES, SEMINARS, WORKSHOPS AND TRAINING IN THE FIELD OF MEDICAL SCREENING AND DIAGNOSIS (U.S. CLS. 100, 101 AND 107).

FIRST USE 5-3-2007; IN COMMERCE 5-3-2007.



4,154,686. BALE/DONEEN METHOD LLC, SPOKANE, WA. SN 85-089,763. PUB. 6-21-2011, FILED 7-21-2010.

BALE/DONEEN METHOD

THE MARK CONSISTS OF STANDARD CHARACTERS WITHOUT CLAIM TO ANY PARTICULAR FONT, STYLE, SIZE, OR COLOR.

NO CLAIM IS MADE TO THE EXCLUSIVE RIGHT TO USE "METHOD", APART FROM THE MARK AS SHOWN.

THE WORDING "BALEDONEEN" HAS NO MEANING IN A FOREIGN LANGUAGE.

FOR EDUCATIONAL SERVICES, NAMELY, PROVIDING INSTRUCTION IN THE NATURE OF CLASSES, COURSES, SEMINARS, WORKSHOPS AND TRAINING IN THE FIELD OF MEDICAL SCREENING AND DIAGNOSIS (U.S. CLS. 100, 101 AND 107).

FIRST USE 5-3-2007; IN COMMERCE 5-3-2007.



4,154,693. NEW WORLD TELEVISION PROGRAMMING, LOS ANGELES, CA. SN 85-095,293. PUB. 1-11-2011, FILED 7-28-2010.

THE WONDER YEARS

THE MARK CONSISTS OF STANDARD CHARACTERS WITHOUT CLAIM TO ANY PARTICULAR FONT, STYLE, SIZE, OR COLOR.

OWNER OF U.S. REG. NO. 1,580,685.

FOR ENTERTAINMENT SERVICES IN THE NATURE OF A TELEVISION SERIES FEATURING DRAMA; ENTERTAINMENT SERVICES IN THE NATURE OF NON-DOWNLOADABLE VIDEOS FEATURING TELEVISION SHOWS TRANSMITTED VIA THE INTERNET AND WIRELESS COMMUNICATION NETWORKS (U.S. CLS. 100, 101 AND 107).

FIRST USE 1-31-1998; IN COMMERCE 1-31-1998.

CLASS 41—(Continued).

4,154,726. SCRIPPS NETWORKS, LLC, KNOXVILLE, TN. SN 85-106,410. PUB. 8-30-2011, FILED 8-12-2010.

HOLLYWOOD AT HOME

THE MARK CONSISTS OF STANDARD CHARACTERS WITHOUT CLAIM TO ANY PARTICULAR FONT, STYLE, SIZE, OR COLOR.

FOR EDUCATIONAL AND ENTERTAINMENT SERVICES, NAMELY, A CONTINUING PROGRAM FEATURING TOURS OF CELEBRITY HOUSES, ACCESSIBLE BY RADIO, TELEVISION, CABLE, FIBER OPTIC NETWORKS, WIRELESS NETWORKS, SATELLITE, AUDIO VIDEO, AND COMPUTER NETWORKS (U.S. CLS. 100, 101 AND 107).

FIRST USE 4-30-2011; IN COMMERCE 4-30-2011.



4,154,731. MUSIC FROM THE MITTEN, LLC, BEVERLY HILLS, CA. SN 85-107,075. PUB. 7-26-2011, FILED 8-13-2010.

D.R.U.G.S.

THE MARK CONSISTS OF STANDARD CHARACTERS WITHOUT CLAIM TO ANY PARTICULAR FONT, STYLE, SIZE, OR COLOR.

FOR ENTERTAINMENT IN THE NATURE OF LIVE PERFORMANCES BY A MUSICAL GROUP (U.S. CLS. 100, 101 AND 107).

FIRST USE 11-28-2010; IN COMMERCE 11-28-2010.



4,154,753. ACCESS INTELLIGENCE LLC, ROCKVILLE, MD. SN 85-115,147. PUB. 2-15-2011, FILED 8-25-2010.

**Via Satellite's Satcom
Technology
For the Engineer by the
Engineer**

THE MARK CONSISTS OF STANDARD CHARACTERS WITHOUT CLAIM TO ANY PARTICULAR FONT, STYLE, SIZE, OR COLOR.

NO CLAIM IS MADE TO THE EXCLUSIVE RIGHT TO USE "SATCOM TECHNOLOGY FOR THE ENGINEER BY THE ENGINEER", APART FROM THE MARK AS SHOWN.

FOR PROVIDING ON-LINE E-ZINES IN THE FIELD OF SATELLITE COMMUNICATIONS (U.S. CLS. 100, 101 AND 107).

FIRST USE 10-31-2010; IN COMMERCE 10-31-2010.

CLASS 41—(Continued).

4,154,766. VERY PERSONAL INCORPORATED, DBA COMPANYWORKS, SAINT PAUL, MN. SN 85-119,597. PUB. 5-3-2011, FILED 8-31-2010.



OWNER OF U.S. REG. NO. 2,882,836.
THE MARK CONSISTS OF A STYLIZED PERSON BESIDE THE WORDS "DOUBLE" ON TOP OF THE WORD "DUTCH".

FOR TRAINING SERVICES IN THE FIELD OF PERSONNEL DEVELOPMENT AND INDIVIDUAL AND ORGANIZATIONAL MANAGEMENT FOR A WORLD CLASS WORKFORCE (U.S. CLS. 100, 101 AND 107).
FIRST USE 7-6-2011; IN COMMERCE 7-6-2011.

4,154,810. DONOVAN, CATHERINE, DBA THEGREENFERN.COM, NORTHBROOK, IL. SN 85-138,456. PUB. 9-20-2011, FILED 9-26-2010.

THEGREENFERN.COM

THE MARK CONSISTS OF STANDARD CHARACTERS WITHOUT CLAIM TO ANY PARTICULAR FONT, STYLE, SIZE, OR COLOR.

FOR PROVIDING A WEBSITE FEATURING INFORMATION IN THE FIELDS OF PARTY PLANNING AND GARDEN PARTY PLANNING (U.S. CLS. 100, 101 AND 107).

FIRST USE 12-22-2011; IN COMMERCE 1-1-2012.

CLASS 41—(Continued).

4,154,844. MMJIP, LLC, SAN FRANCISCO, CA. SN 85-149,743. PUB. 8-9-2011, FILED 10-11-2010.



THE MARK CONSISTS OF ONE BLOCK SURROUNDED BY FOUR OTHERS IN THE UPPER LEFT QUADRANT OF A LARGE SQUARE WITH THE WORD "SPARC" BENEATH.

FOR EDUCATIONAL SERVICES, NAMELY, CONDUCTING COURSES, WORKSHOPS, AND SEMINARS IN THE FIELD OF ALTERNATIVE THERAPIES IN HEALTH AND MEDICINE, NAMELY, MEDITATION, SPIRITUALITY, ACUPRESSURE, AYURVEDIC NUTRITION, AND SUPPORT GROUPS FOCUSED ON WOMEN'S ISSUES, HARM REDUCTION (U.S. CLS. 100, 101 AND 107).

FIRST USE 5-5-2010; IN COMMERCE 5-5-2010.

4,154,860. SHOWTIME NETWORKS INC., NEW YORK, NY. SN 85-157,008. PUB. 8-2-2011, FILED 10-20-2010.

SHOWTIME SPORTS NO ONE GETS YOU CLOSER

THE MARK CONSISTS OF STANDARD CHARACTERS WITHOUT CLAIM TO ANY PARTICULAR FONT, STYLE, SIZE, OR COLOR.

OWNER OF U.S. REG. NOS. 3,412,233, 3,528,037, AND OTHERS.

NO CLAIM IS MADE TO THE EXCLUSIVE RIGHT TO USE "SPORTS", APART FROM THE MARK AS SHOWN.

FOR ENTERTAINMENT SERVICES, NAMELY, PRODUCTION AND DISTRIBUTION OF MOTION PICTURES, COMEDY SHOWS, MUSICAL AND DRAMATIC TELEVISION SERIES, DOCUMENTARIES, AND TELEVISION SERIES FEATURING SPORTING EVENTS RENDERED THROUGH THE MEDIA OF TELEVISION, CABLE, SATELLITE, RADIO, TELEPHONE AND BROADBAND SYSTEMS, AND VIA THE INTERNET, PORTABLE AND WIRELESS COMMUNICATION DEVICES; PROVIDING INFORMATION IN THE FIELD OF ENTERTAINMENT RENDERED VIA THE INTERNET, GLOBAL AND WIRELESS COMMUNICATION DEVICES (U.S. CLS. 100, 101 AND 107).

FIRST USE 6-30-2011; IN COMMERCE 6-30-2011.

CLASS 41—(Continued).

4,154,866. RAZI, TARVELLA, FONTANA, CA. SN 85-159,651. PUB. 3-22-2011, FILED 10-23-2010.

I SHOULD BE FAMOUS

THE MARK CONSISTS OF STANDARD CHARACTERS WITHOUT CLAIM TO ANY PARTICULAR FONT, STYLE, SIZE, OR COLOR.

FOR ENTERTAINMENT SERVICES, NAMELY, AN ON-GOING SERIES FEATURING MUSIC AND A REALITY SHOW COMPETITION IN THE FIELD OF MUSIC PROVIDED THROUGH TELEVISION, INTERNET AND RADIO (U.S. CLS. 100, 101 AND 107).
FIRST USE 3-31-2008; IN COMMERCE 12-31-2010.

4,154,873. BEULAH BAPTIST CHURCH OF BENNETT INC., BENNETT, NC. SN 85-163,154. PUB. 8-16-2011, FILED 10-27-2010.

TRUTH FOR TODAY

THE MARK CONSISTS OF STANDARD CHARACTERS WITHOUT CLAIM TO ANY PARTICULAR FONT, STYLE, SIZE, OR COLOR.

FOR ENTERTAINMENT IN THE NATURE OF ON-GOING TELEVISION PROGRAMS IN THE FIELD OF THE CHRISTIAN RELIGION (U.S. CLS. 100, 101 AND 107).
FIRST USE 1-1-2011; IN COMMERCE 3-6-2011.

4,154,879. COURTROOM TELEVISION NETWORK LLC, NEW YORK, NY. SN 85-169,483. PUB. 10-25-2011, FILED 11-4-2010.

TRUTV PRESENTS: WORLD'S DUMBEST...

THE MARK CONSISTS OF STANDARD CHARACTERS WITHOUT CLAIM TO ANY PARTICULAR FONT, STYLE, SIZE, OR COLOR.

CLASS 41—(Continued).

OWNER OF U.S. REG. NOS. 3,493,740, 3,669,937, AND OTHERS.

FOR ENTERTAINMENT SERVICES, NAMELY, CONTINUING SCRIPTED AND UNSCRIPTED TELEVISION PROGRAM SERIES IN THE FIELD OF COMEDY, DRAMA, ACTION, ADVENTURE AND/OR REALITY PROVIDED THROUGH CABLE TELEVISION, BROADCAST TELEVISION, INTERNET, VIDEO-ON-DEMAND, AND THROUGH OTHER DISTRIBUTION PLATFORMS; PROVIDING INFORMATION, NAMELY, ENTERTAINMENT INFORMATION OVER THE INTERNET (U.S. CLS. 100, 101 AND 107).
FIRST USE 6-30-2011; IN COMMERCE 6-30-2011.

4,154,882. WOLTER, TILL, DBA VINETALK, WEST NEW YORK, NJ. AND MCQUEEN, SEAN, DBA VINETALK, LONG ISLAND CITY, NY. SN 85-172,433. PUB. 4-19-2011, FILED 11-9-2010.

VineTalk

THE MARK CONSISTS OF STANDARD CHARACTERS WITHOUT CLAIM TO ANY PARTICULAR FONT, STYLE, SIZE, OR COLOR.

FOR EDUCATION SERVICES, NAMELY, PROVIDING LIVE AND ON-LINE COURSES IN THE FIELD OF WINE TASTING AND THE HISTORY OF WINE; EDUCATION SERVICES, NAMELY, PROVIDING MENTORING, TUTORING, CLASSES, SEMINARS AND WORKSHOPS IN THE FIELD OF WINE; PROVIDING ON-LINE VIDEOLOGS AND BLOGS IN THE FIELD OF WINE; PROVIDING GENERAL INFORMATION IN THE FIELD OF WINE TASTING; ENTERTAINMENT SERVICES, NAMELY, CONDUCTING FILM FESTIVALS IN THE FIELD OF WINE; EDUCATIONAL SERVICES, NAMELY, CONDUCTING WORKSHOPS AND SEMINARS IN THE FIELD OF WINE; BLOGS IN THE FIELD OF WINE; PLANNING ARRANGEMENT OF SHOWING MOVIES ABOUT WINE; ENTERTAINMENT AND EDUCATIONAL SERVICES, NAMELY, THE PRESENTATION OF SEMINARS, WORKSHOPS AND PANEL DISCUSSIONS, AND ONGOING TELEVISION AND RADIO SHOWS ALL IN THE FIELD OF WINE; EDUCATIONAL SERVICES, NAMELY, TEACHER TRAINING IN THE FIELD OF WINE PROVIDED ON A REAL-TIME BASIS DURING CLASSROOM INSTRUCTION; ENTERTAINMENT SERVICES, NAMELY, PROVIDING A WEB SITE FEATURING NON-DOWNLOADABLE MUSICAL PERFORMANCES, MUSICAL VIDEOS, RELATED FILM CLIPS, PHOTOGRAPHS, AND OTHER MULTIMEDIA MATERIALS FEATURING WINE TASTING; ENTERTAINMENT SERVICES, NAMELY, PROVIDING A WEB SITE FEATURING PHOTOGRAPHIC, AUDIO, VIDEO AND PROSE PRESENTATIONS FEATURING WINE TASTING; ORGANIZING COMMUNITY FESTIVALS FEATURING PRIMARILY WINE TASTING AND ALSO PROVIDING FLEA MARKETS, CRAFTS AND FOOD; PROVIDING A WEBSITE FOR PERSONS TO REGISTER FOR SURPRISE EVENTS AND CLASSES FOR THE PURPOSE OF ENTERTAINMENT (U.S. CLS. 100, 101 AND 107).
FIRST USE 1-1-2008; IN COMMERCE 1-1-2011.

CLASS 41—(Continued).

4,154,939. ORTHOHELIX SURGICAL DESIGNS, INC., MEDINA, OH. SN 85-203,849. PUB. 10-4-2011, FILED 12-22-2010.

ORTHOHELIX UNIVERSITY

THE MARK CONSISTS OF STANDARD CHARACTERS WITHOUT CLAIM TO ANY PARTICULAR FONT, STYLE, SIZE, OR COLOR.

NO CLAIM IS MADE TO THE EXCLUSIVE RIGHT TO USE "UNIVERSITY", APART FROM THE MARK AS SHOWN.

FOR MEDICAL TRAINING OF HEALTHCARE PROFESSIONALS IN THE FIELD OF ORTHOPEDIC SURGERY; PROVIDING CLASSES TO HEALTHCARE PROFESSIONS IN THE FIELD OF ORTHOPEDIC SURGERY (U.S. CLS. 100, 101 AND 107).

FIRST USE 3-24-2011; IN COMMERCE 3-24-2011.

4,154,962. KNOWLEDGE BUREAU INC., WINNIPEG, MANITOBA, CANADA. SN 85-211,112. PUB. 1-31-2012, FILED 1-5-2011.

**DISTINGUISHED ADVISOR
CONFERENCE**

THE MARK CONSISTS OF STANDARD CHARACTERS WITHOUT CLAIM TO ANY PARTICULAR FONT, STYLE, SIZE, OR COLOR.

PRIORITY CLAIMED UNDER SEC. 44(D) ON CANADA APPLICATION NO. 1501312, FILED 10-26-2010.

NO CLAIM IS MADE TO THE EXCLUSIVE RIGHT TO USE "ADVISOR CONFERENCE", APART FROM THE MARK AS SHOWN.

FOR EDUCATIONAL SERVICES, NAMELY, CONDUCTING CONFERENCES AND SEMINARS IN THE FIELD OF FINANCIAL PLANNING (U.S. CLS. 100, 101 AND 107).

FIRST USE 0-0-2004; IN COMMERCE 0-0-2004.

4,154,965. LINDSAY PARROTT, CHICAGO, IL. SN 85-212,275. PUB. 7-19-2011, FILED 1-6-2011.

PARROTT PARTY PRODUCTIONS

THE MARK CONSISTS OF STANDARD CHARACTERS WITHOUT CLAIM TO ANY PARTICULAR FONT, STYLE, SIZE, OR COLOR.

CLASS 41—(Continued).

NO CLAIM IS MADE TO THE EXCLUSIVE RIGHT TO USE "PARTY PRODUCTIONS", APART FROM THE MARK AS SHOWN.

FOR PARTY PLANNING SERVICES; SPECIAL EVENT PLANNING FOR SOCIAL ENTERTAINMENT PURPOSES (U.S. CLS. 100, 101 AND 107).

FIRST USE 1-16-2011; IN COMMERCE 1-16-2011.

4,155,001. STOKELY-VAN CAMP, INC., CHICAGO, IL. SN 85-225,717. PUB. 5-3-2011, FILED 1-25-2011.

EVERYTHING TO PROVE

THE MARK CONSISTS OF STANDARD CHARACTERS WITHOUT CLAIM TO ANY PARTICULAR FONT, STYLE, SIZE, OR COLOR.

FOR ENTERTAINMENT SERVICES, NAMELY, CONTINUING SHOWS BROADCAST OVER TELEVISION AND THE INTERNET THAT CHRONICLE THE JOURNEY OF PROFESSIONAL FOOTBALL PLAYERS THROUGH THEIR FIRST YEAR OF PLAY (U.S. CLS. 100, 101 AND 107).

FIRST USE 1-31-2011; IN COMMERCE 1-31-2011.

4,155,007. PASCUA YAQUI TRIBE, TUCSON, AZ. SN 85-227,592. PUB. 6-7-2011, FILED 1-27-2011.



OWNER OF U.S. REG. NOS. 2,800,090 AND 2,965,247.
NO CLAIM IS MADE TO THE EXCLUSIVE RIGHT TO USE "CASINO" AND "RESORT SPA CONFERENCE CENTER AMPHITHEATER", APART FROM THE MARK AS SHOWN.

THE COLOR(S) BROWN, GOLD, YELLOW, AND RED IS/ARE CLAIMED AS A FEATURE OF THE MARK.

THE MARK CONSISTS OF THE STYLIZED WORDS "CASINO DEL SOL" IN BROWN AND GOLD WITH BROWN AND GOLD OVER-LINING AND UNDERLINING ABOVE THE WORDS "RESORT SPA CONFERENCE CENTER AMPHITHEATER" IN BROWN AND SEPARATED BY GOLD CIRCLES, ALL BELOW A RED DOMED BUILDING WITH BROWN, GOLD AND YELLOW ACCENTS IN FRONT OF BROWN AND GOLD MOUNTAINS AND A YELLOW SUN.

CLASS 41—(Continued).

THE ENGLISH TRANSLATION OF "DEL SOL" IN THE MARK IS "OF THE SUN".

FOR PROVIDING CASINO FACILITIES AND CASINO SERVICES; CONDUCTING ENTERTAINMENT SERVICES, NAMELY, LIVE PERFORMANCES BY MUSICAL BANDS, LIVE MUSIC CONCERTS, LIVE APPEARANCES BY PROFESSIONAL ENTERTAINERS, AND LIVE SPORTING EVENTS IN THE NATURE OF BOXING, WRESTLING, AND MIXED MARTIAL ARTS; PROVIDING FACILITIES FOR SPORTING EVENTS AND COMPETITIONS; ORGANIZATION OF SPORTS COMPETITIONS; CONDUCTING ART FESTIVALS AND FAIRS; CONDUCTING CULINARY COMPETITIONS AND EVENTS IN THE NATURE OF CULINARY FESTIVALS; WEDDING PLANNING, COORDINATION AND HOSTING OF WEDDING CEREMONIES AND RECEPTIONS; ARRANGING AND HOSTING SPECIAL ENTERTAINMENT SOCIAL EVENTS (U.S. CLS. 100, 101 AND 107).

FIRST USE 11-11-2011; IN COMMERCE 11-11-2011.

4,155,026. AVERY, ERIN, FAIR HAVEN, NJ. SN 85-232,995. PUB. 10-11-2011, FILED 2-3-2011.

Best Fit Decisions

THE MARK CONSISTS OF STANDARD CHARACTERS WITHOUT CLAIM TO ANY PARTICULAR FONT, STYLE, SIZE, OR COLOR.

FOR COLLEGE ADMISSION CONSULTING SERVICES, NAMELY, ASSISTING STUDENTS IN FINDING COLLEGES AND UNIVERSITIES AND COMPLETING THE APPLICATION PROCESS; PROVIDING A WEBSITE THAT FEATURES INFORMATION ABOUT ON-LINE HIGHER EDUCATION RESOURCES; PROVIDING INFORMATION ON-LINE RELATING TO HIGHER EDUCATION OPPORTUNITIES AND RESOURCES (U.S. CLS. 100, 101 AND 107).

FIRST USE 12-1-2011; IN COMMERCE 2-1-2012.

4,155,037. REED ELSEVIER PROPERTIES INC., WILMINGTON, DE. SN 85-235,747. PUB. 9-20-2011, FILED 2-7-2011.

ISC PREMIER EDUCATIONAL SERIES

THE MARK CONSISTS OF STANDARD CHARACTERS WITHOUT CLAIM TO ANY PARTICULAR FONT, STYLE, SIZE, OR COLOR.

OWNER OF U.S. REG. NOS. 1,033,255, 3,377,484, AND OTHERS.

NO CLAIM IS MADE TO THE EXCLUSIVE RIGHT TO USE "PREMIER EDUCATIONAL SERIES", APART FROM THE MARK AS SHOWN.

FOR EDUCATIONAL SERVICES, NAMELY, CONDUCTING CLASSES, SEMINARS, CONFERENCES AND WORKSHOPS IN THE FIELD OF SECURITY BOTH LIVE AND ONLINE (U.S. CLS. 100, 101 AND 107).

FIRST USE 3-4-2011; IN COMMERCE 3-4-2011.

CLASS 41—(Continued).

4,155,075. THE BEST OF ORGANIC LLC, WEST BLOOMFIELD, MI. SN 85-243,404. PUB. 9-6-2011, FILED 2-16-2011.

SUPERKIDS WELLNESS

THE MARK CONSISTS OF STANDARD CHARACTERS WITHOUT CLAIM TO ANY PARTICULAR FONT, STYLE, SIZE, OR COLOR.

NO CLAIM IS MADE TO THE EXCLUSIVE RIGHT TO USE "WELLNESS", APART FROM THE MARK AS SHOWN.

FOR EDUCATION SERVICES, NAMELY, PROVIDING CLASSES, SEMINARS, WORKSHOPS IN THE FIELD OF HEALTH, NUTRITION, AND LIFESTYLE (U.S. CLS. 100, 101 AND 107).

FIRST USE 5-0-2009; IN COMMERCE 5-0-2009.

4,155,115. CALLENDER, PAMELA E, NEPTUNE, NJ. SN 85-247,695. PUB. 8-23-2011, FILED 2-21-2011.

My Recycle Buddies

THE MARK CONSISTS OF STANDARD CHARACTERS WITHOUT CLAIM TO ANY PARTICULAR FONT, STYLE, SIZE, OR COLOR.

NO CLAIM IS MADE TO THE EXCLUSIVE RIGHT TO USE "RECYCLE", APART FROM THE MARK AS SHOWN.

FOR EDUCATIONAL SERVICES, NAMELY, PROVIDING ONLINE INSTRUCTION IN THE FIELD OF RECYCLING AND THE ENVIRONMENT VIA AN ONLINE WEBSITE; ENTERTAINMENT SERVICES, NAMELY, PROVIDING A WEBSITE FEATURING GAMES AND PUZZLES; PROVIDING A WEBSITE FEATURING INFORMATION IN THE FIELDS OF EDUCATION AND ENTERTAINMENT FOR CHILDREN (U.S. CLS. 100, 101 AND 107).

FIRST USE 11-15-2011; IN COMMERCE 11-15-2011.

4,155,126. SCOTT-REYES, LAURIE, HAWTHORNE, FL. SN 85-250,197. PUB. 7-19-2011, FILED 2-24-2011.

LOCO-MOTION FITNESS

THE MARK CONSISTS OF STANDARD CHARACTERS WITHOUT CLAIM TO ANY PARTICULAR FONT, STYLE, SIZE, OR COLOR.

CLASS 41—(Continued).

NO CLAIM IS MADE TO THE EXCLUSIVE RIGHT TO USE "FITNESS", APART FROM THE MARK AS SHOWN.
 FOR PHYSICAL FITNESS AND EXERCISE TRAINING SERVICES; PHYSICAL FITNESS INSTRUCTION AND CONSULTATION (U.S. CLS. 100, 101 AND 107).
 FIRST USE 3-1-2012; IN COMMERCE 3-1-2012.

4,155,136. DIVORCE COACHING, INC., TAMPA, FL. SN 85-250,736. PUB. 8-16-2011, FILED 2-24-2011.

**CDC COLLEGE FOR DIVORCE
 COACHING**

THE MARK CONSISTS OF STANDARD CHARACTERS WITHOUT CLAIM TO ANY PARTICULAR FONT, STYLE, SIZE, OR COLOR.

NO CLAIM IS MADE TO THE EXCLUSIVE RIGHT TO USE "COLLEGE FOR DIVORCE COACHING", APART FROM THE MARK AS SHOWN.

FOR EDUCATIONAL SERVICES, NAMELY, PROVIDING CLASSES, SEMINARS, WORKSHOPS, WEBINARS IN THE FIELDS OF PERSONAL DIVORCE COACH TRAINING FOR MENTAL HEALTH COUNSELORS, ATTORNEYS, MEDIATORS, AND OTHER PROFESSIONALS (U.S. CLS. 100, 101 AND 107).

FIRST USE 6-15-2011; IN COMMERCE 6-20-2011.

4,155,204. MEYER, JAYMIE, NEW YORK, NY. SN 85-256,848. PUB. 7-19-2011, FILED 3-3-2011.

BRINGING WOO-WOO TO YOU

THE MARK CONSISTS OF STANDARD CHARACTERS WITHOUT CLAIM TO ANY PARTICULAR FONT, STYLE, SIZE, OR COLOR.

FOR ENTERTAINMENT SERVICES, NAMELY, PROVIDING PODCASTS IN THE FIELDS OF HEALTH CARE AND WELL-BEING (U.S. CLS. 100, 101 AND 107).

FIRST USE 2-7-2012; IN COMMERCE 2-7-2012.

CLASS 41—(Continued).

4,155,209. SAUNDERS ENTERPRISES, LLC, HENDERSON, NV. SN 85-257,047. PUB. 7-19-2011, FILED 3-3-2011.

**THE POWER OF KNOWING HOW
 LIFE WORKS**

THE MARK CONSISTS OF STANDARD CHARACTERS WITHOUT CLAIM TO ANY PARTICULAR FONT, STYLE, SIZE, OR COLOR.

FOR EDUCATIONAL SERVICES, NAMELY, CONDUCTING LECTURES, WORKSHOPS AND SEMINARS IN THE FIELD OF SELF HELP AND PERSONAL AND BUSINESS DEVELOPMENT (U.S. CLS. 100, 101 AND 107).
 FIRST USE 11-17-2011; IN COMMERCE 11-17-2011.

4,155,219. WHOLE WOMAN, INC., ALBUQUERQUE, NM. SN 85-258,315. PUB. 8-2-2011, FILED 3-4-2011.

WHOLE WOMAN YOGA

THE MARK CONSISTS OF STANDARD CHARACTERS WITHOUT CLAIM TO ANY PARTICULAR FONT, STYLE, SIZE, OR COLOR.

OWNER OF U.S. REG. NOS. 3,676,518, 3,918,188, AND OTHERS.

NO CLAIM IS MADE TO THE EXCLUSIVE RIGHT TO USE "WOMAN YOGA", APART FROM THE MARK AS SHOWN.

FOR PROVIDING PHYSICAL FITNESS AND EXERCISE SERVICE, NAMELY, YOGA INSTRUCTION (U.S. CLS. 100, 101 AND 107).

FIRST USE 3-4-2011; IN COMMERCE 4-19-2011.

4,155,235. RAAK LLC, CHANDLER, AZ. SN 85-260,415. PUB. 7-26-2011, FILED 3-7-2011.

"JOIN TO SHARE"

THE MARK CONSISTS OF THE STYLIZED WORDING "'JOIN TO SHARE'".

FOR ON-LINE JOURNALS, NAMELY, BLOGS FEATURING USER DEFINED CONTENT (U.S. CLS. 100, 101 AND 107).

FIRST USE 2-1-2012; IN COMMERCE 2-1-2012.

CLASS 41—(Continued).

4,155,247. WINDBAG LIMITED LIABILITY COMPANY, FREEHOLD, NJ. SN 85-261,601. PUB. 8-2-2011, FILED 3-8-2011.

The Daily Yap

THE MARK CONSISTS OF STANDARD CHARACTERS WITHOUT CLAIM TO ANY PARTICULAR FONT, STYLE, SIZE, OR COLOR.

NO CLAIM IS MADE TO THE EXCLUSIVE RIGHT TO USE "DAILY", APART FROM THE MARK AS SHOWN.

FOR INTERACTIVE ONLINE WEB JOURNALS FEATURING POLITICS AND EVERY DAY LIFE EXPERIENCES (U.S. CLS. 100, 101 AND 107).

FIRST USE 7-11-2011; IN COMMERCE 7-11-2011.

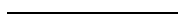

4,155,250. FRENCH, CHRISTY L., PRINCETON, NJ. SN 85-261,898. PUB. 7-26-2011, FILED 3-9-2011.

REACH WITHIN LEAD BEYOND

THE MARK CONSISTS OF STANDARD CHARACTERS WITHOUT CLAIM TO ANY PARTICULAR FONT, STYLE, SIZE, OR COLOR.

FOR PHYSICAL FITNESS INSTRUCTION AND CONSULTATION; YOGA INSTRUCTION (U.S. CLS. 100, 101 AND 107).

FIRST USE 11-1-2011; IN COMMERCE 11-1-2011.



4,155,257. CUEVAS, PAUL, FOOTHILL RANCH, CA. SN 85-262,137. PUB. 8-9-2011, FILED 3-9-2011.

DJ PM

THE MARK CONSISTS OF STANDARD CHARACTERS WITHOUT CLAIM TO ANY PARTICULAR FONT, STYLE, SIZE, OR COLOR.

NO CLAIM IS MADE TO THE EXCLUSIVE RIGHT TO USE "DJ", APART FROM THE MARK AS SHOWN.

FOR DISC JOCKEYS FOR PARTIES AND SPECIAL EVENTS; MULTIMEDIA ENTERTAINMENT SERVICES IN THE NATURE OF RECORDING, PRODUCTION AND POST-PRODUCTION SERVICES IN THE FIELDS OF MUSIC, VIDEO, AND FILMS (U.S. CLS. 100, 101 AND 107).

FIRST USE 10-22-2011; IN COMMERCE 10-22-2011.

CLASS 41—(Continued).

4,155,303. DÉSILETS, ELISABETH, KIHEI, HI. SN 85-267,303. PUB. 8-23-2011, FILED 3-15-2011.

SEX SAVVY WOMAN

THE MARK CONSISTS OF STANDARD CHARACTERS WITHOUT CLAIM TO ANY PARTICULAR FONT, STYLE, SIZE, OR COLOR.

NO CLAIM IS MADE TO THE EXCLUSIVE RIGHT TO USE "SEX" AND "WOMAN", APART FROM THE MARK AS SHOWN.

FOR EDUCATION SERVICES, NAMELY, CONDUCTING SEMINARS, CONFERENCES, WORKSHOPS AND ONLINE COURSES IN THE FIELD OF SEXUALITY AND PSYCHOLOGICAL HEALTH AND WELL-BEING (U.S. CLS. 100, 101 AND 107).

FIRST USE 3-22-2012; IN COMMERCE 3-22-2012.

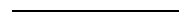

4,155,313. FIRST CONNECTION, INC., FOREST HILL, MD. SN 85-268,482. PUB. 9-6-2011, FILED 3-16-2011.



NO CLAIM IS MADE TO THE EXCLUSIVE RIGHT TO USE "EDUCATING OUR EDUCATORS", APART FROM THE MARK AS SHOWN.

THE MARK CONSISTS OF TWO SILHOUETTED AND STYLIZED FIGURES OF AN ADULT AND A CHILD. THE WORDS "FIRST CONNECTION" APPEAR TO THE RIGHT OF THE FIGURES AND A DOTTED HORIZONTAL LINE APPEARS BELOW THE WORDS "FIRST CONNECTION" AND CURVES BENEATH THE FIGURES. THE WORDS "EDUCATING OUR EDUCATORS" APPEAR BELOW THE DOTTED LINE.

FOR EDUCATION SERVICES, NAMELY, PROVIDING CLASSES, SEMINARS, AND WORKSHOPS TO PRESCHOOL TEACHERS AND CHILD CARE PROVIDERS IN THE FIELDS OF CHILD CARE AND PRESCHOOL EDUCATION; EDUCATIONAL SERVICES, NAMELY, PROVIDING CONTINUING PROFESSIONAL EDUCATION COURSES TO PRESCHOOL TEACHERS AND CHILD CARE PROVIDERS IN THE FIELDS OF CHILD CARE AND PRESCHOOL EDUCATION (U.S. CLS. 100, 101 AND 107).

FIRST USE 3-2-2010; IN COMMERCE 3-2-2010.

CLASS 41—(Continued).

4,155,333. THE ASSOCIATION FOR CORPORATE GROWTH, INC., CHICAGO, IL. SN 85-271,097. PUB. 8-16-2011, FILED 3-18-2011.

ACG UNIVERSITY

THE MARK CONSISTS OF STANDARD CHARACTERS WITHOUT CLAIM TO ANY PARTICULAR FONT, STYLE, SIZE, OR COLOR.

OWNER OF U.S. REG. NOS. 2,816,952, 3,514,522, AND OTHERS.

NO CLAIM IS MADE TO THE EXCLUSIVE RIGHT TO USE "UNIVERSITY", APART FROM THE MARK AS SHOWN.

FOR EDUCATIONAL SERVICES, NAMELY, CONDUCTING CLASSES, SEMINARS, CONFERENCES, WORKSHOPS IN THE FIELD OF FINANCIAL SERVICES AND DISTRIBUTION OF TRAINING MATERIAL IN CONNECTION THEREWITH (U.S. CLS. 100, 101 AND 107).

FIRST USE 6-30-2010; IN COMMERCE 6-30-2010.

4,155,342. SONGY3, LLC, DBA LAUGH LEARN COMETRY, AUSTIN, TX. SN 85-272,540. PUB. 8-16-2011, FILED 3-21-2011.

Cometry

THE MARK CONSISTS OF STANDARD CHARACTERS WITHOUT CLAIM TO ANY PARTICULAR FONT, STYLE, SIZE, OR COLOR.

FOR ENTERTAINMENT AND EDUCATION SERVICES IN THE NATURE OF A SERIES OF LIVE SHOW PERFORMANCES FEATURING COMEDY AND POETRY (U.S. CLS. 100, 101 AND 107).

FIRST USE 4-30-2010; IN COMMERCE 4-30-2010.

4,155,401. GREEN STREET DEVELOPMENT, LLC, SCOTTSDALE, AZ. SN 85-283,029. PUB. 8-30-2011, FILED 3-31-2011.

G UNIVERSITY

THE MARK CONSISTS OF STANDARD CHARACTERS WITHOUT CLAIM TO ANY PARTICULAR FONT, STYLE, SIZE, OR COLOR.

CLASS 41—(Continued).

NO CLAIM IS MADE TO THE EXCLUSIVE RIGHT TO USE "UNIVERSITY", APART FROM THE MARK AS SHOWN.

FOR EDUCATION SERVICES, NAMELY, PROVIDING TUTORIAL SESSIONS IN THE FIELD OF LEADERSHIP IN ENERGY AND ENVIRONMENTAL DESIGN (LEED) (U.S. CLS. 100, 101 AND 107).

FIRST USE 1-31-2011; IN COMMERCE 1-31-2011.

4,155,420. INTERNATIONAL ASSOCIATION FOR HUMAN VALUES, BURLINGTON, MA. SN 85-284,123. PUB. 8-9-2011, FILED 4-1-2011.

TLEX

THE MARK CONSISTS OF STANDARD CHARACTERS WITHOUT CLAIM TO ANY PARTICULAR FONT, STYLE, SIZE, OR COLOR.

FOR EDUCATIONAL SERVICES, NAMELY, CONDUCTING WORKSHOPS AND CORPORATE TRAINING IN THE FIELD OF LEADERSHIP DEVELOPMENT AND STRESS MANAGEMENT AND DISTRIBUTION OF COURSE MATERIAL IN CONNECTION THEREWITH; TRAINING SERVICES IN THE FIELD OF LEADERSHIP DEVELOPMENT AND STRESS MANAGEMENT (U.S. CLS. 100, 101 AND 107).

FIRST USE 1-0-2012; IN COMMERCE 1-0-2012.

4,155,421. ROSENBAUM, KEREN, DEMAREST, NJ. SN 85-284,321. PUB. 8-9-2011, FILED 4-1-2011.

Reflex Invisible Score

THE MARK CONSISTS OF STANDARD CHARACTERS WITHOUT CLAIM TO ANY PARTICULAR FONT, STYLE, SIZE, OR COLOR.

FOR EDUCATION SERVICES, NAMELY, PROVIDING CLASSES, SEMINARS, WORKSHOPS, AND LECTURES IN THE FIELD OF MUSIC NOTATION (U.S. CLS. 100, 101 AND 107).

FIRST USE 2-27-2011; IN COMMERCE 2-27-2011.

CLASS 41—(Continued).

4,155,427. PARK RIDGE SECURITIES CORP., NEW PROVIDENCE, BAHAMAS. SN 85-285,545. PUB. 8-2-2011, FILED 4-4-2011.

ALBANY

THE MARK CONSISTS OF STANDARD CHARACTERS WITHOUT CLAIM TO ANY PARTICULAR FONT, STYLE, SIZE, OR COLOR.

OWNER OF U.S. REG. NOS. 3,578,145 AND 3,912,371. FOR GOLF CLUB SERVICES; GOLF COURSES; PROVIDING GOLF FACILITIES (U.S. CLS. 100, 101 AND 107). FIRST USE 10-4-2010; IN COMMERCE 10-4-2010.

4,155,442. HDS IP HOLDING, LLC, HENDERSON, NV. SN 85-288,548. PUB. 7-5-2011, FILED 4-7-2011.

GREENBLOGIC

THE MARK CONSISTS OF STANDARD CHARACTERS WITHOUT CLAIM TO ANY PARTICULAR FONT, STYLE, SIZE, OR COLOR.

NO CLAIM IS MADE TO THE EXCLUSIVE RIGHT TO USE "GREEN", APART FROM THE MARK AS SHOWN.

FOR PROVISION OF ONLINE JOURNALS, NAMELY, BLOGS FEATURING THE EXCHANGE OF INFORMATION ABOUT USE OF ENVIRONMENTALLY FRIENDLY MATERIALS (U.S. CLS. 100, 101 AND 107). FIRST USE 5-12-2011; IN COMMERCE 5-12-2011.

4,155,467. PASSIONATESPOUSE, INCORPORATED, SUWANEE, GA. SN 85-295,683. PUB. 8-23-2011, FILED 4-14-2011.

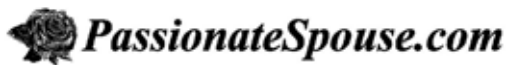

THE STIPPLING IS FOR SHADING PURPOSES ONLY.

CLASS 41—(Continued).

THE MARK CONSISTS OF AN IMAGE OF A ROSE WITH LEAVES SURROUNDING IT. THE ROSE IMAGE IS TO THE LEFT OF THE WORK PHRASE "PASSIONATESPOUSE.COM". THE ROSE IMAGE IS FOLLOWED TO THE RIGHT BY "PASSIONATESPOUSE.COM", USING FONT TYPE TIMES NEW ROMAN ITALIC, AND CAN BE FOUND IN ANY FONT SIZE.

FOR EDUCATIONAL SERVICES, NAMELY, CONDUCTING SEMINARS AND WORKSHOPS IN THE FIELD OF HEALTHY MARRIAGE RELATIONSHIPS AND DISTRIBUTION OF PRINTED MATERIALS IN CONNECTION THEREWITH IN HARD COPY OR ELECTRONIC FORMAT ON THE SAME TOPICS (U.S. CLS. 100, 101 AND 107).

FIRST USE 1-1-2011; IN COMMERCE 1-1-2011.

4,155,484. TELECOMMUNICATION SYSTEMS, INC., ANNAPOLIS, MD. SN 85-299,764. PUB. 9-6-2011, FILED 4-20-2011.

ART OF EXPLOITATION

THE MARK CONSISTS OF STANDARD CHARACTERS WITHOUT CLAIM TO ANY PARTICULAR FONT, STYLE, SIZE, OR COLOR.

OWNER OF U.S. REG. NO. 2,431,278. FOR COMPUTER EDUCATION TRAINING SERVICES (U.S. CLS. 100, 101 AND 107). FIRST USE 11-6-2006; IN COMMERCE 11-6-2006.

4,155,485. SHIRLEY BEANS PRODUCTIONS LLC, NEW YORK, NY. SN 85-299,805. PUB. 9-6-2011, FILED 4-20-2011.

Weird Vibes

THE MARK CONSISTS OF STANDARD CHARACTERS WITHOUT CLAIM TO ANY PARTICULAR FONT, STYLE, SIZE, OR COLOR.

FOR ENTERTAINMENT SERVICES, NAMELY, AN ON-GOING SERIES FEATURING MUSIC PROVIDED THROUGH TELEVISION AND THE INTERNET; ENTERTAINMENT SERVICES, NAMELY, PROVIDING VIDEO PODCASTS IN THE FIELD OF MUSIC; ENTERTAINMENT, NAMELY, A CONTINUING MUSIC SHOW BROADCAST OVER TELEVISION, SATELLITE, AUDIO, AND VIDEO MEDIA (U.S. CLS. 100, 101 AND 107).

FIRST USE 2-16-2011; IN COMMERCE 7-1-2011.

CLASS 41—(Continued).

4,155,493. OPERATION GRAND SLAM, WOODINVILLE, WA. SN 85-301,177. PUB. 9-6-2011, FILED 4-21-2011.

OPERATION GRAND SLAM

THE MARK CONSISTS OF STANDARD CHARACTERS WITHOUT CLAIM TO ANY PARTICULAR FONT, STYLE, SIZE, OR COLOR.

FOR EDUCATION AND ENTERTAINMENT SERVICES; NAMELY, EDUCATIONAL BASEBALL CAMPS FOR GENERAL EDUCATION AND SPECIAL NEEDS CHILDREN (U.S. CLS. 100, 101 AND 107).

FIRST USE 3-30-2011; IN COMMERCE 1-2-2012.

4,155,500. OHIO FARMERS INSURANCE COMPANY, WEST-FIELD CENTER, OH. SN 85-304,502. PUB. 9-13-2011, FILED 4-26-2011.

WESWORKS

THE MARK CONSISTS OF STANDARD CHARACTERS WITHOUT CLAIM TO ANY PARTICULAR FONT, STYLE, SIZE, OR COLOR.

OWNER OF U.S. REG. NO. 3,314,556.

FOR CONSULTING TO COMPANIES IN THE AREA OF TRANSITIONING EMPLOYEES BACK TO WORK, NAMELY, CAREER COUNSELING (U.S. CLS. 100, 101 AND 107).

FIRST USE 4-0-2011; IN COMMERCE 6-0-2011.

4,155,511. ROSEN HOTELS AND RESORTS, INC., ORLANDO, FL. SN 85-308,289. PUB. 10-4-2011, FILED 4-29-2011.



NO CLAIM IS MADE TO THE EXCLUSIVE RIGHT TO USE "2011" AND "FIT", APART FROM THE MARK AS SHOWN.

CLASS 41—(Continued).

THE COLOR(S) NAVY BLUE AND GREY IS/ARE CLAIMED AS A FEATURE OF THE MARK.

THE MARK CONSISTS OF THE WORDING "FIT DEPUTY", THE WORDING "BUSINESSES DEDICATED TO HELPING DEPUTIES STAY FIT AND HEALTHY" AND THE YEAR "2011" WITHIN A DESIGN OF A BADGE. THE WORDING "BUSINESSES DEDICATED TO HELPING DEPUTIES STAY FIT AND HEALTHY" IS DEPICTED IN A CIRCULAR FORMAT ROUND A STYLIZED DESIGN OF TWO DUMBBELLS, WITH TWO DOTS SEPARATING THE TWO PHRASES. THERE ARE STARS ON BOTH SIDES OF THE CIRCULAR WORDING. THE YEAR "2011" IS ALSO FOUND AT THE BOTTOM OF THE BADGE DESIGN. THE WORDING, THE STARS, THE DUMBBELL DESIGN, THE YEAR, THE CIRCULAR DESIGN AND THE OUTLINE OF THE BADGE ARE NAVY BLUE. THE INTERIOR OF THE BADGE DESIGN IS GREY.

FOR PROVIDING INFORMATION TO LAW ENFORCEMENT AND GOVERNMENTAL AGENCIES THROUGH THE GLOBAL COMPUTER NETWORK CONCERNING FITNESS AND EXERCISE FACILITIES, COMPANIES AND ORGANIZATIONS WHICH OFFER HEALTH, FITNESS AND NUTRITIONAL OPPORTUNITIES TO LAW ENFORCEMENT AT SPECIAL RATES (U.S. CLS. 100, 101 AND 107).

FIRST USE 2-16-2012; IN COMMERCE 2-16-2012.

4,155,548. VATTEROTT EDUCATIONAL CENTERS, INC., OLIVETTE, MO. SN 85-322,162. PUB. 1-24-2012, FILED 5-16-2011.

**ex'treme institute - by
Nelly**

THE MARK CONSISTS OF STANDARD CHARACTERS WITHOUT CLAIM TO ANY PARTICULAR FONT, STYLE, SIZE, OR COLOR.

"NELLY" IDENTIFIES THE STAGE NAME OF CORNELL I. HAYNES II, A LIVING INDIVIDUAL WHOSE CONSENT IS OF RECORD.

FOR EDUCATIONAL SERVICES, NAMELY, CONDUCTING CLASSES AND PROVIDING POSTSECONDARY EDUCATION AND VOCATIONAL GUIDANCE IN THE FIELD OF SOUND, VIDEO AND PRODUCTION TECHNOLOGY AS IT RELATES TO THE FIELDS OF MUSIC AND ENTERTAINMENT (U.S. CLS. 100, 101 AND 107).

FIRST USE 11-21-2011; IN COMMERCE 11-21-2011.

CLASS 41—(Continued).

4,155,570. THE PROFESSIONAL GOLFERS' ASSOCIATION OF AMERICA, PALM BEACH GARDENS, FL. SN 85-329,633. PUB. 9-13-2011, FILED 5-25-2011.

Tee It Forward

THE MARK CONSISTS OF STANDARD CHARACTERS WITHOUT CLAIM TO ANY PARTICULAR FONT, STYLE, SIZE, OR COLOR.

FOR EDUCATIONAL AND ENTERTAINMENT SERVICES, NAMELY, PROVIDING INSTRUCTIONAL PROGRAMS IN THE FIELD OF GOLF FOR PLAYERS AT ALL LEVELS AND DISTRIBUTING PRINTED INSTRUCTIONAL AND INFORMATIONAL MATERIALS IN CONNECTION THEREWITH; PROVIDING INSTRUCTION INFORMATION ABOUT THE GAME OF GOLF VIA A WEB SITE ON THE INTERNET (U.S. CLS. 100, 101 AND 107).

FIRST USE 5-25-2011; IN COMMERCE 6-1-2011.

CLASS 41—(Continued).

4,155,586. NATIONAL CONFERENCE FOR COMMUNITY AND JUSTICE OF CONNECTICUT AND WESTERN MASSACHUSETTS, INC., WINDSOR, CT. SN 85-336,215. PUB. 10-25-2011, FILED 6-2-2011.

YES! Youth Establishing Strength

THE MARK CONSISTS OF STANDARD CHARACTERS WITHOUT CLAIM TO ANY PARTICULAR FONT, STYLE, SIZE, OR COLOR.

FOR EDUCATIONAL AND ENTERTAINMENT SERVICES, NAMELY, PROVIDING PRESENTATIONS, SEMINARS, DISCUSSION GROUPS AND INTERACTIVE AND COLLABORATIVE ACTIVITIES IN THE FIELD OF BULLYING AND CYBERBULLYING (U.S. CLS. 100, 101 AND 107).

FIRST USE 10-23-2011; IN COMMERCE 10-23-2011.

4,155,608. GPAMAXX LLC, BOULDER, CO. SN 85-345,796. PUB. 11-15-2011, FILED 6-14-2011.

GPAMaxx

THE MARK CONSISTS OF STANDARD CHARACTERS WITHOUT CLAIM TO ANY PARTICULAR FONT, STYLE, SIZE, OR COLOR.

FOR INFORMATION ABOUT EDUCATION (U.S. CLS. 100, 101 AND 107).

FIRST USE 11-17-2010; IN COMMERCE 5-23-2011.

4,155,572. SHAWN GEE, BALA CYNWYD, PA. AND JULIUS ERVING III, NEW YORK, NY. AND TROY CARTER, BALA CYNWYD, PA. SN 85-330,210. PUB. 10-25-2011, FILED 5-25-2011.

CLOSER TO MY DREAMS TOUR

THE MARK CONSISTS OF STANDARD CHARACTERS WITHOUT CLAIM TO ANY PARTICULAR FONT, STYLE, SIZE, OR COLOR.

NO CLAIM IS MADE TO THE EXCLUSIVE RIGHT TO USE "TOUR", APART FROM THE MARK AS SHOWN.

FOR ENTERTAINMENT, NAMELY, LIVE MUSIC CONCERTS (U.S. CLS. 100, 101 AND 107).

FIRST USE 6-6-2011; IN COMMERCE 6-6-2011.

4,155,614. RKIP, LLC, MIAMI, FL. SN 85-346,647. PUB. 11-1-2011, FILED 6-15-2011.

HornyBirds

THE MARK CONSISTS OF STANDARD CHARACTERS WITHOUT CLAIM TO ANY PARTICULAR FONT, STYLE, SIZE, OR COLOR.

FOR ENTERTAINMENT SERVICES, NAMELY, PROVIDING A WEB SITE FEATURING PHOTOGRAPHIC, AUDIO, VIDEO AND PROSE PRESENTATIONS FEATURING ADULT-ORIENTED SUBJECT MATTER (U.S. CLS. 100, 101 AND 107).

FIRST USE 12-1-2011; IN COMMERCE 12-1-2011.

CLASS 41—(Continued).

4,155,621. ATHELITE, INC., NEW YORK, NY. SN 85-347,541. PUB. 11-1-2011, FILED 6-16-2011.

AthElite

THE MARK CONSISTS OF STANDARD CHARACTERS WITHOUT CLAIM TO ANY PARTICULAR FONT, STYLE, SIZE, OR COLOR.

FOR PROVIDING AN INTERNET WEBSITE PORTAL IN THE FIELD OF ENTERTAINMENT, CULTURAL AND SPORTING EVENTS (U.S. CLS. 100, 101 AND 107). FIRST USE 5-1-2011; IN COMMERCE 12-1-2011.

CLASS 41—(Continued).

4,155,656. THE FORUM CORPORATION OF NORTH AMERICA, BOSTON, MA. SN 85-359,730. PUB. 11-22-2011, FILED 6-29-2011.

SPEED TO MASTERY

THE MARK CONSISTS OF STANDARD CHARACTERS WITHOUT CLAIM TO ANY PARTICULAR FONT, STYLE, SIZE, OR COLOR.

FOR EDUCATIONAL SERVICES, NAMELY, PROVIDING WEB-BASED TRAINING AND EDUCATIONAL PROGRAMS IN THE FIELDS OF BUSINESS SKILLS, BUSINESS MANAGEMENT AND SALES (U.S. CLS. 100, 101 AND 107).

FIRST USE 9-6-2011; IN COMMERCE 9-6-2011.

4,155,633. LEVEL11, LLC, EDEN PRAIRIE, MN. SN 85-350,700. PUB. 1-31-2012, FILED 6-20-2011.

LEVEL11

THE MARK CONSISTS OF STANDARD CHARACTERS WITHOUT CLAIM TO ANY PARTICULAR FONT, STYLE, SIZE, OR COLOR.

FOR ENTERTAINMENT IN THE NATURE OF LIVE PERFORMANCES BY DISC JOCKEYS, MUSICAL ARTISTS, DANCERS AND MASTERS OF CEREMONIES; ENTERTAINMENT IN THE NATURE OF LIGHT SHOWS AND LIGHTING PRODUCTION; ENTERTAINMENT SERVICES, NAMELY, CONDUCTING CONTESTS AND PARTIES; AUDIO RECORDING AND PRODUCTION; MULTIMEDIA ENTERTAINMENT SERVICES IN THE NATURE OF RECORDING, PRODUCTION AND POST-PRODUCTION SERVICES IN THE FIELDS OF MUSIC AND VIDEO; ARRANGING, ORGANIZING, CONDUCTING AND HOSTING NIGHTCLUB ENTERTAINMENT EVENTS, SPECIAL EVENTS FOR SOCIAL ENTERTAINMENT PURPOSES, ENTERTAINMENT EXHIBITIONS AND PRIVATE PARTIES; SPECIAL EVENT PLANNING FOR SOCIAL ENTERTAINMENT PURPOSES; EVENT PLANNING SERVICES FOR SOCIAL ENTERTAINMENT PURPOSES; CONSULTATION IN THE FIELD OF EVENT PLANNING SERVICES FOR SOCIAL ENTERTAINMENT PURPOSES; BOOKING SERVICES FOR ENTERTAINMENT, SPORTING AND CULTURAL EVENTS; EDUCATIONAL SERVICES, NAMELY, CONDUCTING CLASSES, SEMINARS, CONFERENCES AND WORKSHOPS IN THE FIELD OF DISC JOCKEYING AND DISTRIBUTING COURSE MATERIALS IN CONNECTION THEREWITH (U.S. CLS. 100, 101 AND 107).

FIRST USE 6-1-2011; IN COMMERCE 6-1-2011.

4,155,662. FRAUD DOG PRODUCTIONS, LLC, FT. LAUDERDALE, FL. SN 85-360,814. PUB. 12-20-2011, FILED 6-30-2011.



NO CLAIM IS MADE TO THE EXCLUSIVE RIGHT TO USE "FRAUD" AND "PRODUCTIONS", APART FROM THE MARK AS SHOWN.

THE MARK CONSISTS OF THE IMAGE OF A DOG RESTING ATOP THE MARK "FDP" ABOVE "FRAUD DOG PRODUCTIONS".

FOR ENTERTAINMENT SERVICES IN THE NATURE OF AN ONGOING TELEVISION SHOW ABOUT WRONGFUL AND CRIMINAL ACTIVITIES; EDUCATIONAL SERVICES IN THE NATURE OF SEMINARS, WORKSHOPS, AND PRESENTATIONS IN THE FIELD OF WRONGFUL AND CRIMINAL ACTIVITIES AND PROVIDING WRITTEN MATERIALS IN CONNECTION THEREWITH (U.S. CLS. 100, 101 AND 107).

FIRST USE 5-0-2011; IN COMMERCE 5-0-2011.

CLASS 41—(Continued).

4,155,671. HAHN, MARLA R., MILWAUKEE, WI. SN 85-363,374. PUB. 12-20-2011, FILED 7-5-2011.

Splash Studio

THE MARK CONSISTS OF STANDARD CHARACTERS WITHOUT CLAIM TO ANY PARTICULAR FONT, STYLE, SIZE, OR COLOR.

NO CLAIM IS MADE TO THE EXCLUSIVE RIGHT TO USE "STUDIO", APART FROM THE MARK AS SHOWN.

FOR EDUCATIONAL AND ENTERTAINMENT SERVICES, NAMELY, CONDUCTING CLASSES IN THE FIELD OF ART AND DISTRIBUTION OF COURSE MATERIALS IN CONNECTION THEREWITH, AND EDUCATION CONSULTING RELATED THERETO (U.S. CLS. 100, 101 AND 107).

FIRST USE 12-23-2011; IN COMMERCE 1-9-2012.

CLASS 41—(Continued).

4,155,694. AVANTE LEADERSHIP GROUP, LLC, LITTLETON, CO. SN 85-367,036. PUB. 12-6-2011, FILED 7-8-2011.

Evolving Leadership

THE MARK CONSISTS OF STANDARD CHARACTERS WITHOUT CLAIM TO ANY PARTICULAR FONT, STYLE, SIZE, OR COLOR.

FOR BUSINESS EDUCATION AND TRAINING SERVICES, NAMELY, DEVELOPING AND FACILITATING CUSTOMIZED LEADERSHIP AND EXECUTIVE DEVELOPMENT PROGRAMS, PROVIDING EXECUTIVE COACHING SERVICES, AND PROVIDING BUSINESS EDUCATION PROGRAMS TO EMPLOYEES AND EXECUTIVES (U.S. CLS. 100, 101 AND 107).

FIRST USE 3-1-2011; IN COMMERCE 3-1-2011.

4,155,680. A TASTE OF THE OC, LLC, NEWPORT BEACH, CA. SN 85-363,946. PUB. 1-24-2012, FILED 7-6-2011.

Taste of the OC

THE MARK CONSISTS OF STANDARD CHARACTERS WITHOUT CLAIM TO ANY PARTICULAR FONT, STYLE, SIZE, OR COLOR.

NO CLAIM IS MADE TO THE EXCLUSIVE RIGHT TO USE "OC", APART FROM THE MARK AS SHOWN.

FOR ARRANGING AND CONDUCTING WINE AND FOOD FESTIVALS IN ORANGE COUNTY, CALIFORNIA (U.S. CLS. 100, 101 AND 107).

FIRST USE 9-15-2009; IN COMMERCE 6-20-2011.

4,155,714. SPANX, INC., SUITE 1700, GA. SN 85-372,462. PUB. 1-10-2012, FILED 7-15-2011.

THE REAR VIEW

THE MARK CONSISTS OF STANDARD CHARACTERS WITHOUT CLAIM TO ANY PARTICULAR FONT, STYLE, SIZE, OR COLOR.

FOR ONLINE PUBLICATIONS, NAMELY, BLOGS FEATURING NEWS ABOUT CELEBRITIES, FASHION, CLOTHING AND PHILANTHROPY (U.S. CLS. 100, 101 AND 107).

FIRST USE 7-28-2011; IN COMMERCE 7-28-2011.

4,155,687. HERONFIELD ACADEMY, HAMPTON FALLS, NH. SN 85-365,485. PUB. 12-27-2011, FILED 7-7-2011.

HERONFIELD ACADEMY

THE MARK CONSISTS OF STANDARD CHARACTERS WITHOUT CLAIM TO ANY PARTICULAR FONT, STYLE, SIZE, OR COLOR.

NO CLAIM IS MADE TO THE EXCLUSIVE RIGHT TO USE "ACADEMY", APART FROM THE MARK AS SHOWN.

FOR EDUCATIONAL SERVICES, NAMELY, PROVIDING COURSES OF INSTRUCTION AT THE MIDDLE SCHOOL LEVEL (U.S. CLS. 100, 101 AND 107).

FIRST USE 9-30-2011; IN COMMERCE 9-30-2011.

4,155,716. MEDIABISTRO.COM INC., NORWALK, CT. SN 85-372,754. PUB. 12-13-2011, FILED 7-15-2011.

FISHBOWLLA

THE MARK CONSISTS OF STANDARD CHARACTERS WITHOUT CLAIM TO ANY PARTICULAR FONT, STYLE, SIZE, OR COLOR.

OWNER OF U.S. REG. NO. 3,704,983.

FOR PROVIDING ON-LINE PUBLICATIONS IN THE NATURE OF A NEWSLETTER AND BLOG IN THE FIELD OF NEWS, MEDIA, ENTERTAINMENT, AND PUBLIC RELATIONS WITH A PRIMARY FOCUS ON THE LOS ANGELES AREA (U.S. CLS. 100, 101 AND 107).

FIRST USE 1-11-2004; IN COMMERCE 1-11-2004.

CLASS 41—(Continued).

4,155,717. MEDIABISTRO.COM INC., NORWALK, CT. SN 85-372,765. PUB. 12-13-2011, FILED 7-15-2011.

FISHBOWLDC

THE MARK CONSISTS OF STANDARD CHARACTERS WITHOUT CLAIM TO ANY PARTICULAR FONT, STYLE, SIZE, OR COLOR.

OWNER OF U.S. REG. NO. 3,704,983.

FOR PROVIDING ON-LINE PUBLICATIONS IN THE NATURE OF A NEWSLETTER AND BLOG IN THE FIELD OF NEWS, MEDIA, ENTERTAINMENT, AND PUBLIC RELATIONS WITH A PRIMARY FOCUS ON THE WASHINGTON, DC AREA (U.S. CLS. 100, 101 AND 107).

FIRST USE 1-11-2004; IN COMMERCE 1-11-2004.

4,155,749. THE RICHARD STOCKTON COLLEGE OF NEW JERSEY, POMONA, NJ. SN 85-386,208. PUB. 10-18-2011, FILED 8-1-2011.

New Jersey's Distinctive Public College

THE MARK CONSISTS OF STANDARD CHARACTERS WITHOUT CLAIM TO ANY PARTICULAR FONT, STYLE, SIZE, OR COLOR.

NO CLAIM IS MADE TO THE EXCLUSIVE RIGHT TO USE "NEW JERSEY'S" OR "PUBLIC COLLEGE", APART FROM THE MARK AS SHOWN.

FOR EDUCATION SERVICES, NAMELY, PROVIDING COURSES OF INSTRUCTION AND TRAINING AT THE UNDERGRADUATE, GRADUATE, POST-GRADUATE, AND PROFESSIONAL LEVELS, AND CONTINUING EDUCATION; MORE SPECIFICALLY PROVIDING (I) UNDERGRADUATE EDUCATIONAL CLASSES AND TRAINING IN THE FIELDS OF ARTS AND HUMANITIES, GENERAL STUDIES, BUSINESS, HEALTH SCIENCES, SOCIAL AND BEHAVIORAL SCIENCE, NATURAL SCIENCES AND MATHEMATICS, WHICH INCLUDES CLASSES IN MARINE SCIENCE, ENVIRONMENTAL STUDIES, INFORMATION SYSTEMS, ENERGY STUDIES, AND THE FIELD OF EDUCATION, PROVIDING CERTIFICATION IN TEACHER EDUCATION, SPECIAL EDUCATION, AND PRE-SCHOOL EDUCATION; (II) GRADUATE, POST-GRADUATE AND PROFESSIONAL PROGRAMS IN THE FIELDS OF STUDY IN PHYSICAL THERAPY, CRIMINAL JUSTICE, HOLOCAUST AND GENOCIDE STUDIES, BUSINESS ADMINISTRATION, NURSING, OCCUPATIONAL THERAPY AND SOCIAL WORK, AND MASTER OF ARTS IN EDUCATION AND INSTRUCTIONAL TECHNOLOGY, AND (III) PROVIDING CONTINUING EDUCATION COURSES IN THE FIELDS OF HEALTH

CLASS 41—(Continued).

SCIENCE, HUMAN SERVICES AND MANAGEMENT DEVELOPMENT, AND PROFESSIONAL SERVICES; CONDUCTING EDUCATIONAL RESEARCH AT UNDERGRADUATE AND GRADUATE LEVELS IN MARINE SCIENCES AND CONSERVATION, AND IN TOURISM AND THE LOCAL AND STATE ECONOMY AND EDUCATIONAL RESEARCH CONDUCTED IN VARIOUS DISCIPLINES THROUGH GRANTS; ENTERTAINMENT IN THE NATURE OF ORGANIZING AND CONDUCTING ATHLETIC EVENTS AND COMPETITIONS FOR MEN'S AND WOMEN'S SPORTS INCLUDING BASEBALL, SOCCER, BASKETBALL, LACROSSE, TRACK AND FIELD, TENNIS, FIELD HOCKEY, ROWING, SOFTBALL AND CHEERLEADING, CLUB SPORTS AND INTRAMURALS; AND ORGANIZING AND PROVIDING ENTERTAINMENT VENUES FOR PERFORMING ARTS, LECTURES, CONCERTS, AND THEATER PRODUCTIONS, DANCE PERFORMANCES, PUBLIC SPEAKING EVENTS, AND VISUAL, LITERARY AND PERFORMING ARTS PRESENTATIONS (U.S. CLS. 100, 101 AND 107).

FIRST USE 3-29-2011; IN COMMERCE 5-0-2011.

4,155,768. CABLE NEWS NETWORK, INC., ATLANTA, GA. SN 85-394,305. PUB. 1-3-2012, FILED 8-10-2011.



OWNER OF U.S. REG. NOS. 3,791,013, 3,804,102, AND OTHERS.

NO CLAIM IS MADE TO THE EXCLUSIVE RIGHT TO USE ".COM", APART FROM THE MARK AS SHOWN.

THE MARK CONSISTS OF A BRACKET WITH THE LETTERS "HLNTV.COM" ENCLOSED.

FOR ENTERTAINMENT SERVICES, NAMELY, PROVISION OF ONGOING MULTIMEDIA PROGRAMS IN THE FIELD OF NEWS AND CURRENT EVENTS DISTRIBUTED VIA VARIOUS PLATFORMS ACROSS MULTIPLE FORMS OF TRANSMISSION MEDIA (U.S. CLS. 100, 101 AND 107).

FIRST USE 10-27-2011; IN COMMERCE 10-27-2011.

4,155,773. AMERICAN INSTITUTE OF CERTIFIED PUBLIC ACCOUNTANTS, NEW YORK, NY. SN 85-396,613. PUB. 1-17-2012, FILED 8-12-2011.

AICPA INSIGHTS

THE MARK CONSISTS OF STANDARD CHARACTERS WITHOUT CLAIM TO ANY PARTICULAR FONT, STYLE, SIZE, OR COLOR.

CLASS 41—(Continued).

OWNER OF U.S. REG. NOS. 864,285, 1,683,413, AND OTHERS.

FOR ON-LINE JOURNALS, NAMELY, BLOGS FEATURING INFORMATION IN THE FIELDS OF ACCOUNTING AND ACCOUNTANCY; PROVIDING A WEBSITE FEATURING BLOGS AND NON-DOWNLOADABLE PUBLICATIONS IN THE NATURE OF JOURNALS IN THE FIELDS OF ACCOUNTING AND ACCOUNTANCY (U.S. CLS. 100, 101 AND 107).

FIRST USE 1-28-2011; IN COMMERCE 7-11-2011.

4,155,779. HARVEY, STEVE, HOUSTON, TX. SN 85-399,977. PUB. 1-24-2012, FILED 8-17-2011.

The Steve Harvey Show

THE MARK CONSISTS OF STANDARD CHARACTERS WITHOUT CLAIM TO ANY PARTICULAR FONT, STYLE, SIZE, OR COLOR.

OWNER OF U.S. REG. NOS. 3,047,679, 3,482,769, AND OTHERS.

NO CLAIM IS MADE TO THE EXCLUSIVE RIGHT TO USE "SHOW", APART FROM THE MARK AS SHOWN.

THE NAME "STEVE HARVEY" IDENTIFIES A LIVING INDIVIDUAL WHOSE CONSENT IS OF RECORD.

FOR ENTERTAINMENT SERVICES IN THE NATURE OF AN ON-GOING TELEVISION TALK SHOW (U.S. CLS. 100, 101 AND 107).

FIRST USE 9-6-2011; IN COMMERCE 9-6-2011.

4,155,793. CEG WORLDWIDE, LLC, SAN MARTIN, CA. SN 85-407,301. PUB. 1-10-2012, FILED 8-25-2011.

**MASTERING CONVERSATIONAL
MARKETING**

THE MARK CONSISTS OF STANDARD CHARACTERS WITHOUT CLAIM TO ANY PARTICULAR FONT, STYLE, SIZE, OR COLOR.

NO CLAIM IS MADE TO THE EXCLUSIVE RIGHT TO USE "CONVERSATIONAL MARKETING", APART FROM THE MARK AS SHOWN.

FOR EDUCATIONAL SERVICES, NAMELY, TRAINING AND COACHING SERVICES DIRECTED TO PROFESSIONAL FINANCIAL ADVISORS, IN THE FIELDS OF FINANCIAL ADVISOR PRACTICE DEVELOPMENT AND ATTRACTING AND RETAINING FINANCIAL ADVISORY CLIENTS (U.S. CLS. 100, 101 AND 107).

FIRST USE 9-27-2011; IN COMMERCE 9-27-2011.

CLASS 41—(Continued).

4,155,808. THREE ANGELS BROADCASTING NETWORK, INC., WEST FRANKFORT, IL. SN 85-434,758. PUB. 12-13-2011, FILED 9-28-2011.

A Taste of Paradise

THE MARK CONSISTS OF STANDARD CHARACTERS WITHOUT CLAIM TO ANY PARTICULAR FONT, STYLE, SIZE, OR COLOR.

FOR EDUCATIONAL AND ENTERTAINMENT SERVICES, NAMELY, A CONTINUING PROGRAM ABOUT COOKING FROM A CHRISTIAN PERSPECTIVE ACCESSIBLE BY RADIO, TELEVISION, SATELLITE, AUDIO, VIDEO AND COMPUTER NETWORKS (U.S. CLS. 100, 101 AND 107).

FIRST USE 1-1-2012; IN COMMERCE 1-1-2012.

CLASS 42—SCIENTIFIC AND COMPUTER SERVICES

4,154,248. HENRY DONEGER ASSOCIATES, INC., NEW YORK, NY. SN 76-701,641. PUB. 3-22-2011, FILED 2-16-2010.

COLOR PROJECTIONS

THE MARK CONSISTS OF STANDARD CHARACTERS WITHOUT CLAIM TO ANY PARTICULAR FONT, STYLE, SIZE, OR COLOR.

NO CLAIM IS MADE TO THE EXCLUSIVE RIGHT TO USE "COLOR", APART FROM THE MARK AS SHOWN.

FOR CONSULTING SERVICES, NAMELY, COLOR ANALYSIS FOR PURPOSES OF USE IN APPAREL, HOME, CONSUMER GOODS, INTERIOR DESIGN, AND AUTOMOTIVE FIELDS (U.S. CLS. 100 AND 101).

FIRST USE 3-19-2012; IN COMMERCE 3-19-2012.

4,154,289. FLASH SEATS VERTICAL ALLIANCE LLC, CLEVELAND, OH. SN 77-385,263. PUB. 7-8-2008, FILED 1-31-2008.

VERITIX

THE MARK CONSISTS OF STANDARD CHARACTERS WITHOUT CLAIM TO ANY PARTICULAR FONT, STYLE, SIZE, OR COLOR.

FOR CONSULTING SERVICES IN THE FIELD OF DESIGN, SELECTION, IMPLEMENTATION AND USE OF SOFTWARE SYSTEMS FOR OTHERS IN THE FIELD OF DISPENSING OF TICKETS TO ENTERTAINMENT AND SPORTING EVENTS VIA THE INTERNET (U.S. CLS. 100 AND 101).

FIRST USE 2-29-2012; IN COMMERCE 2-29-2012.

CLASS 42—(Continued).

4,154,303. SCISBO, LLC, WILMINGTON, DE. SN 77-457,643. PUB. 1-6-2009, FILED 4-24-2008.



THE MARK CONSISTS OF THE WORD "SCISBO" IN STYLIZED LETTERING AND THE LOGO ALSO INCLUDES TWO INTERLOCKING "C" SHAPES WITH A DROP SHADOW.

FOR PROVIDING TEMPORARY USE OF NON-DOWNLOADABLE COMPUTER SOFTWARE FOR WIRELESS DEVICES THAT ALLOWS USERS TO ACCESS INFORMATION (U.S. CLS. 100 AND 101).

FIRST USE 3-30-2012; IN COMMERCE 3-30-2012.

4,154,314. PURE A.L.P.S. LLC, NEW MILFORD, CT. SN 77-502,977. PUB. 12-29-2009, FILED 6-19-2008.

ALPS

THE MARK CONSISTS OF STANDARD CHARACTERS WITHOUT CLAIM TO ANY PARTICULAR FONT, STYLE, SIZE, OR COLOR.

FOR DESIGN OF APPARATUS AND MACHINES FOR FILLING PURPOSES; DESIGN AND DEVELOPMENT OF PLASTIC BOTTLES, BABY BOTTLES, DISPENSERS AND CONTAINERS FOR STORING AND DISPENSING FOOD AND BEVERAGES (U.S. CLS. 100 AND 101).

FIRST USE 5-4-2007; IN COMMERCE 5-4-2007.

4,154,355. BRISTOL-MYERS SQUIBB COMPANY, NEW YORK, NY. SN 77-567,795. PUB. 1-13-2009, FILED 9-11-2008.

BRISK

THE MARK CONSISTS OF STANDARD CHARACTERS WITHOUT CLAIM TO ANY PARTICULAR FONT, STYLE, SIZE, OR COLOR.

FOR MEDICAL AND SCIENTIFIC RESEARCH, NAMELY, CONDUCTING CLINICAL TRIALS AND CLINICAL STUDIES RELATING TO PHARMACEUTICAL PREPARATIONS FOR HUMAN USE (U.S. CLS. 100 AND 101).

FIRST USE 2-28-2009; IN COMMERCE 2-28-2009.

CLASS 42—(Continued).

4,154,471. OUTBOX TECHNOLOGY CRB INC., MONTREAL, QUEBEC, CANADA. SN 77-835,079. PUB. 8-10-2010, FILED 9-25-2009.

EVENTSHOPPER

THE MARK CONSISTS OF STANDARD CHARACTERS WITHOUT CLAIM TO ANY PARTICULAR FONT, STYLE, SIZE, OR COLOR.

FOR PROVIDING ONLINE NON-DOWNLOADABLE COMPUTER SOFTWARE USED AS TICKET ORDERING INTERFACES VIA A HOSTED PLATFORM TO MARKET, MANAGE AND PROCESS TICKET SALES AND RESERVATIONS IN REAL-TIME IN A MULTI-LANGUAGE, MULTI-CURRENCY ENVIRONMENT (U.S. CLS. 100 AND 101).

FIRST USE 0-0-2008; IN COMMERCE 0-0-2008.

4,154,499. INNOVYZE, INC., BROOMFIELD, CO. SN 77-873,568. PUB. 4-20-2010, FILED 11-16-2009.

INNOVATING FOR SUSTAINABLE INFRASTRUCTURE

THE MARK CONSISTS OF STANDARD CHARACTERS WITHOUT CLAIM TO ANY PARTICULAR FONT, STYLE, SIZE, OR COLOR.

FOR DESIGN AND DEVELOPMENT OF COMPUTER SOFTWARE FOR OTHERS FOR USE IN A VARIETY OF FIELDS AND APPLICATIONS, NAMELY, ENGINEERING APPLICATIONS, CONSTRUCTION DESIGN APPLICATIONS, PROJECT PLANNING AND MANAGEMENT APPLICATIONS, ENVIRONMENTAL ENGINEERING APPLICATIONS, QUALITY CONTROL APPLICATIONS, WATER TREATMENT AND DISTRIBUTION APPLICATIONS, AND HYDROPOWER DESIGN AND CONTROL APPLICATIONS; PROVIDING CONSULTING SERVICES TO OTHERS IN THE DESIGN, SELECTION, IMPLEMENTATION AND THE USE OF SOFTWARE SYSTEMS FOR USE IN A VARIETY OF FIELDS, INDUSTRIES AND APPLICATIONS, NAMELY, ENGINEERING, CONSTRUCTION, ENVIRONMENTAL ENGINEERING, PROJECT PLANNING AND MANAGEMENT, QUALITY CONTROL, WATER TREATMENT AND DISTRIBUTION, AND HYDROPOWER DESIGN AND CONTROL; PROVIDING COMPUTER SOFTWARE TECHNICAL SUPPORT SERVICES, NAMELY, TROUBLESHOOTING OF COMPUTER SOFTWARE PROBLEMS FOR OTHERS IN A VARIETY OF FIELDS, INDUSTRIES AND APPLICATIONS, NAMELY, ENGINEERING, ENVIRONMENTAL ENGINEERING, PROJECT PLANNING AND MANAGEMENT, QUALITY CONTROL, WATER TREATMENT AND DISTRIBUTION, AND HYDROPOWER DESIGN AND CONTROL (U.S. CLS. 100 AND 101).

FIRST USE 11-0-2009; IN COMMERCE 11-0-2009.

CLASS 42—(Continued).

4,154,528. ABRANOVIC, SUSAN J., FORMERLY LAGROSA, SUSAN J., FRANKLIN LAKES, NJ. SN 77-930,677. PUB. 8-3-2010, FILED 2-8-2010.

STAGING GRACE

THE MARK CONSISTS OF STANDARD CHARACTERS WITHOUT CLAIM TO ANY PARTICULAR FONT, STYLE, SIZE, OR COLOR.

NO CLAIM IS MADE TO THE EXCLUSIVE RIGHT TO USE "STAGING", APART FROM THE MARK AS SHOWN.

FOR HOME STAGING CONSULTATION, NAMELY, TEMPORARY INTERIOR AND EXTERIOR HOME DECORATION CONSULTATION FOR THE PURPOSE OF MAKING HOMES MORE APPEALING TO PROSPECTIVE BUYERS (U.S. CLS. 100 AND 101).

FIRST USE 2-1-2010; IN COMMERCE 2-15-2012.

4,154,608. CUNNINGHAM, ARGUS I., FPO AE, ITALY. SN 85-002,207. PUB. 8-31-2010, FILED 3-30-2010.

SHARE GATE

THE MARK CONSISTS OF STANDARD CHARACTERS WITHOUT CLAIM TO ANY PARTICULAR FONT, STYLE, SIZE, OR COLOR.

FOR PROVIDING A WEBSITE FEATURING TECHNOLOGY THAT FACILITATES SHAREHOLDERS' ELECTRONIC COMMUNICATION AND SOCIAL MEDIA INTERACTION FOR THE PURPOSE OF IMPROVING CORPORATE GOVERNANCE OVERSIGHT; PROVIDING ON-LINE NON-DOWNLOADABLE SOFTWARE THAT FACILITATES SHAREHOLDERS' ELECTRONIC COMMUNICATION AND SOCIAL MEDIA INTERACTION FOR THE PURPOSE OF IMPROVING CORPORATE GOVERNANCE OVERSIGHT (U.S. CLS. 100 AND 101).

FIRST USE 11-30-2010; IN COMMERCE 11-30-2011.

4,154,626. BENSON, DEBORAH SUE, DBA BENTIS COMPANIES, LLC, BLAINE, MN. AND TENTIS, PAMELA JEAN, DBA BENTIS COMPANIES, LLC, CIRCLE PINES, MN. SN 85-016,192. PUB. 9-7-2010, FILED 4-16-2010.

Kikker Kiks

THE MARK CONSISTS OF STANDARD CHARACTERS WITHOUT CLAIM TO ANY PARTICULAR FONT, STYLE, SIZE, OR COLOR.

NO CLAIM IS MADE TO THE EXCLUSIVE RIGHT TO USE "KICKS", APART FROM THE MARK AS SHOWN.

CLASS 42—(Continued).

THE WORDING "KIKKER" HAS NO MEANING IN A FOREIGN LANGUAGE. IT IS A DELIBERATE MISSPELLING OF "KICKER".

FOR CUSTOM DESIGN OF APPAREL AND FOOTWEAR ACCESSORIES BASED ON PERSONAL SELECTIONS MADE BY THE CUSTOMER (U.S. CLS. 100 AND 101).

FIRST USE 8-1-2011; IN COMMERCE 8-1-2011.

4,154,632. CASARIVER LLC, ROCKY RIVER, OH. SN 85-028,236. PUB. 10-4-2011, FILED 5-2-2010.

CASARIVER

THE MARK CONSISTS OF STANDARD CHARACTERS WITHOUT CLAIM TO ANY PARTICULAR FONT, STYLE, SIZE, OR COLOR.

THE ENGLISH TRANSLATION OF "CASA" IN THE MARK IS "HOUSE".

FOR CONSULTING SERVICES IN THE FIELD OF COMPUTER-BASED INFORMATION SYSTEMS FOR BUSINESSES; CONSULTING SERVICES IN THE FIELD OF IT PROJECT MANAGEMENT; CONSULTING SERVICES IN THE FIELD OF CONFIGURATION MANAGEMENT FOR COMPUTER HARDWARE AND SOFTWARE (U.S. CLS. 100 AND 101).

FIRST USE 1-9-2012; IN COMMERCE 1-9-2012.

4,154,669. ELOYALTY, LLC, ENGLEWOOD, CO. SN 85-075,683. PUB. 11-23-2010, FILED 7-1-2010.

ICDESKTOP

THE MARK CONSISTS OF STANDARD CHARACTERS WITHOUT CLAIM TO ANY PARTICULAR FONT, STYLE, SIZE, OR COLOR.

FOR SOFTWARE AS A SERVICE (SAAS) SERVICES FEATURING SOFTWARE IN THE FIELD OF CALL CENTER MANAGEMENT, NAMELY, A COMPUTER TELEPHONY INTEGRATION (CTI) APPLICATION TO CONTROL THE AGENT'S PHONE AND PHONE STATE, AND TO ALLOW CONFIGURABLE INTEGRATION WITH OTHER CALL CENTER SOFTWARE (U.S. CLS. 100 AND 101).

FIRST USE 2-8-2011; IN COMMERCE 2-8-2011.

CLASS 42—(Continued).

4,154,674. ELOYALTY, LLC, ENGLEWOOD, CO. SN 85-082,787. PUB. 11-23-2010, FILED 7-12-2010.

ICSPEAK

THE MARK CONSISTS OF STANDARD CHARACTERS WITHOUT CLAIM TO ANY PARTICULAR FONT, STYLE, SIZE, OR COLOR.

FOR SOFTWARE AS A SERVICE (SAAS) SERVICES FEATURING SOFTWARE IN THE FIELD OF CALL CENTER MANAGEMENT, NAMELY, A CUSTOMER VOICE PORTAL (CVP) APPLICATION THAT ALLOWS A CALLER TO RECORD AND MANAGE AUDIO MESSAGES THROUGH THE TELEPHONE (U.S. CLS. 100 AND 101).

FIRST USE 10-25-2010; IN COMMERCE 10-25-2010.

4,154,675. ELOYALTY, LLC, ENGLEWOOD, CO. SN 85-082,797. PUB. 11-23-2010, FILED 7-12-2010.

ICINTELLECT

THE MARK CONSISTS OF STANDARD CHARACTERS WITHOUT CLAIM TO ANY PARTICULAR FONT, STYLE, SIZE, OR COLOR.

FOR SOFTWARE AS A SERVICE (SAAS) SERVICES FEATURING SOFTWARE IN THE FIELD OF CALL CENTER MANAGEMENT FOR USE IN CONSOLIDATING, SUMMARIZING AND REPORTING DATA FROM CONTACT CENTER DATA SOURCES (U.S. CLS. 100 AND 101).

FIRST USE 12-6-2010; IN COMMERCE 12-6-2010.

4,154,712. WILLOW CREEK ASSOCIATION, SOUTH BARRINGTON, IL. SN 85-103,420. PUB. 8-16-2011, FILED 8-9-2010.

ENGAGE

THE MARK CONSISTS OF STANDARD CHARACTERS WITHOUT CLAIM TO ANY PARTICULAR FONT, STYLE, SIZE, OR COLOR.

FOR APPLICATION SERVICE PROVIDER, NAMELY, HOSTING, MANAGING, DEVELOPING, AND MAINTAINING APPLICATIONS AND SOFTWARE, FOR USE BY CHURCHES, MINISTRIES, NONPROFIT ORGANIZATIONS, AND INSTITUTIONS IN THE FIELDS OF SPIRITUAL GROWTH AND TRANSFORMATION (U.S. CLS. 100 AND 101).

FIRST USE 5-5-2010; IN COMMERCE 8-8-2011.

CLASS 42—(Continued).

4,154,741. NEXTGEN MANAGEMENT, LLC, BALTIMORE, MD. SN 85-109,846. PUB. 11-16-2010, FILED 8-17-2010.

DxWeb

THE MARK CONSISTS OF STANDARD CHARACTERS WITHOUT CLAIM TO ANY PARTICULAR FONT, STYLE, SIZE, OR COLOR.

FOR PROVIDING TEMPORARY USE OF ON-LINE NON-DOWNLOADABLE SOFTWARE FOR ELECTRONICALLY PRESCRIBING MEDICAL AND PHARMACEUTICAL PRESCRIPTIONS OVER A GLOBAL COMPUTER NETWORK (U.S. CLS. 100 AND 101).

FIRST USE 1-4-2011; IN COMMERCE 1-4-2011.

4,154,808. IXARIS SYSTEMS LTD, LONDON, UNITED KINGDOM. SN 85-137,623. PUB. 3-8-2011, FILED 9-24-2010.

IXARIS

THE MARK CONSISTS OF STANDARD CHARACTERS WITHOUT CLAIM TO ANY PARTICULAR FONT, STYLE, SIZE, OR COLOR.

FOR DESIGN AND DEVELOPMENT OF COMPUTER HARDWARE AND SOFTWARE (U.S. CLS. 100 AND 101).

FIRST USE 11-15-2010; IN COMMERCE 11-15-2010.

4,154,812. VISI INCORPORATED, EDEN PRAIRIE, MN. SN 85-139,146. PUB. 8-9-2011, FILED 9-27-2010.

CLOUD DONE RIGHT

THE MARK CONSISTS OF STANDARD CHARACTERS WITHOUT CLAIM TO ANY PARTICULAR FONT, STYLE, SIZE, OR COLOR.

CLASS 42—(Continued).

NO CLAIM IS MADE TO THE EXCLUSIVE RIGHT TO USE "CLOUD", APART FROM THE MARK AS SHOWN.

FOR HOSTING THE WEBSITES OF OTHERS; COMPUTER CO-LOCATION SERVICES, NAMELY, PROVIDING FACILITIES FOR THE LOCATION OF COMPUTER SERVERS WITH THE EQUIPMENT OF OTHERS; DISPLAYING THE WEB SITES AND IMAGES OF OTHERS ON A DEDICATED COMPUTER SERVER; E-MAIL SYSTEM DESIGN AND IMPLEMENTATION FOR OTHERS; INFORMATION TECHNOLOGY CONSULTATION; DESIGN, CREATION, HOSTING AND MAINTENANCE OF INTERNET SITES FOR THIRD PARTIES; COMPUTER SERVICES, NAMELY, PROVIDING VIRTUAL AND CLOUD COMPUTING ENVIRONMENTS ACCESSIBLE VIA THE INTERNET AND ORGANIZATIONAL NETWORKS FOR THE PURPOSE OF REMOTE MANAGEMENT IN THE NATURE OF CREATING AND OPERATING ON-LINE COMPUTER APPLICATIONS; PROVIDING A WEB-BASED SYSTEM AND ONLINE PORTAL FOR THIRD PARTIES TO REMOTELY MANAGE, ADMINISTER, MODIFY AND CONTROL VIRTUALIZED COMPUTING RESOURCES, DATA AND SOFTWARE APPLICATIONS IMPLEMENTED VIA DISTRIBUTED COMPUTING ENVIRONMENTS, AND TO REMOTELY MANAGE, ADMINISTER, MODIFY AND CONTROL GEOGRAPHIC DISTRIBUTION OF THE VIRTUALIZED COMPUTING RESOURCES, DATA AND SOFTWARE APPLICATIONS; PROVIDING A WEB-BASED SYSTEM AND ONLINE PORTAL FOR THIRD PARTIES TO REMOTELY MANAGE, ADMINISTER, MODIFY AND CONTROL DISASTER RECOVERY SOLUTIONS RELATING TO THEIR COMPUTER DEVICES, DATA AND SOFTWARE APPLICATIONS; PROVIDING NON-DOWNLOADABLE SOFTWARE, ACCESSIBLE OVER A GLOBAL COMPUTER NETWORK, FOR MANAGING COMPUTER APPLICATIONS AND FOR OPERATING DISTRIBUTED APPLICATIONS AND NETWORKS OF COMPUTERS; AND PROVIDING NON-DOWNLOADABLE SOFTWARE, ACCESSIBLE OVER A GLOBAL COMPUTER NETWORK, FOR ENABLING COMPUTER SYSTEM OPERATORS TO VIRTUALIZE THEIR COMPUTER SYSTEM RESOURCES, MANAGE, ADMINISTER, MODIFY, AND CONTROL THEIR VIRTUALIZED COMPUTING RESOURCES, AND ACCESS VIRTUALIZED GRID AND UTILITY COMPUTING RESOURCES, NAMELY, DISTRIBUTED CLOUD-BASED UTILITY COMPUTING RESOURCES, INFRASTRUCTURE-ON-DEMAND COMPUTING RESOURCES, METERED COMPUTING UTILITY RESOURCES, VIRTUALIZED GLOBALLY DISTRIBUTED COMPUTING RESOURCES, VIRTUALIZED DATACENTER RESOURCES, READY-APPLICATION-STACK COMPUTING RESOURCES, AND HIGH-AVAILABILITY COMPUTING RESOURCES; APPLICATION SERVICE PROVIDER, NAMELY, PROVIDING, HOSTING, MANAGING, DEVELOPING, AND MAINTAINING APPLICATIONS, SOFTWARE, WEBSITES, AND DATABASES FOR OTHERS IN THE FIELDS OF WIRELESS COMMUNICATION, MOBILE INFORMATION ACCESS, AND REMOTE DATA MANAGEMENT FOR WIRELESS DELIVERY OF CONTENT TO HANDHELD COMPUTERS, LAPTOPS AND MOBILE ELECTRONIC DEVICES (U.S. CLS. 100 AND 101).

FIRST USE 10-4-2009; IN COMMERCE 10-4-2009.

4,154,837. GENERAL ELECTRIC COMPANY, SCHENECTADY, NY. SN 85-147,708. PUB. 8-30-2011, FILED 10-7-2010.

TRUESENSE

THE MARK CONSISTS OF STANDARD CHARACTERS WITHOUT CLAIM TO ANY PARTICULAR FONT, STYLE, SIZE, OR COLOR.

CLASS 42—(Continued).

OWNER OF U.S. REG. NO. 3,803,163.

FOR CHEMICAL ENGINEERING SERVICES RELATED TO THE TREATMENT OF AQUEOUS SYSTEMS; MONITORING SERVICES OF AQUEOUS SYSTEMS TO ASSESS TREATMENT; DIAGNOSTIC SERVICES OF AQUEOUS SYSTEMS TO ASSESS TREATMENT (U.S. CLS. 100 AND 101).

FIRST USE 2-26-2008; IN COMMERCE 2-26-2008.

4,154,908. KINDER MORGAN KANSAS, INC., HOUSTON, TX. SN 85-188,673. PUB. 4-12-2011, FILED 12-1-2010.

KMAP

THE MARK CONSISTS OF STANDARD CHARACTERS WITHOUT CLAIM TO ANY PARTICULAR FONT, STYLE, SIZE, OR COLOR.

FOR CONSULTING SERVICES FOR EVALUATION AND ANALYSIS OF PIPELINE INSPECTION DATA (U.S. CLS. 100 AND 101).

FIRST USE 4-1-2011; IN COMMERCE 4-1-2011.

4,154,918. CLAIMSMADEEZ, INC., CHAMPLIN, MN. SN 85-194,652. PUB. 10-25-2011, FILED 12-9-2010.

CLAIMSMADEEZ

THE MARK CONSISTS OF STANDARD CHARACTERS WITHOUT CLAIM TO ANY PARTICULAR FONT, STYLE, SIZE, OR COLOR.

FOR PROVIDING A WEBSITE FEATURING TECHNOLOGY THAT ENABLES USERS TO PROACTIVELY IDENTIFY, CATEGORIZE AND ORGANIZE HOME AND BUSINESS INVENTORY FOR INSURANCE CLAIMS PURPOSES (U.S. CLS. 100 AND 101).

FIRST USE 8-15-2011; IN COMMERCE 8-15-2011.

4,154,930. @LEGAL DISCOVERY LLC, FALLS CHURCH, VA. SN 85-200,798. PUB. 8-9-2011, FILED 12-17-2010.



OWNER OF U.S. REG. NO. 3,918,483.

NO CLAIM IS MADE TO THE EXCLUSIVE RIGHT TO USE "THE UNIFIED EDISCOVERY PLATFORM", APART FROM THE MARK AS SHOWN.

THE COLOR(S) ORANGE, CHARCOAL AND GRAY IS/ ARE CLAIMED AS A FEATURE OF THE MARK.

CLASS 42—(Continued).

THE MARK CONSISTS OF A TRANSPARENT "@" SYMBOL ON A SQUARE ORANGE BACKGROUND WITH CURVED CORNERS WITH "CASEPOINT" WITH "CASE" IN CHARCOAL AND "POINT" IN GRAY AND "THE UNIFIED EDISCOVERY PLATFORM" IN CHARCOAL.

FOR PROVIDING ON-LINE, TEMPORARY USE OF NON-DOWNLOADABLE COMPUTER PROGRAMS FOR DOCUMENT MANAGEMENT; PROVIDING TEMPORARY USE OF NON-DOWNLOADABLE COMPUTER PROGRAMS FOR SEARCHING THE CONTENTS OF COMPUTERS AND COMPUTER NETWORKS BY REMOTE CONTROL; PROVIDING TEMPORARY USE OF NON-DOWNLOADABLE COMPUTER PROGRAMS FOR USING THE INTERNET AND THE WORLD WIDE WEB; PROVIDING TEMPORARY USE OF NON-DOWNLOADABLE COMPUTER SEARCH ENGINE SOFTWARE; PLATFORM AS A SERVICE (PAAS) FEATURING COMPUTING PLATFORM FOR USE IN ELECTRONIC DISCOVERY DATA PROCESSING, DOCUMENT REVIEW AND PRODUCTION OF DATA IN THE LEGAL INDUSTRY; DATA MINING IN THE NATURE OF DOCUMENT MINING SERVICES, INCLUDING EMAIL THREADING, NEAR DUPLICATE IDENTIFICATION, WORD CLOUD, BATCH MANAGEMENT REVIEW, SUGGESTED REVIEW TAGGING AND ELECTRONIC DISCOVERY COMPUTER PROJECT MANAGEMENT (U.S. CLS. 100 AND 101).

FIRST USE 10-0-2010; IN COMMERCE 10-0-2010.

4,154,979. TRANSURANT, INC., OMAHA, NE. SN 85-215,365. PUB. 5-31-2011, FILED 1-11-2011.



THE MARK CONSISTS OF THREE WAVY PAPERS WITH 3 VERTICAL BARS GOING FROM SHORTEST ON THE LEFT TO MEDIUM IN THE MIDDLE AND TALLEST ON THE RIGHT. THE BARS HAVE A ZIG ZAG LINE ARROW STRIKING THROUGH THEM THAT REPRESENT AN INCREASE. TO THE RIGHT THERE IS THE STYLIZED TEXT "TRANSURANT INNOVATIVE REPORTING SOLUTIONS FOR HEALTHCARE".

FOR APPLICATION SERVICE PROVIDER (ASP) FEATURING ONLINE REPORTING SOFTWARE FOR USE IN THE FIELD OF HEALTHCARE; PROVIDING TEMPORARY USE OF ON-LINE NONDOWNLOADABLE SOFTWARE AND APPLICATIONS FOR MEDICAL BILLING QUALITY ASSURANCE, STAFF EDUCATION AND SYSTEM OVERSIGHT; PROVIDING TEMPORARY USE OF ON-LINE NONDOWNLOADABLE SOFTWARE AND APPLICATIONS FOR DATA INTEGRITY CHECKING AND COMPARISON (U.S. CLS. 100 AND 101).

FIRST USE 1-1-2011; IN COMMERCE 10-1-2011.

CLASS 42—(Continued).

4,155,010. SPORTSIDE, LLC, HUNTINGTON, NY. SN 85-228,163. PUB. 1-24-2012, FILED 1-27-2011.

Sportsideo

THE MARK CONSISTS OF STANDARD CHARACTERS WITHOUT CLAIM TO ANY PARTICULAR FONT, STYLE, SIZE, OR COLOR.

FOR PROVIDING A WEBSITE THAT GIVES COMPUTER AND MOBILE DEVICE USERS THE ABILITY TO UPLOAD AND SHARE VIDEOS, MOVIES, PICTURES, IMAGES, TEXT, PHOTOS, AUDIO-CONTENT IN THE FIELD OF SPORTS (U.S. CLS. 100 AND 101).

FIRST USE 11-21-2011; IN COMMERCE 1-3-2012.

4,155,051. GEOEYE IMAGERY COLLECTION SYSTEMS INC., DULLES, VA. SN 85-238,408. PUB. 6-14-2011, FILED 2-9-2011.

ELEVATING INSIGHT

THE MARK CONSISTS OF STANDARD CHARACTERS WITHOUT CLAIM TO ANY PARTICULAR FONT, STYLE, SIZE, OR COLOR.

FOR DATABASE DESIGN AND DEVELOPMENT SERVICES; INTERPRETATION OF DIGITAL AERIAL AND SATELLITE IMAGES OF THE EARTH FOR OTHERS; PHOTOGRAMMETRY SERVICES; MAKING MAPS AND SCALE DRAWINGS FROM AERIAL AND SATELLITE PHOTOGRAPHS; PROVIDING A WEBSITE FEATURING ON-LINE SOFTWARE TOOLS FOR IMAGE EDITING AND MANIPULATION; ENGINEERING SERVICES; PROVIDING INFORMATION IN THE FIELDS OF LOCATION INTELLIGENCE AND GEOSPATIAL INTELLIGENCE; RESEARCH AND DEVELOPMENT AND CONSULTATION RELATED THERETO IN THE FIELDS OF GEOSPATIAL INFORMATION AND DATA, GEOCODING INFORMATION, GEOGRAPHIC INFORMATION SYSTEMS, LOCATION INTELLIGENCE, LOCATION-SPECIFIC INFORMATION, AND LOCATION MONITORING; ANALYSIS SERVICES FOR OTHERS, NAMELY, ANALYSIS AND INTEGRATION OF INFORMATION AND DATA IN THE FIELDS OF GEOSPATIAL INFORMATION, HUMAN TERRAIN INFORMATION, SOCIO-CULTURAL INFORMATION, BEHAVIORAL INFORMATION, AND HUMAN FACTORS INFORMATION, AND CONSULTATION RELATED THERETO (U.S. CLS. 100 AND 101).

FIRST USE 3-0-2011; IN COMMERCE 3-0-2011.

CLASS 42—(Continued).

4,155,083. LARSON, GLEN J., COLORADO SPRINGS, CO. SN 85-243,987. PUB. 8-2-2011, FILED 2-16-2011.

OPTIONS EXPLORER

THE MARK CONSISTS OF STANDARD CHARACTERS WITHOUT CLAIM TO ANY PARTICULAR FONT, STYLE, SIZE, OR COLOR.

NO CLAIM IS MADE TO THE EXCLUSIVE RIGHT TO USE "OPTIONS", APART FROM THE MARK AS SHOWN.

FOR APPLICATION SERVICE PROVIDER (ASP) FEATURING SOFTWARE FOR ELECTRONIC TRADING OF STOCKS AND FOR STOCK PORTFOLIO MANAGEMENT; APPLICATION SERVICE PROVIDER (ASP) FEATURING SOFTWARE FOR INVESTMENT ANALYSIS OF STOCKS AND CREATING INVESTMENT RISK MODELS FOR STOCKS; APPLICATION SERVICE PROVIDER (ASP) FEATURING SOFTWARE FOR PROVIDING ONLINE ACCESS TO COMMERCIAL EXCHANGES AND MARKETS; AND COMPUTER PROGRAMMING IN THE FIELD OF BUILDING SOPHISTICATED AUTOMATED TRADING TOOLS FOR USE IN TRACKING STOCK PRICES AND STOCK OPPORTUNITIES AND MANAGING RISK (U.S. CLS. 100 AND 101).

FIRST USE 2-29-2012; IN COMMERCE 2-29-2012.

4,155,162. CHEATERVILLE, INC, LAS VEGAS, NV. SN 85-253,129. PUB. 7-5-2011, FILED 2-28-2011.



THE MARK CONSISTS OF THE STYLIZED TEXT "CHEATERVILLE "DON'T BE THE LAST TO KNOW"" WITH A BACKGROUND SKYLINE DESIGN CONSISTING OF BUILDINGS AND BRIDGES AND A CARTOON CHARACTER.

FOR COMPUTER SERVICES, NAMELY, CREATING AN ON-LINE COMMUNITY FOR REGISTERED USERS TO PARTICIPATE IN DISCUSSIONS, GET FEEDBACK FROM THEIR PEERS, FORM VIRTUAL COMMUNITIES, AND ENGAGE IN SOCIAL NETWORKING (U.S. CLS. 100 AND 101).

FIRST USE 2-14-2011; IN COMMERCE 2-14-2011.

CLASS 42—(Continued).

4,155,212. CHARITY PANDA, LLC, KATONAH, NY. SN 85-257,179. PUB. 7-19-2011, FILED 3-3-2011.

Charity Panda

THE MARK CONSISTS OF STANDARD CHARACTERS WITHOUT CLAIM TO ANY PARTICULAR FONT, STYLE, SIZE, OR COLOR.

NO CLAIM IS MADE TO THE EXCLUSIVE RIGHT TO USE "CHARITY", APART FROM THE MARK AS SHOWN.

FOR CHARITABLE SERVICES, NAMELY, PROVIDING A WEBSITE THAT FEATURES TECHNOLOGY THAT ENABLES HOSTS OF COMMEMORATIVE OCCASIONS TO INVITE GUESTS, INVITEES AND OTHER INVITATION RECIPIENTS TO DIRECT CONTRIBUTIONS TO CHARITABLE ORGANIZATIONS (U.S. CLS. 100 AND 101).

FIRST USE 11-23-2011; IN COMMERCE 11-23-2011.

4,155,297. NEVAVILLE INC, BRONX, NY. SN 85-266,795. PUB. 8-2-2011, FILED 3-14-2011.

SyncBeats

THE MARK CONSISTS OF STANDARD CHARACTERS WITHOUT CLAIM TO ANY PARTICULAR FONT, STYLE, SIZE, OR COLOR.

FOR COMPUTER SERVICES, NAMELY, CREATING AN ON-LINE COMMUNITY FOR REGISTERED USERS TO PARTICIPATE IN DISCUSSIONS, GET FEEDBACK FROM THEIR PEERS, FORM VIRTUAL COMMUNITIES, AND ENGAGE IN SOCIAL NETWORKING; PROVIDING A WEBSITE ALLOWING USERS TO UPLOAD AND DOWNLOAD MUSIC (U.S. CLS. 100 AND 101).

FIRST USE 9-11-2011; IN COMMERCE 1-10-2012.

4,155,306. VANGLE CONSULTING LLC, AUSTIN, TX. SN 85-267,760. PUB. 7-19-2011, FILED 3-15-2011.

VANGLE

THE MARK CONSISTS OF STANDARD CHARACTERS WITHOUT CLAIM TO ANY PARTICULAR FONT, STYLE, SIZE, OR COLOR.

FOR PRODUCT TESTING CONSULTATION RELATING TO STANDARDS AND EUROPEAN DIRECTIVES FOR "CONFORMITE EUROPEENNE" (CE) MARKING AND "ATMOSPHERES EXPLOSIVES" (ATEX) COMPLIANCE AND CERTIFICATION (U.S. CLS. 100 AND 101).

FIRST USE 4-8-2011; IN COMMERCE 12-21-2011.

CLASS 42—(Continued).

4,155,385. PROMETHEUS HOLDINGS, INC., SAN CLEMENTE, CA. SN 85-280,426. PUB. 8-16-2011, FILED 3-29-2011.

Readerpedia

THE MARK CONSISTS OF STANDARD CHARACTERS WITHOUT CLAIM TO ANY PARTICULAR FONT, STYLE, SIZE, OR COLOR.

FOR COMPUTER SERVICES, NAMELY, CREATING INDEXES OF INFORMATION, SITES, AND OTHER RESOURCES AVAILABLE ON COMPUTER NETWORKS, AND CONVERTING DOCUMENTS FROM PHYSICAL TO ELECTRONIC MEDIA (U.S. CLS. 100 AND 101).

FIRST USE 12-8-2011; IN COMMERCE 12-8-2011.

4,155,418. JU, LEI, PHILADELPHIA, PA. SN 85-284,082. PUB. 8-30-2011, FILED 4-1-2011.

SUNICHEM

THE MARK CONSISTS OF STANDARD CHARACTERS WITHOUT CLAIM TO ANY PARTICULAR FONT, STYLE, SIZE, OR COLOR.

THE WORDING "SUNI" HAS NO MEANING IN A FOREIGN LANGUAGE.

FOR CHEMICAL LABORATORIES; CHEMICAL RESEARCH; DEVELOPMENT AND TEST OF CHEMICAL PRODUCTION METHODS; SCIENTIFIC RESEARCH; WORKING ON AND EVALUATION OF CHEMICAL SYNTHESIS (U.S. CLS. 100 AND 101).

FIRST USE 2-1-2010; IN COMMERCE 2-1-2010.

4,155,443. CAROLINA CENTER FOR OCCUPATIONAL HEALTH, LLC, NORTH CHARLESTON, SC. SN 85-288,780. PUB. 8-16-2011, FILED 4-7-2011.

OPSASSURE

THE MARK CONSISTS OF STANDARD CHARACTERS WITHOUT CLAIM TO ANY PARTICULAR FONT, STYLE, SIZE, OR COLOR.

FOR PROVIDING ON-LINE, NON-DOWNLOADABLE, GLOBAL COMMUNICATIONS NETWORK ACCESSIBLE SOFTWARE APPLICATION FOR MANAGEMENT AND ADMINISTRATION SUPPORT SERVICES OF MEDICAL PRACTICE ORGANIZATIONS FOR THE MANAGEMENT OF HEALTHCARE SERVICES AND HEALTH CARE FACILITIES (U.S. CLS. 100 AND 101).

FIRST USE 6-1-2011; IN COMMERCE 6-1-2011.

CLASS 42—(Continued).

4,155,458. ZIMMEDIA, LLC, LONG ISLAND CITY, NY. SN 85-292,968. PUB. 1-17-2012, FILED 4-12-2011.

OPEN SCHOOL

THE MARK CONSISTS OF STANDARD CHARACTERS WITHOUT CLAIM TO ANY PARTICULAR FONT, STYLE, SIZE, OR COLOR.

FOR COMPUTER SERVICES, NAMELY, HOSTING AN INTERACTIVE WEBSITE THAT ENABLES SCHOOL TEACHERS AND ADMINISTRATORS TO RECORD, ACCESS, REPORT AND MANAGE THEIR STUDENT INFORMATION, PORTFOLIOS AND PERFORMANCE DATA, AND ALLOWS STUDENTS AND PARENTS TO ACCESS SUCH INFORMATION AND DATA IN REAL TIME (U.S. CLS. 100 AND 101).

FIRST USE 1-0-2012; IN COMMERCE 1-0-2012.

4,155,487. TELECOMMUNICATION SYSTEMS, INC., ANNAPOLIS, MD. SN 85-299,914. PUB. 9-6-2011, FILED 4-20-2011.

ART OF EXPLOITATION

THE MARK CONSISTS OF STANDARD CHARACTERS WITHOUT CLAIM TO ANY PARTICULAR FONT, STYLE, SIZE, OR COLOR.

OWNER OF U.S. REG. NO. 2,431,278.

FOR COMPUTER SECURITY CONSULTANCY; COMPUTER SECURITY CONSULTANCY IN THE FIELD OF SCANNING AND PENETRATION TESTING OF COMPUTERS AND NETWORKS TO ASSESS INFORMATION SECURITY VULNERABILITY; COMPUTER SOFTWARE DEVELOPMENT IN THE FIELD OF VULNERABILITY ANALYSIS (U.S. CLS. 100 AND 101).

FIRST USE 11-6-2006; IN COMMERCE 11-6-2006.

4,155,533. GOVERNMENT TRANSACTION SERVICES, INC., VIENNA, VA. SN 85-315,231. PUB. 11-29-2011, FILED 5-8-2011.



NO CLAIM IS MADE TO THE EXCLUSIVE RIGHT TO USE "GOVERNMENT TRANSACTION SERVICES, INC.," APART FROM THE MARK AS SHOWN.

THE COLOR(S) RED, WHITE, GRAY, AND BLUE IS/ARE CLAIMED AS A FEATURE OF THE MARK.

CLASS 42—(Continued).

THE MARK CONSISTS OF THE WORDING "GOVERNMENT TRANSACTION SERVICES, INC." IN BLUE LETTERS. TO THE LEFT OF THE WORDING IS A DESIGN CONSISTING OF TWO STYLIZED SWIRLS RESEMBLING BOOMERANGS IN MOTION, ONE OF WHICH IS RED WITH A WHITE STRIPE, THE OTHER BLUE WITH A WHITE STRIPE. A VERTICAL BLUE LINE SEPARATES THE WORDING AND DESIGN. A SMALL GRAY SHADOW APPEARS BENEATH THE DESIGN.

FOR TRANSACTION PROCESSING, NAMELY, PROVIDING USER AUTHENTICATION SERVICES IN E-COMMERCE TRANSACTIONS, TRANSACTION REPORTING, NAMELY, PROVIDING USER AUTHENTICATION SERVICES IN E-COMMERCE TRANSACTIONS, TRANSACTION COMMUNICATION, NAMELY, PROVIDING USER AUTHENTICATION SERVICES IN E-COMMERCE TRANSACTIONS AND OTHER TRANSACTION INFORMATION SERVICES, NAMELY, PROVIDING USER AUTHENTICATION SERVICES IN E-COMMERCE TRANSACTIONS; CLOUD COMPUTING FEATURING SOFTWARE FOR USE IN ELECTRONIC TRANSACTION PROCESSING IN THE FIELD OF GOVERNMENT TRANSACTIONS; ALL FOR CUSTOMERS ENGAGED IN BUSINESS INTERACTIONS WITH GOVERNMENT (U.S. CLS. 100 AND 101).

FIRST USE 2-15-2011; IN COMMERCE 2-15-2011.

CLASS 42—(Continued).

4,155,545. TRI-FORCE CONSULTING SERVICES, INC., LANSDALE, PA. SN 85-321,589. PUB. 10-11-2011, FILED 5-16-2011.

EXCELLENCE INTEGRITY
CUSTOMIZATION Three forces
 above the competition

THE MARK CONSISTS OF STANDARD CHARACTERS WITHOUT CLAIM TO ANY PARTICULAR FONT, STYLE, SIZE, OR COLOR.

FOR COMPUTER SOFTWARE CONSULTING (U.S. CLS. 100 AND 101).

FIRST USE 0-0-2010; IN COMMERCE 0-0-2010.

4,155,536. BELTRAN, RICARDO, MEXICO CITY, MEXICO. SN 85-317,434. PUB. 1-3-2012, FILED 5-10-2011.

INDAVA

THE MARK CONSISTS OF STANDARD CHARACTERS WITHOUT CLAIM TO ANY PARTICULAR FONT, STYLE, SIZE, OR COLOR.

FOR COMPUTER AND TECHNOLOGICAL PROFESSIONAL SERVICES, NAMELY, IT CONSULTING SERVICES, COMPUTER SOFTWARE SYSTEMS INTEGRATION SERVICES, SOFTWARE DESIGN, REMOTE AND ON-SITE MANAGEMENT OF THE ENTERPRISE INFORMATION TECHNOLOGY SYSTEMS FOR OTHERS, IT PROJECT MANAGEMENT; IT INFRASTRUCTURE DESIGN SERVICES, IT INFRASTRUCTURE MAINTENANCE SERVICES, NAMELY, MAINTENANCE OF COMPUTER SOFTWARE; SOFTWARE DESIGN SERVICES; TECHNOLOGY AUDITING SERVICES, NAMELY, COMPUTER SYSTEMS ANALYSIS SERVICES RELATED TO THE INTEGRITY AND FUNCTIONALITY OF INFORMATION TECHNOLOGY INFRASTRUCTURE (U.S. CLS. 100 AND 101).

FIRST USE 10-1-2011; IN COMMERCE 10-1-2011.

4,155,564. QSOL.COM INC., LOS ANGELES, CA. SN 85-326,739. PUB. 1-17-2012, FILED 5-21-2011.

domaincloud

THE MARK CONSISTS OF STANDARD CHARACTERS WITHOUT CLAIM TO ANY PARTICULAR FONT, STYLE, SIZE, OR COLOR.

FOR CLOUD COMPUTING FEATURING SOFTWARE FOR USE IN PROVIDING SOFTWARE-AS-A-SERVICE (SAAS), INFRASTRUCTURE-AS-A-SERVICE (IAAS), PLATFORM-AS-A-SERVICE (PAAS) AND DESKTOP-AS-A-SERVICE (DAAS) FUNCTIONS; COMPUTER SERVICES, NAMELY, CLOUD HOSTING PROVIDER SERVICES; COMPUTER SERVICES, NAMELY, INTEGRATION OF PRIVATE AND PUBLIC CLOUD COMPUTING ENVIRONMENTS; CONSULTING SERVICES IN THE FIELD OF CLOUD COMPUTING; PROVIDING VIRTUAL COMPUTER SYSTEMS AND VIRTUAL COMPUTER ENVIRONMENTS THROUGH CLOUD COMPUTING; TECHNICAL CONSULTING SERVICES IN THE FIELDS OF DATACENTER ARCHITECTURE, PUBLIC AND PRIVATE CLOUD COMPUTING SOLUTIONS, AND EVALUATION AND IMPLEMENTATION OF INTERNET TECHNOLOGY AND SERVICES; TECHNICAL SUPPORT SERVICES, NAMELY, REMOTE AND ON-SITE INFRASTRUCTURE MANAGEMENT SERVICES FOR MONITORING, ADMINISTRATION AND MANAGEMENT OF PUBLIC AND PRIVATE CLOUD COMPUTING IT AND APPLICATION SYSTEMS (U.S. CLS. 100 AND 101).

FIRST USE 4-19-2010; IN COMMERCE 4-19-2010.

CLASS 42—(Continued).

4,155,616. MONSTER WORLDWIDE, INC., NEW YORK, NY.
SN 85-346,731. PUB. 10-4-2011, FILED 6-15-2011.

SEEMORE

THE MARK CONSISTS OF STANDARD CHARACTERS WITHOUT CLAIM TO ANY PARTICULAR FONT, STYLE, SIZE, OR COLOR.

FOR ONLINE COMPUTER SERVICES, NAMELY, NON-DOWNLOADABLE SOFTWARE FOR UPLOADING AND MANAGING RESUMES (U.S. CLS. 100 AND 101).

FIRST USE 6-0-2011; IN COMMERCE 6-0-2011.

4,155,666. APITVA, INC., DBA LYNXSQUARE, AUSTIN, TX.
SN 85-362,022. PUB. 11-29-2011, FILED 7-1-2011.



THE MARK CONSISTS OF FOUR SQUARES POSITIONED IN A BACKGROUND. FOUR ARMS SUPERIMPOSED OVER THE FOUR SQUARES WHEREIN THE FOUR ARMS ARE ARRANGED IN A GENERALLY HUMAN CHAIN CONFIGURATION SYMBOLIZING A SOCIAL CONNECTION. FOUR CIRCULAR HEADS SUPERIMPOSED OVER THE FOUR SQUARES WHEREIN THE FOUR HEADS ARE POSITIONED ADJACENT TO THE FOUR ARMS AND CONFIGURED IN A GENERALLY CIRCULAR PATTERN.

FOR PROVIDING A WEBSITE FEATURING TECHNOLOGY THAT ENABLES USERS TO BID ON DIGITALLY AND PHYSICALLY TRANSFERABLE MERCHANDISE WHEREIN AT LEAST TWO USERS SHARE THE MERCHANDISE FOR A SPECIFIED PERIOD OF TIME (U.S. CLS. 100 AND 101).

FIRST USE 11-1-2011; IN COMMERCE 11-1-2011.

CLASS 42—(Continued).

4,155,672. ONWARD SYSTEMS INC., DIAMOND BAR, CA.
SN 85-363,581. PUB. 12-20-2011, FILED 7-5-2011.

ONWARD PHYSICIAN

THE MARK CONSISTS OF STANDARD CHARACTERS WITHOUT CLAIM TO ANY PARTICULAR FONT, STYLE, SIZE, OR COLOR.

NO CLAIM IS MADE TO THE EXCLUSIVE RIGHT TO USE "PHYSICIAN", APART FROM THE MARK AS SHOWN.

FOR SOFTWARE AS A SERVICE (SAAS) SERVICES, NAMELY, HOSTING SOFTWARE FOR USE BY OTHERS FOR THE COLLECTION, EDITING, ORGANIZING, MODIFYING, TRANSMISSION, STORAGE AND SHARING OF DATA AND INFORMATION RELATING TO HEALTH CARE SERVICES; SOFTWARE AS A SERVICE (SAAS) SERVICES, NAMELY, HOSTING SOFTWARE FOR USE BY OTHERS FOR POPULATING, ACCESSING, MANAGING, AND ANALYZING ELECTRONIC HEALTH RECORDS FOR BILLING AND MEDICAL PRACTICE MANAGEMENT, AND MANAGEMENT OF HEALTH CARE SERVICES; SOFTWARE AS A SERVICE (SAAS) SERVICES, NAMELY, HOSTING SOFTWARE FOR USE BY OTHERS FOR MANAGING, ACCESSING, AND ARCHIVING MEDICAL DOCUMENTS, MEDICAL IMAGES, DICTATIONS AND TRANSCRIPTIONS IN THE FIELD OF HEALTHCARE; SOFTWARE AS A SERVICE (SAAS) SERVICES, NAMELY, HOSTING SOFTWARE FOR USE BY OTHERS FOR PRE-AUTHORIZATION, SUBMISSION, ADJUDICATION, VERIFICATION AND TRACKING OF INSURANCE CLAIMS IN THE FIELD OF HEALTHCARE (U.S. CLS. 100 AND 101).

FIRST USE 9-5-2011; IN COMMERCE 9-5-2011.

4,155,673. ONWARD SYSTEMS INC., DIAMOND BAR, CA.
SN 85-363,590. PUB. 12-20-2011, FILED 7-5-2011.

ONWARD VET

THE MARK CONSISTS OF STANDARD CHARACTERS WITHOUT CLAIM TO ANY PARTICULAR FONT, STYLE, SIZE, OR COLOR.

CLASS 42—(Continued).

NO CLAIM IS MADE TO THE EXCLUSIVE RIGHT TO USE "VET", APART FROM THE MARK AS SHOWN.

FOR SOFTWARE AS A SERVICE (SAAS) SERVICES, NAMELY, HOSTING SOFTWARE FOR USE BY OTHERS FOR THE COLLECTION, EDITING, ORGANIZING, MODIFYING, TRANSMISSION, STORAGE AND SHARING OF DATA AND INFORMATION RELATING TO VETERINARY SERVICES; SOFTWARE AS A SERVICE (SAAS) SERVICES, NAMELY, HOSTING SOFTWARE FOR USE BY OTHERS FOR POPULATING, ACCESSING, MANAGING, AND ANALYZING ELECTRONIC HEALTH RECORDS FOR BILLING AND MEDICAL PRACTICE MANAGEMENT, AND MANAGEMENT OF VETERINARY SERVICES; SOFTWARE AS A SERVICE (SAAS) SERVICES, NAMELY, HOSTING SOFTWARE FOR USE BY OTHERS FOR MANAGING, ACCESSING, AND ARCHIVING MEDICAL DOCUMENTS, MEDICAL IMAGES, DICTATIONS AND TRANSCRIPTIONS IN THE FIELD OF VETERINARY; SOFTWARE AS A SERVICE (SAAS) SERVICES, NAMELY, HOSTING SOFTWARE FOR USE BY OTHERS FOR PRE-AUTHORIZATION, SUBMISSION, ADJUDICATION, VERIFICATION AND TRACKING OF INSURANCE CLAIMS IN THE FIELD OF VETERINARY SERVICES (U.S. CLS. 100 AND 101).

FIRST USE 10-3-2011; IN COMMERCE 10-3-2011.

4,155,677. BROWN, JEFFREY S., GREENVILLE, SC. SN 85-363,764. PUB. 12-27-2011, FILED 7-6-2011.

COLLEGEBUZZZ

THE MARK CONSISTS OF STANDARD CHARACTERS WITHOUT CLAIM TO ANY PARTICULAR FONT, STYLE, SIZE, OR COLOR.

FOR COMPUTER SERVICES, NAMELY, CREATING AN ON-LINE COMMUNITY FOR REGISTERED USERS TO PARTICIPATE IN DISCUSSIONS AND FORUMS, GET FEEDBACK FROM AND SHARE ADVICE AND TIPS WITH THEIR PEERS, FORM VIRTUAL COMMUNITIES, ENGAGE IN SOCIAL NETWORKING, SHARE AUDIO, VIDEO, PHOTOGRAPHIC AND PROSE PRESENTATIONS, AND CREATE INTERACTIVE SOFTWARE TOOLS AND CHECKLISTS (U.S. CLS. 100 AND 101).

FIRST USE 9-4-2011; IN COMMERCE 3-15-2012.

4,155,692. PROGNOSYS BIOSCIENCES, INC., LA JOLLA, CA. SN 85-366,835. PUB. 12-6-2011, FILED 7-8-2011.

VOILA!

THE MARK CONSISTS OF STANDARD CHARACTERS WITHOUT CLAIM TO ANY PARTICULAR FONT, STYLE, SIZE, OR COLOR.

FOR BIOLOGICAL, BIOCHEMICAL, OR CHEMICAL RESEARCH AND ANALYSIS; DNA ANALYSIS SERVICES (U.S. CLS. 100 AND 101).

FIRST USE 10-3-2011; IN COMMERCE 10-3-2011.

CLASS 42—(Continued).

4,155,695. J.H. FENNER & CO. LIMITED, HESSLE, EAST YORKSHIRE, UNITED KINGDOM. SN 85-368,073. PUB. 11-1-2011, FILED 7-11-2011.

THE BELT WAND

THE MARK CONSISTS OF STANDARD CHARACTERS WITHOUT CLAIM TO ANY PARTICULAR FONT, STYLE, SIZE, OR COLOR.

NO CLAIM IS MADE TO THE EXCLUSIVE RIGHT TO USE "BELT", APART FROM THE MARK AS SHOWN.

FOR INSPECTION, ANALYSIS, AND EVALUATION OF CUSTOMERS' CONVEYOR BELTS AND RELATED CONVEYOR BELT COMPONENTS AND PROVIDING DETAILED INSPECTION REPORTS RELATED THERETO, WHICH REPORTS ALSO CONTAIN INFORMATION ABOUT RECOMMENDED BELT MAINTENANCE AND REPAIR (U.S. CLS. 100 AND 101).

FIRST USE 8-12-2010; IN COMMERCE 8-12-2010.

4,155,751. CHARMING DIRECT, INC., WILMINGTON, DE. SN 85-386,561. PUB. 1-24-2012, FILED 8-2-2011.

FASHION GENIUS

THE MARK CONSISTS OF STANDARD CHARACTERS WITHOUT CLAIM TO ANY PARTICULAR FONT, STYLE, SIZE, OR COLOR.

NO CLAIM IS MADE TO THE EXCLUSIVE RIGHT TO USE "FASHION", APART FROM THE MARK AS SHOWN.

FOR PROVIDING TEMPORARY USE OF A NON-DOWNLOADABLE WEB-BASED SOFTWARE APPLICATION THAT OFFERS PERSONALIZED FIT AND STYLE RECOMMENDATIONS FOR CONSUMERS BASED ON USER INPUTS (U.S. CLS. 100 AND 101).

FIRST USE 9-14-2011; IN COMMERCE 9-14-2011.

4,155,752. BOOKT LLC, HOLLYWOOD, FL. SN 85-387,013. PUB. 1-17-2012, FILED 8-2-2011.

INSTAMANAGER

THE MARK CONSISTS OF STANDARD CHARACTERS WITHOUT CLAIM TO ANY PARTICULAR FONT, STYLE, SIZE, OR COLOR.

FOR APPLICATION SERVICE PROVIDER (ASP) FEATURING NON-DOWNLOADABLE SOFTWARE IN THE FIELD OF VACATION BOOKING AND MANAGEMENT (U.S. CLS. 100 AND 101).

FIRST USE 2-1-2010; IN COMMERCE 4-1-2011.

CLASS 42—(Continued).

4,155,813. MARSH INC., CINCINNATI, OH. SN 85-441,008. PUB. 1-3-2012, FILED 10-6-2011.

MARSH BRAND PARTNERS

THE MARK CONSISTS OF STANDARD CHARACTERS WITHOUT CLAIM TO ANY PARTICULAR FONT, STYLE, SIZE, OR COLOR.

NO CLAIM IS MADE TO THE EXCLUSIVE RIGHT TO USE "BRAND PARTNERS", APART FROM THE MARK AS SHOWN.

FOR DESIGN SERVICES FOR PACKAGING; INNOVATION CONSULTING SERVICES, NAMELY, ADVISING OTHERS IN THE AREAS OF PRODUCT DEVELOPMENT; VISUAL DESIGN SERVICES IN THE NATURE OF DESIGNING VISUAL ELEMENTS FOR ON-LINE, BROADCAST, PRINT, OUTDOOR AND OTHER COMMUNICATION MEDIA; WEBSITE DESIGN AND DEVELOPMENT FOR OTHERS (U.S. CLS. 100 AND 101).
FIRST USE 1-20-2012; IN COMMERCE 1-20-2012.

CLASS 43—HOTEL AND RESTAURANT SERVICES

4,154,263. SWIZZLES HOLDINGS, LLC, BRIDGEPORT, CT. SN 76-706,990. PUB. 8-2-2011, FILED 3-28-2011.

LIVE LIFE NUTRITIOUSLY

THE MARK CONSISTS OF STANDARD CHARACTERS WITHOUT CLAIM TO ANY PARTICULAR FONT, STYLE, SIZE, OR COLOR.

FOR RESTAURANT SERVICES (U.S. CLS. 100 AND 101).

FIRST USE 4-15-2011; IN COMMERCE 4-15-2011.

4,154,330. CALAMARI, INC., WEST YARMOUTH, MA. SN 77-538,985. PUB. 12-23-2008, FILED 8-5-2008.

TONY DIPARMA

THE MARK CONSISTS OF STANDARD CHARACTERS WITHOUT CLAIM TO ANY PARTICULAR FONT, STYLE, SIZE, OR COLOR.

THE NAME(S), PORTRAIT(S), AND/OR SIGNATURE(S) SHOWN IN THE MARK DOES NOT IDENTIFY A PARTICULAR LIVING INDIVIDUAL.

FOR RESTAURANT AND BAR SERVICES (U.S. CLS. 100 AND 101).

FIRST USE 3-16-2012; IN COMMERCE 3-16-2012.

CLASS 43—(Continued).

4,154,363. ADVENTIST HEALTH SYSTEM/SUNBELT, INC., ORLANDO, FL. SN 77-589,566. PUB. 12-9-2008, FILED 10-9-2008.

HEALTH VILLAGE

THE MARK CONSISTS OF STANDARD CHARACTERS WITHOUT CLAIM TO ANY PARTICULAR FONT, STYLE, SIZE, OR COLOR.

FOR RESTAURANT AND CAFÉ SERVICES; CONVENTION, EXHIBITION AND MEETING FACILITIES SERVICES (U.S. CLS. 100 AND 101).

FIRST USE 2-24-2012; IN COMMERCE 2-24-2012.

4,154,401. DISNEY ENTERPRISES, INC., BURBANK, CA. SN 77-687,726. PUB. 10-13-2009, FILED 3-10-2009.

DISNEY FANTASY

THE MARK CONSISTS OF STANDARD CHARACTERS WITHOUT CLAIM TO ANY PARTICULAR FONT, STYLE, SIZE, OR COLOR.

FOR PROVIDING RESORT LODGING, RESTAURANT, RENTAL OF ROOMS ONBOARD SHIPS (U.S. CLS. 100 AND 101).

FIRST USE 3-31-2012; IN COMMERCE 3-31-2012.

4,154,407. BIKINI BOTTOM BAR & GRILL, LLC, BARTLETT, IL. SN 77-697,369. PUB. 7-21-2009, FILED 3-23-2009.

BIKINI BOTTOM

THE MARK CONSISTS OF STANDARD CHARACTERS WITHOUT CLAIM TO ANY PARTICULAR FONT, STYLE, SIZE, OR COLOR.

FOR BAR AND RESTAURANT SERVICES (U.S. CLS. 100 AND 101).

FIRST USE 3-20-2012; IN COMMERCE 3-20-2012.

CLASS 43—(Continued).

4,154,456. HARD ROCK CAFE INTERNATIONAL (USA), INC. ORLANDO, FL. SN 77-814,340. PUB. 1-19-2010, FILED 8-27-2009.

LOVE ALL - SERVE ALL

THE MARK CONSISTS OF STANDARD CHARACTERS WITHOUT CLAIM TO ANY PARTICULAR FONT, STYLE, SIZE, OR COLOR.
OWNER OF U.S. REG. NO. 1,713,000.
FOR HOTEL SERVICES (U.S. CLS. 100 AND 101).
FIRST USE 6-30-2007; IN COMMERCE 6-30-2007.

4,154,530. THE MELTING POT RESTAURANTS, INC., TAMPA, FL. SN 77-931,341. PUB. 6-22-2010, FILED 2-9-2010.

B 21

THE MARK CONSISTS OF STANDARD CHARACTERS WITHOUT CLAIM TO ANY PARTICULAR FONT, STYLE, SIZE, OR COLOR.
FOR RESTAURANT SERVICES (U.S. CLS. 100 AND 101).
FIRST USE 1-7-2011; IN COMMERCE 1-7-2011.

4,154,662. VANSICKLE, RICHARD, MARK, DBA PAPA WHEELIE'S, CHICAGO, IL. SN 85-069,544. PUB. 11-22-2011, FILED 6-23-2010.

Papa Wheelie's

THE MARK CONSISTS OF STANDARD CHARACTERS WITHOUT CLAIM TO ANY PARTICULAR FONT, STYLE, SIZE, OR COLOR.
FOR CAFE AND RESTAURANT SERVICES (U.S. CLS. 100 AND 101).
FIRST USE 6-15-2010; IN COMMERCE 1-10-2012.

CLASS 43—(Continued).

4,154,920. ECLECTIC LLC, STAMFORD, CT. SN 85-197,329. PUB. 4-26-2011, FILED 12-14-2010.

Eclectic

THE MARK CONSISTS OF STANDARD CHARACTERS WITHOUT CLAIM TO ANY PARTICULAR FONT, STYLE, SIZE, OR COLOR.
FOR CATERING SERVICES; RESTAURANT SERVICES (U.S. CLS. 100 AND 101).
FIRST USE 12-15-2011; IN COMMERCE 12-15-2011.

4,154,938. FIVE FISH BISTRO, INC., SEATTLE, WA. SN 85-203,300. PUB. 5-10-2011, FILED 12-21-2010.

FIVE FISH BISTRO

THE MARK CONSISTS OF STANDARD CHARACTERS WITHOUT CLAIM TO ANY PARTICULAR FONT, STYLE, SIZE, OR COLOR.
NO CLAIM IS MADE TO THE EXCLUSIVE RIGHT TO USE "FISH BISTRO", APART FROM THE MARK AS SHOWN.
FOR RESTAURANT SERVICES (U.S. CLS. 100 AND 101).
FIRST USE 1-11-2012; IN COMMERCE 1-11-2012.

4,155,106. HLT DOMESTIC IP LLC, MCLEAN, VA. SN 85-245,974. PUB. 7-19-2011, FILED 2-18-2011.

**YOU CAN COUNT ON US.
GUARANTEED.**

THE MARK CONSISTS OF STANDARD CHARACTERS WITHOUT CLAIM TO ANY PARTICULAR FONT, STYLE, SIZE, OR COLOR.
NO CLAIM IS MADE TO THE EXCLUSIVE RIGHT TO USE "GUARANTEED", APART FROM THE MARK AS SHOWN.
FOR HOTEL SERVICES (U.S. CLS. 100 AND 101).
FIRST USE 3-1-2012; IN COMMERCE 3-1-2012.

CLASS 43—(Continued).

4,155,222. CANAVATI, GERARDO MARTIN, MONTERREY, N. L., MEXICO. SN 85-258,521. PUB. 7-26-2011, FILED 3-4-2011.

Costa Pacifica

THE MARK CONSISTS OF STANDARD CHARACTERS WITHOUT CLAIM TO ANY PARTICULAR FONT, STYLE, SIZE, OR COLOR.

NO CLAIM IS MADE TO THE EXCLUSIVE RIGHT TO USE "PACIFICA", APART FROM THE MARK AS SHOWN.

FOR RESTAURANT AND BAR SERVICES, INCLUDING RESTAURANT CARRYOUT SERVICES (U.S. CLS. 100 AND 101).

FIRST USE 4-14-2011; IN COMMERCE 4-14-2011.

4,155,245. LODGING/HOSPITALITY MANAGEMENT CORPORATION, ST. LOUIS, MO. SN 85-261,357. PUB. 8-2-2011, FILED 3-8-2011.



THREE SIXTY

THE MARK CONSISTS OF STYLIZED DISCONNECTING NUMBERS "3", "6", "0" OVERLAPPING ONE ANOTHER WITH A CIRCLE, SYMBOLIC OF A DEGREE SYMBOL, IMMEDIATELY TO THE RIGHT AND MIDDLE OF THE OVERLAPPING NUMBERS WITH THE WORDS "THREE SIXTY" UNDERNEATH THE OVERLAPPING NUMBERS.

FOR RESTAURANT, BAR AND CATERING SERVICES (U.S. CLS. 100 AND 101).

FIRST USE 3-12-2011; IN COMMERCE 7-25-2011.

CLASS 43—(Continued).

4,155,281. TWO BEER GUYS LLC, DBA GROWLERS BEER BISTRO, PELHAM, NY. SN 85-265,553. PUB. 7-26-2011, FILED 3-13-2011.

HOPPY HOUR

THE MARK CONSISTS OF STANDARD CHARACTERS WITHOUT CLAIM TO ANY PARTICULAR FONT, STYLE, SIZE, OR COLOR.

FOR BAR AND RESTAURANT SERVICES (U.S. CLS. 100 AND 101).

FIRST USE 7-1-2011; IN COMMERCE 9-5-2011.

4,155,295. TAKIZA, LLC, SAN ANTONIO, TX. SN 85-266,716. PUB. 8-2-2011, FILED 3-14-2011.

Takiza

THE MARK CONSISTS OF STANDARD CHARACTERS WITHOUT CLAIM TO ANY PARTICULAR FONT, STYLE, SIZE, OR COLOR.

FOR RESTAURANT AND BAR SERVICES (U.S. CLS. 100 AND 101).

FIRST USE 6-1-2008; IN COMMERCE 3-1-2011.

4,155,481. NATIVE NEW YORKER OF AMERICA, INC., GILBERT, AZ. SN 85-299,372. PUB. 9-6-2011, FILED 4-19-2011.

MORE THAN JUST GREAT WINGS...

THE MARK CONSISTS OF STANDARD CHARACTERS WITHOUT CLAIM TO ANY PARTICULAR FONT, STYLE, SIZE, OR COLOR.

FOR BAR AND RESTAURANT SERVICES (U.S. CLS. 100 AND 101).

FIRST USE 2-0-2011; IN COMMERCE 2-0-2011.

CLASS 43—(Continued).

4,155,543. LBC INDUSTRIES, DOYLESTOWN, PA. SN 85-320,171. PUB. 10-18-2011, FILED 5-13-2011.

Brodo

THE MARK CONSISTS OF STANDARD CHARACTERS WITHOUT CLAIM TO ANY PARTICULAR FONT, STYLE, SIZE, OR COLOR.

THE ENGLISH TRANSLATION OF THE WORD "BRODO" IN THE MARK IS "BROTH".

FOR RESTAURANT SERVICES (U.S. CLS. 100 AND 101).

FIRST USE 3-1-2012; IN COMMERCE 3-15-2012.

4,155,568. YOTEL LIMITED, LONDON, UNITED KINGDOM. SN 85-328,959. PUB. 12-27-2011, FILED 5-24-2011.

DOH YO

THE MARK CONSISTS OF STANDARD CHARACTERS WITHOUT CLAIM TO ANY PARTICULAR FONT, STYLE, SIZE, OR COLOR.

FOR HOTEL SERVICES; MOTEL SERVICES; PROVISION OF TEMPORARY ACCOMMODATION; ARRANGING ACCOMMODATION, NAMELY, MAKING RESERVATIONS AND BOOKING FOR TEMPORARY LODGING; RENTAL OF PORTABLE, SELF-CONTAINED ROOMS USED FOR TEMPORARY ACCOMMODATIONS; BAR AND RESTAURANT SERVICES; SELF-SERVICE RESTAURANTS; TAKE-OUT RESTAURANT SERVICES; CAFE AND CAFETERIA SERVICES; PREPARATION OF FOOD AND BEVERAGES; CATERING SERVICES FOR THE PROVISION OF FOOD AND BEVERAGES; COCKTAIL LOUNGE SERVICES AND INFORMATION, ADVICE AND CONSULTANCY SERVICES IN RELATION THERETO (U.S. CLS. 100 AND 101).

FIRST USE 6-0-2011; IN COMMERCE 6-0-2011.

4,155,575. LOVE STYLE CORPORATION, FORT WORTH, TX. SN 85-332,856. PUB. 10-18-2011, FILED 5-27-2011.

THE WOODSHED SMOKEHOUSE

THE MARK CONSISTS OF STANDARD CHARACTERS WITHOUT CLAIM TO ANY PARTICULAR FONT, STYLE, SIZE, OR COLOR.

CLASS 43—(Continued).

NO CLAIM IS MADE TO THE EXCLUSIVE RIGHT TO USE "SMOKEHOUSE", APART FROM THE MARK AS SHOWN. FOR RESTAURANT AND BAR SERVICES (U.S. CLS. 100 AND 101). FIRST USE 2-1-2012; IN COMMERCE 2-1-2012.

4,155,620. DAY CAMINO RESTAURANT LLC, BOULDER, CO. SN 85-347,437. PUB. 12-6-2011, FILED 6-15-2011.



NO CLAIM IS MADE TO THE EXCLUSIVE RIGHT TO USE "FIRE CRAFTED FOOD+BAR", APART FROM THE MARK AS SHOWN.

THE COLOR(S) RED AND BLACK IS/ARE CLAIMED AS A FEATURE OF THE MARK.

THE MARK CONSISTS OF THE WORDING "IGNITE" IN LOWER CASE WITH AN EXCLAMATION MARK, IN BLACK, BELOW IS THE WORDING "FIRE CRAFTED FOOD+BAR" IN BLACK, ABOVE THE SECOND "I" IN THE WORDING "IGNITE" IS A FLAME IN RED.

FOR RESTAURANT, BAR, COCKTAIL LOUNGE SERVICES, CARRY-OUT RESTAURANT, SIT DOWN FOOD SERVICE, CATERING SERVICES AND RESTAURANTS FEATURING HOME DELIVERY (U.S. CLS. 100 AND 101).

FIRST USE 7-5-2011; IN COMMERCE 7-5-2011.

4,155,641. TROY SPORTS RESTAURANT, LLC, DBA JOE KOOL'S BAR & RESTAURANT, TROY, MI. SN 85-354,258. PUB. 1-17-2012, FILED 6-23-2011.



THE COLOR(S) WHITE, BLUE, RED IS/ARE CLAIMED AS A FEATURE OF THE MARK.

THE MARK CONSISTS OF THE WORDS "JOE KOOL'S" IN WHITE, INSIDE A RECTANGLE WITH A BLUE BACKGROUND, WITH TWO PARTIALLY CURVED SIDES ON THE EACH, LINED IN RED, PLACED IN THE CENTER OF AN OVAL WITH A BLUE BACKGROUND CONTAINING AN INNER OVAL WITH A WHITE BACKGROUND, WITH EACH OVAL LINED IN RED.

FOR RESTAURANT SERVICES; BAR SERVICES; RESTAURANT SERVICES, INCLUDING SIT-DOWN SERVICE OF FOOD AND TAKE-OUT RESTAURANT SERVICES (U.S. CLS. 100 AND 101).

FIRST USE 7-20-2011; IN COMMERCE 7-20-2011.

CLASS 43—(Continued).

4,155,649. WINDY PIZZA PLUS LLC, DBA EATALIAN CAFE, GARDENA, CA. SN 85-356,548. PUB. 11-15-2011, FILED 6-27-2011.

exEat

THE MARK CONSISTS OF STANDARD CHARACTERS WITHOUT CLAIM TO ANY PARTICULAR FONT, STYLE, SIZE, OR COLOR.

FOR BAR AND RESTAURANT SERVICES; CAFE AND RESTAURANT SERVICES; CARRY-OUT RESTAURANTS; ICE CREAM SHOP SERVICES IN THE NATURE OF A RESTAURANT; RESTAURANTS; TAKE-OUT RESTAURANT SERVICES (U.S. CLS. 100 AND 101).
FIRST USE 5-15-2011; IN COMMERCE 5-15-2011.

4,155,682. WINDY PIZZA PLUS LLC, DBA EATALIAN CAFE, GARDENA, CA. SN 85-364,122. PUB. 11-15-2011, FILED 7-6-2011.

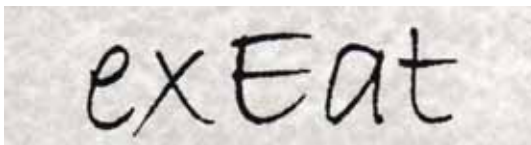

THE COLOR(S) BEIGE, AND BLACK IS/ARE CLAIMED AS A FEATURE OF THE MARK.

THE MARK CONSISTS OF THE FANCIFUL WORD "EXEAT" IN BLACK CURSIVE ON A BEIGE BACKGROUND.

FOR BAR AND RESTAURANT SERVICES; CAFE AND RESTAURANT SERVICES; ICE CREAM SHOP SERVICES IN THE NATURE OF A RESTAURANT; RESTAURANT AND BAR SERVICES; RESTAURANT AND CAFE SERVICES; RESTAURANT AND CATERING SERVICES; RESTAURANTS (U.S. CLS. 100 AND 101).
FIRST USE 5-15-2011; IN COMMERCE 5-15-2011.

4,155,711. FRANK MORANO, STATEN ISLAND, NY. SN 85-371,321. PUB. 1-10-2012, FILED 7-14-2011.

SOHO SQUARE

THE MARK CONSISTS OF STANDARD CHARACTERS WITHOUT CLAIM TO ANY PARTICULAR FONT, STYLE, SIZE, OR COLOR.

NO CLAIM IS MADE TO THE EXCLUSIVE RIGHT TO USE "SOHO", APART FROM THE MARK AS SHOWN.

FOR RESTAURANT AND CARRYOUT SERVICES FEATURING PIZZA (U.S. CLS. 100 AND 101).
FIRST USE 9-1-2011; IN COMMERCE 9-1-2011.

CLASS 43—(Continued).

4,155,740. RLDJ ENTERPRISES, LLC, WACHUNG, NJ. SN 85-384,469. PUB. 1-17-2012, FILED 7-29-2011.



NO CLAIM IS MADE TO THE EXCLUSIVE RIGHT TO USE "JERSEY JOINT", APART FROM THE MARK AS SHOWN.

THE COLOR(S) WHITE AND GREEN IS/ARE CLAIMED AS A FEATURE OF THE MARK.

THE MARK CONSISTS OF THE FOLLOWING: THE WORDING "JERSEY JOINT" IN WHITE LETTERS SUPERIMPOSED OVER TWO NESTED "J"'S ALSO IN WHITE, AND SET ON A HEXAGONAL GREEN BACKGROUND WITH A WHITE BORDER.

FOR RESTAURANT (U.S. CLS. 100 AND 101).
FIRST USE 9-1-2011; IN COMMERCE 3-1-2012.

4,155,758. OBREGON-BANDA LLC, HOUSTON, TX. SN 85-388,818. PUB. 1-24-2012, FILED 8-3-2011.



NO CLAIM IS MADE TO THE EXCLUSIVE RIGHT TO USE "TAQUERIA", APART FROM THE MARK AS SHOWN.

THE MARK CONSISTS OF THE WORD "TAQUERIA" ABOVE THE WORD "LAMACRO".

THE ENGLISH TRANSLATION OF "TAQUERIA" IN THE MARK IS "TACO RESTAURANT".

FOR RESTAURANT SERVICES (U.S. CLS. 100 AND 101).
FIRST USE 1-1-2012; IN COMMERCE 1-14-2012.

CLASS 44—MEDICAL, BEAUTY AND AGRICULTURAL SERVICES

CLASS 44—(Continued).

4,154,388. NORTHEAST PATHOLOGISTS INC., HANNIBAL, MO. SN 77-660,776. PUB. 6-2-2009, FILED 1-31-2009.

CELLDOX

THE MARK CONSISTS OF STANDARD CHARACTERS WITHOUT CLAIM TO ANY PARTICULAR FONT, STYLE, SIZE, OR COLOR.

FOR MEDICAL SERVICES BY PATHOLOGISTS, NAMELY, DRUG USE SCREENING SERVICES (U.S. CLS. 100 AND 101).

FIRST USE 12-31-2010; IN COMMERCE 12-31-2010.

CLASS 44—(Continued).

4,154,514. DECADE DENTAL, MINEOLA, NY. SN 77-901,383. PUB. 1-4-2011, FILED 12-28-2009.

**AT DECADE
DENTAL WE'RE
CARING &
WE'RE
WORKING
HARDER TO
MAKE YOUR
TEETH LAST
LONGER!**

THE MARK CONSISTS OF STANDARD CHARACTERS WITHOUT CLAIM TO ANY PARTICULAR FONT, STYLE, SIZE, OR COLOR.

OWNER OF U.S. REG. NO. 3,869,478.

NO CLAIM IS MADE TO THE EXCLUSIVE RIGHT TO USE "DENTAL", APART FROM THE MARK AS SHOWN.

FOR DENTIST SERVICES (U.S. CLS. 100 AND 101).

FIRST USE 5-1-2009; IN COMMERCE 5-1-2009.

4,154,463. SOCIETY OF CRITICAL CARE MEDICINE, MOUNT PROSPECT, IL. SN 77-824,780. PUB. 3-8-2011, FILED 9-11-2009.



THE MARK CONSISTS OF THE STYLIZED WORDS "C4 = CREATIVE COMMUNITY IN CRITICAL CARE".

FOR PROVIDING AN INTERACTIVE WEBSITE FEATURING INFORMATION IN THE FIELD OF HEALTH-CARE (U.S. CLS. 100 AND 101).

FIRST USE 12-21-2010; IN COMMERCE 12-21-2010.

4,154,547. KINSTON COMMUNITY HEALTH CENTER, INC., KINSTON, NC. SN 77-951,946. PUB. 8-24-2010, FILED 3-5-2010.

4,154,484. UPTAKE MEDICAL CORPORATION, SEATTLE, WA. SN 77-847,593. PUB. 8-10-2010, FILED 10-13-2009.

UPTAKE MEDICAL

THE MARK CONSISTS OF STANDARD CHARACTERS WITHOUT CLAIM TO ANY PARTICULAR FONT, STYLE, SIZE, OR COLOR.

NO CLAIM IS MADE TO THE EXCLUSIVE RIGHT TO USE "MEDICAL", APART FROM THE MARK AS SHOWN.

FOR PROVIDING MEDICAL INFORMATION AND TREATMENT PLANS IN THE FIELD OF EMPHYSEMA AND CHRONIC OBSTRUCTIVE PULMONARY DISEASE (U.S. CLS. 100 AND 101).

FIRST USE 10-24-2011; IN COMMERCE 10-24-2011.



THE MARK CONSISTS OF A PICTURE OF A FAMILY LOOKING UP AT THE PHRASE "HOPE FOR EQUAL ACCESS" WITH A HEART DESIGN REPRESENTING THE "O" IN "HOPE".

FOR FEDERALLY FUNDED HEALTH CENTER FEATURING OB-GYN SERVICES, ADULT AND PEDIATRIC HEALTH CARE SERVICES, AND DENTAL SERVICES; CHARITABLE SERVICES, NAMELY, PATIENT ASSISTANCE PROGRAM TO PROVIDE DRUGS FREE OF CHARGE TO LOW-INCOME PATIENTS WITHOUT PRESCRIPTION DRUG COVERAGE (U.S. CLS. 100 AND 101).

FIRST USE 10-1-2010; IN COMMERCE 10-1-2010.

CLASS 44—(Continued).

4,154,580. BOGOCH FAMILY LLC, NEW YORK, NY. SN 77-982,922. PUB. 5-5-2009, FILED 2-13-2007.

BIORADAR

THE MARK CONSISTS OF STANDARD CHARACTERS WITHOUT CLAIM TO ANY PARTICULAR FONT, STYLE, SIZE, OR COLOR.

FOR MEDICAL TESTING SERVICES FOR DETECTION OF CHEMICAL AND BIOLOGICAL AGENTS HAZARDOUS OR LETHAL TO BIOLOGICAL ENTITIES (U.S. CLS. 100 AND 101).

FIRST USE 11-23-2011; IN COMMERCE 11-23-2011.

4,154,684. BALE/DONEEN METHOD LLC, SPOKANE, WA. SN 85-089,754. PUB. 6-21-2011, FILED 7-21-2010.

BALE/DONEEN

THE MARK CONSISTS OF STANDARD CHARACTERS WITHOUT CLAIM TO ANY PARTICULAR FONT, STYLE, SIZE, OR COLOR.

FOR MEDICAL SCREENING; MEDICAL SERVICES, NAMELY, RELATING TO EVALUATION AND TESTING FOR CARDIOVASCULAR DISEASE PREVENTION; MEDICAL TESTING FOR DIAGNOSTIC OR TREATMENT PURPOSES; PROVIDING INFORMATION IN THE FIELD OF CARDIOVASCULAR DISEASE, AND CARDIOVASCULAR DISEASE PREVENTIONS, SCREENING, DIAGNOSIS AND TREATMENT (U.S. CLS. 100 AND 101).

FIRST USE 5-3-2007; IN COMMERCE 5-3-2007.

4,154,687. BALE/DONEEN METHOD LLC, SPOKANE, WA. SN 85-089,766. PUB. 6-21-2011, FILED 7-21-2010.

BALE/DONEEN METHOD

THE MARK CONSISTS OF STANDARD CHARACTERS WITHOUT CLAIM TO ANY PARTICULAR FONT, STYLE, SIZE, OR COLOR.

NO CLAIM IS MADE TO THE EXCLUSIVE RIGHT TO USE "METHOD", APART FROM THE MARK AS SHOWN.

FOR MEDICAL SCREENING; MEDICAL SERVICES, NAMELY, RELATING TO EVALUATION AND TESTING FOR CARDIOVASCULAR DISEASE PREVENTION; MEDICAL TESTING FOR DIAGNOSTIC OR TREATMENT PURPOSES; PROVIDING INFORMATION IN THE FIELD OF CARDIOVASCULAR DISEASE, AND CARDIOVASCULAR DISEASE PREVENTIONS, SCREENING, DIAGNOSIS AND TREATMENT (U.S. CLS. 100 AND 101).

FIRST USE 5-3-2007; IN COMMERCE 5-3-2007.

CLASS 44—(Continued).

4,154,802. DR. G'S FRANCHISING COMPANIES, LLC., DAVIE, FL. AND JDJ OF MIAMI, INC., AVENTURA, FL. SN 85-135,580. PUB. 8-30-2011, FILED 9-22-2010.



NO CLAIM IS MADE TO THE EXCLUSIVE RIGHT TO USE "WEIGHT LOSS & WELLNESS", APART FROM THE MARK AS SHOWN.

THE NAME(S), PORTRAIT(S), AND/OR SIGNATURE(S) SHOWN IN THE MARK IDENTIFIES THE NICKNAME OF DR. CHARLES L. GOLDSMITH, A LIVING INDIVIDUAL, WHOSE CONSENT(S) TO REGISTER IS MADE OF RECORD.

THE MARK CONSISTS OF THE STYLIZED WORDS "DR. G'S" ABOVE THE STYLIZED WORDS "WEIGHTLOSS & WELLNESS".

FOR MEDICAL CLINICS FEATURING WEIGHT LOSS SOLUTIONS, SERVICES AND PROGRAMS (U.S. CLS. 100 AND 101).

FIRST USE 8-31-2010; IN COMMERCE 8-31-2010.

4,154,845. MMJIP, LLC, SAN FRANCISCO, CA. SN 85-149,753. PUB. 8-9-2011, FILED 10-11-2010.



THE MARK CONSISTS OF ONE BLOCK SURROUNDED BY FOUR OTHERS IN THE UPPER LEFT QUADRANT OF A LARGE SQUARE WITH THE WORD "SPARC" BENEATH.

FOR ONLINE MEDICAL CANNABIS RESOURCES, NAMELY, PROVIDING INFORMATION PERTAINING TO THE BENEFITS OF MEDICINAL USE OF CANNABIS (U.S. CLS. 100 AND 101).

FIRST USE 5-5-2010; IN COMMERCE 5-5-2010.

CLASS 44—(Continued).

4,154,852. AVEDRO, INC., WALTHAM, MA. SN 85-152,906. PUB. 1-18-2011, FILED 10-14-2010.

CLASS 44—(Continued).

4,155,107. REVEAL BODY SCULPTING CENTERS, LLC, PITTSBURGH, PA. SN 85-246,079. PUB. 6-28-2011, FILED 2-18-2011.

LASIK XTRA

THE MARK CONSISTS OF STANDARD CHARACTERS WITHOUT CLAIM TO ANY PARTICULAR FONT, STYLE, SIZE, OR COLOR.

NO CLAIM IS MADE TO THE EXCLUSIVE RIGHT TO USE "LASIK", APART FROM THE MARK AS SHOWN, FOR SURGERY; LASER VISION SURGERY SERVICES (U.S. CLS. 100 AND 101).
FIRST USE 1-0-2011; IN COMMERCE 1-0-2011.

REVEAL

THE MARK CONSISTS OF STANDARD CHARACTERS WITHOUT CLAIM TO ANY PARTICULAR FONT, STYLE, SIZE, OR COLOR.

FOR MEDICAL CLINIC PROVIDING LASER FAT REMOVAL TREATMENTS, CELLULITE TREATMENTS, AND BODY CONTOURING (U.S. CLS. 100 AND 101).
FIRST USE 4-14-2011; IN COMMERCE 4-14-2011.

4,154,870. UHS OF DELAWARE, INC., KING OF PRUSSIA, PA. SN 85-161,599. PUB. 7-26-2011, FILED 10-26-2010.



NO CLAIM IS MADE TO THE EXCLUSIVE RIGHT TO USE "NORTHWEST OKLAHOMA NEUROSCIENCE AND SPINE INSTITUTE", APART FROM THE MARK AS SHOWN.

THE MARK CONSISTS OF AN IMAGE OF A PORTION OF THE SPINAL COLUMN IMPOSED OVER AN IMAGE OF THE BRAIN ALL SET AGAINST A RECTANGULAR BACKGROUND, WITH THE WORDS "NORTHWEST OKLAHOMA NEUROSCIENCE AND SPINE INSTITUTE" TO THE RIGHT THEREOF.
FOR HEALTHCARE; MEDICAL SERVICES (U.S. CLS. 100 AND 101).
FIRST USE 3-19-2012; IN COMMERCE 3-19-2012.

4,155,224. GRANFORS, MELANIE, MOUNTLAKE TERRACE, WA. SN 85-259,296. PUB. 9-20-2011, FILED 3-7-2011.

K911 THERAPY DOGS ON CALL

4,154,877. HILTON, STACEY, WEST COVINA, CA. SN 85-167,604. PUB. 4-12-2011, FILED 11-2-2010.

WiTHIN You Now!

THE MARK CONSISTS OF STANDARD CHARACTERS WITHOUT CLAIM TO ANY PARTICULAR FONT, STYLE, SIZE, OR COLOR.

FOR PSYCHOLOGICAL THERAPY IN THE FIELD OF WEIGHT MANAGEMENT; BEHAVIORAL THERAPY IN THE FIELD OF WEIGHT MANAGEMENT (U.S. CLS. 100 AND 101).
FIRST USE 7-1-2011; IN COMMERCE 7-1-2011.

THE MARK CONSISTS OF STANDARD CHARACTERS WITHOUT CLAIM TO ANY PARTICULAR FONT, STYLE, SIZE, OR COLOR.

NO CLAIM IS MADE TO THE EXCLUSIVE RIGHT TO USE "THERAPY DOGS", APART FROM THE MARK AS SHOWN.
FOR PROVIDING PET THERAPY SERVICES FOR PATIENTS AND PEOPLE IN SETTINGS IN THE NATURE OF HOSPITALS AND NURSING HOMES, PUBLIC AND PRIVATE SCHOOLS, LIBRARIES, CHILDREN'S CENTERS AND OTHER AGENCIES (U.S. CLS. 100 AND 101).
FIRST USE 6-1-2011; IN COMMERCE 6-1-2011.

CLASS 44—(Continued).

4,155,231. SQUARE LEAF LANDSCAPE DESIGN LLC, NEW CANAAN, CT. SN 85-260,131. PUB. 7-26-2011, FILED 3-7-2011.

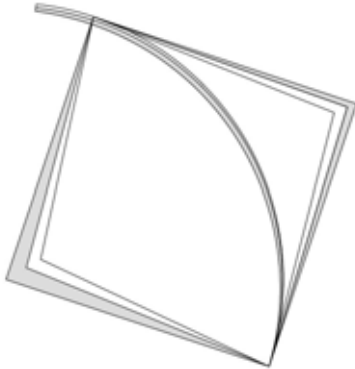

THE MARK CONSISTS OF A SQUARE SHAPE. THE LEFT BOTTOM CORNER IS ELEVATED OFF THE HORIZON AND PIVOTED FROM THE LOWER RIGHT HAND CORNER BY 17 DEGREES. THE MIDDLE CURVED LINE, IS A FRAGMENT OF A CIRCLE, EXTENDING FROM THE BASE (LOWEST POINT OF THE SQUARE) AND EXTENDING TO THE APEX, (HIGHEST POINT OF THE SQUARE). THE LINE WEIGHT OF PERIMETER VARIES; CONSISTING OF ELONGATED TRIANGLES THAT ARE JOINED TOGETHER.

FOR LANDSCAPE DESIGN (U.S. CLS. 100 AND 101).
FIRST USE 3-0-2011; IN COMMERCE 3-15-2012.

4,155,236. NABORS, THOMAS, NASHVILLE, TN. SN 85-260,482. PUB. 10-18-2011, FILED 3-8-2011.

MODULAR PERIODONTAL THERAPY

THE MARK CONSISTS OF STANDARD CHARACTERS WITHOUT CLAIM TO ANY PARTICULAR FONT, STYLE, SIZE, OR COLOR.

NO CLAIM IS MADE TO THE EXCLUSIVE RIGHT TO USE "PERIODONTAL THERAPY", APART FROM THE MARK AS SHOWN.

FOR DENTAL SERVICES, NAMELY, PERFORMING RESTORATIVE AND COSMETIC PROCEDURES, DENTAL HYGIENE SERVICES, PERIODONTAL SERVICES (U.S. CLS. 100 AND 101).

FIRST USE 1-17-2007; IN COMMERCE 8-26-2011.

CLASS 44—(Continued).

4,155,251. FRENCH, CHRISTY L., PRINCETON, NJ. SN 85-261,903. PUB. 7-26-2011, FILED 3-9-2011.

REACH WITHIN LEAD BEYOND

THE MARK CONSISTS OF STANDARD CHARACTERS WITHOUT CLAIM TO ANY PARTICULAR FONT, STYLE, SIZE, OR COLOR.

FOR HEALTH, WELLNESS AND NUTRITIONAL CONSULTING (U.S. CLS. 100 AND 101).

FIRST USE 11-1-2011; IN COMMERCE 11-1-2011.

4,155,454. DRS. SPAGNOLI, CROWLEY, MISIEK, FARRELL, FARRELL & NALE, P.A., CHARLOTTE, NC. SN 85-290,398. PUB. 8-16-2011, FILED 4-8-2011.

MYCENTERS

THE MARK CONSISTS OF STANDARD CHARACTERS WITHOUT CLAIM TO ANY PARTICULAR FONT, STYLE, SIZE, OR COLOR.

FOR MEDICAL SERVICES; DENTAL SERVICES, NAMELY, COSMETIC, IMPLANT AND ORAL SURGERY SERVICES (U.S. CLS. 100 AND 101).

FIRST USE 11-22-2011; IN COMMERCE 11-22-2011.

4,155,496. JENKINS, ANNE, CARLSBAD, CA. SN 85-303,561. PUB. 11-29-2011, FILED 4-25-2011.

Well Being for Life

THE MARK CONSISTS OF STANDARD CHARACTERS WITHOUT CLAIM TO ANY PARTICULAR FONT, STYLE, SIZE, OR COLOR.

FOR CHIROPRACTIC SERVICES; ENERGY HEALING SERVICES, NAMELY, THERAPEUTIC TOUCH SERVICES; HEALTH CARE SERVICES FOCUSING ON THE SPINE; HEALTH CARE SERVICES, NAMELY, WELLNESS PROGRAMS (U.S. CLS. 100 AND 101).

FIRST USE 5-30-2011; IN COMMERCE 5-30-2011.

CLASS 44—(Continued).

4,155,501. OHIO FARMERS INSURANCE COMPANY, WEST-FIELD CENTER, OH. SN 85-304,544. PUB. 9-13-2011, FILED 4-26-2011.

WESWORKS

THE MARK CONSISTS OF STANDARD CHARACTERS WITHOUT CLAIM TO ANY PARTICULAR FONT, STYLE, SIZE, OR COLOR.

OWNER OF U.S. REG. NO. 3,314,556.
FOR CONSULTING TO COMPANIES IN THE AREA OF TRANSITIONING EMPLOYEES BACK TO WORK, NAMELY, PSYCHOLOGICAL COUNSELING AND PHYSICAL THERAPY (U.S. CLS. 100 AND 101).
FIRST USE 4-0-2011; IN COMMERCE 6-0-2011.

4,155,598. PAVEY, LAURA, CINCINNATI, OH. SN 85-341,893. PUB. 11-22-2011, FILED 6-9-2011.

TRANSFORMU *LA*

THE MARK CONSISTS OF THE STYLIZED TEXT "TRANSFORMULA" IN WHICH THE "LA" AT THE END IS LINKED TOGETHER AND ON A LARGER SCALE THAN THE REST OF THE LETTERS.

FOR HEALTH SPA SERVICES FOR HEALTH AND WELLNESS OF THE BODY AND SPIRIT (U.S. CLS. 100 AND 101).
FIRST USE 6-1-2011; IN COMMERCE 3-15-2012.

4,155,718. RELEVANT RECOVERY INC, LIGHTHOUSE POINT, FL. SN 85-373,555. PUB. 1-24-2012, FILED 7-18-2011.

eHab

THE MARK CONSISTS OF STANDARD CHARACTERS WITHOUT CLAIM TO ANY PARTICULAR FONT, STYLE, SIZE, OR COLOR.

THE NAME "EHAB" FORMING THE MARK DOES NOT IDENTIFY A LIVING INDIVIDUAL.
FOR SUBSTANCE AND ALCOHOL ABUSE ONLINE REHABILITATION COUNSELING AND ADDICTION TREATMENT SERVICES (U.S. CLS. 100 AND 101).
FIRST USE 7-12-2011; IN COMMERCE 10-28-2011.

CLASS 44—(Continued).

4,155,724. RELEVANT RECOVERY INC, LIGHTHOUSE POINT, FL. SN 85-375,099. PUB. 12-27-2011, FILED 7-19-2011.

RELEVANT RECOVERY

THE MARK CONSISTS OF STANDARD CHARACTERS WITHOUT CLAIM TO ANY PARTICULAR FONT, STYLE, SIZE, OR COLOR.

NO CLAIM IS MADE TO THE EXCLUSIVE RIGHT TO USE "RECOVERY", APART FROM THE MARK AS SHOWN.
FOR REHABILITATION OF DRUG ADDICTED PATIENTS; REHABILITATION OF ALCOHOL ADDICTED PATIENTS; PROVIDING ON-LINE DRUG AND ALCOHOL ADDICTION RECOVERY COUNSELING SERVICES (U.S. CLS. 100 AND 101).
FIRST USE 7-12-2011; IN COMMERCE 10-28-2011.

4,155,778. PSQUARED PROHEALTH, LLC, MONROE, CT. SN 85-399,219. PUB. 1-17-2012, FILED 8-16-2011.



THE MARK CONSISTS OF AN ASTERISK DESIGN WITH THE WAVES OF A HEART MONITOR READING IN THE CENTER OF THE ASTERISK DESIGN.

FOR HEALTHCARE SERVICES (U.S. CLS. 100 AND 101).
FIRST USE 8-0-2011; IN COMMERCE 8-0-2011.

CLASS 44—(Continued).

4,155,805. H. LEE MOFFITT CANCER CENTER AND RESEARCH INSTITUTE, INC., AKA MOFFITT CANCER CENTER, TAMPA, FL. SN 85-420,343. PUB. 1-10-2012, FILED 9-12-2011.

CLOSER TO OUR PATIENTS.
CLOSER TO A CURE.

THE MARK CONSISTS OF STANDARD CHARACTERS WITHOUT CLAIM TO ANY PARTICULAR FONT, STYLE, SIZE, OR COLOR.

FOR MEDICAL SERVICES, NAMELY, PROVIDING TREATMENT FOR ONCOLOGICAL CONDITIONS AND MEDICAL TESTING FOR DIAGNOSTIC PURPOSES RELATED TO PERSONALIZED MEDICINE (U.S. CLS. 100 AND 101).

FIRST USE 10-30-2011; IN COMMERCE 10-30-2011.

4,155,831. VERINATA HEALTH, INC., REDWOOD CITY, CA. SN 85-976,535. PUB. 8-16-2011, FILED 4-11-2011.



THE MARK CONSISTS OF TWO ARCS, ONE UPWARD TO THE RIGHT AND THE OTHER UPWARD TO THE LEFT, AND TWO DOTS.

FOR MEDICAL TESTING FOR DIAGNOSTIC OR TREATMENT PURPOSES (U.S. CLS. 100 AND 101).

FIRST USE 2-23-2012; IN COMMERCE 2-23-2012.

CLASS 45—PERSONAL AND LEGAL SERVICES**CLASS 45—(Continued).**

4,154,429. LAMBERT, MIRANDA, ATLANTA, GA. SN 77-752,252. PUB. 12-22-2009, FILED 6-4-2009.

MUTTNATION FOUNDATION

THE MARK CONSISTS OF STANDARD CHARACTERS WITHOUT CLAIM TO ANY PARTICULAR FONT, STYLE, SIZE, OR COLOR.

NO CLAIM IS MADE TO THE EXCLUSIVE RIGHT TO USE "FOUNDATION", APART FROM THE MARK AS SHOWN.

FOR ADOPTION SERVICES FOR DOMESTIC ANIMALS (U.S. CLS. 100 AND 101).

FIRST USE 12-22-2009; IN COMMERCE 12-22-2009.

4,154,762. SECURUS TECHNOLOGIES, INC., DALLAS, TX. SN 85-118,341. PUB. 1-25-2011, FILED 8-30-2010.

SECURUS

THE MARK CONSISTS OF STANDARD CHARACTERS WITHOUT CLAIM TO ANY PARTICULAR FONT, STYLE, SIZE, OR COLOR.

FOR ANALYZING DATA IN COMPUTER DATABASES FOR CRIMINAL ACTIVITY; ANALYZING TELEPHONE CALLING PATTERN DATA IN COMPUTER DATABASES FOR CRIMINAL ACTIVITY; COMPUTERIZED SECURITY SERVICES, NAMELY, ELECTRONIC MONITORING, DETECTING, RECORDING AND REPORTING OF SUSPICIOUS USE OF TELECOMMUNICATIONS SYSTEMS PROVIDED TO INMATES AND RELATED PARTIES; ELECTRONIC MONITORING SERVICES FOR SECURITY PURPOSES IN THE FIELD OF LAW ENFORCEMENT; FRAUD DETECTION SERVICES FOR CORRECTIONAL INSTITUTIONS; SURVEILLANCE SERVICES; PROVIDING INFORMATION CONCERNING POSSIBLE CRIMINAL OR SUSPICIOUS ACTIVITIES OF INDIVIDUALS OR ORGANIZATIONS (U.S. CLS. 100 AND 101).

FIRST USE 8-6-2004; IN COMMERCE 8-6-2004.

4,154,773. FRAN M ALBERT, AKA FRANCINE ALBERT, NY, NY. SN 85-121,466. PUB. 2-15-2011, FILED 9-2-2010.

FRANNYONTHEGO

THE MARK CONSISTS OF STANDARD CHARACTERS WITHOUT CLAIM TO ANY PARTICULAR FONT, STYLE, SIZE, OR COLOR.

CLASS 45—(Continued).

"FRANNY" IDENTIFIES THE PSEUDONYM OF "FRAN ALBERT", A LIVING INDIVIDUAL WHOSE CONSENT IS OF RECORD.
 FOR ONLINE SOCIAL NETWORKING IN THE FIELD OF FOOD (U.S. CLS. 100 AND 101).
 FIRST USE 7-7-2008; IN COMMERCE 7-7-2008.

4,154,793. LANDRY, ROBIN, UPPER MARLBORO, MD. SN 85-130,144. PUB. 4-12-2011, FILED 9-15-2010.

Better Days_Better Prospects

THE MARK CONSISTS OF STANDARD CHARACTERS WITHOUT CLAIM TO ANY PARTICULAR FONT, STYLE, SIZE, OR COLOR.
 FOR PROFESSIONAL RESUME PREPARATION SERVICES, NAMELY, PROVIDING PREPARATION OF PROFESSIONAL RESUMES, COVER LETTERS, LETTERS OF RECOMMENDATION (U.S. CLS. 100 AND 101).
 FIRST USE 3-1-2012; IN COMMERCE 3-1-2012.

4,154,903. CHILDS, ANNETTE, RENO, NV. SN 85-188,083. PUB. 4-19-2011, FILED 12-1-2010.

Rx for the Soul

THE MARK CONSISTS OF STANDARD CHARACTERS WITHOUT CLAIM TO ANY PARTICULAR FONT, STYLE, SIZE, OR COLOR.
 FOR GRIEF COUNSELING (U.S. CLS. 100 AND 101).
 FIRST USE 10-5-2008; IN COMMERCE 10-5-2008.

4,155,254. GUNSTER, YOAKLEY & STEWART, P.A., WEST PALM BEACH, FL. SN 85-262,022. PUB. 7-26-2011, FILED 3-9-2011.

EVERY COMPANY IS A TECHNOLOGY COMPANY

THE MARK CONSISTS OF STANDARD CHARACTERS WITHOUT CLAIM TO ANY PARTICULAR FONT, STYLE, SIZE, OR COLOR.
 FOR LEGAL SERVICES (U.S. CLS. 100 AND 101).
 FIRST USE 3-9-2011; IN COMMERCE 10-14-2011.

CLASS 45—(Continued).

4,155,365. HANCE, DONALD, PACIFIC PALISADES, CA. SN 85-277,803. PUB. 8-9-2011, FILED 3-26-2011.

Sportsona

THE MARK CONSISTS OF STANDARD CHARACTERS WITHOUT CLAIM TO ANY PARTICULAR FONT, STYLE, SIZE, OR COLOR.
 FOR SOCIAL NETWORKING VIA A WEBSITE (U.S. CLS. 100 AND 101).
 FIRST USE 12-24-2008; IN COMMERCE 10-10-2011.

4,155,422. MCGIBNEY, JAMES, LAS VEGAS, NV. SN 85-284,396. PUB. 7-12-2011, FILED 4-1-2011.

VEGAS ISN'T THE ONLY SIN CITY

THE MARK CONSISTS OF STANDARD CHARACTERS WITHOUT CLAIM TO ANY PARTICULAR FONT, STYLE, SIZE, OR COLOR.
 FOR ON-LINE SOCIAL NETWORKING SERVICES (U.S. CLS. 100 AND 101).
 FIRST USE 11-17-2011; IN COMMERCE 11-17-2011.

4,155,438. VU, MICHAEL, DAVIS, CA. SN 85-287,314. PUB. 8-16-2011, FILED 4-6-2011.

POPOPS

THE MARK CONSISTS OF STANDARD CHARACTERS WITHOUT CLAIM TO ANY PARTICULAR FONT, STYLE, SIZE, OR COLOR.
 FOR ONLINE SOCIAL NETWORKING SERVICES; ONLINE SOCIAL NETWORKING SERVICES IN THE FIELD OF COMMUNITY POLLS AND CROWD SOURCING (U.S. CLS. 100 AND 101).
 FIRST USE 1-1-2012; IN COMMERCE 1-1-2012.

CLASS 45—(Continued).

4,155,544. BROWN RUDNICK LLP, BOSTON, MA. SN 85-320,424. PUB. 10-11-2011, FILED 5-13-2011.

BECAUSE WINNING MATTERS

THE MARK CONSISTS OF STANDARD CHARACTERS WITHOUT CLAIM TO ANY PARTICULAR FONT, STYLE, SIZE, OR COLOR.

FOR LEGAL SERVICES (U.S. CLS. 100 AND 101).
FIRST USE 5-0-2011; IN COMMERCE 5-0-2011.

4,155,546. DUNLAP CODDING, P.C., OKLAHOMA CITY, OK. SN 85-321,836. PUB. 10-11-2011, FILED 5-16-2011.

YOU GET THE IDEA

THE MARK CONSISTS OF STANDARD CHARACTERS WITHOUT CLAIM TO ANY PARTICULAR FONT, STYLE, SIZE, OR COLOR.

FOR LEGAL SERVICES (U.S. CLS. 100 AND 101).
FIRST USE 11-17-2011; IN COMMERCE 11-17-2011.

4,155,552. SP AFFAIRS LLC, BLOOMFIELD, NJ. SN 85-323,276. PUB. 1-10-2012, FILED 5-17-2011.

SP Affairs
"Your Special and Private Affairs Concierge."

NO CLAIM IS MADE TO THE EXCLUSIVE RIGHT TO USE "AFFAIRS" AND "YOUR SPECIAL AND PRIVATE AFFAIRS CONCIERGE", APART FROM THE MARK AS SHOWN.

THE MARK CONSISTS OF THE STYLIZED TEXT "SP AFFAIRS "YOUR SPECIAL AND PRIVATE AFFAIRS CONCIERGE".

FOR PERSONAL CONCIERGE SERVICES FOR OTHERS COMPRISING MAKING REQUESTED PERSONAL ARRANGEMENTS AND RESERVATIONS, RUNNING ERRANDS AND PROVIDING CUSTOMER SPECIFIC INFORMATION TO MEET INDIVIDUAL NEEDS, ALL RENDERED IN BUSINESS ESTABLISHMENTS, OFFICE BUILDINGS, HOTELS, RESIDENTIAL COMPLEXES AND HOMES (U.S. CLS. 100 AND 101).

FIRST USE 4-12-2010; IN COMMERCE 4-12-2010.

CLASS 45—(Continued).

4,155,653. FALCAR LTD., BRIDGEHAMPTON, NY. SN 85-358,326. PUB. 12-13-2011, FILED 6-28-2011.

2 Love Today Online Dating

THE MARK CONSISTS OF STANDARD CHARACTERS WITHOUT CLAIM TO ANY PARTICULAR FONT, STYLE, SIZE, OR COLOR.

NO CLAIM IS MADE TO THE EXCLUSIVE RIGHT TO USE "ONLINE DATING", APART FROM THE MARK AS SHOWN.

FOR INTERNET-BASED DATING, SOCIAL INTRODUCTION AND SOCIAL NETWORKING SERVICES (U.S. CLS. 100 AND 101).

FIRST USE 2-1-2011; IN COMMERCE 2-1-2011.

4,155,658. RODIN, RACHEL, NEW YORK, NY. SN 85-359,906. PUB. 11-29-2011, FILED 6-29-2011.



RACHEL RODIN

THE NAME "RACHEL RODIN" IDENTIFIES A LIVING INDIVIDUAL WHOSE CONSENT IS OF RECORD.

THE MARK CONSISTS OF THE STYLIZED LETTERS "RR" CENTERED WITHIN A CIRCLE WITH THE CIRCLE POSITIONED ABOVE THE WORDING "RACHEL RODIN".

FOR ORGANIZATIONAL SERVICES FOR PERSONAL PURPOSES, NAMELY, WARDROBES, CLOSET SPACE AND SHOPPING; PERSONAL FASHION CONSULTING SERVICES; PERSONAL IMAGE CONSULTING SERVICES AND PERSONAL LIFESTYLE CONSULTING SERVICES (U.S. CLS. 100 AND 101).

FIRST USE 7-1-2011; IN COMMERCE 7-1-2011.

CLASS 45—(Continued).

4,155,661. O'BRIEN, PATRICK A., NEW YORK, NY. SN 85-360,489. PUB. 12-20-2011, FILED 6-30-2011.

CLASS 45—(Continued).

4,155,706. MONTGOMERY, MCCrackEN, WALKER & RHOADS, LLP, PHILADELPHIA, PA. SN 85-370,302. PUB. 11-1-2011, FILED 7-13-2011.

Renewal Care Partners

THE MARK CONSISTS OF STANDARD CHARACTERS WITHOUT CLAIM TO ANY PARTICULAR FONT, STYLE, SIZE, OR COLOR.

NO CLAIM IS MADE TO THE EXCLUSIVE RIGHT TO USE "CARE PARTNERS", APART FROM THE MARK AS SHOWN.

FOR IN-HOME SUPPORT SERVICES TO SENIOR PERSONS, NAMELY, GERIATRIC CARE MANAGEMENT SERVICES IN THE NATURE OF THE COORDINATION OF NECESSARY SERVICES AND PERSONAL CARE FOR OLDER INDIVIDUALS (U.S. CLS. 100 AND 101).

FIRST USE 6-30-2011; IN COMMERCE 6-30-2011.

CHALLENGE DRIVES US

THE MARK CONSISTS OF STANDARD CHARACTERS WITHOUT CLAIM TO ANY PARTICULAR FONT, STYLE, SIZE, OR COLOR.

FOR LEGAL SERVICES (U.S. CLS. 100 AND 101).

FIRST USE 3-1-2012; IN COMMERCE 3-1-2012.

4,155,684. CREDNET, LLC, ORLANDO, FL. SN 85-365,141. PUB. 12-6-2011, FILED 7-7-2011.

CredNet

THE MARK CONSISTS OF STANDARD CHARACTERS WITHOUT CLAIM TO ANY PARTICULAR FONT, STYLE, SIZE, OR COLOR.

FOR VERIFYING AND MONITORING THE CREDENTIALS OF DOCTORS AND OTHER MEDICAL PROFESSIONALS (U.S. CLS. 100 AND 101).

FIRST USE 10-1-2011; IN COMMERCE 10-1-2011.

4,155,735. HOLLAND & HART LLP, DENVER, CO. SN 85-380,233. PUB. 12-20-2011, FILED 7-25-2011.

4,155,689. MARKOFF KRASNY LLC, CHICAGO, IL. SN 85-366,114. PUB. 12-6-2011, FILED 7-8-2011.

MyEmploymentLawAdvisor

WE COLLECT RESULTS

THE MARK CONSISTS OF STANDARD CHARACTERS WITHOUT CLAIM TO ANY PARTICULAR FONT, STYLE, SIZE, OR COLOR.

FOR LEGAL SERVICES (U.S. CLS. 100 AND 101).

FIRST USE 4-1-2011; IN COMMERCE 4-1-2011.

THE MARK CONSISTS OF STANDARD CHARACTERS WITHOUT CLAIM TO ANY PARTICULAR FONT, STYLE, SIZE, OR COLOR.

FOR LEGAL SERVICES (U.S. CLS. 100 AND 101).

FIRST USE 11-1-2011; IN COMMERCE 11-1-2011.

CLASS 45—(Continued).

4,155,846. SUMMIT ENTERTAINMENT, LLC, SANTA MONICA, CA. SN 85-976,694. PUB. 8-24-2010, FILED 4-6-2010.



THE MARK CONSISTS OF A CIRCULAR TRIBAL TATTOO DESIGN DEPICTING TWO WOLVES FACING ONE ANOTHER IN A HOWLING POSITION, SET AMONGST NUMEROUS INTERWOVEN LINES AND SHAPES AND ALL WITHIN THE CIRCLE.

FOR LICENSING OF MERCHANDISE AND INTELLECTUAL PROPERTY ASSOCIATED WITH MOTION PICTURES (U.S. CLS. 100 AND 101).

FIRST USE 10-1-2009; IN COMMERCE 10-1-2009.

* * * * *

PRIOR UNITED STATES CLASSIFICATION

APPLICATION IN ONE CLASS

COLLECTIVE MEMBERSHIP MARKS

CLASS 200—COLLECTIVE MEMBERSHIP

4,154,524. SCRUM ALLIANCE, INC., INDIANAPOLIS, IN. SN 77-923,582. PUB. 12-21-2010, FILED 1-29-2010.

SCRUM ALLIANCE REP

THE MARK CONSISTS OF STANDARD CHARACTERS WITHOUT CLAIM TO ANY PARTICULAR FONT, STYLE, SIZE, OR COLOR.

OWNER OF U.S. REG. NOS. 3,529,737, 3,738,535, AND OTHERS.

NO CLAIM IS MADE TO THE EXCLUSIVE RIGHT TO USE "REP", APART FROM THE MARK AS SHOWN. SEC. 2(F) AS TO "SCRUM ALLIANCE".

FOR INDICATING MEMBERSHIP IN A(N) ORGANIZATION OF PRODUCT AND SOFTWARE DEVELOPMENT TRAINERS AND EDUCATORS (U.S. CL. 200). FIRST USE 7-0-2010; IN COMMERCE 7-0-2010.

4,154,906. GUTHY-RENKER LLC, PALM DESERT, CA. SN 85-188,659. PUB. 9-6-2011, FILED 12-1-2010.

BE PROACTIV

THE MARK CONSISTS OF STANDARD CHARACTERS WITHOUT CLAIM TO ANY PARTICULAR FONT, STYLE, SIZE, OR COLOR.

OWNER OF U.S. REG. NOS. 1,890,769, 2,574,142, AND OTHERS.

FOR INDICATING MEMBERSHIP IN A CLUB FOR ACNE TREATMENT USERS WHO USE GUTHY-RENKER LLC'S ACNE TREATMENT PRODUCTS (U.S. CL. 200).

FIRST USE 7-11-2011; IN COMMERCE 7-0-2011.

CERTIFICATION MARKS

CLASS A—GOODS

4,154,822. AMERICAN HOME FURNISHINGS ALLIANCE, INC., HIGH POINT, NC. SN 85-141,143. PUB. 7-19-2011, FILED 9-29-2010.



NO CLAIM IS MADE TO THE EXCLUSIVE RIGHT TO USE "SAFETY, HEALTH AND ENVIRONMENTAL PROGRAM", APART FROM THE MARK AS SHOWN.

THE MARK CONSISTS OF THE WORD "ECOHOME" WITH THE NUMBER "3" INSIDE THE FIRST "O" IN "ECOHOME" ON TOP OF THE WORDS "AHFA'S SAFETY, HEALTH AND ENVIRONMENTAL PROGRAM".

THE CERTIFICATION MARK, AS INTENDED TO BE USED BY AUTHORIZED PERSONS, IS INTENDED TO CERTIFY THAT THE GOODS MANUFACTURED UNDER THE CERTIFICATION MARK MEET THE ENVIRONMENTAL STANDARDS SET OUT BY THE CERTIFIER AND THAT THE GOODS ARE OFFERED BY A MEMBER IN GOOD STANDING OF THE CERTIFIER, WHICH MEMBER HAS ADHERED TO THE REGULATIONS AND ENVIRONMENTAL STANDARDS ESTABLISHED BY THE CERTIFIER, AND WHICH MEMBER UNDERTAKES TO RESPECT THE NORMS AND DIRECTIVES DEFINED BY THE CERTIFIER WITH RESPECT TO THE GOODS OFFERED FOR SALE UNDER THE CERTIFICATION MARK.

FOR FURNITURE (U.S. CL. A).

FIRST USE 10-0-2010; IN COMMERCE 10-0-2010.

CERTIFICATION MARKS

CLASS B—SERVICES

4,155,134. DIVORCE COACHING, INC., TAMPA, FL. SN 85-250,721. PUB. 8-16-2011, FILED 2-24-2011.



THE MARK CONSISTS OF STANDARD CHARACTERS WITHOUT CLAIM TO ANY PARTICULAR FONT, STYLE, SIZE, OR COLOR.

THE CERTIFICATION MARK, AS INTENDED TO BE

USED BY AUTHORIZED PERSONS, IS INTENDED TO CERTIFY THAT THE PERSON DISPLAYING THE MARK HAS COMPLETED EDUCATION COURSE WORK REQUIREMENTS AND WORK EXPERIENCE REQUIREMENTS OF THE CERTIFIER, HAS COMPLETED EXAMINATIONS ADMINISTERED BY THE CERTIFIER IN A SATISFACTORY MANNER, HAS AGREED TO ADHERE TO THE CERTIFIER'S STANDARDS OF PROFESSIONAL RESPONSIBILITY, CONTINUING EDUCATION AND OTHER POST-CERTIFICATION REQUIREMENTS.
 FOR PERSONAL DIVORCE COACHING (U.S. CL. B).
 FIRST USE 6-15-2011; IN COMMERCE 6-20-2011.

NO CLAIM IS MADE TO THE EXCLUSIVE RIGHT TO USE "CERTIFIED DIVORCE COACH", APART FROM THE MARK AS SHOWN.

THE CERTIFICATION MARK, AS INTENDED TO BE USED BY AUTHORIZED PERSONS, IS INTENDED TO CERTIFY THAT THE PERSON DISPLAYING THE MARK HAS COMPLETED EDUCATION COURSE WORK REQUIREMENTS AND WORK EXPERIENCE REQUIREMENTS OF THE CERTIFIER, HAS COMPLETED EXAMINATIONS ADMINISTERED BY THE CERTIFIER IN A SATISFACTORY MANNER, HAS AGREED TO ADHERE TO THE CERTIFIER'S STANDARDS OF PROFESSIONAL RESPONSIBILITY, CONTINUING EDUCATION AND OTHER POST-CERTIFICATION REQUIREMENTS.
 FOR PERSONAL DIVORCE COACHING (U.S. CL. B).
 FIRST USE 6-15-2011; IN COMMERCE 6-20-2011.

4,155,135. **DIVORCE COACHING, INC., TAMPA, FL. SN 85-250,725. PUB. 8-16-2011, FILED 2-24-2011.**

CDC CERTIFIED DIVORCE COACH

THE MARK CONSISTS OF STANDARD CHARACTERS WITHOUT CLAIM TO ANY PARTICULAR FONT, STYLE, SIZE, OR COLOR.

* * * * *

SUPPLEMENTAL REGISTER

These registrations are not subject to opposition.

SECTION 1.— INTERNATIONAL CLASSIFICATION

The short titles associated below with the international class numbers are terms designed merely for quick identification and are not an official part of the international classification. The full names of international classes are given in section 6.1 of the trademark rules of practice.

The designation "U.S. Cl." appearing in this section refers to the U.S. class in effect prior to Sep. 1, 1973 rather than the international class which applies to applications filed on or after that date. For adoption of international classification see notice in the OFFICIAL GAZETTE of Jun. 26, 1973 (911 O.G. TM 210).

Application in more than one class

4,155,873. CROSSVILLE, INC., CROSSVILLE, TN. SN 85-136,873. FILED P.R. 9-23-2010; AM. S.R. 4-10-2012.

TILE TAKE-BACK

THE MARK CONSISTS OF STANDARD CHARACTERS WITHOUT CLAIM TO ANY PARTICULAR FONT, STYLE, SIZE, OR COLOR.

CLASS 37—CONSTRUCTION AND REPAIR

FOR COLLECTION OF FIRED TILE WASTE, NAMELY, CERAMIC OR PORCELAIN MATERIAL FOR RECYCLING (U.S. CLS. 100, 103 AND 106).
FIRST USE 6-9-2009; IN COMMERCE 6-9-2009.

CLASS 40—MATERIAL TREATMENT

FOR RECYCLING OF FIRED TILE WASTE, NAMELY, CERAMIC OR PORCELAIN MATERIAL (U.S. CLS. 100, 103 AND 106).
FIRST USE 6-9-2009; IN COMMERCE 6-9-2009.

4,155,879. VENUEAGENT LLC, BURLINGTON, KY. SN 85-175,187. FILED P.R. 11-12-2010; AM. S.R. 4-13-2012.

VENUEAGENT

THE MARK CONSISTS OF STANDARD CHARACTERS WITHOUT CLAIM TO ANY PARTICULAR FONT, STYLE, SIZE, OR COLOR.

CLASS 41—EDUCATION AND ENTERTAINMENT

FOR BOOKING OF ENTERTAINMENT HALLS (U.S. CLS. 100, 101 AND 107).
FIRST USE 1-1-2011; IN COMMERCE 5-20-2011.

CLASS 43—HOTEL AND RESTAURANT SERVICES

FOR BOOKING OF BANQUET AND SOCIAL FUNCTION FACILITIES FOR SPECIAL OCCASIONS SUCH AS WEDDINGS (U.S. CLS. 100 AND 101).
FIRST USE 1-1-2011; IN COMMERCE 5-20-2011.

4,155,883. MENON & ASSOCIATES, INC., SAN DIEGO, CA. SN 85-192,689. FILED P.R. 12-7-2010; AM. S.R. 4-4-2012.

MENON

THE MARK CONSISTS OF STANDARD CHARACTERS WITHOUT CLAIM TO ANY PARTICULAR FONT, STYLE, SIZE, OR COLOR.

CLASS 4—LUBRICANTS AND FUELS

FOR BIOFUEL (U.S. CLS. 1, 6 AND 15).
FIRST USE 8-9-2011; IN COMMERCE 8-9-2011.

CLASS 9—ELECTRICAL AND SCIENTIFIC APPARATUS

FOR ELECTRONIC BIOTREAT DETECTORS (U.S. CLS. 21, 23, 26, 36 AND 38).
FIRST USE 5-4-2011; IN COMMERCE 5-4-2011.

CLASS 31—NATURAL AGRICULTURAL PRODUCTS

FOR ANIMAL FEED (U.S. CLS. 1 AND 46).
FIRST USE 8-9-2011; IN COMMERCE 8-9-2011.

4,155,920. DR. INTERNS, INC., ROBBINSVILLE, NJ. SN 85-303,759. FILED P.R. 4-25-2011; AM. S.R. 4-10-2012.

Dr. Interns

THE MARK CONSISTS OF STANDARD CHARACTERS WITHOUT CLAIM TO ANY PARTICULAR FONT, STYLE, SIZE, OR COLOR.

CLASS 41—EDUCATION AND ENTERTAINMENT

FOR CHARITABLE SERVICES, NAMELY, PROVIDING TRAINING IN THE FIELD OF MEDICAL CARE, HEALTH CARE, AND PATIENT AND COMMUNITY RELATIONS (U.S. CLS. 100, 101 AND 107).
FIRST USE 12-5-2010; IN COMMERCE 12-5-2010.

CLASS 44—MEDICAL, BEAUTY AND AGRICULTURAL SERVICES

FOR CHARITABLE SERVICES, NAMELY, PROVIDING MEDICAL ATTENTION TO THOSE IN DEVELOPING COUNTRIES; CHARITABLE SERVICES, NAMELY, PROVIDING MEDICAL EQUIPMENT AND SERVICES TO UNDERSERVED COMMUNITIES; CHARITABLE SERVICES, NAMELY, PROVIDING MEDICAL SERVICES TO UNDERDEVELOPED COUNTRIES (U.S. CLS. 100 AND 101).
FIRST USE 12-5-2010; IN COMMERCE 12-5-2010.

4,155,930. SERVICE TOOL CO, LLC, NEW IBERIA, LA. SN 85-325,677. FILED P.R. 5-20-2011; AM. S.R. 3-9-2012.

DUCK-N-DEER CAMO

THE MARK CONSISTS OF STANDARD CHARACTERS WITHOUT CLAIM TO ANY PARTICULAR FONT, STYLE, SIZE, OR COLOR.

CLASS 6—METAL GOODS

FOR CAMOUFLAGED METAL TIE DOWN SETS; METAL MOUNTING HARDWARE, NAMELY, D-RINGS (U.S. CLS. 2, 12, 13, 14, 23, 25 AND 50).
FIRST USE 3-1-2012; IN COMMERCE 3-1-2012.

CLASS 8—HAND TOOLS

FOR KNIVES; MANUALLY OPERATED HAND TOOLS IN THE NATURE OF GUT HOOKS FOR USE WITH HUNTING; KNIFE SHEATHS; SHARPENING STONES; HAND TOOLS, NAMELY, SAWS; MACHETES; AXES (U.S. CLS. 23, 28 AND 44).
FIRST USE 3-1-2012; IN COMMERCE 3-1-2012.

CLASS 9—ELECTRICAL AND SCIENTIFIC APPARATUS

FOR BINOCULARS; EYEWEAR STRAPS; COMPASSES; LASER POINTERS; CELLULAR AND WIRELESS TELEPHONE HOLDERS; HUNTING SAFETY VESTS; HUNTING ACCESSORIES, NAMELY, SIGNAL WHISTLES (U.S. CLS. 21, 23, 26, 36 AND 38).
FIRST USE 3-1-2012; IN COMMERCE 3-1-2012.

CLASS 11—ENVIRONMENTAL CONTROL APPARATUS

FOR FLASHLIGHTS; CLIP LIGHTS, NAMELY, LED LIGHTS INCORPORATED INTO AN ATTACHABLE CLIP FOR LIGHTING PURPOSES; OUTDOOR LIGHTING PRODUCTS, NAMELY, HEAD LAMPS; ICE CHESTS (U.S. CLS. 13, 21, 23, 31 AND 34).
FIRST USE 3-1-2012; IN COMMERCE 3-1-2012.

CLASS 13—FIREARMS

FOR HUNTING POUCHES FOR HOLDING AMMUNITION; FIELD BAGS FOR HOLDING AMMUNITION (U.S. CLS. 2 AND 9).
FIRST USE 3-1-2012; IN COMMERCE 3-1-2012.

CLASS 18—LEATHER GOODS

FOR TOOL BAGS SOLD EMPTY; UMBRELLAS; HUNTING POUCHES FOR HOLDING GAME; ALL-PURPOSE FIELD BAGS; GENERAL PURPOSE HUNTING POUCHES (U.S. CLS. 1, 2, 3, 22 AND 41).
FIRST USE 3-1-2012; IN COMMERCE 3-1-2012.

CLASS 20—FURNITURE AND ARTICLES NOT OTHERWISE CLASSIFIED

FOR CUSHIONS (U.S. CLS. 2, 13, 22, 25, 32 AND 50).
FIRST USE 3-1-2012; IN COMMERCE 3-1-2012.

CLASS 21—HOUSEWARES AND GLASS

FOR PORTABLE ICE CHESTS FOR FOOD AND BEVERAGES; PILL CANISTERS FOR PERSONAL USE; PORTABLE INSULATED BEVERAGE CONTAINER HOLDERS FOR PERSONAL USE (U.S. CLS. 2, 13, 23, 29, 30, 33, 40 AND 50).
FIRST USE 3-1-2012; IN COMMERCE 3-1-2012.

CLASS 22—CORDAGE AND FIBERS

FOR CORDING; CARGO AND CARRIER EQUIPMENT FOR VEHICLES, NAMELY, LASHING STRAPS (U.S. CLS. 1, 2, 7, 19, 22, 42 AND 50).
FIRST USE 3-1-2012; IN COMMERCE 3-1-2012.

CLASS 25—CLOTHING

FOR CLOTHING AND ACCESSORIES, NAMELY, GLOVES, CAPS, KNIT HATS, RAIN SUITS, HUNTING VESTS (U.S. CLS. 22 AND 39).
FIRST USE 3-1-2012; IN COMMERCE 3-1-2012.

CLASS 28—TOYS AND SPORTING GOODS

FOR HUNTING ACCESSORIES, NAMELY, MARKING TAPE; HUNTING POUCHES FOR HOLDING HUNTING ACCESSORIES, NAMELY, BIRD AND/OR ANIMAL CALLS OR THE LIKE (U.S. CLS. 22, 23, 38 AND 50).
FIRST USE 3-1-2012; IN COMMERCE 3-1-2012.

4,155,932. TRAVDOG, INC., DBA CHINA CABLES DIRECT, ALISO VIEJO, CA. SN 85-330,331. FILED P.R. 5-25-2011; AM. S.R. 4-23-2012.

CHINA CABLES DIRECT

THE MARK CONSISTS OF STANDARD CHARACTERS WITHOUT CLAIM TO ANY PARTICULAR FONT, STYLE, SIZE, OR COLOR.

NO CLAIM IS MADE TO THE EXCLUSIVE RIGHT TO USE "CABLES", APART FROM THE MARK AS SHOWN.

CLASS 35—ADVERTISING AND BUSINESS

FOR BUSINESS SERVICES, NAMELY, COMBINED STRATEGIC GOODS OR SERVICES SOURCING, PURCHASING AND IMPORT AGENCY SERVICES IN THE FIELD OF DATA COMMUNICATIONS PRODUCTS FOR OTHERS; BUSINESS PROJECT MANAGEMENT SERVICES FOR OTHERS IN THE FIELD OF DATA COMMUNICATIONS PRODUCTS; MANUFACTURERS' REPRESENTATIVES IN THE FIELD OF DATA COMMUNICATIONS PRODUCTS; DISTRIBUTORSHIP SERVICES IN THE FIELD OF DATA COMMUNICATIONS PRODUCTS; FACTORY BUSINESS AUDITING; PERFORMANCE OF BUSINESS MANAGEMENT SERVICES RELATING TO PRODUCT CREATION, COMPLIANCE, ENGINEERING, QUALITY CONTROL, DISTRIBUTION, IMPORTATION, OPERATIONS MANAGEMENT, LOGISTICS, SUPPLY CHAIN, FINANCING AND PRODUCTION SYSTEMS AND DISTRIBUTION SOLUTIONS; PROVIDING OUTSOURCING OF MANUFACTURING COMPONENTS AND COMPLETED PRODUCTS TO THIRD PARTIES IN THE FIELD OF DATA COMMUNICATIONS PRODUCTS (U.S. CLS. 100, 101 AND 102).
FIRST USE 5-8-2006; IN COMMERCE 5-8-2006.

CLASS 40—MATERIAL TREATMENT

FOR MANUFACTURE OF DATA COMMUNICATIONS PRODUCTS AND ACCESSORIES MADE TO ORDER AND UNDER SPECIFICATION OF THIRD PARTIES; MANUFACTURING FOR OTHERS IN THE FIELD OF DATA COMMUNICATIONS AND DATA COMMUNICATIONS PRODUCTS; CUSTOM AND CONTRACT MANUFACTURING IN THE FIELD OF DATA COMMUNICATIONS PRODUCTS (U.S. CLS. 100, 103 AND 106).
FIRST USE 5-8-2006; IN COMMERCE 5-8-2006.

4,155,936. EXOTIC SUPERFOODS NEW YORK, INC., FLUSHING, NY. SN 85-332,463. FILED P.R. 5-27-2011; AM. S.R. 1-30-2012.

Exotic Superfoods

THE MARK CONSISTS OF STANDARD CHARACTERS WITHOUT CLAIM TO ANY PARTICULAR FONT, STYLE, SIZE, OR COLOR.

CLASS 29—MEATS AND PROCESSED FOODS

FOR FRUITS, NAMELY, EXOTIC FRUITS AND COCONUT MEAT THAT ARE FROZEN (U.S. CL. 46).
FIRST USE 9-14-2006; IN COMMERCE 12-2-2008.

CLASS 32—LIGHT BEVERAGES

FOR COCONUT WATER; FROZEN FRUIT DRINKS; SMOOTHIES (U.S. CLS. 45, 46 AND 48).
FIRST USE 9-14-2006; IN COMMERCE 12-2-2008.

4,155,949. OPPORTUNITY BUYS, INC., INDIANAPOLIS, IN. SN 85-349,016. FILED P.R. 6-17-2011; AM. S.R. 3-13-2012.

INDY AROMAS

THE MARK CONSISTS OF STANDARD CHARACTERS WITHOUT CLAIM TO ANY PARTICULAR FONT, STYLE, SIZE, OR COLOR.

CLASS 3—COSMETICS AND CLEANING PREPARATIONS

FOR AROMATIC OILS (U.S. CLS. 1, 4, 6, 50, 51 AND 52).
FIRST USE 8-11-2011; IN COMMERCE 8-11-2011.

CLASS 4—LUBRICANTS AND FUELS

FOR CANDLES (U.S. CLS. 1, 6 AND 15).
FIRST USE 8-11-2011; IN COMMERCE 8-11-2011.

4,155,951. RODNEY HAND & ASSOCIATES MARKETING COMMUNICATIONS, LP, DALLAS, TX. SN 85-351,764. FILED P.R. 6-21-2011; AM. S.R. 3-28-2012.

PATRON

THE MARK CONSISTS OF STANDARD CHARACTERS WITHOUT CLAIM TO ANY PARTICULAR FONT, STYLE, SIZE, OR COLOR.

CLASS 16—PAPER GOODS AND PRINTED MATTER

FOR MAGAZINES IN THE FIELD OF ARTS, ENTERTAINMENT, AND CULTURE (U.S. CLS. 2, 5, 22, 23, 29, 37, 38 AND 50).
FIRST USE 11-1-2011; IN COMMERCE 11-1-2011.

CLASS 41—EDUCATION AND ENTERTAINMENT

FOR PROVIDING ON-LINE MAGAZINES IN THE FIELD OF ARTS, ENTERTAINMENT AND CULTURE (U.S. CLS. 100, 101 AND 107).
FIRST USE 11-1-2011; IN COMMERCE 11-1-2011.

4,155,953. PSYCHOLOGICAL SOFTWARE SOLUTIONS, INC., HOUSTON, TX. SN 85-352,704. FILED P.R. 6-22-2011; AM. S.R. 4-4-2012.

**PSYCHOLOGICAL SOFTWARE
SOLUTIONS**

THE MARK CONSISTS OF STANDARD CHARACTERS WITHOUT CLAIM TO ANY PARTICULAR FONT, STYLE, SIZE, OR COLOR.

CLASS 41—EDUCATION AND ENTERTAINMENT

FOR EDUCATIONAL COURSE MONITORING, NAMELY, TRACKING, ANALYZING AND MANAGING STUDENT BEHAVIORAL PERFORMANCE (U.S. CLS. 100, 101 AND 107).

FIRST USE 9-15-2003; IN COMMERCE 9-15-2003.

CLASS 44—MEDICAL, BEAUTY AND AGRICULTURAL SERVICES

FOR PSYCHOLOGICAL CONSULTATION SERVICES IN THE NATURE OF BEHAVIOR ANALYSIS SERVICES, NAMELY, MANAGING, TRACKING AND MONITORING STUDENT BEHAVIOR FOR SCHOOLS (U.S. CLS. 100 AND 101).

FIRST USE 9-15-2003; IN COMMERCE 9-15-2003.

4,155,966. DAVID N. DEUTSCH & COMPANY LLC, NEW YORK, NY. SN 85-360,546. FILED P.R. 6-30-2011; AM. S.R. 4-3-2012.

**THE STRATEGIC FINANCIAL
ADVISOR OF LEADING
CLOSELY-HELD COMPANIES**

THE MARK CONSISTS OF STANDARD CHARACTERS WITHOUT CLAIM TO ANY PARTICULAR FONT, STYLE, SIZE, OR COLOR.

CLASS 35—ADVERTISING AND BUSINESS

FOR BUSINESS ACQUISITION AND MERGER CONSULTATION (U.S. CLS. 100, 101 AND 102).

FIRST USE 1-1-2008; IN COMMERCE 1-1-2008.

CLASS 36—INSURANCE AND FINANCIAL

FOR FINANCIAL AND INVESTMENT SERVICES, NAMELY, INVESTMENT BANKING, FINANCIAL CONSULTING IN THE FIELD OF MERGERS AND ACQUISITIONS, RAISING CAPITAL FOR COMPANIES AND THEIR OWNERS, FINANCIAL ANALYSIS CONSULTATION, AND INVESTMENT MANAGEMENT AND CONSULTATION (U.S. CLS. 100, 101 AND 102).

FIRST USE 1-1-2008; IN COMMERCE 1-1-2008.

4,155,956. PACKSIZE LLC, SALT LAKE CITY, UT. SN 85-353,545. FILED P.R. 6-22-2011; AM. S.R. 4-2-2012.

ON DEMAND PACKAGING

THE MARK CONSISTS OF STANDARD CHARACTERS WITHOUT CLAIM TO ANY PARTICULAR FONT, STYLE, SIZE, OR COLOR.

NO CLAIM IS MADE TO THE EXCLUSIVE RIGHT TO USE "PACKAGING", APART FROM THE MARK AS SHOWN.

CLASS 7—MACHINERY

FOR MACHINES FOR PRODUCING CORRUGATED CONTAINERS AT THE MOMENT WHEN NEEDED FOR PACKAGING GOODS (U.S. CLS. 13, 19, 21, 23, 31, 34 AND 35).

FIRST USE 9-1-2011; IN COMMERCE 9-1-2011.

CLASS 40—MATERIAL TREATMENT

FOR CUSTOM MANUFACTURE OF CORRUGATED CONTAINERS AT THE MOMENT WHEN NEEDED OUT OF CORRUGATED BOARD (U.S. CLS. 100, 103 AND 106).

FIRST USE 9-1-2011; IN COMMERCE 9-1-2011.

4,155,977. SKYDIVING SCHOOL, INC., DBA SKYDIVE HAWAII, HONOLULU, HI. SN 85-373,394. FILED P.R. 7-18-2011; AM. S.R. 3-4-2012.

SKYDIVE HAWAII

THE MARK CONSISTS OF STANDARD CHARACTERS WITHOUT CLAIM TO ANY PARTICULAR FONT, STYLE, SIZE, OR COLOR.

NO CLAIM IS MADE TO THE EXCLUSIVE RIGHT TO USE "SKYDIVE" FOR CLASS 12, APART FROM THE MARK AS SHOWN.

CLASS 12—VEHICLES

FOR PARACHUTES (U.S. CLS. 19, 21, 23, 31, 35 AND 44).

FIRST USE 1-1-2010; IN COMMERCE 1-1-2010.

CLASS 18—LEATHER GOODS

FOR ALL PURPOSE SPORT BAGS; ALL-PURPOSE ATHLETIC BAGS; ALL-PURPOSE CARRYING BAGS; ATHLETIC BAGS; CARRY-ALL BAGS; SPORT BAGS; TRAVEL BAGS (U.S. CLS. 1, 2, 3, 22 AND 41).

FIRST USE 7-1-2011; IN COMMERCE 7-1-2011.

4,155,982. VIRGINIA VIDRIO, LA PUENTE, CA. SN 85-386,204. FILED P.R. 8-1-2011; AM. S.R. 4-5-2012.

4,155,999. BASIC ESL, INC., TEMECULA, CA. SN 85-430,605. FILED P.R. 9-23-2011; AM. S.R. 4-13-2012.

SGV

BASIC ESL

THE MARK CONSISTS OF STANDARD CHARACTERS WITHOUT CLAIM TO ANY PARTICULAR FONT, STYLE, SIZE, OR COLOR.

THE MARK CONSISTS OF STANDARD CHARACTERS WITHOUT CLAIM TO ANY PARTICULAR FONT, STYLE, SIZE, OR COLOR.

NO CLAIM IS MADE TO THE EXCLUSIVE RIGHT TO USE "ESL", APART FROM THE MARK AS SHOWN.

CLASS 12—VEHICLES

FOR BICYCLES (U.S. CLS. 19, 21, 23, 31, 35 AND 44). FIRST USE 4-1-2009; IN COMMERCE 4-1-2009.

CLASS 9—ELECTRICAL AND SCIENTIFIC APPARATUS

FOR COMPUTER SOFTWARE FOR USE IN LEARNING ENGLISH (U.S. CLS. 21, 23, 26, 36 AND 38). FIRST USE 5-12-2011; IN COMMERCE 5-12-2011.

CLASS 35—ADVERTISING AND BUSINESS

FOR RETAIL STORES FEATURING BICYCLES (U.S. CLS. 100, 101 AND 102). FIRST USE 4-1-2009; IN COMMERCE 4-1-2009.

CLASS 42—SCIENTIFIC AND COMPUTER SERVICES

FOR PROVIDING TEMPORARY USE OF ON-LINE NON-DOWNLOADABLE SOFTWARE FOR USE IN LEARNING ENGLISH (U.S. CLS. 100 AND 101). FIRST USE 5-12-2011; IN COMMERCE 5-12-2011.

4,155,998. INFRARED RESOURCES, LLC, PORTLAND, OR. SN 85-428,581. FILED P.R. 9-21-2011; AM. S.R. 3-21-2012.

4,156,008. INTELLISPHERE, LLC, PLAINSBORO, NJ. SN 85-451,591. FILED P.R. 10-19-2011; AM. S.R. 4-4-2012.

Infrared Resources

VIRTUAL TUMOR BOARD

THE MARK CONSISTS OF STANDARD CHARACTERS WITHOUT CLAIM TO ANY PARTICULAR FONT, STYLE, SIZE, OR COLOR.

NO CLAIM IS MADE TO THE EXCLUSIVE RIGHT TO USE "INFRARED", APART FROM THE MARK AS SHOWN.

THE MARK CONSISTS OF STANDARD CHARACTERS WITHOUT CLAIM TO ANY PARTICULAR FONT, STYLE, SIZE, OR COLOR.

CLASS 9—ELECTRICAL AND SCIENTIFIC APPARATUS

CLASS 9—ELECTRICAL AND SCIENTIFIC APPARATUS

FOR ELECTRONIC EQUIPMENT, NAMELY, TRANSFORMERS, BALUNS, CABLES USED IN CONNECTION WITH COMPUTERS, COMPUTER PERIPHERAL DEVICES, TELEVISIONS, AUDIO-VIDEO EQUIPMENT, CLOSED-CIRCUIT TV EQUIPMENT AND TELECOMMUNICATION EQUIPMENT; TRANSMITTERS AND RECEIVERS FOR AUDIO AND VIDEO SIGNALS FOR TRANSMISSION OVER TWISTED PAIR CABLES (U.S. CLS. 21, 23, 26, 36 AND 38). FIRST USE 7-30-2009; IN COMMERCE 7-30-2009.

FOR ELECTRONIC DOWNLOADABLE PUBLICATIONS, NAMELY, ARTICLES FOR USE BY MEDICAL PROFESSIONALS IN THE FIELD OF SCIENCE AND MEDICINE (U.S. CLS. 21, 23, 26, 36 AND 38). FIRST USE 1-24-2012; IN COMMERCE 1-24-2012.

CLASS 35—ADVERTISING AND BUSINESS

CLASS 41—EDUCATION AND ENTERTAINMENT

FOR ON-LINE RETAIL STORE SERVICES FEATURING IR TECHNOLOGY-RELATED PRODUCTS (U.S. CLS. 100, 101 AND 102). FIRST USE 7-30-2009; IN COMMERCE 7-30-2009.

FOR PROVIDING A WEBSITE FEATURING RESOURCES, NAMELY, NON-DOWNLOADABLE PUBLICATIONS IN THE NATURE OF ARTICLES IN THE FIELD OF ONCOLOGY (U.S. CLS. 100, 101 AND 107). FIRST USE 1-24-2012; IN COMMERCE 1-24-2012.

4,156,019. CHANCELLOR-MADDISON, JACQUELINE JANE, DBA RANCHO SANTA FE MAGAZINE, RANCHO SANTA FE, CA. SN 85-465,445. FILED P.R. 11-5-2011; AM. S.R. 4-23-2012.

Rancho Santa Fe Magazine

THE MARK CONSISTS OF STANDARD CHARACTERS WITHOUT CLAIM TO ANY PARTICULAR FONT, STYLE, SIZE, OR COLOR.

NO CLAIM IS MADE TO THE EXCLUSIVE RIGHT TO USE "MAGAZINE", APART FROM THE MARK AS SHOWN.

CLASS 16—PAPER GOODS AND PRINTED MATTER

FOR MAGAZINES IN THE FIELD OF RANCHO SANTA FE, CALIFORNIA FEATURING PHOTOGRAPHS, ARTICLES, AND ADVERTISEMENTS WITH PROFESSIONAL PROFILES, BUSINESS, FINANCIAL MATTERS, WEALTH MANAGEMENT, LUXURY LIFESTYLE, AND REAL ESTATE (U.S. CLS. 2, 5, 22, 23, 29, 37, 38 AND 50).

FIRST USE 7-1-2011; IN COMMERCE 7-15-2011.

CLASS 35—ADVERTISING AND BUSINESS

FOR PROVIDING ADVERTISING, MARKETING AND PROMOTIONAL SERVICES, NAMELY, DEVELOPMENT OF ADVERTISING CAMPAIGNS PROVIDED THROUGH CABLE TELEVISION BROADCAST, WEB CASTS, RADIO BROADCASTS, NEWSPAPERS, MAGAZINES, ONLINE BANNERS, OUTDOOR BILLBOARDS, WILD POSTINGS, BUS AND SUBWAY ADS (U.S. CLS. 100, 101 AND 102).

FIRST USE 7-1-2011; IN COMMERCE 7-15-2011.

4,156,047. DAVID BOGNER FAMILY FUNERAL HOME INC., NORTH RIDGEVILLE, OH. SN 85-492,525. FILED P.R. 12-12-2011; AM. S.R. 4-25-2012.

BOGNER

THE MARK CONSISTS OF STANDARD CHARACTERS WITHOUT CLAIM TO ANY PARTICULAR FONT, STYLE, SIZE, OR COLOR.

CLASS 40—MATERIAL TREATMENT

FOR CREMATION SERVICES (U.S. CLS. 100, 103 AND 106).

FIRST USE 12-9-2011; IN COMMERCE 12-9-2011.

CLASS 45—PERSONAL AND LEGAL SERVICES

FOR FUNERAL ARRANGEMENT SERVICES; FUNERAL HOMES; FUNERAL SERVICE UNDERTAKING; FUNERAL SERVICES ACCOMPANYING CREMATION (U.S. CLS. 100 AND 101).

FIRST USE 12-9-2011; IN COMMERCE 12-9-2011.

4,156,055. ACTIVETRAK INC., AKA GADGETTRAK, PORTLAND, OR. SN 85-506,096. FILED P.R. 12-30-2011; AM. S.R. 4-6-2012.

CameraTrace

THE MARK CONSISTS OF STANDARD CHARACTERS WITHOUT CLAIM TO ANY PARTICULAR FONT, STYLE, SIZE, OR COLOR.

CLASS 42—SCIENTIFIC AND COMPUTER SERVICES

FOR COMPUTER SERVICES, NAMELY, PROVIDING SEARCH ENGINES FOR OBTAINING DATA ON A GLOBAL COMPUTER NETWORK FOR IDENTIFYING SPECIFIC CAMERAS FROM PHOTOS TAKEN FROM ANY PARTICULAR CAMERA (U.S. CLS. 100 AND 101).

FIRST USE 12-20-2011; IN COMMERCE 12-20-2011.

CLASS 45—PERSONAL AND LEGAL SERVICES

FOR LOST PROPERTY RETURN (U.S. CLS. 100 AND 101).

FIRST USE 12-20-2011; IN COMMERCE 12-20-2011.

4,156,060. INTELLISPHERE, LLC, PLAINSBORO, NJ. SN 85-507,071. FILED 1-2-2012.

BIOMARKERS, PATHWAYS, AND TARGETED THERAPIES

THE MARK CONSISTS OF STANDARD CHARACTERS WITHOUT CLAIM TO ANY PARTICULAR FONT, STYLE, SIZE, OR COLOR.

CLASS 9—ELECTRICAL AND SCIENTIFIC APPARATUS

FOR DOWNLOADABLE ELECTRONIC PUBLICATIONS IN THE NATURE OF JOURNALS AND ARTICLES IN THE FIELD OF ONCOLOGY (U.S. CLS. 21, 23, 26, 36 AND 38).

FIRST USE 12-28-2011; IN COMMERCE 12-28-2011.

JUNE 5, 2012

U.S. PATENT AND TRADEMARK OFFICE

TM 1797

CLASS 41—EDUCATION AND ENTERTAINMENT

FOR PROVIDING A WEBSITE FEATURING NON-DOWNLOADABLE PUBLICATIONS IN THE NATURE OF JOURNALS AND ARTICLES IN THE FIELD OF ONCOLOGY (U.S. CLS. 100, 101 AND 107).
FIRST USE 12-28-2011; IN COMMERCE 12-28-2011.

* * * * *

SECTION 2.— INTERNATIONAL CLASSIFICATION

The short titles associated below with the international class numbers are terms designed merely for quick identification and are not an official part of the international classification. The full names of international classes are given in section 6.1 of the trademark rules of practice.

The designation "U.S. Cl." appearing in this section refers to the U.S. class in effect prior to Sep. 1, 1973 rather than the international class which applies to applications filed on or after that date. For adoption of international classification see notice in the OFFICIAL GAZETTE of Jun. 26, 1973 (911 O.G. TM 210).

Application in one class

CLASS 1—CHEMICALS

4,155,961. GROWTH TECHNOLOGY LTD, TAUNTON TA2 6BX, UNITED KINGDOM. SN 85-355,419. FILED P.R. 6-24-2011; AM. S.R. 4-9-2012.

ORCHID MYST

THE MARK CONSISTS OF STANDARD CHARACTERS WITHOUT CLAIM TO ANY PARTICULAR FONT, STYLE, SIZE, OR COLOR.

FOR A FOLIAR SPRAY FOR PLANTS CONTAINING MINERAL AND ORGANIC NUTRIENTS AND PURE NATURAL OILS TO ENHANCE LEAF CONDITION (U.S. CLS. 1, 5, 6, 10, 26 AND 46).

FIRST USE 11-30-2010; IN COMMERCE 11-30-2010.

4,156,009. PILOT TRAVEL CENTERS LLC, KNOXVILLE, TN. SN 85-451,973. FILED 10-20-2011.

Top it off every time.

THE MARK CONSISTS OF STANDARD CHARACTERS WITHOUT CLAIM TO ANY PARTICULAR FONT, STYLE, SIZE, OR COLOR.

FOR DIESEL EXHAUST FLUID (U.S. CLS. 1, 5, 6, 10, 26 AND 46).

FIRST USE 9-1-2011; IN COMMERCE 9-1-2011.

CLASS 2—PAINTS

TM 1798

CLASS 2—(Continued).

4,155,943. GREENFIELD MANUFACTURING, INC., SARATOGA SPRINGS, NY. SN 85-342,924. FILED P.R. 6-10-2011; AM. S.R. 3-14-2012.

WET-GLOSS

THE MARK CONSISTS OF STANDARD CHARACTERS WITHOUT CLAIM TO ANY PARTICULAR FONT, STYLE, SIZE, OR COLOR.

FOR PROTECTIVE COATING FOR METAL, MASONRY, CEMENT AND WOOD (U.S. CLS. 6, 11 AND 16). FIRST USE 3-14-2012; IN COMMERCE 3-14-2012.

4,156,059. OPALSTONE AUSTRALASIA PTY. LTD., ASHMORE, AUSTRALIA. SN 85-506,799. FILED 12-31-2011.

Carbon**K**free

THE COLOR(S) GRAY, BLACK AND GREEN IS/ARE CLAIMED AS A FEATURE OF THE MARK.

THE MARK CONSISTS OF THE WORDING "CARBON-FREE" IN A STYLIZED FONT. THE WORD "CARBON" IS COLORED GRAY, THE LETTER "K" IS COLORED BLACK AND IS IN BOLD. THE WORD "FREE" IS COLORED GREEN.

FOR INK JET PRINTER INK (U.S. CLS. 6, 11 AND 16). FIRST USE 8-1-2011; IN COMMERCE 8-1-2011.

CLASS 3—COSMETICS AND CLEANING PREPARATIONS

CLASS 3—(Continued).

4,155,908. GOOD BY NATURE LLC, CRESTWOOD, IL. SN 85-267,792. FILED P.R. 3-15-2011; AM. S.R. 12-8-2011.

CLASS 3—(Continued).

4,156,020. NVENTA INCORPORATED, SCOTTSDALE, AZ. SN 85-465,876. FILED P.R. 11-7-2011; AM. S.R. 3-7-2012.

Tu Color Latino

KLEAN

THE MARK CONSISTS OF STANDARD CHARACTERS WITHOUT CLAIM TO ANY PARTICULAR FONT, STYLE, SIZE, OR COLOR.

NO CLAIM IS MADE TO THE EXCLUSIVE RIGHT TO USE "COLOR". APART FROM THE MARK AS SHOWN.

THE ENGLISH TRANSLATION OF "TU COLOR LATINO" IN THE MARK IS "YOUR LATIN COLOR".

FOR HAIRCARE PRODUCTS, NAMELY, HAIR COLOR, HAIR SHAMPOO AND CONDITIONERS, HAIR SPRAY, HAIR GEL AND HAIR MOUSSE (U.S. CLS. 1, 4, 6, 50, 51 AND 52).

FIRST USE 6-1-2009; IN COMMERCE 6-1-2009.

THE MARK CONSISTS OF STANDARD CHARACTERS WITHOUT CLAIM TO ANY PARTICULAR FONT, STYLE, SIZE, OR COLOR.

FOR ALCOHOL FOR CLEANING PURPOSES; ALL PURPOSE CLEANING PREPARATION WITH DEODORIZING PROPERTIES; ALL PURPOSE CLEANING PREPARATIONS; AMMONIA FOR CLEANING PURPOSES; AROMATIC PREPARATIONS, NAMELY, CLEANING PREPARATIONS FOR USE IN CLEANING AND POLISHING JEWELRY, PRECIOUS METALS, SEMI-PRECIOUS METALS, METALS, PEARLS, DIAMONDS, GEMSTONES, COSTUME JEWELRY, AND FASHION JEWELRY; CLEANING AGENTS AND PREPARATIONS; CLEANING AGENTS FOR CLEANING SURFACES; CLEANING AND POLISHING PAPER; CLEANING AND POLISHING PREPARATIONS; CLEANING AND WASHING PREPARATIONS; CLEANING PREPARATIONS; CLEANING PREPARATIONS CONTAINING VITAMINS, MINERALS, PLANT EXTRACTS AND/OR BOTANICALS, USED TO PRESERVE HARD SURFACES BY RENDERING THE SURFACES FREE OF AGING AGENTS; CLEANING PREPARATIONS FOR CLEANING SURFACES; CLEANING PREPARATIONS FOR HOUSEHOLD PURPOSES; CLEANING PREPARATIONS FOR CLEANING PREPARATIONS FOR USE IN CLEANING AND POLISHING JEWELRY, PRECIOUS METALS, SEMI-PRECIOUS METALS, METALS, PEARLS, DIAMONDS, GEMSTONES, COSTUME JEWELRY, AND FASHION JEWELRY; CLEANING SWABS FOR HOUSEHOLD PURPOSES; CLEANING, POLISHING AND SCOURING PREPARATIONS; CLEANING, SCOURING AND POLISHING PREPARATIONS AND SUBSTANCES; CLEANING, WASHING AND POLISHING PREPARATIONS; CLEANSING AND POLISHING PREPARATIONS; CLOTHS IMPREGNATED WITH A DETERGENT FOR CLEANING; DISPOSABLE WIPES IMPREGNATED WITH CLEANING CHEMICALS OR COMPOUNDS FOR INDUSTRIAL AND COMMERCIAL USE; DRY CLEANING FLUIDS; EYEGLOSS LENS CLEANING SOLUTIONS; EYEWEAR CLEANING KITS COMPRISED OF CLEANING FLUID AND A CLEANING CLOTH; GENERAL PURPOSE CLEANING, POLISHING, AND ABRASIVE LIQUIDS AND POWDERS; GUN-CLEANING PREPARATIONS; IMPREGNATED CLEANING CLOTHS; IMPREGNATED CLEANING PADS IMPREGNATED WITH COSMETICS; IMPREGNATED CLEANING PADS IMPREGNATED WITH TOILET PREPARATIONS; IMPREGNATED CLEANING, DUSTING OR POLISHING CLOTHS; IMPREGNATED CLOTHS FOR POLISHING; METAL POLISHING AND CLEANING PREPARATIONS; POLISH FOR MUSICAL INSTRUMENTS; POLISHING POWDERS; POLISHING PREPARATIONS; POLISHING, SCOURING AND ABRASIVE PREPARATIONS; SHINING PREPARATIONS; STONE POLISHING PREPARATIONS (U.S. CLS. 1, 4, 6, 50, 51 AND 52).

FIRST USE 9-11-2011; IN COMMERCE 9-11-2011.

4,155,967. MEEKS, MARY J., CORONA, CA. SN 85-361,196. FILED P.R. 6-30-2011; AM. S.R. 2-29-2012.

OAT-BATH

THE MARK CONSISTS OF STANDARD CHARACTERS WITHOUT CLAIM TO ANY PARTICULAR FONT, STYLE, SIZE, OR COLOR.

FOR NON-MEDICATED PET CARE PREPARATIONS, NAMELY, SHAMPOOS (U.S. CLS. 1, 4, 6, 50, 51 AND 52). FIRST USE 2-1-2000; IN COMMERCE 2-1-2000.

CLASS 3—(Continued).

4,156,053. PERFUME FOR LATINAS LLC, ALAMEDA, CA. SN 85-503,166. FILED 12-23-2011.

PERFUME FOR LATINAS

THE MARK CONSISTS OF STANDARD CHARACTERS WITHOUT CLAIM TO ANY PARTICULAR FONT, STYLE, SIZE, OR COLOR.

NO CLAIM IS MADE TO THE EXCLUSIVE RIGHT TO USE "PERFUME", APART FROM THE MARK AS SHOWN. THE ENGLISH TRANSLATION OF "LATINAS" IN THE MARK IS "WOMEN OF LATIN AMERICAN ORIGIN".

FOR AROMATIC ESSENTIAL OILS; AROMATIC OILS; BODY SPRAYS; COLOGNE; COSMETIC OILS; COSMETIC OILS FOR THE EPIDERMIS; EAU DE COLOGNES; EAU DE PARFUM; EAU DE PERFUME; EAU DE TOILETTE; EAU DE TOILETTE AND EAU DE COLOGNE; EAU-DE-COLOGNE; EAU-DE-TOILETTE; EAUX DE COLOGNE; EAUX DE TOILETTE; ESSENTIAL OILS; ESSENTIAL OILS FOR AROMATHERAPY USE; ESSENTIAL OILS FOR PERSONAL USE; ESSENTIAL OILS FOR USE IN MANUFACTURING OF SCENTED PRODUCTS; ETHEREAL ESSENCES; ETHEREAL OILS; FRAGRANCES; FRAGRANCES AND PERFUMERY; FRAGRANCES FOR PERSONAL USE; LIQUID PERFUMES; NATURAL ESSENTIAL OILS; NON-MEDICATED SKIN CARE PREPARATION, NAMELY, BODY MIST; OILS FOR PERFUMES AND SCENTS; PERFUME; PERFUME OILS; PERFUME OILS FOR THE MANUFACTURE OF COSMETIC PREPARATIONS; PERFUMES; PERFUMES AND COLOGNES; SCENTED BODY SPRAY; SCENTED OILS; SYNTHETIC PERFUMERY (U.S. CLS. 1, 4, 6, 50, 51 AND 52).
FIRST USE 12-20-2011; IN COMMERCE 12-20-2011.

CLASS 5—PHARMACEUTICALS

4,155,897. NUGENICS INTERNATIONAL, LLC, CHICAGO, IL. SN 85-220,601. FILED P.R. 1-19-2011; AM. S.R. 10-20-2011.

Marine-D3

THE MARK CONSISTS OF STANDARD CHARACTERS WITHOUT CLAIM TO ANY PARTICULAR FONT, STYLE, SIZE, OR COLOR.

FOR VITAMIN AND MINERAL SUPPLEMENTS CONTAINING VITAMIN D3 (U.S. CLS. 6, 18, 44, 46, 51 AND 52).
FIRST USE 2-0-2011; IN COMMERCE 2-0-2011.

CLASS 5—(Continued).

4,155,900. PROTICA INC., WHITEHALL, PA. SN 85-225,057. FILED P.R. 1-24-2011; AM. S.R. 3-18-2012.

FRUITLETS

THE MARK CONSISTS OF STANDARD CHARACTERS WITHOUT CLAIM TO ANY PARTICULAR FONT, STYLE, SIZE, OR COLOR.

FOR DIETARY AND NUTRITIONAL SUPPLEMENTS (U.S. CLS. 6, 18, 44, 46, 51 AND 52).
FIRST USE 2-20-2012; IN COMMERCE 2-20-2012.

4,155,929. ANAGALLIS HERBS LLC, CASTLETON, VT. SN 85-325,440. FILED P.R. 5-19-2011; AM. S.R. 2-16-2012.

WOUND BUTTER

THE MARK CONSISTS OF STANDARD CHARACTERS WITHOUT CLAIM TO ANY PARTICULAR FONT, STYLE, SIZE, OR COLOR.

FOR HERBAL TOPICAL CREAMS, GELS, SALVES, SPRAYS, POWDER, BALMS, LINIMENT AND OINTMENTS FOR THE RELIEF OF ACHES AND PAIN (U.S. CLS. 6, 18, 44, 46, 51 AND 52).
FIRST USE 9-30-2010; IN COMMERCE 9-30-2010.

4,155,941. PRIMARY INVESTMENTS GROUP LIMITED, ROAD TOWN, TORTOLA, BR. VIRGIN ISLANDS. SN 85-340,472. FILED P.R. 6-7-2011; AM. S.R. 3-22-2012.

**DOUBLE-POTENCY FISH OIL
PURE**

THE MARK CONSISTS OF STANDARD CHARACTERS WITHOUT CLAIM TO ANY PARTICULAR FONT, STYLE, SIZE, OR COLOR.

NO CLAIM IS MADE TO THE EXCLUSIVE RIGHT TO USE "FISH OIL", APART FROM THE MARK AS SHOWN.

FOR DIETARY SUPPLEMENTS; FOOD SUPPLEMENTS; NUTRITIONAL SUPPLEMENTS; VITAMIN SUPPLEMENTS, ALL CONTAINING FISH OIL (U.S. CLS. 6, 18, 44, 46, 51 AND 52).
FIRST USE 12-6-2011; IN COMMERCE 12-6-2011.

CLASS 5—(Continued).

4,155,990. FOR MOR INTERNATIONAL, CONWAY, AR. SN 85-406,090. FILED P.R. 8-24-2011; AM. S.R. 2-23-2012.

SLIM COCKTAIL

THE MARK CONSISTS OF STANDARD CHARACTERS WITHOUT CLAIM TO ANY PARTICULAR FONT, STYLE, SIZE, OR COLOR.

FOR DIETARY AND NUTRITIONAL SUPPLEMENTS; DIETARY FOOD SUPPLEMENTS; DIETARY SUPPLEMENTAL DRINKS; DIETARY SUPPLEMENTS; DIETARY SUPPLEMENTS FOR HUMAN CONSUMPTION; LIQUID NUTRITIONAL SUPPLEMENT; LIQUID VITAMIN SUPPLEMENTS; MINERAL NUTRITIONAL SUPPLEMENTS; NUTRITIONAL SUPPLEMENTS; NUTRITIONAL SUPPLEMENTS, NAMELY, PROBIOTIC COMPOSITIONS; POWDERED NUTRITIONAL SUPPLEMENT DRINK MIX; POWDERED NUTRITIONAL SUPPLEMENT DRINK MIX AND CONCENTRATE; VITAMIN AND MINERAL SUPPLEMENTS; VITAMIN ENRICHED WATER; VITAMIN FORTIFIED BEVERAGES; VITAMINS (U.S. CLS. 6, 18, 44, 46, 51 AND 52).
FIRST USE 9-1-2011; IN COMMERCE 11-15-2011.

4,155,995. CLEAN CONTROL CORPORATION, WARNER ROBINS, GA. SN 85-418,919. FILED P.R. 9-9-2011; AM. S.R. 3-30-2012.

REAL CITRUS

THE MARK CONSISTS OF STANDARD CHARACTERS WITHOUT CLAIM TO ANY PARTICULAR FONT, STYLE, SIZE, OR COLOR.

FOR AIR FRESHENERS (U.S. CLS. 6, 18, 44, 46, 51 AND 52).
FIRST USE 2-4-2012; IN COMMERCE 2-4-2012.

4,156,006. RAMIREZ MORELES, SELOMITH, IRAPUATO, MEXICO. SN 85-449,386. FILED P.R. 10-17-2011; AM. S.R. 3-7-2012.

HEALTHY COFFEE

THE MARK CONSISTS OF STANDARD CHARACTERS WITHOUT CLAIM TO ANY PARTICULAR FONT, STYLE, SIZE, OR COLOR.

CLASS 5—(Continued).

NO CLAIM IS MADE TO THE EXCLUSIVE RIGHT TO USE "COFFEE", APART FROM THE MARK AS SHOWN.

FOR DIETARY AND NUTRITIONAL SUPPLEMENTS CONTAINING COFFEE FLAVORED GOJI BERRIES, GUARANA SEEDS AND REISHI FUNGUS (U.S. CLS. 6, 18, 44, 46, 51 AND 52).

FIRST USE 1-2-2006; IN COMMERCE 10-5-2008.

CLASS 6—METAL GOODS

4,155,878. TOWN & COUNTRY LINEN CORP., NEW YORK, NY. SN 85-163,993. FILED P.R. 10-28-2010; AM. S.R. 3-7-2012.

HOOK & HOLD

THE MARK CONSISTS OF STANDARD CHARACTERS WITHOUT CLAIM TO ANY PARTICULAR FONT, STYLE, SIZE, OR COLOR.

NO CLAIM IS MADE TO THE EXCLUSIVE RIGHT TO USE "HOOK", APART FROM THE MARK AS SHOWN.

FOR HOOKS MADE OF METAL FOR HANGING A SHOWER CURTAIN AND LINER, HAVING AN ADDITIONAL INTEGRATED ATTACHMENT FOR HANGING A TOWEL OR OTHER ACCESSORIES (U.S. CLS. 2, 12, 13, 14, 23, 25 AND 50).

FIRST USE 3-16-2011; IN COMMERCE 3-16-2011.

4,156,041. LES CABLES BEN-MOR INC., QUEBEC, CANADA. SN 85-488,037. FILED P.R. 12-6-2011; AM. S.R. 3-12-2012.

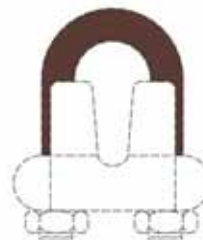

THE COLOR(S) BROWN IS/ARE CLAIMED AS A FEATURE OF THE MARK.

THE MARK CONSISTS OF THE COLOR BROWN APPLIED TO THE SURFACE OF THE VISIBLE PORTION OF THE THREE-DIMENSIONAL U-BOLT OF A THREE DIMENSIONAL WIRE ROPE CLIP. THE SHAPE OF THE U-BOLT, SHOWN IN DOTTED LINES, IS NOT CLAIMED AS A FEATURE OF THE MARK.

FOR METAL WIRE ROPE CLIP (U.S. CLS. 2, 12, 13, 14, 23, 25 AND 50).

FIRST USE 8-31-2008; IN COMMERCE 8-31-2008.

CLASS 6—(Continued).

4,156,042. LES CABLES BEN-MOR INC., QUEBEC, CANADA.
SN 85-488,101. FILED P.R. 12-6-2011; AM. S.R. 3-12-2012.

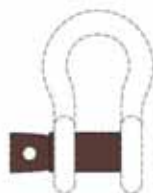

THE COLOR(S) BROWN IS/ARE CLAIMED AS A FEATURE OF THE MARK.

THE MARK CONSISTS OF THE COLOR BROWN APPLIED TO THE SURFACE OF THE VISIBLE PORTIONS OF THE THREE DIMENSIONAL SHACKLE PIN OF A THREE DIMENSIONAL SHACKLE. THE SHAPE OF THE SHACKLE, SHOWN IN DOTTED LINES, IS NOT CLAIMED AS A FEATURE OF THE MARK.

FOR METAL SCREW PIN SHACKLE, ROUND PIN SHACKLE AND BOLT TYPE SHACKLE (U.S. CLS. 2, 12, 13, 14, 23, 25 AND 50).

FIRST USE 8-31-2008; IN COMMERCE 8-31-2008.

CLASS 7—MACHINERY

4,155,927. HORSCH MASCHINEN GMBH, SCHWANDORF,
FED REP GERMANY. SN 85-323,910. FILED P.R. 5-18-2011;
AM. S.R. 4-11-2012.

TERRANO

THE MARK CONSISTS OF STANDARD CHARACTERS WITHOUT CLAIM TO ANY PARTICULAR FONT, STYLE, SIZE, OR COLOR.

OWNER OF ERP N CMNTY TM OFC REG. NO. 010007128, DATED 11-2-2010, EXPIRES 5-30-2021.

FOR TRACTOR TOWED AGRICULTURAL IMPLEMENTS, NAMELY, TILLERS, DISC HARROWS AND CULTIVATORS (U.S. CLS. 13, 19, 21, 23, 31, 34 AND 35).

CLASS 7—(Continued).

4,155,928. HORSCH MASCHINEN GMBH, SCHWANDORF,
FED REP GERMANY. SN 85-324,597. FILED P.R. 5-19-2011;
AM. S.R. 4-11-2012.

HORSCH

THE MARK CONSISTS OF STANDARD CHARACTERS WITHOUT CLAIM TO ANY PARTICULAR FONT, STYLE, SIZE, OR COLOR.

OWNER OF ERP N CMNTY TM OFC REG. NO. 009153479, DATED 11-25-2010, EXPIRES 6-4-2020.

FOR TRACTOR TOWED AGRICULTURAL IMPLEMENTS, NAMELY, TILLERS, DISC HARROWS, CULTIVATORS, AGRICULTURAL SEED PLANTING MACHINES AND SEEDERS (U.S. CLS. 13, 19, 21, 23, 31, 34 AND 35).

4,156,043. WIEBEL LIFT AG, MENZINGEN, SWITZERLAND. SN 85-489,401. FILED 12-7-2011.

WEIBEL

THE MARK CONSISTS OF STANDARD CHARACTERS WITHOUT CLAIM TO ANY PARTICULAR FONT, STYLE, SIZE, OR COLOR.

OWNER OF ERP N CMNTY TM OFC REG. NO. 1026944, DATED 1-4-2010, EXPIRES 1-4-2020.

FOR MECHANICAL LIFTS FOR VIDEO AND FILM PROJECTORS (U.S. CLS. 13, 19, 21, 23, 31, 34 AND 35).

CLASS 8—HAND TOOLS

4,155,916. K.C. CARPET SERVICE, INC., ELK GROVE VILLAGE, IL. SN 85-297,861. FILED P.R. 4-18-2011; AM. S.R. 3-27-2012.

MANLEY

THE MARK CONSISTS OF STANDARD CHARACTERS WITHOUT CLAIM TO ANY PARTICULAR FONT, STYLE, SIZE, OR COLOR.

FOR HAND TOOLS FOR USE IN INSTALLING CARPETS (U.S. CLS. 23, 28 AND 44).

FIRST USE 4-12-2011; IN COMMERCE 4-12-2011.

CLASS 9—ELECTRICAL AND SCIENTIFIC APPARATUS

4,155,860. SONY CORPORATION, TOKYO, JAPAN. SN 77-852,008. FILED P.R. 10-19-2009; AM. S.R. 7-29-2011.

E-mount

THE MARK CONSISTS OF STANDARD CHARACTERS WITHOUT CLAIM TO ANY PARTICULAR FONT, STYLE, SIZE, OR COLOR.

FOR DIGITAL SINGLE-LENS REFLEX CAMERAS, DIGITAL CAMERAS, VIDEO CAMERAS, LENSES, FLASH LIGHTS, TRIPODS, SHOULDER STRAPS FOR CAMERAS, BAGS FOR CAMERAS, RECHARGEABLE BATTERY PACKS FOR DIGITAL CAMERAS, CABLES FOR DIGITAL CAMERAS, AC ADAPTERS FOR DIGITAL CAMERAS (U.S. CLS. 21, 23, 26, 36 AND 38).

FIRST USE 6-30-2010; IN COMMERCE 6-30-2010.

4,155,861. SONY CORPORATION, TOKYO, JAPAN. SN 77-921,103. FILED P.R. 1-27-2010; AM. S.R. 4-9-2012.

Media Backbone

THE MARK CONSISTS OF STANDARD CHARACTERS WITHOUT CLAIM TO ANY PARTICULAR FONT, STYLE, SIZE, OR COLOR.

FOR COMPUTER SOFTWARE FOR OPERATING VIDEO EDITING DEVICES (U.S. CLS. 21, 23, 26, 36 AND 38).

FIRST USE 4-9-2011; IN COMMERCE 4-9-2011.

4,155,893. OLISO, INC., SAN FRANCISCO, CA. SN 85-207,496. FILED P.R. 12-29-2010; AM. S.R. 4-23-2012.

SMART IRON

THE MARK CONSISTS OF STANDARD CHARACTERS WITHOUT CLAIM TO ANY PARTICULAR FONT, STYLE, SIZE, OR COLOR.

NO CLAIM IS MADE TO THE EXCLUSIVE RIGHT TO USE "IRON", APART FROM THE MARK AS SHOWN.

FOR ELECTRIC IRONS (U.S. CLS. 21, 23, 26, 36 AND 38).

FIRST USE 8-30-2009; IN COMMERCE 8-30-2009.

CLASS 9—(Continued).

4,155,914. LITHIUM PRODUCTS, LLC, KNOXVILLE, TN. SN 85-289,185. FILED P.R. 4-7-2011; AM. S.R. 4-5-2012.



THE MARK CONSISTS OF THE LETTER "P" SUPERIMPOSED OVER THE LETTER "L".

FOR LITHIUM-ION AUTOMOBILE BATTERIES, BATTERY CHARGERS FOR LITHIUM-ION AUTOMOBILE BATTERIES, AND BATTERY TRAYS, BOXES, AND TERMINALS THEREFOR (U.S. CLS. 21, 23, 26, 36 AND 38).

FIRST USE 6-14-2011; IN COMMERCE 6-14-2011.

4,155,935. THE MATHWORKS, INC., NATICK, MA. SN 85-332,390. FILED 5-27-2011.

EMBEDDED CODER

THE MARK CONSISTS OF STANDARD CHARACTERS WITHOUT CLAIM TO ANY PARTICULAR FONT, STYLE, SIZE, OR COLOR.

FOR COMPUTER SOFTWARE FOR GENERATING CODE FOR USE WITH COMPUTER HARDWARE (U.S. CLS. 21, 23, 26, 36 AND 38).

FIRST USE 4-20-2011; IN COMMERCE 4-20-2011.

4,155,960. FEVER TAGS, LLC, AMARILLO, TX. SN 85-355,314. FILED P.R. 6-24-2011; AM. S.R. 4-10-2012.

FEVER TAGS

THE MARK CONSISTS OF STANDARD CHARACTERS WITHOUT CLAIM TO ANY PARTICULAR FONT, STYLE, SIZE, OR COLOR.

FOR TEMPERATURE SENSORS USED IN THE MEDICAL FIELD TO MEASURE TEMPERATURE OF MEDICAL SOLUTIONS (U.S. CLS. 21, 23, 26, 36 AND 38).

FIRST USE 11-21-2007; IN COMMERCE 12-15-2009.

CLASS 9—(Continued).

4,155,975. GNM GROUP, LLC, HOUSTON, TX. SN 85-371,154. FILED P.R. 7-14-2011; AM. S.R. 4-11-2012.

Market Dynamics

THE MARK CONSISTS OF STANDARD CHARACTERS WITHOUT CLAIM TO ANY PARTICULAR FONT, STYLE, SIZE, OR COLOR.

FOR DOWNLOADABLE ELECTRONIC PUBLICATIONS IN THE NATURE OF NEWSLETTERS, JOURNALS, MAGAZINES, PAMPHLETS, BROCHURES, AND PERIODICALS AND BOOKS IN THE FIELD OF BUSINESS AND FINANCE (U.S. CLS. 21, 23, 26, 36 AND 38). FIRST USE 3-12-2011; IN COMMERCE 3-17-2011.

4,155,976. EYE CARE AND CURE CORP., TUCSON, AZ. SN 85-371,916. FILED P.R. 7-14-2011; AM. S.R. 2-22-2012.



THE COLOR(S) WHITE, YELLOW, DARK BLUE, AND LAVENDER IS/ARE CLAIMED AS A FEATURE OF THE MARK.

THE MARK CONSISTS OF THE WORK "DIMMERZ" OUTLINED IN LAVENDER AND GOING FROM WHITE, YELLOW, DARK BLUE AND LAVENDER FROM THE LETTER "D" TO THE LETTER "Z" IN A GRADIENT.

FOR MEDICAL APPARATUS, NAMELY, POST DILATION SPECTACLES (U.S. CLS. 21, 23, 26, 36 AND 38). FIRST USE 3-31-2011; IN COMMERCE 3-31-2011.

CLASS 9—(Continued).

4,155,983. FUSION-IO, INC., SALT LAKE CITY, UT. SN 85-386,437. FILED P.R. 8-1-2011; AM. S.R. 3-22-2012.

IOCACHE

THE MARK CONSISTS OF STANDARD CHARACTERS WITHOUT CLAIM TO ANY PARTICULAR FONT, STYLE, SIZE, OR COLOR.

FOR COMPUTER SOFTWARE, NAMELY, COMPUTER PROGRAMS FOR CACHING DATA IN A COMPUTER SYSTEM, IN COMPUTER HARDWARE, IN COMPUTER NETWORKS, AND IN VIRTUAL COMPUTING INFRASTRUCTURES; COMPUTER SOFTWARE FOR CONFIGURING, MANAGING, SECURING, OPTIMIZING, MONITORING, STORING, DIAGNOSING, AND ANALYZING OF COMPUTER SYSTEMS, COMPUTER HARDWARE, COMPUTER NETWORKS, AND VIRTUAL COMPUTING INFRASTRUCTURES FOR THE PURPOSE OF CACHING DATA OF COMPUTER HARDWARE, SOFTWARE AND COMMUNICATION NETWORKS FOR BUSINESSES AND INDIVIDUALS; COMPUTER MANAGEMENT SOFTWARE FOR ACQUIRING, PROCESSING AND PRESENTING DATA; COMPUTER SOFTWARE FOR USE IN PERSONAL COMPUTERS, LAPTOPS, PDAS, PERSONAL INFORMATION MANAGER DEVICES, MOBILE TELEPHONES, DIGITAL APPLIANCES, VIRTUAL MACHINES, VIRTUAL APPLIANCES, AND OTHER MOBILE COMPUTING AND COMMUNICATIONS DEVICES, TO MANAGE, ENHANCE AND OPTIMIZE THE COMPUTING RESOURCES OF SUCH DEVICES (U.S. CLS. 21, 23, 26, 36 AND 38).

FIRST USE 8-30-2011; IN COMMERCE 1-12-2012.

4,155,987. ALIPHCOM, SAN FRANCISCO, CA. SN 85-398,452. FILED P.R. 8-15-2011; AM. S.R. 4-5-2012.

LIVEAUDIO

THE MARK CONSISTS OF STANDARD CHARACTERS WITHOUT CLAIM TO ANY PARTICULAR FONT, STYLE, SIZE, OR COLOR.

FOR SPEAKER TECHNOLOGY, NAMELY, COMPUTER SOFTWARE FOR ENHANCING THE SOUND QUALITY OF AUDIO EQUIPMENT AND DEVICES; AUDIO SPEAKERS (U.S. CLS. 21, 23, 26, 36 AND 38).

FIRST USE 8-23-2011; IN COMMERCE 8-23-2011.

CLASS 9—(Continued).

4,156,021. SOFTWINK, INC., DBA QUADRANT INFORMATION SECURITY, JACKSONVILLE, FL. SN 85-468,171. FILED P.R. 11-9-2011; AM. S.R. 4-11-2012.

Sagan

THE MARK CONSISTS OF STANDARD CHARACTERS WITHOUT CLAIM TO ANY PARTICULAR FONT, STYLE, SIZE, OR COLOR.

THE WORDING "SAGAN" HAS NO MEANING IN A FOREIGN LANGUAGE.

FOR COMPUTER SOFTWARE AND HARDWARE FOR REAL TIME SECURITY EVENT MANAGEMENT AND ANALYSIS (U.S. CLS. 21, 23, 26, 36 AND 38).

FIRST USE 6-1-2010; IN COMMERCE 4-1-2011.

4,156,024. PROLIFIC METHODS, LLC, BETHLEHEM, GA. SN 85-472,335. FILED P.R. 11-14-2011; AM. S.R. 4-16-2012.

Pitch Gauge

THE MARK CONSISTS OF STANDARD CHARACTERS WITHOUT CLAIM TO ANY PARTICULAR FONT, STYLE, SIZE, OR COLOR.

FOR COMPUTER APPLICATION SOFTWARE FOR MOBILE DEVICES, NAMELY, SOFTWARE FOR CALCULATING THE DEGREE OF SLOPE SLANT STATED IN INCHES RISE PER FOOT AND THE SIZE OF A ROOF WHEN GIVEN THE LENGTH, WIDTH, PITCH AND CUT LEVEL (U.S. CLS. 21, 23, 26, 36 AND 38).

FIRST USE 5-1-2010; IN COMMERCE 9-3-2010.

4,156,027. ANSELL LIMITED, RICHMOND, AUSTRALIA. SN 85-474,049. FILED 11-16-2011.



OWNER OF U.S. REG. NO. 3,376,673.

CLASS 9—(Continued).

THE COLOR(S) BLACK AND BURGUNDY IS/ARE CLAIMED AS A FEATURE OF THE MARK.

THE MARK CONSISTS OF THE COLOR BLACK AND BURGUNDY APPLIED TO THE ENTIRE SURFACE OF PROTECTIVE GLOVES WHEREIN THE COLOR BLACK APPEARS ON THE FINGER AND HAND PORTION OF THE GLOVES AND THE BURGUNDY APPEARS ON THE CUFFS. THE MATTER SHOWN IN BROKEN LINES ON THE DRAWING SHOWS POSITIONING OF THE MARK ON THE GOODS AND NEITHER OF THE MATTER SHOW IN BROKEN LINES NOR THE CONFIGURATION OF THE GLOVES IS CLAIMED AS A FEATURE OF THE MARK.

FOR GLOVES FOR PROTECTION AGAINST ACCIDENTS; PROTECTIVE GLOVES FOR INDUSTRIAL USE; PROTECTIVE WORK GLOVES (U.S. CLS. 21, 23, 26, 36 AND 38).

FIRST USE 4-8-2006; IN COMMERCE 4-8-2006.

4,156,030. MONSTER, INC., BRISBANE, CA. SN 85-475,900. FILED P.R. 11-17-2011; AM. S.R. 3-21-2012.

THE ATHLETE'S HEADPHONE

THE MARK CONSISTS OF STANDARD CHARACTERS WITHOUT CLAIM TO ANY PARTICULAR FONT, STYLE, SIZE, OR COLOR.

NO CLAIM IS MADE TO THE EXCLUSIVE RIGHT TO USE "HEADPHONE", APART FROM THE MARK AS SHOWN.

FOR HEADPHONES (U.S. CLS. 21, 23, 26, 36 AND 38).

FIRST USE 9-24-2010; IN COMMERCE 9-24-2010.

CLASS 10—MEDICAL APPARATUS

4,155,875. DAKTARI DIAGNOSTICS, INC., CAMBRIDGE, MA. SN 85-147,936. FILED P.R. 10-7-2010; AM. S.R. 3-14-2012.

DAKTARI

THE MARK CONSISTS OF STANDARD CHARACTERS WITHOUT CLAIM TO ANY PARTICULAR FONT, STYLE, SIZE, OR COLOR.

THE ENGLISH TRANSLATION OF "DAKTARI" IN THE MARK IS "DOCTOR".

FOR MEDICAL DIAGNOSTIC INSTRUMENT, NAMELY, BODY FLUID ANALYZER FOR PROVIDING CELL AND PARTICLE ANALYSIS, DETECTION, OR COUNTING AND FOR REPORTING RESULTS (U.S. CLS. 26, 39 AND 44).

FIRST USE 3-1-2012; IN COMMERCE 3-1-2012.

CLASS 11—ENVIRONMENTAL CONTROL APPARATUS

CLASS 11—(Continued).

4,155,885. ORCHARD SUPPLY HARDWARE, LLC, SAN JOSE, CA. SN 85-198,426. FILED P.R. 12-15-2010; AM. S.R. 4-16-2012.

HOME ACCENTS

THE MARK CONSISTS OF STANDARD CHARACTERS WITHOUT CLAIM TO ANY PARTICULAR FONT, STYLE, SIZE, OR COLOR.

NO CLAIM IS MADE TO THE EXCLUSIVE RIGHT TO USE "HOME", APART FROM THE MARK AS SHOWN. FOR FAUCETS (U.S. CLS. 13, 21, 23, 31 AND 34). FIRST USE 4-0-2010; IN COMMERCE 4-0-2010.

4,155,896. SCENTSY, INC., MERIDIAN, ID. SN 85-217,831. FILED P.R. 1-14-2011; AM. S.R. 7-28-2011.

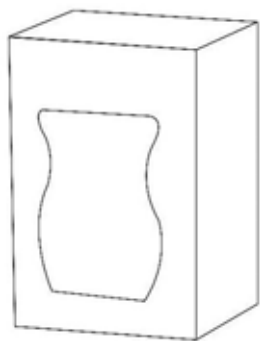

THE MARK CONSISTS OF A THREE-DIMENSIONAL CONFIGURATION FOR PAPER PACKAGING OF SCENTED WICKLESS CANDLE PRODUCTS AND WARMERS, ROUGHLY RECTANGULAR IN SHAPE WITH STRAIGHT SIDES. THE FRONT OF THE PACKAGING CONTAINS AN IMAGE SHAPED IN A CURVED DESIGN. FOR FLAMELESS CANDLES; ELECTRIC CANDLE WARMERS (U.S. CLS. 13, 21, 23, 31 AND 34). FIRST USE 3-1-2010; IN COMMERCE 3-1-2010.

CLASS 11—(Continued).

4,155,915. HATCO CORPORATION, MILWAUKEE, WI. SN 85-290,631. FILED P.R. 4-8-2011; AM. S.R. 1-16-2012.

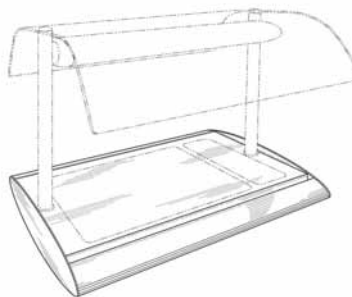

THE MARK CONSISTS OF A THREE-DIMENSIONAL CONFIGURATION FOR AN END PANEL AND BASE SHELF OF A PORTABLE ELECTRIC FOOD WARMER. THE END PANEL HAVING AN ELLIPTICAL SHAPE AND THE SHELF HAVING A TAPERED FRONT EDGE. THE PORTION OF THE MARK SHOWN IN DOTTED LINES IS NOT PART OF THE MARK AND SERVES ONLY TO SHOW POSITIONING OR PLACEMENT OF THE MARK ON THE GOODS.

FOR ELECTRIC FOOD WARMERS FOR HOLDING FOOD AT SERVING TEMPERATURE. PORTABLE FOOD WARMERS, HOLDING AND DISPLAY WARMERS, BUFFET WARMERS, HEATED SHELVES, ALL FOR COMMERCIAL USE (U.S. CLS. 13, 21, 23, 31 AND 34).

FIRST USE 8-19-2008; IN COMMERCE 8-19-2008.

CLASS 12—VEHICLES

4,155,918. TRIPLE E CANADA LTD., WINKLER MANITOBA, CANADA. SN 85-301,256. FILED P.R. 4-21-2011; AM. S.R. 1-30-2012.

LEISURE TRAVEL VANS

THE MARK CONSISTS OF STANDARD CHARACTERS WITHOUT CLAIM TO ANY PARTICULAR FONT, STYLE, SIZE, OR COLOR.

PRIORITY CLAIMED UNDER SEC. 44(D) ON CANADA APPLICATION NO. 1,505,956, FILED 11-30-2010, REG. NO. TMA817,254, DATED 2-8-2012, EXPIRES 2-8-2027.

NO CLAIM IS MADE TO THE EXCLUSIVE RIGHT TO USE "TRAVEL VANS", APART FROM THE MARK AS SHOWN.

FOR RECREATIONAL VEHICLES, NAMELY, VANS, MOTOR HOMES (U.S. CLS. 19, 21, 23, 31, 35 AND 44).

CLASS 12—(Continued).

4,156,064. HAYS, TIM, MATTHEWS, NC. SN 85-508,207. FILED P.R. 1-4-2012; AM. S.R. 4-10-2012.

super slider

THE MARK CONSISTS OF STANDARD CHARACTERS WITHOUT CLAIM TO ANY PARTICULAR FONT, STYLE, SIZE, OR COLOR.

NO CLAIM IS MADE TO THE EXCLUSIVE RIGHT TO USE "SLIDER", APART FROM THE MARK AS SHOWN.

FOR CLUTCH MECHANISMS FOR MOTOR CARS (U.S. CLS. 19, 21, 23, 31, 35 AND 44).

FIRST USE 9-1-2011; IN COMMERCE 9-1-2011.

CLASS 14—JEWELRY

4,155,847. PRECISION SET, INC., DALLAS, TX. SN 76-703,570. FILED P.R. 6-29-2010; AM. S.R. 4-2-2012.

FLUSHFIT

THE MARK CONSISTS OF STANDARD CHARACTERS WITHOUT CLAIM TO ANY PARTICULAR FONT, STYLE, SIZE, OR COLOR.

OWNER OF U.S. REG. NO. 2,852,130. FOR JEWELRY, NAMELY, ENGAGEMENT RINGS MADE OF GOLD OR PLATINUM (U.S. CLS. 2, 27, 28 AND 50).

FIRST USE 12-0-2001; IN COMMERCE 12-0-2001.

4,155,857. VINTAJ NATURAL BRASS CO., GALENA, IL. SN 77-816,830. FILED P.R. 8-31-2009; AM. S.R. 8-8-2011.

VINTAJ ARTE METAL

THE MARK CONSISTS OF STANDARD CHARACTERS WITHOUT CLAIM TO ANY PARTICULAR FONT, STYLE, SIZE, OR COLOR.

OWNER OF U.S. REG. NOS. 3,404,254, 3,469,964, AND 3,634,168.

CLASS 14—(Continued).

NO CLAIM IS MADE TO THE EXCLUSIVE RIGHT TO USE "ARTE METAL", APART FROM THE MARK AS SHOWN.

FOR JEWELRY FINDINGS; CHARMS; BEADING ACCESSORIES, NAMELY, BEADS FOR MAKING JEWELRY; EMBELLISHMENTS, NAMELY, METAL CHARMS FOR MAKING JEWELRY; EMBELLISHMENTS, NAMELY, METAL JEWELRY CHARMS FOR USE IN CRAFTING; NON-DECORATIVE JEWELRY, NAMELY, METAL JEWELRY BLANKS FOR USE CRAFTING AND MAKING DECORATIVE JEWELRY (U.S. CLS. 2, 27, 28 AND 50).

FIRST USE 1-1-2011; IN COMMERCE 1-1-2011.

4,155,859. VINTAJ NATURAL BRASS CO., GALENA, IL. SN 77-833,267. FILED P.R. 9-23-2009; AM. S.R. 8-8-2011.

arte metal

NO CLAIM IS MADE TO THE EXCLUSIVE RIGHT TO USE "METAL", APART FROM THE MARK AS SHOWN.

THE MARK CONSISTS OF THE WORDS "ARTE METAL" IN A STYLIZED METALLIC FONT.

FOR JEWELRY FINDINGS; CHARMS; BEADING ACCESSORIES, NAMELY, BEADS FOR MAKING JEWELRY; EMBELLISHMENTS, NAMELY, METAL CHARMS FOR MAKING JEWELRY; EMBELLISHMENTS, NAMELY, METAL JEWELRY CHARMS FOR USE IN CRAFTING; NON-DECORATIVE JEWELRY, NAMELY, METAL JEWELRY BLANKS FOR USE CRAFTING AND MAKING DECORATIVE JEWELRY (U.S. CLS. 2, 27, 28 AND 50).

FIRST USE 1-1-2011; IN COMMERCE 1-1-2011.

4,155,882. TIMEHOUSE GMBH, EYSTRUP, FED REP GERMANY. SN 85-191,589. FILED P.R. 12-6-2010; AM. S.R. 4-4-2012.



THE MARK CONSISTS OF A CONFIGURATION OF A WATCH.

FOR JEWELRY, NAMELY, WATCHES AND PRECIOUS STONES (U.S. CLS. 2, 27, 28 AND 50).

FIRST USE 3-1-2001; IN COMMERCE 3-1-2001.

CLASS 14—(Continued).

4,155,963. NATURE'S CREATIONS, L.L.C., NAPLES, FL. SN 85-356,251. FILED P.R. 6-25-2011; AM. S.R. 4-11-2012.

BEADNOTES

THE MARK CONSISTS OF STANDARD CHARACTERS WITHOUT CLAIM TO ANY PARTICULAR FONT, STYLE, SIZE, OR COLOR.
FOR JEWELRY (U.S. CLS. 2, 27, 28 AND 50).
FIRST USE 6-14-2011; IN COMMERCE 6-14-2011.

CLASS 14—(Continued).

4,156,038. DOMINIC'S DOWNTOWN INC., GALLUP, NM. SN 85-485,734. FILED P.R. 12-2-2011; AM. S.R. 4-13-2012.



THE MARK CONSISTS OF THE STYLIZED TEXT "ALUMINOUS DESIGNS".
FOR HANDCRAFTED NATIVE-AMERICAN INDIAN JEWELRY OUT MADE FROM ALUMINUM METAL (U.S. CLS. 2, 27, 28 AND 50).
FIRST USE 6-1-2011; IN COMMERCE 6-1-2011.

4,155,985. TWIN TIGER ASSETS CORP., REDONDO BEACH, CA. SN 85-393,771. FILED P.R. 8-9-2011; AM. S.R. 4-2-2012.

GOT BOOBS?

THE MARK CONSISTS OF STANDARD CHARACTERS WITHOUT CLAIM TO ANY PARTICULAR FONT, STYLE, SIZE, OR COLOR.
FOR BRACELETS; RUBBER OR SILICON WRISTBANDS IN THE NATURE OF A BRACELET (U.S. CLS. 2, 27, 28 AND 50).
FIRST USE 7-1-2011; IN COMMERCE 8-5-2011.

4,155,986. TWIN TIGER ASSETS CORP., REDONDO BEACH, CA. SN 85-393,832. FILED P.R. 8-9-2011; AM. S.R. 4-2-2012.

HOLLA IF YA LOVE BOOBIES

THE MARK CONSISTS OF STANDARD CHARACTERS WITHOUT CLAIM TO ANY PARTICULAR FONT, STYLE, SIZE, OR COLOR.
FOR BRACELETS; RUBBER OR SILICON WRISTBANDS IN THE NATURE OF A BRACELET (U.S. CLS. 2, 27, 28 AND 50).
FIRST USE 7-1-2011; IN COMMERCE 8-5-2011.

CLASS 15—MUSICAL INSTRUMENTS

4,155,853. ROLAND CORPORATION, SHIZUOKA, JAPAN. SN 76-708,444. FILED P.R. 7-21-2011; AM. S.R. 3-19-2012.

MESH ELECTRONIC DRUMS

THE MARK CONSISTS OF STANDARD CHARACTERS WITHOUT CLAIM TO ANY PARTICULAR FONT, STYLE, SIZE, OR COLOR.
NO CLAIM IS MADE TO THE EXCLUSIVE RIGHT TO USE "DRUMS", APART FROM THE MARK AS SHOWN.
FOR ELECTRONIC DRUMS (U.S. CLS. 2, 21 AND 36).
FIRST USE 3-9-2012; IN COMMERCE 3-9-2012.

CLASS 16—PAPER GOODS AND PRINTED MATTER

4,155,856. FISHER, STEVEN E, BRISTOL, PA. SN 77-770,312. FILED P.R. 6-29-2009; AM. S.R. 3-27-2012.



THE COLOR(S) RED, WHITE AND BLUE IS/ARE CLAIMED AS A FEATURE OF THE MARK.

CLASS 16—(Continued).

THE MARK CONSISTS OF "UNITED WE SURVIVE" IN WHITE WITHIN AN OVAL SHAPE WITH A RED AND WHITE BORDER ON A BLUE BACKGROUND WITH (3) THREE WHITE STARS ON TOP AND (4) FOUR WHITE STARS ON THE BOTTOM WITHIN THE OVAL.

FOR ALBUMS FOR STICKERS; BUMPER STICKERS; CHILDREN'S WALL STICKERS AND MURALS; DECORATIVE STICKERS FOR HELMETS; STICKER ALBUMS; STICKERS; STICKERS AND DECALCOMANIAS; STICKERS AND STICKER ALBUMS; STICKERS AND TRANSFERS (U.S. CLS. 2, 5, 22, 23, 29, 37, 38 AND 50).
FIRST USE 7-24-2011; IN COMMERCE 7-24-2011.

4,155,890. TREE RING PENS LLC, MISSOULA, MT. SN 85-204,894. FILED P.R. 12-23-2010; AM. S.R. 4-5-2012.

CLASS 16—(Continued).

SHIRT WITH A WHITE COLLAR AND BLUE VERTICAL STRIPS, A BLUE TIE, AND A BROWN JACKET. ALL OF THE BUST AND CLOTHING IS IN A WHITE OVAL PICTURE FRAME, WITH A YELLOW BORDER OUTLINED IN BROWN. ON EACH SIDE OF THE PICTURE IS A WHITE RECTANGULAR SHAPE, EMANATING UPWARDS FROM THE TOP LEFT AND THE TOP RIGHT OF THE OVAL FRAME ARE YELLOW FLAG STRINGS. BELOW THE PICTURE IS A YELLOW AND BROWN RIBBON BANNER WITH THE WORDING "W.B. MASON", IN RED. BELOW THE BANNER IS WITH THE WORDING "WHO BUT" IN RED WITH BLUE LINES ABOVE AND BELOW. BELOW THIS WORDING IS THE WORDING "W.B. MASON" IN RED AND OUTLINED IN BLUE. BELOW THIS WORDING IS THE WORDING "PREMIUM COPY PAPER" IN BLUE.

FOR COPIER PAPER; COPYING PAPER (U.S. CLS. 2, 5, 22, 23, 29, 37, 38 AND 50).
FIRST USE 3-1-2005; IN COMMERCE 3-1-2005.

TREE RING

THE MARK CONSISTS OF STANDARD CHARACTERS WITHOUT CLAIM TO ANY PARTICULAR FONT, STYLE, SIZE, OR COLOR.

FOR WRITING INSTRUMENTS (U.S. CLS. 2, 5, 22, 23, 29, 37, 38 AND 50).
FIRST USE 5-16-2009; IN COMMERCE 3-24-2010.

4,155,944. W.B. MASON CO., INC., BROCKTON, MA. SN 85-345,441. FILED P.R. 6-14-2011; AM. S.R. 4-10-2012.

4,155,945. W.B. MASON CO., INC., BROCKTON, MA. SN 85-346,092. FILED P.R. 6-14-2011; AM. S.R. 4-10-2012.

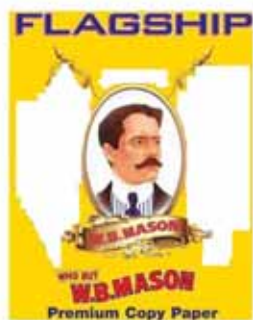

NO CLAIM IS MADE TO THE EXCLUSIVE RIGHT TO USE "PREMIUM COPY PAPER", APART FROM THE MARK AS SHOWN.

THE NAME "W.B. MASON" DOES NOT IDENTIFY A LIVING INDIVIDUAL.

THE COLOR(S) BLUE, BROWN, RED, SKIN TONE, WHITE AND YELLOW IS/ARE CLAIMED AS A FEATURE OF THE MARK.

THE MARK CONSISTS OF A VERTICAL RECTANGLE IN YELLOW. INSIDE THE RECTANGLE AT THE TOP IS THE WORD "FLAGSHIP" IN BLUE WITH A RED BORDER. BENEATH THIS WORDING IS A WHITE RECTANGULAR SHAPE. BELOW THIS RECTANGLE IS THE BUST OF A MAN WITH THE FACE, NECK AND EAR IN SKIN TONE, A MOUSTACHE IN BROWN, LIPS IN RED, EYES WITH BROWN PUPILS INSIDE THE WHITE OF THE EYES, EYEBROWS IN BROWN, AND HAIR IN BROWN. THE BUST INCLUDES CLOTHING CONSISTING OF A WHITE

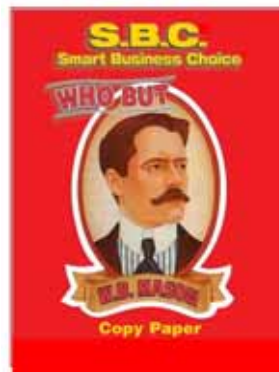

NO CLAIM IS MADE TO THE EXCLUSIVE RIGHT TO USE "BUSINESS" AND "COPY PAPER", APART FROM THE MARK AS SHOWN.

THE COLOR(S) BLUE, BROWN, RED, SKIN TONE, WHITE AND YELLOW IS/ARE CLAIMED AS A FEATURE OF THE MARK.

THE MARK CONSISTS OF A VERTICAL RECTANGLE IN RED. INSIDE THE RECTANGLE AT THE TOP IS THE TERM "SBC" IN YELLOW WITH A BLUE BORDER. BENEATH THIS WORDING IS THE WORDING "SMART BUSINESS CHOICE" IN YELLOW WITH A BLUE BORDER. BENEATH THIS WORDING IS THE BUST OF A MAN WITH THE FACE, NECK AND EAR IN SKIN TONE, A MOUSTACHE IN BROWN, LIPS IN RED, EYES WITH BROWN PUPILS INSIDE THE WHITE OF THE EYES, EYEBROWS IN BROWN, AND HAIR IN BROWN. THE BUST INCLUDES CLOTHING CONSISTING OF A WHITE SHIRT WITH A WHITE COLLAR AND BLUE VERTICAL STRIPS, A BLUE TIE, AND A BROWN JACKET. ALL OF THE BUST AND CLOTHING IS IN A BROWN OVAL PICTURE FRAME, WITH A RED BORDER. BELOW THE PICTURE IS A BROWN RIBBON BANNER WITH THE WORDING "W.B. MASON", IN RED. THE OVAL FRAME AND RIBBON BANNER ARE OUTLINED TOGETHER IN WHITE. BELOW THE BANNER IS WITH THE WORDING "COPY PAPER" IN YELLOW. OVERLAYING THE TOP OF THE OVAL FRAME IS THE WORDING "WHO BUT" IN RED AND OUTLINED IN WHITE, WITH BLUE LINES OUTLINED IN WHITE ABOVE AND BELOW THIS WORDING.

FOR COPIER PAPER; COPY PAPER; COPYING PAPER (U.S. CLS. 2, 5, 22, 23, 29, 37, 38 AND 50).
FIRST USE 3-1-2005; IN COMMERCE 3-1-2005.

CLASS 16—(Continued).

4,155,962. GENERAL FINANCE SUPPLY SOURCE, INC., PASADENA, CA. SN 85-355,590. FILED P.R. 6-24-2011; AM. S.R. 3-28-2012.



NO CLAIM IS MADE TO THE EXCLUSIVE RIGHT TO USE "DINNER NAPKIN", APART FROM THE MARK AS SHOWN.

THE COLOR(S) GREEN, BLACK, AND WHITE IS/ARE CLAIMED AS A FEATURE OF THE MARK.

THE MARK CONSISTS OF THE WORDING "ECO-FRIENDLY" IN BLACK, THE WORDING "3-D NAP" APPEARS IN GREEN LETTERS WRITTEN IN A BLOCK STYLE WITH A BLACK AND WHITE BLOCK BASE. THE WORDING "PREMIUM 3-PLY DINNER NAPKIN" APPEARS IN GREEN.

FOR PAPER NAPKINS (U.S. CLS. 2, 5, 22, 23, 29, 37, 38 AND 50).

FIRST USE 6-24-2011; IN COMMERCE 6-24-2011.

4,155,964. HOUR MEDIA, L.L.C., ROYAL OAK, MI. SN 85-356,614. FILED P.R. 6-27-2011; AM. S.R. 4-5-2012.

OHIO WINE COUNTRY

THE MARK CONSISTS OF STANDARD CHARACTERS WITHOUT CLAIM TO ANY PARTICULAR FONT, STYLE, SIZE, OR COLOR.

FOR PRINTED PERIODICALS FEATURING OHIO TOURISM TOPICS (U.S. CLS. 2, 5, 22, 23, 29, 37, 38 AND 50).

FIRST USE 3-28-2012; IN COMMERCE 3-28-2012.

4,155,965. ADVANCE MAGAZINE PUBLISHERS INC., NEW YORK, NY. SN 85-358,087. FILED P.R. 6-28-2011; AM. S.R. 4-4-2012.

THE GUILTY GIRL'S GUIDE

THE MARK CONSISTS OF STANDARD CHARACTERS WITHOUT CLAIM TO ANY PARTICULAR FONT, STYLE, SIZE, OR COLOR.

NO CLAIM IS MADE TO THE EXCLUSIVE RIGHT TO USE "GUIDE", APART FROM THE MARK AS SHOWN.

FOR PUBLICATIONS, NAMELY, MAGAZINE COLUMNS IN THE FIELD OF WEDDING PLANNING AND ETIQUETTE (U.S. CLS. 2, 5, 22, 23, 29, 37, 38 AND 50).

FIRST USE 10-1-2010; IN COMMERCE 10-1-2010.

CLASS 16—(Continued).

4,155,993. START THE SHOW, LLC, WILMINGTON, DE. SN 85-414,899. FILED P.R. 9-4-2011; AM. S.R. 4-6-2012.



THE MARK CONSISTS OF THE STYLIZED WORD "DUVALIER" INSIDE A RECTANGLE.

FOR ARTISTS' PENS; BALL PENS; BALL POINT PENS; BALL-POINT PENS; BALLPOINT PENS; BUBBLE PENS; COLORED PENS; DESK STANDS AND HOLDERS FOR PENS, PENCILS, AND INK; ELECTRICAL WOOD BURNING ARTISTS' PENS; FELT MARKING PENS; FELT PENS; FELT WRITING PENS; FELT-TIP PENS; FIBERTIP PENS; FOUNTAIN PEN INK CARTRIDGES; FOUNTAIN PENS; GEL ROLLER PENS; GLITTER PENS FOR STATIONERY PURPOSES; GLUE PENS FOR STATIONERY PURPOSES; HIGHLIGHTER PENS; HIGHLIGHTING PENS; INDIA INK PENS; INK PENS; MARKING PENS; PEN AND PENCIL CASES; PEN AND PENCIL CASES AND BOXES; PEN AND PENCIL HOLDERS; PEN AND PENCIL TRAYS; PEN CASES; PEN CLIPS; PEN HOLDERS; PEN INK CARTRIDGES; PEN INK REFILLS; PEN NIBS; PEN OR PENCIL HOLDERS; PEN RESTS; PEN STANDS; PEN TRAYS; PENCIL OR PEN BOXES; PENS; PENS FOR MARKING; POCKET PEN SHIELDS; POROUS TIP PENS; REFILLS FOR BALLPOINT PENS; ROLLER BALL PENS; SCHOOL SUPPLY KITS CONTAINING VARIOUS COMBINATIONS OF SELECTED SCHOOL SUPPLIES, NAMELY, WRITING INSTRUMENTS, PENS, PENCILS, MECHANICAL PENCILS, ERASERS, MARKERS, CRAYONS, HIGHLIGHTER PENS, FOLDERS, NOTEBOOKS, PAPER, PROTRACTORS, PAPER CLIPS, PENCIL SHARPENERS, WRITING GRIPS, GLUE AND BOOK MARKS; STANDS FOR PEN AND PENCIL; STANDS FOR PENS; STANDS FOR PENS AND PENCILS; STEEL PENS; TIPS FOR BALLPOINT PENS; WRITING PEN KITS COMPRISING PARTS FOR MAKING WRITING PENS; WRITING PENS THAT MAY ALSO BE USED TO PERFORM PEN SPINNING TRICKS (U.S. CLS. 2, 5, 22, 23, 29, 37, 38 AND 50).

FIRST USE 6-1-2011; IN COMMERCE 6-5-2011.

4,156,071. BELSITO, JOSEPH, NEW WINDSOR, NY. SN 85-514,812. FILED P.R. 1-12-2012; AM. S.R. 4-27-2012.

OC HEALTHCARE

THE MARK CONSISTS OF STANDARD CHARACTERS WITHOUT CLAIM TO ANY PARTICULAR FONT, STYLE, SIZE, OR COLOR.

FOR MONTHLY NEWSPAPER FOR GENERAL CIRCULATION (U.S. CLS. 2, 5, 22, 23, 29, 37, 38 AND 50).

FIRST USE 12-1-2011; IN COMMERCE 12-1-2011.

CLASS 18—LEATHER GOODS

CLASS 18—(Continued).

4,155,864. PRL USA HOLDINGS, INC., NEW YORK, NY. SN 77-969,573. FILED P.R. 3-26-2010; AM. S.R. 2-8-2012.



THE COLOR(S) YELLOW, GREEN, BLUE AND BLACK IS/ ARE CLAIMED AS A FEATURE OF THE MARK.

THE MARK CONSISTS OF THE LETTERS "RL" IN BLACK IN THE BOTTOM LEFT CORNER OF A TARTAN FABRIC DESIGN WITH THREE REPEATING SQUARE DESIGNS. THE TARTAN IS FORMED BY FOUR IMAGES OF THE SQUARE DESIGN WITH THE OUTER BORDER BEING A YELLOW SQUARE THAT CONTAINS A BLACK AND GREEN SQUARE, THAT CONTAINS A BLUE AND BLACK SQUARE. THE "RL" LETTERS APPEAR IN THE UPPER RIGHT QUARTER THREE-PART SQUARE.

FOR BAGS, NAMELY, HANDBAGS, DUFFLE BAGS, BRIEFCASES, TOTE BAGS, COSMETIC BAGS SOLD EMPTY (U.S. CLS. 1, 2, 3, 22 AND 41).

FIRST USE 0-0-1986; IN COMMERCE 0-0-1986.

CLASS 18—(Continued).

4,155,917. ETHICAL PRODUCTS, INC., BLOOMFIELD, NJ. SN 85-300,732. FILED P.R. 4-21-2011; AM. S.R. 2-16-2012.

OUTDOOR DOG

THE MARK CONSISTS OF STANDARD CHARACTERS WITHOUT CLAIM TO ANY PARTICULAR FONT, STYLE, SIZE, OR COLOR.

NO CLAIM IS MADE TO THE EXCLUSIVE RIGHT TO USE "DOG", APART FROM THE MARK AS SHOWN, FOR PET CLOTHING (U.S. CLS. 1, 2, 3, 22 AND 41). FIRST USE 12-0-2011; IN COMMERCE 12-0-2011.

CLASS 19—NON-METALLIC BUILDING MATERIALS

4,155,848. DIXIE MAT & HARDWOOD, INC., SANDY HOOK, MS. SN 76-705,255. FILED 11-8-2010.

4,155,871. PRL USA HOLDINGS, INC., NEW YORK, NY. SN 85-120,200. FILED P.R. 8-31-2010; AM. S.R. 9-14-2011.

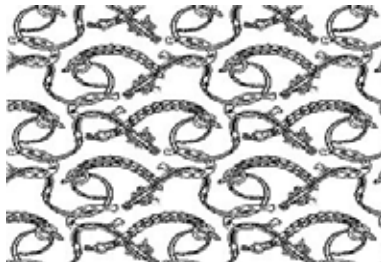

THE MARK CONSISTS OF A REPEATING EQUESTRIAN TACK PATTERN COMPRISING OF BRAIDED LEAD SHANKS INTERTWINED WITH HORSESHOES.

FOR HANDBAGS; ACCESSORIES, NAMELY, WALLET, WRISTLET BAGS, COSMETIC CASES SOLD EMPTY (U.S. CLS. 1, 2, 3, 22 AND 41).

FIRST USE 8-0-2010; IN COMMERCE 8-0-2010.



THE COLOR(S) RED IS/ARE CLAIMED AS A FEATURE OF THE MARK.

THE MARK CONSISTS OF THE COLOR RED APPLIED TO THE EDGES OF INDUSTRIAL HARDWOOD MATS. THE MATTER SHOWN IN BROKEN LINES ON THE DRAWING SHOWS POSITIONING OF THE MARK ON THE GOODS AND NEITHER THE MATTER SHOWN IN BROKEN LINES NOR THE CONFIGURATION OF THE INDUSTRIAL HARDWOOD MATS IS CLAIMED AS A FEATURE OF THE MARKS.

FOR HARDWOOD MATS FOR INDUSTRIAL USES, SPECIFICALLY EXCLUDING LUMBER, TIMBER AND PLYWOOD SOLD SEPARATELY AND SPECIFICALLY EXCLUDING FIRE RETARDANT WOOD (U.S. CLS. 1, 12, 33 AND 50).

FIRST USE 6-1-2006; IN COMMERCE 6-1-2006.

CLASS 19—(Continued).

4,155,921. NATIONAL GYPSUM PROPERTIES, LLC, CHARLOTTE, NC. SN 85-309,521. FILED P.R. 5-2-2011; AM. S.R. 4-4-2012.

HIGH STRENGTH LITE

THE MARK CONSISTS OF STANDARD CHARACTERS WITHOUT CLAIM TO ANY PARTICULAR FONT, STYLE, SIZE, OR COLOR.

FOR WALLBOARD (U.S. CLS. 1, 12, 33 AND 50).
FIRST USE 3-11-2011; IN COMMERCE 3-11-2011.

4,155,946. WHALEY, TIM, PLANO, TX. SN 85-346,393. FILED P.R. 6-15-2011; AM. S.R. 4-4-2012.

GLASSRECYCLED

THE MARK CONSISTS OF STANDARD CHARACTERS WITHOUT CLAIM TO ANY PARTICULAR FONT, STYLE, SIZE, OR COLOR.

FOR RECYCLED GLASS AND PORCELAIN COUNTER TOPS, FLOOR TILES, DECORATIVE WALL PANELS (U.S. CLS. 1, 12, 33 AND 50).

FIRST USE 9-25-2011; IN COMMERCE 9-25-2011.

4,155,974. TEXAS INDUSTRIES, INC., DALLAS, TX. SN 85-367,965. FILED P.R. 7-11-2011; AM. S.R. 3-29-2012.

VELOZ

THE MARK CONSISTS OF STANDARD CHARACTERS WITHOUT CLAIM TO ANY PARTICULAR FONT, STYLE, SIZE, OR COLOR.

THE ENGLISH TRANSLATION OF "VELOZ" IN THE MARK IS "FAST".

FOR CEMENTITIOUS PLASTER (U.S. CLS. 1, 12, 33 AND 50).

FIRST USE 10-1-2010; IN COMMERCE 10-1-2010.

CLASS 19—(Continued).

4,156,001. BLU HOMES, INC., WALTHAM, MA. SN 85-438,661. FILED P.R. 10-4-2011; AM. S.R. 4-6-2012.

LOFTHOUSE

THE MARK CONSISTS OF STANDARD CHARACTERS WITHOUT CLAIM TO ANY PARTICULAR FONT, STYLE, SIZE, OR COLOR.

FOR MODULAR HOMES (U.S. CLS. 1, 12, 33 AND 50).
FIRST USE 3-10-2012; IN COMMERCE 3-10-2012.

CLASS 21—HOUSEWARES AND GLASS

4,155,889. GL & LL OF O.C., LLC, OCEAN CITY, MD. SN 85-203,799. FILED P.R. 12-22-2010; AM. S.R. 4-17-2012.



THE MARK CONSISTS OF THE CONFIGURATION OF A DRINK CONTAINER IN THE SHAPE OF A DUCK WHICH IS DIVIDED IN THE CENTER AND HOLLOW ON THE INSIDE.

FOR DRINKING CONTAINERS (U.S. CLS. 2, 13, 23, 29, 30, 33, 40 AND 50).

FIRST USE 8-7-2002; IN COMMERCE 8-7-2002.

4,155,891. TREE RING PENS LLC, MISSOULA, MT. SN 85-204,919. FILED P.R. 12-23-2010; AM. S.R. 4-5-2012.

TREE RING

THE MARK CONSISTS OF STANDARD CHARACTERS WITHOUT CLAIM TO ANY PARTICULAR FONT, STYLE, SIZE, OR COLOR.

FOR COASTERS NOT OF PAPER AND NOT BEING TABLE LINEN (U.S. CLS. 2, 13, 23, 29, 30, 33, 40 AND 50).
FIRST USE 7-26-2010; IN COMMERCE 7-26-2010.

CLASS 21—(Continued).

4,155,925. MARK ANTHONY INTERNATIONAL SRL, ST. MICHAEL, BARBADOS. SN 85-317,774. FILED P.R. 5-11-2011; AM. S.R. 5-1-2012.

¡JAPIAUAR!

THE MARK CONSISTS OF STANDARD CHARACTERS WITHOUT CLAIM TO ANY PARTICULAR FONT, STYLE, SIZE, OR COLOR.

THE WORDING "JAPIAUAR" HAS NO MEANING IN A FOREIGN LANGUAGE.

FOR THERMAL INSULATED BAGS FOR BEVERAGES; THERMAL INSULATED WRAPS FOR CANS OR BOTTLES (U.S. CLS. 2, 13, 23, 29, 30, 33, 40 AND 50). FIRST USE 5-25-2011; IN COMMERCE 5-25-2011.

4,155,970. SUMMERS RICHELLE J, MURRIETA, CA. SN 85-363,516. FILED P.R. 7-5-2011; AM. S.R. 4-10-2012.

Glitter Glue Organizer

THE MARK CONSISTS OF STANDARD CHARACTERS WITHOUT CLAIM TO ANY PARTICULAR FONT, STYLE, SIZE, OR COLOR.

NO CLAIM IS MADE TO THE EXCLUSIVE RIGHT TO USE "ORGANIZER", APART FROM THE MARK AS SHOWN.

FOR PLASTIC VACUUMED FORMED STORAGE CRAFTING TRAY (U.S. CLS. 2, 13, 23, 29, 30, 33, 40 AND 50).

FIRST USE 12-5-2010; IN COMMERCE 7-5-2011.

4,156,075. JOHNSON & JOHNSON, NEW BRUNSWICK, NJ. SN 85-572,243. FILED P.R. 3-16-2012; AM. S.R. 4-16-2012.

MICRO-GROOVES

THE MARK CONSISTS OF STANDARD CHARACTERS WITHOUT CLAIM TO ANY PARTICULAR FONT, STYLE, SIZE, OR COLOR.

FOR DENTAL FLOSS (U.S. CLS. 2, 13, 23, 29, 30, 33, 40 AND 50).

FIRST USE 7-17-2009; IN COMMERCE 7-17-2009.

CLASS 25—CLOTHING

CLASS 25—(Continued).

4,155,854. STRYKER-INDIGO PUBLISHING COMPANY, INC., DBA STRYKER-INDIGO NEW YORK, LEVIT-TOWN, NY. SN 77-416,816. FILED P.R. 3-8-2008; AM. S.R. 3-21-2012.

Halifax Stanleys

THE MARK CONSISTS OF STANDARD CHARACTERS WITHOUT CLAIM TO ANY PARTICULAR FONT, STYLE, SIZE, OR COLOR.

NO CLAIM IS MADE TO THE EXCLUSIVE RIGHT TO USE "HALIFAX", APART FROM THE MARK AS SHOWN.

FOR SPORTS JERSEYS (U.S. CLS. 22 AND 39). FIRST USE 10-26-2004; IN COMMERCE 11-18-2011.

4,155,855. BC TOURS, INC., NASHVILLE, TN. SN 77-673,267. FILED P.R. 2-18-2009; AM. S.R. 4-10-2012.

PEOPLE ARE CRAZY

THE MARK CONSISTS OF STANDARD CHARACTERS WITHOUT CLAIM TO ANY PARTICULAR FONT, STYLE, SIZE, OR COLOR.

FOR CLOTHING, NAMELY, T-SHIRTS (U.S. CLS. 22 AND 39).

FIRST USE 9-3-2009; IN COMMERCE 9-3-2009.

4,155,870. KEITH D. JONES, MONTGOMERY, AL. AND AUBRIAN SMITH, MONTGOMERY, AL. SN 85-102,912. FILED P.R. 8-9-2010; AM. S.R. 4-25-2012.



THE MARK CONSISTS OF THE WORDS "FLY HEARTS" IN THIN CURSIVE WRITING AT THE TOP, WITH THE FIRST LETTER OF EACH WORD CAPITALIZED. JUST BELOW THOSE WORDS IS AN IMAGE OF A HEART WITH

CLASS 25—(Continued).

CRACKS THROUGHOUT. THE HEART CONTAINS EYEGLASSES NEAR THE TOP ON THE FRONT, A KEYHOLE IN THE MIDDLE ON THE FRONT AND A ADHESIVE BANDAGE BELOW THE KEYHOLE, ON THE FRONT, OVERALL RESEMBLING A HEAD WHEREBY THE EYEGASSES COVER THE EYES, THE KEYHOLE IS IN THE VICINITY OF A NOSE AND THE ADHESIVE BANDAGE IS IN THE VICINITY OF A MOUTH. BELOW THE HEART ARE THE WORDS "NEVER BROKEN" IN THICK PRINT WITH ALL-CAPITAL LETTERS.

FOR WEARING APPAREL, NAMELY, T-SHIRTS, JACKETS, SWEATERS, CAPS, HATS, SWEATSHIRTS, HOODED SWEATSHIRTS (U.S. CLS. 22 AND 39).

FIRST USE 8-18-2010; IN COMMERCE 8-18-2010.

CLASS 25—(Continued).

4,155,909. THE BURTON CORPORATION, BURLINGTON, VT. SN 85-270,740. FILED P.R. 3-18-2011; AM. S.R. 8-18-2011.

WHEEL WASH

THE MARK CONSISTS OF STANDARD CHARACTERS WITHOUT CLAIM TO ANY PARTICULAR FONT, STYLE, SIZE, OR COLOR.

FOR CLOTHING, NAMELY, DENIM PANTS AND JACKETS, PANTS, BOARDSHORTS, WALKING SHORTS, WOVEN TOPS, FLANNEL SHIRTS, KNIT TOPS, FLEECE TOPS, TEE SHIRTS, TANK TOPS, JACKETS, AND SWEATERS (U.S. CLS. 22 AND 39).

FIRST USE 1-15-2011; IN COMMERCE 1-15-2011.

4,155,874. SUNI SCHULZE, GREENSBORO, NC. SN 85-139,049. FILED P.R. 9-27-2010; AM. S.R. 3-12-2012.



THE MARK CONSISTS OF A DESIGN OF A MUFF DECORATED WITH FLOWERS AND LEAVES. THE MUTED DIAMOND DESIGNS ON THE SURFACE OF THE MUFF ARE USED TO DEPICT SHADING AND ARE NOT PART OF THE MARK. THE BROKEN LINES DEPICTING THE ZIPPER, ROPE CARRY HANDLE AND FORMING A HAND ARE FOR SHOWING THE POSITION OF THE MARK ON THE GOODS AND ARE NOT CLAIMED AS FEATURES OF THE MARK.

FOR MUFFS (U.S. CLS. 22 AND 39).

FIRST USE 3-0-2008; IN COMMERCE 3-0-2008.

4,155,980. STYMIE CANINE CANCER FOUNDATION, AURORA, CO. SN 85-379,438. FILED P.R. 7-24-2011; AM. S.R. 4-12-2012.



4,155,903. NEPHEW, PAMELA, FREDERICKSBURG, VA. SN 85-232,862. FILED P.R. 2-3-2011; AM. S.R. 4-24-2012.

BLACK KIDS ROCK!

THE MARK CONSISTS OF STANDARD CHARACTERS WITHOUT CLAIM TO ANY PARTICULAR FONT, STYLE, SIZE, OR COLOR.

FOR CLOTHING, NAMELY, JACKETS, PANTS, SHORTS, T-SHIRTS, SWEATERS, SCARVES, SWEATPANTS, SWEATSHIRTS, JERSEYS, MITTENS, GLOVES, RAIN WEAR, CAPS, SOCKS, BANDANAS, KNIT HATS (U.S. CLS. 22 AND 39).

FIRST USE 9-17-2011; IN COMMERCE 9-17-2011.

THE COLOR(S) PINK AND BLACK IS/ARE CLAIMED AS A FEATURE OF THE MARK.

THE MARK CONSISTS OF A PINK RIBBON ALONG WITH OUR DOGS ACTUAL PAW PRINT ALONG WITH THE WORDING "STYMIE CANINE CANCER FOUNDATION" AND "STYMIECCF.ORG" IN BLACK.

FOR SHIRTS (U.S. CLS. 22 AND 39).

FIRST USE 2-1-2011; IN COMMERCE 2-14-2011.

CLASS 25—(Continued).

4,155,989. ABERCROMBIE & FITCH TRADING CO., NEW ALBANY, OH. SN 85-401,002. FILED 8-18-2011.

BONDI BEACH

THE MARK CONSISTS OF STANDARD CHARACTERS WITHOUT CLAIM TO ANY PARTICULAR FONT, STYLE, SIZE, OR COLOR.

FOR BOTTOMS; TOPS (U.S. CLS. 22 AND 39).
FIRST USE 2-4-2011; IN COMMERCE 2-4-2011.



4,156,007. CHILD OF THE INDIGO, PASADENA, CA. SN 85-451,359. FILED P.R. 10-19-2011; AM. S.R. 3-23-2012.

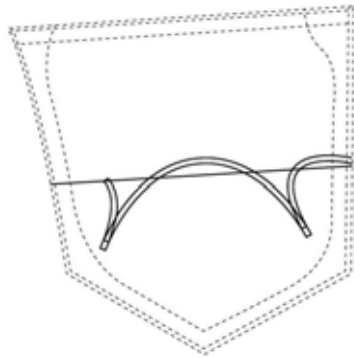

THE MARK CONSISTS OF A HORIZONTAL LINE EXTENDING ACROSS THE POCKET. BEGINNING ON THE LEFT SIDE OF THE HORIZONTAL LINE, AN ARCH EXTENDS BELOW THE HORIZONTAL LINE AND THEN UP AND OVER THE HORIZONTAL LINE, BEFORE EXTENDING BELOW THE HORIZONTAL LINE AND AGAIN EXTENDING ABOVE THE HORIZONTAL LINE. THE ARCH ENDS ABOVE THE HORIZONTAL LINE AT THE EDGE OF THE POCKET. THE SHAPE OF THE POCKET AND BROKEN LINES FORMING THE POCKET ARE NOT PART OF THE MARK BUT ONLY SERVE TO SHOW POSITION OF THE MARK ON THE GOODS.

FOR CLOTHING, NAMELY, PANTS AND DENIM JEANS (U.S. CLS. 22 AND 39).
FIRST USE 3-7-2012; IN COMMERCE 3-7-2012.

CLASS 25—(Continued).

4,156,011. MATHEW ARON, SAN DIEGO, CA. SN 85-453,287. FILED P.R. 10-21-2011; AM. S.R. 3-29-2012.



THE MARK CONSISTS OF A STYLIZED HEART WITH ATTACHED STYLIZED WINGS.

FOR CLOTHING, NAMELY, SHIRTS, T-SHIRTS, UNDER-SHIRTS, NIGHT-SHIRTS, JERSEYS, UNIFORMS, PANTS, TROUSERS, JEANS, DENIM JEANS, JUMP SUITS, SHORTS, BOXER SHORTS, TOPS, CROP TOPS, TANK TOPS, HALTER TOPS, SWEAT SHIRTS, SWEAT SHORTS, SWEAT PANTS, BLOUSES, VESTS, LEATHER VESTS, JACKETS, LEATHER JACKETS, REVERSIBLE JACKETS, COATS, TURTLENECKS, BEANIES, VISORS, SWEAT BANDS, APRONS, BANDANAS, NECKWEAR, PANTIES, TEDDIES, LEG WARMERS, LEGGINGS, LEOTARDS, BASEBALL CAPS, KNIT HATS, CAPS, BERETS, HATS, HEADBANDS, AND HEADWEAR (U.S. CLS. 22 AND 39).
FIRST USE 10-10-2011; IN COMMERCE 10-10-2011.



4,156,012. MATHEW ARON, SAN DIEGO, CA. SN 85-453,328. FILED P.R. 10-21-2011; AM. S.R. 3-29-2012.



THE MARK CONSISTS OF A STYLIZED FEMALE FORM.

FOR CLOTHING, NAMELY, SHIRTS, T-SHIRTS, UNDER-SHIRTS, NIGHT-SHIRTS, JERSEYS, UNIFORMS, PANTS, TROUSERS, JEANS, DENIM JEANS, JUMP SUITS, SHORTS, BOXER SHORTS, TOPS, CROP TOPS, TANK TOPS, HALTER TOPS, SWEAT SHIRTS, SWEAT SHORTS, SWEAT PANTS, BLOUSES, VESTS, LEATHER VESTS, JACKETS, LEATHER JACKETS, REVERSIBLE JACKETS, COATS, TURTLENECKS, BEANIES, VISORS, SWEAT BANDS, APRONS, BANDANAS, NECKWEAR, PANTIES, TEDDIES, LEG WARMERS, LEGGINGS, LEOTARDS, BASEBALL CAPS, KNIT HATS, CAPS, BERETS, HATS, HEADBANDS, AND HEADWEAR (U.S. CLS. 22 AND 39).
FIRST USE 10-10-2011; IN COMMERCE 10-10-2011.

CLASS 25—(Continued).

4,156,018. WEISS, DANNA, NEW YORK, NY. SN 85-462,967.
FILED P.R. 11-2-2011; AM. S.R. 4-5-2012.

Corn

THE MARK CONSISTS OF STANDARD CHARACTERS WITHOUT CLAIM TO ANY PARTICULAR FONT, STYLE, SIZE, OR COLOR.

FOR ECO FRIENDLY WOMEN'S DRESS LINE, NAMELY, DRESSES, TOPS, PANTS, SKIRTS, SKORTS, JACKETS, COATS, SCARVES, PONCHOS, LEG WARMERS, LEGGINGS, HATS, ALL FEATURING CORN (U.S. CLS. 22 AND 39).

FIRST USE 4-5-2012; IN COMMERCE 4-5-2012.

4,156,045. EUCLIDE AVRIDOR, NEW YORK, NY. AND MYLENE DELATTRE, NEW YORK, NY. SN 85-490,087.
FILED P.R. 12-8-2011; AM. S.R. 4-12-2012.

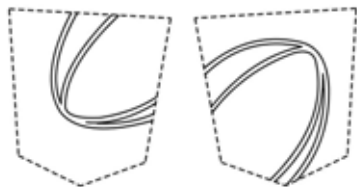

THE MARK CONSISTS OF TWO POCKET DESIGN REPRESENTED BY SOLID LINES. THE BROKEN LINES SURROUNDING THE MARK REPRESENT THE OVERALL SHAPE OF THE POCKET AND SERVE ONLY TO SHOW THE POSITION AND THE PLACEMENT OF THE MARK RELATIVE TO THE OVERALL POCKET.

FOR DENIMS; JEANS; JEGGINGS, NAMELY, PANTS THAT ARE PARTIALLY JEANS AND PARTIALLY LEGGINGS; MEN'S AND WOMEN'S JACKETS, COATS, TROUSERS, VESTS; PANTS; SHIRTS; SHORTS; SKIRTS (U.S. CLS. 22 AND 39).

FIRST USE 9-6-2011; IN COMMERCE 11-19-2011.

CLASS 26—FANCY GOODS

4,155,957. CREATEDHAIR.COM, LOS ANGELES, CA. SN 85-353,621. FILED P.R. 6-22-2011; AM. S.R. 3-29-2012.

WATER WIG

THE MARK CONSISTS OF STANDARD CHARACTERS WITHOUT CLAIM TO ANY PARTICULAR FONT, STYLE, SIZE, OR COLOR.

CLASS 26—(Continued).

NO CLAIM IS MADE TO THE EXCLUSIVE RIGHT TO USE "WIG", APART FROM THE MARK AS SHOWN.

FOR WIGS AND HAIR PIECES (U.S. CLS. 37, 39, 40, 42 AND 50).

FIRST USE 11-15-2011; IN COMMERCE 11-15-2011.

4,156,051. COUSIN CORPORATION OF AMERICA, LARGO, FL. SN 85-500,791. FILED P.R. 12-21-2011; AM. S.R. 4-26-2012.

RAINBOW GLASS BEADS

THE MARK CONSISTS OF STANDARD CHARACTERS WITHOUT CLAIM TO ANY PARTICULAR FONT, STYLE, SIZE, OR COLOR.

NO CLAIM IS MADE TO THE EXCLUSIVE RIGHT TO USE "GLASS BEADS", APART FROM THE MARK AS SHOWN.

FOR BEADS FOR HANDICRAFT WORK (U.S. CLS. 37, 39, 40, 42 AND 50).

FIRST USE 9-1-2000; IN COMMERCE 9-1-2000.

CLASS 28—TOYS AND SPORTING GOODS

4,155,862. BAMBUSA SKATEBOARDS, INC., ROSLYN, PA. SN 77-942,227. FILED P.R. 2-23-2010; AM. S.R. 12-3-2010.

BAMBUSA

THE MARK CONSISTS OF STANDARD CHARACTERS WITHOUT CLAIM TO ANY PARTICULAR FONT, STYLE, SIZE, OR COLOR.

FOR SKATEBOARDS MADE IN WHOLE OR SIGNIFICANT PART OF BAMBOO (U.S. CLS. 22, 23, 38 AND 50).

FIRST USE 3-1-2010; IN COMMERCE 4-1-2010.

4,156,036. CANOPY BOOKS LLC, FLORAL PARK, NY. SN 85-484,307. FILED P.R. 11-30-2011; AM. S.R. 3-20-2012.

TUG & TOSS BALL

THE MARK CONSISTS OF STANDARD CHARACTERS WITHOUT CLAIM TO ANY PARTICULAR FONT, STYLE, SIZE, OR COLOR.

CLASS 28—(Continued).

NO CLAIM IS MADE TO THE EXCLUSIVE RIGHT TO USE "BALL", APART FROM THE MARK AS SHOWN.
 FOR DOG TOYS; PET TOYS (U.S. CLS. 22, 23, 38 AND 50).
 FIRST USE 3-0-2010; IN COMMERCE 3-0-2010.

CLASS 29—(Continued).

4,156,054. ENGSTROM, CHARLES ERIC, MONTAUK, NY.
 SN 85-505,149. FILED P.R. 12-28-2011; AM. S.R. 4-26-2012.



CLASS 29—MEATS AND PROCESSED FOODS

4,155,952. BRAIDWOOD'S, LLC, SARATOGA SPRINGS, NY.
 SN 85-352,653. FILED P.R. 6-22-2011; AM. S.R. 4-3-2012.

NO CLAIM IS MADE TO THE EXCLUSIVE RIGHT TO USE "OYSTERS", APART FROM THE MARK AS SHOWN.
 THE MARK CONSISTS OF AN OVAL WITH A GAP AT THE TOP AND THE BOTTOM. WITHIN THE GAP AT THE TOP IS THE STYLIZED TEXT "MONTAUK OYSTER WORKS" ABOVE THE STYLIZED TEXT "MONTAUK, NY". WITHIN THE GAP AT THE BOTTOM IS THE STYLIZED TEXT "OYSTERS". IN THE CENTER OF THE OVAL IS THE STYLIZED TEXT "MTK".
 FOR OYSTERS (U.S. CL. 46).
 FIRST USE 6-13-2011; IN COMMERCE 10-8-2011.

SARATOGA OLIVE OIL CO.

THE MARK CONSISTS OF STANDARD CHARACTERS WITHOUT CLAIM TO ANY PARTICULAR FONT, STYLE, SIZE, OR COLOR.
 NO CLAIM IS MADE TO THE EXCLUSIVE RIGHT TO USE "OLIVE OIL CO.", APART FROM THE MARK AS SHOWN.
 FOR OLIVE OIL (U.S. CL. 46).
 FIRST USE 4-15-2011; IN COMMERCE 4-15-2011.

4,156,072. HARDEE'S FOOD SYSTEMS, INC., ST. LOUIS, MO. SN 85-516,130. FILED 1-13-2012.

FRESH & JUICY

4,156,004. PEI WEI ASIAN DINER, INC., SCOTTSDALE, AZ.
 SN 85-448,097. FILED P.R. 10-14-2011; AM. S.R. 3-20-2012.

THE MARK CONSISTS OF STANDARD CHARACTERS WITHOUT CLAIM TO ANY PARTICULAR FONT, STYLE, SIZE, OR COLOR.
 FOR CHICKEN (U.S. CL. 46).
 FIRST USE 4-28-1995; IN COMMERCE 4-28-1995.

DINER SELECTS

CLASS 30—STAPLE FOODS

4,155,884. SETPOINT HEALTH CORPORATION, NEWTON UPPER FALLS, MA. SN 85-193,933. FILED P.R. 12-9-2010; AM. S.R. 1-11-2012.

THE MARK CONSISTS OF STANDARD CHARACTERS WITHOUT CLAIM TO ANY PARTICULAR FONT, STYLE, SIZE, OR COLOR.
 FOR COMBINATION MEAL CONSISTING PRIMARILY OF MEAT, SEAFOOD, POULTRY OR VEGETABLES FOR CONSUMPTION ON OR OFF THE PREMISES (U.S. CL. 46).
 FIRST USE 10-10-2011; IN COMMERCE 10-10-2011.

CHEF SET

THE MARK CONSISTS OF STANDARD CHARACTERS WITHOUT CLAIM TO ANY PARTICULAR FONT, STYLE, SIZE, OR COLOR.

CLASS 30—(Continued).

NO CLAIM IS MADE TO THE EXCLUSIVE RIGHT TO USE "SET", APART FROM THE MARK AS SHOWN.

FOR RICE, SEASONINGS AND FLAVORINGS COMBINED IN UNITARY PACKAGES; QUINOA, SEASONINGS AND FLAVORINGS COMBINED IN UNITARY PACKAGES; COUSCOUS, SEASONINGS AND FLAVORINGS COMBINED IN UNITARY PACKAGES (U.S. CL. 46).

FIRST USE 8-26-2010; IN COMMERCE 8-26-2010.

CLASS 30—(Continued).

4,155,958. PHOENIX INTANGIBLES HOLDING COMPANY, GREENVILLE, DE. SN 85-354,555. FILED P.R. 6-23-2011; AM. S.R. 4-2-2012.

CHEESE CRINKLES

THE MARK CONSISTS OF STANDARD CHARACTERS WITHOUT CLAIM TO ANY PARTICULAR FONT, STYLE, SIZE, OR COLOR.

FOR SNACK FOOD, NAMELY, CHEESE FLAVORED PUFFED CORN SNACKS (U.S. CL. 46).

FIRST USE 2-0-2012; IN COMMERCE 2-0-2012.

4,155,923. COFFEE BAR 1, LLC, SAN FRANCISCO, CA. SN 85-314,984. FILED P.R. 5-6-2011; AM. S.R. 4-8-2012.

COFFEE BAR

THE MARK CONSISTS OF STANDARD CHARACTERS WITHOUT CLAIM TO ANY PARTICULAR FONT, STYLE, SIZE, OR COLOR.

NO CLAIM IS MADE TO THE EXCLUSIVE RIGHT TO USE "COFFEE", APART FROM THE MARK AS SHOWN.

FOR COFFEE; COFFEE BEANS (U.S. CL. 46).

FIRST USE 2-22-2007; IN COMMERCE 12-15-2007.

4,156,000. PALO PRODUCTS LLC, DBA PALO TEA, NEW YORK, NY. SN 85-437,379. FILED P.R. 10-3-2011; AM. S.R. 3-23-2012.

ALL NATURAL ROOT TEA

THE MARK CONSISTS OF STANDARD CHARACTERS WITHOUT CLAIM TO ANY PARTICULAR FONT, STYLE, SIZE, OR COLOR.

NO CLAIM IS MADE TO THE EXCLUSIVE RIGHT TO USE "TEA", APART FROM THE MARK AS SHOWN.

FOR BEVERAGES MADE OF TEA; BEVERAGES WITH A TEA BASE; FLAVOURINGS OF TEA; FRUIT TEAS; HERB TEA; HERBAL TEA; ICED TEA; TEA; TEA BAGS; TEA EXTRACTS; TEA FOR INFUSIONS; TEA-BASED BEVERAGES; TEA-BASED BEVERAGES WITH FRUIT FLAVORING (U.S. CL. 46).

FIRST USE 9-22-2011; IN COMMERCE 9-22-2011.

4,155,942. ESSENTIAL LIVING, LLC, WAVERLY, PA. SN 85-342,259. FILED P.R. 6-9-2011; AM. S.R. 3-23-2012.

PRETZEL PUFFS

THE MARK CONSISTS OF STANDARD CHARACTERS WITHOUT CLAIM TO ANY PARTICULAR FONT, STYLE, SIZE, OR COLOR.

NO CLAIM IS MADE TO THE EXCLUSIVE RIGHT TO USE "PRETZEL", APART FROM THE MARK AS SHOWN.

FOR PRETZELS MADE FROM SPROUTED WHOLE GRAIN FLOUR (U.S. CL. 46).

FIRST USE 1-24-2012; IN COMMERCE 1-24-2012.

4,156,005. PEI WEI ASIAN DINER, INC., SCOTTSDALE, AZ. SN 85-448,101. FILED P.R. 10-14-2011; AM. S.R. 3-20-2012.

DINER SELECTS

THE MARK CONSISTS OF STANDARD CHARACTERS WITHOUT CLAIM TO ANY PARTICULAR FONT, STYLE, SIZE, OR COLOR.

FOR COMBINATION MEAL CONSISTING PRIMARILY OF PASTA OR RICE FOR CONSUMPTION ON AND OFF THE PREMISES (U.S. CL. 46).

FIRST USE 10-10-2011; IN COMMERCE 10-10-2011.

CLASS 30—(Continued).

4,156,039. SAVE-A-LOT FOOD STORES, LTD., EARTH CITY, MO. SN 85-486,403. FILED P.R. 12-2-2011; AM. S.R. 3-27-2012.

CLASS 32—(Continued).

4,155,947. SMART PEAKE MEDICAL, L.L.C., LAFAYETTE, LA. SN 85-346,649. FILED P.R. 6-15-2011; AM. S.R. 4-11-2012.

KIGGINS

StudyWater

THE MARK CONSISTS OF STANDARD CHARACTERS WITHOUT CLAIM TO ANY PARTICULAR FONT, STYLE, SIZE, OR COLOR.
FOR BREAKFAST CEREALS (U.S. CL. 46).
FIRST USE 12-20-2011; IN COMMERCE 12-20-2011.

THE MARK CONSISTS OF STANDARD CHARACTERS WITHOUT CLAIM TO ANY PARTICULAR FONT, STYLE, SIZE, OR COLOR.
FOR BOTTLED DRINKING WATER (U.S. CLS. 45, 46 AND 48).
FIRST USE 5-23-2011; IN COMMERCE 5-23-2011.

CLASS 31—NATURAL AGRICULTURAL PRODUCTS

4,155,910. KAPLAN, JEFFREY, FORT LAUDERDALE, FL. SN 85-271,648. FILED P.R. 3-20-2011; AM. S.R. 11-14-2011.

4,155,972. BONFIGLIO, JOSEPH, GLASTONBURY, CT. SN 85-366,465. FILED P.R. 7-8-2011; AM. S.R. 3-21-2012.

TENDER VITTLES

HOCKEY SODA

THE MARK CONSISTS OF STANDARD CHARACTERS WITHOUT CLAIM TO ANY PARTICULAR FONT, STYLE, SIZE, OR COLOR.
FOR CAT FOOD (U.S. CLS. 1 AND 46).
FIRST USE 11-10-2011; IN COMMERCE 11-10-2011.

THE MARK CONSISTS OF STANDARD CHARACTERS WITHOUT CLAIM TO ANY PARTICULAR FONT, STYLE, SIZE, OR COLOR.
NO CLAIM IS MADE TO THE EXCLUSIVE RIGHT TO USE "SODA", APART FROM THE MARK AS SHOWN.
FOR NON-ALCOHOLIC BEVERAGES, NAMELY, CARBONATED BEVERAGES, ENERGY DRINKS AND SOFT DRINKS, NAMELY, SODA (U.S. CLS. 45, 46 AND 48).
FIRST USE 10-26-2011; IN COMMERCE 10-26-2011.

CLASS 32—LIGHT BEVERAGES

4,155,938. SOLORZANO GIL, ALFONSO, IRAPUATO, MEXICO. SN 85-334,493. FILED P.R. 5-31-2011; AM. S.R. 9-16-2011.

SERVICE MARKS
CLASS 35—ADVERTISING AND BUSINESS

4,155,851. GPRA STRATEGIC MANAGEMENT, INC., SILVER SPRING, MD. SN 76-708,140. FILED P.R. 6-24-2011; AM. S.R. 3-29-2012.

aguablanca

STEM Women of Color Conclave

THE MARK CONSISTS OF STANDARD CHARACTERS WITHOUT CLAIM TO ANY PARTICULAR FONT, STYLE, SIZE, OR COLOR.
THE ENGLISH TRANSLATION OF "AGUABLANCA" IN THE MARK IS "CLEAR WATER".
FOR FRUIT JUICE CONCENTRATES; FRUIT JUICES, NAMELY, APPLE, AND GRAPE JUICE; MINERAL WATER; SODA WATER; SPRING WATER; TABLE WATER (U.S. CLS. 45, 46 AND 48).
FIRST USE 4-1-2011; IN COMMERCE 4-1-2011.

THE MARK CONSISTS OF STANDARD CHARACTERS WITHOUT CLAIM TO ANY PARTICULAR FONT, STYLE, SIZE, OR COLOR.
FOR ARRANGING AND CONDUCTING ANNUAL SPECIAL EVENTS FOR BUSINESS PURPOSES (U.S. CLS. 100, 101 AND 102).
FIRST USE 6-5-2010; IN COMMERCE 6-5-2010.

CLASS 35—(Continued).

4,155,863. ENERGYScore, INC, HOCKESSIN, DE. SN 77-960,996. FILED P.R. 3-17-2010; AM. S.R. 4-24-2012.

EnergyScore

THE MARK CONSISTS OF STANDARD CHARACTERS WITHOUT CLAIM TO ANY PARTICULAR FONT, STYLE, SIZE, OR COLOR.

FOR CONSULTATION IN THE FIELD OF ENERGY EFFICIENCY; CONSULTING SERVICES IN THE FIELD OF ENERGY USAGE MANAGEMENT AND ENERGY EFFICIENCY; CONSULTING SERVICES IN THE FIELDS OF ENERGY CONSUMPTION AND USAGE CONSERVATION TO IMPROVE ENERGY EFFICIENCY; ENERGY AUDITING (U.S. CLS. 100, 101 AND 102).

FIRST USE 3-15-2009; IN COMMERCE 1-1-2010.

4,155,865. PENNSYLVANIA LIQUOR CONTROL BOARD, HARRISBURG, PA. SN 77-982,046. FILED P.R. 1-15-2010; AM. S.R. 12-19-2011.



THE MARK CONSISTS OF THE LETTERS THAT COMPRISE THE WORD "SPIRITS" RANDOMLY SCATTERED AND ROTATED ABOUT 90 DEGREE AXES, BOTH CLOCKWISE AND COUNTERCLOCKWISE. THE LETTERS ARE ALL SHOWN IN UPPERCASE FORM. THE LETTERS AND BACKGROUND ARE TEXTURED AND REPEATING.

FOR ONLINE RETAIL STORE AND RETAIL STORE SERVICES FEATURING ALCOHOLIC BEVERAGES, NAMELY, WINE, DISTILLED SPIRITS AND DISTILLED LIQUOR (U.S. CLS. 100, 101 AND 102).

FIRST USE 6-30-2010; IN COMMERCE 6-30-2010.

CLASS 35—(Continued).

4,155,872. VALUE FORWARD GROUP, INC., PEACHTREE CITY, GA. SN 85-121,645. FILED P.R. 9-2-2010; AM. S.R. 4-19-2012.

REVENUE CAPTURE SCORECARD

THE MARK CONSISTS OF STANDARD CHARACTERS WITHOUT CLAIM TO ANY PARTICULAR FONT, STYLE, SIZE, OR COLOR.

FOR BUSINESS MANAGEMENT CONSULTING RELATING TO ORGANIZATIONAL ASSESSMENT AND IMPROVEMENT IN THE DEPARTMENT OF SALES, MARKETING, STRATEGY, FINANCIAL MANAGEMENT AND OPERATIONS USING FORMULATIONS OF BEST PRACTICES FOR BUSINESS MANAGEMENT; BUSINESS CONSULTING WITH REGARD TO THE INTEGRATION OF SALES, MARKETING, STRATEGY, FINANCIAL MANAGEMENT AND OPERATIONS (U.S. CLS. 100, 101 AND 102).

FIRST USE 11-16-2006; IN COMMERCE 11-16-2006.

4,155,876. ROBINSON, TYLER, LOS ALAMITOS, CA. AND HOLDERBAUM, CHRIS, LONG BEACH, CA. SN 85-160,046. FILED P.R. 10-25-2010; AM. S.R. 4-25-2012.



NO CLAIM IS MADE TO THE EXCLUSIVE RIGHT TO USE "SHOP", APART FROM THE MARK AS SHOWN.

THE MARK CONSISTS OF THE STYLIZED WORDING "THE HYDRO SHOP" CONTAINED WITHIN A CONCENTRIC OVAL SHAPED BACKGROUND

FOR ON-LINE RETAIL STORE SERVICES FEATURING GARDENING PRODUCTS; RETAIL STORES FEATURING GARDENING PRODUCTS (U.S. CLS. 100, 101 AND 102).

FIRST USE 6-6-2010; IN COMMERCE 6-6-2010.

4,155,886. COMPREHENSIVE NEUROSCIENCE, INC., MIRAMAR, FL. SN 85-201,170. FILED P.R. 12-17-2010; AM. S.R. 3-30-2012.

COMPREHENSIVE CLINICAL DEVELOPMENT

THE MARK CONSISTS OF STANDARD CHARACTERS WITHOUT CLAIM TO ANY PARTICULAR FONT, STYLE, SIZE, OR COLOR.

CLASS 35—(Continued).

OWNER OF U.S. REG. NOS. 3,449,534, 3,449,536, AND OTHERS.

FOR BUSINESS MANAGEMENT CONSULTING; COST MANAGEMENT FOR THE HEALTH BENEFIT PLANS OF OTHERS; PHARMACEUTICAL COST MANAGEMENT SERVICES AND DRUG UTILIZATION REVIEW SERVICES (U.S. CLS. 100, 101 AND 102).

FIRST USE 3-30-2011; IN COMMERCE 3-30-2011.

CLASS 35—(Continued).

4,155,895. FOR THE KITCHEN, LLC, GLASTONBURY, CT. SN 85-214,120. FILED P.R. 1-10-2011; AM. S.R. 4-26-2012.

FOR THE KITCHEN!

THE MARK CONSISTS OF STANDARD CHARACTERS WITHOUT CLAIM TO ANY PARTICULAR FONT, STYLE, SIZE, OR COLOR.

FOR RETAIL STORE SERVICES FEATURING COOKWARE, KITCHENWARE AND DINING-RELATED PRODUCTS (U.S. CLS. 100, 101 AND 102).

FIRST USE 6-28-2010; IN COMMERCE 6-28-2010.

4,155,892. NEW ORLEANS EXCHANGE, INC., NEW ORLEANS, NJ. SN 85-205,620. FILED P.R. 12-25-2010; AM. S.R. 4-12-2012.

Green Sheets

THE MARK CONSISTS OF STANDARD CHARACTERS WITHOUT CLAIM TO ANY PARTICULAR FONT, STYLE, SIZE, OR COLOR.

FOR CONNECTING BUYERS AND SELLERS OF FINANCIAL ASSETS (U.S. CLS. 100, 101 AND 102).

FIRST USE 6-1-2009; IN COMMERCE 6-1-2009.

4,155,898. COLLABORATIVE FOR LEADERSHIP EXCELLENCE, CHICAGO, IL. SN 85-223,012. FILED P.R. 1-21-2011; AM. S.R. 3-30-2012.

COLLABORATIVE FOR LEADERSHIP EXCELLENCE

THE MARK CONSISTS OF STANDARD CHARACTERS WITHOUT CLAIM TO ANY PARTICULAR FONT, STYLE, SIZE, OR COLOR.

FOR BUSINESS AND MANAGEMENT CONSULTING FOR HEALTHCARE PROVIDERS; CONSULTING IN THE FIELDS OF HEALTHCARE OPERATIONS MANAGEMENT (U.S. CLS. 100, 101 AND 102).

FIRST USE 2-28-2011; IN COMMERCE 2-28-2011.

4,155,894. CU COOPERATIVE SYSTEMS, INC., RANCHO CUCAMONGA, CA. SN 85-208,982. FILED P.R. 1-3-2011; AM. S.R. 9-26-2011.

CO-OP MEMBER CENTER

THE MARK CONSISTS OF STANDARD CHARACTERS WITHOUT CLAIM TO ANY PARTICULAR FONT, STYLE, SIZE, OR COLOR.

OWNER OF U.S. REG. NOS. 2,497,862, 3,683,476, AND OTHERS.

NO CLAIM IS MADE TO THE EXCLUSIVE RIGHT TO USE "CENTER", APART FROM THE MARK AS SHOWN.

FOR OUTSOURCING IN THE FIELD OF CREDIT UNION CUSTOMER SERVICE TELEPHONE CALL CENTERS; OPERATION OF TELEPHONE CALL CENTERS FOR CREDIT UNIONS; OUTSOURCING CONSUMER LENDING SERVICES, NAMELY, PROVIDING OUTSOURCED LOAN ORIGINATION AND UNDERWRITING SERVICES FOR CREDIT UNIONS (U.S. CLS. 100, 101 AND 102).

FIRST USE 11-30-2009; IN COMMERCE 11-30-2009.

4,155,899. COLLABORATIVE FOR LEADERSHIP EXCELLENCE, CHICAGO, IL. SN 85-223,015. FILED P.R. 1-21-2011; AM. S.R. 3-30-2012.

COLLABORATIVE FOR HOSPITAL EXCELLENCE

THE MARK CONSISTS OF STANDARD CHARACTERS WITHOUT CLAIM TO ANY PARTICULAR FONT, STYLE, SIZE, OR COLOR.

FOR BUSINESS AND MANAGEMENT CONSULTING FOR HEALTHCARE PROVIDERS; CONSULTING IN THE FIELDS OF HEALTHCARE OPERATIONS MANAGEMENT (U.S. CLS. 100, 101 AND 102).

FIRST USE 2-28-2011; IN COMMERCE 2-28-2011.

CLASS 35—(Continued).

4,155,907. NOVELLUS HEALTHCARE COMMUNICATIONS, LLC, MONROE TOWNSHIP, NJ. SN 85-267,345. FILED P.R. 3-15-2011; AM. S.R. 3-20-2012.

**INFERTILITY & REPRODUCTIVE
NEWS**

THE MARK CONSISTS OF STANDARD CHARACTERS WITHOUT CLAIM TO ANY PARTICULAR FONT, STYLE, SIZE, OR COLOR.

FOR ADVERTISING SERVICES, NAMELY, PROVIDING ADVERTISING SPACE IN PRINT AND ELECTRONIC JOURNALS, MAGAZINES, NEWSLETTERS, FEATURE REPORTS, PRINT AND ELECTRONIC SUPPLEMENTS AND WEB SITES THAT CONCERN INFORMATION IN THE FIELDS OF OBSTETRICS, GYNECOLOGY, INFERTILITY, UROLOGY, ONCOLOGY, REPRODUCTIVE ENDOCRINOLOGY, REPRODUCTIVE MEDICINE AND NURSING (U.S. CLS. 100, 101 AND 102).

FIRST USE 6-0-2010; IN COMMERCE 1-0-2011.

4,155,912. HOOVER'S, INC., AUSTIN, TX. SN 85-286,597. FILED P.R. 4-5-2011; AM. S.R. 4-10-2012.

RELATIONSHIP MANAGER

THE MARK CONSISTS OF STANDARD CHARACTERS WITHOUT CLAIM TO ANY PARTICULAR FONT, STYLE, SIZE, OR COLOR.

FOR PROVIDING A WEB SITE FEATURING A WIDE VARIETY OF BUSINESS RESEARCH INFORMATION RELATED TO CURRENT BUSINESS NEWS, COMPANY AND INDUSTRY PROFILES, INVESTMENT INFORMATION, JOB SEARCHES, AND RELATED BUSINESS MATTERS; PREPARING MAILING LISTS; BUSINESS MARKETING SERVICES; PROVIDING BUSINESS LEAD GENERATION ACTIVITIES AND SERVICES; CUSTOMER RELATIONSHIP MANAGEMENT SERVICES; SALES PROMOTION SERVICES (U.S. CLS. 100, 101 AND 102).

FIRST USE 11-3-2008; IN COMMERCE 11-3-2008.

4,155,933. PROTRADA PTY LTD, SYDNEY, AUSTRALIA. SN 85-331,234. FILED P.R. 5-26-2011; AM. S.R. 11-10-2011.

THE DOMAIN EXCHANGE

THE MARK CONSISTS OF STANDARD CHARACTERS WITHOUT CLAIM TO ANY PARTICULAR FONT, STYLE, SIZE, OR COLOR.

CLASS 35—(Continued).

NO CLAIM IS MADE TO THE EXCLUSIVE RIGHT TO USE "DOMAIN", APART FROM THE MARK AS SHOWN.

FOR SERVICES RELATING TO THE ANALYSIS, EVALUATION, CREATION AND BRAND ESTABLISHMENT OF DOMAIN NAMES; ON-LINE AUCTION SERVICES FEATURING WEBSITES AND DOMAIN NAMES; BARTER EXCHANGE SERVICES, NAMELY, PROVIDING COMMERCIAL BARTER AND TRADE EXCHANGE OF WEBSITES AND DOMAINS VIA A GLOBAL COMPUTER INFORMATION NETWORK; DOMAIN BUYING AND SELLING SERVICES, NAMELY, FACILITATING THE LISTING OF DOMAINS FOR SALE ON THIRD PARTY PLATFORMS AND THE BIDDING AND BUYING OF DOMAINS FROM THIRD PARTY PLATFORMS (U.S. CLS. 100, 101 AND 102).

FIRST USE 4-1-2011; IN COMMERCE 5-1-2011.

4,155,950. STOCKWELL COMMUNICATIONS LLP, LONDON, UNITED KINGDOM. SN 85-349,253. FILED P.R. 6-17-2011; AM. S.R. 4-5-2012.

STOCKWELL

THE MARK CONSISTS OF STANDARD CHARACTERS WITHOUT CLAIM TO ANY PARTICULAR FONT, STYLE, SIZE, OR COLOR.

PRIORITY CLAIMED UNDER SEC. 44(D) ON UNITED KINGDOM APPLICATION NO. 2567476, FILED 12-20-2010, REG. NO. 2567476, DATED 4-22-2011, EXPIRES 12-20-2020.

FOR ADVERTISING SERVICES; BUSINESS RISK MANAGEMENT CONSULTATION; CONDUCTING MARKETING STUDIES; MARKET RESEARCH; PUBLIC RELATIONS (U.S. CLS. 100, 101 AND 102).

FIRST USE 12-1-2010; IN COMMERCE 5-1-2011.

4,155,959. SNEAKER CON EVENTS, NEW YORK, NY. SN 85-354,950. FILED P.R. 6-24-2011; AM. S.R. 4-2-2012.

SNEAKER CON

THE MARK CONSISTS OF STANDARD CHARACTERS WITHOUT CLAIM TO ANY PARTICULAR FONT, STYLE, SIZE, OR COLOR.

NO CLAIM IS MADE TO THE EXCLUSIVE RIGHT TO USE "CON", APART FROM THE MARK AS SHOWN.

FOR ORGANIZING AND CONDUCTING EXHIBITIONS AND TRADE FAIRS FEATURING SNEAKERS FOR BUSINESS AND PROMOTIONAL PURPOSES (U.S. CLS. 100, 101 AND 102).

FIRST USE 3-8-2008; IN COMMERCE 3-1-2009.

CLASS 35—(Continued).

4,155,984. BAMBOO MAUI INC., WAILUKU, HI. SN 85-388,667. FILED P.R. 8-3-2011; AM. S.R. 4-6-2012.

BAMBOO MAUI

THE MARK CONSISTS OF STANDARD CHARACTERS WITHOUT CLAIM TO ANY PARTICULAR FONT, STYLE, SIZE, OR COLOR.

FOR RETAIL STORE SERVICES FEATURING BAMBOO FLOORING, FURNITURE, STRUCTURAL PANELS, FENCING, MILLWORK, AND COUNTERTOPS, AS WELL AS HARDWOOD AND CORK FLOORING; FLOORING UNDERLAYMENT, GLUES, AND FINISH MATERIALS; AND ENVIRONMENTALLY CONSCIOUS, SUSTAINABLY HARVESTED FLOORING AND RELATED MATERIALS (U.S. CLS. 100, 101 AND 102).

FIRST USE 1-0-2010; IN COMMERCE 1-0-2010.

4,155,991. CODA PARTNERS, INC., DADE CITY, FL. SN 85-412,275. FILED P.R. 8-31-2011; AM. S.R. 3-12-2012.

Leader P.O.V.

THE MARK CONSISTS OF STANDARD CHARACTERS WITHOUT CLAIM TO ANY PARTICULAR FONT, STYLE, SIZE, OR COLOR.

FOR BUSINESS CONSULTING SERVICES IN THE FIELD OF BUSINESS MANAGEMENT, ORGANIZATIONAL AND LEADERSHIP DEVELOPMENT (U.S. CLS. 100, 101 AND 102).

FIRST USE 2-0-2009; IN COMMERCE 2-0-2009.

4,155,996. B2B PROSPECTING, LLC, DBA THE B2B PROSPECTING SOURCE, KERRVILLE, TX. SN 85-427,691. FILED P.R. 9-20-2011; AM. S.R. 4-6-2012.

The B2B Prospecting Source

THE MARK CONSISTS OF STANDARD CHARACTERS WITHOUT CLAIM TO ANY PARTICULAR FONT, STYLE, SIZE, OR COLOR.

FOR APPOINTMENT SCHEDULING SERVICES (U.S. CLS. 100, 101 AND 102).

FIRST USE 2-1-2011; IN COMMERCE 2-1-2011.

CLASS 35—(Continued).

4,156,016. HANSEN, CATHY, DBA GLAMPERS, TEXAS CITY, TX. AND LYNELL CRAWFORD, DBA GLAMPERS, TEXAS CITY, TX. SN 85-461,774. FILED P.R. 11-1-2011; AM. S.R. 4-5-2012.

Glampers

THE MARK CONSISTS OF STANDARD CHARACTERS WITHOUT CLAIM TO ANY PARTICULAR FONT, STYLE, SIZE, OR COLOR.

FOR CLUB SERVICES, NAMELY, PROMOTING THE INTERESTS OF CAMPING (U.S. CLS. 100, 101 AND 102).

FIRST USE 2-2-2012; IN COMMERCE 2-2-2012.

4,156,023. UNIFIED PURCHASING GROUP, LLC, SOUTH JORDAN, UT. SN 85-471,519. FILED P.R. 11-14-2011; AM. S.R. 4-12-2012.

UNIFIED PURCHASING GROUP

THE MARK CONSISTS OF STANDARD CHARACTERS WITHOUT CLAIM TO ANY PARTICULAR FONT, STYLE, SIZE, OR COLOR.

NO CLAIM IS MADE TO THE EXCLUSIVE RIGHT TO USE "PURCHASING GROUP", APART FROM THE MARK AS SHOWN.

FOR BUSINESS SERVICES, NAMELY, COMBINED STRATEGIC GOODS OR SERVICES SOURCING AND COOPERATIVE PURCHASING FOR OTHERS; ADMINISTERING GROUP PURCHASING PROGRAMS, NAMELY, NEGOTIATING CONTRACTS WITH VENDORS AND SUPPLIERS TO ENABLE ASSOCIATION MEMBERS TO OBTAIN GROUP PURCHASING DISCOUNTS AND ROYALTIES (U.S. CLS. 100, 101 AND 102).

FIRST USE 1-1-2008; IN COMMERCE 1-1-2008.

4,156,032. MATTRESS DEPOT USA, INC, BELLEVUE, WA. SN 85-480,029. FILED P.R. 11-23-2011; AM. S.R. 4-6-2012.

**LOW PRICES EVERYDAY AT
MATTRESS DEPOT USA**

THE MARK CONSISTS OF STANDARD CHARACTERS WITHOUT CLAIM TO ANY PARTICULAR FONT, STYLE, SIZE, OR COLOR.

FOR RETAIL STORE AND ON-LINE RETAIL STORE SERVICES FEATURING MATTRESSES, BOX SPRINGS, HEAD BOARDS, BED FRAMES, BUNK BEDS, DAY BEDS, AND SLEEPERS (U.S. CLS. 100, 101 AND 102).

FIRST USE 2-1-2009; IN COMMERCE 2-1-2009.

CLASS 35—(Continued).

4,156,034. CRT INC., DBA DAVIS DISTRIBUTION SYSTEMS, NEWELL, WV. SN 85-482,304. FILED P.R. 11-29-2011; AM. S.R. 3-29-2012.

CLASS 35—(Continued).

4,156,050. PAYANO, ALLEN, JERSEY CITY, NJ. SN 85-500,435. FILED P.R. 12-20-2011; AM. S.R. 4-4-2012.

Easter Crosses

THE MARK CONSISTS OF STANDARD CHARACTERS WITHOUT CLAIM TO ANY PARTICULAR FONT, STYLE, SIZE, OR COLOR.

NO CLAIM IS MADE TO THE EXCLUSIVE RIGHT TO USE "CROSSES", APART FROM THE MARK AS SHOWN.

FOR WHOLESALE DISTRIBUTORSHIPS FEATURING PLASTIC AND WOODEN CROSSES (U.S. CLS. 100, 101 AND 102).

FIRST USE 10-27-2011; IN COMMERCE 10-27-2011.

4,156,040. PHILIP LAW INC, NEWPORT BEACH, CA. SN 85-487,744. FILED P.R. 12-6-2011; AM. S.R. 4-11-2012.

GET CLIENTS WITH PRESENTATIONS

THE MARK CONSISTS OF STANDARD CHARACTERS WITHOUT CLAIM TO ANY PARTICULAR FONT, STYLE, SIZE, OR COLOR.

FOR BUSINESS MANAGEMENT CONSULTING SERVICES TO FINANCIAL INSTITUTIONS AND PROFESSIONAL SERVICE FIRMS IN THE FIELD OF THE CONTENT, DATA-GRAPHICS AND DELIVERY OF ORAL SALES PRESENTATIONS TO PROSPECTIVE CLIENTS (U.S. CLS. 100, 101 AND 102).

FIRST USE 11-30-2011; IN COMMERCE 11-30-2011.

4,156,048. AMERICAN MADE DORM, LLC, LOUISVILLE, KY. SN 85-498,260. FILED P.R. 12-18-2011; AM. S.R. 4-6-2012.

American Made Dorm

THE MARK CONSISTS OF STANDARD CHARACTERS WITHOUT CLAIM TO ANY PARTICULAR FONT, STYLE, SIZE, OR COLOR.

NO CLAIM IS MADE TO THE EXCLUSIVE RIGHT TO USE "DORM", APART FROM THE MARK AS SHOWN.

FOR COMPUTERIZED ON-LINE RETAIL STORE SERVICES IN THE FIELD OF BEDDING, LINENS, AND DORM ROOM DECOR, ALL MANUFACTURED IN THE UNITED STATES OF AMERICA (U.S. CLS. 100, 101 AND 102).

FIRST USE 10-3-2011; IN COMMERCE 11-15-2011.

Payano

THE MARK CONSISTS OF STANDARD CHARACTERS WITHOUT CLAIM TO ANY PARTICULAR FONT, STYLE, SIZE, OR COLOR.

FOR ADVERTISING, MARKETING AND PROMOTION SERVICES IN THE FIELD OF DIGITAL AND SOCIAL MEDIA AND FILM PRODUCTION (U.S. CLS. 100, 101 AND 102).

FIRST USE 12-24-2011; IN COMMERCE 12-24-2011.

4,156,052. WENDT COMMUNICATION PARTNERS LLC, MECHANICSBURG, PA. SN 85-501,873. FILED P.R. 12-22-2011; AM. S.R. 4-4-2012.

Brand-Driven Leadership

THE MARK CONSISTS OF STANDARD CHARACTERS WITHOUT CLAIM TO ANY PARTICULAR FONT, STYLE, SIZE, OR COLOR.

FOR ADVERTISING AND MARKETING; ADVERTISING SERVICES, NAMELY, CREATING CORPORATE AND BRAND IDENTITY FOR OTHERS (U.S. CLS. 100, 101 AND 102).

FIRST USE 7-0-2009; IN COMMERCE 7-0-2009.

CLASS 35—(Continued).

4,156,065. OMNIBIN, BARRINGTON, IL. SN 85-508,569.
FILED P.R. 1-4-2012; AM. S.R. 4-9-2012.

Pay Per Insert

THE MARK CONSISTS OF STANDARD CHARACTERS WITHOUT CLAIM TO ANY PARTICULAR FONT, STYLE, SIZE, OR COLOR.

FOR ADVERTISING AND PROMOTIONAL SERVICES ON BEHALF OF OTHERS; PROMOTIONAL SERVICES, NAMELY, PROMOTING THE GOODS AND SERVICES OF OTHERS THROUGH ELECTRONIC MAIL, CALENDAR LISTINGS, ANNOUNCEMENTS, ALERTS, REMINDERS, SUBSCRIPTIONS, AUDIO, VIDEO AND GRAPHICS OVER THE INTERNET OR OTHER COMMUNICATION NETWORK; DEVELOPING AND PROVIDING MARKETING PROGRAMS FOR ADVERTISERS, MARKETERS, AND CONTENT PROVIDERS; PROVIDING A WEBSITE WHERE ADVERTISERS, MARKETERS, AND CONTENT PROVIDERS CAN REACH, ENGAGE, AND INTERACT WITH ONLINE USERS FOR THE PURPOSES OF PROMOTION OR ADVERTISING (U.S. CLS. 100, 101 AND 102).
FIRST USE 9-22-2010; IN COMMERCE 10-26-2010.

4,156,074. IRENKO AUTO SALES CORP, MIAMI, FL. SN 85-522,732. FILED P.R. 1-23-2012; AM. S.R. 5-1-2012.

TU DEALER VENEZOLANO

THE MARK CONSISTS OF STANDARD CHARACTERS WITHOUT CLAIM TO ANY PARTICULAR FONT, STYLE, SIZE, OR COLOR.

NO CLAIM IS MADE TO THE EXCLUSIVE RIGHT TO USE "DEALER", APART FROM THE MARK AS SHOWN.

THE ENGLISH TRANSLATION OF "TU DEALER VENEZOLANO" IN THE MARK IS "YOUR VENEZUELAN DEALER".

FOR AUTOMOBILE DEALERSHIPS (U.S. CLS. 100, 101 AND 102).

FIRST USE 1-1-2012; IN COMMERCE 1-1-2012.

CLASS 36—INSURANCE AND FINANCIAL**CLASS 36—(Continued).**

4,155,969. QBI, LLC, DBA QUALIFIED BENEFITS, WOODLAND HILLS, CA. SN 85-363,507. FILED P.R. 7-5-2011; AM. S.R. 4-5-2012.

QUALIFIED BENEFITS

THE MARK CONSISTS OF STANDARD CHARACTERS WITHOUT CLAIM TO ANY PARTICULAR FONT, STYLE, SIZE, OR COLOR.

NO CLAIM IS MADE TO THE EXCLUSIVE RIGHT TO USE "BENEFITS", APART FROM THE MARK AS SHOWN. FOR FINANCIAL ADMINISTRATION OF RETIREMENT PLANS (U.S. CLS. 100, 101 AND 102).

FIRST USE 2-0-2010; IN COMMERCE 2-0-2010.

4,155,971. US MASTERS RESIDENTIAL PROPERTY (USA) FUND, JERSEY CITY, NJ. SN 85-364,519. FILED P.R. 7-6-2011; AM. S.R. 4-6-2012.

NJCASHFORHOMES.COM

THE MARK CONSISTS OF STANDARD CHARACTERS WITHOUT CLAIM TO ANY PARTICULAR FONT, STYLE, SIZE, OR COLOR.

FOR REAL ESTATE ACQUISITION SERVICES (U.S. CLS. 100, 101 AND 102).

FIRST USE 7-1-2011; IN COMMERCE 7-1-2011.

4,156,013. BRUNO, STEPHANIE, DENVER, CO. SN 85-453,444. FILED P.R. 10-21-2011; AM. S.R. 3-28-2012.

Private Wealth Retreat

THE MARK CONSISTS OF STANDARD CHARACTERS WITHOUT CLAIM TO ANY PARTICULAR FONT, STYLE, SIZE, OR COLOR.

CLASS 36—(Continued).

NO CLAIM IS MADE TO THE EXCLUSIVE RIGHT TO USE "PRIVATE WEALTH", APART FROM THE MARK AS SHOWN.

FOR PROVIDING INFORMATION AND ADVICE IN THE FIELD OF FINANCE, FINANCIAL INVESTMENTS, FINANCIAL VALUATIONS, AND THE FINANCIAL ASPECTS OF RETIREMENT; FINANCIAL SERVICES, NAMELY, INVESTMENT ADVICE AND INVESTMENT MANAGEMENT; FINANCIAL SERVICES, NAMELY, PROVIDING CONSULTATION, INFORMATION, AND ADVICE IN THE FIELDS OF WEALTH BUILDING, WEALTH PROTECTION, AND ASSET PROTECTION; INVESTMENT CONSULTATION AND INVESTMENT OF FUNDS FOR OTHERS, INCLUDING PRIVATE AND PUBLIC EQUITY AND DEBT INVESTMENT SERVICES; FINANCIAL ADVICE AND CONSULTANCY SERVICES; FINANCIAL SERVICES, NAMELY, WEALTH MANAGEMENT SERVICES AND PERSONAL FINANCE ADVICE; PROVIDING ADVICE RELATING TO INVESTMENTS AND FINANCIAL GOAL-SETTING (U.S. CLS. 100, 101 AND 102).

FIRST USE 6-1-2011; IN COMMERCE 6-1-2011.

4,156,014. DEMETER POWER GROUP, INC., WEST PALM BEACH, FL. SN 85-457,074. FILED P.R. 10-26-2011; AM. S.R. 3-15-2012.

PACE3P

THE MARK CONSISTS OF STANDARD CHARACTERS WITHOUT CLAIM TO ANY PARTICULAR FONT, STYLE, SIZE, OR COLOR.

FOR FINANCING SERVICES, NAMELY, A THIRD-PARTY OWNERSHIP FINANCING PROGRAM OFFERED TO A PROPERTY OWNER FOR IMPROVEMENTS TO PROPERTY THROUGH A "PROPERTY ASSESSED CLEAN ENERGY" OR "PACE" PROGRAM OR SIMILAR PROGRAM THAT UTILIZES A LOCAL GOVERNMENT'S AUTHORITY TO PROVIDE FINANCING TO A PROPERTY OWNER AND OBTAIN REPAYMENT THROUGH A GOVERNMENTAL ASSESSMENT OR OTHER COLLECTION MECHANISM (U.S. CLS. 100, 101 AND 102).

FIRST USE 12-8-2011; IN COMMERCE 12-8-2011.

4,156,028. REVERSE MORTGAGE USA, INC., AUSTIN, TX. SN 85-474,391. FILED 11-16-2011.

REVERSE MORTGAGE USA

THE MARK CONSISTS OF STANDARD CHARACTERS WITHOUT CLAIM TO ANY PARTICULAR FONT, STYLE, SIZE, OR COLOR.

CLASS 36—(Continued).

NO CLAIM IS MADE TO THE EXCLUSIVE RIGHT TO USE "REVERSE MORTGAGE", APART FROM THE MARK AS SHOWN.

FOR MAINTAINING MORTGAGE ESCROW ACCOUNTS; MORTGAGE BANKING; MORTGAGE BANKING SERVICES, NAMELY, ORIGINATION, ACQUISITION, SERVICING, SECURITIZATION AND BROKERAGE OF MORTGAGE LOANS; MORTGAGE BROKERAGE; MORTGAGE LENDING; MORTGAGE PROCUREMENT FOR OTHERS; MORTGAGE SERVICES, NAMELY, BUYER PRE-QUALIFICATION OF MORTGAGES FOR MORTGAGE BROKERS AND BANKS (U.S. CLS. 100, 101 AND 102).

FIRST USE 9-19-2011; IN COMMERCE 9-19-2011.

4,156,049. PROMONTORY INTERFINANCIAL NETWORK, LLC, ARLINGTON, VA. SN 85-498,932. FILED 12-19-2011.

INSURED CASH SWEEP

THE MARK CONSISTS OF STANDARD CHARACTERS WITHOUT CLAIM TO ANY PARTICULAR FONT, STYLE, SIZE, OR COLOR.

OWNER OF U.S. REG. NO. 4,053,744.

NO CLAIM IS MADE TO THE EXCLUSIVE RIGHT TO USE "CASH SWEEP", APART FROM THE MARK AS SHOWN.

FOR BANKING SERVICES; FINANCIAL SERVICES, NAMELY, ASSISTING FINANCIAL INSTITUTIONS WITH THE MANAGEMENT OF CUSTOMER FUNDS AND FACILITATING THE TRANSFER OF FUNDS BETWEEN FUND SOURCES AND DEPOSIT ACCOUNTS; FINANCIAL SERVICES, NAMELY, THE MANAGEMENT OF DEPOSIT ACCOUNTS AND FACILITATING THE TRANSFER OF FUNDS BETWEEN FUND SOURCES AND DEPOSIT ACCOUNTS; FINANCIAL SERVICES, NAMELY, FUNDS TRANSFER AND TRANSACTION SERVICES; FINANCIAL SERVICES, NAMELY, ALLOCATION OF FUNDS TO AND PLACEMENT OF FUNDS IN DEPOSIT ACCOUNTS; FINANCIAL TRANSACTION SERVICES, NAMELY, MAINTAINING CUSTOMER RECORDS FOR FINANCIAL TRANSACTIONS, CUSTODIAL AND SUB-CUSTODIAL SERVICES, AND SETTLEMENT SERVICES; FDIC INSURANCE CLAIM PROCESSING SERVICES (U.S. CLS. 100, 101 AND 102).

FIRST USE 0-0-2010; IN COMMERCE 0-0-2010.

4,156,056. HOPEGIVERS INTERNATIONAL, INC., COLUMBUS, GA. SN 85-506,223. FILED P.R. 12-30-2011; AM. S.R. 4-6-2012.

DOWRY CASTAWAYS

THE MARK CONSISTS OF STANDARD CHARACTERS WITHOUT CLAIM TO ANY PARTICULAR FONT, STYLE, SIZE, OR COLOR.

FOR CHARITABLE FUND RAISING SERVICES (U.S. CLS. 100, 101 AND 102).

FIRST USE 9-19-2011; IN COMMERCE 9-19-2011.

CLASS 36—(Continued).

4,156,058. DOERR REALTY, SAN ANTONIO, TX. SN 85-506,646. FILED P.R. 12-30-2011; AM. S.R. 4-9-2012.

Doerr Realty

THE MARK CONSISTS OF STANDARD CHARACTERS WITHOUT CLAIM TO ANY PARTICULAR FONT, STYLE, SIZE, OR COLOR.

NO CLAIM IS MADE TO THE EXCLUSIVE RIGHT TO USE "REALTY", APART FROM THE MARK AS SHOWN.

FOR REAL ESTATE BROKERAGE (U.S. CLS. 100, 101 AND 102).

FIRST USE 2-26-2009; IN COMMERCE 2-26-2009.

4,156,069. INTRINSIC VALUATION, DENVER, CO. SN 85-513,875. FILED 1-11-2012.

INTRINSIC VALUATION

THE MARK CONSISTS OF STANDARD CHARACTERS WITHOUT CLAIM TO ANY PARTICULAR FONT, STYLE, SIZE, OR COLOR.

FOR BUSINESS VALUATION SERVICES NAMELY, TRANSACTION SUPPORT, VALUATIONS FOR FINANCIAL REPORTING, SUCCESSION AND SHAREHOLDER PLANNING, EXPERT OPINIONS, AND CORPORATE TAX COMPLIANCE (U.S. CLS. 100, 101 AND 102).

FIRST USE 1-1-2010; IN COMMERCE 1-1-2010.

CLASS 37—CONSTRUCTION AND REPAIR

4,155,849. DISCOUNT CLOSETS, INC., MIAMI, FL. SN 76-705,776. FILED P.R. 12-23-2010; AM. S.R. 10-7-2011.

DISCOUNT CLOSETS

THE MARK CONSISTS OF STANDARD CHARACTERS WITHOUT CLAIM TO ANY PARTICULAR FONT, STYLE, SIZE, OR COLOR.

NO CLAIM IS MADE TO THE EXCLUSIVE RIGHT TO USE "CLOSETS", APART FROM THE MARK AS SHOWN.

FOR CUSTOM BUILDING OF CLOSETS; INSTALLATION OF SHELVING AND CABINETS FOR CLOSETS (U.S. CLS. 100, 103 AND 106).

FIRST USE 6-1-1998; IN COMMERCE 6-1-1998.

CLASS 37—(Continued).

4,155,867. ORKIN EXPANSION, INC., WILMINGTON, DE. SN 85-049,124. FILED P.R. 5-27-2010; AM. S.R. 4-20-2012.

PEST 411

THE MARK CONSISTS OF STANDARD CHARACTERS WITHOUT CLAIM TO ANY PARTICULAR FONT, STYLE, SIZE, OR COLOR.

NO CLAIM IS MADE TO THE EXCLUSIVE RIGHT TO USE "PEST", APART FROM THE MARK AS SHOWN.

FOR PROVIDING A PORTAL VIA MOBILE DEVICES AND THE INTERNET FEATURING A PEST CONTROL DATABASE FOR IDENTIFICATION OF INSECTS AND RODENTS FROM A LIBRARY OF PICTURES AND FACTS ABOUT SPECIFIC INSECT AND RODENT THREATS AND HABITS (U.S. CLS. 100, 103 AND 106).

FIRST USE 4-15-2009; IN COMMERCE 4-15-2009.

4,155,868. AERONAUTICAL SYSTEMS, INCORPORATED, STERLING, VA. SN 85-061,330. FILED P.R. 6-12-2010; AM. S.R. 3-28-2012.

AERONAUTICAL SYSTEMS

THE MARK CONSISTS OF STANDARD CHARACTERS WITHOUT CLAIM TO ANY PARTICULAR FONT, STYLE, SIZE, OR COLOR.

OWNER OF U.S. REG. NOS. 4,094,745, 4,120,282, AND OTHERS.

FOR REPAIR AND MAINTENANCE OF AIRCRAFT, EACH EXCLUDING AS SUCH RELATES TO UNMANNED DRONES (U.S. CLS. 100, 103 AND 106).

FIRST USE 10-17-1988; IN COMMERCE 10-17-1988.

4,155,922. UPWARD ARROW, LLC, PHILADELPHIA, PA. SN 85-310,042. FILED P.R. 5-2-2011; AM. S.R. 2-16-2012.

EraseMyLaptop

THE MARK CONSISTS OF STANDARD CHARACTERS WITHOUT CLAIM TO ANY PARTICULAR FONT, STYLE, SIZE, OR COLOR.

FOR COMPUTER SERVICES, NAMELY, COMPUTER HARDWARE MAINTENANCE AND REFURBISHING SERVICES, NAMELY, ERASING OF FILES, STORAGE MEDIA AND COMPUTER MEMORIES; COMPUTER HARDWARE DISPOSAL (U.S. CLS. 100, 103 AND 106).

FIRST USE 12-1-2009; IN COMMERCE 4-5-2010.

CLASS 37—(Continued).

4,156,010. NATIONWIDE CARPET UPHOLSTERY & TILE CLEANING, INC. WEST PALM BEACH, FL. SN 85-452,568. FILED P.R. 10-20-2011; AM. S.R. 4-25-2012.



NO CLAIM IS MADE TO THE EXCLUSIVE RIGHT TO USE "CARPET & UPHOLSTERY CLEANING", APART FROM THE MARK AS SHOWN.

THE MARK CONSISTS OF AN IMAGE OF THE CONTINENTAL UNITED STATES WITH THE STYLIZED TEXT "NATIONWIDE CARPET & UPHOLSTERY CLEANING" OVERLAPPING IT, WHERE "NATIONWIDE" APPEARS ABOVE "CARPET & UPHOLSTERY CLEANING".

FOR CARPET CLEANING (U.S. CLS. 100, 103 AND 106).

FIRST USE 1-20-1999; IN COMMERCE 10-28-2002.

4,156,066. CYGNUS BUSINESS MEDIA, INC., FORT ATKINSON, WI. SN 85-509,251. FILED 1-5-2012.

FORCONSTRUCTIONPROS.COM

THE MARK CONSISTS OF STANDARD CHARACTERS WITHOUT CLAIM TO ANY PARTICULAR FONT, STYLE, SIZE, OR COLOR.

FOR PROVIDING A WEB SITE FEATURING NEWS AND INFORMATION IN THE CONSTRUCTION FIELD (U.S. CLS. 100, 103 AND 106).

FIRST USE 3-0-2005; IN COMMERCE 3-0-2005.

4,156,068. CETANI, MATT, MORGAN HILL, CA. SN 85-511,812. FILED P.R. 1-9-2012; AM. S.R. 4-11-2012.

NORTHERN CALIFORNIA FIRE PROTECTION INDUSTRY

THE MARK CONSISTS OF STANDARD CHARACTERS WITHOUT CLAIM TO ANY PARTICULAR FONT, STYLE, SIZE, OR COLOR.

FOR BUILDING CONSTRUCTION SERVICES, NAMELY, INSTALLATION, TESTING, MAINTENANCE, AND REPAIR OF FIRE SPRINKLERS, STANDPIPES, AND FIRE PUMP SYSTEMS (U.S. CLS. 100, 103 AND 106).

FIRST USE 4-1-2010; IN COMMERCE 4-1-2010.

CLASS 38—COMMUNICATION

4,155,911. JOINT COMMISSION ON ACCREDITATION OF HEALTHCARE ORGANIZATIONS, OAKBROOK TERRACE, IL. SN 85-273,094. FILED P.R. 3-22-2011; AM. S.R. 3-27-2012.

CORE MEASURE SOLUTION EXCHANGE

THE MARK CONSISTS OF STANDARD CHARACTERS WITHOUT CLAIM TO ANY PARTICULAR FONT, STYLE, SIZE, OR COLOR.

NO CLAIM IS MADE TO THE EXCLUSIVE RIGHT TO USE "EXCHANGE", APART FROM THE MARK AS SHOWN.

FOR PROVIDING AN ON-LINE FORUM FOR EXCHANGING INFORMATION AMONGST HEALTHCARE PROFESSIONALS (U.S. CLS. 100, 101 AND 104).

FIRST USE 4-30-2011; IN COMMERCE 4-30-2011.

4,155,934. VELOCITY INTERNATIONAL, INC., PITTSBURGH, PA. SN 85-331,988. FILED P.R. 5-27-2011; AM. S.R. 4-13-2012.

HD₂PC

THE COLOR(S) RED, WHITE, GRAY, AND BLACK IS/ ARE CLAIMED AS A FEATURE OF THE MARK.

THE MARK CONSISTS OF "HD" IN RED LETTERS SEPARATED BY A VERTICAL LINE AND A SUBSCRIPT "2" IN GRAY FROM THE LETTERS "PC" IN WHITE OUTLINED IN BLACK.

FOR AUDIO AND VIDEO BROADCASTING SERVICES OVER THE INTERNET; AUDIO AND VIDEO BROADCASTING SERVICES OVER THE INTERNET IN THE FIELD OF PRIVATE EVENT BROADCASTING; BROADCASTING PROGRAMS VIA A GLOBAL COMPUTER NETWORK; INTERNET BROADCASTING SERVICES; VIDEO BROADCASTING; WEBCASTING SERVICES (U.S. CLS. 100, 101 AND 104).

FIRST USE 2-15-2011; IN COMMERCE 2-15-2011.

4,155,937. DIRECTIONAL NETWORKS, LLC, APEX, NC. SN 85-332,934. FILED P.R. 5-27-2011; AM. S.R. 3-15-2012.

DIRECTIONAL NETWORKS

THE MARK CONSISTS OF STANDARD CHARACTERS WITHOUT CLAIM TO ANY PARTICULAR FONT, STYLE, SIZE, OR COLOR.

CLASS 38—(Continued).

NO CLAIM IS MADE TO THE EXCLUSIVE RIGHT TO USE "NETWORKS", APART FROM THE MARK AS SHOWN.
 FOR TELECOMMUNICATIONS, NAMELY, SATELLITE TELEVISION BROADCASTING, WIRED AND WIRELESS INTERNET SERVICE PROVIDER AND IP BASED DATA SERVICES, NAMELY, VOICE OVER IP SERVICES (U.S. CLS. 100, 101 AND 104).
 FIRST USE 5-5-2011; IN COMMERCE 5-5-2011.

CLASS 40—(Continued).

4,156,015. SPRINGBOARD DEVELOPMENT COMPANY INC., ROCHESTER, MN. SN 85-457,610. FILED P.R. 10-27-2011; AM. S.R. 3-27-2012.

CLASS 39—TRANSPORTATION AND STORAGE

4,155,924. AMERICAN RIDER, LLC., MIAMI, FL. SN 85-315,608. FILED P.R. 5-9-2011; AM. S.R. 2-6-2012.

AMERICAN RIDER

THE MARK CONSISTS OF STANDARD CHARACTERS WITHOUT CLAIM TO ANY PARTICULAR FONT, STYLE, SIZE, OR COLOR.
 FOR ARRANGING TRAVEL TOURS; MOTORCYCLE RENTAL; ORGANIZATION OF TRAVEL (U.S. CLS. 100 AND 105).
 FIRST USE 6-8-2009; IN COMMERCE 6-8-2009.

4,155,978. CLEARWATER BEACH TRAVEL, LLC, CLEARWATER BEACH, FL. SN 85-376,638. FILED P.R. 7-20-2011; AM. S.R. 4-30-2012.

Green Building Travel

THE MARK CONSISTS OF STANDARD CHARACTERS WITHOUT CLAIM TO ANY PARTICULAR FONT, STYLE, SIZE, OR COLOR.
 NO CLAIM IS MADE TO THE EXCLUSIVE RIGHT TO USE "GREEN" AND "TRAVEL", APART FROM THE MARK AS SHOWN.
 FOR TRAVEL AGENCY SERVICES, NAMELY, MAKING RESERVATIONS AND BOOKINGS FOR TRANSPORTATION (U.S. CLS. 100 AND 105).
 FIRST USE 5-14-2011; IN COMMERCE 5-14-2011.

CLASS 40—MATERIAL TREATMENT

AFFORDABLEBUTTONS

THE MARK CONSISTS OF STANDARD CHARACTERS WITHOUT CLAIM TO ANY PARTICULAR FONT, STYLE, SIZE, OR COLOR.
 OWNER OF U.S. REG. NO. 3,711,517.
 FOR CUSTOM IMPRINTING OF PIN BACKED BUTTONS WITH MESSAGES; CUSTOM MANUFACTURE OF PIN BACKED BUTTONS (U.S. CLS. 100, 103 AND 106).
 FIRST USE 9-1-2003; IN COMMERCE 9-1-2003.

4,156,046. LANDA MOBILE SYSTEMS LLC, WEST FORK, AR. SN 85-492,365. FILED 12-11-2011.

Landa Mobile Systems

THE MARK CONSISTS OF STANDARD CHARACTERS WITHOUT CLAIM TO ANY PARTICULAR FONT, STYLE, SIZE, OR COLOR.
 NO CLAIM IS MADE TO THE EXCLUSIVE RIGHT TO USE "MOBILE SYSTEMS", APART FROM THE MARK AS SHOWN.
 FOR CUSTOM MANUFACTURE OF PORTABLE COMMUNICATIONS TOWERS ON TRAILERS FOR OTHERS (U.S. CLS. 100, 103 AND 106).
 FIRST USE 9-1-2011; IN COMMERCE 9-1-2011.

CLASS 41—EDUCATION AND ENTERTAINMENT

CLASS 41—(Continued).

4,155,858. BFI BUSINESS FINANCE, CAMPBELL, CA. SN 77-825,790. FILED P.R. 9-14-2009; AM. S.R. 2-24-2012.

Cars.TV

THE MARK CONSISTS OF STANDARD CHARACTERS WITHOUT CLAIM TO ANY PARTICULAR FONT, STYLE, SIZE, OR COLOR.

FOR ENTERTAINMENT SERVICES, NAMELY, ONGOING TELEVISION PROGRAMS IN THE FIELD OF AUTOMOBILES; ONGOING TELEVISION PROGRAMS PRESENTED ON THE INTERNET IN THE FIELD OF AUTOMOBILES; PROVIDING ENTERTAINMENT AND INFORMATIONAL PROGRAMMING IN THE FIELD OF AUTOMOBILES ACCESSIBLE BY INTERNET (U.S. CLS. 100, 101 AND 107).

FIRST USE 11-0-2009; IN COMMERCE 11-0-2009.

4,155,888. FISHER, FREDRICK, GREENSBORO, NC. SN 85-203,544. FILED P.R. 12-22-2010; AM. S.R. 4-7-2012.

E-QUALITY PRESS

THE MARK CONSISTS OF STANDARD CHARACTERS WITHOUT CLAIM TO ANY PARTICULAR FONT, STYLE, SIZE, OR COLOR.

OWNER OF U.S. REG. NO. 3,997,463.

NO CLAIM IS MADE TO THE EXCLUSIVE RIGHT TO USE "PRESS", APART FROM THE MARK AS SHOWN.

FOR PUBLICATION OF E-BOOKS, NAMELY, E-BOOKS CONTAINING NOVELS AND/OR STORIES, EITHER SINGLY OR IN COLLECTIONS AND EXCLUDING PUBLICATION OF PRINTED MATERIALS AND ANY AND ALL MATERIALS PERTAINING TO QUALITY OR QUALITY ISSUES (U.S. CLS. 100, 101 AND 107).

FIRST USE 3-3-2010; IN COMMERCE 11-24-2010.

CLASS 41—(Continued).

4,155,901. QAI TRAINING, LLC, DBA QAI, LLC, INDIANAPOLIS, IN. SN 85-231,921. FILED P.R. 2-2-2011; AM. S.R. 11-1-2011.

THE ISO14000 ADVISOR

THE MARK CONSISTS OF STANDARD CHARACTERS WITHOUT CLAIM TO ANY PARTICULAR FONT, STYLE, SIZE, OR COLOR.

FOR BUSINESS TRAINING AND PROVIDING A WEBSITE FEATURING NON-DOWNLOADABLE EDUCATIONAL VIDEOS IN THE FIELDS OF BUSINESS TRAINING AND BUSINESS MANAGEMENT TRAINING (U.S. CLS. 100, 101 AND 107).

FIRST USE 10-31-2011; IN COMMERCE 10-31-2011.

4,155,902. RUZYLLO, JERZY, STATE COLLEGE, PA. SN 85-232,643. FILED P.R. 2-2-2011; AM. S.R. 4-28-2012.

SEMICONDUCTOR HALL OF FAME

THE MARK CONSISTS OF STANDARD CHARACTERS WITHOUT CLAIM TO ANY PARTICULAR FONT, STYLE, SIZE, OR COLOR.

NO CLAIM IS MADE TO THE EXCLUSIVE RIGHT TO USE "HALL OF FAME", APART FROM THE MARK AS SHOWN.

FOR ORGANIZATION OF EXHIBITIONS FOR CULTURAL OR EDUCATIONAL PURPOSES (U.S. CLS. 100, 101 AND 107).

FIRST USE 1-1-2004; IN COMMERCE 4-1-2012.

4,155,904. NEW FREEDOM HOLDINGS LLC, CAREFREE, AZ. SN 85-255,962. FILED P.R. 3-2-2011; AM. S.R. 10-5-2011.

PROFESSIONAL IMPROVEMENT PROGRAM

THE MARK CONSISTS OF STANDARD CHARACTERS WITHOUT CLAIM TO ANY PARTICULAR FONT, STYLE, SIZE, OR COLOR.

FOR (BASED ON USE IN COMMERCE) PROVIDING INSTRUCTIONAL SERVICES, NAMELY, WORKSHOPS, SEMINARS, AND CLASSES THAT FOCUS ON GOAL ACHIEVEMENT FOR THERAPISTS; (BASED ON INTENT TO USE) PROVIDING INSTRUCTIONAL SERVICES, NAMELY, WORKSHOPS, SEMINARS, AND CLASSES THAT FOCUS ON GOAL ACHIEVEMENT FOR CORPORATE ENTITIES (U.S. CLS. 100, 101 AND 107).

FIRST USE 9-12-2006; IN COMMERCE 9-12-2006.

CLASS 41—(Continued).

4,155,905. MARKETING RESEARCH ASSOCIATION, INC., WASHINGTON, DC. SN 85-263,156. FILED P.R. 3-10-2011; AM. S.R. 7-6-2011.

Corporate Researchers Conference

THE MARK CONSISTS OF STANDARD CHARACTERS WITHOUT CLAIM TO ANY PARTICULAR FONT, STYLE, SIZE, OR COLOR.

NO CLAIM IS MADE TO THE EXCLUSIVE RIGHT TO USE "CONFERENCE", APART FROM THE MARK AS SHOWN.

FOR EDUCATIONAL SERVICES, NAMELY, CONDUCTING CONFERENCES IN THE FIELD OF MARKETING RESEARCH, SURVEY RESEARCH AND OPINION RESEARCH (U.S. CLS. 100, 101 AND 107).

FIRST USE 4-12-2011; IN COMMERCE 4-12-2011.

CLASS 41—(Continued).

4,155,919. NOVELLUS HEALTHCARE COMMUNICATIONS, LLC, MONROE TOWNSHIP, NJ. SN 85-302,348. FILED P.R. 4-22-2011; AM. S.R. 3-20-2012.

INFERTILITY & REPRODUCTIVE NEWS

THE MARK CONSISTS OF STANDARD CHARACTERS WITHOUT CLAIM TO ANY PARTICULAR FONT, STYLE, SIZE, OR COLOR.

FOR ONLINE EDUCATIONAL SERVICES, NAMELY, PROVIDING CONTINUING EDUCATION COURSES AND EXAMS IN THE FIELDS OF OBSTETRICS, GYNECOLOGY, INFERTILITY, UROLOGY, ONCOLOGY, REPRODUCTIVE ENDOCRINOLOGY, REPRODUCTIVE MEDICINE AND NURSING VIA A GLOBAL COMPUTER INFORMATION NETWORK; PROVIDING ONLINE INFORMATION ABOUT CONTINUING EDUCATION IN THE FIELDS OF OBSTETRICS, GYNECOLOGY, INFERTILITY, UROLOGY, ONCOLOGY, REPRODUCTIVE ENDOCRINOLOGY, REPRODUCTIVE MEDICINE AND NURSING (U.S. CLS. 100, 101 AND 107).

FIRST USE 6-0-2010; IN COMMERCE 1-0-2011.

4,155,913. NATIONAL SORTING COW HORSE ASSOCIATION, CALEDONIA, MO. SN 85-287,154. FILED P.R. 4-5-2011; AM. S.R. 4-2-2012.

The National Sorting Cow Horse Association

THE MARK CONSISTS OF STANDARD CHARACTERS WITHOUT CLAIM TO ANY PARTICULAR FONT, STYLE, SIZE, OR COLOR.

NO CLAIM IS MADE TO THE EXCLUSIVE RIGHT TO USE "ASSOCIATION", APART FROM THE MARK AS SHOWN.

FOR ENTERTAINMENT SERVICES, NAMELY, ARRANGING AND CONDUCTING OF COMPETITIONS FOR RANCH SORTING (U.S. CLS. 100, 101 AND 107).

FIRST USE 1-1-2009; IN COMMERCE 1-1-2010.

4,155,926. TRIBUS, KAMALA E.R., PENSACOLA, FL. SN 85-323,570. FILED P.R. 5-18-2011; AM. S.R. 3-14-2012.

Hydranencephaly Foundation

THE MARK CONSISTS OF STANDARD CHARACTERS WITHOUT CLAIM TO ANY PARTICULAR FONT, STYLE, SIZE, OR COLOR.

NO CLAIM IS MADE TO THE EXCLUSIVE RIGHT TO USE "FOUNDATION", APART FROM THE MARK AS SHOWN.

FOR EDUCATION SERVICES, NAMELY, PROVIDING TUTORIAL SESSIONS IN THE FIELD(S) OF HYDRANENCEPHALY (U.S. CLS. 100, 101 AND 107).

FIRST USE 4-28-2011; IN COMMERCE 4-28-2011.

CLASS 41—(Continued).

4,155,948. TEAM TCT, LLC, SPRING, TX. SN 85-348,519.
FILED P.R. 6-16-2011; AM. S.R. 4-4-2012.



NO CLAIM IS MADE TO THE EXCLUSIVE RIGHT TO USE "TRAINING CENTERS", APART FROM THE MARK AS SHOWN.

THE MARK CONSISTS OF AN IMAGE OF A MAP OF THE STATE OF TEXAS THAT IS CASTING A SHADOW ALONG ITS LEFT SIDE. SUPERIMPOSED OVER THE MAP IMAGE ARE THE WORDS "TRAINING CENTERS OF TEXAS".

FOR VOCATIONAL EDUCATION IN THE FIELDS OF ESL AND MEDICAL CAREERS (U.S. CLS. 100, 101 AND 107).

FIRST USE 7-6-2009; IN COMMERCE 7-6-2009.

4,155,973. MACCULLOUGH, SCOTT A., DBA EVERYTHING HIGH SCHOOL SPORTS LLC, PEMBROKE PINES, FL. SN 85-367,295. FILED P.R. 7-9-2011; AM. S.R. 4-20-2012.

Everything High School Sports

THE MARK CONSISTS OF STANDARD CHARACTERS WITHOUT CLAIM TO ANY PARTICULAR FONT, STYLE, SIZE, OR COLOR.

NO CLAIM IS MADE TO THE EXCLUSIVE RIGHT TO USE "HIGH SCHOOL SPORTS", APART FROM THE MARK AS SHOWN.

FOR ENTERTAINMENT SERVICES, NAMELY, PROVIDING AN ON-GOING RADIO PROGRAM IN THE FIELD OF HIGH SCHOOL SPORTS; PROVIDING A WEB SITE FEATURING INFORMATION ON YOUTH SPORTS (U.S. CLS. 100, 101 AND 107).

FIRST USE 7-30-2010; IN COMMERCE 9-20-2010.

CLASS 41—(Continued).

4,155,988. JEFFERY, INC., MIAMI BEACH, FL. SN 85-400,464.
FILED P.R. 8-17-2011; AM. S.R. 4-12-2012.

SPEECH AND ACCENT ACADEMY

THE MARK CONSISTS OF STANDARD CHARACTERS WITHOUT CLAIM TO ANY PARTICULAR FONT, STYLE, SIZE, OR COLOR.

NO CLAIM IS MADE TO THE EXCLUSIVE RIGHT TO USE "ACADEMY", APART FROM THE MARK AS SHOWN.

FOR BUSINESS EDUCATION SERVICES AND TRAINING SERVICES, NAMELY, CLASSES, SEMINARS, WORKSHOPS, PUBLIC PRESENTATIONS, COMMUNICATION SKILLS, BUSINESS WRITING, SPEECH, ARTICULATION AND ACCENT REDUCTION (U.S. CLS. 100, 101 AND 107).

FIRST USE 5-0-2011; IN COMMERCE 5-0-2011.

4,155,992. BEGIER, LYNNE, JAMAICA PLAIN, MA. SN 85-413,452. FILED P.R. 9-1-2011; AM. S.R. 3-26-2012.

Hip Hop Yoga

THE MARK CONSISTS OF STANDARD CHARACTERS WITHOUT CLAIM TO ANY PARTICULAR FONT, STYLE, SIZE, OR COLOR.

NO CLAIM IS MADE TO THE EXCLUSIVE RIGHT TO USE "YOGA", APART FROM THE MARK AS SHOWN.

FOR YOGA INSTRUCTION (U.S. CLS. 100, 101 AND 107).

FIRST USE 3-1-2008; IN COMMERCE 3-1-2008.

4,155,994. KUSHCON LLC, CALABASAS, CA. SN 85-417,844.
FILED P.R. 9-8-2011; AM. S.R. 3-22-2012.

KushCon

THE MARK CONSISTS OF STANDARD CHARACTERS WITHOUT CLAIM TO ANY PARTICULAR FONT, STYLE, SIZE, OR COLOR.

FOR EDUCATION SERVICES, NAMELY, PROVIDING SEMINARS AND CLASSES IN THE FIELD OF MEDICAL MARIJUANA; ENTERTAINMENT, NAMELY, LIVE MUSIC CONCERTS; PROVIDING FACILITIES FOR EDUCATIONAL CONVENTIONS (U.S. CLS. 100, 101 AND 107).

FIRST USE 10-1-2010; IN COMMERCE 10-1-2010.

CLASS 41—(Continued).

4,155,997. ASHDON, INC., LAS VEGAS, NV. SN 85-427,932. FILED P.R. 9-21-2011; AM. S.R. 4-5-2012.

MOTORCYCLE CENTER.COM BLOG

THE MARK CONSISTS OF STANDARD CHARACTERS WITHOUT CLAIM TO ANY PARTICULAR FONT, STYLE, SIZE, OR COLOR.

NO CLAIM IS MADE TO THE EXCLUSIVE RIGHT TO USE "MOTORCYCLE" AND "BLOG", APART FROM THE MARK AS SHOWN.

FOR ON-LINE JOURNALS, NAMELY, BLOGS FEATURING NEWS AND INFORMATION RELATING TO MOTORCYCLES AND THE SPORT OF MOTORCYCLE RIDING; PROVIDING A WEBSITE FEATURING BLOGS AND NON-DOWNLOADABLE PUBLICATIONS IN THE NATURE OF ARTICLES AND NEWS UPDATES IN THE FIELD(S) OF NEWS AND INFORMATION RELATING TO MOTORCYCLES AND THE SPORT OF MOTORCYCLE RIDING; PROVIDING A WEBSITE FEATURING INFORMATION RELATING TO THE SPORT OF NEWS AND INFORMATION RELATING TO MOTORCYCLES AND THE SPORT OF MOTORCYCLE RIDING (U.S. CLS. 100, 101 AND 107).

FIRST USE 7-1-2010; IN COMMERCE 7-1-2010.

4,156,002. WESTON, LORI ANN, INDIO, CA. SN 85-438,919. FILED P.R. 10-4-2011; AM. S.R. 3-19-2012.

THE ESTHETICIAN MENTOR

THE MARK CONSISTS OF STANDARD CHARACTERS WITHOUT CLAIM TO ANY PARTICULAR FONT, STYLE, SIZE, OR COLOR.

FOR EDUCATION SERVICES, NAMELY, MENTORING IN THE FIELD OF BUSINESS AND BUSINESS MARKETING FOR ESTHETICIANS AND SKIN CARE PROFESSIONALS; EDUCATIONAL AND ENTERTAINMENT SERVICES, NAMELY, PROVIDING MOTIVATIONAL SPEAKING SERVICES IN THE FIELD OF BUSINESS AND BUSINESS MARKETING FOR ESTHETICIANS AND SKIN CARE PROFESSIONALS; EDUCATIONAL SERVICES, NAMELY, CONDUCTING PUBLIC SPEAKING EVENTS, WORKSHOPS AND SEMINARS IN THE FIELDS OF BUSINESS AND BUSINESS MARKETING FOR ESTHETICIANS AND SKIN CARE PROFESSIONALS AND DISTRIBUTION OF TRAINING MATERIALS IN CONNECTION THEREWITH; ON-LINE JOURNALS, NAMELY, BLOGS FEATURING INFORMATION IN THE FIELD OF BUSINESS AND BUSINESS MARKETING FOR ESTHETICIANS AND SKIN CARE PROFESSIONALS; PROFESSIONAL COACHING SERVICES IN THE FIELD OF BUSINESS AND BUSINESS MARKETING FOR ESTHETICIANS AND SKIN CARE PROFESSIONALS; PROVIDING ON-LINE NEWSLETTERS IN THE FIELD OF BUSINESS AND BUSINESS MARKETING FOR ESTHETICIANS AND SKIN CARE PROFESSIONALS (U.S. CLS. 100, 101 AND 107).

FIRST USE 1-20-2012; IN COMMERCE 1-20-2012.

CLASS 41—(Continued).

4,156,025. UFC ULTIMATE FITNESS CENTER LLC., CHULA VISTA, CA. SN 85-473,174. FILED P.R. 11-15-2011; AM. S.R. 3-13-2012.

CORE SPECIFIC REVOLUTION

THE MARK CONSISTS OF STANDARD CHARACTERS WITHOUT CLAIM TO ANY PARTICULAR FONT, STYLE, SIZE, OR COLOR.

OWNER OF U.S. REG. NO. 4,103,363.

FOR GROUP EXERCISE FITNESS CLASSES; INSTRUCTION OF PHYSICAL FITNESS (U.S. CLS. 100, 101 AND 107).

FIRST USE 6-1-2011; IN COMMERCE 6-1-2011.

4,156,026. AMERICAN EXPRESS MARKETING & DEVELOPMENT CORP., NEW YORK, NY. SN 85-474,033. FILED P.R. 11-16-2011; AM. S.R. 2-15-2012.

TRAVEL RESEARCH APPRENTICE

THE MARK CONSISTS OF STANDARD CHARACTERS WITHOUT CLAIM TO ANY PARTICULAR FONT, STYLE, SIZE, OR COLOR.

NO CLAIM IS MADE TO THE EXCLUSIVE RIGHT TO USE "APPRENTICE", APART FROM THE MARK AS SHOWN.

FOR BUSINESS TRAINING IN THE FIELD OF TRAVEL SERVICES, PROVIDING EDUCATIONAL MENTORING SERVICES AND PROGRAMS IN THE FIELD OF TRAVEL SERVICES (U.S. CLS. 100, 101 AND 107).

FIRST USE 10-31-2010; IN COMMERCE 10-31-2010.

4,156,035. AMERICAN BUSINESS ALLIANCE, INC., AKA BUSINESS ALLIANCE, INC., SEATTLE, WA. SN 85-482,685. FILED P.R. 11-29-2011; AM. S.R. 3-13-2012.

REGISTERED FRANCHISE CONSULTANTS

THE MARK CONSISTS OF STANDARD CHARACTERS WITHOUT CLAIM TO ANY PARTICULAR FONT, STYLE, SIZE, OR COLOR.

FOR BUSINESS TRAINING CONSULTANCY SERVICES (U.S. CLS. 100, 101 AND 107).

FIRST USE 1-3-2007; IN COMMERCE 1-3-2007.

CLASS 41—(Continued).

4,156,037. THE PAR 3 TOUR LLC., APPLE VALLEY, CA. SN 85-485,476. FILED P.R. 12-2-2011; AM. S.R. 4-13-2012.

PAR 3 TOUR

THE MARK CONSISTS OF STANDARD CHARACTERS WITHOUT CLAIM TO ANY PARTICULAR FONT, STYLE, SIZE, OR COLOR.

FOR ENTERTAINMENT IN THE NATURE OF GOLF TOURNAMENTS; ORGANIZATION OF GOLF TOURNAMENT AND COMPETITIONS (U.S. CLS. 100, 101 AND 107).

FIRST USE 7-11-2011; IN COMMERCE 7-26-2011.

4,156,061. MEDIASPHERE MEDICAL, LLC, PHILADELPHIA, PA. SN 85-507,133. FILED P.R. 1-2-2012; AM. S.R. 4-8-2012.

INNOVATIONS IN CARDIAC RHYTHM MANAGEMENT

THE MARK CONSISTS OF STANDARD CHARACTERS WITHOUT CLAIM TO ANY PARTICULAR FONT, STYLE, SIZE, OR COLOR.

OWNER OF U.S. REG. NO. 4,107,053.
FOR EDUCATIONAL PUBLICATIONS, NAMELY, PROVIDING AN ON-LINE JOURNAL IN THE FIELDS OF ELECTROPHYSIOLOGY AND CARDIOLOGY (U.S. CLS. 100, 101 AND 107).

FIRST USE 0-0-2010; IN COMMERCE 0-0-2010.

4,156,062. TWIN CITIES TOXICOLOGY CONSORTIUM, LLC, CANNON FALLS, MN. SN 85-507,285. FILED 1-2-2012.

ToxTRENDS

THE MARK CONSISTS OF STANDARD CHARACTERS WITHOUT CLAIM TO ANY PARTICULAR FONT, STYLE, SIZE, OR COLOR.

FOR EDUCATION SERVICES, NAMELY, PROVIDING LIVE AND ON-LINE CLASSES, SEMINARS, AND WORKSHOPS IN THE FIELD OF CLINICAL AND TACTICAL TOXICOLOGY (U.S. CLS. 100, 101 AND 107).
FIRST USE 1-1-2012; IN COMMERCE 1-1-2012.

CLASS 41—(Continued).

4,156,067. GABRIELLA SENZA, HOUSATONIC, MA. SN 85-509,595. FILED P.R. 1-5-2012; AM. S.R. 4-10-2012.

COMPUTER TUTOR GALS

THE MARK CONSISTS OF STANDARD CHARACTERS WITHOUT CLAIM TO ANY PARTICULAR FONT, STYLE, SIZE, OR COLOR.

NO CLAIM IS MADE TO THE EXCLUSIVE RIGHT TO USE "COMPUTER TUTOR", APART FROM THE MARK AS SHOWN.

FOR EDUCATION SERVICES, NAMELY, PROVIDING TUTORING IN THE FIELD OF THE USE OF PERSONAL COMPUTERS, HAND-HELD DEVICES, AND THE INTERNET (U.S. CLS. 100, 101 AND 107).

FIRST USE 9-1-2011; IN COMMERCE 9-1-2011.

4,156,070. DANDURAND, TROY M, ST. CLOUD, MN. SN 85-514,061. FILED P.R. 1-11-2012; AM. S.R. 4-24-2012.

ConsumerCentric

THE MARK CONSISTS OF STANDARD CHARACTERS WITHOUT CLAIM TO ANY PARTICULAR FONT, STYLE, SIZE, OR COLOR.

FOR BUSINESS TRAINING; BUSINESS TRAINING CONSULTANCY SERVICES; BUSINESS TRAINING IN THE FIELD OF SELLING AND SALES TRAINING; EDUCATION SERVICES, NAMELY, PROVIDING CAREER RE-TRAINING SELLING IN THE FIELDS OF SALES TRAINING.; TRAINING COURSES IN STRATEGIC PLANNING RELATING TO ADVERTISING, PROMOTION, MARKETING AND BUSINESS (U.S. CLS. 100, 101 AND 107).

FIRST USE 12-22-2011; IN COMMERCE 12-24-2011.

CLASS 42—SCIENTIFIC AND COMPUTER SERVICES

4,155,850. GRAVITY TECHNOLOGIES, SAN FRANCISCO, CA. SN 76-708,034. FILED P.R. 6-17-2011; AM. S.R. 4-9-2012.



THE COLOR(S) RED, GREEN AND BLACK IS/ARE CLAIMED AS A FEATURE OF THE MARK.

CLASS 42—(Continued).

THE MARK CONSISTS OF A BLACK OUTER RECTANGLE WITHIN WHICH IS A GREEN RECTANGLE ON THE LEFT AND A RED RECTANGLE ON THE RIGHT. THE ELEMENTS SHOWN IN DOTTED LINES ARE NOT A FEATURE OF THE MARK AND MERELY SHOW THE POSITIONING OF THE MARK. THE COLOR WHITE IS NOT A FEATURE OF THE MARK AND THE WHITE AREAS MERELY REPRESENT THE TRANSPARENT AREAS IN THE MARK.

FOR PROVIDING TEMPORARY USE OF ONLINE, NON-DOWNLOADABLE SOFTWARE FOR FACILITATING, MANAGING AND AUGMENTING EMPLOYMENT HIRING, RECRUITING, PLACEMENT AND STAFFING (U.S. CLS. 100 AND 101).

FIRST USE 1-5-2009; IN COMMERCE 1-5-2009.

4,155,866. GAMING LABORATORIES INTERNATIONAL LLC, LAKEWOOD, NJ. SN 85-006,269. FILED P.R. 4-5-2010; AM. S.R. 3-19-2012.

POINT.CLICK.TRANSFER

THE MARK CONSISTS OF STANDARD CHARACTERS WITHOUT CLAIM TO ANY PARTICULAR FONT, STYLE, SIZE, OR COLOR.

FOR ONLINE TESTING, ANALYSIS AND EVALUATION SERVICES EMPLOYING PREVIOUSLY UPLOADED DATA AND SOFTWARE FOR THE PURPOSE OF CERTIFYING GAMING EQUIPMENT OF OTHERS AND ONLINE WEBSITES OF OTHERS BASED UPON THE PREVIOUSLY UPLOADED DATA AND SOFTWARE (U.S. CLS. 100 AND 101).

FIRST USE 10-23-2008; IN COMMERCE 10-23-2008.

4,155,880. BRADLEY COMMUNICATIONS CORP., BROOKING, PA. SN 85-183,898. FILED P.R. 11-23-2010; AM. S.R. 3-20-2012.

REPORTER CONNECTION

THE MARK CONSISTS OF STANDARD CHARACTERS WITHOUT CLAIM TO ANY PARTICULAR FONT, STYLE, SIZE, OR COLOR.

NO CLAIM IS MADE TO THE EXCLUSIVE RIGHT TO USE "REPORTER", APART FROM THE MARK AS SHOWN.

FOR HOSTING AN ONLINE COMMUNITY WEBSITE FEATURING SHARED COMMUNICATION BETWEEN JOURNALISTS AND SOURCES FOR THEIR STORIES (U.S. CLS. 100 AND 101).

FIRST USE 2-26-2005; IN COMMERCE 12-21-2009.

CLASS 42—(Continued).

4,155,881. BIOMED HEALTH SOLUTIONS, LLC, DETROIT, MI. SN 85-188,290. FILED P.R. 12-1-2010; AM. S.R. 4-3-2012.

BIOMED SPECIALTY PHARMACY

THE MARK CONSISTS OF STANDARD CHARACTERS WITHOUT CLAIM TO ANY PARTICULAR FONT, STYLE, SIZE, OR COLOR.

NO CLAIM IS MADE TO THE EXCLUSIVE RIGHT TO USE "SPECIALTY PHARMACY", APART FROM THE MARK AS SHOWN.

FOR PHARMACEUTICAL DRUG DEVELOPMENT SERVICES, NAMELY, CUSTOMIZING PRESCRIPTION AND NON PRESCRIPTION DRUGS, USING FDA APPROVED DRUGS AND CHEMICALS, AND REDESIGNING OF DOSAGE FORM, STRENGTH AND ROUTE OF ADMINISTRATION BASED ON PRESCRIPTIONS TO MEET NEEDS OF A INDIVIDUAL PATIENTS (U.S. CLS. 100 AND 101).

FIRST USE 6-4-2009; IN COMMERCE 6-4-2009.

4,155,887. COMPREHENSIVE NEUROSCIENCE, INC., MIRAMAR, FL. SN 85-201,174. FILED P.R. 12-17-2010; AM. S.R. 3-30-2012.

COMPREHENSIVE CLINICAL DEVELOPMENT

THE MARK CONSISTS OF STANDARD CHARACTERS WITHOUT CLAIM TO ANY PARTICULAR FONT, STYLE, SIZE, OR COLOR.

FOR MEDICAL AND SCIENTIFIC RESEARCH; PHARMACEUTICAL PRODUCT EVALUATION; PHARMACEUTICAL RESEARCH SERVICES (U.S. CLS. 100 AND 101).

FIRST USE 3-30-2011; IN COMMERCE 3-30-2011.

4,155,939. INTERNET ENGINE, LLC, LIBERTYVILLE, IL. SN 85-334,907. FILED P.R. 6-1-2011; AM. S.R. 4-10-2012.

INTERNET ENGINE

THE MARK CONSISTS OF STANDARD CHARACTERS WITHOUT CLAIM TO ANY PARTICULAR FONT, STYLE, SIZE, OR COLOR.

OWNER OF U.S. REG. NO. 3,318,024.

CLASS 42—(Continued).

NO CLAIM IS MADE TO THE EXCLUSIVE RIGHT TO USE "INTERNET", APART FROM THE MARK AS SHOWN.

FOR INTERNET OPTIMIZATION SERVICE, NAMELY, DESIGN, CREATION, AND MAINTENANCE OF CUSTOMIZED WEBSITES AND COMPUTER NETWORK SEARCH ENGINES FOR OTHERS (U.S. CLS. 100 AND 101).

FIRST USE 3-1-2002; IN COMMERCE 3-1-2002.

CLASS 42—(Continued).

4,156,003. REED GROUP, LTD., WESTMINSTER, CO. SN 85-439,243. FILED P.R. 10-4-2011; AM. S.R. 4-5-2012.

4,155,968. IPAYMENT, INC., NASHVILLE, TN. SN 85-361,991. FILED P.R. 7-1-2011; AM. S.R. 4-3-2012.

IHOMEPAGE

THE MARK CONSISTS OF STANDARD CHARACTERS WITHOUT CLAIM TO ANY PARTICULAR FONT, STYLE, SIZE, OR COLOR.

FOR HOSTING WEBSITES ON THE INTERNET; WEBSITE DESIGN AND DEVELOPMENT FOR OTHERS (U.S. CLS. 100 AND 101).

FIRST USE 1-1-2012; IN COMMERCE 1-1-2012.

4,155,979. IPAYMENT, INC., NASHVILLE, TN. SN 85-378,911. FILED P.R. 7-22-2011; AM. S.R. 4-3-2012.

IACCOUNTING

THE MARK CONSISTS OF STANDARD CHARACTERS WITHOUT CLAIM TO ANY PARTICULAR FONT, STYLE, SIZE, OR COLOR.

FOR PROVIDING A WEBSITE FEATURING NON-DOWNLOADABLE SOFTWARE FOR THE MANAGEMENT OF INVENTORY; PROVIDING A WEBSITE FEATURING NON-DOWNLOADABLE SOFTWARE USED TO TRACK AND MANAGE ONLINE PAYMENTS AND PAYMENT RECEIVABLES; PROVIDING A WEBSITE FEATURING NON-DOWNLOADABLE SOFTWARE USED TO CONVERT DATA INTO DIFFERENT FILE FORMATS (U.S. CLS. 100 AND 101).

FIRST USE 1-1-2012; IN COMMERCE 1-1-2012.

LEAVE OF ABSENCE ADVISOR

THE MARK CONSISTS OF STANDARD CHARACTERS WITHOUT CLAIM TO ANY PARTICULAR FONT, STYLE, SIZE, OR COLOR.

FOR PROVIDING TEMPORARY USE OF NON-DOWNLOADABLE COMPUTER SOFTWARE FOR ADMINISTRATION AND MANAGEMENT OF EMPLOYEE LEAVE; CLOUD COMPUTING FEATURING SOFTWARE FOR USE IN ADMINISTRATION AND MANAGEMENT OF EMPLOYEE LEAVE (U.S. CLS. 100 AND 101).

FIRST USE 7-26-2011; IN COMMERCE 7-26-2011.

4,156,022. SCHEDULEINTERPRETER.COM, INC., OVERLAND PARK, KS. SN 85-468,228. FILED 11-9-2011.

ScheduleInterpreter

THE COLOR(S) ORANGE, TURQUOISE IS/ARE CLAIMED AS A FEATURE OF THE MARK.

THE MARK CONSISTS OF THE STYLIZED PHRASE "SCHEDULEINTERPRETER", WITH "S" CAPITALIZED AND "I" CAPITALIZED, NO SPACE BETWEEN THE WORDS, LETTERS IN THE WORD "SCHEDULE" ARE IN ORANGE COLOR, LETTERS IN THE WORD INTERPRETER ARE IN TURQUOISE COLOR.

FOR CLOUD COMPUTING FEATURING SOFTWARE FOR USE IN SCHEDULING AND MANAGEMENT OF FOREIGN LANGUAGE AND AMERICAN SIGN LANGUAGE INTERPRETING SERVICES (U.S. CLS. 100 AND 101).

FIRST USE 11-3-2011; IN COMMERCE 11-3-2011.

CLASS 42—(Continued).

4,156,031. LABATE, MICHAEL N., PHILADELPHIA, PA. SN 85-478,120. FILED 11-21-2011.

Social Decision Making

THE MARK CONSISTS OF STANDARD CHARACTERS WITHOUT CLAIM TO ANY PARTICULAR FONT, STYLE, SIZE, OR COLOR.

FOR COMPUTER SERVICES, NAMELY, CREATING AN ON-LINE COMMUNITY FOR REGISTERED USERS TO CREATE AND SHARE PUBLIC AND PRIVATE SURVEYS, PARTICIPATE IN PUBLIC AND PRIVATE SURVEYS, ACQUIRE FEEDBACK FROM PARTICIPANTS, PROVIDE FEEDBACK TO PARTICIPANTS, AND ENGAGE IN SOCIAL NETWORKING FOR PURPOSES OF OBTAINING INPUT AND FEEDBACK FROM MULTIPLE PARTICIPANTS (U.S. CLS. 100 AND 101).

FIRST USE 10-1-2011; IN COMMERCE 10-1-2011.



4,156,033. UBISTOR, INC., SCHAUMBURG, IL. SN 85-481,210. FILED P.R. 11-28-2011; AM. S.R. 3-29-2012.

SafeHost

THE MARK CONSISTS OF STANDARD CHARACTERS WITHOUT CLAIM TO ANY PARTICULAR FONT, STYLE, SIZE, OR COLOR.

OWNER OF U.S. REG. NOS. 3,137,512, 3,662,189, AND 3,688,444.

FOR COMPUTER SERVICES, NAMELY, DATA ENCRYPTION, BACKUP AND RECOVERY (U.S. CLS. 100 AND 101).

FIRST USE 11-1-2011; IN COMMERCE 11-1-2011.



4,156,044. SUSSMAN-AUTOMATIC CORPORATION, LONG ISLAND CITY, NY. SN 85-490,011. FILED P.R. 12-7-2011; AM. S.R. 3-29-2012.

VIRTUAL SPA SYSTEM

THE MARK CONSISTS OF STANDARD CHARACTERS WITHOUT CLAIM TO ANY PARTICULAR FONT, STYLE, SIZE, OR COLOR.

FOR PROVIDING AN ON-LINE NON-DOWNLOADABLE SOFTWARE PROGRAM THAT ENABLES USERS TO CUSTOM DESIGN RESIDENTIAL STEAM BATHS, SPAS AND ACCESSORIES (U.S. CLS. 100 AND 101).

FIRST USE 12-7-2011; IN COMMERCE 12-7-2011.

CLASS 42—(Continued).

4,156,057. ECO-IT NETWORKING, INC, SAN JOSE, CA. SN 85-506,619. FILED P.R. 12-30-2011; AM. S.R. 4-5-2012.

ECO-IT

THE MARK CONSISTS OF STANDARD CHARACTERS WITHOUT CLAIM TO ANY PARTICULAR FONT, STYLE, SIZE, OR COLOR.

FOR COMPUTER SERVICES, NAMELY, CLOUD HOSTING PROVIDER SERVICES; IT CONSULTING SERVICES; IT INTEGRATION SERVICES (U.S. CLS. 100 AND 101).

FIRST USE 5-15-2008; IN COMMERCE 7-1-2008.



4,156,063. SOELLNER, RAND, CASHIERS, NC. SN 85-507,793. FILED P.R. 1-3-2012; AM. S.R. 4-12-2012.

HOME ARCHITECTS

THE MARK CONSISTS OF STANDARD CHARACTERS WITHOUT CLAIM TO ANY PARTICULAR FONT, STYLE, SIZE, OR COLOR.

NO CLAIM IS MADE TO THE EXCLUSIVE RIGHT TO USE "ARCHITECTS", APART FROM THE MARK AS SHOWN.

FOR ARCHITECTURAL DESIGN SERVICES (U.S. CLS. 100 AND 101).

FIRST USE 4-27-2010; IN COMMERCE 4-27-2010.



CLASS 43—HOTEL AND RESTAURANT SERVICES

4,155,852. SCHULZE, STEPHEN, NEWPORT BEACH, CA. SN 76-708,191. FILED P.R. 6-29-2011; AM. S.R. 4-25-2012.



NO CLAIM IS MADE TO THE EXCLUSIVE RIGHT TO USE "JUICE BAR", APART FROM THE MARK AS SHOWN.

CLASS 43—(Continued).

THE MARK CONSISTS OF THE WORD "NĒKTER" IN LOWER CASE WITH AN ACCENT ABOVE THE FIRST "E" AND WITH THE SECOND "E" APPEARING UPSIDE DOWN AND BACKWARDS; THE WORDS "JUICE BAR" IN UPPER CASE ON THE SECOND LINE AND LOCATED FLUSH RIGHT UNDER THE "KTER" OF THE LINE ABOVE.
FOR JUICE AND SMOOTHIE BAR (U.S. CLS. 100 AND 101).

FIRST USE 10-1-2010; IN COMMERCE 10-1-2010.

4,155,906. THE LAST BEST BEEF, LLC, LAS VEGAS, NV. SN 85-264,016. FILED P.R. 3-10-2011; AM. S.R. 4-9-2012.

Glamping

THE MARK CONSISTS OF STANDARD CHARACTERS WITHOUT CLAIM TO ANY PARTICULAR FONT, STYLE, SIZE, OR COLOR.

FOR EXTENDED-STAY HOTELS; HOTEL ACCOMMODATION SERVICES; HOTEL AND MOTEL SERVICES; HOTEL AND RESTAURANT RESERVATION SERVICES; HOTEL AND RESTAURANT SERVICES; HOTEL SERVICES; HOTEL SERVICES FOR PREFERRED CUSTOMERS; HOTEL, BAR AND RESTAURANT SERVICES; HOTEL, MOTEL, RESTAURANT, BAR AND CATERING SERVICES; HOTEL, RESTAURANT AND BAR SERVICES; HOTEL, RESTAURANT AND CATERING SERVICES; HOTELS; MAKING HOTEL RESERVATIONS FOR OTHERS; RESERVATION OF HOTEL ROOMS FOR TRAVELERS; RESERVATION OF HOTEL ROOMS FOR TRAVELLERS; RESORT HOTELS; RESTAURANT AND HOTEL SERVICES (U.S. CLS. 100 AND 101).

FIRST USE 6-1-2007; IN COMMERCE 6-1-2007.

4,155,931. MEXICAN STREET FOOD, LLC, SAN DIEGO, CA. SN 85-329,143. FILED P.R. 5-24-2011; AM. S.R. 3-6-2012.

Puesto

Mexican Street Food

NO CLAIM IS MADE TO THE EXCLUSIVE RIGHT TO USE "MEXICAN STREET FOOD", APART FROM THE MARK AS SHOWN.

THE MARK CONSISTS OF THE WORD "PUesto" OVER THE WORDS "MEXICAN STREET FOOD".

FOR RESTAURANT SERVICES (U.S. CLS. 100 AND 101).

FIRST USE 2-10-2012; IN COMMERCE 2-10-2012.

CLASS 44—MEDICAL, BEAUTY AND AGRICULTURAL SERVICES**CLASS 44—(Continued).**

4,155,869. LASER SPINE INSTITUTE, LLC, TAMPA, FL. SN 85-064,233. FILED P.R. 6-16-2010; AM. S.R. 4-12-2012.

The leader in endoscopic spine surgery

THE MARK CONSISTS OF STANDARD CHARACTERS WITHOUT CLAIM TO ANY PARTICULAR FONT, STYLE, SIZE, OR COLOR.

NO CLAIM IS MADE TO THE EXCLUSIVE RIGHT TO USE "ENDOSCOPIC SPINE SURGERY", APART FROM THE MARK AS SHOWN.

FOR HEALTHCARE; SURGERY (U.S. CLS. 100 AND 101).

FIRST USE 1-1-2009; IN COMMERCE 1-1-2009.

4,155,940. DIANE RICHARDSON, CHATTANOOGA, TN. SN 85-337,248. FILED P.R. 6-3-2011; AM. S.R. 3-26-2012.

RELATIONAL ENERGETICS

THE MARK CONSISTS OF STANDARD CHARACTERS WITHOUT CLAIM TO ANY PARTICULAR FONT, STYLE, SIZE, OR COLOR.

FOR ENERGY HEALING SERVICES, NAMELY, STRESS MANAGEMENT AND STRESS REDUCTION COUNSELING FOR INDIVIDUALS TO ENHANCE THEIR LIVES; MENTAL HEALTH COUNSELING AND PSYCHOTHERAPY AS IT RELATES TO RELATIONSHIPS (U.S. CLS. 100 AND 101).

FIRST USE 12-31-2008; IN COMMERCE 12-31-2008.

4,155,955. AMERICA'S FAMILY DOCTORS, PLLC, BRENTWOOD, TN. SN 85-353,512. FILED P.R. 6-22-2011; AM. S.R. 4-4-2012.

AMERICA'S FAMILY DOCTORS

THE MARK CONSISTS OF STANDARD CHARACTERS WITHOUT CLAIM TO ANY PARTICULAR FONT, STYLE, SIZE, OR COLOR.

CLASS 44—(Continued).

NO CLAIM IS MADE TO THE EXCLUSIVE RIGHT TO USE "FAMILY DOCTORS", APART FROM THE MARK AS SHOWN.

FOR CONSULTING TO INDIVIDUALS AND COMMUNITIES ENGAGED IN GROUP WEIGHT LOSS PROGRAMS; DIETARY AND NUTRITIONAL GUIDANCE; NUTRITION COUNSELING; PHYSICIAN SERVICES; PROVIDING WEIGHT LOSS PROGRAM SERVICES; PROVIDING WELLNESS SERVICES, NAMELY, WEIGHT LOSS PROGRAMS OFFERED AT A WELLNESS CENTER; WEIGHT MANAGEMENT SERVICES, NAMELY, PROVIDING WEIGHT LOSS AND/OR WEIGHT MAINTENANCE PROGRAMS; WEIGHT REDUCTION DIET PLANNING AND SUPERVISION (U.S. CLS. 100 AND 101).

FIRST USE 7-1-2002; IN COMMERCE 9-23-2003.

4,156,017. CLARK, NATHANIEL G., EAST FALMOUTH, MA. SN 85-462,292. FILED P.R. 11-2-2011; AM. S.R. 4-14-2012.

Diabetes Center of Cape Cod

THE MARK CONSISTS OF STANDARD CHARACTERS WITHOUT CLAIM TO ANY PARTICULAR FONT, STYLE, SIZE, OR COLOR.

NO CLAIM IS MADE TO THE EXCLUSIVE RIGHT TO USE "DIABETES CENTER", APART FROM THE MARK AS SHOWN.

FOR MEDICAL SERVICES (U.S. CLS. 100 AND 101).
FIRST USE 3-1-2012; IN COMMERCE 3-1-2012.

4,156,073. ALAN F. BAIN, DBA CHICAGO HEALTH AND WELLNESS ALLIANCE, CHICAGO, IL. SN 85-519,360. FILED 1-18-2012.

Convergent Therapeutics

THE MARK CONSISTS OF STANDARD CHARACTERS WITHOUT CLAIM TO ANY PARTICULAR FONT, STYLE, SIZE, OR COLOR.

NO CLAIM IS MADE TO THE EXCLUSIVE RIGHT TO USE "THERAPEUTICS", APART FROM THE MARK AS SHOWN.

FOR MEDICAL SERVICES FEATURING AN APPROACH TO PATIENTS THAT MELTS HOLISTIC MEDICINE WITH TRADITIONAL MEDICINE (U.S. CLS. 100 AND 101).

FIRST USE 0-0-2010; IN COMMERCE 0-0-2010.

CLASS 45—PERSONAL AND LEGAL SERVICES**CLASS 45—(Continued).**

4,155,877. FISHER, RUSHMER, WERREN RATH, DICKSON, TALLEY & DUNLAP, P.A., AKA FISHER RUSHMER, ORLANDO, FL. SN 85-162,032. FILED P.R. 10-27-2010; AM. S.R. 3-23-2012.

Florida Law Alliance

THE MARK CONSISTS OF STANDARD CHARACTERS WITHOUT CLAIM TO ANY PARTICULAR FONT, STYLE, SIZE, OR COLOR.

NO CLAIM IS MADE TO THE EXCLUSIVE RIGHT TO USE "LAW ALLIANCE", APART FROM THE MARK AS SHOWN.

FOR LEGAL SERVICES (U.S. CLS. 100 AND 101).
FIRST USE 9-19-2011; IN COMMERCE 10-1-2011.

4,155,954. INC. LEGAL, APC, CARLSBAD, CA. SN 85-353,383. FILED P.R. 6-22-2011; AM. S.R. 3-28-2012.

INC. LEGAL

THE MARK CONSISTS OF STANDARD CHARACTERS WITHOUT CLAIM TO ANY PARTICULAR FONT, STYLE, SIZE, OR COLOR.

NO CLAIM IS MADE TO THE EXCLUSIVE RIGHT TO USE "LEGAL", APART FROM THE MARK AS SHOWN.

FOR LEGAL SERVICES (U.S. CLS. 100 AND 101).
FIRST USE 5-8-2011; IN COMMERCE 5-8-2011.

4,155,981. BURGER, STEVEN, NEWPORT BEACH, CA. SN 85-381,690. FILED P.R. 7-26-2011; AM. S.R. 3-16-2012.



NO CLAIM IS MADE TO THE EXCLUSIVE RIGHT TO USE "MINISTRIES", APART FROM THE MARK AS SHOWN.

THE COLOR(S) PURPLE, BLUE, BLACK, WHITE, YELLOW, AND RED IS/ARE CLAIMED AS A FEATURE OF THE MARK.

CLASS 45—(Continued).

CLASS 45—(Continued).

4,156,029. BASHAM, ROBIN, SAN JOSE, CA. SN 85-475,757.
FILED 11-17-2011.

**EnterpriseGRC Solutions,
Inc.**

THE MARK CONSISTS OF AN IMAGE OF THE GALAXY IN WHITE, PURPLE, BLUE AND BLACK WITH CELESTIAL BODIES, STARS, AND NATURAL PHENOMENA, WITH "HIM HEAVENLY INTIMACY MINISTRIES" IN WHITE AT THE TOP LEFT OF THE IMAGE WITH A PURPLE, BLUE, YELLOW AND RED COLORED PHOENIX AT THE RIGHT OF THE WORDS AND "WINDOW TO THE FUTURE" IN WHITE AT THE TOP RIGHT OF THE IMAGE.

FOR RELIGIOUS AND SPIRITUAL SERVICES, PROVIDING A WEBSITE FEATURING INFORMATION ABOUT RELIGIOUS BELIEFS (U.S. CLS. 100 AND 101).
FIRST USE 1-1-2011; IN COMMERCE 1-1-2011.

THE MARK CONSISTS OF STANDARD CHARACTERS WITHOUT CLAIM TO ANY PARTICULAR FONT, STYLE, SIZE, OR COLOR.

NO CLAIM IS MADE TO THE EXCLUSIVE RIGHT TO USE "INC.", APART FROM THE MARK AS SHOWN.

FOR REGULATORY COMPLIANCE CONSULTING IN THE FIELD OF ENTERPRISE GOVERNANCE, RISK AND COMPLIANCE (GRC) ARCHITECTURE AND STRATEGY, NAMELY, IMPLEMENTING TEMPLATES AND BASELINE PRODUCTS TOWARDS ACHIEVING ENTERPRISE COMPLIANCE WITH STANDARD FRAMEWORKS AND REGULATIONS (U.S. CLS. 100 AND 101).

FIRST USE 9-3-2011; IN COMMERCE 10-3-2011.

* * * * *

TRADEMARK REGISTRATIONS RENEWED

The designation "U.S. Cl." appearing in this section refers to the U.S. class in effect prior to Sep. 1, 1973 rather than the international class which applies to applications filed on or after that date. For adoption of international classification see notice in the OFFICIAL GAZETTE of Jun. 26, 1973 (911 O.G. TM 210).

86,340.	HOYO DE MONTERREY (STYLIZED). U.S. CL. 17. (INT. CL. 34). REG. 4-30-1912.	732,788.	HOSTESS. U.S. CL. 46. (INT. CL. 30). REG. 6-12-1962.
86,452.	MISCELLANEOUS DESIGN. U.S. CL. 17. (INT. CL. 34). REG. 5-7-1912.	733,786.	LEITZ. U.S. CL. 37. (INT. CL. 16). REG. 7-3-1962.
155,547.	MISCELLANEOUS DESIGN. U.S. CL. 22. (INT. CL. 16). REG. 5-30-1922.	733,994.	INTEX. U.S. CL. 1. (INT. CL. 17). REG. 7-10-1962.
159,596.	SHASTA (STYLIZED). U.S. CL. 29. (INT. CLS. 16 AND 21). REG. 9-26-1922.	734,800.	STOPS RUST. U.S. CL. 16. (INT. CL. 2). REG. 7-24-1962.
165,252.	BANGOR DAILY NEWS (STYLIZED). U.S. CL. 38. (INT. CL. 16). REG. 3-6-1923.	736,933.	THE MUSEUM OF MODERN ART. U.S. CL. 107. (INT. CL. 41). REG. 8-28-1962.
289,135.	CERANINE. U.S. CL. 6. (INT. CLS. 1, 2, 3, 4 AND 5). REG. 11-17-1931.	739,236.	TREFLAN. U.S. CL. 6. (INT. CL. 5). REG. 10-16-1962.
289,138.	THIOTAN. U.S. CL. 6. (INT. CLS. 1, 2, 3, 4 AND 5). REG. 11-17-1931.	741,597.	FUMIGUIDE. U.S. CL. 26. (INT. CL. 9). REG. 12-4-1962.
294,978.	ROYAL OAK. U.S. CL. 1. (INT. CL. 4). REG. 6-14-1932.	747,209.	C CORNWELL AND DESIGN. U.S. CL. 23. (INT. CL. 7). REG. 3-26-1963.
301,721.	LIFE GUARD (STYLIZED). U.S. CL. 46. (INT. CL. 31). REG. 3-14-1933.	747,210.	CORNWELL. U.S. CL. 23. (INT. CL. 7). REG. 3-26-1963.
395,907.	MISCELLANEOUS DESIGN. U.S. CL. 47. (INT. CL. 33). REG. 6-16-1942.	748,204.	KAY. U.S. CL. 101. (INT. CL. 42). REG. 4-16-1963.
548,683.	WARDIA. U.S. CL. 52. (INT. CL. 3). REG. 9-25-1951.	922,393.	I AND DESIGN. U.S. CLS. 36, 38 AND 107. (INT. CLS. 9, 16 AND 41). REG. 10-19-1971.
556,239.	WARDIA (STYLIZED). U.S. CL. 51. (INT. CLS. 3 AND 5). REG. 3-18-1952.	923,232.	INLINGUA (STYLIZED). U.S. CLS. 36, 38 AND 107. (INT. CLS. 9, 16 AND 41). REG. 11-2-1971.
557,959.	EXALSTONE. U.S. CL. 51. (INT. CL. 3). REG. 4-22-1952.	926,649.	KORWALL. U.S. CL. 12. (INT. CL. 19). REG. 1-11-1972.
558,182.	PY-O-MY (STYLIZED). U.S. CL. 46. (INT. CL. 30). REG. 4-29-1952.	932,563.	FUJICOLOR. U.S. CL. 26. (INT. CL. 1). REG. 4-18-1972.
558,208.	ORONITE. U.S. CL. 6. (INT. CL. 1). REG. 4-29-1952.	932,564.	FUJICHROME. U.S. CL. 26. (INT. CL. 1). REG. 4-18-1972.
558,498.	SHEETROCK. U.S. CL. 16. (INT. CL. 2). REG. 5-6-1952.	933,067.	MARKSMAN. U.S. CLS. 9 AND 22. (INT. CLS. 13 AND 28). REG. 5-2-1972.
558,774.	X (STYLIZED). U.S. CL. 35. (INT. CL. 12). REG. 5-13-1952.	933,253.	MS. U.S. CL. 38. (INT. CL. 16). REG. 5-2-1972.
558,784.	MOGEN DAVID. U.S. CL. 47. (INT. CL. 33). REG. 5-13-1952.	933,460.	S AND DESIGN. U.S. CL. 8. (INT. CL. 34). REG. 5-9-1972.
559,141.	"FIST-GRIP" (STYLIZED). U.S. CL. 13. (INT. CL. 6). REG. 5-20-1952.	933,731.	BARDAC. U.S. CL. 6. (INT. CL. 5). REG. 5-16-1972.
561,547.	MISCELLANEOUS DESIGN. U.S. CL. 46. (INT. CL. 29). REG. 7-15-1952.	933,856.	901. U.S. CL. 21. (INT. CL. 9). REG. 5-16-1972.
563,190.	KAPPA ALPHA THETA. U.S. CL. 100. (INT. CL. 42). REG. 8-19-1952.	934,053.	FESTIVAL. U.S. CL. 46. (INT. CL. 29). REG. 5-16-1972.
568,281.	BONDERLUBE. U.S. CL. 6. (INT. CL. 1). REG. 12-23-1952.	934,188.	RED WING SHOES AND DESIGN. U.S. CL. 101. (INT. CL. 42). REG. 5-16-1972.
729,597.	SUPER RAINBOW. U.S. CL. 10. (INT. CL. 1). REG. 4-10-1962.	934,776.	BARLENE. U.S. CL. 6. (INT. CL. 1). REG. 5-30-1972.
729,754.	WHO'S WHO OF AMERICAN WOMEN. U.S. CL. 38. (INT. CL. 16). REG. 4-10-1962.	934,777.	SUPPOCIRE. U.S. CL. 6. (INT. CLS. 1, 2, 3, 4 AND 5). REG. 5-30-1972.
729,968.	MAGNUS. U.S. CL. 13. (INT. CL. 6). REG. 4-17-1962.	935,087.	INTEREST. U.S. CL. 52. (INT. CL. 3). REG. 5-30-1972.
730,017.	COAXICON. U.S. CL. 21. (INT. CL. 9). REG. 4-17-1962.	936,344.	S AND DESIGN.
730,028.	MC CRACKEN. U.S. CL. 23. (INT. CL. 7). REG. 4-17-1962.	936,384.	GOLDEN MALRIN. U.S. CL. 6. (INT. CL. 5). REG. 6-27-1972.
730,072.	POLAROID. U.S. CL. 26 ONLY. (INT. CLS. 1, 9 AND 10). REG. 4-17-1962.	937,259.	FORDWAY. U.S. CL. 101. (INT. CL. 35). REG. 7-4-1972.
730,263.	GRAM-PAC. U.S. CL. 6. (INT. CL. 1). REG. 4-24-1962.	937,684.	MISCELLANEOUS DESIGN. U.S. CL. 46. (INT. CLS. 1, 5, 29, 30, 31 AND 32). REG. 7-11-1972.
730,450.	WHERE. U.S. CL. 38. (INT. CL. 16). REG. 4-24-1962.	938,249.	BAKE-OFF. U.S. CL. 101. (INT. CL. 35). REG. 7-18-1972.
730,652.	DYNA QUIP (STYLIZED). U.S. CL. 13. (INT. CL. 6). REG. 5-1-1962.	941,046.	KOA AND DESIGN. U.S. CL. 50. (INT. CL. 20). REG. 8-15-1972.
730,996.	RAPID TAP AND DESIGN. U.S. CL. 6. (INT. CL. 1). REG. 5-8-1962.	951,245.	ZEE TOYS AND DESIGN. U.S. CL. 22. (INT. CL. 28). REG. 1-23-1973.
731,934.	RICHVIEW (STYLIZED). U.S. CL. 46. (INT. CL. 31). REG. 5-22-1962.	955,538.	ENVIRO-SEP AND DESIGN. U.S. CL. 6. (INT. CL. 5). REG. 3-20-1973.
732,043.	CYANOX. U.S. CL. 6. (INT. CL. 1). REG. 5-29-1962.	1,162,380.	GILCHRIST & SOAMES. INT. CL. 3. (U.S. CLS. 51 AND 52). REG. 7-28-1981.
732,353.	SPEEDSERTS (STYLIZED). U.S. CL. 13. (INT. CL. 6). REG. 6-5-1962.	1,173,110.	MINOTOUR. INT. CL. 12. (U.S. CL. 19). REG. 10-13-1981.
		1,173,613.	LUBE 'N GO (STYLIZED). INT. CL. 37. (U.S. CL. 103). REG. 10-13-1981.
		1,174,674.	FR. INT. CL. 1. (U.S. CL. 6). REG. 10-27-1981.
		1,175,354.	150G. INT. CL. 28. (U.S. CL. 22). REG. 10-27-1981.
		1,185,867.	JAZZ. INT. CL. 25. (U.S. CL. 39). REG. 1-12-1982.

- 1,188,853. DAIRY DELITE AND DESIGN. INT. CL. 30. (U.S. CL. 46). REG. 2-2-1982.
- 1,192,951. B 33. INT. CL. 3. (U.S. CL. 51). REG. 4-6-1982.
- 1,192,957. JUNGLE LAND. INT. CL. 5. (U.S. CL. 18). REG. 4-6-1982.
- 1,193,466. SCOTTY. INT. CL. 1. (U.S. CL. 6). REG. 4-13-1982.
- 1,193,503. STRONG-ARM. INT. CL. 6. (U.S. CL. 13). REG. 4-13-1982.
- 1,193,516. FILMEX. INT. CL. 7. (U.S. CL. 23). REG. 4-13-1982.
- 1,193,581. UNI-TRAK. INT. CL. 12. (U.S. CL. 19). REG. 4-13-1982.
- 1,193,683. FEELS TERRIFIC. INT. CL. 25. (U.S. CL. 39). REG. 4-13-1982.
- 1,193,711. MAC'S (STYLIZED). INT. CL. 29. (U.S. CL. 46). REG. 4-13-1982.
- 1,193,831. ORIOLE BRAND AND DESIGN. INT. CL. 2. (U.S. CLS. 6 AND 16). REG. 4-20-1982.
- 1,194,045. ARMAGEDDON. INT. CL. 28. (U.S. CL. 22). REG. 4-20-1982.
- 1,194,194. VALIANT. INT. CL. 5. (U.S. CL. 44). REG. 4-27-1982.
- 1,194,227. THE ART OF NEGOTIATING. INT. CLS. 9 AND 16. (U.S. CLS. 21, 36 AND 38). REG. 4-27-1982.
- 1,194,884. THE LENOX SHOP. INT. CL. 42. (U.S. CL. 101). REG. 5-4-1982.
- 1,195,015. KAISER (STYLIZED). INT. CL. 7. (U.S. CL. 23). REG. 5-11-1982.
- 1,195,325. COUNTRY PRIDE (STYLIZED). INT. CL. 31. (U.S. CL. 46). REG. 5-11-1982.
- 1,195,412. FOUR SEASONS HOTELS. INT. CL. 42. (U.S. CL. 100). REG. 5-11-1982.
- 1,195,582. SEAL-X. INT. CL. 9. (U.S. CL. 21). REG. 5-18-1982.
- 1,195,712. MISCELLANEOUS DESIGN. INT. CL. 16. (U.S. CL. 38). REG. 5-18-1982.
- 1,196,491. SUPERWELL (STYLIZED). INT. CL. 42. (U.S. CL. 101). REG. 5-25-1982.
- 1,196,526. LIONS CLUBS INTERNATIONAL. U.S. CL. 200. REG. 5-25-1982.
- 1,197,050. POLY-SET. INT. CL. 6. (U.S. CL. 13). REG. 6-1-1982.
- 1,197,300. NEW ERA. INT. CL. 21. (U.S. CLS. 2, 13 AND 23). REG. 6-8-1982.
- 1,197,413. K AND DESIGN. INT. CL. 39. (U.S. CL. 105). REG. 6-8-1982.
- 1,197,883. MARGARD. INT. CL. 17. (U.S. CL. 1). REG. 6-15-1982.
- 1,198,145. "EL POPOCATEPETL". INT. CL. 30. (U.S. CL. 46). REG. 6-15-1982.
- 1,198,991. STANDISH FARMS. INT. CL. 30. (U.S. CL. 46). REG. 6-22-1982.
- 1,199,552. S AND DESIGN. INT. CL. 18. (U.S. CLS. 3 AND 41). REG. 6-29-1982.
- 1,199,630. S AND DESIGN. INT. CL. 25. (U.S. CL. 39). REG. 6-29-1982.
- 1,199,722. SUNTEX. INT. CL. 29. (U.S. CL. 46). REG. 6-29-1982.
- 1,200,318. FAT-O-METER. INT. CL. 10. (U.S. CLS. 26 AND 44). REG. 7-6-1982.
- 1,202,002. KOH-I-NOOR RAPIDOGRAPH AND DESIGN. INT. CL. 16. (U.S. CLS. 11 AND 37). REG. 7-20-1982.
- 1,202,741. THRIFTY DIAMOND. INT. CL. 20. (U.S. CL. 50). REG. 7-27-1982.
- 1,202,935. HERMANN J. WIEMER AND DESIGN. INT. CL. 33. (U.S. CL. 47). REG. 7-27-1982.
- 1,202,969. CENTROL. INT. CLS. 35 AND 42. (U.S. CLS. 100 AND 101). REG. 7-27-1982.
- 1,203,038. MUNCIE AND DESIGN. INT. CLS. 37 AND 42. (U.S. CLS. 100 AND 103). REG. 7-27-1982.
- 1,203,392. RM (STYLIZED). INT. CL. 7. (U.S. CL. 23). REG. 8-3-1982.
- 1,203,812. PRESIDENTE. INT. CL. 32. (U.S. CL. 48). REG. 8-3-1982.
- 1,205,178. DENCO. INT. CL. 8. (U.S. CL. 23). REG. 8-17-1982.
- 1,207,343. MISCELLANEOUS DESIGN. INT. CL. 25. (U.S. CL. 39). REG. 9-7-1982.
- 1,207,394. SCHLEICH S AND DESIGN. INT. CL. 28. (U.S. CL. 22). REG. 9-7-1982.
- 1,207,810. PRECOR. INT. CL. 5. (U.S. CL. 6). REG. 9-14-1982.
- 1,208,850. BEECH-NUT AND DESIGN. INT. CL. 34. (U.S. CL. 17). REG. 9-14-1982.
- 1,209,010. MISCELLANEOUS DESIGN. INT. CLS. 37 AND 42. (U.S. CLS. 101 AND 103). REG. 9-14-1982.
- 1,211,217. ERY-TAB. INT. CL. 5. (U.S. CL. 18). REG. 10-5-1982.
- 1,211,426. IN TOUCH MINISTRIES. INT. CLS. 9, 16 AND 41. (U.S. CLS. 21, 23, 26, 36, 38 AND 107). REG. 10-5-1982.
- 1,213,648. BE PREPARED AND DESIGN. U.S. CL. 200. REG. 10-19-1982.
- 1,213,651. BE PREPARED AND DESIGN. U.S. CL. 200. REG. 10-19-1982.
- 1,213,886. THE STATE JOURNAL-REGISTER. INT. CL. 16. (U.S. CL. 38). REG. 10-26-1982.
- 1,213,974. OVER KOTE AND DESIGN. INT. CL. 19. (U.S. CL. 12). REG. 10-26-1982.
- 1,214,231. TABLE MAID. INT. CL. 29. (U.S. CL. 46). REG. 10-26-1982.
- 1,215,983. BOLCO. INT. CL. 28. (U.S. CL. 22). REG. 11-9-1982.
- 1,216,731. ARAUCO. INT. CL. 19 ONLY. (U.S. CL. 12). REG. 11-16-1982.
- 1,217,441. LUCIFER (STYLIZED). INT. CL. 11. (U.S. CL. 21). REG. 11-23-1982.
- 1,217,537. MISCELLANEOUS DESIGN. INT. CL. 16. (U.S. CL. 38). REG. 11-23-1982.
- 1,218,143. PERKY. INT. CL. 8. (U.S. CL. 23). REG. 11-30-1982.
- 1,222,941. THE CRICKETS. INT. CL. 41. (U.S. CL. 107). REG. 1-4-1983.
- 1,223,003. PJ'S PANCAKE HOUSE. INT. CL. 42. (U.S. CL. 100). REG. 1-4-1983.
- 1,223,943. OMNITHRUSTER. INT. CL. 7. (U.S. CLS. 23 AND 26). REG. 1-18-1983.
- 1,231,282. MISCELLANEOUS DESIGN. INT. CL. 32. (U.S. CL. 45). REG. 3-15-1983.
- 1,231,287. BRITISH NAVY PUSSEY'S RUM. INT. CL. 33. (U.S. CL. 49). REG. 3-15-1983.
- 1,233,355. FEDERAL REPORTER. INT. CL. 16 ONLY. (U.S. CL. 38). REG. 4-5-1983.
- 1,234,237. SUTTOCID. INT. CL. 5. (U.S. CL. 6). REG. 4-12-1983.
- 1,234,368. SOUTH EASTERN REPORTER. INT. CLS. 9 AND 16. (U.S. CLS. 26 AND 38). REG. 4-12-1983.
- 1,234,562. WORDS AND PHRASES. INT. CL. 16. (U.S. CL. 38). REG. 4-12-1983.
- 1,235,559. LYTOR. INT. CL. 1. (U.S. CL. 6). REG. 4-26-1983.
- 1,457,962. VETRX AND DESIGN. INT. CL. 5. (U.S. CL. 18). REG. 9-22-1987.
- 1,531,105. BRIDOR. INT. CL. 30. (U.S. CL. 46). REG. 3-21-1989.
- 1,628,514. MISCELLANEOUS DESIGN. INT. CL. 30. (U.S. CL. 46). REG. 12-18-1990.
- 1,649,653. WALDENBOOKS PREFERRED READER. INT. CLS. 35 AND 42. (U.S. CLS. 100 AND 101). REG. 7-2-1991.
- 1,658,752. BIOCONJUGATE CHEMISTRY. INT. CL. 16. (U.S. CL. 38). REG. 9-24-1991.
- 1,659,694. DREAM HOME. INT. CL. 35 ONLY. (U.S. CL. 101). REG. 10-8-1991.
- 1,659,942. TEE TEEKANNE SEIT 1882 AND DESIGN. INT. CL. 30. (U.S. CL. 46). REG. 10-8-1991.
- 1,660,546. CRIMP 'N SEAL. INT. CL. 9. (U.S. CL. 21). REG. 10-15-1991.
- 1,660,715. INSERTA TEE AND DESIGN. INT. CL. 11. (U.S. CL. 13). REG. 10-15-1991.
- 1,661,498. HENRY. INT. CL. 9 ONLY. (U.S. CLS. 21 AND 23). REG. 10-22-1991.
- 1,662,197. XTRA FLEX. INT. CL. 6. (U.S. CL. 13). REG. 10-29-1991.
- 1,662,513. SAMURAI IL CAREZZADENTI AND DESIGN. INT. CL. 21. (U.S. CLS. 21, 29 AND 44). REG. 10-29-1991.
- 1,662,527. CHATHAM. INT. CL. 24. (U.S. CLS. 42 AND 50). REG. 10-29-1991.
- 1,663,974. AURORA. INT. CL. 9. (U.S. CL. 38). REG. 11-12-1991.
- 1,671,672. CEROS. INT. CL. 10. (U.S. CL. 44). REG. 1-14-1992.
- 1,672,724. CHICO NUT COMPANY AND DESIGN. INT. CL. 31. (U.S. CL. 46). REG. 1-21-1992.
- 1,680,097. MC MICRO CRYSTAL AND DESIGN. INT. CL. 9. (U.S. CLS. 21 AND 26). REG. 3-24-1992.
- 1,680,154. COOPER SOUND SONUS CLARUS. INT. CL. 9. (U.S. CL. 21). REG. 3-24-1992.
- 1,680,272. BLUE JAYS. INT. CLS. 16 AND 25. (U.S. CLS. 2, 5, 22, 23, 29, 37, 38, 39 AND 50). REG. 3-24-1992.
- 1,680,388. PP PRINCIPE AND DESIGN. INT. CL. 18. (U.S. CLS. 1, 2, 3, 22 AND 41). REG. 3-24-1992.

- 1,680,439. YVES SAINT LAURENT RIVE GAUCHE AND DESIGN. INT. CL. 25. (U.S. CL. 39). REG. 3-24-1992.
- 1,681,739. CPI. INT. CLS. 4 AND 42. (U.S. CLS. 1, 6, 15 AND 100). REG. 4-7-1992.
- 1,681,936. ELAN VARSHAY. INT. CL. 14. (U.S. CL. 28). REG. 4-7-1992.
- 1,682,661. KWIK KLEAN. INT. CL. 7. (U.S. CL. 23). REG. 4-14-1992.
- 1,682,723. MISCELLANEOUS DESIGN. INT. CL. 9. (U.S. CL. 21). REG. 4-14-1992.
- 1,682,819. DELTABOX. INT. CL. 12. (U.S. CL. 19). REG. 4-14-1992.
- 1,682,842. ROBYN NICHOLS. INT. CL. 14. (U.S. CL. 28). REG. 4-14-1992.
- 1,682,910. KARD LETS. INT. CL. 16. (U.S. CL. 38). REG. 4-14-1992.
- 1,682,914. FOLD-PAK AND DESIGN. INT. CL. 16. (U.S. CLS. 2 AND 37). REG. 4-14-1992.
- 1,682,973. POLY GLASS. INT. CL. 20. (U.S. CL. 2). REG. 4-14-1992.
- 1,683,023. CHIANGO. INT. CL. 25. (U.S. CL. 39). REG. 4-14-1992.
- 1,683,101. MONTAGNOLO. INT. CL. 29. (U.S. CL. 46). REG. 4-14-1992.
- 1,683,112. KRISPY KREME DOUGHNUTS AND DESIGN. INT. CLS. 30 AND 42. (U.S. CLS. 46 AND 101). REG. 4-14-1992.
- 1,683,165. PRIMARY EYECARE NETWORK AND DESIGN. INT. CLS. 35, 41 AND 42. (U.S. CLS. 100, 101 AND 107). REG. 4-14-1992.
- 1,683,234. MINTIE CORPORATION. INT. CL. 37. (U.S. CL. 103). REG. 4-14-1992.
- 1,683,267. SCIENTIFIC. INT. CL. 39. (U.S. CLS. 100 AND 105). REG. 4-14-1992.
- 1,683,275. SW SOUTHWEST UNITED INDUSTRIES AND DESIGN. INT. CL. 40. (U.S. CL. 106). REG. 4-14-1992.
- 1,683,293. FRESH AIR. INT. CL. 41. (U.S. CL. 107). REG. 4-14-1992.
- 1,683,333. INVENTORY LOCATOR SERVICE. INT. CL. 42. (U.S. CLS. 100 AND 101). REG. 4-14-1992.
- 1,683,497. MISCELLANEOUS DESIGN. INT. CL. 16. (U.S. CL. 38). REG. 4-14-1992.
- 1,683,546. GRANDMA'S SECRET POTION SUPER GRO AND DESIGN. INT. CL. 3. (U.S. CLS. 1, 4, 6, 50, 51 AND 52). REG. 4-21-1992.
- 1,683,633. WOLFFPACK AND DESIGN. INT. CLS. 9 AND 42. (U.S. CLS. 38, 100 AND 101). REG. 4-21-1992.
- 1,683,837. DRICHEM. INT. CL. 24. (U.S. CL. 42). REG. 4-21-1992.
- 1,683,879. 33. INT. CL. 28. (U.S. CL. 22). REG. 4-21-1992.
- 1,683,886. BUICK. INT. CL. 28. (U.S. CLS. 22, 23, 38 AND 50). REG. 4-21-1992.
- 1,684,032. GRUCCI SPECIAL EVENTS PRODUCTIONS. INT. CL. 41. (U.S. CL. 107). REG. 4-21-1992.
- 1,684,098. THE FASHION GROUP INTERNATIONAL. U.S. CL. 200. REG. 4-21-1992.
- 1,684,103. PIROUETTE. INT. CL. 9 ONLY. (U.S. CL. 38). REG. 4-21-1992.
- 1,684,189. DRY MIX 211. INT. CL. 19. (U.S. CL. 12). REG. 4-21-1992.
- 1,684,249. CEPESA AND DESIGN. INT. CL. 4. (U.S. CL. 15). REG. 4-28-1992.
- 1,684,262. FIRST RESPONSE. INT. CL. 5. (U.S. CL. 18). REG. 4-28-1992.
- 1,684,287. CLEAN-SWEEP. INT. CL. 6. (U.S. CL. 13). REG. 4-28-1992.
- 1,684,289. GASGUARD. INT. CL. 6. (U.S. CLS. 2, 26 AND 32). REG. 4-28-1992.
- 1,684,387. E AND DESIGN. INT. CL. 14. (U.S. CL. 28). REG. 4-28-1992.
- 1,684,393. R AND DESIGN. INT. CL. 14. (U.S. CL. 28). REG. 4-28-1992.
- 1,684,448. EXCLUSIVE KEY-LOCK AIRSEAL CORNER TRUE NORTH LOG HOMES AND DESIGN. INT. CL. 19. (U.S. CLS. 1, 12, 33 AND 50). REG. 4-28-1992.
- 1,684,482. DOUBLE KEY. INT. CL. 22. (U.S. CLS. 1, 2, 7, 19, 22, 42 AND 50). REG. 4-28-1992.
- 1,684,546. SUPREME NUT & CANDY. INT. CL. 29. (U.S. CL. 46). REG. 4-28-1992.
- 1,684,578. LUCILE'S AND DESIGN. INT. CL. 30. (U.S. CL. 46). REG. 4-28-1992.
- 1,684,666. SAMARITAN. INT. CL. 37. (U.S. CL. 103). REG. 4-28-1992.
- 1,684,684. BERMUDA LIMOUSINE INTERNATIONAL. INT. CL. 39. (U.S. CL. 105). REG. 4-28-1992.
- 1,684,726. MEDALLION. INT. CL. 42. (U.S. CLS. 100 AND 101). REG. 4-28-1992.
- 1,684,768. SEMA. INT. CL. 42. (U.S. CL. 100). REG. 4-28-1992.
- 1,684,809. QUALIFACTS. INT. CL. 9. (U.S. CL. 38). REG. 4-28-1992.
- 1,684,823. HOLOSYNCH. INT. CL. 9. (U.S. CL. 36). REG. 4-28-1992.
- 1,684,879. ALL TUNE. INT. CL. 37. (U.S. CL. 103). REG. 4-28-1992.
- 1,684,936. MIZUKASIL. INT. CL. 1. (U.S. CLS. 1 AND 6). REG. 5-5-1992.
- 1,685,006. SHEARGLIDE. INT. CL. 4. (U.S. CL. 15). REG. 5-5-1992.
- 1,685,013. PIN-X. INT. CL. 5. (U.S. CL. 18). REG. 5-5-1992.
- 1,685,064. DURAFLO. INT. CL. 7. (U.S. CLS. 23 AND 35). REG. 5-5-1992.
- 1,685,067. VEHMA. INT. CLS. 7, 40 AND 42 ONLY. (U.S. CLS. 23, 100, 101, 103 AND 106). REG. 5-5-1992.
- 1,685,080. SUPERBEE. INT. CL. 7. (U.S. CL. 23). REG. 5-5-1992.
- 1,685,357. CHRISTMAS IN THE CITY (STYLIZED). INT. CL. 21. (U.S. CL. 50). REG. 5-5-1992.
- 1,685,475. FRY-IT. INT. CL. 29. (U.S. CL. 46). REG. 5-5-1992.
- 1,685,626. CLARENCE. INT. CL. 41. (U.S. CLS. 100, 101 AND 107). REG. 5-5-1992.
- 1,685,714. SPORTSCARE AND DESIGN. INT. CL. 42. (U.S. CL. 100). REG. 5-5-1992.
- 1,685,785. WILSONART. INT. CL. 17. (U.S. CL. 1). REG. 5-5-1992.
- 1,685,802. FULL THROTTLE. INT. CL. 25. (U.S. CLS. 22 AND 39). REG. 5-5-1992.
- 1,685,805. NAGARAYA CRACKER NUTS AND DESIGN. INT. CL. 30. (U.S. CL. 46). REG. 5-5-1992.
- 1,685,895. BIO-NEUTRALIZER. INT. CL. 1. (U.S. CL. 6). REG. 5-12-1992.
- 1,685,994. MISCELLANEOUS DESIGN. INT. CL. 6. (U.S. CLS. 12 AND 13). REG. 5-12-1992.
- 1,686,005. ANDERSON FITTINGS. INT. CL. 6. (U.S. CL. 13). REG. 5-12-1992.
- 1,686,106. DYNAMIC GRAPHICS, INC. AND DESIGN. INT. CL. 9. (U.S. CL. 38). REG. 5-12-1992.
- 1,686,150. NATCO. INT. CLS. 9 AND 11. (U.S. CLS. 26, 31 AND 34). REG. 5-12-1992.
- 1,686,288. MISCELLANEOUS DESIGN. INT. CL. 12. (U.S. CL. 19). REG. 5-12-1992.
- 1,686,354. ARMY FLIER. INT. CL. 16. (U.S. CL. 38). REG. 5-12-1992.
- 1,686,465. VERTEX. INT. CL. 21. (U.S. CLS. 2, 30 AND 33). REG. 5-12-1992.
- 1,686,544. RACE DRIVIN' STANDARD CHARACTER MARK. INT. CL. 9. (U.S. CLS. 21, 23, 26, 36 AND 38). REG. 5-12-1992.
- 1,687,042. THE MONITOR AND DESIGN. INT. CL. 9. (U.S. CL. 21). REG. 5-12-1992.
- 1,687,258. TINAPA. INT. CL. 29. (U.S. CL. 46). REG. 5-12-1992.
- 1,687,273. DOME DOG. INT. CL. 30. (U.S. CL. 46). REG. 5-12-1992.
- 1,687,302. REDEXPRESS. INT. CL. 35. (U.S. CL. 101). REG. 5-12-1992.
- 1,687,336. FOUR SEASONS RESORT. INT. CL. 42. (U.S. CLS. 100 AND 107). REG. 5-12-1992.
- 1,687,481. MISCELLANEOUS DESIGN. INT. CL. 3. (U.S. CL. 51). REG. 5-19-1992.
- 1,687,892. COMFORT REST. INT. CL. 20. (U.S. CL. 32). REG. 5-19-1992.
- 1,687,909. EMILIO PUCCI. INT. CL. 25 ONLY. (U.S. CLS. 22 AND 39). REG. 5-19-1992.
- 1,688,083. TRUMP TOWER. INT. CL. 36. (U.S. CLS. 100, 101 AND 102). REG. 5-19-1992.
- 1,688,206. PARISIAN. INT. CL. 42. (U.S. CL. 101). REG. 5-19-1992.
- 1,688,885. PROMODEL. INT. CL. 9. (U.S. CL. 38). REG. 5-26-1992.
- 1,689,388. QUALIFACTS SYSTEMS. INT. CL. 42. (U.S. CL. 100). REG. 5-26-1992.
- 1,689,424. SCIENTIFIC. INT. CL. 42. (U.S. CL. 101). REG. 5-26-1992.
- 1,689,466. DFS. INT. CL. 42. (U.S. CL. 101). REG. 5-26-1992.
- 1,689,726. BIOCOAT. INT. CL. 1. (U.S. CL. 6). REG. 6-2-1992.

- 1,690,447. THE NEW AMERICAN HOME. INT. CL. 35. (U.S. CL. 101). REG. 6-2-1992.
- 1,690,799. EARTHWISE. INT. CL. 16. (U.S. CLS. 2, 32 AND 37). REG. 6-2-1992.
- 1,690,840. ACOUSTI-MAT. INT. CL. 27. (U.S. CLS. 20 AND 42). REG. 6-2-1992.
- 1,691,226. ELOQUENCE. INT. CL. 9 ONLY. (U.S. CL. 38). REG. 6-9-1992.
- 1,691,460. Q-PACK. INT. CL. 16. (U.S. CLS. 2 AND 37). REG. 6-9-1992.
- 1,691,554. PNEUMOSTOP. INT. CL. 17. (U.S. CL. 35). REG. 6-9-1992.
- 1,691,558. ALVIERO MARTINI AND 1A CLASSE (STYLIZED). INT. CL. 18. (U.S. CLS. 1, 2, 3, 22 AND 41). REG. 6-9-1992.
- 1,691,693. COTILLION. INT. CL. 25. (U.S. CL. 39). REG. 6-9-1992.
- 1,692,164. THE AUTOMATION CHEMICAL COMPANY. INT. CLS. 7 AND 9. (U.S. CLS. 23 AND 26). REG. 6-9-1992.
- 1,692,242. SIERRA. INT. CL. 1. (U.S. CLS. 1, 5, 6, 10, 26 AND 46). REG. 6-9-1992.
- 1,692,330. LA TAN AND DESIGN. INT. CL. 3. (U.S. CLS. 1, 4, 6, 50, 51 AND 52). REG. 6-9-1992.
- 1,692,437. SCRAPPER. INT. CL. 7. (U.S. CL. 23). REG. 6-9-1992.
- 1,693,366. BROWNIE BITES. INT. CL. 30. (U.S. CL. 46). REG. 6-9-1992.
- 1,693,841. LIPHATECH. INT. CL. 5 ONLY. (U.S. CLS. 6, 18, 44, 46, 51 AND 52 ONLY). REG. 6-16-1992.
- 1,694,393. REBOUND ACE. INT. CL. 19. (U.S. CLS. 1, 12, 33 AND 50). REG. 6-16-1992.
- 1,694,690. STONE MOUNTAIN COFFEE ROASTERS AND DESIGN. INT. CL. 30. (U.S. CL. 46). REG. 6-16-1992.
- 1,695,057. PUTTING TECHNOLOGY IN ITS PLACE. INT. CL. 42. (U.S. CL. 100). REG. 6-16-1992.
- 1,695,108. MAGNOLIAS UPTOWN DOWN SOUTH AND DESIGN. INT. CL. 42. (U.S. CL. 100). REG. 6-16-1992.
- 1,695,315. QUICKTITE. INT. CL. 16. (U.S. CL. 5). REG. 6-16-1992.
- 1,695,789. SDI (STYLIZED). INT. CL. 8. (U.S. CL. 23). REG. 6-23-1992.
- 1,696,084. PERMACOTE. INT. CL. 17. (U.S. CL. 12). REG. 6-23-1992.
- 1,696,403. RANCHO SISQUOC. INT. CL. 33. (U.S. CL. 47). REG. 6-23-1992.
- 1,696,555. W AND DESIGN. INT. CL. 41. (U.S. CL. 107). REG. 6-23-1992.
- 1,696,770. AUTORINSE (STYLIZED). INT. CL. 7. (U.S. CL. 23). REG. 6-23-1992.
- 1,696,948. CONGRESSIONAL. INT. CL. 19. (U.S. CL. 12). REG. 6-23-1992.
- 1,697,188. SUPERPAD. INT. CL. 20. (U.S. CLS. 32 AND 50). REG. 6-23-1992.
- 1,697,324. TEARS NATURALE FREE. INT. CL. 5. (U.S. CL. 18). REG. 6-30-1992.
- 1,697,498. AKI JET (STYLIZED). INT. CL. 11. (U.S. CL. 13). REG. 6-30-1992.
- 1,697,553. CHIMES OF KYOTO AND DESIGN. INT. CL. 15. (U.S. CL. 36). REG. 6-30-1992.
- 1,697,639. MALO. INT. CL. 18. (U.S. CLS. 1, 2, 3, 22 AND 41). REG. 6-30-1992.
- 1,697,685. RE-UZ-IT. INT. CL. 21. (U.S. CL. 29). REG. 6-30-1992.
- 1,697,937. PROPERTY BY OWNER FOR SALE AND DESIGN. INT. CL. 35. (U.S. CL. 101). REG. 6-30-1992.
- 1,698,004. NEW YORK LIFE AND DESIGN. INT. CL. 36. (U.S. CL. 102). REG. 6-30-1992.
- 1,698,170. AMERICAN COLLEGE OF VETERINARY PATHOLOGISTS. U.S. CLS. 200 AND 100. (INT. CL. 42). REG. 6-30-1992.
- 1,698,171. ACVP. U.S. CLS. 200 AND 100. (INT. CL. 42). REG. 6-30-1992.
- 1,698,660. JOMAX. INT. CL. 1. (U.S. CL. 6). REG. 7-7-1992.
- 1,698,978. MISCELLANEOUS DESIGN. INT. CL. 14. (U.S. CL. 28). REG. 7-7-1992.
- 1,699,302. SHADY PLACE. INT. CL. 31. (U.S. CL. 1). REG. 7-7-1992.
- 1,699,540. DD AND DESIGN. INT. CL. 42. (U.S. CL. 100). REG. 7-7-1992.
- 1,700,058. ALL WEATHER. INT. CL. 1. (U.S. CL. 6). REG. 7-14-1992.
- 1,700,059. ALL WEATHER AND DESIGN. INT. CL. 1. (U.S. CL. 6). REG. 7-14-1992.
- 1,700,437. REYCO SYSTEMS (STYLIZED). INT. CL. 11. (U.S. CLS. 13, 23 AND 34). REG. 7-14-1992.
- 1,700,481. THE NURSE PRACTITIONER. INT. CL. 16. (U.S. CL. 38). REG. 7-14-1992.
- 1,700,539. SMART WIPES. INT. CL. 16. (U.S. CL. 37). REG. 7-14-1992.
- 1,700,694. WM. BOLTHOUSE FARMS AND DESIGN. INT. CL. 29. (U.S. CL. 46). REG. 7-14-1992.
- 1,700,733. MADISON PARKS. INT. CL. 31. (U.S. CLS. 1 AND 10). REG. 7-14-1992.
- 1,700,750. PRIMARY EYECARE NETWORK. INT. CLS. 35, 41 AND 42. (U.S. CLS. 101 AND 107). REG. 7-14-1992.
- 1,701,055. SORB PAK. INT. CL. 1. (U.S. CL. 6). REG. 7-14-1992.
- 1,701,086. MPIS. INT. CL. 9. (U.S. CL. 21). REG. 7-14-1992.
- 1,701,408. BAL. INT. CLS. 6 AND 8. (U.S. CLS. 19 AND 23). REG. 7-21-1992.
- 1,702,000. BAR-B-Q HEAVEN. INT. CL. 30. (U.S. CL. 46). REG. 7-21-1992.
- 1,702,415. AUTODILUTE (STYLIZED). INT. CL. 9. (U.S. CL. 26). REG. 7-21-1992.
- 1,702,830. DUKE UNIVERSITY (STYLIZED). INT. CLS. 6, 16, 18 AND 24. (U.S. CLS. 2, 3, 13, 25, 32, 37, 38, 42 AND 50). REG. 7-28-1992.
- 1,703,107. KAB AND DESIGN. INT. CL. 12. (U.S. CL. 19). REG. 7-28-1992.
- 1,703,914. NORTH COAST ELECTRIC COMPANY. INT. CL. 42. (U.S. CL. 101). REG. 7-28-1992.
- 1,704,429. PLAID. INT. CLS. 1, 2 AND 16. (U.S. CLS. 5, 6, 16, 37 AND 38). REG. 8-4-1992.
- 1,704,431. AMSPERSE. INT. CL. 1. (U.S. CLS. 1, 5, 6, 10, 26 AND 46). REG. 8-4-1992.
- 1,704,530. BAL (STYLIZED). INT. CLS. 6 AND 8. (U.S. CLS. 19 AND 23). REG. 8-4-1992.
- 1,704,885. FASTRACK. INT. CL. 16. (U.S. CL. 38). REG. 8-4-1992.
- 1,705,041. MIKASA. INT. CL. 20. (U.S. CL. 32). REG. 8-4-1992.
- 1,705,502. MISCELLANEOUS DESIGN. INT. CL. 41. (U.S. CL. 107). REG. 8-4-1992.
- 1,705,808. ACRYSOFF. INT. CL. 10. (U.S. CL. 44). REG. 8-4-1992.
- 1,706,300. THE EDGE CUTTER. INT. CL. 8. (U.S. CLS. 23 AND 44). REG. 8-11-1992.
- 1,706,917. RAINFOREST. INT. CL. 25. (U.S. CL. 39). REG. 8-11-1992.
- 1,707,145. MISCELLANEOUS DESIGN. INT. CL. 35. (U.S. CLS. 101 AND 105). REG. 8-11-1992.
- 1,707,235. SCIENTIFIC. INT. CL. 37. (U.S. CL. 103). REG. 8-11-1992.
- 1,707,263. JTB. INT. CL. 39. (U.S. CLS. 100 AND 105). REG. 8-11-1992.
- 1,707,696. FINAL INSPECTION. INT. CL. 3. (U.S. CL. 52). REG. 8-18-1992.
- 1,707,855. ROBOPAK. INT. CL. 9. (U.S. CL. 26). REG. 8-18-1992.
- 1,708,101. WHITE ROSE. INT. CL. 16. (U.S. CLS. 2, 5, 22, 23, 29, 37, 38 AND 50). REG. 8-18-1992.
- 1,708,291. MISCELLANEOUS DESIGN. INT. CL. 25. (U.S. CLS. 22 AND 39). REG. 8-18-1992.
- 1,708,515. VELVETREAD. INT. CL. 31. (U.S. CL. 1). REG. 8-18-1992.
- 1,709,751. SUSIE SIMON. INT. CL. 9. (U.S. CL. 26). REG. 8-25-1992.
- 1,711,452. FARLIN (STYLIZED). INT. CL. 10. (U.S. CL. 44). REG. 9-1-1992.
- 1,711,453. REFLECTION (STYLIZED). INT. CL. 10. (U.S. CL. 44). REG. 9-1-1992.
- 1,711,938. EL SABROSO AND DESIGN. INT. CL. 29. (U.S. CL. 46). REG. 9-1-1992.
- 1,712,640. VERI-FLAME. INT. CL. 9. (U.S. CL. 26). REG. 9-1-1992.
- 1,712,647. RINGMAX. INT. CL. 9. (U.S. CLS. 21, 23, 26, 36 AND 38). REG. 9-1-1992.
- 1,715,226. KELLYCO AND DESIGN. INT. CL. 9. (U.S. CL. 26). REG. 9-15-1992.
- 1,715,562. THE INDIVIDUAL INVESTOR. INT. CL. 16. (U.S. CLS. 37 AND 38). REG. 9-15-1992.
- 1,716,140. MISCELLANEOUS DESIGN. INT. CL. 29. (U.S. CL. 46). REG. 9-15-1992.
- 1,716,250. EARTHCARPET. INT. CL. 31. (U.S. CL. 1). REG. 9-15-1992.

- 1,716,296. JUAREZ AND DESIGN. INT. CL. 33. (U.S. CL. 49). REG. 9-15-1992.
- 1,717,889. RECARO. INT. CL. 12. (U.S. CL. 19). REG. 9-22-1992.
- 1,717,969. MEANS. INT. CLS. 16, 35, 41 AND 42. (U.S. CLS. 2, 5, 22, 23, 29, 37, 38, 50, 100, 101, 102 AND 107). REG. 9-22-1992.
- 1,718,452. ALLAN AND DESIGN. INT. CL. 30. (U.S. CL. 46). REG. 9-22-1992.
- 1,719,108. FUTURES FOR CHILDREN. INT. CL. 42. (U.S. CL. 100). REG. 9-22-1992.
- 1,719,730. DO IT BEST AND DESIGN. INT. CL. 1. (U.S. CLS. 1, 5, 6, 10, 26 AND 46). REG. 9-29-1992.
- 1,719,828. MISCELLANEOUS DESIGN. INT. CL. 7. (U.S. CLS. 19 AND 21). REG. 9-29-1992.
- 1,720,137. PIRANESI AND DESIGN. INT. CL. 14. (U.S. CL. 28). REG. 9-29-1992.
- 1,720,171. THE COUNSELOR. INT. CL. 16. (U.S. CL. 38). REG. 9-29-1992.
- 1,720,658. LDI. INT. CL. 35. (U.S. CL. 101). REG. 9-29-1992.
- 1,721,251. CHEMBETAINE. INT. CL. 1. (U.S. CL. 6). REG. 10-6-1992.
- 1,721,436. QUADRIIVE. INT. CL. 7. (U.S. CL. 23). REG. 10-6-1992.
- 1,721,438. R M AND DESIGN. INT. CL. 7. (U.S. CL. 23). REG. 10-6-1992.
- 1,721,620. SURVEYFIRST. INT. CL. 9. (U.S. CL. 38). REG. 10-6-1992.
- 1,721,621. EZSURVEY. INT. CL. 9. (U.S. CL. 38). REG. 10-6-1992.
- 1,721,623. USURVEY. INT. CL. 9. (U.S. CL. 38). REG. 10-6-1992.
- 1,721,839. CARIBBEAN BUSINESS. INT. CL. 16. (U.S. CL. 38). REG. 10-6-1992.
- 1,722,885. PERMA-WHITE. INT. CL. 2. (U.S. CL. 16). REG. 10-6-1992.
- 1,725,901. SILVERLIT. INT. CL. 28. (U.S. CL. 22). REG. 10-20-1992.
- 1,725,963. MISCELLANEOUS DESIGN. INT. CL. 29. (U.S. CL. 46). REG. 10-20-1992.
- 1,726,797. FLEXOMER. INT. CL. 1. (U.S. CL. 6). REG. 10-27-1992.
- 1,727,054. HARMONIC DRIVE TECHNOLOGIES AND DESIGN. INT. CLS. 7 AND 9. (U.S. CLS. 23 AND 26). REG. 10-27-1992.
- 1,727,391. REPTI THERM. INT. CL. 11. (U.S. CL. 34). REG. 10-27-1992.
- 1,728,006. RECORD COPY SERVICES. INT. CL. 35. (U.S. CL. 101). REG. 10-27-1992.
- 1,728,573. 427 S/C. INT. CL. 12. (U.S. CLS. 19 AND 23). REG. 10-27-1992.
- 1,729,151. HALE. INT. CL. 11. (U.S. CLS. 13 AND 14). REG. 11-3-1992.
- 1,730,274. CONCEPT ONE. INT. CL. 9. (U.S. CL. 26). REG. 11-3-1992.
- 1,730,515. UCARFLOC. INT. CL. 1. (U.S. CL. 6). REG. 11-10-1992.
- 1,730,944. TTX AND DESIGN. INT. CL. 12. (U.S. CL. 19). REG. 11-10-1992.
- 1,730,959. MU PHI GAMMA KAPPA ALPHA THETA AND DESIGN. INT. CL. 14. (U.S. CL. 28). REG. 11-10-1992.
- 1,731,155. MISCELLANEOUS DESIGN. INT. CL. 21. (U.S. CLS. 2, 30, 33 AND 50). REG. 11-10-1992.
- 1,731,194. MU PHI GAMMA KAPPA ALPHA THETA AND DESIGN. INT. CL. 25. (U.S. CL. 39). REG. 11-10-1992.
- 1,731,478. HANGTOWN. INT. CL. 33. (U.S. CL. 47). REG. 11-10-1992.
- 1,732,854. HTI. INT. CL. 11. (U.S. CL. 21). REG. 11-17-1992.
- 1,733,763. GUADALAJARA GRILL CHARLIE'S BAR & PJOJO CAFE SINCE 1991 AND DESIGN. INT. CL. 42. (U.S. CL. 100). REG. 11-17-1992.
- 1,734,492. HIGH BRIDGE AND DESIGN. INT. CL. 9. (U.S. CL. 36). REG. 11-24-1992.
- 1,735,072. KRESTO. INT. CL. 30. (U.S. CL. 45). REG. 11-24-1992.
- 1,735,559. GROWN IN IDAHO IDAHO POTATOES AND DESIGN. U.S. CL. A. REG. 11-24-1992.
- 1,736,101. GEMINI. INT. CL. 7. (U.S. CLS. 23 AND 34). REG. 12-1-1992.
- 1,737,188. MISCELLANEOUS DESIGN. INT. CL. 41. (U.S. CLS. 100, 101 AND 107). REG. 12-1-1992.
- 1,737,259. SPARC. INT. CL. 42. (U.S. CL. 100). REG. 12-1-1992.
- 1,737,364. SAM & HARRY'S. INT. CL. 42. (U.S. CL. 100). REG. 12-1-1992.
- 1,739,383. MISCELLANEOUS DESIGN. INT. CL. 3. (U.S. CLS. 51 AND 52). REG. 12-15-1992.
- 1,740,093. ANTIGUA. INT. CL. 33. (U.S. CL. 47). REG. 12-15-1992.
- 1,740,460. SUBLIME. INT. CL. 1. (U.S. CL. 6). REG. 12-15-1992.
- 1,740,664. GOVPX, INC.. INT. CL. 36. (U.S. CL. 102). REG. 12-15-1992.
- 1,741,706. DFA. INT. CL. 36. (U.S. CLS. 101 AND 102). REG. 12-22-1992.
- 1,742,592. USC (STYLIZED). INT. CL. 1. (U.S. CL. 6). REG. 12-29-1992.
- 1,742,648. CLEAN TIPS. INT. CL. 3. (U.S. CLS. 44 AND 51). REG. 12-29-1992.
- 1,743,759. INTERAGES. INT. CL. 42. (U.S. CL. 100). REG. 12-29-1992.
- 1,744,294. D.C. AMERICA. INT. CL. 8. (U.S. CL. 23). REG. 1-5-1993.
- 1,745,535. SAFETY AND DESIGN. INT. CL. 7. (U.S. CLS. 13 AND 23). REG. 1-12-1993.
- 1,746,587. SYNCOAL. INT. CL. 42. (U.S. CL. 100). REG. 1-12-1993.
- 1,747,754. MEDIFLECTOR. INT. CL. 11. (U.S. CL. 21). REG. 1-19-1993.
- 1,749,024. HEARING ZONE. INT. CL. 42. (U.S. CL. 100). REG. 1-26-1993.
- 1,750,383. THE PRESERVE. INT. CLS. 36 AND 37. (U.S. CLS. 101, 102 AND 103). REG. 2-2-1993.
- 1,750,671. MISCELLANEOUS DESIGN. INT. CL. 42. (U.S. CL. 100). REG. 2-2-1993.
- 1,750,690. S (STYLIZED). INT. CL. 1. (U.S. CL. 6). REG. 2-2-1993.
- 1,751,436. MISCELLANEOUS DESIGN. INT. CL. 30 ONLY. (U.S. CL. 46). REG. 2-9-1993.
- 1,753,042. USPA. INT. CL. 42. (U.S. CL. 100). REG. 2-16-1993.
- 1,753,609. FISHER AND DESIGN. INT. CL. 7. (U.S. CL. 23). REG. 2-23-1993.
- 1,754,637. MAGGIANO'S LITTLE ITALY. INT. CL. 42. (U.S. CL. 100). REG. 2-23-1993.
- 1,754,887. HYPER-JET. INT. CL. 7. (U.S. CL. 23). REG. 3-2-1993.
- 1,755,854. NATIONAL MIDDLE SCHOOL ASSOCIATION. INT. CL. 42. (U.S. CL. 100). REG. 3-2-1993.
- 1,756,421. +T-I-F-C-O- AND DESIGN. INT. CL. 6. (U.S. CL. 13). REG. 3-9-1993.
- 1,757,992. BAYSHOCK. INT. CL. 6. (U.S. CLS. 12, 13 AND 14). REG. 3-16-1993.
- 1,759,157. GOLDEN DIAMOND. INT. CL. 13. (U.S. CL. 9). REG. 3-16-1993.
- 1,759,627. ASTRO LITE AND DESIGN. INT. CL. 9. (U.S. CL. 21). REG. 3-23-1993.
- 1,759,977. SNOWBIRD AND DESIGN. INT. CL. 25. (U.S. CLS. 22 AND 39). REG. 3-23-1993.
- 1,760,091. LOSURDO. INT. CLS. 29 AND 30. (U.S. CL. 46). REG. 3-23-1993.
- 1,762,551. NCS CORPORATION (STYLIZED). INT. CLS. 9 AND 42. (U.S. CLS. 26 AND 100). REG. 4-6-1993.
- 1,762,668. PRESSURE CURE. INT. CL. 11. (U.S. CL. 34). REG. 4-6-1993.
- 1,763,543. BBB. U.S. CL. B. REG. 4-6-1993.
- 1,764,085. EAST-WEST CENTER. INT. CLS. 25 AND 41 ONLY. (U.S. CLS. 39 AND 107). REG. 4-13-1993.
- 1,764,121. PERCEPTION II. INT. CL. 9. (U.S. CLS. 26 AND 38). REG. 4-13-1993.
- 1,765,213. HEX-L. INT. CL. 8. (U.S. CL. 23). REG. 4-13-1993.
- 1,766,889. YO-J. INT. CL. 32. (U.S. CL. 46). REG. 4-20-1993.
- 1,767,222. T-LINER. INT. CL. 8. (U.S. CL. 23). REG. 4-27-1993.
- 1,767,418. BROADSIDE. INT. CL. 16. (U.S. CL. 38). REG. 4-27-1993.
- 1,767,961. K AND DESIGN. INT. CL. 9. (U.S. CL. 26). REG. 4-27-1993.
- 2,429,421. HYDROCLEAN. INT. CL. 7. (U.S. CLS. 13, 19, 21, 23, 31, 34 AND 35). REG. 2-20-2001.
- 2,437,912. ADAPTIVE (STYLIZED). INT. CL. 9. (U.S. CLS. 21, 23, 26, 36 AND 38). REG. 3-27-2001.
- 2,460,772. IMMUNOSPOT AND DESIGN. INT. CLS. 5, 9 AND 10. (U.S. CLS. 6, 18, 21, 23, 26, 36, 38, 39, 44, 46, 51 AND 52). REG. 6-19-2001.
- 2,483,141. MAC. INT. CL. 11. (U.S. CLS. 13, 21, 23, 31 AND 34). REG. 8-28-2001.

- 2,489,726. CFOS. INT. CLS. 9, 16 AND 42. (U.S. CLS. 2, 5, 21, 22, 23, 26, 29, 36, 37, 38, 50, 100 AND 101). REG. 9-18-2001.
- 2,491,811. ARTIST'S PALETTE. INT. CL. 16 ONLY. (U.S. CLS. 2, 5, 22, 23, 29, 37, 38 AND 50). REG. 9-25-2001.
- 2,491,830. CAP - CHUR AND DESIGN. INT. CLS. 5 AND 10. (U.S. CLS. 6, 18, 26, 39, 44, 46, 51 AND 52). REG. 9-25-2001.
- 2,495,787. EWEEK. INT. CL. 42 ONLY. (U.S. CLS. 100 AND 101). REG. 10-9-2001.
- 2,495,851. HD 2000. INT. CL. 12. (U.S. CLS. 19, 21, 23, 31, 35 AND 44). REG. 10-9-2001.
- 2,496,093. MEDCO AND DESIGN. INT. CL. 35. (U.S. CLS. 100, 101 AND 102). REG. 10-9-2001.
- 2,496,439. HOT PLATE. INT. CL. 9. (U.S. CLS. 21, 23, 26, 36 AND 38). REG. 10-9-2001.
- 2,496,472. AHI AMERICAN HEALTHCARE INDEMNITY COMPANY. INT. CL. 36. (U.S. CLS. 100, 101 AND 102). REG. 10-9-2001.
- 2,496,602. AIRWAVE. INT. CL. 11 ONLY. (U.S. CLS. 13, 21, 23, 31 AND 34). REG. 10-9-2001.
- 2,496,861. MISCELLANEOUS DESIGN. INT. CL. 5. (U.S. CLS. 6, 18, 44, 46, 51 AND 52). REG. 10-9-2001.
- 2,496,972. FIREKING. INT. CL. 41. (U.S. CLS. 100, 101 AND 107). REG. 10-9-2001.
- 2,497,004. Q COUNT. INT. CL. 9. (U.S. CLS. 21, 23, 26, 36 AND 38). REG. 10-9-2001.
- 2,497,012. ACMA AND DESIGN. INT. CL. 35. (U.S. CLS. 100, 101 AND 102). REG. 10-9-2001.
- 2,497,196. THE COVENANT. INT. CL. 25. (U.S. CLS. 22 AND 39). REG. 10-9-2001.
- 2,497,783. FOOD PROCESSING AND DESIGN. INT. CL. 30 ONLY. (U.S. CL. 46). REG. 10-16-2001.
- 2,497,785. PROMISELAND. INT. CL. 42 ONLY. (U.S. CLS. 100 AND 101). REG. 10-16-2001.
- 2,497,824. RYDERSHIP. INT. CL. 39. (U.S. CLS. 100 AND 105). REG. 10-16-2001.
- 2,497,877. VAUGHAN AND DESIGN. INT. CL. 8. (U.S. CLS. 23, 28 AND 44). REG. 10-16-2001.
- 2,497,907. CITY GYM BOYS. INT. CL. 16. (U.S. CLS. 2, 5, 22, 23, 29, 37, 38 AND 50). REG. 10-16-2001.
- 2,498,006. ROCK A LONG. INT. CL. 28. (U.S. CLS. 22, 23, 38 AND 50). REG. 10-16-2001.
- 2,498,085. FRONTIER. INT. CL. 16. (U.S. CLS. 2, 5, 22, 23, 29, 37, 38 AND 50). REG. 10-16-2001.
- 2,498,120. INAUTIX. INT. CL. 42. (U.S. CLS. 100 AND 101). REG. 10-16-2001.
- 2,498,137. BABY'S. INT. CL. 42. (U.S. CLS. 100 AND 101). REG. 10-16-2001.
- 2,498,317. NETEXCHANGE CLIENT. INT. CL. 36. (U.S. CLS. 100, 101 AND 102). REG. 10-16-2001.
- 2,498,392. TEXTILLERY. INT. CL. 35. (U.S. CLS. 100, 101 AND 102). REG. 10-16-2001.
- 2,498,564. FRENCH PICNIC AND DESIGN. INT. CL. 30. (U.S. CL. 46). REG. 10-16-2001.
- 2,498,873. THE POWER OF PERSHING. INT. CL. 36. (U.S. CLS. 100, 101 AND 102). REG. 10-16-2001.
- 2,499,222. BUGFREE. INT. CL. 37. (U.S. CLS. 100, 103 AND 106). REG. 10-16-2001.
- 2,499,335. MINNESOTA NONPROFITS ASSISTANCE FUND. INT. CL. 36. (U.S. CLS. 100, 101 AND 102). REG. 10-23-2001.
- 2,499,396. COMPGEEKS.COM. INT. CL. 35 ONLY. (U.S. CLS. 100, 101 AND 102). REG. 10-23-2001.
- 2,499,540. FALLEN ANGEL. INT. CLS. 9 AND 41. (U.S. CLS. 21, 23, 26, 36, 38, 100, 101 AND 107). REG. 10-23-2001.
- 2,499,842. N-S P A C E T E C H N O L O G Y AND DESIGN. INT. CL. 42. (U.S. CLS. 100 AND 101). REG. 10-23-2001.
- 2,500,121. MISCELLANEOUS DESIGN. INT. CL. 42. (U.S. CLS. 100 AND 101). REG. 10-23-2001.
- 2,500,145. KIDSHAPE. INT. CL. 41. (U.S. CLS. 100, 101 AND 107). REG. 10-23-2001.
- 2,500,560. BLATROL. INT. CL. 5. (U.S. CLS. 6, 18, 44, 46, 51 AND 52). REG. 10-23-2001.
- 2,500,716. ENERGIX. INT. CLS. 35 AND 42. (U.S. CLS. 100, 101 AND 102). REG. 10-23-2001.
- 2,501,192. SENTINEL. INT. CL. 9. (U.S. CLS. 21, 23, 26, 36 AND 38). REG. 10-30-2001.
- 2,501,488. EDWARD MARTIN'S ORIGINAL HOOF COATING. INT. CL. 3. (U.S. CLS. 1, 4, 6, 50, 51 AND 52). REG. 10-30-2001.
- 2,501,522. MISCELLANEOUS DESIGN. INT. CL. 41. (U.S. CLS. 100, 101 AND 107). REG. 10-30-2001.
- 2,501,647. 4 1/2 ACRES OF SOVEREIGN U.S. TERRITORY. INT. CLS. 37 AND 39. (U.S. CLS. 100, 103, 105 AND 106). REG. 10-30-2001.
- 2,501,709. FRANK R. WALKER COMPANY. INT. CLS. 9, 16 AND 35. (U.S. CLS. 2, 5, 21, 22, 23, 26, 29, 36, 37, 38, 50, 100, 101 AND 102). REG. 10-30-2001.
- 2,502,099. TRANSDISC. INT. CL. 7. (U.S. CLS. 13, 19, 21, 23, 31, 34 AND 35). REG. 10-30-2001.
- 2,502,505. ROVCON. INT. CLS. 7 AND 37. (U.S. CLS. 13, 19, 21, 23, 31, 34, 35, 100, 103 AND 106). REG. 10-30-2001.
- 2,503,626. HOMESTYLE DIRECT. INT. CLS. 29 AND 39. (U.S. CLS. 46, 100 AND 105). REG. 11-6-2001.
- 2,503,823. IT'S OUR PARTY! AND DESIGN. INT. CL. 41. (U.S. CLS. 100, 101 AND 107). REG. 11-6-2001.
- 2,503,856. RIPPLE EFFECT. INT. CL. 16. (U.S. CLS. 2, 5, 22, 23, 29, 37, 38 AND 50). REG. 11-6-2001.
- 2,504,329. POWER TOOLS. INT. CL. 3. (U.S. CLS. 1, 4, 6, 50, 51 AND 52). REG. 11-6-2001.
- 2,505,931. WE KEEP BUSINESS IN BUSINESS. INT. CLS. 35 AND 37. (U.S. CLS. 100, 101, 102, 103 AND 106). REG. 11-13-2001.
- 2,506,622. T TEDESCHI FOOD SHOPS FAST & FRIENDLY AND DESIGN. INT. CL. 35. (U.S. CLS. 100, 101 AND 102). REG. 11-13-2001.
- 2,507,650. RELEAF. INT. CL. 10. (U.S. CLS. 26, 39 AND 44). REG. 11-13-2001.
- 2,508,728. NUTRITION WAREHOUSE. INT. CL. 5. (U.S. CLS. 6, 18, 44, 46, 51 AND 52). REG. 11-20-2001.
- 2,508,894. MISCELLANEOUS DESIGN. INT. CL. 9. (U.S. CLS. 21, 23, 26, 36 AND 38). REG. 11-20-2001.
- 2,510,654. HAIR X HAIR LOSS RELIEF (STYLIZED). INT. CL. 5. (U.S. CLS. 6, 18, 44, 46, 51 AND 52). REG. 11-20-2001.
- 2,512,609. MARDI GRAS. INT. CL. 36. (U.S. CLS. 100, 101 AND 102). REG. 11-27-2001.
- 2,512,773. ENGINEERED TO BE ESSENTIAL. INT. CL. 6. (U.S. CLS. 2, 12, 13, 14, 23, 25 AND 50). REG. 11-27-2001.
- 2,514,916. SANTA BARBARA DESIGNS. INT. CLS. 18 AND 35. (U.S. CLS. 1, 2, 3, 22, 41, 100, 101 AND 102). REG. 12-4-2001.
- 2,516,842. DECLARATION. INT. CL. 14. (U.S. CLS. 2, 27, 28 AND 50). REG. 12-11-2001.
- 2,518,672. RENT A WHEEL AND DESIGN. INT. CL. 39. (U.S. CLS. 100 AND 105). REG. 12-11-2001.
- 2,519,760. THE ART OF ITALIAN CUISINE. INT. CLS. 29 AND 30. (U.S. CL. 46). REG. 12-18-2001.
- 2,520,525. VBXX AND DESIGN. INT. CL. 7. (U.S. CLS. 13, 19, 21, 23, 31, 34 AND 35). REG. 12-18-2001.
- 2,520,892. WOLF STEEL LTD.. INT. CL. 11. (U.S. CLS. 13, 21, 23, 31 AND 34). REG. 12-18-2001.
- 2,524,716. ALPHACORP (STYLIZED). INT. CL. 9. (U.S. CLS. 21, 23, 26, 36 AND 38). REG. 1-1-2002.
- 2,526,711. VIRGINIA CRANE (STYLIZED). INT. CL. 7. (U.S. CLS. 13, 19, 21, 23, 31, 34 AND 35). REG. 1-8-2002.
- 2,527,146. GRAPHIC ARTS BLUE BOOK. INT. CL. 42. (U.S. CLS. 100 AND 101). REG. 1-8-2002.
- 2,528,865. CAC. INT. CLS. 9, 37 AND 42. (U.S. CLS. 21, 23, 26, 36, 38, 100, 101, 103 AND 106). REG. 1-15-2002.
- 2,529,685. THE ULTIMATE BATHING EXPERIENCE. INT. CL. 11. (U.S. CLS. 13, 21, 23, 31 AND 34). REG. 1-15-2002.
- 2,530,319. PROCIDIA WHERE PROCESS CONTROL MEETS THE INTERNET AND DESIGN. INT. CL. 9. (U.S. CLS. 21, 23, 26, 36 AND 38). REG. 1-15-2002.
- 2,534,372. UTILISIMA. INT. CLS. 16 AND 41. (U.S. CLS. 2, 5, 22, 23, 29, 37, 38, 50, 100, 101 AND 107). REG. 1-29-2002.
- 2,536,715. CARACOL. INT. CL. 38. (U.S. CLS. 100, 101 AND 104). REG. 2-5-2002.
- 2,538,261. NX AND DESIGN. INT. CL. 42. (U.S. CLS. 100 AND 101). REG. 2-12-2002.
- 2,539,222. CORVU. INT. CL. 9. (U.S. CLS. 21, 23, 26, 36 AND 38). REG. 2-19-2002.
- 2,540,150. THE ACADEMIC SEAL OF RICE UNIVERSITY LETTER SCIENCE ART AND DESIGN. INT. CL. 18. (U.S. CLS. 1, 2, 3, 22 AND 41). REG. 2-19-2002.
- 2,541,381. TRAVEL INTELLIGENCE. INT. CL. 39. (U.S. CLS. 100 AND 105). REG. 2-19-2002.
- 2,541,395. BAZUCA.COM. INT. CL. 35. (U.S. CLS. 100, 101 AND 102). REG. 2-19-2002.

- 2,546,772. DYNAC. INT. CL. 9. (U.S. CLS. 21, 23, 26, 36 AND 38). REG. 3-12-2002.
- 2,546,900. NCS NORTH CENTRAL SECURITY SERVICES AND DESIGN. INT. CL. 42. (U.S. CLS. 100 AND 101). REG. 3-12-2002.
- 2,547,559. OAK CREEK. INT. CL. 37. (U.S. CLS. 100, 103 AND 106). REG. 3-12-2002.
- 2,547,693. MISCELLANEOUS DESIGN. INT. CL. 16. (U.S. CLS. 2, 5, 22, 23, 29, 37, 38 AND 50). REG. 3-12-2002.
- 2,547,790. RTP. INT. CL. 7. (U.S. CLS. 13, 19, 21, 23, 31, 34 AND 35). REG. 3-12-2002.
- 2,548,384. WHERE THE CITY MEETS THE COUNTRY. INT. CL. 36. (U.S. CLS. 100, 101 AND 102). REG. 3-12-2002.
- 2,548,970. CARTOON CUTS HAIR. WE CAN REALLY CUT IT. AND DESIGN. INT. CL. 42. (U.S. CLS. 100 AND 101). REG. 3-19-2002.
- 2,549,258. BRINGING YOU TO THE WORLD OF GOLF. INT. CL. 35. (U.S. CLS. 100, 101 AND 102). REG. 3-19-2002.
- 2,550,650. SEQUENCE. INT. CL. 28. (U.S. CLS. 22, 23, 38 AND 50). REG. 3-19-2002.
- 2,552,100. ENVIRONMENT FRIENDLY AND DESIGN. INT. CL. 19. (U.S. CLS. 1, 12, 33 AND 50). REG. 3-26-2002.
- 2,553,864. BORN IN BROOKLYN. INT. CL. 25. (U.S. CLS. 22 AND 39). REG. 3-26-2002.
- 2,554,503. LITTLE BILL. INT. CL. 41. (U.S. CLS. 100, 101 AND 107). REG. 4-2-2002.
- 2,554,631. MARS. INT. CL. 9. (U.S. CLS. 21, 23, 26, 36 AND 38). REG. 4-2-2002.
- 2,555,277. NEW YORK STATE PUBLIC HIGH SCHOOL ATHLETIC ASSOCIATION. AND DESIGN. INT. CL. 42. (U.S. CLS. 100 AND 101). REG. 4-2-2002.
- 2,555,578. EAST COAST GREENWAY. INT. CL. 41. (U.S. CLS. 100, 101 AND 107). REG. 4-2-2002.
- 2,555,597. SUNDER (STYLIZED). INT. CL. 10. (U.S. CLS. 26, 39 AND 44). REG. 4-2-2002.
- 2,555,948. GIRLS ON THE RUN. INT. CL. 41. (U.S. CLS. 100, 101 AND 107). REG. 4-2-2002.
- 2,555,951. CONFORM. INT. CL. 28. (U.S. CLS. 22, 23, 38 AND 50). REG. 4-2-2002.
- 2,556,759. TUNE-UP. INT. CL. 9. (U.S. CLS. 21, 23, 26, 36 AND 38). REG. 4-2-2002.
- 2,556,914. WORLD MARKET. INT. CLS. 3, 4, 8, 11, 14, 16, 20, 21, 24, 27, 28, 29, 30, 32 AND 35. (U.S. CLS. 1, 2, 4, 5, 6, 13, 15, 19, 20, 21, 22, 23, 25, 27, 28, 29, 30, 31, 32, 33, 34, 37, 38, 40, 42, 44, 45, 46, 48, 50, 51, 52, 100, 101 AND 102). REG. 4-2-2002.
- 2,556,919. TRIPLE H. INT. CL. 19. (U.S. CLS. 1, 12, 33 AND 50). REG. 4-2-2002.
- 2,557,318. TY-D. INT. CL. 6. (U.S. CLS. 2, 12, 13, 14, 23, 25 AND 50). REG. 4-2-2002.
- 2,557,527. EVAHEART. INT. CL. 10. (U.S. CLS. 26, 39 AND 44). REG. 4-9-2002.
- 2,557,645. PHYCOLINK. INT. CLS. 1 AND 5. (U.S. CLS. 1, 5, 6, 10, 18, 26, 44, 46, 51 AND 52). REG. 4-9-2002.
- 2,557,677. PHYSIOLAB. INT. CL. 42. (U.S. CLS. 100 AND 101). REG. 4-9-2002.
- 2,557,679. PHYSIOLAB. INT. CL. 9. (U.S. CLS. 21, 23, 26, 36 AND 38). REG. 4-9-2002.
- 2,557,707. MEXICANISIMA. INT. CL. 41 ONLY. (U.S. CLS. 100, 101 AND 107). REG. 4-9-2002.
- 2,557,715. UMASCH AND DESIGN. INT. CLS. 9 AND 42 ONLY. (U.S. CLS. 21, 23, 26, 36, 38, 100 AND 101). REG. 4-9-2002.
- 2,557,722. CAPVEST. INT. CLS. 35 AND 36. (U.S. CLS. 100, 101 AND 102). REG. 4-9-2002.
- 2,557,727. DYNAMIC EDUCATION DYNED AND DESIGN. INT. CLS. 9, 16, 41 AND 42. (U.S. CLS. 2, 5, 21, 22, 23, 26, 29, 36, 37, 38, 50, 100, 101 AND 107). REG. 4-9-2002.
- 2,557,739. BABY BOP. INT. CLS. 16, 25, 28 AND 41 ONLY. (U.S. CLS. 2, 5, 22, 23, 29, 37, 38, 39, 50, 100, 101 AND 107). REG. 4-9-2002.
- 2,557,744. ACMA AND DESIGN. INT. CL. 41. (U.S. CLS. 100, 101 AND 107). REG. 4-9-2002.
- 2,557,783. SOLO. INT. CL. 20. (U.S. CLS. 2, 13, 22, 25, 32 AND 50). REG. 4-9-2002.
- 2,557,801. CASI. INT. CL. 31. (U.S. CLS. 1 AND 46). REG. 4-9-2002.
- 2,557,803. NASS 45. INT. CL. 6. (U.S. CLS. 2, 12, 13, 14, 23, 25 AND 50). REG. 4-9-2002.
- 2,557,830. TAB TECHNOLOGIES ADVANCING BUSINESS COMPUTER SYSTEMS, INC. AND DESIGN. INT. CL. 9. (U.S. CLS. 21, 23, 26, 36 AND 38). REG. 4-9-2002.
- 2,557,858. RECOMAT. INT. CLS. 16 AND 24. (U.S. CLS. 2, 5, 22, 23, 29, 37, 38, 42 AND 50). REG. 4-9-2002.
- 2,557,863. FIPA. INT. CL. 9. (U.S. CLS. 21, 23, 26, 36 AND 38). REG. 4-9-2002.
- 2,557,884. GENETIC ID. INT. CL. 42. (U.S. CLS. 100 AND 101). REG. 4-9-2002.
- 2,557,898. BOARD OF REGISTERED POLYSOMNOGRAPHIC TECHNOLOGISTS. INT. CL. 41. (U.S. CLS. 100, 101 AND 107). REG. 4-9-2002.
- 2,557,963. LEAR. INT. CL. 12. (U.S. CLS. 19, 21, 23, 31, 35 AND 44). REG. 4-9-2002.
- 2,558,094. ART & ARCHITECTURE THESAURUS. INT. CL. 42. (U.S. CLS. 100 AND 101). REG. 4-9-2002.
- 2,558,112. ABOVE AND BEYOND.. INT. CL. 12. (U.S. CLS. 19, 21, 23, 31, 35 AND 44). REG. 4-9-2002.
- 2,558,160. MEDJET ASSISTANCE. INT. CL. 39. (U.S. CLS. 100 AND 105). REG. 4-9-2002.
- 2,558,188. MISCELLANEOUS DESIGN. INT. CLS. 25, 28 AND 41. (U.S. CLS. 22, 23, 38, 39, 50, 100, 101 AND 107). REG. 4-9-2002.
- 2,558,227. THE 15 MINUTE CHEF. INT. CLS. 16 AND 41. (U.S. CLS. 2, 5, 22, 23, 29, 37, 38, 50, 100, 101 AND 107). REG. 4-9-2002.
- 2,558,301. CARDIOTABS. INT. CL. 5. (U.S. CLS. 6, 18, 44, 46, 51 AND 52). REG. 4-9-2002.
- 2,558,328. MISCELLANEOUS DESIGN. INT. CL. 42. (U.S. CLS. 100 AND 101). REG. 4-9-2002.
- 2,558,340. CITIZIP AND DESIGN. INT. CL. 38. (U.S. CLS. 100, 101 AND 104). REG. 4-9-2002.
- 2,558,414. TF2. INT. CL. 28. (U.S. CLS. 22, 23, 38 AND 50). REG. 4-9-2002.
- 2,558,475. ARCSDE (STYLIZED). INT. CLS. 9 AND 16. (U.S. CLS. 2, 5, 21, 22, 23, 26, 29, 36, 37, 38 AND 50). REG. 4-9-2002.
- 2,558,493. LINDBERG. INT. CLS. 5, 29 AND 35. (U.S. CLS. 6, 18, 44, 46, 51, 52, 100, 101 AND 102). REG. 4-9-2002.
- 2,558,617. PRINTLOC. INT. CL. 1. (U.S. CLS. 1, 5, 6, 10, 26 AND 46). REG. 4-9-2002.
- 2,558,639. PLAN4DEMAND. INT. CL. 35 ONLY. (U.S. CLS. 100, 101 AND 102). REG. 4-9-2002.
- 2,558,642. CAPTAIN D'S PLEASE. INT. CL. 42. (U.S. CLS. 100 AND 101). REG. 4-9-2002.
- 2,558,677. MINI-BAK. INT. CL. 20. (U.S. CLS. 2, 13, 22, 25, 32 AND 50). REG. 4-9-2002.
- 2,558,678. KEY-BAK. INT. CL. 20. (U.S. CLS. 2, 13, 22, 25, 32 AND 50). REG. 4-9-2002.
- 2,558,692. VOYAGER. INT. CL. 11. (U.S. CLS. 13, 21, 23, 31 AND 34). REG. 4-9-2002.
- 2,558,731. WATTA. INT. CL. 32. (U.S. CLS. 45, 46 AND 48). REG. 4-9-2002.
- 2,558,811. HANSEL 'N GRETEL. INT. CL. 29. (U.S. CL. 46). REG. 4-9-2002.
- 2,558,817. MASS NUTRITION (STYLIZED). INT. CL. 35. (U.S. CLS. 100, 101 AND 102). REG. 4-9-2002.
- 2,558,873. SPANISH GARDEN. INT. CLS. 29 AND 30. (U.S. CL. 46). REG. 4-9-2002.
- 2,558,893. PRO ARC ADAPTABLE REPLACEMENT CLEATS AND DESIGN. INT. CL. 25. (U.S. CLS. 22 AND 39). REG. 4-9-2002.
- 2,558,924. METAVISTA. INT. CL. 42. (U.S. CLS. 100 AND 101). REG. 4-9-2002.
- 2,558,947. AMERICA'S DRIVE-IN. INT. CL. 42. (U.S. CLS. 100 AND 101). REG. 4-9-2002.
- 2,559,001. 1.800HOME123.COM. INT. CL. 36. (U.S. CLS. 100, 101 AND 102). REG. 4-9-2002.
- 2,559,054. CHALLENGER LEARNING EDVENTURES. INT. CL. 41. (U.S. CLS. 100, 101 AND 107). REG. 4-9-2002.
- 2,559,055. JAR JAR BINKS. INT. CL. 28. (U.S. CLS. 22, 23, 38 AND 50). REG. 4-9-2002.
- 2,559,068. WASP. INT. CL. 9. (U.S. CLS. 21, 23, 26, 36 AND 38). REG. 4-9-2002.
- 2,559,112. KOSHILUCK. INT. CL. 9. (U.S. CLS. 21, 23, 26, 36 AND 38). REG. 4-9-2002.
- 2,559,121. A.G. FERRARI FOODS. INT. CL. 42. (U.S. CLS. 100 AND 101). REG. 4-9-2002.
- 2,559,146. PERMATUFT. INT. CL. 27. (U.S. CLS. 19, 20, 37, 42 AND 50). REG. 4-9-2002.
- 2,559,195. TORIC ANGLE. INT. CL. 10. (U.S. CLS. 26, 39 AND 44). REG. 4-9-2002.

- 2,559,205. DURABAND. INT. CL. 7. (U.S. CLS. 13, 19, 21, 23, 31, 34 AND 35). REG. 4-9-2002.
- 2,559,213. ZUCRUM INTERNATIONAL INC. AND DESIGN. INT. CL. 30. (U.S. CL. 46). REG. 4-9-2002.
- 2,559,218. ROY AND DESIGN. INT. CL. 25 ONLY. (U.S. CLS. 22 AND 39). REG. 4-9-2002.
- 2,559,241. WORK CLEAN AND DESIGN. INT. CL. 9. (U.S. CLS. 21, 23, 26, 36 AND 38). REG. 4-9-2002.
- 2,559,303. MISCELLANEOUS DESIGN. INT. CL. 36. (U.S. CLS. 100, 101 AND 102). REG. 4-9-2002.
- 2,559,325. EZID. INT. CL. 9. (U.S. CLS. 21, 23, 26, 36 AND 38). REG. 4-9-2002.
- 2,559,355. DICK'S. INT. CL. 35. (U.S. CLS. 100, 101 AND 102). REG. 4-9-2002.
- 2,559,403. SAFE T FEED. INT. CL. 6. (U.S. CLS. 2, 12, 13, 14, 23, 25 AND 50). REG. 4-9-2002.
- 2,559,409. RODALE. INT. CLS. 9, 41 AND 42 ONLY. (U.S. CLS. 21, 23, 26, 36, 38, 100, 101 AND 107). REG. 4-9-2002.
- 2,559,428. RIVALIS.COM. INT. CLS. 38, 41 AND 42. (U.S. CLS. 100, 101, 104 AND 107). REG. 4-9-2002.
- 2,559,462. DON MARCOS. INT. CL. 30. (U.S. CL. 46). REG. 4-9-2002.
- 2,559,526. HEXMC. INT. CL. 17. (U.S. CLS. 1, 5, 12, 13, 35 AND 50). REG. 4-9-2002.
- 2,559,536. DUWOP. INT. CL. 3. (U.S. CLS. 1, 4, 6, 50, 51 AND 52). REG. 4-9-2002.
- 2,559,551. MADE WITH LOVE AND DESIGN. INT. CL. 35. (U.S. CLS. 100, 101 AND 102). REG. 4-9-2002.
- 2,559,573. HIGHMARK TECHNOLOGIES. INT. CL. 20. (U.S. CLS. 2, 13, 22, 25, 32 AND 50). REG. 4-9-2002.
- 2,559,584. STARBOARD CRUISE SERVICES. INT. CL. 35 ONLY. (U.S. CLS. 100, 101 AND 102). REG. 4-9-2002.
- 2,559,621. OPTITRAC. INT. CL. 9. (U.S. CLS. 21, 23, 26, 36 AND 38). REG. 4-9-2002.
- 2,559,631. CHILTON. INT. CL. 39. (U.S. CLS. 100 AND 105). REG. 4-9-2002.
- 2,559,645. MISCELLANEOUS DESIGN. INT. CL. 31. (U.S. CLS. 1 AND 46). REG. 4-9-2002.
- 2,559,684. NECCARE. INT. CL. 42. (U.S. CLS. 100 AND 101). REG. 4-9-2002.
- 2,559,725. FRE. INT. CL. 9. (U.S. CLS. 21, 23, 26, 36 AND 38). REG. 4-9-2002.
- 2,559,743. BID YOU WELL. INT. CL. 35. (U.S. CLS. 100, 101 AND 102). REG. 4-9-2002.
- 2,559,744. WETJET. INT. CLS. 3, 7, 16 AND 21. (U.S. CLS. 1, 2, 4, 5, 6, 13, 19, 21, 22, 23, 29, 30, 31, 33, 34, 35, 37, 38, 40, 50, 51 AND 52). REG. 4-9-2002.
- 2,559,761. SISTERSINC.. INT. CL. 41. (U.S. CLS. 100, 101 AND 107). REG. 4-9-2002.
- 2,559,863. CELEBRATE VIRGINIA. INT. CL. 36. (U.S. CLS. 100, 101 AND 102). REG. 4-9-2002.
- 2,559,864. CELEBRATE VIRGINIA. INT. CL. 37. (U.S. CLS. 100, 103 AND 106). REG. 4-9-2002.
- 2,559,888. ACCUBUILT AND DESIGN. INT. CL. 12. (U.S. CLS. 19, 21, 23, 31, 35 AND 44). REG. 4-9-2002.
- 2,559,935. TEAM REALTREE. INT. CLS. 8, 9 AND 28 ONLY. (U.S. CLS. 21, 22, 23, 26, 28, 36, 38, 44 AND 50). REG. 4-9-2002.
- 2,559,950. DYNETECH. INT. CL. 35. (U.S. CLS. 100, 101 AND 102). REG. 4-9-2002.
- 2,560,008. PIECE. INT. CLS. 32, 40 AND 42. (U.S. CLS. 45, 46, 48, 100, 101, 103 AND 106). REG. 4-9-2002.
- 2,560,176. GRANDE MILK MARKETING, LLC. INT. CLS. 35, 39 AND 42. (U.S. CLS. 100, 101, 102 AND 105). REG. 4-9-2002.
- 2,560,203. FRANCO MIGUEL. INT. CL. 3. (U.S. CLS. 1, 4, 6, 50, 51 AND 52). REG. 4-9-2002.
- 2,560,325. EZ HANGER. INT. CL. 6. (U.S. CLS. 2, 12, 13, 14, 23, 25 AND 50). REG. 4-9-2002.
- 2,560,334. SIDEBURNERS. INT. CL. 7. (U.S. CLS. 13, 19, 21, 23, 31, 34 AND 35). REG. 4-9-2002.
- 2,560,350. ONE STEP. INT. CLS. 19 AND 27. (U.S. CLS. 1, 12, 19, 20, 33, 37, 42 AND 50). REG. 4-9-2002.
- 2,560,355. FIT FOR THE CURE. INT. CL. 36. (U.S. CLS. 100, 101 AND 102). REG. 4-9-2002.
- 2,560,423. HANDI-CLAMP. INT. CL. 8. (U.S. CLS. 23, 28 AND 44). REG. 4-9-2002.
- 2,560,462. SHOWTIME WOMEN. INT. CL. 41. (U.S. CLS. 100, 101 AND 107). REG. 4-9-2002.
- 2,560,528. GREEN DIESEL TECHNOLOGY. INT. CL. 42. (U.S. CLS. 100 AND 101). REG. 4-9-2002.
- 2,560,640. THE ALPACA GALLERY. INT. CL. 35. (U.S. CLS. 100, 101 AND 102). REG. 4-9-2002.
- 2,560,683. GREATLITE. INT. CL. 9. (U.S. CLS. 21, 23, 26, 36 AND 38). REG. 4-9-2002.
- 2,560,714. DONATE A PHONE. INT. CL. 36. (U.S. CLS. 100, 101 AND 102). REG. 4-9-2002.
- 2,560,739. 1922 VIRGINIA GOLD CUP ASSOCIATION AND DESIGN. INT. CL. 41. (U.S. CLS. 100, 101 AND 107). REG. 4-16-2002.
- 2,560,756. IMPVIEW. INT. CL. 9. (U.S. CLS. 21, 23, 26, 36 AND 38). REG. 4-16-2002.
- 2,560,761. CYCLACEL. INT. CL. 42 ONLY. (U.S. CLS. 100 AND 101). REG. 4-16-2002.
- 2,560,789. WELLBEING AND DESIGN. INT. CL. 16. (U.S. CLS. 2, 5, 22, 23, 29, 37, 38 AND 50). REG. 4-16-2002.
- 2,560,792. MISCELLANEOUS DESIGN. INT. CL. 9. (U.S. CLS. 21, 23, 26, 36 AND 38). REG. 4-16-2002.
- 2,560,840. IVARA. INT. CL. 9. (U.S. CLS. 21, 23, 26, 36 AND 38). REG. 4-16-2002.
- 2,560,851. BILLY BLANKS. INT. CLS. 9, 25 AND 41 ONLY. (U.S. CLS. 21, 22, 23, 26, 36, 38, 39, 100, 101 AND 107). REG. 4-16-2002.
- 2,560,877. KGAL AND DESIGN. INT. CL. 36. (U.S. CLS. 100, 101 AND 102). REG. 4-16-2002.
- 2,560,888. 360 MODENA (STYLIZED). INT. CL. 12. (U.S. CLS. 19, 21, 23, 31, 35 AND 44). REG. 4-16-2002.
- 2,560,896. MAGNUM. INT. CL. 12. (U.S. CLS. 19, 21, 23, 31, 35 AND 44). REG. 4-16-2002.
- 2,560,936. VFS. INT. CLS. 9 AND 42. (U.S. CLS. 21, 23, 26, 36, 38, 100 AND 101). REG. 4-16-2002.
- 2,560,943. U SAVE. INT. CL. 21. (U.S. CLS. 2, 13, 23, 29, 30, 33, 40 AND 50). REG. 4-16-2002.
- 2,560,975. XP (STYLIZED). INT. CL. 19. (U.S. CLS. 1, 12, 33 AND 50). REG. 4-16-2002.
- 2,560,978. SWI. INT. CL. 6. (U.S. CLS. 2, 12, 13, 14, 23, 25 AND 50). REG. 4-16-2002.
- 2,560,998. YOTUEL. INT. CLS. 3 AND 5. (U.S. CLS. 1, 4, 6, 18, 44, 46, 50, 51 AND 52). REG. 4-16-2002.
- 2,561,012. ASTROPOLITAN PICTURES. INT. CL. 41. (U.S. CLS. 100, 101 AND 107). REG. 4-16-2002.
- 2,561,017. CONCEPT 2 AND DESIGN. INT. CL. 28. (U.S. CLS. 22, 23, 38 AND 50). REG. 4-16-2002.
- 2,561,033. SPEEDLINE CORSE (STYLIZED). INT. CL. 12 ONLY. (U.S. CLS. 19, 21, 23, 31, 35 AND 44). REG. 4-16-2002.
- 2,561,043. CDLC CERTIFIED DECORATIVE LIGHTING CONSULTANT. INT. CL. 42. (U.S. CLS. 100 AND 101). REG. 4-16-2002.
- 2,561,073. BBVA (STYLIZED). INT. CL. 36. (U.S. CLS. 100, 101 AND 102). REG. 4-16-2002.
- 2,561,077. METHOD. INT. CL. 35. (U.S. CLS. 100, 101 AND 102). REG. 4-16-2002.
- 2,561,078. MISCELLANEOUS DESIGN. INT. CL. 1 ONLY. (U.S. CLS. 1, 5, 6, 10, 26 AND 46). REG. 4-16-2002.
- 2,561,102. SAFEZONE. INT. CL. 9 ONLY. (U.S. CLS. 21, 23, 26, 36 AND 38). REG. 4-16-2002.
- 2,561,103. SOOTHIES. INT. CL. 5. (U.S. CLS. 6, 18, 44, 46, 51 AND 52). REG. 4-16-2002.
- 2,561,117. BRPT. INT. CL. 41. (U.S. CLS. 100, 101 AND 107). REG. 4-16-2002.
- 2,561,144. THANECURE. INT. CL. 1. (U.S. CLS. 1, 5, 6, 10, 26 AND 46). REG. 4-16-2002.
- 2,561,173. CHROME HEARTS AND DESIGN. INT. CL. 8. (U.S. CLS. 23, 28 AND 44). REG. 4-16-2002.
- 2,561,181. ESQUIRE SETTLEMENT SERVICES. INT. CL. 36. (U.S. CLS. 100, 101 AND 102). REG. 4-16-2002.
- 2,561,193. CRS SCREEN HIGHLIGHTER. INT. CL. 9. (U.S. CLS. 21, 23, 26, 36 AND 38). REG. 4-16-2002.
- 2,561,203. PETROWEB. INT. CLS. 40 AND 42 ONLY. (U.S. CLS. 100, 101, 103 AND 106). REG. 4-16-2002.
- 2,561,225. BERLITZ AND DESIGN. INT. CLS. 9, 16, 35 AND 41 ONLY. (U.S. CLS. 2, 5, 21, 22, 23, 26, 29, 36, 37, 38, 50, 100, 101, 102 AND 107). REG. 4-16-2002.
- 2,561,251. REACHING UP. INT. CLS. 35, 36, 41 AND 42. (U.S. CLS. 100, 101, 102 AND 107). REG. 4-16-2002.
- 2,561,290. CORINE DE FARMER AND DESIGN. INT. CL. 3. (U.S. CLS. 1, 4, 6, 50, 51 AND 52). REG. 4-16-2002.
- 2,561,292. TARSUS AND DESIGN. INT. CLS. 16 AND 35. (U.S. CLS. 2, 5, 22, 23, 29, 37, 38, 50, 100, 101 AND 102). REG. 4-16-2002.
- 2,561,295. NATURAL BY DREW ESTATE. INT. CL. 34. (U.S. CLS. 2, 8, 9 AND 17). REG. 4-16-2002.
- 2,561,333. S (STYLIZED). INT. CLS. 35 AND 39. (U.S. CLS. 100, 101, 102 AND 105). REG. 4-16-2002.
- 2,561,353. WEST COAST THUNDER. INT. CL. 41. (U.S. CLS. 100, 101 AND 107). REG. 4-16-2002.

- 2,561,362. COLGIN CELLARS. INT. CL. 33. (U.S. CLS. 47 AND 49). REG. 4-16-2002.
- 2,561,369. ROYAL HOLLANDIA AND DESIGN. INT. CL. 29. (U.S. CL. 46). REG. 4-16-2002.
- 2,561,382. CYPRESS PAINTING & DECORATING. INT. CL. 37. (U.S. CLS. 100, 103 AND 106). REG. 4-16-2002.
- 2,561,388. FREEERISA.COM. INT. CL. 36. (U.S. CLS. 100, 101 AND 102). REG. 4-16-2002.
- 2,561,420. AMERICAN ACADEMY OF AUDIOLOGY AND DESIGN. INT. CLS. 41 AND 42. (U.S. CLS. 100, 101 AND 107). REG. 4-16-2002.
- 2,561,438. CELLOMICS. INT. CL. 1 ONLY. (U.S. CLS. 1, 5, 6, 10, 26 AND 46). REG. 4-16-2002.
- 2,561,457. NSCA-CPT. U.S. CL. B. REG. 4-16-2002.
- 2,561,484. MISCELLANEOUS DESIGN. INT. CL. 42. (U.S. CLS. 100 AND 101). REG. 4-16-2002.
- 2,561,492. CLINI-TECH. INT. CL. 5. (U.S. CLS. 6, 18, 44, 46, 51 AND 52). REG. 4-16-2002.
- 2,561,505. NORTH JERSEY COMMUNITY NEWSPAPERS. INT. CL. 35. (U.S. CLS. 100, 101 AND 102). REG. 4-16-2002.
- 2,561,507. REFLECTIX. INT. CL. 17. (U.S. CLS. 1, 5, 12, 13, 35 AND 50). REG. 4-16-2002.
- 2,561,519. SHOP ACROSS TEXAS. INT. CL. 16. (U.S. CLS. 2, 5, 22, 23, 29, 37, 38 AND 50). REG. 4-16-2002.
- 2,561,547. MISCELLANEOUS DESIGN. INT. CLS. 5, 29 AND 31. (U.S. CLS. 1, 6, 18, 44, 46, 51 AND 52). REG. 4-16-2002.
- 2,561,562. CAMP DANBEE. INT. CL. 41. (U.S. CLS. 100, 101 AND 107). REG. 4-16-2002.
- 2,561,564. MARTIAL ARTS PROFESSIONAL. INT. CL. 16. (U.S. CLS. 2, 5, 22, 23, 29, 37, 38 AND 50). REG. 4-16-2002.
- 2,561,581. CANAL INSURANCE COMPANY. INT. CL. 36. (U.S. CLS. 100, 101 AND 102). REG. 4-16-2002.
- 2,561,583. B AND DESIGN. INT. CL. 37. (U.S. CLS. 100, 103 AND 106). REG. 4-16-2002.
- 2,561,588. CANAL INDEMNITY COMPANY. INT. CL. 36. (U.S. CLS. 100, 101 AND 102). REG. 4-16-2002.
- 2,561,607. TOP-CHEM. INT. CL. 17. (U.S. CLS. 1, 5, 12, 13, 35 AND 50). REG. 4-16-2002.
- 2,561,655. DIM PRODUCTIONS. INT. CLS. 9 AND 41. (U.S. CLS. 21, 23, 26, 36, 38, 100, 101 AND 107). REG. 4-16-2002.
- 2,561,663. PLANET. INT. CL. 9. (U.S. CLS. 21, 23, 26, 36 AND 38). REG. 4-16-2002.
- 2,561,717. WILD ABOUT DOLPHINS. INT. CL. 39. (U.S. CLS. 100 AND 105). REG. 4-16-2002.
- 2,561,751. CABLEVISION UNIVERSITY AND DESIGN. INT. CL. 41 ONLY. (U.S. CLS. 100, 101 AND 107). REG. 4-16-2002.
- 2,561,770. GUNCON AND DESIGN. INT. CL. 9. (U.S. CLS. 21, 23, 26, 36 AND 38). REG. 4-16-2002.
- 2,561,775. INTERVIEWING TODAY'S WORKFORCE. INT. CL. 16. (U.S. CLS. 2, 5, 22, 23, 29, 37, 38 AND 50). REG. 4-16-2002.
- 2,561,776. INTERVIEWING TODAY'S WORKFORCE. INT. CL. 9. (U.S. CLS. 21, 23, 26, 36 AND 38). REG. 4-16-2002.
- 2,561,784. DEX. INT. CL. 16. (U.S. CLS. 2, 5, 22, 23, 29, 37, 38 AND 50). REG. 4-16-2002.
- 2,561,794. SKI VERMONT AND DESIGN. INT. CLS. 16 AND 35. (U.S. CLS. 2, 5, 22, 23, 29, 37, 38, 50, 100, 101 AND 102). REG. 4-16-2002.
- 2,561,895. KERBER'S (STYLIZED). INT. CLS. 29 AND 42 ONLY. (U.S. CLS. 46, 100 AND 101). REG. 4-16-2002.
- 2,561,954. PASS. INT. CL. 36. (U.S. CLS. 100, 101 AND 102). REG. 4-16-2002.
- 2,561,976. DAHLHOUSE. INT. CL. 3. (U.S. CLS. 1, 4, 6, 50, 51 AND 52). REG. 4-16-2002.
- 2,561,978. MILES OF PRODUCTS AND PLENTY OF PARKING. INT. CL. 35. (U.S. CLS. 100, 101 AND 102). REG. 4-16-2002.
- 2,561,987. WESTHILL. INT. CL. 25. (U.S. CLS. 22 AND 39). REG. 4-16-2002.
- 2,561,988. CATUSED.COM. INT. CL. 35. (U.S. CLS. 100, 101 AND 102). REG. 4-16-2002.
- 2,561,989. HARD ROCK LIVE. INT. CL. 25. (U.S. CLS. 22 AND 39). REG. 4-16-2002.
- 2,562,023. SUNTERRA FARMS. INT. CLS. 29 AND 31. (U.S. CLS. 1 AND 46). REG. 4-16-2002.
- 2,562,062. THE BEST OF SHOWTIME...ANYTIME. INT. CL. 41. (U.S. CLS. 100, 101 AND 107). REG. 4-16-2002.
- 2,562,079. CAVALLOSAN. INT. CL. 31. (U.S. CLS. 1 AND 46). REG. 4-16-2002.
- 2,562,080. ORO DE ESPANA. INT. CL. 29. (U.S. CL. 46). REG. 4-16-2002.
- 2,562,085. LOGILITY VALUE CHAIN SOLUTIONS. INT. CL. 9. (U.S. CLS. 21, 23, 26, 36 AND 38). REG. 4-16-2002.
- 2,562,090. KARMA KULA. INT. CL. 16. (U.S. CLS. 2, 5, 22, 23, 29, 37, 38 AND 50). REG. 4-16-2002.
- 2,562,110. PARTNER. INT. CL. 20. (U.S. CLS. 2, 13, 22, 25, 32 AND 50). REG. 4-16-2002.
- 2,562,132. THE EXPERTS. INT. CL. 35. (U.S. CLS. 100, 101 AND 102). REG. 4-16-2002.
- 2,562,152. NUTFAST. INT. CL. 7. (U.S. CLS. 13, 19, 21, 23, 31, 34 AND 35). REG. 4-16-2002.
- 2,562,185. X-WING. INT. CL. 9. (U.S. CLS. 21, 23, 26, 36 AND 38). REG. 4-16-2002.
- 2,562,189. THE JONES COLLECTION. INT. CL. 20. (U.S. CLS. 2, 13, 22, 25, 32 AND 50). REG. 4-16-2002.
- 2,562,207. "SAILOR JERRY". INT. CL. 33. (U.S. CLS. 47 AND 49). REG. 4-16-2002.
- 2,562,215. MISCELLANEOUS DESIGN. INT. CLS. 9, 16, 41 AND 42 ONLY. (U.S. CLS. 2, 5, 21, 22, 23, 26, 29, 36, 37, 38, 50, 100, 101 AND 107). REG. 4-16-2002.
- 2,562,216. RODALE AND DESIGN. INT. CLS. 9, 16, 41 AND 42 ONLY. (U.S. CLS. 2, 5, 21, 22, 23, 26, 29, 36, 37, 38, 50, 100, 101 AND 107). REG. 4-16-2002.
- 2,562,221. PENN E. WISE KID'S CLUB AND DESIGN. INT. CLS. 16, 36 AND 41. (U.S. CLS. 2, 5, 22, 23, 29, 37, 38, 50, 100, 101, 102 AND 107). REG. 4-16-2002.
- 2,562,222. AMAZEING ART. INT. CL. 16. (U.S. CLS. 2, 5, 22, 23, 29, 37, 38 AND 50). REG. 4-16-2002.
- 2,562,225. DR. ED. INT. CL. 42. (U.S. CLS. 100 AND 101). REG. 4-16-2002.
- 2,562,300. ZODIAQ. INT. CL. 20. (U.S. CLS. 2, 13, 22, 25, 32 AND 50). REG. 4-16-2002.
- 2,562,324. OPERA. INT. CL. 12. (U.S. CLS. 19, 21, 23, 31, 35 AND 44). REG. 4-16-2002.
- 2,562,371. SUN STRINGZ. INT. CL. 9. (U.S. CLS. 21, 23, 26, 36 AND 38). REG. 4-16-2002.
- 2,562,396. PAUL & SHARK YACHTING AND DESIGN. INT. CL. 18. (U.S. CLS. 1, 2, 3, 22 AND 41). REG. 4-16-2002.
- 2,562,417. TRIPRO. INT. CL. 31. (U.S. CLS. 1 AND 46). REG. 4-16-2002.
- 2,562,447. EMPOWER. INT. CL. 20. (U.S. CLS. 2, 13, 22, 25, 32 AND 50). REG. 4-16-2002.
- 2,562,491. JOURNEYFORTH. INT. CL. 16. (U.S. CLS. 2, 5, 22, 23, 29, 37, 38 AND 50). REG. 4-16-2002.
- 2,562,503. TUCK'N MIN BLANKET BAG (STYLIZED). INT. CL. 18. (U.S. CLS. 1, 2, 3, 22 AND 41). REG. 4-16-2002.
- 2,562,536. GIRASOL. INT. CL. 31. (U.S. CLS. 1 AND 46). REG. 4-16-2002.
- 2,562,591. BOARD BUDDY. INT. CL. 28. (U.S. CLS. 22, 23, 38 AND 50). REG. 4-16-2002.
- 2,562,594. SHOWTIME WOMEN. INT. CL. 38. (U.S. CLS. 100, 101 AND 104). REG. 4-16-2002.
- 2,562,663. SPLIT LEVEL. INT. CL. 7. (U.S. CLS. 13, 19, 21, 23, 31, 34 AND 35). REG. 4-16-2002.
- 2,562,664. AMERICAN CYCLE & FITNESS. INT. CL. 35. (U.S. CLS. 100, 101 AND 102). REG. 4-16-2002.
- 2,562,791. ENGINEERED FOR LIFE. INT. CL. 25. (U.S. CLS. 22 AND 39). REG. 4-23-2002.
- 2,562,797. BLOND BRILLIANCE. INT. CL. 3. (U.S. CLS. 1, 4, 6, 50, 51 AND 52). REG. 4-23-2002.
- 2,562,863. NATUREPRINT (STYLIZED). INT. CL. 30. (U.S. CL. 46). REG. 4-23-2002.
- 2,562,867. BBVA. INT. CL. 16. (U.S. CLS. 2, 5, 22, 23, 29, 37, 38 AND 50). REG. 4-23-2002.
- 2,562,913. DOMINATOR. INT. CL. 12. (U.S. CLS. 19, 21, 23, 31, 35 AND 44). REG. 4-23-2002.
- 2,562,925. NEXGEN. INT. CL. 9. (U.S. CLS. 21, 23, 26, 36 AND 38). REG. 4-23-2002.
- 2,562,929. BBVA (STYLIZED). INT. CL. 16. (U.S. CLS. 2, 5, 22, 23, 29, 37, 38 AND 50). REG. 4-23-2002.
- 2,562,932. 101 THINGS TO DO. INT. CL. 16. (U.S. CLS. 2, 5, 22, 23, 29, 37, 38 AND 50). REG. 4-23-2002.
- 2,562,993. WORD OF LIFE BIBLE INSTITUTE HOLDING FORTH THE WORD OF LIFE - PHIL 2:16 INTERNATIONAL WORD OF LIFE AND DESIGN. INT. CL. 41. (U.S. CLS. 100, 101 AND 107). REG. 4-23-2002.

- 2,563,024. WIRING HARNESS MANUFACTURERS ASSOCIATION. INT. CL. 42. (U.S. CLS. 100 AND 101). REG. 4-23-2002.
- 2,563,049. N AND DESIGN. INT. CLS. 12, 18 AND 25 ONLY. (U.S. CLS. 1, 2, 3, 19, 21, 22, 23, 31, 35, 39, 41 AND 44). REG. 4-23-2002.
- 2,563,067. MISCELLANEOUS DESIGN. INT. CLS. 35, 36, 38 AND 41. (U.S. CLS. 100, 101, 102, 104 AND 107). REG. 4-23-2002.
- 2,563,121. FOXRIVER AND DESIGN. INT. CL. 25. (U.S. CLS. 22 AND 39). REG. 4-23-2002.
- 2,563,158. EJMS. INT. CL. 36. (U.S. CLS. 100, 101 AND 102). REG. 4-23-2002.
- 2,563,206. INSTASTAIN. INT. CLS. 1 AND 5. (U.S. CLS. 1, 5, 6, 10, 18, 26, 44, 46, 51 AND 52). REG. 4-23-2002.
- 2,563,232. AGRISMART (STYLIZED). INT. CL. 9. (U.S. CLS. 21, 23, 26, 36 AND 38). REG. 4-23-2002.
- 2,563,317. SMARTPUMP. INT. CL. 10. (U.S. CLS. 26, 39 AND 44). REG. 4-23-2002.
- 2,563,319. SOX (STYLIZED). INT. CL. 41. (U.S. CLS. 100, 101 AND 107). REG. 4-23-2002.
- 2,563,347. SURE FOOT. INT. CL. 10. (U.S. CLS. 26, 39 AND 44). REG. 4-23-2002.
- 2,563,370. ASSAULT COMMANDO. INT. CL. 28. (U.S. CLS. 22, 23, 38 AND 50). REG. 4-23-2002.
- 2,563,433. BABY PIPER. INT. CL. 33. (U.S. CLS. 47 AND 49). REG. 4-23-2002.
- 2,563,436. ROTARY INBAY TECHNOLOGY AND DESIGN. INT. CL. 7. (U.S. CLS. 13, 19, 21, 23, 31, 34 AND 35). REG. 4-23-2002.
- 2,563,474. GELIGNE. INT. CL. 3. (U.S. CLS. 1, 4, 6, 50, 51 AND 52). REG. 4-23-2002.
- 2,563,494. CARDINALS AND DESIGN. INT. CL. 28. (U.S. CLS. 22, 23, 38 AND 50). REG. 4-23-2002.
- 2,563,669. THE WINCHESTER TILE COMPANY AND DESIGN. INT. CL. 19. (U.S. CLS. 1, 12, 33 AND 50). REG. 4-23-2002.
- 2,563,732. HIPURFORMER. INT. CL. 1. (U.S. CLS. 1, 5, 6, 10, 26 AND 46). REG. 4-23-2002.
- 2,563,875. AQUA BREEZE. INT. CL. 11. (U.S. CLS. 13, 21, 23, 31 AND 34). REG. 4-23-2002.
- 2,563,903. EQUISLEEVE. INT. CL. 10. (U.S. CLS. 26, 39 AND 44). REG. 4-23-2002.
- 2,563,967. BITMICRO. INT. CL. 9. (U.S. CLS. 21, 23, 26, 36 AND 38). REG. 4-23-2002.
- 2,563,971. LIQUIDAM. INT. CL. 10. (U.S. CLS. 26, 39 AND 44). REG. 4-23-2002.
- 2,564,060. MISCELLANEOUS DESIGN. INT. CL. 16. (U.S. CLS. 2, 5, 22, 23, 29, 37, 38 AND 50). REG. 4-23-2002.
- 2,564,106. ONVIA. INT. CL. 35. (U.S. CLS. 100, 101 AND 102). REG. 4-23-2002.
- 2,564,120. USA GOLD BY MICHAEL ANTHONY. INT. CL. 14. (U.S. CLS. 2, 27, 28 AND 50). REG. 4-23-2002.
- 2,564,142. INSTYLE STANDARD CHARACTER MARK. INT. CL. 41. (U.S. CLS. 100, 101 AND 107). REG. 4-23-2002.
- 2,564,185. BRUCE'S YAMS AND DESIGN. INT. CL. 30. (U.S. CL. 46). REG. 4-23-2002.
- 2,564,212. MISCELLANEOUS DESIGN. INT. CL. 20. (U.S. CLS. 2, 13, 22, 25, 32 AND 50). REG. 4-23-2002.
- 2,564,320. ACCUBUILT. INT. CL. 12. (U.S. CLS. 19, 21, 23, 31, 35 AND 44). REG. 4-23-2002.
- 2,564,419. ROLL-A-DECK. INT. CL. 6. (U.S. CLS. 2, 12, 13, 14, 23, 25 AND 50). REG. 4-23-2002.
- 2,564,459. CALLTROL. INT. CL. 9. (U.S. CLS. 21, 23, 26, 36 AND 38). REG. 4-23-2002.
- 2,564,526. MAYBELLINE. INT. CL. 21. (U.S. CLS. 2, 13, 23, 29, 30, 33, 40 AND 50). REG. 4-23-2002.
- 2,564,536. GO-BETWEENS. INT. CL. 21. (U.S. CLS. 2, 13, 23, 29, 30, 33, 40 AND 50). REG. 4-23-2002.
- 2,564,571. KANETSU AND DESIGN. INT. CL. 25. (U.S. CLS. 22 AND 39). REG. 4-23-2002.
- 2,564,573. FAILSAFE. INT. CL. 9. (U.S. CLS. 21, 23, 26, 36 AND 38). REG. 4-23-2002.
- 2,564,650. MAMA'S CHOICE. INT. CL. 30. (U.S. CL. 46). REG. 4-23-2002.
- 2,564,681. ELAN. INT. CL. 11. (U.S. CLS. 13, 21, 23, 31 AND 34). REG. 4-23-2002.
- 2,564,845. SURFACE PROTECTION SPECIALISTS. INT. CL. 17. (U.S. CLS. 1, 5, 12, 13, 35 AND 50). REG. 4-30-2002.
- 2,564,849. PAC. INT. CL. 3. (U.S. CLS. 1, 4, 6, 50, 51 AND 52). REG. 4-30-2002.
- 2,564,866. GENIE MAGIC. INT. CL. 9. (U.S. CLS. 21, 23, 26, 36 AND 38). REG. 4-30-2002.
- 2,564,873. MISCELLANEOUS DESIGN. INT. CL. 38 ONLY. (U.S. CLS. 100, 101 AND 104). REG. 4-30-2002.
- 2,564,880. NAKED ZOO. INT. CLS. 39 AND 41. (U.S. CLS. 100, 101, 105 AND 107). REG. 4-30-2002.
- 2,564,891. H H H. INT. CL. 26. (U.S. CLS. 37, 39, 40, 42 AND 50). REG. 4-30-2002.
- 2,564,938. SALUD TOTAL PARA LA MUJER. INT. CL. 16. (U.S. CLS. 2, 5, 22, 23, 29, 37, 38 AND 50). REG. 4-30-2002.
- 2,564,968. AGRO TRADE AND DESIGN. INT. CL. 35. (U.S. CLS. 100, 101 AND 102). REG. 4-30-2002.
- 2,564,970. MISCELLANEOUS DESIGN. INT. CL. 3. (U.S. CLS. 1, 4, 6, 50, 51 AND 52). REG. 4-30-2002.
- 2,565,021. CONVERSIM. INT. CL. 9. (U.S. CLS. 21, 23, 26, 36 AND 38). REG. 4-30-2002.
- 2,565,128. COMMLINK. INT. CL. 9 ONLY. (U.S. CLS. 21, 23, 26, 36 AND 38). REG. 4-30-2002.
- 2,565,133. ILEOS. INT. CLS. 16 AND 42 ONLY. (U.S. CLS. 2, 5, 22, 23, 29, 37, 38, 50, 100 AND 101). REG. 4-30-2002.
- 2,565,151. FORWARD. THINKING.. INT. CL. 36. (U.S. CLS. 100, 101 AND 102). REG. 4-30-2002.
- 2,565,213. CARDINALS AND DESIGN. INT. CL. 16. (U.S. CLS. 2, 5, 22, 23, 29, 37, 38 AND 50). REG. 4-30-2002.
- 2,565,219. SMARTCHOCOLATE. INT. CL. 30. (U.S. CL. 46). REG. 4-30-2002.
- 2,565,234. SNAP-ON. INT. CL. 7. (U.S. CLS. 13, 19, 21, 23, 31, 34 AND 35). REG. 4-30-2002.
- 2,565,261. DISARRAY (STYLIZED). INT. CL. 9. (U.S. CLS. 21, 23, 26, 36 AND 38). REG. 4-30-2002.
- 2,565,287. ULTRATHERM2. INT. CL. 11. (U.S. CLS. 13, 21, 23, 31 AND 34). REG. 4-30-2002.
- 2,565,293. CLASHPOINTS. INT. CL. 41. (U.S. CLS. 100, 101 AND 107). REG. 4-30-2002.
- 2,565,329. GILLY. INT. CL. 16. (U.S. CLS. 2, 5, 22, 23, 29, 37, 38 AND 50). REG. 4-30-2002.
- 2,565,410. FRENCH SOLE. INT. CL. 35. (U.S. CLS. 100, 101 AND 102). REG. 4-30-2002.
- 2,565,427. CASSIDA. INT. CL. 4. (U.S. CLS. 1, 6 AND 15). REG. 4-30-2002.
- 2,565,476. PARAMAX. INT. CLS. 40 AND 42. (U.S. CLS. 100, 101, 103 AND 106). REG. 4-30-2002.
- 2,565,489. HOMESTEPS. INT. CL. 36. (U.S. CLS. 100, 101 AND 102). REG. 4-30-2002.
- 2,565,511. GOT IT!. INT. CL. 28. (U.S. CLS. 22, 23, 38 AND 50). REG. 4-30-2002.
- 2,565,557. FORVIA. INT. CL. 5. (U.S. CLS. 6, 18, 44, 46, 51 AND 52). REG. 4-30-2002.
- 2,565,605. IMPRESARIO. INT. CL. 9. (U.S. CLS. 21, 23, 26, 36 AND 38). REG. 4-30-2002.
- 2,565,611. Y S AND DESIGN. INT. CL. 36. (U.S. CLS. 100, 101 AND 102). REG. 4-30-2002.
- 2,565,612. MXRAIL. INT. CL. 9. (U.S. CLS. 21, 23, 26, 36 AND 38). REG. 4-30-2002.
- 2,565,648. COOL DOG. INT. CL. 30. (U.S. CL. 46). REG. 4-30-2002.
- 2,565,651. LOVERGIRL. INT. CL. 35. (U.S. CLS. 100, 101 AND 102). REG. 4-30-2002.
- 2,565,684. HANDS ON CREATIONS. INT. CL. 42. (U.S. CLS. 100 AND 101). REG. 4-30-2002.
- 2,565,755. DELITAINER. INT. CL. 21. (U.S. CLS. 2, 13, 23, 29, 30, 33, 40 AND 50). REG. 4-30-2002.
- 2,565,830. HEAVY HITTAZ HH (STYLIZED). INT. CL. 25. (U.S. CLS. 22 AND 39). REG. 4-30-2002.
- 2,565,916. MAPS. INT. CL. 11. (U.S. CLS. 13, 21, 23, 31 AND 34). REG. 4-30-2002.
- 2,565,999. NOVOMESH. INT. CL. 6. (U.S. CLS. 2, 12, 13, 14, 23, 25 AND 50). REG. 4-30-2002.
- 2,566,053. STYLISSIMO. INT. CL. 42. (U.S. CLS. 100 AND 101). REG. 4-30-2002.
- 2,566,061. WONDER BRIGHT. INT. CL. 11. (U.S. CLS. 13, 21, 23, 31 AND 34). REG. 4-30-2002.
- 2,566,071. MISCELLANEOUS DESIGN. INT. CLS. 9, 25 AND 41. (U.S. CLS. 21, 22, 23, 26, 36, 38, 39, 100, 101 AND 107). REG. 4-30-2002.
- 2,566,123. THE MEYER RESOURCE GROUP. INT. CLS. 9 AND 16. (U.S. CLS. 2, 5, 21, 22, 23, 26, 29, 36, 37, 38 AND 50). REG. 4-30-2002.
- 2,566,155. LITMUS AND DESIGN. INT. CL. 25. (U.S. CLS. 22 AND 39). REG. 4-30-2002.
- 2,566,359. WEEDEX. INT. CL. 5. (U.S. CLS. 6, 18, 44, 46, 51 AND 52). REG. 5-7-2002.

- 2,566,366. SS SMARTSERIES AND DESIGN. INT. CL. 9. (U.S. CLS. 21, 23, 26, 36 AND 38). REG. 5-7-2002.
- 2,566,398. MISCELLANEOUS DESIGN. INT. CL. 9. (U.S. CLS. 21, 23, 26, 36 AND 38). REG. 5-7-2002.
- 2,566,415. POWER-PAD. INT. CL. 7. (U.S. CLS. 13, 19, 21, 23, 31, 34 AND 35). REG. 5-7-2002.
- 2,566,725. KIRKPATRICK. INT. CL. 19. (U.S. CLS. 1, 12, 33 AND 50). REG. 5-7-2002.
- 2,566,758. BAY PARK COMMUNITY HOSPITAL. INT. CL. 42. (U.S. CLS. 100 AND 101). REG. 5-7-2002.
- 2,566,777. INETSOLUTION. INT. CL. 42. (U.S. CLS. 100 AND 101). REG. 5-7-2002.
- 2,566,860. PENSKE RACING AUTHENTICS. INT. CL. 28. (U.S. CLS. 22, 23, 38 AND 50). REG. 5-7-2002.
- 2,567,056. USAA CAPITAL GROWTH FUND. INT. CL. 36. (U.S. CLS. 100, 101 AND 102). REG. 5-7-2002.
- 2,567,093. ACRYLINE. INT. CL. 11. (U.S. CLS. 13, 21, 23, 31 AND 34). REG. 5-7-2002.
- 2,567,111. OXYPRO. INT. CL. 11. (U.S. CLS. 13, 21, 23, 31 AND 34). REG. 5-7-2002.
- 2,567,227. MISCELLANEOUS DESIGN. INT. CLS. 35 AND 37. (U.S. CLS. 100, 101, 102, 103 AND 106). REG. 5-7-2002.
- 2,567,271. RESEARCH YOU CAN COUNT ON. PRODUCTS YOU CAN TRUST.. INT. CL. 5. (U.S. CLS. 6, 18, 44, 46, 51 AND 52). REG. 5-7-2002.
- 2,567,308. RALPH LAUREN. INT. CL. 11. (U.S. CLS. 13, 21, 23, 31 AND 34). REG. 5-7-2002.
- 2,567,341. EQUILATERAL TECHNOLOGIES AND DESIGN. INT. CL. 9. (U.S. CLS. 21, 23, 26, 36 AND 38). REG. 5-7-2002.
- 2,567,400. TOUGH & TENDER. INT. CL. 3. (U.S. CLS. 1, 4, 6, 50, 51 AND 52). REG. 5-7-2002.
- 2,567,582. CLAUSSEN. INT. CL. 30. (U.S. CL. 46). REG. 5-7-2002.
- 2,567,878. SERVASSURE D E A L E R S AND DESIGN. INT. CL. 37. (U.S. CLS. 100, 103 AND 106). REG. 5-7-2002.
- 2,567,890. BLANCHARD. INT. CL. 41. (U.S. CLS. 100, 101 AND 107). REG. 5-7-2002.
- 2,567,943. ESPLANADE. INT. CL. 36. (U.S. CLS. 100, 101 AND 102). REG. 5-7-2002.
- 2,568,102. VODMOCHKA GRAFFIX. INT. CL. 25. (U.S. CLS. 22 AND 39). REG. 5-7-2002.
- 2,568,104. SOLAR ENERGY FOR THE 21ST CENTURY. INT. CLS. 29 AND 30. (U.S. CL. 46). REG. 5-7-2002.
- 2,568,191. UJC. INT. CL. 36. (U.S. CLS. 100, 101 AND 102). REG. 5-7-2002.
- 2,568,222. SPARTASHELL. INT. CL. 2. (U.S. CLS. 6, 11 AND 16). REG. 5-7-2002.
- 2,568,328. CHEMZOIL (STYLIZED). INT. CL. 9. (U.S. CLS. 21, 23, 26, 36 AND 38). REG. 5-7-2002.
- 2,568,421. STERI-CYCLE. INT. CL. 9. (U.S. CLS. 21, 23, 26, 36 AND 38). REG. 5-7-2002.
- 2,568,449. GLACIERS END. INT. CL. 33. (U.S. CLS. 47 AND 49). REG. 5-7-2002.
- 2,568,543. THE LEADER IN FOOTWEAR. INT. CL. 35. (U.S. CLS. 100, 101 AND 102). REG. 5-7-2002.
- 2,568,627. AZ NEWS CHANNEL. INT. CL. 38. (U.S. CLS. 100, 101 AND 104). REG. 5-7-2002.
- 2,568,628. AZ NEWS CHANNEL AND DESIGN. INT. CL. 38. (U.S. CLS. 100, 101 AND 104). REG. 5-7-2002.
- 2,568,667. WHOLESALE EXCHANGE. INT. CL. 35. (U.S. CLS. 100, 101 AND 102). REG. 5-7-2002.
- 2,568,708. BROADBAND DAILY. INT. CL. 42 ONLY. (U.S. CLS. 100 AND 101). REG. 5-7-2002.
- 2,568,793. STAF. INT. CL. 11 ONLY. (U.S. CLS. 13, 21, 23, 31 AND 34). REG. 5-14-2002.
- 2,568,868. BILLS.COM. INT. CL. 35. (U.S. CLS. 100, 101 AND 102). REG. 5-14-2002.
- 2,568,940. DOWN UNDIES STANDARD CHARACTER MARK. INT. CL. 25. (U.S. CLS. 22 AND 39). REG. 5-14-2002.
- 2,568,943. SAF-T-RAP. INT. CL. 16. (U.S. CLS. 2, 5, 22, 23, 29, 37, 38 AND 50). REG. 5-14-2002.
- 2,568,992. NCB. INT. CL. 10. (U.S. CLS. 26, 39 AND 44). REG. 5-14-2002.
- 2,569,011. RUBIS TWIST. INT. CL. 8 ONLY. (U.S. CLS. 23, 28 AND 44). REG. 5-14-2002.
- 2,569,053. BBVA (STYLIZED). INT. CL. 9. (U.S. CLS. 21, 23, 26, 36 AND 38). REG. 5-14-2002.
- 2,569,082. ISOICHEM AND DESIGN. INT. CLS. 1 AND 42 ONLY. (U.S. CLS. 1, 5, 6, 10, 26, 46, 100 AND 101). REG. 5-14-2002.
- 2,569,099. ZOJIRUSHI (STYLIZED). INT. CL. 21 ONLY. (U.S. CLS. 2, 13, 23, 29, 30, 33, 40 AND 50). REG. 5-14-2002.
- 2,569,133. IPG. INT. CLS. 35 AND 41. (U.S. CLS. 100, 101, 102 AND 107). REG. 5-14-2002.
- 2,569,152. DYNASTY AND DESIGN. INT. CL. 9. (U.S. CLS. 21, 23, 26, 36 AND 38). REG. 5-14-2002.
- 2,569,190. FRESH CUTS. INT. CL. 16. (U.S. CLS. 2, 5, 22, 23, 29, 37, 38 AND 50). REG. 5-14-2002.
- 2,569,196. EAT FISH, LIVE LONGER. INT. CL. 35. (U.S. CLS. 100, 101 AND 102). REG. 5-14-2002.
- 2,569,281. RUBICON. INT. CL. 21. (U.S. CLS. 2, 13, 23, 29, 30, 33, 40 AND 50). REG. 5-14-2002.
- 2,569,305. VIKING READY MIX. INT. CL. 19. (U.S. CLS. 1, 12, 33 AND 50). REG. 5-14-2002.
- 2,569,306. GOLDEN EMPIRE CONCRETE CO. INT. CL. 19. (U.S. CLS. 1, 12, 33 AND 50). REG. 5-14-2002.
- 2,569,339. YOUR LUBRICATION SOLUTION PARTNERS. INT. CL. 4. (U.S. CLS. 1, 6 AND 15). REG. 5-14-2002.
- 2,569,453. BOB VILA. INT. CL. 35. (U.S. CLS. 100, 101 AND 102). REG. 5-14-2002.
- 2,569,636. ORANGE AID (STYLIZED). INT. CL. 10. (U.S. CLS. 26, 39 AND 44). REG. 5-14-2002.
- 2,569,638. ALFALCO. INT. CL. 5. (U.S. CLS. 6, 18, 44, 46, 51 AND 52). REG. 5-14-2002.
- 2,569,700. AMERICAN COLLEGE OF VETERINARY BEHAVIORISTS. U.S. CL. 200. REG. 5-14-2002.
- 2,569,938. PINK PONY. INT. CL. 36. (U.S. CLS. 100, 101 AND 102). REG. 5-14-2002.
- 2,569,990. MARTIN SADDLERY. INT. CL. 18. (U.S. CLS. 1, 2, 3, 22 AND 41). REG. 5-14-2002.
- 2,570,144. MFS AND DESIGN. INT. CL. 12. (U.S. CLS. 19, 21, 23, 31, 35 AND 44). REG. 5-14-2002.
- 2,570,233. ELECTRONIC BOULEVARD AND DESIGN. INT. CL. 35. (U.S. CLS. 100, 101 AND 102). REG. 5-14-2002.
- 2,570,444. AMBROSIA. INT. CL. 34. (U.S. CLS. 2, 8, 9 AND 17). REG. 5-14-2002.
- 2,570,510. KORNSPITZ. INT. CL. 30. (U.S. CL. 46). REG. 5-21-2002.
- 2,570,527. TRAFFICA. INT. CL. 9 ONLY. (U.S. CLS. 21, 23, 26, 36 AND 38). REG. 5-21-2002.
- 2,570,974. HAMMER STRENGTH (STYLIZED). INT. CL. 28. (U.S. CLS. 22, 23, 38 AND 50). REG. 5-21-2002.
- 2,571,102. PATIENT ONLINE. INT. CL. 9 ONLY. (U.S. CLS. 21, 23, 26, 36 AND 38). REG. 5-21-2002.
- 2,571,109. MAXIM HEALTH SYSTEMS. INT. CL. 42. (U.S. CLS. 100 AND 101). REG. 5-21-2002.
- 2,571,110. MAXIM STAFFING SOLUTIONS. INT. CL. 35. (U.S. CLS. 100, 101 AND 102). REG. 5-21-2002.
- 2,571,171. PROGROWTH PANDA PALS. INT. CL. 36. (U.S. CLS. 100, 101 AND 102). REG. 5-21-2002.
- 2,571,285. ALIEN ANT FARM. INT. CLS. 9, 25 AND 41. (U.S. CLS. 21, 22, 23, 26, 36, 38, 39, 100, 101 AND 107). REG. 5-21-2002.
- 2,571,287. RENU. INT. CL. 9. (U.S. CLS. 21, 23, 26, 36 AND 38). REG. 5-21-2002.
- 2,571,471. MISCELLANEOUS DESIGN. INT. CL. 14. (U.S. CLS. 2, 27, 28 AND 50). REG. 5-21-2002.
- 2,571,482. CPC AND DESIGN. INT. CLS. 25 AND 41. (U.S. CLS. 22, 39, 100, 101 AND 107). REG. 5-21-2002.
- 2,571,547. FLYING FISH BREWING CO. AND DESIGN. INT. CLS. 25 AND 32. (U.S. CLS. 22, 39, 45, 46 AND 48). REG. 5-21-2002.
- 2,571,657. STRATHMORE. INT. CL. 16. (U.S. CLS. 2, 5, 22, 23, 29, 37, 38 AND 50). REG. 5-21-2002.
- 2,571,735. VIRTUBE. INT. CL. 9. (U.S. CLS. 21, 23, 26, 36 AND 38). REG. 5-21-2002.
- 2,571,778. KING OF SNACKS. INT. CL. 30. (U.S. CL. 46). REG. 5-21-2002.
- 2,571,790. FRIPPLETOWN. INT. CL. 9. (U.S. CLS. 21, 23, 26, 36 AND 38). REG. 5-21-2002.
- 2,571,814. CORNER SEAL. INT. CL. 7. (U.S. CLS. 13, 19, 21, 23, 31, 34 AND 35). REG. 5-21-2002.
- 2,571,881. MISCELLANEOUS DESIGN. INT. CL. 21. (U.S. CLS. 2, 13, 23, 29, 30, 33, 40 AND 50). REG. 5-21-2002.
- 2,571,894. HEXWEB. INT. CLS. 6 AND 17. (U.S. CLS. 1, 2, 5, 12, 13, 14, 23, 25, 35 AND 50). REG. 5-21-2002.
- 2,572,038. TRYSCIENCE. INT. CLS. 38, 41 AND 42. (U.S. CLS. 100, 101, 104 AND 107). REG. 5-21-2002.
- 2,572,472. PARAGON AQUATICS. INT. CLS. 6, 11 AND 28. (U.S. CLS. 2, 12, 13, 14, 21, 22, 23, 25, 31, 34, 38 AND 50). REG. 5-28-2002.

- 2,572,493. SCUMTRAPPR. INT. CL. 11. (U.S. CLS. 13, 21, 23, 31 AND 34). REG. 5-28-2002.
- 2,572,616. DJ ICEY. INT. CLS. 9 AND 41. (U.S. CLS. 21, 23, 26, 36, 38, 100, 101 AND 107). REG. 5-28-2002.
- 2,572,789. OPNET. INT. CL. 42. (U.S. CLS. 100 AND 101). REG. 5-28-2002.
- 2,572,792. SPECTRUM EXPLORER. INT. CL. 9. (U.S. CLS. 21, 23, 26, 36 AND 38). REG. 5-28-2002.
- 2,572,806. CLASSIC FURNITURE FOR THE GREAT OUTDOORS. INT. CL. 20. (U.S. CLS. 2, 13, 22, 25, 32 AND 50). REG. 5-28-2002.
- 2,572,874. THE PEABODY (STYLIZED). INT. CL. 25. (U.S. CLS. 22 AND 39). REG. 5-28-2002.
- 2,572,875. DATA ROOM EXPLORER AND DESIGN. INT. CL. 36. (U.S. CLS. 100, 101 AND 102). REG. 5-28-2002.
- 2,572,942. NYSE CAP. INT. CL. 36. (U.S. CLS. 100, 101 AND 102). REG. 5-28-2002.
- 2,572,943. NYSE COMMON ACCESS POINT. INT. CL. 36. (U.S. CLS. 100, 101 AND 102). REG. 5-28-2002.
- 2,573,066. BAKIR. INT. CL. 3. (U.S. CLS. 1, 4, 6, 50, 51 AND 52). REG. 5-28-2002.
- 2,573,307. AAO INSURANCE COMPANY A RISK RETENTION GROUP AND DESIGN. INT. CL. 36. (U.S. CLS. 100, 101 AND 102). REG. 5-28-2002.
- 2,573,438. HONEY JUG. INT. CL. 37. (U.S. CLS. 100, 103 AND 106). REG. 5-28-2002.
- 2,573,704. BRAVO. INT. CL. 9. (U.S. CLS. 21, 23, 26, 36 AND 38). REG. 5-28-2002.
- 2,573,723. VANGUARD.COM. INT. CL. 36. (U.S. CLS. 100, 101 AND 102). REG. 5-28-2002.
- 2,573,729. TRUELEAF. INT. CL. 11. (U.S. CLS. 13, 21, 23, 31 AND 34). REG. 5-28-2002.
- 2,573,987. NAVAJO. INT. CL. 24. (U.S. CLS. 42 AND 50). REG. 5-28-2002.
- 2,574,030. SNAP GUARD. INT. CL. 6. (U.S. CLS. 2, 12, 13, 14, 23, 25 AND 50). REG. 5-28-2002.
- 2,574,214. MYCHART. INT. CL. 9. (U.S. CLS. 21, 23, 26, 36 AND 38). REG. 5-28-2002.
- 2,574,241. GOD'S CHILD. INT. CL. 41. (U.S. CLS. 100, 101 AND 107). REG. 5-28-2002.
- 2,574,551. SIGHTSEER. INT. CL. 12. (U.S. CLS. 19, 21, 23, 31, 35 AND 44). REG. 5-28-2002.
- 2,574,867. GD GAYLORD AND DESIGN. INT. CLS. 6, 20, 21, 28 AND 42. (U.S. CLS. 2, 12, 13, 14, 22, 23, 25, 29, 30, 32, 33, 38, 40, 50, 100 AND 101). REG. 6-4-2002.
- 2,575,110. BENARY AND DESIGN. INT. CL. 31. (U.S. CLS. 1 AND 46). REG. 6-4-2002.
- 2,575,167. TARZAN. INT. CLS. 9 AND 28 ONLY. (U.S. CLS. 21, 22, 23, 26, 36, 38 AND 50). REG. 6-4-2002.
- 2,575,266. 02MICRO (STYLIZED). INT. CL. 9. (U.S. CLS. 21, 23, 26, 36 AND 38). REG. 6-4-2002.
- 2,575,329. MASTER AID. INT. CL. 5. (U.S. CLS. 6, 18, 44, 46, 51 AND 52). REG. 6-4-2002.
- 2,575,363. PCH PACIFIC COAST HIGHWAY AND DESIGN. INT. CL. 25. (U.S. CLS. 22 AND 39). REG. 6-4-2002.
- 2,575,398. FULL MOON SIGNS & GRAPHICS. INT. CL. 42. (U.S. CLS. 100 AND 101). REG. 6-4-2002.
- 2,575,472. BABYS LAS VEGAS AND DESIGN. INT. CL. 42. (U.S. CLS. 100 AND 101). REG. 6-4-2002.
- 2,575,532. LA NEW AND DESIGN. INT. CL. 25. (U.S. CLS. 22 AND 39). REG. 6-4-2002.
- 2,575,728. ADVANTAGE PERFORMANCE DISTRIBUTING AND DESIGN. INT. CL. 35. (U.S. CLS. 100, 101 AND 102). REG. 6-4-2002.
- 2,575,899. VF. INT. CL. 3. (U.S. CLS. 1, 4, 6, 50, 51 AND 52). REG. 6-4-2002.
- 2,575,901. BROADACRES CREEDE AND DESIGN. INT. CL. 41. (U.S. CLS. 100, 101 AND 107). REG. 6-4-2002.
- 2,575,976. SAN FRANCISCO HAT COMPANY. INT. CL. 25. (U.S. CLS. 22 AND 39). REG. 6-4-2002.
- 2,576,012. PRI - 400. INT. CL. 19. (U.S. CLS. 1, 12, 33 AND 50). REG. 6-4-2002.
- 2,576,223. CSS ANTENNA AND DESIGN. INT. CL. 9. (U.S. CLS. 21, 23, 26, 36 AND 38). REG. 6-4-2002.
- 2,576,332. VAN-TG. INT. CL. 7. (U.S. CLS. 13, 19, 21, 23, 31, 34 AND 35). REG. 6-4-2002.
- 2,576,631. ORBEA. INT. CL. 12. (U.S. CLS. 19, 21, 23, 31, 35 AND 44). REG. 6-4-2002.
- 2,576,950. DIALY-NATE. INT. CL. 10. (U.S. CLS. 26, 39 AND 44). REG. 6-11-2002.
- 2,577,048. FORTE HARDWOOD FLOORING. INT. CLS. 3 AND 19 ONLY. (U.S. CLS. 1, 4, 6, 12, 33, 50, 51 AND 52). REG. 6-11-2002.
- 2,577,054. SERVOMETER. INT. CLS. 7 AND 9. (U.S. CLS. 13, 19, 21, 23, 26, 31, 34, 35, 36 AND 38). REG. 6-11-2002.
- 2,577,131. MUDCAT. INT. CLS. 9 AND 41. (U.S. CLS. 21, 23, 26, 36, 38, 100, 101 AND 107). REG. 6-11-2002.
- 2,577,164. FORIS. INT. CL. 33. (U.S. CLS. 47 AND 49). REG. 6-11-2002.
- 2,577,300. TEACHERS-TEACHERS.COM AND DESIGN. INT. CL. 35. (U.S. CLS. 100, 101 AND 102). REG. 6-11-2002.
- 2,577,313. FROZUN FOODS INCORPORATED AND DESIGN. INT. CL. 29. (U.S. CL. 46). REG. 6-11-2002.
- 2,577,340. BREATHING LIFE INTO MOBILITY. INT. CL. 9. (U.S. CLS. 21, 23, 26, 36 AND 38). REG. 6-11-2002.
- 2,577,349. WAXWEAR. INT. CL. 24. (U.S. CLS. 42 AND 50). REG. 6-11-2002.
- 2,577,417. BUILDERS CONCRETE. INT. CL. 19. (U.S. CLS. 1, 12, 33 AND 50). REG. 6-11-2002.
- 2,577,637. AHEAD OF THE CURVE IN REFRIGERATED LOGISTICS. INT. CL. 39. (U.S. CLS. 100 AND 105). REG. 6-11-2002.
- 2,577,687. G&W. INT. CL. 5 ONLY. (U.S. CLS. 6, 18, 44, 46, 51 AND 52). REG. 6-11-2002.
- 2,577,964. BOYLE. INT. CLS. 36 AND 37. (U.S. CLS. 100, 101, 102, 103 AND 106). REG. 6-11-2002.
- 2,578,146. THERAGUARD. INT. CL. 9. (U.S. CLS. 21, 23, 26, 36 AND 38). REG. 6-11-2002.
- 2,578,479. THE SWORD AND SHIELD FOR PEOPLE OF FAITH. INT. CL. 42. (U.S. CLS. 100 AND 101). REG. 6-11-2002.
- 2,578,633. EAGLE ZONE. INT. CL. 41. (U.S. CLS. 100, 101 AND 107). REG. 6-11-2002.
- 2,578,776. BIFIDUS BALANCE. INT. CL. 5. (U.S. CLS. 6, 18, 44, 46, 51 AND 52). REG. 6-11-2002.
- 2,579,145. SPACECONES AND DESIGN. INT. CL. 30. (U.S. CL. 46). REG. 6-11-2002.
- 2,579,236. BEL-TRAK. INT. CL. 1. (U.S. CLS. 1, 5, 6, 10, 26 AND 46). REG. 6-11-2002.
- 2,579,498. ALIBABA. INT. CLS. 35 AND 38. (U.S. CLS. 100, 101, 102 AND 104). REG. 6-11-2002.
- 2,579,535. AGILENT VEE. INT. CL. 9. (U.S. CLS. 21, 23, 26, 36 AND 38). REG. 6-11-2002.
- 2,579,536. SAFE HARBOR. INT. CL. 6. (U.S. CLS. 2, 12, 13, 14, 23, 25 AND 50). REG. 6-11-2002.
- 2,579,650. PASSION. INT. CL. 30. (U.S. CL. 46). REG. 6-11-2002.
- 2,579,871. METASOMES. INT. CL. 1. (U.S. CLS. 1, 5, 6, 10, 26 AND 46). REG. 6-11-2002.
- 2,580,200. JOURNEY. INT. CL. 20. (U.S. CLS. 2, 13, 22, 25, 32 AND 50). REG. 6-11-2002.
- 2,580,478. LO MEXICANO. INT. CL. 41. (U.S. CLS. 100, 101 AND 107). REG. 6-11-2002.
- 2,580,846. MONOGRAM. INT. CL. 21. (U.S. CLS. 2, 13, 23, 29, 30, 33, 40 AND 50). REG. 6-18-2002.
- 2,580,990. V EXPRESS. INT. CL. 19. (U.S. CLS. 1, 12, 33 AND 50). REG. 6-18-2002.
- 2,581,052. KOM-TECH. INT. CL. 25. (U.S. CLS. 22 AND 39). REG. 6-18-2002.
- 2,581,160. BOBVILA.COM. INT. CL. 35. (U.S. CLS. 100, 101 AND 102). REG. 6-18-2002.
- 2,581,214. THK (STYLIZED). INT. CL. 35. (U.S. CLS. 100, 101 AND 102). REG. 6-18-2002.
- 2,581,236. EODB AND DESIGN. INT. CL. 36. (U.S. CLS. 100, 101 AND 102). REG. 6-18-2002.
- 2,581,242. BURRIS REFRIGERATED LOGISTICS. INT. CL. 39. (U.S. CLS. 100 AND 105). REG. 6-18-2002.
- 2,581,434. CARTOON NETWORK AND DESIGN. INT. CL. 20. (U.S. CLS. 2, 13, 22, 25, 32 AND 50). REG. 6-18-2002.
- 2,581,914. HELIFIN. INT. CL. 11. (U.S. CLS. 13, 21, 23, 31 AND 34). REG. 6-18-2002.
- 2,581,941. COLLEGE ISSUE. INT. CL. 25. (U.S. CLS. 22 AND 39). REG. 6-18-2002.
- 2,582,036. CENTER FOR THE STUDY AND PRACTICE OF SPIRITUAL PSYCHOLOGY. INT. CL. 41. (U.S. CLS. 100, 101 AND 107). REG. 6-18-2002.
- 2,582,100. RASTA BLEND. INT. CL. 30. (U.S. CL. 46). REG. 6-18-2002.
- 2,582,110. THINK FAST. INT. CL. 42. (U.S. CLS. 100 AND 101). REG. 6-18-2002.
- 2,582,563. STI (STYLIZED). INT. CL. 12. (U.S. CLS. 19, 21, 23, 31, 35 AND 44). REG. 6-18-2002.
- 2,582,589. SMART MATRIX. INT. CL. 35. (U.S. CLS. 100, 101 AND 102). REG. 6-18-2002.

- 2,582,644. PHOSFREE. INT. CL. 1. (U.S. CLS. 1, 5, 6, 10, 26 AND 46). REG. 6-18-2002.
- 2,582,704. COURAGE THE COWARDLY DOG. INT. CL. 41. (U.S. CLS. 100, 101 AND 107). REG. 6-18-2002.
- 2,582,791. THE KEN BLANCHARD COMPANIES. INT. CL. 41. (U.S. CLS. 100, 101 AND 107). REG. 6-18-2002.
- 2,583,328. ZEUS. INT. CL. 12. (U.S. CLS. 19, 21, 23, 31, 35 AND 44). REG. 6-18-2002.
- 2,583,761. DELTA AND DESIGN. INT. CL. 11. (U.S. CLS. 13, 21, 23, 31 AND 34). REG. 6-18-2002.
- 2,583,780. RACE-IN AND DESIGN. INT. CL. 35. (U.S. CLS. 100, 101 AND 102). REG. 6-18-2002.
- 2,583,781. RACE-IN. INT. CL. 35. (U.S. CLS. 100, 101 AND 102). REG. 6-18-2002.
- 2,583,893. CLEANVIEW. INT. CL. 7. (U.S. CLS. 13, 19, 21, 23, 31, 34 AND 35). REG. 6-18-2002.
- 2,583,955. HEARTWIRE. INT. CL. 38. (U.S. CLS. 100, 101 AND 104). REG. 6-18-2002.
- 2,584,186. HORIZON BANK. INT. CL. 36. (U.S. CLS. 100, 101 AND 102). REG. 6-25-2002.
- 2,584,437. NATIONAL ORGANIZATIONS FOR YOUTH SAFETY. INT. CL. 42. (U.S. CLS. 100 AND 101). REG. 6-25-2002.
- 2,584,792. EVAP-A-WRAPPA. INT. CL. 21. (U.S. CLS. 2, 13, 23, 29, 30, 33, 40 AND 50). REG. 6-25-2002.
- 2,584,860. TAPICU, INCORPORATED. INT. CL. 42. (U.S. CLS. 100 AND 101). REG. 6-25-2002.
- 2,585,048. NBR. INT. CLS. 35 AND 42. (U.S. CLS. 100, 101 AND 102). REG. 6-25-2002.
- 2,585,068. CREATORS OF SPECIALTY FOODS (STYLIZED). INT. CLS. 29 AND 30. (U.S. CL. 46). REG. 6-25-2002.
- 2,585,256. SHOMI. INT. CL. 42. (U.S. CLS. 100 AND 101). REG. 6-25-2002.
- 2,585,281. RNT AND DESIGN. INT. CL. 28. (U.S. CLS. 22, 23, 38 AND 50). REG. 6-25-2002.
- 2,585,303. HANCOCK FORESTRY. INT. CL. 36. (U.S. CLS. 100, 101 AND 102). REG. 6-25-2002.
- 2,585,348. NOT AFRAID OF THE DARK. INT. CL. 9. (U.S. CLS. 21, 23, 26, 36 AND 38). REG. 6-25-2002.
- 2,585,753. A-POC. INT. CL. 25 ONLY. (U.S. CLS. 22 AND 39). REG. 6-25-2002.
- 2,585,965. ALIGNONE. INT. CL. 36. (U.S. CLS. 100, 101 AND 102). REG. 6-25-2002.
- 2,586,192. ZOMIG-ZMT. INT. CL. 5. (U.S. CLS. 6, 18, 44, 46, 51 AND 52). REG. 6-25-2002.
- 2,586,355. ARCH. INT. CL. 11. (U.S. CLS. 13, 21, 23, 31 AND 34). REG. 6-25-2002.
- 2,586,379. E ESPRIX (STYLIZED). INT. CL. 1 ONLY. (U.S. CLS. 1, 5, 6, 10, 26 AND 46). REG. 6-25-2002.
- 2,586,855. INTERNATIONAL FREESTYLE MOTOCROSS ASSOCIATION. INT. CL. 41. (U.S. CLS. 100, 101 AND 107). REG. 6-25-2002.
- 2,587,018. GIFT AVENUE. INT. CL. 35. (U.S. CLS. 100, 101 AND 102). REG. 7-2-2002.
- 2,587,458. SOTTOCENERE. INT. CL. 29. (U.S. CL. 46). REG. 7-2-2002.
- 2,587,539. EODB EASE OF DOING BUSINESS AND DESIGN. INT. CL. 36. (U.S. CLS. 100, 101 AND 102). REG. 7-2-2002.
- 2,587,616. SWRI. INT. CL. 42. (U.S. CLS. 100 AND 101). REG. 7-2-2002.
- 2,587,944. GRAINBELT. INT. CL. 7. (U.S. CLS. 13, 19, 21, 23, 31, 34 AND 35). REG. 7-2-2002.
- 2,588,150. LUCIANO RISTORANTE ITALIANO. INT. CL. 42. (U.S. CLS. 100 AND 101). REG. 7-2-2002.
- 2,588,301. CDN. INT. CL. 9. (U.S. CLS. 21, 23, 26, 36 AND 38). REG. 7-2-2002.
- 2,588,317. TIGRIND. INT. CL. 19. (U.S. CLS. 1, 12, 33 AND 50). REG. 7-2-2002.
- 2,588,451. CYPRESS POINT CLUB AND DESIGN. INT. CLS. 25 AND 28. (U.S. CLS. 22, 23, 38, 39 AND 50). REG. 7-2-2002.
- 2,588,629. MISCELLANEOUS DESIGN. INT. CL. 15. (U.S. CLS. 2, 21 AND 36). REG. 7-2-2002.
- 2,588,644. SARA BLAKELY. INT. CL. 25. (U.S. CLS. 22 AND 39). REG. 7-2-2002.
- 2,588,744. HAVAHART. INT. CLS. 9 AND 35. (U.S. CLS. 21, 23, 26, 36, 38, 100, 101 AND 102). REG. 7-2-2002.
- 2,589,029. REGIS SIGNATURE SALON. INT. CL. 42. (U.S. CLS. 100 AND 101). REG. 7-2-2002.
- 2,589,793. SERVALL. INT. CL. 42. (U.S. CLS. 100 AND 101). REG. 7-2-2002.
- 2,590,408. WRIGHT. INT. CLS. 6, 7 AND 20. (U.S. CLS. 2, 12, 13, 14, 19, 21, 22, 23, 25, 31, 32, 34, 35 AND 50). REG. 7-9-2002.
- 2,590,576. GUALA. INT. CL. 21. (U.S. CLS. 2, 13, 23, 29, 30, 33, 40 AND 50). REG. 7-9-2002.
- 2,590,663. TICKET2SPORTS. INT. CL. 38. (U.S. CLS. 100, 101 AND 104). REG. 7-9-2002.
- 2,590,683. BOB VILA'S. INT. CL. 9. (U.S. CLS. 21, 23, 26, 36 AND 38). REG. 7-9-2002.
- 2,590,758. NOETIX AND DESIGN. INT. CL. 9. (U.S. CLS. 21, 23, 26, 36 AND 38). REG. 7-9-2002.
- 2,590,856. CREATURES OF THE SEA. INT. CL. 10. (U.S. CLS. 26, 39 AND 44). REG. 7-9-2002.
- 2,591,117. ULTIMATE TOUCH. INT. CLS. 8 AND 21. (U.S. CLS. 2, 13, 23, 28, 29, 30, 33, 40, 44 AND 50). REG. 7-9-2002.
- 2,591,519. DAVID BRUCE. INT. CL. 33. (U.S. CLS. 47 AND 49). REG. 7-9-2002.
- 2,592,027. FIT 2 AIM. INT. CL. 28. (U.S. CLS. 22, 23, 38 AND 50). REG. 7-9-2002.
- 2,592,219. HIWARE. INT. CL. 35. (U.S. CLS. 100, 101 AND 102). REG. 7-9-2002.
- 2,593,010. CHEF'S CHOPPER. INT. CL. 7. (U.S. CLS. 13, 19, 21, 23, 31, 34 AND 35). REG. 7-9-2002.
- 2,593,030. VENUS (STYLIZED). INT. CL. 8. (U.S. CLS. 23, 28 AND 44). REG. 7-9-2002.
- 2,593,462. TOPTUL. INT. CL. 8. (U.S. CLS. 23, 28 AND 44). REG. 7-16-2002.
- 2,593,555. CEOFIX. INT. CL. 1. (U.S. CLS. 1, 5, 6, 10, 26 AND 46). REG. 7-16-2002.
- 2,593,730. VALENCIA (STYLIZED). INT. CL. 15. (U.S. CLS. 2, 21 AND 36). REG. 7-16-2002.
- 2,593,778. COMPAL. INT. CLS. 2 AND 40. (U.S. CLS. 6, 11, 16, 100, 103 AND 106). REG. 7-16-2002.
- 2,594,489. THE WEB. INT. CLS. 35 AND 41. (U.S. CLS. 100, 101, 102 AND 107). REG. 7-16-2002.
- 2,594,681. REDDEVIL. INT. CL. 11. (U.S. CLS. 13, 21, 23, 31 AND 34). REG. 7-16-2002.
- 2,595,043. W2W. INT. CLS. 9 AND 38. (U.S. CLS. 21, 23, 26, 36, 38, 100, 101 AND 104). REG. 7-16-2002.
- 2,595,177. THE LIACOURAS CENTER. INT. CL. 41. (U.S. CLS. 100, 101 AND 107). REG. 7-16-2002.
- 2,595,527. RF 3000. INT. CL. 10. (U.S. CLS. 26, 39 AND 44). REG. 7-16-2002.
- 2,595,641. LA NUESTRA. INT. CL. 29. (U.S. CL. 46). REG. 7-16-2002.
- 2,595,838. VIRTU. INT. CL. 9. (U.S. CLS. 21, 23, 26, 36 AND 38). REG. 7-16-2002.
- 2,596,633. DELTA PHI OMEGA. U.S. CL. 200. REG. 7-23-2002.
- 2,597,112. MR. GRAB BAR (STYLIZED). INT. CL. 37. (U.S. CLS. 100, 103 AND 106). REG. 7-23-2002.
- 2,597,277. CARDINALS AND DESIGN. INT. CL. 25. (U.S. CLS. 22 AND 39). REG. 7-23-2002.
- 2,597,405. STREIT'S AND DESIGN. INT. CLS. 29 AND 30. (U.S. CL. 46). REG. 7-23-2002.
- 2,597,533. ACCESS OAKLAND AND DESIGN. INT. CLS. 35 AND 36 ONLY. (U.S. CLS. 100, 101 AND 102). REG. 7-23-2002.
- 2,597,618. PORTMANN'S. INT. CL. 30. (U.S. CL. 46). REG. 7-23-2002.
- 2,597,700. SNAPLOCK. INT. CL. 19. (U.S. CLS. 1, 12, 33 AND 50). REG. 7-23-2002.
- 2,597,754. ADARA HEALTHCARE STAFFING AND DESIGN. INT. CL. 35. (U.S. CLS. 100, 101 AND 102). REG. 7-23-2002.
- 2,597,780. P.E.O. EDUCATIONAL LOAN FUND. INT. CL. 36. (U.S. CLS. 100, 101 AND 102). REG. 7-23-2002.
- 2,597,919. AVALON. INT. CL. 10. (U.S. CLS. 26, 39 AND 44). REG. 7-23-2002.
- 2,597,921. HANCOCK FORESTRY. INT. CL. 35. (U.S. CLS. 100, 101 AND 102). REG. 7-23-2002.
- 2,597,963. AT&S AND DESIGN. INT. CLS. 23 AND 35. (U.S. CLS. 43, 100, 101 AND 102). REG. 7-23-2002.
- 2,598,003. SLDN. INT. CL. 42. (U.S. CLS. 100 AND 101). REG. 7-23-2002.
- 2,598,189. BUFFALO (STYLIZED). INT. CL. 25. (U.S. CLS. 22 AND 39). REG. 7-23-2002.
- 2,598,219. TINKERBELL. INT. CLS. 16 AND 21. (U.S. CLS. 2, 5, 13, 22, 23, 29, 30, 33, 37, 38, 40 AND 50). REG. 7-23-2002.
- 2,598,587. S SKILCRAFT AND DESIGN. INT. CL. 11. (U.S. CLS. 13, 21, 23, 31 AND 34). REG. 7-23-2002.
- 2,598,697. PROSCAN. INT. CL. 35. (U.S. CLS. 100, 101 AND 102). REG. 7-23-2002.

- 2,599,142. ENDORSE. INT. CL. 5. (U.S. CLS. 6, 18, 44, 46, 51 AND 52). REG. 7-23-2002.
- 2,599,329. STREAMZAP. INT. CL. 9. (U.S. CLS. 21, 23, 26, 36 AND 38). REG. 7-23-2002.
- 2,600,068. TRAHK (STYLIZED). INT. CLS. 16 AND 36 ONLY. (U.S. CLS. 2, 5, 22, 23, 29, 37, 38, 50, 100, 101 AND 102). REG. 7-30-2002.
- 2,600,604. EQUIPEX, LTD.. INT. CL. 11. (U.S. CLS. 13, 21, 23, 31 AND 34). REG. 7-30-2002.
- 2,601,077. EDCOR. INT. CL. 35. (U.S. CLS. 100, 101 AND 102). REG. 7-30-2002.
- 2,601,177. ENLIGHTED. INT. CLS. 25 AND 26. (U.S. CLS. 22, 37, 39, 40, 42 AND 50). REG. 7-30-2002.
- 2,601,507. ZEUS (STYLIZED). INT. CL. 9. (U.S. CLS. 21, 23, 26, 36 AND 38). REG. 7-30-2002.
- 2,601,650. MISCELLANEOUS DESIGN. INT. CLS. 16, 25 AND 33. (U.S. CLS. 2, 5, 22, 23, 29, 37, 38, 39, 47, 49 AND 50). REG. 7-30-2002.
- 2,601,814. SKILCRAFT. INT. CL. 11. (U.S. CLS. 13, 21, 23, 31 AND 34). REG. 7-30-2002.
- 2,601,974. SCHULT. INT. CL. 35. (U.S. CLS. 100, 101 AND 102). REG. 7-30-2002.
- 2,602,204. ARCTIC AVENUE. INT. CL. 35. (U.S. CLS. 100, 101 AND 102). REG. 7-30-2002.
- 2,602,541. POWERPRO. INT. CL. 35. (U.S. CLS. 100, 101 AND 102). REG. 7-30-2002.
- 2,602,555. LFX LARGE FORMAT EXPERIENCE. INT. CL. 41. (U.S. CLS. 100, 101 AND 107). REG. 7-30-2002.
- 2,602,650. MISCELLANEOUS DESIGN. INT. CL. 12. (U.S. CLS. 19, 21, 23, 31, 35 AND 44). REG. 7-30-2002.
- 2,602,738. LEADINGEDGE. INT. CL. 9. (U.S. CLS. 21, 23, 26, 36 AND 38). REG. 7-30-2002.
- 2,603,940. MARKETINGWORKS, INC. THE EDUCATION MARKETPLACE CONNECTION AND DESIGN. INT. CL. 35. (U.S. CLS. 100, 101 AND 102). REG. 8-6-2002.
- 2,604,588. BREATHE EASY. INT. CL. 1. (U.S. CLS. 1, 5, 6, 10, 26 AND 46). REG. 8-6-2002.
- 2,604,720. M AND DESIGN. INT. CL. 9. (U.S. CLS. 21, 23, 26, 36 AND 38). REG. 8-6-2002.
- 2,605,304. SPECTRA. INT. CL. 12. (U.S. CLS. 19, 21, 23, 31, 35 AND 44). REG. 8-6-2002.
- 2,605,570. CENTS & SENSIBILITY. INT. CL. 36. (U.S. CLS. 100, 101 AND 102). REG. 8-6-2002.
- 2,605,967. WHIRLPOOL. INT. CLS. 3 AND 21 ONLY. (U.S. CLS. 1, 2, 4, 6, 13, 23, 29, 30, 33, 40, 50, 51 AND 52). REG. 8-6-2002.
- 2,605,968. WHIRLPOOL AND DESIGN. INT. CLS. 3 AND 21 ONLY. (U.S. CLS. 1, 2, 4, 6, 13, 23, 29, 30, 33, 40, 50, 51 AND 52). REG. 8-6-2002.
- 2,606,372. SUMMER DREAMS. INT. CL. 30. (U.S. CL. 46). REG. 8-13-2002.
- 2,606,615. NATIONAL READY-MIX. INT. CL. 19. (U.S. CLS. 1, 12, 33 AND 50). REG. 8-13-2002.
- 2,606,729. BLUE TOP. INT. CL. 33. (U.S. CLS. 47 AND 49). REG. 8-13-2002.
- 2,606,833. KOSSE WHITE. INT. CL. 19. (U.S. CLS. 1, 12, 33 AND 50). REG. 8-13-2002.
- 2,607,095. THOMPSON STREET CAPITAL PARTNERS. INT. CL. 36. (U.S. CLS. 100, 101 AND 102). REG. 8-13-2002.
- 2,608,367. POW-R AND DESIGN. INT. CL. 9. (U.S. CLS. 21, 23, 26, 36 AND 38). REG. 8-20-2002.
- 2,608,548. HELMET HUGGER. INT. CL. 10. (U.S. CLS. 26, 39 AND 44). REG. 8-20-2002.
- 2,608,564. RUDOLPH INDUSTRIES. INT. CLS. 7 AND 37. (U.S. CLS. 13, 19, 21, 23, 31, 34, 35, 100, 103 AND 106). REG. 8-20-2002.
- 2,608,663. THE PEABODY. INT. CL. 25. (U.S. CLS. 22 AND 39). REG. 8-20-2002.
- 2,609,022. FILLS ALL AND DESIGN. INT. CL. 7. (U.S. CLS. 13, 19, 21, 23, 31, 34 AND 35). REG. 8-20-2002.
- 2,609,242. RICE UNIVERSITY. INT. CL. 14. (U.S. CLS. 2, 27, 28 AND 50). REG. 8-20-2002.
- 2,609,556. Y YBARRA. INT. CL. 30. (U.S. CL. 46). REG. 8-20-2002.
- 2,609,680. THE SECOND LOOK PROJECT. INT. CL. 35. (U.S. CLS. 100, 101 AND 102). REG. 8-20-2002.
- 2,609,732. BROWN ATTENTION-DEFICIT DISORDER SCALES. INT. CL. 16. (U.S. CLS. 2, 5, 22, 23, 29, 37, 38 AND 50). REG. 8-20-2002.
- 2,609,816. DEAN AND DESIGN. INT. CL. 15. (U.S. CLS. 2, 21 AND 36). REG. 8-20-2002.
- 2,609,859. SCREENPRO. INT. CL. 9. (U.S. CLS. 21, 23, 26, 36 AND 38). REG. 8-20-2002.
- 2,609,935. TURBODESIGN (STYLIZED). INT. CL. 9. (U.S. CLS. 21, 23, 26, 36 AND 38). REG. 8-20-2002.
- 2,609,964. TWINKLE CANDY. INT. CL. 30. (U.S. CL. 46). REG. 8-20-2002.
- 2,610,075. BOOMERANG. INT. CL. 41. (U.S. CLS. 100, 101 AND 107). REG. 8-20-2002.
- 2,610,533. READYCELLS. INT. CL. 5. (U.S. CLS. 6, 18, 44, 46, 51 AND 52). REG. 8-20-2002.
- 2,610,534. QUATRACIN. INT. CL. 5. (U.S. CLS. 6, 18, 44, 46, 51 AND 52). REG. 8-20-2002.
- 2,610,685. EQUILATERAL. INT. CL. 9. (U.S. CLS. 21, 23, 26, 36 AND 38). REG. 8-20-2002.
- 2,611,169. AQUI. INT. CL. 42. (U.S. CLS. 100 AND 101). REG. 8-27-2002.
- 2,611,401. EMS AND DESIGN. INT. CLS. 37 AND 42. (U.S. CLS. 100, 101, 103 AND 106). REG. 8-27-2002.
- 2,611,898. BIO-CHANNEL. INT. CL. 19. (U.S. CLS. 1, 12, 33 AND 50). REG. 8-27-2002.
- 2,612,511. FLEXITARIAN. INT. CL. 30. (U.S. CL. 46). REG. 8-27-2002.
- 2,612,913. THE WEATHER WORKSHOP. INT. CL. 35. (U.S. CLS. 100, 101 AND 102). REG. 8-27-2002.
- 2,613,079. LYNDA.COM. INT. CL. 16. (U.S. CLS. 2, 5, 22, 23, 29, 37, 38 AND 50). REG. 8-27-2002.
- 2,613,201. CROMA. INT. CL. 8. (U.S. CLS. 23, 28 AND 44). REG. 8-27-2002.
- 2,613,503. INKA CHIPS. INT. CL. 29. (U.S. CL. 46). REG. 8-27-2002.
- 2,613,679. PRO WHITE. INT. CL. 19. (U.S. CLS. 1, 12, 33 AND 50). REG. 9-3-2002.
- 2,613,694. DORNIER COMPACT DELTA. INT. CL. 10. (U.S. CLS. 26, 39 AND 44). REG. 9-3-2002.
- 2,613,752. LEN THOMPSON. INT. CL. 28. (U.S. CLS. 22, 23, 38 AND 50). REG. 9-3-2002.
- 2,613,971. HUDSON RIVER PARK TRUST AND DESIGN. INT. CL. 41. (U.S. CLS. 100, 101 AND 107). REG. 9-3-2002.
- 2,614,273. TRUETIP. INT. CL. 16. (U.S. CLS. 2, 5, 22, 23, 29, 37, 38 AND 50). REG. 9-3-2002.
- 2,614,613. CHRISTIAN ART. INT. CL. 16. (U.S. CLS. 2, 5, 22, 23, 29, 37, 38 AND 50). REG. 9-3-2002.
- 2,614,859. LIDA BADAY. INT. CL. 25 ONLY. (U.S. CLS. 22 AND 39). REG. 9-3-2002.
- 2,615,153. MISCELLANEOUS DESIGN. INT. CL. 12. (U.S. CLS. 19, 21, 23, 31, 35 AND 44). REG. 9-3-2002.
- 2,615,155. APICAL. INT. CL. 12. (U.S. CLS. 19, 21, 23, 31, 35 AND 44). REG. 9-3-2002.
- 2,615,279. RICE. INT. CL. 24. (U.S. CLS. 42 AND 50). REG. 9-3-2002.
- 2,615,280. RICE. INT. CL. 14. (U.S. CLS. 2, 27, 28 AND 50). REG. 9-3-2002.
- 2,615,281. RICE. INT. CL. 21. (U.S. CLS. 2, 13, 23, 29, 30, 33, 40 AND 50). REG. 9-3-2002.
- 2,615,626. SCUBA DIVING INTERNATIONAL AND DESIGN. INT. CL. 41. (U.S. CLS. 100, 101 AND 107). REG. 9-3-2002.
- 2,615,816. SLIDELIFT LIFTGATE SERIES AND DESIGN. INT. CL. 7. (U.S. CLS. 13, 19, 21, 23, 31, 34 AND 35). REG. 9-3-2002.
- 2,615,855. MARY'S PRIDE. INT. CL. 31. (U.S. CLS. 1 AND 46). REG. 9-3-2002.
- 2,615,987. EAGLE EYE. INT. CL. 9. (U.S. CLS. 21, 23, 26, 36 AND 38). REG. 9-3-2002.
- 2,616,374. THE WORK OF BYRON KATIE. INT. CL. 41. (U.S. CLS. 100, 101 AND 107). REG. 9-10-2002.
- 2,616,500. FRESH CATCH. INT. CL. 16. (U.S. CLS. 2, 5, 22, 23, 29, 37, 38 AND 50). REG. 9-10-2002.
- 2,617,198. VALLEY POOLS & SPAS AND DESIGN. INT. CLS. 11 AND 19. (U.S. CLS. 1, 12, 13, 21, 23, 31, 33, 34 AND 50). REG. 9-10-2002.
- 2,617,363. SRS SPECIALTY RISK SERVICES AND DESIGN. INT. CL. 36. (U.S. CLS. 100, 101 AND 102). REG. 9-10-2002.
- 2,617,402. DEL MAR. INT. CL. 18. (U.S. CLS. 1, 2, 3, 22 AND 41). REG. 9-10-2002.
- 2,617,993. PROCOPIO, CORY, HARGREAVES & SAVITCH LLP. INT. CL. 42. (U.S. CLS. 100 AND 101). REG. 9-10-2002.
- 2,618,006. CYPRESS POINT CLUB CPC AND DESIGN. INT. CLS. 16 AND 28. (U.S. CLS. 2, 5, 22, 23, 29, 37, 38 AND 50). REG. 9-10-2002.
- 2,618,035. AVERSIONION. INT. CL. 9. (U.S. CLS. 21, 23, 26, 36 AND 38). REG. 9-10-2002.
- 2,618,157. SEED HAWK. INT. CL. 7. (U.S. CLS. 13, 19, 21, 23, 31, 34 AND 35). REG. 9-10-2002.

- 2,618,231. SCOOBY-DOO. INT. CL. 5. (U.S. CLS. 6, 18, 44, 46, 51 AND 52). REG. 9-10-2002.
- 2,618,686. THEARTOFTEACHING. INT. CL. 41. (U.S. CLS. 100, 101 AND 107). REG. 9-10-2002.
- 2,619,051. NATURALLY SMOOTH. INT. CL. 33. (U.S. CLS. 47 AND 49). REG. 9-10-2002.
- 2,619,056. MONROE & MAIN. INT. CL. 35. (U.S. CLS. 100, 101 AND 102). REG. 9-10-2002.
- 2,619,134. EASYTURN. INT. CL. 6. (U.S. CLS. 2, 12, 13, 14, 23, 25 AND 50). REG. 9-10-2002.
- 2,619,394. AMERICAN BLACK. INT. CL. 19. (U.S. CLS. 1, 12, 33 AND 50). REG. 9-17-2002.
- 2,620,268. RICE OWLS AND DESIGN. INT. CL. 21. (U.S. CLS. 2, 13, 23, 29, 30, 33, 40 AND 50). REG. 9-17-2002.
- 2,620,483. ECO-CUISINE. INT. CLS. 30 AND 42. (U.S. CLS. 46, 100 AND 101). REG. 9-17-2002.
- 2,620,628. COURAGE TO TEACH. INT. CL. 41. (U.S. CLS. 100, 101 AND 107). REG. 9-17-2002.
- 2,620,669. HALF RUBBER. INT. CL. 28. (U.S. CLS. 22, 23, 38 AND 50). REG. 9-17-2002.
- 2,620,676. TELEPERM. INT. CL. 9. (U.S. CLS. 21, 23, 26, 36 AND 38). REG. 9-17-2002.
- 2,620,781. THE POWERPUFF GIRLS. INT. CL. 41. (U.S. CLS. 100, 101 AND 107). REG. 9-17-2002.
- 2,621,373. THE PINK STUFF. INT. CL. 1. (U.S. CLS. 1, 5, 6, 10, 26 AND 46). REG. 9-17-2002.
- 2,621,475. THE QUICK MUZZLE. INT. CL. 18. (U.S. CLS. 1, 2, 3, 22 AND 41). REG. 9-17-2002.
- 2,622,290. CREATE 21. INT. CL. 41. (U.S. CLS. 100, 101 AND 107). REG. 9-17-2002.
- 2,622,303. REVEAL THE GODDESS IN YOU. INT. CL. 8. (U.S. CLS. 23, 28 AND 44). REG. 9-17-2002.
- 2,622,735. BUFFALO TRACE AND DESIGN. INT. CLS. 16, 21, 25 AND 33. (U.S. CLS. 2, 5, 13, 22, 23, 29, 30, 33, 37, 38, 39, 40, 47, 49 AND 50). REG. 9-24-2002.
- 2,624,193. FIRST STEPS IN MUSIC AND DESIGN. INT. CLS. 16 AND 41. (U.S. CLS. 2, 5, 22, 23, 29, 37, 38, 50, 100, 101 AND 107). REG. 9-24-2002.
- 2,624,809. HAWK AND DESIGN. INT. CL. 7. (U.S. CLS. 13, 19, 21, 23, 31, 34 AND 35). REG. 9-24-2002.
- 2,624,913. DURANGO AND DESIGN. INT. CL. 34. (U.S. CLS. 2, 8, 9 AND 17). REG. 9-24-2002.
- 2,625,088. ACT. INT. CL. 35. (U.S. CLS. 100, 101 AND 102). REG. 9-24-2002.
- 2,625,458. PAGO. INT. CLS. 7, 16 AND 20. (U.S. CLS. 2, 5, 13, 19, 21, 22, 23, 25, 29, 31, 32, 34, 35, 37, 38 AND 50). REG. 9-24-2002.
- 2,625,473. COURAGE THE COWARDLY DOG. INT. CL. 38. (U.S. CLS. 100, 101 AND 104). REG. 9-24-2002.
- 2,625,638. RXSTRESS. INT. CL. 30. (U.S. CL. 46). REG. 9-24-2002.
- 2,626,310. UNIVERSAL'S ISLANDS OF ADVENTURE AND DESIGN. INT. CL. 41. (U.S. CLS. 100, 101 AND 107). REG. 9-24-2002.
- 2,626,439. HEART PLUS. INT. CL. 41. (U.S. CLS. 100, 101 AND 107). REG. 9-24-2002.
- 2,626,663. THE KEY TO SAFE DRIVING. INT. CL. 41. (U.S. CLS. 100, 101 AND 107). REG. 9-24-2002.
- 2,627,224. PATIO PLACE. INT. CL. 35. (U.S. CLS. 100, 101 AND 102). REG. 10-1-2002.
- 2,627,465. SELLERY AND DESIGN. INT. CL. 9. (U.S. CLS. 21, 23, 26, 36 AND 38). REG. 10-1-2002.
- 2,627,597. SHERIFF LOS ANGELES COUNTY AND DESIGN. INT. CL. 42. (U.S. CLS. 100 AND 101). REG. 10-1-2002.
- 2,628,250. CAMP MERRIE WOOD. INT. CL. 41. (U.S. CLS. 100, 101 AND 107). REG. 10-1-2002.
- 2,628,975. MYUNIVERSITYSTORE.COM. INT. CL. 35. (U.S. CLS. 100, 101 AND 102). REG. 10-1-2002.
- 2,629,176. INNOVATIVE PRODUCTS FROM THE SYNERGY OF NATURE AND TECHNOLOGY. INT. CL. 3. (U.S. CLS. 1, 4, 6, 50, 51 AND 52). REG. 10-1-2002.
- 2,629,238. AUDIA. INT. CL. 9. (U.S. CLS. 21, 23, 26, 36 AND 38). REG. 10-1-2002.
- 2,629,609. SUPREMO. INT. CL. 15. (U.S. CLS. 2, 21 AND 36). REG. 10-8-2002.
- 2,629,842. TRAHK TRACKER FUND OF HONG KONG (STYLIZED). INT. CLS. 16 AND 36 ONLY. (U.S. CLS. 2, 5, 22, 23, 29, 37, 38, 50, 100, 101 AND 102). REG. 10-8-2002.
- 2,630,120. B AND DESIGN. INT. CLS. 36 AND 37. (U.S. CLS. 100, 101, 102, 103 AND 106). REG. 10-8-2002.
- 2,630,306. DBK SERVTRACK. INT. CL. 42. (U.S. CLS. 100 AND 101). REG. 10-8-2002.
- 2,630,481. OMOTO REEL AND DESIGN. INT. CL. 28. (U.S. CLS. 22, 23, 38 AND 50). REG. 10-8-2002.
- 2,630,539. GIANT EAGLE. INT. CLS. 1, 3, 5, 6, 9, 16, 21, 30 AND 32 ONLY. (U.S. CLS. 1, 2, 4, 5, 6, 10, 12, 13, 14, 18, 21, 22, 23, 25, 26, 29, 30, 33, 36, 37, 38, 40, 44, 45, 46, 48, 50, 51 AND 52). REG. 10-8-2002.
- 2,631,187. LUMISCOPE. INT. CL. 10. (U.S. CLS. 26, 39 AND 44). REG. 10-8-2002.
- 2,631,444. MAMA'S MINERALS. INT. CL. 35. (U.S. CLS. 100, 101 AND 102). REG. 10-8-2002.
- 2,631,996. THE RDI GROUP (STYLIZED). INT. CL. 7. (U.S. CLS. 13, 19, 21, 23, 31, 34 AND 35). REG. 10-8-2002.
- 2,632,022. TALL BLONDE. INT. CL. 32. (U.S. CLS. 45, 46 AND 48). REG. 10-8-2002.
- 2,632,378. TRU FLOW. INT. CL. 11. (U.S. CLS. 13, 21, 23, 31 AND 34). REG. 10-8-2002.
- 2,632,403. GENETICS & YOUR PRACTICE. INT. CL. 41. (U.S. CLS. 100, 101 AND 107). REG. 10-8-2002.
- 2,632,430. CASTER EXPRESS. INT. CL. 35. (U.S. CLS. 100, 101 AND 102). REG. 10-8-2002.
- 2,633,142. TEAMINE COMPLEX. INT. CL. 3. (U.S. CLS. 1, 4, 6, 50, 51 AND 52). REG. 10-8-2002.
- 2,633,476. MISCELLANEOUS DESIGN. INT. CL. 11. (U.S. CLS. 13, 21, 23, 31 AND 34). REG. 10-8-2002.
- 2,634,066. UNIGLOBE 7*24 RESCUE LINE. INT. CL. 39 ONLY. (U.S. CLS. 100 AND 105). REG. 10-15-2002.
- 2,634,766. A DE P ANGELOU DE PARIS AND DESIGN. INT. CL. 14. (U.S. CLS. 2, 27, 28 AND 50). REG. 10-15-2002.
- 2,635,387. AUTUMN LANE. INT. CL. 42. (U.S. CLS. 100 AND 101). REG. 10-15-2002.
- 2,635,388. NEGOTIATE FROM KNOWLEDGE. INT. CL. 42. (U.S. CLS. 100 AND 101). REG. 10-15-2002.
- 2,635,413. PHANTOM WORKS. INT. CL. 42. (U.S. CLS. 100 AND 101). REG. 10-15-2002.
- 2,635,443. 1888PETMEDS AND DESIGN. INT. CL. 35. (U.S. CLS. 100, 101 AND 102). REG. 10-15-2002.
- 2,635,829. THINMAIL. INT. CL. 38. (U.S. CLS. 100, 101 AND 104). REG. 10-15-2002.
- 2,636,375. PROMOGRAN. INT. CL. 5. (U.S. CLS. 6, 18, 44, 46, 51 AND 52). REG. 10-15-2002.
- 2,636,714. P AND DESIGN. INT. CLS. 36 AND 37. (U.S. CLS. 100, 101, 102, 103 AND 106). REG. 10-15-2002.
- 2,636,831. ERGRO. INT. CL. 1. (U.S. CLS. 1, 5, 6, 10, 26 AND 46). REG. 10-15-2002.
- 2,636,873. EAGLE MOUNTAIN. INT. CL. 25. (U.S. CLS. 22 AND 39). REG. 10-15-2002.
- 2,636,909. TABBY'S PLACE A CAT SANCTUARY. INT. CL. 42. (U.S. CLS. 100 AND 101). REG. 10-15-2002.
- 2,637,604. COMPLETE CARE. INT. CL. 36. (U.S. CLS. 100, 101 AND 102). REG. 10-15-2002.
- 2,637,729. KRIKORIAN'S METROPLEX THEATRES. INT. CL. 41. (U.S. CLS. 100, 101 AND 107). REG. 10-15-2002.
- 2,638,263. Q AND DESIGN. INT. CLS. 38 AND 41. (U.S. CLS. 100, 101, 104 AND 107). REG. 10-22-2002.
- 2,638,435. PLATINUM. INT. CL. 12. (U.S. CLS. 19, 21, 23, 31, 35 AND 44). REG. 10-22-2002.
- 2,638,558. GIANT EAGLE AND DESIGN. INT. CLS. 1, 3, 5, 6, 9, 16, 29, 30 AND 32 ONLY. (U.S. CLS. 1, 2, 4, 5, 6, 10, 12, 13, 14, 18, 21, 22, 23, 25, 26, 29, 36, 37, 38, 44, 45, 46, 48, 50, 51 AND 52). REG. 10-22-2002.
- 2,639,844. AMERICA'S FAVORITE FEAST. INT. CL. 30. (U.S. CL. 46). REG. 10-22-2002.
- 2,639,965. SHINE-ON. INT. CL. 3. (U.S. CLS. 1, 4, 6, 50, 51 AND 52). REG. 10-22-2002.
- 2,640,205. HEAVENLY LIGHT. INT. CL. 29. (U.S. CL. 46). REG. 10-22-2002.
- 2,640,285. STRADDEX. INT. CL. 11. (U.S. CLS. 13, 21, 23, 31 AND 34). REG. 10-22-2002.
- 2,640,861. ACGT. INT. CL. 36. (U.S. CLS. 100, 101 AND 102). REG. 10-22-2002.
- 2,640,978. PROFERO SYSTEMS. INT. CL. 7. (U.S. CLS. 13, 19, 21, 23, 31, 34 AND 35). REG. 10-22-2002.
- 2,641,700. H HOSCO FINISHING SYSTEM COMPONENTS AND DESIGN. INT. CLS. 9 AND 17. (U.S. CLS. 1, 5, 12, 13, 21, 23, 26, 35, 36, 38 AND 50). REG. 10-29-2002.
- 2,642,314. HTE. INT. CL. 40. (U.S. CLS. 100, 103 AND 106). REG. 10-29-2002.

- 2,642,318. RETROSCRIPT. INT. CL. 1. (U.S. CLS. 1, 5, 6, 10, 26 AND 46). REG. 10-29-2002.
- 2,642,397. GAZELLES. INT. CL. 41. (U.S. CLS. 100, 101 AND 107). REG. 10-29-2002.
- 2,642,616. MISCELLANEOUS DESIGN. INT. CL. 41. (U.S. CLS. 100, 101 AND 107). REG. 10-29-2002.
- 2,642,617. LINCOLN UNIVERSITY OF THE COMMONWEALTH SYSTEM OF HIGHER EDUCATION 1972 FOUNDED 1854 LINCOLN UNIVERSITY, PENNSYLVANIA AND DESIGN. INT. CL. 41. (U.S. CLS. 100, 101 AND 107). REG. 10-29-2002.
- 2,643,267. COOLDRIIVE. INT. CL. 9. (U.S. CLS. 21, 23, 26, 36 AND 38). REG. 10-29-2002.
- 2,643,376. SECURI MAX. INT. CL. 8. (U.S. CLS. 23, 28 AND 44). REG. 10-29-2002.
- 2,643,657. HELLO.DELII. INT. CL. 42. (U.S. CLS. 100 AND 101). REG. 10-29-2002.
- 2,643,839. WORKMASTER (STYLIZED). INT. CL. 7. (U.S. CLS. 13, 19, 21, 23, 31, 34 AND 35). REG. 10-29-2002.
- 2,644,392. PROFERO. INT. CL. 7. (U.S. CLS. 13, 19, 21, 23, 31, 34 AND 35). REG. 10-29-2002.
- 2,644,629. REVOLUCION. INT. CL. 34. (U.S. CLS. 2, 8, 9 AND 17). REG. 10-29-2002.
- 2,646,344. THAI FOOD KING AND DESIGN. INT. CL. 30. (U.S. CL. 46). REG. 11-5-2002.
- 2,646,585. PURASEP. INT. CL. 7. (U.S. CLS. 13, 19, 21, 23, 31, 34 AND 35). REG. 11-5-2002.
- 2,646,876. PERISTATS. INT. CL. 42. (U.S. CLS. 100 AND 101). REG. 11-5-2002.
- 2,647,126. ENJOY. INT. CL. 3. (U.S. CLS. 1, 4, 6, 50, 51 AND 52). REG. 11-5-2002.
- 2,647,883. BOOKMOBILE. INT. CL. 42. (U.S. CLS. 100 AND 101). REG. 11-12-2002.
- 2,648,761. SFHAT. INT. CL. 25. (U.S. CLS. 22 AND 39). REG. 11-12-2002.
- 2,649,158. EXAMWRITER. INT. CL. 9. (U.S. CLS. 21, 23, 26, 36 AND 38). REG. 11-12-2002.
- 2,649,304. FREEDOM. INT. CL. 41. (U.S. CLS. 100, 101 AND 107). REG. 11-12-2002.
- 2,650,209. LONGHORN GLASS. INT. CL. 40. (U.S. CLS. 100, 103 AND 106). REG. 11-12-2002.
- 2,650,974. DYNASTREAM. INT. CL. 9. (U.S. CLS. 21, 23, 26, 36 AND 38). REG. 11-19-2002.
- 2,651,355. 360METRICS. INT. CLS. 9 AND 35. (U.S. CLS. 21, 23, 26, 36, 38, 100, 101 AND 102). REG. 11-19-2002.
- 2,651,691. PROFERO SYSTEMS AND DESIGN. INT. CL. 7. (U.S. CLS. 13, 19, 21, 23, 31, 34 AND 35). REG. 11-19-2002.
- 2,653,038. LAND SHARK AND DESIGN. INT. CL. 28. (U.S. CLS. 22, 23, 38 AND 50). REG. 11-26-2002.
- 2,653,095. PRIME. INT. CL. 42. (U.S. CLS. 100 AND 101). REG. 11-26-2002.
- 2,653,465. ITUNES. INT. CL. 9. (U.S. CLS. 21, 23, 26, 36 AND 38). REG. 11-26-2002.
- 2,653,488. XTREMEPLAY (STYLIZED). INT. CL. 28. (U.S. CLS. 22, 23, 38 AND 50). REG. 11-26-2002.
- 2,654,170. MORTAR HIT TYPE V. INT. CL. 13. (U.S. CLS. 2 AND 9). REG. 11-26-2002.
- 2,654,388. BLUE THUNDER. INT. CLS. 25 AND 41. (U.S. CLS. 22, 39, 100, 101 AND 107). REG. 11-26-2002.
- 2,654,435. HOT SWAP. INT. CL. 37. (U.S. CLS. 100, 103 AND 106). REG. 11-26-2002.
- 2,654,644. FLUMPA. INT. CL. 28. (U.S. CLS. 22, 23, 38 AND 50). REG. 11-26-2002.
- 2,655,126. VETERINARY SELECT. INT. CL. 31. (U.S. CLS. 1 AND 46). REG. 11-26-2002.
- 2,655,144. CHURCHWEAR (STYLIZED). INT. CL. 25. (U.S. CLS. 22 AND 39). REG. 11-26-2002.
- 2,656,389. SMART SYMPHONIES. INT. CL. 9. (U.S. CLS. 21, 23, 26, 36 AND 38). REG. 12-3-2002.
- 2,656,959. AAA GIFT CARD. INT. CL. 9. (U.S. CLS. 21, 23, 26, 36 AND 38). REG. 12-3-2002.
- 2,657,039. DESIGN-CONTACT. INT. CL. 42. (U.S. CLS. 100 AND 101). REG. 12-3-2002.
- 2,657,075. THE GRIM ADVENTURES OF BILLY & MANDY AND DESIGN. INT. CL. 41. (U.S. CLS. 100, 101 AND 107). REG. 12-3-2002.
- 2,657,632. RCL RAILROAD CONTROLS LIMITED AND DESIGN. INT. CL. 9. (U.S. CLS. 21, 23, 26, 36 AND 38). REG. 12-10-2002.
- 2,657,730. SHOTGUN REPORT. INT. CL. 41. (U.S. CLS. 100, 101 AND 107). REG. 12-10-2002.
- 2,658,819. TITER-TOPS. INT. CL. 17. (U.S. CLS. 1, 5, 12, 13, 35 AND 50). REG. 12-10-2002.
- 2,659,134. CODE BLUE. INT. CL. 9. (U.S. CLS. 21, 23, 26, 36 AND 38). REG. 12-10-2002.
- 2,659,485. INSECO. INT. CL. 2. (U.S. CLS. 6, 11 AND 16). REG. 12-10-2002.
- 2,659,703. AAA AND DESIGN. INT. CL. 36. (U.S. CLS. 100, 101 AND 102). REG. 12-10-2002.
- 2,660,046. HEXFLOW. INT. CL. 1. (U.S. CLS. 1, 5, 6, 10, 26 AND 46). REG. 12-10-2002.
- 2,660,219. KWIKTAG. INT. CLS. 35 AND 39. (U.S. CLS. 100, 101, 102 AND 105). REG. 12-10-2002.
- 2,660,378. COLOR RESOLUTIONS INTERNATIONAL. INT. CL. 2. (U.S. CLS. 6, 11 AND 16). REG. 12-10-2002.
- 2,660,477. AGRINTELLIGENCE (STYLIZED). INT. CL. 42. (U.S. CLS. 100 AND 101). REG. 12-10-2002.
- 2,660,888. DESYPHER ANALYTIC SERVICES. INT. CL. 42. (U.S. CLS. 100 AND 101). REG. 12-10-2002.
- 2,661,400. DCI DOOR CONTROLS INTERNATIONAL AND DESIGN. INT. CLS. 6 AND 9. (U.S. CLS. 2, 12, 13, 14, 21, 23, 25, 26, 36, 38 AND 50). REG. 12-17-2002.
- 2,662,689. ASSET REPORT. INT. CL. 16. (U.S. CLS. 2, 5, 22, 23, 29, 37, 38 AND 50). REG. 12-17-2002.
- 2,663,047. PEACH BOWL. INT. CL. 41. (U.S. CLS. 100, 101 AND 107). REG. 12-17-2002.
- 2,663,293. SUGARHILL GANG. INT. CL. 41. (U.S. CLS. 100, 101 AND 107). REG. 12-17-2002.
- 2,664,541. MAX-VISION. INT. CL. 12. (U.S. CLS. 19, 21, 23, 31, 35 AND 44). REG. 12-17-2002.
- 2,665,479. ABCSTUFF. INT. CL. 16. (U.S. CLS. 2, 5, 22, 23, 29, 37, 38 AND 50). REG. 12-24-2002.
- 2,666,020. COLLEGE PLANNING & MANAGEMENT. INT. CL. 16. (U.S. CLS. 2, 5, 22, 23, 29, 37, 38 AND 50). REG. 12-24-2002.
- 2,666,107. NEW AIRPLANE-SAFE TECHNOLOGY AND DESIGN. INT. CL. 16. (U.S. CLS. 2, 5, 22, 23, 29, 37, 38 AND 50). REG. 12-24-2002.
- 2,666,425. SPEEDCOMPOUNDER. INT. CL. 7. (U.S. CLS. 13, 19, 21, 23, 31, 34 AND 35). REG. 12-24-2002.
- 2,667,396. MISCELLANEOUS DESIGN. INT. CL. 30. (U.S. CL. 46). REG. 12-24-2002.
- 2,667,444. WWII HISTORY. INT. CL. 16. (U.S. CLS. 2, 5, 22, 23, 29, 37, 38 AND 50). REG. 12-24-2002.
- 2,668,125. PITZ. INT. CL. 1. (U.S. CLS. 1, 5, 6, 10, 26 AND 46). REG. 12-31-2002.
- 2,669,248. CINDER'S AND DESIGN. INT. CL. 43. (U.S. CLS. 100 AND 101). REG. 12-31-2002.
- 2,669,320. ELLISON. INT. CL. 41. (U.S. CLS. 100, 101 AND 107). REG. 12-31-2002.
- 2,669,369. ASPEN. INT. CL. 20. (U.S. CLS. 2, 13, 22, 25, 32 AND 50). REG. 12-31-2002.
- 2,669,371. ARAPAHOE. INT. CL. 20. (U.S. CLS. 2, 13, 22, 25, 32 AND 50). REG. 12-31-2002.
- 2,669,372. WINTER PARK. INT. CL. 20. (U.S. CLS. 2, 13, 22, 25, 32 AND 50). REG. 12-31-2002.
- 2,669,373. TELLURIDE. INT. CL. 20. (U.S. CLS. 2, 13, 22, 25, 32 AND 50). REG. 12-31-2002.
- 2,669,374. SNOWMASS. INT. CL. 20. (U.S. CLS. 2, 13, 22, 25, 32 AND 50). REG. 12-31-2002.
- 2,670,779. MARK V. INT. CLS. 1, 3 AND 4. (U.S. CLS. 1, 4, 5, 6, 10, 15, 26, 46, 50, 51 AND 52). REG. 1-7-2003.
- 2,670,989. GIGPAC (STYLIZED). INT. CL. 18. (U.S. CLS. 1, 2, 3, 22 AND 41). REG. 1-7-2003.
- 2,671,793. RUFFGRIP DOG LEASH AND DESIGN. INT. CL. 18. (U.S. CLS. 1, 2, 3, 22 AND 41). REG. 1-7-2003.
- 2,672,376. BRAGTAG. INT. CL. 12. (U.S. CLS. 19, 21, 23, 31, 35 AND 44). REG. 1-7-2003.
- 2,672,781. AMANTE. INT. CL. 30. (U.S. CL. 46). REG. 1-7-2003.
- 2,672,985. CENTRAL DRUG SYSTEM. INT. CL. 42. (U.S. CLS. 100 AND 101). REG. 1-7-2003.
- 2,673,333. ZAFARANI. INT. CL. 30. (U.S. CL. 46). REG. 1-7-2003.
- 2,673,782. KARNEY. INT. CL. 41. (U.S. CLS. 100, 101 AND 107). REG. 1-14-2003.
- 2,673,973. TECHNOLPOLIS. INT. CL. 42. (U.S. CLS. 100 AND 101). REG. 1-14-2003.
- 2,674,766. THE PATRIOT-NEWS. INT. CL. 16. (U.S. CLS. 2, 5, 22, 23, 29, 37, 38 AND 50). REG. 1-14-2003.
- 2,675,626. I. B. LIEV'N. INT. CL. 25. (U.S. CLS. 22 AND 39). REG. 1-14-2003.
- 2,676,932. YOU COULD BE NEXT! AND DESIGN. INT. CL. 41. (U.S. CLS. 100, 101 AND 107). REG. 1-21-2003.
- 2,677,037. SCHOOL PLANNING & MANAGEMENT. INT. CL. 16. (U.S. CLS. 2, 5, 22, 23, 29, 37, 38 AND 50). REG. 1-21-2003.

- 2,677,265. NEW HAMPSHIRE LOTTERY. INT. CL. 41. (U.S. CLS. 100, 101 AND 107). REG. 1-21-2003.
- 2,677,307. OMNIGRIP. INT. CL. 1. (U.S. CLS. 1, 5, 6, 10, 26 AND 46). REG. 1-21-2003.
- 2,677,825. TALKTECH. INT. CL. 40. (U.S. CLS. 100, 103 AND 106). REG. 1-21-2003.
- 2,680,074. TIVOL. INT. CL. 14. (U.S. CLS. 2, 27, 28 AND 50). REG. 1-28-2003.
- 2,680,260. REQUEST. INT. CLS. 29 AND 30. (U.S. CL. 46). REG. 1-28-2003.
- 2,680,368. KCAM. INT. CL. 9. (U.S. CLS. 21, 23, 26, 36 AND 38). REG. 1-28-2003.
- 2,680,428. PETE'S ARENA PIZZA THE ORIGINAL AND DESIGN. INT. CL. 42. (U.S. CLS. 100 AND 101). REG. 1-28-2003.
- 2,680,991. SIX. INT. CL. 33. (U.S. CLS. 47 AND 49). REG. 1-28-2003.
- 2,681,052. CAPITOL SOLUTIONS. INT. CL. 35. (U.S. CLS. 100, 101 AND 102). REG. 1-28-2003.
- 2,681,107. TECHNOPOPOLIS. INT. CL. 42. (U.S. CLS. 100 AND 101). REG. 1-28-2003.
- 2,681,451. CITIMAP. INT. CL. 16. (U.S. CLS. 2, 5, 22, 23, 29, 37, 38 AND 50). REG. 1-28-2003.
- 2,681,652. NANOTIP. INT. CL. 10. (U.S. CLS. 26, 39 AND 44). REG. 1-28-2003.
- 2,682,103. STARFISH. INT. CL. 29. (U.S. CL. 46). REG. 2-4-2003.
- 2,682,586. SOCCER WATER. INT. CL. 32. (U.S. CLS. 45, 46 AND 48). REG. 2-4-2003.
- 2,682,997. HOCKEYGIANT. INT. CL. 35. (U.S. CLS. 100, 101 AND 102). REG. 2-4-2003.
- 2,683,231. QG. INT. CL. 14. (U.S. CLS. 2, 27, 28 AND 50). REG. 2-4-2003.
- 2,683,589. LIZZARD FILMS. INT. CL. 41. (U.S. CLS. 100, 101 AND 107). REG. 2-4-2003.
- 2,683,860. PARTY TOWN USA. INT. CL. 35. (U.S. CLS. 100, 101 AND 102). REG. 2-4-2003.
- 2,684,741. PACIFIC AND DESIGN. INT. CL. 7. (U.S. CLS. 13, 19, 21, 23, 31, 34 AND 35). REG. 2-4-2003.
- 2,685,393. WHIRL OUT. INT. CL. 1. (U.S. CLS. 1, 5, 6, 10, 26 AND 46). REG. 2-11-2003.
- 2,685,998. THE NORFOLK & DEDHAM GROUP. INT. CL. 36. (U.S. CLS. 100, 101 AND 102). REG. 2-11-2003.
- 2,686,201. CREATIVE BUSINESS IDEA. INT. CL. 35. (U.S. CLS. 100, 101 AND 102). REG. 2-11-2003.
- 2,686,351. PROTOQUOTE. INT. CL. 40. (U.S. CLS. 100, 103 AND 106). REG. 2-11-2003.
- 2,686,589. EXPERIENCE THE VANGUARD DIFFERENCE. INT. CL. 36. (U.S. CLS. 100, 101 AND 102). REG. 2-11-2003.
- 2,687,402. ROLLER SOAKER. INT. CL. 41. (U.S. CLS. 100, 101 AND 107). REG. 2-11-2003.
- 2,687,475. PYROCLEAR. INT. CL. 9. (U.S. CLS. 21, 23, 26, 36 AND 38). REG. 2-11-2003.
- 2,687,959. MARTIN AND DESIGN. INT. CLS. 19 AND 37. (U.S. CLS. 1, 12, 33, 50, 100, 103 AND 106). REG. 2-18-2003.
- 2,688,324. N&D (STYLIZED). INT. CL. 36. (U.S. CLS. 100, 101 AND 102). REG. 2-18-2003.
- 2,688,573. NO-SAG. INT. CL. 6. (U.S. CLS. 2, 12, 13, 14, 23, 25 AND 50). REG. 2-18-2003.
- 2,688,641. MIGUELENA. INT. CL. 29. (U.S. CL. 46). REG. 2-18-2003.
- 2,688,807. X-FLEX. INT. CL. 12. (U.S. CLS. 19, 21, 23, 31, 35 AND 44). REG. 2-18-2003.
- 2,689,346. SPAGGREGATE. INT. CL. 36. (U.S. CLS. 100, 101 AND 102). REG. 2-18-2003.
- 2,689,933. PRECISION. INT. CL. 2. (U.S. CLS. 6, 11 AND 16). REG. 2-25-2003.
- 2,690,002. TEVRON. INT. CLS. 9 AND 42. (U.S. CLS. 21, 23, 26, 36, 38, 100 AND 101). REG. 2-25-2003.
- 2,690,564. SELF CAP. INT. CL. 36. (U.S. CLS. 100, 101 AND 102). REG. 2-25-2003.
- 2,690,646. SWAY-A-WAY. INT. CL. 12. (U.S. CLS. 19, 21, 23, 31, 35 AND 44). REG. 2-25-2003.
- 2,690,788. ISLANDS FINE BURGERS & DRINKS AND DESIGN. INT. CL. 43. (U.S. CLS. 100 AND 101). REG. 2-25-2003.
- 2,691,326. PRESENTABOWLS. INT. CL. 21. (U.S. CLS. 2, 13, 23, 29, 30, 33, 40 AND 50). REG. 2-25-2003.
- 2,691,485. PRESENTABOWLS AND DESIGN. INT. CL. 21. (U.S. CLS. 2, 13, 23, 29, 30, 33, 40 AND 50). REG. 2-25-2003.
- 2,691,636. INTEGRAL MOLECULAR. INT. CL. 42. (U.S. CLS. 100 AND 101). REG. 2-25-2003.
- 2,691,706. CERTIFIED RISK PROFESSIONAL. INT. CL. 41. (U.S. CLS. 100, 101 AND 107). REG. 2-25-2003.
- 2,691,756. KOLACHE CANDLE. INT. CL. 4. (U.S. CLS. 1, 6 AND 15). REG. 2-25-2003.
- 2,692,318. NO TROUBLE. INT. CL. 7. (U.S. CLS. 13, 19, 21, 23, 31, 34 AND 35). REG. 3-4-2003.
- 2,692,755. VERSIPLY. INT. CL. 19. (U.S. CLS. 1, 12, 33 AND 50). REG. 3-4-2003.
- 2,693,095. CDC AND DESIGN. INT. CL. 36. (U.S. CLS. 100, 101 AND 102). REG. 3-4-2003.
- 2,693,376. SANSA. INT. CL. 39. (U.S. CLS. 100 AND 105). REG. 3-4-2003.
- 2,693,406. MREXCEL. INT. CL. 42. (U.S. CLS. 100 AND 101). REG. 3-4-2003.
- 2,693,416. DOUBLESET. INT. CL. 27. (U.S. CLS. 19, 20, 37, 42 AND 50). REG. 3-4-2003.
- 2,693,441. PATTI'S 1880'S SETTLEMENT AND DESIGN. INT. CLS. 35 AND 43. (U.S. CLS. 100, 101 AND 102). REG. 3-4-2003.
- 2,693,460. MISCELLANEOUS DESIGN. INT. CL. 37. (U.S. CLS. 100, 103 AND 106). REG. 3-4-2003.
- 2,693,563. COUNTRY CARES. INT. CL. 36. (U.S. CLS. 100, 101 AND 102). REG. 3-4-2003.
- 2,693,702. HEARINGPLANET STANDARD CHARACTER MARK. INT. CL. 35 ONLY. (U.S. CLS. 100, 101 AND 102). REG. 3-4-2003.
- 2,693,935. IN TOYZ. INT. CL. 28. (U.S. CLS. 22, 23, 38 AND 50). REG. 3-4-2003.
- 2,694,063. GDS GLOBAL DENTAL SOLUTIONS, L.L.C. AND DESIGN. INT. CL. 10. (U.S. CLS. 26, 39 AND 44). REG. 3-4-2003.
- 2,695,811. THE POWER OF THE RIGHT WORD. INT. CL. 35. (U.S. CLS. 100, 101 AND 102). REG. 3-11-2003.
- 2,695,828. GOLDEN & ASSOCIATES CONSTRUCTION, LLC AND DESIGN. INT. CL. 37. (U.S. CLS. 100, 103 AND 106). REG. 3-11-2003.
- 2,695,985. EXSTREAM. INT. CL. 25. (U.S. CLS. 22 AND 39). REG. 3-11-2003.
- 2,696,086. SO THE WORLD MAY HEAR. INT. CL. 42. (U.S. CLS. 100 AND 101). REG. 3-11-2003.
- 2,696,291. INTERNAL BALANCE. INT. CLS. 35 AND 42. (U.S. CLS. 100, 101 AND 102). REG. 3-11-2003.
- 2,696,363. MISCELLANEOUS DESIGN. INT. CL. 42. (U.S. CLS. 100 AND 101). REG. 3-11-2003.
- 2,696,776. PREVENTA. INT. CL. 16. (U.S. CLS. 2, 5, 22, 23, 29, 37, 38 AND 50). REG. 3-11-2003.
- 2,696,802. WYSTON. INT. CL. 16. (U.S. CLS. 2, 5, 22, 23, 29, 37, 38 AND 50). REG. 3-11-2003.
- 2,697,903. PAGERUNNER. INT. CL. 38. (U.S. CLS. 100, 101 AND 104). REG. 3-18-2003.
- 2,698,147. TRADECARD AND DESIGN. INT. CL. 39. (U.S. CLS. 100 AND 105). REG. 3-18-2003.
- 2,698,173. SAV-A-BUNDLE AND DESIGN. INT. CL. 35. (U.S. CLS. 100, 101 AND 102). REG. 3-18-2003.
- 2,698,319. BEN BUSINESS ENTERPRISE NETWORK (STYLIZED). INT. CL. 42. (U.S. CLS. 100 AND 101). REG. 3-18-2003.
- 2,698,359. SKALLY'S OLD WORLD BAKERY AND DESIGN. INT. CL. 30. (U.S. CL. 46). REG. 3-18-2003.
- 2,698,486. STARR PUFFS BAKERY. INT. CL. 30. (U.S. CL. 46). REG. 3-18-2003.
- 2,698,818. AQUINAS. INT. CL. 33. (U.S. CLS. 47 AND 49). REG. 3-18-2003.
- 2,698,870. LITTLE JENNY JOHNS. INT. CL. 25. (U.S. CLS. 22 AND 39). REG. 3-18-2003.
- 2,698,953. FINE CLOSET FURNISHINGS. INT. CL. 20. (U.S. CLS. 2, 13, 22, 25, 32 AND 50). REG. 3-18-2003.
- 2,699,044. THE BROKER FORUM. INT. CL. 35. (U.S. CLS. 100, 101 AND 102). REG. 3-25-2003.
- 2,699,154. MUSIK INNOVATIONS. INT. CLS. 16, 35, 37 AND 41 ONLY. (U.S. CLS. 2, 5, 22, 23, 29, 37, 38, 50, 100, 101, 102, 103, 106 AND 107). REG. 3-25-2003.
- 2,699,292. BALEEN. INT. CL. 42. (U.S. CLS. 100 AND 101). REG. 3-25-2003.
- 2,699,419. NATIONAL CENTER FOR STATE COURTS. INT. CL. 42. (U.S. CLS. 100 AND 101). REG. 3-25-2003.
- 2,699,528. GENO-TRONICS. INT. CL. 9. (U.S. CLS. 21, 23, 26, 36 AND 38). REG. 3-25-2003.
- 2,699,633. PLANTTOOLS. INT. CLS. 9 AND 36. (U.S. CLS. 21, 23, 26, 36, 38, 100, 101 AND 102). REG. 3-25-2003.
- 2,699,753. ARIZONA FEDERAL. INT. CL. 36. (U.S. CLS. 100, 101 AND 102). REG. 3-25-2003.
- 2,699,828. REALFEEL. INT. CL. 9. (U.S. CLS. 21, 23, 26, 36 AND 38). REG. 3-25-2003.

- 2,699,967. WE KNOW WHAT PERMANENT MEANS!. INT. CLS. 1 AND 2. (U.S. CLS. 1, 5, 6, 10, 11, 16, 26 AND 46). REG. 3-25-2003.
- 2,700,106. FIRST & FINEST IN ACHIEVEMENT FRAMING. INT. CL. 20. (U.S. CLS. 2, 13, 22, 25, 32 AND 50). REG. 3-25-2003.
- 2,700,334. LEGACY COURT. INT. CL. 42. (U.S. CLS. 100 AND 101). REG. 3-25-2003.
- 2,700,610. W2. INT. CL. 25. (U.S. CLS. 22 AND 39). REG. 3-25-2003.
- 2,700,771. GROUCHO'S FAMOUS AND DESIGN. INT. CL. 30. (U.S. CL. 46). REG. 3-25-2003.
- 2,700,992. MAINSTAY. INT. CL. 38. (U.S. CLS. 100, 101 AND 104). REG. 3-25-2003.
- 2,701,749. U.S. VENTURE PARTNERS. INT. CL. 36. (U.S. CLS. 100, 101 AND 102). REG. 4-1-2003.
- 2,701,836. TRAVEL HEALTH RESOURCE AND DESIGN. INT. CL. 42. (U.S. CLS. 100 AND 101). REG. 4-1-2003.
- 2,701,911. H AND DESIGN. INT. CL. 5. (U.S. CLS. 6, 18, 44, 46, 51 AND 52). REG. 4-1-2003.
- 2,701,912. HIMALAYA HERBAL HEALTHCARE AND DESIGN. INT. CL. 5. (U.S. CLS. 6, 18, 44, 46, 51 AND 52). REG. 4-1-2003.
- 2,702,155. M.V.I. PEDIATRIC. INT. CL. 5. (U.S. CLS. 6, 18, 44, 46, 51 AND 52). REG. 4-1-2003.
- 2,702,196. NORA. INT. CL. 43. (U.S. CLS. 100 AND 101). REG. 4-1-2003.
- 2,702,329. HEALTH ALERT. INT. CL. 16. (U.S. CLS. 2, 5, 22, 23, 29, 37, 38 AND 50). REG. 4-1-2003.
- 2,702,376. MISCELLANEOUS DESIGN. INT. CL. 41. (U.S. CLS. 100, 101 AND 107). REG. 4-1-2003.
- 2,702,473. MONT BLANC. INT. CL. 30. (U.S. CL. 46). REG. 4-1-2003.
- 2,702,568. FIBER MAX. INT. CL. 5. (U.S. CLS. 6, 18, 44, 46, 51 AND 52). REG. 4-1-2003.
- 2,702,837. TRANSFER FACTOR PLUS. INT. CL. 5. (U.S. CLS. 6, 18, 44, 46, 51 AND 52). REG. 4-1-2003.
- 2,703,248. SMARTCAFE. INT. CL. 9. (U.S. CLS. 21, 23, 26, 36 AND 38). REG. 4-1-2003.
- 2,703,302. STURGIS RIDER. INT. CL. 16. (U.S. CLS. 2, 5, 22, 23, 29, 37, 38 AND 50). REG. 4-1-2003.
- 2,703,332. WIRED-FOR-BUSINESS. INT. CL. 42. (U.S. CLS. 100 AND 101). REG. 4-1-2003.
- 2,703,566. TAMARACK VILLAGE. INT. CL. 36. (U.S. CLS. 100, 101 AND 102). REG. 4-8-2003.
- 2,703,786. VINCEVOUYER. INT. CLS. 9 AND 41. (U.S. CLS. 21, 23, 26, 36, 38, 100, 101 AND 107). REG. 4-8-2003.
- 2,703,800. NOTTAGE HILL. INT. CL. 33. (U.S. CLS. 47 AND 49). REG. 4-8-2003.
- 2,703,942. SELECT MEDICAL REHABILITATION SERVICES. INT. CLS. 41 AND 42. (U.S. CLS. 100, 101 AND 107). REG. 4-8-2003.
- 2,704,041. CONCORD. INT. CL. 20. (U.S. CLS. 2, 13, 22, 25, 32 AND 50). REG. 4-8-2003.
- 2,704,070. DYG DIGIT. INT. CLS. 9 AND 16. (U.S. CLS. 2, 5, 21, 22, 23, 26, 29, 36, 37, 38 AND 50). REG. 4-8-2003.
- 2,704,331. HOUSE HOLDER. INT. CL. 37. (U.S. CLS. 100, 103 AND 106). REG. 4-8-2003.
- 2,704,371. UNION INSTITUTE & UNIVERSITY. INT. CL. 41. (U.S. CLS. 100, 101 AND 107). REG. 4-8-2003.
- 2,704,436. STREPAIM. INT. CL. 5. (U.S. CLS. 6, 18, 44, 46, 51 AND 52). REG. 4-8-2003.
- 2,704,600. TECHNOPOLIS. INT. CL. 35. (U.S. CLS. 100, 101 AND 102). REG. 4-8-2003.
- 2,704,688. ESCAPE!. INT. CL. 42. (U.S. CLS. 100 AND 101). REG. 4-8-2003.
- 2,704,728. CORPORATE RISK SOLUTIONS AND DESIGN. INT. CLS. 35, 42 AND 45. (U.S. CLS. 100, 101 AND 102). REG. 4-8-2003.
- 2,704,775. POSTURE STIMULUS. INT. CL. 20. (U.S. CLS. 2, 13, 22, 25, 32 AND 50). REG. 4-8-2003.
- 2,704,818. DYNAMIC FOAM. INT. CL. 20. (U.S. CLS. 2, 13, 22, 25, 32 AND 50). REG. 4-8-2003.
- 2,705,134. BARR + BARR AND DESIGN. INT. CL. 25. (U.S. CLS. 22 AND 39). REG. 4-8-2003.
- 2,705,339. MILL CITY MUSEUM. INT. CL. 41. (U.S. CLS. 100, 101 AND 107). REG. 4-8-2003.
- 2,707,608. MISCELLANEOUS DESIGN. INT. CL. 9. (U.S. CLS. 21, 23, 26, 36 AND 38). REG. 4-15-2003.
- 2,708,560. SPECTRA. INT. CL. 2. (U.S. CLS. 6, 11 AND 16). REG. 4-22-2003.
- 2,709,832. VAPOR PRO. INT. CL. 9. (U.S. CLS. 21, 23, 26, 36 AND 38). REG. 4-22-2003.
- 2,710,419. WEICON. INT. CLS. 1, 2 AND 8. (U.S. CLS. 1, 5, 6, 10, 11, 16, 23, 26, 28, 44 AND 46). REG. 4-29-2003.
- 2,710,515. MISA. INT. CL. 3. (U.S. CLS. 1, 4, 6, 50, 51 AND 52). REG. 4-29-2003.
- 2,710,762. DATIA. INT. CL. 42. (U.S. CLS. 100 AND 101). REG. 4-29-2003.
- 2,710,889. YEAR BOOK OF OBSTETRICS, GYNECOLOGY, AND WOMEN'S HEALTH. INT. CL. 16. (U.S. CLS. 2, 5, 22, 23, 29, 37, 38 AND 50). REG. 4-29-2003.
- 2,712,011. ACCELERATED WRITER. INT. CL. 9. (U.S. CLS. 21, 23, 26, 36 AND 38). REG. 4-29-2003.

* * * * *

TRADEMARK REGISTRATIONS CANCELED

The designation "U.S. Cl." appearing in this section refers to the U.S. class in effect prior to Sep. 1, 1973 rather than the international class which applies to applications filed on or after that date. For adoption of international classification see notice in the OFFICIAL GAZETTE of Jun. 26, 1973 (911 O.G. TM 210).

SECTION 7(D)

2,643,764. IMPRESS. INT. CL. 3 ONLY. REG. 10-29-2002.
3,004,049. TELEKOM BASKETS BONN AND DESIGN. INT. CL. 9. REG. 10-4-2005.
3,004,050. TELEKOM BASKETS BONN AND DESIGN. INT. CL. 16. REG. 10-4-2005.
3,004,053. TELEKOM BASKETS BONN AND DESIGN. INT. CL. 35. REG. 10-4-2005.
3,004,054. TELEKOM BASKETS BONN AND DESIGN. INT. CL. 18. REG. 10-4-2005.
3,004,057. TELEKOM BASKETS BONN AND DESIGN. INT. CL. 42. REG. 10-4-2005.
3,004,059. TELEKOM BASKETS BONN AND DESIGN. INT. CL. 41. REG. 10-4-2005.
3,004,060. TELEKOM BASKETS BONN AND DESIGN. INT. CL. 39. REG. 10-4-2005.
3,004,061. TELEKOM BASKETS BONN AND DESIGN. INT. CL. 38. REG. 10-4-2005.
3,004,062. TELEKOM BASKETS BONN AND DESIGN. INT. CL. 36. REG. 10-4-2005.
3,004,063. TELEKOM BASKETS BONN AND DESIGN. INT. CL. 32. REG. 10-4-2005.
3,011,790. PAN CREMA. INT. CL. 30. REG. 11-1-2005.
3,042,554. FIRST CRUSH. INT. CL. 33. REG. 1-10-2006.
3,074,950. ENVIRONMENTALLAWYERS.COM STANDARD CHARACTER MARK. INT. CL. 35. REG. 3-28-2006.
3,081,030. AVIATIONATTORNEYS.COM STANDARD CHARACTER MARK. INT. CL. 35. REG. 4-11-2006.
3,099,759. AIR SURFING AND DESIGN. INT. CL. 39. REG. 6-6-2006.
3,221,991. NATURE'S MESQUITE AND DESIGN. INT. CL. 4. REG. 3-27-2007.
3,304,588. CONCOURS EDITION PUTCO AND DESIGN. INT. CL. 12. REG. 10-2-2007.
3,304,589. CONCOURS EDITION PUTCO AND DESIGN. INT. CL. 12. REG. 10-2-2007.
3,429,809. NOTHING CUTS LIKE A DIAMOND STANDARD CHARACTER MARK. INT. CL. 7. REG. 5-20-2008.
3,529,088. WINCAN STANDARD CHARACTER MARK. INT. CLS. 9, 41 AND 42. REG. 11-4-2008.
3,556,159. IZO JUICE FEAST STANDARD CHARACTER MARK. INT. CL. 32. REG. 1-6-2009.
3,579,061. MONSTER MINI GOLF AND DESIGN. INT. CL. 41. REG. 2-24-2009.
3,685,119. THE PIT AUTHENTIC BARBECUE WHOLE HOG PIT-COOKED ED MITCHELL-PITMASTER AND DESIGN. INT. CL. 43. REG. 9-22-2009.
3,697,600. PRESS 101 STANDARD CHARACTER MARK. INT. CL. 43. REG. 10-20-2009.
3,730,238. AIR QUALITY FLAG PROGRAM STANDARD CHARACTER MARK. INT. CL. 35. REG. 12-22-2009.
3,861,658. FAST & FURIOUS ENERGY STANDARD CHARACTER MARK. INT. CL. 5. REG. 10-12-2010.
3,925,901. NATURE'S GRILLING AND DESIGN. INT. CL. 4. REG. 3-1-2011.
3,926,608. BRYAN KEITH STANDARD CHARACTER MARK. INT. CL. 24. REG. 3-1-2011.

3,935,296. MISCELLANEOUS DESIGN. INT. CL. 24. REG. 3-22-2011.
3,972,100. STREAMING MEDIA CLOUD INC STANDARD CHARACTER MARK. INT. CL. 42. REG. 5-31-2011.
3,974,937. DORM DOCTOR STANDARD CHARACTER MARK. INT. CL. 5. REG. 6-7-2011.
4,029,879. CORNBOARD STANDARD CHARACTER MARK. INT. CL. 19. REG. 9-20-2011.
4,032,937. COLA CAPS (STYLIZED). INT. CL. 20. REG. 9-27-2011.
4,066,801. MR. DADDY BLOG STANDARD CHARACTER MARK. INT. CL. 41. REG. 12-6-2011.

SECTION 8

693,072. ORETIC. U.S. CL. 18. REG. 2-16-1960.
1,139,201. TRISA. INT. CLS. 11 AND 21. REG. 9-2-1980.
1,170,448. MISCELLANEOUS DESIGN. INT. CLS. 29, 30 AND 32. REG. 9-22-1981.
1,233,355. FEDERAL REPORTER. INT. CL. 9 ONLY. REG. 4-5-1983.
1,458,255. PERSONALITY DYNAMICS INVENTORY. INT. CL. 16. REG. 9-22-1987.
1,552,980. THREE-PEAT. INT. CL. 25. REG. 8-22-1989.
1,584,798. ZERO GRAVITY. INT. CL. 25. REG. 2-27-1990.
1,599,551. LA SPORTS AND DESIGN. INT. CLS. 16, 18, 20 AND 25. REG. 6-5-1990.
1,606,645. PRECISE. INT. CLS. 35, 41 AND 42. REG. 7-17-1990.
1,606,650. PRECISE AND DESIGN. INT. CLS. 35, 41 AND 42. REG. 7-17-1990.
1,658,093. CLIFFORD & WILLS. INT. CLS. 9, 18 AND 25. REG. 9-24-1991.
1,659,694. DREAM HOME. INT. CL. 16 ONLY. REG. 10-8-1991.
1,684,103. PIROUETTE. INT. CL. 16 ONLY. REG. 4-21-1992.
1,685,067. VEHMA. INT. CL. 12 ONLY. REG. 5-5-1992.
1,691,226. ELOQUENCE. INT. CL. 16 ONLY. REG. 6-9-1992.
1,693,841. LIPHATECH. INT. CL. 1 ONLY. REG. 6-16-1992.
1,751,436. MISCELLANEOUS DESIGN. INT. CL. 29 ONLY. REG. 2-9-1993.
1,764,085. EAST-WEST CENTER. INT. CL. 9 ONLY. REG. 4-13-1993.
2,268,645. DURA LIFE (STYLIZED). INT. CL. 40. REG. 8-10-1999.
2,389,685. EZSCHOOL. INT. CL. 9. REG. 9-26-2000.
2,390,011. BEVEL. INT. CL. 9. REG. 9-26-2000.
2,421,145. RRD'S CHINATOWN CAFE AND DESIGN. INT. CL. 42. REG. 1-16-2001.
2,449,886. STRETTA AND DESIGN. INT. CL. 42. REG. 5-8-2001.
2,466,379. STRETTA AND DESIGN. INT. CL. 10. REG. 7-3-2001.
2,491,651. SILVER SWAN. INT. CL. 11. REG. 9-25-2001.
2,491,658. ARCSTAR. INT. CL. 37. REG. 9-25-2001.
2,491,659. THE LONGVIEW FUND. INT. CL. 36. REG. 9-25-2001.

- 2,491,662. RAKEHAND (STYLIZED). INT. CL. 7. REG. 9-25-2001.
- 2,491,666. POLIFACE. INT. CLS. 19 AND 27. REG. 9-25-2001.
- 2,491,678. PASSKEY. INT. CL. 36. REG. 9-25-2001.
- 2,491,685. BIOZYME. INT. CLS. 1 AND 5. REG. 9-25-2001.
- 2,491,694. G.S.T.. INT. CL. 14. REG. 9-25-2001.
- 2,491,700. MECKLENBURG ELECTRIC COOPERATIVE AND DESIGN. INT. CL. 28. REG. 9-25-2001.
- 2,491,714. KAR IGAN. INT. CL. 42. REG. 9-25-2001.
- 2,491,717. XIRING AND DESIGN. INT. CLS. 9, 16, 28, 36, 38 AND 42. REG. 9-25-2001.
- 2,491,722. "THE FACE OF PRO-LIFE". INT. CL. 41. REG. 9-25-2001.
- 2,491,728. 2AP. INT. CLS. 1 AND 17. REG. 9-25-2001.
- 2,491,730. INFORMATION TECHNOLOGY SERVICES MARKETING ASSOCIATION. INT. CL. 35. REG. 9-25-2001.
- 2,491,737. STARQUEST LEARNING SYSTEMS, INC. AND DESIGN. INT. CL. 41. REG. 9-25-2001.
- 2,491,765. STONE ART THE ABSORBENT COASTER (STYLIZED). INT. CL. 20. REG. 9-25-2001.
- 2,491,771. AUDIO VIDEO EXCELLENCE. INT. CL. 37. REG. 9-25-2001.
- 2,491,777. MAINSTREAM. INT. CLS. 7 AND 9. REG. 9-25-2001.
- 2,491,792. C WITHIN. INT. CL. 9. REG. 9-25-2001.
- 2,491,801. PARADIGM. INT. CL. 41. REG. 9-25-2001.
- 2,491,802. WESTIFORM. INT. CLS. 6, 9, 11, 19, 20, 35, 37 AND 40. REG. 9-25-2001.
- 2,491,803. W AND DESIGN. INT. CLS. 6, 9, 11, 19, 20, 35, 37 AND 40. REG. 9-25-2001.
- 2,491,808. SAVVYSEARCH. INT. CL. 42. REG. 9-25-2001.
- 2,491,810. E.CAUMARTIN. INT. CL. 11. REG. 9-25-2001.
- 2,491,811. ARTIST'S PALETTE. INT. CL. 20 ONLY. REG. 9-25-2001.
- 2,491,815. TINNEA L'ACQUA. INT. CL. 32. REG. 9-25-2001.
- 2,491,816. HEARTWISE. INT. CL. 5. REG. 9-25-2001.
- 2,491,817. CENELUZ AND DESIGN. INT. CL. 19. REG. 9-25-2001.
- 2,491,825. ATTITUDES. INT. CL. 27. REG. 9-25-2001.
- 2,491,826. MISCELLANEOUS DESIGN. INT. CLS. 9 AND 16. REG. 9-25-2001.
- 2,491,829. SURE SCORE AND DESIGN. INT. CL. 8. REG. 9-25-2001.
- 2,491,832. SYNCING UP. INT. CL. 41. REG. 9-25-2001.
- 2,491,833. TRADSTAT. INT. CLS. 9, 35, 36, 38 AND 42. REG. 9-25-2001.
- 2,491,848. DMC (STYLIZED). INT. CLS. 12 AND 35. REG. 9-25-2001.
- 2,491,868. AT. INT. CL. 26. REG. 9-25-2001.
- 2,491,869. CVM. INT. CL. 35. REG. 9-25-2001.
- 2,491,874. SHOBU GEKKEIKAN SAKE PREMIUM QUALITY PREMIUM SELECT AND DESIGN. INT. CL. 33. REG. 9-25-2001.
- 2,491,887. WALTER'S WAY AND DESIGN. INT. CL. 35. REG. 9-25-2001.
- 2,491,889. THRASHER. INT. CL. 6. REG. 9-25-2001.
- 2,491,895. WATERLILY. INT. CL. 11. REG. 9-25-2001.
- 2,491,896. FIBRSKOPE. INT. CL. 9. REG. 9-25-2001.
- 2,491,903. RENATA. INT. CL. 20. REG. 9-25-2001.
- 2,491,916. COMPLIANCE DIRECT. INT. CL. 35. REG. 9-25-2001.
- 2,491,922. SITHE. INT. CL. 40. REG. 9-25-2001.
- 2,491,931. GENERATION - D. INT. CLS. 9, 16, 25, 28 AND 35. REG. 9-25-2001.
- 2,491,958. E-LOGIA. INT. CL. 9. REG. 9-25-2001.
- 2,491,966. CRESCENDO ESTATE. INT. CL. 9. REG. 9-25-2001.
- 2,492,022. EINSTRUCTION AND DESIGN. INT. CL. 41. REG. 9-25-2001.
- 2,492,041. THUNDERON. INT. CL. 24. REG. 9-25-2001.
- 2,492,073. ONELINE GUIDE. INT. CL. 9. REG. 9-25-2001.
- 2,492,090. MUSICIANSFRIEND.COM AND DESIGN. INT. CL. 35. REG. 9-25-2001.
- 2,492,097. PRECISION CABINETS. INT. CL. 20. REG. 9-25-2001.
- 2,492,111. DESTINY I N T E R A C T I V E AND DESIGN. INT. CL. 9. REG. 9-25-2001.
- 2,492,130. RELATIONSHIPS THAT WORK, PLACEMENTS THAT LAST. INT. CL. 35. REG. 9-25-2001.
- 2,492,138. TRULY BE HEARD. INT. CL. 42. REG. 9-25-2001.
- 2,492,139. EDS SOLVED. AND DESIGN. INT. CL. 38. REG. 9-25-2001.
- 2,492,157. PROTECT WHAT YOU PRODUCE. INT. CL. 42. REG. 9-25-2001.
- 2,492,160. INTERNATIONAL FOOTSTEPS. INT. CL. 42. REG. 9-25-2001.
- 2,492,161. SUDDENLY WE'RE SENIORS. INT. CL. 41. REG. 9-25-2001.
- 2,492,168. ORIGINAL PREMIUM QUALITY STO PRO VERITATE HOUSE OF MCGEE MADE IN ENGLAND AND DESIGN. INT. CL. 25. REG. 9-25-2001.
- 2,492,176. MISCELLANEOUS DESIGN. INT. CL. 35. REG. 9-25-2001.
- 2,492,178. THE HARTFORD. INT. CL. 16. REG. 9-25-2001.
- 2,492,182. THESPAK.COM. INT. CLS. 38 AND 41. REG. 9-25-2001.
- 2,492,185. UNDERGROUND SOCIETY. INT. CL. 41. REG. 9-25-2001.
- 2,492,188. ROASTER'S COVE AND DESIGN. INT. CLS. 30 AND 35. REG. 9-25-2001.
- 2,492,189. JIMA AND DESIGN. INT. CL. 7. REG. 9-25-2001.
- 2,492,192. INTELLI LITE. INT. CL. 11. REG. 9-25-2001.
- 2,492,193. SUPPLIER MAC (STYLIZED). INT. CL. 36. REG. 9-25-2001.
- 2,492,200. SDS. INT. CL. 42. REG. 9-25-2001.
- 2,492,209. SUPER DRYTEX. INT. CL. 24. REG. 9-25-2001.
- 2,492,219. ENCORE. INT. CL. 7. REG. 9-25-2001.
- 2,492,220. "I WANT YOUR BOD!". INT. CL. 3. REG. 9-25-2001.
- 2,492,232. SUSHI SOLUTION. INT. CLS. 29 AND 30. REG. 9-25-2001.
- 2,492,239. STIRLING GOURMET FLAVORS. INT. CL. 32. REG. 9-25-2001.
- 2,492,248. THE RIGHT MUSIC. INT. CL. 41. REG. 9-25-2001.
- 2,492,255. SILHOUETTES FROM DESIGN ALLIANCE. INT. CL. 27. REG. 9-25-2001.
- 2,492,267. GIFTS IN KIND AND DESIGN. INT. CL. 42. REG. 9-25-2001.
- 2,492,278. FLOBOTS. INT. CL. 9. REG. 9-25-2001.
- 2,492,287. AC AND DESIGN. INT. CL. 37. REG. 9-25-2001.
- 2,492,303. CLOS CERI. INT. CL. 33. REG. 9-25-2001.
- 2,492,306. DECONNA ICE CREAM TRIPLE CROWN VANILLA ICE CREAM WITH CHOCOLATE FLAVORED COATING AND DESIGN. INT. CL. 30. REG. 9-25-2001.
- 2,492,309. MM MM SYSTEMS AND DESIGN. INT. CLS. 6, 17, 19 AND 42. REG. 9-25-2001.
- 2,492,312. LUXURY OPTICS. INT. CL. 9. REG. 9-25-2001.
- 2,492,320. SPEED LEASING. INT. CL. 42. REG. 9-25-2001.
- 2,492,325. BLACK COFFEE. INT. CL. 9. REG. 9-25-2001.
- 2,492,327. TRIXTER-TAG. INT. CL. 9. REG. 9-25-2001.
- 2,492,329. SIGNWEB. INT. CL. 9. REG. 9-25-2001.
- 2,492,330. VISUALSTORE. INT. CL. 9. REG. 9-25-2001.
- 2,492,331. SCREENWEB. INT. CL. 9. REG. 9-25-2001.
- 2,492,333. ALPHA 8. INT. CL. 2. REG. 9-25-2001.
- 2,492,334. PUMPKIN PATCH. INT. CL. 16. REG. 9-25-2001.
- 2,492,346. GHETTOSTAR. INT. CL. 9. REG. 9-25-2001.
- 2,492,352. COOKIES WITH ATTITUDE. INT. CL. 30. REG. 9-25-2001.
- 2,492,354. NEFF RANCH. INT. CLS. 31 AND 32. REG. 9-25-2001.
- 2,492,377. NILES TOWNSHIP SWIMMING & DIVING AND DESIGN. INT. CL. 41. REG. 9-25-2001.
- 2,492,386. MYSTIC RIVER JELLYFISH. INT. CL. 41. REG. 9-25-2001.
- 2,492,388. KENT SEATECH CORPORATION. INT. CL. 29. REG. 9-25-2001.
- 2,492,395. JELFINE 52. INT. CL. 5. REG. 9-25-2001.
- 2,492,401. PAPAYA PLEASURE. INT. CL. 29. REG. 9-25-2001.
- 2,492,402. TAILORED COURIER SERVICES "CUSTOM FIT DELIVERIES" I II III IV V VI VII VIII IX X XI XII AND DESIGN. INT. CL. 39. REG. 9-25-2001.
- 2,492,411. EXPRESS LEARNING. INT. CL. 42. REG. 9-25-2001.

- 2,492,412. HADLEY DATE GARDENS. INT. CL. 29. REG. 9-25-2001.
- 2,492,427. YUKON. INT. CL. 17. REG. 9-25-2001.
- 2,492,430. PLASTIRALE. INT. CL. 16. REG. 9-25-2001.
- 2,492,431. CHIN-CHUM. INT. CL. 15. REG. 9-25-2001.
- 2,492,432. GET CONNECTED. INT. CL. 42. REG. 9-25-2001.
- 2,492,436. DESIGNATED DIVER. INT. CL. 25. REG. 9-25-2001.
- 2,492,440. VALLIANO. INT. CL. 14. REG. 9-25-2001.
- 2,492,442. AWF. INT. CL. 9. REG. 9-25-2001.
- 2,492,445. TULIP TEMPLE. INT. CL. 42. REG. 9-25-2001.
- 2,492,446. GIGABARRIER. INT. CL. 24. REG. 9-25-2001.
- 2,492,454. LEVINSON MEDICAL CENTER FOR LEARNING DISABILITIES. INT. CL. 42. REG. 9-25-2001.
- 2,492,458. VERTICAL NATION. INT. CLS. 9, 41 AND 42. REG. 9-25-2001.
- 2,492,461. JACK ROGERS (STYLIZED). INT. CL. 25. REG. 9-25-2001.
- 2,492,463. IPSO AND DESIGN. INT. CLS. 6 AND 40. REG. 9-25-2001.
- 2,492,480. DRM SYSTEM AND DESIGN. INT. CL. 37. REG. 9-25-2001.
- 2,492,503. DIGIMOLE. INT. CL. 11. REG. 9-25-2001.
- 2,492,507. B.I.P.. INT. CL. 10. REG. 9-25-2001.
- 2,492,511. PHAT FARM (STYLIZED). INT. CL. 18. REG. 9-25-2001.
- 2,492,516. THE GENETIC HORIZONS GROUP. INT. CL. 35. REG. 9-25-2001.
- 2,492,519. MISCELLANEOUS DESIGN. INT. CL. 16. REG. 9-25-2001.
- 2,492,532. PROSKAUER ROSE. INT. CL. 16. REG. 9-25-2001.
- 2,492,534. GREATPRINT. INT. CL. 16. REG. 9-25-2001.
- 2,492,537. MANGO PUNCH. INT. CL. 41. REG. 9-25-2001.
- 2,492,545. NUTRISYSTEM.COM AND DESIGN. INT. CL. 42. REG. 9-25-2001.
- 2,492,546. NUTRISYSTEM.COM. INT. CL. 42. REG. 9-25-2001.
- 2,492,548. EVANS COMMUNICATIONS AND DESIGN. INT. CL. 38. REG. 9-25-2001.
- 2,492,560. OPTIMIZER PLUS. INT. CL. 9. REG. 9-25-2001.
- 2,492,561. INTERNATIONAL WOOD PRODUCTS. INT. CL. 19. REG. 9-25-2001.
- 2,492,576. STRIKER WORLDWIDE. INT. CL. 28. REG. 9-25-2001.
- 2,492,603. LAMBERTSON TRUEX. INT. CL. 25. REG. 9-25-2001.
- 2,492,605. BUYSENSE AND DESIGN. INT. CL. 35. REG. 9-25-2001.
- 2,492,608. QUADRA-PAD. INT. CL. 7. REG. 9-25-2001.
- 2,492,609. GROWTHERAPY (STYLIZED). INT. CL. 42. REG. 9-25-2001.
- 2,492,619. CARER. INT. CLS. 7 AND 12. REG. 9-25-2001.
- 2,492,627. WE'RE NEVER OUT OF OUR DEPTH.. INT. CL. 37. REG. 9-25-2001.
- 2,492,628. 123 (STYLIZED). INT. CLS. 35 AND 36. REG. 9-25-2001.
- 2,492,631. COP IN THE BOX. INT. CL. 9. REG. 9-25-2001.
- 2,492,638. PERIOCONCEPTS. INT. CL. 42. REG. 9-25-2001.
- 2,492,646. SPEEDY EGGBERT. INT. CL. 9. REG. 9-25-2001.
- 2,492,647. PTSC. INT. CL. 9. REG. 9-25-2001.
- 2,492,648. FIRST LINE COMMUNICATIONS. INT. CL. 37. REG. 9-25-2001.
- 2,492,671. LAUDA AIR. INT. CL. 39. REG. 9-25-2001.
- 2,492,672. GBC THE GROSSMAN BURN CENTER. INT. CL. 42. REG. 9-25-2001.
- 2,492,675. ON THE JOB WITH YOU. INT. CL. 42. REG. 9-25-2001.
- 2,492,695. CRESTWOOD. INT. CL. 11. REG. 9-25-2001.
- 2,492,711. AVENTURAS EN ODISEA. INT. CL. 9. REG. 9-25-2001.
- 2,492,722. R ROSY BULL MUSIC AND DESIGN. INT. CL. 9. REG. 9-25-2001.
- 2,492,730. BABYBRAZIL.COM. INT. CLS. 25 AND 42. REG. 9-25-2001.
- 2,492,731. THE SHIFT CENTER. INT. CL. 42. REG. 9-25-2001.
- 2,492,744. HOME PARADE.COM AND DESIGN. INT. CL. 36. REG. 9-25-2001.
- 2,492,763. AT (STYLIZED). INT. CL. 42. REG. 9-25-2001.
- 2,492,767. DROME. INT. CL. 9. REG. 9-25-2001.
- 2,492,774. ABREVA AND DESIGN. INT. CL. 5. REG. 9-25-2001.
- 2,492,775. PYRO. INT. CL. 9. REG. 9-25-2001.
- 2,492,780. DTX-EZ. INT. CL. 9. REG. 9-25-2001.
- 2,492,781. WHERE THE CROWDS CAN'T GO. INT. CL. 39. REG. 9-25-2001.
- 2,492,807. DEEP WORSHIP. INT. CL. 16. REG. 9-25-2001.
- 2,492,817. THE HOME DEPOT. INT. CL. 36. REG. 9-25-2001.
- 2,492,821. DRAGON. INT. CL. 9. REG. 9-25-2001.
- 2,492,822. SYNTHES-EYEZ. INT. CL. 9. REG. 9-25-2001.
- 2,492,830. OUR FAVORITE PILLOW. INT. CL. 20. REG. 9-25-2001.
- 2,492,840. DEPADE (STYLIZED). INT. CL. 5. REG. 9-25-2001.
- 2,492,846. VISIO. INT. CL. 28. REG. 9-25-2001.
- 2,492,852. MISCELLANEOUS DESIGN. INT. CLS. 1, 40 AND 42. REG. 9-25-2001.
- 2,492,891. POCKETPARTNER. INT. CL. 9. REG. 9-25-2001.
- 2,492,904. 10TH MAN. INT. CL. 21. REG. 9-25-2001.
- 2,492,905. 6TH WOMAN. INT. CL. 21. REG. 9-25-2001.
- 2,492,911. ESSENCE RAFFINANTE. INT. CL. 3. REG. 9-25-2001.
- 2,492,913. BROADWAY LOAN BY PHONE. INT. CL. 36. REG. 9-25-2001.
- 2,492,920. CAM-PAC. INT. CL. 17. REG. 9-25-2001.
- 2,492,921. FLOWER FAIRIES. INT. CL. 28. REG. 9-25-2001.
- 2,492,928. HEAVENLY NIGHTS. INT. CL. 5. REG. 9-25-2001.
- 2,492,934. WILLIFT. INT. CL. 7. REG. 9-25-2001.
- 2,492,938. BOUNDARY GARD. INT. CL. 9. REG. 9-25-2001.
- 2,492,939. LOAN ENERGIZER. INT. CL. 9. REG. 9-25-2001.
- 2,492,942. PRIMO. INT. CL. 9. REG. 9-25-2001.
- 2,492,951. MANGER. INT. CL. 9. REG. 9-25-2001.
- 2,492,952. CERIX. INT. CL. 14. REG. 9-25-2001.
- 2,492,956. CELLULIFT. INT. CL. 10. REG. 9-25-2001.
- 2,492,963. LIVE BIG. INT. CL. 25. REG. 9-25-2001.
- 2,492,970. CLOBEVATE. INT. CL. 5. REG. 9-25-2001.
- 2,492,972. HUMMINGBIRD. INT. CL. 10. REG. 9-25-2001.
- 2,492,973. QUICK SHIELD. INT. CL. 17. REG. 9-25-2001.
- 2,492,979. PUB LIST AND DESIGN. INT. CL. 35. REG. 9-25-2001.
- 2,492,985. MASTERSEAL. INT. CL. 10. REG. 9-25-2001.
- 2,492,988. FROZEN TEARS. INT. CLS. 14 AND 20. REG. 9-25-2001.
- 2,493,004. CONQUEROR. INT. CL. 28. REG. 9-25-2001.
- 2,493,031. MISCELLANEOUS DESIGN. INT. CL. 36. REG. 9-25-2001.
- 2,493,034. 1 STEP (STYLIZED). INT. CL. 7. REG. 9-25-2001.
- 2,493,037. CALTEX AND DESIGN. INT. CLS. 1 AND 4. REG. 9-25-2001.
- 2,493,052. EURME. INT. CL. 14. REG. 9-25-2001.
- 2,493,072. REDDIE. INT. CL. 10. REG. 9-25-2001.
- 2,493,079. SUN WHEEL. INT. CL. 41. REG. 9-25-2001.
- 2,493,083. THE LEADER'S JOURNEY. INT. CLS. 9, 16 AND 41. REG. 9-25-2001.
- 2,493,098. THE WAY OF THE NOODLE IS LONG AND NARROW. INT. CL. 42. REG. 9-25-2001.
- 2,493,099. HEALTH AND WISDOM IN A BOWL. INT. CL. 42. REG. 9-25-2001.
- 2,493,103. REPON AND DESIGN. INT. CL. 6. REG. 9-25-2001.
- 2,493,108. THE KHAKI COLLECTION CALVIN KLEIN. INT. CL. 21. REG. 9-25-2001.
- 2,493,115. BCS. INT. CL. 9. REG. 9-25-2001.
- 2,493,121. ZIPM. INT. CL. 35. REG. 9-25-2001.
- 2,493,122. FREEZE-IT. INT. CL. 1. REG. 9-25-2001.
- 2,493,123. OREGANO-POWER. INT. CL. 5. REG. 9-25-2001.
- 2,493,148. R-TYPE DELTA. INT. CL. 9. REG. 9-25-2001.
- 2,493,151. GRIPWALK. INT. CL. 6. REG. 9-25-2001.
- 2,493,153. RECAPS. INT. CL. 5. REG. 9-25-2001.
- 2,493,155. BLUE MAXX. INT. CL. 24. REG. 9-25-2001.
- 2,493,160. PSYCLONE. INT. CL. 9. REG. 9-25-2001.
- 2,493,161. BEST ONE TIRE & SERVICE AND DESIGN. INT. CL. 35. REG. 9-25-2001.
- 2,493,162. BUNTKINS. INT. CL. 4. REG. 9-25-2001.
- 2,493,166. OTW. INT. CL. 14. REG. 9-25-2001.
- 2,493,170. CREDIT UNION VILLAGE. INT. CLS. 35, 36, 37, 38, 41 AND 42. REG. 9-25-2001.

- 2,493,178. M.D. SKIN CARE. INT. CL. 3. REG. 9-25-2001.
 2,493,180. MISCELLANEOUS DESIGN. INT. CL. 30. REG. 9-25-2001.
 2,493,181. FIND WHAT YOU'RE LOOKING FOR. INT. CL. 42. REG. 9-25-2001.
 2,493,200. SOFWIRE. INT. CL. 25. REG. 9-25-2001.
 2,493,203. ALBATROSS (STYLIZED). INT. CL. 9. REG. 9-25-2001.
 2,493,232. HATCH. INT. CL. 9. REG. 9-25-2001.
 2,493,236. FIRST DATA AND DESIGN. INT. CL. 16. REG. 9-25-2001.
 2,493,237. ID FIRST DATA AND DESIGN. INT. CLS. 36 AND 40. REG. 9-25-2001.
 2,493,239. FIRST FRUITS. INT. CL. 29. REG. 9-25-2001.
 2,493,245. BEHAVEN.COM. INT. CL. 42. REG. 9-25-2001.
 2,493,258. CREDIT CARD GAMES. INT. CL. 28. REG. 9-25-2001.
 2,493,264. SUNYSES AND DESIGN. INT. CL. 3. REG. 9-25-2001.
 2,493,266. SISTEMA DE FONETICA SCOTT FORESMAN AND DESIGN. INT. CL. 16. REG. 9-25-2001.
 2,493,273. CASH RADIO. INT. CL. 38. REG. 9-25-2001.
 2,493,274. NEWENERGY. INT. CLS. 35 AND 42. REG. 9-25-2001.
 2,493,278. IPHRASE. INT. CL. 9. REG. 9-25-2001.
 2,493,286. PGA AND DESIGN. INT. CL. 9. REG. 9-25-2001.
 2,493,300. FABRIFLEX. INT. CL. 17. REG. 9-25-2001.
 2,493,301. CALENCE. INT. CL. 35. REG. 9-25-2001.
 2,493,314. MERGERWEEK. INT. CL. 42. REG. 9-25-2001.
 2,493,315. MERGERMONTH. INT. CL. 42. REG. 9-25-2001.
 2,493,318. DRIVING BUSINESS BETTER. INT. CL. 36. REG. 9-25-2001.
 2,493,334. BABY FACES. INT. CL. 9. REG. 9-25-2001.
 2,493,343. ENTERPRISE ADVANTAGE PROGRAM. INT. CL. 35. REG. 9-25-2001.
 2,493,355. HOMEEXCITEMENT.COM. INT. CL. 35. REG. 9-25-2001.
 2,493,356. EQUIPFIX.COM. INT. CL. 37. REG. 9-25-2001.
 2,493,359. BEAUTY IS JUST A STONE'S THROW AWAY. INT. CL. 37. REG. 9-25-2001.
 2,493,366. BUSINESS BASIC JUST GOT BETTER. INT. CL. 9. REG. 9-25-2001.
 2,493,371. DEHNGAP (STYLIZED). INT. CL. 9. REG. 9-25-2001.
 2,493,375. TOY COMMANDER. INT. CL. 9. REG. 9-25-2001.
 2,493,377. JUST FOR TOES. INT. CL. 25. REG. 9-25-2001.
 2,493,379. GLYQUIN. INT. CL. 3. REG. 9-25-2001.
 2,493,380. A SPECTRUM OF CHOICES A LIFETIME OF PROTECTION. INT. CL. 36. REG. 9-25-2001.
 2,493,406. PANCRASE HYBRID WRESTLING AND DESIGN. INT. CL. 25. REG. 9-25-2001.
 2,493,409. IDASL. INT. CL. 36. REG. 9-25-2001.
 2,493,416. GREEN GEM. INT. CL. 5. REG. 9-25-2001.
 2,493,420. SGT. INT. CL. 9. REG. 9-25-2001.
 2,493,426. RUBRIX. INT. CL. 42. REG. 9-25-2001.
 2,493,427. CLINEXUS. INT. CL. 42. REG. 9-25-2001.
 2,493,435. KIT KITTREDGE. INT. CL. 25. REG. 9-25-2001.
 2,493,438. MATADI. INT. CL. 30. REG. 9-25-2001.
 2,493,444. FEED-N-GRO. INT. CLS. 1 AND 5. REG. 9-25-2001.
 2,493,446. LA EXPRESS. INT. CL. 42. REG. 9-25-2001.
 2,493,447. IMGAMES. INT. CL. 41. REG. 9-25-2001.
 2,493,450. GEOCAL. INT. CL. 9. REG. 9-25-2001.
 2,493,451. WILD HANGERS. INT. CL. 28. REG. 9-25-2001.
 2,493,452. AUTOVAL. INT. CL. 9. REG. 9-25-2001.
 2,493,454. DIETSMART. INT. CL. 42. REG. 9-25-2001.
 2,493,465. AGORARE.COM. INT. CL. 36. REG. 9-25-2001.
 2,493,483. TYLER MOUNTAIN (STYLIZED). INT. CL. 25. REG. 9-25-2001.
 2,493,487. PHILADELPHIA. INT. CL. 30. REG. 9-25-2001.
 2,493,489. MIND COMMERCE. INT. CLS. 35 AND 41. REG. 9-25-2001.
 2,493,490. BUY AMERICAN REAL ESTATE CORPORATION AND DESIGN. INT. CL. 36. REG. 9-25-2001.
 2,493,500. HYBQUEST. INT. CLS. 1 AND 5. REG. 9-25-2001.
 2,493,510. PEEPGUARD. INT. CL. 9. REG. 9-25-2001.
 2,493,520. JERKY PLUS. INT. CL. 31. REG. 9-25-2001.
 2,493,536. FUN GUY AND DESIGN. INT. CL. 28. REG. 9-25-2001.
 2,493,539. PRINTPROBE. INT. CL. 42. REG. 9-25-2001.
 2,493,542. RUSH. INT. CL. 14. REG. 9-25-2001.
 2,493,558. ALASE. INT. CL. 42. REG. 9-25-2001.
 2,493,568. THE BUBBLEGUM BUNCH. INT. CL. 30. REG. 9-25-2001.
 2,493,584. RIP IT BURN IT SLAP IT RAPPIT. INT. CL. 16. REG. 9-25-2001.
 2,493,595. GLADIATOR. INT. CL. 8. REG. 9-25-2001.
 2,493,603. ALKA-SELTZER MORNING RELIEF. INT. CL. 5. REG. 9-25-2001.
 2,493,610. TESTMAKER. INT. CL. 9. REG. 9-25-2001.
 2,493,620. THE LOAN SUPERSTORE. INT. CL. 36. REG. 9-25-2001.
 2,493,628. TEXAS HORSE RACING HALL OF FAME. INT. CL. 41. REG. 9-25-2001.
 2,493,637. EXPO-CONVENTION. INT. CL. 42. REG. 9-25-2001.
 2,493,638. DIVERSIFIED FLEET SERVICES INTERNATIONAL. INT. CLS. 35 AND 42. REG. 9-25-2001.
 2,493,659. MS ACTIVESOURCE. INT. CL. 16. REG. 9-25-2001.
 2,493,665. CONTRACTORHUB.COM. INT. CL. 36. REG. 9-25-2001.
 2,493,671. ST. LOUIS HOMES & LIFESTYLES. INT. CL. 16. REG. 9-25-2001.
 2,493,675. BERARDI & ASSOCIATES. INT. CL. 35. REG. 9-25-2001.
 2,493,688. SENIORADVOCATE. INT. CL. 36. REG. 9-25-2001.
 2,495,787. EWEEK. INT. CL. 16 ONLY. REG. 10-9-2001.
 2,496,602. AIRWAVE. INT. CL. 19 ONLY. REG. 10-9-2001.
 2,497,783. FOOD PROCESSING AND DESIGN. INT. CL. 3 ONLY. REG. 10-16-2001.
 2,497,785. PROMISELAND. INT. CLS. 9, 16 AND 41 ONLY. REG. 10-16-2001.
 2,499,396. COMPGEEKS.COM. INT. CL. 42 ONLY. REG. 10-23-2001.
 2,501,016. PICTURE PERFECT MAIDS. INT. CL. 37. REG. 10-23-2001.
 2,557,715. UMASCH AND DESIGN. INT. CLS. 35 AND 38 ONLY. REG. 4-9-2002.
 2,557,739. BABY BOP. INT. CLS. 9, 18 AND 21 ONLY. REG. 4-9-2002.
 2,558,639. PLAN4DEMAND. INT. CL. 42 ONLY. REG. 4-9-2002.
 2,559,409. RODALE. INT. CL. 25 ONLY. REG. 4-9-2002.
 2,560,761. CYCLACEL. INT. CL. 5 ONLY. REG. 4-16-2002.
 2,561,102. SAFEZONE. INT. CL. 7 ONLY. REG. 4-16-2002.
 2,561,225. BERLITZ AND DESIGN. INT. CL. 42 ONLY. REG. 4-16-2002.
 2,561,895. KERBER'S (STYLIZED). INT. CLS. 30 AND 32 ONLY. REG. 4-16-2002.
 2,562,215. MISCELLANEOUS DESIGN. INT. CL. 25 ONLY. REG. 4-16-2002.
 2,562,216. RODALE AND DESIGN. INT. CL. 25 ONLY. REG. 4-16-2002.
 2,565,128. COMMLINK. INT. CL. 42 ONLY. REG. 4-30-2002.
 2,568,708. BROADBAND DAILY. INT. CL. 16 ONLY. REG. 5-7-2002.
 2,569,082. ISOICHEM AND DESIGN. INT. CL. 5 ONLY. REG. 5-14-2002.
 2,577,048. FORTE HARDWOOD FLOORING. INT. CL. 2 ONLY. REG. 6-11-2002.
 2,585,753. A-POC. INT. CLS. 18 AND 24 ONLY. REG. 6-25-2002.
 2,586,379. E ESPRIX (STYLIZED). INT. CL. 40 ONLY. REG. 6-25-2002.
 2,593,565. ZOJIRUSHI AND DESIGN. INT. CL. 7 ONLY. REG. 7-16-2002.
 2,609,380. TAX OPERATE. INT. CL. 35. REG. 8-20-2002.
 2,630,539. GIANT EAGLE. INT. CLS. 8, 10, 11 AND 29 ONLY. REG. 10-8-2002.
 2,638,558. GIANT EAGLE AND DESIGN. INT. CLS. 8, 10, 11 AND 21 ONLY. REG. 10-22-2002.
 2,724,224. TLC MOVING AND DESIGN. INT. CL. 39. REG. 6-10-2003.
 2,899,849. QUADRA-HULL. INT. CL. 11. REG. 11-2-2004.
 2,912,058. STANCIEL. INT. CLS. 3 AND 5. REG. 12-21-2004.

- 2,912,869. ALICE CORPORATION (STYLIZED). INT. CL. 42. REG. 12-21-2004.
- 2,922,334. PATIO PARK STANDARD CHARACTER MARK. INT. CL. 21. REG. 2-1-2005.
- 2,938,247. SOLIDARITY SOFTWARE STANDARD CHARACTER MARK. INT. CL. 9. REG. 4-5-2005.
- 2,939,409. MARIO'S GELATI STANDARD CHARACTER MARK. INT. CL. 30. REG. 4-12-2005.
- 2,939,410. MARIO'S GELATI AND DESIGN. INT. CL. 30. REG. 4-12-2005.
- 2,939,788. EZLEASH AND DESIGN. INT. CL. 18. REG. 4-12-2005.
- 2,941,446. KING-O-MEAT STANDARD CHARACTER MARK. INT. CL. 29. REG. 4-19-2005.
- 2,947,325. MESSENGER. INT. CL. 3. REG. 5-10-2005.
- 2,951,152. EN GAUGE STANDARD CHARACTER MARK. INT. CL. 25. REG. 5-17-2005.
- 2,951,392. ARLA MILK BITES. INT. CL. 29. REG. 5-17-2005.
- 2,953,906. TZONE SKIN CARE (STYLIZED). INT. CL. 3. REG. 5-17-2005.
- 2,956,561. TETESEPT. INT. CLS. 3 AND 5. REG. 5-31-2005.
- 2,959,212. MAGICAL PARTNERS STANDARD CHARACTER MARK. INT. CL. 41. REG. 6-7-2005.
- 2,996,237. EOCAM. INT. CLS. 9 AND 10. REG. 9-20-2005.
- 2,996,241. MISCELLANEOUS DESIGN. INT. CL. 3. REG. 9-20-2005.
- 2,996,249. WHOOP ASS ENERGY COLA. INT. CL. 32. REG. 9-20-2005.
- 2,996,256. CENTER PARCS AND DESIGN. INT. CLS. 39, 41 AND 42. REG. 9-20-2005.
- 2,996,258. PAGE THREE. INT. CLS. 9, 16, 35, 41 AND 42. REG. 9-20-2005.
- 2,996,269. CLASSIC SPRITZ. INT. CL. 32. REG. 9-20-2005.
- 2,998,504. MINDVISION. INT. CL. 9. REG. 9-20-2005.
- 2,998,505. WM MUTUAL FUNDS. INT. CL. 36. REG. 9-20-2005.
- 2,998,506. NEVER BE OUT OF BALANCE. INT. CL. 30. REG. 9-20-2005.
- 2,998,507. FOOD CLUB FULL CIRCLE. INT. CLS. 29, 30 AND 32. REG. 9-20-2005.
- 2,998,512. PROGENESIS. INT. CL. 42. REG. 9-20-2005.
- 2,998,514. DECORA DIGITAL. INT. CL. 9. REG. 9-20-2005.
- 2,998,515. PRIMACRYL. INT. CL. 1. REG. 9-20-2005.
- 2,998,516. CAV. GIUSEPPE COCCO ARTIGIANO PASTAIO ABRUZZI-ITALY AND DESIGN. INT. CLS. 29 AND 30. REG. 9-20-2005.
- 2,998,520. LOVE MY WORLD. INT. CL. 42. REG. 9-20-2005.
- 2,998,525. APS HEALTHCARE INC.. INT. CLS. 35 AND 42. REG. 9-20-2005.
- 2,998,526. HELPING PEOPLE LEAD HEALTHIER LIVES. INT. CLS. 35 AND 42. REG. 9-20-2005.
- 2,998,528. GROW TO KNOW. INT. CLS. 9, 16 AND 41. REG. 9-20-2005.
- 2,998,530. STAR POINT. INT. CL. 7. REG. 9-20-2005.
- 2,998,533. NATURE'S BEST SCHOOL OF PHOTOGRAPHY. INT. CL. 41. REG. 9-20-2005.
- 2,998,534. NATURE'S BEST FOUNDATION. INT. CLS. 16 AND 35. REG. 9-20-2005.
- 2,998,536. ABBOTT'S LABOR LINK. INT. CL. 35. REG. 9-20-2005.
- 2,998,537. THE HOME PLANET. INT. CL. 41. REG. 9-20-2005.
- 2,998,538. HOMERUN FIBER. INT. CL. 38. REG. 9-20-2005.
- 2,998,540. ARJIBUS. INT. CL. 42. REG. 9-20-2005.
- 2,998,541. GODSPEED TRAVELERS. INT. CL. 42. REG. 9-20-2005.
- 2,998,542. FIDELITY. INT. CL. 9. REG. 9-20-2005.
- 2,998,543. CORCAP. INT. CL. 10. REG. 9-20-2005.
- 2,998,544. LUSH. INT. CL. 4. REG. 9-20-2005.
- 2,998,548. CARIBE. INT. CL. 16. REG. 9-20-2005.
- 2,998,549. OMNI. INT. CL. 33. REG. 9-20-2005.
- 2,998,550. PARTNERSMITH. INT. CL. 9. REG. 9-20-2005.
- 2,998,551. IGO HOME PRODUCTS AND DESIGN. INT. CL. 7. REG. 9-20-2005.
- 2,998,555. RELAY. INT. CL. 31. REG. 9-20-2005.
- 2,998,556. BEAST OF GILFER. INT. CL. 28. REG. 9-20-2005.
- 2,998,557. INTERACTIX. INT. CL. 9. REG. 9-20-2005.
- 2,998,558. SUPER-7. INT. CL. 4. REG. 9-20-2005.
- 2,998,561. DYNASPORT. INT. CL. 12. REG. 9-20-2005.
- 2,998,562. BIOMETRICS HEALTH. INT. CL. 42. REG. 9-20-2005.
- 2,998,563. LASER COAT. INT. CL. 5. REG. 9-20-2005.
- 2,998,565. P NETKEY AND DESIGN. INT. CL. 9. REG. 9-20-2005.
- 2,998,567. SCORPION. INT. CL. 9. REG. 9-20-2005.
- 2,998,568. DIPO (STYLIZED). INT. CL. 9. REG. 9-20-2005.
- 2,998,570. COLOURS-WRAPPED-IN-COMFORT. INT. CL. 9. REG. 9-20-2005.
- 2,998,573. MEGA-RAINMAKER. INT. CL. 35. REG. 9-20-2005.
- 2,998,574. CHANGING THE WAY THE WORLD PRINTS. INT. CLS. 41 AND 42. REG. 9-20-2005.
- 2,998,576. WHAT'S NEW SCOOPY-DOO. INT. CL. 16. REG. 9-20-2005.
- 2,998,578. AWAKENING BUYER/SELLER "CHEMISTRY". INT. CL. 41. REG. 9-20-2005.
- 2,998,579. NAUTILUS OFFSHORE COMPANY, INC. AND DESIGN. INT. CLS. 37 AND 42. REG. 9-20-2005.
- 2,998,582. MISCELLANEOUS DESIGN. INT. CLS. 35, 41 AND 43. REG. 9-20-2005.
- 2,998,583. POLLENWATCH. INT. CL. 44. REG. 9-20-2005.
- 2,998,584. HRX (STYLIZED). INT. CL. 35. REG. 9-20-2005.
- 2,998,587. HOISTMASTER. INT. CL. 7. REG. 9-20-2005.
- 2,998,590. EXCEPTIONAL INVESTMENTS, EXTRAORDINARY WORLD. INT. CL. 36. REG. 9-20-2005.
- 2,998,592. SOLUTION 21. INT. CLS. 7, 9 AND 42. REG. 9-20-2005.
- 2,998,593. SCOTTSDALE CONVENTION BUREAU. INT. CL. 35. REG. 9-20-2005.
- 2,998,594. SCOTTSDALE CONVENTION BUREAU. INT. CL. 35. REG. 9-20-2005.
- 2,998,595. MORTGEDGE. INT. CL. 36. REG. 9-20-2005.
- 2,998,596. LDP LEAN DOCUMENT PRODUCTION AND DESIGN. INT. CL. 35. REG. 9-20-2005.
- 2,998,598. PIZZARETTES STANDARD CHARACTER MARK. INT. CL. 30. REG. 9-20-2005.
- 2,998,601. DOME. INT. CLS. 9, 35, 38, 41, 42 AND 44. REG. 9-20-2005.
- 2,998,604. POWER BUYS. INT. CL. 35. REG. 9-20-2005.
- 2,998,607. REVOLVER-Z. INT. CL. 11. REG. 9-20-2005.
- 2,998,609. SYMFLOW. INT. CL. 7. REG. 9-20-2005.
- 2,998,610. HOME SAFE STREET SAFE. INT. CL. 9. REG. 9-20-2005.
- 2,998,616. DAP/DNA. INT. CL. 9. REG. 9-20-2005.
- 2,998,619. RAM LASER. INT. CL. 28. REG. 9-20-2005.
- 2,998,622. COLLECTIONS OF STEIN MART. INT. CL. 35. REG. 9-20-2005.
- 2,998,633. FOR AMERICA'S GREAT HUNTERS STANDARD CHARACTER MARK. INT. CLS. 13 AND 25. REG. 9-20-2005.
- 2,998,635. AA AMERICA'S ARMY AND DESIGN. INT. CL. 14. REG. 9-20-2005.
- 2,998,639. REGENAT. INT. CLS. 37 AND 40. REG. 9-20-2005.
- 2,998,642. AM AMCO PRODUCTS COMPANY AND DESIGN. INT. CL. 37. REG. 9-20-2005.
- 2,998,644. DUET. INT. CL. 8. REG. 9-20-2005.
- 2,998,645. THE FIELD GENERALS. INT. CL. 36. REG. 9-20-2005.
- 2,998,646. CAMBAR. INT. CL. 21. REG. 9-20-2005.
- 2,998,648. PURITAN. INT. CL. 14. REG. 9-20-2005.
- 2,998,651. SLIM CREAM AND DESIGN. INT. CL. 3. REG. 9-20-2005.
- 2,998,652. KEEP US ON YOUR RADAR SCREEN. INT. CL. 36. REG. 9-20-2005.
- 2,998,653. PLANLABX3. INT. CL. 9. REG. 9-20-2005.
- 2,998,654. FAMILY STRENGTHENING POLICY CENTER. INT. CLS. 16, 41 AND 42. REG. 9-20-2005.
- 2,998,656. THERMAGUARD. INT. CL. 9. REG. 9-20-2005.
- 2,998,657. CURVEBALL LIVER TREATS. INT. CL. 31. REG. 9-20-2005.
- 2,998,667. NEAT FLEET. INT. CL. 37. REG. 9-20-2005.
- 2,998,668. DRAFT. INT. CL. 35. REG. 9-20-2005.
- 2,998,669. DRAFT (STYLIZED). INT. CL. 35. REG. 9-20-2005.
- 2,998,673. TRASHPAK AND DESIGN. INT. CL. 16. REG. 9-20-2005.
- 2,998,678. PARK LANE. INT. CLS. 6 AND 19. REG. 9-20-2005.

- 2,998,690. VERDICON. INT. CLS. 1, 5 AND 31. REG. 9-20-2005.
- 2,998,698. STG AND DESIGN. INT. CL. 9. REG. 9-20-2005.
- 2,998,700. PETIT LIN (STYLIZED). INT. CL. 25. REG. 9-20-2005.
- 2,998,708. PRIMA BELLA. INT. CL. 25. REG. 9-20-2005.
- 2,998,710. ROBERT JONES SIMPLE BEAUTE (STYLIZED). INT. CL. 16. REG. 9-20-2005.
- 2,998,711. ROBERT JONES SIMPLE BEAUTE (STYLIZED). INT. CL. 44. REG. 9-20-2005.
- 2,998,713. MISCELLANEOUS DESIGN. INT. CL. 21. REG. 9-20-2005.
- 2,998,718. DUROVAY. INT. CL. 23. REG. 9-20-2005.
- 2,998,727. SUPER SCRABBLE. INT. CL. 28. REG. 9-20-2005.
- 2,998,728. NUCUSHION. INT. CL. 7. REG. 9-20-2005.
- 2,998,731. CHORUS. INT. CL. 33. REG. 9-20-2005.
- 2,998,732. PAGENT. INT. CL. 20. REG. 9-20-2005.
- 2,998,733. VILLAGE CROSS. INT. CL. 20. REG. 9-20-2005.
- 2,998,734. MALIBU BREEZE. INT. CL. 5. REG. 9-20-2005.
- 2,998,735. MEGALAQ. INT. CL. 2. REG. 9-20-2005.
- 2,998,744. UNGER. INT. CL. 25. REG. 9-20-2005.
- 2,998,748. ACOUSTIC EAR. INT. CL. 10. REG. 9-20-2005.
- 2,998,750. M AND DESIGN. INT. CL. 35. REG. 9-20-2005.
- 2,998,757. DURAYARN (STYLIZED). INT. CL. 22. REG. 9-20-2005.
- 2,998,760. ONLY NATURE CAN COPY US STANDARD CHARACTER MARK. INT. CL. 19. REG. 9-20-2005.
- 2,998,765. DR. BASH STANDARD CHARACTER MARK. INT. CL. 32. REG. 9-20-2005.
- 2,998,829. AXCESS AND DESIGN. INT. CL. 9. REG. 9-20-2005.
- 2,998,830. MEDICARE ADVANTAGE PPO. INT. CLS. 35 AND 36. REG. 9-20-2005.
- 2,998,831. HI!BILITY. INT. CL. 9. REG. 9-20-2005.
- 2,998,832. MOGU. INT. CLS. 10 AND 20. REG. 9-20-2005.
- 2,998,834. KAY UNGER STANDARD CHARACTER MARK. INT. CLS. 20 AND 24. REG. 9-20-2005.
- 2,998,835. M AND DESIGN. INT. CL. 5. REG. 9-20-2005.
- 2,998,836. MISCELLANEOUS DESIGN. INT. CL. 9. REG. 9-20-2005.
- 2,998,842. ITSDIVORCE. INT. CLS. 9, 35 AND 42. REG. 9-20-2005.
- 2,998,843. COT-N-ANI. INT. CL. 31. REG. 9-20-2005.
- 2,998,844. BIOPROTECH. INT. CL. 40. REG. 9-20-2005.
- 2,998,846. JSI. INT. CL. 9. REG. 9-20-2005.
- 2,998,848. FORD GT. INT. CL. 12. REG. 9-20-2005.
- 2,998,850. THE INTELLIGENT CONVERGENCE OF STORAGE AND NETWORKING. INT. CL. 9. REG. 9-20-2005.
- 2,998,853. TRECO THE REAL ESTATE CONSULTING OFFICE AND DESIGN. INT. CLS. 36 AND 37. REG. 9-20-2005.
- 2,998,854. FLOTREL (STYLIZED). INT. CL. 5. REG. 9-20-2005.
- 2,998,857. LIGHT TAPE AND DESIGN. INT. CLS. 9 AND 11. REG. 9-20-2005.
- 2,998,859. TENORIO. INT. CL. 33. REG. 9-20-2005.
- 2,998,860. THE PIEH LEGACY COLLECTION. INT. CL. 8. REG. 9-20-2005.
- 2,998,863. R ROMAN'S AND DESIGN. INT. CLS. 25 AND 35. REG. 9-20-2005.
- 2,998,864. DIRECTTOP. INT. CLS. 19 AND 40. REG. 9-20-2005.
- 2,998,866. STONEHEDGE FINANCIAL. INT. CL. 36. REG. 9-20-2005.
- 2,998,868. ZENASIS. INT. CL. 9. REG. 9-20-2005.
- 2,998,879. ALL GOLD. INT. CL. 30. REG. 9-20-2005.
- 2,998,881. MANDATE. INT. CL. 34. REG. 9-20-2005.
- 2,998,882. BOOTS MEDITERRANEAN. INT. CL. 3. REG. 9-20-2005.
- 2,998,885. WAREHOUSE PARTNER AND DESIGN. INT. CL. 9. REG. 9-20-2005.
- 2,998,894. AUCTIONDROP. INT. CLS. 35, 36 AND 39. REG. 9-20-2005.
- 2,998,895. SPENDING SOLUTIONS. INT. CLS. 36 AND 41. REG. 9-20-2005.
- 2,998,896. ! AND DESIGN. INT. CL. 35. REG. 9-20-2005.
- 2,998,897. BION OPTIMUS. INT. CL. 10. REG. 9-20-2005.
- 2,998,901. EZ-SET. INT. CL. 11. REG. 9-20-2005.
- 2,998,904. LIFESYSTEMS. INT. CL. 16. REG. 9-20-2005.
- 2,998,905. VK MOBILE (STYLIZED). INT. CL. 9. REG. 9-20-2005.
- 2,998,907. CLEAN MACHINE. INT. CL. 3. REG. 9-20-2005.
- 2,998,911. SIGNATURE SUMMARY STANDARD CHARACTER MARK. INT. CL. 35. REG. 9-20-2005.
- 2,998,913. ALASKA EAGLE CLAWS. INT. CL. 21. REG. 9-20-2005.
- 2,998,915. CRITTER CORNER. INT. CL. 28. REG. 9-20-2005.
- 2,998,916. BOOORN IN THE SAUCE. INT. CL. 30. REG. 9-20-2005.
- 2,998,918. QUALITÀ E TRADIZIONE BIRRAMORETTI DAL 1859 AND DESIGN. INT. CL. 32. REG. 9-20-2005.
- 2,998,919. EVERPOWER! STANDARD CHARACTER MARK. INT. CL. 16. REG. 9-20-2005.
- 2,998,921. GRCLIVE STANDARD CHARACTER MARK. INT. CL. 38. REG. 9-20-2005.
- 2,998,927. WEALTH GENE. INT. CLS. 16 AND 35. REG. 9-20-2005.
- 2,998,931. CRABTREE & EVELYN HOME. INT. CLS. 20, 21, 24 AND 35. REG. 9-20-2005.
- 2,998,932. RED24 AND DESIGN. INT. CL. 35. REG. 9-20-2005.
- 2,998,933. BALLPOINT ELEGANCE. INT. CL. 41. REG. 9-20-2005.
- 2,998,935. EUROPEAN CLASS. INT. CL. 20. REG. 9-20-2005.
- 2,998,939. EVERDREAMER! STANDARD CHARACTER MARK. INT. CL. 16. REG. 9-20-2005.
- 2,998,941. BODY QUOTIENT (BODY Q). INT. CLS. 8, 21 AND 24. REG. 9-20-2005.
- 2,998,944. TANGO. INT. CL. 20. REG. 9-20-2005.
- 2,998,945. THE SPIRIT OF COMMUNICATION. INT. CL. 38. REG. 9-20-2005.
- 2,998,947. RIVERBLAST. INT. CL. 41. REG. 9-20-2005.
- 2,998,951. LIFA. U.S. CL. B. REG. 9-20-2005.
- 2,998,959. NATURAL CONCEPTS PHOTOGRAPHY. INT. CL. 41. REG. 9-20-2005.
- 2,998,964. FLASHPAC. INT. CL. 11. REG. 9-20-2005.
- 2,998,965. WET-LINC. INT. CL. 7. REG. 9-20-2005.
- 2,998,966. SCENTMATRIX. INT. CL. 1. REG. 9-20-2005.
- 2,998,969. BOSOUNG. INT. CL. 35. REG. 9-20-2005.
- 2,998,971. BASSNBABE. INT. CL. 25. REG. 9-20-2005.
- 2,998,973. POWERPRO. INT. CL. 7. REG. 9-20-2005.
- 2,998,974. THE FEVER. INT. CL. 41. REG. 9-20-2005.
- 2,998,976. LUCY'S CHOCOLATE FACTORY "I LOVE LUCY" AND DESIGN. INT. CL. 14. REG. 9-20-2005.
- 2,998,977. LUCY'S CHOCOLATE FACTORY I LOVE LUCY AND DESIGN. INT. CL. 9. REG. 9-20-2005.
- 2,998,980. ACU-I-DROP. INT. CL. 10. REG. 9-20-2005.
- 2,998,992. VH1 AND DESIGN. INT. CL. 16. REG. 9-20-2005.
- 2,998,996. SECRETS OF INDIA. INT. CL. 3. REG. 9-20-2005.
- 2,999,001. THE HAND SHELL. INT. CL. 8. REG. 9-20-2005.
- 2,999,003. CORELLI AND DESIGN. INT. CL. 25. REG. 9-20-2005.
- 2,999,005. HAYMARKET SQUARE. INT. CLS. 8 AND 21. REG. 9-20-2005.
- 2,999,018. WE DO THE DIFFICULT WELL. INT. CL. 36. REG. 9-20-2005.
- 2,999,019. TRIAMINIC CLINIC. INT. CL. 5. REG. 9-20-2005.
- 2,999,020. CIRCLE ATHLETICS AND DESIGN. INT. CLS. 25 AND 28. REG. 9-20-2005.
- 2,999,022. FULLY INVESTED IN OUR CLIENTS. INT. CL. 36. REG. 9-20-2005.
- 2,999,033. PROFILE. INT. CL. 11. REG. 9-20-2005.
- 2,999,037. MORSAS. INT. CL. 30. REG. 9-20-2005.
- 2,999,039. KITCHEN SUDS AND DESIGN. INT. CL. 21. REG. 9-20-2005.
- 2,999,047. CASA BELLA DESIGN CENTER. INT. CL. 37. REG. 9-20-2005.
- 2,999,048. "THE WAY NATURE INTENDED". INT. CLS. 29 AND 30. REG. 9-20-2005.
- 2,999,050. 40 PLUS. INT. CL. 21. REG. 9-20-2005.
- 2,999,054. ST. GOTTARDI. INT. CL. 33. REG. 9-20-2005.

- 2,999,064. FUNCTIONAL. BY DESIGN. STANDARD CHARACTER MARK. INT. CL. 20. REG. 9-20-2005.
- 2,999,071. FULL TERM STANDARD CHARACTER MARK. INT. CL. 5. REG. 9-20-2005.
- 2,999,093. ENHANCE INTERACTIVE STANDARD CHARACTER MARK. INT. CLS. 35 AND 42. REG. 9-20-2005.
- 2,999,095. CLICK & SLIDE STANDARD CHARACTER MARK. INT. CL. 16. REG. 9-20-2005.
- 2,999,105. MONITORING LIFE STANDARD CHARACTER MARK. INT. CLS. 10 AND 44. REG. 9-20-2005.
- 2,999,273. COVAL. INT. CL. 5. REG. 9-20-2005.
- 2,999,274. BOOTS BOTANICS AND DESIGN. INT. CL. 3. REG. 9-20-2005.
- 2,999,275. THE DREAM GIVER. INT. CL. 9. REG. 9-20-2005.
- 2,999,282. MISCELLANEOUS DESIGN. INT. CLS. 38, 42 AND 45. REG. 9-20-2005.
- 2,999,283. MISCELLANEOUS DESIGN. INT. CLS. 38, 42 AND 45. REG. 9-20-2005.
- 2,999,284. SNAP TV. INT. CLS. 9 AND 42. REG. 9-20-2005.
- 2,999,285. SWE STANDARD CHARACTER MARK. INT. CL. 25. REG. 9-20-2005.
- 2,999,333. RESPECT THE HELMET. INT. CL. 25. REG. 9-20-2005.
- 3,000,382. TOGETHER WE CAN STANDARD CHARACTER MARK. INT. CL. 25. REG. 9-27-2005.
- 3,003,538. FORGECONTROL. INT. CL. 9 ONLY. REG. 10-4-2005.
- 3,006,832. MISCELLANEOUS DESIGN. INT. CLS. 16 AND 35 ONLY. REG. 10-18-2005.
- 3,006,862. TRUMPF AND DESIGN. INT. CLS. 35 AND 40 ONLY. REG. 10-18-2005.
- 3,006,989. SASS (STYLIZED). INT. CL. 25. REG. 10-18-2005.
- 3,007,247. STYLE UP. INT. CL. 38 ONLY. REG. 10-18-2005.
- 3,009,861. RBC FINANCIAL GROUP. INT. CLS. 35 AND 42 ONLY. REG. 11-1-2005.
- 3,018,992. WILLIAMS. INT. CL. 29 ONLY. REG. 11-29-2005.
- 3,061,633. NORTH GEORGIA COLLEGE AND STATE UNIVERSITY 1873 TRUTH AND WISDOM AND DESIGN. INT. CLS. 6 AND 16 ONLY. REG. 2-28-2006.
- 3,077,868. IKARAOKE. INT. CL. 35 ONLY. REG. 4-4-2006.
- 3,081,122. SIMPLY PARENTING. INT. CL. 41 ONLY. REG. 4-18-2006.
- 3,081,144. ESCC AND DESIGN. INT. CLS. 7 AND 9 ONLY. REG. 4-18-2006.
- 3,081,530. EDGESTONE CAPITAL PARTNERS. INT. CL. 41 ONLY. REG. 4-18-2006.
- 3,083,913. CLEAN GREEN POWER MACHINE. INT. CLS. 39 AND 40 ONLY. REG. 4-18-2006.
- 3,084,846. REDEFINING STANDARD CHARACTER MARK. INT. CL. 42 ONLY. REG. 4-25-2006.
- 3,085,730. VILLAGE VOICE MEDIA. INT. CL. 16 ONLY. REG. 4-25-2006.
- 3,087,190. USTERIZED STANDARD CHARACTER MARK. INT. CLS. 22, 24, 26 AND 27 ONLY. REG. 5-2-2006.
- 3,088,019. MYSPEECHLAB STANDARD CHARACTER MARK. INT. CL. 9 ONLY. REG. 5-2-2006.
- 3,107,916. UNTOLD LEGENDS STANDARD CHARACTER MARK. INT. CL. 41 ONLY. REG. 6-20-2006.
- 3,137,895. MATIF STANDARD CHARACTER MARK. INT. CLS. 9, 35, 38, 41 AND 42 ONLY. REG. 9-5-2006.
- 3,204,819. AUTOOTHANE. INT. CL. 17 ONLY. REG. 2-6-2007.
- 3,216,929. DANBALSAM.COM STANDARD CHARACTER MARK. INT. CL. 42 ONLY. REG. 3-13-2007.
- 1,402,085. NEW YORKER. INT. CL. 14. REG. 7-22-1986.
- 2,988,867. SULLY'S AND DESIGN. INT. CL. 43. REG. 8-30-2005.
- 3,113,887. MK MERCO KOSHER AND DESIGN. INT. CL. 42. REG. 7-11-2006.
- 3,131,514. EWAP EXECUTIVE WEALTH ACCUMULATION PROGRAM AND DESIGN. INT. CLS. 9, 16, 35, 36, 41 AND 42. REG. 8-22-2006.
- 3,234,012. MAHIA LE FIG STANDARD CHARACTER MARK. INT. CL. 33. REG. 4-24-2007.
- 3,267,104. BM BM AUDIO LABS AND DESIGN. INT. CL. 9. REG. 7-24-2007.
- 3,291,386. MAHIA STANDARD CHARACTER MARK. INT. CL. 33. REG. 9-11-2007.
- 3,332,170. SUPERFRUIT STANDARD CHARACTER MARK. INT. CL. 30. REG. 11-6-2007.
- 3,352,866. NATURES BLEND STANDARD CHARACTER MARK. INT. CL. 30. REG. 12-11-2007.
- 3,442,720. LIFT STANDARD CHARACTER MARK. INT. CLS. 9 AND 41. REG. 6-3-2008.
- 3,468,491. TASTE OF PARADISE GRILL STANDARD CHARACTER MARK. INT. CL. 43. REG. 7-15-2008.
- 3,471,261. PROLOGO STANDARD CHARACTER MARK. INT. CL. 33. REG. 7-22-2008.
- 3,555,926. COASTAL CASHMERE NANTUCKET AND DESIGN. INT. CL. 25. REG. 1-6-2009.
- 3,570,608. BRAVADO FIGHT GEAR SHOW 'EM UP KNOCK 'EM OUT AND DESIGN. INT. CL. 25. REG. 2-3-2009.
- 3,634,040. JELART STANDARD CHARACTER MARK. INT. CL. 30. REG. 6-9-2009.
- 3,663,187. CALIFORNIA ROASTERS CO. AND DESIGN. INT. CL. 30. REG. 8-4-2009.
- 3,929,473. SLIIP AND DESIGN. INT. CL. 20. REG. 3-8-2011.

SECTION 71

- 2,970,798. AXALTO (STYLIZED). INT. CLS. 9, 38 AND 42. REG. 7-19-2005.
- 2,998,353. ALPENDORF STANDARD CHARACTER MARK. INT. CL. 29. REG. 9-20-2005.
- 2,998,354. FREE OIL STANDARD CHARACTER MARK. INT. CLS. 3 AND 5. REG. 9-20-2005.
- 2,998,355. MISCELLANEOUS DESIGN. INT. CLS. 14, 25 AND 36. REG. 9-20-2005.
- 2,998,356. HELIT STANDARD CHARACTER MARK. INT. CLS. 1 AND 3. REG. 9-20-2005.
- 2,998,358. BO KLOK STANDARD CHARACTER MARK. INT. CLS. 19, 36 AND 37. REG. 9-20-2005.
- 2,998,359. GOLDEN INTERSTAR AND DESIGN. INT. CL. 9. REG. 9-20-2005.
- 2,998,360. INDIS STANDARD CHARACTER MARK. INT. CL. 33. REG. 9-20-2005.
- 2,998,361. THE SPA COLLECTION HOTELS & RESORTS AND DESIGN. INT. CLS. 35, 39 AND 43. REG. 9-20-2005.
- 2,998,363. FROTTEE AND DESIGN. INT. CL. 3. REG. 9-20-2005.
- 2,998,367. ACTIPUR STANDARD CHARACTER MARK. INT. CL. 1. REG. 9-20-2005.
- 2,998,368. BOOMTOWN AND DESIGN. INT. CL. 38. REG. 9-20-2005.
- 3,029,483. OXBOW STANDARD CHARACTER MARK. INT. CLS. 20, 35 AND 36 ONLY. REG. 12-13-2005.
- 3,055,688. FAGERHULT STANDARD CHARACTER MARK. INT. CL. 42. REG. 1-31-2006.

SECTION 18

- 341,153. RON SUPR PUERTO RICO AND DESIGN. U.S. CL. 49. REG. 12-1-1936.

TM 1866

OFFICIAL GAZETTE

JUNE 5, 2012

3,057,927. SIKACURE STANDARD CHARACTER MARK.
INT. CLS. 1 AND 17 ONLY. REG. 2-7-2006.

* * * * *

TRADEMARK REGISTRATIONS AMENDED, CORRECTED, ETC.

The designation "U.S. Cl." appearing in this section refers to the U.S. class in effect prior to Sep. 1, 1973 rather than the international class which applies to applications filed on or after that date. For adoption of international classification see notice in the OFFICIAL GAZETTE of Jun. 26, 1973 (911 O.G. TM 210).

Any change to the registration will be indicated at the bottom of each entry under ELEMENTS AMENDED, CORRECTED OR RESTRICTED. With the exception of changes to the goods and services, additions to the registration will appear in asterisks and deletions of the registration will appear in brackets. Elements which are only changed will be listed with no punctuation. As to the goods/services statement, amendments to the goods/services will appear in asterisks and deletions will appear in brackets. In addition if any change to the goods/services occurs, the element "Goods/Services" will be listed under ELEMENTS AMENDED, CORRECTED OR RESTRICTED.

910,403. REG. 3-23-1971. KENNAMETAL INC. (PENNSYLVANIA CORPORATION) 1600 TECHNOLOGY WAY, LATROBE, PA, 156500231, SN 72-359,295. FILED 5-11-1970. PRINCIPAL REGISTER.

KENNAMETAL

OWNER OF U.S. REG. NOS. 569,164, 602,676 AND 870,441. INT. CLS. 6, 7, 8, 9, 11, 12, 16, 21 AND 28/U.S. CL. 23

FOR WEAR-RESISTING PIECES CONSISTING OF CEMENTED HARD METALLIC COMPOSITIONS—NAMELY, TOOLS AND INSERTS FOR TOOLS TO BE USED FOR WORKING, CUTTING OR SHAPING METAL AND OTHER MATERIALS, IN DIES, IN CENTERS FOR LATHES AND GRINDING MACHINES, IN BEARINGS, IN PUMP VALVES AND PARTS THEREOF, IN TEETH FOR SAWS, IN FILES, IN GUIDES, AND IN [GLASS-HANDLING TONGS; IN] WEARING SURFACE PARTS—NAMELY, PINS, ROLLERS, CAM FOLLOWERS, BUSHINGS, HAMMERS, DIES, RAMS, [MORTARS, PESTLES,] CYLINDER LINERS, CONTACT POINTS, GAUGE BLOCKS AND TIPS, BALLS, GRIP PLATES, WORK RESTS AND PARTS THEREOF.

FIRST USE 5-26-1938; IN COMMERCE 5-26-1938.

ELEMENTS AMENDED
MARK

924,162. REG. 11-23-1971. ASICS CORPORATION (JAPAN CORPORATION) 1-1 MINATOJIMA-NAKAMACHI, 7-CHOME, CHUO-KU, KOBE CITY, HYOGO PREFECTURE, JAPAN., SN 72-347,422. FILED 12-30-1969. PRINCIPAL REGISTER.



Onitsuka
Tiger

OWNER OF U.S. REG. NOS. 832,457 AND 876,427. INT. CL. 25/U.S. CLS. 22 AND 39

FOR TRACK AND FIELD SHOES, MARATHON SHOES, [GOLF SHOES,] ALPINE SHOES, [WEIGHTLIFTING SHOES, SOCCER SHOES, RUGBY SHOES, SOFTBALL SHOES, BOXING AND WRESTLING SHOES,] RUNNING [AND SPIKE] SHOES, [SKI AND] BOWLING SHOES, AND FENCING SHOES, VOLLEYBALL SHOES, [GYMNASTIC SHOES, BADMINTON SHOES, HANDBALL SHOES,] BASKETBALL SHOES, [TABLE TENNIS SHOES,] OUTDOOR TENNIS SHOES, [DANCING SHOES, BALLET TOE SHOES,] AND SLIPPERS.

FIRST USE 1-27-1965; IN COMMERCE 3-1-1965.

ELEMENTS AMENDED
GOODS/SERVICES

1,195,712. REG. 5-18-1982. THE CHRISTIAN AND MISSIONARY ALLIANCE (NEW YORK NONPROFIT CORPORATION) 8595 EXPLORER DRIVE, COLORADO SPRINGS, CO, 80920, SN 73-307,826. FILED 4-27-1981. PRINCIPAL REGISTER.

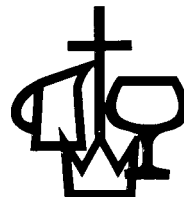

INT. CL. 16/U.S. CL. 38

FOR RELIGIOUS MAGAZINES, BOOKS AND PAMPHLETS CONCERNING CHURCH, MISSIONARY AND EVANGELICAL ACTIVITIES, AND CALENDARS.

FIRST USE 9-0-1975; IN COMMERCE 9-0-1975.

ELEMENTS CORRECTED
CITIZENSHIP
ENTITY

1,686,544. REG. 5-12-1992. WARNER BROS. ENTERTAINMENT INC. (DELAWARE CORPORATION) 4000 WARNER BLVD., BURBANK, CA, 91522, SN 74-093,312. FILED 8-31-1990. PRINCIPAL REGISTER.

RACE DRIVIN'

THE MARK CONSISTS OF STANDARD CHARACTERS WITHOUT CLAIM TO ANY PARTICULAR FONT, STYLE, SIZE, OR COLOR.

INT. CL. 9/U.S. CLS. 21, 23, 26, 36 AND 38

FOR [COIN-OPERATED VIDEO OUTPUT GAME MACHINES; KITS FOR COIN-OPERATED VIDEO OUTPUT GAME MACHINES COMPRISING LABELS, DECALS, INTEGRATED CIRCUITS, CABLES, WASHERS, SCREWS, STANDOFFS, PRINTED CIRCUIT BOARDS, WIRES, METAL PLATES, TAPE, AND INSTRUCTION MANUALS; AND PARTS FOR COIN-OPERATED VIDEO OUTPUT GAME MACHINES AND] COMPUTER VIDEO GAME SOFTWARE.

FIRST USE 8-1-1990; IN COMMERCE 8-15-1990.

ELEMENTS AMENDED
GOODS/SERVICES
MARK
INTERNATIONAL CLASS(ES)
DATE OF FIRST USE
DATE OF FIRST USE IN COMMERCE

1,887,539. REG. 4-4-1995. ROSE BROOKS CENTER, INC. (MISSOURI NON-PROFIT CORPORATION) POST OFFICE BOX 10453, KANSAS CITY, MO, 641710453, SN 74-500,684. FILED 3-16-1994. PRINCIPAL REGISTER.

PROJECT SAFE

INT. CL. 41/U.S. CLS. 101 AND 107

FOR EDUCATIONAL SERVICES; NAMELY, CONDUCTING SEMINARS AND DISTRIBUTING MATERIALS REGARDING THE PREVENTION OF DATING VIOLENCE, CHILD ABUSE, SUBSTANCE ABUSE AND DOMESTIC VIOLENCE.

FIRST USE 12-9-1993; IN COMMERCE 12-16-1993.

ELEMENTS CORRECTED
OWNER NAME
OWNER ADDRESS
ENTITY

1,994,562. REG. 8-20-1996. ETON FASHION AB (SWEDEN CORPORATION) STORA VÄGEN 8, 507 71 GÄNGHESTER, SWEDEN., SN 74-608,967. FILED 12-9-1994. PRINCIPAL REGISTER.



SEC. 2(F).
INT. CL. 25/U.S. CLS. 22 AND 39

FOR SHIRTS, T-SHIRTS, BLOUSES, SWEATERS * NOT INCLUDING SPORTSWEAR *
FIRST USE 12-0-1955; IN COMMERCE 12-0-1986.

ELEMENTS AMENDED
GOODS/SERVICES

2,264,940. REG. 7-27-1999. SOCIETY FOR HUMAN RESOURCE MANAGEMENT (OHIO CORPORATION) 1800 DUKE STREET, ALEXANDRIA, VA, 223143499, SN 75-513,772. FILED 7-6-1998. PRINCIPAL REGISTER.

SOCIETY FOR HUMAN RESOURCE MANAGEMENT

OWNER OF U.S. REG. NOS. 2,047,061 AND 2,114,983.
NO CLAIM IS MADE TO THE EXCLUSIVE RIGHT TO USE "SOCIETY", APART FROM THE MARK AS SHOWN.
SEC. 2(F).

INT. CL. 42/U.S. CLS. 100 AND 101

FOR ASSOCIATION SERVICES, NAMELY PROMOTING THE HUMAN RESOURCE MANAGEMENT PROFESSION.

FIRST USE 9-0-1989; IN COMMERCE 9-0-1989.

ELEMENTS CORRECTED
ENTITY

2,273,797. REG. 8-31-1999. APOLLO PRODUCTS, INC. (MISSOURI CORPORATION) 2255 N.W. VIVION ROAD, KANSAS CITY, MO, 64150, SN 75-430,539. FILED 2-9-1998. PRINCIPAL REGISTER.

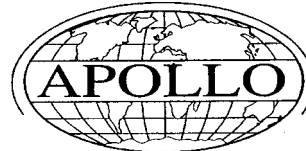

OWNER OF U.S. REG. NOS. 1,020,216, 1,815,943 AND OTHERS.

THE LINING SHOWN IN THE DRAWING IS A FEATURE OF THE MARK AND NOT INTENDED TO INDICATE COLOR.

INT. CL. 3/U.S. CLS. 1, 4, 6, 50, 51 AND 52

FOR HAIR CARE PREPARATIONS; NAMELY, HAIR CLEANER, SHAMPOO, CONDITIONER, HAIR SPRAY, HAIR STYLING MOUSSE, HAIRPIECE CLEANER, HAIRPIECE REMOVER AND HAIRPIECE ADHESIVE REMOVER [; SKIN LOTION; AND COLOGNE].

FIRST USE 10-0-1995; IN COMMERCE 10-0-1995.

INT. CL. 26/U.S. CLS. 37, 39, 40, 42 AND 50

FOR HAIRPIECES AND HAIRPIECE TAPE.
FIRST USE 10-0-1995; IN COMMERCE 10-0-1995.

INT. CL. 35/U.S. CLS. 100, 101 AND 102

FOR RETAIL STORE SERVICES IN THE FIELD OF HAIR CARE PREPARATIONS, SKIN LOTIONS, COLOGNES, WIGS, TOUPEES, AND OTHER TYPES OF HAIRPIECES.

FIRST USE 10-0-1995; IN COMMERCE 10-0-1995.

INT. CL. 42/U.S. CLS. 100 AND 101

FOR CUSTOM DESIGN AND FITTING OF ARTIFICIAL AND NATURAL HAIRPIECES TO THE SCALP TO CORRECT BALDNESS; HAIR STYLING SALON SERVICES; HAIR REPLACEMENT SERVICES.
FIRST USE 10-0-1995; IN COMMERCE 10-0-1995.

ELEMENTS AMENDED
GOODS/SERVICES

2,443,093. REG. 4-10-2001. AMERICAN BLOSSOM CORPORATION (CALIFORNIA CORPORATION) 2671 MCCONE AVENUE, HAYWARD, CA, 94545, SN 75-537,287. FILED 8-17-1998. PRINCIPAL REGISTER.

BLOSSOM

INT. CL. 5/U.S. CLS. 6, 18, 44, 46, 51 AND 52
FOR GERMICIDAL HAND LOTION CONTAINING AN ANTIMICROBIAL AGENT FOR MEDICAL USE.
FIRST USE 8-18-1998; IN COMMERCE 11-30-1999.

ELEMENTS CORRECTED
GOODS/SERVICES

2,542,641. REG. 2-26-2002. MILWAUKEE BREWERS BASEBALL CLUB, LIMITED PARTNERSHIP (WISCONSIN LIMITED PARTNERSHIP) MILLER PARK, ONE BREWERS WAY, MILWAUKEE, WI, 53214, SN 76-157,790. FILED 11-1-2000. PRINCIPAL REGISTER.



OWNER OF U.S. REG. NOS. 1,062,749, 2,136,439 AND OTHERS.
INT. CL. 25/U.S. CLS. 22 AND 39
FOR CLOTHING, NAMELY, CAPS, HATS, HEADWEAR, SHIRTS, T-SHIRTS, TURTLENECKS, SHORTS, BASEBALL UNIFORMS, JERSEYS, SWEATSHIRTS, [BOXER SHORTS,] SLEEPWEAR, JACKETS, INFANTWEAR, [ROMPERS,] FOOTWEAR, SOCKS.
FIRST USE 4-3-2000; IN COMMERCE 4-3-2000.

ELEMENTS CORRECTED
OWNER NAME

2,555,330. REG. 4-2-2002. BUXTON COMPANY (TEXAS CORPORATION) 2651 SOUTH POLARIS DRIVE, FORT WORTH, TX, 76137, SN 76-133,198. FILED 9-21-2000. PRINCIPAL REGISTER.

BUXTON

SEC. 2(F).
INT. CL. 35/U.S. CLS. 100, 101 AND 102
FOR MARKET RESEARCH, FEATURING GEOGRAPHIC MARKET RESEARCH.
FIRST USE 3-0-1994; IN COMMERCE 3-0-1994.

ELEMENTS CORRECTED
OWNER NAME

2,564,142. REG. 4-23-2002. TIME INC. (DELAWARE CORPORATION) 1271 AVENUE OF THE AMERICAS, NEW YORK, NY, 10020, SN 75-747,034. FILED 6-16-1999. PRINCIPAL REGISTER.

INSTYLE

THE MARK CONSISTS OF STANDARD CHARACTERS WITHOUT CLAIM TO ANY PARTICULAR FONT, STYLE, SIZE, OR COLOR.
OWNER OF U.S. REG. NOS. 1,851,469 AND 2,202,536.
INT. CL. 41/U.S. CLS. 100, 101 AND 107
FOR ON-LINE INFORMATION SERVICES, NAMELY, PROVIDING INFORMATION CONCERNING CELEBRITY LIFESTYLES AND EVENTS, ENTERTAINMENT NEWS, FASHION, BEAUTY AND CULTURE, OFFERED VIA A GLOBAL COMPUTER NETWORK.
FIRST USE 10-31-2000; IN COMMERCE 10-31-2000.

ELEMENTS AMENDED
MARK

2,571,049. REG. 5-21-2002. CAFEPRESS INC. (DELAWARE CORPORATION) 1850 GATEWAY DRIVE, SUITE 300, SAN MATEO, CA, 94404, SN 76-139,831. FILED 10-3-2000. PRINCIPAL REGISTER.

CAFEPRESS

INT. CL. 35/U.S. CLS. 100, 101 AND 102
FOR SPECIALTY MERCHANDISING SERVICES, NAMELY, PROMOTING THE GOODS AND SERVICES OF OTHERS THROUGH THE DISTRIBUTION OF CUSTOMIZED ADVERTISING MATERIALS, NAMELY, CUSTOMIZED T-SHIRTS, SWEATSHIRTS, BABY DOLL T-SHIRTS, BASEBALL CAPS, COFFEE MUGS, MOUSE PADS, TOTE BAGS, BUMPER STICKERS AND POSTERS; AND COMPUTERIZED ON-LINE RETAIL STORES FEATURING CUSTOMIZED T-SHIRTS, SWEATSHIRTS, BABY DOLL T-SHIRTS, BASEBALL CAPS, COFFEE MUGS, MOUSE PADS, TOTE BAGS, BUMPER STICKERS AND POSTERS.
FIRST USE 6-0-1997; IN COMMERCE 7-0-1997.

ELEMENTS AMENDED
MARK

2,576,553. REG. 6-4-2002. PEDAGOGUE SOLUTIONS, INC. (NEW JERSEY CORPORATION) 1060 STATE ROAD, SUITE 101, PRINCETON, NJ, 085401466, SN 75-866,480. FILED 12-7-1999. PRINCIPAL REGISTER.

2,600,786. REG. 7-30-2002. ALAMO CEMENT COMPANY II, LTD. (TEXAS LIMITED PARTNERSHIP) P. O. BOX 34807, SAN ANTONIO, TX, 78265, SN 76-262,490. FILED 5-25-2001. PRINCIPAL REGISTER.

EXAMSDIRECT

INT. CL. 41/U.S. CLS. 100, 101 AND 107
FOR EDUCATIONAL TESTING AND VOCATIONAL TESTING VIA A GLOBAL COMPUTER NETWORK IN THE FIELDS OF MEDICINE, PHARMACEUTICALS, FINANCIAL SERVICES AND LAW.
FIRST USE 1-2-1999; IN COMMERCE 1-2-1999.

ELEMENTS AMENDED
MARK

2,590,554. REG. 7-9-2002. TOM HOM GROUP, LLC, THE (CALIFORNIA LIMITED LIABILITY COMPANY) P.O. BOX 6950, SAN DIEGO, CA, 92166, SN 76-070,999. FILED 6-15-2000. PRINCIPAL REGISTER.

WE PUT THE "PLUS" IN SRO +

INT. CL. 35/U.S. CLS. 100, 101 AND 102
FOR BUSINESS MANAGEMENT, PLANNING AND SUPERVISION OF RESIDENTIAL PROPERTIES.
FIRST USE 2-25-2000; IN COMMERCE 2-25-2000.
INT. CL. 36/U.S. CLS. 100, 101 AND 102
FOR REAL ESTATE MANAGEMENT AND LEASING OF REAL ESTATE .
FIRST USE 2-25-2000; IN COMMERCE 2-25-2000.

ELEMENTS CORRECTED
ENTITY

2,592,956. REG. 7-9-2002. NOONAN, SUZANNAH R. (UNITED STATES INDIVIDUAL) 1451 BERNE CT, INCLINE VILLAGE, NV, 89451, SN 78-004,857. FILED 4-19-2000. PRINCIPAL REGISTER.

HEALTHYFIX

INT. CL. 5/U.S. CLS. 6, 18, 44, 46, 51 AND 52
FOR NUTRITIONAL SUPPLEMENTS AND NUTRITIONAL DRINK MIX FOR USE AS A MEAL REPLACEMENT.
FIRST USE 4-1-2000; IN COMMERCE 4-19-2000.
INT. CL. 44/U.S. CLS. 100 AND 101
FOR PHYSICAL FITNESS CONSULTATION.
FIRST USE 4-1-2000; IN COMMERCE 4-19-2000.

ELEMENTS AMENDED
GOODS/SERVICES
INTERNATIONAL CLASS(ES)
DATE OF FIRST USE
DATE OF FIRST USE IN COMMERCE

ALAMO

INT. CL. 19/U.S. CLS. 1, 12, 33 AND 50
FOR HYDRAULIC CEMENT, CONCRETE, SAND, GRAVEL, AGGREGATE AND READY-MIX CONCRETE.
FIRST USE 12-31-1880; IN COMMERCE 12-31-1880.

ELEMENTS CORRECTED
OWNER NAME
ENTITY

2,602,738. REG. 7-30-2002. TRI-TRONICS COMPANY, INC. (FLORIDA CORPORATION) P.O. BOX 25135, TAMPA, FL, 33622, SN 76-248,721. FILED 5-1-2001. PRINCIPAL REGISTER.

LEADINGEDGE

INT. CL. 9/U.S. CLS. 21, 23, 26, 36 AND 38
FOR PHOTOELECTRIC LIGHT SCREEN ELEVATOR DOOR CONTROLS; ELECTRICAL SENSING EDGES FOR POWER OPERATED DOORS.
FIRST USE 11-19-2001; IN COMMERCE 11-19-2001.

ELEMENTS CORRECTED
CITIZENSHIP

2,603,301. REG. 8-6-2002. DAISHOWA SEIKI KABUSHIKI KAISHA (JAPAN COMPANY), DBA DAISHOWA SEIKI CO LTD, NISHIISHIKIRICHO 3-3-39, HIGASHIOSAKASHI OSAKA, JAPAN, 579-8013, SN 75-639,038. FILED 2-10-1999. PRINCIPAL REGISTER.

BIG PLUS

OWNER OF JAPAN REG. NO. 4215623, DATED 11-27-1998, EXPIRES 11-27-2008.

NO CLAIM IS MADE TO THE EXCLUSIVE RIGHT TO USE "BIG", APART FROM THE MARK AS SHOWN.

INT. CL. 7/U.S. CLS. 13, 19, 21, 23, 31, 34 AND 35
FOR METAL TOOL MACHINES, NAMELY MACHINING CENTERS, LATHES, BORING MACHINES, BROACHING MACHINES, MILLING MACHINES, GRINDING MACHINES AND THREADING MACHINES; TOOL HOLDERS FOR MOUNTING METAL CUTTING TOOLS IN METAL TOOL MACHINES; AND METAL PROCESSING TOOLS.
FIRST USE 7-16-1992; IN COMMERCE 7-16-1992.

ELEMENTS CORRECTED
DBA/KA
OWNER NAME
OWNER ADDRESS

2,620,638. REG. 9-17-2002. ALAMO CEMENT COMPANY II, LTD. (TEXAS LIMITED LIABILITY COMPANY) P. O. BOX 34807, SAN ANTONIO, TX, 78265, SN 76-262,487. FILED 5-25-2001. PRINCIPAL REGISTER.

2,648,698. REG. 11-12-2002. ALAMO CEMENT COMPANY II, LTD. (TEXAS LIMITED LIABILITY COMPANY) P.O. BOX 34807, SAN ANTONIO, TX, 78265, SN 76-262,486. FILED 5-25-2001. PRINCIPAL REGISTER.

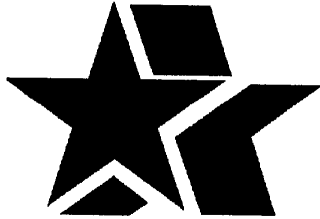

INT. CL. 19/U.S. CLS. 1, 12, 33 AND 50
FOR READY-MIX CONCRETE.
FIRST USE 12-31-1989; IN COMMERCE 12-31-1989.

NO CLAIM IS MADE TO THE EXCLUSIVE RIGHT TO USE "TRANSIT COMPANY II, LTD.", APART FROM THE MARK AS SHOWN.
THE LINING SHOWN IN THE DRAWING IS A FEATURE OF THE MARK AND NOT INTENDED TO INDICATE COLOR.
INT. CL. 39/U.S. CLS. 100 AND 105
FOR VEHICULAR TRANSPORT OF SAND, GRAVEL, AGGREGATE, AND WET CEMENT AND CONCRETE.
FIRST USE 12-30-1995; IN COMMERCE 12-30-1995.

ELEMENTS CORRECTED
OWNER NAME
ENTITY

ELEMENTS CORRECTED
OWNER NAME
ENTITY

2,643,764. REG. 10-29-2002. NAVAJO MANUFACTURING CO. (COLORADO CORPORATION) 5330 FOX STREET, DENVER, CO, 80216, SN 76-038,819. FILED 5-2-2000. PRINCIPAL REGISTER.

2,693,608. REG. 3-4-2003. SACRAMENTO KINGS LIMITED PARTNERSHIP, L.P. (CALIFORNIA LIMITED PARTNERSHIP), THE GENERAL PARTNER, ROYAL KINGS LIMITED PARTNERSHIP, A CALIFORNIA LIMITED PARTNERSHIP, COMPOSED OF THE GENERAL PARTNER, MALOOF SPORTS, INC., A CALIFORNIA CORPORATION, ONE SPORTS PARKWAY, SACRAMENTO, CA, 95834, SN 75-510,797. FILED 6-30-1998. PRINCIPAL REGISTER.

IMPRESS



INT. CL. 3/U.S. CLS. 1, 4, 6, 50, 51 AND 52
FOR [EMERY BOARDS].
FIRST USE 2-1-2001; IN COMMERCE 2-1-2001.
INT. CL. 25/U.S. CLS. 22 AND 39
FOR SHOWER CAPS.
FIRST USE 2-1-2001; IN COMMERCE 2-1-2001.
INT. CL. 26/U.S. CLS. 37, 39, 40, 42 AND 50
FOR HAIR PINS, METAL HAIR BARRETtes, ELASTIC PONYTAIL HOLDERS, HAIR NETS, AND PLASTIC HAIR BARRETtes.
FIRST USE 2-1-2001; IN COMMERCE 2-1-2001.

OWNER OF U.S. REG. NO. 1,785,042 AND OTHERS.
NO CLAIM IS MADE TO THE EXCLUSIVE RIGHT TO USE "CINCINNATI" , APART FROM THE MARK AS SHOWN.
INT. CL. 16/U.S. CLS. 2, 5, 22, 23, 29, 37, 38 AND 50

ELEMENTS AMENDED
GOODS/SERVICES

FOR PUBLICATIONS AND PRINTED MATTER, NAMELY, BASKETBALL TRADING CARDS, DANCE TEAM TRADING CARDS, MASCOT TRADING CARDS, ENTERTAINMENT TRADING CARDS, STICKERS, DECALS, COMMEMORATIVE BASKETBALL STAMPS, COLLECTIBLE CARDBOARD TRADING DISCS, COMPUTER MONITOR CARDBOARD FRAME, MEMO BOARDS, CLIPBOARDS, COASTERS, POST CARDS, PLACE MATS, NOTE CARDS, MEMO PADS, BALL POINT PENS, PENCILS, 3-RING BINDERS, STATIONERY FOLDERS, WIREBOUND NOTEBOOKS, PORTFOLIO NOTEBOOKS, UNMOUNTED AND MOUNTED PHOTOGRAPHS, POSTERS, CALENDARS, BUMPER STICKERS, BOOK COVERS, WRAPPING PAPER, CHILDREN'S ACTIVITY BOOKS, STATISTICAL BOOKS, GUIDE BOOKS AND REFERENCE BOOKS FOR BASKETBALL, MAGAZINES IN THE FIELD OF BASKETBALL, COMMEMORATIVE GAME PROGRAMS, PAPER PENNANTS, STATIONERY, STATIONERY-TYPE PORTFOLIOS, AND STATISTICAL SHEETS FOR BASKETBALL TOPICS, NEWSLETTERS AND PAMPHLETS IN THE FIELD OF BASKETBALL FOR DISTRIBUTION TO THE TELEVISION AND RADIO MEDIA.

FIRST USE 2-0-1997; IN COMMERCE 2-0-1997.

ELEMENTS CORRECTED
ENTITY

2,698,308. REG. 3-18-2003. MANDALAY CORPORATE ENTERPRISES, LLC (CALIFORNIA LIMITED LIABILITY COMPANY) 5555 MELROSE AVENUE, LEWIS BUILDING, HOLLYWOOD, CA, 90038, SN 76-087,619. FILED 7-12-2000. PRINCIPAL REGISTER.



OWNER OF U.S. REG. NOS. 2,076,104 AND 2,217,502. THE MARK HAS BEEN STIPPLED FOR SHADING, AND SHADING IS A FEATURE OF THE MARK.

INT. CL. 35/U.S. CLS. 100, 101 AND 102 FOR PROMOTING SPORTS COMPETITIONS AND/OR EVENTS OF OTHERS.

FIRST USE 7-15-2000; IN COMMERCE 7-15-2000.
INT. CL. 41/U.S. CLS. 100, 101 AND 107 FOR ENTERTAINMENT SERVICES IN THE NATURE OF THE PRODUCTION AND PRESENTATION OF SPORTING EVENTS AND SPORTS EXHIBITIONS, RENDERED LIVE OR THROUGH RADIO, TELEVISION AND FILM MEDIA, AND VIA THE INTERNET.
FIRST USE 1-1-1997; IN COMMERCE 1-1-1997.

ELEMENTS CORRECTED
OWNER ADDRESS
ENTITY

2,765,885. REG. 9-16-2003. QOL LABS, LLC (DELAWARE LIMITED LIABILITY COMPANY) 2975 WESTCHESTER AVENUE, SUITE G-01, PURCHASE, NY, 10577, SN 76-359,710. FILED P.R. 1-17-2002; AM. S.R. 4-25-2003. SUPPLEMENTAL REGISTER.

KINOKO

INT. CL. 5/U.S. CLS. 6, 18, 44, 46, 51 AND 52 FOR DIETARY SUPPLEMENTS CONTAINING KINOKO MUSHROOMS.
FIRST USE 10-0-2002; IN COMMERCE 10-0-2002.

ELEMENTS CORRECTED
OWNER NAME
OWNER ADDRESS
ENTITY

2,889,180. REG. 9-28-2004. HUMAN RESOURCE CERTIFICATION INSTITUTE (D.C. CORPORATION) 1800 DUKE STREET, ALEXANDRIA, VA, 22314, SN 78-281,913. FILED 8-1-2003. PRINCIPAL REGISTER.

HRCI

INT. CL. 42/U.S. CLS. 100 AND 101 FOR SERVICES IN CONNECTION WITH DEVELOPING AND ADMINISTERING STANDARDS AND PROCEDURES FOR CERTIFYING HUMAN RESOURCE PROFESSIONALS.
FIRST USE 6-25-1990; IN COMMERCE 6-25-1990.

ELEMENTS CORRECTED
ENTITY

2,893,888. REG. 10-12-2004. THINADDICTIVES INC. (CANADA CORPORATION) 1000 SHERBROOKE STREET WEST, SUITE 2700, MONTREAL, QUEBEC, H3A 3G4, SN 78-187,664. FILED 11-21-2002. PRINCIPAL REGISTER.

THINADDICTIVES

INT. CL. 30/U.S. CL. 46 FOR BAKED GOODS, NAMELY, COOKIES.
FIRST USE 10-15-2002; IN COMMERCE 12-20-2002.

ELEMENTS CORRECTED
OWNER NAME

2,925,410. REG. 2-8-2005. SOCIETY FOR HUMAN RESOURCE MANAGEMENT (OHIO CORPORATION) 1800 DUKE STREET, ALEXANDRIA, VA, 22314, SN 78-369,112. FILED 2-17-2004. PRINCIPAL REGISTER.

2,997,119. REG. 9-20-2005. UNIWORLD GROUP, INC. (DELAWARE CORPORATION) 1 METROTECH CENTER NORTH, 11TH FLOOR, BROOKLYN, NY, 112013875, SN 78-348,445. FILED 1-6-2004. PRINCIPAL REGISTER.

HR LEADING PEOPLE
LEADING
ORGANIZATIONS



THE MARK CONSISTS OF STANDARD CHARACTERS WITHOUT CLAIM TO ANY PARTICULAR FONT, STYLE, SIZE, OR COLOR.

NO CLAIM IS MADE TO THE EXCLUSIVE RIGHT TO USE HR, APART FROM THE MARK AS SHOWN.

INT. CL. 35/U.S. CLS. 100, 101 AND 102

FOR ASSOCIATION SERVICES, NAMELY, PROMOTING THE INTERESTS OF THE HUMAN RESOURCE MANAGEMENT PROFESSION AND THE INTERESTS OF MEMBERS OF THE HUMAN RESOURCE MANAGEMENT PROFESSION.

FIRST USE 4-1-2003; IN COMMERCE 4-1-2003.

ELEMENTS CORRECTED
ENTITY

INT. CL. 35/U.S. CLS. 100, 101 AND 102

FOR ADVERTISING, MARKETING AND COMMUNICATIONS SERVICES, NAMELY, PUBLIC RELATIONS AND MARKETING RESEARCH SERVICES; PROMOTING RADIO LISTENERSHIP AND EVENT MARKETING THROUGH THE USE OF BROADCAST MEDIA AND DIRECT MAIL ADVERTISING; BUSINESS MARKETING CONSULTING SERVICES, NAMELY, PROVIDING MARKET AND DEMOGRAPHIC RESEARCH ANALYSIS, EVENT AND MARKETING STRATEGY DEVELOPMENT, FIELD AND WEB-BASED PROMOTIONAL DEVELOPMENT AND IMPLEMENTATION AND PRODUCT PLACEMENT ADVISORY SERVICES.

FIRST USE 1-1-1969; IN COMMERCE 1-1-1969.

ELEMENTS AMENDED
MARK

3,008,031. REG. 10-18-2005. WXIIHOFORDDTC REAL ESTATE, LLC (DELAWARE CORPORATION) 350 WEST HUBBARD STREET, SUITE 450, CHICAGO, IL, 60610, SN 76-458,137. FILED P.R. 10-7-2002; AM. S.R. 8-24-2004. SUPPLEMENTAL REGISTER.

2,934,752. REG. 3-22-2005. HUMAN RESOURCE CERTIFICATION INSTITUTE (D.C. CORPORATION) 1800 DUKE STREET, ALEXANDRIA, VA, 22314, SN 78-283,154. FILED 8-5-2003. PRINCIPAL REGISTER.

SPHR

THE NATIONAL CONFERENCE
CENTER

THE MARK, AS USED BY AUTHORIZED PERSONS, CERTIFIES THAT THE SERVICES ARE PERFORMED BY INDIVIDUALS WHO HAVE MET A MINIMUM AMOUNT OF PROFESSIONAL EXPERIENCE AND HAVE PASSED A WRITTEN EXAMINATION.

INT. CL. B /U.S. CL. B

FOR HUMAN RESOURCE MANAGEMENT.

FIRST USE 1-1-1984; IN COMMERCE 1-1-1984.

ELEMENTS CORRECTED
ENTITY

THE MARK CONSISTS OF STANDARD CHARACTERS WITHOUT CLAIM TO ANY PARTICULAR FONT, STYLE, SIZE, OR COLOR.

NO CLAIM IS MADE TO THE EXCLUSIVE RIGHT TO USE "CONFERENCE CENTER", APART FROM THE MARK AS SHOWN.

INT. CL. 43/U.S. CLS. 100 AND 101

FOR HOSPITALITY SERVICES NAMELY HOTEL SERVICES, PROVISION OF CONFERENCE FACILITIES AND CONSULTING IN THE FIELD OF HOSPITALITY.

FIRST USE 3-0-2002; IN COMMERCE 3-0-2002.

ELEMENTS AMENDED
MARK

3,030,884. REG. 12-13-2005. HUNTER FAN COMPANY (DELAWARE CORPORATION) 7130 GOODLETT FARMS PARKWAY, SUITE 400, MEMPHIS, TN, 38016, SN 78-481,697. FILED P.R. 9-10-2004; AM. S.R. 10-11-2005. SUPPLEMENTAL REGISTER.

WOBBLE FREE

THE MARK CONSISTS OF STANDARD CHARACTERS WITHOUT CLAIM TO ANY PARTICULAR FONT, STYLE, SIZE, OR COLOR.

INT. CL. 11/U.S. CLS. 13, 21, 23, 31 AND 34

FOR MOUNTING SYSTEM FOR ELECTRIC CEILING FANS COMPRISED OF A CEILING CANOPY HAVING A METAL SEAT ADAPTED TO RECEIVE A NONMETAL TRI-LOBULAR SHAPED BALL FOR THE PURPOSE OF SECURING THE FAN TO THE CANOPY.

FIRST USE 12-31-2002; IN COMMERCE 12-31-2002.

ELEMENTS AMENDED
MARK

3,047,652. REG. 1-24-2006. DORMONT MANUFACTURING COMPANY (PENNSYLVANIA CORPORATION) 6015 ENTERPRISE DRIVE, EXPORT, PA, 15632, SN 76-593,823. FILED 5-24-2004. PRINCIPAL REGISTER.

FLEX TUBE

THE MARK CONSISTS OF STANDARD CHARACTERS WITHOUT CLAIM TO ANY PARTICULAR FONT, STYLE, SIZE, OR COLOR.

NO CLAIM IS MADE TO THE EXCLUSIVE RIGHT TO USE "TUBE", APART FROM THE MARK AS SHOWN.

SEC. 2(F).

INT. CL. 6/U.S. CLS. 2, 12, 13, 14, 23, 25 AND 50

FOR METAL GAS CONNECTORS FOR USE IN THE CONNECTION OF GAS APPLIANCES AND FOR THE TRANSMISSION OF GAS IN GAS APPLIANCES.

FIRST USE 12-0-1996; IN COMMERCE 12-0-1996.

ELEMENTS CORRECTED
MARK

3,072,474. REG. 3-28-2006. PHOENIX INTANGIBLES HOLDING COMPANY (DELAWARE CORPORATION) TWO GREENVILLE CROSSING, GREENVILLE, DE, 19807, SN 76-588,843. FILED 4-23-2004. PRINCIPAL REGISTER.



NO CLAIM IS MADE TO THE EXCLUSIVE RIGHT TO USE "CARD", APART FROM THE MARK AS SHOWN.

THE COLOR(S) WHITE, BLUE, RED, DARK RED, ORANGE, DARK YELLOW, AND YELLOW IS/ARE CLAIMED AS A FEATURE OF THE MARK.

THE COLOR RED IS THE BACKGROUND FOR THE WORDS (IN WHITE) GIANT EAGLE. THE OVERALL BACKGROUND IS BLUE. THE RIBBON DEVICE INCLUDES THE COLORS, STACKED IN ORDER, OF PINK, RED, ORANGE, DARK YELLOW AND YELLOW. A STRIPE AT THE BOTTOM OF THE MARK ON THE CARD INCLUDES AN UPPER AND LOWER BORDER OF ORANGE AND A MIDDLE PORTION OF YELLOW.

THE MARK CONSISTS OF A CARD HAVING A MULTI-COLOR RIBBON DEVICE WITH THE WORDS "GIANT EAGLE" IN A RED SHIELD DEVICE AND THE WORDS "ADVANTAGE CARD" IN BLOCK TYPE WITH A HORIZONTAL STRIPE AT THE BOTTOM OF THE CARD

INT. CL. 35/U.S. CLS. 100, 101 AND 102

FOR RETAIL SUPERMARKET SERVICES FEATURING A SPECIAL IDENTIFICATION CARD FOR PREFERRED CUSTOMERS.

FIRST USE 10-0-1994; IN COMMERCE 10-0-1994.

ELEMENTS AMENDED
MARK
DESCRIPTION OF MARK
COLOR DESCRIPTION STATEMENT

3,078,434. REG. 4-11-2006. FOLLMANN & CO. GESELLSCHAFT FUR CHEMIE-WERKSTOFFE UND-VERFAHRENSTECHNIK MBH & CO. KG. (FED REP GERMANY CORPORATION) KARLSTRABE 59, MINDEN, FED REP GERMANY, D-32423, SN 78-227,238. FILED 3-19-2003. PRINCIPAL REGISTER.

FOLCO Scent

THE MARK CONSISTS OF STANDARD CHARACTERS WITHOUT CLAIM TO ANY PARTICULAR FONT, STYLE, SIZE, OR COLOR.

PRIORITY CLAIMED UNDER SEC. 44(D) ON FED REP GERMANY APPLICATION NO. 30247651.203, FILED 9-26-2002, REG. NO. 30247651, DATED 12-2-2002, EXPIRES 9-30-2012.

INT. CL. 3/U.S. CLS. 1, 4, 6, 50, 51 AND 52

FOR PERFUMERY; ESSENTIAL OILS, NAMELY, PERFUME OILS, FRAGRANCES FOR PERSONAL USE, ROOM FRAGRANCES IN MICRO-CAPSULES; ESSENTIAL OILS, NAMELY, PERFUME OILS, FRAGRANCES FOR PERSONAL USE, ROOM FRAGRANCES IN MICRO-POROUS AND SPONGE-LIKE CARRIERS FOR THE DELAYED RELEASE OF SCENTS.

FIRST USE ; IN COMMERCE .

INT. CL. 16/U.S. CLS. 2, 5, 22, 23, 29, 37, 38 AND 50

FOR MICRO-CAPSULES ON PAPER AND CARDBOARD, SOLD EMPTY, MAINLY FOR USE WITH PERFUMES AND RELATED FRAGRANCES IN THE FORM OF OILS; MICRO-POROUS, SPONGE-LIKE CARRIERS, NAMELY, DECORATIVE PAPER AND CARDBOARD, SOLD EMPTY, MAINLY FOR USE WITH PERFUMES AND RELATED FRAGRANCES IN THE FORM OF OILS FOR THE DELAYED RELEASE OF SCENTS.

FIRST USE ; IN COMMERCE .

INT. CL. 21/U.S. CLS. 2, 13, 23, 29, 30, 33, 40 AND 50

FOR MICRO-CAPSULES IN ARTICLES FOR CLEANING PURPOSES AND SPONGES NOT OF PAPER AND CARDBOARD, SOLD EMPTY, MAINLY FOR USE WITH PERFUMES AND RELATED FRAGRANCES IN THE FORM OF OIL AND AROMAS; SPONGES NOT OF PAPER AND CARDBOARD, SOLD EMPTY, MAINLY FOR USE WITH PERFUMES AND RELATED FRAGRANCES IN THE FORM OF OIL FOR THE DELAYED RELEASE OF SCENTS.

FIRST USE ; IN COMMERCE .

INT. CL. 35/U.S. CLS. 100, 101 AND 102

FOR ADVERTISING SERVICES, NAMELY, DIRECT MAIL ADVERTISING, DISSEMINATION OF ADVERTISING MATTER AND FRAGRANCE SAMPLE DISTRIBUTION USING MICRO-CAPSULES OR MICRO-POROUS, SPONGE-LIKE CARRIERS, CONTAINING SCENTS; DISTRIBUTORSHIPS IN THE FIELD OF MICRO-POROUS AND SPONGE-LIKE CARRIERS CONTAINING AROMAS IN POWDER FORM FOR THE DELAYED RELEASE OF AROMAS FOR USE WITH FOODSTUFFS, LACQUER COVERINGS, AND FOOD PACKAGING; RETAIL STORE SERVICES FEATURING MICRO-POROUS AND SPONGE-LIKE CARRIERS CONTAINING AROMAS IN POWDER FORM FOR THE DELAYED RELEASE OF AROMAS FOR USE WITH FOODSTUFFS, LACQUER COVERINGS, AND FOOD PACKAGING.

FIRST USE ; IN COMMERCE .
INT. CL. 39/U.S. CLS. 100 AND 105

FOR WAREHOUSING SERVICES, NAMELY DISTRIBUTION OF MICRO-POROUS AND SPONGE-LIKE CARRIERS CONTAINING AROMAS IN POWDER FORM FOR THE DELAYED RELEASE OF AROMAS IN FOODSTUFFS, LACQUER COVERINGS AND FOOD PACKAGING FOR OTHERS; SUPPLY CHAIN, LOGISTICS AND REVERSE LOGISTICS SERVICES, NAMELY, STORAGE, TRANSPORTATION AND DELIVERY OF MICRO-POROUS AND SPONGE-LIKE CARRIERS CONTAINING AROMAS IN POWDER FORM FOR THE DELAYED RELEASE OF AROMAS IN FOODSTUFFS, LACQUER COVERINGS AND FOOD PACKAGING FOR OTHERS BY AIR, RAIL, SHIP OR TRUCK.

FIRST USE ; IN COMMERCE .
INT. CL. 40/U.S. CLS. 100, 103 AND 106

FOR CUSTOM MANUFACTURE OF MICRO-CAPSULES CONTAINING SCENTS, IN PARTICULAR PERFUMES OR FRAGRANCES, MAINLY IN THE FORM OF OILS OR AROMAS, FOR A THIRD PARTY OR THE APPLYING OF SCENTS TO MICRO-POROUS, SPONGE-LIKE CARRIERS, IN PARTICULAR PERFUMES OR FRAGRANCES, MAINLY IN THE FORM OF OILS AND AROMAS TO THE ORDER AND/OR SPECIFICATIONS OF OTHERS.

FIRST USE ; IN COMMERCE .

ELEMENTS CORRECTED
OWNER NAME

3,081,294, REG. 4-18-2006. SOCIETY FOR HUMAN RESOURCE MANAGEMENT (OHIO NON-PROFIT CORPORATION) 1800 DUKE STREET, ALEXANDRIA, VA, 22314, SN 76-614,010. FILED 9-27-2004. PRINCIPAL REGISTER.

SHRM GLOBAL LEARNING SYSTEM

THE MARK CONSISTS OF STANDARD CHARACTERS WITHOUT CLAIM TO ANY PARTICULAR FONT, STYLE, SIZE, OR COLOR.

OWNER OF U.S. REG. NOS. 2,295,514 AND 2,324,158.
NO CLAIM IS MADE TO THE EXCLUSIVE RIGHT TO USE "LEARNING SYSTEM" AS TO ALL CLASSES AND "GLOBAL LEARNING SYSTEM" AS TO INTERNATIONAL CLASS 41 ONLY, APART FROM THE MARK AS SHOWN.
INT. CL. 16/U.S. CLS. 2, 5, 22, 23, 29, 37, 38 AND 50

FOR EDUCATIONAL PRODUCTS, STUDY MATERIALS, AND PROFESSIONAL DEVELOPMENT PROGRAMS, NAMELY, BOOKS AND PRINTED MATERIALS, IN THE FIELD OF HUMAN RESOURCES.
FIRST USE 1-0-2004; IN COMMERCE 1-0-2004.
INT. CL. 41/U.S. CLS. 100, 101 AND 107

FOR EDUCATIONAL SERVICES, NAMELY, PROVIDING PROFESSIONAL DEVELOPMENT PROGRAMS IN THE NATURE OF COURSES, SEMINARS, AND WEBCASTS, FOR THE PURPOSE OF ASSISTING PARTICIPANTS IN OBTAINING PROFESSIONAL ACCREDITATION AND CERTIFICATION, IN THE FIELD OF HUMAN RESOURCES.
FIRST USE 1-0-2004; IN COMMERCE 1-0-2004.

ELEMENTS CORRECTED
ENTITY

3,084,372. REG. 4-25-2006. LIMITED LIABILITY COMPANY "WHITEHALL-CENTER" (RUSSIAN FED. LIMITED LIABILITY COMPANY) BLDG. 5, 33, DMITROVSKOE HIGHWAY, MOSCOW, RUSSIAN FED., 127550, SN 78-201,414. FILED 1-8-2003. PRINCIPAL REGISTER.



PRIORITY CLAIMED UNDER SEC. 44(D) ON RUSSIAN FED. APPLICATION NO. 2002722548, FILED 10-14-2002, REG. NO. 242940, DATED 4-10-2003.

THE LINING SHOWN IN THE DRAWING IS A FEATURE OF THE MARK.

THE MARK CONSISTS OF THE CONFIGURATION OF A BOTTLE IN A STYLIZED DROP SHAPE WITH THE WORDS KAUFFMAN PRIVATE COLLECTION THEREON.

INT. CL. 3/U.S. CLS. 1, 4, 6, 50, 51 AND 52

FOR [ESSENTIAL OILS FOR USE IN THE MANUFACTURE OF AROMATICS; ESSENTIAL OILS FOR BEVERAGE FLAVORINGS; SCENTED WATER, NAMELY, JAVELLE WATER, LAVENDER WATER; TOILET WATER; PERFUMES; PERFUMERY; SHAVING PREPARATIONS; HAIR LOTIONS; LOTIONS FOR COSMETIC PURPOSES; ESSENTIAL OILS FOR COSMETIC PURPOSES; ESSENTIAL OILS FOR PERFUMES AND SCENTS; ESSENTIAL OILS FOR COSMETIC PURPOSES; ESSENTIAL OILS FOR TOILET PURPOSES; ESSENTIAL OILS OF LEMON; ESSENTIAL OILS OF KEDARWOOD; BERGAMOT OIL; GAULTHERIA OIL; JASMINE OIL; LAVENDER OIL; ALMOND OIL; ROSE OIL; CLEANSING MILK FOR TOILET PURPOSES; ALMOND MILK FOR COSMETIC PURPOSES; ESSENTIAL OIL OF MUSK; EAU DE COLOGNE; MOUTH WASHES NOT FOR MEDICAL PURPOSES; COSMETICS; COSMETIC PREPARATIONS FOR SKIN CARE; DETERGENTS, NAMELY, DETERGENT SOAP, DETERGENTS FOR AUTOMOBILES, DETERGENTS FOR MACHINE DISHWASHING, DETERGENTS PREPARED FROM PETROLEUM; DECOLORANT BLEACHING PREPARATIONS FOR COSMETIC PURPOSES; ESSENTIAL OIL OF TERPENES; SHAMPOOS; EXTRACTS OF FLOWERS; BADIEN ESSENCE; ESSENTIAL OIL OF MINT ESSENCE].
FIRST USE ; IN COMMERCE .

INT. CL. 32/U.S. CLS. 45, 46 AND 48

FOR [NON-ALCOHOLIC APERITIFS; DRINKING WATER; NON-ALCOHOLIC COCKTAIL MIXES; PEANUT MILK-BASED BEVERAGES; ALMOND MILK-BASED BEVERAGES; LEMONADE; NON-ALCOHOLIC BEVERAGES, NAMELY, PUNCH, SPORTS DRINKS, SWEET CIDER; ISOTONIC DRINKS; WHEY BEVERAGES; NON-ALCOHOLIC FRUIT EXTRACTS USED IN THE PREPARATION OF BEVERAGES; FRUIT NECTARS; ORGEAT BEER; SARSAPARILLA; SOFT DRINKS; SYRUPS FOR LEMONADE; SYRUPS FOR MAKING SOFT DRINKS; TOMATO JUICE; APPLE JUICE; VEGETABLE JUICE; FRUIT JUICE; EXTRACTS OF HOPS FOR MAKING BEER ; ESSENCES FOR USE IN MAKING BEVERAGES, NAMELY, SOFT DRINKS, NOT IN THE NATURE OF ESSENTIAL OILS].

FIRST USE ; IN COMMERCE .
INT. CL. 33/U.S. CLS. 47 AND 49

FOR [APERITIFS; ORAK; BRANDY; WINE; WHISKEY; GIN;] VODKA; [PREPARED ALCOHOLIC COCKTAILS; LIQUEURS; ALCOHOLIC BEVERAGES, NAMELY, ALCOHOLIC COFFEE-BASED BEVERAGE; ALCOHOLIC TEA-BASED BEVERAGE; ALCOHOLIC PUNCH; CALVADOS; CHAMPAGNE; COGNAC; CURA-CAO; HERB LIQUEURS; OUZO; SCHNAPPS; TEQUILA; ALCOHOLIC BEVERAGES CONTAINING FRUIT; DISTILLED SPIRITS; MEAD; PEPPERMINT LIQUEURS; ALCOHOLIC BITTERS; RUM; SAKE; HARD CIDER; RICE ALCOHOL].

FIRST USE ; IN COMMERCE .

ELEMENTS AMENDED
GOODS/SERVICES
OWNER ADDRESS

FOR CLOTHING FOR MEN, WOMEN AND CHILDREN NAMELY SUITS MADE OF LEATHER, SHIRTS, BLOUSES, SKIRTS, JACKETS, TROUSERS, SHORTS, VESTS, JERSEYS, PAJAMAS, STOCKINGS, SINGLETS, CORSETS, GARTERS, PANTS, PETTICOATS, HATS, SCARVES, NECKTIES, RAINCOATS, OVERCOATS, GREATCOATS, BATHING SUITS, SPORT OVERALLS, WIND-RESISTANT JACKETS, SKI PANTS, BELTS, FUR COATS, FUR HATS, DRESSING GOWNS, FOOTWEAR NAMELY SLIPPERS, SHOES, SPORTS SHOES AND BOOTS.

FIRST USE 6-28-2004; IN COMMERCE 6-28-2004.

ELEMENTS AMENDED
GOODS/SERVICES

3,108,433. REG. 6-27-2006. GADO S.R.L (ITALY LIMITED LIABILITY COMPANY) VIA GOLDONI, 10, MILANO, ITALY, 20129, SN 76-599,454. FILED 6-28-2004. PRINCIPAL REGISTER.

3,108,608. REG. 6-27-2006. SOCIETY FOR HUMAN RESOURCE MANAGEMENT (OHIO CORPORATION) 1800 DUKE STREET, ALEXANDRIA, VA, 22314, SN 78-325,644. FILED 11-10-2003. PRINCIPAL REGISTER.

D&G

THE MARK CONSISTS OF STANDARD CHARACTERS WITHOUT CLAIM TO ANY PARTICULAR FONT, STYLE, SIZE, OR COLOR.

INT. CL. 3/U.S. CLS. 1, 4, 6, 50, 51 AND 52

FOR PERFUMES, SOLID PERFUMES, PERSONAL DEODORANTS, SOAPS FOR PERSONAL USE; LIQUID SOAPS, TOILET SOAPS, BATH FOAMS, [TOOTH-PASTES, SHAMPOOS, ESSENTIAL OILS FOR PERSONAL USE, HAIR LOTIONS,] HAIR GELS, BATH GELS, [STYLING GELS, HAIR DYES,] FACE CREAMS, EYELINERS, EYE SHADOWS, MAKE UP PENCILS, FACE EARTH, LIPSTICKS, FOND DE TEINT, BODY CREAMS [NAIL POLISHES, NAIL HARDENERS, NAIL POLISH REMOVERS, TANNING OILS AND CREAMS].

FIRST USE 0-0-1999; IN COMMERCE 0-0-1999.

INT. CL. 9/U.S. CLS. 21, 23, 26, 36 AND 38

FOR SPECTACLES, SUNGLASSES, SPECTACLE FRAMES, SPECTACLE LENSES, SPECTACLE CASES [CONTACT LENSES].

FIRST USE 0-0-1998; IN COMMERCE 0-0-1998.

INT. CL. 14/U.S. CLS. 2, 27, 28 AND 50

FOR WATCHES, CLOCKS, WRISTWATCHES, TABLE CLOCKS, POCKET WATCHES, ALARM CLOCKS, DIGITAL CLOCKS, WATERPROOF CLOCKS, WATCH CASES, WATCH CHAINS, WATCH CRYSTALS AND LENSES, WATCH BANDS, CHRONOGRAPHS FOR USE AS A WATCH, JEWELRY ARTICLES AND COSTUME JEWELRY ARTICLES.

FIRST USE 0-0-2001; IN COMMERCE 0-0-2001.

INT. CL. 18/U.S. CLS. 1, 2, 3, 22 AND 41

FOR TOTE BAGS, BOOK BAGS AND SHOULDER BAGS, HANDBAGS, SUITCASES, BRIEFCASES, PURSES, DOCUMENT CASES, HAND PURSES, KEY CASES, TRAVELING TRUNKS, LEATHER AND IMITATION OF HIDES AND LEATHER SOLD IN BULK, PARASOLS, UMBRELLAS, WALKING STICKS, HARNESSES AND OTHER SADDLERY ARTICLES.

FIRST USE 6-28-2004; IN COMMERCE 6-28-2004.

INT. CL. 25/U.S. CLS. 22 AND 39

SHRM LEARNING SYSTEM

THE MARK CONSISTS OF STANDARD CHARACTERS WITHOUT CLAIM TO ANY PARTICULAR FONT, STYLE, SIZE, OR COLOR.

OWNER OF U.S. REG. NOS. 1,668,891, 2,154,782 AND OTHERS.

NO CLAIM IS MADE TO THE EXCLUSIVE RIGHT TO USE "LEARNING SYSTEM", APART FROM THE MARK AS SHOWN.

INT. CL. 16/U.S. CLS. 2, 5, 22, 23, 29, 37, 38 AND 50

FOR EDUCATIONAL PRODUCTS, NAMELY, STUDY MATERIALS AND PROFESSIONAL DEVELOPMENT PROGRAMS IN THE NATURE OF BOOKS AND WORKBOOKS IN THE FIELD OF HUMAN RESOURCES.

FIRST USE 12-1-1987; IN COMMERCE 12-1-1987.

INT. CL. 41/U.S. CLS. 100, 101 AND 107

FOR EDUCATIONAL SERVICES, NAMELY PROVIDING PROFESSIONAL DEVELOPMENT PROGRAMS IN THE NATURE OF SEMINARS FOR THE PURPOSE OF ASSISTING PARTICIPANTS IN OBTAINING PROFESSIONAL ACCREDITATION AND CERTIFICATION IN THE FIELD OF HUMAN RESOURCES.

FIRST USE 12-1-1987; IN COMMERCE 12-1-1987.

ELEMENTS CORRECTED
ENTITY

3,131,348. REG. 8-15-2006. L. SCHULTZ, INC. (CALIFORNIA CORPORATION), DBA LEE'S AQUARIUM & PET PRODUCTS, 130 VENTURE STREET, ATLANTA, GA, 92078, SN 78-363,200. FILED P.R. 2-5-2004; AM. S.R. 4-14-2006. SUPPLEMENTAL REGISTER.

3,152,788. REG. 10-10-2006. MRM HOLDINGS LIMITED (MAURITIUS LIMITED LIABILITY COMPANY) SUITE 802, ST. JAMES CT, PORT LOUIS, MAURITIUS., SN 78-410,279. FILED 4-29-2004. PRINCIPAL REGISTER.

HERP HABITAT

EXOMESH

THE MARK CONSISTS OF STANDARD CHARACTERS WITHOUT CLAIM TO ANY PARTICULAR FONT, STYLE, SIZE, OR COLOR.

NO CLAIM IS MADE TO THE EXCLUSIVE RIGHT TO USE "HABITAT", APART FROM THE MARK AS SHOWN. INT. CL. 16/U.S. CLS. 2, 5, 22, 23, 29, 37, 38 AND 50 FOR TERRARIUM FOR HOUSING PETS, NAMELY AMPHIBIANS, REPTILES AND SIMILAR CREATURES. FIRST USE 3-30-2004; IN COMMERCE 3-30-2004.

THE MARK CONSISTS OF STANDARD CHARACTERS WITHOUT CLAIM TO ANY PARTICULAR FONT, STYLE, SIZE, OR COLOR.

PRIORITY CLAIMED UNDER SEC. 44(D) ON ERPNTY TM OFC APPLICATION NO. 003495777, FILED 10-31-2003. INT. CL. 6/U.S. CLS. 2, 12, 13, 14, 23, 25 AND 50 FOR METAL SECURITY DEVICES, NAMELY, METAL NETTING AND METAL-REINFORCED CLOTH. FIRST USE 1-31-2004; IN COMMERCE 1-31-2004.

ELEMENTS CORRECTED
DBA/AKA
OWNER NAME
OWNER ADDRESS

ELEMENTS CORRECTED
OWNER ADDRESS
ENTITY

3,136,521. REG. 8-29-2006. HS TM, LLC (DELAWARE LIMITED LIABILITY COMPANY) 220 CONTINENTAL DRIVE, SUITE 115, NEWARK, DE, 19713, SN 78-335,551. FILED 12-3-2003. PRINCIPAL REGISTER.

3,202,141. REG. 1-23-2007. THE COLUMBUS ZOOLOGICAL PARK ASSOCIATION (OHIO NON-PROFIT CORPORATION) 9990 RIVERSIDE DRIVE, P.O. BOX 400, POWELL, OH, 43065, SN 78-858,513. FILED 4-11-2006. PRINCIPAL REGISTER.

CRITERION



THE MARK CONSISTS OF STANDARD CHARACTERS WITHOUT CLAIM TO ANY PARTICULAR FONT, STYLE, SIZE, OR COLOR.

INT. CL. 5/U.S. CLS. 6, 18, 44, 46, 51 AND 52 FOR GAUZE FOR MEDICAL, DENTAL AND VETERINARY USE. FIRST USE 3-0-2004; IN COMMERCE 3-0-2004.

THE MARK CONSISTS OF THE LETTERS "JAZ" FOLLOWED BY A STYLIZED LETTER "Z" IN THE FORM OF A SAXOPHONE WITH AN EXOTIC BIRD HEAD FOLLOWED BY THE LETTERS "OO".

INT. CL. 41/U.S. CLS. 100, 101 AND 107 FOR ENTERTAINMENT, NAMELY LIVE MUSIC CONCERTS. FIRST USE 7-21-2006; IN COMMERCE 7-21-2006.

ELEMENTS CORRECTED
OWNER ADDRESS

ELEMENTS CORRECTED
OWNER NAME

3,204,911. REG. 2-6-2007. US AVIATION FINANCE, LLC (DELAWARE LIMITED LIABILITY COMPANY) P.O. BOX 999, RICHMOND, VT, 05477, SN 76-658,097. FILED 4-10-2006. PRINCIPAL REGISTER.



OWNER OF U.S. REG. NO. 2,440,114.
 NO CLAIM IS MADE TO THE EXCLUSIVE RIGHT TO USE "US AIRCRAFT FINANCE", APART FROM THE MARK AS SHOWN.
 INT. CL. 36/U.S. CLS. 100, 101 AND 102
 FOR LOAN FINANCING SERVICES RELATING TO THE PURCHASE OF AIRCRAFT.
 FIRST USE 11-30-2005; IN COMMERCE 11-30-2005.

ELEMENTS CORRECTED
 CITIZENSHIP

3,213,439. REG. 2-27-2007. SAN ANTONIO GOLF ASSOCIATION, INC. (TEXAS NON-PROFIT CORPORATION) P.O. BOX 690330, SAN ANTONIO, TX, 78269, SN 78-883,963. FILED 5-15-2006. PRINCIPAL REGISTER.

GOLF SAN ANTONIO

THE MARK CONSISTS OF STANDARD CHARACTERS WITHOUT CLAIM TO ANY PARTICULAR FONT, STYLE, SIZE, OR COLOR.
 OWNER OF U.S. REG. NOS. 2,358,909 AND 2,372,737.
 NO CLAIM IS MADE TO THE EXCLUSIVE RIGHT TO USE "GOLF", APART FROM THE MARK AS SHOWN.
 SEC. 2(F).
 INT. CL. 36/U.S. CLS. 100, 101 AND 102
 FOR CHARITABLE FUNDRAISING SERVICES.
 FIRST USE 2-24-1999; IN COMMERCE 2-24-1999.
 INT. CL. 41/U.S. CLS. 100, 101 AND 107
 FOR ENTERTAINMENT SERVICES IN THE NATURE OF GOLF TOURNAMENTS.
 FIRST USE 2-24-1999; IN COMMERCE 2-24-1999.

ELEMENTS CORRECTED
 ENTITY

3,217,585. REG. 3-13-2007. AUGMENTIX CORPORATION (DELAWARE CORPORATION) 4030 W. BRAKER LANE, BUILDING 2-100, AUSTIN, TX, 78759, SN 78-864,293. FILED 4-18-2006. PRINCIPAL REGISTER.

AUGMENTIX

THE MARK CONSISTS OF STANDARD CHARACTERS WITHOUT CLAIM TO ANY PARTICULAR FONT, STYLE, SIZE, OR COLOR.
 INT. CL. 9/U.S. CLS. 21, 23, 26, 36 AND 38
 FOR COMPUTER HARDWARE, NAMELY COMPUTER SERVERS AND COMPUTER SERVER OPERATING SOFTWARE; INTEGRATED COMPUTER SERVER HARDWARE AND SOFTWARE FOR THE MONITORING, REPORTING, AUTONOMOUS RECOVERY AND REMOTE MANAGEMENT OF COMPUTERS AND SERVERS OVER A GLOBAL COMPUTER NETWORK, AND INSTRUCTION MANUALS SOLD THERewith.
 FIRST USE 11-0-2004; IN COMMERCE 11-0-2004.

ELEMENTS CORRECTED
 CITIZENSHIP

3,232,151. REG. 4-24-2007. WINBROOK COMMUNICATIONS SERVICES, INC. (MASSACHUSETTS CORPORATION) 15 ALEXANDER ROAD, BILLERICA, MA, 018215045, SN 76-648,245. FILED 10-11-2005. PRINCIPAL REGISTER.

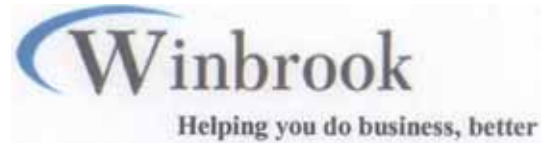

THE COLOR(S) BLACK AND BLUE IS/ARE CLAIMED AS A FEATURE OF THE MARK.
 THE COLOR BLUE APPEARS IN THE CURVED BAR DESIGNS AND THE COLOR BLACK APPEAR IN THE LITERAL ELEMENTS OF THE MARK.
 INT. CL. 35/U.S. CLS. 100, 101 AND 102
 FOR BUSINESS SERVICES, NAMELY, SUPPLY CHAIN MANAGEMENT IN THE PRINTING INDUSTRY.
 FIRST USE 6-20-2005; IN COMMERCE 6-20-2005.

ELEMENTS CORRECTED
 OWNER NAME

3,287,670. REG. 9-4-2007. MRM HOLDINGS LIMITED (MAURITIUS LIMITED LIABILITY COMPANY) ST. JAMES CT ST. DENIS STREET, SUITE 802, PORT LOUIS, MAURITIUS., SN 77-052,819. FILED 11-29-2006. PRINCIPAL REGISTER.

PROSAFE

THE MARK CONSISTS OF STANDARD CHARACTERS WITHOUT CLAIM TO ANY PARTICULAR FONT, STYLE, SIZE, OR COLOR.
 INT. CL. 6/U.S. CLS. 2, 12, 13, 14, 23, 25 AND 50

FOR METAL LOCKS, NAMELY, PADLOCKS, METAL LOCKS, METAL PADLOCKS, COMBINATION LOCKS, CARABINER LOCKS, CABLE LOCKS, METAL SASH LOCKS AND RETRACTABLE CABLE LOCKS; AND LOCKS FOR BAGS, LUGGAGE AND BACKPACKS.
FIRST USE 1-31-2004; IN COMMERCE 1-31-2004.

3,451,810. REG. 6-24-2008. MOSS, LANCE BARNARD (UNITED STATES INDIVIDUAL) 923 CHOCTAWHATCHEE DRIVE, NICEVILLE, FL, 32578, SN 76-683,270. FILED 10-24-2007. PRINCIPAL REGISTER.

ELEMENTS CORRECTED
OWNER ADDRESS
ENTITY

3,317,501. REG. 10-23-2007. PLUM TV, LLC (DELAWARE LIMITED LIABILITY COMPANY) 419 LAFAYETTE STREET, 7TH FLOOR, NEW YORK, NY, 10012, SN 78-839,216. FILED 3-16-2006. PRINCIPAL REGISTER.



OWNER OF U.S. REG. NO. 2,964,562.
THE COLOR(S) PURPLE AND WHITE IS/ARE CLAIMED AS A FEATURE OF THE MARK.
THE MARK CONSISTS OF A PURPLE PLUM DESIGN WITH WHITE LETTERING.
INT. CL. 41/U.S. CLS. 100, 101 AND 107
FOR PRODUCTION AND DISTRIBUTION OF TELEVISION PROGRAMS .
FIRST USE 1-1-2004; IN COMMERCE 1-1-2004.

ELEMENTS CORRECTED
OWNER NAME

3,415,487. REG. 4-22-2008. LIBERTAD BANK SSB (TEXAS STATE SAVINGS BANK), TA LIBERTAD BANK, 512 EAST RIVERSIDE DRIVE, SUITE 100, AUSTIN, TX, 78704, SN 78-262,101. FILED 6-13-2003. PRINCIPAL REGISTER.

LIBERTADFINANCIAL

INT. CL. 36/U.S. CLS. 100, 101 AND 102
FOR FINANCIAL SERVICES, NAMELY, BILL PAYMENT SERVICES, CHECK CASHING AND PROCESSING, CHECKING ACCOUNT SERVICES, CURRENCY EXCHANGE AND ADVICE, ELECTRONIC FUNDS TRANSFER, MONEY LENDING, COMMERCIAL LENDING SERVICES, CREDIT CARD SERVICES, DEBT COUNSELING SERVICES, SAVINGS AND LOAN SERVICES, SAVINGS ACCOUNT SERVICES, DEBIT AND STORED-VALUE CARD SERVICES, MONEY ORDER SERVICES, MORTGAGE BANKING, FINANCIAL PLANNING SERVICES, INVESTMENT MANAGEMENT, [INSURANCE CONSULTATION SERVICES, INSURANCE BROKERAGE,] REAL ESTATE CONSULTATION, AND REAL ESTATE INVESTMENT.
FIRST USE 9-3-2003; IN COMMERCE 12-31-2007.

ELEMENTS AMENDED
GOODS/SERVICES

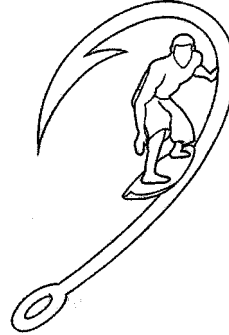

INT. CL. 16/U.S. CLS. 2, 5, 22, 23, 29, 37, 38 AND 50
FOR DECALS CONTAINING LOGOS.
FIRST USE 1-9-2004; IN COMMERCE 1-9-2004.
INT. CL. 25/U.S. CLS. 22 AND 39
FOR CLOTHING CONTAINING LOGO CONSISTING OF HATS, VISORS, T-SHIRTS AND SHIRTS, WALK SHORTS, PANTS, SWEATSHIRTS AND JACKETS, RASHGUARDS, BOARDSHORTS, BAGGIES IN THE NATURE OF SURFING TRUNKS AND SWIM WEAR.
FIRST USE 1-9-2004; IN COMMERCE 1-9-2004.
INT. CL. 39/U.S. CLS. 100 AND 105
FOR ARRANGING OF TOURS FOR THE PURPOSE OF SURFING AND FISHING; CHARTERING OF BOAT AND VEHICLE FOR THE PURPOSE OF SURFING AND FISHING.
FIRST USE 1-9-2004; IN COMMERCE 1-9-2004.

ELEMENTS CORRECTED
DATE OF FIRST USE
DATE OF FIRST USE IN COMMERCE

3,460,213. REG. 7-8-2008. MONSTER TRUCK LTD. (VIRGINIA CORPORATION) 2593 MULCH LANDING RD., VIRGINIA BEACH, VA, 23453, SN 77-105,657. FILED 2-12-2007. PRINCIPAL REGISTER.

StoneCrusher Monster

THE MARK CONSISTS OF STANDARD CHARACTERS WITHOUT CLAIM TO ANY PARTICULAR FONT, STYLE, SIZE, OR COLOR.
NO CLAIM IS MADE TO THE EXCLUSIVE RIGHT TO USE "MONSTER", APART FROM THE MARK AS SHOWN.
INT. CL. 41/U.S. CLS. 100, 101 AND 107
FOR ENTERTAINMENT IN THE NATURE OF AUTOMOBILE RACES; ENTERTAINMENT IN THE NATURE OF MONSTER TRUCK RACING; ENTERTAINMENT SERVICES, NAMELY, PARTICIPATION IN MONSTER TRUCK RACING.
FIRST USE 1-1-2004; IN COMMERCE 1-1-2004.

ELEMENTS CORRECTED
OWNER NAME
OWNER ADDRESS
ENTITY

3,500,660. REG. 9-16-2008. MONSTER TRUCKS LTD. (VIRGINIA CORPORATION) 2593 MULCH LANDING RD., VIRGINIA BEACH, VA, 23453, SN 77-105,664. FILED 2-12-2007. PRINCIPAL REGISTER.

STONE CRUSHER

THE MARK CONSISTS OF STANDARD CHARACTERS WITHOUT CLAIM TO ANY PARTICULAR FONT, STYLE, SIZE, OR COLOR.

INT. CL. 41/U.S. CLS. 100, 101 AND 107

FOR ENTERTAINMENT IN THE NATURE OF AUTOMOBILE RACES; ENTERTAINMENT IN THE NATURE OF MONSTER TRUCK RACING; ENTERTAINMENT SERVICES, NAMELY, PARTICIPATION IN MONSTER TRUCK RACING.

FIRST USE 1-1-2004; IN COMMERCE 1-1-2004.

ELEMENTS CORRECTED

OWNER NAME
OWNER ADDRESS
ENTITY

3,591,454. REG. 3-17-2009. OMIKRON DATA QUALITY GMBH (FED REP GERMANY COMPANY WITH LIMITED LIABILITY) PFÄLZERSTRASSE 35, 75177 PFORZHEIM, FED REP GERMANY., SN 79-051,476. FILED 2-6-2008. PRINCIPAL REGISTER.

Worldmatch

THE MARK CONSISTS OF STANDARD CHARACTERS WITHOUT CLAIM TO ANY PARTICULAR FONT, STYLE, SIZE, OR COLOR.

PRIORITY DATE OF 8-6-2007 IS CLAIMED.

OWNER OF INTERNATIONAL REGISTRATION 0957672 DATED 2-6-2008, EXPIRES 2-6-2018.

INT. CL. 9/U.S. CLS. 21, 23, 26, 36 AND 38

FOR APPARATUS FOR RECORDING, TRANSMISSION OR REPRODUCTION OF DATA, SOUND OR IMAGES; BLANK OPTICAL DATA CARRIERS; BLANK MAGNETIC DATA CARRIERS; DATA PROCESSORS; COMPUTERS; COMPUTER PERIPHERALS; RECORDED OR DOWNLOADABLE DATA PROCESSING PROGRAMS AND SOFTWARE, IN PARTICULAR SOFTWARE FOR COMPUTERS; PARTS AND FITTINGS FOR THE AFORESAID GOODS.

FIRST USE ; IN COMMERCE .

INT. CL. 16/U.S. CLS. 2, 5, 22, 23, 29, 37, 38 AND 50

FOR PAPER, CARDBOARD AND GOODS MADE FROM THESE MATERIALS, NAMELY, BOXES AND PACKAGING CONTAINERS OF CARDBOARD OR PAPER * EXCEPT MAGAZINES, NEWSPAPERS AND PERIODICALS *; PRINTED MATTER, NAMELY, DATA PROCESSING PROGRAMS AND SOFTWARE IN PRINTED FORM; HANDBOOKS [IN THE FIELD OF DATA PROCESSING PROGRAMS AND] * FOR * SOFTWARE; MANUALS [IN THE FIELD OF DATA PROCESSING PROGRAMS AND] * FOR * SOFTWARE; PARTS AND FITTINGS FOR THE AFORESAID GOODS.

FIRST USE ; IN COMMERCE .

INT. CL. 38/U.S. CLS. 100, 101 AND 104

FOR [TELECOMMUNICATION SERVICES, NAMELY, TRANSMISSION OF DATA, SOUND OR IMAGES BY TELECOMMUNICATION NETWORKS, WIRELESS COMMUNICATION NETWORKS, THE INTERNET, INFORMATION SERVICES NETWORKS AND DATA NETWORKS;] PROVIDING ACCESS TO THE INTERNET; PROVIDING INTERNET PLATFORMS AND INTERNET PORTALS, NAMELY, INTERNET FORUMS, NEWSGROUPS, WEBSITES FOR DOWNLOADING, USING OR DEMONSTRATING DATA PROCESSING PROGRAMS AND SOFTWARE; [PROVIDING INTERNET CHATROOMS; ELECTRONIC TRANSMISSION OF MESSAGES AND IMAGES;] PROVIDING ACCESS TO DATABASES .

FIRST USE ; IN COMMERCE .

INT. CL. 42/U.S. CLS. 100 AND 101

FOR DESIGN AND DEVELOPMENT OF DATA PROCESSING EQUIPMENT AND COMPUTERS; DESIGN AND DEVELOPMENT OF PERIPHERAL EQUIPMENT FOR COMPUTERS; DESIGN AND DEVELOPMENT OF DATA PROCESSING PROGRAMS AND SOFTWARE, IN PARTICULAR SOFTWARE FOR COMPUTERS; CREATING AND UPDATING DATA PROCESSING PROGRAMS AND SOFTWARE, IN PARTICULAR SOFTWARE FOR COMPUTERS; CREATING AND MAINTAINING WEB SITES FOR OTHERS; PROVIDING SEARCH ENGINES FOR THE INTERNET; CONSULTANCY IN THE FIELD OF DEVELOPMENT AND CREATION OF DATA PROCESSING PROGRAMS AND SOFTWARE, IN PARTICULAR SOFTWARE FOR COMPUTERS; ENGINEERING IN THE FIELD OF DATA PROCESSING; INSTALLATION AND MAINTENANCE OF DATA PROCESSING PROGRAMS AND SOFTWARE, IN PARTICULAR SOFTWARE FOR COMPUTERS; TECHNICAL PROJECT MANAGEMENT IN THE FIELD OF DATA PROCESSING; RENTAL OF DATA PROCESSING EQUIPMENT AND COMPUTERS; RENTAL OF PERIPHERAL EQUIPMENT FOR COMPUTERS; RENTAL OF DATA PROCESSING PROGRAMS AND SOFTWARE, IN PARTICULAR SOFTWARE FOR COMPUTERS; RENTAL OF WEB SERVERS.

FIRST USE ; IN COMMERCE .

ELEMENTS CORRECTED
GOODS/SERVICES

3,605,350. REG. 4-14-2009. WESTERN NEWS&INFO, INC. (ARIZONA CORPORATION) 1748 SOUTH ARIZONA AVENUE, YUMA, AZ, 85364, SN 77-494,483. FILED 6-9-2008. PRINCIPAL REGISTER.

CAMP VERDE BUGLE

THE MARK CONSISTS OF STANDARD CHARACTERS WITHOUT CLAIM TO ANY PARTICULAR FONT, STYLE, SIZE, OR COLOR.

NO CLAIM IS MADE TO THE EXCLUSIVE RIGHT TO USE "CAMP VERDE", APART FROM THE MARK AS SHOWN.

INT. CL. 41/U.S. CLS. 100, 101 AND 107

FOR ONLINE ELECTRONIC PUBLISHING OF BOOKS AND PERIODICALS FROM THE PRIMARY SOURCE.

FIRST USE 1-1-1985; IN COMMERCE 1-1-1985.

ELEMENTS CORRECTED
OWNER NAME

3,606,961. REG. 4-14-2009. HALO LABS, LLC (DELAWARE LIMITED LIABILITY COMPANY) 7TH FLOOR, 419 LA-FAYETTE STREET, NEW YORK, NY, 10003, SN 77-338,448. FILED 11-28-2007. PRINCIPAL REGISTER.

OWNER ADDRESS

CODEBLUE

THE MARK CONSISTS OF STANDARD CHARACTERS WITHOUT CLAIM TO ANY PARTICULAR FONT, STYLE, SIZE, OR COLOR.

INT. CL. 5/U.S. CLS. 6, 18, 44, 46, 51 AND 52
FOR ELECTROLYTE REPLACEMENT SOLUTIONS.
FIRST USE 1-13-2009; IN COMMERCE 1-13-2009.
INT. CL. 32/U.S. CLS. 45, 46 AND 48
FOR FRUIT-FLAVORED BEVERAGES.
FIRST USE 1-13-2009; IN COMMERCE 1-13-2009.

ELEMENTS AMENDED
MARK

3,612,379. REG. 4-28-2009. LEATHER GOODS, INC. (GEORGIA CORPORATION), DBA W. KLEINBERG, 56 EAST ANDREWS DR., SUITE 35, ATLANTA, GA, 30305, SN 77-602,878. FILED 10-29-2008. PRINCIPAL REGISTER.

KLEINBERG SHERRILL

THE MARK CONSISTS OF STANDARD CHARACTERS WITHOUT CLAIM TO ANY PARTICULAR FONT, STYLE, SIZE, OR COLOR.

INT. CL. 25/U.S. CLS. 22 AND 39
FOR BELTS; BELTS MADE OF LEATHER; FABRIC BELTS; LEATHER BELTS.
FIRST USE 5-5-2006; IN COMMERCE 5-5-2006.

ELEMENTS CORRECTED
OWNER NAME
OWNER ADDRESS

3,612,382. REG. 4-28-2009. LEATHER GOODS, INC. (GEORGIA CORPORATION), DBA W. KLEINBERG, 56 EAST ANDREWS DR., SUITE 35, ATLANTA, GA, 30305, SN 77-603,797. FILED 10-30-2008. PRINCIPAL REGISTER.

KLEINBERG SHERRILL

THE MARK CONSISTS OF STANDARD CHARACTERS WITHOUT CLAIM TO ANY PARTICULAR FONT, STYLE, SIZE, OR COLOR.

INT. CL. 18/U.S. CLS. 1, 2, 3, 22 AND 41
FOR EVENING HANDBAGS; FASHION HANDBAGS; HANDBAGS; HANDBAGS, PURSES AND WALLETS; LEATHER HANDBAGS.
FIRST USE 11-5-2002; IN COMMERCE 11-5-2002.

ELEMENTS CORRECTED
OWNER NAME

3,622,233. REG. 5-19-2009. BODY CONTOUR CENTERS, LLC (WASHINGTON LIMITED LIABILITY COMPANY) 13030 121ST WAY NE, SUITE 200, KIRKLAND, WA, 98034, SN 77-562,114. FILED 9-4-2008. PRINCIPAL REGISTER.

SONO BELLO

THE MARK CONSISTS OF STANDARD CHARACTERS WITHOUT CLAIM TO ANY PARTICULAR FONT, STYLE, SIZE, OR COLOR.

THE FOREIGN WORDING IN THE MARK TRANSLATES INTO ENGLISH AS "I AM BEAUTIFUL".

INT. CL. 44/U.S. CLS. 100 AND 101
FOR COSMETIC AND PLASTIC SURGERY, NAMELY, LIPOSUCTION, LASER BODY SCULPTING AND REMOVAL OF FAT CELLS, SURGICAL PROCEDURES THAT TIGHTEN LOOSE SKIN, SURGICAL PROCEDURES THAT REDUCE CELLULITE AND DIMINISH STRETCH MARKS, AND SURGICAL PROCEDURES INVOLVING CELLULOSE REDUCTION USING INFRARED-LIGHT HEAT PROCEDURES.
FIRST USE 6-15-2008; IN COMMERCE 6-15-2008.

ELEMENTS CORRECTED
OWNER NAME

3,642,704. REG. 6-23-2009. LEATHER GOODS, INC. (GEORGIA CORPORATION), DBA W. KLEINBERG, 56 EAST ANDREWS DR., SUITE 35, ATLANTA, GA, 30305, SN 77-602,842. FILED 10-29-2008. PRINCIPAL REGISTER.



THE MARK CONSISTS OF STYLIZED LETTERS "W" AND "K" SEPARATED BY A DIAMOND.

INT. CL. 26/U.S. CLS. 37, 39, 40, 42 AND 50
FOR BELT BUCKLES; BELT BUCKLES OF PRECIOUS METAL; BUCKLES FOR CLOTHING; CLOTHING BUCKLES; STRAP BUCKLES.
FIRST USE 10-5-2005; IN COMMERCE 10-5-2005.

ELEMENTS CORRECTED
OWNER NAME
OWNER ADDRESS

3,658,264. REG. 7-21-2009. ENPEVITA GMBH (FED REP GERMANY LIMITED LIABILITY COMPANY) HOLZ-DAMM 28-32, 20099 HAMBURG, FED REP GERMANY., SN 79-056,774. FILED 4-15-2008. PRINCIPAL REGISTER.



PRIORITY DATE OF 10-19-2007 IS CLAIMED.
OWNER OF INTERNATIONAL REGISTRATION 0972019 DATED 4-15-2008, EXPIRES 4-15-2018.

OWNER OF U.S. REG. NO. 3,436,293.
THE COLOR(S) RED, YELLOW, GREEN AND GREY IS/ARE CLAIMED AS A FEATURE OF THE MARK.

THE MARK CONSISTS OF THREE OVERLAPPING CIRCLE DESIGNS AND THE TERM "ENPENET". THE FIRST CIRCLE IS RED, THE SECOND CIRCLE IS YELLOW, AND THE THIRD CIRCLE IS GREEN. THE TERM "ENPENET" IS GREY.

INT. CL. 9/U.S. CLS. 21, 23, 26, 36 AND 38

FOR COMPUTER SOFTWARE FOR THE COLLECTION, EDITING, ORGANIZING, MODIFYING, BOOK MARKING, TRANSMISSION, STORAGE AND SHARING OF DATA AND INFORMATION; * NONE OF THE AFORESAID GOODS FINANCIAL-RELATED *

FIRST USE : IN COMMERCE .

INT. CL. 35/U.S. CLS. 100, 101 AND 102

FOR BUSINESS MARKETING; PUBLIC RELATIONS; ADVERTISING, IN PARTICULAR BY ADVERTISING BROCHURES, BY RENTAL OF ADVERTISING SPACE AND BY PUBLICATION OF PUBLICITY TEXTS * ALL THE ABOVE SERVICES ALSO WITHIN THE FRAMEWORK OF ELECTRONIC MEDIA *: ONLINE MARKETING, PUBLIC RELATIONS AND ADVERTISING SERVICES; COMPILATION AND SYSTEMATIZATION OF INFORMATION IN COMPUTER DATABASES; * NONE OF THE AFORESAID SERVICES FINANCIAL-RELATED *

FIRST USE : IN COMMERCE .

INT. CL. 38/U.S. CLS. 100, 101 AND 104

FOR TELECOMMUNICATIONS, IN PARTICULAR PROVISION OF E-MAIL OFFERS, CHAT LINES AND FORUMS FOR COMMUNICATIONS ON THE INTERNET, NAMELY, PROVIDING E-MAIL SERVICES, INTERNET CHAT ROOMS AND ONLINE FORUMS FOR TRANSMISSION OF MESSAGES AMONG COMPUTER USERS CONCERNING THE EXCHANGE OF INFORMATION AND EXPERIENCE ON COMPLEX TOPICS, IN PARTICULAR TECHNICAL TOPICS, MEDICAL TOPICS, VETERINARY TOPICS AND SCIENTIFIC TOPICS; SETTING UP AND OPERATING A COMMUNICATIONS NETWORK ON THE INTERNET, NAMELY, PROVIDING REMOTE INTERNET ACCESS; RENTAL OF ACCESS TIME TO DATABASES, NAMELY, RENTAL OF ACCESS TIME TO GLOBAL COMPUTER NETWORKS; * NONE OF THE AFORESAID SERVICES FINANCIAL-RELATED *

FIRST USE : IN COMMERCE .

INT. CL. 42/U.S. CLS. 100 AND 101

FOR DEVELOPMENT AND DESIGN OF COMPUTER SOFTWARE; COMPUTER PROGRAMMING; DESIGN OF INTERNET SITES, NAMELY, DESIGN OF HOMEPAGES AND WEBSITES; PROVISION OF DATA ON AN INTERNET WEBSITE, NAMELY, CONFIGURATION AND CUSTOMIZATION OF COMPUTER DATABASES CONTAINING INFORMATION REGARDING COMPLEX TOPICS, IN PARTICULAR MEDICAL TOPICS, TECHNICAL TOPICS, VETERINARY TOPICS, SCIENTIFIC TOPICS; * NONE OF THE AFORESAID SERVICES FINANCIAL-RELATED *

FIRST USE : IN COMMERCE .

INT. CL. 44/U.S. CLS. 100 AND 101

FOR HYGIENIC AND BEAUTY CARE, NAMELY, PROVIDING HYGIENIC AND BEAUTY CARE INFORMATION, CONSULTANCY AND ADVISORY SERVICES; ADVICE IN MEDICAL QUESTIONS, NAMELY, PROVIDING MEDICAL INFORMATION, CONSULTANCY AND ADVISORY SERVICES; * NONE OF THE AFORESAID SERVICES FINANCIAL-RELATED *

FIRST USE : IN COMMERCE .

ELEMENTS CORRECTED
GOODS/SERVICES

ENTITY

3,663,727. REG. 8-4-2009. TARGET BRANDS, INC. (MINNESOTA CORPORATION) TPS-3165, 1000 NICOLLET MALL, MINNEAPOLIS, MN, 55403, SN 78-794,492. FILED 1-19-2006. PRINCIPAL REGISTER.



OWNER OF U.S. REG. NOS. 972,082, 2,473,434 AND OTHERS.

THE COLOR(S) RED AND BLACK IS/ARE CLAIMED AS A FEATURE OF THE MARK.

THE MARK CONSISTS OF THE WORDS "EXPECT MORE. PAY LESS." IN BLACK WITHIN A CONCENTRIC CIRCLE DESIGN WHERE THE OUTER RING AND CENTER CIRCLE ARE IN RED AND THE INNER RING HAS NO COLOR.

INT. CL. 35/U.S. CLS. 100, 101 AND 102

FOR RETAIL STORES FEATURING A WIDE VARIETY OF CONSUMER GOODS.

FIRST USE 1-15-2006; IN COMMERCE 1-15-2006.

ELEMENTS AMENDED

DESCRIPTION OF MARK

MARK

COLOR DESCRIPTION STATEMENT

[TRANSLITERATION STATEMENT]

3,676,388. REG. 9-1-2009. CRISPIN CIDER COMPANY (MINNESOTA CORPORATION) 405 CENTRAL AVENUE SE, SUITE 110, MINNEAPOLIS, MN, 55414, SN 77-676,173. FILED 2-23-2009. PRINCIPAL REGISTER.

CRISPIN

THE MARK CONSISTS OF STANDARD CHARACTERS WITHOUT CLAIM TO ANY PARTICULAR FONT, STYLE, SIZE, OR COLOR.

INT. CL. 33/U.S. CLS. 47 AND 49

FOR [ALCOHOLIC BEVERAGES EXCEPT BEERS;] HARD CIDER.

FIRST USE 7-27-2007; IN COMMERCE 9-17-2008.

ELEMENTS AMENDED

GOODS/SERVICES

OWNER ADDRESS

3,723,187. REG. 12-8-2009. HOTELS.COM, LP (TEXAS LIMITED PARTNERSHIP) 10440 N. CENTRAL EXPRESSWAY, DALLAS, TX, 75231, SN 77-466,108. FILED 5-5-2008. PRINCIPAL REGISTER.

WELCOME REWARDS

THE MARK CONSISTS OF STANDARD CHARACTERS WITHOUT CLAIM TO ANY PARTICULAR FONT, STYLE, SIZE, OR COLOR.

INT. CL. 35/U.S. CLS. 100, 101 AND 102

FOR CONDUCTING INCENTIVE AWARD PROGRAMS TO PROMOTE THE SALE OF ACCOMMODATIONS, HOTEL AND MOTEL ROOMS; CONSUMER LOYALTY SERVICES FOR COMMERCIAL, PROMOTIONAL, AND ADVERTISING PURPOSES, NAMELY, ADMINISTRATION OF FREQUENT TRAVELER PROGRAM; CUSTOMER LOYALTY SERVICES AND CUSTOMER CLUB SERVICES, FOR COMMERCIAL, PROMOTIONAL AND/OR ADVERTISING PURPOSES. FIRST USE 6-9-2008; IN COMMERCE 6-9-2008.

ELEMENTS AMENDED
MARK

3,743,493. REG. 1-26-2010. QOL LABS, LLC (DELAWARE LIMITED LIABILITY COMPANY) 2975 WESTCHESTER AVENUE, SUITE G-01, PURCHASE, NY, 10577, SN 77-726,160. FILED P.R. 4-30-2009; AM. S.R. 12-2-2009. SUPPLEMENTAL REGISTER.

CoQ10-SR

THE MARK CONSISTS OF STANDARD CHARACTERS WITHOUT CLAIM TO ANY PARTICULAR FONT, STYLE, SIZE, OR COLOR.

INT. CL. 5/U.S. CLS. 6, 18, 44, 46, 51 AND 52

FOR DIETARY SUPPLEMENTS. FIRST USE 8-19-2009; IN COMMERCE 8-19-2009.

ELEMENTS CORRECTED
OWNER NAME

3,751,995. REG. 2-23-2010. ARMAND AGRA, INC. (NEVADA CORPORATION) P.O. BOX 12760, RENO, NV, 89510, SN 77-782,099. FILED 7-15-2009. PRINCIPAL REGISTER.



WHOLESALE MEAT & SEAFOOD PURVEYORS
RENO, NV

NO CLAIM IS MADE TO THE EXCLUSIVE RIGHT TO USE "MEAT & SEAFOOD" AND "EST. 1948" AND "WHOLESALE MEAT & SEAFOOD PURVEYORS RENO, NV", APART FROM THE MARK AS SHOWN.

THE MARK CONSISTS OF A HORIZONTAL OVAL WITH THE NAME "SIERRA MEAT & SEAFOOD" WITHIN THE OVAL. TREES AND MOUNTAINS AT THE CENTER OF THE OVAL, THE TEXT "EST." IN A DIAMOND-SHAPED DESIGN WITHIN THE OVAL TO THE LEFT, THE TEXT "1948" IN A DIAMOND-SHAPED DESIGN WITHIN THE OVAL TO THE RIGHT, AND THE TEXT "WHOLESALE MEAT & SEAFOOD PURVEYORS RENO, NV" BELOW THE OVAL.

INT. CL. 35/U.S. CLS. 100, 101 AND 102

FOR WHOLESALE FOOD DISTRIBUTORSHIP SERVICES.

FIRST USE 0-0-2005; IN COMMERCE 0-0-2005.

ELEMENTS CORRECTED
DATE OF FIRST USE

3,784,929. REG. 5-4-2010. THE FURUKAWA ELECTRIC CO., LTD. (JAPAN CORPORATION) 2-3, MARUNOUCHI 2-CHOME, CHIYODA-KU; TOKYO 100-8322, JAPAN., SN 79-066,048. FILED 11-20-2008. PRINCIPAL REGISTER.



PRIORITY DATE OF 10-10-2008 IS CLAIMED. OWNER OF INTERNATIONAL REGISTRATION 0995420 DATED 11-20-2008, EXPIRES 11-20-2018.

NO CLAIM IS MADE TO THE EXCLUSIVE RIGHT TO USE "E FRIENDLY", APART FROM THE MARK AS SHOWN.

THE COLOR(S) GREEN AND WHITE IS/ARE CLAIMED AS A FEATURE OF THE MARK.

THE MARK CONSISTS OF A GREEN LEAF WITH THE LETTER "E" IN WHITE AND THREE WHITE DOTS OF DIFFERENT SIZES APPEARING ON THE LEAF, FOLLOWED BY THE WORDING "FRIENDLY" IN GREEN.

INT. CL. 6/U.S. CLS. 2, 12, 13, 14, 23, 25 AND 50

FOR NONFERROUS METALS AND THEIR ALLOYS; METAL MATERIALS FOR BUILDING OR CONSTRUCTION, NAMELY, WATER-PIPES OF METAL, TILES OF METAL, STEEL FRAMES FOR BUILDING, HINGES OF METAL, CEILING TILE BOARDS OF METAL, DOORS OF METAL, PILLARS OF METAL, NAMELY, METAL BEAMS, WINDOWS OF METAL, FLOOR BOARDS OF METAL; KITS FOR MAKING PREFABRICATED METAL BUILDINGS; METAL JUNCTIONS FOR PIPES; METAL FLANGES; METAL HARDWARE, NAMELY, NUTS, SPRINGS, WASHERS, PLUGS, AND BOLTS. FIRST USE ; IN COMMERCE .

INT. CL. 9/U.S. CLS. 21, 23, 26, 36 AND 38

FOR MEASURING OR TESTING MACHINES AND INSTRUMENTS, NAMELY, DERIVED-UNIT MEASURING MACHINES AND APPARATUS, STRAIGHTNESS TESTING MACHINES AND APPARATUS FOR TESTING OPTICAL CONNECTORS, BROADBAND SYSTEMS, NETWORK EQUIPMENT, FLOW CYTOMETERS, AND MACHINE ELEMENTS FOR LAND VEHICLES, MATERIAL TESTING MACHINES FOR TESTING METALS, PLASTIC SEMI-WORKED PRODUCTS; SURVEYING MACHINES AND INSTRUMENTS; POWER DISTRIBUTION OR CONTROL DEVICES AND APPARATUS, NAMELY, ELECTRIC POWER DISTRIBUTION BLOCKS, ELECTRIC POWER DISTRIBUTION BOXES, ELECTRIC SWITCHES, ELECTRIC RELAYS, CIRCUIT BREAKERS, POWER CONTROLLERS, CURRENT RECTIFIERS, ELECTRIC CONNECTORS, ELECTRIC CIRCUIT CLOSER, ELECTRIC CAPACITORS, ELECTRIC RESISTORS, PLUG ADAPTORS, FUSES FOR ELECTRIC CURRENT, ELECTRIC TRANSFORMERS; ROTARY CONVERTERS; PHASE MODIFIERS FOR REGULATING ELECTRICAL VOLTAGE; BATTERIES, DRY CELLS, WET CELLS, AND PHOTO VOLTAIC CELLS; ELECTRIC WIRES AND CABLES; WIRE HARNESS COMPRISING ELECTRIC WIRES FOR AUTOMOBILES; TELECOMMUNICATION DEVICES AND APPARATUS, NAMELY, FIBER TO THE HOME (FTTH) SYSTEMS, GIGABIT ETHERNET-PASSIVE OPTICAL NETWORK (GE-PON FTTH) SYSTEMS,

FIBER TO THE X (WDM FTTX) SYSTEMS, COMMUNITY ANTENNA TELEVISION (CATV) SYSTEMS, AND ASYNCHRONOUS TRANSFER MODE DEVICES, ALL COMPRISING TELECOMMUNICATIONS TOWERS, TELECOMMUNICATIONS CABLES, TELECOMMUNICATIONS EXCHANGERS, TELECOMMUNICATIONS SWITCHES, NETWORK ROUTERS, NETWORK HUBS, AND COMMUNICATION SWITCHING HUBS; TELECOMMUNICATION DEVICES AND APPARATUS, NAMELY, OPTICAL MONITORING SYSTEMS COMPRISING OPTICAL FIBER CABLES; TRANSCEIVERS; ELECTRONIC DEVICES, APPARATUS AND THEIR PARTS, NAMELY, HEAT-RESISTANT TAPE INSULATED MAGNETIC WIRES SOLD AS INTEGRATED COMPONENTS OF HEAT SINKS FOR USE IN COMPUTERS AND ELECTRONICS; HEAT PIPES SOLD AS INTEGRATED COMPONENTS OF HEAT SINKS FOR USE IN COMPUTERS AND ELECTRONICS; CRIMP FIN HEAT SINKS FOR USE IN COMPUTERS AND ELECTRONICS; CHIP ANTENNAS; PRINTED CIRCUIT BOARDS; DISC MEMORIES.

FIRST USE ; IN COMMERCE .

INT. CL. 12/U.S. CLS. 19, 21, 23, 31, 35 AND 44

FOR MACHINE ELEMENTS FOR LAND VEHICLES, NAMELY, DRIVE SHAFTS, AXLES OR SPINDLES FOR VEHICLE AXLES, WHEEL BEARINGS, DRIVE SHAFT COUPLINGS OR CONNECTORS, POWER TRANSMISSIONS AND DRIVE GEARINGS, SHOCK ABSORBERS, SHOCK SPRINGS, BRAKES; ANTI-THEFT ALARMS FOR VEHICLES [; VESSELS AND THEIR PARTS AND FITTINGS; AIRCRAFT AND THEIR STRUCTURAL PARTS AND STRUCTURAL FITTINGS; RAILWAY ROLLING STOCK AND THEIR STRUCTURAL PARTS AND STRUCTURAL FITTINGS; AUTOMOBILES AND THEIR STRUCTURAL PARTS AND STRUCTURAL FITTINGS; TWO-WHEELED MOTOR VEHICLES, BICYCLES AND THEIR STRUCTURAL PARTS AND STRUCTURAL FITTINGS] .

FIRST USE ; IN COMMERCE .

INT. CL. 17/U.S. CLS. 1, 5, 12, 13, 35 AND 50

FOR JUNCTIONS NOT OF METAL FOR PLASTIC AND METAL PIPES FOR INDUSTRIAL PURPOSES; JOINT PACKING FOR METAL AND PLASTIC PIPES FOR INDUSTRIAL PURPOSES; ELECTRICAL INSULATING MATERIALS; INDUSTRIAL PACKAGING CONTAINERS OF RUBBER; RUBBER STOPPERS; RUBBER LIDS AND CAPS FOR INDUSTRIAL PACKAGING CONTAINERS; [PLASTIC SHEETING FOR AGRICULTURAL PURPOSES;] PLASTIC SEMI-WORKED PRODUCTS FOR USE AS MATERIAL, NAMELY, SYNTHETIC PLASTIC AS SEMI-FINISHED PRODUCTS IN FORM OF FOILS, PLATES, RODS, PROFILES, HOSES, TUBES, BLOCKS; RUBBER.

FIRST USE ; IN COMMERCE .

INT. CL. 35/U.S. CLS. 100, 101 AND 102

FOR RETAIL STORE SERVICES AND WHOLESALE DISTRIBUTORSHIP SERVICES FEATURING NON-FERROUS METALS AND THEIR ALLOYS, METAL MATERIALS FOR BUILDING OR CONSTRUCTION, METAL HARDWARE, MEASURING OR TESTING MACHINES AND INSTRUMENTS, BATTERIES AND CELLS, ELECTRIC WIRES AND CABLES, TELECOMMUNICATION DEVICES AND APPARATUS, ELECTRONIC MACHINES, APPARATUS AND THEIR PARTS, [AUTOMOBILES AND THEIR PARTS AND FITTINGS.] ELECTRICAL INSULATING MATERIALS, AND PLASTIC SEMI-WORKED PRODUCTS FOR USE AS MATERIAL.

FIRST USE ; IN COMMERCE .

ELEMENTS CORRECTED
GOODS/SERVICES

3,801,217. REG. 6-8-2010. CENTRAL GARDEN & PET COMPANY (DELAWARE CORPORATION) 1340 TREAT BOULEVARD, SUITE 600, WALNUT CREEK, CA, 94597, SN 78-791,374. FILED 1-13-2006. PRINCIPAL REGISTER.

PET BLISS

THE MARK CONSISTS OF STANDARD CHARACTERS WITHOUT CLAIM TO ANY PARTICULAR FONT, STYLE, SIZE, OR COLOR.

NO CLAIM IS MADE TO THE EXCLUSIVE RIGHT TO USE "PET", APART FROM THE MARK AS SHOWN.

INT. CL. 3/U.S. CLS. 1, 4, 6, 50, 51 AND 52

FOR [NON-MEDICATED GROOMING PREPARATIONS FOR PETS, NAMELY, WIPES] .

FIRST USE 10-6-2009; IN COMMERCE 10-19-2009.

INT. CL. 28/U.S. CLS. 22, 23, 38 AND 50

FOR DOG TOYS; PET TOYS.

FIRST USE 1-7-2010; IN COMMERCE 1-19-2010.

INT. CL. 31/U.S. CLS. 1 AND 46

FOR CONSUMABLE PET CHEWS; DIGESTIBLE CHEWING BONES FOR DOGS; DOG TREATS.

FIRST USE 1-7-2010; IN COMMERCE 1-19-2010.

ELEMENTS AMENDED
GOODS/SERVICES

3,828,376. REG. 8-3-2010. KABUSHIKI KAISHA SQUARE ENIX HOLDINGS (ALSO TRADING AS SQUARE ENIX HOLDINGS CO., LTD.) (JAPAN CORPORATION) 3-22-7 YOYOGI, SHIBUYA-KU, TOKYO, JAPAN., SN 78-310,830. FILED 10-8-2003. PRINCIPAL REGISTER.

DRAGON QUEST

OWNER OF JAPAN REG. NO. 4925996, DATED 2-3-2006, EXPIRES 2-3-2016.

INT. CL. 9/U.S. CLS. 21, 23, 26, 36 AND 38

FOR (BASED ON USE IN COMMERCE AND BASED ON 44(E)) COMPUTER GAME SOFTWARE; VIDEO GAME SOFTWARE; (BASED ON 44(E)) MOUSE PADS; MEMORY CARDS; MEMORY CARD CASES; CD CASES; COMPUTER KEYBOARDS; COMPUTER AND VIDEO GAME JOYSTICKS; VIDEO GAME CONTROLLERS; DOWNLOADABLE VIDEO RECORDINGS FEATURING CARTOON CHARACTERS AND/OR VIDEO GAME CHARACTERS; DOWNLOADABLE MUSICAL AND SOUND RECORDINGS; DOWNLOADABLE GAME PROGRAMS.

FIRST USE 5-27-1986; IN COMMERCE 11-15-2005.

INT. CL. 16/U.S. CLS. 2, 5, 22, 23, 29, 37, 38 AND 50

FOR COMPUTER GAME STRATEGY GUIDE BOOKS; VIDEO GAME STRATEGY GUIDEBOOKS.

FIRST USE 8-31-1988; IN COMMERCE 11-15-2005.

INT. CL. 28/U.S. CLS. 22, 23, 38 AND 50

FOR DOLLS; TOY FIGURES; STUFFED TOYS.

FIRST USE 0-0-1990; IN COMMERCE 10-0-2005.

INT. CL. 41/U.S. CLS. 100, 101 AND 107

FOR (BASED ON 44(E)) PROVIDING ON-LINE COMPUTER GAMES AND/OR ON-LINE VIDEO GAMES; PROVIDING INFORMATION ON COMPUTER GAME STRATEGIES AND VIDEO GAME STRATEGIES VIA COMPUTER NETWORKS AND/OR GLOBAL COMMUNICATION NETWORKS; PROVIDING ON-LINE NON-DOWNLOADABLE COMICS; PROVIDING ON-LINE NON-DOWNLOADABLE MAGAZINES IN THE FIELD OF COMPUTER GAMES, VIDEO GAMES, CARTOONS AND GENERAL ENTERTAINMENT.
FIRST USE ; IN COMMERCE .

3,872,637. REG. 11-9-2010. ASCENSION TECHNOLOGY CORPORATION (DELAWARE CORPORATION) PO BOX 527, BURLINGTON, VT, 05402, SN 77-949,161. FILED 3-3-2010. PRINCIPAL REGISTER.

ELEMENTS CORRECTED
GOODS/SERVICES

3D GUIDANCE TRAKSTAR

3,845,301. REG. 9-7-2010. EMERGO (CYPRUS) LIMITED (CYPRUS LIMITED LIABILITY COMPANY) DIMITRA-KOPOULOU 2, 1090 NICOSIA, CYPRUS., SN 78-291,299. FILED 8-22-2003. PRINCIPAL REGISTER.

THE MARK CONSISTS OF STANDARD CHARACTERS WITHOUT CLAIM TO ANY PARTICULAR FONT, STYLE, SIZE, OR COLOR.

OWNER OF U.S. REG. NOS. 3,428,889 AND 3,615,025.
NO CLAIM IS MADE TO THE EXCLUSIVE RIGHT TO USE "3D", APART FROM THE MARK AS SHOWN.
INT. CL. 9/U.S. CLS. 21, 23, 26, 36 AND 38

FOR ELECTRONIC TRACKING SENSOR APPARATUS THAT POSITIONS, MEASURES, AND SENSES THE PRESENCE OF HUMAN AND INSTRUMENT MOVEMENTS AND RECORDS SUCH MOVEMENTS INTO A COMPUTER GRAPHIC SYSTEM; POSITION AND ORIENTATION MOTION CAPTURE ELECTRONIC SENSORS FOR INPUTTING HUMAN MOTION INTO A COMPUTER GRAPHICS SYSTEM.
FIRST USE 4-4-2008; IN COMMERCE 4-4-2008.

ELEMENTS CORRECTED
OWNER NAME

EMERGO

THE MARK CONSISTS OF STANDARD CHARACTERS WITHOUT CLAIM TO ANY PARTICULAR FONT, STYLE, SIZE, OR COLOR.

PRIORITY CLAIMED UNDER SEC. 44(D) ON ERP CMNTY TM OFC APPLICATION NO. 3280344, FILED 8-13-2003, REG. NO. 003280344, DATED 5-14-2009, EXPIRES 8-13-2013.

INT. CL. 35/U.S. CLS. 100, 101 AND 102
FOR ADVERTISING SERVICES; MARKET RESEARCH AND ANALYSIS, RENDERING ADVICE TO ENTERPRISES REGARDING BUSINESS ORGANIZATION; BUSINESS-ECONOMIC CONSULTANCY; BUSINESS CONSULTANCY AND MEDIATION SERVICES IN THE FIELD OF MERGERS AND TAKEOVERS; INTERIM AND BUSINESS PROJECT MANAGEMENT, AS WELL AS CONDUCTING RESEARCH AND CONSULTANCY IN THESE FIELDS; BUSINESS CONSULTANCY AT DRAWING UP BUSINESS PLANS; THE CONTROL AND BUSINESS MANAGEMENT OF COMPANIES AND ORGANIZATIONS, EITHER OR NOT ON INTERIM PROJECT BASIS; PROFESSIONAL CONSULTATION IN THE BUSINESS FIELD; DRAWING UP BUSINESS EXPERTS' REPORTS.

INT. CL. 36/U.S. CLS. 100, 101 AND 102
FOR FINANCIAL SERVICES, NAMELY, FINANCIAL ANALYSIS, CONSULTATION AND MANAGEMENT; CAPITAL INVESTMENT CONSULTATION AND MANAGEMENT AND INVESTMENT CONSULTATION AND MANAGEMENT; RESEARCH AND CONSULTANCY IN THE FIELD OF FINANCINGS AND SHARE HOLDING; LEASE SECURITIZATION SERVICES; REAL ESTATE BROKERAGE..

ELEMENTS CORRECTED
ENTITY

3,872,638. REG. 11-9-2010. ASCENSION TECHNOLOGY CORPORATION (DELAWARE CORPORATION) PO BOX 527, BURLINGTON, VT, 05402, SN 77-949,167. FILED 3-3-2010. PRINCIPAL REGISTER.

3D GUIDANCE DRIVEBAY

THE MARK CONSISTS OF STANDARD CHARACTERS WITHOUT CLAIM TO ANY PARTICULAR FONT, STYLE, SIZE, OR COLOR.

OWNER OF U.S. REG. NOS. 3,428,889 AND 3,615,025.
NO CLAIM IS MADE TO THE EXCLUSIVE RIGHT TO USE "3D", APART FROM THE MARK AS SHOWN.
INT. CL. 9/U.S. CLS. 21, 23, 26, 36 AND 38

FOR ELECTRONIC TRACKING SENSOR APPARATUS THAT POSITIONS, MEASURES, AND SENSES THE PRESENCE OF HUMAN AND INSTRUMENT MOVEMENTS AND RECORDS SUCH MOVEMENTS INTO A COMPUTER GRAPHIC SYSTEM; POSITION AND ORIENTATION MOTION CAPTURE ELECTRONIC SENSORS FOR INPUTTING HUMAN MOTION INTO A COMPUTER GRAPHICS SYSTEM.
FIRST USE 4-3-2008; IN COMMERCE 4-3-2008.

ELEMENTS CORRECTED
OWNER NAME

3,883,652. REG. 11-30-2010. QOL LABS, LLC (DELAWARE LIMITED LIABILITY COMPANY) 2975 WESTCHESTER AVENUE, SUITE G-01, PURCHASE, NY, 10577, SN 77-714,107. FILED 4-15-2009. PRINCIPAL REGISTER.

Allerfin

THE MARK CONSISTS OF STANDARD CHARACTERS WITHOUT CLAIM TO ANY PARTICULAR FONT, STYLE, SIZE, OR COLOR.

INT. CL. 5/U.S. CLS. 6, 18, 44, 46, 51 AND 52
FOR DIETARY AND NUTRITIONAL SUPPLEMENTS.
FIRST USE 12-7-2009; IN COMMERCE 12-7-2009.

ELEMENTS CORRECTED
OWNER NAME

3,909,060. REG. 1-18-2011. QOL LABS, LLC (DELAWARE LIMITED LIABILITY COMPANY) 2975 WESTCHESTER AVENUE, SUITE G-01, PURCHASE, NY, 10577, SN 77-860,208. FILED 10-29-2009. PRINCIPAL REGISTER.

Coremax

THE MARK CONSISTS OF STANDARD CHARACTERS WITHOUT CLAIM TO ANY PARTICULAR FONT, STYLE, SIZE, OR COLOR.

INT. CL. 5/U.S. CLS. 6, 18, 44, 46, 51 AND 52
FOR ALGAE BASED DIETARY AND NUTRITIONAL SUPPLEMENTS FOR BONE HEALTH.
FIRST USE 4-12-2010; IN COMMERCE 4-12-2010.

ELEMENTS CORRECTED
OWNER NAME

3,918,520. REG. 2-15-2011. EMERGO (CYPRUS) LIMITED (CYPRUS INCORPORATED LIMITED LIABILITY COMPANY) DIMITRAKOPOULOU 2, 1090 NICOSIA, CYPRUS., SN 77-785,144. FILED 7-20-2009. PRINCIPAL REGISTER.

EMERGO ENERGY

THE MARK CONSISTS OF STANDARD CHARACTERS WITHOUT CLAIM TO ANY PARTICULAR FONT, STYLE, SIZE, OR COLOR.

OWNER OF ERPN CMNTY TM OFC REG. NO. 8435349, DATED 8-30-2010, EXPIRES 10-15-2019.
NO CLAIM IS MADE TO THE EXCLUSIVE RIGHT TO USE "ENERGY", APART FROM THE MARK AS SHOWN.
INT. CL. 35/U.S. CLS. 100, 101 AND 102

FOR MARKET RESEARCH AND ANALYSIS, RENDERING ADVICE TO ENTERPRISES REGARDING BUSINESS ORGANIZATION; BUSINESS-ECONOMIC CONSULTANCY; BUSINESS CONSULTANCY AND MEDIATION SERVICES IN THE FIELD OF MERGERS, TAKE-OVERS, INVESTMENTS, DISINVESTMENTS, FINANCINGS AND SHARE HOLDINGS WITH REGARD TO ENTERPRISES; INTERIM AND BUSINESS PROJECT MANAGEMENT, AS WELL AS CONDUCTING RESEARCH AND CONSULTANCY IN THESE FIELDS; BUSINESS CONSULTANCY AT DRAWING UP BUSINESS PLANS; THE CONTROL AND BUSINESS MANAGEMENT OF COMPANIES AND ORGANIZATIONS, EITHER OR NOT ON AN INTERIM BASIS; PROFESSIONAL CONSULTATION IN THE BUSINESS FIELD; PREPARING AND DRAWING UP BUSINESS EXPERTS' REPORTS.

FIRST USE ; IN COMMERCE .
INT. CL. 36/U.S. CLS. 100, 101 AND 102

FOR FINANCIAL SERVICES, NAMELY, FINANCIAL ANALYSIS, CONSULTATION AND MANAGEMENT; INVESTMENT SERVICES, NAMELY, INVESTMENT CONSULTATION AND MANAGEMENT SERVICES, CAPITAL INVESTMENT CONSULTATION AND MANAGEMENT SERVICES, PRIVATE EQUITY INVESTMENT CONSULTATION AND MANAGEMENT SERVICES, PRIVATE EQUITY INVESTMENT SERVICES, INVESTING FUNDS FOR OTHERS; RESEARCH AND CONSULTANCY IN THE FIELD OF FINANCINGS AND SHARE HOLDING; FINANCIAL AND INVESTMENT SERVICES IN THE AREA OF ENERGY AND NATURAL RESOURCES, OIL, GAS AND MINING, NAMELY, FINANCIAL ANALYSIS, CONSULTATION AND MANAGEMENT, INVESTMENT CONSULTATION AND MANAGEMENT SERVICES, CAPITAL INVESTMENT CONSULTATION AND MANAGEMENT SERVICES, PRIVATE EQUITY INVESTMENT CONSULTATION AND MANAGEMENT SERVICES, PRIVATE EQUITY INVESTMENT SERVICES, INVESTING FUNDS FOR OTHERS; LEASE SECURITIZATION SERVICES, GUARANTEEING LOANS.

ELEMENTS CORRECTED
OWNER ADDRESS
ENTITY

3,924,813. REG. 3-1-2011. SHIN NIPPON SEITETSU KABUSHIKI KAISHA (ALSO DOING BUSINESS AS NIPPON STEEL CORPORATION) (JAPAN CORPORATION) NO. 6-1, MARUNOUCHI 2-CHOME, CHIYODA-KU, TOKYO, JAPAN, 1008071, SN 79-057,725. FILED 3-12-2008. PRINCIPAL REGISTER.

On the Leading Edge:Nippon Steel

PRIORITY DATE OF 3-4-2008 IS CLAIMED.
OWNER OF INTERNATIONAL REGISTRATION 0974303 DATED 3-12-2008, EXPIRES 3-12-2018.

NO CLAIM IS MADE TO THE EXCLUSIVE RIGHT TO USE "STEEL", APART FROM THE MARK AS SHOWN.
AS TO "NIPPON STEEL".

INT. CL. 1/U.S. CLS. 1

FOR ACRYLIC RESINS, UNPROCESSED; [ADHESIVES FOR INDUSTRIAL PURPOSES;] ALKALIES; ALKALINE IODIDES FOR INDUSTRIAL PURPOSES, NAMELY, ALUMINUM IODIDE, SILVER IODIDE; ALKALINE METALS, NAMELY, SODIUM, POTASSIUM CYANATE, POTASSIUM FERRICYANIDE, POTASSIUM SULPHATE FERTILIZER; ALKALINE-EARTH METALS; ALUMINA; ALUMINUM CHLORIDE; ALUMINUM HYDRATE; ALUMINUM SILICATE; AMMONIA FOR INDUSTRIAL PURPOSES; ANHYDRIDES, NAMELY, PHOSPHORIC ANHYDRIDES, PHTHALIC ANHYDRIDES; ARGON; UNPROCESSED ARTIFICIAL RESINS; AUXILIARY FLUIDS FOR USE WITH ABRASIVES FOR GENERAL INDUSTRIAL USE; BARIUM COMPOUNDS, NAMELY, BARIUM CHLORIDE, BARIUM HYDROXIDE; [BARYTES; BENTONITE;] BENZENE DERIVATIVES BEING INDUSTRIAL CHEMICALS FOR USE IN BIOTECHNOLOGY, PHARMACEUTICALS; BENZOIC ACID; FOUNDRY BINDING SUBSTANCES, NAMELY, FOUNDRY SAND; BRAZING FLUXES; CAR-

BON IN THE NATURE OF NATURAL GRAPHITE; CARBON BLACK FOR INDUSTRIAL PURPOSES; ABSORBING CARBON FOR FILTERS; CATALYSTS, FOR USE IN THE MANUFACTURE OF INDUSTRIAL CHEMICALS; [CERAMIC GLAZINGS;] COMPOSITIONS FOR THE MANUFACTURE OF TECHNICAL CERAMICS, NAMELY, CERAMIC POWDERS FOR MANUFACTURING; CHEMICAL PREPARATIONS FOR FACILITATING THE ALLOYING OF METALS; DRY ICE; UNPROCESSED EPOXY RESINS; FERTILIZERS; UNPROCESSED PLASTICS IN THE NATURE OF FILTERING MATERIALS FOR IMPURITIES REMOVAL IN METAL INDUSTRIES; HELIUM; HYDROGEN; INDUSTRIAL CHEMICALS; KRYPTON; LIME CARBONATE; MAGNESIUM CARBONATE; NAPHTHALENE; NEON; NITROGEN; OXYGEN; PHENOL FOR INDUSTRIAL PURPOSES; UNPROCESSED PLASTICS; RARE EARTHS; CHEMICAL REAGENTS OTHER THAN FOR MEDICAL OR VETERINARY PURPOSES; RAW SALT, NAMELY, SALTS FROM RARE EARTH MINERALS; SALTS AS CHEMICAL PREPARATIONS, NAMELY, METALLATES; SALTS AS FERTILIZERS; SALTS FOR INDUSTRIAL PURPOSES, NAMELY, MAGNESIUM SALTS; SALTS FROM RARE EARTH METALS, NAMELY, SALTS OF ALKALINE METALS, SALTS OF PRECIOUS RARE EARTH METALS FOR INDUSTRIAL PURPOSES; SILICATES, NAMELY, ALUMINUM SILICATE, ZINC SILICATE, SILICON; SODA ASH; SOLDERING FLUXES; SULPHUR; SULPHURIC ACID; UNPROCESSED SYNTHETIC RESINS; TITANIUM DIOXIDE FOR INDUSTRIAL PURPOSES; TOLUENE; WELDING CHEMICALS, NAMELY, GASES FOR WELDING; XENON; INDUSTRIAL CHEMICALS, NAMELY, ZIRCONIA; METAL WELDING FLUXES; AMMONIUM SULPHATE; CALCIUM SILICATE; SILICA GEL; METHANOL; ANTHRACENE; STYRENE MONOMER; CYCLOHEXENE; CHEMICALS FOR INDUSTRIAL USE, NAMELY, BIPHENYLS, ACENAPHTHENES; CHEMICALS FOR INDUSTRIAL USE, NAMELY, TERPHE-NYL; DECAHYDRONAPHTHALENE; TETRAHYDRONAPHTHALENE; CHEMICALS FOR INDUSTRIAL USE, NAMELY, METHYLNAPHTHALENES, PYRENE, FLUORINE, COUMARONE RESIN, PHENANTHRENE, CYCLOHEXANE, BISPHENOL A, CRESOL, XYLENOL, PHTHALIC ANHYDRIDE, PARA-BENZYL-BIPHENYL, INDOLES, SKATOLE, COUMARIN, DIHYDROCOUMARIN, INDENES, ISOQUINOLINES, QUINALDINE, TETRACHLOROPHTHALIC ANHY-DRIDE, DIVINYLBENZENE, DIPHENYLBENZENE, CARBAZOLE, THIOPHEN, AND PYRIDINE; CEMENT BLENDING AGENTS, NAMELY, CONTACT CEMENTS, OIL CEMENT; [SOIL IMPROVING AGENTS;] PHE-NOLIC RESINS; POLYAMIDE RESINS; POLYSTYRENE RESINS; POLYPROPYLENE RESINS; ORGANOME-TALLIC COMPOUNDS, NAMELY, TETRAETHYL LEAD; AMMONIUM SULPHATE FERTILIZER; LIQUID CRYSTAL BEING SINGLE CRYSTAL SOURCE MATERIALS IN THE NATURE OF REFRACTORY METALS FOR USE IN LIQUID CRYSTAL DISPLAY; CERAMIC COMPOSITIONS IN THE FORM OF GRANULES AND POWDERS USED IN THE SINTERING PROCESS OF MANU-FACTURING.

FIRST USE ; IN COMMERCE .

INT. CL. 6/U.S. CLS. 2, 12, 13, 14, 23, 25 AND 50

FOR ALLOYS OF COMMON METAL; ALUMINUM ALLOY, ALUMINUM INGOTS; ALUMINUM FOIL; ALUMINUM WIRE; BALLS OF STEEL; BOXES OF COMMON METAL; BRACKETS OF METAL FOR BUILDING; UNWROUGHT OR SEMI-WROUGHT BRASS; BRAZING ALLOYS; RODS OF METAL FOR BRAZING; METAL BOARDS FOR BUILDING; PREFABRICATED BUILDINGS OF METAL; [CABLE JOINTS OF METAL, NON-ELECTRIC;] UNWROUGHT OR SEMI-WROUGHT CAST IRON; CAST STEEL; UNWROUGHT OR SEMI-WROUGHT COMMON METALS; CONTAINERS OF METAL FOR STORAGE; [CONTAINERS OF METAL FOR TRANSPORT;] UNWROUGHT OR SEMI-WROUGHT COPPER ORES; CRASH BARRIERS OF METAL FOR ROADS; FITTINGS OF METAL FOR BUILDING, NAMELY, STEEL FRAMES FOR BUILDING, METAL WINDOW FRAMES; FLANGES OF METAL; FOUNDRY CHILL-MOULDERS OF METAL; FRAMEWORK OF METAL FOR BUILDING; GOLD SOLDER; [SMALL HARDWARE OF METAL, NAMELY, SPRINGS, NUTS, BOLTS, NAILS, RIVETS, SCREWS AND WASHERS;] INDIUM ORES; INGOTS OF COMMON METAL; IRON ORES; UNWROUGHT OR SEMI-WROUGHT IRON; IRON WIRE; JOISTS OF METAL; UNWROUGHT OR SEMI-WROUGHT LEAD; LININGS

OF METAL FOR BUILDING PURPOSES; MANHOLE COVERS OF METAL; MANUALLY-OPERATED MANIFOLDS OF METAL FOR USE WITH HYDRAULIC AND PNEUMATIC PIPELINE SYSTEMS; MATERIALS OF METAL FOR FUNICULAR RAILWAY PERMANENT TRACKS; METALS IN POWDER FORM USED IN MANUFACTURING; NICKEL; NIOBIUM ORES; [NUTS OF METAL;] PRE-FABRICATED ARCHITECTURAL PILLARS OF METAL FOR BUILDINGS; PIPE MUFFS OF METAL; POLES OF METAL; POSTS OF METAL; CONSTRUCTION SUPPORT PROPS OF METAL; RAILROAD TIES OF METAL; RAILS OF METAL; RAILWAY MATERIAL OF METAL; [RAILWAY POINTS;] RAILWAY SLEEPERS OF METAL; REINFORCING MATERIALS OF METAL FOR BUILDING; SHEET PILES OF METAL; METAL IN THE FORM OF SHEETS AND PLATES; SILVER PLATED TIN ALLOY; SILVER SOLDER; METAL HARDWARE, NAMELY, CABLE JUNCTION SLEEVES; SOLDERING WIRE OF METAL; [METAL SPRINGS;] STEEL ALLOYS; [PREFABRICATED, PORTABLE STEEL BUILDINGS;] STEEL PIPES; STEEL SHEETS; STEEL IN THE FORM OF STRIPS; UNWROUGHT OR SEMI-WROUGHT STEEL; STEEL WIRE; [METAL STEP LADDERS; STOP PIPE COLLARS OF METAL; STOPS OF METAL, NAMELY, METAL VALVES;] STRAP-HINGES OF METAL; TANTALUM; TIN; TINFOIL; TINPLATE; TIN PACKINGS, NAMELY, TIN CANS, SOLD EMPTY; TITANIUM; TITANIUM IRON ORE; TOMBAC; TRELLIS OF METAL; TUBES OF METAL; TUNGSTEN; [METAL TURNABLES FOR RAILWAYS;] VANADIUM; RODS OF METAL FOR WELDING; [WIRE GAUZE;] WIRE OF COMMON METAL; WIRE OF COMMON METAL ALLOYS, EXCEPT FUSE WIRE; WIRE ROPE; ZIRCONIUM ALLOY TUBES AND STRAPS; STEEL BARS; STEEL STRANDS; NON-ELECTRIC STEEL CABLES; STEEL REFRACTORY SHAPES; WIRE OF METAL FOR WELDING; HEAVY PLATE STEEL; HOT-ROLLED STEEL SHEETS AND COILS; COLD-ROLLED STEEL SHEETS AND COILS; TIN FREE STEEL SHEETS AND COILS; ELECTRICAL STEEL SHEETS; GALVANIZED STEEL SHEETS AND COILS.

FIRST USE ; IN COMMERCE .

INT. CL. 7/U.S. CLS. 13, 19, 21, 23, 31, 34 AND 35

FOR [AERATORS;] AIR SUCTION MACHINES; [ANTI-POLLUTION DEVICES FOR MOTORS AND ENGINES;] ATOMIZER MACHINES, NAMELY, SPRAY GUNS FOR PAINT, SPRAYING MACHINES; BEARINGS BEING PARTS OF MACHINES;] BENDING MACHINES; [BOOKBINDING MACHINES FOR INDUSTRIAL PURPOSES;] CATALYTIC CONVERTERS; COMPRESSED AIR ENGINES NOT FOR LAND VEHICLES; COMPRESSED AIR MACHINES; COMPRESSED AIR PUMPS; COMPRESSORS FOR MACHINES; AIR CONDENSING INSTALLATIONS * FOR CHEMICAL PROCESSING *; [CONNECTING RODS FOR MACHINES, MOTORS AND ENGINES;] HYDRAULIC AND PNEUMATIC CONTROL MECHANISMS FOR METALWORKING MACHINES, MINING MACHINES, CONSTRUCTION MACHINES, LOADING-UNLOADING MACHINES * AND CHEMICAL PROCESSING *; [SEMICONDUCTOR MANU-FACTURING MACHINES, ENGINES AND MOTORS;] COUPLINGS FOR MACHINES OTHER THAN FOR LAND VEHICLES;] WASTE CRUSHING MACHINES * FOR METALWORKING, CONSTRUCTION LOADING-UNLOADING AND CHEMICAL PROCESSING *; CUTTING MACHINES * FOR METALWORKING AND CONSTRUCTION *; DRAIN COCKS BEING MACHINE ELEMENTS NOT FOR LAND VEHICLES; DRAINAGE MACHINES FOR CONSTRUCTION IN THE NATURE OF ELECTRIC PUMPS; DRAINAGE MACHINES FOR AGRICULTURE IN THE NATURE OF ELECTRIC PUMPS; APPARATUS FOR DRESSING, NAMELY, POWER-OPERATED CULTIVATORS * FOR METALWORKING *; EXHAUSTS FOR MOTORS AND ENGINES, NAMELY, EXHAUST PIPES FOR LAND VEHICLES; FINISHING MACHINES, NAMELY, CONCRETE FINISHING MACHINES, PLYWOOD FINISHING MACHINES * FOR METALWORKING *; GASIFIERS; GENERATORS OF ELECTRICITY; GRINDING MACHINES; GUIDES FOR METALWORKING MACHINES; HAND-HELD TOOLS, OTHER THAN HAND-OPERATED, NAMELY, POWER-OPERATED TOOLS, NAMELY, BUFFERS; HEAT EXCHANGERS FOR CHEMICAL PROCESSING MACHINES, FOOD OR VEGETABLE PROCESSING MACHINES, HEATING EXCHANGERS BEING PARTS OF ENGINES NOT FOR LAND VEHICLES; HEMMING MACHINE, MACHINE TOOLS HOLDERS * FOR METALWORKING *; INKING APPARATUS FOR PRINTING MACHINES; JOURNAL BOXES

BEING PARTS OF MACHINES; JOURNALS BEING PARTS OF MACHINES; APPARATUS FOR * METALWORKING * MACHINING, NAMELY, METAL WORKING MACHINES, NAMELY, MACHINING CENTERS; EXHAUST MANIFOLD FOR ENGINES; METAL WIRE DRAWING MACHINES; METALWORKING MACHINES, NAMELY, MILLING MACHINES, HORNING MACHINES; COMPRESSION AND EXTRUSION MOULDING MACHINES; FORGING MOULDS; [MUFFLERS FOR MOTORS AND ENGINES; PRINTING MACHINES FOR COMMERCIAL OR INDUSTRIAL USE IN THE NATURE OF PAPER FEEDER MACHINES;] PAPERMAKING MACHINES; PARING MACHINES FOR METALWORKING AND WOODWORKING; PNEUMATIC TRANSPORTERS; ELECTRIC MACHINES AND APPARATUS FOR POLISHING METAL; ELECTRIC MACHINES AND APPARATUS FOR POLISHING STONES; METAL EXTRUSION PRESSES; INDUSTRIAL MACHINE PRESSES; PRESSURE REGULATORS BEING COMPONENT PARTS OF METAL WORKING MACHINES; PRINTING CYLINDERS BEING PARTS OF MACHINES; [PRINTING MACHINES;] PRINTING PLATES; PRINTING PRESSES; PRINTING ROLLERS FOR MACHINES; PROPULSION MECHANISMS OTHER THAN FOR LAND VEHICLES, NAMELY, PROPELLERS FOR MACHINES; PILE DRIVERS; ROLLING MILL CYLINDERS BEING PARTS OF MACHINES; ROLLING MILLS; [ROTARY PRINTING PRESSES;] SEWAGE PULVERIZERS BEING MACHINES; [SHEAF-BINDING MACHINES; SILENCERS AS PART OF EXHAUST SYSTEMS FOR VEHICLE MOTORS AND ENGINES;] SLIDE RESTS BEING PARTS OF MACHINES; [HYDRAULIC CONTROLS IN THE NATURE OF SPEED GOVERNORS FOR MACHINES, ENGINES AND MOTORS, PNEUMATIC CONTROLS IN THE NATURE OF SPEED GOVERNORS FOR MACHINES, ENGINES AND MOTORS; TRANSMISSIONS FOR MACHINES;] METAL TRIMMING MACHINES; [TURBINES OTHER THAN FOR LAND VEHICLES; TYMPANS BEING PARTS OF PRINTING PRESSES;] VIBRATORS MACHINES FOR INDUSTRIAL USE, NAMELY, CONCRETE VIBRATORS; [VULCANIZATION MACHINES;] WASTE COMPACTING MACHINES; WASTE DISPOSERS MACHINES; [WATER HEATERS BEING COMPONENT PARTS OF DISH WASHING MACHINES;] GAS OPERATED WELDING MACHINES; ELECTRIC WELDING MACHINES; [MINING WORKING MACHINES, NAMELY, DRILLS FOR THE MINING INDUSTRY;] INDUSTRIAL ROBOTS FOR METAL WORKING; CONTINUOUS CASTING MACHINES; MACHINES FOR GIVING A PICKLING TREATMENT ON THE SURFACE OF METAL; METAL SURFACE TINNING APPARATUS, NAMELY, A MACHINE FOR TIN-PLATING ON THE SURFACE OF METAL; ANNEALING MACHINES.

FIRST USE ; IN COMMERCE .

INT. CL. 9/U.S. CLS. 21, 23, 26, 36 AND 38

FOR ELECTRONIC AGENDAS; [ANODES;] BAR CODE READERS; BATTERIES, [ELECTRIC; CAPACITORS; CATHODES;] CENTRAL PROCESSING UNITS; INTEGRATED CIRCUIT CHIPS; [CINEMATOGRAPHIC CAMERAS;] RECORDED COMPUTER OPERATING PROGRAMS; COMPUTER PERIPHERAL DEVICES; DOWNLOADABLE COMPUTER SOFTWARE FOR DATABASE MANAGEMENT; COMPUTER SOFTWARE, FOR DATABASE MANAGEMENT RECORDED ON DATA MEDIA; COMPUTERS; [ELECTRIC CONNECTIONS; CONNECTIONS FOR ELECTRIC LINES; ELECTRIC CONTACTS; ELECTRIC CONTACTS OF PRECIOUS METAL;] DATA PROCESSORS; [ELECTRIC DISTRIBUTION CONSOLES;] ELECTRIC ARC CUTTERS; ELECTRIC ARC WELDERS; [ELECTRIC TEMPERATURE LOSS INDICATOR; ELECTRIC PRESSURE LOSS INDICATOR;] ELECTRIC WELDING APPARATUS, NAMELY, LASER WELDING DEVICES; GALVANIZING MACHINES; [ELECTROLYSERS;] SMART CARDS, NAMELY, INTEGRATED CIRCUIT CARDS; INTEGRATED CIRCUITS; INTERCOMMUNICATION APPARATUS, NAMELY, INTERCOMS, WALKIE-TALKIES; [ACCUMULATOR JARS;] JUKE BOXES FOR COMPUTERS; JUNCTION SLEEVES FOR ELECTRIC CABLES; LASERS, NOT FOR MEDICAL PURPOSES; BLANK MAGNETIC DATA MEDIA; MAGNETIC ENCODERS; [MATERIAL TESTING INSTRUMENTS AND MACHINES, NAMELY, RADIATION-MEASURING INSTRUMENTS, METAL COMPRESSION TESTING MACHINES, METAL HARDNESS TESTING MACHINES, METAL STRENGTH TESTING MACHINES; MATHEMATICAL INSTRUMENTS, NAMELY, MEASURING CUPS; MEASURING APPARATUS, NAMELY, BEVELS,

RAIN GAUGES, PRESSURE GAUGE, ACCELEROMETERS, CONCENTRATION METERS, SURFACE ROUGHNESS TESTING MACHINES AND INSTRUMENTS; MEASURING INSTRUMENTS, NAMELY, RESISTANCE MEASURING INSTRUMENTS, INSTRUMENTS FOR MEASURING LENGTH; [OPTICAL MIRRORS; COMPUTER SOFTWARE TO MONITOR AND CONTROL FACTORY MANUFACTURING PROCESSES;] OPTICAL APPARATUS AND INSTRUMENTS, NAMELY, OPTICAL SCANNERS; [OPTICAL CHARACTER READERS;] OPTICAL CONDENSERS; [OPTICAL DATA MEDIA, NAMELY, BLANK OPTICAL DISKS;] PHOTOGRAPHIC, ELECTROSTATIC AND THERMIC PHOTOCOPIERS; [PLATES FOR BATTERIES; PORTABLE TELEPHONES; PRINTED CIRCUITS;] PRISMS; ELECTRIC RESISTANCES; [SEMI-CONDUCTORS; SOLAR BATTERIES; TELEPHONE APPARATUS; TELECOMMUNICATIONS TRANSMITTERS; TELECOMMUNICATIONS TRANSMITTING SETS; VIDEO TELEPHONES; SILICON WAFERS;] WELDING ELECTRODES; [COLOR FILTERS FOR LIQUID CRYSTAL DISPLAY; FLEXIBLE PRINT CIRCUITS; ELECTRICAL COILS; METAL SURFACE GALVANIZING MACHINES; SPARK-GUARDS FOR WELDING, NAMELY, FACE-PROTECTION SHIELDS; DOWNLOADABLE ELECTRONIC PUBLICATIONS, NAMELY, INFORMATION PAMPHLETS, CATALOGUES, NEWSLETTERS AND BOOKS IN THE FIELD OF STEELMAKING, ENGINEERING AND CONSTRUCTION.

FIRST USE ; IN COMMERCE .

INT. CL. 11/U.S. CLS. 13, 21, 23, 31 AND 34

FOR AIR CONDITIONING APPARATUS; AIR CONDITIONING INSTALLATIONS; [AIR COOLING APPARATUS;] ELECTRIC AIR DEODORIZING APPARATUS * FOR INDUSTRIAL PURPOSES *; AIR FILTERING INSTALLATIONS * FOR INDUSTRIAL PURPOSES *; AIR PURIFYING APPARATUS AND MACHINES * FOR INDUSTRIAL PURPOSES *; AIR STERILIZERS * FOR INDUSTRIAL PURPOSES *; ELECTRICAL BOILERS, FURNACE BOILERS, AND HEATING BOILERS, OTHER THAN PARTS OF MACHINES; COOLERS FOR * INDUSTRIAL * FURNACES; COOLING APPLIANCES AND INSTALLATIONS, NAMELY, COOLING DOMES; COOLING INSTALLATIONS AND MACHINES, NAMELY, EVAPORATIVE AIR COOLERS; WATER DESALINATION PLANTS; DISTILLATION APPARATUS; ELECTRIC LAMPS; EVAPORATORS; FILTERS FOR AIR CONDITIONING * FOR INDUSTRIAL PURPOSES *; AIR FILTERS FOR INDUSTRIAL FURNACES; AIR FILTERS FOR INDUSTRIAL BOILERS; AIR FILTERS FOR AIR-CONDITIONING INSTALLATIONS FOR INDUSTRIAL PURPOSES; AIR FILTERS FOR GARBAGE INCINERATORS FOR DOMESTIC USE, AIR FILTERS FOR GARBAGE INCINERATORS FOR INDUSTRIAL INSTALLATIONS; WATER FILTERS FOR WATER PURIFYING APPARATUS; [AIR FILTERS FOR HOUSEHOLD ELECTROTHERMIC APPLIANCES; SHAPED FITTINGS FOR FURNACES, NAMELY, COCKS, BAFFLES;] ECONOMIZERS, NAMELY, DEVICES FOR WARMING FEED WATER IN HEATING BOILERS; FURNACE GRATES BEING COMPONENT PARTS OF INDUSTRIAL FURNACE AND NUCLEAR REACTORS; FURNACE GRATES BEING COMPONENT PARTS OF INDUSTRIAL BOILERS; [FURNACE GRATES BEING COMPONENT PARTS OF INDUSTRIAL COOKING OVENS;] * INDUSTRIAL * FURNACES; AIR COOLING APPARATUS, NAMELY, COOLING VATS FOR * INDUSTRIAL * FURNACES; GAS SCRUBBERS; HEAT EXCHANGERS, NOT PARTS OF MACHINES; HEATING APPARATUS FOR SOLID, LIQUID OR GASEOUS FUELS, NAMELY, HOT-WATER SPACE HEATING APPARATUS; HEATING ELEMENTS * FOR INDUSTRIAL PURPOSES *; HOT WATER HEATING INSTALLATIONS; HOT AIR APPARATUS, NAMELY, HOT AIR SPACE HEATING APPARATUS, HOT AIR BLOWERS; [LIGHTING APPARATUS AND INSTALLATIONS, NAMELY, ELECTRIC LIGHTING FIXTURES, FLAT PANEL LIGHTING APPARATUS, LED (LIGHT EMITTING DIODE) LIGHTING FIXTURES;] LOADING APPARATUS BEING COMPONENT PARTS OF FURNACES; [MIXER TAPS FOR WATER PIPES; PASTEURIZERS FOR USE IN FOOD, BEVERAGE, PHARMACEUTICALS;] PURIFICATION INSTALLATIONS FOR SEWAGE; [REFRIGERATING APPARATUS AND MACHINES, NAMELY, GAS REFRIGERATORS; REFRIGERATING APPLIANCES AND INSTALLATIONS; REFRIGERATING CABINETS; REGULATING ACCESSORIES FOR WATER APPARATUS AND PIPES,

NAMELY, METERED VALVES; SANITARY APPARATUS AND INSTALLATIONS, NAMELY, BATH TUBS, TOILET STOOL UNITS WITH A WASHING WATER SQUIRTER;] STEAM GENERATING INSTALLATIONS; [TOILETS;] WATER FILTERING APPARATUS * FOR INDUSTRIAL PURPOSES *; WATER FLUSHING INSTALLATIONS, NAMELY, FLUSH LEVERS * FOR INDUSTRIAL PURPOSES *; WATER PURIFICATION INSTALLATIONS; WATER PURIFYING APPARATUS AND MACHINES; [WATER STERILIZERS;] WASTE MELTING APPARATUS, NAMELY, WASTE MELTING FURNACE.

FIRST USE ; IN COMMERCE .

INT. CL. 37/U.S. CLS. 100, 103 AND 106

FOR BUILDING CONSTRUCTION; INSTALLATION OF BUILDING INSULATING; BUILDING SEALING; BUILDING DAMP-PROOFING; DEMOLITION OF BUILDINGS; CONSTRUCTION OF AIRPORTS; CONSTRUCTION OF AQUATIC FACILITIES; CONSTRUCTION OF TELECOMMUNICATION TOWERS; HARBOUR CONSTRUCTION; PIER CONSTRUCTION; RESIDENTIAL AND COMMERCIAL BUILDING CONSTRUCTION; ROAD CONSTRUCTION; EARTHWORKS OR CONCRETE CONSTRUCTION; CONSTRUCTION OF BASE-ISOLATION AND VIBRATION-CONTROL DEVICE FOR BUILDING; STEEL STRUCTURE CONSTRUCTION; WAREHOUSE CONSTRUCTION; CONSTRUCTION OF ARTIFICIAL ISLANDS; CONSTRUCTION OF TUNNELS; CONSTRUCTION OF STADIUMS; CONSTRUCTION OF STORAGE TANKS; DRILLING OF WELLS; FACTORY CONSTRUCTION; FURNACE INSTALLATION AND REPAIR; MACHINERY INSTALLATION; PIPELINE CONSTRUCTION AND MAINTENANCE; PLUMBING; RIVETING; UNDERWATER CONSTRUCTION; UNDERWATER REPAIR; CONSTRUCTION OF NATURAL OIL DRILLING PLATFORMS; CONSTRUCTION OF NATURAL GAS DRILLING PLATFORMS; BRIDGE CONSTRUCTION; CONSTRUCTION OF OFFSHORE STRUCTURES; CONSTRUCTION OF COASTAL STRUCTURES; CONSTRUCTION INFORMATION; BUILDING CONSTRUCTION SUPERVISION; INSTALLATION, MAINTENANCE AND REPAIR OF ELECTRICAL POWER PLANTS; INSTALLATION, MAINTENANCE AND REPAIR OF CHEMICAL PLANTS; INSTALLATION, MAINTENANCE AND REPAIR OF STEEL PLANTS; INSTALLATION, MAINTENANCE AND REPAIR OF WASTE TREATMENT PLANTS; INSTALLATION, MAINTENANCE AND REPAIR OF POLYCHLORINATED BIPHENYL TREATMENT PLANT; INSTALLATION, MAINTENANCE AND REPAIR OF RECYCLING PLANTS; INSTALLATION, MAINTENANCE AND REPAIR OF ENERGY PLANTS; INSTALLATION, MAINTENANCE AND REPAIR OF LIQUEFIED NATURAL GAS PLANTS; AIR CONDITIONING APPARATUS INSTALLATION AND REPAIR; INSTALLATION, MAINTENANCE AND REPAIR OF COMPUTER HARDWARE; TELEPHONE INSTALLATION AND REPAIR; ELECTRIC APPLIANCE INSTALLATION AND REPAIR; BOILER CLEANING AND REPAIR; BURNER MAINTENANCE AND REPAIR; PUMP REPAIR [; RENTAL OF BULLDOZERS; RENTAL OF CONSTRUCTION EQUIPMENT; RENTAL OF CRANES FOR CONSTRUCTION; RENTAL OF EXCAVATORS] .

FIRST USE ; IN COMMERCE .

INT. CL. 42/U.S. CLS. 100 AND 101

FOR ARCHITECTURAL CONSULTATION; ARCHITECTURE, NAMELY, ARCHITECTURAL DESIGN; CONSTRUCTION DRAFTING; URBAN PLANNING; ARCHITECTURAL ANALYSIS; ENGINEERING SERVICES IN THE FIELD OF ELECTRICAL POWER PLANT; ENGINEERING SERVICES IN THE FIELD OF CHEMICAL PLANT; ENGINEERING SERVICES IN THE FIELD OF STEEL PLANT; ENGINEERING SERVICES IN THE FIELD OF WASTE TREATMENT PLANT; ENGINEERING SERVICES IN THE FIELD OF POLYCHLORINATED BIPHENYL TREATMENT PLANT; ENGINEERING SERVICES IN THE FIELD OF LIQUEFIED NATURAL GAS PLANTS; ENGINEERING SERVICES IN THE FIELD OF RECYCLING PLANT; ENGINEERING SERVICES IN THE FIELD OF ENERGY PLANTS; ENGINEERING SERVICES IN THE FIELD OF RECEIVING AND STORAGE PLANTS; ENGINEERING SERVICES IN THE FIELD OF FLOATING STRUCTURES; ENGINEERING SERVICES IN THE FIELD OF OFFSHORE STEEL STRUCTURES; DESIGN FOR OTHERS OF BASE-ISOLATION AND VIBRATION-CONTROL DEVICES; TECHNICAL CONSULTATION IN THE FIELD OF EN-

GINEERING SERVICES IN THE FIELD OF ELECTRICAL POWER PLANTS; TECHNICAL CONSULTATION IN THE FIELD OF ENGINEERING SERVICES IN THE FIELD OF CHEMICAL PLANTS; TECHNICAL CONSULTATION IN THE FIELD OF ENGINEERING SERVICES IN THE FIELD OF STEEL PLANTS; TECHNICAL CONSULTATION IN THE FIELD OF ENGINEERING SERVICES IN THE FIELD OF WASTE TREATMENT PLANTS; TECHNICAL CONSULTATION IN THE FIELD OF ENGINEERING SERVICES IN THE FIELD OF POLYCHLORINATED BIPHENYL TREATMENT PLANTS; TECHNICAL CONSULTATION IN THE FIELD OF ENGINEERING SERVICES IN THE FIELD OF LIQUEFIED NATURAL GAS PLANTS; TECHNICAL CONSULTATION IN THE FIELD OF ENGINEERING SERVICES IN THE FIELD OF RECYCLING PLANTS; TECHNICAL CONSULTATION IN THE FIELD OF ENERGY PLANTS; TECHNICAL CONSULTATION IN THE FIELD OF ENGINEERING SERVICES IN THE FIELD OF RECEIVING AND STORAGE PLANTS; TECHNICAL CONSULTATION IN THE FIELD OF ENGINEERING SERVICES IN THE FIELD OF FLOATING STRUCTURES; TECHNICAL CONSULTATION IN THE FIELD OF OFFSHORE STEEL STRUCTURES; TECHNICAL CONSULTANCY IN RELATION TO STEEL MAKING; CONSULTANCY IN THE FIELD OF COMPUTER HARDWARE; COMPUTER PROGRAMMING; COMPUTER SOFTWARE DESIGN; COMPUTER SYSTEM DESIGN; COMPUTER SYSTEM ANALYSIS; COMPUTER VIRUS PROTECTION SERVICES; MAINTENANCE OF COMPUTER SOFTWARE; UPDATING OF COMPUTER SOFTWARE; CONVERSION OF DATA OR DOCUMENTS FROM PHYSICAL TO ELECTRONIC MEDIA; CREATING AND MAINTAINING WEB SITES FOR OTHERS; DATA CONVERSION OF COMPUTER PROGRAMS AND DATA, NOT PHYSICAL CONVERSION; DUPLICATION OF COMPUTER PROGRAMS; INSTALLATION OF COMPUTER SOFTWARE; PROVIDING SEARCH ENGINES FOR OBTAINING DATA ON A GLOBAL COMPUTER NETWORK; RECOVERY OF COMPUTER DATA; COMPUTER SOFTWARE CONSULTANCY; [CHEMICAL ANALYSIS; CHEMICAL RESEARCH; CHEMISTRY SERVICES;] MECHANICAL RESEARCH; TESTING, INSPECTION OR RESEARCH OF PHARMACEUTICALS, COSMETICS OR FOODSTUFF; RESEARCH ON BUILDING CONSTRUCTION OR CITY PLANNING; TESTING OR RESEARCH ON PREVENTION OF POLLUTION; TESTING OR RESEARCH ON ELECTRICITY; TESTING OR RESEARCH ON CIVIL ENGINEERING; TESTING, INSPECTION OR RESEARCH ON AGRICULTURE, LIVESTOCK BREEDING OR FISHERIES; TESTING OR RESEARCH ON MACHINES, APPARATUS AND INSTRUMENTS; MATERIAL TESTING; RESEARCH IN THE FIELD OF ENVIRONMENTAL PROTECTION; UNDERWATER EXPLORATION; COMPUTER RENTAL; RENTAL OF COMPUTER SOFTWARE; RENTAL OF WEB SERVERS; HOSTING COMPUTER WEB SITES FOR OTHERS; CALIBRATION; [TECHNICAL WRITING IN THE NATURE OF DRAFTING OF STANDARD PRACTICE INSTRUCTION FOR OTHERS;] TECHNICAL WRITING IN THE NATURE OF DRAFTING OF STANDARD PRACTICE INSTRUCTION MANUAL * FOR STEELMAKING * FOR OTHERS.

FIRST USE ; IN COMMERCE .

ELEMENTS CORRECTED
GOODS/SERVICES

3,936,174. REG. 3-29-2011. CASABELLA HOLDINGS, LLC (DELAWARE LIMITED LIABILITY COMPANY) 400 CORPORATE DRIVE, BLAUVELT, NY, 10913, SN 77-446,212. FILED 4-11-2008. PRINCIPAL REGISTER.



NO CLAIM IS MADE TO THE EXCLUSIVE RIGHT TO USE "CLEAN", APART FROM THE MARK AS SHOWN. THE COLOR(S) ORANGE IS/ARE CLAIMED AS A FEATURE OF THE MARK.

THE MARK CONSISTS OF THE STYLIZED WORD "BE" IN ORANGE OVER THE STYLIZED WORD "CLEAN" IN ORANGE, SEPARATED BY AN ORANGE HORIZONTAL LINE.

INT. CL. 20/U.S. CLS. 2, 13, 22, 25, 32 AND 50 FOR HOUSEHOLD CLEANING TOOLS, NAMELY, SPONGES, MOPS, BROOMS, BRUSHES AND DUSTERS. FIRST USE 3-15-2008; IN COMMERCE 3-15-2008.

ELEMENTS CORRECTED
OWNER NAME



3,949,592. REG. 4-19-2011. KW AUTOMOTIVE NORTH AMERICA, INC. (CALIFORNIA CORPORATION) 1075 NORTH AVENUE, SANGER, CA, 93657, SN 85-163,198. FILED P.R. 10-28-2010; AM. S.R. 2-28-2011. SUPPLEMENTAL REGISTER.

COMPETITION

THE MARK CONSISTS OF STANDARD CHARACTERS WITHOUT CLAIM TO ANY PARTICULAR FONT, STYLE, SIZE, OR COLOR.

INT. CL. 12/U.S. CLS. 19, 21, 23, 31, 35 AND 44 FOR SUSPENSION SYSTEMS FOR AUTOMOBILES AND COMPONENT PARTS THEREFOR; COILOVERS, SHOCKS, STRUTS, AND SPRINGS, ALL FOR SUSPENSION SYSTEMS FOR AUTOMOBILES. FIRST USE 12-31-2006; IN COMMERCE 12-31-2006.

ELEMENTS CORRECTED
OWNER ADDRESS

3,950,020. REG. 4-26-2011. EMERGO (CYPRUS) LIMITED (CYPRUS INCORPORATED LIMITED LIABILITY COMPANY) PRODROMOU AND DEMETRAKOPOULOU 2, CY-1090 NICOSIA, CYPRUS., SN 79-075,456. FILED 7-9-2009. PRINCIPAL REGISTER.



EMERGO

OWNER OF INTERNATIONAL REGISTRATION 1019746 DATED 7-9-2009, EXPIRES 7-9-2019.

THE MARK CONSISTS OF THE WORDING "EMERGO" WITH THE DESIGN OF A BOAT.

INT. CL. 35/U.S. CLS. 100, 101 AND 102 FOR BUSINESS MANAGEMENT, BUSINESS ADMINISTRATION AND OFFICE FUNCTION SERVICES, NAMELY, MARKET RESEARCH AND ANALYSIS, RENDERING ADVICE TO ENTERPRISES REGARDING BUSINESS ORGANIZATION, BUSINESS CONSULTANCY AT DRAWING UP BUSINESS PLANS, THE CONTROL AND BUSINESS MANAGEMENT OF COMPANIES AND ORGANIZATIONS, PREPARING AND DRAWING UP BUSINESS EXPERTS' REPORTS, INTERIM AND BUSINESS PROJECT MANAGEMENT, BUSINESS CONSULTANCY IN THE FIELD OF MERGERS, TAKEOVERS, INVESTMENTS, DISINVESTMENTS, FINANCINGS AND SHARE HOLDINGS WITH REGARD TO ENTERPRISES; BUSINESS MANAGEMENT; BUSINESS ADMINISTRATION.

FIRST USE ; IN COMMERCE .
INT. CL. 36/U.S. CLS. 100, 101 AND 102

FOR FINANCIAL AND MONETARY AFFAIRS, NAMELY, FINANCIAL ANALYSIS, CONSULTATION AND MANAGEMENT, INVESTMENT CONSULTATION AND MANAGEMENT SERVICES, CAPITAL INVESTMENT CONSULTATION AND MANAGEMENT SERVICES, PRIVATE EQUITY INVESTMENT CONSULTATION AND MANAGEMENT SERVICES, PRIVATE EQUITY INVESTMENT SERVICES, INVESTING FUNDS FOR OTHERS; RESEARCH AND CONSULTANCY IN THE FIELD OF FINANCINGS AND SHARE HOLDING; LEASE SECURITIZATION SERVICES, GUARANTEEING LOANS.

FIRST USE ; IN COMMERCE .

ELEMENTS CORRECTED
ENTITY

3,951,550. REG. 4-26-2011. QOL LABS, LLC (DELAWARE LIMITED LIABILITY COMPANY) 2975 WESTCHESTER AVENUE, SUITE G-01, PURCHASE, NY, 10577, SN 77-787,833. FILED 7-23-2009. PRINCIPAL REGISTER.

4,008,399. REG. 8-9-2011. PLUM TV, INC. (DELAWARE CORPORATION) 555 WASHINGTON AVENUE, MIAMI BEACH, FL, 33139, SN 85-068,158. FILED 6-21-2010. PRINCIPAL REGISTER.

GeniKinoko

THE BEST THINGS IN LIFE ARE PLUM

THE MARK CONSISTS OF STANDARD CHARACTERS WITHOUT CLAIM TO ANY PARTICULAR FONT, STYLE, SIZE, OR COLOR.

INT. CL. 5/U.S. CLS. 6, 18, 44, 46, 51 AND 52
FOR DIETARY AND NUTRITIONAL SUPPLEMENTS.
FIRST USE 8-30-2002; IN COMMERCE 8-30-2002.

THE MARK CONSISTS OF STANDARD CHARACTERS WITHOUT CLAIM TO ANY PARTICULAR FONT, STYLE, SIZE, OR COLOR.

OWNER OF U.S. REG. NOS. 2,964,562 AND 3,317,501.

INT. CL. 41/U.S. CLS. 100, 101 AND 107

FOR PRODUCTION AND DISTRIBUTION OF TELEVISION PROGRAMMING; PRODUCTION AND DISTRIBUTION OF NON-DOWNLOADABLE TELEVISION PROGRAMS VIA VIDEO-ON-DEMAND SERVICE; ENTERTAINMENT SERVICES, NAMELY, PROVIDING AN INTERACTIVE COMMUNITY WEBSITE FEATURING ON-GOING TELEVISION PROGRAMS ABOUT UPSCALE LIFESTYLES AND LINKS TO THE ENTERTAINMENT INFORMATION WEBSITES OF OTHERS VIA THE INTERNET, WIRELESS NETWORKS, INTERACTIVE TELEVISION, IPTV AND INTERNET PROTOCOL BASED DELIVERY METHODS; ONLINE NON-DOWNLOADABLE VIDEOS AND BLOGS FEATURING NEWS AND INFORMATION IN THE FIELDS OF CURRENT EVENT NEWS, ENTERTAINMENT, RECREATION, FOOD, LEISURE AND EDUCATION.

FIRST USE 9-15-2009; IN COMMERCE 9-15-2009.

ELEMENTS CORRECTED
OWNER NAME

ELEMENTS CORRECTED
OWNER NAME
OWNER ADDRESS
ENTITY

3,976,535. REG. 6-14-2011. MIRACOR MEDICAL SYSTEMS GMBH (AUSTRIA PRIVATE LIMITED COMPANY) MARIANNENGASSE 14/14, A-1090 WIEN, AUSTRIA., SN 79-068,469. FILED 3-9-2009. PRINCIPAL REGISTER.

4,013,103. REG. 8-16-2011. REVLOX CONSUMER PRODUCTS CORPORATION (DELAWARE CORPORATION) 237 PARK AVENUE, NEW YORK, NY, 10017, SN 77-891,566. FILED 12-11-2009. PRINCIPAL REGISTER.



Anti-Bite

OWNER OF INTERNATIONAL REGISTRATION 1001851 DATED 3-9-2009, EXPIRES 3-9-2019.

NO CLAIM IS MADE TO THE EXCLUSIVE RIGHT TO USE "MEDICAL SYSTEMS", APART FROM THE MARK AS SHOWN.

THE MARK CONSISTS OF THE WORDING "MIRACOR MEDICAL SYSTEMS" WHERE THE LETTER "O" IN "MIRACOR" IS REPRESENTED BY THE DESIGN OF HIGHLY STYLIZED HEART.

THE WORD "MIRACOR" HAS NO MEANING IN ANY FOREIGN LANGUAGE.

INT. CL. 10/U.S. CLS. 26, 39 AND 44

FOR MEDICAL DEVICES CONSISTING OF A CONSOLE AND CATHETERS FOR USE DURING INTERVENTIONAL CARDIOLOGY OR CARDIAC SURGERY TO INTERMITTENTLY OCCLUDE THE CORONARY SINUS AND FOR USE DURING EXPERIMENTAL PROCEDURES TO UNDERSTAND THE NATURE OF HEMODYNAMICS DURING CORONARY SINUS OCCLUSION, * EXCLUDING DEVICES FOR DENTAL, ORAL SURGERY AND ORTHODONTIC PURPOSES * .

FIRST USE ; IN COMMERCE .
INT. CL. 42/U.S. CLS. 100 AND 101

FOR SCIENTIFIC RESEARCH FOR MEDICAL PURPOSES; RESEARCH ON THERAPEUTIC METHODS, NAMELY, MEDICAL AND SCIENTIFIC RESEARCH IN THE FIELD OF SURGICAL PROCEDURES AND MEDICAL DEVICES FOR INTERVENTIONAL CARDIOLOGY AND CARDIAC SURGERY TO INTERMITTENTLY OCCLUDE THE CORONARY SINUS AND TO UNDERSTAND HEMODYNAMICS DURING CORONARY SINUS OCCLUSION, * ALL AFOREMENTIONED SERVICES, EXCEPT FOR DENTAL, ORAL SURGERY AND ORTHODONTIC PURPOSES * .

FIRST USE ; IN COMMERCE .

THE MARK CONSISTS OF STANDARD CHARACTERS WITHOUT CLAIM TO ANY PARTICULAR FONT, STYLE, SIZE, OR COLOR.

INT. CL. 3/U.S. CLS. 1, 4, 6, 50, 51 AND 52

FOR NAIL POLISH; NAIL CARE PREPARATIONS.
FIRST USE 1-31-2010; IN COMMERCE 1-31-2010.

ELEMENTS CORRECTED
GOODS/SERVICES

ELEMENTS CORRECTED
OWNER NAME

4,020,390. REG. 8-30-2011. SCHROEDER & TREMAYNE, INC. (MISSOURI CORPORATION) 8500 VALCOUR, ST. LOUIS, MO, 63123, SN 85-060,790. FILED 6-11-2010. PRINCIPAL REGISTER.



NO CLAIM IS MADE TO THE EXCLUSIVE RIGHT TO USE "KITCHEN", APART FROM THE MARK AS SHOWN.

THE MARK CONSISTS OF A RECTANGLE DESIGN WITH THE STYLIZED WORDING "KITCHEN BASICS" INSIDE THE RECTANGLE AND WITH A FORK AND KNIFE DESIGN REPRESENTING THE "I" IN "KITCHEN" AND "BASICS". THE OUTER RECTANGLE IS INTENDED TO DELINEATE THE LIMIT OF THE MARK, AND IS NOT CLAIMED AS A FEATURE OF THE MARK.

INT. CL. 21/U.S. CLS. 2, 13, 23, 29, 30, 33, 40 AND 50
 FOR ABSORBENT DISH DRYING MATS MADE OF MICROFIBER FABRICS.
 FIRST USE 2-28-2010; IN COMMERCE 2-28-2010.

ELEMENTS CORRECTED
 GOODS/SERVICES
 DATE OF FIRST USE
 DATE OF FIRST USE IN COMMERCE

4,030,050. REG. 9-20-2011. PRODUCTORES DE MAGUEY Y MEZCAL LOS TRESREYES, S.P.R. DE R.L. (MEXICO SOCIEDAD DE PRODUCCION RURAL DE RESPONSABILIDAD LIMITADA) CALLE NACIONAL NO. 90, BARRIO DE FATIMA, TLACOLULA, OAXACA, MEXICO, 70495, SN 85-124,305. FILED P.R. 9-7-2010; AM. S.R. 7-7-2011. SUPPLEMENTAL REGISTER.

WAHAKA

THE MARK CONSISTS OF STANDARD CHARACTERS WITHOUT CLAIM TO ANY PARTICULAR FONT, STYLE, SIZE, OR COLOR.

INT. CL. 33/U.S. CLS. 47 AND 49
 FOR ALCOHOLIC BEVERAGES, NAMELY, MEZCAL.
 FIRST USE 3-1-2011; IN COMMERCE 3-1-2011.

ELEMENTS CORRECTED
 OWNER NAME

4,040,454. REG. 10-18-2011. GLOBAL UNIT CO., LTD. (JAPAN CORPORATION) 125-3, OAZA UCHIKAWA, CHIKUMASHI, NAGANO 389-0802, JAPAN., SN 79-097,724. FILED 3-10-2011. PRINCIPAL REGISTER.

GOOGIES
 ゲーギーズ

OWNER OF INTERNATIONAL REGISTRATION 1078196 DATED 3-10-2011, EXPIRES 3-10-2021.

THE NON-LATIN CHARACTERS IN THE MARK TRANSLITERATE TO "GU-GI-ZU" AND THIS MEANS "GOOGIES" IN ENGLISH.

INT. CL. 25/U.S. CLS. 22 AND 39

FOR CLOTHING, NAMELY, SHIRTS, JEANS, SWEATSHIRTS, T-SHIRTS, AND BASEBALL JACKETS; GARTERS; SOCK SUSPENDERS; SUSPENDERS (BRACES); WAISTBANDS; BELTS (CLOTHING); SHOES AND BOOTS, OTHER THAN PARTS THEREOF SUCH AS SHOE DOWELS, SHOE PEGS, TONGUES OR PULLSTRAPS FOR SHOES AND BOOTS, HOBNAI LS AND PROTECTIVE METAL FITTINGS FOR SHOES; JAPANESE STYLE WOODEN CLOGS (GETA); JAPANESE STYLE SANDALS (ZORI).

FIRST USE ; IN COMMERCE .

ELEMENTS CORRECTED
 OWNER ADDRESS

4,040,455. REG. 10-18-2011. WINEINC PTY LTD, ACN 110 809 348 (AUSTRALIA PROPRIETARY COMPANY LIMITED BY SHARES) C/- TRADEMARK WORKS, LEVEL 29, CHIFLEY TOWER 2, CHIFLEY SQUARE, SYDNEY, AUSTRALIA., SN 79-097,863. FILED 3-29-2011. PRINCIPAL REGISTER.

SXS

THE MARK CONSISTS OF STANDARD CHARACTERS WITHOUT CLAIM TO ANY PARTICULAR FONT, STYLE, SIZE, OR COLOR.

PRIORITY DATE OF 2-17-2011 IS CLAIMED.

OWNER OF INTERNATIONAL REGISTRATION 1078618 DATED 3-29-2011, EXPIRES 3-29-2021.

INT. CL. 33/U.S. CLS. 47 AND 49

FOR WINE; ALCOHOLIC BEVERAGES (EXCEPT BEER).

FIRST USE ; IN COMMERCE .

ELEMENTS CORRECTED
 OWNER ADDRESS

4,041,520. REG. 10-18-2011. II-VI DELAWARE, INC. (DELAWARE CORPORATION) 1105 NORTH MARKET STREET, SUITE 1300, WILMINGTON, DE, 19801, SN 85-267,099. FILED 3-15-2011. PRINCIPAL REGISTER.

4,049,577. REG. 11-1-2011. GIORDANO VINI S.P.A. (ITALY COMPANY) VIA CANE GUIDO N. 47 BIS- 50, 12055 VALLE TALLORIA DI DIANO D'ALBA, CUNEO, ITALY., SN 77-489,516. FILED 6-3-2008. PRINCIPAL REGISTER.

II-VI

THE MARK CONSISTS OF STANDARD CHARACTERS WITHOUT CLAIM TO ANY PARTICULAR FONT, STYLE, SIZE, OR COLOR.

OWNER OF U.S. REG. NO. 1,637,468.
 INT. CL. 9/U.S. CLS. 21, 23, 26, 36 AND 38
 FOR OPTICAL PRODUCTS, NAMELY, LENSES, REFLECTORS, MIRRORS, WINDOWS, BEAM EXPANDER-CONDENSERS, WAVEPLATES, PHASE RETARDERS, POLARIZER-ANALYZER-ATTENUATORS, THIN FILM POLARIZERS AND ELECTRO-OPTICAL MODULATORS.

FIRST USE 6-30-2004; IN COMMERCE 6-30-2004.

ELEMENTS CORRECTED
 OWNER NAME
 OWNER ADDRESS
 CITIZENSHIP

4,042,933. REG. 10-18-2011. STAYSTAFFED TECHNOLOGIES, LLC (FLORIDA LIMITED LIABILITY COMPANY) SUITE 203, 1615 SOUTH FEDERAL HIGHWAY, BOCA RATON, FL, 33432, SN 85-040,357. FILED 5-17-2010. PRINCIPAL REGISTER.

CANDIDATE DIRECT MARKETPLACE

THE MARK CONSISTS OF STANDARD CHARACTERS WITHOUT CLAIM TO ANY PARTICULAR FONT, STYLE, SIZE, OR COLOR.

OWNER OF U.S. REG. NOS. 3,299,242 AND 3,695,390.
 NO CLAIM IS MADE TO THE EXCLUSIVE RIGHT TO USE "CANDIDATE" AND "MARKETPLACE", APART FROM THE MARK AS SHOWN.

INT. CL. 35/U.S. CLS. 100, 101 AND 102
 FOR PROVIDING A WEBSITE FEATURING NEWS AND INFORMATION IN THE FIELD OF HEALTHCARE STAFFING, WHERE INDIVIDUAL HEALTHCARE PRACTITIONERS, AGENCIES AND EMPLOYERS IN THE HEALTHCARE FIELD CAN ADVERTISE AVAILABLE POSITIONS, DISCUSS AND COME TO TERMS WITH REGARD TO SERVICES AND PRICING AND MANAGE THEIR STAFFING FUNCTIONS.

FIRST USE 6-30-2010; IN COMMERCE 6-30-2010.

ELEMENTS CORRECTED
 [PRIOR U.S. REGS.]

TERRE DEI GIGLI

THE MARK CONSISTS OF STANDARD CHARACTERS WITHOUT CLAIM TO ANY PARTICULAR FONT, STYLE, SIZE, OR COLOR.

THE ENGLISH TRANSLATION OF "TERRE DEI GIGLI" IN THE MARK IS "LANDS OF LILIES".

INT. CL. 29/U.S. CL. 46
 FOR EXTRA VIRGIN OLIVE OIL.
 FIRST USE 4-10-2010; IN COMMERCE 4-10-2010.
 INT. CL. 30/U.S. CL. 46
 FOR TOASTED BREAD OLIVE-TASTING, EGG NOODLES.
 FIRST USE 4-10-2010; IN COMMERCE 4-10-2010.

ELEMENTS CORRECTED
 OWNER ADDRESS

4,058,230. REG. 11-22-2011. FMS WERTMANAGEMENT AÖR (FED REP GERMANY PUBLIC-LAW INSTITUTION) FREISINGER STRASSE 11, 85716 UNTERSCHLEISSHEIM, FED REP GERMANY., SN 79-092,390. FILED 10-27-2010. PRINCIPAL REGISTER.

FMS-WM

THE MARK CONSISTS OF STANDARD CHARACTERS WITHOUT CLAIM TO ANY PARTICULAR FONT, STYLE, SIZE, OR COLOR.

OWNER OF INTERNATIONAL REGISTRATION 1064585 DATED 10-27-2010, EXPIRES 10-27-2020.

INT. CL. 16/U.S. CLS. 2, 5, 22, 23, 29, 37, 38 AND 50
 FOR PRINTED MATTER, NAMELY, BOOKS, MANUALS, NEWSLETTERS, PRESS-RELEASES, BOOKLETS, BROCHURES, LEAFLETS AND PAMPHLETS, ALL IN THE FIELDS OF INSURANCE, BANKING AND FINANCIAL SERVICES.

FIRST USE ; IN COMMERCE .
 INT. CL. 35/U.S. CLS. 100, 101 AND 102
 FOR ADVERTISING, PARTICULARLY ADVERTISING FOR BANKING AND FINANCIAL SERVICES; BUSINESS MARKETING SERVICES FOR OTHERS IN THE FIELD OF FINANCE, INSURANCE AND INVESTMENTS.

FIRST USE ; IN COMMERCE .
 INT. CL. 36/U.S. CLS. 100, 101 AND 102

FOR INSURANCE SERVICES, NAMELY, INSURANCE UNDERWRITING CONSULTATION; FINANCIAL SERVICES, NAMELY, FINANCIAL ASSET MANAGEMENT AND ADMINISTRATION, FINANCIAL ANALYSIS AND PLANNING; FINANCIAL ADVISORY AND CONSULTANCY SERVICES; FINANCIAL TRANSACTION SERVICES, NAMELY, FINANCING OF REAL ESTATE AND INFRASTRUCTURE PROJECTS, PROVIDING FINANCING AND LOANS TO CORPORATIONS AND INDUSTRY; TAKEOVER OF INSURANCE AND SECURITIES TRANSACTIONS EMISSION GUARANTEES, NAMELY, GUARANTEE ASSURANCE UNDERWRITING .
 FIRST USE ; IN COMMERCE .

ELEMENTS CORRECTED
 GOODS/SERVICES

4,062,512. REG. 11-29-2011. EMERGO (CYPRUS) LIMITED (CYPRUS INCORPORATED LIMITED LIABILITY COMPANY) DIMITRAKOPOULOU 2, 1090 NICOSIA, CYPRUS., SN 85-219,845. FILED 1-18-2011. PRINCIPAL REGISTER.



PRIORITY CLAIMED UNDER SEC. 44(D) ON ERP N CMNTY TM OFC APPLICATION NO. 9480773, FILED 10-28-2010, REG. NO. 009480773, DATED 3-14-2011, EXPIRES 10-28-2020.

OWNER OF U.S. REG. NOS. 3,081,588, 3,950,020 AND OTHERS.

NO CLAIM IS MADE TO THE EXCLUSIVE RIGHT TO USE "ENERGY", APART FROM THE MARK AS SHOWN.

THE COLOR(S) LIGHT BLUE, BLUE AND GREEN IS/ARE CLAIMED AS A FEATURE OF THE MARK.

THE MARK CONSISTS OF THE WORDS "EMERGO" AND "ENERGY" IN BLUE WITH A SHADOW AND A BLUE WATER DROP IN BETWEEN. INSIDE THE WATER DROP TO THE BOTTOM RIGHT IS A BOAT. THE BOAT IS GREEN, WITH A BLUE SAIL, A GREEN FLAG, AND IS ON A BLUE WAVE. ABOVE THE BOAT IN THE WATER DROP IS A SPOT OF LIGHT THAT PROJECTS LIGHT BLUE LINES FROM ITS RIGHT AND LEFT SIDE THAT STRIKE THROUGH THE WORDS "EMERGO" AND "ENERGY". SURROUNDING THE WATER DROP IS A BLUE CIRCLE AURA. THE COLOR WHITE IS NOT A FEATURE OF THE MARK AND THE WHITE AREAS IN THE DRAWING REPRESENT THE TRANSPARENT AREAS IN THE MARK. INT. CL. 35/U.S. CLS. 100, 101 AND 102

FOR MARKET RESEARCH AND ANALYSIS; DEVELOPMENT OF MARKETING STRATEGIES AND CONCEPTS; RENDERING ADVICE TO ENTERPRISES REGARDING BUSINESS ORGANIZATION, BUSINESS PLANNING, BUSINESS ANALYSIS, BUSINESS MANAGEMENT AND BUSINESS MARKETING; BUSINESS-ECONOMIC CONSULTANCY; BUSINESS CONSULTANCY IN THE FIELD OF MERGERS, TAKE-OVERS, INVESTMENTS, DISINVESTMENTS, FINANCING AND SHARE HOLDINGS WITH REGARD TO ENTERPRISES; BUSINESS ADVICE RELATING TO ACQUISITIONS; BUSINESS PROJECT MANAGEMENT, AS WELL AS CONDUCTING RESEARCH AND CONSULTANCY IN THIS FIELD; BUSINESS CONSULTANCY RELATING TO DRAWING UP BUSINESS PLANS; BUSINESS MANAGEMENT OF COMPANIES AND ORGANIZATIONS, BOTH ON AN INTERIM OR LONG-TERM BASIS; PROFESSIONAL CONSULTATION IN THE BUSINESS FIELD; PREPARING AND DRAWING UP BUSINESS EXPERTS' REPORTS.

FIRST USE ; IN COMMERCE .
INT. CL. 36/U.S. CLS. 100, 101 AND 102

FOR FINANCIAL SERVICES, NAMELY, FINANCIAL ANALYSIS, CONSULTATION AND MANAGEMENT; FINANCIAL MANAGEMENT OF ASSETS; FINANCING IN RELATION TO THE BUYING AND SELLING OF BUSINESSES; EQUITY FINANCING; INVESTMENT SERVICES, NAMELY, INVESTMENT CONSULTATION AND MANAGEMENT SERVICES, CAPITAL INVESTMENT CONSULTATION AND MANAGEMENT SERVICES, PRIVATE EQUITY INVESTMENT SERVICES, PRIVATE EQUITY INVESTMENT SERVICES, EQUITY CAPITAL INVESTMENT SERVICES, INVESTING FUNDS FOR OTHERS; RESEARCH AND CONSULTANCY IN THE FIELD OF FINANCING AND INVESTING RELATING TO SHARE HOLDING; FINANCIAL AND INVEST-

MENT SERVICES IN THE AREA OF ENERGY AND NATURAL RESOURCES, OIL, GAS AND MINING, NAMELY, FINANCIAL ANALYSIS, CONSULTATION AND MANAGEMENT, INVESTMENT CONSULTATION AND MANAGEMENT SERVICES, CAPITAL INVESTMENT CONSULTATION AND MANAGEMENT SERVICES, PRIVATE EQUITY INVESTMENT CONSULTATION AND MANAGEMENT SERVICES, PRIVATE EQUITY INVESTMENT SERVICES, INVESTING FUNDS FOR OTHERS; CONSULTANCY CONCERNING FINANCING OF ENERGY PROJECTS; LEASE SECURITIZATION SERVICES, GUARANTEEING LOANS.

ELEMENTS CORRECTED
ENTITY

4,065,272. REG. 12-6-2011. MTG CO., LTD. (JAPAN CORPORATION) MTG HIKARI BLDG. 32, HONJIN-DORI 2-CHOME, NAKAMURA-KU, NAGOYA-SHI, AICHI-KEN, JAPAN, 4530041, SN 79-090,667. FILED 10-18-2010. PRINCIPAL REGISTER.

ReFa

PRIORITY DATE OF 8-24-2010 IS CLAIMED.
OWNER OF INTERNATIONAL REGISTRATION 1060243 DATED 10-18-2010, EXPIRES 10-18-2020.
INT. CL. 10/U.S. CLS. 26, 39 AND 44

FOR [ESTHETIC MASSAGE APPARATUS;] ESTHETIC MASSAGE APPARATUS FOR INDUSTRIAL PURPOSES; MASSAGE APPARATUS FOR MEDICAL PURPOSES; [ELECTRIC ESTHETIC MASSAGE APPARATUS FOR HOUSEHOLD USE; ELECTRIC MASSAGE APPARATUS FOR THE FACE FOR HOUSEHOLD USE;] HAND-OPERATED COSMETIC MASSAGE ROLLER FOR HOUSEHOLD USE.

FIRST USE ; IN COMMERCE .
INT. CL. 21/U.S. CLS. 2, 13, 23, 29, 30, 33, 40 AND 50
FOR COSMETIC AND TOILET UTENSILS, NAMELY, COSMETIC BRUSHES, HAND-OPERATED COSMETIC ROLLERS.

FIRST USE ; IN COMMERCE .

ELEMENTS CORRECTED
GOODS/SERVICES

4,069,278. REG. 12-13-2011. SÄGEN-MEHRING GMBH - SÄGENFABRIK (FED REP GERMANY LIMITED LIABILITY COMPANY) 2. INDUSTRIESTRASSE 10, 68766 HOCKENHEIM, FED REP GERMANY., SN 79-096,282. FILED 2-3-2011. PRINCIPAL REGISTER.



OWNER OF INTERNATIONAL REGISTRATION 1074178 DATED 2-3-2011, EXPIRES 2-3-2021.

NO CLAIM IS MADE TO THE EXCLUSIVE RIGHT TO USE "SÄGEN", APART FROM THE MARK AS SHOWN.

THE COLOR(S) WHITE, BLACK AND RED IS/ARE CLAIMED AS A FEATURE OF THE MARK.

RED COLOR: HKS 15, RAL 3020.

THE MARK CONSISTS OF A RECTANGLE DIVIDED HORIZONTALLY INTO TWO SEGMENTS; THE TOP SEGMENT IS BLACK, AND CONTAINS THE WORD "RIX" IN WHITE STYLIZED LETTERS; THE BOTTOM SEGMENT IS RED AND CONTAINS THE WORD "SÄGEN" IN WHITE LETTERS.

THE ENGLISH TRANSLATION OF "SÄGEN" IN THE MARK IS SAW. THE WORDING "RIX" HAS NO MEANING IN A FOREIGN LANGUAGE.

INT. CL. 7/U.S. CLS. 13, 19, 21, 23, 31, 34 AND 35

FOR PARTS OF MACHINES, NAMELY, SAW BLADES * FOR METALWORKING OR WOODWORKING * .

FIRST USE ; IN COMMERCE .

INT. CL. 8/U.S. CLS. 23, 28 AND 44

FOR PARTS OF HAND TOOLS, NAMELY, SAW BLADES.

FIRST USE ; IN COMMERCE .

ELEMENTS CORRECTED
GOODS/SERVICES

4,075,644. REG. 12-27-2011. CHRISTOPH KOTZ (FED REP GERMANY INDIVIDUAL) RATHELBECKERWEG 42, ERKRATH, FED REP GERMANY, 40699, SN 77-814,837. FILED 8-28-2009. PRINCIPAL REGISTER.

skater boys

THE MARK CONSISTS OF STANDARD CHARACTERS WITHOUT CLAIM TO ANY PARTICULAR FONT, STYLE, SIZE, OR COLOR.

OWNER OF ERPN CMNTY TM OFC REG. NO. 004137824, DATED 1-31-2006, EXPIRES 11-23-2014.

INT. CL. 16/U.S. CLS. 2, 5, 22, 23, 29, 37, 38 AND 50

FOR PRINTED MATTER, NAMELY, PAMPHLETS, BROCHURES, NEWSLETTERS, JOURNALS, MAGAZINES, BOOKS, ALL IN THE FIELD OF ADULT ENTERTAINMENT AND WITHOUT ANY RELATION TO SKATEBOARDS AND SKATEBOARDING AND NOT IN THE FIELD OF SPORTS.

FIRST USE ; IN COMMERCE .
INT. CL. 35/U.S. CLS. 100, 101 AND 102

FOR ADVERTISING AND MARKETING, MODELING AGENCIES, ALL WITHOUT ANY RELATION TO SKATEBOARDS AND SKATEBOARDING AND NOT IN THE FIELD OF SPORTS.

FIRST USE ; IN COMMERCE .
INT. CL. 41/U.S. CLS. 100, 101 AND 107

FOR EROTIC FILM AND EROTIC MUSIC PRODUCTION, EROTIC PHOTOGRAPHY, ORGANIZATION AND PRESENTATION OF EROTIC ENTERTAINMENT AND EROTIC EVENTS IN THE NATURE OF EROTIC PARTIES, WITHOUT ANY RELATION TO SKATEBOARDS AND SKATEBOARDING AND NOT IN THE FIELD OF SPORTS.

FIRST USE ; IN COMMERCE .

ELEMENTS CORRECTED
FOREIGN REG. EXPIRATION DATE

4,081,728. REG. 1-10-2012. AMADEUS ALEXANDER MAY (SWITZERLAND INDIVIDUAL) BÖHLELI 7, CH-9050 APPENZELL, SWITZERLAND., SN 79-068,210. FILED 12-3-2008. PRINCIPAL REGISTER.



PRIORITY DATE OF 7-1-2008 IS CLAIMED.

OWNER OF INTERNATIONAL REGISTRATION 1001172 DATED 12-3-2008, EXPIRES 12-3-2018.

NO CLAIM IS MADE TO THE EXCLUSIVE RIGHT TO USE "IMMUNE MANAGEMENT", APART FROM THE MARK AS SHOWN.

THE MARK CONSISTS OF A SHADED CIRCLE FEATURING THE WORDING "TOTAL IMMUNE MANAGEMENT" IN STYLIZED LETTERS CURVED AROUND THE DESIGN ELEMENT OF A POLYGON FIGURE AND TWO SHADED, CURVED ARROWS.

INT. CL. 1/U.S. CLS. 1

FOR CHEMICALS, NAMELY, CHEMICALS FOR USE IN THE MANUFACTURE OF FERMENTATION EXTRACTS; FERMENTS FOR CHEMICAL USE, NAMELY, FERMENTATION EXTRACTS.

INT. CL. 3/U.S. CLS. 1, 4, 6, 50, 51 AND 52

FOR FACE AND BODY CARE COSMETICS, HAIR LOTIONS, BLEACHING PREPARATIONS AND OTHER SUBSTANCES, NAMELY, SOFTENERS FOR LAUNDRY USE; CLEANING, POLISHING, SCOURING PREPARATIONS FOR USE ON SKIN; ABRASIVE PREPARATIONS FOR USE ON SKIN; SOAPS, NAMELY, SKIN SOAPS; PERFUMERY; ESSENTIAL OILS; DENTIFRICES.

INT. CL. 5/U.S. CLS. 6, 18, 44, 46, 51 AND 52

FOR FERMENTS FOR PHARMACEUTICAL PURPOSES; PHARMACEUTICAL PREPARATIONS FOR TREATMENT OF INFLAMMATORY CONDITIONS, IMMUNE DISEASES AND ENZYME UNDERPRODUCTION; AND VETERINARY PREPARATIONS, NAMELY, PAIN RELIEF MEDICATION; TREATMENT OF SKIN AND HAIR, TREATMENT OF INFLAMMATORY CONDITIONS, IMMUNE DISEASES; HEALTH CARE PREPARATIONS, NAMELY, LIQUID FOR TREATING INFLAMMATORY CONDITIONS, IMMUNE DISEASES AND ENZYME UNDERPRODUCTION; DIETETIC SUBSTANCES, NAMELY, DIETETIC FOOD FOR MEDICAL USE; MINERAL FOOD SUPPLEMENTS; FOOD SUPPLEMENTS MADE WITH AMINO-ACIDS; FOOD SUPPLEMENTS MADE WITH MINERALS; FOOD SUPPLEMENTS MADE WITH TRACE ELEMENTS; FOOD SUPPLEMENTS MADE FOR MEDICAL PURPOSES; VITAMIN PREPARATIONS; DIETARY SUPPLEMENTS MADE WITH VITAMINS.

FIRST USE ; IN COMMERCE .

INT. CL. 44/U.S. CLS. 100 AND 101

FOR MEDICAL SERVICES; VETERINARY SERVICES; HYGIENIC AND BEAUTY CARE FOR HUMAN BEINGS OR ANIMALS, NAMELY, NUTRITIONAL CONSULTANCY, HEALTH CONSULTANCY, HEALTH AND BEAUTY CARE, HEALTH AND BEAUTY SERVICES.

ELEMENTS CORRECTED
GOODS/SERVICES
[INTERNATIONAL CLASS(ES)]

4,085,659. REG. 1-17-2012. SIMFY AG (FED REP GERMANY PUBLIC LIMITED COMPANY) VOGELSANGER STR. 187, 50825 KÖLN, FED REP GERMANY., SN 79-081,967. FILED 3-5-2010. PRINCIPAL REGISTER.



THE MARK CONSISTS OF STANDARD CHARACTERS WITHOUT CLAIM TO ANY PARTICULAR FONT, STYLE, SIZE, OR COLOR.

OWNER OF INTERNATIONAL REGISTRATION 1037029 DATED 3-5-2010, EXPIRES 3-5-2020.

THE WORDING "SIMFY" HAS NO MEANING IN A FOREIGN LANGUAGE.

INT. CL. 9/U.S. CLS. 21, 23, 26, 36 AND 38

FOR COMPUTER SOFTWARE FOR PROCESSING DIGITAL MUSIC FILES; AUDIO RECORDINGS FEATURING MUSIC; VIDEO RECORDINGS FEATURING MUSIC; AND DOWNLOADABLE MULTIMEDIA FILES FEATURING MUSIC; ACCESSORIES FOR THE AFOREMENTIONED GOODS, INCLUDED IN THIS CLASS, NAMELY, BLANK USB FLASH DRIVES, PRE-RECORDED USB FLASH DRIVES FEATURING MUSIC, MUSIC VIDEOS, LYRICS AND PICTURES; BLANK RECORDABLE CD-RS, PRE-RECORDED CDS FEATURING MUSIC, MUSIC VIDEOS, LYRICS, AND PICTURES; MEMORY CARDS; * NONE OF THE FOREGOING BEING USED FOR HOME AUTOMATION AND BUILDING MANAGEMENT *.

FIRST USE ; IN COMMERCE .

INT. CL. 35/U.S. CLS. 100, 101 AND 102

FOR RETAIL STORE SERVICES IN THE ENTERTAINMENT SECTOR FEATURING RECORDED MUSICAL AND AUDIOVISUAL WORKS AS WELL AS MUSIC-RELATED ELECTRONIC PRODUCTS PROVIDED VIA THE INTERNET AND OTHER ELECTRONIC AND COMMUNICATION NETWORKS; RETAIL STORE SERVICES OFFERED VIA COMMUNICATION NETWORKS FEATURING CONSUMER ELECTRONICS; PROVIDING AN ON-LINE SEARCHABLE DATABASE FEATURING CLASSIFIED AD LISTINGS FOR THIRD PARTIES FOR ADVERTISING PURPOSES; ORGANIZATION BUSINESS CONSULTING IN THE FIELD OF SYSTEMATIZATION AND COMPILATION OF DATA IN COMPUTER DATABASES; DISSEMINATION OF ADVERTISEMENT FOR THIRD PARTIES VIA THE INTERNET AND OTHER COMMUNICATION NETWORKS.

FIRST USE ; IN COMMERCE .

INT. CL. 38/U.S. CLS. 100, 101 AND 104

FOR TRANSMISSION OF NEWS AND PRESS REPORTS VIA THE INTERNET AND OTHER COMMUNICATION NETWORKS; PROVIDING ACCESS TO REGISTERS ON THE INTERNET IN THE FIELD OF MUSIC, VIDEO, FILM, BOOKS, TV CONCERTS, RADIO, NEWS, CULTURAL EVENTS AND ENTERTAINMENT, GAMES AND SPORTS FIELDS; PROVIDING ACCESS TO DATABASES WITH INTERNET ADDRESSES AND LINKS; TRANSMITTING NEWS BETWEEN USERS WITH RESPECT TO MUSIC, NEWS, CURRENT EVENTS, ENTERTAINMENT, AS WELL AS ART AND LEISURE; BROADCASTING RADIO, AUDIO AND TV PROGRAMS, PROVIDING ACCESS TO DATABASES IN THE MUSIC, VIDEO, RADIO, TV, FILM, NEWS, SPORTS, GAMES, CULTURAL EVENTS, ENTERTAINMENT AND ARTS AND LEISURE FIELD VIA COMMUNICATION NETWORKS; * NONE OF THE FOREGOING BEING USED FOR HOME AUTOMATION AND BUILDING MANAGEMENT *.

FIRST USE ; IN COMMERCE .

INT. CL. 41/U.S. CLS. 100, 101 AND 107

FOR EDUCATIONAL, TRAINING, ENTERTAINMENT, SPORTS AND CULTURAL SERVICES, ESPECIALLY WITH RESPECT TO RECORDED MUSIC AND AUDIOVISUAL PRODUCTS, NAMELY, COMPUTER EDUCATION TRAINING, MUSIC RECORDING TRAINING, MUSIC PRODUCTION TRAINING; PROVIDING INFORMATION IN THE FIELD OF MUSIC; PROVIDING A WEBSITE FEATURING NON-DOWNLOADABLE ELECTRONIC PUBLICATIONS IN THE NATURE OF MAGAZINES IN THE FIELD OF MUSIC; PUBLISHING OF PRINTED REPORTS; ONLINE INFORMATION SERVICES EXCEPT FOR ADVERTISING PURPOSES, NAMELY, PROVIDING INFORMATION IN THE FIELD OF MUSIC, LIVE MUSIC CONCERTS, RADIO ENTERTAINMENT PRODUCTION, SPORTS NEWS; PUBLISHING OF MULTIMEDIA CONTENTS, IN THE NATURE OF AUDIO, VIDEO, GRAPHIC, TEXT AND OTHER MULTIMEDIA CONTENTS EXCEPT FOR ADVERTISING PURPOSES IN THE MUSIC, VIDEO, RADIO, TV, FILM, ENTERTAINMENT, NEWS, SPORTS, GAMES, CULTURAL EVENTS, ENTERTAINMENT AND ARTS AND LEISURE FIELDS VIA COMMUNICATION NETWORKS, NAMELY, MUSIC PUBLISHING SERVICES; PUBLISHING OF TEXT, GRAPHIC, AUDIO AND VIDEO WORK VIA COMMUNICATION NETWORKS EXCEPT FOR ADVERTISING PURPOSES, NAMELY, DIGITAL VIDEO, AUDIO, AND MULTIMEDIA PUBLISHING SERVICES; * NONE OF THE FOREGOING BEING USED FOR HOME AUTOMATION AND BUILDING MANAGEMENT *.

FIRST USE ; IN COMMERCE .

INT. CL. 42/U.S. CLS. 100 AND 101

FOR WRITING, DEVELOPING, UPDATING, MAINTAINING AND INSTALLING SOFTWARE; PROVIDING SEARCH ENGINES FOR THE INTERNET FOR RETRIEVING DATA FROM A WORLDWIDE COMPUTER NETWORK; COMPUTER PROGRAMMING/SOFTWARE DESIGN FOR THE PURPOSE OF PROVIDING MEANS FOR IDENTIFYING, LOCATING, CLASSIFYING, DISSEMINATING AND MANAGING DATA AND LINKS TO COMPUTER SERVERS AND COMPUTER PROCESSORS OF THIRD PARTIES AND OTHER COMPUTER USERS FOR THE USERS OF ELECTRONIC COMMUNICATION NETWORKS; LEASING STORAGE SPACE ON SERVERS, NAMELY, RENTAL OF WEB SERVERS; ELECTRONIC STORING OF DATA FOR THIRD PARTIES; PROVIDING SEARCH ENGINES FOR THE INTERNET, PARTICULARLY FOR USE IN THE MUSIC, VIDEO, FILM, BOOKS, TV, CONCERTS, RADIO, NEWS, CULTURAL EVENTS AND ENTERTAINMENT, GAMES AND SPORTS FIELDS; * NONE OF THE FOREGOING BEING USED FOR HOME AUTOMATION AND BUILDING MANAGEMENT *

FIRST USE ; IN COMMERCE .
 INT. CL. 45/U.S. CLS. 100 AND 101
 FOR LICENSING OF SOFTWARE; * EXCLUDING SOFTWARE USED FOR HOME AUTOMATION AND BUILDING MANAGEMENT *
 FIRST USE ; IN COMMERCE .

ELEMENTS CORRECTED
 CITIZENSHIP
 GOODS/SERVICES

4,092,806. REG. 1-31-2012. MEDISCAN GMBH & CO KG (AUSTRIA GMBH & CO. KG) BAD HALLER STRASSE 34, A-4550 KREMSMÜNSTER, AUSTRIA., SN 79-088,883. FILED 9-7-2010. PRINCIPAL REGISTER.



OWNER OF INTERNATIONAL REGISTRATION 0992849 DATED 10-1-2008, EXPIRES 10-1-2018.

NO CLAIM IS MADE TO THE EXCLUSIVE RIGHT TO USE "SCAN", APART FROM THE MARK AS SHOWN.

THE MARK CONSISTS OF THE STYLIZED WORDING "MEDI" ABOVE THE STYLIZED WORD "SCAN" WITH TWO CURVED LINES FORMING A PARTIAL OVAL AROUND THE WORDING.

INT. CL. 10/U.S. CLS. 26, 39 AND 44
 FOR MEDICAL STERILIZING APPARATUS, NAMELY, ELECTRON - BEAM ACCELERATORS AND LINEAR ACCELERATORS.

FIRST USE ; IN COMMERCE .
 INT. CL. 40/U.S. CLS. 100, 103 AND 106

FOR TREATMENT OF MATERIALS, NAMELY, STERILIZING AND TREATMENT OF WATER; WATER TREATMENT VIA ELECTRON - BEAM OZONE METHOD; WATER TREATMENT IN THE NATURE OF REMOVAL OF HORMONES FROM WATER.

FIRST USE ; IN COMMERCE .
 INT. CL. 42/U.S. CLS. 100 AND 101

FOR SCIENTIFIC RESEARCH, TECHNOLOGICAL CONSULTING, TECHNOLOGICAL CONSULTING AND RESEARCH AND DESIGN FOR OTHERS RELATING THERETO IN THE FIELD OF USE OF IONIZING RADIATION, NAMELY, FOR STERILIZATION, SANITATION, DISINFESTATIONS AND TREATMENT OF PLASTIC MATERIALS; DESIGN OF FACILITIES, EQUIPMENT, PROCESSES AND METHODS FOR THIRD PARTIES; INDUSTRIAL ANALYSIS OF GOODS TREATED WITH IONIZING RADIATION, NAMELY, MICROBIOLOGICAL, ELECTROPHYSICAL, PHYSICO-CHEMICAL, RADIOPHYSICAL AND CHEMICAL ANALYSIS; INDUSTRIAL RESEARCH IN THE FIELD OF APPLICATION OF IONIZING RADIATION.

FIRST USE ; IN COMMERCE .

ELEMENTS CORRECTED
 CITIZENSHIP

4,095,029. REG. 2-7-2012. I.S.O. ITALIA S.P.A. (ITALY SOCIETA PER AZIONI) VIA G. DI VITTORIO, 30, I-30029 S. STINO DI LIVENZA (VE), ITALY., SN 79-079,870. FILED 11-25-2009. PRINCIPAL REGISTER.



OWNER OF INTERNATIONAL REGISTRATION 1031346 DATED 11-25-2009, EXPIRES 11-25-2019.

NO CLAIM IS MADE TO THE EXCLUSIVE RIGHT TO USE "LIGHT", APART FROM THE MARK AS SHOWN.

THE TRADEMARK CONSISTS OF THE STYLISED WORDS "EVOLUTION LIGHT" AND BELOW, A MUSTACHE REPRESENTING A SMALL SUNBED.

INT. CL. 10/U.S. CLS. 26, 39 AND 44

FOR BEAUTY APPARATUS, NAMELY, AESTHETIC MASSAGE APPARATUS; LAMPS FOR MEDICAL PURPOSES, NAMELY, HEAT LAMPS FOR MEDICAL USE, MEDICAL EXAMINATION LAMPS, QUARTZ LAMPS FOR MEDICAL PURPOSES, SURGICAL LAMPS, ULTRAVIOLET LAMPS FOR MEDICAL USE.

FIRST USE ; IN COMMERCE .
 INT. CL. 11/U.S. CLS. 13, 21, 23, 31 AND 34

FOR APPARATUS FOR SUN-TANNING, NAMELY, UV LAMPS-TANNING MACHINES, TANNING BEDS AND SHOWERS; LAMPS FOR AESTHETIC PURPOSES, ALL SPECIFICALLY EXCLUDING LIGHTING FIXTURES.

FIRST USE ; IN COMMERCE .

ELEMENTS CORRECTED
 GOODS/SERVICES

4,096,228. REG. 2-7-2012. DOUGLAS BUENZ (UNITED STATES INDIVIDUAL), DBA DAB MARKETING, INC., SUITE 101, 900 MAIN STREET, PLEASANTON, CA, 94566, SN 85-358,366. FILED 6-28-2011. PRINCIPAL REGISTER.



THE MARK CONSISTS OF STANDARD CHARACTERS WITHOUT CLAIM TO ANY PARTICULAR FONT, STYLE, SIZE, OR COLOR.

NO CLAIM IS MADE TO THE EXCLUSIVE RIGHT TO USE "HOMES", APART FROM THE MARK AS SHOWN.

SEC. 2(F).
 INT. CL. 36/U.S. CLS. 100, 101 AND 102
 FOR PROVIDING A DATABASE OF INFORMATION ABOUT RESIDENTIAL REAL ESTATE LISTINGS IN DIFFERENT NEIGHBORHOODS AND COMMUNITIES; PROVIDING AN INTERNET WEBSITE PORTAL OFFERING INFORMATION IN THE FIELDS OF REAL ESTATE CONCERNING THE PURCHASE AND SALE OF NEW AND RESALE HOMES AND CONDOS; PROVIDING REAL ESTATE LISTINGS AND REAL ESTATE INFORMATION VIA THE INTERNET; REAL ESTATE AGENCIES; REAL ESTATE BROKERAGE; REAL ESTATE CONSULTATION; REAL ESTATE FINANCING SERVICES; REAL ESTATE LISTING.
 FIRST USE 12-17-1999; IN COMMERCE 12-17-1999.

ELEMENTS CORRECTED
 OWNER NAME

4,097,720. REG. 2-14-2012. RHEINBRAUN BRENNSTOFF GMBH (FED REP GERMANY LIMITED LIABILITY COMPANY) STÜTTGENWEG 2, KÖLN, FED REP GERMANY, 50935, SN 79-100,656. FILED 5-31-2011. PRINCIPAL REGISTER.

LSC

THE MARK CONSISTS OF STANDARD CHARACTERS WITHOUT CLAIM TO ANY PARTICULAR FONT, STYLE, SIZE, OR COLOR.
 PRIORITY DATE OF 4-26-2011 IS CLAIMED.
 OWNER OF INTERNATIONAL REGISTRATION 1085680 DATED 5-31-2011, EXPIRES 5-31-2021.
 INT. CL. 4/U.S. CLS. 1, 6 AND 15
 FOR LIGNITE COKE.

ELEMENTS CORRECTED
 MARK

4,097,749. REG. 2-14-2012. ACCENT S.P.A. (ITALY SHARE CAPITAL COMPANY) 485 OREGON AVENUE, PALO ALTO, CA, 94301, SN 85-018,892. FILED 4-20-2010. PRINCIPAL REGISTER.

ASMgrid

THE MARK CONSISTS OF STANDARD CHARACTERS WITHOUT CLAIM TO ANY PARTICULAR FONT, STYLE, SIZE, OR COLOR.
 NO CLAIM IS MADE TO THE EXCLUSIVE RIGHT TO USE ASM, APART FROM THE MARK AS SHOWN.
 INT. CL. 9/U.S. CLS. 21, 23, 26, 36 AND 38

FOR SEMICONDUCTORS AND PLATFORMS, COMPRISED OF EMBEDDED SOFTWARE FOR RESPECTIVE SEMICONDUCTOR DEVICE, AND HARDWARE AND SOFTWARE DEVELOPMENT TOOLS ENABLING USERS TO DEVELOP APPLICATION SOFTWARE FOR PLATFORM.
 FIRST USE 9-1-2009; IN COMMERCE 9-1-2009.

ELEMENTS AMENDED
 DISCLAIMER

4,098,129. REG. 2-14-2012. NBCUNIVERSAL MEDIA, LLC (DELAWARE LIMITED LIABILITY COMPANY) 30 ROCKEFELLER PLAZA, NEW YORK, NY, 10112, SN 85-227,187. FILED 1-26-2011. PRINCIPAL REGISTER.

GO HEALTHY

THE MARK CONSISTS OF STANDARD CHARACTERS WITHOUT CLAIM TO ANY PARTICULAR FONT, STYLE, SIZE, OR COLOR.
 NO CLAIM IS MADE TO THE EXCLUSIVE RIGHT TO USE "HEALTHY", APART FROM THE MARK AS SHOWN.
 INT. CL. 35/U.S. CLS. 100, 101 AND 102
 FOR PROMOTING AWARENESS OF HEALTH-RELATED ISSUES .
 FIRST USE 6-14-2010; IN COMMERCE 6-14-2010.

ELEMENTS CORRECTED
 OWNER NAME

4,099,085. REG. 2-14-2012. THE WEATHER UNDERGROUND, INC. (MICHIGAN CORPORATION) SUITE 240, 300 NORTH FIFTH AVENUE, ANN ARBOR, MI, 48104, SN 85-365,903. FILED 7-7-2011. PRINCIPAL REGISTER.

WUNDERPOLL

THE MARK CONSISTS OF STANDARD CHARACTERS WITHOUT CLAIM TO ANY PARTICULAR FONT, STYLE, SIZE, OR COLOR.
 INT. CL. 35/U.S. CLS. 100, 101 AND 102
 FOR ON-LINE PUBLIC OPINION SURVEYS.
 FIRST USE 10-15-2004; IN COMMERCE 10-15-2004.

ELEMENTS CORRECTED
 DATE OF FIRST USE
 DATE OF FIRST USE IN COMMERCE

4,099,307. REG. 2-14-2012. LORNAMEAD, INC. (DELAWARE CORPORATION) 175 COOPER AVENUE, TONAWANDA, NY, 14150, SN 77-539,026. FILED 8-5-2008. PRINCIPAL REGISTER.

4,103,242. REG. 2-21-2012. ALTICOR INC. (MICHIGAN CORPORATION) 7575 FULTON STREET EAST, 78-2M, ADA, MI, 49355, SN 85-976,006. FILED 11-17-2010. PRINCIPAL REGISTER.

AQUA NET

WELLSONA

THE MARK CONSISTS OF STANDARD CHARACTERS WITHOUT CLAIM TO ANY PARTICULAR FONT, STYLE, SIZE, OR COLOR.

OWNER OF U.S. REG. NO. 857,632.
 INT. CL. 3/U.S. CLS. 1, 4, 6, 50, 51 AND 52
 FOR HAIR STYLING PREPARATIONS; HAIRSPRAYS; STYLING SPRAYS FOR THE HAIR; STYLING GELS FOR THE HAIR.
 FIRST USE 12-1-2009; IN COMMERCE 12-1-2009.

THE MARK CONSISTS OF STANDARD CHARACTERS WITHOUT CLAIM TO ANY PARTICULAR FONT, STYLE, SIZE, OR COLOR.

INT. CL. 5/U.S. CLS. 6, 18, 44, 46, 51 AND 52
 FOR DIETARY AND NUTRITIONAL SUPPLEMENTS.
 FIRST USE 4-4-2011; IN COMMERCE 4-4-2011.

ELEMENTS CORRECTED
 GOODS/SERVICES

ELEMENTS CORRECTED
 OWNER ADDRESS

4,105,650. REG. 2-28-2012. YFY, LLC (ILLINOIS LIMITED LIABILITY COMPANY) 4094 PONDEROSA WAY, LAS VEGAS, NV, 89118, SN 85-387,712. FILED 8-2-2011. PRINCIPAL REGISTER.

4,101,542. REG. 2-21-2012. UERLINGS, RENÉ (BELGIUM INDIVIDUAL) RUE DE L'ARTISANAT 1, WELKENRAEDT, BELGIUM, 4840, SN 85-318,891. FILED 5-12-2011. PRINCIPAL REGISTER.

SWEET. YUMMY. IRRESISTIBLE.



THE MARK CONSISTS OF STANDARD CHARACTERS WITHOUT CLAIM TO ANY PARTICULAR FONT, STYLE, SIZE, OR COLOR.

INT. CL. 43/U.S. CLS. 100 AND 101
 FOR FROZEN YOGURT SHOP SERVICES IN THE NATURE OF A RESTAURANT * SERVING PRIMARILY FROZEN YOGURT, FROZEN YOGURT BASED FOOD, AND FROZEN YOGURT BASED BEVERAGES* [; RESTAURANT SERVICES].
 FIRST USE 11-25-2010; IN COMMERCE 11-25-2010.

ELEMENTS AMENDED
 GOODS/SERVICES

OWNER OF ERPN CMNTY TM OFC REG. NO. 008276719, DATED 11-22-2009, EXPIRES 11-22-2018.

THE MARK CONSISTS OF THE WORDS "MIXED APE" WRITTEN VERTICALLY AND TO THE RIGHT OF A FANCIFUL DEPICTION OF AN APE ABOVE A WHITE RECTANGLE.

INT. CL. 21/U.S. CLS. 2, 13, 23, 29, 30, 33, 40 AND 50
 FOR BEVERAGE GLASS WARE; COCKTAIL SHAKERS; NON-ELECTRIC FOOD MIXERS.

FIRST USE ; IN COMMERCE .
 INT. CL. 25/U.S. CLS. 22 AND 39
 FOR CLOTHING, NAMELY, T-SHIRTS; HEADGEAR.
 FIRST USE ; IN COMMERCE .

INT. CL. 32/U.S. CLS. 45, 46 AND 48
 FOR NON-ALCOHOLIC COCKTAILS; NON-ALCOHOLIC COCKTAIL MIXES.

FIRST USE ; IN COMMERCE .
 INT. CL. 33/U.S. CLS. 47 AND 49
 FOR ALCOHOLIC COCKTAILS; ALCOHOLIC COCKTAIL MIXES.

FIRST USE ; IN COMMERCE .

ELEMENTS CORRECTED
 OWNER ADDRESS

4,106,922. REG. 2-28-2012. NO BAD IDEAS, INC. (INDIANA CORPORATION) 7946 ZIONSVILLE ROAD, INDIANAPOLIS, IN, 46268, SN 85-976,063. FILED 4-7-2010. PRINCIPAL REGISTER.



NO CLAIM IS MADE TO THE EXCLUSIVE RIGHT TO USE "CLOTHING COMPANY", APART FROM THE MARK AS SHOWN.

THE MARK CONSISTS OF A CROWN ON A SHIELD WITH THE WORDS "NO BAD" ABOVE THE CROWN AND "IDEAS" BELOW. A RIBBON APPEARS IN FRONT OF THE SHIELD UPON WHICH THE WORDS "CLOTHING COMPANY" APPEAR.

INT. CL. 25/U.S. CLS. 22 AND 39

FOR HATS, SHORT-SLEEVED T-SHIRTS, HOODED SWEATSHIRTS.

FIRST USE 8-1-2009; IN COMMERCE 8-1-2009.

ELEMENTS CORRECTED
GOODS/SERVICES

4,108,810. REG. 3-6-2012. EI DYNAMICS, INC. (IDAHO CORPORATION) 3943 IRVINE BLVD., SUITE 110, IRVINE, CA, 92602. SN 85-381,501. FILED 7-26-2011. PRINCIPAL REGISTER.

DYNAMIC BPM

THE MARK CONSISTS OF STANDARD CHARACTERS WITHOUT CLAIM TO ANY PARTICULAR FONT, STYLE, SIZE, OR COLOR.

NO CLAIM IS MADE TO THE EXCLUSIVE RIGHT TO USE "BPM", APART FROM THE MARK AS SHOWN.

INT. CL. 9/U.S. CLS. 21, 23, 26, 36 AND 38

FOR COMPUTER SOFTWARE THAT PROVIDES REAL-TIME, INTEGRATED BUSINESS MANAGEMENT INTELLIGENCE BY COMBINING INFORMATION FROM VARIOUS DATABASES AND PRESENTING IT IN AN EASY-TO-UNDERSTAND USER INTERFACE.

FIRST USE 2-1-2009; IN COMMERCE 2-1-2009.

ELEMENTS CORRECTED
OWNER NAME
OWNER ADDRESS

4,109,852. REG. 3-6-2012. BUILDING MATERIALS HOLDING CORPORATION (DELAWARE CORPORATION) SUITE 200, 720 PARK BOULEVARD, BOISE, ID, 83712. SN 85-181,688. FILED 11-19-2010. PRINCIPAL REGISTER.



OWNER OF U.S. REG. NOS. 2,015,252, 2,772,209 AND 2,931,314.

NO CLAIM IS MADE TO THE EXCLUSIVE RIGHT TO USE "BUILDING MATERIALS AND CONSTRUCTION SERVICES", APART FROM THE MARK AS SHOWN.

THE COLOR(S) WHITE, BURGUNDY, DARK BLUE, LIGHT BLUE AND BLACK IS/ARE CLAIMED AS A FEATURE OF THE MARK.

THE MARK CONSISTS OF A STYLIZED DESIGN OF THE OUTWARD FORM OF A HOUSE CONSISTING OF AN IRREGULAR TRIANGLE ON THE LEFT TOP OF THE DESIGN IN BURGUNDY AND AN IRREGULAR SMALLER TRIANGLE ON THE RIGHT TOP OF THE DESIGN IN LIGHT BLUE. BELOW THESE IRREGULAR TRIANGLES IS A WHITE LINE THAT SIMULATES THE ROOF OUTLINE OF A HOUSE. THE FORM OF THE HOUSE IS DARK BLUE WITH THE WORDS "BMC" SHOWN IN WHITE INSIDE THE HOUSE. BELOW THE STYLIZED DESIGN ARE THE WORDS, "BUILDING MATERIALS AND CONSTRUCTION SERVICES" SHOWN IN BLACK.

INT. CL. 37/U.S. CLS. 100, 103 AND 106

FOR SERVICES IN THE BUILDING CONSTRUCTION FIELD, NAMELY, PROVIDING RETAIL STORE SERVICES FEATURING BUILDING MATERIALS INCLUDING ENGINEERED LUMBER PRODUCTS, DIMENSIONAL FRAMING LUMBER, CONSTRUCTION HARDWARE, WINDOWS, DOORS, MILLWORK, ROOF AND FLOOR TRUSSES, AND MANUFACTURED WALL PANELS TO HIGH-VOLUME AND CUSTOM HOME-BUILDERS.

FIRST USE 11-15-2010; IN COMMERCE 11-15-2010.

ELEMENTS CORRECTED
CITIZENSHIP

4,110,080. REG. 3-6-2012. RHE HATCO, INC. (DELAWARE CORPORATION) 601 MARION DRIVE, GARLAND, TX, 75042. SN 85-227,839. FILED 1-27-2011. PRINCIPAL REGISTER.

RANCHO ESTANCIA

THE MARK CONSISTS OF STANDARD CHARACTERS WITHOUT CLAIM TO ANY PARTICULAR FONT, STYLE, SIZE, OR COLOR.

THE ENGLISH TRANSLATION OF "RANCHO ESTANCIA" IN THE MARK IS "RANCH STAY".

INT. CL. 25/U.S. CLS. 22 AND 39

FOR CLOTHING, NAMELY, SHIRTS, TOPS, T-SHIRTS.

FIRST USE 6-30-2011; IN COMMERCE 6-30-2011.

ELEMENTS CORRECTED
GOODS/SERVICES

4,110,573. REG. 3-13-2012. 1400446 ALBERTA LTD. (CANADA CORPORATION) SUITE 200, 17410 - 107 AVENUE, EDMONTON, CANADA, T5S1E9. SN 77-618,297. FILED 11-20-2008. PRINCIPAL REGISTER.

HALIA

THE MARK CONSISTS OF STANDARD CHARACTERS WITHOUT CLAIM TO ANY PARTICULAR FONT, STYLE, SIZE, OR COLOR.

PRIORITY CLAIMED UNDER SEC. 44(D) ON CANADA APPLICATION NO. 1396270, FILED 5-20-2008, REG. NO. TMA798071, DATED 5-19-2011, EXPIRES 5-19-2026.

INT. CL. 14/U.S. CLS. 2, 27, 28 AND 50

FOR JEWELRY, NAMELY, GOLD, GOLD PLATED OR STERLING SILVER RINGS, EARRINGS, PINS, BROOCHES, BODY JEWELRY, WITH OR WITHOUT PEARLS, PRECIOUS AND SEMI-PRECIOUS GEMSTONES.
FIRST USE ; IN COMMERCE .

ELEMENTS CORRECTED
OWNER ADDRESS

4,110,574. REG. 3-13-2012. 1400446 ALBERTA LTD. (CANADA CORPORATION) SUITE 200, 17410 - 107 AVENUE, EDMONTON, CANADA, T5S1E9, SN 77-618,303. FILED 11-20-2008. PRINCIPAL REGISTER.



PRIORITY CLAIMED UNDER SEC. 44(D) ON CANADA APPLICATION NO. 1396271, FILED 5-20-2008, REG. NO. TMA798074, DATED 5-19-2011, EXPIRES 5-19-2026.

THE MARK CONSISTS OF THE LETTERS "HALIA" IN A STYLIZED FONT WITH THE DOT OVER THE LETTER "I" IN A SWIRL DESIGN.

INT. CL. 14/U.S. CLS. 2, 27, 28 AND 50

FOR JEWELRY, NAMELY, GOLD, GOLD PLATED OR STERLING SILVER RINGS, EARRINGS, PINS, BROOCHES, BODY JEWELRY, WITH OR WITHOUT PEARLS, PRECIOUS AND SEMI-PRECIOUS GEMSTONES.

FIRST USE ; IN COMMERCE .

ELEMENTS CORRECTED
GOODS/SERVICES

4,110,928. REG. 3-13-2012. KW AUTOMOTIVE NORTH AMERICA, INC. (CALIFORNIA CORPORATION) 1075 NORTH AVENUE, SANGER, CA, 93657, SN 85-163,192. FILED 10-28-2010. PRINCIPAL REGISTER.



THE MARK CONSISTS OF STANDARD CHARACTERS WITHOUT CLAIM TO ANY PARTICULAR FONT, STYLE, SIZE, OR COLOR.

OWNER OF U.S. REG. NO. 2,258,536.

INT. CL. 12/U.S. CLS. 19, 21, 23, 31, 35 AND 44

FOR SUSPENSION SYSTEMS FOR AUTOMOBILES AND COMPONENT PARTS THEREFOR; SPRINGS FOR SUSPENSION SYSTEMS FOR AUTOMOBILES.

FIRST USE 2-28-2005; IN COMMERCE 2-28-2005.

ELEMENTS CORRECTED
OWNER ADDRESS

4,112,646. REG. 3-13-2012. DAVID C COOK (ILLINOIS NON-PROFIT CORPORATION), FORMERLY COOK COMMUNICATIONS MINISTRIES, 4050 LEE VANCE VIEW, COLORADO SPRINGS, CO, 80918, SN 85-140,853. FILED 9-29-2010. PRINCIPAL REGISTER.



THE MARK CONSISTS OF STANDARD CHARACTERS WITHOUT CLAIM TO ANY PARTICULAR FONT, STYLE, SIZE, OR COLOR.

INT. CL. 16/U.S. CLS. 2, 5, 22, 23, 29, 37, 38 AND 50

FOR NEWSLETTERS IN THE FIELD OF CHRISTIAN EDUCATION; PUBLICATIONS, NAMELY, BROCHURES, BOOKLETS, AND TEACHING MATERIALS IN THE FIELD OF CHRISTIANITY.

FIRST USE 9-0-2011; IN COMMERCE 9-0-2011.

ELEMENTS CORRECTED
ENTITY

4,112,933. REG. 3-13-2012. PUREBRANDS, LLC (DELAWARE LIMITED LIABILITY COMPANY) 1040 HOLLAND DRIVE, BOCA RATON, FL, 33487, SN 85-217,115. FILED 1-13-2011. PRINCIPAL REGISTER.



THE MARK CONSISTS OF STANDARD CHARACTERS WITHOUT CLAIM TO ANY PARTICULAR FONT, STYLE, SIZE, OR COLOR.

INT. CL. 5/U.S. CLS. 6, 18, 44, 46, 51 AND 52

FOR DISSOLVABLE ORAL STRIPS CONTAINING [NUTRIENTS] * NUTRITIONAL * SUPPLEMENTS, DIETARY SUPPLEMENTS, VITAMINS, ANALGESICS, AND CENTRAL NERVOUS SYSTEMS STIMULANTS.

FIRST USE 5-27-2011; IN COMMERCE 5-27-2011.

ELEMENTS CORRECTED
GOODS/SERVICES

4,113,557. REG. 3-20-2012. KIRCHDORFER FERTIGTEIL-HOLDING GMBH (AUSTRIA LIMITED LIABILITY COMPANY) FEUERWERK SANSTALT, A-2752 WÖLLERSDORF, AUSTRIA., SN 79-096,444. FILED 12-7-2010. PRINCIPAL REGISTER.



PRIORITY DATE OF 6-10-2010 IS CLAIMED.
OWNER OF INTERNATIONAL REGISTRATION 1074606 DATED 12-7-2010, EXPIRES 12-7-2020.
OWNER OF U.S. REG. NO. 2,170,972.

THE MARK CONSISTS OF THE STYLIZED WORDING "DELTABLOC" TO THE RIGHT OF A SLIGHTLY INDENTED TRIANGLE EMBEDDED WITHIN A LARGER INDENTED TRIANGLE WHICH IS OPEN AT THE TOP.
INT. CL. 19/U.S. CLS. 1, 12, 33 AND 50

FOR NON-METALLIC RIGID PIPES FOR BUILDING; NON-METALLIC TRANSPORTABLE BUILDINGS; ROAD SAFETY DEVICES CONSISTING OF PREFABRICATED CONCRETE BLOCKS; BARRIERS, FENCES AND TRAFFIC CHANNELIZERS FOR ROAD PROTECTION, FOR DIRECTION OF TRAFFIC, FOR TRAFFIC DETOURS AND FOR ROAD PAVEMENT SEPARATION, ALL BEFOREMENTIONED GOODS NOT OF METAL AND NOT INCLUDED IN OTHER CLASSES *AND SOLELY FOR USE IN ROAD CONSTRUCTION FOR ROAD SAFETY OR IN URBAN AREAS FOR SAFETY *; CONSTRUCTION ELEMENTS NOT MADE OF METAL, NAMELY, SUPPORTS FOR TRAFFIC SIGNS, DELINEATOR POSTS AND TRAFFIC CHANNELIZERS.

FIRST USE ; IN COMMERCE .
INT. CL. 37/U.S. CLS. 100, 103 AND 106

FOR BUILDING CONSTRUCTION; REPAIR AND INSTALLATION OF BARRIERS ON ROADS AND URBAN AREAS; REPAIR AND INSTALLATION OF ROAD SAFETY DEVICES CONSISTING OF PREFABRICATED CONCRETE BLOCKS; REPAIR AND INSTALLATION OF BARRIERS, FENCES AND TRAFFIC CHANNELIZERS FOR ROAD PROTECTION, FOR DIRECTION OF TRAFFIC, FOR TRAFFIC DETOURS AND FOR ROAD PAVEMENT SEPARATION; REPAIR AND INSTALLATION OF CONSTRUCTION ELEMENTS NOT MADE OF METAL, NAMELY, SUPPORTS FOR TRAFFIC SIGNS, DELINEATOR POSTS AND TRAFFIC CHANNELIZERS.

ELEMENTS CORRECTED
GOODS/SERVICES

4,113,946. REG. 3-20-2012. R&A MOTORSPORTS, INC. (MISSOURI CORPORATION) 25110 E. 97TH STREET, LEE'S SUMMIT, MO, 64086, SN 85-231,398. FILED 2-1-2011. PRINCIPAL REGISTER.



NO CLAIM IS MADE TO THE EXCLUSIVE RIGHT TO USE "MOTORSPORTS, INC." AND "SINCE 1975", APART FROM THE MARK AS SHOWN.

THE MARK CONSISTS OF TWO CONCENTRIC PENTAGONS FORMING A SHIELD. THE INTERNAL PENTAGON CONTAINS TWO VERTICAL STRIPES IN THE CENTER, THE LETTERS "R & A" IN A DOWNWARD DIAGONAL FROM LEFT TO RIGHT, AND THE WORDS "SINCE 1975" IN THE UPPER RIGHT CORNER. A CHECKERED FLAG SPANS THE LOWER LEFT CORNER OF BOTH PENTAGONS AND THE WORDS "MOTORSPORTS, INC." ARE CONTAINED WITHIN THE BOTTOM OF THE OUTER PENTAGON.

INT. CL. 37/U.S. CLS. 100, 103 AND 106

FOR VEHICLE REPAIR SERVICES, RESTORATION SERVICES, COATING AND PAINTING SERVICES; VEHICLE CUSTOMIZATION SERVICES.

FIRST USE 6-1-2006; IN COMMERCE 6-1-2006.

ELEMENTS CORRECTED
OWNER ADDRESS

4,116,460. REG. 3-20-2012. BRIGHTWELL PAYMENTS, INC. (DELAWARE CORPORATION) 4401 NORTHSIDE PARKWAY, NW STE 560, ATLANTA, GA, 30327, SN 85-342,974. FILED P.R. 6-10-2011; AM. S.R. 1-25-2012. SUPPLEMENTAL REGISTER.

Brightwell Payments

THE MARK CONSISTS OF STANDARD CHARACTERS WITHOUT CLAIM TO ANY PARTICULAR FONT, STYLE, SIZE, OR COLOR.

NO CLAIM IS MADE TO THE EXCLUSIVE RIGHT TO USE "PAYMENTS", APART FROM THE MARK AS SHOWN.
INT. CL. 36/U.S. CLS. 100, 101 AND 102

FOR PREPAID DEBIT CARD SERVICES FUNDED FROM PAYROLL DISTRIBUTIONS; DEBIT CARD SERVICES; PREPAID DEBIT CARD SERVICES; CONSULTATION SERVICES IN THE FINANCIAL SERVICES FIELD, SPECIALIZING IN THE FINANCIAL ADMINISTRATION AND FINANCIAL MANAGEMENT OF PREPAID DEBIT CARD PRODUCTS AND SERVICES, NAMELY, GIFT CARDS, GENERAL PURPOSE RELOADABLE PREPAID CARDS, PAYROLL CARDS, LOYALTY, AWARD AND PROMOTIONAL INCENTIVE CARDS, [VIRTUAL CARDS IN THE NATURE OF DOWNLOADABLE SOFTWARE USED TO PROCESS, COLLECT, STORE, AND RETRIEVE DATA,] MONEY TRANSFER CARDS, AND FLEXIBLE SPENDING ACCOUNT CARDS.

FIRST USE 1-9-2012; IN COMMERCE 1-9-2012.

ELEMENTS AMENDED
GOODS/SERVICES

4,116,765. REG. 3-27-2012. PLAMBECK HOLDING AG (FED REP GERMANY CORPORATION) BAUDIREKTORHAHN-STRASSE 20, 27472 CUXHAVEN, FED REP GERMANY., SN 79-096,031. FILED 2-23-2011. PRINCIPAL REGISTER.



PRIORITY DATE OF 9-1-2010 IS CLAIMED.

OWNER OF INTERNATIONAL REGISTRATION 1073637 DATED 2-23-2011, EXPIRES 2-23-2021.

OWNER OF U.S. REG. NOS. 3,658,264 AND 3,924,913. THE COLOR(S) RED, YELLOW, GREEN AND GREY IS/ ARE CLAIMED AS A FEATURE OF THE MARK.

THE MARK CONSISTS OF THREE OVERLAPPING CIRCLE DESIGNS AND THE TERM "ENPEVET"; THE FIRST CIRCLE IS RED, THE SECOND ONE IS YELLOW AND THE THIRD ONE IS GREEN. THE FIRST PART "ENPE" OF THE TERM "ENPEVET" IS GREY AND THE SECOND PART "VET" IS GREEN.

INT. CL. 9/U.S. CLS. 21, 23, 26, 36 AND 38

FOR COMPUTER SOFTWARE FOR THE COLLECTION, EDITING, ORGANIZING, MODIFYING, BOOK MARKING, TRANSMISSION, STORAGE AND SHARING OF DATA AND INFORMATION; * NONE OF THE AFORESAID GOODS FINANCIAL-RELATED * .

FIRST USE ; IN COMMERCE .

INT. CL. 38/U.S. CLS. 100, 101 AND 104

FOR TELECOMMUNICATIONS, IN PARTICULAR PROVISION OF E-MAIL OFFERS, CHAT LINES AND FORUMS FOR COMMUNICATIONS ON THE INTERNET, NAMELY, PROVIDING E-MAIL SERVICES, INTERNET CHAT ROOMS AND ONLINE FORUMS FOR TRANSMISSION OF MESSAGES AMONG COMPUTER USERS CONCERNING THE EXCHANGE OF INFORMATION AND EXPERIENCE ON COMPLEX TOPICS, IN PARTICULAR TECHNICAL TOPICS, MEDICAL TOPICS, VETERINARY TOPICS AND SCIENTIFIC TOPICS; SETTING UP AND OPERATING A COMMUNICATIONS NETWORK ON THE INTERNET, NAMELY, PROVIDING REMOTE INTERNET ACCESS; RENTAL OF ACCESS TIME TO DATABASES, NAMELY, RENTAL OF ACCESS TIME TO GLOBAL COMPUTER NETWORKS; * NONE OF THE AFORESAID SERVICES FINANCIAL-RELATED *

FIRST USE ; IN COMMERCE .

ELEMENTS CORRECTED
GOODS/SERVICES

4,119,818. REG. 3-27-2012. BRIGHTWELL PAYMENTS, INC. (DELAWARE CORPORATION) 4401 NORTHSIDE PARKWAY, NW STE 560, ATLANTA, GA, 30327, SN 85-342,880. FILED P.R. 6-10-2011; AM. S.R. 1-26-2012. SUPPLEMENTAL REGISTER.

Brightwell Payments

THE MARK CONSISTS OF STANDARD CHARACTERS WITHOUT CLAIM TO ANY PARTICULAR FONT, STYLE, SIZE, OR COLOR.

NO CLAIM IS MADE TO THE EXCLUSIVE RIGHT TO USE "PAYMENTS", APART FROM THE MARK AS SHOWN. INT. CL. 9/U.S. CLS. 21, 23, 26, 36 AND 38

FOR MAGNETICALLY ENCODED PREPAID CARDS FOR MAKING PAYMENTS AND ACCESSING CASH AT AN AUTOMATED TELLER MACHINE (ATM), NAMELY, GIFT CARDS, GENERAL PURPOSE RELOADABLE PREPAID DEBIT CARDS, PAYROLL CARDS, LOYALTY, AWARD AND PROMOTIONAL INCENTIVE CARDS, [VIRTUAL CARDS IN THE NATURE OF DOWNLOADABLE SOFTWARE USED TO PROCESS, COLLECT, STORE, AND RETRIEVE DATA.] MONEY TRANSFER CARDS AND FLEXIBLE SPENDING ACCOUNT CARDS.

FIRST USE 1-9-2012; IN COMMERCE 1-9-2012.

ELEMENTS AMENDED
GOODS/SERVICES

4,120,046. REG. 4-3-2012. AGUSTA WESTLAND S.P.A. (ITALY JOINT STOCK COMPANY) VIA GIOVANNI AGUSTA 520, FRAZIONE CASCINA COSTA SAMARATE (VA), ITALY., SN 79-088,899. FILED 10-4-2010. PRINCIPAL REGISTER.

Planning System



PRIORITY DATE OF 9-1-2010 IS CLAIMED.
OWNER OF INTERNATIONAL REGISTRATION 1055415 DATED 10-4-2010, EXPIRES 10-4-2020.

NO CLAIM IS MADE TO THE EXCLUSIVE RIGHT TO USE "PLANNING SYSTEM", APART FROM THE MARK AS SHOWN.

THE TRADEMARK CONSISTS OF THE WORD "SKY-FLIGHT" IN PARTICULAR CHARACTERS CROSSED TO THE LEFT AND TO THE RIGHT OF THE LETTER "Y" BY A STRAIGHT LINE; OVER THE LETTER "Y" THERE IS A GEOMETRICAL FIGURE IN THE SHAPE OF RECTANGLES THAT CROSSED; OVER THIS WORD THERE IS THE WORDING "PLANNING SYSTEM".

INT. CL. 9/U.S. CLS. 21, 23, 26, 36 AND 38

FOR ELECTRONIC APPARATUS AND INSTRUMENTS RELATING TO AIR LOCOMOTION APPARATUS AND HELICOPTERS, NAMELY, MISSION PLANNING SYSTEMS COMPRISED OF COMPUTERS AND SOFTWARE FOR FLIGHT MISSION DATA PREPARATION, FLIGHT PLANNING SYSTEMS COMPRISED OF COMPUTERS AND SOFTWARE FOR FLIGHT ROUTE DATA PREPARATION, MISSION PLANNING AND ANALYSIS SYSTEMS COMPRISED OF COMPUTERS AND SOFTWARE FOR FLIGHT MISSION DATA PREPARATION AND ANALYSIS, MISSION PLANNING AND DEBRIEFING SYSTEMS COMPRISED OF COMPUTERS AND SOFTWARE FOR FLIGHT MISSION DATA PREPARATION AND DISPLAY, MISSION PLANNING STATIONS, FLIGHT PLANNING STATIONS, ROUTE PLANNING SYSTEMS COMPRISED OF COMPUTERS AND SOFTWARE FOR ROUTE DATA PREPARATION ; ELECTRONIC APPARATUS AND INSTRUMENTS FOR ROUTE AND MISSION PLANNING USE WITH HELICOPTERS, NAMELY, A COMPUTER BASED SYSTEM COMPRISED OF COMPUTER, PERIPHERALS AND SOFTWARE FOR DRAWING FLIGHT PLANS ON A DIGITALIZED MAP AND CHECKING ITS FEASIBILITY.

FIRST USE ; IN COMMERCE .

INT. CL. 42/U.S. CLS. 100 AND 101

FOR [DESIGN AND DEVELOPMENT OF SOFTWARE AND HARDWARE.] DESIGN AND DEVELOPMENT OF SOFTWARE AND HARDWARE FOR PLANNING HELICOPTER FLIGHTS.

FIRST USE ; IN COMMERCE .

ELEMENTS CORRECTED
GOODS/SERVICES
OWNER ADDRESS

4,123,510. REG. 4-10-2012. SIEMAG TECBERG GMBH (FED REP GERMANY GMBH) KALTEICHE-RING 28-32, 35708 HAIGER, FED REP GERMANY., SN 79-087,689. FILED 6-1-2010. PRINCIPAL REGISTER.

Cold Oak

THE MARK CONSISTS OF STANDARD CHARACTERS WITHOUT CLAIM TO ANY PARTICULAR FONT, STYLE, SIZE, OR COLOR.

PRIORITY DATE OF 3-3-2010 IS CLAIMED.
OWNER OF INTERNATIONAL REGISTRATION 1052078 DATED 6-1-2010, EXPIRES 6-1-2020.

INT. CL. 6/U.S. CLS. 2, 12, 13, 14, 23, 25 AND 50

FOR COMMON METALS AND THEIR ALLOYS.

FIRST USE ; IN COMMERCE .

INT. CL. 7/U.S. CLS. 13, 19, 21, 23, 31, 34 AND 35

FOR MECHANICAL CONVEYORS AND MECHANICAL HOISTING DEVICES AND INSTALLATIONS COMPOSED THEREOF, CONVEYING MACHINES, SHAFT HOISTING INSTALLATIONS, NAMELY, SKIP AND CAGE HOISTING INSTALLATIONS FOR SHAFTS, INCLINE HOISTING INSTALLATIONS, HOISTING MACHINES, IN THE NATURE OF KOEPE MACHINES, NAMELY, WINDERS AND SHAFT HOISTING MACHINES, AND IN THE NATURE OF DRUM MACHINES FOR REELING, FOR ONE OR MORE ROPES, NAMELY, HAULAGE APPARATUS, REELS, WINDING TOWERS, CONVEYOR BELTS, SKIPS, AND TROLLEY CIRCULATION SYSTEMS IN THE NATURE OF LOADING RAMPS, MECHANICAL WINCHES, NAMELY, FOR

ROPE HANDLING, MOBILE FRICTION WINCHES, MOBILE SHAFT WINCHES, LOADING AND UNLOADING MACHINERY, MECHANICAL TRANSFER AND UNLOADING DEVICES, NAMELY, UNLOADING MACHINES, EQUIPMENT, NAMELY, LIFTING APPARATUS FOR THE ABOVE MENTIONED HOISTING INSTALLATIONS, NAMELY, ROPE LIFTING GEARS FOR MACHINES, FIXING DEVICES IN THE NATURE OF JACKS, ROPE CHANGING DEVICES IN THE NATURE OF WINCHES AND JACKS; BRAKE SYSTEMS FOR HOISTING MACHINES AND WINDLASSES, NAMELY, DISC BRAKE SYSTEMS CONSISTING OF BRAKE SHOES, HYDRAULIC AND ELECTRICAL CONTROLS; MECHANICAL FLOW CONVEYORS AND CONVEYING APPARATUS COMPOSED OF HYDRAULIC CONVEYORS FOR THE HORIZONTAL OR VERTICAL TRANSPORT OF SOLID MATERIALS IN PIPELINES OR SHAFT PIPES, MECHANICAL CONVEYORS FOR LIQUIDS, NAMELY, COOLING LIQUIDS, PRESSURE EXCHANGERS BEING PARTS OF MACHINES, MECHANICAL CONVEYORS AND INSTALLATIONS, NAMELY, CONVEYING APPARATUS FOR DISPOSAL ENGINEERING, NAMELY, FOR DISPOSAL OF MATERIALS UNDERGROUND; MECHANICAL CONVEYORS FOR TRANSPORTING WASTE AND INSTALLATIONS FOR WASTE TRANSPORT IN THE NATURE OF RADIOACTIVE AND TOXIC WASTE; TRANSFER AND TRANSPORT CASKS BEING PARTS OF MACHINES AND USED FOR SAFELY ENCLOSING WASTE IN THE NATURE OF RADIOACTIVE AND TOXIC WASTE, CRANES FOR HANDLING TRANSFER CASKS, ROLLER-CONVEYOR APPARATUS, LIFTING AND LOADING DEVICES IN THE NATURE OF LIFTING INSTALLATIONS FOR THE TRANSPORT OF PERSONS AND GOODS, EQUIPMENT FOR PACKAGING APPARATUS, NAMELY, SURGE BIN AND FILLING BOX, TABLET BIN WITH OUTWARD-TRANSFER BOX, BORE-HOLE PIPES INCLUDING SAMPLE TYPES FOR HIGH ACTIVE WASTE (HAW) MOLDS AND APPARATUS FOR STORING RADIOACTIVE AND TOXIC WASTE, ALL THE AFORESAID GOODS BEING PARTS OF MACHINES, AND CONTROL DEVICES FOR AUTOMATING ALL THE AFORESAID MACHINES AND APPARATUS; RELATED PARTS FOR FIXING ROPES, NAMELY, LIFTING AND CLAMPING DEVICES FOR SHAFT HOISTING INSTALLATIONS; AND REPLACEMENT AND STRUCTURAL PARTS FOR ALL THE AFORESAID GOODS.

FIRST USE ; IN COMMERCE .
 INT. CL. 35/U.S. CLS. 100, 101 AND 102

FOR ORGANIZATIONAL PROJECT MANAGEMENT AND PROJECT ANALYSIS FOR OTHERS, NAMELY, BUSINESS ORGANIZATIONAL PROJECT MANAGEMENT CONSULTANCY AND BUSINESS PROJECT ANALYSIS IN THE FIELDS OF ENGINEERING AND CONSTRUCTION.

INT. CL. 37/U.S. CLS. 100, 103 AND 106
 FOR INSTALLATION, SERVICING, REPAIR AND MAINTENANCE OF SHAFT HOISTING, NAMELY, SKIP AND CAGE HOISTING INSTALLATIONS FOR SHAFTS; ASSEMBLY OF PRODUCTS FOR OTHERS, NAMELY, HOISTING MACHINES AND CONSTRUCTION PLANNING, CONSTRUCTION PROJECT MANAGEMENT SERVICES, CONSTRUCTION OF TECHNICAL INSTALLATIONS IN THE NATURE OF SHAFT HOISTING PLANTS, NAMELY, SKIP AND CAGE HOISTING INSTALLATIONS FOR SHAFTS, AND TECHNICAL SUPPORT SERVICES, NAMELY, PROVIDING TECHNICAL ADVICE IN THE FIELD OF INSTALLATION, SERVICING, REPAIR AND MAINTENANCE OF SHAFT HOISTING MACHINES * IN THE FIELD OF MINING * .
 FIRST USE ; IN COMMERCE .

INT. CL. 41/U.S. CLS. 100, 101 AND 107
 FOR ORGANIZATION AND IMPLEMENTATION OF TRAINING IN THE FIELD OF ENGINEERING AND CONSTRUCTION; ORGANIZATION AND IMPLEMENTATION OF SEMINARS AND WORKSHOPS; ALL OF THE AFORESAID TRAINING IN THE FIELD OF ENGINEERING AND CONSTRUCTION * IN THE FIELD OF MINING * .
 FIRST USE ; IN COMMERCE .

INT. CL. 42/U.S. CLS. 100 AND 101
 FOR ENGINEERING SERVICES, NAMELY, ENGINEERING FOR THE UNDERGROUND MINING INDUSTRY; ENGINEERING SERVICES, NAMELY, TECHNICAL PROJECT PLANNING OF SHAFT HOISTING INSTALLATIONS; COMPUTER SOFTWARE DEVELOPMENT IN THE FIELD OF AUTOMATION SOFTWARE; TECHNICAL PROJECT MANAGEMENT IN THE NATURE OF ENGINEERING SERVICES IN THE FIELDS OF UNDERGROUND MINING AND SHAFT HOISTING INSTALLATIONS.

ELEMENTS CORRECTED
 GOODS/SERVICES

* * * * *

TRADEMARK REGISTRATIONS—NEW CERTIFICATES

New Certificates issued under section 7(d) of the Trademark Act of 1946 for the unexpired term of the original registrations.

1,776,182. SINFUL COLORS. INT. CL. 3. MIRAGE COSMETICS INC., BELTSVILLE, MD. REG. 6-15-1993. NEW CERT. SEC. 7(D) TO REGISTRANT.

MARK. INT. CL. 3. CHRIS CHON, BETHESDA, MD. REG. 5-13-2008. NEW CERT. SEC. 7(D) TO REGISTRANT.

2,057,729. WILD AND CRAZY. INT. CL. 3. MIRAGE COSMETICS, INC., BELTSVILLE, MD. REG. 4-29-1997. NEW CERT. SEC. 7(D) TO REGISTRANT.

3,664,635. ECOMINERALS STANDARD CHARACTER MARK. INT. CL. 3. MIRAGE COSMETICS INC., BELTSVILLE, MD. REG. 8-4-2009. NEW CERT. SEC. 7(D) TO REGISTRANT.

2,581,052. KOM-TECH. INT. CL. 25. KOMBI LTD., ESSEX JUNCTION, VT. REG. 6-18-2002. NEW CERT. SEC. 7(D) TO REGISTRANT.

3,673,784. GAMES2U STANDARD CHARACTER MARK. INT. CL. 41. GAMES 2 U, L.L.C., AUSTIN, TX. REG. 8-25-2009. NEW CERT. SEC. 7(D) TO REGISTRANT.

3,130,234. SOLARA. INT. CL. 3. VML COMPANY, LLC, MEMPHIS, TN. REG. 8-15-2006. NEW CERT. SEC. 7(D) TO REGISTRANT.

3,975,345. BOOGER WARS STANDARD CHARACTER MARK. INT. CL. 28. GAMES 2 U, L.L.C. DBA GAMES2U, AUSTIN, TX. REG. 6-7-2011. NEW CERT. SEC. 7(D) TO REGISTRANT.

3,352,363. FRESHMINERALS STANDARD CHARACTER MARK. INT. CL. 3. CHRIS CHON, BETHESDA, MD. REG. 12-11-2007. NEW CERT. SEC. 7(D) TO REGISTRANT.

4,065,878. ARISTOCRAZY STANDARD CHARACTER MARK. INT. CLS. 14 AND 25. ARISTOCRAZY, S.A., 48009 BILBAO, VIZCAYA, SPAIN. REG. 12-6-2011. NEW CERT. SEC. 7(D) TO REGISTRANT.

3,427,700. FRESHCOVER STANDARD CHARACTER

* * * * *

This page is intentionally blank

INDEX OF REGISTRANTS

JUNE 5, 2012

(Registered; Renewed; Canceled; Amended, Corrected, etc.; New Certificates; 12c Publications.)

The designation "U.S. Cl." appearing in this section refers to the U.S. class in effect prior to Sep. 1, 1973 rather than the international class which applies to applications filed on or after that date. For adoption of international classification see notice in the OFFICIAL GAZETTE of Jun. 26, 1973 (911 O.G. TM 210).

@LEGAL DISCOVERY LLC, FALLS CHURCH, VA:
4,154,930, INT. CL. 42.

A A CARBIDES, INC., SALT LAKE CITY, UT:
2,567,227. REN. 4-27-12. MULTIPLE CLASS, INT. CLS. 35
AND 37.

A FINE GAUGE, INC., NEW YORK, NY:
2,700,610. REN. 5-3-12. INT. CL. 25.

A KIERAN COLLECTION LLC, MINNEAPOLIS, MN:
4,154,926, INT. CL. 33.

A TASTE OF THE OC, LLC, NEWPORT BEACH, CA:
4,155,680, INT. CL. 41.

A. GUMINIAK, JEFFREY, LEHIGH ACRES, FL:
4,154,769, MULTIPLE CLASS, INT. CLS. 35 AND 39.

A. JAFFE, INC., NEW YORK, NY:
4,154,737, INT. CL. 14.
4,154,756, INT. CL. 14.

A.B.C. COMPOUNDING COMPANY, INC., MORROW, GA:
4,154,890, INT. CL. 3.

A.C.V. INTERNATIONAL, NAAMLOZE VENNOOTSCHAP,
BELGIUM:
4,152,420, PUB. 3-20-2012. INT. CL. 11.

A.E.M. HOLDINGS LTD., ASHFORD, CT:
4,153,437, PUB. 3-20-2012. INT. CL. 9.

A.E.M. HOLDINGS LTD., ASHFORD, MA:
4,153,438, PUB. 3-20-2012. INT. CL. 9.

A&B BUSINESS, INC, SIOUX FALLS, SD:
4,152,110, PUB. 3-20-2012. INT. CL. 35.

A&E TELEVISION NETWORKS, LLC, NEW YORK, NY:
4,152,149, PUB. 3-20-2012. MULTIPLE CLASS, INT. CLS. 9
AND 41.

A-TLC MOVING, INC., COLUMBIA, MO:
2,724,224, CANC. INT. CL. 39.

AARON PROCESS EQUIPMENT COMPANY, CHICAGO, IL:
2,562,663. REN. 5-3-12. INT. CL. 7.

AARON SPELLING PRODUCTIONS INC., STUDIO CITY,
CA:
4,153,480, PUB. 3-20-2012. INT. CL. 9.

ABB/CON-CISE OPTICAL GROUP LLC, CORAL SPRINGS,
FL, PRIMARY EYECARE NETWORK, SAN RAMON, CA:
1,683,165. REN. 5-1-12. MULTIPLE CLASS, INT. CLS. 35,
41 AND 42.
1,700,750. REN. 5-1-12. MULTIPLE CLASS, INT. CLS. 35,
41 AND 42.

ABBOTT LABORATORIES, ABBOT PARK, IL:
693,072, CANC. U.S. CL. 18.

ABBOTT RESOURCE GROUP, INC., SANTA ANA, CA:
2,998,536, CANC. INT. CL. 35.

ABERCROMBIE & FITCH TRADING CO., NEW ALBANY,
OH:
2,568,940. REN. 5-1-12. INT. CL. 25.
4,155,989, INT. CL. 25.

ABL IP HOLDING LLC, CONYERS, GA:
2,492,695, CANC. INT. CL. 11.

ABRANOVIC, SUSAN J., FRANKLIN LAKES, NJ, FOR-
MERLY LAGROSA, SUSAN J.:
4,154,528, INT. CL. 42.

ABRO INDUSTRIES, INC., SOUTH BEND, IN:
4,153,256, PUB. 3-20-2012. INT. CL. 1.

ABSECON MILLS, INC., COLOGNE, NJ:
2,998,718, CANC. INT. CL. 23.

ACADEMI LLC, MOYOCK, NC:
4,154,400, INT. CL. 25.

ACADEMY OF NUTRITION AND DIETETICS, CHICAGO,
IL:
4,152,741, PUB. 3-20-2012. INT. CL. 44.

ACANDIS GMBH & CO. KG, FED REP GERMANY:
4,152,262, PUB. 3-20-2012. INT. CL. 10.

ACCELMED, LLC, INDIANAPOLIS, IN:
4,153,076, PUB. 3-20-2012. MULTIPLE CLASS, INT. CLS.
35 AND 41.

ACCENT S.P.A., PALO ALTO, CA:
4,097,749, AM. INT. CL. 9.

ACCESS INTELLIGENCE LLC, ROCKVILLE, MD:
4,154,753, INT. CL. 41.

ACCESS SCIENCES CORPORATION, HOUSTON, TX:
4,153,793, PUB. 3-20-2012. INT. CL. 25.

ACCIDENT INJURY CENTERS OF ATLANTA, INC., SAN-
DY SPRINGS, GA:
4,152,570, PUB. 3-20-2012. INT. CL. 44.

ACCOLADE WINES AUSTRALIA LIMITED, REYNELLA,
AUSTRALIA:
2,703,800. REN. 4-27-12. INT. CL. 33.
2,998,549, CANC. INT. CL. 33.

ACCOUNTING CONNECTIONS, LLC, FIFE, WA:
4,153,797, PUB. 3-20-2012. INT. CL. 35.

ACCUBILT INC., CINCINNATI, OH, ACCUBILT INC.,
CINCINNATI, OH:
2,564,320. REN. 5-2-12. INT. CL. 12.

ACCUBILT, INC., CINCINNATI, OH, ACCUBILT, INC.,
CINCINNATI, OH:
2,559,888. REN. 4-30-12. INT. CL. 12.

ACE COATING CO., INC., LA MESA, CA:
2,492,333, CANC. INT. CL. 2.

ACE CONTROLS, INC., FARMINGTON, MI:
2,998,728, CANC. INT. CL. 7.

ACE IMPEX, ANDHERI (EAST), MUMBAI, INDIA:
4,152,090, PUB. 3-20-2012. INT. CL. 25.

ACELERANT INCORPORATED, JUPITER, FL, DBA STIN-
GRAY TACKLE COMPANY:
4,153,530, PUB. 3-20-2012. INT. CL. 41.

ACERO Y ARTES DE TOLEDO, S.L., OLIAS DEL REY
(TOLEDO), SPAIN:
4,155,085, INT. CL. 8.

ACORN CARDIOVASCULAR, INC., ST. PAUL, MN:
2,998,543, CANC. INT. CL. 10.

ACOSTA, INC., JACKSONVILLE, FL:
4,153,906, PUB. 3-20-2012. INT. CL. 16.

ACTIVETRAK INC., PORTLAND, OR, AKA GADGET-
TRAK:
4,156,055, MULTIPLE CLASS, INT. CLS. 42 AND 45.

ADAMS U.S.A., INC., COOKEVILLE, TN:
1,215,983. REN. 5-3-12. INT. CL. 28.

ADAMS, DANIEL NELSON, JR., OLD GREENWICH, CT:
4,152,742, PUB. 3-20-2012. INT. CL. 35.
4,152,744, PUB. 3-20-2012. INT. CL. 35.

ADAMS, JASON, LOGANDALE, NV:
4,155,171, MULTIPLE CLASS, INT. CLS. 9 AND 25.

ADAMS, MICHAEL A., TUSCON, AZ:
4,152,542, PUB. 3-20-2012. INT. CL. 35.

ADC MARKETING, INC., BLAINE, WA, DBA MAGELLAN
GROUP, LTD.:
4,155,663, INT. CL. 21.

ADCO PRODUCTS, INC., MICHIGAN CITY, MI:
4,152,760, PUB. 3-20-2012. MULTIPLE CLASS, INT. CLS.

- 1, 2 AND 17.
ADELMAN TRAVEL SYSTEMS, INC., MILWAUKEE, WI:
4,155,291, INT. CL. 38.
- ADEPT-MED INTERNATIONAL, INC., DIAMOND SPRINGS, CA:
2,492,507, CANC. INT. CL. 10.
- ADMIRALS BANK, CRANSTON, RI:
4,154,696, INT. CL. 36.
- ADO STAFFING, INC., MELVILLE, NY:
2,562,132, REN. 5-2-12, INT. CL. 35.
- ADVANCE BEAUTY COLLEGE, LLC, WARRENTON, MO:
4,153,764, PUB. 3-20-2012, MULTIPLE CLASS, INT. CLS. 41 AND 44.
- ADVANCE MAGAZINE PUBLISHERS INC., NEW YORK, NY:
4,153,426, PUB. 3-20-2012, INT. CL. 16.
4,154,577, MULTIPLE CLASS, INT. CLS. 41 AND 45.
4,155,105, INT. CL. 16.
4,155,965, INT. CL. 16.
- ADVANCE RELOCATION AND STORAGE INC., OLD BETHPAGE, NY:
4,152,905, PUB. 3-20-2012, MULTIPLE CLASS, INT. CLS. 39 AND 43.
- ADVANCE RESEARCH, LTD, OREGON CITY, OR:
4,153,229, PUB. 3-20-2012, INT. CL. 19.
- ADVANCE SALES GROUP, INC., LOS ANGELES, CA:
4,154,110, PUB. 3-20-2012, INT. CL. 25.
- ADVANCED BALLOT SOLUTIONS LLC, OMAHA, NE:
4,154,535, INT. CL. 35.
- ADVANCED DESIGN TECHNOLOGY LIMITED, LONDON, ENGLAND:
2,609,935, REN. 5-3-12, INT. CL. 9.
- ADVANCED DRAINAGE SYSTEMS, INC., HILLARD, OH:
1,660,715, REN. 5-1-12, INT. CL. 11.
- ADVANCED ENERGY EFFICIENCY AND ENVIRONMENTAL QUALITY, MESA, AZ:
4,153,881, PUB. 3-20-2012, MULTIPLE CLASS, INT. CLS. 37 AND 41.
- ADVANCED MEDICAL/MENTAL HEALTH OUTREACH SERVICES TEAM, INC., MELBOURNE, FL:
4,152,129, PUB. 3-20-2012, INT. CL. 44.
- ADVANCED MICRO DEVICES, INC., SUNNYVALE, CA:
1,691,460, REN. 5-2-12, INT. CL. 16.
- ADVANCED NUTRIENTS LTD., ABBOTSFORD, BC, CANADA:
4,152,621, PUB. 3-20-2012, INT. CL. 1.
- ADVANCED TECHNOLOGY & CAPITAL INC., ENGLEWOOD CLIFFS, NJ:
4,155,774, INT. CL. 10.
- ADVANCED WELLNESS, MARLBORO, NJ:
4,155,296, INT. CL. 10.
- ADVANCEPIERRE FOODS, INC., CINCINNATI, OH:
4,155,729, INT. CL. 30.
- ADVANCING ECO-AGRICULTURE, LLC, MIDDLEFIELD, OH:
4,153,258, PUB. 3-20-2012, INT. CL. 1.
- ADVANT-EDGE PAVING EQUIPMENT, LLC, LOUDONVILLE, NY:
4,153,514, PUB. 3-20-2012, INT. CL. 7.
- ADVANTAGE PERFORMANCE DISTRIBUTING, INC., RIVERSIDE, CA:
2,575,728, REN. 4-27-12, INT. CL. 35.
- ADVENTIST HEALTH SYSTEM/SUNBELT, INC., ORLANDO, FL:
4,154,363, INT. CL. 43.
- AEDAS LTD., QUARRY BAY, HONG KONG:
4,152,964, PUB. 3-20-2012, MULTIPLE CLASS, INT. CLS. 42 AND 44.
- AERATION SYSTEMS, FALMOUTH, ME:
2,567,111, REN. 5-2-12, INT. CL. 11.
- AERO DESIGN & MANUFACTURING COMPANY, INC., DULUTH, MN:
2,584,792, REN. 5-2-12, INT. CL. 21.
- AERO DESIGN AND MANUFACTURING COMPANY, INC., DULUTH, MN:
2,558,414, REN. 5-2-12, INT. CL. 28.
2,564,571, REN. 5-3-12, INT. CL. 25.
- AERONAUTICAL SYSTEMS, INCORPORATED, STERLING, VA:
4,155,868, INT. CL. 37.
- AES NEWENERGY, INC., LOS ANGELES, CA TO EXELON CORPORATION, PHILADELPHIA, PA:
2,493,274, CANC. MULTIPLE CLASS, INT. CLS. 35 AND 42.
- AFC ENTERPRISES, INC., ATLANTA, GA:
4,155,285, MULTIPLE CLASS, INT. CLS. 29 AND 43.
4,155,287, MULTIPLE CLASS, INT. CLS. 29 AND 43.
4,155,288, MULTIPLE CLASS, INT. CLS. 29 AND 43.
- AFFENTALER WINZERGENSENSCHAFT BÜHL EG, 77815 BÜHL, FED REP GERMANY:
4,152,258, PUB. 3-20-2012, INT. CL. 33.
- AFFILIATES RISK MANAGEMENT SERVICES, INC., NEW YORK, NY:
4,153,783, PUB. 3-20-2012, INT. CL. 35.
- AFFINITY GAMING, LLC, LAS VEGAS, NV:
4,153,626, PUB. 3-20-2012, INT. CL. 35.
4,153,627, PUB. 3-20-2012, INT. CL. 41.
- AGC ENGINEERING CO., LTD., CHIBA, JAPAN:
4,152,471, PUB. 1-17-2012, MULTIPLE CLASS, INT. CLS. 9, 10 AND 11.
- AGENCE SPATIALE EUROPEENNE (ESA), 75015 PARIS, FRANCE:
3,081,144, CANC. MULTIPLE CLASS, INT. CLS. 7 AND 9.
- AGENCE SPATIALE EUROPEENNE (ESA), FRANCE:
4,152,177, PUB. 3-20-2012, INT. CL. 9.
- AGGRESSIVE COMBATIVES LIMITED, KOWLOON, HONG KONG:
4,153,266, PUB. 3-20-2012, INT. CL. 25.
- AGILENT TECHNOLOGIES, INC., SANTA CLARA, CA:
2,579,535, REN. 4-27-12, INT. CL. 9.
- AGR MARKETING SOLUTIONS, LLC, ESTERO, FL:
4,152,960, PUB. 3-20-2012, INT. CL. 35.
- AGRIUM INC., CALGARY, ALBERTA, CANADA:
4,152,126, PUB. 3-20-2012, INT. CL. 1.
- AGUIAR, TOMAS, MIAMI, FL:
4,153,319, PUB. 3-20-2012, INT. CL. 10.
- AGUSTA WESTLAND S.P.A., ITALY:
4,120,046, COR. MULTIPLE CLASS, INT. CLS. 9 AND 42.
- AHHE EAST COAST CHAPTER, INC., NEW YORK, NY:
4,152,711, PUB. 3-20-2012, INT. CL. 35.
- AHMADIYYA MOVEMENT IN ISLAM, INC., SILVER SPRING, MD:
4,152,983, PUB. 3-20-2012, INT. CL. 45.
- AHOLD LICENSING SARL, GENEVA, SWITZERLAND:
4,153,936, PUB. 3-20-2012, INT. CL. 35.
- AIPTEK, INC., IRVINE, CA:
2,998,542, CANC. INT. CL. 9.
- AIR LIQUIDE AMERICA SPECIALTY GASES LLC., HOUSTON, TX:
1,193,466, REN. 4-27-12, INT. CL. 1.
- AIR PRODUCTS AND CHEMICALS, INC., ALLENTOWN, PA:
1,684,289, REN. 5-2-12, INT. CL. 6.
- AIRDRI LIMITED, OXFORD OX8 1TH, UNITED KINGDOM:
2,561,102, REN. 5-3-12, INT. CL. 9.
2,561,102, CANC. INT. CL. 7.
- AIRFLOW CATALYST SYSTEMS, INC., ROCHESTER, NY:
4,154,955, INT. CL. 7.
- AIRSEC (S.A.S.), CHOISY LE ROI, FRANCE:
2,491,728, CANC. MULTIPLE CLASS, INT. CLS. 1 AND 17.
- AIRSOFT ZONE CORPORATION, IRWINDALE, CA:
4,153,547, PUB. 3-20-2012, INT. CL. 35.
- AJ & J ENTERPRISES, INC., BLOOMINGTON, IN:
2,498,392, REN. 4-30-12, INT. CL. 35.
- AJINOMOTO U.S.A., INC., NEW YORK, NY:
2,998,843, CANC. INT. CL. 31.
- AKA KIDS, INC., MIAMI, FL:
4,154,677, MULTIPLE CLASS, INT. CLS. 20 AND 35.
- AKERS, MENERVIA M, MARBLEHEAD, MA:
4,152,053, PUB. 3-20-2012, INT. CL. 25.
- AKIYAMA INTERNATIONAL CORPORATION (USA), CERRITOS, CA:
4,152,089, PUB. 3-20-2012, INT. CL. 7.

AL LIEBERS GOLF EQUIPMENT, INC., NEW YORK, NY:
2,549,258. REN. 5-3-12. INT. CL. 35.

ALAMO CEMENT COMPANY II, LTD., SAN ANTONIO, TX:
2,600,786, COR. INT. CL. 19.
2,620,638, COR. INT. CL. 19.
2,648,698, COR. INT. CL. 39.

ALAN F. BAIN, CHICAGO, IL, DBA CHICAGO HEALTH
AND WELLNESS ALLIANCE:
4,156,073, INT. CL. 44.

ALAN J. PIVEN MANAGEMENT GROUP, LLC, NEW
YORK, NY:
4,155,032, INT. CL. 25.

ALAN WAYNE STRANG, OXLEY QLD 4075, AUSTRALIA:
4,152,354, PUB. 3-20-2012. INT. CL. 18.

ALANDA LLC, SCOTCH PLAINS, NJ:
4,154,163, PUB. 3-20-2012. INT. CL. 42.

ALBAN VINEYARDS, INC., ARROYO GRANDE, CA:
4,153,311, PUB. 3-20-2012. INT. CL. 33.

ALBERT METZ GMBH & CO. KG, BLUMBERG, FED REP
GERMANY:
4,155,509, INT. CL. 9.

ALBERTSSON, CANDICE, NORTH TONAWANDA, NY:
4,154,304, INT. CL. 35.
4,154,305, INT. CL. 35.

ALBION INDUSTRIES INC., ALBION, MI:
2,632,430. REN. 5-2-12. INT. CL. 35.

ALBRECHT, KATE, LOS ANGELES, CA, DBA MR. KATE:
4,154,216, PUB. 3-20-2012. INT. CL. 41.

ALCOA INC., PITTSBURGH, PA:
4,155,556, INT. CL. 6.

ALCON (PUERTO RICO), INC., FORT WORTH, TX:
1,697,324. REN. 4-28-12. INT. CL. 5.

ALCON RESEARCH, LTD., FORT WORTH, TX, ALCON
SURGICAL, INC., FORT WORTH, TX:
1,705,808. REN. 5-2-12. INT. CL. 10.

ALDERAAN HOLDINGS CO. LLC, PITTSBURGH, PA:
4,152,701, PUB. 3-20-2012. INT. CL. 16.

ALETHIA SKIN CARE LLC, ARDMORE, PA:
4,155,203, INT. CL. 3.

ALEX AND ANI, INC., CRANSTON, RI:
4,153,055, PUB. 3-20-2012. INT. CL. 9.
4,153,056, PUB. 3-20-2012. INT. CL. 14.
4,153,057, PUB. 3-20-2012. MULTIPLE CLASS, INT. CLS. 9
AND 35.
4,153,058, PUB. 3-20-2012. MULTIPLE CLASS, INT. CLS.
9, 14 AND 35.

ALEXANDER DOLL COMPANY, INC., NEW YORK, NY:
4,152,765, PUB. 3-20-2012. INT. CL. 28.
4,152,766, PUB. 3-20-2012. INT. CL. 28.
4,152,767, PUB. 3-20-2012. INT. CL. 28.
4,152,768, PUB. 3-20-2012. INT. CL. 28.

ALEXANDER, ADRIAN, MIAMI, FL:
4,154,758, INT. CL. 3.

ALEXANIAN, GEORGE, FRESNO, CA:
2,493,115, CANC. INT. CL. 9.

ALFA ELECTRONICS LTD., CANTON, GA:
4,153,275, PUB. 3-20-2012. INT. CL. 35.

ALIAxis S.A., BRUSSELS, BELGIUM:
4,153,237, PUB. 3-20-2012. MULTIPLE CLASS, INT. CLS.
11, 17, 19 AND 35.

ALIBABA GROUP HOLDING LIMITED, GRAND CAY-
MAN, CAYMAN ISLANDS:
2,579,498. REN. 4-27-12. MULTIPLE CLASS, INT. CLS. 35
AND 38.
4,152,587, PUB. 3-20-2012. MULTIPLE CLASS, INT. CLS.
9, 16, 35, 36, 38, 39, 41 AND 42.

ALICE CORPORATION PTY LTD, MELBOURNE, VICTOR-
IA, AUSTRALIA:
2,912,869, CANC. INT. CL. 42.

ALIEN ANT FARM, ENCINO, CA:
2,571,285. REN. 4-27-12. MULTIPLE CLASS, INT. CLS. 9,
25 AND 41.

ALIMENTS IN FOODS INC., MONTREAL, QUEBEC:
4,152,131, PUB. 3-20-2012. MULTIPLE CLASS, INT. CLS.
29 AND 30.

ALIPHCOM, SAN FRANCISCO, CA:
4,155,987, INT. CL. 9.

ALIZZANO, LLC, SANTA MONICA, CA:
4,154,343, INT. CL. 35.

ALKOS COSMETIQUES SAS, FRANCE:
4,152,331, PUB. 3-20-2012. INT. CL. 3.

ALL ACCESS APPAREL, INC., MONTEBELLO, CA:
4,153,654, PUB. 3-20-2012. INT. CL. 25.

ALLAN TORP JENSEN, DENMARK:
4,152,396, PUB. 3-20-2012. MULTIPLE CLASS, INT. CLS.
38, 39 AND 43.

ALLEGORY STUDIOS, INC., SARATOGA SPRINGS, NY:
4,153,478, PUB. 3-20-2012. INT. CL. 35.

ALLIANCE BANK, N.A., SYRACUSE, NY:
4,155,127, INT. CL. 36.

ALLIANCE DATA SYSTEMS CORPORATION, PLANO, TX:
4,154,883, MULTIPLE CLASS, INT. CLS. 35 AND 36.

ALLIANCE TRADING, INC., COVINGTON, LA:
4,154,237, PUB. 3-20-2012. INT. CL. 35.

ALLISON; JERRY, LYLES, TN:
1,222,941. REN. 4-27-12. INT. CL. 41.

ALLSTAR MARKETING GROUP, LLC, HAWTHORNE, NY:
4,154,631, INT. CL. 21.

ALPHA SIGMA ALPHA, INDIANAPOLIS, IN:
4,153,880, PUB. 3-20-2012. INT. CL. 35.

ALPHACORP, COAST VALLEY CITY, UT:
2,524,716. REN. 5-1-12. INT. CL. 9.

ALPHARMA INC., MADISON, NJ:
2,492,609, CANC. INT. CL. 42.

ALPHATREK, INC., ASHTON, MD:
4,153,873, PUB. 3-20-2012. INT. CL. 38.

ALSTOM, FRANCE:
4,152,318, PUB. 3-20-2012. MULTIPLE CLASS, INT. CLS.
9, 12, 37 AND 39.

ALTERNATIVE CONTINUUM OF CARE OF IOWA, LLC,
MADISON, WI:
2,635,387. REN. 4-27-12. INT. CL. 42.

ALTICOR INC., ADA, MI:
4,103,242, COR. INT. CL. 5.

ALTRO LIMITED, UNITED KINGDOM:
4,152,390, PUB. 3-20-2012. INT. CL. 27.

ALVIERO MARTINI S.P.A., MILANO, ITALY:
1,691,558. REN. 4-30-12. INT. CL. 18.

AMADEUS ALEXANDER MAY, SWITZERLAND:
4,081,728, COR. MULTIPLE CLASS, INT. CLS. 1, 3, 5
AND 44.

AMADOR, LUZ M, FRESNO, CA, DBA SYSTEMS AND
ENGINEERING CONSULTING:
4,152,477, PUB. 6-28-2011. INT. CL. 1.

AMALGAMATED BANK, NEW YORK, NY:
2,491,659, CANC. INT. CL. 36.

AMATE LIFE, LEXINGTON PARK, MD:
4,153,503, PUB. 3-20-2012. INT. CL. 5.

AMBION, INC., AUSTIN, TX:
2,642,318. REN. 4-27-12. INT. CL. 1.

AMBOY TECHNOLOGIES LLC, PORTLAND, OR:
4,154,056, PUB. 3-20-2012. INT. CL. 39.

AMER SPORTS INTERNATIONAL OY, HELSINKI, FIN-
LAND:
4,154,521, MULTIPLE CLASS, INT. CLS. 9, 28 AND 41.

AMERICA'S DRIVE-IN BRAND PROERTIES LLC, OKLA-
HOMA CITY, OK:
2,558,947. REN. 5-2-12. INT. CL. 42.

AMERICA'S FAMILY DOCTORS, PLLC, BRENTWOOD, TN:
4,155,955, INT. CL. 44.

AMERICAN ACADEMY OF AUDIOLOGY, RESTON, VA:
2,561,420. REN. 5-3-12. MULTIPLE CLASS, INT. CLS. 41
AND 42.

AMERICAN AIMERS, INC., EMPORIA, KS:
4,153,919, PUB. 3-20-2012. INT. CL. 9.

AMERICAN ASSOCIATION OF INDIVIDUAL INVESTORS,
INC., CHICAGO, IL:
1,715,562. REN. 5-2-12. INT. CL. 16.

AMERICAN ASSOCIATION OF ORTHODONTISTS INSUR-
ANCE COMPANY, ST. LOUIS, MO, AKA AMERICAN
ASSOCIATION OF ORTHODONTISTS INSURANCE
COMPANY (RRG):
2,573,307. REN. 4-30-12. INT. CL. 36.

- AMERICAN ASSOCIATION OF PROFESSIONAL LANDMEN, FORT WORTH, TX:
4,153,555, PUB. 3-20-2012. INT. CL. 35.
- AMERICAN AUTOMOBILE ASSOCIATION, INC., HEATHROW, FL:
2,626,663. REN. 5-3-12. INT. CL. 41.
2,656,959. REN. 5-2-12. INT. CL. 9.
2,659,703. REN. 5-3-12. INT. CL. 36.
- AMERICAN AUTOMOBILE ASSOCIATION, INC., HEATHROW, MD:
2,681,451. REN. 5-3-12. INT. CL. 16.
- AMERICAN AUTOMOBILE ASSOCIATION, INC., HEATHROW, FL:
2,693,460. REN. 5-3-12. INT. CL. 37.
- AMERICAN BASEBALL COMPANY LLC, LAKEWOOD, NJ:
4,153,612, PUB. 3-20-2012. INT. CL. 35.
- AMERICAN BLINDS AND DRAPERIES, INC., HAYWARD, CA:
4,154,749, INT. CL. 24.
- AMERICAN BUSINESS ALLIANCE, INC., SEATTLE, WA, AKA BUSINESS ALLIANCE, INC.:
4,156,035, INT. CL. 41.
- AMERICAN CANCER SOCIETY, INC., ATLANTA, GA:
4,155,022, MULTIPLE CLASS, INT. CLS. 35 AND 36.
4,155,023, MULTIPLE CLASS, INT. CLS. 35 AND 36.
- AMERICAN CASE MANAGEMENT ASSOCIATION, LITTLE ROCK, AR:
2,497,012. REN. 4-27-12. INT. CL. 35.
2,557,744. REN. 4-27-12. INT. CL. 41.
- AMERICAN CHEMICAL SOCIETY, WASHINGTON, DC:
1,658,752. REN. 5-2-12. INT. CL. 16.
- AMERICAN COLLEGE OF RADIOLOGY, RESTON, VA:
4,153,101, PUB. 3-20-2012. MULTIPLE CLASS, INT. CLS. 16, 35, 41, 42 AND 44.
- AMERICAN COLLEGE OF VETERINARY BEHAVIORISTS, COLLEGE STATION, TX:
2,569,700. REN. 4-30-12. U.S. CL. 200.
- AMERICAN COLLEGE OF VETERINARY PATHOLOGISTS ACVP, THE, MIDDLETON, WI:
1,698,170. REN. 5-2-12. MULTIPLE CLASS, U.S. CL. 200 INT. CL. 42.
1,698,171. REN. 5-2-12. MULTIPLE CLASS, U.S. CL. 200 INT. CL. 42.
- AMERICAN COMPOSERS FORUM, ST. PAUL, MN:
4,155,439, INT. CL. 16.
4,155,440, INT. CL. 16.
- AMERICAN CYCLE & FITNESS, INC., WALLED LAKE, MI:
2,562,664. REN. 5-1-12. INT. CL. 35.
- AMERICAN DE ROSA LAMPARTS LLC, COMMERCE, CA:
4,154,931, INT. CL. 11.
- AMERICAN EXPRESS MARKETING & DEVELOPMENT CORP., NEW YORK, NY:
4,156,026, INT. CL. 41.
- AMERICAN GIRL, LLC, EL SEGUNDO, CA:
2,493,435, CANC. INT. CL. 25.
- AMERICAN HEALTHCARE INDEMNITY COMPANY, LOS ANGELES, CA:
2,496,472. REN. 4-27-12. INT. CL. 36.
- AMERICAN HIGH-INCOME MUNICIPAL BOND FUND, LOS ANGELES, CA:
4,153,272, PUB. 3-20-2012. INT. CL. 36.
- AMERICAN HOME FURNISHINGS ALLIANCE, INC., HIGH POINT, NC:
4,154,822, U.S. CL. A.
- AMERICAN INSTITUTE OF CERTIFIED PUBLIC ACCOUNTANTS, NEW YORK, NY:
4,155,773, INT. CL. 41.
4,155,785, INT. CL. 35.
- AMERICAN KNOCKOUT WEAR, LLC, DUMFRIES, VA:
4,155,763, INT. CL. 25.
- AMERICAN LEBANESE SYRIAN ASSOCIATED CHARITIES, INC., MEMPHIS, TN:
2,693,563. REN. 4-30-12. INT. CL. 36.
- AMERICAN LUNG ASSOCIATION OF CALIFORNIA, OAKLAND, CA:
3,730,238, CANC. INT. CL. 35.
- AMERICAN MACHINE AND TOOL CO., INC. OF PENNSYLVANIA, ROYERSFORD, PA:
4,153,915, PUB. 3-20-2012. INT. CL. 7.
- AMERICAN MADE DORM, LLC, LOUISVILLE, KY:
4,156,048, INT. CL. 35.
- AMERICAN MODULAR SYSTEMS, INC., MANTECA, CA:
4,154,546, MULTIPLE CLASS, INT. CLS. 6 AND 40.
- AMERICAN PUBLIC POWER ASSOCIATION, WASHINGTON, DC:
4,154,139, PUB. 3-20-2012. INT. CL. 35.
- AMERICAN RESIDENTIAL SERVICES LLC, MEMPHIS, TN:
4,153,579, PUB. 3-20-2012. INT. CL. 37.
- AMERICAN RIDER, LLC., MIAMI, FL:
4,155,924, INT. CL. 39.
- AMERICAN SKIN LABS, INC., DELRAY BEACH, FL:
4,154,829, INT. CL. 5.
- AMERICAN SOCIETY FOR TECHNION - ISRAEL INSTITUTE OF TECHNOLOGY, INC., NEW YORK, NY:
4,155,038, INT. CL. 36.
- AMERICAN SOCIOLOGICAL ASSOCIATION, WASHINGTON, DC:
4,153,416, PUB. 3-20-2012. INT. CL. 35.
- AMERICAN SPORTS LICENSING, INC., WILMINGTON, DE, AMERICAN SPORTS LICENSING, INC., WILMINGTON, DE:
2,559,355. REN. 4-27-12. INT. CL. 35.
- AMERICAN SPORTS LICENSING, INC., WILMINGTON, DE:
2,998,604, CANC. INT. CL. 35.
- AMERICAN TAI CHI ASSOCIATION, PHILADELPHIA, PA:
4,152,774, PUB. 3-20-2012. INT. CL. 41.
- AMERICAN TEXTILE INDUSTRIES, LLC, DULUTH, GA:
2,492,209, CANC. INT. CL. 24.
- AMERICAN THEOLOGICAL LIBRARY ASSOCIATION, CHICAGO, IL:
4,153,675, PUB. 3-20-2012. INT. CL. 41.
- AMERICANS FOR PROSPERITY FOUNDATION, ARLINGTON, VA:
4,153,068, PUB. 3-20-2012. MULTIPLE CLASS, INT. CLS. 35 AND 36.
- AMIN LAW OFFICES, LTD., SCHAUMBURG, IL:
4,155,119, INT. CL. 35.
- AMPLEFORTH ABBEY TRUST, NORTH YORKSHIRE, UNITED KINGDOM:
4,152,463, PUB. 1-17-2012. MULTIPLE CLASS, INT. CLS. 16, 30, 32, 33, 41, 43 AND 45.
- AMS ACQUISITION, LLC, MILWAUKEE, WI:
2,437,912. REN. 4-29-12. INT. CL. 9.
- AMSPEC CHEMICAL CORPORATION, BEAR, DE:
1,704,431. REN. 4-27-12. INT. CL. 1.
- ANAGALLIS HERBS LLC, CASTLETON, VT:
4,155,929, INT. CL. 5.
- ANALIS, 5000 NAMUR, BELGIUM:
2,593,555. REN. 5-1-12. INT. CL. 1.
- ANALYX SP. Z O.O. SP.K., POZNAN, POLAND:
4,152,593, PUB. 3-20-2012. MULTIPLE CLASS, INT. CLS. 35 AND 42.
- ANASTASI & ASSOCIATE, P.A., STILLWATER, MN:
4,153,769, PUB. 3-20-2012. INT. CL. 45.
- ANDALUSIAN GOURMET CONCEPT S.L., MÁLAGA, SPAIN:
4,154,107, PUB. 3-20-2012. INT. CL. 43.
- ANDERSON COPPER AND BRASS COMPANY LLC, OAK FOREST, IL:
1,686,005. REN. 5-2-12. INT. CL. 6.
- ANDERSON VALLEY ACQUISITION COMPANY, LLC, BOONVILLE, CA, DBA ANDERSON VALLEY BREWING COMPANY:
4,152,721, PUB. 3-20-2012. INT. CL. 30.
- ANDERSON-MARTIN MACHINE COMPANY, FORT SMITH, AR:
2,998,642, CANC. INT. CL. 37.
- ANDERSON, KENT GEORGE, BISMARCK, ND:
2,579,145. REN. 4-30-12. INT. CL. 30.
- ANDERSON, R. HARRY, WEATHERFORD, TX:
4,155,047, INT. CL. 31.

ANDERSON, REGINA M., WESTLAND, MI, DBA SUN THINGZ:
2,562,371. REN. 5-3-12. INT. CL. 9.

ANDIS COMPANY, STURTEVANT, WI:
1,767,222. REN. 5-3-12. INT. CL. 8.

ANDRASIK, BENJAMIN D, PASADENA, MD, DBA PET-METRIC:
4,153,561, PUB. 3-20-2012. INT. CL. 45.

ANDREA M. GRISWELL, STONE MOUNTAIN, GA:
4,155,432, INT. CL. 28.

ANDUPWARDS, INC., BRANDON, FL:
4,155,667, INT. CL. 9.

ANGELIQUE DE PARIS, INC., ALLENTOWN, PA:
2,634,766. REN. 4-27-12. INT. CL. 14.

ANHEUSER-BUSCH, LLC, ST. LOUIS, MO:
4,154,223, PUB. 3-20-2012. INT. CL. 32.

ANKASA LTD, NEW YORK, NY:
4,152,817, PUB. 3-20-2012. INT. CL. 25.

ANSELL LIMITED, RICHMOND, AUSTRALIA:
4,156,027, INT. CL. 9.

ANSON & HIGGINS PLASTIC SURGERY ASSOCIATES, LLP, LAS VEGAS, NV:
4,154,359, INT. CL. 41.
4,154,360, INT. CL. 41.

ANT PRECISION INDUSTRY CO., LTD, NEW TAIPEI CITY, TAIWAN:
4,152,825, PUB. 3-20-2012. INT. CL. 9.

ANTHONY F. BERARDI III, POTTSTOWN, PA, DBA SCORPION TABLES:
4,154,177, PUB. 3-20-2012. INT. CL. 10.

APA - THE ENGINEERED WOOD ASSOCIATION, TACOMA, WA:
2,576,012. REN. 5-3-12. INT. CL. 19.

APICAL INDUSTRIES, INC., OCEANSIDE, CA:
2,615,153. REN. 5-2-12. INT. CL. 12.
2,615,155. REN. 5-2-12. INT. CL. 12.

APITVA, INC., AUSTIN, TX, DBA LYNXSQUARE:
4,155,666, INT. CL. 42.

APOC RESTAURANT, INC., NEW YORK, NY:
4,154,298, INT. CL. 21.

APOLLO (ZHUHAI) ELECTRONICS LIMITED COMPANY, 519000 GUANGDONG, CHINA:
4,152,181, PUB. 3-20-2012. MULTIPLE CLASS, INT. CLS. 9 AND 11.

APOLLO PRODUCTS, INC., KANSAS CITY, MO:
2,273,797, AM. MULTIPLE CLASS, INT. CLS. 3, 26, 35 AND 42.

APOLLO REEF LED, LLC, GOULDSBORO, PA, AKA APOLLO REEF LED:
4,153,173, PUB. 3-20-2012. INT. CL. 11.

APOTHEKER WALTER BOUHON GMBH, D-90427 NÜRNBERG, FED REP GERMANY:
2,998,354.

APPEALPROPERTYTAX.COM, INC., HOUSTON, TX:
4,152,783, PUB. 3-20-2012. INT. CL. 35.

APPICLE, OLATHE, KS:
4,154,998, INT. CL. 9.

APPLE INC., CUPERTINO, CA:
2,638,263. REN. 5-2-12. MULTIPLE CLASS, INT. CLS. 38 AND 41.
2,653,465. REN. 5-2-12. INT. CL. 9.
4,155,659, INT. CL. 9.

APPLIED BIOSYSTEMS, LLC, FOSTER CITY, CA:
4,154,287, INT. CL. 5.

APPLIED MATERIALS GMBH & CO. KG, FED REP GERMANY:
4,152,431, PUB. 3-20-2012. INT. CL. 7.

APPLIED PSYCHOLOGICAL TECHNIQUES, INC., DARIEN, CT:
2,651,355. REN. 4-27-12. MULTIPLE CLASS, INT. CLS. 9 AND 35.

APPLIED STORYTELLING, INC., OAKLAND, CA:
4,153,799, PUB. 3-20-2012. INT. CL. 35.

APPLIED SYSTEMS DEVELOPMENT CORPORATION, GAINESVILLE, GA:
2,998,748, CANC. INT. CL. 10.

APPTERA, INC., SUNNYVALE, CA:
4,155,514, MULTIPLE CLASS, INT. CLS. 9, 35, 38 AND 42.
4,155,515, MULTIPLE CLASS, INT. CLS. 9, 35, 38 AND 42.

APPZERO SOFTWARE CORP., OTTAWA, ONTARIO, CANADA:
4,152,109, PUB. 3-20-2012. MULTIPLE CLASS, INT. CLS. 9 AND 42.

APRIL MALMSTEEN, MIAMI, FL AND YNGWIE MALMSTEEN, MIAMI, FL:
4,154,653, INT. CL. 41.

APS HEALTHCARE BETHESDA, INC., SILVER SPRING, MD:
2,998,525, CANC. MULTIPLE CLASS, INT. CLS. 35 AND 42.
2,998,526, CANC. MULTIPLE CLASS, INT. CLS. 35 AND 42.

AQUA-LEISURE INDUSTRIES, INC., AVON, MA:
4,154,814, INT. CL. 28.

AQUAPAC INTERNATIONAL LIMITED, LONDON, UNITED KINGDOM:
2,998,964, CANC. INT. CL. 11.

AQUATROLS CORPORATION OF AMERICA, PAULSBORO, NJ:
4,153,128, PUB. 3-20-2012. INT. CL. 1.

ARACELI SOLIS RABAGO, GUADALAJARA, MEXICO:
4,152,514, PUB. 3-20-2012. INT. CL. 42.

ARAG INSURANCE COMPANY, DES MOINES, IA:
2,493,688, CANC. INT. CL. 36.

ARAUJO, WILLIAM, BAKERSFIELD, CA:
4,153,018, PUB. 3-20-2012. INT. CL. 35.

ARBALEST LEGAL FUNDING LLC, BOULDER, CO:
4,155,610, INT. CL. 36.

ARBOR PHARMACEUTICALS, RALEIGH, NC:
1,211,217. REN. 4-30-12. INT. CL. 5.

ARC RISK MANAGEMENT GROUP PLC, WOKINGHAM, UNITED KINGDOM:
2,998,932, CANC. INT. CL. 35.

ARCODE CORPORATION, BETHESDA, MD:
4,155,838, MULTIPLE CLASS, INT. CLS. 9, 38 AND 42.

ARCSOFT, INC., FREMONT, CA:
4,155,386, INT. CL. 9.

ARDEN HOLDINGS INC., ST. LAURENT, QUEBEC, CANADA:
4,152,630, PUB. 2-7-2012. MULTIPLE CLASS, INT. CLS. 3, 9, 14, 18, 25 AND 26.

ARETE ENTERTAINMENT, INC., SHERMAN OAKS, CA:
2,493,160, CANC. INT. CL. 9.

ARETE USA I LLC, NEW YORK, NY:
4,155,065, INT. CL. 30.
4,155,066, INT. CL. 30.

ARETE VENTURES, LLC, CINCINNATI, OH:
4,155,259, INT. CL. 16.
4,155,260, INT. CL. 16.
4,155,266, INT. CL. 16.
4,155,430, INT. CL. 16.

ARISTAVET VETERINAERSPEZIALITAETEN GMBH, 88189 RAVENSBURG, FED REP GERMANY:
2,562,079. REN. 4-27-12. INT. CL. 31.

ARISTOCRAT TECHNOLOGIES AUSTRALIA PTY LIMITED, NORTH RYDE, NSW, AUSTRALIA:
2,564,866. REN. 5-2-12. INT. CL. 9.

ARISTOCRAT TECHNOLOGIES AUSTRALIA PTY LTD., NORTH RYDE, AUSTRALIA:
4,152,873, PUB. 3-20-2012. INT. CL. 9.

ARISTOCRAT TECHNOLOGIES AUSTRALIA PTY LTD, NORTH RYDE, NSW, AUSTRALIA:
4,154,630, INT. CL. 9.

ARIZONA EDUCATIONAL FOUNDATION, INC., SCOTTSDALE, AZ:
4,153,977, PUB. 3-20-2012. INT. CL. 36.
4,153,979, PUB. 3-20-2012. INT. CL. 41.

ARIZONA FEDERAL CREDIT UNION, PHOENIX, AZ:
2,699,753. REN. 4-27-12. INT. CL. 36.

ARIZONA INSTRUMENT LLC, CHANDLER, AZ:
2,709,832. REN. 4-30-12. INT. CL. 9.

ARLA FOODS AMBA, VIBY J, DENMARK:
2,951,392, CANC. INT. CL. 29.

- ARLINGTON STEEL BUILDINGS COMPANY LLC, WILMINGTON, DE:
4,154,781, INT. CL. 6.
- ARMISTEAD, JOHN T., GLEN ARM, MD:
2,492,763, CANC. INT. CL. 42.
- ARMOUR, HELENA, LOVELAND, OH:
2,953,906, CANC. INT. CL. 3.
- ARMSTRONG, JENNIFER, MINERAL, VA:
4,153,155, PUB. 3-20-2012. INT. CL. 25.
- ARMSTRONG, STEPHEN GEOFFREY, TORONTO, CANADA:
4,154,370, INT. CL. 16.
- ARNOLD, ERIC M, MEDINA, OH, DBA BATS, BIRDS, & MORE:
4,153,776, PUB. 3-20-2012. INT. CL. 37.
- ARO MEDICAL, LLC, NORTH ANDOVER, MA:
4,154,301, INT. CL. 10.
- ARON STREIT, INC., NEW YORK, NY:
2,597,405, REN. 4-30-12. MULTIPLE CLASS, INT. CLS. 29 AND 30.
- ARRINDELL, CHARLES, OAKVILLE, CT:
4,155,191, INT. CL. 30.
- ARROW ROCK & STONE, LLC, WEST JORDAN, UT:
4,152,640, PUB. 3-20-2012. INT. CL. 35.
- ARTA PLAST AB, TYRESO, SWEDEN:
4,155,238, INT. CL. 20.
- ARTAZAAR, LLC, STOCKTON, CA:
4,155,200, INT. CL. 35.
- ARTDECO COSMETIC GMBH, 85757 KARLSFELD, FED REP GERMANY:
4,152,272, PUB. 3-20-2012. MULTIPLE CLASS, INT. CLS. 3, 8, 14, 18 AND 21.
- ARTEMISS, LLC, NEW YORK, NY:
1,658,093, CANC. MULTIPLE CLASS, INT. CLS. 9, 18 AND 25.
- ARTHROCARE CORPORATION, AUSTIN, TX:
2,492,972, CANC. INT. CL. 10.
- ARTISTIC CAFES INC., SAN JOSE, CA, DBA BON VIVANT CAFE:
4,155,217, INT. CL. 33.
- ARYLESSENCE, INC., MARIETTA, GA:
4,154,794, INT. CL. 1.
- ARYMAR INC., MIAMI LAKES, FL:
4,153,044, PUB. 12-13-2011. INT. CL. 5.
- ARYSTA LIFESCIENCE NORTH AMERICA, LLC, CARY, NC, TOMEN AGRO, INC., SAN FRANCISCO, CA:
2,599,142, REN. 5-2-12. INT. CL. 5.
- ASCENDUM SOLUTIONS, LLC, CINCINNATI, OH:
4,153,591, PUB. 3-20-2012. INT. CL. 42.
- ASCENSION TECHNOLOGY CORPORATION, BURLINGTON, VT:
3,872,637, COR. INT. CL. 9.
3,872,638, COR. INT. CL. 9.
- ASCENTIA HEALTH, INC., ROCKFORD, IL:
4,154,550, INT. CL. 10.
- ASHDON, INC., LAS VEGAS, NV:
4,155,997, INT. CL. 41.
- ASHEEV LLC, STOCKBRIDGE, GA:
4,152,074, PUB. 3-29-2011. INT. CL. 41.
- ASHLEY FURNITURE INDUSTRIES, INC., ARCADIA, WI:
1,687,892, REN. 5-3-12. INT. CL. 20.
- ASHLEY SCRUPPS, KIRKLAND, WA:
4,153,151, PUB. 3-20-2012. INT. CL. 5.
- ASICS CORPORATION, CHUO-KU, KOBE CITY, HYOGO PREFECTURE, JAPAN:
924,162, AM. U.S. CL. 25.
- ASIS INTERNATIONAL, INC., ALEXANDRIA, VA:
4,153,551, PUB. 3-20-2012. INT. CL. 41.
- ASKARI, KWAME S., ATLANTA, GA:
4,153,844, PUB. 3-20-2012. MULTIPLE CLASS, INT. CLS. 9 AND 25.
- ASLAN GLOBAL MANAGEMENT, LLC, NAPLES, FL:
4,155,188, INT. CL. 35.
- ASPEN SEARCH ADVISORS, LLC, NEW YORK, NY:
4,152,633, PUB. 3-20-2012. INT. CL. 35.
- ASPEN, MARILYN JEAN, PARK CITY, UT:
4,155,207, INT. CL. 30.
- ASPIRA ASSOCIATION, INC., WASHINGTON, DC:
4,153,529, PUB. 3-20-2012. INT. CL. 41.
- ASPIRE CELLARS LLC, ASHLAND, NE, DBA CELLAR 426:
4,154,721, INT. CL. 33.
- ASSISTED LIVING TECHNOLOGIES, INC., MERIDEN, CT:
4,155,118, MULTIPLE CLASS, INT. CLS. 35 AND 37.
- ASSOCIATED STEEL COMPANY, INC., CLEVELAND, OH:
2,557,803, REN. 4-27-12. INT. CL. 6.
- ASSOCIATES OF CAPE COD, INCORPORATED, EAST FALMOUTH, MA:
2,687,475, REN. 4-30-12. INT. CL. 9.
- ASSOCIATION OF AMERICAN MEDICAL COLLEGES, WASHINGTON, DC:
4,152,908, PUB. 3-20-2012. INT. CL. 41.
- ASSURANT, INC., NEW YORK, NY:
4,154,378, MULTIPLE CLASS, INT. CLS. 36, 37 AND 42.
- ASSURED GUARANTY LTD., HAMILTON HM 08, BERMUDA:
4,154,708, INT. CL. 36.
- ASTRAZENECA UK LIMITED, LONDON, UNITED KINGDOM:
2,586,192, REN. 5-1-12. INT. CL. 5.
- ASTROPOLITAN PICTURES, INC., LOS ANGELES, CA:
2,561,012, REN. 5-1-12. INT. CL. 41.
- AT&T INTELLECTUAL PROPERTY II, L.P., RENO, NV:
2,998,945, CANC. INT. CL. 38.
4,154,792, INT. CL. 38.
- ATARI GAMES CORPORATION, MILPITAS, CA TO WARNER BROS. ENTERTAINMENT INC., BURBANK, CA:
1,686,544, AM. INT. CL. 9.
- ATHELITE, INC., NEW YORK, NY:
4,155,621, INT. CL. 41.
- ATHENAHEALTH, INC., WATERTOWN, MA:
4,153,526, PUB. 3-20-2012. MULTIPLE CLASS, INT. CLS. 35 AND 42.
- ATHLETIC ALL PURPOSE PRODUCTS, L.L.C., OAK PARK, MI:
4,153,634, PUB. 3-20-2012. INT. CL. 25.
- ATKINSON, PATRICK J., BISMARCK, ND:
2,574,241, REN. 4-30-12. INT. CL. 41.
- ATL INTERNATIONAL, INC., MILLERSVILLE, MD:
1,684,879, REN. 5-2-12. INT. CL. 37.
- ATLANTA ART LICENSING AND MARKETING, INC., DULUTH, GA:
4,154,504, MULTIPLE CLASS, INT. CLS. 14, 16 AND 25.
- ATLANTA INTERNATIONAL B.V., NL-9601 MD HOOGEZAND, NETHERLANDS:
4,152,178, PUB. 3-20-2012. MULTIPLE CLASS, INT. CLS. 9 AND 20.
- ATLANTIC BOTTLING, LLC, LONG BRANCH, NJ:
3,234,012, CANC. INT. CL. 33.
3,291,386, CANC. INT. CL. 33.
- ATLANTIC MEDIA COMPANY, WASHINGTON, DC:
4,152,944, PUB. 3-20-2012. INT. CL. 16.
- ATLANTIC THREAD & SUPPLY COMPANY, INC., BALTIMORE, MD:
2,597,963, REN. 5-2-12. MULTIPLE CLASS, INT. CLS. 23 AND 35.
- ATLANTIS SPORTSWEAR, INC., PIQUA, OH:
2,581,941, REN. 4-30-12. INT. CL. 25.
- ATLAS COPCO TOOLS AB, SWEDEN:
4,152,395, PUB. 3-20-2012. MULTIPLE CLASS, INT. CLS. 7 AND 9.
- ATLAS PROGRAMMING MANAGEMENT, INC., LAFAYETTE, CA:
4,155,757, INT. CL. 9.
- ATOMIC RECORDS INCORPORATED, HOLLYWOOD, CA:
4,152,731, PUB. 3-20-2012. INT. CL. 9.
- ATRONIC INTERNATIONAL GMBH, LUBBECKE, FED REP GERMANY:
2,998,831, CANC. INT. CL. 9.
- ATSUMI CAR EQUIPMENT, INC., WYTHEVILLE, VA:
4,152,847, PUB. 3-20-2012. MULTIPLE CLASS, INT. CLS. 7 AND 12.
- ATTENTION, INC., ROANOKE, VA:
4,155,590, INT. CL. 9.
- AU OPTRONICS CORP., HSINCHU CITY, TAIWAN:
4,154,983, INT. CL. 9.

AU, HAMLIN, LITTLE ROCK, AR:
4,155,527, INT. CL. 16.

AUCTIONDROP, INC., FREMONT, CA:
2,998,894, CANC. MULTIPLE CLASS, INT. CLS. 35, 36
AND 39.

AUGMENTIX CORPORATION, AUSTIN, TX:
3,217,585, COR. INT. CL. 9.

AUGUST HAT COMPANY, INC., OXNARD, CA:
4,153,276, PUB. 3-20-2012. INT. CL. 35.

AUGUST STORCK KG, 13403 BERLIN, FED REP GER-
MANY:
4,152,424, PUB. 3-20-2012. MULTIPLE CLASS, INT. CLS.
29 AND 30.

AUSTRALIAN GOLD, LLC, INDIANAPOLIS, IN:
4,152,451, PUB. 3-20-2012. INT. CL. 3.
4,154,194, PUB. 3-20-2012. INT. CL. 18.
4,155,809, INT. CL. 3.

AUTHORITY LIGHTING INC., EDMONTON, CANADA,
DBA AUTHORITY LIGHTING:
4,152,100, PUB. 3-20-2012. INT. CL. 9.

AUTO ELEX CO., LTD., KIMHAE-CITY, KYOUNGNAM
621-843, REPUBLIC OF KOREA:
4,152,249, PUB. 3-20-2012. INT. CL. 7.

AUTO-KAPS, LLC, RIVERHEAD, NY:
2,609,022, REN. 4-30-12. INT. CL. 7.

AUTODROMO LLC, BROOKLYN, NY:
4,155,827, INT. CL. 14.

AUTOMATED SYSTEMS, INC., TAMPA, FL:
2,998,885, CANC. INT. CL. 9.

AUTOMOTIVE RENTALS, INC., MT. LAUREL, NJ:
2,493,638, CANC. MULTIPLE CLASS, INT. CLS. 35 AND
42.

AUTOZONE PARTS, INC., MEMPHIS, TN:
4,155,632, INT. CL. 35.

AVANTE LEADERSHIP GROUP, LLC, LITTLETON, CO:
4,155,694, INT. CL. 41.

AVANTEXT, INC., CONSHOHOCKEN, PA:
4,154,733, INT. CL. 9.
4,154,734, INT. CL. 9.

AVATAR ENTERPRISES, INC., WINONA, MN, DBA COM-
FORTEX:
4,153,107, PUB. 3-20-2012. INT. CL. 10.

AVEDIA SYSTEM INC., SHENZHEN, GUANGDONG, CHI-
NA:
4,152,215, PUB. 12-13-2011. MULTIPLE CLASS, INT. CLS.
9 AND 42.

AVEDRO, INC., WALTHAM, MA:
4,154,852, INT. CL. 44.

AVEN CORPORATION, TEMECULA, CA:
4,155,009, INT. CL. 36.

AVENUE K MARKETING, LLC, LOS ANGELES, CA:
4,155,835, INT. CL. 35.

AVEOS FLEET PERFORMANCE INC., SAINT-LAURENT,
QUEBEC, CANADA:
4,152,111, PUB. 3-20-2012. MULTIPLE CLASS, INT. CLS.
16, 35, 37, 39, 41 AND 42.
4,152,112, PUB. 3-20-2012. MULTIPLE CLASS, INT. CLS.
16, 35, 37, 39, 41 AND 42.

AVER INFORMATION INC., NEW TAIPEI CITY, TAIWAN:
2,618,035, REN. 5-2-12. INT. CL. 9.

AVERBUG, ANDRE, POTOMAC, MD:
4,155,034, INT. CL. 35.

AVERY, ERIN, FAIR HAVEN, NJ:
4,155,026, INT. CL. 41.

AVID TECHNOLOGY, INC., BURLINGTON, MA:
4,154,274, INT. CL. 35.

AVON PRODUCTS, INC., NEW YORK, NY:
2,998,907, CANC. INT. CL. 3.
2,998,996, CANC. INT. CL. 3.

AVON PRODUCTS, INC., NEW YORK, NY:
4,155,488, INT. CL. 3.

AWASTHI, TANESHA, SAN JOSE, CA, DBA GIRL WITH
CURVES:
4,154,074, PUB. 3-20-2012. INT. CL. 41.

AWIATECH CORPORATION, AUSTIN, TX:
4,153,330, PUB. 3-20-2012. INT. CL. 35.

AXALTO HOLDING NV, NETHERLANDS:
2,970,798.

AXEL KAUS, FED REP GERMANY:
2,998,361.

AXIP LIMITED, AUCKLAND, NEW ZEALAND:
4,152,806, PUB. 3-20-2012. MULTIPLE CLASS, INT. CLS.
6, 19 AND 45.

AXVECO B.V., NETHERLANDS:
4,152,386, PUB. 3-20-2012. INT. CL. 37.

AZAR DISTILLING, LLC, SAN ANTONIO, TX:
4,155,535, INT. CL. 33.

AZIENDA AGRICOLA VIGNA DOGARINA SAS DI TONUS
GUIDO & C., I-31040 SALGAREDA (TV), ITALY:
4,152,373, PUB. 3-20-2012. MULTIPLE CLASS, INT. CLS.
33, 35 AND 43.

AZIMUT-BENETTI S.P.A., I-55049 VIAREGGIO (LU), ITALY:
4,152,429, PUB. 3-20-2012. INT. CL. 12.

AZZURO HOLDINGS LTD., RICHMOND, BC, CANADA:
4,152,128, PUB. 3-20-2012. INT. CL. 3.

AZZURRO SYSTEMS INTEGRATION LLC, NORTHVALE,
NJ:
4,154,538, INT. CL. 9.

B & B MANUFACTURING CORPORATION, SAN JUAN,
PUERTO RICO:
4,152,649, PUB. 3-20-2012. INT. CL. 7.

B.V.T.V., INC., NEW YORK, NY:
2,581,160, REN. 5-3-12. INT. CL. 35.
2,590,683, REN. 5-2-12. INT. CL. 9.

B&B ISLAND DISTRIBUTING, LLC, HONOLULU, HI:
2,998,941, CANC. MULTIPLE CLASS, INT. CLS. 8, 21
AND 24.

B-K LIGHTING, INC., MADERA, CA:
4,155,183, INT. CL. 11.

BAC FLORIDA BANK, CORAL GABLES, FL:
4,154,170, PUB. 3-20-2012. INT. CL. 36.

BACARELLA TRANSPORTATION SERVICES, INC., SHEL-
TON, CT:
4,153,307, PUB. 3-20-2012. INT. CL. 39.

BACHEN, ROBERT, WAGON MOUND, NM:
2,501,488, REN. 4-30-12. INT. CL. 3.

BACK TO NATURE, INC., BROOKLYN, NY:
3,352,866, CANC. INT. CL. 30.

BACKALDRIN OESTERREICH THE KORNSPITZ COM-
PANY GMBH, A-1230 VIENNA, AUSTRIA:
2,570,510, REN. 5-1-12. INT. CL. 30.

BACKJOY ORTHOTICS, LLC, VALENCIA, CA:
4,153,510, PUB. 3-20-2012. INT. CL. 10.

BACON, JEFF, GARDEN CITY, ID:
1,767,418, REN. 5-2-12. INT. CL. 16.

BADGER METER, INC., MILWAUKEE, WI:
2,492,942, CANC. INT. CL. 9.

BAEK, JOUNG-HYUN, SEOUL, REPUBLIC OF KOREA:
2,998,969, CANC. INT. CL. 35.

BAGLINOX, S.L., SPAIN:
4,152,280, PUB. 3-20-2012. INT. CL. 27.

BAILEY METAL PRODUCTS LIMITED, CONCORD, ON-
TARIO, CANADA:
4,154,709, INT. CL. 6.

BAINS ULTRA INC., SAINT-NICOLAS QUEBEC, CANADA:
4,152,155, PUB. 3-20-2012. INT. CL. 11.

BAKER, SUSAN M, NORTH HOLLYWOOD, CA:
4,153,790, PUB. 3-20-2012. INT. CL. 41.

BAL SEAL ENGINEERING, FOOTHILL RANCH, CA:
4,154,482, INT. CL. 6.

BALANCE BAR COMPANY, VALHALLA, NY:
2,998,506, CANC. INT. CL. 30.

BALCHEM CORPORATION, NEW HAMPTON, NY:
4,154,477, INT. CL. 5.

BALE/DONEEN METHOD LLC, SPOKANE, WA:
4,154,684, INT. CL. 44.
4,154,685, INT. CL. 41.
4,154,686, INT. CL. 41.
4,154,687, INT. CL. 44.

BALENA, DANNY, BOCA RATON, FL:
4,153,341, PUB. 3-20-2012. INT. CL. 25.

BALLET AUSTIN INCORPORATED, AUSTIN, TX AND
EDUCATIONAL GRAPHICS PRESS, INC., AUSTIN, TX:
2,585,348, REN. 5-1-12. INT. CL. 9.

- BALLY GAMING, INC., LAS VEGAS, NV, DBA BALLY TECHNOLOGIES:
4,153,470, PUB. 3-20-2012. INT. CL. 9.
4,154,121, PUB. 3-20-2012. INT. CL. 9.
4,154,944, INT. CL. 9.
- BAMBINOS!, LLC, EVERGREEN, CO:
4,155,788, INT. CL. 21.
- BAMBOO MAUI INC., WAILUKU, HI:
4,155,984, INT. CL. 35.
- BAMBUSA SKATEBOARDS, INC, ROSLYN, PA:
4,155,862, INT. CL. 28.
- BANCO BILBAO VIZCAYA ARGENTARIA, S.A., 48005 BILBAO, SPAIN, BANCO BILBAO VIZCAYA ARGENTARIA, S.A., 48005 BILBAO, SPAIN:
2,561,073, REN. 4-30-12. INT. CL. 36.
2,562,867, REN. 5-2-12. INT. CL. 16.
2,562,929, REN. 4-30-12. INT. CL. 16.
2,569,053, REN. 4-27-12. INT. CL. 9.
- BANFI PRODUCTS CORPORATION, OLD BROOKVILLE, NY:
4,155,483, INT. CL. 33.
- BANGKOK BOXING & ENTERTAINMENT, LLC, NORCROSS, GA:
4,152,672, PUB. 3-20-2012. INT. CL. 41.
- BANGKOK CITY, INC., DALLAS, TX:
4,153,553, PUB. 3-20-2012. INT. CL. 43.
- BANGKOK INTERNATIONAL CUISINE CO., LTD, KLONG TOEI, BANGKOK, THAILAND:
4,154,564, INT. CL. 29.
- BANGO CATERING FRANCHISE INTERNATIONAL GROUP LIMITED, WANCHAI, HONG KONG:
4,154,086, PUB. 3-20-2012. INT. CL. 43.
- BANGOR PUBLISHING COMPANY, BANGOR, ME:
165,252, REN. 5-3-12. U.S. CL. 38 (INT. CL. 16).
- BANK ADMINISTRATION INSTITUTE, CHICAGO, IL:
2,691,706, REN. 4-27-12. INT. CL. 41.
4,152,528, PUB. 3-20-2012. INT. CL. 42.
- BANKERS LIFE AND CASUALTY COMPANY, CHICAGO, IL:
4,152,511, PUB. 3-20-2012. INT. CL. 36.
- BANOM, INC., WAYNE, PA:
4,154,652, INT. CL. 9.
4,155,345, INT. CL. 9.
- BAR NND RANCHES, LLC, MIDLAND, TX:
4,154,358, INT. CL. 21.
- BAR-B-Q HEAVEN, INC., INDIANAPOLIS, IN:
1,702,000, REN. 5-3-12. INT. CL. 30.
- BARBARA CREATIONS, INC., SKOKIE, IL:
2,493,334, CANC. INT. CL. 9.
- BARBOUR VINEYARDS LLC, NAPA, CA:
4,153,225, PUB. 3-20-2012. INT. CL. 44.
- BARCO NV, KORTRIJK, BELGIUM:
2,609,859, REN. 5-2-12. INT. CL. 9.
- BARILLA G.E. R. FRATELLI - SOCIETÀ PER AZIONI, I-43100 PARMA, ITALY:
4,152,300, PUB. 3-20-2012. MULTIPLE CLASS, INT. CLS. 29 AND 30.
- BARKADA CREATIVE, LLC, CHICAGO, IL:
4,153,295, PUB. 3-20-2012. INT. CL. 41.
- BARKER SLEEP MEDICINE PROFESSIONALS, PLLC, KNOXVILLE, TN:
4,152,541, PUB. 3-20-2012. INT. CL. 41.
- BARKER, MARY W., CHARLOTTE, NC:
2,555,948, REN. 4-27-12. INT. CL. 41.
- BARKING SPIDER VISUAL THEATRE INC, AUSTRALIA:
4,152,338, PUB. 3-20-2012. INT. CL. 41.
- BARLEY AND HOPS TAVERN, OCCIDENTAL, CA:
4,154,031, PUB. 3-20-2012. INT. CL. 32.
- BARNES & NOBLE, INC., NEW YORK, NY, WALDEN BOOK COMPANY, INC., STAMFORD, CT, DBA WALDENBOOKS:
1,649,653, REN. 5-1-12. MULTIPLE CLASS, INT. CLS. 35 AND 42.
- BARNESANDNOBLE.COM LLC, NEW YORK, NY:
4,154,532, MULTIPLE CLASS, INT. CLS. 9, 16, 41 AND 42.
4,154,533, MULTIPLE CLASS, INT. CLS. 9, 16, 41 AND 42.
- BARR + BARR, NEW YORK, NY:
2,705,134, REN. 4-30-12. INT. CL. 25.
- BARR, ROBERT, COARSEGOLD, CA, ROBERT BARR TRUST, THE, CLOVIS, CA, DBA RB ENTERPRISES:
1,687,042, REN. 5-2-12. INT. CL. 9.
- BARRAS S.R.L., I-20063 CERNUSCO SUL NAVIGLIO (MI), ITALY:
4,152,295, PUB. 3-20-2012. INT. CL. 25.
- BARRE N9NE STUDIO, DANVERS, MA:
4,152,749, PUB. 3-20-2012. INT. CL. 41.
- BARRICELLI, PETER, OLD ORCHARD BEACH, ME:
2,565,511, REN. 5-3-12. INT. CL. 28.
- BASEY DEVELOPMENT, INC, MARKLEVILLE, IN:
4,154,084, PUB. 3-20-2012. INT. CL. 43.
- BASF SE, FED REP GERMANY:
2,998,367.
- BASHAM, ROBIN, SAN JOSE, CA:
4,156,029, INT. CL. 45.
- BASHAS' INC., CHANDLER, AZ:
2,998,765, CANC. INT. CL. 32.
- BASIC ESL, INC., TEMECULA, CA:
4,155,999, MULTIPLE CLASS, INT. CLS. 9 AND 42.
- BASIS INTERNATIONAL LTD., ALBUQUERQUE, NM:
2,493,366, CANC. INT. CL. 9.
- BATES TROY, INC., BINGHAMTON, NY:
4,153,636, PUB. 3-20-2012. INT. CL. 37.
4,153,661, PUB. 3-20-2012. INT. CL. 37.
- BATH & BODY WORKS BRAND MANAGEMENT, INC., REYNOLDSBURG, OH:
4,154,937, MULTIPLE CLASS, INT. CLS. 3 AND 4.
- BATRUS HOLLWEG INTERNATIONAL SELECTION SERVICES, LTD., PLANO, TX:
4,152,592, PUB. 3-20-2012. INT. CL. 35.
- BATTELLE FOR KIDS, COLUMBUS, OH:
4,154,208, PUB. 3-20-2012. INT. CL. 41.
- BAUMER FOODS, INC., METAIRIE, LA:
1,751,436, REN. 4-30-12. INT. CL. 30.
1,751,436, CANC. INT. CL. 29.
- BAUSCH & LOMB INCORPORATED, ROCHESTER, NY:
2,571,287, REN. 4-30-12. INT. CL. 9.
- BAUZA, MARIA DEL ROSARIO, ENCINO, CA:
4,153,060, PUB. 3-20-2012. INT. CL. 41.
- BAXTER, FRANK, LARGO, FL, DBA PIANO WORLD:
4,152,610, PUB. 3-20-2012. MULTIPLE CLASS, INT. CLS. 35 AND 38.
- BAXTER, JENNIFER B., ATLANTA, GA:
4,153,779, PUB. 3-20-2012. INT. CL. 44.
- BAY BREEZE HOLDINGS, LLC, RIVERVIEW, FL:
3,861,658, CANC. INT. CL. 5.
- BAY PARK COMMUNITY HOSPITAL, TOLEDO, OH:
2,566,758, REN. 5-3-12. INT. CL. 42.
- BAY TEK GAMES, INC., PULASKI, WI:
4,155,630, INT. CL. 28.
- BAYER AKTIENGESELLSCHAFT, LEVERKUSEN, FED REP GERMANY:
4,153,023, PUB. 3-20-2012. INT. CL. 5.
- BAYER HEALTHCARE LLC, TARRYTOWN, NY:
2,493,603, CANC. INT. CL. 5.
- BAZUCA.COM CHILE S.A., SANTIAGO, CHILE:
2,541,395, REN. 5-1-12. INT. CL. 35.
- BB&T CORPORATION, WINSTON-SALEM, NC:
4,155,267, INT. CL. 36.
- BBK TOBACCO & FOODS, LLP, PHOENIX, AZ, DBA HBI INTERNATIONAL:
4,153,415, PUB. 3-20-2012. INT. CL. 34.
- BC CARD CO., LTD., SEOUL, REPUBLIC OF KOREA:
4,154,683, MULTIPLE CLASS, INT. CLS. 9 AND 36.
- BC TOURS, INC., NASHVILLE, TN:
4,155,855, INT. CL. 25.
- BDSRCO, INC., WILMINGTON, DE:
4,155,356, INT. CL. 14.
4,155,357, INT. CL. 9.
- BE THE BREATH, LLC, FORT MYERS, FL:
4,152,930, PUB. 10-18-2011. MULTIPLE CLASS, INT. CLS. 25, 28 AND 41.
- BEAKS OF EAGLES, ROYAL OAKS, CA:
4,153,541, PUB. 3-20-2012. INT. CL. 25.
4,153,544, PUB. 3-20-2012. INT. CL. 25.
- BEALE, ALAN J., MILWAUKEE, WI:
2,998,540, CANC. INT. CL. 42.

BEAN, COLLIN W., EXCELSIOR, MN:
4,155,293, MULTIPLE CLASS, INT. CLS. 25 AND 41.

BEAT COSMETICS LLC, LOS ANGELES, CA:
4,152,666, PUB. 3-20-2012. INT. CL. 44.

BEATRIZ CILANTRO SALSA CORP., DELRAY BEACH, FL:
4,154,440, INT. CL. 30.

BEAULIEU GROUP, LLC, DALTON, GA:
2,492,255, CANC. INT. CL. 27.

BEAUTY HOLDING LLC, DENTON, TX:
2,562,797. REN. 5-2-12. INT. CL. 3.

BEAUTY SPECIALS LLC, ORANGE, CA:
4,154,420, INT. CL. 3.

BECAID, LLC, NEW HAVEN, CT:
4,155,612, INT. CL. 9.

BEECH-NUT NUTRITION CORPORATION, AMSTERDAM, NY:
4,155,300, INT. CL. 29.

BEETLEFARM, LLC, SAN FRANCISCO, CA, DBA CUBAN COUNCIL:
4,153,336, PUB. 3-20-2012. INT. CL. 9.

BEFIT COLLECTIVE LLC, ARVADA, CO:
4,153,924, PUB. 3-20-2012. INT. CL. 9.

BEGIER, LYNNE, JAMAICA PLAIN, MA:
4,155,992, INT. CL. 41.

BEHAVIORAL HEALTH PSYCHOLOGY, PLLC, KALAMAZOO, MI:
2,493,245, CANC. INT. CL. 42.

BEIJING SANJU ENVIRONMENTAL PROTECTION AND NEW MATERIAL CO., LTD., HAIDIAN DISTRICT, 100080 BEIJING, CHINA:
4,152,307, PUB. 3-20-2012. INT. CL. 1.

BEKO TECHNOLOGIES GMBH, 41468 NEUSS, FED REP GERMANY:
4,152,301, PUB. 3-20-2012. MULTIPLE CLASS, INT. CLS. 9, 37 AND 42.

BELCAM, INC., ROUSES POINT, NY, DELAGAR PRODUCTS, INC., ROUSES POINT, NY:
1,205,178. REN. 5-2-12. INT. CL. 8.

BELK STORES SERVICES, INC., CHARLOTTE, NC:
1,688,206. REN. 5-2-12. INT. CL. 42.

BELLATOR SPORT WORLDWIDE LLC, CHICAGO, IL:
4,154,581, INT. CL. 28.

BELLMAN & SYMFON EUROPE AB, VASTRA FROLUNDA, SWEDEN:
1,712,647. REN. 5-1-12. INT. CL. 9.

BELO CORP., DALLAS, TX, BELO CORP., DALLAS, TX:
2,568,627. REN. 4-27-12. INT. CL. 38.
2,568,628. REN. 4-27-12. INT. CL. 38.

BELSITO, JOSEPH, NEW WINDSOR, NY:
4,156,071, INT. CL. 16.

BELTRAN, RICARDO, MEXICO CITY, MEXICO:
4,155,536, INT. CL. 42.

BEN FRANK, COSTA MESA, CA, DBA 212 SPORTS, LLC:
4,153,084, PUB. 3-20-2012. INT. CL. 41.

BENAYOUN STÉPHANE PAUL, F-77111 SOIGNOLLES-EN-BRIE, FRANCE:
4,152,254, PUB. 3-20-2012. MULTIPLE CLASS, INT. CLS. 35, 38, 41 AND 42.

BENCHMARK BRANDS, INC., NORCROSS, GA:
4,154,893, INT. CL. 10.

BENCHMARK SOLUTIONS HOLDINGS INC., NEW YORK, NY:
4,154,970, INT. CL. 35.
4,154,971, INT. CL. 35.
4,154,973, INT. CL. 35.
4,155,140, INT. CL. 35.
4,155,142, INT. CL. 35.
4,155,143, INT. CL. 35.

BENCHMARK, LLC, ASOTIN, WA:
4,154,265, INT. CL. 19.

BENDA-LUTZ WERKE GMBH, NUSSDORF OB DER TRAISEN, AUSTRIA:
2,593,778. REN. 5-3-12. MULTIPLE CLASS, INT. CLS. 2 AND 40.

BENEFIT COSMETICS LLC, SAN FRANCISCO, CA:
4,155,400, INT. CL. 3.

BENESOLUTIONS, INC., WASHINGTON, DC:
2,998,830, CANC. MULTIPLE CLASS, INT. CLS. 35 AND 36.

BENITO, MARIA ANGELES DE PABLO, 28029 MADRID, SPAIN, AKA MARIA ANGELES DE PABLO:
2,562,080. REN. 5-3-12. INT. CL. 29.

BENSON, DEBORAH SUE, BLAINE, MN, DBA BENTIS COMPANIES, LLC AND TENTIS, PAMELA JEAN, CIRCLE PINES, MN, DBA BENTIS COMPANIES, LLC:
4,154,626, INT. CL. 42.

BENTENSHU MEIOJI, IBARAKI CITY, OSAKA, JAPAN:
1,217,537. REN. 5-3-12. INT. CL. 16.

BENTLEY SYSTEMS, INCORPORATED, EXTON, PA:
2,565,612. REN. 4-30-12. INT. CL. 9.

BERG, CHRISTOPHER, BERKELEY, CA:
2,562,222. REN. 5-3-12. INT. CL. 16.

BERKSHIRE BLANKET INC., WARE, MA:
4,154,338, INT. CL. 25.

BERLITZ INVESTMENT CORPORATION, WILMINGTON, DE:
2,561,225. REN. 5-2-12. MULTIPLE CLASS, INT. CLS. 9, 16, 35 AND 41.
2,561,225, CANC. INT. CL. 42.

BERMUDA LIMOUSINE INTERNATIONAL, INC., BRONX, NY:
1,684,684. REN. 5-3-12. INT. CL. 39.

BERNARD DUMAS, A FRENCH SOCIETE PAR ACTIONS SIMPLIFIEE, CREYSSE, FRANCE:
2,557,858. REN. 4-27-12. MULTIPLE CLASS, INT. CLS. 16 AND 24.

BERNARDO SHTEREMBERG, DORAL, FL:
4,153,662, PUB. 3-20-2012. INT. CL. 9.

BERNHARD FÖRSTER GMBH, FED REP GERMANY:
4,152,322, PUB. 3-20-2012. INT. CL. 10.

BERNSTEIN, GABRIELLE, NEW YORK, NY:
4,153,187, PUB. 3-20-2012. INT. CL. 41.

BERRY PLASTICS CORPORATION, EVANSVILLE, IN:
4,155,354, INT. CL. 21.

BERRYMAN PRODUCTS, INC., ARLINGTON, TX:
1,192,951. REN. 4-30-12. INT. CL. 3.

BESSER COMPANY USA, ALPENA, MI, CONCRETE PIPE MACHINERY COMPANY, SIOUX CITY, IA:
730,028. REN. 5-2-12. U.S. CL. 23 (INT. CL. 7).

BEST BRANDS CONSUMER PRODUCTS, INC., NEW YORK, NY:
4,154,599, INT. CL. 9.

BEST WAY TECHNOLOGIES, LLC, WAUWATOSA, WI:
4,152,643, PUB. 3-20-2012. INT. CL. 9.

BESTFIT INTERNATIONAL, INC., CITY OF INDUSTRY, CA, INTERSHOE INC., MILLERSBURG, PA:
1,185,867. REN. 5-3-12. INT. CL. 25.

BESTSELLINGCAR AWARD, INC., LA HABRA, CA, DBA BESTSELLINGCAR AWARD, INC.:
4,153,080, PUB. 3-20-2012. INT. CL. 41.

BETA ANALYTIC, INC., MIAMI, FL:
4,153,487, PUB. 3-20-2012. INT. CL. 42.

BEULAH BAPTIST CHURCH OF BENNETT INC., BENNETT, NC:
4,154,873, INT. CL. 41.

BEVERAGE MARKETING USA, INC., WOODBURY, NY:
2,625,638. REN. 4-30-12. INT. CL. 30.

BEVERLY COAT HANGER CO., INC., SAN FRANCISCO, CA:
2,698,953. REN. 5-1-12. INT. CL. 20.

BEYOND MEDICINE, LLC, THOMASVILLE, GA:
4,155,239, INT. CL. 35.

BFI BUSINESS FINANCE, CAMPBELL, CA:
4,155,858, INT. CL. 41.

BG STAR PRODUCTIONS, INC., HIDDEN HILLS, CA:
2,560,851. REN. 5-2-12. MULTIPLE CLASS, INT. CLS. 9, 25 AND 41.

BI-INVEST HOLDINGS S.A., LUXEMBOURG, LUXEMBOURG:
4,152,082, PUB. 3-20-2012. MULTIPLE CLASS, INT. CLS. 35 AND 36.
4,152,083, PUB. 3-20-2012. MULTIPLE CLASS, INT. CLS. 35 AND 36.

BI-LO, LLC, GREENVILLE, SC:
2,491,887, CANC. INT. CL. 35.

- BIAMP SYSTEMS CORPORATION, BEAVERTON, OR:
2,629,238. REN. 5-3-12. INT. CL. 9.
- BIANCHI CORPORATION, REDLANDS, CA:
4,153,214. PUB. 3-20-2012. INT. CL. 41.
- BIBIT, LLC, SPOKANE, WA:
4,154,413. INT. CL. 25.
- BICKFORD'S AUSTRALIA PTY. LTD., NORTH PLYMPTON, AUSTRALIA:
2,996,269. CANC. INT. CL. 32.
- BIG BANG, CROLLES, FRANCE:
4,153,327. PUB. 3-20-2012. MULTIPLE CLASS, INT. CLS. 16, 41 AND 42.
- BIG FISH AMERICA, L.L.C., BEMIDJI, MN:
4,155,336. INT. CL. 28.
- BIG FISH CANDY COMPANY LLC, NEW YORK, NY:
4,154,271. INT. CL. 30.
- BIG HARRY DEALS, INC., LAKE LAND, FL:
4,152,754. PUB. 3-20-2012. INT. CL. 35.
- BIGIO, PABLO, MARLBORO, NJ:
4,153,355. PUB. 3-20-2012. INT. CL. 25.
- BIKEPATH COUNTRY, INC., YORKTOWN HEIGHTS, NY:
4,154,109. PUB. 3-20-2012. INT. CL. 35.
- BIKINI BOTTOM BAR & GRILL, LLC, BARTLETT, IL:
4,154,407. INT. CL. 43.
- BILL GOOD MARKETING, INC., DRAPER, UT:
2,491,826. CANC. MULTIPLE CLASS, INT. CLS. 9 AND 16.
- BILLS.COM, LLC, SAN MATEO, CA:
2,568,868. REN. 4-30-12. INT. CL. 35.
- BIO COSMETICS, S.L., 28023 MADRID, SPAIN:
2,560,998. REN. 5-2-12. MULTIPLE CLASS, INT. CLS. 3 AND 5.
- BIO-MEDICAL RESEARCH LIMITED, GALWAY, IRELAND:
4,154,549. INT. CL. 10.
- BIOFINA, INC., CONCORD, CA:
4,155,082. MULTIPLE CLASS, INT. CLS. 16, 17 AND 21.
- BIOGEN IDEC MA INC., WESTON, MA:
2,493,659. CANC. INT. CL. 16.
- BIOKEEN INC., PALO ALTO, CA:
4,153,655. PUB. 3-20-2012. INT. CL. 35.
- BIOLOG-ID, FRANCE:
4,152,308. PUB. 3-20-2012. MULTIPLE CLASS, INT. CLS. 9 AND 42.
- BIOMED HEALTH SOLUTIONS, LLC, DETROIT, MI:
4,155,881. INT. CL. 42.
- BIONEST TECHNOLOGIES INC., GRAND-MÈRE, CANADA:
4,154,380. INT. CL. 11.
- BIO THERM HYDRONIC, INC., COTATI, CA:
2,573,729. REN. 5-1-12. INT. CL. 11.
- BIOVIGIL HYGIENE TECHNOLOGIES, LLC, ANN ARBOR, MI:
4,153,039. PUB. 3-20-2012. INT. CL. 9.
- BIOZYM HOLDING, BV, 6374 XW LANDGRAAF, NETHERLANDS:
2,699,528. REN. 5-2-12. INT. CL. 9.
- BISCO, INC., SCHAUMBURG, IL:
4,154,830. INT. CL. 5.
- BISON CAPITAL LLC, VENICE, FL:
4,154,288. INT. CL. 33.
4,154,315. MULTIPLE CLASS, INT. CLS. 32 AND 33.
- BISSELL HOMECARE, INC., GRAND RAPIDS, MI:
2,583,893. REN. 5-3-12. INT. CL. 7.
- BISSLAND, MARVIN, MT PLEASANT, SC:
4,155,759. INT. CL. 25.
- BITMICRO NETWORKS, INC., FREMONT, CA, BITMICRO NETWORKS, INC., FREMONT, CA:
2,563,967. REN. 4-30-12. INT. CL. 9.
- BITTYLAB, LLC, NEW YORK, NY:
4,153,163. PUB. 3-20-2012. INT. CL. 10.
- BIZHUB LLC, BIRMINGHAM, MI:
4,152,746. PUB. 3-20-2012. INT. CL. 35.
4,152,747. PUB. 3-20-2012. INT. CL. 35.
- BIZNESS APPS, CHICO, CA:
4,153,630. PUB. 3-20-2012. INT. CL. 42.
- BK FRAMES, CORP., MIAMI BEACH, FL:
4,155,015. INT. CL. 9.
- BKD ACQUISITION, INC., OAKBROOK, IL:
4,155,480. INT. CL. 21.
- BLACK & DECKER CORPORATION, THE, TOWSON, MD:
2,556,759. REN. 4-27-12. INT. CL. 9.
- BLACK DIAMOND BREWING COMPANY, INC., CONCORD, CA:
4,153,243. PUB. 3-20-2012. INT. CL. 32.
- BLACK HILLS AMMUNITION, INC., RAPID CITY, SD:
4,152,757. PUB. 3-20-2012. INT. CL. 13.
4,152,758. PUB. 3-20-2012. INT. CL. 13.
4,152,759. PUB. 3-20-2012. INT. CL. 13.
- BLACK-I TECHNOLOGIES, LLC, BAY HARBOR IS., FL:
4,155,360. INT. CL. 9.
- BLACKBERRY PATCH, INC., THOMASVILLE, GA:
2,564,650. REN. 5-1-12. INT. CL. 30.
- BLACKDIVINE, NEW YORK, NY:
4,153,879. PUB. 3-20-2012. INT. CL. 42.
- BLACKHAWK INDUSTRIAL DISTRIBUTION, INC., TULSA, OK:
4,153,491. PUB. 3-20-2012. INT. CL. 39.
- BLACKROCK CAPITAL CORPORATION, LAS VEGAS, NV:
2,998,866. CANC. INT. CL. 36.
- BLACKROCK, INC., NEW YORK, NY:
4,155,437. MULTIPLE CLASS, INT. CLS. 36 AND 42.
- BLACKSTONE TM L.L.C., NEW YORK, NY:
4,153,945. PUB. 3-20-2012. MULTIPLE CLASS, INT. CLS. 35 AND 36.
- BLAKENSHIP, BRAD, DALLAS, TX:
4,154,470. INT. CL. 25.
- BLANCHARD TRAINING AND DEVELOPMENT, INC., ESCONDIDO, CA:
2,567,890. REN. 5-2-12. INT. CL. 41.
2,582,791. REN. 5-2-12. INT. CL. 41.
- BLANCO, MARIO, TEMPLE CITY, CA, DBA CELIACAID:
4,153,251. PUB. 3-20-2012. INT. CL. 5.
- BLANKEN, DOUGLAS P., BATESVILLE, IN AND BLANKEN, KATHRYN ELOIZA, BATESVILLE, IN:
4,154,649. INT. CL. 30.
- BLING TIME, LLC, ANKENY, IA:
4,153,616. PUB. 3-20-2012. INT. CL. 14.
4,153,617. PUB. 3-20-2012. INT. CL. 14.
- BLOHM + VOSS INDUSTRIES GMBH, HAMBURG, FED REP GERMANY:
1,691,554. REN. 5-2-12. INT. CL. 17.
- BLOOD LOGIC, INC., MT. KISCO, NY:
4,153,220. PUB. 3-20-2012. MULTIPLE CLASS, INT. CLS. 5 AND 9.
- BLU HOMES, INC., WALTHAM, MA:
4,156,001. INT. CL. 19.
- BLUE CROSS & BLUE SHIELD OF MISSISSIPPI, A MUTUAL INSURANCE COMPANY, JACKSON, MS:
4,153,054. PUB. 3-20-2012. INT. CL. 36.
- BLUE CROSS BLUE SHIELD OF ALABAMA, BIRMINGHAM, AL:
4,153,350. PUB. 3-20-2012. INT. CL. 35.
- BLUE EQUITY PUBLISHING LOUISVILLE LLC, LOUISVILLE, KY:
4,152,553. PUB. 3-20-2012. INT. CL. 41.
- BLUE MYSTIQUE, INC., PALMETTO BAY, FL:
4,152,796. PUB. 3-20-2012. INT. CL. 31.
- BLUE SKIN S.A., LEVALLOIS-PERRET, FRANCE:
4,152,072. PUB. 3-20-2012. MULTIPLE CLASS, INT. CLS. 3, 5, 10 AND 25.
- BLUE WORLD CRETE, INC, DEERFIELD BEACH, FL:
4,153,716. PUB. 3-20-2012. INT. CL. 19.
- BLUEBAY ASSET MANAGEMENT LTD, UNITED KINGDOM:
4,152,281. PUB. 1-17-2012. INT. CL. 36.
- BLUESTEM LEARNING, LLC, PRAIRIE VILLAGE, KS:
4,155,504. INT. CL. 35.
- BLUESWOMEN WORKS, LLC, REHOBOTH BEACH, DE:
4,154,122. PUB. 3-20-2012. INT. CL. 15.
- BLUFI LENDING CORPORATION, CARLSBAD, CA:
4,153,658. PUB. 3-20-2012. INT. CL. 36.
- BLUMENTHAL DISTRIBUTING, INC., ONTARIO, CA, DBA OFFICE STAR PRODUCTS, INC.:

BLUSKY RESTORATION CONTRACTORS, INC., CENTENNIAL, CO:
4,152,453, PUB. 12-13-2011. INT. CL. 35.

BLYTH, ALISON, REHOBOTH BEACH, DE:
4,155,013, MULTIPLE CLASS, INT. CLS. 25 AND 43.

BM AUDIO LABS, INC., WILMINGTON, DE:
3,267,104, CANC. INT. CL. 9.

BOARD OF REGENTS OF THE UNIVERSITY SYSTEM OF GEORGIA, ATLANTA, GA:
3,061,633, CANC. MULTIPLE CLASS, INT. CLS. 6 AND 16.
4,154,832, MULTIPLE CLASS, INT. CLS. 6, 14, 16, 18, 21, 25 AND 41.
4,154,833, MULTIPLE CLASS, INT. CLS. 6, 14, 16, 18, 21, 25 AND 41.

BOARD OF REGISTERED POLYSOMNOGRAPHIC TECHNOLOGISTS, INC., MCLEAN, VA:
2,557,898, REN. 4-27-12. INT. CL. 41.
2,561,117, REN. 5-2-12. INT. CL. 41.

BOB EVANS FARMS, INC., COLUMBUS, OH:
4,155,393, INT. CL. 29.

BOB JONES UNIVERSITY, INC., GREENVILLE, SC:
2,562,491, REN. 5-1-12. INT. CL. 16.

BOB SMITH INDUSTRIES, ATASCADERO, CA:
4,153,139, PUB. 3-20-2012. INT. CL. 1.

BOBBILICIOUS BAKING COMPANY LLC, SAN RAFAEL, CA:
4,152,693, PUB. 3-20-2012. INT. CL. 30.

BOBICH, JASON, ANCHORAGE, AK:
4,153,613, PUB. 3-20-2012. INT. CL. 42.

BOBRICK WASHROOM EQUIPMENT, INC., NORTH HOLLYWOOD, CA:
2,564,681, REN. 4-27-12. INT. CL. 11.

BODEGA LA SOTERRAÑA, S.L., SPAIN:
4,152,329, PUB. 3-20-2012. INT. CL. 33.

BODY CONTOUR CENTERS, LLC, KIRKLAND, WA:
3,622,233, COR. INT. CL. 44.

BODYPLUS INTERNATIONAL K.K., SENDAI, JAPAN:
4,153,210, PUB. 3-20-2012. MULTIPLE CLASS, INT. CLS. 5 AND 29.
4,153,211, PUB. 3-20-2012. MULTIPLE CLASS, INT. CLS. 5 AND 29.

BOEGER WINERY, INC., PLACERVILLE, CA:
1,731,478, REN. 5-2-12. INT. CL. 33.

BOGOCH FAMILY LLC, NEW YORK, NY:
4,154,580, INT. CL. 44.

BOKLOK AB, SE-211 23 MALMÖ, SWEDEN:
2,998,358.

BOLLINGER, BRANSON, GRAND PRAIRIE, TX, DBA PRSONA AND BOLLINGER, BRENDON, GRAND PRAIRIE, TX, DBA PRSONA:
4,152,730, PUB. 3-20-2012. INT. CL. 35.

BONA VITA RX CORPORATION, CHULA VISTA, CA:
4,155,153, INT. CL. 32.

BONFIGLIO, JOSEPH, GLASTONBURY, CT:
4,155,972, INT. CL. 32.

BONNET, CHUCK L., DICKSON, TN:
2,565,261, REN. 5-2-12. INT. CL. 9.

BOOKBOTTLES, LLC, ROSEVILLE, MN:
4,153,638, PUB. 3-20-2012. INT. CL. 43.

BOOKT LLC, HOLLYWOOD, FL:
4,155,752, INT. CL. 42.

BOOTS RETAIL HOLDINGS (USA) INC., STAMFORD, CT:
2,998,882, CANC. INT. CL. 3.
2,999,274, CANC. INT. CL. 3.

BORGREN, THOMAS M, DULUTH, MN:
4,155,172, INT. CL. 20.

BOROWSKI, JASON, BONITA SPRINGS, FL:
4,152,846, PUB. 3-20-2012. INT. CL. 9.

BOSE CORPORATION, FRAMINGHAM, MA, BOSE CORPORATION, NATICK, MA:
933,856, REN. 5-2-12. U.S. CL. 21 (INT. CL. 9).

BOSTON ACOUSTICS, INC., WOBURN, MA:
2,573,704, REN. 4-27-12. INT. CL. 9.

BOSTON BAR ASSOCIATION, BOSTON, MA:
4,153,513, PUB. 3-20-2012. INT. CL. 35.

BOSTON PROPERTIES LIMITED PARTNERSHIP, BOSTON, MA:
2,630,120, REN. 4-27-12. MULTIPLE CLASS, INT. CLS. 36 AND 37.
4,153,147, PUB. 3-20-2012. INT. CL. 36.
4,153,148, PUB. 3-20-2012. INT. CL. 36.

BOSTON SCIENTIFIC NEUROMODULATION CORPORATION, VALENCIA, CA:
2,998,897, CANC. INT. CL. 10.

BOSTON SCIENTIFIC SCIMED, INC., MAPLE GROVE, MN:
2,595,527, REN. 5-2-12. INT. CL. 10.

BOTTOM LINE FOOD PROCESSORS, INC., AUSTIN, TX, DBA MICHAEL ANGELO'S GOURMET FOODS, INC.:
2,519,760, REN. 5-3-12. MULTIPLE CLASS, INT. CLS. 29 AND 30.

BOUCHAIB CHAKIR, FED REP GERMANY:
2,998,359.

BOURBEAU & BONILLA, LLP, HULL, MA:
4,154,174, PUB. 3-20-2012. INT. CL. 45.

BOWLERS TO VETERANS LINK, INC., FAIRFAX, VA:
4,153,078, PUB. 3-20-2012. INT. CL. 36.
4,153,079, PUB. 3-20-2012. INT. CL. 36.

BOXCAR CANDLE COMPANY, LLC, HALES CORNERS, WI:
4,152,516, PUB. 3-20-2012. INT. CL. 4.

BOXWAVE CORPORATION, BELLEVUE, WA:
4,152,054, PUB. 3-20-2012. INT. CL. 9.

BOY SCOUTS OF AMERICA, IRVING, TX:
1,213,648, REN. 5-2-12. U.S. CL. 200.
1,213,651, REN. 5-2-12. U.S. CL. 200.

BOYD GAMING CORPORATION, LAS VEGAS, NV:
2,503,823, REN. 5-3-12. INT. CL. 41.

BOYLE INVESTMENT COMPANY, MEMPHIS, TN:
2,577,964, REN. 5-2-12. MULTIPLE CLASS, INT. CLS. 36 AND 37.

BOYUKLIEV, DIMITRE, BRONX, NY:
4,152,720, PUB. 3-20-2012. INT. CL. 45.

BP PRODUCTS NORTH AMERICA, INC., NAPERVILLE, IL:
2,602,204, REN. 5-3-12. INT. CL. 35.

BRACCI, STEPHEN P., NEW YORK, NY:
4,154,654, MULTIPLE CLASS, INT. CLS. 3 AND 5.

BRADFORD, RICHARD N., LONGWOOD, FL:
2,492,576, CANC. INT. CL. 28.

BRADLEY COMMUNICATIONS CORP., BROOMAIL, PA:
4,155,880, INT. CL. 42.

BRADLEY COMMUNICATIONS GROUP, INC., NEW YORK, NY, DBA BOYER COMMUNICATIONS GROUP:
4,152,861, PUB. 3-20-2012. MULTIPLE CLASS, INT. CLS. 16 AND 41.

BRADLEY FIXTURES CORPORATION, MENOMONEE FALLS, WI:
2,633,476, REN. 5-3-12. INT. CL. 11.

BRADLEY IAN BERGER, MANALAPAN, NJ:
4,153,659, PUB. 3-20-2012. INT. CL. 45.
4,153,660, PUB. 3-20-2012. INT. CL. 45.
4,154,211, PUB. 3-20-2012. INT. CL. 45.

BRADLEY RAGUSE, WHEATON, MN:
4,152,942, PUB. 3-20-2012. INT. CL. 39.

BRADLEY, STEPHEN T., RIDGEFIELD, CT, DBA AUTHOR-BEE:
4,153,918, PUB. 3-20-2012. INT. CL. 42.

BRADSHAW INTERNATIONAL, INC., RANCHO CUCA-MONGA, CA:
2,999,039, CANC. INT. CL. 21.

BRAGTAG INC., CEDAR RAPIDS, IA:
2,672,376, REN. 5-1-12. INT. CL. 12.

BRAIDWOOD'S, LLC, SARATOGA SPRINGS, NY:
4,155,952, INT. CL. 29.

BRAIN TECHNOLOGIES CORPORATION, GAINESVILLE, FL:
2,662,689, REN. 5-1-12. INT. CL. 16.

BRAINSTORMPRODUCTS, LLC, LA JOLLA, CA:
4,154,797, INT. CL. 21.

BRAKER, STEVE ABBOT, NORTHFIELD, MN, DBA WORTHWHILE FILMS:
4,152,692, PUB. 3-20-2012. INT. CL. 41.

BRAM STOKER LLC, AIKEN, SC:
4,154,239, PUB. 3-20-2012. INT. CL. 9.

- BRANDIVATION LLC, RIVERWOODS, IL:
2,559,001. REN. 5-1-12. INT. CL. 36.
- BRANDT INDUSTRIES LTD., REGINA, SASKATCHEWAN, CANADA:
2,587,944. REN. 4-27-12. INT. CL. 7.
- BRANER, JEFFREY M., DULUTH, GA:
3,000,382. CANC. INT. CL. 25.
- BRAY, MICHAEL S., SOMERS POINT, NJ:
4,153,773. PUB. 3-20-2012. INT. CL. 21.
- BREATHE NEW HAMPSHIRE, MANCHESTER, NH:
4,154,602. INT. CL. 35.
- BREATHE TECHNOLOGIES, INC., IRVINE, CA:
4,154,573. INT. CL. 10.
- BREATHE YOGA & JUICE BAR, INC., PITTSFORD, NY:
4,153,095. PUB. 3-20-2012. MULTIPLE CLASS, INT. CLS. 35, 41, 43 AND 44.
- BREEJ TECHNOLOGIES, INC., BURLINGTON, MA:
2,629,176. REN. 5-2-12. INT. CL. 3.
- BRENNAN AGENCY, INC., OVERLAND PARK, KS:
4,154,952. INT. CL. 36.
- BRENT INDUSTRIES, INC., BRENT, AL:
2,561,583. REN. 5-2-12. INT. CL. 37.
- BREW1 TECHNOLOGIES, INC., DANVERS, MA:
4,153,198. PUB. 3-20-2012. MULTIPLE CLASS, INT. CLS. 11 AND 30.
- BRIAN J. PLACHTA, GRAND RAPIDS, MI:
4,154,034. PUB. 3-20-2012. INT. CL. 45.
- BRICKELL FINANCIAL SERVICES-MOTOR CLUB, INC., CHICAGO, IL:
4,152,559. PUB. 3-20-2012. MULTIPLE CLASS, INT. CLS. 39 AND 45.
- BRIDGE ENTERTAINMENT, INC., ENCINO, CA:
4,152,540. PUB. 3-20-2012. INT. CL. 35.
- BRIDGE WORKER'S UNION, INC., BROOKLYN, NY:
4,153,750. PUB. 3-20-2012. INT. CL. 42.
- BRIDGESTONE CORPORATION, TOKYO, JAPAN:
4,152,114. PUB. 12-8-2009. INT. CL. 7.
- BRIDGET MARSH, ROCHESTER, NY:
4,153,580. PUB. 3-20-2012. INT. CL. 25.
- BRIDGEWATER, INC., SALT LAKE CITY, UT:
4,154,670. MULTIPLE CLASS, INT. CLS. 1, 3 AND 5.
- BRIDGEWATER, LLC, SALT LAKE CITY, UT, GROOM INDUSTRIES, INC., ROCKFORD, IL:
1,218,143. REN. 5-2-12. INT. CL. 8.
- BRIDGEWORKS II, LLC, MINNETONKA, MN:
2,565,293. REN. 5-2-12. INT. CL. 41.
- BRIDOR INC., BOUCHERVILLE, QUEBEC, CANADA, LES PRODUITS BRIDOR INC., BOUCHERVILLE, QUEBEC, CANADA:
1,531,105. REN. 4-30-12. INT. CL. 30.
- BRIGHT LIGHT EDUCATION LLC, JERSEY CITY, NJ, AKA BRIGHT LIGHT EDUCATION:
4,153,013. PUB. 12-13-2011. INT. CL. 41.
- BRIGHT MARKET, LLC, SANTA BARBARA, CA, DBA FASTSPRING:
4,155,181. MULTIPLE CLASS, INT. CLS. 35, 36 AND 42.
4,155,182. MULTIPLE CLASS, INT. CLS. 35, 36 AND 42.
- BRIGHTLINE CPAS AND ASSOCIATES, INC., TAMPA, FL:
4,152,854. PUB. 3-20-2012. INT. CL. 42.
- BRIGHTWELL PAYMENTS, INC., ATLANTA, GA:
4,116,460. AM. INT. CL. 36.
4,119,818. AM. INT. CL. 9.
- BRILLKIDS, INC., CENTRAL, HONG KONG:
4,154,118. PUB. 3-20-2012. INT. CL. 41.
- BRINKER INTERNATIONAL PAYROLL COMPANY, L.P., DALLAS, TX:
1,754,637. REN. 5-2-12. INT. CL. 42.
- BRINSON, AVIN, RUSTON, LA:
4,153,238. PUB. 3-20-2012. INT. CL. 41.
- BRISTOL-MYERS SQUIBB COMPANY, NEW YORK, NY:
4,154,355. INT. CL. 42.
- BRO & SIS HOLDING, FRANCE:
4,152,234. PUB. 3-20-2012. MULTIPLE CLASS, INT. CLS. 14 AND 35.
- BROADWAY BANCSHARES, INC., SAN ANTONIO, TX:
2,492,913. CANC. INT. CL. 36.
- BROCADE COMMUNICATIONS SYSTEMS, INC., SAN JOSE, CA:
4,153,910. PUB. 3-20-2012. INT. CL. 9.
- BRODA ENTERPRISES INC., KITCHENER, ONTARIO, CANADA:
4,155,089. INT. CL. 12.
- BROOKS SPORTS, INC., BOTHELL, WA:
4,155,528. INT. CL. 25.
4,155,609. INT. CL. 25.
- BROOKS, TROYAL G., NASHVILLE, TN:
2,594,489. REN. 4-30-12. MULTIPLE CLASS, INT. CLS. 35 AND 41.
- BROOKSHIER, RANDALL, TUCSON, AZ:
4,153,410. PUB. 3-20-2012. INT. CL. 35.
- BROOKSIDE FARMS HOMEMADE, CLARKESVILLE, GA:
4,155,387. INT. CL. 30.
- BROWN RUDNICK LLP, BOSTON, MA:
4,155,544. INT. CL. 45.
- BROWN SHOE COMPANY, INC., ST. LOUIS, MO:
2,568,543. REN. 4-30-12. INT. CL. 35.
- BROWN, JEFFREY S., GREENVILLE, SC:
4,155,677. INT. CL. 42.
- BROWN, KEVIN, SCOTTSDALE, AZ:
4,154,203. PUB. 3-20-2012. INT. CL. 41.
- BROWN, PAUL, NEWPORT BEACH, CA AND BROWN, BLAKE, NEWPORT BEACH, CA:
4,155,516. INT. CL. 25.
- BROWN, SHERI, EL CAJON, CA AND SCHER, THERESA, EL CAJON, CA:
4,153,968. PUB. 3-20-2012. INT. CL. 45.
- BRUCE FOODS CORPORATION, NEW IBERIA, LA:
2,564,185. REN. 5-3-12. INT. CL. 30.
- BRUNO, STEPHANIE, DENVER, CO:
4,156,013. INT. CL. 36.
- BRUNSWICK CORPORATION, LAKE FOREST, IL:
2,570,974. REN. 5-2-12. INT. CL. 28.
- BRYANT JR., CURTIS G., LINCOLN, NE:
4,153,595. PUB. 3-20-2012. INT. CL. 35.
- BSH BOSCH UND SIEMENS HAUSGERATE GMBH, MUNICH, FED REP GERMANY:
4,153,081. PUB. 3-20-2012. MULTIPLE CLASS, INT. CLS. 9, 35 AND 41.
4,153,109. PUB. 3-20-2012. INT. CL. 41.
- BSH HOME APPLIANCES CORPORATION, HUNTINGTON BEACH, CA:
4,154,784. INT. CL. 11.
4,154,785. INT. CL. 11.
- BUBBA FOODS, LLC, JACKSONVILLE, FL:
4,153,672. PUB. 3-20-2012. INT. CL. 43.
- BUBBLES PET SPA, TORRANCE, CA:
4,153,557. PUB. 3-20-2012. INT. CL. 44.
- BUFFALO BOOTS GMBH, HOCHHEIM, FED REP GERMANY:
2,598,189. REN. 5-1-12. INT. CL. 25.
- BUFFALO CHIP CAMPGROUND, LLC, STURGIS, SD:
2,703,302. REN. 5-3-12. INT. CL. 16.
- BUFFALO WILD WINGS, INC., MINNEAPOLIS, MN:
4,152,108. PUB. 3-20-2012. INT. CL. 35.
- BUGFREEHOME.COM, CORP., OKLAHOMA, OK:
2,499,222. REN. 4-30-12. INT. CL. 37.
- BUILDING BETTER SOLUTIONS GROUP, INC, MONROE, NY:
4,153,305. PUB. 3-20-2012. INT. CL. 16.
- BUILDING MATERIALS HOLDING CORPORATION, BOISE, ID:
4,109,852. COR. INT. CL. 37.
- BULLET GEAR LLC, AUBURN HILLS, MI:
4,155,138. INT. CL. 25.
- BULLET INTERNATIONAL, SA DE CV, NAUCALPAN, EDOMEX, MEXICO:
4,152,734. PUB. 3-20-2012. INT. CL. 9.
- BUMBLEBEE CELEBRATIONS LLC, SAN FRANCISCO, CA, DBA BUMBLEBEE BAKESHOP:
4,153,586. PUB. 3-20-2012. INT. CL. 30.
- BURGER, STEVEN, NEWPORT BEACH, CA:
4,155,981. INT. CL. 45.
- BURLEN CORPORATION, NEW YORK, NY:
4,152,727. PUB. 3-20-2012. INT. CL. 25.

BURMAN ENTERPRISES, INC., ST. LOUIS, MO, DBA FIRE STOP AMERICA:
4,153,576, PUB. 3-20-2012. INT. CL. 37.

BURNETT DAIRY COOPERATIVE, GRANSTBURG, WI:
4,153,146, PUB. 3-20-2012. INT. CL. 29.

BURRIS HOLDINGS, INC., MILFORD, DE:
2,577,637. REN. 5-3-12. INT. CL. 39.
2,581,242. REN. 5-3-12. INT. CL. 39.

BUSHKO, RENATA G, HOPKINTON, MA, DBA FUTURE OF HEALTH TECHNOLOGY INSTITUTE:
4,152,660, PUB. 3-20-2012. INT. CL. 16.

BUSHONG, ELIZABETH, C., JOHNSON CITY, TN, DBA LIZ BUSHONG:
4,155,196, INT. CL. 20.

BUTANI CAPITAL PARTNERS LLC, NEW YORK, NY:
4,152,755, PUB. 8-30-2011. INT. CL. 25.

BUTLER, DAVID O., TARPON SPRINGS, FL:
4,155,534, INT. CL. 18.

BUTTERFLY SAFETY PRODUCTS LLC, BUFFALO, NY:
4,155,150, INT. CL. 20.

BUXTON ACQUISITION CO., L.L.C., SPRINGFIELD, MA:
4,155,770, INT. CL. 18.

BUXTON COMPANY, FORT WORTH, TX:
2,555,330. COR. INT. CL. 35.

BUY AMERICAN REAL ESTATE CORPORATION, TAMPA, FL:
2,493,490, CANC. INT. CL. 36.

BUYSMART, COLUMBIA, SC, AKA BUYSMARTAUTO-NOW.COM:
4,152,623, PUB. 3-20-2012. INT. CL. 35.

BWA WATER ADDITIVES UK LIMITED, GREATER MANCHESTER, UNITED KINGDOM, BIOLAB SERVICES, INC., WILMINGTON, DE:
2,579,236. REN. 5-3-12. INT. CL. 1.

BYRON KATIE INTERNATIONAL, INC., OJAI, CA:
2,616,374. REN. 4-27-12. INT. CL. 41.

BYSTRONIC LASER AG, SWITZERLAND:
4,152,382, PUB. 3-20-2012. MULTIPLE CLASS, INT. CLS. 7, 9 AND 40.

B2B CFO, LLC, GILBERT, AZ:
4,152,663, PUB. 3-20-2012. INT. CL. 35.

B2B PROSPECTING, LLC, KERRVILLE, TX, DBA THE B2B PROSPECTING SOURCE:
4,155,996, INT. CL. 35.

B2LEAD, LLC, SAN FRANCISCO, CA, DBA CLOUDPAPERS:
4,152,924, PUB. 3-20-2012. INT. CL. 42.

C & E VISION SERVICES, INC., SAN CLEMENTE, CA:
4,155,639, INT. CL. 9.

C LA FUNCH CONSULTING, LAS VEGAS, NV, DBA HEARTS WITH HELPING HANDS:
4,153,590, PUB. 3-20-2012. INT. CL. 44.

C.A.R.E.R. CARRELLIFICIO ELETTRICO ROMAGNOLO DELL'ING. ANGELO GAETANI E C. S.N.C., COTIGNOLA (RAVENNA), ITALY:
2,492,619, CANC. MULTIPLE CLASS, INT. CLS. 7 AND 12.

C.D.E.F. HOLDING B.V., NL-3511 EP UTRECHT, NETHERLANDS:
4,152,296, PUB. 3-20-2012. MULTIPLE CLASS, INT. CLS. 35, 41, 42 AND 45.
4,152,333, PUB. 3-20-2012. MULTIPLE CLASS, INT. CLS. 35, 41, 42 AND 45.

C.H. ROBINSON WORLDWIDE, INC., EDEN PRAIRIE, MN:
4,155,839, INT. CL. 31.

C.R. DANIELS, INC., ELLICOTT CITY, MD:
2,577,349. REN. 5-1-12. INT. CL. 24.

C&C TECHNOLOGIES, INC., LAFAYETTE, LA:
4,155,613, INT. CL. 9.

CABINET GRANGER, FRANCE:
4,152,242, PUB. 3-20-2012. MULTIPLE CLASS, INT. CLS. 8, 14, 16, 18, 20, 21, 24, 26 AND 35.

CABLE NEWS NETWORK, INC., ATLANTA, GA:
4,155,768, INT. CL. 41.
4,155,769, INT. CL. 38.

CACTI GROUP, INC., ANN ARBOR, MI:
4,153,827, PUB. 3-20-2012. INT. CL. 9.

CADILLAC JACK, INC., DULUTH, GA:
4,154,898, INT. CL. 9.

CADWORKS, CHICAGO, IL:
4,152,076, PUB. 3-20-2012. INT. CL. 9.

CAFEPRESS INC., SAN MATEO, CA:
2,571,049, AM. INT. CL. 35.

CALAMARI, INC., WEST YARMOUTH, MA:
4,154,330, INT. CL. 43.

CALIFORNIA CUSTOM FRUITS AND FLAVORS, INC., IRWINDALE, CA, DBA CALIFORNIA CUSTOM FRUITS AND FLAVORS, INC.:
4,155,655, INT. CL. 30.

CALIFORNIA HOSPITAL ASSOCIATION, SACREMENTO, CA:
4,153,876, PUB. 3-20-2012. INT. CL. 41.

CALIFORNIA MILK PROCESSOR BOARD, SAN CLEMENTE, CA:
4,154,361, INT. CL. 25.

CALIFORNIA ROASTERS COMPANY, LLC, PALMDALE, CA:
3,663,187, CANC. INT. CL. 30.

CALIPER CORPORATION, PRINCETON, NJ:
1,458,255, CANC. INT. CL. 16.

CALIX, INC., PETALUMA, CA:
2,707,608. REN. 4-27-12. INT. CL. 9.

CALLENDER, PAMELA E, NEPTUNE, NJ:
4,155,115, INT. CL. 41.

CALLTROL CORPORATION, HAWTHORNE, NY:
2,564,459. REN. 4-30-12. INT. CL. 9.

CALON CARDIO TECHNOLOGY LTD, SWANSEA, UNITED KINGDOM:
4,153,320, PUB. 3-20-2012. INT. CL. 10.
4,153,321, PUB. 3-20-2012. INT. CL. 10.

CALVIN KLEIN TRADEMARK TRUST, WILMINGTON, DE:
2,493,108, CANC. INT. CL. 21.

CAMANO ISLAND MANAGEMENT, INC., CAMANO ISLAND, WA:
4,153,521, PUB. 3-20-2012. INT. CL. 30.

CAMBIA HEALTH SOLUTIONS, INC., PORTLAND, OR:
4,152,872, PUB. 3-20-2012. MULTIPLE CLASS, INT. CLS. 36, 44 AND 45.
4,152,874, PUB. 3-20-2012. MULTIPLE CLASS, INT. CLS. 36, 44 AND 45.

CAMBRIDGE MICHIGAN LANGUAGE ASSESSMENT LLC, ANN ARBOR, MI:
4,152,669, PUB. 3-20-2012. INT. CL. 16.

CAMELION BATTERY CO., LTD., 518041 GUANGDONG, CHINA:
4,152,238, PUB. 3-20-2012. MULTIPLE CLASS, INT. CLS. 9 AND 11.

CAMISASCA AUTOMOTIVE MANUFACTURING, INC., LAKE FOREST, CA:
4,154,099, PUB. 3-20-2012. INT. CL. 12.

CAMP MERRIE-WOODE, SAPPHIRE, NC:
2,628,250. REN. 5-3-12. INT. CL. 41.

CAMUTO CONSULTING, INC., GREENWICH, CT, DBA CAMUTO GROUP:
4,154,568, MULTIPLE CLASS, INT. CLS. 9, 14, 25 AND 35.

CAN MANUFACTURERS INSTITUTE, INC., WASHINGTON, DC:
4,152,674, PUB. 3-20-2012. MULTIPLE CLASS, INT. CLS. 35 AND 40.

CANACHEME INC., TORONTO, ONTARIO, CANADA:
4,152,037, PUB. 3-20-2012. INT. CL. 16.

CANAL INSURANCE COMPANY, GREENVILLE, SC:
2,561,581. REN. 5-3-12. INT. CL. 36.
2,561,588. REN. 5-3-12. INT. CL. 36.

CANALES MARES, FRANCISCO JAVIER, GUANAJUATO, MEXICO:
4,153,247, PUB. 3-20-2012. INT. CL. 25.

CANAVATI, GERARDO MARTIN, MONTERREY, N. L., MEXICO:
4,155,222, INT. CL. 43.

CANDICE BOEHM, BUDA, TX:
4,153,454, PUB. 3-20-2012. INT. CL. 25.

- CANETE, VERONICA, SKOKIE, IL AND KWASIGROCH, MARK F., SKOKIE, IL:
3,634,040, CANC. INT. CL. 30.
- CANON U.S.A., INC., LAKE SUCCESS, NY:
4,153,855, PUB. 3-20-2012. INT. CL. 36.
- CANOPY BOOKS LLC, FLORAL PARK, NY:
4,156,036, INT. CL. 28.
- CAPITOL SOLUTIONS GOVERNMENT RELATIONS CONSULTANTS, LLC, WASHINGTON, DC:
2,681,052, REN. 5-3-12. INT. CL. 35.
- CAPLIN, LEE, ENCINO, CA:
2,561,663, REN. 5-3-12. INT. CL. 9.
- CAPTAIN D'S ENTERPRISES, LLC, NASHVILLE, TN, CAPTAIN D'S HOLDINGS, INC., NASHVILLE, TN:
2,558,642, REN. 4-27-12. INT. CL. 42.
- CAPTAIN HOPE'S KIDS, DALLAS, TX:
2,512,609, REN. 4-27-12. INT. CL. 36.
- CAPTAIN RECRUITER LLC, SAN FRANCISCO, CA:
4,153,581, PUB. 3-20-2012. INT. CL. 35.
- CAPVEST LIMITED, LONDON SW1Y5NQ, UNITED KINGDOM:
2,557,722, REN. 4-30-12. MULTIPLE CLASS, INT. CLS. 35 AND 36.
- CARACAS PAPER COMPANY, S.A., MARACAY, EDO. ARAGUA, VENEZUELA:
2,998,548, CANC. INT. CL. 16.
- CARACOL BROADCASTING INC., MIAMI, FL:
2,536,715, REN. 4-30-12. INT. CL. 38.
- CARAFFA OLIVES, INC., LONDON, CANADA:
4,153,046, PUB. 3-20-2012. INT. CL. 29.
- CARBON FIBER HEATING TECHNOLOGIES, LLC, FORESTVILLE, CT:
4,155,226, INT. CL. 11.
- CARD KINGDOM, INC., SEATTLE, WA:
4,154,219, PUB. 3-20-2012. MULTIPLE CLASS, INT. CLS. 41 AND 43.
- CARDINAL COLORGROUP PRINTING CORPORATION, ITASCA, IL:
4,153,955, PUB. 3-20-2012. INT. CL. 40.
- CARELLE LTD., NEW YORK, NY:
4,153,886, PUB. 3-20-2012. INT. CL. 14.
- CARHARTT, INC., DEARBORN, MI:
4,152,455, PUB. 3-20-2012. INT. CL. 25.
4,152,594, PUB. 3-20-2012. MULTIPLE CLASS, INT. CLS. 18 AND 25.
- CARL STAHL GMBH, FED REP GERMANY:
4,152,194, PUB. 3-20-2012. MULTIPLE CLASS, INT. CLS. 6, 7, 8, 20, 22 AND 37.
- CARL ZEISS VISION GMBH, AALEN, FED REP GERMANY:
4,153,402, PUB. 3-20-2012. INT. CL. 9.
- CARLEY, TORRANCE, CA:
1,747,754, REN. 5-3-12. INT. CL. 11.
- CARLSON, BRIAN LESLEY, PORT WASHINGTON, WI:
4,155,202, INT. CL. 30.
- CARMAN DEV GROUP LLC - VEHWK SERIES, DRAPER, UT:
4,153,695, PUB. 3-20-2012. INT. CL. 9.
- CARNES AND ASSOCIATES, INC., ST. LOUIS, MO:
4,153,916, PUB. 3-20-2012. INT. CL. 41.
- CAROLINA CENTER FOR OCCUPATIONAL HEALTH, LLC, NORTH CHARLESTON, SC:
4,155,443, INT. CL. 42.
- CAROLON COMPANY, RURAL HALL, NC:
4,154,408, INT. CL. 10.
- CARPENTER, THOMAS, CHESTERFIELD TWP., MI AND SMITH, EDWARD, CHESTERFIELD TWP, MI:
2,999,333, CANC. INT. CL. 25.
- CARPETS OF EDEN, LITTLETON, CO:
4,155,025, INT. CL. 35.
- CARROLL COMPANY, GARLAND, TX, FULD BROTHERS, INCORPORATED, BALTIMORE, MD:
955,538, REN. 5-3-12. U.S. CL. 6 (INT. CL. 5).
- CARROLL HALL SHELBY TRUST, LOS ANGELES, CA:
1,728,573, REN. 5-3-12. INT. CL. 12.
- CARTIER INTERNATIONAL A.G., 6312 STEINHAUSEN, SWITZERLAND:
2,516,842, REN. 5-1-12. INT. CL. 14.
2,547,693, REN. 4-30-12. INT. CL. 16.
- CARTOON CUTS, FORT LAUDERDALE, FL:
2,548,970, REN. 5-1-12. INT. CL. 42.
- CARTOON NETWORK, INC., THE, ATLANTA, GA:
2,582,704, REN. 4-27-12. INT. CL. 41.
- CARTOON NETWORK, INC., THE, ATLANTA, GA, THE CARTOON NEWTWORK LP, LLLP, ATLANTA, GA:
2,610,075, REN. 4-27-12. INT. CL. 41.
- CARTOON NETWORK, INC., THE, ATLANTA, GA:
2,620,781, REN. 4-27-12. INT. CL. 41.
2,625,473, REN. 4-27-12. INT. CL. 38.
2,657,075, REN. 4-27-12. INT. CL. 41.
- CASA BELLA DESIGN CENTER, LLC, NAPERVILLE, IL:
2,999,047, CANC. INT. CL. 37.
- CASABELLA HOLDINGS, LLC, BLAUVELT, NY:
3,936,174, COR. INT. CL. 20.
- CASAL THAUERO S.R.L., OROTONA, CHIETI, ITALY:
2,998,731, CANC. INT. CL. 33.
- CASARIVER LLC, ROCKY RIVER, OH:
4,154,632, INT. CL. 42.
- CASCADIA EQUITY LEASING, LLC, SEATTLE, WA:
4,154,141, PUB. 3-20-2012. INT. CL. 36.
- CASHFLOW TECHNOLOGIES, INC., SCOTTSDALE, AZ:
4,154,601, INT. CL. 41.
- CASIANO COMMUNICATIONS INC., SAN JUAN, PUERTO RICO:
1,721,839, REN. 5-2-12. INT. CL. 16.
- CASSIDIAN COMMUNICATIONS, INC., TEMECULA, CA:
2,501,192, REN. 5-3-12. INT. CL. 9.
- CASTALIA OUTDOORS, INC., FROSTPROOF, FL:
4,153,219, PUB. 2-14-2012. INT. CL. 28.
- CASTER, FRANCE:
4,152,261, PUB. 3-20-2012. INT. CL. 3.
4,152,264, PUB. 3-20-2012. INT. CL. 1.
- CASTER, F-75008 PARIS, FRANCE:
4,152,273, PUB. 3-20-2012. INT. CL. 3.
- CASTIEL, MAURICE, LAS VEGAS, NV, DBA EUROPEAN & FOREIGN IMPORTS., INC.:
4,154,622, INT. CL. 2.
- CATALINA MARKETING CORPORATION, ST. PETERSBURG, FL:
2,491,916, CANC. INT. CL. 35.
- CATALYST SEARCH PARTNERS LLC, CAMBRIDGE, MA:
4,153,207, PUB. 3-20-2012. INT. CL. 35.
- CATERPILLAR INC., PEORIA, IL:
2,561,988, REN. 5-3-12. INT. CL. 35.
- CATHAY HOME FASHIONS INC, NEW YORK, NY:
3,929,473, CANC. INT. CL. 20.
- CB OPERATORS, LLC, SAN ANTONIO, TX:
4,155,771, INT. CL. 37.
- CBS BROADCASTING INC., NEW YORK, NY:
2,998,976, CANC. INT. CL. 14.
2,998,977, CANC. INT. CL. 9.
- CBS INTERACTIVE INC., NEW YORK, NY:
2,491,808, CANC. INT. CL. 42.
- CDOC, INC., CARMEL, IN:
4,155,412, INT. CL. 9.
4,155,413, INT. CL. 9.
4,155,414, MULTIPLE CLASS, INT. CLS. 35 AND 36.
4,155,415, INT. CL. 35.
4,155,416, INT. CL. 35.
- CEDALION ENTERPRISES LLC, MARIETTA, GA:
4,152,860, PUB. 3-20-2012. MULTIPLE CLASS, INT. CLS. 35 AND 45.
- CEDAR BAY ENTERTAINMENT LLC, BRANSON, MO:
4,153,255, PUB. 3-20-2012. INT. CL. 41.
- CEDAR FARMS CO., INC., PHILADELPHIA, PA:
4,155,668, MULTIPLE CLASS, INT. CLS. 6, 8, 16, 20, 21, 29, 30, 31, 32 AND 33.
- CEG WORLDWIDE, LLC, SAN MARTIN, CA:
4,155,793, INT. CL. 41.
- CEJA VINEYARDS, INC., NAPA, CA:
4,153,611, PUB. 3-20-2012. INT. CL. 41.
- CELENCE, INC., TEMPE, AZ TO CALENCE LLC, TEMPE, AZ:
2,493,301, CANC. INT. CL. 35.

CELLCO PARTNERSHIP, BASKING RIDGE, NJ, DBA VERIZON WIRELESS:
4,153,894, PUB. 3-20-2012. INT. CL. 9.
4,155,382, INT. CL. 9.

CELLMADE SAS, FRANCE:
4,152,186, PUB. 3-20-2012. MULTIPLE CLASS, INT. CLS. 5 AND 44.

CELLMARK PAPER, INC., NORWALK, CT:
4,154,175, PUB. 3-20-2012. INT. CL. 16.

CELLOMICS, INC., PITTSBURGH, PA:
2,561,438, REN. 5-2-12. INT. CL. 1.

CELLULAR TECHNOLOGY LIMITED, SHAKER HEIGHTS, OH:
2,460,772, REN. 5-1-12. MULTIPLE CLASS, INT. CLS. 5, 9 AND 10.

CELSIUS PROPERTY B.V. AMSTERDAM (NL), 8200 SCHAFFHAUSEN, SWITZERLAND:
4,154,915, INT. CL. 5.

CELULOSA ARAUCO Y CONSTITUCION S.A., SANTIAGO, CHILE:
1,216,731, REN. 4-30-12. INT. CL. 19.

CEN JIEQIANG, FOSHAN, GUANGDONG, CHINA:
4,153,926, PUB. 3-20-2012. INT. CL. 9.

CENGAGE LEARNING, INC., STAMFORD, CT, W.G. NICHOLS, INC., WEST CHESTER, PA:
2,559,631, REN. 4-27-12. INT. CL. 39.

CENTER FOR COURAGE & RENEWAL, BAINBRIDGE ISLAND, WA:
2,620,628, REN. 4-27-12. INT. CL. 41.

CENTER FOR CULTURAL AND TECHNICAL INTERCHANGE BETWEEN EAST AND WEST, INC., HONOLULU, HI:
1,764,085, REN. 5-2-12. MULTIPLE CLASS, INT. CLS. 25 AND 41.
1,764,085, CANC. INT. CL. 9.

CENTER PARCS EUROPE N.V., ROTTERDAM, NETHERLANDS:
2,996,256, CANC. MULTIPLE CLASS, INT. CLS. 39, 41 AND 42.

CENTERPOINTE RESEARCH INSTITUTE, INC., BEAVERTON, OR:
1,684,823, REN. 5-2-12. INT. CL. 9.

CENTRAL GARDEN & PET COMPANY, WALNUT CREEK, CA:
3,801,217, AM. MULTIPLE CLASS, INT. CLS. 28 AND 31.

CENTRAL NATIONAL-GOTTESMAN INC., PURCHASE, NY:
2,498,085, REN. 5-2-12. INT. CL. 16.

CENTRAL SOURCE LLC, ATLANTA, GA:
4,152,650, PUB. 10-18-2011. INT. CL. 35.

CENTRIC GROUP, LLC, ST. LOUIS, MO:
4,154,386, INT. CL. 30.

CENTRIX SOLUTIONS INC, LINCOLN, NE:
4,152,662, PUB. 3-20-2012. INT. CL. 42.

CENTS & SENSIBILITY, INC., PLEASANTON, CA:
2,605,570, REN. 4-27-12. INT. CL. 36.

CENTURY SYSTEMS, INC., DAYTON, OH:
2,654,435, REN. 4-27-12. INT. CL. 37.

CENTURY 21 REAL ESTATE LLC, PARSIPPANY, NJ:
2,622,290, REN. 4-30-12. INT. CL. 41.

CERTONA CORPORATION, DEL MAR, CA:
2,499,842, REN. 5-3-12. INT. CL. 42.

CERVECERIA NACIONAL DOMINICANA C. POR A., SANTO DOMINGO, DOMINICAN REP:
1,203,812, REN. 4-27-12. INT. CL. 32.

CESCE - SOCIEDADE AGRÍCOLA, EXPLORAÇÃO, TRANSFORMAÇÃO E COMERCIALIZAÇÃO AGRÍCOLAS, S.A., P-1250-143 LISBOA, PORTUGAL:
4,152,225, PUB. 3-20-2012. INT. CL. 33.

CETALUS LLC, ANDOVER, MA:
4,154,164, PUB. 3-20-2012. MULTIPLE CLASS, INT. CLS. 35 AND 45.

CETANI, MATT, MORGAN HILL, CA:
4,156,068, INT. CL. 37.

CGI TECHNOLOGIES AND SOLUTIONS INC., FAIRFAX, VA:
2,492,605, CANC. INT. CL. 35.

CHAIN & CHARM, INC., LOS ANGELES, CA:
4,154,567, INT. CL. 14.

CHALLENGER CENTER FOR SPACE SCIENCE EDUCATION, ALEXANDRIA, VA:
2,559,054, REN. 4-30-12. INT. CL. 41.

CHAMPION AEROSPACE, LLC, LIBERTY, SC, UNISON INDUSTRIES LIMITED PARTNERSHIP, JACKSONVILLE, FL:
1,719,828, REN. 5-3-12. INT. CL. 7.

CHANCELLOR-MADDISON, JACQUELINE JANE, RANCHO SANTA FE, CA, DBA RANCHO SANTA FE MAGAZINE:
4,156,019, MULTIPLE CLASS, INT. CLS. 16 AND 35.

CHANEL, INC., NEW YORK, NY:
1,687,481, REN. 5-1-12. INT. CL. 3.

CHANG CHIH-CHEN, TAICHUNG, TAIWAN:
4,152,985, PUB. 3-20-2012. INT. CL. 25.

CHANG, JAIME, TAICHUNG CITY 421, TAIWAN:
4,154,160, PUB. 3-20-2012. INT. CL. 25.

CHANTELLE K. OLUWABUNMI ABDUL, NEW YORK, NY:
4,154,108, PUB. 3-20-2012. INT. CL. 25.

CHANTEST CORPORATION, CLEVELAND, OH:
4,154,544, INT. CL. 1.

CHAPMAN, WILLIAM P. JR., GREENVILLE, SC:
1,683,546, REN. 5-1-12. INT. CL. 3.

CHARENTE, PATRICIA M., BEVERLY, MA:
4,155,163, INT. CL. 25.

CHARITY GLOBAL, INC., NEW YORK, NY:
4,154,006, PUB. 3-20-2012. INT. CL. 36.

CHARITY PANDA, LLC, KATONAH, NY:
4,155,212, INT. CL. 42.

CHARLES HOLMES, ROXIE, MS:
4,153,070, PUB. 3-20-2012. INT. CL. 28.

CHARLOTTE ALLIANCE FOR A SAFE & DRUG FREE COMMUNITY, PORT CHARLOTTE, FL, DBA DRUG FREE CHARLOTTE COUNTY:
4,152,038, PUB. 3-20-2012. MULTIPLE CLASS, INT. CLS. 16, 20 AND 25.

CHARMANT GROUP, INC., USA, MORRIS PLAINS, NJ TO CHARMANT INC., FUKUI-KEN, JAPAN:
2,492,822, CANC. INT. CL. 9.

CHARMING DIRECT, INC., WILMINGTON, DE:
4,155,751, INT. CL. 42.

CHART INDUSTRIES, INC., GARFIELD HEIGHTS, OH:
4,153,180, PUB. 3-20-2012. MULTIPLE CLASS, INT. CLS. 35, 37, 40 AND 42.

CHARTPAK, INC., LEEDS, MA:
1,202,002, REN. 5-3-12. INT. CL. 16.

CHATAM INTERNATIONAL INCORPORATED, WILMINGTON, DE:
4,154,317, INT. CL. 33.

CHATHAN IMPORTS, INC., BRONX, NY, LOU SCHARF INCORPORATED, NEW YORK, NY:
1,231,282, REN. 5-3-12. INT. CL. 32.

CHATTANOOGA PUBLISHING COMPANY, CHATTANOOGA, TN:
4,153,605, PUB. 3-20-2012. MULTIPLE CLASS, INT. CLS. 16 AND 41.

CHEATERTVILLE, INC, LAS VEGAS, NV:
4,155,162, INT. CL. 42.

CHECKERS DRIVE-IN RESTAURANTS, INC., TAMPA, FL:
1,750,671, REN. 5-2-12. INT. CL. 42.
4,152,628, PUB. 3-20-2012. INT. CL. 30.

CHEF NIGEL, INC., STATEN ISLAND, NY:
4,152,986, PUB. 3-20-2012. INT. CL. 30.

CHELSEA RHONE COMPANY, ANN ARBOR, MI:
2,690,564, REN. 4-28-12. INT. CL. 36.

CHEMFIRST INC., JACKSON, MS:
2,492,852, CANC. MULTIPLE CLASS, INT. CLS. 1, 40 AND 42.

CHEMPLEX AUTOMOTIVE GROUP, INC., FULLERTON, CA:
4,154,742, INT. CL. 1.

CHEMPLEX INDUSTRIES, INC., PALM CITY, FL:
4,152,636, PUB. 12-13-2011. INT. CL. 9.

CHEMSTREAM, INC., STOYSTOWN, PA:
4,154,033, PUB. 3-20-2012. MULTIPLE CLASS, INT. CLS. 1 AND 40.

- CHEMTURA CORPORATION, MIDDLEBURY, CT:
4,155,194, INT. CL. 5.
- CHENG UEI PRECISION INDUSTRY CO., LTD., TU-CHENG, TAIPEI HSIEN, TAIWAN:
2,493,203, CANC. INT. CL. 9.
- CHESAPEAKE RESEARCH REVIEW, INC., COLUMBIA, MD:
4,153,394, PUB. 3-20-2012. MULTIPLE CLASS, INT. CLS. 41 AND 45.
4,153,395, PUB. 3-20-2012. MULTIPLE CLASS, INT. CLS. 41 AND 45.
- CHESNEY, KENNY, ATLANTA, GA:
4,154,278, INT. CL. 25.
- CHEVAL AMOUR, INC., CRESWELL, OR:
4,155,262, MULTIPLE CLASS, INT. CLS. 18, 25 AND 35.
4,155,263, MULTIPLE CLASS, INT. CLS. 18, 25 AND 35.
- CHEVEUX CORP., NEW YORK, NY:
4,155,669, INT. CL. 25.
- CHEVRON INTELLECTUAL PROPERTY LLC, SAN RAMON, CA, ORONITE CHEMICAL COMPANY, WILMINGTON, DE:
558,208, REN. 5-3-12. U.S. CL. 6 (INT. CL. 1).
- CHEVRON INTELLECTUAL PROPERTY LLC, SAN RAMON, CA:
2,493,037, CANC. MULTIPLE CLASS, INT. CLS. 1 AND 4.
- CHICAGO WHITE SOX, LTD., CHICAGO, IL:
2,563,319, REN. 5-3-12. INT. CL. 41.
- CHICAGO-SOFT, LTD, HANOVER, NH, DBA SPORTSCAR VINTAGE RACING ASSOCIATION:
4,153,483, PUB. 3-20-2012. INT. CL. 35.
- CHICKEN IN A BARREL BBQ, PRINCEVILLE, HI:
4,153,629, PUB. 3-20-2012. MULTIPLE CLASS, INT. CLS. 30 AND 43.
- CHICO NUT COMPANY, CHICO, CA:
1,672,724, REN. 5-3-12. INT. CL. 31.
- CHILD OF THE INDIGO, PASADENA, CA:
4,156,007, INT. CL. 25.
- CHILDS, ANNETTE, RENO, NV:
4,154,903, INT. CL. 45.
- CHIMES, LLC, MOUNTAIN LAKES, NJ:
2,491,869, CANC. INT. CL. 35.
- CHINA DEMOCRACY JOURNAL, INC., FLUSHING, NY:
4,152,664, PUB. 3-20-2012. MULTIPLE CLASS, INT. CLS. 35 AND 38.
- CHIPPENHOOK SERVICES, LLC, LEWISVILLE, TX:
4,154,701, MULTIPLE CLASS, INT. CLS. 20 AND 40.
- CHIRIKJIAN, PH.D., DR. JACK G., POTOMAC, MD:
2,563,206, REN. 4-27-12. MULTIPLE CLASS, INT. CLS. 1 AND 5.
- CHIVAS HOLDINGS (IP) LIMITED, UNITED KINGDOM:
4,152,304, PUB. 3-20-2012. INT. CL. 33.
- CHOICE HOTELS INTERNATIONAL, INC., SILVER SPRING, MD:
4,152,950, PUB. 3-20-2012. INT. CL. 3.
- CHOICE PROPERTY RESOURCES, INC., COLUMBUS, OH:
4,153,974, PUB. 3-20-2012. INT. CL. 35.
4,153,976, PUB. 3-20-2012. INT. CL. 35.
- CHOLEWA, OLIVIA MARIA, EUGENE, OR:
4,153,098, PUB. 3-20-2012. INT. CL. 16.
- CHOU, BELLE, UNION CITY, CA:
4,154,104, PUB. 3-20-2012. MULTIPLE CLASS, INT. CLS. 9 AND 10.
- CHOZEN INC., LAS VEGAS, NV:
4,155,753, INT. CL. 18.
- CHRIS FASH, HOMER GLEN, IL:
4,152,892, PUB. 10-18-2011. MULTIPLE CLASS, INT. CLS. 25 AND 28.
- CHRISTIAN AND MISSIONARY ALLIANCE, THE, COLORADO SPRINGS, CO:
1,195,712, COR. INT. CL. 16.
- CHRISTIE MAYER, INC., NEW YORK, NY:
2,566,053, REN. 5-1-12. INT. CL. 42.
- CHRISTOPH KOTZ, ERKRATH, FED REP GERMANY:
4,075,644, COR. MULTIPLE CLASS, INT. CLS. 16, 35 AND 41.
- CHRISTOPHER CLEMENTE, RESTON, VA:
4,153,647, PUB. 3-20-2012. INT. CL. 37.
- CHROME HEARTS LLC, HOLLYWOOD, CA:
2,561,173, REN. 5-2-12. INT. CL. 8.
- CHRYSLER GROUP LLC, AUBURN HILLS, MI:
4,155,520, INT. CL. 12.
- CHS INC., INVER GROVE HEIGHTS, MN, FARMERS UNION CENTRAL EXCHANGE, INCORPORATED, INNER GROVE HEIGHTS, MN:
1,202,969, REN. 5-3-12. MULTIPLE CLASS, INT. CLS. 35 AND 42.
- CHUN YU WORKS & CO., LTD., KAOHSIUNG COUNTY, TAIWAN:
4,154,835, MULTIPLE CLASS, INT. CLS. 6 AND 7.
- CHUNG-LOY, HAROLD, LINDEN, NJ:
2,582,100, REN. 5-3-12. INT. CL. 30.
- CHURCH & DWIGHT CO., INC., PRINCETON, NJ, CARTER-WALLACE, INC., NEW YORK, NY:
1,684,262, REN. 5-2-12. INT. CL. 5.
- CHURCH ON THE MOVE INTL. INC, GRANDVIEW, MO:
4,152,638, PUB. 3-20-2012. INT. CL. 41.
- CHURCHILL, KEN, MONTEREY, CA:
2,558,731, REN. 4-27-12. INT. CL. 32.
- CH2M HILL, INC., ENGLEWOOD, CO:
2,998,896, CANC. INT. CL. 35.
- CIA, MONTERROSAS, S.A. DE C.V., PUEBLA, MEXICO:
4,154,698, INT. CL. 33.
- CICOA AGING & IN-HOME SOLUTIONS, INDIANAPOLIS, IN:
4,153,174, PUB. 3-20-2012. INT. CL. 41.
- CIGNA INTELLECTUAL PROPERTY, INC., WILMINGTON, DE:
4,152,615, PUB. 3-20-2012. MULTIPLE CLASS, INT. CLS. 41 AND 44.
- CINDY GOULET, PASCO, WA, DBA FLORENTYNAS:
4,152,526, PUB. 3-20-2012. INT. CL. 43.
- CINTAS HOLDINGS, LLC, MASON, OH:
4,154,615, MULTIPLE CLASS, INT. CLS. 39 AND 41.
- CIPEX INTERNATIONAL LIMITED, SANTA FE SPRINGS, CA:
4,152,832, PUB. 3-20-2012. INT. CL. 9.
- CIRCLE CITY MARKETING & DISTRIBUTING, INC., CARMEL, IN:
4,155,206, INT. CL. 30.
- CIRCOR ENERGY PRODUCTS, INC., OKLAHOMA CITY, OK:
1,729,151, REN. 4-27-12. INT. CL. 11.
- CISCO COMPANIES, THE, INDIANAPOLIS, IN:
4,154,910, MULTIPLE CLASS, INT. CLS. 2 AND 3.
- CISCO TECHNOLOGY, INC., SAN JOSE, CA:
4,154,862, INT. CL. 9.
- CITCO ENTERPRISES, GOLETA, CA:
4,153,517, PUB. 3-20-2012. INT. CL. 35.
- CITI TRENDS, INC., POOLER, GA:
4,152,504, PUB. 2-15-2011. INT. CL. 35.
- CITIZEN ELECTRONICS CO., LTD., FUJIYOSHIDA-SHI, YAMANASHI-KEN, JAPAN:
2,560,792, REN. 4-30-12. INT. CL. 9.
- CITIZENS TELEPHONE COOPERATIVE, INC, FLOYD, VA:
2,558,340, REN. 5-3-12. INT. CL. 38.
- CITY GYM BOYS, INC., NEW YORK, NY:
2,497,907, REN. 5-3-12. INT. CL. 16.
- CITY OF MURPHY, TEXAS, MURPHY, TX:
4,152,803, PUB. 3-20-2012. INT. CL. 35.
- CITY OF POMPANO BEACH FLORIDA, POMPANO BEACH, FL:
4,155,384, INT. CL. 35.
- CITY THEATRICAL, INC., CARLSTADT, NJ:
4,155,505, INT. CL. 9.
4,155,506, INT. CL. 9.
- CITYDOG! CLUB, LLC, VALENCIA, CA:
4,153,368, PUB. 3-20-2012. INT. CL. 43.
- CLAESSENS ' KIDS SÄRL, SWITZERLAND:
4,152,388, PUB. 3-20-2012. MULTIPLE CLASS, INT. CLS. 14 AND 28.
- CLAIMS-X-CHANGE, LLC, MADISON, WI:
4,154,897, INT. CL. 35.
- CLAIMSMADEEZ, INC., CHAMPLIN, MN:
4,154,918, INT. CL. 42.

CLAREHOUSE INC., TULSA, OK:
4,153,396, PUB. 3-20-2012. MULTIPLE CLASS, INT. CLS. 43 AND 45.
4,153,398, PUB. 3-20-2012. MULTIPLE CLASS, INT. CLS. 43 AND 45.

CLARIANCE S.A.S, F-62000 DAINVILLE, FRANCE:
4,152,212, PUB. 3-20-2012. INT. CL. 10.

CLARIANT AG, MUTTENZ, SWITZERLAND, SANDOZ CHEMICAL WORKS, INC., NEW YORK CITY, NY:
289,135. REN. 5-3-12. U.S. CL. 6 (INT. CLS. 1, 2, 3, 4 AND 5).

CLARIANT AG, MUTTENZ, SWITZERLAND:
289,138. REN. 5-3-12. U.S. CL. 6 (INT. CLS. 1, 2, 3, 4 AND 5).

CLARION BATHWARE, INC., SHIPPENVILLE, PA:
4,154,884, INT. CL. 11.

CLARION PARTNERS, LLC, NEW YORK, NY:
4,153,784, PUB. 3-20-2012. INT. CL. 36.
4,154,233, PUB. 3-20-2012. MULTIPLE CLASS, INT. CLS. 9, 16 AND 41.

CLARK CONSULTING, LLC, GREENSBORO, NC:
2,585,965. REN. 4-30-12. INT. CL. 36.

CLARK, MR. DAVID, FRANKFORT, KY:
4,153,250, PUB. 3-20-2012. INT. CL. 45.

CLARK, NATHANIEL G., EAST FALMOUTH, MA:
4,156,017, INT. CL. 44.

CLARKSVILLE TRADING COMPANY, LLC, MID-LOTHIAN, VA:
4,155,241, INT. CL. 34.

CLAY CARLISLE LAKE WYLIE, SC:
4,152,801, PUB. 3-20-2012. MULTIPLE CLASS, INT. CLS. 9 AND 41.

CLEAN CONTROL CORPORATION, WARNER ROBINS, GA:
4,155,995, INT. CL. 5.

CLEAN FACILITIES GROUP, INC., WALTHAM, MA:
4,155,538, INT. CL. 37.

CLEAR-VIEW-TECHNOLOGIES INC., SAN JOSE, CA:
4,152,694, PUB. 3-20-2012. INT. CL. 9.

CLEARCHOICE HOLDINGS, LLC, GREENWOOD VIL-LAGE, CO:
4,152,444, PUB. 3-20-2012. INT. CL. 44.

CLEARPOINT FINANCIAL SOLUTIONS, INC., RICH-MOND, VA:
2,693,095. REN. 4-28-12. INT. CL. 36.

CLEARSTAR, INC., ALPHARETTA, GA:
4,154,156, PUB. 3-20-2012. INT. CL. 45.

CLEARWATER BEACH TRAVEL, LLC, CLEARWATER BEACH, FL:
4,155,978, INT. CL. 39.

CLEVELETTE AUSTIN, MIAMI, FL:
4,154,986, INT. CL. 26.

CLEVVVER MEDIA, LLC, LAS VEGAS, NV:
4,153,821, PUB. 3-20-2012. MULTIPLE CLASS, INT. CLS. 38 AND 41.
4,153,822, PUB. 3-20-2012. MULTIPLE CLASS, INT. CLS. 38 AND 41.

CLICK SUITE LIMITED, WELLINGTON, NEW ZEALAND:
4,154,716, MULTIPLE CLASS, INT. CLS. 9, 38, 41 AND 42.

CLICKDIMENSIONS, LLC, DUNWOODY, GA:
4,153,663, PUB. 3-20-2012. INT. CL. 42.

CLICKERS PTY LTD, LIVERPOOL, NSW, AUSTRALIA:
4,152,142, PUB. 3-20-2012. INT. CL. 25.

CLICKHOSTELS LLC, NEW YORK, NY:
4,153,774, PUB. 3-20-2012. INT. CL. 35.

CLIGNOSIS, INC., BOSTON, MA:
2,493,426, CANC. INT. CL. 42.
2,493,427, CANC. INT. CL. 42.

CLIMATE FRIENDLY PTY LTD, SYDNEY NSW 2011, AUSTRALIA:
4,152,192, PUB. 3-20-2012. MULTIPLE CLASS, INT. CLS. 35, 36, 42 AND 45.

CLIMATE TECHNOLOGIES PTY LTD, SOUTH AUSTRALIA, AUSTRALIA:
2,999,033, CANC. INT. CL. 11.

CLINICAL INK, INC., WINSTON-SALEM, NC:
4,155,361, INT. CL. 9.

CLOELLE DESIGNS INC., TORONTO, CANADA:
4,155,844, INT. CL. 14.

CLON 3D, ALBUQUERQUE, NM:
4,154,813, INT. CL. 10.

CLOVERVALE FARMS, INC., AMHERST, OH:
1,170,448, CANC. MULTIPLE CLASS, INT. CLS. 29, 30 AND 32.

CLUVER, RENNIE, CLINTON, IL:
4,154,012, PUB. 3-20-2012. INT. CL. 41.

CMH MANUFACTURING WEST, INC., MARYVILLE, TN, GOLDEN WEST LEASING, LLC, LAS VEGA, NV:
2,601,974. REN. 5-3-12. INT. CL. 35.

COACH HOUSE, INC., NOKOMIS, FL:
2,638,435. REN. 4-27-12. INT. CL. 12.

COALE, ANSLEY J., UKIAH, CA:
4,155,622, INT. CL. 33.

CODA PARTNERS, INC., DADE CITY, FL:
4,155,991, INT. CL. 35.

CODDINGTON, BOYD LEE, KANSAS CITY, MO:
4,154,227, PUB. 3-20-2012. INT. CL. 12.

CODEMASS, INC., SAN FRANCISCO, CA:
4,153,543, PUB. 3-20-2012. INT. CL. 9.

COFFEE BAR 1, LLC, SAN FRANCISCO, CA:
4,155,923, INT. CL. 30.

COFFEE JOULIES, LLC, SHERRILL, NY:
4,153,037, PUB. 3-20-2012. INT. CL. 21.

COHEN, DANIEL, ROLLING HILLS ESTATES, CA:
4,153,796, PUB. 3-20-2012. INT. CL. 36.

COHEN, ELLEN, CHESTNUT HILL, MA:
4,152,580, PUB. 3-20-2012. MULTIPLE CLASS, INT. CLS. 36 AND 41.
4,152,581, PUB. 3-20-2012. MULTIPLE CLASS, INT. CLS. 36 AND 41.

COLAS, BOULOGNE BILLANCOURT, FRANCE:
4,154,621, MULTIPLE CLASS, INT. CLS. 1, 19 AND 37.

COLD FORGED PRODUCTS NO.1 PTY LTD, CARINGBAH, NSW, AUSTRALIA, TA COLD FORGED PRODUCTS:
4,154,715, MULTIPLE CLASS, INT. CLS. 6 AND 14.

COLD SPRING BREWING COMPANY, COLD SPRINGS, MN:
4,154,819, INT. CL. 32.

COLDWORLD ENTERPRISES, LOS ANGELES, CA:
4,155,158, INT. CL. 25.

COLE, ANDREW, BOCA RATON, FL:
4,153,440, PUB. 3-20-2012. INT. CL. 9.

COLGIN CELLARS, INC., ST. HELENA, CA:
2,561,362. REN. 5-1-12. INT. CL. 33.

COLLABORATIVE FOR LEADERSHIP EXCELLENCE, CHI-CAGO, IL:
4,155,898, INT. CL. 35.
4,155,899, INT. CL. 35.

COLLIN STREET BAKERY, INC, CORSICANA, TX:
4,154,144, PUB. 3-20-2012. INT. CL. 30.

COLLINS AUTO GROUP, LLC, LOUISVILLE, KY:
4,153,481, PUB. 3-20-2012. INT. CL. 35.

COLLINS, ASHA, WINTER PARK, FL:
4,155,754, INT. CL. 35.

COLOMBIAN SWEEPER COMPANY CSC S.A.S, BARRAN-QUILLA, COLOMBIA:
4,155,348, INT. CL. 1.
4,155,349, INT. CL. 1.

COLONY BRANDS, INC., MONROE, WI, KUBLY, RAY-MOND R., MONROE, WI, DBA THE SWISS COLONY:
561,547. REN. 4-27-12. U.S. CL. 46 (INT. CL. 29).

COLONY BRANDS, INC., MONROE, WI:
2,619,056. REN. 4-27-12. INT. CL. 35.

COLONY RESORTS LVH ACQUISITIONS, LLC, LAS VE-GAS, NV:
4,153,444, PUB. 3-20-2012. MULTIPLE CLASS, INT. CLS. 41 AND 43.
4,153,445, PUB. 3-20-2012. MULTIPLE CLASS, INT. CLS. 41 AND 43.

COLOR MAKE, INC, MIAMI, FL:
4,154,924, INT. CL. 2.

COLOR RESOLUTIONS INTERNATIONAL LLC, FAIR-FIELD, OH:
2,660,378. REN. 5-3-12. INT. CL. 2.

- COLORADO BOXED BEEF CO., AUBURNDALE, FL:
4,152,520, PUB. 3-20-2012. INT. CL. 29.
- COLORADO ENERGY MANAGEMENT, LLC, LAFAYETTE, CO:
4,152,505, PUB. 3-20-2012. INT. CL. 42.
- COLTENE/WHALEDENT, INC., CUYAHOGA FALLS, OH:
4,152,819, PUB. 3-20-2012. INT. CL. 10.
- COLUMBIA ELEVATOR PRODUCTS CO., INC., BRIDGEPORT, CT:
4,154,253, INT. CL. 7.
- COLUMBIA INSURANCE COMPANY, OMAHA, NE, LOWELL SHOE, INC., LOWELL, MA:
1,193,683, REN. 4-30-12. INT. CL. 25.
- COLUMBIA INSURANCE COMPANY, OMAHA, NE:
4,154,419, INT. CL. 25.
4,154,656, INT. CL. 25.
- COMAROTO-RAYNAL, MARYANNE T., GREENBRAG, CA:
2,585,256, REN. 5-3-12. INT. CL. 42.
- COMBINED ENERGY SERVICES, MONTICELLO, NY:
4,153,568, PUB. 3-20-2012. INT. CL. 39.
- COMEY & SHEPHERD HOLDING COMPANY, INC., CINCINNATI, OH:
4,153,946, PUB. 3-20-2012. INT. CL. 36.
- COMICX, S.A. DE C.V., HERMOSILLO, SONORA, MEXICO:
4,153,002, PUB. 3-20-2012. INT. CL. 43.
- COMITÉ INTERNATIONAL OLYMPIQUE, 1007 LAUSANNE, SWITZERLAND:
4,152,658, PUB. 3-20-2012. MULTIPLE CLASS, INT. CLS. 1, 2, 3, 4, 5, 6, 7, 9, 10, 11, 12, 14, 16, 17, 18, 19, 25, 28, 29, 30, 32, 35, 36, 37, 38, 39, 40, 41, 42 AND OTHERS.
- COMMERCIAL COMPUTER SERVICES, INC., SCOTTSDALE, AZ:
4,152,545, PUB. 3-20-2012. MULTIPLE CLASS, INT. CLS. 35, 37 AND 41.
- COMMUNICATION DEVICES, INC., BOONTON, NJ:
4,152,855, PUB. 3-20-2012. INT. CL. 9.
4,152,856, PUB. 3-20-2012. INT. CL. 9.
- COMMUNITY PARTNERSHIP FOR HOMELESS, INC., MIAMI, FL:
4,155,626, MULTIPLE CLASS, INT. CLS. 35, 36, 41, 43, 44 AND 45.
- COMPACTION TECHNOLOGIES, INC., MENDOTA HEIGHTS, MN:
4,154,325, INT. CL. 40.
- COMPAGNIE CHAMPENOISE PH-CH. PIPER-HEIDSIECK - ANCIENNE MAISON FONDEE EN 1785, 51100 REIMS, FRANCE:
2,563,433, REN. 5-3-12. INT. CL. 33.
- COMPAGNIE FINANCIERE SARBEK, SOCIETE ANONYME, NEUVILLE EN FERRAIN, FRANCE:
2,561,290, REN. 5-3-12. INT. CL. 3.
- COMPAGNIE NATIONALE DU RHÔNE, FRANCE:
4,152,257, PUB. 3-20-2012. MULTIPLE CLASS, INT. CLS. 9, 12, 39 AND 42.
- COMPANIA ESPANOLA DE PETROLEOS, S.A. (CEPSA), 28042 MADRID, SPAIN:
1,684,249, REN. 5-2-12. INT. CL. 4.
- COMPANY DATA TREES, INC., SAN DIEGO, CA:
4,155,698, INT. CL. 35.
- COMPGEEEKS.COM, OCEANSIDE, CA, DBA COMPUTER GEEKS DISCOUNT OUTLET:
2,499,396, REN. 4-30-12. INT. CL. 35.
2,499,396, CANC. INT. CL. 42.
- COMPLEMENTARY COATINGS CORP., STONY POINT, NY:
2,998,735, CANC. INT. CL. 2.
- COMPLETE GENOMICS, INC., MOUNTAIN VIEW, CA:
4,154,692, MULTIPLE CLASS, INT. CLS. 42 AND 45.
- COMPLETE SOLUTIONS TECHNOLOGIES, LLC, MOORESTOWN, NJ:
4,153,975, PUB. 3-20-2012. INT. CL. 3.
- COMPLIANCE IMPLEMENTATION SERVICES, MEDIA, PA, AKA CIS:
4,155,624, MULTIPLE CLASS, INT. CLS. 35, 36 AND 45.
4,155,625, MULTIPLE CLASS, INT. CLS. 35, 36 AND 45.
4,155,765, MULTIPLE CLASS, INT. CLS. 35 AND 45.
- COMPONENT DESIGN NORTHWEST, INC., PORTLAND, OR:
2,588,301, REN. 4-27-12. INT. CL. 9.
- COMPREHENSIVE NEUROSCIENCE, INC., MIRAMAR, FL:
4,155,886, INT. CL. 35.
4,155,887, INT. CL. 42.
- COMPUTER SCIENCES CORPORATION, EL SEGUNDO, CA:
2,493,343, CANC. INT. CL. 35.
- CONAGRA FOODS RDM, INC., OMAHA, NE:
2,559,645, REN. 4-27-12. INT. CL. 31.
4,154,375, INT. CL. 30.
- CONAIR CORPORATION, STAMFORD, CT:
4,152,115, PUB. 3-20-2012. INT. CL. 21.
4,154,180, PUB. 3-20-2012. INT. CL. 21.
4,154,642, INT. CL. 11.
4,154,956, INT. CL. 21.
4,154,957, INT. CL. 21.
4,154,961, INT. CL. 21.
4,155,426, INT. CL. 11.
- CONCEPT ENGINEERING GMBH, 79111 FREIBURG, FED REP GERMANY:
4,155,180, INT. CL. 9.
- CONCEPT II, INC., MORRISVILLE, VT:
2,561,017, REN. 5-3-12. INT. CL. 28.
- CONCORD INDUSTRIES, INC., ADDISON, TX:
2,704,041, REN. 5-3-12. INT. CL. 20.
- CONCORDIA INVESTMENT PARTNERS, INC., TAMPA, FL:
2,609,816, REN. 4-30-12. INT. CL. 15.
- CONCORDIA INVESTMENT PARTNERS, INC. - IN TRUST BY THE ML TRUST, TAMPA, FL AND THE ML TRUST ITF ARMADILLO DISTRIBUTION ENTERPRISES, INC., CONCORDIA INVESTMENT PARTNERS, INC. AND WASHBURN INTERNATIONAL, INC., MUNDELEIN, IL:
2,588,629, REN. 4-30-12. INT. CL. 15.
- CONDUITY, LLC, EDMONDS, WA:
4,153,049, PUB. 3-20-2012. INT. CL. 9.
- CONEXUS MEDIA TECHNOLOGIES, INC., BLOOMFIELD TOWNSHIP, MI:
4,153,270, PUB. 3-20-2012. INT. CL. 35.
- CONFLUENCE HOLDINGS CORP., EASLEY, SC:
4,154,754, INT. CL. 25.
- CONGRATS BOOKS INC., POMPAHO BEACH, FL:
4,154,921, MULTIPLE CLASS, INT. CLS. 9, 16, 41 AND 45.
- CONNECT HEARING, INC., BRENTWOOD, TN, DBA HEARINGPLANET:
2,693,702, REN. 5-2-12. INT. CL. 35.
- CONNEXUS CORPORATION, EL SEGUNDO, CA:
2,493,447, CANC. INT. CL. 41.
- CONOPCO, INC., ENGLEWOOD CLIFFS, NJ:
4,155,053, INT. CL. 3.
- CONOPTICA AS, N-7540 KLÆBU, NORWAY:
4,152,170, PUB. 3-20-2012. MULTIPLE CLASS, INT. CLS. 7, 9 AND 42.
- CONROY FOODS, INC., PITTSBURGH, PA:
4,153,089, PUB. 3-20-2012. INT. CL. 30.
- CONSEJO REGULADOR DE LA DENOMINACION DE ORIGEN TORO, E-49800 TORO (ZAMORA), SPAIN:
4,152,407, PUB. 3-20-2012. INT. CL. 33.
- CONSOLIDATED PROPERTY HOLDINGS, INC., LAS VEGAS, NV:
4,153,343, PUB. 3-20-2012. INT. CL. 35.
- CONSONA CORPORATION, INDIANAPOLIS, IN:
2,491,958, CANC. INT. CL. 9.
- CONSORZIO PER LA TUTELA DEL FORMAGGIO MOZZARELLA DI BUFALA CAMPANA CONSORTIUM ITALY, SAN NICOLA LA STRADA, ITALY:
4,152,952, PUB. 3-20-2012. INT. CL. 29.
- CONSUMER BENEFIT SERVICES, INC., NAPERVILLE, IL, DBA CBSI:
4,152,626, PUB. 3-20-2012. INT. CL. 35.
- CONSUMER PROGRAMS INCORPORATED, ST. LOUIS, MO:
4,154,776, MULTIPLE CLASS, INT. CLS. 40 AND 41.
- CONTINENTAL DATALABEL, INC., ELGIN, IL:
2,493,584, CANC. INT. CL. 16.

CONTINENTAL DISC CORPORATION, LIBERTY, MO:
1,684,287. REN. 5-2-12. INT. CL. 6.

CONTINENTAL ENGINEERING SERVICES GMBH,
FRANKFURT, FED REP GERMANY:
4,152,724, PUB. 3-20-2012. INT. CL. 42.

CONTINUOUS COATING CORP., ORANGE, CA:
4,153,298, PUB. 3-20-2012. INT. CL. 6.

CONTRACTORHUB.COM, INC., KIRKLAND, WA:
2,493,665, CANC. INT. CL. 36.

CONTRACTORS HEALTH TRUST, DENVER, CO:
4,153,204, PUB. 3-20-2012. INT. CL. 36.

CONWAY & FRATES, LLC, TULSA, OK:
2,492,111, CANC. INT. CL. 9.

COOK INCORPORATED, BLOOMINGTON, IN:
4,154,506, INT. CL. 10.

COOK MEDICAL TECHNOLOGIES LLC, BLOOMINGTON,
IN:
4,152,740, PUB. 3-20-2012. INT. CL. 10.

COOK, KEVIN, CLOVIS, NM:
4,152,962, PUB. 3-20-2012. INT. CL. 25.

COOKING CHANNEL, LLC, NEW YORK, NY:
4,154,218, PUB. 3-20-2012. INT. CL. 41.

COOKING MAMA LIMITED, KOWLOON, HONG KONG,
CHINA:
4,154,403, INT. CL. 41.
4,154,414, INT. CL. 41.

COOL EARTH ACTION, LONDON, UNITED KINGDOM:
4,154,293, MULTIPLE CLASS, INT. CLS. 36, 41, 42 AND
44.

COOL FOODS, LLC, BOSTON, MA:
2,565,648. REN. 4-30-12. INT. CL. 30.

COOPER TECHNOLOGIES COMPANY, HOUSTON, TX:
2,493,151, CANC. INT. CL. 6.
4,155,815, INT. CL. 11.

COOPER, ANDREW R.P., SAN JUAN CAPISTRANO, CA,
DBA COOPER SOUND SYSTEMS:
1,680,154. REN. 5-2-12. INT. CL. 9.

COOPER, FRANK, J., FOUNTAIN VALLEY, CA:
4,154,264, INT. CL. 5.

COOPERATIVA PROVINCIAL AGRARIA Y GANADERA
SAN ISIDRO, SOCIEDAD COOPERATIVA ANDALUZA,
04120 LA CANADA, ALMERIA, SPAIN:
2,557,801. REN. 4-27-12. INT. CL. 31.

COOPERSURGICAL, INC., TRUMBULL, CT:
4,154,990, INT. CL. 10.

COPSIDAS JR, FRANK, PORTLAND, ME:
4,153,168, PUB. 3-20-2012. INT. CL. 35.

CORE PRODUCTS GROUP LLC, LIVONIA, MI:
4,155,355, INT. CL. 17.

COREBEAUTY, LLC, SAN DIEGO, CA:
4,155,256, INT. CL. 3.

CORELINK, LLC, ST. LOUIS, MO:
4,155,539, INT. CL. 10.

CORELOGIC SOLUTIONS, LLC, SANTA ANA, CA:
2,561,954. REN. 5-3-12. INT. CL. 36.

CORNEAL LENS CORPORATION NEW ZEALAND LIM-
ITED, CHRISTCHURCH, NEW ZEALAND:
2,493,286, CANC. INT. CL. 9.

CORNING CABLE SYSTEMS BRANDS, INC., WILMING-
TON, DE:
4,154,053, PUB. 3-20-2012. INT. CL. 41.

CORNWELL QUALITY TOOLS CO., THE, WADSWORTH,
OH:
747,209. REN. 5-2-12. U.S. CL. 23 (INT. CL. 7).
747,210. REN. 5-2-12. U.S. CL. 23 (INT. CL. 7).

CORO, PETER, GLENDALE, CA:
4,153,932, PUB. 3-20-2012. INT. CL. 25.

CORONA CIGAR COMPANY, ORLANDO, FL:
2,570,444. REN. 5-2-12. INT. CL. 34.

CORPORATE RISK SOLUTIONS INC., LENEXA, KS:
2,704,728. REN. 5-3-12. MULTIPLE CLASS, INT. CLS. 35,
42 AND 45.

CORPORATIVO INTERNACIONAL MEXICANO, S. DE R.L.
DE C.V., MEXICO CITY, MEXICO:
3,011,790, CANC. INT. CL. 30.

CORRECT CRAFT IP HOLDINGS, LLC, ORLANDO, FL:
2,563,049. REN. 4-27-12. MULTIPLE CLASS, INT. CLS. 12,
18 AND 25.

CORRELATED MAGNETICS RESEARCH, LLC, NEW
HOPE, AL:
4,154,475, MULTIPLE CLASS, INT. CLS. 40 AND 42.
4,154,476, INT. CL. 9.

CORRINGTON'S ALASKAN IVORY LTD., SKAGWAY, AK:
2,998,913, CANC. INT. CL. 21.

CORSAIR MEMORY INC., FREEMONT, CA:
4,154,702, INT. CL. 9.
4,154,704, INT. CL. 9.

COSBY JR. MR. WILLIAM H., NEW YORK, NY:
2,554,503. REN. 5-3-12. INT. CL. 41.

COSMETICS & CLEANERS INTERNATIONAL, LLC, MED-
LEY, FL:
4,153,683, PUB. 3-20-2012. INT. CL. 3.

COST PLUS MANAGEMENT SERVICES, INC., OAKLAND,
CA, COST PLUS MARKETING SERVICES, INC., OAK-
LAND, CA:
2,556,914. REN. 4-27-12. MULTIPLE CLASS, INT. CLS. 3,
4, 8, 11, 14, 16, 20, 21, 24, 27, 28, 29, 30, 32 AND 35.

COSWORTH LIMITED, UNITED KINGDOM:
4,152,163, PUB. 3-20-2012. MULTIPLE CLASS, INT. CLS.
7, 12, 25 AND 42.

COTSEN FAMILY FOUNDATION, LOS ANGELES, CA:
2,618,686. REN. 4-30-12. INT. CL. 41.

COUNCIL OF SUPPLY CHAIN MANAGEMENT PROFES-
SIONALS, LOMBARD, IL:
4,152,550, PUB. 3-20-2012. INT. CL. 35.

COUNSELORS OF REAL ESTATE, THE, CHICAGO, IL,
AMERICAN SOCIETY OF REAL ESTATE COUNSELORS,
THE, CHICAGO, IL:
1,720,171. REN. 4-28-12. INT. CL. 16.

COUNTRY HEDGING, INC., INVER GROVE HEIGHTS,
MN:
4,153,678, PUB. 3-20-2012. INT. CL. 9.

COUPONGY, INC., JACKSONVILLE, FL:
4,153,963, PUB. 3-20-2012. INT. CL. 35.

COURTESY PRODUCTS, LLC, ST. LOUIS, MO:
2,558,692. REN. 4-27-12. INT. CL. 11.

COURTROOM TELEVISION NETWORK LLC, NEW YORK,
NY:
4,153,071, PUB. 3-20-2012. INT. CL. 41.
4,153,075, PUB. 3-20-2012. INT. CL. 9.
4,154,878, INT. CL. 9.
4,154,879, INT. CL. 41.

COUSIN CORPORATION OF AMERICA, LARGO, FL:
4,156,051, INT. CL. 26.

COVAS, JACQUELINE ANN, NEW YORK, NY AND GIR-
TEN, CODEY, NEW YORK, NY:
4,154,953, INT. CL. 19.

COVENANT HOUSE, NEW YORK, NY:
4,153,479, PUB. 3-20-2012. MULTIPLE CLASS, INT. CLS.
35, 36, 41, 43, 44 AND 45.
4,154,204, PUB. 3-20-2012. MULTIPLE CLASS, INT. CLS.
35 AND 36.

COX, THOMAS M. GRANITE BAY, CA:
4,153,598, PUB. 3-20-2012. INT. CL. 9.

CPC CELLARS LLC, KIRKLAND, WA:
4,152,153, PUB. 3-20-2012. INT. CL. 33.
4,152,154, PUB. 3-20-2012. INT. CL. 33.

CPI ENGINEERING SERVICES, INC., MIDLAND, MI:
1,681,739. REN. 5-2-12. MULTIPLE CLASS, INT. CLS. 4
AND 42.

CR MINERALS LLC, SAN JUAN PUEBLO, NM, DBA CR
MINERALS, LLC:
4,154,657, INT. CL. 11.

CRA INTERNATIONAL, CO., MIAMI, FL:
2,998,651, CANC. INT. CL. 3.

CRABAR/GBF, INC., MIDLOTHIAN, TX:
4,154,226, PUB. 3-20-2012. MULTIPLE CLASS, INT. CLS.
16 AND 40.

CRABTREE & EVELYN, LTD., WOODSTOCK, CT:
2,998,931, CANC. MULTIPLE CLASS, INT. CLS. 20, 21, 24
AND 35.

CRAIN CONSTRUCTION, INC., NASHVILLE, TN:
4,153,785, PUB. 3-20-2012. INT. CL. 37.

CRASCHE NEW YORK LLC, WOODBURY, NY:
4,154,969, INT. CL. 9.

- CREATEDHAIR.COM, LOS ANGELES, CA:
4,155,957, INT. CL. 26.
- CREATIVE CELEBRATIONS INC., STONE MOUNTAIN, GA:
1,694,690, REN. 5-2-12, INT. CL. 30.
- CREATIVE CONTROL FILMS, INC., SHREVEPORT, LA:
4,153,086, PUB. 3-20-2012, INT. CL. 41.
4,153,110, PUB. 3-20-2012, INT. CL. 41.
- CREATIVE CUSTOM FURNISHINGS CORPORATION, TORONTO, ONTARIO, CANADA:
2,562,189, REN. 5-3-12, INT. CL. 20.
- CREATIVE DISTINCTIONS, LLC, MIAMI, FL:
4,154,786, MULTIPLE CLASS, INT. CLS. 21 AND 25.
- CREATIVE LABORATORIES, INC., EAGAN, MN:
1,692,330, REN. 4-28-12, INT. CL. 3.
- CREDIT UNION CAREERS, INC., TALLAHASSEE, FL:
2,998,584, CANC. INT. CL. 35.
- CREDNET, LLC, ORLANDO, FL:
4,155,684, INT. CL. 45.
- CREIGHTON UNIVERSITY, OMAHA, NE:
4,154,268, INT. CL. 41.
- CRESCENDO INTERACTIVE, INC., CAMARILLO, CA:
2,491,966, CANC. INT. CL. 9.
- CRESCENT TIDE LLC, SAINT PAUL, MN:
4,153,964, PUB. 3-20-2012, INT. CL. 45.
- CRISPIN CIDER COMPANY, MINNEAPOLIS, MN:
3,676,388, AM. INT. CL. 33.
- CRIST, FRANK L., PORTLAND, MI:
2,608,548, REN. 4-27-12, INT. CL. 10.
- CRITICAL MASS MEDIA, INC., SAN ANTONIO, TX:
4,153,766, PUB. 3-20-2012, INT. CL. 9.
- CROOKSTON, GARR J., SYRACUSE, UT:
1,749,024, REN. 5-2-12, INT. CL. 42.
- CROP PRODUCTION SERVICES, INC., LOVELAND, CO, INTERNATIONAL MINERALS & CHEMICAL CORPORATION, SKOKIE, IL:
729,597, REN. 5-3-12, U.S. CL. 10 (INT. CL. 1).
- CROSSBOW CONSULTING, L.P., RICHARDSON, TX:
2,491,714, CANC. INT. CL. 42.
- CROSSMARK, INC., PLANO, TX:
4,153,850, PUB. 3-20-2012, INT. CL. 35.
4,153,851, PUB. 3-20-2012, INT. CL. 35.
4,153,852, PUB. 3-20-2012, INT. CL. 35.
- CROSSVILLE, INC., CROSSVILLE, TN:
4,154,804, INT. CL. 19.
4,154,805, INT. CL. 19.
4,155,873, MULTIPLE CLASS, INT. CLS. 37 AND 40.
- CROWN BIOSCIENCE INC., SANTA CLARA, CA:
4,152,629, PUB. 3-20-2012, INT. CL. 42.
- CRT INC., NEWELL, WV, DBA DAVIS DISTRIBUTION SYSTEMS:
4,156,034, INT. CL. 35.
- CRUISE LINE HOLDINGS CO., MIAMI, FL, CRUISE LINE HOLDINGS CO., MIAMI, FL:
2,559,584, REN. 4-27-12, INT. CL. 35.
- CRUSHIQ, LLC, WILMINGTON, NC:
4,153,846, PUB. 3-20-2012, MULTIPLE CLASS, INT. CLS. 35 AND 41.
- CRYSTAL RIVER ORGANICS LLC, CARBONDALE, CO:
4,152,732, PUB. 3-20-2012, INT. CL. 30.
- CRYSTALEX CZ, S.R.O., CZECH REPUBLIC:
4,152,303, PUB. 3-20-2012, MULTIPLE CLASS, INT. CLS. 21 AND 35.
- CRYSTALLINE HEALTH & BEAUTY FROM THE DEAD SEA LTD, TEL AVIV, ISRAEL:
4,155,367, INT. CL. 3.
- CS TECHNOLOGY, INC., NEW YORK, NY:
4,153,121, PUB. 3-20-2012, INT. CL. 42.
- CSC HOLDINGS, LLC, BETHPAGE, NY:
2,561,751, REN. 5-2-12, INT. CL. 41.
- CSS ANTENNA, INC., EDGEWOOD, MD:
2,576,223, REN. 5-2-12, INT. CL. 9.
- CU COOPERATIVE SYSTEMS, INC., RANCHO CUCAMONGA, CA:
4,155,894, INT. CL. 35.
- CU* ANSWERS, INC., GRAND RAPIDS, MI:
4,153,283, PUB. 3-20-2012, INT. CL. 35.
- CUEVAS, PAUL, FOOTHILL RANCH, CA:
4,155,257, INT. CL. 41.
- CULLIGAN INTERNATIONAL COMPANY, ROSEMONT, IL:
2,899,849, CANC. INT. CL. 11.
- CULTIVE FRANCHISE, LLC, DAVIS, CA:
4,154,936, MULTIPLE CLASS, INT. CLS. 30 AND 43.
- CUMMINGS, MICHAEL, HAWAIIAN GARDENS, CA:
4,153,085, PUB. 3-20-2012, INT. CL. 25.
- CUNNINGHAM, ARGUS I., FPO AE, ITALY:
4,154,608, INT. CL. 42.
- CURON MEDICAL, INC., SUNNYVALE, CA TO MEDERI THERAPEUTICS INC., GREENWICH, CT:
2,449,886, CANC. INT. CL. 42.
2,466,379, CANC. INT. CL. 10.
- CURVEBEAM, LLC, WARRINGTON, PA:
4,155,352, INT. CL. 10.
- CUSTOM BUILDING PRODUCTS, INC., SEAL BEACH, CA:
2,677,307, REN. 4-27-12, INT. CL. 1.
- CUSTOM MARKETING CO., LLC, CLAYTON, MO:
1,762,668, REN. 4-27-12, INT. CL. 11.
- CUT NUCLEAR, INC., HOUMA, LA:
4,152,042, PUB. 3-20-2012, INT. CL. 7.
- CUVILLAGE.COM, INC., PLYMOUTH, MI:
2,493,170, CANC. MULTIPLE CLASS, INT. CLS. 35, 36, 37, 38, 41 AND 42.
- CYBER-TEST INC., LONGWOOD, FL:
2,493,356, CANC. INT. CL. 37.
- CYBERSPACE TO PARADISE, INC., ORANGE CITY, FL:
4,153,533, PUB. 3-20-2012, INT. CL. 42.
- CYCLACEL LIMITED, LONDON NW1 4JL, UNITED KINGDOM:
2,560,761, REN. 5-1-12, INT. CL. 42.
2,560,761, CANC. INT. CL. 5.
- CYCLEVISION NETWORK, INC, CHICAGO, IL:
4,153,351, PUB. 3-20-2012, INT. CL. 38.
- CYGNUS BUSINESS MEDIA, INC., FORT ATKINSON, WI:
4,156,066, INT. CL. 37.
- CYPRESS PAINTING & DECORATING, INC., CARMEL, CA:
2,561,382, REN. 5-3-12, INT. CL. 37.
- CYPRESS POINT CLUB, PEBBLE BEACH, CA:
2,571,482, REN. 5-2-12, MULTIPLE CLASS, INT. CLS. 25 AND 41.
2,588,451, REN. 4-27-12, MULTIPLE CLASS, INT. CLS. 25 AND 28.
2,618,006, REN. 4-27-12, MULTIPLE CLASS, INT. CLS. 16 AND 28.
- CYTEC TECHNOLOGY CORP., WILMINGTON, DE, AMERICAN CYANAMID COMPANY, NEW YORK, NY:
732,043, REN. 5-1-12, U.S. CL. 6 (INT. CL. 1).
- CYTEC TECHNOLOGY CORP., WILMINGTON, DE:
2,668,125, REN. 4-30-12, INT. CL. 1.
- CYTYC CORPORATION, MARLBOROUGH, MA:
2,999,071, CANC. INT. CL. 5.
- D & L DISTRIBUTION, LLC, LANCASTER, PA:
4,155,272, INT. CL. 1.
- D. W. MANAGEMENT ENTERPRISES INC., CULVER CITY, CA:
4,153,377, PUB. 3-20-2012, INT. CL. 44.
- D. WHITTELEY, INC., MIAMI, FL:
2,552,100, REN. 5-3-12, INT. CL. 19.
- D-GENERATION, INC., DAYTONA BEACH, FL:
2,491,931, CANC. MULTIPLE CLASS, INT. CLS. 9, 16, 25, 28 AND 35.
- DADDI, LLC, REYNOLDSBURG, OH, DBA ILPRADIO:
4,153,780, PUB. 3-20-2012, INT. CL. 25.
- DAFF SRL, I-50059 SOVIGLIANA VINCI (FI), ITALY AND ROBERTO DALLARMI, I-50056 MONTELUPO F.NO (FI), ITALY AND SIMONE MELANI, I-50053 EMPOLI (FI), ITALY AND RAAL S.R.L., I-47122 FORLÌ (FO), ITALY:
4,152,244, PUB. 3-20-2012, MULTIPLE CLASS, INT. CLS. 18 AND 25.
- DAHL, CINTHIA, SHERMAN OAKS, CA, DBA DAHL-HOUSE PRODUCTIONS:
2,561,976, REN. 5-3-12, INT. CL. 3.

DAIHATSU INDÚSTRIA E COMÉRCIO DE MÓVEIS E APARELHOS DOMÉSTICOS LTDA., SÃO PAULO, BRAZIL:
4,155,030, INT. CL. 11.

DAIMLER AG, STUTTGART, FED REP GERMANY:
4,152,565, PUB. 3-20-2012. INT. CL. 12.
4,152,849, PUB. 3-20-2012. MULTIPLE CLASS, INT. CLS. 38 AND 39.
4,152,929, PUB. 3-20-2012. INT. CL. 12.

DAIRY DELITE OF COLORADO, INC., LOVELAND, CO:
1,188,853, REN. 5-3-12. INT. CL. 30.

DAISHOWA SEIKI KABUSHIKI KAISHA, HIGASHIOSAKA, OSAKA, JAPAN, DBA BIG DAISHOWA SEIKI CO LTD:
2,603,301, COR. INT. CL. 7.

DAKTARI DIAGNOSTICS, INC., CAMBRIDGE, MA:
4,155,875, INT. CL. 10.

DAMA S.P.A., VARESE, ITALY:
2,562,396, REN. 4-30-12. INT. CL. 18.

DAMIAN ROSS, IRVING, TX, DBA GLOBOOGIE:
4,155,424, INT. CL. 35.

DAN'S FAN CITY, INC., OLDSMAR, FL:
4,154,092, PUB. 3-20-2012. INT. CL. 11.

DANBEE OPERATING CO., LLC, WHITE PLAINS, NY:
2,561,562, REN. 5-2-12. INT. CL. 41.

DANCE DAZE, ALAMEDA, CA:
4,153,186, PUB. 3-20-2012. INT. CL. 41.

DANDURAND, TROY M, ST. CLOUD, MN:
4,156,070, INT. CL. 41.

DANIEL HARI VASWANI, UNION CITY, CA:
4,155,699, INT. CL. 35.

DANIEL L. BALSAM, SAN FRANCISCO, CA:
3,216,929, CANC. INT. CL. 42.

DARLINGTON FARMS, INDIANAPOLIS, IN:
2,492,352, CANC. INT. CL. 30.

DARREN MATSUBARA, LAS VEGAS, NV:
4,153,619, PUB. 3-20-2012. INT. CL. 41.

DART CONTAINER CORPORATION, MASON, MI:
2,691,326, REN. 4-30-12. INT. CL. 21.
2,691,485, REN. 4-30-12. INT. CL. 21.

DATA TRANSLATION, INC., MARLBORO, MA:
2,492,780, CANC. INT. CL. 9.

DATAGEAR, INC., SANTA ANA, CA:
4,152,040, PUB. 3-20-2012. MULTIPLE CLASS, INT. CLS. 35, 37 AND 42.

DAUGHTERS OF PENELOPE FOUNDATION INCORPORATION, WASHINGTON, DC:
4,153,461, PUB. 3-20-2012. INT. CL. 36.

DAVID BOGNER FAMILY FUNERAL HOME INC., NORTH RIDGEVILLE, OH:
4,156,047, MULTIPLE CLASS, INT. CLS. 40 AND 45.

DAVID BRUCE WINERY, INC., LOS GATOS, CA:
2,591,519, REN. 5-1-12. INT. CL. 33.

DAVID C COOK, COLORADO SPRINGS, CO, FORMERLY COOK COMMUNICATIONS MINISTRIES:
4,112,646, COR. INT. CL. 16.

DAVID E. CHILTON, ANTIOCH, TN, DBA DC COMPANY:
4,155,715, INT. CL. 32.

DAVID N. DEUTSCH & COMPANY LLC, NEW YORK, NY:
4,155,966, MULTIPLE CLASS, INT. CLS. 35 AND 36.

DAVID REYNOLDS, ROSAMOND, CA, DBA LEONA VALLEY WINERY:
4,153,053, PUB. 3-20-2012. INT. CL. 33.

DAVIDS PINOT VINEYARDS, INC., LOMPOC, CA, DBA SEA SMOKE CELLARS:
4,154,131, PUB. 3-20-2012. INT. CL. 33.

DAVINCI BIOSCIENCES LLC, COSTA MESA, CA:
4,152,848, PUB. 3-20-2012. INT. CL. 42.

DAVIS INSTRUMENTS, HAYWARD, CA:
1,764,121, REN. 5-1-12. INT. CL. 9.

DAVIS-STANDARD, LLC, PAWCATUCK, CT, CROMPTON & KNOWLES CORPORATION, STAMFORD, CT:
1,692,437, REN. 5-2-12. INT. CL. 7.

DAVIS, ELIZABETH, LONG BEACH, CA:
2,492,519, CANC. INT. CL. 16.

DAVIS, SUSIE L., SKOKIE, IL:
2,492,377, CANC. INT. CL. 41.

DAVISSON, DJ, MARYSVILLE, WA:
4,154,032, PUB. 3-20-2012. INT. CL. 30.

DAWSON INTERNATIONAL HOLDINGS (UK) LIMITED, UNITED KINGDOM:
4,152,345, PUB. 3-20-2012. INT. CL. 25.

DAXWELL, LLC, HOUSTON, TX:
4,153,668, PUB. 3-20-2012. MULTIPLE CLASS, INT. CLS. 8, 10 AND 21.

DAY CAMINO RESTAURANT LLC, BOULDER, CO:
4,155,620, INT. CL. 43.

DAY, STEPHANIE, CHANDLER, AZ:
4,155,674, INT. CL. 9.
4,155,675, INT. CL. 9.

DBC SMARTSOFTWARE INC., KITCHENER, ONTARIO, CANADA:
2,563,232, REN. 5-3-12. INT. CL. 9.

DBD, INC., CONSHOHOCKEN, PA:
4,153,523, PUB. 3-20-2012. INT. CL. 41.

DBK CONCEPTS, INC., MIAMI, FL:
2,630,306, REN. 4-30-12. INT. CL. 42.

DBT WORLDWIDE, LLC, FISHERS, IN:
4,153,649, PUB. 3-20-2012. INT. CL. 25.

DC COMICS, NEW YORK, NY, DC COMICS INC., NEW YORK, NY:
1,199,552, REN. 4-28-12. INT. CL. 18.
1,199,630, REN. 4-27-12. INT. CL. 25.

DCW REHABS, LLC, ALFORD, FL:
4,153,594, PUB. 3-20-2012. INT. CL. 34.

DDH HOLDINGS, LLC, BIRMINGHAM, AL:
4,155,517, INT. CL. 2.

DDI GLOBAL CORP., ANAHEIM, CA:
4,154,339, INT. CL. 9.
4,154,340, INT. CL. 9.

DE LA MORA, ROBERT, DOWNEY, CA:
4,153,534, PUB. 3-20-2012. INT. CL. 37.

DE' LONGHI BENELUX S.A., LUXEMBOURG, LUXEMBOURG:
4,153,950, PUB. 3-20-2012. INT. CL. 11.
4,153,973, PUB. 3-20-2012. INT. CL. 11.
4,153,989, PUB. 3-20-2012. INT. CL. 11.
4,153,994, PUB. 3-20-2012. INT. CL. 11.

DEBRA A. HORTON, BRANSON, MO AND DONALD L. WRIGHT, BRANSON, MO:
4,154,081, PUB. 3-20-2012. INT. CL. 9.

DECADE DENTAL, MINEOLA, NY:
4,154,514, INT. CL. 44.

DECAS CRANBERRY PRODUCTS INC, CARVER, MA:
4,152,561, PUB. 3-20-2012. INT. CL. 29.

DECHNER, ITZHAK, OAK PARK, CA AND DECHNER, DANIEL, OAK PARK, CA:
4,155,490, INT. CL. 3.

DECIMUS, JEAN D, BROOKLYN, NY:
4,154,486, INT. CL. 37.

DECISION SIMULATION, LLC, CHADDS FORD, PA:
4,153,465, PUB. 3-20-2012. INT. CL. 9.

DECOART, INC., STANFORD, KY:
4,155,368, MULTIPLE CLASS, INT. CLS. 2 AND 16.

DECONNA ICE CREAM COMPANY INC., ORANGE LAKE, FL:
2,492,306, CANC. INT. CL. 30.

DEEPER CALLING MEDIA, INC., BUFORD, GA:
2,492,807, CANC. INT. CL. 16.

DEERE & COMPANY, MOLINE, IL:
4,153,164, PUB. 3-20-2012. INT. CL. 36.

DEERPOINT GROUP, INC., FRESNO, CA:
4,155,728, INT. CL. 37.

DEFRANCISCI MACHINE COMPANY LLC, WEST MELBOURNE, FL:
4,153,901, PUB. 3-20-2012. INT. CL. 7.

DEG MUSIC PRODUCTS, INC., LAKE GENEVA, WI:
2,670,989, REN. 4-30-12. INT. CL. 18.

DEHN + SOHNE GMBH & CO. KG, 92306 NEUMARKT/OPF., FED REP GERMANY:
2,493,371, CANC. INT. CL. 9.

DEL RIO MARKETING, INC., EXETER, CA:
4,153,897, PUB. 3-20-2012. INT. CL. 9.
4,153,904, PUB. 3-20-2012. INT. CL. 12.

DELAVAL INC., KANSAS CITY, MO:
2,492,219, CANC. INT. CL. 7.

- DELCZEG INC, BELMONT, CA:
4,153,815, PUB. 3-20-2012. INT. CL. 5.
- DELIVR, BOHEMIA, NY:
4,153,944, PUB. 3-20-2012. INT. CL. 42.
- DELO INDUSTRIAL ADHESIVES LLC, HAUPPAUGE, NY:
4,154,418, INT. CL. 11.
- DELOREAN MOTOR COMPANY, HUMBLE, TX:
2,491,848, CANC. MULTIPLE CLASS, INT. CLS. 12 AND 35.
- DELTA KAPPA EPSILON FRATERNITY, ANN ARBOR, MI:
4,153,645, PUB. 3-20-2012. INT. CL. 45.
- DELTA PHI OMEGA, CYPRESS, TX:
2,596,633, REN. 5-1-12. U.S. CL. 200.
- DELTA T CORPORATION, LEXINGTON, KY:
4,155,701, INT. CL. 11.
- DEMETER POWER GROUP, INC., WEST PALM BEACH, FL:
4,156,014, INT. CL. 36.
- DEMOCRASOFT, INC., SANTA ROSA, CA:
4,154,660, MULTIPLE CLASS, INT. CLS. 9 AND 42.
- DENTAL USA, MCHENRY, IL:
4,153,152, PUB. 3-20-2012. INT. CL. 10.
- DENTSPLY INTERNATIONAL INC., YORK, PA:
4,153,069, PUB. 3-20-2012. INT. CL. 11.
4,153,136, PUB. 3-20-2012. INT. CL. 40.
4,154,235, PUB. 3-20-2012. INT. CL. 10.
- DENVER MATTRESS CO., LLC, DENVER, CO:
2,669,369, REN. 4-30-12. INT. CL. 20.
2,669,371, REN. 4-30-12. INT. CL. 20.
2,669,372, REN. 4-30-12. INT. CL. 20.
2,669,373, REN. 4-30-12. INT. CL. 20.
2,669,374, REN. 4-30-12. INT. CL. 20.
- DEPARTMENT OF THE ARMY, ARLINGTON, VA:
2,998,635, CANC. INT. CL. 14.
- DEPARTMENT OF THE ARMY, THE, WASHINGTON, DC:
1,686,354, REN. 4-27-12. INT. CL. 16.
- DER SHENG CO., LTD., CHANGHUA COUNTY, TAIWAN:
4,155,705, INT. CL. 6.
4,155,707, INT. CL. 20.
- DEROYAL INDUSTRIES, INC., POWELL, TN:
4,153,536, PUB. 3-20-2012. INT. CL. 35.
4,153,538, PUB. 3-20-2012. INT. CL. 35.
- DESE ENTERPRISE, INC., CITY OF INDUSTRY, CA:
4,152,523, PUB. 3-20-2012. INT. CL. 35.
- DESERT MECHANICAL, INC., LAS VEGAS, NV:
4,153,172, PUB. 3-20-2012. INT. CL. 37.
- DESIGN POOL LIMITED, CENTRAL, HONG KONG:
4,152,510, PUB. 3-20-2012. INT. CL. 9.
- DESIGN-CONTACT, INC., NEW YORK, NY:
2,657,039, REN. 4-30-12. INT. CL. 42.
- DESIGNATED SPORTS, INC., ST. AUGUSTINE, FL:
2,492,436, CANC. INT. CL. 25.
- DESTINATION ATHLETE LLC, PITTSSTOWN, NJ:
4,153,476, PUB. 3-20-2012. MULTIPLE CLASS, INT. CLS. 35 AND 41.
- DESTINY CHOCOLATES, LLC, OAK CREEK, WI:
4,152,894, PUB. 3-20-2012. INT. CL. 30.
- DESTROY ATHLETICS, LLC, OLD SAYBROOK, CT:
4,152,631, PUB. 3-20-2012. INT. CL. 25.
- DETOXIFY, LLC, SCOTTSDALE, AZ:
2,567,271, REN. 4-27-12. INT. CL. 5.
- DEUTSCHE TELEKOM AG, BONN, FED REP GERMANY:
3,004,049, CANC. INT. CL. 9.
3,004,050, CANC. INT. CL. 16.
3,004,053, CANC. INT. CL. 35.
3,004,054, CANC. INT. CL. 18.
3,004,057, CANC. INT. CL. 42.
3,004,059, CANC. INT. CL. 41.
3,004,060, CANC. INT. CL. 39.
3,004,061, CANC. INT. CL. 38.
3,004,062, CANC. INT. CL. 36.
3,004,063, CANC. INT. CL. 32.
- DEUTSCHES WEINTOR EG, ILBESHEIM, FED REP GERMANY:
4,154,738, INT. CL. 33.
4,154,739, INT. CL. 33.
- DEVEDIA HOLDINGS, INC., WASHINGTON, DC:
4,154,318, MULTIPLE CLASS, INT. CLS. 16 AND 35.
- DEVICOM INTERNATIONAL, INC., CERRITOS, CA, DBA SNEAKERHEAD:
4,153,871, PUB. 3-20-2012. INT. CL. 35.
- DEX MEDIA, INC., CARY, NC:
2,561,784, REN. 4-29-12. INT. CL. 16.
- DFLABS S.R.L., 26013 CREMA CR, ITALY:
4,155,328, INT. CL. 9.
- DFS GROUP L.P., SAN FRANCISCO, CA:
1,689,466, REN. 5-2-12. INT. CL. 42.
- DG PERFORMANCE SPECIALTIES, INC., ANAHEIM, CA:
2,560,334, REN. 4-30-12. INT. CL. 7.
- DIAGNOSTIC HYBRIDS INC., ATHENS, OH:
2,610,533, REN. 5-3-12. INT. CL. 5.
- DIAMOND MOWERS, INC., SIOUX FALLS, SD:
3,429,809, CANC. INT. CL. 7.
- DIANE RICHARDSON, CHATTANOOGA, TN:
4,155,940, INT. CL. 44.
- DIC CORPORATION, JAPAN:
4,152,401, PUB. 3-20-2012. INT. CL. 1.
4,152,432, PUB. 3-20-2012. INT. CL. 1.
- DICARO DESIGN INC., PROVIDENCE, RI:
2,493,052, CANC. INT. CL. 14.
- DIETSMART, INC., NEW YORK, NY TO EDIETS.COM, INC., FORT LAUDERDALE, FL:
2,493,454, CANC. INT. CL. 42.
- DIGITAL AGE LEARNING, LOS ANGELES, CA, DBA DEVELOPENTOR:
4,153,134, PUB. 3-20-2012. INT. CL. 41.
- DIGITAL INNOVATIONS, LLC, ARLINGTON HEIGHTS, IL:
4,155,635, INT. CL. 9.
- DIGITAL PROCESSING SOLUTIONS, INC., MELVILLE, NY:
4,155,379, INT. CL. 36.
- DILLARD PROPERTIES LLC, PENNS GROVE, NJ:
4,152,452, PUB. 3-20-2012. INT. CL. 35.
- DILLARD'S, INC., LITTLE ROCK, AR:
1,691,693, REN. 4-28-12. INT. CL. 25.
- DILLARDS, LITTLE ROCK, AR:
4,153,759, PUB. 3-20-2012. INT. CL. 25.
- DIMENSIONAL FUND ADVISORS LP, SANTA MONICA, CA:
1,741,706, REN. 5-3-12. INT. CL. 36.
- DINE DEVELOPMENT CORPORATION, WINDOW ROCK, AZ:
2,573,987, REN. 4-30-12. INT. CL. 24.
- DINESH, ASHA, FREMONT, CA:
2,389,685, CANC. INT. CL. 9.
- DINGWELL, VANESSA, LOS ANGELES, CA AND ZAL, ROXANA, LOS ANGELES, CA:
4,153,860, PUB. 3-20-2012. INT. CL. 25.
- DINIUS, MICHAEL, RICHLAND, WA, DBA PERFORMANCE MANAGEMENT CONSULTING, LLC:
4,155,042, INT. CL. 35.
- DINNING, BRIAN RAY, STOYSTOWN, PA, DBA THE BIG GAME TV SHOW:
4,153,841, PUB. 3-20-2012. INT. CL. 41.
- DIOSA SPIRITS, LLC, N. LAS VEGAS, NV:
4,155,074, INT. CL. 33.
4,155,156, INT. CL. 33.
- DIPO, SOCIETE ANONYME, 34830 CLAPIERS, FRANCE:
2,998,568, CANC. INT. CL. 9.
- DIRECT 2U WHOLESALE LLC, LUTZ, FL:
4,152,558, PUB. 3-20-2012. INT. CL. 3.
- DIRECTIONAL NETWORKS, LLC, APEX, NC:
4,155,937, INT. CL. 38.
- DIRECTV, LLC, EL SEGUNDO, CA:
2,492,073, CANC. INT. CL. 9.
- DIRK HOFFIUS, GRAND RAPIDS, MI:
4,153,983, PUB. 3-20-2012. INT. CL. 25.
- DISA, ROLLA, MO:
4,153,111, PUB. 1-3-2012. INT. CL. 41.
- DISCOUNT CLOSETS, INC., MIAMI, FL:
4,155,849, INT. CL. 37.
- DISCOUNT STEEL, INC., MINNEAPOLIS, MN:
4,153,431, PUB. 3-20-2012. INT. CL. 35.
4,153,434, PUB. 3-20-2012. INT. CL. 35.

DISCOVERY LABWARE, INC., FRANKLIN LAKES, DE, COLLABORATIVE RESEARCH, INCORPORATED, BEDFORD, MA:
1,689,726. REN. 5-2-12. INT. CL. 1.

DISCUS DENTAL, LLC, LOS ANGELES, CA:
2,563,971. REN. 4-27-12. INT. CL. 10.

DISH NETWORK L.L.C., ENGLEWOOD, CO:
4,155,800, INT. CL. 9.
4,155,801, INT. CL. 9.

DISHAKA GOURMET IMPORTS, L.L.C., HOUSTON, TX:
2,673,333. REN. 4-30-12. INT. CL. 30.

DISNEY ENTERPRISES, INC., BURBANK, CA:
2,493,079, CANC. INT. CL. 41.

DISNEY ENTERPRISES, INC., BURBANK, CA, FINANZ ST. HONORE B.V., 1017 CG AMSTERDAN, NETHERLANDS:
2,598,219. REN. 5-3-12. MULTIPLE CLASS, INT. CLS. 16 AND 21.

DISNEY ENTERPRISES, INC., BURBANK, CA:
4,154,300, INT. CL. 16.
4,154,401, INT. CL. 43.
4,154,402, INT. CL. 39.
4,155,277, INT. CL. 20.
4,155,278, INT. CL. 3.

DISPROMEDICA LLC, MIAMI, FL:
4,155,378, INT. CL. 3.

DISTINCTIVE LIFESTYLES, LLC, LAWRENCEVILLE, GA:
2,493,671, CANC. INT. CL. 16.

DIVALISH DESIGNS, LLC, SILVER SPRING, MD:
4,155,473, INT. CL. 25.

DIVERSEY, INC., STURTEVANT, WI, BASF WYANDOTTE CORPORATION, WYANDOTTE, MI:
935,087. REN. 5-2-12. U.S. CL. 52 (INT. CL. 3).

DIVERSIFIED BIOTECH, DEDHAM, MA:
2,604,588. REN. 4-27-12. INT. CL. 1.

DIVERSIFIED BIOTECH, BOSTON, MA:
2,658,819. REN. 4-27-12. INT. CL. 17.

DIVINE SKIN, INC., MIAMI, FL, DBA DS LABORATORIES, INC.:
4,152,980, PUB. 3-20-2012. MULTIPLE CLASS, INT. CLS. 3 AND 5.

DIVORCE COACHING, INC., TAMPA, FL:
4,155,134, U.S. CL. B.
4,155,135, U.S. CL. B.
4,155,136, INT. CL. 41.

DIXIE MAT & HARDWOOD, INC., SANDY HOOK, MS:
4,155,848, INT. CL. 19.

DÉSILETS, ELISABETH, KIHEI, HI:
4,155,303, INT. CL. 41.

DJF ENTERPRISES, NEW YORK, NY:
4,154,940, INT. CL. 3.

DKM INC., BETHLEHEM, PA:
4,152,957, PUB. 3-20-2012. INT. CL. 43.

DNA HEALTH INSTITUTE, CRYOGENIC DIVISION, LLC, VENTURA, CA:
4,153,467, PUB. 3-20-2012. INT. CL. 3.

DO IT BEST CORP., FORT WAYNE, IN, HARDWARE WHOLESALEERS, INC., FORT WAYNE, IN:
1,719,730. REN. 4-27-12. INT. CL. 1.

DOAN, ALEX, GARDEN GROVE AVENUE, CA:
4,153,862, PUB. 3-20-2012. INT. CL. 37.

DOBBS, KENNETH J, BROOKFIELD, WI:
4,153,736, PUB. 3-20-2012. INT. CL. 35.

DOC POPCORN FRANCHISING, INC., GREENWOOD VILLAGE, CO:
4,153,059, PUB. 3-20-2012. MULTIPLE CLASS, INT. CLS. 35 AND 43.

DOCKWEILER AG, FED REP GERMANY:
4,152,414, PUB. 3-20-2012. INT. CL. 6.

DOCTORDOS CONSULTING, LTD., GLEN ELLYN, IL, DBA PROFESSIONAL NERDS:
4,152,943, PUB. 3-20-2012. MULTIPLE CLASS, INT. CLS. 37 AND 42.

DOELEGAL, LLC, WILMINGTON, DE:
4,152,492, PUB. 3-20-2012. INT. CL. 42.

DOERR REALTY, SAN ANTONIO, TX:
4,156,058, INT. CL. 36.

DOLBY LABORATORIES LICENSING CORPORATION, SAN FRANCISCO, CA:
1,699,540. REN. 4-27-12. INT. CL. 42.

DOLLAR FINANCIAL GROUP, INC., BERWYN, PA:
4,153,287, PUB. 3-20-2012. MULTIPLE CLASS, INT. CLS. 35 AND 36.

DOMAIN SURGICAL, INC., SALT LAKE CITY, UT:
4,154,507, INT. CL. 10.

DOMAINCONTEXT INC., WILMINGTON, DE:
4,153,652, PUB. 3-20-2012. INT. CL. 45.

DOMAINE ST. GEORGE, SAN FRANCISCO, CA, DBA CLOS CERI:
2,492,303, CANC. INT. CL. 33.

DOME CLEANING, INC., SAN FRANCISCO, CA:
4,153,808, PUB. 3-20-2012. INT. CL. 37.

DOMINANT BRANDS LLC, BAYSIDE, NY:
4,154,981, MULTIPLE CLASS, INT. CLS. 35 AND 36.

DOMINIC'S DOWNTOWN INC., GALLUP, NM:
4,156,038, INT. CL. 14.

DOMINICAN TOBACCO PRODUCTS LLC, MIAMI, FL:
4,154,997, INT. CL. 34.

DOMINION VOTING SYSTEMS, INC., DENVER, CO:
4,153,203, PUB. 3-20-2012. INT. CL. 9.

DOMINO PRINTING SCIENCES PLC, UNITED KINGDOM:
4,152,357, PUB. 3-20-2012. INT. CL. 9.

DOMINO'S IP HOLDER LLC, ANN ARBOR, MI:
2,639,844. REN. 4-30-12. INT. CL. 30.

DONALD A. GARDNER INTERACTIVE, LLC, GREENVILLE, SC:
2,493,355, CANC. INT. CL. 35.

DONOVAN, CATHERINE, NORTHBROOK, IL, DBA THE-GREENFERN.COM:
4,154,810, INT. CL. 41.

DOOR CONTROLS, INC., DEXTER, MI:
2,661,400. REN. 5-1-12. MULTIPLE CLASS, INT. CLS. 6 AND 9.

DOORN DESIGN LLC, STILLWATER, MN:
4,155,657, INT. CL. 25.

DORA'S NATURALS, INC., SOUTH HACKENSACK, NJ:
4,155,347, INT. CL. 30.

DORCY INTERNATIONAL, INC., COLUMBUS, OH:
2,564,573. REN. 5-3-12. INT. CL. 9.

DORINA/SO-GOOD, INC., UNION, IL:
4,152,066, PUB. 3-20-2012. INT. CL. 30.

DORIS CLAYTON ENTERPRISE, FAYETTEVILLE, NC:
4,154,850, INT. CL. 35.

DORMONT MANUFACTURING COMPANY, EXPORT, PA:
3,047,652, COR. INT. CL. 6.

DORNIER MEDTECH AMERICA, INC., KENNESAW, GA:
2,613,694. REN. 4-27-12. INT. CL. 10.

DOSKOCIL MANUFACTURING COMPANY, INC., ARLINGTON, TX:
2,619,134. REN. 5-1-12. INT. CL. 6.
4,152,535, PUB. 3-20-2012. INT. CL. 21.
4,152,536, PUB. 3-20-2012. INT. CL. 21.

DOUGHERTY, MARY ANN, VALENCIA, PA AND MOLETZ, FIORE, VALENCIA, PA:
2,998,667, CANC. INT. CL. 37.

DOUGLAS BUENZ, PLEASANTON, CA, DBA DAB MARKETING:
4,096,228, COR. INT. CL. 36.

DOUGLAS DYNAMICS, L.L.C., MILWAUKEE, WI, DOUGLAS DYNAMICS, INC., MILWAUKEE, WI:
1,753,609. REN. 4-30-12. INT. CL. 7.

DOUGLAS W. GASTELUM, LONG BEACH, CA, DBA EL IMAGENERO:
4,153,131, PUB. 3-20-2012. MULTIPLE CLASS, INT. CLS. 16 AND 41.

DOVE, TROY V., SIERRA MADRE, CA, DBA HARVESTOR INVESTMENTS:
4,154,143, PUB. 3-20-2012. INT. CL. 14.

DOW AGROSCIENCES LLC, INDIANAPOLIS, IN:
739,236. REN. 4-28-12. U.S. CL. 6 (INT. CL. 5).
741,597. REN. 5-1-12. U.S. CL. 26 (INT. CL. 9).

DOW JONES TRADEMARK HOLDINGS LLC, NEW YORK, NY:
4,153,208, PUB. 3-20-2012. INT. CL. 9.
4,153,209, PUB. 3-20-2012. INT. CL. 16.

- DPALS LIMITED, ROTHERHAM, UNITED KINGDOM:
4,152,103, PUB. 3-20-2012. INT. CL. 41.
- DR. ED, INC., MONUMENT, CO:
2,562,225. REN. 5-2-12. INT. CL. 42.
- DR. G'S FRANCHISING COMPANIES, LLC., DAVIE, FL
AND JDJ OF MIAMI, INC., AVENTURA, FL:
4,154,802, INT. CL. 44.
- DR. INTERNS, INC., ROBBINSVILLE, NJ:
4,155,920, MULTIPLE CLASS, INT. CLS. 41 AND 44.
- DRAFT WORLDWIDE, INC, CHICAGO, IL:
2,998,668, CANC. INT. CL. 35.
2,998,669, CANC. INT. CL. 35.
- DRAGON CLAW (U.S.A.), INCORPORATED, IRWINDALE,
CA, DBA D.C. AMERICA:
1,744,294. REN. 5-2-12. INT. CL. 8.
- DRAKE-MCLAUGHLIN, MIGUEL, BROOKLYN, NY AND
SELKOWITZ, ADRIAN A, HARRISBURG, PA:
4,155,315, INT. CL. 35.
- DREAM BELIEVE KNOW IT FOUNDATION, FORTY FORT,
PA, AKA DBK:
4,153,689, PUB. 3-20-2012. INT. CL. 41.
- DREAMSTAR CASH, S.L., 03580 ALTEA (ALICANTE),
SPAIN:
4,154,513, MULTIPLE CLASS, INT. CLS. 9, 38 AND 41.
- DREAMWELL, LTD., LAS VEGAS, NV:
4,155,720, INT. CL. 20.
- DREW ESTATE HOLDING COMPANY LLC, MIAMI, FL:
2,561,295. REN. 5-1-12. INT. CL. 34.
- DREW LAYNE, L.L.C., LEWISVILLE, TX:
4,152,708, PUB. 3-20-2012. INT. CL. 25.
- DRINKER BIDDLE & REATH LLP, PHILADELPHIA, PA:
2,492,675, CANC. INT. CL. 42.
- DRINKOLOGY, LLC, DALLAS, TX:
4,154,454, INT. CL. 32.
- DRIVE THRU TECHNOLOGY, INC., LOS ANGELES, CA:
4,153,322, PUB. 3-20-2012. INT. CL. 42.
4,153,324, PUB. 3-20-2012. MULTIPLE CLASS, INT. CLS. 9
AND 42.
- DRS. SPAGNOLI, CROWLEY, MISIEK, FARRELL, FAR-
RELL & NALE, P.A., CHARLOTTE, NC:
4,155,454, INT. CL. 44.
- DRUG & ALCOHOL TESTING INDUSTRY ASSOCIATION,
INC., WASHINGTON, D.C., DC:
2,710,762. REN. 5-3-12. INT. CL. 42.
- DRY BASEMENT, INC., KANSAS CITY, MO:
2,704,331. REN. 4-30-12. INT. CL. 37.
- DRZAL, JEREMY, ROUND ROCK, TX:
4,153,809, PUB. 3-20-2012. INT. CL. 42.
- DS WATERS OF AMERICA, INC., ATLANTA, GA:
4,152,122, PUB. 3-20-2012. INT. CL. 32.
- DSI - DIMONA SILICA INDUSTRIES LTD, DIMONA,
ISRAEL:
4,155,268, INT. CL. 19.
- DSR PARTNERS, LLC, LITITZ, PA:
4,153,892, PUB. 3-20-2012. INT. CL. 12.
- DSW SHOE WAREHOUSE, INC., COLUMBUS, OH:
4,153,700, PUB. 3-20-2012. INT. CL. 35.
4,154,224, PUB. 3-20-2012. INT. CL. 35.
4,154,228, PUB. 3-20-2012. INT. CL. 35.
- DUACARRIER ELECTRONICS TECHNOLOGY, INC.,
KNOXVILLE, TN:
4,152,811, PUB. 3-20-2012. INT. CL. 9.
- DUAL ACOUSTICS LLC, OAK PARK, IL:
4,154,935, INT. CL. 17.
- DUCLAW BREWERY LLC, BEL AIR, MD:
4,154,008, PUB. 3-20-2012. INT. CL. 32.
4,154,138, PUB. 3-20-2012. INT. CL. 32.
4,154,207, PUB. 3-20-2012. INT. CL. 32.
- DUDECK, DANIEL, ATLANTA, GA:
2,577,131. REN. 4-27-12. MULTIPLE CLASS, INT. CLS. 9
AND 41.
- DUFFY GALLEGOS LLC, NEW YORK, NY:
4,152,483, PUB. 3-20-2012. INT. CL. 37.
- DUKE UNIVERSITY, DURHAM, NC:
1,702,830. REN. 5-2-12. MULTIPLE CLASS, INT. CLS. 6,
16, 18 AND 24.
- DULCICH, INC., CLACKAMAS, OR:
2,682,103. REN. 5-2-12. INT. CL. 29.
- DUMB LUCK DESIGNS, PALM BEACH GARDENS, FL:
4,153,935, PUB. 3-20-2012. INT. CL. 25.
- DUMPLOADS ON US, WALNUT CREEK, CA:
4,154,469, INT. CL. 30.
- DUNCAN MEADOWS, CHULA VISTA, CA:
4,153,866, PUB. 3-20-2012. INT. CL. 35.
- DUNLAP CODDING, P.C., OKLAHOMA CITY, OK:
4,155,546, INT. CL. 45.
- DUNN-EDWARDS CORPORATION, LOS ANGELES, CA:
2,568,222. REN. 5-3-12. INT. CL. 2.
- DUPLOMATIC OLEODINAMICA S.P.A., I-20015 PARABIA-
GO (MILANO), ITALY:
4,152,172, PUB. 3-20-2012. INT. CL. 7.
- DURASOL AWNINGS, INC., MIDDLETOWN, NY:
4,152,791, PUB. 3-20-2012. INT. CL. 22.
- DUWOP, LLC, VAN NUYS, CA:
2,559,536. REN. 4-27-12. INT. CL. 3.
- DWYER FRANCHISING LLC, WACO, TX:
4,154,466, MULTIPLE CLASS, INT. CLS. 37, 39 AND 44.
- DYG HOLDINGS, INC., DANBURY, CT:
2,704,070. REN. 5-1-12. MULTIPLE CLASS, INT. CLS. 9
AND 16.
- DYNA CONTROLS CORPORATION, ST. CLAIR, MO:
730,652. REN. 5-2-12. U.S. CL. 13 (INT. CL. 6).
- DYNA-COATINGS GROUP, LLC, KANSAS CITY, MO:
4,154,751, INT. CL. 2.
- DYNACCO, INC., MONROE, WA:
2,571,881. REN. 5-1-12. INT. CL. 21.
- DYNAMIC DENTAL PLLC, STATEN ISLAND, NY:
4,152,652, PUB. 3-20-2012. INT. CL. 44.
- DYNAMIC GRAPHICS, INC., ALAMEDA, CA:
1,686,106. REN. 5-1-12. INT. CL. 9.
- DYNAMIC SPORTS NUTRITION, LLC, HOUSTON, TX:
4,152,696, PUB. 3-20-2012. INT. CL. 5.
- DYNAMITE GYMNASTICS CENTER, LLC, ROCKVILLE,
MD:
4,153,404, PUB. 3-20-2012. INT. CL. 41.
- DYNASTY CONSOLIDATED INDUSTRIES, INC., DALLAS,
TX:
2,704,775. REN. 4-30-12. INT. CL. 20.
2,704,818. REN. 4-30-12. INT. CL. 20.
- DYNASTY STAINLESS STEEL & METAL INDUSTRIES
INC., FLUSHING, NY:
2,569,152. REN. 5-3-12. INT. CL. 9.
- DYNED INTERNATIONAL, INC., BURLINGAME, CA:
2,557,727. REN. 4-27-12. MULTIPLE CLASS, INT. CLS. 9,
16, 41 AND 42.
- DYNETECH HOLDINGS CORPORATION, ORLANDO, FL:
2,559,950. REN. 4-27-12. INT. CL. 35.
- DZNR CHIC L.L.C., SAN DIEGO, CA:
4,152,916, PUB. 3-20-2012. MULTIPLE CLASS, INT. CLS.
18, 25 AND 45.
- E. & J. GALLO WINERY, MODESTO, CA:
1,708,291. REN. 4-27-12. INT. CL. 25.
- E. A. SWEEN COMPANY, EDEN PRAIRIE, MN:
2,492,188, CANC. MULTIPLE CLASS, INT. CLS. 30 AND
35.
- E. I. DU PONT DE NEMOURS AND COMPANY, WILMING-
TON, DE:
2,562,300. REN. 5-1-12. INT. CL. 20.
2,562,925. REN. 4-30-12. INT. CL. 9.
- E. LAND LTD, SEOUL, REPUBLIC OF KOREA:
2,492,168, CANC. INT. CL. 25.
- E. LAND WORLD LTD., SEOUL, REPUBLIC OF KOREA:
2,998,700, CANC. INT. CL. 25.
- E. WALDO WARD & SON, INC., SIERRA MADRE, CA:
4,155,148, INT. CL. 30.
- EAGLE ATM, LLC, PORTLAND, ME, AKA EAGLE ATM:
4,153,332, PUB. 3-20-2012. INT. CL. 9.
- EAGLE ZONE, LLC, GREENVILLE, SC:
2,578,633. REN. 4-27-12. INT. CL. 41.
- EARL G. GRAVES PUBLISHING CO., INC., NEW YORK,
NY:
2,559,761. REN. 4-27-12. INT. CL. 41.
- EARTH FRIENDS CONSERVATION FUND, JACKSON, WY:
4,152,822, PUB. 3-20-2012. MULTIPLE CLASS, INT. CLS.
35 AND 36.
4,152,823, PUB. 3-20-2012. MULTIPLE CLASS, INT. CLS.

35 AND 36.
EARTHTEC SOLUTIONS LLC, VINELAND, NJ:
4,153,928, PUB. 3-20-2012. INT. CL. 42.
EAST COAST GREENWAY ALLIANCE, DURHAM, NC:
2,555,578. REN. 4-27-12. INT. CL. 41.
EAST PENN MANUFACTURING CO., LYON STATION, PA,
TBC CORPORATION, MEMPHIS, TN:
1,759,627. REN. 5-2-12. INT. CL. 9.
EASTMAN KODAK COMPANY, ROCHESTER, NY:
4,154,831, INT. CL. 9.
EASTMAN OUTDOORS, INC., FLUSHING, MI:
4,155,311, INT. CL. 28.
EASY APP OVEN, LLC, ALPHARETTA, GA:
4,153,995, PUB. 3-20-2012. INT. CL. 42.
EASY-DO PRODUCTS LIMITED, UNITED KINGDOM:
4,152,217, PUB. 3-20-2012. INT. CL. 21.
4,152,374, PUB. 3-20-2012. INT. CL. 3.
EASY-SIT, INC., CHEYENNE, WY:
4,154,788, INT. CL. 20.
EAT, DRINK, & BEAT LLC, DURHAM, NH:
4,152,921, PUB. 3-20-2012. INT. CL. 19.
EBERHARD VON HUENE & ASSOCIATES INC., VAU-
DREUIL, QUEBEC, CANADA, AKA EVH & ASSOCIATES
INC.:
4,152,836, PUB. 3-20-2012. INT. CL. 20.
EBONITE HOLDINGS, INC., HOPKINSVILLE, KY:
2,999,020, CANC. MULTIPLE CLASS, INT. CLS. 25 AND
28.
EBRAHIM, MOHIB S., OTTAWA, ONTARIO, CANADA:
4,152,036, PUB. 3-20-2012. INT. CL. 9.
EBS HOLDING HB, STOCKHOLM, SWEDEN:
2,492,767, CANC. INT. CL. 9.
EBSICO INDUSTRIES, INC., BIRMINGHAM, AL:
4,152,665, PUB. 3-20-2012. INT. CL. 28.
4,154,127, PUB. 3-20-2012. INT. CL. 28.
ECHO DELTA, INC., LOS ANGELES, CA:
4,155,319, INT. CL. 20.
ECLECTIC LLC, STAMFORD, CT:
4,154,920, INT. CL. 43.
ECLIPSE, INC., ROCKFORD, IL:
1,712,640. REN. 5-2-12. INT. CL. 9.
4,154,328, INT. CL. 11.
ECO-CUISINE, INC., BOULDER, CO:
2,612,511. REN. 5-3-12. INT. CL. 30.
2,620,483. REN. 5-3-12. MULTIPLE CLASS, INT. CLS. 30
AND 42.
ECO-IT NETWORKING, INC, SAN JOSE, CA:
4,156,057, INT. CL. 42.
ECOLAB USA INC., ST. PAUL, MN:
2,598,697. REN. 5-3-12. INT. CL. 35.
ECOLAB USA INC., SAINT PAUL, MN:
4,152,481, PUB. 3-20-2012. INT. CL. 42.
ECOPHARMA, LLC, NEW YORK, NY:
4,154,703, INT. CL. 3.
EDCOR DATA SERVICES LLC, TROY, MI:
2,601,077. REN. 4-27-12. INT. CL. 35.
EDGAR RICE BURROUGHS, INC., TARZANA, CA:
2,575,167. REN. 5-2-12. MULTIPLE CLASS, INT. CLS. 9
AND 28.
EDGESTONE CAPITAL PARTNERS, INC., TORONTO, ON-
TARIO, CANADA:
3,081,530, CANC. INT. CL. 41.
EDIBLE COMMUNITIES, INC., SANTA BARBARA, CA:
4,153,870, PUB. 3-20-2012. INT. CL. 16.
EDIS COMPANY, INC., WILMINGTON, DE:
4,152,868, PUB. 3-20-2012. INT. CL. 37.
4,152,869, PUB. 3-20-2012. INT. CL. 37.
EDITH A. MILLER, LLC, NEW YORK, NY:
4,152,770, PUB. 3-20-2012. MULTIPLE CLASS, INT. CLS.
18 AND 25.
4,152,771, PUB. 3-20-2012. MULTIPLE CLASS, INT. CLS.
18 AND 25.
EDMUND FRETTE S.A.R.L., LUXEMBOURG, LUXEM-
BOURG:
4,153,282, PUB. 3-20-2012. MULTIPLE CLASS, INT. CLS.
3, 8, 18 AND 21.
EDOFF, JUDITH ANN, WEST HURLEY, NY:
2,558,328. REN. 4-30-12. INT. CL. 42.
EDUPOWER, INC., AMHERST, MA:
4,152,965, PUB. 3-20-2012. INT. CL. 16.
EELTOWN ENTERPRISES, LLC, ST. PETERSBURG, FL:
4,154,149, PUB. 3-20-2012. INT. CL. 29.
4,154,150, PUB. 3-20-2012. INT. CL. 29.
EFFICIENCY3 CORP, ARLINGTON, VA:
4,152,656, PUB. 3-20-2012. MULTIPLE CLASS, INT. CLS.
35 AND 42.
EFI GLOBAL, INC., HUMBLE, TX:
4,154,800, INT. CL. 9.
EFMLA, INC., SPRINGFIELD, VA:
4,153,294, PUB. 3-20-2012. MULTIPLE CLASS, INT. CLS.
35 AND 45.
EFTEC EUROPE HOLDING AG, ZUG, SWITZERLAND:
4,152,698, PUB. 3-20-2012. MULTIPLE CLASS, INT. CLS.
1, 2, 3, 17 AND 37.
EGAMES, INC., LANGHORNE, PA:
2,492,646, CANC. INT. CL. 9.
EGGERT, WALLACE MARTIN, ST. PETERSBURG, FL:
2,559,218. REN. 4-27-12. INT. CL. 25.
EGOV CONSULTING AND DEVELOPMENT GMBH, FED
REP GERMANY:
4,152,426, PUB. 3-20-2012. MULTIPLE CLASS, INT. CLS.
9, 38 AND 42.
EGRANDBUY, INC, INDUSTRY, CA:
4,154,220, PUB. 3-20-2012. INT. CL. 28.
EGS GAUGING, INC., BILLERICA, MA:
2,998,592, CANC. MULTIPLE CLASS, INT. CLS. 7, 9 AND
42.
EHMKE MANUFACTURING, INC., PHILADELPHIA, PA:
4,154,777, MULTIPLE CLASS, INT. CLS. 5, 9 AND 13.
EI DYNAMICS, INC., IRVINE, CA:
4,108,810, COR. INT. CL. 9.
EINSTOK BEER COMPANY, L.P., PACIFIC PALISADES,
CA:
4,155,046, INT. CL. 32.
EINSTRUCTION CORPORATION, DENTON, TX:
2,492,022, CANC. INT. CL. 41.
EIRCOM LIMITED, DUBLIN 2, IRELAND, EIRCOM PUB-
LIC LIMITED COMPANY, DUBLIN 2, IRELAND:
2,564,873. REN. 5-3-12. INT. CL. 38.
EJMS SERVICES, LLC, LOS GATOS, CA:
2,563,158. REN. 5-1-12. INT. CL. 36.
EKLIND TOOL CO., FRANKLIN PARK, IL:
1,765,213. REN. 5-2-12. INT. CL. 8.
EL PEKA FOODS LLC, NEW LONDON, CT:
4,154,255, INT. CL. 30.
EL POPOCATEPETL INDUSTRIES, INC., CHICAGO, IL:
1,198,145. REN. 4-28-12. INT. CL. 30.
ELAINE STEVEN BEAUTY COLLEGE, INC., ST. LOUIS,
MO:
4,153,767, PUB. 3-20-2012. MULTIPLE CLASS, INT. CLS.
41 AND 44.
ELBEX VIDEO, LTD., SHINAGAWA-KU, TOKYO 141,
JAPAN:
2,493,510, CANC. INT. CL. 9.
ELBO, INC., GRAPEVINE, TX:
4,154,460, MULTIPLE CLASS, INT. CLS. 35 AND 41.
ELDRIDGE, ARTHUR, DAYTONA BEACH, FL:
4,153,393, PUB. 3-20-2012. INT. CL. 41.
ELECTROCRAFT, INC., DOVER, NH:
4,154,320, MULTIPLE CLASS, INT. CLS. 7, 9 AND 12.
4,154,321, MULTIPLE CLASS, INT. CLS. 7 AND 12.
4,154,322, MULTIPLE CLASS, INT. CLS. 7 AND 12.
4,154,323, MULTIPLE CLASS, INT. CLS. 7 AND 12.
4,154,324, MULTIPLE CLASS, INT. CLS. 7 AND 12.
ELECTROLUX HOME CARE PRODUCTS, INC., CHAR-
LOTTE, NC:
4,154,678, INT. CL. 7.
ELECTRONIC ARTS INC., REDWOOD CITY, CA:
4,154,699, INT. CL. 9.
ELECTRONIC DATA SYSTEMS CORPORATION, PLANO,
TX:
2,492,139, CANC. INT. CL. 38.
ELECTRONIC REMEDY, INC., NATICK, MA:
4,155,399, INT. CL. 38.
ELECTRONICS FOR IMAGING, INC., FOSTER CITY, CA:
2,998,574, CANC. MULTIPLE CLASS, INT. CLS. 41 AND

42.
ELEVATOR BOUTIQUE LLC, WEST HOLLYWOOD, CA:
4,154,088, PUB. 3-20-2012. INT. CL. 7.
4,154,089, PUB. 3-20-2012. INT. CL. 7.
- ELI LILLY AND COMPANY, INDIANAPOLIS, IN:
4,154,350, INT. CL. 5.
4,154,366, INT. CL. 5.
- ELINCHROM S.A. (ELINCHROM LTD), SWITZERLAND:
4,152,190, PUB. 3-20-2012. MULTIPLE CLASS, INT. CLS. 9 AND 11.
- ELIZABETH F. CALLAHAN, M.D., LLC, BRADENTON, FL, DBA SKINSMART DERMATOLOGY:
4,153,988, PUB. 3-20-2012. INT. CL. 44.
- ELKHART BRASS MANUFACTURING COMPANY, INC., ELKHART, IN:
4,155,184, INT. CL. 9.
4,155,186, INT. CL. 9.
- ELLIOTT, JAMES ROBERT, BEECHER, IL:
2,492,988, CANC. MULTIPLE CLASS, INT. CLS. 14 AND 20.
- ELLISON EDUCATIONAL EQUIPMENT, INC., LAKE FOREST, CA:
2,669,320, REN. 5-3-12. INT. CL. 41.
- ELLISON GLASSWORKS LLC, CHICAGO, IL:
4,154,071, PUB. 3-20-2012. INT. CL. 9.
- ELOCAL USA LLC, DRESHER, PA:
4,152,456, PUB. 3-20-2012. INT. CL. 35.
4,152,457, PUB. 3-20-2012. INT. CL. 35.
- ELOYALTY, LLC, ENGLEWOOD, CO:
4,154,669, INT. CL. 42.
4,154,674, INT. CL. 42.
4,154,675, INT. CL. 42.
- ELSEVIER INC., NEW YORK, NY:
2,710,889, REN. 5-3-12. INT. CL. 16.
- ELSEVIER PROPERTIES SA, 2000 NEUCHÂTEL, SWITZERLAND:
4,153,065, PUB. 3-20-2012. INT. CL. 42.
- EMAT CAPITAL MANAGEMENT, INC., LOS ANGELES, CA:
4,154,398, INT. CL. 36.
- EMERGO (CYPRUS) LIMITED, NICOSIA, CYPRUS:
3,845,301, COR. MULTIPLE CLASS, INT. CLS. 35 AND 36.
3,918,520, COR. MULTIPLE CLASS, INT. CLS. 35 AND 36.
- EMERGO (CYPRUS) LIMITED, CYPRUS:
3,950,020, COR. MULTIPLE CLASS, INT. CLS. 35 AND 36.
- EMERGO (CYPRUS) LIMITED, NICOSIA, CYPRUS:
4,062,512, COR. MULTIPLE CLASS, INT. CLS. 35 AND 36.
- EMERSON CLIMATE TECHNOLOGIES, INC., SIDNEY, OH:
4,155,359, INT. CL. 9.
- EMERSON RADIO CORP., HACKENSACK, NJ:
4,154,588, INT. CL. 9.
- EMERSON, ERNEST, HARBOR CITY, CA:
2,493,595, CANC. INT. CL. 8.
- EMI YOSHI INC., NORTH BRUNSWICK, NJ:
4,155,445, MULTIPLE CLASS, INT. CLS. 8 AND 21.
- EMILIO PUCCI INTERNATIONAL B.V., KN BAARN, NETHERLANDS, AKA EMILIO PUCCI INTERNATIONAL BV, EMILIO PUCCI INT. BV, EMILIO PUCCI S.R.L., FIRENZE, ITALY:
1,687,909, REN. 5-3-12. INT. CL. 25.
- EMITEC GESELLSCHAFT FÜR EMISSIONSTECHNOLOGIE MBH, FED REP GERMANY:
4,152,360, PUB. 3-20-2012. INT. CL. 7.
- EMPLOYEE STAFF, LLC, KNOXVILLE, TN:
4,153,108, PUB. 3-20-2012. MULTIPLE CLASS, INT. CLS. 35 AND 36.
- EMPLOYEE TRANSFER CORPORATION, PHILADELPHIA, PA:
4,153,217, PUB. 3-20-2012. MULTIPLE CLASS, INT. CLS. 35 AND 36.
- EMTURN, LLC, WASHINGTON, DC:
4,154,815, MULTIPLE CLASS, INT. CLS. 18 AND 25.
- ENBALA POWER NETWORKS INC., TORONTO, ON, CANADA:
4,152,529, PUB. 3-20-2012. MULTIPLE CLASS, INT. CLS. 9 AND 42.
- ENCORE RAIL SYSTEMS, INC., CHICAGO, IL:
4,153,882, PUB. 3-20-2012. INT. CL. 17.
4,153,883, PUB. 3-20-2012. INT. CL. 17.
- ENDO PHARMACEUTICALS INC., CHADDS FORD, PA:
4,153,422, PUB. 3-20-2012. MULTIPLE CLASS, INT. CLS. 16 AND 44.
- ENDURING WEALTH ADVISORS, TEMECULA, CA, FORMERLY JENICLYN, INC.:
4,152,911, PUB. 10-25-2011. INT. CL. 36.
- ENERGY EYE, INC., POWAY, CA:
4,155,218, INT. CL. 9.
- ENERGY FOCUS, INC., SOLON, OH:
4,154,748, INT. CL. 11.
- ENERGY LAND CONSULTANTS, EDMOND, OK:
4,155,309, INT. CL. 36.
- ENERGY MANAGEMENT SPECIALISTS, INC., CLEVELAND, OH:
2,611,401, REN. 5-2-12. MULTIPLE CLASS, INT. CLS. 37 AND 42.
- ENERGYSCORE, INC, HOCKESSIN, DE:
4,155,863, INT. CL. 35.
- ENGELMAN, LEE D., OSHKOSH, WI:
2,669,248, REN. 5-3-12. INT. CL. 43.
- ENGINEERING & RESEARCH ASSOCIATES, INC., TUCSON, AZ:
4,154,673, MULTIPLE CLASS, INT. CLS. 7 AND 8.
- ENGSTROM, CHARLES ERIC, MONTAUK, NY:
4,156,054, INT. CL. 29.
- ENLIGHTED DESIGNS INC., ENCINITAS, CA:
2,601,177, REN. 4-30-12. MULTIPLE CLASS, INT. CLS. 25 AND 26.
- ENPENET GMBH, 27472 CUXHAVEN, FED REP GERMANY:
3,658,264, COR. MULTIPLE CLASS, INT. CLS. 9, 35, 38, 42 AND 44.
- ENTE AUTONOMO PER LE FIERE DI VERONA, ITALY:
4,152,325, PUB. 3-20-2012. MULTIPLE CLASS, INT. CLS. 35, 41 AND 43.
- ENTEGRIS, INC., BILLERICA, MA:
4,152,464, PUB. 3-20-2012. INT. CL. 11.
4,154,799, INT. CL. 17.
- ENTELOS HOLDING CORP., SAN MATEO, CA:
2,557,677, REN. 4-27-12. INT. CL. 42.
2,557,679, REN. 4-27-12. INT. CL. 9.
- ENTERATE INSURANCE, LLC, MIAMI, FL:
4,154,043, PUB. 3-20-2012. INT. CL. 36.
- ENTERPRISEDB CORPORATION, BEDFORD, MA:
4,154,349, INT. CL. 9.
- ENTRAVISION COMMUNICATIONS CORPORATION, SANTA MONICA, CA:
2,557,707, REN. 5-3-12. INT. CL. 41.
- ENVIRONMENTAL CONTROL SYSTEMS, INC., EAST PROVIDENCE, RI, DBA AQUASGROUP:
4,152,589, PUB. 3-20-2012. MULTIPLE CLASS, INT. CLS. 7, 11 AND 42.
- ENVIRONMENTAL SYSTEMS RESEARCH INSTITUTE, INC., REDLANDS, CA:
2,558,475, REN. 4-27-12. MULTIPLE CLASS, INT. CLS. 9 AND 16.
- ENWAVE OPTRONICS, INC., IRVINE, CA:
4,155,232, INT. CL. 9.
- EPHRIAM, CHARLES, LOS ANGELES, CA AND EPHRIAM, JESTIN, LOS ANGELES, CA AND EPHRIAM, CHRISTIAN, LOS ANGELES, CA:
4,153,772, PUB. 3-20-2012. INT. CL. 41.
- EPIC SYSTEMS CORPORATION, VERONA, WI:
2,574,214, REN. 5-3-12. INT. CL. 9.
- EPLADY 2000 L.L.C., HATZOR HAGLILIT, ISRAEL:
2,998,644, CANC. INT. CL. 8.
- EPPCO ENTERPRISES, INC., CLEVELAND, OH:
4,154,891, MULTIPLE CLASS, INT. CLS. 9 AND 12.
- EPROJECTS GROUP LIMITED LIABILITY COMPANY, HOBOKEN, NJ:
4,152,816, PUB. 3-20-2012. INT. CL. 42.

EPS HOLDING GMBH, FED REP GERMANY:
4,152,206, PUB. 3-20-2012. MULTIPLE CLASS, INT. CLS. 11 AND 44.

EPSON AMERICA, INC., LONG BEACH, CA:
4,153,542, PUB. 3-20-2012. INT. CL. 16.

EPSTEIN, JAMI, WEST HOLLYWOOD, CA:
4,153,340, PUB. 3-20-2012. INT. CL. 41.

EQUATORIAN IMPORTS, INC., DALLAS, TX:
1,684,387. REN. 5-2-12. INT. CL. 14.

EQUAVIE, FRANCE:
4,152,162, PUB. 3-20-2012. MULTIPLE CLASS, INT. CLS. 5, 29 AND 30.

EQUIBRAND CORPORATION, GRANBURY, TX:
2,569,990. REN. 5-2-12. INT. CL. 18.

EQUILATERAL TECHNOLOGIES, INC., LEXINGTON, MA:
2,567,341. REN. 5-3-12. INT. CL. 9.
2,610,685. REN. 5-3-12. INT. CL. 9.

EQUIPEX HOLDINGS LTD., PROVIDENCE, RI:
2,600,604. REN. 4-30-12. INT. CL. 11.

ERGO INTERNATIONAL, CORPORATION, MISSOURI CITY, TX:
2,636,831. REN. 4-27-12. INT. CL. 1.

ERICKSON INTERNATIONAL LLC, LAS VEGAS, NV, AKA AMERICAN STANDARD WINDOW FILM:
4,154,468, INT. CL. 17.

ERNI ELECTRONICS GMBH, FED REP GERMANY:
4,152,408, PUB. 3-20-2012. MULTIPLE CLASS, INT. CLS. 9, 17, 35, 37, 40 AND 42.

ERNST BENARY SAMENZUCHT GMBH, D-34346 HANN.-MUNDEN, FED REP GERMANY:
2,575,110. REN. 5-1-12. INT. CL. 31.

ERNST MÜHLBAUER GMBH & CO. KG, FED REP GERMANY:
4,152,269, PUB. 3-20-2012. MULTIPLE CLASS, INT. CLS. 1, 3, 5, 7, 10 AND 41.

ERUDISTIC, CHICAGO, IL:
4,152,991, PUB. 3-20-2012. INT. CL. 41.

ESCOBAR, DELIA P., CHINO, CA:
4,153,140, PUB. 3-20-2012. INT. CL. 18.

ESCROW ASSOCIATES, LLC, ATLANTA, GA:
1,685,357. REN. 5-3-12. INT. CL. 21.

ESES GLOBAL, INC., NEW YORK, NY:
4,155,790, INT. CL. 9.

ESF FINANCIAL, INC., MANHATTAN BEACH, CA:
4,155,650, INT. CL. 36.

ESPLANADE CAPITAL LLC, BOSTON, MA:
2,567,943. REN. 5-2-12. INT. CL. 36.

ESPRIX TECHNOLOGIES, L.P., SARASOTA, FL:
2,586,379. REN. 5-3-12. INT. CL. 1.
2,586,379. CANC. INT. CL. 40.

ESQUIRE SETTLEMENT SERVICES, INC., LAKE RIDGE, VA:
2,561,181. REN. 5-3-12. INT. CL. 36.

ESS TECHNOLOGIES, LLC, SAN ANTONIO, TX:
4,152,958, PUB. 3-20-2012. INT. CL. 35.

ESSELTE CORPORATION, MELVILLE, NY, ESSELTE PEN-DAFLEX CORPORATION, GARDEN CITY, NY:
1,690,799. REN. 5-1-12. INT. CL. 16.

ESSELTE IPR AB, SOLNA, SWEDEN:
733,786. REN. 4-30-12. U.S. CL. 37 (INT. CL. 16).

ESSENCE HEALING, INC., SHAKOPEE, MN:
4,153,317, PUB. 3-20-2012. INT. CL. 44.

ESSENTIAL LIVING, LLC, WAVERLY, PA:
4,155,942, INT. CL. 30.

EST 19XX, LLC, NEW YORK, NY:
4,152,949, PUB. 3-20-2012. INT. CL. 25.

ESTEREL TECHNOLOGIES, INC., MOUNTAIN VIEW, CA:
4,155,098, INT. CL. 9.

ETAPARA AG, FED REP GERMANY:
4,152,253, PUB. 3-20-2012. MULTIPLE CLASS, INT. CLS. 35, 38 AND 42.

ETEL S.A., CH-2112 MOTIERS, SWITZERLAND:
4,154,379, INT. CL. 9.

ETHICAL PRODUCTS, INC., BLOOMFIELD, NJ:
4,155,917, INT. CL. 18.

ETHNOMEDICINE PRESERVATION PROJECT, BOULDER, CO:
4,153,687, PUB. 3-20-2012. INT. CL. 35.

ETIENNE MARCEL LLC, LOS ANGELES, CA:
4,154,917, INT. CL. 25.

ETON FASHION AB, 507 71 GÅNGHESTER, SWEDEN:
1,994,562, AM. INT. CL. 25.

ETRAILER CORPORATION, ST. CHARLES, MO:
4,152,772, PUB. 3-20-2012. MULTIPLE CLASS, INT. CLS. 9 AND 12.

EUCLIDE AVRIDOR, NEW YORK, NY AND MYLENE DELATTRE, NEW YORK, NY:
4,156,045, INT. CL. 25.

EURAND MICROENCAPSULATION S.A., CHIASSO CH-6830, SWITZERLAND:
2,492,200, CANC. INT. CL. 42.

EURO-CAN MANUFACTURING INC., NEW HAMBURG, ONTARIO N3A2K5, CANADA:
4,152,046, PUB. 3-20-2012. INT. CL. 31.

EURONEXT PARIS SA, PARIS, FRANCE:
3,137,895, CANC. MULTIPLE CLASS, INT. CLS. 9, 35, 38, 41 AND 42.

EUROTEC VERTICAL FLIGHT SOLUTIONS, LLC, EUDORA, KS:
4,152,125, PUB. 3-20-2012. MULTIPLE CLASS, INT. CLS. 7, 9, 12, 37 AND 39.

EVA GABOR INTERNATIONAL, LTD., KANSAS CITY, MO:
4,155,820, INT. CL. 26.

EVANS COMMUNICATIONS, TURLOCK, CA:
2,492,548, CANC. INT. CL. 38.

EVANS FOODS PRODUCTS CO., CHICAGO, IL, MAC'S OLD PLANTATION CRACKLINGS, INC., DALLAS, TX:
1,193,711. REN. 5-2-12. INT. CL. 29.

EVANS, LAURA, GLENDALE, CA:
4,153,427, PUB. 3-20-2012. INT. CL. 45.

EVCO S.P.A., ITALY:
4,152,176, PUB. 3-20-2012. MULTIPLE CLASS, INT. CLS. 9, 11 AND 42.

EVE BUCWINSKI, JUPITER, FL:
4,152,637, PUB. 3-20-2012. INT. CL. 44.

EVENFLO COMPANY, INC., MIAMISBURG, OH:
2,574,551. REN. 5-3-12. INT. CL. 12.

EVENPRO MARKETING GROUP, LLC, SAN JUAN, PUERTO RICO:
4,153,235, PUB. 3-20-2012. INT. CL. 35.

EVERETT HUBER, ISLETON, CA:
4,153,413, PUB. 3-20-2012. INT. CL. 16.

EVERWARE INTERNATIONAL, DIAMOND BAR, CA:
4,155,320, MULTIPLE CLASS, INT. CLS. 8 AND 21.

EVERYDAY SHORTS INCORPORATED, CALGARY, ALBERTA, CANADA:
4,152,661, PUB. 3-20-2012. INT. CL. 3.

EVETS CORPORATION, CAMARILLO, CA:
2,492,325, CANC. INT. CL. 9.

EVIIEGGPLANT STUDIOS SARL, JBEIL, LEBANON:
4,153,691, PUB. 3-20-2012. INT. CL. 9.
4,153,692, PUB. 3-20-2012. INT. CL. 9.

EVOLIS, FRANCE:
4,152,323, PUB. 3-20-2012. MULTIPLE CLASS, INT. CLS. 9 AND 37.

EVONIK MEMBRANE EXTRACTION TECHNOLOGY LTD., UNITED KINGDOM:
4,152,223, PUB. 3-20-2012. MULTIPLE CLASS, INT. CLS. 9 AND 17.

EVOX PRODUCTIONS, LLC, RANCHO DOMINGUEZ, CA:
4,154,182, PUB. 3-20-2012. INT. CL. 45.

EVRIHOLDER PRODUCTS LLC, ANAHEIM, CA:
4,154,982, INT. CL. 21.

EW STEREOEAST INC., FRISCO, TX:
4,155,097, INT. CL. 9.

EXCO INTOUCH LTD., SAWBRIDGEWORTH, HERTS, UNITED KINGDOM:
4,154,038, PUB. 3-20-2012. INT. CL. 35.

EXECUTIVE WEALTH MANAGEMENT LIMITED, ST. PETER PORT, GUERNSEY, CHANNEL ISLANDS:
3,131,514, CANC. MULTIPLE CLASS, INT. CLS. 9, 16, 35, 36, 41 AND 42.

EXEL INDUSTRIES, FRANCE:
4,152,213, PUB. 3-20-2012. INT. CL. 8.

EXIT STRATEGY INC., CHICAGO, IL:
4,154,434, INT. CL. 41.

- EXO PRODUCTS, INC., CLIFTON PARK, NY:
4,153,782, PUB. 3-20-2012. INT. CL. 21.
- EXOTIC SUPERFOODS NEW YORK, INC., FLUSHING, NY:
4,155,936, MULTIPLE CLASS, INT. CLS. 29 AND 32.
- EXP GLOBAL INC., BRAMPTON, ONTARIO, CANADA:
4,155,052, MULTIPLE CLASS, INT. CLS. 37 AND 42.
- EXPLORE TOURS, LLC, ANCHORAGE, AK:
4,153,967, PUB. 3-20-2012. MULTIPLE CLASS, INT. CLS. 39 AND 43.
- EXPRESS LEARNING, INC., BURNSVILLE, MN:
2,492,411, CANC. INT. CL. 42.
- EXTREME SAILING SERIES S.A., SWITZERLAND:
4,152,193, PUB. 3-20-2012. MULTIPLE CLASS, INT. CLS. 3, 9, 14, 16, 18, 28 AND 41.
- EYE CARE AND CURE CORP., TUCSON, AZ:
4,155,976, INT. CL. 9.
- EYEFINITY, INC., RACHO CORDOVA, CA:
2,649,158, REN. 4-28-12. INT. CL. 9.
- EYGN LIMITED, NASSAU, BAHAMAS TO EYGN LIMITED, NASSAU, BAHAMAS:
2,609,380, CANC. INT. CL. 35.
- EZ-TEK INDUSTRIES, INC., SPRING LAKE PARK, MN:
2,998,567, CANC. INT. CL. 9.
- EZID, LLC, DENVER, CO:
2,559,325, REN. 4-27-12. INT. CL. 9.
- E3 DESIGN LLC, HAYDEN LAKE, ID:
4,154,942, INT. CL. 22.
- FABRICTECH 2000, LLC, CEDAR GROVE, NJ:
4,154,488, INT. CL. 24.
- FACE OF PRO-LIFE INC., THE, ASHFORD, CT:
2,491,722, CANC. INT. CL. 41.
- FACEY ENTERPRISES N.V. LTD., SAN MARINO, CA:
2,575,363, REN. 5-2-12. INT. CL. 25.
- FAGERHULTS BELYSNING AB, SWEDEN:
3,055,688.
- FALCAR LTD., BRIDGEHAMPTON, NY:
4,155,653, INT. CL. 45.
- FALK, KEVIN A, SAN DIEGO, CA:
4,153,489, PUB. 3-20-2012. INT. CL. 41.
- FAMILIES THRU INTERNATIONAL ADOPTION, INC., EVANSVILLE, IN:
2,492,160, CANC. INT. CL. 42.
- FAMILY PAWS LLC, CARY, NC:
4,153,494, PUB. 3-20-2012. INT. CL. 44.
- FAMOUS DAVE'S OF AMERICA, INC., MINNETONKA, MN:
4,152,982, PUB. 3-20-2012. MULTIPLE CLASS, INT. CLS. 29 AND 30.
- FAN PAGE GENERATOR, LLC, MILL VALLEY, CA:
4,152,733, PUB. 3-20-2012. MULTIPLE CLASS, INT. CLS. 35, 41 AND 42.
- FANATICS, LLC, JACKSONVILLE, FL:
4,154,503, INT. CL. 35.
- FAPCO, INC., BUCHANAN, MI:
1,707,145, REN. 5-2-12. INT. CL. 35.
- FARIAS VILLARREAL, MARTIN JESUS GERARDO, HOUSTON, TX:
4,154,909, INT. CL. 3.
- FARLING INDUSTRIAL CO., LTD., CHANGHUA, TAIWAN:
1,711,452, REN. 5-2-12. INT. CL. 10.
- FASHION GROUP INTERNATIONAL, THE, NEW YORK, NY:
1,684,098, REN. 4-27-12. U.S. CL. 200.
- FASTENAL IP COMPANY, WINONA, MN:
4,155,476, INT. CL. 35.
- FATHIPOUR, MO, WOODLAND HILLS, CA:
4,153,921, PUB. 3-20-2012. INT. CL. 41.
- FATTY LE ROCK LLC, TEANECK, NJ:
4,154,522, MULTIPLE CLASS, INT. CLS. 9, 25 AND 41.
- FAYE BENNETT, HAYWARD, CA AND OCTAVIO BENNETT, HAYWARD, CA:
4,155,429, INT. CL. 25.
- FAZIO, NANCY, INDIALANTIC, FL AND BOBB, ASHLEY, INDIALANTIC, FL:
4,153,403, PUB. 3-20-2012. INT. CL. 25.
- FD SWEDEN AB, ASKIM, SWEDEN:
4,153,189, PUB. 3-20-2012. INT. CL. 9.
- FEDERAL APD INCORPORATED, NOVI, MI:
4,154,417, INT. CL. 9.
- FEDERAL HOME LOAN MORTGAGE CORPORATION, MCLEAN, VA:
2,565,489, REN. 4-27-12. INT. CL. 36.
- FEDERAL RESERVE BANK OF DALLAS, DALLAS, TX:
4,153,178, PUB. 3-20-2012. MULTIPLE CLASS, INT. CLS. 35 AND 36.
- FEDERATED SPORTS & GAMING, INC., WASHINGTON, DC:
4,153,025, PUB. 3-20-2012. MULTIPLE CLASS, INT. CLS. 16 AND 41.
4,153,026, PUB. 3-20-2012. MULTIPLE CLASS, INT. CLS. 16 AND 41.
- FEDEX FREIGHT CORPORATION, MEMPHIS, TN:
2,698,173, REN. 5-3-12. INT. CL. 35.
- FEINTECHNIK GMBH EISFELD, FED REP GERMANY:
2,613,201, REN. 4-27-12. INT. CL. 8.
- FELD MOTOR SPORTS, INC., VIENNA, VA, SFX MOTOR SPORTS, INC., HOUSTON, TX:
2,586,855, REN. 4-30-12. INT. CL. 41.
- FELD MOTOR SPORTS, INC., VIENNA, IL:
2,654,388, REN. 4-30-12. MULTIPLE CLASS, INT. CLS. 25 AND 41.
- FELLERS, JAMES D., ROUND ROCK, TX:
4,154,280, MULTIPLE CLASS, INT. CLS. 35, 38, 41 AND 42.
- FEMHUB INC., RENO, NV:
4,153,286, PUB. 3-20-2012. INT. CL. 42.
- FEMWELL GROUP HEALTH, INC., COCONUT GROVE, FL:
4,152,828, PUB. 3-20-2012. INT. CL. 35.
- FERGUSON ENTERPRISES, INC., NEWPORT NEWS, VA:
4,152,446, PUB. 3-20-2012. INT. CL. 8.
- FERMERSKE GOSPODARSTVO "VLADAM", UKRAINE:
4,152,400, PUB. 3-20-2012. MULTIPLE CLASS, INT. CLS. 29, 30, 31 AND 32.
- FERRARA PAN CANDY CO., INC., FOREST PARK, IL:
4,152,512, PUB. 3-20-2012. INT. CL. 30.
- FERRARI S.P.A. 41100 MODENA, ITALY:
2,560,888, REN. 4-27-12. INT. CL. 12.
- FERRARI S.P.A., MODENA, ITALY:
4,152,160, PUB. 3-20-2012. MULTIPLE CLASS, INT. CLS. 9, 16 AND 28.
- FERRARI S.P.A., ITALY:
4,152,289, PUB. 3-20-2012. MULTIPLE CLASS, INT. CLS. 9, 12, 16, 18, 25, 28 AND 35.
- FERRING B.V., 2132 JX HOOFFDORP, NETHERLANDS:
4,154,387, MULTIPLE CLASS, INT. CLS. 16 AND 42.
- FERTRELL COMPANY, THE, BAINBRIDGE, PA:
2,493,444, CANC. MULTIPLE CLASS, INT. CLS. 1 AND 5.
- FETCH MATES PET SERVICES INCORPORATED, NEW YORK, NY, DBA FETCH MATES PET SERVICES INCORPORATED:
4,153,874, PUB. 3-20-2012. INT. CL. 44.
- FEVER TAGS, LLC, AMARILLO, TX:
4,155,960, INT. CL. 9.
- FEY INDUSTRIES, INC., EDGERTON, MN:
2,492,327, CANC. INT. CL. 9.
2,492,334, CANC. INT. CL. 16.
- FIAT GROUP AUTOMOBILES S.P.A., ITALY:
4,152,350, PUB. 3-20-2012. MULTIPLE CLASS, INT. CLS. 9, 12 AND 38.
- FIAT GROUP AUTOMOBILES S.P.A., I-10135 TORINO, ITALY:
4,152,351, PUB. 3-20-2012. MULTIPLE CLASS, INT. CLS. 9, 12 AND 38.
- FIELD FORENSICS, INC., LARGO, FL:
4,152,531, PUB. 3-20-2012. INT. CL. 1.
- FIELDPOINT B.V., NETHERLANDS:
4,152,342, PUB. 3-20-2012. INT. CL. 11.
- FIEROTEC, INC., BALTIMORE, MD:
3,077,868, CANC. INT. CL. 35.
- FIERRES, INC., SAN JUAN, PUERTO RICO:
4,153,891, PUB. 3-20-2012. INT. CL. 25.
- FIGG ENGINEERING GROUP, TALLAHASSEE, FL:
4,154,345, MULTIPLE CLASS, INT. CLS. 37 AND 42.

FIGHTER FOUNDATION, RICHMOND, VA, DBA FIGHTER FOUNDATION:
4,152,782, PUB. 3-20-2012. INT. CL. 36.

FILERTEK INTERNATIONAL PTY LTD, QUEENSLAND 4064, AUSTRALIA:
4,152,739, PUB. 3-20-2012. INT. CL. 16.

FILIPINO-AMERICAN LAW ENFORCEMENT OFFICERS ASSOCIATION, SAN FRANCISCO, CA:
4,153,226, PUB. 3-20-2012. INT. CL. 25.

FILTHY GRILL, INC., AGOURA HILLS, CA:
4,154,947, INT. CL. 37.

FILTREXX INTERNATIONAL LLC, GRAFTON, OH:
4,155,589, INT. CL. 19.

FINANCIAL TIMES LIMITED, THE, LONDON, UNITED KINGDOM:
4,152,602, PUB. 3-20-2012. MULTIPLE CLASS, INT. CLS. 35, 38 AND 41.

FINCOR HOLDINGS, INC., LANSING, MI:
4,153,260, PUB. 3-20-2012. MULTIPLE CLASS, INT. CLS. 36 AND 41.

FINE TOUCH DENTAL MANAGEMENT CORPORATION, OTTAWA, CANADA:
4,152,075, PUB. 3-20-2012. MULTIPLE CLASS, INT. CLS. 35 AND 36.

FINLEASE S.R.L., ITALY:
4,152,165, PUB. 3-24-2009. INT. CL. 28.

FINTRAX GROUP HOLDING LIMITED, GALWAY, IRELAND:
2,565,611. REN. 5-2-12. INT. CL. 36.

FIREBIRDS INTERNATIONAL LLC, CHARLOTTE, NC:
4,154,136, PUB. 3-20-2012. INT. CL. 43.
4,154,137, PUB. 3-20-2012. INT. CL. 43.

FIRESTORM EMERGENCY SERVICES LTD., RIVERSIDE, CA:
4,154,373, INT. CL. 9.

FIREWORKS BY GRUCCI, INC., BROOKHAVEN, NY:
1,684,032. REN. 4-30-12. INT. CL. 41.

FIRMENICH SA, GENEVA, SWITZERLAND, FIRMENICH & CO., NEW YORK, NY:
548,683. REN. 5-1-12. U.S. CL. 52 (INT. CL. 3).

FIRMENICH SA, GENEVA, SWITZERLAND:
556,239. REN. 5-3-12. U.S. CL. 51 (INT. CLS. 3 AND 5).
557,959. REN. 4-27-12. U.S. CL. 51 (INT. CL. 3).

FIRMENICH SA, CH-1211 GENEVE 8, SWITZERLAND:
2,562,863. REN. 5-3-12. INT. CL. 30.

FIRST AMERICAN FINANCIAL CORPORATION, SANTA ANA, CA:
4,155,531, INT. CL. 35.

FIRST CONNECTION, INC., FOREST HILL, MD:
4,155,313, INT. CL. 41.

FIRST DATA CORPORATION, GREENWOOD VILLAGE, CO:
2,493,236, CANC. INT. CL. 16.
2,493,237, CANC. MULTIPLE CLASS, INT. CLS. 36 AND 40.

FIRST FINANCIAL ADMINISTRATORS, INC., HOUSTON, TX:
4,154,093, PUB. 3-20-2012. INT. CL. 36.

FIRST HORIZON NATIONAL CORPORATION, MEMPHIS, TN:
2,584,186. REN. 5-2-12. INT. CL. 36.
2,999,018, CANC. INT. CL. 36.

FIRST STEPS IN MUSIC LLC, SIMSBURY, CT:
2,624,193. REN. 5-2-12. MULTIPLE CLASS, INT. CLS. 16 AND 41.

FISCHER PACKING COMPANY, HAMPTON, VA, WILSON-SINCLAIR CO., CHICAGO, IL:
934,053. REN. 4-30-12. U.S. CL. 46 (INT. CL. 29).

FISHER SCIENTIFIC COMPANY L.L.C., PITTSBURGH, PA, FISHER SCIENTIFIC COMPANY, PITTSBURGH, PA:
730,263. REN. 5-2-12. U.S. CL. 6 (INT. CL. 1).

FISHER, FREDRICK, GREENSBORO, NC:
4,155,888, INT. CL. 41.

FISHER, RUSHMER, WERRENATH, DICKSON, TALLEY & DUNLAP, P.A., ORLANDO, FL, AKA FISHER RUSHMER:
4,155,877, INT. CL. 45.

FISHER, STEVEN E, BRISTOL, PA:
4,155,856, INT. CL. 16.

FIST ENTERPRISES, WEST PALM BEACH, FL:
4,155,012, MULTIPLE CLASS, INT. CLS. 9 AND 12.

FIT COMPANY INSTITUTE LLC, AUSTIN, TX:
4,153,665, PUB. 3-20-2012. INT. CL. 41.

FIT ESTEEM, LLC, SOUTH ORANGE, NJ:
4,153,931, PUB. 3-20-2012. INT. CL. 41.
4,153,953, PUB. 3-20-2012. INT. CL. 41.

FIT2AIM LLC, MUKILTEO, WA:
2,592,027. REN. 4-30-12. INT. CL. 28.

FIVE BROTHERS MORTGAGE COMPANY SERVICES AND SECURING, INC., WARREN, MI:
4,153,050, PUB. 3-20-2012. MULTIPLE CLASS, INT. CLS. 36, 37 AND 42.

FIVE DEGREES CONSULTING, LLC, SALT LAKE CITY, UT:
4,153,177, PUB. 3-20-2012. MULTIPLE CLASS, INT. CLS. 35 AND 41.

FIVE FISH BISTRO, INC., SEATTLE, WA:
4,154,938, INT. CL. 43.

FIVE SEASONS S.R.L., ITALY:
4,152,399, PUB. 3-20-2012. INT. CL. 25.

FLASH & PARTNERS S.P.A., TOMBOLO (PADOVA), ITALY:
4,152,513, PUB. 3-20-2012. INT. CL. 25.

FLASH SEATS VERTICAL ALLIANCE LLC, CLEVELAND, OH:
4,154,289, INT. CL. 42.

FLASHVIC, INC., SUNNY ISLES, FL:
4,154,134, PUB. 3-20-2012. INT. CL. 35.

FLAT-OUT BACKEN', BLACKFOOT, ID:
4,154,443, INT. CL. 11.

FLATWORLD SOLUTIONS INC., PRINCETON, NJ:
4,154,825, MULTIPLE CLASS, INT. CLS. 35 AND 42.
4,154,826, MULTIPLE CLASS, INT. CLS. 35 AND 42.
4,154,827, MULTIPLE CLASS, INT. CLS. 35 AND 42.
4,154,828, MULTIPLE CLASS, INT. CLS. 35 AND 42.
4,154,839, MULTIPLE CLASS, INT. CLS. 35 AND 42.

FLEET ENGINEERS, INC., MUSKEGON, MI:
2,688,807. REN. 5-1-12. INT. CL. 12.

FLEET STREET LTD., NEW YORK, NY:
1,683,023. REN. 4-28-12. INT. CL. 25.

FLEET WHOLESALE SUPPLY CO., INC., APPLETON, WI:
4,154,123, PUB. 3-20-2012. INT. CL. 21.

FLIP TECHNOLOGIES LIMITED, DANGAN, COUNTY GALWAY, IRELAND:
4,152,891, PUB. 3-20-2012. INT. CL. 10.

FLIR SYSTEMS, INC., WILSONVILLE, OR:
4,152,833, PUB. 3-20-2012. INT. CL. 9.

FLOCK 12, INC, CHARLOTTE, NC:
4,152,835, PUB. 3-20-2012. INT. CL. 35.

FLOOD RANCH CO., SAN FRANCISCO, CA, DBA RANCHO SISQUOC WINERY:
1,696,403. REN. 5-2-12. INT. CL. 33.

FLORIDA AVENUE PARTNERSHIP, WASHINGTON, DC:
2,702,196. REN. 5-2-12. INT. CL. 43.

FLORIDA VIRTUAL SCHOOL, ORLANDO, FL:
4,152,641, PUB. 3-20-2012. INT. CL. 41.

FLOW CONSULTING, INC., SUMMERFIELD, FL:
4,152,585, PUB. 3-20-2012. INT. CL. 35.

FLUFF ICE, LLC, MONTEREY PARK, CA, DBA FLUFF ICE:
4,152,482, PUB. 3-20-2012. INT. CL. 30.

FLYING FISH BREWING CO., LLC, CHERRY HILL, NJ:
2,571,547. REN. 5-3-12. MULTIPLE CLASS, INT. CLS. 25 AND 32.

FMC CORPORATION, PHILADELPHIA, PA, DBA FMC CORPORATION:
4,154,336, INT. CL. 5.

FMC KONGSBERG HOLDING AS, 3616 KONGSBERG, NORWAY:
2,502,505. REN. 4-28-12. MULTIPLE CLASS, INT. CLS. 7 AND 37.

FME JEANS, LLC, LOS ANGELES, CA:
4,155,072, INT. CL. 25.

FMF OF OREGON, LLC, SALOME, AZ:
4,152,055, PUB. 3-20-2012. INT. CL. 7.

- FMS WERTMANAGEMENT AÖR, 85716 UNTERSCHLEIS-SHEIM, FED REP GERMANY:
4,058,230, COR. MULTIPLE CLASS, INT. CLS. 16, 35 AND 36.
- FOCUS ON THE FAMILY, COLORADO SPRINGS, CO:
2,492,711, CANC. INT. CL. 9.
- FOCUSED, LLC, WYOMISSING, PA:
4,152,058, PUB. 3-20-2012. INT. CL. 41.
- FOHAWX, LLC, BAYONNE, NJ:
4,154,886, INT. CL. 9.
- FOHAWX, LLC, BAYONNE, NJ:
4,154,888, INT. CL. 9.
- FOLEY MATERIAL HANDLING CO., INC., ASHLAND, VA:
2,526,711, REN. 4-30-12. INT. CL. 7.
- FOLLMANN & CO. GESELLSCHAFT FÜR CHEMIE-WERKSTOFFE UND-VERFAHRENSTECHNIK MBH & CO. KG., MINDEN, FED REP GERMANY:
3,078,434, COR. MULTIPLE CLASS, INT. CLS. 3, 16, 21, 35, 39 AND 40.
- FONDATION BETTENCOURT SCHUELLER, FRANCE:
4,152,219, PUB. 3-20-2012. MULTIPLE CLASS, INT. CLS. 35, 36, 41, 42 AND 45.
- FONDATION DE LA HAUTE HORLOGERIE, CH-1205 GENÈVE, SWITZERLAND:
4,152,266, PUB. 3-20-2012. MULTIPLE CLASS, INT. CLS. 9, 16, 38 AND 41.
- FONDER CONSULTING, LLC, MESA, AZ, DBA DIRECT BUSINESS MARKETING:
4,153,778, PUB. 3-20-2012. INT. CL. 36.
- FONG, PETER SUI LUN, MONTEREY PARK, CA:
2,498,006, REN. 5-1-12. INT. CL. 28.
- FOOD AND CULINARY TECHNOLOGY GROUP, INC., CALGARY, CANADA:
4,154,853, INT. CL. 30.
- FOOD INDUSTRIES, INC., MAKATI CITY, PHILIPPINES:
1,685,805, REN. 5-3-12. INT. CL. 30.
- FOR MOR INTERNATIONAL, CONWAY, AR:
4,155,990, INT. CL. 5.
- FOR THE KITCHEN, LLC, GLASTONBURY, CT:
4,155,895, INT. CL. 35.
- FORBO FINANCIAL SERVICES AG, SWITZERLAND:
4,152,259, PUB. 3-20-2012. INT. CL. 27.
- FORD GUM AND MACHINE COMPANY, INC., AKRON, NY:
937,259, REN. 5-1-12. U.S. CL. 101 (INT. CL. 35).
- FORD MOTOR COMPANY, DEARBORN, MI:
1,686,288, REN. 5-3-12. INT. CL. 12.
2,998,848, CANC. INT. CL. 12.
- FOREFRONT ENTERPRISES, LLC, SAND SPRINGS, OK:
4,153,230, PUB. 2-14-2012. INT. CL. 34.
- FOREMOST LABS, LAGUNA NIGUEL, CA:
2,496,861, REN. 4-27-12. INT. CL. 5.
- FOREST LAWN MORTUARY, GLENDALE, CA:
4,152,877, PUB. 3-20-2012. MULTIPLE CLASS, INT. CLS. 44 AND 45.
- FOREVER CHEESE, INC., LONG ISLAND, NY:
2,587,458, REN. 5-3-12. INT. CL. 29.
- FOREVERCARDS LLC, FORT LAUDERDALE, FL:
4,155,243, MULTIPLE CLASS, INT. CLS. 16 AND 20.
- FORIS VINEYARDS WINERY, CAVE JUNCTION, OR:
2,577,164, REN. 5-2-12. INT. CL. 33.
- FORMULA ONE LICENSING BV, ROTTERDAM, NETHERLANDS:
4,152,624, PUB. 3-20-2012. INT. CL. 18.
4,152,625, PUB. 3-20-2012. INT. CL. 33.
- FORT WORTH CREW CHARITIES, INC., FORT WORTH, TX:
4,153,475, PUB. 3-20-2012. INT. CL. 36.
- FORT WORTH PROMOTIONAL AND DEVELOPMENT FUND, FORT WORTH, TX:
4,155,165, INT. CL. 35.
- FORTE HARDWOOD FLOORING, INC., SOUTH BURLINGTON, VT:
2,577,048, REN. 4-30-12. MULTIPLE CLASS, INT. CLS. 3 AND 19.
2,577,048, CANC. INT. CL. 2.
- FORTNER, TRAVIS C, LA CROSSE, WI, DBA PROVEIL:
4,153,016, PUB. 3-20-2012. INT. CL. 13.
- FORTUNE DYNAMIC INC., CITY OF INDUSTRY, CA:
4,155,149, INT. CL. 25.
- FOSS NIRSYSTEMS, INC., LAUREL, MD:
2,493,452, CANC. INT. CL. 9.
- FOSSIL, INC., RICHARDSON, TX:
4,154,201, PUB. 3-20-2012. INT. CL. 18.
- FOUNDATION FOR PROFESSIONAL PEST MANAGEMENT, FAIRFAX, VA, DBA QUALITYPRO:
4,152,989, PUB. 3-20-2012. U.S. CL. B.
- FOUNDATION FOR PROFESSIONAL PEST MANAGEMENT, FAIRFAX, VA, DBA GREENPRO:
4,152,990, PUB. 3-20-2012. U.S. CL. B.
- FOUNTAIN OF MAGIC, INC., MATTITUCK, NY:
4,153,803, PUB. 3-20-2012. INT. CL. 43.
- FOUR BRIX, LLC, SIMI VALLEY, CA, DBA FOUR BRIX WINERY:
4,154,625, INT. CL. 33.
- FOUR FLAGS OVER ASPEN, INC., ST. CLAIR, MN:
2,621,475, REN. 5-1-12. INT. CL. 18.
- FOUR PAWS PRODUCTS LTD., HAUPPAUGE, NY:
2,591,117, REN. 4-27-12. MULTIPLE CLASS, INT. CLS. 8 AND 21.
- FOUR SEASONS HOTELS LIMITED, TORONTO, ONTARIO, CANADA:
1,195,412, REN. 5-2-12. INT. CL. 42.
1,687,336, REN. 5-2-12. INT. CL. 42.
- FOUR STAR GREENHOUSE, INC., CARLETON, MI:
4,153,129, PUB. 3-20-2012. INT. CL. 31.
- FOUR-D SOFTWARE, INC, PULASKI, TN:
4,153,066, PUB. 12-13-2011. INT. CL. 42.
- FOX INTERNATIONAL CHANNELS US, INC., LOS ANGELES, CA:
2,534,372, REN. 5-3-12. MULTIPLE CLASS, INT. CLS. 16 AND 41.
- FOX RIVER MILLS, INC., OSAGE, IA:
2,563,121, REN. 5-2-12. INT. CL. 25.
- FOX 40 INTERNATIONAL INC., STONEY CREEK, ONTARIO, CANADA:
4,155,561, INT. CL. 28.
4,155,562, INT. CL. 28.
- FOZZY NETWORKS, LLC, CAPE CORAL, FL, DBA SPICESTER:
4,153,820, PUB. 3-20-2012. INT. CL. 3.
- FRAN M ALBERT, NY, NY, AKA FRANCINE ALBERT:
4,154,773, INT. CL. 45.
- FRANÇOIS BOGACZ, PORTUGAL:
4,152,239, PUB. 3-20-2012. MULTIPLE CLASS, INT. CLS. 35 AND 41.
- FRANCHISE DIRECT USA, INC., ATLANTA, GA:
4,152,709, PUB. 3-20-2012. INT. CL. 35.
- FRANCISCO JAVIER PUJOLAR PLA, SPAIN:
4,152,243, PUB. 3-20-2012. INT. CL. 25.
- FRANK COPSIDAS JR, PORTLAND, ME:
4,153,169, PUB. 3-20-2012. INT. CL. 35.
- FRANK MORANO, STATEN ISLAND, NY:
4,155,711, INT. CL. 43.
- FRANK R. WALKER COMPANY, LOMBARD, IL:
2,501,709, REN. 5-1-12. MULTIPLE CLASS, INT. CLS. 9, 16 AND 35.
- FRANK'S SEPTIC SERVICE, INC., VACAVILLE, CA:
2,998,844, CANC. INT. CL. 40.
- FRANKLIN INTERNATIONAL, INC., COLUMBUS, OH:
2,563,732, REN. 5-3-12. INT. CL. 1.
- FRANKLIN T.Y. NG, BROOKLYN, NY:
4,154,885, INT. CL. 5.
- FRAU PETRA BEDFORD, FED REP GERMANY:
4,152,436, PUB. 3-20-2012. MULTIPLE CLASS, INT. CLS. 3, 14, 18, 24 AND 25.
- FRAUD DOG PRODUCTIONS, LLC, FT. LAUDERDALE, FL:
4,155,662, INT. CL. 41.
- FRAZIER, DEBORAH, RIO RANCHO, NM:
4,153,552, PUB. 3-20-2012. INT. CL. 37.
- FRED & BARREL, INC., CLARKSVILLE, MD:
4,154,243, INT. CL. 16.
- FRED WEHRENBERG CIRCUIT OF THEATRES, INC., ST. LOUIS, MO:
1,737,188, REN. 4-27-12. INT. CL. 41.

- FREDERICK BUECHNER LITERARY ASSETS, LLC, CAMBRIDGE, MA:
4,154,427, MULTIPLE CLASS, INT. CLS. 16 AND 28.
- FREDERICK WARNE & CO., LTD., MIDDLESEX UB7 ODA, UNITED KINGDOM:
2,492,921, CANC. INT. CL. 28.
- FREEDOM FRANCHISE SYSTEMS, LLC, SARASOTA, FL:
2,649,304, REN. 4-27-12, INT. CL. 41.
- FREEDOMS, RANCHO PALOS VERDES, CA:
4,154,023, PUB. 3-20-2012, INT. CL. 25.
- FRELIFE INTERNATIONAL HOLDINGS, LLC, PHOENIX, AZ:
2,702,568, REN. 5-3-12, INT. CL. 5.
- FREEMAN MANUFACTURING CO., STURGIS, MI:
1,711,453, REN. 5-3-12, INT. CL. 10.
- FREEMAN, ALGEANIA WARREN, MCCORDSVILLE, IN:
4,154,480, MULTIPLE CLASS, INT. CLS. 16 AND 41.
- FREEMAN, JERAMY K., EAST SYRACUSE, NY:
4,155,465, INT. CL. 5.
- FREEZE TAG, INC., TUSTIN, CA:
4,155,697, INT. CL. 9.
- FREIXE, HÉLÈNE LAURÉ, NEW YORK, NY:
4,154,342, INT. CL. 25.
- FREMONT INDUSTRIES, INC., SHAKOPEE, MN:
4,154,730, INT. CL. 1.
4,154,732, INT. CL. 1.
- FRENCH, CHRISTY L., PRINCETON, NJ:
4,155,250, INT. CL. 41.
4,155,251, INT. CL. 44.
- FRES-CO SYSTEM USA, INC., TELFORD, PA:
2,571,814, REN. 5-3-12, INT. CL. 7.
- FRESH CREEK TECHNOLOGIES, INC., CEDAR GROVE, NJ:
4,153,787, PUB. 3-20-2012, MULTIPLE CLASS, INT. CLS. 11 AND 40.
- FRESHLY WILD, INC., PORTLAND, OR:
4,154,542, INT. CL. 29.
- FRIDAY MEDIA GROUP LIMITED, SAYERS COMMON, UNITED KINGDOM:
4,152,951, PUB. 3-20-2012, INT. CL. 35.
- FRIEND, MAX DANIEL, BROOKLYN, NY:
4,153,761, PUB. 3-20-2012, MULTIPLE CLASS, INT. CLS. 41 AND 42.
- FRIENDSHIP HOSPITAL FOR ANIMALS, INC., WASHINGTON, DC:
4,153,705, PUB. 3-20-2012, INT. CL. 44.
4,153,706, PUB. 3-20-2012, INT. CL. 44.
- FRIESLAND BRANDS B.V., NETHERLANDS:
4,152,368, PUB. 3-20-2012, INT. CL. 29.
- FRIESLAND BRANDS BV, 7943 PE MEPPEL, NETHERLANDS:
2,561,369, REN. 4-27-12, INT. CL. 29.
- FRITO-LAY NORTH AMERICA, INC., PLANO, TX:
4,153,215, PUB. 3-20-2012, INT. CL. 30.
- FROST WINES, LLC, DUNDEE, NY, WIEMER; HERMANN J., DUNDEE, NY, DBA HERMANN J. WIEMER VINEYARDS:
1,202,935, REN. 5-3-12, INT. CL. 33.
- FROSTBLAND PTY LTD, AUSTRALIA:
4,152,380, PUB. 3-20-2012, MULTIPLE CLASS, INT. CLS. 3, 4 AND 5.
- FROZSUN, INC., PLACENTIA, CA:
2,577,313, REN. 5-3-12, INT. CL. 29.
- FRÖHLICH & DÖRKEN GMBH, SPROCKHÖVEL, FED REP GERMANY:
4,152,377, PUB. 3-20-2012, MULTIPLE CLASS, INT. CLS. 6, 7 AND 40.
- FS/NY SHOES, LTD., NEW YORK, NY:
2,565,410, REN. 4-27-12, INT. CL. 35.
- FSI INTERNATIONAL, INC., CHASKA, MN:
2,998,609, CANC. INT. CL. 7.
- FTG ASSOCIATION INC., GRAN BLANC, MI:
2,493,536, CANC. INT. CL. 28.
- FUCHS PETROLUB AG, MANNHEIM, FED REP GERMANY:
2,565,427, REN. 4-27-12, INT. CL. 4.
- FUGEIA NV, BELGIUM:
4,152,361, PUB. 3-20-2012, INT. CL. 1.
- FUJI FOOD PRODUCTS, INC., SANTA FE SPRINGS, CA:
4,154,644, MULTIPLE CLASS, INT. CLS. 29 AND 30.
- FUJI JUKOGYO KABUSHIKI KAISHA, SHINJUKU-KU, TOKYO, JAPAN, TA FUJI HEAVY INDUSTRIES LTD.:
2,582,563, REN. 5-3-12, INT. CL. 12.
- FUJI XEROX KABUSHIKI KAISHA D/B/A FUJI XEROX CO., LTD., TOKYO, JAPAN:
2,998,616, CANC. INT. CL. 9.
- FUJIFILM CORPORATION, TOKYO, JAPAN:
932,563, REN. 5-1-12, U.S. CL. 26 (INT. CL. 1).
932,564, REN. 5-1-12, U.S. CL. 26 (INT. CL. 1).
- FULL RISE ELECTRONIC CO., LTD., JONGLI CITY, TAOYUAN, TAIWAN:
2,559,725, REN. 4-27-12, INT. CL. 9.
- FULLSHARE GROUP LIMITED, WANCHAI, HONG KONG:
4,152,776, PUB. 3-20-2012, MULTIPLE CLASS, INT. CLS. 5, 31, 35, 36, 37, 41, 43 AND 44.
- FUNDACION PARA LA INVESTIGACION BIOMEDICA DEL HOSPITAL UNIVERSITARIO LA PAZ, 28046 MADRID, SPAIN:
4,153,047, PUB. 3-20-2012, MULTIPLE CLASS, INT. CLS. 9 AND 42.
- FUNDINGSHIELD, NEW YORK, NY:
4,152,726, PUB. 3-20-2012, MULTIPLE CLASS, INT. CLS. 42 AND 45.
- FUSION UV SYSTEMS, INC., GAITHERSBURG, MD:
4,152,525, PUB. 3-20-2012, MULTIPLE CLASS, INT. CLS. 37 AND 42.
- FUSION-IO, INC., SALT LAKE CITY, UT:
4,155,983, INT. CL. 9.
- FUTBOL CLUB BARCELONA, SPAIN:
4,152,306, PUB. 3-20-2012, MULTIPLE CLASS, INT. CLS. 9 AND 38.
- FUTURE FRUIT, LLC, VISALIA, CA:
4,154,426, INT. CL. 31.
- FUTURE TECHNOLOGY DEVICES; INTERNATIONAL LIMITED, UNITED KINGDOM:
4,152,168, PUB. 5-3-2011, MULTIPLE CLASS, INT. CLS. 9, 16 AND 42.
- FUTURES FOR CHILDREN, ALBUQUERQUE, NM:
1,719,108, REN. 5-2-12, INT. CL. 42.
- FUZZY'S TACO HOLDINGS, LLC, FORT WORTH, TX:
4,152,976, PUB. 3-20-2012, INT. CL. 35.
- G.A. BRAUN, INC., N. SYRACUSE, NY:
4,155,070, INT. CL. 7.
- G.H. MUMM & CIE, SOCIETE VINICOLE DE CHAMPAGNE SUCCESSEUR S.A., REIMS, FRANCE, G. H. MUMM CHAMPAGNE AND ASSOCIATES INCORPORATED (SOCIETE VINICOLE DE CHAMPAGNE, SUCCESSEUR), NEW YORK, NY:
395,907, REN. 5-2-12, U.S. CL. 47 (INT. CL. 33).
- G.I. GROUP LLC, FLUSHING, NY:
4,155,776, INT. CL. 14.
- G&A OUTSOURCING, INC., HOUSTON, TX, DBA G&A PARTNERS:
4,152,842, PUB. 3-20-2012, MULTIPLE CLASS, INT. CLS. 35 AND 36.
- G&W LABORATORIES, INC., SOUTH PLAINFIELD, NJ:
2,577,687, REN. 5-2-12, INT. CL. 5.
- GA.VO MECCANICA S.N.C. DI TANCREDI & C., ITALY:
4,152,227, PUB. 3-20-2012, INT. CL. 7.
- GABBIDON, ANDREW, QUEENS VILLAGE, NY AND GABBIDON, KISHA, QUEENS VILLAGE, NY:
4,154,302, INT. CL. 16.
- GABRIEL W. SHARP, TALCO, TX, DBA HAY N' SPRAY:
4,154,515, INT. CL. 7.
- GABRIELLA SENZA, HOUSATONIC, MA:
4,156,067, INT. CL. 41.
- GABRIELLE STUDIO, INC., NEW YORK, NY:
4,154,367, INT. CL. 8.
4,154,368, INT. CL. 21.
- GADO S.R.L., MILANO, ITALY:
3,108,433, AM. MULTIPLE CLASS, INT. CLS. 3, 9, 14, 18 AND 25.
- GAINES GROUP, LLC, HOUSTON, TX:
4,154,327, MULTIPLE CLASS, INT. CLS. 3 AND 5.
- GAK ENTERPRISES, INC., LAS VEGAS, NV:
4,153,291, PUB. 3-20-2012, INT. CL. 31.

- GAMEPLAY LLC, PLYMOUTH, MI:
4,153,588, PUB. 3-20-2012. INT. CL. 35.
- GAMES 2 U, INC., AUSTIN, TX:
3,673,784 NEW CERT. 6-5-2012. INT. CL. 41.
3,975,345 NEW CERT. 6-5-2012. INT. CL. 28.
- GAMING LABORATORIES INTERNATIONAL LLC, LAKEWOOD, NJ:
4,155,866, INT. CL. 42.
- GANDER MOUNTAIN COMPANY, ST. PAUL, MN:
4,153,877, PUB. 3-20-2012. INT. CL. 18.
4,154,650, INT. CL. 35.
- GANDONA, INC., ST. HELENA, CA:
4,155,764, INT. CL. 33.
- GAOLI XI'AN, SHAANXI PROVINCE, CHINA:
4,155,519, INT. CL. 9.
- GAP (APPAREL), LLC, SAN FRANCISCO, CA:
4,155,497, INT. CL. 35.
4,155,498, INT. CL. 36.
- GARAGA INC., ST-GEORGES DE BEAUCE, CANADA:
4,152,547, PUB. 3-20-2012. INT. CL. 6.
- GARCIA, ANTONIO, SYILMAR, CA:
4,155,331, INT. CL. 25.
- GARCIA, BERNARDO BALDERRAMA, SINALOA, MEXICO:
4,154,449, MULTIPLE CLASS, INT. CLS. 30 AND 40.
- GARCIA, RICHARD, MISSION VIEJO, CA:
4,153,696, PUB. 3-20-2012. INT. CL. 41.
- GARDENS OF TAXCO, INC., WEST HOLLYWOOD, CA:
2,998,916, CANC. INT. CL. 30.
- GARDETTO'S BAKERY, INC., MINNEAPOLIS, MN:
4,153,818, PUB. 3-20-2012. INT. CL. 30.
- GARDNER, GREG, LIHUE, HI:
2,562,932, REN. 5-2-12. INT. CL. 16.
- GARLAND COMPANY, INC., THE, CLEVELAND, OH:
2,692,755, REN. 5-2-12. INT. CL. 19.
- GARMIN SWITZERLAND GMBH, SCHAFFHAUSEN, SWITZERLAND, DYNASTREAM INNOVATIONS INC., COCHRANE, ALBERTA TOL OW3, CANADA:
2,650,974, REN. 4-30-12. INT. CL. 9.
- GARMIN SWITZERLAND GMBH, SCHAFFHAUSEN, SWITZERLAND:
4,155,187, INT. CL. 9.
- GARRETT, MEREDITH, LOS ANGELES, CA:
4,153,903, PUB. 3-20-2012. INT. CL. 25.
- GARY LEGATOR, IRVINE, CA:
4,153,159, PUB. 3-20-2012. INT. CL. 25.
- GASEOSAS COLOMBIANAS S.A., MEDELLIN, COLOMBIA:
4,152,554, PUB. 3-20-2012. INT. CL. 32.
- GASPARI NUTRITION, INC., LAKEWOOD, NJ:
4,154,566, INT. CL. 5.
- GATEHOUSE MEDIA ILLINOIS HOLDINGS II, INC., FAIRPORT, NY:
1,213,886, REN. 5-2-12. INT. CL. 16.
- GATES CORPORATION, THE, DENVER, CO:
2,602,541, REN. 5-2-12. INT. CL. 35.
- GATTEFOSSE SAS, SAINT-PRIEST, FRANCE, ETABLISSEMENTS GATTEFOSSE SOCIETE ANONYME, SAINT-PRIEST, RHONE, FRANCE:
934,777, REN. 4-27-12. U.S. CL. 6 (INT. CLS. 1, 2, 3, 4 AND 5).
- GAUMARD SCIENTIFIC COMPANY, INC., MIAMI, FL:
1,709,751, REN. 5-1-12. INT. CL. 9.
2,659,134, REN. 5-1-12. INT. CL. 9.
- GAY COFFEE, WILLIAMSBURG, MA:
4,155,739, INT. CL. 30.
- GAYLORD DESIGN CORP., CHUNGLI, TAOYUAN, TAIWAN:
2,574,867, REN. 4-27-12. MULTIPLE CLASS, INT. CLS. 6, 20, 21, 28 AND 42.
- GAZELLES, INC., ASHBURN, VA:
2,642,397, REN. 4-30-12. INT. CL. 41.
- GE HEALTHCARE LIMITED, BUCKINGHAMSHIRE, UNITED KINGDOM:
4,154,635, INT. CL. 5.
- GEAR DOG LLC, KENNESAW, GA:
4,155,794, INT. CL. 5.
- GEBLER, KATHRYN, BELL CANYON, CA:
4,154,714, INT. CL. 9.
- GECOFIN S.P.A., ITALY:
4,152,285, PUB. 3-20-2012. MULTIPLE CLASS, INT. CLS. 7 AND 42.
- GEISLER, ANNA C., WAYZATA, MN:
2,562,503, REN. 5-3-12. INT. CL. 18.
- GEISTWERK, LLC, SAN DIEGO, CA:
4,153,824, PUB. 3-20-2012. INT. CL. 39.
- GEKKEIKAN SAKE COMPANY, LTD., FUSHIMI-KU, KYOTO, JAPAN:
2,491,874, CANC. INT. CL. 33.
- GELLER, ANA L., NEW YORK, NY:
4,153,791, PUB. 3-20-2012. INT. CL. 25.
- GENAL STRAP, INC., LONG ISLAND CITY, NY:
4,154,700, INT. CL. 9.
- GENERAL CHEMICAL PERFORMANCE PRODUCTS LLC, PARSIPPANY, NJ:
4,153,063, PUB. 3-20-2012. INT. CL. 1.
- GENERAL CHEMICAL PERFORMANCE PRODUCTS, LLC, PARSIPPANY, NJ:
4,153,138, PUB. 3-20-2012. INT. CL. 1.
- GENERAL CIGAR CO., INC., RICHMOND, VA, SEYCHER, LUTGARDA GENER Y, BARCELONA, SPAIN:
86,340, REN. 5-1-12. U.S. CL. 17 (INT. CL. 34).
- GENERAL ELECTRIC COMPANY, SCHENECTADY, NY:
4,154,837, INT. CL. 42.
4,155,159, MULTIPLE CLASS, INT. CLS. 9, 37 AND 42.
4,155,370, INT. CL. 36.
- GENERAL FINANCE SUPPLY SOURCE, INC., PASADENA, CA:
4,155,962, INT. CL. 16.
- GENERAL GENETICS, INC., EL PASO, TX:
4,153,439, PUB. 3-20-2012. INT. CL. 5.
- GENERAL MEDIA COMMUNICATIONS, INC., BOCA RATON, FL:
4,154,587, INT. CL. 32.
- GENERAL MILLS, INC., MINNEAPOLIS, MN:
4,155,593, INT. CL. 30.
- GENERAL MOTORS LLC, DETROIT, MI:
1,683,886, REN. 5-1-12. INT. CL. 28.
- GENERAL SALES AND SERVICE, INC., DECATUR, MI:
2,493,122, CANC. INT. CL. 1.
- GENERATIONS COMMUNITY WELLNESS CENTERS, SUNNYVALE, CA:
4,154,392, MULTIPLE CLASS, INT. CLS. 41 AND 44.
- GENEROUS ART, LLC, AUSTIN, TX:
4,155,139, INT. CL. 36.
- GENESIS COMMUNICATIONS II, INC., LARGO, FL:
4,152,065, PUB. 3-20-2012. INT. CL. 41.
- GENETIC HORIZONS GROUP, INCORPORATED, MADISON, WI:
2,492,516, CANC. INT. CL. 35.
- GENNCO INT'L INC., WHEELING, IL:
2,493,166, CANC. INT. CL. 14.
- GENWORTH FINANCIAL WEALTH MANAGEMENT, INC., PLEASANT HILL, CA:
4,155,087, INT. CL. 36.
4,155,088, INT. CL. 36.
- GEO-TECH SERVICES, LLC, LAREDO, TX:
4,153,248, PUB. 3-20-2012. INT. CL. 1.
4,153,249, PUB. 3-20-2012. INT. CL. 1.
- GEOCEL CORPORATION, ELKHART, IN:
2,492,973, CANC. INT. CL. 17.
- GEOEYE IMAGERY COLLECTION SYSTEMS INC., DULLES, VA:
4,155,048, INT. CL. 9.
4,155,049, INT. CL. 16.
4,155,050, INT. CL. 35.
4,155,051, INT. CL. 42.
- GEOFFREY, LLC, WAYNE, NJ:
2,998,915, CANC. INT. CL. 28.
- GEOFROY, DAVID R, DORAL, FL:
4,154,026, PUB. 3-20-2012. INT. CL. 5.
- GEORGIA-PACIFIC CHEMICALS LLC, ATLANTA, GA:
1,235,559, REN. 5-1-12. INT. CL. 1.
- GEORGIA-PACIFIC CORPORATION, ATLANTA, GA:
2,998,911, CANC. INT. CL. 35.
- GERMAINE LABORATORIES, INC., SAN ANTONIO, TX:
2,704,436, REN. 5-1-12. INT. CL. 5.

GERSON & GERSON, INC., NEW YORK, NY:
4,152,607, PUB. 3-20-2012. INT. CL. 25.

GESAT GESELLSCHAFT FÜR SOFTWARE, AUTOMATISIERUNG + TECHNIK MBH, FED REP GERMANY:
4,152,349, PUB. 3-20-2012. INT. CL. 38.

GET YOUR MOTIVATION ON, EVERGREEN PARK, IL:
4,155,006, INT. CL. 25.

GF HEALTH PRODUCTS, INC., ATLANTA, GA, AKA GRAHAM FIELD:
2,631,187. REN. 5-1-12. INT. CL. 10.

GIACCHINO, RICARDO ARMANDO, C100AAT BUENOS AIRES, ARGENTINA:
1,687,302. REN. 4-28-12. INT. CL. 35.

GID DEVELOPMENT CORPORATION, YORBA LINDA, CA:
4,155,617, INT. CL. 9.

GIFT OF LIFE BONE MARROW FOUNDATION, INC., BOCA RATON, FL:
4,153,003, PUB. 3-20-2012. INT. CL. 35.
4,153,006, PUB. 3-20-2012. INT. CL. 35.
4,153,008, PUB. 3-20-2012. INT. CL. 35.

GIFTCRAFT LTD., BRAMPTON, CANADA:
4,152,091, PUB. 3-20-2012. MULTIPLE CLASS, INT. CLS. 4, 6, 9, 11, 20, 21 AND 28.

GIFTS IN KIND INTERNATIONAL, ALEXANDRIA, VA:
2,492,267, CANC. INT. CL. 42.

GILBERT, STEPHEN, SPOKANE, WA:
4,154,676, INT. CL. 6.

GILCHRIST & SOAMES, INC., INDIANAPOLIS, IN, KANDELL DESIGNS, LTD., GIBBSBORO, NJ:
1,162,380. REN. 5-3-12. INT. CL. 3.

GILLETTE COMPANY, THE, BOSTON, MA:
2,593,030. REN. 5-3-12. INT. CL. 8.
2,622,303. REN. 5-3-12. INT. CL. 8.

GILSTER-MARY LEE CORPORATION, CHESTER, IL, KITCHEN ART FOODS, INC., CHICAGO, IL:
558,182. REN. 5-1-12. U.S. CL. 46 (INT. CL. 30).

GIORDANO VINI S.P.A., CUNEO, ITALY:
4,049,577, COR. MULTIPLE CLASS, INT. CLS. 29 AND 30.

GIOVACCHINI, CINDY L., GROVER BEACH, CA:
4,155,230, INT. CL. 35.

GIOVANE LTD., NEW YORK, NY:
1,720,137. REN. 5-2-12. INT. CL. 14.

GIOVANNI HOLDINGS, LLC, LINDON, UT:
4,153,000, PUB. 3-20-2012. INT. CL. 41.

GKRADIO, LLC, REYNOLDSBURG, OH, DBA GOOD KARMA RADIO:
4,154,070, PUB. 3-20-2012. INT. CL. 38.

GL & LL OF O.C., LLC, OCEAN CITY, MD:
4,155,889, INT. CL. 21.

GLASS, BARBARA W., SHEFFIELD, MA, AKA BOBBIE GLASS:
2,492,161, CANC. INT. CL. 41.

GLEN A. MCCOY, GLEN ALLEN, VA:
4,153,725, PUB. 3-20-2012. INT. CL. 28.

GLEN ELLYN INDUSTRIES, LLC, GLEN ELLYN, IL:
2,998,673, CANC. INT. CL. 16.

GLJR WINE LLC, NAPA, CA:
4,155,210, INT. CL. 33.

GLOBAL ABRASIVE PRODUCTS, INC., LOCKPORT, NY:
2,492,608, CANC. INT. CL. 7.

GLOBAL BENEFITS GROUP, INC., FOOTHILL RANCH, CA:
4,152,925, PUB. 12-13-2011. INT. CL. 36.

GLOBAL DENTAL SOLUTIONS, L.L.C., ATLANTA, GA:
2,694,063. REN. 4-27-12. INT. CL. 10.

GLOBAL EYE CLINIC, INC., PALATINE, IL:
4,153,067, PUB. 3-20-2012. INT. CL. 45.

GLOBAL PERFORMANCE GROUP, INC., CABOT, AR:
4,154,841, INT. CL. 29.
4,154,842, INT. CL. 29.

GLOBAL PROMOTIONS, INC., NEW PORT RICHEY, FL:
4,153,504, PUB. 3-20-2012. MULTIPLE CLASS, INT. CLS. 9 AND 45.

GLOBAL SURF TRAVEL PTY LTD., MIAMI, QUEENSLAND 4220, AUSTRALIA:
3,099,759, CANC. INT. CL. 39.

GLOBAL TOTAL OFFICE,, DOWNSVIEW ONTARIO, CANADA:
2,491,903, CANC. INT. CL. 20.

GLOBAL UNIT CO., LTD., JAPAN:
4,040,454, COR. INT. CL. 25.

GLOBAL VILLAGE KIDS, LLC, LA MESA, CA:
4,153,971, PUB. 3-20-2012. INT. CL. 9.

GLORIA MED S.P.A., ITALY:
4,152,398, PUB. 3-20-2012. MULTIPLE CLASS, INT. CLS. 10 AND 25.
4,152,404, PUB. 3-20-2012. MULTIPLE CLASS, INT. CLS. 10, 25 AND 35.
4,152,416, PUB. 3-20-2012. MULTIPLE CLASS, INT. CLS. 3, 5, 10 AND 25.

GLUKIES, ROBBINSVILLE, NJ:
4,153,743, PUB. 3-20-2012. INT. CL. 5.

GLV FINANCE HUNGARY KFT., ACTING THROUGH ITS LUXEMBOURG BRANCH, MUNSBACH, LUXEMBOURG:
4,152,679, PUB. 3-20-2012. INT. CL. 7.

GMC SOFTWARE AG, SWITZERLAND:
4,152,286, PUB. 3-20-2012. MULTIPLE CLASS, INT. CLS. 9, 38 AND 42.

GMH INTERNATIONAL INC., BELMONT, MA, DBA CIGNIFI:
4,153,274, PUB. 3-20-2012. INT. CL. 35.

GN RESOUND A/S, DENMARK:
4,152,422, PUB. 3-20-2012. INT. CL. 9.

GNM GROUP, LLC, HOUSTON, TX:
4,155,975, INT. CL. 9.

GO TROPPO, INC., BROOKLINE, MA:
4,155,264, INT. CL. 30.

GOLAN HEIGHTS WINERY LTD., GOLAN HEIGHTS, ISRAEL:
4,154,902, INT. CL. 33.

GOLD-DWORKIN, HEIDI, MILFORD, CT:
4,152,797, PUB. 3-20-2012. INT. CL. 41.

GOLDEN & ASSOCIATES CONSTRUCTION, LLC, BIRMINGHAM, AL:
2,695,828. REN. 4-30-12. INT. CL. 37.

GOLDEN CLASS AUTO ENTERPRISES INC., SAN DIMAS, CA:
4,153,813, PUB. 3-20-2012. INT. CL. 37.

GOLDEN PRODUCTS LLC., HOWARD BEACH, NY:
4,154,428, INT. CL. 3.

GOLDEN STAR INC., KANSAS CITY, MO:
4,153,563, PUB. 3-20-2012. MULTIPLE CLASS, INT. CLS. 5, 21 AND 24.

GOLDEN TRIM SPORTS, INC., LOS ANGELES, CA:
4,152,871, PUB. 3-20-2012. INT. CL. 25.

GOLFMIX, INC., PHOENIX, AZ:
4,152,648, PUB. 2-28-2012. MULTIPLE CLASS, INT. CLS. 41 AND 45.

GOLFTEC INTELLECTUAL PROPERTY LLC, CENTENNIAL, CO:
4,152,893, PUB. 3-20-2012. MULTIPLE CLASS, INT. CLS. 38 AND 41.

GOLTERMAN & SABO, INC., ST. LOUIS, MO:
4,153,252, PUB. 3-20-2012. INT. CL. 17.

GONZAGARREDI SOCIETA' COOPERATIVA, GONZAGA (MANTOVA), ITALY:
4,152,365, PUB. 3-20-2012. MULTIPLE CLASS, INT. CLS. 16, 20 AND 28.

GOOD BY NATURE LLC, CRESTWOOD, IL:
4,155,908, INT. CL. 3.

GOOD NEWS PUBLISHERS, WHEATON, IL:
4,153,642, PUB. 3-20-2012. INT. CL. 9.
4,153,721, PUB. 3-20-2012. INT. CL. 16.

GOOD SPORT PLUS LTD., INGLEWOOD, CA:
4,153,312, PUB. 3-20-2012. INT. CL. 41.

GOOD THINGS HEALTH, LLC, KANSAS CITY, MO:
2,558,301. REN. 4-27-12. INT. CL. 5.

GOODBIDDING FOUNDATION, INC., RAYTOWN, MO:
4,152,689, PUB. 3-20-2012. INT. CL. 35.

GOODING III, WILLIAM RONEL, MONCKS CORNER, SC, DBA HUNTING WITH A HERO:
4,152,130, PUB. 3-20-2012. INT. CL. 41.

- GOODING, MELISSA, NEW YORK, NY:
4,153,546, PUB. 3-20-2012. INT. CL. 41.
- GOODRICH, ROBERT, AMARILLO, TX:
4,154,316, INT. CL. 35.
- GOODWIN, ROBERT W., BELLINGHAM, WA:
4,154,951, INT. CL. 20.
- GOODWINOL PRODUCTS CORPORATION, PIERCE, CO,
VETREE PRODUCTS LTD., EAST NORTHPORT, NY:
1,457,962. REN. 5-2-12. INT. CL. 5.
- GOODYEAR TIRE & RUBBER COMPANY, THE, AKRON,
OH:
2,492,427, CANC. INT. CL. 17.
- GOOGLE INC., MOUNTAIN VIEW, CA:
4,154,185, PUB. 3-20-2012. MULTIPLE CLASS, INT. CLS.
35 AND 42.
- GORDINI U.S.A. INC., ESSEX JUNCTION, VT:
4,155,086, MULTIPLE CLASS, INT. CLS. 21 AND 28.
- GOSS INTERNATIONAL CORPORATION, DURHAM, NH:
2,491,777, CANC. MULTIPLE CLASS, INT. CLS. 7 AND 9.
- GOT SHADES, INC., EL MONTE, CA:
4,155,518, INT. CL. 18.
- GOTEC GORSCHLUETER GMBH, FED REP GERMANY:
4,152,410, PUB. 3-20-2012. MULTIPLE CLASS, INT. CLS.
1, 6 AND 40.
- GOTFREDSON, MICHAEL B., LA JOLLA, CA:
4,154,082, PUB. 3-20-2012. INT. CL. 41.
- GOTTSCHALK, DAVE, DENVER, CO, DBA INCOMER-
CIALS LLC:
4,153,970, PUB. 3-20-2012. INT. CL. 35.
- GOULD, CHERYL, SAN DIEGO, CA, DBA IMAGINE THE
GOOD:
4,153,093, PUB. 3-20-2012. INT. CL. 41.
- GOURMET PILGRIM PTY LTD, MELROSE PARK NSW,
AUSTRALIA:
4,152,603, PUB. 3-20-2012. MULTIPLE CLASS, INT. CLS.
16 AND 41.
- GOUYEA'S & PURITY FOODS, INC., HONOLULU, HI:
4,155,044, INT. CL. 30.
- GOVDEALS, INC., MONGOMERY, AL:
2,563,067. REN. 5-2-12. MULTIPLE CLASS, INT. CLS. 35,
36, 38 AND 41.
- GOVERNMENT TRANSACTION SERVICES, INC., VIENNA,
VA:
4,155,533, INT. CL. 42.
- GOVERNMENTAL AND EDUCATIONAL ASSISTANCE
CORP., HOPKINS, MN:
4,154,943, MULTIPLE CLASS, INT. CLS. 43 AND 45.
- GOYA FOODS, INC., SECAUCUS, NJ:
1,687,258. REN. 4-30-12. INT. CL. 29.
- GPAMAXX LLC, BOULDER, CO:
4,155,608, INT. CL. 41.
- GPRA STRATEGIC MANAGEMENT, INC., SILVER
SPRING, MD:
4,155,851, INT. CL. 35.
- GRABOWSKI, CAREY, CRANSTON, RI:
4,153,737, PUB. 3-20-2012. INT. CL. 25.
- GRABZOOM PTY LTD, AUSTRALIA:
4,152,233, PUB. 3-20-2012. INT. CL. 12.
- GRACE LITES CORPORATION, TEMECULA, CA:
4,154,665, INT. CL. 35.
- GRAND VISION GAMING, LLC, BILLINGS, MT:
4,154,963, INT. CL. 9.
- GRANDE CHEESE COMPANY, BROWNSVILLE, WI:
2,560,176. REN. 4-27-12. MULTIPLE CLASS, INT. CLS. 35,
39 AND 42.
- GRANFORS, MELANIE, MOUNTLAKE TERRACE, WA:
4,155,224, INT. CL. 44.
- GRANGE MUTUAL CASUALTY COMPANY, COLUMBUS,
OH:
2,581,236. REN. 5-2-12. INT. CL. 36.
2,587,539. REN. 5-2-12. INT. CL. 36.
- GRANT, KYLE D, JACKSONVILLE, FL:
4,152,972, PUB. 3-20-2012. INT. CL. 37.
- GRAPHIC PACKAGING CORPORATION, MARIETTA, GA:
2,569,190. REN. 5-3-12. INT. CL. 16.
- GRAPHIC PACKAGING INTERNATIONAL, INC., MAR-
IETTA, GA:
2,616,500. REN. 5-3-12. INT. CL. 16.
- GRAPHIK DIMENSIOONS, LTD., HIGH POINT, NC:
4,152,683, PUB. 3-20-2012. MULTIPLE CLASS, INT. CLS.
16 AND 20.
- GRASSROOTS COMMUNICATIONS, INC., PALM DESERT,
CA:
2,998,921, CANC. INT. CL. 38.
- GRATITUDE SEASHELLS, LLC, WEST BLOOMFIELD, MI:
4,152,697, PUB. 3-20-2012. INT. CL. 16.
- GRAVITY TECHNOLOGIES, SAN FRANCISCO, CA:
4,155,850, INT. CL. 42.
- GREAT NECK SAW MANUFACTURERS, INC., MINEOLA,
NY:
2,560,683. REN. 5-2-12. INT. CL. 9.
- GREAT OUTDOOR NETWORK, INC., PORT ST. LUCIE, FL:
4,153,442, PUB. 3-20-2012. INT. CL. 38.
- GREE ELECTRIC APPLIANCES, INC. OF ZHUHAI, CHINA:
4,152,228, PUB. 3-20-2012. MULTIPLE CLASS, INT. CLS.
7, 9, 11, 16, 35 AND 37.
- GREEN FUSE BOTANICALS, INC., SANTA MONICA, CA:
4,155,326, INT. CL. 31.
- GREEN LIGHT INITIATIVE CORP., LONG ISLAND CITY,
NY:
4,152,595, PUB. 3-20-2012. INT. CL. 42.
- GREEN STREET DEVELOPMENT, LLC, SCOTTSDALE, AZ:
4,155,401, INT. CL. 41.
4,155,402, INT. CL. 35.
4,155,404, INT. CL. 35.
- GREEN TURTLE AMERICAS LTD., CHARLOTTE, NC:
4,152,714, PUB. 3-20-2012. INT. CL. 11.
4,152,715, PUB. 3-20-2012. INT. CL. 11.
- GREEN, NICHOLAS TYLER, BOLLINGBROOK, IL:
4,153,505, PUB. 3-20-2012. INT. CL. 41.
- GREENBAUM, KENNETH S, BELLEVUE, WA:
4,153,299, PUB. 3-20-2012. INT. CL. 42.
- GREENBEV LLC, ATLANTA, GA:
4,152,687, PUB. 3-20-2012. INT. CL. 42.
- GREENFIELD MANUFACTURING, INC., SARATOGA
SPRINGS, NY:
4,155,943, INT. CL. 2.
- GREENVITY COMMUNICATIONS, INC., MILPITAS, CA:
4,155,585, INT. CL. 9.
- GREER, DUDLEY, TOLLESON, AZ:
1,195,325. REN. 5-2-12. INT. CL. 31.
- GREGORY GARRETT, NEWPORT NEWS, VA:
4,155,444, INT. CL. 31.
- GREINER VIBROGRAF AG, SWITZERLAND:
4,152,229, PUB. 3-20-2012. MULTIPLE CLASS, INT. CLS.
1, 7, 8, 9, 11, 14, 35 AND 42.
- GREYSTAR PRODUCTS, INC., SAN JUAN CAPISTRANO,
CA:
4,155,305, INT. CL. 21.
- GRIDSENSE INC., WEST SACRAMENTO, CA:
4,154,904, INT. CL. 9.
- GRIFFITH, ROBERT, KIMBERLY, ID, DBA HOMESTYLE
DIRECT:
2,503,626. REN. 4-27-12. MULTIPLE CLASS, INT. CLS. 29
AND 39.
- GRIFOLS, S.A., BARCELONA, SPAIN:
4,153,005, PUB. 1-31-2012. INT. CL. 10.
- GRIP COLLECTIONS, INC., BROOKLYN, NY:
4,154,256, INT. CL. 25.
- GROHE AG, 58675 HEMER, FED REP GERMANY:
4,152,634, PUB. 1-17-2012. INT. CL. 11.
- GROOV-PIN CORPORATION, SMITHFIELD, RI, NEWTON
INSERT CO., LOS ANGELES, CA:
732,353. REN. 5-1-12. U.S. CL. 13 (INT. CL. 6).
- GROSS, DENNIS F., NEW YORK, NY:
2,493,178, CANC. INT. CL. 3.
- GROSS, KEITH, ATLANTA, GA AND MARR, SCOTT,
ATLANTA, GA:
4,153,464, PUB. 3-20-2012. INT. CL. 37.
- GROSSMAN MEDICAL GROUP, INC., SHERMAN OAKS,
CA:
2,492,672, CANC. INT. CL. 42.
- GROUCHO'S FRANCHISE SYSTEMS, LLC, COLUMBIA, SC:
2,700,771. REN. 5-1-12. INT. CL. 30.

GROUP III INTERNATIONAL LTD., INC., POMPAÑO BEACH, FL:
4,155,410, INT. CL. 18.

GROUPE LACASSE LLC, HOLLAND, MI:
2,998,944, CANC. INT. CL. 20.

GROUPLAGIC, INC., ARLINGTON, VA:
4,155,147, INT. CL. 9.

GROWTH TECHNOLOGY LTD, TAUNTON TA2 6BX, UNITED KINGDOM:
4,155,961, INT. CL. 1.

GROWTH-FOCUSED LIVING, INC., ROGERS, AR:
4,154,623, INT. CL. 41.

GROZ-BECKERT KG, ALBSTADT, FED REP GERMANY:
2,491,868, CANC. INT. CL. 26.

GRUPO BIMBO, S.A. B. DE C.V., MEXICO CITY, MEXICO:
2,999,037, CANC. INT. CL. 30.

GRUPO PENAFLORES S.A., BUENOS AIRES, ARGENTINA:
4,154,465, INT. CL. 33.

GRUPO YBARRA ALIMENTACION, S.L., DOS HERMANAS-SEVILLA, SPAIN:
2,609,556, REN. 5-3-12, INT. CL. 30.

GRUPO YSANT C.A, EL HATILLO, MIRANDA, VENEZUELA:
4,155,583, INT. CL. 16.
4,155,584, INT. CL. 16.

GSENSE INC., BRIARCLIFF MANOR, NY:
4,155,093, INT. CL. 35.
4,155,094, INT. CL. 35.

GSTAAD SAANENLAND TOURISMUS, GSTAAD, SWITZERLAND:
4,152,507, PUB. 3-20-2012, MULTIPLE CLASS, INT. CLS. 3, 7, 9, 11, 12, 14, 16, 18, 20, 21, 22, 28, 29, 30, 33, 34, 35, 39, 41, 43 AND 44.

GT VIRTUAL CONCEPTS LLC, NEWNAN, GA:
4,154,790, MULTIPLE CLASS, INT. CLS. 13 AND 42.

GUALA DISPENSING S.P.A., 15047 ALESSANDRIA, ITALY:
2,590,576, REN. 4-30-12, INT. CL. 21.

GUANGDONG JIADA ELECTRONIC TECHNOLOGY HOLDING CO., LTD., SHANTOU CITY, CHINA:
4,152,353, PUB. 3-20-2012, INT. CL. 28.

GUANGDONG YINGAO KITCHEN UTENSILS CO., LTD., SHUNDE, FOSHAN, CHINA:
4,155,283, INT. CL. 11.
4,155,284, INT. CL. 21.

GUANGDONG YINGNAIER APPAREL COMPANY LIMITED, GUANG DONG PROVINCE, CHINA:
4,153,194, PUB. 3-20-2012, INT. CL. 25.

GUANGZHOU CANUDILO FASHION & ACCESSORIES CO., LTD., GUANGZHOU, GUANGDONG, CHINA:
4,155,095, INT. CL. 18.
4,155,096, INT. CL. 25.

GUARINO, JOSEPH M., TRENTON, NJ:
4,154,576, INT. CL. 9.

GUERRERO HOWE, LLC, CHICAGO, IL:
4,155,234, INT. CL. 16.

GUIGNARD COMPANY, LONGWOOD, FL:
4,153,335, PUB. 3-20-2012, INT. CL. 36.

GUILLA BOYZ ENTERTAINMENT, CENTRALIA, IL:
4,152,900, PUB. 3-20-2012, INT. CL. 41.

GULF PUBLISHING COMPANY, HOUSTON, TX:
4,154,059, PUB. 3-20-2012, INT. CL. 35.

GULF SHORE PUBLISHING COMPANY, INC., NAPLES, FL TO PITTSBURGH HOME & GARDEN SHOW, INC., PITTSBURGH, PA:
1,659,694, CANC. INT. CL. 16.

GUMGUM, INC., SANTA MONICA, CA:
4,153,807, PUB. 3-20-2012, INT. CL. 35.

GUNDERSEN LUTHERAN MEDICAL FOUNDATION, INC., LA CROSSE, WI:
4,153,765, PUB. 3-20-2012, INT. CL. 41.

GUNDERSEN LUTHERAN MEDICAL FOUNDATION, INC., LACROSSE, WI:
4,154,199, PUB. 3-20-2012, INT. CL. 41.

GUNSTER, YOAKLEY & STEWART, P.A., WEST PALM BEACH, FL:
4,155,254, INT. CL. 45.

GUNTHER SCHLINK GMBH, BAD KREUZNACH, FED REP GERMANY:
2,999,054, CANC. INT. CL. 33.

GUTEKUNST, BRENT L. SAN DIEGO, CA:
4,154,098, PUB. 3-20-2012, INT. CL. 42.
4,154,151, PUB. 3-20-2012, INT. CL. 33.

GUTHY-RENKER LLC, PALM DESERT, CA:
4,154,906, U.S. CL. 200.
4,155,383, INT. CL. 5.

GXP CONSULTING LLC, SAN FRANCISCO, CA, DBA GXP CONSULTING LLC:
4,154,024, PUB. 3-20-2012, INT. CL. 41.

GYPSY 05, INC., LOS ANGELES, CA:
4,153,145, PUB. 3-20-2012, INT. CL. 25.

H & H CLOTHING, LLC, LAS VEGAS, NV:
4,154,807, MULTIPLE CLASS, INT. CLS. 9, 18, 25 AND 35.

H & S ASSOCIATES, INC., TROY, MI:
4,153,885, PUB. 3-20-2012, INT. CL. 41.
4,154,095, PUB. 3-20-2012, INT. CL. 41.

H. LEE MOFFITT CANCER CENTER AND RESEARCH INSTITUTE, INC., TAMPA, FL, AKA MOFFITT CANCER CENTER:
4,155,805, INT. CL. 44.

H.H. BROWN SHOE COMPANY, INC., GREENWICH, CT:
4,154,377, INT. CL. 25.

H.J. MARTIN AND SON, INC., GREEN BAY, WI:
2,687,959, REN. 4-30-12, MULTIPLE CLASS, INT. CLS. 19 AND 37.

H.O.C. WINE INC., NEW YORK, NY:
4,153,253, PUB. 3-20-2012, INT. CL. 43.

H&H ASIA LTD., TAIPEI, TAIWAN:
4,154,705, MULTIPLE CLASS, INT. CLS. 8 AND 21.

HACHETTE FILIPACCHI PRESSE, LEVALLOIS-PERRET CEDEX, FRANCE:
4,154,861, INT. CL. 14.

HADLEY, INC., THERMAL, CA:
2,492,412, CANC. INT. CL. 29.

HAESUNG ENTERPRISE CO., LTD., BUSAN, REPUBLIC OF KOREA:
4,153,242, PUB. 3-20-2012, INT. CL. 28.
4,153,244, PUB. 3-20-2012, INT. CL. 28.

HAGELE, JAMES, NEVADA CITY, CA:
2,998,980, CANC. INT. CL. 10.

HAGEMEYER NORTH AMERICA, INC., ALPHARETTA, GA:
2,998,646, CANC. INT. CL. 21.

HAGN, CLAUDIA, ROSENGARTEN, FED REP GERMANY:
4,154,319, MULTIPLE CLASS, INT. CLS. 24 AND 25.

HAHN, MARLA R., MILWAUKEE, WI:
4,155,671, INT. CL. 41.

HAIDER, SAM, BRAMPTON, ONTARIO, CANADA:
4,154,052, PUB. 3-20-2012, INT. CL. 30.

HAIR PROSTHESIS INSTITUTE, NASHVILLE, TN:
4,152,506, PUB. 3-20-2012, INT. CL. 44.

HAJI, BEHNAM, BANGKOK, THAILAND:
4,153,920, PUB. 3-20-2012, INT. CL. 45.

HALF RUBBER, L.L.C., CHARLESTON, SC:
2,653,038, REN. 4-27-12, INT. CL. 28.

HALF RUBBER, LLC, CHARLESTON, SC:
2,620,669, REN. 4-27-12, INT. CL. 28.

HALL ENGINEERING GROUP, INC., TAMPA, FL:
4,154,068, PUB. 3-20-2012, INT. CL. 42.

HALLMARK HARDWOODS, INC., ONTARIO, CA:
4,153,450, PUB. 3-20-2012, INT. CL. 19.
4,153,451, PUB. 3-20-2012, INT. CL. 19.
4,153,452, PUB. 3-20-2012, INT. CL. 19.

HALO LABS, LLC, NEW YORK, NY:
3,606,961, AM. MULTIPLE CLASS, INT. CLS. 5 AND 32.

HALTER WINERY LLC, PASO ROBLES, CA:
4,155,071, INT. CL. 33.

HAMILTON PARKER COMPANY, LLC, COLUMBUS, OH:
4,153,500, PUB. 3-20-2012, INT. CL. 19.

HAMPTON PRODUCTS INTERNATIONAL CORPORATION, FOOTHILL RANCH, CA:
2,590,408, REN. 4-27-12, MULTIPLE CLASS, INT. CLS. 6, 7 AND 20.
4,153,156, PUB. 3-20-2012, MULTIPLE CLASS, INT. CLS. 7 AND 22.

- HANBITSOFT, INC., SEOUL, REPUBLIC OF KOREA:
4,154,446, INT. CL. 9.
4,154,447, INT. CL. 41.
- HANCE, DONALD, PACIFIC PALISADES, CA:
4,155,365, INT. CL. 45.
- HANCOCK NATURAL RESOURCE GROUP, INC., BOSTON, MA:
2,585,303, REN. 4-30-12, INT. CL. 36.
2,597,921, REN. 4-27-12, INT. CL. 35.
- HANDELABRA STUDIO LLC, UNIVERSITY HEIGHTS, OH:
4,153,930, PUB. 3-20-2012, INT. CL. 9.
- HANFEISE INTERNATIONAL FASHION CO., LTD., DONGGUAN, GUANGDONG, CHINA, DBA HANFEISE INTERNATIONAL CO., LTD.:
4,153,263, PUB. 3-20-2012, INT. CL. 25.
- HANKINS, GARY R., SAN ANTONIO, TX:
1,687,273, REN. 5-1-12, INT. CL. 30.
- HANKOOK TIRE CO., LTD., SEOUL, REPUBLIC OF KOREA:
2,998,561, CANC. INT. CL. 12.
- HANKY PANKY LTD., NEW YORK, NY:
4,155,803, INT. CL. 25.
- HANNA-BARBERA PRODUCTIONS, INC., BURBANK, CA:
2,618,231, REN. 4-28-12, INT. CL. 5.
2,998,576, CANC. INT. CL. 16.
- HANNA, MICHAEL, MIAMI, FL:
4,154,558, INT. CL. 25.
- HANNAH BAJOR, CHESHIRE, CT:
4,155,441, INT. CL. 25.
- HANOVER PREST PAVING COMPANY, HANOVER, PA:
1,696,948, REN. 5-3-12, INT. CL. 19.
- HANSEL 'N GRETEL BRAND, INC., GLENDALE, NY:
2,558,811, REN. 4-27-12, INT. CL. 29.
- HANSEN, CATHY, TEXAS CITY, TX, DBA GLAMPERS AND LYNELL CRAWFORD, TEXAS CITY, TX, DBA GLAMPERS:
4,156,016, INT. CL. 35.
- HANSEN, CHRISTOPHER JOHN, BEVERLY HILLS, CA:
4,154,595, INT. CL. 33.
- HAPPY HILL FARM CHILDREN'S HOME, INC., GRANBURY, TX:
2,559,551, REN. 4-27-12, INT. CL. 35.
- HARBOR FURNITURE MANUFACTURING, INC., ELBERTA, AL:
4,152,060, PUB. 3-20-2012, INT. CL. 2.
4,152,061, PUB. 3-20-2012, INT. CL. 20.
- HARD ROCK CAFE INTERNATIONAL (USA), INC, ORLANDO, FL:
4,154,456, INT. CL. 43.
- HARD ROCK CAFE INTERNATIONAL (USA), INC., ORLANDO, FL:
2,561,989, REN. 4-27-12, INT. CL. 25.
- HARDEE'S FOOD SYSTEMS, INC., ST. LOUIS, MO:
4,156,072, INT. CL. 29.
- HARDWOOD FEDERATION, WASHINGTON, DC, DBA AMERICAN HARDWOODS:
4,152,867, PUB. 3-20-2012, INT. CL. 35.
- HARLEYSVILLE MUTUAL INSURANCE COMPANY, HARLEYSVILLE, PA:
4,152,133, PUB. 3-20-2012, INT. CL. 36.
- HARMONIC DRIVE LLC, PEABODY, MA:
1,727,054, REN. 4-27-12, MULTIPLE CLASS, INT. CLS. 7 AND 9.
- HARMONY HEARTH LLC, BETHESDA, MD:
4,153,347, PUB. 3-20-2012, INT. CL. 41.
- HARNETT, SHAWN, NASHVILLE, TN:
4,153,621, PUB. 3-20-2012, MULTIPLE CLASS, INT. CLS. 9 AND 25.
- HARQEN LLC, MILWAUKEE, WI:
4,154,720, MULTIPLE CLASS, INT. CLS. 35, 38 AND 39.
- HARRELL, RODNEY D, MONTGOMERY, AL:
4,153,369, PUB. 3-20-2012, INT. CL. 25.
- HARRINGTON, SEAN PATRICK, PROVINCETOWN, MA:
4,155,292, INT. CL. 3.
- HARRIS-SHAPIRO, JON, S. ELKINS PARK, PA:
2,660,888, REN. 5-3-12, INT. CL. 42.
- HARRISON, LESLEY, FOSTER CITY, CA:
4,153,200, PUB. 3-20-2012, INT. CL. 40.
- HARTE-HANKS DATA TECHNOLOGIES, INC., SAN ANTONIO, TX:
4,154,645, MULTIPLE CLASS, INT. CLS. 9 AND 42.
- HARTFORD FIRE INSURANCE COMPANY, HARTFORD, CT:
2,492,178, CANC. INT. CL. 16.
4,152,465, PUB. 3-20-2012, INT. CL. 9.
4,152,466, PUB. 3-20-2012, INT. CL. 9.
4,152,975, PUB. 3-20-2012, INT. CL. 36.
- HARVARD MAINTENANCE, INC., NEW YORK, NY:
4,154,958, MULTIPLE CLASS, INT. CLS. 37 AND 45.
- HARVEY, STEVE, HOUSTON, TX:
4,155,779, INT. CL. 41.
- HASBRO, INC., PAWTUCKET, RI:
2,493,258, CANC. INT. CL. 28.
2,998,727, CANC. INT. CL. 28.
- HASTINGS, RAYMOND P., HADDON HEIGHTS, NJ:
4,155,339, INT. CL. 30.
- HATCH, INC., WINSTON-SALEM, NC:
2,493,232, CANC. INT. CL. 9.
- HATCO CORPORATION, MILWAUKEE, WI:
4,155,915, INT. CL. 11.
- HATTERAS ENTERPRISES, INC., TARZANA, CA:
4,152,539, PUB. 3-20-2012, INT. CL. 3.
- HATTERAS HAMMOCKS, INC., GREENVILLE, NC:
2,998,757, CANC. INT. CL. 22.
- HAVAS NORTH AMERICA, INC., NEW YORK, NY:
2,686,201, REN. 4-28-12, INT. CL. 35.
- HAYER ANALYTICS, INC., NEW YORK, NY:
4,153,849, PUB. 3-20-2012, INT. CL. 35.
4,153,867, PUB. 3-20-2012, INT. CL. 38.
4,153,942, PUB. 3-20-2012, INT. CL. 42.
4,153,956, PUB. 3-20-2012, INT. CL. 38.
4,153,969, PUB. 3-20-2012, INT. CL. 9.
- HAWKINS, DUSTIN LEE, SOUTH OGDEN, UT:
4,152,677, PUB. 3-20-2012, INT. CL. 41.
- HAWTHORNE, STEPHANIE, EL MONTE, CA:
4,155,318, INT. CL. 25.
- HAYNES CORPORATION, NAPLES, FL:
4,153,744, PUB. 3-20-2012, INT. CL. 7.
- HAYS, TIM, MATTHEWS, NC:
4,156,064, INT. CL. 12.
- HBI BRANDED APPAREL LIMITED, INC., WINSTON-SALEM, NC:
4,154,967, INT. CL. 25.
- HBIMED AG, CHUR, SWITZERLAND:
4,152,138, PUB. 3-20-2012, MULTIPLE CLASS, INT. CLS. 9, 10 AND 42.
- HDN DEVELOPMENT CORPORATION, WINSTON-SALEM, NC, KRISPY KREME DOUGHNUT CORPORATION, WINSTON-SALEM, NC:
1,683,112, REN. 4-28-12, MULTIPLE CLASS, INT. CLS. 30 AND 42.
- HDS IP HOLDING, LLC, HENDERSON, NV:
4,155,442, INT. CL. 41.
- HEADSPROUT, INC., SEATTLE, WA:
2,998,528, CANC. MULTIPLE CLASS, INT. CLS. 9, 16 AND 41.
- HEADWAY EMOTIONAL HEALTH SERVICES, RICHFIELD, MN:
4,153,596, PUB. 3-20-2012, MULTIPLE CLASS, INT. CLS. 44 AND 45.
- HEALING HEART THERAPY DOGS, INC., CRETE, NE:
4,153,279, PUB. 3-20-2012, INT. CL. 44.
- HEALTH EVER BIO-TECH CO., LTD., TAIPEI, TAIWAN:
4,155,302, INT. CL. 5.
- HEALTHTRONICS, INC., CHADDS FORD, PA:
4,154,119, PUB. 3-20-2012, INT. CL. 44.
- HEALTHY & TASTY VENTURES, LLC, BOCA RATON, FL:
4,153,329, PUB. 3-20-2012, INT. CL. 43.
- HEAL2BFREE, LLC, ASHBURN, VA:
4,153,391, PUB. 3-20-2012, MULTIPLE CLASS, INT. CLS. 41 AND 44.
- HEARTIVATION, LLC, STAMFORD, CT:
4,153,673, PUB. 3-20-2012, INT. CL. 35.
- HEARTLAND PAYMENT SYSTEMS, INC., PRINCETON, NJ:
4,152,876, PUB. 3-20-2012, INT. CL. 36.

HEAT-N-AIR GUYS, DARBY, PA:
4,153,710, PUB. 3-20-2012. INT. CL. 37.

HEAVY MEDITATIONS, LLC, BAYPORT, NY:
4,153,857, PUB. 3-20-2012. INT. CL. 9.

HEB GROCERY COMPANY, LP, SAN ANTONIO, TX:
4,154,311, INT. CL. 5.
4,155,431, INT. CL. 30.

HEFFNER, CARL, SPRINGDALE, AR:
4,153,484, PUB. 3-20-2012. INT. CL. 35.

HEIDSIECK & CO MONOPOLE, 51200 EPERNAY, FRANCE:
2,606,729. REN. 4-30-12. INT. CL. 33.

HEINEKEN ITALIA S.P.A., 11020 POLLEIN (AO), ITALY:
2,998,918, CANC. INT. CL. 32.

HEINZ KAISER LTD., RUMLANG, ZURICH, SWITZERLAND:
1,195,015. REN. 4-27-12. INT. CL. 7.

HEINZ-JOSEF, KAPPE, LOHMAR, FED REP GERMANY:
4,152,577, PUB. 3-20-2012. MULTIPLE CLASS, INT. CLS. 9 AND 11.

HELD GMBH, FED REP GERMANY:
4,152,362, PUB. 3-20-2012. MULTIPLE CLASS, INT. CLS. 9, 12 AND 25.

HELEN OF TROY LIMITED, ST. MICHAEL, BARBADOS:
2,594,681. REN. 5-3-12. INT. CL. 11.

HELENA HOLDING COMPANY, COLLIERVILLE, TN:
2,660,477. REN. 5-2-12. INT. CL. 42.

HENDERSON CO-OP TELEPHONE COMPANY, HENDERSON, NE:
2,700,992. REN. 5-2-12. INT. CL. 38.

HENDRICKSEN, SETH, NEW YORK, NY:
2,492,722, CANC. INT. CL. 9.

HENKEL AG & CO. KGAA, DUESSELDORF, FED REP GERMANY:
568,281. REN. 4-30-12. U.S. CL. 6 (INT. CL. 1).

HENKEL CORPORATION, ROCKY HILL, CT:
1,695,315. REN. 5-2-12. INT. CL. 16.

HENNESSY INDUSTRIES, INC., LAVERGNE, TN:
4,154,254, INT. CL. 9.

HENNESSY, MOLLY DUGAN, ATLANTA, GA:
4,154,778, INT. CL. 26.
4,154,779, INT. CL. 26.
4,154,780, INT. CL. 26.

HENRY DONEGER ASSOCIATES, INC., NEW YORK, NY:
4,154,248, INT. CL. 42.

HENRY, STEVEN C., GENEVA, IL:
2,998,842, CANC. MULTIPLE CLASS, INT. CLS. 9, 35 AND 42.

HER MAJESTY THE QUEEN IN RIGHT OF CANADA, AS REPRESENTED BY THE MINISTER OF INDUSTRY, THROUGH THE COMMUNICATIONS RESEARCH CENTRE CANADA, OTTAWA, ONTARIO, CANADA:
2,572,792. REN. 5-2-12. INT. CL. 9.

HERBALIFE INTERNATIONAL, INC., LOS ANGELES, CA:
4,152,748, PUB. 3-20-2012. MULTIPLE CLASS, INT. CLS. 5 AND 32.

HERFF JONES, INC., INDIANAPOLIS, IN:
2,700,106. REN. 4-27-12. INT. CL. 20.

HERMAN MILLER, INC., ZEELAND, MI:
2,564,212. REN. 4-30-12. INT. CL. 20.

HEROIC RACING APPAREL, LLC, OAKLAND GARDENS, NY:
4,153,679, PUB. 3-20-2012. INT. CL. 25.
4,153,682, PUB. 3-20-2012. INT. CL. 25.

HEROLDT, SCOTT A., PHOENIX, AZ:
4,154,817, INT. CL. 25.

HERON, PETER, C, NEW YORK, NY, DBA I AM NOT A VIRGIN:
4,154,382, INT. CL. 25.

HERONFIELD ACADEMY, HAMPTON FALLS, NH:
4,155,687, INT. CL. 41.

HERRERA, ORLANDO A., HOLLYWOOD, FL AND GOLDMEER, CONSTANCE, HOLLYWOOD, FL AND THE WORLD PEACE PROGRAM, LLC, HOLLYWOOD, FL:
4,154,222, PUB. 3-20-2012. INT. CL. 36.

HERMANN, JOHN, CHIPPEWA FALLS, WI:
4,152,725, PUB. 3-20-2012. INT. CL. 28.

HERSCH AND COMPANY, LOS ANGELES, CA:
4,154,295, INT. CL. 28.

HERSEY, MORGAN, TACOMA, WA:
4,152,997, PUB. 3-20-2012. INT. CL. 28.

HERSHEY CHOCOLATE & CONFECTIONERY CORPORATION, WHEAT RIDGE, CO:
4,152,566, PUB. 3-20-2012. INT. CL. 30.
4,152,610, PUB. 3-20-2012. INT. CL. 30.
4,155,499, INT. CL. 30.

HERZENBERG, JANET, NEW YORK, NY:
4,154,154, PUB. 3-20-2012. INT. CL. 9.

HERZON, RANDALL GARRETT, EUREKA, CA:
4,153,232, PUB. 3-20-2012. INT. CL. 45.
4,153,233, PUB. 3-20-2012. INT. CL. 45.
4,153,234, PUB. 3-20-2012. INT. CL. 41.

HETTICH, DOMINIK, MÜNCHEN, FED REP GERMANY:
4,153,024, PUB. 3-20-2012. INT. CL. 35.

HEWY WINE CHILLERS, LLC, ORLANDO, FL:
4,154,974, INT. CL. 21.

HEXCEL CORPORATION, DUBLIN, CA:
2,559,526. REN. 4-27-12. INT. CL. 17.
2,571,894. REN. 4-27-12. MULTIPLE CLASS, INT. CLS. 6 AND 17.
2,660,046. REN. 4-27-12. INT. CL. 1.

HI-TECH COMPRESSOR & PUMP PRODUCTS, INC., TULLYTOWN, PA:
4,155,403, INT. CL. 7.

HIGH SIERRA SPORT COMPANY, VERNON HILLS, IL:
4,155,035, INT. CL. 18.

HIGH SPEED PRODUCTIONS, INC., SAN FRANCISCO, CA:
2,491,889, CANC. INT. CL. 6.

HIGH, MARIA LOUISE, BALTIMORE, MD, DBA LITTEL BLUE STUDIO:
4,153,492, PUB. 3-20-2012. INT. CL. 35.

HIGH, MARIA LOUISE, BALTIMORE, MD, DBA LITTLE BLUE STUDIO:
4,153,493, PUB. 3-20-2012. MULTIPLE CLASS, INT. CLS. 14 AND 26.

HIGHBRIDGE COMPANY I, LLC, MINNEAPOLIS, MN, HIGHBRIDGE COMPANY, ST. PAUL, MN:
1,734,492. REN. 5-1-12. INT. CL. 9.

HIGHLAND GRAPHICS, INC., SPRINGFIELD, TN:
2,491,765, CANC. INT. CL. 20.

HIGHLAND PRIVATE WEALTH MANAGEMENT, LLC, BELLEVUE, WA:
4,152,859, PUB. 3-20-2012. INT. CL. 36.

HIGHMARK TECHNOLOGIES LLC, FORT WAYNE, IN:
2,559,573. REN. 4-27-12. INT. CL. 20.

HILL-ROM SERVICES, INC., BATESVILLE, IN:
4,154,049, PUB. 3-20-2012. INT. CL. 9.

HILL, ANDREW W, SAN ANTONIO, TX AND NELSON, CHADE V, SAN ANTONIO, TX:
4,152,599, PUB. 3-20-2012. INT. CL. 36.

HILL'S PET NUTRITION, INC., TOPEKA, KS:
2,493,520, CANC. INT. CL. 31.

HILLARD HEINTZE, LLC, CHICAGO, IL:
4,154,029, PUB. 3-20-2012. INT. CL. 45.
4,154,030, PUB. 3-20-2012. INT. CL. 45.

HILLSTONE RESTAURANT GROUP, INC., PHOENIX, AZ:
4,152,890, PUB. 3-20-2012. INT. CL. 43.

HILTON, PARIS, BEVERLY HILLS, CA:
4,154,422, INT. CL. 21.

HILTON, STACEY, WEST COVINA, CA:
4,154,877, INT. CL. 44.

HIMALAYA GLOBAL HOLDINGS LTD., DUBAI, UNITED ARAB EMIR.:
2,701,911. REN. 4-30-12. INT. CL. 5.
2,701,912. REN. 4-30-12. INT. CL. 5.

HINOJOSA RODRIGUEZ, JOSE J., SAN ANTONIO, TX:
1,733,763. REN. 5-2-12. INT. CL. 42.

HIPPOCRATES UNIVERSITY, LAS VEGAS, NV AND ANTONIN HRABAL, LAS VEGAS, NV:
4,152,713, PUB. 3-20-2012. INT. CL. 45.

HIPPOE HOLDINGS, LLC, NEW YORK, NY, DBA CHEEKY SANDWICHES:
4,152,651, PUB. 3-20-2012. INT. CL. 30.

HIREWARE.COM LLC, POTSDAM, NY:
2,592,219. REN. 4-30-12. INT. CL. 35.

- HISPANIC FOOD DISTRIBUTORS, INC., MCALLEN, TX:
2,562,536. REN. 5-3-12. INT. CL. 31.
- HIUT LIMITED, CARDIGAN, CEREDIGION SA43 3DR,
UNITED KINGDOM:
4,152,343. PUB. 3-20-2012. MULTIPLE CLASS, INT. CLS.
16, 18 AND 25.
- HKS INTELLECTUAL PROPERTIES LIMITED, ROAD
TOWN, TORTOLA, BR. VIRGIN ISLANDS:
2,951,152. CANC. INT. CL. 25.
- HLT DOMESTIC IP LLC, MCLEAN, VA:
4,155,106. INT. CL. 43.
- HMH EDUCATION COMPANY LIMITED, DUBLIN, IRE-
LAND, RIVERDEEP INTERACTIVE LEARNING, LTD.,
DUBLIN 2, IRELAND:
2,508,894. REN. 5-1-12. INT. CL. 9.
- HMH IP COMPANY LIMITED, DUBLIN, IRELAND, RIV-
ERDEEP INTERACTIVE LEARNING LIMITED, DUBLIN,
IRELAND:
2,571,790. REN. 4-30-12. INT. CL. 9.
- HNI TECHNOLOGIES INC., MUSCATINE, IA:
2,562,447. REN. 5-3-12. INT. CL. 20.
- HNO GREEN FUELS, INC., TEMECULA, CA:
4,153,922. PUB. 3-20-2012. INT. CL. 11.
- HO-B MAX, DURHAM, NC:
4,154,116. PUB. 3-20-2012. INT. CL. 28.
- HOBBY LOBBY STORES, INC., OKLAHOMA CITY, OK:
4,154,901. INT. CL. 23.
- HOKKAIDO FEDERATION OF FISHERIES COOPERATIVE
ASSOCIATIONS, SAPPORO, HOKKAIDO, JAPAN:
1,725,963. REN. 5-3-12. INT. CL. 29.
- HOLIDAYCHECK AG, SWITZERLAND:
4,152,411. PUB. 3-20-2012. MULTIPLE CLASS, INT. CLS.
35, 38, 39, 41, 42 AND 43.
- HOLLAND & HART LLP, DENVER, CO:
4,155,735. INT. CL. 45.
- HOLLEY PERFORMANCE PRODUCTS INC., BOWLING
GREEN, KY:
2,692,318. REN. 4-28-12. INT. CL. 7.
- HOLLIDAY, LARRY R., BEND, OR:
4,152,668. PUB. 3-20-2012. INT. CL. 9.
- HOLLYWOOD BEAUTY IMPORTS, INC., MIAMI, FL:
1,739,383. REN. 4-27-12. INT. CL. 3.
- HOME DYNAMIX, LLC, MOONACHIE, NJ:
4,153,768. PUB. 3-20-2012. INT. CL. 27.
- HOME HEALTH CARE OF FLORIDA, MELBOURNE, FL:
4,153,532. PUB. 3-20-2012. INT. CL. 44.
- HOME HOUSE LIMITED, LONDON, UNITED KINGDOM:
4,152,476. PUB. 11-29-2011. MULTIPLE CLASS, INT. CLS.
16, 41, 43 AND 45.
- HOMEHOP, NEW YORK, NY:
4,153,992. PUB. 3-20-2012. INT. CL. 43.
- HOMEOCARE LABORATORIES, INC., BRONX, NY:
2,500,560. REN. 4-30-12. INT. CL. 5.
2,510,654. REN. 4-30-12. INT. CL. 5.
- HOMER TLC, INC., CLAYMONT, DE:
2,492,817. CANC. INT. CL. 36.
- HONDA MOTOR CO., LTD., TOKYO, JAPAN:
4,152,157. PUB. 3-20-2012. INT. CL. 12.
- HONEY JUG MARINE SANITATION, INC., CHICAGO, IL:
2,573,438. REN. 5-1-12. INT. CL. 37.
- HONEYWELL INTERNATIONAL INC., MORRISTOWN, NJ,
OHMART CORPORATION, THE, CINCINNATI, OH:
1,730,274. REN. 5-2-12. INT. CL. 9.
- HONEYWELL INTERNATIONAL INC., MORRISTOWN, NJ:
4,154,329. INT. CL. 11.
4,154,529. INT. CL. 9.
4,155,581. INT. CL. 35.
- HOORAY FOR BOOBIES!, INC., NEW YORK, NY:
4,153,996. PUB. 3-20-2012. INT. CL. 25.
- HOOVER'S, INC., AUSTIN, TX:
4,155,912. INT. CL. 35.
- HOP DODDY, LLC, SCOTTSDALE, AZ:
4,153,528. PUB. 3-20-2012. INT. CL. 43.
- HOPE ACRES FARM, LLC, BROGUE, PA:
2,999,048. CANC. MULTIPLE CLASS, INT. CLS. 29 AND
30.
- HOPEGIVERS INTERNATIONAL, INC., COLUMBUS, GA:
4,156,056. INT. CL. 36.
- HORIZON ASSET MANAGEMENT LLC, NEW YORK, NY:
4,153,179. PUB. 3-20-2012. INT. CL. 36.
- HORIZON HOBBY, INC., CHAMPAIGN, IL:
4,152,787. PUB. 3-20-2012. MULTIPLE CLASS, INT. CLS. 9
AND 28.
4,152,879. PUB. 3-20-2012. MULTIPLE CLASS, INT. CLS. 9
AND 28.
- HORIZON TECHNOLOGY, LLC, LAKE FOREST, CA:
4,153,318. PUB. 3-20-2012. INT. CL. 42.
- HORIZONS INCORPORATED, CLEVELAND, OH:
4,154,605. INT. CL. 9.
- HORSCH MASCHINEN GMBH, SCHWANDORF, FED REP
GERMANY:
4,155,927. INT. CL. 7.
4,155,928. INT. CL. 7.
- HORSEAD.COM, EAST AMHERST, NY:
4,155,730. INT. CL. 25.
- HORTON, TODD, FOUNTAIN VALLEY, CA:
2,672,985. REN. 5-3-12. INT. CL. 42.
- HOSCO FITTINGS, LLC, LIVONIA, MI:
2,641,700. REN. 4-30-12. MULTIPLE CLASS, INT. CLS. 9
AND 17.
- HOSLEY INTERNATIONAL, INC., LYNWOOD, IL:
4,154,633. MULTIPLE CLASS, INT. CLS. 3 AND 31.
- HOSPIRA BOULDER, INC., LAKE FOREST, IL, AAIPHAR-
MA LLC, WILLMINGTON, NC:
2,702,155. REN. 5-3-12. INT. CL. 5.
- HOSPITALITY MANAGEMENT GROUP, INC., CHARLES-
TON, SC:
1,695,108. REN. 4-28-12. INT. CL. 42.
- HOSTBROOK S.P.A., FIRENZE, ITALY:
2,491,815. CANC. INT. CL. 32.
- HOSTESS BRANDS, INC., IRVING, TX, CONTINENTAL
BAKING COMPANY, RYE, NY:
732,788. REN. 4-30-12. U.S. CL. 46 (INT. CL. 30).
- HOSTESS BRANDS, INC., IRVING, TX, INTERSTATE
BRANDS CORPORATION, KANSAS CITY, MO:
1,198,991. REN. 4-27-12. INT. CL. 30.
- HOSTESS BRANDS, INC., IRVING, TX:
1,693,366. REN. 5-2-12. INT. CL. 30.
- HOTELS.COM, LP, DALLAS, TX:
3,723,187. AM. INT. CL. 35.
4,154,531. INT. CL. 35.
- HOURLY MEDIA, L.L.C., ROYAL OAK, MI:
4,155,964. INT. CL. 16.
- HOUSEY, AMBER J., TROY, MI:
4,154,501. INT. CL. 16.
- HOWARD, PHILIP, SACRAMENTO, CA:
2,492,248. CANC. INT. CL. 41.
- HPI, LLC, HOUSTON, TX:
4,154,002. PUB. 3-20-2012. INT. CL. 9.
4,154,003. PUB. 3-20-2012. INT. CL. 9.
- HRHH IP, LLC, NEW YORK, NY:
2,498,137. REN. 5-2-12. INT. CL. 42.
2,500,121. REN. 5-3-12. INT. CL. 42.
2,575,472. REN. 5-3-12. INT. CL. 42.
- HRP CREATIVE SERVICES CO., LLC, CELEBRATION, FL:
3,468,491. CANC. INT. CL. 43.
- HSI SERVICE CORP., NEWARK, DE:
3,136,521. COR. INT. CL. 5.
- HUANG, JING, CAMARILLO, CA:
4,153,115. PUB. 3-20-2012. INT. CL. 5.
- HUAWEI TECHNOLOGIES CO., LTD., SHENZHEN, CHINA:
4,155,606. INT. CL. 9.
- HUBBARD, JODINE, SARASOTA, FL, DBA THE OTHER
SIDE OF GOOD:
4,155,648. INT. CL. 28.
- HUBBELL INCORPORATED, ORANGE, CT:
1,195,582. REN. 5-2-12. INT. CL. 9.
- HUBBELL INCORPORATED, ORANGE, CT, HUBBELL
INCORPORATED, ORANGE, CT:
2,566,366. REN. 4-27-12. INT. CL. 9.
- HUDSON RIVER PARK TRUST, NEW YORK, NY:
2,613,971. REN. 5-1-12. INT. CL. 41.
- HUELER INVESTMENT SERVICES, INC., EDEN PRAIRIE,
MN:
4,154,600. INT. CL. 36.

HUGO BOSS; TRADE MARK MANAGEMENT GMBH & CO. KG, FED REP GERMANY:
4,152,164, PUB. 9-7-2010. INT. CL. 3.

HUHOT MONGOLIAN GRILLS, LLC, MISSOULA, MT:
4,152,761, PUB. 3-20-2012. INT. CL. 30.

HUMAN INTELLIGENCE LLC, LEBANON, CT:
4,154,954, INT. CL. 35.

HUMAN RESOURCE CERTIFICATION INSTITUTE, ALEXANDRIA, VA:
2,889,180, COR. INT. CL. 42.
2,934,752, COR. U.S. CL. B.

HUMCO HOLDING GROUP, INC., TEXARKANA, TX:
2,497,783, REN. 5-1-12. INT. CL. 30.
2,497,783, CANC. INT. CL. 3.

HUNGRYGENIUS HOLDING CO., SAN DIEGO, CA:
4,153,082, PUB. 3-20-2012. INT. CL. 35.

HUNTER FAN COMPANY, MEMPHIS, TN:
3,030,884, AM. INT. CL. 11.

HUNTINGTON INGALLS INCORPORATED, NEWPORT NEWS, VA:
2,501,647, REN. 5-2-12. MULTIPLE CLASS, INT. CLS. 37 AND 39.

HYBRID NATION, NORTHFIELD, MN:
4,155,073, INT. CL. 25.

HYBRIDYNE IMAGING TECHNOLOGIES, INC., BLUE BELL, PA:
4,154,364, INT. CL. 10.

HYDROTEX PARTNERS, LTD., FARMERS BRANCH, TX:
2,569,339, REN. 5-2-12. INT. CL. 4.

HYUNDAI HEAVY INDUSTRIES CO., LTD., REPUBLIC OF KOREA:
4,152,314, PUB. 3-20-2012. MULTIPLE CLASS, INT. CLS. 7 AND 9.

I.P. HOLDINGS, INC., GRAND PRAIRIE, TX:
2,491,811, REN. 5-1-12. INT. CL. 16.
2,491,811, CANC. INT. CL. 20.

I.S.E.L., INC., JACKSONVILLE, FL:
4,153,572, PUB. 3-20-2012. INT. CL. 4.

I.SO ITALIA S.P.A., ITALY:
4,095,029, COR. MULTIPLE CLASS, INT. CLS. 10 AND 11.

I-STAR ENTERTAINMENT LLC, GREAT NECK, NY:
4,152,657, PUB. 3-20-2012. INT. CL. 28.

IAN ADRIAN DAVID RUSSELL, AND RACHEL VICTORIA RUSSELL, UNITED KINGDOM:
4,152,298, PUB. 3-20-2012. INT. CL. 30.

IAP WORLDWIDE SERVICES, INC., CAPE CANAVERAL, FL:
4,153,213, PUB. 3-20-2012. MULTIPLE CLASS, INT. CLS. 35, 37, 40 AND 45.

IBERO ALCORENSE, S.L., 12110 ALCORA (CASTELLON), SPAIN:
2,491,817, CANC. INT. CL. 19.

IBUSINESS SOLUTIONS, INC., EDINA, MN:
4,153,373, PUB. 3-20-2012. MULTIPLE CLASS, INT. CLS. 35 AND 41.
4,153,374, PUB. 3-20-2012. MULTIPLE CLASS, INT. CLS. 35 AND 41.

ICAP SERVICES NORTH AMERICA, LLC, JERSEY CITY, NJ:
1,740,664, REN. 4-28-12. INT. CL. 36.

ICONNEWMEDIA, INC., HENDERSON, NV:
4,152,802, PUB. 2-14-2012. MULTIPLE CLASS, INT. CLS. 9, 16, 38 AND 41.

IDEAL PROMOTIONS, INC., CHICAGO, IL:
4,154,270, INT. CL. 35.

IDEELI INC., NEW YORK, NY:
4,153,201, PUB. 3-20-2012. MULTIPLE CLASS, INT. CLS. 39 AND 41.

IDENTITY ATELIER, LLC, NEW YORK, NY:
4,154,846, INT. CL. 35.

IDX SYSTEMS CORPORATION, SOUTH BURLINGTON, VT:
2,571,102, REN. 4-30-12. INT. CL. 9.

IFEELGOOD 24/7 PTY LTD, COOPERS PLAINS, QLD, AUSTRALIA:
4,152,569, PUB. 9-13-2011. INT. CL. 41.

IFP ENERGIES NOUVELLES, RUEIL-MALMAISON CEDEX, FRANCE:
2,565,476, REN. 5-2-12. MULTIPLE CLASS, INT. CLS. 40 AND 42.

IGA, INC., CHICAGO, IL:
4,154,424, MULTIPLE CLASS, INT. CLS. 3, 4, 6, 8, 16, 29, 30, 31 AND 32.
4,154,425, MULTIPLE CLASS, INT. CLS. 3, 6, 8, 16, 29, 30, 31 AND 32.

IGT, RENO, NV:
4,154,451, INT. CL. 9.
4,154,840, INT. CL. 9.
4,154,907, INT. CL. 9.
4,155,332, INT. CL. 9.

II-VI INCORPORATED, SAXONBURG, PA:
4,041,520, COR. INT. CL. 9.

IJET TRAVEL INTELLIGENCE, INC., ANNAPOLIS, MD, IJET TRAVEL INTELLIGENCE, INC., ANNAPOLIS, MD:
2,541,381, REN. 5-3-12. INT. CL. 39.

IKON GLOBAL MARKETS, INC., NEW YORK, NY, DBA IKON GLOBAL MARKETS, INC.:
4,152,632, PUB. 3-20-2012. INT. CL. 36.

ILEOS, 75015 PARIS, FRANCE:
2,565,133, REN. 5-2-12. MULTIPLE CLASS, INT. CLS. 16 AND 42.

ILLINOIS TOOL WORKS INC., GLENVIEW, IL, SIGNODE STEEL STRAPPING COMPANY, CHICAGO, IL:
729,968, REN. 4-28-12. U.S. CL. 13 (INT. CL. 6).

ILLINOIS TOOL WORKS INC., GLENVIEW, IL:
1,197,050, REN. 4-27-12. INT. CL. 6.

ILLINOIS TOOL WORKS INC., GLENVIEW, IL, HOBART BROTHERS COMPANY, TROY, OH:
1,707,855, REN. 4-27-12. INT. CL. 9.

ILLINOIS TOOL WORKS INC., GLENVIEW, IL, TEXWIPE COMPANY, THE, UPPER SADDLE RIVER, NJ:
1,742,648, REN. 5-2-12. INT. CL. 3.

ILLINOIS TOOL WORKS INC., GLENVIEW, IL:
2,491,896, CANC. INT. CL. 9.
2,998,973, CANC. INT. CL. 7.

ILLUMINUP LLC, SAN JACINTO, CA:
4,155,011, INT. CL. 27.

ILOUNGE, INC., IRVINE, CA:
4,153,447, PUB. 3-20-2012. INT. CL. 9.

ILSCO CORPORATION, CINCINNATI, OH:
1,660,546, REN. 4-30-12. INT. CL. 9.

ILYON LIMITED, GENEVA 11, SWITZERLAND:
4,153,017, PUB. 3-20-2012. INT. CL. 35.

IMAGE HUNTER PUBLISHING, INC., MCLEAN, VA:
2,998,533, CANC. INT. CL. 41.
2,998,534, CANC. MULTIPLE CLASS, INT. CLS. 16 AND 35.

IMAGETAG, INC., TEMPE, AZ:
2,660,219, REN. 5-2-12. MULTIPLE CLASS, INT. CLS. 35 AND 39.

IMBERT ELLIOT, FRANCE:
4,152,326, PUB. 3-20-2012. INT. CL. 10.

IMBRIUM SYSTEMS CORPORATION, TORONTO, ONTARIO, CANADA:
4,153,041, PUB. 3-20-2012. MULTIPLE CLASS, INT. CLS. 11, 19 AND 40.
4,153,042, PUB. 3-20-2012. MULTIPLE CLASS, INT. CLS. 11, 19 AND 40.

IMD COMPANIES, INC., TAMPA, FL:
2,500,145, REN. 4-30-12. INT. CL. 41.

IMERYS KAOLIN, INC., ROSWELL, GA:
4,155,723, INT. CL. 17.

IMI INNOVATIONS, INC., NAPERVILLE, IL:
4,154,353, INT. CL. 9.
4,154,354, INT. CL. 9.

IMPAC MORTGAGE HOLDINGS, INC., IRVINE, CA:
2,493,409, CANC. INT. CL. 36.

IMPACT CONFECTIONS, INC., LITTLETON, CO:
4,155,792, INT. CL. 30.

IMPACT TECHNOLOGIES GROUP, INC., CHARLOTTE, NC:
2,998,653, CANC. INT. CL. 9.

- IMPAKT PROTECTIVE INC., KANATA, ONTARIO, CANADA:
4,153,114, PUB. 3-20-2012. INT. CL. 9.
- IMPERA WEALTH MANAGEMENT, LLC, METAIRIE, LA:
4,155,734, INT. CL. 36.
- IMS TRADING, LLC, STUDIO CITY, CA:
2,998,734, CANC. INT. CL. 5.
- IN TOUCH MINISTRIES, INC., ATLANTA, GA:
1,211,426, REN. 4-27-12. MULTIPLE CLASS, INT. CLS. 9,
16 AND 41.
- INC. LEGAL, APC, CARLSBAD, CA:
4,155,954, INT. CL. 45.
- INCITE INTERNATIONAL, INC., BLUE SPRINGS, MO:
2,390,011, CANC. INT. CL. 9.
- INDEPENDENT ASSOCIATION OF BUSINESSES, ARLINGTON, TX:
4,152,067, PUB. 3-20-2012. INT. CL. 35.
- INDIGO IMP BREWERY, LTD., CLEVELAND, OH:
4,152,881, PUB. 3-20-2012. INT. CL. 32.
- INDY FOUNDERS, LLC, INDIANAPOLIS, IN:
4,153,192, PUB. 3-20-2012. INT. CL. 35.
- INETSOLUTION, INC., ALMONT, MI:
2,566,777, REN. 4-27-12. INT. CL. 42.
- INFANTE INTERNATIONAL, UPLAND, CA:
4,155,060, INT. CL. 33.
- INFAS PUBLICATIONS, INC., TOKYO, JAPAN, KABUSHIKI KAISHA RYUKOUTSUUSINSHA, SHINJUKU-KU, TOKYO, JAPAN:
1,683,497, REN. 5-2-12. INT. CL. 16.
- INFINITY HEALTHCARE, INC., MILWAUKEE, WI:
4,152,107, PUB. 3-20-2012. MULTIPLE CLASS, INT. CLS. 35, 36 AND 41.
- INFINITY INSURANCE, INC., SANDY, UT:
2,492,631, CANC. INT. CL. 9.
- INFODESK, INC., TARRYTOWN, NY:
4,152,716, PUB. 3-20-2012. MULTIPLE CLASS, INT. CLS. 9 AND 42.
- INFOJOBS, S.A., BARCELONA, SPAIN:
4,152,139, PUB. 3-20-2012. INT. CL. 38.
- INFOMETRIX, INC., BOTHELL, WA:
1,684,103, REN. 5-2-12. INT. CL. 9.
1,684,103, CANC. INT. CL. 16.
- INFORMATICS HOLDINGS, INC., PLANO, TX:
2,559,068, REN. 4-27-12. INT. CL. 9.
- INFORMATION TECHNOLOGY INDUSTRY COUNCIL, LTD., WASHINGTON, DC:
4,152,807, PUB. 3-20-2012. MULTIPLE CLASS, INT. CLS. 35 AND 42.
4,152,809, PUB. 3-20-2012. MULTIPLE CLASS, INT. CLS. 35 AND 42.
- INFOSTREAM GROUP, INC., LAS VEGAS, NV:
4,155,033, MULTIPLE CLASS, INT. CLS. 41 AND 45.
- INFOTRIEVE, INC., WILTON, CT TO INFOTRIEVE, INC., WILTON, CT:
2,492,979, CANC. INT. CL. 35.
- INFRARED RESOURCES, LLC, PORTLAND, OR:
4,155,998, MULTIPLE CLASS, INT. CLS. 9 AND 35.
- INGENIOUS DESIGNS LLC, ST. PETERSBURG, FL:
2,999,001, CANC. INT. CL. 8.
- INGETEAM, S.A., ZAMUDIO, SPAIN:
4,152,959, PUB. 3-20-2012. INT. CL. 9.
- INGOT METAL COMPANY LIMITED, NORTH YORK, ONTARIO, CANADA:
4,155,076, INT. CL. 6.
- INGRAM ENTERPRISES, INC., SPRINGFIELD, MO:
1,759,157, REN. 4-28-12. INT. CL. 13.
- INKA CROPS, S.A., LIMA36, PERU:
2,613,503, REN. 4-30-12. INT. CL. 29.
- INLINGUA INTERNATIONAL LTD., BERN, SWITZERLAND:
922,393, REN. 4-30-12. MULTIPLE CLASS, U.S. CLS. 36 (INT. CL. 9), 38 (INT. CL. 16) AND 107 (INT. CL. 41).
923,232, REN. 4-30-12. MULTIPLE CLASS, U.S. CLS. 36 (INT. CL. 9), 38 (INT. CLS. 9 AND 16) AND 107 (INT. CL. 41).
- INNER CIRCLE DESIGNS, LLC, MARIETTA, GA:
4,154,995, INT. CL. 14.
- INNOSEARCH, S.L., ESPLUGUES DE LLOBREGAT, SPAIN:
4,152,340, PUB. 3-20-2012. INT. CL. 3.
- INNOVATIVE DESIGN & SOURCING, LLC, MILFORD, CT:
4,155,405, INT. CL. 28.
- INNOVATIVE MOVING SYSTEMS, OOSTBURG, WI:
4,154,079, PUB. 3-20-2012. INT. CL. 12.
- INNOVYZE, INC., BROOMFIELD, CO:
4,154,499, INT. CL. 42.
- INNOWA MEMBRANE GMBH, 71409 SCHWAIKHEIM, FED REP GERMANY:
4,152,197, PUB. 3-20-2012. MULTIPLE CLASS, INT. CLS. 1, 7, 9, 11, 17, 24, 40 AND 42.
- INOVERA BIOSCIENCE, INC., AMBLER, PA:
2,565,557, REN. 4-28-12. INT. CL. 5.
- INPETNET, LLC, HOLLYWOOD, FL:
4,152,988, PUB. 3-20-2012. INT. CL. 44.
- INPRO/SEAL LLC, ROCK ISLAND, IL:
2,520,525, REN. 5-1-12. INT. CL. 7.
- INSACO INCORPORATED, QUAKERTOWN, PA:
4,153,285, PUB. 3-20-2012. INT. CL. 40.
- INSECO, INC., FORT MYERS, FL:
2,659,485, REN. 5-2-12. INT. CL. 2.
- INSIGHTFUL DEVELOPMENTS, LLC, MERRICK, NY:
4,155,605, MULTIPLE CLASS, INT. CLS. 5 AND 32.
- INSPIRE INSURANCE SOLUTIONS, INC., NORTH RICHLAND HILLS, TX:
4,154,516, MULTIPLE CLASS, INT. CLS. 36 AND 42.
- INSPIRAFS, INC., PITTSBURGH, PA, DBA TOTAL IRA:
4,153,632, PUB. 3-20-2012. INT. CL. 36.
- INSPIRATO, LLC., DENVER, CO:
4,154,911, MULTIPLE CLASS, INT. CLS. 36, 41, 43, 44 AND 45.
- INSTITUT CURIE, FRANCE:
2,998,355.
- INSTITUTE OF FOOD TECHNOLOGISTS, CHICAGO, IL:
4,152,489, PUB. 3-20-2012. INT. CL. 35.
- INSTITUTO DE TURISMO DE ESPAÑA (TURESPAÑA), E-28036 MADRID, SPAIN:
4,152,277, PUB. 3-20-2012. MULTIPLE CLASS, INT. CLS. 16, 39, 41 AND 43.
- INTEGRA TRADING INTERNATIONAL CORPORATION, LAKE WORTH, FL:
2,636,873, REN. 4-30-12. INT. CL. 25.
- INTEGRADIGM CORPORATION, FORT WAYNE, IN:
4,155,573, INT. CL. 7.
- INTEGRADORA DE FRUTAS FINAS SOCONUSCO S.A. DE C.V., TAPACHULA, MEXICO, TA FRUTAS FINAS SOCONUSCO:
4,153,265, PUB. 3-20-2012. INT. CL. 31.
- INTEGRAL MOLECULAR, INC., PHILADELPHIA, PA:
2,691,636, REN. 5-3-12. INT. CL. 42.
- INTEGRATED BANK TECHNOLOGIES, INC., CEDAR PARK, TX:
4,152,059, PUB. 3-20-2012. INT. CL. 42.
- INTEGRITY MEDIA, INC., MOBILE, AL:
2,492,458, CANC. MULTIPLE CLASS, INT. CLS. 9, 41 AND 42.
- INTELLIGENT MANAGEMENT SOLUTIONS, INC, PENSACOLA, FL:
4,153,224, PUB. 3-20-2012. INT. CL. 35.
- INTELLISPHERE, LLC, PLAINSBORO, NJ:
4,156,008, MULTIPLE CLASS, INT. CLS. 9 AND 41.
4,156,060, MULTIPLE CLASS, INT. CLS. 9 AND 41.
- INTEMATIX CORPORATION, FREMONT, CA:
4,154,875, MULTIPLE CLASS, INT. CLS. 1 AND 11.
- INTERACTIVE DRAMA, INC., BETHESDA, MD:
2,565,021, REN. 5-2-12. INT. CL. 9.
- INTERACTIX CORPORATION, CHICAGO, IL:
2,998,557, CANC. INT. CL. 9.

INTERCONTINENTAL PACKAGING CO., ST. PAUL, MN:
 4,154,968, INT. CL. 33.
 4,155,043, INT. CL. 33.
 4,155,777, INT. CL. 33.
 4,155,799, INT. CL. 33.
 4,155,811, INT. CL. 33.
 4,155,814, INT. CL. 33.
 4,155,818, INT. CL. 33.
 4,155,819, INT. CL. 33.
 4,155,821, INT. CL. 33.

INTERNAL BALANCE, INC., KINGWOOD, TX:
 2,696,291. REN. 5-1-12. MULTIPLE CLASS, INT. CLS. 35 AND 42.

INTERNATIONAL TRUCK INTELLECTUAL PROPERTY COMPANY LLC, WARRENVILLE, IL, INTERNATIONAL TRUCK AND ENGINE CORPORATION, CHICAGO, IL:
 2,560,528. REN. 4-27-12. INT. CL. 42.

INTERNATIONAL ASSOCIATION FOR HUMAN VALUES, BURLINGTON, MA:
 4,155,420, INT. CL. 41.

INTERNATIONAL ASSOCIATION OF LIONS CLUBS, THE, OAK BROOK, IL:
 1,196,526. REN. 5-2-12. U.S. CL. 200.

INTERNATIONAL CHAPTER P.E.O. SISTERHOOD, DES MOINES, IA:
 2,597,780. REN. 4-30-12. INT. CL. 36.

INTERNATIONAL FLORA TECHNOLOGIES, LTD., CHANDLER, AZ:
 2,579,871. REN. 5-3-12. INT. CL. 1.

INTERNATIONAL FRANCHISE INC., MARKHAM, ONTARIO, CANADA:
 4,154,094, PUB. 3-20-2012. INT. CL. 30.

INTERNATIONAL RESEARCH ASSOCIATION, LLC, CAMBRIDGE, MA:
 2,998,951, CANC. U.S. CL. B.

INTERNATIONAL SECURITIES EXCHANGE, LLC, NEW YORK, NY:
 4,155,396, INT. CL. 35.
 4,155,397, INT. CL. 35.

INTERNET BRANDS, INC., EL SEGUNDO, CA:
 3,074,950, CANC. INT. CL. 35.
 3,081,030, CANC. INT. CL. 35.

INTERNET ENGINE, LLC, LIBERTYVILLE, IL:
 4,155,939, INT. CL. 42.

INTERNUM, LLC, HOUSTON, TX:
 4,155,428, MULTIPLE CLASS, INT. CLS. 20 AND 35.

INTERPRO TECHNOLOGY, INC., ROCHESTER, MI:
 4,153,890, PUB. 3-20-2012. INT. CL. 42.

INTERSECTIONS INC., CHANTILLY, VA:
 4,154,240, PUB. 8-16-2011. MULTIPLE CLASS, INT. CLS. 35, 36 AND 45.

INTERSIL AMERICAS INC., MILPITAS, CA TO INTERSIL AMERICAS LLC, MILPITAS, CA:
 2,565,128, CANC. INT. CL. 42.

INTERSIL AMERICAS INC., MILPITAS, CA:
 2,998,656, CANC. INT. CL. 9.

INTERSIL AMERICAS LLC, MILPITAS, CA, INTERSIL AMERICAS INC., MILPITAS, CA:
 2,565,128. REN. 4-30-12. INT. CL. 9.

INTERWELL NORWAY AS, NORWAY:
 4,152,320, PUB. 3-20-2012. MULTIPLE CLASS, INT. CLS. 37 AND 42.
 4,152,321, PUB. 3-20-2012. MULTIPLE CLASS, INT. CLS. 37 AND 42.

INTEX RECREATION CORP., LONG BEACH, CA, ZEE TOYS, INC., GARDENA, CA:
 951,245. REN. 5-3-12. U.S. CL. 22 (INT. CL. 28).

INTEX RECREATION CORP., LONG BEACH, CA:
 2,693,935. REN. 4-29-12. INT. CL. 28.

INTRADEVCO INDUSTRIAL S.A., LIMA, PERU:
 4,153,339, PUB. 3-20-2012. INT. CL. 3.

INTRAPACE, INC., MOUNTAIN VIEW, CA:
 4,152,840, PUB. 3-20-2012. MULTIPLE CLASS, INT. CLS. 38, 42 AND 45.

INTRINSIC VALUATION, DENVER, CO:
 4,156,069, INT. CL. 36.

INTUITIVE RESEARCH AND TECHNOLOGY CORPORATION, HUNTSVILLE, AL:
 4,153,853, PUB. 3-20-2012. INT. CL. 42.

INTUNE CORPORATION, VENTURA, CA:
 2,492,904, CANC. INT. CL. 21.
 2,492,905, CANC. INT. CL. 21.

INVENSYS SYSTEMS, INC., FOXBORO, MA:
 4,154,593, INT. CL. 9.

INVENTORY LOCATOR SERVICE LLC, MEMPHIS, TN, INVENTORY LOCATOR SERVICE, INC., MEMPHIS, TN:
 1,683,333. REN. 4-30-12. INT. CL. 42.

INVIA PAVEMENT TECHNOLOGIES, RICHMOND, VA:
 4,154,999, INT. CL. 19.

IOIP HOLDINGS, LLC, FORT WAYNE, IN:
 2,685,393. REN. 5-1-12. INT. CL. 1.

ION IMAGINATION ENTERTAINMENT, INC., NASHVILLE, TN:
 2,654,644. REN. 4-30-12. INT. CL. 28.

IONBOND AG OLTEN, CH-4600 OLTEN, SWITZERLAND:
 4,152,182, PUB. 3-20-2012. MULTIPLE CLASS, INT. CLS. 6, 7, 14 AND 40.

IOPENER HOLDINGS LIMITED, UNITED KINGDOM:
 4,152,367, PUB. 3-20-2012. MULTIPLE CLASS, INT. CLS. 9, 16, 35, 41, 42 AND 45.

IOWA MOLD TOOLING CO., INC., GARNER, IA:
 2,562,913. REN. 5-3-12. INT. CL. 12.

IPAYMENT, INC., NASHVILLE, TN:
 4,155,968, INT. CL. 42.
 4,155,979, INT. CL. 42.

IPH INTERNATIONAL PTY. LTD., ORMEAU, QUEENSLAND, AUSTRALIA:
 4,154,430, INT. CL. 6.

IPHRASE TECHNOLOGIES, INC., CAMBRIDGE, MA TO INTERNATIONAL BUSINESS MACHINES CORPORATION, ARMONK, NY, AKA IBM CORPORATION:
 2,493,278, CANC. INT. CL. 9.

IPRIZE LLC, HENDERSON, NV:
 4,152,775, PUB. 3-20-2012. INT. CL. 9.

IPSCO INC., REGINA, SASKATCHEWAN, CANADA:
 2,492,463, CANC. MULTIPLE CLASS, INT. CLS. 6 AND 40.

IQ PRODUCTS COMPANY, HOUSTON, TX:
 4,152,902, PUB. 3-20-2012. INT. CL. 3.

IREM SOFTWARE ENGINEERING INC., ISHIKAWA, JAPAN:
 2,493,148, CANC. INT. CL. 9.

IRENKO AUTO SALES CORP, MIAMI, FL:
 4,156,074, INT. CL. 35.

IRMA SHORELL, INC., ORLANDO, FL:
 2,573,066. REN. 5-3-12. INT. CL. 3.

IRVINE COMPANY LLC, THE, NEWPORT BEACH, CA, IRVINE COMPANY, THE, NEWPORT BEACH, CA:
 2,547,559. REN. 5-3-12. INT. CL. 37.

IRWIN INDUSTRIAL TOOL COMPANY, ATLANTA, GA:
 2,560,423. REN. 5-2-12. INT. CL. 8.

ISABELLE ADJANI C/O ISIA FILMS, FRANCE:
 4,152,283, PUB. 3-20-2012. INT. CL. 18.

ISGN CORPORATION, BENSLEM, PA:
 4,154,022, PUB. 3-20-2012. MULTIPLE CLASS, INT. CLS. 9, 36 AND 42.

ISI BRANDS INC., GRAND RAPIDS, MI:
 2,493,123, CANC. INT. CL. 5.

ISLANDS RESTAURANTS, L.P., CARLSBAD, CA:
 2,690,788. REN. 5-3-12. INT. CL. 43.

ISMIE MUTUAL INSURANCE COMPANY, CHICAGO, IL:
 4,152,454, PUB. 3-20-2012. INT. CL. 36.

ISOICHEM, S.A., 91710 VERT LE PETIT, FRANCE:
 2,569,082. REN. 5-2-12. MULTIPLE CLASS, INT. CLS. 1 AND 42.
 2,569,082, CANC. INT. CL. 5.

ISP INVESTMENTS INC., WILMINGTON, DE:
 1,234,237. REN. 5-1-12. INT. CL. 5.

ITALY HOTLINE PRIVATE AND CUSTOM TOURS LLC, PORT TOWNSEND, WA, DBA ITALY HOTLINE PRIVATE AND CUSTOM TOURS LLC:
 4,153,908, PUB. 3-20-2012. INT. CL. 39.

ITI HOLDINGS, INC., JENSEN BEACH, FL:
 2,615,626. REN. 5-3-12. INT. CL. 41.

- ITT MANUFACTURING ENTERPRISES, LLC, WILMINGTON, DE:
2,562,791. REN. 4-30-12. INT. CL. 25.
- IVARA CORPORATION, BURLINGTON, ONTARIO, CANADA, IVARA CORPORATION, BURLINGTON, ONTARIO, CANADA:
2,560,840. REN. 5-3-12. INT. CL. 9.
- IVIDENCE, PARIS, FRANCE:
4,153,052, PUB. 3-20-2012. MULTIPLE CLASS, INT. CLS. 9, 35 AND 42.
- IVIVITY INC., NORCROSS, GA:
2,998,850, CANC. INT. CL. 9.
- IVOCLAR VIVADENT, INC, AMHERST, NY, DENTSPLY INTERNATIONAL INC., YORK, PA:
1,194,194. REN. 5-2-12. INT. CL. 5.
- IVOGHLI, SEAN, MISSION VIEJO, CA:
4,154,148, PUB. 3-20-2012. INT. CL. 42.
- IXARIS SYSTEMS LTD, LONDON, UNITED KINGDOM:
4,154,808, INT. CL. 42.
- IZO FORCE ENERGY PRODUCTS LLC, HOLLYWOOD, CA:
3,556,159, CANC. INT. CL. 32.
- J & A, LLC, VAIL, CO:
4,153,972, PUB. 3-20-2012. INT. CL. 30.
- J. FRANK SCHMIDT & SON CO., BORING, OR:
4,155,455, INT. CL. 31.
- J. PAUL BUCHANAN & ASSOCIATES, INC., CARLSBAD, CA:
4,155,627, INT. CL. 14.
- J. WALTER THOMPSON COMPANY, NEW YORK, NY:
4,155,389, MULTIPLE CLASS, INT. CLS. 35 AND 42.
- J.A. WOOLLAM CO., INC., LINCOLN, NE:
4,154,267, INT. CL. 9.
- J.C. RAGS B.V., NETHERLANDS:
4,152,278, PUB. 3-20-2012. MULTIPLE CLASS, INT. CLS. 18 AND 25.
- J.D. BYRIDER ADVERTISING GROUP, INC., CARMEL, IN:
2,492,628, CANC. MULTIPLE CLASS, INT. CLS. 35 AND 36.
- J.H. FENNER & CO. LIMITED, HESSLE, EAST YORKSHIRE, UNITED KINGDOM:
4,155,695, INT. CL. 42.
- J.S. JOHNSON, LTD., COLUMBUS, OH:
4,155,363, INT. CL. 14.
- J.T. POSEY COMPANY, ARCADIA, CA:
4,154,490, INT. CL. 10.
- J.V. DRIVER CORPORATION INC., LEDUC, ALBERTA, CANADA:
4,154,540, MULTIPLE CLASS, INT. CLS. 37 AND 40.
- JAC-RACK, INC., PONTIAC, MI:
4,152,503, PUB. 3-20-2012. MULTIPLE CLASS, INT. CLS. 6 AND 9.
- JACK JOHN INVESTMENTS, INC., PASA ROBLES, CA:
4,155,168, INT. CL. 33.
- JACK ROGERS OPERATING COMPANY, LLC, NEW YORK, NY:
2,492,461, CANC. INT. CL. 25.
- JACK'S MAGIC PRODUCTS, INC., LARGO, FL:
2,621,373. REN. 5-3-12. INT. CL. 1.
- JACOBS & TURNER LIMITED, UNITED KINGDOM:
4,152,232, PUB. 3-20-2012. INT. CL. 25.
- JACQUES LEMANS GESMBH, AUSTRIA:
4,152,332, PUB. 3-20-2012. MULTIPLE CLASS, INT. CLS. 9, 14 AND 16.
- JAFFE, MAX, DALLAS, TX:
2,998,895, CANC. MULTIPLE CLASS, INT. CLS. 36 AND 41.
- JAFRA COSMETICS INTERNATIONAL, INC., WESTLAKE VILLAGE, CA:
4,155,704, INT. CL. 3.
- JAMES BOWERS, AUSTRALIA:
4,152,209, PUB. 3-20-2012. INT. CL. 11.
- JAMES FRANK JAROLIMEK, ESTES PARK, CO:
2,998,959, CANC. INT. CL. 41.
- JAMIE TARA-ANN GETZWILLER, SONOITA, AZ:
4,153,763, PUB. 3-20-2012. INT. CL. 28.
- JANELL CIRKL, BLOOMINGTON, MN:
4,153,865, PUB. 3-20-2012. INT. CL. 25.
- JANLYNN CORP., CHICOPEE, MA:
4,155,737, INT. CL. 28.
- JANOME AMERICA, INC., MAHWAH, NJ:
2,493,034, CANC. INT. CL. 7.
- JANOVER, JENNIFER, NORWALK, CT:
4,153,733, PUB. 3-20-2012. INT. CL. 41.
- JARROLD, THOMAS, NEW YORK, NY AND SCRIVENS, MATTHEW, NEW YORK, NY:
4,154,724, INT. CL. 35.
- JARROW FORMULAS, INC., LOS ANGELES, CA:
2,578,776. REN. 5-3-12. INT. CL. 5.
- JASON M. GRINTER, D.D.S., P.C., CHICAGO, IL:
4,153,601, PUB. 3-20-2012. INT. CL. 44.
- JATZ INTERNATIONAL CORP, MIAMI, FL:
2,560,350. REN. 5-3-12. MULTIPLE CLASS, INT. CLS. 19 AND 27.
- JAX LTD., PLYMOUTH, MN:
2,550,650. REN. 4-27-12. INT. CL. 28.
- JBCM, LLC, ANAHEIM, CA:
4,153,088, PUB. 3-20-2012. MULTIPLE CLASS, INT. CLS. 36, 37 AND 41.
4,153,090, PUB. 3-20-2012. MULTIPLE CLASS, INT. CLS. 36, 37 AND 41.
- JBR, INC., LINCOLN, CA:
4,154,173, PUB. 3-20-2012. INT. CL. 30.
- JBZ ENTERPRISES LLC, NEW YORK, NY:
4,152,659, PUB. 3-20-2012. MULTIPLE CLASS, INT. CLS. 24 AND 25.
- JCP SPECIALTY FOODS COMPANY, NORTHBROOK, IL, J.C. POTTER SAUSAGE COMPANY, DURANT, OK:
1,716,140. REN. 5-1-12. INT. CL. 29.
- JD KOA ENTERPRISES, LLC, THOUSAND OAKS, CA:
4,155,631, INT. CL. 18.
- JE MATADI, INC., STAFFORD, TX:
4,153,414, PUB. 3-20-2012. INT. CL. 3.
- JEAN-PAUL TOLKOWSKY, ANTWERPEN, BELGIUM:
2,491,694, CANC. INT. CL. 14.
- JEFFERSON BANK, SAN ANTONIO, TX:
4,155,686, INT. CL. 36.
- JEFFERY, FRANK, CHICAGO, IL AND GIANDONATO, MICHAEL, CHICAGO, IL:
2,560,203. REN. 4-27-12. INT. CL. 3.
- JEFFERY, INC., MIAMI BEACH, FL:
4,155,988, INT. CL. 41.
- JELD-WEN, INC., KLAMATH FALLS, OR:
2,492,561, CANC. INT. CL. 19.
- JENKINS, ANNE, CARLSBAD, CA:
4,155,496, INT. CL. 44.
- JENKINS, COZETTA A., MISSION, KS, AKA SISTER R.E.I.G.N.:
4,152,878, PUB. 3-20-2012. INT. CL. 41.
- JENKINSON, PHILIP, LILLE, FRANCE:
4,152,798, PUB. 3-20-2012. MULTIPLE CLASS, INT. CLS. 35, 36 AND 45.
- JENSEN, JEREMY LEVI, LOGAN, UT, DBA JEREMY JENSEN MEDIA:
4,153,300, PUB. 3-20-2012. INT. CL. 28.
- JEON, ARTHUR, SANTA MONICA, CA:
4,152,508, PUB. 3-20-2012. INT. CL. 38.
- JERILL INC., STANFORD, CA:
2,554,631. REN. 4-27-12. INT. CL. 9.
- JERSEY SURF INC., A NEW JERSEY NOT FOR PROFIT CORP, MOUNT HOLLY, NJ:
4,153,477, PUB. 3-20-2012. INT. CL. 25.
- JESSICA MORENO, BOCA RATON, FL:
4,153,982, PUB. 3-20-2012. INT. CL. 45.
- JESSICA OLTMANS, SAN JUAN CAPISTRANO, CA:
4,153,884, PUB. 3-20-2012. INT. CL. 41.
- JETER, STARRA, COLUMBUS, OH:
2,492,346, CANC. INT. CL. 9.
- JEWEL KADE HOLDINGS LLC, ALPINE, UT:
4,154,077, PUB. 3-20-2012. INT. CL. 9.
4,154,168, PUB. 3-20-2012. INT. CL. 42.
- JEWISH COUNCIL FOR THE AGING OF GREATER WASHINGTON, INC., ROCKVILLE, MD:
1,743,759. REN. 4-30-12. INT. CL. 42.
- JEWISH HOME LIFECARE, NEW YORK, NY:
4,152,583, PUB. 3-20-2012. MULTIPLE CLASS, INT. CLS.

- 36, 37, 43, 44 AND 45.
 JF STROTHMAN DISTILLERY, INC., GRAND JUNCTION, CO:
 4,155,530, INT. CL. 33.
 JFC INTERNATIONAL, INC., SOUTH SAN FRANCISCO, CA:
 2,492,232, CANC. MULTIPLE CLASS, INT. CLS. 29 AND 30.
 JHL CAPITAL GROUP LLC, CHICAGO, IL:
 4,153,308, PUB. 3-20-2012. INT. CL. 36.
 JIAN, WANG, XI'AN, SHAANXI, CHINA:
 4,152,994, PUB. 12-13-2011. INT. CL. 25.
 JILL JOANNE, LLC, NEWPORT COAST, CA:
 4,154,791, INT. CL. 18.
 JILL L. LESHIN, SCOTTSDALE, AZ, DBA THE TRAVELING TUTOR, LLC:
 4,153,775, PUB. 3-20-2012. INT. CL. 41.
 JIM BEAM BRANDS CO., DEERFIELD, IL:
 4,155,274, INT. CL. 33.
 4,155,825, INT. CL. 33.
 JIMA INTERNATIONAL CO., LTD., PUSHING, CHANGHUA, TAIWAN:
 2,492,189, CANC. INT. CL. 7.
 JJISCO INC., OCONOMOWOC, WI:
 4,152,735, PUB. 3-20-2012. INT. CL. 1.
 JMC BRANDS, LLC, DOYLESTOWN, OH, DBA JMC BRANDS, LLC:
 4,153,092, PUB. 3-20-2012. INT. CL. 35.
 JMI SPORTSWEAR, PTE. LTD., SINGAPORE, SINGAPORE:
 4,155,398, MULTIPLE CLASS, INT. CLS. 9 AND 25.
 JNJ INDUSTRIES INC., FRANKLIN, MA:
 1,700,539, REN. 5-2-12. INT. CL. 16.
 JOHN B. STETSON COMPANY, HOBOKEN, NJ:
 4,154,308, INT. CL. 3.
 JOHN MEZZALINGUA ASSOCIATES, INC., EAST SYRACUSE, NY, DBA PPC:
 4,154,610, INT. CL. 9.
 JOHN MIDDLETON CO., RICHMOND, VA, R. J. REYNOLDS TOBACCO COMPANY, WINSTON SALEM, NC:
 86,452, REN. 4-30-12. U.S. CL. 17 (INT. CL. 34).
 JOHN VONS LLC, NEW YORK, NY:
 4,154,372, INT. CL. 9.
 JOHNS MANVILLE, DENVER, CO, MANVILLE CORPORATION, DENVER, CO:
 1,696,084, REN. 5-3-12. INT. CL. 17.
 JOHNSON & JOHNSON, NEW BRUNSWICK, NJ:
 2,998,515, CANC. INT. CL. 1.
 2,998,570, CANC. INT. CL. 9.
 2,998,713, CANC. INT. CL. 21.
 4,154,246, MULTIPLE CLASS, INT. CLS. 36 AND 41.
 4,154,508, MULTIPLE CLASS, INT. CLS. 3, 5 AND 45.
 4,154,545, INT. CL. 10.
 4,154,619, INT. CL. 5.
 4,154,620, INT. CL. 5.
 4,155,298, INT. CL. 3.
 4,155,299, INT. CL. 3.
 4,156,075, INT. CL. 21.
 JOHNSON CONTROLS TECHNOLOGY COMPANY, HOLLAND, MI:
 4,155,596, INT. CL. 9.
 JOHNSTEK, INC., MIRAMAR, FL:
 4,153,313, PUB. 3-20-2012. INT. CL. 42.
 JOHNSTON, MARIANA A. BOZEMAN, MT:
 4,153,425, PUB. 3-20-2012. INT. CL. 41.
 JOHNSTON, MATTHEW, COSTA MESA, CA, DBA SUIPLOVE:
 4,154,736, MULTIPLE CLASS, INT. CLS. 12, 25, 28 AND 41.
 JOINT COMMISSION ON ACCREDITATION OF HEALTHCARE ORGANIZATIONS, OAKBROOK TERRACE, IL:
 4,155,911, INT. CL. 38.
 JOLICLOUD, FRANCE:
 4,152,302, PUB. 3-20-2012. MULTIPLE CLASS, INT. CLS. 9, 35, 38 AND 42.
 JONES INTERNATIONAL, LTD., ENGLEWOOD, CO TO JONES INTERNATIONAL, LTD., ENGLEWOOD, CO:
 2,493,610, CANC. INT. CL. 9.
 JONES SODA CO. (USA) INC., SEATTLE, WA:
 2,996,249, CANC. INT. CL. 32.
 4,154,725, INT. CL. 32.
 JONES, DENNIS R., CHESAPEAKE, VA:
 4,154,309, INT. CL. 3.
 JONES, ROBERT, DALLAS, TX:
 2,998,710, CANC. INT. CL. 16.
 2,998,711, CANC. INT. CL. 44.
 JORDAN OUTDOOR ENTERPRISES, LTD., COLUMBUS, GA:
 2,559,935, REN. 4-27-12. MULTIPLE CLASS, INT. CLS. 8, 9 AND 28.
 2,560,325, REN. 4-27-12. INT. CL. 6.
 JOSE GONZALEZ CLEMENTE & CO., MAYAGUEZ, PUERTO RICO TO DESTILERIA SERRALLES, INC., MERCE-DITA, PUERTO RICO:
 341,153, CANC. U.S. CL. 49.
 JOSEPH M. MCGRATH, CRESTWOOD, IL:
 4,155,108, INT. CL. 32.
 JOSEPH P. WHITE, BERLIN, CT:
 4,155,077, INT. CL. 40.
 JOSN ELECTRONIC CO., LTD., TAIPEI COUNTY 241, TAIWAN:
 4,152,784, PUB. 3-20-2012. INT. CL. 9.
 JOY MM DELAWARE, INC., WILMINGTON, DE:
 4,154,124, PUB. 3-20-2012. INT. CL. 9.
 JPJ INVESTMENT HOLDING CO., CARSON CITY, NV:
 4,153,259, PUB. 3-20-2012. INT. CL. 21.
 JPMORGAN CHASE & CO., NEW YORK, NY:
 2,503,856, REN. 5-3-12. INT. CL. 16.
 2,998,505, CANC. INT. CL. 36.
 JTB CORP., TOKYO, JAPAN, JAPAN TRAVEL BUREAU INTERNATIONAL, INC., NEW YORK, NY:
 1,707,263, REN. 4-28-12. INT. CL. 39.
 JU, LEI, PHILADELPHIA, PA:
 4,155,418, INT. CL. 42.
 JUDY B. SWARTZ, WEST HOLLYWOOD, CA:
 4,154,534, INT. CL. 25.
 JULIE DEILY, ROCKLEDGE, FL:
 4,154,147, PUB. 3-20-2012. INT. CL. 41.
 JULIE INDUSTRIES, INC., NORTH READING, MA:
 4,152,707, PUB. 3-20-2012. INT. CL. 27.
 JULIEN MACDONALD LIMITED, UNITED KINGDOM:
 4,152,208, PUB. 3-20-2012. MULTIPLE CLASS, INT. CLS. 18, 24 AND 25.
 JULIAN JOSHUA PRESTON-POWERS, C/O THERMAHELM LIMITED, UNITED KINGDOM:
 4,152,397, PUB. 3-20-2012. INT. CL. 12.
 JUMIO INC., MOUNTAIN VIEW, CA:
 4,155,691, MULTIPLE CLASS, INT. CLS. 9 AND 36.
 JUMP AROUND PARTY RENTALS, LLC, WANTAGH, NY:
 4,153,245, PUB. 3-20-2012. MULTIPLE CLASS, INT. CLS. 41 AND 43.
 JUNCTION SOLUTIONS, INC., ENGLEWOOD, CO:
 4,153,105, PUB. 3-20-2012. INT. CL. 35.
 JUST POP IN, INC., INDIANAPOLIS, IN:
 4,152,743, PUB. 3-20-2012. INT. CL. 30.
 JUSTGOB LLC, LOS ANGELES, CA:
 4,152,586, PUB. 3-20-2012. INT. CL. 35.
 K & COMPANY LLC, KANSAS CITY, MO 64108, MO:
 4,154,690, INT. CL. 16.
 4,154,691, INT. CL. 16.
 4,154,694, INT. CL. 16.
 K. HOV IP, II, INC., RED BANK, NJ:
 4,152,642, PUB. 3-20-2012. INT. CL. 41.
 K.C. CARPET SERVICE, INC., ELK GROVE VILLAGE, IL:
 4,155,916, INT. CL. 8.
 K-FOUR, INC., ROCKVILLE, MD:
 2,998,562, CANC. INT. CL. 42.
 KA, TAT-YIK JARVIS, INDIANAPOLIS, IN:
 4,152,124, PUB. 3-20-2012. INT. CL. 42.
 KAANLAR GIDA SANAYI VE TICARET ANONIM SIRKETI, TURKEY:
 4,152,202, PUB. 3-20-2012. INT. CL. 29.
 KAATZ, EVELYN, BELMONT, MA:
 4,155,760, INT. CL. 28.

- KAB SEATING LIMITED, NORTHAMPTON, NN3 4RS, ENGLAND:
1,703,107. REN. 5-2-12. INT. CL. 12.
- KABBALAH CENTRE INTERNATIONAL, INC., LOS ANGELES, CA:
4,154,221. PUB. 3-20-2012. INT. CL. 9.
- KABUSHIKI KAISHA IKEUCHI, AWAZA, NISHIKU, OSAKA, JAPAN:
1,697,498. REN. 4-30-12. INT. CL. 11.
- KABUSHIKI KAISHA MIYAKE DESIGN JIMUSHO, TOKYO, JAPAN, DBA MIYAKE DESIGN STUDIO:
2,585,753. REN. 5-2-12. INT. CL. 25.
2,585,753, CANC. MULTIPLE CLASS, INT. CLS. 18 AND 24.
- KABUSHIKI KAISHA NOEVIR (DOING BUSINESS AS NOEVIR CO., LTD.), JAPAN:
4,152,378. PUB. 3-20-2012. INT. CL. 3.
- KABUSHIKI KAISHA SONY COMPUTER ENTERTAINMENT, MINATO-KU, TOKYO, JAPAN, TA SONY COMPUTER ENTERTAINMENT INC.:
2,996,241, CANC. INT. CL. 3.
- KABUSHIKI KAISHA SQUARE ENIX HOLDINGS (ALSO TRADING AS SQUARE ENIX HOLDINGS CO., LTD.), TOKYO, JAPAN:
3,828,376, COR. MULTIPLE CLASS, INT. CLS. 9, 16, 28 AND 41.
- KABUSHIKI KAISHA SUN MEDICAL GIJUTSU KENKYUSHO, SUWA-SHI, NAGANO-KEN, JAPAN, DBA SUN MEDICAL TECHNOLOGY RESEARCH CORP.:
2,557,527. REN. 4-27-12. INT. CL. 10.
- KABUSHIKI KAISHA TOPCON, TOKYO 174-8580, JAPAN:
4,155,145, INT. CL. 9.
- KACZYNSKI, ANTHONY M., BOSTON, MA:
2,496,972. REN. 4-27-12. INT. CL. 41.
- KADE RESEARCH LTD., MORDEN, MANITOBA, CANADA:
2,492,176, CANC. INT. CL. 35.
- KAHN LUCAS LANCASTER, INC., NEW YORK, NY:
4,153,397, PUB. 3-20-2012. MULTIPLE CLASS, INT. CLS. 24 AND 28.
- KAHN, LEONARD C., BOYNTON BEACH, FL:
2,491,829, CANC. INT. CL. 8.
- KALARIS, CONSTANTINE, HIGHLAND, MD:
4,152,671, PUB. 3-20-2012. INT. CL. 33.
- KALYN DENNY, SALT LAKE CITY, UT, DBA KALYN'S KITCHEN:
4,153,887, PUB. 3-20-2012. INT. CL. 41.
- KAM INTER VIVOS TRUST, CHICAGO, IL:
4,153,191, PUB. 3-20-2012. INT. CL. 25.
- KAM MAN FOOD INC., EDISON, NJ:
4,154,509, MULTIPLE CLASS, INT. CLS. 29 AND 30.
4,154,510, INT. CL. 35.
- KAMPGROUNDS OF AMERICA, INC., BILLINGS, MT:
941,046. REN. 5-1-12. U.S. CL. 50 (INT. CL. 20).
- KANE, RUSSELL D., HOUSTON, TX:
4,153,011, PUB. 1-3-2012. INT. CL. 43.
- KANGOL LIMITED, SHIREBROOK, UNITED KINGDOM:
4,153,667, PUB. 3-20-2012. INT. CL. 25.
- KANUI, JAN EBERLE, EAST LANSING, MI, DBA SUPREMO:
2,629,609. REN. 5-3-12. INT. CL. 15.
- KAPLAN, JEFFREY, FORT LAUDERDALE, FL:
4,153,293, PUB. 3-20-2012. INT. CL. 25.
4,155,910, INT. CL. 31.
- KAPPA ALPHA THETA FRATERNITY, INC., INDIANAPOLIS, IN, KAPPA ALPHA THETA FRATERNITY, CHICAGO, IL:
563,190. REN. 4-28-12. U.S. CL. 100 (INT. CL. 42).
- KAPPA ALPHA THETA FRATERNITY, INC., INDIANAPOLIS, IN:
1,730,959. REN. 4-28-12. INT. CL. 14.
1,731,155. REN. 4-28-12. INT. CL. 21.
1,731,194. REN. 4-28-12. INT. CL. 25.
- KARATE INSTITUTE, INC., CLEVELAND, OH:
4,152,777, PUB. 3-20-2012. MULTIPLE CLASS, INT. CLS. 35 AND 41.
- KAREN DILLARD'S COLLEGE PREP, L.P., PLANO, TX:
4,152,919, PUB. 3-20-2012. INT. CL. 41.
- KARL BISSINGER, INC., ST. LOUIS, MO:
4,154,464, INT. CL. 35.
- KARL STORZ GMBH & CO. KG., D-78532 TUTTLINGEN, FED REP GERMANY:
2,996,237, CANC. MULTIPLE CLASS, INT. CLS. 9 AND 10.
- KARNEY, ANNA, SAN FRANCISCO, CA:
2,673,782. REN. 5-1-12. INT. CL. 41.
- KARPIEL, JAN, ZAKOPANE, POLAND:
4,153,875, PUB. 3-20-2012. INT. CL. 12.
- KARSTEN MANUFACTURING CORPORATION, PHOENIX, AZ:
4,154,212, PUB. 3-6-2012. INT. CL. 28.
4,154,217, PUB. 3-6-2012. INT. CL. 18.
- KASEREI CHAMPIGNON HOFMEISTER GMBH & CO. KG, HEISING, FED REP GERMANY:
1,683,101. REN. 4-28-12. INT. CL. 29.
- KASPAR WALTER GMBH & CO. KG MASCHINENFABRIK, FED REP GERMANY:
4,152,299, PUB. 3-20-2012. MULTIPLE CLASS, INT. CLS. 1 AND 3.
- KATE SPADE LLC, NEW YORK, NY:
4,155,450, INT. CL. 18.
4,155,451, INT. CL. 25.
4,155,452, INT. CL. 35.
4,155,475, INT. CL. 24.
4,155,479, INT. CL. 21.
- KAUFMAN ANALYTICS, LTD., FREEPORT, BAHAMAS:
4,155,029, INT. CL. 36.
- KAWASAKI JUKOGYO KABUSHIKI KAISHA (KAWASAKI HEAVY INDUSTRIES LTD.), CHUO-KU, KOBE, HYOGO, JAPAN, KAWASAKI MOTORS CORP. U.S.A., SANTA ANA, CA:
1,193,581. REN. 4-28-12. INT. CL. 12.
- KBE SOFTWARE, INC., CENTERVILLE, OH:
2,492,442, CANC. INT. CL. 9.
- KEE ACTION SPORTS I LLC, SEWELL, NJ:
4,154,313, MULTIPLE CLASS, INT. CLS. 28 AND 35.
- KEEP A BREAST FOUNDATION, CARLSBAD, CA:
4,154,609, INT. CL. 14.
- KEIRAN WYATT-NICOLLE, GUERNSEY, UNITED KINGDOM:
4,153,473, PUB. 3-20-2012. INT. CL. 33.
- KEITH D. JONES, MONTGOMERY, AL AND AUBRIAN SMITH, MONTGOMERY, AL:
4,155,870, INT. CL. 25.
- KELLEY STYRING, NEWBERG, OR:
4,152,572, PUB. 3-20-2012. INT. CL. 35.
- KELLEY, KEVIN W., SAN RAFAEL, CA:
2,998,537, CANC. INT. CL. 41.
- KELLOGG NORTH AMERICA COMPANY, BATTLE CREEK, MI:
4,154,214, PUB. 3-20-2012. INT. CL. 30.
4,154,215, PUB. 3-20-2012. INT. CL. 30.
- KELLY VAN GOGH HAIR COLOR COSMETICS, LLC, NEW YORK, NY:
4,154,809, INT. CL. 3.
- KEMPS LLC, MINNEAPOLIS, MN, MARIGOLD FOODS, INC., MINNEAPOLIS, MN:
1,766,889. REN. 4-27-12. INT. CL. 32.
- KENALL MANUFACTURING COMPANY, GURNEE, IL:
4,154,009, PUB. 3-20-2012. INT. CL. 11.
- KENCRAFT, INC., ALPINE, UT:
2,493,568, CANC. INT. CL. 30.
- KENNAMETAL INC., LATROBE, PA TO KENNAMETAL INC., LATROBE, PA:
910,403, AM. U.S. CL. 23.
- KENT SEATECH CORPORATION, SAN DIEGO, CA:
2,492,388, CANC. INT. CL. 29.
- KENT SPORTING GOODS, INC., LONDON, OH, FULL THROTTLE FLOTATION, INC., HUNTINGTON BEACH, CA:
1,685,802. REN. 5-1-12. INT. CL. 25.
- KENTASH, LLC, MORGANVILLE, NJ, DBA NJ SMOKES:
4,153,943, PUB. 3-20-2012. INT. CL. 34.

KENTON COUNTY AIRPORT BOARD, CINCINNATI, OH, DBA CINCINNATI/NORTHERN KENTUCKY INTERNATIONAL AIRPORT:
4,153,449, PUB. 3-20-2012. MULTIPLE CLASS, INT. CLS. 35 AND 39.

KERAMIK HOLDING AG LAUFEN, CH-4242 LAUFEN, SWITZERLAND:
4,152,169, PUB. 3-20-2012. MULTIPLE CLASS, INT. CLS. 11, 20 AND 21.

KERBER'S, INC., NORTH HUNTINGDON, PA:
2,561,895, REN. 4-27-12. MULTIPLE CLASS, INT. CLS. 29 AND 42.
2,561,895, CANC. MULTIPLE CLASS, INT. CLS. 30 AND 32.

KERIVAN, JAMES, WEST DUNDEE, IL, DBA INTRA CUSTOM DISTRIBUTORS:
4,153,570, PUB. 3-20-2012. INT. CL. 29.
4,153,573, PUB. 3-20-2012. INT. CL. 29.

KERN, GERALD LEE, WADENA, MN:
2,680,368, REN. 5-1-12. INT. CL. 9.

KESSLER MCGUINNESS & ASSOCIATES, NEWTON, MA, DBA KESSLER MCGUINNESS & ASSOCIATES:
4,153,365, PUB. 3-20-2012. INT. CL. 42.

KETT, KEVIN, CHINO VALLEY, AZ:
4,032,937, CANC. INT. CL. 20.

KEURIG, INCORPORATED, READING, MA:
4,154,856, INT. CL. 11.
4,155,472, INT. CL. 11.

KEYCORP, CLEVELAND, OH:
2,491,678, CANC. INT. CL. 36.

KFC CORPORATION, LOUISVILLE, KY:
4,153,012, PUB. 3-20-2012. INT. CL. 29.
4,153,091, PUB. 3-20-2012. INT. CL. 43.

KGAL GMBH & CO. KG, 82031 GR?NWALD, FED REP GERMANY:
2,560,877, REN. 4-30-12. INT. CL. 36.

KHM CONSULTING INC., BRUNSWICK, OH, DBA KHM TRAVEL GROUP:
4,155,576, INT. CL. 39.

KHM CONSULTING, INC., BRUNSWICK, OH, DBA KHM TRAVEL GROUP:
4,155,738, INT. CL. 39.

KHYBER TECHNOLOGIES CORPORATION, FAIRLAWN, OH:
2,492,891, CANC. INT. CL. 9.

KIA MOTORS AMERICA, INC., IRVINE, CA:
2,605,304, REN. 5-3-12. INT. CL. 12.
4,154,511, INT. CL. 9.

KICKBALL CONCEPTS LLC, GREAT FALLS, VA:
4,154,394, MULTIPLE CLASS, INT. CLS. 20 AND 24.

KID RO PRODUCTIONS, INC., NEW YORK, NY:
4,153,302, PUB. 3-20-2012. INT. CL. 41.

KIELB, FRANK, BROOMALL, PA:
4,153,446, PUB. 3-20-2012. INT. CL. 41.

KIERIG, JEREMY, CHICO, CA:
4,152,584, PUB. 3-20-2012. INT. CL. 9.

KIM INTERNATIONAL MFG. L.P., DALLAS, TX:
4,154,561, INT. CL. 14.

KIM, CHRISTNA, STANTON, CA:
3,570,608, CANC. INT. CL. 25.

KIM, TAE-WEON, SEOUL 140-774, REPUBLIC OF KOREA:
4,155,130, INT. CL. 10.

KIMBALL INTERNATIONAL, INC., JASPER, IN:
2,580,200, REN. 4-27-12. INT. CL. 20.

KIMBERLY KEARNEY, VAN NUYS, CA:
4,154,412, INT. CL. 41.

KIMPEX INC., DRUMMONDVILLE, QUEBEC, CANADA:
4,152,560, PUB. 3-20-2012. MULTIPLE CLASS, INT. CLS. 9 AND 25.

KINDER MORGAN KANSAS, INC., HOUSTON, TX:
4,154,908, INT. CL. 42.

KINEMATIC VENTURES, LLC, WASHINGTON, DC:
2,563,347, REN. 5-2-12. INT. CL. 10.

KING SPORTS GROUP, LLC, ORLANDO, FL:
4,152,955, PUB. 3-20-2012. INT. CL. 35.

KING-O-MEAT, INC., FRESNO, CA:
2,941,446, CANC. INT. CL. 29.

KINGFISHER AIRLINES LIMITED, BANGALORE 560 001, INDIA:
4,152,084, PUB. 3-20-2012. INT. CL. 39.

KINGFISHER MEDIA, LLC, MURRAY, UT:
4,153,578, PUB. 3-20-2012. INT. CL. 5.

KINSTON COMMUNITY HEALTH CENTER, INC., KINSTON, NC:
4,154,547, INT. CL. 44.

KIRCHDORFER FERTIGTEILHOLDING GMBH, AUSTRIA:
4,113,557, COR. MULTIPLE CLASS, INT. CLS. 19 AND 37.

KISSNER MILLING CO. LTD., CAMBRIDGE, ONTARIO, CANADA:
4,153,096, PUB. 3-20-2012. INT. CL. 1.

KIZAN INTERNATIONAL, INC., BRISBANE, CA:
2,561,987, REN. 5-3-12. INT. CL. 25.

KJAER WEIS, KIRSTEN, NEW YORK, NY:
4,153,624, PUB. 3-20-2012. INT. CL. 3.

KL TEXAS, LP, TYLER, TX, DBA SUMMIT INDUSTRIAL PRODUCTS, SUMMIT OIL COMPANY, INC., TYLER, TX:
1,740,460, REN. 4-27-12. INT. CL. 1.

KLEBCHÉMIE M.G. BECKER GMBH & CO. KG, WEINGARTEN/BADEN, FED REP GERMANY:
4,153,685, PUB. 3-20-2012. MULTIPLE CLASS, INT. CLS. 1 AND 2.

KLIMENKO, ELENA, NEW YORK, NY:
4,153,466, PUB. 3-20-2012. INT. CL. 5.

KLINE, GIL, GAITHERSBURG, MD:
4,153,144, PUB. 3-20-2012. INT. CL. 41.

KLINGEMANN, HANS, BOSTON, MA:
4,154,244, INT. CL. 1.

KLIPSCH GROUP, INC., INDIANAPOLIS, IN:
4,153,792, PUB. 3-20-2012. INT. CL. 9.

KMBJ INC., ARCADIA, CA:
4,153,643, PUB. 3-20-2012. INT. CL. 33.

KMCONSOLIDATED, LLC, GILBERT, SC:
4,153,419, PUB. 3-20-2012. INT. CL. 9.

KMJ BBRAND HOLDINGS LLC, NEW YORK, NY:
4,154,459, INT. CL. 24.

KNEE CREATIONS, LLC, WEST CHESTER, PA:
4,154,374, INT. CL. 10.

KNOWLEDGE BUREAU INC., WINNIPEG, MANITOBA, CANADA:
4,154,962, INT. CL. 41.

KNOWLEDGE CANDY MEDIA, HOUSTON, TX:
4,153,176, PUB. 3-20-2012. INT. CL. 9.

KNOWLEDGEWORKS FOUNDATION, CINCINNATI, OH:
4,154,611, MULTIPLE CLASS, INT. CLS. 16 AND 41.

KNOWLES, MATHEW, HOUSTON, TX:
4,154,286, INT. CL. 9.

KO OLINA GOLF CLUB, LLC, HONOLULU, HI:
2,558,188, REN. 5-1-12. MULTIPLE CLASS, INT. CLS. 25, 28 AND 41.

KO OLINA INTANGIBLES, LLC, HONOLULU, HI:
4,153,554, PUB. 3-20-2012. MULTIPLE CLASS, INT. CLS. 39, 41, 43 AND 44.

KOA PUNA MOTORCYCLE CLUB, EWA BEACH, HI:
4,153,296, PUB. 3-20-2012. INT. CL. 35.
4,153,297, PUB. 3-20-2012. MULTIPLE CLASS, INT. CLS. 25 AND 35.

KOHL'S ILLINOIS, INC., AURORA, IL:
4,155,524, MULTIPLE CLASS, INT. CLS. 8 AND 21.

KOITEH, ZAHRAA, BRONX, NY:
4,152,978, PUB. 3-20-2012. INT. CL. 3.

KOMATSU AMERICA CORP., ROLLING MEADOWS, IL:
4,154,113, PUB. 3-20-2012. INT. CL. 37.
4,154,114, PUB. 3-20-2012. INT. CL. 37.

KONAMI DIGITAL ENTERTAINMENT CO., LTD., MINATO-KU, TOKYO, JAPAN:
2,998,556, CANC. INT. CL. 28.

KONAMI GAMING, INC., LAS VEGAS, NV:
4,154,562, INT. CL. 9.
4,155,175, INT. CL. 9.
4,155,176, INT. CL. 9.
4,155,177, INT. CL. 9.
4,155,178, INT. CL. 9.

- KONINKLIJKE PHILIPS ELECTRONICS N.V., BA EINDHOVEN, NETHERLANDS:
4,152,199, PUB. 3-20-2012. INT. CL. 9.
- KONINKLIJKE PHILIPS ELECTRONICS N.V., EINDHOVEN, NETHERLANDS:
4,152,282, PUB. 3-20-2012. INT. CL. 9.
- KONTAGENT, INC., SAN FRANCISCO, CA:
4,153,170, PUB. 3-20-2012. MULTIPLE CLASS, INT. CLS. 35 AND 42.
- KOREA AGRO-FISHERIES & FOOD TRADE CORPORATION, SEOUL, REPUBLIC OF KOREA:
2,564,968. REN. 4-30-12. INT. CL. 35.
- KORI M CLARK, BRADENTON, FL, DBA PAPER AND PIGTAILS:
4,152,912, PUB. 3-20-2012. INT. CL. 42.
- KORNYLAK CORPORATION, HAMILTON, OH:
2,502,099. REN. 4-30-12. INT. CL. 7.
- KORWALL INDUSTRIES, INC., ARLINGTON, TX:
926,649. REN. 5-1-12. U.S. CL. 12 (INT. CL. 19).
- KOSAREFF, MICHAEL JOHN, COSTA MESA, CA, DBA IBLD.COM:
4,153,161, PUB. 3-20-2012. INT. CL. 35.
- KOVALI, IREN, DANIA BEACH, FL AND MCVAY, GARY, NORTH MIAMI, FL:
4,153,929, PUB. 3-20-2012. INT. CL. 39.
- KOVAR'S INC., CARMICHAEL, CA:
2,998,610, CANC. INT. CL. 9.
- KOYA'S IP, MARINA DEL REY, CA:
4,154,129, PUB. 3-20-2012. INT. CL. 35.
- KRAFT FOODS GLOBAL BRANDS LLC, NORTHFIELD, IL:
2,493,487, CANC. INT. CL. 30.
2,567,582. REN. 5-3-12. INT. CL. 30.
4,154,806, INT. CL. 32.
- KRAS, AMANDA J., HIGHLANDS, NJ:
4,155,786, INT. CL. 3.
- KREUZER, TANYA, MESA, AZ:
2,998,971, CANC. INT. CL. 25.
- KRIKORIAN, GEORGE, TORRANCE, CA:
2,602,555. REN. 4-30-12. INT. CL. 41.
2,637,729. REN. 4-27-12. INT. CL. 41.
- KRIS HOLM UNICYCLES LTD., VANCOUVER, CANADA:
4,153,264, PUB. 3-20-2012. INT. CL. 12.
- KRISTEN J. HAFNER, WESTLAKE VILLAGE, CA:
4,154,126, PUB. 3-20-2012. INT. CL. 36.
- KRISTY LEWELLYN, LINTON, IN, AKA LEWELLYN SAFETY:
4,152,653, PUB. 3-20-2012. INT. CL. 9.
- KRONOS TECHNOLOGY SYSTEMS LIMITED PARTNERSHIP, CHELMSFORD, MA:
1,767,961. REN. 5-1-12. INT. CL. 9.
- KRONOTEX U.S.A. HOLDINGS, INC., BARNWELL, SC:
4,154,285, INT. CL. 19.
- KRUGER PRODUCTS L.P., MISSISSAUGA, CANADA:
4,152,616, PUB. 3-20-2012. MULTIPLE CLASS, INT. CLS. 16, 21 AND 35.
- KRUSH INC., CAMBRIDGE, MA:
4,154,671, INT. CL. 35.
- KS BANK, INC., SMITHFIELD, NC:
2,559,303. REN. 4-27-12. INT. CL. 36.
- KUMASAMA PRODUCT CO., LTD., TAICHUNG CITY, TAIWAN:
2,630,481. REN. 5-1-12. INT. CL. 28.
- KURT MANUFACTURING COMPANY, INC., FRIDLEY, MN:
4,152,756, PUB. 3-20-2012. MULTIPLE CLASS, INT. CLS. 35 AND 36.
- KURTH, JOHN, HUNTINGTON BEACH, CA:
4,155,731, INT. CL. 35.
4,155,733, INT. CL. 35.
- KUSHCON LLC, CALABASAS, CA:
4,155,994, INT. CL. 41.
- KUUSAMON UISTIN OY, KUUSAMO, FINLAND:
4,154,559, INT. CL. 28.
- KW AUTOMOTIVE NORTH AMERICA, INC., FRESNO, CA:
3,949,592, COR. INT. CL. 12.
4,110,928, COR. INT. CL. 12.
- KYPKE, CAMIE, ABILENE, TX, DBA WILD ABOUT SKIN:
4,155,555, INT. CL. 3.
- KYRIAKAKIS DENTAL INCORPORATED, HONOLULU, HI, DBA GEMINI DENTAL:
4,153,241, PUB. 3-20-2012. INT. CL. 44.
- K1 SPEED, INC., IRVINE, CA:
4,153,310, PUB. 3-20-2012. INT. CL. 41.
- L & L MANUFACTURING CO., INC., EL SEGUNDO, CA:
4,155,466, INT. CL. 25.
- L. RAND INC., PHILADELPHIA, PA, DBA SOUP OF THE DAY SEARCH AND WILDERSON, LESLIE RAND, PHILADELPHIA, PA:
4,152,808, PUB. 3-20-2012. INT. CL. 35.
- L. SCHULTZ, INC., SAN MARCOS, CA, DBA LEE'S AQUARIUM & PET PRODUCTS:
3,131,348, COR. INT. CL. 16.
- L.C. LICENSING, LLC, NEW YORK, NY:
2,999,285, CANC. INT. CL. 25.
- L&M COMPANIES, INC., RALEIGH, NC:
4,154,744, INT. CL. 31.
4,154,745, MULTIPLE CLASS, INT. CLS. 39 AND 44.
- L&P PROPERTY MANAGEMENT COMPANY, SOUTH GATE, CA:
2,688,573. REN. 5-1-12. INT. CL. 6.
- L&P PROPERTY MANAGEMENT COMPANY, SOUTH GATE, CA, FOAMEX CARPET CUSHION LLC, WILMINGTON, DE:
2,693,416. REN. 5-1-12. INT. CL. 27.
- L'ETOILE ROYALE, NEW YORK CITY, NY:
4,152,601, PUB. 3-20-2012. INT. CL. 35.
- L'OREAL USA CREATIVE, INC., NEW YORK, NY:
2,564,526. REN. 5-1-12. INT. CL. 21.
4,154,925, INT. CL. 3.
4,155,406, INT. CL. 3.
4,155,712, INT. CL. 3.
4,155,841, INT. CL. 3.
- LA CORNUÉ, F-95310 SAINT-OUEN L'AUMONE, FRANCE:
4,152,292, PUB. 3-20-2012. MULTIPLE CLASS, INT. CLS. 11 AND 20.
- LA DUNI CONCEPTS, LLC, DALLAS, TX:
4,153,441, PUB. 3-20-2012. INT. CL. 35.
- LA GROU, JOHN, PLACERVILLE, CA, DBA VINHEART:
4,153,831, PUB. 3-20-2012. INT. CL. 36.
- LA HERRADURA LTD., KEY BISCAYNE, FL:
4,154,431, INT. CL. 25.
- LA NEW INTERNATIONAL CORPORATION, HSI CHIH CHEN, TAIPEI HSIEN, TAIWAN:
2,575,532. REN. 4-30-12. INT. CL. 25.
- LA TRIENNALE DI MILANO, ITALY:
4,152,189, PUB. 3-20-2012. MULTIPLE CLASS, INT. CLS. 35, 41, 42 AND 43.
- LA WEIGHT LOSS LLC, WILMINGTON, DE:
2,493,446, CANC. INT. CL. 42.
- LABATE, MICHAEL N., PHILADELPHIA, PA:
4,156,031, INT. CL. 42.
- LABEL MARKETING INTERNATIONAL, INC., CITY OF INDUSTRY, CA:
1,584,798, CANC. INT. CL. 25.
- LACOUR, INC., FAIRFIELD, NJ:
1,695,057. REN. 5-1-12. INT. CL. 42.
- LACTALIS FORLASA, S.L.U., SPAIN:
4,152,339, PUB. 3-20-2012. INT. CL. 29.
- LAFORGE, 02190 GUIGNICOURT, FRANCE:
4,153,143, PUB. 3-20-2012. MULTIPLE CLASS, INT. CLS. 7 AND 12.
- LAFORME, JOHN JR., SHERMAN OAKS, CA:
2,703,786. REN. 4-30-12. MULTIPLE CLASS, INT. CLS. 9 AND 41.
- LAKESIDE PRIDE MUSIC ENSEMBLES, INC., CHICAGO, IL:
4,153,889, PUB. 3-20-2012. INT. CL. 41.
- LAKSHMI INC, MEMPHIS, TN, DBA YOGO -N- SWEETS:
4,153,488, PUB. 3-20-2012. INT. CL. 43.
- LAMBERT, MIRANDA, ATLANTA, GA:
4,154,429, INT. CL. 45.
- LAMON, HILARY B., WOODRIDGE, IL:
4,152,622, PUB. 3-20-2012. INT. CL. 18.
- LAMPS PLUS, INC., CHATSWORTH, CA:
2,561,043. REN. 5-3-12. INT. CL. 42.

LANCASTER, JANET, SAN DIEGO, CA, DBA SAVE THE PLANET JANET:
4,155,261, INT. CL. 35.

LAND TEJAS COMPANIES, LTD., HOUSTON, TX:
4,152,773, PUB. 3-20-2012. INT. CL. 37.

LANDA MOBILE SYSTEMS LLC, WEST FORK, AR:
4,156,046, INT. CL. 40.

LANDAU, KRISTEN MARIE, MERCER ISLAND, WA:
3,006,989, CANC. INT. CL. 25.

LANDEC AG, INC., MONTICELLO, IN:
2,998,555, CANC. INT. CL. 31.

LANDRY, ROBIN, UPPER MARLBORO, MD:
4,154,793, INT. CL. 45.

LANDRY'S TRADEMARK, INC., HOUSTON, TX:
4,153,954, PUB. 3-20-2012. INT. CL. 43.

LANER, STEVE, PARKER, CO:
4,154,818, INT. CL. 25.

LANG, DARRELL RICHARD, SCOTTSDALE, AZ:
2,562,591, REN. 5-3-12. INT. CL. 28.

LANGE, MIA P., BOCA RATON, FL:
4,153,734, PUB. 3-20-2012. MULTIPLE CLASS, INT. CLS. 18 AND 25.

LANSINOH LABORATORIES, INC., ALEXANDRIA, VA:
2,561,103, REN. 5-3-12. INT. CL. 5.

LANX, INC., BROOMFIELD, CO:
4,155,489, INT. CL. 10.

LANXESS DEUTSCHLAND GMBH, LEVERKUSEN, FED REP GERMANY:
4,155,526, INT. CL. 2.

LAPOINT BLASE IND. INC., KIRKWOOD, MO, DBA EWR WEATHER RADAR:
4,154,007, PUB. 3-20-2012. INT. CL. 9.

LAPORTE, A PROFESSIONAL ACCOUNTING CORPORATION, METAIRIE, LA, FORMERLY LAPORTE, SEHRT, ROMIG AND HAND, A PROFESSIONAL ACCOUNTING CORPORATION:
4,153,113, PUB. 3-20-2012. INT. CL. 35.

LARGE DOCUMENT IMAGING, INC., NORCROSS, GA:
1,720,658, REN. 5-1-12. INT. CL. 35.

LARSON, GLEN J., COLORADO SPRINGS, CO:
4,155,083, INT. CL. 42.

LAS VEGAS CONVENTION AND VISITORS AUTHORITY, LAS VEGAS, NV:
4,155,722, INT. CL. 35.

LASER SPINE INSTITUTE, LLC, TAMPA, FL:
4,155,869, INT. CL. 44.

LASHAWNDA ANIKA LEE ROBBINS, MINNEAPOLIS, MN:
4,153,777, PUB. 3-20-2012. INT. CL. 3.

LASOLEIL, L.L.C., DALLAS, TX:
2,575,901, REN. 4-30-12. INT. CL. 41.

LASTAR, INC., DAYTON, OH:
4,153,010, PUB. 3-20-2012. INT. CL. 9.

LASTING IMPRINT, INC., MANKATO, MN:
4,153,758, PUB. 3-20-2012. MULTIPLE CLASS, INT. CLS. 35 AND 36.

LATHAM JR, CHARLES W, CHARLESTON, SC:
4,154,381, INT. CL. 25.

LATHEM TIME CORPORATION, ATLANTA, GA:
4,154,728, INT. CL. 9.

LATI INDUSTRIA TERMOPLASTICI S.P.A., ITALY:
4,152,355, PUB. 3-20-2012. MULTIPLE CLASS, INT. CLS. 1 AND 17.
4,152,356, PUB. 3-20-2012. MULTIPLE CLASS, INT. CLS. 1 AND 17.

LATIBEAUDIERE DELMAR O, CINCINNATI, OH, AKA FEARLESS KID:
4,152,552, PUB. 3-20-2012. INT. CL. 41.

LATIN BREED, INC., NORTH RICHLAND HILLS, TX:
4,153,987, PUB. 3-20-2012. INT. CL. 41.

LATTIG, MICHAEL D., REDMOND, OR, DBA CLEAR-WATER NATIVE NURSERY:
4,154,526, INT. CL. 31.

LAUDA AIR LUFTFAHRT GMBH, NEW YORK, NY:
2,492,671, CANC. INT. CL. 39.

LAWRENCE DARNELL STUART, RESEDA, CA, DBA FIVE LIONS ENTERTAINMENT:
4,155,174, INT. CL. 25.

LAWRENCE Q. MARKX, CHRISTMAS, FL:
4,153,836, PUB. 3-20-2012. INT. CL. 42.

LAX GAL, LLC, WINDERMERE, FL:
4,153,833, PUB. 3-20-2012. INT. CL. 25.

LAYTON CAPITAL CORPORATION, SANTA FE SPRINGS, CA:
2,615,816, REN. 5-1-12. INT. CL. 7.

LBC INDUSTRIES, DOYLESTOWN, PA:
4,155,543, INT. CL. 43.

LBU INTERNATIONAL, INC., DEERFIELD BEACH, FL:
4,152,795, PUB. 3-20-2012. INT. CL. 35.

LCY ELASTOMERS LP, BAYTOWN, TX:
4,154,028, PUB. 3-20-2012. INT. CL. 17.

LE, TRAMERICA Q., SAN DIEGO, CA, DBA TRADE EMBASSY:
4,154,458, INT. CL. 35.

LEADBETTERS BAKE SHOP LLC, SAN FRANCISCO, CA:
2,498,564, REN. 4-27-12. INT. CL. 30.

LEADBRIDGE PARTNERS, LLC, ANDOVER, MA, AKA LEADBRIDGE:
4,152,704, PUB. 3-20-2012. INT. CL. 35.

LEADERSHIP CONFERENCE ON CIVIL RIGHTS, WASHINGTON, DC:
4,154,512, MULTIPLE CLASS, INT. CLS. 16, 35 AND 41.

LEADERSHIP INSTITUTE FOR TEENS, NEWPORT COAST, CA:
3,442,720, CANC. MULTIPLE CLASS, INT. CLS. 9 AND 41.

LEAN-SLIM, LLC, LAS VEGAS, NV:
4,153,753, PUB. 3-20-2012. INT. CL. 5.

LEAR CORPORATION, SOUTHFIELD, MI:
2,557,963, REN. 4-27-12. INT. CL. 12.
4,154,272, MULTIPLE CLASS, INT. CLS. 12 AND 24.

LEATHER GOODS, INC., ATLANTA, GA, DBA W. KLEINBERG:
3,612,379, COR. INT. CL. 25.
3,612,382, COR. INT. CL. 18.
3,642,704, COR. INT. CL. 26.

LEE MEMORIAL HEALTH SYSTEM, FORT MYERS, FL:
4,154,236, PUB. 3-20-2012. INT. CL. 16.

LEE, ERIC, KALAMAZOO, MI:
4,153,550, PUB. 3-20-2012. INT. CL. 6.

LEE'S SANDWICHES INTERNATIONAL, INC., SAN JOSE, CA:
4,152,820, PUB. 3-20-2012. INT. CL. 35.

LEFFINGWELL, APRIL A, SAN DIEGO, CA:
4,154,636, INT. CL. 3.

LEFTHAND DISTRIBUTION LLC, WORTHINGTON, OH:
4,153,354, PUB. 3-20-2012. INT. CL. 35.

LEGACY HEAT TREATING, INC., MILWAUKEE, WI:
2,642,314, REN. 4-30-12. INT. CL. 40.

LEHIGH VALLEY DISCOUNTS & MORE (LVD), ALLENTOWN, PA:
4,155,676, INT. CL. 25.

LEICA BIOSYSTEMS RICHMOND, INC., RICHMOND, IL:
4,155,198, INT. CL. 1.

LEKITHOS, INC., PALM BEACH GARDENS, FL:
4,155,628, INT. CL. 5.

LENAGHAN, DONNA, HIALEAH, FL:
4,153,460, PUB. 3-20-2012. INT. CL. 41.

LENNOX HEARTH PRODUCTS LLC, NASHVILLE, TN:
4,155,330, INT. CL. 11.

LENNOX INDUSTRIES INC, RICHARDSON, TX:
2,637,604, REN. 4-30-12. INT. CL. 36.

LENOX CORPORATION, BRISTOL, PA, LENOX INCORPORATED, LAWRENCEVILLE, NJ:
1,194,884, REN. 4-30-12. INT. CL. 42.

LENZING AKTIENGESELLSCHAFT, AUSTRIA:
4,152,393, PUB. 3-20-2012. MULTIPLE CLASS, INT. CLS. 1, 22 AND 23.

LEO ARRETIN, INC., WALNUT, CA:
2,609,964, REN. 5-1-12. INT. CL. 30.

LEOKADIA PTY LTD., MANLY, AUSTRALIA:
4,155,063, INT. CL. 32.

LEON, STEVEN J., AUSTIN, TX:
2,673,973, REN. 5-3-12. INT. CL. 42.

- LEON, STEVEN J., AUSTIN, TX, DBA TECHNOLIS COMMUNICATIONS:
2,681,107. REN. 5-3-12. INT. CL. 42.
2,704,600. REN. 5-3-12. INT. CL. 35.
- LEONG, ROLAND, GLEN ROCK, NJ:
2,657,730. REN. 5-1-12. INT. CL. 41.
- LES CABLES BEN-MOR INC., QUEBEC, CANADA:
4,156,041, INT. CL. 6.
4,156,042, INT. CL. 6.
- LES MILLS INTERNATIONAL LIMITED, AUCKLAND, NEW ZEALAND:
4,152,468, PUB. 3-20-2012. INT. CL. 41.
- LES PARFUMS KEIKO MECHEI, BEVERLY HILLS, CA:
4,152,563, PUB. 3-20-2012. INT. CL. 3.
- LES PROMOTIONS ATLANTIQUES INC./ ATLANTIC PROMOTIONS INC., LONGUEUIL (QUEBEC), CANADA:
2,643,376. REN. 5-2-12. INT. CL. 8.
- LESLIE, DENIE, HOLLISTER, CA:
2,492,648, CANC. INT. CL. 37.
- LESSNAU, JAMES G., DEARBORN, MI:
2,988,867, CANC. INT. CL. 43.
- LEU, MEI, SAN FRANCISCO, CA:
4,155,604, INT. CL. 30.
- LEVEL11, LLC, EDEN PRAIRIE, MN:
4,155,633, INT. CL. 41.
- LEVINE, LORRAINE, PACIFIC PALISADES, CA:
4,155,644, INT. CL. 16.
- LEVINSON MEDICAL CENTER FOR LEARNING DISABILITIES, INC., GREAT NECK, NY:
2,492,454, CANC. INT. CL. 42.
- LEVITON MANUFACTURING CO., INC., LITTLE NECK, NY:
2,998,514, CANC. INT. CL. 9.
- LEVY, JEFFREY, TORONTO, ONTARIO, CANADA:
4,152,567, PUB. 3-20-2012. INT. CL. 35.
- LEWIS, BECA /BECA LEWIS, CORTLAND, OH:
2,492,731, CANC. INT. CL. 42.
- LEWIS, THOMAS, SAN ANTONIO, TX:
4,155,642, INT. CL. 35.
- LEXNET CONSULTING GROUP, SAN FRANCISCO, CA:
4,153,429, PUB. 3-20-2012. INT. CL. 42.
- LEYANT INDUSTRY CO., TAICHUNG HSIEN, TAIWAN:
4,152,159, PUB. 3-20-2012. INT. CL. 11.
- LF 20, INC., FRANKLIN SQUARE, NY:
4,155,470, INT. CL. 25.
4,155,471, INT. CL. 25.
- LF, LLC, MOUNT MOURNE, NC:
4,154,483, INT. CL. 6.
- LG ELECTRONICS INC., SEOUL, REPUBLIC OF KOREA:
4,152,120, PUB. 3-20-2012. MULTIPLE CLASS, INT. CLS. 7, 9, 10, 11 AND 35.
4,152,441, PUB. 3-20-2012. INT. CL. 11.
4,152,448, PUB. 3-20-2012. INT. CL. 9.
4,152,449, PUB. 3-20-2012. INT. CL. 9.
4,152,486, PUB. 3-20-2012. INT. CL. 11.
- LG ELECTRONICS INC., SEOUL 150-721, REPUBLIC OF KOREA:
4,152,534, PUB. 3-20-2012. INT. CL. 9.
- LIANG, DANIEL, CERRITOS, CA, AKA LIANG, CHIA TUNG:
4,155,447, INT. CL. 22.
4,155,449, INT. CL. 22.
- LIBERSOHN, MEIR, CIUDAD DE BUENOS AIRES, ARGENTINA:
3,113,887, CANC. INT. CL. 42.
- LIBERTAD BANK SSB, AUSTIN, TX, TA LIBERTAD BANK:
3,415,487, AM. INT. CL. 36.
- LIBERTY BELL EQUIPMENT CORPORATION, THE, PHILADELPHIA, PA:
2,496,093. REN. 5-2-12. INT. CL. 35.
- LIBERTY FRUIT COMPANY, INC., KANSAS CITY, KS:
2,615,855. REN. 4-29-12. INT. CL. 31.
- LIBERTY MEDIA FOR WOMEN LLC, ARLINGTON, VA, MAJORITY ENTERPRISES, INC., NEW YORK, NY:
933,253. REN. 4-30-12. U.S. CL. 38 (INT. CL. 16).
- LIBERTY MUTUAL INSURANCE COMPANY, BOSTON, MA:
2,493,380, CANC. INT. CL. 36.
4,155,151, MULTIPLE CLASS, INT. CLS. 36 AND 42.
- LIBERTY PL SERVICES, LLC, SPRING, TX, AKA LIBERTY PIPELINE SERVICES, LLC:
4,153,014, PUB. 3-20-2012. INT. CL. 35.
4,153,015, PUB. 3-20-2012. INT. CL. 35.
- LIDA BADAY DESIGN LTD., TORONTO, CANADA:
2,614,859. REN. 5-3-12. INT. CL. 25.
- LIDESTRI FOODS, INC., FAIRPORT, NY:
4,155,244, INT. CL. 30.
4,155,832, INT. CL. 29.
- LIDL STIFTUNG & CO. KG, FED REP GERMANY:
2,998,353.
4,152,327, PUB. 3-20-2012. INT. CL. 33.
- LIFESTYLE BRANDS CORPORATION, ENGLEWOOD, CO:
4,154,517, INT. CL. 28.
- LIFESYSTEMS, SAN JOSE, CA:
2,998,904, CANC. INT. CL. 16.
- LIFETIME BRANDS, INC., GARDEN CITY, NY:
1,705,041. REN. 5-3-12. INT. CL. 20.
- LIFTED RESEARCH GROUP INC., IRVINE, CA:
4,154,594, MULTIPLE CLASS, INT. CLS. 16, 24 AND 28.
- LIGHTHOUSE PRINTING, INC., MOKENA, IL:
4,153,401, PUB. 3-20-2012. INT. CL. 40.
- LILY ORGANICS, INC, HENDERSON, CO, DBA LILY FARM FRESH SKIN CARE:
4,155,507, INT. CL. 3.
- LIMA, THERESE, SILVER SPRING, MD:
2,492,730, CANC. MULTIPLE CLASS, INT. CLS. 25 AND 42.
- LIMAX INTERNATIONAL INC., TAIPEI CITY 105, TAIWAN:
4,155,623, INT. CL. 28.
- LIMITED LIABILITY COMPANY "WHITEHALL-CENTER", MOSCOW, RUSSIAN FED.:
3,084,372, AM. INT. CL. 33.
- LIN, AI GUO, JINJIANG CITY, CHINA:
4,155,599, INT. CL. 11.
4,155,619, INT. CL. 25.
- LINCOLN UNIVERSITY OF THE COMMONWEALTH SYSTEM OF HIGHER EDUCATION, LINCOLN UNIVERSITY, PA:
2,642,616. REN. 5-2-12. INT. CL. 41.
2,642,617. REN. 5-3-12. INT. CL. 41.
- LINDBERG, EVA ARIELA, SAN GERONIMO, CA:
2,492,445, CANC. INT. CL. 42.
- LINDSAY PARROTT, CHICAGO, IL:
4,154,965, INT. CL. 41.
- LINKSUS CORPORATION, CORAL SPRINGS, FL:
4,153,909, PUB. 3-20-2012. INT. CL. 39.
- LINMAR TECHNOLOGY INC., BROOKLYN, NY:
4,154,565, INT. CL. 3.
- LINZER PRODUCTS CORP., WEST BABYLON, NY:
4,153,703, PUB. 3-20-2012. INT. CL. 16.
- LION GLOBAL INVESTORS LIMITED, SINGAPORE:
4,152,402, PUB. 3-20-2012. INT. CL. 36.
- LION NATHAN USA, INC., OVERLAND PARK, KS:
4,153,993, PUB. 3-20-2012. INT. CL. 35.
4,153,997, PUB. 3-20-2012. INT. CL. 35.
4,154,000, PUB. 3-20-2012. INT. CL. 33.
- LION-WINE PTY LTD, SYDNEY, NSW 2000, AUSTRALIA:
4,154,001, PUB. 3-20-2012. MULTIPLE CLASS, INT. CLS. 9, 33 AND 43.
- LIPHA LYONNAISE INDUSTRIELLE PHARMACEUTIQUE, F-69008 LYON, FRANCE TO LIPHATECH S.A., FONTENAY-SOUS-BOIS, FRANCE:
1,693,841, CANC. INT. CL. 1.
- LIPHATECH S.A., FONTENAY-SOUS-BOIS, FRANCE, LIPHA LYONNAISE INDUSTRIELLE PHARMACEUTIQUE, F-69008 LYON, FRANCE:
1,693,841. REN. 5-2-12. INT. CL. 5.
- LIQUID COMMON, LLC, ALBUQUERQUE, NM:
4,153,166, PUB. 3-20-2012. INT. CL. 35.
- LISTEN TO YOUR MOTHER, LLC, MADISON, WI:
4,152,907, PUB. 3-20-2012. INT. CL. 41.

LITEMAN, GODNI AMIR, NEW YORK, NY:
 4,154,383, INT. CL. 41.
 4,154,384, INT. CL. 41.
 4,154,385, INT. CL. 41.

LITHIUM PRODUCTS, LLC, KNOXVILLE, TN:
 4,155,914, INT. CL. 9.

LITMUS CO., LTD., SEOUL, REPUBLIC OF KOREA:
 2,566,155. REN. 4-27-12. INT. CL. 25.

LITTLE OWL SOAP LLC, METUCHEN, NJ, AKA LITTLE OWL SOAP:
 4,153,038, PUB. 3-20-2012. INT. CL. 3.

LITTLE WOMBAT IP PTY LTD, BEECHMONT, QUEENSLAND, AUSTRALIA:
 4,152,613, PUB. 1-10-2012. INT. CL. 11.

LIVE EYEWEAR, INC., SAN LUIS OBISPO, CA:
 4,153,789, PUB. 3-20-2012. INT. CL. 9.
 4,153,794, PUB. 3-20-2012. INT. CL. 9.
 4,153,798, PUB. 3-20-2012. INT. CL. 9.
 4,153,804, PUB. 3-20-2012. INT. CL. 9.

LIVE SOFTWARE LLC, BROOKFIELD, WI:
 4,153,193, PUB. 3-20-2012. INT. CL. 42.

LIVING PROOF, INC., CAMBRIDGE, MA:
 4,153,556, PUB. 3-20-2012. INT. CL. 3.

LIVING YOUR BEST LLC, HUDSON, MA:
 4,153,334, PUB. 3-20-2012. INT. CL. 29.

LIVON LABORATORIES, INC., HENDERSON, NV:
 4,154,230, PUB. 3-20-2012. MULTIPLE CLASS, INT. CLS. 35, 41 AND 44.

LIWE ESPAÑOLA, S.A., SPAIN:
 4,152,376, PUB. 3-20-2012. INT. CL. 35.

LIZ CLAIBORNE, INC., NEW YORK, NY:
 2,998,829. CANC. INT. CL. 9.

LIZZARD FILMS, CA:
 2,683,589. REN. 5-1-12. INT. CL. 41.

LMC PARTNERS, SOUTH SAN FRANCISCO, CA:
 4,155,255, INT. CL. 21.

LMSJ LIMITED, ESSEX, UNITED KINGDOM:
 4,152,814, PUB. 3-20-2012. INT. CL. 25.

LOANSTAR FUNDING GROUP, INC., BRYAN, TX:
 2,998,595. CANC. INT. CL. 36.

LODER, JORDAN N., NORTH EGREMONT, MA, DBA PLANNED PARTYHOOD:
 4,153,216, PUB. 3-20-2012. INT. CL. 41.

LODESTAR ANSTALT (A LIECHTENSTEIN COMPANY), VADUZ, LIECHTENSTEIN:
 4,152,287, PUB. 3-20-2012. INT. CL. 33.
 4,152,288, PUB. 3-20-2012. INT. CL. 33.

LODGING/HOSPITALITY MANAGEMENT CORPORATION, ST. LOUIS, MO:
 4,155,245, INT. CL. 43.

LOEWE, S.A., SPAIN:
 4,152,315, PUB. 3-20-2012. INT. CL. 3.

LOFRUMENTO, MARY ANN, MORRISTOWN, NJ:
 3,081,122. CANC. INT. CL. 41.

LOGILITY, INC., ATLANTA, GA:
 2,562,085. REN. 4-27-12. INT. CL. 9.

LOLA KIMONI INC., PACIFIC PALISADES, CA:
 4,155,017, INT. CL. 25.

LOMBARD & MEDOT (SOCIÉTÉ ANONYME À DIRECTOIRE ET CONSEIL DE SURVEILLANCE), FRANCE:
 4,152,211, PUB. 3-20-2012. MULTIPLE CLASS, INT. CLS. 33 AND 35.

LONG HUEI HELMET CO., YUNG-KANG CITY, TAINAN, TAIWAN:
 2,601,507. REN. 5-1-12. INT. CL. 9.

LONG ISLAND UNIVERSITY, BROOKVILLE, NY:
 4,153,112, PUB. 3-20-2012. MULTIPLE CLASS, INT. CLS. 25 AND 41.

LONGHORN GLASS MANUFACTURING, L.P., ST. LOUIS, MO:
 2,650,209. REN. 5-2-12. INT. CL. 40.

LONZA COLOGNE AG, 50829 KÖLN, FED REP GERMANY:
 4,152,218, PUB. 3-20-2012. MULTIPLE CLASS, INT. CLS. 9 AND 42.

LONZA INC., ALLENDALE, NJ, BAIRD CHEMICAL INDUSTRIES, INC., FAIRLAWN, NJ:
 933,731. REN. 5-2-12. U.S. CL. 6 (INT. CL. 5).
 934,776. REN. 5-2-12. U.S. CL. 6 (INT. CL. 1).

LOOPLANE.COM, LLC, HENDERSON, NV:
 4,153,770, PUB. 3-20-2012. INT. CL. 45.

LOOSE LEAF CONCEPTS, LLC, PHILADELPHIA, PA:
 4,153,760, PUB. 3-20-2012. MULTIPLE CLASS, INT. CLS. 35 AND 42.

LOPEMAN, JAMIE, RICHMOND, IN AND JOHNSON, MICHAEL, SENECA, PA:
 4,154,666, INT. CL. 25.

LOPEZ FOODS, INC., MIDLAND, TX, DBA JORGE'S MEXICAN CAFE:
 4,152,915, PUB. 3-20-2012. INT. CL. 43.

LORD'S COMPANY OF ORLANDO, THE, WINTER SPRINGS, FL:
 1,715,226. REN. 5-2-12. INT. CL. 9.

LOREX TECHNOLOGY INC., MARKHAM, ONTARIO, CANADA:
 4,153,072, PUB. 3-20-2012. INT. CL. 35.
 4,153,073, PUB. 3-20-2012. INT. CL. 35.

LORNAMEAD, INC., TONAWANDA, NY:
 4,099,307. COR. INT. CL. 3.

LOS ANGELES COUNTY SHERIFF'S DEPARTMENT, MONTEREY PARK, CA:
 2,627,597. REN. 5-2-12. INT. CL. 42.

LOS ANGELES POLICE PROTECTIVE LEAGUE, LOS ANGELES, CA:
 4,155,371, INT. CL. 35.

LOS ANGELES SPORTS COUNCIL, LOS ANGELES, CA:
 1,599,551, CANC. MULTIPLE CLASS, INT. CLS. 16, 18, 20 AND 25.

LOSS PREVENTION GROUP, INC., THE, STATEN ISLAND, NY, DBA METRO LOSS PREVENTION SERVICES GROUP:
 4,152,745, PUB. 3-20-2012. INT. CL. 45.

LOSURDO FOODS, INC., HACKENSACK, NJ:
 1,760,091. REN. 4-30-12. MULTIPLE CLASS, INT. CLS. 29 AND 30.

LOTHAMER FRANCHISE CORPORATION, LANSING, MI:
 4,153,680, PUB. 3-20-2012. INT. CL. 35.

LOTIONS LIMITED, LLC, MADISON, WI:
 4,154,612, INT. CL. 10.

LOUD TRUCK EFG, LLC, SPOKANE, WA:
 4,155,595, INT. CL. 5.

LOUISVILLE BEDDING COMPANY, LOUISVILLE, KY:
 4,154,421, INT. CL. 20.

LOVE MY WORLD, INC., MADISON, CT:
 2,998,520. CANC. INT. CL. 42.

LOVE STYLE CORPORATION, FORT WORTH, TX:
 4,155,575, INT. CL. 43.

LOVELAND PRODUCTS, INC., LOVELAND, CO:
 2,998,690, CANC. MULTIPLE CLASS, INT. CLS. 1, 5 AND 31.

LOVELOCKS AT LOVER'S GATE, ST. GEORGE, UT:
 4,154,249, MULTIPLE CLASS, INT. CLS. 6 AND 41.

LOVER'S LANE I.P., LTD., PLYMOUTH, MI:
 2,565,651. REN. 5-1-12. INT. CL. 35.

LOWE & LEE MARKETING LLC, ALBUQUERQUE, NM:
 4,152,918, PUB. 3-20-2012. INT. CL. 10.

LOYAL AMERICAN LIFE INSURANCE COMPANY, AUSTIN, TX, TA LOYAL AMERICAN LIFE INSURANCE COMPANY:
 4,155,812, INT. CL. 36.

LUBE'N GO, INC., EL PASO, TX:
 1,173,613. REN. 5-1-12. INT. CL. 37.

LUCA MOSCHINI, ASHLAND, OR:
 4,153,690, PUB. 3-20-2012. INT. CL. 44.

LUCASFILM ENTERTAINMENT COMPANY LTD., SAN FRANCISCO, CA:
 2,559,055. REN. 4-27-12. INT. CL. 28.
 2,562,185. REN. 4-30-12. INT. CL. 9.

LUCIFER LIGHTING COMPANY, SAN ANTONIO, TX, EMMANUEL LIGHTING COMPANY, SAN ANTONIO, TX:
 1,217,441. REN. 5-3-12. INT. CL. 11.

LUCILE'S, LTD., BOULDER, CO, DBA LUCILE'S CREOLE CAFE:
 1,684,578. REN. 4-30-12. INT. CL. 30.

- LUDERS, CHRISTOPH, 53113 BONN, FED REP GERMANY AND WINKLER, MARTIN, 5311 BONN, FED REP GERMANY:
2,489,726. REN. 5-3-12. MULTIPLE CLASS, INT. CLS. 9, 16 AND 42.
- LUDWICK, MATTHEW, BURBANK, CA:
4,155,189, INT. CL. 25.
- LUFT INDUSTRIE, INC., OAKLAND, CA:
4,155,521, INT. CL. 21.
- LUMENPULSE LIGHTING, INC., MONTREAL, QUEBEC, CANADA:
4,154,206, PUB. 3-20-2012. INT. CL. 9.
- LUMI-LITE CANDLE COMPANY, INC., NORWICH, OH:
2,493,162, CANC. INT. CL. 4.
- LUMMUS TECHNOLOGY INC., BLOOMFIELD, NJ:
2,581,914. REN. 4-27-12. INT. CL. 11.
- LUNDGREN DOLPH, SWEDEN:
4,152,200, PUB. 3-20-2012. MULTIPLE CLASS, INT. CLS. 9, 16 AND 41.
- LUNDSTROM INSURANCE AGENCY, INC., ELGIN, IL:
4,152,821, PUB. 3-20-2012. INT. CL. 36.
- LUNHE INVESTMENT LTD., LAS VEGAS, NV:
4,155,446, INT. CL. 9.
- LUSH CANDLES, INC., DALLAS, TX:
2,998,544, CANC. INT. CL. 4.
- LUXCO, INC., ST. LOUIS, MO:
1,716,296. REN. 5-2-12. INT. CL. 33.
- LUXE VAULT LTD., NEW YORK, NY:
4,155,069, INT. CL. 14.
- LUXEXCEL HOLDING B.V., NETHERLANDS:
4,152,330, PUB. 3-20-2012. INT. CL. 40.
- LUXGEN MOTOR CO., LTD., MIAOLI COUNTY 367, TAIWAN:
4,155,055, INT. CL. 35.
4,155,056, INT. CL. 37.
- LUXURY GOODS INTERNATIONAL (L.G.I.) S.A., 6814 CADEMPINO, SWITZERLAND:
1,680,439. REN. 4-30-12. INT. CL. 25.
- LVTM, INC., ENCINO, CA:
2,566,725. REN. 5-3-12. INT. CL. 19.
2,569,305. REN. 5-2-12. INT. CL. 19.
2,569,306. REN. 5-2-12. INT. CL. 19.
2,577,417. REN. 5-2-12. INT. CL. 19.
2,580,990. REN. 5-2-12. INT. CL. 19.
2,606,615. REN. 5-2-12. INT. CL. 19.
- LYKKE.IT S.R.L., I-20020 COGLIATE (MB), ITALY:
4,152,418, PUB. 3-20-2012. INT. CL. 28.
- LYNCH, JOHN G., SAN FRANCISCO, CA, DBA SEA HUNT PEARLS:
4,153,045, PUB. 3-20-2012. INT. CL. 14.
- LYNDA.COM INC., CARPINTERIA, CA:
2,613,079. REN. 5-3-12. INT. CL. 16.
- LYONS PARTNERSHIP, L.P., RICHARDSON, TX:
2,557,739. REN. 5-1-12. MULTIPLE CLASS, INT. CLS. 16, 25, 28 AND 41.
2,557,739, CANC. MULTIPLE CLASS, INT. CLS. 9, 18 AND 21.
- L2T, INC., ALHAMBRA, CA:
4,154,582, MULTIPLE CLASS, INT. CLS. 9, 20, 24, 25, 27 AND 35.
- M & C TOY CENTRE LTD., TSIMSHATSUI EAST, KOWLOON, HONG KONG:
2,493,004, CANC. INT. CL. 28.
- M & C TOY CENTRE LTD., KOWLOON, HONG KONG:
2,563,370. REN. 4-27-12. INT. CL. 28.
- M & Z, LLP, MONROE, IN:
2,493,161, CANC. INT. CL. 35.
- M. SLAVIN & SONS, LTD., BRONX, NY:
2,569,196. REN. 5-3-12. INT. CL. 35.
- M.E.P. CAD, INC., RENO, NV:
4,154,391, INT. CL. 9.
- M.E.R.I.T. INVESTIGATIVE SERVICES, INC., NEWARK, NJ:
4,152,794, PUB. 3-20-2012. INT. CL. 42.
- M&S CRENEAU, INC., PALM BEACH GARDENS, FL:
4,154,820, INT. CL. 5.
- MAAT RESOURCES, INC., SOUTH SAN FRANCISCO, CA:
2,665,479. REN. 4-30-12. INT. CL. 16.
- MABEL'S LABELS INC., HAMILTON, ONTARIO, CANADA:
4,152,123, PUB. 3-20-2012. INT. CL. 35.
- MACCULLOUGH, SCOTT A., PEMBROKE PINES, FL, DBA EVERYTHING HIGH SCHOOL SPORTS LLC:
4,155,973, INT. CL. 41.
- MACHEREY-NAGEL & CO. HANDELSGESELLSCHAFT, DUEREN, FED REP GERMANY, DBA MACHEREY-NAGEL:
4,153,314, PUB. 3-20-2012. INT. CL. 9.
- MACK, RHIANNA, ARLINGTON, TX:
4,153,835, PUB. 3-20-2012. INT. CL. 25.
- MACLAINE, JOANNE M., FEDERAL WAY, WA:
2,922,334, CANC. INT. CL. 21.
- MACOMBER, LESLIE, COEUR DE ALENE, ID:
4,154,062, PUB. 3-20-2012. INT. CL. 41.
- MACQUARIE GROUP LIMITED, SYDNEY NSW, AUSTRALIA:
2,565,151. REN. 5-3-12. INT. CL. 36.
- MAD SCIENTISTS BREWING PARTNERS LLC, BROOKLYN, NY, DBA SIXPOINT CRAFT ALES:
4,154,044, PUB. 3-20-2012. INT. CL. 32.
- MAD SECURITY, LLC, HENDERSON, NV:
4,153,571, PUB. 3-20-2012. INT. CL. 41.
- MADAVA SUGAR MAPLE, LLC, DOVER PLAINS, NY:
4,153,535, PUB. 3-20-2012. INT. CL. 30.
- MADE IN THE SHADE, INC., OXNARD, CA:
2,514,916. REN. 4-27-12. MULTIPLE CLASS, INT. CLS. 18 AND 35.
- MADECASSE, LLC, BROOKLYN, NY:
4,153,540, PUB. 3-20-2012. INT. CL. 30.
- MADRONA PROPERTY COMPANY, SAN FRANCISCO, CA:
4,155,294, INT. CL. 33.
- MADRONA SPECIALTY FOODS, LLC, TUKWILA, WA:
4,154,101, PUB. 3-20-2012. INT. CL. 30.
- MADSTONE COMPANY, INC., NEW YORK, NY:
4,154,505, INT. CL. 41.
- MAGENIC TECHNOLOGIES, INC., GOLDEN VALLEY, MN:
4,152,048, PUB. 3-20-2012. INT. CL. 42.
- MAGGIEMOO'S FRANCHISE BRANDS, LLC, NORCROSS, GA:
4,153,674, PUB. 3-20-2012. INT. CL. 30.
- MAGICAL PARTNERS, INC., SEMINOLE, FL:
2,959,212, CANC. INT. CL. 41.
- MAGLINGER CORPORATION, OWENSBORO, KY:
2,492,744, CANC. INT. CL. 36.
- MAGNATROL VALVE CORPORATION, HAWTHORNE, NJ:
4,154,025, PUB. 3-20-2012. INT. CL. 9.
- MAGNUM NUTRACEUTICALS INC, SURREY, CANADA:
4,153,399, PUB. 3-20-2012. INT. CL. 5.
- MAGNUS INTERNATIONAL, LLC, WALNUT, CA:
4,154,834, INT. CL. 25.
- MAHALAXMI EXPORTS FZE, DUBAI, UNITED ARAB EMIR.:
4,153,549, PUB. 3-20-2012. INT. CL. 30.
- MAHFUZ, EDUARDO, JACKSONVILLE, FL:
4,155,798, INT. CL. 35.
- MAHONEY LIMITED PARTNERSHIP, JOLIET, IL:
4,154,187, PUB. 3-20-2012. MULTIPLE CLASS, INT. CLS. 39 AND 40.
- MAJEED, MUHAMMED, EDISON, NJ:
4,154,590, INT. CL. 3.
- MAJESTY'S ANIMAL NUTRITION, BEND, OR:
4,153,482, PUB. 3-20-2012. INT. CL. 5.
- MAJOR LEAGUE BASEBALL PROPERTIES, INC., NEW YORK, NY:
4,152,579, PUB. 3-20-2012. INT. CL. 41.
- MAKING YOUR EVENT SPECIAL LLC, CARMEL, IN:
4,155,121, MULTIPLE CLASS, INT. CLS. 35 AND 41.
- MAKROTEKS TEXTILE, LLC, ROCKY HILL, CT:
4,153,958, PUB. 3-20-2012. INT. CL. 24.
- MALAGON, RACHEL, SAN CLEMENTE, CA:
4,152,681, PUB. 3-20-2012. INT. CL. 33.
- MALISH CORPORATION, THE, WILLOUGHBY, OH:
2,566,415. REN. 5-1-12. INT. CL. 7.
- MALLINCKRODT INC., HAZELWOOD, MO TO MALLINCKRODT INC., HAZELWOOD, MO:
2,492,840, CANC. INT. CL. 5.

MALLYGIRL LLC, TOWSON, MD:
4,154,596, INT. CL. 3.

MALO S.P.A., 50013 CAMPI BISENZIO, FLORENCE, ITALY:
1,697,639. REN. 5-3-12. INT. CL. 18.

MAMA'S MINERALS, INC., ALBUQUERQUE, NM:
2,631,444. REN. 5-1-12. INT. CL. 35.

MAMALAW MEDIA GROUP, SILVER SPRING, MD:
4,154,537, INT. CL. 41.

MAN IN BLACK LLC, EL PASO, TX:
4,154,502, INT. CL. 33.

MANAGED MARKETING, LLC, PORTSMOUTH, NH:
4,152,786, PUB. 3-20-2012. MULTIPLE CLASS, INT. CLS.
35 AND 41.
4,153,007, PUB. 3-20-2012. MULTIPLE CLASS, INT. CLS.
35 AND 41.

MANAGEMENT SYSTEMS DEVELOPMENT, INC., ENCI-
NO, CA:
2,492,939, CANC. INT. CL. 9.

MANAGEMENT TEAM CONSULTANTS INC., SAN RA-
FAEL, CA:
2,561,775. REN. 4-30-12. INT. CL. 16.
2,561,776. REN. 4-30-12. INT. CL. 9.

MANCIN, SABRINA, CORAL GABLES, FL AND NOCITA,
JOHN, CORAL GABLES, FL:
4,155,745, INT. CL. 16.

MANDALAY CORPORATE ENTERPRISES, LLC, HOLLY-
WOOD, CA:
2,698,308, COR. MULTIPLE CLASS, INT. CLS. 35 AND
41.

MANGER, DANIELA, 17, D-97638 MELLRICHSTADT, FED
REP GERMANY:
2,492,951, CANC. INT. CL. 9.

MANHEIM, INC., ATLANTA, GA:
4,153,034, PUB. 3-20-2012. INT. CL. 35.

MANIFOLD SOFTWARE LIMITED, WANCHAI, HONG
KONG:
4,152,889, PUB. 3-20-2012. INT. CL. 9.

MANOUCHER FINE FOODS INC., TORONTO, ONTARIO,
CANADA:
2,606,372. REN. 5-3-12. INT. CL. 30.

MAP OIL TOOLS, INC., NEW IBERIA, LA:
4,153,103, PUB. 3-20-2012. INT. CL. 7.

MAPLES INDUSTRIES, INC., SCOTTSBORO, AL:
2,559,146. REN. 4-27-12. INT. CL. 27.

MARC ICEBERG, ORLANDO, FL:
4,155,061, INT. CL. 18.

MARCH OF DIMES FOUNDATION, WHITE PLAINS, NY:
2,632,403. REN. 5-3-12. INT. CL. 41.
2,646,876. REN. 5-3-12. INT. CL. 42.

MARCHEX, INC., SEATTLE, WA:
2,999,093, CANC. MULTIPLE CLASS, INT. CLS. 35 AND
42.

MARCHFIVE, LLC, WYNDMOOR, PA:
4,155,787, INT. CL. 8.

MARCO INDUSTRIES INC., PORTLAND, OR:
4,155,433, INT. CL. 1.

MARIA FOTIADOU, 54013 THESSALONIKI, GREECE:
4,152,864, PUB. 3-20-2012. INT. CL. 45.

MARINER PARTNERS INC., NEW BRUNSWICK, CANADA:
4,152,136, PUB. 3-20-2012. MULTIPLE CLASS, INT. CLS. 9
AND 42.
4,152,137, PUB. 3-20-2012. MULTIPLE CLASS, INT. CLS. 9
AND 42.

MARIO DIAB LLC, NEW YORK, NY:
4,152,530, PUB. 3-20-2012. INT. CL. 5.

MARIO'S GELATI LTD., VANCOUVER, BRITISH COLUM-
BIA, CANADA:
2,939,409, CANC. INT. CL. 30.
2,939,410, CANC. INT. CL. 30.

MARK ANTHONY INTERNATIONAL SRL, ST. MICHAEL,
BARBADOS:
4,155,925, INT. CL. 21.

MARK C. SCAMMEL, CPA LLC, DALLAS, TX:
4,155,522, INT. CL. 35.

MARK D. BOSSES, BOCA RATON, FL:
4,154,933, INT. CL. 7.

MARK FRIEL, CALGARY, ALBERTA, CANADA:
4,155,054, MULTIPLE CLASS, INT. CLS. 16 AND 24.

MARK HART, STATELINE, NV:
4,155,743, INT. CL. 16.
4,155,744, INT. CL. 16.

MARK V PRODUCTS, INC., CORONA, CA:
2,670,779. REN. 4-27-12. MULTIPLE CLASS, INT. CLS. 1,
3 AND 4.

MARKET AMERICA, INC., GREENSBORO, NC:
4,155,746, INT. CL. 14.
4,155,747, INT. CL. 14.

MARKETING RESEARCH ASSOCIATION, INC., WA-
SHINGTON, DC:
4,155,905, INT. CL. 41.

MARKETINGWORKS, INC., DOYLESTOWN, PA:
2,603,940. REN. 4-30-12. INT. CL. 35.

MARKETWIZ LIMITED, LONDON, UNITED KINGDOM:
4,152,690, PUB. 3-20-2012. INT. CL. 10.

MARKHAM, THOMAS WOODSON, RESTON, VA:
4,155,327, INT. CL. 32.

MARKOFF KRASNY LLC, CHICAGO, IL:
4,155,689, INT. CL. 45.

MARKY SPARKY, INC., ESCONDIDO, CA, DBA CALIFOR-
NIA CHARIOT COMPANY:
4,153,167, PUB. 3-20-2012. INT. CL. 28.

MARQUIS WHO'S WHO LLC., BERKELEY HEIGHTS, NJ,
MARQUIS-WHO'S WHO, INC., CHICAGO, IL:
729,754. REN. 4-27-12. U.S. CL. 38 (INT. CL. 16).

MARRIOTT INTERNATIONAL, INC., BETHESDA, MD:
2,703,332. REN. 5-3-12. INT. CL. 42.
2,704,688. REN. 5-2-12. INT. CL. 42.

MARS ADVERTISING, INC., SOUTHFIELD, MI:
4,152,789, PUB. 3-20-2012. INT. CL. 41.

MARSH INC., CINCINNATI, OH:
4,155,813, INT. CL. 42.

MARSHALL EXCELSIOR COMPANY, MARSHALL, MI:
4,153,135, PUB. 3-20-2012. INT. CL. 9.

MARSHALL, ANDREW, SEATTLE, WA:
2,496,439. REN. 4-27-12. INT. CL. 9.

MARTA FERNANDEZ GUADAÑO, E-28010 MADRID,
SPAIN:
4,152,403, PUB. 3-20-2012. INT. CL. 35.

MARTHA CLARA VINEYARDS, LLC, RIVERHEAD, NY:
2,568,449. REN. 5-2-12. INT. CL. 33.

MARTIAL ARTS MARKETING, INCORPORATED, GOLD-
EN, CO:
2,561,564. REN. 5-3-12. INT. CL. 16.

MARTIN, SCOTT W, HOLLADAY, UT:
4,153,699, PUB. 3-20-2012. INT. CL. 5.

MARUHACHI MURAMATSU, INC., SHIZUOKA, JAPAN:
4,152,582, PUB. 3-20-2012. MULTIPLE CLASS, INT. CLS.
29, 30 AND 31.

MARUKYU CO., LTD., SAITAMA, JAPAN:
4,153,786, PUB. 3-20-2012. INT. CL. 28.

MARX, STEVEN J., CHICAGO, IL:
2,635,388. REN. 4-30-12. INT. CL. 42.

MARXMEIER SOFTWARE AG, WUPPERTAL, FED REP
GERMANY:
1,691,226. REN. 5-1-12. INT. CL. 9.
1,691,226. CANC. INT. CL. 16.

MARY JACKSON, PORTLAND, ME:
4,153,353, PUB. 3-20-2012. INT. CL. 45.

MARY KAY INC., ADDISON, TX:
4,154,783, INT. CL. 3.

MARZ, KEITH, VAN NUYS, CA:
4,152,573, PUB. 10-25-2011. INT. CL. 5.

MASCHINENFABRIK REINHAUSEN GMBH, FED REP
GERMANY:
4,152,421, PUB. 3-20-2012. INT. CL. 9.

MASCO CORPORATION OF INDIANA, INDIANAPOLIS,
IN:
2,583,761. REN. 4-29-12. INT. CL. 11.

MASTER METER, INC., MANSFIELD, TX:
2,604,720. REN. 5-2-12. INT. CL. 9.

MASTER WALL, INC., MIDLAND, GA:
4,152,497, PUB. 3-20-2012. MULTIPLE CLASS, INT. CLS. 2
AND 19.

MASTERCARD INTERNATIONAL INCORPORATED, PUR-
CHASE, NY:
4,154,273, INT. CL. 36.

- MASTERS OF BEVERAGES, LLC, THE, CORONA, CA:
4,155,028, INT. CL. 32.
- MATER ACADEMY, INC., HIALEAH GARDENS, FL:
4,153,980, PUB. 3-20-2012. INT. CL. 41.
- MATHEW ARON, SAN DIEGO, CA:
4,156,011, INT. CL. 25.
4,156,012, INT. CL. 25.
- MATHIOS REFRACTORIES S.A., RENIS 18233, GREECE:
2,998,760, CANC. INT. CL. 19.
- MATHUR ENTERPRISES, L.L.C., BELVIDERE, IL, DBA VALUEIDEAS:
4,153,516, PUB. 3-20-2012. INT. CL. 35.
4,153,519, PUB. 3-20-2012. INT. CL. 35.
- MATHYS AG BETTLACH, 2544 BETTLACH, SWITZERLAND:
1,671,672, REN. 5-3-12. INT. CL. 10.
- MATOS, WANDERLEY A., FAIRFIELD, CT:
4,152,470, PUB. 3-20-2012. INT. CL. 16.
- MATSUSHITA ELECTRIC INDUSTRIAL CO., LTD., OSAKA-FU, JAPAN:
2,998,836, CANC. INT. CL. 9.
- MATTEL, INC., EL SEGUNDO, CA:
4,152,480, PUB. 3-20-2012. INT. CL. 28.
4,152,557, PUB. 3-20-2012. INT. CL. 28.
4,155,411, INT. CL. 9.
4,155,688, INT. CL. 28.
- MATTHEW LUDWICK, BURBANK, CA:
4,155,373, INT. CL. 25.
- MATTRESS DEPOT USA, INC, BELLEVUE, WA:
4,156,032, INT. CL. 35.
- MAVERICK ANGELS, LLC, AGOURA HILLS, CA:
4,152,472, PUB. 3-20-2012. INT. CL. 36.
- MAVILI ELEKTRONIK TIC. VE SAN. A.S., TURKEY:
4,152,195, PUB. 3-20-2012. INT. CL. 9.
- MAXIM CRANE WORKS, L.P., BRIDGEVILLE, PA:
2,492,287, CANC. INT. CL. 37.
- MAXIM HEALTHCARE SERVICES, INC., COLUMBIA, MD:
2,571,109, REN. 4-27-12. INT. CL. 42.
2,571,110, REN. 4-27-12. INT. CL. 35.
- MAXLITE, INC., WEST CALDWELL, NJ:
4,153,878, PUB. 3-20-2012. INT. CL. 11.
- MAXONS RESTORATIONS, INC., NEW YORK, NY:
4,152,753, PUB. 3-20-2012. MULTIPLE CLASS, INT. CLS. 37 AND 42.
- MAXXON CORPORATION, HAMEL, MN:
1,690,840, REN. 5-2-12. INT. CL. 27.
- MAY WILHELM, LLC, PHOENIX, AZ:
4,153,653, PUB. 3-20-2012. INT. CL. 28.
- MAYBE TONIGHT, INC., WINDERMERE, FL:
4,154,251, INT. CL. 3.
- MAYS TFJ REALTY, L.L.C., NEW YORK, NY:
4,154,262, INT. CL. 25.
- MAYTAG PROPERTIES, LLC, ST. JOSEPH, MI:
4,154,461, INT. CL. 11.
4,154,478, INT. CL. 11.
4,154,479, INT. CL. 7.
4,154,614, INT. CL. 11.
- MBDA FRANCE, FRANCE:
4,152,341, PUB. 3-20-2012. MULTIPLE CLASS, INT. CLS. 6, 7, 9, 11, 12, 13, 16, 17, 19, 37, 40, 41 AND 42.
- MC MACHINERY SYSTEMS, INC., WOOD DALE, IL:
2,576,332, REN. 4-27-12. INT. CL. 7.
- MCALPINE, DAVID B, FORT WORTH, TX:
2,998,879, CANC. INT. CL. 30.
- MCCOLLUM, DELORES L., CLEVELAND, OH:
4,152,056, PUB. 3-20-2012. INT. CL. 41.
- MCCORMACK, JOHN F., SACRAMENTO, CA, DBA RAINBOW ELECTRONICS:
4,154,142, PUB. 3-20-2012. INT. CL. 9.
- MCCRACKEN, DAVID, NEW YORK, NY:
2,561,655, REN. 5-3-12. MULTIPLE CLASS, INT. CLS. 9 AND 41.
- MCGIBNEY, JAMES, LAS VEGAS, NV:
4,155,422, INT. CL. 45.
- MCINTYRE, MARTY, BELTON, TX, TA GARQUEST:
4,153,718, PUB. 3-20-2012. INT. CL. 41.
- MCLIND CORPORATION, TORRANCE, CA:
2,558,493, REN. 4-27-12. MULTIPLE CLASS, INT. CLS. 5, 29 AND 35.
- MCPHERSON, NATHAN, TULSA, OK, DBA SPEXTON JEWELRY:
4,153,560, PUB. 3-20-2012. INT. CL. 14.
- MD WELLSRING, LLC, ATLANTA, GA:
4,155,836, INT. CL. 16.
- MEAD JOHNSON & COMPANY, LLC, EVANSVILLE, IN:
2,656,389, REN. 5-2-12. INT. CL. 9.
- MEADWESTVACO CORPORATION, RICHMOND, VA:
4,154,183, PUB. 3-20-2012. INT. CL. 16.
- MEC A/S, DENMARK:
4,152,434, PUB. 3-20-2012. MULTIPLE CLASS, INT. CLS. 9, 37 AND 42.
- MECKLENBURG ELECTRIC COOPERATIVE, CHASE CITY, VA:
2,491,700, CANC. INT. CL. 28.
- MEDALLION ASSOCIATES, LTD., NEW YORK, NY, AKA MEDALLION RETAIL:
1,684,726, REN. 5-2-12. INT. CL. 42.
- MEDAXIOM CARDIOLOGY, LLC, NEPTUNE BEACH, FL:
4,154,161, PUB. 3-20-2012. INT. CL. 41.
- MEDIA SPOON, LLC, SALEM, MA:
4,153,947, PUB. 3-20-2012. INT. CL. 42.
- MEDIABISTRO.COM INC., NORWALK, CT:
4,155,716, INT. CL. 41.
4,155,717, INT. CL. 41.
- MEDIASPHERE MEDICAL, LLC, PHILADELPHIA, PA:
4,156,061, INT. CL. 41.
- MEDIATEC PUBLISHING, INC., CHICAGO, IL:
4,154,752, INT. CL. 35.
- MEDIC ALERT FOUNDATION UNITED STATES, INC., ITURLOCK, CA:
1,698,978, REN. 5-2-12. INT. CL. 14.
- MEDICOMP SYSTEMS, INC., CHANTILLY, VA:
4,155,353, INT. CL. 9.
- MEDICYTE GMBH, 69120 HEIDELBERG, FED REP GERMANY:
4,152,087, PUB. 4-13-2010. MULTIPLE CLASS, INT. CLS. 1, 5, 10, 35, 42 AND 44.
- MEDISCAN GMBH & CO KG, A-4550 KREMSMÜNSTER, AUSTRIA:
4,092,806, COR. MULTIPLE CLASS, INT. CLS. 10, 40 AND 42.
- MEDITOUREXPO LLC, LAS VEGAS, NV:
4,154,432, INT. CL. 41.
- MEDJET ASSISTANCE, LLC, BIRMINGHAM, AL:
2,558,160, REN. 4-27-12. INT. CL. 39.
- MEDLINE INDUSTRIES, INC., CHICAGO, IL:
4,154,637, INT. CL. 5.
- MEDTROL, INC., NILES, IL:
2,561,492, REN. 5-1-12. INT. CL. 5.
- MEEHL, DR. CHRIS, LYNNFIELD, MA:
4,154,869, INT. CL. 31.
- MEEKO LLC, POMPANO BEACH, FL, DBA GREEN EYE AUTO PARTS:
4,153,430, PUB. 3-20-2012. INT. CL. 35.
- MEEKS, MARY J., CORONA, CA:
4,155,967, INT. CL. 3.
- MEGA BRANDS INTERNATIONAL, LUXEMBOURG, ZUG BRANCH, ZUG, SWITZERLAND:
2,999,095, CANC. INT. CL. 16.
4,155,670, INT. CL. 16.
- MEGGITT (MARYLAND), INC., GERMANTOWN, MD, AKA MEGGITT SENSING SYSTEMS:
4,152,920, PUB. 3-20-2012. INT. CL. 9.
- MEGTEC SYSTEMS, INC., DEPERE, WI:
2,998,607, CANC. INT. CL. 11.
- MEGUIAR'S, INC., IRVINE, CA:
1,707,696, REN. 4-27-12. INT. CL. 3.
- MEHDI LAISSAOUI, RIDGELAND, MS, AKA MOROCCO YANKEE:
4,152,043, PUB. 3-20-2012. INT. CL. 25.
- MEHRKENS, LORI, ROCKVILLE CENTRE, NY, DBA ABOVE ALL LIGHTING & BULBS INC:
4,155,109, INT. CL. 11.
- MEI HUA SIANG CO., LTD., CHANGHUA COUNTY, TAIWAN:
4,152,953, PUB. 3-20-2012. INT. CL. 30.

MEI, INC., WEST CHESTER, PA:
4,154,867, INT. CL. 9.

MEIJER, INC., GRAND RAPIDS, MI:
2,998,750, CANC. INT. CL. 35.

MEISEL ACCESSORIES, WEST ORANGE, NJ:
2,492,431, CANC. INT. CL. 15.

MELALEUCA, INC., IDAHO FALLS, ID:
2,567,400, REN. 4-27-12, INT. CL. 3.

MELMED CENTER, SCOTTSDALE, AZ:
4,153,498, PUB. 3-20-2012, INT. CL. 44.

MEMORIAL HEALTH SERVICES, FOUNTAIN VALLEY, CA:
4,152,699, PUB. 3-20-2012, MULTIPLE CLASS, INT. CLS. 41 AND 44.
4,152,700, PUB. 3-20-2012, MULTIPLE CLASS, INT. CLS. 41 AND 44.
4,152,763, PUB. 3-20-2012, INT. CL. 42.

MEMORYBISTRO CORPORATION, TULSA, OK:
4,153,392, PUB. 3-20-2012, INT. CL. 45.

MENN, CYNDY A., BRYAN, TX, DBA LITES OF AVALON:
2,691,756, REN. 4-30-12, INT. CL. 4.

MENON & ASSOCIATES, INC., SAN DIEGO, CA:
4,155,883, MULTIPLE CLASS, INT. CLS. 4, 9 AND 31.

MERCHANT GENERAL CORPORATION, OLDSMAR, FL:
4,153,153, PUB. 3-20-2012, INT. CL. 16.
4,153,154, PUB. 3-20-2012, INT. CL. 16.

MERCK SHARP & DOHME CORP., WHITEHOUSE STATION, NJ:
4,154,896, INT. CL. 16.

MERELINDA FARM LLC, WHITMORE LAKE, MI, DBA ALPACA.COM LLC:
2,560,640, REN. 4-27-12, INT. CL. 35.

MERENDINO CEMETERY CARE, LLC, LINDEN, NJ:
4,154,912, MULTIPLE CLASS, INT. CLS. 35 AND 44.

MERIDIAN MEDICAL TECHNOLOGIES, INC., COLUMBIA, MD:
4,154,718, INT. CL. 5.

MERIDIUM, INC., ROANOKE, VA:
4,153,074, PUB. 3-20-2012, INT. CL. 41.

MERIT MEDICAL SYSTEMS, INC., SOUTH JORDAN, UT:
4,155,741, INT. CL. 10.

MERRIMACK PHARMACEUTICALS, INC., CAMBRIDGE, MA:
2,998,835, CANC. INT. CL. 5.

MERRYVALE VINEYARDS LLC, ST. HELENA, CA, MERRYVALE VENTURE, ST. HELENA, CA, DBA MERRYVALE VINEYARDS:
1,740,093, REN. 4-27-12, INT. CL. 33.

MERZ PHARMA GMBH & CO. KGAA, FRANKFURT AM MAIN, FED REP GERMANY:
2,956,561, CANC. MULTIPLE CLASS, INT. CLS. 3 AND 5.

MESA ACQUISITION, INC., LOUISVILLE, KY, MESA FOOD PRODUCTS, INC., LOUISVILLE, KY:
1,628,514, REN. 5-1-12, INT. CL. 30.

METAVERSE CORPORATION, MONMOUTH JUNCTION, NJ:
4,152,917, PUB. 3-20-2012, INT. CL. 35.

METAVISTA CONSULTING GROUP, INC., SACRAMENTO, CA:
2,558,924, REN. 4-30-12, INT. CL. 42.

METCALF, ANDREA, CHICAGO, IL:
4,154,946, INT. CL. 16.

METHOD INC., SAN FRANCISCO, CA:
2,561,077, REN. 4-30-12, INT. CL. 35.

METRIC INSIGHTS, INC., SAN FRANCISCO, CA:
4,154,858, INT. CL. 9.

METRO CREDIT UNION, SPRINGFIELD, MO:
4,152,148, PUB. 3-20-2012, INT. CL. 36.

METROPOLITAN LIFE INSURANCE COMPANY, NEW YORK, NY:
4,153,048, PUB. 10-18-2011, INT. CL. 36.

METTLER-TOLEDO, INC., COLUMBUS, OH:
2,493,450, CANC. INT. CL. 9.

MEXICAN STREET FOOD, LLC, SAN DIEGO, CA:
4,155,931, INT. CL. 43.

MEXPO INTERNATIONAL INC., HAYWARD, CA:
2,443,093, COR. INT. CL. 5.

MEYER RESOURCE GROUP, INC., THE, WACO, TX:
2,566,123, REN. 5-1-12, MULTIPLE CLASS, INT. CLS. 9 AND 16.

MEYER, BRETT, SAN DIEGO, CA:
4,155,679, INT. CL. 16.

MEYER, JAYMIE, NEW YORK, NY:
4,155,204, INT. CL. 41.

MEYER, MATIAS, BUENOS AIRES, ARGENTINA AND MEYER, ALEJANDRO, BUENOS AIRES, ARGENTINA:
4,152,459, PUB. 3-20-2012, INT. CL. 9.

MGC MORTGAGE, INC., PLANO, TX:
4,153,724, PUB. 3-20-2012, INT. CL. 36.

MH ACOUSTICS, LLC, SUMMIT, NJ:
4,153,269, PUB. 3-20-2012, INT. CL. 9.
4,154,697, INT. CL. 9.

MIA ELECTRIC GMBH, FED REP GERMANY:
4,152,263, PUB. 3-20-2012, MULTIPLE CLASS, INT. CLS. 12, 35 AND 37.
4,152,275, PUB. 3-20-2012, MULTIPLE CLASS, INT. CLS. 12, 35 AND 37.

MIAMI MARLINS, L.P., MIAMI, FL:
4,154,423, INT. CL. 41.

MIAMI TRIBE OF OKLAHOMA BUSINESS DEVELOPMENT AUTHORITY, A TRIBAL ENTERPRISE OF THE MIAMI TRIBE OF OKLAHOMA, MIAMI, OK:
4,155,456, INT. CL. 9.

MIAMICA OF NEW YORK, INC., A DIVISION OF SHALOM INTERNATIONAL, CORP., PERTH AMBOY, NJ:
4,154,250, INT. CL. 21.

MICHAEL & SUSAN DELL FOUNDATION, AUSTIN, TX:
4,155,578, MULTIPLE CLASS, INT. CLS. 35 AND 42.
4,155,579, MULTIPLE CLASS, INT. CLS. 35 AND 42.
4,155,580, MULTIPLE CLASS, INT. CLS. 35 AND 42.

MICHAEL FOODS OF DELAWARE, INC., MINNEAPOLIS, MN:
4,154,498, INT. CL. 29.

MICHAEL J MANHARDT, LOS ANGELES, CA, DBA FAMILY WRISTBANDS:
4,152,729, PUB. 3-20-2012, INT. CL. 36.

MICHAEL PRAIG, AUSTRIA:
4,152,173, PUB. 3-20-2012, MULTIPLE CLASS, INT. CLS. 18, 25 AND 28.

MICHAEL ROLLIG, AUSTRIA AND ALEXANDRA-ROXANA DIACONU, AUSTRIA:
4,152,235, PUB. 3-20-2012, MULTIPLE CLASS, INT. CLS. 18 AND 25.

MICHAEL STAPLETON ASSOCIATES, LTD., NEW YORK, NY:
4,152,717, PUB. 3-20-2012, INT. CL. 45.

MICHAEL WALTRIP RACING HOLDINGS, LLC, CORNELIUS, NC:
4,154,450, INT. CL. 41.

MICHEL ET MERE, INC., DENVER, CO, DBA MONT BLANC GOURMET:
2,702,473, REN. 4-27-12, INT. CL. 30.

MICHELIN NORTH AMERICA, INC., GREENVILLE, SC, MANUFACTURE DE CAOUTCHOUC MICHELIN, CLERMONT-FERRAND (PUY-DE-DOME), FRANCE:
558,774, REN. 5-2-12, U.S. CL. 35 (INT. CL. 12).

MICHELLE HAUNOLD, DAVIS, CA, AKA GEARHEAD PRODUCTIONS, INC:
4,152,144, PUB. 3-20-2012, INT. CL. 9.

MICHIGAN CHRISTIAN CAMPUS MINISTRIES, INC., EAST LANSING, MI, DBA HIS HOUSE CHRISTIAN FELLOWSHIP:
4,153,507, PUB. 3-20-2012, INT. CL. 45.

MICRO CRYSTAL AG (MICRO CRYSTAL SA) (MICRO CRYSTAL LTD), GRENCHEN, SWITZERLAND:
1,680,097, REN. 4-30-12, INT. CL. 9.

MICROMATIC LLC, BERNE, IN:
4,152,779, PUB. 3-20-2012, INT. CL. 42.

MICROMATIC, LLC, BERNE, IN:
4,152,778, PUB. 3-20-2012, INT. CL. 7.

MICROSOFT CORPORATION, REDMOND, WA:
2,999,282, CANC. MULTIPLE CLASS, INT. CLS. 38, 42 AND 45.
2,999,283, CANC. MULTIPLE CLASS, INT. CLS. 38, 42

- AND 45.
4,154,927, MULTIPLE CLASS, INT. CLS. 35, 41 AND 43.
- MIDBASS DISTRIBUTION LIMITED, SUTTON COLD-FIELD, ENGLAND:
4,154,932, INT. CL. 9.
4,154,948, MULTIPLE CLASS, INT. CLS. 9, 35 AND 42.
- MIDMARK CORPORATION, VERSAILLES, OH:
4,154,976, MULTIPLE CLASS, INT. CLS. 9 AND 10.
4,155,008, INT. CL. 10.
- MIDWEST DAIRY ASSOCIATION, ST. PAUL, MN:
4,152,533, PUB. 3-20-2012. MULTIPLE CLASS, INT. CLS. 41 AND 44.
- MIDWEST EQUITY MORTGAGE, LLC, OAK BROOK, IL, DBA MIDWEST EQUITY MORTGAGE:
4,153,618, PUB. 3-20-2012. INT. CL. 36.
- MIKROMASCH EESTI LTD., 11313 TALLINN, ESTONIA:
2,557,715, REN. 4-27-12. MULTIPLE CLASS, INT. CLS. 9 AND 42.
2,557,715, CANC. MULTIPLE CLASS, INT. CLS. 35 AND 38.
- MILLENNIUM FITNESS LTD, MINNEAPOLIS, MN, DBA G-WERX:
4,152,946, PUB. 3-20-2012. MULTIPLE CLASS, INT. CLS. 9, 16, 25 AND 28.
- MILLER, KAREN, CAMPBELL, CA:
4,152,938, PUB. 3-20-2012. INT. CL. 35.
- MILLER, RYAN, HAMPSTEAD, NC:
4,153,362, PUB. 3-20-2012. INT. CL. 35.
- MILLERCOORS LLC, CHICAGO, IL:
2,632,022, REN. 5-2-12. INT. CL. 32.
4,155,205, INT. CL. 32.
- MILLIKEN & COMPANY, SPARTANBURG, SC:
2,491,825, CANC. INT. CL. 27.
- MILTENYI BIOTEC GMBH, FED REP GERMANY:
4,152,205, PUB. 3-20-2012. MULTIPLE CLASS, INT. CLS. 1, 2, 5, 9 AND 10.
- MILUX HOLDING S.A., LUXEMBOURG, LUXEMBOURG:
4,152,127, PUB. 3-20-2012. MULTIPLE CLASS, INT. CLS. 9, 10 AND 44.
- MILWAUKEE BREWERS BASEBALL CLUB, LIMITED PARTNERSHIP, MILWAUKEE, WI:
2,542,641, COR. INT. CL. 25.
- MIND'S EYE ENTERPRISES INCORPORATED, LAKE MARY, FL:
4,152,045, PUB. 3-20-2012. INT. CL. 41.
- MINDCOMMERCE.COM, LOUISVILLE, CO:
2,493,489, CANC. MULTIPLE CLASS, INT. CLS. 35 AND 41.
- MINI MELTS, INC., NORWICH, CT:
4,154,231, PUB. 3-20-2012. INT. CL. 30.
- MINK CHOCOLATES INC., VANCOUVER, B.C., CANADA:
4,152,094, PUB. 3-20-2012. MULTIPLE CLASS, INT. CLS. 30 AND 43.
- MINNESOTA HISTORICAL SOCIETY, THE, ST. PAUL, MN:
2,705,339, REN. 5-2-12. INT. CL. 41.
- MINNESOTA VIKINGS FOOTBALL, LLC, EDEN PRAIRIE, MN:
4,154,472, MULTIPLE CLASS, INT. CLS. 16, 24, 28, 36 AND 41.
- MINNETONKA MOCCASIN COMPANY, INC., MINNEAPOLIS, MN:
4,153,181, PUB. 3-20-2012. MULTIPLE CLASS, INT. CLS. 18 AND 25.
- MINNTECH CORPORATION, MINNEAPOLIS, MN:
4,155,005, INT. CL. 3.
- MINT MCKINLEY LLC, ADA, OK:
4,155,477, INT. CL. 3.
- MINTIE CORPORATION, LOS ANGELES, CA:
1,683,234, REN. 5-3-12. INT. CL. 37.
- MIPI ALLIANCE, INC., PISCATAWAY, NJ:
4,154,406, MULTIPLE CLASS, INT. CLS. 35 AND 42.
- MIRACOR MEDICAL SYSTEMS GMBH, AUSTRIA:
3,976,535, COR. MULTIPLE CLASS, INT. CLS. 10 AND 42.
- MIRCONA AB, SWEDEN:
4,152,183, PUB. 3-20-2012. MULTIPLE CLASS, INT. CLS. 7, 8 AND 9.
- MIREGO INC., QUÉBEC, CANADA:
4,152,736, PUB. 3-20-2012. MULTIPLE CLASS, INT. CLS. 35 AND 42.
- MIRUS BIO CORPORATION, MADISON, WI:
2,493,500, CANC. MULTIPLE CLASS, INT. CLS. 1 AND 5.
- MIRZA, ASMA, PISCATAWAY, NJ:
4,154,252, INT. CL. 5.
- MISA COSMETIC PRODUCTS, INC., FOLCROFT, PA:
2,710,515, REN. 5-2-12. INT. CL. 3.
- MISCALÉ, LLC, NEWTON, MA:
4,152,549, PUB. 3-20-2012. INT. CL. 9.
- MISSION PRODUCT HOLDINGS, INC., NEW YORK, NY:
4,155,566, INT. CL. 5.
- MISSION SAVE A SMILE, CRYSTAL LAKE, IL:
4,152,886, PUB. 3-20-2012. INT. CL. 44.
- MISSISSIPPI RIVER DISTILLING COMPANY, LE CLAIRE, IA:
4,155,346, INT. CL. 33.
- MITCHELL ARMATA, TORONTO, ONTARIO, CANADA:
4,152,475, PUB. 3-20-2012. INT. CL. 35.
- MITCHELL GROUP USA LLC, MIAMI, FL:
4,155,258, MULTIPLE CLASS, INT. CLS. 3 AND 5.
- MITCHELL, SHAHN WILLIAM, IRVINGTON, NJ:
2,565,830, REN. 4-27-12. INT. CL. 25.
- MITCHELL'S MARTIAL ARTS, INC., SALISBURY, MD:
4,153,522, PUB. 3-20-2012. INT. CL. 41.
4,153,525, PUB. 3-20-2012. INT. CL. 41.
- MITEK CORPORATION, PHOENIX, AZ:
2,560,896, REN. 4-27-12. INT. CL. 12.
- MITSUBISHI CHEMICAL CORPORATION, MINATO-KU, TOKYO, JAPAN:
4,152,904, PUB. 3-20-2012. MULTIPLE CLASS, INT. CLS. 9 AND 11.
- MITSUBISHI ELECTRIC CORPORATION, CHIYODA-KU, TOKYO, JAPAN:
4,154,977, INT. CL. 9.
- MITSUBISHI ENPITSU KABUSHIKI KAISHA, TOYKO, JAPAN:
2,666,107, REN. 4-27-12. INT. CL. 16.
- MITSUBISHI MATERIALS CORPORATION, TOKYO 100, JAPAN:
2,998,530, CANC. INT. CL. 7.
- MIVA, INC., FT. MYERS, FL, AKA MIVA:
2,493,181, CANC. INT. CL. 42.
- MIZUHO ORTHOPEDIC SYSTEMS, INC, SACRAMENTO, CA:
2,569,636, REN. 5-1-12. INT. CL. 10.
- MIZUSAWA INDUSTRIAL CHEMICALS, LTD., CHUO-KU, TOKYO, JAPAN:
1,684,936, REN. 4-27-12. INT. CL. 1.
- MÉTIER, LTD., SANTA ROSA, CA:
4,153,469, PUB. 3-20-2012. MULTIPLE CLASS, INT. CLS. 9 AND 42.
- MM SYSTEMS CORPORATION, PENDERGRASS, GA:
2,492,309, CANC. MULTIPLE CLASS, INT. CLS. 6, 17, 19 AND 42.
- MMJIP, LLC, SAN FRANCISCO, CA:
4,154,844, INT. CL. 41.
4,154,845, INT. CL. 44.
- MMM HOLDINGS, INC., SAN JUAN, PUERTO RICO:
4,153,301, PUB. 3-20-2012. INT. CL. 41.
- MMRV, LLC, ALBUQUERQUE, NM:
2,643,657, REN. 5-1-12. INT. CL. 42.
- MNY GROUP, LLC, BLOOMINGTON, MN:
4,153,914, PUB. 3-20-2012. INT. CL. 19.
- MOBIOLOGIC, INC., LEAWOOD, KS:
2,697,903, REN. 4-30-12. INT. CL. 38.
- MOBIX CAR SERVICES LLC, BARRINGTON, RI:
4,154,765, INT. CL. 37.
- MOBUBBLE, INC, MURRIETA, CA, DBA MOBUBBLE, INC:
4,152,973, PUB. 3-20-2012. INT. CL. 9.
- MOCHINSKI, JACOB, EVERETT, WA, DBA AIRCRAFT-KEEPERS:
4,154,975, INT. CL. 14.
- MODERN MANAGEMENT SERVICES, LLC, HONOLULU, HI:
4,153,277, PUB. 3-20-2012. INT. CL. 43.

MODULAR ARTS, INC., SEATTLE, WA:
4,153,648, PUB. 3-20-2012. INT. CL. 19.

MOET HENNESSY USA, INC., NEW YORK, NY:
4,155,019, INT. CL. 33.

MOHAWK FINE PAPERS INC., COHOES, NY:
2,571,657. REN. 5-2-12. INT. CL. 16.

MOJO SPORTSWEAR COMPANY INC., FORT WALTON BEACH, FL:
4,152,588, PUB. 3-20-2012. INT. CL. 25.

MOLE-RICHARDSON COMPANY, HOLLYWOOD, CA:
2,492,503, CANC. INT. CL. 11.

MOLLAHAN, NATHAN, PORTLAND, OR:
4,155,462, INT. CL. 25.

MONARCH TOWEL COMPANY, INC., PERTH AMBOY, NJ:
4,153,715, PUB. 3-20-2012. MULTIPLE CLASS, INT. CLS. 24 AND 27.

MONDAY LIFE, THE, CHAPEL HILL, NC:
4,155,390, INT. CL. 36.

MONDO S.P.A., ITALY:
4,152,334, PUB. 3-20-2012. INT. CL. 25.

MONSTER TRUCK LTD., VIRGINIA BEACH, VA:
3,460,213, COR. INT. CL. 41.

MONSTER TRUCKS LTD., VIRGINIA BEACH, VA:
3,500,660, COR. INT. CL. 41.

MONSTER WORLDWIDE, INC., NEW YORK, NY:
4,155,616, INT. CL. 42.

MONSTER, INC., BRISBANE, CA:
4,156,030, INT. CL. 9.

MONTALVAN'S SALES, INC., ONTARIO, CA:
2,595,641. REN. 5-2-12. INT. CL. 29.

MONTANA STATE UNIVERSITY, BOZEMAN, MT:
4,154,312, INT. CL. 36.

MONTES DE OCA, CARLYN, SAN ANSELMO, CA:
4,153,965, PUB. 3-20-2012. INT. CL. 44.

MONTES S.A., SANTIAGO, CHILE:
4,152,804, PUB. 3-20-2012. INT. CL. 33.

MONTGOMERY, MCCRACKEN, WALKER & RHOADS, LLP, PHILADELPHIA, PA:
4,155,706, INT. CL. 45.

MOO MOO MUSICA, LLC, MARINA DEL REY, CA, DBA MOO MOO MUSICA:
4,152,737, PUB. 3-20-2012. MULTIPLE CLASS, INT. CLS. 9 AND 41.

MOORE, DIANA, GERMANTOWN, MD:
4,153,795, PUB. 3-20-2012. INT. CL. 26.

MOREHEAD, JESSE, STAFFORD, KS:
4,155,338, INT. CL. 25.

MOREY, VINCENT, LOS ANGELES, CA:
4,153,816, PUB. 3-20-2012. INT. CL. 44.

MORISEI KAKO CO., LTD., SUMIDA-KU, TOKYO 131-0041, JAPAN:
4,152,284, PUB. 3-20-2012. INT. CL. 17.

MOROMISATO, GEORGE, SAN MATEO, CA:
4,153,848, PUB. 3-20-2012. INT. CL. 9.

MORRIS MATERIALS HANDLING LTD., LOUGHBOROUGH LE11 1RL, LEICESTERSHIRE, UNITED KINGDOM:
2,998,587, CANC. INT. CL. 7.

MORRIS VISITOR PUBLICATIONS, LLC, AUGUSTA, GA, WHERE WHAT WHEN, INC., DETROIT, MI:
730,450. REN. 5-2-12. U.S. CL. 38 (INT. CL. 16).

MORRIS, RUFUS, CICERO, NY:
4,153,375, PUB. 3-20-2012. INT. CL. 9.

MORTGAGE WAREHOUSE, LTD., MELVILLE, NY:
2,493,620, CANC. INT. CL. 36.

MORTON & HUDSON, LLC, SAN DIEGO, CA:
4,155,833, INT. CL. 18.

MOSS, LANCE BARNARD, NICEVILLE, FL:
3,451,810, COR. MULTIPLE CLASS, INT. CLS. 16, 25 AND 39.

MOTIV METALS, LLC, BRIDGEVILLE, PA:
4,153,575, PUB. 3-20-2012. INT. CL. 35.

MOUNTAINTOP MINISTRIES WORLDWIDE INC., LAKE CITY, FL:
4,153,859, PUB. 3-20-2012. INT. CL. 45.

MOXIE ATHLETICS, ASTORIA, NY:
4,152,606, PUB. 3-20-2012. MULTIPLE CLASS, INT. CLS. 41 AND 44.

MOYER MACHINE AND TOOL, LLC., LOVELAND, CO:
4,152,970, PUB. 3-20-2012. INT. CL. 40.

MP ASSOCIATES, INC., IONE, CA:
2,654,170. REN. 4-28-12. INT. CL. 13.

MPOWER TRADING SYSTEMS, LLC, HAVERFORD, PA:
4,152,752, PUB. 3-20-2012. MULTIPLE CLASS, INT. CLS. 41 AND 42.

MR. CARPET COMPANY, CHICAGO, IL:
4,155,190, MULTIPLE CLASS, INT. CLS. 35 AND 37.

MR. GRAB BAR INC., NAPLES, FL:
2,597,112. REN. 5-3-12. INT. CL. 37.

MRM HOLDINGS LIMITED, PORT LOUIS, MAURITIUS:
3,152,788, COR. INT. CL. 6.

MRM HOLDINGS LIMITED, PORT LOUIS, HONG KONG:
3,287,670, COR. INT. CL. 6.

MRM HOLDINGS LIMITED, PORT LOUIS, MAURITIUS:
4,154,992, INT. CL. 18.

MSH SOUTH INC., WILMINGTON, DE:
2,687,402. REN. 5-3-12. INT. CL. 41.

MSI, LLC, DEERFIELD BEACH, FL, TA MSI-SSL:
4,154,571, INT. CL. 11.

MSLO SHARED IP SUB LLC, NEW YORK, NY:
4,154,641, INT. CL. 11.

MT INVESTMENTS INC., OKOTOKS, ALBERTA, CANADA:
1,197,413. REN. 4-30-12. INT. CL. 39.

MTG CO., LTD., AICHI-KEN, JAPAN:
4,065,272, COR. MULTIPLE CLASS, INT. CLS. 10 AND 21.

MU LEI, MONROVIA, CA:
4,154,848, INT. CL. 2.

MUDD, INC., CEDAR FALLS, IA:
2,625,088. REN. 5-3-12. INT. CL. 35.

MUL-T-LOCK TECHNOLOGIES LTD., YAVNE, ISRAEL AND STARCOM G.P.S SYSTEMS LTD., RAMAT GAN, ISRAEL:
4,152,461, PUB. 3-20-2012. MULTIPLE CLASS, INT. CLS. 6 AND 9.

MULTIPET INTERNATIONAL, INC., MOONACHIE, NJ:
4,155,090, INT. CL. 28.

MULTNOMAH PUBLISHERS, INC., SISTERS, OR:
2,999,275, CANC. INT. CL. 9.

MUNCIE POWER PRODUCTS, INC., MUNCIE, IN:
1,203,038. REN. 5-1-12. MULTIPLE CLASS, INT. CLS. 37 AND 42.

MUNICH AMERICAN REASSURANCE COMPANY, ATLANTA, GA:
2,493,465, CANC. INT. CL. 36.

MUNICH REINSURANCE AMERICA, INC., PRINCETON, NJ:
2,493,031, CANC. INT. CL. 36.

MUNN GROUP, INC., THE, LEXINGTON, MA:
2,491,730, CANC. INT. CL. 35.

MUNROE, LESLIE R., BLANDFORD, MA:
2,671,793. REN. 4-27-12. INT. CL. 18.

MUNSTERER, REBECCA J, NORWICH, VT:
4,155,748, INT. CL. 35.

MURPHY CAP & GOWN COMPANY, ST. PETERSBURG, FL:
2,655,144. REN. 4-27-12. INT. CL. 25.

MUSEUM OF MODERN ART, THE, NEW YORK, NY:
736,933. REN. 5-3-12. U.S. CL. 107 (INT. CL. 41).

MUSIC FROM THE MITTEN, LLC, BEVERLY HILLS, CA:
4,154,731, INT. CL. 41.

MUSICIAN'S FRIEND, INC., MEDFORD, OR:
2,492,090, CANC. INT. CL. 35.

MUSSA ADDIS, FED REP GERMANY:
4,152,251, PUB. 3-20-2012. MULTIPLE CLASS, INT. CLS. 9, 25 AND 41.

MW ENGINEERING SPRL, LIEGE, BELGIUM:
4,153,895, PUB. 3-20-2012. INT. CL. 35.

MY CONCIERGE NURSE, LLC, OMAHA, NE:
4,153,781, PUB. 3-20-2012. INT. CL. 44.

MY OWN KIDZ LLC, NORTH RICHLAND HILLS, TX:
4,154,987, INT. CL. 14.
4,154,988, INT. CL. 14.

MYCO SUITE LIMITED, CENTRAL, HONG KONG:
4,152,923, PUB. 3-20-2012. INT. CL. 42.

- MYCOLOGIX LIMITED, LONDON, UNITED KINGDOM:
4,152,501, PUB. 3-20-2012. MULTIPLE CLASS, INT. CLS. 1, 4, 7, 35, 40 AND 42.
- MYCORPORATESTORE, LLC, ADDISON, TX:
2,628,975. REN. 4-29-12. INT. CL. 35.
- MYDORMDOC, LLC, SAN ANTONIO, TX:
3,974,937, CANC. INT. CL. 5.
- MYSTIC SEAPORT MUSEUM, INC., MYSTIC, CT:
2,492,386, CANC. INT. CL. 41.
- NA, CHUN KYUN, SEOUL, REPUBLIC OF KOREA:
4,154,283, INT. CL. 25.
- NABORS, THOMAS, NASHVILLE, TN:
4,155,236, INT. CL. 44.
- NABTO APS, DENMARK:
4,152,417, PUB. 3-20-2012. INT. CL. 9.
- NACIONAL NAME HOLDING, LLC, BRIDGETON, MO:
4,153,998, PUB. 3-20-2012. MULTIPLE CLASS, INT. CLS. 35, 36 AND 37.
- NAKED HAIR SALON, DELRAY BEACH, FL:
4,152,941, PUB. 3-20-2012. INT. CL. 44.
- NAKED ZOO ENTERPRISES, INC., ST. PAUL, MN:
2,564,880. REN. 5-3-12. MULTIPLE CLASS, INT. CLS. 39 AND 41.
- NAMCO BANDAI GAMES INC., TOKYO, JAPAN:
2,561,770. REN. 5-3-12. INT. CL. 9.
4,154,444, INT. CL. 9.
- NAMCO BANDAI GAMES INC., SHINAGAWA-KU TOKYO, JAPAN:
4,154,789, INT. CL. 28.
4,155,221, INT. CL. 9.
4,155,304, INT. CL. 9.
- NAMIKI SHOJI CO., LTD., SHINJUKU-KU, TOKYO, JAPAN:
4,153,157, PUB. 3-20-2012. INT. CL. 1.
- NAN JUEN INDUSTRIAL CO., LTD., TAIPEI HSIEN, TAIWAN:
2,493,103, CANC. INT. CL. 6.
- NANOPORE INSULATION LLC, ALBUQUERQUE, NM:
4,154,655, INT. CL. 17.
- NANTUCKET PJM CORPORATION, NANTUCKET, MA:
3,555,926, CANC. INT. CL. 25.
- NAPOLITANO MATTHEW J, MILPITAS, CA, DBA HIGH-GROUND INDUSTRIES:
4,153,246, PUB. 3-20-2012. INT. CL. 9.
- NARANJA PAWN, INC., HOMESTEAD, FL:
4,153,741, PUB. 3-20-2012. INT. CL. 36.
- NASE WORLDWIDE, INC., JACKSONVILLE, FL:
4,154,849, MULTIPLE CLASS, INT. CLS. 9, 28 AND 39.
- NASTYGOAT CORPORATION, DALLAS, TX:
4,153,222, PUB. 3-20-2012. INT. CL. 35.
4,153,223, PUB. 3-20-2012. INT. CL. 35.
- NATIONAL ASSEMBLY OF HEALTH & HUMAN SERVICE ORGANIZATIONS, WASHINGTON, DC:
2,998,654, CANC. MULTIPLE CLASS, INT. CLS. 16, 41 AND 42.
- NATIONAL ASSOCIATION FOR STOCK CAR AUTO RACING, INC., DAYTONA BEACH, FL:
4,155,381, INT. CL. 37.
4,155,549, INT. CL. 28.
4,155,550, INT. CL. 28.
- NATIONAL ASSOCIATION OF EMERGENCY MEDICAL TECHNICIANS, CLINTON, MS, AKA NAEMT:
4,153,356, PUB. 3-20-2012. INT. CL. 41.
- NATIONAL ASSOCIATION OF HISPANIC NURSES, WASHINGTON, DC:
4,153,349, PUB. 3-20-2012. INT. CL. 41.
- NATIONAL ASSOCIATION OF HOME BUILDERS OF THE UNITED STATES, WASHINGTON, DC:
1,690,447. REN. 4-30-12. INT. CL. 35.
- NATIONAL BUREAU OF ASIAN RESEARCH, THE, SEATTLE, WA:
2,585,048. REN. 4-27-12. MULTIPLE CLASS, INT. CLS. 35 AND 42.
- NATIONAL CENTER FOR STATE COURTS, WILLIAMSBURG, VA:
2,699,419. REN. 4-27-12. INT. CL. 42.
- NATIONAL CONFERENCE FOR COMMUNITY AND JUSTICE OF CONNECTICUT AND WESTERN MASSACHUSETTS, INC., WINDSOR, CT:
4,155,586, INT. CL. 41.
- NATIONAL GEOGRAPHIC SOCIETY, WASHINGTON, DC:
4,154,586, MULTIPLE CLASS, INT. CLS. 9, 35, 38 AND 41.
- NATIONAL GYPSUM PROPERTIES, LLC, CHARLOTTE, NC:
4,155,921, INT. CL. 19.
- NATIONAL INDUSTRIES FOR THE BLIND, ALEXANDRIA, VA:
2,598,587. REN. 5-2-12. INT. CL. 11.
2,601,814. REN. 5-2-12. INT. CL. 11.
- NATIONAL MANUFACTURING CO., STERLING, IL:
1,193,503. REN. 5-1-12. INT. CL. 6.
- NATIONAL MIDDLE SCHOOL ASSOCIATION, WESTERVILLE, OH:
1,755,854. REN. 5-2-12. INT. CL. 42.
- NATIONAL ORGANIZATIONS FOR YOUTH SAFETY, GAINESVILLE, VA:
2,584,437. REN. 5-3-12. INT. CL. 42.
- NATIONAL SORTING COW HORSE ASSOCIATION, CALEDONIA, MO:
4,155,913, INT. CL. 41.
- NATIONAL SPORTING GOODS ASSOCIATION, MOUNT PROSPECT, IL:
4,153,913, PUB. 3-20-2012. MULTIPLE CLASS, INT. CLS. 35 AND 41.
4,154,045, PUB. 3-20-2012. MULTIPLE CLASS, INT. CLS. 35 AND 41.
- NATIONAL STRENGTH AND CONDITIONING ASSOCIATION, COLORADO SPRINGS, CO:
2,561,457. REN. 4-27-12. U.S. CL. B.
- NATIONAL TANK COMPANY, HOUSTON, TX:
1,686,150. REN. 5-1-12. MULTIPLE CLASS, INT. CLS. 9 AND 11.
- NATIONAL TOBACCO CO., L.P., LOUISVILLE, KY:
2,624,913. REN. 5-3-12. INT. CL. 34.
- NATIONAL TOBACCO COMPANY, L.P., LOUISVILLE, KY:
1,208,850. REN. 5-1-12. INT. CL. 34.
- NATIONAL WESTERN LIFE INSURANCE COMPANY, AUSTIN, TX:
4,154,257, INT. CL. 36.
4,154,258, INT. CL. 36.
4,154,259, INT. CL. 36.
- NATIONAL YOUTH EDUCATION COUNCIL, LLC, BOCA RATON, FL:
4,154,229, PUB. 3-20-2012. INT. CL. 41.
- NATIONWIDE CARPET UPHOLSTERY & TILE CLEANING, INC, WEST PALM BEACH, FL:
4,156,010, INT. CL. 37.
- NATIONWIDE PAYMENT SOLUTIONS, LLC, SCARBOROUGH, ME:
4,152,113, PUB. 3-20-2012. INT. CL. 36.
- NATIVE NEW YORKER OF AMERICA, INC., GILBERT, AZ:
4,155,481, INT. CL. 43.
- NATROL ACQUISITION CORP., CHATSWORTH, CA TO NATROL, INC., CHATSWORTH, CA:
2,492,928, CANC. INT. CL. 5.
- NATURAL CHEMISTRY LLC, NORWALK, CT:
2,582,644. REN. 5-3-12. INT. CL. 1.
- NATURE'S CREATIONS, L.L.C., NAPLES, FL:
4,155,963, INT. CL. 14.
- NATURE'S GRILLING PRODUCTS LLC, WESTMINSTER, CO, DBA NRG INTERNATIONAL LLC:
3,925,901, CANC. INT. CL. 4.
- NATURE'S PALLIATIVE, HAMILTON, MT:
4,152,738, PUB. 3-20-2012. INT. CL. 5.
- NATURE'S WAY PRODUCTS, LLC, GREEN BAY, WI:
2,569,638. REN. 4-27-12. INT. CL. 5.
- NATUS MEDICAL INCORPORATED, SAN CARLOS, CA:
4,153,501, PUB. 3-20-2012. MULTIPLE CLASS, INT. CLS. 9 AND 10.
- NAUTILUS OFFSHORE COMPANY, INC., THE WOODLANDS, TX:
2,998,579, CANC. MULTIPLE CLASS, INT. CLS. 37 AND 42.

NAVAJO MANUFACTURING CO., DENVER, CO:
 2,643,764, CANC. INT. CL. 3.
 2,643,764, AM. MULTIPLE CLASS, INT. CLS. 25 AND 26.

NAVAJO NATION GAMING ENTERPRISE, CHURCH
 ROCK, NM:
 4,154,457, MULTIPLE CLASS, INT. CLS. 37 AND 41.

NAVITAS WEALTH ADVISORS, INC., RIDGELAND, MS:
 4,153,122, PUB. 3-20-2012. MULTIPLE CLASS, INT. CLS.
 35 AND 36.

NBC UNIVERSAL MEDIA, LLC, NEW YORK, NY:
 4,098,129, COR. INT. CL. 35.

NCS CORPORATION, COLUMBUS, OH:
 1,762,551. REN. 5-2-12. MULTIPLE CLASS, INT. CLS. 9
 AND 42.

NCS PEARSON, INC., BLOOMINGTON, MN:
 2,609,732. REN. 5-1-12. INT. CL. 16.

NEDERLANDSE ORGANISATIE VOOR TOEGEPAST-NAT-
 UURWETENSCHAPPELIJK ONDERZOEK TNO, NL-2628
 VK DELFT, NETHERLANDS:
 4,152,250, PUB. 3-20-2012. MULTIPLE CLASS, INT. CLS.
 9, 35 AND 42.

NEDERLANDSE ORGANISATIE VOOR TOEGEPAST-NAT-
 UURWETENSCHAPPELIJK ONDERZOEK TNO, NETH-
 ERLANDS:
 4,152,274, PUB. 3-20-2012. MULTIPLE CLASS, INT. CLS.
 9, 16 AND 42.

NEDRY, MADELINE, POMPANO BEACH, FL:
 4,155,780, INT. CL. 14.

NEENAH PAPER FR, LLC, ALPHARETTA, GA:
 2,492,534, CANC. INT. CL. 16.

NEFF RANCH, LTD., IRVINE, CA:
 2,492,354, CANC. MULTIPLE CLASS, INT. CLS. 31 AND
 32.

NEGOTIATION.COM, LLC, NEW YORK, NY:
 1,194,227. REN. 5-2-12. MULTIPLE CLASS, INT. CLS. 9
 AND 16.

NEIDIG HEALTH CARE LTD, NEWCOMERSTOWN, OH,
 DBA MEDI-WISE LTC PHARMACY:
 4,153,832, PUB. 3-20-2012. INT. CL. 35.

NEIGHBORHOOD UNITY FOUNDATION, SAN DIEGO,
 CA:
 4,152,555, PUB. 3-20-2012. MULTIPLE CLASS, INT. CLS.
 35 AND 36.

NEIL F. NEIMARK, M.D., INC., IRVINE, CA:
 4,154,076, PUB. 3-20-2012. INT. CL. 44.

NEIL, LAURA, LA QUINTA, CA, DBA LILY'S LAUNDRY:
 4,153,843, PUB. 3-20-2012. MULTIPLE CLASS, INT. CLS.
 25 AND 41.

NEOGEN CORPORATION, LANSING, MI:
 2,563,903. REN. 4-27-12. INT. CL. 10.

NEPHEW, PAMELA, FREDERICKSBURG, VA:
 4,155,903, INT. CL. 25.

NEPTUNE RESEACH & DEVELOPMENT, INC., WEST
 CALDWELL, NJ:
 2,643,267. REN. 5-3-12. INT. CL. 9.

NET CYLINDER, INC., HAUPPAUGE, NY, DBA APPRO-
 VALTREE.COM:
 4,153,029, PUB. 3-20-2012. INT. CL. 35.
 4,153,033, PUB. 3-20-2012. INT. CL. 35.

NETGROCER, LLC, COLCHESTER, VT:
 4,153,326, PUB. 3-20-2012. INT. CL. 35.

NETPROPAGATE CORPORATION, LOS ANGELES, CA:
 4,154,334, INT. CL. 9.
 4,154,335, INT. CL. 9.

NETTER, EDWARD, STAMFORD, CT:
 2,640,861. REN. 5-2-12. INT. CL. 36.

NETWORK BRANDED PREPAID CARD ASSOCIATION,
 MONTVALE, NJ:
 4,154,964, INT. CL. 35.

NETXPOSURE, INC., PORTLAND, OR:
 2,538,261. REN. 4-27-12. INT. CL. 42.

NEUROBRANDS LLC, SANTA MONICA, CA:
 4,154,416, MULTIPLE CLASS, INT. CLS. 5 AND 32.

NEVAVILLE INC, BRONX, NY:
 4,155,297, INT. CL. 42.

NEW ALBERTSON'S, INC., EDEN PRAIRIE, MN:
 2,680,991. REN. 4-29-12. INT. CL. 33.

NEW BELGIUM BREWING COMPANY, INC., FORT COL-
 LINS, CO:
 4,154,397, INT. CL. 32.

NEW CLASSIC HOME FURNISHING, INC., FONTANA, CA:
 4,153,130, PUB. 3-20-2012. INT. CL. 20.

NEW ENDIAN LLC, ASTORIA, NY, DBA NEW ENDIAN:
 4,153,697, PUB. 3-20-2012. INT. CL. 9.

NEW ENGLAND LINEN SUPPLY, PAWTUCKET, RI:
 4,155,582, MULTIPLE CLASS, INT. CLS. 43 AND 45.

NEW ERA, INC., CLARKSVILLE, TN, VOLLRATH COM-
 PANY, THE, SHEBOYGAN, WI:
 1,197,300. REN. 4-27-12. INT. CL. 21.

NEW FREEDOM HOLDINGS LLC, CAREFREE, AZ:
 4,155,904, INT. CL. 41.

NEW GLOBAL MARKETING INC., DRUMS, PA:
 2,644,629. REN. 4-27-12. INT. CL. 34.

NEW HAMPSHIRE LOTTERY COMMISSION, CONCORD,
 NH:
 2,677,265. REN. 5-3-12. INT. CL. 41.

NEW HEALTH AGE ADVISORS, LLC, BRADENTON, FL:
 4,153,199, PUB. 3-20-2012. MULTIPLE CLASS, INT. CLS.
 35, 41 AND 44.

NEW MANAGEMENT, INC., FREMONT, CA:
 4,153,702, PUB. 3-20-2012. INT. CL. 25.
 4,153,704, PUB. 3-20-2012. INT. CL. 25.

NEW ORLEANS EXCHANGE, INC., NEW ORLEANS, NJ:
 4,155,892, INT. CL. 35.

NEW PENDULUM CORP., WILMINGTON, DE:
 1,697,685. REN. 5-3-12. INT. CL. 21.

NEW TECH CUTTING TOOLS, INC., KENT, WA:
 1,685,080. REN. 5-1-12. INT. CL. 7.

NEW WAVE ENVIRO PRODUCTS, INC., GREENWOOD
 VILLAGE, CO:
 4,154,437, INT. CL. 21.

NEW WORLD PASTA COMPANY, HARRISBURG, PA:
 2,493,180, CANC. INT. CL. 30.

NEW WORLD TELEVISION PROGRAMMING, LOS AN-
 GELES, CA:
 4,154,693, INT. CL. 41.

NEW YORK CHIROPRACTIC COLLEGE, SENECA FALLS,
 NY:
 4,153,290, PUB. 3-20-2012. INT. CL. 41.

NEW YORK HALL OF SCIENCE, FLUSHING MEADOWS
 CORONA PARK, NY:
 2,572,038. REN. 5-1-12. MULTIPLE CLASS, INT. CLS. 38,
 41 AND 42.

NEW YORK LIFE INSURANCE COMPANY, NEW YORK,
 NY:
 1,698,004. REN. 4-30-12. INT. CL. 36.

NEW YORK STATE PUBLIC HIGH SCHOOL ATHLETIC
 ASSOCIATION, INC., LATHAM, NY:
 2,555,277. REN. 4-27-12. INT. CL. 42.

NEWBURY CORPORATION, DEDHAM, MA:
 2,685,998. REN. 5-3-12. INT. CL. 36.
 2,688,324. REN. 5-3-12. INT. CL. 36.

NEWFREY LLC, NEWARK, DE:
 2,562,152. REN. 5-3-12. INT. CL. 7.

NEWS AMERICA MARKETING PROPERTIES L.L.C., CHI-
 CAGO, IL, NEWS AMERICA MARKETING FSI, INC.,
 NEW YORK, NY:
 2,582,589. REN. 5-3-12. INT. CL. 35.

NEWS GROUP NEWSPAPERS LIMITED, LONDON, UNI-
 TED KINGDOM:
 2,996,258, CANC. MULTIPLE CLASS, INT. CLS. 9, 16, 35,
 41 AND 42.

NEWSOM, LINDA J., OKLAHOMA CITY, OK:
 4,155,358, INT. CL. 35.

NEWSRING INDUSTRIAL CORPORATION, LAKE FOR-
 EST, IL:
 2,565,755. REN. 5-2-12. INT. CL. 21.

NEXT GENERATION FOCUS, INC., CUMMING, GA:
 4,153,132, PUB. 3-20-2012. INT. CL. 41.

NEXTGEN MANAGEMENT, LLC, BALTIMORE, MD:
 4,154,741, INT. CL. 42.

NEXTWAVE TECHNOLOGY LTD, BELIZE CITY, BELIZE:
 2,492,775, CANC. INT. CL. 9.

NG, ISABELLE, METRO MANILA, PHILIPPINES:
 4,153,102, PUB. 3-20-2012. INT. CL. 25.

- NGL CLEANING TECHNOLOGY S.A., SWITZERLAND:
2,998,356.
- NGM ITALIA S.R.L., ITALY:
4,152,309, PUB. 3-20-2012. INT. CL. 9.
- NGUYEN, KIMHONG THI, SAN JOSE, CA, DBA BAMBU
SNACKS AND COFFEE CORPORATION:
4,152,524, PUB. 3-20-2012. MULTIPLE CLASS, INT. CLS.
29, 30, 32 AND 43.
- NGUYEN, MAI-TRANG THI, SANTA CLARA, CA:
4,155,708, INT. CL. 25.
- NIBMOR PROJECT, LLC., HUNTINGTON, NY:
4,153,284, PUB. 3-20-2012. INT. CL. 30.
- NICHOLAS RUSSELL HART, UNITED KINGDOM:
4,152,394, PUB. 3-20-2012. MULTIPLE CLASS, INT. CLS.
3, 18 AND 25.
- NICHOLS, ROBYN, KANSAS CITY, MO:
1,682,842, REN. 5-2-12. INT. CL. 14.
- NICHOLSON, RANDY, MARIETTA, GA:
4,152,906, PUB. 3-20-2012. INT. CL. 10.
- NICO EAST, LOS ANGELES, CA:
4,153,407, PUB. 3-20-2012. INT. CL. 41.
- NIEDNAGEL, JONATHAN P., THORNFIELD, MO:
4,153,345, PUB. 3-20-2012. INT. CL. 42.
- NIHON SANMO SENSHOKU KABUSHIKI KAISHA, KYO-
TO-SHI, KYOTO-FU, JAPAN, AKA NIHON SANMO DYE-
ING CO., LTD.:
2,492,041, CANC. INT. CL. 24.
- NIKON CORPORATION, TOKYO, JAPAN:
4,155,702, INT. CL. 9.
4,155,703, INT. CL. 9.
- NINGBO YOUNGOR WORSTED SPINNING WEAVING &
DYEING CO., LTD., CHINA:
4,152,265, PUB. 3-20-2012. INT. CL. 24.
- NINJAI GANG, LLC, KALIUA, HI:
2,562,090, REN. 5-3-12. INT. CL. 16.
- NINTENDO OF AMERICA INC., REDMOND, WA:
4,155,592, INT. CL. 9.
- NIPPON DENKI KABUSHIKI KAISHA, TOKYO, JAPAN,
DBA NEC CORPORATION:
2,559,684, REN. 4-30-12. INT. CL. 42.
- NIPPON STEEL TOPY BRIDGE CO., LTD., AICHI, JAPAN:
4,152,460, PUB. 4-19-2011. MULTIPLE CLASS, INT. CLS. 6
AND 37.
- NISOURCE CORPORATE SERVICES COMPANY, MER-
RILLVILLE, IN:
4,152,447, PUB. 3-20-2012. INT. CL. 35.
4,153,051, PUB. 3-20-2012. MULTIPLE CLASS, INT. CLS.
35, 36, 37, 39 AND 42.
- NITRATE FREE, INC., VAN NUYS, CA, DBA SIBERIA
WATERS:
4,152,963, PUB. 3-20-2012. INT. CL. 32.
- NO BAD IDEAS, INC., INDIANAPOLIS, IN:
4,106,922, COR. INT. CL. 25.
- NOBERASCO S.P.A., ITALY:
4,152,412, PUB. 3-20-2012. INT. CL. 29.
- NOBLE HOUSE HOTELS & RESORTS, KIRKLAND, WA:
2,699,292, REN. 5-3-12. INT. CL. 42.
- NOCTIS INK, LLC, TEMPE, AZ:
4,154,011, PUB. 3-20-2012. INT. CL. 25.
- NOEMIE LENOIR, PARIS, FRANCE:
4,152,140, PUB. 3-20-2012. MULTIPLE CLASS, INT. CLS.
3, 14 AND 25.
- NOETIX CORPORATION, REDMOND, WA:
2,590,758, REN. 4-30-12. INT. CL. 9.
- NOKIA SIEMENS NETWORKS OY, ESPOO, FINLAND:
2,570,527, REN. 5-1-12. INT. CL. 9.
- NONPROFITS ASSISTANCE FUND, MINNEAPOLIS, MN:
2,499,335, REN. 5-2-12. INT. CL. 36.
- NOODLE BAR, INC., PLEASANTON, CA:
2,493,098, CANC. INT. CL. 42.
2,493,099, CANC. INT. CL. 42.
- NOONAN, SUZANNAH R., INCLINE VILLAGE, NV:
2,592,956, AM. MULTIPLE CLASS, INT. CLS. 5 AND 44.
- NORBIS INNOVATIONS COMPANY, LLC, BROOKLINE,
MA:
4,153,896, PUB. 3-20-2012. INT. CL. 10.
- NORCO INDUSTRIES, INC., COMPTON, CA:
1,701,408, REN. 5-2-12. MULTIPLE CLASS, INT. CLS. 6
AND 8.
1,704,530, REN. 5-2-12. MULTIPLE CLASS, INT. CLS. 6
AND 8.
- NORDBEAUTY S.R.L., I-46045 MARMIROLO (MN), ITALY:
4,152,179, PUB. 3-20-2012. INT. CL. 3.
- NORDBEAUTY S.R.L., ITALY:
4,152,180, PUB. 3-20-2012. MULTIPLE CLASS, INT. CLS.
3, 10 AND 44.
- NORTH AMERICAN SOCCER LEAGUE, LLC, MIAMI, FL:
4,155,461, INT. CL. 28.
- NORTH CENTRAL SECURITY SERVICES, LAFAYETTE,
TN:
2,546,900, REN. 5-3-12. INT. CL. 42.
- NORTH COAST ELECTRIC COMPANY, SEATTLE, WA:
1,703,914, REN. 5-1-12. INT. CL. 42.
- NORTH COUNTRY WIND BELLS, INC., ROUND POND,
ME:
4,153,961, PUB. 3-20-2012. INT. CL. 6.
- NORTH JERSEY MEDIA GROUP INC., WOODLAND PARK,
NJ, NORTH JERSEY MEDIA GROUP INC., WOODLAND
PARK, NJ:
2,558,227, REN. 4-27-12. MULTIPLE CLASS, INT. CLS. 16
AND 41.
- NORTH JERSEY MEDIA GROUP INC., HACKENSACK, NJ,
NORTH JERSEY MEDIA GROUP INC., HACKENSACK,
NJ:
2,561,505, REN. 5-2-12. INT. CL. 35.
- NORTH SHORE TOWERS APARTMENTS INCORPO-
RATED, FLORAL PARK, NY:
2,548,384, REN. 5-3-12. INT. CL. 36.
- NORTH SHORE-LONG ISLAND JEWISH HEALTH SYS-
TEM, INC., GREAT NECK, NY:
4,154,489, MULTIPLE CLASS, INT. CLS. 9 AND 35.
- NORTHEAST PATHOLOGISTS INC., HANNIBAL, MO:
4,154,388, INT. CL. 44.
- NORTHERN TOOL & EQUIPMENT COMPANY, INC.,
BURNSVILLE, MN:
4,154,462, MULTIPLE CLASS, INT. CLS. 7, 8, 9 AND 12.
- NORTHSTAR VETS, ROBBINSVILLE, NJ, FORMERLY
VETERINARY SURGICAL AND DIAGNOSTIC SPECIA-
LISTS:
4,153,817, PUB. 3-20-2012. INT. CL. 44.
- NORWALK WASTEWATER EQUIPMENT COMPANY,
NORWALK, OH:
1,685,895, REN. 4-30-12. INT. CL. 1.
- NOTIFY TECHNOLOGY CORPORATION, SAN JOSE, CA:
4,152,605, PUB. 3-20-2012. INT. CL. 9.
- NOVALASH, INC., HOUSTON, TX:
4,155,726, MULTIPLE CLASS, INT. CLS. 9 AND 16.
- NOVALOGIC, INC., MALIBU, CA:
4,154,297, MULTIPLE CLASS, INT. CLS. 9 AND 41.
- NOVARTIS AG, BASEL, SWITZERLAND:
2,999,019, CANC. INT. CL. 5.
- NOVARTIS AG, SWITZERLAND:
4,152,348, PUB. 3-20-2012. INT. CL. 5.
4,152,419, PUB. 3-20-2012. MULTIPLE CLASS, INT. CLS. 5
AND 10.
- NOVAVALL SYSTEMS, INC., ALEXANDRIA, VA:
4,154,040, PUB. 3-20-2012. INT. CL. 24.
- NOVEL PRODUCTS, INC., ROCKTON, IL:
1,200,318, REN. 4-30-12. INT. CL. 10.
- NOVELLUS HEALTHCARE COMMUNICATIONS, LLC,
MONROE TOWNSHIP, NJ:
4,155,907, INT. CL. 35.
4,155,919, INT. CL. 41.
- NOVOSEL, JOHN M. SR., LEAWOOD, KS:
4,153,123, PUB. 3-20-2012. INT. CL. 28.
- NOVUSWORKS LLC, BOSTON, MA:
4,153,022, PUB. 3-20-2012. MULTIPLE CLASS, INT. CLS.
35 AND 42.
- NOWELL, ANDREW M, WASHINGTON, DC, DBA DA-
SOUL:
4,153,421, PUB. 3-20-2012. INT. CL. 25.
- NOXELL CORPORATION, HUNT VALLEY,, MD:
4,154,332, INT. CL. 8.
- NOXELL CORPORATION, HUNT VALLEY, MD:
4,154,333, INT. CL. 8.

NRG ENERGY, INC., PRINCETON, NJ:
4,155,678, MULTIPLE CLASS, INT. CLS. 35, 36, 37 AND 40.
4,155,791, INT. CL. 35.

NRG INTERNATIONAL, LLC, LOUISVILLE, CO:
3,221,991, CANC. INT. CL. 4.

NTT COMMUNICATIONS KABUSHIKI KAISHA, TOKYO, JAPAN, DBA NTT COMMUNICATIONS CORPORATION:
2,491,658, CANC. INT. CL. 37.

NUGENICS INTERNATIONAL, LLC, CHICAGO, IL:
4,155,897, INT. CL. 5.

NUK USA LLC, HACKENSACK, NJ:
2,568,328, REN. 5-2-12. INT. CL. 9.

NUMATIC INTERNATIONAL LIMITED, CAMBERLEY, SURREY, ENGLAND:
1,661,498, REN. 5-1-12. INT. CL. 9.

NUROTRON BIOTECHNOLOGY, INC., IRVINE, CA:
4,154,242, MULTIPLE CLASS, INT. CLS. 9 AND 10.

NUTRI/SYSTEM IPHC, INC., WILMINGTON, DE:
2,492,545, CANC. INT. CL. 42.
2,492,546, CANC. INT. CL. 42.

NUTZO, LLC, LOS ANGELES, CA:
4,154,723, INT. CL. 14.

NUVIEW HEALTH, LLC, ATLANTIS, FL, DBA NUIVIEW HEALTH, LLC:
4,152,998, PUB. 3-20-2012. INT. CL. 44.

NV BEKAERT SA, BELGIUM:
4,152,384, PUB. 3-20-2012. INT. CL. 11.

NV BISCUITS DELACRE SA, B-17002 GROOT BIJGAARDEN, BELGIUM:
2,493,438, CANC. INT. CL. 30.

NVENTA BIOPHARMACEUTICALS CORPORATION, VICTORIA, BRITISH COLUMBIA:
2,999,273, CANC. INT. CL. 5.

NVENTA INCORPORATED, SCOTTSDALE, AZ:
4,156,020, INT. CL. 3.

NXSTAGE MEDICAL, INC., LAWRENCE, MA:
2,492,985, CANC. INT. CL. 10.

NYGREN, WESTEN, TOMBALL, TX:
4,153,001, PUB. 3-20-2012. INT. CL. 25.

NYSE GROUP, INC., NEW YORK, NY:
2,572,942, REN. 5-3-12. INT. CL. 36.
2,572,943, REN. 5-3-12. INT. CL. 36.

NYT MANAGEMENT SERVICES, INC., NEW YORK, NY:
4,153,545, PUB. 3-20-2012. INT. CL. 41.

O.C. SEACRETS, INC., OCEAN CITY, MD:
4,152,068, PUB. 3-20-2012. INT. CL. 43.
4,152,069, PUB. 3-20-2012. MULTIPLE CLASS, INT. CLS. 41 AND 43.

O.M. INCORPORATED, SAN JOSE, CA:
2,611,169, REN. 5-3-12. INT. CL. 42.

O'BRIEN, PATRICK A., NEW YORK, NY:
4,155,661, INT. CL. 45.

O'FARRELL, LAURA, DUNCANVILLE, PA:
2,597,754, REN. 4-28-12. INT. CL. 35.

O'HARA, RUSSELL EUGENE, PALM DESERT, CA:
2,493,273, CANC. INT. CL. 38.

O'KEEFE, TERESA ANN, ANNAPOLIS, MD:
4,153,381, PUB. 3-20-2012. INT. CL. 44.

O'NEIL GUM COMPANY, LLC, CORONA DEL MAR, CA:
4,155,603, MULTIPLE CLASS, INT. CLS. 5 AND 30.

OAK LAWN MARKETING, INC., JAPAN:
4,152,305, PUB. 3-20-2012. INT. CL. 29.

OAKLAND COUNTY, PONTIAC, MI:
2,597,533, REN. 5-3-12. MULTIPLE CLASS, INT. CLS. 35 AND 36.

OAKLAND UNIVERSITY, ROCHESTER, MI:
4,153,597, PUB. 3-20-2012. MULTIPLE CLASS, INT. CLS. 25 AND 41.

OBREGON-BANDA LLC, HOUSTON, TX:
4,155,758, INT. CL. 43.

OCCOM HOLDINGS, LLC, BOULDER, CO:
2,672,781, REN. 5-1-12. INT. CL. 30.

OCS, INCORPORATED, SCOTTSBORO, AL, FORMERLY UNCLAIMED BAGGAGE CENTER, INC.:
4,153,599, PUB. 3-20-2012. MULTIPLE CLASS, INT. CLS. 35 AND 41.
4,153,600, PUB. 3-20-2012. MULTIPLE CLASS, INT. CLS. 35 AND 41.

OCTAPHARMA AG, SWITZERLAND:
4,152,387, PUB. 3-20-2012. INT. CL. 5.

OCUSOFT, INC., RICHMOND, TX:
2,998,563, CANC. INT. CL. 5.

ODL, INCORPORATED, ZEELAND, MI:
4,155,290, INT. CL. 40.

ODZA, AGIM TONY, ANNA, TX:
4,154,536, INT. CL. 30.

OFFSHORE SAILING SCHOOL LTD., INC., FORT MYERS, FL:
1,207,343, REN. 5-1-12. INT. CL. 25.

OFL ONLINE FUTURE LTD., NICOSIA, CYPRUS:
4,155,478, MULTIPLE CLASS, INT. CLS. 25 AND 45.

Ogilvie, KRISTY, SALT LAKE CITY, UT:
4,153,548, PUB. 3-20-2012. INT. CL. 42.

OHIO FARMERS INSURANCE COMPANY, WESTFIELD CENTER, OH:
4,155,500, INT. CL. 41.
4,155,501, INT. CL. 44.

OHMAN, CHRIS, TULSA, OK:
4,152,073, PUB. 3-20-2012. INT. CL. 18.

OIL & GAS ASSET CLEARINGHOUSE, INC., HOUSTON, TX:
2,572,875, REN. 4-27-12. INT. CL. 36.

OIL-DRI CORPORATION OF AMERICA, CHICAGO, IL:
4,153,036, PUB. 12-13-2011. INT. CL. 31.

OLD WORLD INDUSTRIES, LLC, NORTHBROOK, IL:
1,692,242, REN. 4-27-12. INT. CL. 1.
1,700,058, REN. 5-2-12. INT. CL. 1.
1,700,059, REN. 5-2-12. INT. CL. 1.
2,664,541, REN. 4-30-12. INT. CL. 12.

OLDE GRANDDAD INDUSTRIES, INC., KEARNY, NJ:
4,152,071, PUB. 3-20-2012. INT. CL. 3.

OLISO, INC., SAN FRANCISCO, CA:
4,155,893, INT. CL. 9.

OLIVER EUGENE ANDERSON, LAS VEGAS, NV AND CHARLES LORENZO HAYES, HUNTINGTON BEACH, CA:
4,153,842, PUB. 3-20-2012. INT. CL. 33.

OLSTEN SERVICE CORP., IRVING, TX:
1,606,645, CANC. MULTIPLE CLASS, INT. CLS. 35, 41 AND 42.
1,606,650, CANC. MULTIPLE CLASS, INT. CLS. 35, 41 AND 42.

OLTMANN, STEVEN W., STERLING, IL:
4,154,348, INT. CL. 11.

OLYMPUS MEDICAL SYSTEMS CORP., TOKYO, JAPAN:
4,154,404, INT. CL. 10.

OMEGA NETWORKS, INC., ATLANTA, GA:
2,590,663, REN. 5-2-12. INT. CL. 38.

OMG KLEEN, LLC, LUBBOCK, TX:
4,154,050, PUB. 3-20-2012. INT. CL. 37.

OMIKRON DATA QUALITY GMBH, FED REP GERMANY:
3,591,454, COR. MULTIPLE CLASS, INT. CLS. 9, 16, 38 AND 42.

OMKASA, HIGHLANDS RANCH, CO:
4,154,291, MULTIPLE CLASS, INT. CLS. 24 AND 35.

OMNIBIN, BARRINGTON, IL:
4,156,065, INT. CL. 35.

OMNITHRUSTER, INC., TWINSBURG, OH:
1,223,943, REN. 4-27-12. INT. CL. 7.

ON THE DOT LLC, PORTLAND, OR:
4,153,923, PUB. 3-20-2012. INT. CL. 16.

ON-MESSAGE PUBLIC RELATIONS LLC, NEEDHAM, MA:
2,695,811, REN. 5-3-12. INT. CL. 35.

ONCPROTECH LLC, ANN ARBOR, MI:
4,154,041, PUB. 3-20-2012. INT. CL. 42.

ONE PASS IMPLEMENTS INC., LANGBANK, SASKATCHEWAN, CANADA:
2,618,157, REN. 4-28-12. INT. CL. 7.

ONE PASS IMPLEMENTS INC., SASKATCHEWAN, CANADA:
2,624,809, REN. 4-28-12. INT. CL. 7.

ONEIDA VICTOR, INC., LTD., EUCLID, OH:
4,155,380, INT. CL. 6.

- ONEKIND CHARITY, EDINBURGH EH2 4PG, UNITED KINGDOM:
4,152,171, PUB. 3-20-2012. MULTIPLE CLASS, INT. CLS. 16, 35, 36 AND 41.
- ONEMAIN FINANCIAL HOLDINGS, INC., WILMINGTON, DE:
4,155,323, INT. CL. 36.
4,155,324, INT. CL. 36.
- ONEXONE FOUNDATION, MONTREAL, QUEBEC, CANADA:
4,155,525, INT. CL. 36.
- ONFIBER COMMUNICATIONS, INC., ENGLEWOOD, CO:
2,998,538, CANC. INT. CL. 38.
- ONG SHAO DENTAL, INC., HUNTINGTON BEACH, CA, DBA SUNRISE DENTAL CENTER:
4,153,212, PUB. 3-20-2012. INT. CL. 44.
- ONIX SYSTEMS INC., KINGWOOD, TX:
2,528,865, REN. 4-30-12. MULTIPLE CLASS, INT. CLS. 9, 37 AND 42.
- ONVIA, INC., SEATTLE, WA, ONVIA.COM, INC., SEATTLE, WA:
2,564,106, REN. 4-27-12. INT. CL. 35.
- ONWARD SYSTEMS INC., DIAMOND BAR, CA:
4,155,672, INT. CL. 42.
4,155,673, INT. CL. 42.
- ONYX CREATIVE GROUP, INC., TALLAHASSEE, FL:
4,154,005, PUB. 3-20-2012. INT. CL. 35.
- OPALTONE AUSTRALASIA PTY. LTD., ASHMORE, AUSTRALIA:
4,156,059, INT. CL. 2.
- OPEN DATA CENTER ALLIANCE, INC., BEAVERTON, OR:
4,152,764, PUB. 3-20-2012. MULTIPLE CLASS, INT. CLS. 35 AND 42.
- OPERATION GRAND SLAM, WOODINVILLE, WA:
4,155,493, INT. CL. 41.
- OPERATION INTERDEPENDENCE, GRAND JUNCTION, CO:
4,153,344, PUB. 3-20-2012. INT. CL. 35.
- OPERATION STARS & STRIPES, INC., MARIETTA, GA:
4,153,646, PUB. 3-20-2012. MULTIPLE CLASS, INT. CLS. 35 AND 36.
- OPINICUS CORPORATION, LUTZ, FL:
2,699,828, REN. 5-3-12. INT. CL. 9.
- OPNET TECHNOLOGIES, INC., BETHESDA, MD:
2,572,789, REN. 5-2-12. INT. CL. 42.
4,152,800, PUB. 3-20-2012. INT. CL. 9.
- OPPORTUNITY BUYS, INC., INDIANAPOLIS, IN:
4,155,949, MULTIPLE CLASS, INT. CLS. 3 AND 4.
- OPTEC USA, INC., LAWRENCEVILLE, GA:
4,155,369, INT. CL. 10.
- OPTEX CO., LTD., SHIGA, JAPAN:
2,492,938, CANC. INT. CL. 9.
- ORBEA, S. COOP. LTDA., MALLABIA (VIZCAYA), SPAIN:
2,576,631, REN. 5-2-12. INT. CL. 12.
- ORBEA, S. COOP. LTDA., 48. - 48269 MALLARIA (VIZCAYA), SPAIN:
2,583,328, REN. 5-2-12. INT. CL. 12.
- ORCA BEVERAGE, INC., MUKILTEO, WA:
4,155,059, INT. CL. 32.
- ORCHARD SUPPLY HARDWARE, LLC, SAN JOSE, CA:
4,155,885, INT. CL. 11.
- OREGON HEALTHCARE ENTERPRISES, INC., LAKE OSWEGO, OR:
4,155,696, INT. CL. 35.
- ORIENT POWER HOLDINGS LIMITED, KOWLOON, HONG KONG:
2,998,846, CANC. INT. CL. 9.
- ORIGINAL STYLE LIMITED, EXETER, DEVON, EX4 4HJ, UNITED KINGDOM:
2,563,669, REN. 4-30-12. INT. CL. 19.
- ORIONS THREE KINGS, UNION, NJ:
4,154,972, INT. CL. 5.
- ORIZONIA DESTINATION MANAGEMENT, S.L., PALMA DE MALLORCA, SPAIN:
4,152,548, PUB. 8-23-2011. MULTIPLE CLASS, INT. CLS. 16, 39 AND 43.
- ORKIN EXPANSION, INC., WILMINGTON, DE:
4,155,867, INT. CL. 37.
- ORTHO TECHNOLOGY, INC, TAMPA, FL:
2,590,856, REN. 5-3-12. INT. CL. 10.
- ORTHO TECHNOLOGY, INC., TAMPA, FL:
2,597,919, REN. 5-3-12. INT. CL. 10.
- ORTHOHELIX SURGICAL DESIGNS, INC., MEDINA, OH:
4,154,939, INT. CL. 41.
- OS ID AS, NORWAY:
4,152,381, PUB. 3-20-2012. MULTIPLE CLASS, INT. CLS. 6 AND 20.
- OSBORNE PROPERTIES LIMITED PARTNERSHIP, BURNSVILLE, MN, DBA KRAUS-ANDERSON INSURANCE:
4,154,795, MULTIPLE CLASS, INT. CLS. 36 AND 42.
4,154,796, MULTIPLE CLASS, INT. CLS. 36, 41 AND 45.
- OSCAR E. ONTIVEROS, EL PASO, TX:
4,154,760, INT. CL. 9.
- OSPIG GMBH & CO. KG, FED REP GERMANY:
4,152,276, PUB. 3-20-2012. INT. CL. 25.
- OSRAM AG, MUENCHEN, FED REP GERMANY, AKA OSRAM AKTIENGESELLSCHAFT:
1,732,854, REN. 4-30-12. INT. CL. 11.
- OSRAM AG, 81543 MÜNCHEN, FED REP GERMANY:
4,152,406, PUB. 3-20-2012. MULTIPLE CLASS, INT. CLS. 9 AND 11.
- OSRAM AG, MUENCHEN, FED REP GERMANY, DBA/ AKA/TA/FORMERLY OSRAM G.M.B.H.:
4,152,413, PUB. 3-20-2012. INT. CL. 11.
- OSRAM AG, 81543 MÜNCHEN, FED REP GERMANY:
4,152,423, PUB. 3-20-2012. MULTIPLE CLASS, INT. CLS. 9 AND 11.
- OSTERMAN & COMPANY, INC., CHESHIRE, CT:
4,152,081, PUB. 12-13-2011. MULTIPLE CLASS, INT. CLS. 17, 35, 40 AND 42.
- OTT LIGHT SYSTEMS, INC., SANTA BARBARA, CA:
2,492,192, CANC. INT. CL. 11.
- OUTBOX TECHNOLOGY CRB INC., MONTREAL, QUEBEC, CANADA:
4,154,471, INT. CL. 42.
- OUTILS RUBIS SA, CH-6855 STABIO, SWITZERLAND:
2,569,011, REN. 4-27-12. INT. CL. 8.
- OVE PETERSEN, FED REP GERMANY:
4,152,220, PUB. 3-20-2012. MULTIPLE CLASS, INT. CLS. 6, 9, 19 AND 25.
- OVIVO LUXEMBOURG S.A.R.L., MUNSBACH, LUXEMBOURG:
2,572,493, REN. 4-30-12. INT. CL. 11.
- OWEN, LINDA, GOTHA, FL:
4,155,540, INT. CL. 3.
- OWBOW (SOCIÉTÉ PAR ACTIONS SIMPLIFIÉE), FRANCE:
3,029,483.
- OY KWC ORGANIZATION LTD, FINLAND:
4,152,240, PUB. 3-20-2012. INT. CL. 41.
- O2 MICRO INTERNATIONAL LIMITED, GEORGETOWN, CAYMAN ISLANDS:
2,575,266, REN. 5-3-12. INT. CL. 9.
2,577,340, REN. 5-3-12. INT. CL. 9.
- P. H. GLATFELTER COMPANY, YORK, PA:
2,558,617, REN. 4-27-12. INT. CL. 1.
- P.F. CHANG'S CHINA BISTRO, INC., SCOTTSDALE, AZ:
4,153,009, PUB. 3-20-2012. INT. CL. 43.
- P.J.'S ON NASSAU, INC., PRINCETON, NJ, DBA PJ'S PANCAKE HOUSE:
1,223,003, REN. 4-30-12. INT. CL. 42.
- PACIFIC COAST FEATHER COMPANY, SEATTLE, WA:
2,492,830, CANC. INT. CL. 20.
4,155,486, INT. CL. 20.
- PACIFIC COAST PRODUCERS, LODI, CA:
4,154,980, INT. CL. 29.
- PACIFIC ENTERTAINMENT CORPORATION, SAN DIEGO, CA:
4,154,640, INT. CL. 41.
- PACIFIC STEAMEX CLEANING SYSTEMS, INC., MUSKOGON, MI:
2,684,741, REN. 4-27-12. INT. CL. 7.
- PACIFIC ZIPPER CO., LTD., KYOUNGKI-DO, REPUBLIC OF KOREA:
2,564,891, REN. 4-27-12. INT. CL. 26.
- PACKSIZE LLC, SALT LAKE CITY, UT:
4,155,956, MULTIPLE CLASS, INT. CLS. 7 AND 40.

PAGAN, EBEN, LAS VEGAS, NV:
4,153,278, PUB. 3-20-2012. INT. CL. 9.

PAGO HOLDING AG, POSTFACH CH-9472, SWITZERLAND:
2,625,458. REN. 5-1-12. MULTIPLE CLASS, INT. CLS. 7, 16 AND 20.

PAGODA BOX, INC., REXBURG, ID:
4,153,565, PUB. 3-20-2012. INT. CL. 42.
4,153,566, PUB. 3-20-2012. INT. CL. 42.

PAIN CENTERS IP, LLC, PEORIA, AZ:
4,152,676, PUB. 10-18-2011. INT. CL. 44.

PAINTHOLICS LLC, SPRING HILL, FL:
4,153,236, PUB. 3-20-2012. INT. CL. 37.

PALIDIUM, INC., HUGO, MN:
4,155,468, INT. CL. 25.

PALISADES CORPORATION, SPOKANE, WA:
4,153,420, PUB. 3-20-2012. MULTIPLE CLASS, INT. CLS. 35 AND 44.

PALMER CAP - CHUR EQUIPMENT, INC., DOUGLASVILLE, GA:
2,491,830. REN. 5-3-12. MULTIPLE CLASS, INT. CLS. 5 AND 10.

PALMETTO MARINE CONSTRUCTION, INC, LITTLE RIVER, SC:
4,153,077, PUB. 3-20-2012. INT. CL. 37.

PALO PRODUCTS LLC, NEW YORK, NY, DBA PALO TEA:
4,156,000, INT. CL. 30.

PALOS VERDES FOOTWEAR, INC., CARSON, CA:
4,154,105, PUB. 3-20-2012. INT. CL. 25.

PAN AMERICAN WORLD AIRWAYS, INC., DOVER, NH:
4,155,834, MULTIPLE CLASS, INT. CLS. 14, 18, 25 AND 41.

PAN OTO RADYATÖR MAKINA SANAYI VE TICARET ANONIM SIRKETI, TURKEY:
4,152,297, PUB. 3-20-2012. MULTIPLE CLASS, INT. CLS. 7 AND 12.

PAN PARAG INDIA LIMITED, KANPUR, INDIA:
4,154,569, INT. CL. 34.

PANASUK, CURTIS, SAN CARLOS, CA:
4,154,112, PUB. 3-20-2012. INT. CL. 9.

PANDUIT CORP., TINLEY PARK, IL:
2,998,565, CANC. INT. CL. 9.

PANTHER TRADING, INC., BALTIMORE, MD:
4,152,063, PUB. 2-7-2012. INT. CL. 8.

PAPA, NICHOLAS, SAUNDERSTOWN, RI AND ARNOUX, JIM, EXETER, RI:
4,152,956, PUB. 3-20-2012. INT. CL. 31.

PARADIGM GEOPHYSICAL CORP., HOUSTON, TX:
4,154,331, INT. CL. 9.

PARADIGM STRATEGY GROUP, INC., RIVERSIDE, CT:
2,491,801, CANC. INT. CL. 41.

PARFUMS CARON, FRANCE:
4,152,268, PUB. 3-20-2012. INT. CL. 3.

PARFUMS CHRISTIAN DIOR, S.A., PARIS, FRANCE:
2,564,970. REN. 4-30-12. INT. CL. 3.

PARFUMS DE COEUR, LTD., NORTH DARIEN, CT:
2,492,220, CANC. INT. CL. 3.

PARIS ACCESSORIES, INC., NEW YORK, NY:
2,998,633, CANC. MULTIPLE CLASS, INT. CLS. 13 AND 25.

PARIS PRESENTS INCORPORATED, GURNEE, IL:
4,155,122, INT. CL. 3.

PARK LANE CONSERVATORIES LTD., POYNTON, CHESHIRE SK1 21YL, UNITED KINGDOM:
2,998,678, CANC. MULTIPLE CLASS, INT. CLS. 6 AND 19.

PARK PLACE RECREATION DESIGNS, INC., SAN ANTONIO, TX:
4,154,042, PUB. 3-20-2012. INT. CL. 28.

PARK RIDGE SECURITIES CORP., LYFORD CAY, NEW PROVIDENCE, BAHAMAS:
4,154,277, INT. CL. 41.

PARK RIDGE SECURITIES CORP., NEW PROVIDENCE, BAHAMAS:
4,155,427, INT. CL. 41.

PARKER HOUSE SAUSAGE COMPANY, CHICAGO, IL:
4,152,647, PUB. 3-20-2012. INT. CL. 29.

PARKER MCCRORY MFG. CO., KANSAS CITY, MO, BAY MILLS LIMITED, OAKVILLE, ONTARIO, CANADA:
1,757,992. REN. 4-30-12. INT. CL. 6.

PARKER, PATRICK, DUBLIN, OH:
4,152,493, PUB. 3-20-2012. INT. CL. 9.

PARRAGH, ISTVAN, LAS VEGAS, NV:
2,568,102. REN. 5-2-12. INT. CL. 25.

PARTICLE MEASURING SYSTEMS, INC., BOULDER, CO:
4,154,851, INT. CL. 9.

PARTS-PEOPLE.COM, INC., AUSTIN, TX:
4,153,304, PUB. 3-20-2012. INT. CL. 9.

PARTY TOWN USA, INC., PORT SAINT LUCIE, FL:
2,683,860. REN. 4-27-12. INT. CL. 35.

PARTYDRAGON LIMITED, CENTRAL, HONG KONG:
4,154,346, INT. CL. 28.

PASCUA YAQUI TRIBE, TUCSON, AZ:
4,155,007, INT. CL. 41.

PASCUA, VANCE J., HANAPEPE, HI:
4,153,864, PUB. 3-20-2012. INT. CL. 28.

PASSCHENDAELE RIDGE PTY LTD, AUSTRALIA:
2,998,360.

PASSION FOOD SIX, LLC, WASHINGTON, DC, DBA BURGER TAP AND SHAKE:
4,154,213, PUB. 3-20-2012. INT. CL. 33.

PASSIONATESPOUSE, INCORPORATED, SUWANEE, GA:
4,155,467, INT. CL. 41.

PASSIVSYSTEMS LIMITED, NEWBURY, UNITED KINGDOM:
4,152,635, PUB. 3-20-2012. INT. CL. 9.

PASSTOUCH, LLC, SURF CITY, NC:
4,155,197, INT. CL. 9.
4,155,216, INT. CL. 9.

PASTIFICIO ARTIGIANO CAV. GIUSEPPE COCCO S.N.C., FARA S. MARTINO (CH), ITALY:
2,998,516, CANC. MULTIPLE CLASS, INT. CLS. 29 AND 30.

PASTOR, JENNIFER, NEW YORK, NY:
4,153,382, PUB. 3-20-2012. INT. CL. 44.

PATCH PRODUCTS, INC., BELOIT, WI:
4,154,928, INT. CL. 28.
4,154,929, INT. CL. 28.

PATCHES AND BADGES FOR KIDS, NFP, BETHALTO, IL:
4,153,196, PUB. 3-20-2012. INT. CL. 36.

PATEL, SANDIP, ISELIN, NJ, DBA CHOWPATTY:
4,152,062, PUB. 3-20-2012. INT. CL. 43.

PATERSON, PAGE, WILMINGTON, NC:
4,154,352, INT. CL. 41.

PATHFINDER PAYMENT SOLUTIONS, INC., COLUMBIA, MD:
4,155,273, INT. CL. 36.

PATRICIA KIM STURGESS, CALGARY, CANADA:
4,152,085, PUB. 3-20-2012. MULTIPLE CLASS, INT. CLS. 11 AND 21.

PATRIOT SCIENTIFIC CORPORATION, SAN DIEGO, CA:
2,492,647, CANC. INT. CL. 9.

PATRIOT-NEWS CO., THE, MECHANICSBURG, PA:
2,674,766. REN. 4-28-12. INT. CL. 16.

PATTI'S ENTERPRISES, L.L.C., GRAND RIVERS, KY:
2,693,441. REN. 5-3-12. MULTIPLE CLASS, INT. CLS. 35 AND 43.

PAUL BARNETT, INC., NEW YORK, NY, DBA NOW WHAT RESEARCH:
4,153,165, PUB. 3-20-2012. INT. CL. 35.

PAUL CARROLL, PORTLAND, OR:
4,152,156, PUB. 2-8-2011. MULTIPLE CLASS, INT. CLS. 24 AND 25.

PAUL FRANK INDUSTRIES LLC, LOS ANGELES, CA:
2,571,471. REN. 4-29-12. INT. CL. 14.

PAUL G. WOLF, ESBJERG V, DENMARK:
4,153,951, PUB. 3-20-2012. INT. CL. 41.
4,153,952, PUB. 3-20-2012. INT. CL. 38.

PAUL HADJUK, MIDDLEBURG HEIGHTS, OH, DBA VIA-SOUND:
4,152,851, PUB. 3-20-2012. INT. CL. 35.

PAUL NESBIHAL CLOTHING, LLC, HOBOKEN, NJ:
4,153,902, PUB. 3-20-2012. INT. CL. 25.

- PAUL PONZIO, JR., LAKEVILLE, MA, SAMARITANIA, INC., KENWOOD CIRCLE, MA:
1,684,666. REN. 4-27-12. INT. CL. 37.
- PAULSEN, LEIGH A., MANCHESTER, NH:
2,998,864. CANC. MULTIPLE CLASS, INT. CLS. 19 AND 40.
- PAVEY, LAURA, CINCINNATI, OH:
4,155,598. INT. CL. 44.
- PAYANO, ALLEN, JERSEY CITY, NJ:
4,156,050. INT. CL. 35.
- PC CONNECTION SALES CORPORATION, MERRIMACK, NH:
2,492,320. CANC. INT. CL. 42.
- PCA DESIGN, INC., RED LION, PA:
4,155,529. INT. CL. 20.
- PEABODY MANAGEMENT, INC., MEMPHIS, TN:
2,572,874. REN. 5-1-12. INT. CL. 25.
2,608,663. REN. 5-1-12. INT. CL. 25.
- PEACE, LOVE AND LITTLE DONUTS, MOON TOWNSHIP, PA:
4,153,589. PUB. 3-20-2012. INT. CL. 35.
- PEACH BOWL, INC., ATLANTA, GA:
2,663,047. REN. 5-2-12. INT. CL. 41.
- PEARISON, INC., CYNTHIANA, IN:
4,155,554. MULTIPLE CLASS, INT. CLS. 3, 9, 14, 18, 24, 25, 26 AND 28.
- PEARL FAMILY VINEYARDS INC., CONCORD, ONTARIO, CANADA, DBA PEARLMORISSETTE:
4,152,097. PUB. 9-7-2010. INT. CL. 33.
- PEARL MINISTRIES, INC., BIRMINGHAM, AL:
4,153,746. PUB. 3-20-2012. MULTIPLE CLASS, INT. CLS. 35 AND 36.
4,153,748. PUB. 3-20-2012. MULTIPLE CLASS, INT. CLS. 35 AND 36.
- PEARSON EDUCATION, INC., UPPER SADDLE RIVER, NJ:
2,493,266. CANC. INT. CL. 16.
3,088,019. CANC. INT. CL. 9.
- PEAVEY ELECTRONICS CORPORATION, MERIDIAN, MS:
1,682,723. REN. 5-2-12. INT. CL. 9.
- PECORINO, ALLEN D., TALLAHASSEE, FL:
2,575,398. REN. 5-3-12. INT. CL. 42.
- PECTOR, JEFFREY STUART, OAKLAND, CA:
2,938,247. CANC. INT. CL. 9.
- PEDAGOGUE SOLUTIONS, INC., PRINCETON, NJ:
2,576,553. AM. INT. CL. 41.
- PEDI-BEAR, LLC, FURLONG, PA:
4,154,438. MULTIPLE CLASS, INT. CLS. 16 AND 28.
- PEGASYSTEMS INC., CAMBRIDGE, MA:
4,153,752. PUB. 3-20-2012. INT. CL. 35.
- PEI WEI ASIAN DINER, INC., SCOTTSDALE, AZ:
4,156,004. INT. CL. 29.
4,156,005. INT. CL. 30.
- PEIRCE-PHELPS, INC., PHILADELPHIA, PA:
2,567,878. REN. 5-2-12. INT. CL. 37.
- PEM MANAGEMENT, INC., WILMINGTON, DE:
2,557,318. REN. 5-1-12. INT. CL. 6.
- PENGUIN BRANDS, INC., SHARON HILL, PA:
2,558,893. REN. 4-27-12. INT. CL. 25.
- PENNSYLVANIA LIQUOR CONTROL BOARD, HARRISBURG, PA:
4,154,518. MULTIPLE CLASS, INT. CLS. 16, 18 AND 35.
4,155,865. INT. CL. 35.
- PENNWELL CORPORATION, TULSA, OK:
4,153,742. PUB. 3-20-2012. INT. CL. 44.
4,153,858. PUB. 3-20-2012. INT. CL. 9.
- PENSKE SYSTEM, INC., BLOOMFIELD HILLS, MI:
2,566,860. REN. 5-1-12. INT. CL. 28.
- PENTAIR RESIDENTIAL FILTRATION, LLC, MILWAUKEE, WI:
1,682,973. REN. 4-27-12. INT. CL. 20.
- PENTAIR WATER POOL AND SPA, INC., SANFORD, NC, PENTAIR POOL PRODUCTS, INC., LAGRANGEVILLE, NY:
2,572,472. REN. 5-1-12. MULTIPLE CLASS, INT. CLS. 6, 11 AND 28.
- PEPI, GRETCHEN, SHREWSBURY, MA, DBA WHOLE-SOME HEALERS:
4,153,828. PUB. 3-20-2012. INT. CL. 3.
- PERCONA, INC., SEVERNA PARK, MD:
4,153,423. PUB. 3-20-2012. INT. CL. 9.
- PERFECT CIRCLE PUBLISHING, INC., TULSA, OK:
4,153,218. PUB. 3-20-2012. INT. CL. 16.
- PERFECT EYEWEAR GROUP INC., BROOKLYN, NY:
2,492,312. CANC. INT. CL. 9.
- PERFORMANCE INSIGHTS INC., SMYRNA, GA:
4,152,645. PUB. 3-20-2012. INT. CL. 35.
- PERFUME FOR LATINAS LLC, ALAMEDA, CA:
4,156,053. INT. CL. 3.
- PERIOCONCEPTS, PLLC, WA:
2,492,638. CANC. INT. CL. 42.
- PERLSON, KIP, LOS ANGELES, CA:
4,152,999. PUB. 3-20-2012. INT. CL. 9.
- PERPETUAL IMAGES, INC., THOUSAND OAKS, CA:
2,499,540. REN. 5-1-12. MULTIPLE CLASS, INT. CLS. 9 AND 41.
- PERRY EQUIPMENT CORPORATION, MINERAL WELLS, TX:
2,646,585. REN. 4-27-12. INT. CL. 7.
- PERSHING INVESTMENTS LLC, NEWARK, DE:
2,498,120. REN. 5-3-12. INT. CL. 42.
2,498,317. REN. 5-3-12. INT. CL. 36.
2,498,873. REN. 5-3-12. INT. CL. 36.
- PET KENNEL COMPANY, LLC, VAN BUREN, IN:
4,154,140. PUB. 3-20-2012. INT. CL. 31.
- PETELKA INVESTMENTS LTD., BURLINGTON, ONTARIO, CANADA:
4,152,151. PUB. 3-20-2012. INT. CL. 12.
- PETELKA INVESTMENTS LTD., BURLINGTON, ONTARIO, CANADA AND PETELKA, JEFFREY ROY WILLIAM, BURLINGTON, ONTARIO, CANADA:
4,152,685. PUB. 3-20-2012. MULTIPLE CLASS, INT. CLS. 6, 12 AND 22.
- PETER J. MIELE, RED WING, MN:
4,153,171. PUB. 3-20-2012. INT. CL. 16.
- PETER JARTOFT, SWEDEN:
4,152,372. PUB. 3-20-2012. INT. CL. 39.
- PETER LI, INC, DAYTON, OH:
2,666,020. REN. 5-3-12. INT. CL. 16.
- PETER LI, INC., DAYTON, OH:
2,677,037. REN. 5-3-12. INT. CL. 16.
- PETER ZELLER, SWITZERLAND:
4,152,241. PUB. 3-20-2012. MULTIPLE CLASS, INT. CLS. 9, 16, 18, 35 AND 39.
- PETEXEC, COLORADO SPRINGS, CO:
4,154,075. PUB. 3-20-2012. INT. CL. 42.
- PETMED EXPRESS, INC., POMPANO BEACH, FL:
2,635,443. REN. 4-30-12. INT. CL. 35.
- PETOSKEY PLASTICS, INC., PETOSKEY, MI:
4,152,574. PUB. 3-20-2012. MULTIPLE CLASS, INT. CLS. 16 AND 18.
- PETRO-DRILL CORPORATION, HOUSTON, TX:
4,153,485. PUB. 3-20-2012. INT. CL. 41.
- PETROWEB, INC., DENVER, CO:
2,561,203. REN. 5-2-12. MULTIPLE CLASS, INT. CLS. 40 AND 42.
- PETSPORT USA, INC., PITTSBURG, CA:
4,155,664. INT. CL. 28.
- PEYTON, JAMES W., SAN ANTONIO, TX:
2,580,478. REN. 4-27-12. INT. CL. 41.
- PHANTOM MFG. (INT'L) LTD, ABBOTSFORD, CANADA:
4,154,409. MULTIPLE CLASS, INT. CLS. 6 AND 19.
- PHARMA MEDICO UK LIMITED, BRISTOL, UNITED KINGDOM:
4,154,597. MULTIPLE CLASS, INT. CLS. 3 AND 5.
- PHARMATHENE, INC., ANNAPOLIS, MD:
4,154,326. INT. CL. 5.
- PHAT FASHIONS LLC, NEW YORK, NY:
2,492,511. CANC. INT. CL. 18.
- PHG ENERGY, LLC, LA VERGNE, TN:
4,154,722. INT. CL. 7.
- PHILIP LAW INC, NEWPORT BEACH, CA:
4,156,040. INT. CL. 35.
- PHILIP MORRIS USA INC., RICHMOND, VA:
4,152,850. PUB. 3-20-2012. INT. CL. 34.
- PHILIPPE COUSTEAU FOUNDATION, WASHINGTON, DC:
3,006,832. CANC. MULTIPLE CLASS, INT. CLS. 16 AND

35.
 PHILLIPS, JAMES L, HOUSTON, TX:
 4,153,412, PUB. 3-20-2012. INT. CL. 41.
- PHILOSYS INC, NEW YORK, NY:
 4,154,128, PUB. 3-20-2012. MULTIPLE CLASS, INT. CLS. 5 AND 10.
- PHITEN USA, INC., TORRANCE, CA, CA:
 4,155,092, INT. CL. 3.
- PHOENIX ENVIRONMENTAL CARE, LLC, VALDOSTA, GA:
 4,154,647, INT. CL. 5.
- PHOENIX INTANGIBLES HOLDING COMPANY, GREENVILLE, DE:
 2,630,539. REN. 4-27-12. MULTIPLE CLASS, INT. CLS. 1, 3, 5, 6, 9, 16, 21, 30 AND 32.
 2,630,539, CANC. MULTIPLE CLASS, INT. CLS. 8, 10, 11 AND 29.
 2,638,558. REN. 4-30-12. MULTIPLE CLASS, INT. CLS. 1, 3, 5, 6, 9, 16, 29, 30 AND 32.
 2,638,558, CANC. MULTIPLE CLASS, INT. CLS. 8, 10, 11 AND 21.
 3,072,474, AM. INT. CL. 35.
 4,155,958, INT. CL. 30.
- PHOSEON TECHNOLOGY, INC., HILLSBORO, OR:
 4,154,864, INT. CL. 11.
 4,154,865, INT. CL. 11.
- PHYSICIAN'S SCIENCE & NATURE, INC., NEWPORT BEACH, CA:
 4,155,173, INT. CL. 5.
- PICALATA PRODUCTIONS, LLC, PONTE VEDRA, FL:
 4,154,887, INT. CL. 16.
- PICTURE PERFECT MAIDS, INC., MOORESVILLE, NC:
 2,501,016, CANC. INT. CL. 37.
- PIECE, L.L.C., CHICAGO CHICAGO, IL:
 2,560,008. REN. 4-27-12. MULTIPLE CLASS, INT. CLS. 32, 40 AND 42.
- PIEH, AMY LYNNE, CAMP VERDE, AZ:
 2,998,860, CANC. INT. CL. 8.
- PIERRE FABRE Dermo-Cosmetique, 92100 BOULOGNE, FRANCE:
 2,947,325, CANC. INT. CL. 3.
- PIERRE FABRE S.A., 75008 PARIS, FRANCE:
 2,912,058, CANC. MULTIPLE CLASS, INT. CLS. 3 AND 5.
- PIETRASANTA PHARMA S.P.A., VIAREGGIO (LUCCA), ITALY:
 2,575,329. REN. 5-3-12. INT. CL. 5.
- PILLIS, GINA MARIA, BROOKLYN, NY AND PILLIS, III, STANLEY VITO, BROOKLYN, NY:
 2,492,185, CANC. INT. CL. 41.
- PILOT TRAVEL CENTERS LLC, KNOXVILLE, TN:
 4,156,009, INT. CL. 1.
- PILSZAK, GEORGE H., FRANKLIN, PA:
 4,154,735, INT. CL. 20.
- PINARELLO HOLDING SPA, VILLORBA (TREVISO), ITALY:
 2,562,324. REN. 5-1-12. INT. CL. 12.
- PINCKNEY, CRAIG, CHESTER, VA:
 4,155,225, INT. CL. 25.
- PINE HILL GROUP, LLC, MULLICA HILL, NJ:
 4,153,087, PUB. 3-20-2012. MULTIPLE CLASS, INT. CLS. 35 AND 36.
- PINHIPARTNERS, LLC, SAINT LOUIS, MO:
 4,152,600, PUB. 3-20-2012. INT. CL. 28.
- PINNACLE ENTERTAINMENT, INC., LAS VEGAS, NV:
 4,155,474, INT. CL. 35.
- PIOLI, SCOTT P., ENGLEWOOD CLIFFS, NJ:
 4,153,027, PUB. 3-20-2012. INT. CL. 41.
- PIONEER HI-BRED INTERNATIONAL, INC., JOHNSTON, IA:
 4,154,589, INT. CL. 31.
- PIPPENBURG, AUTUMN DOLORES, NAPERVILLE, IL, DBA SHOWGIRLZ ENTERTAINMENT, INC.:
 4,152,576, PUB. 3-20-2012. INT. CL. 35.
- PITTSBURGH HOME & GARDEN SHOW, INC., PITTSBURGH, PA, GULF SHORE PUBLISHING COMPANY, INC., NAPLES, FL:
 1,659,694. REN. 4-27-12. INT. CL. 35.
- PITTSBURGH THREE RIVERS MARATHON, INC., PITTSBURGH, PA:
 4,153,432, PUB. 3-20-2012. INT. CL. 41.
 4,153,435, PUB. 3-20-2012. MULTIPLE CLASS, INT. CLS. 9, 14, 16, 18, 21 AND 25.
- PIVOTSTONE GROUP, LLC, FAIRFAX, VA:
 4,155,502, INT. CL. 35.
- PLAID ENTERPRISES, INC., NORCROSS, GA, DKM, LTD., NORCROSS, GA, DBA PLAID ENTERPRISES:
 1,704,429. REN. 4-28-12. MULTIPLE CLASS, INT. CLS. 1, 2 AND 16.
- PLAMBECK HOLDING AG, FED REP GERMANY:
 4,116,765, COR. MULTIPLE CLASS, INT. CLS. 9 AND 38.
- PLAN B - ADULT CARE SOLUTIONS, LLC, DESTIN, FL, DBA PLAN B - ADULT CARE SOLUTIONS:
 4,152,839, PUB. 3-20-2012. MULTIPLE CLASS, INT. CLS. 43 AND 45.
- PLANPRESCRIBER, INC., MAYNARD, MA:
 4,154,554, INT. CL. 35.
 4,154,606, MULTIPLE CLASS, INT. CLS. 35 AND 36.
- PLANT DEVAS, INC., SAN DIEGO, CA:
 4,153,004, PUB. 3-20-2012. INT. CL. 3.
- PLANTOOLS, LLC, CHARLOTTE, NC:
 2,699,633. REN. 5-3-12. MULTIPLE CLASS, INT. CLS. 9 AND 36.
- PLAN4DEMAND SOLUTIONS, INC., PITTSBURGH, PA:
 2,558,639. REN. 4-27-12. INT. CL. 35.
 2,558,639, CANC. INT. CL. 42.
- PLASTIRALE LAVAL INC., LAVAL, PROVINCE OF QUEBEC H7L 4P8, CANADA:
 2,492,430, CANC. INT. CL. 16.
- PLATEME CORPORATION, DES PLAINES, IL:
 4,153,925, PUB. 3-20-2012. INT. CL. 9.
- PLAYCORE IP SUB, INC., CHATTANOOGA, TN:
 2,653,488. REN. 5-3-12. INT. CL. 28.
- PLAYZONE INC, ARTESIA, CA:
 4,153,490, PUB. 3-20-2012. INT. CL. 28.
- PLOCHMAN, INC., MANTENO, IL:
 937,684. REN. 5-1-12. U.S. CL. 46 (INT. CLS. 1, 5, 29, 30, 31 AND 32).
- PLR IP HOLDINGS, LLC, MINNETONKA, MN:
 730,072. REN. 5-3-12. U.S. CL. 26 (INT. CLS. 1, 9 AND 10).
- PLUM TV, INC., NEW YORK, NY:
 4,008,399, COR. INT. CL. 41.
- PLUM TV, LLC, NEW YORK, NY:
 3,317,501, COR. INT. CL. 41.
- PM COMPANY, FAIRFIELD, OH:
 2,696,776. REN. 5-3-12. INT. CL. 16.
- PMC TRADE EXPORT & IMPORT CORP., DORAL, FL:
 4,153,863, PUB. 3-20-2012. INT. CL. 3.
- PODNOD INC., BERKELEY, CA:
 4,155,683, INT. CL. 9.
- POLIMERI EUROPA UK LIMITED, SOUTHAMPTON, UNITED KINGDOM:
 733,994. REN. 4-30-12. U.S. CL. 1 (INT. CL. 17).
- POLMOS ZYRARDOW SPOLKA Z OGRANICZONA ODPOWIEDZIALNOSCIA, ZYRARDOW, POLAND:
 2,619,051. REN. 4-30-12. INT. CL. 33.
- POLSINELLI SHUGHART PC, KANSAS CITY, MO:
 2,492,157, CANC. INT. CL. 42.
- POLYQUEST, INCORPORATED, WILMINGTON, NC:
 4,152,057, PUB. 3-20-2012. INT. CL. 1.
- POLYTYPE S.A., FRIBOURG, SWITZERLAND:
 2,595,838. REN. 5-2-12. INT. CL. 9.
- PONCHILLOW, SAN CLEMENTE, CA:
 4,155,125, INT. CL. 24.
- PONTICELLI, ROBERT, J., CAMARILLO, CA:
 2,998,857, CANC. MULTIPLE CLASS, INT. CLS. 9 AND 11.
- POOLMAID (USA) INC., OAKLAND PARK, FL:
 4,154,592, INT. CL. 7.
- POOR RICHARD'S DISTRIBUTING CORPORATION, PORT COQUITLAM, BC, CANADA:
 4,154,130, PUB. 3-20-2012. MULTIPLE CLASS, INT. CLS. 29 AND 32.
- POPARUBA, LLC, DENVER, CO:
 4,155,068, INT. CL. 30.

- POPCORN, LLC, PALO ALTO, CA:
4,153,267, PUB. 3-20-2012. MULTIPLE CLASS, INT. CLS. 38 AND 42.
- POPPED.LLC, LAS VEGAS, NV:
4,153,474, PUB. 3-20-2012. INT. CL. 30.
- POR-15, INC., WHIPPANY, NJ:
2,699,967. REN. 5-3-12. MULTIPLE CLASS, INT. CLS. 1 AND 2.
- PORTIONPAC CHEMICAL CORPORATION, CHICAGO, IL:
2,564,849. REN. 4-27-12. INT. CL. 3.
- POTBELLY SANDWICH WORKS, LLC, CHICAGO, IL:
4,154,485, INT. CL. 25.
- POTH PIERRE, FRANCE:
4,152,311, PUB. 3-20-2012. MULTIPLE CLASS, INT. CLS. 25 AND 35.
- POULIN HOLDINGS LLC, BOSTON, MA:
4,154,341, INT. CL. 9.
- POVADDO LLC, ALEXANDRIA, VA:
4,152,995, PUB. 3-20-2012. INT. CL. 35.
- POWDR-WOODWARD PA LLC, PARK CITY, UT:
4,152,993, PUB. 3-20-2012. INT. CL. 41.
- POWER ASSURE, INC., SANTA CLARA, CA:
4,155,494, INT. CL. 9.
- POWER PILATES LLC, NEW YORK, NY:
2,566,071. REN. 5-2-12. MULTIPLE CLASS, INT. CLS. 9, 25 AND 41.
- POWERRAIL DISTRIBUTION INC., DURYEY, PA:
4,153,709, PUB. 3-20-2012. INT. CL. 35.
4,153,713, PUB. 3-20-2012. INT. CL. 35.
- PRACTICEWISE, LLC, SATELLITE BEACH, FL:
4,152,948, PUB. 3-20-2012. MULTIPLE CLASS, INT. CLS. 41, 42 AND 44.
- PRAGMATIC WORKS SOFTWARE, INC, MIDDLEBURG, FL, DBA PRAGMATIC WORKS:
4,154,120, PUB. 3-20-2012. INT. CL. 9.
4,154,135, PUB. 3-20-2012. INT. CL. 9.
- PRAIRIE VIEW A&M FOUNDATION, AUSTIN, TX:
4,153,315, PUB. 3-20-2012. INT. CL. 36.
- PRECISION CABINETS, INC., BATAVIA, IL:
2,492,097, CANC. INT. CL. 20.
- PRECISION FLEET BRAKES, INC., AUSTIN, TX:
4,154,919, INT. CL. 12.
- PRECISION FOODS, INC., ST. LOUIS, MO:
4,155,565, MULTIPLE CLASS, INT. CLS. 29 AND 30.
- PRECISION LABORATORIES, INC., COTTONWOOD, AZ:
4,154,774, MULTIPLE CLASS, INT. CLS. 1 AND 5.
- PRECISION MANUFACTURING GROUP, LLC, CEDAR GROVE, NJ:
2,577,054. REN. 4-30-12. MULTIPLE CLASS, INT. CLS. 7 AND 9.
- PRECISION SET, INC., DALLAS, TX:
4,155,847, INT. CL. 14.
- PRECISION TECHNOLOGY LLC, MEMPHIS, TN:
2,689,933. REN. 4-27-12. INT. CL. 2.
- PREFERRED FREEZER SERVICES, LLC, CHATHAM, NJ:
4,155,310, MULTIPLE CLASS, INT. CLS. 39 AND 40.
- PREGEL AMERICA, INC., CONCORD, NC:
4,154,362, MULTIPLE CLASS, INT. CLS. 16 AND 25.
- PREMARK RWP HOLDINGS, INC., WILMINGTON, DE, RALPH WILSON PLASTICS COMPANY, TEMPLE, TX:
1,685,785. REN. 5-1-12. INT. CL. 17.
- PREMIER MANUFACTURING GROUP, INC., SHELTON, CT:
4,154,949, INT. CL. 9.
4,154,950, INT. CL. 9.
- PREMIER VALUE ALLIANCE, LLC, BOCA RATON, FL:
4,155,132, INT. CL. 35.
- PREPMUNCH INC., HOUSTON, TX:
4,152,939, PUB. 3-20-2012. INT. CL. 42.
- PRESERVE AT GREENWOOD VILLAGE, THE, DENVER, CO:
1,750,383. REN. 4-27-12. MULTIPLE CLASS, INT. CLS. 36 AND 37.
- PRESS GANEY ASSOCIATES, INC, INDIANA, IN:
4,153,331, PUB. 3-20-2012. INT. CL. 35.
4,153,342, PUB. 3-20-2012. INT. CL. 35.
4,153,371, PUB. 3-20-2012. INT. CL. 35.
4,153,372, PUB. 3-20-2012. INT. CL. 35.
4,153,383, PUB. 3-20-2012. INT. CL. 35.
4,153,384, PUB. 3-20-2012. INT. CL. 35.
4,153,385, PUB. 3-20-2012. INT. CL. 35.
4,153,386, PUB. 3-20-2012. INT. CL. 35.
4,153,387, PUB. 3-20-2012. INT. CL. 35.
4,153,388, PUB. 3-20-2012. INT. CL. 35.
- PRESS 101 DEVELOPMENT, LLC, ORLANDO, FL:
3,697,600, CANC. INT. CL. 43.
- PRETTY BIRD PICTURES, INC., CULVER CITY, CA:
4,153,448, PUB. 3-20-2012. INT. CL. 41.
- PRETTYTROUBLE, LLC, SCHWENKSVILLE, PA:
4,155,375, INT. CL. 16.
- PRICE WAITER, LLC, CHATTANOOGA, TN:
4,153,729, PUB. 3-20-2012. INT. CL. 35.
4,153,730, PUB. 3-20-2012. INT. CL. 9.
- PRIDE MOBILITY PRODUCTS CORPORATION, EXETER, PA:
4,154,855, INT. CL. 36.
4,154,857, INT. CL. 36.
- PRIMARY INVESTMENTS GROUP LIMITED, ROAD TOWN, TORTOLA, BR.VIRGIN ISLANDS:
4,155,941, INT. CL. 5.
- PRINCESS & THE P, LLC, SHEPHERDSTOWN, WV:
4,154,166, PUB. 3-20-2012. INT. CL. 29.
- PRINCESS FREE ZONE, INC., TUCKER, GA:
4,154,574, INT. CL. 25.
- PRINCIPE S.P.A., 21100 CALCINATE (VARESE), ITALY:
1,680,388. REN. 5-3-12. INT. CL. 18.
- PRINCIPLE POWER, INC., SEATTLE, WA:
4,155,824, MULTIPLE CLASS, INT. CLS. 7, 37 AND 42.
- PRINT NINJA, LLC, BEAVERTON, OR:
4,152,712, PUB. 3-20-2012. INT. CL. 40.
- PRINTPROBE TECHNOLOGY, LLC, CANDIA, NH:
2,493,539, CANC. INT. CL. 42.
- PRIVITY VENTURES, INC., CARSON CITY, NV:
2,703,248. REN. 4-27-12. INT. CL. 9.
- PRL USA HOLDINGS, INC., NEW YORK, NY:
2,567,308. REN. 4-30-12. INT. CL. 11.
2,569,938. REN. 5-3-12. INT. CL. 36.
4,154,821, INT. CL. 18.
4,155,864, INT. CL. 18.
4,155,871, INT. CL. 18.
- PRO FORTUNE INDUSTRIAL CO., LTD., TAMSHUI TOWN, TAIPEI COUNTY, TAIWAN:
2,602,650. REN. 4-27-12. INT. CL. 12.
- PRO TECT ASSOCIATES, INC., NORTHFIELD, IL:
2,564,845. REN. 5-1-12. INT. CL. 17.
- PROBE INVESTMENTS, INC, COVINGTON, LA, DBA PROBE INVESTMENTS:
4,154,803, INT. CL. 11.
- PROCESS GROUP PTY LTD, ROWVILLE VIC 3178, AUSTRALIA:
4,152,230, PUB. 3-20-2012. MULTIPLE CLASS, INT. CLS. 7, 11, 40 AND 42.
4,152,231, PUB. 3-20-2012. MULTIPLE CLASS, INT. CLS. 7, 11, 40 AND 42.
- PROCESS SYSTEMS ENTERPRISE LIMITED, LONDON, UNITED KINGDOM:
4,153,116, PUB. 1-3-2012. MULTIPLE CLASS, INT. CLS. 9 AND 42.
4,153,117, PUB. 1-3-2012. MULTIPLE CLASS, INT. CLS. 9 AND 42.
4,153,118, PUB. 1-3-2012. MULTIPLE CLASS, INT. CLS. 9 AND 42.
4,153,119, PUB. 1-3-2012. MULTIPLE CLASS, INT. CLS. 9 AND 42.
4,153,120, PUB. 1-3-2012. MULTIPLE CLASS, INT. CLS. 9 AND 42.
- PROCOPIO, CORY, HARGREAVES & SAVITCH LLP, SAN DIEGO, CA:
2,617,993. REN. 4-30-12. INT. CL. 42.
- PROCOVAL USA, LLC, WESTON, FL:
2,999,003, CANC. INT. CL. 25.

PROCTER & GAMBLE COMPANY, THE, CINCINNATI, OH:
 2,559,744. REN. 4-30-12. MULTIPLE CLASS, INT. CLS. 3,
 7, 16 AND 21.
 4,154,905. INT. CL. 3.
 PRODISC TECHNOLOGY INC., NEW TAIPEI CITY, TAI-
 WAN:
 4,153,650. PUB. 3-20-2012. INT. CL. 9.
 PRODUCTORES DE MAGUEY Y MEZCAL LOS TRES
 REYES, S.P.R. DE R.L., TLACOLULA, OAXACA, MEX-
 ICO:
 4,030,050. COR. INT. CL. 33.
 PROELL, BRUNO, YOUNTVILLE, CA:
 4,152,049. PUB. 3-20-2012. INT. CL. 11.
 PROFERO SYSTEMS, INC., DALLAS, NC, PROFERO SYS-
 TEMS, INC., DALLAS, NC:
 2,640,978. REN. 5-2-12. INT. CL. 7.
 2,644,392. REN. 5-2-12. INT. CL. 7.
 PROFERO SYSTEMS, INC., DALLAS, NC:
 2,651,691. REN. 5-2-12. INT. CL. 7.
 PROFESSIONAL LIABILITY UNDERWRITING SOCIETY,
 MINNEAPOLIS, MN:
 4,155,601. MULTIPLE CLASS, INT. CLS. 9, 16, 35 AND 41.
 4,155,602. MULTIPLE CLASS, INT. CLS. 9, 16, 35 AND 41.
 PROFESSIONAL PLASTICS, INC., FULLERTON, CA:
 4,154,197. PUB. 3-20-2012. INT. CL. 17.
 4,154,198. PUB. 3-20-2012. INT. CL. 17.
 PROGENESIS, INC., JEFFERSON CITY, MO:
 2,998,512. CANC. INT. CL. 42.
 PROGNOSYS BIOSCIENCES, INC., LA JOLLA, CA:
 4,155,692. INT. CL. 42.
 4,155,693. MULTIPLE CLASS, INT. CLS. 1, 9 AND 42.
 PROGRESSIVE GROWTH CORP., GAYLORD, MN:
 2,571,171. REN. 5-3-12. INT. CL. 36.
 PROLIFIC METHODS, LLC, BETHLEHEM, GA:
 4,156,024. INT. CL. 9.
 PROMETHEUS HOLDINGS, INC., SAN CLEMENTE, CA:
 4,155,385. INT. CL. 42.
 PROMETRIC INC., BALTIMORE, MD:
 4,154,299. INT. CL. 35.
 PROMODEL CORPORATION, OREM, UT, PRODUCTION
 MODELING CORPORATION, OREM, UT:
 1,688,885. REN. 4-27-12. INT. CL. 9.
 PROMONTORY INTERFINANCIAL NETWORK, LLC, AR-
 LINGTON, VA:
 4,156,049. INT. CL. 36.
 PROMOTION IN MOTION, INC., CLOSTER, NJ:
 2,493,239. CANC. INT. CL. 29.
 PROMOTION STORE, LLC, PALM COAST, FL:
 4,153,693. PUB. 3-20-2012. INT. CL. 40.
 PRONTO GENERAL AGENCY, LTD, BROWNSVILLE, TX:
 4,155,110. MULTIPLE CLASS, INT. CLS. 35 AND 36.
 PROPERTY BY OWNER, INC., BOISE, ID, WEISSHAUPT,
 RUDY, BOISE, ID, DBA PROPERTY BY OWNER:
 1,697,937. REN. 4-30-12. INT. CL. 35.
 PROPEX OPERATING COMPANY, LLC, CHATTANOOGA,
 TN:
 2,565,999. REN. 5-1-12. INT. CL. 6.
 PROQUEST-CSA, LLC, BETHESDA, MD:
 2,998,601. CANC. MULTIPLE CLASS, INT. CLS. 9, 35, 38,
 41, 42 AND 44.
 PROSKAUER ROSE LLP, NEW YORK, NY:
 2,492,532. CANC. INT. CL. 16.
 PROSPECT MORTGAGE, LLC, SHERMAN OAKS, CA:
 4,152,947. PUB. 3-20-2012. INT. CL. 36.
 PROSPERITY PRANA, LLC, NEW YORK, NY:
 4,152,884. PUB. 3-20-2012. INT. CL. 41.
 PROSPERITY PRODUCTIONS, INC., NEW YORK, NY:
 4,154,894. MULTIPLE CLASS, INT. CLS. 35 AND 41.
 PROTECT PLUS, LLC, HICKORY, NC:
 4,152,474. PUB. 5-10-2011. INT. CL. 21.
 PROTECTSTAR, INC., MIAMI, FL:
 4,152,703. PUB. 3-20-2012. INT. CL. 9.
 PROTICA INC., WHITEHALL, PA:
 4,155,900. INT. CL. 5.
 PROTO LABS, INC., MAPLE PLAIN, MN:
 2,686,351. REN. 5-3-12. INT. CL. 40.
 PROTRADA PTY LTD, SYDNEY, AUSTRALIA:
 4,155,933. INT. CL. 35.
 PROVASI ROBERTO, ITALY:
 4,152,270. PUB. 3-20-2012. MULTIPLE CLASS, INT. CLS.
 18, 25 AND 28.
 4,152,271. PUB. 3-20-2012. MULTIPLE CLASS, INT. CLS.
 18, 25 AND 28.
 PROXIMO SPIRITS, INC., JERSEY CITY, NJ:
 4,154,527. INT. CL. 33.
 PROZYME, INC., SAN LEANDRO, CA:
 2,557,645. REN. 4-27-12. MULTIPLE CLASS, INT. CLS. 1
 AND 5.
 PRUFROCK LLC, LOS ANGELES, CA:
 4,154,344. INT. CL. 32.
 4,154,347. INT. CL. 18.
 PRYM CONSUMER USA INC., SPARTANBURG, SC:
 4,155,491. INT. CL. 24.
 PSQUARED PROHEALTH, LLC, MONROE, CT:
 4,155,778. INT. CL. 44.
 PSYCHOLOGICAL SOFTWARE SOLUTIONS, INC., HOUS-
 TON, TX:
 4,155,953. MULTIPLE CLASS, INT. CLS. 41 AND 44.
 PTG TOOLS, INC., TYNGSBORO, MA:
 4,154,770. INT. CL. 9.
 PUBLIC SERVICE CREDIT UNION, DENVER, CO:
 4,152,830. PUB. 3-20-2012. INT. CL. 36.
 PUJOL, JAIME, MIAMI, FL:
 4,154,616. INT. CL. 28.
 PUPPY AND PET PRODUCTS INTERNATIONAL, LLC,
 SCOTTSDALE, AZ, DBA PAPPY:
 2,939,788. CANC. INT. CL. 18.
 PURCELL ROAD MEDIA, LLC, BELLEVILLE, WI:
 4,154,004. PUB. 3-20-2012. MULTIPLE CLASS, INT. CLS.
 41 AND 42.
 PURE & NATURAL COMPANY, SCOTTSDALE, AZ:
 4,154,966. INT. CL. 3.
 PURE A.L.P.S. LLC, NEW MILFORD, CT:
 4,154,314. INT. CL. 42.
 PURE FIX CYCLES, LLC, BURBANK, CA:
 4,153,418. PUB. 3-20-2012. INT. CL. 12.
 PURE JOY JEWELRY, PONTIAC, MI:
 4,155,282. INT. CL. 14.
 PUREBRANDS, LLC, BOCA RATON, FL:
 4,112,933. COR. INT. CL. 5.
 PURELINE, LLC, CHEYENNE, WY:
 4,154,365. MULTIPLE CLASS, INT. CLS. 9 AND 11.
 PURELY ENTERPRISES, LLC, KNOXVILLE, TN:
 4,154,543. INT. CL. 11.
 PUROLATOR FILTERS NA LLC, FAYETTEVILLE, NC:
 4,155,057. INT. CL. 7.
 PUSSEY'S RUM LTD., ROAD TOWN, TORTOLA, BR. VIR-
 GIN ISLANDS, PUSSEY'S LTD. U.S.A., WASHINGTON,
 DC:
 1,231,287. REN. 5-2-12. INT. CL. 33.
 PUTCO, INC., STORY CITY, IA:
 3,304,588. CANC. INT. CL. 12.
 3,304,589. CANC. INT. CL. 12.
 PWE PRODUCTIONS LLC, LAS VEGAS, NV:
 4,152,882. PUB. 3-20-2012. INT. CL. 41.
 4,152,883. PUB. 3-20-2012. INT. CL. 41.
 PYBUS, TREVOR, MARKET WEIGHTON, UNITED KING-
 DOM:
 4,154,072. PUB. 3-20-2012. INT. CL. 44.
 PYROTEK, INC., SPOKANE, WA:
 2,483,141. REN. 5-3-12. INT. CL. 11.
 P4Q ELECTRONICS, S.L., ALONSOTEGI (VIZCAYA),
 SPAIN:
 4,154,448. MULTIPLE CLASS, INT. CLS. 9, 37 AND 42.
 Q-CELLS SE, FED REP GERMANY:
 4,152,207. PUB. 3-20-2012. MULTIPLE CLASS, INT. CLS.
 9, 38 AND 42.
 QAI TRAINING, LLC, INDIANAPOLIS, IN, DBA QAI, LLC:
 4,155,901. INT. CL. 41.
 QBI, LLC, WOODLAND HILLS, CA, DBA QUALIFIED
 BENEFITS:
 4,155,969. INT. CL. 36.
 QEP RESOURCES, INC., DENVER, CO:
 4,154,759. MULTIPLE CLASS, INT. CLS. 4, 35, 37 AND 42.
 QFIT4LIFE, LLC, COLUMBUS, OH:
 4,152,064. PUB. 3-20-2012. INT. CL. 41.

- QIU WENRUI, CHENGHAI DIST, SHANTOU, CHINA:
4,154,087, PUB. 3-20-2012. INT. CL. 28.
- QRHERE LLC, NASHVILLE, TN:
4,154,767, MULTIPLE CLASS, INT. CLS. 9 AND 42.
4,154,768, MULTIPLE CLASS, INT. CLS. 9 AND 42.
- QSOL.COM INC., LOS ANGELES, CA:
4,155,564, INT. CL. 42.
- QUADO MEDIA INC., SUNNYVALE, CA:
4,154,563, INT. CL. 9.
- QUALCOMM INCORPORATED, SAN DIEGO, CA:
4,154,410, INT. CL. 9.
- QUALIFACTS SYSTEMS, INC., NASHVILLE, TN, RECIPS,
INC., SEMINOLE, FL:
1,684,809. REN. 4-28-12. INT. CL. 9.
1,689,388. REN. 4-28-12. INT. CL. 42.
- QUALITY GOLD, INC., FAIRFIELD, OH:
2,683,231. REN. 5-1-12. INT. CL. 14.
- QUALITY OF LIFE LABORATORIES, INC., PURCHASE,
NY:
2,765,885, COR. INT. CL. 5.
3,743,493, COR. INT. CL. 5.
3,883,652, COR. INT. CL. 5.
3,909,060, COR. INT. CL. 5.
3,951,550, COR. INT. CL. 5.
4,155,193, INT. CL. 5.
- QUARTZ SPECIALTY PHARMACEUTICALS, LLC, HUNTS-
VILLE, AL:
1,685,013. REN. 5-3-12. INT. CL. 5.
- QUAXAR.COM, INC., MIAMI, FL:
4,152,718, PUB. 3-20-2012. INT. CL. 9.
- QUBICAAMF WORLDWIDE, S.A.R.L., LUXEMBOURG,
LUXEMBOURG:
4,155,084, INT. CL. 28.
- QUEENSWAY INVESTMENT HOLDINGS, LLC, DEL MAR,
CA:
4,154,376, INT. CL. 33.
- QUESOS LA RICURA, LTD., HICKSVILLE, NY:
2,688,641. REN. 5-3-12. INT. CL. 29.
- QUEST INTERNATIONAL FLAVORS AND FRAGRANCES
INC., MOUNT OLIVE, NJ:
2,998,966, CANC. INT. CL. 1.
- QUEST TECHNOLOGIES, INC, MARIETTA, GA, DBA
CRYSTAL QUEST MFG:
4,152,150, PUB. 3-20-2012. INT. CL. 11.
- QUIKSILVER AMERICAS, INC., HUNTINGTON BEACH,
CA:
4,154,578, INT. CL. 25.
- QUIKTRIP WEST, INC., WICHITA, KS:
4,155,823, INT. CL. 32.
- QUINNOVA PHARMACEUTICALS, INC., JAMISON, PA:
4,155,607, INT. CL. 5.
- QUINSTREET, INC., FOSTER CITY, CA:
2,495,787. REN. 4-27-12. INT. CL. 42.
2,495,787, CANC. INT. CL. 16.
- QUINTILES TRANSNATIONAL CORP., DURHAM, NC:
4,154,771, MULTIPLE CLASS, INT. CLS. 42 AND 44.
- QUIVER, LLC, IRVINE, CA:
4,152,070, PUB. 3-20-2012. INT. CL. 35.
- QUONIX NETWORKS, INC., KING OF PRUSSIA, PA:
4,153,938, PUB. 3-20-2012. INT. CL. 42.
- QWIK SLATE, INC., POULTNEY, VT:
4,153,623, PUB. 3-20-2012. INT. CL. 19.
4,153,625, PUB. 3-20-2012. INT. CL. 19.
- QWIZDOM, INC., PUYALLUP, WA:
4,154,672, MULTIPLE CLASS, INT. CLS. 38 AND 41.
- R & D INSTRUCTIONAL SOLUTIONS LLC, BALTIMORE,
MD:
4,152,491, PUB. 3-20-2012. MULTIPLE CLASS, INT. CLS. 9
AND 16.
- R. SEELIG & HILLE OHG, 40526 DUSSELDORF, FED REP
GERMANY:
1,659,942. REN. 5-3-12. INT. CL. 30.
- R. WAVE PARTNERS LLC, KIHEI, HI:
4,153,911, PUB. 3-20-2012. INT. CL. 41.
- R.S. MEANS COMPANY LLC, KINGSTON, MA:
1,717,969. REN. 5-1-12. MULTIPLE CLASS, INT. CLS. 16,
35, 41 AND 42.
- R&A MOTORSPORTS, INC., LEE'S SUMMIT, MO:
4,113,946, COR. INT. CL. 37.
- R&D CLOUD, INC., MARINA DEL REY, CA:
4,153,061, PUB. 3-20-2012. INT. CL. 42.
4,153,062, PUB. 3-20-2012. INT. CL. 42.
- RAAK LLC, CHANDLER, AZ:
4,155,235, INT. CL. 41.
- RACINES SA, F-34980 ST GELY DU FESC, FRANCE:
4,152,358, PUB. 3-20-2012. INT. CL. 29.
- RADIO FREQUENCY SYSTEMS, INC., MERIDEN, CT:
2,492,560, CANC. INT. CL. 9.
- RADIO SHOPPING SHOW, INC., ELGIN, IL:
4,152,095, PUB. 3-20-2012. INT. CL. 41.
- RADLO FOODS LLC, WATERTOWN, MA:
4,154,292, INT. CL. 29.
- RADO UHREN AG (RADO WATCH CO. LTD.) (MONTRES
RADO S.A.), 2543 LENGNAU BE, SWITZERLAND:
2,492,952, CANC. INT. CL. 14.
- RAGGIO, JEREMY A. LANCASTER, CA:
4,154,727, INT. CL. 25.
- RAHMAN, IBRAHIM L, KENT, WA:
4,154,027, PUB. 3-20-2012. MULTIPLE CLASS, INT. CLS.
38 AND 41.
- RAIDER, IRA F.G., WEST CHESTER, PA, DBA RAIDER
PRODUCTIONS:
2,566,398. REN. 4-27-12. INT. CL. 9.
- RAILROAD CONTROLS, L.L.C., BENBROOK, TX:
2,657,632. REN. 4-30-12. INT. CL. 9.
- RAINDANCER COFFEE, LLC, PORTLAND, OR:
4,155,513, INT. CL. 30.
- RAINFOREST, INC., NEW YORK, NY:
1,706,917. REN. 5-2-12. INT. CL. 25.
- RAISE YOUR VOICE, INC., BOULDER, CO:
4,153,358, PUB. 3-20-2012. MULTIPLE CLASS, INT. CLS.
38 AND 42.
- RAKUDA CORPORATION, PORTLAND, OR:
2,507,650. REN. 4-30-12. INT. CL. 10.
- RALEIGH PITMASTER EMPIRE, LLC, RALEIGH, NC:
3,685,119, CANC. INT. CL. 43.
- RAMIREZ MORELES, SELOMITH, IRAPUATO, MEXICO:
4,156,006, INT. CL. 5.
- RANIR, LLC, GRAND RAPIDS, MI:
4,155,742, INT. CL. 10.
- RAO, POTLURI M., SEATTLE, WA AND RAO, CATHERINE
MCDOLE, SEATTLE, WA:
1,721,620. REN. 4-27-12. INT. CL. 9.
1,721,621. REN. 4-27-12. INT. CL. 9.
1,721,623. REN. 4-27-12. INT. CL. 9.
- RAPID ENTERPRISES, INC., SALT LAKE CITY, UT:
4,152,522, PUB. 3-20-2012. INT. CL. 39.
- RASOLLI FOOTWEAR CORP., NEW YORK, NY:
4,155,242, INT. CL. 25.
- RAST, LISA, CHANDLER, AZ:
4,155,392, INT. CL. 30.
- RAUCUS NATURE, INC., ELK GROVE VILLIAGE, IL:
4,153,455, PUB. 3-20-2012. INT. CL. 25.
- RAUCUS NATURE, INC., ELK GROVE VILLAGE, IL:
4,153,456, PUB. 3-20-2012. INT. CL. 25.
- RAW ENERGY MATERIALS CORPORATION, POMPANO
BEACH, FL:
4,155,417, INT. CL. 19.
4,155,419, INT. CL. 19.
- RAY PRODUCTS COMPANY, INC., ONTARIO, CA:
4,155,021, INT. CL. 40.
- RAYMOND CORPORATION, THE, GREENE, NY:
2,558,112. REN. 5-1-12. INT. CL. 12.
- RAYNOR MARKETING LTD., WEST HEMPSTEAD, NY,
DBA THE RAYNOR GROUP:
4,154,801, INT. CL. 20.
- RAZI, TARVELLA, FONTANA, CA:
4,154,866, INT. CL. 41.
- RAZOR USA LLC, CERRITOS, CA:
4,152,987, PUB. 3-20-2012. INT. CL. 28.
- RCD HOLDINGS, INC., GROSSE POINTE ROAD, MI:
2,565,219. REN. 5-3-12. INT. CL. 30.
- RCD HOLDINGS, INC., GROSSE POINTE PARK, MI, RCD
HOLDINGS, INC., GROSSE POINTE PARK, MI:
2,579,650. REN. 5-3-12. INT. CL. 30.

RD SPECIALTIES LTD, DES PLAINES, IL, DBA RD SPECIALTIES LTD:
4,155,569, INT. CL. 30.

RDI GROUP, INC., THE, ITASCA, IL:
2,631,996, REN. 4-30-12. INT. CL. 7.

RE-BODY, LLC, TAMPA, FL:
4,155,036, INT. CL. 5.

REACHING UP, INC., NEW YORK, NY:
2,561,251, REN. 5-3-12. MULTIPLE CLASS, INT. CLS. 35, 36, 41 AND 42.

READY MOBILE LLC, HIAWATHA, IA:
4,155,152, INT. CL. 38.

REAL KOSHER ICE CREAM, INC., BROOKLYN, NY:
4,154,433, INT. CL. 30.

REAL RESOURCES, INC., MINNEAPOLIS, MN:
4,153,899, PUB. 3-20-2012. INT. CL. 41.

REALITY CLICK INC., TORONTO, ONTARIO M5M 2S8, CANADA:
2,492,138, CANC. INT. CL. 42.

REBEL BAIL BONDS, INC., DUCHESNE, UT:
4,155,058, INT. CL. 36.

REBOUND ACE SPORTS PTY LTD, CAROLE PARK QUEENSLAND, AUSTRALIA:
1,694,393, REN. 5-1-12. INT. CL. 19.

RECAPS, LLC, BELLEVUE, WA TO RECAPS, LLC, BELLEVUE, WA:
2,493,153, CANC. INT. CL. 5.

RECARO BETEILIGUNGS-GMBH, KAISERSLAUTERN, FED REP GERMANY, KEIPER RECARO GMBH & CO., REMSCHEID 1, FED REP GERMANY:
1,717,889, REN. 5-2-12. INT. CL. 12.

RECKITT & COLMAN (OVERSEAS) LIMITED, HULL HU87DS, ENGLAND:
4,152,080, PUB. 3-20-2012. MULTIPLE CLASS, INT. CLS. 1, 3 AND 5.

RECKITT BENCKISER LLC, PARSIPPANY, NJ:
4,154,688, INT. CL. 29.

RECKITT BENCKISER N.V., HOOFDDORP, NETHERLANDS:
2,561,078, REN. 5-2-12. INT. CL. 1.

RECORD COPY SERVICES CO., CHICAGO, IL:
1,728,006, REN. 5-3-12. INT. CL. 35.

RECURSION VENTURES, BROOKLYN, NY:
4,153,424, PUB. 3-20-2012. MULTIPLE CLASS, INT. CLS. 9 AND 42.

RED CHIP COMPANY LTD., TORTOLA, BR.VIRGIN ISLANDS:
2,571,735, REN. 4-29-12. INT. CL. 9.

RED DEVELOPMENT, LLC, KANSAS CITY, MO:
3,084,846, CANC. INT. CL. 42.

RED ROCK BREWING COMPANY, SALT LAKE CITY, UT:
4,155,229, INT. CL. 32.

RED WING SHOE COMPANY, INC., RED WING, MN:
934,188, REN. 5-3-12. U.S. CL. 101 (INT. CL. 42).

REDAPT, INC., REDMOND, WA:
4,154,080, PUB. 3-20-2012. INT. CL. 42.
4,154,083, PUB. 3-20-2012. INT. CL. 9.

REDCATS USA, L.P., INDIANAPOLIS, IN:
2,998,863, CANC. MULTIPLE CLASS, INT. CLS. 25 AND 35.

REED & GRAHAM, INC., SAN JOSE, CA:
1,213,974, REN. 4-27-12. INT. CL. 19.

REED ELSEVIER INC., NEWTON, MA:
2,527,146, REN. 5-2-12. INT. CL. 42.

REED ELSEVIER PROPERTIES INC., WILMINGTON, DE:
4,154,172, PUB. 3-20-2012. MULTIPLE CLASS, INT. CLS. 9 AND 41.
4,155,037, INT. CL. 41.

REED GROUP, LTD., WESTMINSTER, CO:
4,156,003, INT. CL. 42.

REENTEL INTERNATIONAL INC., WESTMONT, IL:
4,153,608, PUB. 3-20-2012. INT. CL. 7.

REFLECTIX, INC., ELMWOOD PARK, NJ:
2,561,507, REN. 4-30-12. INT. CL. 17.

REGAL BELOIT EPC INC., BELOIT, WI:
4,155,618, INT. CL. 7.

REGAL CINEMEDIA CORPORATION, ENGLEWOOD, CO:
2,998,582, CANC. MULTIPLE CLASS, INT. CLS. 35, 41 AND 43.

REGAL-BELOIT CORPORATION, BELOIT, WI:
2,998,965, CANC. INT. CL. 7.

REGENAT USA HOLDING CORP., GREENWICH, CT:
2,998,639, CANC. MULTIPLE CLASS, INT. CLS. 37 AND 40.

REGIS INC., MINNEAPOLIS, MN:
2,589,029, REN. 5-2-12. INT. CL. 42.

REGO MANUFACTURING COMPANY, INC., BUCYRUS, OH:
1,684,393, REN. 5-2-12. INT. CL. 14.

REINFELDT, SUSAN, FRANKLIN, TN:
4,153,826, PUB. 3-20-2012. INT. CL. 16.

RELADYNE, LLC, SHARONVILLE, OH:
4,154,371, MULTIPLE CLASS, INT. CLS. 4, 35, 37, 40, 41 AND 42.

RELENTLESS SOFTWARE LIMITED, BRIGHTON, UNITED KINGDOM:
4,153,281, PUB. 3-20-2012. MULTIPLE CLASS, INT. CLS. 16, 25, 28 AND 41.

RELEVANT RECOVERY INC, LIGHTHOUSE POINT, FL:
4,155,718, INT. CL. 44.
4,155,724, INT. CL. 44.

RELIANT CORP, EDISON, NJ:
4,155,736, INT. CL. 21.

RELTON CORPORATION, ARCADIA, CA:
730,996, REN. 5-3-12. U.S. CL. 6 (INT. CL. 1).

REMAR, INC., LEBANON, TN:
4,155,492, INT. CL. 35.

REMARK USA, INC., MINNETONKA, MN:
4,155,067, INT. CL. 35.

REMEMBER US: THE HOLOCAUST BNAI MITZVAH PROJECT, SANTA MONICA, CA:
4,153,502, PUB. 3-20-2012. INT. CL. 41.

REMKO MARK B.V., NETHERLANDS:
4,152,184, PUB. 3-20-2012. MULTIPLE CLASS, INT. CLS. 6 AND 19.
4,152,191, PUB. 3-20-2012. MULTIPLE CLASS, INT. CLS. 6 AND 19.

RENAISSANCE LEARNING, INC., WISCONSIN RAPIDS, WI:
2,712,011, REN. 5-1-12. INT. CL. 9.
4,152,639, PUB. 3-20-2012. MULTIPLE CLASS, INT. CLS. 16 AND 41.

RENEWABLE ENERGY DEVELOPMENT CORPORATION, SOUTH JORDAN, UT, DBA REDCO:
4,153,751, PUB. 3-20-2012. INT. CL. 40.

RENOVATION REALTY, INC., LA MESA, CA:
4,155,700, MULTIPLE CLASS, INT. CLS. 35, 36 AND 37.

RENSON GROUP, LTD., MALVERN, PA:
4,155,553, MULTIPLE CLASS, INT. CLS. 35 AND 41.

RENSOW HEALTH CARE SUPPLIES INCORPORATED, MASPETH, NY:
4,154,389, MULTIPLE CLASS, INT. CLS. 3, 5, 10, 21, 24, 25 AND 35.

RENT A WHEEL, LOS ANGELES, CA:
2,518,672, REN. 5-1-12. INT. CL. 39.

RENT-A-CENTER WEST, INC., PLANO, TX:
4,153,948, PUB. 3-20-2012. INT. CL. 36.
4,154,195, PUB. 3-20-2012. INT. CL. 35.
4,154,196, PUB. 3-20-2012. INT. CL. 36.

REPROCAD ASSOCIATES, INC., CHESTERFIELD, MO, DBA REPRMAX:
4,152,564, PUB. 3-20-2012. MULTIPLE CLASS, INT. CLS. 35 AND 37.

REPUBLIC OF TEA, INC., THE, NOVATO, CA:
4,154,415, INT. CL. 5.

REQUEST FOODS, INC., HOLLAND, MI:
2,680,260, REN. 5-2-12. MULTIPLE CLASS, INT. CLS. 29 AND 30.

REQUISITE SOLUTIONS INCORPORATED, CHICAGO, IL:
4,155,240, INT. CL. 28.

RESCH, JACKIE, BASALT, CO, AKA JOHN C. RESCH:
4,155,637, INT. CL. 32.

RESCUE RESPONSE GROUP INC, FREMONT, CA, DBA MR. DRAIN INC:
4,154,010, PUB. 3-20-2012. INT. CL. 37.

- RESPONSE GENETICS, INC., LOS ANGELES, CA:
4,154,436, MULTIPLE CLASS, INT. CLS. 42 AND 44.
- RESTORING SIGHT INTERNATIONAL, INC., WEST ROXBURY, MA:
4,152,544, PUB. 10-4-2011. MULTIPLE CLASS, INT. CLS. 36 AND 41.
- RETAIL CONCEPTS, INC., HOUSTON, TX:
2,627,224, REN. 5-2-12. INT. CL. 35.
- RETAIL RESTAURANT DEVELOPMENT, LLC, LAKEWOOD, WA:
2,421,145, CANC. INT. CL. 42.
- RETAIL ROYALTY COMPANY, LAS VEGAS, NV:
4,154,133, PUB. 3-20-2012. INT. CL. 9.
4,155,301, INT. CL. 3.
- RETAMA PARK CHARITABLE FOUNDATION, SAN ANTONIO, TX TO RETAMA PARK CHARITABLE FOUNDATION, SAN ANTONIO, TX:
2,493,628, CANC. INT. CL. 41.
- RETICKR LLC, CHATTANOOGA, TN:
4,153,379, PUB. 3-20-2012. INT. CL. 42.
4,153,380, PUB. 3-20-2012. INT. CL. 42.
- RETROFITNESS IP, LLC, COLTS NECK, NJ:
4,153,933, PUB. 3-20-2012. INT. CL. 9.
- RETTIG, HEIDI K., WINCHESTER, VA:
4,155,725, INT. CL. 5.
4,155,795, INT. CL. 5.
4,155,796, INT. CL. 5.
4,155,797, INT. CL. 5.
- REUNION ISLAND COFFEE LIMITED, OAKVILLE, ONTARIO, CANADA:
4,153,726, PUB. 3-20-2012. INT. CL. 30.
4,153,727, PUB. 3-20-2012. INT. CL. 30.
4,153,728, PUB. 3-20-2012. INT. CL. 30.
- REV-A-SHELF COMPANY, LLC, JEFFERSONTOWN, KY:
4,154,245, INT. CL. 11.
- REVCO ELECTRICAL SUPPLY, INC., SOUTHAMPTON, NY:
4,155,039, INT. CL. 35.
- REVEAL BODY SCULPTING CENTERS, LLC, PITTSBURGH, PA:
4,155,107, INT. CL. 44.
- REVEAL MEDSPA, LLC, VIENNA, VA:
2,493,558, CANC. INT. CL. 42.
- REVERSE MORTGAGE USA, INC., AUSTIN, TX:
4,156,028, INT. CL. 36.
- REVISION, L.P., DALLAS, TX:
2,633,142, REN. 4-30-12. INT. CL. 3.
- REVIVO, ZION, NORTHRIDGE, CA:
4,154,607, INT. CL. 35.
- REVLON CONSUMER PRODUCTS CORPORATION, NEW YORK, NY:
1,776,182 NEW CERT. 6-5-2012. INT. CL. 3.
2,057,729 NEW CERT. 6-5-2012. INT. CL. 3.
3,352,363 NEW CERT. 6-5-2012. INT. CL. 3.
3,427,700 NEW CERT. 6-5-2012. INT. CL. 3.
3,664,635 NEW CERT. 6-5-2012. INT. CL. 3.
4,013,103, COR. INT. CL. 3.
- REXNORD INDUSTRIES, LLC, MILWAUKEE, WI:
1,721,436, REN. 4-27-12. INT. CL. 7.
- REYWA, LLC, OAKLAND, CA:
4,153,740, PUB. 3-20-2012. INT. CL. 45.
- REYCO SYSTEMS, INC., CALDWELL, ID, REY INDUSTRIES, INC., MERIDIAN, ID:
1,700,437, REN. 5-3-12. INT. CL. 11.
- REYNOLDS CYCLING, L.L.C., WEST JORDAN, UT, DBA PACIFIC RIMS USA:
4,154,941, INT. CL. 12.
- REYNOLDS INNOVATIONS INC., WINSTON-SALEM, NC:
4,155,594, INT. CL. 34.
- REYNOLDS, JONATHAN HAL, MCGREGOR, TX:
4,153,837, PUB. 3-20-2012. INT. CL. 16.
- REYNOSO, DANIEL, RIVERSIDE, CA AND MANZANO, FRANKIE, RIVERSIDE, CA:
4,154,613, INT. CL. 25.
- REZCONNECT TECHNOLOGIES, INC, ENGLEWOOD CLIFFS, NJ, DBA TRAVEL NETWORK:
4,152,609, PUB. 3-20-2012. INT. CL. 35.
- REZK, ELINOR C., WALL TOWNSHIP, NJ, DBA INVISIBLE SUN:
4,155,155, INT. CL. 25.
- RFR MANAGEMENT LLC, NEW YORK, NY:
2,998,744, CANC. INT. CL. 25.
2,998,834, CANC. MULTIPLE CLASS, INT. CLS. 20 AND 24.
- RHE HATCO, INC., GARLAND, TX:
4,110,080, COR. INT. CL. 25.
- RHEA, LARRY R., SHAWNEE, KS:
2,559,743, REN. 4-27-12. INT. CL. 35.
- RHEIN CHEMIE RHEINAU GMBH, MANNHEIM, FED REP GERMANY:
4,152,517, PUB. 3-20-2012. MULTIPLE CLASS, INT. CLS. 1, 4 AND 40.
4,152,518, PUB. 3-20-2012. MULTIPLE CLASS, INT. CLS. 1, 4 AND 40.
- RHEINBRAUN BRENNSTOFF GMBH, KÖLN, FED REP GERMANY:
4,097,720, COR. INT. CL. 4.
- RHOADES, CONNIE, SPRINGFIELD, MO:
4,153,869, PUB. 3-20-2012. INT. CL. 16.
- RHYTHMIC CIRCUS, LLC., COON RAPIDS, MN, DBA RHYTHMIC CIRCUS:
4,153,657, PUB. 3-20-2012. MULTIPLE CLASS, INT. CLS. 9 AND 41.
- RICARDO BEVERLY HILLS, INC., LA MIRADA, CA:
2,617,402, REN. 5-1-12. INT. CL. 18.
- RICE, JOHN T, RALEIGH, NC:
2,998,541, CANC. INT. CL. 42.
- RICH KLINGER DICHTUNGSTECHNIK GMBH & CO. KG, GUMPOLDSKIRCHEN, AUSTRIA:
2,561,607, REN. 4-27-12. INT. CL. 17.
- RICH-N-TONE CALLS, INC., STUTTGART, AR:
2,585,281, REN. 4-27-12. INT. CL. 28.
- RICH, TIMOTHY C., WAKEFIELD, RI:
4,153,436, PUB. 3-20-2012. INT. CL. 9.
- RICHARD ALESSANDRO DICLEMENTE, RICHEYVILLE, PA, DBA STARSELF:
4,153,823, PUB. 3-20-2012. INT. CL. 45.
- RICHARD BROWN, NEW YORK, NY:
4,154,604, INT. CL. 41.
- RICHARD COHEN, BIRMINGHAM, MI:
4,152,442, PUB. 3-20-2012. INT. CL. 25.
- RICHARD J. HELFERICH, ENCINITAS, CA:
2,595,043, REN. 5-3-12. MULTIPLE CLASS, INT. CLS. 9 AND 38.
- RICHARD KOON, WINTER HAVEN, FL:
4,153,325, PUB. 3-20-2012. INT. CL. 41.
- RICHARD LEEDS INTERNATIONAL, INC., NEW YORK, NY:
2,698,870, REN. 5-3-12. INT. CL. 25.
- RICHARD LÖFFLER, FED REP GERMANY:
4,152,260, PUB. 3-20-2012. MULTIPLE CLASS, INT. CLS. 24 AND 25.
- RICHARDS HOMEWARES, INC., PORTLAND, OR:
4,154,399, INT. CL. 20.
- RICHLINE GROUP, INC., NEW YORK, NY:
2,564,120, REN. 5-2-12. INT. CL. 14.
- RICHTER SPIELGERAETE GMBH, FRASDORF, FED REP GERMANY:
4,153,031, PUB. 3-20-2012. INT. CL. 28.
- RICHVIEW, INC., OXNARD, CA:
731,934, REN. 5-2-12. U.S. CL. 46 (INT. CL. 31).
- RIDDEL, HOLLY M., BEVERLY HILLS, CA:
4,152,863, PUB. 3-20-2012. INT. CL. 25.
- RIEMANN FUNERAL HOMES, INC., GULFPORT, MS:
4,152,931, PUB. 3-20-2012. MULTIPLE CLASS, INT. CLS. 16, 36 AND 45.
- RIEPE INDUSTRIES INC., COCKEYSVILLE, MD:
1,193,831, REN. 4-27-12. INT. CL. 2.
- RIGBY VENTURES, LLC, DALLAS, TX:
4,153,228, PUB. 3-20-2012. INT. CL. 13.
- RILES & COMPANY, INC., LOS ANGELES, CA:
1,552,980, CANC. INT. CL. 25.
- RIO GRANDE PRODUCTS, INC., LAUREL, MD:
4,155,141, INT. CL. 29.

RISDON, ELIZABETH, LONGMONT, CO:
4,153,637, PUB. 3-20-2012. INT. CL. 41.

RISING PHOENIX ENTERPRISES, INC., BEVERLY HILLS, CA:
4,155,448, INT. CL. 16.

RISTORANTE LUCIANO, INC., SAN ANTONIO, TX:
2,588,150. REN. 4-27-12. INT. CL. 42.

RITCHIE, RYAN, WEST HILLS, CA, DBA GARDEN LOVE STONES:
4,155,634, INT. CL. 19.

RIVER GREEN GROUP, WOODSTOCK, GA:
4,152,967, PUB. 3-20-2012. INT. CL. 36.

RIVER GREEN INVESTMENT MANAGEMENT, WOODSTOCK, GA:
4,152,974, PUB. 3-20-2012. INT. CL. 36.
4,152,979, PUB. 3-20-2012. INT. CL. 36.

RIVER LIGHT V, L.P., NEW YORK, NY:
4,152,706, PUB. 3-20-2012. INT. CL. 18.

RIVERA AMPLIFICATION INC., BURBANK, CA:
4,154,945, MULTIPLE CLASS, INT. CLS. 9 AND 15.

RIVERSIDE MFG., LLC, FT. WAYNE, IN:
2,615,987. REN. 5-3-12. INT. CL. 9.

RIVERSIDE MOTORCYCLE, INC., RIVERSIDE, CA:
2,561,353. REN. 4-30-12. INT. CL. 41.

RKIP, LLC, MIAMI, FL:
4,155,614, INT. CL. 41.

RLDJ ENTERPRISES, LLC, WACHUNG, NJ:
4,155,740, INT. CL. 43.

RML JACKSON, LLC, LOS ANGELES, CA:
4,152,117, PUB. 3-20-2012. INT. CL. 41.
4,152,118, PUB. 3-20-2012. INT. CL. 41.
4,152,119, PUB. 3-20-2012. INT. CL. 41.

ROADRUNNER FOOD BANK, INC., ALBUQUERQUE, NM:
4,152,458, PUB. 12-13-2011. INT. CL. 39.

ROADSAFE HOLDINGS, INC., CHICAGO, IL:
4,154,695, MULTIPLE CLASS, INT. CLS. 37 AND 45.

ROBBINS & MYERS, INC., DAYTON, OH:
1,203,392. REN. 5-3-12. INT. CL. 7.
1,721,438. REN. 5-3-12. INT. CL. 7.

ROBBINS INC., CINCINNATI, OH:
2,611,898. REN. 4-27-12. INT. CL. 19.

ROBBINS RESEARCH INTERNATIONAL, INC., ESCONDI-DO, CA:
4,154,395, MULTIPLE CLASS, INT. CLS. 9 AND 41.

ROBBINS, NORMAN, FRESNO, CA:
4,154,960, INT. CL. 16.

ROBERT P. NICKELL, TORRANCE, CA:
4,066,801, CANC. INT. CL. 41.

ROBERT ROBINSON, DALLAS, TX:
4,153,496, PUB. 3-20-2012. INT. CL. 25.

ROBERTSON, JARRUN TERON, KINGSVILLE, TX:
4,153,810, PUB. 3-20-2012. INT. CL. 25.

ROBINSON, JOSEPH R., JR., ENGLEWOOD, NJ:
2,663,293. REN. 5-2-12. INT. CL. 41.

ROBINSON, TYLER, LOS ALAMITOS, CA AND HOLDER-BAUM, CHRIS, LONG BEACH, CA:
4,155,876, INT. CL. 35.

ROBOT ENTERTAINMENT, INC., PLANO, TX:
4,155,842, MULTIPLE CLASS, INT. CLS. 9, 25 AND 41.

ROCHHOLZ, ROBERT, COUPEVILLE, WA:
4,155,223, INT. CL. 9.

ROCK OF AGES CORPORATION, GRANITEVILLE, VT:
2,619,394. REN. 5-2-12. INT. CL. 19.

ROCK PAINT DISTRIBUTING CORP., MILTON, WI:
4,154,158, PUB. 3-20-2012. INT. CL. 2.

ROCK WALL CORPORATION, PHOENIX, AZ, DBA DISC-OFF:
4,153,239, PUB. 3-20-2012. INT. CL. 28.

ROCK-TENN SHARED SERVICES, LLC, NORCROSS, GA, FOLD-PAK CORPORATION, NEWARK, NY:
1,682,914. REN. 5-2-12. INT. CL. 16.

ROCKET GAMING SYSTEMS, LLC, GROVE, OK:
4,154,761, INT. CL. 9.

ROCKET SOFTWARE, INC., NEWTON, MA:
2,539,222. REN. 4-27-12. INT. CL. 9.

ROCKY MOUNTAIN TISSUE BANK, AURORA, CO:
4,153,812, PUB. 3-20-2012. INT. CL. 5.

RODALE INC., EMMAUS, PA, RODALE INC., EMMAUS, PA:
2,559,409. REN. 4-27-12. MULTIPLE CLASS, INT. CLS. 9, 41 AND 42.

RODALE INC., EMMAUS, PA TO RODALE INC., EMMAUS, PA:
2,559,409, CANC. INT. CL. 25.

RODALE INC., EMMAUS, PA:
2,562,215. REN. 5-2-12. MULTIPLE CLASS, INT. CLS. 9, 16, 41 AND 42.
2,562,215, CANC. INT. CL. 25.
2,562,216. REN. 5-2-12. MULTIPLE CLASS, INT. CLS. 9, 16, 41 AND 42.
2,562,216, CANC. INT. CL. 25.
2,564,938. REN. 4-27-12. INT. CL. 16.
4,154,152, PUB. 3-20-2012. INT. CL. 9.
4,154,153, PUB. 3-20-2012. INT. CL. 9.

RODIAL LIMITED, LONDON, UNITED KINGDOM:
4,153,043, PUB. 3-20-2012. INT. CL. 3.

RODIN, RACHEL, NEW YORK, NY:
4,155,658, INT. CL. 45.

RODNEY HAND & ASSOCIATES MARKETING COMMU-NICATIONS, LP, DALLAS, TX:
4,155,951, MULTIPLE CLASS, INT. CLS. 16 AND 41.

ROF FERRARI LENDING I, LLC, SAN LEANDRO, CA, A.G. FERRARI FOODS, SAN LEANDRO, CA:
2,559,121. REN. 4-30-12. INT. CL. 42.

ROGER MAIER, SWITZERLAND:
4,152,174, PUB. 3-20-2012. MULTIPLE CLASS, INT. CLS. 3, 12 AND 25.
4,152,198, PUB. 3-20-2012. MULTIPLE CLASS, INT. CLS. 3, 5, 9, 12, 18, 25 AND 41.

ROGERS BLUE JAYS BASEBALL PARTNERSHIP, TORON-TO, ONTARIO, CANADA, TORONTO BLUE JAYS BASE-BALL CLUB, TORONTO, ONTARIO, CANADA:
1,680,272. REN. 4-30-12. MULTIPLE CLASS, INT. CLS. 16 AND 25.

ROGERS, BARBARA, HENDERSON, NV:
4,153,531, PUB. 3-20-2012. INT. CL. 10.

ROGERS, LYSSA, PORTLAND, OR:
4,153,032, PUB. 3-20-2012. INT. CL. 25.

ROHNEX, ATLANTA, GA, AKA ROHNEX LLC:
4,155,227, INT. CL. 19.

ROLAND CORPORATION, SHIZUOKA, JAPAN:
4,155,853, INT. CL. 15.

ROLAND DG CORPORATION, SHIZUOKA-KEN, JAPAN:
4,152,971, PUB. 1-31-2012. INT. CL. 9.

ROLLESE, INC., STAMFORD, CT:
2,512,773. REN. 5-1-12. INT. CL. 6.

ROMANOFF PRODUCTS, INC., CHATHAM, NY:
4,152,880, PUB. 3-20-2012. INT. CL. 16.

ROMLA COMPANY, SAN DIEGO, CA:
2,496,602. REN. 4-27-12. INT. CL. 11.
2,496,602, CANC. INT. CL. 19.

RONCO HOLDINGS, INC., AUSTIN, TX:
2,998,504, CANC. INT. CL. 9.

ROSE BROOKS CENTER, INC., KANSAS CITY, MO:
1,887,539. COR. INT. CL. 41.

ROSEN HOTELS AND RESORTS, INC., ORLANDO, FL:
4,155,511, INT. CL. 41.

ROSENBAUM, KEREN, DEMAREST, NJ:
4,155,421, INT. CL. 41.

ROSENFELD, RICHARD A., BASALT, CO:
4,155,647, INT. CL. 30.

ROSENFELD, TODD, MIAMI, FL:
2,558,817. REN. 4-27-12. INT. CL. 35.

ROSKAM BAKING COMPANY, GRAND RAPID, MI:
2,667,396. REN. 5-3-12. INT. CL. 30.

ROSKAM BAKING COMPANY, GRAND RAPIDS, MI:
2,698,486. REN. 4-30-12. INT. CL. 30.

ROTAR MACHINERY INDUSTRIAL CO., LTD., TAIPING CITY, TAICHUNG, TAIWAN:
2,593,462. REN. 5-2-12. INT. CL. 8.

ROTARY DRILLING TOOLS USA, BEASLY, TX:
4,155,120, INT. CL. 6.

ROTELLINI, BRANDON C., MURRIETA, CA AND BATES, JENNIFER N., MURRIETA, CA:
4,155,000, INT. CL. 25.

- ROUND HILL CELLARS, ST. HELENA, CA, DBA RUTHERFORD WINE COMPANY:
4,154,069, PUB. 3-20-2012. INT. CL. 33.
- ROVIO ENTERTAINMENT LTD, FINLAND:
4,152,185, PUB. 3-20-2012. MULTIPLE CLASS, INT. CLS. 9 AND 28.
- ROWSHAN, SOHRAB, NEWPORT BEACH, CA:
4,153,104, PUB. 3-20-2012. INT. CL. 35.
- ROY FARMS, INC., MOXEE, WA:
4,152,914, PUB. 3-20-2012. INT. CL. 32.
- ROYAL BANK OF CANADA, MONTREAL, QUEBEC H3C 3A9, CANADA:
3,009,861, CANC. MULTIPLE CLASS, INT. CLS. 35 AND 42.
- ROYAL OAK ENTERPRISES, LLC, ROSWELL, GA, CROSSETT CHEMICAL COMPANY, THE, CROSSETT, AR:
294,978. REN. 5-3-12. U.S. CL. 1 (INT. CL. 4).
- ROYAL YACHTING ASSOCIATION, HAMBLE, SOUTHAMPTON, UNITED KINGDOM:
4,152,710, PUB. 3-20-2012. INT. CL. 41.
- RU MINDAN, BEIJING, 100061, CHINA:
4,154,913, INT. CL. 14.
- RUBIE'S COSTUME CO., INC., RICHMOND HILL, NY:
2,497,196. REN. 5-3-12. INT. CL. 25.
- RUBLE, SCOTT, J, SANTA CRUZ, CA:
4,154,487, INT. CL. 28.
- RUF, GARY, DENVER, CO:
4,154,066, PUB. 3-20-2012. INT. CL. 10.
- RUFIN COSMETIC GMBH, FED REP GERMANY:
2,998,363.
- RUGBY XV, INC, ALTADENA, CA, AKA RXV, RUGBY XV:
4,155,018, MULTIPLE CLASS, INT. CLS. 25, 28 AND 41.
- RUGGIERO, CHRISTIAN, NEW YORK, NY AND JASPER, GEREMY, NEW YORK, NY:
2,998,974, CANC. INT. CL. 41.
- RUN ATHLETICS INTERNATIONAL, LLC, NEW YORK, NY:
4,154,455, INT. CL. 25.
- RUNNYMEDE FARM, INC., PARIS, KY:
4,153,106, PUB. 3-20-2012. MULTIPLE CLASS, INT. CLS. 41 AND 44.
- RURO INCORPORATED, FREDERICK, MD, DBA RURO INC.:4,154,171, PUB. 3-20-2012. INT. CL. 9.
- RUSS, YOACHIM C., ANNAPOLIS, MD:
4,154,266, INT. CL. 9.
- RUSSO, TAYLOR, KATY, TX:
2,492,402, CANC. INT. CL. 39.
- RUST-OLEUM INTERNATIONAL, LLC, VERNON HILLS, IL:
734,800. REN. 5-1-12. U.S. CL. 16 (INT. CL. 2).
- RUTH GOMES, D.M.D., INC., ST. LOUIS, MO:
4,152,568, PUB. 3-20-2012. INT. CL. 44.
- RUTLAND FIRE CLAY COMPANY, RUTLAND, VT, DBA RUTLAND PRODUCTS:
1,684,189. REN. 5-2-12. INT. CL. 19.
- RUZYLLO, JERZY, STATE COLLEGE, PA:
4,155,902, INT. CL. 41.
- RYDER SYSTEM, INC., MIAMI, FL:
2,497,824. REN. 5-3-12. INT. CL. 39.
- S & H ENTERPRISES, INC., GLENS FALLS, NY, DBA NATIONWIDE LIFTS:
4,153,949, PUB. 3-20-2012. INT. CL. 37.
- S & S INDUSTRIES, INC., LONG ISLAND CITY, NY:
2,493,200, CANC. INT. CL. 25.
- S A S SAFETY CORP., LONG BEACH, CA:
4,155,364, INT. CL. 9.
- S. C. JOHNSON & SON, INC., RACINE, WI:
4,155,781, MULTIPLE CLASS, INT. CLS. 4 AND 5.
4,155,782, MULTIPLE CLASS, INT. CLS. 4 AND 5.
4,155,783, MULTIPLE CLASS, INT. CLS. 4 AND 5.
4,155,784, MULTIPLE CLASS, INT. CLS. 4 AND 5.
- S.H.E. 4.LIFE, LLC, MARION, IN:
4,155,541, INT. CL. 5.
4,155,542, INT. CL. 25.
- S-L SNACKS NATIONAL, LLC, CHARLOTTE, NC:
4,155,325, INT. CL. 30.
- S/R INDUSTRIES, INC., HUNTINGTON BEACH, CA, L & R INDUSTRIES, INC., TORRANCE, CA:
933,067. REN. 4-30-12. MULTIPLE CLASS, U.S. CLS. 9 (INT. CL. 13) AND 22 (INT. CL. 28).
- SÄGEN-MEHRING GMBH - SÄGENFABRIK, FED REP GERMANY:
4,069,278, COR. MULTIPLE CLASS, INT. CLS. 7 AND 8.
- SABIC INNOVATIVE PLASTICS IP B.V., BERGEN OP ZOOM, NETHERLANDS:
1,197,883. REN. 4-27-12. INT. CL. 17.
- SACA TECHNOLOGIES, INC., ANAHEIM HILLS, CA:
4,152,488, PUB. 3-20-2012. MULTIPLE CLASS, INT. CLS. 9 AND 42.
- SACRAMENTO KINGS LIMITED PARTNERSHIP, L.P., SACRAMENTO, CA:
2,693,608, COR. INT. CL. 16.
- SACRAMENTO MUNICIPAL UTILITY DISTRICT, SACRAMENTO, CA, AKA SMUD:
4,155,286, INT. CL. 35.
- SADLER BROTHERS OIL CO., INC., EMPORIA, VA:
2,561,333. REN. 4-27-12. MULTIPLE CLASS, INT. CLS. 35 AND 39.
2,583,780. REN. 4-27-12. INT. CL. 35.
2,583,781. REN. 4-27-12. INT. CL. 35.
- SAF-T-PAK INC., EDMONTON, T5S 2X3, CANADA:
2,568,943. REN. 4-27-12. INT. CL. 16.
- SAFARI CLUB INTERNATIONAL, LOS ANGELES AND ORANGE COUNTY CHAPTERS, MISSION VIEJO, CA:
4,153,990, PUB. 3-20-2012. INT. CL. 41.
- SAFE HARBOR ACCESS SYSTEMS II, LLC, FLORENCE, SC:
2,579,536. REN. 5-1-12. INT. CL. 6.
- SAFETY AUTO PARTS CORPORATION, CITY OF INDUSTRY, CA:
1,745,535. REN. 4-27-12. INT. CL. 7.
- SAFEWAY INC., PLEASANTON, CA:
4,154,241, MULTIPLE CLASS, INT. CLS. 30 AND 35.
- SAINT'S COFFEE IMPORT, INC, BROOKLYN, NY:
4,153,030, PUB. 3-20-2012. INT. CL. 30.
- SAKURAI HIROKATSU, TOKYO 101-0044, JAPAN:
4,152,391, PUB. 3-20-2012. INT. CL. 28.
- SALAS O'BRIEN ENGINEERS, INC., SAN JOSE, CA, DBA SALAS O'BRIEN:
4,154,639, INT. CL. 35.
- SALIM HIOUEL, CHARLESTON, SC:
4,153,021, PUB. 3-20-2012. INT. CL. 2.
- SALON DEVELOPMENT, INC., ST. PAUL, MN, DBA SALON DEVELOPMENT CORPORATION:
4,154,750, MULTIPLE CLASS, INT. CLS. 16 AND 41.
- SALTS HEALTHCARE LIMITED, WEST MIDLANDS B7 4AA, UNITED KINGDOM:
4,152,705, PUB. 3-20-2012. INT. CL. 10.
- SAM & HARRY'S MANAGEMENT COMPANY, MCLEAN, VA:
1,737,364. REN. 5-2-12. INT. CL. 42.
- SAMSUNG ELECTRONICS CO., LTD., SUWON-SI, GYEONGGI-DO, REPUBLIC OF KOREA:
4,152,092, PUB. 3-20-2012. MULTIPLE CLASS, INT. CLS. 37 AND 40.
4,155,269, INT. CL. 9.
4,155,270, INT. CL. 9.
4,155,271, INT. CL. 9.
- SAMYA TECHNOLOGY CO., LTD., TAOYUAN COUNTY 33460, TAIWAN:
4,153,762, PUB. 3-20-2012. INT. CL. 9.
- SAN ANTONIO GOLF ASSOCIATION, INC., SAN ANTONIO, TX:
3,213,439, COR. MULTIPLE CLASS, INT. CLS. 36 AND 41.
- SAN ANTONIO LIVESTOCK EXPOSITION, INC., SAN ANTONIO, TX:
4,152,896, PUB. 3-20-2012. INT. CL. 26.
4,152,897, PUB. 3-20-2012. INT. CL. 18.
4,152,898, PUB. 3-20-2012. INT. CL. 21.
4,152,899, PUB. 3-20-2012. INT. CL. 33.
- SAN ANTONIO WINERY, INC., LOS ANGELES, CA:
4,155,341, INT. CL. 33.
- SAN DIEGO COUNTY CREDIT UNION, SAN DIEGO, CA:
4,154,591, MULTIPLE CLASS, INT. CLS. 35 AND 36.

SAN DIEGO EYE BANK, SAN DIEGO, CA:
2,561,484. REN. 4-27-12. INT. CL. 42.

SAN DIEGO HYDROPONICS & ORGANICS, SAN DIEGO, CA:
4,153,499. PUB. 3-20-2012. INT. CL. 44.

SANC MATERIALS, INC., RANCHO CUCAMONGA, CA:
4,155,276. INT. CL. 7.

SANDERS, BRAD, FAYETTEVILLE, CA:
1,685,626. REN. 4-30-12. INT. CL. 41.

SANDMOLD SYSTEMS, INC., NEWAYGO, MI:
2,666,425. REN. 5-2-12. INT. CL. 7.

SANDPLAY THERAPISTS OF AMERICA, WALNUT CREEK, CA:
4,152,106. PUB. 3-20-2012. INT. CL. 41.

SANDRIDGE ENERGY, INC., OKLAHOMA CITY, OK:
4,154,057. PUB. 3-20-2012. INT. CL. 37.

SANFORD, FARGO, ND:
4,155,789. INT. CL. 36.

SANFORD, L.P., OAK BROOK, IL:
4,154,520. MULTIPLE CLASS, INT. CLS. 2 AND 16.

SANKYO CO., LTD., NISHIWAKISHI, HYOGO, JAPAN:
2,998,832. CANC. MULTIPLE CLASS, INT. CLS. 10 AND 20.

SANOFI, PARIS, FRANCE:
4,152,865. PUB. 3-20-2012. INT. CL. 10.
4,152,866. PUB. 3-20-2012. INT. CL. 10.

SANTANA, ANGEL, MILLBURY, MA:
4,155,611. INT. CL. 16.

SANYO CHEMICAL INDUSTRIES, LTD., HIGASHIYAMA-KU, KYOTO, JAPAN:
936,344. REN. 4-27-12. MULTIPLE CLASS, U.S. CLS. 1 (INT. CL. 1), 6 (INT. CLS. 1 AND 5) AND 15 (INT. CLS. 1 AND 4).

SAPPHIRE TECHNOLOGY LTD., SHANTIN, NT, HONG KONG:
4,153,231. PUB. 3-20-2012. INT. CL. 9.

SARAH GRACE LLC, MOUNT HOREB, WI:
4,154,993. INT. CL. 5.

SARAVANA BHAVAN HOLDINGS LIMITED, KARAMA, UNITED ARAB EMIR.:
4,152,098. PUB. 3-20-2012. MULTIPLE CLASS, INT. CLS. 35 AND 43.

SAS D. CATHIARD, FRANCE:
4,152,294. PUB. 3-20-2012. INT. CL. 33.

SASSY STRINGS, LLC, FT. MYERS, FL:
4,154,500. INT. CL. 26.

SATELLITE WEBSITE CORPORATION, CHICAGO, IL:
4,153,357. PUB. 3-20-2012. INT. CL. 42.

SATO & TAO (SOCIÉTÉ PAR ACTIONS SIMPLIFIÉE), FRANCE:
4,152,369. PUB. 3-20-2012. MULTIPLE CLASS, INT. CLS. 30, 35 AND 43.

SATO ET TAO (SOCIÉTÉ PAR ACTIONS SIMPLIFIÉE), FRANCE:
4,152,370. PUB. 3-20-2012. MULTIPLE CLASS, INT. CLS. 30, 35 AND 43.

SATO OFFICE GMBH, FED REP GERMANY:
4,152,379. PUB. 3-20-2012. INT. CL. 20.

SAUNDERS ENTERPRISES, LLC, HENDERSON, NV:
4,155,209. INT. CL. 41.

SAUTER, WENDY A, MISSION VIEJO, CA:
4,155,062. INT. CL. 25.

SAVAGE, JACOB W, CORDOVA, TN:
4,153,937. PUB. 3-20-2012. INT. CL. 42.
4,153,941. PUB. 3-20-2012. INT. CL. 42.

SAVE-A-LOT FOOD STORES, LTD., EARTH CITY, MO:
2,597,618. REN. 4-27-12. INT. CL. 30.
4,156,039. INT. CL. 30.

SAVERGLASS, FRANCE:
4,152,439. PUB. 3-20-2012. INT. CL. 40.

SAVINELLI S.P.A., MILANO, ITALY:
933,460. REN. 5-2-12. U.S. CL. 8 (INT. CL. 34).

SAZERAC CO., INC., METAIRIE, LA:
2,622,735. REN. 4-29-12. MULTIPLE CLASS, INT. CLS. 16, 21, 25 AND 33.

SAZERAC COMPANY, INC., METAIRIE, LA:
2,601,650. REN. 4-29-12. MULTIPLE CLASS, INT. CLS. 16, 25 AND 33.

4,153,512. PUB. 3-20-2012. INT. CL. 33.

SAZERAC NORTH AMERICA, INC., FRANKFORT, KY:
4,155,146. INT. CL. 39.

SAZZI FOOTWEAR, LLC, NEWPORT BEACH, CA:
4,154,863. INT. CL. 25.

SCANFLAVOUR A/S, DENMARK:
4,152,392. PUB. 3-20-2012. MULTIPLE CLASS, INT. CLS. 5, 29 AND 30.

SCARLETT DESIGNS, INC., HOWARD BEACH, NY:
4,153,749. PUB. 3-20-2012. INT. CL. 14.

SCAT ENTERPRISES, INC., REDONDO BEACH, CA:
4,152,551. PUB. 3-20-2012. INT. CL. 12.

SCBT FINANCIAL CORPORATION, COLUMBIA, SC:
4,155,806. INT. CL. 36.

SCENTSYS, INC., MERIDIAN, ID:
4,155,896. INT. CL. 11.

SCHAFFER, BRIAN, SAN DIEGO, CA, DBA AUDIO VIDEO EXCELLENCE:
2,491,771. CANC. INT. CL. 37.

SCHEDULEINTERPRETER.COM, INC., OVERLAND PARK, KS:
4,156,022. INT. CL. 42.

SCHEID VINEYARDS CALIFORNIA INC., SALINAS, CA:
4,155,031. INT. CL. 33.

SCHINZINGER, STEFAN, SAN LEANDRO, CA, DBA SCHINZINGER KELLMAN DESIGN:
2,575,976. REN. 4-30-12. INT. CL. 25.
2,648,761. REN. 4-30-12. INT. CL. 25.

SCHIPPER & COMPANY U.S.A., INC., BRIDGEPORT, CT:
4,155,495. INT. CL. 31.

SCHLEICH GMBH, SCHWABISCH GMUND, FED REP GERMANY, SCHLEICH GMBH & CO. KG, SCHWABISCH, GMUND-HERLIKOFEN, FED REP GERMANY:
1,207,394. REN. 4-30-12. INT. CL. 28.

SCHLUMBERGER TECHNOLOGY CORPORATION, ROSHARON, TX:
2,492,920. CANC. INT. CL. 17.

SCHMIDT, DIANE, NORTH RIDGEVILLE, OH:
4,152,467. PUB. 3-20-2012. INT. CL. 35.

SCHOOL NUTRITION ASSOCIATION, OXON HILL, MD:
4,153,254. PUB. 3-20-2012. INT. CL. 35.

SCHOTT AKTIENGESELLSCHAFT, 55122 MAINZ, FED REP GERMANY:
4,152,335. PUB. 3-20-2012. MULTIPLE CLASS, INT. CLS. 11, 20 AND 21.

SCHROEDER & TREMAYNE, INC., ST. LOUIS, MO:
4,020,390. COR. INT. CL. 21.

SCHROEDER INDUSTRIES, LEETSDALE, PA:
4,154,539. INT. CL. 11.
4,154,541. INT. CL. 7.

SCHULTZ, BRUCE, WOODLAND HILLS, CA, DBA BODY-LINES:
4,153,417. PUB. 3-20-2012. INT. CL. 28.

SCHULTZ, SHANNON H, CHARLOTTE, NC:
4,155,317. MULTIPLE CLASS, INT. CLS. 18, 20 AND 28.

SCHULZE, STEPHEN, NEWPORT BEACH, CA:
4,155,852. INT. CL. 43.

SCHUYLKILL RIVER DEVELOPMENT CORPORATION, PHILADELPHIA, PA:
4,153,999. PUB. 3-20-2012. MULTIPLE CLASS, INT. CLS. 39 AND 41.

SCHWAN'S IP, LLC, MARSHALL, MN:
4,155,537. INT. CL. 30.

SCHWARTZ & CO. ENTERPRISES, LTD., CEDAR RAPIDS, IA:
2,563,875. REN. 4-27-12. INT. CL. 11.

SCIENTIFIC BRAKE AND EQUIPMENT CO., SAGINAW, MI:
1,683,267. REN. 4-27-12. INT. CL. 39.
1,689,424. REN. 4-27-12. INT. CL. 42.
1,707,235. REN. 4-27-12. INT. CL. 37.

SCISBO, LLC, WILMINGTON, DE:
4,154,303. INT. CL. 42.

SCOTT KEENEY, LOS ANGELES, CA:
4,152,688. PUB. 3-20-2012. INT. CL. 41.

SCOTT TECHNOLOGIES, INC., BOCA RATON, FL:
4,154,880. INT. CL. 9.

- SCOTT-REYES, LAURIE, HAWTHORNE, FL:
4,155,126, INT. CL. 41.
- SCOTTSDALE CONVENTION AND VISITORS BUREAU,
INC., SCOTTSDALE, AZ:
2,998,593, CANC. INT. CL. 35.
2,998,594, CANC. INT. CL. 35.
- SCRIPPS NETWORKS, LLC, KNOXVILLE, TN:
4,154,726, INT. CL. 41.
- SCRIPPSHEALTH, SAN DIEGO, CA:
4,153,539, PUB. 3-20-2012. INT. CL. 36.
- SCRIPT TO SCREEN PRODUCTIONS, SANTA ANA, CA:
4,152,702, PUB. 3-20-2012. INT. CL. 35.
- SCRUM ALLIANCE, INC., INDIANAPOLIS, IN:
4,154,523, MULTIPLE CLASS, INT. CLS. 41 AND 42.
4,154,524, U.S. CL. 200.
- SD AUTO, LLC, ASHEVILLE, NC:
4,153,628, PUB. 3-20-2012. INT. CL. 43.
- SDI CORPORATION, TA JWU LI, CHANG HUA, TAIWAN:
1,695,789. REN. 5-1-12. INT. CL. 8.
- SEA GULL LIGHTING PRODUCTS, LLC, RIVERSIDE, NJ:
2,586,355. REN. 4-27-12. INT. CL. 11.
- SEA HAWK CORP., ARCADIA, CA:
4,153,468, PUB. 3-20-2012. INT. CL. 5.
- SEA WATCH RESORT, LLC, MYRTLE BEACH, SC:
4,153,651, PUB. 3-20-2012. INT. CL. 43.
- SEAI AMERICA, INC., IRVINE, CA:
4,155,508, MULTIPLE CLASS, INT. CLS. 11 AND 37.
- SEARS BRANDS, LLC, HOFFMAN ESTATES, IL:
4,154,584, INT. CL. 39.
4,155,828, INT. CL. 36.
- SEAWELL LIMITED, UNITED KINGDOM:
4,152,279, PUB. 3-20-2012. MULTIPLE CLASS, INT. CLS.
9, 37 AND 42.
- SECTOR 42 TECHNOLOGIES INC., QUEBEC, CANADA:
4,153,583, PUB. 3-20-2012. INT. CL. 9.
4,153,584, PUB. 3-20-2012. INT. CL. 9.
4,153,585, PUB. 3-20-2012. INT. CL. 9.
- SECURE-24, INC., SOUTHFIELD, MI:
4,152,670, PUB. 3-20-2012. MULTIPLE CLASS, INT. CLS.
35, 37, 39, 42 AND 45.
- SECURUS TECHNOLOGIES, INC., DALLAS, TX:
4,154,762, INT. CL. 45.
4,154,763, INT. CL. 35.
4,154,764, INT. CL. 38.
- SEDGWICK CLAIMS MANAGEMENT SERVICES, INC.,
MEMPHIS, TN:
2,617,363. REN. 4-27-12. INT. CL. 36.
- SEEK PUBLISHING, INC., BIRMINGHAM, AL:
1,682,910. REN. 4-27-12. INT. CL. 16.
- SEGA CORPORATION, OHTA-KU, TOKYO, JAPAN:
2,493,375, CANC. INT. CL. 9.
- SEIDLER, CARL W., WINTERSET, IA:
4,029,879, CANC. INT. CL. 19.
- SEIKO HOLDINGS KABUSHIKI KAISHA, TOKYO, JAPAN,
TA SEIKO HOLDINGS CORPORATION:
4,153,757, PUB. 3-20-2012. INT. CL. 14.
4,154,178, PUB. 1-24-2012. INT. CL. 14.
4,155,732, INT. CL. 9.
- SELECT MEDIA SERVICES, LLC, SMYRNA, GA:
4,152,862, PUB. 3-20-2012. MULTIPLE CLASS, INT. CLS.
35 AND 39.
- SELECTMARK, INC., WILMINGTON, DE:
2,703,942. REN. 4-27-12. MULTIPLE CLASS, INT. CLS. 41
AND 42.
- SELFRELIANCE UKRAINIAN AMERICAN FEDERAL
CREDIT UNION, CHICAGO, IL:
4,152,691, PUB. 3-20-2012. INT. CL. 36.
- SELLERY, INC., ARCADIA, CA:
2,627,465. REN. 4-27-12. INT. CL. 9.
- SELUX CORPORATION, HIGHLAND, NY:
2,640,285. REN. 4-27-12. INT. CL. 11.
- SEMPRAE LABORATORIES, INC., SADDLE BROOK, NJ:
4,155,425, INT. CL. 5.
- SEMPRIS, LLC, MINNEAPOLIS, MN:
4,154,497, INT. CL. 35.
- SENATES, BEKIR, BOSTON, MA:
4,152,780, PUB. 3-20-2012. INT. CL. 41.
- SENIOR INVESTMENTS AG, 8201 SCHAFFHAUSEN, SWIT-
ZERLAND, PATHWAY BELLOWS, INC., OAK RIDGE,
TN:
1,683,837. REN. 5-3-12. INT. CL. 24.
- SENIOR LIFESTYLE CORPORATION, CHICAGO, IL:
2,700,334. REN. 4-27-12. INT. CL. 42.
- SENSA PRODUCTS, LLC, EL SEGUNDO, CA:
4,153,028, PUB. 12-13-2011. INT. CL. 5.
- SEQUIN, LLC, NEW YORK, NY:
4,153,754, PUB. 3-20-2012. INT. CL. 35.
- SERCHLITE MULTIMEDIA, WINDEMERE, FL:
4,154,978, INT. CL. 9.
- SERENA WILLIAMS, NEW YORK, NY:
4,154,396, MULTIPLE CLASS, INT. CLS. 14, 18 AND 25.
- SERENE INNOVATION, INC., NORWALK, CA:
4,152,654, PUB. 3-20-2012. MULTIPLE CLASS, INT. CLS.
10 AND 21.
- SERGIO RICARDO DIAZ FLORES, TEGUCIGALPA DC,
HONDURAS:
4,153,861, PUB. 3-20-2012. INT. CL. 29.
- SERRA, DIANIC, SAN DIEGO, CA, DBA DIVA LASH
BOUTIQUE:
4,153,040, PUB. 3-20-2012. INT. CL. 3.
- SERVICE OFFICE & SUPPLY, INC., COFFEYVILLE, KS,
AKA SERVICE OFFICE:
4,153,537, PUB. 3-20-2012. INT. CL. 35.
- SERVICE TOOL CO, LLC, NEW IBERIA, LA:
4,155,930, MULTIPLE CLASS, INT. CLS. 6, 8, 9, 11, 13, 18,
20, 21, 22, 25 AND 28.
- SERVICEMEMBERS LEGAL DEFENSE NETWORK INC.,
WASHINGTON, DC:
2,598,003. REN. 5-2-12. INT. CL. 42.
- SERVICIOS AEREOS NACIONALES, S.A., SAN JOSE,
COSTA RICA:
2,693,376. REN. 4-30-12. INT. CL. 39.
- SES S.A., LUXEMBOURG:
4,152,385, PUB. 3-20-2012. INT. CL. 38.
- SESDERMA, S.L., VALENCIA, SPAIN:
2,493,264, CANC. INT. CL. 3.
- SETPOINT HEALTH CORPORATION, NEWTON UPPER
FALLS, MA:
4,155,884, INT. CL. 30.
- SEVENTH GENERATION, INC., BURLINGTON, VT:
4,154,583, MULTIPLE CLASS, INT. CLS. 3, 5, 9, 16, 35
AND 38.
- SEVILLA FUTBOL CLUB SOCIEDAD DEPORTIVA, S.A.D.,
SPAIN:
4,152,210, PUB. 3-20-2012. MULTIPLE CLASS, INT. CLS.
25, 35 AND 41.
- SEYMOUR, JONATHAN C, DENVER, CO:
4,153,083, PUB. 3-20-2012. INT. CL. 9.
- SE2, INC., TOPEKA, KS:
4,154,847, MULTIPLE CLASS, INT. CLS. 35, 36 AND 42.
- SF INVESTMENTS, INC., WILMINGTON, DE:
4,155,651, INT. CL. 29.
- SFP MEDIA, INC., CLAREMONT, CA:
4,152,888, PUB. 3-20-2012. INT. CL. 41.
- SGD S.A., PUTEAUX, FRANCE:
2,560,943. REN. 5-3-12. INT. CL. 21.
- SHAKE-N-GO FASHION, INC., PORT WASHINGTON, NY:
4,154,854, INT. CL. 26.
- SHAKLEE CORPORATION, PLEASANTON, CA:
4,154,638, INT. CL. 5.
4,155,464, INT. CL. 5.
- SHALOND ESSIX, BATON ROUGE, LA, DBA CAPSTONE
CLOTHING COMPANY:
4,152,515, PUB. 3-20-2012. INT. CL. 25.
- SHAMOOIL, DANIEL, GREAT NECK, NY:
4,155,482, INT. CL. 36.
- SHANDONG WANDA BOTO TYRE CO., LTD., DONGYING,
SHANDONG, CHINA:
4,153,927, PUB. 3-20-2012. INT. CL. 12.
- SHANXI CHUANGLING PHOTOVOLTAIC; ELECTRIC CO.
LTD., CHINA:
4,152,437, PUB. 3-20-2012. INT. CL. 9.
- SHARON ANN DEWALD, LAKEVILLE, MN AND CRAIG L.
DEWALD, LAKEVILLE, MN:
4,152,728, PUB. 3-20-2012. INT. CL. 25.

SHARSHERET, INC., TEANECK, NJ:
4,154,996, MULTIPLE CLASS, INT. CLS. 44 AND 45.

SHASHINKA, LINDA, SANDY SPRINGS, GA:
4,154,310, INT. CL. 41.

SHAUGHNESSY, THOMAS J, RIO RANCHO, NM:
4,153,694, PUB. 3-20-2012, INT. CL. 41.

SHAWN GEE, BALA CYNWYD, PA AND JULIUS ERVING III, NEW YORK, NY AND TROY CARTER, BALA CYNWYD, PA:
4,155,572, INT. CL. 41.

SHELTER-PRO, LLC, STEARNS, KY:
4,154,100, PUB. 3-20-2012, INT. CL. 25.

SHENZHEN JUMPER MEDICAL EQUIPMENT CO., LTD., SHENZHEN, CHINA:
4,152,509, PUB. 3-20-2012, INT. CL. 10.

SHEPHERD, ALLEN S., III, DUBLIN, OH:
2,682,586, REN. 4-30-12, INT. CL. 32.

SHEVACK, BRETT, NEW YORK, NY:
2,553,864, REN. 5-1-12, INT. CL. 25.

SHIATZY INTERNATIONAL COMPANY LIMITED, TAIPEI CITY, TAIWAN, CHINA:
4,152,188, PUB. 3-20-2012, MULTIPLE CLASS, INT. CLS. 3, 9, 14, 18, 20, 24, 25, 26 AND 42.

SHIELER TRADING CORP., NEW YORK, NY:
4,155,457, INT. CL. 14.

SHIN NIPPON SEITETSU KABUSHIKI KAISHA (ALSO DOING BUSINESS AS NIPPON STEEL CORPORATION), TOKYO, JAPAN:
3,924,813, COR. MULTIPLE CLASS, INT. CLS. 1, 6, 7, 9, 11, 37 AND 42.

SHIN, KEVIN, CARLSBAD, CA:
4,154,186, PUB. 3-20-2012, INT. CL. 25.

SHINMAYWA INDUSTRIES, LTD., HYOGO, JAPAN:
4,154,658, INT. CL. 7.

SHIRK, TRAVIS M., LEBANON, PA:
4,155,154, INT. CL. 25.

SHIRLEY BEANS PRODUCTIONS LLC, NEW YORK, NY:
4,155,485, INT. CL. 41.

SHIRLEY, DEBORAH, LAFAYETTE, GA:
4,154,021, PUB. 3-20-2012, INT. CL. 35.

SHISEIDO COMPANY, INC., TOKYO, 104-10, JAPAN:
2,492,911, CANC. INT. CL. 3.

SHMIRSHKY UNIVERSAL, LLC, CORONADO, CA:
4,154,473, INT. CL. 25.

4,154,474, MULTIPLE CLASS, INT. CLS. 16 AND 25.

SHOEBACCA, LTD., IRVING, TX:
4,153,978, PUB. 3-20-2012, INT. CL. 36.
4,153,986, PUB. 3-20-2012, INT. CL. 36.

SHOLTIS, STEVEN, EL DORADO HILLS, CA:
4,154,013, PUB. 3-20-2012, INT. CL. 35.

SHOPPER SCIENTIST LLC, CORBETT, OR:
4,154,775, INT. CL. 35.

SHOWSEASON ANIMAL PRODUCTS, LLC, TUCKER, GA:
4,153,273, PUB. 3-20-2012, INT. CL. 3.

SHOWTIME NETWORKS INC., NEW YORK, NY:
2,560,462, REN. 5-2-12, INT. CL. 41.
2,562,062, REN. 4-27-12, INT. CL. 41.
2,562,594, REN. 5-3-12, INT. CL. 38.
4,154,757, INT. CL. 38.
4,154,860, INT. CL. 41.

SHROOMBOB, LLC, BOZEMAN, MT:
4,154,719, INT. CL. 25.

SIEMAG TECBERG GMBH, FED REP GERMANY:
4,123,510, COR. MULTIPLE CLASS, INT. CLS. 6, 7, 35, 37, 41 AND 42.

SIEMENS AKTIENGESELLSCHAFT, MUNCHEN, FED REP GERMANY:
2,620,676, REN. 4-27-12, INT. CL. 9.

SIEMENS AKTIENGESELLSCHAFT, FED REP GERMANY:
4,152,405, PUB. 3-20-2012, MULTIPLE CLASS, INT. CLS. 1, 40 AND 42.
4,152,415, PUB. 2-14-2012, INT. CL. 9.

SIEMENS INDUSTRY, INC., ALPHARETTA, GA, SIEMENS MOORE PROCESS AUTOMATION, INC., SPRING HOUSE, PA:
2,530,319, REN. 5-2-12, INT. CL. 9.

SIEMENS SCHWEIZ AG, SWITZERLAND:
4,152,175, PUB. 3-20-2012, MULTIPLE CLASS, INT. CLS. 9 AND 11.

SIERRA CITRUS ASSOCIATION, LINDSAY, CA, LINDSAY FARM BUREAU FRUIT ASSN., LINDSAY, CA:
301,721, REN. 4-30-12, U.S. CL. 46 (INT. CL. 31).

SIERRA MEAT COMPANY, RENO, NV:
3,751,995, COR. INT. CL. 35.

SIERRA PACKAGING & CONVERTING, LLC, SPARKS, NV:
4,155,246, INT. CL. 16.

SIFIM S.R.L., ITALY:
4,152,196, PUB. 3-20-2012, INT. CL. 11.

SIG SAUER INC., EXETER, NH:
4,154,202, PUB. 3-20-2012, INT. CL. 13.

SIGN POSTMAN, LLC, LAKE LAND, FL:
4,153,609, PUB. 3-20-2012, INT. CL. 35.

SIGNATURE CONTROL SYSTEMS, INC., IRVINE, CA:
4,152,050, PUB. 3-20-2012, INT. CL. 9.
4,152,051, PUB. 3-20-2012, MULTIPLE CLASS, INT. CLS. 9 AND 11.

SIGNATURE FUNDRAISING, INC., LANCASTER, CA:
2,587,018, REN. 5-2-12, INT. CL. 35.

SIGNATURE SYSTEMS GROUP, LLC, NEW YORK, NY:
4,153,364, PUB. 3-20-2012, INT. CL. 19.

SIGNET ARMORLITE EUROPE LIMITED, GLOUCESTER, UNITED KINGDOM:
4,152,086, PUB. 8-24-2010, INT. CL. 35.

SIGNUM INTERNATIONAL S.A.R.L., L-1637 LUXEMBOURG, LUXEMBOURG:
4,153,361, PUB. 3-20-2012, MULTIPLE CLASS, INT. CLS. 16, 35 AND 41.

SIKA AG, SWITZERLAND:
3,057,927.

SILIPOS INC., NEW YORK, NY:
2,563,474, REN. 5-1-12, INT. CL. 3.

SILTRONIC AG, MUNICH, FED REP GERMANY:
4,152,750, PUB. 3-20-2012, MULTIPLE CLASS, INT. CLS. 1 AND 9.

SILVERLIT LIMITED, CAUSEWAY BAY, HONG KONG, HONG KONG:
1,725,901, REN. 5-2-12, INT. CL. 28.

SILVERS, JOSHUA, WEST PALM BEACH, FL:
4,152,984, PUB. 3-20-2012, INT. CL. 16.

SIMFY AG, FED REP GERMANY:
4,085,659, COR. MULTIPLE CLASS, INT. CLS. 9, 35, 38, 41, 42 AND 45.

SIMIOSYS, LLC, OVIEDO, FL:
4,154,667, INT. CL. 9.

SIMMS FISHING PRODUCTS LLC, BOZEMAN, MT:
2,695,985, REN. 5-3-12, INT. CL. 25.

SIMON & SCHUSTER, INC., NEW YORK, NY:
2,564,060, REN. 5-3-12, INT. CL. 16.

SIMPLICITY LAW, INC., LITTLETON, CO:
4,153,133, PUB. 3-20-2012, INT. CL. 45.

SIMPLY MORSELS, LLC, ISSAQUAH, WA:
4,154,115, PUB. 3-20-2012, INT. CL. 30.

SIMPSON STRONG-TIE COMPANY, INC., PLEASANTON, CA:
1,685,994, REN. 5-1-12, INT. CL. 6.

SINGER EQUIPMENT COMPANY, INC., ELVERSON, PA:
4,153,150, PUB. 3-20-2012, INT. CL. 35.

SINGER NY, LLC, ELVERSON, PA:
4,153,149, PUB. 3-20-2012, INT. CL. 35.

SINGING SUCCESS INCORPORATED, NASHVILLE, TN:
4,152,667, PUB. 3-20-2012, INT. CL. 41.

SINGLETON, WILLIAM, CLEVELAND HEIGHTS, OH:
4,154,445, INT. CL. 25.

SINITUOTE OY, FINLAND:
4,152,226, PUB. 3-20-2012, MULTIPLE CLASS, INT. CLS. 3, 8, 12, 20 AND 21.

SIP RIGHTS LLC, BECA RATON, FL:
2,559,863, REN. 5-1-12, INT. CL. 36.
2,559,864, REN. 5-1-12, INT. CL. 37.

SIR MAX B.V., NL-1016 CB AMSTERDAM, NETHERLANDS:
4,152,313, PUB. 3-20-2012, MULTIPLE CLASS, INT. CLS. 18, 25 AND 35.

SISMA S.P.A., MANTOVA, ITALY:
1,662,513, REN. 5-1-12, INT. CL. 21.

SITHE ENERGIES, INC., HOUSTON, TX:
2,491,922, CANC. INT. CL. 40.

- SJØTROLL HAVBRUK AS C/O SJØTROLL AS, NORWAY:
 4,152,347, PUB. 3-20-2012. MULTIPLE CLASS, INT. CLS.
 29, 31 AND 42.
- SKAGGS, MARK, OAK HARBOR, WA:
 4,155,600, MULTIPLE CLASS, INT. CLS. 25 AND 28.
- SKALLY'S OLD WORLD BAKERY, INC., CINCINNATI, OH:
 2,698,359. REN. 5-2-12. INT. CL. 30.
- SKECHERS U.S.A., INC. II, MANHATTAN BEACH, CA:
 4,154,281, INT. CL. 18.
 4,154,393, INT. CL. 25.
- SKINI, INC., OGLESBY, IL:
 4,153,712, PUB. 3-20-2012. INT. CL. 35.
- SKY B NATION LLC, HOUSTON, TX:
 4,154,091, PUB. 3-20-2012. INT. CL. 25.
- SKY ONE, INC., WALNUT, CA, DBA VERTEX CHINA:
 1,686,465. REN. 4-27-12. INT. CL. 21.
 2,569,281. REN. 5-3-12. INT. CL. 21.
- SKYBUILT POWER, INC., ARLINGTON, VA:
 3,083,913, CANC. MULTIPLE CLASS, INT. CLS. 39 AND
 40.
- SKYDIVING SCHOOL, INC., HONOLULU, HI, DBA SKYD-
 IVE HAWAII:
 4,155,977, MULTIPLE CLASS, INT. CLS. 12 AND 18.
- SKYLINE COMMERCIAL REAL ESTATE, LLC, WAYNE,
 PA:
 2,998,652, CANC. INT. CL. 36.
- SKYPE, DUBLIN 2, IRELAND:
 4,154,663, INT. CL. 38.
- SKYWARD PARTNERS, LLC, WASHOUGAL, WA:
 4,153,615, PUB. 3-20-2012. INT. CL. 36.
- SLP PERFORMANCE PARTS, INC., TOMS RIVER, NJ:
 4,155,004, MULTIPLE CLASS, INT. CLS. 12 AND 37.
- SM INVESTMENTS CORPORATION, CBP-1A, PASAY CITY,
 PHILIPPINES:
 4,152,546, PUB. 9-13-2011. INT. CL. 36.
- SMART BRANDS USA INTL, LLC, AVENTURA, FL:
 4,152,903, PUB. 3-20-2012. INT. CL. 25.
- SMART COUNSEL, LLC, GREENSBURG, PA:
 4,154,494, INT. CL. 41.
 4,154,495, INT. CL. 41.
 4,154,496, INT. CL. 41.
- SMART PEAKE MEDICAL, L.L.C., LAFAYETTE, LA:
 4,155,947, INT. CL. 32.
- SMART, LLC, WOODBRIDGE, NJ:
 4,153,271, PUB. 3-20-2012. INT. CL. 35.
- SMARTDRIVE SYSTEMS, INC., SAN DIEGO, CA:
 4,154,356, MULTIPLE CLASS, INT. CLS. 9, 35 AND 38.
- SMAXTEC ANIMAL CARE SALES GMBH, AUSTRIA:
 4,152,203, PUB. 3-20-2012. MULTIPLE CLASS, INT. CLS.
 9, 10 AND 42.
- SMG BRANDS, INC., WILMINGTON, DE:
 4,154,872, INT. CL. 1.
- SMITH & NEPHEW, INC., MEMPHIS, TN TO DJ ORTHO-
 PEDICS DEVELOPMENT CORPORATION, VISTA, CA:
 2,493,072, CANC. INT. CL. 10.
- SMITH & NEPHEW, INC., MEMPHIS, TN:
 4,155,660, INT. CL. 10.
- SMITH, BOBBY, TYLER, TX:
 4,153,684, PUB. 3-20-2012. INT. CL. 30.
- SMITH, JAMES H., SHERMAN OAKS, CA:
 4,153,577, PUB. 3-20-2012. INT. CL. 28.
- SMITH, RUSSELL, LONGWOOD, FL:
 4,155,316, INT. CL. 25.
- SMITHKLINE BEECHAM (CORK) LIMITED, CARRIGA-
 LINE, IRELAND:
 2,492,774, CANC. INT. CL. 5.
- SMOCKED RUNWAY, LLC, DALLAS, TX:
 4,153,137, PUB. 3-20-2012. INT. CL. 25.
- SMOKY SYSTEMS, LLC, WEBSTER CITY, IA:
 4,153,182, PUB. 3-20-2012. INT. CL. 29.
- SMS MEER GMBH, MONCHENGLADBACH, FED REP
 GERMANY:
 3,003,538, CANC. INT. CL. 9.
- SMS MEVAC GMBH, ESSEN, FED REP GERMANY:
 4,152,927, PUB. 3-20-2012. MULTIPLE CLASS, INT. CLS.
 7, 9 AND 11.
- SMUSH LLC, HOBOKEN, NJ:
 4,155,640, INT. CL. 30.
- SNAK KING CORP., CITY OF INDUSTRY, CA:
 2,571,778. REN. 5-2-12. INT. CL. 30.
- SNAK KING CORPORATION, CITY OF INDUSTRY, CA:
 1,711,938. REN. 5-2-12. INT. CL. 29.
- SNAP GREET LLC, CHEYENNE, WY:
 4,152,673, PUB. 3-20-2012. INT. CL. 45.
- SNAP LOCK INDUSTRIES, INC., SALT LAKE CITY, UT:
 2,597,700. REN. 4-29-12. INT. CL. 19.
- SNAP TV, INC., SANTA MONICA, CA:
 2,999,284, CANC. MULTIPLE CLASS, INT. CLS. 9 AND
 42.
- SNAP-ON INCORPORATED, KENOSHA, WI:
 2,565,234. REN. 4-30-12. INT. CL. 7.
- SNAPTAGZ, LLC, BROOKLYN, NY:
 4,155,563, INT. CL. 26.
- SNEAKER CON EVENTS, NEW YORK, NY:
 4,155,959, INT. CL. 35.
- SNEAKY COCKTAILS, LLC, ROSWELL, GA:
 4,155,727, INT. CL. 33.
- SNOWBIRD CORPORATION, SNOWBIRD, UT:
 1,759,977. REN. 4-30-12. INT. CL. 25.
- SNOWDEN, DONTRELL, WESTMINSTER, MD:
 4,154,557, INT. CL. 41.
- SNYDER, KENNETH C., WHITEHALL, PA:
 4,155,469, INT. CL. 10.
- SNYDER, VIRGINIE, TOPANGA, CA:
 4,154,548, INT. CL. 41.
- SOBHE, ASHKAN, LOS ANGELES, CA:
 4,152,781, PUB. 3-20-2012. INT. CL. 35.
- SOCIAL ESQUIRE, MIAMI, FL:
 4,153,604, PUB. 3-20-2012. INT. CL. 36.
- SOCIETE COOPERATIVE VINICOLE DE LUGNY "L'AUR-
 ORE", LUGNY, FRANCE:
 4,154,895, INT. CL. 33.
- SOCIETE DES PRODUITS NESTLE S.A., VEVEY, SWITZER-
 LAND:
 4,155,523, INT. CL. 31.
- SOCIETE FINANCIERE DE LACANCHE - SOFILAC, AR-
 NAY LE DUC, FRANCE:
 2,491,810, CANC. INT. CL. 11.
- SOCIETY FOR HUMAN RESOURCE MANAGEMENT,
 ALEXANDRIA, VA:
 2,264,940, COR. INT. CL. 42.
 2,925,410, COR. INT. CL. 35.
 3,081,294, COR. MULTIPLE CLASS, INT. CLS. 16 AND
 41.
 3,108,608, COR. MULTIPLE CLASS, INT. CLS. 16 AND
 41.
- SOCIETY FOR MARTIAL ARTS INSTRUCTION, NEW
 YORK, NY:
 4,153,825, PUB. 3-20-2012. INT. CL. 41.
- SOCIETY OF CRITICAL CARE MEDICINE, MOUNT PRO-
 SPECT, IL:
 4,154,463, INT. CL. 44.
- SOCIETY OF URODYNAMICS, FEMALE PELVIC MEDI-
 CINE & UROGENITAL RECONSTRUCTION, SCHAUM-
 BURG, IL:
 4,153,524, PUB. 3-20-2012. U.S. CL. 200.
- SOCIÉTÉ DES PRODUITS NESTLÉ S.A., 1800 VEVEY,
 SWITZERLAND:
 4,152,834, PUB. 3-20-2012. INT. CL. 5.
 4,152,843, PUB. 3-20-2012. INT. CL. 5.
 4,152,844, PUB. 3-20-2012. INT. CL. 5.
 4,152,845, PUB. 3-20-2012. INT. CL. 5.
- SOELLNER, RAND, CASHIERS, NC:
 4,156,063, INT. CL. 42.
- SOFIC CORPORATION, CHATTANOOGA, TN:
 1,750,690. REN. 5-1-12. INT. CL. 1.
- SOFTWARE FREEDOM CONSERVANCY, BROOKLYN, NY:
 4,153,569, PUB. 3-20-2012. INT. CL. 9.
- SOFTWARE PARADIGMS INTERNATIONAL GROUP LLC,
 ATLANTA, GA:
 4,152,597, PUB. 3-20-2012. MULTIPLE CLASS, INT. CLS.
 35 AND 42.
- SOFTWARE SERVICE AND DEVELOPMENT, INC., LONG
 BEACH, CA:
 4,152,769, PUB. 3-20-2012. INT. CL. 42.

SOFTWINK, INC., JACKSONVILLE, FL, DBA QUADRANT INFORMATION SECURITY:
4,156,021, INT. CL. 9.

SOLADIGM, INC., MILPITAS, CA:
4,154,117, PUB. 3-20-2012. MULTIPLE CLASS, INT. CLS. 9 AND 19.

SOLAR GROUP, INC., BUFFALO, NY:
4,155,547, INT. CL. 6.

SOLAR RATING & CERTIFICATION CORPORATION (SRCC), COCOA, FL:
4,153,378, PUB. 3-20-2012. U.S. CL. A.

SOLOMON-PAGE GROUP LLC, NEW YORK, NY TO SOLOMON-PAGE GROUP LLC, NEW YORK, NY:
2,493,675, CANC. INT. CL. 35.

SOLORZANO GIL, ALFONSO, IRAPUATO, MEXICO:
4,155,938, INT. CL. 32.

SOMERSET WAREHOUSING PLUS INC., SOMERSET, NJ, DBA SMART WORKS CONSUMER PRODUCTS:
4,152,132, PUB. 8-31-2010. INT. CL. 8.

SOMERVILLE BREWING COMPANY, SOMERVILLE, MA:
4,155,710, INT. CL. 32.

SOMMERS, ALLISON, PALMETTO BAY, FL:
4,154,682, INT. CL. 5.

SONAE - INDUSTRIA DE REVESTIMENTOS S.A., MAIA, PORTUGAL:
2,491,666, CANC. MULTIPLE CLASS, INT. CLS. 19 AND 27.

SONEPAR DISTRIBUTION NEW ENGLAND, INC., CANTON, MA:
4,153,515, PUB. 3-20-2012. INT. CL. 35.

SONGY3, LLC, AUSTIN, TX, DBA LAUGH LEARN COME-TRY:
4,155,342, INT. CL. 41.

SONIA RYKIEL CREATION ET DIFFUSION DE MODELES, FRANCE:
4,152,201, PUB. 3-20-2012. MULTIPLE CLASS, INT. CLS. 20, 24 AND 26.

SONOSITE, INC., BOTHELL, WA:
4,152,870, PUB. 3-20-2012. INT. CL. 10.

SONOVA HOLDING AG, SWITZERLAND:
4,152,383, PUB. 3-20-2012. INT. CL. 10.

SONY CORPORATION, TOKYO, JAPAN:
4,155,860, INT. CL. 9.
4,155,861, INT. CL. 9.

SONY MOBILE COMMUNICATIONS AB, LUND, SWEDEN:
3,007,247, CANC. INT. CL. 38.

SONY ONLINE ENTERTAINMENT LLC, SAN DIEGO, CA:
3,107,916, CANC. INT. CL. 41.

SOOK HAN LIM, SHANGHAI, CHINA, AKA MADDIE LIM:
4,154,106, PUB. 3-20-2012. INT. CL. 25.

SOPHIE JAWORSKI, NEW YORK, NY:
4,152,678, PUB. 3-20-2012. INT. CL. 25.

SOR, INC., LENEXA, KS:
2,493,420, CANC. INT. CL. 9.

SOSBEACON INC., BERKELEY, CA:
4,153,811, PUB. 3-20-2012. MULTIPLE CLASS, INT. CLS. 9 AND 42.

SOURCE ATLANTIQUE, INC., ENGLEWOOD CLIFFS, NJ:
2,558,873, REN. 4-27-12. MULTIPLE CLASS, INT. CLS. 29 AND 30.

SOURCECENTRIX, LLC, CALIFON, NJ, DBA HOBNOB ONLINE:
4,152,620, PUB. 3-20-2012. INT. CL. 9.

SOUTH BAY TRADING INC., ONTARIO, CA:
4,154,103, PUB. 3-20-2012. INT. CL. 9.
4,154,179, PUB. 3-20-2012. INT. CL. 9.
4,154,190, PUB. 3-20-2012. INT. CL. 9.
4,154,200, PUB. 3-20-2012. INT. CL. 9.
4,154,209, PUB. 3-20-2012. INT. CL. 9.

SOUTH COAST WINERY, INC., SANTA ANA, CA:
4,154,553, INT. CL. 33.

SOUTH CROSS TRADING COMPANY LLC, MEDFORD, NJ:
2,492,401, CANC. INT. CL. 29.

SOUTH MOON SALES, INC., BERLIN, MD:
4,155,113, INT. CL. 25.

SOUTHERN FRATTIRE, BRISTOL, VA:
4,153,400, PUB. 3-20-2012. INT. CL. 25.

SOUTHERN IMPERIAL, INC., ROCKFORD, IL:
4,152,079, PUB. 3-20-2012. MULTIPLE CLASS, INT. CLS. 6, 16 AND 20.

SOUTHSTAR ENGINEERING & CONSULTING, INC., RIVERSIDE, CA:
4,153,184, PUB. 3-20-2012. INT. CL. 42.

SOUTHWEST RESEARCH INSTITUTE, SAN ANTONIO, TX:
2,587,616, REN. 5-3-12. INT. CL. 42.

SOUTHWEST UNITED INDUSTRIES, INC., TULSA, OK:
1,683,275, REN. 5-1-12. INT. CL. 40.

SOUTHWESTERN ENERGY COMPANY, HOUSTON, TX:
4,152,719, PUB. 3-20-2012. INT. CL. 4.

SOVEREIGN MEDIA COMPANY, INC., MCLEAN, VA:
2,667,444, REN. 4-27-12. INT. CL. 16.

SOXLAND INDUSTRIAL, INC., HILLSIDE, NJ:
4,153,141, PUB. 3-20-2012. INT. CL. 25.
4,153,142, PUB. 3-20-2012. INT. CL. 25.

SP AFFAIRS LLC, BLOOMFIELD, NJ:
4,155,552, INT. CL. 45.

SP-GMBH & CO. KG, 50259 PULHEIM, FED REP GERMANY:
4,152,375, PUB. 3-20-2012. MULTIPLE CLASS, INT. CLS. 3, 11, 35, 41 AND 42.

SPACELABS HEALTHCARE, LLC, ISSAQUAH, WA:
2,565,605, REN. 4-29-12. INT. CL. 9.

SPANGLER, MARY, FULLERTON, CA:
4,155,179, MULTIPLE CLASS, INT. CLS. 41 AND 44.

SPANX, INC., ATLANTA, GA:
2,588,644, REN. 4-27-12. INT. CL. 25.
4,154,560, INT. CL. 25.

SPANX, INC., SUITE 1700, GA:
4,155,714, INT. CL. 41.

SPARC INTERNATIONAL, INC., CAMPBELL, CA:
1,737,259, REN. 5-2-12. INT. CL. 42.

SPARKHOUND, INC., BATON ROUGE, LA:
4,152,590, PUB. 3-20-2012. INT. CL. 42.
4,152,591, PUB. 3-20-2012. INT. CL. 42.

SPARKNOTES LLC, NEW YORK, NY:
2,492,182, CANC. MULTIPLE CLASS, INT. CLS. 38 AND 41.

SPECIAL SPRINGS S.R.L., ITALY:
4,152,336, PUB. 3-20-2012. MULTIPLE CLASS, INT. CLS. 6 AND 7.

SPECIALTY EQUIPMENT MARKET ASSOCIATION, DIAMOND BAR, CA:
1,684,768, REN. 4-27-12. INT. CL. 42.

SPECIALTY FASHION GROUP LTD, ALEXANDRIA NSW, AUSTRALIA:
4,152,575, PUB. 3-20-2012. MULTIPLE CLASS, INT. CLS. 25 AND 35.

SPECIALTY POLYMER COATINGS, INC., LANGLEY, B.C., CANADA:
4,152,484, PUB. 3-20-2012. INT. CL. 2.
4,152,485, PUB. 3-20-2012. INT. CL. 2.

SPECS SURFACE NANO ANALYSIS GMBH, FED REP GERMANY:
4,152,245, PUB. 3-20-2012. MULTIPLE CLASS, INT. CLS. 9, 41 AND 42.
4,152,247, PUB. 3-20-2012. MULTIPLE CLASS, INT. CLS. 9, 41 AND 42.

SPECTRA COLORS CORP., KEARNY, NJ:
2,708,560, REN. 5-3-12. INT. CL. 2.

SPEEDCAP, LLC, THOMASVILLE, PA:
4,155,114, INT. CL. 25.

SPEEDLINE S.R.L., 30036 SANTA MARIA DI SALA, ITALY:
2,561,033, REN. 5-2-12. INT. CL. 12.

SPIESS-URANIA CHEMICALS GMBH, D-20097 HAMBURG, FED REP GERMANY:
4,152,044, PUB. 3-20-2012. MULTIPLE CLASS, INT. CLS. 1 AND 5.

SPILO WORLDWIDE, INC., LOS ANGELES, CA, MEHAZ INTERNATIONAL, INC., THOUSAND OAKS, CA:
1,706,300, REN. 4-27-12. INT. CL. 8.

SPIN MASTER LTD., TORONTO ONTARIO, CANADA:
4,152,105, PUB. 3-20-2012. INT. CL. 28.

SPIRAC ENGINEERING AB, 211 35 MALMO, SWEDEN:
1,685,064, REN. 5-3-12. INT. CL. 7.

- SPIRAL BIOTECH, INC., NORWOOD, MA:
 2,497,004. REN. 4-27-12. INT. CL. 9.
- SPIRO INTERNATIONAL S.A., SWITZERLAND:
 4,152,256. PUB. 3-20-2012. MULTIPLE CLASS, INT. CLS.
 6, 7 AND 11.
- SPOON IT UP FROZEN YOGURT, LLC, INDEPENDENCE,
 OH:
 4,154,467. MULTIPLE CLASS, INT. CLS. 30 AND 43.
- SPOON, SANDRA, SAHUARITA, AZ:
 4,155,279. INT. CL. 14.
- SPORT ELLE, INC., NEW YORK, NY:
 2,998,708. CANC. INT. CL. 25.
- SPORTS ACCESSORIES TRADEMARKS HOLDING, LLC,
 ESSEX JUNCTION, VT:
 2,581,052. REN. 4-30-12. INT. CL. 25.
 2,581,052 NEW CERT. 6-5-2012. INT. CL. 25.
- SPORTS CAR CLUB OF AMERICA, INC., THE, TOPEKA,
 KS, AKA SCCA:
 1,704,885. REN. 4-30-12. INT. CL. 16.
- SPORTSBALLER LLC, STATELINE, NV:
 4,153,847. PUB. 3-20-2012. INT. CL. 41.
- SPORTSGIANT, LLC, CARLSBAD, CA:
 2,682,997. REN. 5-3-12. INT. CL. 35.
- SPORTSIDE, LLC, HUNTINGTON, NY:
 4,155,010. INT. CL. 42.
- SPORTSTEC LIMITED, WARRIEWOOD, NSW, AUSTRA-
 LIA:
 4,154,125. PUB. 3-20-2012. MULTIPLE CLASS, INT. CLS.
 35 AND 41.
- SPORTWORKS NORTHWEST, INC, WOODINVILLE, WA:
 4,155,654. MULTIPLE CLASS, INT. CLS. 6 AND 12.
- SPORTY K9, LTD., PHOENIX, AZ:
 2,998,657. CANC. INT. CL. 31.
- SPRIM USA, SAN FRANCISCO, CA, DBA SPRIM USA:
 4,154,155. PUB. 3-20-2012. MULTIPLE CLASS, INT. CLS.
 35 AND 42.
- SPRING AIR IP HOLDING, LLC, ELK GROVE VILLAGE, IL:
 2,998,935. CANC. INT. CL. 20.
- SPRINGBOARD DEVELOPMENT COMPANY INC., RO-
 CHESTER, MN:
 4,156,015. INT. CL. 40.
- SPRINGS CREATIVE PRODUCTS GROUP, LLC, ROCK
 HILL, SC:
 4,155,192. INT. CL. 24.
- SPRINT COMMUNICATIONS COMPANY L.P., OVERLAND
 PARK, KS:
 4,153,124. PUB. 3-20-2012. INT. CL. 36.
- SQUARE LEAF LANDSCAPE DESIGN LLC, NEW CA-
 NAAN, CT:
 4,155,231. INT. CL. 44.
- SQUARE-H BRANDS, INC., LOS ANGELES, CA:
 4,152,134. PUB. 3-20-2012. INT. CL. 29.
- SRI SPORTS LIMITED, KOBESH, HYOGO, JAPAN:
 4,155,314. INT. CL. 28.
- SRMX CAPITAL, LLC, ORLANDO, FL:
 4,154,162. PUB. 3-20-2012. INT. CL. 11.
- SSB TECHNOLOGY PTY LTD, SCORESBY VIC 3179, AUS-
 TRALIA:
 4,152,344. PUB. 3-20-2012. INT. CL. 10.
- ST MEDIA GROUP INTERNATIONAL, INC., CINCINNATI,
 OH:
 2,492,329. CANC. INT. CL. 9.
 2,492,330. CANC. INT. CL. 9.
 2,492,331. CANC. INT. CL. 9.
- ST. LOUIS CARDINALS, LLC, ST. LOUIS, MO:
 2,563,494. REN. 4-27-12. INT. CL. 28.
 2,565,213. REN. 5-2-12. INT. CL. 16.
- ST. LOUIS CARDINALS, LLC, ST LOUIS, MO:
 2,597,277. REN. 5-3-12. INT. CL. 25.
- ST. LOUIS COMMUNITY CREDIT UNION, ST. LOUIS, MO:
 4,155,721. INT. CL. 36.
- ST. NORBERT COLLEGE, INC., DE PERE, WI:
 4,153,631. PUB. 3-20-2012. INT. CL. 41.
- STABILIX CORPORATION, SAN ANTONIO, TX:
 4,153,829. PUB. 3-20-2012. INT. CL. 42.
- STANDARD & POOR'S FINANCIAL SERVICES LLC, NEW
 YORK, NY:
 1,763,543. REN. 5-1-12. U.S. CL. B.
- STANDARD LIFE INVESTMENTS LIMITED, EDINBURGH,
 EH2 2LL, UNITED KINGDOM:
 2,998,590. CANC. INT. CL. 36.
- STANDARD PARKING CORPORATION, CHICAGO, IL:
 4,153,268. PUB. 3-20-2012. INT. CL. 39.
- STANLEY FOSTER REED & ASSOCIATES, INC., CHARLES-
 TON, SC:
 2,493,314. CANC. INT. CL. 42.
 2,493,315. CANC. INT. CL. 42.
- STANOJEVIC, DEJAN, DOWNEY, CA:
 4,155,574. INT. CL. 25.
 4,155,629. MULTIPLE CLASS, INT. CLS. 25 AND 41.
- STANTON PUBLICATION SERVICES, INC., MINNEAPO-
 LIS, MN:
 2,647,883. REN. 4-29-12. INT. CL. 42.
- STARBUCKS CORPORATION, SEATTLE, WA, DBA STAR-
 BUCKS COFFEE COMPANY:
 4,153,316. PUB. 3-20-2012. MULTIPLE CLASS, INT. CLS.
 35 AND 36.
 4,154,234. PUB. 3-20-2012. INT. CL. 30.
- STARECASING INC., COLUMBUS, OH:
 4,152,527. PUB. 3-20-2012. INT. CL. 19.
- STARKEY HEARING FOUNDATION, THE, EDEN PRAIRIE,
 MN:
 2,696,086. REN. 5-2-12. INT. CL. 42.
- STARKEY LABORATORIES, INC., EDEN PRAIRIE, MN:
 4,154,102. PUB. 3-20-2012. INT. CL. 10.
- STARQUEST LEARNING SYSTEMS, INC., GOLDEN, CO:
 2,491,737. CANC. INT. CL. 41.
- STARRY LTD., QUARRY BAY, HONG KONG:
 4,154,284. INT. CL. 28.
- STARS AND STRIPES MARKETING LLC, JOHNSTOWN,
 CO:
 4,153,962. PUB. 3-20-2012. INT. CL. 16.
- START THE SHOW, LLC, WILMINGTON, DE:
 4,155,993. INT. CL. 16.
- STARTUP FLORIDA INC., SARASOTA, FL:
 4,153,562. PUB. 3-20-2012. INT. CL. 35.
- STATE OF IDAHO POTATO COMMISSION, EAGLE, ID:
 1,735,559. REN. 4-28-12. U.S. CL. A.
- STATESIDE MEDIA LIMITED, UNITED KINGDOM:
 4,152,409. PUB. 3-20-2012. MULTIPLE CLASS, INT. CLS.
 16, 35 AND 41.
- STATICWORX, INC., WATERTOWN, MA:
 4,155,195. INT. CL. 19.
- STAYSTAFFED TECHNOLOGIES, LLC, BOCA RATON, FL:
 4,042,933. COR. INT. CL. 35.
- STEC, INC., ANDERSON, SC:
 4,154,035. PUB. 3-20-2012. INT. CL. 35.
- STEEL CUT AUDIO LLC, NEW YORK, NY:
 4,153,280. PUB. 3-20-2012. INT. CL. 41.
- STEELBIRD GHETTO PROPERTIES LLC, SONOMA, CA:
 2,698,818. REN. 4-27-12. INT. CL. 33.
- STEIN MART BUYING CORP., JACKSONVILLE, FL:
 2,998,622. CANC. INT. CL. 35.
- STELTON A/S, DENMARK:
 4,152,221. PUB. 3-20-2012. MULTIPLE CLASS, INT. CLS. 8
 AND 21.
- STEMPNOWSKI, RICHARD, FORT MYERS, FL:
 4,154,085. PUB. 3-20-2012. INT. CL. 21.
- STERLING JEWELERS INC., AKRON, OH, KAY JEWELRY
 STORES, INC., WASHINGTON, DC:
 748,204. REN. 5-2-12. U.S. CL. 101 (INT. CL. 42).
- STERLING PUBLISHING CO., INC., NEW YORK, NY:
 4,154,525. INT. CL. 16.
- STEVEN CAMPS, HUNTINGTON BEACH, CA, DBA RKG
 CAMPS:
 4,155,591. INT. CL. 3.
- STEVEN PRICE, MONROVIA, CA, DBA TECH ROCK-
 STARS:
 4,152,932. PUB. 3-20-2012. INT. CL. 42.
- STEVENS, JESSICA, TEMECULA, CA, DBA DESIGN SAV-
 VY:
 4,153,188. PUB. 3-20-2012. INT. CL. 42.
- STEWART, APRIL WADDELL, FRANKLIN, TN:
 2,675,626. REN. 4-27-12. INT. CL. 25.
- STIEFEL LABORATORIES, INC., WILMINGTON, DE:
 2,492,970. CANC. INT. CL. 5.

STIRLING FOODS, INC., KENT, WA:
2,492,239, CANCELLATION INT. CL. 32.

STOCK DISTRIBUTORS, INC., SARASOTA, FL:
4,153,686, PUB. 3-20-2012. INT. CL. 41.

STOCKWELL COMMUNICATIONS LLP, LONDON, UNITED KINGDOM:
4,155,950, INT. CL. 35.

STOKELY-VAN CAMP, INC., CHICAGO, IL:
4,155,001, INT. CL. 41.

STONE STREET CAPITAL, LLC, BETHESDA, MD:
4,153,656, PUB. 3-20-2012. INT. CL. 36.

STONEWALL KITCHEN, LLC, YORK, ME:
2,585,068, REN. 5-1-12. MULTIPLE CLASS, INT. CLS. 29 AND 30.

STORM SOLUTIONS, INC., ESSEX, CT:
4,155,350, INT. CL. 19.

STORMES, SEAN, LENEXA, KS:
4,155,275, MULTIPLE CLASS, INT. CLS. 9, 16, 35, 38 AND 41.

STORYMANAGER, INC., HONOLULU, HI:
4,153,838, PUB. 3-20-2012. INT. CL. 35.

STOVER, COREY, ANACOCO, LA:
4,153,732, PUB. 3-20-2012. INT. CL. 1.

STOXX AG, SWITZERLAND:
4,152,187, PUB. 3-20-2012. MULTIPLE CLASS, INT. CLS. 9, 35, 36 AND 41.

STRAIGHT ARROW PRODUCTS, INC., BETHLEHEM, PA:
2,610,534, REN. 5-3-12. INT. CL. 5.
2,639,965, REN. 5-3-12. INT. CL. 3.

STRATEGIC EXPRESSIONS, LLC, GAINESVILLE, VA:
4,154,039, PUB. 3-20-2012. INT. CL. 38.

STRATEGIC SYSTEMS & TECHNOLOGY CORP., SUWANEE, GA:
4,154,351, INT. CL. 9.

STRATEGICELEVATION, LLC, PALATINE, IL:
2,998,573, CANCELLATION INT. CL. 35.

STRAWBERRY DESIGN LTD, UNITED KINGDOM:
4,152,248, PUB. 3-20-2012. MULTIPLE CLASS, INT. CLS. 16 AND 18.

STREAMING MEDIA CLOUD, INC., PORTLAND, OR:
3,972,100, CANCELLATION INT. CL. 42.

STREAMZAP, INC., HOOD RIVER, OR:
2,599,329, REN. 4-30-12. INT. CL. 9.

STREETCARSHOPS.COM, LLC, PRAIRIEVILLE, LA:
4,155,199, INT. CL. 35.

STRICKLAND, RICHARD, D., MOORESVILLE, NC:
4,153,606, PUB. 3-20-2012. INT. CL. 9.

STRICKLING, JONATHAN S., SHAKER HTS., OH, DBA THE DRIVE INSIDE:
4,153,370, PUB. 3-20-2012. INT. CL. 25.

STRIKE HOLDINGS LLC, NEW YORK, NY:
4,154,210, PUB. 3-20-2012. MULTIPLE CLASS, INT. CLS. 25, 41 AND 43.

STRUCTURED INVESTMENT MANAGEMENT, INC., NEW YORK, NY:
4,155,713, INT. CL. 36.

STRYKER CORPORATION, KALAMAZOO, MI:
4,154,146, PUB. 3-20-2012. INT. CL. 10.

STRYKER INSTRUMENTS DIVISION, KALAMAZOO, MI:
2,563,317, REN. 5-3-12. INT. CL. 10.

STRYKER-INDIGO PUBLISHING COMPANY, INC., LEVITOWN, NY, DBA STRYKER-INDIGO NEW YORK:
4,155,854, INT. CL. 25.

STUDIO HAMBURG DOCLIGHTS GMBH, FED REP GERMANY:
4,152,316, PUB. 3-20-2012. MULTIPLE CLASS, INT. CLS. 9, 35, 38, 40, 41 AND 45.

STYLE HUNTERS, LLC, HIGH POINT, NC:
4,155,337, MULTIPLE CLASS, INT. CLS. 35 AND 42.

STYLUS MEDIA GROUP LIMITED, LONDON, UNITED KINGDOM:
4,152,479, PUB. 3-20-2012. INT. CL. 35.

STYMIE CANINE CANCER FOUNDATION, AURORA, CO:
4,155,980, INT. CL. 25.

STYPE BROTHERS, INC., POMPANO BEACH, FL:
2,493,483, CANCELLATION INT. CL. 25.

SUAN FARMA, INC., HACKENSACK, NJ:
4,154,811, INT. CL. 1.

SUAREZ H. S.A., BILBAO, VIZCAYA, SPAIN:
4,065,878 NEW CERT. 6-5-2012. MULTIPLE CLASS, INT. CLS. 14 AND 25.

SUCCESS DNA, INC, MINDEN, NV:
2,998,927, CANCELLATION MULTIPLE CLASS, INT. CLS. 16 AND 35.

SUCCESS SCIENCES, INC., LUTZ, FL:
2,491,832, CANCELLATION INT. CL. 41.

SUD-CHEME, INC., LOUISVILLE, KY, UNITED CATALYSTS INC., LOUISVILLE, KY:
1,701,055, REN. 5-3-12. INT. CL. 1.

SUGAR PUBLISHING INCORPORATED, SAN FRANCISCO, CA:
4,155,169, INT. CL. 35.

SUHR, WALTER, HOUSTON, TX:
2,492,537, CANCELLATION INT. CL. 41.

SUITER, DONALD, FERGUS FALLS, MN:
4,152,940, PUB. 3-20-2012. INT. CL. 21.

SUMIDA FLEXIBLE CONNECTIONS GMBH, 01454 RADEBERG, FED REP GERMANY:
4,152,440, PUB. 3-20-2012. INT. CL. 9.

SUMITOMO BAKELITE CO., LTD., JAPAN:
4,152,427, PUB. 3-20-2012. INT. CL. 10.

SUMITOMO CHEMICAL CO., LTD., TOKYO, JAPAN:
4,154,276, INT. CL. 1.

SUMITOMO RUBBER INDUSTRIES, LTD, KOBE 651, JAPAN:
2,570,144, REN. 5-1-12. INT. CL. 12.

SUMMERS RICHELLE J, MURRIETA, CA:
4,155,970, INT. CL. 21.

SUMMIT ENTERTAINMENT, LLC, SANTA MONICA, CA:
4,154,579, INT. CL. 25.
4,154,585, INT. CL. 20.
4,154,617, INT. CL. 20.
4,154,618, INT. CL. 30.
4,155,840, INT. CL. 18.
4,155,845, INT. CL. 26.
4,155,846, INT. CL. 45.

SUN-MAID GROWERS OF CALIFORNIA, KINGSBURG, CA:
2,568,104, REN. 4-30-12. MULTIPLE CLASS, INT. CLS. 29 AND 30.

SUNBURST FARMS, INC., MIAMI, FL:
4,155,551, INT. CL. 31.

SUNDANCE MARKETING SOLUTIONS, INC., LAS VEGAS, NV:
4,155,645, INT. CL. 27.
4,155,646, INT. CL. 27.

SUNDANCE REHABILITATION CORPORATION, ALBUQUERQUE, NM:
4,152,838, PUB. 3-20-2012. MULTIPLE CLASS, INT. CLS. 35, 36 AND 41.
4,152,913, PUB. 3-20-2012. MULTIPLE CLASS, INT. CLS. 35, 36 AND 41.

SUNDER BIOMEDICAL TECH. CO., LTD., TAICHUNG CITY, TAIWAN:
2,555,597, REN. 4-30-12. INT. CL. 10.

SUNERGETICS, LLC, SEDONA, AZ:
4,153,175, PUB. 3-20-2012. INT. CL. 3.
4,153,195, PUB. 3-20-2012. INT. CL. 3.

SUNI SCHULZE, GREENSBORO, NC:
4,155,874, INT. CL. 25.

SUNKIST GROWERS, INC., SHERMAN OAKS, CA:
4,154,145, PUB. 3-20-2012. INT. CL. 35.

SUNLIGHT MANUFACTURING, INC., OTTAWA, KS:
4,154,899, INT. CL. 11.

SUNLOGICS ENERGY SOLUTIONS, LLC, MODESTO, CA:
4,153,670, PUB. 3-20-2012. INT. CL. 6.

SUNMARKS, LLC, WILMINGTON, DE:
4,155,133, INT. CL. 4.
4,155,321, INT. CL. 4.

SUNSET SLEEP CENTER INC., WILMINGTON, NC:
4,153,559, PUB. 3-20-2012. INT. CL. 35.

SUNSHINE MILLS, INC., RED BAY, AL:
2,655,126, REN. 5-3-12. INT. CL. 31.

SUNSTAR AMERICAS, INC., CHICAGO, IL:
2,564,536, REN. 5-3-12. INT. CL. 21.

- SUNTERRA FOOD CORPORATION, CALGARY AB, CANADA:
2,562,023. REN. 5-3-12. MULTIPLE CLASS, INT. CLS. 29 AND 31.
- SUPER DUPER INC., GREENVILLE, SC, DBA SUPER DUPER PUBLICATIONS:
4,153,376, PUB. 3-20-2012. INT. CL. 41.
- SUPER DUPER, INC., GREENVILLE, SC, DBA SUPER DUPER PUBLICATIONS:
4,154,036, PUB. 3-20-2012. INT. CL. 28.
- SUPER PRODUCTS LLC, NEW BERLIN, WI:
4,155,643, INT. CL. 7.
- SUPER T EVENTS, LLC, DE PERE, WI:
4,153,714, PUB. 3-20-2012. INT. CL. 41.
- SUPERMEDIA LLC, DFW AIRPORT, TX:
4,154,624, INT. CL. 35.
- SUPRACOR, INC., SAN JOSE, CA:
4,153,359, PUB. 3-20-2012. MULTIPLE CLASS, INT. CLS. 12, 20, 21, 27 AND 28.
- SUPREME NUT & CANDY COMPANY, CINCINNATI, OH:
1,684,546. REN. 4-27-12. INT. CL. 29.
- SUPREME OIL COMPANY, ENGLEWOOD, NJ:
1,685,475. REN. 5-2-12. INT. CL. 29.
- SURVEY PLANET, LLC, SANTA MONICA, CA:
4,155,124, MULTIPLE CLASS, INT. CLS. 35 AND 42.
4,155,830, MULTIPLE CLASS, INT. CLS. 35 AND 42.
- SURVEY PLANET, LLC., SANTA MONICA, CA:
4,155,123, MULTIPLE CLASS, INT. CLS. 35 AND 42.
- SUSAN G. KOMEN BREAST CANCER FOUNDATION, THE, DALLAS, TX:
2,560,355. REN. 4-30-12. INT. CL. 36.
- SUSSMAN-AUTOMATIC CORPORATION, LONG ISLAND CITY, NY:
4,156,044, INT. CL. 42.
- SUSTAINABLE COMMUNITY DEVELOPMENT, L.L.C. D/B/A SCD PROBIOTICS, KANSAS CITY, MO:
4,153,019, PUB. 3-20-2012. INT. CL. 1.
- SUZI Q BAIL BONDS INC., ROCKVILLE, MD:
4,152,675, PUB. 3-20-2012. INT. CL. 36.
- SUZUKI TECHNO AMERICA, INC., CHERRY HILL, NJ:
2,998,698, CANC. INT. CL. 9.
- SWAG OUTDOORS, JACKSON, MS:
4,153,868, PUB. 3-20-2012. INT. CL. 25.
- SWALLOW, JAMES, WOOD DALE, IL:
4,155,557, INT. CL. 20.
- SWAROVSKI-OPTIK KG, AUSTRIA:
4,152,319, PUB. 3-20-2012. INT. CL. 9.
- SWAY-A-WAY INC., CHATSWORTH, CA:
2,690,646. REN. 4-27-12. INT. CL. 12.
- SWEENEY GROUP, INC., WHEELING, WV:
2,676,932. REN. 4-27-12. INT. CL. 41.
- SWEETPINE RECORDS, LLC, MIAMI, FL:
4,152,680, PUB. 3-20-2012. INT. CL. 41.
- SWI VALVE CO., LTD., KYUNGKI-DO, REPUBLIC OF KOREA:
2,560,978. REN. 5-3-12. INT. CL. 6.
- SWIFT BIOSCIENCES, INC., ANN ARBOR, MI:
4,154,985, INT. CL. 1.
4,155,252, INT. CL. 1.
4,155,253, INT. CL. 1.
- SWIZZLES HOLDINGS, LLC, BRIDGEPORT, CT:
4,154,263, INT. CL. 43.
- SWOPE, GAILE, DOUGLAS, AK:
4,153,738, PUB. 3-20-2012. INT. CL. 25.
- SYMONS INTERNATIONAL GROUP, INC., INDIANAPOLIS, IN:
2,493,318, CANC. INT. CL. 36.
- SYMPHONIC SOURCE, DALLAS, TX:
4,153,939, PUB. 3-20-2012. INT. CL. 42.
4,153,940, PUB. 3-20-2012. INT. CL. 42.
4,154,157, PUB. 3-20-2012. INT. CL. 42.
- SYMRISE AG, HOLZMINDEN, FED REP GERMANY:
4,152,922, PUB. 3-20-2012. INT. CL. 42.
- SYMRISE AG, HOLZMINDEN 37603, FED REP GERMANY:
4,152,981, PUB. 3-20-2012. INT. CL. 42.
- SYNCOAL SOLUTIONS INC., CENTENNIAL, CO, ROSEBUD SYNCOAL PARTNERSHIP, BILLINGS, MT:
1,746,587. REN. 5-3-12. INT. CL. 42.
- SYNERON BEAUTY INC., CAMBRIDGE, ONTARIO, CANADA:
4,155,636, INT. CL. 10.
- SYNTEL, LLC, JONESBORO, AR:
4,152,143, PUB. 3-20-2012. INT. CL. 9.
- SYNTHESIS INTELLECTUAL PROPERTY, LLC, EVANSTON, IL, AKA SYNTHESIS IP:
4,153,506, PUB. 3-20-2012. INT. CL. 45.
- SYSCO GUEST SUPPLY, LLC, MONMOUTH JUNCTION, NJ:
4,154,296, INT. CL. 25.
- SYSTAGENIX WOUND MANAGEMENT (US), INC., NEW YORK, NY:
2,636,375. REN. 4-30-12. INT. CL. 5.
- SYSTEM CAPITAL CORPORATION, HOUSTON, TX:
2,492,193, CANC. INT. CL. 36.
- SYSTEM 3R INTERNATIONAL AB, S-162 50 VALLINGBY, SWEDEN:
2,643,839. REN. 5-1-12. INT. CL. 7.
- SYSTEMS PAVING, INC., NEWPORT BEACH, CA:
2,493,359, CANC. INT. CL. 37.
- SYX SERVICES INC., MIAMI, FL:
4,153,671, PUB. 3-20-2012. INT. CL. 41.
- SZYMANSKI, ERIK, CANONSBURG, PA:
4,155,366, INT. CL. 35.
- T.H.Y. AND ASSOCIATES, INC., KEAAU, HI:
4,155,233, INT. CL. 18.
- T.R. RIZZUTO PIZZA CRUST, INC., SPOKANE, WA:
4,153,292, PUB. 3-20-2012. INT. CL. 30.
- T/M INDUSTRIAL SUPPLY, INC., ERIE, PA:
1,754,887. REN. 5-2-12. INT. CL. 7.
- TÜRKIYE VAKIFLAR BANKASI T.A.O., TURKEY:
4,152,224, PUB. 3-20-2012. INT. CL. 36.
- TA HYDRONICS AKTIEBOLAG, LJUNG, S-524, SWEDEN:
2,568,793. REN. 5-3-12. INT. CL. 11.
- TAB COMPUTER SYSTEMS, INC., EAST HARTFORD, CT:
2,557,830. REN. 4-27-12. INT. CL. 9.
- TABATA CO., LTD., SUMIDA-KU, TOKYO 130, JAPAN:
2,492,846, CANC. INT. CL. 28.
- TABBY'S PLACE: A CAT SANCTUARY, INC., RINGOES, NJ:
2,636,909. REN. 5-3-12. INT. CL. 42.
- TABLETOPS UNLIMITED, INC., CARSON, CA:
4,155,532, INT. CL. 21.
- TACITLOGIC, INC., DENVER, CO:
4,153,603, PUB. 3-20-2012. INT. CL. 45.
- TACKETT HOLDINGS, INC., HOPKINSVILLE, KY, DBA ISHOP-X:
4,154,755, INT. CL. 16.
- TACTICA INTERNATIONAL, INC., NEW YORK, NY TO TACTICA INTERNATIONAL, INC., NEW YORK, NY:
2,492,956, CANC. INT. CL. 10.
- TAGASAURIS, INC., NEW YORK, NY:
4,153,888, PUB. 3-20-2012. INT. CL. 42.
- TAIWAN CHLORELLA MANUFACTURING CO. LTD., TAIPEI, TAIWAN:
2,493,416, CANC. INT. CL. 5.
- TAIZHOU BAILLY CHEMICAL CO., LTD., JIANGSU PROVINCE, CHINA:
4,152,328, PUB. 3-20-2012. INT. CL. 1.
- TAKE 'EM OFFS, LTD., NEW YORK, NY:
4,154,984, INT. CL. 25.
- TAKE 5 SOLUTIONS, LLC, BOCA RATON, FL:
4,152,841, PUB. 3-20-2012. MULTIPLE CLASS, INT. CLS. 35 AND 42.
- TAKIZA, LLC, SAN ANTONIO, TX:
4,155,295, INT. CL. 43.
- TALENT MUSIC GROUP, INC., STANTON, CA:
4,152,052, PUB. 3-20-2012. INT. CL. 9.
- TALK TECHNOLOGIES INCORPORATED, VICTORIA BRITISH COLUMBIA, CANADA:
2,677,825. REN. 5-3-12. INT. CL. 40.
- TAMARACK VILLAGE SHOPPING CENTER, EDINA, MN:
2,703,566. REN. 4-27-12. INT. CL. 36.
- TANDARICH, MICHAEL R, KENNETT SQUARE, PA, PA:
4,155,014, INT. CL. 25.
- TANGI-PAC, L.L.C., PONCHATOULA, LA:
2,562,417. REN. 5-2-12. INT. CL. 31.

TAP WORLDWIDE, LLC, COMPTON, CA:
4,155,435, INT. CL. 12.

TAPICU, INCORPORATED, LONG BEACH, CA:
2,584,860. REN. 4-27-12. INT. CL. 42.

TAQSEEM, INC., SACRAMENTO, CA:
4,154,078, PUB. 3-20-2012. INT. CL. 34.

TARAN FAMILY, LLC, SERIES 13, SAN FRANCISCO, CA:
2,636,714. REN. 5-2-12. MULTIPLE CLASS, INT. CLS. 36 AND 37.

TARGET BRANDS, INC., MINNEAPOLIS, MN:
3,663,727, AM. INT. CL. 35.
4,155,719, INT. CL. 20.

TARGUS GROUP INTERNATIONAL, INC., ANAHEIM, CA:
4,154,282, INT. CL. 9.

TARR INC., SIOUX FALLS, SD:
2,589,793. REN. 5-2-12. INT. CL. 42.

TARSUS GROUP, PLC, HAMMERSMITH, LONDON, ENGLAND:
2,561,292. REN. 5-2-12. MULTIPLE CLASS, INT. CLS. 16 AND 35.

TASCOTT CAPITAL, LLC, JACKSONVILLE, FL:
4,152,682, PUB. 3-20-2012. INT. CL. 41.

TASSERON SENSORS, INC., WILLIAMSPORT, PA:
4,155,099, INT. CL. 9.
4,155,100, INT. CL. 9.
4,155,101, INT. CL. 9.
4,155,102, INT. CL. 9.
4,155,103, INT. CL. 9.
4,155,104, INT. CL. 9.

TASTY COCKTAILS, LLC, HENDERSON, NV:
4,154,269, INT. CL. 33.

TBH TECHNOLOGY LLC, PLEASANTON, CA:
4,153,390, PUB. 3-20-2012. MULTIPLE CLASS, INT. CLS. 42 AND 44.

TCI INTERNET LLC, RAMSEY, NJ:
2,561,978. REN. 5-2-12. INT. CL. 35.
2,570,233. REN. 5-2-12. INT. CL. 35.

TDC A/S, DENMARK:
2,998,368.

TEACHERS-TEACHERS.COM, INC., COLUMBIA, MD:
2,577,300. REN. 5-2-12. INT. CL. 35.

TEAM INTERNATIONAL MUSIC CO., LTD., KUAN-HSI-CHEN, HSIN-CHU-HSIEN, TAIWAN:
2,593,730. REN. 4-27-12. INT. CL. 15.

TEAM TCT, LLC, SPRING, TX:
4,155,948, INT. CL. 41.

TEAMBACKPACK, SAN RAMON, CA:
4,153,805, PUB. 3-20-2012. INT. CL. 41.

TECHLINE USA, LLC, MADISON, WI:
2,999,064, CANC. INT. CL. 20.

TECHNOLOGIES INTERACTIVES MEDIAGRIF INC./MEDIAGRIF INTERACTIVE TECHNOLOGIES INC., LONGUEUIL, QUÉBEC, CANADA:
2,699,044. REN. 4-27-12. INT. CL. 35.

TECILLA COS-MED UG, GERETSRIED, FED REP GERMANY:
4,153,985, PUB. 3-20-2012. INT. CL. 10.

TECO DIAGNOSTICS, ANAHEIM, CA:
4,153,486, PUB. 3-20-2012. INT. CL. 5.

TEDESCHI FOOD SHOPS, INC, ROCKLAND, MA:
2,506,622. REN. 5-1-12. INT. CL. 35.

TEDKO, ROCKVILLE, CT, AKA HANGTIME HOT SAUCE:
4,152,684, PUB. 3-20-2012. INT. CL. 30.

TEEPLES, JILL, HERMOSA BEACH, CA:
4,153,471, PUB. 3-20-2012. INT. CL. 42.

TEGA TECHNOLOGIES, LLC, IRVINE, CA:
4,153,337, PUB. 3-20-2012. INT. CL. 42.

TEIJIN KABUSHIKI KAISHA (TEIJIN LIMITED), CHUOKU, OSAKA, JAPAN:
2,492,446, CANC. INT. CL. 24.

TEKNION LIMITED, TORONTO, ONTARIO, CANADA, TEKNION FURNITURE SYSTEMS LIMITED, TORONTO, ONTARIO, CANADA:
2,562,110. REN. 5-3-12. INT. CL. 20.

TELCARE, INC., BETHESDA, MD:
4,155,214, INT. CL. 10.
4,155,215, INT. CL. 10.

TELEBRANDS CORP., FAIRFIELD, NJ:
4,155,503, INT. CL. 3.

TELECOMMUNICATION SYSTEMS, INC., ANNAPOLIS, MD:
4,155,484, INT. CL. 41.
4,155,487, INT. CL. 42.

TELMETRICS, INC., MISSISSAUGA, ONTARIO, CANADA:
4,153,574, PUB. 3-20-2012. INT. CL. 35.

TEMPLE UNIVERSITY OF THE COMMONWEALTH SYSTEM OF HIGHER EDUCATION, PHILADELPHIA, PA:
2,595,177. REN. 5-2-12. INT. CL. 41.

TENNESSEE MEMBERS 1ST FEDERAL CREDIT UNION, OAK RIDGE, TN:
2,562,221. REN. 5-2-12. MULTIPLE CLASS, INT. CLS. 16, 36 AND 41.

TENNIS CORPORATION OF AMERICA, CHICAGO, IL:
1,685,714. REN. 4-30-12. INT. CL. 42.

TEO PET L.L.C., LITTLETON, CO, DBA TEOPET:
4,152,887, PUB. 3-20-2012. INT. CL. 31.

TERAFORMA HEALTH, INC., HOUSTON, TX:
2,491,816, CANC. INT. CL. 5.

TERAGRO INC., CALGARY, CANADA, WEED-MASTER WESTERN, INC., REGINA, SASKATCHEWAN, S4P 3J8, CANADA:
2,566,359. REN. 5-1-12. INT. CL. 5.

TERAMASU.COM LLC, CLEARWATER, FL, DBA TERAMASU ACCESSORIES AND TERAMASU LLC, PINEHURST, NC:
4,153,688, PUB. 3-20-2012. MULTIPLE CLASS, INT. CLS. 14, 18 AND 25.

TERRY ASPHALT MATERIALS INC., HAMILTON, OH:
2,492,480, CANC. INT. CL. 37.

TERRY D KROLL, ALISO VIEJO, CA, DBA MAXIM MANUFACTURING & MARKETING:
4,155,024, INT. CL. 32.

TESLA S.R.L., ITALY:
4,152,161, PUB. 12-28-2010. MULTIPLE CLASS, INT. CLS. 7 AND 9.

TESSILFORM SPA, I-50013 CAMPI BISENZIO (FI), ITALY:
4,152,222, PUB. 12-13-2011. MULTIPLE CLASS, INT. CLS. 9, 14, 18 AND 25.

TETRA TECHNOLOGIES, INC., THE WOODLANDS, TX:
4,152,969, PUB. 3-20-2012. INT. CL. 7.

TEVRON, LLC, BEDFORD, NH:
2,690,002. REN. 4-30-12. MULTIPLE CLASS, INT. CLS. 9 AND 42.

TEXAA, FRANCE:
4,152,293, PUB. 3-20-2012. MULTIPLE CLASS, INT. CLS. 17, 20 AND 24.

TEXAS HOME-LAND REALTY, MASON, TX:
4,152,815, PUB. 3-20-2012. INT. CL. 36.

TEXAS INDUSTRIES, INC., DALLAS, TX:
4,155,974, INT. CL. 19.

TEXCO UNLIMITED, INC., BRENHAM, TX:
2,491,662, CANC. INT. CL. 7.

TEXT APPEAL LIMITED, LONDON, UNITED KINGDOM:
4,155,829, INT. CL. 35.

TEXTILE HI TEC, SAINT-PONS, FRANCE:
4,152,785, PUB. 1-24-2012. MULTIPLE CLASS, INT. CLS. 5 AND 10.

TFG, INC., IRVINE, CA:
4,152,762, PUB. 3-20-2012. INT. CL. 41.

TGIB MARKETING INC., ROCHESTER, NY:
4,153,640, PUB. 3-20-2012. INT. CL. 28.

TGS JEWELERS, LLC, SYOSSET, NY:
4,153,669, PUB. 3-20-2012. INT. CL. 14.

THAI WORLD IMPORT & EXPORT CO., LTD., BANGKOK 10120, THAILAND:
2,646,344. REN. 5-1-12. INT. CL. 30.

THAYER, LEE, FLAT ROCK, NC:
2,493,083, CANC. MULTIPLE CLASS, INT. CLS. 9, 16 AND 41.

THE ALLAN CANDY COMPANY LIMITED, MISSISSAUGA, ONTARIO, CANADA, ALLAN CANDY INTERNATIONAL INC., HAMILTON, ONTARIO L8N 3G9, CANADA:
1,718,452. REN. 5-1-12. INT. CL. 30.

- THE ALUMINUM ASSOCIATION INC., ARLINGTON, VA:
4,154,019, PUB. 3-20-2012. INT. CL. 35.
- THE ARELI GROUP, LLC, BLOOMSBURY, NJ:
4,155,137, MULTIPLE CLASS, INT. CLS. 9 AND 35.
- THE ARGEN CORPORATION, SAN DIEGO, CA:
2,492,395, CANC. INT. CL. 5.
- THE ART OF YING, BEVERLY HILLS, CA:
4,153,352, PUB. 3-20-2012. INT. CL. 41.
- THE ASSOCIATION FOR CORPORATE GROWTH, INC., CHICAGO, IL:
4,155,333, INT. CL. 41.
- THE BAILEY COMPANY, LLLP, GOLDEN, CO:
4,155,079, MULTIPLE CLASS, INT. CLS. 35 AND 36.
- THE BANK OF EAST ASIA, LIMITED, CENTRAL HONG KONG, HONG KONG:
4,154,439, MULTIPLE CLASS, INT. CLS. 16 AND 36.
- THE BEASLEY FIRM, LLC, PHILADELPHIA, PA:
4,153,633, PUB. 3-20-2012. INT. CL. 45.
- THE BEST OF ORGANIC LLC, WEST BLOOMFIELD, MI:
4,155,075, INT. CL. 41.
- THE BETTER FOR BRIAN FOUNDATION, SAND SPRINGS, OK, DBA DEADTOWN CLOTHING COMPANY:
4,154,016, PUB. 3-20-2012. INT. CL. 25.
- THE BOARD OF REGENTS OF THE UNIVERSITY OF WISCONSIN SYSTEM, MADISON, WI:
4,153,567, PUB. 3-20-2012. INT. CL. 41.
- THE BOEING COMPANY, SEAL BEACH, CA:
2,635,413, REN. 4-30-12. INT. CL. 42.
- THE BRITISH COMPUTER SOCIETY, SWINDON SN2 1FA, UNITED KINGDOM:
4,152,167, PUB. 3-20-2012. MULTIPLE CLASS, INT. CLS. 16, 35, 38, 41 AND 42.
- THE BUILDERS EXCHANGE, INC., VALLEY VIEW, OH:
4,153,520, PUB. 3-20-2012. INT. CL. 9.
- THE BURCHARD GROUP LLC, PORTLAND, OR:
4,152,934, PUB. 3-20-2012. MULTIPLE CLASS, INT. CLS. 9, 16, 35 AND 41.
4,152,935, PUB. 3-20-2012. MULTIPLE CLASS, INT. CLS. 9, 16, 35 AND 41.
4,152,937, PUB. 3-20-2012. MULTIPLE CLASS, INT. CLS. 9, 16, 35 AND 41.
- THE BUREAU OF NATIONAL AFFAIRS, INC., ARLINGTON, VA:
2,568,708, REN. 4-27-12. INT. CL. 42.
2,568,708, CANC. INT. CL. 16.
- THE BURTON CORPORATION, BURLINGTON, VT:
4,155,909, INT. CL. 25.
- THE CANCER RESEARCH INSTITUTE, NEW YORK, NY:
4,154,552, MULTIPLE CLASS, INT. CLS. 41 AND 42.
- THE CARTOON NETWORK, INC., ATLANTA, GA:
2,581,434, REN. 4-30-12. INT. CL. 20.
- THE CHANGE GROUP INTERNATIONAL PLC, LONDON W1H 5EP, UNITED KINGDOM:
4,152,502, PUB. 3-20-2012. INT. CL. 36.
- THE CHICAGO LIGHTHOUSE FOR PEOPLE WHO ARE BLIND OR VISUALLY IMPAIRED, CHICAGO, IL:
4,153,845, PUB. 3-20-2012. MULTIPLE CLASS, INT. CLS. 35, 41 AND 44.
- THE CHRISTIAN AND MISSIONARY ALLIANCE, COLORADO SPRINGS, CO:
1,195,712, REN. 5-3-12. INT. CL. 16.
- THE CHUBB CORPORATION, WARREN, NJ:
4,154,232, PUB. 3-20-2012. INT. CL. 36.
- THE CLEAN PLATE CLUB, INC., GRANGER, IN:
4,153,183, PUB. 3-20-2012. INT. CL. 43.
4,153,185, PUB. 3-20-2012. INT. CL. 43.
- THE CLOROX COMPANY, OAKLAND, CA:
4,155,638, INT. CL. 3.
- THE COILED SNAKE, LLC, FAIRFAX, VA:
4,153,035, PUB. 12-13-2011. MULTIPLE CLASS, INT. CLS. 13 AND 40.
- THE COLLEGE OF WILLIAM AND MARY IN VIRGINIA, WILLIAMSBURG, VA:
4,153,257, PUB. 3-20-2012. INT. CL. 35.
- THE COLUMBUS ZOOLOGICAL PARK ASSOCIATION, POWELL, OH:
3,202,141, COR. INT. CL. 41.
- THE COMFORT CANDLE COMPANY, L.C., COMFORT, TX:
4,154,307, INT. CL. 4.
- THE CONDITIONALS, NORTH HILLS, NY:
4,153,094, PUB. 3-20-2012. INT. CL. 41.
- THE CONSTRUCTION USERS ROUNDTABLE, CINCINNATI, OH:
4,153,677, PUB. 3-20-2012. INT. CL. 35.
- THE CONTAINER STORE, INC., COPPELL, TX:
4,153,788, PUB. 3-20-2012. INT. CL. 35.
- THE COUNTRY VINTNER, ASHLAND, VA:
4,154,014, PUB. 3-20-2012. INT. CL. 35.
4,154,015, PUB. 3-20-2012. INT. CL. 35.
- THE CROSBY GROUP LLC, TULSA, OK, THOMAS LAUGHLIN COMPANY, THE, PORTLAND, ME:
559,141, REN. 4-27-12. U.S. CL. 13 (INT. CL. 6).
- THE CUPCAKE DELIVERS, FAIRFAX, VA:
4,153,099, PUB. 3-20-2012. INT. CL. 39.
- THE CURVON CORPORATION, TINTON FALLS, NJ:
4,153,719, PUB. 3-20-2012. INT. CL. 18.
4,153,720, PUB. 3-20-2012. INT. CL. 18.
4,153,723, PUB. 3-20-2012. INT. CL. 18.
4,153,731, PUB. 3-20-2012. INT. CL. 18.
- THE DENTISTS WIFE HOLDINGS LLC, DUNEDIN, FL:
4,153,409, PUB. 3-20-2012. INT. CL. 35.
- THE DOW CHEMICAL COMPANY, MIDLAND, MI:
3,204,819, CANC. INT. CL. 17.
4,154,481, INT. CL. 19.
- THE FIELD GENERALS, LLC, ATLANTA, GA:
2,998,645, CANC. INT. CL. 36.
- THE FORUM CORPORATION OF NORTH AMERICA, BOSTON, MA:
4,155,656, INT. CL. 41.
- THE FURUKAWA ELECTRIC CO., LTD., JAPAN:
3,784,929, COR. MULTIPLE CLASS, INT. CLS. 6, 9, 12, 17 AND 35.
- THE GATES CORPORATION, DENVER, CO:
4,154,205, PUB. 3-20-2012. INT. CL. 41.
- THE GIFT SHOPPE, INC., NORMAN, OK, DBA FLAUNT:
4,152,598, PUB. 3-20-2012. INT. CL. 25.
- THE GORMAN-RUPP COMPANY, MANSFIELD, OH:
4,155,453, INT. CL. 7.
- THE GREAT LAKES BREWING CO., CLEVELAND, OH:
4,153,453, PUB. 3-20-2012. INT. CL. 32.
4,153,457, PUB. 3-20-2012. INT. CL. 32.
4,153,458, PUB. 3-20-2012. INT. CL. 32.
4,153,459, PUB. 3-20-2012. INT. CL. 32.
4,153,462, PUB. 3-20-2012. INT. CL. 32.
4,153,463, PUB. 3-20-2012. INT. CL. 32.
- THE GREATER KANSAS CITY SPORTS COMMISSION, KANSAS CITY, MO:
4,152,751, PUB. 3-20-2012. INT. CL. 35.
- THE GREEN SQUAD, INC., TARPON SPRINGS, FL:
4,154,275, INT. CL. 35.
- THE HILLMAN GROUP, INC., CINCINNATI, OH:
4,152,788, PUB. 3-20-2012. INT. CL. 6.
- THE I.T. WORKSHOP, L.L.C., GILBERT, AZ:
4,153,745, PUB. 3-20-2012. INT. CL. 37.
- THE IOWA CLINIC, P.C., WEST DES MOINES, IA:
4,154,707, MULTIPLE CLASS, INT. CLS. 35 AND 41.
- THE J. PAUL GETTY TRUST, LOS ANGELES, CA:
4,152,608, PUB. 3-20-2012. INT. CL. 35.
4,152,617, PUB. 3-20-2012. INT. CL. 41.
- THE JACKLOC COMPANY LIMITED, UNITED KINGDOM:
4,152,389, PUB. 3-20-2012. INT. CL. 6.
- THE JEWISH FEDERATIONS OF NORTH AMERICA, INC., NEW YORK, NY, UNITED JEWISH COMMUNITIES, INC., NEW YORK, NY:
2,568,191, REN. 4-27-12. INT. CL. 36.
- THE KROGER CO. OF MICHIGAN, NOVI, MI:
4,154,782, INT. CL. 30.
- THE LAMBS FARM, INC., LIBERTYVILLE, IL:
4,155,016, MULTIPLE CLASS, INT. CLS. 29, 30, 35, 36, 41 AND 42.
- THE LAST BEST BEEF, LLC, LAS VEGAS, NV:
4,155,906, INT. CL. 43.
- THE LEARNING INTERNET, INC., PORTLAND, OR:
4,152,521, PUB. 3-20-2012. MULTIPLE CLASS, INT. CLS. 41 AND 42.

- THE LUBRIZOL CORPORATION, WICKLIFFE, OH, CHEM-
RON CORPORATION, PASO ROBLES, CA:
1,721,251. REN. 4-30-12. INT. CL. 1.
- THE MARLEY-WYLAIN COMPANY, MICHIGAN CITY, IN:
4,154,934. INT. CL. 11.
- THE MASTERS OF BEVERAGES, LLC, CORONA, CA:
4,155,027. INT. CL. 32.
- THE MATHWORKS, INC., NATICK, MA:
4,155,935. INT. CL. 9.
- THE MCMANUS GROUP, INC., RIVERSIDE, CA:
4,153,405. PUB. 3-20-2012. INT. CL. 36.
- THE MEATLOAF BAKERY LLC, CHICAGO, IL:
4,154,096. PUB. 3-20-2012. INT. CL. 29.
4,154,097. PUB. 3-20-2012. INT. CL. 29.
4,154,181. PUB. 3-20-2012. INT. CL. 43.
- THE MELTING POT RESTAURANTS, INC., TAMPA, FL:
4,154,530. INT. CL. 43.
- THE MUPPETS STUDIO, LLC, BURBANK, CA:
4,154,390. INT. CL. 28.
- THE NATIONAL UNDERWRITER COMPANY, ERLAN-
GER, KY:
2,561,388. REN. 4-27-12. INT. CL. 36.
- THE NAVIGATORS, COLORADO SPRINGS, CO:
4,154,188. PUB. 3-20-2012. INT. CL. 45.
4,154,189. PUB. 3-20-2012. INT. CL. 16.
4,154,659. INT. CL. 16.
4,154,661. INT. CL. 9.
- THE NPD GROUP, INC., PORT WASHINGTON, NY:
4,154,994. MULTIPLE CLASS, INT. CLS. 35 AND 42.
- THE OFFICE CLUB, INC., BOCA RATON, FL:
4,154,492. MULTIPLE CLASS, INT. CLS. 9, 16 AND 18.
4,154,493. MULTIPLE CLASS, INT. CLS. 9, 16 AND 18.
- THE ONE CAMPAIGN, WASHINGTON, DC:
4,154,603. INT. CL. 41.
- THE ORIGINAL BROOKLYN WATER BAGEL CO., INC.,
BOCA RATON, FL:
4,154,238. PUB. 3-20-2012. INT. CL. 32.
- THE PAR 3 TOUR LLC., APPLE VALLEY, CA:
4,156,037. INT. CL. 41.
- THE PARADISE PROJECT, VENICE, CA, DBA THE PARA-
DISE PROJECT:
4,153,408. PUB. 3-20-2012. INT. CL. 45.
- THE PEACEFUL PACK, INC., BROOKLYN, NY:
4,153,839. PUB. 3-20-2012. MULTIPLE CLASS, INT. CLS.
41, 43 AND 44.
- 4,153,840. PUB. 3-20-2012. MULTIPLE CLASS, INT. CLS.
41, 43 AND 44.
- THE PILLSBURY COMPANY, LLC, MINNEAPOLIS, MN:
938,249. REN. 4-27-12. U.S. CL. 101 (INT. CL. 35).
- THE PNC FINANCIAL SERVICES GROUP, INC., PITTS-
BURGH, PA:
4,155,571. INT. CL. 36.
- THE PORTABLES EXHIBIT SYSTEMS LIMITED, BRITISH
COLUMBIA, CANADA:
2,557,783. REN. 4-30-12. INT. CL. 20.
- THE PROCTER & GAMBLE COMPANY, CINCINNATI, OH:
4,155,436. INT. CL. 5.
- THE PROFESSIONAL GOLFERS' ASSOCIATION OF AMER-
ICA, PALM BEACH GARDENS, FL:
4,155,570. INT. CL. 41.
- THE PROTECTION INSTITUTE LLC, JOHNS ISLAND, SC:
4,153,288. PUB. 3-20-2012. INT. CL. 41.
- THE QUAKER OATS COMPANY, CHICAGO, IL:
4,154,892. INT. CL. 30.
- THE RICHARD STOCKTON COLLEGE OF NEW JERSEY,
POMONA, NJ:
4,155,749. INT. CL. 41.
- THE RICHDALE GROUP, OMAHA, NE:
4,152,443. PUB. 3-20-2012. INT. CL. 43.
- THE RITZ HOTEL, LIMITED, PARIS, FRANCE:
4,152,996. PUB. 3-20-2012. INT. CL. 11.
- THE RUSSIAN SCHOOL OF MATHEMATICS, INC., NEW-
TON, MA:
4,152,910. PUB. 3-20-2012. INT. CL. 41.
- THE SIROKY GROUP INC., MARKHAM, ONTARIO, CA-
NADA:
4,152,116. PUB. 3-20-2012. INT. CL. 42.
- THE SKINNY PANTRY, FORT MYERS, FL:
4,153,160. PUB. 3-20-2012. INT. CL. 5.
- THE SLANTED LENS, LA CRESCENTA, CA, DBA JAY P.
MORGAN:
4,153,100. PUB. 3-20-2012. INT. CL. 41.
- THE SNOBOARD SHOP INC., WHISTLER, CANADA:
4,153,328. PUB. 3-20-2012. INT. CL. 41.
- THE SOFTWARE MACKIEV COMPANY, BOSTON, MA:
4,154,054. PUB. 3-20-2012. INT. CL. 9.
- THE SOUTH KENT SCHOOL CORPORATION, SOUTH
KENT, CT:
4,153,306. PUB. 3-20-2012. INT. CL. 41.
- THE STATE OF FLORIDA DEPARTMENT OF THE LOT-
TERY, TALLAHASSEE, FL:
4,153,202. PUB. 3-20-2012. INT. CL. 41.
- THE SUSAN G. KOMEN BREAST CANCER FOUNDATION,
INC., DALLAS, TX:
4,153,205. PUB. 3-20-2012. MULTIPLE CLASS, INT. CLS.
35, 36 AND 41.
- 4,153,206. PUB. 3-20-2012. MULTIPLE CLASS, INT. CLS.
35, 36 AND 41.
- THE TEMPLE OF THE PRESENCE, INC., TUCSON, AZ:
4,152,146. PUB. 3-20-2012. U.S. CL. 200.
- THE TJX COMPANIES, INC., FRAMINGHAM, MA:
2,999,005. CANC. MULTIPLE CLASS, INT. CLS. 8 AND
21.
- THE TOPLINE CORPORATION, BELLEVUE, WA:
4,154,290. INT. CL. 14.
- THE TRANSTEC GROUP, INC., AUSTIN, TX:
4,153,558. PUB. 3-20-2012. INT. CL. 9.
- THE TRUSTEE OF THE SAMI LADEKI TRUST, LA JOLLA,
CA:
4,152,966. PUB. 3-20-2012. INT. CL. 43.
- THE TRUSTEES OF COLUMBIA UNIVERSITY OF THE
CITY OF NEW YORK, NEW YORK, NY:
4,153,097. PUB. 3-20-2012. INT. CL. 41.
- THE TRUSTEES OF PURDUE UNIVERSITY, WEST LAFAY-
ETTE, IN:
4,152,145. PUB. 7-20-2010. INT. CL. 41.
4,152,147. PUB. 7-20-2010. INT. CL. 41.
- THE TRUSTEES OF THE HOPKINS TRUST DATED FEB-
RUARY 9, 2001, A CALIFORNIA TRUST, THE TRUSTEES
COMPRISING VINCENT R. HOPKINS AND DANETTE L.
HOPKINS, BOTH U.S. CITIZENS., CAMARILLO, CA:
2,998,578. CANC. INT. CL. 41.
- THE TRUSTEES OF THE J. PAUL GETTY TRUST, A
CALIFORNIA CHARITABLE TRUST, THE TRUSTEES
COMPRISING, LEWIS W. BERNARD, JOHN H. BIGGS,
LOUISE H. BRYSON, RAMON C. CORTINES, ROBERT F.
ERBURU, DAVID P. GARDNER, VARTAN GREGORIAN,
AGNES GUND, HELENE L. KAPLAN, BARRY MUNITZ,
BLENDIA J. WILSON, AND IRA E. YELLIN, ALL U.S.
CITIZENS, LOS ANGELES, CA:
2,558,094. REN. 4-27-12. INT. CL. 42.
- THE TRUSTEES OF THE QUEEN ELIZABETH II HEALTH
SCIENCES CENTRE FOUNDATION, HALIFAX, NOVA
SCOTIA, CANADA:
4,152,473. PUB. 1-31-2012. MULTIPLE CLASS, INT. CLS.
9, 14, 16, 18, 20, 21, 25, 28, 36 AND 41.
- THE TRUSTEES OF THE STONERIDGE TRUST, AUCK-
LAND, NEW ZEALAND:
4,152,619. PUB. 3-20-2012. MULTIPLE CLASS, INT. CLS. 7
AND 12.
- THE UNGAR GROUP, LLC, INDIANAPOLIS, IN, DBA U/S
SPORTS ADVISORS:
4,153,756. PUB. 3-20-2012. INT. CL. 41.
4,153,854. PUB. 3-20-2012. INT. CL. 41.
4,153,872. PUB. 3-20-2012. INT. CL. 45.
- THE VERA COMPANY, LLC, ATLANTA, GA, DBA THE
VERA COMPANY:
4,155,289. INT. CL. 3.
- THE WAGMAN PRIMUS GROUP, LP, LECITTOWN, PA,
WAGMAN-GRENAMAYER, INC., PHILADELPHIA, PA:
1,684,482. REN. 4-30-12. INT. CL. 22.
- THE WEATHER UNDERGROUND, INC., ANN ARBOR, MI:
4,099,085. COR. INT. CL. 35.

- THE WELLNESS PROVIDER NETWORK LLC, SPRINGFIELD, MO:
4,152,961, PUB. 3-20-2012. INT. CL. 35.
- THE WHITAKER LLC, WILMINGTON, DE, AMP INCORPORATED, HARRISBURG, PA:
730,017. REN. 4-27-12. U.S. CL. 21 (INT. CL. 9).
- THE WHITE DOVE GROUP INC, HENDERSONVILLE, TN, DBA WHITE DOVE:
4,153,564, PUB. 3-20-2012. INT. CL. 16.
- THE WILDERNESS SOCIETY, WASHINGTON, DC:
4,153,664, PUB. 3-20-2012. INT. CL. 35.
- THE WINE GROUP LLC, TRACY, CA:
3,042,554, CANC. INT. CL. 33.
4,155,826, INT. CL. 33.
- THE WISHING WORD INC., SAN MARCOS, TX:
4,154,051, PUB. 3-20-2012. INT. CL. 35.
- THE 3/50 PROJECT LLC, GOLDEN VALLEY, MN:
4,155,374, INT. CL. 9.
- THE 6TH MAN FOUNDATION, CLARKSBURG, MD:
4,153,856, PUB. 3-20-2012. MULTIPLE CLASS, INT. CLS. 41 AND 44.
- THEBESTDAY PTY LTD, AUSTRALIA:
4,152,317, PUB. 3-20-2012. INT. CL. 45.
- THERADIX SYSTEMS, INC., PRINCETON JUNCTION, NJ:
2,578,146. REN. 4-30-12. INT. CL. 9.
- THERATASE PLC, LONDON SW1Y 4AU, ENGLAND:
2,491,685. CANC. MULTIPLE CLASS, INT. CLS. 1 AND 5.
- THERMO FISHER SCIENTIFIC (ASHEVILLE) LLC, WALTHAM, MA, THERMO FORMA INC., MARIETTA, OH:
2,568,421. REN. 5-1-12. INT. CL. 9.
- THERMO FLUIDS INC., PHOENIX, AZ:
4,152,853, PUB. 3-20-2012. MULTIPLE CLASS, INT. CLS. 39 AND 40.
- THINGWORX, INC., EXTON, PA:
4,155,228, INT. CL. 9.
- THINKAGE LTD., KITCHENER, ONTARIO N2R 1H6, CANADA:
2,491,792, CANC. INT. CL. 9.
- THINMAIL, INC., SUDBURY, MA, THINMAIL, INC., SUDBURY, MA:
2,635,829. REN. 4-27-12. INT. CL. 38.
- THIRD MAN, INC., NEW YORK, NY:
4,154,900, INT. CL. 3.
- THIRD SKY, INC., ALAMEDA, CA:
4,154,067, PUB. 3-20-2012. MULTIPLE CLASS, INT. CLS. 41 AND 42.
- THISELTON, DOVE, ORANGE, CA, DBA AS CUTE AS IT GETS:
4,153,907, PUB. 3-20-2012. INT. CL. 41.
- THK CO., LTD., SHINAGAWA-KU, TOKYO 141-8503, JAPAN:
2,581,214. REN. 4-27-12. INT. CL. 35.
- THOM LITTLE ASSOCIATES, LTD., KEENE, NH:
2,696,363. REN. 5-3-12. INT. CL. 42.
- THOMAS & BETTS INTERNATIONAL, INC., WILMINGTON, DE:
2,565,916. REN. 4-27-12. INT. CL. 11.
2,574,030. REN. 5-2-12. INT. CL. 6.
- THOMAS BUILT BUSES, INC., HIGH POINT, NC, THOMAS BUILT BUSES, INC., HIGH POINT, NC:
1,173,110. REN. 5-1-12. INT. CL. 12.
- THOMAS HINE & CO, JARNAC, FRANCE:
4,154,111, PUB. 3-20-2012. INT. CL. 33.
- THOMAS MORE CENTER FOR LAW & JUSTICE, ANN ARBOR, MI:
2,578,479. REN. 5-3-12. INT. CL. 42.
- THOMAS, DEBBIE, PACIFIC GROVE, CA:
4,155,588, INT. CL. 16.
- THOMPSON MARKETING LLC, HOUSTON, TX:
4,153,602, PUB. 3-20-2012. INT. CL. 41.
- THOMPSON, LEVI, CONYERS, GA:
4,155,111, INT. CL. 25.
- THOMPSON STREET CAPITAL GP LLC, ST. LOUIS, MO:
2,607,095. REN. 5-2-12. INT. CL. 36.
- THOMPSON-PALLISTER BAIT CO. LTD., LACOMBE, ALBERTA, T4L 1E7, CANADA:
2,613,752. REN. 5-3-12. INT. CL. 28.
- THOMPSON, ROBERT, BROOKLYN, NY:
4,155,078, INT. CL. 25.
- THOMSON REUTERS CANADA LIMITED, TORONTO, CANADA:
4,152,543, PUB. 3-20-2012. MULTIPLE CLASS, INT. CLS. 35, 36 AND 41.
- THOMSON SCIENTIFIC INC., PHILADELPHIA, PA:
2,491,833, CANC. MULTIPLE CLASS, INT. CLS. 9, 35, 36, 38 AND 42.
- THOR TECH, INC., JACKSON CENTER, OH:
4,154,711, INT. CL. 12.
4,154,772, INT. CL. 12.
4,155,804, INT. CL. 12.
- THORPE, K. L., BOULDER, CO:
4,152,686, PUB. 3-20-2012. INT. CL. 44.
- THRASHER, BENJAMIN, LONG BEACH, CA:
4,155,460, INT. CL. 25.
- THREE ANGELS BROADCASTING NETWORK, INC., WEST FRANKFORT, IL:
4,155,808, INT. CL. 41.
- THREE RIVERS MAIL ORDER CORP., CLEARWATER, FL:
2,565,329. REN. 5-3-12. INT. CL. 16.
- TIBURON, INC., PLEASANTON, CA:
4,152,537, PUB. 3-20-2012. INT. CL. 42.
- TICKLING KEYS, INC., UNIONTOWN, OH:
2,693,406. REN. 5-3-12. INT. CL. 42.
- TIFCO INDUSTRIES, INC., CYPRESS, TX:
1,756,421. REN. 4-30-12. INT. CL. 6.
- TIFFANY (NJ) LLC, PARSIPPANY, NJ:
4,154,018, PUB. 3-20-2012. MULTIPLE CLASS, INT. CLS. 9, 14, 16, 18, 21, 26, 28 AND 34.
4,154,184, PUB. 3-20-2012. INT. CL. 14.
4,154,729, INT. CL. 14.
- TIFFANY AND COMPANY, NEW YORK, NY:
2,492,603, CANC. INT. CL. 25.
- TIFFANY ANNE LLC, HOPE SOUND, FL:
4,155,681, INT. CL. 20.
- TII NETWORK TECHNOLOGIES, INC., EDGEWOOD, NY:
4,152,695, PUB. 3-20-2012. INT. CL. 9.
- TIM BORN, CHAMPAIGN, IL:
4,154,442, INT. CL. 9.
- TIME CUFFS, LLC, NORTH CHARLESTON, SC:
4,154,743, INT. CL. 20.
- TIME FRAME PHOTOGRAPHY & ART ILLUSTRATION, BOULDER, CO:
4,154,225, PUB. 3-20-2012. INT. CL. 35.
- TIME INC., NEW YORK, NY:
2,564,142. REN. 5-2-12. INT. CL. 41.
2,564,142, AM. INT. CL. 41.
- TIME STYLE S.R.L., ITALY:
4,152,363, PUB. 3-20-2012. INT. CL. 14.
4,152,364, PUB. 3-20-2012. INT. CL. 14.
- TIME-CAP LABORATORIES, INC., FARMINGDALE, NY:
4,155,391, INT. CL. 40.
- TIMEHOUSE GMBH, EYSTRUP, FED REP GERMANY:
4,155,882, INT. CL. 14.
- TIMEX GROUP USA, INC., MIDDLEBURY, CT:
2,493,542, CANC. INT. CL. 14.
- TINSLEY TRANSFERS, INC., SUN VALLEY, CA:
4,152,578, PUB. 3-20-2012. INT. CL. 25.
- TITAN INTERNATIONAL, INC., QUINCY, IL:
2,495,851. REN. 4-27-12. INT. CL. 12.
- TITAN SPORT TECH CO., LTD., TAICHUNG CITY, TAIWAN:
4,154,073, PUB. 3-20-2012. INT. CL. 25.
- TIVOL PLAZA INC., KANSAS CITY, KS:
2,680,074. REN. 4-30-12. INT. CL. 14.
- TMP INTELLECTUAL PROPERTY HOLDINGS, LLC, NEW YORK, NY:
4,154,713, MULTIPLE CLASS, INT. CLS. 35, 38 AND 42.
- TOLLESON WEALTH MANAGEMENT, INC., DALLAS, TX:
4,152,611, PUB. 3-20-2012. INT. CL. 36.
4,152,612, PUB. 3-20-2012. INT. CL. 36.
- TOM HOM GROUP, LLC, THE, SAN DIEGO, CA:
2,590,554, COR. MULTIPLE CLASS, INT. CLS. 35 AND 36.
- TOM JAMES COMPANY, FRANKLIN, TN:
4,154,838, INT. CL. 25.

TONY B. WHITESIDE, SHEPHERDSVILLE, KY:
 4,155,045, INT. CL. 28.

TOOLOVATION, LLC, BEACHWOOD, OH:
 2,998,551, CANC. INT. CL. 7.

TOP QUALITY FLOORS INC., RENO, NV, DBA FULL
 CIRCLE FLOORING:
 4,152,644, PUB. 3-20-2012. MULTIPLE CLASS, INT. CLS.
 35 AND 37.

TOPCO HOLDINGS, INC., SKOKIE, IL:
 1,192,957, REN. 4-27-12. INT. CL. 5.
 2,998,507, CANC. MULTIPLE CLASS, INT. CLS. 29, 30
 AND 32.
 4,154,868, INT. CL. 32.

TORERO SPECIALTY PRODUCTS, LLC, MONROVIA, CA:
 4,154,169, PUB. 3-20-2012. INT. CL. 20.

TORIC ANGLE L.C., FRUITPORT, MI:
 2,559,195, REN. 4-30-12. INT. CL. 10.

TORRES, LUIS EDUARDO DE LA VEGA, SAN NICOLAS
 LOS GARZA, MEXICO:
 4,153,127, PUB. 3-20-2012. INT. CL. 39.

TOSETTI, LINDA, DURHAM, CT, DBA LEGAL REPRESENTATIVE
 FOR THE HEIRS OF DOROTHY RUTH PIRONE
 AND STEVENS, JULIA RUTH, CONWAY, NH AND BABE
 RUTH LEAGUE, INC, TRENTON, NJ:
 4,154,519, INT. CL. 25.

TOTAL COAT DE VENEZUELA, C.A., VALENCIA, CARA-
 BOBO, VENEZUELA:
 4,155,750, INT. CL. 1.

TOURNEAU, LLC, NEW YORK, NY:
 1,402,085, CANC. INT. CL. 14.

TOWN & COUNTRY LINEN CORP., NEW YORK, NY:
 4,155,878, INT. CL. 6.

TOWN OF SUPERIOR, COLORADO, SUPERIOR, CO:
 4,153,348, PUB. 3-20-2012. MULTIPLE CLASS, INT. CLS.
 25, 35 AND 41.

TOYO BOSEKI KABUSHIKI KAISHA, KITA-KU, OSAKA,
 JAPAN, TA TOYOBO CO., LTD.:
 4,154,159, PUB. 3-20-2012. INT. CL. 1.

TPAC UNDERWRITERS, INC., MINNEAPOLIS, MN:
 2,689,346, REN. 4-30-12. INT. CL. 36.

TRACEY PALUMBO, VALLEY VILLAGE, CA:
 4,153,262, PUB. 3-20-2012. INT. CL. 41.

TRACH, ANN, ROSE, JACKSONVILLE BEACH, FL:
 4,152,478, PUB. 3-20-2012. INT. CL. 16.

TRACIE MARTYN INTERNATIONAL LLC, NEW YORK,
 NY:
 4,155,340, INT. CL. 3.

TRACKSIDE INTELLIGENCE PTY LTD, AUSTRALIA:
 4,152,433, PUB. 3-20-2012. MULTIPLE CLASS, INT. CLS. 9
 AND 37.

TRACTOR SUPPLY CO. OF TEXAS, LP, BRENTWOOD, TN:
 4,155,117, INT. CL. 31.
 4,155,170, INT. CL. 7.

TRADECARD, INC., NEW YORK, NY:
 2,698,147, REN. 5-2-12. INT. CL. 39.

TRADENOMIX INC., WEST VANCOUVER, B.C., CANADA:
 4,152,556, PUB. 3-20-2012. INT. CL. 36.

TRADINGSREEN, INC., NEW YORK, NY:
 4,155,463, MULTIPLE CLASS, INT. CLS. 9 AND 42.

TRAFIGURA BEHEER BV, AMSTERDAM, NETHER-
 LANDS:
 4,152,088, PUB. 10-5-2010. MULTIPLE CLASS, INT. CLS.
 36, 37 AND 39.

TRAHK LIMITED, ONE CONNAUGHT PLACE, HONG
 KONG:
 2,600,068, REN. 5-2-12. MULTIPLE CLASS, INT. CLS. 16
 AND 36.
 2,629,842, REN. 5-2-12. MULTIPLE CLASS, INT. CLS. 16
 AND 36.

TRANCOS, INC., PLEASANTON, CA:
 4,153,957, PUB. 3-20-2012. INT. CL. 35.

TRANSDYN, INC., PLEASANTON, CA:
 2,546,772, REN. 5-3-12. INT. CL. 9.

TRANSGLOBAL ALLIANCES ID, INC., FAIRFIELD, IA:
 2,557,884, REN. 4-27-12. INT. CL. 42.

TRANSLOGIC CORPORATION, DENVER, CO:
 2,559,205, REN. 5-1-12. INT. CL. 7.

TRANSOCEAN INC., HOUSTON, TX:
 2,492,627, CANC. INT. CL. 37.

TRANSURANT, INC., OMAHA, NE:
 4,154,979, INT. CL. 42.

TRAVDOG, INC., ALISO VIEJO, CA, DBA CHINA CABLES
 DIRECT:
 4,155,932, MULTIPLE CLASS, INT. CLS. 35 AND 40.

TRAVEL HEALTH RESOURCE, INC., WHEATON, IL:
 2,701,836, REN. 5-3-12. INT. CL. 42.

TRAVELER OVERSEAS MAGAZINE, L.L.C., DALLAS, TX:
 4,152,519, PUB. 3-20-2012. INT. CL. 39.

TREC HOLDINGS, INC., VANCOUVER, BRITISH CO-
 LUMBIA:
 2,998,853, CANC. MULTIPLE CLASS, INT. CLS. 36 AND
 37.

TREDEGAR FILM PRODUCTS CORPORATION, RICH-
 MOND, VA TO TREDEGAR FILM PRODUCTS COR-
 PORATION, RICHMOND, VA:
 2,493,300, CANC. INT. CL. 17.

TREE RING PENS LLC, MISSOULA, MT:
 4,155,890, INT. CL. 16.
 4,155,891, INT. CL. 21.

TREK AMERICA TRAVEL LIMITED, CRAWLEY, WEST
 SUSSEX, ENGLAND:
 2,492,781, CANC. INT. CL. 39.

TREK BICYCLE CORPORATION, WATERLOO, WI:
 4,154,881, INT. CL. 9.

TREC HOLDINGS, LLC, COLUMBUS, OH:
 4,154,664, INT. CL. 25.

TREVOR BRAZILE, DECATUR, TX:
 4,155,334, INT. CL. 22.

TRI-FORCE CONSULTING SERVICES, INC., LANSDALE,
 PA:
 4,155,545, INT. CL. 42.

TRI-STATE CONSUMER INSURANCE COMPANY, JERI-
 CHO, NY, DBA TSC DIRECT:
 4,153,309, PUB. 3-20-2012. INT. CL. 36.

TRI-TRONICS COMPANY, INC., TAMPA, FL:
 2,602,738, REN. 4-27-12. INT. CL. 9.
 2,602,738, COR. INT. CL. 9.

TRIBUS, KAMALA E.R., PENSACOLA, FL:
 4,155,926, INT. CL. 41.

TRIMARK SPORTSWEAR CANADA INC., RICHMOND
 HILL, ONTARIO, CANADA:
 4,152,926, PUB. 3-20-2012. MULTIPLE CLASS, INT. CLS.
 25 AND 35.

TRIMBLE NAVIGATION LIMITED, SUNNYVALE, CA:
 4,155,577, INT. CL. 9.

TRIPLE E CANADA LTD., WINKLER MANITOBA, CANA-
 DA:
 4,155,918, INT. CL. 12.

TRIPLE H CONCRETE PRODUCTS LTD., PUTNAM, ON-
 TARIO, CANADA:
 2,556,919, REN. 4-27-12. INT. CL. 19.

TRIPLEGIFT, INC., PLEASANTON, CA:
 4,155,423, INT. CL. 16.

TRISA BURSTENFABRIK AG TRIENGEN, 6234 TRIEN-
 GEN, SWITZERLAND:
 1,139,201, CANC. MULTIPLE CLASS, INT. CLS. 11 AND
 21.

TROIKA INTERNATIONAL, INC., DUARTE, CA:
 4,153,190, PUB. 3-20-2012. INT. CL. 26.

TROPICAL CHEESE INDUSTRIES, INC., PERTH AMBOY,
 NJ:
 4,154,260, INT. CL. 29.
 4,154,261, INT. CL. 29.

TROPICAL PARADISE, INC., BEDFORD, MA:
 4,153,511, PUB. 3-20-2012. INT. CL. 32.

TROY SPORTS RESTAURANT, LLC, TROY, MI, DBA JOE
 KOOL'S BAR & RESTAURANT:
 4,155,641, INT. CL. 43.

TRUCOLOR CAPITAL MANAGEMENT, LLC, NEWTON,
 MA:
 4,153,366, PUB. 3-20-2012. INT. CL. 36.

TRUE NORTH LOG HOMES, INC., BRACEBRIDGE, ON-
 TARIO, CANADA, TRUE NORTH LOG HOME MACHIN-
 ERY INC., BRACEBRIDGE, ONTARIO, CANADA:
 1,684,448, REN. 4-27-12. INT. CL. 19.

- TRUE TEXTILES, INC., GRAND RAPIDS, MI:
1,662,527. REN. 5-2-12. INT. CL. 24.
4,154,306, INT. CL. 24.
- TRUETIP, LLC, FAIRFAX, VA:
2,614,273. REN. 5-3-12. INT. CL. 16.
- TRUETONIQS, LLC, LONGMONT, CO:
4,152,901, PUB. 3-20-2012. INT. CL. 5.
- TRUHEARING, INC., WEST JORDAN, UT:
4,152,852, PUB. 3-20-2012. INT. CL. 10.
- TRUMP, DONALD J., NEW YORK, NY:
1,688,083. REN. 5-2-12. INT. CL. 36.
- TRUMPF GMBH & CO. KG, 71254 DITZINGEN, FED REP GERMANY:
3,006,862, CANC. MULTIPLE CLASS, INT. CLS. 35 AND 40.
- TRUSSBILT, LLC, VADNAIS HEIGHTS, MN, ASSA ABLOY DOOR GROUP, LLC, NEW HAVEN, CT:
2,559,403. REN. 4-28-12. INT. CL. 6.
- TRUSTEE OF THE HERMAN FAMILY TRUST, LOS ANGELES, CA:
4,154,648, MULTIPLE CLASS, INT. CLS. 18 AND 25.
- TRUSTEES OF THE UNIVERSITY OF PENNSYLVANIA, PHILADELPHIA, PA:
2,698,319. REN. 5-2-12. INT. CL. 42.
- TRUSTNODE, INC., SAN FRANCISCO, CA:
4,152,875, PUB. 3-20-2012. MULTIPLE CLASS, INT. CLS. 36, 41 AND 42.
- TRX TECHNOLOGY SERVICES, DALLAS, TX:
2,561,193. REN. 5-2-12. INT. CL. 9.
- TRY PLAN B, L.L.C., PROVIDENCE, RI:
3,579,061, CANC. INT. CL. 41.
- TRØNDERENERGI NETT AS, NORWAY:
4,152,290, PUB. 3-20-2012. MULTIPLE CLASS, INT. CLS. 9, 37 AND 42.
- TSA STORES, INC., ENGLEWOOD, CO:
2,998,619, CANC. INT. CL. 28.
- TSAI, JASON LEE, JERSEY CITY, NJ:
4,155,237, INT. CL. 3.
- TSE INDUSTRIES, INC., CLEARWATER, FL:
2,561,144. REN. 5-3-12. INT. CL. 1.
- TT COMPANIES, INC., LENEXA, KS, FORMERLY TERRACON, INC.:
4,153,917, PUB. 3-20-2012. MULTIPLE CLASS, INT. CLS. 16 AND 42.
- TTX COMPANY, CHICAGO, IL:
1,730,944. REN. 4-27-12. INT. CL. 12.
- TUPPERWARE PRODUCTS S.A., FRIBOURG, SWITZERLAND:
4,155,690, INT. CL. 3.
- TURN3 CREATIVE, INC., ARCADIA, CA:
4,153,698, PUB. 3-20-2012. INT. CL. 3.
- TURTLE CONSERVANCY, NEW YORK, NY:
4,152,469, PUB. 3-20-2012. INT. CL. 42.
- TUTTLE, DEXTER, FORT WORTH, TX:
4,155,810, MULTIPLE CLASS, INT. CLS. 1 AND 4.
- TUTTLE, KRIS, BOSTON, MA:
4,155,322, INT. CL. 36.
- TW CRYOGENICS LLC, THEODORE, AL:
4,155,408, MULTIPLE CLASS, INT. CLS. 6 AND 11.
4,155,409, MULTIPLE CLASS, INT. CLS. 6 AND 11.
- TWD INDUSTRIAL COMPANY, LIMITED, ROAD TOWN, TORTOLA, BR.VIRGIN ISLANDS:
2,492,821, CANC. INT. CL. 9.
- TWENTIETH CENTURY FOX FILM CORPORATION, LOS ANGELES, CA:
4,154,628, INT. CL. 41.
- TWIN CITIES TOXICOLOGY CONSORTIUM, LLC, CANNON FALLS, MN:
4,156,062, INT. CL. 41.
- TWIN MAPLES, INC., BLOCK ISLAND, RI:
4,154,555, MULTIPLE CLASS, INT. CLS. 16 AND 25.
- TWIN TIGER ASSETS CORP., REDONDO BEACH, CA:
4,155,985, INT. CL. 14.
4,155,986, INT. CL. 14.
- TWISTED NOODLES EXPRESS, CORP., BUENA PARK, CA:
4,153,893, PUB. 3-20-2012. INT. CL. 43.
- TWO BEER GUYS LLC, PELHAM, NY, DBA GROWLERS BEER BISTRO:
4,155,281, INT. CL. 43.
- TYJA CORPORATION, CALVERTON, NY:
4,154,405, MULTIPLE CLASS, INT. CLS. 18 AND 24.
- TYLER CANDLE COMPANY, L.L.C., TYLER, TX:
4,152,102, PUB. 3-20-2012. INT. CL. 4.
- TYSON HOLDINGS LIMITED, BRITISH VIRGIN ISLANDS, BR.VIRGIN ISLANDS:
4,153,701, PUB. 3-20-2012. INT. CL. 20.
- U.S. MEDICAL MANAGEMENT, LLC, TROY, MI:
4,152,723, PUB. 3-20-2012. INT. CL. 44.
- U.S. DEPARTMENT OF HEALTH AND HUMAN SERVICES, BETHESDA, MD:
4,154,798, MULTIPLE CLASS, INT. CLS. 9, 16, 42 AND 45.
- U.S. SILICA COMPANY, FREDERICK, MD:
2,588,317. REN. 5-2-12. INT. CL. 19.
2,606,833. REN. 5-2-12. INT. CL. 19.
2,613,679. REN. 5-2-12. INT. CL. 19.
- U.S. VENTURE, INC., APPLETON, WI:
1,685,006. REN. 4-28-12. INT. CL. 4.
- U-GO STATIONS, INC., PHILADELPHIA, PA:
4,154,959, MULTIPLE CLASS, INT. CLS. 9 AND 37.
- U-HAUL INTERNATIONAL, INC., PHOENIX, AZ:
4,154,876, INT. CL. 36.
- UAB "SERVEA", LT-50220 KAUNAS, LITHUANIA:
4,152,255, PUB. 3-20-2012. MULTIPLE CLASS, INT. CLS. 2 AND 37.
- UAB SERVEA, LT-50220 KAUNAS, LITHUANIA:
4,152,246, PUB. 3-20-2012. INT. CL. 37.
- UBISTOR, INC., SCHAUMBURG, IL:
4,156,033, INT. CL. 42.
- UBS AG, CH-8001 ZÜRICH, SWITZERLAND:
4,152,337, PUB. 3-20-2012. INT. CL. 36.
- UCB, S.A., BRUSSELS, BELGIUM:
2,998,583, CANC. INT. CL. 44.
- UERLINGS, RENÉ, WELKENRAEDT, BELGIUM:
4,101,542, COR. MULTIPLE CLASS, INT. CLS. 21, 25, 32 AND 33.
- UFC ULTIMATE FITNESS CENTER LLC., CHULA VISTA, CA:
4,156,025, INT. CL. 41.
- UGLY POOLS USA, INC., PEORIA, AZ:
4,154,132, PUB. 3-20-2012. INT. CL. 37.
- UGUR MAKINA SANAYI GIDA INSAAT TAAHHÜT ENDÜSTRİYEL YAPILAR TURIZM TARIM DIS TICARET LIMITED SIRKETI, TURKEY:
4,152,366, PUB. 3-20-2012. INT. CL. 7.
- UHS OF DELAWARE, INC., KING OF PRUSSIA, PA:
4,154,870, INT. CL. 44.
- ULTIMUS, INC., CARY, NC:
2,492,278, CANC. INT. CL. 9.
- ULTRA ATHLETE LLC, INDIANAPOLIS, IN:
4,155,761, INT. CL. 10.
4,155,762, INT. CL. 10.
- ULTRA RACING (M) SDN. BHD, KUALA LUMPUR, MALAYSIA:
4,153,814, PUB. 3-20-2012. INT. CL. 12.
- ULTRADENT PRODUCTS, INC., SOUTH JORDAN, UT:
2,681,652. REN. 5-1-12. INT. CL. 10.
- ULTRAFRYER SYSTEMS, INC., SAN ANTONIO, TX:
2,565,287. REN. 5-1-12. INT. CL. 11.
- ULTRALINE, LLC, SAN ANTONIO, TX:
4,152,824, PUB. 3-20-2012. INT. CL. 42.
- ULTRAVIOLET DEVICES, INC., VALENCIA, CA:
4,155,388, INT. CL. 11.
- UMAMI BURGER LICENSING USA, LLC, LOS ANGELES, CA:
4,153,126, PUB. 3-20-2012. INT. CL. 43.
- UMEGASTAR, BRONXVILLE, NY:
4,154,787, INT. CL. 9.
- UMICORE AG & CO. KG, HANAU-WOLFGANG, FED REP GERMANY:
4,152,324, PUB. 3-20-2012. MULTIPLE CLASS, INT. CLS. 14, 40 AND 42.
- UMPQUA OATS, INC., ROSEBURG, OR:
4,154,167, PUB. 3-20-2012. INT. CL. 30.

UNCOMMON KNOWLEDGE AND ACHIEVEMENT, INC., NEW YORK, NY:
4,155,559, MULTIPLE CLASS, INT. CLS. 35 AND 41.
4,155,560, MULTIPLE CLASS, INT. CLS. 35 AND 41.

UNDER ARMOUR, INC., BALTIMORE, MD:
4,155,020, INT. CL. 25.

UNGERSTEDT, JOHAN, SE-122 64 ENSKEDE, SWEDEN AND PALMQVIST, LARS, SE-122 64 ENSKEDE, SWEDEN:
4,152,359, PUB. 3-20-2012. MULTIPLE CLASS, INT. CLS. 5 AND 30.

UNIFIED PURCHASING GROUP, LLC, SOUTH JORDAN, UT:
4,156,023, INT. CL. 35.

UNIFIRST CORPORATION, WILMINGTON, MA:
4,153,981, PUB. 3-20-2012. INT. CL. 27.

UNIGLOBE TRAVEL INTERNATIONAL LIMITED PARTNERSHIP, VANCOUVER, CANADA:
2,634,066, REN. 5-1-12. INT. CL. 39.

UNILEVER PLC, MERSEYSIDE, UNITED KINGDOM:
2,504,329, REN. 5-2-12. INT. CL. 3.

UNION CARBIDE CORPORATION, MIDLAND, MI:
1,726,797, REN. 4-28-12. INT. CL. 1.
1,730,515, REN. 4-30-12. INT. CL. 1.

UNION INSTITUTE & UNIVERSITY, CINCINNATI, OH:
2,702,376, REN. 5-1-12. INT. CL. 41.
2,704,371, REN. 5-1-12. INT. CL. 41.

UNION PACIFIC RAILROAD COMPANY, OMAHA, NE, NEXTERNA, INC, OMAHA, NE:
2,559,621, REN. 4-27-12. INT. CL. 9.

UNISMACK ANONYMI VIOMICHANIKI KE EMPORIKI ETERIA TROFIMON, STAVROCHORI, GREECE, TA U&S UNISMACK AVEE:
4,152,538, PUB. 3-20-2012. INT. CL. 30.

UNITED AUTO CREDIT CORPORATION, IRVINE, CA:
4,155,362, INT. CL. 36.

UNITED DURALUME PRODUCTS INC., FULLERTON, CA:
4,154,551, INT. CL. 19.

UNITED FOOD IMPORT, INC., DAYTON, NJ:
4,154,598, MULTIPLE CLASS, INT. CLS. 29, 30 AND 32.

UNITED SALT CORPORATION, HOUSTON, TX:
1,742,592, REN. 5-2-12. INT. CL. 1.

UNITED SERVICES AUTOMOBILE ASSOCIATION, SAN ANTONIO, TX:
2,567,056, REN. 4-27-12. INT. CL. 36.

UNITED SITE SERVICES, INC., WESTBOROUGH, MA:
4,155,160, MULTIPLE CLASS, INT. CLS. 37, 39 AND 44.
4,155,161, MULTIPLE CLASS, INT. CLS. 37, 39 AND 44.

UNITED STATES CONFERENCE OF CATHOLIC BISHOPS, WASHINGTON, DC:
2,609,680, REN. 5-1-12. INT. CL. 35.

UNITED STATES DISTILLED PRODUCTS COMPANY, PRINCETON, MN:
4,154,491, INT. CL. 33.

UNITED STATES GYPSUM COMPANY, CHICAGO, IL:
558,498, REN. 4-30-12. U.S. CL. 16 (INT. CL. 2).

UNITED STATES PIPE AND FOUNDRY COMPANY, LLC, BIRMINGHAM, AL, UNITED STATES PIPE AND FOUNDRY COMPANY, BIRMINGHAM, AL:
1,662,197, REN. 5-1-12. INT. CL. 6.

UNITED STATES PIPE AND FOUNDRY COMPANY, LLC, BIRMINGHAM, AL:
4,152,490, PUB. 3-20-2012. INT. CL. 6.

UNITED STATES PLAYING CARD COMPANY, THE, ER-LANGER, KY:
155,547, REN. 5-2-12. U.S. CL. 22 (INT. CL. 16).

UNITED STATES POLO ASSOCIATION, WELLINGTON, FL:
1,753,042, REN. 5-3-12. INT. CL. 42.

UNITED TACTICALS HOLDING LLC, SARASOTA, FL:
4,153,360, PUB. 3-20-2012. INT. CL. 28.

UNITED TECHNOLOGY ALLIANCE INC., LAS VEGAS, NV:
4,153,406, PUB. 3-20-2012. INT. CL. 9.

UNITEDHEALTH GROUP INCORPORATED, MINNETONKA, MN:
4,154,046, PUB. 3-20-2012. INT. CL. 35.
4,154,047, PUB. 3-20-2012. INT. CL. 35.
4,154,048, PUB. 3-20-2012. INT. CL. 35.

UNIT4; BUSINESS SOFTWARE HOLDING B.V., NETHERLANDS:
4,152,428, PUB. 3-20-2012. MULTIPLE CLASS, INT. CLS. 9 AND 42.

UNIVERSAL CITY STUDIOS LLC, UNIVERSAL CITY, CA, UNIVERSAL CITY STUDIOS, INC., UNIVERSAL CITY, CA:
1,705,502, REN. 4-27-12. INT. CL. 41.

UNIVERSAL CITY STUDIOS LLC, UNIVERSAL CITY, CA:
2,626,310, REN. 5-2-12. INT. CL. 41.

UNIVERSAL HOLDING GROUP, INC., NEW YORK, NY:
4,153,389, PUB. 3-20-2012. INT. CL. 11.

UNIVERSAL MAGAZINES PTY LIMITED, NORTH RYDE, NEW SOUTH WALES, AUSTRALIA:
2,560,789, REN. 4-27-12. INT. CL. 16.

UNIVERSAL MELODY SERVICES, LLC, DALLAS, TX, DBA BROOK MAYS MUSIC COMPANY:
4,152,992, PUB. 3-20-2012. MULTIPLE CLASS, INT. CLS. 35, 37 AND 41.

UNIVERSAL PACIFIC DIAMONDS & JEWELRY, LLC, NEW YORK, NY:
4,153,681, PUB. 3-20-2012. INT. CL. 14.

UNIVERSITY OF NORTH TEXAS, DENTON, TX:
4,152,462, PUB. 3-20-2012. MULTIPLE CLASS, INT. CLS. 21 AND 41.

UNIVERSITY OF SANTA MONICA, SANTA MONICA, CA:
2,582,036, REN. 5-1-12. INT. CL. 41.

UNIWORLD GROUP, INC., BROOKLYN, NY:
2,997,119, AM. INT. CL. 35.

UPFRONT MEGATAINMENT, INC., ATLANTA, GA:
4,152,445, PUB. 3-20-2012. MULTIPLE CLASS, INT. CLS. 28 AND 41.

UPTAKE MEDICAL CORPORATION, SEATTLE, WA:
4,154,484, INT. CL. 44.

UPWARD ARROW, LLC, PHILADELPHIA, PA:
4,155,922, INT. CL. 37.

URBAN ATTITUDES, NEW YORK, NY:
4,153,338, PUB. 3-20-2012. INT. CL. 18.

URBAN BASEBALL FOUNDATION, WASHINGTON, DC, DBA UBF:
4,155,459, INT. CL. 35.

URBAN GIRL SQUAD LLC, NEW YORK, NY:
4,152,618, PUB. 3-20-2012. MULTIPLE CLASS, INT. CLS. 41 AND 45.

URBAN RACONTEUR INC., SAN FRANCISCO, CA, DBA BAWDY STORYTELLING:
4,152,831, PUB. 3-20-2012. INT. CL. 41.

US AVIATION FINANCE, LLC, RICHMOND, VT:
3,204,911, COR. INT. CL. 36.

US FOODS, INC., ROSEMONT, IL:
2,580,846, REN. 5-2-12. INT. CL. 21.

US MASTERS RESIDENTIAL PROPERTY (USA) FUND, JERSEY CITY, NJ:
4,155,971, INT. CL. 36.

US MILK CORPORATION, CORONA, CA:
4,155,144, INT. CL. 3.

USA MILLENNIUM, L.P., BEAUMONT, TX:
2,998,881, CANC. INT. CL. 34.

USABLENET INC., NEW YORK, NY:
4,152,858, PUB. 3-20-2012. INT. CL. 42.

USFALCON, INC., MORRISVILLE, NC:
4,152,077, PUB. 3-20-2012. MULTIPLE CLASS, INT. CLS. 35, 37 AND 42.

USP INC., OCEANSIDE, CA:
2,647,126, REN. 5-2-12. INT. CL. 3.

USTER TECHNOLOGIES AG, CH-8610 USTER, SWITZERLAND:
3,087,190, CANC. MULTIPLE CLASS, INT. CLS. 22, 24, 26 AND 27.

USVP MANAGEMENT COMPANY LLC, MENLO PARK, CA:
2,701,749, REN. 4-27-12. INT. CL. 36.

UT BATTELLE, LLC, OAK RIDGE, TN:
4,154,836, MULTIPLE CLASS, INT. CLS. 6 AND 40.

UTAH MEDICAL PRODUCTS, INC., MIDVALE, UT, UTAH MEDICAL PRODUCTS, INC., MIDVALE, UT:
2,576,950, REN. 4-28-12. INT. CL. 10.

- UTILITY TOOL COMPANY, INC., BIRMINGHAM, AL:
4,153,363, PUB. 3-20-2012. INT. CL. 9.
- V BEAUTE LLC, NEW YORK, NY:
4,154,923, INT. CL. 3.
4,155,041, INT. CL. 3.
4,155,064, INT. CL. 3.
- V. SUAREZ & CO., INC., CRUCE BUCHANAN, CATANO, PUERTO RICO:
1,735,072. REN. 5-2-12. INT. CL. 30.
- V.I.S. VERSATILE INTERMARKET SOLUTIONS INC., VILLE ST-LAURENT, QUEBEC, CANADA:
2,893,888, COR. INT. CL. 30.
- V&V SUPREMO FOODS, INC., CHICAGO, IL:
4,152,152, PUB. 3-20-2012. MULTIPLE CLASS, INT. CLS. 29 AND 30.
- V-MODA, HOLLYWOOD, CA:
4,153,227, PUB. 3-20-2012. INT. CL. 9.
- VA BIEN INTERNATIONAL, INC., AGUAS BUENAS, PUERTO RICO:
4,154,017, PUB. 3-20-2012. INT. CL. 25.
- VAL DU CHARRON WINES (PTY) LTD, CENTURY CITY, SOUTH AFRICA:
4,155,407, INT. CL. 33.
- VALASSIS COMMUNICATIONS, INC., LIVONIA, MI:
4,152,532, PUB. 3-20-2012. INT. CL. 35.
- VALEANT PHARMACEUTICALS NORTH AMERICA, ALISO VIEJO, CA:
2,493,379, CANC. INT. CL. 3.
- VALENT U.S.A. CORPORATION, WALNUT CREEK, CA:
4,154,570, INT. CL. 5.
- VALENTINO S.P.A., ITALY:
4,152,166, PUB. 3-20-2012. MULTIPLE CLASS, INT. CLS. 11, 36 AND 43.
- VALIO LTD., HELSINKI, FINLAND:
2,640,205. REN. 4-30-12. INT. CL. 29.
- VALL LABORATORIES CONSORTIUM GROUP LLC, MIAMI, FL:
4,155,002, INT. CL. 5.
4,155,003, INT. CL. 5.
- VALLE DE LA PUERTA S.A., LA RIOJA, ARGENTINA:
2,998,859, CANC. INT. CL. 33.
- VALLEY GREEN NATURALS, LLC, BROAD RUN, VA:
4,154,055, PUB. 3-20-2012. INT. CL. 3.
4,154,058, PUB. 3-20-2012. INT. CL. 3.
4,154,061, PUB. 3-20-2012. INT. CL. 3.
4,154,063, PUB. 3-20-2012. INT. CL. 3.
- VALLEY POOLS, INC., BURNSVILLE, MN:
2,617,198. REN. 4-27-12. MULTIPLE CLASS, INT. CLS. 11 AND 19.
- VALLEY SOLUTIONS, INC., CINCINNATI, OH, DBA TOWING.COM:
4,153,966, PUB. 3-20-2012. MULTIPLE CLASS, INT. CLS. 35 AND 39.
- VALLEY TIRE CO., INC., CHARLEROI, PA:
4,153,411, PUB. 3-20-2012. INT. CL. 37.
- VALLEY VIEW INDUSTRIES H.C., CRESTWOOD, IL, WAYNE MANAGEMENT CORPORATION, CRESTWOOD, IL:
1,202,741. REN. 5-1-12. INT. CL. 20.
- VALLIANOS, LAURA, SAN LEANDRO, CA:
2,492,440, CANC. INT. CL. 14.
- VALSPAR CORPORATION, THE, MINNEAPOLIS, MN:
4,155,166, INT. CL. 2.
- VALSPAR SOURCING, INC., MINNEAPOLIS, MN:
4,154,337, INT. CL. 2.
- VALUE FORWARD GROUP, INC., PEACHTREE CITY, GA:
4,155,872, INT. CL. 35.
- VAM DRILLING FRANCE, COSNE-COURS-SUR-LOIRE, FRANCE:
2,429,421. REN. 5-3-12. INT. CL. 7.
- VAN BORTEL AIRCRAFT, INC., ARLINGTON, TX:
4,154,740, INT. CL. 7.
- VAN HEES GMBH, 65396 WALLUF, FED REP GERMANY:
4,152,039, PUB. 3-20-2012. INT. CL. 1.
- VANACORE MUSIC PUBLISHING, LLC, SANTA CLARITA, CA:
4,152,812, PUB. 3-20-2012. INT. CL. 41.
4,152,813, PUB. 3-20-2012. INT. CL. 9.
- VANGLE CONSULTING LLC, AUSTIN, TX:
4,155,306, INT. CL. 42.
- VANGUARD GROUP, INC., THE, MALVERN, PA:
2,686,589. REN. 5-2-12. INT. CL. 36.
- VANGUARD GROUP, INC. THE, MALVERN, PA:
2,573,723. REN. 5-1-12. INT. CL. 36.
- VANGUARD SOAP, LLC, MEMPHIS, TN, DBA VANGUARD SOAP:
3,130,234 NEW CERT. 6-5-2012. INT. CL. 3.
- VANSICKLE, RICHARD, MARK, CHICAGO, IL, DBA PAPA WHEELIE'S:
4,154,662, INT. CL. 43.
- VANTAGE LEARNING (USA), LLC, NEW HOPE, PA, DBA VANTAGE LEARNING:
4,153,587, PUB. 3-20-2012. INT. CL. 42.
4,153,819, PUB. 3-20-2012. INT. CL. 42.
- VANTAGE TECHNOLOGIES, INC., BOSTON, MA:
2,998,550, CANC. INT. CL. 9.
- VANTAUSZ INCORPORATED, PHOENIX, AZ, DBA IMAGE PROPERTY SERVICES:
4,153,346, PUB. 3-20-2012. INT. CL. 37.
- VANZEBO LASER, NOVATO, CA:
2,505,931. REN. 5-1-12. MULTIPLE CLASS, INT. CLS. 35 AND 37.
- VARSHAY, ELAN, SANTA FE, NM:
1,681,936. REN. 4-27-12. INT. CL. 14.
- VASCUTEK LIMITED, INCHINNAN, RENFREWSHIRE PA4 9RR, UNITED KINGDOM:
4,152,310, PUB. 3-20-2012. INT. CL. 10.
- VASOLABS, INC., BOUNTIFUL, UT, DBA VASOLABS:
4,152,895, PUB. 3-20-2012. INT. CL. 44.
- VASTAS VALF ARMATÜR SANAYI TICARET ANONIM SIRKETI, OKMEYDANI SISLI ISTANBUL, TURKEY:
4,152,236, PUB. 3-20-2012. MULTIPLE CLASS, INT. CLS. 6 AND 7.
- VATTEROTT EDUCATIONAL CENTERS, INC., OLIVETTE, MO:
4,155,548, INT. CL. 41.
- VAUGHAN & BUSHNELL MANUFACTURING COMPANY, HEBRON, IL:
2,497,877. REN. 5-2-12. INT. CL. 8.
- VAUTHIER, ERIC, BELGIUM:
4,152,291, PUB. 3-20-2012. MULTIPLE CLASS, INT. CLS. 33 AND 41.
- VB VENTURES PTY LTD, FORTITUDE VALLEY, AUSTRALIA:
4,152,078, PUB. 9-8-2009. MULTIPLE CLASS, INT. CLS. 35, 36, 39, 41 AND 43.
- VC COLLECTION LIMITED, KOWLOON, HONG KONG:
4,154,294, INT. CL. 25.
- VEGAS WOOD INDUSTRIES, INC., LAS VEGAS, NV:
4,154,629, MULTIPLE CLASS, INT. CLS. 9 AND 41.
- VEHICLE SERVICE GROUP, LLC, MADISON, IN:
2,563,436. REN. 5-3-12. INT. CL. 7.
- VEHMA INTERNATIONAL OF AMERICA, INC., TROY, MI:
1,685,067. REN. 4-30-12. MULTIPLE CLASS, INT. CLS. 7, 40 AND 42.
1,685,067, CANC. INT. CL. 12.
- VEKA INC., FOMBELL, PA:
4,155,597, INT. CL. 17.
- VELOCITY INTERNATIONAL, INC., PITTSBURGH, PA:
4,155,934, INT. CL. 38.
- VELOSMITH BICYCLE STUDIO, INC., WILLMETTE, IL:
4,153,607, PUB. 3-20-2012. INT. CL. 35.
- VELOX PRODUCTS, LLC, WESTON, FL:
4,152,857, PUB. 3-20-2012. INT. CL. 5.
- VENA, DEBORAH, HESPERIA, CA:
4,154,357, INT. CL. 25.
- VENDMORE SYSTEMS, LLC, STAMFORD, CT:
4,152,596, PUB. 3-20-2012. MULTIPLE CLASS, INT. CLS. 9, 35 AND 38.
- VENICE BAKING COMPANY, EL SEGUNDO, CA:
4,153,959, PUB. 3-20-2012. INT. CL. 30.
- VENTRADE B.V., NETHERLANDS:
4,152,346, PUB. 3-20-2012. MULTIPLE CLASS, INT. CLS. 7 AND 10.
- VENTURA FOODS LLC, CITY OF INDUSTRY, CA:
1,214,231. REN. 4-27-12. INT. CL. 29.

VENTURA FOODS, LLC, BREA, CA, SUNNYLAND REFINING COMPANY, INC., BIRMINGHAM, AL:
1,199,722. REN. 4-30-12. INT. CL. 29.

VENTURE PACIFIC INSURANCE SERVICES, INC., MISSION VIEJA, CA:
4,153,635, PUB. 3-20-2012. INT. CL. 36.

VENTURE VI, LLC, CHARLOTTE, NC:
4,153,707, PUB. 3-20-2012. INT. CL. 44.

VENUEAGENT LLC, BURLINGTON, KY:
4,155,879, MULTIPLE CLASS, INT. CLS. 41 AND 43.

VEOLIA WATER AMERICAS, LLC, CHICAGO, IL:
4,155,434, MULTIPLE CLASS, INT. CLS. 41 AND 42.

VERACITY PAYMENT SOLUTIONS, ATLANTA, GA:
4,153,620, PUB. 3-20-2012. INT. CL. 36.
4,153,622, PUB. 3-20-2012. INT. CL. 36.

VERIGREEN ENERGY & LIGHT SOLUTIONS, LLC, ASHBURN, VA:
4,153,747, PUB. 3-20-2012. INT. CL. 42.

VERINATA HEALTH, INC., REDWOOD CITY, CA:
4,155,831, INT. CL. 44.

VERISOLV TECHNOLOGIES, INC., HERNDON, VA:
4,153,717, PUB. 3-20-2012. INT. CL. 42.

VERMONT SKI AREAS ASSOCIATION, INC., MONTPELIER, VT, DBA SKI VERMONT:
2,561,794. REN. 5-1-12. MULTIPLE CLASS, INT. CLS. 16 AND 35.

VERSARIES, LLC, FAIRFIELD, OH:
4,155,080, INT. CL. 9.
4,155,081, INT. CL. 9.

VERY PERSONAL INCORPORATED, SAINT PAUL, MN, DBA COMPANYWORKS:
4,154,766, INT. CL. 41.

VESPERA LIFE, LLC, POMPANO BEACH, FL:
4,154,165, PUB. 3-20-2012. INT. CL. 36.

VETOQUINOL N.-A. INC., LAVALTRIE, CANADA:
4,152,135, PUB. 3-20-2012. INT. CL. 5.

VETROTECH SAINT-GOBAIN (INTERNATIONAL) AG, SWITZERLAND:
4,152,312, PUB. 3-20-2012. MULTIPLE CLASS, INT. CLS. 12, 19, 21 AND 42.

VIACOM INTERNATIONAL INC., NEW YORK, NY:
2,998,919, CANC. INT. CL. 16.
2,998,939, CANC. INT. CL. 16.
2,998,992, CANC. INT. CL. 16.

VIACOR POLYMER GMBH, FED REP GERMANY:
4,152,438, PUB. 3-20-2012. MULTIPLE CLASS, INT. CLS. 1, 37, 40 AND 42.

VIANA CANADA INC., WOODBRIDGE, ONTARIO, CANADA:
4,152,141, PUB. 3-20-2012. INT. CL. 25.

VIBRA FINISH COMPANY, HAMILTON, OH:
2,575,899. REN. 4-27-12. INT. CL. 3.

VICKERY, MAUREEN M., HOUSTON, TX:
2,998,933, CANC. INT. CL. 41.

VICTORIA CLASSICS LTD., NEW YORK, NY:
3,926,608, CANC. INT. CL. 24.
3,935,296, CANC. INT. CL. 24.

VICTORIA COOK, CARY, IL, DBA THE GUILT-FREE COACH:
4,152,885, PUB. 3-20-2012. INT. CL. 41.

VICTORIA'S SECRET STORES BRAND MANAGEMENT, INC., REYNOLDSBURG, OH:
4,155,652, INT. CL. 3.
4,155,766, INT. CL. 3.
4,155,802, INT. CL. 3.

VICTORIOUS SOLUTIONS LLC, MONROE, NY:
4,155,615, INT. CL. 30.

VIDA LIFESTYLE, INC., NORTH HOLLYWOOD, CA:
4,154,556, INT. CL. 11.

VIEIRA, DAVID, WEST HILLS, CA AND VIEIRA, PETRA, WEST HILLS, CA:
4,153,497, PUB. 3-20-2012. INT. CL. 43.

VIGNATURE, INC., FRISCO, TX:
4,154,916, INT. CL. 9.

VILA, ROBERT J., CAMBRIDGE, MA:
2,569,453. REN. 5-3-12. INT. CL. 35.

VILKON N.A., INC., SEATAC, WA, DBA VILKON NORTH AMERICA:
4,154,176, PUB. 3-20-2012. MULTIPLE CLASS, INT. CLS. 35 AND 39.

VILLAGE FARMS L.P., EATONTOWN, NJ:
4,155,265, INT. CL. 35.

VILLAGE R.V., INC., ROSEVILLE, CA:
2,492,963, CANC. INT. CL. 25.

VILLAGE VOICE MEDIA HOLDINGS, LLC, PHOENIX, AZ:
3,085,730, CANC. INT. CL. 16.

VINA CASA SILVA S.A., SAN FERNANDO, CHILE:
4,155,351, INT. CL. 33.

VINOS Y LICORES AZTECA. S.A. DE C.V., ZAPOPAN, JALISCO, MEXICO:
4,154,646, INT. CL. 33.

VINTAJ NATURAL BRASS CO., GALENA, IL:
4,155,857, INT. CL. 14.
4,155,859, INT. CL. 14.

VIRGINIA GOLD CUP ASSOCIATION, INC., THE, WARRENTON, VA:
2,560,739. REN. 5-2-12. INT. CL. 41.

VIRGINIA VIDRIO, LA PUENTE, CA:
4,155,982, MULTIPLE CLASS, INT. CLS. 12 AND 35.

VIÑA FRANCISCO DE AGUIRRE S.A., OVALLE, CHILE:
3,471,261, CANC. INT. CL. 33.

VISCOTEK CORPORATION, HOUSTON, TX:
2,557,863. REN. 4-27-12. INT. CL. 9.

VISI INCORPORATED, EDEN PRAIRIE, MN:
4,154,812, INT. CL. 42.

VISION SERVICE PLAN, RANCHO CORDOVA, CA, DBA VSP:
4,154,843, INT. CL. 35.

VISIONCARE OPHTHALMIC TECHNOLOGIES, INC., SARATOGA, CA:
4,153,125, PUB. 3-20-2012. MULTIPLE CLASS, INT. CLS. 36 AND 44.

VISPRONET, INC., HARRISBURG, PA:
4,155,837, MULTIPLE CLASS, INT. CLS. 6, 20, 24 AND 40.

VISTAPRINT LIMITED, HAMILTON, BERMUDA:
4,154,411, MULTIPLE CLASS, INT. CLS. 9, 16, 18, 20, 21, 25, 35, 38, 40 AND 42.

VISUAL GRAPHIC SYSTEMS INC., CARLSTADT, NJ:
4,155,510, MULTIPLE CLASS, INT. CLS. 6 AND 19.

VITAL HOLDINGS, LLC, MEMPHIS, TN:
4,152,495, PUB. 3-20-2012. MULTIPLE CLASS, INT. CLS. 35, 39, 40 AND 41.
4,152,496, PUB. 3-20-2012. MULTIPLE CLASS, INT. CLS. 35 AND 39.
4,152,498, PUB. 3-20-2012. MULTIPLE CLASS, INT. CLS. 35, 39 AND 41.
4,152,499, PUB. 3-20-2012. MULTIPLE CLASS, INT. CLS. 35 AND 39.
4,152,500, PUB. 3-20-2012. MULTIPLE CLASS, INT. CLS. 35 AND 39.

VITALICO LLC, SAN MATEO, CA:
4,155,091, INT. CL. 30.

VITAMIN WORLD, INC, RONKONKOMA, NY:
2,508,728. REN. 5-2-12. INT. CL. 5.

VITONOMY, LLC, PHOENIX, AZ:
4,155,512, MULTIPLE CLASS, INT. CLS. 5, 16, 32 AND 35.

VITRICO CORPORATION, SAN LEANDRO, CA, DBA FIRE-LIGHT GLASS:
2,491,895, CANC. INT. CL. 11.

VIVINT, INC., PROVO, UT:
4,153,443, PUB. 3-20-2012. INT. CL. 21.

VIVOMETRICS, INC., VENTURA, CA:
2,999,105, CANC. MULTIPLE CLASS, INT. CLS. 10 AND 44.

VK CORPORATION, PYONGTAEK-CITY, KYONGGI-DO, REPUBLIC OF KOREA:
2,998,905, CANC. INT. CL. 9.

VMG CREATIVE, LLC, NEW YORK, NY:
4,152,827, PUB. 3-20-2012. INT. CL. 35.

VOD MEDIA TECH, INC., EL PASO, TX:
4,153,518, PUB. 3-20-2012. INT. CL. 38.

VOGEL SEED & FERTILIZER, INC., JACKSON, WI, DBA SPRING VALLEY TURF PRODUCTS:
4,154,435, INT. CL. 1.

- VOGELZANG INTERNATIONAL CORPORATION, HOLLAND, MI:
4,155,116, INT. CL. 11.
- VOGLER ENTERPRISES, INC., EXCELSIOR SPRINGS, MO:
4,153,240, PUB. 3-20-2012. INT. CL. 35.
- VOIGT & SCHWEITZER, LLC, COLUMBUS, OH:
4,155,167, INT. CL. 40.
- VOLK PROTECTIVE PRODUCTS, INC., WILMETTE, IL, SAFETY TODAY, INC., COLUMBUS, OH:
2,559,241. REN. 5-2-12. INT. CL. 9.
- VONGERICHTEN-SUAREZ, LLC, NEW YORK, NY:
2,653,095. REN. 5-3-12. INT. CL. 42.
- VORNADO AIR, LLC, ANDOVER, KS, AKA KANSAS AIR HOLDINGS, LLC:
2,491,651, CANC. INT. CL. 11.
- VOTEBLAST, INC., WEST HOLLYWOOD, CA:
4,155,128, MULTIPLE CLASS, INT. CLS. 35 AND 42.
4,155,129, MULTIPLE CLASS, INT. CLS. 35 AND 42.
4,155,131, MULTIPLE CLASS, INT. CLS. 35 AND 42.
- VTI GAMES LLC, HOUSTON, TX:
4,152,826, PUB. 3-20-2012. INT. CL. 9.
- VU, MICHAEL, DAVIS, CA:
4,155,438, INT. CL. 45.
- W. RUDOLPH INVESTMENTS LTD., MISSISSAUGA, ONTARIO, CANADA:
2,608,564. REN. 5-2-12. MULTIPLE CLASS, INT. CLS. 7 AND 37.
- W.B. MASON CO., INC., BROCKTON, MA:
4,155,944, INT. CL. 16.
4,155,945, INT. CL. 16.
- W.C. BRADLEY/ZEBCO HOLDINGS INC., TULSA, OK:
1,683,879. REN. 5-2-12. INT. CL. 28.
- W-A-Y WIDENING ADVANCEMENTS FOR YOUTH, BELLEVILLE, MI:
4,153,984, PUB. 3-20-2012. INT. CL. 41.
- WADLEY HOLDINGS, LLC, ATLANTA, GA:
2,572,806. REN. 4-30-12. INT. CL. 20.
- WAGT TELEVISION, INC., AUGUSTA, GA:
2,998,947, CANC. INT. CL. 41.
- WAHL CLIPPER CORPORATION, STERLING, IL:
4,155,395, INT. CL. 10.
- WAL-MART STORES, INC., BENTONVILLE, AR:
2,998,648, CANC. INT. CL. 14.
2,998,732, CANC. INT. CL. 20.
2,998,733, CANC. INT. CL. 20.
- WALDO WELLNESS GROUP, KANSAS CITY, MO:
4,153,806, PUB. 3-20-2012. INT. CL. 44.
- WALKER, JON, GRAHAM, TX:
4,153,802, PUB. 3-20-2012. INT. CL. 30.
- WALTEL, JOSEPH, MANORVILLE, NY:
4,152,933, PUB. 3-20-2012. INT. CL. 41.
- WALTER LANTZ PRODUCTIONS, INC., UNIVERSAL CITY, CA:
1,696,555. REN. 4-28-12. INT. CL. 41.
- WALTERS, CHAZ, CHICAGO, IL:
4,152,627, PUB. 3-20-2012. INT. CL. 36.
- WARNER BROS. ENTERTAINMENT INC., BURBANK, CA, ATARI GAMES CORPORATION, MILPITAS, CA:
1,686,544. REN. 5-3-12. INT. CL. 9.
- WARNER PRESS, INC., ANDERSON, IN:
2,614,613. REN. 4-27-12. INT. CL. 16.
- WASH & ROLL, LLC, RALEIGH, NC:
4,155,040, INT. CL. 37.
- WATER MANAGEMENT TECHNOLOGIES, INC., MIAMI, FL:
4,153,934, PUB. 3-20-2012. INT. CL. 11.
- WATTENBARGER, JOSEPH, BAKERSFIELD, CA AND OSBORNE, THOMAS, BAKERSFIELD, CA:
4,152,928, PUB. 3-20-2012. INT. CL. 34.
- WAYMAN, GARY, VISTA, CA:
4,154,871, INT. CL. 35.
- WAYNE CHEMICAL INC., FORT WAYNE, IN:
1,692,164. REN. 4-27-12. MULTIPLE CLASS, INT. CLS. 7 AND 9.
1,696,770. REN. 4-27-12. INT. CL. 7.
1,702,415. REN. 5-3-12. INT. CL. 9.
- WAYNE E WOLF, LAS VEGAS, NV, DBA MODULARHYDRO:
4,153,527, PUB. 3-20-2012. INT. CL. 21.
- WAYNE WILLIAMS STUDIO, LLC, SHERMAN OAKS, CA:
4,153,261, PUB. 3-20-2012. INT. CL. 41.
- WEALTH PLANNING TECHNOLOGY, LLC, PRINCETON JUNCTION, NJ:
4,152,646, PUB. 3-20-2012. INT. CL. 9.
- WEATHER WORKSHOP, LLC, THE, SPRING VALLEY, OH:
2,612,913. REN. 5-2-12. INT. CL. 35.
- WEAVER'S OUTDOOR, INC., HUMMELSTOWN, PA:
4,154,859, INT. CL. 28.
- WEAVEXX, LLC, YOUNGSVILLE, NC:
2,493,155, CANC. INT. CL. 24.
- WEBFILINGS LLC, AMES, IA, FORMERLY WEB FILINGS, LLC:
4,153,722, PUB. 3-20-2012. INT. CL. 42.
- WEBMD LLC, NEW YORK, NY:
2,583,955. REN. 5-3-12. INT. CL. 38.
- WEBSTER FINANCIAL CORPORATION, WATERBURY, CT:
4,154,651, INT. CL. 35.
- WEEKS, RHONDA H., BATON ROUGE, LA, DBA SPHERE CONTROL:
4,155,157, INT. CL. 35.
- WEIBEL CDS AG, SWITZERLAND:
4,152,267, PUB. 3-20-2012. MULTIPLE CLASS, INT. CLS. 9 AND 10.
- WEICON GMBH & CO. KG, D-48157 MUENSTER, GERMAN DEM REP:
2,710,419. REN. 5-2-12. MULTIPLE CLASS, INT. CLS. 1, 2 AND 8.
- WEISMAN GROUP, INC., THE, ROSLYN, NY:
2,492,130, CANC. INT. CL. 35.
- WEISS; GARY D., REDDING, CA:
1,194,045. REN. 4-28-12. INT. CL. 28.
- WEISS, DANNA, NEW YORK, NY:
4,156,018, INT. CL. 25.
- WELCH'S FOODS INC., A COOPERATIVE, CONCORD, MA:
4,154,706, INT. CL. 30.
- WELCOME HOME RELOCATION, INC., BELLEAIR, FL:
4,153,323, PUB. 3-20-2012. MULTIPLE CLASS, INT. CLS. 39, 41 AND 45.
- WELLFOUNT, CORPORATION, INDIANAPOLIS, IN, DBA WELLFOUNT PHARMACY:
4,153,592, PUB. 3-20-2012. INT. CL. 35.
4,153,593, PUB. 3-20-2012. INT. CL. 35.
- WELLMARK INTERNATIONAL, SCHAUMBURG, IL, THURON INDUSTRIES, INC., DALLAS, TX:
936,384. REN. 5-2-12. U.S. CL. 6 (INT. CL. 5).
- WELLMARK INTERNATIONAL, SCHAUMBURG, IL, ZOECON CORPORATION, PALO ALTO, CA:
1,207,810. REN. 5-3-12. INT. CL. 5.
- WELLNESS DESIGNED BY AMY, LLC, SHORT HILLS, NJ:
4,153,020, PUB. 3-20-2012. INT. CL. 44.
- WELLNESS, INC., BOSTON, MA:
4,154,065, PUB. 3-20-2012. INT. CL. 41.
- WELLS ENTERPRISES, INC., LE MARS, IA:
3,332,170, CANC. INT. CL. 30.
- WELLS FARGO & COMPANY, SAN FRANCISCO, CA:
4,152,093, PUB. 3-20-2012. INT. CL. 36.
- WELLS FARGO & COMPANY, MINNEAPOLIS, MN:
4,154,452, MULTIPLE CLASS, INT. CLS. 35, 36 AND 45.
4,155,211, INT. CL. 36.
- WELLS FARGO ADVISORS, LLC, ST. LOUIS, MO:
2,999,022, CANC. INT. CL. 36.
- WENDT COMMUNICATION PARTNERS LLC, MECHANICSBURG, PA:
4,156,052, INT. CL. 35.
- WENDY W. BENCHLEY, WASHINGTON, DC:
4,152,799, PUB. 3-20-2012. INT. CL. 16.
- WENGER CORPORATION, OWATONNA, MN:
2,564,419. REN. 5-2-12. INT. CL. 6.
- WERNER GOURMET MEAT SNACKS, INC., TILLAMOOK, OR:
4,154,989, INT. CL. 29.
4,154,991, INT. CL. 29.

WERNER PADDLES, INC., SULTAN, WA:
 4,155,665, INT. CL. 12.
 WEST & ASSOCIATES, A PC, WALNUT CREEK, CA:
 4,153,582, PUB. 3-20-2012. INT. CL. 45.
 WEST COAST CHAIN MFG. CO., ONTARIO, CA:
 2,558,677. REN. 4-27-12. INT. CL. 20.
 2,558,678. REN. 4-27-12. INT. CL. 20.
 WEST PUBLISHING CORPORATION, EAGAN, MN:
 1,233,355. REN. 5-1-12. INT. CL. 16.
 1,233,355, CANC. INT. CL. 9.
 1,234,368. REN. 5-2-12. MULTIPLE CLASS, INT. CLS. 9
 AND 16.
 1,234,562. REN. 5-2-12. INT. CL. 16.
 WEST VIRGINIA UNIVERSITY, MORGANTOWN, WV:
 4,155,709, MULTIPLE CLASS, INT. CLS. 41 AND 44.
 WEST, BRUCE, MONTEREY, CA:
 2,702,329. REN. 4-27-12. INT. CL. 16.
 WESTEK ELECTRONICS, INC., WATSONVILLE, CA:
 4,154,279, INT. CL. 9.
 WESTERN AUTO SUPPLY COMPANY, ROANOKE, MO:
 1,209,010. REN. 4-30-12. MULTIPLE CLASS, INT. CLS. 37
 AND 42.
 WESTERN INDUSTRIES, INC., WINFIELD, KS:
 4,155,213, INT. CL. 20.
 WESTERN INTERNATIONAL GAS & CYLINDERS, INC.,
 BELLVILLE, TX:
 4,152,041, PUB. 3-20-2012. MULTIPLE CLASS, INT. CLS.
 1, 4 AND 35.
 WESTERN NEWS&INFO, INC., YUMA, AZ:
 3,605,350, COR. INT. CL. 41.
 WESTERN SAGE DESIGNS LTD., LANGLEY, BC, CANA-
 DA:
 4,152,101, PUB. 3-20-2012. MULTIPLE CLASS, INT. CLS.
 1, 5, 29 AND 30.
 WESTIFORM HOLDING AG, BÜRGLEN, SWITZERLAND:
 2,491,802, CANC. MULTIPLE CLASS, INT. CLS. 6, 9, 11,
 19, 20, 35, 37 AND 40.
 2,491,803, CANC. MULTIPLE CLASS, INT. CLS. 6, 9, 11,
 19, 20, 35, 37 AND 40.
 WESTLAKE LONGVIEW CORPORATION, HOUSTON, TX:
 2,500,716. REN. 4-30-12. MULTIPLE CLASS, INT. CLS. 35
 AND 42.
 4,154,643, INT. CL. 1.
 WESTLAND, DEVON, MASHPEE, MA:
 4,153,666, PUB. 3-20-2012. INT. CL. 25.
 WESTON DISTANCE LEARNING, INC., FT. COLLINS, CO:
 4,153,991, PUB. 3-20-2012. INT. CL. 41.
 WESTON, LORI ANN, INDIAN, CA:
 4,156,002, INT. CL. 41.
 WESTWARD LEANING, SAN FRANCISCO, CA:
 4,155,767, INT. CL. 9.
 4,155,822, INT. CL. 9.
 WHALEY, TIM, PLANO, TX:
 4,155,946, INT. CL. 19.
 WHAM-O, INC., SAN FRANCISCO, CA, WHAM-O MFG.
 CO., SAN FRANCISCO, CA:
 1,175,354. REN. 4-30-12. INT. CL. 28.
 WHAT A PIX, INC., HOUSTON, TX:
 4,155,248, MULTIPLE CLASS, INT. CLS. 9 AND 40.
 4,155,249, MULTIPLE CLASS, INT. CLS. 9 AND 40.
 WHICH WAY TO PAY LTD, SURREY, SM2 6PY, UNITED
 KINGDOM:
 4,152,494, PUB. 3-20-2012. MULTIPLE CLASS, INT. CLS.
 35 AND 36.
 WHIRLPOOL PROPERTIES, INC., SAINT JOSEPH, MI:
 2,593,010. REN. 4-27-12. INT. CL. 7.
 WHIRLPOOL PROPERTIES, INC., ST. JOSEPH, MI:
 2,605,967. REN. 5-3-12. MULTIPLE CLASS, INT. CLS. 3
 AND 21.
 2,605,968. REN. 5-3-12. MULTIPLE CLASS, INT. CLS. 3
 AND 21.
 4,153,614, PUB. 3-20-2012. INT. CL. 7.
 WHITE MOUNTAIN IMAGING, MOUNT VERNON, NY,
 CINE MAGNETICS, INC., MAMARONECK, NY:
 1,174,674. REN. 4-30-12. INT. CL. 1.
 WHITE PAPER ENTERTAINMENT LLC, LANSING, MI:
 4,153,834, PUB. 3-20-2012. INT. CL. 41.
 WHITE ROSE INC., ROBESONIA, PA:
 1,708,101. REN. 5-2-12. INT. CL. 16.
 WHITEHILL ORAL TECHNOLOGIES, INC., STAFFORD,
 TX:
 2,999,050, CANC. INT. CL. 21.
 WHITELINE MARKETING, INC., GRAND HAVEN, MI,
 DBA TACK-IT:
 4,155,280, INT. CL. 35.
 WHITES MANUFACTURING, LTD., SAANICHTON, BC
 V8M 1ZP, CANADA:
 4,152,571, PUB. 3-20-2012. MULTIPLE CLASS, INT. CLS. 9
 AND 25.
 WHOLE FOODS MARKET IP, L.P., AUSTIN, TX:
 4,154,191, PUB. 3-20-2012. INT. CL. 36.
 4,154,192, PUB. 3-20-2012. INT. CL. 36.
 4,154,193, PUB. 3-20-2012. INT. CL. 36.
 WHOLE SHIFT LLC, DUNEDIN, FL:
 4,153,905, PUB. 3-20-2012. INT. CL. 44.
 WHOLE WOMAN, INC., ALBUQUERQUE, NM:
 4,155,219, INT. CL. 41.
 WHOLESALE EXCHANGE, INC., PEMBROKE PINES, FL:
 2,568,667. REN. 4-27-12. INT. CL. 35.
 WHR HOLDINGS, LLC, HOLLYWOOD, FL:
 4,154,668, MULTIPLE CLASS, INT. CLS. 6 AND 7.
 WHY, INCORPORATED, PHILADELPHIA, PA:
 1,683,293. REN. 5-2-12. INT. CL. 41.
 WIBERG CORPORATION, OAKVILLE, ONTARIO, CANA-
 DA:
 2,998,598, CANC. INT. CL. 30.
 WIEBEL LIFT AG, MENZINGEN, SWITZERLAND:
 4,156,043, INT. CL. 7.
 WIEDEMANN, HARTY, QUINCY, FL:
 4,152,562, PUB. 3-20-2012. INT. CL. 35.
 WIELAND DENTAL + TECHNIK GMBH & CO. KG,
 PFORZHEIM, FED REP GERMANY:
 4,154,060, PUB. 3-20-2012. INT. CL. 7.
 WIHP, F-75011 PARIS, FRANCE:
 4,152,216, PUB. 3-20-2012. MULTIPLE CLASS, INT. CLS.
 35, 38, 42 AND 43.
 WILBUR-ELLIS COMPANY, SAN FRANCISCO, CA:
 4,155,312, INT. CL. 1.
 WILCOX, DAWN, SANTA MONICA, CA:
 4,153,221, PUB. 3-20-2012. INT. CL. 35.
 WILD ABOUT DOLPHINS, INC., KEY WEST, FL:
 2,561,717. REN. 5-1-12. INT. CL. 39.
 WILD OWL, VALERIE, HOPEDALE, MA:
 4,155,335, INT. CL. 35.
 WILDCAT LIGHTING, LLC, NEW BRAUNFELS, TX:
 4,152,792, PUB. 3-20-2012. INT. CL. 35.
 4,152,793, PUB. 3-20-2012. INT. CL. 11.
 4,152,810, PUB. 3-20-2012. INT. CL. 11.
 WILDECK, INC., WAUKESHA, WI:
 2,492,934, CANC. INT. CL. 7.
 WILDER, LASHANA, MONCK'S CORNER, SC:
 4,152,829, PUB. 3-20-2012. INT. CL. 42.
 WILDFOX COUTURE IP HOLDINGS, LLC, LOS ANGELES,
 CA:
 4,154,572, INT. CL. 25.
 WILDGAME INNOVATIONS, LLC, BROUSSARD, LA:
 4,155,394, MULTIPLE CLASS, INT. CLS. 28 AND 31.
 WILDLIFE ARTISTS, INC., BETHEL, CT:
 2,493,451, CANC. INT. CL. 28.
 WILLEMS COMMERCIAL PRINTING, INC., FOWLER, CA:
 4,154,874, INT. CL. 40.
 WILLIAM GRANT & SONS LIMITED, DUFFTOWN,
 BANFFSHIRE, UNITED KINGDOM:
 2,562,207. REN. 4-30-12. INT. CL. 33.
 WILLIAM MARSH RICE UNIVERSITY, HOUSTON, TX:
 2,540,150. REN. 5-3-12. INT. CL. 18.
 2,609,242. REN. 4-30-12. INT. CL. 14.
 2,615,279. REN. 4-30-12. INT. CL. 24.
 2,615,280. REN. 4-30-12. INT. CL. 14.
 2,615,281. REN. 5-1-12. INT. CL. 21.
 2,620,268. REN. 4-30-12. INT. CL. 21.
 WILLIAMS FOODS, INC., SAN ANTONIO, TX:
 3,018,992, CANC. INT. CL. 29.

- WILLOW CREEK ASSOCIATION, SOUTH BARRINGTON, IL:
2,497,785. REN. 5-2-12. INT. CL. 42.
2,497,785. CANC. MULTIPLE CLASS, INT. CLS. 9, 16 AND 41.
4,154,712. INT. CL. 42.
- WILMOUTH, RITA S, PITTSBURGH, PA:
2,699,154. REN. 4-27-12. MULTIPLE CLASS, INT. CLS. 16, 35, 37 AND 41.
- WILSON SPORTING GOODS CO., CHICAGO, IL:
2,555,951. REN. 4-27-12. INT. CL. 28.
- WINBROOK COMMUNICATIONS SERVICES, INC., BILLERICA, MA:
3,232,151. COR. INT. CL. 35.
- WINCAN AMERICA, INC., ALBUQUERQUE, NM:
3,529,088. CANC. MULTIPLE CLASS, INT. CLS. 9, 41 AND 42.
- WINCHESTER REO, LLC, C/O WELLS FARGO BANK, N.A., CHARLOTTE, NC:
2,501,522. REN. 4-30-12. INT. CL. 41.
- WIND SONG PRODUCTIONS, FRESNO, CA:
4,154,453. MULTIPLE CLASS, INT. CLS. 35 AND 41.
- WINDBAG LIMITED LIABILITY COMPANY, FREEHOLD, NJ:
4,155,247. INT. CL. 41.
- WINDMILL HEALTH PRODUCTS, LLC, W. CALDWELL, NJ:
4,154,914. INT. CL. 5.
- WINDMOLLER & HOLSCHER, LENGERICH, FED REP GERMANY:
1,193,516. REN. 5-1-12. INT. CL. 7.
- WINDREAM GMBH, 44799 BOCHUM, FED REP GERMANY:
2,560,936. REN. 5-2-12. MULTIPLE CLASS, INT. CLS. 9 AND 42.
- WINDY CITY STRATEGIES, INC., ALGONQUIN, IL:
4,153,289. PUB. 3-20-2012. MULTIPLE CLASS, INT. CLS. 35 AND 42.
- WINDY PIZZA PLUS LLC, GARDENA, CA, DBA EATALIAN CAFE:
4,155,649. INT. CL. 43.
4,155,682. INT. CL. 43.
- WINE GROUP LLC, THE, TRACY, CA, WINE CORPORATION OF AMERICA, CHICAGO, IL:
558,784. REN. 4-30-12. U.S. CL. 47 (INT. CL. 33).
- WINE MASTERS ACADEMY, INC, COOPERSBURG, PA:
4,153,676. PUB. 3-20-2012. INT. CL. 35.
- WINEGARD COMPANY, BURLINGTON, IA:
4,155,772. INT. CL. 9.
4,155,807. INT. CL. 9.
- WINEINC PTY LTD, ACN 110 809 348, AUSTRALIA:
4,040,455. COR. INT. CL. 33.
- WINERY EXCHANGE, INC., NOVATO, CA:
4,155,816. INT. CL. 33.
- WINFIELD SOLUTIONS, LLC, SHOREVIEW, MN:
1,699,302. REN. 5-3-12. INT. CL. 31.
1,700,733. REN. 5-2-12. INT. CL. 31.
1,708,515. REN. 5-3-12. INT. CL. 31.
1,716,250. REN. 5-3-12. INT. CL. 31.
- WINGITS INNOVATIONS, LLC, BRADLEY BEACH, NJ:
4,152,450. PUB. 3-20-2012. MULTIPLE CLASS, INT. CLS. 6 AND 20.
- WINKELHORN, KARIN-MARIA K., LAS VEGAS, NV:
2,493,637. CANC. INT. CL. 42.
- WINN, ROBERT T., BIG SANDY, TX, DBA TEXAS CREEK FARMS:
4,154,689. INT. CL. 5.
- WINTHROP VENTURE MANAGEMENT, INC., FT. LAUDERDALE, FL:
2,559,462. REN. 4-27-12. INT. CL. 30.
- WIRELESS FOUNDATION, THE, WASHINGTON, DC:
2,560,714. REN. 4-27-12. INT. CL. 36.
- WIRESPEED NETWORKS, INC., IRVINE, CA, DBA STABLEPATH:
4,153,898. PUB. 3-20-2012. INT. CL. 42.
4,153,900. PUB. 3-20-2012. INT. CL. 42.
- WIRING HARNESS MANUFACTURERS ASSOCIATION, EDEN PRAIRIE, MN:
2,563,024. REN. 4-30-12. INT. CL. 42.
- WIZARDS OF THE COAST LLC, PAWTUCKET, RI:
4,155,329. INT. CL. 28.
- WLR CONSORTIUM, LLC, PLACERVILLE, CA, AKA POWER CONSORTIUM:
2,608,367. REN. 5-2-12. INT. CL. 9.
- WM. BOLTHOUSE FARMS, INC., BAKERSFIELD, CA:
1,700,694. REN. 5-1-12. INT. CL. 29.
- WM. W. MEYER & SONS, INC., SKOKIE, IL:
1,682,661. REN. 5-2-12. INT. CL. 7.
- WMS GAMING INC., WAUKEGAN, IL:
4,155,112. INT. CL. 9.
- WOHALI OUTDOORS, LLC, CLAREMORE, OK:
4,155,587. INT. CL. 25.
- WOLF STEEL LTD., BARRIE, ONTARIO, CANADA:
2,520,892. REN. 4-27-12. INT. CL. 11.
- WOLF, CARL, CHERRY HILL, NJ, DBA ATLANTIC BEAUTY SALES:
4,155,164. INT. CL. 3.
- WOLFE ELECTRIC, INC., WICHITA, KS:
4,152,818. PUB. 3-20-2012. INT. CL. 11.
- WOLFFPACK, INC., BLUFF POINT, NY:
1,683,633. REN. 4-27-12. MULTIPLE CLASS, INT. CLS. 9 AND 42.
- WOLTER, TILL, WEST NEW YORK, NJ, DBA VINETALK AND MCQUEEN, SEAN, LONG ISLAND CITY, NY, DBA VINETALK:
4,154,882. INT. CL. 41.
- WOLTERS KLUWER HEALTH, INC., PHILADELPHIA, PA, VERNON PUBLICATIONS INC., BELLEVUE, WA:
1,700,481. REN. 4-30-12. INT. CL. 16.
- WOLVERINE WORLD WIDE, INC., ROCKFORD, MI:
4,154,369. INT. CL. 25.
- WOLVERT, TERRY D, WILSONVILLE, OR:
4,153,960. PUB. 3-20-2012. INT. CL. 9.
- WONDER WORKS AMERICA, INC., ENGLEWOOD, NJ:
2,566,061. REN. 5-1-12. INT. CL. 11.
- WOOD ROYALTY MANAGEMENT COMPANY, WILMINGTON, DE:
2,565,684. REN. 5-3-12. INT. CL. 42.
2,680,428. REN. 5-3-12. INT. CL. 42.
- WOODHEAD INDUSTRIES, INC., LINCOLNSHIRE, IL:
1,701,086. REN. 5-3-12. INT. CL. 9.
- WOODSTOCK PERCUSSION, INC., SHOKAN, NY:
1,697,553. REN. 5-2-12. INT. CL. 15.
- WOODSTOCK VENTURES LC, NEW YORK, NY:
4,153,158. PUB. 3-20-2012. INT. CL. 41.
- WOODSTOCKS INTERNATIONAL LTD.; JAN AUKSTOLIS, SURREY GU5 9LB, UNITED KINGDOM:
4,152,430. PUB. 3-20-2012. MULTIPLE CLASS, INT. CLS. 18 AND 20.
- WOODSTREAM CORPORATION, LITITZ, PA:
2,588,744. REN. 5-3-12. MULTIPLE CLASS, INT. CLS. 9 AND 35.
- WOODWORKER'S SUPPLY, INC., CASPER, WY:
1,697,188. REN. 4-27-12. INT. CL. 20.
- WOOLSLAYER COMPANIES, INC., TULSA, OK:
4,154,681. INT. CL. 7.
- WOOSTER BRUSH COMPANY, THE, WOOSTER, OH:
159,596. REN. 4-27-12. U.S. CL. 29 (INT. CLS. 16 AND 21).
- WORD OF LIFE FELLOWSHIP, INC., SCHROON LAKE, NY:
2,562,993. REN. 4-27-12. INT. CL. 41.
- WORLD CLASS DEALER SERVICES INCORPORATED, QUAKERTOWN, PA:
4,152,909. PUB. 3-20-2012. MULTIPLE CLASS, INT. CLS. 16 AND 41.
- WORLD CLASS TECHNOLOGY CORPORATION, MCMINNVILLE, OR:
4,155,755. INT. CL. 35.
- WORLD KICKBOXING LEAGUE, MIAMI BEACH, FL:
4,154,090. PUB. 3-20-2012. INT. CL. 41.
- WORLD MAGIC INTERNATIONAL (W.M.I) AVV, ORANJESTAD, ARUBA:
4,154,247. MULTIPLE CLASS, INT. CLS. 28 AND 41.
- WORLD PANCRASE CREATE, INC., TOKYO, JAPAN:
2,493,406. CANC. INT. CL. 25.
- WORLD RESOURCES INSTITUTE, WASHINGTON, DC:
4,153,739. PUB. 3-20-2012. INT. CL. 39.

WORLD TRADE VALLEY, INC, MIAMI, FL:
 4,155,376, INT. CL. 35.
 WORLWIDE PROJECT CONSORTIUM (HOLDINGS) LIMITED, 00130 HELSINKI, FINLAND:
 4,152,977, PUB. 3-20-2012. INT. CL. 39.
 WOUNDED WARRIOR PROJECT, INC., JACKSONVILLE, FL:
 4,155,558, INT. CL. 36.
 WP COMPANY LLC, WASHINGTON, DC:
 4,155,220, INT. CL. 35.
 WPP PROPERTIES, NEW YORK, NY:
 4,154,441, MULTIPLE CLASS, INT. CLS. 35 AND 42.
 WRIGHT FLOW TECHNOLOGIES LIMITED, EASTBOURNE, UNITED KINGDOM:
 2,547,790. REN. 4-30-12. INT. CL. 7.
 WRIGHT PRINTING CO., OMAHA, NE:
 2,582,110. REN. 4-27-12. INT. CL. 42.
 WU, JACK, NEW YORK, NY:
 4,155,756, INT. CL. 9.
 WWW.LETTERMATCH.COM LLC, MILWAUKEE, WI:
 4,153,830, PUB. 3-20-2012. INT. CL. 35.
 WXIIIQXFORDDTC REAL ESTATE, LLC, CHICAGO, IL:
 3,008,031, AM. INT. CL. 43.
 WYATT TECHNOLOGY CORPORATION, SANTA BARBARA, CA:
 1,663,974. REN. 5-1-12. INT. CL. 9.
 WYETH LLC, MADISON, NJ:
 4,154,823, INT. CL. 5.
 WYNDHAM TM CORP., LAS VEGAS, NV:
 4,155,843, INT. CL. 35.
 WYSTON BOOKS, INC., MIDDLETOWN, NY:
 2,696,802. REN. 4-27-12. INT. CL. 16.
 X PLUS ONE SOLUTIONS, INC., NEW YORK, NY:
 4,154,575, MULTIPLE CLASS, INT. CLS. 9, 35 AND 42.
 XENOLITH MEDICAL, LTD, KIRYAT GAT, ISRAEL:
 4,154,922, INT. CL. 10.
 XEROX CORPORATION, NORWALK, CT:
 2,998,596, CANC. INT. CL. 35.
 XIAMEN WING TECHNOLOGY CO., LTD, CHINA:
 4,152,425, PUB. 3-20-2012. INT. CL. 11.
 XIKAR, INC., KANSAS CITY, MO:
 4,154,064, PUB. 3-20-2012. INT. CL. 34.
 XINHUI RIXING STAINLESS; STEEL PRODUCTS CO., LTD., CHINA:
 4,152,435, PUB. 3-20-2012. MULTIPLE CLASS, INT. CLS. 6 AND 20.
 XIRING, SURESNES CEDEX, FRANCE:
 2,491,717, CANC. MULTIPLE CLASS, INT. CLS. 9, 16, 28, 36, 38 AND 42.
 XLNT ADVANCED TECHNOLOGIES B.V., NETHERLANDS:
 4,152,371, PUB. 3-20-2012. INT. CL. 6.
 XPOTENTIAL PRODUCTS INC., WINNIPEG, MANITOBA, CANADA:
 2,560,975. REN. 5-2-12. INT. CL. 19.
 YAGI AKIRA, JAPAN:
 4,152,214, PUB. 3-20-2012. MULTIPLE CLASS, INT. CLS. 9, 18, 28, 29, 30, 31, 35 AND 43.
 YAHOO! INC., SUNNYVALE, CA, JBS SPORTS, INC., BRENTWOOD, TN:
 2,559,428. REN. 4-30-12. MULTIPLE CLASS, INT. CLS. 38, 41 AND 42.
 YALER GMBH, SWITZERLAND:
 4,152,352, PUB. 3-20-2012. INT. CL. 9.
 YAMAHA HATSUDOKI KABUSHIKI KAISHA, SHIZUOKA-KEN, JAPAN:
 1,682,819. REN. 4-30-12. INT. CL. 12.
 YANKEE BOOK PEDDLER, INC., CONTOOCOOK, NH:
 4,153,303, PUB. 3-20-2012. INT. CL. 42.
 YARITZ, BRADLEY JOHN, WHITE BEAR LAKE, MN, DBA CATCH IT!:
 4,155,775, INT. CL. 28.
 YARN GAMES AND MORE, LLC, SAN FRANCISCO, CA:
 4,154,816, INT. CL. 28.
 YEAGER, LISA C., MISSOULA, MT:
 2,998,854, CANC. INT. CL. 5.
 YELLOW HOUSE CAFE, INC., LOS ANGELES, CA, DBA YELLOW CAFE:
 4,152,614, PUB. 3-20-2012. INT. CL. 43.
 YELLOWBOOK INC., UNIONDALE, NY:
 4,154,889, INT. CL. 35.
 YELLOWPAGES.COM, LLC, GLENDALE, CA:
 4,154,717, MULTIPLE CLASS, INT. CLS. 35 AND 41.
 YFY, LLC, LAS VEGAS, NV:
 4,105,650, AM. INT. CL. 43.
 YFY, LLC, CRYSTAL LAKE, IL:
 4,155,307, INT. CL. 25.
 4,155,308, INT. CL. 25.
 YIANOLATOS, LINDA, SOUTH ORANGE, NJ:
 4,155,372, MULTIPLE CLASS, INT. CLS. 14, 21 AND 25.
 YIPE MEDIA, INC., ROCHESTER, WA:
 4,154,824, INT. CL. 28.
 YO FRESH, LLC, NEW YORK, NY:
 4,152,722, PUB. 3-20-2012. INT. CL. 43.
 YOASIS FRANCHISING SYSTEMS, LLC, SALT LAKE CITY, UT:
 4,154,746, MULTIPLE CLASS, INT. CLS. 29, 30 AND 32.
 4,154,747, MULTIPLE CLASS, INT. CLS. 29, 30 AND 32.
 YOGA MONKEY KIDS, LLC, MCLEAN, VA:
 4,152,790, PUB. 3-20-2012. MULTIPLE CLASS, INT. CLS. 25 AND 41.
 YOGD, LLC, SAINT HELENS, OR:
 4,153,800, PUB. 3-20-2012. INT. CL. 33.
 4,153,801, PUB. 3-20-2012. INT. CL. 33.
 YOGURT BLISS, LLC, MIAMI, FL:
 4,152,655, PUB. 3-20-2012. INT. CL. 43.
 YOTEL LIMITED, LONDON WIW 8DH, UNITED KINGDOM:
 4,155,567, MULTIPLE CLASS, INT. CLS. 7 AND 43.
 YOTEL LIMITED, LONDON, UNITED KINGDOM:
 4,155,568, INT. CL. 43.
 YOU CAN DO ANYTHING LLC, ALDIE, VA:
 4,153,508, PUB. 3-20-2012. INT. CL. 41.
 4,153,509, PUB. 3-20-2012. INT. CL. 41.
 YOU CO., LTD., KYOTO-CITY, JAPAN:
 2,559,112. REN. 4-27-12. INT. CL. 9.
 YOU GOT LISTINGS, INC., ALLSTON, MA:
 4,153,333, PUB. 3-20-2012. INT. CL. 42.
 YOU'RE CLUELESS, INC., HIGHLAND PARK, IL:
 4,154,037, PUB. 3-20-2012. MULTIPLE CLASS, INT. CLS. 16 AND 35.
 YOUNG WOMEN'S CHRISTIAN ASSOCIATION OF THE UNITED STATES OF AMERICA, INC., WASHINGTON, DC:
 2,626,439. REN. 5-1-12. INT. CL. 41.
 YOUNG, RICHARD, EASTWOOD, AUSTRALIA, DBA TOTALLY PUMPED:
 4,152,805, PUB. 3-20-2012. MULTIPLE CLASS, INT. CLS. 38 AND 41.
 YOUNG'S MARKET COMPANY, TUSTIN, CA:
 1,196,491. REN. 5-1-12. INT. CL. 42.
 YOUTHFRONT, INC., SHAWNEE MISSION, KS:
 2,492,432, CANC. INT. CL. 42.
 YTV CANADA, INC., TORONTO, CANADA:
 4,152,158, PUB. 1-24-2012. MULTIPLE CLASS, INT. CLS. 38 AND 41.
 YUKIGUNI MAITAKE CO., LTD., UONUMA-GUN NIIGATA PREFECTURE, JAPAN:
 2,561,547. REN. 4-30-12. MULTIPLE CLASS, INT. CLS. 5, 29 AND 31.
 YUMI ECOSOLUTIONS, INC., WESTPORT, CT:
 4,154,627, INT. CL. 21.
 YUMYUM WARRIOR, INC., RALEIGH, NC:
 4,152,837, PUB. 3-20-2012. INT. CL. 43.
 ZAFFERANO CAPITAL LIMITED, GRAND CAYMAN, CAYMAN ISLANDS:
 4,153,162, PUB. 3-20-2012. INT. CL. 36.
 ZANOX.DE AG, 10245 BERLIN, FED REP GERMANY:
 4,152,237, PUB. 12-13-2011. MULTIPLE CLASS, INT. CLS. 35, 38 AND 42.
 ZAPPOS IP, INC., HENDERSON, NV:
 4,154,634, INT. CL. 25.
 ZAXCOM, INC., POMPTON PLAINS, NJ:
 4,153,367, PUB. 3-20-2012. INT. CL. 9.

- ZEEFAX LIMITED, LONDON, UNITED KINGDOM:
2,560,756. REN. 5-2-12. INT. CL. 9.
- ZEFON INTERNATIONAL, INC., OCALA, FL:
1,736,101. REN. 4-30-12. INT. CL. 7.
- ZEISEL, LAURA, PLAINFIELD, VT:
4,152,047. PUB. 3-20-2012. INT. CL. 18.
- ZENASIS TECHNOLOGIES, INC., CAMPBELL, CA:
2,998,868. CANC. INT. CL. 9.
- ZERO WASTE ENERGY SYSTEMS USA LLC, JACKSON, MS:
4,154,020. PUB. 3-20-2012. INT. CL. 35.
- ZERONINES TECHNOLOGY, INC., CASTLE ROCK, CO:
4,154,679. MULTIPLE CLASS, INT. CLS. 9 AND 39.
4,154,680. INT. CL. 9.
- ZHANGZHOU GUANGZHAOREN TEA CO., LTD., FUJIAN, CHINA:
4,155,185. INT. CL. 30.
- ZHEJIANG DAHUA TECHNOLOGY CO., LTD., HANGZHOU, CHINA:
4,155,201. INT. CL. 9.
- ZHEJIANG RUYI GIFTS & CRAFT CO.,LTD., CHINA:
4,152,204. PUB. 3-20-2012. INT. CL. 28.
- ZHONG RENKANG, SHENZHEN, CHINA:
4,155,343. INT. CL. 9.
4,155,344. INT. CL. 18.
- ZIMMEDIA, LLC, LONG ISLAND CITY, NY:
4,155,458. INT. CL. 42.
- ZIMMER GMBH, WINTERTHUR, SWITZERLAND:
2,568,992. REN. 4-27-12. INT. CL. 10.
- ZING TECHNOLOGIES, LLC, CARMEL, IN:
4,152,096. PUB. 3-20-2012. INT. CL. 42.
- ZINSSER BRANDS COMPANY, MEDINA, OH, ZEHRUNG CORPORATION, PORTLAND, OR:
1,698,660. REN. 4-28-12. INT. CL. 1.
- ZINSSER BRANDS COMPANY, MEDINAH, OH, WILLIAM ZINSSER & CO., SOMERSET, NJ:
1,722,885. REN. 4-28-12. INT. CL. 2.
- ZIPM, INC., CHICAGO, IL:
2,493,121. CANC. INT. CL. 35.
- ZIYA BUSINESS INC, DECATUR, GA, DBA Z-CELL:
4,153,428. PUB. 3-20-2012. INT. CL. 9.
- ZOE'S MEATS, PETALUMA, CA, DBA YIORYO:
4,153,433. PUB. 3-20-2012. INT. CL. 29.
- ZOELLER PUMP COMPANY, LLC, LOUISVILLE, KY, ZOELLER COMPANY, LOUISVILLE, KY:
2,632,378. REN. 5-1-12. INT. CL. 11.
- ZOJIRUSHI CORPORATION, KITA-KU, OSAKA, JAPAN:
2,569,099. REN. 5-1-12. INT. CL. 21.
2,593,565. CANC. INT. CL. 7.
- ZONE RECORDS, INC., MAITLAND, FL:
2,572,616. REN. 5-2-12. MULTIPLE CLASS, INT. CLS. 9 AND 41.
- ZOO MED LABORATORIES, INC., SAN LUIS OBISPO, CA:
1,727,391. REN. 4-30-12. INT. CL. 11.
- ZOOKAWARE, LLC, MESA, AZ:
4,153,639. PUB. 3-20-2012. INT. CL. 9.
4,153,641. PUB. 3-20-2012. INT. CL. 9.
4,153,644. PUB. 3-20-2012. INT. CL. 9.
- ZOOLOGICAL SOCIETY OF SAN DIEGO, SAN DIEGO, CA:
4,152,604. PUB. 3-20-2012. INT. CL. 41.
- ZORZAL INCORPORATED, CALGARY, CANADA:
4,152,104. PUB. 3-20-2012. INT. CL. 33.
- ZOTEFOAMS PLC, CROYDON SURREY, UNITED KINGDOM:
4,152,487. PUB. 2-14-2012. INT. CL. 17.
- ZUCRUM FOODS, L.L.C., RIO RICO, AZ:
2,559,213. REN. 4-27-12. INT. CL. 30.
- ZURN INDUSTRIES, INC., ERIE, PA:
2,998,901. CANC. INT. CL. 11.
- ZYDECO STUDIOS, RIVERWOODS, IL:
4,153,735. PUB. 3-20-2012. INT. CL. 26.
- ZYLOWARE CORPORATION, PORT CHESTER, NY:
4,155,208. INT. CL. 9.
- ZZIMA INTERNATIONAL, SARL, MAMER / CAPELLEN, LUXEMBOURG:
4,153,064. PUB. 3-20-2012. MULTIPLE CLASS, INT. CLS. 35, 38, 41, 42 AND 45.
- IPG, INC., ASHBURN, VA:
2,569,133. REN. 5-1-12. MULTIPLE CLASS, INT. CLS. 35 AND 41.
- 1ST CHAIR SKIN CARE, INC., OGLESBY, IL, DBA ARIVA:
4,153,708. PUB. 3-20-2012. INT. CL. 35.
4,153,711. PUB. 3-20-2012. INT. CL. 44.
- 10 CLAY ENTERPRISES, LLC, HASTINGS, MN, DBA LIQUORVILLE:
4,152,936. PUB. 3-20-2012. INT. CL. 35.
- 10KINFO, INC., BELLEVUE, WA:
4,153,912. PUB. 3-20-2012. INT. CL. 42.
- 1147785 ONTARIO LTD., HUNTSVILLE, ONTARIO, CANADA, DBA MUSKOKA ROASTERY COFFEE COMPANY:
4,152,968. PUB. 3-20-2012. MULTIPLE CLASS, INT. CLS. 30, 35 AND 40.
- 1400446 ALBERTA LTD., EDMONTON, CANADA:
4,110,573. COR. INT. CL. 14.
4,110,574. COR. INT. CL. 14.
- 2ND BEST LLC, BEVERLY HILLS, CA:
4,153,472. PUB. 3-20-2012. INT. CL. 9.
- 2ND CHANCE ENTERPRISES, LLC, BURNSVILLE, MN:
4,153,495. PUB. 3-20-2012. INT. CL. 41.
- 2008474 ONTARIO INC., TORONTO, ONTARIO, CANADA:
4,152,121. PUB. 3-29-2011. INT. CL. 32.
- 21ST EDITIONS, INC., SOUTH DENNIS, MA:
4,153,755. PUB. 3-20-2012. INT. CL. 16.
- 24/7 BRANDS PTY LTD, AUSTRALIA:
4,152,252. PUB. 3-20-2012. MULTIPLE CLASS, INT. CLS. 35 AND 41.
- 3D RESULTS, LLC, LIBERTYVILLE, IL:
4,152,954. PUB. 3-20-2012. MULTIPLE CLASS, INT. CLS. 35, 41 AND 42.
- 300 BELOW, INC, DECATUR, IL:
2,268,645. CANC. INT. CL. 40.
- 305 FILMS, INC, MIAMI, FL:
4,153,771. PUB. 3-20-2012. MULTIPLE CLASS, INT. CLS. 35 AND 41.
- 31, INC., NEWCOMERSTOWN, OH:
4,154,710. INT. CL. 9.
- 4LIFE TRADEMARKS, LLC, SANDY, UT:
2,702,837. REN. 4-28-12. INT. CL. 5.
4,152,945. PUB. 3-20-2012. MULTIPLE CLASS, INT. CLS. 5 AND 29.
- 4WARRANTY CORPORATION, ORANGE PARK, FL:
4,155,685. INT. CL. 36.
- 53RD STREET, INC., DALLAS, TX, DBA THE DEALEY GROUP:
2,561,519. REN. 5-3-12. INT. CL. 16.
- 6751342 CANADA, INC., WESTMOUNT QUEBEC, CANADA:
4,152,099. PUB. 3-20-2012. MULTIPLE CLASS, INT. CLS. 25, 41 AND 44.
- 7-ELEVEN, INC., DALLAS, TX:
2,998,558. CANC. INT. CL. 4.
- 7933657 CANADA, INC., MONTREAL QUEBEC, CANADA:
2,493,377. CANC. INT. CL. 25.
- 7949987 CANADA INC., WATERLOO, ONTARIO, CANADA:
2,529,685. REN. 5-2-12. INT. CL. 11.
2,567,093. REN. 5-2-12. INT. CL. 11.
- 8NET, INC., CERRITOS, CA:
4,155,817. INT. CL. 37.
- 800RESPONSE MARKETING, LLC, BURLINGTON, VT:
4,153,197. PUB. 3-20-2012. MULTIPLE CLASS, INT. CLS. 35 AND 38.